

48X/32X/48X Max CD-RW 光碟機



# 使用手冊



48X/32X/48X Max CD-RW 光碟機



# 使用手冊

**註:** 在使用本資訊及其支援的產品之前，請先閱讀附錄中的資訊。

---

## 安全資訊：請先閱讀

安裝本產品之前，請先閱讀「安全資訊」。

مج، يجب قراءة دات السلامة

Antes de instalar este produto, leia as Informações de Segurança.

Prije instalacije ovog produkta obavezno pročitajte Sigurnosne Upute.

Před instalací tohoto produktu si přečtěte příručku bezpečnostních instrukcí.

Læs sikkerhedsforskrifterne, før du installerer dette produkt.

Ennen kuin asennat tämän tuotteen, lue turvaohjeet kohdasta Safety Information.

Avant d'installer ce produit, lisez les consignes de sécurité.

Vor der Installation dieses Produkts die Sicherheitshinweise lesen.

Πριν εγκαταστήσετε το προϊόν αυτό, διαβάστε τις πληροφορίες ασφάλειας (safety information).

לפני שתתקינו מוצר זה, קראו את הוראות הבטיחות.

A termék telepítése előtt olvassa el a Biztonsági előírásokat!

Prima di installare questo prodotto, leggere le Informazioni sulla Sicurezza.

製品の設置の前に、安全情報をお読みください。

본 제품을 설치하기 전에 안전 정보를 읽으십시오.

Пред да се инсталира овој продукт, прочитајте информацијата за безбедност.

Lees voordat u dit product installeert eerst de veiligheidsvoorschriften.

Les sikkerhetsinformasjonen (Safety Information) før du installerer dette produktet.

Przed zainstalowaniem tego produktu, należy zapoznać się z książką "Informacje dotyczące bezpieczeństwa" (Safety Information).

Antes de instalar este produto, leia as Informações sobre Segurança.

Перед установкой продукта прочтите инструкции по технике безопасности.

Pred inštaláciou tohto zariadenia si pečítajte Bezpečnostné predpisy.

Pred namestitvijo tega proizvoda preberite Varnostne informacije.

Antes de instalar este producto lea la información de seguridad.

Läs säkerhetsinformationen innan du installerar den här produkten.

安裝本產品之前，請先閱讀「安全資訊」。

# 目錄

安全資訊：請先閱讀	iii
關於本書	vii
註冊您的選用設備	vii
安裝與使用手冊	1
簡介	1
產品說明	1
軟體說明	1
開始之前	2
系統需求	2
搬動指示	2
產品外觀	2
光碟機的正面	3
光碟機的背面	3
安裝光碟機	4
步驟 1. 打開電腦	4
步驟 2. 打開光碟機包裝	4
步驟 3. 選取 IDE 埠	4
步驟 4. 設定配置跳接器	5
步驟 5. 裝載光碟機到機槽	5
步驟 6. 連接光碟機接線	5
步驟 7. 完成硬體安裝	6
步驟 8. 更新電腦配置	6
步驟 9. 安裝 CD-RW 光碟機軟體	6
使用 CD-R 和 CD-RW 光碟	7
搬運與維護 CD	8
使用光碟機	9
維護 CD-RW 光碟機	9
載入 CD	9
手動退出 CD	10
使用軟體	10
附錄 A. 產品規格	13
附錄 B. 問題解決	17
疑難排解	17

您的電腦或 CD-RW 光碟機無法正確操作，或是忙 碌指示燈並未亮著	17
您無法格式化 CD-RW 光碟	17
您無法建立多重階段光碟	18
您無法順利寫入到 CD-R 或 CD-RW 光碟	18
您無法退出光碟	18
在順利寫入 CD 之後，您無法讀取此 CD	18
您無法存取 CD-RW 光碟機，或是光碟機圖示並未 顯示 (Windows XP)	19
無法讀取此 CD	19
這張 CD 沒有聲音	20
在音訊接線上提供的接頭，與您音訊配接卡上的接 頭不符	20
在複製 CD 或製作資料 CD 時，您收到 "buffer underrun" 錯誤訊息	20
電腦無法關機或待機	20
電腦在開機時當機	20

## 附錄 C. 自訂裝置驅動程式的配置設定 . . . 21

變更 Windows Me 的「自動插入通知」及 DMA 參 數	21
變更 Windows XP 的 DMA 參數設定	21
啓用 Windows 2000 Professional 的 DMA	22

## 附錄 D. Service and Support . . . . . 23

Online technical support	23
Telephone technical support	23

## 附錄 E. IBM Statement of Limited Warranty - Z125-4753-07 - 11/2002 . . . 25

Part 2 - Country-unique Terms	28
Part 3 - Warranty Information	40

## 附錄 F. Notices . . . . . 43

Federal Communications Commission (FCC) statement	44
Trademarks	47





---

## 關於本書

本手冊含有如何安裝、配置 IBM® 48X/32X/48X Max CD-RW 光碟機以及疑難排解的指示。本手冊分成下列幾節：

### 安裝與使用手冊

本手冊含有下列語言的產品說明以及安裝指示：

- 巴西葡萄牙文
- 捷克文
- 英文
- 法文
- 德文
- 義大利文
- 日文
- 簡體中文
- 斯洛伐克文
- 西班牙文
- 繁體中文
- 土耳其文

### 附錄

本附錄含有裝置驅動程式的特殊配置設定，以及協助和服務資訊。它們同時也含有產品保證及注意事項。

**註：** 本手冊中的圖例可能稍微不同於您的硬體。

---

## 註冊您的選用設備

感謝您購買 IBM 產品。請用一點時間為產品註冊，並提供一些相關資訊，這將有助於 IBM 在未來提供您更好的服務。您的意見對我們的產品開發和服務十分寶貴，也促進您和我們更良好的溝通。您可以在下列 IBM 網站註冊您的選用設備：

<http://www.ibm.com/pc/register>

除非您在網站的問卷指出您不想收到進一步資訊，否則 IBM 會提供您所註冊的產品資訊及更新。



---

## 安裝與使用手冊

本節提供產品說明、安裝指示以及如何使用與維護 IBM 48X/32X/48X Max CD 可讀寫 (CD-RW) 光碟機的指示。

---

### 簡介

本節說明本選用設備及其隨附的軟體。本節還含有您安裝選用設備之前必須知道的一些資訊。

### 產品說明

IBM 48X/32X/48X Max CD-RW 光碟機可讀寫 CD-RW 以及可燒錄 CD (CD-R) 光碟，也可以讀取大量壓製的 CD。使用此光碟機建立的 CD 和可讀取 CD-RW 光碟及其他媒體的多重讀取 CD 與 DVD 光碟機，以及只可讀取 CD-R 與 CD-ROM 光碟的舊型非多次讀取 CD 光碟機相容。

此光碟機可以用標準 CD-ROM 速度的 48 倍寫入 CD-R，記錄資料的速率每秒可達 7200 KB<sup>1</sup>。在這種速率下，光碟機燒錄 80 分鐘的 CD-R 光碟約需三分多鐘。光碟機以不同的速度燒錄 CD-RW 和 CD-R 光碟。此光碟機寫入超高速 CD-RW 光碟時速度為標準 CD-ROM 速度的 32 倍。記錄資料的速率每秒高達 4800 KB。在這種速率，光碟機燒錄 80 分鐘的 CD-RW 光碟少於四分鐘。此光碟機讀取資料速度約為標準 CD-ROM 速度的 48 倍。

本光碟機使用 EasyWrite 技術。EasyWrite 是專為簡化 CD-RW 的使用性而制定的開放業界標準。優點包括背景格式化及光碟機執行實體錯誤管理。如需其他相關資訊，請跳至 [www.mt-rainier.org](http://www.mt-rainier.org)。

CD-RW 光碟機只可安裝在使用整合式磁碟機電子 (IDE) 或擴充式 IDE (EIDE) 架構的電腦。

除了使用手冊和軟體 CD 上提供的手冊之外，選用套件還包含：

- 48X/32X/48X Max CD-RW 光碟機
- 一條音訊線
- 四個裝載螺絲
- 一條 IDE 接線
- 雷射安裝手冊

物品若有遺漏或損壞，請和您附近的經銷商聯絡。請記得保留您的購買證明。要求保證服務時可能需要。請參閱第 25 頁的附錄 E，『IBM Statement of Limited Warranty - Z125-4753-07 - 11/2002』來取得保證資訊。

### 軟體說明

本使用手冊與軟體 CD 含有下列軟體：

---

1. 在指資料傳送速度時，KB 約等於 1024 位元組。

- IBM RecordNow：供您以各種方式燒錄 CD。您可以使用 CD 拷貝機功能來備份 CD，或從硬碟中的檔案建立資料 CD。您可以使用 MP3 檔或其他音樂 CD 建立音樂 CD。RecordNow 也能夠在硬碟上建立磁碟影像檔以及燒錄之前建立的磁碟影像檔至 CD 中。
- IBM Drive Letter Access (DLA)：您可以使用 DLA 以使用磁碟機代號存取 CD-RW 光碟機。您可以使用 Windows 指令行或使用拖放方法複製檔案到可燒錄媒體。
- UDF Reader：您可以使用 UDF Reader 在其他 PC 讀取您燒錄的 CD。

---

## 開始之前

請先閱讀下列資訊再開始安裝。您必須完成下列步驟才能夠安裝光碟機。

1. 判斷要使用的 IDE 埠以及對應的配置設定。
2. 放置或變更光碟機上的配置跳接器（您可能要變更其他裝的配置跳接器）。
3. 安裝光碟機到光碟機槽。
4. 配置系統。
5. 安裝軟體。

如果您不了解這些程序或不確定可自行完成所有這些描述的程序，請要求合格的電腦技術人員為您安裝 CD-RW 光碟機。

## 系統需求

在開始安裝光碟機之前，請先確定電腦符合下列系統需求。

- 微處理器最低需求：Intel® Pentium® 處理器（或同等級的處理器）
- 最低 RAM 需求：32 MB
- 可用的 IDE 連線。
- 可用的內部電源連接。
- 可用的 5.25 英吋光碟機槽
- 以下任一種作業系統：
  - Microsoft® Windows® Millennium Edition (Me)
  - Microsoft Windows 2000 Professional
  - Microsoft Windows XP

您必須備妥平頭或十字螺絲起子來完成安裝。您可能還必須參閱電腦隨附的說明文件。請務必要備妥該說明文件。

## 搬動指示

安裝期間，請採取下列預防措施來保護您的 CD-RW 光碟機：

- 請小心搬動光碟機。光碟機掉落或震動可能會損壞光碟機機體中的元件。
- 將 CD-RW 光碟機存放在防靜電袋中，直到要開始安裝到電腦時才取出。盡量不要移動。移動容易產生靜電。
- 不要強迫插入電源線。這樣做可能損壞接頭或光碟機。

---

## 產品外觀

以下章節說明 CD-RW 光碟機的正面與背面。

## 光碟機的正面

請參閱下列圖例來識別安裝指示中提及的零件。

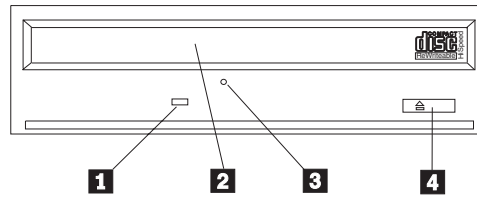

註：前方擋板的設計可能不同（因供應商而不同）。

- 1 忙碌指示燈**：這個指示燈會在光碟機讀取、寫入或顯示 CD 時亮起。
- 2 CD 托盤**：請使用此托盤載入及卸載 CD。
- 3 手動退出孔**：這個孔可在正常退出程序不作用時提供從光碟機取出 CD 的退出機制。
- 4 退出/載入按鈕**：按下此按鈕時可開啓或關閉 CD 托盤。

## 光碟機的背面

請參閱下列圖例來識別安裝指示中提及的零件。

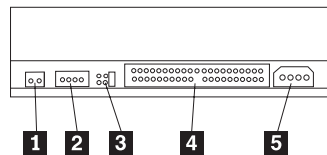

- 1 保留**
- 2 音效輸出接頭**：請使用這個接頭連接 CD-RW 光碟機至音訊配接卡。
- 3 配置接腳**：這些接腳用來設定光碟機配置。
- 4 IDE 接頭**：請使用這個接頭連接 CD-RW 光碟機至 IDE 接線。
- 5 DC 電源接頭**：請使用接頭連接 CD-RW 光碟機至電腦的電源供應器接線。

---

## 安裝光碟機

要安裝光碟機到電腦，請執行下列步驟：

### 步驟 1. 打開電腦

要打開電腦，請執行下列步驟：

1. 關閉電腦以及所有附屬裝置的電源。
2. 拔下電腦以及所有附屬裝置的電源線。
3. 取下電腦的外殼。請參閱電腦的說明文件來取得如何取下外殼的指示。

### 步驟 2. 打開光碟機包裝

要打開光碟機包裝，請執行下列步驟：

1. 觸摸未上漆的金屬表面至少兩秒鐘，來釋放任何累積的靜電。請掃拿光碟機的包裝袋同時將包裝袋接觸未上漆的金屬表約兩秒鐘。
2. 從袋中取出光碟機。

如果您必須放下光碟機，請將防靜電袋放置在理平的表面，然後將光碟機含元件的面朝上的方式放置在防靜電袋上。

### 步驟 3. 選取 IDE 埠

較新型的電腦通常有兩個 IDE 埠。如果您有兩個 IDE 埠，請使用次要 IDE 埠來連接 CD-RW 光碟機。通常次要 IDE 埠和連到硬碟的主要 IDE 埠緊鄰。您選取的 IDE 埠以及選取的接線位置將決定您在對光碟機使用的配置跳接器設定。請參閱第 5 頁的『步驟 4. 設定配置跳接器』來取得如何設定配置跳接器的指示。

- 如果您有兩個 IDE 埠，請使用隨附光碟機的 IDE 接線將 CD-RW 光碟機連到次要 IDE 埠。如果 CD-RW 光碟機是次要 IDE 埠上唯一的裝置，您要使用主要配置設定。如果次要連接埠上除了 CD-RW 光碟機之外還有其他裝置，您要使用附屬配置設定。
- 如果您必須將 CD-RW 光碟機連到同一個 IDE 埠當作高速裝置如硬碟機，請對 CD-RW 光碟機使用附屬設定，而對高速裝置使用主要設定。在某些情況下，如果同一條接線上有其他裝置配置為附屬，硬碟機可能需要「同時有主要與附屬」的設定。有關如何在其他裝置設定配置跳接器的進一步資訊，請參閱電腦或裝置隨附說明文件的相關章節。
- 有些非 IBM 電腦支援接線選取設定，裝置在接線上的位置將決定裝置為主要或附屬。請參閱電腦隨附的說明文件來判斷您的電腦是否支援這種設定。

#### 步驟 4. 設定配置跳接器

下列圖例顯示主要 **1** 設定、附屬 **2** 設定以及接線選取 **3** 設定。請根據在步驟 3 中選擇的設定，將一對接腳插入跳接器來配置 CD-RW 光碟機。

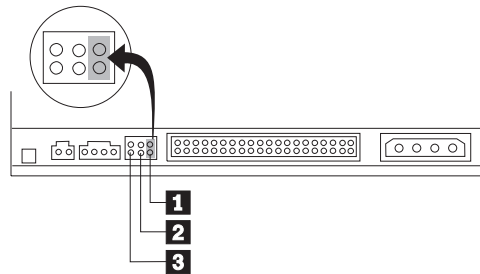

- 如果您要將光碟機配置為主要，請將跳接器設成主要 **1** 裝置設定。（這是光碟機出廠時的設定。）如果 IDE 埠上有第二個裝置，請檢查該裝置是否配置為附屬。
- 如果您要將光碟機配置為附屬，請將跳接器設成附屬 **2** 裝置設定。請檢查 IDE 埠上的其他裝置是否配置為主要（或 master-with-slave-present）。
- 如果您要將光碟機配置為接線選取，請將跳接器設成接線選取 **3** 裝置設定。如果 IDE 埠上有其他裝置，請檢查該裝置是否也是配置為接線選取。

#### 步驟 5. 裝載光碟機到機槽

**警告：** 當您將螺絲直接拴入光碟機時，請務必要使用選用設備包裝中所附的裝載螺絲。使用太長的螺絲可能會損壞磁帶機。

您可以將 CD-RW 光碟機水平或垂直安裝在電腦中。如果您垂直裝載光碟機，您必須先固定放入的 CD，然後才可以關閉光碟機托盤，否則 CD-RW 光碟機可能無法正常讀取 CD。有關如何在垂直裝載的光碟機固定 CD，請參閱第 9 頁的『載入 CD』。

1. 將光碟機滑入機槽中。您的電腦安裝儲存裝置時可能需要特殊必要的程序。請參閱閱電腦隨附的說明文件來取得進一步的指示。
2. 將光碟機槽螺絲孔對準光碟機體或裝載托架上的螺紋孔。請務必要使用光碟機隨附的裝載螺絲。使用長度錯誤的螺絲可能會損壞光碟機。請輕推螺絲來檢查它們的位置。通常每一邊各使用二個螺絲。
3. 先檢查是否對齊，然後再拴緊螺絲來固定磁碟機。請不要拴太緊。

#### 步驟 6. 連接光碟機接線

連接接線至 CD-RW 光碟機如下：

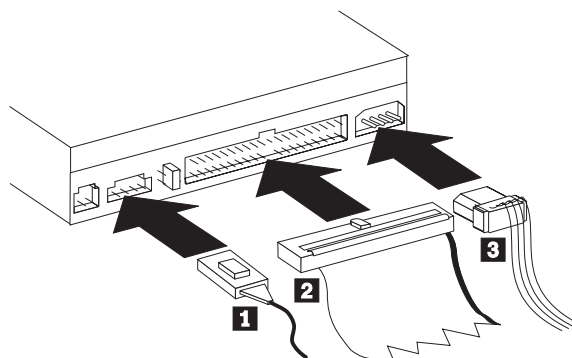

1. 如果您要連接 CD-RW 光碟機至音訊配接卡或主機板上的音效功能，請找出所附的音訊接線，同時判斷哪一種接線和音訊配接卡上的 CD 音效輸入連接埠最匹配。請將選用的音訊線一端連到 CD-RW 光碟機音效輸出接頭 **1**，以及將另一頭連到音訊配接卡 CD 音效輸入連接埠。請保存多餘的接線供以後其他的音訊配接卡使用。

**註：**有些電腦的接頭較小，和所附的音訊線不相容。如果您的電腦屬於這種接頭，您必須訂購新的音訊線。

2. 連接 40 接腳 IDE 接線接頭 **2** 至光碟機上的 IDE 接頭。請對齊接線，標示彩色編碼的邊緣要最接近電源線接頭 **3**。如果沒有接線連到 IDE 埠或 IDE 接線上只有一個裝置接頭時，請使用隨附於此選用設備的 IDE 接線。如果您使用隨附的 IDE 接線，請將接線的一端連到主機板 IDE 埠或 IDE 配接卡，將 IDE 接線的另一端連到 CD-RW 光碟機。
3. 找出一個連到電腦電源的可用電源線。請將四個插腳的電源線 **3** 連到 CD-RW 光碟機 DC 電源接頭。

## 步驟 7. 完成硬體安裝

要完成硬體安裝，請執行下列步驟：

1. 請確定光碟機裝載穩固以及接頭確實接妥。
2. 確定接線不要干擾電腦外殼以及不會組斷任何風扇葉片以及通風流路徑。
3. 重新安裝電腦外殼。
4. 重新連接所有裝置並檢查有無切斷連接的裝置如鍵盤、滑鼠及顯示器。
5. 連接所有電源線至電源插座。

## 步驟 8. 更新電腦配置

完成硬體安裝後，請重新啟動電腦。通常，當您打開電腦電源時，會顯示配置設定畫面。如果您未看到這個畫面，請查閱電腦說明文件中與存取配置或設定公用程式相關的資訊。

在大部份的 IBM 電腦要檢查配置資訊，請在螢幕右上角顯示 IBM 圖形時按 F1。檢查完資訊後，請儲存變更並結束。

## 步驟 9. 安裝 CD-RW 光碟機軟體

本使用手冊與軟體 CD 含有二個軟體應用程式，用於 CD-RW 光碟機的 CD 寫入功能：

- IBM RecordNow
- IBM Drive Letter Access (DLA)

還有另一個應用程式在某些情況很有用。

- UDF Reader

有關這些應用程式的資訊，請參閱第 1 頁的『軟體說明』。

要安裝這些應用程式，請執行下列步驟：

1. 插入使用手冊與軟體 CD 到 CD-RW 光碟機中。
2. 如果 CD 自動啟動，請遵循螢幕上的指示執行。如果未自動啟動，請執行下列步驟：
  - a. 按一下**開始** -> **執行**，接著鍵入 `e:\engage.bat`，其中 `e` 是 CD 光碟機的磁碟機代號。
  - b. 按一下**確定**。



3. 選取您的語言。
4. 選取您要安裝的應用程式。
5. 遵循螢幕上的指示執行。

---

## 使用 CD-R 和 CD-RW 光碟

CD-RW 光碟機可寫入 CD-R 與 CD-RW 光碟。CD-RW 光碟可抹除及重複使用多次，CD-R 光碟只可寫入一次。





操作及清理光碟時要小心，特別是可寫入的媒體類型，例如 CD-R 和 CD-RW 光碟，以便讓它們保持可讀取。遵照下列指示可以延長光碟的壽命：

- 用原來的包裝來存放 CD-ROM
- 不要將 CD-ROM 存放在陽光直射處
- 請避免將 CD-ROM 存放在直接的熱源處
- 不使用時，請將 CD-ROM 從電腦取出
- 每次使用之前，請檢查 CD-ROM 是否毀損
- 請勿強行將 CD-ROM 放入至電腦/包裝中
- 請勿彎曲或折彎 CD-ROM

### 附註：

1. CD-R 光碟可在大部份的音效 CD 播放程式播放。CD-RW 光碟只可在某些音效 CD 播放程式上播放。
2. 有些客戶的音效播放程式僅會撥放錄製在專門標示為音效媒體的光碟。
3. CD-R 媒體是以燒錄速度分類。在 48x 寫入模式，必須使用 48x 媒體。為取得最佳效果，請將寫入速度限制在媒體速度分類內。選用設備套件中隨附的 Record Now Software 可限制燒錄速度上限。
4. CD-RW 媒體也是依燒錄速度分類。IBM 48X/32X/48X 光碟機只支援 4x 或以上的 CD-RW 光碟燒錄。燒錄速度上限將列印在媒體封包或光碟本身上。

5. 以下表格顯示超高速、高速、低速 CD-RW 媒體的相容性資料：

媒體分類	寫入
無分類，2x 	不支援
多種速度，1x2x4x、4x、1x-4x 	是
高速，4x-10x、4x-12x、8-10x 	是
超高速，16x-24x、32x 	是

## 搬運與維護 CD

CD 是一種高密度媒體，必須小心搬運以及保持乾淨，才能夠正常讀取。這些預防措施可協助延長 CD 的使用壽命。

**警告：** 沿著 CD 中心擦拭光碟可能會引起資料遺失。

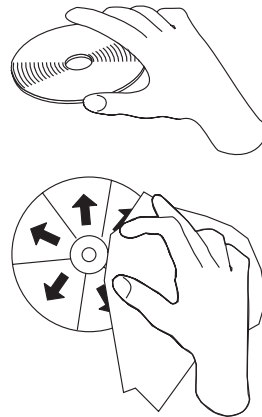

**警告：** 不要使用損壞的 CD。

- 請握拿 CD 的邊緣或中央的小孔。請不要觸摸 CD 的表面。
- 要除去灰塵或指紋，請使用柔軟沒有線絮的布從中心往邊緣方向擦拭。
- 不要在光碟表面寫字。
- 不要讓太陽直射 CD。
- 不要使用市售清潔劑清潔 CD。
- 不要彎曲 CD。

## 使用光碟機

本節提供如何操作 CD-RW 光碟機，以及如何載入 CD 到 CD-RW 光碟機的資訊。

### 維護 CD-RW 光碟機

要在作業期間護 CD-RW 光碟機，請採取下列預防措施：

- 搬動光碟機時，請取出光碟機中的 CD。
- 不要將異物插入光碟機中。
- 不要卸下光碟機外殼或企圖修理光碟機。
- 不要在下列任一種情況下操作光碟機：
  - 高溫、高濕度或陽光直射
  - 連續震動、突然震動或傾斜表面
  - 過多灰塵

### 載入 CD

若要載入 CD 到水平裝載的 CD-RW 光碟機，請執行下列步驟：

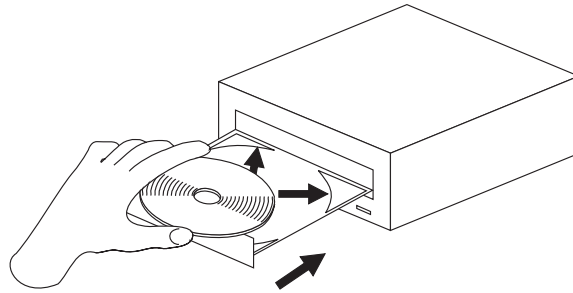

1. 按**退出/載入**按鈕。托盤會滑出光碟機。
2. 插入 CD 至載入托盤。
3. 按**退出/載入**按鈕或輕輕推入托盤來載入托盤。

**警告：** 不要強迫打開托盤，也不要插入異物到 CD 托盤中。如果您按**退出/載入**按鈕時托盤未開啓，請參閱第 10 頁的『手動退出 CD』。

若要載入 CD 到垂直裝載的 CD-RW 光碟機，請執行下列步驟：

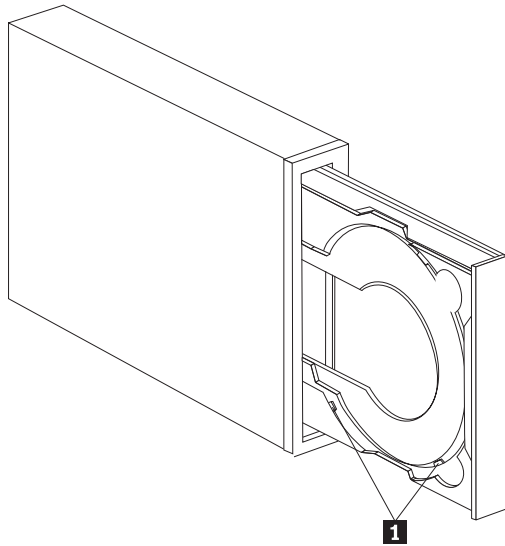

**註：**光碟機 CD 托盤設計可能和所顯示的不同（因供應商而不同）。

1. 按**退出/載入**按鈕。
2. 將 CD 插入托盤，同時確定光碟確實固定在垂直裝載卡栓 **1** 後方。
3. 按**退出/載入**按鈕或輕輕推入托盤來載入托盤。

## 手動退出 CD

如果您按**退出/載入**按鈕時托盤未滑出，請關電腦的電源。如圖所示請拉直大別針來當作工具。拉直後長度必須至少 45 公釐（1.8 英吋）。將拉直的一端插入光碟機前面的手動退出孔（請參閱第 3 頁的『光碟機的正面』）。請將別針推入孔中，直到托盤打開為止。請輕輕拉出托盤，直到可取出 CD 為止。

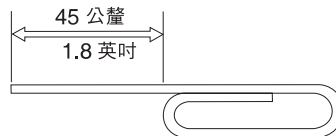

## 使用軟體

本節說明與 CD-RW 光碟機相關聯的軟體。

### 在 CD-RW 光碟機使用 Windows XP 內建的燒錄功能

本 CD-RW 光碟機和 Windows XP 內建的燒錄功能完全相容。如果使用 Windows XP，您不需要額外的軟體便可以資料 CD。如果您安裝 CD-RW 光碟機隨附的 DLA 軟體，Windows 的內建燒錄功能會被關閉並由 DLA 執行格式化及燒錄功能。使用 Windows 內建燒錄功能建立的 CD 可被大多數的 Windows 讀取而不需要特殊的讀取程式。

要使用 Windows XP 內建燒錄功能複製檔案至 CD，請使用「檔案總管」將檔案拖曳至磁碟機代號。Windows 會將檔案暫存至暫時位置。您備妥要寫入至 CD 後，請打開磁碟機代號，然後按一下**寫入這些檔案至 CD**。

**註：**嘗試退出光碟片時，會提示您是否要燒錄檔案。

## 使用 IBM Drive Letter Access (DLA)

IBM Drive Letter Access (DLA) 隨附在**使用手冊與軟體 CD** 中，可用來寫入資料至 CD-RW 和 CD-R 媒體。

CD-RW 光碟的格式化方法有兩種。第一種是一般 UDF，第二種是 UDF 含 EasyWrite 擴充。EasyWrite 擴充容許背景方式格式化同時寫入資料到其中。這種方式較方便，但 EasyWrite 燒錄的光碟在其他電腦時，必須具有 UDF Reader 才能夠讀取。

若要格式化空白 CD-R 或 CD-RW，請執行下列步驟：

1. 插入空白光碟到 CD-RW 光碟機。
2. 開啓**我的電腦**。
3. 在光碟機圖示上按一下滑鼠右鍵，接著選取**格式化**。
4. 勾選 EasyWrite 勾選框以執行光碟的背景格式化，或不勾選以執行一般格式化。

若要寫入格式化媒體，請執行下列步驟：

1. 插入已經格式化的光碟到 CD-RW 光碟機。光碟將裝載為可寫入。
2. 將檔案拖放至 CD-RW/CD-R 光碟機代號圖示，或透過 Windows 檔案總管來移動檔案。

若要將 CD-R 媒體設成與其他電腦相容，請執行下列步驟：

1. 在**我的電腦**，在光碟機代號上按一下滑鼠右鍵。
2. 按一下**設成相容**。

**註：**當製作相容性並附加 9 次之後，CD-R 光碟會變成唯讀。

**註：**CD-RW 媒體可重複寫入多次，CD-R 媒體只可寫入一次。

**註：**在 EasyWrite 光碟，需要花 20 到 60 秒來暫停或關閉您的電腦。中斷此程序會導致資料流失。

**註：**磁碟機指示燈在 EasyWrite 進行背景格式化時不會亮。

## 使用 UDF Reader

UDF Reader 軟體可在未安裝 DLA 的 PC 上讀取 DLA 燒錄的光碟。當您將 DLA 安裝到系統上時，UDF Reader 安裝程式的副本將同時複製到您的電腦。您可以安裝 UDF Reader 到其他電腦來讀取您 UDF 建立的光碟。

**註：**已經安裝 DLA 的電腦不需要 UDF Reader。它只可用於要共享 DLA 燒錄的媒體的電腦上。

**註：**未安裝 EasyWrite UDF Reader 的電腦無法讀取 EasyWrite 格式的媒體。

**註：**若要在未安裝 CD-RW 光碟機的電腦讀取 DLA 格式化的 CD-R 光碟，請使用光碟機內容功能表中列出的**建立相容**功能。

## 使用 RecordNow 軟體

RecordNow 供您燒錄音樂 CD、資料 CD 以及複製現有的 CD。有關 RecordNow 的詳細使用資訊，包含在 RecordNow 說明檔案中。您可以按 RecordNow 功能表中的來存取 RecordNow 說明。

若要在 Windows Me 或 Windows 2000 啓動 RecordNow，請選取**開始 -> 程式集 -> IBM RecordNow**。

若要在 Windows XP 啓動 RecordNow，請選取**開始 -> 所有程式 -> RecordNow**。

RecordNow 啓動後，請從下列三個程序中選取一個：

- 製作完全副本：選取這個選項可備份已有的 CD 或製作之前建立之 CD 的副本。您選取這個選項後，RecordNow 會先提示您插入要複製的光碟機，接著再提示您插入空白光碟。
- 製作音樂光碟：選取這個選項可建立音樂 CD。第二個畫面將詢問您是要否要從硬碟上的 MP3 以及 Wave 檔或從其他音樂 CD 製作音樂 CD。還有一種選擇可製作 MP3 播放程式的光碟，這是一種特殊的格式化資料光碟，可供獨立式 MP3 播放程式播放。
- 製作資料光碟：選取這個選項可建立含有硬碟中之資料的光碟。RecordNow 會詢問您要格式化 DLA 的光碟，或是要製作與他人共享的資料光碟。RecordNow 會提示您插入空白光碟。接著會出現一個螢幕，供您拖放檔案，或瀏覽尋找硬碟中的檔案。
- 一旦 RecordNow 啓動了，您也可以執行兩個特殊作業：
  - 按一下**我的最愛**按鈕，可以讓您載入先前儲存的音訊、資料、MP3、或光碟影像檔以燒錄一份新的副本。
  - 將資料光碟的 ISO 或 GI 光碟影像檔放到檔案框中，會將該影像檔直接錄製到光碟中。
  - 若要利用 RecordNow 製作 CD 的 ISO 影像檔，請選取**複製 CD** 並將目的地燒錄機設為**燒錄檔案至硬碟**。

**註：**要限制 RecordNow 的燒錄速度，請選取「選項」，接著在「進階」標籤視窗中標題為**限制燒錄器速度上限** 的下接方塊中選取您要的選擇。

---

## 附錄 A. 產品規格

在附錄中包括下列的資訊：

- 實體規格
- 電源需求
- 環境需求
- 磁碟機寫入/讀取速度
- 磁碟機效能
- 格式化功能

### 實體規格

<sup>2</sup>48X/32X/48X Max CD-RW 光碟機實體規格，會列示於下表中。

實體規格：	
高度	42 公釐 (1.7 吋)
寬度	149 公釐 (5.9 吋)
長度	185 公釐 (7.7 吋)
重量	1.0 公斤 (2.2 磅)

### 電源需求

下表按照 48X/32X/48X Max CD-RW 光碟機的電壓等級，來列出電源規格。電源規格是在光碟機電源接頭處測量的，並且為額定值。

電源規格：		
電壓	+12 V dc	+5 V dc
作業的電流等級為	1.5 A	1.0 A

---

2. 產品說明資料代表著 IBM 設計的目標，並且提供作為比較用途；實際上的結果會有所不同，視種種的因素而定。這項產品資料並非提供一項保證。資料會隨時變更而不另行通知。

下表列出 CD-RW 光碟機的環境規格。您可以垂直或水平方式來裝載本光碟機。

### 環境需求

環境需求：		
規格	作業	非作業
溫度（未凝結）	+5° C 到 +45° C (+41° F 到 +113° F)	-40° C 到 +60° C (-40° F 到 + 140° F)
相對濕度（非凝結）	8% 到 80%	5% 到 90%

### 寫入/讀取速度

下表列出 CD-RW 光碟機的寫入/讀取速度。

光碟機寫入/讀取速度：	
功能	支援的速度
讀取 (CD-ROM/CD-R)	20-48x (CAV)
讀取 (CD-RW/音訊)	17-40x (CAV)
寫入 (CD-R 光碟)	20-48x (CAV)
寫入 (CD-RW 光碟)	16-32x (Z-CAV) 或 20-32x (P-CAV)

### 媒體速度相容性

下表列出 CD-RW 光碟機的媒體速度相容性。

功能	CD-R 媒體相容性	CD-RW 媒體相容性
讀取	全部	全部
寫入	4x、8x、12x、16x、24x、 32x、40x、48x	多種速度 (1x2x4x、4x、1x-4x)  高速 (4x-10x、8x-10x、10x、12x)  超高速 (24x、32x)
註：媒體或光碟機速度必須支援媒體的寫入速度。		

### 光碟機效能規格

下表列出 CD-RW 光碟機的效能規格。

光碟機效能：	
特性	規格
瞬間資料傳輸率	(ATA PIO Mode 4) 每秒 16.7 MB (1 MB 約為 1 000 000 個位元組的資料)，(ATA multi-word DMA Mode 2) 每秒 16.7 MB，(Ultra DMA Mode 2) 每秒 33.3 MB
平均存取時間（包括潛在因素）	100 毫秒 (20-48x, CAV)



快取記憶體（讀取/寫入）	2 MB
光碟直徑	12 公分（4.7 英吋）（8 公分 [3 英吋]）
轉速（CD-ROM/CD-R）	9600 rpm
平均故障間隔（MTBF）	125 000 POH（使用 10%）
緩衝不足保護	SuperLink® 或 SmartBURN®

下表彙總了 RecordNow 程式的 CD 格式功能。請參閱 Sonic 軟體線上使用手冊，以取得關於 CD 格式功能最新的資訊。

格式	複製功能	建立功能
CD-DA（紅皮書）	是	是
CD+G	是	否
CD TEXT	是	是
CD-ROM（黃皮書）	是	是
CD-ROM XA（模式 2）	是	否
CD-I（綠皮書）	是	否
CD-I Bridge	否	否
Video CD（黃皮書）	是	否
CD-R（橘皮書 P II）	是	是
CD-RW（橘皮書 P III）	是	是
Multisession CD	是	是
CD Extra（藍皮書）	是	否
Photo CD	是	否
Mixed-Mode CD	是	否
Bootable CD	是	否
Disc at Once	是	否
Track at Once	是	是
Session at Once	是	否

本 CD-RW 光碟機使用下列方法，將檔案寫入 CD 中：

- **Disc at Once**：光碟機一次便寫入整張光碟；之後便無法再新增資料。
- **Track at Once**：光碟機一次先複製一軌到光碟上。
- **Multisession**：光碟機先寫入數個階段作業到光碟中；每一個階段作業至少為一軌。

下面列出在表中出現之不同 CD 格式的說明。

**CD-Digital Audio**：此格式可以記錄音樂 CD，可以在音樂 CD 播放器上播放。

**CD Extra**：此格式可將音樂及資料記錄在多重階段格式中。

**CD TEXT**：此格式可記錄音樂 CD，並附上專輯名稱及已編碼的歌曲名稱。

**CD-ROM (Mode 1)**：此格式適用於大部份的 CD-ROM 應用程式。

**CD-ROM XA (Mode 2 Form 1 和 Mode 2 Form 2) 或 CD-ROM 延伸架構**：這項標準的建立，是用於播放多媒體內容。

**CD-I (Mode 2 Form 1 和 Mode 2 Form 2) 及 CD-I Ready<sup>3</sup>**：此格式是用於家庭娛樂系統。

**CD-I Bridge**：此格式會記錄 Kodak Photo CD 及視訊 CD 的組合，可以在 TV Set-Top 播放器及個人電腦上播放。

**Photo CD (單一及多重階段)**：此格式可記錄能在 TV Set-Top 視訊 CD 播放器，以及大部份 DVD 系統上播放的 CD。

---

3. CD-RW 光碟機並未具有必要的音訊電路，以及 CD-I 播放的解碼功能，但它可以讀取和寫入這種格式的 CD。

---

## 附錄 B. 問題解決

電腦的問題，可能是由於硬體、軟體或使用者錯誤所造成的。您可以使用本節中的資訊，來自行解決問題，或是收集有幫助的資訊，以便傳送給維修技術人員。

請複查下表，並找出適合您狀況的問題描述。

---

### 疑難排解

#### 您的電腦或 CD-RW 光碟機無法正確操作，或是忙碌指示燈並未亮著。

請採取下列動作：

1. 檢查這張 CD 在載入時，標籤面是否朝上。
2. 檢查所有的裝置，是否正確地連接到電腦以及電源插座。如果所有裝置均已正確連接，但是您仍然有問題時，請跳至步驟 3。
3. 關閉電腦的電源，從電源插座中拔出您電腦及所有連接裝置的接線，然後再取下電腦外殼。
4. 檢查所有電源及 IDE 接線是否已連接妥當。切斷 IDE 接線，並檢查是否有彎曲或不齊的接腳。如果您未發現任何問題，請重新連接 IDE 接線。重新連接所有的接線及電源線，再重新裝上電腦外殼。開啓電腦的電源，重新啓動系統，然後再試著按下**退出/載入**按鈕來開啓 CD 托盤。如果托盤無法開啓，而且忙碌指示燈也未亮起，請關閉電腦的電源，然後再試另一條 4 接腳 DC 電源線。
5. 檢查 IDE 接線上的彩色編碼邊緣，是否對齊 IDE 埠上的接腳 1，並且最靠近 48X/32X/48X Max CD 可讀寫光碟機上的電源線，請參閱第 4 頁的『步驟 3. 選取 IDE 埠』。
6. 檢查 IDE 接線是否連接到正確的 IDE 埠連線。如需其他相關資訊，請參閱第 4 頁的『步驟 3. 選取 IDE 埠』。
7. 檢查 CD-RW 光碟機以及 IDE 接線上任何其他的裝置，其主要/從屬 (master/slave) 跳接器設定是否正確。如需其他相關資訊，請參閱第 5 頁的『步驟 4. 設定配置跳接器』。
8. 如果 IDE 接線上中間的接頭，連接到主機板上的 IDE 埠，請先取下此接頭，再重新連接接線。如果在 IDE 埠上只有一項裝置時，請將接線一端的接頭，連接到 IDE 埠，而另一端上的接頭，則連接到該裝置，讓中間的接頭（如果有一個的話）能空出來。如果在 IDE 埠上有兩項裝置時，請將接線一端的接頭，連接到 IDE 埠。如果有一部硬碟機，請將它連接到接線另一端的接頭，再將 CD-RW 光碟機連接到中間的接頭。

#### 您無法格式化 CD-RW 光碟

請採取下列動作：

1. 檢查您的媒體。本 CD-RW 光碟機無法格式化 1X 或 2X 倍速的媒體。
2. 請以下列程序來消除 CD-RW，然後再格式化一次。
  - 請從光碟機中取出所有的光碟。
  - 啓動 RecordNow。

- 選取 **Erase**。
  - 選取 **For use with record now**。
  - 在出現提示時，請插入您的媒體。
  - 出現提示 "The disc you have inserted is not blank, would you like to erase it now?" 時，請選取 **Yes**。
  - 在媒體消除完成之後，選取 RecordNow 中的 **Cancel** 按鈕
  - 結束 RecordNow。
  - 退出此媒體。
3. 如果您使用的是協力廠商的 bus-master 驅動程式，請與驅動程式製造廠商聯繫，確定它是否支援 CD-RW 光碟機。

### 您無法建立多重階段光碟。

請確定在此媒體上，剩餘的空間足夠用於另一個階段作業。除了記錄的資料之外，寫入一個階段作業需要約 15 MB。

### 您無法順利寫入到 CD-R 或 CD-RW 光碟。

請採取下列動作：

1. 驗證這項程序並未因為螢幕保護、防毒程式、網際網路或電子郵件程式，或是其他軟體而中斷。請停用可能會中斷寫入作業的功能。
2. 驗證您的電腦具備本選項之系統需求中，所列出的最小處理器。如需其他相關資訊，請參閱第 2 頁的『系統需求』。
3. 驗證硬碟機是否已完成重組作業。
4. 如果光碟損壞或刮傷時，請更換另一片。
5. 驗證此光碟的寫入速度是否正確。

### 您無法退出光碟。

在確定光碟機不在寫入程序中之後，請採取下列動作：

1. 關閉所有的應用程式。
2. 以軟體應用程式來退出這張 CD。連按兩下**我的電腦**。按一下 **CDR/RW** 圖示。按一下**退出**。
3. 使用**退出/載入**按鈕。
4. 關閉電腦。請等待 45 秒；然後再開啓電腦的電源，再試著一次使用**退出/載入**按鈕。
5. 如果其他方法都不行的話，請使用第 10 頁的『手動退出 CD』中所提供的指示，來使用手動退出孔。

### 在順利寫入 CD 之後，您無法讀取此 CD。

請採取下列動作：

1. 如果您可以在另一部 CD 播放器中讀取此 CD，或者是您可以看到上一個階段作業時，在容體上的目錄資訊可能已經損壞，而造成無法讀取。請檢查 Sonic 軟體線上使用手冊，以取得其他疑難排解的方法。
2. 您的 CD-R 或 CD-RW 光碟可能已經損壞了。請試另一張新的 CD-R 光碟或 CD-RW 光碟，或是另一個廠牌的光碟。

3. 如果您可以在 CD-RW 光碟機中讀取此 CD-RW 光碟，但在另一部光碟機中卻不行，請確定 UDF Reader 程式是否安裝在包含其他光碟機的電腦上。有關 UDF Reader 程式的相關資訊，請參閱第 11 頁的『使用 UDF Reader』。
4. 請驗證您並未在極惡劣的環境條件中，嘗試寫入這張光碟，如下所示：
  - 低溫：5° C (41° F) 或更低
  - 高溫：45° C (113 °F) 或更高
  - 過大的撞擊：>0.5 G
  - 過多的震動：>0.1 G
5. 請確定已經關閉 CD-R 階段作業。請參閱第 11 頁的『使用 RecordNow 軟體』以取得協助。未關閉的音樂光碟，無法在您的車子或家用 CD 播放器上播放。

### 您無法存取 CD-RW 光碟機，或是光碟機圖示並未顯示 (Windows XP)

如果已經適當地安裝 CD-RW 光碟機，則在「我的電腦」視窗中，應該會有光碟機的圖示。如果您連按兩下我的電腦圖示之後，在顯示的視窗中並未出現光碟機圖示，請查看這部光碟機是否已適當地安裝，以及配置接腳是否設定正確無誤。如需其他相關資訊，請參閱第 5 頁的『步驟 4. 設定配置跳接器』。接著，請重新啟動您的電腦。如果仍找不到光碟機圖示，請繼續執行下列步驟。

1. 按一下**開始** → **設定** → **控制台**。
2. 按一下**系統**。
3. 按一下**裝置管理員**索引標籤。
4. 連按兩下**按類型來查看裝置**。
  - a. 按一下「裝置管理員」清單上的**硬碟控制卡**。確定控制卡並未發生任何衝突。確定裝置狀態指示控制卡已正確地運作。
  - b. 從**裝置管理員**清單中，選取 **CD-RW**。驗證 CD-RW 裝置是否存在，而且沒有任何衝突。裝置狀態將會指示這個裝置已正確地運作。
5. 按一下**確定**。
6. 重新啟動電腦。

如果裝置圖示仍未出現，請檢查接線的連接、裝置接腳的設定，並解決任何存在的衝突。

如果您有安裝 Microsoft Media Player 9.x，並發生此問題，請執行下列步驟：

1. 插入 CD-RW 使用手冊和軟體 CD。
2. 開啓我的電腦和瀏覽 CD-RW 光碟機。
3. 連按兩下 **cdrtlfx.exe**
4. 重新啟動電腦。

### 無法讀取此 CD。

請採取下列動作：

1. CD 可能不乾淨；請使用第 8 頁的『搬運與維維護 CD』中所說明的方式來進行清潔。
2. CD 可能已經毀損；請再試另一張 CD。
3. CD 並非 ISO-9660 或是與 High Sierra Group 不相容。請聯絡您的購買店家。

## 這張 CD 沒有聲音。

請採取下列動作：

1. 檢查您所使用的是音樂 CD，而不是資料 CD。
2. 調整聲音配接卡音量控制。請參閱聲音配接卡及音樂 CD 播放器隨附的說明文件。
3. 關閉電腦的電源，從電源插座中拔出您電腦及所有連接裝置的接線，然後再取下電腦外殼。檢查音訊訊號接線，是否已將 48X/32X/48X Max CD-RW 光碟機連接到音訊配接卡。

## 在音訊接線上提供的接頭，與您音訊配接卡上的接頭不符。

有些音訊配接卡可能需要特殊的接線。請參閱您的聲音配接卡所隨附的說明文件。

您可能必須為 48X/32X/48X Max CD-RW 光碟機購買個別的音訊接線。在 48X/32X/48X Max CD-RW 光碟機上的音效輸出接頭，需要 MPC-2 相符的 Molex 70553 或同級的接頭。（如果要找到光碟機的音訊接頭，請參閱第 3 頁的『光碟機的背面』）。如果您所使用的是 IBM 電腦或 IBM 聲音配接卡，請參閱第 25 頁的附錄 E，『IBM Statement of Limited Warranty - Z125-4753-07 - 11/2002』以取得協助。

## 在複製 CD 或製作資料 CD 時，您收到 "buffer underrun" 錯誤訊息。

請採取下列動作：

- 如果檔案來源為網路或可移除式裝置，請先將檔案複製到本端硬碟上。
- 如果是使用 CD 複製程式，請選取**進階**，然後再勾選**複製到硬碟**選項。
- 如果是使用 RecordNow，請選取 **Options->Advanced**，並確定已經勾選 **Burn-Proof**。
- 試著降低寫入速度。
- 請確定來源及目標光碟機，都是在 DMA 模式中運作。如需其他相關資訊，請參閱第 21 頁的附錄 C，『自訂裝置驅動程式的配置設定』。

## 電腦無法關機或待機

- 如果您使用 EasyWrite 光碟，請從**我的電腦**將其退出。
- 如果 Record Now 為開啓狀態，請將其關閉。

## 電腦在開機時當機

- 從磁碟機裡移除媒體，然後重新啓動。
- 請向電腦製造廠商索取可以適當辨識 EasyWrite 光碟的更新版 BIOS。

---

## 附錄 C. 自訂裝置驅動程式的配置設定

Windows XP 及 Window Me 具有兩項裝置驅動程式配置參數：「自動插入通知」及 DMA。

「自動插入通知」參數可讓電腦在插入 CD 到 CD-RW 光碟機時，便立刻啓動音樂 CD 軟體。

DMA 參數可以讓電腦 DMA 控制卡來處理從 CD 到記憶體的资料傳輸，並釋放電腦微處理器來執行更重要的工作，並藉此來增進電腦的效能。例如，啓動 DMA 可以讓電腦及遊戲執行得更順暢，因為微處理器會配置更多的處理時間給視訊。

---

### 變更 Windows Me 的「自動插入通知」及 DMA 參數

如果要變更 Windows Me 中的「自動插入通知」及 DMA 參數，請執行下列步驟：

1. 按一下**開始** → **設定** → **控制台**。
2. 按一下**檢視所有的控制台選項**。
3. 連按兩下**系統**。
4. 按一下**裝置管理員**索引標籤。
5. 連按兩下 **CD-ROM**。
6. 在您想修改的光碟機上按一下。
7. 按一下**設定**索引標籤。
8. 按一下以選取或清除**自動插入通知**核取方塊及 **DMA** 核取方塊，視您想要啓用或停用的參數而定。
9. 按一下**確定**。

---

### 變更 Windows XP 的 DMA 參數設定

如果要在 Windows XP 桌面上變更 DMA 參數設定，請執行下列步驟：

1. 按一下**開始** → **控制台**。
2. 按一下**切換到傳統檢視畫面**。
3. 連按兩下**系統**。
4. 按一下**硬體**索引標籤。
5. 按一下**裝置管理員**按鈕。
6. 按一下 **IDE ATA/ATAPI 控制卡**來展開樹狀結構。
7. 連按兩下對應到您的 CD-RW 所在的控制卡（**主要 IDE** 或**次要 IDE**）。
8. 按一下**進階設定**索引標籤。
9. 選取對應到 CD-RW 位置適當的**傳輸模式**下拉項目（**主要 (Master)** 為**裝置 0**，而**附屬 (Slave)** 為**裝置 1**）。
10. 選取使用 **DMA**（如果可用的話）。
11. 按一下**確定**。

---

## 啓用 Windows 2000 Professional 的 DMA

如果要變更 Windows 2000 的參數設定，請執行下列步驟：

1. 按一下**開始** → **設定** → **控制台**。
2. 連按兩下**系統**。
3. 按一下**硬體索引標籤**。
4. 按一下**裝置管理員**。
5. 按一下 **IDE ATA/ATAPI** 來展開樹狀結構。
6. 按一下對應到您 CD-RW 光碟機所在控制卡的裝置（**主要 IDE** 或**次要 IDE**）。
7. 按一下**進階設定索引標籤**。
8. 按一下**傳輸模式**，再選取 **DMA**（如果可用的話）。
9. 按一下**確定**。
10. 按一下**關閉**，關閉「系統內容」視窗。這時便會顯示一道訊息，通知您系統設定已經變更。
11. 按一下**確定**來重新啓動您的電腦。



---

## 附錄 D. Service and Support

The following information describes the technical support that is available for your product, during the warranty period or throughout the life of the product. Refer to your IBM Statement of Limited Warranty for a full explanation of IBM warranty terms.

---

### Online technical support

Online technical support is available during the life of your product through the Personal Computing Support Web site at [www-3.ibm.com/pc/support/site.wss/](http://www-3.ibm.com/pc/support/site.wss/).

During the warranty period, assistance for replacement or exchange of defective components is available. In addition, if your IBM option is installed in an IBM computer, you might be entitled to service at your location. Your technical support representative can help you determine the best alternative.

---

### Telephone technical support

Installation and configuration support through the IBM HelpCenter<sup>®</sup> will be withdrawn or made available for a fee, at IBM's discretion, 90 days after the option has been withdrawn from marketing. Additional support offerings, including step-by-step installation assistance, are available for a nominal fee.

To assist the technical support representative, have available as much of the following information as possible:

- Option name
- Option number
- Proof of purchase
- Computer manufacturer, model, serial number (if IBM), and manual
- Exact wording of the error message (if any)
- Description of the problem
- Hardware and software configuration information for your system

If possible, be at your computer. Your technical support representative might want to walk you through the problem during the call.

For the support telephone number and support hours by country, refer to the following table. If the number for your country or region is not listed, contact your IBM reseller or IBM marketing representative. Response time may vary depending on the number and nature of the calls received.

Phone numbers are subject to change without notice. For the latest phone number list, go to [www-3.ibm.com/pc/support/site.wss/](http://www-3.ibm.com/pc/support/site.wss/) and click **Support Phone List**.

<b>Country or Region</b>	<b>Telephone Number</b>	<b>Country or Region</b>	<b>Telephone Number</b>
Argentina	0800-666-0011	Malaysia	03-7727-7800
Australia	1300-130-426	Mexico	001-866-434-2080
Austria	01-24592-5901	Netherlands	020-514-5770
Belgium	Dutch 02-210-9820 French 02-210-9800	New Zealand	0800-446-149
Bolivia	0800-0189	Norway	66 81 11 00
Brazil	55-11-3889-8986	Peru	0-800-50-866
Canada	1-800-565-3344 Toronto 416-383-3344	Philippines	632-995-2225
Chile	800-224-488	Portugal	21-791 51 47
China (PRC)	800-810-1818	Russia	095-940-2000
China (Hong Kong S.A.R.)	852-2825-7799	Singapore	1800-840-9911
Columbia	980-912-3021	Spain	91-662 49 16
Denmark	45 20 82 00	Sweden	08-477 4420
Ecuador	1-800-426911 (option #4)	Switzerland	058-333-09-00
Finland	09-459 69 60	Taiwan	886-2-2725-9799
France	02 38 55 74 50	Thailand	66-2-273-4000
Germany	07032-1549 201	Turkey	00-800-446-32-041
Indonesia	021-523-8535	United Kingdom	0-1475-555 055
Ireland	01-815-9202	United States	1-800-426-7378
Italy	02-7031-6101	Uruguay	000-411-005-6649
Japan	Consumer customers 0120-887-870  Business customers 0120-887-874	Venezuela	0-800-100-2011
Luxembourg	298-977 5063	Vietnam	848-8295-160

---

## 附錄 E. IBM Statement of Limited Warranty - Z125-4753-07 - 11/2002

### Part 1 - General Terms

*This Statement of Limited Warranty includes Part 1 - General Terms, Part 2 - Country-unique Terms, and Part 3 - Warranty Information. The terms of Part 2 replace or modify those of Part 1. The warranties provided by IBM in this Statement of Limited Warranty apply only to Machines you purchase for your use, and not for resale. The term "Machine" means an IBM machine, its features, conversions, upgrades, elements, or accessories, or any combination of them. The term "Machine" does not include any software programs, whether pre-loaded with the Machine, installed subsequently or otherwise. **Nothing in this Statement of Limited Warranty affects any statutory rights of consumers that cannot be waived or limited by contract.***

### What this Warranty Covers

IBM warrants that each Machine 1) is free from defects in materials and workmanship and 2) conforms to IBM's Official Published Specifications ("Specifications") which are available on request. The warranty period for the Machine starts on the original Date of Installation and is specified in Part 3 - Warranty Information. The date on your invoice or sales receipt is the Date of Installation unless IBM or your reseller informs you otherwise. Many features, conversions, or upgrades involve the removal of parts and their return to IBM. A part that replaces a removed part will assume the warranty service status of the removed part. Unless IBM specifies otherwise, these warranties apply only in the country or region in which you purchased the Machine.

**THESE WARRANTIES ARE YOUR EXCLUSIVE WARRANTIES AND REPLACE ALL OTHER WARRANTIES OR CONDITIONS, EXPRESS OR IMPLIED, INCLUDING, BUT NOT LIMITED TO, THE IMPLIED WARRANTIES OR CONDITIONS OF MERCHANTABILITY AND FITNESS FOR A PARTICULAR PURPOSE. SOME STATES OR JURISDICTIONS DO NOT ALLOW THE EXCLUSION OF EXPRESS OR IMPLIED WARRANTIES, SO THE ABOVE EXCLUSION MAY NOT APPLY TO YOU. IN THAT EVENT, SUCH WARRANTIES ARE LIMITED IN DURATION TO THE WARRANTY PERIOD. NO WARRANTIES APPLY AFTER THAT PERIOD. SOME STATES OR JURISDICTIONS DO NOT ALLOW LIMITATIONS ON HOW LONG AN IMPLIED WARRANTY LASTS, SO THE ABOVE LIMITATION MAY NOT APPLY TO YOU.**

### What this Warranty Does not Cover

This warranty does not cover the following:

- any software programs, whether pre-loaded or shipped with the Machine, or installed subsequently;
- failure resulting from misuse (including but not limited to use of any Machine capacity or capability, other than that authorized by IBM in writing), accident, modification, unsuitable physical or operating environment, or improper maintenance by you;

- failure caused by a product for which IBM is not responsible; and
- any non-IBM products, including those that IBM may procure and provide with or integrate into an IBM Machine at your request.

The warranty is voided by removal or alteration of identification labels on the Machine or its parts.

IBM does not warrant uninterrupted or error-free operation of a Machine.

Any technical or other support provided for a Machine under warranty, such as assistance via telephone with "how-to" questions and those regarding Machine set-up and installation, is provided **WITHOUT WARRANTIES OF ANY KIND**.

### **How to Obtain Warranty Service**

If the Machine does not function as warranted during the warranty period, contact IBM or your reseller to obtain warranty service. If you do not register the Machine with IBM, you may be required to present proof of purchase as evidence of your entitlement to warranty service.

### **What IBM Will Do to Correct Problems**

When you call for service, you must follow the problem determination and resolution procedures that IBM specifies. A technician will attempt to make an initial diagnosis of your problem and help you resolve it over the telephone.

The type of warranty service applicable to your Machine is specified in Part 3 - Warranty Information.

You are responsible for downloading and installing designated Machine Code (microcode, basic input/output system code (called "BIOS"), utility programs, device drivers, and diagnostics delivered with an IBM Machine ) and other software updates from an IBM Internet Web site or from other electronic media, and following the instructions that IBM provides.

If your problem can be resolved with a Customer Replaceable Unit ("CRU") (e.g., keyboard, mouse, speaker, memory, hard disk drive and other easily replaceable parts), IBM will ship these parts to you for replacement by you.

If the Machine does not function as warranted during the warranty period and your problem cannot be resolved over the telephone, through your application of Machine Code or software updates, or with a CRU, IBM or your reseller, if approved by IBM to provide warranty service, will either, at its discretion, 1) repair it to make it function as warranted, or 2) replace it with one that is at least functionally equivalent. If IBM is unable to do either, you may return the Machine to your place of purchase and your money will be refunded.

IBM or your reseller will also manage and install selected engineering changes that apply to the Machine.

### **Exchange of a Machine or Part**

When the warranty service involves the exchange of a Machine or part, the item IBM or your reseller replaces becomes its property and the replacement becomes yours. You represent that all removed items are genuine and unaltered. The replacement may not be new, but will be in good working order and at least functionally equivalent to the item replaced. The replacement assumes the warranty service status of the replaced item.

### **Your Additional Responsibilities**

Before IBM or your reseller exchanges a Machine or part, you agree to remove all features, parts, options, alterations, and attachments not under warranty service.

You also agree to:

1. ensure that the Machine is free of any legal obligations or restrictions that prevent its exchange;
2. obtain authorization from the owner to have IBM or your reseller service a Machine that you do not own; and
3. where applicable, before service is provided:
  - a. follow the service request procedures that IBM or your reseller provides;
  - b. backup or secure all programs, data, and funds contained in the Machine;
  - c. IBM or your reseller with sufficient, free, and safe access to your facilities to permit IBM to fulfill its obligations; and
  - d. inform IBM or your reseller of changes in the Machine's location.
4. (a) ensure all information about identified or identifiable individuals (Personal Data) is deleted from the Machine (to the extent technically possible), (b) allow IBM, your reseller or an IBM supplier to process on your behalf any remaining Personal Data as IBM or your reseller considers necessary to fulfill its obligations under this Statement of Limited Warranty (which may include shipping the Machine for such processing to other IBM service locations around the world), and (c) ensure that such processing complies with any laws applicable to such Personal Data.

### **Limitation of Liability**

IBM is responsible for loss of, or damage to, your Machine only while it is 1) in IBM's possession or 2) in transit in those cases where IBM is responsible for the transportation charges.

Neither IBM nor your reseller are responsible for any of your confidential, proprietary or personal information contained in a Machine which you return to IBM for any reason. You should remove all such information from the Machine prior to its return.

Circumstances may arise where, because of a default on IBM's part or other liability, you are entitled to recover damages from IBM. In each such instance, regardless of the basis on which you are entitled to claim damages from IBM (including fundamental breach, negligence, misrepresentation, or other contract or tort claim), except for any liability that cannot be waived or limited by applicable laws, IBM is liable for no more than

1. damages for bodily injury (including death) and damage to real property and tangible personal property; and

2. the amount of any other actual direct damages, up to the charges (if recurring, 12 months' charges apply) for the Machine that is subject of the claim. For purposes of this item, the term "Machine" includes Machine Code and Licensed Internal Code ("LIC").

This limit also applies to IBM's suppliers and your reseller. It is the maximum for which IBM, its suppliers, and your reseller are collectively responsible.

**UNDER NO CIRCUMSTANCES IS IBM, ITS SUPPLIERS OR RESELLERS LIABLE FOR ANY OF THE FOLLOWING EVEN IF INFORMED OF THEIR POSSIBILITY: 1) THIRD PARTY CLAIMS AGAINST YOU FOR DAMAGES (OTHER THAN THOSE UNDER THE FIRST ITEM LISTED ABOVE); 2) LOSS OF, OR DAMAGE TO, DATA; 3) SPECIAL, INCIDENTAL, OR INDIRECT DAMAGES OR FOR ANY ECONOMIC CONSEQUENTIAL DAMAGES; OR 4) LOST PROFITS, BUSINESS REVENUE, GOODWILL OR ANTICIPATED SAVINGS. SOME STATES OR JURISDICTIONS DO NOT ALLOW THE EXCLUSION OR LIMITATION OF INCIDENTAL OR CONSEQUENTIAL DAMAGES, SO THE ABOVE LIMITATION OR EXCLUSION MAY NOT APPLY TO YOU. SOME STATES OR JURISDICTIONS DO NOT ALLOW LIMITATIONS ON HOW LONG AN IMPLIED WARRANTY LASTS, SO THE ABOVE LIMITATION MAY NOT APPLY TO YOU.**

#### **Governing Law**

Both you and IBM consent to the application of the laws of the country in which you acquired the Machine to govern, interpret, and enforce all of your and IBM's rights, duties, and obligations arising from, or relating in any manner to, the subject matter of this Statement of Limited Warranty, without regard to conflict of law principles.

**THESE WARRANTIES GIVE YOU SPECIFIC LEGAL RIGHTS AND YOU MAY ALSO HAVE OTHER RIGHTS WHICH VARY FROM STATE TO STATE OR JURISDICTION TO JURISDICTION.**

#### **Jurisdiction**

All of our rights, duties, and obligations are subject to the courts of the country in which you acquired the Machine.

---

## **Part 2 - Country-unique Terms**

### **AMERICAS**

#### **ARGENTINA**

**Governing Law:** *The following is added after the first sentence:*

Any litigation arising from this Statement of Limited Warranty will be settled exclusively by the Ordinary Commercial Court of the city of Buenos Aires.

#### **BRAZIL**

**Governing Law:** *The following is added after the first sentence:*

Any litigation arising from this Statement of Limited Warranty will be settled exclusively by the court of Rio de Janeiro, RJ.

## **Peru**

**Limitation of Liability:** *The following is added at the end of this section:*

In accordance with Article 1328 of the Peruvian Civil Code the limitations and exclusions specified in this section will not apply to damages caused by IBM's willful misconduct ("dolo") or gross negligence ("culpa inexcusable").

## **NORTH AMERICA**

**How to Obtain Warranty Service:** *The following is added to this Section:*

To obtain warranty service from IBM in Canada or the United States, call 1-800-IBM-SERV (426-7378).

## **CANADA**

**Limitation of Liability:** *The following replaces item 1 of this section:*

1. damages for bodily injury (including death) or physical harm to real property and tangible personal property caused by IBM's negligence; and

**Governing Law:** *The following replaces 『laws of the country in which you acquired the Machine』 in the first sentence:*  
laws in the Province of Ontario.

## **UNITED STATES**

**Governing Law:** *The following replaces 『laws of the country in which you acquired the Machine』 in the first sentence:*  
laws of the State of New York.

## **ASIA PACIFIC**

### **AUSTRALIA**

**What this Warranty Covers:** *The following paragraph is added to this Section:*

The warranties specified in this Section are in addition to any rights you may have under the Trade Practices Act 1974 or other similar legislation and are only limited to the extent permitted by the applicable legislation.

**Limitation of Liability:** *The following is added to this Section:*

Where IBM is in breach of a condition or warranty implied by the Trade Practices Act 1974 or other similar legislation, IBM's liability is limited to the repair or replacement of the goods or the supply of equivalent goods. Where that condition or warranty relates to right to sell, quiet possession or clear title, or the goods are of a kind ordinarily acquired for personal, domestic or household use or consumption, then none of the limitations in this paragraph apply.

**Governing Law:** *The following replaces 『laws of the country in which you acquired the Machine』 in the first sentence:*  
laws of the State or Territory.

### **CAMBODIA, LAOS, AND VIETNAM**

**Governing Law:** *The following replaces 『laws of the country in which you acquired the Machine』 in the first sentence:*  
laws of the State of New York, United States of America.

### **CAMBODIA, INDONESIA, LAOS, AND VIETNAM**

*Arbitration: The following is added under this heading:*

Disputes arising out of or in connection with this Statement of Limited Warranty shall be finally settled by arbitration which shall be held in Singapore in accordance with the Arbitration Rules of Singapore International Arbitration Center ("SIAC Rules") then in effect. The arbitration award shall be final and binding for the parties without appeal and shall be in writing and set forth the findings of fact and the conclusions of law.

The number of arbitrators shall be three, with each side to the dispute being entitled to appoint one arbitrator. The two arbitrators appointed by the parties shall appoint a third arbitrator who shall act as chairman of the proceedings. Vacancies in the post of chairman shall be filled by the president of the SIAC. Other vacancies shall be filled by the respective nominating party. Proceedings shall continue from the stage they were at when the vacancy occurred.

If one of the parties refuses or otherwise fails to appoint an arbitrator within 30 days of the date the other party appoints its, the first appointed arbitrator shall be the sole arbitrator, provided that the arbitrator was validly and properly appointed.

All proceedings shall be conducted, including all documents presented in such proceedings, in the English language. The English language version of this Statement of Limited Warranty prevails over any other language version.

### **HONG KONG S.A.R. OF CHINA AND MACAU S.A.R. OF CHINA**

**Governing Law:** *The following replaces 『laws of the country in which you acquired the Machine』 in the first sentence:*  
laws of Hong Kong Special Administrative Region of China.

### **INDIA**

**Limitation of Liability:** *The following replaces items 1 and 2 of this Section:*

1. liability for bodily injury (including death) or damage to real property and tangible personal property will be limited to that caused by IBM's negligence; and
2. as to any other actual damage arising in any situation involving nonperformance by IBM pursuant to, or in any way related to the subject of this Statement of Limited Warranty, , the charge paid by you for the individual Machine that is the subject of the claim. For purposes of this item, the term "Machine" includes Machine Code and Licensed Internal Code ("LIC").



**Arbitration:** *The following is added under this heading :*

Disputes arising out of or in connection with this Statement of Limited Warranty shall be finally settled by arbitration which shall be held in Bangalore, India in accordance with the laws of India then in effect. The arbitration award shall be final and binding for the parties without appeal and shall be in writing and set forth the findings of fact and the conclusions of law.

The number of arbitrators shall be three, with each side to the dispute being entitled to appoint one arbitrator. The two arbitrators appointed by the parties shall appoint a third arbitrator who shall act as chairman of the proceedings. Vacancies in the post of chairman shall be filled by the president of the Bar Council of India. Other vacancies shall be filled by the respective nominating party. Proceedings shall continue from the stage they were at when the vacancy occurred.

If one of the parties refuses or otherwise fails to appoint an arbitrator within 30 days of the date the other party appoints its, the first appointed arbitrator shall be the sole arbitrator, provided that the arbitrator was validly and properly appointed.

All proceedings shall be conducted, including all documents presented in such proceedings, in the English language. The English language version of this Statement of Limited Warranty prevails over any other language version.

## **JAPAN**

**Governing Law:** *The following sentence is added to this section:*

Any doubts concerning this Statement of Limited Warranty will be initially resolved between us in good faith and in accordance with the principle of mutual trust.

## **MALAYSIA**

**Limitation of Liability:** *The word "SPECIAL" in item 3 of the fifth paragraph is deleted.*

## **NEW ZEALAND**

**What this Warranty Covers:** *The following paragraph is added to this section:*

The warranties specified in this section are in addition to any rights you may have under the Consumer Guarantees Act 1993 or other legislation which cannot be excluded or limited. The Consumer Guarantees Act 1993 will not apply in respect of any goods which IBM provides, if you require the goods for the purposes of a business as defined in that Act.

**Limitation of Liability:** *The following is added to this section:*

Where Machines are not acquired for the purposes of a business as defined in the Consumer Guarantees Act 1993, the limitations in this section are subject to the limitations in that Act.

## **PEOPLE'S REPUBLIC OF CHINA (PRC)**

**Governing Law:** *The following replaces "laws of the country in which you acquired the Machine" in the first sentence:*

laws of the State of New York, United States of America (except when local law requires otherwise).

## **PHILIPPINES**

**Limitation of Liability:** *Item 3 in the fifth paragraph is replaced by the following:*

**SPECIAL (INCLUDING NOMINAL AND EXEMPLARY DAMAGES), MORAL, INCIDENTAL, OR INDIRECT DAMAGES FOR ANY ECONOMIC CONSEQUENTIAL DAMAGES; OR**

**Arbitration:** The following is added under this heading

Disputes arising out of or in connection with this Statement of Limited Warranty shall be finally settled by arbitration which shall be held in Metro Manila, Philippines in accordance with the laws of the Philippines then in effect. The arbitration award shall be final and binding for the parties without appeal and shall be in writing and set forth the findings of fact and the conclusions of law.

The number of arbitrators shall be three, with each side to the dispute being entitled to appoint one arbitrator. The two arbitrators appointed by the parties shall appoint a third arbitrator who shall act as chairman of the proceedings. Vacancies in the post of chairman shall be filled by the president of the Philippine Dispute Resolution Center, Inc.. Other vacancies shall be filled by the respective nominating party. Proceedings shall continue from the stage they were at when the vacancy occurred.

If one of the parties refuses or otherwise fails to appoint an arbitrator within 30 days of the date the other party appoints its, the first appointed arbitrator shall be the sole arbitrator, provided that the arbitrator was validly and properly appointed.

All proceedings shall be conducted, including all documents presented in such proceedings, in the English language. The English language version of this Statement of Limited Warranty prevails over any other language version.

## **SINGAPORE**

**Limitation of Liability:** The words "**SPECIAL**" and "**ECONOMIC**" in item 3 in the fifth paragraph are deleted.

## **EUROPE, MIDDLE EAST, AFRICA (EMEA)**

### ***THE FOLLOWING TERMS APPLY TO ALL EMEA COUNTRIES:***

The terms of this Statement of Limited Warranty apply to Machines purchased from IBM or an IBM reseller.

**Hot to Obtain Warranty Service:** If you purchase a Machine in Austria, Belgium, Cyprus, Denmark, Estonia, Finland, France, Germany, Greece, Iceland, Ireland, Italy, Latvia, Liechtenstein, Lithuania, Luxembourg, Monaco, Netherlands, Norway, Portugal, Spain, San Marino, Sweden, Switzerland, United Kingdom or Vatican State, you may obtain warranty service for that Machine in any of those countries from either (1) an IBM reseller approved to perform warranty service or (2) from IBM, provided the Machine has been announced and made available by IBM in the country in which you wish to obtain service. If you

purchased a Personal Computer Machine in Albania, Armenia, Belarus, Bosnia and Herzegovina, Bulgaria, Croatia, Czech Republic, Georgia, Hungary, Kazakhstan, Kyrgyzstan, Federal Republic of Yugoslavia, Former Yugoslav Republic of Macedonia (FYROM), Moldova, Poland, Romania, Russia, Slovak Republic, Slovenia, or Ukraine, you may obtain warranty service for that Machine in any of those countries from either (1) an IBM reseller approved to perform warranty service or (2) from IBM.

If you purchase a Machine in a Middle Eastern or African country, you may obtain warranty service for that Machine from the IBM entity within the country of purchase, if that IBM entity provides warranty service in that country, or from an IBM reseller, approved by IBM to perform warranty service on that Machine in that country. Warranty service in Africa is available within 50 kilometers of an IBM approved service provider. You are responsible for transportation costs for Machines located outside 50 kilometers of an IBM approved service provider.

*Add the following paragraph in **Western Europe** (Austria, Belgium, Cyprus, Denmark, Finland, France, Germany, Greece, Iceland, Ireland, Italy, Liechtenstein, Luxembourg, Monaco, Netherlands, Norway, Portugal, Spain, San Marino, Sweden, Switzerland, United Kingdom, Vatican State):*

The warranty for Machines acquired in Western Europe shall be valid and applicable in all Western Europe countries provided the Machines have been announced and made available in such countries.

#### **Governing Law:**

*The phrase "the laws of the country in which you acquired the Machine" is replaced by:*

1) "the laws of Austria" in **Albania, Armenia, Azerbaijan, Belarus, Bosnia-Herzegovina, Bulgaria, Croatia, Georgia, Hungary, Kazakhstan, Kyrgyzstan, FYR Macedonia, Moldova, Poland, Romania, Russia, Slovakia, Slovenia, Tajikistan, Turkmenistan, Ukraine, Uzbekistan, and FR Yugoslavia;**  
2) "the laws of France" in **Algeria, Benin, Burkina Faso, Cameroon, Cape Verde, Central African Republic, Chad, Comoros, Congo Republic, Djibouti, Democratic Republic of Congo, Equatorial Guinea, French Guiana, French Polynesia, Gabon, Gambia, Guinea, Guinea-Bissau, Ivory Coast, Lebanon, Madagascar, Mali, Mauritania, Mauritius, Mayotte, Morocco, New Caledonia, Niger, Reunion, Senegal, Seychelles, Togo, Tunisia, Vanuatu, and Wallis & Futuna;** 3) "the laws of Finland" in **Estonia, Latvia, and Lithuania;** 4) "the laws of England" in **Angola, Bahrain, Botswana, Burundi, Egypt, Eritrea, Ethiopia, Ghana, Jordan, Kenya, Kuwait, Liberia, Malawi, Malta, Mozambique, Nigeria, Oman, Pakistan, Qatar, Rwanda, Sao Tome, Saudi Arabia, Sierra Leone, Somalia, Tanzania, Uganda, United Arab Emirates, the United Kingdom, West Bank/Gaza, Yemen, Zambia, and Zimbabwe;** and 5) "the laws of South Africa" in **South Africa, Namibia, Lesotho and Swaziland.**

**Jurisdiction:** *The following exceptions are added to this section:*

1) **In Austria** the choice of jurisdiction for all disputes arising out of this Statement of Limited Warranty and relating thereto, including its existence, will be the competent court of law in Vienna, Austria (Inner-City); 2) **in Angola, Bahrain, Botswana, Burundi, Egypt, Eritrea, Ethiopia, Ghana, Jordan, Kenya, Kuwait, Liberia, Malawi, Malta, Mozambique, Nigeria, Oman, Pakistan, Qatar, Rwanda, Sao Tome, Saudi Arabia, Sierra Leone, Somalia, Tanzania, Uganda, United Arab Emirates, West Bank/Gaza, Yemen, Zambia, and Zimbabwe** all disputes arising out of this Statement of Limited Warranty or related to its execution, including summary proceedings, will be submitted to the exclusive jurisdiction of the English courts; 3) **in Belgium and Luxembourg**, all disputes arising out of this Statement of Limited Warranty or related to its interpretation or its execution, the law, and the courts of the capital city, of the country of your registered office and/or commercial site location only are competent; 4) **in France, Algeria, Benin, Burkina Faso, Cameroon, Cape Verde, Central African Republic, Chad, Comoros, Congo Republic, Djibouti, Democratic Republic of Congo, Equatorial Guinea, French Guiana, French Polynesia, Gabon, Gambia, Guinea, Guinea-Bissau, Ivory Coast, Lebanon, Madagascar, Mali, Mauritania, Mauritius, Mayotte, Morocco, New Caledonia, Niger, Reunion, Senegal, Seychelles, Togo, Tunisia, Vanuatu, and Wallis & Futuna** all disputes arising out of this Statement of Limited Warranty or related to its violation or execution, including summary proceedings, will be settled exclusively by the Commercial Court of Paris; 5) **in Russia**, all disputes arising out of or in relation to the interpretation, the violation, the termination, the nullity of the execution of this Statement of Limited Warranty shall be settled by Arbitration Court of Moscow; 6) **in South Africa, Namibia, Lesotho and Swaziland**, both of us agree to submit all disputes relating to this Statement of Limited Warranty to the jurisdiction of the High Court in Johannesburg; 7) **in Turkey** all disputes arising out of or in connection with this Statement of Limited Warranty shall be resolved by the Istanbul Central (Sultanahmet) Courts and Execution Directorates of Istanbul, the Republic of Turkey; 8) in each of the following specified countries, any legal claim arising out of this Statement of Limited Warranty will be brought before, and settled exclusively by, the competent court of a) Athens for **Greece**, b) Tel Aviv-Jaffa for **Israel**, c) Milan for **Italy**, d) Lisbon for **Portugal**, and e) Madrid for **Spain**; and 9) **in the United Kingdom**, both of us agree to submit all disputes relating to this Statement of Limited Warranty to the jurisdiction of the English courts.

**Arbitration:** *The following is added under this heading:*

**In Albania, Armenia, Azerbaijan, Belarus, Bosnia-Herzegovina, Bulgaria, Croatia, Georgia, Hungary, Kazakhstan, Kyrgyzstan, FYR Macedonia, Moldova, Poland, Romania, Russia, Slovakia, Slovenia, Tajikistan, Turkmenistan, Ukraine, Uzbekistan, and FR Yugoslavia** all disputes arising out of this Statement of Limited Warranty or related to its violation, termination or nullity will be finally settled under the Rules of Arbitration and Conciliation of the International Arbitral Center of the Federal Economic Chamber in Vienna (Vienna Rules) by three arbitrators appointed in accordance with these rules. The arbitration will be held in Vienna, Austria, and the official language of the proceedings will be English. The decision of the arbitrators will be final and binding upon both parties. Therefore, pursuant to paragraph 598 (2) of the Austrian Code of Civil Procedure, the parties expressly waive the application of paragraph 595 (1) figure 7 of the Code. IBM may, however, institute proceedings in a competent court in the country of installation.

**In Estonia, Latvia and Lithuania** all disputes arising in connection with this Statement of Limited Warranty will be finally settled in arbitration that will be held in Helsinki, Finland in accordance with the arbitration laws of Finland then in effect. Each party will appoint one arbitrator. The arbitrators will then jointly appoint the chairman. If arbitrators cannot agree on the chairman, then the Central Chamber of Commerce in Helsinki will appoint the chairman.

## **EUROPEAN UNION (EU)**

### ***THE FOLLOWING TERMS APPLY TO ALL EU COUNTRIES:***

Consumers have legal rights under applicable national legislation governing the sale of consumer goods. Such rights are not affected by the warranties provided in this Statement of Limited Warranty.

**How to Obtain Warranty Service:** *The following is added to this section:*

To obtain warranty service from IBM in EU countries, see the telephone listing in Part 3 - Warranty Information.

You may contact IBM at the following address:

IBM Warranty & Service Quality Dept.

PO Box 30

Spango Valley

Greenock

Scotland PA 16 OAH

## **AUSTRIA, DENMARK, FINLAND, GREECE, ITALY, NETHERLANDS, PORTUGAL, SPAIN, SWEDEN AND SWITZERLAND**

**Limitation of Liability:** *The following replaces the terms of this section in its entirety:*

Except as otherwise provided by mandatory law:

1. IBM's liability for any damages and losses that may arise as a consequence of the fulfillment of its obligations under or in connection with this Statement of Limited Warranty or due to any other cause related to this Statement of Limited Warranty is limited to the compensation of only those damages and losses proved and actually arising as an immediate and direct consequence of the non-fulfillment of such obligations (if IBM is at fault) or of such cause, for a maximum amount equal to the charges you paid for the Machine. For purposes of this item, the term "Machine" includes Machine Code and Licensed Internal Code ("LIC").

The above limitation shall not apply to damages for bodily injuries (including death) and damages to real property and tangible personal property for which IBM is legally liable.

2. **UNDER NO CIRCUMSTANCES IS IBM, ITS SUPPLIERS OR RESELLERS LIABLE FOR ANY OF THE FOLLOWING, EVEN IF INFORMED OF THEIR**

**POSSIBILITY: 1) LOSS OF, OR DAMAGE TO, DATA; 2) INCIDENTAL OR INDIRECT DAMAGES, OR FOR ANY ECONOMIC CONSEQUENTIAL DAMAGES; 3) LOST PROFITS, EVEN IF THEY ARISE AS AN IMMEDIATE CONSEQUENCE OF THE EVENT THAT GENERATED THE DAMAGES; OR 4) LOSS OF BUSINESS, REVENUE, GOODWILL, OR ANTICIPATED SAVINGS.**

## **FRANCE AND BELGIUM**

**Limitation of Liability:** *The following replaces the terms of this section in its entirety:*

Except as otherwise provided by mandatory law:

1. IBM's liability for any damages and losses that may arise as a consequence of the fulfillment of its obligations under or in connection with this Statement of Limited Warranty is limited to the compensation of only those damages and losses proved and actually arising as an immediate and direct consequence of the non-fulfillment of such obligations (if IBM is at fault), for a maximum amount equal to the charges you paid for the Machine that has caused the damages. For purposes of this item, the term "Machine" includes Machine Code and Licensed Internal Code ("LIC").

The above limitation shall not apply to damages for bodily injuries (including death) and damages to real property and tangible personal property for which IBM is legally liable.

2. **UNDER NO CIRCUMSTANCES IS IBM, ITS SUPPLIERS OR RESELLERS LIABLE FOR ANY OF THE FOLLOWING, EVEN IF INFORMED OF THEIR POSSIBILITY: 1) LOSS OF, OR DAMAGE TO, DATA; 2) INCIDENTAL OR INDIRECT DAMAGES, OR FOR ANY ECONOMIC CONSEQUENTIAL DAMAGES; 3) LOST PROFITS, EVEN IF THEY ARISE AS AN IMMEDIATE CONSEQUENCE OF THE EVENT THAT GENERATED THE DAMAGES; OR 4) LOSS OF BUSINESS, REVENUE, GOODWILL, OR ANTICIPATED SAVINGS.**

**THE FOLLOWING TERMS APPLY TO THE COUNTRY SPECIFIED:**

### **AUSTRIA**

**What this Warranty Covers:** *The following replaces the first sentence of the first paragraph of this section:*

The warranty for an IBM Machine covers the functionality of the Machine for its normal use and the Machine's conformity to its Specifications.

*The following paragraphs are added to this Section:*

The minimum warranty period for Machines is 12 months from the date of delivery. . The limitation period for consumers in action for breach of warranty is the statutory period as a minimum. In case IBM or your reseller is unable to repair an IBM Machine, you can alternatively ask for a partial refund as far as justified by the reduced value of the unrepaired Machine or ask for a cancellation of the respective agreement for such Machine and get your money refunded.

*The second paragraph does not apply.*

**What IBM Will Do to Correct Problems:** *The following is added to this section:*

During the warranty period, transportation for delivery of the failing Machine to IBM will be at IBM's expense.

**Limitation of Liability:** *The following paragraph is added to this section:*

The limitations and exclusions specified in the Statement of Limited Warranty will not apply to damages caused by IBM with fraud or gross negligence and for express warranty.

*The following sentence is added to the end of item 2:*

IBM's liability under this item is limited to the violation of essential contractual terms in cases of ordinary negligence.

## **EGYPT**

**Limitation of Liability:** *The following replaces item 2 in this section:*

as to any other actual direct damages, IBM's liability will be limited to the total amount you paid for the Machine that is the subject of the claim. For purposes of this item, the term 『Machine』 includes Machine Code and Licensed Internal Code (LIC).

*Applicability of suppliers and resellers (unchanged).*

## **FRANCE**

**Limitation of Liability:** *The following replaces the second sentence of the first paragraph of this section:*

In such instances, regardless of the basis on which you are entitled to claim damages from IBM, IBM is liable for no more than: *(items 1 and 2 unchanged).*

## **GERMANY**

**What this Warranty Covers:** *The following replaces the first sentence of the first paragraph of this section:*

The warranty for an IBM Machine covers the functionality of the Machine for its normal use and the Machine's conformity to its Specifications.

*The following paragraphs are added to this section:*

The minimum warranty period for Machines is twelve months. In case IBM or your reseller is unable to repair an IBM Machine, you can alternatively ask for a partial refund as far as justified by the reduced value of the unrepaired Machine or ask for a cancellation of the respective agreement for such Machine and get your money refunded.

*The second paragraph does not apply.*

**What IBM Will Do to Correct Problems:** *The following is added to this section:*

During the warranty period, transportation for delivery of the failing Machine to IBM will be at IBM's expense.

**Limitation of Liability:** *The following paragraph is added to this section:*

The limitations and exclusions specified in the Statement of Limited Warranty will not apply to damages caused by IBM with fraud or gross negligence and for express warranty.

*The following sentence is added to the end of item 2:*

IBM's liability under this item is limited to the violation of essential contractual terms in cases of ordinary negligence.

## **HUNGARY**

**Limitation of Liability:** *The following is added at the end of this section:*

The limitation and exclusion specified herein shall not apply to liability for a breach of contract damaging life, physical well-being, or health that has been caused intentionally, by gross negligence, or by a criminal act.

The parties accept the limitations of liability as valid provisions and state that the Section 314.(2) of the Hungarian Civil Code applies as the acquisition price as well as other advantages arising out of the present Statement of Limited Warranty balance this limitation of liability.

## **IRELAND**

**What this Warranty Covers:** *The following is added to this section:*

Except as expressly provided in these terms and conditions, all statutory conditions, including all warranties implied, but without prejudice to the generality of the foregoing all warranties implied by the Sale of Goods Act 1893 or the Sale of Goods and Supply of Services Act 1980 are hereby excluded.

**Limitation of Liability:** *The following replaces the terms of this section in its entirety:*

For the purposes of this section, a "Default" means any act, statement, omission, or negligence on the part of IBM in connection with, or in relation to, the subject matter of this Statement of Limited Warranty in respect of which IBM is legally liable to you, whether in contract or tort. A number of Defaults which together result in, or contribute to, substantially the same loss or damage will be treated as one Default occurring on the date of occurrence of the last such Default.

Circumstances may arise where, because of a Default, you are entitled to recover damages from IBM.

This section sets out the extent of IBM's liability and your sole remedy.

1. IBM will accept unlimited liability for death or personal injury caused by the negligence of IBM.
2. Subject always to the Items for Which IBM is Not Liable below, IBM will accept unlimited liability for physical damage to your tangible property resulting from the negligence of IBM.
3. Except as provided in items 1 and 2 above, IBM's entire liability for actual damages for any one Default will not in any event exceed the greater of 1) EUR 125,000, or 2) 125% of the amount you paid for the Machine directly relating to the Default.



## **Items for Which IBM is Not Liable**

Save with respect to any liability referred to in item 1 above, under no circumstances is IBM, its suppliers or resellers liable for any of the following, even if IBM or they were informed of the possibility of such losses:

1. loss of, or damage to, data;
2. special, indirect, or consequential loss; or
3. loss of profits, business, revenue, goodwill, or anticipated savings.

## **SLOVAKIA**

**Limitation of Liability:** *The following is added to the end of the last paragraph:*

The limitations apply to the extent they are not prohibited under §§ 373-386 of the Slovak Commercial Code.

## **SOUTH AFRICA, NAMIBIA, BOTSWANA, LESOTHO AND SWAZILAND**

**Limitation of Liability:** *The following is added to this section:*

IBM's entire liability to you for actual damages arising in all situations involving nonperformance by IBM in respect of the subject matter of this Statement of Warranty will be limited to the charge paid by you for the individual Machine that is the subject of your claim from IBM.

## **UNITED KINGDOM**

**Limitation of Liability:** *The following replaces the terms of this section in its entirety:*

For the purposes of this section, a "Default" means any act, statement, omission, or negligence on the part of IBM in connection with, or in relation to, the subject matter of this Statement of Limited Warranty in respect of which IBM is legally liable to you, whether in contract or tort. A number of Defaults which together result in, or contribute to, substantially the same loss or damage will be treated as one Default.

Circumstances may arise where, because of a Default, you are entitled to recover damages from IBM.

This section sets out the extent of IBM's liability and your sole remedy.

1. IBM will accept unlimited liability for:
  - a. death or personal injury caused by the negligence of IBM; and
  - b. any breach of its obligations implied by Section 12 of the Sale of Goods Act 1979 or Section 2 of the Supply of Goods and Services Act 1982, or any statutory modification or re-enactment of either such Section.
2. IBM will accept unlimited liability, subject always to the Items for Which IBM is Not Liable below, for physical damage to your tangible property resulting from the negligence of IBM.

3. IBM's entire liability for actual damages for any one Default will not in any event, except as provided in items 1 and 2 above, exceed the greater of 1) Pounds Sterling 75,000, or 2) 125% of the total purchase price payable or the charges for the Machine directly relating to the Default.

These limits also apply to IBM's suppliers and resellers. They state the maximum for which IBM and such suppliers and resellers are collectively responsible.

### **Items for Which IBM is Not Liable**

Save with respect to any liability referred to in item 1 above, under no circumstances is IBM or any of its suppliers or resellers liable for any of the following, even if IBM or they were informed of the possibility of such losses:

1. loss of, or damage to, data:
2. special, indirect, or consequential loss; or
3. loss of profits, business, revenue, goodwill, or anticipated savings.

---

## **Part 3 - Warranty Information**

This Part 3 provides information regarding the warranty applicable to your Machine, including the warranty period and type of warranty service IBM provides.

### **Warranty Period**

The warranty period may vary by country or region and is specified in the table below. NOTE: "Region" means either Hong Kong or Macau Special Administrative Region of China.

#### **48X/32X/48X Max CD-RW Drive**

<b>Country or Region of Purchase</b>	<b>Warranty Period</b>	<b>Type of Warranty Service</b>
Worldwide	1 year	1, 4

A warranty period of 1 year on parts and 1 year on labor means that IBM provides warranty service without charge for parts and labor during the 1 year warranty period.

### **Types of Warranty Service**

If required, IBM provides repair or exchange service depending on the type of warranty service specified for your Machine in the above table and as described below. Warranty service may be provided by your reseller if approved by IBM to perform warranty service. Scheduling of service will depend upon the time of your call and is subject to parts availability. Service levels are response time objectives and are not guaranteed. The specified level of warranty service may not be available in all worldwide locations, additional charges may apply outside IBM's normal service area, contact your local IBM representative or your reseller for country and location specific information.

#### **1. Customer Replaceable Unit ("CRU") Service**

IBM will ship CRU parts to you for your replacement. If IBM instructs you to return the replaced CRU, you are responsible for returning it to IBM in accordance with IBM's instructions. If you do not return the defective CRU, if IBM so instructs, within 30 days of your receipt of the replacement CRU, IBM may charge you for the replacement.

## 2. On-site Service

IBM or your reseller will either repair or exchange the failing Machine at your location and verify its operation. You must provide suitable working area to allow disassembly and reassembly of the IBM Machine. The area must be clean, well lit and suitable for the purpose. **For some Machines, certain repairs may require sending the Machine to an IBM service center.**

## 3. Courier or Depot Service<sup>4</sup>

You will disconnect the failing Machine for collection arranged by IBM. IBM will provide you with a shipping container for you to return your Machine to a designated service center. A courier will pick up your Machine and deliver it to the designated service center. Following its repair or exchange, IBM will arrange the return delivery of the Machine to your location. You are responsible for its installation and verification.

## 4. Customer Carry-In or Mail-In Service

You will deliver or mail as IBM specifies (prepaid unless IBM specifies otherwise) the failing Machine suitably packaged to a location IBM designates. After IBM has repaired or exchanged the Machine, IBM will make it available for your collection or, for Mail-in Service, IBM will return it to you at IBM's expense, unless IBM specifies otherwise. You are responsible for the subsequent installation and verification of the Machine.

The IBM Machine Warranty worldwide web site at [http://www.ibm.com/servers/support/machine\\_warranties/](http://www.ibm.com/servers/support/machine_warranties/) provides a worldwide overview of IBM's Limited Warranty for Machines, a Glossary of IBM definitions, Frequently Asked Questions (FAQs) and Support by Product (Machine) with links to Product Support pages. **The IBM Statement of Limited Warranty is also available on this site in 29 languages.**

To obtain warranty service contact IBM or your IBM reseller. In Canada or the United States, call 1-800-IBM-SERV (426-7378). For other countries, see the telephone numbers below.

Phone numbers are subject to change without notice. For the latest phone number list, go to [www-3.ibm.com/pc/support/site.wss/](http://www-3.ibm.com/pc/support/site.wss/) and click **Support Phone List**.

Country or Region	Telephone Number	Country or Region	Telephone Number
Argentina	0800-666-0011	Malaysia	03-7727-7800
Australia	1300-130-426	Mexico	001-866-434-2080
Austria	01-24592-5901	Netherlands	020-514-5770

---

4. This type of service is called ThinkPad EasyServ or EasyServ in some countries.

<b>Country or Region</b>	<b>Telephone Number</b>	<b>Country or Region</b>	<b>Telephone Number</b>
Belgium	Dutch 02-210-9820 French 02-210-9800	New Zealand	0800-446-149
Bolivia	0800-0189	Norway	66 81 11 00
Brazil	55-11-3889-8986	Peru	0-800-50-866
Canada	1-800-565-3344 Toronto 416-383-3344	Philippines	632-995-2225
Chile	800-224-488	Portugal	21-791 51 47
China (PRC)	800-810-1818	Russia	095-940-2000
China (Hong Kong S.A.R.)	852-2825-7799	Singapore	1800-840-9911
Columbia	980-912-3021	Spain	91-662 49 16
Denmark	45 20 82 00	Sweden	08-477 4420
Ecuador	1-800-426911 (option #4)	Switzerland	058-333-09-00
Finland	09-459 69 60	Taiwan	886-2-2725-9799
France	02 38 55 74 50	Thailand	66-2-273-4000
Germany	07032-1549 201	Turkey	00-800-446-32-041
Indonesia	021-523-8535	United Kingdom	0-1475-555 055
Ireland	01-815-9202	United States	1-800-426-7378
Italy	02-7031-6101	Uruguay	000-411-005-6649
Japan	Consumer customers 0120-887-870  Business customers 0120-887-874	Venezuela	0-800-100-2011
Luxembourg	298-977 5063	Vietnam	848-8295-160

---

## 附錄 F. Notices

IBM may not offer the products, services, or features discussed in this document in all countries. Consult your local IBM representative for information on the products and services currently available in your area. Any reference to an IBM product, program, or service is not intended to state or imply that only that IBM product, program, or service may be used. Any functionally equivalent product, program, or service that does not infringe any IBM intellectual property right may be used instead. However, it is the user's responsibility to evaluate and verify the operation of any non-IBM product, program, or service.

IBM may have patents or pending patent applications covering subject matter described in this document. The furnishing of this document does not give you any license to these patents. You can send license inquiries, in writing, to:

*IBM Director of Licensing  
IBM Corporation  
North Castle Drive  
Armonk, NY 10504-1785  
U.S.A.*

INTERNATIONAL BUSINESS MACHINES CORPORATION PROVIDES THIS PUBLICATION 『AS IS』 WITHOUT WARRANTY OF ANY KIND, EITHER EXPRESS OR IMPLIED, INCLUDING, BUT NOT LIMITED TO, THE IMPLIED WARRANTIES OF NON-INFRINGEMENT, MERCHANTABILITY OR FITNESS FOR A PARTICULAR PURPOSE. Some jurisdictions do not allow disclaimer of express or implied warranties in certain transactions, therefore, this statement may not apply to you.

This information could include technical inaccuracies or typographical errors. Changes are periodically made to the information herein; these changes will be incorporated in new editions of the publication. IBM may make improvements and/or changes in the product(s) and/or the program(s) described in this publication at any time without notice.

The products described in this document are not intended for use in implantation or other life support applications where malfunction may result in injury or death to persons. The information contained in this document does not affect or change IBM product specifications or warranties. Nothing in this document shall operate as an express or implied license or indemnity under the intellectual property rights of IBM or third parties. All information contained in this document was obtained in specific environments and is presented as an illustration. The result obtained in other operating environments may vary.

IBM may use or distribute any of the information you supply in any way it believes appropriate without incurring any obligation to you.

Any references in this publication to non-IBM Web sites are provided for convenience only and do not in any manner serve as an endorsement of those Web sites. The materials at those Web sites are not part of the materials for this IBM product, and use of those Web sites is at your own risk.

Any performance data contained herein was determined in a controlled environment. Therefore, the result obtained in other operating environments may vary significantly. Some measurements may have been made on development-level systems and there is no guarantee that these measurements will be the same on generally available systems. Furthermore, some measurements may have been estimated through extrapolation. Actual results may vary. Users of this document should verify the applicable data for their specific environment.

---

## Federal Communications Commission (FCC) statement

48X/32X/48X Max CD-RW Drive

**Note:** This equipment has been tested and found to comply with the limits for a Class B digital device, pursuant to Part 15 of the FCC Rules. These limits are designed to provide reasonable protection against harmful interference in a residential installation. This equipment generates, uses, and can radiate radio frequency energy and, if not installed and used in accordance with the instructions, may cause harmful interference to radio communications. However, there is no guarantee that interference will not occur in a particular installation. If this equipment does cause harmful interference to radio or television reception, which can be determined by turning the equipment off and on, the user is encouraged to try to correct the interference by one or more of the following measures:

- Reorient or relocate the receiving antenna.
- Increase the separation between the equipment and receiver.
- Connect the equipment into an outlet on a circuit different from that to which the receiver is connected.
- Consult an IBM authorized dealer or service representative for help.

Properly shielded and grounded cables and connectors must be used in order to meet FCC emission limits. Proper cables and connectors are available from IBM authorized dealers. IBM is not responsible for any radio or television interference caused by using other than recommended cables and connectors or by unauthorized changes or modifications to this equipment. Unauthorized changes or modifications could void the user's authority to operate the equipment.

This device complies with Part 15 of the FCC Rules. Operation is subject to the following two conditions: (1) this device may not cause harmful interference, and (2) this device must accept any interference received, including interference that may cause undesired operation.

Responsible party:

International Business Machines Corporation  
New Orchard Road  
Armonk, NY 10504  
Telephone: 1-919-543-2193



Tested To Comply  
With FCC Standards

FOR HOME OR OFFICE USE

### **Industry Canada Class B emission compliance statement**

This Class B digital apparatus complies with Canadian ICES-003.

### **Avis de conformité a la réglementation d'Industrie Canada**

Cet appareil numérique de la classe B est conforme à la norme NMB-003 du Canada.

### **Deutsche EMV-Direktive (electromagnetische Verträglichkeit)**

Zulassungsbeseinigunglaut dem Deutschen Gesetz über die elektromagnetische Verträglichkeit von Geräten (EMVG) vom 30. August 1995 (bzw. der EMC EG Richtlinie 89/336):

Dieses Gerät ist berechtigt in Übereinstimmungmit dem Deutschen EMVG das EG-Konformitätszeichen - CE - zu führen. Verantwortlich für die Konformitätserklärung nach Paragraph 5 des EMVG ist die:

IBM Deutschland Informationssysteme GmbH, 70548 Stuttgart.

Informationen in Hinsicht EMVG Paragraph 3 Abs. (2) 2:

Das Gerät erfüllt die Schutzanforderungen nach EN 55024:1998 und EN 55022:1998 Klasse B.
--

EN 55022 Hinweis:

『Wird dieses Gerät in einer industriellen Umgebung betrieben (wie in EN 55022:B festgelegt), dann kann es dabei eventuell gestört werden. In solch einem FA11 ist der Abstand bzw. die Abschirmungzu der industriellen Störquelle zu vergrößern.』

Anmerkung:

Um die Einhaltung des EMVG sicherzustellen sind die Geräte, wie in den IBM Handbüchern angegeben, zu installieren und zu betreiben.

### **European Union - emission directive**

This product is in conformity with the protection requirements of EU Council Directive 89/336/ECC on the approximation of the laws of the Member States relating to electromagnetic compatibility.

IBM can not accept responsibility for any failure to satisfy the protection requirements resulting from a non-recommended modification of the product, including the fitting of non-IBM option cards.

This product has been tested and found to comply with the limits for Class B Information Technology Equipment according to European Standard EN 55022. The limits for Class B equipment were derived for typical residential environments to provide reasonable protection against interference with licensed communication devices.

### **Union Européenne - Directive Conformité électromagnétique**

Ce produit est conforme aux exigences de protection de la Directive 89/336/EEC du Conseil de l'UE sur le rapprochement des lois des États membres en matière de compatibilité électromagnétique.

IBM ne peut accepter aucune responsabilité pour le manquement aux exigences de protection résultant d'une modification non recommandée du produit, y compris l'installation de cartes autres que les cartes IBM.

Ce produit a été testé et il satisfait les conditions de l'équipement informatique de Classe B en vertu de Standard européen EN 55022. Les conditions pour l'équipement de Classe B ont été définies en fonction d'un contexte résidentiel ordinaire afin de fournir une protection raisonnable contre l'interférence d'appareils de communication autorisés.

### **Unione Europea - Directiva EMC (Conformidad electromagnética)**

Este producto satisface los requisitos de protección del Consejo de la UE, Directiva 89/336/CEE en lo que a la legislación de los Estados Miembros sobre compatibilidad electromagnética se refiere.

IBM no puede aceptar responsabilidad alguna si este producto deja de satisfacer dichos requisitos de protección como resultado de una modificación no recomendada del producto, incluyendo el ajuste de tarjetas de opción que no sean IBM.

Este producto ha sido probado y satisface los límites para Equipos Informáticos Clase B de conformidad con el Estándar Europeo EN 55022. Los límites para los equipos de Clase B se han establecido para entornos residenciales típicos a fin de proporcionar una protección razonable contra las interferencias con dispositivos de comunicación licenciados.

### **Union Europea - Normativa EMC**

Questo prodotto è conforme alle normative di protezione ai sensi della Direttiva del Consiglio dell'Unione Europea 89/336/CEE sull'armonizzazione legislativa degli stati membri in materia di compatibilità elettromagnetica.

IBM non accetta responsabilità alcuna per la mancata conformità alle normative di protezione dovuta a modifiche non consigliate al prodotto, compresa l'installazione di schede e componenti di marca diversa da IBM.

Le prove effettuate sul presente prodotto hanno accertato che esso rientra nei limiti stabiliti per le apparecchiature di informatica Classe B ai sensi della Norma Europea EN 55022. I limiti delle apparecchiature della Classe B sono stati stabiliti al fine di fornire ragionevole protezione da interferenze mediante dispositivi di comunicazione in concessione in ambienti residenziali tipici.

이 기기는 가정용으로 전자파 적합등록을 한 기기로서  
주거지역에서는 물론 모든 지역에서 사용할 수 있습니다.



この装置は、情報処理装置等電波障害自主規制協議会（VCCI）の基準に基づきクラスB情報技術装置です。この装置は、家庭環境で使用することを目的としていますが、この装置がラジオやテレビジョン受信機に近接して使用されると、受信障害を引き起こすことがあります。  
取扱説明書に従って正しい取り扱いをして下さい。

**Japanese statement of compliance for products less than or equal to 20 A per phase**

## 高調波ガイドライン適合品

---

### Trademarks

The following terms are trademarks of International Business Machines Corporation in the United States, other countries, or both:

- IBM
- IBM Logo
- HelpCenter

Microsoft, Windows, and Windows NT are trademarks of Microsoft Corporation in the United States, other countries, or both.

Other company, product, or service names may be trademarks or service marks of others.



Part Number: 22P7046

Printed in U.S.A.

(1P) P/N: 22P7046

