



**Hardware Maintenance Service  
for Service Level A**

Machine Type 2283/6274

**Personal  
Computer**

First Edition (August, 2001)

The following paragraph does not apply to any state or country where such provisions are inconsistent with local law: INTERNATIONAL BUSINESS MACHINES CORPORATION PROVIDES THIS PUBLICATION "AS IS" WITHOUT WARRANTY OF ANY KIND, EITHER EXPRESSED OR IMPLIED, INCLUDING, BUT NOT LIMITED TO, THE IMPLIED WARRANTIES OF MERCHANTABILITY OR FITNESS FOR A PARTICULAR PURPOSE.

References to IBM products, programs, or services do not imply that IBM intends to make them available outside the United States. This publication could include technical inaccuracies or typographical errors. Changes are periodically made to the information herein; these changes will be made in later editions. IBM may make improvements and/or changes in the product(s) and/or the program(s) at any time. Address comments about this publication to IBM Corporation, Dept. E23/962-2, 455 Park Place, Lexington, KY 40511-1856, USA. Information you supply may be used by IBM without obligation. For copies of publications related to this product, call toll free 1-800-IBM-7282 in the Continental U.S.A. In Canada, call toll free 1-800-465-7999.

**© Copyright International Business Machines Corporation 2001.**  
**All rights reserved.**

Note to U.S. Government Users - Documentation related to restricted rights - Use, duplication or disclosure is subject to restrictions set forth in GSA ADP Schedule Contract with IBM Corp.

---

# Contents

<b>Contents</b> .....	<b>iii</b>
<b>Notices</b> .....	<b>vii</b>
Safety Information .....	viii
Laser Compliance Statement .....	xxx
Trademarks .....	xxx
Preface .....	xxxii
<b>General Information</b> .....	<b>1</b>
Introduction .....	2
Product Overview .....	3
Processor .....	3
Memory .....	3
External Ports.....	4
Hard Disk Drive .....	4
CD-ROM Drive .....	4
DVD-ROM Drive.....	4
CD-RW Drive .....	4
DVD/CD-RW Combo Drive .....	4
Multimedia.....	4
Power Management .....	5
Power Supply .....	5
Internal Cabling-15" and 17" MTM model .....	5
Internal Cabling-Touch panel model .....	6
Keyboard.....	6
Mouse .....	6
Hardware Interfaces .....	7
CMOS Reset .....	8
User(Power-On) Password .....	9
Flash (BIOS) Update Procedure .....	10
BIOS Configuration/Setup Utility .....	11
Working with the Configuration/Setup Utility Menu .....	11
Main Menu .....	13
Devices Menu .....	15
Startup Menu.....	18
Advanced Menu .....	20
Security Menu .....	21
Power Menu .....	25
Exit Menu .....	29
Specifications .....	31
Dimension (width x depth x height).....	31
Weight .....	31
Environment .....	31

Power consumption.....	32
Electrical requirement .....	32
<b>Check Procedures .....</b>	<b>33</b>
Introduction .....	34
Start .....	35
Index of Symptoms, Messages, Error Codes, or Beeps .....	40
Troubleshooting .....	56
Factory-Installed Storage Devices .....	56
Factory-Installed Modem Card .....	60
Audio (Not Supported by Diagnostics Program) ..	62
CD/DVD-ROM Drive .....	65
Memory .....	67
Keyboard .....	69
Mouse .....	70
Power Supply .....	72
Monitor .....	75
Undetermined Problems .....	77
<b>Diagnostic Aids .....</b>	<b>79</b>
Introduction .....	80
Power-On Self Test .....	81
Diagnostic Program .....	83
Using Diagnostic Program from Service Partition .....	83
Using Diagnostic Program from Recovery CD .....	84
Diagnostics Program Features.....	85
<b>Repair Information .....</b>	<b>89</b>
Removals and Replacements .....	90
Handling ESD-Sensitive Parts .....	91
Cover.....	92
Hard Disk Drive .....	93
Optical Drive.....	95
Modem Card and Add-on Card .....	97
Memory(DIMM) .....	98
Intel Pentium 4 Willamette Processor .....	100
System Backup Battery.....	102
Inverter Board (15" LCD only). .....	103
System Board.....	106
TFT Subassembly .....	108
TouchPad Screen .....	111
Indicator LED and Cable .....	112
Speaker.....	113

LCD Panel.....	114
<b>Parts/Test Point Locations .....</b>	<b>115</b>
Introduction .....	116
System Board Jumpers and Connectors .....	117
Power Brick Connectors and Voltages .....	119
Factory-Installed Modem Card Layout .....	120
3.5-In. Hard Disk Drive Jumper Settings .....	121
CD-ROM Drive .....	123
CD-ROM Drive Rear Panel Connectors and Jumpers .....	125
CD-ROM R/W Drive .....	126
CD-ROM R/W Drive Rear Panel Connectors and Jumpers .....	127
DVD-ROM Drive.....	128
DVD-ROM Drive Rear Panel Connectors and Jumpers .....	129
DIMM Configurations .....	130
System Board Connector Pin Signals .....	131
Monitor Port Signals.....	131
Parallel Port Signals.....	132
Mouse Port Signals.....	132
Keyboard Port Signals .....	132
IDE Cable Connector Signals .....	133
<b>Safety Inspection Guide .....</b>	<b>135</b>
General Guidelines .....	136
<b>2283 Parts Catalog .....</b>	<b>137</b>
Abbreviations .....	138
System Assembly .....	139
Assembly 1: System Unit .....	139
Assembly 2: LCD .....	141
Assembly 3: Diskette and Hard Drive .....	143
Assembly 4: Optical Drive, Adapter Card and Speaker.....	144
Assembly 5: Power Cord.....	145
Assembly 6: Keyboard and Mouse .....	146
Assembly 7: Recovery CD .....	150
<b>6274 Parts Catalog .....</b>	<b>153</b>
Abbreviations .....	154
System Assembly .....	155
Assembly 1: System Unit .....	155
Assembly 2: LCD .....	157
Assembly 3: Diskette and Hard Drive .....	159
Assembly 4: Optical Drive, Adapter Card .... and	

Speaker .....	160
Assembly 5: Power Cord.....	161
Assembly 6: Keyboard and Mouse .....	162
Assembly 7: Recovery CD .....	164
<b>2283 Appendix A. FRU Number List .....</b>	<b>167</b>
<b>6274 Appendix A. FRU Number List .....</b>	<b>173</b>
<b>Appendix B. On-line Support Information .....</b>	<b>179</b>

---

## Notices

References in this publication to IBM products, programs, or services do not imply that IBM intends to make these available in all countries in which IBM operates. Any reference to an IBM product, program, or service is not intended to state or imply that only IBM's product, program, or service may be used. Any functionally equivalent product, program, or service that does not infringe any of IBM's intellectual property rights, or other legally protected rights, may be used instead of the IBM product, program, or service. References in this publication to IBM products, programs, or services are purely hardware-related and do not cover circumstances of software problems. Evaluation and verification of operation in conjunction with other products, program, or services, except those expressly designated by IBM are the user's responsibility.

IBM may have patents or pending patent applications covering subject matter in this document. The featuring of these patents, pending or otherwise, in this document does not give you any license to these patents. You can send license inquires, in writing, to the IBM director of Commercial Relations, IBM Corporation, Purchase, NY10577.

---

## Safety Information



### DANGER

To avoid a shock hazard, do not connect or disconnect any cables or perform installation, maintenance, or re-configuration of this product during an electrical storm.

To avoid shock hazard:

- The power cord must be connected to a properly wired and grounded receptacle.
- Any equipment to which this product will be attached must also be connected to properly wired receptacles.

When possible, use one hand to connect or disconnect signal cables to prevent a possible shock from touching two surfaces with different electrical potentials.

Electrical current from power, telephone, and communications cables is hazardous. To avoid shock hazard, connect and disconnect cables as described following when installing, moving, or opening covers of this product or attached devices.

To Connect	To Disconnect
1. Turn Everything OFF.	1. Turn Everything OFF.
2. First, attach all cables to devices.	2. First, remove power cord(s) from outlet.
3. Attach signal cables to receptacles.	3. Remove signal cables from receptacles.
4. Attach power cord(s) to outlet.	4. Remove all cables from devices.
5. Turn device ON	

### IMPORTANT:

When replacing the battery, use only IBM Part Number 33F8354 or an equivalent type battery recommended by the manufacturer. If your system has a module containing a lithium battery, replace it only with the same module type made by the same manufacturer. The



battery contains lithium and can explode if not properly used, handled, or disposed of.

**Do not:**

- Throw or immerse into water
- Heat to more than 100°C (212°F)
- Repair or disassemble

Dispose of the battery as required by local ordinances or regulations.



**IMPORTANT:**

When a CD-ROM drive is installed, note the following.

Use of controls or adjustments or performance of procedures other than those specified herein might result in hazardous radiation exposure.

Removing the covers of the CD-ROM drive could result in exposure to hazardous laser radiation. There are no serviceable parts inside the CD-ROM drive. Do not remove the CD-ROM drive covers.

**DANGER**

Some CD-ROM drives contain an embedded Class 3A or Class 3B laser diode. Note the following.

Laser radiation when open. Do not stare into the beam, do not view directly with optical instruments, and avoid direct exposure to the beam.



**IMPORTANT:**

Electrical current from power, telephone, and communication cables can be hazardous. To avoid personal injury or equipment damage, disconnect the attached power cords, telecommunications systems, networks, and modems before you open the server covers, unless instructed otherwise in the installation and configuration procedures.



## **PERIGO:**

Para evitar choques elétricos, não conecte ou desconecte nenhum cabo, nem efetue instalação, manutenção ou reconfiguração deste produto durante uma tempestade com raios.

Para evitar choques elétricos:

- O cabo de alimentação deve ser conectado a um receptáculo corretamente instalado e aterrado.
- Todos os equipamentos aos quais este produto será conectado devem também ser conectados a receptáculos corretamente instalados.

Quando possível, utilize uma das mãos para conectar ou desconectar cabos de sinal, para evitar um possível choque ao tocar duas superfícies com potenciais elétricos diferentes.

A corrente elétrica proveniente de cabos de alimentação, de telefone e de comunicação é perigosa. Para evitar choques elétricos, conecte e desconecte os cabos conforme descrito a seguir, ao instalar, movimentar ou abrir tampas deste produto ou de dispositivos conectados.

<b>Para Conectar</b>	<b>Para Desconectar</b>
1. DESLIGUE tudo.	1. DESLIGUE tudo.
2. Conecte primeiro todos os cabos nos dispositivos.	2. Remova primeiro o(s) cabo(s) de alimentação das tomadas.
3. Conecte os cabos de sinal nos receptáculos.	3. Remova os cabos de sinal dos receptáculos.
4. Conecte o(s) cabo(s) de alimentação nas tomadas.	4. Remova todos os cabos dos dispositivos
5. LIGUE o dispositivo	

**CUIDADO:**

Ao substituir a bateria, utilize apenas o Número de Peça IBM 33F8354 ou um tipo de bateria equivalente recomendado pelo fabricante. Se seu sistema possuir um módulo com uma bateria de lítio, substitua-o apenas pelo mesmo tipo de módulo, produzido pelo mesmo fabricante. A bateria contém lítio e pode explodir se não for utilizada, manuseada e descartada de forma adequada.

Não:

- Jogue ou coloque na água
- Aqueça a mais de 100°C (212°F)
- Conserte nem desmonte.

Descarte a bateria conforme requerido pelas disposições e regulamentações locais.

**CUIDADO:**

Quando uma unidade de CD-ROM estiver instalada, observe o seguinte.

A utilização de controles ou ajustes ou a execução de procedimentos diferentes daqueles especificados nesta publicação pode resultar em exposição perigosa à radiação.

A remoção das tampas da unidade de CD-ROM pode resultar em exposição a radiação perigosa de laser. Não existem peças que possam ser consertadas no interior da unidade de CD-ROM. Não remova as tampas da unidade de CD-ROM.

**PERIGO:**

Algumas unidades de CD-ROM contém um diodo de laser da Classe 3A ou da Classe 3B. Observe o seguinte.

Radiação de laser quando aberto. Não olhe diretamente para o feixe de laser, não olhe

diretamente com instrumentos óticos, e evite exposição direta ao raio.



**CUIDADO:**

A corrente elétrica proveniente de cabos de alimentação, de telefone e de comunicação é perigosa. Para evitar ferimentos pessoais ou danos aos equipamentos, desconecte os cabos de alimentação, sistemas de telecomunicação, redes e modems antes de abrir as tampas do servidor, a menos que receba outras instruções nos procedimentos de instalação e configuração.

## 声明 10



### 注意！

电源线、电话线以及通信电缆中的电流非常危险。为避免人身伤害或设备损坏，除非在安装和配置过程中特别指明，请在打开服务器外盖前断开已连接的全部电源线、电信系统、网络及调制解调器。

## 声明 1



### 危险！

为避免电击危险，请不要在暴风雨期间连接或断开任何电缆，或是进行此产品的安装、维护或重新配置操作。

为避免电击危险：

- 电源线必须连接到适当的电线及接地插座。
- 此产品将要连接的所有设备也必须连接到正确接线的插座上。

如果可能，请使用一只手连接或断开连接信号电缆，以避免在接触两个具有不同电势的表面时遭到电击。

电源线、电话线以及通信电缆中的电流非常危险。为避免电击，请在安装、移动或打开本产品或连接设备的外盖时，按照下述步骤连接或断开电缆。

#### 要连接电缆

1. 关闭所有设备。
2. 首先将所有电缆与设备连接。
3. 将信号线连接到插座。
4. 将电源线连接到电源插座。
5. 打开设备。

#### 要断开电缆

1. 关闭所有设备。
2. 首先从电源插座拔下电源线。
3. 从插座拔下信号电缆。
4. 从设备上拔下所有电缆。

## 声明 2



### 注意！

当更换电池时，仅可使用 IBM 部件号为 33F8354 的产品或由制造商推荐的同等电池。如果系统中有包含锂电池的模块，则只能使用由相同制造商制造的相同类型模块更换。该电池含有锂，如果使用、操作或处理不当会发生爆炸。

### 不要：

- 将其投入或浸于水中
- 加热超过100°C (212°F)
- 修理或拆卸

应按照当地法规和条例对此电池进行处理。

## 声明 3



### 注意！

在已安装 CD-ROM 驱动器的情况下，请注意下面的内容。

不遵循此处指定的控制、调整、或操作过程的操作将可能导致危险的辐射泄漏。

取下 CD-ROM 驱动器的外盖会导致危险的激光辐射泄漏。CD-ROM 驱动器内没有可以使用的部件。请不要取下 CD-ROM 驱动器的外盖。

## 声明 4

### 危险！

一些 CD-ROM 驱动器中包含内置的 3A 类或 3B 类激光二极管。  
请注意下述内容。

打开驱动器会产生激光辐射。请不要凝视激光束，请不要使用光学仪器直接观看激光束，同时也要避免人体直接暴露在激光束下。

• 聲明 10



注意：  
電源、電話及通信電纜上均有電流通過。在安裝及架構之時，若非專家指導，為了避免人員受傷、設備受損，在開啓伺服器蓋子之前，請切斷電源線、電信系統、網路及數據機。

• 聲明 1



危險

為了避免雷擊，在閃電期間，請勿連接或拔掉本裝置上的任何電纜線，或請勿安裝、維修或重新架構本產品。

為了避免雷擊：

- 電源線必須連接到接線及接地正確的插座。
- 本產品所連接的設備也必須連接到接線正確的插座。

儘可能使用單手來連接或拔掉信號電纜，以避免因接觸兩個不同電位的平面，而受到電擊。

電源、電話及通信電纜上均有電流通過。為了避免電擊，在安裝、移動本產品，或開啓本產品的蓋子或與本產品連接之裝置的蓋子時，請依照下列「連接」及「拔掉」電纜線的步驟操作。

連接

1. 關掉所有開關。
2. 首先，將所有電纜線連接到裝置。
3. 將信號電纜連接到信號插座。
4. 將電源線連接到電源插座。
5. 開啓裝置電源。

拔掉

1. 關掉所有開關。
2. 首先，自電源插座拔掉電源線。
3. 拔掉信號插座上的所有信號電纜。
4. 拔掉裝置上的所有電纜線。

• 聲明 2



注意：

更換電池時，只可使用 IBM 零件編號 33F8354 的電池，或廠商建議的相當類型的電池。如您系統中的模組含有鋰電池，更換時，請使用相同廠商製造的相同模組類型。如未正常使用、處理或捨棄含有鋰的電池時，可能會造成爆炸。

嚴禁：

- 丟入或浸入水中
- 加熱超過攝氏100度（華氏 212 度）
- 修補或拆解

處理廢棄電池時，請遵照當地法令規章處理。

• 聲明 3



注意：

安裝光碟機時，請注意下列事項：

不依此處所指示的控制、調整或處理步驟，恐有遭致輻射之虞。

移開光碟機蓋子，恐有遭致雷射輻射之虞。光碟機中沒有需要維修的部分。請勿移開光碟機的蓋子。

• 聲明 4



危險

光碟機含有內嵌式 Class 3A 或 Class 3B 雷射二極體時，請注意下列事項：

開啓時會產生雷射輻射。請勿凝視光束，不要使用光學儀器直接觀察，且應避免直接暴露在光束下。





## **PERIGO:**

Pour éviter tout risque de choc électrique, ne manipulez aucun câble et n'effectuez aucune opération d'installation, d'entretien ou de reconfiguration de ce produit au cours d'un orage.

Pour éviter tout risque de choc électrique :

- Les cordons d'alimentation du présent produit et de tous les appareils qui lui sont connectés doivent être branchés sur des socles de prise de courant correctement câblés et mis à la terre.

Afin d'éviter tout risque de choc électrique provenant d'une différence de potentiel de terre, n'utilisez qu'une main, lorsque cela est possible, pour connecter ou déconnecter les cordons d'interface.

Le courant électrique passant dans les câbles de communication, ou les cordons téléphoniques et d'alimentation peut être dangereux. Pour éviter tout risque de choc électrique, lorsque vous installez ou que vous déplacez le présent produit ou des périphériques qui lui sont raccordés, reportez-vous aux instructions ci-dessous pour connecter et déconnecter les différents cordons.

<b>Connexion</b>	<b>Déconnexion</b>
1. Mettez les unités hors tension.	1. Mettez les unités hors tension.
2. Commencez par brancher tous les cordons sur les unités.	2. Commencez pas débrancher les cordons alimentation des socles de prise de courant.
3. Branchez les câbles d'interface sur les prises.	3. Débranchez les câbles d'interface des prises.
4. Branchez les cordons d'alimentation sur un socle de prise de courant.	4. Débranchez tous les câbles des unités.
5. Mettez les unités sous tension.	

**ATTENTION:**

Remplacez la pile usagée par une pile de référence identique exclusivement - voir la référence IBM - ou par une pile équivalente recommandée par le fabricant. Si votre système est doté d'un module contenant une pile au lithium, vous devez le remplacer uniquement par un module identique, produit par le même fabricant. La pile contient du lithium et présente donc un risque d'explosion en cas de mauvaise manipulation ou utilisation.

- Ne la jetez pas à l'eau.
- Ne l'exposez pas à une température supérieure à 100°C.
- Ne cherchez pas à la réparer ou à la démonter.

Pour la mise au rebut, reportez-vous à la réglementation en vigueur.

**ATTENTION:**

Si une unité de CD-ROM est installée, prenez connaissance des informations suivantes :

Pour éviter tout risque d'exposition au rayon laser, respectez les consignes de réglage et d'utilisation des commandes, ainsi que les procédures décrites dans le présent document.

Pour éviter une exposition directe au rayon laser, n'ouvrez pas l'unité de CD-ROM. Vous ne pouvez effectuer aucune opération de maintenance à l'intérieur.

**PERIGO:**

Certaines unités de CD-ROM contiennent une diode laser de classe 3A ou 3B. Prenez connaissance des informations suivantes :

Rayonnement laser lorsque le carter est ouvert.  
Évitez de regarder fixement le faisceau ou de

l'observer à l'aide d'instruments optiques. Évitez une exposition directe au rayon.



**ATTENTION:**

Le courant électrique circulant dans les câbles de communication et les cordons téléphoniques et d'alimentation peut être dangereux. Pour votre sécurité et celle de l'équipement, avant de retirer les carters du serveur, mettez celui-ci hors tension et déconnectez ses cordons d'alimentation, ainsi que les câbles qui le relient aux réseaux, aux systèmes de télécommunication et aux modems (sauf instruction contraire mentionnée dans les procédures d'installation et de configuration)



## **VORSICHT:**

Aus Sicherheitsgründen bei Gewitter an diesem Gerät keine Kabel anschließen oder lösen. Ferner keine Installations-, Wartungs- oder Rekonfigurationsarbeiten durchführen.

Aus Sicherheitsgründen:

- Gerät nur an eine Schutzkontaktsteckdose mit ordnungsgemäß geerdetem Schutzkontakt anschließen.
- Alle angeschlossenen Geräte ebenfalls an Schutzkontaktsteckdosen mit ordnungsgemäß geerdetem Schutzkontakt anschließen.

Signalkabel möglichst einhändig anschließen oder lösen, um einen Stromschlag durch Berühren von Oberflächen mit unterschiedlichem elektrischem Potential zu vermeiden.

Elektrische Spannungen von Netz-, Telefon- und Datenübertragungsleitungen sind gefährlich. Um einen Stromschlag zu vermeiden, nur nach den Anweisungen arbeiten, die für Installation, Transport oder Öffnen von Gehäusen dieses Produkts oder angeschlossenen Einheiten gelten.

<b>Kabel anschließen</b>	<b>Kabel lösen</b>
1. Alle Geräte ausschalten und Netzstecker ziehen.	1. Alle Geräte ausschalten.
2. Zuerst alle Kabel an Einheiten anschließen.	2. Zuerst Netzstecker von Steckdose lösen.
3. Signalkabel an Anschlußbuchsen anschließen.	3. Signalkabel von Anschlußbuchsen lösen.
4. Netzstecker an Steckdose anschließen.	4. Alle Kabel von Einheiten lösen.
5. Gerät einschalten.	

**ACHTUNG:**

Eine verbrauchte Batterie nur durch eine Batterie mit der IBM Teilenummer 33F8354 oder durch eine vom Hersteller empfohlene Batterie ersetzen. Wenn Ihr System ein Modul mit einer Lithium-Batterie enthält, ersetzen Sie es immer mit dem selben Modultyp vom selben Hersteller. Die Batterie enthält Lithium und kann bei unsachgemäßer Verwendung, Handhabung oder Entsorgung explodieren.

Die Batterie nicht

- mit Wasser in Berührung bringen.
- über 100 C erhitzen.
- reparieren oder zerlegen.

Die örtlichen Bestimmungen für die Entsorgung von Sondermüll beachten.

**ACHTUNG:**

Wenn ein CD-ROM-Laufwerk installiert ist, beachten Sie folgendes. Steuer- und Einstellelemente sowie Verfahren nur entsprechend den Anweisungen im vorliegenden Handbuch einsetzen. Andernfalls kann gefährliche Laserstrahlung auftreten.

Das Entfernen der Abdeckungen des CD-ROM-Laufwerks kann zu gefährlicher Laserstrahlung führen. Es befinden sich keine Teile innerhalb des CD-ROM-Laufwerks, die vom Benutzer gewartet werden müssen. Die Verkleidung des CD-ROM-Laufwerks nicht öffnen.

**VORSICHT:**

Manche CD-ROM-Laufwerke enthalten eine eingebaute Laserdiode der Klasse 3A oder 3B. Die nachfolgend aufgeführten Punkte beachten.

Laserstrahlung bei geöffneter Tür. Niemals direkt in den Laserstrahl sehen, nicht direkt mit optischen

Instrumenten betrachten und den Strahlungsbereich meiden.



**ACHTUNG:**

An Netz-, Telefon- und Datenleitungen können gefährliche elektrische Spannungen anliegen. Um eine Gefährdung des Benutzers oder Beschädigung des Geräts zu vermeiden, ist der Server auszuschalten. Die Verbindung zu den angeschlossenen Netzkabeln, Telekommunikationssystemen, Netzwerken und Modems ist vor dem Öffnen des Servergehäuses zu unterbrechen (sofern in Installations- und Konfigurationsanweisungen nicht anders angegeben)



**PERICOLO:**

Per evitare il pericolo di scosse elettriche durante i temporali, non collegare o scollegare cavi, non effettuare l'installazione, la manutenzione o la riconfigurazione di questo prodotto.

Per evitare il pericolo di scosse elettriche:

- collegare il cavo di alimentazione ad una presa elettrica correttamente cablata e munita di terra di sicurezza;
- collegare qualsiasi apparecchiatura collegata a questo prodotto ad una presa elettrica correttamente cablata e munita di terra di sicurezza.

Quando possibile, collegare o scollegare i cavi di segnale con una sola mano per evitare il rischio di scosse derivanti dal contatto con due superfici a diverso potenziale elettrico.

La corrente elettrica circolante nei cavi di alimentazione, del telefono e di segnale è pericolosa. Per evitare scosse elettriche, collegare e scollegare

icavi come descritto quando si effettuano l'installazione, la rimozione o l'apertura dei coperchi di questo prodotto o durante il collegamento delle unità.

<b>Per collegare</b>	<b>Per scollegare</b>
1.SPEGNERE tutti i dispositivi.	1.SPEGNERE tutti i dispositivi.
2.Collegare prima tutti I cavi alle unità.	2.Rimuovere prima il(i) cavo(i) di alimentazione dalla presa elettrica.
3.Collegare i cavi di segnale alle prese.	3.Rimuovere i cavi di segnale dalle prese.
4.Collegare il(i) cavo(i) di alimentazione alla presa elettrica.	4.Rimuovere tutti i cavi dalle unità.
5.ACCENDERE le unità.	



#### **ATTENZIONE:**

Quando si sostituisce la batteria, utilizzare solo una batteria IBM o batterie dello stesso tipo o di tipo equivalente consigliate dal produttore. Se il sistema di cui si dispone è provvisto di un modulo contenente una batteria al litio, sostituire tale batteria solo con un tipo di modulo uguale a quello fornito dal produttore. La batteria contiene litio e può esplodere se utilizzata, maneggiata o smaltita impropriamente.

Evitare di:

- Gettarla o immergerla in acqua
- Riscaldarla ad una temperatura superiore ai 100°C
- Cercare di ripararla o smaltirla

Smaltire secondo la normativa in vigore (D.Lgs 22 del 5/2/97) e successive disposizioni nazionali e locali.

**ATTENZIONE:**

Quando è installata un'unità CD-ROM, notare quanto segue:

L'utilizzo di controlli, regolazioni o l'esecuzione di procedure non descritti nel presente manuale possono provocare l'esposizione a radiazioni pericolose.

L'apertura di un'unità CD-ROM può determinare l'esposizione a radiazioni laser pericolose. All'interno dell'unità CD-ROM non vi sono parti su cui effettuare l'assistenza tecnica. Non rimuovere i coperchi dell'unità CD-ROM.

**PERICOLO:**

Alcune unità CD-ROM contengono all'interno un diodo laser di Classe 3A o Classe 3B. Prestare attenzione a quanto segue:

Aperto l'unità vengono emesse radiazioni laser. Non fissare il fascio, non guardarlo direttamente con strumenti ottici ed evitare l'esposizione diretta al fascio.

**ATTENZIONE:**

La corrente circolante nei cavi di alimentazione, del telefono e di segnale è pericolosa. Per evitare situazioni pericolose per le persone o danneggiamenti all'apparecchiatura, scollegare i cavi di alimentazione, i sistemi di telecomunicazioni, le reti e ed i modem prima di aprire i coperchi del server se non diversamente indicato nelle procedure di installazione e configurazione.





**주의:**

전원, 전화 및 통신 케이블로부터 흘러 나오는 전류는 위험합니다. 설치 및 구성 절차에 다른 지시가 없으면, 다치거나 장비 손상이 생기지 않게 하기 위해 서버 덮개를 열기 전에 접속된 전선, 원격 통신 시스템, 네트워크 및 모뎀의 연결을 끊으십시오.

경고문 1



**위험**

전기 충격을 피하려면 날씨가 나쁠 때(예: 눈 또는 비가 오거나 천둥 번개가 칠 때)는 케이블을 연결하거나 끊지 않도록 하고 이 제품의 설치, 유지보수 또는 재구성 등의 작업을 수행하지 않도록 하십시오.

전기 충격을 피하려면 다음과 같아야 합니다.

- 고압선은 적절한 배선 및 접지 상태의 콘센트로 연결되어야 합니다.
- 이 제품이 접속될 모든 장비도 적절한 배선 상태의 콘센트로 연결되어야 합니다.

다른 전위를 가진 두 표면을 만졌을 때 발생할 수 있는 전기 충격을 피하려면 한 손으로 신호선을 연결하거나 끊으십시오.

전원, 전화 및 통신 케이블로부터 흘러 나오는 전류는 위험합니다. 전기 충격을 피하려면 이 제품이나 접속 장치를 설치, 이동 및 덮개를 열 때 다음 설명에 따라 케이블을 연결하고 끊도록 하십시오.

연결하려면	연결해제하려면
1. 모든 스위치를 켜다.	1. 모든 스위치를 끈다.
2. 먼저 모든 케이블을 장치에 연결한다.	2. 먼저 모든 케이블을 장치에 제거한다.
3. 신호선을 콘센트에 연결한다.	3. 신호선을 콘센트에서 제거한다.
4. 전원을 콘센트에 연결한다.	4. 장치에서 모든 케이블을 제거한다.
5. 장치 스위치를 켜다.	

경고문 2



**주의:**

배터리를 교체할 때는 IBM 부품 번호 &PN. 또는 제조업체에서 추천하는 동등한 유형의 배터리를 사용하십시오. 시스템에 리튬 배터리를 포함하는 모듈이 있으면 이것은 동일한 제조업체에서 생산된 동일한 모듈 유형으로만 교체하십시오. 배터리에 리튬이 포함되어 있으므로 제대로 사용, 처리 또는 처분하지 않으면 폭발할 수 있습니다.

다음을 주의하십시오.

- 던지거나 물에 담그지 않도록 하십시오.
- 100°C(212°F) 이상으로 가열하지 않도록 하십시오.
- 수리하거나 분해하지 않도록 하십시오.

지역 법령이나 규정의 요구에 따라 배터리를 처분하십시오.

경고문 3



**주의:**

CD-ROM 드라이브가 설치되어 있으면 다음 사항을 명심하십시오.

여기에서 지정하지 않은 방식으로 CD-ROM 드라이브를 제어 또는 조절하거나 다른 절차로 사용하면 위험한 방사능 노출이 발생할 수 있습니다.

CD-ROM 드라이브의 덮개를 제거하면 위험한 레이저 방사능이 노출될 수 있습니다.

CD-ROM 드라이브 내에는 정비할 수 있는 부품이 없습니다. CD-ROM 드라이브 덮개를 제거하지 않도록 하십시오.

경고문 4

**위험**

일부 CD-ROM 드라이브에는 클래스 3A 또는 3B 레이저 2급 진공관(다이오드)이 들어 있습니다. 다음 사항을 명심하십시오.

열면 레이저 방사능이 노출됩니다. 광선을 주시하거나 광학 기계를 직접 쳐다보지 않도록 하고 광선에 노출되지 않도록 하십시오.



## **PELIGRO:**

Para evitar una posible descarga eléctrica, no conecte ni desconecte los cables ni lleve a cabo ninguna operación de instalación, de mantenimiento o de reconfiguración de este producto durante una tormenta eléctrica.

Para evitar una posible descarga:

- El cable de alimentación debe conectarse a un receptáculo con una instalación eléctrica correcta y con toma de tierra.
- Los aparatos a los que se conecte este producto también deben estar conectados a receptáculos con la debida instalación eléctrica.

Cuando sea posible, utilice una sola mano para conectar o desconectar los cables de señal a fin de evitar una posible descarga al tocar dos superficies con distinto potencial eléctrico.

La corriente eléctrica de los cables de comunicaciones, teléfono y alimentación puede resultar peligrosa. Para evitar una posible descarga, siga las indicaciones de conexión y desconexión de los cables siempre que tenga que instalar, mover o abrir las cubiertas de este producto o de los dispositivos acoplados.

<b>Instrucciones de conexión</b>	<b>Instrucciones de desconexión</b>
1. Apague todos los componentes (OFF).	1. Encienda todos los componentes (ON).
2. En primer lugar, conecte todos los cables a los dispositivos.	2. En primer lugar, retire los cables de alimentación de las tomas.
3. Conecte los cables de señal a los receptáculos.	3. Retire los cables de señal de los receptáculos.
4. Conecte los cables de alimentación a las tomas.	4. Retire todos los cables de los dispositivos.
5. Encienda el dispositivo (ON).	

**IMPORTANT:**

Al cambiar la batería, utilice únicamente la batería IBM Número de pieza 33F8354 o un tipo de batería equivalente recomendado por el fabricante. Si el sistema tiene un módulo que contiene una batería de litio, sustitúyalo únicamente por el mismo tipo de módulo del mismo fabricante. La batería contiene litio y puede explotar si no se utiliza, manipula o desecha correctamente.

Lo que no debe hacer

- Tirar o sumergir el producto en agua.
- Exponer el producto a una temperatura superior a 100°C.
- Reparar o desmontar el producto.

Cuando quiera desechar la batería, siga las disposiciones y reglamentaciones locales.

**IMPORTANT:**

Cuando instale una unidad de CD-ROM, tenga en cuenta la siguiente información.

Si se llevan a cabo controles o ajustes o se utilizan métodos que no se atengan a lo aquí especificado, se puede producir una exposición peligrosa a las radiaciones.

Si se retiran las cubiertas de la unidad de CD-ROM, se puede producir una peligrosa exposición a radiaciones de láser. Dentro de la unidad de CD-ROM no existen piezas reparables. No retire las cubiertas de la unidad de CD-ROM.

**PELIGRO:**

Algunas unidades de CD-ROM tienen incorporado un diodo de láser de Clase 3A o de Clase 3B. Tenga en cuenta la siguiente información.

Cuando la unidad está abierta se generan emisiones de rayos láser. No dirija la mirada al haz, no lo observe directamente con instrumentos ópticos y evite la exposición directa.



**IMPORTANT:**

La corriente eléctrica de los cables de comunicaciones, de teléfono y de alimentación puede resultar peligrosa. Para evitar posibles lesiones o daños del aparato, desconecte los cables de alimentación, los sistemas de telecomunicaciones, las redes y los módems antes de abrir las cubiertas del servidor, salvo que se indique lo contrario en las instrucciones de las operaciones de instalación y configuración.

---

## Laser Compliance Statement

The CD-ROM drive in the computer is a laser product. The CD-ROM drive's classification label (sample shown below) is located on the drive.



The CD-ROM drive is certified in the U.S. to conform to the requirements of the Department of Health and Human Services 21 Code of Federal Regulations (DHHS 21 CFR) Subchapter J for Class 1 laser products.

In other countries, the drive is certified to conform to the requirements of EN60825.

Class 1 laser products are not considered to be hazardous. The CD-ROM drive has an internal Class 1, 0.5-milliwatt, aluminum gallium-arsenide laser that operates at a wavelength of 760 to 810 nanometers.

The design of the laser system and the CD-ROM drive ensures that there is no exposure to laser radiation above a Class 1 level during normal operation, user maintenance, or servicing conditions.

---

## Trademarks

The following are trademarks of the IBM Corporation in the United States or other countries or both:

AT  
HelpCenter  
IBM  
Operating System/2  
OS/2  
Personal System/2  
PS/1  
PS/2

Intel, Pentium, MMX, EtherExpress, and LANDesk are trademarks or registered trademarks of Intel Corporation.

Microsoft, MS-DOS, Windows, and Windows NT are trademarks or registered trademarks of Microsoft Corporation.

Other company, product, and service names may be trademarks or service marks of others.

---

## Preface

This manual contains service information for the **2283 & 6274 Service Level A (SL-A)** model of the IBM Personal Computer, worldwide. This manual is intended to be used as a stand-alone document to service machine type 2283 & 6274 products. It is divided into the following chapters:

**Notices** contains important safety information and notices required to service this computer.

**General Information** contains a brief description of this manual.

**Check Procedures** provides step-by-step instructions that aid in locating the failing Field Replaceable Unit (FRU).

**Diagnostic Aids** explains how to use the diagnostics tools for isolating failures.

**Repairing Information** contains illustrations and descriptions to disassemble and reassemble the computer.

**Parts/Test Point Locations** contains illustrations and descriptions of the locations of the major parts, jumpers, and connectors.

**Safety Inspection Guide** contains information about inspecting a machine for safety problems before putting the machine under a Maintenance Agreement.

**Parts Catalog** contains descriptions, illustrations, and part numbers for individual FRUs.

**Appendix A, FRU Number Index** contains part numbers listed in numerical order.



---

# General Information

Introduction .....	2
Product Overview .....	3
Processor .....	3
Memory .....	3
External Ports .....	4
Hard Disk Drive .....	4
CD-ROM Drive .....	4
DVD-ROM Drive .....	4
CD-RW Drive .....	4
DVD/CD-RW Combo Drive .....	4
Multimedia .....	4
Power Management .....	5
Power Supply .....	5
Internal Cabling-15" and 17" MTM model .....	5
Internal Cabling-Touch panel model .....	6
Keyboard .....	6
Mouse .....	6
Hardware Interfaces .....	7
CMOS Reset .....	8
User(Power-On) Password .....	9
Flash (BIOS) Update Procedure .....	10
BIOS Configuration/Setup Utility .....	11
Working with the Configuration/ Setup Utility Menu .....	11
Main Menu .....	13
Devices Menu .....	15
Startup Menu .....	18
Advanced Menu .....	20
Security Menu .....	21
Power Menu .....	25
Exit Menu .....	29
Specifications .....	31
Dimension (width x depth x height) .....	31
Weight .....	31
Environment .....	31
Power consumption .....	32
Electrical requirement .....	32

---

## **Introduction**

This chapter gives a general overview of the Personal Computer Type 6274 and 2283, describes the standard and optional features, and details its functional and environmental specifications.

---

## Product Overview

Personal Computer Type 6274 and 2283 has two PCI slots and supports most 478 pin Pentium 4 processor with Socket mPGA478 processor package type.

The Personal Computer Type 6274 and 2283 supports Accelerated Graphics Port (AGP) 2X / 4X, which enhances 3D graphical display performance.

Listed below are 6274 and 2283 system features:

### Processor

- Socket mPGA478 connector.
- 128 KB of on-chip level one (L1) cache
- 256 KB level two (L2) cache support for Willamette
- Most 478 pin Intel Pentium 4 processor; up to 1.80 GHz, Streaming SIMD Extensions 2 (SSE2) extends MMX<sup>TH</sup> and SSE technology

### Memory

- 168-pin Synchronous Dynamic Random Access Memory (SDRAM), dual in-line Memory Module (DIMM) sockets.
  - 2 DIMM sockets.
  - 128MB and 256MB DIMM.
  - 512MB and 1GB DIMM optional.
  - PC-133, +3.3V, no-ECC, with gold contacts
  - Maximum memory is 2GB

SDRAM Technology	Increments	Maximum (2 channels)
128MB	32MB	1GB
256MB	64MB	2GB

## **External Ports**

- One multi-mode parallel port (25-pin D-type connector)
- One PS/2 keyboard port and one PS/2 mouse port
- Seven USB ports (2 external and 1 internal (for factory installed touch screen only and is not designed to be user accessible) are top mounted, and the other 4 in the rear side)
- One microphone-in jack
- One line-out/headphone-out jack
- One line-in jack
- One RJ45 connector to support 10/100 Ethernet LAN
- One DC power brick connector

## **Hard Disk Drive**

- 3.5-in., 1-in. height IDE drive. (3.5-in may be in acoustic mounting bracket), and 5400/7200rpm.
- 128 KB “look-ahead” cache memory inside the hard disk drive.
- Average and minimum 12 ms seek time, access time varies for the hard disk drive and the hard disk drive manufacturer.

## **CD-ROM Drive**

- 5.25-in. 1/2-height, 48X CD-ROM IDE/AT drive.

## **DVD-ROM Drive**

- 5.25-in. high-performance, 16X/48X DVD-ROM IDE/AT drive.

## **CD-RW Drive**

- 5.25-in. high-performance, 16X/10X/40X CD-RW IDE/AT drive.

## **DVD/CD-RW Combo Drive**

- 5.25-in. high-performance, 8X-8X/4X/32X DVD-ROM IDE/AT drive.

## **Multimedia**

- A pair of speakers is built-in to meet user’s multimedia demands.

## **Power Management**

- Support ACPI (Advanced Configuration and Power Interface) power management.
- ACPI v1.0b and APM v1.2 compliant
- CPU clock throttling and clock stop control for complete ACPI S3 state support
- PCI bus clock run, Power Management enable (PME) control, PCI/CPU color generator stop control.
- Power-on Switch must support Soft-Off and Full-Off.
  - Touch for 1 second or less to put system on Suspend state.
  - Touch and hold for 4 seconds to put system on Full-Off state (Power Supply standby remains).
- System enters standby mode if any of following conditions are met:
  - Execute standby from Windows 2000 and XP Start menu
  - Press system power button if it is set to act as standby function
  - System is idle and the standby timer set in the Windows 2000 and XP Power Management Property elapses
- 8 bytes of BIOS scratch register

## **Power Supply**

- External power bricks (160W for 15" TFT models; 160W for 17" TFT models)

## **Internal Cabling-15" and 17" MTM model**

- One ribbon cable for hard disk drive and CD/DVD-ROM drive
- One ribbon cable for four rear USB ports and one parallel port
- One 4-wire cable for hard disk drive and CD/DVD-ROM power
- One 6-wire cable for system power
- One 4-in audio cable

## **Internal Cabling-Touch panel model**

- One ribbon cable for hard disk drive and CD/DVD-ROM drive
- One ribbon cable for four rear USB ports and one speaker port
- One 4-wire cable for hard disk drive and CD/DVD-ROM power
- One 6-wire cable for system power
- One 4-in audio cable
- One 2-pin TFT power cable
- One USB cable for signal
- One DVI-D cable
- One Interface Board to Inverter Board cable
- One Control Board to Interface Board cable

## **Keyboard**

- Silitex (Lite-on), USB RAK3 Lite w/No USB ports dark color
- Wireless Kybd/Mouse Kit
- 104-key, Chicony™ USB Standard w/NoUSB ports dark color keyboard with 1.8-m (5.8-ft.) cable

## **Mouse**

- 3 Button, Primax USB ScrollPoint™ III - Stealth black mouse with 1.8-m (5.8-ft.) cable

---

## Hardware Interfaces

The following peripheral interfaces for adapters, options, and drives are supported in the system unit

Item	Interface
Expansion slot for I/O adapter cards	Two low-profile PCI (Peripheral Component Interconnect) v2.2 compatible expansion slots that operates at 33 MHz bus speed.
Hard disk drives	One Dual Channel Bus Master IDE ports support Ultra ATA/100, PIO Mode 3/4, ATAPI IDE CD-ROM, CD-R, CD-RW, and LS120.
CD-ROM/DVD-ROM/CD-RW drive	5.25-in. high-performance, IDE/AT drive. Support Bootable CD-ROM Format specification version 1.0. Compliant to Audio-CD, Video-CD, CD-ROM/XA, Karaoke-CD, and Photo-CD (both single and multi-session) format.
Video	No standard VGA port is provided (internal DVI connection only for integrated TFT). Support Accelerated Graphics Port (AGP) 2X and 4X
Audio	Compatible to AC'97
Pointing device	USB compatible mouse
Keyboard device	USB compatible keyboard
Parallel port	Supports SPP (IBM PC/XT, PC/AT, PS/2) compatible, EPP (IEEE 1284 compliance), ECP (IEEE 1284 compliance) interface. IEEE 1284 compliant
USB	Supports Universal UHCI Specification for USB 1.1

---

## **CMOS Reset**

This system does not deny access to Configuration/Setup Utility, if Supervisor(Administrator) Password is not set. Execute "Load Setup Default" in BIOS Configuration/Setup Utility to clear the corrupted CMOS data. See "Restore Settings" on page 29.



---

## User(Power-On) Password

A user password denies access to the system by an unauthorized user when the system is powered on. When a user password is active, the password prompt appears on the screen each time the system is powered on. The system starts after the proper password is entered. See “User(Power-On) Password” on page 9 for more information about how to change, remove and set password in Configuration/Setup Utility.

In some cases, you might be required to service a system with an active and unknown user password. To clear a password from the system, follow these steps.

1. Turn off system unit.
2. Unplug power cable from the electrical outlet.

**IMPORTANT:** Do not attempt these steps with the power cord plugged into the electrical outlet. The power supply maintains +5 Vdc of standby power when the power cord is plugged. System damage might result if the power cord is not unplugged during jumper setting.

3. Set JP33 to 2-3 position to clear BIOS setting as original manufacture setting. See “System Board Jumpers and Connectors” on page 117.

**IMPORTANT:** To reinstall the password, the user must enter a password in the Configuration/Setup Utility. If Enhanced Security is enabled and the password is forgotten, the system board must be replaced.

---

## Flash (BIOS) Update Procedure

1. Adjust the Startup Sequence in BIOS Startup Menu. Set "FDD" as the first one.
2. Run the "22jt06a.EXE" file

**NOTE:** 06a indicates the file version, which changes when new version released.

3. Follow the instruction shown. Create a bootable DOS diskette.
4. Insert the diskette and reboot from drive A.

**WARNING:** Do not boot with any memory related driver such as HIMEM.SYS, EMS.SYS....

5. The program asks you to choose language versions. Default is 1; United States. Other available languages are France (2), Italy (3), Germany (4), Spain (5), Brazil (6), and Japan (7).
6. The program then asks you "Would you like to update the Serial Number?". Choose Yes, to update Serial Number. Choose No, to remain the current one.
7. The program then asks you "Would you like to update the Machine Type/Model?". Choose Yes, to update the current information. Choose No, to remain the same.
8. The program updates the BIOS automatically.

**WARNING:** Do not turn off the system power while the BIOS is programming, or the flash ROM will be destroyed.

9. Power off system after the BIOS is completely updated.

---

## BIOS Configuration/Setup Utility

The Configuration/Setup Utility lets you review and change important information about the computer and its hardware.

### Working with the Configuration/Setup Utility Menu

#### Starting the Configuration/Setup Utility

Follow these steps to enter Setup when the computer is off:

1. Turn on your monitor.
2. Press and hold **F1**.
3. Turn on the system unit.

If you have previously set a password, you are prompted to type in the password after you press the **F1** key. Refer to the Configuration/Setup Utility Main Menu below.

Main	Devices	Startup	Advanced	Security	Power	Exit
▶ System Summary						
Product Data:						
Machine Type / Model		XXXX / XXXX				
Flash EEPROM Revision Level		22KT05AUS				
Boot Block Revision Level		2205A				
System Board Identifier		XXXXXXXXXX				
System Serial Number		XXXXXXXXXX				
BIOS Date (MM/DD/YY)		XX/XX/XX				
▶ System UUID						
System Time (HH:MM:SS):		[XX:XX:XX]				
System Date (MM/DD/YYYY):		[XX/XX/XXXX]				
Language:		[English (US) ]				
F1: Help    ↑↓: Up/Down    - / + : Select Values    F9: Setup Defaults						
Esc: Exit    ←→: Left/Right    Enter: Select    F10: Save & Exit						

The following table lists specific keys on the keyboard that will help you move through the Configuration/Setup Utility Menus:

<b>Keys</b>	<b>Function</b>
F1	Press this key if you want help for a selected menu option.
Up or Down arrow key	Use these arrow keys to go up and down for highlighting an option on the menu. (Press the Enter key to choose the option.)
-/+	Press this key to change parameter settings.
F9	Restore setup defaults
Esc	After viewing or making changes to the settings on a menu, press this key to exit the menu.
<-- or -->	Use these arrow keys to go left and right for highlighting an option on the menu. (Press the Enter key to choose the option.)
Enter	Press this key to choose a highlighted option from a menu, or select sub-menu.
F10	Press this key if you want to save and exit the current settings for a line

## **Changing Parameter Settings**

In the Configuration/Setup Utility Menus, the configuration information that you can change is enclosed in brackets like these: [ ]. You cannot change any information that is not enclosed in brackets or is shown in grey instead of black color. Use the up- or down- arrow keys to highlight options then press **Enter** to display a menu. When changing the setting of a particular parameter, highlight the setting then use the - or + arrow key to change the setting. Refer to the Configuration/Setup Utility help for details on the configured parameters in each menu.

## **Main Menu**

To view general hardware information about your computer, select the Configuration/Setup Utility Main Menu.

Setup automatically updates this menu when you do either of the following:

- Add or change hardware on your computer
- Make changes to other menus in Setup and save those changes

To view the computer information such as the Machine Type / Model, Serial Number, BIOS Date, System Time, System Date, and UUID, the items are configured and shown automatically. For language displayed, you can choose from English (US), Spanish, French, Deutsche, Italian, Netherlands and Japanese. The default language is English (US).

In Main Menu, you can also find further information for system as below.

## **System Summary**

This menu displays information about your system.

### **CPU Type, CPU Speed, System Memory, Memory Bus Speed, and Active Video**

Those information are configured and shown automatically.

### **Audio Support**

Default is Enabled.

### **Fan 1, Fan 2**

Default is Operating.

### **Diskette A**

Default is Disabled.

### **IDE Drive 0, 1, 2, 3**

System detected components connected to IDE automatically. Normally, IDE Drive 0 is HDD information. IDE Drive 1 is CD/DVD-ROM, or CD-RW. 6274 and 2283 models have only one IDE for HDD.

## **System UUID**

Select this option to view the system's Universal Unique Identification (UUID) string.

## **System Time, System Date**

System Time, and System Date are configured and shown automatically.

## **Devices Menu**

### **PS/2 Mouse**

This field indicates whether a PS/2-style pointing device is installed. Default is Enabled.

### **USB Setup**

Select this option to configure your system's USB ports.

### **USB Support**

Select whether to enable or disable the Universal Serial Bus (USB) feature. Default is Enabled.

### **USB Device Support**

Select whether to enable BIOS support for USB devices (such as a mouse or keyboard) when the system is started. USB devices should work in the operating system even when this option is disabled. Default is Enabled.

### **Parallel Port Setup**

Select this option to configure your system's parallel port.

### **Parallel Port**

Default is Automatic. Other options are Disabled, Enabled and OS Controlled.

### **Video Setup**

Select this line to see the Video Setup menu.

### **Active Video**

The active video parameter is configured and shown automatically.

### **Select Active Video**

Select the video that is to be active when the computer is started. If the selected video is not available, the computer will select a default video. Default is PCI. Other options are AGP and Integrated.

## **Graphic Aperture**

Select the size of the Graphics Aperture for the AGP video device. Default is 64 MB. Other options are 32MB, 128MB, and 256MB.

## **IDE Drives Setup**

Select this line to see the IDE Drives Setup menu.

### **IDE Drive 0**

The maximum capacity of Hard Disk Drive is configured and shown automatically.

Default of IDE Performance is High Performance. The other option is Compatible. If an IDE device attached to the system board IDE controller does not function properly or causes other IDE devices attached to the same controller do not function properly, set this field to the Compatible mode.

Default of IDE Read Prefetch is Disabled. The other option is Enabled. Read Prefetch can improve the performance of your system. IDE CD-ROM devices and some operating systems may not work properly with this feature Enabled.

### **IDE Drive 1**

The component type connected to IDE Drive 1 is shown here. With the same setting, options of IDE Performance and IDE Read Prefetch as IDE Drive 0.

## **Audio Setup**

Select this option to configure the Audio feature.

### **Audio Support**

Default is Enabled. The other option is Disabled.

## **Network Setup**

Select this option to configure the Network feature.

### **PXE Boot Agent**

Select whether to load the Preboot Execution Environment (PXE) Boot Agent to enable startup from the integrated network device. This option must be enabled to display the MAC Address for the



integrated network. Default is Enabled. The other option is Disabled.

### **PXE Base Code**

Select whether to load the Preboot Execution Environment (PXE) Version 2.x Base Code image when a network device is detected. The Base Code is normally required to allow startup from network devices. Default is Enabled. The other option is Disabled.

### **MAC Address**

Default is Not Available.

## **Startup Menu**

### **Startup Sequence**

Select this option to change the system Startup Sequence.

### **Keyboard NumLock State**

This field indicates the state of the NumLock feature of the keyboard after Startup. If NumLock is “On”, the keys on the keypad will act as numeric keys. If NumLock is “Off”, the keys on the keypad will act as cursor keys. Default is On.

### **Keyboard Speed**

Use this field to set the speed at which the keyboard places characters on the screen when you type. The “Normal” keyboard speed places characters on the screen at a rate of 10 characters-per-second. The “Fast” keyboard speed places characters on the screen at a rate of 30 characters-per-second. Default is Fast. The other option is Normal.

### **Keyboardless Operation**

The keyboardless operation mode allows the system to function without a keyboard or mouse. This mode of operation is commonly used when the system has been set up as a network server. Default is Disabled.

### **CD-ROM Drop Down**

Select to enable/disable the push button on the front panel which makes the CD-ROM accessible. Default is Enabled.

### **Power On Self Test**

Set the level of system testing that will be done when the machine is turned on. Default is Quick. The other option is Enhanced.

### **Power On Logo**

This option controls the display of the logo when the system is turned on. Select Disabled if you do not want the logo to be displayed. Select Enabled to display the logo. Default is Enabled.

## **Option Keys Display**

This option controls the prompt of the system software option keys (such as the F1 and Esc keys) when the system is turned on. This may or may not affect the function of a specific key. Select “Enabled” to display the prompts. Default is Enabled.

## **Startup Device Menu Prompt**

This option allows the Startup Device Menu to be displayed by pressing F12 after the system is turned on. The Startup Device Menu allows the sequence of startup devices to be temporarily changed. Default is Enabled.

## **Virus Detection**

The system has a built-in virus detection program. The virus detection program runs at boot time, and can be enabled or disabled from this field. Default is Disabled.

## **Advanced Menu**

### **PCI Parity**

This option allows parity checking of data across the PCI bus. Some adapters do not generate parity and will require this option to be Disabled. Default is Enabled.

### **Plug and Play Operating System**

Select “Yes” if you are experiencing POST errors numbered 185x and your system will be booting a Plug and Play compliant operating system. Consult your operating system documentation to determine if your operating system supports this function. Default is No.

### **Processor 0 ID**

The processor ID is configured and shown automatically.

### **MicroCode Revision (MM/DD/YYYY)**

The revision date is configured and shown automatically.

### **Legacy Fan Control**

Select the fan speed mode for non-ACPI Operating Systems. Select “Quiet” to reduce the amount of system noise by reducing fan speed. This setting might also cause the processor speed to be reduced. Select “Normal” to get the best processor performance. Default is Normal.

## **Security Menu**

### **Adapter ROM Security**

Default is No. If Yes, the keyboard will be locked during adapter ROM initialization. This can be used in conjunction with an Administrator password to prevent the use of adapter ROM based utilities.

### **Security Profile by Device**

Select this menu to control the level of security for bootable devices.

### **IDE Controller**

All devices attached to the system board IDE controller can be disabled using this field. When Disabled, IDE hard disk drives, IDE CDROM drives or any other devices attached to the system board, IDE controller will not appear in the system configuration. Default is Enabled.

### **Diskette Drive Access**

The diskette drives attached to the system board can be disabled using this field. Default is Enabled.

### **Diskette Write Protect**

When Enabled, the diskette drive(s) will treat all diskettes as write protected. Default is Disabled.

### **Password to request before booting**

#### **Removable Media Devices**

Default is User. Other options are Administrator or Not Required.

User: The User password or Administrator password will be required to boot from the device.

Administrator: Only the Administrator password will allow the system to boot from the device.

Not required: No password is required to boot from the device.

## Hard Disk Devices

Default is User. Other options are Administrator or Not Required. Function of each parameter is the same as above.

## Network Devices

Default is User. Other options are Administrator or Not Required. Function of each parameter is the same as above.

## Remote Administration

Select this item to view the Remote Administration menu.

### Remote Administration

Select “Enabled” to allow Remote Administration, such as the POST/BIOS Update Utility, to be run from a remote system without requiring entry of your Administrator password. Default is Enabled.

**NOTE:** If the Password Prompt is set to “On”, it will be reset when Remote Administration is set to Enabled.

## Network Boot Integrity Services

Select whether to use the Boot Integrity Services (BIS) protocol prior to startup from the network. Before allowing a network startup, BIS ensures the startup image is valid and is authorized for this system. Default is Disabled.

## Set Passwords

Select this option to set up the User and Administrator Passwords.

### User Password

#### Set User Password

Select this line to set, change, or delete the User password. Once a User password is set, you will be prompted for this password every time the system is turned on before you can use it. Default is Enter.

**NOTE:** To delete user password, enter blank fields for each New Password line item.

## **Password Prompt**

On: The system will prompt the user for a password (except in Remote Admin. mode).

Off: The keyboard remains locked until the correct User Password is entered.

Dual: "On" function after the system wakes by the power switch; "Off" function after an unattended wake up.

Default is Dual.

## **Administrator Password**

### **Set Administrator Password**

Select this line to set, change, or delete the Administrator password. Once an Admin. password is set, you will be prompted for this password before access to the Setup Utility is permitted. Default is Enter.

**NOTE:** To delete Admin. password, enter blank fields for each New Password line item.

### **Require Admin. Pass. when Flashing**

Default is No. If No, the Administrator password will not be required when updating the system software.

### **User password changeable by user**

Default is No. If Yes, the user will be able to change the User password with an Administrator password set. If No, the user will not be able to change the User password with an Administrator password set.

### **Require User password on warm boot**

Default is No. If Yes, the User password will be required whenever the system is restarted. If No, the User password will only be requested when the system is started with a cold boot.

## **Asset ID**

This enables wireless RF communication for AssetID.

## **IBM Security Chip**

Default is Disabled. This option allows you to enable or disable the IBM Security Chip feature. When

Enabled, you may use the IBM Security Chip software to set the password.

### **Clear IBM Security Chip**

Default is No. Select “Yes” to delete the IBM Security Chip password and all key encryption values after exiting Setup. This will also disable the IBM Security Chip feature.



## **Power Menu**

### **ACPI BIOS IRQ**

This field controls what IRQ the Advanced Configuration and Power Interface (ACPI) will use. Default is IRQ9. Other options are IRQ10 and IRQ11.

### **ACPI Standby Mode**

Select which power level your system goes to during standby. If S1 is selected, power is maintained to all devices but all processor activity is halted. If S3 is selected, power is maintained only for the main memory. Exit from the S3 state may not be supported by all installed adapters. Default is S3.

### **APM BIOS Mode**

This field controls the Advanced Power Management (APM) BIOS support. This should be enabled when your operating system supports APM-enabled machines. When this option is disabled, all APM BIOS support is disabled. Default is Enabled.

### **Power Savings**

Maximum Power Savings conserves the greatest amount of system power. Maximum Performance conserves power but allows greatest system performance. To alter these settings, choose Customized. To turn off power management, choose Disabled. Default is Customized.

### **Standby Timeout**

Amount of time the system needs to be in Idle Mode before entering the Standby Mode. Standby Mode turns off various devices in the system, including the screen, until you start using the computer again. Default is Off. Other options are 4 minutes, 6, 8, 12, 16, 20, and 30 minutes.

### **Hard Disk Timeout**

Allows hard disks connected to the system board to automatically enter low power mode after a period of inactivity (about 20 minutes). Hard disk adapters may not support this function. Default is Disabled.

## **After Power Failure**

Select the mode of operation if an AC/Power Loss occurs. Default is Last State. Other options are Power On and Stay Off.

## **Low Power Entry Activity Monitor**

Select this item to set up the system activities which will be monitored for automatic power management.

## **PS/2 Keyboard/Mouse**

“Enabled” includes the selected hardware in the group of items monitored for system activity.

“Disabled” excludes the item from this monitored group. Default is Enabled.

## **Diskette, Serial and Parallel Ports**

Default is Enabled. Same description as above.

## **IDE Hard Disks**

Default is Enabled. Same description as above.

## **IDE CD/DVD-ROM**

Default is Disabled. Same description as above.

## **Low Power Exit Activity Monitor**

Select this item to set up the system activities which will be monitored for automatic power management.

## **PS/2 Keyboard**

Default is Enabled. “Enabled” includes the selected hardware in the group of items monitored for system activity. “Disabled” excludes the item from this monitored group.

## **PS/2 Mouse**

Default is Enabled. Same description as above.

## **Serial Port A**

Default is Enabled. Same description as above.

## **Serial Port B**

Default is Enabled. Same description as above.

## **LAN**

Default is Enabled. Same description as above.

## **Automatic Power On**

Select this item to control Automatic Power On when your system is unattended.

## **Wake on LAN**

Select whether Wake on LAN is enabled, and/or which Startup Sequence to use after a Wake on LAN event. Default is Automatic. Other options are Primary and Disabled.

## **Serial Port A Ring Detect**

Select whether wake from Serial Port A Ring Detect is enabled, and/or which Startup Sequence to use after a serial port wake even. Default is Primary. Other options are Disabled and Automatic.

## **PCI Modem Ring Detect**

Select whether wake from a PCI modem Ring Detect is enabled, and/or which Startup Sequence to use after a PCI modem wake event. Default is Primary. Other options are Disabled and Automatic.

## **Wake Up on Alarm**

Use this option to turn on your system on a specific day of the month, specific day of the week, or daily. Default is Disabled.

## **Alarm Date (MM/DD/YYYY)**

User can input targeted alarm date, If Wake Up on Alarm is Enabled.

## **Alarm Time (HH:MM:SS)**

User can input targeted alarm time, If Wake Up on Alarm is Enabled.

## **Alarm Day of Week**

Users can adjust to one of the weekdays, if Wake Up on Alarm is Enabled.

## **Startup Sequence**

Users can adjust to other options, if Wake Up on Alarm is Enabled.

## **PCI Wake Up**

Select whether wake from any PCI device is enabled, and/or which Startup Sequence to use after a PCI device wake event. Default is Primary.

## Exit Menu

If you want to setup exit procedures, choose Exit Menu. There are Exit Saving Changes, Exit Discarding Changes, Load Setup Defaults, Discard Changes, and Save Changes.

## Save Settings

Select this parameter, there will be another sub-menu asking you to confirm saving configuration changes. The default value is Yes. If Yes, all the changes made before will be saved.

## Restore Settings

Select this parameter, there will be another sub-menu asking you to confirm loading previous configuration. The default value is Yes. If Yes, all the changes made before will be undone.

## Load Default Settings

The computer is already configured for use. The original configuration settings, also called factory or default settings, are stored in the CMOS. Setup includes an option Load Setup Defaults that lets you reload the original configuration at any time.

To load the default settings, follow these steps:

1. Use down-arrow key to select Load Setup Defaults in Exit Menu. A dialog box appears confirming if you want to load the default settings.
2. Use the left-arrow key to select Yes, then press **Enter**.
3. Press **Esc** to exit Setup.  
A dialog box appears confirming if you want to save the settings (in this case, the default settings that you reloaded).
4. Use the left-arrow key to select Yes, then press **Enter** to exit.

You must load the Setup default settings in the following instances:

- When you replace the system battery.
- When you customize the system configuration settings and some resource assignments conflict causing the computer to stop responding.

## **Save and exit the Setup Utility**

After changing any parameter in the Setup Configuration setting, return to Configuration/Setup Utility Exit Menu and select Exit Saving Changes to save all the settings you have changed. Click Yes, to save the configuration changes and exit.

## **Exit the Setup Utility without saving**

Press **Esc** to return to the Main Menu when you have finished viewing settings and making changes. Then, Select Exit Menu, from this location, you can choose Exit Discarding Changes to exit Setup but without saving your changes.

---

## Specifications

### Dimension (width x depth x height)

#### 15" without touch panel

- System unit: 421.5 mm x 303.5 mm x 432.5 mm

#### 15" with touch panel

- System unit: 421.5 mm x 303.5 mm x 432.5 mm

#### 17" without touch panel

- System unit: 464 mm x 303.5 mm x 488 mm

#### 17" with touch panel

- System unit: 464 mm x 303.5 mm x 488 mm

### Weight

#### 15" without touch panel

- System unit: 10.8 KG

#### 15" with touch panel

- System unit: 11.6 KG

#### 17" without touch panel

- System unit: 13 KG

#### 17" with touch panel

- System unit: 14 KG

### Environment

- Temperature for system unit:
  - Operating: 10° to 35°C (50° to 95°F)
  - Non-operating: -10° to 60°C (14° to 140°F)
- Humidity for system unit:
  - Operating: 10% to 80% RH, non-condensing (10% per hour)
  - Storage: 10% to 90% RH, non-condensing (10% per hour)
  - Transit: 10% to 90% RH, non-condensing (10% per hour)
  - Wet bulb temperature: Operating: 25 degree C (max). Non-operating: 40 degree C (max)

- Vibration
  - Operating: Sine wave, from 5 to 500 Hz, 0.5G (0 to peak), 15 min. 3 axes. (but without LCD panel).
  - Non-operating: Random, 1.48 Grms. PSD  $0.015G^2/Hz$  from 5 to 100Hz, -6dB/Octave from 100 to 200Hz. Time: each axis 1 hour, three axes.

## **Power consumption**

- System unit: Maximum 160 Watts

## **Electrical requirement**

- Input Line Voltage: 90Vac to 265Vac
- Output Voltage: 11.4Vdc to 12.6Vdc
- Input Frequency Range: 47 Hz to 63 Hz
- Maximum Input Current: 2.1A



---

# Check Procedures

Introduction .....	34
Start .....	35
Index of Symptoms, Messages, Error Codes, or Beeps .....	40
Troubleshooting .....	56
Factory-Installed Storage Devices .....	56
Factory-Installed Modem Card .....	60
Audio (Not Supported by Diagnostics Program) ..	62
CD/DVD-ROM Drive .....	65
Memory .....	67
Keyboard .....	69
Mouse .....	70
Power Supply .....	72
Monitor .....	75
Undetermined Problems .....	77

---

## Introduction

This chapter contains the check procedures used to diagnose the causes of product failures. The diagnostic information consists of:

**Start:** This is the starting point for any diagnostic action. Based on high-level symptoms, the check procedure directs you to more detailed procedures to help resolve machine failures.

**Index of Symptoms, Messages, Error Codes, or Beeps:** The tables for BIOS Error Messages, Codes, Beeps, and Error Symptoms list symptoms along with their probable causes, and direct you to the applicable check procedures to help resolve machine failures. These tables also list the field replaceable units (FRUs) most likely to cause a particular problem.

**Check Procedures:** When the Start check procedure or the Index of Symptoms, Messages, Error Codes, or Beeps tables point you to a specific check procedure, proceed to that section. If there are any notes or instructions at the top of the page, read them before you begin with the procedure. Carefully read each step of the check procedure and perform the steps as instructed. If you do not remember the location of a specific part or test point, or an adjustment or removal procedure, see the chapter that contains that information. Always return to the check procedure after you do this. In some cases, you are referred to other check procedures to detect the cause of the failure.

---

## Start

This is the entry point for all check procedures. The check procedures use failure symptoms, Power-On Self Test (POST) error codes, or beeps to help determine the defective field replaceable unit (FRU). Follow the suggested check procedures or use the diagnostics program from the service partition to determine the problem FRU.

**IMPORTANT:** Replace FRUs ONLY when it is determined that the error is not a result of software, loose contacts, or dirty component surfaces. Any FRU change should be verified by running a complete test (“Diagnostics - All Tests” in PC-Doctor diagnostics program).

POST error codes and error messages are displayed on the screen after the IBM logo. Meanwhile, error beeps could be issued to help diagnose system problem. Please refer to “Index of Symptoms, Messages, Error Codes, or Beeps” on page 40 for additional help.

All voltages in the check procedures are positive unless otherwise indicated. Use frame ground for all voltage checks unless otherwise specified.

**NOTE:** If the check procedures instruct you to replace a FRU and the error message persists, an option adapter card might be causing the failure. Remove all option adapter cards, one at a time, until the error changes or the problem is no longer apparent. Replace the last option adapter card removed.

The hard disk drive contains pre-loaded software. Be sure to reload the software on the primary hard disk drive (Drive C) when replacing it.

**IMPORTANT:** The drives in the system you are servicing may have been rearranged, or the drive startup sequence has changed. Be extremely careful during write operations, such as copying, saving, or formatting. Data or programs can be overwritten if you select an incorrect drive. **Ask the customer to back up any additional software from the hard disk drive before you reload the software.**

**How to Diagnose Combined FRUs:** If an adapter or device consists of more than one FRU, any of the FRUs might cause an error code. Before replacing the device or adapter, remove the FRUs one by one to see if the symptoms change.

**If a newly replaced FRU does not correct the problem:** If you have reached this point of the check procedures and were instructed to replace a FRU but doing so did not correct the problem, reinstall the original FRU and go through “Start” again.

If you want to print a copy of a Configuration/Setup Utility screen to an attached printer, press **Print Screen** key while the following screen is displayed.

### **READ THE FOLLOWING:**

**Human Error is a cause for concern when applied to check procedures. It exists in every first time set of analysis procedures. It is therefore essential for effective and time-efficient servicing that each stage of every procedure be verified. (For example: When a symptom is found, or when a symptom appears to have been cured; the preceding steps should be repeated for accuracy of analysis.)**

### **001 - START**

- To begin, note the following:
- Disable the setting of “Fast POST Mode” in Configuration/Setup Utility.
- To disable or reset the power-on password, see “User(Power-On) Password” on page 9.
- Disconnect all external cables and devices including speakers and microphone from the system unit, except for the keyboard, mouse, and monitor.
- Power off the system unit (unplug the power cord) before moving it or when replacing FRUs.
- Remove all adapter cards, except for the factory-installed modem adapter card and any other IBM Personal Computer factory-installed adapter cards.
- Disconnect all drives except:
  - 3.5-in. diskette drive
  - Hard disk drive

- IBM Personal Computer factory-installed devices (such as a CD-ROM drive)
- Ensure that all power cords and cables are connected properly.
- Ensure that the monitor brightness and contrast controls are not turned down.
- Power on the system unit.

**NOTE:** Some monitors have a detachable system I/O signal cable between the monitor and the system unit. In this case, check this signal cable before replacing the unit. See “Monitor Port Signals” on page 131 for pin identification.

- Ensure correct monitor refresh rate.
- Note any symptoms, messages, error codes, or beeps.
- Make sure that there are no diskettes or CDs in the drives.

**002 - DOES AN IBM LOGO SCREEN APPEAR? (YES, READ AHEAD. NO, GO TO STEP 004.)**

- Run the diagnostics program from the service partition.

**003 - DOES SYSTEM LOAD THE DIAGNOSTICS PROGRAM FROM THE SERVICE PARTITION? (YES, READ AHEAD. NO, GO TO STEP 004.)**

- Follow the instructions on the screen and select Utility from the diagnostics program menu.
- Select Tech Support Form from the menu, press **F5** to execute, then generate a system configuration report.
- Compare the system configuration list with the actual devices installed in system.

**NOTE:** If necessary, remove the machine cover and visually compare the devices installed in system to those shown in the system configuration report.

- Go to step 006.

**004 - DO ANY MESSAGES, ERROR CODES, OR SYMPTOMS APPEAR? (YES, READ AHEAD. NO, GO TO STEP 005)**

- Go to “Index of Symptoms, Messages, Error Codes, or Beeps” on page 40.
- End.

**005 -**

- If the keyboard responds incorrectly, go to “Keyboard” on page 69.
- If monitor problems appear, such as jittering, shifting, or being out of focus, go to “Monitor” on page 75.

**006 - DOES THE SYSTEM CONFIGURATION REPORT CORRECTLY IDENTIFY THE DEVICES INSTALLED IN SYSTEM? (YES, READ AHEAD. NO, GO TO STEP 007.)**

- Select Diagnostics from the diagnostics program menu.
- Select and execute **All Tests**.
  - Go to step 008.

**007 -**

- The system configuration report shows only those devices supported by the diagnostics program.
- If a device is missing from the list and is not factory installed, refer to the service manual provided for that device.

**008 - DO THE DIAGNOSTICS FINISH WITHOUT ANY ERRORS? (YES, READ AHEAD. NO, GO TO STEP 009.)**

- If the Diagnostics \ All Tests did not detect a failure but the system still indicates a failure:
  - Check all adapter card jumper settings.
  - Check all adapter card switch settings.
  - Check all adapter card cables and connectors. Make sure that all of the above are set correctly and show the correct voltages and continuity. Replace any defective cables or adapter cards. See “Introduction” on page 116.
  - Run the Diagnostics \ All Tests again.

- If an error or other symptom is displayed, go to “Index of Symptoms, Messages, Error Codes, or Beeps” on page 40.
- If no error can be detected or the symptom is intermittent, go to “Undetermined Problems” on page 77.
- End

**009 -**

- If the last test stops and you cannot continue, first make sure all switches, power connectors, cables, and jumpers are set correctly and show the correct voltages and continuity.
- Take note of any messages, error codes, beeps, or new symptoms. Go to “Index of Symptoms, Messages, Error Codes, or Beeps” on page 40.
- If there is no error symptom or the error symptom is intermittent, go to “Undetermined Problems” on page 77.

---

## Index of Symptoms, Messages, Error Codes, or Beeps

**How to Use Error Messages:** Use the messages, error codes, and beeps combinations that occur to diagnose failures. If more than one failure occurs, begin the diagnosis from the first failure that appeared. The cause of the first failure can result in false messages, error codes, or beeps. If you did not receive any messages, error codes, or beeps, see if the symptom is listed in “Table 2-3 Error Symptoms List” on page 47.

**CAUTION:** When you have deemed it necessary to replace a FRU, and have done so, you must run a total system check to ensure that no other activity has been affected by the change. This system check can be done through the diagnostics program (Select Diagnostics, then select and execute All Tests from PC-Doctor).

**POST:** Some diagnostic aids are resident in the machine, such as the Power-On Self Test (POST). The machine performs the POST each time it is powered on. Use this information throughout the diagnostic procedures. The POST is a series of system checks and initialization that verify the correct operation of the base system.

After a successful POST, the system attempts to load the operating system. The system can be customized for different startup (boot) methods by the BIOS Configuration/Setup Utility. See “BIOS Configuration/Setup Utility” on page 11.

The system's default startup sequence automatically looks for the operating system files in the hard disk if these files are not found in the diskette.

**WARNING:** Remember that POST does not test all areas, but only those that allow the system to operate well enough to run the diagnostics program.

Table 2-1 lists BIOS error codes, messages, and their possible causes. Table 2-2 lists BIOS beeps and their possible causes. Table 2-3 lists error symptoms and their possible causes. The most likely cause is listed first. Make sure you complete all items in the cause or



“Action/FRU” column. When servicing a system, always begin with “Start” on page 35.

If you are unable to correct the problem using these two index tables, go to “Undetermined Problems” on page 77.

**NOTE:**

1. If an error message and incorrect audio response occur, diagnose the error message first.
2. If you cannot run the diagnostics program tests but did receive a POST error code and message, use “Table 2-1 POST Error Codes and Messages List” on page 42 to diagnose system problems.
3. If you cannot run the diagnostics program tests but did receive POST error beeps, use See “Table 2-2 BIOS Error Beeps List” on page 46 to diagnose system problems.
4. If you did not receive any error message, look for a description of your error symptoms in “Table 2-3 Error Symptoms List” on page 47.

**IMPORTANT:** Check all power supply voltages, switch, and jumper settings before you replace the system board. Also check the power supply voltages if you have a “system no-power” condition.

5. If you are unable to correct the problem by using the “BIOS Error Codes, Messages, And Beeps List” table and “Error Symptoms List” table, go to “Undetermined Problems” on page 77.

Table 2-1 POST Error Codes and Messages List

**NOTE:** To diagnose a problem, first find the BIOS error messages or codes in left column. If directed to a check procedure, replace the FRU indicated in the check procedure. If no check procedure is indicated, the first Action/FRU listed in right column is the most likely cause.

<b>BIOS Error Codes, Messages</b>	<b>Action/FRU</b>
0200 Failure Fixed Disk	<ol style="list-style-type: none"> <li>1. Check to see if fixed disk is attached properly.</li> <li>2. Run Setup. Find out if the fixed disk type is correctly identified.</li> <li>3. Check the indicated disk, by trying to fix another one.</li> </ol>
0210 Stuck Key	<ol style="list-style-type: none"> <li>1. Check keyboard</li> <li>2. Check system board</li> </ol>
0211 Keyboard Error	<ol style="list-style-type: none"> <li>1. Re-connect keyboard</li> <li>2. Enter Configuration/ Setup Utility and load the default settings</li> <li>3. Check keyboard</li> <li>4. Check system board</li> </ol>
0212 Keyboard Controller Failed	<ol style="list-style-type: none"> <li>1. Check keyboard controller</li> </ol>
0213 Keyboard Locked - Unlock Key Switch	<ol style="list-style-type: none"> <li>1. Unlock the system to proceed</li> </ol>
0220 Monitor Type Does Not Match CMOS - Run SETUP	<ol style="list-style-type: none"> <li>1. Monitor type not correctly identified in Setup</li> </ol>
0230 Shadow RAM Failed at Offset: nnnn 0231 System RAM Failed at Offset: nnnn 0232 Extended RAM Failed at Offset: nnnn	<ol style="list-style-type: none"> <li>1. Insert the memory modules in the DIMM sockets properly, then reboot the system</li> <li>2. Memory module. See "005 -" on page 67 to replace memory module</li> <li>3. System board</li> </ol>

Table 2-1 POST Error Codes and Messages List

**NOTE:** To diagnose a problem, first find the BIOS error messages or codes in left column. If directed to a check procedure, replace the FRU indicated in the check procedure. If no check procedure is indicated, the first Action/FRU listed in right column is the most likely cause.

<b>BIOS Error Codes, Messages</b>	<b>Action/FRU</b>
0250 System Battery is Dead- Replace and Run SETUP	1. Check system battery. If replaced, re-run Setup
0251 System CMOS Checksum Bad-Default Configuration Used	1. Run Setup. Load the default settings, or enter Setup to key-in your own values. 2. Check system battery
0260 System Timer Error 0270 Real Time Clock Error	1. Check system board
0271 Check Date and Time Settings	1. Run Setup. Reset the Real-Time clock.
0280 Previous Boot Incomplete- Default Configuration Used	1. Run Setup. Verify if the wait-state configuration is correct.
0281 Memory Size Found by POST Differed from CMOS	1. Check system battery
02B0 Diskette Drive A Error	1. Re-connect floppy disk drive 2. Enter Configuration/ Setup Utility and load the default settings. 3. Floppy disk drive 4. System board
02B1 Diskette Drive B Error	1. Re-connect floppy disk drive 2. Enter Configuration/ Setup Utility and load the default settings. 3. Floppy disk drive 4. System board

Table 2-1 POST Error Codes and Messages List

**NOTE:** To diagnose a problem, first find the BIOS error messages or codes in left column. If directed to a check procedure, replace the FRU indicated in the check procedure. If no check procedure is indicated, the first Action/FRU listed in right column is the most likely cause.

<b>BIOS Error Codes, Messages</b>	<b>Action/FRU</b>
02B2 Incorrect Drive A Type-Run SETUP	<ol style="list-style-type: none"> <li>1. Re-connect floppy disk drive</li> <li>2. Enter Configuration/ Setup Utility and load the default settings.</li> <li>3. Floppy disk drive</li> <li>4. System board</li> </ol>
02B3 Incorrect Drive B Type-Run SETUP	<ol style="list-style-type: none"> <li>1. Re-connect floppy disk drive</li> <li>2. Enter Configuration/ Setup Utility and load the default settings.</li> <li>3. Floppy disk drive</li> <li>4. System board</li> </ol>
02D0 System Cache Error-Cache Disabled	<ol style="list-style-type: none"> <li>1. Replace processor</li> </ol>
02F0 CPU ID:	<ol style="list-style-type: none"> <li>1. Check CPU</li> </ol>
02F4 EISA CMOS Not Writable	<ol style="list-style-type: none"> <li>1. Check EISA CMOS</li> </ol>
02F5 DMA Test Failed	<ol style="list-style-type: none"> <li>1. Check DMA (Direct Memory Access) registers.</li> </ol>
02F6 Software NMI Failed	<ol style="list-style-type: none"> <li>1. Check Software</li> </ol>
02F7 Fail-Safe Timer NMI Failed	<ol style="list-style-type: none"> <li>1. Check the Fail-Safe timer</li> </ol>
Device Address Conflict	<ol style="list-style-type: none"> <li>1. Enter Configuration/ Setup Utility and reset the device address</li> </ol>
Allocation Error for: device	<ol style="list-style-type: none"> <li>1. Run ISA or EISA Configuration Utility to resolve resource conflict for the specified device.</li> </ol>

Table 2-1 POST Error Codes and Messages List

**NOTE:** To diagnose a problem, first find the BIOS error messages or codes in left column. If directed to a check procedure, replace the FRU indicated in the check procedure. If no check procedure is indicated, the first Action/FRU listed in right column is the most likely cause.

<b>BIOS Error Codes, Messages</b>	<b>Action/FRU</b>
Failing Bits: nnnn	1. Refer to Error Codes 0230, 0231, and 0232 for actions.
Invalid System Configuration Data	1. Enter Configuration/ Setup Utility and load the default settings.
I/O Device IRQ Conflict	1. Enter Configuration/ Setup Utility and reset the IRQ
Operating System not Found	1. Enter Configuration/ Setup Utility and see if fixed disk and drive are properly identified.

Table 2-2 BIOS Error Beeps List

**NOTE:** To diagnose a problem, first find the BIOS beeps in left column. If directed to a check procedure, replace the FRU indicated in the check procedure. If no check procedure is indicated, the first Action/FRU listed in right column is the most likely cause.

BIOS Error Beeps	Action/FRU
1-2-2-3 BIOS ROM checksum	<ol style="list-style-type: none"> <li>1. Bootblock recovery</li> <li>2. Check ROM</li> <li>3. Check System board</li> </ol>
1-3-1-1 Test DRAM refresh	<ol style="list-style-type: none"> <li>1. Check DIMM</li> <li>2. Check system board.</li> </ol>
1-3-1-3 Test 8742 Keyboard controller	<ol style="list-style-type: none"> <li>1. Check keyboard</li> <li>2. Refresh BIOS</li> <li>3. Check system board</li> </ol>
1-3-4-1 RAM failure on address line	<ol style="list-style-type: none"> <li>1. Check DIMM</li> </ol>
1-3-4-3 RAM failure on data	<ol style="list-style-type: none"> <li>1. Check DIMM</li> </ol>
2-1-2-3 Check ROM copyright notice	<ol style="list-style-type: none"> <li>1. Bootblock recovery</li> <li>2. Check system board</li> </ol>
2-2-3-1 Test for unexpected interrupts	<ol style="list-style-type: none"> <li>1. Check components one by one</li> </ol>
1-2 Checksum failure on option ROM	<ol style="list-style-type: none"> <li>1. Check video card</li> <li>2. Bootblock recovery</li> <li>3. Check system board</li> </ol>
Long-Short-Short	<ol style="list-style-type: none"> <li>1. Check video card</li> <li>2. Check ROM module</li> </ol>

Table 2-3 Error Symptoms List

**NOTE:** To diagnose a problem, first find the error symptom in the left column. If directed to a check procedure, replace the FRU indicated in the check procedure. If no check procedure is indicated, the first Action/FRU listed in right column is the most likely cause.

Error Symptoms	Action/FRU
<b>Processor / Processor Fan</b>	
<b>NOTE:</b> Normally, the processor fan should be operative, and the processor clock setting should be exactly set to match its speed requirement before diagnosing any processor problems.	
Processor fan does not run but power supply fan runs.	<ol style="list-style-type: none"> <li>1. Ensure that the system is not in power saving mode and the "Stop CPU clock in sleep state" is not set to Yes. See "Power Management" on page 5.</li> <li>2. With the system power on, measure the voltage of processor fan connector FN2. Its reading should be +12Vdc. See "System Board Jumpers and Connectors" on page 117.</li> <li>3. Processor fan.</li> <li>4. System board.</li> </ol>
Processor test failed.	<ol style="list-style-type: none"> <li>1. Processor.</li> <li>2. System board.</li> </ol>
<b>System Board and Memory</b>	
<b>NOTE:</b> Ensure that the memory modules are installed properly and the contact leads are clean before diagnosing any system problems.	
Memory test failed.	<ol style="list-style-type: none"> <li>1. See "Memory" on page 67.</li> <li>2. System board</li> </ol>

<b>Error Symptoms</b>	<b>Action/FRU</b>
Incorrect memory size shown or repeated during POST.	<ol style="list-style-type: none"> <li>1. Insert the memory modules in the DIMM sockets properly, then reboot the system.</li> <li>2. Memory module. See "005 -" on page 67 to replace memory module.</li> <li>3. System board.</li> </ol>
System works but fails to enter power saving mode when the Power Management Mode is set to [Enabled], and power saving timer set in BIOS has elapsed.	<ol style="list-style-type: none"> <li>1. Enter Configuration/ Setup Utility and load default settings.</li> <li>2. In Windows XP or Windows 2000, check settings in Power Management Property of Control Panel.</li> <li>3. Reload software from Recovery CD.</li> </ol>
System hangs before system boot.	<ol style="list-style-type: none"> <li>1. See "Index of Symptoms, Messages, Error Codes, or Beeps" on page 40.</li> <li>2. See "Undetermined Problems" on page 77</li> </ol>
System hangs after system boot.	<ol style="list-style-type: none"> <li>1. Execute a system test ("Diagnostics / All Tests" in PC-Doctor diagnostics program) and set it to stop at "Halt on Error" to see the potential cause of the problem.</li> <li>2. "Undetermined Problems" on page 77.</li> </ol>
Blinking cursor only; system does not work.	<ol style="list-style-type: none"> <li>1. See "Start" on page 35.</li> <li>2. Diskette/IDE drive connection/cables</li> <li>3. Diskette/IDE disk drives</li> <li>4. See "Undetermined Problems" on page 77</li> <li>5. System board</li> </ol>



Error Symptoms	Action/FRU
<b>Diskette Drive</b>	
<p><b>NOTE:</b> Ensure that the diskette drive is configured correctly in Configuration/Setup Utility and its read/write head is clean before diagnosing any diskette drive problems.</p>	
<p>Media and drive are mismatched.</p>	<ol style="list-style-type: none"> <li>1. Ensure that the diskette drive is configured correctly in the Disk Drives of Configuration/Setup Utility. See "Hard Disk Drive" on page 4.</li> <li>2. Ensure that the diskette drive is correctly formatted.</li> <li>3. Diskette drive connection/cable</li> <li>4. Diskette drive</li> <li>5. System board</li> </ol>
<p>Diskette drive does not work.</p>	<ol style="list-style-type: none"> <li>1. Ensure that the diskette drive is not set to [None] in the Disk Drives of Configuration/Setup Utility. See "Hard Disk Drive" on page 4.</li> <li>2. Diskette drive power</li> <li>3. Diskette drive connection/cable</li> <li>4. Diskette drive</li> <li>5. System board</li> </ol>
<p>Diskette drive read/write error.</p>	<ol style="list-style-type: none"> <li>1. Diskette.</li> <li>2. Ensure that the diskette drive is not set to [Write protect] in the Security Options of Configuration/Setup Utility.</li> <li>3. Diskette drive cable.</li> <li>4. Diskette drive.</li> <li>5. System board.</li> </ol>
<p>Diskette drive LED comes on for more than 2 minutes when reading data.</p>	<ol style="list-style-type: none"> <li>1. Diskette</li> <li>2. Diskette drive connection/cable</li> <li>3. Diskette drive</li> <li>4. System board</li> </ol>

Error Symptoms	Action/FRU
Diskette drive LED fails to light, and the drive is unable to access for more than 2 minutes.	<ol style="list-style-type: none"> <li>1. Diskette</li> <li>2. Diskette drive power</li> <li>3. Diskette drive connection/cable</li> <li>4. Diskette drive</li> <li>5. System board</li> </ol>
Diskette drive test failed.	<ol style="list-style-type: none"> <li>1. Diskette</li> <li>2. Diskette drive</li> <li>3. Diskette drive cable</li> <li>4. System board</li> </ol>
<b>Hard Disk Drive</b>	
<p><b>NOTE:</b> Ensure hard disk drive is configured correctly in Configuration/Setup Utility, and cables/jumpers are set correctly before diagnosing any hard disk drive problems.</p>	
Hard disk drive test failed.	<ol style="list-style-type: none"> <li>1. Enter Configuration/Setup Utility and Load default settings.</li> <li>2. Hard disk drive cable.</li> <li>3. Hard disk drive.</li> <li>4. System board.</li> </ol>
Hard disk drive format error.	<ol style="list-style-type: none"> <li>1. Enter Configuration/Setup Utility and Load default settings.</li> <li>2. Hard disk drive cable.</li> <li>3. Hard disk drive.</li> <li>4. System board.</li> </ol>
Hard disk drive write error.	<ol style="list-style-type: none"> <li>1. Enter Configuration/Setup Utility and Load default settings.</li> <li>2. Hard disk drive.</li> </ol>

Error Symptoms	Action/FRU
<p>Hard disk drive LED fails to light, but system operates normally.</p>	<ol style="list-style-type: none"> <li>1. With the system power on, measure the voltage of hard disk LED connector CN6. The reading should be:  CN6 HDD Idle / Active  pin-1 pin-1 +5Vdc/ --  pin-2 pin-2 +5Vdc/ 0Vdc  pin-3 pin-3 +5Vdc/ 0Vdc  pin-4 pin-4 +5Vdc/ --</li> <li>2. See "System Board Jumpers and Connectors" on page 117.</li> <li>3. Hard drive LED cable.</li> </ol>
<b>CD/DVD-ROM Drive</b>	
<p><b>NOTE:</b> Ensure CD/DVD-ROM drive is configured correctly in Configuration/Setup Utility, and cables/jumpers are set correctly and its laser beam is clean before diagnosing any CD/DVD-ROM drive problems.</p>	
<p>CD/DVD-ROM drive LED flashes for more than 30 seconds before LED shutting off.</p> <p>Software asks to reinstall disc.</p> <p>Software displays a reading CD/DVD error.</p>	<ol style="list-style-type: none"> <li>1. CD/DVD may have dirt or foreign material on it. Check with a known good disc.</li> <li>2. CD/DVD is not inserted properly.</li> <li>3. CD/DVD is damaged.</li> </ol>
<p>CD/DVD-ROM drive LED doesn't come on but works normally.</p>	<ol style="list-style-type: none"> <li>1. CD/DVD-ROM drive</li> </ol>
<p>CD/DVD-ROM drive cannot load or eject when the system is turned on and its eject button is pressed and held.</p>	<ol style="list-style-type: none"> <li>1. See "CD-ROM Emergency-Eject" on page 124.</li> <li>2. Disconnect all cables from CD/DVD-ROM drive except power cable, then press eject button to try to unload the disk.</li> <li>3. CD/DVD-ROM drive power.</li> <li>4. CD/DVD-ROM drive</li> </ol>

<b>Error Symptoms</b>	<b>Action/FRU</b>
CD/DVD-ROM drive does not read and there are no error codes or messages are displayed.	<ol style="list-style-type: none"> <li>1. CD may have dirt or foreign material on it. Check with a known good disc.</li> <li>2. Ensure that the CD/DVD-ROM driver is installed properly. See "CD/DVD-ROM Drive" on page 65.</li> <li>3. CD/DVD-ROM drive.</li> </ol>
CD/DVD-ROM drive can play audio CD but no sound output.	<ol style="list-style-type: none"> <li>1. Ensure that the headphone jack of the CD/DVD-ROM has an output, then check if the audio cable from CD/DVD-ROM drive to system board CN20 is connected properly. See "System Board Jumpers and Connectors" on page 117.</li> <li>2. Turn up the sound volume.</li> <li>3. Speaker power/connection/cable.</li> <li>4. CD/DVD-ROM drive.</li> </ol>
<b>Real-Time Clock</b>	
Real-time clock is inaccurate.	<ol style="list-style-type: none"> <li>1. Ensure that the information in the Date and Time of Configuration/Setup Utility is set correctly.</li> <li>2. Load default settings.</li> <li>3. CMOS battery.</li> <li>4. System board</li> </ol>
<b>Audio</b>	
Audio software program invokes but no sound comes from speakers.	<ol style="list-style-type: none"> <li>1. Speaker power/connection/cable.</li> </ol>
<b>Modem</b>	
Data/fax modem software program invokes but cannot receive/send data/fax	<ol style="list-style-type: none"> <li>1. See "Factory-Installed Modem Card" on page 60.</li> </ol>

<b>Error Symptoms</b>	<b>Action/FRU</b>
Fax modem software program invokes but has no sound output. (Data files are received normally; voice from modem cannot be produced, but system sound feature works normally.)	<ol style="list-style-type: none"> <li>1. Ensure that the modem voice-in cable from modem adapter card to system board CN21 is connected properly. See "System Board Jumpers and Connectors" on page 117.</li> <li>2. "Factory-Installed Modem Card" on page 60.</li> </ol>
Modem ring cannot wake up system from suspend mode.	<ol style="list-style-type: none"> <li>1. Ensure the "Modem Wake-Up on Ring" in Configuration/Setup Utility is set to [Enabled]. "Power Management" on page 5.</li> <li>2. If PCI modem card is used, reinsert the modem card to PCI slot firmly or replace modem card.</li> <li>3. If ISA modem card is used, ensure the modem ring-in cable from the modem card to system board CN16 is connected properly. See "System Board Jumpers and Connectors" on page 117.</li> <li>4. In Windows or other OS ensure that telephone application is configured correctly for your modem and set to receive messages and/or fax.</li> </ol>
<b>Video and Monitor</b>	
Video memory test failed. Video adapter failed.	<ol style="list-style-type: none"> <li>1. Remove all non factory-installed cards.</li> <li>2. Load default settings (if screen is readable).</li> <li>3. System board</li> </ol>

Error Symptoms	Action/FRU
Display problem: - Incorrect colors - No high intensity - Missing, broken, or incorrect characters - Blank monitor(dark) - Blank monitor(bright) - Distorted image - Unreadable monitor - Other monitor problems	1. Monitor signal connection/cable. 2. Monitor 3. Video adapter card 4. System board
Display changing colors.	1. Monitor signal connection/cable 2. Monitor 3. System board
Display problem not listed above (including blank or illegible monitor).	1. "Monitor" on page 75. 2. Load default settings (if screen is readable). 3. System board
<b>Parallel/Serial Ports</b>	
<b>NOTE:</b> Execute "Load BIOS Default Settings" in Configuration/Setup Utility to confirm ports' presence before diagnosing any parallel/serial ports problems.	
Serial or parallel port loop-back test failed.	1. Make sure that the LPT# or COM# you test is the same as is set in Configuration/Setup Utility. 2. Loop-back. 3. System board.
Printing failed.	1. Ensure that the printer driver is properly installed. 2. Refer to the service manual for the printer. 3. Printer. 4. Printer cable. 5. System board.
Printer problems.	1. Refer to the service manual for the printer.
<b>Joystick</b>	

<b>Error Symptoms</b>	<b>Action/FRU</b>
Game port does not respond or does not work.	<ol style="list-style-type: none"> <li>1. Connect a joystick to the game port, then execute "Interactive Test/Joystick" test in PC-Doctor diagnostics program.</li> <li>2. System board.</li> </ol>
<b>Diagnostic Program</b>	
Diagnostics programs cannot be executed.	<ol style="list-style-type: none"> <li>1. Reboot the system from the diagnostics program located in service partition.</li> <li>2. Load default settings.</li> <li>3. Diagnostics program.</li> <li>4. Memory module.</li> <li>5. System board.</li> </ol>
Missing diagnostics file(s).	<ol style="list-style-type: none"> <li>1. Diagnostics program.</li> </ol>
<b>Keyboard</b>	
Some or all keys on keyboard do not work.	<ol style="list-style-type: none"> <li>1. "Keyboard" on page 69.</li> </ol>
<b>Power Supply</b>	
Pressing power switch does not turn off system. (Only unplugging power cord from electrical outlet can turn off system.)	<ol style="list-style-type: none"> <li>1. Power switch cable assembly</li> <li>2. "Power Supply" on page 72</li> </ol>
Pressing power switch does not turn on system.	<ol style="list-style-type: none"> <li>1. Power switch cable assembly.</li> </ol>
Executing software shutdown from Windwos2000, Windows XP, Windows NT, or the other operating system, Start menu does not turn off system. (Only pressing power switch can turn off the system).	<ol style="list-style-type: none"> <li>1. Load default settings.</li> <li>2. Reload software from Recovery CD.</li> </ol>
No system power, or power supply fan is not running.	<ol style="list-style-type: none"> <li>1. "Power Supply" on page 72</li> <li>2. System board.</li> </ol>
<b>Other Problems</b>	
Any other problems.	<ol style="list-style-type: none"> <li>1. See "Undetermined Problems" on page 77</li> </ol>

---

## Troubleshooting

**Failing Parts or Assemblies:** The check procedures generally help you trace a problem to one part or assembly. The last step of the specific check procedure you are using indicates that a part or assembly is failing. You should inspect the part or assembly before you decide to replace it. It might be loose, dirty, or in need of a small repair. The check procedures might lead you to two, or even three, possible failing parts or assemblies. The parts that might be failing are listed in order of the most probable failure. Also, the FRU parts are defined as replaced units and are not repaired in the field.

**Measuring Voltages:** Some check procedure steps instruct you to measure voltages on cable plugs and electronic board connectors. If you are asked to measure voltage at several places on a plug or connector, a chart next to or near the instruction indicates the number of the plug or connector, the pin numbers you should measure, the signal name, and the correct voltage for the condition you are measuring. Measure the voltage only at the pins listed in the chart. Remember to set the meter on the correct scale and to put the meter leads in the correct position for the voltage you are asked to measure.

**NOTE:** Use frame ground as the ground reference. Attach the black (ground) lead of meter to frame ground, except where specified otherwise.

### Factory-Installed Storage Devices

Use this check procedure to test any factory-installed drives, including Zip drives.

**ATTENTION:** The customer may have customized settings in the Configuration/Setup Utility (other than default settings) on the computer you are servicing. Running the Configuration/Setup Utility might alter those settings. Take note of the current settings and verify that the customer settings are in place when service is complete.



**NOTE:** If you cannot access the hard disk drive or load a diskette from Drive A or load a CD from the CD-ROM drive, make sure that the Configuration/Setup Utility has the startup sequence set with diskette, CD ROM, and hard disk drives.

### **001 - START**

- Power-off then power-on the system unit.
- Run the Diagnostics program from the service partition.

### **002 - DO ANY POST MESSAGES, ERROR CODES, BEEPS, OR SYMPTOMS OCCUR? (YES, READ AHEAD. NO, GO TO STEP 003)**

- Go to “Index of Symptoms, Messages, Error Codes, or Beeps” on page 40.
- End.

### **003 -**

- Select Utility from the menu.
- Select and execute Tech Support Form from the menu to generate a system configuration report.
- Compare the system configuration list with the actual devices installed in system.

**NOTE:** If necessary, remove the cover and visually compare the devices installed in the system unit to those shown in the Tech Support Form.

### **004 - IF THE NUMBER OF DISKETTE, HARD DISK, OR CD-ROM DRIVE IS NOT CORRECT, READ AHEAD; OR GO TO STEP 005.**

- Check the cable installation of all disk drives.(See “System Board Jumpers and Connectors” on page 117)
  - Diskette drive should be connected to the system board connector FLOPPY.
  - IDE Primary Channel Master and Slave Drives in Configuration/Setup Utility should be connected to the system board connector PRIMARY.
- Check all power supply voltages, switch, and jumper settings before you replace the system board. (See “System Board Jumpers and Connectors” on page 117)

- Check the power supply voltages if you have a “system no-power” condition. See “Power Brick Connectors and Voltages” on page 119.
- Check the hard disk and CD-ROM drives jumper settings. See “3.5-In. Hard Disk Drive Jumper Settings” on page 121. Check the voltages of all disk drive power connectors. See “Power Brick Connectors and Voltages” on page 119.
- Correct the parameter settings under Disk Drives in the Configuration/Setup Utility. See “Hard Disk Drive” on page 4.
  - In the Configuration/Setup Utility, check that the correct drive size is set for the flagged drive shown in the System Information.
- Enter Configuration/Setup Utility and load default settings.  
If the problem remains, check the continuity on the drive and the cable and replace it if necessary. If that does not fix the problem, replace the system board.
- End.

#### **005 -**

- Select Diagnostics from the PC-Doctor diagnostics program main menu. Select and execute Floppy Disk Test if you want to test diskette drive. Select and execute Hard Disk Test if you want to test hard disk drive.
- Select Interactive Tests from the PC-Doctor diagnostics program main menu, then select and execute CD-ROM/DVD Test if you want to test CD-ROM drive.

- If the diagnostics program did not detect a failure, but the system still displays a failure:
  - If an error or other symptom appears, go to “Index of Symptoms, Messages, Error Codes, or Beeps” on page 40.
  - If no error can be detected or the symptom is intermittent, go to “Undetermined Problems” on page 77.
- End.

---

## Factory-Installed Modem Card

**NOTE:** The factory-installed modem is a 56.6 Kbps modem with a cable of microphone-in and speaker-out from system board.

### 001 - START

- In Windows XP or Windows 2000 Device Manager, ensure that the modem is not configured with a conflicting COM port and IRQ setting.
- Ensure that the communication software is configured with the correct COM and IRQ settings (same COM port and IRQ as the modem).
- Ensure that all communication parameters (baud rate, data, stop and parity bits) are properly configured and are identical on both sides.
- Connect the phone line to the LINE port of the modem card.
- Power off the system unit.

**NOTE:** Check the outside phone line by connecting a working telephone to the telephone wall jack. Listen for a dial tone to ensure that the phone line is good.

### 002 -

- Power on the system unit.
- Run the Diagnostics program from the service partition.
- Select All Tests, then execute Modem test.

### 003 - DOES THE MODEM PASS THE TEST? (YES, READ AHEAD. NO, GO TO STEP 004.)

- Power off the system unit.
- Remove all adapter cards.
- Connect a hard disk drive with pre-loaded Windows XP, Windows 2000, or the other operating system.
- Power on the system unit.
- Perform the following steps under Windows XP, Windows 2000.

**NOTE:** If an operating system other than Microsoft Windows XP or Windows 2000 is installed, the

program screens and icons may differ from these instructions.

1. Start Microsoft Windows XP or Windows 2000.
2. Select the **Start** icon.
3. Select **Program**, then select **Accessories, Hyper Terminal**.
4. Select an on-line service station, dial and connect to it.

**004 - CAN THE MODEM DIAL OUT AND CONNECT TO ANY BBS SUCCESSFULLY? (YES, READ AHEAD. NO, GO TO STEP 005.)**

- The modem adapter functions normally.
- End.

**005 -**

- Ensure that Windows XP, Windows 2000 or the other operating system is properly installed, then power off the system unit.
- Plug the modem adapter card into a different PCI expansion slot.
- Go to step 002.
- If the error symptom still remains, replace the modem adapter card.
- End.

---

## **Audio (Not Supported by Diagnostics Program)**

**IMPORTANT:** Audio tests for the sound card cannot be carried out in the PC-Doctor DOS diagnostics program. It is, however, possible to carry out a dial tone test for the modem. While performing this check, you may need to enter and exit Microsoft Windows XP, Windows 2000 or the other operating system several times. When instructed to select an icon or button, double click on the item with the mouse.

**NOTE:** For more information about using Microsoft Windows XP or Windows 2000, see the user's guide that came with the computer. If an operating system other than Microsoft Windows XP or Windows 2000 is installed, the program screens and icons may differ from these instructions.

### **001 - START**

- Power off the system unit.
- Remove all adapter cards.
- Connect a hard disk drive with pre-loaded Windows XP, Windows 2000 or the other operating system.
- Power on the system unit.
- Load default settings in setup (audio may be disabled).

### **002 - DO ANY POST MESSAGES, ERROR CODES, BEEPS, OR SYMPTOMS APPEAR? (YES, READ AHEAD. NO, GO TO STEP 003)**

- Go to "Index of Symptoms, Messages, Error Codes, or Beeps" on page 40.
- End.

### **003 - DO ANY MESSAGES OR ERROR CODES DISPLAY AFTER POST COMPLETES BUT BEFORE MICROSOFT Windows XP, Windows 2000, or the other operating system STARTS? (YES, READ AHEAD. NO, GO TO STEP 004)**

**NOTE:** If POST does not complete, answer this

question “No.”

- Ensure that the operation system is properly installed.
- End.

#### **004 -**

- Perform the following under Windows XP or Windows 2000.

**NOTE:** If an operating system other than Microsoft Windows XP or Windows 2000 is installed, the program screens and icons may differ from these instructions.

1. Start Microsoft Windows XP or Windows 2000.
2. Select the **Start** icon.
3. Select **Settings**, then select **Control Panel**.
4. Select the **Sound** icon.
5. In the Sound window, select chimes from the **Names** field. (To test other adapter card software, select an action from a menu in that software.)

#### **005 - IS THE PREVIEW BUTTON, OR ACTION IN OTHER SOFTWARE, SELECTABLE ON THE SCREEN (SHOWN IN BLACK AND NOT GRAY)? (YES, GO TO STEP 006. NO, READ AHEAD.)**

- Ensure that Windows XP, Windows 2000 or the other operating system is properly installed.
- Go to step 001.

#### **006 -**

- Select the Preview button from the Sound window.

#### **007 - DO YOU HEAR ANY SOUND FROM THE SPEAKER? (YES, READ AHEAD. NO, GO TO STEP 008.)**

- The audio feature is functioning normally. Click Cancel to close the dialog box. Exit Microsoft Windows XP or Windows 2000.
- If the symptom remains or has changed, go to “Index of Symptoms, Messages, Error Codes, or Beeps” on page 40.
- End.

**008 -**

- Make sure that the volume control is not turned low.
- Make sure that the speaker and its adapter are not damaged.
- Make sure that the speaker is plugged in speak-out jack. See “System Board Jumpers and Connectors” on page 117.
- If the error cannot be resolved, replace the system board.
- End.



---

## CD/DVD-ROM Drive

### 001 - START

- Run the Diagnostics program located in service partition.
- Select **Interactive Tests** menu, then select and execute **CD/DVD-ROM Test**.

### 002 - DO YOU SEE A MESSAGE “NO CD/DVD-ROM DRIVE OR MSCDEX DEVICE DRIVER INSTALLED.”? (YES, READ AHEAD. NO, GO TO 003.)

- Exit the diagnostics program and power off the system.
- Check and ensure that the CD/DVD-ROM drive power cable and audio and data cables are not damaged and are connected properly.
- Check and ensure that the CD/DVD-ROM drive driver is loaded correctly.
- Load default settings.

### 003 - DO THE TESTS OF OPEN/CLOSE TRAY BY DIAGNOSTICS PROGRAM AND BY DEPRESSING CD/DVD-ROM DRIVE BUTTON WORK? (YES, READ AHEAD. NO, GO TO STEP 006.)

- Load a known good data CD/DVD into the CD/DVD-ROM drive and try to read its content by typing DIR at DOS prompt.

### 004 - CAN A CD/DVD BE READ FROM THE CD/DVD-ROM DRIVE? (YES, THEN THE CD/DVD-ROM DRIVE FUNCTIONS NORMALLY. NO, READ AHEAD.)

- Try reading the CD/DVD with a known good CD/DVD-ROM drive.

**005 - IS THE CD/DVD STILL NOT READABLE?  
(YES, READ AHEAD. NO, GO TO STEP 006.)**

- Replace system board.
- End.

**006 -**

- Replace CD/DVD-ROM drive.
- End.

---

# Memory

## 001 - START

- Power off the system unit.
- Ensure that all DIMMs are installed correctly.
- Power on the system unit.
- Run the Diagnostics program located in service partition.
- Take note of any messages, error codes, or symptoms.

## 002 - DO YOU RECEIVE POST MEMORY ERROR MESSAGE? (YES, READ AHEAD. NO, GO TO STEP003)

- Enter Configuration/Setup Utility then reboot the system. Take note of any messages, error codes, or symptoms. If the error message remains, go to step 005.

## 003 -

- Follow the screen instructions to run the Memory test.

## 004 - DOES THE MEMORY TEST COMPLETE WITHOUT AN ERROR? (YES, READ AHEAD. NO, GO TO STEP005)

- The system memory is now functioning correctly. If you suspect an intermittent problem, run the Memory test again.
- End.

## 005 -

- Replace the defective DIMM based on the result of running Diagnostics program, with a known working DIMM of the same size and type.
- If the problem does not appear, it means that the last DIMM replaced is defective. If all DIMMs on the system board, have been replaced and the problem remains, replace system board.
- Go to step 001.

**NOTE:** If system board has no memory installed, you will hear L-L-S-S-S. (L: long beep, S: short

beep) beeps during POST.

---

# Keyboard

## **001 - START**

- Power off system unit and ensure the keyboard or receiver plug is connected properly.

## **002 -**

- Power on the system unit.
- Run the Diagnostics program located in service partition.
- Select Interactive Tests menu, then execute Keyboard test.

## **003 - DOES THE KEYBOARD FUNCTION CORRECTLY? (YES, READ AHEAD. NO, GO TO STEP 004.)**

- Keyboard is functioning normally.
- End.

## **004 - ARE THERE ANY STUCK KEYS OR ANY GRIME IN THE GAP OF KEYCAPS? (YES, READ AHEAD. NO, GO TO STEP 005.)**

- Power off the system unit. Carefully remove the grime and solve the stuck keys problem.
- Go to step 001.

## **005 - ARE THERE ANY BROKEN PINS IN THE KEYBOARD PLUG? (YES, GO TO STEP 007. NO, READ AHEAD.)**

- Try with a known good keyboard.

## **006 - DOES THE ERROR SYMPTOM STILL REMAIN? (YES, READ AHEAD. NO, GO TO STEP 007.)**

- Replace the system board.
- End.

## **007 -**

- Replace the keyboard.
- End.

---

## Mouse

**NOTE:** A sticking key button can cause the mouse to operate incorrectly. If you suspect this, go to “Keyboard” on page 69.

### 001 - START

- Make sure that the mouse ball turns freely.
- Make sure that the mouse plug connects properly.
- Make sure that the receiver connects properly and is able to receive signals for wireless mouse.

### 002 -

- Power off the system unit.
- Power on the system unit.
- Run the Diagnostics program located in service partition.
- Select Interactive Tests menu, then execute Mouse test.

### 003 - DO YOU SEE THE MOUSE CURSOR IN THE DIAGNOSTICS PROGRAM? (YES, READ AHEAD. NO, GO TO STEP 011)

- Test right (left) button and check if right (left) button works.

### 004 - DOES THE MOUSE BUTTON WORK? (YES, READ AHEAD. NO, GO TO STEP 007)

- Test mouse cursor movement.

### 005 - DOES THE MOUSE MOVE SMOOTHLY AND KEEP X AND Y COORDINATES CHANGED? (YES, READ AHEAD. NO, GO TO STEP 006)

- Mouse is functioning normally.
- End.

### 006 -

- Power off the system unit.
- Open mouse bottom cover and clean track ball.
- Readjust the receiver position or checking the receiver’s connection for wireless mouse.
- Go to step 002.

**007**

- Power off the system unit.
- Check the mouse or receiver plug.

**008 - ARE THERE ANY BROKEN PINS IN THE MOUSE PLUG? (YES, GO TO STEP 010. NO, READ AHEAD.)**

- Try with a known good mouse.

**009 - DO THE ERROR SYMPTOMS STILL REMAIN? (YES, READ AHEAD. NO, GO TO STEP 010.)**

- Replace the system board.
- End.

**010 -**

- Replace the mouse.
- End.

**011 -**

- Exit diagnostics program.
- Ensure that the mouse driver is properly installed.
- Go to step 002.

---

## Power Supply

### 001 - START

- Power off (unplug) the system unit. Check the power cord for continuity. Replace if necessary.
- Check for the correct line voltage from the power outlet, and verify that the voltage selector switch (if present) is set to the correct voltage.
- Power on the system unit.

### 002 - DOES THE POWER SUPPLY FAN RUN? (YES, GO TO STEP 003. NO, GO TO STEP 004.)

### 003 - DOES THE SYSTEM FAIL TO SHUT OFF WHEN THE ON/OFF SWITCH IS PRESSED? (YES, READ AHEAD. NO, GO TO STEP 005.)

- You might have a damaged on/off switch cable assembly.
- Disconnect the on/off switch cable assembly connector from the power supply connector and take an ohm reading.
- Go to step 007.

### 004 -

- Disconnect the power cord from the back of the system unit.
- Disconnect all power and switch cable connectors from the system board and the power supply.
- Disconnect the power connectors to all drives.
- Connect any one of the power connector to system board or drive as power load for driving up power supply.
- Reconnect the power cord and turn on the power supply.



**005 - DOES THE POWER SUPPLY FAN RUN?  
(YES, READ AHEAD. NO, GO TO STEP 009)**

- With the system powered on and the power supply fan running, check the voltages of the power supply connectors for the system board and all drive connectors, as shown in the following figures.

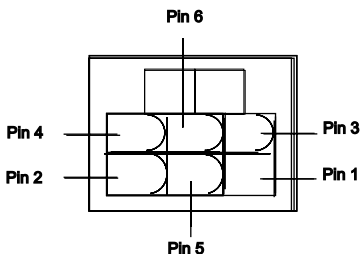

**006 - ARE THE VOLTAGES CORRECT AND DOES THE FAN RUN?  
(YES, READ AHEAD. NO, GO TO STEP 009.)**

- The power supply is working normally.
- If you suspect the on/off switch cable assembly, see Step 003.
- If the fan continues to run when all connectors are plugged back in, go to See “Undetermined Problems” on page 77.
- If the fan stops running when a drive connector is plugged back in, go to “Start” on page 35.

**007 - DO YOU HAVE AN OHM READING WHEN THE SWITCH IS PRESSED AND AN OPEN READING WHEN THE SWITCH IS RELEASED? (YES, READ AHEAD. NO, GO TO STEP 008.)**

- Replace the on/off switch cable assembly.

**008 -**

- Replace the system board.
- End.

**009 -**

- Replace the power supply.
- End.

---

## Monitor

First, set the system to VGA mode. To do this in Windows XP or Windows 2000, depress the F8 function key during startup. Safe mode (VGA) will be set for Windows XP or Windows 2000. Use the operating system's video setup to change the monitor resolution.

The monitors that come with the system are VESA Display Data Channel and DDWG DVI compliant. While starting Windows XP or Windows 2000, the DDC2 monitor passes resolution and frequency information to the system. The system interprets the data and sets up the proper refresh rate.

If the monitor type is set to the power saving mode, the screen remains black and the LED lights or flashes in amber color. When the monitor is turned on alone, or is turned on and connected to a powered-off system unit, the monitor LED blinks in amber color. Under the normal operating conditions, the LED lights in green color.

### 001 - START

- Power off the system unit and monitor.
- Remove all adapter cards.
- Make sure that the TFT LCD power connector is properly connected to the system board and monitor.
- Make sure that the power cords are properly connected to the system unit, and that the line voltage is correct.
- Make sure that the monitor contrast and brightness controls are not turned too low.
- Power on the system.
- Run the Diagnostics program located in service partition.

### 002 - IS THE SCREEN READABLE? (YES, READ AHEAD. NO, GO TO STEP 004)

**NOTE:** If the screen shows a blinking cursor with no memory count running, answer this question "No."

- Select Interactive Tests from the Main Menu.

- Select and execute Video test from the menu.
- Follow the prompts and perform the video test.
- Go to “Index of Symptoms, Messages, Error Codes, or Beeps” on page 40.
- You might have to adjust the monitor controls to obtain the best image.

**003 - DOES THE MONITOR SUCCESSFULLY PASS ALL TESTS? (YES, READ AHEAD. NO, GO TO STEP 004)**

- You have successfully completed the video diagnostics tests. If the problem remains, go to “Index of Symptoms, Messages, Error Codes, or Beeps” on page 40
- End.

**004 -**

- Power off the system unit.
- Remove the hard disk drive system cable.
- Power on the system unit.

**005 - IS THE SCREEN STILL NOT READABLE?**

- Replace the TFT LCD. If the symptom remains, replace the system board.
- End.

---

## Undetermined Problems

If an error code, error message or error beeps is present, go to “Index of Symptoms, Messages, Error Codes, or Beeps” on page 40. If you did not receive any messages, error codes, or beeps, see if the symptom is listed in “Table 2-3 Error Symptoms List” on page 47. If you still cannot solve the problem, continue with this check:

1. Check the power supply voltages (See “Power Brick Connectors and Voltages” on page 119). If the voltages are correct, return here and continue with the following steps:
2. Power off the system unit.
3. Perform the following checks, one by one, until you have isolated the problem FRU (refer to “Introduction” on page 116 for locations):
  - Load default settings in setup.
  - Check all system board jumper positions and switch settings.
  - Check all adapter card jumper positions.
  - Check all device jumper positions.
  - Check all cables and connectors for proper installation.
4. If the jumpers, switch, and voltage settings are correct, continue with the following steps:
  - Remove or disconnect the following, one at a time:
    - Non-IBM devices
    - External devices
    - Any adapter card (modem card or video card, if installed)
    - CD-ROM drive
    - Diskette drive
    - Hard disk drive
    - DIMM
    - Processor
    - System board
5. Power on the system unit.
6. Repeat steps 2 through 5 until you find the failing device or adapter.
7. If software related, reload software from Recovery CD.

8. If the symptom changes, go to “Index of Symptoms, Messages, Error Codes, or Beeps” on page 40 or to the check procedure for the last item tested.

Replace the last item tested if the system operates normally after removing the last item.

---

## Diagnostic Aids

Introduction .....	80
Power-On Self Test .....	81
Diagnostic Program .....	83
Using Diagnostic Program from Service Partition .....	83
Using Diagnostic Program from Recovery CD .....	84
Diagnostics Program Features .....	85

---

## **Introduction**

This section explains the diagnostic aids, power-on self test (POST) and diagnostics program (PC-Doctor), that are available for troubleshooting problems on the system.



---

## Power-On Self Test

Each time you power-on the system, the power-on self test (POST) is initiated. Several items are tested during POST, but are for the most part transparent to the user.

POST checks the following:

- CPU
- Cache Memory
- Hard Diskette Drive(s)
- Mouse
- Memory Size
- Memory Speed
- CD-ROM
- BIOS Version

To start POST, turn on the monitor and then the system unit. The following will happen:

1. The IBM Personal Computer logo will appear on the screen.
2. At this time one of two hot-keys may be used. The F1 key will cause the system Configuration/Setup Utility menu to appear. The Esc key will switch the graphical IBM logo screen to the traditional text-based system startup screen, which displays information of BIOS version, CPU, Hard Diskette Drive(s), CD-ROM, Mouse and system memory.
3. If an error is detected during POST, the IBM logo screen will automatically switch to the text-based screen and display the error message or code with a beep. Depending on the criticalness of the POST error, the system may halt and/or display the message "Press <F1> to enter to the Setup or <Esc> to continue..."
4. During the POST, press <F12>, a Boot Menu will appear. You can decide Boot options here or in system Configuration/Setup Utility menu, Startup sub-menu.

If this message appears, pressing the **Esc** key will allow the system to attempt to proceed despite the reported error; pressing **F1** will cause the system Configuration/Setup Utility menu to appear.

5. If no keyboard keys are pressed, and if POST is completed without errors, the system will then proceed with the loading of Windows ME, 2000, NT or the other operating system from a hard disk drive or diskette drive A or CD-ROM drive, depending on the Startup options selected in the Configuration/Setup Utility.

If any errors are detected by POST, there will be an error message accompanied with an error code shown on display screen and a beep. See “Index of Symptoms, Messages, Error Codes, or Beeps” on page 40 to find the most likely cause and countermeasure.

---

## Diagnostic Program

**WARNING:** This manual is intended to test the IBM Personal Computer Type 6274 and 2283 machine type only. Testing devices which are not included with the original product package, including other IBM products, prototype cards, or modifying hardware settings may give false errors and invalid system responses. The diagnostics not specifically made for this model may also report incorrect errors and information.

The diagnostics program can be run from the service partition or from the Recovery CD. This version of PC-Doctor diagnostics program, developed by Watergate for IBM, is the primary method of testing the computer. You can use it to test the IBM components of the system and some external devices. The amount of time required to test components depends on the number of components installed and selected. The more devices you have attached to your system and selected in PC-Doctor, the longer the testing will take.

### Using Diagnostic Program from Service Partition

1. Power-off the system unit.
2. Power-on the system unit.

**NOTE:** Do not press **F1** during POST. If any POST errors appear after POST, make a note of the errors.

3. After POST completes, press **F11**, before enter the operating system.
4. IBM Product Recovery program will load. Choose System utilities in Main menu, then Run diagnostics. Follow the screen instructions to operate.

## Using Diagnostic Program from Recovery CD

1. Insert the Personal Computer recovery CD into the CD-ROM drive then restart computer.
2. Press **F1** while POST to enter Configuration/Setup Utility menu. Select and enter Startup Sub-Menu, set the first priority of boot sequence to CD-ROM. Save and exit from Configuration/Setup Utility.
3. Reboot the system.
4. IBM Product Recovery program will load. Choose System utilities in Main menu, then Run diagnostics. Follow the screen instructions to operate.

## Diagnostics Program Features

Diagnostics program (PC-Doctor) DOS version includes the following features:

Table 3- 1 Diagnostic Program Main Menu Selections

Main Menu Selections	Submenu Selections
Diagnostics	<ul style="list-style-type: none"> <li>• Run Normal Test</li> <li>• Run Quick Test</li> <li>• CPU/Coprocessor</li> <li>• System board</li> <li>• Video Adapter</li> <li>• Serial Ports</li> <li>• Parallel Ports</li> <li>• Fixed Disks</li> <li>• Diskette Drive</li> <li>• Other Devices</li> <li>• Zip Drive</li> <li>• HiFD Drive</li> <li>• SCSI Fixed Disk</li> <li>• LS-120/240 Drive</li> <li>• CD-ROM/DVD Drive</li> <li>• Memory Test-Full</li> <li>• Memory Test-Quick</li> </ul>
Interactive Tests	<ul style="list-style-type: none"> <li>• Keyboard</li> <li>• Video</li> <li>• Internal Speaker</li> <li>• Mouse</li> <li>• Joystick Test</li> <li>• Diskette</li> <li>• System Load</li> <li>• Printer Test</li> <li>• SCSI Test</li> <li>• CD-ROM/DVD Test</li> <li>• Stereo Speaker</li> </ul>
Hardware Info	<ul style="list-style-type: none"> <li>• System Configuration</li> <li>• Memory Contents</li> <li>• IRQ and DMA Use</li> <li>• Device Drivers</li> <li>• COM and LPT Ports</li> <li>• Physical Disk Drives</li> <li>• Logical Disk Drives</li> </ul>

Table 3- 1 Diagnostic Program Main Menu Selections  
(Continued)

Main Menu Selections	Submenu Selections
Hardware Info	<ul style="list-style-type: none"> <li>• VGA Information</li> <li>• Software Interrupts</li> <li>• SCSI Devices</li> <li>• I/O Use</li> <li>• IDE Drive Info</li> <li>• PCI Information</li> <li>• PNPISA Information</li> <li>• SMBIOS Information</li> <li>• DIMM/RIMM Info</li> <li>• Asset EEPROM Info</li> </ul>
Utility	<ul style="list-style-type: none"> <li>• Run External Test</li> <li>• Surface Scan Hard Disk</li> <li>• Benchmark System</li> <li>• DOS Shell</li> <li>• Tech. Support Form</li> <li>• Select Languages</li> <li>• View Test Log</li> <li>• Print Log</li> <li>• Save Log</li> <li>• Full Erase Hard Drive</li> <li>• Quick Erase Hard Drive</li> <li>• Asset EEPROM Backup</li> <li>• View Stored Results</li> </ul>
Quit	<ul style="list-style-type: none"> <li>• Exit Diagnostics</li> <li>• Park HD</li> <li>• Reboot</li> <li>• About</li> </ul>

Diagnostics program (PC-Doctor) Windows version includes the following features:

Table 3- 1 Diagnostic Program Main Menu Selections

<b>Main Menu Selections</b>	<b>Submenu Selections</b>
Diagnostics	<ul style="list-style-type: none"><li>• CPU Test</li><li>• Hard Drive Test</li><li>• Floppy Test</li><li>• LS-120 Drive Test</li><li>• CD-ROM/DVD Test</li><li>• ZIP Drive Test</li><li>• Memory Test</li><li>• PCI Test</li><li>• Video Test</li><li>• AGP Test</li><li>• Modem Test</li><li>• SCSI Test</li><li>• IR Driver Test</li><li>• PCMCIA Test</li><li>• SMART Test</li><li>• SMART Test-Extended</li><li>• USB Test</li><li>• CMOS Test</li><li>• Keyboard Test</li><li>• AVI Video Test</li><li>• Microphone Test</li><li>• Audio Test</li><li>• Mouse Test</li><li>• Monitor Test</li><li>• Printer Test</li><li>• Joystick Test</li></ul>

Table 3- 1 Diagnostic Program Main Menu Selections  
(Continued)

Main Menu Selections	Submenu Selections
System Information	<ul style="list-style-type: none"> <li>• System Info</li> <li>• VGA Info</li> <li>• Drive Info</li> <li>• IDE Info</li> <li>• SMART Info</li> <li>• PCI Info</li> <li>• DMI Info</li> <li>• PC Card Info</li> <li>• Plug and Play</li> <li>• Multimedia Info</li> <li>• Memory Info</li> <li>• Module Info</li> <li>• Modem Info</li> <li>• Task Info</li> <li>• Virtual Drivers</li> <li>• COM Class Info</li> <li>• OLE Class Info</li> <li>• Class Info</li> <li>• SCSI Info</li> <li>• Extension Info</li> <li>• Interrupts</li> <li>• Statistics</li> <li>• USB Info</li> </ul>
Tools	<ul style="list-style-type: none"> <li>• MS Defrag</li> <li>• MS System Monitor</li> <li>• MS Resource Meter</li> <li>• MS Scandisk</li> </ul>



---

## Repair Information

Removals and Replacements .....	90
Handling ESD-Sensitive Parts .....	91
Cover.....	92
Hard Disk Drive .....	93
Optical Drive.....	95
Modem Card and Add-on Card .....	97
Memory(DIMM) .....	98
Intel Pentium 4 Willamette Processor .....	100
System Backup Battery .....	102
Inverter Board (15" LCD only) .....	103
System Board.....	106
TFT Subassembly .....	108
TouchPad Screen .....	111
Indicator LED and Cable .....	112
Speaker.....	113
LCD Panel.....	114

---

## Removals and Replacements

BEFORE REMOVING ANY FRU, POWER-OFF THE COMPUTER, UNPLUG ALL POWER CORDS FROM ELECTRICAL OUTLETS, THEN DISCONNECT ANY INTERCONNECTING CABLES.

**ATTENTION:** The system board, processors, adapter cards, DIMMs, and upgrade processors can be damaged by electrostatic discharge. Use an electrostatic discharge (ESD) strap to establish personal grounding. If you don't have an ESD strap, establish personal grounding by touching a ground point with one hand before touching the static-sensitive FRUs.

The arrows in the removals and replacements procedures show the direction of movement to remove a field-replaceable unit (FRU), to turn a screw, or the direction to press a tab to release the FRU.

Begin all removals by removing the cover (and rear cover, if applicable).

When other FRUs must be removed prior to removing the failing FRU, they are listed at the top of the page. Go to the removal procedure for each FRU listed, remove the FRU, and then continue with the removal of the failing FRU.

To replace a FRU, reverse the removal procedure and follow any notes that pertain to replacement.

Before disconnecting any cables, note their location and orientation. Reinstall any new FRUs with cabling in their original location.

---

## Handling ESD-Sensitive Parts

Many electronic parts are sensitive to electrostatic discharge (ESD). To prevent damage when working with ESD-sensitive parts, observe the following instructions. Do these in addition to taking all the usual precautions, such as switching off the power and unplugging the power cord.

- Keep the ESD-sensitive part in its original shipping container (or special ESD bag) until you are ready to install the part.
- Make the fewest possible movements with your body to prevent an increase of static electricity from clothing fibers, carpets, and furniture.
- Put the ESD wrist strap on your wrist. Ensure the machine is turned off. Connect the wrist strap to the serial bracket mounting screw. This discharges any static electricity in your body to the machine frame.
- Hold the ESD-sensitive part by its edge connector shroud (cover). Do not touch its pins. If you are removing a plug-able module, use the correct tools.
- Do not place the ESD-sensitive part on the machine cover or on a metal table. If you need to put down the ESD-sensitive part for any reason, put it into its original container.
- Machine covers and metal tables are electrical grounds. They increase the risk of damage because they make a discharge path from your body through the ESD-sensitive part. (Large metal objects can be discharge paths without being grounded.)
- Prevent ESD-sensitive parts from being accidentally touched by other persons. Reinstall machine covers when you are not working on the machine.
- If possible, keep all ESD-sensitive parts in a grounded metal cabinet.
- Be extra careful when working with ESD-sensitive parts while cold-weather heating is being used. Low humidity increases static electricity.

## Cover

- Press the two blue latches inward and lift up the cover.

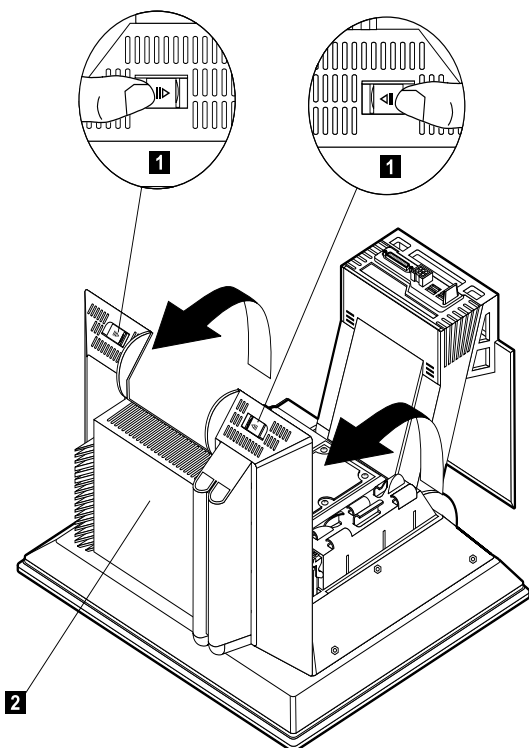

- Touch the bare metal frame of the system to dissipate any static electricity from your body (do not touch any of the components inside the frame until you have done this). Do not touch any component(s) with a voltage warning label.

### **NOTE:** Replacing the Cover

- To replace the cover, pressing in on the sides so the hooks inside the cover fit over the ledge of the cover. Slide the cover forward into place. Cover is secured when the two blue latches hooked with the system firmly. You hear a crispy clip when it's secured.

**CAUTION:** When you replace the cover, there are hooks inside the cover that help fit it to the tower.

## Hard Disk Drive

- Remove the IDE and power cables.
- Press the blue latch inward.
- Lift up the Hard Disk Drive chassis.
- Remove the cables.

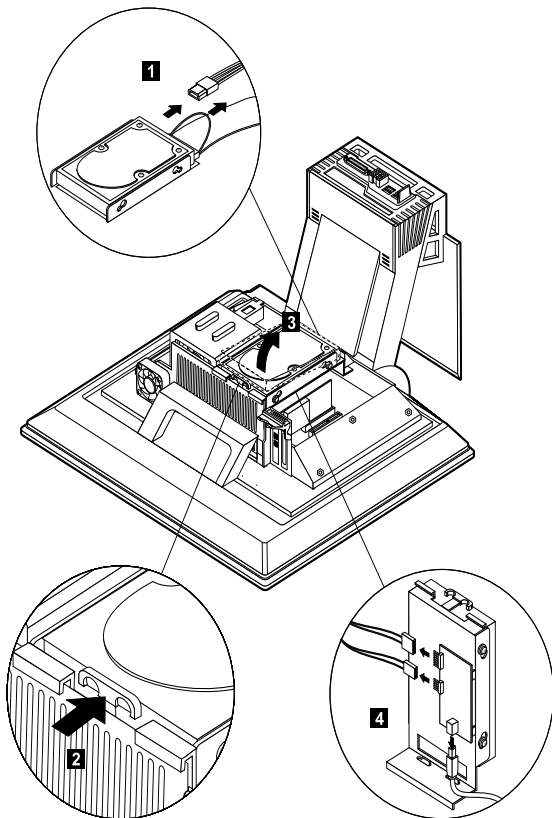

- Remove the screws.
- Pull out the drive.

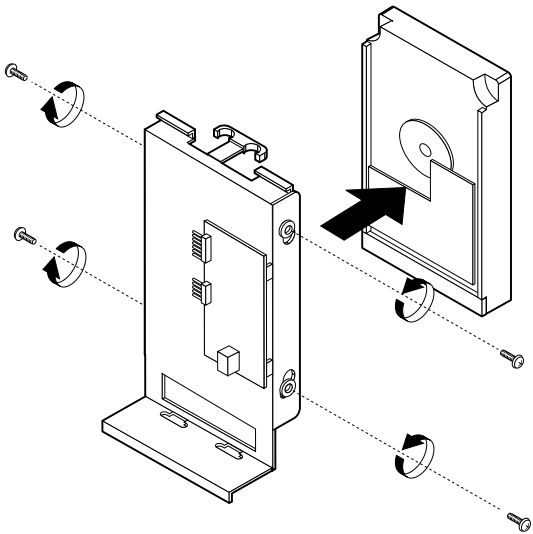

## Optical Drive

- Press the latch under the LCD inward, to lower the optical drive.

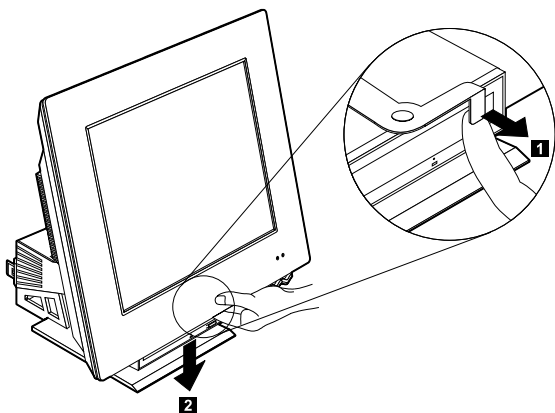

- Press the rear cover inward and backward at the same time.
- Remove the rear cover.
- Remove the optical drive cover.
- Remove all the IDE, power cable (using needle-nose pliers) and audio cable.
- Release the two black latches outward and press the optical drive forward.
- Remove the optical drive.

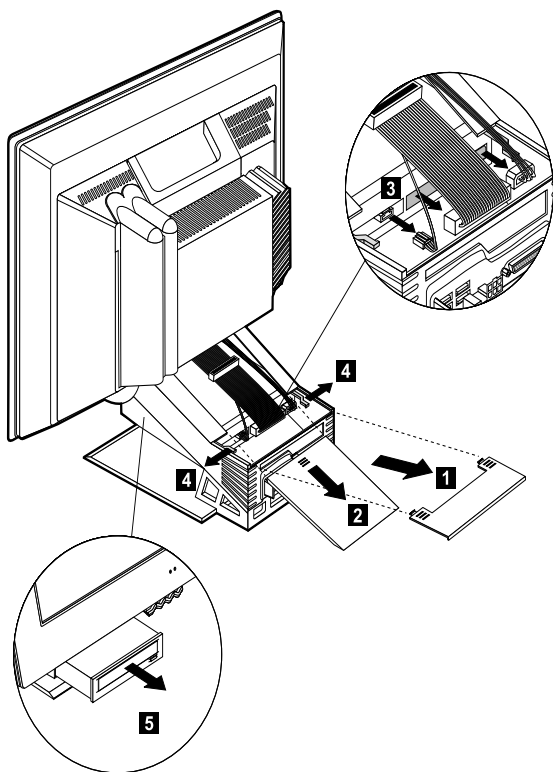



## Modem Card and Add-on Card

- Press the blue latch outward.
- Lift up the modem card or add-on card.

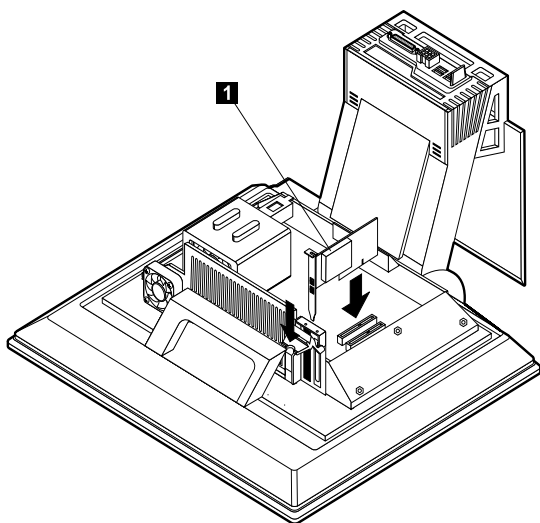

## Memory(DIMM)

Your computer has two connectors for dual in-line memory modules (DIMMs) that provide up to a maximum of 2 GB of system memory.

The IBM-installed DIMMs that come with your computer are ECC (error checking and correction) Synchronous Dynamic Random Access Memory (SDRAM) modules.

When installing or replacing DIMMs, take the following information into consideration:

- Each DIMM connector supports a maximum of 256 MB of memory.
- Install only ECC DIMMs to enable ECC. If you use ECC and non-ECC memory together, it will function as non-ECC memory.
- DIMM connectors do not support random in-line memory modules (DIMMs).

## Removing a DIMM

To remove a DIMM:

- 1.To locate the DIMM connectors inside your computer. There are located under the Hard Disk Drive.
- 2.At both ends of the DIMM connector on the system board, push outward on the retaining clips until the module is loosened. Lift the DIMM out of the connector.

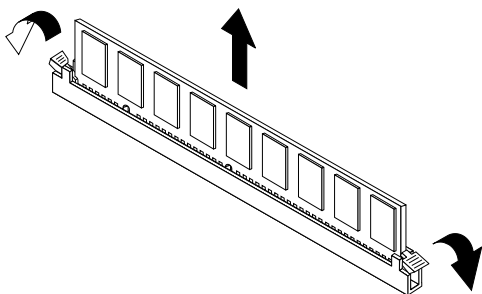

**NOTE:** Be careful not to push too hard on the retaining clips, because the DIMM might eject too quickly.

- 3.Store the DIMM in a static-protective package. Do not

discard or lose this part. It might be needed later if you change your memory configuration.

## Installing a DIMM

To install a DIMM:

1. Touch the static-protective package containing the DIMM to any unpainted metal surface in the computer, and then remove the DIMM.
2. If the retaining clips are not already open, open them.

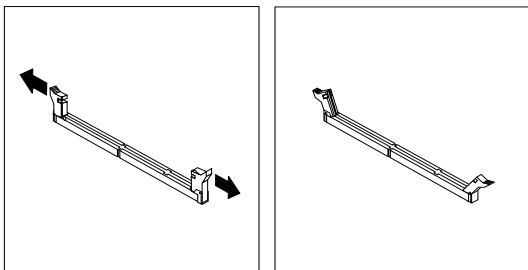

3. Position the DIMM above the connector so that the two notches on the bottom edge of the module align properly with the empty connector.
4. Firmly push the module straight down into the connector until the retaining clips pop up and fit snugly around both ends of the module.

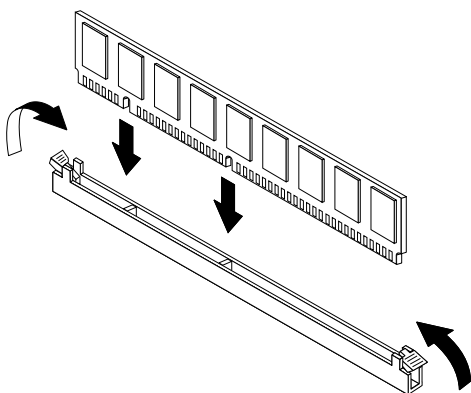

# Intel Pentium 4 Willamette Processor

**NOTE:** Determine the type of processor you are installing and make sure the jumpers are set correctly. Run the Configuration/Setup Utility after correctly installing a processor.

**CAUTION:** Processors are sensitive to static discharge.

- Detach the fan cable from the fan connector.
- Remove the CPU fan.
- Remove the two screws.
- Remove the CPU heat sink.
- Lift up the bar securing the CPU.
- Remove the CPU from the system.

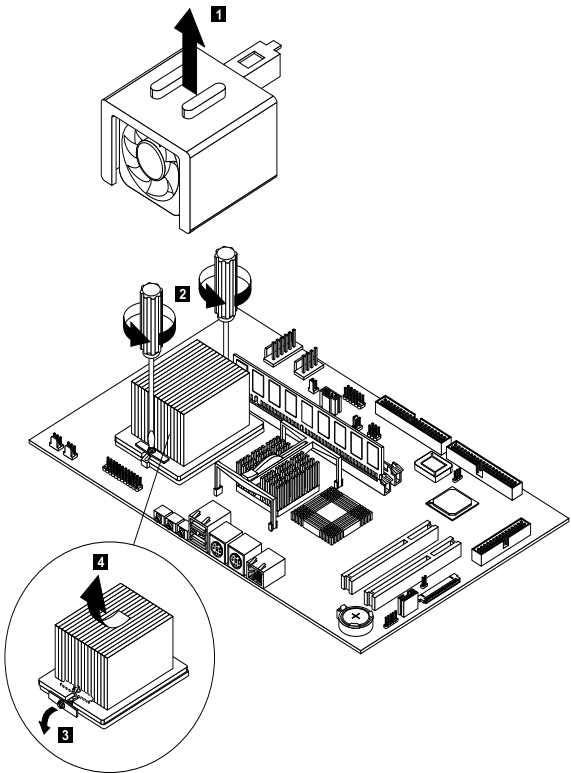

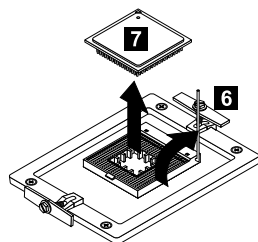
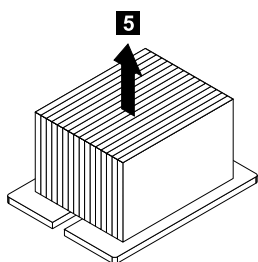

## System Backup Battery

**CAUTION:** All BIOS configuration settings will be lost when the backup battery is removed!

**ATTENTION:** Be careful when removing the backup battery. If the metal lever is damaged or broken, the system board must be replaced.

- Gently pull the metal lever away from the backup battery.
- Lift the backup battery out.

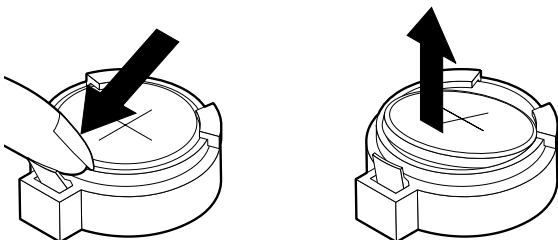

**IMPORTANT:** Make sure to insert the battery with the positive side facing up. A plus(+) sign indicates the positive side.

- If you replace the system battery, you need to reset the system date and time. You can perform this task from the Windows 2000, NT, XP desktop or from the Configuration/Setup Utility. To reset the system date and time in the Configuration/Setup Utility, select the Main Menu.

## Inverter Board (15" LCD only).

- Loose the thumb screw secured the bracket.

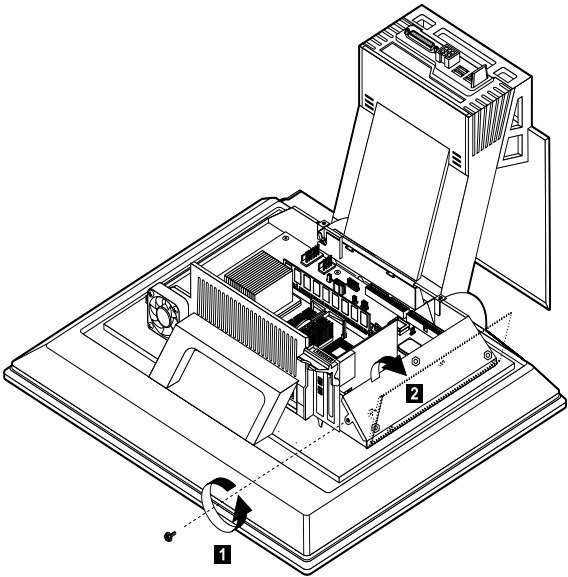

- Turn the inverter board module outward.
- Disconnect all cables connected to the inverter board. Note the location and orientation of all cables.
- Remove the inverter board module from the system.

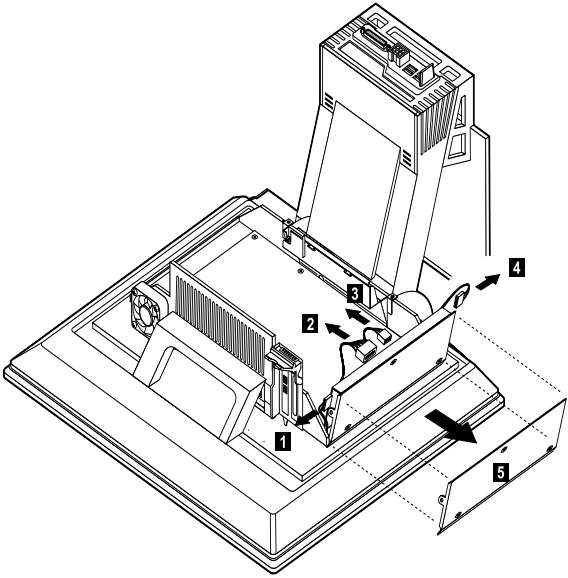

- Remove the three screws secured the inverter board.
- Remove the inverter board.



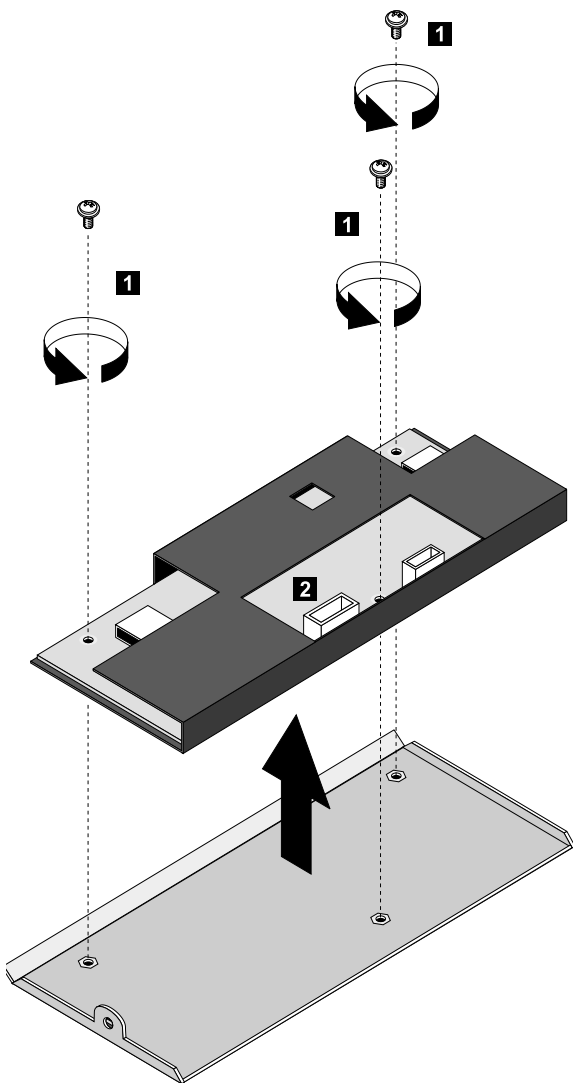

## System Board

- Remove all adapter cards.
- Disconnect all cables connected to the system board. Note the location and orientation of all cables.
- Remove the five screws securing the system board to the chassis.

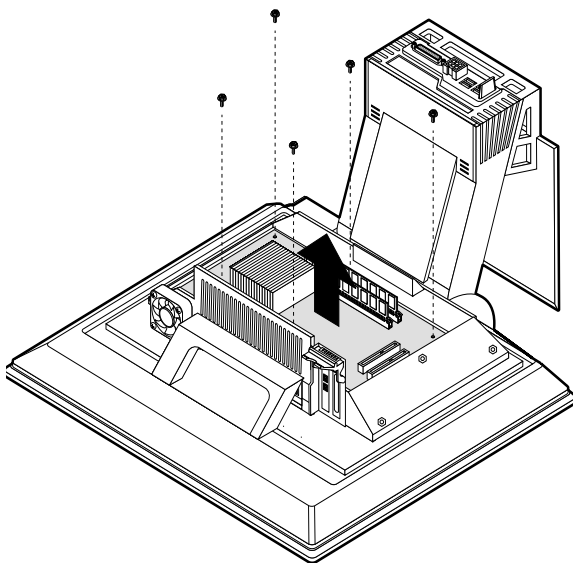

- Lift the system board to remove from chassis.
- Remove memory (DIMM) if applicable.
- Remove processor if necessary.

### **NOTE:** System Board Installation

- Before reinstallation, position the housing on its side. When installing a new system board, push the board to the rear and align it with the front locating pin. Visually verify that the board is aligned properly, then press the board down.
- Be sure to reinstall the processor, DIMMs, I/O port bracket onto the new system board if applicable.
- After installing the system board, secure with original screws.

- Change all jumper settings to match those of the original board.
- Reinstall other components into the machine i.e. drives, power supply, cables, etc.
- Upgrade the BIOS version on the new system board using the BIOS upgrade utility.
- Change the Machine Type and Serial Number in the BIOS to match the original planar BIOS settings.
- Reboot the system and run the Configuration/Setup Utility.

## TFT Subassembly

- Loose the thumb screw secured the bracket.

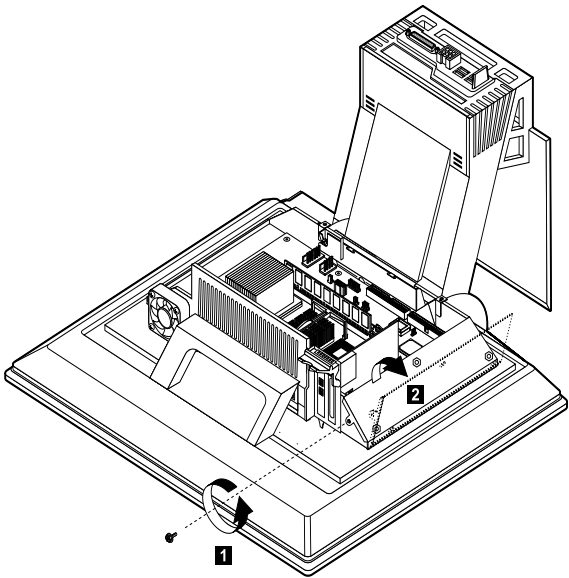

- Turn the inverter board module outward.
- Disconnect all cables connected to the inverter board. Note the location and orientation of all cables.
- Remove the inverter board module from the system.

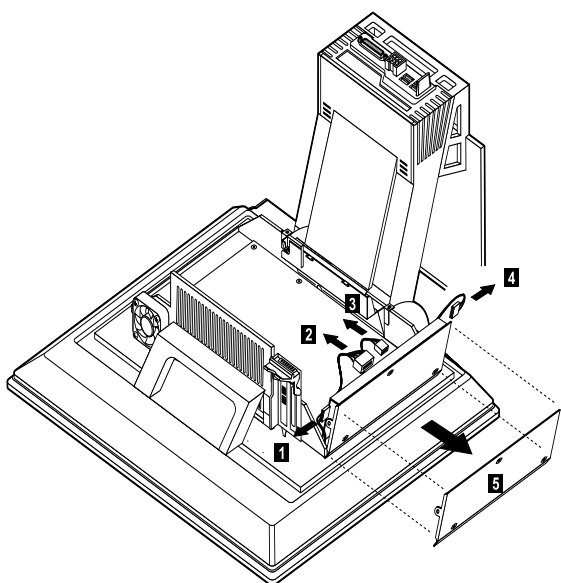

- Unplugging of TFT related cables to the motherboard board.
- Remove the thumb screw between the system chassis and TFT subassembly.

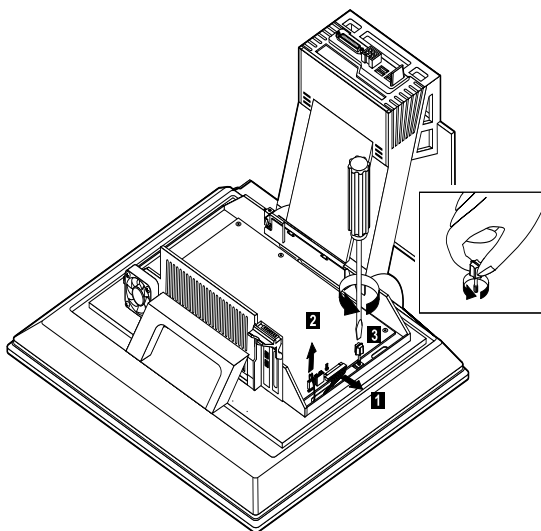

- Releasing TFT subassembly from latching

- Releasing TFT subassembly from latching mechanism in system chassis by first sliding leftward then upward while routing cables thru appropriate cable access holes in the system chassis.

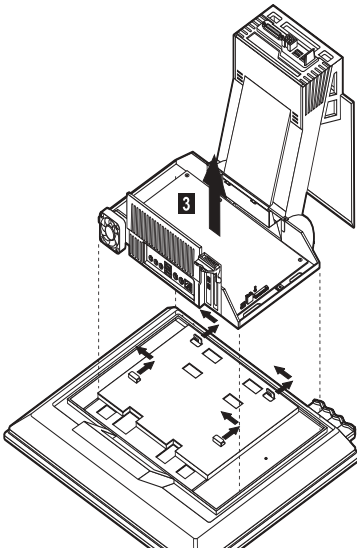
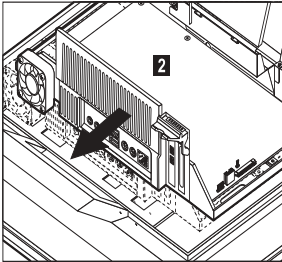
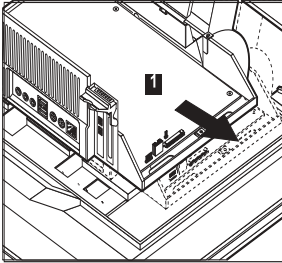

## TouchPad Screen

- Remove the five screws.
- Separate the LCD panel from front cover.
- Remove the touchpad screen from front cover.

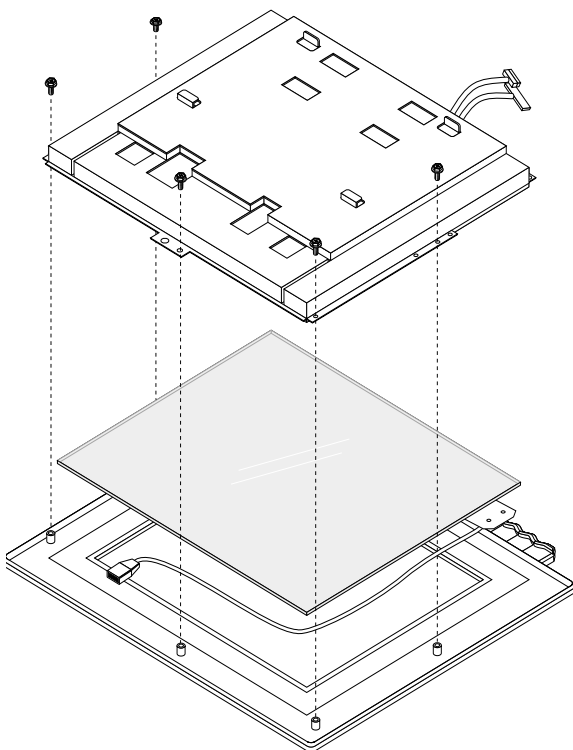

## Indicator LED and Cable

- Remove the two screws.
- Remove the cable.
- Remove the LED board.

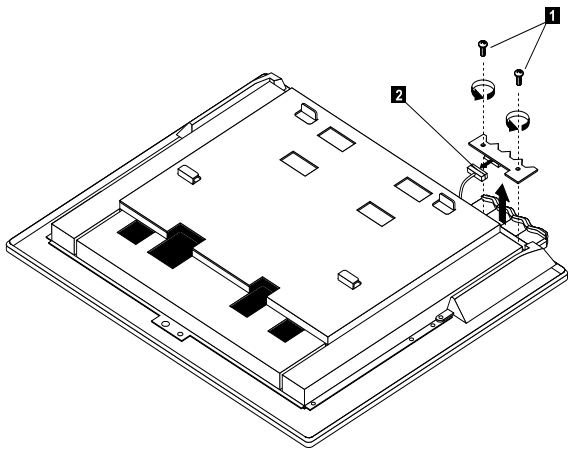



## Speaker

- Remove the two screws.
- Remove the speakers.

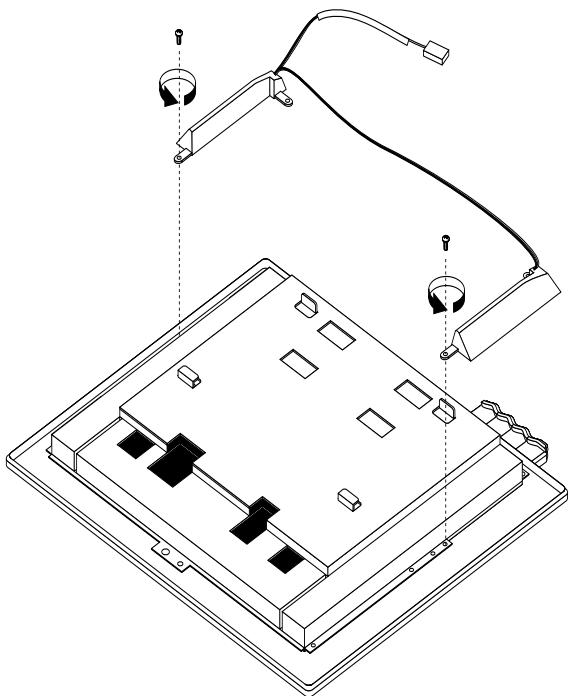

## LCD Panel

- Remove the five screws.
- Remove the LCD bracket.
- Remove the two boards secured in the back of LCD panel.
- Remove the LCD panel.

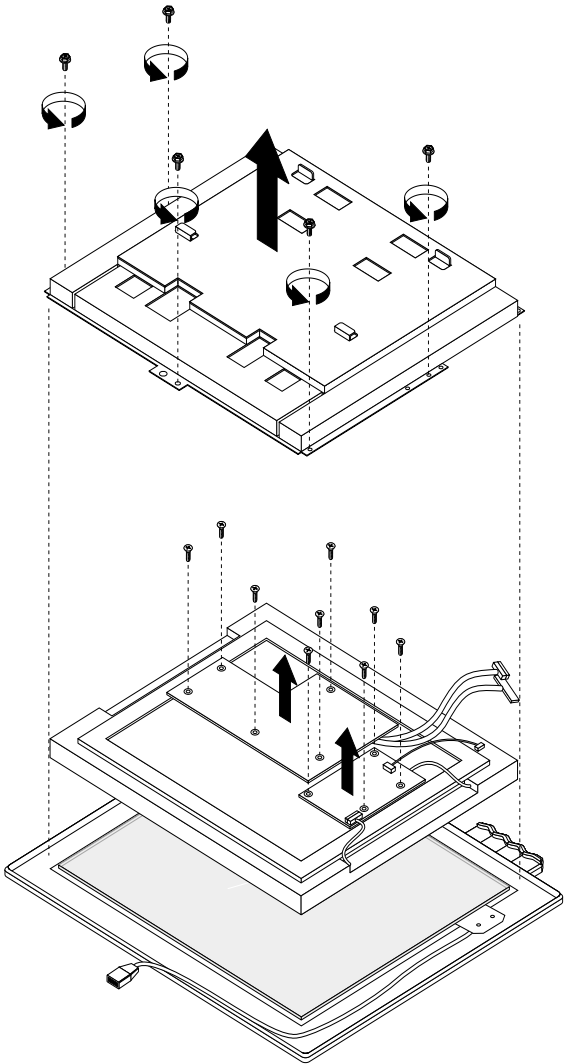

---

## Parts/Test Point Locations

Introduction .....	116
System Board Jumpers and Connectors .....	117
Power Brick Connectors and Voltages .....	119
Factory-Installed Modem Card Layout .....	120
3.5-In. Hard Disk Drive Jumper Settings .....	121
CD-ROM Drive .....	123
CD-ROM Drive Rear Panel Connectors and Jumpers .....	125
CD-ROM R/W Drive .....	126
CD-ROM R/W Drive Rear Panel Connectors and Jumpers .....	127
DVD-ROM Drive .....	128
DVD-ROM Drive Rear Panel Connectors and Jumpers .....	129
DIMM Configurations .....	130
System Board Connector Pin Signals .....	131
Monitor Port Signals .....	131
Parallel Port Signals .....	132
Mouse Port Signals .....	132
Keyboard Port Signals .....	132
IDE Cable Connector Signals .....	133

---

## **Introduction**

This chapter contains system board layouts and jumper settings. It is useful when you are asked to measure voltages. Use this information to help you locate parts such as electronic boards, connectors, pin numbers, and test points. This chapter also contains jumper settings for the hard disk drive, CD-ROM, and the connector information for modem adapter card.

# System Board Jumpers and Connectors

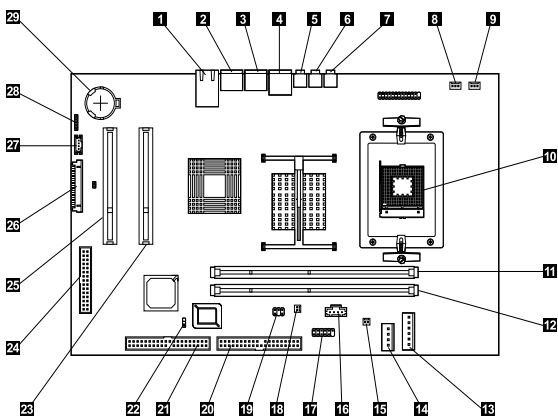

**NOTE:** The blackened pin of a jumper represents pin 1.

## System Board Jumper Settings

Jumper/Settings	Function
JP33	CMOS Setup
1-2	*Normal
2-3	Clear CMOS

## System Board Connector Functions

Number	Jumper	Function	Connect to...
1	J17	LAN RJ-45 connector	LAN cable
2	J24	PS/2 mouse connector	PS/2 mouse
3	J23	PS/2 keyboard connector	PS/2 keyboard
4	J1	USB connector (2)	USB devices
5	J30	Line-in connector	Input device
6	J26	Line-out connector	Output device

## System Board Connector Functions

7	J5	Microphone connector	Microphone
8	J19	CPU fan connector	CPU fan
9	J22	System fan connector	System fan
10		Microprocessor connector	CPU
11		DIMM socket	DIMM
12		DIMM socket	DIMM
13	J12	Main power connector	Power brick
14	J29	HDD/CD-ROM power connector	HDD, CD-ROM, DVD-ROM, or CD-RW
15	J14	Solenoid connector	Solenoid
16	J7	Audio input connector	CD-ROM, DVD-ROM or CD-RW
17	J3	COM1 port connector	COM1 devices
18	J21	Touch panel power connector	Touch panel
19	J8	Touch panel signal connector	Touch panel
20	J11	USB/Printer port connector	USB device and printer
21	J10	IDE connector	IDE devices
22	J33	CMOS setup	
23		PCI expansion slot	
24	J16	POV card connector	POV card
25		PCI expansion slot	
26	J2	TMDS connector	
27	J20	TMDS signal	TFT LCD
28	J4	Internal speaker connector	Speaker

**NOTE:** The white corner of the jumper block represents pin 1.

## Power Brick Connectors and Voltages

Refer to the following figures when checking for voltages on power brick cable connectors.

When checking voltages, the power brick fan must be running. To power-on the power brick without using the on/off switch, use a screwdriver or other tool to short the connector, or use a connection (jumper) to short the 6-pin connectors on power brick.

6-pin Power Connector

+12V Power Connector

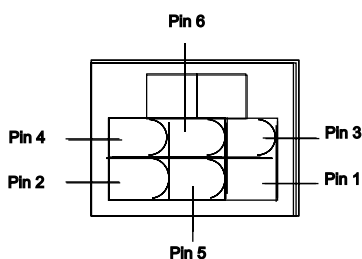

Cable side view

### Power Brick Output Pin Assignment

Pin	Voltage	Cable Color
1	12V	Black (Inside Red)
2	12V	Black (Inside Red)
3	12V	Black (Inside Red)
4	Ground	Black (Inside Black)
5	Ground	Black (Inside Black)
6	Ground	Black (Inside Black)

# Factory-Installed Modem Card Layout

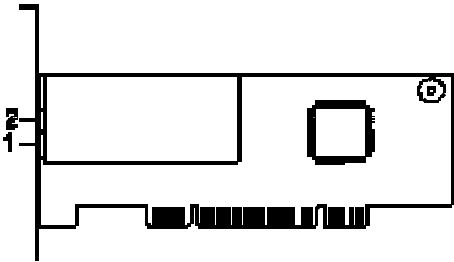

GVC Factory-Installed Modem Card Connector

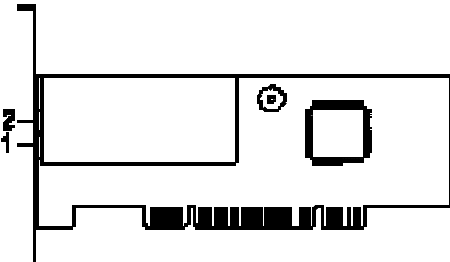

ASKEY Factory-Installed Modem Card Connector Functions

Item	Function	Connect to...
1	Telephone	Telephone set
2	Line Some modem adapters may come without this jack.	Telephone line



## 3.5-In. Hard Disk Drive Jumper Settings

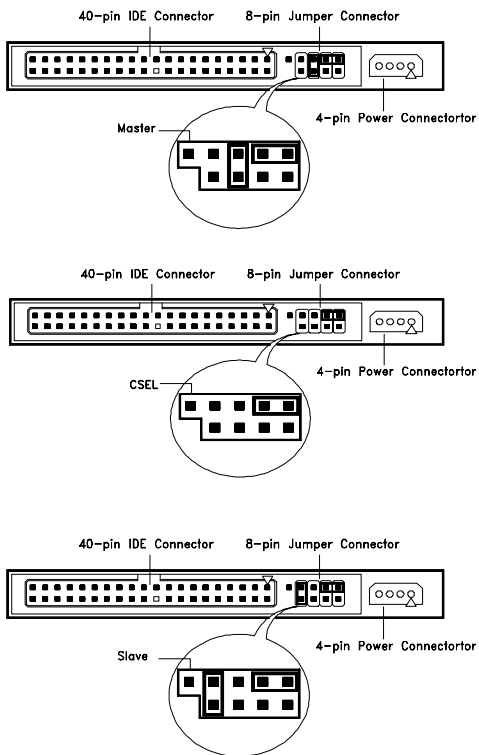

### 3.5-In IBM Hard Disk

The configuration of the following jumpers control the drive's mode of operation:

- Master
- Slave
- CSEL - Cable Select

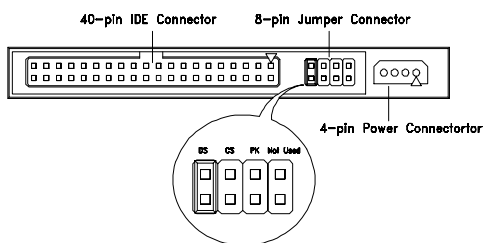

### 3.5-In Quantum Fireball Series Hard Disk

The configuration of the following jumpers control the drive's mode of operation:

- DS - Drive Select (For Master only)
- CS - Cable Select
- PK - Park, used as a place to store a jumper

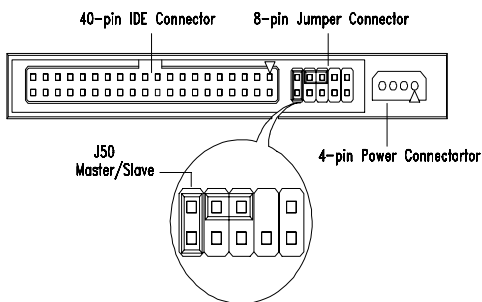

### 3.5-In Maxtor Hard Disk

#### 3.5-In Maxtor Hard Disk Drive Jumper Settings

J50	Description
On	Drive configured as Master or Drive configured as Master, with an attached Slave
Off	Drive configured as Slave.

---

## CD-ROM Drive

**ATTENTION:** Either <option 1> or <option 2> CD-ROM drive may come with your machine. Their front panel buttons, indicators and emergency eject method may be different.

Lite-On

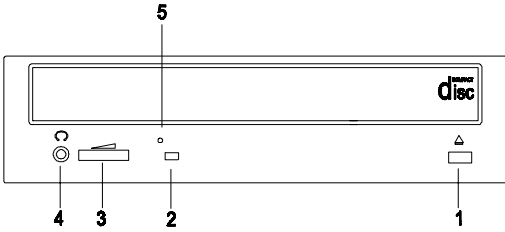

## CD-ROM Front Panel Introduction

Item	Description
1	Load / eject button
2	Headphone jack
3	Power-on / busy indicator, lights up in green color when the drive is mounting a disc or performing a read, seek, or play operation; lights up and flashes in amber color during data read or seek operation.
4	Headphone volume control
5	Emergency eject hole. See CD-ROM Emergency-Eject below. Disc tray and Emergency Eject .

### CD-ROM Emergency-Eject

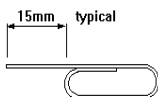

If for any reason the tray does not eject automatically, insert and press an eject-bar inside the emergency eject hole to manually eject the tray. A straightened paper clip with a diameter of 1.2 mm (typical) can be used as an eject-bar.

**ATTENTION:** Make sure to turn off the power before manual disc eject operation.

# CD-ROM Drive Rear Panel Connectors and Jumpers

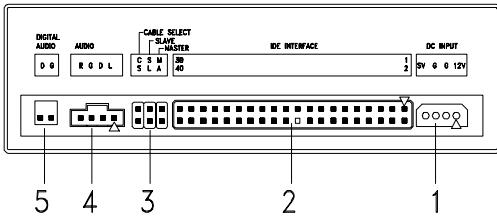

**NOTE:** CD-ROM drives may come with item no. 5 (digital audio output) connectors.

## CD-ROM Drive Rear Panel Connectors and Jumpers

Item	Function	Connect to...																
1	Power brick connector	J29																
2	Interface connector	System board																
3	Configuration jumper. <table border="0" style="margin-left: 20px;"> <tr> <td><u>CS</u></td> <td><u>SL</u></td> <td><u>MA</u></td> <td><u>Description</u></td> </tr> <tr> <td>--</td> <td>--</td> <td>On</td> <td>Master</td> </tr> <tr> <td>--</td> <td>On</td> <td>--</td> <td>Slave (default)</td> </tr> <tr> <td>On</td> <td>--</td> <td>--</td> <td>Cable select</td> </tr> </table>	<u>CS</u>	<u>SL</u>	<u>MA</u>	<u>Description</u>	--	--	On	Master	--	On	--	Slave (default)	On	--	--	Cable select	--
<u>CS</u>	<u>SL</u>	<u>MA</u>	<u>Description</u>															
--	--	On	Master															
--	On	--	Slave (default)															
On	--	--	Cable select															
4	Audio line out connector	System board																
5	Digital audio output	--																

---

## CD-ROM R/W Drive

**ATTENTION:** Either <option 1> or <option 2> CD-ROM R/W drive may come with your Personal Computer. Their front panel buttons, indicators and emergency eject methods may be different.

LG

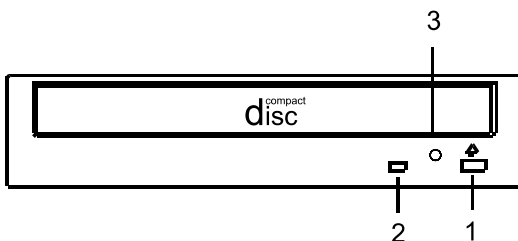

### CD-ROM R/W Front Panel Introduction

Item	Description
1	Load / eject button
2	Power-on / busy indicator, lights up in green color while disc is in ready state; lights up and flashes in amber color during data read or seek operation.
3	Emergency eject hole. See "CD-ROM Emergency-Eject" on page 124 Disc tray and emergency eject .

# CD-ROM R/W Drive Rear Panel Connectors and Jumpers

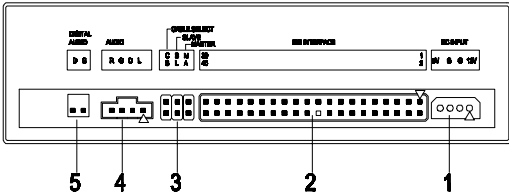

**NOTE:** CD-ROM R/W drives may come with item no. 5 (digital audio output and testing jumper) connectors.

## CD-ROM R/W Drive Rear Panel Connectors and Jumpers

Item	Function	Connect to...																
1	Power brick connector	J29																
2	Interface connector	System board																
3	Configuration jumper. <table border="1" style="width: 100%; border-collapse: collapse;"> <thead> <tr> <th><u>CS</u></th> <th><u>SL</u></th> <th><u>MA</u></th> <th><u>Description</u></th> </tr> </thead> <tbody> <tr> <td>--</td> <td>--</td> <td>On</td> <td>Master</td> </tr> <tr> <td>--</td> <td>On</td> <td>--</td> <td>Slave (default)</td> </tr> <tr> <td>On</td> <td>--</td> <td>--</td> <td>Cable select</td> </tr> </tbody> </table>	<u>CS</u>	<u>SL</u>	<u>MA</u>	<u>Description</u>	--	--	On	Master	--	On	--	Slave (default)	On	--	--	Cable select	--
<u>CS</u>	<u>SL</u>	<u>MA</u>	<u>Description</u>															
--	--	On	Master															
--	On	--	Slave (default)															
On	--	--	Cable select															
4	Audio line out connector	Depends on sound card																
5	Digital audio output	--																

## DVD-ROM Drive

### Front Panel and Emergency-Eject

Hitachi

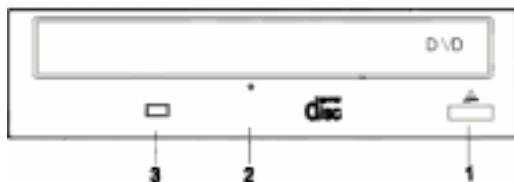

#### DVD-ROM Front Panel Introduction

Item	Description
1	Open/Close Button
2	Emergency eject hole. See "CD-ROM Emergency-Eject" on page 124. Disc tray and emergency eject
3	Disc Indicator



# DVD-ROM Drive Rear Panel Connectors and Jumpers

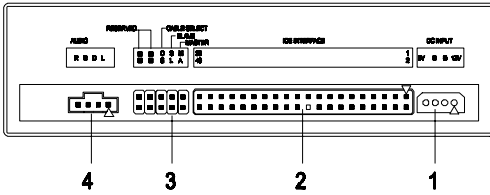

## DVD-ROM Drive Rear Panel Connectors and Jumpers

Item	Function	Connect to...																								
1	Power connector	J29																								
2	IDE Interface connector	System board CN12																								
3	Configuration jumper. <table border="1" style="width: 100%; border-collapse: collapse;"> <thead> <tr> <th>RD<sup>a</sup></th> <th>RD</th> <th>CS</th> <th>SL</th> <th>MA</th> <th>Description</th> </tr> </thead> <tbody> <tr> <td>--</td> <td>--</td> <td>--</td> <td>--</td> <td>On</td> <td>Master</td> </tr> <tr> <td>--</td> <td>--</td> <td>--</td> <td>On</td> <td>--</td> <td>Slave(default)</td> </tr> <tr> <td>--</td> <td>--</td> <td>On</td> <td>--</td> <td>--</td> <td>Cable select</td> </tr> </tbody> </table>	RD <sup>a</sup>	RD	CS	SL	MA	Description	--	--	--	--	On	Master	--	--	--	On	--	Slave(default)	--	--	On	--	--	Cable select	--
RD <sup>a</sup>	RD	CS	SL	MA	Description																					
--	--	--	--	On	Master																					
--	--	--	On	--	Slave(default)																					
--	--	On	--	--	Cable select																					
4	Audio Out	Depended on sound card																								

- a. RD -- Configuration jumper (RD indicates Reserved)

---

## DIMM Configurations

The system board has two DIMM sockets. A maximum of 2GB memory may be installed. You can install 64MB, 128MB, 256MB, or 512MB, PC-100/PC-133 DIMM in any sockets and with any combinations.

**NOTE:** Some system boards require that DIMM socket number one be occupied. If after installing memory the system does not boot successfully and both DIMM sockets are not occupied, switch the DIMM to the unoccupied socket and reboot the system.

# System Board Connector Pin Signals

## Monitor Port Signals

Pin	Signal Name	I/O	Pin	Signal Name	I/O
1	Red Video	O	9	+5 V dc	
2	Green Video	O	10	Synch Ground	
3	Blue Video	O	11	Monitor ID Bit 0	
4	Monitor ID Bit 2	I	12	SDA	I
5	Synch Ground		13	Horizontal Synch	O
6	Red Ground		14	Vertical Synch	O
7	Green Ground		15	SCL	I
8	Blue Ground				

## Parallel Port Signals

Pin	Signal Name	I/O	Pin	Signal Name	I/O
1	Strobe	O	14	Auto Feed	N/A
2	Data Bit 0	I/O	15	Error	I
3	Data Bit 1	I/O	16	Initialize	O
4	Data Bit 2	I/O	17	Select (In)	O
5	Data Bit 3	I/O	18	Ground	P
6	Data Bit 4	I/O	19	Ground	Power
7	Data Bit 5	I/O	20	Ground	Power
8	Data Bit 6	I/O	21	Ground	Power
9	Data Bit 7	I/O	22	Ground	Power
10	Acknowledge	I	23	Ground	Power
11	Busy	I	24	Ground	Power
12	Paper Empty	I	25	Ground	Power
13	Select	O	--	--	--

## Mouse Port Signals

Pin	Signal Name	I/O	Pin	Signal Name	I/O
1	Mouse Data	I/O	4	+5 V dc	Power
2	No Connection	--	5	Mouse Clock	I/O
3	Ground	Power	6	No Connection	--

## Keyboard Port Signals

Pin	Signal Name	I/O	Pin	Signal Name	I/O
1	Data	I/O	4	+5 V dc	Power
2	No Connection		5	Clock	I/O
3	Ground	Power	6	No Connection	--

## IDE Cable Connector Signals

Pin	Signal Name	I/O	Pin	Signal Name	I/O
1	Device Reset	I/O	21	DMARQ (DMA ReQuest)	I
2	Ground		22	Ground	
3	Data 7	I/O	23	Device IOW	I/O
4	Data 8	I/O	24	Ground	
5	Data 6	I/O	25	Device IOR	I/O
6	Data 9	I/O	26	Ground	
7	Data 5	I/O	27	I/O Channel Ready	I
8	Data 10	I/O	28	No Connection	
9	Data 4	I/O	29	DMACK (DMA aCKnowled ge)	O
10	Data 11	I/O	30	Ground	
11	Data 3	I/O	31	INTRQ (INTerrupt ReQuest)	I
12	Data 12	I/O	32	No Connection	
13	Data 2	I/O	33	Device A1	I/O
14	Data 13	I/O	34	No Connection	
15	Data 1	I/O	35	Device A0	I/O
16	Data 14	I/O	36	Device A2	I/O
17	Data 0	I/O	37	Device CS0	I/O
18	Data 15	I/O	38	Device CS1	I/O
19	Ground		39	DRIVE ACTIVE bar (Drive Active/Slave Present)	I
20	No Connection		40	Ground	



---

# Safety Inspection Guide

General Guidelines ..... 136

---

## General Guidelines

The purpose of this Safety Inspection Guide is to help you identify possible unsafe conditions on machines that are being inspected for a Maintenance Agreement. Each machine has necessary functions items installed to provide the operators and service personnel with an acceptable level of safety. This guide lists only these items. Good judgment should be used to identify possible safety conditions not covered by this Safety Inspection Guide.

If any unsafe conditions are present, you must find out how serious the hazard is and if you can continue before you correct the hazard.

All current IBM Personal Computer service supplements outlining feature/model changes, along with the machine history, should be reviewed.

Check the following items:

- Damaged, missing, or changed parts, especially in the area of the On/Off switch and the power supply.
- Damaged, missing, or changed covers.
- Possible safety exposure from any non-IBM attachments.



---

## 2283 Parts Catalog

Abbreviations .....	138
System Assembly .....	139
Assembly 1: System Unit .....	139
Assembly 2: LCD .....	141
Assembly 3: Diskette and Hard Drive .....	143
Assembly 4: Optical Drive, Adapter Card and Speaker .....	144
Assembly 5: Power Cord.....	145
Assembly 6: Keyboard and Mouse .....	146
Assembly 7: Recovery CD .....	150

---

## Abbreviations

In this chapter, the following abbreviations are used to identify country and language version:

<b>Country</b>	<b>Language Version</b>
AT	Austria
AU	Australia
BD	Belgium - Dutch
BF	Belgium - French
CA	Canada
CE	Canada - English
CF	Canada - French
CN	China
DK	Denmark - Danish
FI	Finland - Finnish
FR	France
GE	Germany
HK	Hong Kong
IT	Italy
JP	Japan
LS	LA-Spanish
ND	Netherlands - Dutch
NL	Netherlands - Dutch
NO	Norway - Norwegian
SF	Swiss - French
SG	Swiss - German
SP	Spain
SW	Sweden - Swedish
TW	Taiwan
UK	United Kingdom
US	United States
SZ	Switzerland

# System Assembly

## Assembly 1: System Unit

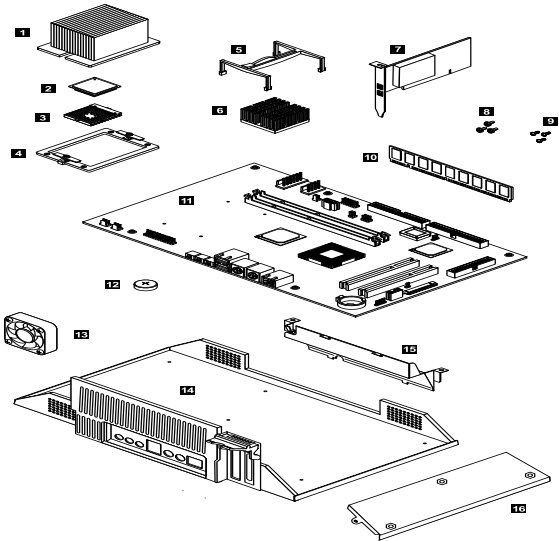

Asm-Index	FRU Number	Description
1-11	24P6101	IBM MONTECRISTO MOTHERBOARD
1-11	24P6102	IBM MONTECRISTO MOTHERBOARD W/ POV
1-2	25P5040	mPGA478 PENTIUM 4 1.5 GHZ
1-2	25P5114	mPGA478 Pentium 4 1.6 GHZ
1-2	25P5115	mPGA478 Pentium 4 1.8 GHZ
1-10	10K0058	128MB NP 133MHZ
1-10	10K0060	256MB NP 133MHZ
1-NS	32P3248	REAR BUCKET ASM W/EMC SHIELD AND LATCHES
1-NS	32P3250	BAFFLE/FAN ASM
1-NS	32P3257	BUTTON CONTROL ASM
1-14	32P3254	MAIN CHASIS
1-NS	32P3252	PLANAR I/O EMC SHIELD AND PCI LATCH
1-NS	32P3261	KEY LOCK

<b>Asm-Index</b>	<b>FRU Number</b>	<b>Description</b>
1-1	32P3253	FRU - HEAT SINK (1.3 - 1.8 GHz)
1-NS	32P3262	POWER CABLE AND USB TOUCH CABLE KIT (FOR TOUCH PANEL CONTROL CARD)
1-NS	32P3267	INTERNAL POWER CABLE ASM
1-NS	32P3259	SCUBA TANKS
1-NS	32P3338	THROAT PLATE (HOLDS HDD IN PLACE)
1-NS	32P3341	BASE COVER KIT
1-NS	32P3342	SOLENOID (DROPS OPTICAL DRIVE BAY) INCLUDES TWO SCREWS
1-13	32P3344	FAN, 50x15MM (INCLUDES 2 RUBBER ISOLATION MOUNTS)
1-13	32P3345	FAN, 60x15MM (INCLUDES 2 RUBBER ISOLATION MOUNTS)
1-NS	09K9827	C2 SWITCH
1-NS	03K9654	RF ANTENNA
1-NS	24P6869	160W POWER BRICK (15" & 17") W/ PFC
1-NS	32P3249	HANDLE KIT FOR 15" & 17" (INCLUDES HANDLE/MOUNTING BRACKETS/SCREWS)
1-NS	32P3391	BRACKET
1-NS	32P3343	DAUGHTER CARD, POWER/USB PARALLEL PORT CONNECTOR KIT
1-NS	32P3258	SCREW PACK
1-NS	19K2965	GVC/ASKEY LP US 56K MODEM
1-NS	19K2963	GVC/ASKEY LP WT 56K MODEM

## Assembly 2: LCD

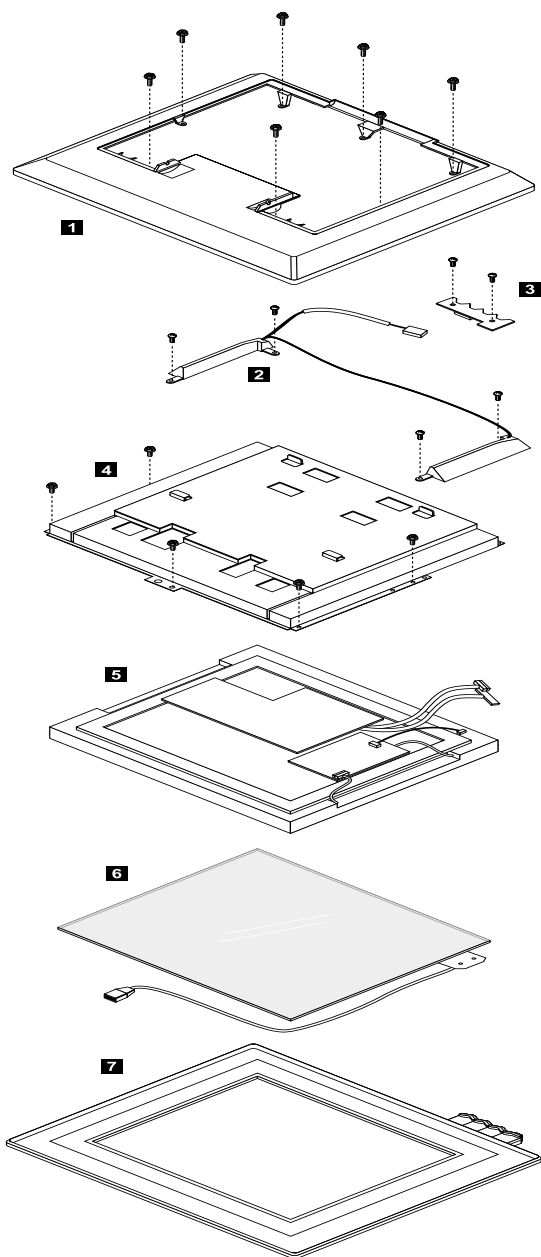

<b>Asm-index</b>	<b>FRU No.</b>	<b>Description</b>
2-6	32P3270	15" TOUCH SCREEN
2-6	33P3524	17" TOUCH SCREEN
2-NS	33P3525	TOUCH PANEL CONTROL CARD
2-3	32P3268	INVERTER CARD 15"
2-NS	31P5597	INVERTER CARD PLATE
2-5	32P3271	TFT ASM 15"
2-5	32P3272	TFT ASM 17"
2-NS	32P3251	TCO99 BEZEL 15" X1+ 17"X1 (SPECIFIC COLOR FOR EUROPE MODEL)
2-NS	32P3340	15" TFT PLASTIC KIT
2-2	24P6099	SPEAKER ASM FOR 15"
2-2	24P6100	SPEAKER ASM FOR 17"
2-NS	32P3255	15" TFT PLASTICS KIT

## Assembly 3: Diskette and Hard Drive

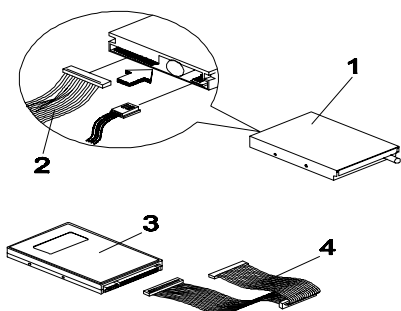

Asm-Index	FRU Number	Description
3-3	19K1560	20GB, 5400 RPM
3-3	19K1562	40GB, 5400 RPM
3-3	19K1568	40GB, 7200 RPM
3-3	19K1570	60GB, 7200 RPM
3-NS	32P3256	HDD BRACKET (INCLUDES 4 SREWS AND GROMMETS)
3-4	32P3265	PARALLEL/IDE CABLE ASM

## Assembly 4: Optical Drive, Adapter Card and Speaker

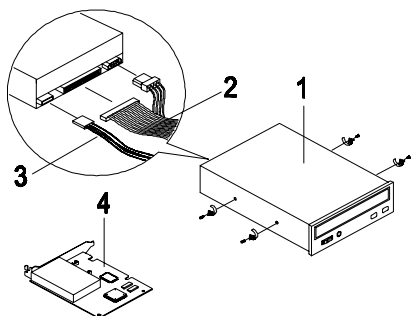

Asm-Index	FRU Number	Description
4-1	19K1531	CD-ROM, 48X LITE-ON
4-1	06P5281	CD-ROM, 48X
4-1	24P3605	CD-ROM, 48X LG
4-NS	32P3260	CD-ROM TRAY (INCLUDES SCREWS)
4-1	24P3627	CD-RW TEAC 16X10X40 CD-RW NO HP JACK
4-1	24P3631	CD-RW 16X10X40 CD-RW NO HP JACK
4-1	06P5289	DVD CD/RW, 8X4X32X8
4-1	33P3203	FRU, 48X LG, BLACK, WHPJ
4-1	33P3207	FRU, LITEON, BLACK, WHPJ
4-1	33P3227	FRU, SAMSUNG, COMBO. BLACK



## Assembly 5: Power Cord

<b>Asm-Index</b>	<b>FRU Number</b>	<b>Description</b>
5-NS	1838576	LINE CORD, 1.8M 10A/125VAC
5-NS	13F9978	LINE CORD, 1.8M 10A/125VAC
5-NS	13F9996	LINE CORD, 1.8M 10A/125VAC
5-NS	14F0050	LINE CORD, 1.8M 10A/125VAC
5-NS	14F0086	LINE CORD, 1.8M 10A/125VAC
5-NS	14F0068	LINE CORD, 1.8M 10A/125VAC
5-NS	14F0014	LINE CORD, 1.8M 10A/125VAC
5-NS	14F0032	LINE CORD, 1.8M 10A/125VAC
5-NS	13F9939	LINE CORD, 1.8M 10A/125VAC
5-NS	02K0545	LINE CORD, 1.8M 10A/125VAC
5-NS	36L8879	LINE CORD, 1.8M 10A/125VAC
5-NS	6952301	LINE CORD, 1.8M 10A/125VAC

## Assembly 6: Keyboard and Mouse

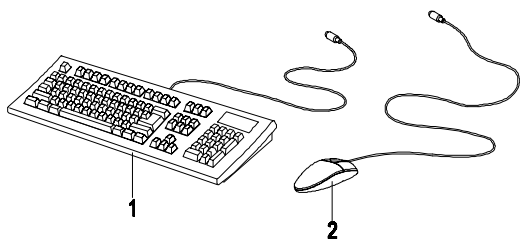

Asm-Index	FRU Number	Description
6-1	19K1910	US ENGLISH
6-1	19K1911	ARABIC
6-1	19K1912	BELGIAN/FRENCH
6-1	19K1913	BELGIAN/UK
6-1	19K1914	BULGARIAN
6-1	19K1915	CHINESE/US
6-1	19K1916	CZECH
6-1	19K1917	DANISH
6-1	19K1918	DUTCH
6-1	19K1919	FRENCH
6-1	19K1920	FRENCH CANADIAN
6-1	19K1921	FRENCH CANADIAN
6-1	19K1922	GERMAN
6-1	19K1923	GREEK
6-1	19K1924	HEBREW
6-1	19K1925	HUNGARIAN
6-1	19K1926	ICELAND
6-1	19K1927	ITALIAN
6-1	19K1928	JAPANESE
6-1	19K1929	KOREAN
6-1	19K1930	LA SPANISH
6-1	19K1931	NORWEGIAN
6-1	19K1932	POLISH
6-1	19K1933	PORTUGUESE
6-1	19K1934	ROMANIAN

<b>Asm-Index</b>	<b>FRU Number</b>	<b>Description</b>
6-1	19K1935	RUSSIAN
6-1	19K1936	RUSSIAN/CY
6-1	19K1937	SERBIAN/CYRILIC
6-1	19K1938	SLOVAK
6-1	19K1939	SPANISH
6-1	19K1940	SWEDISH/FINN
6-1	19K1941	SWISS, F/G
6-1	19K1942	THAILAND
6-1	19K1943	TURKISH
6-1	19K1944	TURKISH
6-1	19K1945	UK ENGLISH
6-1	19K1946	US INTERTIONAL
6-1	19K1947	YUGOSLAV/LATIN
6-1	19K1948	BRAZIL/PORTUGUESE
6-1	19K1908	JAPANESE
6-1	22P5183	KEYBOARD MOUSE COMBO - US ENGLISH
6-1	22P7250	KEYBOARD MOUSE COMBO - ARABIC
6-1	22P7251	KEYBOARD MOUSE COMBO - BELGIUM/FRENCH
6-1	22P7252	KEYBOARD MOUSE COMBO - BELGIUM/UK
6-1	22P7253	KEYBOARD MOUSE COMBO - BRAZIL/PORTUGUESE
6-1	22P7254	KEYBOARD MOUSE COMBO - BULAGARIAN
6-1	22P7255	KEYBOARD MOUSE COMBO - CHINESE/ENGLISH
6-1	22P7256	KEYBOARD MOUSE COMBO - CZECH
6-1	22P7257	KEYBOARD MOUSE COMBO - DANISH
6-1	22P7258	KEYBOARD MOUSE COMBO - DUTCH
6-1	22P7259	KEYBOARD MOUSE COMBO - FRENCH
6-1	22P7260	KEYBOARD MOUSE COMBO - FRENCH CANADIAN

<b>Asm-Index</b>	<b>FRU Number</b>	<b>Description</b>
6-1	22P7261	KEYBOARD MOUSE COMBO - FRENCH CANADIAN
6-1	22P7262	KEYBOARD MOUSE COMBO - GERMAN
6-1	22P7263	KEYBOARD MOUSE COMBO - GREEK
6-1	22P7264	KEYBOARD MOUSE COMBO - HEBREW
6-1	22P7265	KEYBOARD MOUSE COMBO - HUNGARIAN
6-1	22P7266	KEYBOARD MOUSE COMBO - ICELAND
6-1	22P7267	KEYBOARD MOUSE COMBO - ITALY
6-1	22P7268	KEYBOARD MOUSE COMBO - JAPANESE
6-1	22P7269	KEYBOARD MOUSE COMBO - LA SPANISH
6-1	22P7270	KEYBOARD MOUSE COMBO - NORWEGIAN
6-1	22P7271	KEYBOARD MOUSE COMBO - POLISH
6-1	22P7272	KEYBOARD MOUSE COMBO - PORTUGUESE
6-1	22P7273	KEYBOARD MOUSE COMBO - ROMANIAN
6-1	22P7274	KEYBOARD MOUSE COMBO - RUSSIAN
6-1	22P7275	KEYBOARD MOUSE COMBO - RUSSIAN/CY
6-1	22P7276	KEYBOARD MOUSE COMBO - SERBIAN/CYRILIC
6-1	22P7277	KEYBOARD MOUSE COMBO - SLOVAK
6-1	22P7278	KEYBOARD MOUSE COMBO - SPANISH
6-1	22P7279	KEYBOARD MOUSE COMBO - SWEDISH/FINN
6-1	22P7280	SWISS, F/G
6-1	22P7281	KEYBOARD MOUSE COMBO - THAILAND

<b>Asm-Index</b>	<b>FRU Number</b>	<b>Description</b>
6-1	22P7282	KEYBOARD MOUSE COMBO - TURKISH
6-1	22P7283	KEYBOARD MOUSE COMBO - TURKISH
6-1	22P7284	KEYBOARD MOUSE COMBO - UK ENGLISH
6-1	22P7285	KEYBOARD MOUSE COMBO - US INTERTIONAL
6-1	22P7286	YUGOSLAV/LATIN
6-2	24P0485	USB SCROLL POINT III - STEALTH BLACK

## Assembly 7: Recovery CD

Asm-Index	FRU Number	Description
7-NS	32P4279	Win 2000 US
7-NS	32P4282	Win 2000 AP
7-NS	32P4285	Win 2000 UK
7-NS	32P4315	Win 2000 AE
7-NS	32P4321	Win 2000 Spanish
7-NS	32P4288	Win 2000 FR
7-NS	32P4306	Win 2000 DK
7-NS	32P4300	Win 2000 NL
7-NS	32P4312	Win 2000 FI
7-NS	32P4294	Win 2000 C/F
7-NS	32P4291	Win 2000 GR
7-NS	32P4309	Win 2000 IT
7-NS	32P4310	Win 2000 NO
7-NS	32P4318	Win 2000 LA/S
7-NS	32P4297	Win 2000 SV
7-NS	33P2051	Win 2000 Hebrew
7-NS	32P4303	Win 2000 NO
7-NS	32P4324	XP Pro US
7-NS	32P4333	XP Pro AE
7-NS	32P4336	XP Pro Spanish
7-NS	32P4339	XP Pro FR
7-NS	32P4342	XP Pro DK
7-NS	32P4345	XP Pro NL
7-NS	32P4348	XP Pro FI
7-NS	32P4354	XP Pro GR
7-NS	32P4357	XP Pro IT
7-NS	32P4360	XP Pro NO
7-NS	32P4366	XP Pro SV
7-NS	33P2057	XP Pro Hebrew
7-NS	32P4369	XP Home US
7-NS	32P4378	XP Home AE
7-NS	32P4381	XP Home Spanish
7-NS	32P4384	XP Home FR
7-NS	32P4387	XP Home DK

<b>Asm-Index</b>	<b>FRU Number</b>	<b>Description</b>
7-NS	32P4390	XP Home NL
7-NS	32P4393	XP Home FI
7-NS	32P4396	XP Home C/F
7-NS	32P4399	XP Home GR
7-NS	32P4402	XP Home IT
7-NS	32P4405	XP Home NO
7-NS	32P4411	XP Home SV
7-NS	33P2054	XP Home Hebrew





---

## 6274 Parts Catalog

Abbreviations .....	154
System Assembly .....	155
Assembly 1: System Unit .....	155
Assembly 2: LCD .....	157
Assembly 3: Diskette and Hard Drive .....	159
Assembly 4: Optical Drive, Adapter Card and Speaker .....	160
Assembly 5: Power Cord.....	161
Assembly 6: Keyboard and Mouse .....	162
Assembly 7: Recovery CD .....	164

---

## Abbreviations

In this chapter, the following abbreviations are used to identify country and language version:

Country	Language Version
AT	Austria
AU	Australia
BD	Belgium - Dutch
BF	Belgium - French
CA	Canada
CE	Canada - English
CF	Canada - French
CN	China
DK	Denmark - Danish
FI	Finland - Finnish
FR	France
GE	Germany
HK	Hong Kong
IT	Italy
JP	Japan
LS	LA-Spanish
ND	Netherlands - Dutch
NL	Netherlands - Dutch
NO	Norway - Norwegian
SF	Swiss - French
SG	Swiss - German
SP	Spain
SW	Sweden - Swedish
TW	Taiwan
UK	United Kingdom
US	United States
SZ	Switzerland

# System Assembly

## Assembly 1: System Unit

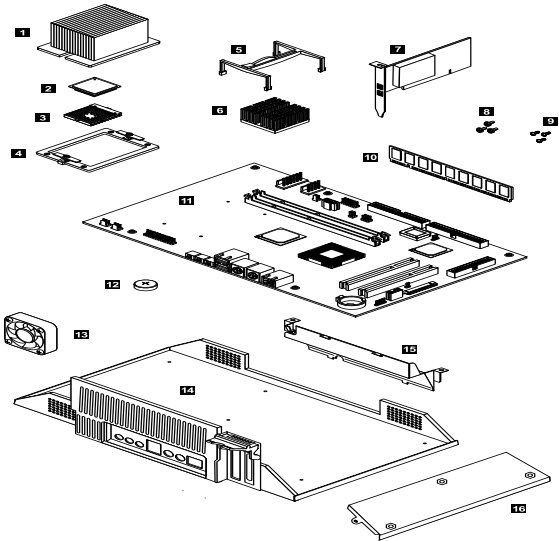

Asm-Index	FRU Number	Description
1-11	24P6101	IBM MONTECRISTO MOTHERBOARD
1-11	24P6102	IBM MONTECRISTO MOTHERBOARD W/ POV
1-2	25P5040	mPGA478 PENTIUM 4 1.5 GHz
1-2	25P5114	mPGA478 PENTIUM 4 1.6 GHz
1-2	25P5115	mPGA478 PENTIUM 4 1.8GHz
1-10	10K0058	128MB NP 133MHz
1-10	10K0060	256MB NP 133MHz
1-NS	32P3248	REAR BUCKET ASM W/ EMC SHIELD AND LATCHES
1-NS	32P3250	BAFFLE/FAN ASM
1-NS	32P3257	BUTTON CONTROL ASM
1-14	32P3254	MAIN CHASIS
1-NS	32P3252	PLANAR I/O EMC SHIELD AND PCI LATCH
1-NS	32P3261	KEY LOCK

<b>Asm-Index</b>	<b>FRU Number</b>	<b>Description</b>
1-1	32P3253	FRU - HEAT SINK (1.3 - 1.8 GHz)
1-NS	32P3262	POWER CABLE AND USB TOUCH CABLE KIT (FOR TOUCH PANEL CONTROL CARD)
1-NS	32P3267	INTERNAL POWER CABLE ASM
1-NS	32P3259	SCUBA TANKS
1-NS	32P3338	THROAT PLATE (HOLDS HDD IN-PLACE)
1-NS	32P3341	BASE COVER KIT
1-NS	32P3342	SOLENOID (DROPS OPTICAL DRIVE BAY) INCLUDES TWO SCREWS
1-8,9	32P3258	SCREW PACK
1-13	32P3344	FAN, 50x15MM (INCLUDES TWO RUBBER ISOLATION MOUNTS)
1-13	32P3345	FAN, 60x15MM (INCLUDES TWO RUBBER ISOLATION MOUNTS)
1-NS	09K9827	C2 SWITCH
1-NS	03K9654	RF ANTENNA
1-NS	24P6869	160W POWER BRICK (15" & 17") W/ FPC
1-NS	32P3249	HANDLE KIT FOR 15" & 17" (INCLUDES HANDLE/MOUNTING BRACKETS/SCREWS)
1-NS	32P3391	BRACKET
1-NS	32P3343	DAUGHTER CARD, POWER/USB/ PARALLEL PORT CONNECTOR KIT

## Assembly 2: LCD

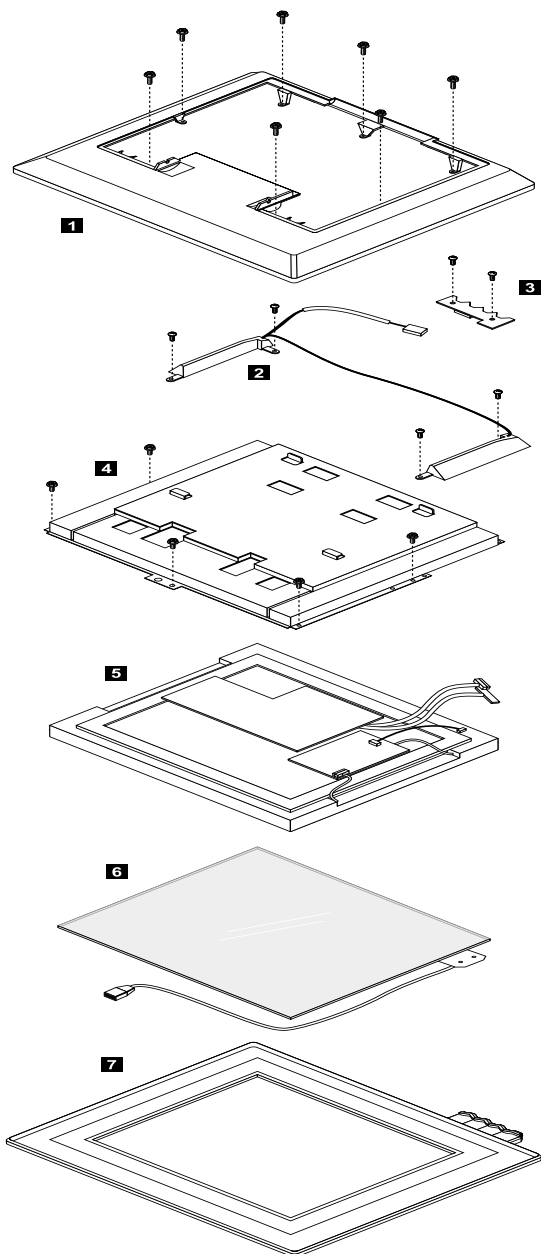

<b>Asm-index</b>	<b>FRU No.</b>	<b>Description</b>
2-6	32P3270	15" TOUCH SCREEN
2-6	33P3524	17" TOUCH SCREEN
2-NS	33P3525	TOUCH PANEL CONROL CARD
2-3	32P3268	INVERTER CARD 15"
2-NS	31P5597	INVERTER CARD PLATE
2-5	32P3271	TFT ASM 15"
2-5	32P3272	TFT ASM 17"
2-NS	32P3251	TCO99 BEZEL 15"X1 + 17"X1 (SPECIFIC COLOR FOR EUROPE MODEL)
2-NS	32P3340	17" TFT PLASTICS KIT
2-2	24P6099	SPEAKER ASM FOR 15"
2-2	24P6100	SPEAKER ASM FOR 17"
2-NS	32P3255	15" TFT PLASTICS KIT

## Assembly 3: Diskette and Hard Drive

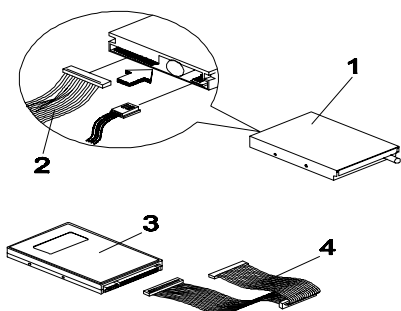

Asm-Index	FRU Number	Description
3-3	19K1560	20GB, 5400 RPM
3-3	19K1562	40GB, 5400 RPM
3-3	19K1568	40GB, 7200 RPM
3-NS	32P3256	HDD BRACKET
3-4	32P3265	PARALLEL IDE CABLE ASM

## Assembly 4: Optical Drive, Adapter Card and Speaker

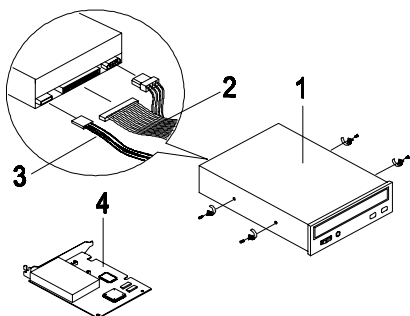

Asm-Index	FRU Number	Description
4-1	19K1531	CD-ROM, 48X LITE-ON
4-1	06P5281	CD-ROM, 48X
4-1	24P3605	CD-ROM, 48X LG
4-NS	32P3260	CD-ROM TRAY (INCLUDES SCREWS)
4-1	24P3623	DVD, 16X (48X) W/ RAM READ
4-1	24P3619	DVD, PANASONIC 16X48X DVD-ROM W/ RAM READ
4-1	06P5289	DVD CD/RW, 8X4X32X8
4-1	33P3203	FRU, 48X LG, BLACK, WHPJ
4-1	33P3207	FRU, LITEON, BLACK, WHPJ



## Assembly 5: Power Cord

<b>Asm-Index</b>	<b>FRU Number</b>	<b>Description</b>
5-NS	1838576	LINE CORD, 1.8M 10A/125VAC
5-NS	13F9978	LINE CORD, 1.8M 10A/125VAC
5-NS	13F9996	LINE CORD, 1.8M 10A/125VAC
5-NS	14F0050	LINE CORD, 1.8M 10A/125VAC
5-NS	14F0086	LINE CORD, 1.8M 10A/125VAC
5-NS	14F0068	LINE CORD, 1.8M 10A/125VAC
5-NS	14F0014	LINE CORD, 1.8M 10A/125VAC
5-NS	14F0032	LINE CORD, 1.8M 10A/125VAC
5-NS	13F9939	LINE CORD, 1.8M 10A/125VAC
5-NS	02K0545	LINE CORD, 1.8M 10A/125VAC
5-NS	36L8879	LINE CORD, 1.8M 10A/125VAC
5-NS	6952301	LINE CORD, 1.8M 10A/125VAC

## Assembly 6: Keyboard and Mouse

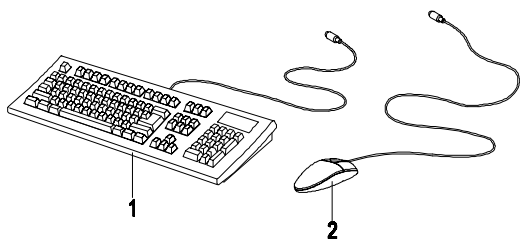

Asm-Index	FRU Number	Description
6-1	09N5590	USB Standard Dark Color - US ENGLISH
6-1	09N5591	USB Standard Dark Color - ARABIC
6-1	09N5592	USB Standard Dark Color - BELGIUM/FRENCH
6-1	09N5593	USB Standard Dark Color - BELGIUM/UK
6-1	09N5594	USB Standard Dark Color - BULGARIAN
6-1	09N5595	USB Standard Dark Color - CHINESE/US
6-1	09N5596	USB Standard Dark Color - CZECH
6-1	09N5597	USB Standard Dark Color - DANISH
6-1	09N5598	USB Standard Dark Color - DUTCH
6-1	09N5599	USB Standard Dark Color - FRENCH
6-1	09N5601	USB Standard Dark Color - FRENCH CANADIAN
6-1	09N5602	USB Standard Dark Color - GERMAN
6-1	09N5603	USB Standard Dark Color - GREEK
6-1	09N5604	USB Standard Dark Color - HEBREW
6-1	09N5605	USB Standard Dark Color - HUNGARIAN
6-1	09N5606	USB Standard Dark Color - ICELAND
6-1	09N5607	USB Standard Dark Color - ITALY
6-1	09N5608	USB Standard Dark Color - JAPANESE
6-1	09N5609	USB Standard Dark Color - KOREAN

<b>Asm-Index</b>	<b>FRU Number</b>	<b>Description</b>
6-1	09N5610	USB Standard Dark Color - LA SPANISH
6-1	09N5611	USB Standard Dark Color - NORWEGIAN
6-1	09N5612	USB Standard Dark Color - POLISH
6-1	09N5613	USB Standard Dark Color - PORTUGUESE
6-1	09N5614	USB Standard Dark Color - ROMANIAN
6-1	09N5615	USB Standard Dark Color - RUSSIAN
6-1	09N5616	USB Standard Dark Color - RUSSIAN/CY
6-1	09N5617	USB Standard Dark Color - SERBIAN/CYRILIC
6-1	09N5618	USB Standard Dark Color - SLOVAK
6-1	09N5619	USB Standard Dark Color - SPANISH
6-1	09N5620	USB Standard Dark Color - SWEDISH/FINN
6-1	09N5621	USB Standard Dark Color - SWISS, F/G
6-1	09N5622	USB Standard Dark Color - THAILAND
6-1	09N5623	USB Standard Dark Color - TURKISH
6-1	09N5624	USB Standard Dark Color - TURKISH
6-1	09N5625	USB Standard Dark Color - UK ENGLISH
6-1	09N5626	USB Standard Dark Color - US INTERNATIONAL
6-1	09N5627	USB Standard Dark Color - YUGOSLAVIA/LATIN
6-2	24P0485	Mouse -USB Scroll Point III, Black

## Assembly 7: Recovery CD

Asm-Index	FRU Number	Description
7-NS	32P4279	Win 2000 US
7-NS	32P4282	Win 2000 AP
7-NS	32P4285	Win 2000 UK
7-NS	32P4315	Win 2000 AE
7-NS	32P4321	Win 2000 Spanish
7-NS	32P4288	Win 2000 FR
7-NS	32P4306	Win 2000 DK
7-NS	32P4300	Win 2000 NL
7-NS	32P4312	Win 2000 FI
7-NS	32P4291	Win 2000 GR
7-NS	32P4294	Win 2000 C/F
7-NS	32P4309	Win 2000 IT
7-NS	32P4318	Win 2000 LA/S
7-NS	32P4297	Win 2000 SV
7-NS	33P2051	Win 2000 Hebrew
7-NS	32P4303	Win 2000 NO
7-NS	32P4324	XP Pro US
7-NS	32P4327	XP Pro AP
7-NS	32P4336	XP Pro Spanish
7-NS	32P4339	XP Pro FR
7-NS	32P4342	XP Pro DK
7-NS	32P4345	XP Pro NL
7-NS	32P4348	XP Pro FI
7-NS	32P4354	XP Pro GR
7-NS	32P4357	XP Pro IT
7-NS	32P4360	XP Pro NO
7-NS	32P4366	XP Pro SV
7-NS	33P2057	XP Pro Hebrew
7-NS	32P4369	XP Home US
7-NS	32P4378	XP Home AE
7-NS	32P4381	XP Home Spanish
7-NS	32P4384	XP Home FR
7-NS	32P4387	XP Home DK
7-NS	32P4390	XP Home NL

<b>Asm-Index</b>	<b>FRU Number</b>	<b>Description</b>
7-NS	32P4393	XP Home FI
7-NS	32P4399	XP Home GR
7-NS	32P4402	XP Home IT
7-NS	32P4405	XP Home NO
7-NS	32P4411	XP Home SV
7-NS	33P2054	XP Home Hebrew



---

## 2283 Appendix A. FRU Number List

FRU Number	Asm-Index	Page
02K0545	5-NS	145
03K9654	1-NS	140
06P5281	4-1	144
06P5289	4-1	144
09K9827	1-NS	140
10K0058	1-10	139
10K0060	1-10	139
13F9939	5-NS	145
13F9978	5-NS	145
13F9996	5-NS	145
14F0014	5-NS	145
14F0032	5-NS	145
14F0050	5-NS	145
14F0068	5-NS	145
14F0086	5-NS	145
1838576	5-NS	145
19K1531	4-1	144
19K1560	3-3	143
19K1562	3-3	143
19K1568	3-3	143
19K1570	3-3	143
19K1908	6-1	147
19K1910	6-1	146
19K1911	6-1	146
19K1912	6-1	146
19K1913	6-1	146
19K1914	6-1	146
19K1915	6-1	146
19K1916	6-1	146
19K1917	6-1	146
19K1918	6-1	146
19K1919	6-1	146
19K1920	6-1	146

<b>FRU Number</b>	<b>Asm-Index</b>	<b>Page</b>
19K1921	6-1	146
19K1922	6-1	146
19K1923	6-1	146
19K1924	6-1	146
19K1925	6-1	146
19K1926	6-1	146
19K1927	6-1	146
19K1928	6-1	146
19K1929	6-1	146
19K1930	6-1	146
19K1931	6-1	146
19K1932	6-1	146
19K1933	6-1	146
19K1934	6-1	146
19K1935	6-1	147
19K1936	6-1	147
19K1937	6-1	147
19K1938	6-1	147
19K1939	6-1	147
19K1940	6-1	147
19K1941	6-1	147
19K1942	6-1	147
19K1943	6-1	147
19K1944	6-1	147
19K1945	6-1	147
19K1946	6-1	147
19K1947	6-1	147
19K1948	6-1	147
19K2963	1-NS	140
19K2965	1-NS	140
22P5183	6-1	147
22P7250	6-1	147
22P7251	6-1	147
22P7252	6-1	147
22P7253	6-1	147
22P7254	6-1	147



<b>FRU Number</b>	<b>Asm-Index</b>	<b>Page</b>
22P7255	6-1	147
22P7256	6-1	147
22P7257	6-1	147
22P7258	6-1	147
22P7259	6-1	147
22P7260	6-1	147
22P7261	6-1	148
22P7262	6-1	148
22P7263	6-1	148
22P7264	6-1	148
22P7265	6-1	148
22P7266	6-1	148
22P7267	6-1	148
22P7268	6-1	148
22P7269	6-1	148
22P7270	6-1	148
22P7271	6-1	148
22P7272	6-1	148
22P7273	6-1	148
22P7274	6-1	148
22P7275	6-1	148
22P7276	6-1	148
22P7277	6-1	148
22P7278	6-1	148
22P7279	6-1	148
22P7280	6-1	148
22P7281	6-1	148
22P7282	6-1	149
22P7283	6-1	149
22P7284	6-1	149
22P7285	6-1	149
22P7286	6-1	149
24P0485	6-2	149
24P3605	4-1	144
24P3627	4-1	144
24P3631	4-1	144

<b>FRU Number</b>	<b>Asm-Index</b>	<b>Page</b>
24P6099	2-2	142
24P6100	2-2	142
24P6101	1-11	139
24P6102	1-11	139
24P6869	1-NS	140
25P5040	1-2	139
25P5114	1-2	139
25P5115	1-2	139
31P5597	2-NS	142
32P3248	1-NS	139
32P3249	1-NS	140
32P3250	1-NS	139
32P3251	2-NS	142
32P3252	1-NS	139
32P3253	1-1	140
32P3254	1-14	139
32P3255	2-NS	142
32P3256	3-NS	143
32P3257	1-NS	139
32P3258	1-NS	140
32P3259	1-NS	140
32P3260	4-NS	144
32P3261	1-NS	139
32P3262	1-NS	140
32P3265	3-4	143
32P3267	1-NS	140
32P3268	2-3	142
32P3270	2-6	142
32P3271	2-5	142
32P3272	2-5	142
32P3338	1-NS	140
32P3340	2-NS	142
32P3341	1-NS	140
32P3342	1-NS	140
32P3343	1-NS	140
32P3344	1-13	140

<b>FRU Number</b>	<b>Asm-Index</b>	<b>Page</b>
32P3345	1-13	140
32P3391	1-NS	140
32P4279	7-NS	150
32P4282	7-NS	150
32P4285	7-NS	150
32P4288	7-NS	150
32P4291	7-NS	150
32P4294	7-NS	150
32P4297	7-NS	150
32P4300	7-NS	150
32P4303	7-NS	150
32P4306	7-NS	150
32P4309	7-NS	150
32P4310	7-NS	150
32P4312	7-NS	150
32P4315	7-NS	150
32P4318	7-NS	150
32P4321	7-NS	150
32P4324	7-NS	150
32P4333	7-NS	150
32P4336	7-NS	150
32P4339	7-NS	150
32P4342	7-NS	150
32P4345	7-NS	150
32P4348	7-NS	150
32P4354	7-NS	150
32P4357	7-NS	150
32P4360	7-NS	150
32P4366	7-NS	150
32P4369	7-NS	150
32P4378	7-NS	151
32P4381	7-NS	151
32P4384	7-NS	151
32P4387	7-NS	151
32P4390	7-NS	151
32P4393	7-NS	151

<b>FRU Number</b>	<b>Asm-Index</b>	<b>Page</b>
32P4396	7-NS	151
32P4399	7-NS	151
32P4402	7-NS	151
32P4405	7-NS	151
32P4411	7-NS	151
33P2051	7-NS	150
33P2054	7-NS	151
33P2057	7-NS	150
33P3203	4-1	144
33P3207	4-1	144
33P3227	4-1	144
33P3524	2-6	142
33P3525	2-NS	142
36L8879	5-NS	145
6952301	5-NS	145

---

## 6274 Appendix A. FRU Number List

FRU Number	Asm-Index	Page
02K0545	5-NS	161
03K9654	1-NS	156
06P5281	4-1	160
06P5289	4-1	160
09K9827	1-NS	156
09N5590	6-1	162
09N5591	6-1	162
09N5592	6-1	162
09N5593	6-1	162
09N5594	6-1	162
09N5595	6-1	162
09N5596	6-1	162
09N5597	6-1	162
09N5598	6-1	162
09N5599	6-1	162
09N5601	6-1	162
09N5602	6-1	162
09N5603	6-1	162
09N5604	6-1	162
09N5605	6-1	162
09N5606	6-1	162
09N5607	6-1	162
09N5608	6-1	163
09N5609	6-1	163
09N5610	6-1	163
09N5611	6-1	163
09N5612	6-1	163
09N5613	6-1	163
09N5614	6-1	163
09N5615	6-1	163
09N5616	6-1	163
09N5617	6-1	163
09N5618	6-1	163

<b>FRU Number</b>	<b>Asm-Index</b>	<b>Page</b>
09N5619	6-1	163
09N5620	6-1	163
09N5621	6-1	163
09N5622	6-1	163
09N5623	6-1	163
09N5624	6-1	163
09N5625	6-1	163
09N5626	6-1	163
09N5627	6-1	163
10K0058	1-10	155
10K0060	1-10	155
13F9939	5-NS	161
13F9978	5-NS	161
13F9996	5-NS	161
14F0014	5-NS	161
14F0032	5-NS	161
14F0050	5-NS	161
14F0068	5-NS	161
14F0086	5-NS	161
1838576	5-NS	161
19K1531	4-1	160
19K1560	3-3	159
19K1562	3-3	159
19K1568	3-3	159
24P0485	6-2	163
24P3605	4-1	160
24P3619	4-1	160
24P3623	4-1	160
24P6099	2-2	158
24P6100	2-2	158
24P6101	1-11	155
24P6102	1-11	155
24P6869	1-NS	156
25P5040	1-2	155
25P5114	1-2	155
25P5115	1-NS	155

<b>FRU Number</b>	<b>Asm-Index</b>	<b>Page</b>
31P5597	2-NS	158
32P3248	1-NS	155
32P3249	1-NS	156
32P3250	1-NS	155
32P3251	2-NS	158
32P3252	1-NS	155
32P3253	1-1	156
32P3254	1-14	155
32P3255	2-NS	158
32P3256	3-NS	159
32P3257	1-NS	155
32P3258	1-8, 9	156
32P3259	1-NS	156
32P3260	4-NS	160
32P3261	1-NS	155
32P3262	1-NS	156
32P3265	3-4	159
32P3267	1-NS	156
32P3268	2-3	158
32P3270	2-6	158
32P3271	2-5	158
32P3272	2-5	158
32P3338	1-NS	156
32P3340	2-NS	158
32P3341	1-NS	156
32P3342	1-NS	156
32P3343	1-NS	156
32P3344	1-13	156
32P3345	1-13	156
32P3391	1-NS	156
32P4279	7-NS	164
32P4282	7-NS	164
32P4285	7-NS	164
32P4288	7-NS	164
32P4291	7-NS	164
32P4294	7-NS	164

<b>FRU Number</b>	<b>Asm-Index</b>	<b>Page</b>
32P4297	7-NS	164
32P4300	7-NS	164
32P4303	7-NS	164
32P4306	7-NS	164
32P4309	7-NS	164
32P4312	7-NS	164
32P4315	7-NS	164
32P4318	7-NS	164
32P4321	7-NS	164
32P4324	7-NS	164
32P4327	7-NS	164
32P4336	7-NS	164
32P4339	7-NS	164
32P4342	7-NS	164
32P4345	7-NS	164
32P4348	7-NS	164
32P4354	7-NS	164
32P4357	7-NS	164
32P4360	7-NS	164
32P4366	7-NS	164
32P4369	7-NS	164
32P4378	7-NS	165
32P4381	7-NS	165
32P4384	7-NS	165
32P4387	7-NS	165
32P4390	7-NS	165
32P4393	7-NS	165
32P4399	7-NS	165
32P4402	7-NS	165
32P4405	7-NS	165
32P4411	7-NS	165
33P2051	7-NS	164
33P2054	7-NS	165
33P2057	7-NS	164
33P3203	4-1	160
33P3207	4-1	160



<b>FRU Number</b>	<b>Asm-Index</b>	<b>Page</b>
33P3524	2-6	158
33P3525	2-NS	158
36L8879	5-NS	161
6952301	5-NS	161



---

## Appendix B. On-line Support Information

This section describes on-line technical support services available to help repair the Personal Computer.

This section covers:

- IBM PC Company Fax-Back Service (US and Canada only)
- IBM On-line Help Center on America On-line
- IBM useful sites on the World Wide Web (WWW)

On-line technical support offers convenient and valuable information when you need it. IBM offers support areas on several on-line services where you can work with IBM technicians for solutions to your questions, download key files, and access database information for the personal computer.

The IBM PC Company offers on-line resources including several Internet World Wide Web sites, the IBM On-line Help Center support areas, and a Fax-Back service.

The IBM PC Company Automated Fax-Back System offers a variety of IBM computer-related articles. To access this service, call 800-IBM-3395.

Technical support is offered through the IBM On-line Help Centers on America On-line.

IBM on-line support areas on all of the services can assist with your technical questions. These areas offer message boards monitored by IBM technicians, databases of computer-related solutions, and file libraries.

You can reach the IBM On-line Help Center on America On-line using keyword: **IBM Connection**. For information about America On-line, please call (800) 827-6364 (U.S. and Canada only). America On-line has limited international availability.

To access the IBM PC Company Internet sites, you will need to acquire Internet access. Please check with your local Internet provider for more information. (Members of AOL can reach these sites through the Internet capabilities of the services.)

Here are some useful IBM Internet addresses for Personal Computer information:

**<http://www.ibm.com/pc>**

PC Company Home Page

**<http://www.ibm.com/pc/us/netvista>**

Netvista Home Page

**<http://www.ibm.com/support>**

IBM Support Site



Printed in U.S.A.

International Business Machines Corporation  
Old Orchard Road,  
Armonk, New York 10504

Part Number: 24P2957