

Bull ESCALA S Series

System User's Guide

ORDER REFERENCE
86 A1 89JX 01

Bull ESCALA S Series

System User's Guide

Hardware

October 1998

BULL ELECTRONICS
CEDOC
34 Rue du Nid de Pie – BP 428
49004 ANGERS CEDEX 01
FRANCE

ORDER REFERENCE
86 A1 89JX 01

The following copyright notice protects this book under the Copyright laws of the United States of America and other countries which prohibit such actions as, but not limited to, copying, distributing, modifying, and making derivative works.

Copyright © Bull S.A. 1992, 1998

Printed in France

Suggestions and criticisms concerning the form, content, and presentation of this book are invited. A form is provided at the end of this book for this purpose.

To order additional copies of this book or other Bull Technical Publications, you are invited to use the Ordering Form also provided at the end of this book.

Trademarks and Acknowledgements

We acknowledge the right of proprietors of trademarks mentioned in this book.

AIX[®] is a registered trademark of International Business Machines Corporation, and is being used under licence.

UNIX is a registered trademark in the United States of America and other countries licensed exclusively through the Open Group.

The information in this document is subject to change without notice. Groupe Bull will not be liable for errors contained herein, or for incidental or consequential damages in connection with the use of this material.

Table of Contents

Communications Statements	vii
Safety Notices	x
Environmental Notices	xiii
About This Book	xv
ISO 9000	xv
Related Publications	xv
Chapter 1. System Startup	1-1
Thank you for selecting the ESCALA S100 and ESCALA S120	1-1
Before You Begin	1-2
Unpacking Your System Unit	1-3
ESCALA S100 System Features	1-4
ESCALA S120 System Features	1-6
Installing Options	1-11
Connecting the Cables	1-11
Checking the Voltage Setting	1-12
Finishing the Installation	1-13
Chapter 2. Using the System Unit	2-1
Starting the System Unit	2-1
Console Selection	2-2
POST Indicators	2-3
Stopping the System Unit	2-4
Power Switch and Indicator	2-5
Operator Panel and Reset Switch	2-5
System Startup Options	2-5
Default Boot List	2-6
Custom Boot List	2-6
Service Mode Boot: Loading Diagnostics	2-6
Booting in Service Mode from the Default Boot List	2-6
Booting in Service Mode from the Custom Boot List	2-7
Standalone vs. Online Diagnostics	2-7
Recommended Boot Options	2-7
Summary: Boot Options and Control Keys	2-8
Using the Keyboards	2-9
Using The Mouse	2-10
Handling the Mouse Correctly	2-11
Using the 3.5-Inch Diskette Drive	2-13
Diskette Compatibility	2-13
Using the CD-ROM Drive	2-14

Chapter 3. System Management Services	3-1
System Management Services	3-1
Graphical System Management Services	3-1
Config	3-4
MultiBoot (ESCALA S120 only)	3-6
Boot (ESCALA S100 only)	3-8
Utilities	3-9
Password	3-11
Audio (ESCALA S100 only)	3-14
Hard Disk Spin Up Delay (ESCALA S120 only)	3-14
Error Log	3-15
RIPL	3-16
SCSI ID	3-18
Firmware Update	3-19
Firmware Recovery	3-20
Text-Based System Management Services	3-21
Display Configuration	3-22
Select Boot Devices (ESCALA S100)	3-23
Multiboot (ESCALA S120)	3-24
Select Boot Devices	3-25
Utilities	3-26
Set Password and Unattended Start Mode	3-27
Audio (ESCALA S100 only)	3-28
Hard Disk pin-Up Delay (ESCALA S120 only)	3-28
Display Error Log	3-28
Remote Initial Program Load Setup	3-29
Change SCSI ID	3-31
Update System Firmware	3-31
Select Language	3-32
Open Firmware Command Line	3-32
Chapter 4. Installing and Removing Options	4-1
Available options	4-1
Safety Considerations	4-2
Handling Static-Sensitive Devices	4-3
Electrostatic Discharge Protection	4-3
Tools Required	4-3
Removing the Cover	4-4
Locating options	4-6
Disabling the Power-On Password	4-8
Enabling the Privileged-Access Password	4-12
Enabling Automatic Power-Up	4-16
Installing Memory-Modules	4-21
Removing Memory Modules	4-25
L2 Cache Card Installation (for ESCALA S100)	4-28
332-MHz Processor Upgrade for ESCALA S100	4-32
Installing Adapters	4-41
Removing Adapters	4-45
Internal Drives	4-47
Installing or Removing Internal Drives	4-48
Setting the SCSI Security Jumpers	4-58
Installing a Security Tether	4-61
Changing the Battery	4-63
Completing the Installation	4-67

Connecting external options	4-69
Input/Output Connectors	4-70
Chapter 5. Using the Online and Standalone Diagnostics	5-1
Sources for the Diagnostics	5-1
Standalone and Online Diagnostics Operating Considerations	5-1
Selecting a Console Display	5-1
Identifying the Terminal Type to Diagnostics	5-1
Undefined Terminal Types	5-1
Resetting the Terminal	5-1
Running Standalone Diagnostics	5-2
Running Online Diagnostics	5-2
Running the Diagnostics from a TTY Terminal	5-3
Online Diagnostic Modes of Operation	5-3
Service Mode	5-3
Concurrent Mode	5-4
Maintenance Mode	5-5
Standalone Diagnostics Operation	5-5
Location Codes	5-6
Chapter 6. Location Codes (Model S120 only)	6-1
Physical Location Codes	6-1
Location Code Format	6-1
AIX Location Codes	6-2
Chapter 7. Using the System Verification Procedure	7-1
Step 3. Running System Verification	7-2
Step 4. Additional System Verification	7-3
Step 5. Stopping the Diagnostics	7-3
Chapter 8. Hardware Problem Determination	8-1
Problem Determination Using the Standalone or Online Diagnostics	8-1
Problem Determination When Unable to Load Diagnostics	8-8
Chapter 9. Introduction to Tasks and Service Aids	9-1
Appendix A. System Records	A-1
Record the identification numbers	A-1
Devices Records	A-2
Device Records	A-3
Appendix B. Adapters and Peripherals Placement Notes	B-1
Installing an Adapter in an ESCALA S100	B-1
Adapters Placement	B-1
Installing an Adapter in an ESCALA S120	B-2
Adapters Placement	B-2
Installing a Peripheral in an ESCALA S100	B-3
Peripherals Placement	B-4
Installing a Peripheral in an ESCALA S120	B-4
Peripherals Placement	B-5

Appendix C. IRQ and DMA-Channel Assignments and ISA Adapters Configuration	C-1
IRQ Assignments	C-1
DMA-Channel Assignments	C-2
ISA Adapters Configuration (for ESCALA S100 only)	C-2
Appendix D. SCSI Bus termination	D-1
For ESCALA S100 only	D-1
For ESCALA S100 and S120	D-1
Index	X-1

Communications Statements

The following statement applies to this product. The statement for other products intended for use with this product will appear in their accompanying manuals.

Federal Communications Commission (FCC) Statement

Note: This equipment has been tested and found to comply with the limits for a Class B digital device, pursuant to Part 15 of the FCC Rules. These limits are designed to provide reasonable protection against harmful interference when the equipment is operated in a commercial environment. This equipment generates, uses, and can radiate radio frequency energy and, if not installed and used in accordance with the instruction manual, may cause harmful interference to radio communications. However, there is no guarantee that interference will not occur in a particular installation. If this equipment does cause harmful interference to radio or television reception, which can be determined by tuning the equipment off and on, the user is encouraged to try to correct the interference by one or more of the following measures:

- Reorient or relocate the receiving antenna.
- Increase the separation between the equipment and receiver.
- Connect the equipment into an outlet on a circuit different from that to which the receiver is connected.
- Consult an authorized dealer or service representative for help.

Properly shielded and grounded cables and connectors must be used in order to meet FCC emission limits. Neither the provider nor the manufacturer are responsible for any radio or television interference caused by using other than recommended cables and connectors or by unauthorized changes or modifications to this equipment. Unauthorized changes or modifications could void the user's authority to operate the equipment.

This device complies with Part 15 of the FCC Rules. Operation is subject to the following two conditions: (1) this device may not cause harmful interference, and (2) this device must accept any interference received, including interference that may cause undesired operation.

United Kingdom Telecommunications Safety Requirements

This equipment is manufactured to the International Safety Standard EN60950 and as such is approved in the UK under the General Approval Number NS/G/1234/J/100003 for indirect connection to the public telecommunication network.

The network adapter interfaces housed within this equipment are approved separately, each one having its own independent approval number. These interface adapters, supplied by the manufacturer, do not use or contain excessive voltages. An excessive voltage is one which exceeds 70.7 V peak ac or 120 V dc. They interface with this equipment using Safe Extra Low Voltages only. In order to maintain the separate (independent) approval of the manufacturer's adapters, it is essential that other optional cards, not supplied by the manufacturer, do not use main voltages or any other excessive voltages. Seek advice from a competent engineer before installing other adapters not supplied by the manufacturer.

European Union (EU) Statement

This product is in conformity with the protection requirements of EU Council Directive 89/336/EEC on the approximation of the laws of the Member States relating to electromagnetic compatibility.

Neither the provider nor the manufacturer can accept responsibility for any failure to satisfy the protection requirements resulting from a non-recommended modification of the product, including the fitting of option cards not supplied by the manufacturer.

This product has been tested and found to comply with the limits of Class B Information Technology Equipment according to CISPR 22 / European Standard EN 55022. The limits of Class B equipment were derived for typical residential environments to provide reasonable protection against interference with licensed communication devices.

International Electrotechnical Commission (IEC) Statement

This product has been designed and built to comply with IEC Standard 950.

Avis de conformité aux normes du ministère des Communications du Canada

Cet appareil numérique de la Classe B respecte toutes les exigences du Règlement sur le matériel brouilleur du Canada.

Canadian Department of Communications Compliance Statement

This Class B digital apparatus meets the requirements of the Canadian Interference-Causing Equipment Regulations.

VCCI Statement

この装置は、情報処理装置等電波障害自主規制協議会（VCCI）の基準に基づくクラスB情報技術装置です。この装置は、家庭環境で使用することを目的としていますが、この装置がラジオやテレビジョン受信機に近接して使用されると、受信障害を引き起こすことがあります。
取扱説明書に従って正しい取り扱いをして下さい。

The following is a summary of the VCCI Japanese statement in the box above.

This is a Class B product based on the standard of the Voluntary Control Council for Interference from Information Technology Equipment (VCCI). If it is used near a radio or television receiver in a domestic environment, it may cause radio interference. Install and use the equipment according to the instruction manual. When used near a radio or a TV receiver, it may become the cause of radio interference.
Read the instructions for correct handling.

Radio Protection for Germany

Dieses Gerät ist berechtigt in Übereinstimmung mit dem deutschen EMVG vom 9.Nov.92 das EG-Konformitätszeichen zu führen.

Der Aussteller der Konformitätserklärung ist die IBM Germany.

Dieses Gerät erfüllt die Bedingungen der EN 55022 Klasse B.

Safety Notices

A *danger* notice indicates the presence of a hazard that has the potential of causing death or serious personal injury. *Danger* notices appear on the following pages:

4-2

A *caution* notice indicates the presence of a hazard that has the potential of causing moderate or minor personal injury. *Caution* notices appear on the following pages:

xi

1-3

2-14

4-2

4-63

Laser Safety Information

The optical drive is a laser product. The optical drive has a label that identifies its classification. The label, located on the drive is shown below.

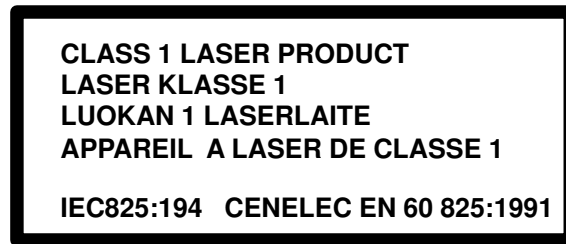

The optical drive is certified in the US to conform to the requirements of the Department of Health and Human Services 21 Code of Federal Regulations (DHHS 21 CFR) Subchapter J for Class 1 laser products. Elsewhere, the drive is certified to conform to the requirements of the International Electrotechnical Commission (IEC), 825 (1st edition 1984) and CENELEC EN 60 825/1991 for Class 1 laser products.

CAUTION:

A class 3 laser is contained in the device. Do not attempt to operate the drive while it is disassembled. Do not attempt to open the covers of the drive as it is not serviceable and is to be replaced as a unit.

Class 1 laser products are not considered to be hazardous. The optical drive contains internally a Class 3B gallium-arsenide laser that is nominally 30 milliwatts at 830 nanometers. The design incorporates a combination of enclosures, electronics, and redundant interlocks such that there is no exposure to laser radiation above a Class 1 level during normal operation, user maintenance, or servicing conditions.

Power Cables

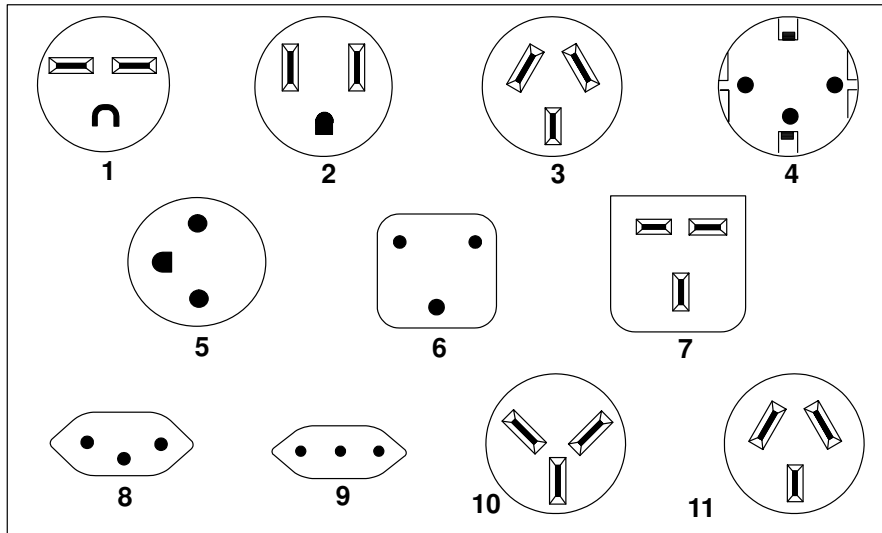

Index	Part Number	Country
1	1838574	Bahamas, Barbados, Bolivia, Brazil, Canada, Costa Rica, Dominican Republic, El Salvador, Ecuador, Guatemala, Guyana, Haiti, Honduras, Jamaica, Japan, Netherlands Antilles, Panama, Peru, Philippines, Taiwan, Thailand, Trinidad, Tobago, U.S.A. (except Chicago), Venezuela
2	6952300	Bahamas, Barbados, Bermuda, Bolivia, Brazil, Canada, Cayman Islands, Colombia, Costa Rica, Dominican Republic, Ecuador, El Salvador, Guatemala, Guyana, Haiti, Honduras, Jamaica, Japan, Korea (South), Mexico, Netherlands Antilles, Nicaragua, Panama, Peru, Philippines, Puerto Rico, Saudi Arabia, Suriname, Trinidad, Taiwan, U.S.A. (except Chicago), Venezuela
2	62X0663	Chicago, U.S.A.
3	6952311	Argentina, Australia, New Zealand
4	13F9979	Abu Dhabi, Austria, Belgium, Bulgaria, Botswana, Egypt, Finland, France, Germany, Greece, Iceland, Indonesia, Korea (South), Lebanon, Luxembourg, Macau, Netherlands, Norway, Portugal, Saudi Arabia, Spain, Sudan, Sweden, Turkey, Yugoslavia
5	13F9997	Denmark
6	14F0015	Bangladesh, Burma, Pakistan, South Africa, Sri Lanka
7	14F0033	Bahrain, Bermuda, Brunei, Channel Islands, Cyprus, Ghana, Hong Kong, India, Iraq, Ireland, Jordan, Kenya, Kuwait, Malawi, Malaysia, Nigeria, Oman, People's Republic of China, Qatar, Sierra Leone, Singapore, Tanzania, Uganda, United Arab Emirates (Dubai), United Kingdom, Zambia
8	14F0051	Liechtenstein, Switzerland
9	14F0069	Chile, Ethiopia, Italy
10	14F0087	Israel
11	6952291	Paraguay, Colombia, Uruguay

Environmental Notices

Product Recycling and Disposal

Components of the system unit, such as structural parts and circuit cards, can be recycled where recycling facilities exist. Companies are available to disassemble, reutilize, recycle, or dispose of electronics products. This system unit contains batteries and circuit boards with lead solder. Before you dispose of this unit, these batteries and circuit boards must be removed and discarded according to local regulations or recycled where facilities exist. This book contains specific information on each battery type where applicable.

About This Book

This book provides information on how to install and remove options, use the system, diagnostics, and service aids, and verify system operation. This book also provides information to help you solve problems that might occur. Chapter 7, “Hardware Problem Determination” on page 7-1, is the place you should go when you have a problem with the system unit. It contains procedures for determining if a problem is hardware or software related.

If a problem is software related, consult your operating system documentation.

ISO 9000

ISO 9000 registered quality systems were used in the development and manufacturing of this product.

Related Publications

The following publications are available:

The *ESCALA S Series Setup Instructions*, order number 86 A1 88JX, is a pictorial guide designed to help you quickly set up your system unit if no internal modifications are needed.

The *ESCALA S Series System Service Guide*, order number 86 A1 91JX, contains error codes, maintenance analysis procedures (MAPs), removal and replacement procedures, and a parts catalog.

The *Diagnostics Information for Multiple Bus Systems*, order number 86 A1 26HX, contains information and procedures that are common to all systems.

The *Adapters, Devices, and Cable Information Manual for Multiple Bus Systems*, order number 86 A1 27HX, contains cabling and technical information about some of the adapters and devices available for your system unit.

The *Disks and Tapes Configuration Information*, order number 86 A1 88GX, gives the jumper and switch settings to configure disks and tapes peripherals that use the Small Computer System Interface (SCSI).

Chapter 1. System Startup

Thank you for selecting the ESCALA S100 and ESCALA S120

These systems combine PowerPC 604 microprocessor performance and system expandability, ensuring that your system units adapt to handle ever-changing operating requirements. These systems are specifically designed to support the demands of network environments.

The systems incorporate the new, advanced peripheral component interconnect (PCI) bus, which is faster than the industry standard architecture (ISA) bus. But the ESCALA S100 also offers an ISA bus to accommodate businesses that already have invested in ISA-based devices.

This book helps you set up and use your system unit, install and remove options, configure your system, and use the system programs that are provided. This book also provides information to help you solve some of the simpler problems that might occur, and how to obtain assistance and service. Appendix A, "System Records" on page A-1 provides a section for you to record all the important information about your system unit.

Before You Begin

- Make sure you have the proper type and level of operating system supported for your system unit. ESCALA S100 supports AIX Versions 4.2.1 and 4.3.1. ESCALA S120 supports AIX Versions 4.2.1 or 4.3.2 and later. If you are unsure about whether or not an operating system is supported on your system unit, please call your marketing representative.
- Your system unit has a voltage-selection switch. Make sure you know the correct voltage setting for your country (the U.S. and Canada use the 115-volt setting). If you are not sure of the voltage setting for your country, contact your authorized reseller or marketing representative.
- Make sure you have an adequate number of properly grounded electrical outlets for your system unit, display, and any other options you intend to install.
- Place your system unit in a location that is dry. Rain or spilled liquids might damage your system unit.
- Leave about 50 mm (2 in.) of space around the system unit to allow the cooling system to work properly.
- Collect the following tools, and keep them handy:
 - Small flat-blade screwdriver
 - Medium flat-blade screwdriver
 - Trays to hold screws.

SAFETY NOTE: Before continuing, refer to the *System Unit Safety Information* book for Danger and Caution notices. Do *not* plug any cables into the system unit, adapters, or electrical outlets until you have reviewed this information.

Make sure none of the power cords are connected before continuing to the next step.

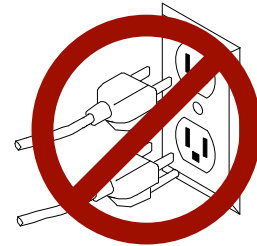

Unpacking Your System Unit

CAUTION:

To avoid possible injury while moving or lifting your system unit, ask another person to help you.

Preinstallation Checklist: After you unpack your system unit, display or ASCII terminal, and optional devices, make sure you have the following items:

- System unit and power cord.
- ASCII terminal, or mouse, display, and keyboard (if ordered).
- Your operating system and documentation.
- Options you want to install such as adapters, media drives, or external devices.

Contact your authorized reseller or marketing representative if any items are missing or damaged.

ESCALA S100 System Features

Bus Architecture

Five adapter slots are available:

- Slot 1, PCI primary
- Slot 2, ISA/PCI primary
- Slot 3, ISA/PCI secondary
- Slot 4 and 5, PCI secondary

Microprocessor

- PowerPC 604e 233 or 332 MHz, with:
 - 64KB internal cache
 - 1 MB parity synchronous L2 cache

Memory

- 64MB–768 MB
- 6 memory module sockets for 32MB, 64MB or 128MB dual inline memory modules with ECC EDO (extended data out).

Diskette Drive

Hard Disk Drives

- 4.5 GB and 9.1 GB high performance fast/wide SCSI–2
- Maximum supported: 3 internal

CD-ROM drive

- 12x - 20x speed 5.25 inch, with sliding tray (no caddy required).

Other Drives

- Drive bays can accommodate 5.25–inch or 3.5–inch drives such as hard disk drives, tape drives or other removable media drives.

Power Supply

- 250–watt, usable with 115 Vac or 230 Vac (Supports Wakeup–on–LAN)

Keyboard and Mouse

- Standard: 101 key Enhanced keyboard
- Optional: 101/102 or 106 Enhanced Keyboard
- Standard: 3–button mouse

Front–Panel Display

- 4–digit LED diagnostics display

Input/Output Ports

- 25–pin Parallel

- 9-pin Serial (2)
- 8-pin Tablet
- Keyboard
- Mouse
- SCSI-2 (16-bit) Fast/Wide
- 10Base5 Ethernet
- 10BaseT Ethernet
- Audio Line-in and Audio Line-out
- Microphone
- Headphone

Security Features

- Cover lock
- Tie-down (optional)
- Power-on password
- Privileged-access password
- SCSI security jumpers on system board

ESCALA S120 System Features

Bus Architecture

Five 32-bit PCI adapter slots are available:

- Slots 2 and 3, primary
- Slots 1, 4, and 5, secondary

Microprocessor

- PowerPC 604e 375 MHz, with 1 MB parity synchronous L2 cache

Memory

- 128MB–1GB
- 4 memory module sockets for 64MB, 128MB, or 256MB dual inline memory modules with ECC SDRAM EDO (extended data out).

Diskette Drive

Hard Disk Drives

- 4.5 GB and 9.1 GB Ultra SCSI drives
- Maximum supported: 3 internal

CD-ROM drive

- 32x speed 5.25 inch, with sliding tray (no caddy required)

Other Drives

- Drive bays can accommodate 5.25–inch or 3.5–inch drives such as hard disk drives, CD-ROM drives, tape drives or other removable media drives.

Power Supply

- Autoranging 250–watt, usable with 115 Vac or 230 Vac (Supports Wakeup–on–LAN)

Keyboard and Mouse

- Standard: 101 key Enhanced keyboard
- Optional: 101/102 or 106 Enhanced Keyboard
- Standard: 3–button mouse

Front–Panel Display

- 4–digit LED diagnostics display

Input/Output Ports

- 25–pin Parallel
- 9–pin Serial (2)
- 8–pin Tablet
- Keyboard
- Mouse

- Ultra SCSI (16-bit)
- 100/10 Base5 Ethernet
- 100/10 BaseT Ethernet
- Audio Line-in and Audio Line-out
- Microphone
- Headphone

Security Features

- Cover lock
- Tie-down (optional)
- Power-on password
- Privileged-access password
- SCSI security jumpers on system board

Front View

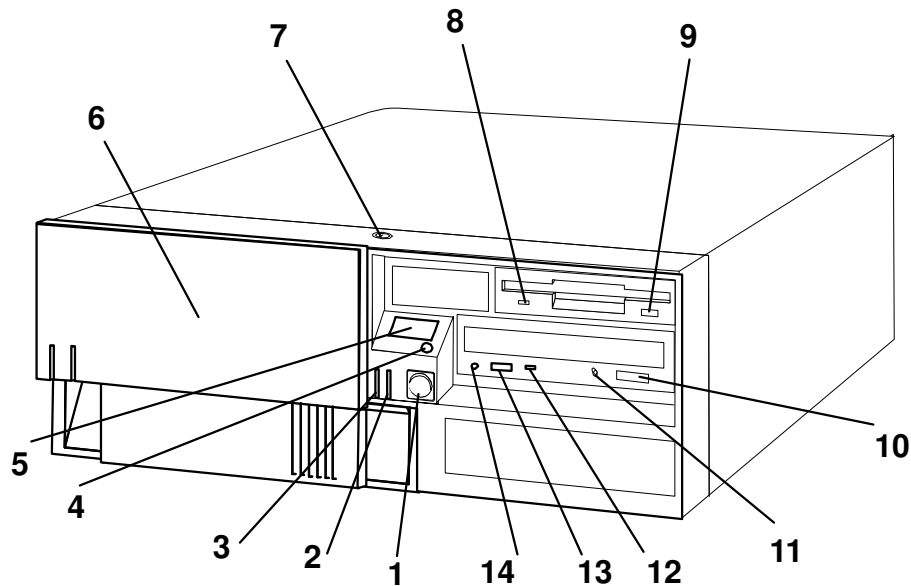

1 Power Switch: Turns computer power on and off.

2 Power-On Light: Glows when computer is on.

3 Hard Disk Drive In-Use Light: Glows when computer is reading from or writing to the hard disk.

4 Reset Button: Function depends upon the operating system installed.

5 Operator Panel Display: Function depends upon the operating system installed; may display current status of system unit startup, or diagnostic information in the event of a hardware problem.

6 Media Bay Cover: Covers the diskette and CD-ROM drives when they are not in use.

7 Cover Lock: Security feature. Prevents the cover from being removed.

8 Diskette-Drive status Light: Glows when computer is reading from or writing to a diskette.

9 Diskette Eject Button: Releases diskette from 3.5-inch diskette drive.

10 CD-ROM Eject Button: Releases the CD-ROM from the CD-ROM drive.

11 CD-ROM Emergency Eject: Ejects CD-ROM from the CD-ROM drive if power is not available.

12 CD-ROM Status Light: Indicates when the CD-ROM drive is active.

13 CD-ROM Volume Control: Controls the volume for the CD-ROM headphone jack.

14 CD-ROM Headphone Jack: CD-ROM Headphone connector.

Rear View

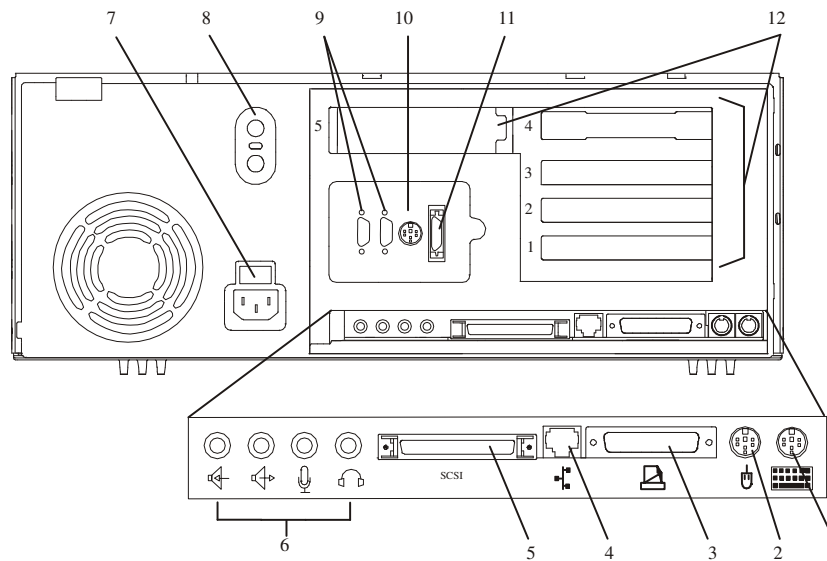

1 Keyboard Port: (): For keyboard connection.

2 Mouse Port (): For mouse connection.

3 Parallel Port (): For connecting a parallel printer or other parallel devices.

4 Ethernet Port (): For attaching your computer to an Ethernet/Twisted pair connection through a 10 Base T or 100/10 Base T connector. (ESCALA S100 uses 10 Base T; ESCALA S120 uses 100/10 Base T.)

5 External SCSI Port ():
For connecting external SCSI devices.

6 Audio Ports:

 Headphone

 Microphone

 Audio line out

 Audio line in

7 Voltage–Selection Switch (ESCALA S100 only): Select either 115–V or 230–V setting (available on specific systems). Voltage selection is not needed on ESCALA S120 as it uses an autoranging power supply.

8 Security tether attachment: Attachment point for a security tether.

9 9–Pin Serial Ports

( 1 and  2): For a TTY terminal, Modem, or other serial devices.

10 Tablet Port (): For attaching a digitizing tablet to your computer.

11 Ethernet Port (): For attaching your computer to an Ethernet thick connection (or Ethernet thin connection, using an optional transceiver) through a 10 Base 5 or 100/10 Base 5 connector. (ESCALA S100 uses 10 Base 5; ESCALA S120 uses 100/10 Base 5.)

12 Expansion Slots: For adding ISA and PCI adapters.

Installing Options

If you have options (such as adapters, hard disk drives, or memory-module kits) to install go to Chapter 4, "Installing and Removing Options" on page 4-1 to install them. After you complete option installation and have updated your configuration, return to this chapter to connect the cables and complete the system unit installation.

Connecting the Cables

1. If you are using a keyboard and display:
 - Attach the keyboard cable to the keyboard connector and the display to the display connector on the back of the display adapter in one of the expansion slots.
 - If you are installing a mouse or other pointing device, connect that cable.
 - Connect the display power cord to the display.

If you are using an ASCII terminal:

- Connect the ASCII terminal cable to the SI port on the system unit.
 - Connect the ASCII terminal power cord to the ASCII terminal.
2. Attach adapter cables to any adapters installed in the expansion slots. For more instructions on adapter cabling, please refer to the documentation that came with your *Adapters, Devices, and Cable Information Manual for Multiple Bus Systems*.

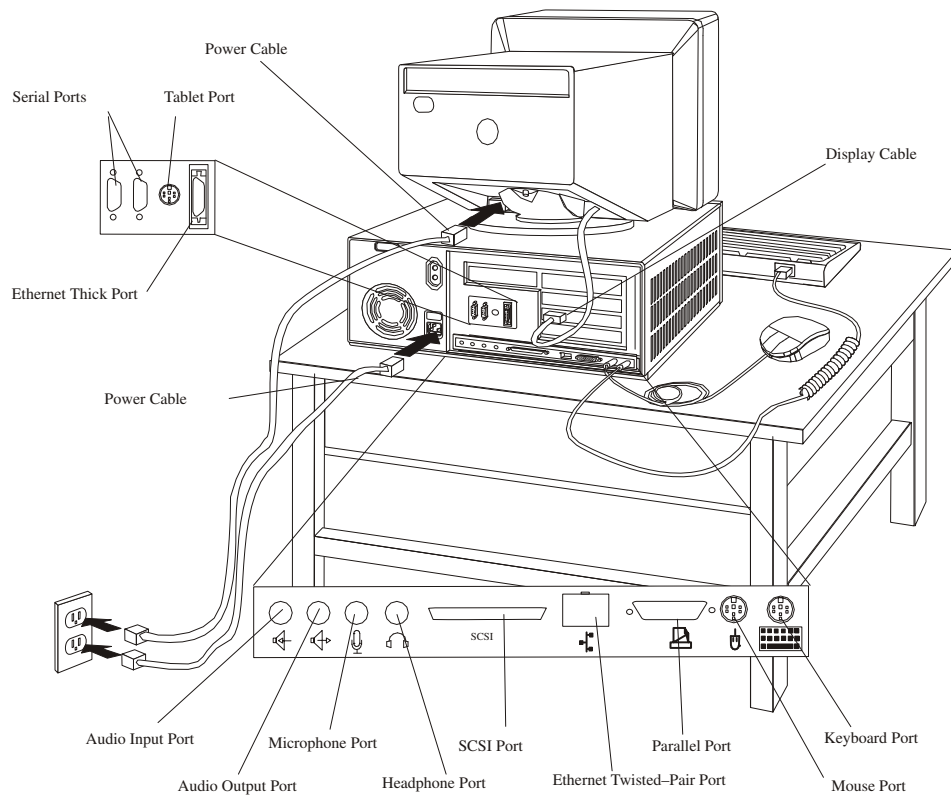

3. Make sure the voltage selection switch (directly above the power cable connector on the rear of the system unit) is set to the voltage appropriate for the voltage available in your area.
4. Make sure all externally attached devices are turned off.

5. Connect the system unit power cord to the power connector on the system unit. *Secure all these connections*, then plug the display power cord and the system unit power cord into properly grounded electrical outlets.

ATTENTION: As soon as the system unit power cord is plugged in to the system unit and power outlet, the power is on within the system unit ***whether or not the system unit is turned on***. Do not plug in the system unit power cord if the covers of the system unit are removed.

Checking the Voltage Setting

ATTENTION: On some systems a label covers the power connector, which is located at the rear of your system unit. Remove the label and then check the voltage–selection switch to verify that it is in the correct position. If you set this voltage switch to the wrong position, you might permanently damage your system unit when you turn it on.

Check the setting of the voltage–selection switch at the rear of your system unit.

- If the voltage range in your country is between 100 and 125 volts, check to see that 115 is visible. (Use the 115–volt setting in the U.S. and Canada.)
- If the voltage range in your country is between 200 and 240 volts, check to see that 230 is visible.
- If no voltage-selection switch is present, your system unit has an auto-ranging power supply. The power supply automatically switches to the correct setting.

If you need to adjust the voltage setting, slide the switch to the correct position.

Note: Voltage selection is not needed on ESCALA S120 as it uses an autoranging power supply.

Finishing the Installation

Important

- Be sure to maintain at least 50 mm (2 in.) of space at the rear of the system unit to allow the cooling system to work properly. Blocking the air vents can cause overheating, which might result in a malfunction or permanent damage.

Your system unit hardware is set up, and you are ready to learn about your system and make backup copies of important software. The order in which you do these tasks is up to you. Use the following checklist as a guide.

Record your Identification numbers

Your system unit has important identification information that you might need if you have it serviced.

Appendix A, "System Records" on page A-1 shows where to find these numbers, and provides space to record and retain this information.

Install the Operating System

AIX is preinstalled in your system unit. If you plan to reinstall AIX yourself, refer to the AIX documentation for instructions.

Install application programs

To install application programs, follow the instructions supplied with each application program.

Chapter 2. Using the System Unit

Starting the System Unit

1. Turn on all attached devices.
2. Turn on the system unit.

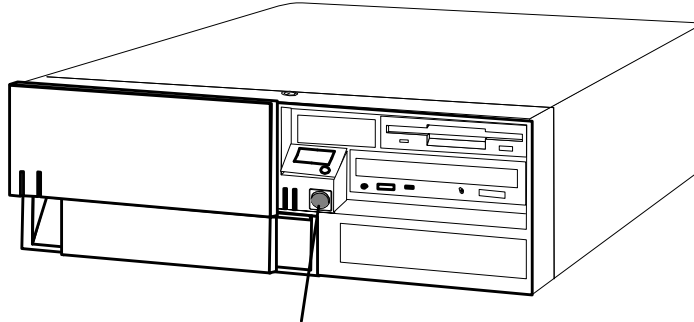

PowerSwitch

3. If power does not come on when you turn on the system unit, ensure that the power cord, located at the back of the system unit, is plugged into a grounded electrical wall outlet. If this does not solve the problem, go to Chapter 8, "Hardware Problem Determination" on page 8-1.

When you turn on the system unit, the Power LED comes on and the system starts a POST (power-on self test). During this test, the disk activity LED flashes intermittently. The system beeps a short beep, and progress indicators appear on the operator panel display.

Console Selection

After the system starts up, you have the opportunity to select the system console for your system unit if one has not been chosen before (or if your display adapter configuration has changed). The system console functions as the primary display and keyboard for your system unit.

On a graphical display, the console selection screen looks like the following illustration.

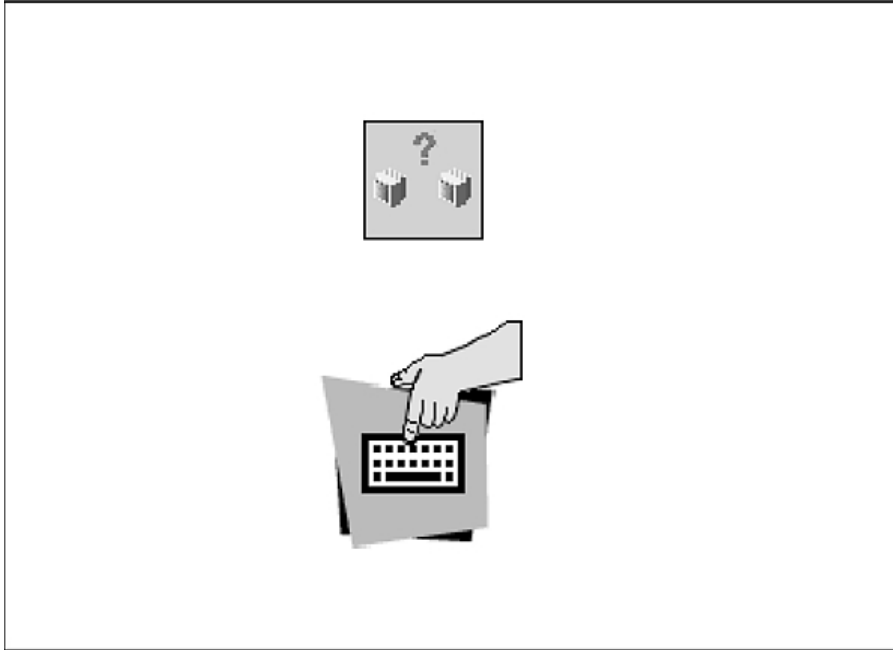

If the console selection screen appears, each display and ASCII terminal attached to your system unit appears with a number. To define a display or ASCII terminal as your system console, press the number on the keyboard that corresponds to the system console you choose.

If a console is not chosen after a certain amount of time, the system unit automatically chooses an ASCII terminal as the system console (whether or not one is installed). To choose another system console, you must shut down and restart the system unit.

POST Indicators

If you are using an ASCII terminal (attached to serial port 1), a series of POST indicators appear on the screen as each subsystem is initialized.

If you are using a directly-attached keyboard and a graphical display attached to a display adapter, then the POST progress indicators appear as icons across the bottom of the display as follows.



Memory Modules: Tests system memory.



Keyboard: Initializes the keyboard and mouse.

When this icon appears, you can choose one of several different startup options.

- Pressing the F1 key activates the System Management Services.
- Pressing the F5 or F6 key chooses a service-mode boot from the default or custom boot list.
- Pressing the F8 key selects the Open Firmware Command line.

If any of these keys are pressed, the chosen option occurs after all of the following POST icons appear. If no keys are pressed, the system unit boots from the default boot list and starts the operating system after all POST icons appear.



Network: Initialize network adapters



SCSI: Initializes SCSI adapters



Audio: Initializes the audio system. Any startup option keys must be pressed before the end of audio initialization in order to take effect.

If the POST process stops and indicates an error in any one of these subsystems, record the error number and refer to Chapter 8, "Hardware Problem Determination" on page 8-1.

For more information on:

- The System Management Services (started by pressing F1), see to "System Management Services" on page 3-1.
- The Open Firmware command line (started by pressing F8), see "System Management Services" on page 3-1.
- Alternate boot modes (started by pressing F5 or F6), see "System Startup Options" on page 2-5.

The last indicator to appear is the boot indicator. This indicator shows that the system unit hardware is working and preparing to load and start the operating system.



At this point, the system prompts you for the power-on password or the privileged-access password, if they have been set. (See "System Management Services" on page 3-1 for instructions on setting passwords.)

If three incorrect responses are given to the password prompt, the system locks up and must be turned off and turned on again to be reset. If the power-on password has been lost, then the power-on password jumper must be reset or disabled:

- To reset the power-on password, remove the system unit power cable, then remove the system unit battery for 30 seconds.
- To disable the power-on password, see "Disabling the Power-On Password" on page 4-8

ATTENTION: Removing the battery may also erase system configuration information stored in the nonvolatile random access memory (NVRAM), such as the custom boot list.

Note: If the privileged-access password has been lost, contact your authorized reseller or marketing representative.

If no bootable operating system image is found on any of the storage devices listed in the system firmware boot list, then the system unit attempts to boot again. With each attempt, you have the opportunity to start the System Management Services (SMS) as described in "System Management Services" on page 3-1.

Stopping the System Unit

ATTENTION: When using the shutdown procedure for your system, enter the correct shutdown command for your operating system before you stop the system unit. Failure to do so may result in the loss of data. If you need information on the shutdown procedure for your operating system, see the operating system documentation.

1. Before stopping the programs and operating system, notify your system administrator and users that the system will be shut down.
2. After you shut down the operating system, turn off the system unit.
3. Set the power switches of the attached devices to Off.

Power Switch and Indicator

The power switch and indicators on the front of your system unit allow you to control power to the system unit, observe system power status, and observe disk activity.

These features also have other built-in capabilities to assist you in diagnosing system problems and observing system status:

- When the system unit is turned on by pressing the power switch, the power LED lights steadily.
- The disk drive LED lights whenever the hard disk drives within the system unit are being used.
- If AIX is installed and running, a memory dump of system information can be requested.
 - To enable this function, the **sysdumpdev -K** command must be executed before an error condition exists.
 - To request the memory dump, press the reset button on the operator panel. Requesting a memory dump directs AIX to save system information to a predefined file before turning off the system. This feature can be used to assist in recovery from system problems.
 - When a memory dump has been requested the power LED blinks quickly (about 10 flashes per second) to indicate that the dump has been started. This blinking ceases after about a minute whether or not the dump is complete, and the LED returns to its steady, lit state until the system turns off or reboots when the dump is complete.
 - The memory dump file can be viewed by entering the AIX command **sysdumpdev -L**.

Operator Panel and Reset Switch

The operator panel on the front of the system unit contains a four-digit display and reset button. The four-digit display is used by your system unit to display progress indicators during system startup, and may also display error messages.

The function of the reset button depends on the operating system installed in the system unit. Please consult your operating system documentation for a description of its function.

System Startup Options

If no keys are pressed after the system unit power is turned on, the system unit searches a list of devices (the **default boot llist**) for a bootable image. If a bootable image is found, then the system unit loads and starts the operating system. This is called a **normal boot**.

The system unit can also be booted from a **custom boot list**, which can be changed through the System Management Services.

If certain keys are pressed during system startup, the system unit searches the default or custom boot list for a bootable image to start in **service mode** instead of normal mode. After a successful service mode boot, the diagnostic programs are started automatically.

The following pages describe the default and custom boot lists, and how to boot from these in either normal or service mode.

Default Boot List

The **default boot list** is composed of the first device found of each of the following types:

1. Diskette drive
2. CD-ROM drive
3. Disk Drive
4. Network device

If this default boot list is used during system startup, the system unit attempts to boot from the diskette drive, then the first CD-ROM drive encountered, then the first disk drive encountered, and finally the first network connection encountered.

Custom Boot List

The contents of the **custom boot list** can be defined by using the graphical System Management Services (see "Boot" on page 3-8) or the text-based System Management Services (see "Select Boot Devices" on page 3-23). When the custom boot list is utilized during system startup, system unit attempts to boot in turn from each specific device in the custom boot list.

Note: Only the specific devices contained in the custom boot list are checked for a bootable image. Other devices of the same type are **not** searched for a bootable image unless they are also specified in the custom boot list. Refer to Chapter 3, "System Management Services" for more information on custom boot lists.

If no bootable image is found in the custom boot list, then the system restarts and attempts to boot again..

If the custom boot list is discovered to be corrupted, the system rebuilds the custom boot list according to the default boot list.

Service Mode Boot: Loading Diagnostics

The system unit can be booted in **service mode** (instead of **normal mode**) from either the default boot list or custom boot list. After a successful service mode boot, the diagnostic programs are started automatically.

Booting in Service Mode from the Default Boot List

To boot in service mode from the **default** boot list, do the following:

1. Before stopping the programs and operating system, notify your system administrator and users that the system is going to be shut down.
2. Insert the diagnostic CD-ROM into the CD-ROM drive, if you intend to run standalone diagnostics.
3. Turn off the system.
4. Wait 30 seconds, then turn on the system.
5. When the keyboard indicator appears during startup, press the **F5** key if the system console is a directly-attached keyboard, or the **5** key if the system console is an ASCII terminal.
6. Enter any passwords.

Diagnostics loaded from CD-ROM are called **standalone** diagnostics. Since the default boot list checks the CD-ROM drive before the disk drive, this procedure is used to start standalone diagnostics.

Booting in Service Mode from the Custom Boot List

To boot in service mode from the **eustom** boot list, do the following:

1. Verify with the system administrator and users that all programs are to be stopped, then do so.
2. Turn off the system.
3. Wait 30 seconds, then turn on the system.
4. When the keyboard indicator appears during startup, press the **F6** key if the system console is a directly-attached keyboard, or the **6** key if the system console is an ASCII terminal.
5. Enter any passwords.

Diagnostics loaded from a disk drive or network are called **online** diagnostics. (Online diagnostics can be used only if AIX is installed.) Since the custom boot list should list the disk drive or network device before the CD-ROM drive, this procedure is used to start online diagnostics. To ensure that using the custom boot list starts online diagnostics, do not insert the diagnostics CD-ROM.

Standalone vs. Online Diagnostics

When the system unit attempts to boot in service mode (from either the default or custom boot list) and locates a diagnostics CD-ROM before any other bootable image, then the system unit starts **standalone diagnostics**.

Standalone diagnostics can be used on system units installed with any supported operating system.

When the system unit attempts to boot in service mode (from either the default or custom boot list) and first locates a bootable image on disk drive or network connections then the system unit starts **online diagnostics**.

Online diagnostics can only be used on system units installed with the AIX operating System.

Because the type of diagnostics started (standalone or online) depends on the source from which they are loaded, changing the boot list used during system startup can affect which diagnostics are run.

Recommended Boot Options

The procedures under "Service Mode Boot: Loading Diagnostics" on page 2-6 produce the following recommended results:

- Default boot list (F5 or 5 key) with diagnostics CD-ROM inserted loads **Standalone Diagnostics**.
- Custom boot list (F6 or 6 key) without diagnostics CD-ROM inserted loads **Online Diagnostics**, if AIX is installed on a device in the custom boot list.

Summary: Boot Options and Control Keys

The following keys can be pressed when the keyboard POST indicator appears.

Key	Result
F1 (display keyboard)	Normal mode boot, graphical System Management Services starts
1 (ASCII keyboard)	Normal mode boot, text-based System Management Services starts.
F5 (display keyboard)	Service mode boot, default boot list.
5 (ASCII keyboard)	Service mode boot, default boot list.
F6 (display keyboard)	Service mode boot, custom boot list.
6 (ASCII keyboard)	Service mode boot, custom boot list.
F8 (display keyboard)	Normal mode boot, Open Firmware command line.
8 (ASCII keyboard)	Normal mode boot, Open Firmware command line.

Using the Keyboards

There are several keyboards available with the system unit. The keyboards have various keys that enter data and control the cursor location. The keyboards can be engraved for the languages of different countries.

The functions of each keyboard depend on the software used. The character sets for the keyboards are contained and explained in the information for your operating system.

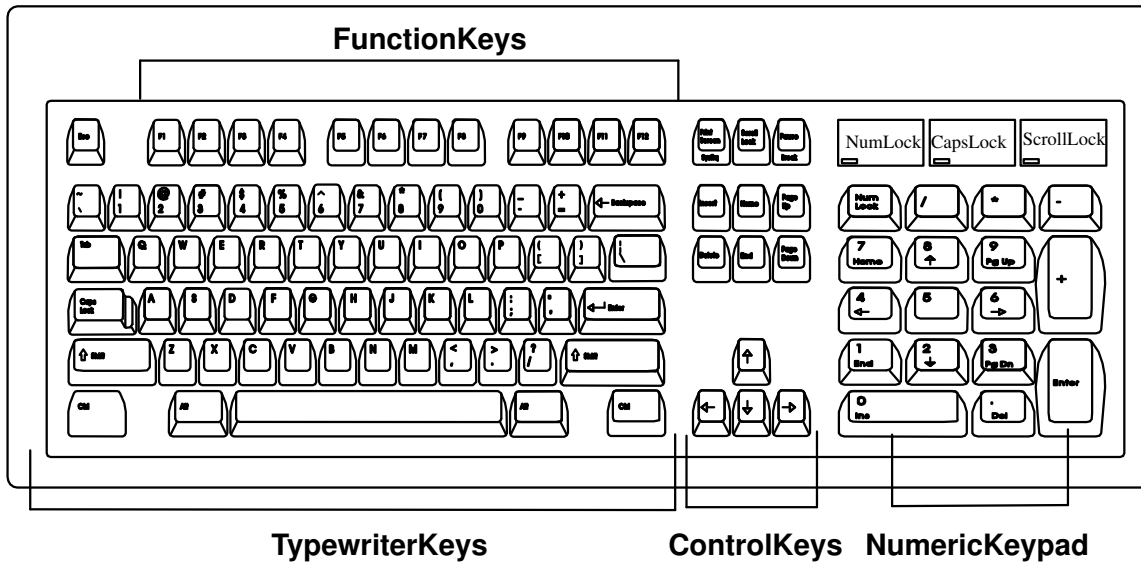

The keyboard is divided into four sections:

- The function keys are multipurpose keys and their function is controlled by the operating system.
- The typewriter keys are similar to a standard typewriter. Their function is controlled by the software.
- The control keys move the cursor on the screen and do programmed control functions. The movement and functions depend upon the application used.
- The numeric keypad is arranged like a calculator to help when typing numbers.

On all of the keyboards, you can adjust the tilt position for typing comfort. To tilt the keyboard, pull out on the keyboard legs. The legs snap into position. To decrease the tilt of the keyboard, rotate the keyboard legs until they snap into the bottom of the keyboard case.

The keyboard cable plugs into the connector at the rear of the system unit.

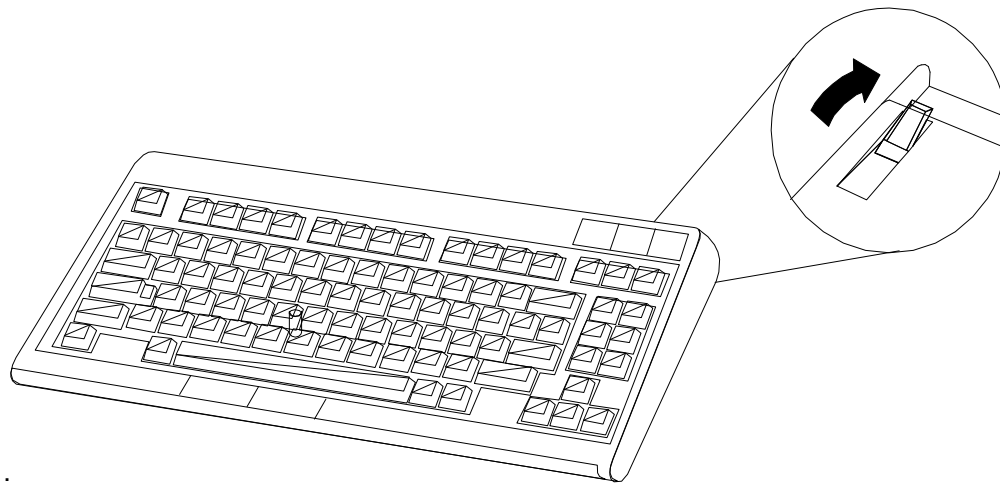

Using The Mouse

The mouse is a hand-operated locating device. Consult your application publication for the exact use of the three-button mouse.



You can use the mouse to perform functions such as positioning a cursor, selecting items from a menu, or moving around in your document much easier and faster than if you used only the keyboard. The cursor moves exactly as you move the mouse on a flat surface, such as a desktop.

When you move the mouse around on a flat surface as shown in the following illustration, the cursor moves on the display screen; the movement changes the position of the cursor.

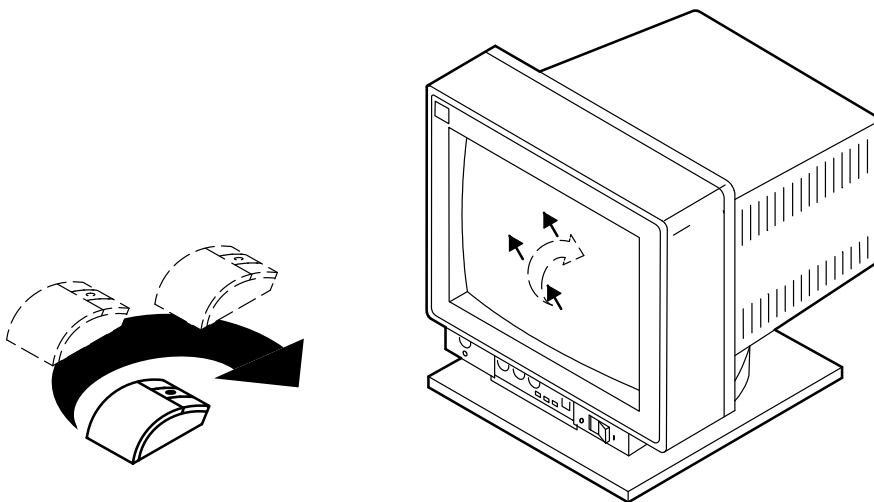

With the mouse buttons, you can perform functions such as selecting and deselecting options, extending your selection, or choosing a command. The precise function of your mouse depends on the software you are using.

The mouse has a cable that plugs into a connector at the rear of the system unit.

Handling the Mouse Correctly

For best operation, handle the mouse with care. Incorrect handling can damage the mouse.

Do not:

- Operate the mouse on cloth, unfinished wood, newspaper, or carpet.
- Drop or hit the mouse.
- Carry the mouse by holding onto the cable.
- Expose the mouse to extreme temperatures or direct sunlight.
- Place the mouse in liquid spills.

Care of the Mouse

The operating surface for the mouse should be smooth, clean, and flat. For example, you can operate the mouse on the following surfaces:

- Finished wood
- Glass
- Enamel
- Plastic
- Paper (except newspaper)
- Metal

Rough surfaces collect contaminants that can be transferred to the interior of the mouse by the ball. The surface you use should be free from spills, dirt, dust, lint, wax, eraser dust, and other foreign matter. Rough surfaces can also cause the pads located on the bottom of the mouse to prematurely wear. A deeply pitted surface could cause erratic operation of the mouse.

- Inspect the work surface for spills or other contaminants.
- Dust the work surface.
- If you are using a paper pad, inspect it for wear and replace it if necessary.

Cleaning the Mouse

1. Remove the retaining ring by turning it counterclockwise, in the direction of the arrow as shown in the illustration.

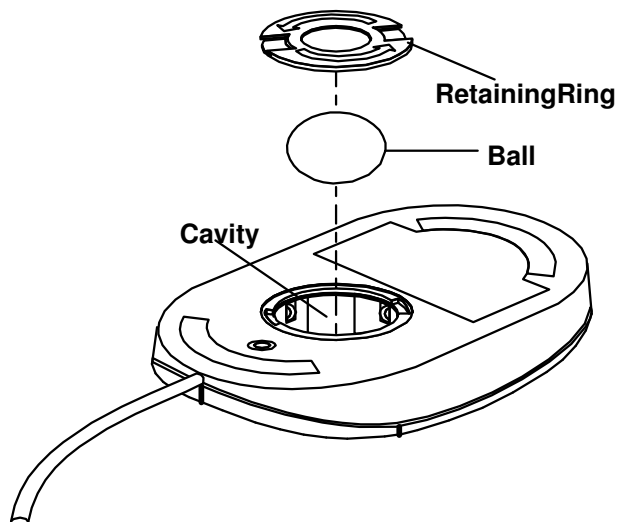

2. Remove the ball.
3. Inspect the ball for contaminants. Wipe it clean with a dry, lint-free cloth.
4. If the ball is dirty, wash it in warm, soapy water. Rinse and wipe the ball with a lint-free cloth until dry
5. Inspect the ball cavity in the mouse for foreign materials. If there are any foreign materials, remove them.
6. Replace the ball.
7. Replace the retaining ring on the mouse and align it with the open slots in the ball cavity.
8. Turn the retaining ring clockwise until the open slots are covered and you hear the ring snap into place.

Using the 3.5-Inch Diskette Drive

Diskette Compatibility

The system unit has a 1.44MB diskette drive installed.

The 1.44MB diskette drive can format, read, and write diskettes compatible with the following diskette drives:

- 1.0MB diskettes with 720KB formatted data capacity.
- 2.0MB diskettes with 1.44MB formatted data capacity (HD).

Format the diskette according to its specified capacity.

Write-Protecting 3.5-Inch Diskettes

Write-protecting diskettes is necessary so that important information is not accidentally lost. When diskettes are write-protected, you can read information from the diskettes, but you cannot write information on to them.

There is a write-protect tab on the 3.5-inch diskette.

To locate the write-protect tab, turn the diskette over with the label facing down.

- To prevent writing onto a diskette, slide the write-protect tab to open the protect slot.

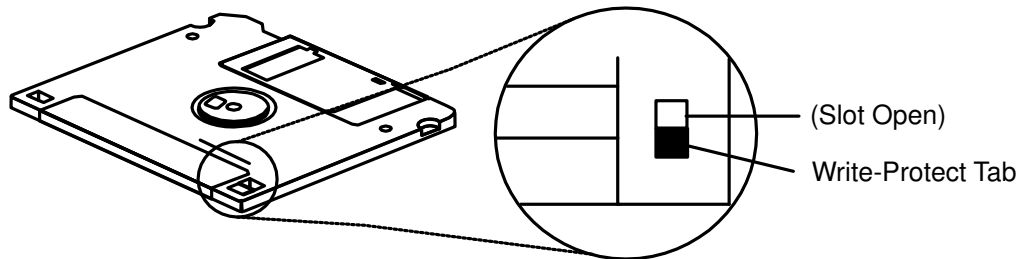

- To allow writing onto a diskette, slide the write-protect tab to cover the protect slot.

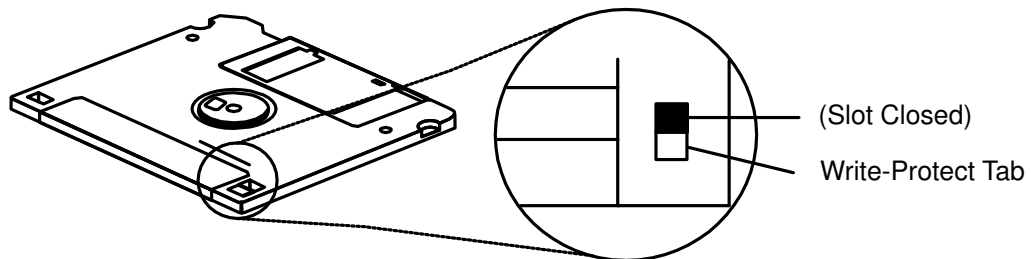

Loading and Unloading the 3.5-Inch Diskette

To load a diskette into the drive, insert the diskette in the diskette drive with the labeled metal shutter first. Push the diskette into the drive until you hear a click. The click indicates that the diskette is securely in position in the drive.

To unload the diskette, push the diskette-unload button. The diskette unloads partially from the drive. Pull the diskette out.

Using the CD-ROM Drive

CAUTION:

A Class 3 laser is contained in the device. Do not attempt to operate the device while it is disassembled. Do not attempt to open the covers of the device, as it is not serviceable and is to be replaced as a unit.

The CD-ROM is located in bay 2 of the system unit. Your CD-ROM drive looks like the one shown in the illustration, and the controls are located as indicated.

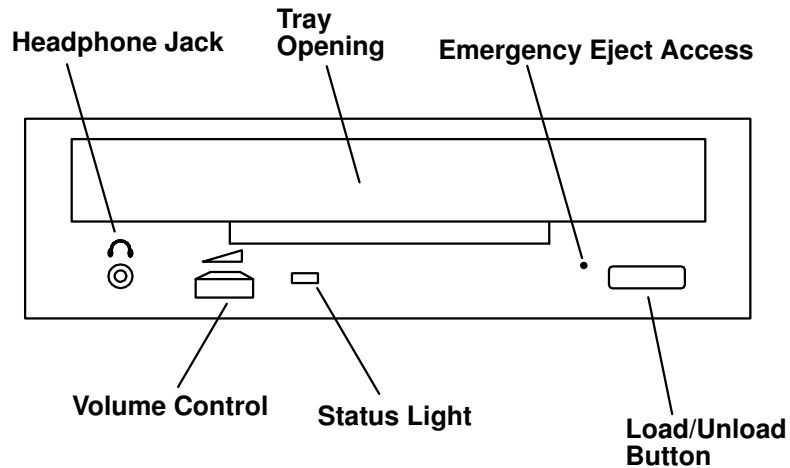

When the CD-ROM is set to On, the status light indicates one of several conditions. The following are status light states and the respective conditions of the CD-ROM drive:

- Off during standby with the CD-ROM loaded or unloaded.
- Blinks from the closing of the tray to completion of initialization.
- Blinks slowly when either the lens or disc is dusty.
- Blinks quickly when in the audio mode.
- Lights during data transfer operations.
- Lights steadily when some condition exists that should be checked.

Loading the CD-ROM Drive

Press the unload button to open the tray. Place the disc in the tray with the printed side up. Push gently on the load/unload button. The drive automatically pulls the tray into the drive and prepares the disc for reading.

If the CD-ROM drive is in the vertical position, slip out the lower tabs to hold the disc in place.

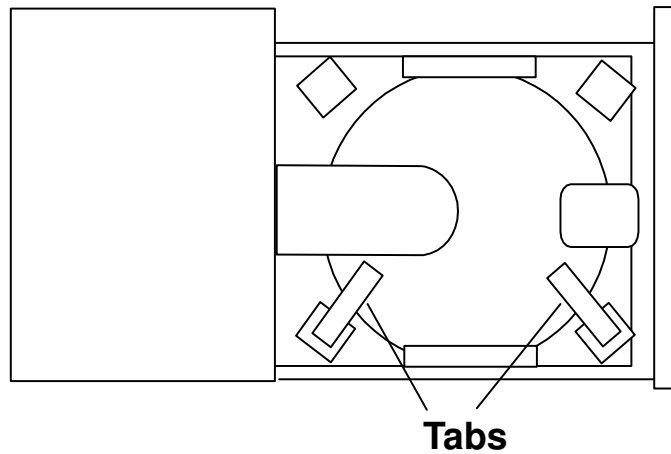

Unloading the CD-ROM Drive

Push and hold the unload button until the drawer comes out and then remove the disc.

Cleaning the CD-ROM Drive

This CD-ROM drive has an internal head-cleaning mechanism, and therefore does not require an external cleaning device. The internal cleaning mechanism cleans the head every time the tray is closed with a disc in the tray.

Always handle discs carefully by the edges to avoid leaving fingerprints or scratching them (this helps the disc to maintain good readability.) Wipe discs with a soft, lint-free cloth or lens tissue. Always wipe in a straight line from the inner hub to the outer rim.

Performing an Emergency Eject

Note: Execute the following procedure only in an emergency, such as when the tray does not open if the unload button has been pressed.

1. Insert a small diameter rod, such as a straightened paper clip, into the emergency eject hole. (Refer to the illustration below for the location of the emergency eject access.)
2. Push the tool in until some resistance is felt.
3. Maintain a small amount of pressure on the rod while pulling on the tray with your finger nail.
4. Pull the tray open and remove the disc.

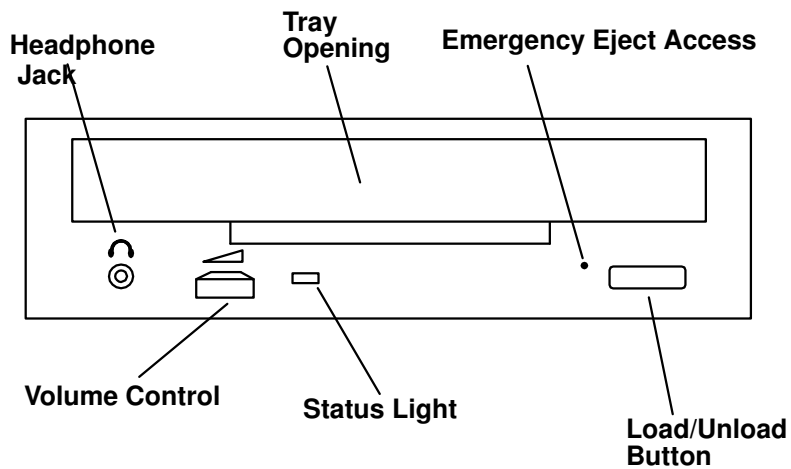

Note: Normally the tray makes a ratcheting sound when pulling it open using the above procedure.

Chapter 3. System Management Services

System Management Services

The System Management Services make it possible for you to view information about your computer and to perform such tasks as setting passwords and changing device configurations.

If you have chosen a graphical display as your system console, you can use the graphical System Management Services described below. If you are using an ASCII display as your system console, see "Text-Based System Management Services" on page 3-21.

Graphical System Management Services

To start the Open Firmware command line or graphical System Management Services, turn on or restart the computer.

The firmware version installed in your system unit is displayed at the bottom right-handed corner of the initial logo screen. Please note the version number; processor upgrades may require a specified version of firmware to be installed in your system unit. (Update System Firmware is an option under the Utilities menu in the System Management Services).

After the logo is displayed, initialization icons appear across the bottom of the screen.

To enter the graphical System Management Services, you must press the **F1** key *after the keyboard icon appears* during startup.

If you have pressed the **F1** key, the System Management Services appears after the initialization and power-on self test (POST) are complete.

Note: If you have installed a privileged-access password, you will be prompted for this password before gaining access to the System Management Services menu.

After the System Management Services starts, the following screen appears.



The System Management Services screen contains the following choices.



Config: Enables you to view your system setup.

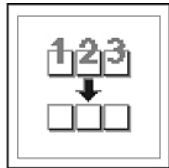

Multi-Boot (ESCALA S120 only): Enables you to set and view the default operating system, modify the boot sequence, access the Open Firmware command prompt, and other options.



Boot (ESCALA S100): Allows you to modify the boot sequence.

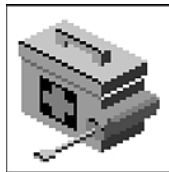

Utilities: Enables you to set and remove passwords, control the playing of system tones, enable the unattended start mode, set and view the addresses of your system's SCSI controllers, select the active console, view or clear the error log, and update your system unit's firmware program.

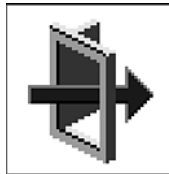

Exit: Returns you to the previous screen.



To select an icon, move the cursor with the arrow keys to choose which icon is highlighted, then press the **Enter** key. You can also select an icon by clicking on it with your left mouse button. To leave the current screen, either press the **Esc** key or select the **Exit** icon.

Config



Selecting this icon makes it possible for you to view information about the setup of your system unit. A list similar to the following appears when you select the **Config** icon.

```
<Device Name>
PowerPC, 604
L2-Cache, 0512K
Memory
    slot A=8 MB
    slot B=8 MB
LPT
    addr=3BC
IDE
    addr=1F0
COM
    addr=3F8
COM
    addr=2F8
Audio
Keyboard
Mouse
Diskette
    addr=3F0
Integrated Ethernet
    addr=9999FF111B
Video
    enhanced graphics
```

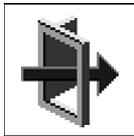
Exit

If more than one screen of information is available, a blue arrow in the top right corner of the screen appears. Use the Page Up and Page Down keys to scroll through the pages.

SCSI cntrl id=7
CD-ROM id=3
1084 MB Hardisk Id=6

PCI Adapters
SCSI cnttlr Id=7
slot=1

Security	OK
x.x	Firmware Version
1/06/1997	Firmare Date
40H5174	Firmware P/N
xxxxxxx	Serial Number

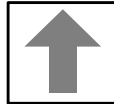
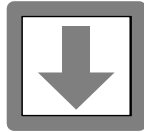

Exit

Note that this configuration information does not include **ISA** adapters installed in the system unit.

MultiBoot (ESCALA S120 only)

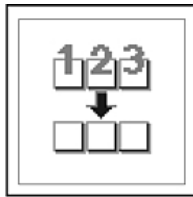

The options available from this screen allow you to view and set various options regarding the operating system and boot sequence.

Note: The SMS software on the ESCALA S100 do not have this menu option. On this system, this menu is replaced by the Boot menu. See "Boot (ESCALA S100 only)" for details.

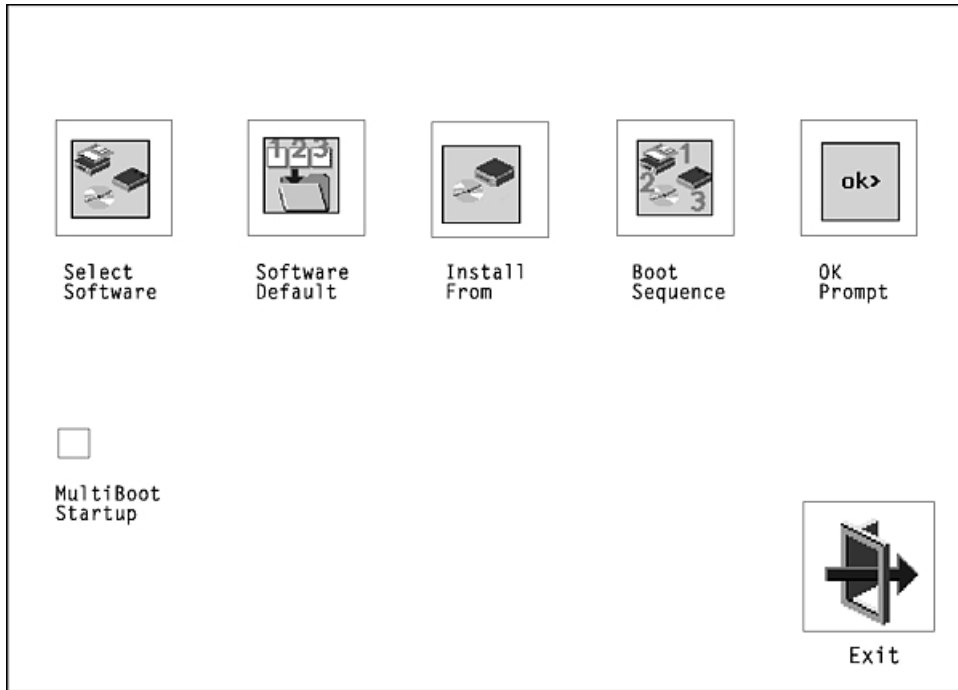

The following describes the choices available on this screen.



Select Software: The Select Software option, if supported by the operating system, allows you to choose which operating system to use. This option is supported by AIX. Not all operating systems support this option.

If you receive an informational message saying that no operating system is installed, then the system information in non-volatile storage may have been lost. This can happen if the battery has been removed. To correct this situation, refer to the bootlist reference in your AIX operating system documentation.



Software Default: This option, if supported by the operating system, enables you to select an operating system as the default operating system for your system unit.

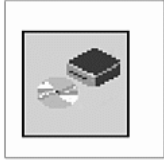

Install From: Enables you to select a media drive from which to install an operating system.



Boot Sequence: Enables you to view and change the custom boot list (the sequence in which devices are searched for operating system code). You may choose from 1 to 5 devices for the custom boot list.

The default boot sequence is:

5. The primary diskette drive.
6. The CD-ROM drive.
7. Tape drive.
8. Hard disk drive.
9. Network device.

To change the custom boot list, enter a new order in the New column, then click on the Save icon. The list of boot devices is updated to reflect the new order.

ATTENTION: To change the custom boot list back to the default values, click on **Default**. If you change your startup sequence, you must be extremely careful when performing write operations (for example, copying, saving, or formatting). You can accidentally overwrite data or programs if you select the wrong drive.



OK Prompt: Enables you to go directly to the Open Firmware command prompt. The Open Firmware command prompt is used for debugging and device driver development. For more information about the operation of the Open Firmware command prompt, refer to IEEE Standard 1275.

Multiboot Startup: Clicking on this button toggles whether the Multiboot menu appears automatically at startup.

Boot (ESCALA S100 only)



This selection enables you to view and change the custom boot list (the sequence in which devices are searched for operating system startup code).

New		List of Boot Devices
–	[1]	Diskette
1	[2]	SCSI CD-ROM id=3 (slot=1)
3	[3]	SCSI 2168 MB Harddisk id=6 (slot=1)
2	[4]	Ethernet (Integrated)

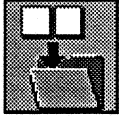
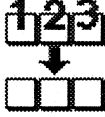
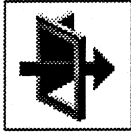
Save Default Exit

ATTENTION: If you change your startup sequence, you must be extremely careful when performing *write* operations (for example, copying, saving, or formatting). You can accidentally overwrite data or programs if you select the wrong drive.

The default boot list consists of the first device found of each of the following types

- Diskette drive
- CD-ROM drive
- Hard disk drive
- Network device

To change the custom boot list, enter a new order in the **New** column, then select **Save**. The List of Boot Devices is updated to reflect the order you have chosen.

You can choose 1 to 4 devices for the custom boot list. To change the boot sequence back to the default values, select **Default**. (The default sequence is automatically saved.)

ATTENTION: If no user-defined boot-list exists, and the privileged-access password has been enabled, you will be asked for the privileged-access password at startup every time you boot up your system. See "Privileged-Access Password" on page 3-13 for more information on the privileged-access password.

Utilities



Selecting this icon enables you to perform various tasks and view additional information about your system unit.

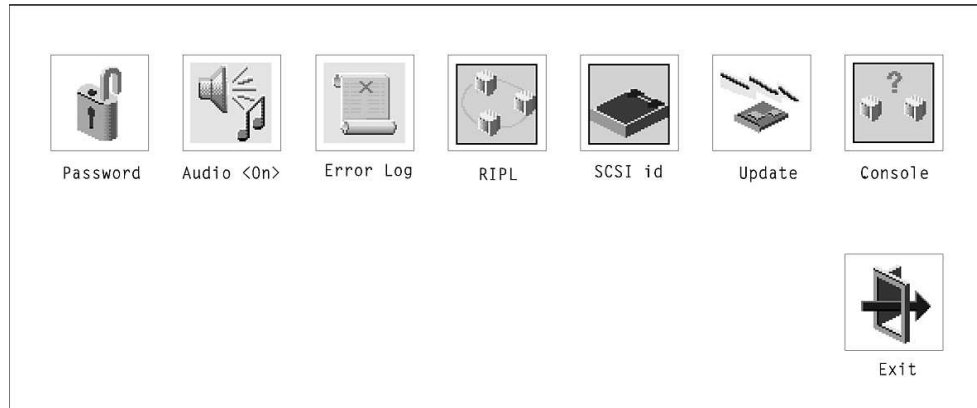

The following describes the choices available on this screen.



Password: Enables you to set password protection for turning on the system unit and for using system administration tools.



Audio (ESCALA S100 only): Enables you to turn on or off the system tones heard when the system is turned on.

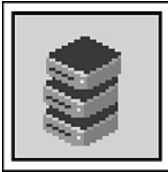

Hard Disk Spin Up Delay (ESCALA S120 only): Enables you to change the spin up delay for SCSI hard disk drives attached to your system.



Error Log: Enables you to view and clear error log information for your system unit.



RIPL (Remote Initial Program Load): Allows you to select a remote system from which to load programs via a network adapter when your system unit is first turned on. This option also allows you to configure network adapters which require setup.

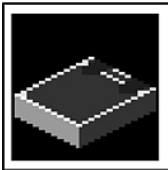

SCSI ID: Allows you to view and change the addresses (IDs) of the SCSI controllers attached to your system unit.



Update: Allows you to update the system firmware program



Console: If you have more than one keyboard and display attached to your system unit, or if you have an ASCII terminal attached to your system unit in addition to a keyboard and display, this tool allows you to define which one is active.

Password



When you select this icon, the following screen is displayed.

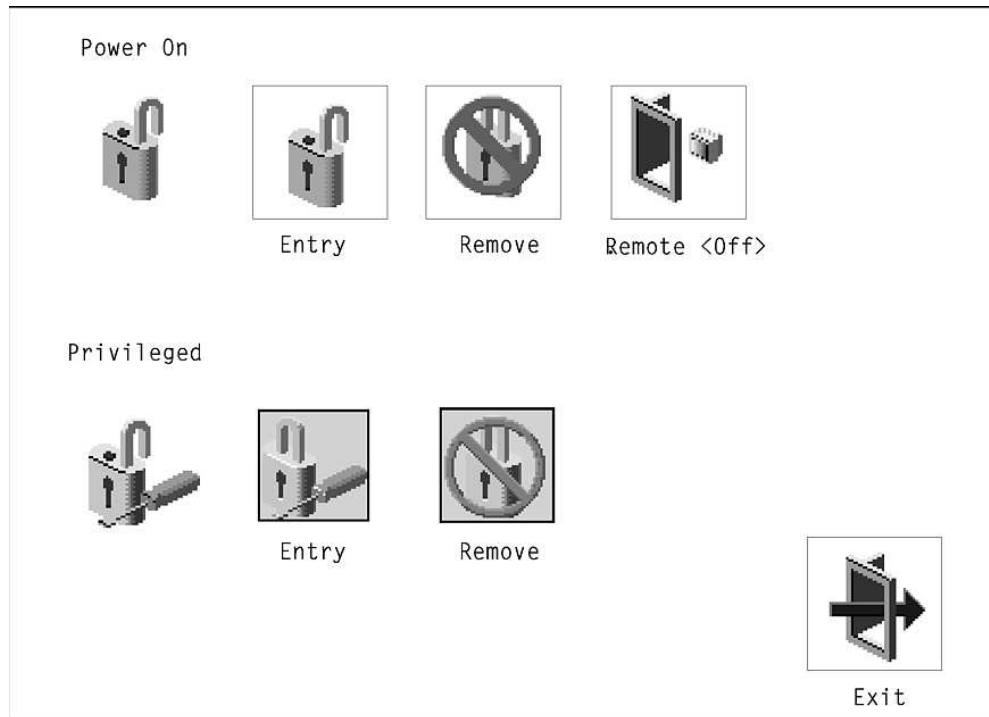

Power-On Password: Setting a power-on password helps protect information stored in your system unit. If a power-on password is set for your system unit, the Power-On status icon is shown in the locked position; if a power-on password is not set, then the Power-On status icon is shown in the unlocked position (as in the screen above).

When you select the Entry icon, a screen with 8 empty boxes appears. Type your password in these boxes. You can use any combination of up to eight characters (A-Z, a-z, and 0-9) for your password. As you type a character, a key appears in the box.

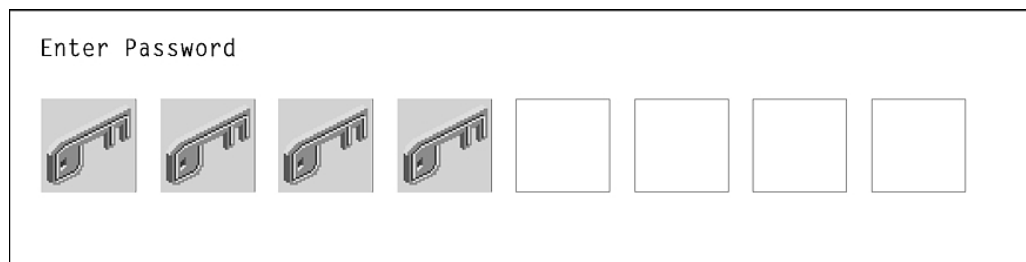

Press **Enter** when you are finished; you must type the password again for verification.

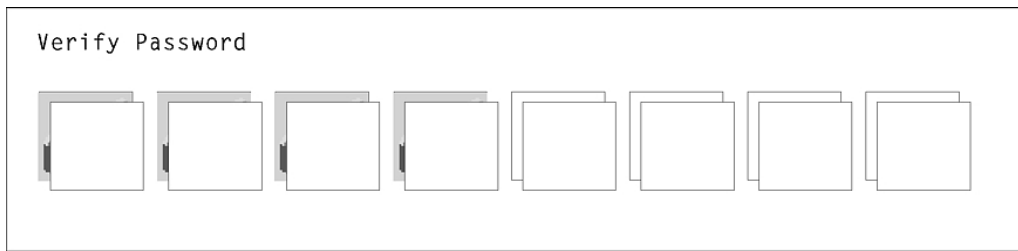

If you make a mistake, press the **Esc** key and start again.

After you have entered and verified the password, the power-on password status icon flashes and changes to the locked position to indicate that the power-on password is installed.

If you previously had set a power-on password and want to remove it, select the Remove icon.



Notes:

1. If you want to disable an installed power-on password (but not erase it) move the power-on password jumper as described in the section beginning on page 4-8. Moving the jumper back to the default position will re-enable the power-on password, unless it has been removed in the System Management Services Utilities or by removing the battery.
2. If you *forget* the power-on password, you can erase the password by shutting down the system unit and removing the battery for at least 30 seconds. See "Changing the Battery" on page 4-63 for details.
3. The system unit power cable **must** be disconnected before removing the battery.

A password becomes effective only after the system is turned off and back on again.

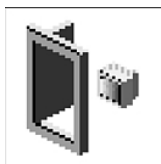

Remote Mode: The remote mode, when enabled, allows the system to start from the defined boot device. This mode is ideal for network servers and other system units that operate unattended. You *must* set a power-on password before you can enable the remote mode. When the remote mode is set, the icon changes to **Remote <On>**.

If you remove the power-on password, the remote mode is automatically reset, and the icon returns to **Remote <Off>**.

Note: In order to use the remote mode feature for booting unattended devices, you must enable the automatic power-up feature. See "Enabling Automatic Power-up" on page 4-16 for instructions on enabling the automatic power-up feature, which allows the system unit to turn on whenever AC power is applied to the system (instead of having the system unit wait for the power button to be pushed).

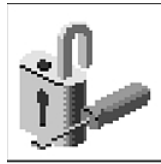

Privileged-Access Password: The privileged-access password protects against the unauthorized starting of the system programs.

To set the privileged-access password, you must first change a jumper on the system board. See Chapter 4, "Installing and Removing Options" on page 4-1 to locate and change the password-enabling jumper, then return here.

If the password-enabling jumper has been changed, select the Entry icon to set and verify the privileged-access password.

When you select the Entry icon, a screen with 8 empty boxes appears. Type your password in these boxes. You can use any combination of up to eight characters (A-Z, a-z, and 0-9) for your password. As you type a character, a key appears in the box.

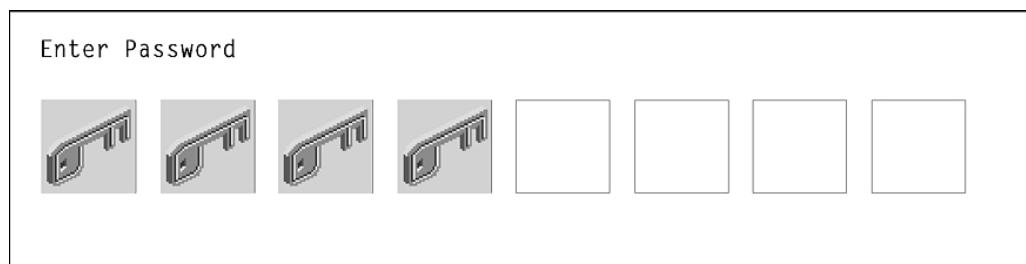

Press **Enter** when you are finished; you must type the password again for verification.

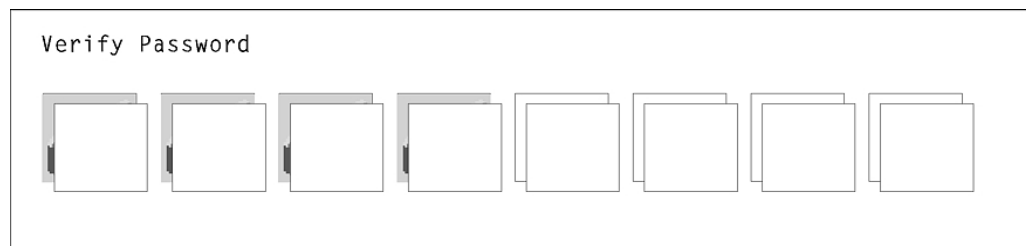

If you make a mistake, press the **Esc** key and start again.

Note: If an error occurs when you attempt to set the privileged-access password, then make sure the password-enabling jumper has been changed.

After you have entered and verified the password, the privileged-access password icon flashes and changes to the locked position to indicate that your system unit now requires the password you just entered before running system programs.

ATTENTION : Once the password-enabling jumper has been changed and privileged-access password has been set, great care must be taken to preserve the privileged-access password. If you set the privileged-access password and later misplace the password, your system must be returned for service.

In order to prevent loss of system use, please record the privileged-access password immediately whenever it is changed.

ATTENTION : If no user-defined boot-list exists, and the privileged-access password has been enabled, you will be asked for the privileged-access password at startup every time you boot up your system unit.

Moving the password-enabling jumper back to the default position does **NOT** disable or erase the privileged-access password. Moving the jumper back to the default position only prohibits changing or disabling this password with the System Management Services. Removing the battery does not affect the state of the privileged-access password at all.

Audio (ESCALA S100 only)



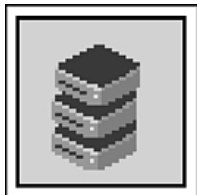

This icon enables you to turn on or off the system tones heard at power-on time. To change the audio status, use the arrow keys or mouse to highlight the audio icon, then press the Enter key.

Hard Disk Spin Up Delay (ESCALA S120 only)

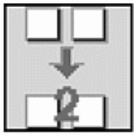

This selection allows you to change the spin up delay for SCSI hard disk drives attached to your system. Spin up delay values can be entered manually or a default setting can be used. All values are measured in seconds. The default is two seconds. After you have entered the new Spin up delay values, use the arrow keys to highlight the Save icon and press the Enter key.

Harddisk Spin Up Delay
Current Spin Up Value - 112233
Enter New Value - ___111___ (secs)

Save Default Exit



Error Log



Selecting this icon displays the log of errors your system unit has encountered during operations.

System Error Log

1. 96/01/29 00:51:32 12345678 00000000
2. No entry

Clear Exit

Selecting the Clear icon erases the entries in this log.

RIPL



Selecting the Remote Initial Program Load (RIPL) icon above gives you access to the following selections.

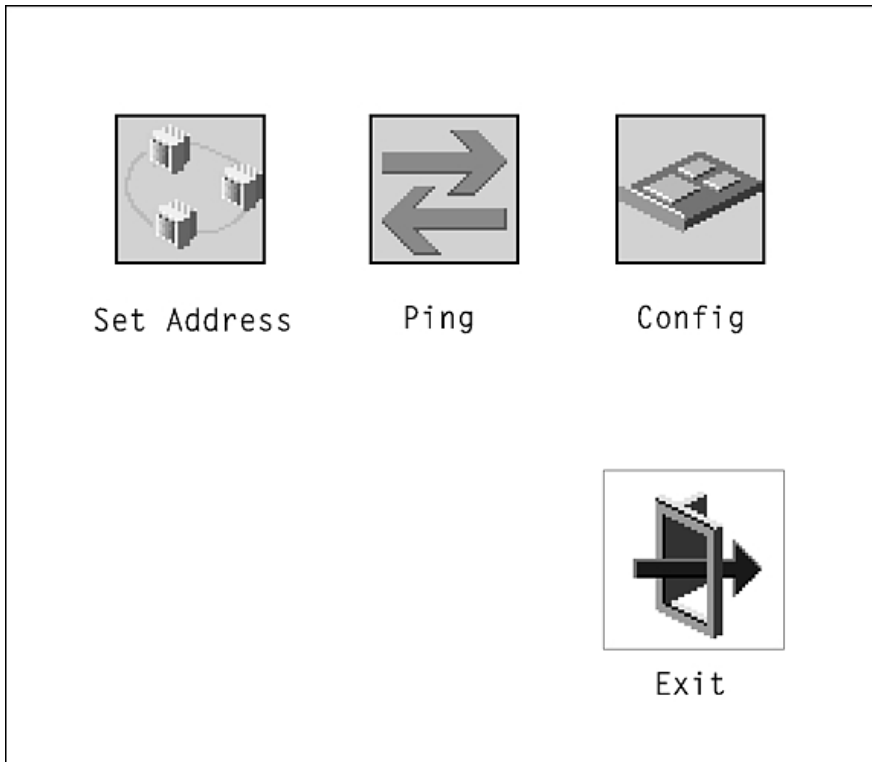

The Set Address icon allows you to define addresses from which your system unit can receive RIPL code.

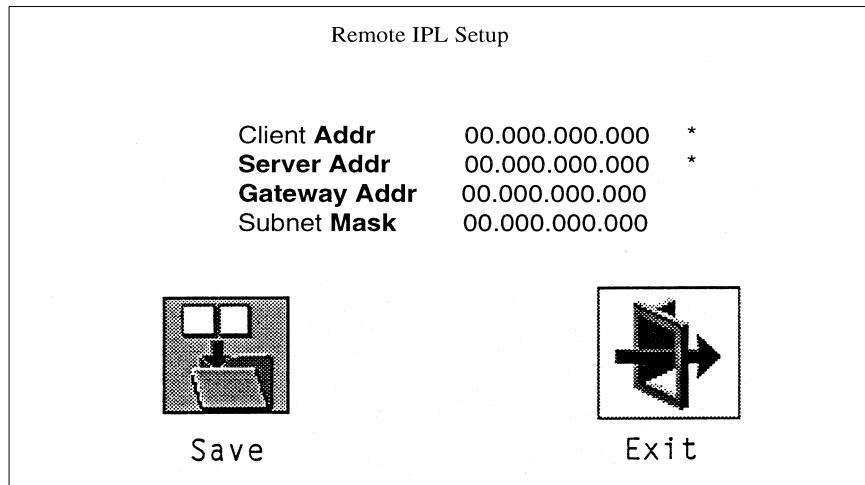

Note: Those addresses indicated with an asterisk (*) are required.

If any of the addresses is incomplete or contains a number other than 0 to 255, an error message is displayed when you select the Save icon. To clear this error, change the improper address and select Save again.



The Ping icon allows you to confirm that a specified address is valid by sending a test transmission to that address.

After choosing the Ping option, you may be asked to indicate which communications adapter (Token Ring or Ethernet) should be used to send the test transmission.

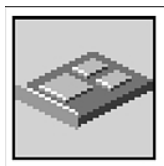

The Config icon allows you to configure network adapters which require setup. Selecting the Config icon presents a list of the adapters requiring configuration. Use the arrow keys or mouse to highlight an adapter, press the spacebar to select the adapter, then highlight the OK icon and press the Enter key.

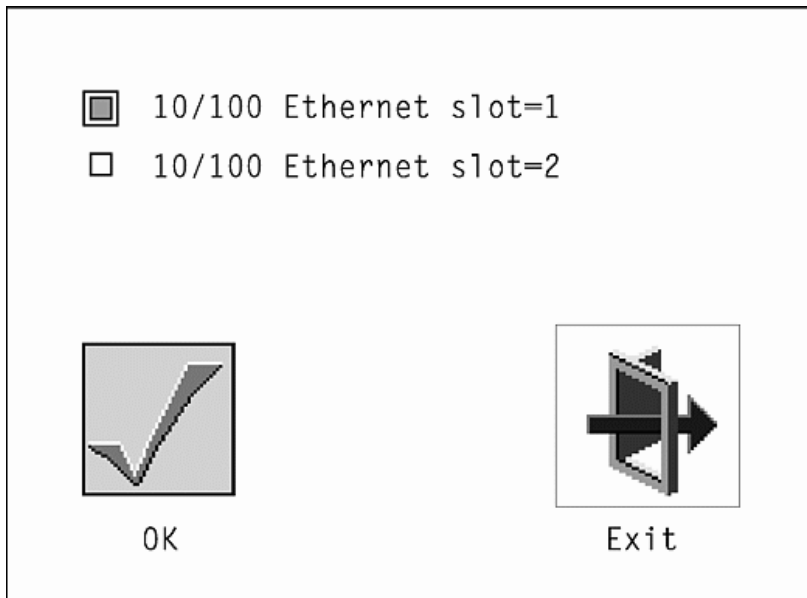

The next screen allows you to select the type of adapter you have just chosen (or allow the system to select the type automatically). Use the arrow keys or mouse to highlight a selection. To choose the highlighted selection, press the spacebar, then highlight the OK icon and press the Enter key.

After choosing the adapter to configure, you can select the communications mode of the chosen adapter (or allow the system to select the communications mode automatically). As on the previous screen, use the arrow keys or mouse to highlight, then press the spacebar to select. When you have selected the communications mode, highlight the OK icon and press the Enter key.

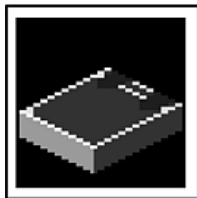

SCSI ID



This selection allows you to view and change the addresses (IDs) of the SCSI controllers attached to your system unit. To change an ID, highlight the entry by moving the arrow keys, then enter another number. After you have entered the new address, use the arrow keys or mouse to highlight the Save icon and press the Enter key.

At any time in this process, you can select the Default icon to change the SCSI IDs to the default values.

Change SCSI ID			
Type	Slot	ID	Max ID
Fast	5	7	7
Fast/Wide	7	7	15

		
Save	Default	Exit

Firmware Update



This selection allows you to update the firmware in your system unit from an image on a 3.5 inch diskette.

When prompted, insert the firmware update diskette containing the new firmware image.

ATTENTION: While the new firmware image is being copied into your system unit, you must **not** turn off the system unit. Turning off the system unit during the update process may render your system unit inoperable.

After the firmware update is complete, shut down and restart the system unit.

If the firmware update does not complete successfully or the system unit does not restart after the firmware update, contact your authorized reseller or marketing representative.

Firmware Recovery

If a troubleshooting procedure has indicated that the firmware information in your system unit has been damaged, then you must perform a firmware recovery.

To perform a firmware recovery, do the following:

1. Locate your firmware update diskette.
2. Using another system unit, rename the *.img file on the firmware update diskette to **precover.img**.
3. Make sure your system unit is turned off.
4. Insert the firmware recovery diskette into your system unit.
5. Turn on your system unit.
6. When the keyboard indicator appears, press the **1** key if the system console is an ASCII terminal, or the **FI** key if the system console is a directly-attached keyboard.
7. When the System Management Services appear, choose Utilities and perform a Firmware Update as described above.

Text-Based System Management Services

The text-based Open Firmware command line and System Management Services are available if an ASCII terminal is attached to your system unit.

To start the text-based System Management Services instead of the Open Firmware command line, press 1 on the ASCII terminal keyboard when the keyboard text symbol appears during startup.

After the text-based System Management Services starts, the following screen appears.

Note: The version of firmware currently installed in your system unit is displayed at the top of each screen in the text-based System Management Services. Please note the version number; processor upgrades may require a specified version of firmware to be installed in your system unit. Update System Firmware is an option under the `Utilities` menu.

Text-based System Management Services – Main Menu (ESCALA S100)

```
System Management Services

1      Display Configuration
2      Select Boot Devices
3      Utilities
4      Select Language

==>                                     [ X=Exit ]
```

Text-based System Management Services – Main Menu (ESCALA S120)

```
System Management Services

1      Display Configuration
2      Multiboot
3      Utilities
4      Select Language

==>                                     [ X=Exit ]
```

Selecting the numbered options provide capabilities described on the following pages.

After you have finished using the text-based System Management Services, entering `x` (for exit) boots your system unit.

Display Configuration

This option provides information about the setup of your computer. A screen similar to the following is displayed.

```
<Device Name>

PowerPC 604
L2-Cache, 0512K
Memory
  slot A=8MB
  slotB=8MB
LPT
  addr=3BC
COM
  addr=3F8
COM
  addr=3F8
Audio
Keyboard
Mouse
Diskette
  addr=3F0
Integrated Ethertnet
  addr=80005AF67BD
SCSI cntlr  id=7

[P=prev-page] [N=Next-page] [X=Exit]
```

Note that this configuration information does not include ISA adapters installed in the system unit.

Select Boot Devices (ESCALA S100)

This selection enables you to view and change the custom boot list, which is the sequence of devices read at startup time.

Select Boot Devices

- 1 Display Current Settings
- 2 Restore Default Settings
- 3 Configure 1st Boot Device
- 4 Configure 2nd Boot Device
- 5 Configure 3rd Boot Device
- 6 Configure 4th Boot Device

X=Exit

==>

Selecting the Display Current Settings option lists the current order of devices in the boot list. The following screen shows an example of this display.

Current Boot Sequence

- 1 Diskette
- 2 Ethernet (Integrated)
- 3 SCSI CD-ROM id=3 (slot=1)
- 4 SCSI 2168MB Hard Disk id=6 (slot=1)

X=Exit

==>

Selecting any of the Configure Boot Device options displays the following screen.

Configure Nth Boot Device

Device Number	Current Position	Device Name
1	1	Diskette
2	2	Ethernet
3	3	SCSI CD-ROM
4	4	SCSI 500MB Hard Disk
5	-	None

P=prev-page N=Next-page X=Exit

==>

ATTENTION: If no user-defined boot-list exists, and the privileged-access password has been enabled, you will be asked for the privileged-access password at startup every time you boot up your system. See "Privileged-Access Password" on page 3-28 for more information on the privileged-access password.

Multiboot (ESCALA S120)

The options available from this screen allow you to view and set various options regarding the operating system and boot sequence.

Note: The SMS software on the ESCALA S100 do not have this menu option. On this system, this menu is replaced by the Boot menu. See "Select Boot Devices" for details.

Text-based System Management Services – Multiboot Menu

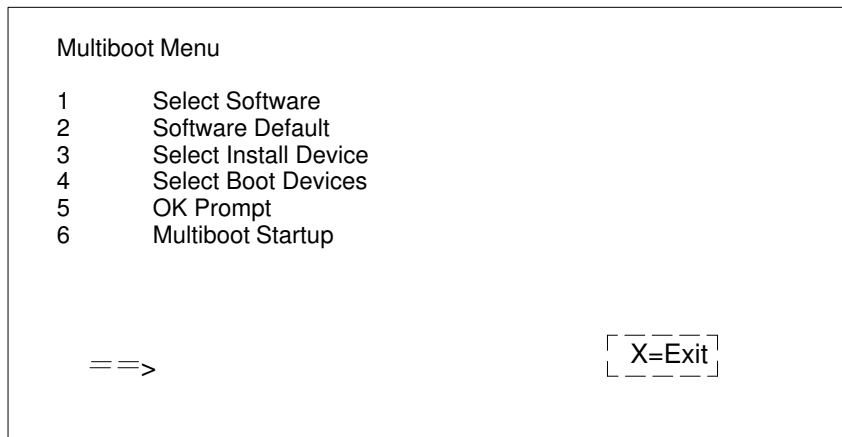

Select Software: If supported by the operating system, this option shows the names of the operating system installed. This option may not be supported by all operating systems.

In the case of AIX this is a supported option, if you receive a message saying that:

```
No Operating System Installed
```

this would mean that information in non-volatile storage could have been lost, as would happen if the battery had been removed. In order to recreate this value, issue the **bootlist** command under AIX with the appropriate parameters as to the location of the operating system in a particular hard disk. Please see the explanation of the bootlist command in your AIX documentation

Software Default: If supported by the operating system, lets you select the default operating system to start the system. This option may not be supported by all operating systems.

Select Install Device: Produces a list of devices, for example the CD-ROM, where the operating system is installed from. You select one of the devices and the system searches the device for an operating system to install and if supported by the operating system in that device, the name of the operating system displays.

Select Boot Device: Provides a list of devices that can be selected to be stored on the boot list. Up to 5 devices are supported.

OK Prompt: Provides access to the Open Firmware command prompt.

Multiboot Start Option: Toggles between OFF and ON and selects if the Multiboot menu invokes automatically on startup or not.

Select Boot Devices

This selection enables you to view and change the custom boot list, which is the sequence of devices read at startup time.

Text-based System Management Services – Select Boot Devices Menu

```
Select Boot Devices

1      Display Current Settings
2      Restore Default Settings
3      Configure 1st Boot Device
4      Configure 2nd Boot Device
5      Configure 3rd Boot Device
6      Configure 4th Boot Device
7      Configure 5th Boot Device

==>                                     [ X=Exit ]
```

Display Current Settings: Lists the current order of devices in the boot list. The following screen shows an example of this display.

```
Current Boot Sequence

1      Diskette
2      Ethernet      (Integrated)
3      SCSI CD-ROM      id=3 (slot=1)
4      SCSI 500MB Hard Disk id=6 (slot=1)
5      SCSI 500MB Hard Disk id=5 (slot=5)

==>                                     [ X=Exit ]
```

Restore Default Settings: Restores the boot list to the default sequence of:

- The primary diskette drive
- CD-ROM drive
- Tape id=5
- Hard disk drive id=6
- Network device.

Selecting any of the Configure Boot Device options displays the following screen.

Text-based System Management Services – Configure Boot Device Screen

```
Configure Nth Boot Device

Device Number      Current Position      Device Name
-----
          1              1              Diskette
          2              2              Ethernet
          3              3              SCSI CD-ROM
          4              4              SCSI 500MB Hard Disk
          5              -              None

[P=prev-page] [N=Next-page] [X=Exit]

==>
```

ATTENTION: If no user-defined boot-list exists, and the privileged-access password has been enabled, you will be asked for the privileged-access password at startup every time you boot up your system. See "Privileged-Access Password" on page 3-28 for more information on the privileged-access password.

Utilities

The Utilities screen enables you to select from the following system management tools.

Text-based System Management Services – Utilities Menu (ESCALA S100)

```
Utilities

1. Set Password and Unattended Start Node
2. Audio < ON>
3. Display Error Log
4. Remote Initial Program Load Setup
5. Change SCI id
6. Update System Firmware
7. Select Console

[X=Exit]

==>
```

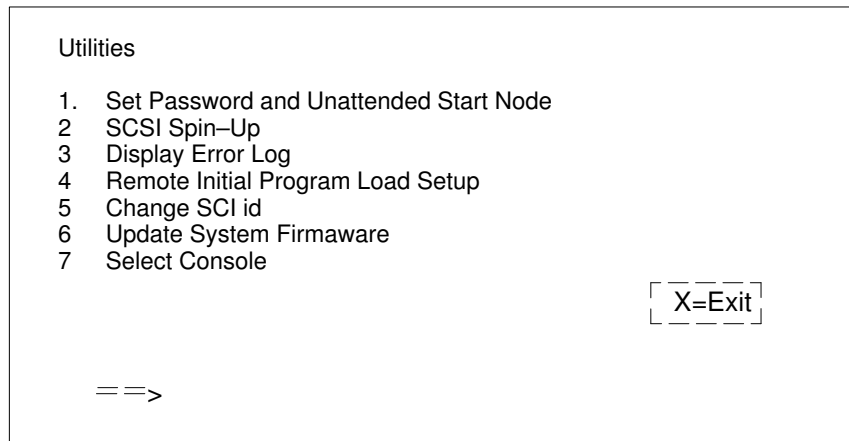

Set Password and Unattended Start Mode

Entering this selection permits access to the following options.

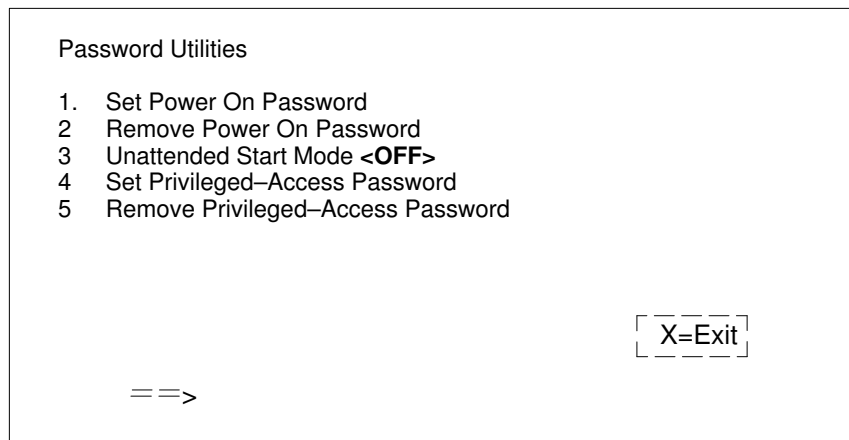

Set Power On Password: Setting a power-on password helps protect information stored in your computer. You can use any combination of up to eight characters (A–Z, a–z, and 0–9) for your password. The password you type is not displayed on the screen. Press **Enter** when you are finished; you must type the password again for verification.

If you previously had set a power-on password and wanted to remove it, select **Remove Power-On Password**.

Notes:

1. If you want to disable an installed power-on password (but not erase it) move the power-on password jumper as described in the section beginning on page 4-8. Moving the jumper back to the default position will re-enable the power-on password, unless it has been removed in the System Management Services Utilities or by removing the battery.
2. If you *forget* your password, you must shut down the computer and remove the battery for at least 30 seconds to disable the password. See "Changing the Battery" on page 4-63 for details.
3. The system unit power cable must be disconnected before removing the battery.

A password becomes effective only after the system is turned off and back.

Set Privileged-Access Password: The privileged-access password protects against the unauthorized starting of the system programs.

To set the privileged-access password, you must first change a jumper on your computer's system board. See Chapter 4, "Installing and Removing Options" on page 4-1 to locate and change the password-enabling jumper.

If the password-enabling jumper has been changed, select Set privileged-access password to set and verify the privileged-access password.

ATTENTION: Once the password-enabling jumper has been changed and privileged-access password has been set, great care must be taken to preserve the privileged-access password. If you set the privileged-access password and later misplace the password, your system must be returned for service.

In order to prevent loss of system use, please file the privileged-access password immediately whenever it is changed.

ATTENTION: If no user-defined boot-list exists, and the privileged-access password has been enabled, you will be asked for the privileged-access password at startup every time you boot up your system unit.

Moving the password-enabling jumper back to the default position does **NOT** disable or erase the privileged-access password. Moving the jumper back to the default position only prohibits changing or disabling this password with the System Management Services. Removing the battery does not affect the state of the privileged-access password at all.

If you previously had set a privileged-access password and want to remove it, select **Remove Privileged-Access Password**.

Audio (ESCALA S100 only)

Selecting this utility turns on or off the system tones heard at power-on time.

Hard Disk pin-Up Delay (ESCALA S120 only)

Selecting this utility allows you to adjust the hard disk spin-up delay in your system unit.

Display Error Log

A screen similar to the following is displayed when you select this option. Here, you can view or clear your computer error log.

Error log				
	Date	Time	ErrorCode	Location
Entry 1.	01/04/96	12:13:22	25A80011	00-00
Entry 2.	no error logged			

C=Clear Error Log

X=Exit

Remote Initial Program Load Setup

This option allows you to enable and set up the remote startup capability of your computer. First, you are asked to specify the network parameters.

```
Network Parameters

1. IP Parameters
2. Adapter Parameters
3. Ping

                                [X=Exit]

==>
```

Selecting the IP Parameters option displays the following screen.

```
IP Parameters

1. Client IP Address  [000.000.000.000]
2. Server IP Address [000.000.000.000]
3. Gateway IP Address [000.000.000.000]
4. Subnet Mask       [000.000.000.000]

                                [X=Exit]

==>
```

Selecting the Adapter Parameters option allows you to view an adapter hardware address, as well as configure network adapters that require setup.

```
Adapter Parameters

Device      HW Address

1 token-ring 800032E54A12

                                [X=Exit]

==>
```

Selecting option 1 displays the following 100MB Ethernet configuration menus:

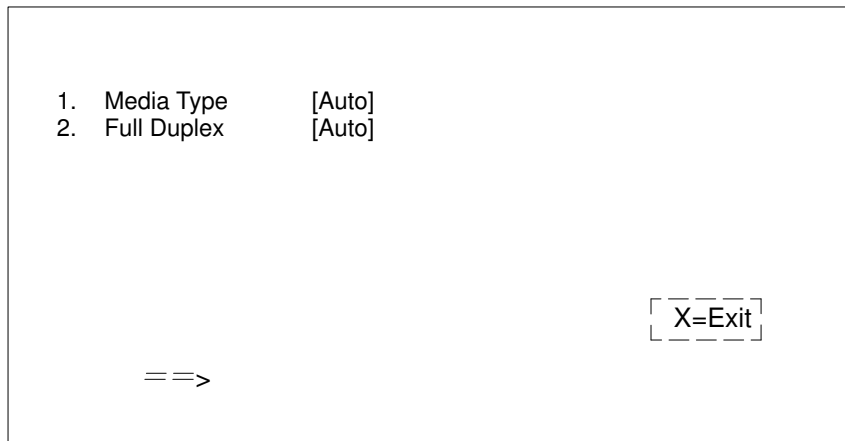

Selecting the Media Type option allows you to change the media employed by the Ethernet adapter:

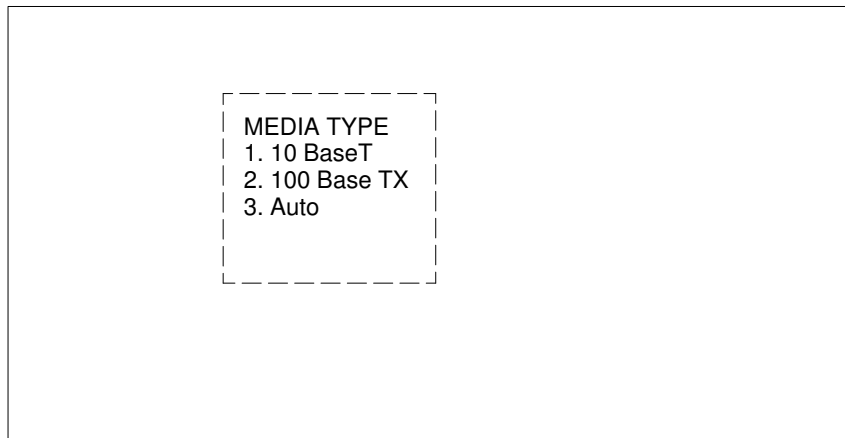

Selecting the Full Duplex option allows you to change how the Ethernet adapter communicates with the network:

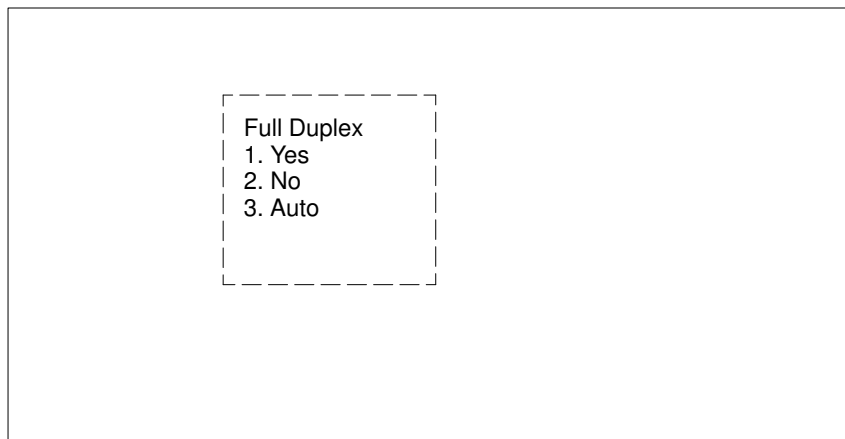

Ping, the last option available from the Network Parameters menu, allows you to test a connection to a remote system unit. After selecting the Ping option, you must choose which adapter communicates with the remote system.

```
Interface

1. Ethernet
2. Token Ring

==>
```

After choosing which adapter to use to ping the remote system, you must provide the addresses needed to communicate with the remote system.

```
Ping

1. Client IP Address [129.132.4.20]
2. Server IP Address [129.132.4.10]
3. Gateway Ip Address [129.132.4.30]
4. Subnet Mask [255.255.255.0]

[E=Execute] [X=Exit]

==>
```

Change SCSI ID

This option allows you to view and change the addresses of the SCSI controllers attached to your computer.

Update System Firmware

This option allows you to update your system firmware. Note that you must insert a diskette containing the firmware update image after you see the following confirmation screen.

```
This selection will update your System Firmware. Do you want
to continue? Press Y(Yes) N(No).
```

Firmware Recovery. If a troubleshooting procedure has indicated that the firmware information in your system unit has been damaged, then you must perform a firmware recovery.

To perform a firmware recovery, do the following:

1. Locate your firmware update diskette.
2. Using another system unit, rename the *.img file on the firmware update diskette to **precover.img**.
3. Make sure your system unit is turned off.
4. Insert the firmware recovery diskette into your system unit.
5. Turn on your system unit.
6. When the keyboard indicator appears, press the **1** key on the system console ASCII terminal.
7. When the System Management Services appear, choose Utilities and perform a System Firmware Update as described above.

Select Console: Selecting this option allows you to define which display is used by the system for system management.

Select Language

This option allows you to change the language used by the text-based System Management Services screens.

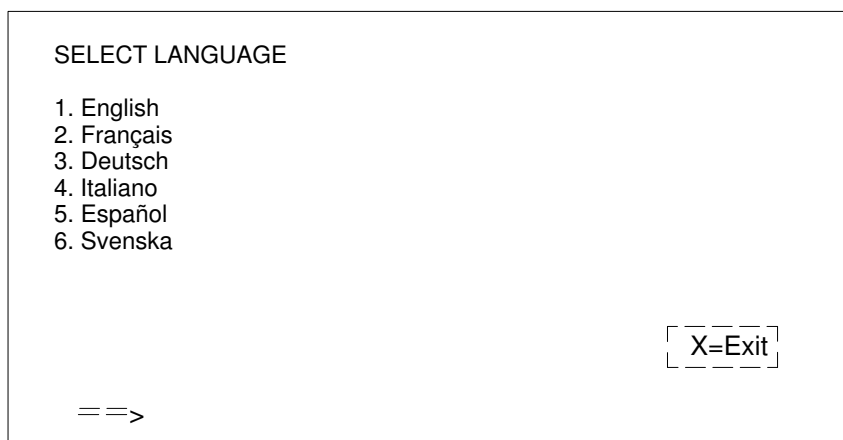

Note: Your tty must support the ISO-8859 character set in order to properly display languages other than English.

Open Firmware Command Line

The text-based Open Firmware command line allows you to configure some adapters, and the System Management Services makes it possible for you to view information about your system unit and to perform such tasks as setting passwords and changing device configurations.

To enter the Open Firmware command line, you must press the **8** key *after the keyboard text symbol appears* during startup.

If you have pressed the **8** key, the Open Firmware command line (an "OK" prompt) appears after the initialization and power-on self tests (POST) are complete.

The Open Firmware command line can be used to set up adapters that are not configurable with the System Management Services. Your adapter documentation directs you to use this option if it is needed.

Chapter 4. Installing and Removing Options

Adding hardware options to your system increases its capabilities. Many options are available (see "Available Options" below). This section can help you decide which options to add to your system unit, and shows you how to install them. When adding an option, use these instructions along with those that came with the option.

If you have installed (or removed) options before, you might be able to perform some activities without detailed instructions. These activities are listed in the "Before you begin" boxes of the procedures.

Before you install or remove an option, be sure you are familiar with the safety procedures and component-handling guidelines described in "Safety Considerations" on page 4-2. These precautions and guidelines help you work safely with your system unit or options.

Available options

Following are some of the options available for your system unit. Check with your authorized reseller or marketing representative for the latest information.

- Industry Standard Architecture (ISA) adapters
- Peripheral Component Interconnection (PCI) adapters
- Additional system memory in the form of memory modules
- Internal drives
- Microprocessor upgrades
- L2 cache upgrades
- Enable or disable the power-on password
- Enable or disable the privileged-access password
- Enable or disable automatic power-up
- Enable or disable the external SCSI connector
- Security tie-down cable

Safety Considerations

Observe the following safety precautions any time you work with the system unit.

DANGER

An electrical outlet that is not correctly wired could place hazardous voltage on metal parts of the system or the devices that attach to the system. It is the responsibility of the customer to ensure that the outlet is correctly wired and grounded to prevent any electrical shock.

Before installing or removing signal cables, ensure that the power cables for the system unit and all attached devices are unplugged.

When adding or removing any additional devices to or from the system, ensure that the power cables for those devices are unplugged before the signal cables are connected. If possible, disconnect all power cables from the existing system before you add a device.

Use one hand, when possible, to connect or disconnect signal cables to prevent a possible shock from touching two surfaces with different electrical potentials.

During an electrical storm, do not connect cables for display stations, printers, telephones, or station protectors for communication lines.

CAUTION:

This product is equipped with a three wire power cable and plug for the user's safety. Use this power cable with a properly grounded electrical outlet to avoid electrical shock.

DANGER

To prevent electrical shock hazard, disconnect the power cable from the electrical outlet before relocating the system.

Handling Static-Sensitive Devices

Attention: Static electricity can damage this device and your system unit. To avoid damage, keep this device in its static protective bag until you are ready to install it. To reduce the possibility of electrostatic discharge, follow the precautions listed below.

Electrostatic Discharge Protection

To prevent electrostatic discharge:

- Limit your movement. Movement can cause static electricity to build up around you.
- Handle the device carefully, holding it by its edges or its frame.
- Do not touch solder joints, pins, or exposed printed circuitry.
- Do not leave the device where others can handle and possibly damage the device.
- While the device is still in its anti-static package, touch it to an unpainted metal part of the system unit for at least two seconds (this drains static electricity from the package and from your body).
- Remove the device from its package and install it directly into your system unit without setting it down. If it is necessary to set the device down, place it on its static-protective package (if your device is an adapter, place it component side up). Do not place the device on your system unit cover or on a metal table.
- Take additional care when handling devices during cold weather as heating reduces indoor humidity and increases static electricity.

Tools Required

To install or remove options from your system unit, you need a flat-blade screwdriver. Any additional tools needed depend upon the specific option and are noted in the instructions that come with the option.

Removing the Cover

Before you begin:

- Locate the cover lock key.
- Read "Safety Considerations" on page 4-2, and "Handling Static-Sensitive Devices" on page 4-3.

Note: The floor stand is not shown in some of the following steps to better illustrate the important details. It is not necessary to remove the floor stand when you remove the system unit cover.

1. Unlock the cover lock and slide the drive bay cover all the way to the left.
2. Remove any media (diskette or CD) from the drives.
3. Shut down programs as described in your operating system documentation.

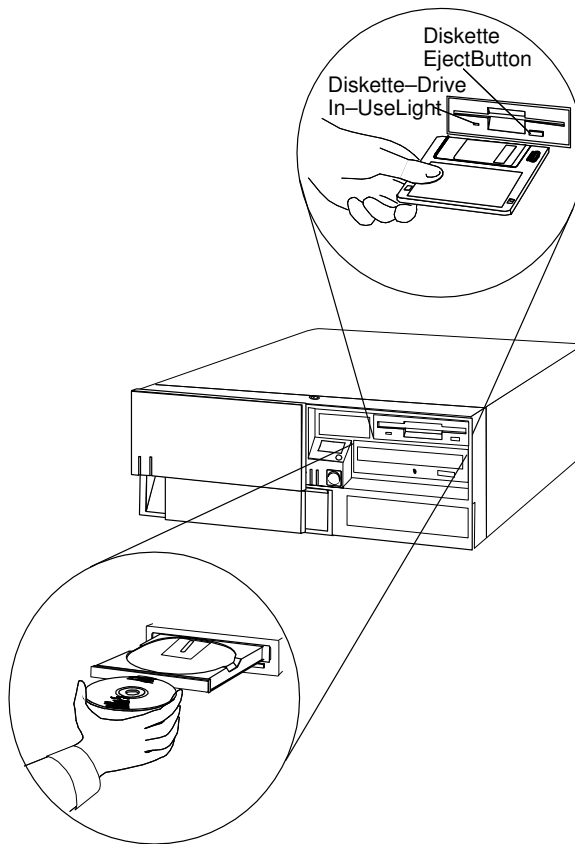

4. Turn off all attached devices and the system unit.
5. If you have a modem or fax machine attached to the system unit, disconnect the telephone line from the outlet and the system unit.

6. Unplug all power cords (cables) from electrical outlets.

ATTENTION: As soon as the system unit power cord is plugged in to the system unit and power outlet, the power is on within the system unit **whether or not the system unit is turned on**. Do not plug in the system unit power cord if the covers of the system unit are removed.

7. Make a note of where the other cables and cords are connected to the back of the system unit, then disconnect them.

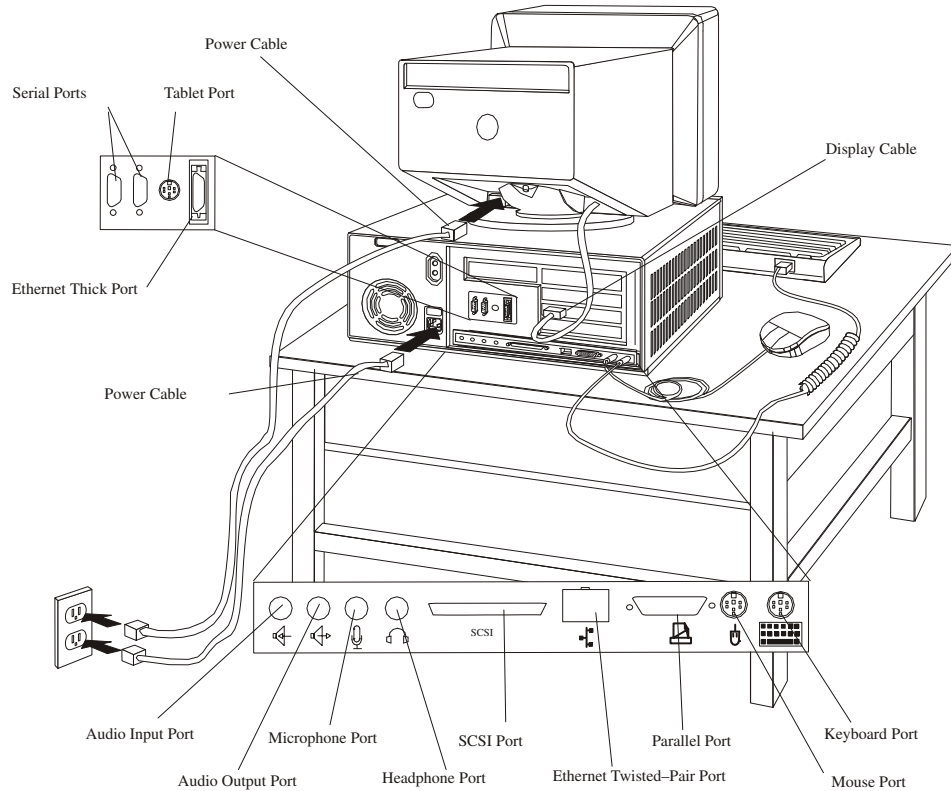

8. If you have not already done so, remove the display from the top of the system unit.

9. While holding down the cover latch at the rear of the system unit, slide the cover to the rear approximately 1 inch. Grasp the cover on both sides and lift it away from the system unit.

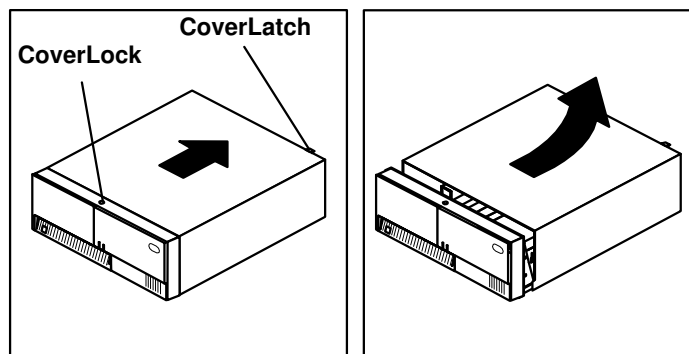

Locating options

To locate various options in the system unit, use the following figure.

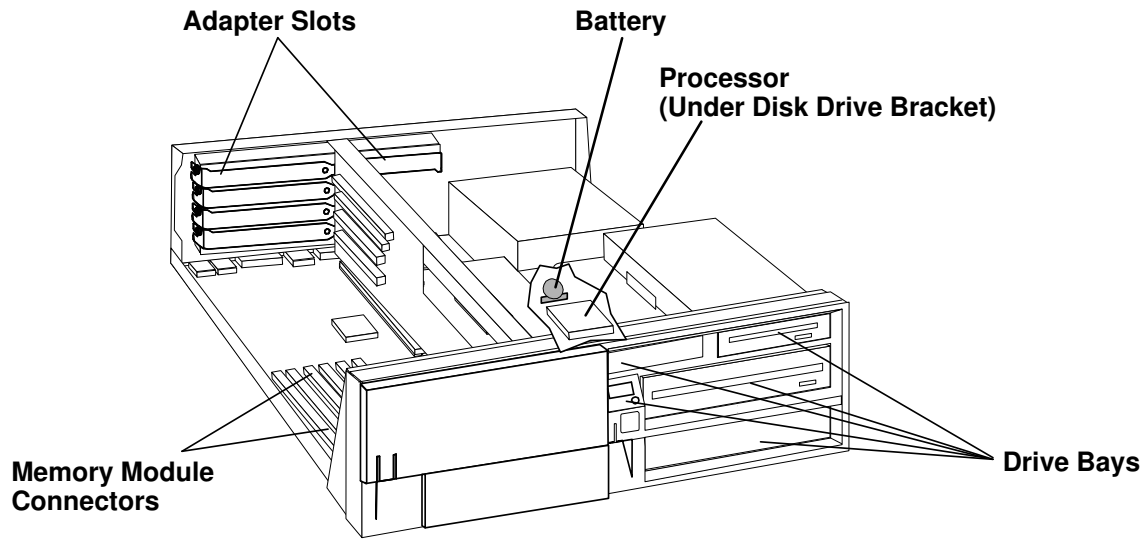

Note: There are 6 memory DIMM slots on the ESCALA S100, and 4 memory DIMM slots on the ESCALA S120.

What to do next?

To enable or disable:

- The privileged-access password, go to page 4-12
- The automatic power-up feature, go to page 4-16
- The power-on password, go to page 4-8
- The external SCSI connector, go to page 4-58

To install:

- A memory module, go to page 4-21
- An L2 cache card, go to page 4-28
- A 332-Mhz processor upgrade for ESCALA S100, go to page 4-32
- An adapter, go to page 4-41
- An internal drive, go to page 4-47
- A security tether, go to page 4-61
- A new battery, go to page 4-63

To remove:

- An adapter, go to page 4-45
- A memory module, go to page 4-25
- An internal drive, go to page 4-47

To complete the installation, go to page 4-67

Disabling the Power-On Password

Before you begin:

- Read "Safety Considerations" on page 4-2, and "Handling Static-Sensitive Devices" on page 4-3.
- Remove the system unit cover (see "Removing the Cover" on page 4-4)

Your system unit arrives from the factory with the power-on password enabled (but unset). You can disable the power-on password by changing the position of a jumper on the system board.

Note:

1. Moving the jumper back to the default position will re-enable the power-on password, unless it has been removed in the System Management Services Utilities or by removing the battery.
2. If you *forget* the power-on password, you can erase the password by shutting down the system unit and removing the battery for at least 30 seconds. See "Changing the battery" on page 4-63 for details.
3. The system unit cable **must** be disconnected before removing the battery.

To disable the power-on password, complete the following steps:

1. Remove the disk drive bracket assembly from the system unit and carefully place it on top of the power supply. Any adapters installed in slot 5 may have to be temporarily removed in order to remove the disk drive bracket. Refer to "Removing Adapters" on page 4-45 for adapter removal instructions.

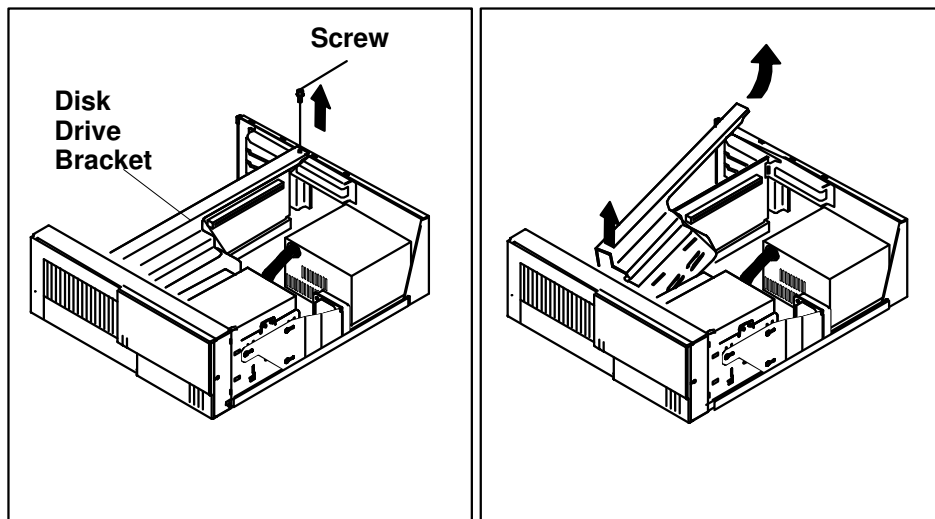

2. If you have an ESCALA S100, locate jumper J90 using the following illustration.

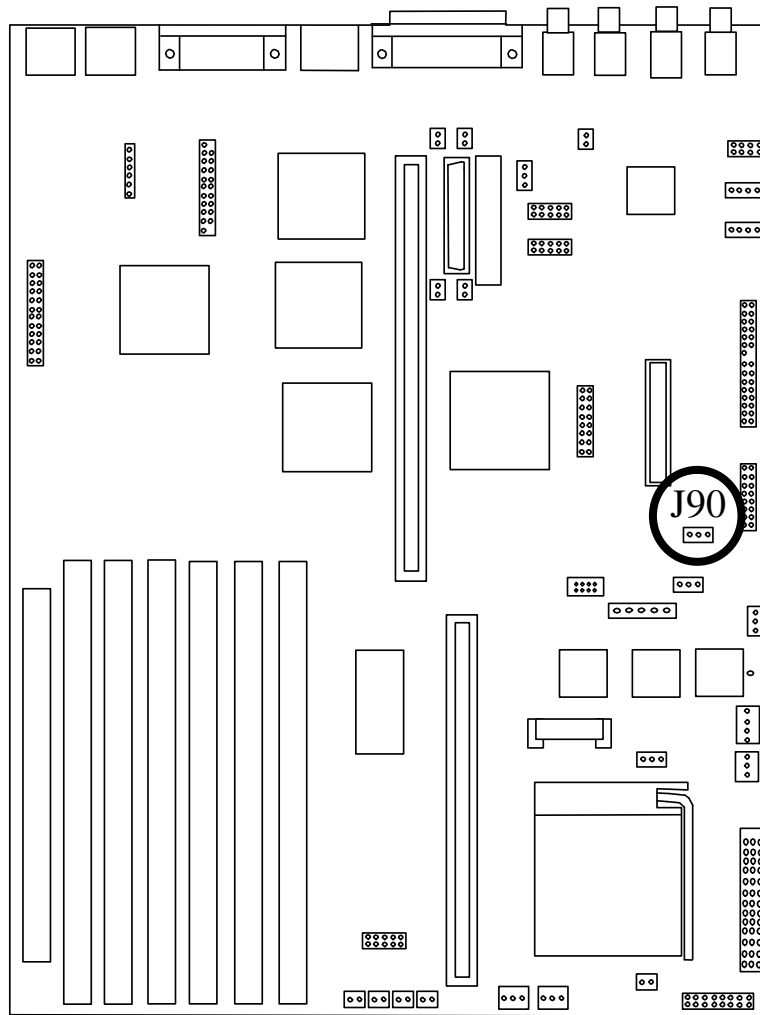

3. To disable the power-on password, move the jumper J90 to the two rightmost pins.

4. If you have an ESCALA S120, locate jumper J20 using the following illustration.

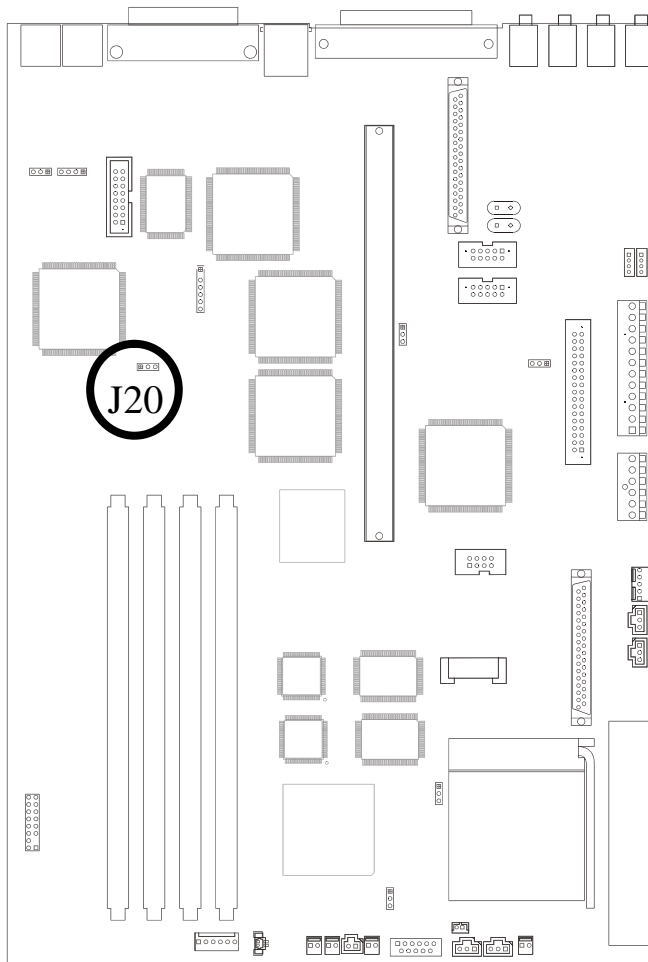

5. To disable the power-on password, move the jumper J20 to the two rightmost pins.

6. Reinstall any adapters you have removed.

Note: To set the power-on password, the jumper must be in the default position (on the two leftmost pins). You must also install all other options (such as internal drives, memory, adapters) if you are planning to install them now. After you have installed these options and replaced the covers of your system unit, start the System Management Services to set the power-on password. For more information on the System Management Services, see "System Management Services" on page 3-1.

What to do next?

To enable or disable:

- The privileged-access password, go to page 4-12
- The automatic power-up feature, go to page 4-16
- The power-on password, go to page 4-8
- The external SCSI connector, go to page 4-58

To install:

- A memory module, go to page 4-21
- An L2 cache card, go to page 4-28
- A 332-Mhz processor upgrade for ESCALA S100, go to page 4-32
- An adapter, go to page 4-41
- An internal drive, go to page 4-47
- A security tether, go to page 4-61
- A new battery, go to page 4-63

To remove:

- An adapter, go to page 4-45
- A memory module, go to page 4-25
- An internal drive, go to page 4-47

To complete the installation, go to page 4-67

Enabling the Privileged-Access Password

Before you begin:

- Read "Safety Considerations" on page 4-2 and "Handling Static-Sensitive Devices" on page 4-3.
- Remove the system unit cover (see "Removing the Cover" on page 4-4).

To enable the privileged-access password, you must first change the jumper on the system board which blocks the use of the privileged-access password.

This procedure should only be performed one time.

1. Remove the disk drive bracket assembly from the system unit and carefully place it on top of the power supply.

Note: Any adapters installed in slot 5 may have to be temporarily removed in order to remove the disk drive bracket. Refer to "Removing Adapters" on page 4-45 for adapter removal instructions.

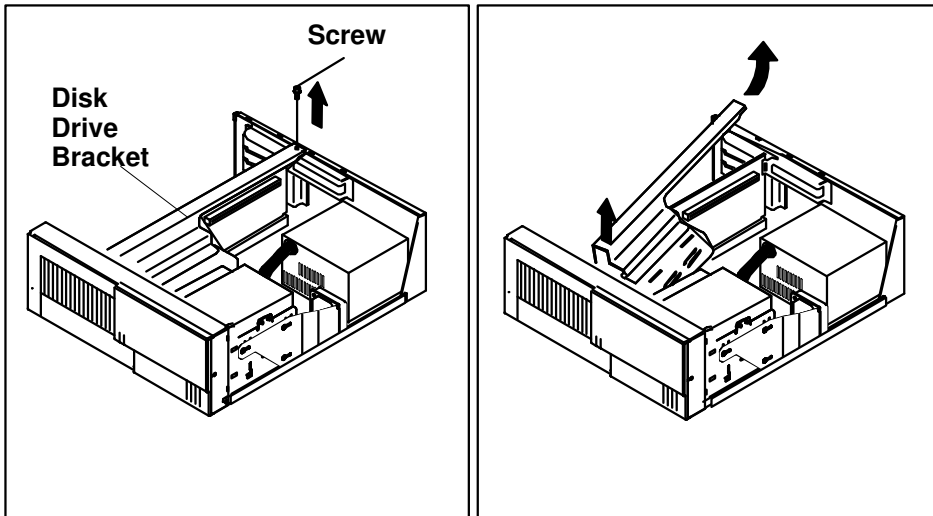

2. If you have an ESCALA S100:

a. Locate jumper J21 using the following illustration.

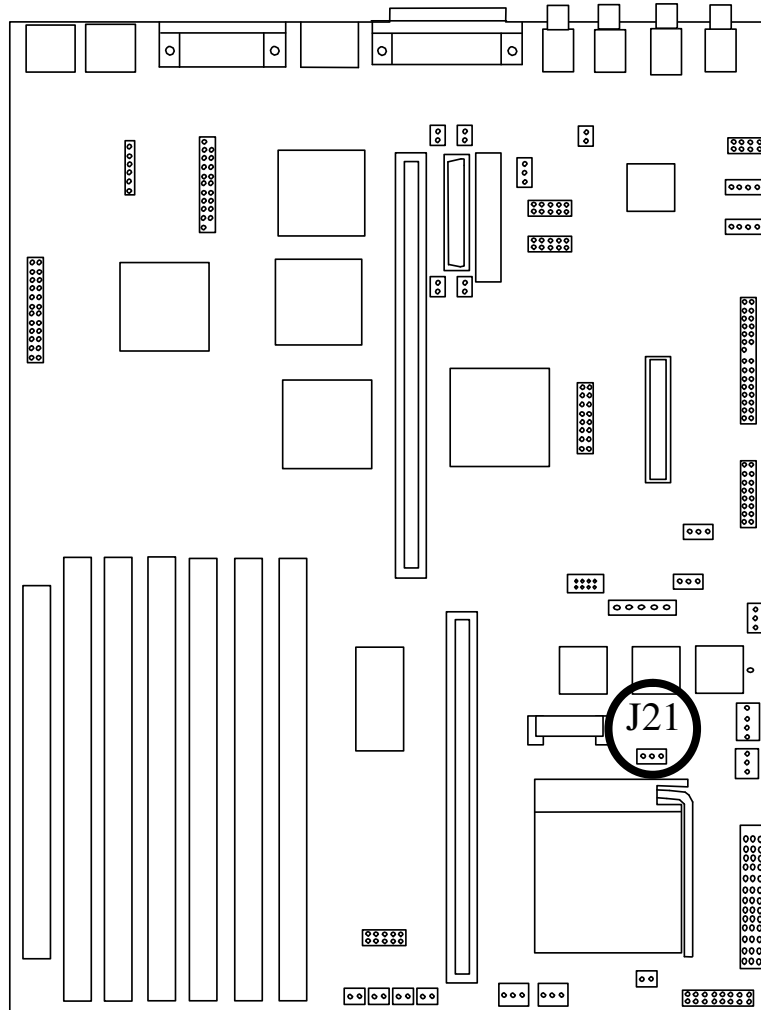

b. To enable the privileged-access password, first touch the metal frame of the system unit, then gently pull upward on the small box (Jumper) covering the pins. Replace the jumper so that it covers the left two pins instead of the right two.

3. If you have an ESCALA S120:
 - a. Locate jumper J32 using the following illustration.

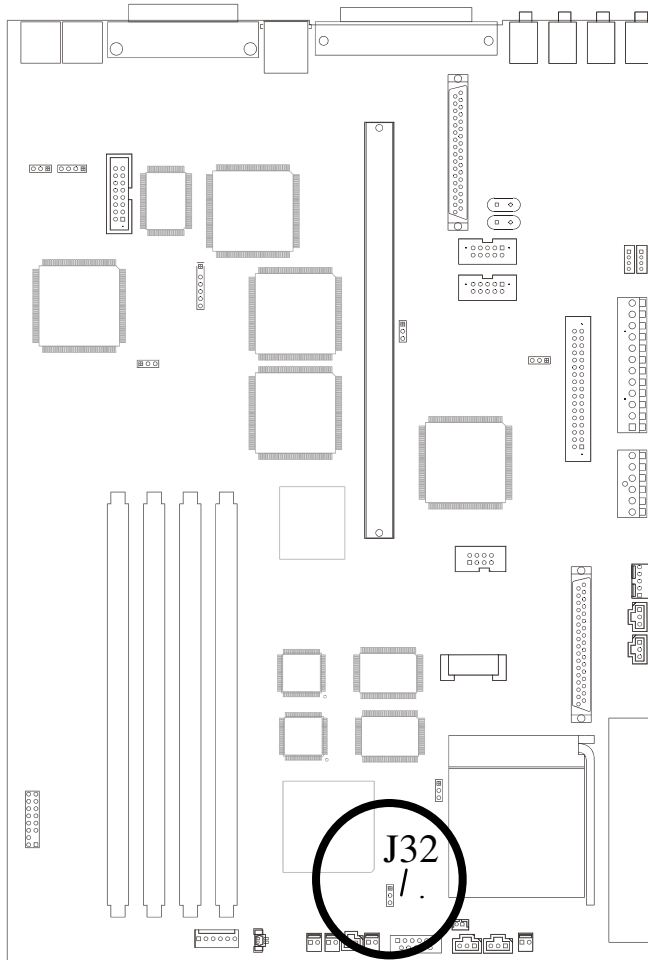

- b. To enable the privileged-access password, first touch the metal frame of the system unit, then gently pull upward on the small box (Jumper) covering the pins. Replace the jumper so that it covers the left two pins instead of the right two.
4. Reinstall any adapters you have removed.
5. To set the privileged-access password, you must first install all other options (such as internal drives, memory, adapters) if you are planning to install them now. After you have installed these options and replaced the covers of your system unit, start the System Management Services to set the privileged-access password. For more information on the System Management Services, see "System Management Services" on page 3-1.

What to do next?

To enable or disable:

- The privileged-access password, go to page 4-12
- The automatic power-up feature, go to page 4-16
- The power-on password, go to page 4-8
- The external SCSI connector, go to page 4-58

To install:

- A memory module, go to page 4-21
- An L2 cache card, go to page 4-28
- A 332-Mhz processor upgrade for ESCALA S100, go to page 4-32
- An adapter, go to page 4-41
- An internal drive, go to page 4-47
- A security tether, go to page 4-61
- A new battery, go to page 4-63

To remove:

- An adapter, go to page 4-45
- A memory module, go to page 4-25
- An internal drive, go to page 4-47

To complete the installation, go to page 4-67

Enabling Automatic Power-Up

Before you begin:

- Read "Safety Considerations" on page 4-2 and "Handling Static-Sensitive Devices" on page 4-3.
- Remove the system unit cover (see "Removing the Cover" on page 4-4).

Your system unit can be set to automatically turn on as soon as AC power is applied. This allows unattended restart after AC power has been interrupted by a power outage, for example.

When the automatic power-up capability is enabled, the system unit turns on when AC power is applied after having been interrupted, even if the system was not turned on before the interruption.

The factory setting for this capability is automatic power-up disabled.

Note: If the power-on password is set, then the system unit still turns on but will **not** boot unless the Remote Mode is enabled. To set the power-on password and Remote Mode, see "System Management Services" on page 3-1.

To enable the automatic power-up feature, do the following:

1. Remove the disk drive bracket assembly from the system unit and carefully place it on top of the power supply.

Note: Any adapters installed in slot 5 may have to be temporarily removed in order to remove the disk drive bracket. Refer to "Removing Adapters" on page 4-45 for adapter removal instructions.

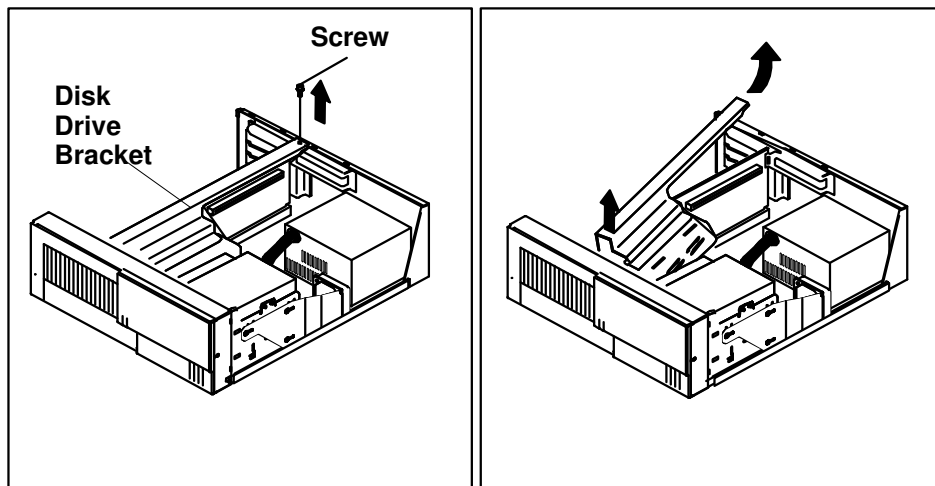

2. If you have an ESCALA S100:

a. Locate jumper J15 using the in the following illustration.

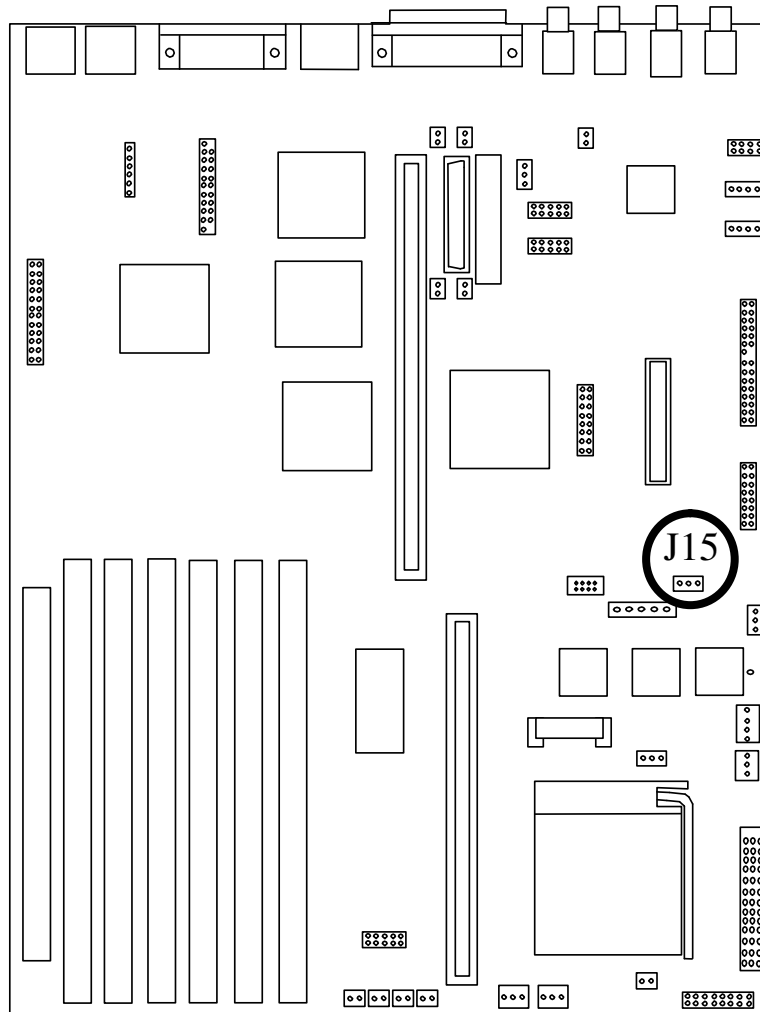

b. To move the jumper, first touch the metal frame of the system unit, then gently pull upward on the small box (jumper) covering the pins.

- To enable the automatic power-up feature, place the jumper over the left two pins.
- To disable the automatic power-up feature, place the jumper over the right two pins. This is the factory default setting.

3. If you have an ESCALA S120:

a. Locate jumper J15 using the following illustration.

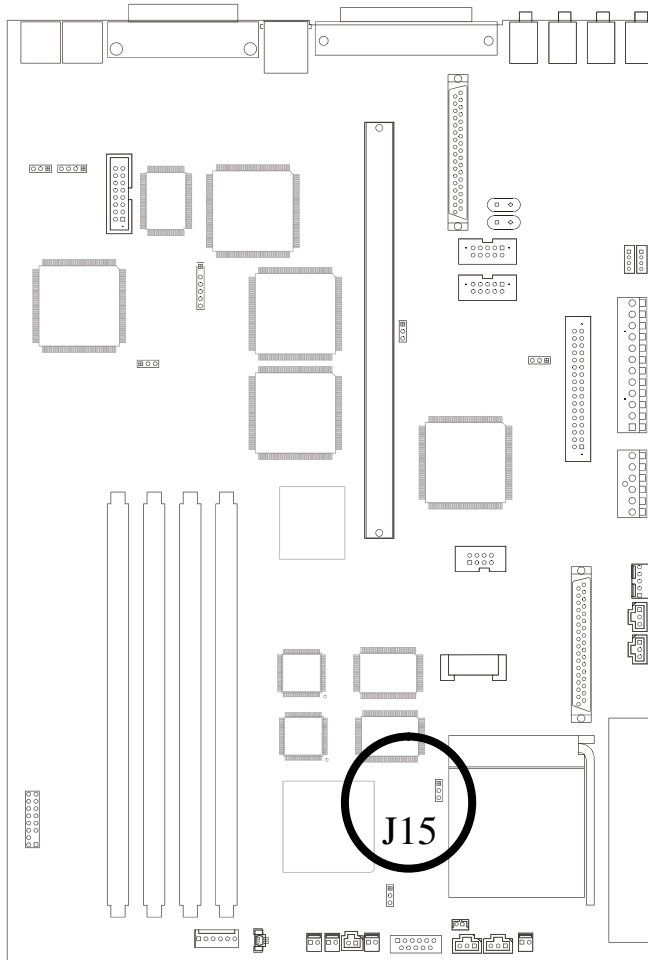

b. To move the jumper, first touch the metal frame of the system unit, then gently pull upward on the small box (jumper) covering the pins.

- To enable the automatic power-up feature, place the jumper over the left two pins.
- To disable the automatic power-up feature, place the jumper over the right two pins. This is the factory default setting.

4. Reinstall the disk drive bracket assembly.

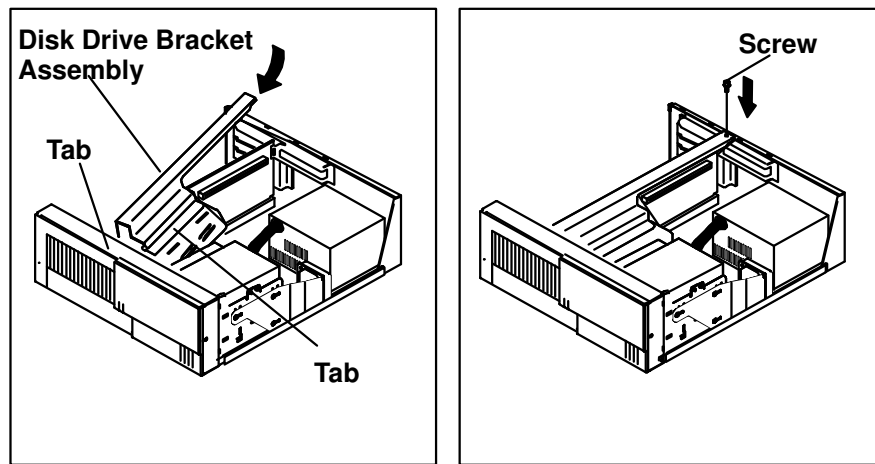

5. Reinstall any adapter you may have removed.

What to do next?

To enable or disable:

- The privileged-access password, go to page 4-12
- The automatic power-up feature, go to page 4-16
- The power-on password, go to page 4-8
- The external SCSI connector, go to page 4-58

To install:

- A memory module, go to page 4-21
- An L2 cache card, go to page 4-28
- A 332-Mhz processor upgrade for ESCALA S100, go to page 4-32
- An adapter, go to page 4-41
- An internal drive, go to page 4-47
- A security tether, go to page 4-61
- A new battery, go to page 4-63

To remove:

- An adapter, go to page 4-45
- A memory module, go to page 4-25
- An internal drive, go to page 4-47

To complete the installation, go to page 4-67

Installing Memory-Modules

You can increase the amount of memory in your system by installing *memory modules*. Your system uses 168-pin, 3.3 volt, dual inline Error Correcting Code (ECC) memory modules (DIMMs) to increase system memory.

You install memory modules into connectors inside the system. You can install up to 1024MB of ECC memory in the ESCALA S120, and up to 768MB of memory in the ESCALA S100. (1MB equals approximately 1 000000 bytes.) The memory module sizes available for your system include 256MB, 128MB, 64MB, and 32MB. The available speed for these memory modules is 60 ns (10 ns for SDRAM on an ESCALA S120).

ATTENTION: The ESCALA S100 does not support channel memory, such as memory expansion adapters.

Before you begin:

- Read "Safety Considerations" on page 4-2 and "Handling Static-Sensitive Devices" on page 4-3. Remove the system unit cover (see "Removing the Cover" on page 4-3).
- Remove the system unit cover (see "Removing the Cover" on page 4-4).

Note: When installing memory modules, install the new modules into the first available connector, starting at slot A.

1. Locate the memory module connectors.

To locate the six memory module slots in the ESCALA S100, use the following figure.

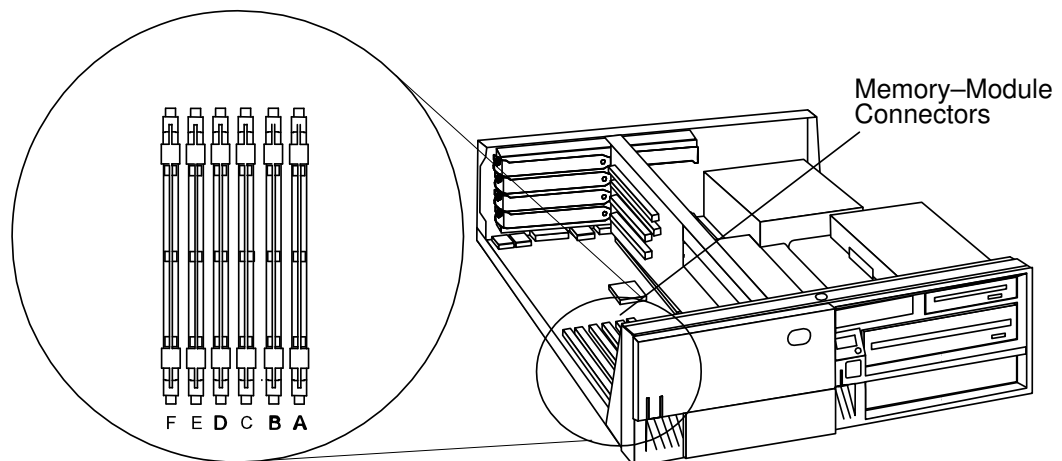

To locate the four memory module slots in the ESCALA S120, use the following figure.

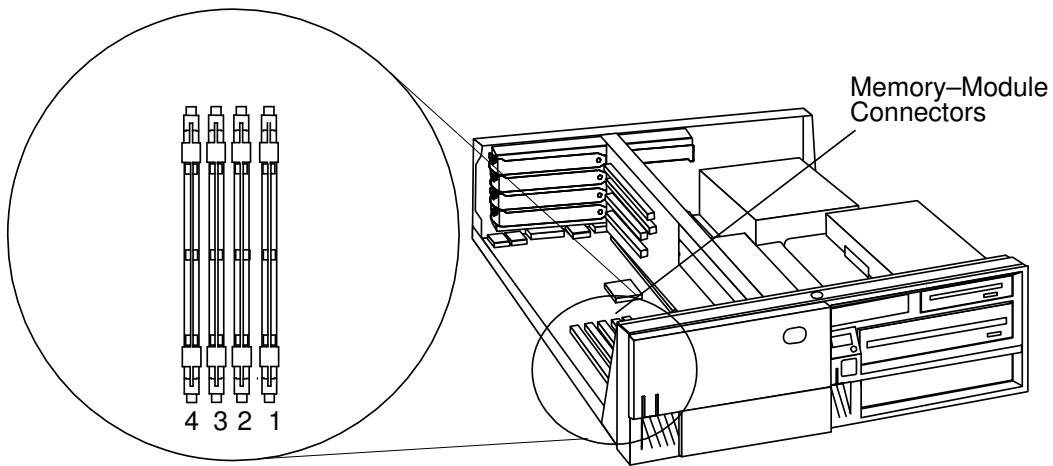

Note: When installing memory in the ESCALA S120, install the first memory DIMM in slot 4, the second in slot 3, etc.

2. Remove any adapters that are blocking the memory module connectors (see "Removing Adapters" on page 4-45).
3. Touch the static-protective package containing the option to any unpainted metal surface on the system unit, then remove the option from the package.

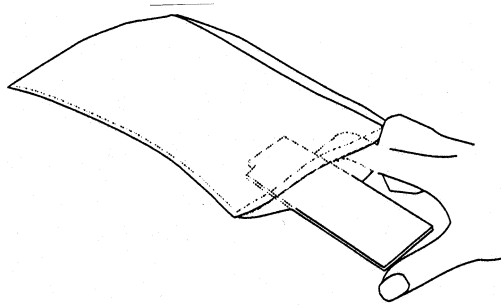

4. Choose an empty memory module connector for the new memory module.
5. Install the memory module.

Note: New memory modules must be installed in the first available vacant connector, starting at location A. See the figure above.

- The memory modules are keyed so that they can only be inserted one way. Align the memory module notches with the keys in the memory connector.

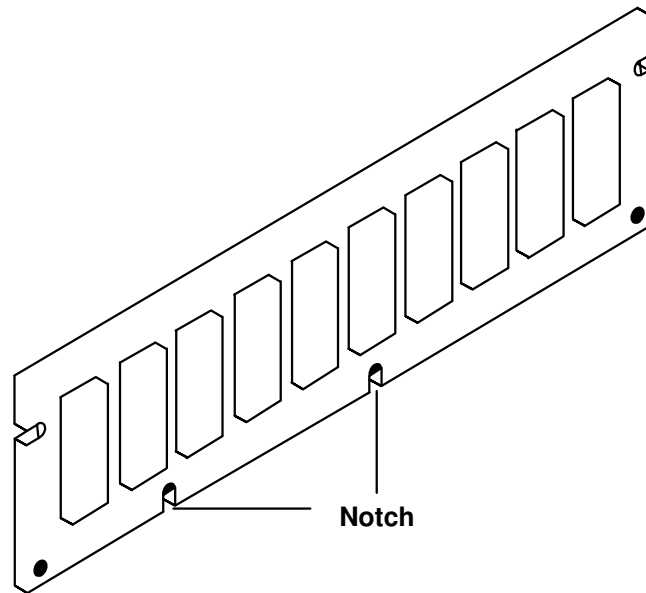

- Insert the memory module into the first unused memory connector. Push down on the memory module until the latch tabs lock the memory module into the connector. (Do not attempt to move the latch tabs yourself. They lock automatically when you have fully inserted the memory module.)

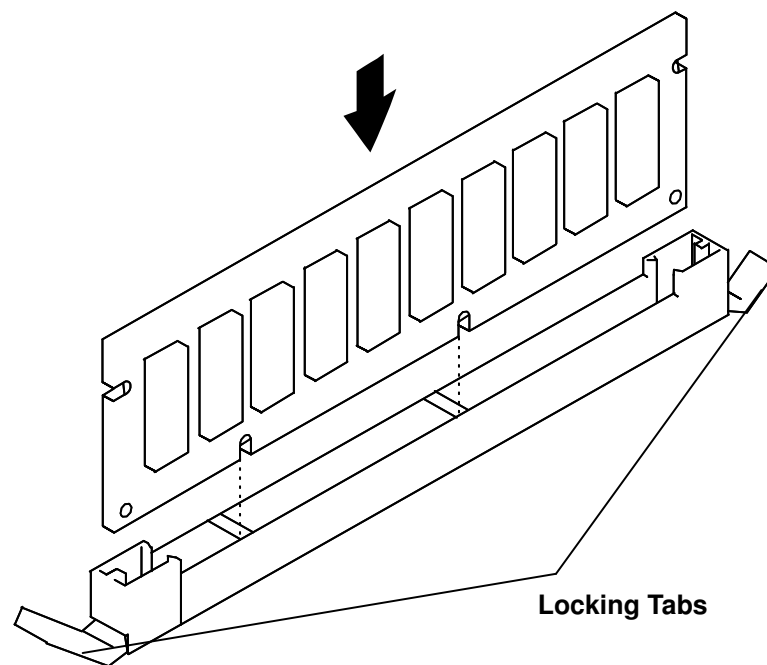

ATTENTION: Inserting the memory module at an angle may cause damage.

- Inspect each memory module and ensure the module is fully inserted into the socket.
- Reinstall any adapters you removed into their original connectors. (If you need further information for installing adapters, see "Installing Adapters" on page 4-41).
- Go to "Device Records" on page A-2 and update the system memory information. Return here to continue.

What to do next?

To enable or disable:

- The privileged-access password, go to page 4-12
- The automatic power-up feature, go to page 4-16
- The power-on password, go to page 4-8
- The external SCSI connector, go to page 4-58

To install:

- A memory module, go to page 4-21
- An L2 cache card, go to page 4-28
- A 332-Mhz processor upgrade for ESCALA S100, go to page 4-32
- An adapter, go to page 4-41
- An internal drive, go to page 4-47
- A security tether, go to page 4-61
- A new battery, go to page 4-63

To remove:

- An adapter, go to page 4-45
- A memory module, go to page 4-25
- An internal drive, go to page 4-47

To complete the installation, go to page 4-67

Removing Memory Modules

Before you begin:

- Read "Safety Considerations" on page 4-2 and "Handling Static-Sensitive Devices" on page 4-3.
- Remove the system unit cover (see "Removing the Cover" on page 4-4).

1. Locate the memory module connectors on the system board.

The memory module connectors for the ESCALA S100 are shown in the following figure.

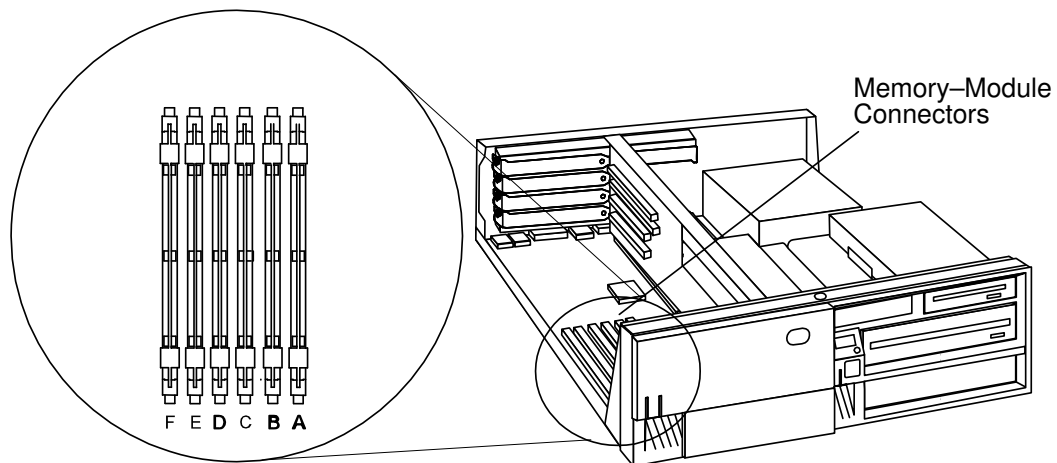

The memory module connectors for the ESCALA S120 are shown in the following figure.

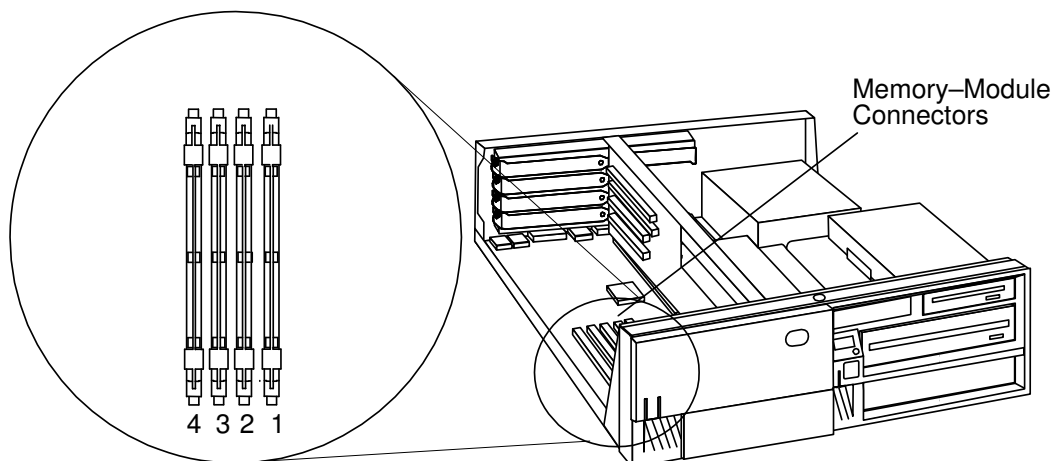

2. Remove any adapters that are blocking the memory module connectors (see "Removing Adapters" on page 4-45).
3. Determine which memory modules you want to remove.

Note: If your system is an ESCALA S100, slot A must contain a memory module in order for the system unit to function.

4. Remove the memory modules:

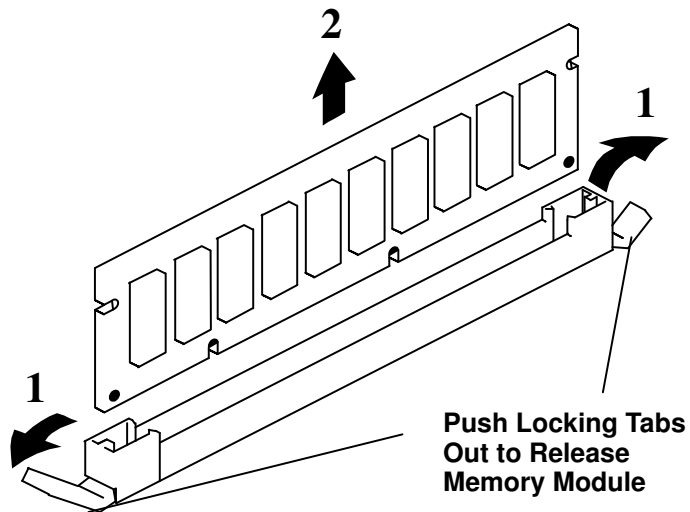

5. Store any memory modules you are no longer using in a static-protective package. Make a note of the memory module size and speed for future reference.

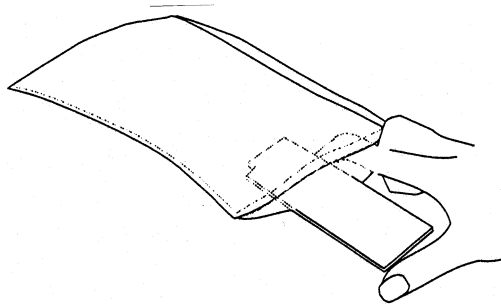

What to do next?

- To install a memory module, go to page 4-21
 - If you have completed memory module removal, continue with the next step.
6. Install any adapters you removed into their original connectors. If you need further information on installing adapters, see "Installing Adapters" on page 4-41).
 7. Go to "Device Records" on page A-2 and update the system memory information. Return here to continue.

What to do next?

To enable or disable:

- The privileged-access password, go to page 4-12
- The automatic power-up feature, go to page 4-16
- The power-on password, go to page 4-8
- The external SCSI connector, go to page 4-58

To install:

- A memory module, go to page 4-21
- An L2 cache card, go to page 4-28
- A 332-Mhz processor upgrade for ESCALA S100, go to page 4-32
- An adapter, go to page 4-41
- An internal drive, go to page 4-47
- A security tether, go to page 4-61
- A new battery, go to page 4-63

To remove:

- An adapter, go to page 4-45
- A memory module, go to page 4-25
- An internal drive, go to page 4-47

To complete the installation, go to page 4-67

L2 Cache Card Installation (for ESCALA S100)

Before you begin:

- Read "Safety Considerations" on page 4-2 and "Handling Static-Sensitive Devices" on page 4-3.
- Remove the system unit cover (see "Removing the Cover" on page 4-4).

The ESCALA S100 system has the capability of using a separate L2 cache card to enhance system performance.

The L2 cache card is installed toward the front of the system unit, to the left of the media drive bracket.

To install or upgrade the L2 cache card, do the following:

1. Remove the disk drive bracket assembly from the system unit and carefully place it on top of the power supply.

Note: Any adapters installed in slot 5 may have to be temporarily removed in order to remove the disk drive bracket. Refer to "Removing Adapters" on page 4-45 for adapter removal instructions.

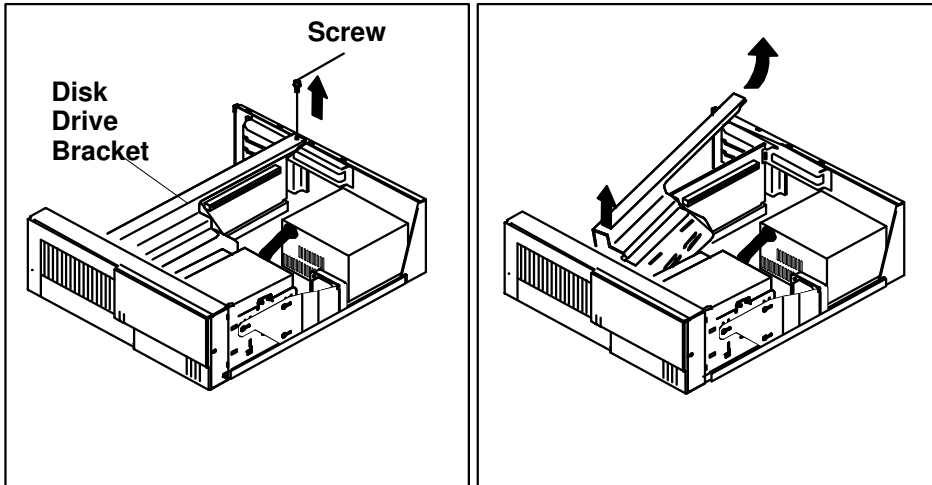

2. Locate the L2 cache connector on the system board.

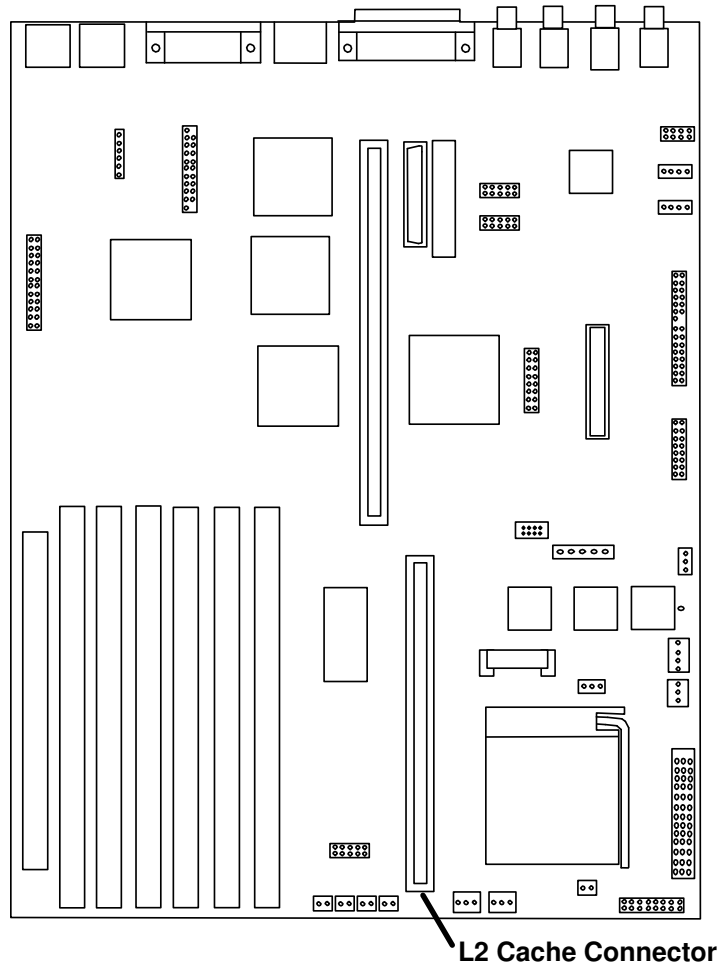

3. If you are upgrading or replacing your existing L2 cache card, gently pull upward on the L2 cache card, remove it from the system unit, and store it in a safe place.
4. To install the new L2 cache card, align the card with the L2 cache connector on the system board. Note that the L2 cache card only fits in the connector one way.
5. Gently push the L2 cache card into the connector, making sure that the card is fully seated in the connector.

6. Reinstall the disk drive bracket assembly.

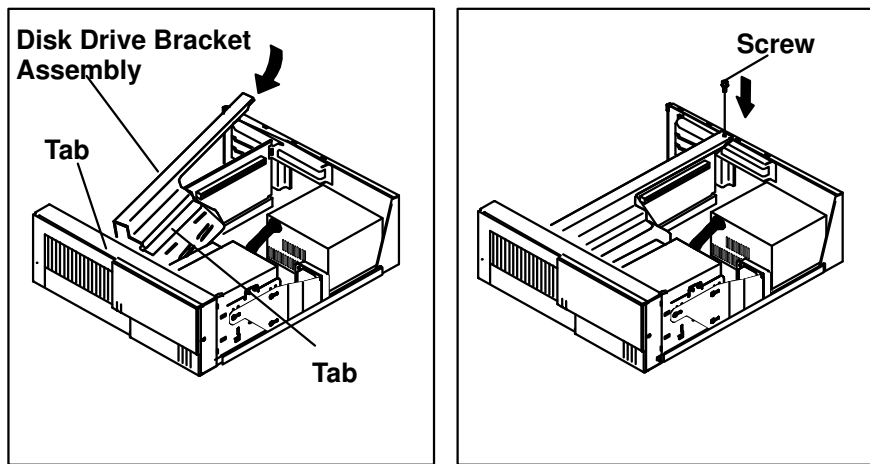

7. Reinstall any adapter you may have removed.

What to do next?

To enable or disable:

- The privileged-access password, go to page 4-12
- The automatic power-up feature, go to page 4-16
- The power-on password, go to page 4-8
- The external SCSI connector, go to page 4-58

To install:

- A memory module, go to page 4-21
- An L2 cache card, go to page 4-28
- A 332-Mhz processor upgrade for ESCALA S100, go to page 4-32
- An adapter, go to page 4-41
- An internal drive, go to page 4-47
- A security tether, go to page 4-61
- A new battery, go to page 4-63

To remove:

- An adapter, go to page 4-45
- A memory module, go to page 4-25
- An internal drive, go to page 4-47

To complete the installation, go to page 4-67

332-MHz Processor Upgrade for ESCALA S100

This section explains the procedure for installing a 332-MHz processor upgrade kit into your ESCALA S100 system.

Before you begin:

- Read "Safety Considerations" on page 4-2 and "Handling Static-Sensitive Devices" on page 4-3.
- Remove the system unit cover (see "Removing the Cover" on page 4-4).
- Locate the following additional items:
 - A flat-head screwdriver.
 - A paper towel for the thermal grease.
 - Make sure you know the level of firmware installed in your system unit. To determine which level is currently installed, see "System Management Services" on page 3-1.

1. Check your inventory. The processor upgrade kit consists of the following:

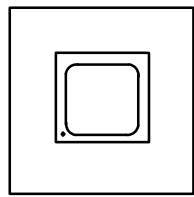

Processor

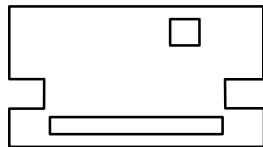

Voltage Regulator Card

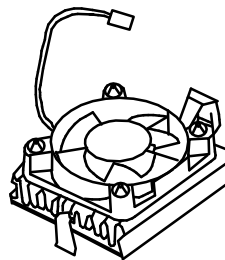

Fansink Assembly

xxxx xxx MHz

FrontLabel

xxx MHz
FRU: xxxxxxx

System Board Label

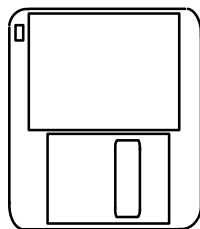

System Firmware Diskette

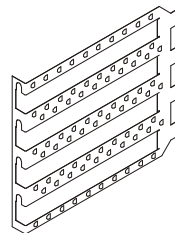

4-Slot EMC shield

2. Locate the diskette included in the processor upgrade kit containing the most recent version of the firmware for your system. If the firmware on your system is an earlier version than the firmware version printed on the diskette, upgrade your system's firmware now.

You may upgrade and check the version of your system's firmware with the System Management Services. For instructions, see "System Management Services" on page 3-1.

Attention: It is very important that you upgrade your firmware before replacing the processor in your system. Your system will not restart if the proper version of firmware is not installed. Check and, if necessary, upgrade your firmware before installing the new processor.

3. Locate your four-slot EMC shield included in your processor upgrade kit. The shield must be installed if your system unit is not already shielded.
 - a. Check if a four-slot EMC shield is installed in your system unit. The four-slot EMC shield is a thin sheet of metal attached to the inside of the back of your system unit around adapter slots 1, 2, 3, and 4. If a four-slot EMC shield is installed in your system unit, then your system unit is already properly shielded. Skip to Step 4.

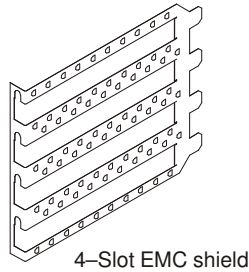

- b. If a four-slot EMC shield is **not** already installed in your system unit, remove all adapters, slot covers, and one-slot EMC shields in slots 1, 2, 3, and 4, noting which adapter was in each slot. (see "Removing Adapters" on page 4-45 for adapter removal instructions.)
 - c. To install the four-slot EMC shield, insert the four-slot EMC shield around slots 1, 2, 3, and 4, making sure the tabs on the EMC shield are inserted in the slots behind the system unit riser card. To keep the four-slot EMC shield in place, you may want to temporarily attach the shield with one of the adapter slot screws.

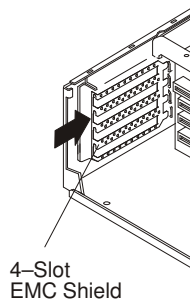

- d. Reinstall all adapters and slot covers (but not one-EMC shields) you have removed from slots 1, 2, 3, and 4. See "Installing Adapters" on page 4-41 for adapter installation instructions.
 4. Remove the disk drive bracket assembly from the system unit and carefully place it on top of the power supply.

Note: Any adapters installed in slot 5 may have to be temporarily removed in order to remove the disk drive bracket. Refer to "Removing Adapters" on page 4-45 for adapter removal instructions.

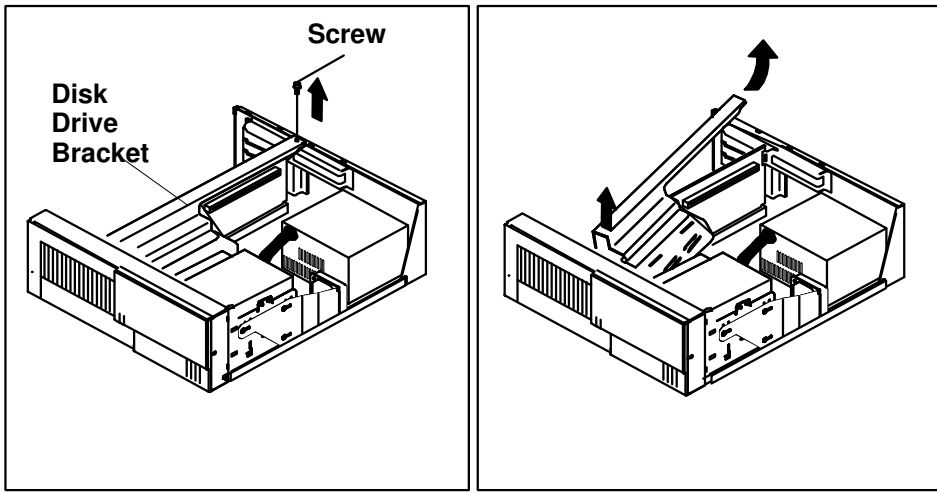

5. Locate the processor socket on the system board.

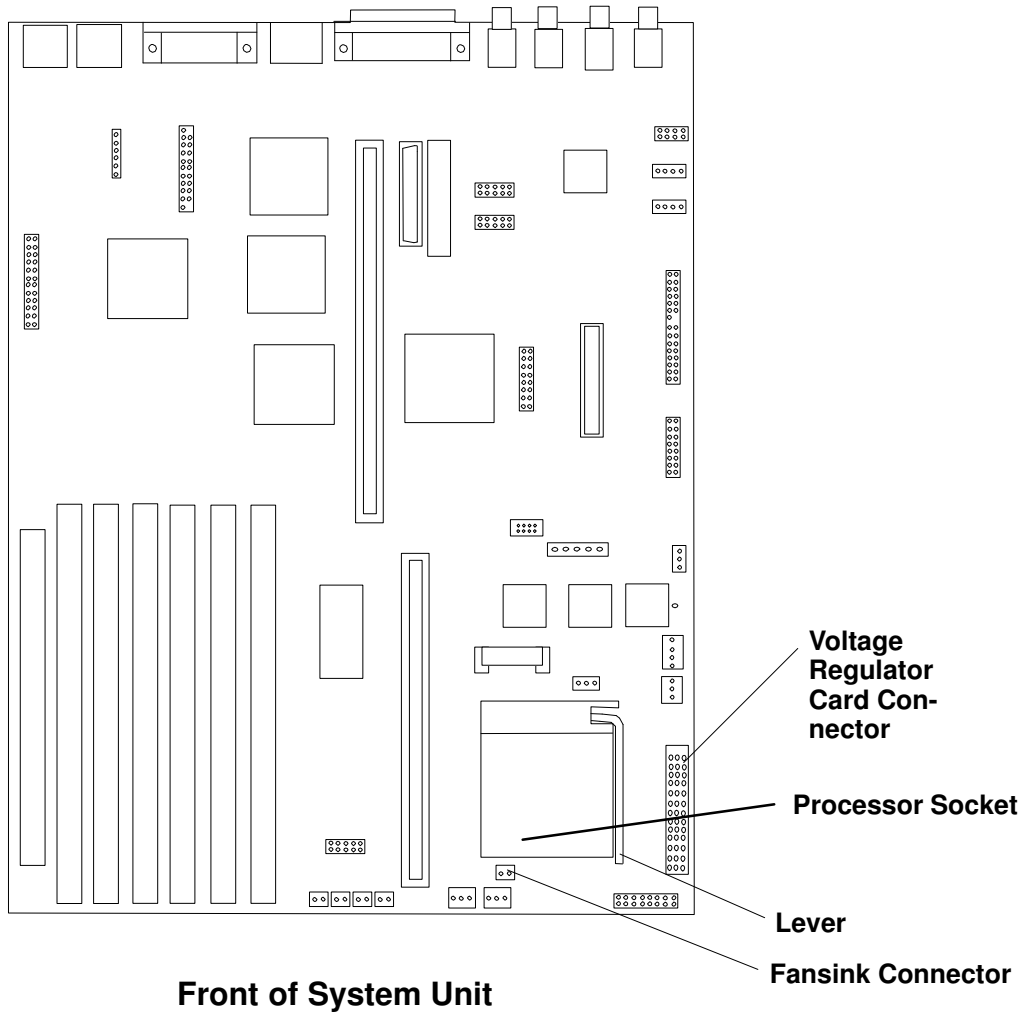

6. The fansink is a cooling fan mounted on top of the processor and must be removed to install the processor upgrade. The fansink is held on the processor with two buckles that are hooked over tabs on the processor socket.

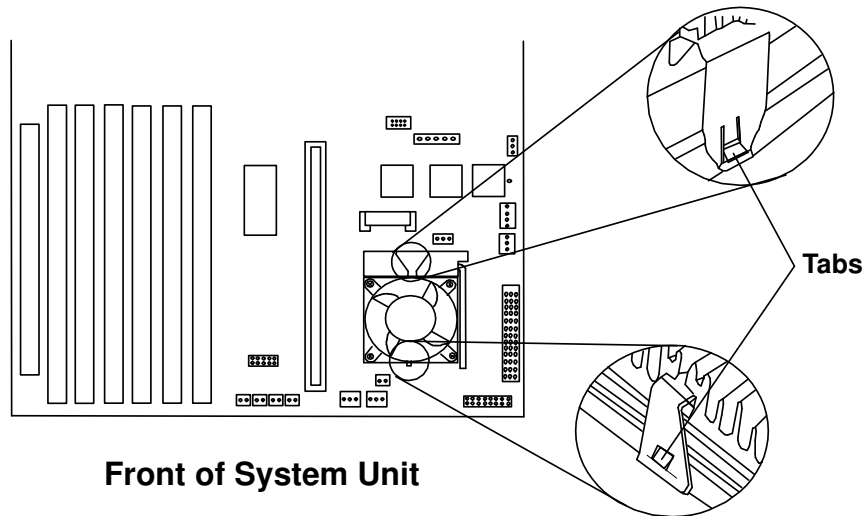

7. To remove the old fansink do the following:
 - a. Disconnect the fansink power cable from the system board.
 - b. While pressing down on the wide buckle, pull the buckle toward the rear of the system unit until the buckle clears the socket tab.
 - c. Tilt the fansink toward the front of the system unit and slide the narrow buckle off of the socket tab.
 - d. Store the old fansink in a safe location.

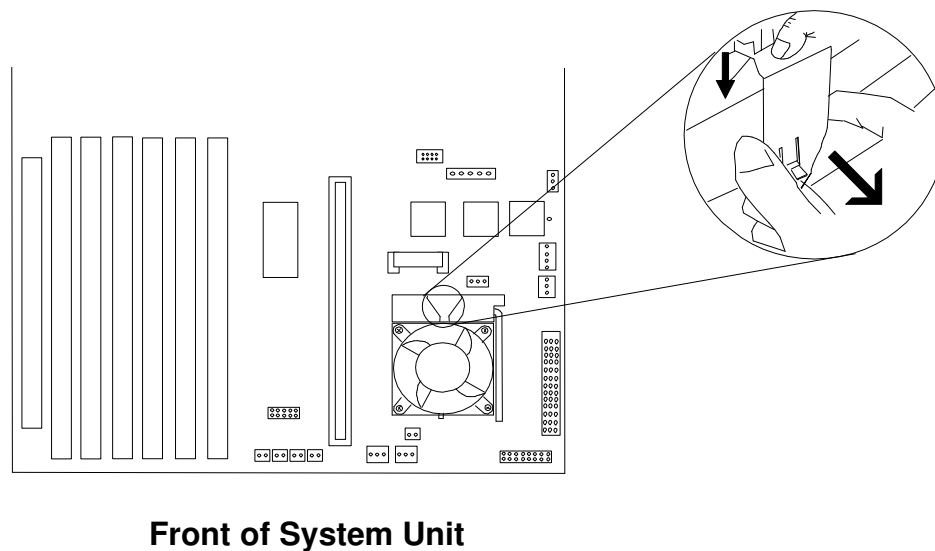

- Remove the old voltage regulator card by pushing down on the latches as shown. Lift the card up and out of the system unit.

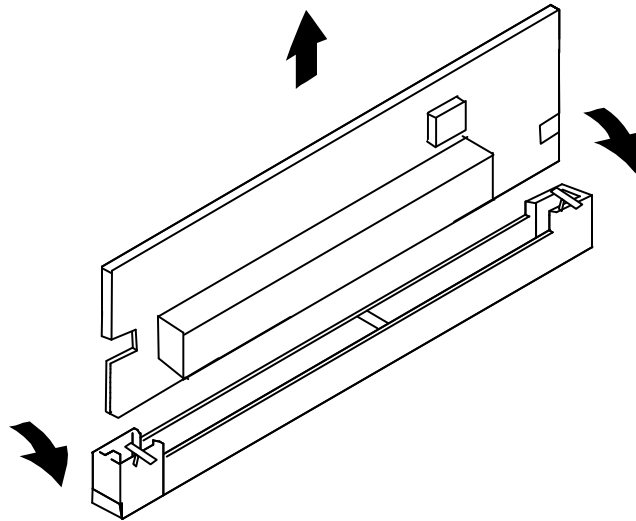

- Store the voltage regulator card in a static-protective package.
- Install the new voltage regulator card, pressing down until the latches click into place.
- Before handling the PowerPC 604e microprocessor, read "Safety Considerations" on page 4-2 and "Handling Static Sensitive Devices" on page 4-3 .

Lift the processor socket lever up and remove the existing processor. Store the processor in a safe place.

- The new PowerPC 604e microprocessor is mounted on a small circuit board with an array of connector pins underneath. The pin array has one missing pin at one corner so that the PowerPC 604e microprocessor can only be installed in one direction. The processor side of the circuit board is keyed with a small white dot that indicates the corner with the missing pin.

The processor socket on the planar is keyed with a matching missing female socket, as shown in the diagram below. Take care to ensure you have aligned the new processor correctly.

The PowerPC 604e microprocessor does not require any force when you plug it into the socket. Take care not to bend or break the pins on the processor board.

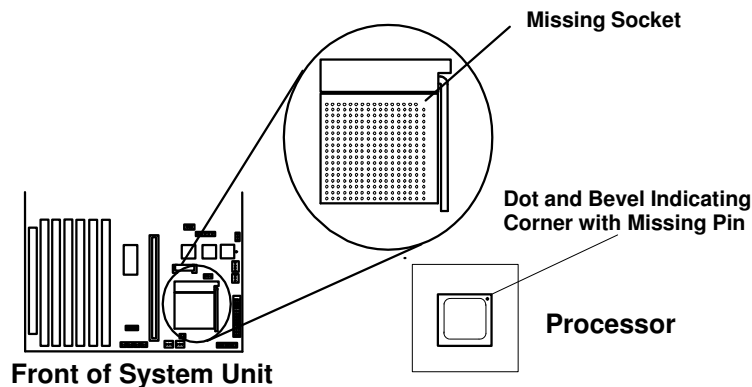

13. Place the new PowerPC 604e microprocessor into position on the processor socket. Make sure that all the pins are seated correctly and that no pin holes are visible. Lower the socket lever to lock the processor in place, making sure that the locking tab is visible.

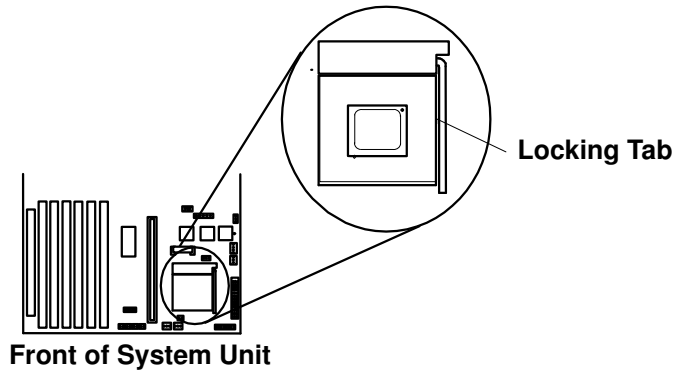

14. Peel back, remove, and throw away the plastic tab from the bottom of the new fansink assembly. The bottom of the new fansink assembly should have a coating of thermal grease on it. Ensure that no dust, dirt, or foreign objects get into the thermal grease. Wipe excess grease from your hands before continuing.

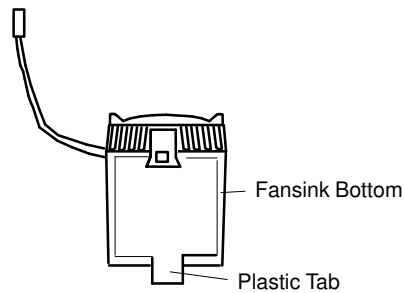

15. The new fansink sits on top of the PowerPC 604e microprocessor and attaches to the processor socket with two buckles as shown. One buckle has a small tab to assist with locking the buckles into place. The fansink buckle with the tab attaches to the wide shoulder on the processor socket where the lever pivots.

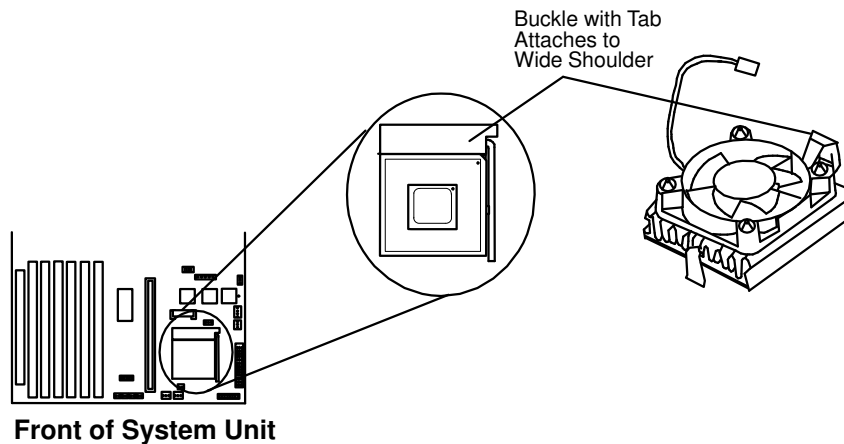

16. While tilting the fansink, hook the buckle without the tab over the front of the processor socket as shown.

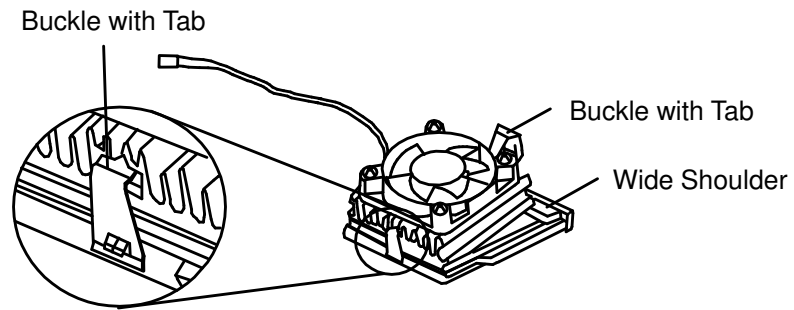

17. Press down on the buckle with the tab, as shown, to lock the fansink in place. You will hear a "click" indicating that the buckle is in place.

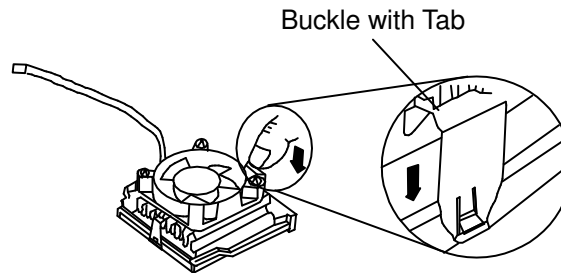

18. Connect the new fansink's assembly cable to the fansink cable connector on the system board.

19. Reinstall the disk drive bracket assembly.

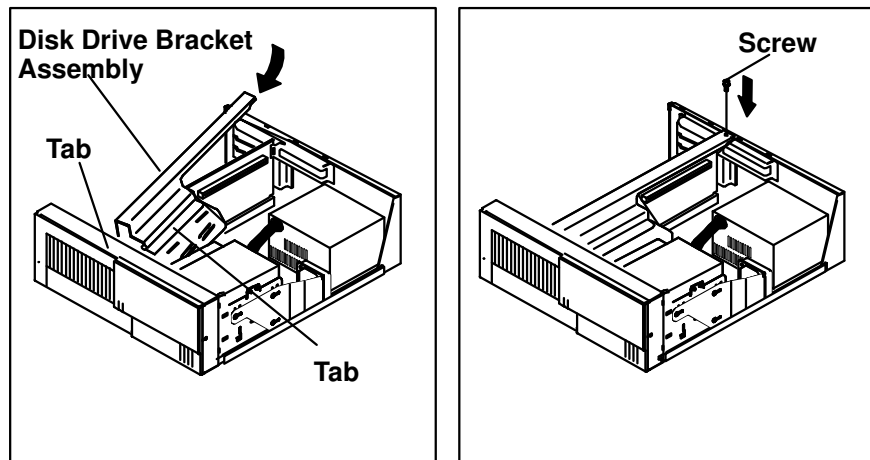

20. Reinstall any adapters you may have removed.

21. Place the new system board label beside the existing label on the system board.

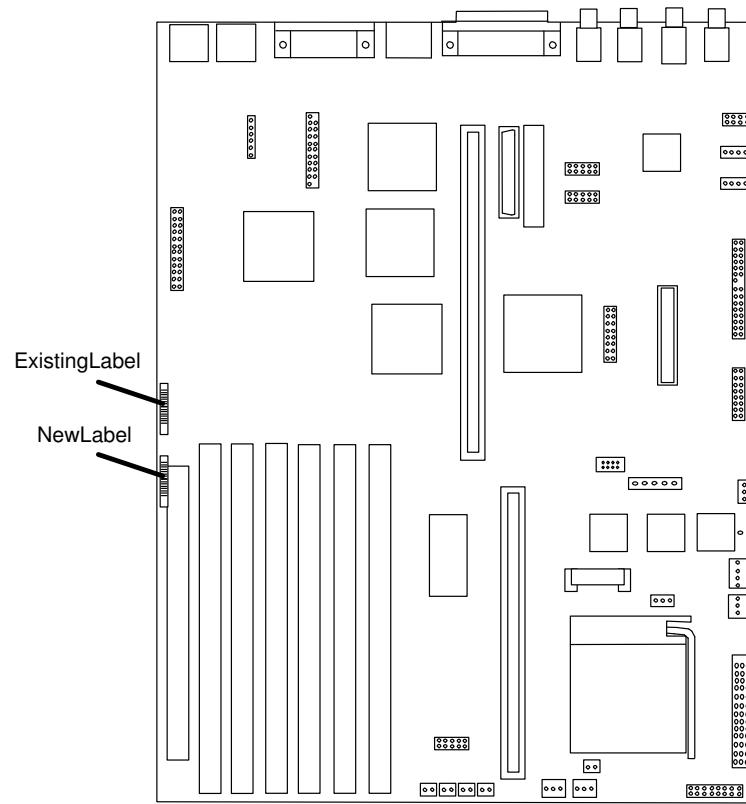

Front of System Unit

22. Reinstall the system unit cover.

23. Place the front label on the system unit as shown.

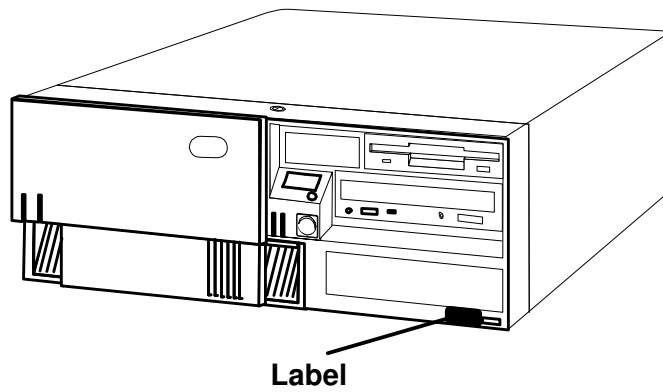

What to do next?

To enable or disable:

- The privileged-access password, go to page 4-12
- The automatic power-up feature, go to page 4-16
- The power-on password, go to page 4-8
- The external SCSI connector, go to page 4-58

To install:

- A memory module, go to page 4-21
- An L2 cache card, go to page 4-28
- A 332-Mhz processor upgrade for ESCALA S100, go to page 4-32
- An adapter, go to page 4-41
- An internal drive, go to page 4-47
- A security tether, go to page 4-61
- A new battery, go to page 4-63

To remove:

- An adapter, go to page 4-45
- A memory module, go to page 4-25
- An internal drive, go to page 4-47

To complete the installation, go to page 4-67

Installing Adapters

Before you begin:

- Read “ Safety Considerations” on page 4-2 and “Handling Static-Sensitive Devices” on page 4-3.
- Read the instructions that came with the adapter.
- Refer to Appendix B, “Adapter Placement Notes”, for placement requirements.
- Remove the system unit cover (see “Removing the Cover’ on page 4-4).

1. If you are also installing memory modules, go to “Installing Memory-Modules” on page 4-21, and then return here.
2. Check the instructions that came with the adapter for setting jumpers and switches.
3. Select a slot for the adapter:

Refer to Appendix B, “Adapter Placement Notes”, for placement requirements.

ATTENTION: Failure to install your graphics adapter in the correct slot may result in your adapter, or your system unit not functioning correctly.

If you have an ESCALA S100, your system unit has the following slots:

- Slot 1: 32-bit, 5-volt, PCI short card (primary)
- Slot 2: 32-bit, 5-volt, ISA or PCI (primary)
- Slot 3: 32-bit, 5-volt, ISA or PCI (secondary)
- Slot 4: 32-bit, 5-volt, PCI (secondary)
- Slot 5: 32-bit, 5-volt, PCI short card (secondary)

Note: Slot 1 can accommodate a long PCI card if DIMMs taller than 2.5cm (1 inch), such as 64MB or 128MB, are not installed.

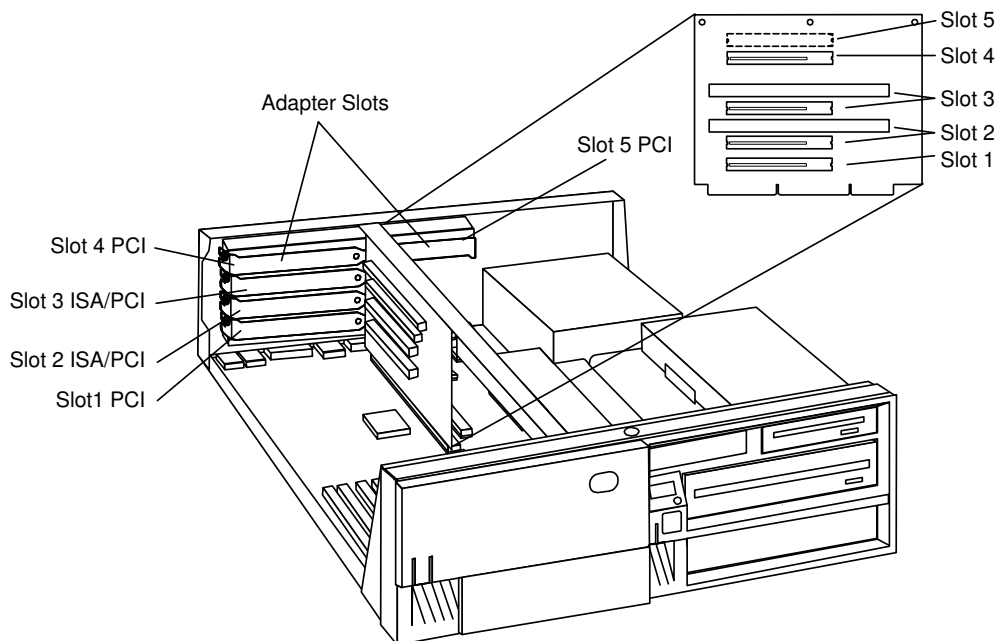

If you have an ESCALA S120, your system unit has the following slots:

- Slot 1: 32-bit, 5-volt, PCI short card (secondary)
- Slot 2: 32-bit, 5-volt, PCI (primary)
- Slot 3: 32-bit, 5-volt, PCI (primary)
- Slot 4: 32-bit, 5-volt, PCI (secondary)
- Slot 5: 32-bit, 5-volt, PCI short card (secondary)

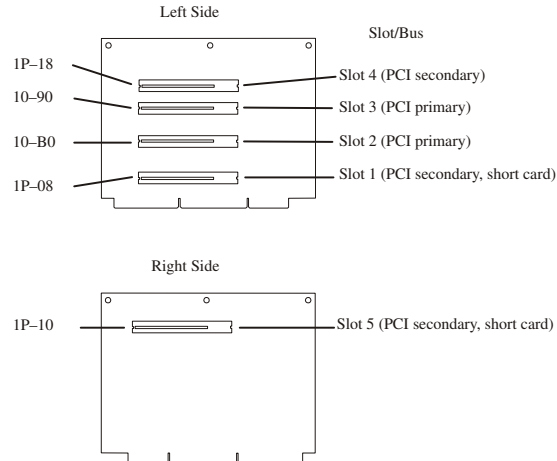

4. Remove the expansion-slot screw and cover. Save the cover in case you later remove an adapter.

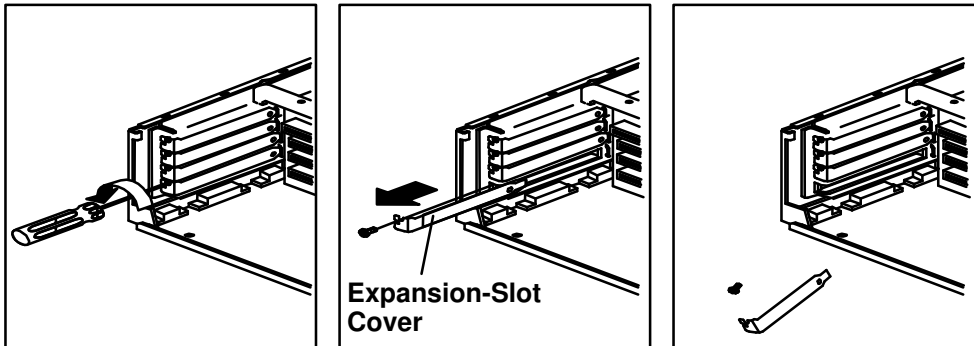

5. Touch the static-protective package containing the option to any unpainted metal surface on the system unit; then remove the option from the package.
6. Slide the adapter through the opening and press it *firmly* into the socket until the gold connector is fully inserted in the socket.

7. Replace the expansion-slot screw.

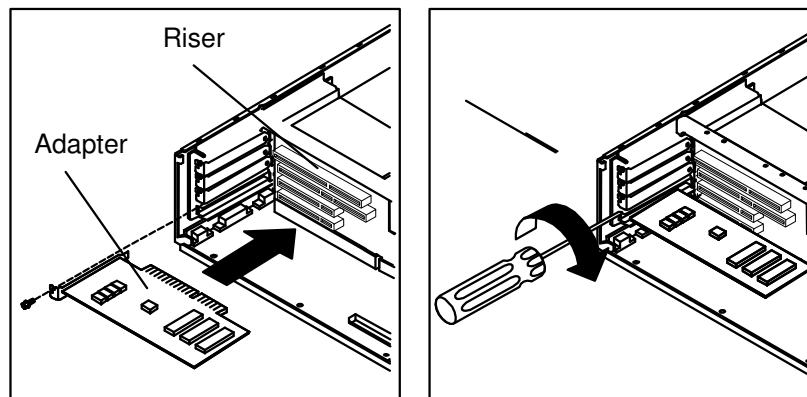

8. Connect appropriate cables.

Note: If connecting a coax adapter cable in slots 1 and 5, you may not be able to lock the cable into position.

9. If you have installed an ISA adapter, refer to Appendix C, "IRQ and DMA-Channel Assignments" on page C-1 for suggested ISA adapter configurations.
10. Go to "Device Records" on page A-2 and update the system memory information. Return here to continue.

What to do next?

To enable or disable:

- The privileged-access password, go to page 4-12
- The automatic power-up feature, go to page 4-16
- The power-on password, go to page 4-8
- The external SCSI connector, go to page 4-58

To install:

- A memory module, go to page 4-21
- An L2 cache card, go to page 4-28
- A 332-Mhz processor upgrade for ESCALA S100, go to page 4-32
- An adapter, go to page 4-41
- An internal drive, go to page 4-47
- A security tether, go to page 4-61
- A new battery, go to page 4-63

To remove:

- An adapter, go to page 4-45
- A memory module, go to page 4-25
- An internal drive, go to page 4-47

To complete the installation, go to page 4-67

Removing Adapters

Before you begin:

- Read "Safety Considerations" on page 4-2 and "Handling Static-Sensitive Devices" on page 4-3.
- Remove the system unit cover (see "Removing the Cover" on page 4-4).

1. Note the location of the adapter you are removing.

Note: If the adapter you are removing has a grounding strap or a plate that attaches it to the frame of the system unit, remove it now.

2. Remove the expansion-slot screw for the adapter; then grasp the adapter and pull it free from the socket.

Note: If the adapter you are removing has a ground wire or a bracket attached to the frame of the system unit, remove it now.

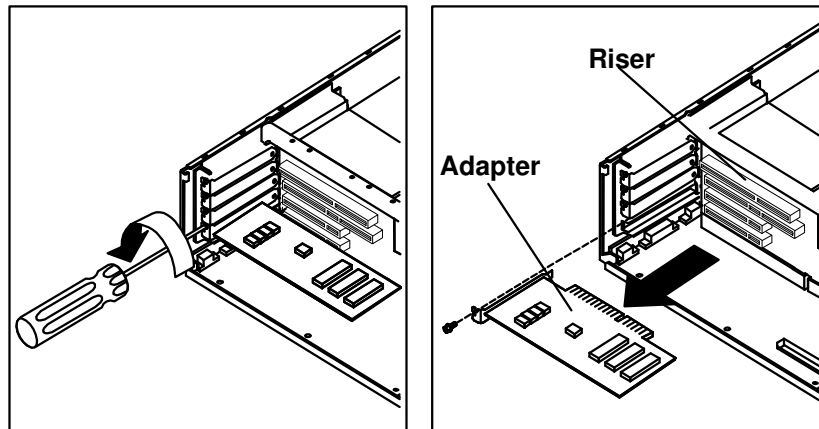

3. Place the removed adapter in a safe place, such as a static-protection bag if available.
4. If you are not replacing the adapter in this slot, install an expansion-slot cover into the empty expansion slot.
5. Go to "Device Records" on page A-2 and update the system memory information. Return here to continue.

What to do next?

To enable or disable:

- The privileged-access password, go to page 4-12
- The automatic power-up feature, go to page 4-16
- The power-on password, go to page 4-8
- The external SCSI connector, go to page 4-58

To install:

- A memory module, go to page 4-21
- An L2 cache card, go to page 4-28
- A 332-Mhz processor upgrade for ESCALA S100, go to page 4-32
- An adapter, go to page 4-41
- An internal drive, go to page 4-47
- A security tether, go to page 4-61
- A new battery, go to page 4-63

To remove:

- An adapter, go to page 4-45
- A memory module, go to page 4-25
- An internal drive, go to page 4-47

To complete the installation, go to page 4-67

Internal Drives

Adding different types of drives enables your system unit to read a variety of media and provides more storage for your system unit.

Internal drives are installed in *bays*. Your system unit has 5 bays:

- Bay 1 has a 3.5-inch diskette drive installed.
- Bay 2 has a CD-ROM drive installed *.

Note: if a VDAT is installed, the CD-ROM is in bay 3.

- Bay 3 can accommodate the following devices, up to half-height (43mm, 1.7 in) tall:
 - tape drives
 - CD-ROM drives
 - 3.5-inch disk drives (with mounting brackets)
- Bay 4 can accommodate only 3.5-inch disk drives up to 25mm (1 in) in height.
- Bay 5 can accommodate only 3.5-inch disk drives.
 - Up to 25-mm (1-inch) disk drives can be used.

*: If an internal 8mm VDAT Tape Drive is installed in the system, the CD-ROM is installed in Bay 3 and the 8mm VDAT Tape Drive in Bay 2.

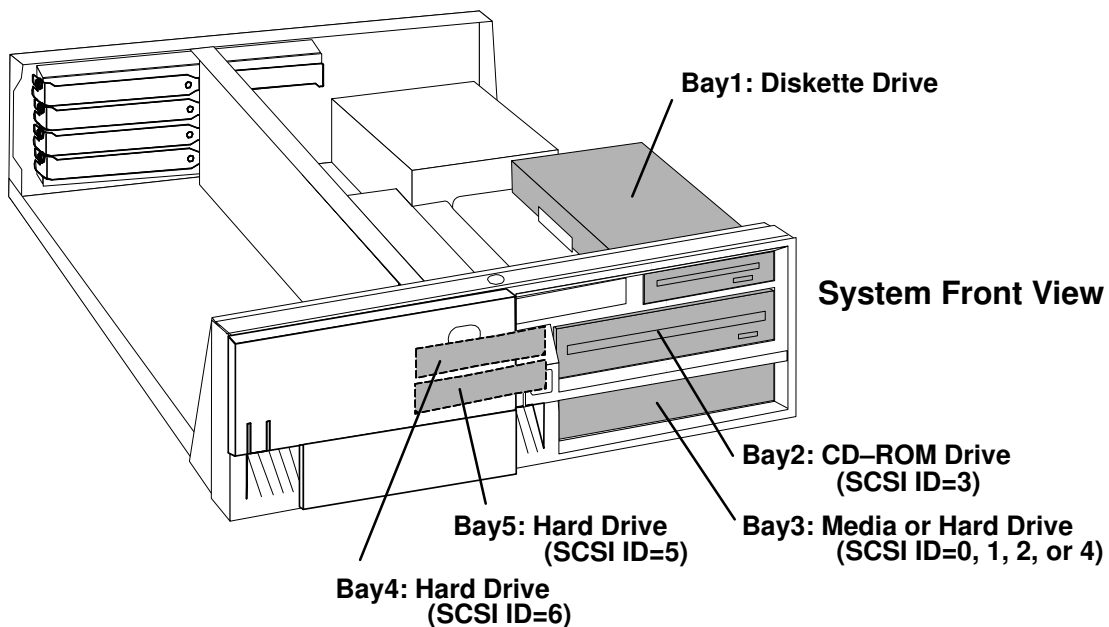

Installing or Removing Internal Drives

Before you begin:

- Read the "Laser Safety Information" on page xi.
- Read "Safety Considerations" on page 4-2 and "Handling Static-Sensitive Devices" on page 4-3.
- Read the manual that came with the internal drive for instructions on setting switches, jumpers, and device terminators.
- If you are installing a 3.5-inch drive in bay 3, make sure you have the optional 3.5-inch drive mounting brackets.
- Use the System Management Services or your operating system to record the addresses of the existing drives in your system unit **before** beginning this procedure. You must choose SCSI addresses for the any new drives which do not conflict with addresses of drives already installed.
- Remove the system unit cover (see "Removing the Cover" on page 4-4).

1. Determine the location for the drive you want to install. If there is a drive already installed in that bay, these instructions direct you to remove the existing drive before installing the new drive.
2. Touch the static-protective package to any unpainted metal surface on the system unit, then remove the drive from the package.
3. Using the instructions that came with the drive, check that any switches or jumpers on the drive are set correctly (see the *Disks and Tapes Configuration Information* manual).
4. Disconnect the signal and power cables from any drives installed in bay 4 or bay 5.

Note: Removing cables from a drive in bay 4 is shown to illustrate this procedure.

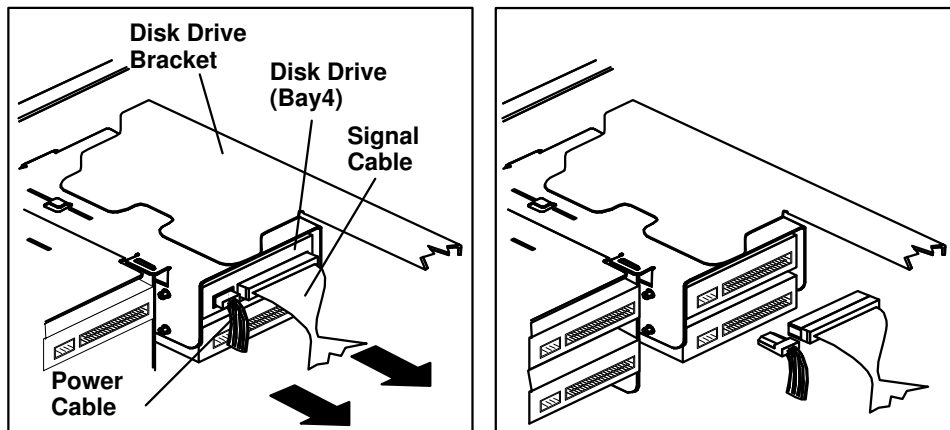

5. Remove the disk drive bracket assembly from the system unit.

Note: Any adapters installed in slot 5 may have to be temporarily removed in order to remove the disk drive bracket. Refer to "Removing Adapters" on page 4-45 for adapter removal instructions.

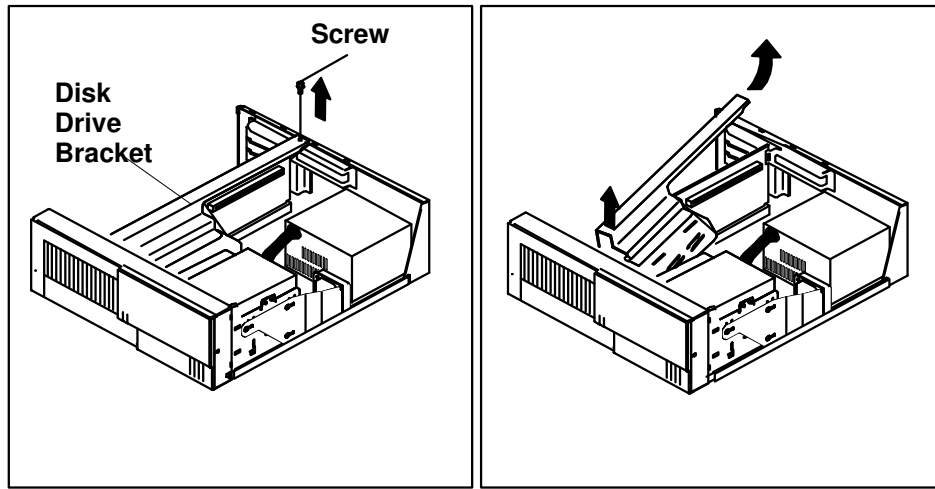

What to do next?

- To install or remove a drive in bay 2 or 3, continue with the next step.
- To install or remove a drive in bay 4 or 5, go to step 23 on page 4-54.

6. Remove the media fan assembly from the media drive bracket.

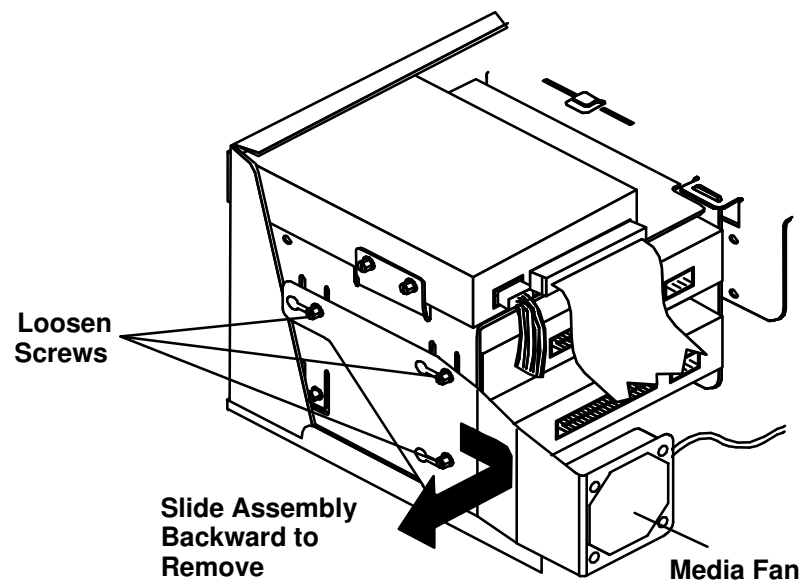

7. Disconnect the signal and power cable from the drives in bays 1, 2, and 3.

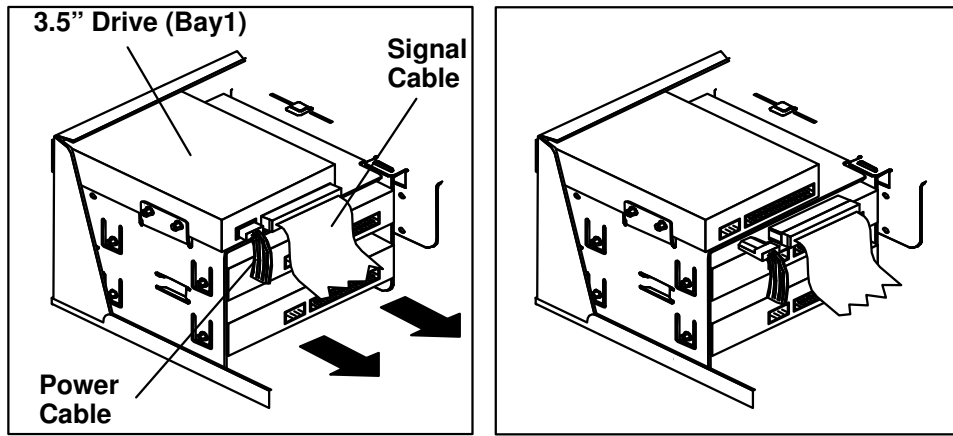

8. Remove the media drive bracket attachment pin located at the left rear corner of the media drive bracket. This pin is not needed after your system unit is delivered, and must be removed in order to complete installation of drives in bay 2 or bay 3.

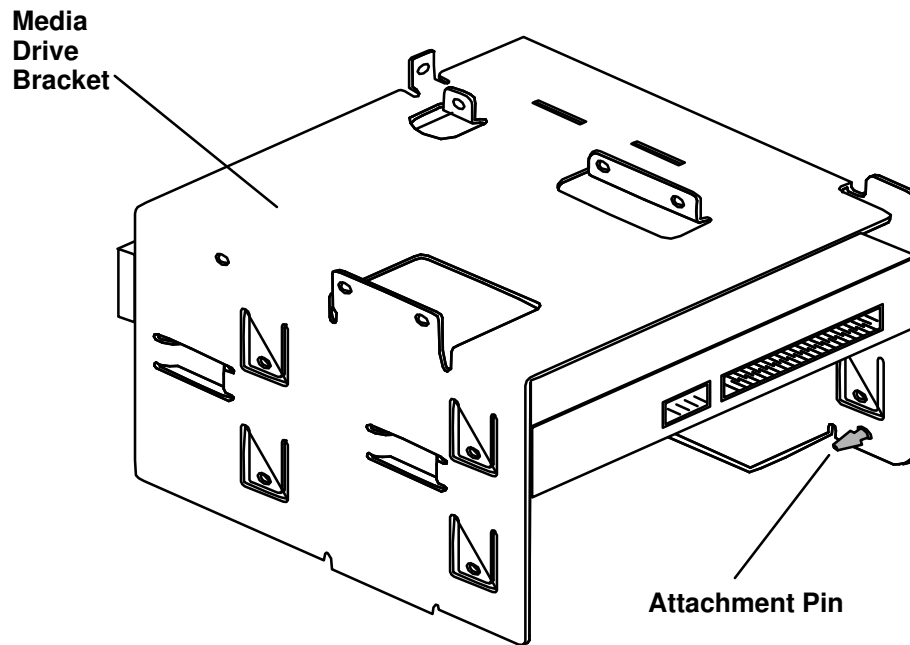

9. Remove the media drive bracket from the system unit.

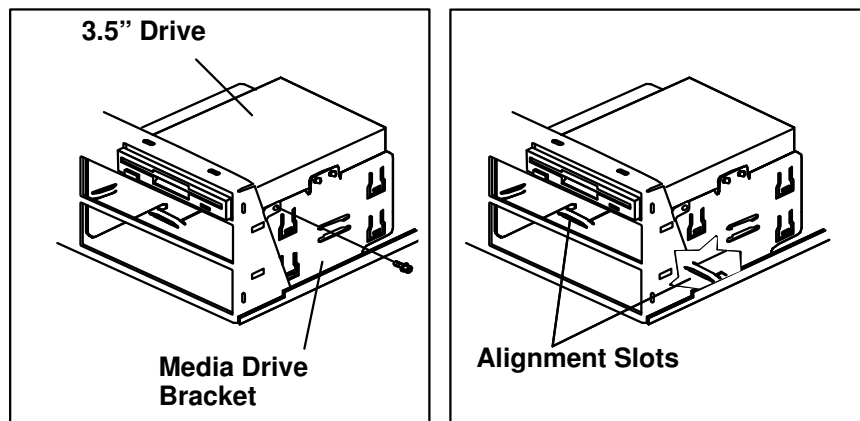

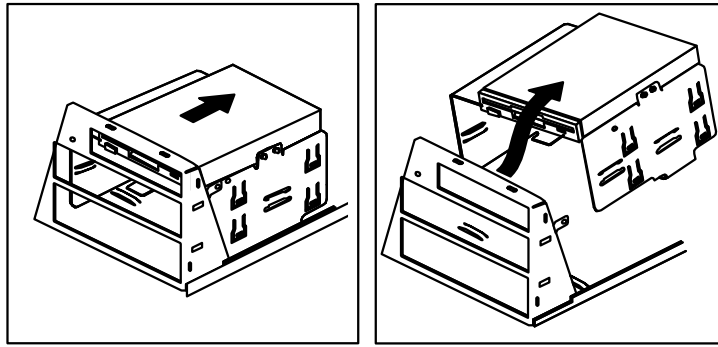

What to do next?

- To install or remove a drive in bay 2, continue with the next step.
- To install or remove a 5.25–inch drive in bay 3, continue with step 13 on page 4-52
- To install or remove a 3.5–inch drive in bay 3, go to step 18 on page 4-52
- To install or remove a drive in bay 4 or 5, go to step 23 on page 4-54.
- If you have no more drives to install or remove, go to step 20 on page 4-53.

10. If a drive is already installed in bay 2, remove the four screws attaching the drive to the media drive bracket.
11. Set the SCSI ID of the new drive to an address that does not conflict with drives already installed.
12. Insert the new drive into bay 2 and attach the drive to the media drive bracket with four screws.

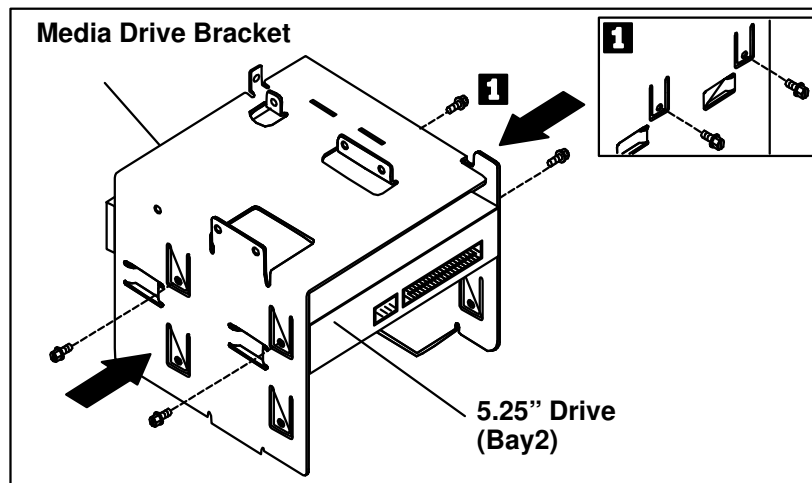

What to do next?

- To install or remove a 5.25–inch drive in bay 3, continue with step 13 on page 4-52
- To install or remove a 3.5–inch drive in bay 3, go to step 18 on page 4-52
- To install or remove a drive in bay 4 or 5, go to step 23 on page 4-54.
- If you have no more drives to install or remove, go to step 20 on page 4-53.

13. If a drive is already installed in bay 3, remove the four screws attaching the drive to the media drive bracket.
14. Set the SCSI ID of the new drive to an address that does not conflict with drives already installed.
15. Insert the new drive into bay 3 and attach the drive to the media drive bracket with four screws.

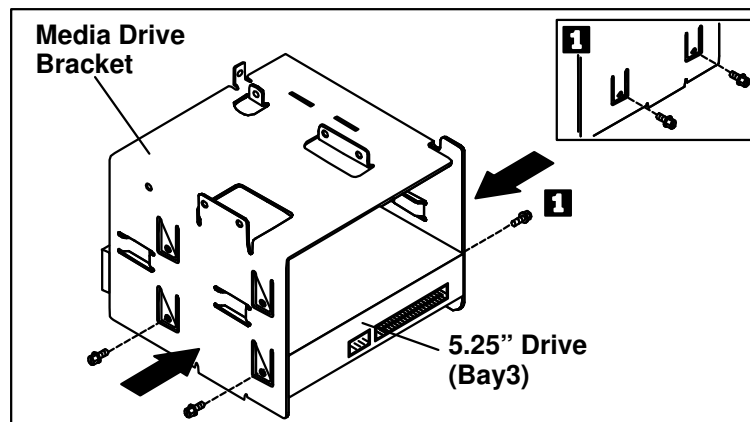

16. If the drive you are installing is a removable media drive (such as a CD-ROM drive or tape drive), remove the bay panel from bay 3 and store the bay panel in a safe place in case you ever need to use it again.

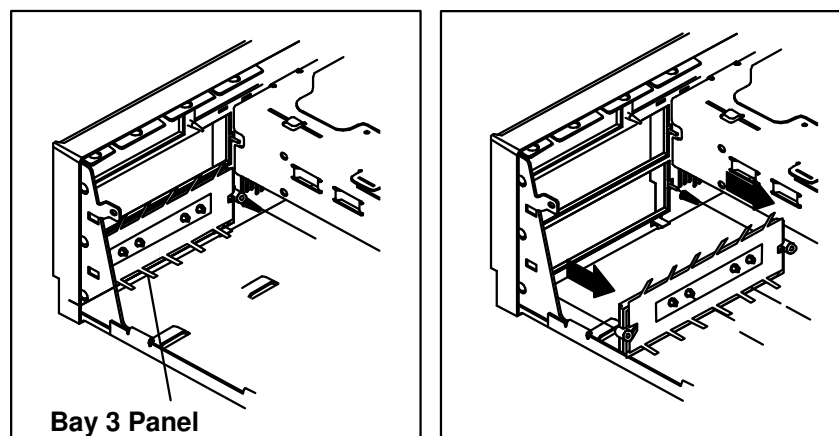

17. To reinstall the media drive bracket containing the new drive, go to step 20 on page 4-53.
18. To install a 3.5 inch disk drive in bay 3, first attach the optional mounting brackets to the 3.5 inch disk drive so that the mounting brackets are centered on the 3.5 inch disk drive as shown. The screws attaching the mounting brackets to the disk drive should pass through the lower set of slots on the mounting brackets (if possible).

Note: Two different types of screws are included with the 3.5 inch disk drive mounting brackets. Make sure that you attach the mounting brackets to the disk drive using the screws with the **larger threads**. The other screws cannot be inserted properly into the disk drive.

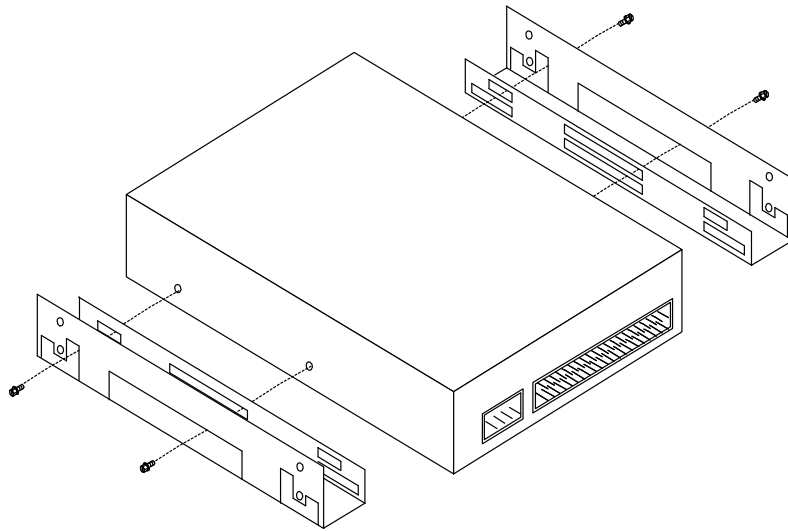

19. Insert the disk drive and mounting bracket assembly into the media drive bracket, and attach the disk drive assembly to the media drive bracket using the screws with the **smaller threads**. The screws attaching the disk drive assembly should thread through the media drive bracket and into the lower set of holes in the mounting bracket (if possible).

20. Reinstall the media drive bracket.

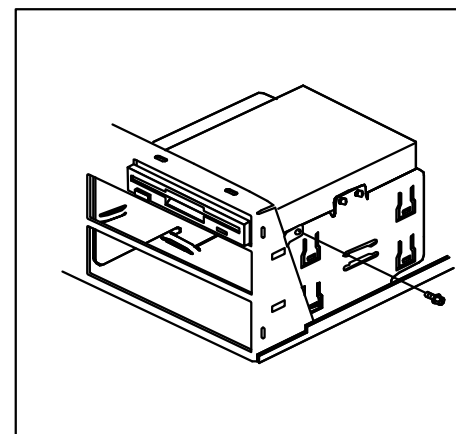
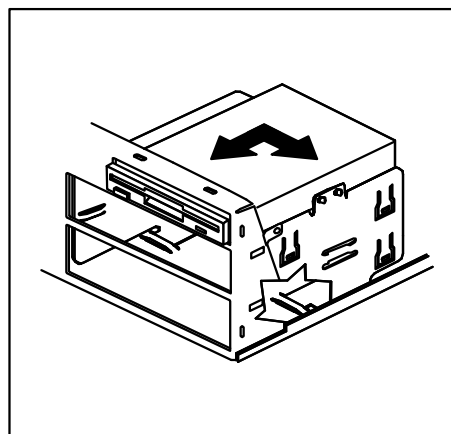
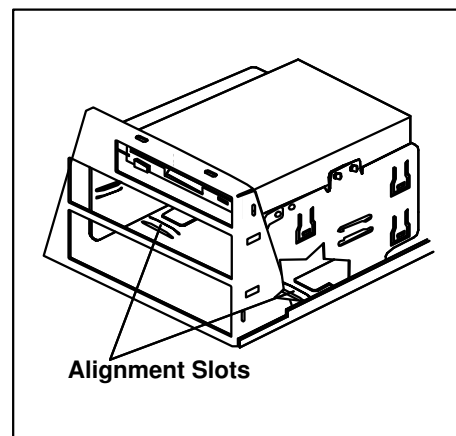
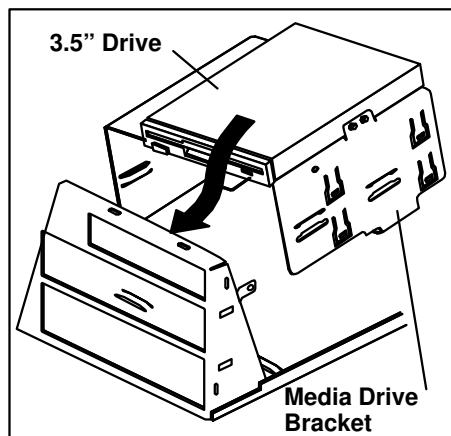

21. Connect the signal and power cable to each of the installed drives. Connecting cables to the drive in bay 3 is shown to illustrate this procedure.

If you have difficulty connecting a cable, turn the cable connector over and try again. Cable connectors are keyed and connect only one way. These cables have multiple connectors so that one cable can connect to more than one drive.

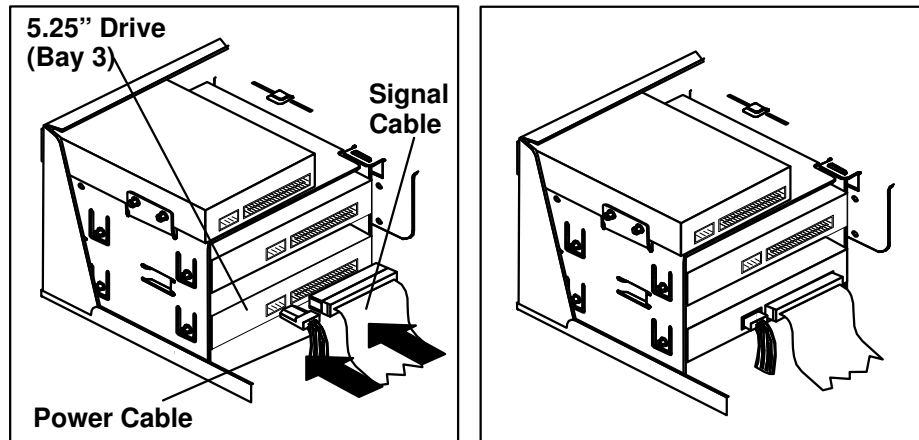

22. Reinstall the media fan assembly and reconnect the media fan cable.

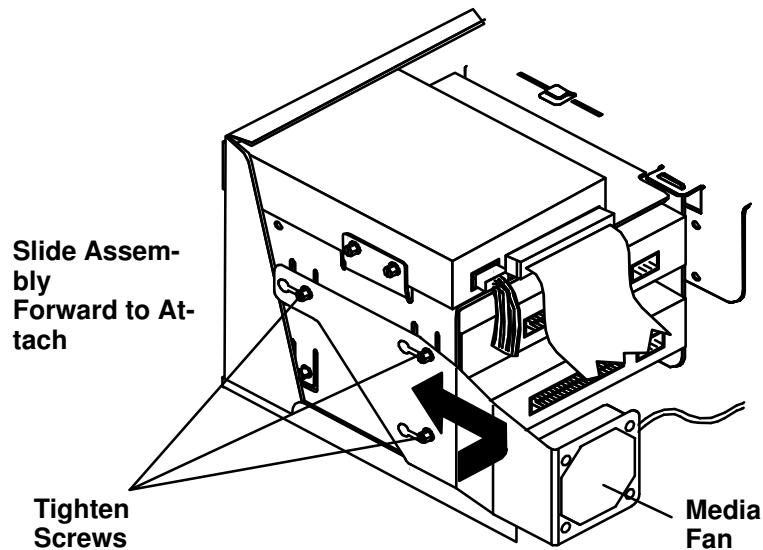

What to do next?

- To install or remove a drive in bay 4, continue with the next step.
- To install or remove a drive in bay 5, go to step 26 on page 4-55.
- If you have no more drives to install or remove, go to step 29 on page 4-56.

23. If a drive is already installed in bay 4, remove the four screws attaching the drive assembly to the disk drive bracket.

24. Set the SCSI ID of the new drive to an address that does not conflict with drives already installed.

25. Insert the drive into bay 4 and attach the drive to the disk drive bracket with four screws.

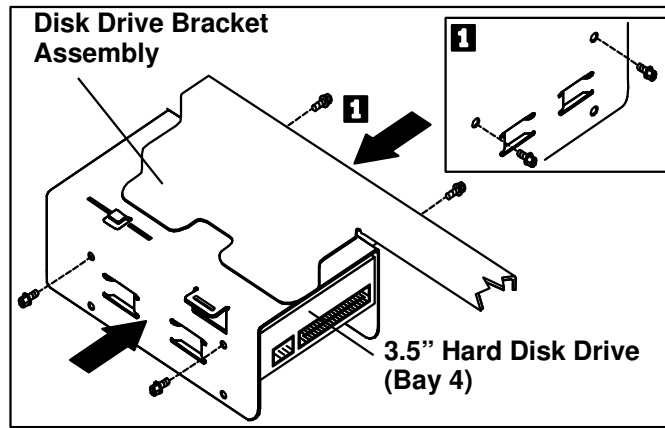

What to do next?

- To install or remove a drive in bay 5, continue with the next step.
- If you have no more drives to install or remove, go to step 29 on page 4-56.

26. If a drive is already installed in bay 5, remove the four screws attaching the drive assembly to the disk drive bracket.

27. Set the SCSI ID of the new drive to an address that does not conflict with drives already installed.

28. Insert the new drive into bay 5 and attach the drive to the disk drive bracket with four screws.

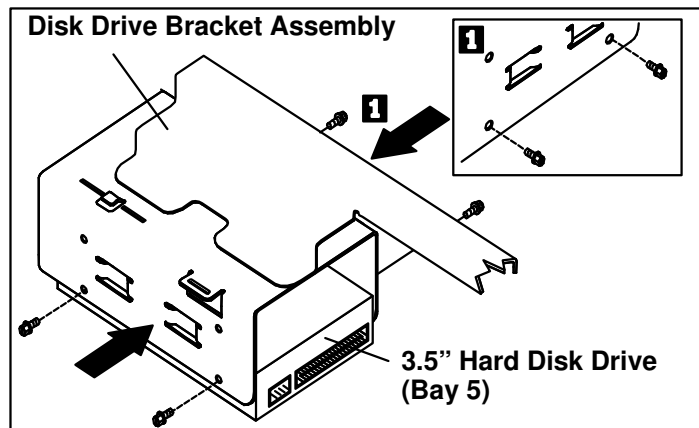

29.Reinstall the disk drive bracket assembly.

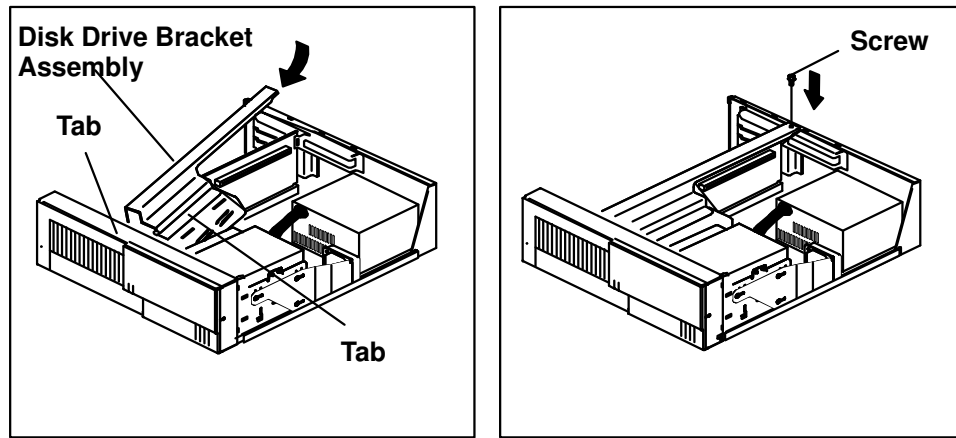

30.Connect the signal and power cable to each of the installed drives. Connecting cables to the drive in bay 4 is shown to illustrate this procedure.

Note: If you have difficult connecting a cable, turn the cable connector over and try again. Cable connectors are keyed and connect only one way. These cables have multiple connectors so that one cable can connect to more than one drive.

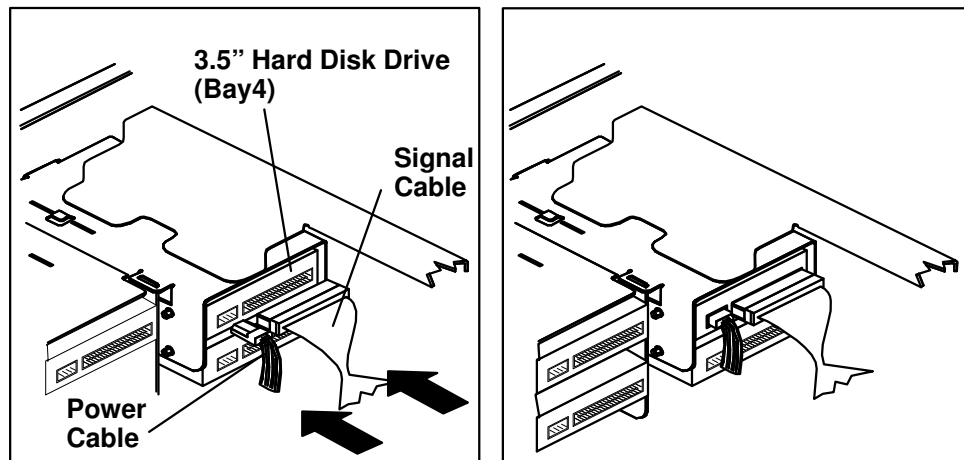

31.Reinstall any adapters you may have removed.

32.Go to "Device Records" on page A-2 and update the system information. Return here to continue.

What to do next?

To enable or disable:

- The privileged-access password, go to page 4-12
- The automatic power-up feature, go to page 4-16
- The power-on password, go to page 4-8
- The external SCSI connector, go to page 4-58

To install:

- A memory module, go to page 4-21
- An L2 cache card, go to page 4-28
- A 332-Mhz processor upgrade for ESCALA S100, go to page 4-32
- An adapter, go to page 4-41
- An internal drive, go to page 4-47
- A security tether, go to page 4-61
- A new battery, go to page 4-63

To remove:

- An adapter, go to page 4-45
- A memory module, go to page 4-25
- An internal drive, go to page 4-47

To complete the installation, go to page 4-67

Setting the SCSI Security Jumpers

Before you begin:

- Read the "Laser Safety Information" on page xi.
- Read "Safety Considerations" on page 4-2 and "Handling Static-Sensitive Devices" on page 4-3.
- Remove the system unit cover (see "Removing the Cover" on page 4-4).

To increase system unit security, the external SCSI connector can be disabled by changing jumpers inside the system unit.

1. If you have an ESCALA S100 model, locate the SCSI security jumpers in the following figure.

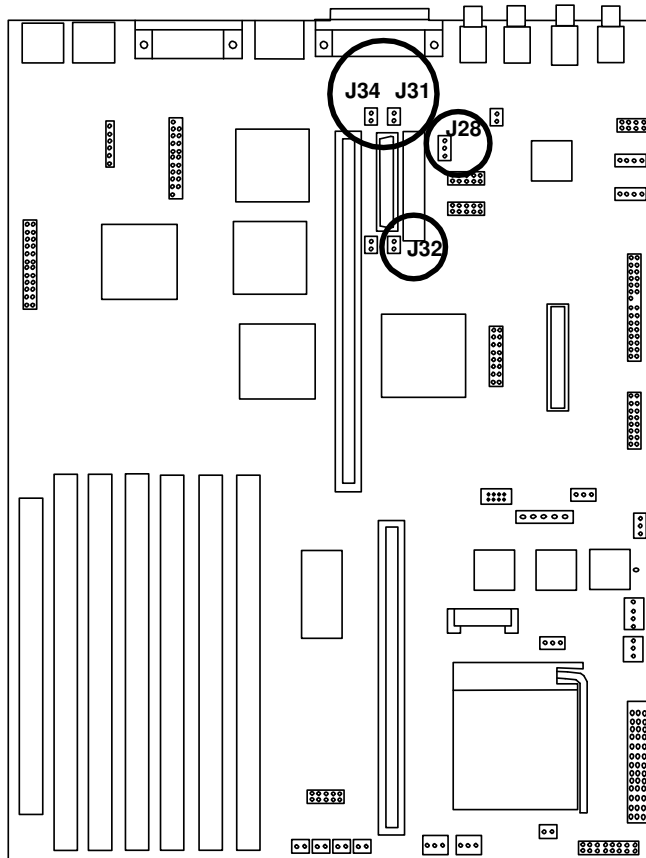

2. To disable the external SCSI connector, remove the jumpers from J31, J32, and J34. Move the jumper on J28 to the two frontmost pins. Save all of the removed jumpers for future use.

3. If you have an ESCALA S120 model, locate the SCSI security jumpers in the following figure.

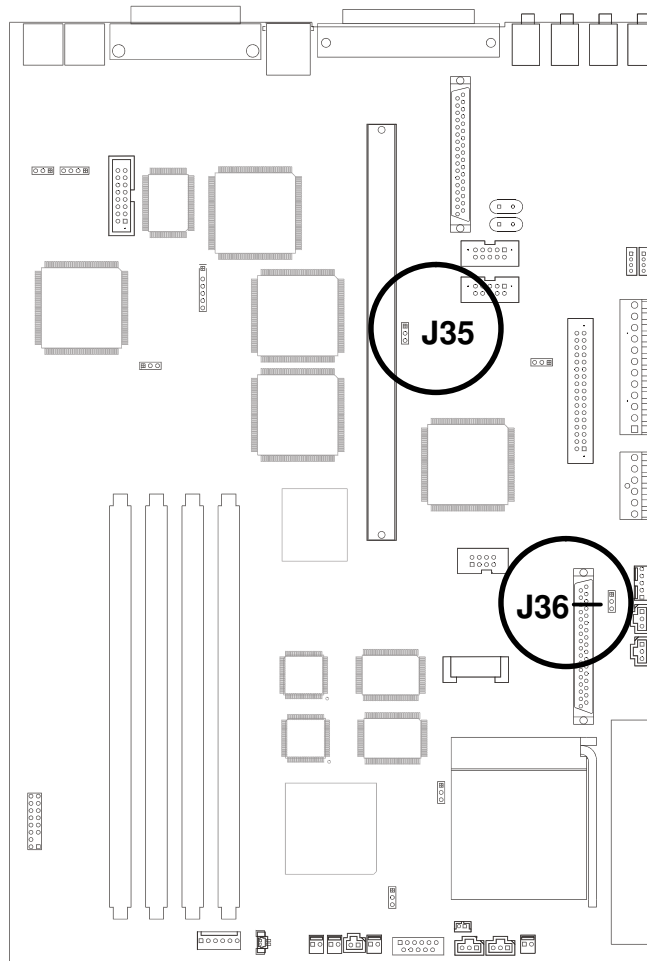

4. To disable the external SCSI connector, move the jumper on J35 to the front two pins, and move the jumper on J36 to the rear two pins.

What to do next?

To enable or disable:

- The privileged-access password, go to page 4-12
- The automatic power-up feature, go to page 4-16
- The power-on password, go to page 4-8
- The external SCSI connector, go to page 4-58

To install:

- A memory module, go to page 4-21
- An L2 cache card, go to page 4-28
- A 332-Mhz processor upgrade for ESCALA S100, go to page 4-32
- An adapter, go to page 4-41
- An internal drive, go to page 4-47
- A security tether, go to page 4-61
- A new battery, go to page 4-63

To remove:

- An adapter, go to page 4-45
- A memory module, go to page 4-25
- An internal drive, go to page 4-47

To complete the installation, go to page 4-67

Installing a Security Tether

A security tie-down option is available to help prevent theft of your system unit. For easy relocation of your system unit, obtain a lock, such as a combination lock or padlock.

Before you begin:

- Obtain the following:
 - A flat-blade screwdriver
 - An adjustable wrench
 - A 19 mm (3/4-inch) U-bolt or wire rope (similar to National Manufacturing No. 3230, Stock No. 176-735)
 - Threaded nuts that fit the U-bolt
 - A security cable
 - A lock, such as a combination lock or a padlock.
- Read “ Safety Considerations” on page 4-2 and “Handling Static-Sensitive Devices” on page 4-3.
- Turn off the system unit.
- Disconnect all external cables and power cords.
- Remove the system unit cover (see “Removing the Cover” on page 4-4).

1. Remove the plastic plug from the rear panel.
2. Install the U-bolt.

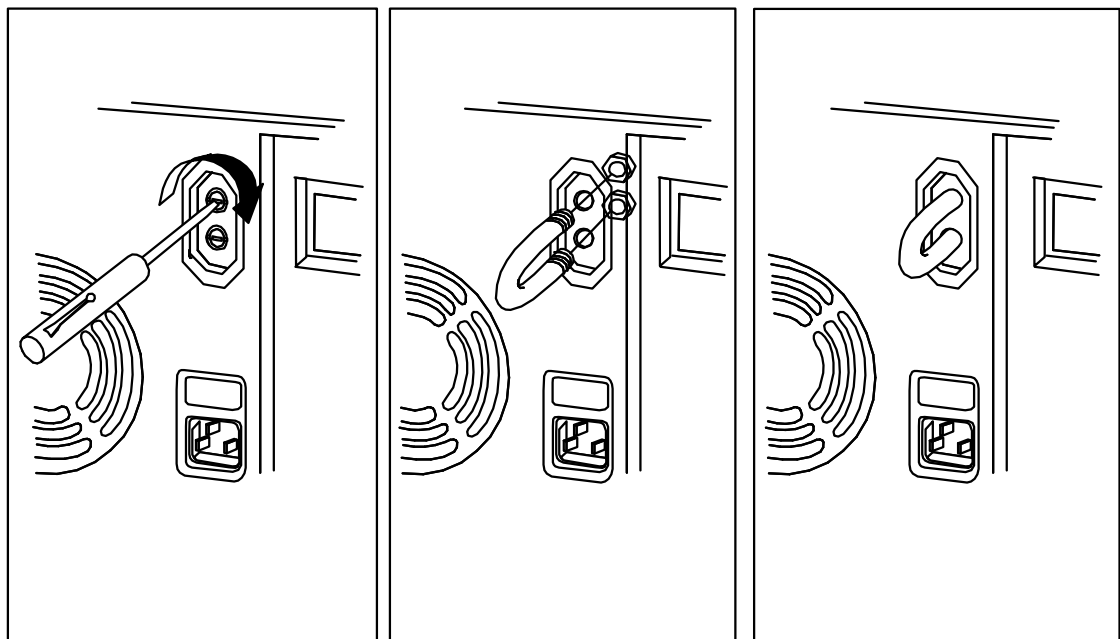

3. Thread the cable through the U-bolt and around an object from which it cannot be removed, then fasten the cable ends together with a lock.

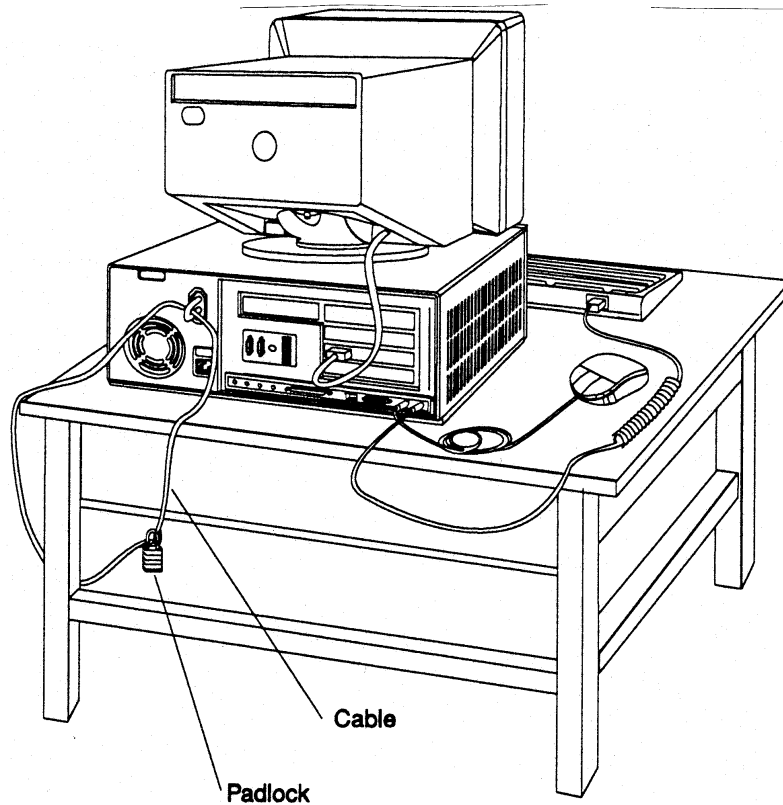

What to do next?

If you have completed installing the U-bolt and do not want to install any other internal options, replace the system unit cover and reconnect all external cables and power cords (see "Completing the Installation" on page 4-67 if you need additional information).

Changing the Battery

Before you begin:

- Read “ Safety Considerations” on page 4-2.
- Follow any special handling and installation instructions supplied with the replacement battery
- Disconnect all external cables and power cords.
- Disconnect all external cables and power cords, then remove the system unit cover (see “Removing the Cover” on page 4-4 if you need additional information).

CAUTION:

The lithium battery can cause fire, explosion, or a severe burn. Do not recharge, disassemble, heat above 100°C (212°F), solder directly to the cell, incinerate, or expose cell contents to water. Keep away from children. Replace only with the part number specified for your system. Use of another battery may present a risk of fire or explosion.

The battery connector is polarized; do not attempt to reverse polarity. Dispose of the battery according to local regulations.

ATTENTION: Removing the battery may erase the Power-On Password, the current time and date, the customized boot list, and any other customized configuration information. After changing the battery, you may have to reset these values using the System Management Services and your operating system.

Make sure that the power cable is disconnected from the system unit before changing the battery.

Note: Skin oils can cause corrosion and loss of battery contact if left on the battery for long periods of time. Using a paper tissue when changing the battery can minimize skin contact with the battery and promote proper battery function.

The battery is located as shown in the following figure.

Note: You may have to temporarily remove adapters in order to change the battery.

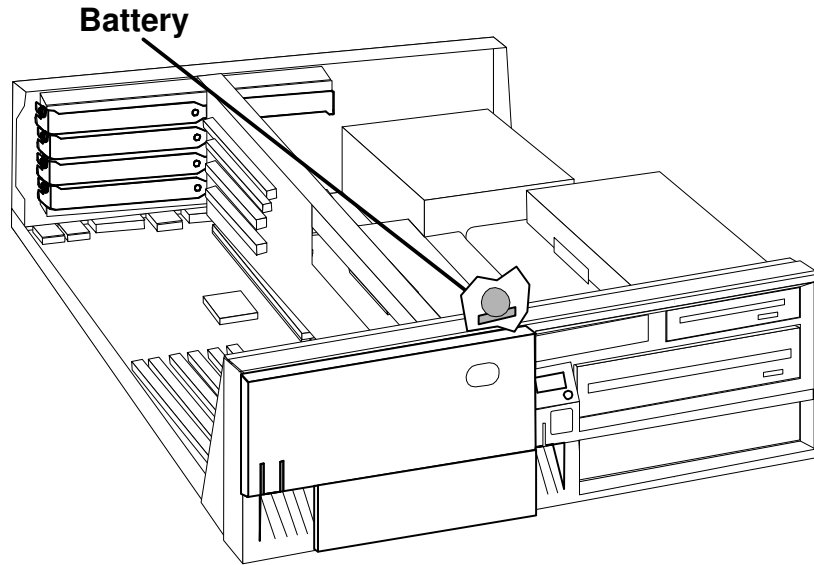

Notes:

- a. The disk drive bracket must be removed to change the battery. Carefully place it on top of the power supply.
 - b. Any adapters installed in slot 5 may have to be temporarily removed in order to remove the disk drive bracket. refer to "Removing Adapters" on page 4-25 for adapter removal instructions.
1. Remove the disk drive bracket assembly.

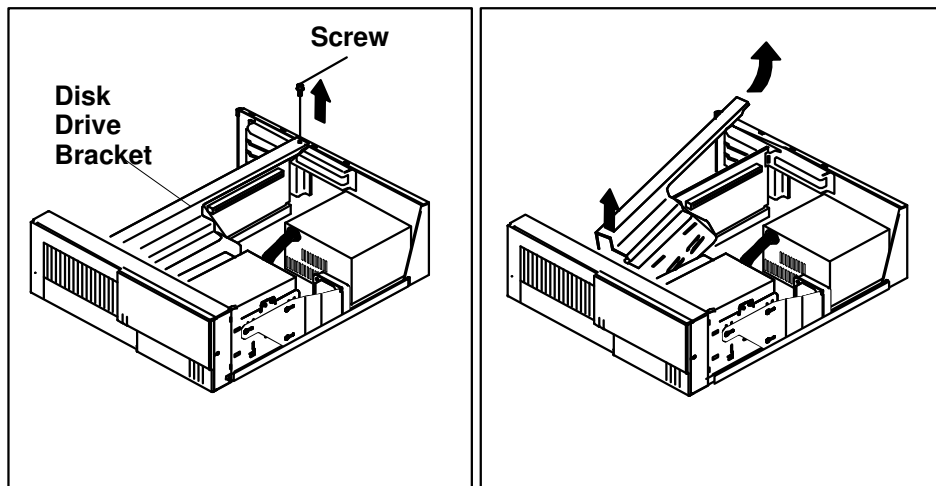

2. Remove the battery as shown. To replace the battery, reverse the motions.

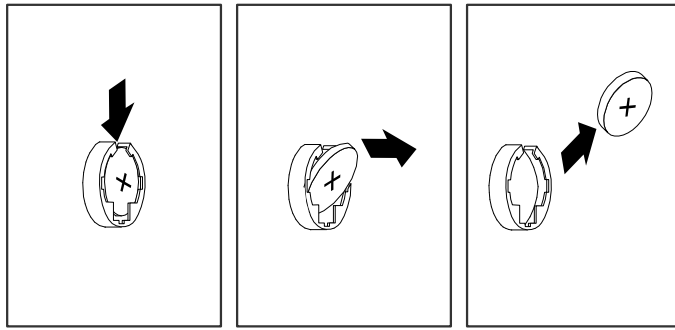

3. Reinstall the disk drive bracket assembly.

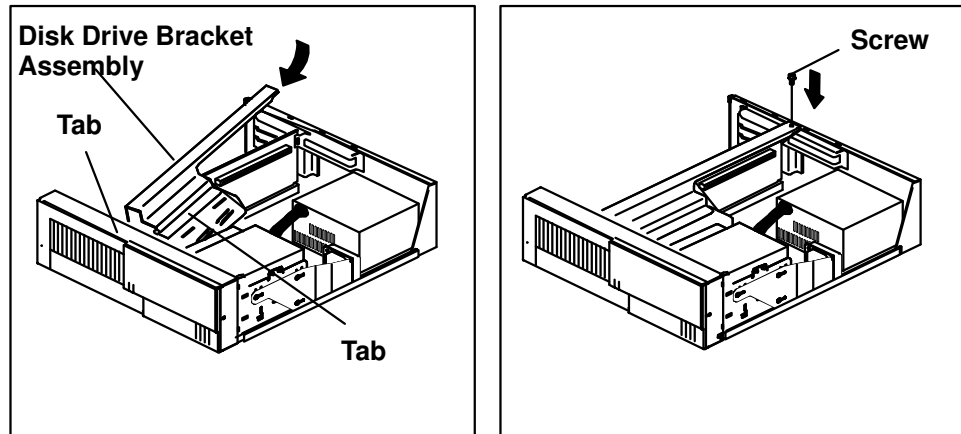

4. Reinstall any adapters you may have removed.

What to do next?

To enable or disable:

- The privileged-access password, go to page 4-12
- The automatic power-up feature, go to page 4-16
- The power-on password, go to page 4-8
- The external SCSI connector, go to page 4-58

To install:

- A memory module, go to page 4-21
- An L2 cache card, go to page 4-28
- A 332-Mhz processor upgrade for ESCALA S100, go to page 4-32
- An adapter, go to page 4-41
- An internal drive, go to page 4-47
- A security tether, go to page 4-61
- A new battery, go to page 4-63

To remove:

- An adapter, go to page 4-45
- A memory module, go to page 4-25
- An internal drive, go to page 4-47

To complete the installation, go to page 4-67

Completing the Installation

Before you begin:

Complete all the installation procedures for the options you have chosen to install

1. Make sure that system unit cover lock is unlocked.
2. Install the cover by placing it close to the front of the system unit, as shown. Slide the cover toward the front of the system unit while holding down the cover latch.

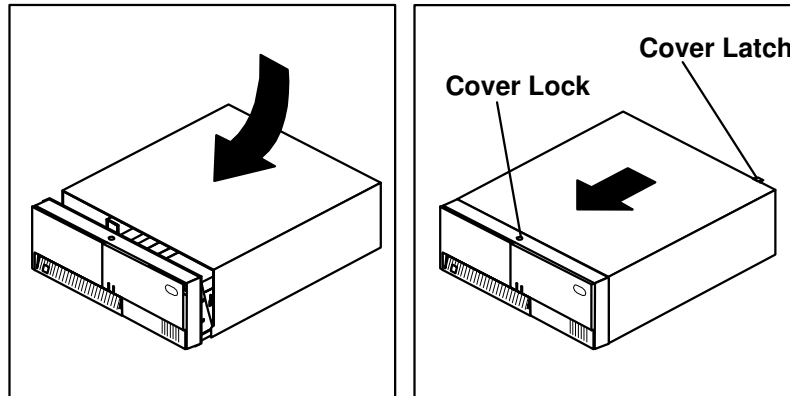

3. Reconnect all device cables, such as the printer and display, then plug the power cords into properly grounded electrical outlets.

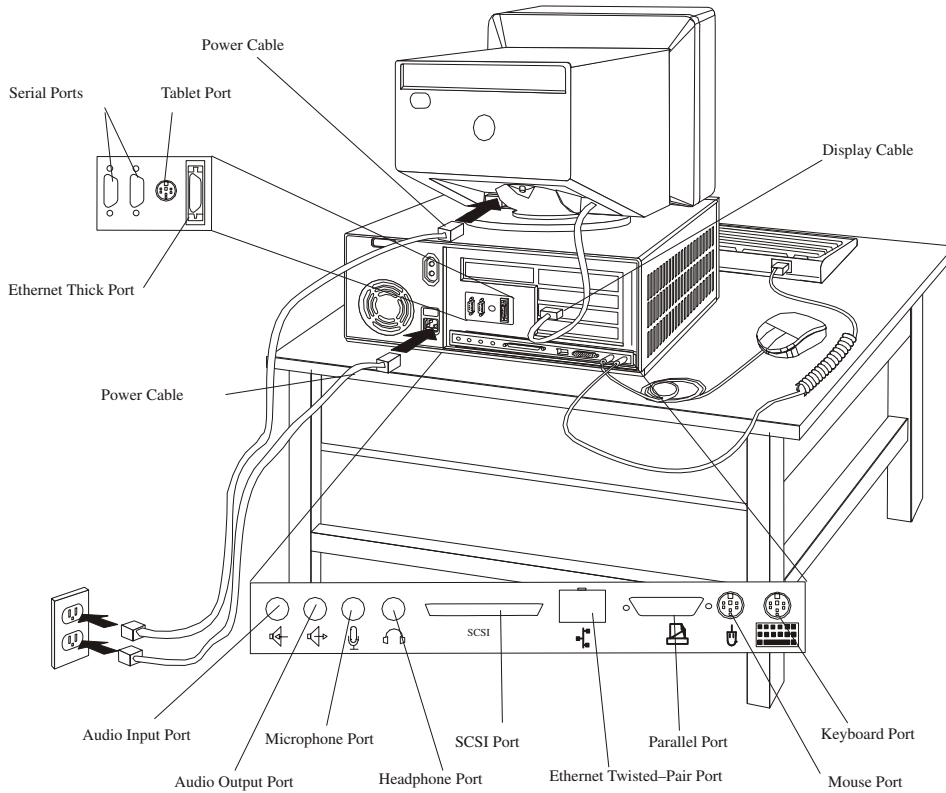

4. If you have a modem or fax machine attached to the system unit, reconnect the telephone line to the system unit and the outlet.

What to do next?

- Install any required device drivers, and update configuration information as specified in your operating-system documentation.
- If the only changes you made involved a floor stand, jumper setting, or security cable, your system unit is now ready to use.

Connecting external options

Before you begin:







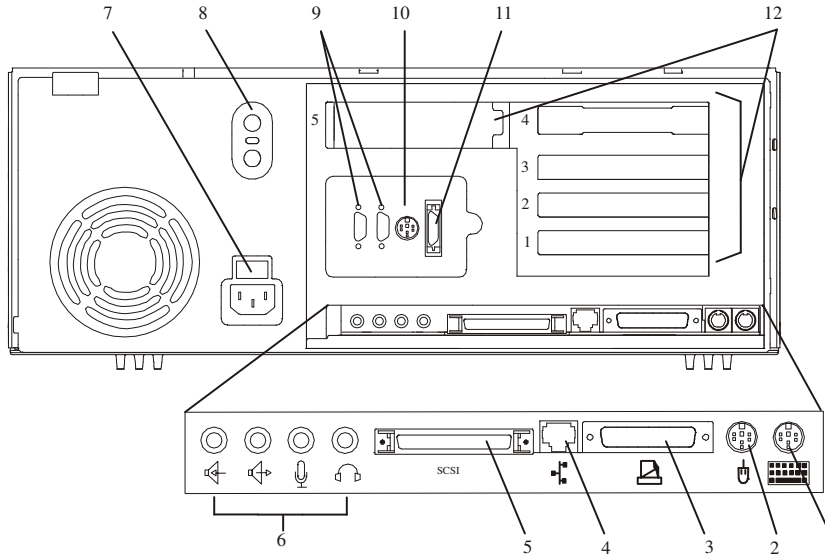

- Read “ Safety Considerations” on page 4-2 and “Handling Static–Sensitive Devices” on page 4–3.
- Install all your internal options.
- Read the manual that came with the external options.
- Install the system unit cover (see page 4-67).

1. Prepare the option for installation using the instructions that came with the option. You might find instructions for:
 - Setting a SCSI device ID
 - Removing or installing a SCSI device terminator
 - Setting jumpers or switches
2. Connect the option to the system unit as described in the instructions that came with the option. The following figure shows describes the input/output connectors that are used to connect many external options.

Input/Output Connectors

Rear View



- 1 Keyboard Port (): For keyboard connection.
- 2 Mouse Port (): For mouse connection.
- 3 Parallel Port (): For connecting a parallel printer or other parallel devices.
- 4 Ethernet Port (): For attaching your computer to an Ethernet/Twisted pair connection through a 10 Base T or 100/10 Base T connector. (ESCALA S100 uses 10 Base T; ESCALA S120 uses 100/10 Base T.)
- 5 External SCSI Port ():
For connecting external SCSI devices.
- 6 Audio Ports:
 -  Headphone
 -  Microphone
 -  Audio line out
 -  Audio line in
- 7 Voltage–Selection Switch (ESCALA S100 only): Select either 115–V or 230–V setting (available on specific systems). Voltage selection is not needed on ESCALA S120 as it uses an autoranging power supply.
- 8 Security tether attachment: Attachment point for a security tether.

9 9-Pin Serial Ports

(1 and 2): For a TTY terminal, Modem, or other serial devices.

10 Tablet Port (): For attaching a digitizing tablet to your computer.

11 Ethernet Port (): For attaching your computer to an Ethernet thick connection (or Ethernet thin connection, using an optional transceiver) through a 10 Base 5 or 100/10 Base 5 connector. (ESCALA S100 uses 10 Base 5; ESCALA S120 uses 100/10 Base 5.)

12 Expansion Slots: For adding ISA and PCI adapters.

Chapter 5. Using the Online and Standalone Diagnostics

Sources for the Diagnostics

The diagnostics consist of Standalone Diagnostics and Online Diagnostics. Standalone Diagnostics are packaged on removable media and can be run regardless of the operating system installed on the system unit. They must be booted or mounted before they can be run. If booted, they have no access to the AIX Error Log or the AIX Configuration Data (If AIX is installed). However, if mounted, they have access to the AIX Error Log and the AIX Configuration Data (if AIX is installed).

Online Diagnostics can be used only when AIX is installed on the the system unit. Online diagnostics reside with AIX in the file system. They can be booted in single user mode (referred to as service mode), run in maintenance mode (referred to as maintenance mode), or run concurrently (referred to as concurrent mode) with other applications. They have access to the AIX Error Log and the AIX Configuration Data.

Standalone and Online Diagnostics Operating Considerations

The following items identify some things to consider before using the diagnostics.

1. Online diagnostic support is optionally installed with the AIX operating system and therefore may not be installed on some systems. When diagnostics are installed, the device support for some devices may not get installed. If this is the case, that device will not appear in the diagnostic test list when running disk based diagnostics.
2. Support for some TTY terminale is optionally installed. If you attach a TTY terminal to a system to run diagnostics be aware that it may not work properly since the AIX support for the terminal may not be installed.

Selecting a Console Display

When you run Standalone Diagnostics and under some conditions Online Diagnostics, you need to select the console display. The diagnostics display instructions on any graphics display and the terminal attached to the Serial 1 port.

Identifying the Terminal Type to Diagnostics

Note: This is not the same as selecting a console display.

When you run diagnostics, the diagnostics must know what type of terminal you are using. If the terminal type is not known when the FUNCTION SELECTION menu is displayed, the diagnostics do not allow you to continue until a terminal is selected from the DEFINE TERMINAL option menu. Select **lt** for graphical displays.

Undefined Terminal Types

If an undefined terminal type from the DEFINE TERMINAL option menu is entered, the menu will prompt the user to enter a valid terminal type, and the menu is redisplayed until either a valid type is entered or the user exits the DEFINE TERMINAL option.

Resetting the Terminal

If the user enters a terminal type that is valid (according to the DEFINE TERMINAL option menu) but is not the correct type for the ASCII terminal being used, difficulty may be encountered in reading the screen, using the function keys or the Enter key. These

difficulties can be bypassed by pressing Ctrl-C to reset the terminal. The screen display which results from this resetting action varies with the mode in which the system is being run:

- Online Normal or Maintenance Mode – The command prompt appears.
- Standalone Mode or Online Service Mode –The terminal type is reset to "dumb", the Diagnostic Operating Instruction panel is displayed, and the user is required to go through the DEFINE TERMINAL process again.

Running Standalone Diagnostics

Consider the following when you run Standalone Diagnostics:

- The diagnostic disc must remain in the CD-ROM drive for the entire time that diagnostics are executing.
- The diagnostic CD-ROM disc cannot be ejected from the CD-ROM drive once the diagnostics have loaded. The disc can only be ejected after the system has been turned off and then turned on (standalone mode) or after the diagnostics program has terminated (Online concurrent mode). The disc must be ejected prior to the system attempting to load the diagnostics again.
- The CD-ROM drive from which diagnostics were loaded cannot be tested.
- The SCSI adapter (or circuitry) controlling the CD-ROM drive from which diagnostics were loaded cannot be tested.

Running Online Diagnostics

Consider the following when you run the Online Diagnostics from a server or a disk:

- The diagnostics cannot be loaded and run from a disk until the AIX operating system has been installed and configured. After the AIX operating system has been installed, all three modes of operation are available.
- The diagnostics cannot be loaded on a system (client) from a server if that system is not set up to boot from a server over a network. When the system is set up to boot from a server, the diagnostics are run in the same manner as they are from disk.
- If the diagnostics are loaded from disk or a server, you must shutdown the AIX operating system before turning the system unit off to prevent possible damage to disk data. This is done in one of two ways:
 - If the diagnostics were loaded in standalone mode, press the F3 key until DIAGNOSTIC OPERATING INSTRUCTIONS displays; then press the F3 key once again to shutdown the AIX operating system.
 - If the diagnostics were loaded in maintenance or concurrent mode, enter the shutdown **-F** command
- Under some conditions the system may stop, with instructions displayed on attached displays and terminale. Follow the instructions to select a console display.
- Your system unit must be configured to receive boot over the network or the server must be setup to send a service mode boot of the diagnostics.

Running the Diagnostics from a TTY Terminal

Consider the following when you run diagnostics using a TTY-type terminal as the console display:

- See the operator manual for your type of tty terminal to find the key sequences you need to respond to the diagnostics.

Refer to *Terminals and Printers Configuration Guide*, order number 86 A1 22WE, for more information about terminals settings.

Online Diagnostic Modes of Operation

The Online diagnostics can be run in three modes:

- Service mode allows checking of most system resources.
- Concurrent mode allows the normal system functions to continue while selected resources are being checked.
- Maintenance mode allows checking of most system resources.

Service Mode

Service mode provides the most complete checkout of the system resources. This mode also requires that no other programs be running on the system. All system resources except the SCSI adapter, and the disk drives used for paging can be tested. However, note that the memory and processor are only tested during POST.

Error log analysis is done in maintenance mode when you select the **Problem Determination** option on the DIAGNOSTIC MODE SELECTION menu.

Running the Diagnostics in Maintenance Mode

To run Online diagnostics in service mode, take the following steps:

1. Stop all programs including the AIX operating system (get help if needed).
2. Turn the power off.
3. Remove all tapes, diskettes, and CD-ROMs.
4. Turn the power on.
 - c. When or after the diskette indicator appears, press F6 on the directly-attached keyboard or 6 on the ASCII terminal keyboard to indicate that diagnostics are to be loaded.
 - d. Enter any requested passwords.
 - e. Follow any instructions to select a console.
5. After the diagnostic controller loads, DIAGNOSTIC OPERATING INSTRUCTIONS appear on the console display.
6. Follow the displayed instructions to checkout the desired resources.
7. When testing is complete; use the F3 key to return to the DIAGNOSTIC OPERATING INSTRUCTIONS.
8. Press the F3 key (from a defined terminal) or press 99 (for an undefined terminal) to shutdown the diagnostics before turning off the system unit.

Note: Pressing the F3 key (from a defined terminal) produces a "Confirm Exit" popup menu which offers two options: continuing with the shutdown by pressing F3; or returning to diagnostics by pressing Enter.

For undefined terminals, pressing 99 produces a full screen menu which offers two options: continuing with the shutdown by pressing 99 and then Enter; or returning to diagnostics by pressing Enter.

Concurrent Mode

Concurrent mode provides a way to run diagnostics on some of the system resources during normal system activity.

Because the system is running in normal operation, some of the resources cannot be tested in concurrent mode. The following resources *cannot* be tested in Concurrent mode:

- SCSI adapters connected to paging devices
- The disk drive used for paging
- Some display adapters.
- Memory
- Processor

There are three levels of testing in concurrent mode:

- The **share-test level** tests a resource while the resource is being shared by programs running in the normal operation. This testing is mostly limited to normal commands that test for the presence of a device or adapter.
- The **sub-test level** tests a portion of a resource while the remaining part of the resource is being used in normal operation. For example, this test could test one port of a multiport device while the other ports are being used in normal operation.
- The **full-test level** requires the device not be assigned to or used by any other operation. This level of testing on a disk drive may require the use of the **varyoff** command. The diagnostics display menus to allow you to vary off the needed resource.

Error log analysis is done in concurrent mode when you select the **Problem Determination** option on the DIAGNOSTIC MODE SELECTION menu.

To run the Online diagnostics in concurrent mode you must be logged onto the AIX operating system and have proper authority to issue the commands (if needed, get help)

The **diag** command loads the diagnostic controller and displays the Online diagnostic menus.

Running the Online Diagnostics in Concurrent Mode

To run Online diagnostics in concurrent mode, take the following steps:

- Log on to the AIX operating system as root or superuser.
- Enter the **diag** command.
- When the DIAGNOSTIC OPERATING INSTRUCTIONS are displayed, follow the instructions to check out the desired resources.
- When testing is complete; use the F3 key to return to the DIAGNOSTIC OPERATING INSTRUCTIONS. Then press the F3 key again to return to the operating system prompt. Be sure to *vary on* any disk drives you had varied to off.
- Press the Ctrl-D key sequence to log off from `root` or `superuser`.

Maintenance Mode

Maintenance mode runs the Online diagnostics using the customer's version of the AIX operating system. This mode requires that all activity on the AIX operating system be stopped so the Online diagnostics have most of the resources available to check. All of the system resources except the SCSI adapters and the disk drive used for paging can be checked.

Error log analysis is done in maintenance mode when you select the **Problem Determination** option on the DIAGNOSTIC MODE SELECTION menu.

The **shutdown -m** command is used to stop all activity on Version 3 of the operating system and put the operating system into maintenance mode. Then the **diag** command is used to load the diagnostic controller so you can run the diagnostic programs from the menus. After the diagnostic controller is loaded, follow the normal diagnostic instructions.

Running the Online Diagnostics in Maintenance Mode

To run the Online diagnostics in maintenance mode you must be logged on to the customer's version of the AIX operating system as *root* or *superuser* and use the **shutdown -m** and **diag** commands. Use the following steps to run the Online diagnostics in maintenance mode:

1. Stop all programs except the AIX operating system (get help if needed).
2. Log onto the AIX operating system as *root* or *superuser*.
3. Enter the **shutdown -m** command.
4. When a message indicates the system is in maintenance mode, enter the **diag** command.

Note: It may be necessary to set *TERM* type again.

5. When DIAGNOSTIC OPERATING INSTRUCTIONS is displayed, follow the displayed instructions to checkout the desired resources.
6. When testing is complete; use the F3 key to return to DIAGNOSTIC OPERATING INSTRUCTIONS. Then press the F3 key again to return to the operating system prompt.
7. Press Ctrl-D to log off from *root* or *superuser*.

Standalone Diagnostics Operation

Standalone Diagnostics provide a method to test the system when the Online Diagnostics are not installed and a method of testing the disk drives that cannot be tested by the Online Diagnostics.

No Error Log Analysis is done by the Standalone Diagnostics.

The CD-ROM drive and the SCSI controller that controls it cannot be tested by the Standalone Diagnostics.

Running the Standalone Diagnostics

To run Standalone diagnostics in service mode, take the following steps:

1. Verify with the system administrator and system users that the system unit may be shut down, then stop all programs including the AIX operating system. (Refer to the AIX operating system documentation shutdown command information.)
2. Remove all tapes, diskettes, and CD-ROMs.
3. Insert the Diagnostic CD-ROM into the CD-ROM drive.
4. Turn off the system unit.

5. Turn the power on.
 - f. When or after the diskette indicator appears, press F5 on the direct attached keyboard or 5 on the tty keyboard to indicate that diagnostics are to be loaded.
 - g. Enter any requested passwords.
 - h. Follow any instructions to select a console.
6. After the diagnostic controller loads, DIAGNOSTIC OPERATING INSTRUCTIONS appear on the console display.
7. Follow the displayed instructions to checkout the desired resources.
8. When testing is complete; use the **F3** key to return to the DIAGNOSTIC OPERATING INSTRUCTIONS.

Location Codes

The basic format of the system unit's location code is:

AB - CD - EF - GH	Non-SCSI
G,H	SCSI

For planars, cards, and non-SCSI devices the location code is defined as:

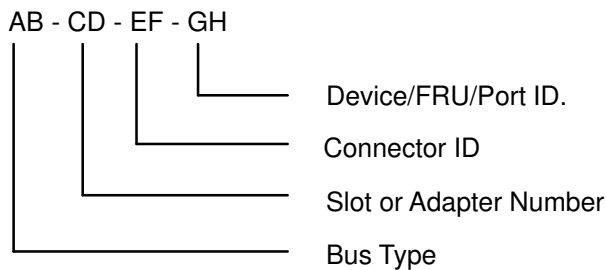

AB identifies a bus type, CD identifies a slot or adapter number, EF a connector identifier, and GH is a port identifier, address, memory module, device, or FRU. Adapters/cards are identified with just AB-CD.

The possible values for AB are as follows:

- 00 for processor bus
- 01 for ISA buses
- 04 for PCI buses
- 05 for PCMCIA buses (not supported)

The possible values for CD depend on the adapter or card. For pluggable adapters/cards this is a two digit slot number in the range from 01 to 99. However, in the case of ISA cards these numbers do not actually correspond to the physical slot numbers. They are simply based on the order the ISA cards are defined/configured either by SMIT or the ISA Adapter Configuration Service Aid.

For integrated adapters the first character in CD is a letter in the range from A to Z. This letter is based on the order that the integrated adapters are defined in residual data and ensures unique location codes for the integrated adapters. The D is set to 0.

EF is the Connector ID. It is used to identify the adapter connector to which a resource is attached.

GH is a port identifier, address, memory module, device, or FRU. It identifies a port, device, or a FRU. GH has several meanings depending upon the resource type. They are:

- For memory cards GH defines a memory module. Values for GH are 1 through 16.

For systems that have memory modules that plug directly into the system planar the location code are 00-00-00-GH where GH is the memory module slot. For system that have memory cards with memory modules, the location code is 00-CD-EF-GH where CD is the card slot and GH is the memory module slot.

- For caches GH defines the cache. Values for GH are 1 through 16.
- For PCMIAs GH defines the PCMIA. Values for GH are 1 through 16.
- For async devices GH defines the port on the fanout box. Values are 00 to 15.
- For a diskette drive H defines which diskette drive 1 or 2. G is always 0.
- For all other devices GH is equal to 00.

For integrated adapters, EF-GH is the same as the definition for a pluggable adapter. For example, the location code for a diskette drive is 01-H0-00-00.

For SCSI the Location Code is defined as:

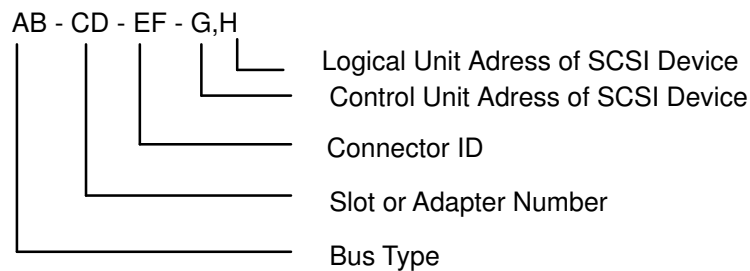

Where AB-CD-EF are the same as non-SCSI devices.

G defines the control unit address of the device. Values of 0 to 15 are valid.

H defines the logical unit address of the device. Values of 0 to 255 are valid.

Examples

```

Processor-PCI bus
00-00          PCI bus

Memory module in systemplanar
00-00-00-01

Memory module in card
00-0A-00-01

Integrated PCI adapters for
04-A0          ISA bus (Integrated PCI-ISA bridge)
04-B0          Secondary PCI bus (Integrated PCI-PCI
              bridge)
04-C0          Integrated PCI SCSI controller

Non-integrated PCI adapters
04-01          Any PCI card in slot 1
04-02          Any PCI card in slot 2
    
```

Integrated ISA adapters

01-A0	Diskette adapter
01-B0	Parallel port adapter
01-C0	Serial port 1 adapter
01-D0	Serial port 2 adapter
01-E0	Keyboard adapter
01-F0	Mouse adapter

Non-integrated ISA adapters

01-01	First ISA card defined/configured
01-02	Second ISA card defined/configured

Device attached to SCSI controller

04-C0-01-4,0	Device attached to Integrated PCI SCSI controller
--------------	---

Chapter 6. Location Codes (Model S120 only)

This system unit uses physical location codes in conjunction with AIX location codes to provide mapping of the failing field replaceable units. The location codes are produced by the system unit's firmware and AIX.

Physical Location Codes

Physical location codes provide a mapping of logical functions in a platform (or expansion sites for logical functions, such as connectors or ports) to their specific locations within the physical structure of the platform.

Location Code Format

The format for the location code is an alphanumeric string of variable length, consisting of a series of location identifiers, separated by the standard dash (–) or slash (/) character. The series is hierarchical; that is, each location identifier in the string is a physical child of the one preceding it.

- The – (dash) separator character represents a normal structural relationship where the child is a separate physical package and it plugs into (or is connected to) the parent. For example, P1–C1 is a CPU card (C1) plugged into a planar (P1), or P1–M1 is a memory card (M1) plugged into a planar (P1).
- The / (slash) separator character separates the base location code of a function from any extended location information. A group of logical devices can have the same base location code because they are all on the same physical package, but may require extended location information to describe the connectors they support. For example, P2/S1 describes the location of the serial port 1 controller and its connector (S1), which is located on planar P2 (its base location code), but the / indicates that further devices can be connected to it at the external S1 serial connector. The keyboard controller and its connector likewise have location code P2/K1, which means they have the same base location code (P2) as serial port 1, but a different external connector. In contrast, the location code P2–K1 actually points to the device connected to connector K1; that is, the keyboard. The location code P2/Z1 indicates an integrated SCSI controller which drives connector Z1, while location codes of P2–Z1–... point to the actual SCSI bus and devices.

Each location identifier consists of one alpha prefix character that identifies a location type, and a decimal integer number (typically one or two digits) that identifies a specific instance of this location type. Certain location types may also support secondary sub-locations, which are indicated by appending a period (".") character and a sub-location instance number.

Specifically, the format of a location code is defined as follows:

n] [– or /]pn[.n] [– or /]...

Where p is a defined alpha location type prefix, n is a location instance number, and [.n] is a sub-location instance number (where applicable). Sub-location notation is used only for location types which have clearly defined and limited expansion sites; for example, memory module slots on a memory card. Primarily, the [.n] sub-location notation is intended for use as an abbreviation of the location code in cases where:

9. Based on the device structure, the abbreviated sub–location code conveys the same information in a more concise form than an additional level of location identifier – for example:
 - P1–M1.4 (pluggable module 4 on Memory Card 1 on Planar 1), rather than P1–M1–M4
 - P1–C1.1 (pluggable CPU 1 on CPU Card 1 on Planar 1), rather than P1–C1–C1
 - P2–Z1–A3.1 (LUN 1 at SCSI ID 3 on integrated SCSI bus 1 from Planar 2), rather than P2–Z1–A3–A1
10. The sub–location is either a basic physical extension or sub–enclosure of the base location, but does not represent additional function or connectivity; for example, a drawer in a rack (U1.2) or a riser card on an I/O board (P2.1).

AIX Location Codes

The basic formats of the AIX location codes are:

AB - CD - EF - GH	Non-SCSI
AB - CD - EF - G,H	SCSI

For planars, cards, and non-SCSI devices the location code is defined as:

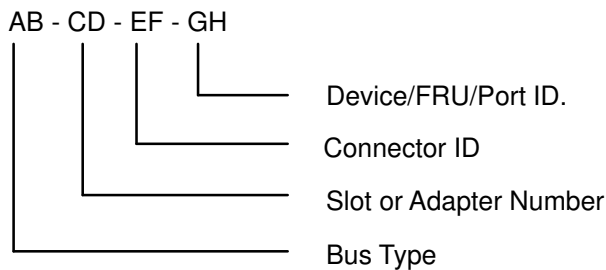

AB value identifies a bus type or PCI parent bus as assigned by the firmware.

CD value identifies adapter number, adapter's devfunc number, or physical location. The devfunc number is defined as the PCI device number times 8, plus the function number.

EF value identifies a connector.

GH value identifies a port, address, device, or FRU.

Adapters and cards are identified with just AB-CD.

The possible values for AB are as follows:

- 00 Processor bus
- 01 ISA bus
- 02 EISA bus
- 03 MCA BUS
- 04 PCI bus used in the case where the PCI bus cannot be identified
- 05 PCMCIA buses

xy For PCI adapters where x is equal to or greater than 1. The x and y are characters in the range of 0-9, A-H, J-N, P-Z (O, I, and lower case are omitted) and are equal to the parent bus's ibm, aix-loc Open Firmware Property.

The possible values for CD depend on the adapter or card.

For pluggable PCI adapters/cards, CD is the device's devfunc number (PCI device number times 8, plus the function number). The C and D are characters in the range of 0–9, and A–F (hex numbers). This allows the location code to uniquely identify multiple adapters on individual PCI cards.

For pluggable ISA adapters, CD is equal to the order the ISA cards defined/configured either by SMIT or the ISA Adapter Configuration Service Aid.

For integrated ISA adapters, CD is equal to a unique code identifying the ISA adapter. In most cases this is equal to the adapter's physical location code. In cases where a physical location code is not available, CD is be FF.

EF is the Connector ID. It is used to identify the adapter connector to which a resource is attached.

GH is a port identifier, address, memory module, device, or FRU. It identifies a port, device, or a FRU. GH has several meanings depending upon the resource type. They are:

For async devices GH defines the port on the fanout box. The values are 00 to 15.

For a diskette drive H defines which diskette drive 1 or 2. G is always 0.

For all other devices GH is equal to 00.

For integrated adapters, EF–GH is the same as the definition for a pluggable adapter. For example, the location code for a diskette drive is 01–D1–00–00. A second diskette drive is 01–D1–00–01.

For SCSI the Location Code is defined as:

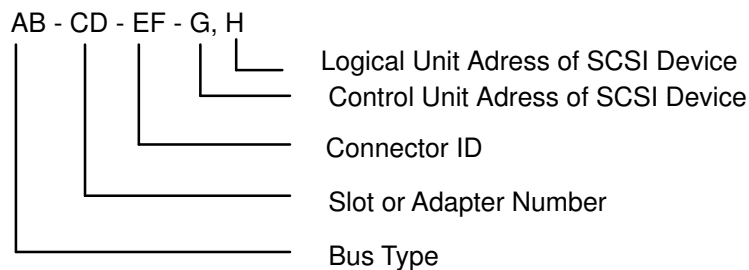

Where AB–CD–EF are the same as non–SCSI devices.

G defines the control unit address of the device. Values of 0 to 15 are valid.

H defines the logical unit address of the device. Values of 0 to 255 are valid.

There is also a bus location code that is generated as '00–XXXXXXXX' where XXXXXXXX is equivalent to the node's unit address.

Examples of physical location codes displayed by AIX are:

Processor card in slot 1 of planar 1

P1–C1

Memory module in system planar slot 2

P1–M2

Memory module 12 in card in slot 2 of system planar

U1–P1–M2 . 12

Examples of AIX location codes displayed are:

Integrated PCI adapter

10-80	Ethernet
10-60	Integrated SCSI Port 1
10-88	Integrated SCSI Port 2

Pluggable PCI adapters

20-58 to 20-5F Any PCI card in slot 1
20-60 to 20-67 Any PCI card in slot 2
10-68 to 10-6F Any PCI card in slot 3
10-70 to 10-77 Any PCI card in slot 4
10-78 to 10-7F Any PCI card in slot 5

Integrated ISA adapters adapters

01-D1 Diskette adapter
01-R1 Parallel port adapter
01-S1 Serial port 1 adapter
01-S2 Serial port 2 adapter
01-S3 Serial port 3 adapter
01-K1 Keyboard adapter

Device attached to SCSI controller

10-60-00-4,0 Device attached to Integrated SCSI Port 1

Chapter 7. Using the System Verification Procedure

The system verification procedure is used to check the system for correct operation.

When you are analyzing a hardware problem, you should use Chapter 8, "Hardware Problem Determination" on page 8-1.

Step 1. Considerations before Performing This Procedure

Notes::

1. If this system unit is directly attached to another system unit or attached to a network, be sure communications with the other system unit is stopped.
 2. This procedure requires use of all of the system resources. No other activity can be running on the system while you are doing this procedure.
- This procedure requires a display connected to the video port or an ASCII terminal attached to the S1 port.
 - Before starting this procedure, you should stop all programs and the operating system.
 - This procedure runs the Online Diagnostics in Service mode or Standalone Diagnostics. If the Online Diagnostics are installed, they should be run. See the operator manual for your type of ASCII terminal to find the key sequences you need in order to respond to the diagnostics.
 - If a console display is not selected, the diagnostics stop. The instructions for selecting a console display are displayed on all of the graphic displays and any terminal attached to the S1 port. Follow the displayed instructions to select a console display.
 - ISA adapters cannot be detected by the system. The ISA adapter Configuration Service Aid allows the identification and configuration of ISA adapters when running standalone diagnostics.
 - Go to Step 2.

Step 2. Loading the Diagnostics

1. Stop all application programs running on the operating system.
2. Stop the operating system.
3. Power the system off.
4. If you are loading the Standalone Diagnostics and running them from an ASCII terminal:
 - The attributes for the terminal must be set to match the defaults of the diagnostics.
 - Return to substep 5 when you finish checking the attributes.
5. Turn the power on.
 - i. When the initial menu appears, press the F5 key on the directly-attached keyboard (number 5 on the ASCII terminal keyboard) to load the Standalone Diagnostics or F6 on the directly-attached keyboard (6 on the ASCII terminal keyboard) to load the Online Diagnostics.
 - j. Enter any requested passwords.
 - k. Follow any instructions to select a console.
6. When the Diagnostic Operating Instructions display, go to Step 3.

If you are unable to load the diagnostics, go to "Problem Determination When Unable to Load Diagnostics" on page 8-8.

Step 3. Running System Verification

The DIAGNOSTIC OPERATING INSTRUCTIONS should be displayed.

1. Press the Enter key.
2. If the terminal type has not been defined, you must use the `Initialize Terminal` option on the `FUNCTION SELECTION` menu to initialize the operating system environment before you can continue with the diagnostics.
3. If you want to do a general checkout without much operator action, select the `Diagnostic Routines` option on the `FUNCTION SELECTION` menu.

If you want to do a more complete checkout including the use of wrap plugs, select the `Advanced Diagnostics` option on the `FUNCTION SELECTION` menu. The advanced diagnostics are primarily for the service representative; they may instruct you to install wrap plugs to better isolate a problem.
4. Select the `System Verification` option on the `DIAGNOSTIC MODE SELECTION` menu.
5. If you want to run a general checkout of all installed resources, select the `System Checkout` option on the `DIAGNOSTIC SELECTION` menu.

If you want to check one particular resource, select that resource on the `DIAGNOSTIC SELECTION` menu.
6. Go to Step 4.

Step 4. Additional System Verification

The checkout programs end with either the TESTING COMPLETE menu and a message stating No trouble was found or the A PROBLEM WAS DETECTED ON (Time stamp) menu with a service reference number (SRN).

1. Press Enter to return to the DIAGNOSTIC SELECTION menu.
2. If you want to check other resources, select the resource. When you have checked all of the resources you need to check, go to Step 5.

Step 5. Stopping the Diagnostics

1. If running Online diagnostics, the system should first be shut down using the following procedure:
 - a. Press F3 repeatedly until you get to the DIAGNOSTIC OPERATING INSTRUCTIONS, then follow the displayed instructions.
 - b. Press F3 once and follow the displayed instructions to shut down the system.
2. If you changed any attributes on your ASCII terminal to run the diagnostics, change the settings back to normal.
3. This completes the system verification. Report the SRN to the service organization if you received one. To do a normal IPL, turn off the system unit, wait 30 seconds, and then set the power switch of the system unit to On.

Chapter 8. Hardware Problem Determination

Problem Determination Using the Standalone or Online Diagnostics

Use this procedure to obtain a service request number (SRN) when you are able to load the Standalone or Online Diagnostics. If you are unable to load the Standalone or Online Diagnostics, go to "Problem Determination When Unable to Load Diagnostics" on page 8-8. The service organisation uses the SRN to determine which field replaceable units (FRUS) are needed to restore the system to correct operation.

Step 1. Considerations before Running This Procedure

Note: See the operator manual for your ASCII terminal to find the key sequences you need to respond to the diagnostic programs.

- The diagnostics can use a display connected to the video port or an ASCII terminal attached to serial port 1.
- This procedure asks you to select the type of diagnostics you want to run. If you need more information about the types, see "Standalone and Online Diagnostics Operating Considerations" on page 5-1.
- ISA adapters cannot be detected by the system. The ISA adapter Configuration Service Aid allows the identification and configuration of ISA adapters for Standalone Diagnostics. ISA adapters must be identified and configured before they can be tested.
- Go to Step 2.

Step 2

Are the Online Diagnostics installed on this system?

NO Go to Step 15.

YES Go to Step 3.

Step 3

Determine if the operating system is accepting commands.

Is the operating system accepting commands?

NO The system must be turned off in order to run diagnostics.

Verify with the system administration and users that the system maybe turned off. If so, then turn off the system unit and go to Step 6.

YES Go to Step 4.

Step 4

Diagnostic tests can be run on many resources while the operating system is running. However, more extensive problem isolation is obtained by running Online diagnostics in Service mode.

Do you want to run the Online diagnostics In Service mode?

NO Go to Step 5.

YES Do the following to shut down your system:

1. At the system prompt, stop the operating system using the proper command for your operating system.
2. After the operating system is stopped, power off the system unit.
3. Go to Step 6.

Step 5

This step invokes the Online Diagnostics in concurrent mode.

1. Log on as `root` or as `superuser`.
2. Enter the **diag** command.
3. Wait until the words `DIAGNOSTIC OPERATING INSTRUCTIONS` are displayed, or for three minutes.

Are the `DIAGNOSTIC OPERATING INSTRUCTIONS` displayed without any obvious console display problems?

NO Do the following to shut down your system:

1. At the system prompt, stop the operating system.
2. After the operating system is stopped, power off the system unit.
3. Go to Step 6.

YES Go to Step 10.

Step 6

This step loads Online diagnostics in service mode. If you are unable to load the diagnostics, go to Step 7.

1. Turn the power on.
2. When the initial menu appears, press the F6 key on the directly-attached keyboard or number 6 on the ASCII terminal keyboard to indicate that diagnostics are to be loaded.
3. Follow any instructions to select a console.

Did the Diagnostics Operating Instructions display without any obvious display problem?

NO Go to Step 7.

YES Go to Step 9.

Step 7

1. Starting at the top of the following table, find your symptom and follow the instructions given in the Action column.

Symptom	Action
The system stops with the <code>DIAGNOSTIC OPERATING INSTRUCTIONS</code> display with an obvious display problem.	Go to Step 8.
All other symptoms.	Go to "Problem Determination When Unable to Load Diagnostics" on page 8-8.

Step 8

The following steps analyze a console display problem.

Find your type of console display in the following table; then follow the instructions given in the Action column.

Console Display	Action
Display Device	Go to the your display documentation for problem determination.
ASCII terminal	Go to the documentation for problem determination for this type of terminal.

Step 9

The diagnostic loaded correctly.

Press the Enter key.

Is the `FUNCTION SELECTION` menu displayed?

NO Go to Step 10.

YES Go to Step 11.

Step 10

There is a problem with the keyboard.

Find the type of keyboard you are using in the following table; then follow the instructions given in the Action column.

Keyboard Type	Action
101-key keyboard. Identify by the type of Enter key used. The Enter key is within one horizontal row of keys.	Record error code MOKBD001 and report the problem to the service organization.
102-key keyboard. Identify by the type of Enter key used. The Enter key extends into two horizontal rows of keys.	Record error code MOKBD002 and report the problem to the service organization.
Kanji keyboard. Identify by the Japanese characters.	Record error code MOKBD003 and report the problem to the service organization.
ASCII-terminal keyboard. This applies to all attached terminals.	Go to the documentation for problem determination for this type terminal.

Step 11

1. If the terminal type has not been defined, you must use the `Initialize Terminal` option on the `FUNCTION SELECTION` menu to initialize the operating system environment before you can continue with the diagnostics. This is a separate and different operation than selecting the console display.
2. Select `Diagnostic Routines`.
3. Press the Enter key.
4. In the following table, find the menu or system response you received when you selected `Diagnostic Routines`; then follow the instructions given in the Action column.

System Response	Action
The <code>DIAGNOSTIC MODE SELECTION</code> menu is displayed.	Select <code>Problem Determination</code> , and then go to Step 12.
The <code>MISSING RESOURCE</code> menu is displayed.	Follow the displayed instructions until either the <code>DIAGNOSTIC SELECTION</code> menu or an SRN is displayed. If the <code>DIAGNOSTIC SELECTION</code> menu is displayed, go to Step 12. If you get an SRN, record it, and go to Step 14.

The NEW RESOURCE menu is displayed.	<p>Follow the displayed instructions.</p> <p>Note: Devices attached to serial ports S1 or S2 will not appear on the NEW RESOURCE menu. Also, ISA adapters do not appear unless they have been identified and configured.</p> <p>If the Diagnostic Mode Selection menu is displayed, select Problem Determination and go to Step 12.</p> <p>If you get an SRN, record it, and go to Step 14.</p> <p>If you do <i>not</i> get an SRN, go to Step 17.</p>
The system does not respond to selecting diagnostics	Go to Step 10.

Step 12

Did the Diagnostic Selection Menu display?

NO If Problem Determination was selected from the Diagnostic Mode Selection menu, and if a recent error has been logged in the error log, the diagnostics automatically begin testing the resource.

Follow the displayed instructions and do one of the following:

- If the No Trouble Found screen is displayed, press Enter.
- If another resource is tested, repeat this step.
- If the Diagnostic Selection menu is displayed, go to Step 12.
- If an SRN is displayed, record it, and go to Step 14.

YES Go to Step 13.

Step 13

The system checkout option checks most of the configured adapters and devices.

Notes::

1. System checkout is only supported in Online Diagnostics in Service Mode.
2. ISA adapters cannot be detected by the system. The ISA adapter Configuration Service Aid allows the identification and configuration of ISA adapters for Standalone Diagnostics.

ISA adapters must be identified and configured before they can be tested.

Select and run the diagnostic tests on the resources you are having problems with or run system checkout to check all of the configured resources. Find the response in the following table and take the action for it.

Diagnostic Response	Action
An SRN is displayed.	Go to Step 4.
The system hangs	Report SRN 109–200
The TESTING COMPLETE menu and the No trouble was found message is displayed, and you have <i>not</i> tested all of the resources.	Press Enter and continue with the testing.
The TESTING COMPLETE menu and the No trouble was found message displayed and you <i>have</i> tested all of the resources.	Go to Step 17.

Step 14

The diagnostic programs produced an SRN for this problem.

1. Record the SRN and any other numbers.
2. Report the SRN to the service organization.
3. **STOP.** You have completed these procedures.

Step 15

When you are loading the Standalone Diagnostics, the attributes for the terminal must be set to match the defaults of the diagnostic programs. The tty terminal must be attached to port S1 on the system unit.

Are you going to load Standalone Diagnostics and run them from an ASCII terminal?

NO Go to Step 16.

YES Go to “Running the Diagnostic Programs from a tty Terminal” on page 5-3 and be sure your terminal attributes are set to work with the diagnostic programs.

Return to Step 16 when you finish checking the attributes. Record any settings that are changed.

Step 16

This step loads the Standalone Diagnostics. If you are unable to load the diagnostics, go to Step 7.

1. Set the power to on.
2. Insert the diagnostic CD-ROM into the CD-ROM drive.
3. When the keyboard indicator starts blinking, press the F5 key on the direct attached keyboard or number 5 on the ASCII keyboard to indicate that diagnostics are to be loaded.
4. Enter any requested passwords.
5. Follow any instructions to select a console.

Did the Diagnostics Operating Instructions display without any obvious display problem?

NO Go to Step 7.

YES Go to Step 9.

Step 17

The diagnostics did not find a hardware problem. If you still have a problem, contact your software support center. If you are attached to another system, refer to Chapter 2 and check your configuration before calling the software support center.

Problem Determination When Unable to Load Diagnostics

Use this procedure to obtain an error code. The service organisation uses the error code to determine which field replaceable units (FRUs) are needed to restore the system to correct operation.

Step 1. Considerations before Running This Procedure

- The diagnostics can use a display connected to the video port or an ASCII terminal attached to serial port 1.
- Go to Step 2.

Step 2

Are the Online Diagnostics installed on this system?

NO Go to Step 4.

YES Go to Step 3.

Step 3

This step attempts to load Online diagnostics in service mode.

1. Set the power to off.
2. Set the power to on.
3. When the keyboard indicator starts blinking, press the F6 key on the direct attached keyboard or the number 6 on the ASCII keyboard to indicate that diagnostics are to be loaded.
4. Enter any requested passwords.
5. Follow any instructions to select a console.
6. Wait until the diagnostics load or the system appears to stop.

Did the diagnostics load?

NO Go to Step 5.

YES Go to Step 6

Step 4

This step attempts to load the Standalone diagnostics.

1. Turn the power to off.
2. Turn the power to on.
3. Insert the diagnostic CD-ROM into the CD-ROM drive.
4. When the keyboard indicator begins blinking, press the F5 key on the direct attached keyboard or number 5 on the ASCII keyboard to indicate that diagnostics are to be loaded.
5. Follow any instructions to select a console.
6. Wait until the diagnostics load or the system appears to stop.

Did the diagnostics load?

NO Go to Step 5.

YES Go to Step 6.

Step 5

Starting at the top of the following table, find your symptom and follow the instructions given in the Action column.

Symptom	Action
The system does not respond when the password is entered.	Go to Step 7.
The system login prompt is displayed.	You may not have pressed the correct key or you may not have pressed the key soon enough when you were to indicate a Service Mode boot of diagnostic programs. If this was the case, start over at the beginning of this step. If you are sure you pressed the correct key in a timely manner go to Step 7.
The system stops with an eight-digit error code(s) displayed on the console.	Record the error code(s) and report the problem to the service organization.
The system stops with a prompt to enter a password.	Enter the password. You will not be allowed to continue until a correct password has been entered. When you have entered a valid password, wait for one of the other conditions to occur.
The system stops with the Diagnostic Operating Instructions displayed.	Go to Step 6.

Symptom	Action
The power-on light does not come on, or comes on and does not stay on.	<p>Check the power cable to the outlet. Check the circuit breakers and check for power at the outlet.</p> <p>Assure the room temperature is within 60- 90° F.</p> <p>If you do not find a problem, record error code MOPS0000 and report the problem to the service organisation.</p>
Flashing 888, followed by additional error codes.	Report the error code sequence.
The system stops with a three-digit code in the operator panel display.	Report the error code

Step 6

The diagnostic loaded correctly.

Go to "Problem Determination Using the Standalone or Online Diagnostics" on page 7-1.

Step 7

There is a problem with the keyboard.

Find the type of keyboard you are using in the following table; then follow the instructions given in the Action column.

101-key keyboard. Identify by the type of Enter key used. The Enter key is within one horizontal row of keys.	Record error code MOKBD001 and report the problem to the service organization.
102-key keyboard. Identify by the type of Enter key used. The Enter key extends into two horizontal rows of keys.	Record error code MOKBD002 and report the problem to the service organization.
Kanji keyboard. Identify by the Japanese characters.	Record error code MOKBD003 and report the problem to the service organization.
ASCII-terminal keyboard. This applies to all attached terminals.	Go to the documentation for problem determination for this type terminal.

Chapter 9. Introduction to Tasks and Service Aids

The AIX Diagnostic Package contains programs that are called Tasks. Tasks can be thought of as "performing a specific function on a resource"; for example, running diagnostics, or performing a service aid on a resource. This chapter refers to the Tasks available in AIX Diagnostics Version 4.2 and later.

Note: Many of these programs work on all system model architectures. Some programs are only accessible from Online Diagnostics in Service or Concurrent mode, others may be accessible only from Standalone Diagnostics. While still other programs may only be supported on a particular system architecture, such as CHRP (Common Hardware Reference Platform), or RSPC (PowerPC Reference Platform). ESCALA S100 uses RSPC architecture. ESCALA S120 uses CHRP architecture.

To perform one of these tasks, use the Task Selection option from the FUNCTION SELECTION menu.

Once a task is selected, a resource menu may be presented showing all resources supported by the task.

A fast path method is also available to perform a task by using the diag command and the -T flag. This means the user does not have to go through most of the introductory menus just to get to a particular task. Instead, the user is presented with a list of resources available to support the specified task. The current fast path tasks are:

- Certify – certifies media
- Chkspares – checks for the availability of spare sectors
- Download – downloads microcode to an adapter or device
- Disp_mcode – displays current level of microcode
- Format – formats media
- Identify – identifies the PCI RAID physical disks

To run these tasks directly from the command line, specify the resource and other task unique flags. Use the descriptions in Chapter 27 of "*Diagnostic Information for Multiple Bus Systems*" to understand which flags are needed for a given task.

For more information about Tasks and Service Aids, refer to "*Diagnostic Information for Multiple Bus Systems*", order number 86 A1 26HX, revision level 04 or higher.

Tasks

The following tasks are described in Chapter 27 of "*Diagnostic Information for Multiple Bus Systems*":

- Add Resource to Resource List
- AIX Shell Prompt
- Analyze Adapter Internal Log
- Backup and Restore Media
- Certify Media
- Change Hardware Vital Product Data
- Configure Dials and LPFKeys
- Configure ISA Adapters
- Configure Reboot Policy
- Configure Remote Maintenance Policy
- Configure Ring Indicate Power On
- Configure Ring Indicate Power On Policy
- Configure Service Processor (RSPC)

- Configure Surveillance Policy
- Create Customized Configuration Diskette
- Delete Resource from Resource List
- Disk Maintenance
- Display Configuration and Resource List
- Display Firmware Device Node Information
- Display Hardware Error Report
- Display Hardware Vital Product Data
- Display Machine Check Error Log
- Display Microcode Level
- Display or Change Bootlist
- Display or Change Diagnostic Run Time Options
- Display Previous Diagnostic Results
- Display Resource Attributes
- Display Service Hints
- Display Software Product Data
- Display System Environmental Sensors
- Display Test Patterns
- Download Microcode
- Fibre Channel RAID Service Aids
- Flash SK-NET FDDI Firmware
- Format Media
- Generic Microcode Download
- Local Area Network Analyzer
- Periodic Diagnostics
- PCI RAID Physical Disk Identify
- Process Supplemental Media
- Run Diagnostics
- Run Error Log Analysis
- Run Exercisers
- Save or Restore Hardware Management Policies
- Save or Restore Service Processor Configuration
- SCSI Bus Analyzer
- SCSI Device Identification and Removal
- SCSD Tape Drive Service Aid
- Spare Sector Availability
- SSA Service Aid
- Update Disk Based Diagnostics
- Update System or Service Processor Flash
- Update System Flash
- 7135 RAIDiant Array Service Aids
- 7318 Serial Communication Network Server

Appendix A. System Records

Record the identification numbers

Record and retain the following information

Product Name	
Machine Type/Model	_____
Serial Number	_____
Key Serial Number	_____

The location of the system's identification number is shown below.

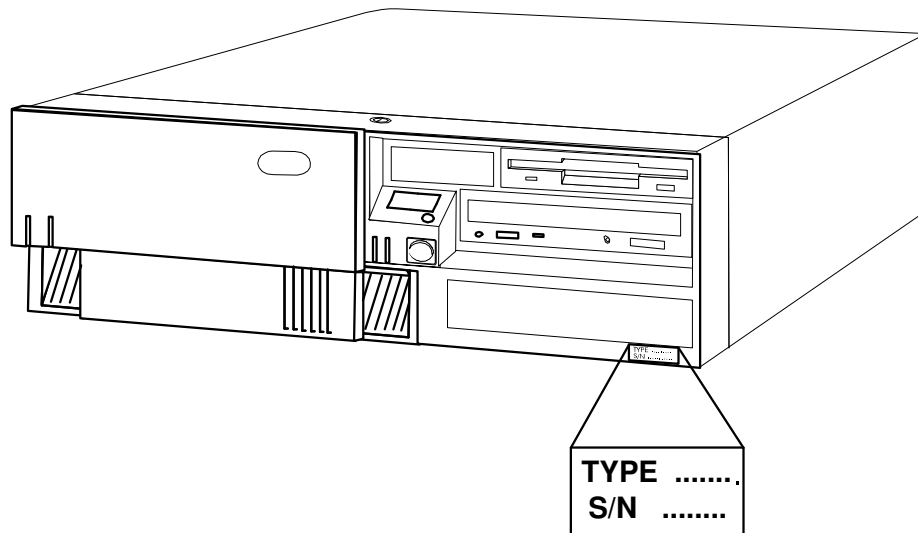

Store the keys and the tag that has the key serial number on it in a safe place. Anyone who has access to the key serial number and manufacturer's address can order duplicata keys.

Devices Records

Use the following tables to keep a record of the options installed in or attached to your system. This information can be helpful when you install additional options in your system or if you ever need to have your system serviced.

Table A-1 Internal and External Options

Location	Option Description
Memory A	<u>32MB</u> <input type="checkbox"/> <u>64MB</u> <input type="checkbox"/> <u>128MB</u> <input type="checkbox"/> <u>256MB</u>
Memory B	<u>32MB</u> <input type="checkbox"/> <u>64MB</u> <input type="checkbox"/> <u>128MB</u> <input type="checkbox"/> <u>256MB</u>
Memory C	<u>32MB</u> <input type="checkbox"/> <u>64MB</u> <input type="checkbox"/> <u>128MB</u> <input type="checkbox"/> <u>256MB</u>
Memory D	<u>32MB</u> <input type="checkbox"/> <u>64MB</u> <input type="checkbox"/> <u>128MB</u> <input type="checkbox"/> <u>256MB</u>
Memory E	<u>32MB</u> <input type="checkbox"/> <u>64MB</u> <input type="checkbox"/> <u>128MB</u> (S100)
Memory F	<u>32MB</u> <input type="checkbox"/> <u>64MB</u> <input type="checkbox"/> <u>128MB</u> (S100)
Mouse Connector	<u>Mouse</u> <input type="checkbox"/> Other: _____
Keyboard Connector	<u>Enhanced</u> <input type="checkbox"/> Other: _____
Expansion Slot 1	_____
Expansion Slot 2	_____
Expansion Slot 3	_____
Expansion Slot 4	_____
Expansion Slot 5	_____
Parallel Port	_____
Serial Port1	_____
Serial Port1	_____

Device Records

Location	Option Description
Drive Bay 1	1.44MB Diskette Drive
Drive Bay 2	CD-ROM Drive
Drive Bay 3	_____
Drive Bay 4	_____
Drive Bay 5	_____

Appendix B. Adapters and Peripherals Placement Notes

This appendix lists a few important considerations regarding placement of adapters within your system unit.

Installing an Adapter in an ESCALA S100

This section outlines adapters slot placement and adapter support configurations that are specific to your system unit. Not all of the adapters supported in stated maximum configurations, run at per adapter maximum performance.

Note: PCI is identified with a 'P', and ISA with a "I" in figure and in tables.

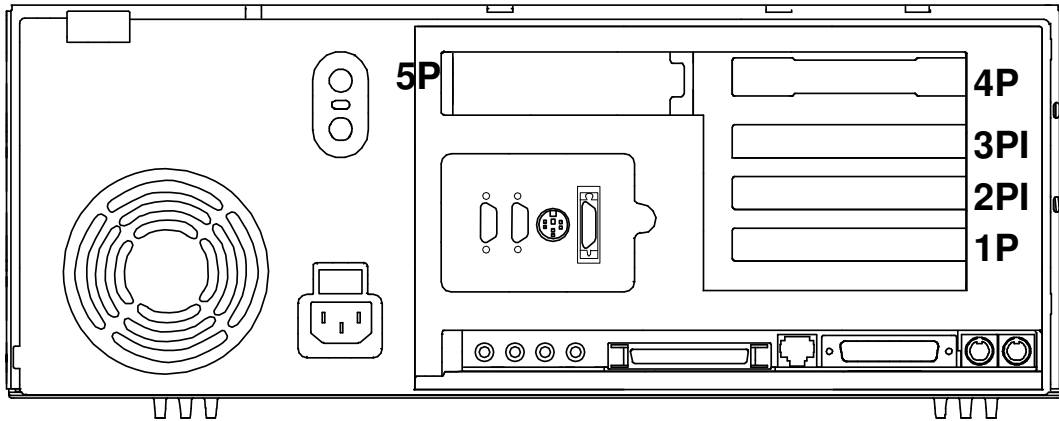

(System Unit rear view with numbered slots)

Adapters Placement

Some adapters must be placed in specific system unit slots to function correctly at highest performance. Use the following tables to determine where to install these adapters in your system unit.

Use the rear view diagram above to identify slot locations described in the following table.

	Slot 1P PCI_1	Slot 2PI ISA / PCI_1	Slot 3PI ISA / PCI_2	Slot 4P PCI_2	Slot 5P PCI_2
Ultra SCSI DE	Y	Y	Y	Y	Y
F/W SCSI DE	Y	Y	Y	Y	Y
Ethernet	Y	Y	Y	Y	Y
FDDI	Y	Y	Y	Y	Y
1-Port Sync.	Y	Y	Y	Y	Y
4-Port Sync.	Y	Y	Y	Y	N
8-Port Async.	Y	Y	Y	Y	Y
64-Port Async	Y	Y	Y	Y	Y
GXT120P *	Y**	Y**	Y	Y	Y
GXT255P *	Y**	Y**	Y	Y	Y
Modem	N	Y	Y	N	N
Token Ring	Y	Y	Y	Y	Y
ATM	Y	Y	Y	Y	Y

* maximum 4 GXT120P, 2 GXT255P

** preferred slots

Installing an Adapter in an ESCALA S120

This section outlines adapters slot placement and adapter support configurations that are specific to your system unit. Not all of the adapters supported in stated maximum configurations, run at per adapter maximum performance.

Note: PCI is identified with a 'P' in figure and in tables.

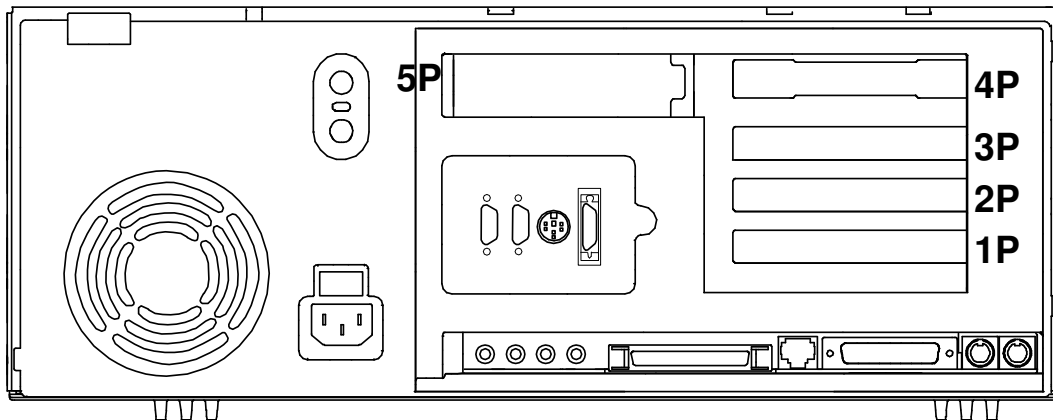

(System Unit rear view with numbered slots)

Adapters Placement

Some adapters must be placed in specific system unit slots to function correctly at highest performance. Use the following tables to determine where to install these adapters in your system unit.

Use the rear view diagram above to identify slot locations described in the following table.

	Slot 1P PCI_1	Slot 2P PCI_2	Slot 3P PCI_3	Slot 4P PCI_4	Slot 5P PCI_5
Ultra SCSI DE	Y	Y	Y	Y	Y
F/W SCSI DE	Y	Y	Y	Y	Y
Ethernet	Y	Y	Y	Y	Y
FDDI	Y	Y	Y	Y	Y
1-Port Sync.	Y	Y	Y	Y	Y
4-Port Sync.	N	Y	Y	Y	N
8-Port Async.	Y	Y	Y	Y	Y
64-Port Async	Y	Y	Y	Y	Y
GXT120P *	Y**	Y**	Y	Y	Y
GXT255P *	Y**	Y**	Y	Y	Y
Token Ring	Y	Y	Y	Y	Y
ATM	Y	Y	Y	Y	Y

* maximum 4 GXT120P, 4 GXT255P

** preferred slots

Installing a Peripheral in an ESCALA S100

This section outlines peripherals bay placement that are specific to your system unit.

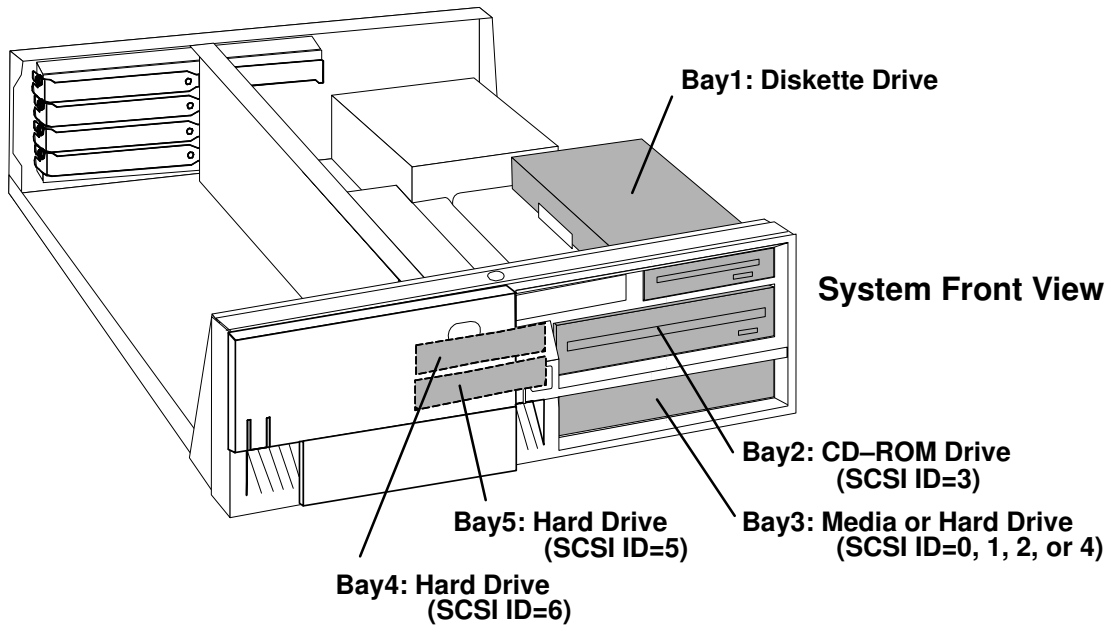

(System Unit front view with numbered bays)

Peripherals Placement

Use the front view diagram above to identify slot locations described in the following table.

	Bay 1	Bay 2	Bay 3	Bay 4	Bay 5
4.3 GB Disk	Floppy	CD-ROM	Y	Basic Disk	Y
9.1 GB Disk	Floppy	CD-ROM	Y	Basic Disk	Y
4/16 GB 4mm DAT	Floppy	CD-ROM	Y	Basic Disk	N
12/24 GB 4mm DAT	Floppy	CD-ROM	Y	Basic Disk	N
2,5/5 GB QIC	Floppy	CD-ROM	Y *	Basic Disk	N
16/32 GB QIC	Floppy	CD-ROM	Y *	Basic Disk	N
8mm VDAT	Floppy	Y	CD-ROM	Basic Disk	N

* **ATTENTION:** two types of connectors are available for the peripherals power supplies: with side outlets or with rear outlets. For connecting the 16/32 GB QIC Tape, it is mandatory to use the model with side outlets.

Installing a Peripheral in an ESCALA S120

This section outlines peripherals bay placement that are specific to your system unit.

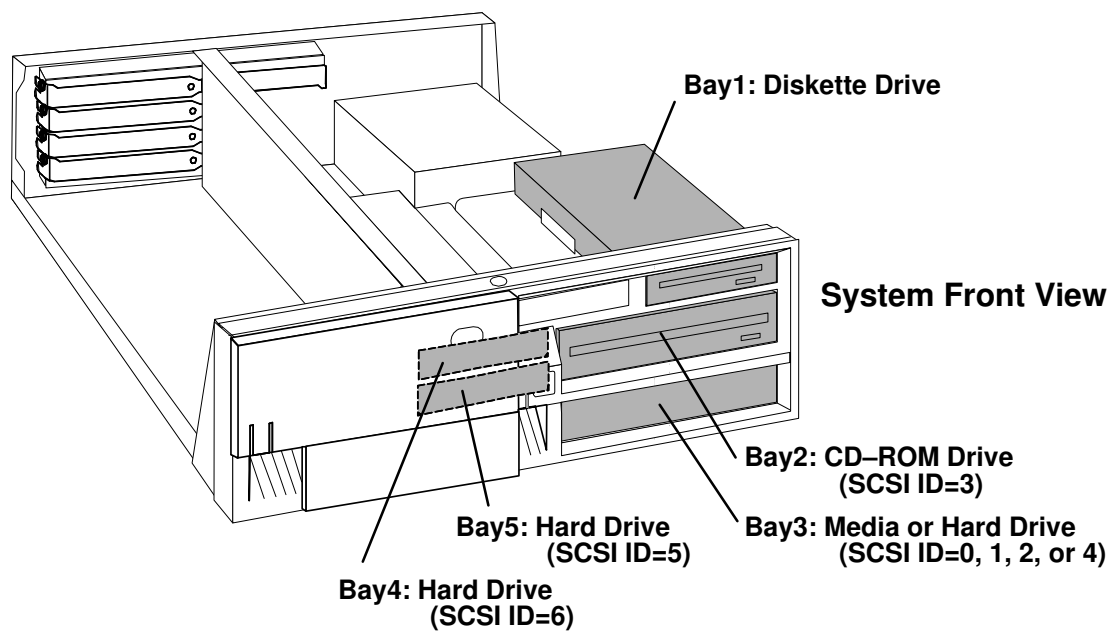

(System Unit front view with numbered bays)

Peripherals Placement

Use the front view diagram above to identify slot locations described in the following table.

	Bay 1	Bay 2	Bay 3	Bay 4	Bay 5
4.3 GB Disk	Floppy	CD-ROM	Y	Basic Disk	Y
9.1 GB Disk	Floppy	CD-ROM	Y	Basic Disk	Y
4/16 GB 4mm DAT	Floppy	CD-ROM	Y	Basic Disk	N
12/24 GB 4mm DAT	Floppy	CD-ROM	Y	Basic Disk	N
2,5/5 GB QIC	Floppy	CD-ROM	Y *	Basic Disk	N
16/32 GB QIC	Floppy	CD-ROM	Y *	Basic Disk	N
25/50 GB QIC	Floppy	CD-ROM	Y*	Basic Disk	N
8mm VDAT	Floppy	Y	CD-ROM	Basic Disk	N

* **ATTENTION:** two types of connectors are available for the peripherals power supplies: with side outlets or with rear outlets. For connecting the 16/32 GB or the 25/50 GB QIC Tapes, it is mandatory to use the model with side outlets.

Appendix C. IRQ and DMA-Channel Assignments and ISA Adapters Configuration

This appendix lists the interrupt-request (IRQ) and direct-memory-access (DMA)-channel assignments for your system unit.

Note: If you install ISA adapters in your system unit, be sure that no interrupts or DMA channels conflict with existing resources. For example, do not set an ISA adapter to use interrupt (IRQ) 6, because IRQ6 is used by the diskette drive.

IRQ Assignments

The following table shows the interrupt-request assignments.

IRQ	Description
0	Interval timer
1	Keyboard
2	Cascade from controller 2 (Not available)
3	Serial port 2
4	Serial port 1
5	Available for ISA bus if not used for audio
6	Diskette drive
7	Parallel port 1 or Audio
8	Real-time clock
9	Available for ISA bus
10	Available for ISA bus
11	Available for ISA bus
12	Available for ISA bus if not used for mouse
13	Scatter Gather
14	Available for ISA bus
15	Available for ISA bus if not used for tablet port

DMA-Channel Assignments

The following table shows the DMA–channel assignments.

DMA Channel	Description
0	Available for ISA bus if not used for audio
1	Available for ISA bus if not used for audio
2	Diskette drive controller
3	Available for ISA bus if not used for parallel port (ECP must be enabled)
4	Cascade (Not Available)
5	Available for ISA bus
6	Available for ISA bus
7	Available for ISA bus

Notes::

DMA operations can be performed only between ISA or system–board devices and ISA memory, PCI memory, or system memory.

Audio needs up to 2 channels, they can only be mapped to DMA channels 0 and 1. ECP needs only one channel, 0, 1, or 3.

ISA Adapters Configuration (for ESCALA S100 only)

The only ISA adapter on this system is the ISA Modem.

Refer to the *ISA Modem Installation and Service Guide*, order number 86 A1 05HX, for more information about configuring this adapter.

Appendix D. SCSI Bus termination

For ESCALA S100 only

Your system's internal SCSI chain must be terminated by the last drive in the chain, which must be configured as a self-terminating drive by setting jumpers on the drive. Please consult the "*Disks and Tapes Configuration Information*" manual to find how to set the jumpers.

Note: only the last drive in each SCSI chain should be configured as self-terminating.

For ESCALA S100 and S120

External SCSI chains must be terminated by a separate SCSI terminator.

If the internal SCSI chain is properly terminated and no external SCSI devices are attached, then the external SCSI chain is also properly terminated.

Refer also to "*ESCALA S Series Setup Instructions*", shipped with your system.

Index

A

- adapter
 - ISA, configuration, C-1
 - placement, B-1
- adapters
 - installing, 4-41
 - removing, 4-45
- automatic power-up, enabling, 4-16
- available options
 - access password, enabling, 4-12
 - cover, 4-4
 - list, 4-1
 - location, 4-6

B

- battery, changing, 4-63
- before you begin, 1-2

C

- central unit
 - boot (S100 only), System Management Services, 3-8
 - MultiBoot (S120 only), System Management Services, 3-6
- control key, 2-9
- cover, removal, 4-4

D

- diagnostic programs
 - modes for running, 5-3
 - concurrent mode, 5-4
 - maintenance mode, 5-3, 5-5
 - operating considerations
 - identifying a terminal, 5-1
 - running from a TTY terminal, 5-3
 - selecting a console, 5-1
- Diagnostics, 5-1

E

- external options, connecting, 4-69

F

- function key, 2-9

H

- hardware problem determination procedure, 7-1, 8-1, 8-8

I

- installation, completing, 4-67
- internal drives, 4-47
 - installing removing, 4-48

L

- L2 Cache Card Installation, Model S100, 4-28
- location code, 5-6
- Location Codes (S120), 6-1

M

- memory modules
 - installing, 4-21
 - removing, 4-25

N

- numeric keypad, 2-9

O

- optional devices
 - installation, 4-1
 - removal, 4-1

P

- password
 - power-on, disabling, 4-8
 - privileged-access, enabling, 4-12
- peripherals, placement, B-1

- placement
 - adapters, B-1
 - peripherals, B-1
- power cable
 - part number and country, xii
 - type, xii
- power-on password, disabling, 4-8
- problem determination procedure, 7-1, 8-1, 8-8
- processor upgrade, 332MHz, 4-32

S

- safety considerations, 4-2
- SCSI, bus termination, D-1
- security jumpers, SCSI, 4-58
- security tether, installing, 4-61
- static sensitive, 4-3
- System Management Services, 3-1
 - graphical, 3-1
 - audio (S100 only), 3-14
 - boot (S100 only), 3-8
 - configuration, 3-4
 - firmware recovery, 3-20
 - firmware update, 3-19
 - hard disk spin up delay (S120 only), 3-14
 - log file, 3-15
 - MultiBoot (S120 only), 3-6

- password, 3-11
- RIPL, 3-16
- SCSI ID, 3-18
- utilities, 3-9
- text-based, 3-21
 - display configuration, 3-22
 - multiboot (S120), 3-24
 - open firmware command line, 3-32
 - select boot devices (S100), 3-23
 - select language, 3-32
 - utilities, 3-26

system management services. *See* System Management Services

- system unit
 - ESCALA S100 features, 1-4
 - ESCALA S120 features, 1-6
 - startup, 1-1
 - unpacking, 1-3
- system verification procedure
 - diagnostics, stopping, 7-3
 - running, 7-2

T

- typewriter key, 2-9

U

- upgrade, processor, 332MHz, 4-32

Vos remarques sur ce document / Technical publication remark form

Titre / Title : Bull ESCALA S Series System User's Guide

N° Référence / Reference N° : 86 A1 89JX 01

Daté / Dated : October 1998

ERREURS DETECTEES / ERRORS IN PUBLICATION

AMELIORATIONS SUGGEREES / SUGGESTIONS FOR IMPROVEMENT TO PUBLICATION

Vos remarques et suggestions seront examinées attentivement.

Si vous désirez une réponse écrite, veuillez indiquer ci-après votre adresse postale complète.

Your comments will be promptly investigated by qualified technical personnel and action will be taken as required.

If you require a written reply, please furnish your complete mailing address below.

NOM / NAME : _____ Date : _____

SOCIETE / COMPANY : _____

ADRESSE / ADDRESS : _____

Remettez cet imprimé à un responsable BULL ou envoyez-le directement à :

Please give this technical publication remark form to your BULL representative or mail to:

BULL ELECTRONICS

CEDOC

34 Rue du Nid de Pie – BP 428

49004 ANGERS CEDEX 01

FRANCE

Technical Publications Ordering Form

Bon de Commande de Documents Techniques

To order additional publications, please fill up a copy of this form and send it via mail to:

Pour commander des documents techniques, remplissez une copie de ce formulaire et envoyez-la à :

BULL ELECTRONICS
CEDOC
ATTN / MME DUMOULIN
34 Rue du Nid de Pie – BP 428
49004 ANGERS CEDEX 01
FRANCE

Managers / Gestionnaires :
Mrs. / Mme : **C. DUMOULIN** +33 (0) 2 41 73 76 65
Mr. / M : **L. CHERUBIN** +33 (0) 2 41 73 63 96
FAX : +33 (0) 2 41 73 60 19
E-Mail / Courrier Electronique : srv.Cedoc@franp.bull.fr

Or visit our web site at: / Ou visitez notre site web à:

<http://www-frec.bull.com> (PUBLICATIONS, Technical Literature, Ordering Form)

CEDOC Reference # N° Référence CEDOC	Qty Qté	CEDOC Reference # N° Référence CEDOC	Qty Qté	CEDOC Reference # N° Référence CEDOC	Qty Qté
__ __ __ __ __ [__]		__ __ __ __ __ [__]		__ __ __ __ __ [__]	
__ __ __ __ __ [__]		__ __ __ __ __ [__]		__ __ __ __ __ [__]	
__ __ __ __ __ [__]		__ __ __ __ __ [__]		__ __ __ __ __ [__]	
__ __ __ __ __ [__]		__ __ __ __ __ [__]		__ __ __ __ __ [__]	
__ __ __ __ __ [__]		__ __ __ __ __ [__]		__ __ __ __ __ [__]	
__ __ __ __ __ [__]		__ __ __ __ __ [__]		__ __ __ __ __ [__]	
__ __ __ __ __ [__]		__ __ __ __ __ [__]		__ __ __ __ __ [__]	

[__]: **no revision number means latest revision** / pas de numéro de révision signifie révision la plus récente

NOM / NAME : _____ Date : _____

SOCIETE / COMPANY : _____

ADRESSE / ADDRESS : _____

PHONE / TELEPHONE : _____ FAX : _____

E-MAIL : _____

For Bull Subsidiaries / Pour les Filiales Bull :

Identification: _____

For Bull Affiliated Customers / Pour les Clients Affiliés Bull :

Customer Code / Code Client : _____

For Bull Internal Customers / Pour les Clients Internes Bull :

Budgetary Section / Section Budgétaire : _____

For Others / Pour les Autres :

Please ask your Bull representative. / Merci de demander à votre contact Bull.

**BULL ELECTRONICS
CEDOC
34 Rue du Nid de Pie – BP 428
49004 ANGERS CEDEX 01
FRANCE**

**ORDER REFERENCE
86 A1 89JX 01**

PLACE BAR CODE IN LOWER
LEFT CORNER



Utiliser les marques de découpe pour obtenir les étiquettes.
Use the cut marks to get the labels.

┌ ────┐ ┌ ────┐
ESCALA S
Series
System User's
Guide

86 A1 89JX 01

└ ────┘ └ ────┘

┌ ────┐ ┌ ────┐
ESCALA S
Series
System User's
Guide

86 A1 89JX 01

└ ────┘ └ ────┘

┌ ────┐ ┌ ────┐
ESCALA S
Series
System User's
Guide

86 A1 89JX 01

└ ────┘ └ ────┘

