

# EDR1 removal and replacement procedures

ESCALA Power7



REFERENCE  
86 A1 26FK 01



# EDR1 removal and replacement procedures

The ESCALA Power7 publications concern the following models:

- Bull Escala E1-700 (Power 710 / 8231-E2B)
- Bull Escala E1-705 (Power 710 / 8231-E1C)
- Bull Escala E2-700 / E2-700T (Power 720 / 8202-E4B)
- Bull Escala E2-705 / E2-705T (Power 720 / 8202-E4C)
- Bull Escala E3-700 (Power 730 / 8231-E2B)
- Bull Escala E3-705 (Power 730 / 8231-E2C)
- Bull Escala E4-700 / E4-700T (Power 740 / 8205-E6B)
- Bull Escala E4-705 (Power 740 / 8205-E6C)
- Bull Escala E5-700 (Power 750 / 8233-E8B)
- Bull Escala M6-700 (Power 770 / 9117-MMB)
- Bull Escala M6-705 (Power 770 / 9117-MMC)
- Bull Escala M6-715 (Power 770 / 9117-MMD)
- Bull Escala M7-700 (Power 780 / 9179-MHB)
- Bull Escala M7-705 (Power 780 / 9179-MHC)
- Bull Escala M7-715 (Power 780 / 9179-MHD)

References to Power 755 / 8236-E8C models are irrelevant.

## Hardware

November 2012

BULL CEDOC  
357 AVENUE PATTON  
B.P.20845  
49008 ANGERS CEDEX 01  
FRANCE

**REFERENCE**  
**86 A1 26FK 01**

The following copyright notice protects this book under Copyright laws which prohibit such actions as, but not limited to, copying, distributing, modifying, and making derivative works.

Copyright © Bull SAS 2012

Printed in France

## **Trademarks and Acknowledgements**

We acknowledge the rights of the proprietors of the trademarks mentioned in this manual.

All brand names and software and hardware product names are subject to trademark and/or patent protection.

Quoting of brand and product names is for information purposes only and does not represent trademark misuse.

*The information in this document is subject to change without notice. Bull will not be liable for errors contained herein, or for incidental or consequential damages in connection with the use of this material.*

---

# Contents

<b>Safety notices</b> . . . . .	<b>v</b>
<b>EDR1 PCIe storage enclosure removal and replacement procedures</b> . . . . .	<b>1</b>
Removing and installing a fan assembly for an EDR1 PCIe storage enclosure . . . . .	3
Removing and installing a midplane for an EDR1 PCIe storage enclosure . . . . .	4
Removing and installing a power supply for an EDR1 PCIe storage enclosure . . . . .	17
Removing and installing a PCIe cable for an EDR1 PCIe storage enclosure . . . . .	19
Removing and installing a PCIe cable with the power off . . . . .	20
Removing and installing a PCIe cable with the power on . . . . .	21
Removing and installing a solid-state drive for an EDR1 PCIe storage enclosure . . . . .	26
Removing and installing an enclosure RAID module assembly for an EDR1 PCIe storage enclosure . . . . .	26
Removing and installing an enclosure RAID module assembly with the power off. . . . .	26
Removing and installing an enclosure RAID module assembly with the power on in the AIX environment . . . . .	28
Removing and installing an enclosure RAID module assembly with the power on in the Linux environment. . . . .	34
<b>Notices</b> . . . . .	<b>39</b>
Trademarks . . . . .	40
Electronic emission notices . . . . .	40
Class A Notices . . . . .	40
Class B Notices . . . . .	44
Terms and conditions . . . . .	46



---

## Safety notices

Safety notices may be printed throughout this guide.

- **DANGER** notices call attention to a situation that is potentially lethal or extremely hazardous to people.
- **CAUTION** notices call attention to a situation that is potentially hazardous to people because of some existing condition.
- **Attention** notices call attention to the possibility of damage to a program, device, system, or data.

### World Trade safety information

Several countries require the safety information contained in product publications to be presented in their national languages. If this requirement applies to your country, a safety information booklet is included in the publications package shipped with the product. The booklet contains the safety information in your national language with references to the U.S. English source. Before using a U.S. English publication to install, operate, or service this product, you must first become familiar with the related safety information in the booklet. You should also refer to the booklet any time you do not clearly understand any safety information in the U.S. English publications.

### Laser safety information

The servers can use I/O cards or features that are fiber-optic based and that utilize lasers or LEDs.

#### Laser compliance

The servers may be installed inside or outside of an IT equipment rack.

## DANGER

When working on or around the system, observe the following precautions:

Electrical voltage and current from power, telephone, and communication cables are hazardous. To avoid a shock hazard:

- Connect power to this unit only with the provided power cord. Do not use the provided power cord for any other product.
- Do not open or service any power supply assembly.
- Do not connect or disconnect any cables or perform installation, maintenance, or reconfiguration of this product during an electrical storm.
- The product might be equipped with multiple power cords. To remove all hazardous voltages, disconnect all power cords.
- Connect all power cords to a properly wired and grounded electrical outlet. Ensure that the outlet supplies proper voltage and phase rotation according to the system rating plate.
- Connect any equipment that will be attached to this product to properly wired outlets.
- When possible, use one hand only to connect or disconnect signal cables.
- Never turn on any equipment when there is evidence of fire, water, or structural damage.
- Disconnect the attached power cords, telecommunications systems, networks, and modems before you open the device covers, unless instructed otherwise in the installation and configuration procedures.
- Connect and disconnect cables as described in the following procedures when installing, moving, or opening covers on this product or attached devices.

To Disconnect:

1. Turn off everything (unless instructed otherwise).
2. Remove the power cords from the outlets.
3. Remove the signal cables from the connectors.
4. Remove all cables from the devices.

To Connect:

1. Turn off everything (unless instructed otherwise).
2. Attach all cables to the devices.
3. Attach the signal cables to the connectors.
4. Attach the power cords to the outlets.
5. Turn on the devices.

(D005a)

## DANGER



Observe the following precautions when working on or around your IT rack system:

- Heavy equipment—personal injury or equipment damage might result if mishandled.
- Always lower the leveling pads on the rack cabinet.
- Always install stabilizer brackets on the rack cabinet.
- To avoid hazardous conditions due to uneven mechanical loading, always install the heaviest devices in the bottom of the rack cabinet. Always install servers and optional devices starting from the bottom of the rack cabinet.
- Rack-mounted devices are not to be used as shelves or work spaces. Do not place objects on top of rack-mounted devices.



- Each rack cabinet might have more than one power cord. Be sure to disconnect all power cords in the rack cabinet when directed to disconnect power during servicing.
- Connect all devices installed in a rack cabinet to power devices installed in the same rack cabinet. Do not plug a power cord from a device installed in one rack cabinet into a power device installed in a different rack cabinet.
- An electrical outlet that is not correctly wired could place hazardous voltage on the metal parts of the system or the devices that attach to the system. It is the responsibility of the customer to ensure that the outlet is correctly wired and grounded to prevent an electrical shock.

#### CAUTION

- Do not install a unit in a rack where the internal rack ambient temperatures will exceed the manufacturer's recommended ambient temperature for all your rack-mounted devices.
- Do not install a unit in a rack where the air flow is compromised. Ensure that air flow is not blocked or reduced on any side, front, or back of a unit used for air flow through the unit.
- Consideration should be given to the connection of the equipment to the supply circuit so that overloading of the circuits does not compromise the supply wiring or overcurrent protection. To provide the correct power connection to a rack, refer to the rating labels located on the equipment in the rack to determine the total power requirement of the supply circuit.
- *(For sliding drawers.)* Do not pull out or install any drawer or feature if the rack stabilizer brackets are not attached to the rack. Do not pull out more than one drawer at a time. The rack might become unstable if you pull out more than one drawer at a time.
- *(For fixed drawers.)* This drawer is a fixed drawer and must not be moved for servicing unless specified by the manufacturer. Attempting to move the drawer partially or completely out of the rack might cause the rack to become unstable or cause the drawer to fall out of the rack.

(R001)

**CAUTION:**

Removing components from the upper positions in the rack cabinet improves rack stability during relocation. Follow these general guidelines whenever you relocate a populated rack cabinet within a room or building:

- Reduce the weight of the rack cabinet by removing equipment starting at the top of the rack cabinet. When possible, restore the rack cabinet to the configuration of the rack cabinet as you received it. If this configuration is not known, you must observe the following precautions:
  - Remove all devices in the 32U position and above.
  - Ensure that the heaviest devices are installed in the bottom of the rack cabinet.
  - Ensure that there are no empty U-levels between devices installed in the rack cabinet below the 32U level.
- If the rack cabinet you are relocating is part of a suite of rack cabinets, detach the rack cabinet from the suite.
- Inspect the route that you plan to take to eliminate potential hazards.
- Verify that the route that you choose can support the weight of the loaded rack cabinet. Refer to the documentation that comes with your rack cabinet for the weight of a loaded rack cabinet.
- Verify that all door openings are at least 760 x 230 mm (30 x 80 in.).
- Ensure that all devices, shelves, drawers, doors, and cables are secure.
- Ensure that the four leveling pads are raised to their highest position.
- Ensure that there is no stabilizer bracket installed on the rack cabinet during movement.
- Do not use a ramp inclined at more than 10 degrees.
- When the rack cabinet is in the new location, complete the following steps:
  - Lower the four leveling pads.
  - Install stabilizer brackets on the rack cabinet.
  - If you removed any devices from the rack cabinet, repopulate the rack cabinet from the lowest position to the highest position.
- If a long-distance relocation is required, restore the rack cabinet to the configuration of the rack cabinet as you received it. Pack the rack cabinet in the original packaging material, or equivalent. Also lower the leveling pads to raise the casters off of the pallet and bolt the rack cabinet to the pallet.

(R002)

(L001)



(L002)



(L003)



or



All lasers are certified in the U.S. to conform to the requirements of DHHS 21 CFR Subchapter J for class 1 laser products. Outside the U.S., they are certified to be in compliance with IEC 60825 as a class 1 laser product. Consult the label on each part for laser certification numbers and approval information.

**CAUTION:**

This product might contain one or more of the following devices: CD-ROM drive, DVD-ROM drive, DVD-RAM drive, or laser module, which are Class 1 laser products. Note the following information:

- Do not remove the covers. Removing the covers of the laser product could result in exposure to hazardous laser radiation. There are no serviceable parts inside the device.
- Use of the controls or adjustments or performance of procedures other than those specified herein might result in hazardous radiation exposure.

(C026)

**CAUTION:**

Data processing environments can contain equipment transmitting on system links with laser modules that operate at greater than Class 1 power levels. For this reason, never look into the end of an optical fiber cable or open receptacle. (C027)

**CAUTION:**

This product contains a Class 1M laser. Do not view directly with optical instruments. (C028)

**CAUTION:**

Some laser products contain an embedded Class 3A or Class 3B laser diode. Note the following information: laser radiation when open. Do not stare into the beam, do not view directly with optical instruments, and avoid direct exposure to the beam. (C030)

**CAUTION:**

The battery contains lithium. To avoid possible explosion, do not burn or charge the battery.

*Do Not:*

- \_\_\_ Throw or immerse into water
- \_\_\_ Heat to more than 100°C (212°F)
- \_\_\_ Repair or disassemble

Exchange only with the approved part. Recycle or discard the battery as instructed by local regulations. (C003a)

## **Power and cabling information for NEBS (Network Equipment-Building System) GR-1089-CORE**

The following comments apply to the servers that have been designated as conforming to NEBS (Network Equipment-Building System) GR-1089-CORE:

The equipment is suitable for installation in the following:

- Network telecommunications facilities
- Locations where the NEC (National Electrical Code) applies

The intrabuilding ports of this equipment are suitable for connection to intrabuilding or unexposed wiring or cabling only. The intrabuilding ports of this equipment *must not* be metallically connected to the interfaces that connect to the OSP (outside plant) or its wiring. These interfaces are designed for use as intrabuilding interfaces only (Type 2 or Type 4 ports as described in GR-1089-CORE) and require isolation from the exposed OSP cabling. The addition of primary protectors is not sufficient protection to connect these interfaces metallically to OSP wiring.

**Note:** All Ethernet cables must be shielded and grounded at both ends.

The ac-powered system does not require the use of an external surge protection device (SPD).

The dc-powered system employs an isolated DC return (DC-I) design. The DC battery return terminal *shall not* be connected to the chassis or frame ground.

---

## EDR1 PCIe storage enclosure removal and replacement procedures

Use the removal and replacement procedures when you repair, maintain, or exchange parts for the EDR1 PCI Express (PCIe) storage enclosure (EXP30 Ultra SSD I/O Drawer).

Before you begin a replacement, perform the following tasks:

1. If you are performing a replacement procedure that might put your data at risk, ensure, if possible, that you have a current backup of your system or logical partition (including operating systems, licensed programs, and data).
2. Review the installation or replacement procedure for the feature or part.
3. Note the significance of color on your system.

*Blue* or *terra-cotta* on a part of the hardware indicates a touch point where you can grip the hardware to remove it from or install it in the system, to open or close a latch, and other actions. Blue indicates that the part must be removed and replaced with the system powered off. Terra-cotta indicates that the part can be removed and replaced with the system or logical partition power on. The task might require some action before and after part replacement.

4. If parts are incorrect, missing, or visibly damaged, contact your service provider or next level of support.

## DANGER

When working on or around the system, observe the following precautions:

Electrical voltage and current from power, telephone, and communication cables are hazardous. To avoid a shock hazard:

- Connect power to this unit only with the provided power cord. Do not use the provided power cord for any other product.
- Do not open or service any power supply assembly.
- Do not connect or disconnect any cables or perform installation, maintenance, or reconfiguration of this product during an electrical storm.
- The product might be equipped with multiple power cords. To remove all hazardous voltages, disconnect all power cords.
- Connect all power cords to a properly wired and grounded electrical outlet. Ensure that the outlet supplies proper voltage and phase rotation according to the system rating plate.
- Connect any equipment that will be attached to this product to properly wired outlets.
- When possible, use one hand only to connect or disconnect signal cables.
- Never turn on any equipment when there is evidence of fire, water, or structural damage.
- Disconnect the attached power cords, telecommunications systems, networks, and modems before you open the device covers, unless instructed otherwise in the installation and configuration procedures.
- Connect and disconnect cables as described in the following procedures when installing, moving, or opening covers on this product or attached devices.

To Disconnect:

1. Turn off everything (unless instructed otherwise).
2. Remove the power cords from the outlets.
3. Remove the signal cables from the connectors.
4. Remove all cables from the devices.

To Connect:

1. Turn off everything (unless instructed otherwise).
2. Attach all cables to the devices.
3. Attach the signal cables to the connectors.
4. Attach the power cords to the outlets.
5. Turn on the devices.

(D005a)

**Attention:** Failure to follow the steps sequentially for field-replaceable unit (FRU) removal or installation might result in FRU or system damage.

Use the following precautions whenever you handle electronic components or cables:

- The electrostatic discharge (ESD) kit and the ESD wrist strap must be used when handling logic cards, single chip modules (SCMs), multiple chip modules (MCMs), electronic boards, and disk drives.
- Keep all electronic components in the shipping container or envelope until you are ready to install them.
- If you remove and reinstall an electronic component, temporarily place the component on an ESD pad or blanket.

---

## Removing and installing a fan assembly for an EDR1 PCIe storage enclosure

Use this procedure to service a fan assembly concurrently or nonconcurrently for the EDR1 PCIe storage enclosure (EXP30 Ultra SSD I/O Drawer).

**Attention:** Failure to follow the steps sequentially for this field replaceable unit (FRU) removal or installation might result in damage to the FRU or system.

Use the following precautions whenever you handle electronic components or cables:

- Attach a wrist strap to an unpainted metal surface of your hardware to prevent electrostatic discharge (ESD) from damaging your hardware.
- If you do not have a wrist strap, before removing the product from ESD packaging and installing or replacing hardware, touch an unpainted metal surface of the system for a minimum of 5 seconds.
- Keep all electronic components in the shipping container or envelope until you are ready to install them.
- If you remove and reinstall an electronic component, temporarily place the component on an ESD pad or blanket, if available.

To remove and install a fan assembly, complete the following steps:

1. Use the service indicator light-emitting diodes (LEDs) to help identify the part. See Identifying a part.
2. Remove the enclosure RAID module (ERM) assembly from the PCIe storage enclosure. See “Removing and installing an enclosure RAID module assembly for an EDR1 PCIe storage enclosure” on page 26.
3. Remove the fan assembly from the ERM assembly:
  - a. Place the ERM assembly on a flat surface.
  - b. Press the release button **(A)**, as shown in the following figure, to raise the fan assembly out of the ERM assembly.
  - c. Grasp the fan assembly **(B)** and remove it from the ERM assembly.

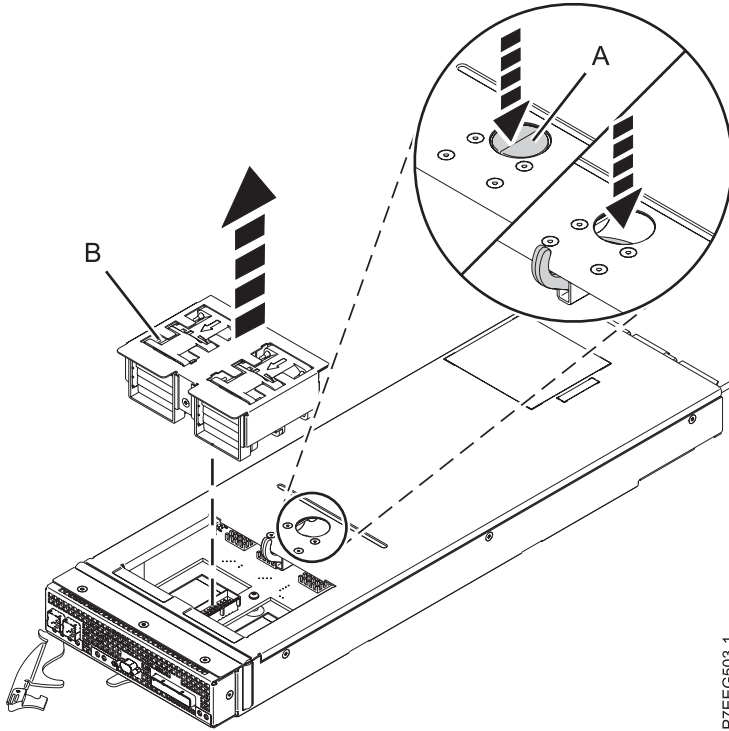

P7EEG503-1

Figure 1. Removing the fan assembly from the ERM assembly

4. Install the fan assembly:
  - a. Insert the fan assembly into the ERM assembly until it stops.
  - b. Install the ERM assembly into the PCIe storage enclosure. See “Removing and installing an enclosure RAID module assembly for an EDR1 PCIe storage enclosure” on page 26.

---

## Removing and installing a midplane for an EDR1 PCIe storage enclosure

Use this procedure to service a midplane nonconcurrently for the EDR1 PCIe storage enclosure (EXP30 Ultra SSD I/O Drawer).

### Notes:

1. Servicing of the midplane must be performed by only trained service personnel.
2. To complete this procedure, you need special bits or drivers (T8 Torx, T10 Torx, and 5.5 mm hex).



**Attention:**

1. Failure to follow the steps sequentially for this field replaceable unit (FRU) removal or installation might result in damage to the FRU or system.
2. The failed midplane must only be replaced with a new midplane that has not yet been installed in another PCIe storage enclosure. If the midplane was previously installed in a different PCIe storage enclosure, the enclosure serial number will not be properly updated during power on.
3. After a midplane is installed and the PCIe storage enclosure is powered on, the midplane cannot be used in a different PCIe storage enclosure.
4. Replace only the midplane FRU in this procedure until power has been applied to the PCIe storage enclosure with the new midplane installed. The original enclosure RAID module (ERM) assemblies must be used in this procedure to preserve the serial number.

Use the following precautions whenever you handle electronic components or cables:

- Attach a wrist strap to an unpainted metal surface of your hardware to prevent electrostatic discharge (ESD) from damaging your hardware.
- If you do not have a wrist strap, before removing the product from ESD packaging and installing or replacing hardware, touch an unpainted metal surface of the system for a minimum of 5 seconds.
- Keep all electronic components in the shipping container or envelope until you are ready to install them.
- If you remove and reinstall an electronic component, temporarily place the component on an ESD pad or blanket, if available.

To remove a midplane, complete the following steps:

1. Use the service indicator light-emitting diodes (LEDs) to help identify the part. See *Identifying a part*.
2. Power off the system or systems that are using the PCIe storage enclosure. See *Powering on and powering off the system*.
3. Label and remove all PCIe cables and serial-attached SCSI (SAS) cables (if present) from the ERM assemblies. Disconnect the power cables from the power supplies.

**Attention:** After the midplane is replaced, the PCIe cables must be installed back into the same connectors from which they were removed. Incorrect cable placement might result in data loss.

4. Remove the six bezels that cover the solid-state drive slots as shown in the following figure.

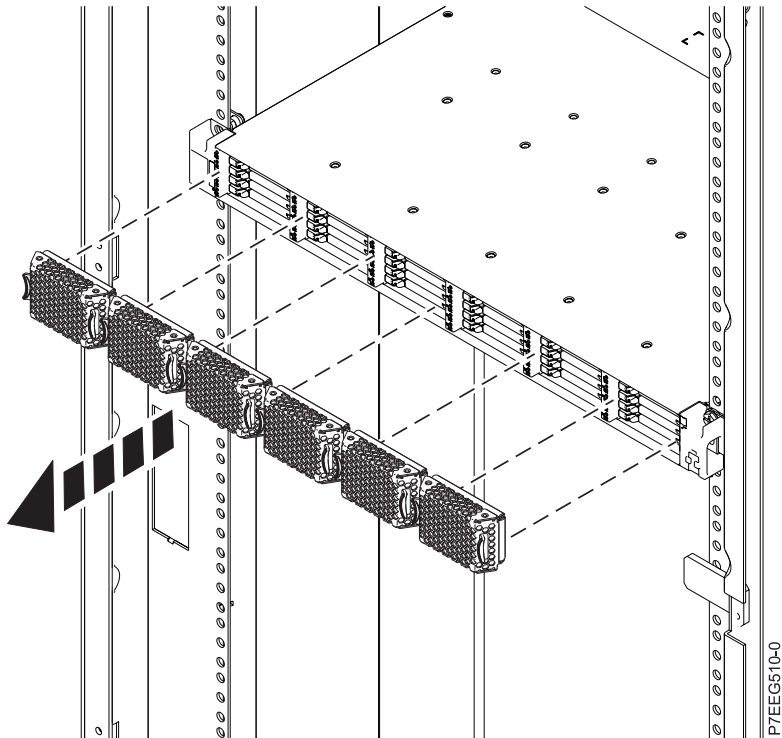
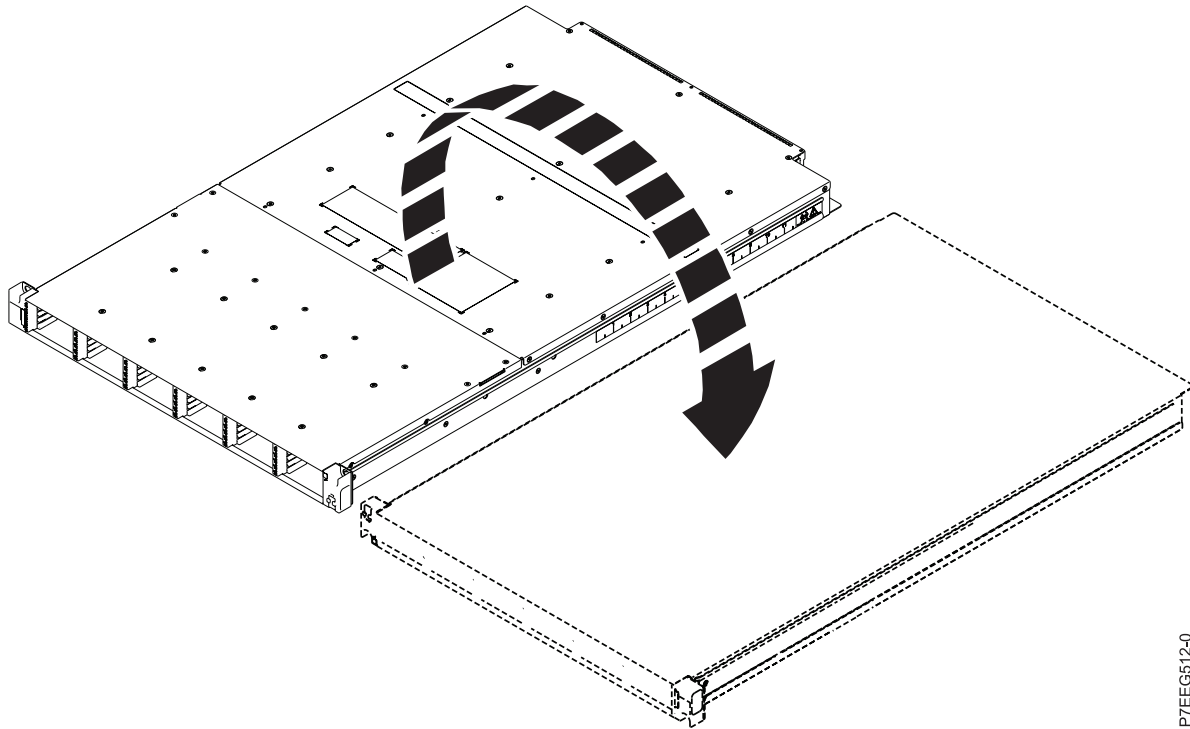

Figure 2. Removing the bezels

5. Carefully remove each solid-state drive and label it with the slot from which it was removed. See “Removing and installing a solid-state drive for an EDR1 PCIe storage enclosure” on page 26.

**Note:** After the midplane is replaced, the solid-state drives must be inserted back into the same slots from which they were removed.

6. Remove the enclosure from the rack. See Removing an enclosure from the rack. Then turn it upside down and place the enclosure on a flat surface.



P7EEG512-0

Figure 3. Turning the enclosure upside down

7. Using the correct size Torx bit or driver, remove the 10 screws from the bottom of the enclosure that are closest to the front of the enclosure.

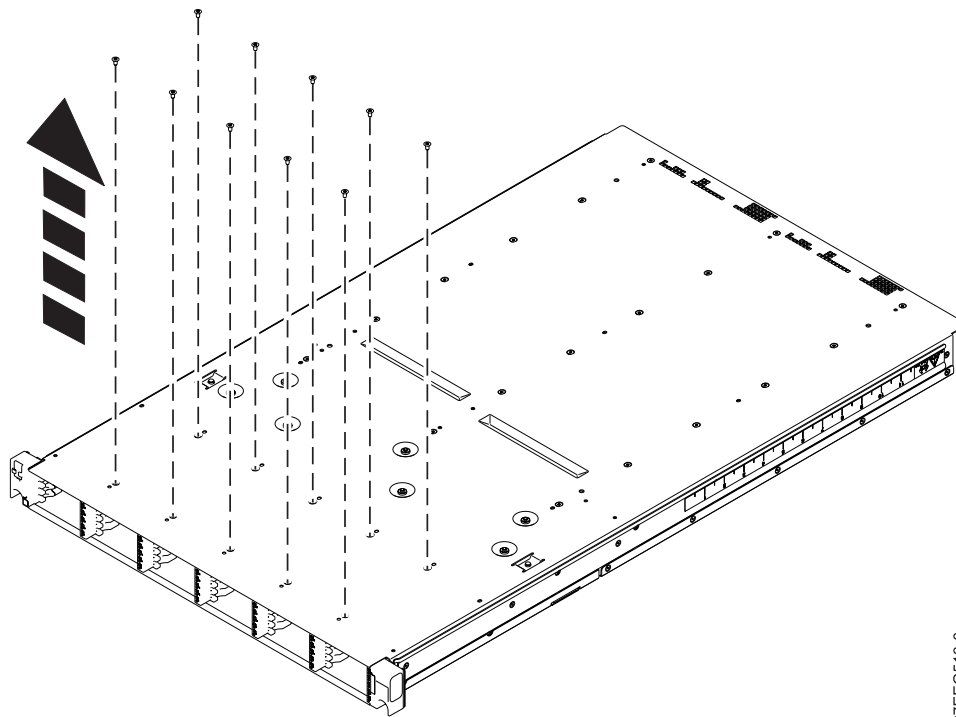

P7EEG513-0

Figure 4. Removing the screws from the bottom of the enclosure

8. Turn the enclosure top side up.

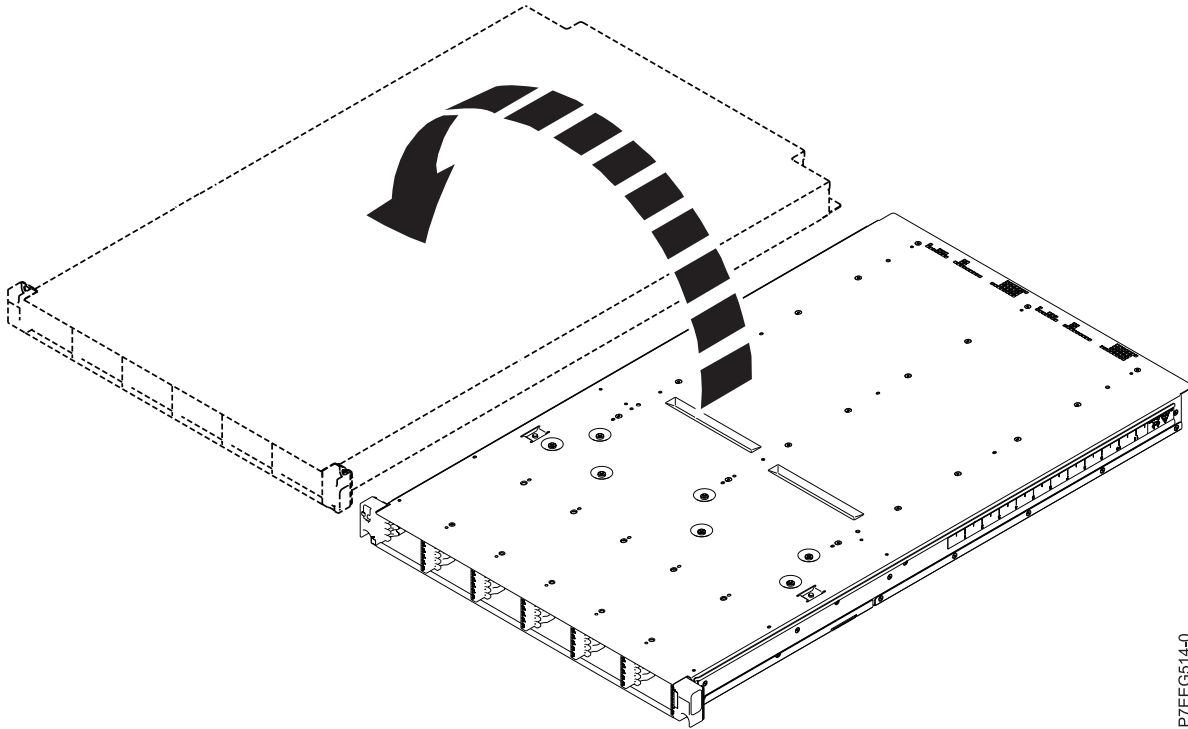

P7EEG514-0

Figure 5. Turning the enclosure top side up

9. Unseat both power supplies.  
To unseat a power supply, press the terra-cotta release tab to the left while sliding the power supply partially out of the enclosure. For more information, see “Removing and installing a power supply for an EDR1 PCIe storage enclosure” on page 17.
10. Unseat both ERM assemblies.  
To unseat an ERM assembly, open the release lever and slide the ERM assembly partially out of the enclosure. For more information, see “Removing and installing an enclosure RAID module assembly for an EDR1 PCIe storage enclosure” on page 26.
11. Remove the 19 screws that secure the top front cover to the enclosure.

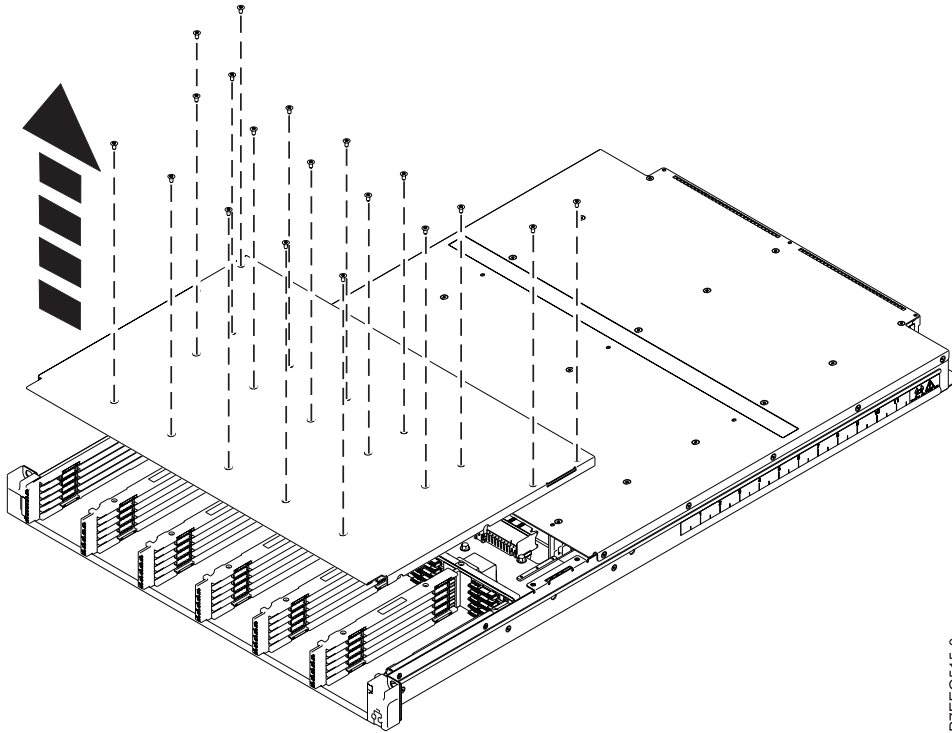

P7EEG515-0

Figure 6. Removing the screws from the top front cover of the enclosure

12. Remove the top front cover.
13. Remove the two screws on the right side of the enclosure and the two screws on the left side of the enclosure that secure the solid-state drive rails to the enclosure.

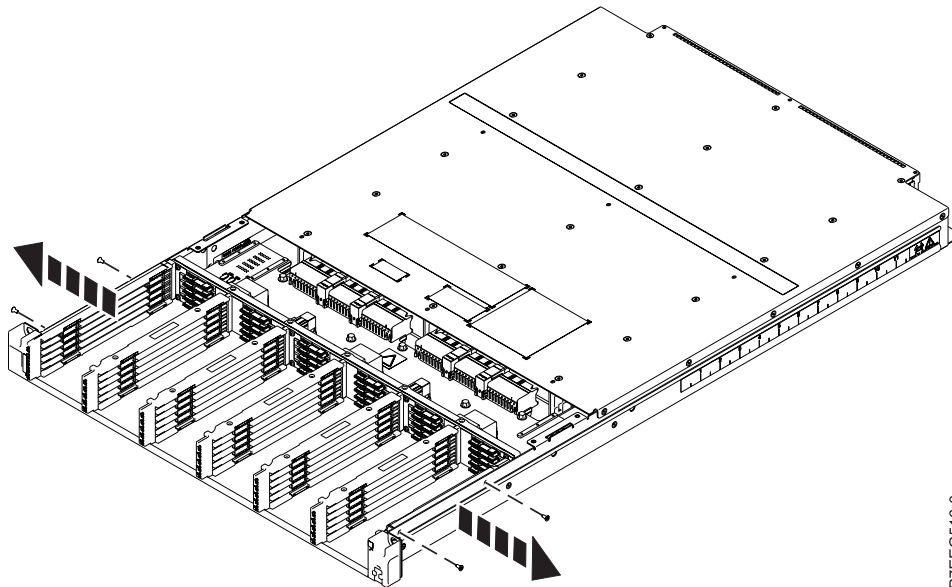

P7EEG516-0

Figure 7. Removing the screws on the right and left sides of the enclosure

14. Remove all seven solid-state drive rails.

**Note:** The EMC springs on the solid-state drive rails can be easily bent. Avoid touching the EMC springs when handling the solid-state drive rails.

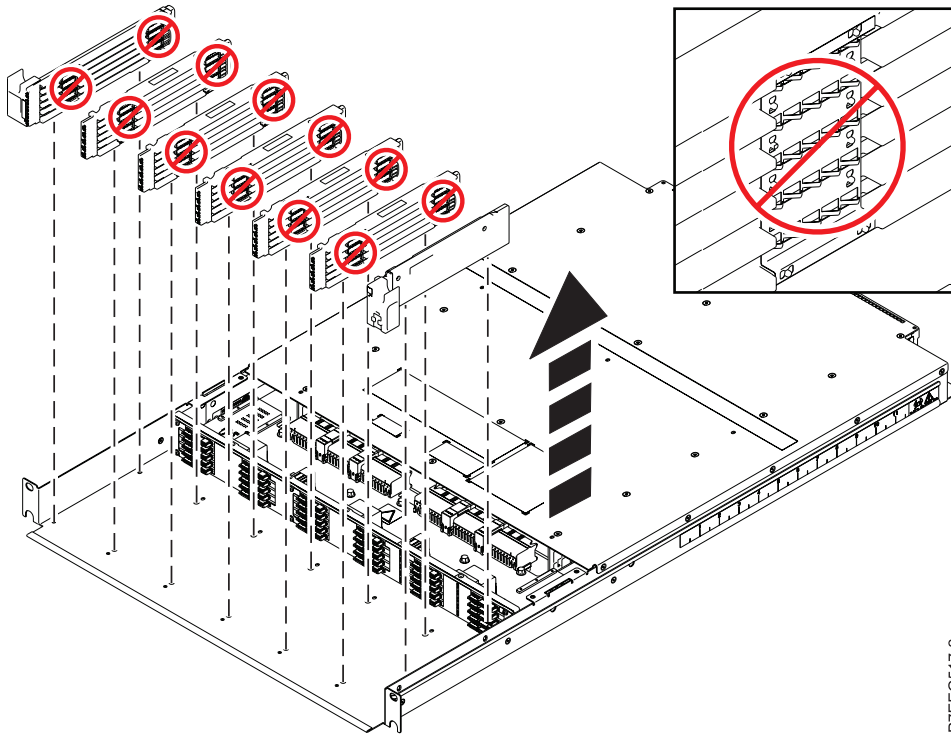

P7EEG517-2

Figure 8. Removing the solid-state drive rails

15. Remove the seven screws that secure the midplane to the enclosure. Do not remove the two screws at the center that attach the midplane to its underplate assembly, which are identified in the following figure.

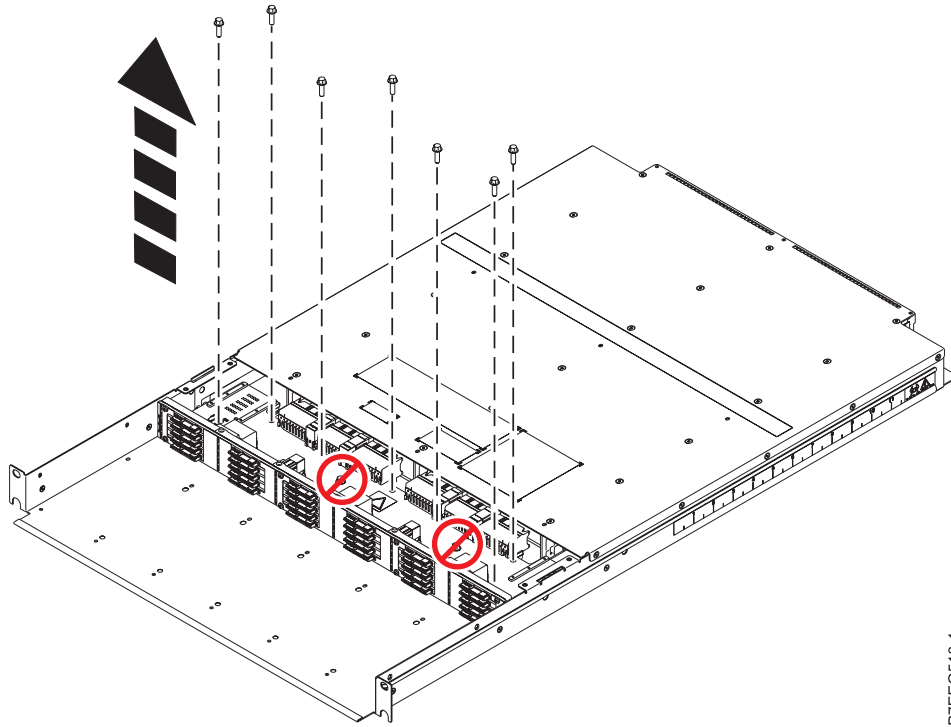

P7EEG518-1

Figure 9. Removing the midplane screws

16. Lift the midplane slightly and pull it forward to remove it from the enclosure.

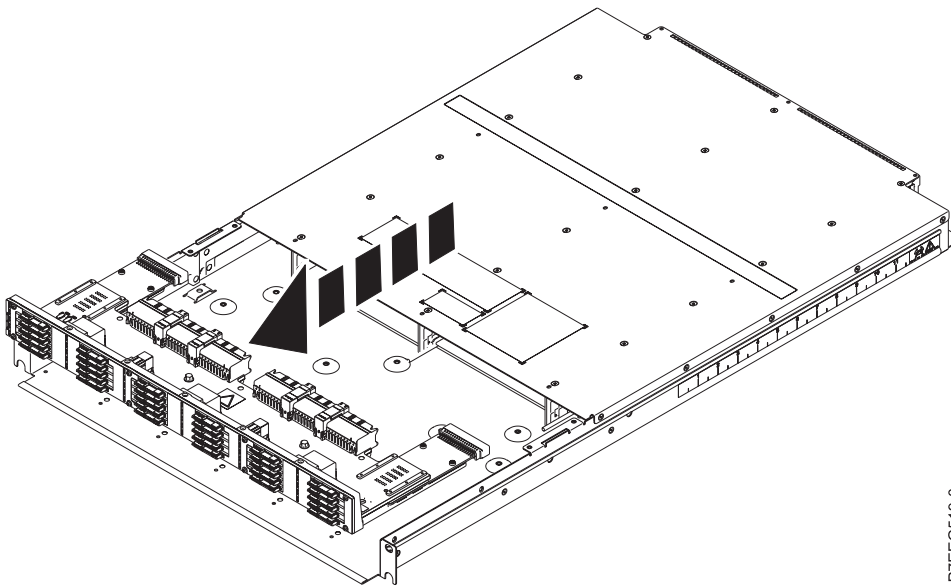

P7EEG519-0

Figure 10. Removing the midplane

To install a midplane, complete the following steps:

1. Install the new midplane, ensuring that the alignment pins are properly seated. When seating the midplane on the alignment pins, do not slide the midplane past the alignment pins in the direction of the rear of the chassis.

**Attention:** Sliding the midplane past the alignment pins might result in damage to the midplane.

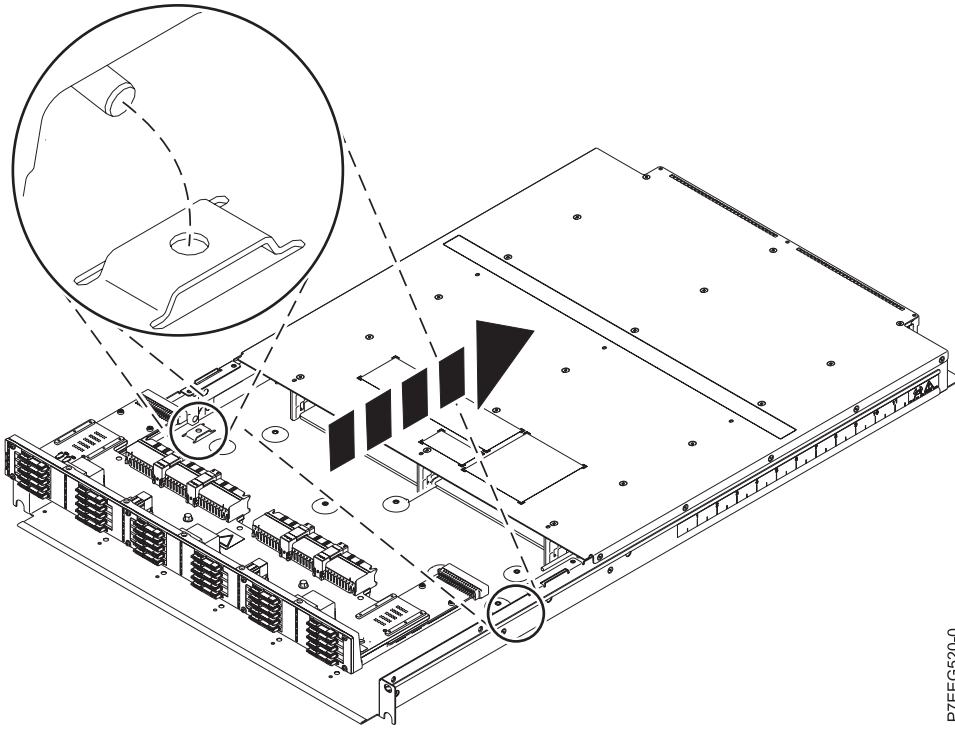

P7EEG520-0

Figure 11. Installing the midplane

- Secure the midplane assembly to the enclosure by using the seven screws that you removed in step 15 in the removing a midplane section.

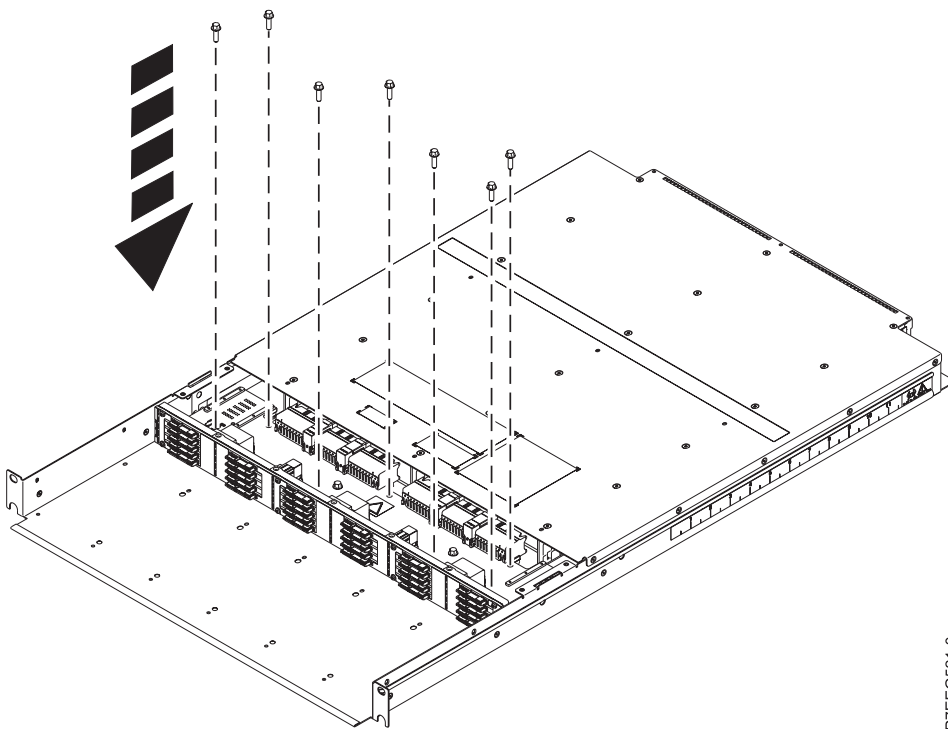

P7EEG521-0

Figure 12. Installing the midplane screws



- Secure the two solid-state drive end rails to the enclosure by using two screws on the right side of the enclosure and two screws on the left side of the enclosure that you removed in step 13 in the removing a midplane section.

**Notes:**

- The solid-state drive end rail on the left side of the enclosure has drive identification numbers. The solid-state drive end rail on the right side of the enclosure does not have drive identification numbers.
  - The EMC springs on the solid-state drive rails can be easily bent. Avoid touching the EMC springs when handling the solid-state drive rails.
- Place the remaining five solid-state drive rails into position, ensuring that the alignment pins on the bottom of each solid-state drive rail are properly seated in the enclosure.

**Note:** Ensure that the solid-state drive rails are positioned so that the drive location numbers are in ascending order from left to right.

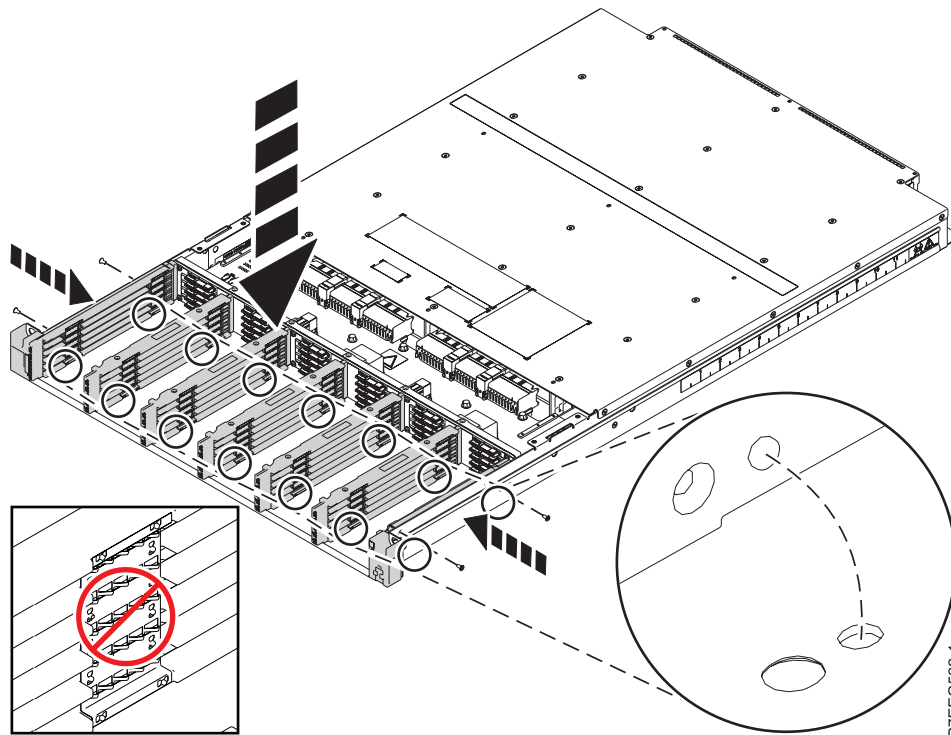
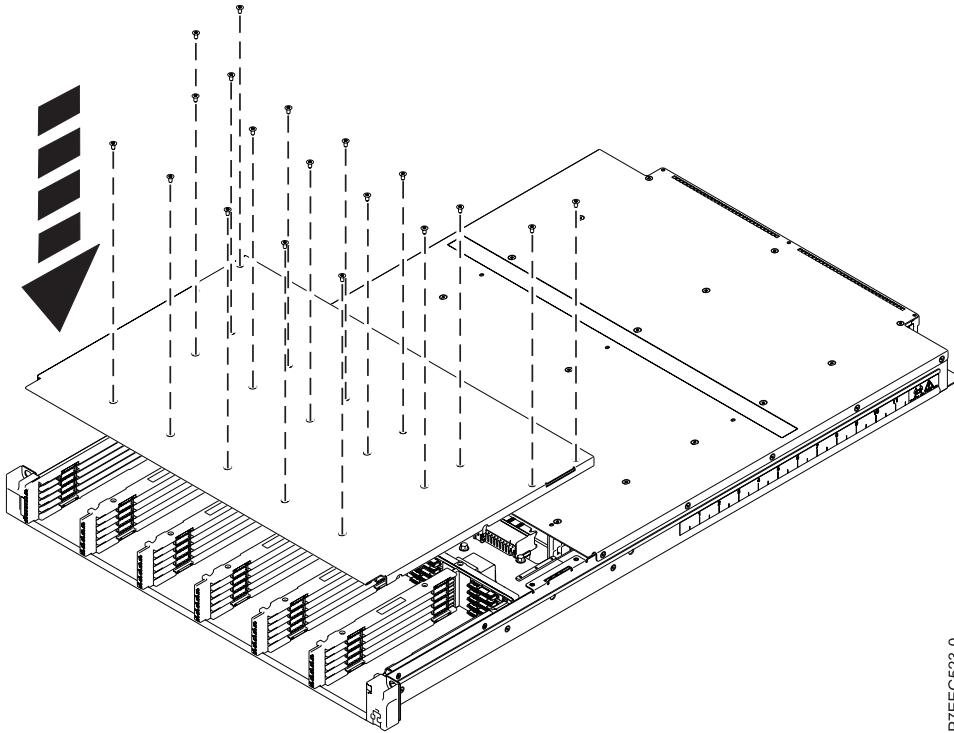

Figure 13. Installing the solid-state drive rails

- Secure the top front cover to the enclosure by using the 19 screws that you removed in step 11 in the removing a midplane section.

**Tip:** Leave these screws slightly loose for easier alignment when you secure the bottom screws.



P7EEG523-0

Figure 14. Installing the screws in the top front cover of the enclosure

6. Reseat both ERM assemblies. To reseat an ERM assembly, ensure that the release lever is in the open position. Then gently slide the ERM assembly into the enclosure until it stops. Push the release lever to the closed position. For more information, see “Removing and installing an enclosure RAID module assembly for an EDR1 PCIe storage enclosure” on page 26.
7. Reseat both power supplies. To reseat a power supply, gently slide the power supply into the enclosure until the terra-cotta release tab latches. For more information, see “Removing and installing a power supply for an EDR1 PCIe storage enclosure” on page 17.
8. Turn the enclosure upside down.

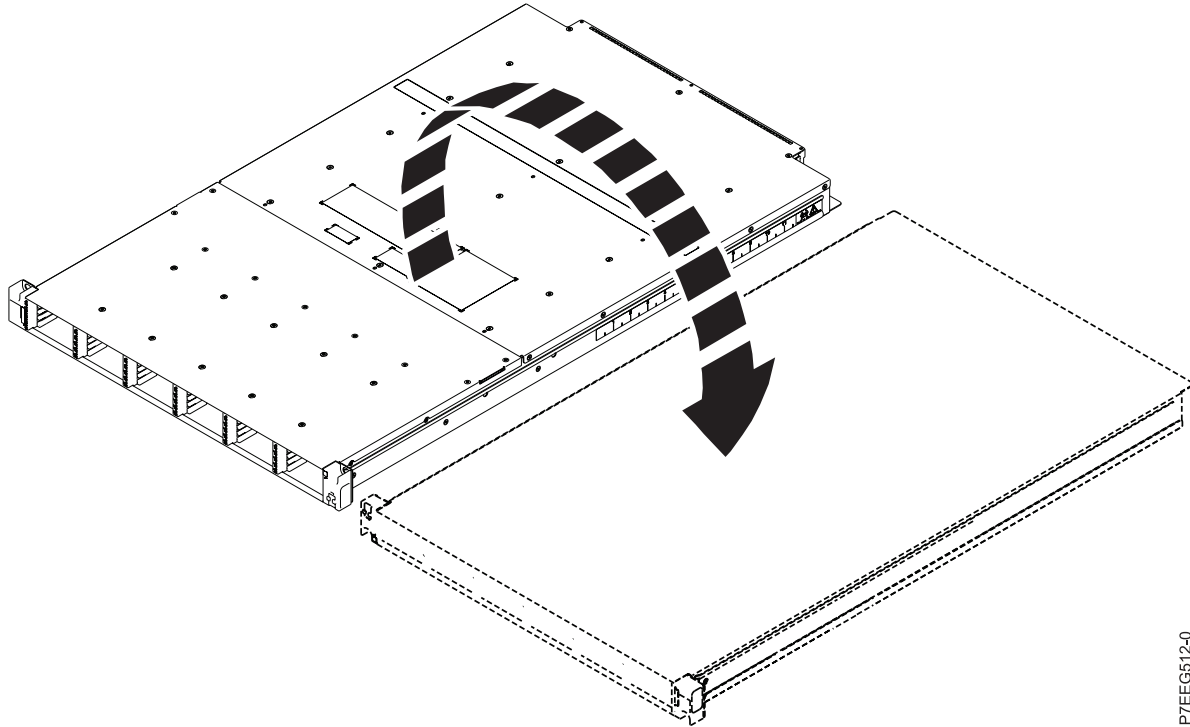

P7EEG512-0

Figure 15. Turning the enclosure upside down

9. Secure the solid-state drive rails to the enclosure by using the 10 screws that you removed in step 6 in the removing a midplane section. Ensure that the alignment pins on the bottom of each solid-state drive rail are properly seated in the enclosure.

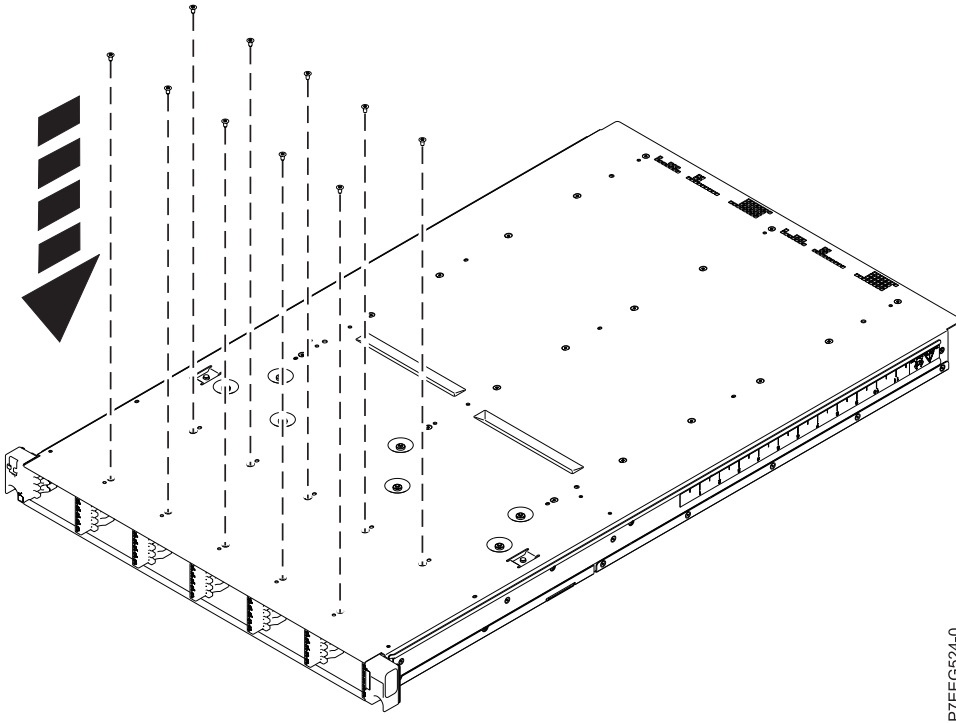

P7EEG524-0

Figure 16. Installing the screws to the bottom of the enclosure

10. Turn the enclosure top side up, tighten the top cover screws and install the enclosure in the rack. See Installing the EDR1 PCIe storage enclosure.

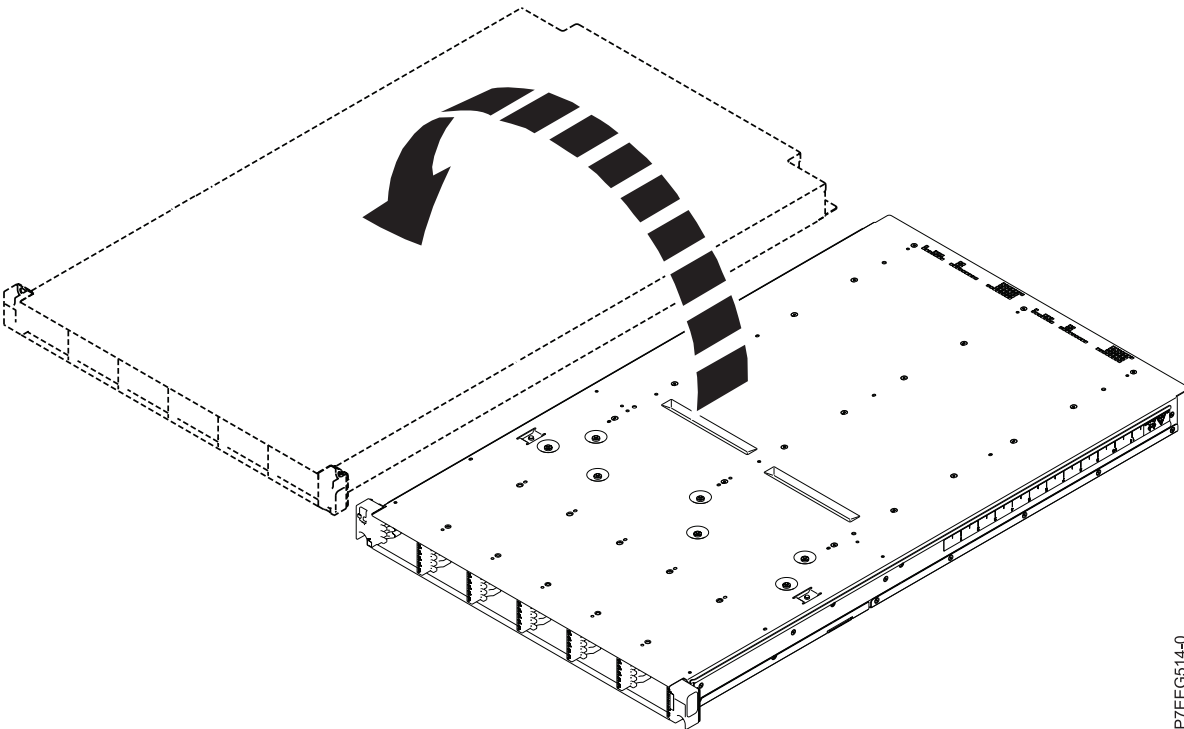

P7EEG514-0

Figure 17. Turning the enclosure top side up

11. Install the solid-state drives by using the location information marked on each drive in step 5 in the removing a midplane section. See “Removing and installing a solid-state drive for an EDR1 PCIe storage enclosure” on page 26.
12. Install the six bezels that cover the solid-state drive slots.
13. Reconnect the PCIe cables and SAS cables (if present) to the ERM assembly by using the location information marked on each cable in step 3 in the removing a midplane section. Reconnect the power cables to the power supplies.  
**Attention:** Incorrect cable placement might result in data loss.
14. Power on the system or systems that are using the PCIe storage enclosure. See Powering on and powering off the system.
15. Check the LEDs to make sure that the enclosure is fully operational.

---

## Removing and installing a power supply for an EDR1 PCIe storage enclosure

Use this procedure to service a power supply concurrently or nonconcurrently for the EDR1 PCIe storage enclosure (EXP30 Ultra SSD I/O Drawer).

**Attention:** Failure to follow the steps sequentially for this field replaceable unit (FRU) removal or installation might result in damage to the FRU or system.

Use the following precautions whenever you handle electronic components or cables:

- Attach a wrist strap to an unpainted metal surface of your hardware to prevent electrostatic discharge (ESD) from damaging your hardware.
- If you do not have a wrist strap, before removing the product from ESD packaging and installing or replacing hardware, touch an unpainted metal surface of the system for a minimum of 5 seconds.
- Keep all electronic components in the shipping container or envelope until you are ready to install them.
- If you remove and reinstall an electronic component, temporarily place the component on an ESD pad or blanket, if available.

To remove and install a power supply, complete the following steps:

1. Use the service indicator light-emitting diodes (LEDs) to help identify the part. See Identifying a part.
2. Determine whether the repair can continue concurrently. To continue the repair concurrently, the second power supply LEDs must be set as follows:
  - The ac power LED (green) is on solid.
  - The dc power LED (green) is on solid.
  - The fault LED (amber) is off.

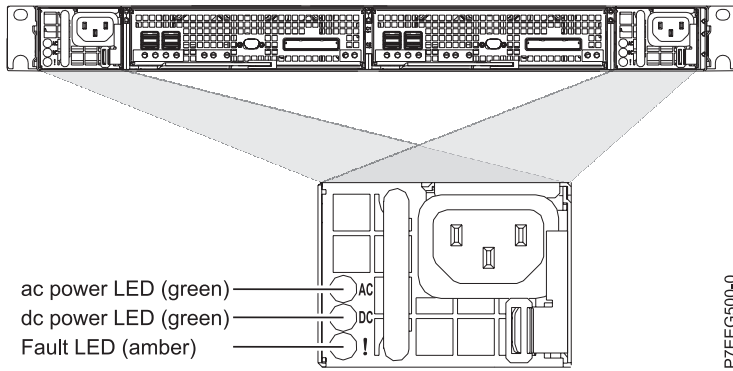

Figure 18. Rear view of power supply

3. If any of these conditions are not true, begin with **The power supply will be serviced nonconcurrently**. Otherwise, continue with **The power supply will be serviced concurrently**.
  - **The power supply will be serviced concurrently.**  
Do not remove power from the working power supply during this procedure. Remove the cable tie that secures the power cable to the cable management bracket. Remove the power cable from the power supply to be removed. Go to step 4.
  - **The power supply will be serviced nonconcurrently.**  
Power off the system or systems that are using the PCIe storage enclosure. Remove the cable tie that secures the power cable to the cable management bracket. Remove the power cables from both the power supplies. Go to step 4.
4. Remove the power supply:
  - a. While pressing the terra-cotta release tab to the left, grasp the handle and gently slide the power supply partially out of the slot.
  - b. Pull the power supply out from the slot, making sure that you support the bottom of the power supply.

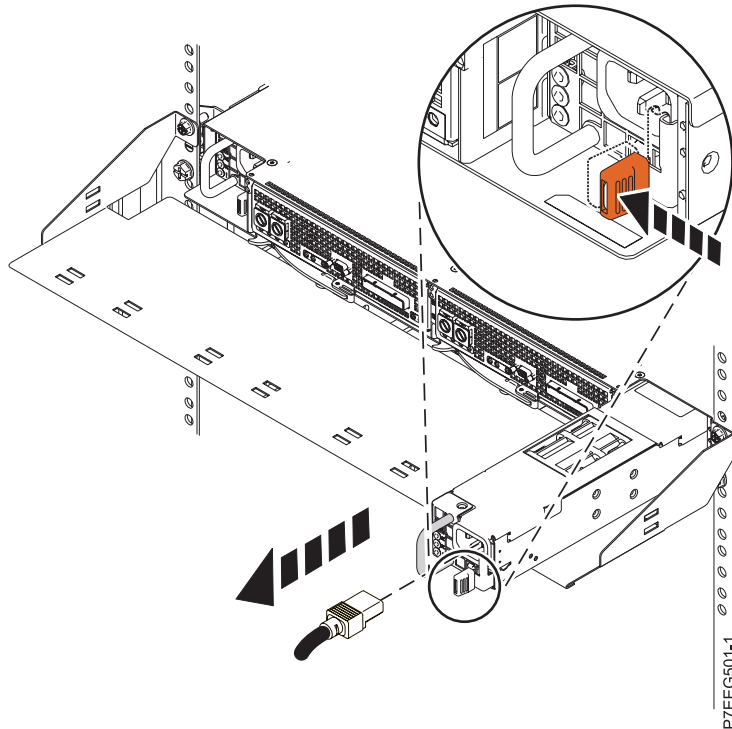

Figure 19. Removing the power supply

5. Install the power supply:
  - a. Gently slide the power supply into the enclosure until the terra-cotta release tab latches.
  - b. Reconnect the power cable to the power supply. Secure the power cable to the cable management bracket by using a cable tie.

**Note:** If this service action was a concurrent repair, the vital product data of the power supply will not be updated until the next time the system or partition is powered off and then powered on.

If this service action was a nonconcurrent repair, reconnect the power cable to the other power supply, secure the power cable to the cable management bracket by using a cable tie, and power on the system or systems.

**Note:** Ensure that the ac and dc power (green) LEDs are lit and that the fault (amber) LED is off.

---

## Removing and installing a PCIe cable for an EDR1 PCIe storage enclosure

Use these procedures to service a PCIe (PCI Express) cable for the EDR1 PCIe storage enclosure (EXP30 Ultra SSD I/O Drawer).

**Note:**

Depending on the model of PCIe storage enclosure that the PCIe cable connects, you might be able to replace the PCIe cable with the system powered on and partitions active.

- If you are replacing a PCIe cable that connects a 5888 PCIe storage enclosure, you must replace the PCIe cable with the system powered off.
- If you are replacing a PCIe cable that connects any other PCIe storage enclosure, you can replace the PCIe cable either with the system powered on and partitions active or with the system powered off.

## Removing and installing a PCIe cable with the power off

Use this procedure to service a PCIe (PCI Express) cable for the EDR1 PCIe storage enclosure (EXP30 Ultra SSD I/O Drawer) with the power off.

**Attention:** Failure to follow the steps sequentially for this field replaceable unit (FRU) removal or installation might result in damage to the FRU or system.

Use the following precautions whenever you handle electronic components or cables:

- Attach a wrist strap to an unpainted metal surface of your hardware to prevent electrostatic discharge (ESD) from damaging your hardware.
- If you do not have a wrist strap, before removing the product from ESD packaging and installing or replacing hardware, touch an unpainted metal surface of the system for a minimum of 5 seconds.
- Keep all electronic components in the shipping container or envelope until you are ready to install them.
- If you remove and reinstall an electronic component, temporarily place the component on an ESD pad or blanket, if available.

To remove and install a PCIe cable, complete the following steps:

1. If the system is not already powered off, power off the system but do not unplug any power cables. For information, see *Stopping a system or logical partition*.
2. To activate the identify indicator for the PCIe connector on the system enclosure to which the PCIe cable is connected, complete the following steps:
  - a. Choose one of the following options to determine the location code of the PCIe connector on the system:
    - Find the PCIe cable location code from a serviceable event or error log.

**Note:** The PCIe cable location code will look similar to *Utttt.mmm.ssssss-Px-Cy-Tz*. Where *tttt* is the feature code, *mmm* is the sequence, *ssssss* is the serial number of the PCIe storage enclosure connected by the PCIe cable, *x* is a number representing the planar position in the system enclosure to which the cable is connected, *y* is a number representing the card position in the planar, and *z* is a number representing the PCIe connector position on the card. An example of an actual PCIe cable location code is *U2C4B.001.DBJ7805-P1-C2-T1*.

- Find the PCIe cable location code from the location code of an I/O slot that connects a PCIe storage enclosure from a serviceable event or error log.

**Note:** The I/O slot location code will look similar to *Utttt.mmm.ssssss-Px-Cy-Tz-L1*. Where *tttt* is the feature code, *mmm* is the sequence, *ssssss* is the serial number of the PCIe storage enclosure connected by the PCIe cable, *x* is a number representing the planar position in the system enclosure to which the cable is connected, *y* is a number representing the card position in the planar, and *z* is a number representing the PCIe connector position on the card. An example of an actual PCIe cable location code is *U2C4B.001.DBJ7805-P1-C2-T1-L1*.

Remove the *L* label from the I/O slot location code and continue with the next step.

**Note:** The *L* label is the part of the location code consisting of the letter *L* and including the number that follows it and the dash (-) that precedes it.

- If you know which PCIe cable you want to repair but do not have the PCIe connector or I/O slot location code.

Determine the location code of the PCIe connector on the system to which the cable is connected. To identify the location code, see *Connector locations*.

- b. Activate the identify indicator for the PCIe connector location found in the step 2. For information about activating the identify indicators, see *Using identify indicators to locate hardware components*.



3. If the system has a rear cover, remove or open it.
4. Remove and install the PCIe cable:
  - a. Locate the PCIe connector on the system with the active identify indicator and disconnect the PCIe cable from this located PCIe connector.
  - b. Disconnect the other end of the PCIe cable from the PCIe storage enclosure.
  - c. Connect the replacement PCIe cable to the PCIe connector from which the faulty PCIe cable was removed in step 4a.
  - d. Connect the other end of the replacement PCIe cable to the PCIe storage enclosure from which the faulty PCIe cable was removed in step 4b.
5. If the system has a rear cover, close it.
6. Record the current date and time for use later in the procedure when checking for serviceable events.
7. Power on the system. For information, see Starting the system or logical partition.
8. Verify the PCIe hardware topology by completing the steps in Verifying the PCIe hardware topology. All PCIe hardware topology problems that are discovered in this step must be corrected before continuing with this procedure.
9. Check for and handle new serviceable events that were generated during the procedure by completing the steps in Checking for new serviceable events. Use the date and time information that you recorded in step 6 as the start time for searching for new serviceable events.

## Removing and installing a PCIe cable with the power on

Use this procedure to service a PCIe (PCI Express) cable for the EDR1 PCIe storage enclosure (EXP30 Ultra SSD I/O Drawer) with the power on.

**Attention:** Failure to follow the steps sequentially for this field replaceable unit (FRU) removal or installation might result in damage to the FRU or system.

Use the following precautions whenever you handle electronic components or cables:

- Attach a wrist strap to an unpainted metal surface of your hardware to prevent electrostatic discharge (ESD) from damaging your hardware.
- If you do not have a wrist strap, before removing the product from ESD packaging and installing or replacing hardware, touch an unpainted metal surface of the system for a minimum of 5 seconds.
- Keep all electronic components in the shipping container or envelope until you are ready to install them.
- If you remove and reinstall an electronic component, temporarily place the component on an ESD pad or blanket, if available.

### Important:

- In order to use this procedure to replace a PCIe cable, the PCIe storage enclosure connected by the cable must be a model that supports hardware maintenance with the system powered on.
- If you are replacing a PCIe cable that connects to a 5888 PCIe storage enclosure, you must follow the steps in “Removing and installing a PCIe cable with the power off” on page 20.
- If you are replacing a PCIe cable that connects to any other PCIe storage enclosure, you can replace it with the system powered on using this procedure.

To remove and install a PCIe cable, complete the following steps:

1. Record the current date and time for use later in the procedure when checking for serviceable events.
2. Determine the identifier string and link identifier for the I/O slot associated with the PCIe cable being replaced by completing the following steps:
  - a. Choose one of the following steps:

- If your system is managed by an Hardware Management Console (HMC), complete the following steps:
    - 1) From the navigation bar, expand **Systems Management**.
    - 2) Click **Servers** and select the server you are working with.
    - 3) In the Tasks area, expand **Hardware Information**.
    - 4) Click **PCIe Hardware Topology**.
  - If your system is not managed by an HMC, complete the following steps:
    - 1) Access the ASMI by using an authority level of administrator or authorized service provider. For details about using the ASMI, see *Managing the Advanced System Management Interface*.
    - 2) In the ASMI navigation area, expand **System Configuration**.
    - 3) Click **PCIe Hardware Topology**.
- b. Choose one of the following options:
- Find the PCIe cable location code from a serviceable event or error log, by completing the following steps:

**Note:** The PCIe cable location code will look similar to *Utttt.mmm.ssssss-Px-Cy-Tz*. Where *tttt* is the feature code, *mmm* is the sequence, *ssssss* is the serial number of the system enclosure connected by the PCIe cable, *x* is a number representing the planar position in the system enclosure to which the cable is connected, *y* is a number representing the card position in the planar, and *z* is a number representing the PCIe connector position on the card. An example of an actual PCIe cable location code is U2C4B.001.DBJ7805-P1-C2-T1.

- 1) Scan the PCIe Hardware Topology data for the entry with a Host Port column value that matches the PCIe cable location code.
  - 2) Record the link identifier and the I/O slot identifier string found in the entry located in the previous step. The link identifier is in the **Link ID** column, and the I/O slot identifier string in the **I/O Slots** column.
- Find the PCIe cable location code from the location code of an I/O slot that connects a PCIe storage enclosure from a serviceable event or error log.

**Note:** The I/O slot location code will look similar to *Utttt.mmm.ssssss-Px-Cy-Tz-L1*. Where *tttt* is the feature code, *mmm* is the sequence, *ssssss* is the serial number of the PCIe storage enclosure connected by the PCIe cable, *x* is a number representing the planar position in the system enclosure to which the cable is connected, *y* is a number representing the card position in the planar, and *z* is a number representing the PCIe connector position on the card. An example of an actual PCIe cable location code is U2C4B.001.DBJ7805-P1-C2-T1-L1.

- 1) Scan the PCIe Hardware Topology data for the entry with an I/O Slot column value that matches the I/O slot location code.
  - 2) Record the link identifier and the I/O slot identifier string found in the entry located in the previous step. The link identifier is in the Link ID column, and the I/O slot identifier string in the I/O Slots column.
- If you know which PCIe cable you want to repair but do not have the PCIe connector or I/O slot location code.
    - 1) Determine the location code of the PCIe connector on the system to which the cable is connected. To identify the location code, see *Connector locations*.
    - 2) Scan the PCIe Hardware Topology data for the entry with a Host Port column value that matches the location code of the PCIe connector determined in the previous step.
    - 3) Record the link identifier and the I/O slot identifier string found in the entry located in the previous step. The link identifier is in the Link ID column, and the I/O slot identifier string in the I/O Slots column.

3. Power off the I/O slot identified in the step 2 on page 21 by completing one of the follow steps:

- If the I/O slot is assigned to a logical partition that is powered on and running the Virtual I/O Server (VIOS) or AIX operating system, complete the following steps:
  - a. Log in to the operating system with admin or service level authority. If you need assistance, contact the system administrator.
  - b. Choose one of the following options:
    - If the partition is running the VIOS operating system, type `diagmenu` at the VIOS command prompt and press Enter.
    - If the partition is running the AIX® operating system, type `diag` at the AIX command prompt and press Enter.
  - c. On the DIAGNOSTIC OPERATING INSTRUCTIONS display press Enter to continue.
  - d. On the FUNCTION SELECTION display, use the arrow keys to select **Task Selection (Diagnostics, Advanced Diagnostics, Service Aids, etc.)** and press Enter.
  - e. On the TASKS SELECTION LIST display, use the arrow keys to select **Hot Plug Task** and press Enter.
  - f. On the Hot Plug Task display, use the arrow keys to select **PCI Hot Plug Manager** and press Enter.
  - g. On the PCI Hot Plug Manager display, use the arrow keys to select **List PCI Hot Plug Slots** and press Enter.
  - h. On the COMMAND STATUS display, locate the entry with the identifier string of the I/O slot in the Slot column, and record the logical device name in the **Devices** column.
  - i. Press **F3** (Exit).
 

**Note:** If your terminal emulation does not support **F3** to exit, press **ESC** then type 3 to exit.
  - j. On the PCI Hot Plug Manager display, use the arrow keys to select **Unconfigure a device**, and press Enter.
  - k. On the Unconfigure a device display, complete the following steps:
    - 1) Enter the logical device name recorded in step 3h for the **Device Name** field.
    - 2) Use the Tab key to select yes for the **Unconfigure any Child Devices** field.
    - 3) Use the Tab key to select no for the **KEEP definition in database** field.
    - 4) Press Enter.
  - l. On the ARE YOU SURE dialog, press Enter.
  - m. On the COMMAND STATUS display, wait for processing to complete and then press **F3** twice to return to the PCI Hot Plug Manager display.
  - n. On the PCI Hot Plug Manager display, use the arrow keys to select **Replace/Remove a PCI Hot Plug Adapter**, and press Enter.
  - o. On the Replace/Remove a PCI Hot Plug Adapter dialog, use the arrow keys to select the entry with the identifier string of the I/O slot in the Slot column, and press Enter.
  - p. On the Replace/Remove a PCI Hot Plug Adapter display, use the Tab key to select the **Remove** operation, and press Enter.
  - q. Follow the online instructions to complete the remove operation. However, do not complete the steps to physically remove the adapter.
- If the I/O slot is assigned to a logical partition that is powered on and running the Linux operating system, complete the following steps:
  - a. Log in to the operating system with admin or service level authority. If you need assistance, contact the system administrator.
  - b. At the Linux command prompt, type `drslot_chrp_pci -r -s io_slot_identifier` (where `io_slot_identifier` is the identifier string of the I/O slot), and press Enter.
  - c. Follow the online instructions to complete the remove operation. However, do not complete the steps to physically remove the adapter.

- If the I/O slot is not assigned to a logical partition that is powered on, continue to the next step.
4. Activate the identify indicator for the PCIe connector to which the PCIe cable is connected by completing the following steps:
    - a. Choose one of the following options:
      - If your system is managed by an HMC, complete the following steps:
        - 1) From the navigation bar, expand **Systems Management**.
        - 2) Click **Servers** and select the server you are working with.
        - 3) In the Tasks area, expand **Hardware Information**.
        - 4) Click **PCIe Hardware Topology**.
      - If your system is not managed by an HMC, complete the following steps:
        - 1) Access the ASMI by using an authority level of administrator or authorized service provider. For details about using the ASMI, see *Managing the Advanced System Management Interface*.
        - 2) In the ASMI navigation area, expand **System Configuration**.
        - 3) Click **PCIe Hardware Topology**.
    - b. Scan the PCIe Hardware Topology data for the entry with the link identifier and I/O slot identifier recorded in step 2 on page 21.
    - c. Select the PCIe link and click **Identify Indicators**.
    - d. On the Identify Indicators display, select both locations and click **Activate LED**.
  5. If the system has a rear cover, remove or open it.
  6. Remove and replace the PCIe cable by completing the following steps:
    - a. Locate the PCIe connector on the system with the active identify indicator and disconnect the PCIe cable from this located PCIe connector.
    - b. Disconnect the other end of the PCIe cable from the PCIe storage enclosure.
    - c. Connect the replacement PCIe cable to the PCIe connector from which the faulty PCIe cable was removed in step 6a.
    - d. Connect the other end of the replacement PCIe cable to the PCIe storage enclosure from which the faulty PCIe cable was removed in step 6b.
  7. If the system has a rear cover, close it.
  8. Deactivate the identify indicator that you activated in step 4 by repeating step 4 as specified, except to click **Deactivate LED**.
  9. Power on the I/O slot identified in the step 2 on page 21 by completing the follow steps:
 

Choose one of the following options:

    - If the I/O slot is assigned to a logical partition that is powered on
    - If the I/O slot is not assigned to a logical partition that is powered on

**If the I/O slot is assigned to a logical partition that is powered on**

**Note:** If your system is not managed by an HMC and is powered on to firmware running state, choose this option.

- If the I/O slot is assigned to a logical partition that is powered on and running the Virtual I/O Server (VIOS) or AIX operating system, complete the following steps:
  - a. Log in to the operating system with admin or service level authority. If you need assistance, contact the system administrator.
  - b. Choose one of the following options:
    - If the logical partition is running the VIOS operating system type diagmenu at the VIOS command prompt, and press Enter.
    - If the logical partition is running the AIX operating system type diag at the AIX command prompt, and press Enter.

- c. On the DIAGNOSTIC OPERATING INSTRUCTIONS display, press Enter to continue.
  - d. On the FUNCTION SELECTION display, use the arrow keys to select **Task Selection (Diagnostics, Advanced Diagnostics, Service Aids, etc.)**, and press Enter.
  - e. On the TASKS SELECTION LIST display, use the arrow keys to select **Hot Plug Task**, and press Enter.
  - f. On the Hot Plug Task display, use the arrow keys to select **PCI Hot Plug Manager**, and press Enter.
  - g. On the PCI Hot Plug Manager display, use the arrow keys to select **Add a PCI Hot Plug Adapter**, and press Enter.
  - h. On the Add a PCI Hot Plug Adapter dialogue, use the arrow keys to select the entry with the identifier string of the I/O slot in the Slot column, and press Enter.
  - i. Follow the instructions that display to complete the add operation. However, do not complete the steps to physically add the adapter.
  - j. Press F10 twice to return to the AIX command prompt.
  - k. For an AIX logical partition: At the command prompt type `cfgmgr -l logical_device_name`, where *logical\_device\_name* is the logical resource name of the I/O slot recorded in step 3h on page 23.  
For a VIOS logical partition: At the command prompt type `cfgdev-dev logical_device_name`, where *logical\_device\_name* is the logical resource name of the I/O slot recorded in step 3h on page 23.
- If the I/O slot is assigned to a logical partition that is powered on and running the Linux operating system, complete the following steps:
    - a. Log in to the operating system with admin or service level authority. If you need assistance, contact the system administrator.
    - b. At the Linux command prompt, type `drslot_chrp_pci -a -s io_slot_identifier` (where *io\_slot\_identifier* is the identifier string of the I/O slot), and press Enter.
    - c. Follow the online instructions to complete the add operation. However, do not complete the steps to physically add the adapter.

**If the I/O slot is not assigned to a logical partition that is powered on**

**Note:** If your system is not managed by an HMC and is powered on to firmware standby state, choose this option.

Choose one of the following options:

- If your system is managed by an HMC, complete the following steps:
  - a. From the navigation bar, expand **Systems Management**.
  - b. Click **Servers** and select the server you are working with.
  - c. In the Tasks area, expand **Hardware Information**.
  - d. Click **PCIe Hardware Topology**.
- If your system is not managed by an HMC, complete the following steps:
  - a. Access the ASMI by using an authority level of administrator or authorized service provider. For details about using the ASMI, see Managing the Advanced System Management Interface.
  - b. In the ASMI navigation area, expand **System Configuration**.
  - c. Click **PCIe Hardware Topology**.
  - d. Scan the PCIe Hardware Topology data for a value in the I/O Slots column that matches the identifier string of the I/O slot, and select the entry.
  - e. Click **Probe Link**.

**Important:** If the Probe Link function fails, verify that the I/O slot is not owned by a partition that is powered on. Then choose from the following options:

- If you determine that the I/O slot is owned by a partition that is powered on, return to step 9 on page 24 and choose the alternative option that supports an I/O slot assigned to a partition that is powered on.
  - If you are certain the I/O slot is not owned by a partition that is powered on, contact your next level of support for assistance.
10. Verify the PCIe hardware topology by completing the steps in Verifying the PCIe hardware topology. All PCIe hardware topology problems that are discovered in this step must be corrected before continuing with this procedure.
  11. Check for and handle new serviceable events that were generated during the procedure by completing the steps in Checking for new serviceable events. Use the date and time information that you recorded in step 1 on page 21 as the start time for searching for new serviceable events.

---

## Removing and installing a solid-state drive for an EDR1 PCIe storage enclosure

Use this procedure to service a solid-state drive concurrently for the EDR1 PCIe storage enclosure (EXP30 Ultra SSD I/O Drawer).

To perform a service action on a solid-state drive, see the following procedures for the machine type and model to which the PCIe storage enclosure is attached:

- Installing a disk drive or solid-state drive in the 9117-MMD and 9179-MHD.
- Removing a disk drive or solid-state drive from the 9117-MMD and 9179-MHD.
- Replacing a disk drive or solid-state drive in the 9117-MMD and 9179-MHD.

---

## Removing and installing an enclosure RAID module assembly for an EDR1 PCIe storage enclosure

Use these procedures to service an enclosure RAID module (ERM) assembly for the EDR1 PCIe storage enclosure (EXP30 Ultra SSD I/O Drawer).

### Removing and installing an enclosure RAID module assembly with the power off

Use this procedure to service an enclosure RAID module (ERM) assembly for the EDR1 PCIe storage enclosure (EXP30 Ultra SSD I/O Drawer) with the power off.

**Attention:** Failure to follow the steps sequentially for this field replaceable unit (FRU) removal or installation might result in damage to the FRU or system.

Use the following precautions whenever you handle electronic components or cables:

- Attach a wrist strap to an unpainted metal surface of your hardware to prevent electrostatic discharge (ESD) from damaging your hardware.
- If you do not have a wrist strap, before removing the product from ESD packaging and installing or replacing hardware, touch an unpainted metal surface of the system for a minimum of 5 seconds.
- Keep all electronic components in the shipping container or envelope until you are ready to install them.
- If you remove and reinstall an electronic component, temporarily place the component on an ESD pad or blanket, if available.
- To prevent loss of enclosure information, do not replace both ERM assemblies at the same time. To replace the second ERM, complete the removal and installation procedures for the first ERM assembly and then replace the second ERM assembly.

To remove and install an ERM assembly, complete the following steps:

1. Use the service indicator light-emitting diodes (LEDs) to help identify the part. See Identifying a part.
2. Power off the system that is connected to the ERM assembly to be removed. See Powering on and powering off the system.
3. Remove the ERM assembly:
  - a. Disconnect the PCIe cables and serial-attached SCSI (SAS) cables (if present) from the ERM assembly and mark each cable label with its location.  
**Attention:** Incorrect cable placement might result in data loss.
  - b. Open the release lever (A) as shown in the following figure.
  - c. Support both sides of the ERM assembly (B) while you slide it out of the enclosure.

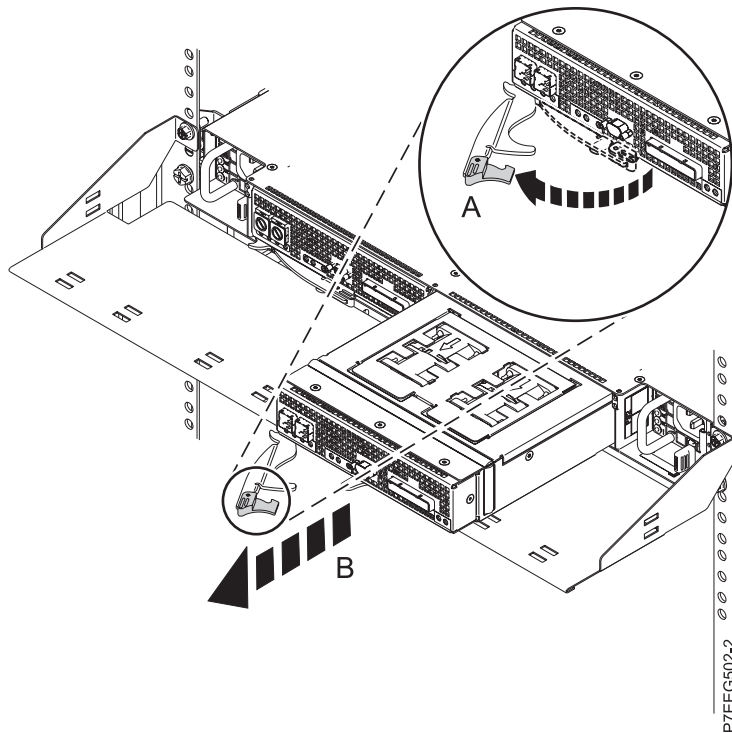

Figure 20. Removing an ERM assembly from the enclosure

4. Are you here because you are only replacing the fan assembly?

**Yes:** Return to the “Removing and installing a fan assembly for an EDR1 PCIe storage enclosure” on page 3 procedure and remove the fan assembly.

**No:** Continue to the next step.

5. Install the ERM assembly:

- a. Ensure that the release lever on the new ERM assembly is in the open position.
- b. Gently slide the ERM assembly into the enclosure until it stops.
- c. Push the release lever to the closed position.
- d. Reconnect the PCIe cables and SAS cables (if present) to the ERM assembly by using the location information marked on each cable in step 3a.

**Attention:**

- Incorrect cable placement might result in data loss.
- To prevent loss of enclosure information, do not replace both ERM assemblies at the same time. To replace the second ERM, power on the system and the partition that is connected to the ERM assembly that you replaced first. Then power off the system that is connected to the second ERM assembly.

6. Are you here because you are only replacing the fan assembly?

**Yes:** Power on the system that is connected to the ERM assembly. See Powering on and powering off the system. **This ends the procedure.**

**No:** Power on the partition that owns the ERM assembly. Then continue with “Updating the vital product data.”

## Updating the vital product data

The vital product data (VPD) must be updated after installing the ERM. To update the VPD, complete the following steps:

1. Power off the partition that owns the ERM assembly.
2. Power on the partition that owns the ERM assembly.

## Removing and installing an enclosure RAID module assembly with the power on in the AIX environment

Use this procedure to service an enclosure RAID module (ERM) assembly for the EDR1 PCIe storage enclosure (EXP30 Ultra SSD I/O Drawer) with the power on in the AIX environment.

**Attention:**

- Failure to follow the steps sequentially for this field replaceable unit (FRU) removal or installation might result in damage to the FRU or system.
- The ERM can only be replaced with the power on if the other ERM in the PCIe storage enclosure is operational. If the fault LED on the other ERM is on solid, go to “Removing and installing an enclosure RAID module assembly with the power off” on page 26.

Use the following precautions whenever you handle electronic components or cables:

- Attach a wrist strap to an unpainted metal surface of your hardware to prevent electrostatic discharge (ESD) from damaging your hardware.
- If you do not have a wrist strap, before removing the product from ESD packaging and installing or replacing hardware, touch an unpainted metal surface of the system for a minimum of 5 seconds.
- Keep all electronic components in the shipping container or envelope until you are ready to install them.
- If you remove and reinstall an electronic component, temporarily place the component on an ESD pad or blanket, if available.
- To prevent loss of enclosure information, do not replace both ERM assemblies at the same time. To replace the second ERM, complete the removing, installing, and updating the vital product data procedures for the first ERM assembly and then replace the second ERM assembly.

The following sections provide information about servicing an ERM:

- “Removing an ERM assembly” on page 29
- “Installing an ERM assembly” on page 31
- “Updating the vital product data” on page 33
- “Completing the procedure” on page 33



## Removing an ERM assembly

To remove an ERM assembly, complete the following steps:

1. Go to the AIX system diagnostics by logging in as the root user or the CE login user, and enter `diag` at the command line.
2. When the DIAGNOSTIC OPERATING INSTRUCTIONS menu is displayed, press Enter.
3. From the FUNCTION SELECTION menu, select **Task Selection**, and then press Enter.
4. Select **Display Previous Diagnostic Results**, and then press Enter
5. From the Display Previous Diagnostic Results display, select **Display Diagnostic Log Summary**. The Display Diagnostic Log display shows a chronological list of events.
6. Look in the T column for the most recent S entry for the ERM (resource name `sissasX` or `sesX`) that you are servicing. Select the row with the most recent S entry in the table, and then press Enter.
7. Select **Commit**. The details of this log entry are displayed.
8. Are you here because you are replacing only the fan assembly or is the ERM resource name `sesX` and not `sissasX`?

**Yes:** Complete the following steps:

- a. Record the `sesX` resource name and the location of the failing ERM fan.
- b. Press F3 or Esc+3 to return to the Tasks Selection list.
- c. From the Tasks Selection list, select **Hot Plug Task** and press Enter.
- d. Select **Expander Suspend and Resume Manager** and press Enter.
- e. Find the `sesX` entry with the same `Un-Px-Cy` location and record the corresponding serial number for that entry.
- f. Find the `sissasX` entry with the serial number you recorded in the previous step. Record the location, the `sissasX` resource name, and the serial number associated with this entry.
- g. Press F3 or Esc+3 to return to the Tasks Selection list. Then continue with the next step.

**No:** Complete the following steps:

- a. Record the location and the `sissasX` resource name.
- b. Is the serial number available in the details of the log entry?

**Yes:** Record the serial number. Press F3 or Esc+3 to return to the Tasks Selection list, and then continue with the next step.

**No:** Complete the following steps:

- 1) Press enter to exit the log entry display, then press F3 or Esc+3 two times to return to the Tasks Selection List.
  - 2) From the Tasks Selection list, select **Display Hardware Vital Product Data** and press Enter.
  - 3) Select the `sissasX` resource name of the failing ERM that you are replacing and press Enter.
  - 4) Press F7 (Commit) or Esc+7, and then press Enter.
  - 5) Record the serial number. Press F3 or Esc+3 to return to the Tasks Selection list, and then continue with the next step.
9. From the Tasks Selection list, select **Hot Plug Task** and press Enter.
  10. Select **PCI Hot Plug Manager** and press Enter.
  11. Select **Unconfigure a Device** and press Enter.
  12. Press F4 or Esc+4.
  13. From the **Device Names** menu, select the `sissasX` resource name of the ERM that you are removing, and then press Enter.

**Attention:** Ensure that the correct ERM is selected, and that the fault LED on the other ERM in the PCIe storage enclosure is not on solid. If the incorrect ERM is selected, complete this procedure to physically remove and install the ERM to reset the fault condition. If the correct ERM is selected, but the other ERM in the PCIe storage enclosure has a fault LED on solid, the procedure must be completed with the power off. For instructions, see “Removing and installing an enclosure RAID module assembly with the power off” on page 26.

14. In the **Unconfigure Child Devices** field, use Tab or ESC+4 to answer YES.
15. In the **Keep Definition** field, use Tab or ESC+4 to answer YES, and press Enter.  
The ARE YOU SURE display is shown.
16. Press Enter to verify the information. A successful deconfiguration is indicated by the message OK, which is shown next to the **Command** field at the top of the window.
17. Press F3 or Esc+3 three times to return to the Tasks Selection list.
18. Is the failing ERM part of a high availability (HA) configuration in which the second ERM is located in a different system or partition?

**Yes:** Work with the customer to determine the system or partition that has the second ERM. From the partition that has the second ERM, complete the following steps:

- a. Go to the AIX system diagnostics by logging in as the root user or the CE login user, and enter `diag` at the command line.
- b. When the DIAGNOSTIC OPERATING INSTRUCTIONS menu is displayed, press Enter.
- c. From the FUNCTION SELECTION menu, select **Task Selection** and press Enter.
- d. Continue with the next step.

**No:** Continue with the next step.

19. From the Tasks Selection list, select **Hot Plug Task** and press Enter.
20. Wait one minute to ensure that the configuration data has been updated. Then select **Expander Suspend and Resume Manager** and press Enter.
21. Select the ses entry with the same serial number as the ERM that you are replacing, and press Enter.  
A warning message is displayed.
22. Select YES and press Enter.
23. Ensure that the ses entry shows a status of suspended, and then continue with the next step.
24. Press F3 or Esc+3 to return to the Tasks Selection list. If the ERM is part of a high availability (HA) configuration, return to the partition that has the failing ERM and continue with the next step.
25. From the Tasks Selection list, select **Hot plug task** and press Enter.
26. Select **PCI Hot Plug Manager** and press Enter.
27. Select **replace/remove PCI Hot Plug adapter** and press Enter.
28. Select the slot with the location of the ERM to be removed from the enclosure, and press Enter.

**Attention:** Ensure that the correct ERM is selected, and that the fault LED on the other ERM in the PCIe storage enclosure is not on solid. If the incorrect ERM is selected, complete this procedure to physically remove and install the ERM to reset the fault condition. If the correct ERM is selected, but the other ERM in the PCIe storage enclosure has a fault LED on solid, the procedure must be completed with the power off. For instructions, see “Removing and installing an enclosure RAID module assembly with the power off” on page 26.

29. Select **Replace** and press Enter.

**Note:** The blue chassis identify LED located at the front of the PCIe storage enclosure turns on solid to identify the enclosure. A fast-blinking amber LED located at the rear of the ERM indicates that the slot is identified.

30. Press Enter. This action places the ERM assembly in the action state, and the ERM assembly is ready to be removed from the enclosure.
  31. Remove the ERM assembly:
- 30 EDR1 removal and replacement procedures

- a. Disconnect the PCIe cables and SAS cables (if present) from the ERM assembly, and mark each cable label with its location.

**Attention:** Incorrect cable placement might result in data loss.

- b. Open the release lever (A) as shown in the following figure.
- c. Support both sides of the ERM assembly (B) while you slide it out of the enclosure.

**Note:** To prevent loss of enclosure information, do not replace both ERM assemblies at the same time. To replace the second ERM, complete the removal and installation procedures for the first ERM assembly and then replace the second ERM assembly.

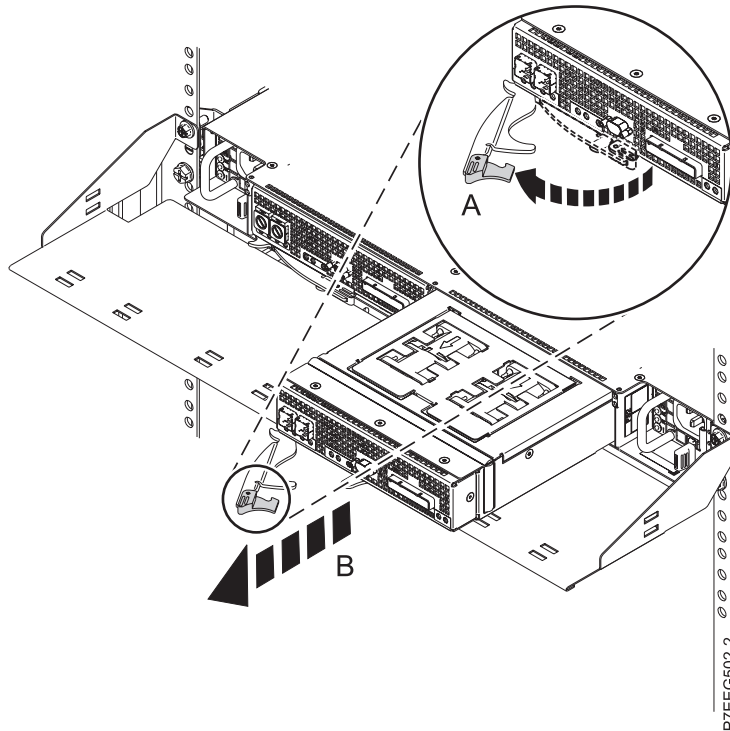

Figure 21. Removing an ERM assembly from the enclosure

32. Are you here because you are replacing only the fan assembly?

**Yes:** Return to the “Removing and installing a fan assembly for an EDR1 PCIe storage enclosure” on page 3 procedure and remove the fan assembly. Then continue with Installing an ERM assembly.

**No:** Continue with Installing an ERM assembly.

## Installing an ERM assembly

To install an ERM assembly, complete the following steps:

1. Install the ERM assembly:
  - a. Ensure that the release lever on the new ERM assembly is in the open position.
  - b. Gently slide the ERM assembly into the enclosure until it stops.
  - c. Push the release lever to the closed position.
  - d. Reconnect the PCIe cables and SAS cables (if present) to the ERM assembly by using the location information marked on each cable.

**Attention:** Incorrect cable placement might result in data loss.

- e. Wait 2 minutes, and then continue with the next step.
- 2. Press Enter, and then continue to follow the displayed instructions until you receive a message that the replacement is successful. A successful replacement is indicated by the message OK, which is shown next to the **Command** field at the top of the window.
- 3. Press F3 or Esc+3 to return to the **PCI Hot-Plug Manager** menu.
- 4. Select **Configure a Defined Device** and press Enter.
- 5. Press F4 or Esc+4.
- 6. From the **Device Names** menu, select from the list the *sissasX* resource name of the ERM that you just replaced, and press Enter.
- 7. On the Configure a Defined Device display, press Enter. When the Command status changes to OK, the device is now configured.
- 8. Press F3 or Esc+3 three times to return to the Tasks Selection list.
- 9. Is the failing ERM part of a high availability (HA) configuration in which the second ERM is located in a different system or partition?
  - Yes:** From the partition with the second ERM, continue with the next step.
  - No:** Continue with the next step.
- 10. From the Tasks Selection list, select **Hot Plug Task** and press Enter.
- 11. Wait one minute to ensure that the configuration data has been updated. Then select **Expander Suspend and Resume Manager** and press Enter.
- 12. Verify the status of the ses entry that has the same serial number as the ERM you just replaced. Is the status Active?
  - Yes:** Continue with the next step.
  - No:** Complete the following steps:
    - a. Select the ses entry that has the same serial number as the ERM you just replaced, and press Enter.
    - b. Ensure that the ses entry shows a status of active. Then continue with the next step.
- 13. Ensure that the ses entry shows a status of active, and then continue with the next step.
- 14. Are you here because you are replacing only the fan assembly?
  - Yes:** Complete the following steps:
    - a. Press F3 or Esc+3 to return to the Tasks Selection list.
    - b. From the Tasks Selection list, select **Log Repair Action**.
    - c. Select the sesX resource name of the failing ERM fan that you replaced and press Enter.
    - d. Press F7 (Commit) or Esc+7, and then press Enter.
    - e. Press F10 or Esc+0 to exit the diagnostic program.
    - f. At the command line, type `cfgmgr -l sissasX`, where *sissasX* is the resource name of the ERM contains the replaced fan. Press Enter.

**This ends the procedure.**
  - No:** Continue with the next step.
- 15. Press F3 or Esc+3 to return to the Tasks Selection list. If the ERM is part of a high availability (HA) configuration, return to the partition that has the failing ERM and continue with the next step.
- 16. From the Tasks Selection list, select **Hot Plug Task** and press Enter.
- 17. Select **PCI Hot Plug Manager** and press Enter.
- 18. Continue with Updating the vital product data.

## Updating the vital product data

The vital product data (VPD) must be updated after installing the ERM. To update the VPD, complete the following steps:

1. From the **PCI Hot-Plug Manager** menu, select **Unconfigure a Device** and press Enter.
2. Press F4 or Esc+4.
3. From the **Device Names** menu, select the *sisasX* resource name of the ERM that you are servicing and press Enter.
4. In the **Unconfigure Child Devices** field, use Tab or ESC+4 to answer YES.
5. In the **Keep Definition** field, use Tab or ESC+4 to answer YES and press Enter.  
The ARE YOU SURE message is displayed.
6. Press Enter to verify the information. A successful deconfiguration is indicated by the message OK, which is shown next to the **Command** field at the top of the window
7. Press F3 or Esc+3 twice to return to the **Hot Plug Manager** menu.
8. Select **replace/remove PCI Hot Plug adapter** and press Enter.
9. Select the slot that has the location of the ERM you replaced and press Enter.
10. Select **Replace** and press Enter.

**Note:** A fast-blinking amber LED located at the rear of the ERM indicates that the slot is identified.

11. Press Enter. This places the ERM assembly in the action state. Do not remove the ERM from the enclosure.
12. Press Enter, and then continue to follow the displayed instructions until you receive a message that the operation is successful. A successful operation is indicated by the message OK, which is shown next to the **Command** field at the top of the window.
13. Press F3 or Esc+3 to return to the **PCI Hot-Plug Manager** menu.
14. Select **Configure a Defined Device** and then press Enter.
15. Press F4 or Esc+4.
16. From the list on the **Device Names** menu, select the *sisasX* resource name of the ERM that you were working with and press Enter.
17. On the Configure a Defined Device display, press Enter. When the Command status changes to OK, the device is now configured.
18. Continue with Completing the procedure.

## Completing the procedure

Complete the following steps:

1. If you replaced the ERM, complete the following steps:
  - a. Press F3 or Esc+3 three times to return to the Tasks Selection List.
  - b. Select **Log Repair Action**.
  - c. Select the *sisasX* resource name of the ERM assembly that you replaced and press Enter.
  - d. Press F7 (Commit) or Esc+7 and press Enter.
  - e. Press F10 or Esc+0 to exit the diagnostic program.
2. At the command line, type `cfgmgr -l sisasX`, where *sisasX* is the resource name of the ERM that was replaced. Press Enter.
3. Verify the ERM assembly by using the following instructions:
  - a. Go to the AIX system diagnostics by logging in as the root user or the CE login user, and enter `diag` at the command line.
  - b. When the DIAGNOSTIC OPERATING INSTRUCTIONS menu is displayed, press Enter.

- c. From the **FUNCTION SELECTION** menu, select **Advance Diagnostic Routines**, and press Enter.
  - d. Select **Problem Determination** and press Enter.
  - e. Is the Previous Diagnostics Results window displayed?
    - Yes:** Select YES and press Enter to view errors. Ignore any errors of type xxxx-9070 or xxxx-9076. For any other errors, contact your next level of support if necessary. Press Enter to continue with the next step.
    - No:** Continue with the next step.
  - f. From the **Advanced Diagnostics Selection** menu, select the name of the resource that you replaced. If the resource that you replaced is not shown, select the resource associated with it. Press Enter, and then press Commit (F7 or Esc+7).
  - g. Did the problem determination identify any problems?
    - Yes:** Contact your next level of support. **This ends the procedure.**
    - No:** Continue with the next step.
4. Press F10 or Esc+0 to exit the diagnostic program. **This ends the procedure.**

## Removing and installing an enclosure RAID module assembly with the power on in the Linux environment

Use this procedure to service an enclosure RAID module (ERM) assembly for the EDR1 PCIe storage enclosure (EXP30 Ultra SSD I/O Drawer) with the power on in the Linux environment.

**Attention:** Failure to follow the steps sequentially for this field-replaceable unit (FRU) removal or installation might result in damage to the FRU or system.

Use the following precautions whenever you handle electronic components or cables:

- Attach a wrist strap to an unpainted metal surface of your hardware to prevent electrostatic discharge (ESD) from damaging your hardware.
- If you do not have a wrist strap, before removing the product from ESD packaging and installing or replacing hardware, touch an unpainted metal surface of the system for a minimum of 5 seconds.
- Keep all electronic components in the shipping container or envelope until you are ready to install them.
- If you remove and reinstall an electronic component, temporarily place the component on an ESD pad or blanket, if available.
- To prevent loss of enclosure information, do not replace both ERM assemblies at the same time. To replace the second ERM, complete the removal and installation procedures for the first ERM assembly and then replace the second ERM assembly.

To remove and install an ERM assembly, complete the following steps:

1. Use the service indicator light-emitting diodes (LEDs) to help identify the part. See Identifying a part.
2. To remove and install the ERM with the power on, iprutils version 2.3.12 or later is required. To update iprutils, see Updating the iprutils package.

Is iprutils version 2.3.12 or later installed?

**Yes:** Continue with the next step.

**No:** The ERM cannot be replaced with the power on. Go to “Removing and installing an enclosure RAID module assembly with the power off” on page 26. **This ends the procedure.**

3. On the Linux command line, type the `iprconfig` command.
4. From the IBM® Power RAID Configuration Utility display, select **Analyze Log**, and press Enter.
5. From the Kernel Messages Log display, select **View ipr error messages**, and press Enter.

6. View the error message that indicates an adapter in a PCIe storage enclosure must be replaced. Record the location of the adapter.
7. Exit the Kernel Messages Log display by using the appropriate command for the editor that you are using.
8. Type `e` and press Enter to exit the Kernel Messages Log display.
9. From the IBM Power RAID Configuration Utility display, select **Display hardware status**, and press Enter.
10. From the Display Hardware Status display, find the entry with the location of the adapter identified in step 5 on page 34. Does the adapter have a status of Operational?
  - Yes:** Complete the following steps:
    - a. Type 1 (Display hardware resource information details) next to the entry.
    - b. Record the serial number shown on the IOA hardware Resource Information Details display.
    - c. Type `e` to exit the display. Then continue with the next step.
  - No:** Use 00000000 as the serial number. Continue with the next step.
11. From the Display Hardware Status window, find the PCI-E SAS RAID Adapter with a machine type and model of 57C3001SISIOA and a remote adapter serial number that matches the serial number identified in step 9. Type 1 (Display hardware resource information details) next to each PCI-E SAS RAID Adapter until the matching remote adapter serial number is found. Ensure that the Machine Type and Model on the IOA Hardware Resource Information Details display is 57C3001SISIOA. Record the PCI Address of the adapter.
12. Return to the IBM Power RAID Configuration Utility display.
13. From the IBM Power RAID Configuration Utility display, select **Work with disk unit recovery**, and press Enter.
14. From the Work with Disk Unit Recovery display, select **Work with disk enclosures**, and press Enter.
15. From the Work with disk enclosures display, find the adapter entry with the PCI address identified in step 11.
16. Expander entries are located directly under adapter entries and have their PCI/Host/Resource Path information indented. Type 2 (Suspend disk enclosure path) next to the expander entry that is under the adapter entry identified in step 15, but has a different serial number than the adapter identified in step 15.
17. From the Suspend Disk Enclosure display, type `c` to continue. Then type `e` two times to exit to the command line.
18. On the Linux command line, type the `drslot_chrp_pci` command to enable an ERM assembly to be replaced.
 

For example, to replace the ERM assembly in slot UEDR1.001.DQD014E-P1-C3, enter the following command:

```
drslot_chrp_pci -R -s UEDR1.001.ssssss
```

Follow the instructions on the display to complete the task.
19. Remove the ERM assembly:
  - a. Disconnect the PCIe cables and serial-attached SCSI (SAS) cables (if present) from the ERM assembly, and mark each cable label with its location.
    - Attention:** Incorrect cable placement might result in data loss.
  - b. Open the release lever (**A**) as shown in the following figure.
  - c. Support both sides of the ERM assembly (**B**) while you slide it out of the enclosure.

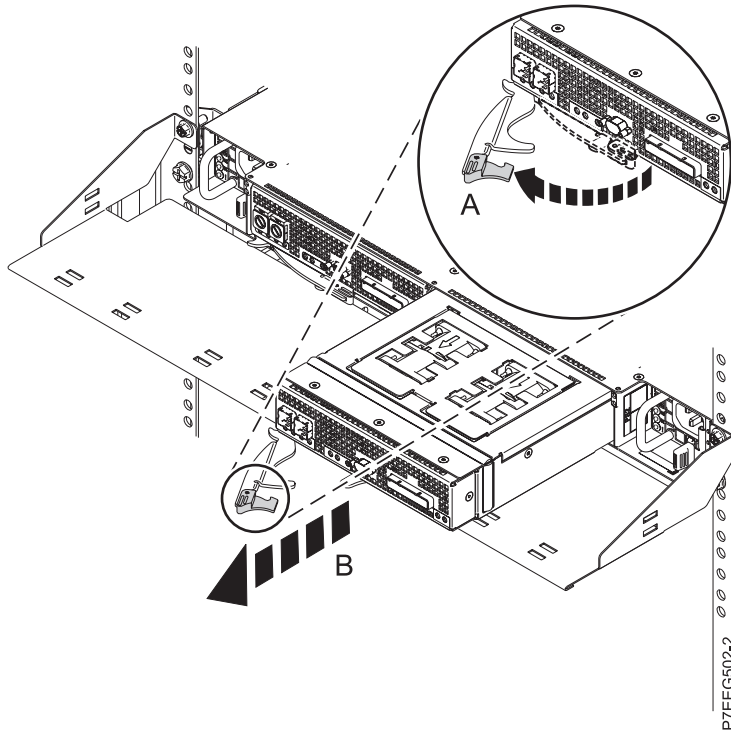

Figure 22. Removing an ERM assembly from the enclosure

20. Are you here because you are replacing only the fan assembly?

**Yes:** Return to the “Removing and installing a fan assembly for an EDR1 PCIe storage enclosure” on page 3 procedure and replace the fan assembly. Then continue with the next step.

**No:** Continue to the next step.

21. Install the ERM assembly:

- a. Ensure that the release lever on the new ERM assembly is in the open position.
- b. Gently slide the ERM assembly into the enclosure until it stops.
- c. Push the release lever to the closed position.
- d. Reconnect the PCIe cables and SAS cables (if present) to the ERM assembly by using the location information marked on each cable in step 8a.

**Attention:** Incorrect cable placement might result in data loss.

22. On the Linux command line, enter `lsslot` to verify that the slot is occupied.

For example, enter `lsslot -c pci -s UEDR1.001.ssssss`.

The following output is an example of the information displayed by this command:

```
# Slot      Description      Device(s)
U5888.001.ssssss xxxxxxxx, xxxxx, 1xxxxxx slot 0001:40:01.0
```

**Note:** To prevent loss of enclosure information, do not replace both ERM assemblies at the same time. To replace the second ERM, complete the removal and installation procedures for the first ERM assembly, and then replace the second ERM assembly.

23. On the Linux command line, type the `iprconfig` command.

24. From the IBM Power RAID Configuration Utility display, select **Work with disk unit recovery**, and press Enter.

25. From the Work with Disk Unit Recovery display, select **Work with disk enclosures**, and press Enter. Two adapters displayed. Each adapter has two expanders listed under it.



26. Type 3 (Resume disk enclosure path) next to the expander entry that you identified in step 16 on page 35.
27. From the Resume Display Enclosure display, type c to continue. Then type e to exit the IBM Power RAID Configuration Utility.
28. Are you here because you are replacing only the fan assembly?  
**Yes:** This ends the procedure.  
**No:** Continue with Updating the vital product data.

## Updating the vital product data

The vital product data (VPD) must be updated after installing the ERM.

To update the VPD, complete the following steps:

1. On the Linux command line, enter `drs1ot_chrp_pci` to enable an ERM assembly to be replaced. For example, to replace the ERM assembly in slot `UEDR1.001.DQD014E-P1-C3`, enter the following command:

```
drs1ot_chrp_pci -R -s UEDR1.001.sssssss
```

Follow the instructions on the display to complete the task.

2. Do not remove the ERM assembly. Continue with the next step.
3. From the Linux command line, enter `lsslots` to verify that the slot is occupied. For example, enter `lsslots -c pci -s UEDR1.001.sssssss`.

The following output is an example of the information displayed by this command:

```
# Slot      Description      Device(s)
U5888.001.sssssss xxxxxxxx, xxxxx, 1xxxxxx slot 0001:40:01.0
```

**This ends the procedure.**



---

## Notices

This information was developed for products and services offered in the U.S.A.

The manufacturer may not offer the products, services, or features discussed in this document in other countries. Consult the manufacturer's representative for information on the products and services currently available in your area. Any reference to the manufacturer's product, program, or service is not intended to state or imply that only that product, program, or service may be used. Any functionally equivalent product, program, or service that does not infringe any intellectual property right of the manufacturer may be used instead. However, it is the user's responsibility to evaluate and verify the operation of any product, program, or service.

The manufacturer may have patents or pending patent applications covering subject matter described in this document. The furnishing of this document does not grant you any license to these patents. You can send license inquiries, in writing, to the manufacturer.

**The following paragraph does not apply to the United Kingdom or any other country where such provisions are inconsistent with local law:** THIS PUBLICATION IS PROVIDED "AS IS" WITHOUT WARRANTY OF ANY KIND, EITHER EXPRESS OR IMPLIED, INCLUDING, BUT NOT LIMITED TO, THE IMPLIED WARRANTIES OF NON-INFRINGEMENT, MERCHANTABILITY OR FITNESS FOR A PARTICULAR PURPOSE. Some states do not allow disclaimer of express or implied warranties in certain transactions, therefore, this statement may not apply to you.

This information could include technical inaccuracies or typographical errors. Changes are periodically made to the information herein; these changes will be incorporated in new editions of the publication. The manufacturer may make improvements and/or changes in the product(s) and/or the program(s) described in this publication at any time without notice.

Any references in this information to websites not owned by the manufacturer are provided for convenience only and do not in any manner serve as an endorsement of those websites. The materials at those websites are not part of the materials for this product and use of those websites is at your own risk.

The manufacturer may use or distribute any of the information you supply in any way it believes appropriate without incurring any obligation to you.

Any performance data contained herein was determined in a controlled environment. Therefore, the results obtained in other operating environments may vary significantly. Some measurements may have been made on development-level systems and there is no guarantee that these measurements will be the same on generally available systems. Furthermore, some measurements may have been estimated through extrapolation. Actual results may vary. Users of this document should verify the applicable data for their specific environment.

Information concerning products not produced by this manufacturer was obtained from the suppliers of those products, their published announcements or other publicly available sources. This manufacturer has not tested those products and cannot confirm the accuracy of performance, compatibility or any other claims related to products not produced by this manufacturer. Questions on the capabilities of products not produced by this manufacturer should be addressed to the suppliers of those products.

All statements regarding the manufacturer's future direction or intent are subject to change or withdrawal without notice, and represent goals and objectives only.

The manufacturer's prices shown are the manufacturer's suggested retail prices, are current and are subject to change without notice. Dealer prices may vary.

This information is for planning purposes only. The information herein is subject to change before the products described become available.

This information contains examples of data and reports used in daily business operations. To illustrate them as completely as possible, the examples include the names of individuals, companies, brands, and products. All of these names are fictitious and any similarity to the names and addresses used by an actual business enterprise is entirely coincidental.

If you are viewing this information in softcopy, the photographs and color illustrations may not appear.

The drawings and specifications contained herein shall not be reproduced in whole or in part without the written permission of the manufacturer.

The manufacturer has prepared this information for use with the specific machines indicated. The manufacturer makes no representations that it is suitable for any other purpose.

The manufacturer's computer systems contain mechanisms designed to reduce the possibility of undetected data corruption or loss. This risk, however, cannot be eliminated. Users who experience unplanned outages, system failures, power fluctuations or outages, or component failures must verify the accuracy of operations performed and data saved or transmitted by the system at or near the time of the outage or failure. In addition, users must establish procedures to ensure that there is independent data verification before relying on such data in sensitive or critical operations. Users should periodically check the manufacturer's support websites for updated information and fixes applicable to the system and related software.

## Homologation statement

This product may not be certified in your country for connection by any means whatsoever to interfaces of public telecommunications networks. Further certification may be required by law prior to making any such connection. Contact an IBM representative or reseller for any questions.

---

## Trademarks

IBM, the IBM logo, and [ibm.com](http://ibm.com) are trademarks or registered trademarks of International Business Machines Corp., registered in many jurisdictions worldwide. Other product and service names might be trademarks of IBM or other companies. A current list of IBM trademarks is available on the web at Copyright and trademark information at [www.ibm.com/legal/copytrade.shtml](http://www.ibm.com/legal/copytrade.shtml).

Linux is a registered trademark of Linus Torvalds in the United States, other countries, or both.

---

## Electronic emission notices

When attaching a monitor to the equipment, you must use the designated monitor cable and any interference suppression devices supplied with the monitor.

## Class A Notices

The following Class A statements apply to the servers.

## Federal Communications Commission (FCC) statement

**Note:** This equipment has been tested and found to comply with the limits for a Class A digital device, pursuant to Part 15 of the FCC Rules. These limits are designed to provide reasonable protection against harmful interference when the equipment is operated in a commercial environment. This equipment generates, uses, and can radiate radio frequency energy and, if not installed and used in accordance with the instruction manual, may cause harmful interference to radio communications. Operation of this

equipment in a residential area is likely to cause harmful interference, in which case the user will be required to correct the interference at his own expense.

Properly shielded and grounded cables and connectors must be used in order to meet FCC emission limits. IBM is not responsible for any radio or television interference caused by using other than recommended cables and connectors or by unauthorized changes or modifications to this equipment. Unauthorized changes or modifications could void the user's authority to operate the equipment.

This device complies with Part 15 of the FCC rules. Operation is subject to the following two conditions: (1) this device may not cause harmful interference, and (2) this device must accept any interference received, including interference that may cause undesired operation.

### **Industry Canada Compliance Statement**

This Class A digital apparatus complies with Canadian ICES-003.

### **Avis de conformité à la réglementation d'Industrie Canada**

Cet appareil numérique de la classe A est conforme à la norme NMB-003 du Canada.

### **European Community Compliance Statement**

This product is in conformity with the protection requirements of EU Council Directive 2004/108/EC on the approximation of the laws of the Member States relating to electromagnetic compatibility. IBM cannot accept responsibility for any failure to satisfy the protection requirements resulting from a non-recommended modification of the product, including the fitting of non-IBM option cards.

This product has been tested and found to comply with the limits for Class A Information Technology Equipment according to European Standard EN 55022. The limits for Class A equipment were derived for commercial and industrial environments to provide reasonable protection against interference with licensed communication equipment.

European Community contact:  
IBM Deutschland GmbH  
Technical Regulations, Department M372  
IBM-Allee 1, 71139 Ehningen, Germany  
Tele: +49 7032 15 2941  
email: lugi@de.ibm.com

**Warning:** This is a Class A product. In a domestic environment, this product may cause radio interference, in which case the user may be required to take adequate measures.

### **VCCI Statement - Japan**

この装置は、クラスA 情報技術装置です。この装置を家庭環境で使用すると電波妨害を引き起こすことがあります。この場合には使用者が適切な対策を講ずるよう要求されることがあります。 VCCI-A

The following is a summary of the VCCI Japanese statement in the box above:

This is a Class A product based on the standard of the VCCI Council. If this equipment is used in a domestic environment, radio interference may occur, in which case, the user may be required to take corrective actions.

**Japanese Electronics and Information Technology Industries Association (JEITA)  
Confirmed Harmonics Guideline (products less than or equal to 20 A per phase)**

高調波ガイドライン適合品

**Japanese Electronics and Information Technology Industries Association (JEITA)  
Confirmed Harmonics Guideline with Modifications (products greater than 20 A per phase)**

高調波ガイドライン準用品

**Electromagnetic Interference (EMI) Statement - People's Republic of China**

**声 明**

此为 A 级产品,在生活环境中,  
该产品可能会造成无线电干扰。  
在这种情况下,可能需要用户对其  
干扰采取切实可行的措施。

Declaration: This is a Class A product. In a domestic environment this product may cause radio interference in which case the user may need to perform practical action.

**Electromagnetic Interference (EMI) Statement - Taiwan**

**警告使用者：**

這是甲類的資訊產品，在  
居住的環境中使用時，可  
能會造成射頻干擾，在這  
種情況下，使用者會被要  
求採取某些適當的對策。

The following is a summary of the EMI Taiwan statement above.

Warning: This is a Class A product. In a domestic environment this product may cause radio interference in which case the user will be required to take adequate measures.

## Electromagnetic Interference (EMI) Statement - Korea

이 기기는 업무용(A급)으로 전자파적합기기로서 판매자 또는 사용자는 이 점을 주의하시기 바라며, 가정외의 지역에서 사용하는 것을 목적으로 합니다.

## Germany Compliance Statement

### Deutschsprachiger EU Hinweis: Hinweis für Geräte der Klasse A EU-Richtlinie zur Elektromagnetischen Verträglichkeit

Dieses Produkt entspricht den Schutzanforderungen der EU-Richtlinie 2004/108/EG zur Angleichung der Rechtsvorschriften über die elektromagnetische Verträglichkeit in den EU-Mitgliedsstaaten und hält die Grenzwerte der EN 55022 Klasse A ein.

Um dieses sicherzustellen, sind die Geräte wie in den Handbüchern beschrieben zu installieren und zu betreiben. Des Weiteren dürfen auch nur von der IBM empfohlene Kabel angeschlossen werden. IBM übernimmt keine Verantwortung für die Einhaltung der Schutzanforderungen, wenn das Produkt ohne Zustimmung von IBM verändert bzw. wenn Erweiterungskomponenten von Fremdherstellern ohne Empfehlung von IBM gesteckt/eingebaut werden.

EN 55022 Klasse A Geräte müssen mit folgendem Warnhinweis versehen werden:

"Warnung: Dieses ist eine Einrichtung der Klasse A. Diese Einrichtung kann im Wohnbereich Funk-Störungen verursachen; in diesem Fall kann vom Betreiber verlangt werden, angemessene Maßnahmen zu ergreifen und dafür aufzukommen."

### Deutschland: Einhaltung des Gesetzes über die elektromagnetische Verträglichkeit von Geräten

Dieses Produkt entspricht dem "Gesetz über die elektromagnetische Verträglichkeit von Geräten (EMVG)". Dies ist die Umsetzung der EU-Richtlinie 2004/108/EG in der Bundesrepublik Deutschland.

### Zulassungsbescheinigung laut dem Deutschen Gesetz über die elektromagnetische Verträglichkeit von Geräten (EMVG) (bzw. der EMC EG Richtlinie 2004/108/EG) für Geräte der Klasse A

Dieses Gerät ist berechtigt, in Übereinstimmung mit dem Deutschen EMVG das EG-Konformitätszeichen - CE - zu führen.

Verantwortlich für die Einhaltung der EMV Vorschriften ist der Hersteller:

International Business Machines Corp.

New Orchard Road

Armonk, New York 10504

Tel: 914-499-1900

Der verantwortliche Ansprechpartner des Herstellers in der EU ist:

IBM Deutschland GmbH

Technical Regulations, Abteilung M372

IBM-Allee 1, 71139 Ehningen, Germany

Tel: +49 7032 15 2941

email: lugi@de.ibm.com

Generelle Informationen:

Das Gerät erfüllt die Schutzanforderungen nach EN 55024 und EN 55022 Klasse A.

## **Electromagnetic Interference (EMI) Statement - Russia**

**ВНИМАНИЕ!** Настоящее изделие относится к классу А.  
В жилых помещениях оно может создавать радиопомехи, для снижения которых необходимы дополнительные меры

## **Class B Notices**

The following Class B statements apply to features designated as electromagnetic compatibility (EMC) Class B in the feature installation information.

### **Federal Communications Commission (FCC) statement**

This equipment has been tested and found to comply with the limits for a Class B digital device, pursuant to Part 15 of the FCC Rules. These limits are designed to provide reasonable protection against harmful interference in a residential installation.

This equipment generates, uses, and can radiate radio frequency energy and, if not installed and used in accordance with the instructions, may cause harmful interference to radio communications. However, there is no guarantee that interference will not occur in a particular installation.

If this equipment does cause harmful interference to radio or television reception, which can be determined by turning the equipment off and on, the user is encouraged to try to correct the interference by one or more of the following measures:

- Reorient or relocate the receiving antenna.
- Increase the separation between the equipment and receiver.
- Connect the equipment into an outlet on a circuit different from that to which the receiver is connected.
- Consult an IBM-authorized dealer or service representative for help.

Properly shielded and grounded cables and connectors must be used in order to meet FCC emission limits. Proper cables and connectors are available from IBM-authorized dealers. IBM is not responsible for any radio or television interference caused by unauthorized changes or modifications to this equipment. Unauthorized changes or modifications could void the user's authority to operate this equipment.

This device complies with Part 15 of the FCC rules. Operation is subject to the following two conditions: (1) this device may not cause harmful interference, and (2) this device must accept any interference received, including interference that may cause undesired operation.

## **Industry Canada Compliance Statement**

This Class B digital apparatus complies with Canadian ICES-003.

## **Avis de conformité à la réglementation d'Industrie Canada**

Cet appareil numérique de la classe B est conforme à la norme NMB-003 du Canada.



## European Community Compliance Statement

This product is in conformity with the protection requirements of EU Council Directive 2004/108/EC on the approximation of the laws of the Member States relating to electromagnetic compatibility. IBM cannot accept responsibility for any failure to satisfy the protection requirements resulting from a non-recommended modification of the product, including the fitting of non-IBM option cards.

This product has been tested and found to comply with the limits for Class B Information Technology Equipment according to European Standard EN 55022. The limits for Class B equipment were derived for typical residential environments to provide reasonable protection against interference with licensed communication equipment.

European Community contact:  
IBM Deutschland GmbH  
Technical Regulations, Department M372  
IBM-Allee 1, 71139 Ehningen, Germany  
Tele: +49 7032 15 2941  
email: lugi@de.ibm.com

## VCCI Statement - Japan

この装置は、クラスB情報技術装置です。この装置は、家庭環境で使用することを目的としていますが、この装置がラジオやテレビジョン受信機に近接して使用されると、受信障害を引き起こすことがあります。

取扱説明書に従って正しい取り扱いをして下さい。 VCCI-B

## Japanese Electronics and Information Technology Industries Association (JEITA) Confirmed Harmonics Guideline (products less than or equal to 20 A per phase)

高調波ガイドライン適合品

## Japanese Electronics and Information Technology Industries Association (JEITA) Confirmed Harmonics Guideline with Modifications (products greater than 20 A per phase)

高調波ガイドライン準用品

## Electromagnetic Interference (EMI) Statement - Korea

이 기기는 가정용(B급)으로 전자파적합기기로서 주로 가정에서 사용하는 것을 목적으로 하며, 모든 지역에서 사용할 수 있습니다.

## Germany Compliance Statement

### Deutschsprachiger EU Hinweis: Hinweis für Geräte der Klasse B EU-Richtlinie zur Elektromagnetischen Verträglichkeit

Dieses Produkt entspricht den Schutzanforderungen der EU-Richtlinie 2004/108/EG zur Angleichung der Rechtsvorschriften über die elektromagnetische Verträglichkeit in den EU-Mitgliedsstaaten und hält die Grenzwerte der EN 55022 Klasse B ein.

Um dieses sicherzustellen, sind die Geräte wie in den Handbüchern beschrieben zu installieren und zu betreiben. Des Weiteren dürfen auch nur von der IBM empfohlene Kabel angeschlossen werden. IBM übernimmt keine Verantwortung für die Einhaltung der Schutzanforderungen, wenn das Produkt ohne Zustimmung von IBM verändert bzw. wenn Erweiterungskomponenten von Fremdherstellern ohne Empfehlung von IBM gesteckt/eingebaut werden.

### Deutschland: Einhaltung des Gesetzes über die elektromagnetische Verträglichkeit von Geräten

Dieses Produkt entspricht dem "Gesetz über die elektromagnetische Verträglichkeit von Geräten (EMVG)". Dies ist die Umsetzung der EU-Richtlinie 2004/108/EG in der Bundesrepublik Deutschland.

### Zulassungsbescheinigung laut dem Deutschen Gesetz über die elektromagnetische Verträglichkeit von Geräten (EMVG) (bzw. der EMC EG Richtlinie 2004/108/EG) für Geräte der Klasse B

Dieses Gerät ist berechtigt, in Übereinstimmung mit dem Deutschen EMVG das EG-Konformitätszeichen - CE - zu führen.

Verantwortlich für die Einhaltung der EMV Vorschriften ist der Hersteller:  
International Business Machines Corp.  
New Orchard Road  
Armonk, New York 10504  
Tel: 914-499-1900

Der verantwortliche Ansprechpartner des Herstellers in der EU ist:  
IBM Deutschland GmbH  
Technical Regulations, Abteilung M372  
IBM-Allee 1, 71139 Ehningen, Germany  
Tel: +49 7032 15 2941  
email: [lugi@de.ibm.com](mailto:lugi@de.ibm.com)

Generelle Informationen:

**Das Gerät erfüllt die Schutzanforderungen nach EN 55024 und EN 55022 Klasse B.**

---

## Terms and conditions

Permissions for the use of these publications are granted subject to the following terms and conditions.

**Applicability:** These terms and conditions are in addition to any terms of use for the the manufacturer website.

**Personal Use:** You may reproduce these publications for your personal, noncommercial use provided that all proprietary notices are preserved. You may not distribute, display or make derivative works of these publications, or any portion thereof, without the express consent of the manufacturer.

**Commercial Use:** You may reproduce, distribute and display these publications solely within your enterprise provided that all proprietary notices are preserved. You may not make derivative works of

these publications, or reproduce, distribute or display these publications or any portion thereof outside your enterprise, without the express consent of the manufacturer.

**Rights:** Except as expressly granted in this permission, no other permissions, licenses or rights are granted, either express or implied, to the Publications or any information, data, software or other intellectual property contained therein.

The manufacturer reserves the right to withdraw the permissions granted herein whenever, in its discretion, the use of the publications is detrimental to its interest or, as determined by the manufacturer, the above instructions are not being properly followed.

You may not download, export or re-export this information except in full compliance with all applicable laws and regulations, including all United States export laws and regulations.

THE MANUFACTURER MAKES NO GUARANTEE ABOUT THE CONTENT OF THESE PUBLICATIONS. THE PUBLICATIONS ARE PROVIDED "AS-IS" AND WITHOUT WARRANTY OF ANY KIND, EITHER EXPRESSED OR IMPLIED, INCLUDING BUT NOT LIMITED TO IMPLIED WARRANTIES OF MERCHANTABILITY, NON-INFRINGEMENT, AND FITNESS FOR A PARTICULAR PURPOSE.





Printed in USA