

Site and hardware planning for the H9-700

ESCALA Power7



REFERENCE
86 A1 19FK 01

Site and hardware planning for the H9-700

The ESCALA Power7 publications concern the following models:

- Bull Escala E1-700 (Power 710 / 8231-E2B)
- Bull Escala E1-705 (Power 710 / 8231-E1C)
- Bull Escala E2-700 / E2-700T (Power 720 / 8202-E4B)
- Bull Escala E2-705 / E2-705T (Power 720 / 8202-E4C)
- Bull Escala E3-700 (Power 730 / 8231-E2B)
- Bull Escala E3-705 (Power 730 / 8231-E2C)
- Bull Escala E4-700 / E4-700T (Power 740 / 8205-E6B)
- Bull Escala E4-705 (Power 740 / 8205-E6C)
- Bull Escala E5-700 (Power 750 / 8233-E8B)
- Bull Escala M6-700 (Power 770 / 9117-MMB)
- Bull Escala M6-705 (Power 770 / 9117-MMC)
- Bull Escala M6-715 (Power 770 / 9117-MMD)
- Bull Escala M7-700 (Power 780 / 9179-MHB)
- Bull Escala M7-705 (Power 780 / 9179-MHC)
- Bull Escala M7-715 (Power 780 / 9179-MHD)

References to Power 755 / 8236-E8C models are irrelevant.

Hardware

November 2012

BULL CEDOC
357 AVENUE PATTON
B.P.20845
49008 ANGERS CEDEX 01
FRANCE

REFERENCE
86 A1 19FK 01

The following copyright notice protects this book under Copyright laws which prohibit such actions as, but not limited to, copying, distributing, modifying, and making derivative works.

Copyright © Bull SAS 2012

Printed in France

Trademarks and Acknowledgements

We acknowledge the rights of the proprietors of the trademarks mentioned in this manual.

All brand names and software and hardware product names are subject to trademark and/or patent protection.

Quoting of brand and product names is for information purposes only and does not represent trademark misuse.

The information in this document is subject to change without notice. Bull will not be liable for errors contained herein, or for incidental or consequential damages in connection with the use of this material.

Contents

Safety notices	vii
Site and hardware physical planning overview	1
Planning activities	3
Planning task checklist	3
General considerations	3
Site preparation and physical planning guidelines	4
Hardware specification sheets	7
Server specifications	7
Model 19F/HB server specifications	7
Plan views	10
Service clearances	14
Doors and covers	18
Raised-floor requirements and preparation	19
Weight distribution	19
Cutting and placing floor panels	22
Configuring power cords	27
Installing the frame tie-down kit	28
Considerations for multiple-system installations	36
Total system power consumption (New installation)	39
Total system power consumption (POWER6 upgrade)	44
Power cord features	49
Electrical requirements (New installation)	50
Electrical requirements (POWER6 upgrade)	51
BPR/BPD configuration and phase imbalance (New installation)	53
BPR/BPD configuration and phase imbalance (POWER6 upgrade)	54
Balancing power panel loads	55
Dual power installation	57
Unit emergency power off	57
Computer room emergency power off	58
Moving the system to the installation site	59
Cooling requirements (New installation)	61
Cooling requirements graph	62
Requirements for the chilled airflow area	63
Cooling requirements (POWER6 upgrade)	64
Cooling requirements graph	66
Requirements for the chilled airflow area	67
Expansion unit and migration tower specifications	68
expansion unit	68
expansion unit	70
58/02 expansion unit	71
5877 expansion unit	72
58/86 expansion unit	73
58/87 expansion unit	74
58/88 expansion unit	75
EDR1 expansion unit	76
Planning for 6954 and 6953 racks	77
Plan views	82
Service clearances	86
Doors and covers	92
Installing the frame tie-down kit	93
Securing the rack	93
Positioning the rack	93

Attaching the rack to a 9 - 13 in. or 12 - 22 in. floor	93
Considerations for multiple-system installations	101
Total system power consumption	103
Electrical requirements	103
Balancing power panel loads	105
BPR/BPD configuration	107
Cutting and placing floor panels	108
Weight distribution	121
Cooling requirements	124
Cooling requirements graph	125
Requirements for the chilled airflow area	126
Rack specifications	127
0551 rack	127
, and 7014 rack configurations	129
Model 14S/11 rack	136
Model 14S/25 rack	138
Planning for the 14T/00 and 14T/42 racks	142
Model 14T/00 rack	142
Model 14T/42, 7014-B42, and 0553 rack	144
14T/00, 14T/42, and 0553 service clearances and caster location	146
14T/00, 14T/00, and 0553 racks multiple attachment	147
14T/00, 14T/42, and 0553 rack weight distribution and floor loading	148
Planning for the 7953-94X rack	149
Model 7953-94X rack	149
Cabling the 7953-94X rack	150
Side stabilizing outriggers	152
Multiple racks	153
Hardware management console specifications	154
42C/07 desktop Hardware Management Console specifications	154
7042-C08 Hardware Management Console specifications	155
7042-CR7 Hardware Management Console specifications	156
Systems Director Management Console specifications	157
7042-CR6 rack-mounted Systems Director Management Console specifications	157
7042-CR7 rack-mounted Systems Director Management Console specifications	158
Rack switch specifications	159
G8052R RackSwitch specification sheet	159
G8124ER RackSwitch specification sheet	160
G8264R RackSwitch specification sheet	161
G8316R RackSwitch specification sheet	161
Rack installation procedures for racks	162
Planning for power	169
Determining your power requirements	169
Server Information Form 3A	170
Workstation Information Form 3B	170
Plugs and receptacles	171
Connecting your server to a country specific receptacle	171
Supported feature cords	171
Internationally available	174
Cord feature code 6489	174
Cord feature code 6491	175
Cord feature code 6653	176
Cord feature code 6656	176
Anguilla	177
Cord feature code 6460	177
Antigua and Barbuda	178
Cord feature code 6469	178
Australia	179
Cord feature code 6657	179
Brazil	180
Cord feature code 6471	181

Bulgaria	181
Cord feature code 6472	181
Canada	182
Cord feature code 6492	183
Cord feature code 6497	183
Cord feature code 6654	184
Cord feature code 6655	185
Chile	186
Cord feature code 6478	186
Cord feature code 6672	187
China	188
Cord feature code 6493	188
Denmark	189
Cord feature code 6473	189
Dominica	190
Cord feature code 6474	191
Italy	192
Cord feature code 6672	192
Israel	192
Cord feature code 6475	192
Japan	193
Cord feature code 6487	193
Cord feature code 6660	194
Liechtenstein	195
Cord feature code 6476	195
Macao	196
Cord feature code 6477	196
Paraguay	197
Cord feature code 6488	197
India	199
Cord feature code 6494	199
Kiribati	199
Cord feature code 6680	199
Korea	200
Cord feature code 6496	200
Cord feature code 6658	201
New Zealand	202
Cord feature code 6657	202
Taiwan	203
Cord feature code 6651	203
Cord feature code 6659	204
United States, Territories, and Possessions	205
Cord feature code 6492	205
Cord feature code 6497	206
Cord feature code 6654	207
Cord feature code RPQ 8A1871	208
Connecting your server to a PDU	209
Cord feature code 6458	209
Cord feature code 6459	210
Cord feature code 6577	211
Cord feature code 6665	211
Cord feature code 6671	212
Cord feature code 6672	212
Uninterruptible power supply	213
Power distribution unit and power cord options for 7014,, rack.	217
Power load calculating for 7188 or 9188 power distribution units	223
Planning for cables	227
Cable management	227
Power cord routing and retention	228
Serial-attached SCSI cable planning	229

SAS cabling for the 5887 drawer	251
Rack installation procedures for racks	267
Notices	273
Trademarks	274
Electronic emission notices	274
Class A Notices.	274
Class B Notices.	278
Terms and conditions.	280

Safety notices

Safety notices may be printed throughout this guide.

- **DANGER** notices call attention to a situation that is potentially lethal or extremely hazardous to people.
- **CAUTION** notices call attention to a situation that is potentially hazardous to people because of some existing condition.
- **Attention** notices call attention to the possibility of damage to a program, device, system, or data.

World Trade safety information

Several countries require the safety information contained in product publications to be presented in their national languages. If this requirement applies to your country, a safety information booklet is included in the publications package shipped with the product. The booklet contains the safety information in your national language with references to the U.S. English source. Before using a U.S. English publication to install, operate, or service this product, you must first become familiar with the related safety information in the booklet. You should also refer to the booklet any time you do not clearly understand any safety information in the U.S. English publications.

Laser safety information

The servers can use I/O cards or features that are fiber-optic based and that utilize lasers or LEDs.

Laser compliance

The servers may be installed inside or outside of an IT equipment rack.

DANGER

When working on or around the system, observe the following precautions:

Electrical voltage and current from power, telephone, and communication cables are hazardous. To avoid a shock hazard:

- Connect power to this unit only with the provided power cord. Do not use the provided power cord for any other product.
- Do not open or service any power supply assembly.
- Do not connect or disconnect any cables or perform installation, maintenance, or reconfiguration of this product during an electrical storm.
- The product might be equipped with multiple power cords. To remove all hazardous voltages, disconnect all power cords.
- Connect all power cords to a properly wired and grounded electrical outlet. Ensure that the outlet supplies proper voltage and phase rotation according to the system rating plate.
- Connect any equipment that will be attached to this product to properly wired outlets.
- When possible, use one hand only to connect or disconnect signal cables.
- Never turn on any equipment when there is evidence of fire, water, or structural damage.
- Disconnect the attached power cords, telecommunications systems, networks, and modems before you open the device covers, unless instructed otherwise in the installation and configuration procedures.
- Connect and disconnect cables as described in the following procedures when installing, moving, or opening covers on this product or attached devices.

To Disconnect:

1. Turn off everything (unless instructed otherwise).
2. Remove the power cords from the outlets.
3. Remove the signal cables from the connectors.
4. Remove all cables from the devices.

To Connect:

1. Turn off everything (unless instructed otherwise).
2. Attach all cables to the devices.
3. Attach the signal cables to the connectors.
4. Attach the power cords to the outlets.
5. Turn on the devices.

(D005a)

DANGER

Observe the following precautions when working on or around your IT rack system:

- Heavy equipment—personal injury or equipment damage might result if mishandled.
- Always lower the leveling pads on the rack cabinet.
- Always install stabilizer brackets on the rack cabinet.
- To avoid hazardous conditions due to uneven mechanical loading, always install the heaviest devices in the bottom of the rack cabinet. Always install servers and optional devices starting from the bottom of the rack cabinet.
- Rack-mounted devices are not to be used as shelves or work spaces. Do not place objects on top of rack-mounted devices.



- Each rack cabinet might have more than one power cord. Be sure to disconnect all power cords in the rack cabinet when directed to disconnect power during servicing.
- Connect all devices installed in a rack cabinet to power devices installed in the same rack cabinet. Do not plug a power cord from a device installed in one rack cabinet into a power device installed in a different rack cabinet.
- An electrical outlet that is not correctly wired could place hazardous voltage on the metal parts of the system or the devices that attach to the system. It is the responsibility of the customer to ensure that the outlet is correctly wired and grounded to prevent an electrical shock.

CAUTION

- Do not install a unit in a rack where the internal rack ambient temperatures will exceed the manufacturer's recommended ambient temperature for all your rack-mounted devices.
- Do not install a unit in a rack where the air flow is compromised. Ensure that air flow is not blocked or reduced on any side, front, or back of a unit used for air flow through the unit.
- Consideration should be given to the connection of the equipment to the supply circuit so that overloading of the circuits does not compromise the supply wiring or overcurrent protection. To provide the correct power connection to a rack, refer to the rating labels located on the equipment in the rack to determine the total power requirement of the supply circuit.
- *(For sliding drawers.)* Do not pull out or install any drawer or feature if the rack stabilizer brackets are not attached to the rack. Do not pull out more than one drawer at a time. The rack might become unstable if you pull out more than one drawer at a time.
- *(For fixed drawers.)* This drawer is a fixed drawer and must not be moved for servicing unless specified by the manufacturer. Attempting to move the drawer partially or completely out of the rack might cause the rack to become unstable or cause the drawer to fall out of the rack.

(R001)

CAUTION:

Removing components from the upper positions in the rack cabinet improves rack stability during relocation. Follow these general guidelines whenever you relocate a populated rack cabinet within a room or building:

- Reduce the weight of the rack cabinet by removing equipment starting at the top of the rack cabinet. When possible, restore the rack cabinet to the configuration of the rack cabinet as you received it. If this configuration is not known, you must observe the following precautions:
 - Remove all devices in the 32U position and above.
 - Ensure that the heaviest devices are installed in the bottom of the rack cabinet.
 - Ensure that there are no empty U-levels between devices installed in the rack cabinet below the 32U level.
- If the rack cabinet you are relocating is part of a suite of rack cabinets, detach the rack cabinet from the suite.
- Inspect the route that you plan to take to eliminate potential hazards.
- Verify that the route that you choose can support the weight of the loaded rack cabinet. Refer to the documentation that comes with your rack cabinet for the weight of a loaded rack cabinet.
- Verify that all door openings are at least 760 x 230 mm (30 x 80 in.).
- Ensure that all devices, shelves, drawers, doors, and cables are secure.
- Ensure that the four leveling pads are raised to their highest position.
- Ensure that there is no stabilizer bracket installed on the rack cabinet during movement.
- Do not use a ramp inclined at more than 10 degrees.
- When the rack cabinet is in the new location, complete the following steps:
 - Lower the four leveling pads.
 - Install stabilizer brackets on the rack cabinet.
 - If you removed any devices from the rack cabinet, repopulate the rack cabinet from the lowest position to the highest position.
- If a long-distance relocation is required, restore the rack cabinet to the configuration of the rack cabinet as you received it. Pack the rack cabinet in the original packaging material, or equivalent. Also lower the leveling pads to raise the casters off of the pallet and bolt the rack cabinet to the pallet.

(R002)

(L001)



(L002)

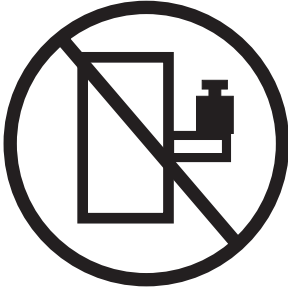

(L003)

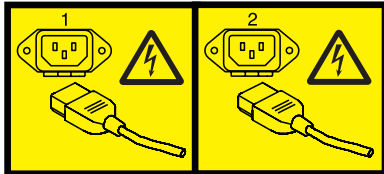

or



All lasers are certified in the U.S. to conform to the requirements of DHHS 21 CFR Subchapter J for class 1 laser products. Outside the U.S., they are certified to be in compliance with IEC 60825 as a class 1 laser product. Consult the label on each part for laser certification numbers and approval information.

CAUTION:

This product might contain one or more of the following devices: CD-ROM drive, DVD-ROM drive, DVD-RAM drive, or laser module, which are Class 1 laser products. Note the following information:

- Do not remove the covers. Removing the covers of the laser product could result in exposure to hazardous laser radiation. There are no serviceable parts inside the device.
- Use of the controls or adjustments or performance of procedures other than those specified herein might result in hazardous radiation exposure.

(C026)

CAUTION:

Data processing environments can contain equipment transmitting on system links with laser modules that operate at greater than Class 1 power levels. For this reason, never look into the end of an optical fiber cable or open receptacle. (C027)

CAUTION:

This product contains a Class 1M laser. Do not view directly with optical instruments. (C028)

CAUTION:

Some laser products contain an embedded Class 3A or Class 3B laser diode. Note the following information: laser radiation when open. Do not stare into the beam, do not view directly with optical instruments, and avoid direct exposure to the beam. (C030)

CAUTION:

The battery contains lithium. To avoid possible explosion, do not burn or charge the battery.

Do Not:

- ___ Throw or immerse into water
- ___ Heat to more than 100°C (212°F)
- ___ Repair or disassemble

Exchange only with the approved part. Recycle or discard the battery as instructed by local regulations. (C003a)

Power and cabling information for NEBS (Network Equipment-Building System) GR-1089-CORE

The following comments apply to the servers that have been designated as conforming to NEBS (Network Equipment-Building System) GR-1089-CORE:

The equipment is suitable for installation in the following:

- Network telecommunications facilities
- Locations where the NEC (National Electrical Code) applies

The intrabuilding ports of this equipment are suitable for connection to intrabuilding or unexposed wiring or cabling only. The intrabuilding ports of this equipment *must not* be metallically connected to the interfaces that connect to the OSP (outside plant) or its wiring. These interfaces are designed for use as intrabuilding interfaces only (Type 2 or Type 4 ports as described in GR-1089-CORE) and require isolation from the exposed OSP cabling. The addition of primary protectors is not sufficient protection to connect these interfaces metallically to OSP wiring.

Note: All Ethernet cables must be shielded and grounded at both ends.

The ac-powered system does not require the use of an external surge protection device (SPD).

The dc-powered system employs an isolated DC return (DC-I) design. The DC battery return terminal *shall not* be connected to the chassis or frame ground.

Site and hardware physical planning overview

Successful installation requires effective planning of your physical and operational environment. You are the most valuable resource in site planning because you know where and how your system, and devices attached to it, will be used.

Site preparation for the complete system is the responsibility of the customer. The primary task of your site planner is to ensure that each system is installed so that it can operate and be serviced efficiently.

This topic collection provides the basic information you need to plan for your system installation. It provides an overview of each planning task, as well as valuable reference information useful throughout the performance of these tasks. Depending on the complexity of the system you ordered and your existing computing resource, you might not need to perform all the steps noted here.

First, with the help of your systems engineer, sales representative, or with the help of those coordinating your installation, list the hardware for which you need to plan. Use the summary of your order to help you when making your list. This list is now your "To Do" list. You can use the Planning task checklist to assist you.

While you are responsible for planning, vendors, contractors, and your sales representative are also available to help with any aspect of the planning. For some system units, a customer service representative will install your system unit and verify correct operation. Some system units are considered customer-installed. If you are not sure, check with your sales representative.

The physical planning section of this topic collection provides the physical characteristics of many system units, and associated products. For information on products not included in this topic collection, contact your sales representative or your authorized dealer.

Before proceeding with planning, ensure that the hardware and software you have chosen meets your needs. Your sales representative is available to answer questions.

While this information is for hardware planning, the system memory and disk storage needed are a function of the software to be used, therefore some things to consider are listed below. Information on software products is generally in or with the software Licensed Program Product itself.

In assessing the adequacy of hardware and software, consider the following:

- Available disk space and system memory for accommodating software, online documentation, and data (including future growth needs resulting from additional users, more data, and new applications)
- Compatibility of all devices
- Compatibility of software packages with each other and with the hardware configuration
- Adequate redundancy or backup capabilities in hardware and software
- Software portability to the new system, if necessary
- Prerequisites and corequisites of chosen software have been satisfied
- Data to be transferred to the new system

Planning activities

You can use this information to help you plan the physical installation for your server.

Proper planning for your system will facilitate a smooth installation and fast system start-up. Sales and installation planning representatives are also available to help you with installation planning.

As part of your planning activity, you will make decisions about where to locate your server and who will operate the system

Planning task checklist

Use this checklist to document your planning progress.

Working with your sales representative, establish completion dates for each of the tasks. You might want to review your planning schedule periodically with your sales representative.

Table 1. Planning task checklist

Planning step	Person responsible	Target date	Completion date
Plan your office or computer room layout (physical planning)			
Prepare for power cords and electrical needs			
Prepare for cables and cabling			
Create or modify communications networks			
Perform building alterations, as needed			
Prepare maintenance, recovery, and security plans			
Develop an education plan			
Order supplies			
Prepare for system delivery			

General considerations

Planning your system requires attention to the numerous details.

When determining the placement of your system, consider the following:

- Adequate space for the devices.
- Working environment of personnel who will be using the devices (their comfort, ability to access the devices, supplies, and reference materials).
- Adequate space for maintaining and servicing the devices.
- Physical security requirements necessary for the devices.
- Weight of the devices.
- Heat output of the devices.
- Operating temperature requirements of the devices.

- Humidity requirements of the devices.
- Air flow requirements of the devices.
- Air quality of the location where the devices will be used. For example, excess dust could damage your system.

Note: The system and devices are designed to operate in normal office environments. Dirty or other poor environments might damage the system or the devices. You are responsible for providing the proper operating environment.

- Altitude limitations of the devices.
- Noise emission levels of the devices.
- Any vibration of equipment near where the devices will be placed.
- Paths of power cords.

The following pages contain the information you need to evaluate these considerations.

Site preparation and physical planning guidelines

These guidelines help you prepare your site for the delivery and installation of your server.

Information contained in the Site preparation and physical planning might be helpful for preparing your data center for the arrival of a server.

The Site preparation and physical planning topic covers the following information:

Site selection, building and space considerations

- Site selection
- Access
- Static electricity and floor resistance
- Space requirements
- Floor construction and floor loading
- Raised floors
- Conductive contamination
- Computer room layout

Site environment, safety, and security

- Vibration and shock
- Lighting
- Acoustics
- Electromagnetic compatibility
- Computer room location
- Material and data storage protection
- Emergency planning for continuous operations

Electrical power and grounding

- General power information
- Power quality
- Voltage and frequency limits
- Power load
- Power source

- Dual power installations

Air conditioning

- Air conditioning determination
- General guidelines for data centers
- Temperature and humidity design criteria
- Temperature and humidity recording instruments
- Relocation and temporary storage
- Acclimation
- System air distribution

Planning for the installation of rear door heat exchangers

- Planning for the installation of rear door heat exchangers
- Heat exchanger specifications
- Water specifications for the secondary cooling loop
- Water delivery specifications for secondary loops
- Layout and mechanical installation
- Suggested sources for secondary loop components

Communications

- Planning for communications

Hardware specification sheets

Hardware specification sheets provide detailed information for your hardware, including dimensions, electrical, power, temperature, environment, and service clearances.

Server specifications

Server specifications provide detailed information for your server, including dimensions, electrical, power, temperature, environment, and service clearances.

Select the appropriate models to view the specifications for your server.

Model 19F/HB server specifications

Server specifications provide detailed information for your server. This includes dimensions, electrical, power, temperature, environment, and service clearances.

Table 2. Rack dimensions

Dimensions	Rack only	Rack with side doors
Height	2014 mm (79.3 in)	2014 mm (79.3 in)
Width	749.3 mm (29.5 in.)	774.7 mm (30.5 in.)
Depth	1272.54 mm (50.1 in.)	1272.54 mm (50.1 in.)

Table 3. Rack with slimline door dimensions

Dimensions	One frame	Two frame	Front and rear door heat exchanger system unit frame
Height	2014 mm (79.3 in)	2014 mm (79.3 in)	2014 mm (79.3 in)
Width	774.7 mm (30.5 in.)	1567.18 mm (61.7 in.)	774.7 mm (30.5 in.)
Depth	1485.9 mm (58.5 in.)	1485.9 mm (58.5 in.)	1521.46 mm (59.9 in.)

Table 4. Rack with acoustic door dimensions

Dimensions	One frame	Two frame	Front and rear door heat exchanger system unit frame
Height	2014 mm (79.3 in)	2014 mm (79.3 in)	2014 mm (79.3 in)
Width	774.7 mm (30.5 in.)	1567.18 mm (61.7 in.)	774.7 mm (30.5 in.)
Depth	1805.94 mm (71.1 in.)	1805.94 mm (71.1 in.)	1795.78 mm (70.7 in.)

Table 5. Full system weights (no covers)

Physical characteristics	Weight
Fully configured system unit frame - Three I/O drawers without integrated battery backup (IBB)	1375 kg (3030 lb)
Fully configured system unit frame - Two I/O drawers with IBB	1466 kg (3230 lb)

Table 6. Cover weights

Physical characteristics	Weight
Side covers, pair	50 kg (110 lb)
Slimline door, single	15 kg (33 lb)
Acoustic door, single	25 kg (56 lb)

Table 7. Shipping dimensions

Physical characteristics	Dimensions
Height	231 cm (91 in.)
Width	94 cm (37 in.)
Depth	162 cm (63.5 in.)
Weight	Varies by configuration. The maximum weight is 1724 kg (3800 lb).

Table 8. Electrical and thermal characteristics for a new POWER7 system

Voltage and frequency	North America and Japan 200-240 V ac	Other Jurisdictions 200-240 V ac	North America 480 V ac	Other Jurisdictions 380-415 V ac	330-520 V dc
System Rating ¹	48 A or 80 A	48 A or 80 A	22 A or 42 A	25.6 A or 43 A	72 A
Maximum Power (kW)	30.2 at 208 V ac	31.9 at 240 V ac	30.8 at 480 V ac	30.6 at 415 V ac	30.8
Thermal Output (BTU/hr)	103047	108847	105094	104412	105094

¹ System rating varies by configuration and line cord.

Table 9. Electrical and thermal characteristics for a POWER6 upgrade

Voltage and frequency	North America and Japan 200-240 V ac	Other Jurisdictions 200-240 V ac	North America 480 V ac	North America 380-415 V ac	Other Jurisdictions 380-415 V ac	330-520 V dc
System Rating ¹	48 A or 80 A	48 A or 80 A	24 A or 34 A	N/A	34 A or 43 A	N/A
Maximum Power (kW)	30.2 at 208 V ac	31.6 at 240 V ac	30.8 at 480 V ac	N/A	30.6 at 415 V ac	30.8
Thermal Output (BTU/hr)	103047	107824	105094	N/A	104412	105094

¹ System rating varies by configuration and line cord.

Table 10. Environment specifications

Environment	Operating	Storage	Shipping
Temperature	10°C - 27°C (50°F - 80.6°F) ¹	1°C - 60°C (33.8°F - 140°F)	-40°C - 60°C (-40°F - 140°F)
Relative humidity	20% - 80%	5% - 80%	5% - 100%
Maximum altitude	3048 m (10 000 ft)		

¹ Derate maximum temperature 2°C per 1000 ft over 7000 ft

Table 11. Declared acoustical noise emissions for typical configuration (four processor nodes and three I/O drawers) of the 19F/HB

Product configuration	Declared A-Weighted Sound Power Level, L_{WAd} (B)	Declared A-Weighted Sound Pressure Level, L_{pAm} (dB)
	Operating	Operating
Slimline door set	8.4	66
Acoustical door set	7.5	57
Slimline heat exchanger door set (slimline front door with heat exchanger rear door)	8.5	67
Acoustical heat exchanger door set (acoustical front door with heat exchanger and acoustical attachment rear door)	8.0	62

¹Declared level L_{WAd} is the upper-limit A-weighted sound power level. Declared level L_{pAm} is the mean A-weighted sound pressure level measured at the 1-meter bystander positions.

²All measurements are made in conformance with ISO 7779 and are declared in conformance with ISO 9296.

³1 Bel (B) equals 10 Decibels (dB).

⁴Meets IT Product Noise Limits for, *Generally Unattended Data Center*, per Statskontoret Technical Standard 26:6.

⁵Meets IT Product Noise Limits for, *Generally Attended Data Center*, per Statskontoret Technical Standard 26:6.

Note: ⁶ Government regulations (such as those prescribed by Occupational Safety and Health Administration (OSHA) or European Community Directives) might govern noise level exposure in the workplace and might apply to you and your server installation. This system is available with an optional acoustical door feature that can help reduce the noise emitted from this system. The actual sound pressure levels in your installation depend on; a variety of factors, including the number of racks in the installation, the size, materials, the configuration of the room where you designate the racks to be installed, the noise levels from other equipment, the room ambient temperature, and employees' location in relation to the equipment. Compliance with such government regulations also depends on a variety of additional factors, including the duration of employees' exposure and whether employees wear hearing protection. It is recommended that you consult qualified experts in this field to determine whether you are in compliance with the applicable regulations.

Table 12. Declared acoustical noise emissions for maximum configuration of the 19F/HB

Product Configuration	Declared A-Weighted Sound Power Level, L_{WAd} (B)	Declared A-Weighted Sound Pressure Level, L_{pAm} (dB)
	Operating	Operating
Slimline door set	8.7	69
Acoustical door set	7.8	60
Slimline heat exchanger door set (slimline front door with heat exchanger rear door)	8.8	70
Acoustical heat exchanger door set (acoustical front door with heat exchanger and acoustical attachment rear door)	8.3	65

Table 12. Declared acoustical noise emissions for maximum configuration of the 19F/HB (continued)

Product Configuration	Declared A-Weighted Sound Power Level, L_{wAd} (B)	Declared A-Weighted Sound Pressure Level, L_{pAm} (dB)
	Operating	Operating
<p>¹ Declared level L_{wAd} is the upper-limit A-weighted sound power level. Declared level L_{pAm} is the mean A-weighted sound pressure level measured at the 1-meter bystander positions.</p> <p>² All measurements are made in conformance with ISO 7779 and declared in conformance with ISO 9296.</p> <p>³ 1 Bel (B) equals 10 Decibels (dB).</p> <p>Note: Government regulations (such as those prescribed by OSHA or European Community Directives) might govern noise level exposure in the workplace and might apply to you and your server installation. This system is available with an optional acoustical door feature that can help reduce the noise emitted from this system. The actual sound pressure levels in your installation depend upon a variety of factors, including the number of racks in the installation, the size, materials, the configuration of the room where you designate the racks to be installed, the noise levels from other equipment, the room ambient temperature, and employees' location in relation to the equipment. Compliance with such government regulations also depends upon a variety of additional factors, including the duration of employees' exposure and whether employees wear hearing protection. It is recommended that you consult qualified experts in this field to determine whether you are in compliance with the applicable regulations.</p>		

Special Hardware Management Console considerations

The Hardware Management Console (HMC) must be provided within the same room and within 8 m (26 ft) of the server. For additional considerations, see Planning for HMC installation and configuration.

Note: As an alternative to the local HMC requirement, you can provide a supported device, such as a PC, with connectivity and authority to operate through a remotely attached HMC. This local device must be in the same room and within 8 m (26 ft) of your server. It must provide functional capabilities equivalent to the HMC that it replaces, and is needed by the service representative to service the system.

This product is not intended to be connected directly or indirectly by any means whatsoever to interfaces of public telecommunications networks.

Electromagnetic compatibility compliance

This server meets the following electromagnetic compatibility specifications: CISPR 22; CISPR 24; FCC, CFR 47, Part 15 (US); VCCI (Japan); Directive 2004/108/EC (EEA); ICES-003, Issue 4 (Canada); ACMA radio communications standard (Australia, New Zealand); CNS 13438 (Taiwan); Radio Waves Act, MIC Rule No. 210 (Korea) ; Commodity Inspection Law (China); TCVN 7189 (Vietnam); MoCI (Saudi Arabia); SI 961 (Israel); GOST R 51318.22, 51318.24 (Russia).

The 6954 base rack is an optional second-base frame with a separate connection to AC power that is designed for use with model 19F/HB. For a complete set of planning information, see “Planning for 6954 and 6953 racks” on page 77.

Plan views

Dimensional planning information is shown in this top down view of your server.

Note: The following dimensions are the same for both a new POWER7 system and a POWER6 upgrade.

The following figure shows dimensional planning information for single-frame systems.

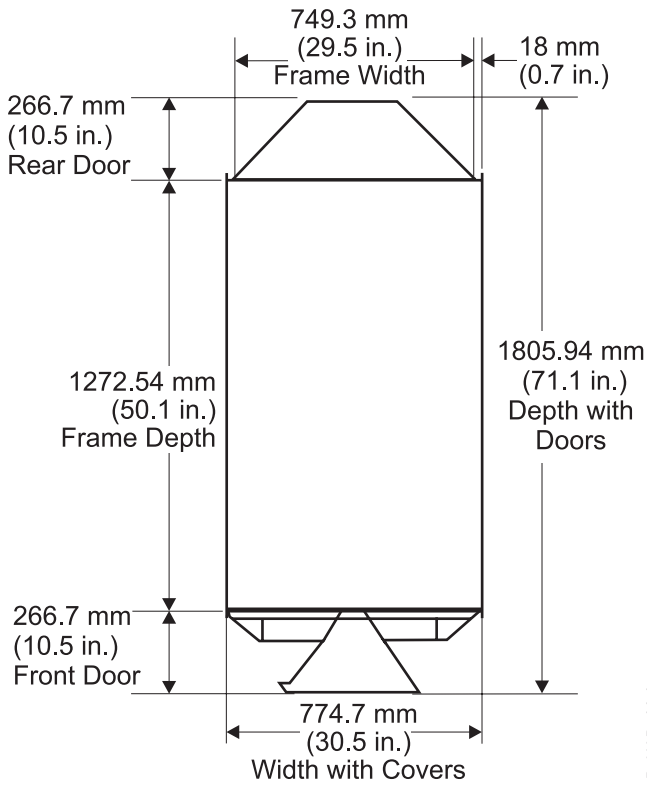

Figure 1. Plan view for single-frame systems with acoustical doors

The following figure shows dimensional planning information for single-frame systems.

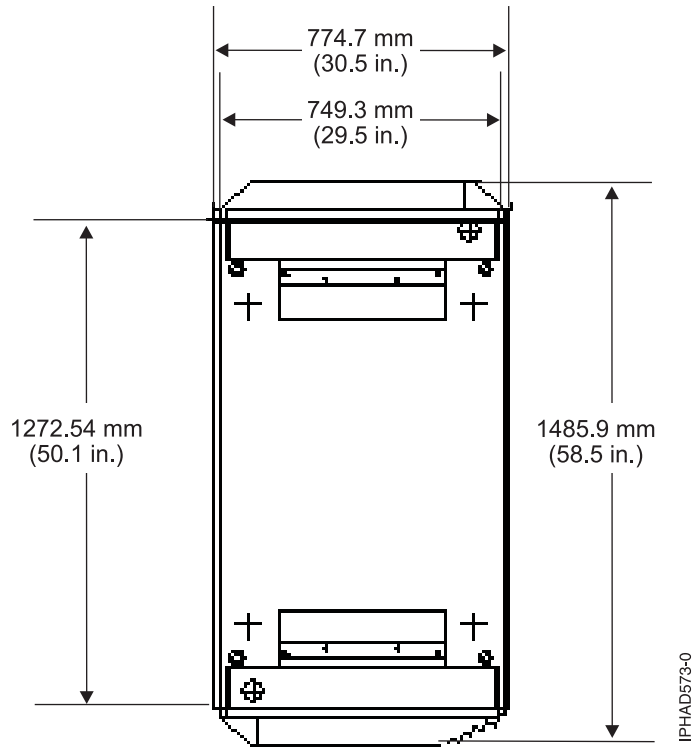

Figure 2. Plan view for single-frame systems with slimline doors

The following figure shows dimensional planning information for single-frame systems.

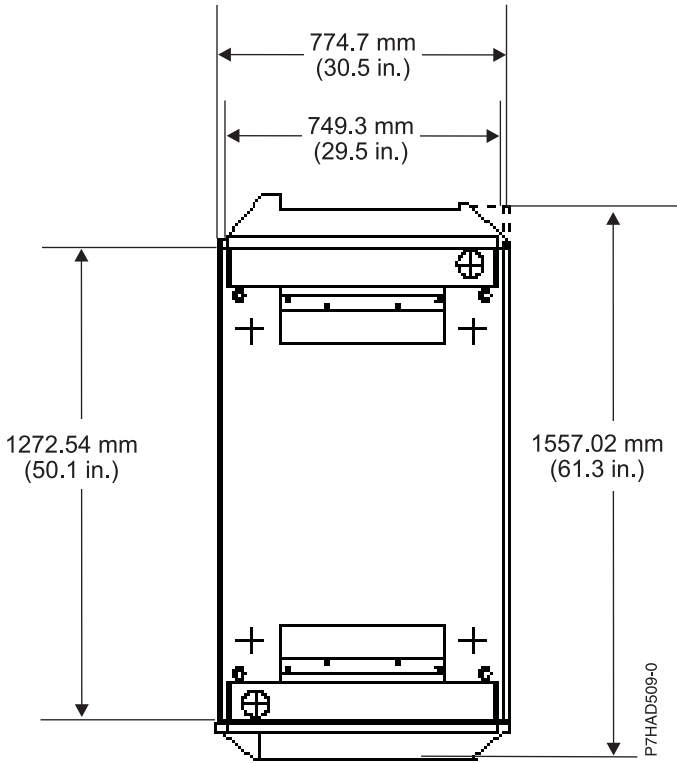

Figure 3. Plan view for single-frame systems with slimline doors and a Rear door heat exchanger

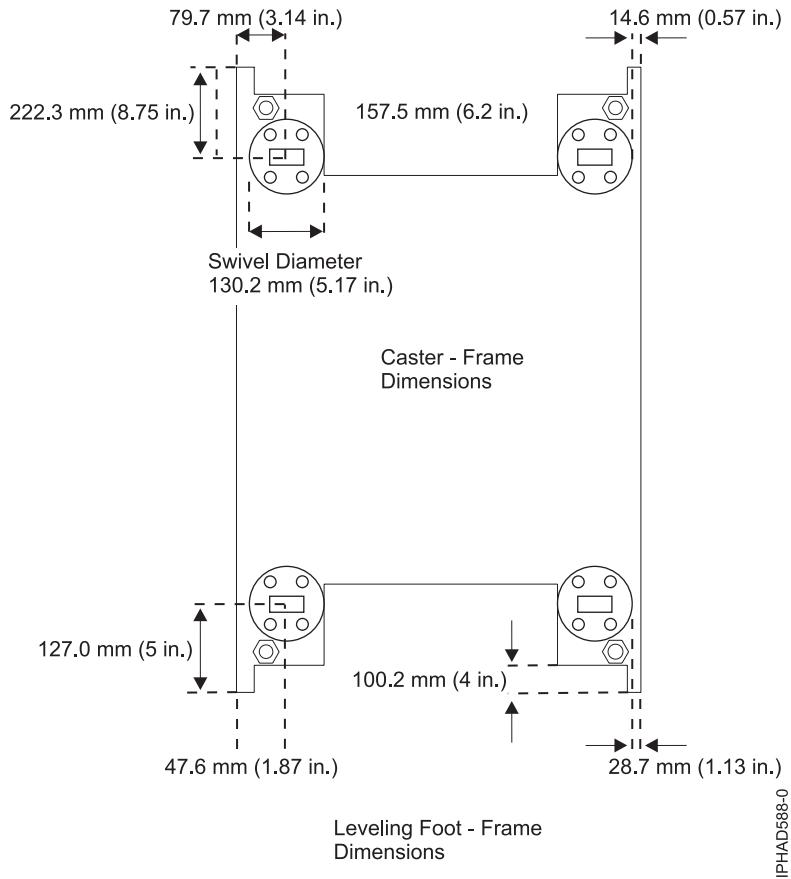

Figure 4. Leveling foot and frame dimensions

Note: When moving the rack, note the caster swivel diameters shown in the following figure. Each caster swivels in an approximate 130 mm (5.1 in.) diameter.

Service clearances

The service clearance area is the area around the server which is needed for the authorized service representatives to service the server.

Note: The following dimensions are the same for both a new POWER7 system and a POWER6 upgrade.

The minimum service clearance for systems with slimline doors is shown in the following figures.

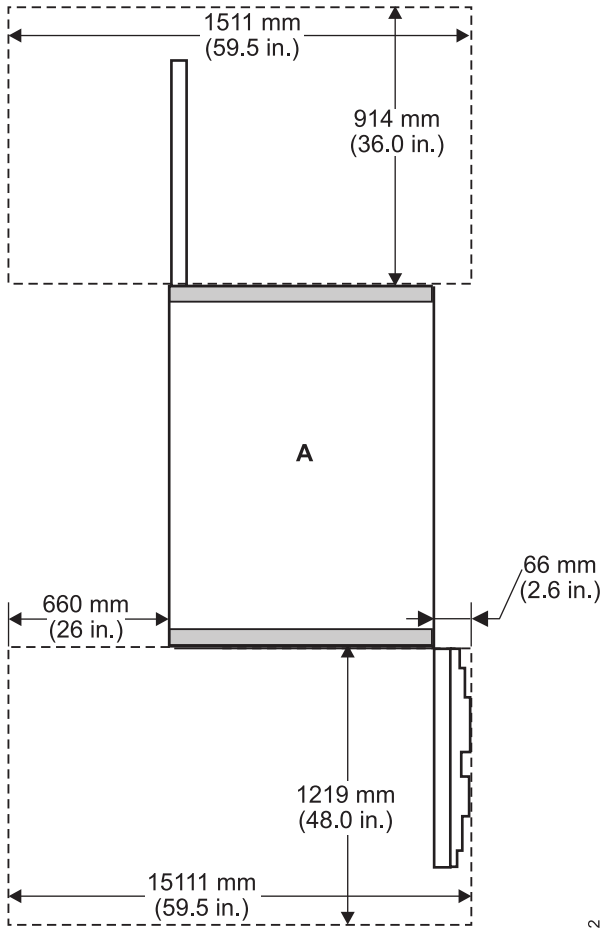

Single-Frame System with
Slimline Doors

IPHAD907-2

Figure 5. Service clearance for single system unit frame or single I/O rack with slimline doors

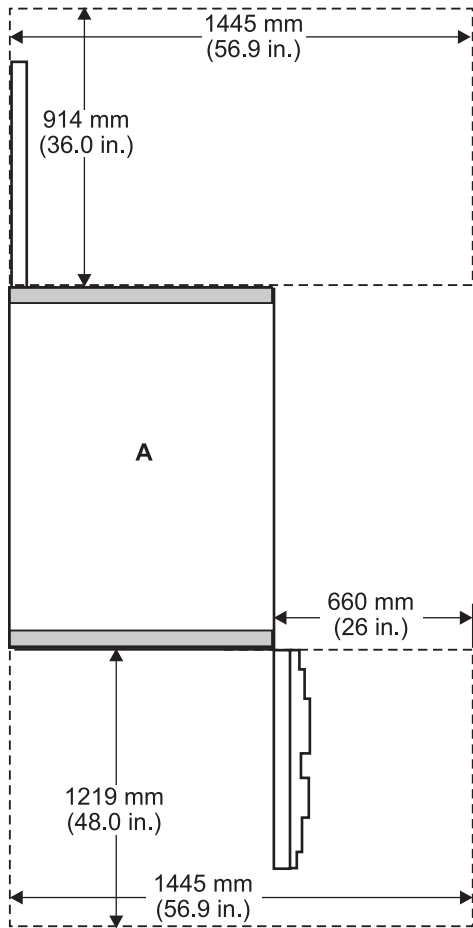

Single-Frame System with Slimline Doors (with alternative right-side service clearance)

IPHAD908-2

Figure 6. Service clearance for single system unit frame or single I/O rack with slimline doors (with alternative right side service clearance)

The minimum service clearance for systems with acoustical doors is shown in the following figures.

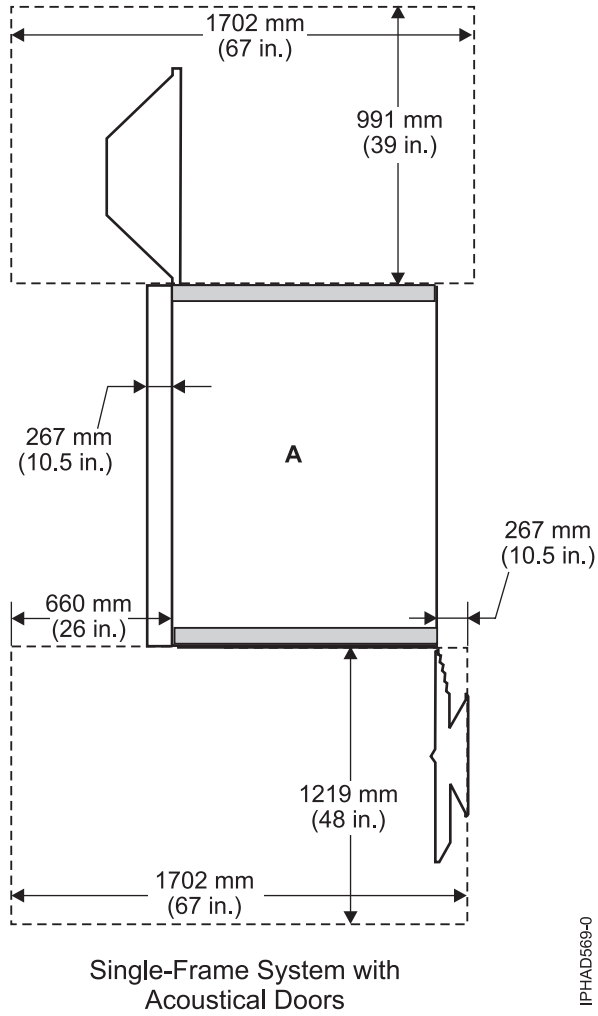
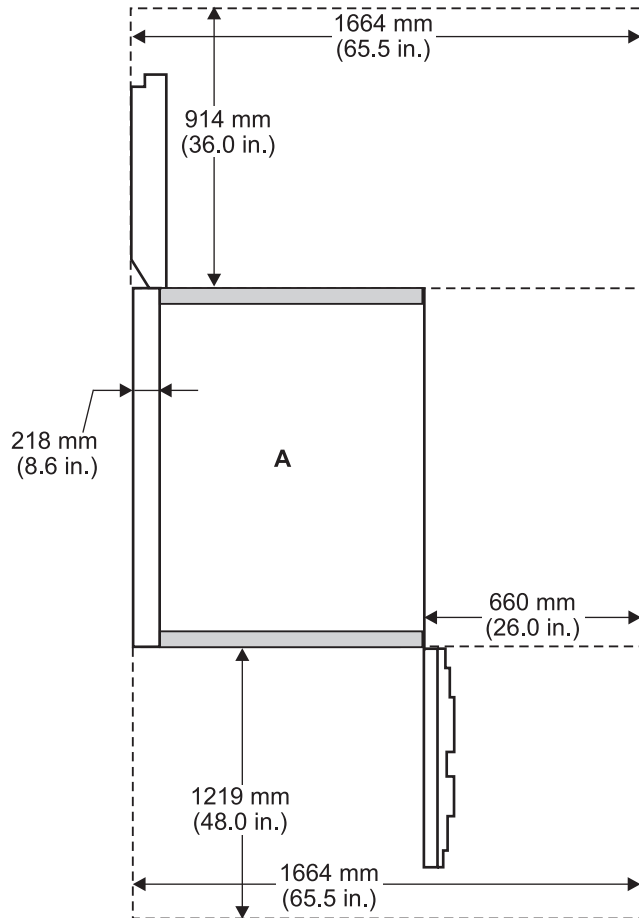

Figure 7. Service clearance for single system unit frame or single I/O rack with acoustic doors



Single-Frame System with Acoustical Doors (with alternative right-side service clearance)

IPHAD903-2

Figure 8. Service clearance for single system unit frame or single I/O rack with acoustic doors (with alternative right side service clearance)

See “Attaching the rack to a 9 - 13 in. or 12 - 22 in. floor” on page 29 for service clearances that are required in a raised-floor installation.

Doors and covers

Doors and covers are an integral part of the system and are required for product safety, proper airflow and cooling, electromagnetic compatibility compliance, and, with certain options, acoustical noise reduction.

The following rear door options are available for model 19F/HB:

- Acoustical door

This feature provides a specially designed, noise-reducing door set that helps maintain lower noise levels in their data center. It also helps you to meet certain acoustical or noise exposure requirements. The acoustical door option consists of a special front door, approximately 250 mm (10 in.) in depth. It contains acoustical treatment and when used with the required rear door heat exchanger, it lowers the noise level of the machine by approximately 5 dB (0.5 B) in comparison to the slimline door option.

Note: A special acoustical attachment is available to provide noise reduction when ordering the rear door heat exchanger.

- Slimline door

This feature provides an option to take up less floor space, when space is more critical than acoustical noise levels. The slimline door option consists of a front and rear door set, approximately 100 mm (4 in.) in depth, to be used in conjunction with the required rear-door heat exchanger previously described. Acoustical treatment is not available for the slimline door option, and the 19F/HB system generally does not meet industry acoustical noise limits with this option installed. The slimline door set is offered as a selectable option for those who are more concerned with floor space than noise levels because each slimline door is about 150 mm (6 in.) less deep than each acoustical door.

- Rear door heat exchanger

The rear-door heat exchanger feature is a water-cooled device that is mounted on the rear of the rack to cool the air that is heated and exhausted by devices inside the rack. A supply hose delivers chilled, conditioned water to the heat exchanger. A return hose delivers warmed water back to the water pump or chiller. Each rear-door heat exchanger can remove up to 50 000 British thermal unit (Btu) (or approximately 15 000 watts) of heat from your data center. See Planning for the installation of rear door heat exchangers for more information.

Note: For declared levels of acoustical noise emissions, see “Model 19F/HB server specifications” on page 7.

Raised-floor requirements and preparation

A raised floor is required for the 19F/HB.

Raised-floor cutouts should be protected by electrically non-conductive molding, appropriately sized, with edges treated to prevent cable damage and to prevent casters from rolling into the floor cutouts.

Front-service access is necessary on the 19F/HB to accommodate a lift tool for the servicing of large drawers (the processor books and I/O drawers). Front and rear service access is necessary to accommodate the lift tool for servicing of the optional integrated battery backup.

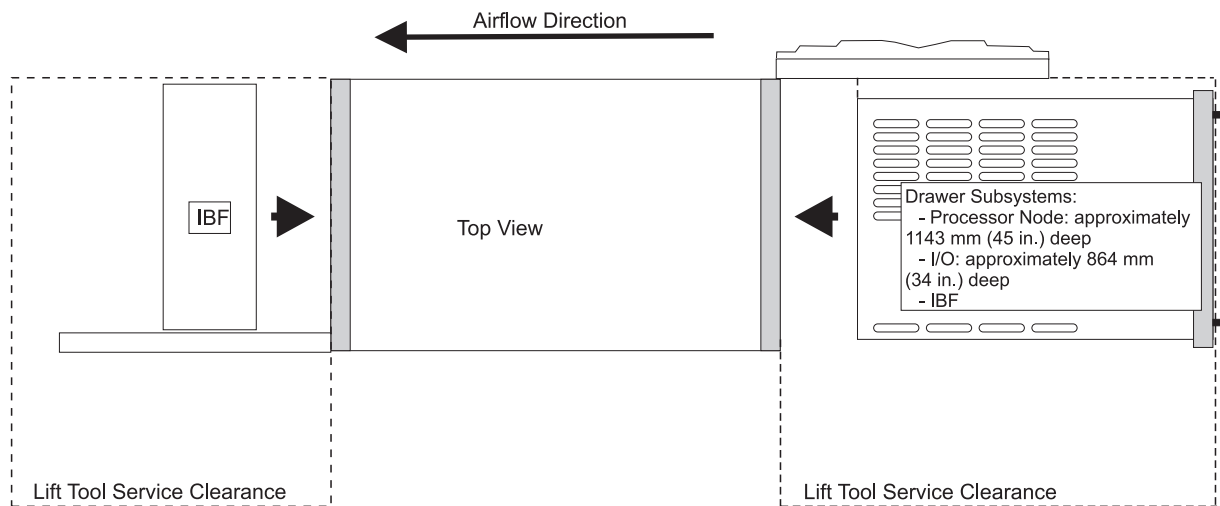

Floor Plan Considerations for Single Units

A4AA5731-1

Figure 9. Floor plan considerations for single units

Weight distribution:

Use the floor loading information to determine the floor loading for various configurations.

The following figure shows the floor loading dimensions for model 19F/HB. Use this figure in conjunction with the tables to determine the floor loading for various configurations.

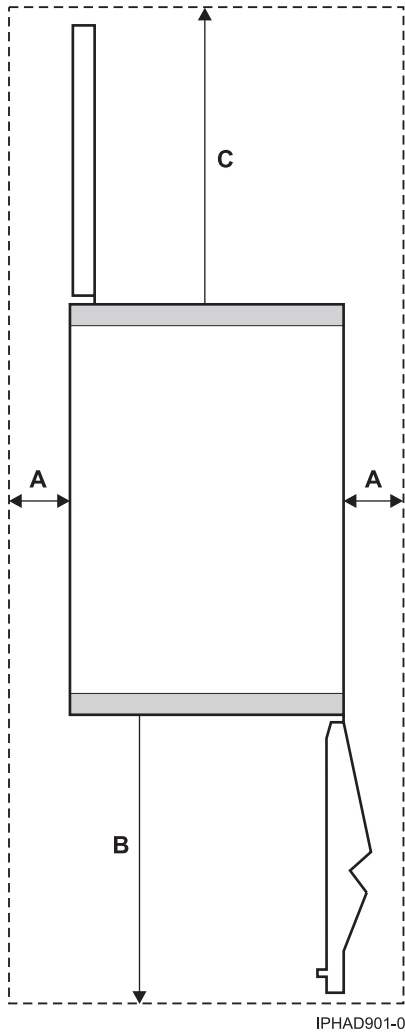

Figure 10. Floor loading dimensions

The following tables show values for calculating floor loading for the model 19F/HB. Weights include acoustical covers. Width and depth are indicated without covers.

Table 13. 8 processor books and 3 I/O drawers

Condition	a (sides)	b (front)	c (back)	System unit	
1	25.4 mm (1 in.)	254 mm (10 in.)	254 mm (10 in.)	222.7 lb/ft ²	1087.2 kg/m ²
2	25.4 mm (1 in.)	508 mm (20 in.)	508 mm (20 in.)	178.8 lb/ft ²	872.9 kg/m ²
3	25.4 mm (1 in.)	762 mm (30 in.)	762 mm (30 in.)	150.9 lb/ft ²	736.5 kg/m ²
4	254 mm (10 in.)	254 mm (10 in.)	254 mm (10 in.)	150.8 lb/ft ²	736.2 kg/m ²
5	254 mm (10 in.)	508 mm (20 in.)	508 mm (20 in.)	122.9 lb/ft ²	599.9 kg/m ²
6	254 mm (10 in.)	762 mm (30 in.)	762 mm (30 in.)	105.1 lb/ft ²	513.1 kg/m ²
7	508 mm (20 in.)	254 mm (10 in.)	254 mm (10 in.)	114.6 lb/ft ²	559.5 kg/m ²
8	508 mm (20 in.)	508 mm (20 in.)	508 mm (20 in.)	94.7 lb/ft ²	462.4 kg/m ²
9	508 mm (20 in.)	762 mm (30 in.)	762 mm (30 in.)	82.0 lb/ft ²	400.6 kg/m ²
10	762 mm (30 in.)	254 mm (10 in.)	254 mm (10 in.)	94.6 lb/ft ²	461.7 kg/m ²

Table 13. 8 processor books and 3 I/O drawers (continued)

Condition	a (sides)	b (front)	c (back)	System unit	
11	762 mm (30 in.)	508 mm (20 in.)	508 mm (20 in.)	79.1 lb/ft ²	386.3 kg/m ²
12	762 mm (30 in.)	762 mm (30 in.)	762 mm (30 in.)	69.3 lb/ft ²	338.3 kg/m ²

Table 14. 4 processor books and 2 I/O drawers

Condition	a (sides)	b (front)	c (back)	System unit	
1	25.4 mm (1 in.)	254 mm (10 in.)	254 mm (10 in.)	169.8 lb/ft ²	829.3 kg/m ²
2	25.4 mm (1 in.)	508 mm (20 in.)	508 mm (20 in.)	137.7 lb/ft ²	672.3 kg/m ²
3	25.4 mm (1 in.)	762 mm (30 in.)	762 mm (30 in.)	117.2 lb/ft ²	572.3 kg/m ²
4	254 mm (10 in.)	254 mm (10 in.)	254 mm (10 in.)	117.2 lb/ft ²	572.1 kg/m ²
5	254 mm (10 in.)	508 mm (20 in.)	508 mm (20 in.)	96.7 lb/ft ²	472.2 kg/m ²
6	254 mm (10 in.)	762 mm (30 in.)	762 mm (30 in.)	83.7 lb/ft ²	408.6 kg/m ²
7	508 mm (20 in.)	254 mm (10 in.)	254 mm (10 in.)	90.6 lb/ft ²	442.6 kg/m ²
8	508 mm (20 in.)	508 mm (20 in.)	508 mm (20 in.)	76.1 lb/ft ²	371.4 kg/m ²
9	508 mm (20 in.)	762 mm (30 in.)	762 mm (30 in.)	66.8 lb/ft ²	326.1 kg/m ²
10	762 mm (30 in.)	254 mm (10 in.)	254 mm (10 in.)	76.0 lb/ft ²	371.0 kg/m ²
11	762 mm (30 in.)	508 mm (20 in.)	508 mm (20 in.)	64.7 lb/ft ²	315.7 kg/m ²
12	762 mm (30 in.)	762 mm (30 in.)	762 mm (30 in.)	57.5 lb/ft ²	280.5 kg/m ²

Table 15. 2 processor books and 1 I/O drawer

Condition	a (sides)	b (front)	c (back)	System unit	
1	25.4 mm (1 in.)	254 mm (10 in.)	254 mm (10 in.)	132.3 lb/ft ²	646.2 kg/m ²
2	25.4 mm (1 in.)	508 mm (20 in.)	508 mm (20 in.)	108.5 lb/ft ²	529.8 kg/m ²
3	25.4 mm (1 in.)	762 mm (30 in.)	762 mm (30 in.)	93.3 lb/ft ²	455.8 kg/m ²
4	254 mm (10 in.)	254 mm (10 in.)	254 mm (10 in.)	93.3 lb/ft ²	455.6 kg/m ²
5	254 mm (10 in.)	508 mm (20 in.)	508 mm (20 in.)	78.1 lb/ft ²	381.6 kg/m ²
6	254 mm (10 in.)	762 mm (30 in.)	762 mm (30 in.)	68.5 lb/ft ²	334.4 kg/m ²
7	508 mm (20 in.)	254 mm (10 in.)	254 mm (10 in.)	73.7 lb/ft ²	359.6 kg/m ²
8	508 mm (20 in.)	508 mm (20 in.)	508 mm (20 in.)	62.9 lb/ft ²	306.9 kg/m ²
9	508 mm (20 in.)	762 mm (30 in.)	762 mm (30 in.)	56.0 lb/ft ²	273.3 kg/m ²
10	762 mm (30 in.)	254 mm (10 in.)	254 mm (10 in.)	62.8 lb/ft ²	306.5 kg/m ²
11	762 mm (30 in.)	508 mm (20 in.)	508 mm (20 in.)	54.4 lb/ft ²	265.6 kg/m ²
12	762 mm (30 in.)	762 mm (30 in.)	762 mm (30 in.)	49.1 lb/ft ²	239.5 kg/m ²

Table 16. 8 processor books, 2 I/O drawers and internal battery feature

Condition	a (sides)	b (front)	c (back)	System unit	
1	25.4 mm (1 in.)	254 mm (10 in.)	254 mm (10 in.)	223.3 lb/ft ²	1090.4 kg/m ²
2	25.4 mm (1 in.)	508 mm (20 in.)	508 mm (20 in.)	179.3 lb/ft ²	875.4 kg/m ²
3	25.4 mm (1 in.)	762 mm (30 in.)	762 mm (30 in.)	151.3 lb/ft ²	738.6 kg/m ²
4	254 mm (10 in.)	254 mm (10 in.)	254 mm (10 in.)	151.2 lb/ft ²	738.2 kg/m ²
5	254 mm (10 in.)	508 mm (20 in.)	508 mm (20 in.)	123.2 lb/ft ²	601.5 kg/m ²
6	254 mm (10 in.)	762 mm (30 in.)	762 mm (30 in.)	105.4 lb/ft ²	514.4 kg/m ²
7	508 mm (20 in.)	254 mm (10 in.)	254 mm (10 in.)	114.9 lb/ft ²	560.9 kg/m ²
8	508 mm (20 in.)	508 mm (20 in.)	508 mm (20 in.)	94.9 lb/ft ²	463.5 kg/m ²
9	508 mm (20 in.)	762 mm (30 in.)	762 mm (30 in.)	82.2 lb/ft ²	401.5 kg/m ²
10	762 mm (30 in.)	254 mm (10 in.)	254 mm (10 in.)	94.8 lb/ft ²	462.9 kg/m ²
11	762 mm (30 in.)	508 mm (20 in.)	508 mm (20 in.)	79.3 lb/ft ²	387.2 kg/m ²
12	762 mm (30 in.)	762 mm (30 in.)	762 mm (30 in.)	69.4 lb/ft ²	339.0 kg/m ²

Floor loading for the system is illustrated in the Proposed Floor Layout for Multiple Systems in *Considerations for multiple system installations*.

Cutting and placing floor panels:

These guidelines specify how to make the necessary openings in the raised floor for installing your server.

Use the following procedure to cut and place floor panels in the raised floor. The x-y alphanumeric grid positions are used to identify relative positions of cutout floor panels that might be cut in advance.

1. Measure the panel size of the raised floor.
2. Verify the floor panel size. The floor panel size illustrated in the following figures is 600 mm (23.6 in.) and 610 mm (24 in.) panels.
3. Ensure adequate floor space is available to place the frames over the floor panels exactly as shown in the following figures. For front-to-back and side-to-side clearances, refer to *Considerations for multiple-system installations*. Use the plan view, if necessary. Consider all obstructions above and below the floor.
4. Identify the panels needed, and list the total quantity of each panel required for the installation.
- 5.

Important: Cut the required quantity of panels. When cutting the panels, you must adjust the size of the cut for the thickness of the edge molding you are using. The dimensions shown in the figures are finished dimensions. For ease of installation, number each panel as it is cut.

Note: For a multiple frame installation, two casters could produce loads as high as 2750 lb.

Notes:

1. The weight distribution bar is a requirement for a model 19F/HB on a raised floor. It is needed to maintain the integrity of the floor that holds the weight of the frame.
2. This floor-tile arrangement is recommended so that the casters or leveling pads are placed on separate floor tiles to minimize the weight on a single floor tile. Load bearing tiles that have cutouts might require additional pedestals to keep their structural integrity. Additionally, the cutouts span two tiles. Raised floors using a stringer system should leave the stringer intact.
3. The *Raised floor with 610 mm (24 in.) floor panels figure* and *Raised floor with 600 mm (23.6 in.) floor panels figure* are intended only to show relative positions and accurate dimensions of floor cutouts. The figures are not intended to be a machine template and is not drawn to scale.

Raised floor with 610 mm (24 in.) floor panels figure

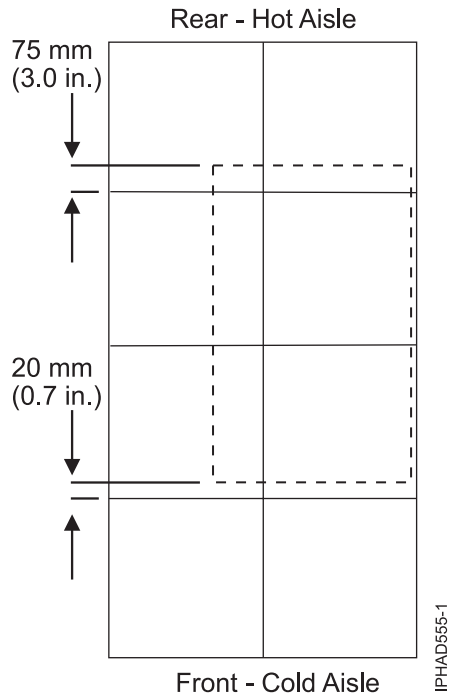

Figure 11. Rack placement for 610 mm (24 in.) tiles

This image shows an overview perspective of the rack placement on floor tiles. The dashed lines represent the rack. The solid lines are used for dimensions.

1. The rear of the server is placed 75 mm (3.0 in.) measuring up from the bottom edge of the first row tile.
2. The front of the server is placed 20 mm (0.7 in.) measuring up from the bottom edge of the third row tile.

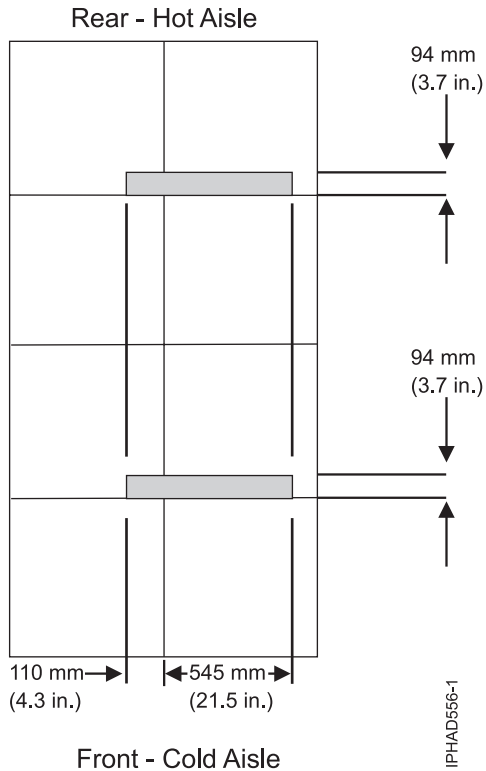

Figure 12. Cable cutout placement 610 mm (24 in.) tiles

This figure shows the floor cutouts for the cables. The solid rectangles indicate the cutouts, and the solid lines are used for dimensions.

1. The first cutout is 94 mm (3.7 in.) high measuring up from the bottom edge of the first row tile. The width of the first cutout is 110 mm (4.3 in.) measuring left from the right edge of the first column tile. Continue cutting out an additional 545 mm (21.5 in.) measuring right from the left edge of the second column tile. The total width of the cutout is 655 mm (25.8 in.).
2. The second cutout is 94 mm (3.7 in.) high measuring up from the bottom edge of the third row tile. The width of the second cutout is 110 (4.3 in.) mm measuring left from the right edge of the first column tile. Continue cutting out an additional 545 mm (21.5 in.) measuring right from the left edge of the second column tile. The total width of the cutout is 655 mm (25.8 in.).

Raised floor with 600 mm (23.6 in.) floor panels figure

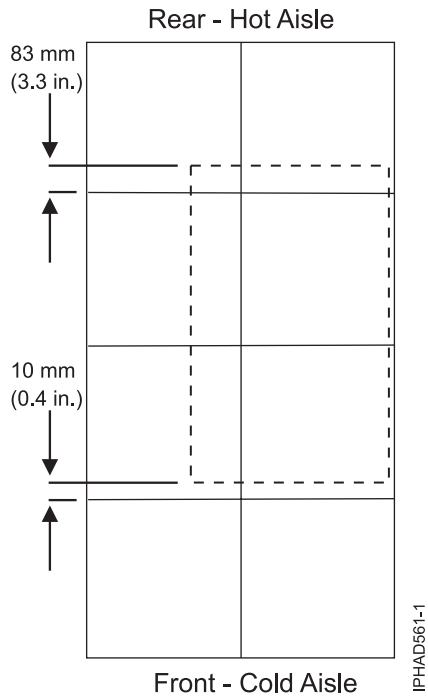
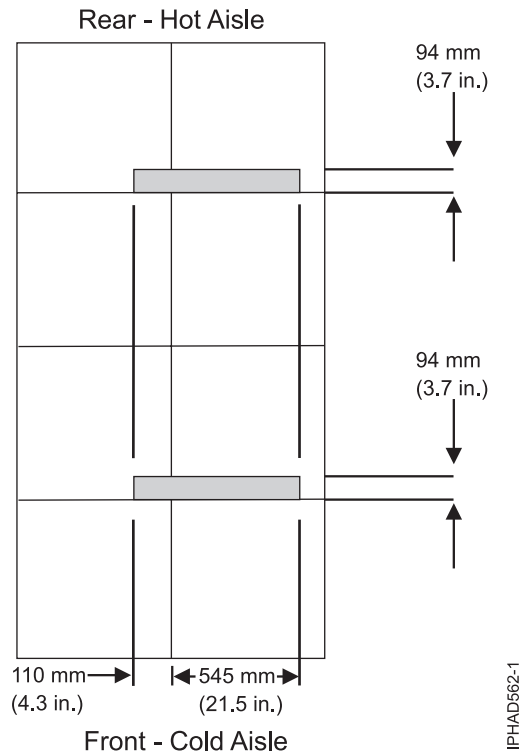

Figure 13. Rack placement for 600 mm (23.6 in.) tiles

This image shows an overview perspective of the rack placement on the floor tiles. The dashed lines represent the rack. The solid lines are used for dimensions.

1. The rear of the server is placed 83 mm (3.3 in.) measuring up from the bottom edge of the first row tile.
2. The front of the server is placed 10 mm (0.4 in.) measuring up from the bottom edge of the third row tile.



IPHAD862-1

Figure 14. Cable cutout placement 600 mm (23.6 in.) tiles

This figure shows the floor cutouts for the cables. The solid rectangles indicate the cutouts, and the solid lines are used for dimensions.

1. The first cutout is 94 mm (3.7 in.) high measuring up from the bottom edge of the first row tile. The width of the first cutout is 110 mm (4.3 in.) measuring left from the right edge of the first column tile. Continue cutting out an additional 545 mm (21.5 in.) measuring right from the left edge of the second column tile. The total width of the cutout is 655 mm (25.8 in.).
2. The second cutout is 94 mm (3.7 in.) high measuring up from the bottom edge of the third row tile. The width of the second cutout is 110 mm (4.3 in.) measuring left from the right edge of the first column tile. Continue cutting out an additional 545 mm (21.5 in.) measuring right from the left edge of the second column tile. The total width of the cutout is 655 mm (25.8 in.).

Additional pedestal placement

Placing large cutouts in the raised floor tiles, such as the cutouts needed for the 19F/HB, can substantially change the structural integrity of each tiles. Additional support pedestals might be needed. Pedestals might be placed approximately under each caster position to prevent tiles from sagging. Pedestals might also be used to support the cut corners of floor tiles. Pedestals might be needed for tiles where the equipment is moving across, even though they are not permanent load bearing tiles. All pedestals should be installed and adjusted to barely contact the underside of each floor panel, before the frames are rolled into place. All pedestal locations are recommendations. Each facility is unique and additional pedestal supports might be needed for certain floors. You are responsible for verifying all floor loading capacities and requirements to determine where any additional pedestals might be needed.

Note: Use the following figure as an example of where the floor pedestals should be placed. It is only intended to show relative positions. This figure is not drawn to scale.

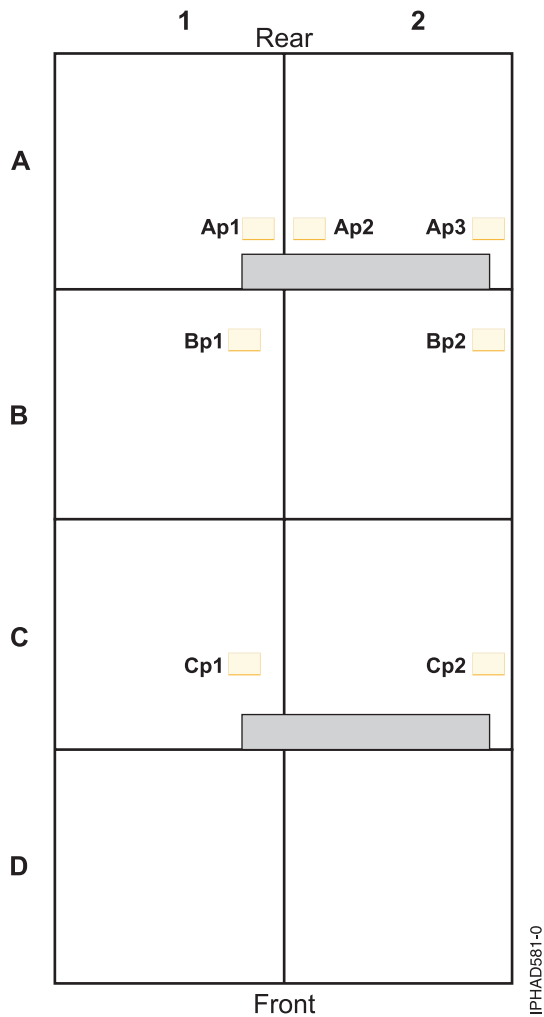

Figure 15. Additional pedestal placement

Important: Extra pedestals might be placed as shown.

1. Pedestals Ap1, Ap2, and Ap3 might be used to support the cut corners of floor tiles. Although these floor tiles are not load-bearing after the machine is installed, the rolling loads put on these tiles during the installation of the machine can place high loads momentarily on these tiles.
2. Pedestals Bp1, Bp2, Cp1, and Cp2 might be placed under each caster position to prevent floor tiles from sagging.

Configuring power cords:

Learn how to route power cords through floor tile cutouts.

The power cords exit the system from different points of the frame as indicated in the following figure. For raised-floor applications, if possible, route both cords to the rear of the frame and through the same floor-tile cutout. For more information about raised-floor applications, refer to *Cutting and placing floor panels*.

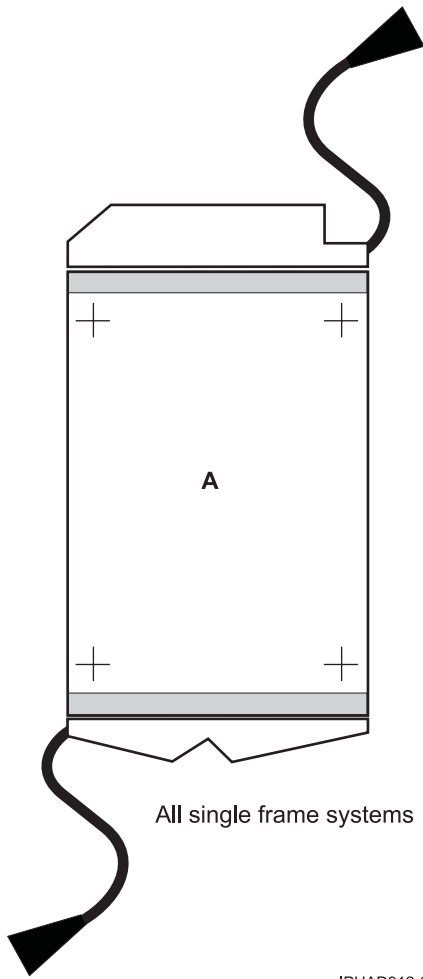

Figure 16. Single-frame system power cord configuration

Installing the frame tie-down kit:

Use the following procedures to install a frame tie-down kit and floor tie-down hardware.

The following procedures describe how to install a frame tie-down kit and floor tie-down hardware to secure a rack to a concrete floor beneath a 228.6 - 330.2 mm (9 -13 in. depth) or a 304.8 - 558.8 mm (12 - 22 in. depth) raised-floor environment or to a nonraised floor.

Positioning the rack:

Use this procedure to unpack and position your rack.

To unpack and position the rack, do the following steps:

Note: Before attempting to position the rack, see “Moving the system to the installation site” on page 59.

1. Remove all of the packing and tape from the rack.
2. Place the last floor covering exactly adjacent to and in the front of the final installation location.
3. Position the rack according to your floor plan.
4. Lock each caster wheel by tightening the thumbscrew on the caster.

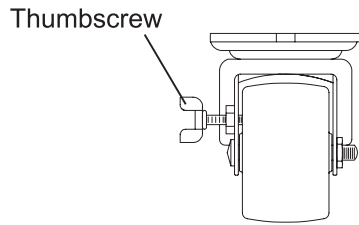

Figure 17. Caster thumbscrew

Note: While moving the system to its final installed location and during relocation, it might be necessary to lay down floor covering, such as Lexan sheets, to prevent floor panel damage.

Securing the rack:

Securing your rack to a concrete (nonraised) floor or to a raised floor prevents movement when vibrations occur.

Note: Securing the rack is an optional procedure. See Vibration and shock for more information.

Before the service representative can perform the tie-down procedure, you must complete the floor preparation as described in “Cutting and placing floor panels” on page 22 and “Attaching the rack to a 9 - 13 in. or 12 - 22 in. floor.”

Attaching the rack to a 9 - 13 in. or 12 - 22 in. floor:

Use these steps to attach your rack to a 228.6 mm to 330.2 mm (9 in. to 13 in. depth). floor.

Attention: The frame tie downs are intended to secure a frame weighing less than 1429 kg (3150 lb). These tie downs are designed to secure the frame on a raised-floor installation.

Use the following to determine your next step:

1. If the rack is being attached to a short-depth raised-floor environment 228.6 - 330.2 mm (9 - 13 in. depth), install the Raised floor tie-down kit (part number 16R1102) described in the following table.

Table 17. Raised floor tie-down kit 228.6 - 330.2 mm (9 - 13 in. depth)

Item	Part number	Quantity	Description
1	44P3438	1	Wrench
2	44P2996	2	Stabilizer bar
3	44P2999	4	Turnbuckle Assembly

2. If the rack is being attached to a deep, raised-floor environment 304.8 - 558.8 mm (12 - 22 in. depth), install the Raised floor tie-down kit (part number 16R1103) described in the following table.

Table 18. Raised floor tie-down kit 304.8 - 558.8 mm (12 - 22 in. depth)

Item	Part number	Quantity	Description
1	44P3438	1	Wrench
2	44P2996	2	Stabilizer bar
3	44P3000	4	Turnbuckle Assembly

It is your responsibility to ensure that the following steps are completed before the service representative performs the tie-down procedure.

This figure shows the location of the rack tiedown for a single rack. The solid rectangles indicate the cutouts, and the solid lines are used for dimensions.

- The first circle, located on the upper left, is 109 mm (4.3 in.) measuring right from the right edge of the first column tile. It is 52 mm (2.0 in.) measuring down from the top edge of the second row tile.
- The second circle, located on the upper right, is 65 mm (2.6 in.) measuring right from the right edge of the second column tile. It is 52 mm (2.0 in.) measuring down from the top edge of the second row tile.
- The third circle, located on the lower left, is 109 mm (4.3 in.) measuring right from the right edge of the first column tile. It is 1019 mm (40.1 in.) measuring down from the first circle.
- The fourth circle, located on the lower right, is 65 mm (2.6 in.) measuring right from the right edge of the second column tile. It is 1019 mm (40.1 in.) measuring down from the second circle.

See *Install the frame tie-down kit* for instructions on how to install a frame tie-down kit and floor tie-down hardware.

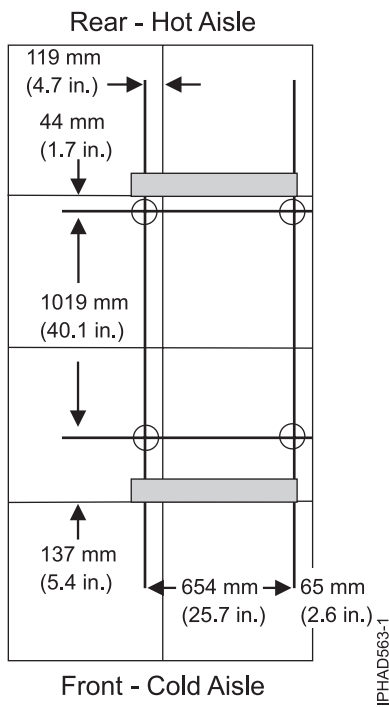

Figure 19. Rack tiedown hole pattern. Raised floor with 600 mm (23.6 in.) floor panels figure

This figure shows the location of the rack tiedown for a single rack. The solid rectangles indicate the cutouts, and the solid lines are used for dimensions.

- The first circle, located on the upper left, is 119 mm (4.7 in.) measuring from the right edge of the first column tile. It is 44 mm (1.7 in.) measuring down from the top edge of the second row tile.
- The second circle, located on the upper right, is 65 mm (2.6 in.) measuring from the right edge of the second column tile. It is 44 mm (1.7 in.) measuring down from the top edge of the second row tile.
- The third circle, located on the lower left, is 119 mm (4.7 in.) measuring from the right edge of the first column tile. It is 1019 mm (40.1 in.) measuring down from the first circle.
- The fourth circle, located on the lower right, is 65 mm (2.6 in.) measuring from the right edge of the second column tile. It is 1019 mm (40.1 in.) measuring down from the second circle.

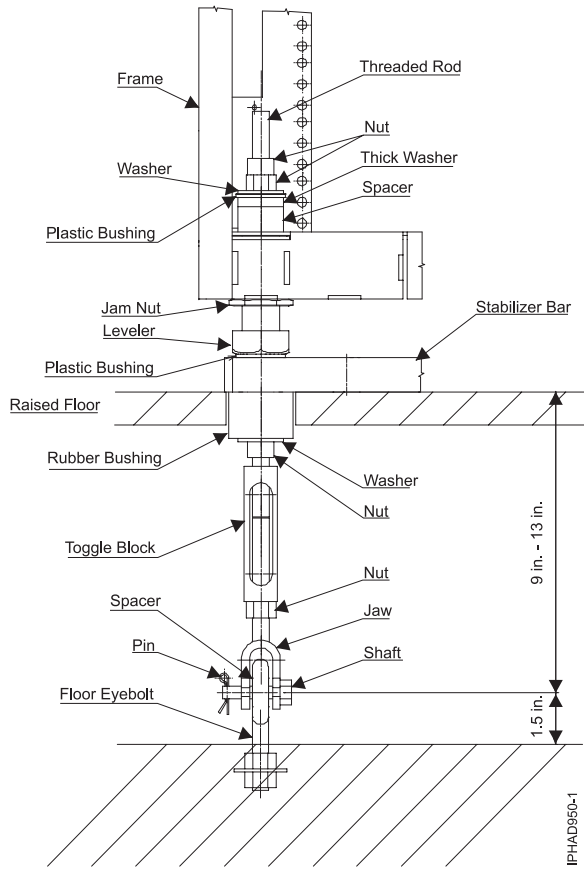

Figure 21. Turnbuckle assembly frame tie-down hardware for 228.6 - 330.2 mm (9 - 13 in.) raised floor (part number 44P2999)

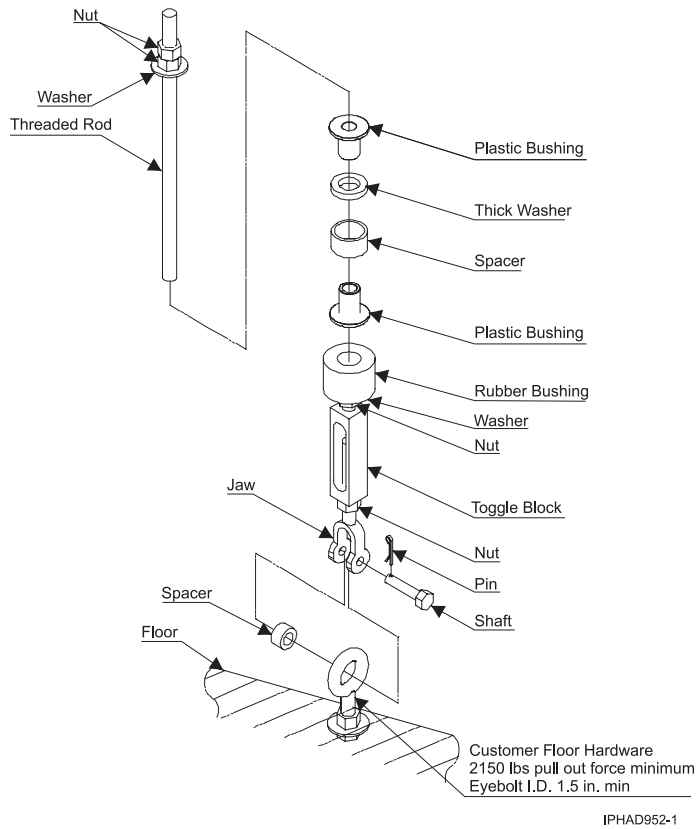

Figure 22. Turnbuckle assembly frame tie-down hardware for 228.6 - 330.2 mm (9 - 13 in.) raised floor (part number 44P2999)

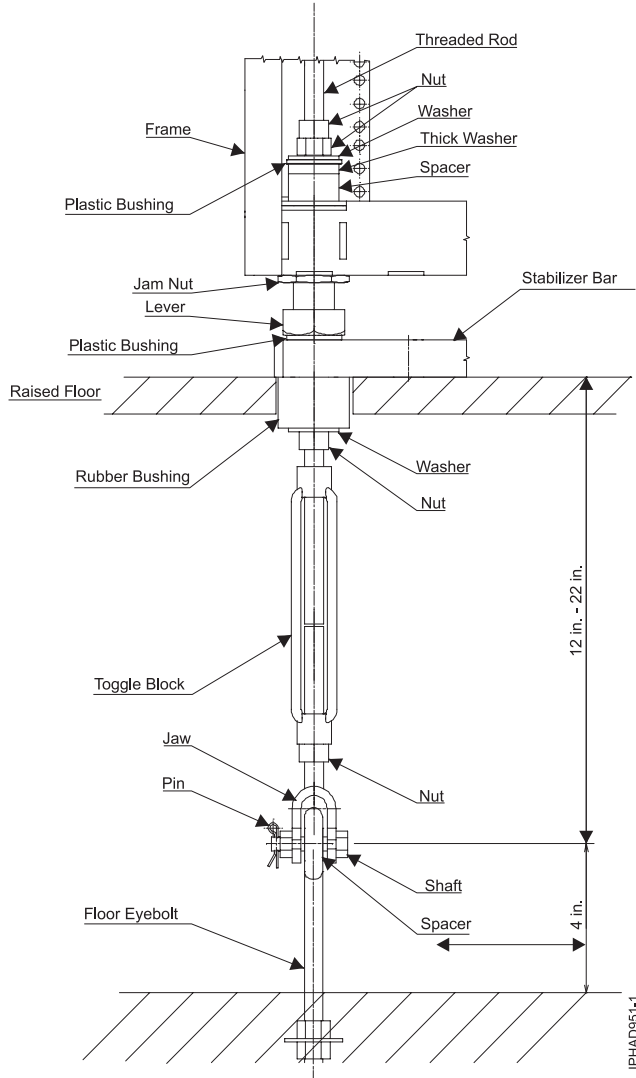

Figure 23. Turnbuckle assembly frame tie-down hardware for 304.8 - 558.8 mm (12 - 22 in.) raised floor (part number 44P3000)

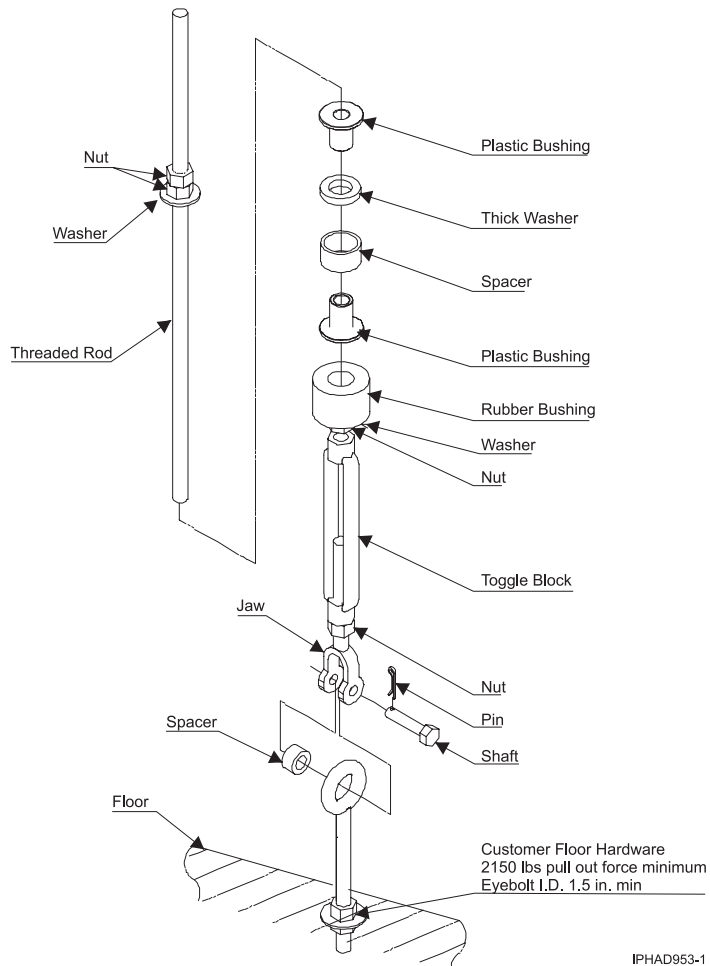

Figure 24. Turnbuckle assembly frame tie-down hardware for 304.8 - 558.8 mm (12 - 22 in.) raised floor (part number 44P3000)

Considerations for multiple-system installations:

Learn about the installation requirements for a multiple-system installation.

In a multiple-system installation, it is possible that a floor tile with cable cutouts (see “Cutting and placing floor panels” on page 22) will bear two concentrated static loads up to 476 kg (1050 lb) per caster and leveler. Thus, the total concentrated load can be as high as 1247.38 kg (2750 lb). Contact the floor tile manufacturer or consult a structural engineer to ensure that the raised-floor assembly can support this load.

When you are integrating model 19F/HB into an existing multiple-system environment or when you are adding additional systems to an installed 19F/HB, consider the following factors:

- Minimum aisle width

For multiple rows of systems containing one or more 19F/HB models, the minimum aisle width in the front of the systems is 1219 mm (48 in.) and the minimum width in the rear of the systems is 914 mm (36 in.). The front and rear clearances are necessary for service operations. Service clearances are measured from the edges of the frame (with doors open) to the nearest obstacle.

- Thermal interactions

Systems should be faced front-to-front and rear-to-rear to create "cold" and "hot" aisles to maintain effective system thermal conditions, as shown in the following figure.

Cold aisles need to be of sufficient width to support the airflow requirements of the installed systems as indicated in "Cooling requirements (New installation)" on page 61 and "Cooling requirements (POWER6 upgrade)" on page 64. The airflow per tile is dependent on the underfloor pressure and perforations in the tile. A typical underfloor pressure of 0.025 in. of water supplies 300 - 400 cubic feet per minute (CFM) through a 25% open 2 ft by 2 ft floor tile.

Proposed Floor Layout for Multiple Systems

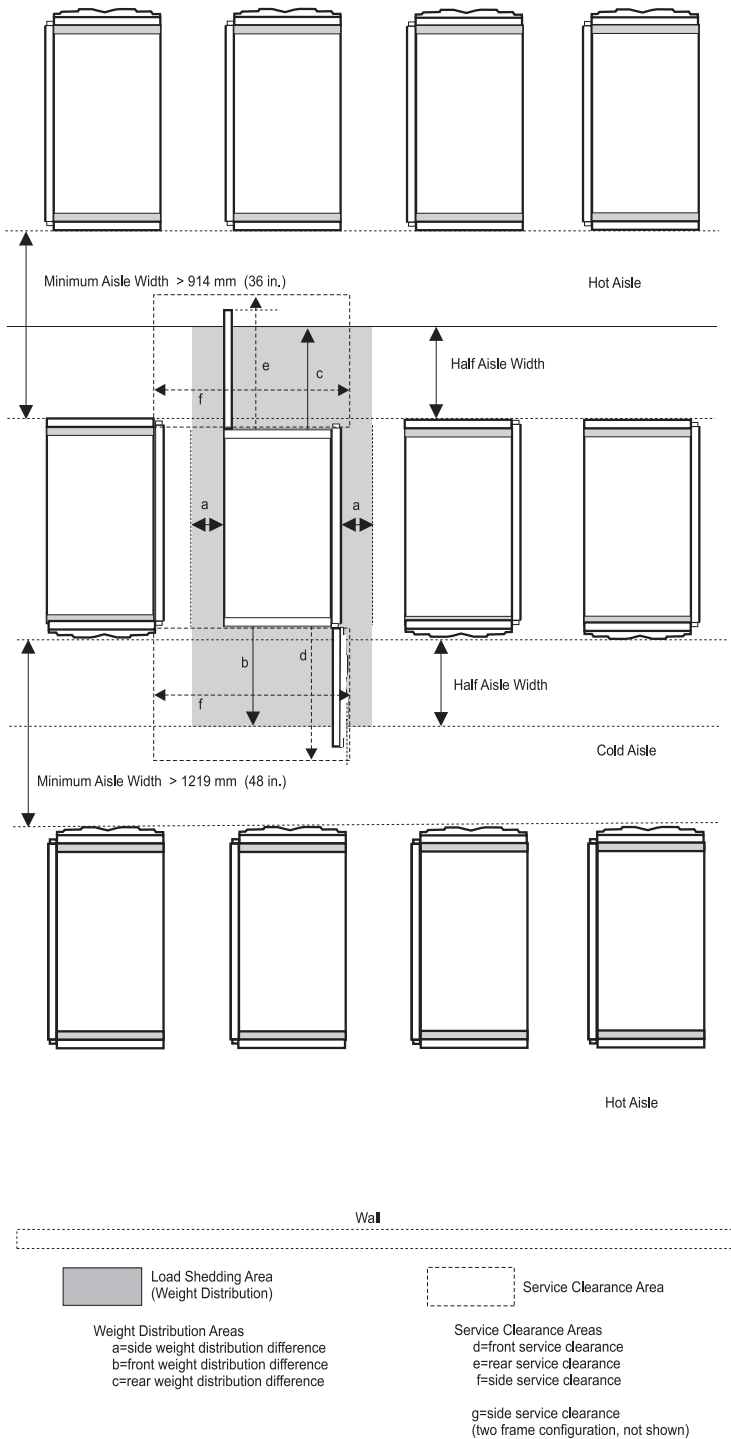

A4AA5733-2

Figure 25. Proposed floor layout for multiple systems

Total system power consumption (New installation)

Use the following tables to determine the total system power consumption for your server's configuration.

The following tables show the maximum utility power in kilowatts. Actual system power is affected by memory configuration and system workload. The actual system power is typically less than the maximum listed amount. BPR current determines power cord size. Systems with two BPRs are unbalanced. A balanced power feature is optionally available for customers whose configuration calls for one or two BPRs but need a simple way to achieve balanced three-phase power loading without having to custom wire their three-phase AC power distribution.

The configuration of the system determines the power cord that is needed. See "Electrical requirements (New installation)" on page 50 for more information. Amperage calculations based on the maximum measured power consumption could exceed the derated circuit breaker value. If this occurs based on the voltage used in the facility, the actual power consumption based on the configuration should be calculated.

The following tables show the maximum nominal power in kilowatts at maximum line voltage while in Turbo mode for a new POWER7 system. Maximum power requirements are higher in turbo mode than in nominal mode.

Table 19. Maximum power requirements - DPS/FP mode (New installation) 208 V ac

208 V ac				
Processor books (nodes)	I/O drawer			
	0	1	2	3
1	5.5	6.5	7.4	8.3
2	8.6	9.5	10.4	11.4
3	13.9	14.8	15.7	16.7
4	16.9 ¹	17.8 ¹	18.8 ¹	19.7 ¹
5	19.9 ¹	20.9 ¹	21.8 ¹	22.8 ¹
6	23.0 ¹	23.9 ¹	24.8 ¹	25.8 ¹
7	26.0 ¹	26.9 ¹	27.9 ¹	28.8 ¹
8	29.1 ¹	30.0 ¹	30.2 ¹	30.2 ¹

¹ A higher rated power cord is required.

Table 20. Maximum power requirements - DPS/FP mode (New installation) 240 V ac

240 V ac				
Processor books (nodes)	I/O drawer			
	0	1	2	3
1	5.5	6.5	7.4	8.3
2	8.6	9.5	10.4	11.4
3	13.9	14.8	15.7	16.7
4	16.9 ¹	17.8 ¹	18.8 ¹	19.7 ¹
5	19.9 ¹	20.9 ¹	21.8 ¹	22.8 ¹
6	23.0 ¹	23.9 ¹	24.8 ¹	25.8 ¹
7	26.0 ¹	26.9 ¹	27.9 ¹	28.8 ¹
8	29.1 ¹	30.0 ¹	30.9 ¹	31.9 ¹

Table 20. Maximum power requirements - DPS/FP mode (New installation) 240 V ac (continued)

240 V ac				
Processor books (nodes)	I/O drawer			
	0	1	2	3
¹ A higher rated power cord is required.				

Table 21. Maximum power requirements - DPS/FP mode (New installation) 380 - 440 V ac

380 - 440 V ac				
Processor books (nodes)	I/O drawer			
	0	1	2	3
1	5.3	6.2	7.1	8.0
2	8.2	9.1	10.0	10.9
3	13.3	14.2	15.1	16.0
4	16.3 ¹	17.2 ¹	18.1 ¹	19.0 ¹
5	19.2 ¹	20.1 ¹	21.0 ¹	21.9 ¹
6	22.1 ¹	23.0 ¹	23.9 ¹	24.8 ¹
7	25.0 ¹	25.9 ¹	26.8 ¹	27.7 ¹
8	27.9 ¹	28.8 ¹	29.7 ¹	30.6 ¹
¹ A higher rated power cord is required. Note: North American installations will always use the higher rated line cord set at 380 - 440 V ac				

Table 22. Maximum power requirements - DPS/FP mode (New installation) 480 V ac

480 V ac				
Processor books (nodes)	I/O drawer			
	0	1	2	3
1	5.4	6.3	7.2	8.1
2	8.3	9.2	10.1	11.0
3	13.4	14.3	15.2	16.1
4	16.4 ¹	17.3 ¹	18.2 ¹	19.1 ¹
5	19.3 ¹	20.2 ¹	21.1 ¹	22.0 ¹
6	22.2 ¹	23.1 ¹	24.0 ¹	24.9 ¹
7	25.2 ¹	26.1 ¹	27.0 ¹	27.9 ¹
8	28.1 ¹	29.0 ¹	29.9 ¹	30.8 ¹
¹ A higher rated power cord is required.				

Table 23. Maximum power requirements - DPS/FP mode (New installation) 380 - 520 V dc

380 - 520 V dc				
Processor books (nodes)	I/O drawer			
	0	1	2	3
1	5.4 ¹	6.3 ¹	7.2 ¹	8.1 ¹
2	8.3 ¹	9.2 ¹	10.1 ¹	11.0 ¹
3	13.4 ¹	14.3 ¹	15.2 ¹	16.1 ¹
4	16.4 ¹	17.3 ¹	18.2 ¹	19.1 ¹

Table 23. Maximum power requirements - DPS/FP mode (New installation) 380 - 520 V dc (continued)

380 - 520 V dc				
Processor books (nodes)	I/O drawer			
	0	1	2	3
5	19.3 ¹	20.2 ¹	21.1 ¹	22.0 ¹
6	22.2 ¹	23.1 ¹	24.0 ¹	24.9 ¹
7	25.2 ¹	26.1 ¹	27.0 ¹	27.9 ¹
8	28.1 ¹	29.0 ¹	29.9 ¹	30.8 ¹

¹ A higher rated power cord is required.

The following tables show the maximum nominal power in kilowatts at maximum line voltage in a worst case environment, workload, and processor sort for a new POWER7 system.

Table 24. Maximum power requirements - Nominal mode (New installation) 200 - 240 V ac

200 - 240 V ac				
Processor books (nodes)	I/O drawer			
	0	1	2	3
1	5.3	6.2	7.1	8.1
2	8.0	8.5	9.9	10.8
3	13.0	14.0	14.9	15.8
4	15.8 ¹	16.7 ¹	17.7 ¹	18.6 ¹
5	18.5 ¹	19.5 ¹	20.4 ¹	21.3 ¹
6	21.3 ¹	22.2 ¹	23.2 ¹	24.1 ¹
7	24.0 ¹	25.0 ¹	25.9 ¹	26.8 ¹
8	26.8 ¹	27.7 ¹	28.7 ¹	29.6 ¹

¹ A higher rated power cord is required.

Table 25. Maximum power requirements - Nominal mode (New installation) 380 - 440 V ac

380 - 440 V ac				
Processor books (nodes)	I/O drawer			
	0	1	2	3
1	5.1	6.0	6.9	7.8
2	7.7	8.6	9.5	10.4
3	12.5	13.4	14.3	15.2
4	15.2 ¹	16.1 ¹	17.0 ¹	17.9 ¹
5	17.8 ¹	18.7 ¹	19.6 ¹	20.5 ¹
6	20.5 ¹	21.4 ¹	22.3 ¹	23.2 ¹
7	23.1 ¹	24.0 ¹	24.9 ¹	25.8 ¹
8	25.8 ¹	26.7 ¹	27.6 ¹	28.5 ¹

¹ A higher rated power cord is required.
Note: North American installations will always use the higher rated line cord set at 380 - 440 V ac

Table 26. Maximum power requirements - Nominal mode (New installation) 480 V ac

480 V ac				
Processor books (nodes)	I/O drawer			
	0	1	2	3
1	5.1	6.0	6.9	7.8
2	7.7	8.6	9.6	10.5
3	12.6	13.5	14.4	15.3
4	15.3 ¹	16.2 ¹	17.1 ¹	18.0 ¹
5	17.9 ¹	18.8 ¹	19.7 ¹	20.6 ¹
6	20.6 ¹	21.5 ¹	22.4 ¹	23.3 ¹
7	23.2 ¹	24.2 ¹	25.1 ¹	26.0 ¹
8	25.9 ¹	26.8 ¹	27.7 ¹	28.6 ¹

¹ A higher rated power cord is required.

Table 27. Maximum power requirements - Nominal mode (New installation) 380 - 520 V dc

380 - 520 V dc				
Processor books (nodes)	I/O drawer			
	0	1	2	3
1	5.1 ¹	6.0 ¹	6.9 ¹	7.8 ¹
2	7.7 ¹	8.6 ¹	9.6 ¹	10.5 ¹
3	12.6 ¹	13.5 ¹	14.4 ¹	15.3 ¹
4	15.3 ¹	16.2 ¹	17.1 ¹	18.0 ¹
5	17.9 ¹	18.8 ¹	19.7 ¹	20.6 ¹
6	20.6 ¹	21.5 ¹	22.4 ¹	23.3 ¹
7	23.2 ¹	24.2 ¹	25.1 ¹	26.0 ¹
8	25.9 ¹	26.8 ¹	27.7 ¹	28.6 ¹

¹ A higher rated power cord is required.

Typical system power consumption

System power consumption can vary greatly depending by components, utilization, ambient temperature and workload. The following tables are provided as power estimates for a smaller configuration at a nominal ambient temperature when compared to the maximum configuration in the total system power consumption. Actual power consumption varies greatly with workload and can also vary with time. These are estimates only. To understand your server's actual power consumption, you should consistently measure and monitor the power draw of the system.

The following tables show the typical utility power in kilowatts, assuming a typical workload, typical processor sort with no processors in Turbo mode.

Table 28. Typical power requirements - Nominal mode (New installation) 200 - 240 V ac

200 - 240 V ac				
Processor books (nodes)	I/O drawers			
	0	1	2	3
1	2.9	3.9	4.8	5.7

Table 28. Typical power requirements - Nominal mode (New installation) 200 - 240 V ac (continued)

200 - 240 V ac				
Processor books (nodes)	I/O drawers			
	0	1	2	3
2	4.9	5.9	6.8	7.7
3	7.6	8.6	9.5	10.4
4	9.6 ¹	10.6 ¹	11.5 ¹	12.4 ¹
5	11.6 ¹	12.6 ¹	13.5 ¹	14.4 ¹
6	13.6 ¹	14.6 ¹	15.5 ¹	16.4 ¹
7	15.6 ¹	16.6 ¹	17.5 ¹	18.5 ¹
8	17.7 ¹	18.6 ¹	19.5 ¹	20.5 ¹

¹ A higher rated power cord is required.

Table 29. Typical power requirements - Nominal mode (New installation) 380 - 440 V ac

380 - 440 V ac				
Processor books (nodes)	I/O drawers			
	0	1	2	3
1	2.8	3.7	4.6	5.5
2	4.7	5.6	6.5	7.4
3	7.3	8.2	9.1	10.0
4	9.3 ¹	10.2 ¹	11.1 ¹	12.0 ¹
5	11.2 ¹	12.1 ¹	13.0 ¹	13.9 ¹
6	13.1 ¹	14.0 ¹	14.9 ¹	15.8 ¹
7	15.0 ¹	15.9 ¹	16.8 ¹	17.7 ¹
8	17.0 ¹	17.9 ¹	18.8 ¹	19.7 ¹

¹ A higher rated power cord is required.
Note: North American installations will always use the higher rated line cord set at 380 - 440 V ac

Table 30. Typical power requirements - Nominal mode (New installation) 480 V ac

480 V ac				
Processor books (nodes)	I/O drawers			
	0	1	2	3
1	2.8	3.7	4.6	5.5
2	4.8	5.7	6.6	7.5
3	7.4	8.3	9.2	10.1
4	9.3 ¹	10.2 ¹	11.1 ¹	12.0 ¹
5	11.2 ¹	12.2 ¹	13.1 ¹	14.0 ¹
6	13.2 ¹	14.1 ¹	15.0 ¹	15.9 ¹
7	15.1 ¹	16.0 ¹	16.9 ¹	17.8 ¹
8	17.1 ¹	18.0 ¹	18.9 ¹	19.8 ¹

¹ A higher rated power cord is required.

Table 31. Typical power requirements - Nominal mode (New installation) 380 - 520 V dc

380 - 520 V dc				
Processor books (nodes)	I/O drawers			
	0	1	2	3
1	2.8 ¹	3.7 ¹	4.6 ¹	5.5 ¹
2	4.8 ¹	5.7 ¹	6.6 ¹	7.5 ¹
3	7.4 ¹	8.3 ¹	9.2 ¹	10.1 ¹
4	9.3 ¹	10.2 ¹	11.1 ¹	12.0 ¹
5	11.2 ¹	12.2 ¹	13.1 ¹	14.0 ¹
6	13.2 ¹	14.1 ¹	15.0 ¹	15.9 ¹
7	15.1 ¹	16.0 ¹	16.9 ¹	17.8 ¹
8	17.1 ¹	18.0 ¹	18.9 ¹	19.8 ¹

¹ A higher rated power cord is required.

Total system power consumption (POWER6 upgrade)

Use the tables to determine the total system power consumption for your server's configuration.

The following tables show the maximum utility power in kilowatts. Actual system power is affected by memory configuration and system workload. The actual system power is typically less than the maximum listed amount. BPR current determines power cord size. Systems with two BPRs are unbalanced. A balanced power feature is optionally available for customers whose configuration calls for one or two BPRs, but need a simple way to achieve balanced three-phase power loading without having to custom wire their three-phase AC power distribution.

The configuration of the system determines the power cord that is needed. See "Electrical requirements (POWER6 upgrade)" on page 51 for more information. Amperage calculations based on the maximum measured power consumption could exceed the derated circuit breaker value. If this occurs based on the voltage used in the facility, the actual power consumption based on the configuration should be calculated.

The following tables show the maximum nominal power in kilowatts at maximum line voltage while in Turbo mode for a POWER6 upgrade. Maximum power requirements are higher in turbo mode than in nominal mode.

Table 32. Maximum power requirements - DPS/FP mode (POWER6 upgrade) 208 V ac

208 V ac				
Processor books (nodes)	I/O drawer			
	0	1	2	3
1	5.4	6.3	7.2	8.2
2	8.4	9.4	10.3	11.2
3	13.6	14.5	15.5	16.4
4	16.6	17.5	18.5	19.4
5	19.6	20.6	21.5 ¹	22.5 ¹
6	22.7 ¹	23.6 ¹	24.6 ¹	25.5 ¹
7	25.7 ¹	26.7 ¹	27.6 ¹	28.5 ¹
8	28.8 ¹	29.7 ¹	30.2 ¹	30.2 ¹

¹A higher rated power cord is required.

Table 33. Maximum power requirements - DPS/FP mode (POWER6 upgrade) 240 V ac

240 V ac				
Processor books (nodes)	I/O drawer			
	0	1	2	3
1	5.4	6.3	7.2	8.2
2	8.4	9.4	10.3	11.2
3	13.6	14.5	15.5	16.4
4	16.6	17.5	18.5	19.4
5	19.6	20.6	21.5 ¹	22.5 ¹
6	22.7 ¹	23.6 ¹	24.6 ¹	25.5 ¹
7	25.7 ¹	26.5 ¹	27.6 ¹	28.5 ¹
8	28.8 ¹	29.7 ¹	30.6 ¹	31.6 ¹

¹A higher rated power cord is required.

Table 34. Maximum power requirements - DPS/FP mode (POWER6 upgrade) 380 - 415 V ac

380 - 415 V ac				
Processor books (nodes)	I/O drawer			
	0	1	2	3
1	5.3	6.2	7.1	8.0
2	8.2	9.1	10.0	10.9
3	13.3	14.2	15.1	16.0
4	16.3	17.2	18.1	19.0
5	19.2	20.1	21.0 ¹	21.9 ¹
6	22.1 ¹	23.0 ¹	23.9 ¹	24.8 ¹
7	25.0 ¹	25.9 ¹	26.8 ¹	27.7 ¹
8	27.9 ¹	28.8 ¹	29.7 ¹	30.6 ¹

¹A higher rated power cord is required.

Table 35. Maximum power requirements - DPS/FP mode (POWER6 upgrade) - 480 V ac

480 V ac				
Processor books (nodes)	I/O drawer			
	0	1	2	3
1	5.4	6.3	7.2	8.1
2	8.3	9.2	10.1	11.0
3	13.4	14.3	15.2	16.1
4	16.4	17.3	18.2	19.1
5	19.3	20.2	21.1 ¹	22.0 ¹
6	22.2 ¹	23.1 ¹	24.0 ¹	24.9 ¹
7	25.2 ¹	26.1 ¹	27.0 ¹	27.9 ¹
8	28.1 ¹	29.0 ¹	29.9 ¹	30.8 ¹

¹A higher rated power cord is required.

Table 36. Maximum power requirements - DPS/FP mode (POWER6 upgrade) 380 - 520 V dc

380 - 520 V dc				
Processor books (nodes)	I/O drawer			
	0	1	2	3
1	N/A - V dc option is not offered for a POWER6 upgrade			
2				
3				
4				
5				
6				
7				
8				

The following tables show the maximum nominal power in kilowatts at maximum line voltage in a worst case environment, workload, and processor sort for a POWER6 upgrade system.

Table 37. Maximum power requirements - Nominal mode (POWER6 upgrade) 200 - 240 V ac

200 - 240 V ac				
Processor books (nodes)	I/O drawer			
	0	1	2	3
1	5.3	6.2	7.1	8.1
2	8.0	8.5	9.9	10.8
3	13.0	14.0	14.9	15.8
4	15.8	16.7	17.7	18.6
5	18.5	19.5	20.4 ¹	21.3 ¹
6	21.3 ¹	22.2 ¹	23.2 ¹	24.1 ¹
7	24.0 ¹	25.0 ¹	25.9 ¹	26.8 ¹
8	26.8 ¹	27.7 ¹	28.7 ¹	29.6 ¹

¹ A higher rated power cord is required.

Table 38. Maximum power requirements - Nominal mode (POWER6 upgrade) 380 - 415 V ac

380 - 415 V ac				
Processor books (nodes)	I/O drawer			
	0	1	2	3
1	5.1	6.0	6.9	7.8
2	7.7	8.6	9.5	10.4
3	12.5	13.4	14.3	15.2
4	15.2	16.1	17.0	17.9
5	17.8	18.7	19.6 ¹	20.5 ¹
6	20.5 ¹	21.4 ¹	22.3 ¹	23.2 ¹
7	23.1 ¹	24.0 ¹	24.9 ¹	25.8 ¹
8	25.8 ¹	26.7 ¹	27.6 ¹	28.5 ¹

¹ A higher rated power cord is required.

Table 39. Maximum power requirements - Nominal mode (POWER6 upgrade) 480 V ac

480 V ac				
Processor books (nodes)	I/O drawer			
	0	1	2	3
1	5.1	6.0	6.9	7.8
2	7.7	8.6	9.6	10.5
3	12.6	13.5	14.4	15.3
4	15.3	16.	17.1	18.0
5	17.9	18.8	19.7 ¹	20.6 ¹
6	20.6 ¹	21.5 ¹	22.4 ¹	24.0 ¹
7	23.2 ¹	24.2 ¹	25.1 ¹	26.0 ¹
8	25.9 ¹	26.8 ¹	27.7 ¹	28.6 ¹

¹ A higher rated power cord is required.

Table 40. Maximum power requirements - Nominal mode (POWER6 upgrade) 380 - 520 V dc

380 - 520 V dc				
Processor books (nodes)	I/O drawer			
	0	1	2	3
1	N/A - V dc option is not offered for a POWER6 upgrade			
2				
3				
4				
5				
6				
7				
8				

Typical system power consumption

System power consumption can vary greatly depending by components, utilization, ambient temperature and workload. The following tables are provided as power estimates for a smaller configuration at a nominal ambient temperature when compared to the maximum configuration in the total system power consumption. Actual power consumption varies greatly with workload and can also vary with time. These are estimates only. To understand your server's actual power consumption, you should consistently measure and monitor the power draw of the system.

The following tables show the typical utility power in kilowatts, assuming a typical workload, typical processor sort with no processors in Turbo mode.

Table 41. Typical power requirements - Nominal mode (POWER6 upgrade) 200 - 240 V ac

200 - 240 V ac				
Processor books (nodes)	I/O drawers			
	0	1	2	3
1	2.9	3.9	4.8	5.7

Table 41. Typical power requirements - Nominal mode (POWER6 upgrade) 200 - 240 V ac (continued)

200 - 240 V ac				
Processor books (nodes)	I/O drawers			
	0	1	2	3
2	4.9	5.9	6.8	7.7
3	7.6	8.6	9.5	10.4
4	9.6 ¹	10.6 ¹	11.5 ¹	12.4 ¹
5	11.6 ¹	12.6 ¹	13.5 ¹	14.4 ¹
6	13.6 ¹	14.6 ¹	15.5 ¹	16.4 ¹
7	15.6 ¹	16.6 ¹	17.5 ¹	18.5 ¹
8	17.7 ¹	18.6 ¹	19.5 ¹	20.5 ¹

¹ A higher rated power cord is required.

Table 42. Typical power requirements - Nominal mode (POWER6 upgrade) 380 - 415 V ac

380 - 415 V ac				
Processor books (nodes)	I/O drawers			
	0	1	2	3
1	2.8	3.7	4.6	5.5
2	4.7	5.6	6.5	7.4
3	7.3	8.2	9.1	10.0
4	9.3 ¹	10.2 ¹	11.1 ¹	12.0 ¹
5	11.2 ¹	12.1 ¹	13.0 ¹	13.9 ¹
6	13.1 ¹	14.0 ¹	14.9 ¹	15.8 ¹
7	15.0 ¹	15.9 ¹	16.8 ¹	17.7 ¹
8	17.0 ¹	17.9 ¹	18.8 ¹	19.7 ¹

¹ A higher rated power cord is required.
Note: North American installations will always use the higher rated line cord set at 380 - 440 V ac

Table 43. Typical power requirements - Nominal mode (POWER6 upgrade) 480 V ac

480 V ac				
Processor books (nodes)	I/O drawers			
	0	1	2	3
1	2.8	3.7	4.6	5.5
2	4.8	5.7	6.6	7.5
3	7.4	8.3	9.2	10.1
4	9.3 ¹	10.2 ¹	11.1 ¹	12.0 ¹
5	11.2 ¹	12.2 ¹	13.1 ¹	14.0 ¹
6	13.2 ¹	14.1 ¹	15.0 ¹	15.9 ¹
7	15.1 ¹	16.0 ¹	16.9 ¹	17.8 ¹
8	17.1 ¹	18.0 ¹	18.9 ¹	19.8 ¹

¹ A higher rated power cord is required.

Table 44. Typical power requirements - Nominal mode (POWER6 upgrade) 380 - 520 V dc

380 - 520 V dc				
Processor books (nodes)	I/O drawers			
	0	1	2	3
1	N/A - V dc option is not offered for a POWER6 upgrade			
2				
3				
4				
5				
6				
7				
8				

Power cord features

Use the power cord features tables to view the power cord specifications available for your server.

The following three-phase power cord features are available for the three-phase model 19F/HB:

Note: All model 19F/HB systems using alternating current (AC) have a voltage tolerance of 180 - 508 V ac and a frequency range of 47 - 63 Hz.

Table 45. Power cord features (AC)

Feature Code (FC)	Size (AWG)	Length (ft)	Plug Type	Plug Rating	Phase/pole/wire	Clock Position	Recommended Receptacle
8677 ¹	8	14	No Plug				
8688	6	14	IEC 309	60 A	3/3/4	9	HBL460R9W
8694 ¹	6	14	No Plug				
8695 ¹	4	14	No Plug				
8696	4	14	IEC 309	100 A	3/3/4	9	HBL4100R9W
8697	8	14	IEC 309	30 A	3/3/4	5	HBL430R7W
8699	6	14	IEC 309	60 A	3/3/4	9	HBL460R7W
RPQ 8A1871	6	14	RussellStoll 7328DP	60 A	3/3/4		RussellStoll 7324-78

¹These power cords are shipped without a plug or receptacle. An electrician might be required to install the plug and receptacle to meet applicable country or region electrical codes.

Table 46. Power cord features (DC)

Feature Code (FC)	Size (AWG)	Length (ft)	Plug Type	Plug Rating	Pole	Wire	Clock Position
8792	4	14	IEC 309	100 A	2	3	5
8789 ¹	4	14	No Plug				

¹These power cords are shipped without a plug or receptacle. An electrician might be required to install the plug and receptacle to meet applicable country or region electrical codes.

Electrical requirements (New installation)

Use this information to determine the system rating and line cord requirements by configurations for the 19F/HB.

Note: The 19F/HB server design incorporates electromagnetic interference filter capacitors required to block electrical noise from penetrating the power grid. A characteristic of filter capacitors, during normal operation, is high leakage currents. Depending on the server configuration, this leakage current can reach 350 mA. For most reliable operation, Ground Fault Circuit Interrupter (GFCI), Earth Leakage Circuit Breaker (ELCB) or Residual Current Circuit Breaker (RCCB) type circuit breakers are not recommended for use with 19F/HB servers. By its internal design and grounding, the 19F/HB server is fully certified for safe operation (compliance with IEC, CN, UL, CSA 60950-1). However, if a leakage detection circuit breaker is required by local electrical practice or standards, the breaker should be sized for a leakage current rating not less than 500 mA in order to reduce the risk of a server outage caused by erroneous and spurious tripping.

The system rating and power cord requirements vary by configuration. Systems with 1, 2, or 3 processor books can use the lower rated line cord set. All other configurations use the higher rated line cord set. Exceptions include the 330 - 520 V dc systems used in North American installations which always use the higher rated line cord set. Use the following tables to determine the electrical requirements for a new POWER7 installation.

Table 47. System electrical requirements (New installation) 200 - 240 V ac

200 - 240 V ac		
North America/Japan	Lower rated set	Higher rated set
Line cord feature code	8688	8696
Plug rating	60 A	100 A
System rating	48 A	80 A
Recommended circuit breaker rating	60 A	100 A
Cord size	6 AWG	4 AWG
All other jurisdictions	Lower rated set	Higher rated set
Line cord feature code	8694	8695
Plug rating	no plug	no plug
System rating	48 A	80 A
Recommended circuit breaker rating	60 - 63 A	100 A
Cord size	6 AWG	4 AWG

Table 48. System electrical requirements (New installation) 380 - 415 V ac

380 - 415 V ac		
All jurisdictions excluding North America/Japan	Lower rated set	Higher rated set
Line cord feature code	8677	8694
Plug rating	no plug	no plug
System rating	25.6 A	48 A
Recommended circuit breaker rating	32 - 40 A	54 - 63 A
Cord size	8 AWG	6 AWG
North America	Lower rated set	Higher rated set
Line cord feature code	N/A	RPQ 8A1871
Plug rating	N/A	60 A

Table 48. System electrical requirements (New installation) 380 - 415 V ac (continued)

System rating	N/A	48 A
Recommended circuit breaker rating	N/A	54 - 63 A
Cord size	N/A	6 AWG

Table 49. System electrical requirements (New installation) - 480 V ac

480 V ac		
North America/Japan	Lower rated set	Higher rated set
Line cord feature code	8697	8699
Plug rating	30 A	60 A
System rating	22 A	42 A
Recommended circuit breaker rating	26 - 30 A	50 - 60 A
Cord size	8 AWG	6 AWG
All other jurisdictions	Lower rated set	Higher rated set
Line cord feature code	N/A	N/A
Plug rating	N/A	N/A
System rating	N/A	N/A
Recommended circuit breaker rating	N/A	N/A
Cord size	N/A	N/A

Table 50. System electrical requirements (New installation) 330 - 520 V dc

330 - 520 V dc		
North America/Japan	Lower rated set	Higher rated set
Line cord feature code	N/A	8792
Plug rating	N/A	100 A
System rating	N/A	72 A
Recommended circuit breaker rating	N/A	100 A
Cord size	N/A	4 AWG
All other jurisdictions	Lower rated set	Higher rated set
Line cord feature code	N/A	8789
Plug rating	N/A	no plug
System rating	N/A	72 A
Recommended circuit breaker rating	N/A	100 A
Cord size	N/A	4 AWG

Electrical requirements (POWER6 upgrade)

Use this information to determine the system rating and line cord requirements by configurations for the 19F/HB.

Note: The 19F/HB server design incorporates electromagnetic interference filter capacitors required to block electrical noise from penetrating the power grid. A characteristic of filter capacitors, during normal operation, is high leakage currents. Depending on the server configuration, this leakage current can reach 350 mA. For most reliable operation, Ground Fault Circuit Interrupter (GFCI), Earth Leakage Circuit Breaker (ELCB) or Residual Current Circuit Breaker (RCCB) type circuit breakers are not recommended

for use with 19F/HB servers. By its internal design and grounding, the 19F/HB server is fully certified for safe operation (compliance with IEC, CN, UL, CSA 60950-1). However, if a leakage detection circuit breaker is required by local electrical practice or standards, the breaker should be sized for a leakage current rating not less than 500 mA in order to reduce the risk of a server outage caused by erroneous and spurious tripping.

The system rating and power cord requirements vary by configuration. Systems with 1 - 4 (I/O drawers 0, 1, 2, and 3) and 5 (I/O drawers 0 and 1) processor books can use the lower rated line cord set. All other configurations use the higher rated line cord set. Use the following tables to determine the electrical requirements for a POWER6 upgrade installation.

Table 51. System electrical requirements (POWER6 upgrade installation) 200 - 240 V ac

200 - 240 V ac		
North America/Japan	Lower rated set	Higher rated set
Line cord Feature Cord	8688	8696
Plug rating	60 A	100 A
System rating	48 A	80 A
Recommended circuit breaker rating	60 A	100 A
Cord size	6 AWG	4 AWG
All other jurisdictions	Lower rated set	Higher rated set
Line cord Feature Cord	8694	8695
Plug rating	no plug	no plug
System rating	48 A	80 A
Recommended circuit breaker rating	60 A	100 A
Cord size	6 AWG	4 AWG

Table 52. System electrical requirements (POWER6 upgrade installation) 380 - 415 V ac

380 - 415 V ac		
North America/Japan	Lower rated set	Higher rated set
Line cord Feature Cord	N/A	RPQ 8A1871
Plug rating	N/A	60 A
System rating	N/A	43 A
Recommended circuit breaker rating	N/A	54 - 63 A
Cord size	N/A	6 AWG
All other jurisdictions	Lower rated set	Higher rated set
Line cord Feature Cord	8677	8694
Plug rating	no plug	no plug
System rating	34 A	43 A
Recommended circuit breaker rating	40 A	63 A
Cord size	8 AWG	6 AWG

Table 53. System electrical requirements (POWER6 upgrade installation) 480 V ac

480 V ac		
North America/Japan	Lower rated set	Higher rated set
Line cord Feature Cord	8697	8699

Table 53. System electrical requirements (POWER6 upgrade installation) 480 V ac (continued)

Plug rating	30 A	60 A
System rating	24 A	34 A
Recommended circuit breaker rating	30 A	60 A
Cord size	8 AWG	6 AWG
All other jurisdictions	Lower rated set	Higher rated set
Line cord Feature Cord	N/A	N/A
Plug rating	N/A	N/A
System rating	N/A	N/A
Recommended circuit breaker rating	N/A	N/A
Cord size	N/A	N/A

Table 54. System electrical requirements (POWER6 upgrade installation) 380 - 520 V dc

380 - 520 V dc		
North America/Japan	Lower rated set	Higher rated set
Line cord Feature Cord	N/A	N/A
Plug rating	N/A	N/A
System rating	N/A	N/A
Recommended circuit breaker rating	N/A	N/A
Cord size	N/A	N/A
All other jurisdictions	Lower rated set	Higher rated set
Line cord Feature Cord	N/A	N/A
Plug rating	N/A	N/A
System rating	N/A	N/A
Recommended circuit breaker rating	N/A	N/A
Cord size	N/A	N/A

BPR/BPD configuration and phase imbalance (New installation)

Use the system BPR/BPD tables to determine the requirements for Bulk Power Regulators (BPRs) and Bulk Power Distribution units (BPDs) for a new POWER7 system.

Depending on the number of BPRs in your system, phase imbalance can occur in line currents. Systems with two BPRs are unbalanced. An additional BPR can be ordered for customers who want to achieve balanced three-phase power loading without custom wiring.

The number of BPRs required for new POWER7 systems is different than the number of BPRs required for POWER6 upgrades.

Table 55. System BPR requirements (New installation)

All Voltage Ranges				
Processor books (nodes)	I/O drawer			
	0	1	2	3
1	2	2	2	2
2	2	2	2	2
3	3	3	3	3

Table 55. System BPR requirements (New installation) (continued)

All Voltage Ranges				
Processor books (nodes)	I/O drawer			
	0	1	2	3
4	3 ¹	3 ¹	3 ¹	3 ¹
5	4 ¹	4 ¹	4 ¹	4 ¹
6	4 ¹	4 ¹	4 ¹	4 ¹
7	4 ¹	4 ¹	4 ¹	4 ¹
8	4 ¹	4 ¹	4 ¹	4 ¹

¹ A higher rated power cord is required.

The number of BPDs required for new POWER7 systems and POWER6 upgrades are the same.

Table 56. System BPD requirements (New installation)

All Voltage Ranges				
Processor books (nodes)	I/O drawer			
	0	1	2	3
1	1	1	1	1
2	1	1	1	1
3	1	1	1	1
4	1 ¹	1 ¹	1 ¹	1 ¹
5	2 ¹	2 ¹	2 ¹	2 ¹
6	2 ¹	2 ¹	2 ¹	2 ¹
7	2 ¹	2 ¹	2 ¹	2 ¹
8	2 ¹	2 ¹	2 ¹	2 ¹

¹ A higher rated power cord is required.

BPR/BPD configuration and phase imbalance (POWER6 upgrade)

Use the system BPR/BPD tables to determine the requirements for Bulk Power Regulators (BPRs) and Bulk Power Distribution units (BPDs) for a new POWER7 system.

Depending on the number of BPRs in your system, phase imbalance can occur in line currents. Systems with two BPRs are unbalanced. An additional BPR can be ordered for customers who want to achieve balanced three-phase power loading without custom wiring.

The number of BPRs required for new POWER7 systems is different than the number of BPRs required for POWER6 upgrades.

Table 57. System BPR requirements (POWER6 upgrade)

All Voltage Ranges				
Processor books (nodes)	I/O drawer			
	0	1	2	3
1	2	2	2	2
2	2	2	2	2
3	3	3	3	3

Table 57. System BPR requirements (POWER6 upgrade) (continued)

All Voltage Ranges				
Processor books (nodes)	I/O drawer			
	0	1	2	3
4	3	3	3	3
5	3	3	3 ¹	4 ¹
6	4 ¹	4 ¹	4 ¹	4 ¹
7	4 ¹	4 ¹	4 ¹	4 ¹
8	4 ¹	4 ¹	4 ¹	4 ¹

¹ A higher rated power cord is required.

The number of BPDs required for new POWER7 systems and POWER6 upgrades are the same.

Table 58. System BPD requirements (POWER6 upgrade)

All Voltage Ranges				
Processor books (nodes)	I/O drawer			
	0	1	2	3
1	1	1	1	1
2	1	1	1	1
3	1	1	1	1
4	1 ¹	1 ¹	1 ¹	1 ¹
5	2 ¹	2 ¹	2 ¹	2 ¹
6	2 ¹	2 ¹	2 ¹	2 ¹
7	2 ¹	2 ¹	2 ¹	2 ¹
8	2 ¹	2 ¹	2 ¹	2 ¹

¹ A higher rated power cord is required.

Balancing power panel loads

Use this information to ensure that power panel loads are balanced.

System configurations using three or four BPRs presents a balanced load to the utility, provided that both line cords are energized. When only one line cord is energized, systems drawing more than 24 kW will present a slightly unbalanced load to the utility. AC systems two BPRs are unbalanced.

The following figure is an example of feeding several loads of this type from two power panels in a way that balances the load among the three-phases.

Note: Use of ground-fault-interrupt (GFI) circuit breakers is not recommended for this system because GFI circuit breakers are earth-leakage-current sensing circuit breakers and this system is a high earth-leakage-current product.

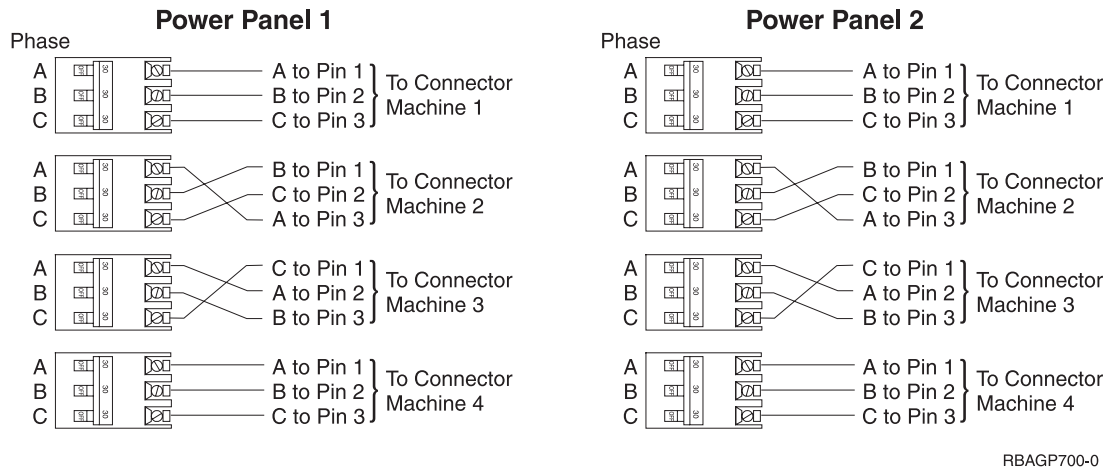

RBAGP700-0

Figure 26. Power panel load balancing

The method illustrated in the preceding figure requires that the connection from the three poles of each breaker to the three-phase pins of a connector be varied. Some electricians might prefer to maintain a consistent wiring sequence from the breakers to the connectors.

The following figure shows a way to balance the load without changing the wiring on the output of any breakers. The three-pole breakers are alternated with single-pole breakers so that the three-pole breakers do not all begin on phase A.

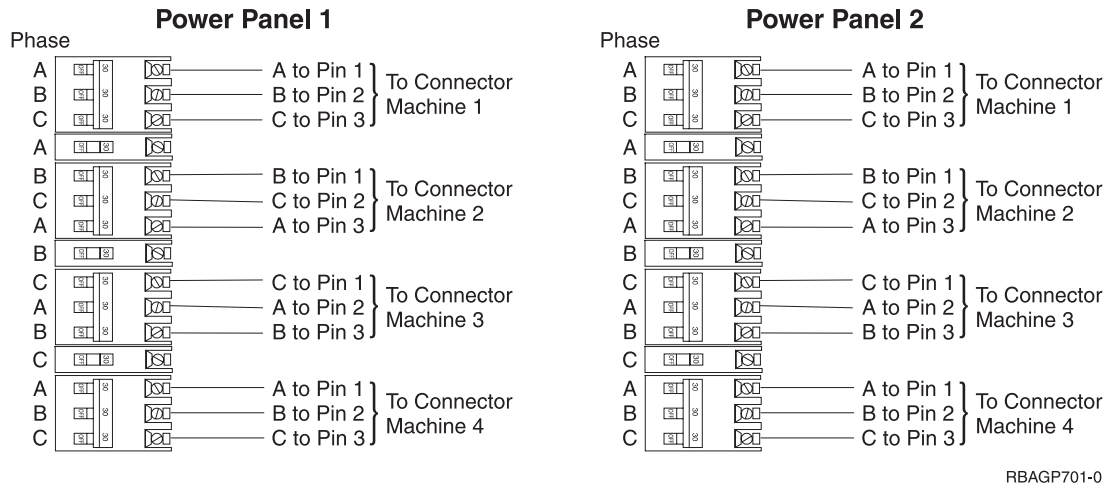

RBAGP701-0

Figure 27. Power panel load balancing

The following figure shows another way of distributing the unbalanced load evenly. In this case, the three-pole breakers are alternated with two-pole breakers.

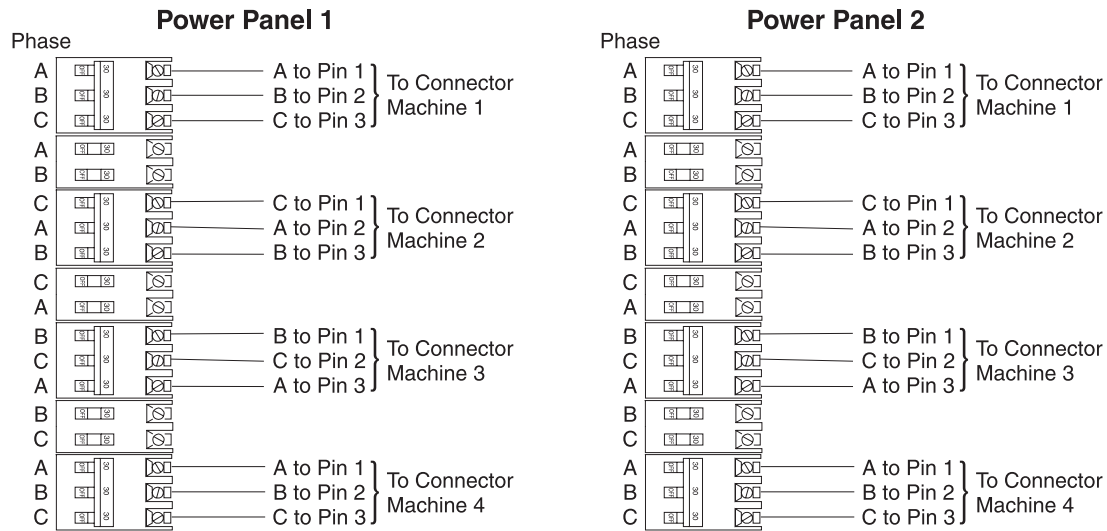

RBAGP702-0

Figure 28. Power panel load balancing

Dual power installation

To take full advantage of the redundancy and reliability that is built into the computer system, the system must be powered from two distribution panels.

Model 19F/HB configurations are designed with a fully redundant power system. These systems have two power cords attached to two power input ports which, in turn, power a fully redundant power distribution system within the system.

Unit emergency power off

The server has a unit emergency power off (EPO) switch on the front of the first frame (A frame). When the switch is reset, the utility power is confined to the system power compartment, and all volatile data is lost.

See the following figure, which shows a simplified unit EPO panel.

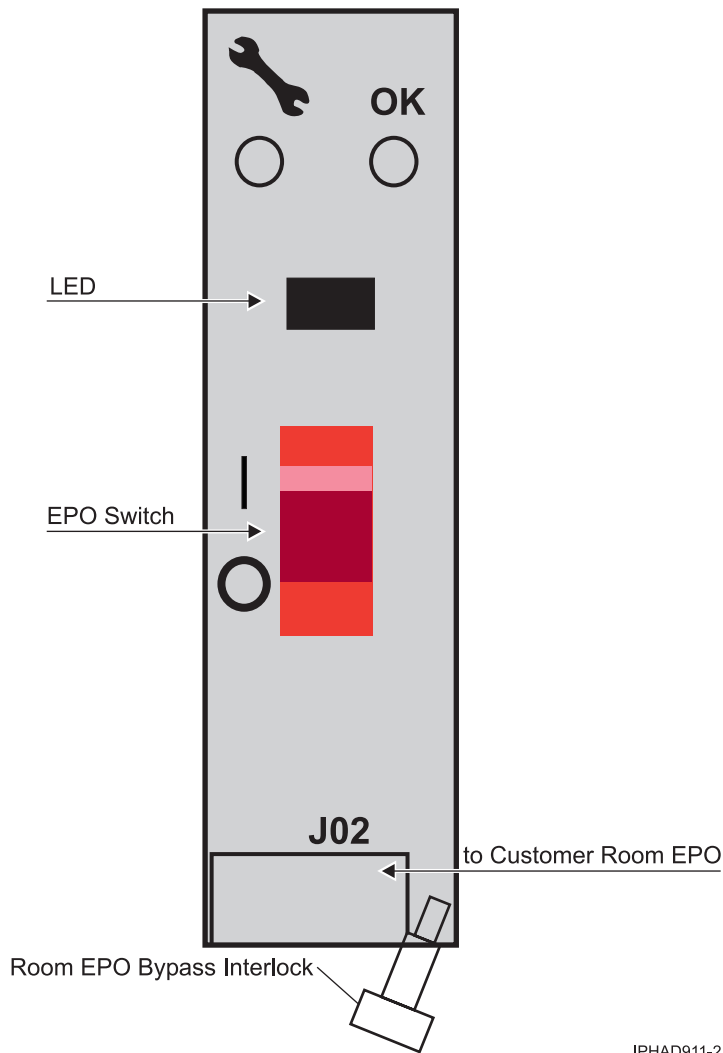

IPHAD911-2

Figure 29. Unit emergency power off

It is possible to attach the computer room emergency power off (EPO) system to the unit EPO. When this is done, resetting the computer room EPO disconnects all power from the power cords and the internal battery backup unit, if it is provided. All volatile data is lost in this case.

If the room EPO is not connected to the unit EPO, resetting the computer room unit EPO removes alternating current power from the system. If the interlock bypass feature is used, the system remains powered for a short time based on system configuration.

Computer room emergency power off

You can incorporate the integrated battery backup into a computer room emergency power off (EPO) system. Otherwise, volatile data can be lost.

When the integrated battery backup is installed and the computer room EPO is reset, the batteries engage and the computer continues to run. It is possible to attach the computer room EPO circuit to the unit EPO. When this is done, resetting the computer room EPO disconnects all power from the power cords and from the internal battery backup unit. In this event, all volatile data will be lost.

To incorporate the integrated battery backup into the computer room EPO circuit, a cable must connect to the back of the unit EPO panel.

This figure illustrates the back of the unit EPO panel with the computer room EPO cable plugging into the system. Notice the switch actuator. After it is moved to make the cable connection possible, the computer room EPO cable must be installed for the system to power on.

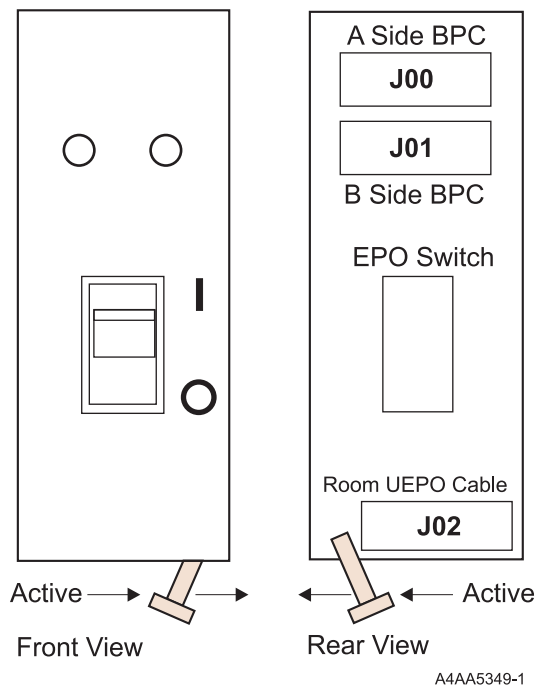
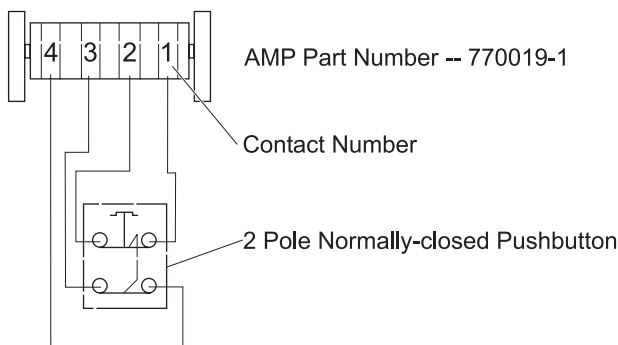

Figure 30. Computer room emergency power off

In the following figure, AMP connector 770019-1 is needed to connect to the unit EPO panel. For computer room EPO cables using wire sizes #20 - #24 AWG, use AMP pins (part number 770010-4). This connection should not exceed 5 Ohms, which is approximately 61 m (200 ft) of #24 AWG.



Room UEPO Switch Schematic

Figure 31. AMP connector

Moving the system to the installation site

Use this information to determine the required tasks for moving the system to the installation site.

Prior to moving the system to the installation site, complete the following tasks:

- Determine the path that must be taken to move the system from the delivery location to the installation site.
- Verify that the height of all doorways, elevators, and small openings are sufficient to allow moving the system to the installation site.

- Verify that the weight limitations of elevators, ramps, floors, floor tiles, and other restricted weight objects are sufficient to allow moving the system to the installation site. If the height or weight of the system can cause a problem when the system is moved to the installation site, contact your local site planner or sales representative.

For more detailed information, see Access.

If needed, you can order the height reduction feature 7960 for 19F/HB. This feature ships the system frame and the expansion frame in two pieces so that it can be assembled at your location. With this feature, the top section of the system frame (including the power subsystem) is removed. The height of the system frame with the upper section removed is reduced by .35 m (14 in.) to approximately 1.64 m (65 in.). Feature code 6850, Weight Reduction Option, can be ordered to reduce the weight of the rack to below 1133.98 kg (2500 lb). This feature allows the system rack to utilize elevators that have a 1133.98 kg (2500 lb) limit.

To determine a more specific system weight for your configuration, start with the maximum system weight and subtract the component values below.

Component	Weight
Processor book (node)	43.1 kg (95 lb)
I/O drawer	55.8 kg (123 lb)
Bulk power enclosure, single	26.8 kg (59 lb)
Bulk power regulator, single	12.7 kg (28 lb)
Bulk power distributor, single	4.5 kg (10 lb)
Internal battery feature with rails, single	51.7 kg (114 lb)
RIO cable, single	5.4 kg (12 lb)
Power cord, single	4.5 kg (10 lb)
Shipping brackets	11.3 kg (25 lb)
Acoustic cover, single	25.4 kg (56 lb)
Side covers, set	49.9 kg (110 lb)
Base redundant bulk power System (includes two bulk power enclosures, two bulk power regulators, and two bulk power distributors)	134.3 kg (296 lb)
Maximum redundant bulk power system (includes two bulk power enclosures, four bulk power distributors and eight bulk power regulators)	195.0 kg (430 lb)

Delivery and subsequent transportation of the equipment

You must prepare your environment to accept the new product based on the installation planning information provided, with assistance from an authorized service provider. In anticipation of the equipment delivery, prepare the final installation site in advance so that professional movers or riggers can transport the equipment to the final installation site within the computer room. If for some reason, this is not possible at the time of delivery, you must make arrangements to have professional movers or riggers return to finish the transportation at a later date. Only professional movers or riggers should transport the equipment. The authorized service provider can only perform minimal frame repositioning within the computer room, as needed, to perform required service actions.

You are also responsible for using professional movers or riggers when you relocate or dispose of equipment.

Cooling requirements (New installation)

Use the system cooling requirements table in conjunction with the cooling requirements graph and chilled airflow area figure to determine the area of floor tiles to supply chilled air to the system.

The model 19F/HB requires air for cooling. As shown in “Considerations for multiple-system installations” on page 36, rows of model 19F/HB systems must face front to front. The use of a raised floor is recommended to provide air through perforated floor panels placed in rows between the fronts of systems. This is shown as cold aisles in “Considerations for multiple-system installations” on page 101.

The following table provide system cooling requirements based on the system configuration. The letter designations in the table correspond to the letter designations in the graph shown in the “Cooling requirements graph” on page 62.

Table 59. Cooling requirements (New installation) 208 V ac

208 V ac				
Processor books (nodes)	I/O drawer			
	0	1	2	3
1	B	C	C	C
2	C	D	D	E
3	E	F	F	G
4	G ¹	G ¹	G ¹	H ¹
5	H ¹	H ¹	I ¹	I ¹
6	I ¹	J ¹	J ¹	J ¹
7	J ¹	K ¹	K ¹	K ¹
8	L ¹	L ¹	L ¹	L ¹

¹ A higher rated power cord is required.

Table 60. Cooling requirements (New installation) 240 V ac

240 V ac				
Processor books (nodes)	I/O drawer			
	0	1	2	3
1	B	C	C	C
2	C	D	D	E
3	E	F	F	G
4	G ¹	G ¹	G ¹	H ¹
5	H ¹	H ¹	I ¹	I ¹
6	I ¹	J ¹	J ¹	J ¹
7	J ¹	K ¹	K ¹	K ¹
8	L ¹	L ¹	L ¹	M ¹

¹ A higher rated power cord is required.

Table 61. Cooling requirements (New installation) 380 - 440 V ac

380 - 440 V ac				
Processor books (nodes)	I/O drawer			
	0	1	2	3
1	B	B	C	C

Table 61. Cooling requirements (New installation) 380 - 440 V ac (continued)

380 - 440 V ac				
Processor books (nodes)	I/O drawer			
	0	1	2	3
2	C	D	D	E
3	E	F	F	F
4	F ¹	G ¹	G ¹	H ¹
5	H ¹	H ¹	H ¹	I ¹
6	I ¹	I ¹	J ¹	J ¹
7	J ¹	J ¹	K ¹	K ¹
8	K ¹	K ¹	L ¹	L ¹

¹ A higher rated power cord is required.
Note: North American installations will always use the higher rated line cord set at 380 - 440 V ac

Table 62. Cooling requirements (New installation) 480 V ac

480 V ac				
Processor books (nodes)	I/O drawer			
	0	1	2	3
1	B	B	C	C
2	C	D	D	E
3	E	E	F	F
4	F ¹	G ¹	G ¹	H ¹
5	H ¹	H ¹	H ¹	I ¹
6	I ¹	I ¹	J ¹	J ¹
7	J ¹	J ¹	K ¹	K ¹
8	K ¹	L ¹	L ¹	L ¹

¹ A higher rated power cord is required.

Table 63. Cooling requirements (New installation) 380 - 520 V dc

380 - 520 V dc				
Processor books (nodes)	I/O drawer			
	0	1	2	3
1	B ¹	B ¹	C ¹	C ¹
2	C ¹	D ¹	D ¹	E ¹
3	E ¹	E ¹	F ¹	F ¹
4	F ¹	G ¹	G ¹	H ¹
5	H ¹	H ¹	H ¹	I ¹
6	I ¹	I ¹	J ¹	J ¹
7	J ¹	J ¹	K ¹	K ¹
8	K ¹	L ¹	L ¹	L ¹

¹ A higher rated power cord is required.

Cooling requirements graph:

Use the cooling requirements graph in conjunction with the cooling requirements tables and the chilled airflow area graphic to determine the area of the floor tiles to supply chilled air to the system.

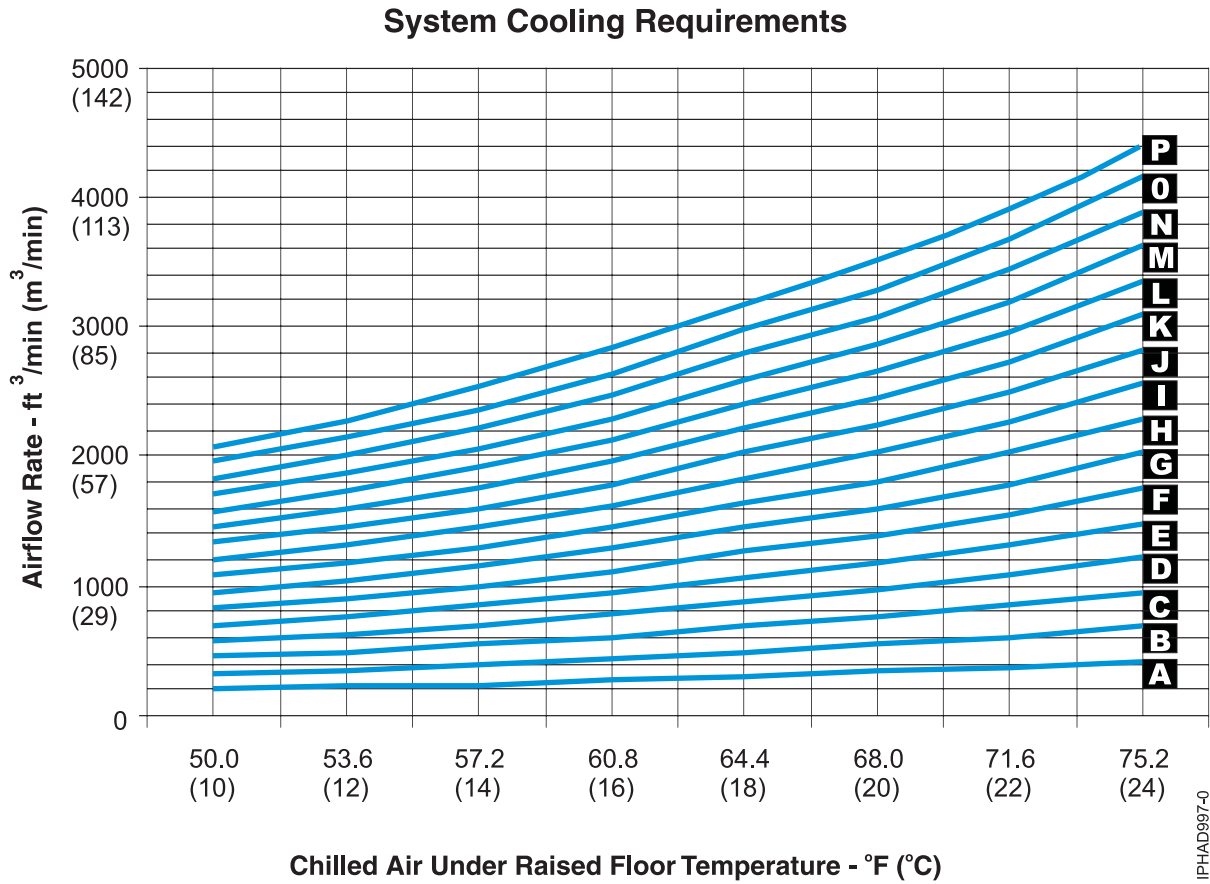

Figure 32. Cooling requirements

Requirements for the chilled airflow area:

Use this information to understand the chilled airflow area that is required for your system.

Use the system cooling requirements tables and the cooling requirements graph to determine the area of floor tiles to supply chilled air to the system.

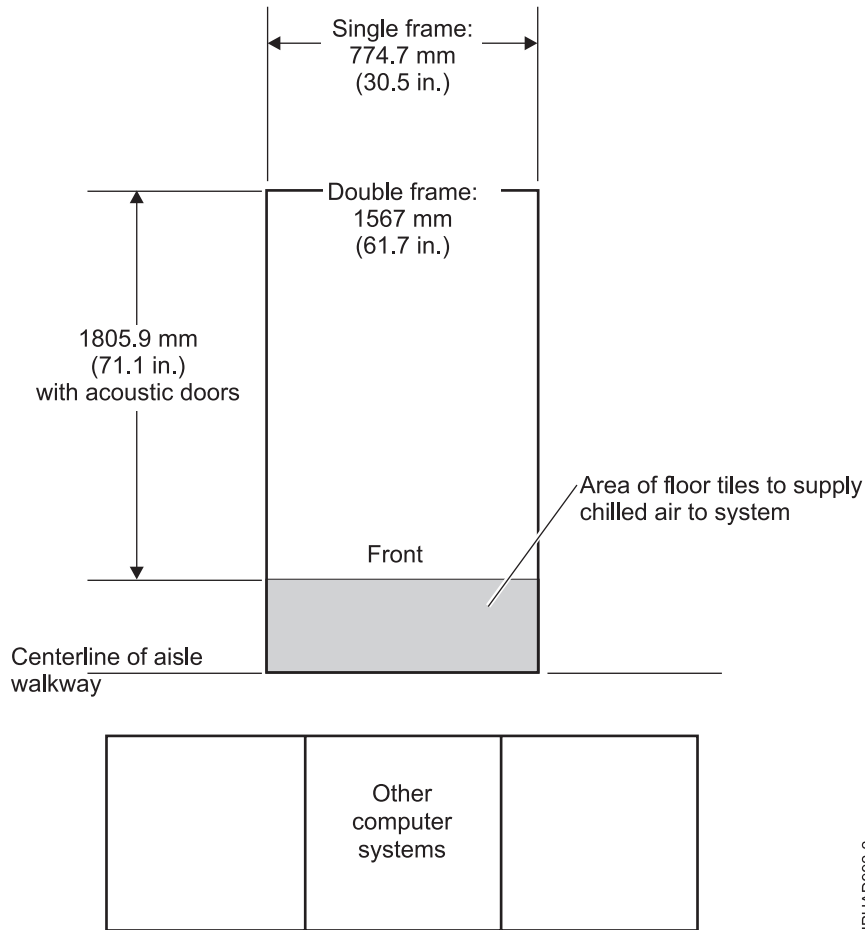

Figure 33. Chilled airflow area requirements

Cooling requirements (POWER6 upgrade)

Use the system cooling requirements table in conjunction with the cooling requirements graph and chilled airflow area figure to determine the area of floor tiles to supply chilled air to the system.

The model 19F/HB requires air for cooling. As shown in “Considerations for multiple-system installations” on page 36, rows of model 19F/HB systems must face front to front. The use of a raised floor is recommended to provide air through perforated floor panels placed in rows between the fronts of systems. This is shown as cold aisles in “Considerations for multiple-system installations” on page 101.

The following table provide system cooling requirements based on the system configuration. The letter designations in the table correspond to the letter designations in the graph shown in the “Cooling requirements graph” on page 62.

Table 64. Typical power requirements (POWER6 upgrade) 208 V ac

208 V ac				
Processor books (nodes)	I/O drawers			
	0	1	2	3
1	B	B	C	C
2	C	D	D	E

Table 64. Typical power requirements (POWER6 upgrade) 208 V ac (continued)

208 V ac				
Processor books (nodes)	I/O drawers			
	0	1	2	3
3	E	F	F	F
4	G	G	G	H
5	H	H	I ¹	I ¹
6	I ¹	I ¹	J ¹	J ¹
7	J ¹	K ¹	K ¹	K ¹
8	K ¹	L ¹	L ¹	L ¹

¹ A higher rated power cord is required.

Table 65. Typical power requirements (POWER6 upgrade) 240 V ac

240 V ac				
Processor books (nodes)	I/O drawers			
	0	1	2	3
1	B	B	C	C
2	C	D	D	E
3	E	F	F	G
4	G	G	G	H
5	H	H	I ¹	I ¹
6	I ¹	I ¹	J ¹	J ¹
7	J ¹	K ¹	K ¹	K ¹
8	K ¹	L ¹	L ¹	M ¹

¹ A higher rated power cord is required.

Table 66. Typical power requirements (POWER6 upgrade) 380 - 415 V ac

380 - 415 V ac				
Processor books (nodes)	I/O drawers			
	0	1	2	3
1	B	B	D	D
2	C	D	D	E
3	E	F	F	F
4	F	G	G	H
5	H	H	H ¹	I ¹
6	I ¹	I ¹	I ¹	J ¹
7	J ¹	J ¹	K ¹	K ¹
8	K ¹	K ¹	L ¹	L ¹

¹ A higher rated power cord is required.

Table 67. Typical power requirements (POWER6 upgrade) 480 V ac

480 V ac				
Processor books (nodes)	I/O drawers			
	0	1	2	3
1	B	B	C	C
2	C	D	D	E
3	E	F	F	F
4	G	G	G	H
5	H	H	H ¹	I ¹
6	I ¹	I ¹	J ¹	J ¹
7	J ¹	J ¹	K ¹	K ¹
8	K ¹	L ¹	L ¹	L ¹

¹ A higher rated power cord is required.

Table 68. Typical power requirements (POWER6 upgrade) 380 - 520 V dc

380 - 520 V dc				
Processor books (nodes)	I/O drawers			
	0	1	2	3
1	N/A - V dc option is not offered for a POWER6 upgrade			
2				
3				
4				
5				
6				
7				
8				

Cooling requirements graph:

Use the cooling requirements graph in conjunction with the cooling requirements tables and the chilled airflow area graphic to determine the area of the floor tiles to supply chilled air to the system.

System Cooling Requirements

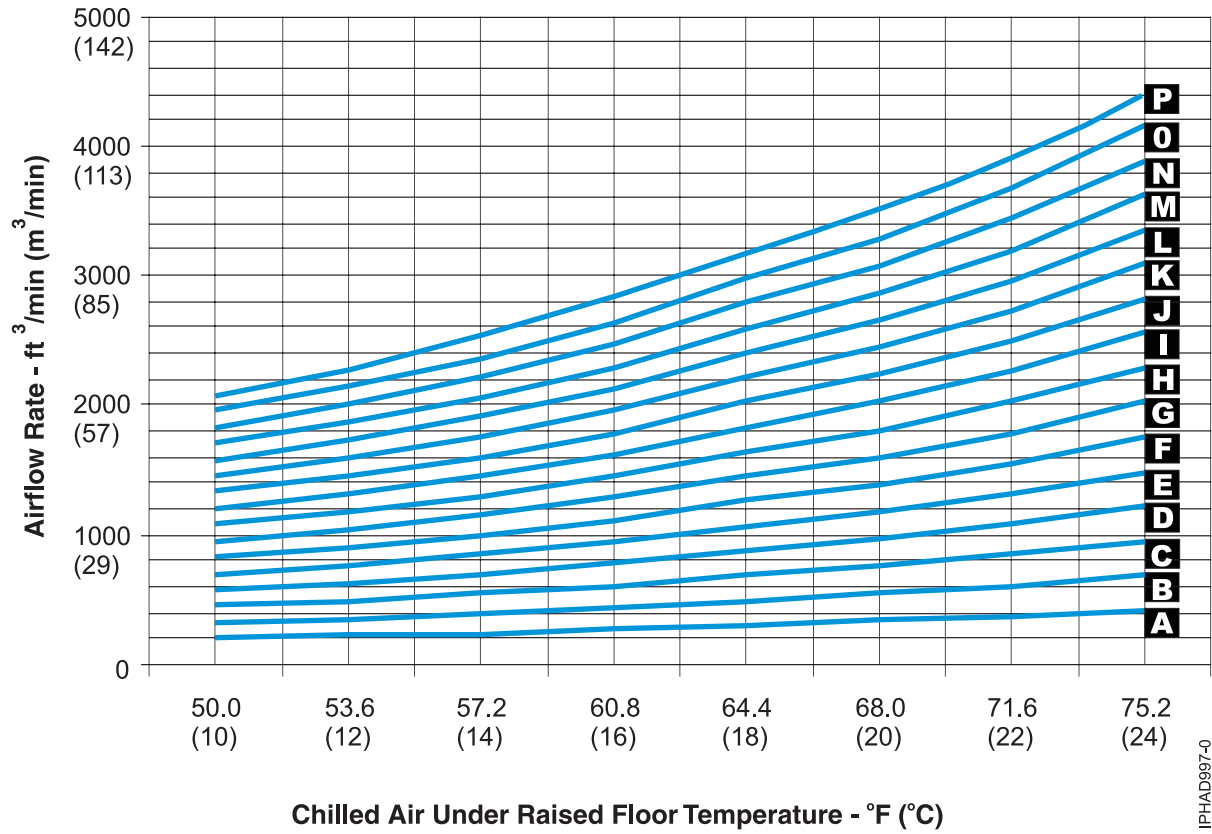

Figure 34. Cooling requirements

Requirements for the chilled airflow area:

Use this information to understand the chilled airflow area that is required for your system.

Use the system cooling requirements tables and the cooling requirements graph to determine the area of floor tiles to supply chilled air to the system.

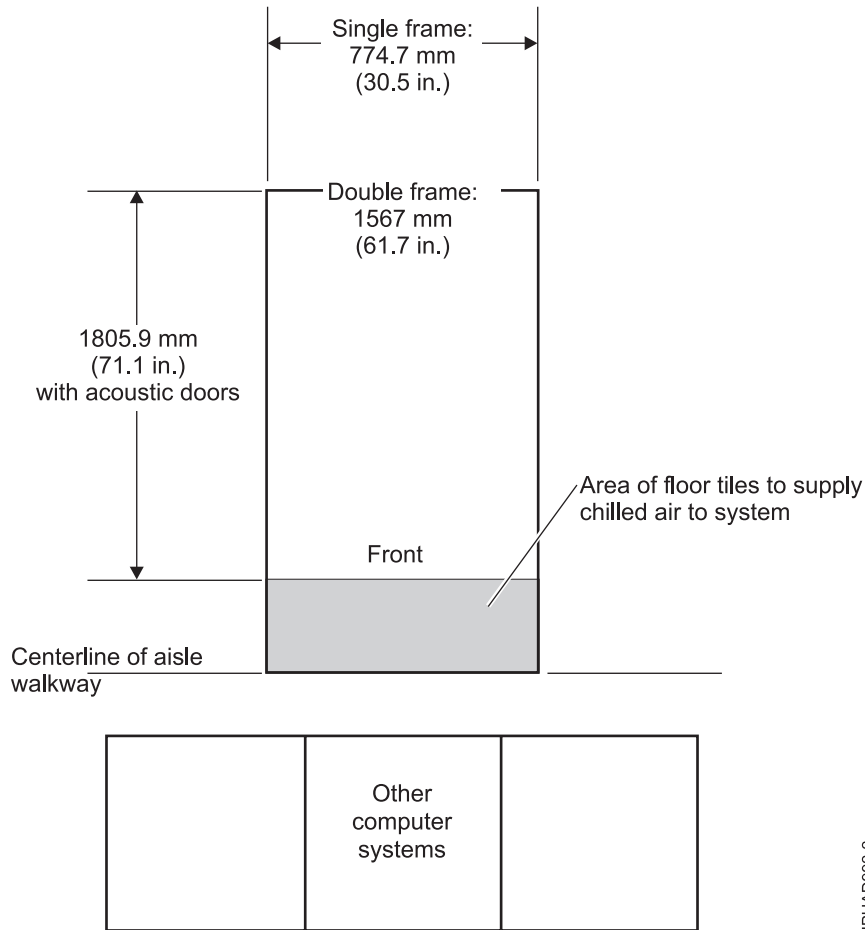

Figure 35. Chilled airflow area requirements

Expansion unit and migration tower specifications

Expansion unit and migration tower specifications provide detailed information for your hardware, including dimensions, electrical, power, temperature, environment, and service clearances.

Select a model to view its specifications.

expansion unit

Hardware specifications provide detailed information for your expansion unit, including dimensions, electrical, power, temperature, environment, and service clearances.

Table 69. Dimensions for rack-mounted expansion unit

Width	Depth	Height	Maximum configuration weight
447 mm (17.5 in.)	660 mm (26 in.)	171 mm (6.75 in.)	54 kg (120 lb)

Table 70. Dimensions for stand-alone expansion unit with stabilizer foot and decorative covers

Width	Depth	Height	Maximum configuration weight
305 mm (12.0 in.)	655 mm (26.0 in.)	508 mm (20.0 in.)	66 kg (145 lb)

Table 71. Electrical

Electrical characteristics	Properties
kVA	0.740
Rated voltage and frequency	100 - 127 V ac at 50-60 plus or minus 3 Hz and 12 A 200 - 240 V ac at 50-60 plus or minus 3 Hz and 6.2 A Machine rating with two redundant power cords
Maximum thermal output	2382 Btu/hr
Maximum power requirements ¹	700 W
Power factor	0.95
Inrush current	55 A per power cord
Maximum leakage current	3.10 mA
Phase	1
¹ All measurements made in conformance with ISO 7779 and declared in conformance with ISO 9296.	

Table 72. Temperature requirements

Operating	Nonoperating
10 - 38°C (50 - 100.4°F) ¹	-40°C to 60°C (-40°F to 140°F)
¹ The maximum 38°C (100.4°F) temperature must be derated 1°C (1.8°F) per 137 m (450 ft) above 1295 m (4250 ft). Maximum altitude is 2134 m (7000 ft).	

Table 73. Environment requirements

Properties	Operating	Nonoperating	Maximum altitude
Noncondensing Humidity	20 - 80% (allowable)	8 - 80% (including condensing)	2134 m (7000 ft) above sea level
	40 - 55% (recommended)		
Wet bulb temperature	21°C (69.8°F)	27°C (80.6°F)	

Table 74. Noise emissions

Models	Properties	Operating	Idle
57/86	L _{WAd}	6.6 bels	6.5 bels
Single 57/86 drawer in standard 19-inch rack with 24 hard drives, nominal environmental conditions, and no front or rear doors on rack.	L _{pAm} (1-meter bystander)	49 dB	49 dB
¹ All measurements made in conformance with ISO 7779 and declared in conformance with ISO 9296.			

Table 75. Service clearances for rack-mounted expansion unit

Front	Back	Sides ¹
914 mm (36 in.)	914 mm (36 in.)	914 mm (36 in.)
¹ Side and top clearances are optional during operation.		

Table 76. Service clearances for stand-alone expansion unit

Front	Back
368.3 mm (14.5 in.)	381 mm (15 in.)

Safety compliance: This hardware is designed and certified to meet the following safety standards: UL 60950; CAN/CSA C22.2 No. 60950-00; EN 60950; IEC 60950 including all National Differences

Related information:

 Acoustics

expansion unit

Hardware specifications provide detailed information for your expansion unit, including dimensions, electrical, power, temperature, environment, and service clearances.

Table 77. Dimensions I/O drawer only

Height	Width	Depth
172 mm (6.8 in.)	224 mm (8.8 in.)	800 mm (31.5 in.)

Table 78. Dimensions - with required I/O drawer mounting enclosure

Height	Width	Depth
176 mm (6.9 in.)	473 mm (18.6 in.)	800 mm (31.5 in.)

Table 79. Maximum configuration weight

One I/O drawer	Two I/O drawers plus the mounting enclosure
20 kg (44 lb)	45.9 kg (101 lb)

Table 80. Electrical

Electrical characteristics	Properties
kVA	0.275
Rated voltage and frequency	200 - 240 V ac at 50 - 60 Hz, V dc not supported
Thermal output	853 Btu/hr
Power requirements (maximum)	250 W
Power factor	0.91

Table 81. Temperature requirements

Operating	Nonoperating	Storage
10°C - 38°C (50°F - 100°F)	1°C - 60°C (33.8°F - 140°F)	1°C - 60°C (33.8°F - 140°F)
The upper limit of the dry bulb temperature must be derated 1°C per 137 m (450 ft) above 915 m (3000 ft).		

Table 82. Environment requirements

Environment	Operating	Nonoperating	Storage	Maximum altitude
Noncondensing humidity	8% - 80%	8% - 80%	5% - 80%	3048 m (10 000 ft)
Wet bulb temperature ⁴	23°C (73.4°F)	27°C (80.6°F)	29°C (84.2°F)	
The upper limit of the wet bulb temperature must be derated 1°C per 274 m (900 ft) above 305 m (1000 ft).				

Table 83. Noise emissions

Properties	Operating	Idle
$L_{WA,d}$	6.2 bels	6.1 bels
$\langle L_{pA} \rangle_m$	44 dB	43 dB
For a description of noise emission values, see Acoustics.		

Table 84. Service clearances

Front	Back	Sides
915 mm (36 in.)	915 mm (36 in.)	915 mm (36 in.)

Related information:

 Acoustics

58/02 expansion unit

Hardware specifications provide detailed information for your expansion unit, including dimensions, electrical, power, temperature, environment, and service clearances.

Table 85. Dimensions for rack-mounted expansion unit

Maximum configuration weight	Width	Depth	Height
54 kg (120 lb)	444.5 mm (17.5 in.)	711.2 mm (28 in.)	4U

Table 86. Electrical

Electrical characteristics	Properties
kVA (maximum)	.768 kVA
Rated voltage and frequency	100 - 127 V ac or 200 - 240 V ac at 50 - 60Hz
Thermal output (maximum)	2542 BTU/hr
Power requirements (maximum)	745 W
Power factor	.97
Leakage current (maximum)	3.5 mA
Phase	Single
Plug type (Canada and U.S.)	26
Power cord length	14 ft

Table 87. Temperature requirements

Operating	Storage	Shipping
10°C - 38°C (32°F - 100.4°F)	1°C - 60°C (33.8°F - 140°F)	-40°C to 60°C (-40°F to 140°F)

Table 88. Environment requirements

Properties	Operating	Nonoperating	Storage	Shipping	Maximum altitude
Noncondensing humidity	Recommended: 34% - 54% Allowable: 20% - 80%	5% - 80%	5% - 80%	5% - 100%	3048 m (10 000 ft)

Table 89. Noise emissions

Models	Properties	Operating	Idle
Feature Code 58/02 - 4U I/O drawer consists of 18 SSF disk drives, 10 PCI-Express 8x slots, and 2 DCAs	L ^{WAd} (B)	7.0	7.0
	L ^{pAm} (dB)	52	52
Notes:			
1. L ^{WAd} is the statistical upper-limit A-weighted sound power level (rounded to the nearest 0.1 B).			
2. L ^{pAm} is the mean A-weighted emission sound pressure level measured at the 1-meter bystander positions (rounded to the nearest dB).			
3. 10 dB (decibel) = 1 B (bel).			
4. All measurements made in conformance with ISO 7779 and declared in conformance with ISO 9296.			

Table 90. Service clearances

Front	Back	Sides
915 mm (36 in.)	915 mm (36 in.)	914 mm (36 in.)

5877 expansion unit

Hardware specifications provide detailed information for your expansion unit, including dimensions, electrical, power, temperature, environment, and service clearances.

Table 91. Dimensions for rack-mounted expansion unit

Maximum configuration weight	Width	Depth	Height
48 kg (105 lb)	444.5 mm (17.5 in.)	711.2 mm (28 in.)	4U

Table 92. Electrical

Electrical characteristics	Properties
kVA (maximum)	0.531 kVA
Rated voltage and frequency	100 - 127 V ac or 200 - 240 V ac at 50 - 60 Hz
Thermal output (maximum)	1760 BTU/hr
Power requirements (maximum)	515 W
Power factor	0.97
Leakage current (maximum)	3.5 mA
Phase	Single
Plug type (Canada and U.S.)	26
Power cord length	14 ft

Table 93. Temperature requirements

Operating	Storage	Shipping
10°C - 38°C (32°F - 100.4°F)	1°C - 60°C (33.8°F - 140°F)	-40°C to 60°C (-40°F to 140°F)

Table 94. Environment requirements

Properties	Operating	Nonoperating	Storage	Shipping	Maximum altitude
Noncondensing humidity	Recommended: 34% - 54% Allowable: 20% - 80%	5% - 80%	5% - 80%	5% - 100%	3048 m (10 000 ft)

Table 95. Service clearances

Front	Back	Sides
915 mm (36 in.)	915 mm (36 in.)	914 mm (36 in.)

58/86 expansion unit

Hardware specifications provide detailed information for your expansion unit, including dimensions, electrical, power, temperature, environment, and service clearances.

Table 96. Dimensions for rack-mounted expansion unit

Weight (with no drives installed)	Width	Depth (including front bezel)	Height
17.7 kg (39 lb)	445 mm (17.5 in.)	521 mm (20.5 in.)	89 mm (3.5 in.)

Table 97. Electrical

Electrical characteristics	Properties
kVA ¹	0.358
Rated voltage and frequency	100 - 240 V ac at 50 - 60 Hz
Thermal Output ¹	1160 Btu/hr
Power requirements (maximum)	340 W
Power factor	0.95
Inrush current	55 A per power cord
Leakage current (maximum)	3.10 mA
Phase	1

¹All measurements made in conformance with ISO 7779 and declared in conformance with ISO 9296.

Table 98. Temperature requirements

Operating	Nonoperating
10 - 38°C (50 - 100.4°F) ¹	-40 - 60°C (-40 - 140°F)

¹The maximum 38°C (100.4°F) temperature must be derated 1°C (1.8 °F) per 137 m (450 ft) above 1295 m (4250 ft).

Table 99. Environmental requirements

Environment	Operating	Nonoperating	Maximum altitude
Noncondensing humidity	20 - 80% (allowable) 40 - 55% (recommended)	8 - 80% (including condensing)	2134 m (7000 ft) above sea level
Wet bulb temperature	21°C (69.8°F)	27°C (80.6°F)	

Table 100. Noise emissions¹

Properties	Operating	Idle
L _{WAd}	6.6 bels	6.5 bels
L _{pAm} (1-meter bystander)	49 dB	49 dB
¹ Single drawer in standard 19-inch rack with 24 hard drives, nominal environmental conditions, and no front or rear doors on rack. For a description of noise emission values, see <i>Acoustics</i> . All measurements made in conformance with ISO 7779 and declared in conformance with ISO 9296.		

Table 101. Service clearances for rack-mounted expansion unit

Front	Back	Sides
914 mm (36 in.)	914 mm (36 in.)	914 mm (36 in.)
Side and top clearances are optional during operation.		

Table 102. Service clearances for stand-alone expansion unit

Front	Back
368.3 mm (14.5 in.)	381 mm (15 in.)

Safety compliance: This hardware is designed and certified to meet the following safety standards: UL 60950; CAN/CSA C22.2 No. 60950-00; EN 60950; IEC 60950 including all National Differences

Related information:

 Acoustics

58/87 expansion unit

Hardware specifications provide detailed information for your expansion unit, including dimensions, electrical, power, temperature, environment, and service clearances.

Table 103. Dimensions for rack-mounted expansion unit

Weight (with drives installed)	Width	Depth (including front bezel)	Height (with support rails)
25.4 kg (56.0 lb)	448.6 mm (17.7 in.)	530 mm (20.9 in.)	87.4 mm (3.4 in.)

Table 104. Electrical

Electrical characteristics	Properties
kVA (maximum) ¹	0.32
Rated voltage and frequency	100 - 127 V ac or 200 - 240 V ac at 50 - 60 Hz
Thermal output (maximum) ¹	1024 Btu/hr
Power requirements (maximum)	300 W

Table 104. Electrical (continued)

Electrical characteristics	Properties
Power factor	0.94
Leakage current (maximum)	1.2 mA
Phase	1
¹ All measurements made in conformance with ISO 7779 and declared in conformance with ISO 9296.	

Table 105. Temperature requirements

Operating	Nonoperating
10°C - 38°C (50°F - 100.4°F) ¹	-40°C - 60°C (-40°F - 140°F)
¹ The maximum 38°C (100.4°F) temperature must be derated 1°C (1.8 °F) per 137 m (450 ft) above 1295 m (4250 ft).	

Table 106. Environmental requirements

Environment	Operating	Nonoperating	Maximum altitude
Noncondensing humidity	20% - 80% (allowable) 40% - 55% (recommended)	8% - 80% (including condensing)	2134 m (7000 ft) above sea level
Wet bulb temperature	21°C (69.8°F)	27°C (80.6°F)	

Table 107. Noise emissions¹

Properties	Operating	Idle
L _{WAd}	6.0 bels	6.0 bels
L _{pAm} (1-meter bystander)	43 dB	43 dB
¹ Single drawer in standard 19-inch rack with 24 hard drives, nominal environmental conditions, and no front or rear doors on rack.		
For a description of noise emission values, see <i>Acoustics</i> .		
All measurements made in conformance with ISO 7779 and declared in conformance with ISO 9296.		

Table 108. Service clearances for rack-mounted expansion unit

Front	Back	Sides
914 mm (36 in.)	914 mm (36 in.)	914 mm (36 in.)
Side and top clearances are optional during operation.		

Safety compliance: This hardware is designed and certified to meet the following safety standards: UL 60950; CAN/CSA C22.2 No. 60950-00; EN 60950; IEC 60950 including all National Differences

Related information:

 Acoustics

58/88 expansion unit

Hardware specifications provide detailed information for your expansion unit, including dimensions, electrical, power, temperature, environment, and service clearances.

Table 109. Dimensions for rack-mounted expansion unit

Weight (with drives installed)	Width	Depth (including front bezel)	Height (with support rails)
21.8 kg (48.0 lb)	444.5 mm (17.5 in.)	762 mm (30 in.)	44.5 mm (1.75 in.)

Table 110. Electrical

Electrical characteristics	Properties
kVA (maximum) ¹	0.46
Rated voltage and frequency	100 - 127 V ac or 200 - 240 V ac at 50 - 60 hz
Thermal output (maximum) ¹	1501 Btu/hr
Power requirements (maximum)	440 W
Phase	1

¹All measurements are made in conformance with ISO 7779 and declared in conformance with ISO 9296.

Table 111. Temperature requirements

Operating	Nonoperating
10°C - 38°C (50°F - 100.4°F) ¹	-40°C to 60°C (-40°F to 140°F)

¹The maximum 38°C (100.4°F) temperature must be derated 1°C (1.8 °F) per 137 m (450 ft) above 1295 m (4250 ft).

Table 112. Environmental requirements

Environment	Operating	Nonoperating	Maximum altitude
Noncondensing humidity	20% - 80% (allowable)	8% - 80% (including condensing)	2134 m (7000 ft) above sea level
	40% - 55% (recommended)		
Wet bulb temperature	21°C (69.8°F)	27°C (80.6°F)	

Safety compliance: This hardware is designed and certified to meet the following safety standards: UL 60950; CAN/CSA C22.2 No. 60950-00; EN 60950; IEC 60950 including all national differences

Related information:

-  Acoustics
-  5888 PCIe storage enclosure

EDR1 expansion unit

Hardware specifications provide detailed information for your expansion unit, including dimensions, electrical, power, temperature, environment, and service clearances.

Table 113. Dimensions for rack-mounted expansion unit

Weight (with drives installed)	Width	Depth (including front bezel)	Height (with support rails)
21.8 kg (48.0 lb)	444.5 mm (17.5 in.)	762 mm (30 in.)	44.5 mm (1.75 in.)

Table 114. Electrical

Electrical characteristics	Properties
kVA (maximum) ¹	0.46
Rated voltage and frequency	100 - 127 V ac or 200 - 240 V ac at 50 - 60 hz

Table 114. Electrical (continued)

Electrical characteristics	Properties
Thermal output (maximum) ¹	1501 Btu/hr
Power requirements (maximum)	440 W
Phase	1
¹ All measurements are made in conformance with ISO 7779 and declared in conformance with ISO 9296.	

Table 115. Temperature requirements

Operating	Nonoperating
10°C - 38°C (50°F - 100.4°F) ¹	-40°C to 60°C (-40°F to 140°F)
¹ The maximum 38°C (100.4°F) temperature must be derated 1°C (1.8 °F) per 137 m (450 ft) above 1295 m (4250 ft).	

Table 116. Environmental requirements

Environment	Operating	Nonoperating	Maximum altitude
Noncondensing humidity	20% - 80% (allowable)	8% - 80% (including condensing)	2134 m (7000 ft) above sea level
	40% - 55% (recommended)		
Wet bulb temperature	21°C (69.8°F)	27°C (80.6°F)	

Safety compliance: This hardware is designed and certified to meet the following safety standards: UL 60950; CAN/CSA C22.2 No. 60950-00; EN 60950; IEC 60950 including all national differences

Planning for 6954 and 6953 racks

Hardware specifications provide detailed information for your rack. This includes dimensions, electrical, power, temperature, environment, and service clearances.

The 6954 base rack is an optional second-base frame with a separate connection to AC power that is designed for use with model 19F/HB. A complete set of planning information is provided to address the resulting system.

Table 117. 6954 base rack components

Feature code	Description
6868	Slimline doors for expansion rack
6888	Acoustic doors for expansion rack
6878	Acoustic doors for bolt on expansion rack
6880	Slimline doors for bolt on expansion rack
Notes:	
1. A Hardware Management Console (HMC) can connect to multiple systems (therefore, a Hardware Management Console might not need to be ordered), or up to two HMCs can connect to the system for redundancy.	
2. A maximum of 32 I/O drawers can be connected to the 19F/HB rack using two FC 6954 and 6953. Typically, I/O drawers are populated in the server frame first.	

Table 118. Full system weights (no doors)

Physical characteristics	Weight
Powered I/O rack	1275 kg (2810 lb)
Powered I/O rack and expansion rack	2341 kg (5160 lb)

Table 119. Cover weights

Physical characteristics	Weight
One acoustic door	25 kg (56 lb)
One non-acoustic door	15 kg (33 lb)

Table 120. Dimensions and weight

Physical characteristics	Slim Line		Acoustic	
	One frame	Two frame	One frame	Two frame
Number of frames	One frame	Two frame	One frame	Two frame
Height	2014 mm (79.3 in)	2014 mm (79.3 in)	2014 mm (79.3 in)	2014 mm (79.3 in)
Width	775 mm (30.5 in)	1567.18 mm (61.7 in.)	775 mm (30.5 in)	1567.18 mm (61.7 in.)
Depth	1485.9 mm (58.5 in.)	1485.9 mm (58.5 in.)	1805.94 mm (71.1 in.)	1805.94 mm (71.1 in.)

Table 121. Maximum rack weights

Physical characteristics	Weight
Powered I/O rack	1388 kg (3060 lb)
Powered I/O rack and bolt on expansion rack	2567 kg (5660 lb)

Table 122. Powered I/O rack without the internal battery feature

I/O drawers	Weight
1	571 kg (1258 lb)
2	668 kg (1473 lb)
3	766 kg (1688 lb)
4	863 kg (1903 lb)
5	986 kg (2174 lb)
6	1084 kg (2389 lb)
7	1181 kg (2604 lb)
8	1279 kg (2819 lb)

Table 123. Powered I/O rack with bolt on expansion rack, without the internal battery feature

I/O drawers	Weight
9	1750 kg (3858 lb)
10	1847 kg (4073 lb)
11	1945 kg (4288 lb)
12	2068 kg (4559 lb)
13	2165 kg (4774 lb)
14	2263 kg (4989 lb)
15	2360 kg (5204 lb)
16	2458 kg (5419 lb)

Table 124. Powered I/O rack with the internal battery feature

I/O drawers	Weight
1	777 kg (1712 lb)

Table 124. Powered I/O rack with the internal battery feature (continued)

I/O drawers	Weight
2	874 kg (1927 lb)
3	972 kg (2142 lb)
4	1095 kg (2413 lb)
5	1192 kg (2628 lb)
6	1290 kg (2843 lb)
7	1387 kg (3058 lb)

Table 125. Powered I/O rack with bolt on expansion rack, with the internal battery feature

I/O drawers	Weight
8	1858 kg (4097 lb)
9	1956 kg (4312 lb)
10	2053 kg (4527 lb)
11	2176 kg (4798 lb)
12	2274 kg (5013 lb)
13	2371 kg (5228 lb)
14	2469 kg (5443 lb)
15	2566 kg (5658 lb)

Table 126. Shipping dimension and weight per rack

Physical characteristics	Dimensions
Height	231 cm (91 in.)
Width	94 cm (37 in.)
Depth	162 cm (63.5 in.)
Weight	1134 kg (2500 lb)

Table 127. System Rating (POWER7 I/O rack new build)

	US, Canada, Japan		US High Voltage		World Trade Corporation		World Trade Corporation	
Voltage and frequency	200 - 240 V ac at 50 - 60 Hz		480 V ac at 50 - 60 Hz		200 - 240 V ac at 50 - 60 Hz		380 - 415 V ac at 50 - 60 Hz	
System rating for the I/O rack	48 A	63 A	22 A	25.6 A	48 A	63 A	25.6 A	32 A

Note:

The system rating varies by configuration. See “Electrical requirements” on page 103 for which system configurations will have the higher rating.

Table 128. System Rating (POWER7 I/O rack upgrade from a POWER6 I/O rack)

	US, Canada, Japan		US High Voltage		World Trade Corporation		World Trade Corporation	
Voltage and frequency	200 - 240 V ac at 50 - 60 Hz		480 V ac at 50 - 60 Hz		200 - 240 V ac at 50 - 60 Hz		380 - 415 V ac at 50 - 60 Hz	
System rating for the I/O rack	48 A	63 A	24 A	24 A	48 A	63 A	34 A	34 A
Note:								
The system rating varies by configuration. See “Electrical requirements” on page 103 for which system configurations will have the higher rating.								

Table 129. Electrical and thermal characteristics

Electrical and thermal characteristics	Properties
Maximum power for a single fully configured powered I/O rack (FC 6954)	11.6 kW
Maximum power for a single fully configured powered I/O rack (FC 6954) and a single fully configured non powered I/O rack (FC 6953)	23.1 kW
Thermal output for a single fully configured powered I/O rack (FC 6954)	39.5 kBTU/hr
Thermal output power for a single fully configured powered I/O rack (FC 6954) and a single fully configured non powered I/O rack (FC 6953)	78.8 kBTU/hr

Table 130. Environment specifications

Environment	Operating	Storage	Shipping
Temperature	50 - 80.6°F (10 - 27°C) ¹	33.8 - 140°F (1 - 60°C)	-40 - 140°F (-40 - 60°C)
Relative humidity	20 - 80%	5 - 80%	5 - 100%
Maximum altitude	3048 m (10 000 ft)		
¹ Derate maximum temperature 2°C per 1000 ft over 7000 ft			

Table 131. Declared acoustical noise emissions for powered I/O rack for the 19F/HB

Product Configuration	Declared A-Weighted Sound Power Level, L _{WAd} (B)		Declared A-Weighted Sound Pressure Level, L _{pAm} (dB)	
	Operating	Idling	Operating	Idling
Single I/O drawer alone in rack with acoustical door set. Blowers at nominal speeds.	7.0	7.0	52	52
Single I/O drawer alone in rack with nonacoustical (slimline) door set. Blowers at nominal speeds.	7.5	7.5	59	59

Table 131. Declared acoustical noise emissions for powered I/O rack for the 19F/HB (continued)

Product Configuration	Declared A-Weighted Sound Power Level, L_{WAd} (B)		Declared A-Weighted Sound Pressure Level, L_{pAm} (dB)	
	Operating	Idling	Operating	Idling
Bulk power assembly alone in rack with acoustical door set. Blowers at nominal speeds.	6.9	6.9	52	52
Bulk power assembly alone in rack with Non-Acoustical (Slimline) Door Set. Blowers at nominal speeds.	7.5	7.5	59	59
Typical configuration of powered I/O rack with acoustical door set: 4 I/O drawers and bulk power assembly. Blowers at nominal speeds.	7.7 ⁵	7.7 ⁵	59	59
Typical configuration of powered I/O rack with nonacoustical (slimline) Door set: 4 I/O drawers and bulk power assembly. Blowers at nominal speeds.	8.2	8.2	66	66
Maximum configuration of powered I/O rack with acoustical door set: 8 I/O drawers and bulk power assembly. Blowers at nominal speeds.	7.9 ⁴	7.9 ⁴	61	61
Maximum configuration of powered I/O rack with nonacoustical (slimline) door set: 8 I/O drawers and bulk power assembly. Blowers at nominal speeds.	8.4	8.4	68	68

Table 131. Declared acoustical noise emissions for powered I/O rack for the 19F/HB (continued)

Product Configuration	Declared A-Weighted Sound Power Level, L_{WAd} (B)		Declared A-Weighted Sound Pressure Level, L_{pAm} (dB)	
	Operating	Idling	Operating	Idling
¹ Declared level L_{WAd} is the upper-limit A-weighted sound power level. Declared level L_{pAm} is the mean A-weighted sound pressure level measured at the 1-meter bystander positions.				
² All measurements made in conformance with ISO 7779 and declared in conformance with ISO 9296.				
³ B, dB, abbreviations for bels and decibels, respectively, where 1 B = 10 dB.				
⁴ Meets IT Product Noise Limits for, <i>Generally Unattended Data Center</i> , per Statskontoret Technical Standard 26:6.				
⁵ Meets IT Product Noise Limits for, <i>Generally Attended Data Center</i> , per Statskontoret Technical Standard 26:6.				

Front-service access is necessary on the 6954 to accommodate a lift tool for the servicing of large drawers (I/O drawers). Front and rear service access is necessary to accommodate the lift tool for servicing of the optional integrated battery backup.

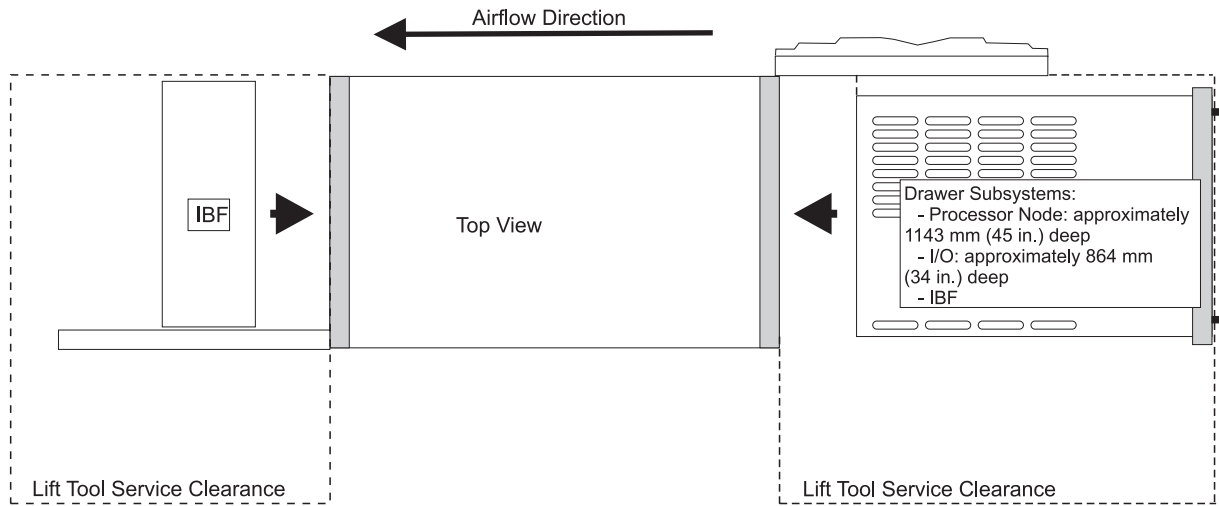

Floor Plan Considerations for Single Units

A4AA5731-1

Figure 36. Floor plan considerations for single units

Plan views

The powered I/O frame, FC 6954, can be placed on either side of the 19F/HB. The maximum distance between the frames is limited by the Infiniband (IB) frame-to-frame communication cables, which are 8 m (26.2 ft) long. When determining the maximum distance the Powered I/O frame can be placed from the 19F/HB, ensure the following lengths are taking into account:

1. The distance from IB cable plug location of the 19F/HB CEC frame to the under floor.
2. The distance along the under floor.
3. The distance from the underfloor to the powered I/O expansion frame IB cable plug location.

The non-powered I/O frame, FC 6953, must be on the left side of the powered I/O frame, when facing the front of the rack.

Dimensional planning information is shown in the following graphics of the top down views of your server.

The following figure shows dimensional planning information for single-frame systems.

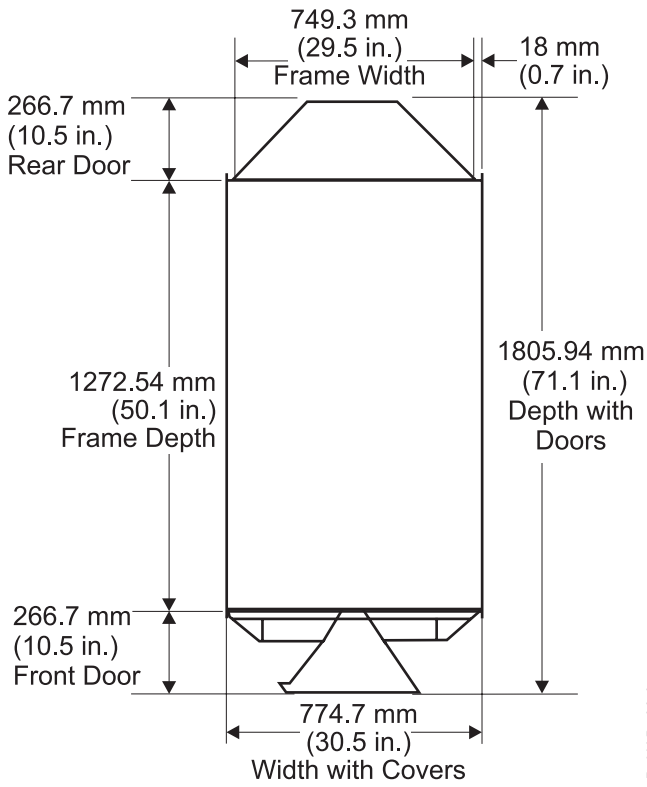

Figure 37. Plan view for single-frame systems with acoustical doors

The following figure shows dimensional planning information for double-frame systems.

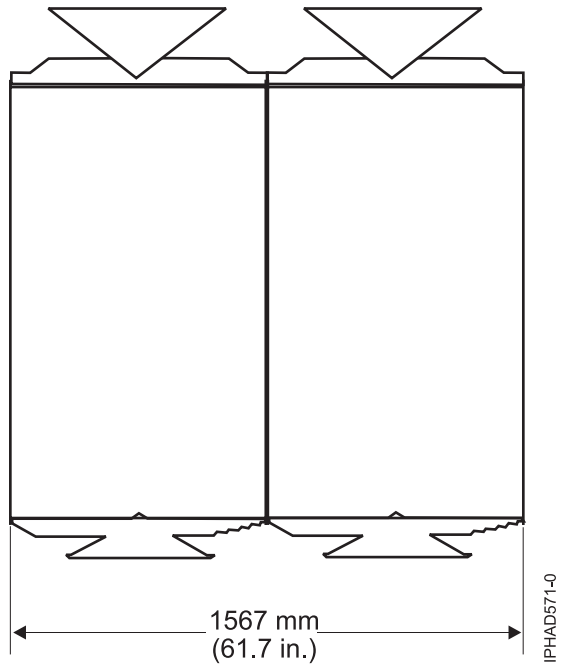

Figure 38. Plan view for double-frame systems with acoustical doors

The following figure shows dimensional planning information for single-frame systems.

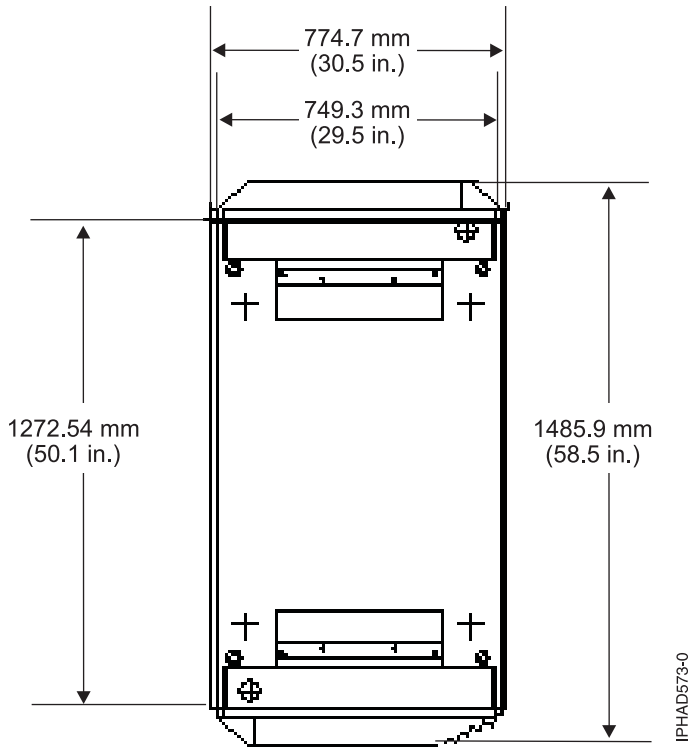

Figure 39. Plan view for single-frame systems with slimline doors

The following figure shows dimensional planning information for single-frame systems.

Note: When moving the rack, note the caster swivel diameters shown in the following figure. Each caster swivels in an approximate 130 mm (5.1 in.) diameter.

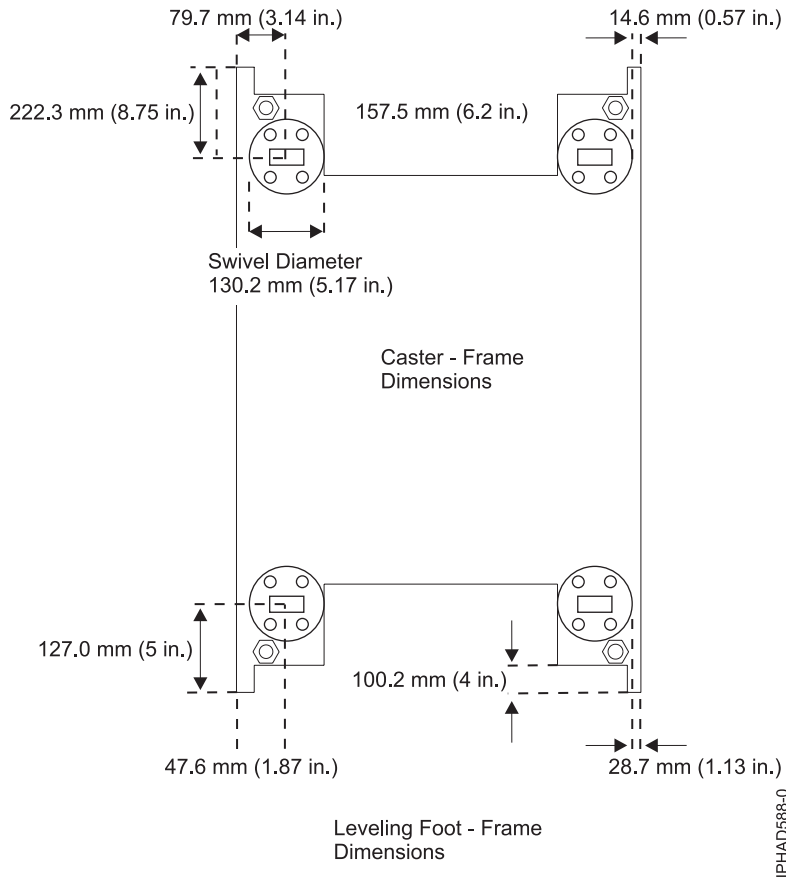
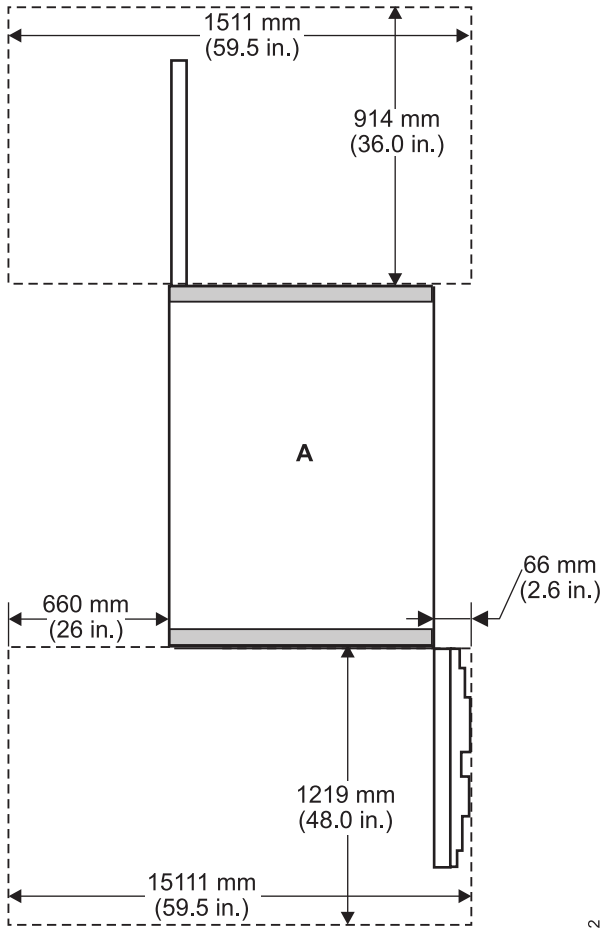

Figure 40. Leveling foot and frame dimensions

Service clearances

The service clearance area is the area around the server which is needed for the authorized service representatives to service the server.

The minimum service clearance for systems with slimline doors is shown in the following figures.



Single-Frame System with
Slimline Doors

IPHAD907-2

Figure 41. Service clearance for single system unit frame or single I/O rack with slimline doors

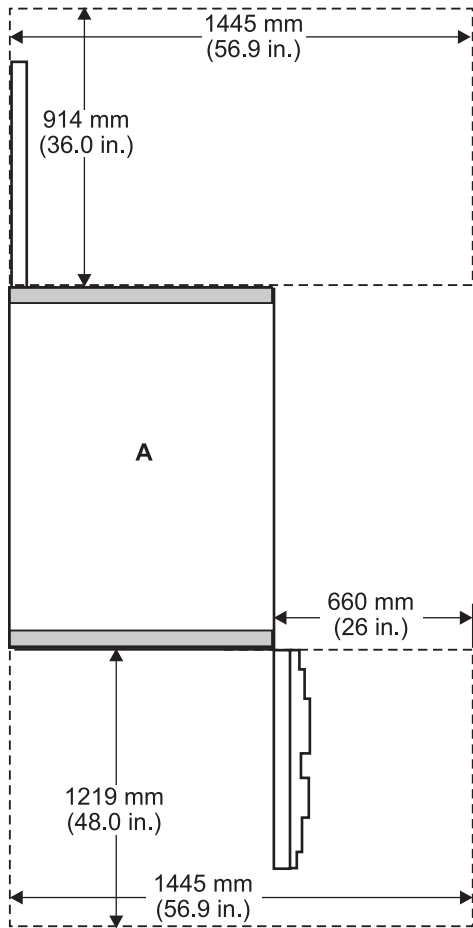

Single-Frame System with Slimline Doors (with alternative right-side service clearance)

IPHAD908-2

Figure 42. Service clearance for single system unit frame or single I/O rack with slimline doors (with alternative right side service clearance)

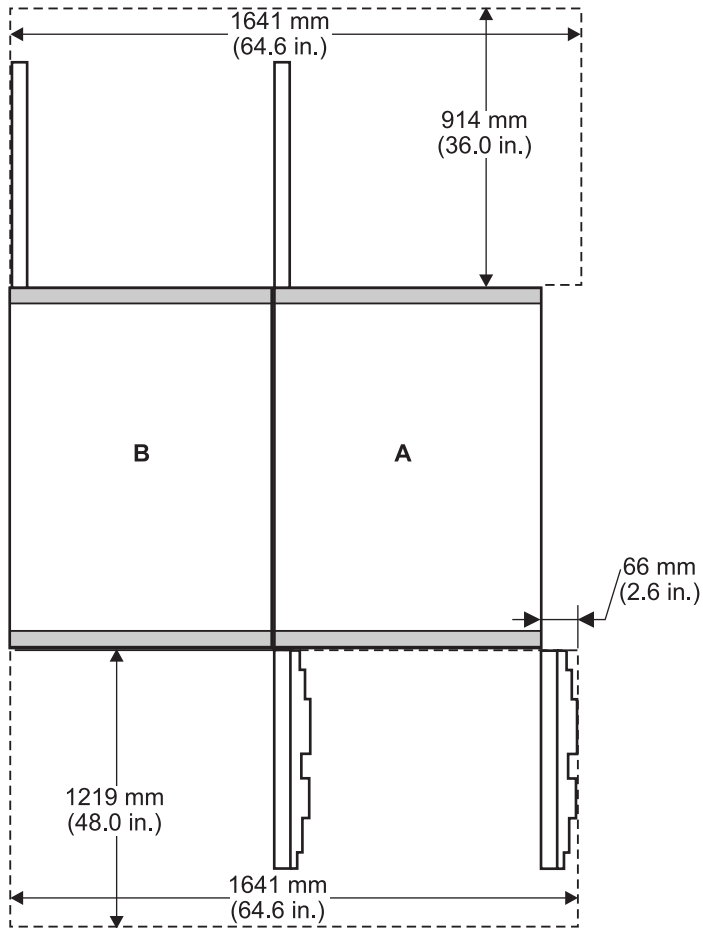

Double-Frame System
with Slimline Doors

IPHAD909-0

Figure 43. Service clearances for double I/O frame systems with slimline doors

The minimum service clearance for systems with acoustical doors is shown in the following figures.

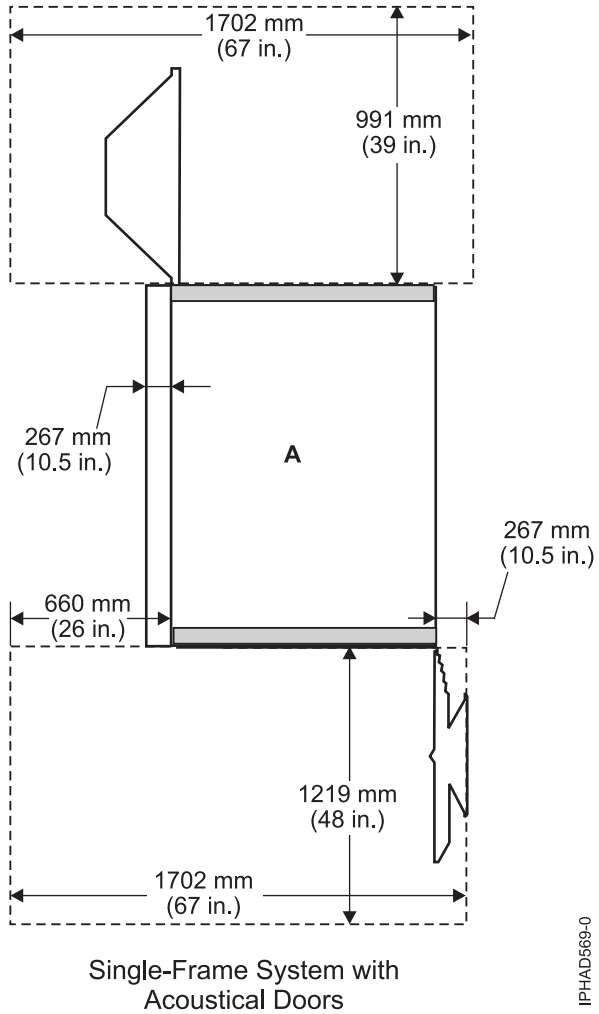
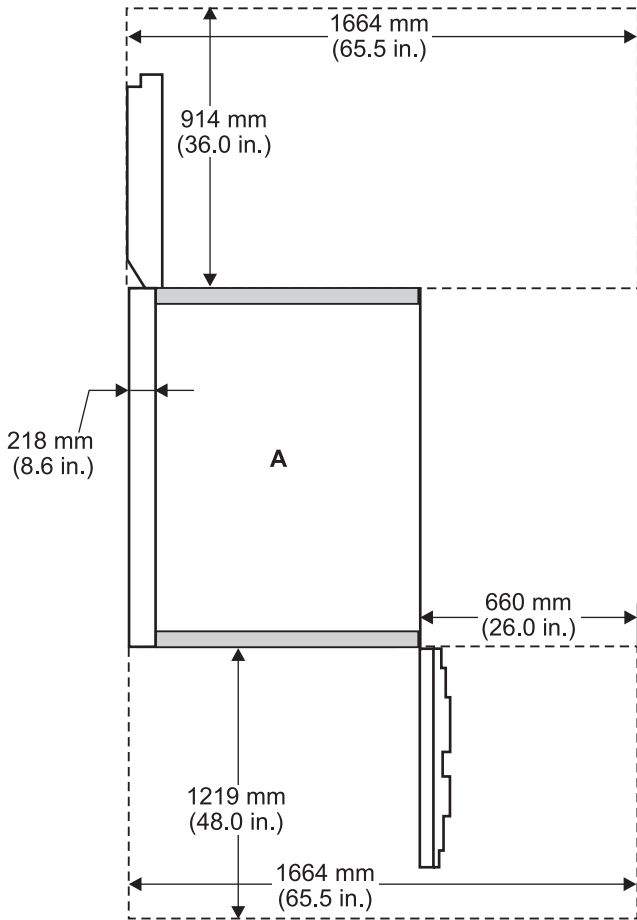

Figure 44. Service clearance for single system unit frame or single I/O rack with acoustic doors



Single-Frame System with
Acoustical Doors (with
alternative right-side service
clearance)

IPHAD903-2

Figure 45. Service clearance for single system unit frame or single I/O rack with acoustic doors (with alternative right side service clearance)

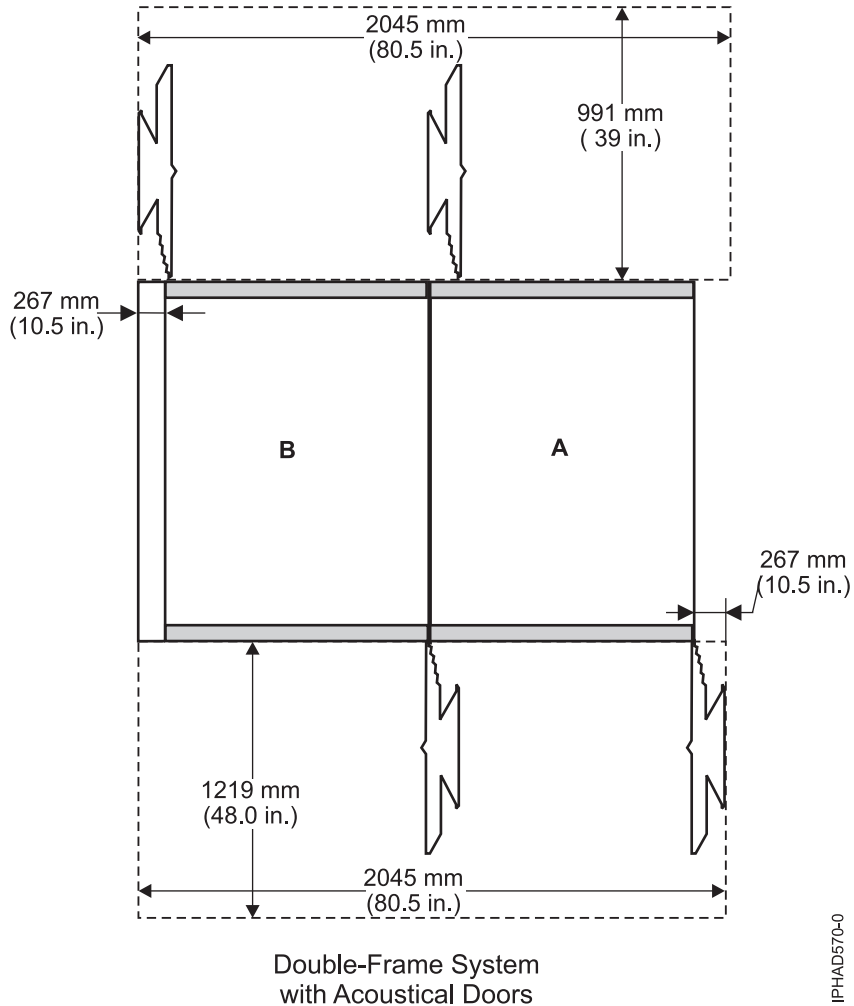

Figure 46. Service clearances for double I/O frame systems with acoustic doors

See “Attaching the rack to a 9 - 13 in. or 12 - 22 in. floor” on page 93 for service clearances that are required in a raised-floor installation.

Doors and covers

Covers are an integral part of the 6954 and are required for product safety, proper airflow and cooling, and electromagnetic compatibility compliance.

The following rear door options are available for the 6954:

- Acoustical door

This feature provides a specially designed, noise-reducing door set that helps maintain lower noise levels in their data center. It also helps you to meet certain acoustical or noise exposure requirements. The acoustical door option consists of a special front door, approximately 250 mm (10 in.) in depth. It contains acoustical treatment and when used with the required rear door heat exchanger, it lowers the noise level of the machine by approximately 7 dB (0.7 B) in comparison to the slimline door option.

- Slimline cover

This feature provides an option to take up less floor space, when space is more critical than acoustical noise levels. The slimline door option consists of a front and rear door set, approximately 100 mm (4 in.) in depth, to be used in conjunction with the required rear-door heat exchanger previously described. Acoustical treatment is not available for the slimline door option, and the 19F/HB system

generally does not meet industry acoustical noise limits with this option installed. The slimline door set is offered as a selectable option for those who are more concerned with floor space than noise levels because each slimline door is about 150 mm (6 in.) less deep than each acoustical door.

Note: For declared levels of acoustical noise emissions, see “Planning for 6954 and 6953 racks” on page 77.

Installing the frame tie-down kit

Use the following procedures to install a frame tie-down kit and floor tie-down hardware.

The following procedures describe how to install a frame tie-down kit and floor tie-down hardware to secure a rack to a concrete floor beneath a 228.6 - 330.2 mm (9 -13 in. depth) or a 304.8 - 558.8 mm (12 - 22 in. depth) raised-floor environment or to a nonraised floor.

Securing the rack:

Securing your rack to a concrete (nonraised) floor or to a raised floor prevents movement when vibrations occur.

Note: Securing the rack is an optional procedure. See Vibration and shock for more information.

Before the service representative can perform the tie-down procedure, you must complete the floor preparation as described in “Cutting and placing floor panels” on page 108 and “Attaching the rack to a 9 - 13 in. or 12 - 22 in. floor.”

Positioning the rack:

Use this procedure to unpack and position your rack.

To unpack and position the rack, do the following steps:

Note: Before attempting to position the rack, see “Moving the system to the installation site” on page 59.

1. Remove all of the packing and tape from the rack.
2. Place the last floor covering exactly adjacent to and in the front of the final installation location.
3. Position the rack according to your floor plan.
4. Lock each caster wheel by tightening the thumbscrew on the caster.

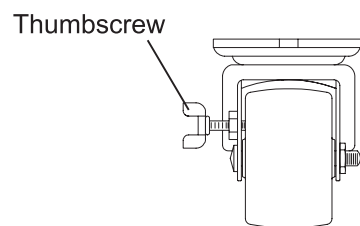

Figure 47. Caster thumbscrew

Note: While moving the system to its final installed location and during relocation, it might be necessary to lay down floor covering, such as Lexan sheets, to prevent floor panel damage.

Attaching the rack to a 9 - 13 in. or 12 - 22 in. floor:

Use these steps to attach your rack to a 228.6 mm to 330.2 mm (9 in. to 13 in. depth). floor.

Attention: The frame tie downs are intended to secure a frame weighing less than 1429 kg (3150 lb). These tie downs are designed to secure the frame on a raised-floor installation.

Use the following to determine your next step:

1. If the rack is being attached to a short-depth raised-floor environment 228.6 - 330.2 mm (9 - 13 in. depth), install the Raised floor tie-down kit (part number 16R1102) described in the following table.

Table 132. Raised floor tie-down kit 228.6 - 330.2 mm (9 - 13 in. depth)

Raised floor tie-down kit (part number 16R1102)			
Item	Part number	Quantity	Description
1	44P3438	1	Wrench
2	44P2996	2	Stabilizer bar
3	44P2999	4	Turnbuckle Assembly

2. If the rack is being attached to a deep, raised-floor environment 304.8 - 558.8 mm (12 - 22 in. depth), install the Raised floor tie-down kit (part number 16R1103) described in the following table.

Table 133. Raised floor tie-down kit 304.8 - 558.8 mm (12 - 22 in. depth)

Raised floor tie-down kit (part number 16R1103)			
Item	Part number	Quantity	Description
1	44P3438	1	Wrench
2	44P2996	2	Stabilizer bar
3	44P3000	4	Turnbuckle Assembly

It is your responsibility to ensure that the following steps are completed before the service representative performs the tie-down procedure.

Note: To accommodate a floor with a depth of more than 558.8 mm (22 in.), a steel beam or a steel channel adapter for mounting the sub-floor eyebolts are required. The customer must supply the floor eyebolts.

Consider the following when preparing the floor for tie-down procedure:

- The hardware is designed to support a frame weighing no more than 1429 kg (3150 lb).
- The estimated maximum concentrated load on one caster for a 1429 kg (3150 lb) system is 476.3 kg (1050 lb). For a multiple-system installation, one floor tile might bear a total concentrated load of 952.5 kg (2100 lb).

To install the eyebolts, do the following steps:

1. Obtain the service of a qualified structural engineer to determine the appropriate installation of the eyebolts.
2. Consider the following before installing the eyebolts:
 - Floor eyebolts must be securely anchored to the concrete floor.
 - For a single-frame installation, four 1/2-in. diameter by 13-in. sub-floor eyebolts should be secured to the sub-floor.
 - The minimum height of the center of the internal diameter is 2.54 mm (1 in.) above the concrete floor surface.
 - The maximum height is 63.5 mm (2.5 in.) above the concrete floor surface. A height greater than 63.5 mm (2.5 in.) can cause excessive lateral deflection to the tie-down hardware.
 - The eyebolt's internal diameter should be 1-3/16 inch, and each eyebolt should be able to withstand 1224.7 kg (2700 lb). The customer should obtain the services of a qualified consultant or structural

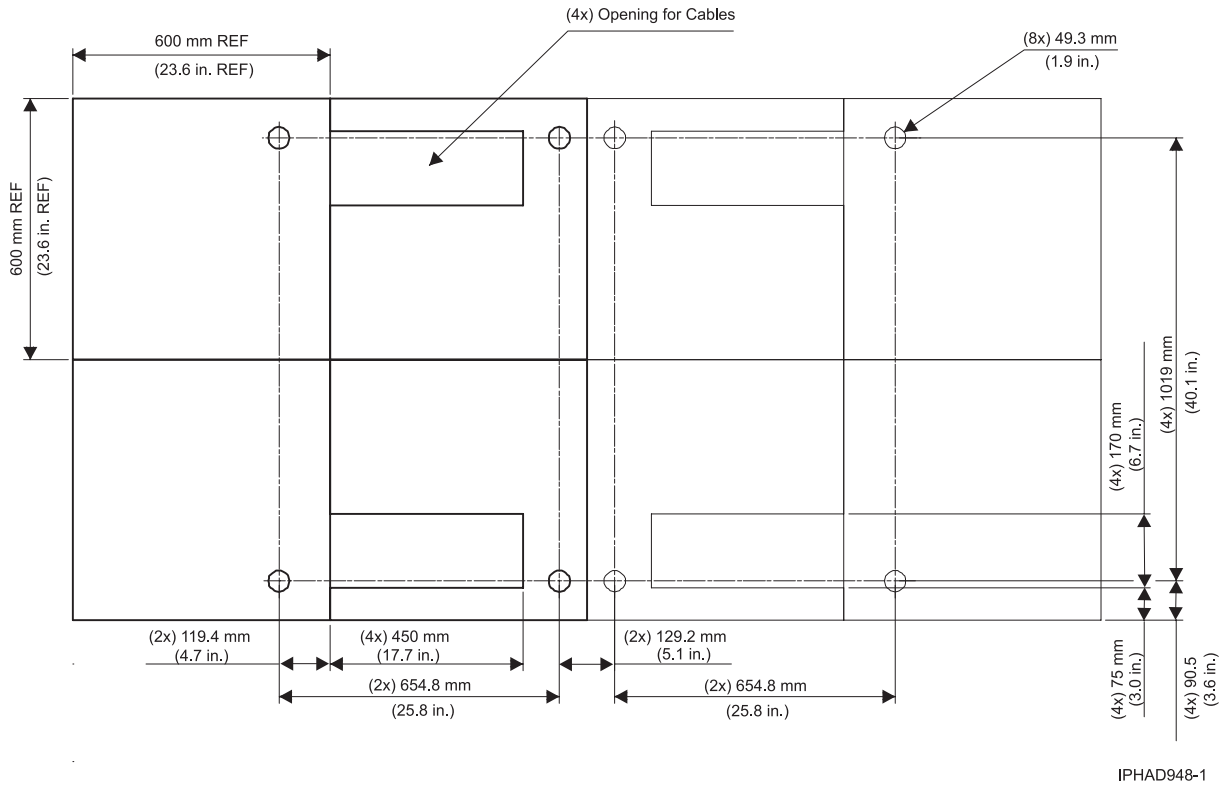

Figure 49. Eyebolt positioning for 600 mm (23.6 in.) floor tile layout

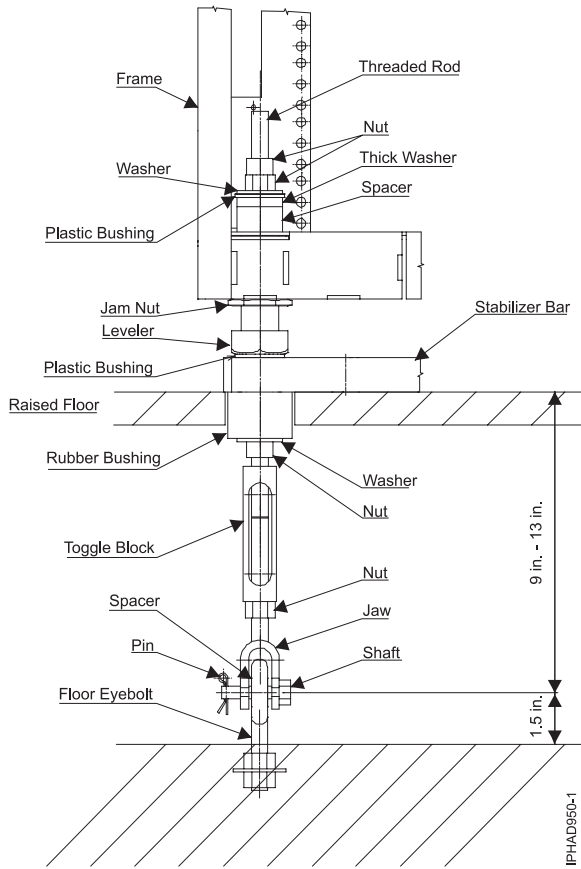

Figure 51. Turnbuckle assembly frame tie-down hardware for 228.6 - 330.2 mm (9 - 13 in.) raised floor (part number 44P2999)

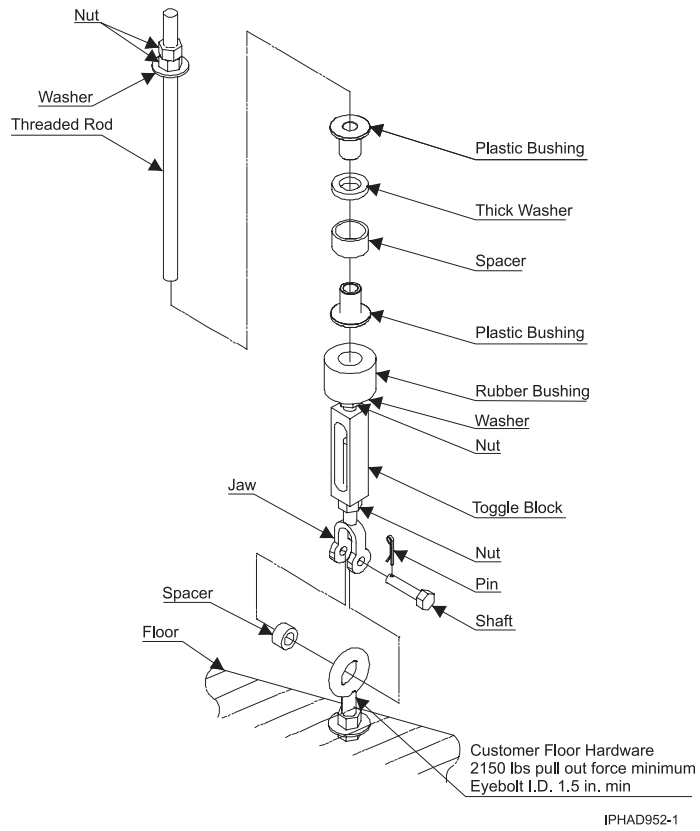

Figure 52. Turnbuckle assembly frame tie-down hardware for 228.6 - 330.2 mm (9 - 13 in.) raised floor (part number 44P2999)

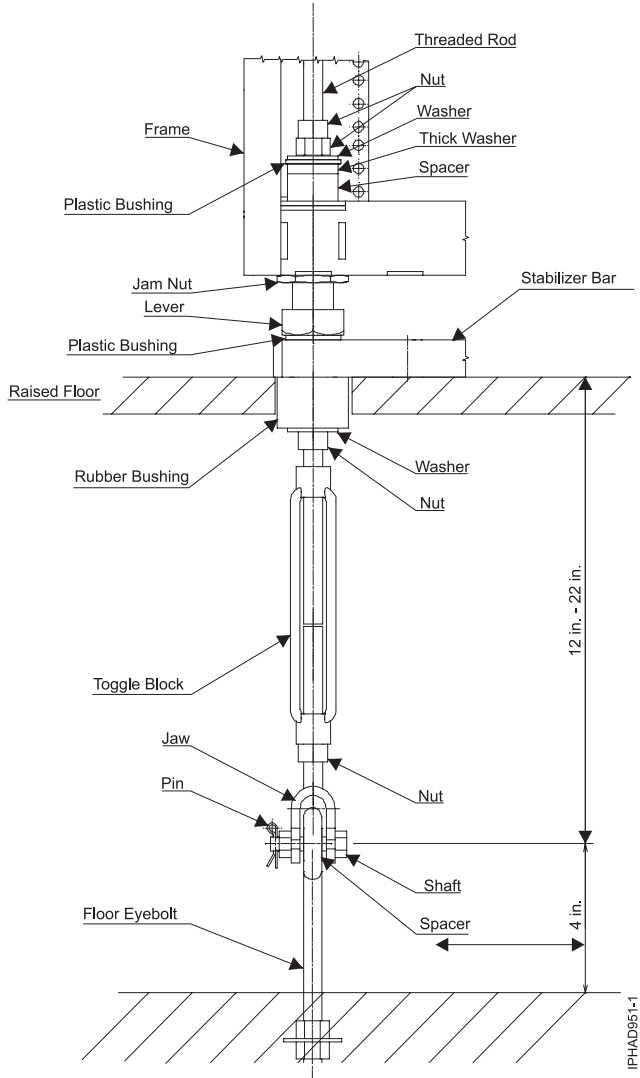

Figure 53. Turnbuckle assembly frame tie-down hardware for 304.8 - 558.8 mm (12 - 22 in.) raised floor (part number 44P3000)

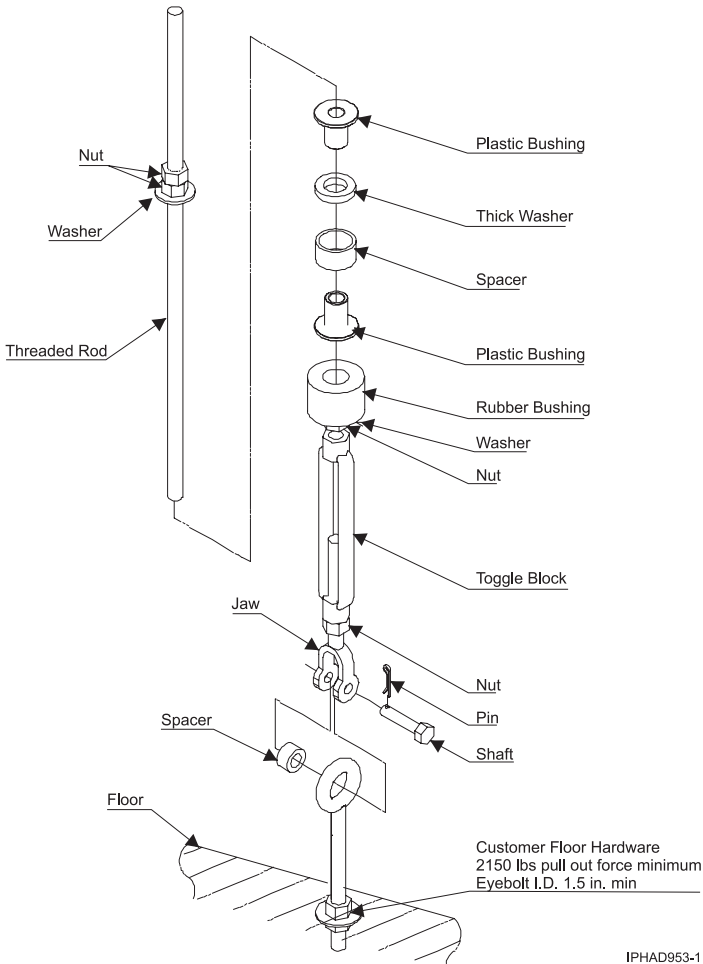

Figure 54. Turnbuckle assembly frame tie-down hardware for 304.8 - 558.8 mm (12 - 22 in.) raised floor (part number 44P3000)

Considerations for multiple-system installations

Learn about the installation requirements for a multiple-system installation.

When you are integrating a 6954 with a model 19F/HB and other products in your data center, consider the following factors:

- Minimum aisle width

The minimum aisle width in the front of the system is 1219 mm (48 in.) and in the rear of the system is 1219 mm (48 in.) to allow room to perform service operations. The minimum aisle width to allow room to perform service operations. Service clearances are measured from the edges of the frame with frame extenders to the nearest obstacle.

- Thermal interactions

Systems must face front-to-front and rear-to-rear to create "cold" and "hot" aisles to maintain effective system thermal conditions. This is shown in the following figure.

Cold aisles need to be of sufficient width to support the airflow requirements of the installed systems as indicated in "Cooling requirements" on page 124. The airflow per tile will be dependent on the under floor pressure and perforations in the tile. A typical under floor pressure of 0.025 in. of water will supply 300 - 400 cfm through a 25% open 0.61 mm by 0.61 m (2 ft by 2 ft) floor tile.

Proposed Floor Layout for Multiple Systems

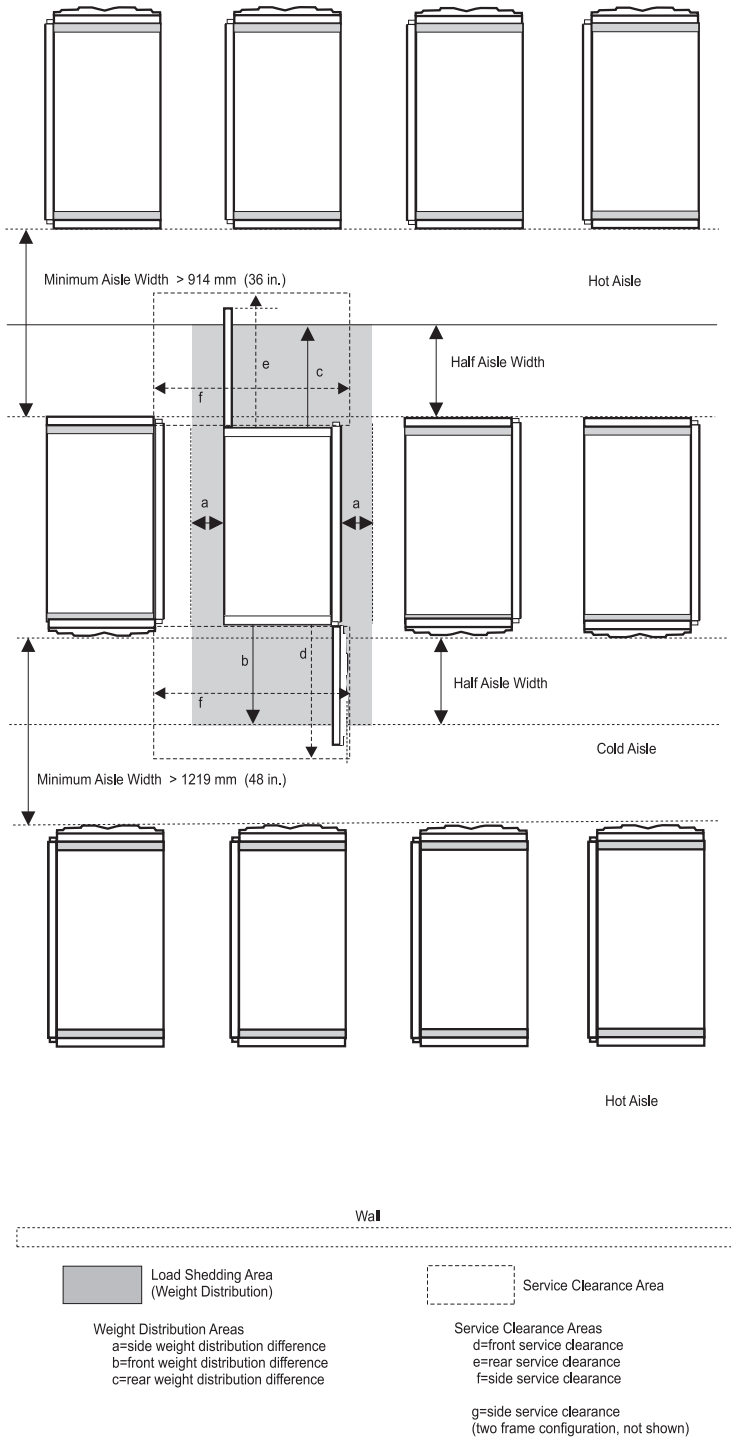

A4AA5733-2

Figure 55. Proposed floor layout for multiple systems

Total system power consumption

Use the following tables to determine the total system power consumption for your server's configuration.

The following tables show the maximum utility power in kilowatts. Actual system power is affected by memory configuration and system workload. The actual system power is typically less than the maximum listed amount. BPR current determines power cord size. Systems with two BPRs are unbalanced. A balanced power feature is optionally available for customers whose configuration calls for one or two BPRs but want a simple way to achieve balanced three-phase power loading without having to custom wire their three-phase AC power distribution.

The power requirements for a POWER7 I/O rack new build or a POWER7 I/O rack upgrade from a POWER6 I/O rack are the same.

Table 134. Powered I/O racks

Drawers	kW
1	1.4
2	2.9
3	4.3
4	5.8
5	7.2
6	8.7
7	10.1
8	11.6
9	13.0 ¹
10	14.5 ¹
11	15.9 ¹
12	17.4 ¹
13	18.8 ¹
14	20.2 ¹
15	21.7 ¹
16	23.1 ¹

¹A higher rated line cord is required.

Electrical requirements

Use the following sections to determine the electrical and power requirements by configuration:

- "System electrical requirements (POWER7 I/O rack - new build)"
- "System electrical requirements (POWER6 I/O rack - supported as is on the 9119-FHB)" on page 105

System electrical requirements (POWER7 I/O rack - new build)

The system rating and power cord requirements vary by configuration. Systems with 1 - 8 expansion drawers can use the lower rated line cord set. All other configurations use the higher rated line cord set. Exceptions include the 380 - 520 V dc systems and the 380 - 440 V ac systems used in North American installations which always use the higher rated line cord set. Use the following tables to determine the electrical requirements for a POWER7 I/O rack new build installation.

Table 135. System electrical requirements (POWER7 I/O rack new build) 200 - 240 V ac

200-240 V ac		
North America/Japan	Lower rated set	Higher rated set
Line cord Feature Cord	8688	8686 or 8696
Plug rating	60 A	100 A
System rating	48 A	63 A
Recommended circuit breaker rating	60 A	80 A
Cord size	6 AWG	4 AWG or 6 AWG
All other jurisdictions	Lower rated set	Higher rated set
Line cord Feature Cord	8694	8694
Plug rating	no plug	no plug
System rating	48 A	63 A
Recommended circuit breaker rating	60-63 A	80 A
Cord size	6 AWG	6 AWG

Table 136. System electrical requirements (POWER7 I/O rack new build) 380 - 440 V ac

380 - 440 V ac ¹		
All jurisdictions excluding North America/Japan	Lower rated set	Higher rated set
Line cord feature code	8677	8694
Plug rating	no plug	no plug
System rating	25.6 A	48 A
Recommended circuit breaker rating	32-40 A	54-63 A
Cord size	8 AWG	6 AWG
¹ 380-415 V ac operation is not supported in North America since there is no approved plug/receptacle available.		

Table 137. System electrical requirements (POWER7 I/O rack new build) 480 V ac

480 V ac		
United States of America	Lower rated set	Higher rated set
Line cord Feature Cord	8697	8699
Plug rating	30 A	60 A
System rating	22 A	25.6 A
Recommended circuit breaker rating	26-30 A	50-60 A
Cord size	8 AWG	6 AWG
All other jurisdictions	Lower rated set	Higher rated set
Line cord Feature Cord	n/a	n/a
Plug rating	n/a	n/a
System rating	n/a	n/a
Recommended circuit breaker rating	n/a	n/a
Cord size	n/a	n/a

Table 138. System electrical requirements (POWER7 I/O rack new build) 380 - 520 V dc

330-600 V dc

Table 138. System electrical requirements (POWER7 I/O rack new build) 380 - 520 V dc (continued)

North America/Japan	Lower rated set	Higher rated set
Line cord Feature Cord	n/a	8792
Plug rating	n/a	100 A
System rating	n/a	63 A
Recommended circuit breaker rating	n/a	80 A
Cord size	n/a	4 AWG
All other jurisdictions	Lower rated set	Higher rated set
Line cord Feature Cord	n/a	8789
Plug rating	n/a	No plug
System rating	n/a	63 A
Recommended circuit breaker rating	n/a	80 A
Cord size	n/a	4 AWG

System electrical requirements (POWER6 I/O rack - supported as is on the 9119-FHB)

The system rating and power cord requirements vary by configuration. Systems with 1, 2, or 3 processor books can use the lower rated line cord set. All other configurations use the higher rated line cord set. Exceptions include the 380-415 V ac systems used in North American installations which always use the higher rated line cord set. Use the following tables to determine the electrical requirements for a POWER6 I/O rack.

Table 139. System electrical requirements (POWER6 I/O rack)

	US, Canada, Japan		US High Voltage		World Trade Corporation			
	200 - 240 V ac		480 V ac		200 - 240 V ac		380 - 415 V ac	
	Lower rated power cord set	Higher rated power cord set	Lower rated power cord set	Higher rated power cord set	Lower rated power cord set	Higher rated power cord set	Lower rated power cord set	Higher rated power cord set
Plug Rating Needed	60 A	100 A ¹	30 A	30 A ¹	No plug	No plug ¹	No plug	No plug ¹
System Rating, I/O rack	48 A	63 A ¹	24 A	24 A ¹	48 A	63 A ¹	34 A	34 A ¹
Recommended circuit breaker rating	60 A	80 A ¹	30 A	30 A ¹	60 A	80A ¹	40 A	40 A ¹
Cord size	6 AWG	6 AWG ¹	8 AWG	8 AWG ¹	6 AWG	6 AWG ¹	8 AWG	8 AWG ¹
Recommended receptacle (Not provided)	IEC60309, 60 A, type 460R9W	IEC60309, 100 A, type 4100R9W ¹	IEC60309, 30 A, type 430R7W	IEC60309, 30 A, type 430R7W ¹	Not specified, electrician installed	Not specified, electrician installed ¹	Not specified, electrician installed	Not specified, electrician installed ¹
Power Cord Feature Code 4.3 m (14 ft)	8688	8686	8697	8697	8694	8694	8677	8677

¹One frame requires the lower rated power cord set. Two frames require the higher rated power cord set.

Balancing power panel loads

Use this information to ensure that power panel loads are balanced.

System configurations using three or four BPRs presents a balanced load to the utility, provided that both line cords are energized. When only one line cord is energized, systems drawing more than 24 kW will present a slightly unbalanced load to the utility. AC systems with two BPRs are unbalanced.

The following figure is an example of feeding several loads from two power panels in a way that balances the load among the three-phases.

Note: Use of ground-fault-interrupt (GFI) circuit breakers is not recommended for this system because GFI circuit breakers are earth-leakage-current sensing circuit breakers and this system is a high earth-leakage-current product.

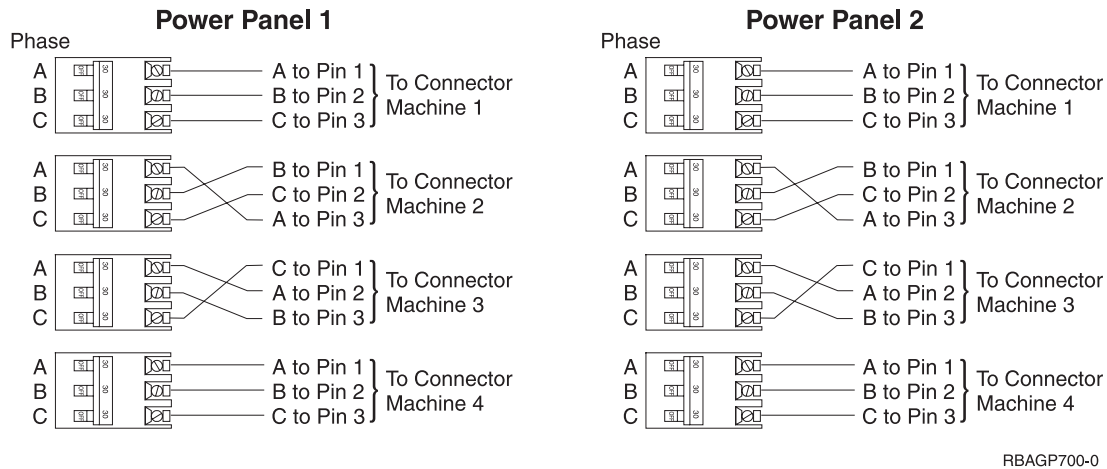

Figure 56. Power panel load balancing

The method illustrated in the previous figure requires that the connection from the three poles of each breaker to the three-phase pins of a connector be varied. Some electricians might prefer to maintain a consistent wiring sequence from the breakers to the connectors.

The following figure shows a way to balance the load without changing the wiring on the output of any breakers. The three-pole breakers are alternated with single-pole breakers so that the three-pole breakers do not all begin on phase A.

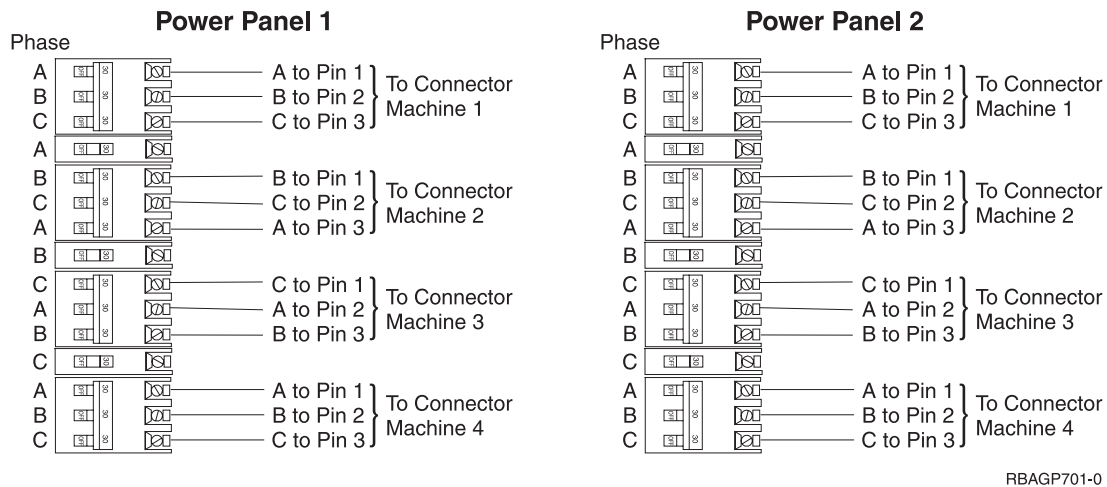
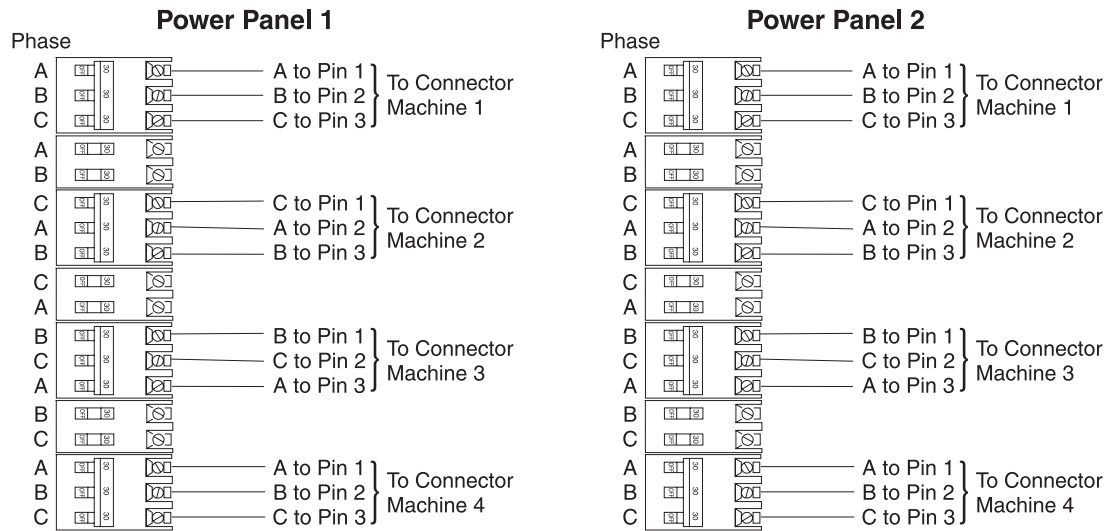

Figure 57. Power panel load balancing

The following figure shows another way of distributing the unbalanced load evenly. In this case, the three-pole breakers are alternated with two-pole breakers.



RBAGP702-0

Figure 58. Power panel load balancing

Dual power installation

All of the 6954 configurations are designed with a fully redundant power system. These systems have two power cords attached to two power input ports, which power a fully redundant power distribution system within the system. To take full advantage of the redundancy and reliability that is built into the computer system, the system must be powered from two distribution panels.

BPR/BPD configuration

Use the below table to find out the requirements for Bulk Power Regulators (BPRs) and Bulk Power Distributions (BPDs) for a POWER7 I/O rack new build. Depending on the number of BPRs in your system, phase imbalance can occur in line currents.

Table 140. System BPR and BPD Requirements (POWER7 I/O rack new build)

Drawers	BPRs	BPDs
1	1	1
2	1	1
3	1	1
4	1	1
5	2	1
6	2	1
7	2	1
8	3	1
9	3 ¹	2 ¹
10	3 ¹	2 ¹
11	3 ¹	2 ¹
12	3 ¹	2 ¹
13	3 ¹	2 ¹
14	3 ¹	2 ¹
15	3 ¹	2 ¹
16	3 ¹	2 ¹

Table 140. System BPR and BPD Requirements (POWER7 I/O rack new build) (continued)

Drawers	BPRs	BPDs
¹ A higher rated line cord is required.		

Cutting and placing floor panels

These guidelines specify how to make the necessary openings in the raised floor for installing your server.

Use the following procedure to cut and place floor panels in the raised floor. The x-y alphanumeric grid positions are used to identify relative positions of cutout floor panels that might be cut in advance.

1. Measure the panel size of the raised floor.
2. Verify the floor panel size. The illustrated floor panel size is 600 mm (23.6 in.) and 610 mm (24 in.) panels.
3. Ensure adequate floor space is available to place the frames over the floor panels exactly as shown in the following figures. For front-to-back and side-to-side clearances, see “Considerations for multiple-system installations” on page 101. Use the plan view, if necessary. Consider all obstructions above and below the floor.
4. Identify the required panels, and list the total quantity of each panel required for the installation.
- 5.

Important: Cut the required quantity of panels. When cutting the panels, you must adjust the size of the cut for the thickness of the edge molding that you are using. The dimensions shown in the figures are finished dimensions. For ease of installation, number each panel as it is cut.

Note: For a multiple frame installation, two casters could produce loads as high as 2750 lb.

Notes:

1. The weight distribution bar is a requirement for model 19F/HB on a raised floor. It is required to maintain the integrity of the floor, which holds the weight of the frame.
2. This floor-tile arrangement is recommended for casters or leveling pads that are placed on separate floor tiles to minimize the weight on a single floor tile. Load bearing tiles that have cutouts might require additional pedestals to keep their structural integrity. Additionally, the cutouts span two tiles. Raised floors utilizing a stringer system should leave the stringer intact.
3. The Figure 59 on page 109 and Figure 65 on page 115 figures are intended only to show relative positions and accurate dimensions of floor cutouts. The figures are not intended to be a machine template and is not drawn to scale.

Raised floor with 610 mm (24 in.) floor panels figure

The following figure shows an overview perspective of the rack placement on floor tiles. The dashed lines represent the rack. The solid lines are used for dimensions.

- The rear of the server is placed 75 mm (3.0 in.) measuring up from the bottom edge of the first row tile.
- The front of the server is placed 20 mm (0.7 in.) measuring up from the bottom edge of the third row tile.

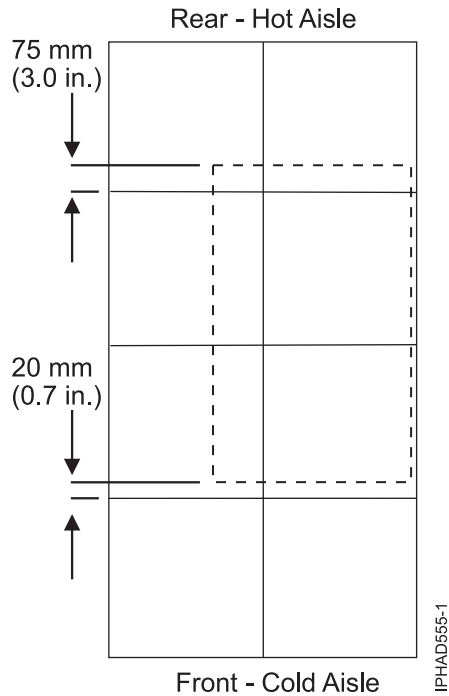

Figure 59. Rack placement for 610 mm (24 in.) tiles

The following figure shows the floor cutouts for the cables. The solid rectangles indicate the cutouts, and the solid lines are used for dimensions.

- The first cutout is 94 mm (3.7 in.) high measuring up from the bottom edge of the first row tile. The width of the first cutout is 110 mm (4.3 in.) measuring left from the right edge of the first column tile. Continue cutting out an additional 545 mm (21.5 in.) measuring right from the left edge of the second column tile. The total width of the cutout is 655 mm (25.8 in.).
- The second cutout is 94 mm (3.7 in.) high measuring up from the bottom edge of the third row tile. The width of the second cutout is 110 (4.3 in.) mm measuring left from the right edge of the first column tile. Continue cutting out an additional 545 mm (21.5 in.) measuring right from the left edge of the second column tile. The total width of the cutout is 655 mm (25.8 in.).

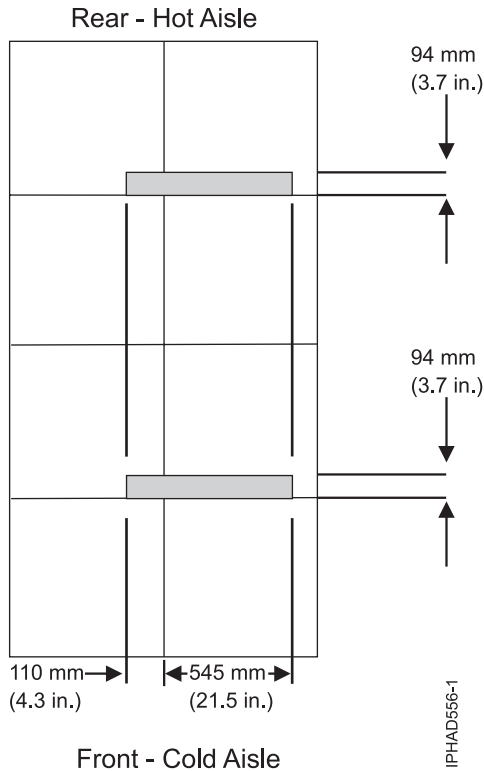

Figure 60. Cable cutout placement 610 mm (24 in.) tiles

The following figure shows the location of the rack tie-down for a single rack. The solid rectangles indicate the cutouts, and the solid lines are used for dimensions.

- The first circle, located on the upper left, is 109 mm (4.3 in.) measuring from the right edge of the first column tile. It is 52 mm (2.0 in.) measuring down from the top edge of the second row tile.
- The second circle, located on the upper right, is 65 mm (2.6 in.) measuring from the right edge of the second column tile. It is 52 mm (2.0 in.) measuring down from the top edge of the second row tile.
- The third circle, located on the lower left, is 109 mm (4.3 in.) measuring from the right edge of the first column tile. It is 1019 mm (40.1 in.) measuring down from the first circle.
- The fourth circle, located on the lower right, is 65 mm (2.6 in.) measuring from the right edge of the second column tile. It is 1019 mm (40.1 in.) measuring down from the second circle.

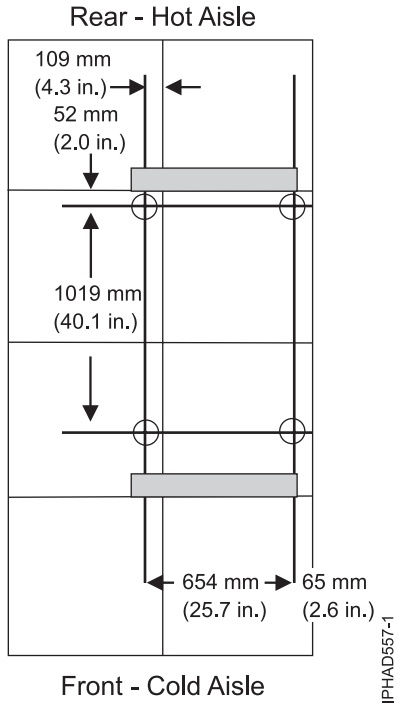

Figure 61. Single rack tie-down hole pattern

See “Installing the frame tie-down kit” on page 93 for instructions on how to install a frame tie-down kit and floor tie-down hardware.

The following figure is an overview image of the placement of two racks on the tiles. The dashed lines represents the racks.

- The rear of the server is placed 75 mm (3.0 in.) measuring up from the bottom edge of the first row tile.
- The front of the server is placed 20 (0.7 in.) mm measuring up from the bottom edge of the third row tile.

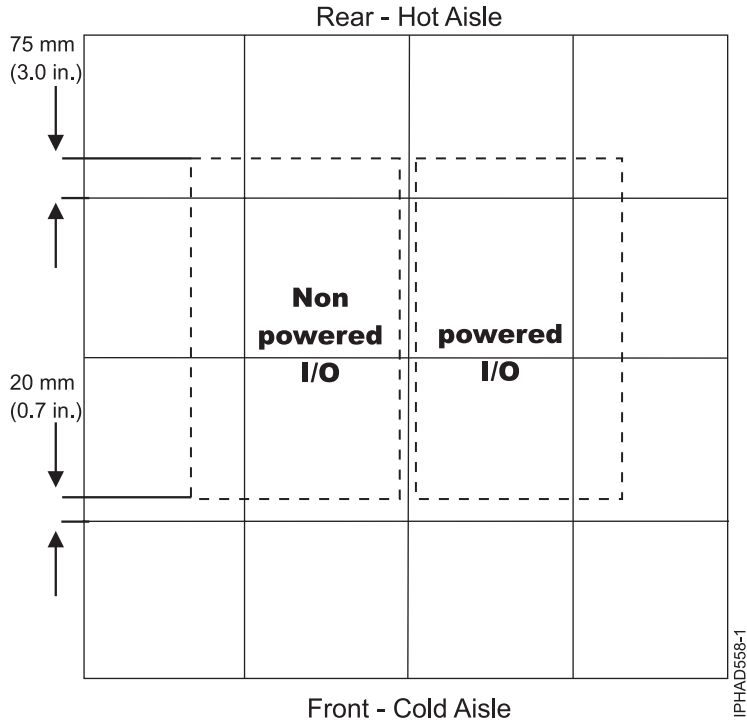

Figure 62. Two rack placement on 610 mm (24 in.) tiles

The following figure is an overview image of the floor cutouts. The solid lines are used for the dimensions.

- The first cutout, located on the upper left, is 94 mm (3.7 in.) high measuring up from the bottom edge of the first row tile. The width is 110 mm (4.3 in.) measuring left from the right edge of the first column tile. Continue cutting out an additional 545 mm (21.5 in.) measuring right from the left edge of the second column tile. The total width of the cutout is 655 mm (25.8 in.).
- The second cutout, located on the upper right, is 94 mm (3.7 in.) high measuring up from the bottom edge of the first row tile. The width is 545 mm (21.5 in.) measuring left from the right edge of the second column tile. Continue cutting out an additional 110 mm (4.3 in.) measuring right from the left edge of the third column tile. The total width of the cutout is 655 mm (25.8 in.).
- The third cutout, located on the lower left, is 94 mm (3.7 in.) high measuring up from the bottom edge of the third row tile. The width is 110 mm (4.3 in.) measuring left from the right edge of the first column tile. Continue cutting out an additional 545 mm (21.5 in.) measuring right from the left edge of the second column tile. The total width of the cutout is 655 mm (25.8 in.).
- The fourth cutout, located on the lower right, is 94 mm (3.7 in.) high measuring up from the bottom edge of the third row tile. The width is 545 mm (21.5 in.) measuring left from the right edge of the third column tile. Continue cutting out an additional 110 mm (4.3 in.) measuring right from the left edge of the third column tile. The total width of the cutout is 655 mm (25.8 in.).

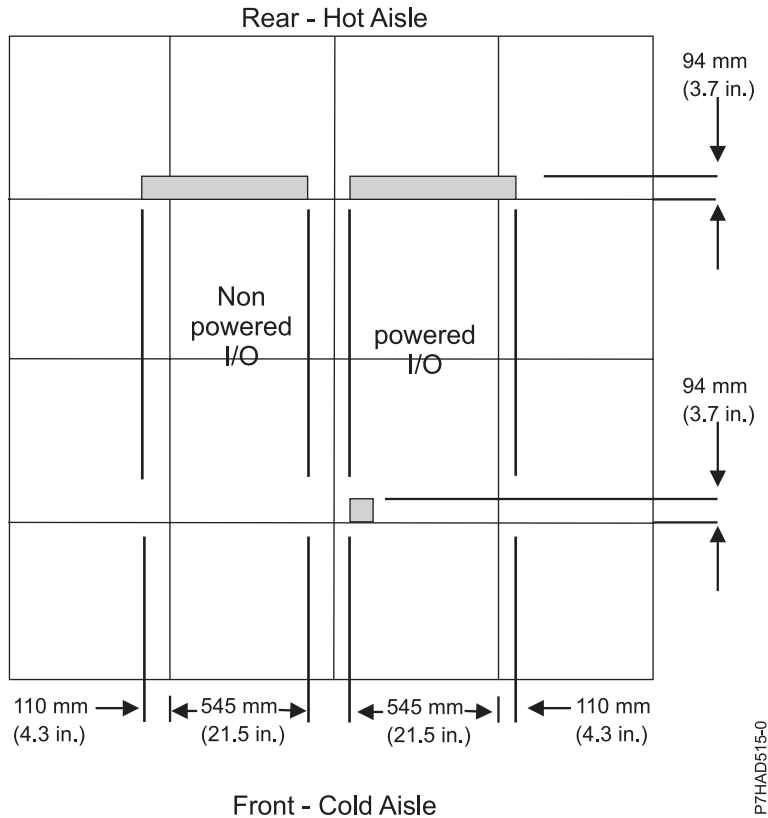

Figure 63. Cable cutout placement for two racks for 610 mm (24 in.) tiles

The following figure shows the location of the rack tie-downs needed for two racks. The solid rectangles indicate the cutouts, and the solid lines are used for dimensions.

- The first circle located, on the upper left, is 109 mm (4.3 in.) measuring left from the right edge of the first column tile. It is 52 mm (2.0 in.) measuring down from the top edge of the second row tile.
- The second circle, located in the upper left center, is 64.5 mm (2.5 in.) measuring left from the right edge of the second column tile. It is 52 mm (2.0 in.) measuring down from the top edge of the second row tile.
- The third circle, located in the upper right center, is 64.5 mm (2.5 in.) measuring right from the left edge of the third tile. It is 52 mm (2.0 in.) measuring down from the top edge of the second row tile.
- The fourth circle, located on the upper right, is 109 mm (4.3 in.) measuring right from the left edge of the third column tile. It is 52 mm (2.0 in.) measuring down from the top edge of the second row tile.
- The fifth circle located, on the lower left, is 109 mm (4.3 in.) measuring right from the left edge of the first column tile. It is 1019 mm (40.1 in.) measuring down from the first circle.
- The sixth circle, located in the lower left center, is 64.5 mm (2.5 in.) measuring left from the right edge of the second tile. It is 1019 mm (40.1 in.) measuring down from the second circle.
- The seventh circle, located in the lower right center, is 64.5 mm (2.5 in.) measuring right from the left edge of the third column tile. It is 1019 mm (40.1 in.) measuring down from the third circle.
- The eighth circle, located on the lower right, is 109 mm (4.3 in.) measuring right from the left edge of the fourth column tile. It is 1019 mm (40.1 in.) measuring down from the fourth circle.

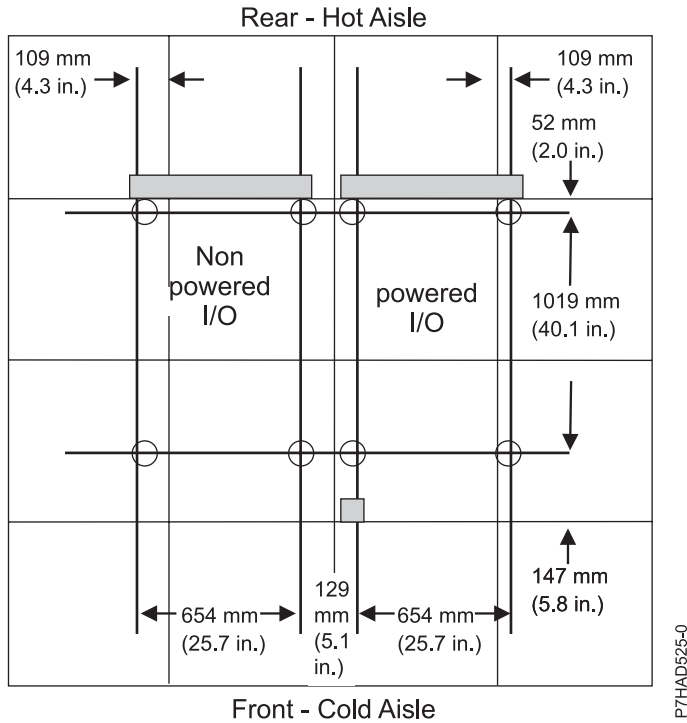

Figure 64. Two rack tie-down hole placement

See “Installing the frame tie-down kit” on page 93 for instructions on how to install a frame tie-down kit and floor tie-down hardware.

Raised floor with 600 mm (23.6 in.) floor panels figure

The following figure shows an overview perspective of the rack placement on the floor tiles. The dashed lines represent the rack. The solid lines are used for dimensions.

- The rear of the server is placed 83 mm (3.3 in.) measuring up from the bottom edge of the first row tile.
- The front of the server is placed 10 mm (0.4 in.) measuring up from the bottom edge of the third row tile.

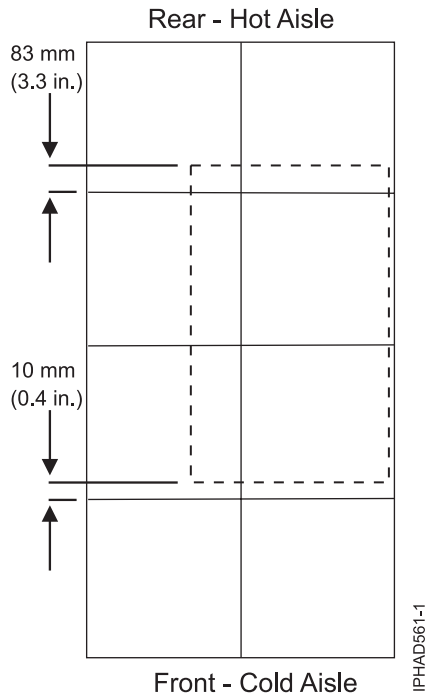
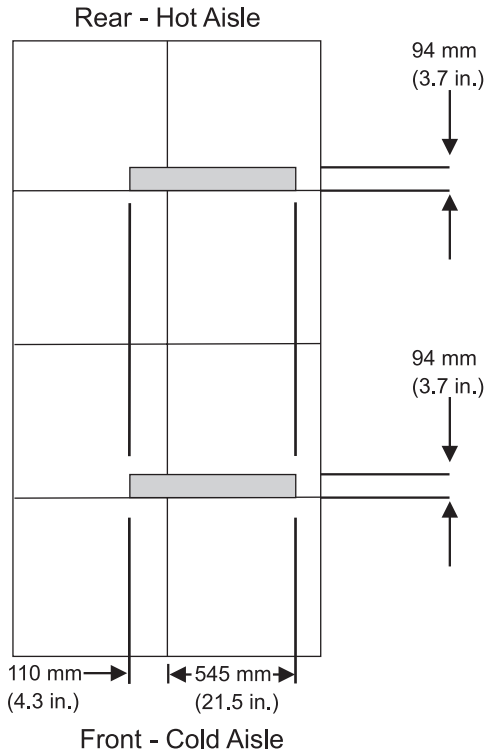

Figure 65. Rack placement for 600 mm (23.6 in.) tiles

The following figure shows the floor cutouts for the cables. The solid rectangles indicate the cutouts, and the solid lines are used for dimensions.

- The first cutout is 94 mm (3.7 in.) high measuring up from the bottom edge of the first row tile. The width of the first cutout is 110 mm (4.3 in.) measuring left from the right edge of the first column tile. Continue cutting out an additional 545 mm (21.5 in.) measuring right from the left edge of the second column tile. The total width of the cutout is 655 mm (25.8 in.).
- The second cutout is 94 mm (3.7 in.) high measuring up from the bottom edge of the third row tile. The width of the second cutout is 110 mm (4.3 in.) measuring left from the right edge of the first column tile. Continue cutting out an additional 545 mm (21.5 in.) measuring right from the left edge of the second column tile. The total width of the cutout is 655 mm (25.8 in.).



IPHAD862-1

Figure 66. Cable cutout placement 600 mm (23.6 in.) tiles

The following figure shows the location of the rack tie-down for a single rack. The solid rectangles indicate the cutouts, and the solid lines are used for dimensions.

- The first circle, located on the upper left, is 119 mm (4.7 in.) measuring from the right edge of the first column tile. It is 44 mm (1.7 in.) measuring down from the top edge of the second row tile.
- The second circle, located on the upper right, is 65 mm (2.6 in.) measuring from the right edge of the second column tile. It is 44 mm (1.7 in.) measuring down from the top edge of the second row tile.
- The third circle, located on the lower left, is 119 mm (4.7 in.) measuring from the right edge of the first column tile. It is 1019 mm (40.1 in.) measuring down from the first circle.
- The fourth circle, located on the lower right, is 65 mm (2.6 in.) measuring from the right edge of the second column tile. It is 1019 mm (40.1 in.) measuring down from the second circle.

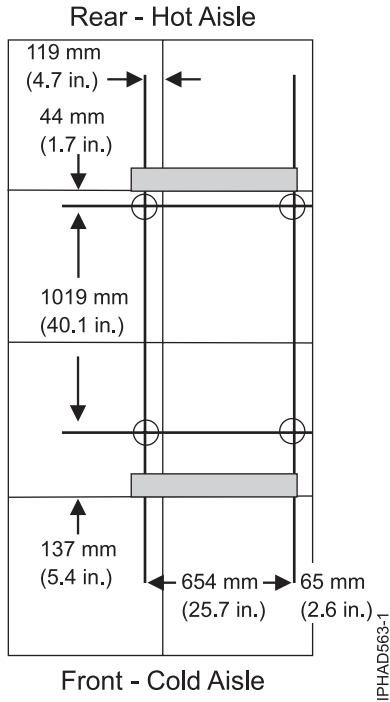

Figure 67. Rack tie-down hole pattern

See "Installing the frame tie-down kit" on page 93 for instructions on how to install a frame tie-down kit and floor tie-down hardware.

The following figure is an overview image of the placement of two racks on the tiles. The dashed lines represents the racks.

- The rear of the server is placed 83 mm (3.3 in.) measuring up from the bottom edge of the first row tile.
- The front of the server is placed 10 mm (0.4 in.) measuring up from the bottom edge of the third row tile.

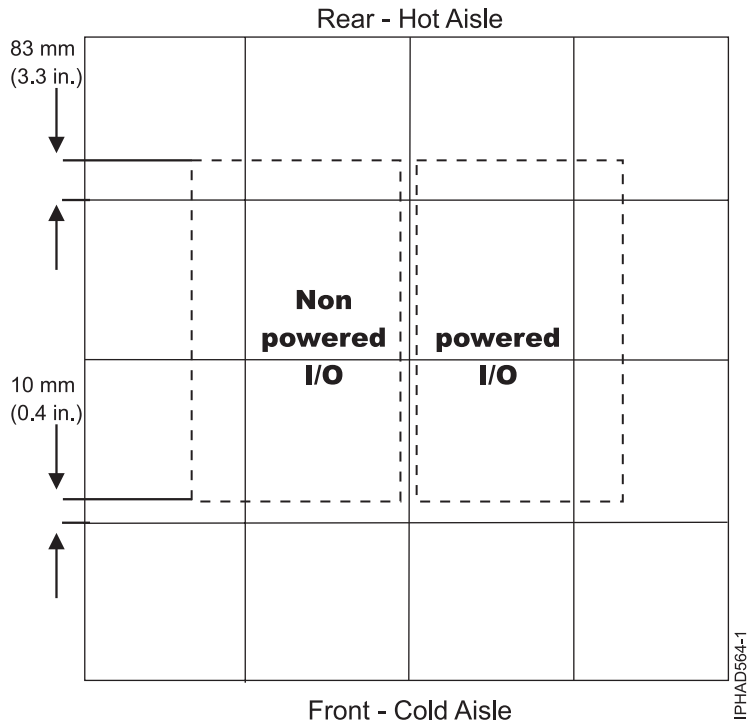
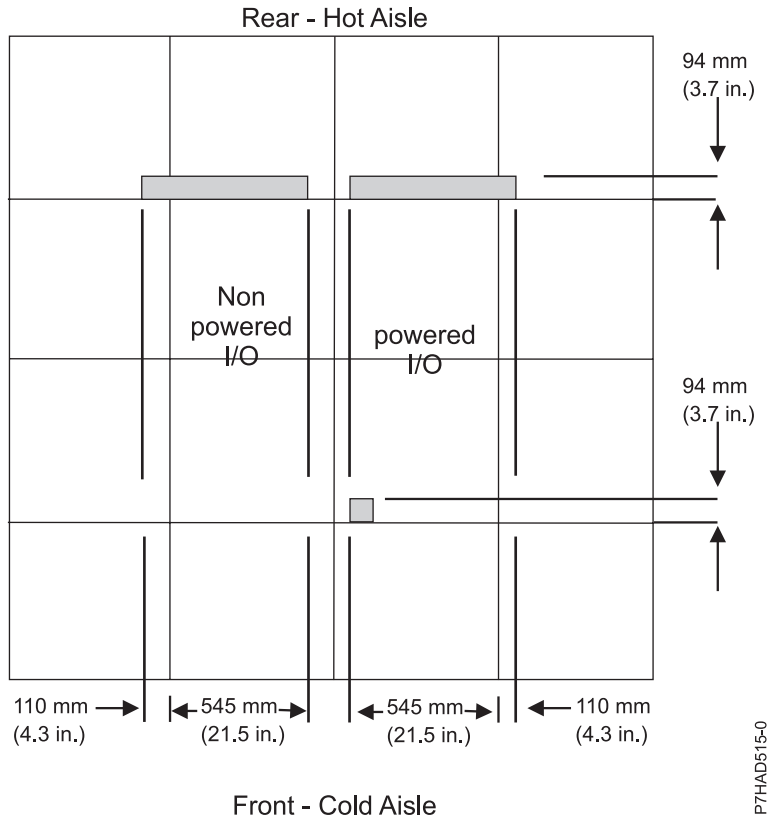

Figure 68. Two rack placement on 600 mm (23.6 in.) tiles

The following figure is an overview image of the floor cutouts. The solid lines are used for the dimensions.

- The first cutout, located on the upper left, is 94 mm (3.7 in.) high measuring up from the bottom edge of the first row tile. The width is 110 mm (4.3 in.) measuring left from the right edge of the first column tile. Continue cutting out an additional 545 mm (21.5 in.) measuring right from the left edge of the second column tile. The total width of the cutout is 655 mm (25.8 in.).
- The second cutout, located on the upper right, is 94 mm (3.7 in.) high measuring up from the bottom edge of the first row tile. The width is 545 mm (21.5 in.) measuring left from the right edge of the second column tile. Continue cutting out an additional 110 mm (4.3 in.) measuring right from the left edge of the third column tile. The total width of the cutout is 655 mm (25.8 in.).
- The third cutout, located on the lower left, is 94 mm (3.7 in.) high measuring up from the bottom edge of the third row tile. The width is 110 mm (4.3 in.) measuring left from the right edge of the first column tile. Continue cutting out an additional 545 mm (21.5 in.) measuring right from the left edge of the second column tile. The total width of the cutout is 655 mm (25.8 in.).
- The fourth cutout, located on the lower right, is 94 mm (3.7 in.) high measuring up from the bottom edge of the third row tile. The width is 545 mm (21.5 in.) measuring left from the right edge of the third column tile. Continue cutting out an additional 110 mm (4.3 in.) measuring right from the left edge of the third column tile. The total width of the cutout is 655 mm (25.8 in.).



P7HAD515-0

Figure 69. Two cable cutout placement for 600 mm (23.6 in.) tiles

The following figure shows the location of the rack tie-downs needed for two racks. The solid rectangles indicate the cutouts, and the solid lines are used for dimensions.

- The first circle located, on the upper left, is 119 mm (4.7 in.) measuring left from the right edge of the first column tile. It is 44 mm (1.7 in.) measuring down from the top edge of the second row tile.
- The second circle, located in the upper left center, is 64.5 mm (2.5 in.) measuring left from the right edge of the second column tile. It is 44 mm (1.7 in.) measuring down from the top edge of the second row tile.
- The third circle, located in the upper right center, is 64.5 mm (2.5 in.) measuring right from the left edge of the third tile. It is 44 mm (1.7 in.) measuring down from the top edge of the second row tile.
- The fourth circle, located on the upper right, is 119 mm (4.7 in.) measuring right from the left edge of the third column tile. It is 44 mm (1.7 in.) measuring down from the top edge of the second row tile.
- The fifth circle located, on the lower left, is 119 mm (4.7 in.) measuring right from the left edge of the first column tile. It is 1019 mm (40.1 in.) measuring down from the first circle.
- The sixth circle, located in the lower left center, is 64.5 mm (2.5 in.) measuring left from the right edge of the second column tile. It is 1019 mm (40.1 in.) measuring down from the second circle.
- The seventh circle, located in the lower right center, is 64.5 mm (2.5 in.) measuring right from the left edge of the third column tile. It is 1019 mm (40.1 in.) measuring down from the third circle.
- The eighth circle, located on the lower right, is 119 mm (4.7 in.) measuring right from the left edge of the fourth column tile. It is 1019 mm (40.1 in.) measuring down from the fourth circle.

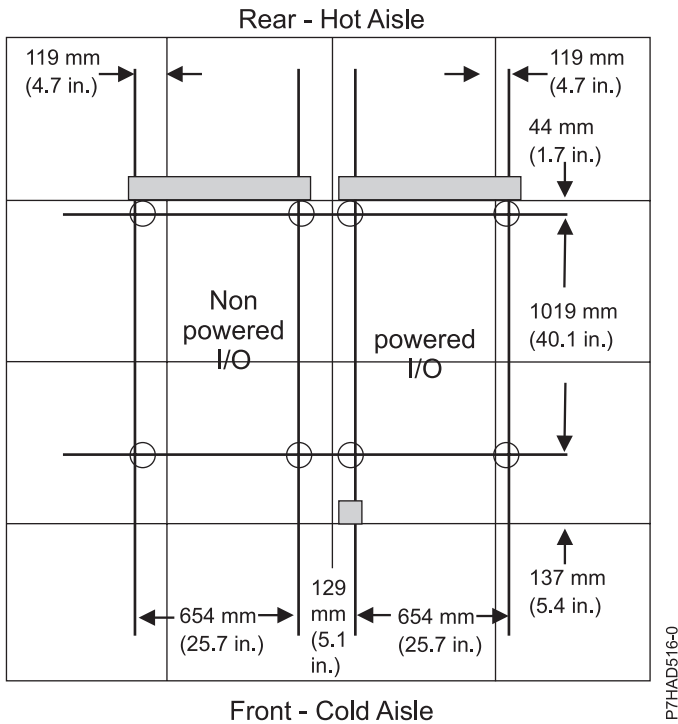

Figure 70. Rack placement for 600 mm (23.6 in.) tiles

See “Installing the frame tie-down kit” on page 93 for instructions on how to install a frame tie-down kit and floor tie-down hardware.

Additional pedestal placement

Placing large cutouts in the raised floor tiles, such as the cutouts needed for the 19F/HB, can substantially change the structural integrity of each tiles. Additional support pedestals might be needed. Pedestals might be placed approximately under each caster position to prevent tiles from sagging. Pedestals might also be used to support the cut corners of floor tiles. Pedestals might be needed for tiles where the equipment is moving across, even though they are not permanent load bearing tiles. All pedestals should be installed and adjusted to barely contact the underside of each floor panel, before the frames are rolled into place. All pedestal locations are recommendations. Each facility is unique and additional pedestal supports might be needed for certain floors. You are responsible for verifying all floor loading capacities and requirements to determine where any additional pedestals might be needed.

Note: Use the following figure as an example of where the floor pedestals should be placed. It is only intended to show relative positions. This figure is not drawn to scale.

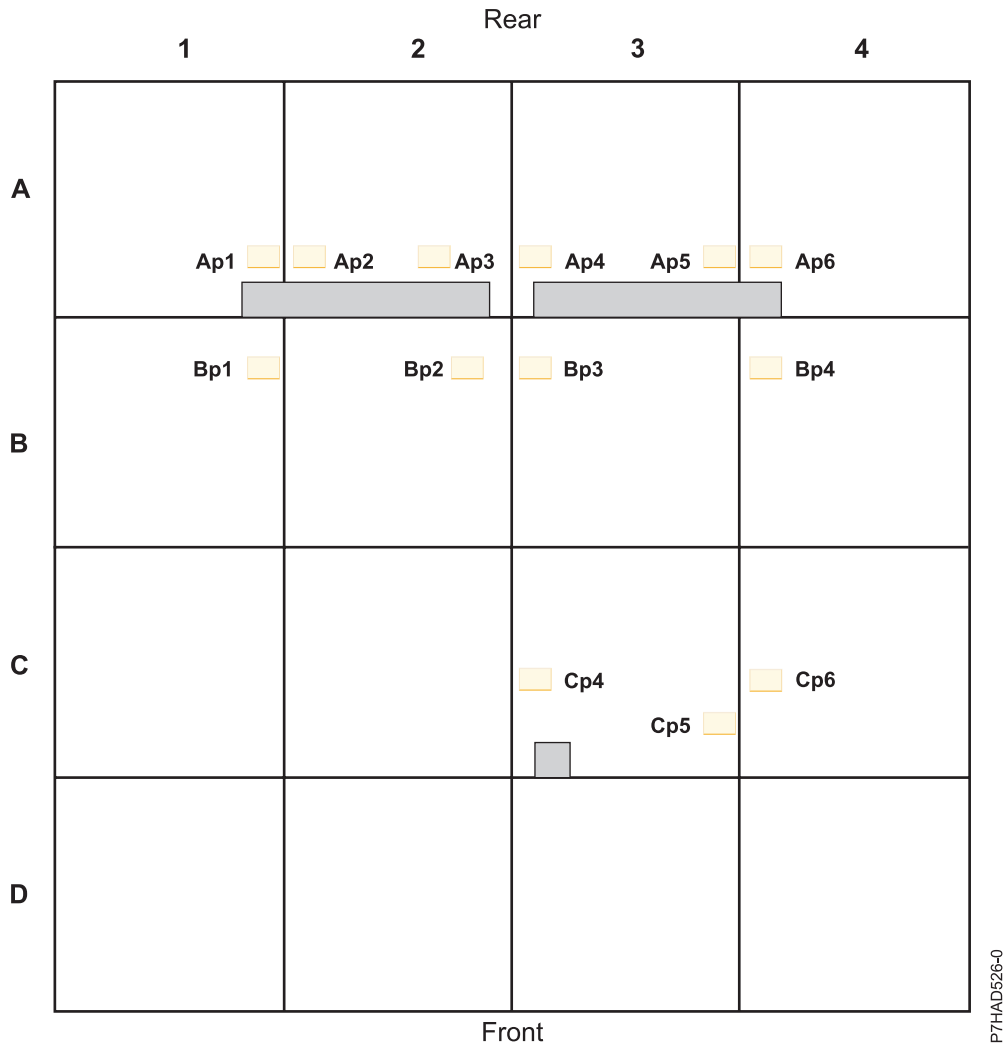

Figure 71. Additional pedestal placement

Important: Extra pedestals might be placed as shown.

- Pedestals Bp1, Bp2, Bp3, Bp4, Cp4, and Cp6 might be placed approximately under each caster position to prevent floor tiles from sagging.
- Pedestals Ap1, Ap2, Ap3, Ap4, Ap5, and Ap6 might be used to support the cut corners of floor tiles A1, A2, A3, and A. Although these floor tiles are not load-bearing, equipment, moving in the row where these floor panels site, might place high loads momentarily on the tiles.

Weight distribution

Use the floor loading information to determine the floor loading for various configurations.

The following figure shows the floor loading dimensions for 6954 and 6953 expansion racks. Use this figure in conjunction with the tables to determine the floor loading for various configurations.

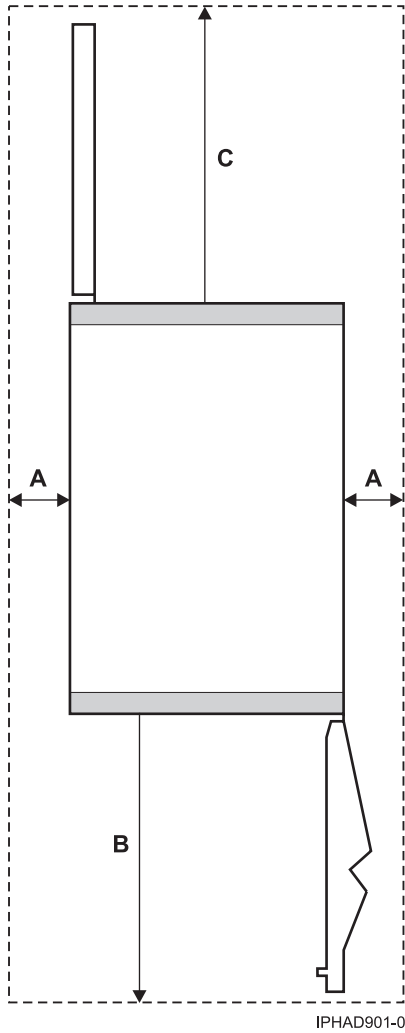

Figure 72. Floor loading dimensions

The following tables show values for calculating floor loading for the 6954 and 6953 expansion racks. Weights include acoustical covers. Width and depth are indicated without covers.

Table 141. Powered I/O rack with eight I/O drawers

Condition	a (sides)	b (front)	c (back)	Powered I/O rack	
1	25.4 mm (1 in.)	254 mm (10 in.)	254 mm (10 in.)	206.0 lb/ft ²	1006.0 kg/m ²
2	25.4 mm (1 in.)	508 mm (20 in.)	508 mm (20 in.)	165.8 lb/ft ²	809.8 kg/m ²
3	25.4 mm (1 in.)	762 mm (30 in.)	762 mm (30 in.)	140.3 lb/ft ²	684.8 kg/m ²
4	254 mm (10 in.)	254 mm (10 in.)	254 mm (10 in.)	140.2 lb/ft ²	684.6 kg/m ²
5	254 mm (10 in.)	508 mm (20 in.)	508 mm (20 in.)	114.6 lb/ft ²	559.7 kg/m ²
6	254 mm (10 in.)	762 mm (30 in.)	762 mm (30 in.)	98.3 lb/ft ²	480.2 kg/m ²
7	508 mm (20 in.)	254 mm (10 in.)	254 mm (10 in.)	107.1 lb/ft ²	522.7 kg/m ²
8	508 mm (20 in.)	508 mm (20 in.)	508 mm (20 in.)	88.8 lb/ft ²	433.8 kg/m ²
9	508 mm (20 in.)	762 mm (30 in.)	762 mm (30 in.)	77.2 lb/ft ²	377.1 kg/m ²
10	762 mm (30 in.)	254 mm (10 in.)	254 mm (10 in.)	88.7 lb/ft ²	433.2 kg/m ²
11	762 mm (30 in.)	508 mm (20 in.)	508 mm (20 in.)	74.6 lb/ft ²	364.1 kg/m ²
12	762 mm (30 in.)	762 mm (30 in.)	762 mm (30 in.)	65.6 lb/ft ²	320.1 kg/m ²

Table 142. Powered I/O rack with four drawers

Condition	a (sides)	b (front)	c (back)	Powered I/O rack	
1	25.4 mm (1 in.)	254 mm (10 in.)	254 mm (10 in.)	146.0 lb/ft ²	713.0 kg/m ²
2	25.4 mm (1 in.)	508 mm (20 in.)	508 mm (20 in.)	119.2 lb/ft ²	581.9 kg/m ²
3	25.4 mm (1 in.)	762 mm (30 in.)	762 mm (30 in.)	102.1 lb/ft ²	498.3 kg/m ²
4	254 mm (10 in.)	254 mm (10 in.)	254 mm (10 in.)	102.0 lb/ft ²	498.1 kg/m ²
5	254 mm (10 in.)	508 mm (20 in.)	508 mm (20 in.)	84.9 lb/ft ²	414.7 kg/m ²
6	254 mm (10 in.)	762 mm (30 in.)	762 mm (30 in.)	74.0 lb/ft ²	361.5 kg/m ²
7	508 mm (20 in.)	254 mm (10 in.)	254 mm (10 in.)	79.9 lb/ft ²	389.9 kg/m ²
8	508 mm (20 in.)	508 mm (20 in.)	508 mm (20 in.)	67.7 lb/ft ²	330.5 kg/m ²
9	508 mm (20 in.)	762 mm (30 in.)	762 mm (30 in.)	59.9 lb/ft ²	292.6 kg/m ²
10	762 mm (30 in.)	254 mm (10 in.)	254 mm (10 in.)	67.6 lb/ft ²	330.1 kg/m ²
11	762 mm (30 in.)	508 mm (20 in.)	508 mm (20 in.)	58.1 lb/ft ²	283.9 kg/m ²
12	762 mm (30 in.)	762 mm (30 in.)	762 mm (30 in.)	52.1 lb/ft ²	254.5 kg/m ²

Table 143. Powered I/O rack with seven drawers and an internal battery feature

Condition	a (sides)	b (front)	c (back)	Powered I/O rack	
1	25.4 mm (1 in.)	254 mm (10 in.)	254 mm (10 in.)	221.6 lb/ft ²	1081.8 kg/m ²
2	25.4 mm (1 in.)	508 mm (20 in.)	508 mm (20 in.)	177.9 lb/ft ²	868.7 kg/m ²
3	25.4 mm (1 in.)	762 mm (30 in.)	762 mm (30 in.)	150.1 lb/ft ²	733.1 kg/m ²
4	254 mm (10 in.)	254 mm (10 in.)	254 mm (10 in.)	150.1 lb/ft ²	732.8 kg/m ²
5	254 mm (10 in.)	508 mm (20 in.)	508 mm (20 in.)	122.3 lb/ft ²	597.2 kg/m ²
6	254 mm (10 in.)	762 mm (30 in.)	762 mm (30 in.)	104.6 lb/ft ²	510.9 kg/m ²
7	508 mm (20 in.)	254 mm (10 in.)	254 mm (10 in.)	114.1 lb/ft ²	557.0 kg/m ²
8	508 mm (20 in.)	508 mm (20 in.)	508 mm (20 in.)	94.3 lb/ft ²	460.5 kg/m ²
9	508 mm (20 in.)	762 mm (30 in.)	762 mm (30 in.)	81.7 lb/ft ²	399.0 kg/m ²
10	762 mm (30 in.)	254 mm (10 in.)	254 mm (10 in.)	94.2 lb/ft ²	459.8 kg/m ²
11	762 mm (30 in.)	508 mm (20 in.)	508 mm (20 in.)	78.8 lb/ft ²	384.9 kg/m ²
12	762 mm (30 in.)	762 mm (30 in.)	762 mm (30 in.)	69.0 lb/ft ²	337.1 kg/m ²

Table 144. Powered I/O and expansion unit with 16 drawers

Condition	a (sides)	b (front)	c (back)	Powered I/O and expansion unit	
1	25.4 mm (1 in.)	254 mm (10 in.)	254 mm (10 in.)	192.9 lb/ft ²	941.9 kg/m ²
2	25.4 mm (1 in.)	508 mm (20 in.)	508 mm (20 in.)	155.6 lb/ft ²	759.9 kg/m ²
3	25.4 mm (1 in.)	762 mm (30 in.)	762 mm (30 in.)	131.9 lb/ft ²	644.1 kg/m ²
4	254 mm (10 in.)	254 mm (10 in.)	254 mm (10 in.)	155.9 lb/ft ²	761.3 kg/m ²
5	254 mm (10 in.)	508 mm (20 in.)	508 mm (20 in.)	126.9 lb/ft ²	619.4 kg/m ²
6	254 mm (10 in.)	762 mm (30 in.)	762 mm (30 in.)	108.4 lb/ft ²	529.1 kg/m ²
7	508 mm (20 in.)	254 mm (10 in.)	254 mm (10 in.)	130.2 lb/ft ²	635.6 kg/m ²
8	508 mm (20 in.)	508 mm (20 in.)	508 mm (20 in.)	106.8 lb/ft ²	521.6 kg/m ²
9	508 mm (20 in.)	762 mm (30 in.)	762 mm (30 in.)	92.0 lb/ft ²	449.0 kg/m ²
10	762 mm (30 in.)	254 mm (10 in.)	254 mm (10 in.)	112.9 lb/ft ²	551.2 kg/m ²
11	762 mm (30 in.)	508 mm (20 in.)	508 mm (20 in.)	93.4 lb/ft ²	455.9 kg/m ²
12	762 mm (30 in.)	762 mm (30 in.)	762 mm (30 in.)	81.0 lb/ft ²	395.3 kg/m ²

Table 145. Powered I/O and expansion unit with nine drawers

Condition	a (sides)	b (front)	c (back)	Powered I/O and expansion unit	
1	25.4 mm (1 in.)	254 mm (10 in.)	254 mm (10 in.)	142.6 lb/ft ²	696.1 kg/m ²
2	25.4 mm (1 in.)	508 mm (20 in.)	508 mm (20 in.)	116.5 lb/ft ²	568.7 kg/m ²
3	25.4 mm (1 in.)	762 mm (30 in.)	762 mm (30 in.)	99.9 lb/ft ²	487.6 kg/m ²
4	254 mm (10 in.)	254 mm (10 in.)	254 mm (10 in.)	116.7 lb/ft ²	569.7 kg/m ²
5	254 mm (10 in.)	508 mm (20 in.)	508 mm (20 in.)	96.3 lb/ft ²	470.3 kg/m ²

Table 145. Powered I/O and expansion unit with nine drawers (continued)

Condition	a (sides)	b (front)	c (back)	Powered I/O and expansion unit	
6	254 mm (10 in.)	762 mm (30 in.)	762 mm (30 in.)	83.4 lb/ft ²	407.0 kg/m ²
7	508 mm (20 in.)	254 mm (10 in.)	254 mm (10 in.)	98.6 lb/ft ²	481.6 kg/m ²
8	508 mm (20 in.)	508 mm (20 in.)	508 mm (20 in.)	82.3 lb/ft ²	401.8 kg/m ²
9	508 mm (20 in.)	762 mm (30 in.)	762 mm (30 in.)	71.9 lb/ft ²	351.0 kg/m ²
10	762 mm (30 in.)	254 mm (10 in.)	254 mm (10 in.)	86.5 lb/ft ²	422.5 kg/m ²
11	762 mm (30 in.)	508 mm (20 in.)	508 mm (20 in.)	72.9 lb/ft ²	355.8 kg/m ² n
12	762 mm (30 in.)	762 mm (30 in.)	762 mm (30 in.)	64.2 lb/ft ²	313.4 kg/m ²

Table 146. Powered I/O and expansion unit with 15 drawers and an internal battery feature

Condition	a (sides)	b (front)	c (back)	Powered I/O and expansion unit	
1	25.4 mm (1 in.)	254 mm (10 in.)	254 mm (10 in.)	200.6 lb/ft ²	979.6 kg/m ²
2	25.4 mm (1 in.)	508 mm (20 in.)	508 mm (20 in.)	161.6 lb/ft ²	789.2 kg/m ²
3	25.4 mm (1 in.)	762 mm (30 in.)	762 mm (30 in.)	136.8 lb/ft ²	668.0 kg/m ²
4	254 mm (10 in.)	254 mm (10 in.)	254 mm (10 in.)	161.9 lb/ft ²	790.6 kg/m ²
5	254 mm (10 in.)	508 mm (20 in.)	508 mm (20 in.)	131.5 lb/ft ²	642.2 kg/m ²
6	254 mm (10 in.)	762 mm (30 in.)	762 mm (30 in.)	112.2 lb/ft ²	547.7 kg/m ²
7	508 mm (20 in.)	254 mm (10 in.)	254 mm (10 in.)	135.0 lb/ft ²	659.2 kg/m ²
8	508 mm (20 in.)	508 mm (20 in.)	508 mm (20 in.)	110.6 lb/ft ²	539.9 kg/m ²
9	508 mm (20 in.)	762 mm (30 in.)	762 mm (30 in.)	95.0 lb/ft ²	464.0 kg/m ²
10	762 mm (30 in.)	254 mm (10 in.)	254 mm (10 in.)	116.9 lb/ft ²	570.9 kg/m ²
11	762 mm (30 in.)	508 mm (20 in.)	508 mm (20 in.)	96.5 lb/ft ²	471.3 kg/m ²
12	762 mm (30 in.)	762 mm (30 in.)	762 mm (30 in.)	83.5 lb/ft ²	407.8 kg/m ²

Table 147. Powered I/O and expansion unit with eight drawers and an internal battery feature

Condition	a (sides)	b (front)	c (back)	Powered I/O and expansion unit	
1	25.4 mm (1 in.)	254 mm (10 in.)	254 mm (10 in.)	150.3 lb/ft ²	733.8 kg/m ²
2	25.4 mm (1 in.)	508 mm (20 in.)	508 mm (20 in.)	122.5 lb/ft ²	598.0 kg/m ²
3	25.4 mm (1 in.)	762 mm (30 in.)	762 mm (30 in.)	104.8 lb/ft ²	511.5 kg/m ²
4	254 mm (10 in.)	254 mm (10 in.)	254 mm (10 in.)	122.7 lb/ft ²	599.0 kg/m ²
5	254 mm (10 in.)	508 mm (20 in.)	508 mm (20 in.)	101.0 lb/ft ²	493.1 kg/m ²
6	254 mm (10 in.)	762 mm (30 in.)	762 mm (30 in.)	87.2 lb/ft ²	425.7 kg/m ²
7	508 mm (20 in.)	254 mm (10 in.)	254 mm (10 in.)	103.5 lb/ft ²	505.2 kg/m ²
8	508 mm (20 in.)	508 mm (20 in.)	508 mm (20 in.)	86.1 lb/ft ²	420.2 kg/m ²
9	508 mm (20 in.)	762 mm (30 in.)	762 mm (30 in.)	75.0 lb/ft ²	366.0 kg/m ²
10	762 mm (30 in.)	254 mm (10 in.)	254 mm (10 in.)	90.6 lb/ft ²	442.2 kg/m ²
11	762 mm (30 in.)	508 mm (20 in.)	508 mm (20 in.)	76.0 lb/ft ²	371.2 kg/m ²
12	762 mm (30 in.)	762 mm (30 in.)	762 mm (30 in.)	66.8 lb/ft ²	325.9 kg/m ²

Cooling requirements

Use the system cooling requirements table in conjunction with the cooling requirements graph and chilled airflow area figure to determine the area of floor tiles to supply chilled air to the system.

The 6954 requires air for cooling. As shown in the figure in “Considerations for multiple-system installations” on page 101, rows of the 6954 systems must face front-to-front. The use of a raised floor is recommended to provide air through perforated floor panels placed in rows between the fronts of systems. This is shown as cold aisles in “Considerations for multiple-system installations” on page 101).

The following table provides system cooling requirements based on system configuration. The letter designations in the table correspond to the letter designations in the graph shown in the “Cooling requirements graph” on page 125.

Table 148. System cooling requirements based on system configuration

Drawers	Letters
1	A
2	A
3	B
4	B
5	C
6	C
7	D
8	E
9	E
10	F
11	F
12	G
13	G
14	H
15	I
16	I

Cooling requirements graph:

Use the cooling requirements graph in conjunction with the cooling requirements tables and the chilled airflow area figure to determine the area of the floor tiles to supply chilled air to the system.

System Cooling Requirements

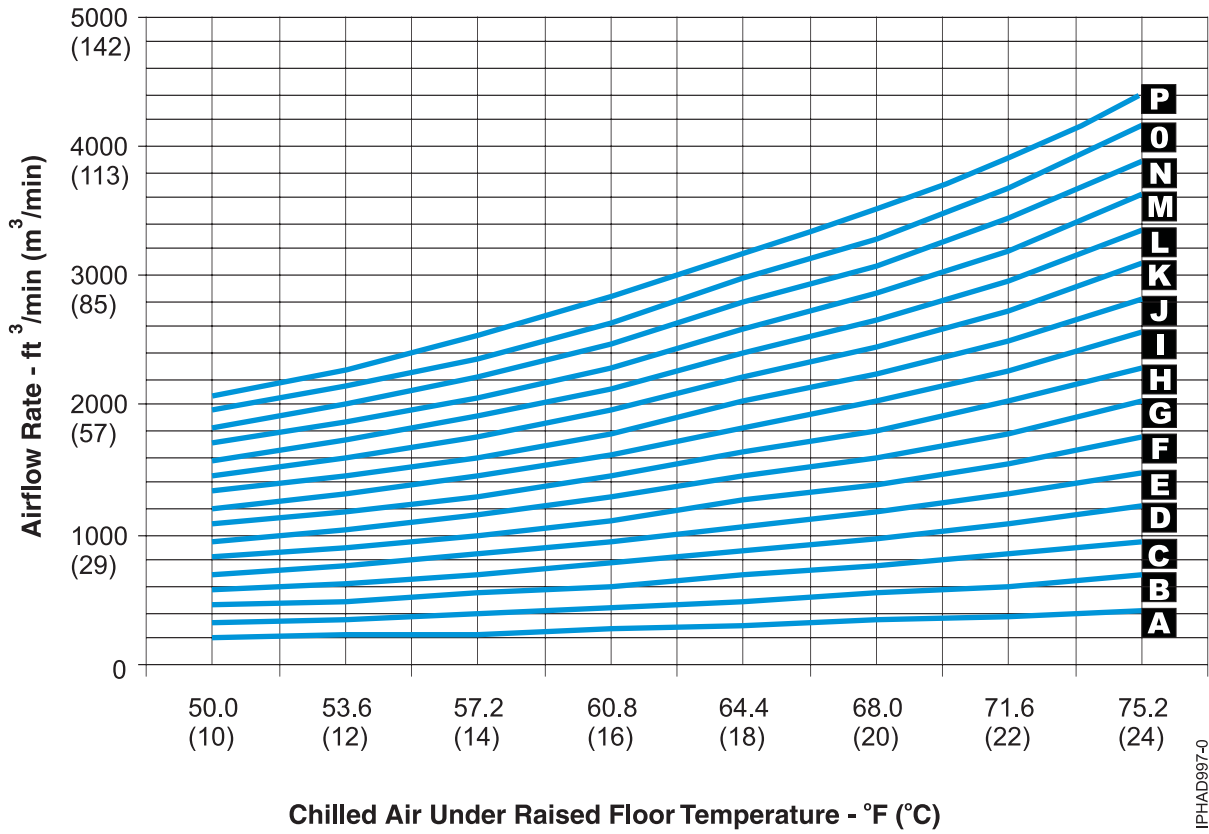

IPHAD997-0

Figure 73. Cooling requirements

Requirements for the chilled airflow area:

The following figure shows the chilled airflow area required for a system.

Use the system cooling requirements tables and the “Cooling requirements graph” on page 125 to determine the area of floor tiles to supply chilled air to the system.

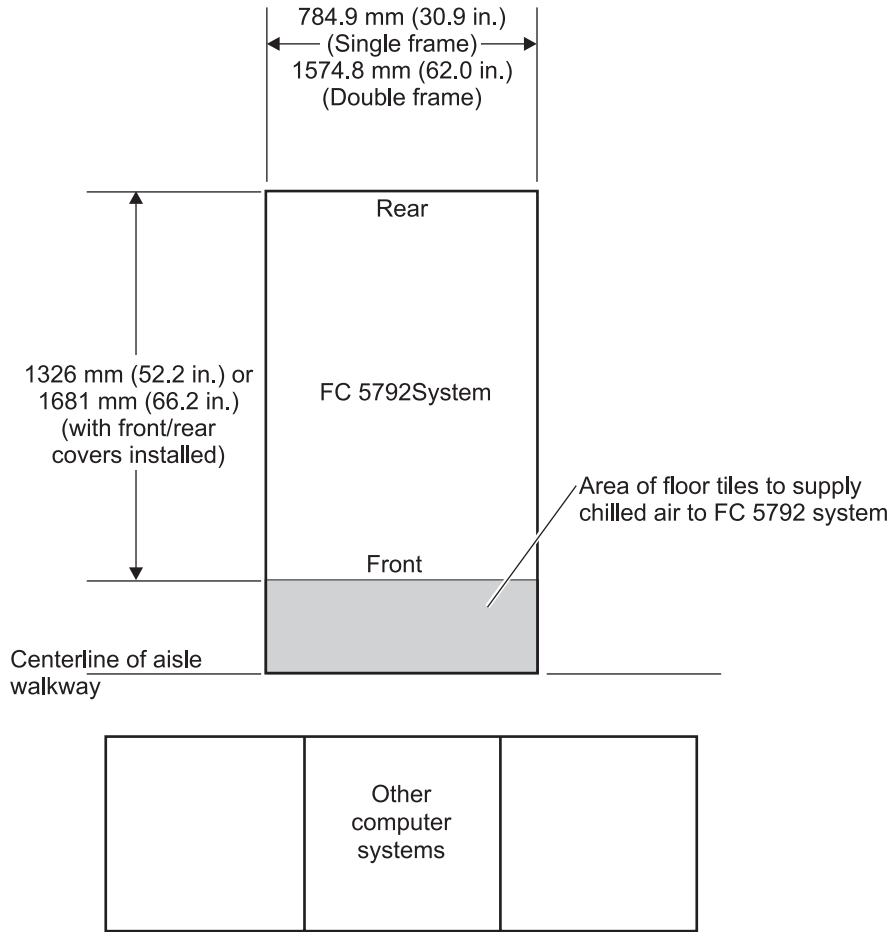

IPHAD922-3

Figure 74. Chilled airflow area

Rack specifications

Rack specifications provide detailed information for your rack, including dimensions, electrical, power, temperature, environment, and service clearances.

Select your rack model to view its specifications.

Related reference:

“Rack installation procedures for racks” on page 162

Learn the requirements and specifications for installing systems into racks .

0551 rack

The 0551 rack specifications provide detailed information for your rack.

The 0551 provides an empty 1.8 m rack (36 EIA units of total space).

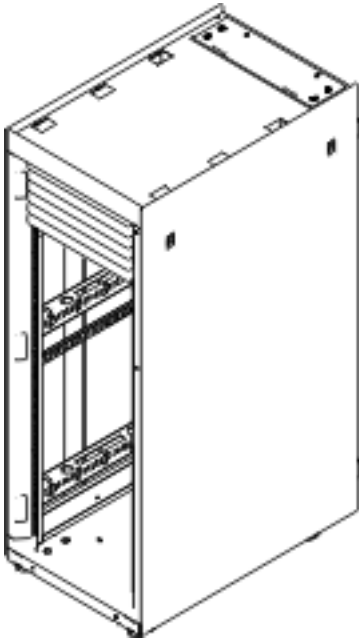

Figure 75. 0551 rack

Table 149. Dimensions

Maximum configuration weight	Width	Depth	Height
The weight of the empty rack is 244 kg (535 lb).	650 mm (25.5 in.)	1020 mm (40.0 in.)	1800 mm (71.0 in.)

Table 150. Temperature requirements

Operating	Nonoperating
10°C - 38°C (50°F - 100.4°F)	1°C - 60°C (33.8°F - 140°F)

Table 151. Environment requirements

Environment	Operating	Nonoperating
Noncondensing humidity	8% - 80%	8% - 80%
Wet bulb temperature	22.8°C (73°F)	22.8°C (73°F)
Maximum altitude	3048 m (10000 ft)	3048 m (10000 ft)
Noise emissions	Rack noise levels are a function of the number and type of drawers installed. See your server or hardware specifications for specific requirements	Rack noise levels are a function of the number and type of drawers installed. See your server or hardware specifications for specific requirements

Table 152. Service clearances

Front	Back	Sides	Top
762 mm (30 in.)	762 mm (30 in.)	762 mm (30 in.)	762 mm (30 in.)
Side and top clearances are optional during operation			

Notes:

1. The 1.8 meter rack has 10 EIA units of space remaining. This space will be filled with a 5 EIA filler panel, a 3 EIA filler panel, and two of the 1 EIA filler panels. Because the rack does not have power distribution, the model 830 requires a power cord of sufficient length to reach the receptacle. The power cord for model 830 must be used to determine the appropriate receptacle.
2. Acoustic doors are available for the racks. Feature code 6248 is available for the 0551 and 14T/00 racks. Feature code 6249 is available for the 0553 and 14T/42 racks. The overall sound reduction is approximately 6 dB. The doors add 381 mm (15 in.) to the depth of the racks.
3. For a description of noise emission values, see Acoustics.

Caster and leveler locations

Figure 76 provides the caster and leveler locations for the 14T/00, 14T/42, 0551, 0553 racks.

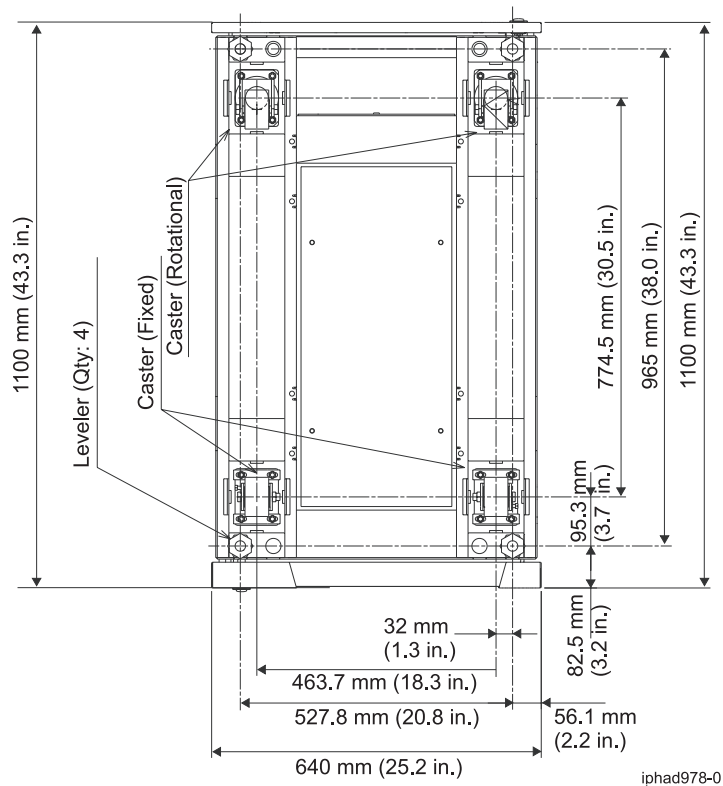

Figure 76. Caster and leveler locations

Related information:

[Acoustics](#)

, and 7014 rack configurations

The 14T/00 provide a 1.8 meter rack (36 EIA units of total space). The 14T/42 or 0553 provides a 2.0 meter rack (42 EIA units of total space).

Model 9406 feature code 7884 and model 9111 rack content specify code 0229. 9406-520 and 115/20 in rack

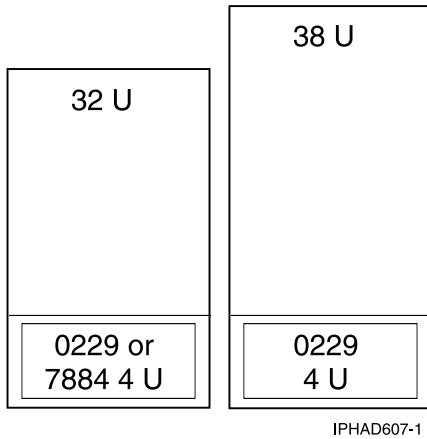

Figure 77. Feature code 7884: 9406-520 and 115/20 in rack

rack	Rack, specify code	PDU support	Power cords
0551 ¹	7884, 0229	0 to 4 ²	7884, PDU ³
0553 ¹			
7014 ⁴			
<p>¹0551 is an empty 1.8 meter rack with 36 EIA units of total space. 0553 is a 2.0 meter rack with 42 EIA units of total space.</p> <p>²0551, 0553, feature codes 5160, 5161, 5163, and 7188. 7014 feature codes 7176, 7177, 7178, and 7188.</p> <p>³If units plug into a power distribution unit (PDU), power jumper cord feature code 6458, 6459, 6095, or 9911 is required. If redundant power supply (feature code 5158) is ordered, a second power jumper cord feature code is required.</p> <p>⁴7014-T00 is a 1.8 meter rack with 36 EIA units of total space. 7014-T42 is a 2.0 meter rack with 42 EIA units of total space. The rack includes one PDU, feature code 9188, 9176, 9177, or 9178.</p>			

9113 rack content, specify code 0230; 9406 rack content, specify code 7886

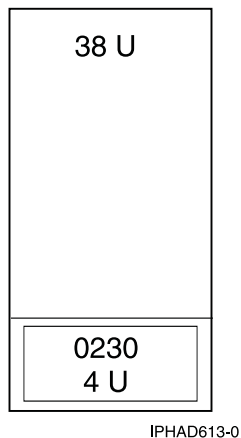

Figure 78. 550 in rack

rack	Rack, specify code	PDU support	Power cords
7014 ¹	0230 (135/50), 7886 (9406-550)	0 to 4 ²	PDU ³
<p>¹7014-T00 is a 1.8 meter rack with 36 EIA units of total space. 7014-T42 is a 2.0 meter rack with 42 EIA units of total space. The rack includes one PDU, feature code 9188, 9176, 9177, or 9178.</p> <p>²0551, 0553, feature codes 5160, 5161, 5163, and 7188. 7014 feature codes 7176, 7177, 7178, and 7188.</p> <p>³If unit plugs into a PDU, two feature code 6458, 6459, 6095, or 9911 power jumper cords are required.</p>			

9406-570 in rack, 175/70 rack content, specify codes 0231, 0232, 0241, 0242

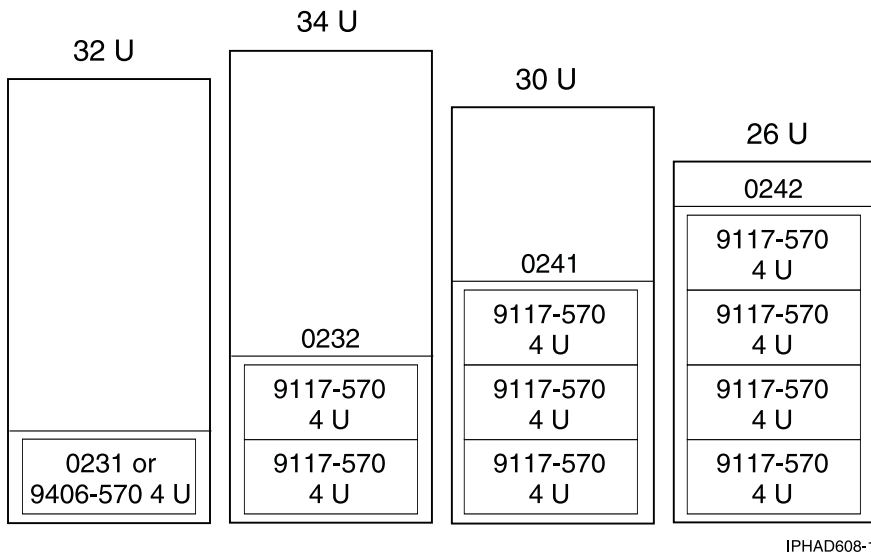
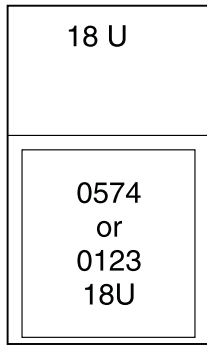

Figure 79. 5/70 in rack

rack	Rack, specify code	PDU support	Power cords
0551 ¹	0231, 0232, 0241, 0242	0 to 4 ²	PDU ⁴
0553 ¹			
7014 ³			
<p>¹0551 is an empty 1.8 meter rack with 36 EIA units of total space. 0553 is a 2.0 meter rack with 42 EIA units of total space.</p> <p>²0551, 0553, feature codes 5160, 5161, 5163, and 7188. 7014 feature codes 7176, 7177, 7178, and 7188.</p> <p>³7014-T00 is a 1.8 meter rack with 36 EIA units of total space. 7014-T42 is a 2.0 meter rack with 42 EIA units of total space. The rack includes one PDU, feature code 9188, 9176, 9177, or 9178.</p> <p>⁴If unit plugs into a PDU, two feature code 6458, 6459, 6095, or 9911 power jumper cords are required.</p>			

Feature code 0123 - 5074 lower expansion unit in rack; feature code 0574 - 5074 equivalent



IPHAD600-0

Figure 80. Feature code 0123

rack	Bottom rack, specify code	Rack, specify code	PDU support	Power cords
0551 ¹ 0553 ¹	0123	0574	0 to 4 ²	0123, 0574, PDU ³
¹ 0551 is an empty 1.8 meter rack with 36 EIA units of total space. 0553 is a 2.0 meter rack with 42 EIA units of total space. ² 0551, 0553, feature codes 5160, 5161, 5163, and 7188. 7014 feature codes 7176, 7177, 7178, and 7188. ³ Feature code 0123 or 0574 do not plug into a PDU.				

Feature code 0694 - 5094 equivalent

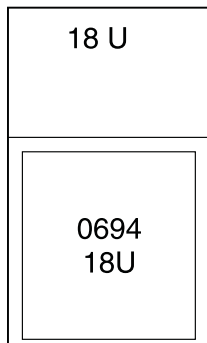

IPHAD601-0

Figure 81. Feature code 0694 - 5094 equivalent

rack	Rack, specify code	PDU support	Power cords
0551 ¹ 0553 ¹	0694	0 to 4 ²	0694, PDU ³

rack	Rack, specify code	PDU support	Power cords
¹ 0551 is an empty 1.8 meter rack with 36 EIA units of total space. 0553 is a 2.0 meter rack with 42 EIA units of total space. ² 0551, 0553, feature codes 5160, 5161, 5163, and 7188. 7014 feature codes 7176, 7177, 7178, and 7188. ³ Feature code 0125 does not plug into a PDU.			

Feature code 0133 - Manufacturing installation in rack (models 9406-800 and 9406-810); feature code 0137 - IBM® service representation installation in rack (models 9406-800 and 9406-810)

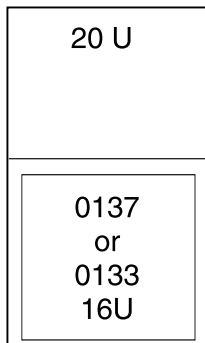

IPHAD602-0

Figure 82. Feature code 0133

rack	Rack, specify code	PDU support	Power cords
0551 ¹ 0553 ¹	0133 ³ , 0137 ³	0 to 4 ²	0133, 0137, PDU ⁴
¹ 0551 is an empty 1.8 meter rack with 36 EIA units of total space. 0553 is a 2.0 meter rack with 42 EIA units of total space. ² 0551, 0553, feature codes 5160, 5161, 5163, and 7188. 7014 feature codes 7176, 7177, 7178, and 7188. ³ IBM service representation installation in rack feature is used to mount a model 9406-270, 9406-800, or 9406-810 system unit (14 U) with attached expansion unit. This feature provides a rack shelf (2 U) with rail assembly, cable-management-arm assembly, adapter plate, and a pair of lift covers. ⁴ If unit plugs into a PDU, two feature code 6458, 6459, 6095, or 9911 power jumper cords are required.			

Feature code 0134 - IBM service representation installation in rack (model 9406-825); feature code 0138 - IBM service representation installation in rack (model 9406-825)

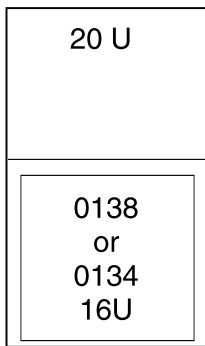

IPHAD603-0

Figure 83. Feature code 0134

rack	Rack, specify code	PDU support	Power cords
0551 ¹	0134 ³ , 0138 ³	0 to 4 ²	0134, 0138, PDU ⁴
0553 ¹			

¹0551 is an empty 1.8 meter rack with 36 EIA units of total space. 0553 is a 2.0 meter rack with 42 EIA units of total space.

²0551, 0553, feature codes 5160, 5161, 5163, and 7188. 7014 feature codes 7176, 7177, 7178, and 7188.

³IBM service representation installation in rack feature is used to mount a model 9406-825 system unit (14 U). This feature provides a rack shelf (2 U), cable-management-arm assembly, adapter plate, and a pair of lift covers.

⁴If unit plugs into a PDU, two feature code 6458, 6459, 6095, or 9911 power jumper cords are required.

Feature code 0578 - PCI-X expansion unit in rack

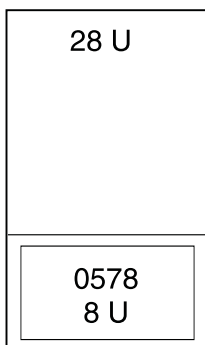

IPHAD604-0

Figure 84. Feature code 0578 - PCI-X expansion unit in rack

rack	Rack, specify code	PDU support	Power cords
0551 ¹	0578	0 to 4 ²	PDU ³
0553 ¹			

rack	Rack, specify code	PDU support	Power cords
¹ 0551 is an empty 1.8 meter rack with 36 EIA units of total space. 0553 is a 2.0 meter rack with 42 EIA units of total space. ² 0551, 0553, feature codes 5160, 5161, 5163, and 7188. 7014 feature codes 7176, 7177, 7178, and 7188. ³ 0578 includes two rack power cords that plug into a PDU.			

Feature code 0588 - PCI-X expansion unit in rack

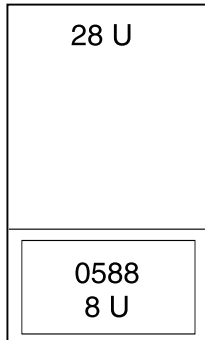

IPHAD605-0

Figure 85. Feature code 0588 - PCI-X expansion unit in rack

rack	Rack, specify code	PDU support	Power cords
0551 ¹	0588	0 to 4 ²	PDU ³
0553 ¹			
¹ 0551 is an empty 1.8 meter rack with 36 EIA units of total space. 0553 is a 2.0 meter rack with 42 EIA units of total space. ² 0551, 0553, feature codes 5160, 5161, 5163, and 7188. 7014 feature codes 7176, 7177, 7178, and 7188. ³ 0588 comes with two rack power cords that plug into a PDU.			

Feature code 0595 - PCI-X expansion unit in rack

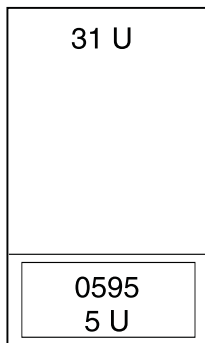

IPHAD606-0

rack	Rack, specify code	PDU support	Power cords
0551 ¹	0595	0 to 4 ²	0595, PDU ³
0553 ¹			

¹0551 is an empty 1.8 meter rack with 36 EIA units of total space. 0553 is a 2.0 meter rack with 42 EIA units of total space.

²0551, 0553, feature codes 5160, 5161, 5163, and 7188. 7014 feature codes 7176, 7177, 7178, and 7188.

³If unit plugs into a PDU, feature code 1422 is required. If redundant power supply (feature code 5138) is ordered, a second feature code 1422 is required.

Note: Supported only on MES orders and includes a rack shelf with rail assembly, adapter plate, and cable-management-arm assembly.

Model 14S/11 rack

Hardware specifications provide detailed information for your rack, including dimensions, electrical, power, temperature, environment, and service clearances.

Table 153. Dimensions

Dimension	Properties
Height	611 mm (24 in.)
Capacity	11 usable EIA units
Height with PDP - DC only	Not applicable
Width without side panels	Not applicable
Width with side panels	518 mm (20.4 in.)
Depth without doors	820 mm (32.3 in.)
Depth with front door	873 mm (34.4 in.)
Depth with sculptured style front door	Not applicable
Weight Base rack (empty)	36 kg (80 lb)
Weight Full rack ¹	218 kg (481 lb)

Table 154. Electrical

Electrical characteristics	Properties
DC rack voltage (nominal)	Not applicable
Power source loading maximum in kVa	Not applicable
Voltage range (V dc)	Not applicable
AC rack	See your server or hardware specifications for specific requirements
Power source loading maximum in kVa (per PDU)	See your server or hardware specifications for specific requirements
Voltage range (V ac)	See your server or hardware specifications for specific requirements
Frequency (Hz)	50 or 60

The 7188 power distribution unit used with this rack is mounted horizontally and requires one EIA unit of space.

Table 155. Service clearances

Front	Back	Sides
915 mm (36 in.)	254 mm (10 in.)	71 mm (2.8 in.)
Recommended minimum vertical service clearance from floor is 2439 mm (8 ft).		

See your server or hardware specifications for specific temperature requirements and humidity requirements.

Rack noise levels are a function of the number and type of drawers installed. See your server or hardware specifications for specific requirements.

Rack airflow requirements are a function of the number and type of drawers installed. Refer to the individual drawer specifications.

Note: Configuration dependent, base rack weight plus the weight of the drawers mounted in the rack. The rack can support up to a maximum weight of 15.9 kg (35 lb) per EIA unit.

Model 14S/11 rack operational clearances

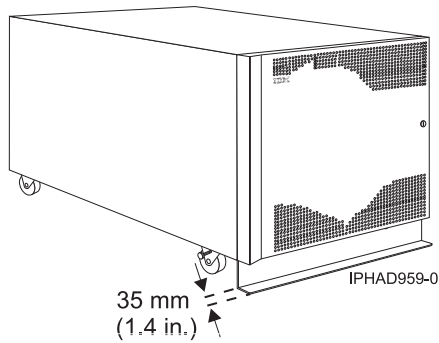

Figure 86. Model 05/54 and 14S/11 with stabilizer bar

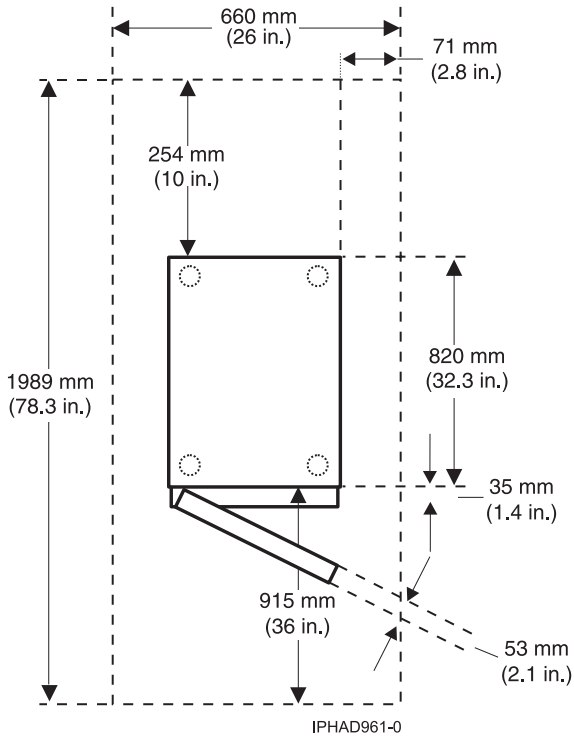
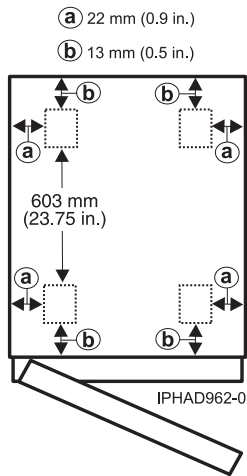

Figure 87. Model 05/54 and 14S/11 plan view

Figure 88. Model 05/54 and 14S/11 caster locations



Model 14S/25 rack

Hardware specifications provide detailed information for your rack, including dimensions, electrical, power, temperature, environment, and service clearances.

Table 156. Dimensions

Dimensions	Properties
Height	1240 mm (49 in.)

Table 156. Dimensions (continued)

Dimensions	Properties
Capacity	25 usable EIA units
Height with PDP - DC only	Not applicable
Width without side panels	590 mm (23.2 in.)
Width with side panels	610 mm (24 in.)
Depth with back door only	996 mm (39.2 in.)
Depth with back door and front door	1000 mm (39.4 in.)
Depth with sculptured style front door	Not applicable
Base rack (empty)	98 kg (217 lb)
Full rack ¹	665 kg (1467 lb)

Table 157. Electrical

Electrical characteristics	Properties
DC rack voltage (nominal)	Not applicable
Power source loading maximum in kVa	Not applicable
Voltage range (V dc)	Not applicable
AC rack	See your server or hardware specifications for specific requirements
Power source loading maximum in kVa (per PDU)	See your server or hardware specifications for specific requirements
Voltage range (V ac)	See your server or hardware specifications for specific requirements
Frequency (Hz)	50 or 60
The 7188 power distribution unit used with this rack is mounted horizontally and requires one EIA unit of space.	

Table 158. Service clearance

Front	Back	Sides
915 mm (36 in.)	760 mm (30 in.)	915 mm (36 in.)

See your server or hardware specifications for specific temperature and humidity requirements.

Rack noise levels are a function of the number and type of drawers installed. See your server or hardware specifications for specific requirements.

Rack airflow requirements are a function of the number and type of drawers installed. Refer to the individual drawer specifications.

Notes:

1. Configuration dependent, base rack weight plus the weight of the drawers mounted in the rack. The rack can support up to a maximum weight of 22.7 kg (50 lb) per EIA unit.
2. Recommended minimum vertical service clearance from floor is 2439 mm (8 ft).

Model 14S/25 rack operational clearances

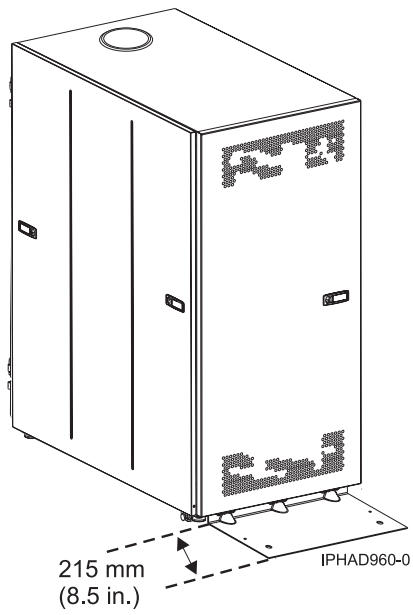

Figure 89. Model 05/55 and 14S/25 with stabilizer foot

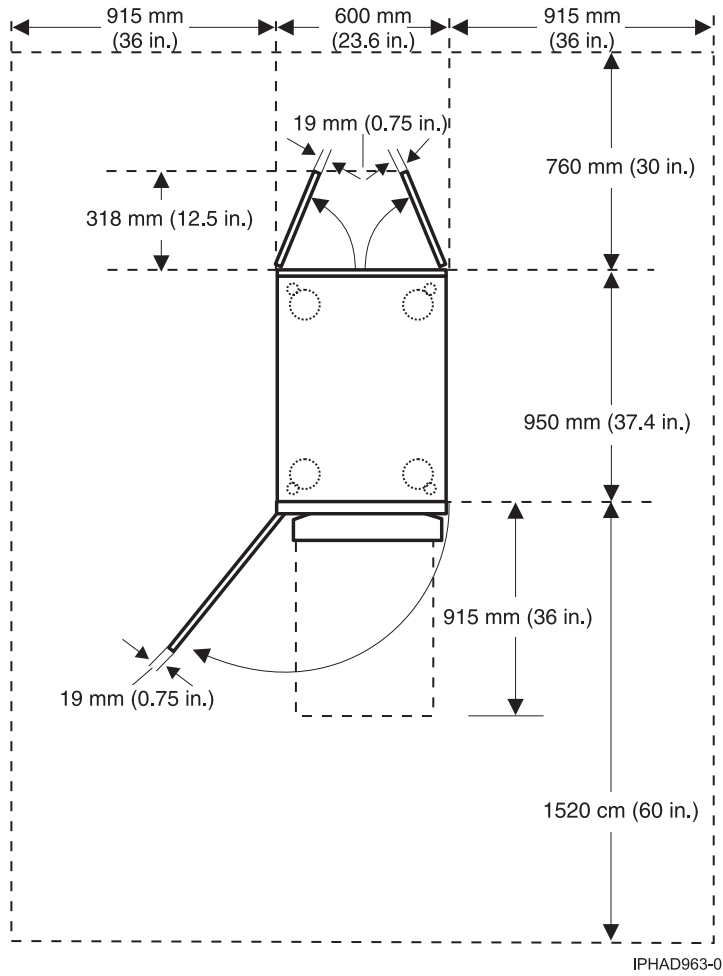

Figure 90. Model 05/55 and 14S/25 plan view

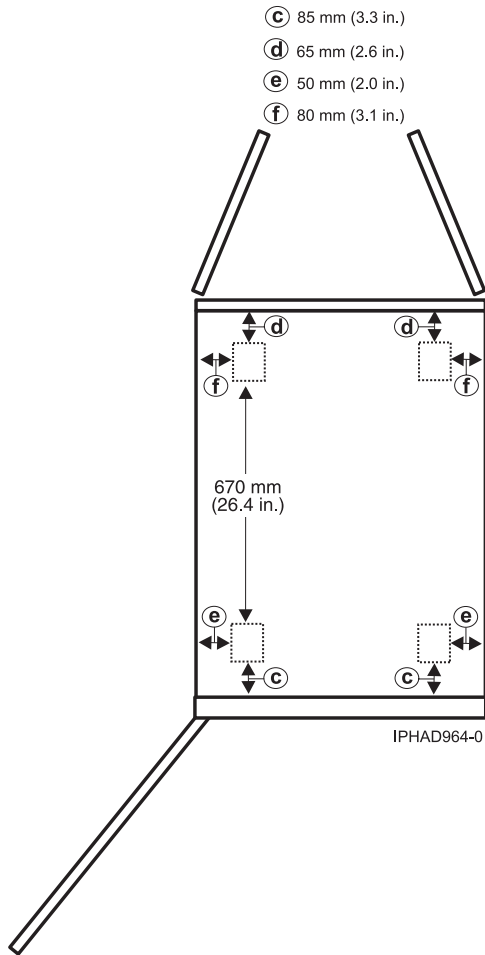

Figure 91. Model 05/55 and 14S/25 caster locations

Planning for the 14T/00 and 14T/42 racks

Rack specifications provide detailed information for your rack, including dimensions, electrical, power, temperature, environment, and service clearances.

The following provide specifications for the 14T/00, and 14T/42 or 0553 racks.

Model 14T/00 rack

Hardware specifications provide detailed information for your rack, including dimensions, electrical, power, temperature, environment, and service clearances.

Table 159. Dimensions

Dimensions	Properties
Height	1804 mm (71.0 in.)
Capacity	36 usable EIA units
Height with PDP - DC only	1926 mm (75.8 in.)
Width without side panels	623 mm (24.5 in.)
Width with side panels	644 mm (25.4 in.)
Depth with rear door only	1042 mm (41.0 in.)

Table 159. Dimensions (continued)

Dimensions	Properties
Depth with rear door and front door	1098 mm (43.3 in.)
Depth with sculptured style front door	1147 mm (45.2 in.)

Table 160. Weight

Base rack (empty)	Full rack
244 kg (535 lb)	816 kg (1795 lb) See 14T/00, 14T/42 and 0553 rack weight distribution and floor loading

Table 161. Electrical¹

Electrical characteristics	Properties
DC rack voltage (nominal)	-48 V dc
Power source loading maximum in kVa ²	See Power distribution unit and power cord options for 7014, 0551, 0553, rack for details
Voltage range (V dc)	-40 - -60
AC rack	683 Btu/hr
Power source loading maximum in kVa (per PDB) ³	135 W
Voltage range (V ac)	200 - 240
Frequency (Hz)	50 or 60
¹ The total rack power should be derived from the sum of the power used by the drawers in the rack. ² The power distribution panel (PDP) on the DC-powered rack can hold up to eighteen (nine per power source) 48-volt, 20 - 50 amperes circuit breakers (configuration dependent). Each power source supports up to 8.4 kVa. ³ Each ac power distribution bus (PDB) can supply 4.8 kVa. A rack can have up to four PDBs as required by the drawers mounted in the rack.	

Table 162. Service clearances

Front	Back	Sides
915 mm (36 in.)	915 mm (36 in.)	915 mm (36 in.)

See your server or hardware specifications for specific temperature and humidity requirements.

Rack noise levels are a function of the number and type of drawers installed. See your server or hardware specifications for specific requirements.

Note: All rack installations require careful site and facilities planning designed to both address the cumulative drawer heat output and provide the airflow volume rates necessary to comply with drawer temperature requirements.

Rack airflow requirements are a function of the number and type of drawers installed.

Note: Acoustic doors are available for the racks. Feature code 6248 is available for the 0551 and 14T/00 racks. Feature code 6249 is available for the 0553 and 14T/42 racks. The overall sound reduction is approximately 6 dB. The doors add 381 mm (15 in.) to the depth of the racks. Refer to the individual drawer specifications.

Related reference:

“14T/00, 14T/42, and 0553 rack weight distribution and floor loading” on page 148

Racks can be heavy when populated with several drawers. Use the Weight distribution distances for racks when loaded and Floor loading for racks when loaded tables to ensure proper floor loading and weight distribution.

Model 14T/42, 7014-B42, and 0553 rack

Hardware specifications provide detailed information for your rack, including dimensions, electrical, power, temperature, environment, and service clearances.

Note: Before installing rear door heat exchangers on your 14T/42 rack, see *Planning for the installation of rear door heat exchangers*.

Table 163. Dimensions

Dimensions	Properties
Height	2015 mm (79.3 in.)
Capacity	42 usable EIA units
Height with PDP - DC only	Not applicable
Width without side panels	623 mm (24.5 in.)
Width with side panels	644 mm (25.4 in)
Depth with back door only	1042 mm (41.0 in.)
Depth with back door and front door	1098 mm (43.3 in.)
Depth with sculptured style front door	1147 mm (45.2 in.)
Weight Base rack (empty)	261 kg (575 lb)
Weight Full rack	930 kg (2045 lb) See 14T/00, 14T/42 and 0553 rack weight distribution and floor loading
Weight Slim doors	15.4 kg (34 lb)
Weight Side covers	16.3 kg (36 lb)

Table 164. Electrical¹

Electrical characteristics	Properties
DC rack voltage (nominal)	-48 V dc
Power source loading maximum in kVa ²	See Power distribution unit and power cord options for 7014, 0551, 0553, and 0555 rack for details
Voltage range (V dc)	-40 - -60
AC rack	683 Btu/hr
Power source loading maximum in kVa (per PDB) ³	135 W
Voltage range (V ac)	200 - 240 V ac
Frequency (Hz)	50 or 60

Table 164. Electrical¹ (continued)

Electrical characteristics	Properties
¹ Recommended minimum vertical service clearance from floor is 2439 mm (8 ft).	
² When installing a model 17M/MB or 9179-MHB in a 14T/42 rack, there are restrictions to what height the rack installation can begin so that SMP and FSP flex assemblies are accommodated. The installation configurations are as follows:	
<ul style="list-style-type: none"> • 16-core configurations (16U) start installation between EIA 1 through EIA 21 • 12-core configurations (12U) start installation between EIA 1 through EIA 25 • 8-core configurations (8U) start installation between EIA 1 through EIA 29 • 4-core configurations (4U) start installation between EIA 1 through EIA 37, EIA 37 through 39 (does not use SMP or SMP flex assemblies) 	
Associated I/O platforms can be mounted in the upper locations of the rack.	
³ Acoustic doors are available for the racks. Feature code 6248 is available for the 0551 and 14T/00 racks. Feature code 6249 is available for the 0553 and 14T/42 racks. The overall sound reduction is approximately 6 dB. The doors add 381 mm (15 in.) to the depth of the racks.	

Table 165. Service clearances

Front	Back	Sides
915 mm (36 in.)	915 mm (36 in.)	915 mm (36 in.)
Recommended minimum vertical service clearance from floor is 2439 mm (8 ft).		

See your server or hardware specifications for specific requirements.

Rack noise levels are a function of the number and type of drawers installed. See your server or hardware specifications for specific requirements.

Note: Acoustic doors are available for the racks. Feature code 6248 is available for the 0551 and 14T/00 racks. Feature code 6249 is available for the 0553 and 14T/42 racks. The overall sound reduction is approximately 6 dB. The doors add 381 mm (15 in.) to the depth of the racks.

Rack airflow requirements are a function of the number and type of drawers installed.

Note: All rack installations require careful site and facilities planning designed to address both the cumulative drawer heat output and provide the airflow volume rates necessary to comply with drawer temperature requirements.

Refer to the individual drawer specifications.

Caster and leveler locations

The following figure provides the caster and leveler locations for the 14T/00, 14T/42, 0551, 0553, racks.

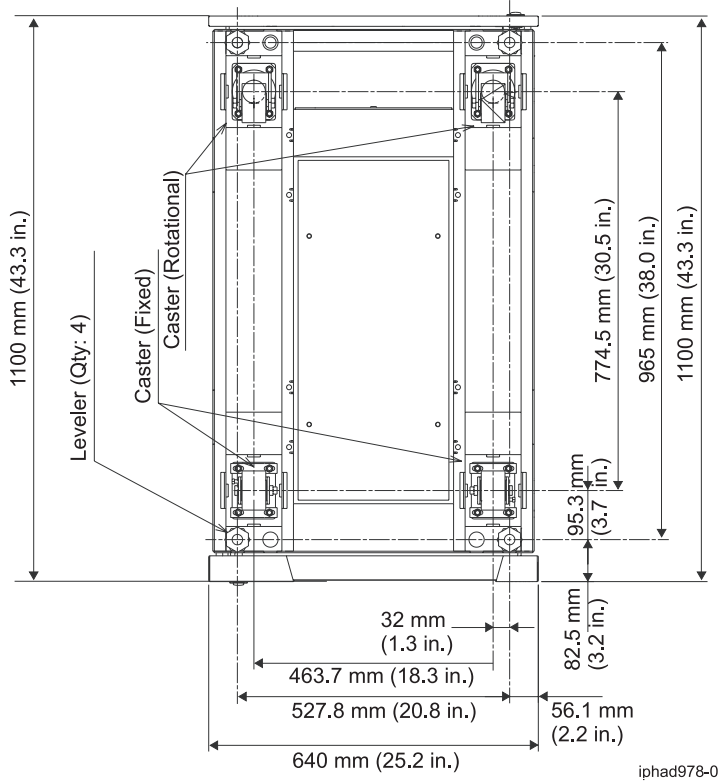

Figure 92. Caster and leveler locations

Related reference:

“14T/00, 14T/42, and 0553 rack weight distribution and floor loading” on page 148
 Racks can be heavy when populated with several drawers. Use the Weight distribution distances for racks when loaded and Floor loading for racks when loaded tables to ensure proper floor loading and weight distribution.

Related information:

➡ Planning for the installation of rear door heat exchangers

14T/00, 14T/42, and 0553 service clearances and caster location

Use the service clearances and caster location for 14T/00, 14T/42 and 0553 racks figure to plan the correct service clearances and caster locations for your rack.

The service clearances and caster locations are shown in the following figure:

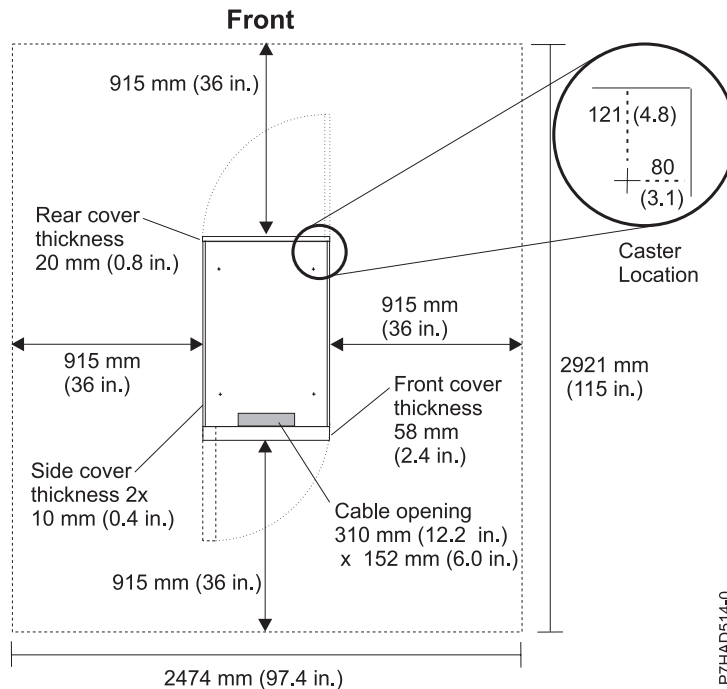
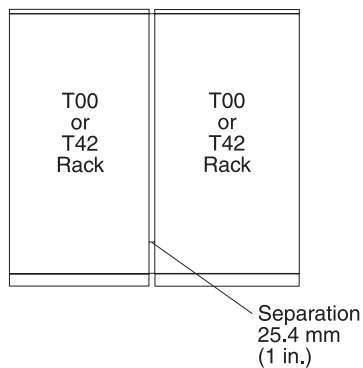

Figure 93. Service clearances and caster location for 14T/00, 14T/42, and 0553 racks

Note: Rack units are large and heavy and are not easily moved. Because maintenance activities require access at both the front and back, extra room needs to be allowed. The footprint shows the radius of the swinging doors on the I/O rack. The figure shows the minimum space required.

14T/00, 14T/00, and 0553 racks multiple attachment

14T/00, 14T/42 or 0553 racks can be bolted together in a multiple rack arrangement. This figure shows that arrangement.



A kit is available including the bolts, spacers, and decorative trim pieces to cover the 25.4 mm (1 in.) space. For service clearances, see the service clearances as shown in the table for the model 14T/00 rack.

Related reference:

“Model 14T/00 rack” on page 142

Hardware specifications provide detailed information for your rack, including dimensions, electrical, power, temperature, environment, and service clearances.

14T/00, 14T/42, and 0553 rack weight distribution and floor loading

Racks can be heavy when populated with several drawers. Use the Weight distribution distances for racks when loaded and Floor loading for racks when loaded tables to ensure proper floor loading and weight distribution.

The 14T/00, 14T/42, and 0553 racks can be extremely heavy when several drawers are present. The following table shows the necessary weight distribution distances for the 14T/00, 14T/42, and 0553 racks when loaded.

Table 166. Weight distribution distances for racks when loaded

Rack	System weight ¹	Width ²	Depth ²	Weight distribution distance ³	
				Front and back	Left and right
14T/00 ⁴	816 kg (1795 lb)	623 mm (24.5 in)	1021 mm (40.2 in)	515.6 mm (20.3 in), 477.5 mm (18.8 in)	467.4 mm (18.4 in)
14T/00 ⁵	816 kg (1795 lb)	623 mm (24.5 in)	1021 mm (40.2 in)	515.6 mm (20.3 in), 477.5 mm (18.8 in)	0
14T/00 ⁶	816 kg (1795 lb)	623 mm (24.5 in)	1021 mm (40.2 in)	515.6 mm (20.3 in), 477.5 mm (18.8 in)	559 mm (22 in)
14T/42 and 0553 ⁴	930 kg (2045 lb)	623 mm (24.5 in)	1021 mm (40.2 in)	515.6 mm (20.3 in), 477.5 mm (18.8 in)	467.4 mm (18.4 in)
14T/42 and 0553 ⁵	930 kg (2045 lb)	623 mm (24.5 in)	1021 mm (40.2 in)	515.6 mm (20.3 in), 477.5 mm (18.8 in)	0
14T/42 and 0553 ⁶	930 kg (2045 lb)	623 mm (24.5 in)	1021 mm (40.2 in)	515.6 mm (20.3 in), 477.5 mm (18.8 in)	686 mm (27 in)

Notes:

1. Maximum weight of fully populated rack, units are lb with kg in parentheses.
2. Dimensions without covers, units are inches with mm in parentheses.
3. The weight distribution distance in all four directions is the area around the rack perimeter (minus covers) necessary to distribute the weight beyond the perimeter of the rack. Weight distribution areas cannot overlap with adjacent computer equipment weight distribution areas. Units are inches with mm in parentheses.
4. Weight distribution distance is 1/2 the service clearance values shown in the figure plus cover thickness.
5. No left and right weight distribution distance.
6. Left and right weight distribution distance required for a 70 lb/ft² raised floor loading objective.

The following table shows the necessary floor loading for the 14T/00, 14T/42 and 0553 racks when loaded.

Table 167. Floor loading for racks when loaded

Rack	Floor loading			
	Raised kg/m ¹	Non-raised kg/m ¹	Raised lb/ft ¹	Non-raised lb/ft ¹
14T/00 ²	366.7	322.7	75	66
14T/00 ³	734.5	690.6	150.4	141.4
14T/00 ⁴	341	297	70	61
14T/42 and 0553 ²	403	359	82.5	73.5
14T/42 and 0553 ³	825	781	169	160

Table 167. Floor loading for racks when loaded (continued)

Rack	Floor loading			
	Raised kg/m ¹	Non-raised kg/m ¹	Raised lb/ft ¹	Non-raised lb/ft ¹
14T/42 and 0553 ⁴	341.4	297.5	70	61
Notes: 1. Dimensions without covers, units are inches with mm in parentheses. 2. Weight distribution distance is 1/2 the service clearance values shown in the figure plus cover thickness. 3. No left and right weight distribution distance. 4. Left and right weight distribution distance required for a 70 lb/ft ² raised floor loading objective.				

Related reference:

“Model 14T/42, 7014-B42, and 0553 rack” on page 144

Hardware specifications provide detailed information for your rack, including dimensions, electrical, power, temperature, environment, and service clearances.

“Model 14T/00 rack” on page 142

Hardware specifications provide detailed information for your rack, including dimensions, electrical, power, temperature, environment, and service clearances.

Planning for the 7953-94X rack

Rack specifications provide detailed information for your rack, including dimensions, electrical, power, temperature, environment, and service clearances.

The following provide specifications for the 7953-94X rack.

Model 7953-94X rack

Hardware specifications provide detailed information for your rack, including dimensions, electrical, power, temperature, environment, and service clearances.

Table 168. Dimensions for rack

Width (without outriggers)	Width (with outriggers)	Depth	Height	Weight (empty with outriggers)	EIA unit capacity
600 mm (23.6 in.)	780 mm (30.7 in.)	1095 mm (43.1 in.)	2002 mm (78.8 in.)	261 kg (575 lb)	42 EIA units

Table 169. Dimensions for doors

Width	Height	Weight
599 mm (23.6 in.)	1932 mm (76.1 in.)	7.7 kg (17 lb)

Table 170. Dimensions for side covers

Width	Height	Weight
885 mm (34.9 in.)	1870 mm (73.6 in.)	17.7 kg (39 lb)

Table 171. Temperature requirements

Operating	Nonoperating
10°C - 38°C (50°F - 100.4°F) ¹	-40°C - 60°C (-40°F - 140°F)
¹ The maximum 38°C (100.4°F) temperature must be derated 1°C (1.8 °F) per 137 m (450 ft) above 1295 m (4250 ft).	

Table 172. Environmental requirements

Environment	Operating	Nonoperating	Maximum altitude
Noncondensing humidity	20% - 80% (allowable) 40% - 55% (recommended)	8% - 80% (including condensing)	2134 m (7000 ft) above sea level
Wet bulb temperature	21°C (69.8°F)	27°C (80.6°F)	

Electrical

For electrical requirements, see Power distribution unit and power cord options.

Features

The 7953-94X rack has the following features available for use:

- Recirculation prevention plate installed at the bottom, front of the rack.
- Stabilizer bracket installed at the front of the rack.

Caster locations

The following diagram provides the caster locations for the 7953-94X rack.

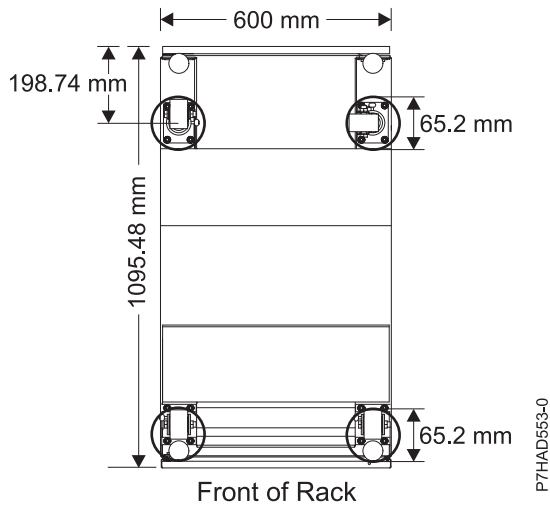

Figure 94. Caster locations

Cabling the 7953-94X rack

Learn about the different cable routing options available for the 7953-94X rack.

Cabling within the rack

Side cable channels are available in the rack to route cables. There are two cable channels on each side of the rack as shown in Figure 95 on page 151.

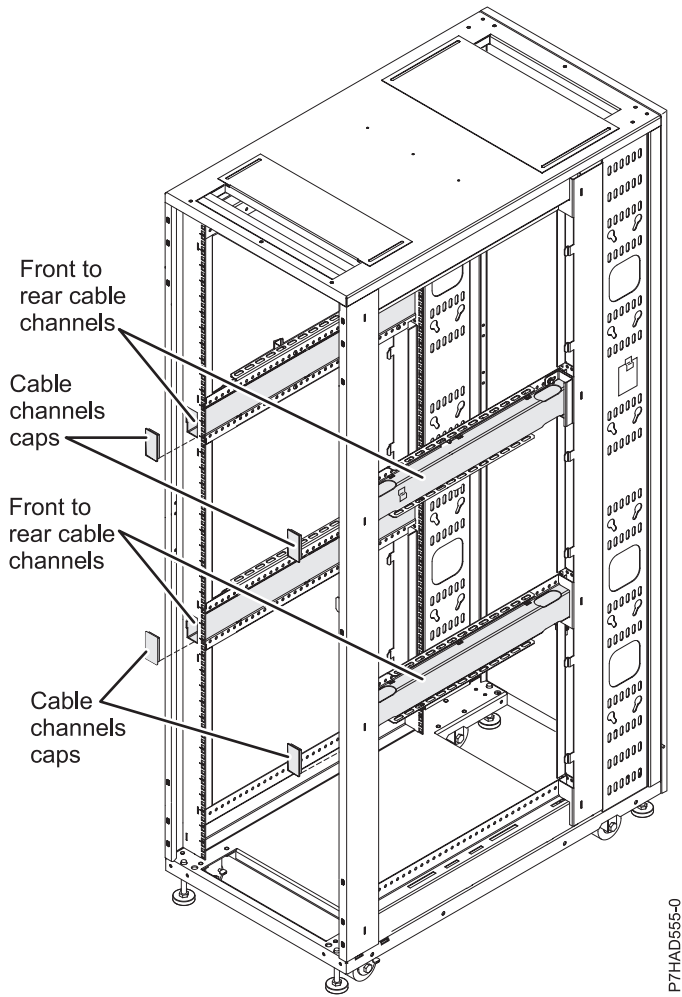

Figure 95. Cabling within the rack

Cabling under the floor

A cable access bar located on the bottom rear of the rack helps to route the cables, leaving the rack in place. This bar can be removed for installation and then reattached after the rack is installed and cabled.

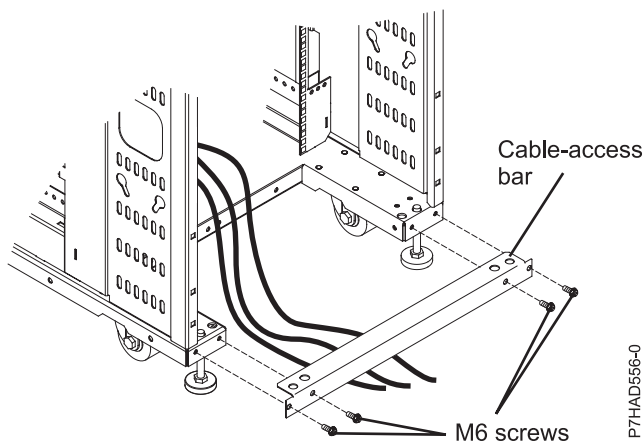

Figure 96. Cable access bar

Cabling overhead

Front and rear rectangular cable access openings located on the top of the rack cabinet allow cables to be routed up and out of the rack. Cable access covers are adjustable by loosening the side screws and sliding the covers forward or backward.

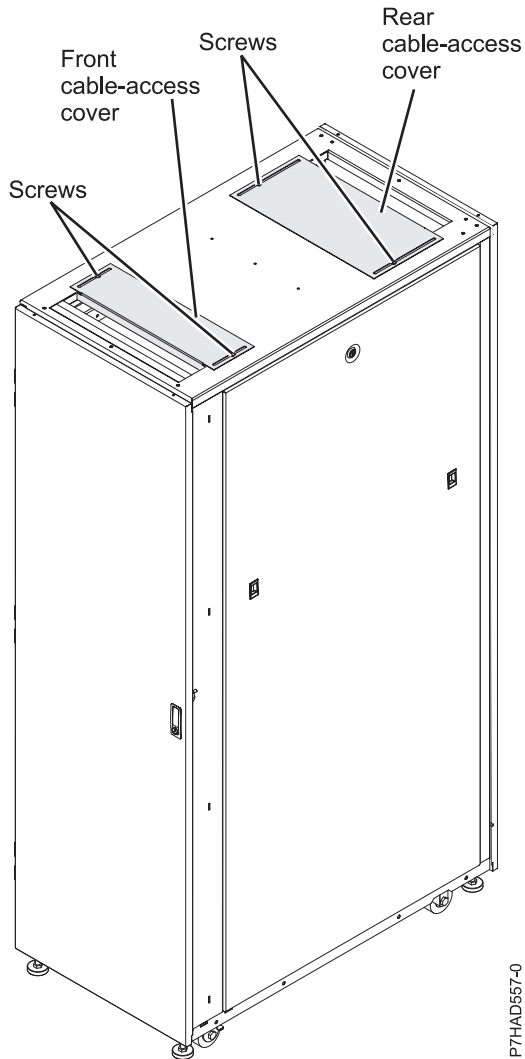

Figure 97. Cable access covers

Side stabilizing outriggers

Learn about the side stabilizing outriggers available for the 7953-94X rack.

The outriggers are stabilizers with wheels installed on the sides of the rack cabinet. The outriggers can be removed only after the rack is in its final location and will not be moved more than 2 meters (6 ft) away in any direction.

To remove the outriggers, use a 6 mm hex wrench to remove the four bolts that attach each outrigger to the rack cabinet.

Keep each of the outriggers and bolts in a safe place for future use when moving the rack. Reinstall the outriggers if you need to move the rack cabinet to another location greater than 2 meters (6 ft) away from its current location.

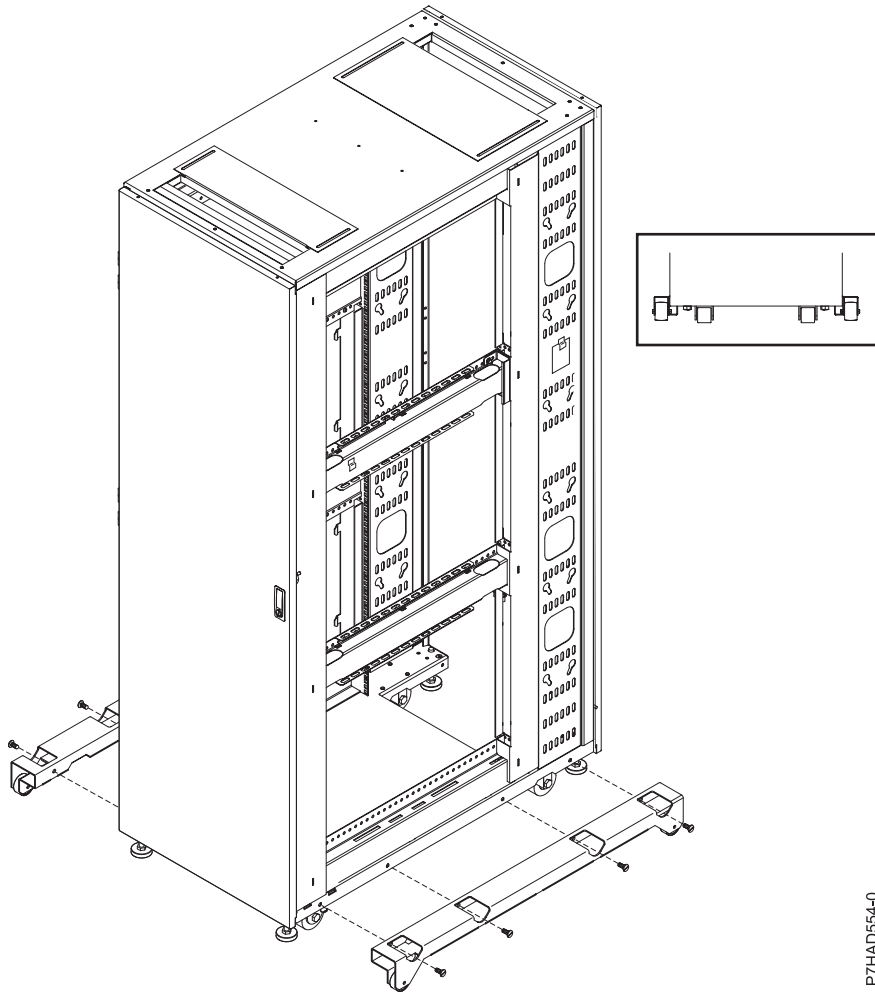

P7HAD554-0

Figure 98. Outrigger locations

Multiple racks

Learn how to attach multiple 7953-94X racks together.

Multiple 7953-94X racks can be attached together via attachment brackets connecting the units at the front of the rack. See Figure 99 on page 154.

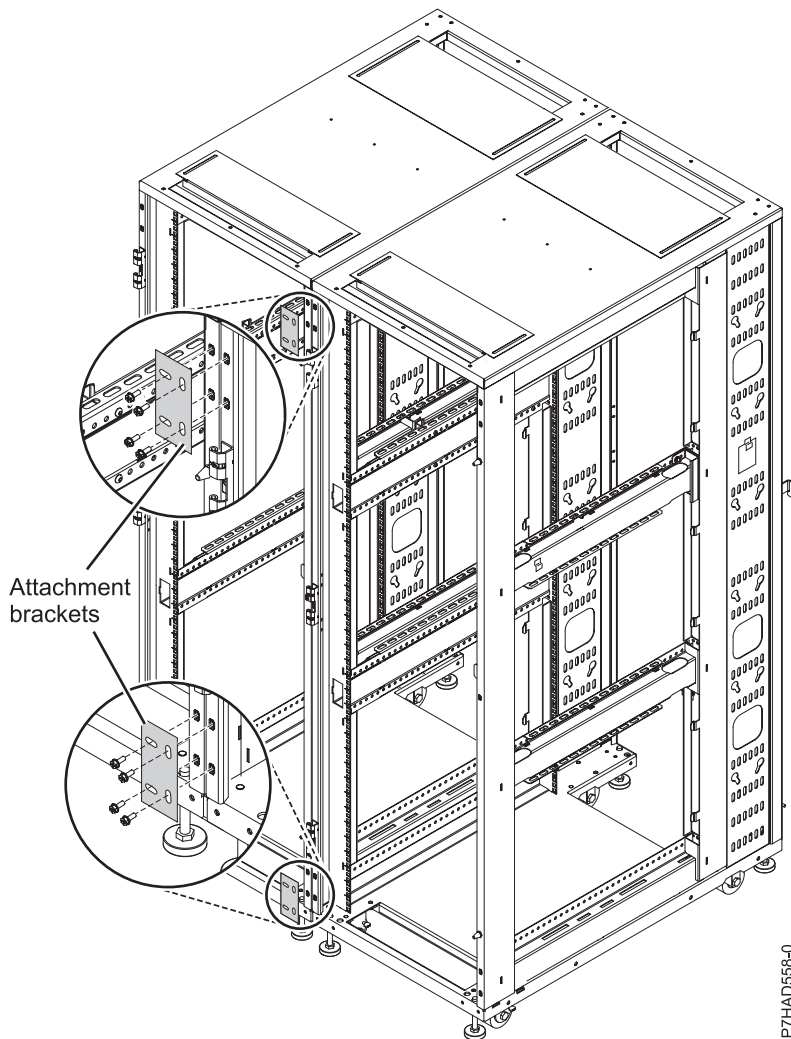

Figure 99. Attachment brackets

Hardware management console specifications

Hardware management console (HMC) specifications provide detailed information for your HMC, including dimensions, electrical, power, temperature, environment, and service clearances.

42C/07 desktop Hardware Management Console specifications

Hardware specifications provide detailed information for your Hardware Management Console (HMC), including dimensions, electrical, power, temperature, and environmental specifications.

The HMC controls managed systems, including the management of logical partitions and the use of capacity on demand. Using service applications, the HMC communicates with managed systems to detect, consolidate, and send information for analysis. The HMC provides service technicians with diagnostic information for systems that can operate in a multiple-partitioned environment.

Use the following specifications to plan for your HMC.

Table 173. Hardware Management Console specifications

Measurements	Width	Depth	Height	Weight (minimum configuration as shipped)	Weight (maximum configuration)
Metric	438 mm	540 mm	216 mm	16.3 kg	25.2 kg
English	17.25 in.	21.25 in.	8.5 in.	36 lb	56 lb
Electrical¹					
Power source loading			0.106 kVa to 0.352 kVa		
Input voltage			100 - 127 V ac (low range)		
			200 - 240 V ac (high range)		
Frequency (hertz)			47 Hz to 53 Hz (low range)		
			57 Hz to 63 Hz (high range)		
Thermal output (minimum)			630 Btu/hr. (185 watts)		
Thermal output (maximum)			1784 Btu/hr. (523 watts)		
Maximum altitude (Server off)			2133 m (7000 ft)		
Air temperature requirements					
Operating			Shipping		
10°C to 32°C (50°F to 89.6°F)			-40°C to 60°C (-40°F to 140°F)		
Humidity requirements					
	Operating		Nonoperating		
Noncondensing humidity	8% - 80%		8% - 80%		
Noise emissions²					
Product description	Declared A-weighted sound power level, L_{wAd} (bels)		Declared A-weighted sound pressure level, L_{pAm} (dB)		
	Operating	Nonoperating	Operating	Nonoperating	
One hard disk drive configuration	5.2	4.8	37	33	
Notes:					
1. Power consumption and heat output vary depending on the number and type of optional features installed and the power management optional features in use.					
2. These levels were measured in controlled acoustical environments according to the procedures specified by the American National Standards Institute (ANSI) S12.10 and ISO 7779 and are reported in accordance with IS) 9296. Actual sound-pressure levels in a given location might exceed the average values stated because of room reflections and other nearby noise sources. The declared sound-power levels indicate an upper limit, below which a large number of computers will operate.					

7042-C08 Hardware Management Console specifications

Hardware specifications for model 7042-C08 provide detailed information for your Hardware Management Console (HMC), including dimensions, electrical, power, temperature, and environmental specifications.

The HMC controls managed systems, including the management of logical partitions and the use of capacity on demand. Using service applications, the HMC communicates with managed systems to

detect, consolidate, and send information for analysis. The HMC provides service technicians with diagnostic information for systems that can operate in a multiple-partitioned environment.

Use the following specifications to plan for your HMC.

Table 174. Dimensions

Width	Depth	Height	Weight
216 mm (8.5 in.)	540 mm (21.25 in.)	438 mm (17.25 in)	19.6 - 21.4 kg (43 - 47 lb)

Table 175. Electrical

Electrical characteristics	Properties
Maximum measured power	523 W
Maximum kVA	.55
Frequency	50 or 60 Hz
Maximum thermal output	1784 BTU/hr
Input voltage low range	100 - 127 V ac
Input voltage high range	200 - 240 V ac

Table 176. Environment requirements

Environment	System requirements	Altitude
Recommended operating temperature	10°C - 35°C (50°F - 95°F)	0 - 914.4 m (0 - 3000 ft)
	10°C - 32°C (50°F - 89.6°F)	914.4 - 2133.6 m (3000 - 7000 ft)
Nonoperating temperature	10°C - 43°C (50°F - 109.4°F)	2133.6 m (7000 ft)
Maximum altitude	NA	2133.6 m (7000 ft)
Shipping temperature	-40°C to 60°C (-40°F to 140°F)	
Operating humidity	8% - 80%	
Nonoperating humidity	8% - 80%	

7042-CR7 Hardware Management Console specifications

Hardware specifications provide detailed information about your Hardware Management Console (HMC), including dimensions, electrical, environmental requirements, and noise emissions.

The HMC controls managed systems, including the management of logical partitions and the use of capacity on demand (CoD). By using service applications, the HMC communicates with managed systems to detect, consolidate, and send information for analysis. The HMC provides service technicians with diagnostic information for systems that can operate in a multiple-partitioned environment.

Use the following specifications to plan for your HMC.

Table 177. Dimensions

Width	Depth	Height	Weight (maximum configuration)
429 mm (16.9 in.)	734 mm (28.9 in.)	43 mm (1.7 in.)	16.4 kg (36.16 lb)

Table 178. Electrical requirements

Electrical characteristics	Properties
Maximum measured power	351 W

Table 178. Electrical requirements (continued)

Electrical characteristics	Properties
Maximum thermal output	1198 Btu/hr
Input voltage low range	100 - 127 V ac
Input voltage high range	200 - 240 V ac
Frequency (Hertz)	50 or 60 Hz (+/- 3 Hz)

Table 179. Environmental requirements

Environment	System requirements	Altitude
Recommended operating temperature	10°C - 35°C (50°F - 95°F)	0 - 915 m (0 - 3000 ft)
	10°C - 32°C (50°F - 90°F)	915 - 2134 m (3000 - 7000 ft)
	10°C - 28°C (50°F - 83°F)	2134 - 3050 m (7000 - 10,000 ft)
Nonoperating temperature	5°C - 45°C (41°F - 113°F)	
Shipping temperature	-40°C to 60°C (-40°F to 140°F)	
Maximum altitude	3048 m (10,000 ft)	
Operating humidity	20% - 80%	
Operating dew point (maximum)	21°C (70°F)	
Nonoperating humidity	8% - 80%	
Nonoperating dew point (maximum)	27°C (81°F)	

Table 180. Noise emissions (Maximum configuration)¹

Acoustical characteristics	Idling	Operating
L _{WAd}	6.2 bels	6.5 bels

1. These levels were measured in controlled acoustical environments according to the procedures specified by the American National Standards Institute (ANSI) S12.10 and ISO 7779 and are reported in accordance with ISO 9296. Actual sound-pressure levels in a specific location might exceed the average values stated because of room reflections and other nearby noise sources. The declared sound-power levels indicate an upper limit, below which a large number of computers will operate.

Systems Director Management Console specifications

Systems Director Management Console (SDMC) specifications provide detailed information for your SDMC, including dimensions, electrical, power, temperature, environment, and service clearances.

7042-CR6 rack-mounted Systems Director Management Console specifications

Hardware specifications provide detailed information for your Systems Director Management Console (SDMC), including dimensions, electrical, environmental requirements, and noise emissions.

The SDMC controls managed systems, including the management of logical partitions and the use of capacity on demand. Using service applications, the SDMC communicates with managed systems to detect, consolidate, and send information for analysis. The SDMC provides service technicians with diagnostic information for systems that can operate in a multiple-partitioned environment.

Use the following specifications to plan for your SDMC.

Table 181. Dimensions

Width	Depth	Height	Weight (maximum configuration)
440 mm (17.3 in.)	711 mm (28.0)	43 mm (1.7 in.)	15.9 kg (35.1 lb)

Table 182. Electrical requirements

Electrical characteristics	Properties
Maximum measured power	675 W
Maximum kVA	0.7 kVA
Minimum thermal output	662 BTU/hr
Maximum thermal output	2302 BTU/hr
Input voltage low range	100 V ac - 127 V ac
Input voltage high range	200 V ac - 240 V ac
Frequency (Hertz)	47 Hz - 63 Hz

Table 183. Environmental requirements

Environment	Temperature
Recommended operating temperature	10°C - 35°C (50°F - 95°F)
Nonoperating temperature	5°C - 45°C (41°F - 113°F)
Maximum altitude	3048 m (10000 ft)
Operating humidity	8% - 80%
Nonoperating humidity	20% - 80%

Table 184. Noise emissions (maximum configuration)¹

	Idling	Operating
L _{WA} d	6.1 bels	6.1 bels

¹ These levels were measured in controlled acoustical environments according to the procedures specified by the American National Standards Institute (ANSI) S12.10 and ISO 7779 and are reported in accordance with ISO 9296. Actual sound-pressure levels in a specific location might exceed the average values stated because of room reflections and other nearby noise sources. The declared sound-power levels indicate an upper limit, below which a large number of computers will operate.

7042-CR7 rack-mounted Systems Director Management Console specifications

Hardware specifications provide detailed information for your Systems Director Management Console (SDMC), including dimensions, electrical, environmental requirements, and noise emissions.

The SDMC controls managed systems, including the management of logical partitions and the use of capacity on demand. Using service applications, the SDMC communicates with managed systems to detect, consolidate, and send information for analysis. The SDMC provides service technicians with diagnostic information for systems that can operate in a multiple-partitioned environment.

Use the following specifications to plan for your SDMC.

Table 185. Dimensions

Width	Depth	Height	Weight (maximum configuration)
429 mm (16.9 in.)	734 mm (28.9 in.)	43 mm (1.7 in.)	16.4 kg (36.16 lb)

Table 186. Electrical requirements

Electrical characteristics	Properties
Maximum measured power	351 W
Maximum thermal output	1198 BTU/hr
Input voltage low range	100 V ac - 127 V ac
Input voltage high range	200 V ac - 240 V ac
Frequency (Hertz)	50 or 60 Hz (+/- 3 Hz)

Table 187. Environmental requirements

Environment	System Requirements	Altitude
Recommended operating temperature	10°C - 35°C (50°F - 95°F)	0 - 915 m (0 - 3000 ft)
	10°C - 32°C (50°F - 90°F)	915 - 2134 m (3000 - 7000 ft)
	10°C - 28°C (50°F - 83°F)	2134 - 3050 m (7000 - 10000 ft)
Nonoperating temperature	5°C - 45°C (41°F - 113°F)	
Shipping temperature	-40°C to 60°C (-40°F to 140°F)	
Maximum altitude	3048 m (10000 ft)	
Operating humidity	20% - 80%	
Operating dew point (maximum)	21°C (70°F)	
Nonoperating humidity	8% - 80%	
Nonoperating dew point (maximum)	27°C (81°F)	

Table 188. Noise emissions (Maximum configuration)¹

	Idling	Operating
L _{WA} d	6.2 bels	6.5 bels

¹ These levels were measured in controlled acoustical environments according to the procedures specified by the American National Standards Institute (ANSI) S12.10 and ISO 7779 and are reported in accordance with ISO 9296. Actual sound-pressure levels in a specific location might exceed the average values stated because of room reflections and other nearby noise sources. The declared sound-power levels indicate an upper limit, below which a large number of computers will operate.

Rack switch specifications

Rack switch specifications provide detailed information for your IBM BNT[®] RackSwitch, including dimensions, electrical, power, temperature, environment, and service clearances.

Select the appropriate models to view the specifications for your rack switch.

G8052R RackSwitch specification sheet

Hardware specifications provide detailed information for your IBM BNT RackSwitch, including dimensions, electrical, power, temperature, environment, and service clearances.

Table 189. Dimensions

Height	Width	Depth	Weight (maximum)
44 mm (1.73 in.)	439 mm (17.3 in.)	445 mm (17.5 in.)	8.3 kg (18.3 lb)

Table 190. Electrical

Electrical characteristics	Properties
Power requirements	200 W
Voltage	90 - 264 V ac
Frequency	47 - 63 Hz
Maximum thermal output	682.4 Btu/hr
Phase	1

Table 191. Environmental and acoustical requirements

Environment/Acoustical	Operating	Storage
Airflow direction	Rear-to-front	
Temperature, ambient operating	0°C - 40°C (32°F - 104°F)	
Temperature, (fan failure) operating	0°C - 35°C (32°F - 95°F)	
Temperature, storage		-40°C to +85°C (-40°F to 185°F)
Relative humidity range (non-condensing)	10% - 90% RH	10% - 90% RH
Maximum altitude	3050 m (10000 ft)	12190 m (40000 ft)
Heat dissipation	444 Btu/hr	
Acoustic noise	Less than 65 dB	

G8124ER RackSwitch specification sheet

Hardware specifications provide detailed information for your IBM BNT RackSwitch, including dimensions, electrical, power, temperature, environment, and service clearances.

Table 192. Dimensions

Height	Width	Depth	Weight (maximum)
44 mm (1.73 in.)	439 mm (17.3 in.)	381 mm (15.0 in.)	6.4 kg (14.1 lb)

Table 193. Electrical

Electrical characteristics	Properties
Power requirements	275 W
Voltage	100 - 240 V ac
Frequency	50 - 60 Hz
Maximum thermal output	938.3 Btu/hr
Phase	1

Table 194. Environmental and acoustical requirements

Environment/Acoustical	Operating	Storage
Airflow direction	Rear-to-front	

Table 194. Environmental and acoustical requirements (continued)

Environment/Acoustical	Operating	Storage
Temperature, ambient operating	0°C - 40°C (32°F - 104°F)	
Temperature (fan failure) operating	0°C - 35°C (32°F - 95°F)	
Temperature, storage		-40°C to +85°C (-40°F to 185°F)
Relative humidity range (non-condensing)	10% - 90% RH	10% - 95% RH
Maximum altitude	3050 m (10000 ft)	4573 m (15000 ft)
Heat dissipation	1100 Btu/hr	
Acoustic noise	Less than 65 dB	

G8264R RackSwitch specification sheet

Hardware specifications provide detailed information for your IBM BNT RackSwitch, including dimensions, electrical, power, temperature, environment, and service clearances.

Table 195. Dimensions

Height	Width	Depth	Weight (maximum)
44 mm (1.73 in.)	439 mm (17.3 in.)	513 mm (20.2 in.)	10.5 kg (23.1 lb)

Table 196. Electrical

Electrical characteristics	Properties
Power requirements	375 W
Voltage	100 - 240 V ac
Frequency	50 - 60 Hz
Maximum thermal output	1280 Btu/hr
Phase	1

Table 197. Environmental and acoustical requirements

Environment/Acoustical	Operating	Storage
Airflow direction	Rear-to-front	
Temperature, ambient operating	0°C - 40°C (32°F - 104°F)	
Temperature (fan failure) operating	0°C - 35°C (32°F - 95°F)	
Temperature, storage		-40°C to +85°C (-40°F to 185°F)
Relative humidity range (non-condensing)	10% - 90% RH	10% - 90% RH
Maximum altitude	1800 m (6000 ft)	12190 m (40000 ft)
Heat dissipation	1127 Btu/hr	
Acoustic noise	Less than 65 dB	

G8316R RackSwitch specification sheet

Hardware specifications provide detailed information for your IBM BNT RackSwitch, including dimensions, electrical, power, temperature, environment, and service clearances.

Table 198. Dimensions

Height	Width	Depth	Weight (maximum)
43.7 mm (1.72 in.)	439 mm (17.3 in.)	483 mm (19.0 in.)	9.98 kg (22.0 lb)

Table 199. Electrical

Electrical characteristics	Properties
Power requirements	400 W
Voltage	100 - 240 V ac
Frequency	50 - 60 Hz
Maximum thermal output	1365 Btu/hr
Phase	1

Table 200. Environmental requirements

Environment	Operating
Airflow direction	Rear-to-front
Temperature, ambient operating	0°C - 40°C (32°F - 104°F)
Relative humidity range (non-condensing)	10% - 90% RH
Maximum altitude	3050 m (10000 ft)
Heat dissipation	1100 Btu/hr

Rack installation procedures for racks

Learn the requirements and specifications for installing systems into racks .

This topic provides requirements and specifications for 19-inch racks. These requirements and specifications are provided as an aid to help you understand the requirements to install systems into racks. It is your responsibility, working with your rack manufacturer, to ensure that the rack chosen meets the requirements and specifications listed here. Mechanical drawings of the rack, if available from the manufacturer, are recommended for comparison against the requirements and specifications.

IBM maintenance services and installation planning services do not cover verification of non-IBM racks for compliance to Power Systems rack specifications. IBM offers racks for IBM products that are tested and verified by IBM development labs to comply with applicable safety and regulatory requirements. These racks are also tested and verified to fit and function well with IBM products. The customer is responsible for verifying with their rack manufacturer that any non-IBM racks comply with IBM specifications.

Note: The IBM 7014-T00, 7014-T42, 7014-B42, 0551, and 0553 racks meet all the requirements and specifications.

Rack specifications

The general rack specifications are:

- The rack or cabinet must meet the EIA Standard EIA-310-D for 19-inch racks published August 24, 1992. The EIA-310-D standard specifies internal dimensions, for example, the width of the rack opening (width of the chassis), the width of the module mounting flanges, the mounting hole spacing, and the depth of the mounting flanges. The EIA-310-D standard does not control the overall external width of the rack. There are no restrictions on the location of side walls and corner posts relative to the internal mounting space.

- The front rack opening must be 451 mm wide + 0.75 mm (17.75 in. + 0.03 in.), and the rail-mounting holes must be 465 mm + 0.8 mm (18.3 in. + 0.03 in.) apart on center (horizontal width between vertical columns of holes on the two front-mounting flanges and on the two rear-mounting flanges).

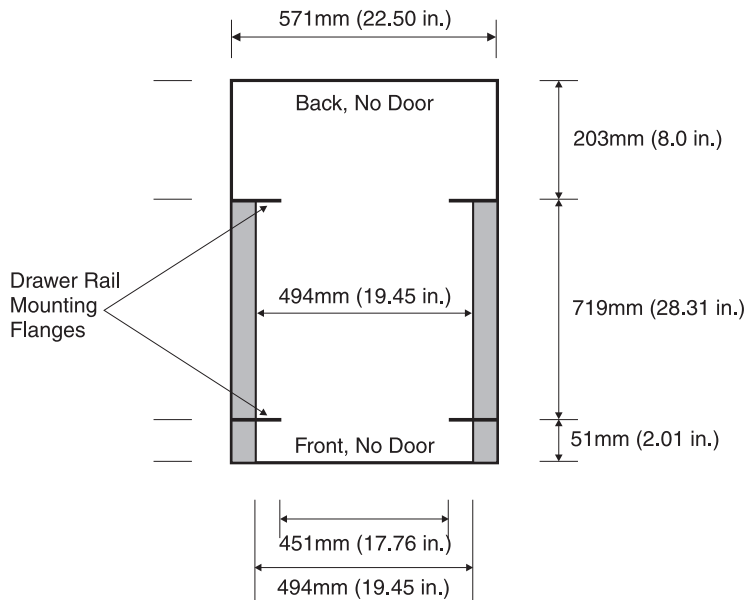

The vertical distance between mounting holes must consist of sets of three holes spaced (from bottom to top) 15.9 mm (0.625 in.), 15.9 mm (0.625 in.), and 12.67 mm (0.5 in.) on center (making each three hole set of vertical hole spacing 44.45 mm (1.75 in.) apart on center). The front and rear mounting flanges in the rack or cabinet must be 719 mm (28.3 in.) apart and the internal width bounded by the mounting flanges at least 494 mm (19.45 in.), for the rails to fit in your rack or cabinet (see the following figure).

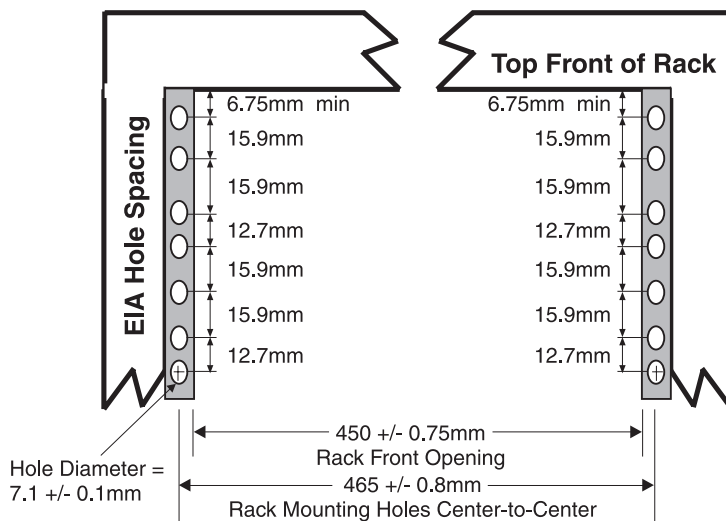

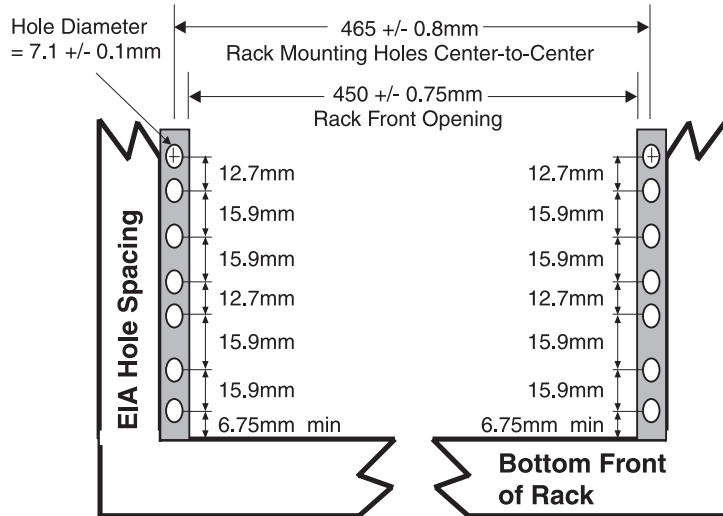

- Models 9117-MMB and 9179-MHB use SMP and FSP flex assemblies that extend beyond the rack mount post width. The front rack opening must be 535 mm (21.06 in.) wide for dimension C (the width between the outsides of the standard mounting flanges, see Figure 100). The back rack opening must be 500 mm (19.69 in.) wide for dimension C (the width between the outsides of the standard mounting flanges).

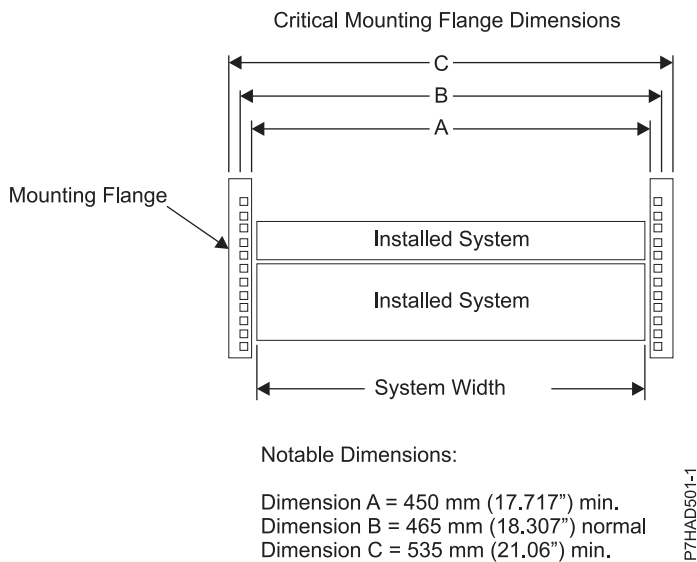
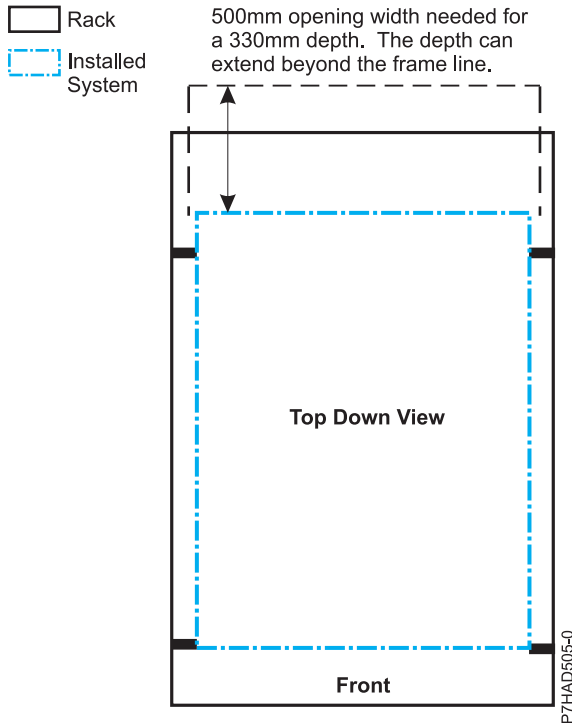

Figure 100. Critical mounting flange dimensions

- A minimum rack opening width of 500 mm (19.69 in.) for a depth of 330 mm (12.99 in.) is needed behind the installed system for maintenance and service. The depth can extend beyond the rack rear door.



- The rack or cabinet must be capable of supporting an average load of 15.9 kg (35 lb) of product weight per EIA unit.

For example, a four EIA drawer has a maximum drawer weight of 63.6 kg (140 lb).

- 7.1 mm plus or minus 0.1 mm
- 9.2 mm plus or minus 0.1 mm
- 12 mm plus or minus 0.1 mm
- All parts shipped with the Power Systems products must be installed.
- Only ac power drawers are supported in the rack or cabinet. It is strongly recommended to use a power distribution unit that meets the same specifications as power distribution units to supply rack power (for example, feature code 7188). Rack or cabinet power distribution devices must meet the drawer voltage, amperage, and power requirements, as well as that of any additional products that will be connected to the same power distribution device.

The rack or cabinet power receptacle (power distribution unit, uninterruptible power supply, or multi-outlet strip) must have a compatible plug type for your drawer or device.

- The rack or cabinet must be compatible with the drawer-mounting rails. The rail-mounting pins and screws should fit securely and snugly into the rack or cabinet rail-mounting holes. It is strongly recommended that the mounting rails and mounting hardware that are included with the product be used to install it in the rack. The mounting rails and mounting hardware that are provided with products have been designed and tested to safely support the product during operation and service activities as well as to safely support the weight of your drawer or device. The rails must facilitate service access by allowing the drawer to be safely extended, if necessary, forward, backward, or both. Some rails provide drawer specific anti-tip brackets, rear lock-down brackets, and cable management guides that require clearance on the rear side of the rails.

Note: If the rack or cabinet has square holes on the mounting flanges, a plug-in hole adapter might be required.

At a minimum, mounting rails must be able to support four times the maximum rated product weight in its worst-case position (fully-extended front and rear positions) for one full minute without catastrophic failure.

- The rack or cabinet must have stabilization feet or brackets installed both in the front and rear of the rack, or have another means of preventing the rack/cabinet from tipping while the drawer or device is pulled into its extreme front or rear service positions.

Note: Examples of some acceptable alternatives: The rack or cabinet might be securely bolted to the floor, ceiling or walls, or to adjacent racks or cabinets in a long and heavy row of racks or cabinets.

- There must be adequate front and rear service clearances (in and around the rack or cabinet). The rack or cabinet must have sufficient horizontal width clearance in the front and rear to allow the drawer to be fully slid into the front and, if applicable, the rear service access positions (typically this requires 914.4 mm (36 in.) clearance in both the front and rear).
- If present, front and rear doors must be able to open far enough to provide unrestrained access for service or be easily removable. If doors must be removed for service, it is the customer's responsibility to remove them prior to service.
- The rack or cabinet must provide adequate clearance around the rack drawer.
- There must be adequate clearance around the drawer bezel so that it can be opened and closed, according to the product specifications.
- Front or rear doors must also maintain a minimum of 51 mm (2 in.) front, 203 mm (8 in.) rear, door to mounting flange clearance, and 494 mm (19.4 in.) front, 571 mm (22.5 in.) rear, side-to-side clearance for drawer bezels and cables.
- The rack or cabinet must provide adequate front-to-back ventilation.

Note: For optimum ventilation, it is recommended the rack or cabinet not have a front door. If the rack or cabinet has doors, the doors must be fully perforated so that there is proper front-to-back airflow to maintain the required drawer ambient inlet temperature as specified in the server specifications. The perforations should yield at least 34 % minimum open area per square inch.

General safety requirements for products installed in a rack or cabinet

The general safety requirements for products installed in racks are:

- Any product or component that plugs into either an power distribution unit or mains power (via a power cord), or uses any voltage over 42 V ac or 60 V dc (considered to be hazardous voltage) must be Safety Certified by a Nationally Recognized Test Laboratory (NRTL) for the country in which it will be installed.

Some of the items that require safety certification might include: the rack or cabinet (if it contains electrical components integral to the rack or cabinet), fan trays, power distribution unit, uninterruptible power supplies, multi-outlet strips, or any other products installed in the rack or cabinet that connect to hazardous voltage.

Examples of OSHA-approved NRTLs for the U.S.:

- UL
- ETL
- CSA (with CSA NRTL or CSA US mark)

Examples of approved NRTLs for Canada:

- UL (Ulc mark)
- ETL (ETLc mark)
- CSA

The European Union requires a CE mark and a Manufacturer's Declaration of Conformity (DOC).

Certified products should have the NRTL logos or marks somewhere on the product or product label. However, proof of certification must be made available upon request. Proof consists of such items as copies of the NRTL license or certificate, a CB Certificate, a Letter of Authorization to apply the NRTL mark, the first few pages of the NRTL certification report, Listing in an NRTL publication, or a copy of the UL Yellow Card. Proof should contain the manufacturers name, product type and model, standard

to which it was certified, the NRTL name or logo, the NRTL file number or license number, and a list of any Conditions of Acceptance or Deviations. A Manufacturer's Declaration is not proof of certification by an NRTL.

- The rack or cabinet must meet all electrical and mechanical safety legal requirements for the country in which it is installed. The rack or cabinet must be free of exposed hazards (such as voltages over 60 V dc or 42 V ac, energy over 240 VA, sharp edges, mechanical pinch points, or hot surfaces).
- There must be an accessible and unambiguous disconnect device for each product in the rack, including any power distribution unit.

A disconnect device might consist of either the plug on the power cord (if the power cord is no longer than 1.8 m (6 ft)), the appliance inlet receptacle (if the power cord is of a detachable type), or a power on/off switch, or an Emergency Power Off switch on the rack, provided all power is removed from the rack or product by the disconnect device.

If the rack or cabinet has electrical components (such as fan trays or lights), the rack must have an accessible and unambiguous disconnect device.

- The rack or cabinet, power distribution unit and multi-outlet strips, and products installed in the rack or cabinet must all be properly grounded to the customer facility ground.

There must be no more than 0.1 Ohms between the ground pin of the power distribution unit or rack plug and any touchable metal or conductive surface on the rack and on the products installed in the rack. Grounding method must comply with applicable country's electric code (such as NEC or CEC). Ground continuity can be verified by your service personnel, after the installation is completed, and should be verified prior to the first service activity.

- The voltage rating of the power distribution unit and multi-outlet strips must be compatible with the products plugged into them.

The power distribution unit or multi-outlet strips current and power ratings are rated at 80% of the building supply circuit (as required by the National Electrical Code and the Canadian Electrical Code). The total load connected to the power distribution unit must be less than the rating of the power distribution unit. For example, a power distribution unit with a 30 A connection will be rated for a total load of 24 A (30 A x 80 %). Therefore, the sum of all equipment connected to the power distribution unit in this example must be lower than the 24 A rating.

If an uninterruptible power supply is installed, it must meet all the electrical safety requirements as described for a power distribution unit (including certification by an NRTL).

- The rack or cabinet, power distribution unit, uninterruptible power supply, multi-outlet strips and all products in the rack or cabinet must be installed according to the manufacturer's instructions, and in accordance with all national, state or province, and local codes and laws.

The rack or cabinet, power distribution unit, uninterruptible power supply, multi-outlet strips and all products in the rack or cabinet must be used as intended by the manufacturer (per manufacturer's product documentation and marketing literature).

- All documentation for use and installation of the rack or cabinet, power distribution unit, uninterruptible power supply, and all products in the rack or cabinet, including safety information, must be available on-site.
- If there is more than one source of power in the rack cabinet, there must be clearly visible safety labels for "Multiple Power Source" (in the languages required for the country in which the product is installed).
- If the rack or cabinet or any products installed in the cabinet had safety or weight labels applied by the manufacturer, they must be intact and translated into the languages required for the country in which the product is installed.
- If the rack or cabinet has doors, the rack becomes a fire enclosure by definition and must meet the applicable flammability ratings (V-0 or better). Totally metal enclosures at least 1 mm (0.04 in.) thick are considered to comply.

Nonenclosure (decorative) materials must have a flammability rating of V-1 or better. If glass is used (such as in rack doors) it must be safety glass. If wood shelves are used in the rack/cabinet, they must be treated with a UL Listed flame-retardant coating.

- The rack or cabinet configuration must comply with all requirements for "safe to service" (contact your Installation Planning Representative for assistance in determining if the environment is safe).

There must be no unique maintenance procedures or tools required for service.

Elevated service installations, where the products to be serviced are installed between 1.5 m and 3.7 m (5 ft and 12 ft) above the floor, require the availability of an OSHA- and CSA-approved nonconductive step ladder. If a ladder is required for service, the customer must supply the OSHA- and CSA-approved nonconductive step ladder (unless other arrangements have been made with the local Service Branch Office). Products installed over 2.9 m (9 ft) above the floor require a Special Bid to be completed before they can be serviced by service personnel.

For products not intended for rack-mounting to be serviced, the products and parts that will be replaced as part of that service must not weigh over 11.4 kg (25 lb) Contact your Installation Planning Representative if in doubt.

There must not be any special education or training required for safe servicing of any of the products installed in the racks. Contact your Installation Planning Representative if you are in doubt.

Related reference:

"Rack specifications" on page 127

Rack specifications provide detailed information for your rack, including dimensions, electrical, power, temperature, environment, and service clearances.

Planning for power

Planning the power for your system requires knowledge of your server's power requirements, the power requirements of compatible hardware, and the uninterruptible power supply needs for your server. Use this information to build a complete power plan.

Before you begin your planning tasks, be sure you have completed the items in the following checklist:

- Know your server power requirements.
- Know your compatible hardware requirements.
- Know your uninterruptible power supply needs.

Review power considerations

Complete the following checklist:

- Consult a qualified electrician regarding power needs.
- Determine an uninterruptible power supply vendor.
- Complete your server information form or forms.

Determining your power requirements

Use these guidelines to ensure that your server has the proper power to operate.

Your server can have power requirements different from a PC (such as, different voltage and different plugs). Your seller supplies power cords with an attached plug that corresponds to the power outlet most commonly used in the country or region to which the product is being shipped. You are responsible for supplying the proper power outlets.

- Plan for system electrical service. For information on power requirements for a specific model, refer to the electrical section in the server specifications for that particular server. For information on power requirements for expansion units or peripherals, select the appropriate device from the list of compatible hardware specifications. For equipment not listed, check your equipment documentation (owner's manuals) for specifications.
- Determine your server's plug and receptacle types: By model so you can have the proper outlets installed.

Tip: Print a copy of your plug and receptacle table and give it to your electrician. The table contains information needed for installing outlets.

- Write down power information in your Server Information Form 3A. Include:
 - Plug type
 - Input voltage
 - Power cord length (optional)
- Plan for power outages. Consider purchasing an uninterruptible power supply to protect your system against power fluctuations and outages. If your company owns a uninterruptible power supply, involve your uninterruptible power supply vendor with any type of uninterruptible power supply modification.
- Plan an emergency power-off switch. As a safety precaution, you should provide some method for disconnecting power to all equipment in your server area. Put emergency power-off switches in locations readily accessible to your systems operator and at designated exits from the room.

Part number	Device type	Device description	Device location	Cable length	Plug type/input voltage	Telephone contact

Plugs and receptacles

Select the country or region link to see plugs and receptacles available by country. Or, if you use a PDU select Connecting your sever to a PDU.

Connecting your server to a country specific receptacle

Choose the country or region in which your system will be installed to assist in determining the feature cord of your system.

Supported feature cords

Find out which feature cords are supported for each system and country.

Use the following tables to determine the appropriate feature cord to use with your system in your country.

Table 201. Supported feature cords for POWER7® systems

Feature cord (FC)	02E/4B and 02E/4C (7/20)	05F/6B and 05E/6C (7/40)	31E/2B, 31E/1C, and 31E/2C (7/10 and 7/30)	33E/8B (7/50)	36E/8C (7/55)	17M/MB, 17M/MC, and 17M/MD (7/70)	19F/HB (7/95)	79M/HB, 79M/HC, and 79M/HD (7/80)
6460	X	X	X	X	X	X	X	X
6469	X	X	X	X	X	X	X	X
6470	X	X	X	X	X	S	X	S
6471	X	X	X	X	X	X	X	X
6472	X	X	X	X	X	X	X	X
6473	X	X	X	X	X	X	X	X
6474	X	X	X	X	X	X	X	X
6475	X	X	X	X	X	X	X	X
6476	X	X	X	X	X	X	X	X
6477	X	X	X	X	X	X	X	X
6478	X	X	X	X	X	X	X	X

Table 201. Supported feature cords for POWER7® systems (continued)

Feature cord (FC)	02E/4B and 02E/4C (7/20)	05F/6B and 05E/6C (7/40)	31E/2B, 31E/1C, and 31E/2C (7/10 and 7/30)	33E/8B (7/50)	36E/8C (7/55)	17M/MB, 17M/MC, and 17M/MD (7/70)	19F/HB (7/95)	79M/HB, 79M/HC, and 79M/HD (7/80)
6479	S	S	S	S	N/S	S	S	S
6488	X	X	X	X	X	X	X	X
6489	X	X	X	X	X	X	X	X
6491	X	X	X	X	X	X	X	X
6492	X	X	X	X	X	X	X	X
6493	X	X	X	X	X	X	X	X
6494	X	X	X	X	X	X	X	X
6495	S	S	S	S	N/S	S	S	S
6496	X	X	X	X	X	X	X	X
6497	S	S	S	S	N/S	X	X	X
6498	S	S	S	S	N/S	S	S	S
6651	X	X	X	X	X	X	X	X
6653	X	X	X	X	X	X	X	X
6654	X	X	X	X	X	X	X	X
6655	X	X	X	X	X	X	X	X
6656	X	X	X	X	X	X	X	X
6657	X	X	X	X	X	X	X	X
6658	X	X	X	X	X	X	X	X
6659	X	X	X	X	X	X	X	X
6660	X	X	X	X	X	X	X	X
6662	S	S	S	S	N/S	S	S	S
6670	S	S	S	S	N/S	S	S	S
6680	X	X	X	X	X	X	X	X
6687	S	S	S	S	N/S	S	S	S
6690	S	S	S	S	N/S	S	S	S
6691	S	S	S	S	N/S	S	S	S
6692	S	S	S	S	N/S	S	S	S
RPQ 8A1871	N/S	N/S	N/S	N/S	N/S	N/S	X	N/S

X = Feature cord is supported and can be purchased.

S = Feature cord is supported, but is no longer available for purchase.

N/S = Feature cord is not supported.

Table 202. Supported feature cords by countries

Feature Cord (FC)	Supported countries
6470	United States, Canada

Table 202. Supported feature cords by countries (continued)

Feature Cord (FC)	Supported countries
6471	Brazil
6472	Afghanistan, Albania, Algeria, Andorra, Angola, Armenia, Austria, Azerbaijan, Belarus, Belgium, Benin, Bosnia and Herzegovina, Bulgaria, Burkina Faso, Burundi, Cambodia, Cameroon, Cape Verde, Central African Republic, Chad, Comoros, Congo (Democratic Republic of), Congo (Republic of), Cote D'Ivoire (Ivory Coast), Croatia (Republic of), Czech Republic, Dahomey, Djibouti, Egypt, Equatorial Guinea, Eritrea, Estonia, Ethiopia, Finland, France, French Guyana, French Polynesia, Gabon, Georgia, Germany, Greece, Guadeloupe, Guinea, Guinea Bissau, Hungary, Iceland, Indonesia, Iran, Kazakhstan, Kyrgyzstan, Laos (Peoples Democratic Republic of), Latvia, Lebanon, Lithuania, Luxembourg, Macedonia (former Yugoslav Republic of), Madagascar, Mali, Martinique, Mauritania, Mauritius, Mayotte, Moldova (Republic of), Monaco, Mongolia, Morocco, Mozambique, Netherlands, New Caledonia, Niger, Norway, Poland, Portugal, Reunion, Romania, Russian Federation, Rwanda, Sao Tome and Principe, Saudi Arabia, Senegal, Serbia, Slovakia, Slovenia (Republic of), Somalia, Spain, Suriname, Sweden, Syrian Arab Republic, Tajikistan, Tahiti, Togo, Tunisia, Turkey, Turkmenistan, Ukraine, Upper Volta, Uzbekistan, Vanuatu, Vietnam, Wallis and Futuna, Yugoslavia (Federal Republic of), Zaire
6473	Denmark
6474	Abu Dhabi, Bahrain, Botswana, Brunei Darussalam, Channel Islands, Cyprus, Dominica, Gambia, Ghana, Grenada, Guyana, Hong Kong, Iraq, Ireland, Jordan, Kenya, Kuwait, Liberia, Malawi, Malaysia, Malta, Myanmar (Burma), Nigeria, Oman, Qatar, Saint Kitts & Nevis, Saint Lucia, Saint Vincent and the Grenadines, Seychelles, Sierra Leone, Singapore, Sudan, Tanzania (United Republic of), Trinidad & Tobago, United Arab Emirates (Dubai), United Kingdom, Yemen, Zambia, Zimbabwe, Uganda
6475	Israel
6476	Liechtenstein, Switzerland
6477	Bangladesh, Lesotho, Macao, Maldives, Namibia, Nepal, Pakistan, Samoa, South Africa, Sri Lanka, Swaziland, Uganda
6478	Italy
6479	Australia, New Zealand
6488	Argentina
6489	Internationally available
6491	Europe
6492	United States, Canada
6493	China
6494	India
6495	Brazil
6496	Korea
6497	United States, Canada
6498	Japan
6651	Taiwan
6653	Internationally available
6654	United States, Canada
6655	United States, Canada
6656	Internationally available
6657	Australia, New Zealand
6658	Korea

Table 202. Supported feature cords by countries (continued)

Feature Cord (FC)	Supported countries
6659	Taiwan
6660	Japan
6662	Taiwan
6670	Japan
6680	Australia, Fiji, Kiribati, Nauru, New Zealand, Papua New Guinea
6687	Japan
6690	Brazil
6691	Japan
6692	Australia, Fiji, Kiribati, Nauru, New Zealand, Papua New Guinea
RPQ 8A1871	Internationally available

Internationally available

The plug and receptacles for this system are available internationally.

Select your system's feature code for more information.

Cord feature code 6489:

Find your plug and receptacle information, voltage and amperage, part number, and cord length.

Plug and receptacle

The plug and receptacle type is IEC 60309 3P+N+E.

Note: This feature code connects the power distribution unit (PDU) in a rack to the wall receptacle.

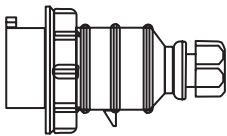

Figure 101. Plug type IEC 60309 3P+N+E

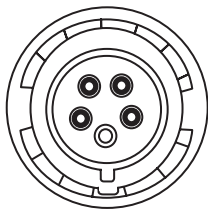

Figure 102. Receptacle type IEC 60309 3P+N+E

Voltage and amperage

The voltage is 240 - 415 V ac, and the amperage is 32 A.

Part number

The part number is:

- 39M5413

Note: This part number meets the European Union Directive 2002/95/EC on the Restriction of the Use of Certain Hazardous Substances in Electrical and Electronic Equipment.

Cord length

The cord length is 4.3 m (14 ft).

Cord feature code 6491:

Find your plug and receptacle information, voltage and amperage, part number, and cord length.

Plug and receptacle

The plug and receptacle type is IEC 60309 P+N+E.

Note: This feature code connects the power distribution unit (PDU) in a rack to the wall receptacle.

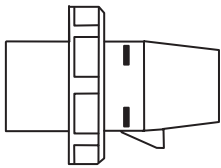

Figure 103. Plug type IEC 60309 P+N+E

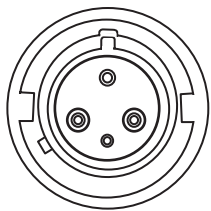

Figure 104. Receptacle type IEC 60309 P+N+E

Voltage and amperage

The voltage is 200 - 240 V ac, and the amperage is 48 A.

Part number

The part number is:

- 39M5415

Note: This part number meets the European Union Directive 2002/95/EC on the Restriction of the Use of Certain Hazardous Substances in Electrical and Electronic Equipment.

Cord length

The cord length is 4.3 m (14 ft).

Cord feature code 6653:

Find your plug and receptacle information, voltage and amperage, part number, and cord length.

Plug and receptacle

The plug and receptacle type is IEC 60309 3P+N+E.

Note: This feature code connects the power distribution unit (PDU) in a rack to the wall receptacle.

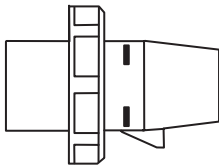

Figure 105. Plug type IEC 60309 3P+N+E

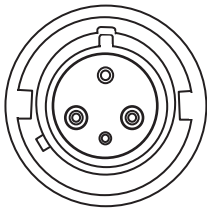

Figure 106. Receptacle type IEC 60309 3P+N+E

Voltage and amperage

The voltage is 415 V ac and the amperage is 16 A.

Part number

The part number is:

- 39M5412

Note: This part number meets the European Union Directive 2002/95/EC on the Restriction of the Use of Certain Hazardous Substances in Electrical and Electronic Equipment.

Cord length

The cord length is 4.3 m (14 ft).

Cord feature code 6656:

Find your plug and receptacle information, voltage and amperage, part number, and cord length.

Plug and receptacle

The plug and receptacle type is IEC 60309 P+N+E.

Note: This feature code connects the power distribution unit (PDU) in a rack to the wall receptacle.

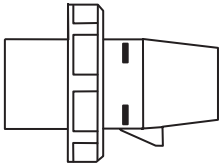

Figure 107. Plug type 60309 P+N+E

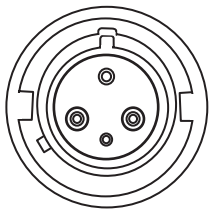

Figure 108. Receptacle type 60309 P+N+E

Voltage and amperage

The voltage is 200 - 240 V ac, and the amperage is 32 A.

Part number

The part number is:

- 39M5414

Note: This part number meets the European Union Directive 2002/95/EC on the Restriction of the Use of Certain Hazardous Substances in Electrical and Electronic Equipment.

Cord length

The cord length is 4.3 m (14 ft).

Anguilla

The plug and receptacles for this system are available in Anguilla.

Select your system's feature code for more information.

Cord feature code 6460:

Find your plug and receptacle information, voltage and amperage, part number, and cord length.

Plug and receptacle

The plug and receptacle type is 4.



Figure 109. Plug type 4

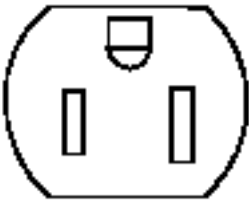

Figure 110. Receptacle type 4

Voltage and amperage

The voltage is 100 - 127 V ac, and the amperage is 15 A.

Part number

The part number is:

- 39M5513

Note: This part number meets the European Union Directive 2002/95/EC on the Restriction of the Use of Certain Hazardous Substances in Electrical and Electronic Equipment.

Cord length

The cord length is 4.3 m (14 ft).

Antigua and Barbuda

The plug and receptacles for this system are available in Antigua and Barbuda.

Select your system's feature code for more information.

Cord feature code 6469:

Find your plug and receptacle information, voltage and amperage, part number, and cord length.

Plug and receptacle

The plug and receptacle type is 5.



Figure 111. Plug type 5

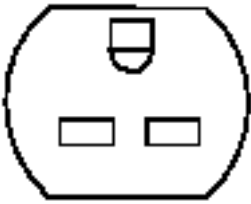

Figure 112. Receptacle type 5

Voltage and amperage

The voltage is 200 - 240 V ac, and the amperage is 15 A.

Part number

The part numbers are:

- 1838573
- 39M5096

Note: This part number meets the European Union Directive 2002/95/EC on the Restriction of the Use of Certain Hazardous Substances in Electrical and Electronic Equipment.

Cord rating

The cord rating is 2.4 kVA.

Cord length

The cord length is 4.3 m (14 ft).

Australia

The plug and receptacles for this system are available in Australia.

Select your system's feature code for more information.

Cord feature code 6657:

Find your plug and receptacle information, voltage and amperage, part number, and cord length.

Plug and receptacle

The plug and receptacle type is PDL.

Note: This feature code connects the power distribution unit (PDU) in a rack to the wall receptacle.

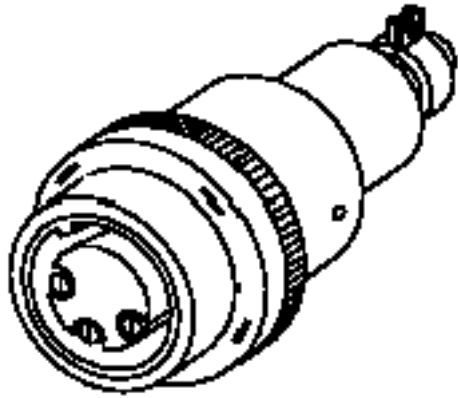

Figure 113. Plug type PDL

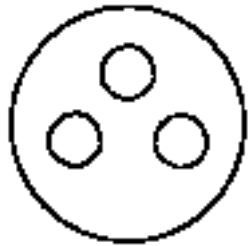

Figure 114. Receptacle type PDL

Voltage and amperage

The voltage is 200 - 240 V ac, and the amperage is 32 A.

Part number

The part number is:

- 39M5419

Note: This part number meets the European Union Directive 2002/95/EC on the Restriction of the Use of Certain Hazardous Substances in Electrical and Electronic Equipment.

Cord length

The cord length is 4.3 m (14 ft).

Brazil

The plug and receptacles for this system are available in Brazil.

Select your system's feature code for more information.

Cord feature code 6471:

Find your plug and receptacle information, voltage and amperage, part number, and cord length.

Note: Line cord FC 6471 is for use in Brazil and cannot be used in the United States.

Plug and receptacle

The plug and receptacle type is 70.



Figure 115. Plug type 70

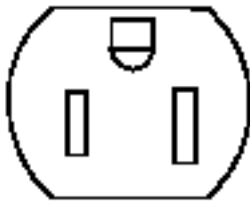

Figure 116. Receptacle type 70

Voltage and amperage

The voltage is 100 - 127 V ac, and the amperage is 10 A.

Part number

The part numbers are:

- 49P2110
- 39M5233

Note: This part number meets the European Union Directive 2002/95/EC on the Restriction of the Use of Certain Hazardous Substances in Electrical and Electronic Equipment.

Cord length

The cord length is 2.7 m (9 ft).

Bulgaria

The plug and receptacles for this system are available in Bulgaria.

Select your system's feature code for more information.

Cord feature code 6472:

Find your plug and receptacle information, voltage and amperage, part number, and cord length.

Plug and receptacle

The plug and receptacle type is 18.

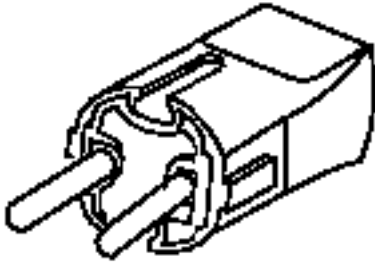

Figure 117. Plug type 18



Figure 118. Receptacle type 18

Voltage and amperage

The voltage is 200 - 240 V ac, and the amperage is 10 A.

Part number

The part numbers are:

- 13F9979
- 39M5123

Note: This part number meets the European Union Directive 2002/95/EC on the Restriction of the Use of Certain Hazardous Substances in Electrical and Electronic Equipment.

Cord rating

The cord rating is 2.4 kVA.

Cord length

The cord length is 2.7 m (9 ft).

Canada

The plug and receptacles for this system are available in Canada.

Select your system's feature code for more information.

Cord feature code 6492:

Find your plug and receptacle information, voltage and amperage, part number, and cord length.

Plug and receptacle

The plug and receptacle type is IEC 60309 2P+E.

Note: This feature code connects the power distribution unit (PDU) in a rack to the wall receptacle.

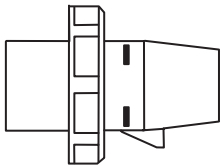

Figure 119. Plug type IEC 60309 2P+E

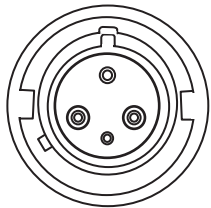

Figure 120. Receptacle type IEC 60309 2P+E

Voltage and amperage

The voltage is 200 - 240 V ac, and the amperage is 63 A.

Part number

The part number is:

- 39M5417

Note: This part number meets the European Union Directive 2002/95/EC on the Restriction of the Use of Certain Hazardous Substances in Electrical and Electronic Equipment.

Cord length

The cord length is 4.3 m (14 ft).

Cord feature code 6497:

Find your plug and receptacle information, voltage and amperage, part number, and cord length.

Plug and receptacle

The plug and receptacle type is 10.



Figure 121. Plug type 10



Figure 122. Receptacle type 10

Voltage and amperage

The voltage is 200 - 240 V ac, and the amperage is 10 A.

Part number

The part number is:

- 41V1961

Note: This part number meets the European Union Directive 2002/95/EC on the Restriction of the Use of Certain Hazardous Substances in Electrical and Electronic Equipment.

Cord length

The cord length is 1.8 m (6 ft).

Cord feature code 6654:

Find your plug and receptacle information, voltage and amperage, part number, and cord length.

Plug and receptacle

The plug and receptacle type is 12.

Note: This feature code connects the power distribution unit (PDU) in a rack to the wall receptacle.



Figure 123. Plug type 12



Figure 124. Receptacle type 12

Voltage and amperage

The voltage is 200 - 240 V ac, and the amperage is 24 A.

Part number

The part number is:

- 39M5416

Note: This part number meets the European Union Directive 2002/95/EC on the Restriction of the Use of Certain Hazardous Substances in Electrical and Electronic Equipment.

Cord length

The cord length is 4.3 m (14 ft).

Cord feature code 6655:

Find your plug and receptacle information, voltage and amperage, part number, and cord length.

Plug and receptacle

The plug and receptacle type is 40.

Note: This feature code connects the power distribution unit (PDU) in a rack to the wall receptacle.

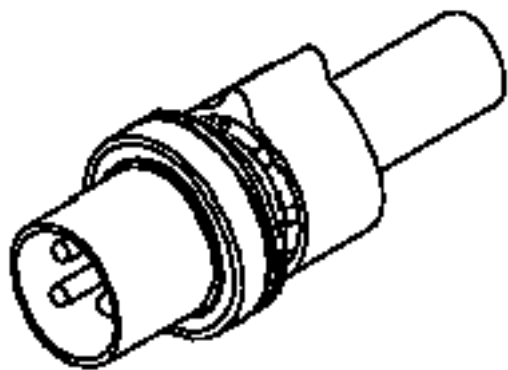

Figure 125. Plug type 40



Figure 126. Receptacle type 40

Voltage and amperage

The voltage is 200 - 240 V and the amperage is ac 24 A.

Part number

The part number is:

- 39M5418

Note: This part number meets the European Union Directive 2002/95/EC on the Restriction of the Use of Certain Hazardous Substances in Electrical and Electronic Equipment.

Cord length

The cord length is 4.3 m (14 ft).

Chile

The plug and receptacles for this system are available in Chile.

Select your system's feature code for more information.

Cord feature code 6478:

Find your plug and receptacle information, voltage and amperage, part number, and cord length.

Plug and receptacle

The plug and receptacle type is 25.



Figure 127. Plug type 25



Figure 128. Receptacle type 25

Voltage and amperage

The voltage is 200 - 240 V ac, and the amperage is 10 A.

Part number

The part numbers are:

- 14F0069
- 39M5165

Note: This part number meets the European Union Directive 2002/95/EC on the Restriction of the Use of Certain Hazardous Substances in Electrical and Electronic Equipment.

Cord rating

The cord rating is 2.4 kVA.

Cord length

The cord length is 2.7 m (9 ft).

Cord feature code 6672:

Find your plug and receptacle information, voltage and amperage, part number, and cord length.

Plug and receptacle

The plug and receptacle type is 26.

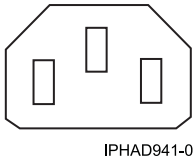

Figure 129. Plug type 26

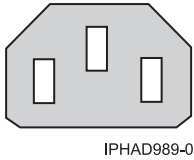

Figure 130. Receptacle type 26

Voltage and amperage

The voltage is 200 - 240 V ac, and the amperage is 10 A.

Part number

The part numbers are:

- 36L8860
- 39M5375

Note: This part number meets the European Union Directive 2002/95/EC on the Restriction of the Use of Certain Hazardous Substances in Electrical and Electronic Equipment.

Cord length

The cord length is 1.5 m (5 ft).

China

The plug and receptacles for this system are available in China.

Select your system's feature code for more information.

Cord feature code 6493:

Find your plug and receptacle information, voltage and amperage, part number, and cord length.

Plug and receptacle

The plug and receptacle type is 62.



Figure 131. Plug type 62



Figure 132. Receptacle type 62

Voltage and amperage

The voltage is 200 - 240 V ac, and the amperage is 10 A.

Part number

The part numbers are:

- 02K0546
- 39M5206

Note: This part number meets the European Union Directive 2002/95/EC on the Restriction of the Use of Certain Hazardous Substances in Electrical and Electronic Equipment.

Cord rating

The cord rating is 2.4 kVA.

Cord length

The cord length is 2.7 m (9 ft).

Denmark

The plug and receptacles for this system are available in Denmark.

Select your system's feature code for more information.

Cord feature code 6473:

Find your plug and receptacle information, voltage and amperage, part number, and cord length.

Plug and receptacle

The plug and receptacle type is 19.



Figure 133. Plug type 19



Figure 134. Receptacle type 19

Voltage and amperage

The voltage is 200 - 240 V ac, and the amperage is 10 A.

Part number

The part numbers are:

- 13F9997
- 39M5130

Note: This part number meets the European Union Directive 2002/95/EC on the Restriction of the Use of Certain Hazardous Substances in Electrical and Electronic Equipment.

Cord rating

The cord rating is 2.4 kVA.

Cord length

The cord length is 2.7 m (9 ft).

Dominica

The plug and receptacles for this system are available in Dominica.

Select your system's feature code for more information.

Cord feature code 6474:

Find your plug and receptacle information, voltage and amperage, part number, and cord length.

Plug and receptacle

The plug and receptacle type is 23

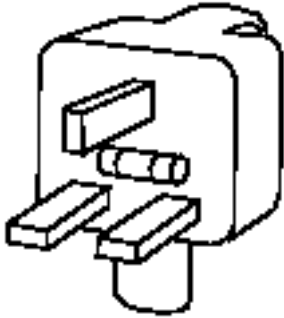

Figure 135. Plug type 23

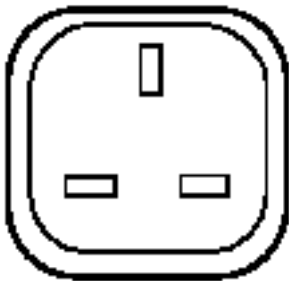

Figure 136. Receptacle type 23

Voltage and amperage

The voltage is 200 - 240 V ac, and the amperage is 10 A.

Part number

The part numbers are:

- 14F0034
- 39M5151

Note: This part number meets the European Union Directive 2002/95/EC on the Restriction of the Use of Certain Hazardous Substances in Electrical and Electronic Equipment.

Cord length

The cord length is 2.7 m (9 ft).

Italy

The plug and receptacles for this system are available in Italy.

Select your system's feature code for more information.

Cord feature code 6672:

Find your plug and receptacle information, voltage and amperage, part number, and cord length.

Plug and receptacle

The plug and receptacle type is 26.

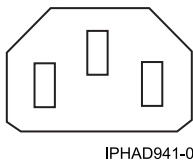

Figure 137. Plug type 26

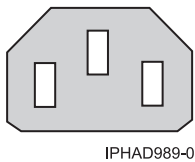

Figure 138. Receptacle type 26

Voltage and amperage

The voltage is 200 - 240 V ac, and the amperage is 10 A.

Part number

The part numbers are:

- 36L8860
- 39M5375

Note: This part number meets the European Union Directive 2002/95/EC on the Restriction of the Use of Certain Hazardous Substances in Electrical and Electronic Equipment.

Cord length

The cord length is 1.5 m (5 ft).

Israel

The plug and receptacles for this system are available in Israel.

Select your system's feature code for more information.

Cord feature code 6475:

Find your plug and receptacle information, voltage and amperage, part number, and cord length.

Plug and receptacle

The plug and receptacle type is 59.



Figure 139. Plug type 59

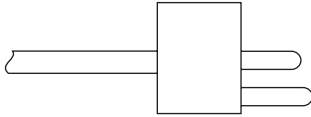

Figure 140. Receptacle type 59

Voltage and amperage

The voltage is 200 - 240 V ac, and the amperage is 10 A.

Part number

The part numbers are:

- 14F0087
- 39M5172

Note: This part number meets the European Union Directive 2002/95/EC on the Restriction of the Use of Certain Hazardous Substances in Electrical and Electronic Equipment.

Cord rating

The cord rating is 2.4 kVA.

Cord length

The cord length is 2.7 m (9 ft).

Japan

The plug and receptacles for this system are available in Japan.

Select your system's feature code for more information.

Cord feature code 6487:

Find your plug and receptacle information, voltage and amperage, part number, and cord length.

Plug and receptacle

The plug and receptacle type is 5.



Figure 141. Plug type 5

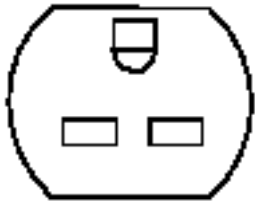

Figure 142. Receptacle type 5

Voltage and amperage

The voltage is 200 - 240 V ac, and the amperage is 15 A.

Part number

The part numbers are:

- 1838576
- 39M5094

Note: This part number meets the European Union Directive 2002/95/EC on the Restriction of the Use of Certain Hazardous Substances in Electrical and Electronic Equipment.

Cord rating

The cord rating is 2.4 kVA.

Cord length

The cord length is 1.8 m (6 ft).

Cord feature code 6660:

Find your plug and receptacle information, voltage and amperage, part number, and cord length.

Plug and receptacle

The plug and receptacle type is 59.



JIS C-8303-1983
Type 59
nonlocking

IPHAD939-0

Figure 143. Plug type 59

Voltage and amperage

The voltage is 100 - 127 V ac, and the amperage is 15 A.

Part number

The part number is:

- 39M5200

Note: This part number meets the European Union Directive 2002/95/EC on the Restriction of the Use of Certain Hazardous Substances in Electrical and Electronic Equipment.

Cord length

The cord length is 4.3 m (14 ft).

Liechtenstein

The plug and receptacles for this system are available in Liechtenstein.

Select your system's feature code for more information.

Cord feature code 6476:

Find your plug and receptacle information, voltage and amperage, part number, and cord length.

Plug and receptacle

The plug and receptacle type is 24.



Figure 144. Plug type 24



Figure 145. Receptacle type 24

Voltage and amperage

The voltage is 200 - 240 V ac, and the amperage is 10 A.

Part number

The part numbers are:

- 14F0051
- 39M5158

Note: This part number meets the European Union Directive 2002/95/EC on the Restriction of the Use of Certain Hazardous Substances in Electrical and Electronic Equipment.

Cord rating

The cord rating is 2.4 kVA.

Cord length

The cord length is 2.7 m (9 ft).

Macao

The plug and receptacles for this system are available in Macao.

Select your system's feature code for more information.

Cord feature code 6477:

Find your plug and receptacle information, voltage and amperage, part number, and cord length.

Plug and receptacle

The plug and receptacle type is 22.



Figure 146. Plug type 22

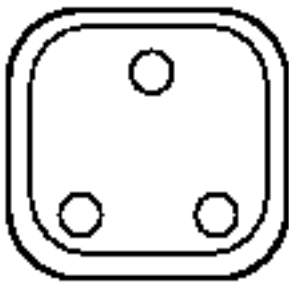

Figure 147. Receptacle type 22

Voltage and amperage

The voltage is 200 - 240 V ac, and the amperage is 16 A.

Part number

The part numbers are:

- 14F0015
- 39M5144

Note: This part number meets the European Union Directive 2002/95/EC on the Restriction of the Use of Certain Hazardous Substances in Electrical and Electronic Equipment.

Cord length

The cord length is 2.7 m (9 ft).

Paraguay

The plug and receptacles for this system are available in Paraguay.

Select your system's feature code for more information.

Cord feature code 6488:

Find your plug and receptacle information, voltage and amperage, part number, and cord length.

Plug and receptacle

The plug and receptacle type is 2.



Figure 148. Plug type 2



Figure 149. Receptacle type 2

Voltage and amperage

The voltage is 200 - 240 V ac, and the amperage is 10 A.

Part number

The part numbers are:

- 36L8880
- 39M5068

Note: This part number meets the European Union Directive 2002/95/EC on the Restriction of the Use of Certain Hazardous Substances in Electrical and Electronic Equipment.

Cord rating

The cord rating is 2.4 kVA.

Cord length

The cord length is 2.7 m (9 ft).

India

The plug and receptacles for this system are available in India.

Select your system's feature code for more information.

Cord feature code 6494:

Find your plug and receptacle information, voltage and amperage, part number, and cord length.

Plug and receptacle

The plug and receptacle type is 69.



Figure 150. Plug type 69



Figure 151. Receptacle type 69

Voltage and amperage

The voltage is 200 - 240 V ac, and the amperage is 10 A.

Part number

The part number is:

- 39M5226

Note: This part number meets the European Union Directive 2002/95/EC on the Restriction of the Use of Certain Hazardous Substances in Electrical and Electronic Equipment.

Cord length

The cord length is 2.7 m (9 ft).

Kiribati

The plug and receptacles for this system are available in Kiribati.

Select your system's feature code for more information.

Cord feature code 6680:

Find your plug and receptacle information, voltage and amperage, part number, and cord length.

Plug and receptacle

The plug and receptacle type is 6.



Figure 152. Plug type 6



Figure 153. Receptacle type 6

Voltage and amperage

The voltage is 250 V ac and the amperage is 10 A.

Part number

The part number is:

- 39M5102

Note: This part number meets the European Union Directive 2002/95/EC on the Restriction of the Use of Certain Hazardous Substances in Electrical and Electronic Equipment.

Cord length

The cord length is 2.7 m (9 ft).

Korea

The plug and receptacles for this system are available in Korea.

Select your system's feature code for more information.

Cord feature code 6496:

Find your plug and receptacle information, voltage and amperage, part number, and cord length.

Plug and receptacle

The plug and receptacle type is 66.

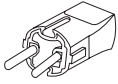

Figure 154. Plug type 66



Figure 155. Receptacle type 66

Voltage and amperage

The voltage is 200 - 240 V ac, and the amperage is 10 A.

Part number

The part numbers are:

- 24P6873
- 39M5219

Note: This part number meets the European Union Directive 2002/95/EC on the Restriction of the Use of Certain Hazardous Substances in Electrical and Electronic Equipment.

Cord length

The cord length is 2.7 m (9 ft).

Cord feature code 6658:

Find your plug and receptacle information, voltage and amperage, part number, and cord length.

Plug and receptacle

The plug and receptacle type is KP.

Note: This feature code connects the power distribution unit (PDU) in a rack to the wall receptacle.



Figure 156. Plug type KP



Figure 157. Receptacle type KP

Voltage and amperage

The voltage is 200 - 240 V ac, and the amperage is 24 A.

Part number

The part number is:

- 39M5420

Note: This part number meets the European Union Directive 2002/95/EC on the Restriction of the Use of Certain Hazardous Substances in Electrical and Electronic Equipment.

Cord length

The cord length is 4.3 m (14 ft).

New Zealand

The plug and receptacles for this system are available in New Zealand.

Select your system's feature code for more information.

Cord feature code 6657:

Find your plug and receptacle information, voltage and amperage, part number, and cord length.

Plug and receptacle

The plug and receptacle type is PDL.

Note: This feature code connects the power distribution unit (PDU) in a rack to the wall receptacle.

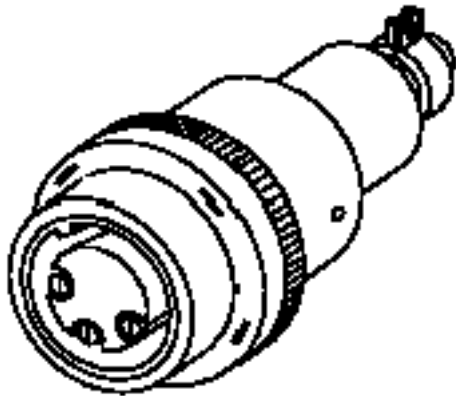

Figure 158. Plug type PDL



Figure 159. Receptacle type PDL

Voltage and amperage

The voltage is 200 - 240 V ac, and the amperage is 32 A.

Part number

The part number is:

- 39M5419

Note: This part number meets the European Union Directive 2002/95/EC on the Restriction of the Use of Certain Hazardous Substances in Electrical and Electronic Equipment.

Cord length

The cord length is 4.3 m (14 ft).

Taiwan

The plug and receptacles for this system are available in Taiwan.

Select your system's feature code for more information.

Cord feature code 6651:

Find your plug and receptacle information, voltage and amperage, part number, and cord length.

Plug and receptacle

The plug and receptacle type is 75.

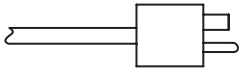

Figure 160. Plug type 75



Figure 161. Receptacle type 75

Voltage and amperage

The voltage is 100 -127 V ac, and the amperage is 15 A.

Part number

The part number is:

- 39M5463

Note: This part number meets the European Union Directive 2002/95/EC on the Restriction of the Use of Certain Hazardous Substances in Electrical and Electronic Equipment.

Cord length

The cord length is 2.7 m (9 ft).

Cord feature code 6659:

Find your plug and receptacle information, voltage and amperage, part number, and cord length.

Plug and receptacle

The plug and receptacle type is 76.



Figure 162. Plug type 76

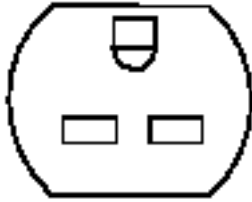

Figure 163. Receptacle type 76

Voltage and amperage

The voltage is 200 - 240 V ac, and the amperage is 15 A.

Part number

The part number is:

- 39M5254

Note: This part number meets the European Union Directive 2002/95/EC on the Restriction of the Use of Certain Hazardous Substances in Electrical and Electronic Equipment.

Cord length

The cord length is 2.7 m (9 ft).

United States, Territories, and Possessions

The plug and receptacles for this system are available in the United States, Territories, and Possessions.

Select your system's feature code for more information.

Cord feature code 6492:

Find your plug and receptacle information, voltage and amperage, part number, and cord length.

Plug and receptacle

The plug and receptacle type is IEC 60309 2P+E.

Note: This feature code connects the power distribution unit (PDU) in a rack to the wall receptacle.

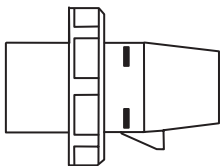

Figure 164. Plug type IEC 60309 2P+E

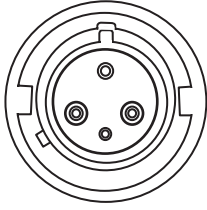

Figure 165. Receptacle type IEC 60309 2P+E

Voltage and amperage

The voltage is 200 - 240 V ac, and the amperage is 63 A.

Part number

The part number is:

- 39M5417

Note: This part number meets the European Union Directive 2002/95/EC on the Restriction of the Use of Certain Hazardous Substances in Electrical and Electronic Equipment.

Cord length

The cord length is 4.3 m (14 ft).

Cord feature code 6497:

Find your plug and receptacle information, voltage and amperage, part number, and cord length.

Plug and receptacle

The plug and receptacle type is 10.



Figure 166. Plug type 10



Figure 167. Receptacle type 10

Voltage and amperage

The voltage is 200 - 240 V ac, and the amperage is 10 A.

Part number

The part number is:

- 41V1961

Note: This part number meets the European Union Directive 2002/95/EC on the Restriction of the Use of Certain Hazardous Substances in Electrical and Electronic Equipment.

Cord length

The cord length is 1.8 m (6 ft).

Cord feature code 6654:

Find your plug and receptacle information, voltage and amperage, part number, and cord length.

Plug and receptacle

The plug and receptacle type is 12.

Note: This feature code connects the power distribution unit (PDU) in a rack to the wall receptacle.



Figure 168. Plug type 12



Figure 169. Receptacle type 12

Voltage and amperage

The voltage is 200 - 240 V ac, and the amperage is 24 A.

Part number

The part number is:

- 39M5416

Note: This part number meets the European Union Directive 2002/95/EC on the Restriction of the Use of Certain Hazardous Substances in Electrical and Electronic Equipment.

Cord length

The cord length is 4.3 m (14 ft).

Cord feature code RPQ 8A1871:

Find your plug and receptacle information, voltage and amperage, part number, and cord length.

Plug and receptacle

The plug type is RS 7328DP and the receptacle type is RS 7324-78.

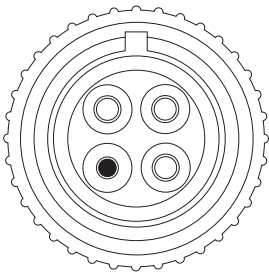

Figure 170. Plug type RS 7328DP

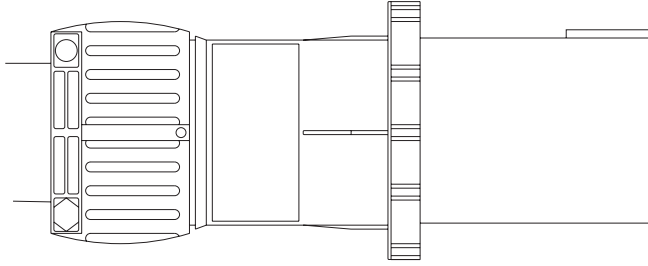

Figure 171. Receptacle type RS 7324-78

Voltage and amperage

The voltage is 380 - 415 V ac, and the amperage is 60 A.

Part number

The part number is:

- 45D9456

Note: This part number meets the European Union Directive 2002/95/EC on the Restriction of the Use of Certain Hazardous Substances in Electrical and Electronic Equipment.

Cord length

The cord length is 4.3 m (14 ft).

Connecting your server to a PDU

Select this option if your system uses a power distribution unit (PDU). These cords are available worldwide as they connect the system to a PDU (instead of a wall plug outlet where the receptacle is country specific).

Select your system's feature code for more information.

Cord feature code 6458

Find your plug and receptacle information, voltage and amperage, part number, and cord length.

Plug and receptacle

The plug and receptacle type is 26.

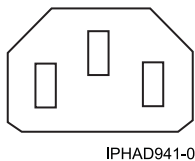

Figure 172. Plug type 26

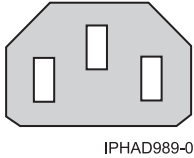

Figure 173. Receptacle type 26

Voltage and amperage

The voltage is 200 - 240 V ac, and the amperage is 10 A.

Part number

The part numbers are:

- 36L8861
- 39M5378

Note: This part number meets the European Union Directive 2002/95/EC on the Restriction of the Use of Certain Hazardous Substances in Electrical and Electronic Equipment.

Cord length

The cord length is 4.3 m (14 ft).

Cord feature code 6459

Find your plug and receptacle information, voltage and amperage, part number, and cord length.

Plug and receptacle

The plug and receptacle type is a 26 Right angle.

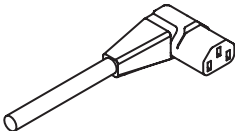

Figure 174. Plug and receptacle type 26

Voltage and amperage

The voltage is 250 V ac and the amperage is 10 A.

Part number

The part numbers are:

- 00P2401
- 41U0114

Note: This part number meets the European Union Directive 2002/95/EC on the Restriction of the Use of Certain Hazardous Substances in Electrical and Electronic Equipment.

Cord length

The cord length is 3.7 m (12 ft).

Cord feature code 6577

Find your plug and receptacle information, voltage and amperage, part number, and cord length.

Plug and receptacle

The plug and receptacle type 15.

Voltage and amperage

The voltage is 200 - 240 V ac, and the amperage is 10 A.

Cord length

There are three different cord lengths¹:

- 1.5 m (5 ft)
- 2.7 m (9 ft)
- 4.2 m (13.8 ft)

¹ For this feature, IBM Manufacturing chooses the optimum cord length when assembling systems into a rack.

Cord feature code 6665

Find your plug and receptacle information, voltage and amperage, part number, and cord length.

Plug and receptacle

The plug and receptacle type is 61.

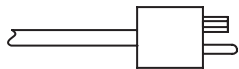

Figure 175. Plug type 61

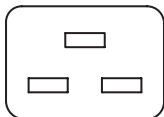

Figure 176. Receptacle type 61

Voltage and amperage

The voltage is 200 - 240 V ac, and the amperage is 10 A.

Part number

The part numbers are:

- 74P4430
- 39M5392

Note: This part number meets the European Union Directive 2002/95/EC on the Restriction of the Use of Certain Hazardous Substances in Electrical and Electronic Equipment.

Cord length

The cord length is 3.0 m (10 ft).

Cord feature code 6671

Find your plug and receptacle information, voltage and amperage, part number, and cord length.

Plug and receptacle

The plug and receptacle type is 26.

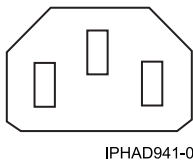

Figure 177. Plug type 26

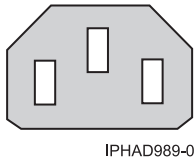

Figure 178. Receptacle type 26

Voltage and amperage

The voltage is 200 - 240 V ac, and the amperage is 10 A.

Part number

The part numbers are:

- 36L8886
- 39M5377

Note: This part number meets the European Union Directive 2002/95/EC on the Restriction of the Use of Certain Hazardous Substances in Electrical and Electronic Equipment.

Cord length

The cord length is 2.8 m (9 ft).

Cord feature code 6672

Find your plug and receptacle information, voltage and amperage, part number, and cord length.

Plug and receptacle

The plug and receptacle type is 26.

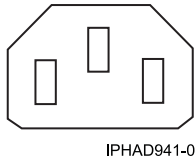

Figure 179. Plug type 26

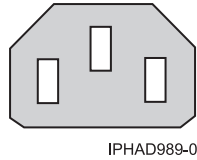

Figure 180. Receptacle type 26

Voltage and amperage

The voltage is 200 - 240 V ac, and the amperage is 10 A.

Part number

The part numbers are:

- 36L8860
- 39M5375

Note: This part number meets the European Union Directive 2002/95/EC on the Restriction of the Use of Certain Hazardous Substances in Electrical and Electronic Equipment.

Cord length

The cord length is 1.5 m (5 ft).

Uninterruptible power supply

Uninterruptible power supplies are available to meet the power protection needs of servers. The uninterruptible power supply is the type 9910.

The 9910 uninterruptible power supply solutions are compatible with the power requirements for these servers and have passed testing procedures. The uninterruptible power supplies are intended to provide a single source for purchase and protection of servers. All 9910 uninterruptible power supplies include a premium warranty package that is designed to enhance the potential for return on investment over the uninterruptible power supplies available on the market today.

Type 9910 uninterruptible power supply solutions are available from *Eaton*.

Feature Code 1827 service processor communications port to uninterruptible power supply cable

Both ends of the cable have a female 9-pin D-shell connector. The following figure shows the serial to uninterruptible power supply converter cable end (designated B) that plugs into the service processor communications port. It has external threads that mate with the cable retention on the service processor communications port. The other end of the cable (designated A) plugs into the uninterruptible power supply vendor-supplied cable for System i[®] communications. It has threads that mate with the cable's

external threads on the uninterruptible power supply.

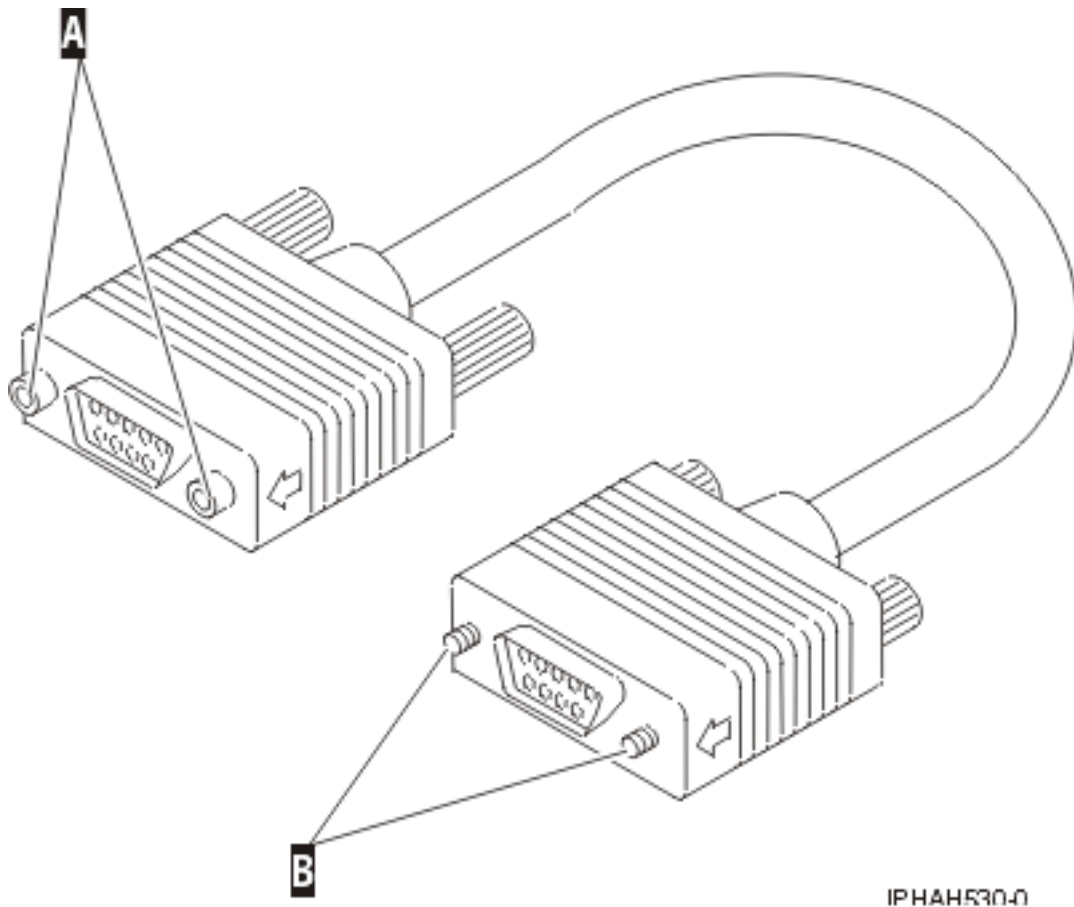

Figure 181. Uninterruptible power supply connector for the uninterruptible power supply communications cable

The service processor communications port supports two modes: RS-232 service processor communications port mode and uninterruptible power supply mode. Only one mode is supported at a time. The service processor will detect the presence of an uninterruptible power supply when the 1827 cable is attached and the server is started. The service processor will set the control hardware to condition the signals for the uninterruptible power supply. The mode cannot be changed unless the system is started again. The following figure shows the converter cable wiring.

Feature Code 3930 RJ45 service processor communications port to uninterruptible power supply cable

The 3930 is a 290 mm (11.4 in.) RJ45 service processor communications power to uninterruptible power supply cable for certain POWER[®] system models.

Figure 3 shows the 3930 cable. One end of the cable, letter A, has an RJ45 connector that plugs into the service processor communications port. The other end of the cable, letter B, has a male 9-pin D-shell connector that plugs into the uninterruptible power supply vendor-supplied cable for System i communications. It has threads that mate with the cable external threads on the uninterruptible power supply.

Connecting POWER product uninterruptible power supply communications for IBM i operating system

Use the following information to connect communications for a POWER system operating IBM i operating system.

Note: Serial ports are rendered useless for AIX[®] use when a Hardware Management Console (HMC) is connected. However, platform connection to the UPS, which is managed by the FSP, is independent of an HMC being attached. Whether or not an HMC is connected, the designated serial port for UPS attach will setup correctly in feature code 1827 is connected before power is applied to the server (UPS attach is detected on FSP IPL). The serial ports are not standard EIA-232 ports. Therefore, the UPS must be attached through the 1827 cable and a relay contact interface (such as IBM type 9910, feature code 2939) via the UPS to use the IBM platform managed solution.

To use a standard UPS manufacturer serial interface and UPS monitoring application for the AIX[®] operating system, an asynchronous adapter (such as 2943 and 5723) must be installed and configured in AIX. The IBM i operating system only supports the IBM platform managed solution.

33E/8B and 36E/8C uninterruptible power supply communications

Attach the 1827 cable to the POWER server at the P1-T2 location.

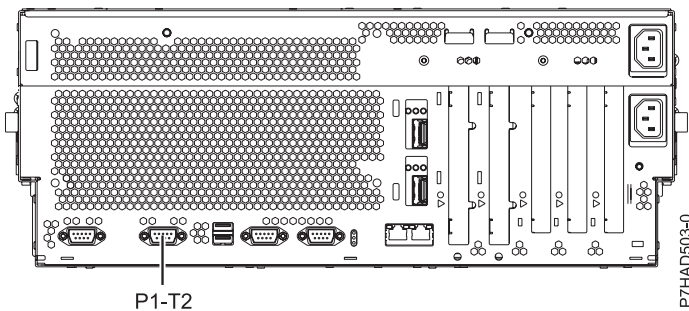

Figure 182. 33E/8B and 36E/8C rear view with cable installation location

17M/MB, 17M/MC, 79M/HB, 79M/HC, and 5208 or 5877 uninterruptible power supply communications

Uninterruptible power supply support via the Serial to SPCN feature code (1827) is not supported on the 17M/MB, 17M/MC, 79M/HB, and 79M/HC. UPS support may be added by using a 5802 or 5877 expansion unit. SPCN cables are used to attach the 17M/MB, 17M/MC, 79M/HB, 79M/HC, and 5802 or 5877 SPCN ports, as shown in Figure 183 on page 216. The connection from the UPS to the 5802 or 5877 is made directly from the UPS to the port labelled P2-T1. The 1827 is not needed.

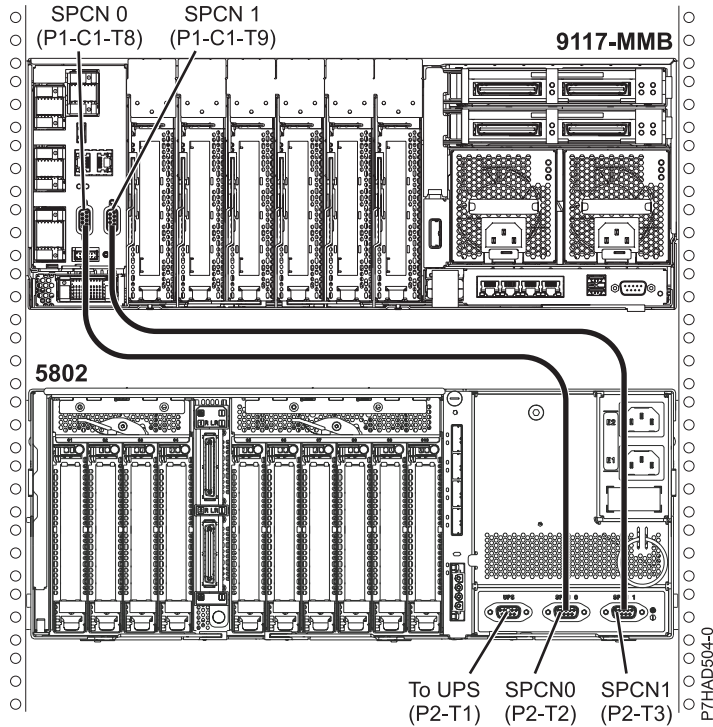

Figure 183. 17M/MB, 17M/MC, 79M/HB, and 79M/HC and 5208 or 5877 rear view cable installation location

02E/4B, 02E/4C, 05F/6B, 05E/6C, 31E/2B, 31E/1C, and 31E/2C Uninterruptible power supply communications

For POWER 710 Express and POWER 730 Express (31E/2B, 31E/1C, and 31E/2C), POWER 720 Express (02E/4B and 02E/4C), and POWER 740 Express (05F/6B and 05E/6C), feature code 3930 is used in addition to feature code 1827. Uninterruptible power supply communications are supported through a designated RJ45 port via the 3930 cable. See Figure 184 and Figure 185 on page 217. The 9 pin, male end of the 3930 cable then attaches to the end of the 9 pin, female end of the 1827 cable. See Figure 186 on page 217.

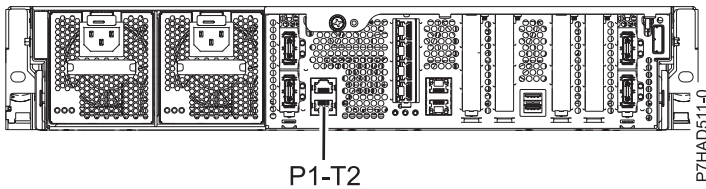

Figure 184. 31E/2B, 31E/1C, and 31E/2C rear view with cable installation location

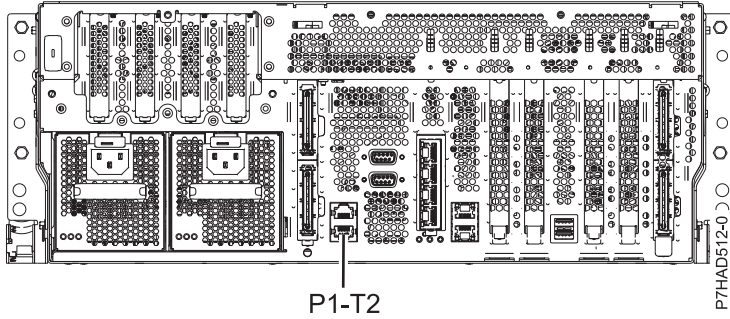

Figure 185. 02E/4B, 02E/4C, 05F/6B, and 05E/6C rear view with cable installation location

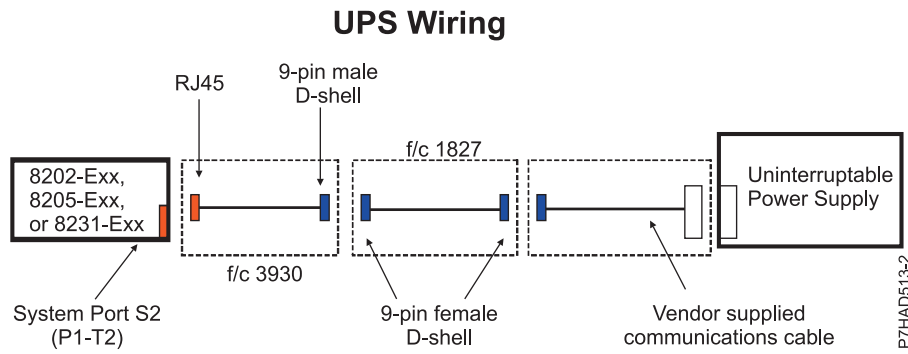

Figure 186. UPS wiring for the 02E/4B, 02E/4C, 05F/6B, 05E/6C, 31E/2B, 31E/1C, and 31E/2C

Power distribution unit and power cord options for 7014,, rack

Power distribution units (PDUs) can be used with the 7014, racks. The various configurations and specifications are provided.

Power distribution unit

The following figure shows the four vertical PDU locations in a rack.

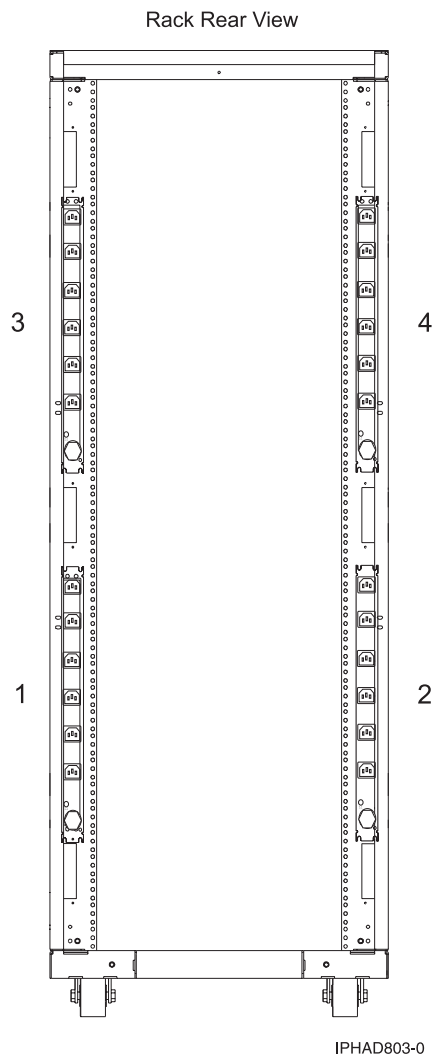

Power distribution units (PDUs) are required with 14T/00, 14T/42 racks. If a PDU is not defaulted or ordered, a power cord is provided with each individual rack-mounted drawer for connection to a country-specific utility mains receptacle or uninterruptible power supply. See the individual rack-mounted drawer specifications for the appropriate power cords.

9188 or 7188 universal PDU

Table 203. 9188 universal PDU features

PDU Number	Racks usage	Supported power cords PDU to wall
9188 universal PDU	14T/00 and 14T/42 racks	<ul style="list-style-type: none"> • 6489 • 6491 • 6492 • 6653 • 6654 • 6655 • 6656 • 6657 • 6658

Table 204. 7188 universal PDU features

PDU Number	Racks usage	Supported power cords PDU to wall
7188 universal PDU	14T/00, 14T/42, racks.	<ul style="list-style-type: none"> • 6489 • 6491 • 6492 • 6653 • 6654 • 6655 • 6656 • 6657 • 6658

The amperage rating of the PDU is either 16 A, 24 A, or 48 A, single phase or three-phase, depending on the power cord.

Note: All power cords are 4.3 m (14 ft). For installation in Chicago, only 2.8 m (6 ft) of the 4.3 m (14 ft) power cord can extend beyond the perimeter of the rack frame. If more than 2.8 m (6 ft) can exit the rack, retain any additional cordage within the rack frame with hook-and-loop fastener ties in the cable management space until 2.8 (6 ft) or less exits the rack.

The PDU has twelve customer-usable IEC 320-C13 outlets rated at 200-240 V ac. There are six groups of two outlets fed by six circuit breakers. Each outlet is rated up to 10 A, but each group of two outlets is fed from one 20 A circuit breaker derated to 16 A.

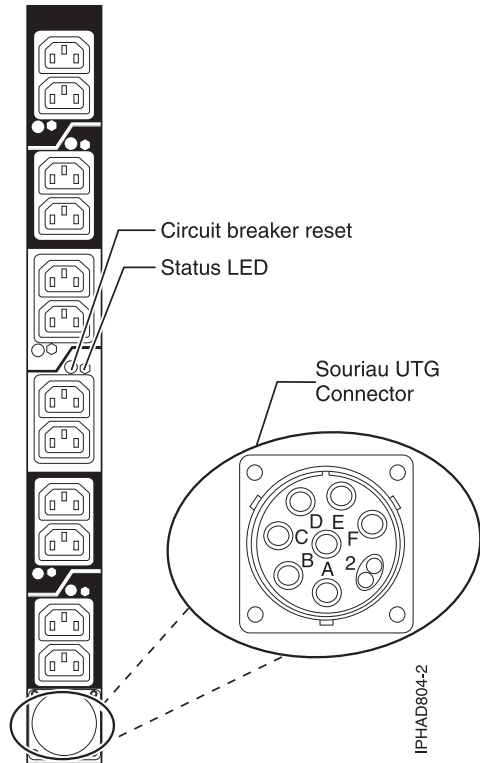

5160 single phase PDU

Table 205. 5160 single phase PDU features

PDU Number	Racks usage	Supported power cords PDU to wall
5160 single phase PDU	0551, 0553, racks	This is a hard wired power cord with a NEMA L6-30P (30A, 250VAC).

Typical rack and PDU configurations

See 7014, and 05/55 rack configurations for typical configurations and PDUs when the rack is populated with various server models.

Power distribution unit plus specifications

The power distribution unit plus (PDU+) has power-monitoring capabilities. The PDU+ is an intelligent ac power distribution unit (PDU+) that monitors the amount of power being used by the devices that are plugged into it. The PDU+ provides twelve C13 power outlets and receives power through a Souriau UTG connector. It can be used in many geographies and for many applications by varying the PDU-to-wall power cord, which must be ordered separately. Each PDU+ requires one PDU-to-wall power cord. When the PDU+ is connected to a dedicated power source, it conforms to UL60950, CSA C22.2-60950, EN-60950, and IEC-60950 standards.

5889 PDU+

Table 206. 5889 PDU+ features

PDU Number	Racks usage	Supported power cords PDU to wall
5889 PDU+	7014 racks	<ul style="list-style-type: none"> • 6489 • 6491 • 6492 • 6653 • 6654 • 6655 • 6656 • 6657 • 6658

Table 207. 5889 PDU+ specifications

Characteristics	Properties
PDU number	5889
Height	43.9 mm (1.73 in.)
Width	447 mm (17.6 in.)
Depth	350 mm (13.78 in.)
Additional clearance	25 mm (0.98 in.) for circuit breakers
	3 mm (0.12 in.) for outlets
Weight (not including power cord)	6.3 kg (13.8 lb)
Weight of power cord (approximate)	5.4 kg (11.8 lb)
Operating temperature at 0 - 914 m (0 - 3000 ft) (room ambient)	10 - 32°C (50 - 90°F)
Operating temperature at 914 - 2133 m (3000 - 7000 ft) (room ambient)	10 - 35°C (50 - 95°F)
Operating humidity	8 - 80% (noncondensing)
Localized air temperature in PDU	60 °C (140°F) maximum
Rated frequency (all feature codes)	50 - 60 Hz
Circuit breakers	Six double-pole branch rated circuit breakers rated at 20 A
Power outlet	12 IEC 320-C13 outlets rated at 10 A (VDE) or 15 A (UL/CSA)

7189 PDU+

Table 208. 7189 PDU+ features

PDU number	Racks usage	Supported power cords PDU to wall
7189 PDU+	7014-B42 rack	<ul style="list-style-type: none"> • 6489 • 6491 • 6492 • 6653

Table 209. 7189 PDU+ specifications

Characteristics	Properties
PDU number	7189
Height	43.9 mm (1.73 in.)
Width	447 mm (17.6 in.)
Depth	350 mm (13.78 in.)
Additional clearance	25 mm (0.98 in.) for circuit breakers
	3 mm (0.12 in.) for outlets
Weight (not including power cord)	6.3 kg (13.8 lb)
Weight of power cord (approximate)	5.4 kg (11.8 lb)
Operating temperature at 0 - 914 m (0 - 3000 ft) (room ambient)	10 - 32°C (50 - 90°F)
Operating temperature at 914 - 2133 m (3000 - 7000 ft) (room ambient)	10 - 35°C (50 - 95°F)
Operating humidity	8 - 80% (noncondensing)
Localized air temperature in PDU	60°C (140°F) maximum
Rated frequency (all feature codes)	50 - 60 Hz
Circuit breakers	Six double-pole branch rated circuit breakers rated at 20 A
Power outlet	Six IEC 320-C19 outlets rated at 16 A (VDE) or 20 A (UL/CSA)

7196 PDU+

Table 210. 7196 PDU+ features

PDU Number	Racks usage	Supported power cords PDU to wall
7196 PDU+	7014-B42	Fixed power cord with IEC 60309, 3P+E, 60 A plug

Table 211. 7196 PDU+ specifications

Characteristics	Properties
PDU number	7196
Height	43.9 mm (1.73 in.)
Width	447 mm (17.6 in.)
Depth	350 mm (13.78 in.)
Additional clearance	25 mm (0.98 in.) for circuit breakers
	3 mm (0.12 in.) for outlets
Weight (not including power cord)	6.3 kg (13.8 lb)
Weight of power cord (approximate)	5.4 kg (11.8 lb)
Operating temperature at 0 - 914 m (0 - 3000 ft) (room ambient)	10 - 32°C (50 - 90°F)
Operating temperature at 914 - 2133 m (3000 - 7000 ft) (room ambient)	10 - 35°C (50 - 95°F)
Operating humidity	8 - 80% (noncondensing)
Localized air temperature in PDU	60 °C (140 °F) maximum
Rated frequency (all feature codes)	50 - 60 Hz
Circuit breakers	Six double-pole branch rated circuit breakers rated at 20 A

Table 211. 7196 PDU+ specifications (continued)

Characteristics	Properties
Power outlet	Six IEC 320-C19 outlets rated at 16 A (VDE) or 20 A (UL/CSA)

7109 PDU+

Table 212. 7109 PDU+ features

PDU Number	Racks usage	Supported power cords PDU to wall
7109 PDU+	0551, 0553, racks	<ul style="list-style-type: none"> • 6489 • 6491 • 6492 • 6653 • 6654 • 6655 • 6656 • 6657 • 6658

Table 213. 7109 PDU+ specifications

Characteristics	Properties
PDU number	7109
Height	43.9 mm (1.73 in.)
Width	447 mm (17.6 in.)
Depth	350 mm (13.78 in.)
Additional clearance	25 mm (0.98 in.) for circuit breakers
	3 mm (0.12 in.) for outlets
Weight (not including power cord)	6.3 kg (13.8 lb)
Weight of power cord (approximate)	5.4 kg (11.8 lb)
Operating temperature at 0 - 914 m (0 - 3000 ft) (room ambient)	10 - 32°C (50 - 90°F)
Operating temperature at 914 - 2133 m (3000 - 7000 ft) (room ambient)	10 - 35°C (50 - 95°F)
Operating humidity	8 - 80% (noncondensing)
Localized air temperature in PDU	60°C (140°F) maximum
Rated frequency (all feature codes)	50 - 60 Hz
Circuit breakers	Six double-pole branch rated circuit breakers rated at 20 A
Power outlet	12 IEC 320-C13 outlets rated at 10 A (VDE) or 15 A (UL/CSA)

Power load calculating for 7188 or 9188 power distribution units

Learn how to calculate the power load for power distribution units.

Rack-mounted 7188 or 9188 power distribution unit

This topic provides the power loading requirements and proper loading sequence for the 7188 or 9188 power distribution unit.

The 7188 or 9188 rack-mounted power distribution unit (PDU) contains 12 IEC 320-C13 outlets connected to six 20 A circuit breakers (two outlets per circuit breaker). The PDU employs an inlet current that allows a variety of power cord options that are listed in the following chart. Based on the power cord that is used, the PDU can supply from 4.8 kVa to 19.2 kVa.

Table 214. Power cord options

Feature code	Power cord description	KVa available
6489	Power cord, PDU to wall, 4.3 m (14 ft), 3-phase, Souriau UTG, IEC 60309 32 A 3P+N+E plug	21.0
6491	Power cord, PDU to wall, 4.3 m (14 ft), 200 - 240 V ac, Souriau UTG, IEC 60309 63 A P+N+E plug	9.6
6492	Power cord, PDU to wall, 4.3 m (14 ft), 200 - 240 V ac, Souriau UTG, IEC 60309 60 A 2P+E plug	9.6
6653	Power cord, PDU to wall, 4.3 m (14 ft), 3-phase, Souriau UTG, IEC 60309 16A 3P+N+E plug	9.6
6654	Power cord, PDU to wall, 4.3 m (14 ft), 200 - 240 V ac, Souriau UTG, Plug type 12 plug	4.8
6655	Power cord, PDU to wall, 4.3 m (14 ft), 200 - 240 V ac, Souriau UTG, Plug type 40 plug	4.8
6656	Power cord, PDU to wall, 4.3 m (14 ft), 200 - 240 V ac, Souriau UTG, IEC 60309 32 A P+N+E plug	4.8
6657	Power cord, PDU to wall, 4.3 m (14 ft), 200 - 240 V ac, Souriau UTG, Plug type PDL plug	4.8
6658	Power cord, PDU to wall, 4.3 m (14 ft), 200 - 240 V ac, Souriau UTG, Plug type KP plug	4.8

Loading requirements

The power loading of the 7188 or 9188 PDU must follow these rules:

1. Total power load connected to the PDU must be limited to below the kVa listed in the table.
2. Total power load connected to any one circuit breaker must be limited to 16 A (derating of circuit breaker).
3. Total power load connected to any one IEC320-C13 outlet must be limited to 10 A.

Note: The load on the PDU when a dual line configuration is used will only be half the total load of the system. When calculating the power load on the PDU, you must include the total power load of each drawer even if the load is distributed over two PDUs.

Loading sequence

Follow these loading sequence steps:

1. Collect power requirements for all units that will be connected to the 7188 or 9188 PDU. See your server specifications for specific power requirements.
2. Sort list by total power required from highest power draw to lowest power draw.
3. Connect highest power drawer to outlet 1 on circuit breaker 1.
4. Connect next highest power drawer to outlet 3 on circuit breaker 2.
5. Connect next highest power drawer to outlet 5 on circuit breaker 3.
6. Connect next highest power drawer to outlet 7 on circuit breaker 4.
7. Connect next highest power drawer to outlet 9 on circuit breaker 5.

8. Connect next highest power drawer to outlet 11 on circuit breaker 6.
9. Connect next highest power drawer to outlet 12 on circuit breaker 6.
10. Connect next highest power drawer to outlet 10 on circuit breaker 5.
11. Connect next highest power drawer to outlet 8 on circuit breaker 4.
12. Connect next highest power drawer to outlet 6 on circuit breaker 3.
13. Connect next highest power drawer to outlet 4 on circuit breaker 2.
14. Connect next highest power drawer to outlet 2 on circuit breaker 1.

Following these rules will allow the load to be distributed more evenly across the six PDU circuit breakers. Ensure that your total power load is below the maximum listed in the table and that each circuit breaker is not loaded above 15 A.

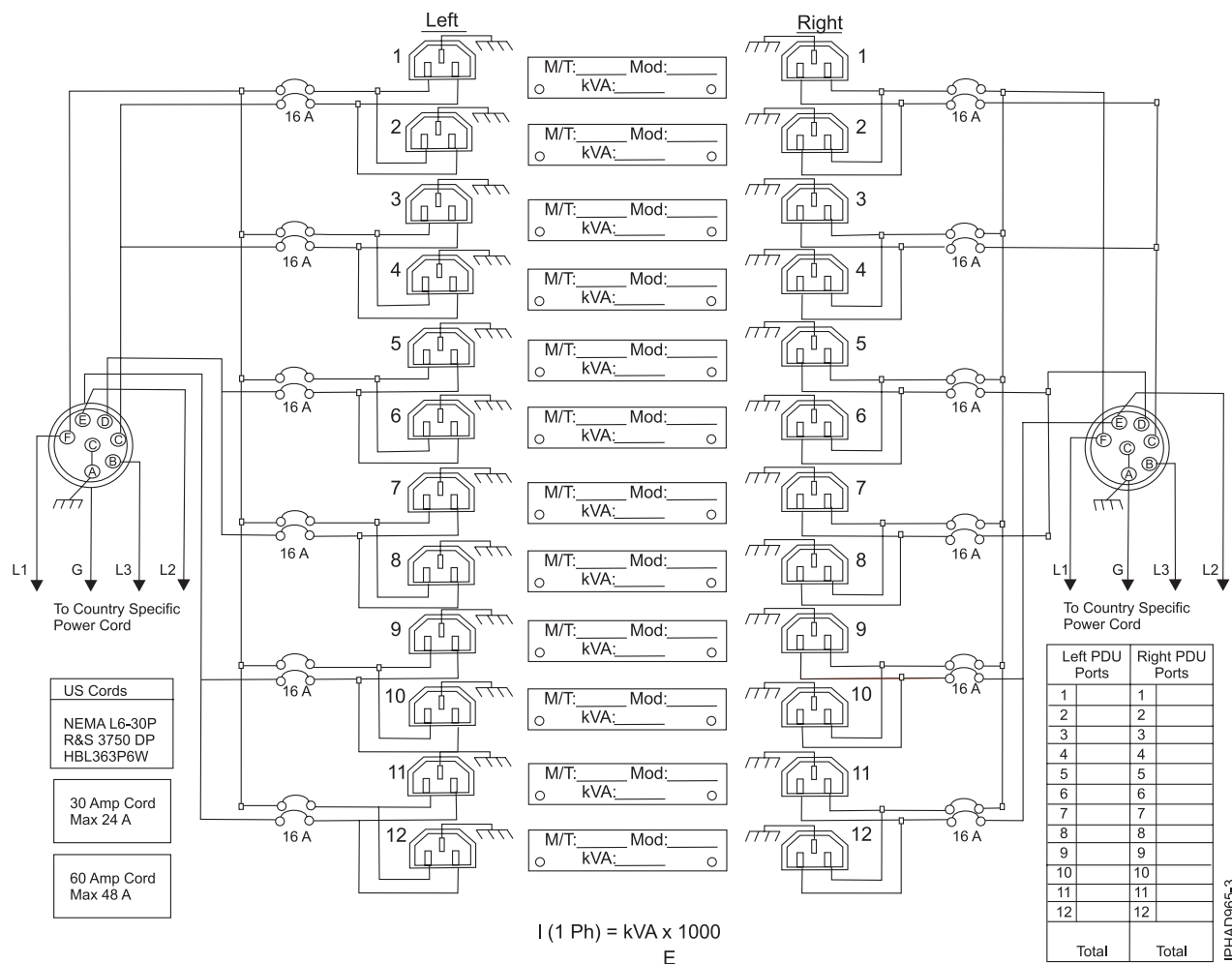

Planning for cables

Learn how to develop plans for cabling your server and devices.

Cable management

These guidelines ensure that your system and its cables have optimal clearance for maintenance and other operations. The guidelines also provide guidance in correctly cabling your system and using the appropriate cables.

The following guidelines provide cabling information for installing, migrating, relocating, or upgrading your system:

- Position drawers in racks to allow enough space, where possible, for cable routing on the bottom and top of the rack, and between drawers.
- Shorter drawers should not be placed between longer drawers in the rack (for example, placing a 19-inch drawer between two 24-inch drawers).
- When a specific cable plugging sequence is required, for example, for concurrent maintenance (symmetric multiprocessing cables), label the cables appropriately and note the sequence order.
- To facilitate cable routing, install cables in the following order:
 1. System power control network (SPCN) cables
 2. Power cables
 3. Communications (serial attached SCSI, InfiniBand, remote input/output, and peripheral component interconnect express) cables

Note: Install and route the communications cables, starting with the smallest diameter first and then progressing to the largest diameter. This applies to installing them into the cable management arm and retaining them to the rack, brackets, and other features that may be provided for cable management.

- Install and route the communications cables, starting with smallest diameter first and then progressing to the largest diameter.
- Use the innermost cable-management bridge lances for SPCN cables.
- Use the middle cable-management bridge lances for power and communications cables.
- The outermost row of cable-management bridge lances are available for use when routing cables.
- Use the cable raceways on the sides of the rack to manage excess SPCN and power cables.
- There are four cable-management bridge lances on the top of the rack. Use these bridge lances to route the cables from one side of the rack to the other, by routing to the top of the rack, where possible. This routing helps to avoid having a cable bundle that blocks the cable exit opening at the bottom of the rack.
- Use the cable management brackets provided with the system to maintain concurrent maintenance routing.
- Maintain a minimum bend diameter of 101.6 mm (4 in.) for communications (SAS, IB, RIO, and PCIe) cables.
- Maintain a minimum bend diameter of 50.8 mm (2 in.) for power cables.
- Maintain a minimum bend diameter of 25.4 mm (1 in.) for SPCN cables.
- Use the shortest-length cable available for each point-to-point connection.
- If cables have to be routed across the rear of a drawer, leave enough slack to reduce the tension on the cables for maintenance of the drawer.

- When routing cables, leave enough slack around the power connection on the power distribution unit (PDU) so that the wall-to-PDU line cord can be attached to the PDU.
- Use hook-and-loop fasteners where necessary.

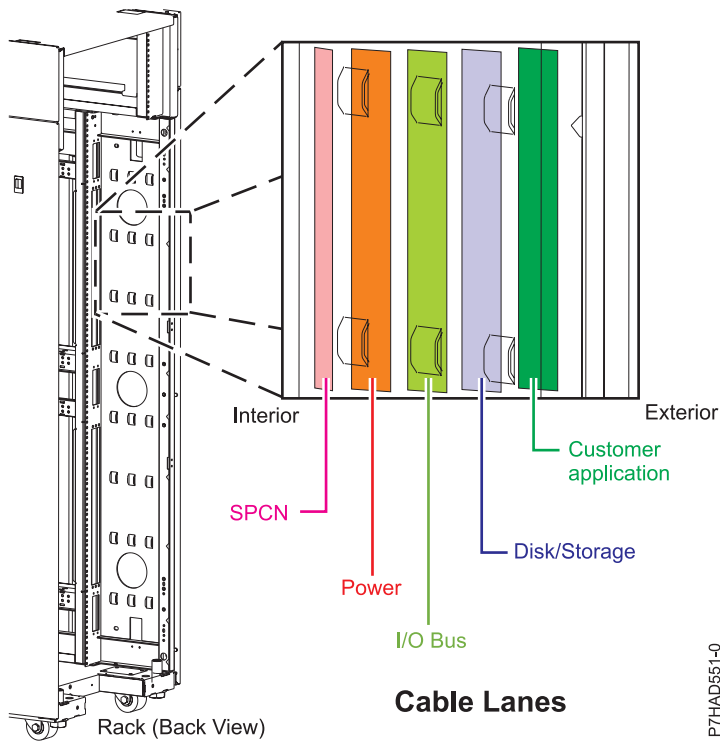

Figure 187. Cable management bridge lances

Cable bend radius

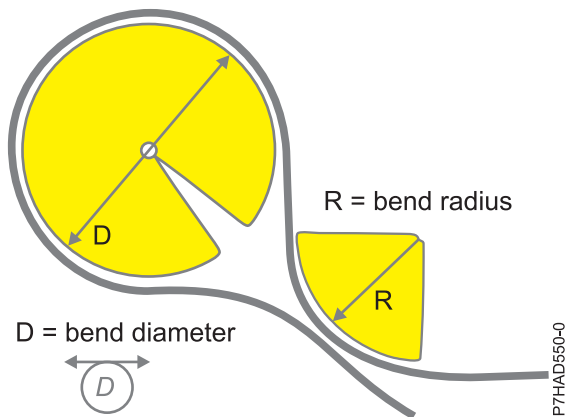

Figure 188. Cable bend radius

Power cord routing and retention

Proper power cord routing and retention ensures your system remains connected to a power supply.

The primary purpose of power cord retention is to prevent unexpected power loss to your system that could potentially cause system operations to stop functioning.

Different types of power cord retention are available. Some of the most commonly used types of retention include:

- Cable management arms
- Rings
- Clamps
- Plastic straps
- Hook-and-loop fasteners

Power cord retainers are typically found at the rear of the unit and on the chassis or pedestal near the alternating current (AC) power cord input.

Systems that are rack mounted and are on rails should use the provided cable management arm.

Systems that are rack mounted, but are not on rails should use the provided rings, clamps, or straps.

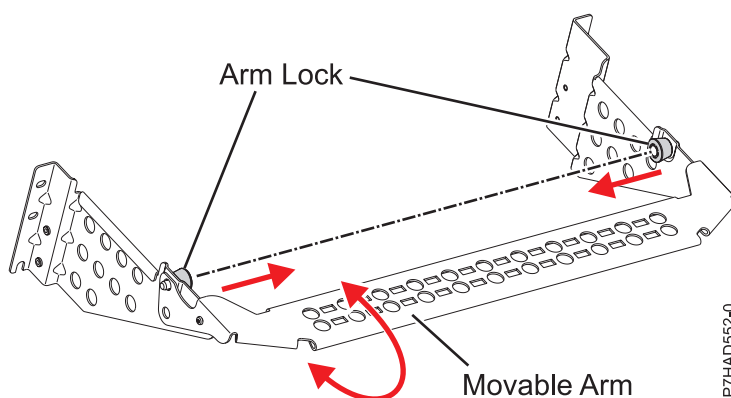

Figure 189. Cable management bracket

Serial-attached SCSI cable planning

Serial-attached SCSI (SAS) cables provide serial communication for transfer of data for directly attached devices, such as hard disk drives, solid-state drives, and CD-ROM drives.

SAS cable overview

Serial-attached SCSI (SAS) is an evolution of the parallel SCSI device interface into a serial point-to-point interface. SAS physical links are a set of four wires used as two differential signal pairs. One differential signal transmits in one direction while the other differential signal transmits in the opposite direction. Data might be transmitted in both directions simultaneously. SAS physical links are contained in ports. A port contains one or more SAS physical links. A port is a wide port if there are more than one SAS physical link in the port. Wide ports are designed to enhance performance and provide redundancy in case an individual SAS physical link fail.

There are two types of SAS connectors, mini SAS and mini SAS high density (HD). High density cables are typically needed to support 6 Gb/s SAS.

Each SAS cable contains four SAS physical links that are typically organized into either a single 4x SAS port or two 2x SAS ports. Each end of the cable uses a mini SAS or mini SAS HD 4x connector. Review the following design and installation criteria before installing your SAS cables:

- Only specific cabling configurations are supported. Many configurations could be constructed that are not supported and will either not function correctly or will generate errors. See “SAS cabling configurations” on page 232 for figures of the supported cabling configurations.

- Each mini-SAS 4x connector is keyed to help prevent cabling an unsupported configuration.
- Each cable end has a label that graphically describes the correct component port to which it is connected, such as:
 - SAS adapter
 - Expansion drawer
 - System external SAS port
 - Internal SAS disk slots connection.
- Cable routing is important. For example, YO, YI, and X cables must be routed along the right side of the rack frame (as viewed from the rear) when connecting to a disk expansion drawer. Additionally, X cables must be attached to the same numbered port on both SAS adapters to which it connects.
- When a choice of cable lengths is available, select the shortest cable that will provide the needed connectivity.
- Always use care when inserting or removing a cable. The cable should slide easily into the connector. Forcing a cable into a connector can cause damage to the cable or connector.
- The X cables are only supported on all SAS PCI (RAID) adapters and only when RAID is enabled.
- Not all cabling configurations are supported when using solid-state drives (SSD). See *Installing and configuring Solid State Drives* for more information.

Supported SAS cable information

The following table contains a list of the supported serial-attached SCSI (SAS) cable types and their designed usage.

Table 215. Functions for supported SAS cables

Cable type	Function
AA cable	This cable is used to connect between the top ports on two tri-port SAS adapters in a RAID configuration.
AI cable	This cable is used to connect from a SAS adapter to internal SAS disk slots that uses an FC 3650 or FC 3651 cable card, or by using an FC 3669 to the system external SAS port on your system.
AE cable	These cables are used to connect a SAS adapter to a media expansion drawer. These cables can also be used to connect two SAS adapters to a disk expansion drawer in a unique JBOD configuration.
AT cable	This cable is used with a PCIe 12X I/O drawer to connect from a PCIe SAS adapter to the internal SAS disk slots.
EE cable	This cable is used to connect one disk expansion drawer to another in a cascaded configuration. Disk expansion drawers can only be cascaded one level deep, and only in certain configurations.
YO cable	This cable is used to connect a SAS adapter to a disk expansion drawer. The cable must be routed along the right side of the rack frame (as viewed from the rear) when connecting to a disk expansion drawer.
YI cable	This cable is used to connect a system external SAS port to a disk expansion drawer. The cable must be routed along the right side of the rack frame (as viewed from the rear) when connecting to a disk expansion drawer.

Table 215. Functions for supported SAS cables (continued)

Cable type	Function
X cable	This cable is used to connect two SAS adapters to a disk expansion drawer in a RAID configuration. The cable must be routed along the right side of the rack frame (as viewed from the rear) when connecting to a disk expansion drawer.

The following table contains specific information about each supported SAS cable.

The following table contains cable label information. The graphic labels are designed to match the correct component port to which the cable end is to be attached.

Cable section lengths

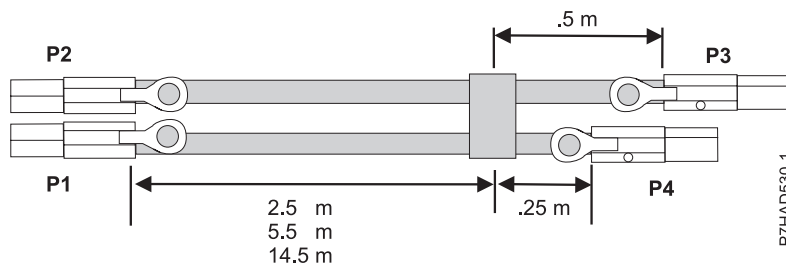

Figure 190. SAS external X cable assembly cable lengths

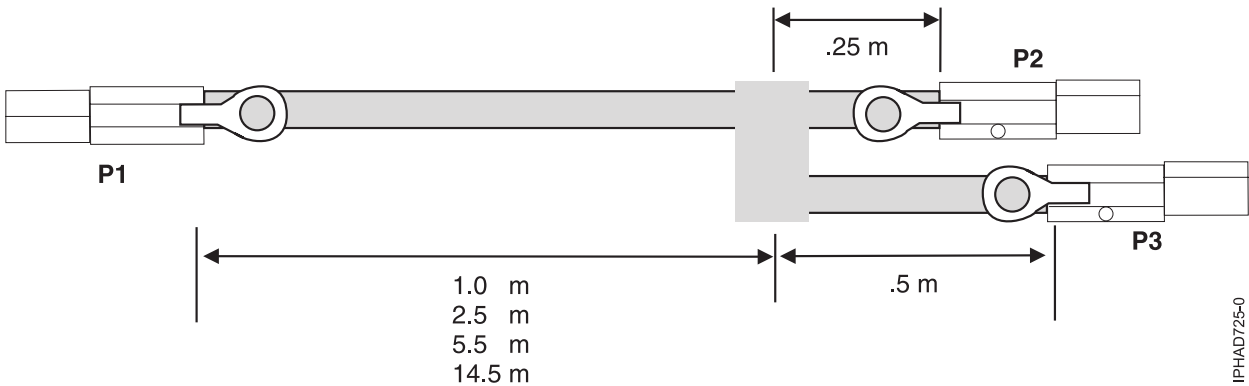

Figure 191. SAS external YO-cable assembly cable lengths

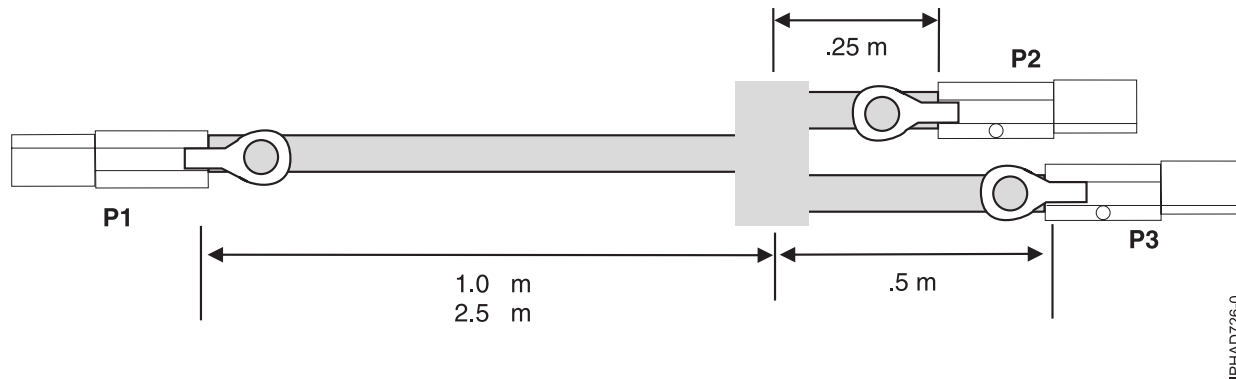

Figure 192. SAS external YI-cable assembly cable lengths

SAS cabling configurations

The following sections provide the typical supported SAS cabling configurations. Many configurations could be constructed that are not supported and will either not function correctly or will generate errors. To avoid problems, restrict cabling to only the general types of configurations shown in the following sections.

- "SAS adapter to disk expansion drawers"
- "SAS adapter to media expansion drawer" on page 235
- "SAS adapter to expansion drawer combinations" on page 236
- "System external SAS port to disk expansion drawer" on page 237
- "SAS adapter to internal SAS disk slots " on page 238
- "Two SAS adapters to disk expansion drawer multi-initiator high availability (HA) RAID configuration" on page 240
- "Two RAID SAS adapters with HD connectors to disk expansion drawer in a multi-initiator high availability (HA) mode" on page 244
- "Two SAS adapters to disk expansion drawer - multi-initiator HA JBOD configuration" on page 248
- PCIe SAS adapter in PCIe 12X I/O drawer to the internal SAS disk slots
- SAS cabling to the 5887 drawer

SAS adapter to disk expansion drawers

Figure 193 on page 233, Figure 194 on page 233, Figure 195 on page 234, and Figure 196 on page 235 illustrate connecting a SAS adapter to one, two, three, or four disk expansion drawers. It is also possible to connect three disk expansion drawers by omitting one of the cascaded drawers shown in Figure 195 on page 234. Disk expansion drawers can be cascaded only one level deep.

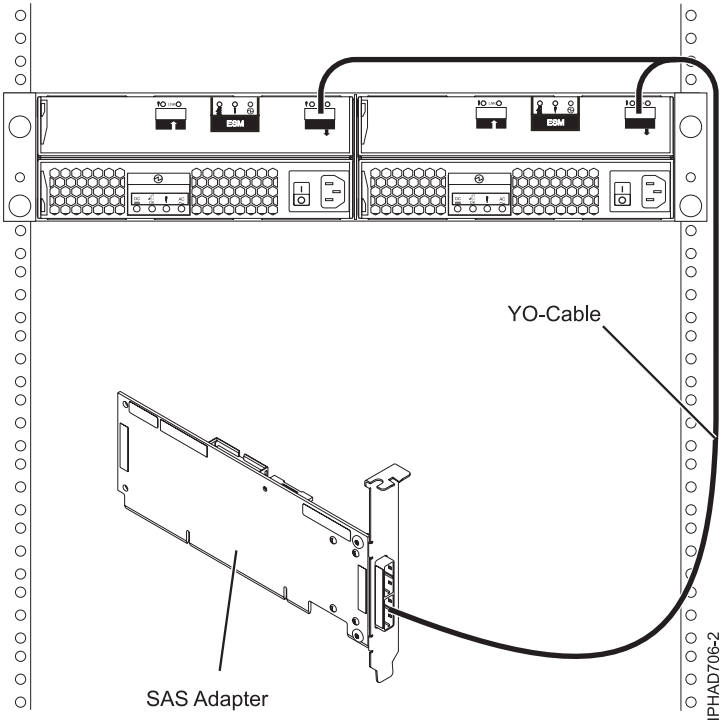

Figure 193. SAS adapter to a disk expansion drawer

Note: The YO cable must be routed along the right side of the rack frame.

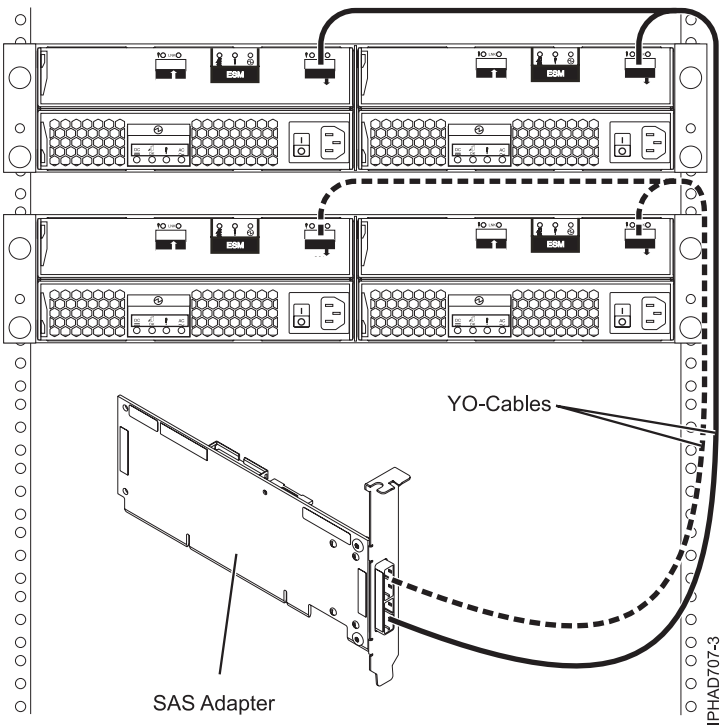

Figure 194. SAS adapter to two disk expansion drawers

Note: The YO cable must be routed along the right side of the rack frame.

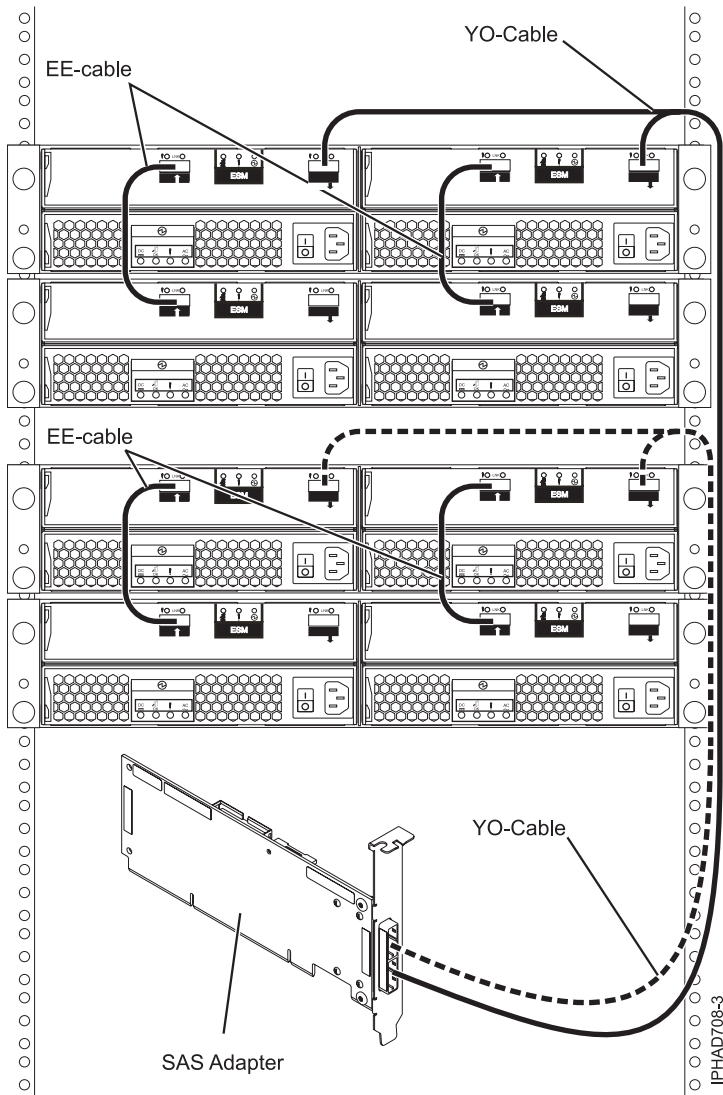

Figure 195. SAS adapter to four disk expansion drawers

Note: The YO cable must be routed along the right side of the rack frame.

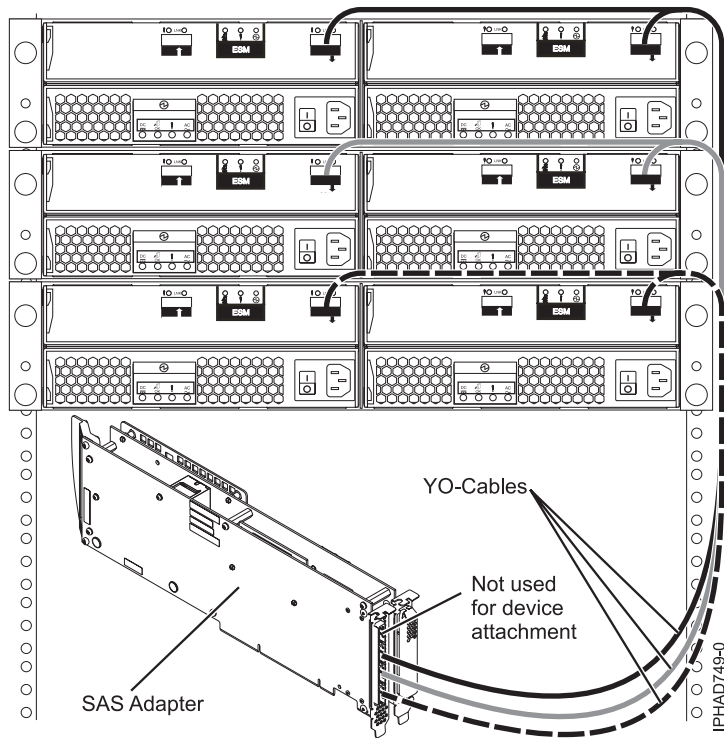

Figure 196. Tri-port SAS adapter to disk expansion drawers

When attaching only hard disk drives, it is also possible to cascade a second disk expansion drawer off of two out of the three drawers for a maximum of five disk expansion drawers per adapter. See Figure 195 on page 234. Disk expansion drawers can be cascaded only one level deep.

Note: The YO cable must be routed along the right side of the rack frame.

SAS adapter to media expansion drawer

Figure 197 on page 236 illustrates connecting a SAS adapter to a media expansion drawer. It is also possible to connect a second media expansion drawer to the second port of the SAS adapter.

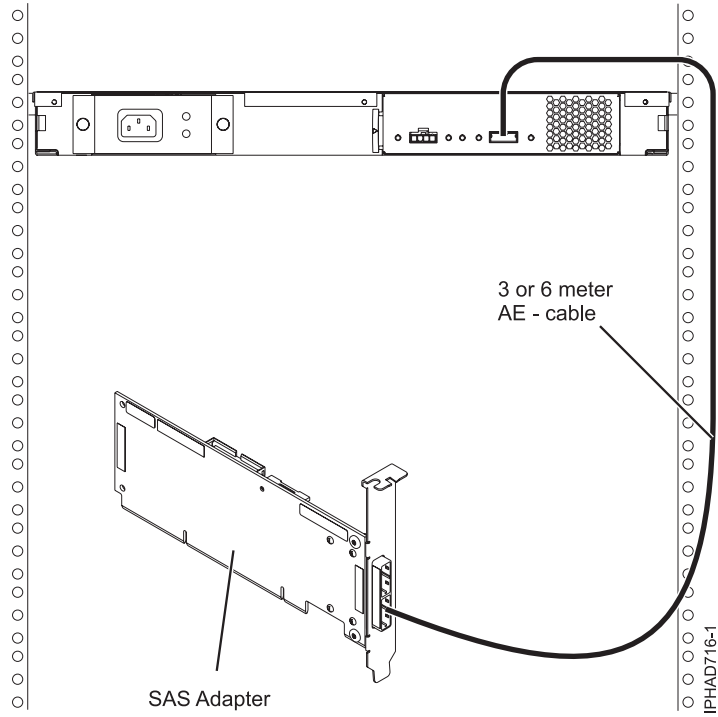

Figure 197. SAS adapter to a media expansion drawer

SAS adapter to expansion drawer combinations

Figure 198 on page 237 illustrates connecting a SAS adapter to both a disk expansion drawer and a media expansion drawer on separate adapter ports. It is also possible to cascade a second disk expansion drawer (see Figure 195 on page 234).

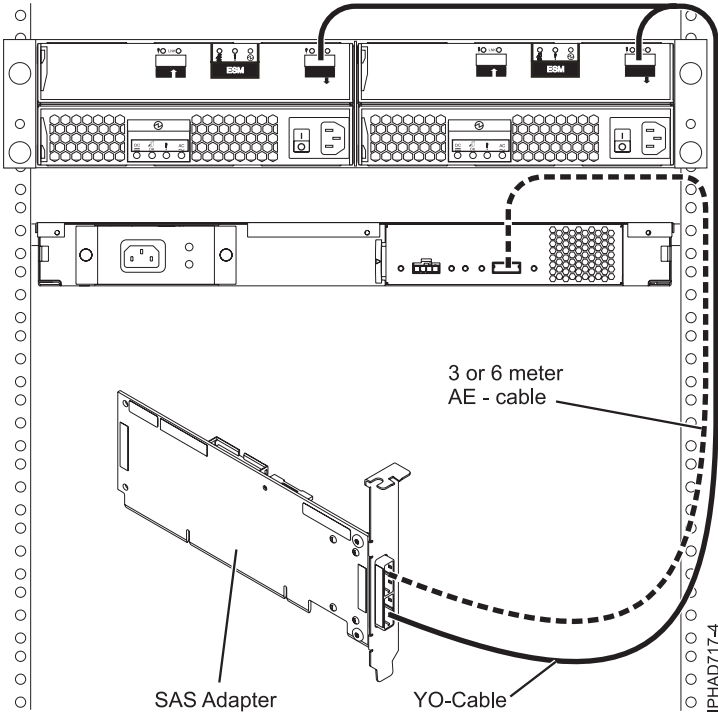

Figure 198. SAS adapter to both a disk expansion drawer and a media expansion drawer

Note: The YO cable must be routed along the right side of the rack frame.

System external SAS port to disk expansion drawer

Figure 199 on page 238 illustrates connecting a system external SAS port to a disk expansion drawer. Disk expansion drawers cannot be cascaded.

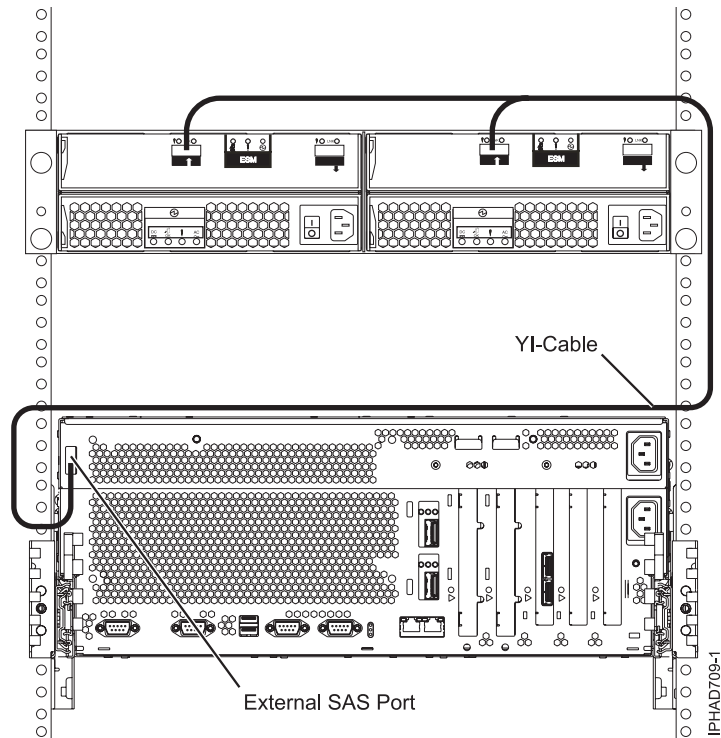

Figure 199. System external SAS adapter port to a disk expansion drawer

Note: The YI cable must be routed along the right side of the rack frame.

SAS adapter to internal SAS disk slots

Figure 200 on page 239 illustrates connecting a SAS adapter to internal SAS disk slots through the system external SAS port.

Note: Internal cable FC 3669 must be installed to enable this configuration. For more information, see Installing the external SAS port.

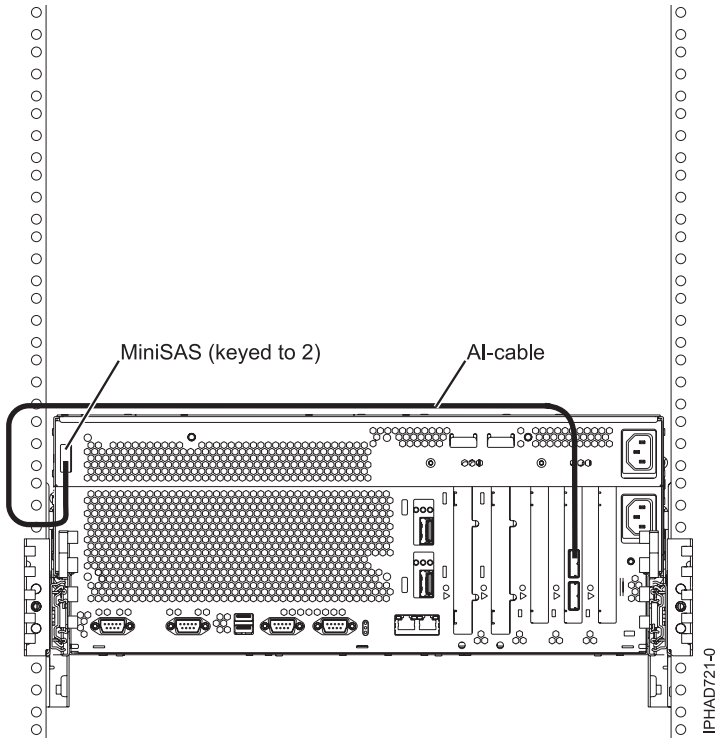

Figure 200. SAS adapter to internal SAS disk slots through the system external SAS port

Notes:

- Internal cable FC 3669 must be installed to enable this configuration (Models 33E/8B and 36E/8C). For more information, see Installing the external SAS port.
- The second connector on the adapter can be used to attach a disk expansion or media expansion drawer as shown in Figure 193 on page 233 or Figure 197 on page 236.

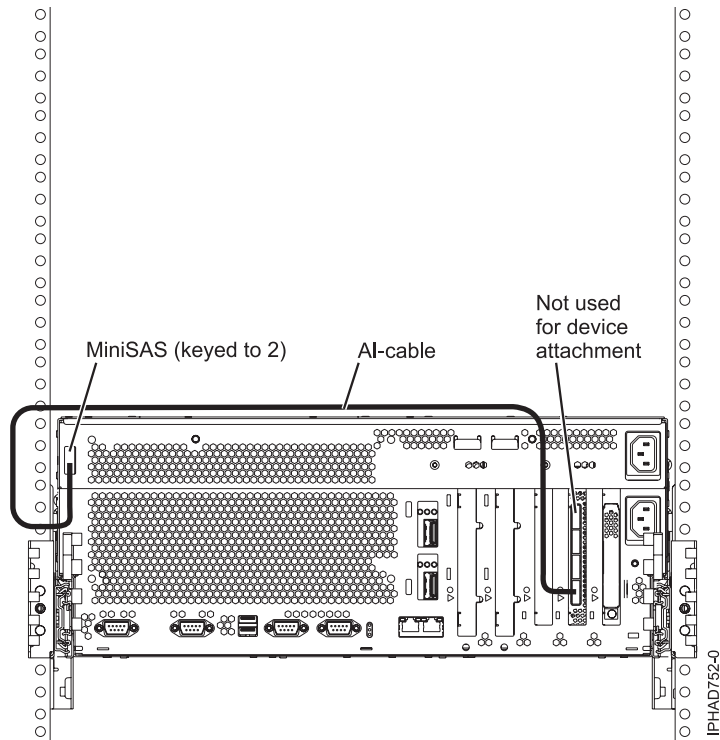

Figure 201. FC5904 or FC5908 adapter attached to disk expansion drawers

Note:

- The remaining two connectors on the adapter can be used to attach disk expansion drawers as shown in Figure 196 on page 235.

Two SAS adapters to disk expansion drawer multi-initiator high availability (HA) RAID configuration

Figure 202 on page 241, Figure 203 on page 242, Figure 204 on page 243, and Figure 205 on page 244 illustrate connecting two SAS adapters to one, two, or four disk expansion drawers in a RAID configuration. It is also possible to connect three disk expansion drawers by omitting one of the cascaded drawers shown in Figure 204 on page 243. Disk expansion drawers can be cascaded only one level deep.

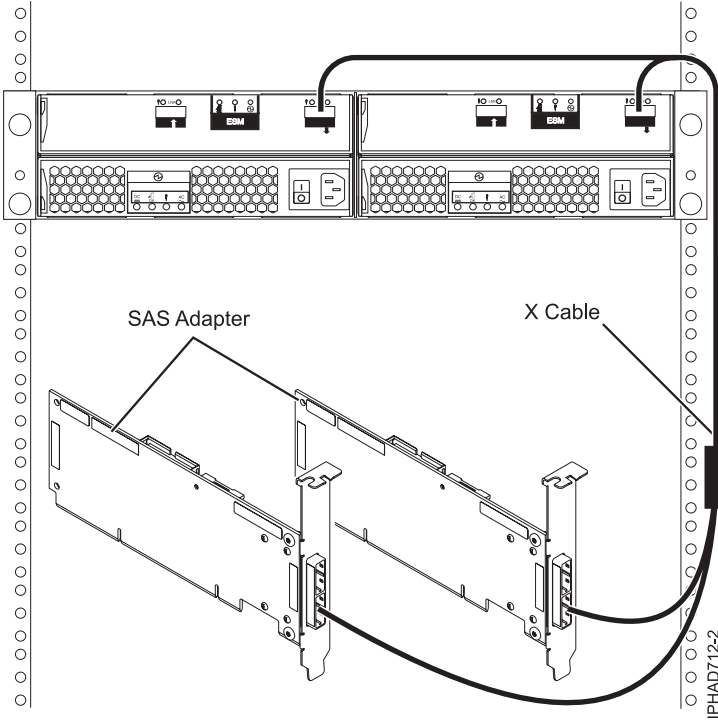

Figure 202. Two SAS RAID adapters to a disk expansion drawer in a multi-initiator HA RAID configuration

Notes:

- The X cable must be routed along the right side of the rack frame.
- The X cable must be attached to the same numbered port on all adapters.

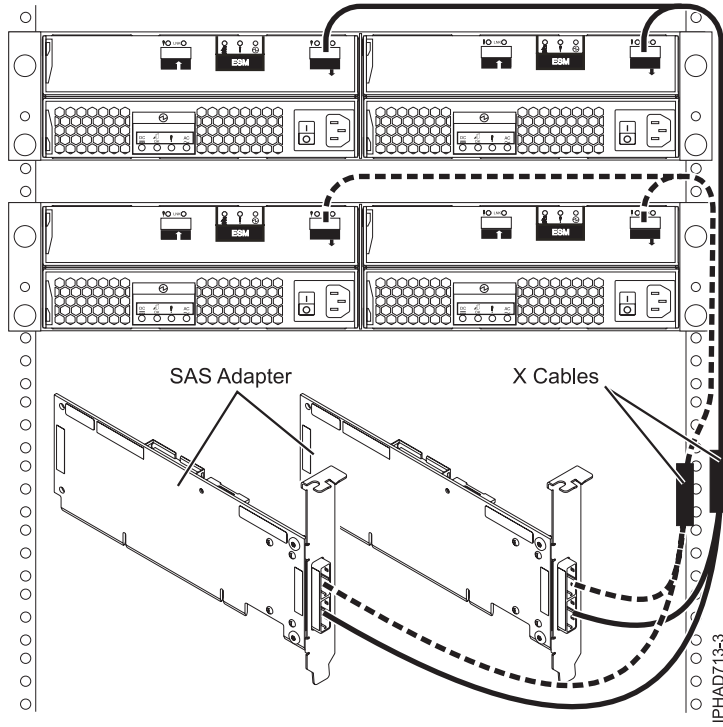

Figure 203. Two SAS RAID adapters to two disk expansion drawers in a multi-initiator HA RAID configuration

Notes:

- The X cable must be routed along the right side of the rack frame.
- The X cable must be attached to the same numbered port on all adapters.

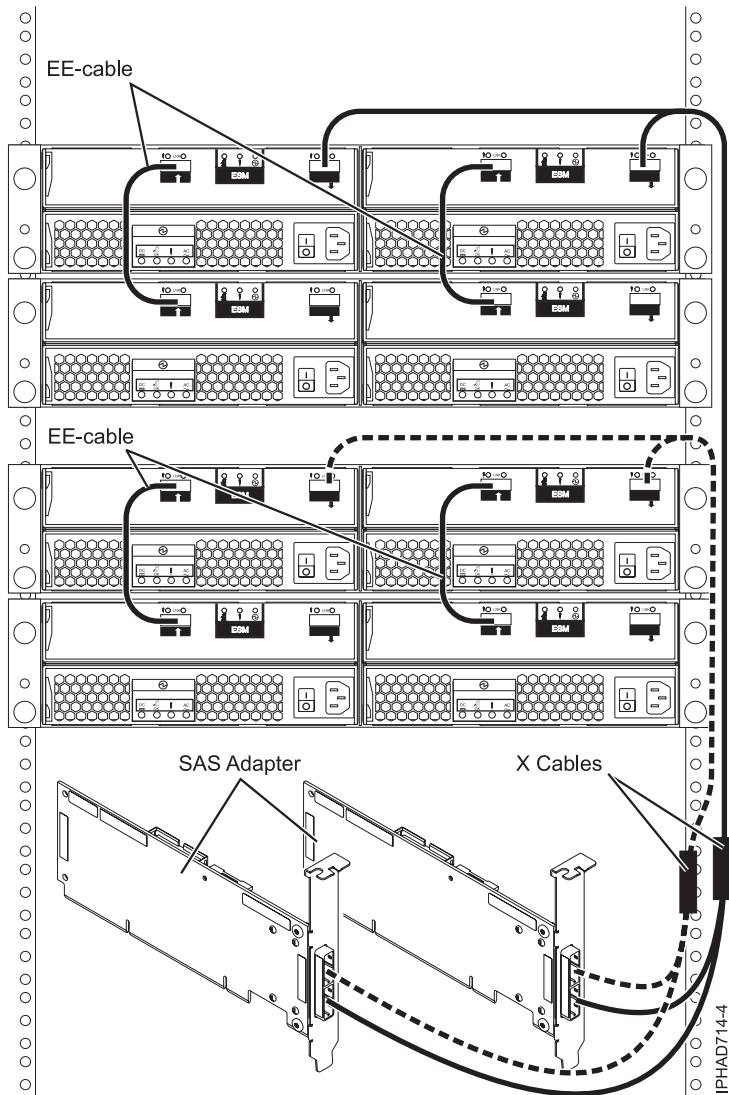
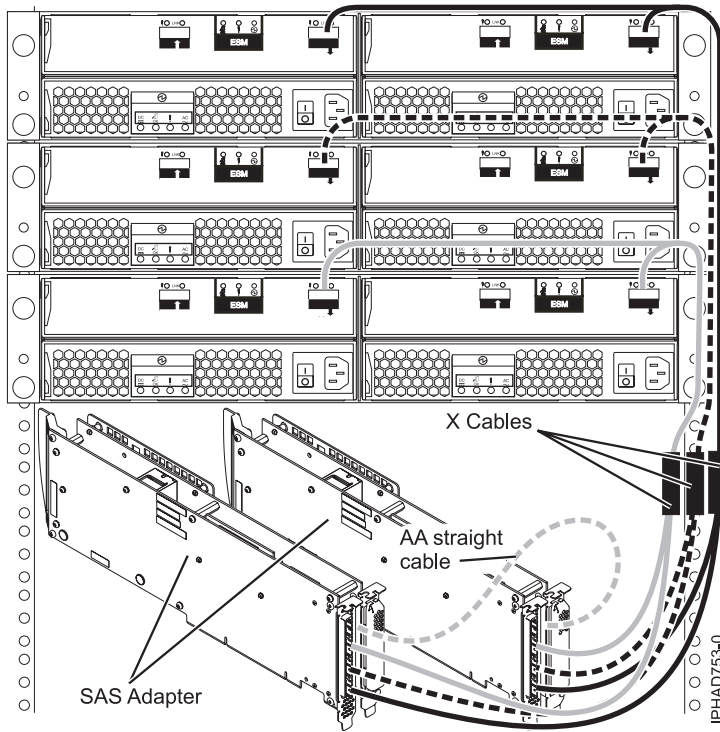

Figure 204. Two SAS RAID adapters to four disk expansion drawers in a multi-initiator HA RAID configuration

Notes:

- The X cable must be routed along the right side of the rack frame.
- The X cable must be attached to the same numbered port on all adapters.



When attaching only hard disk drives, it is also possible to cascade a second disk expansion drawer off of two out of the three drawers for a maximum of five disk expansion drawers per adapter. See Figure 195 on page 234.

Notes:

- Disk expansion drawers can be cascaded only one level deep.
- The X cable must be routed along the right side of the rack frame.
- The X cable must be attached to the same numbered port on all adapters.

Figure 205. Two Tri-port SAS adapters to disk expansion drawers in a multi-initiator HA raid configuration

Two RAID SAS adapters with HD connectors to disk expansion drawer in a multi-initiator high availability (HA) mode

Figure 206 on page 245, Figure 207 on page 246, and Figure 208 on page 247 illustrate connecting two SAS RAID adapters with HD connectors to one, two, or three disk expansion drawers in a multi-initiator HA mode.

Figure 209 on page 248 illustrate connecting two pair of SAS RAID adapters with HD connectors to one disk expansion drawer in a multi-initiator HA mode.

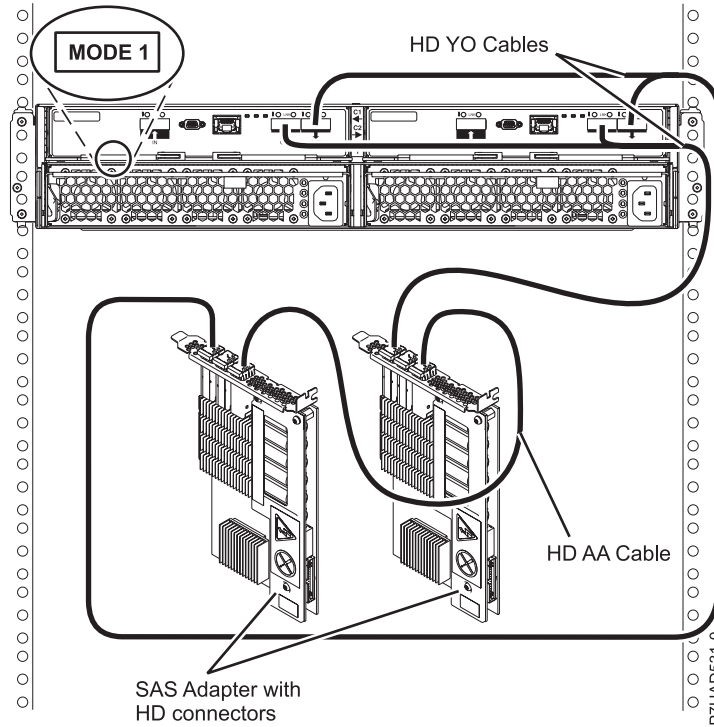

Notes:

- No cascading allowed for the 5887 storage drawer.
- HD AA cable is required.

Figure 206. Two RAID SAS adapters with HD connectors to a disk expansion drawer in a multi-initiator HA mode

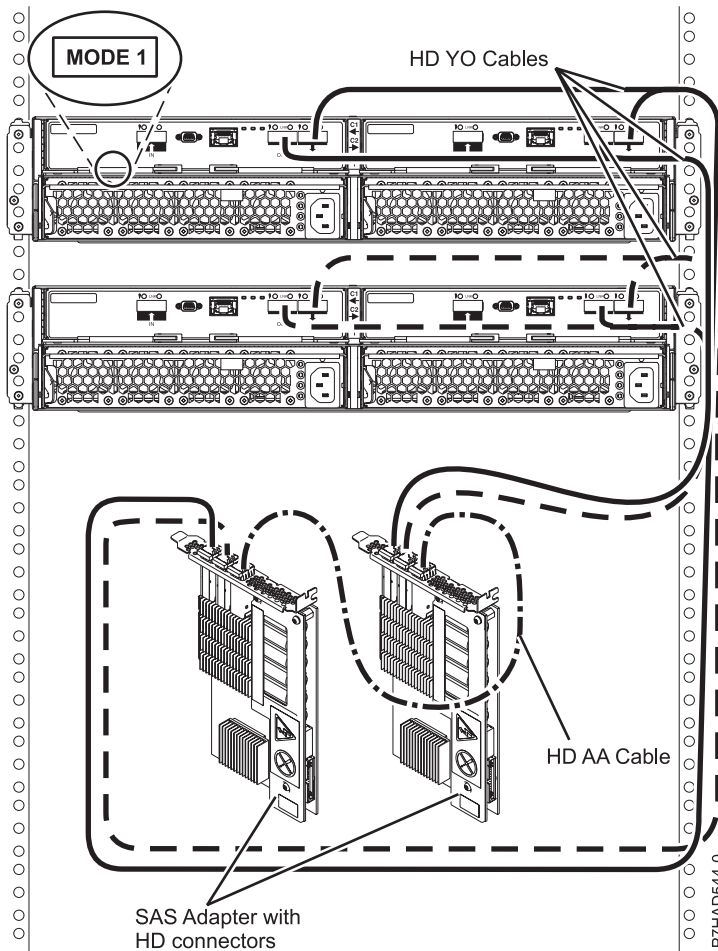

Note:

- No cascading allowed for the 5887 storage drawer.
- HD AA cable is required.

Figure 207. Two RAID SAS adapters with HD connectors to two disk expansion drawer in a multi-initiator HA mode

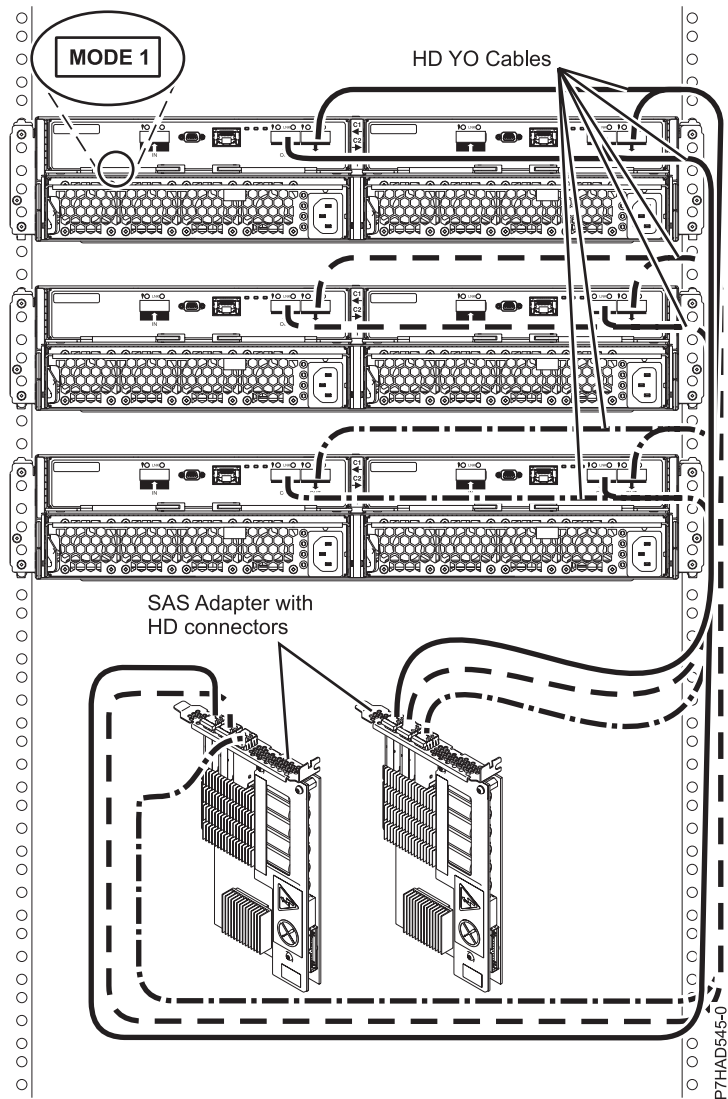

Notes:

- No cascading allowed for the 5887 storage drawer.

Figure 208. Two RAID SAS adapters with HD connectors to three disk expansion drawers in a multi-initiator HA mode

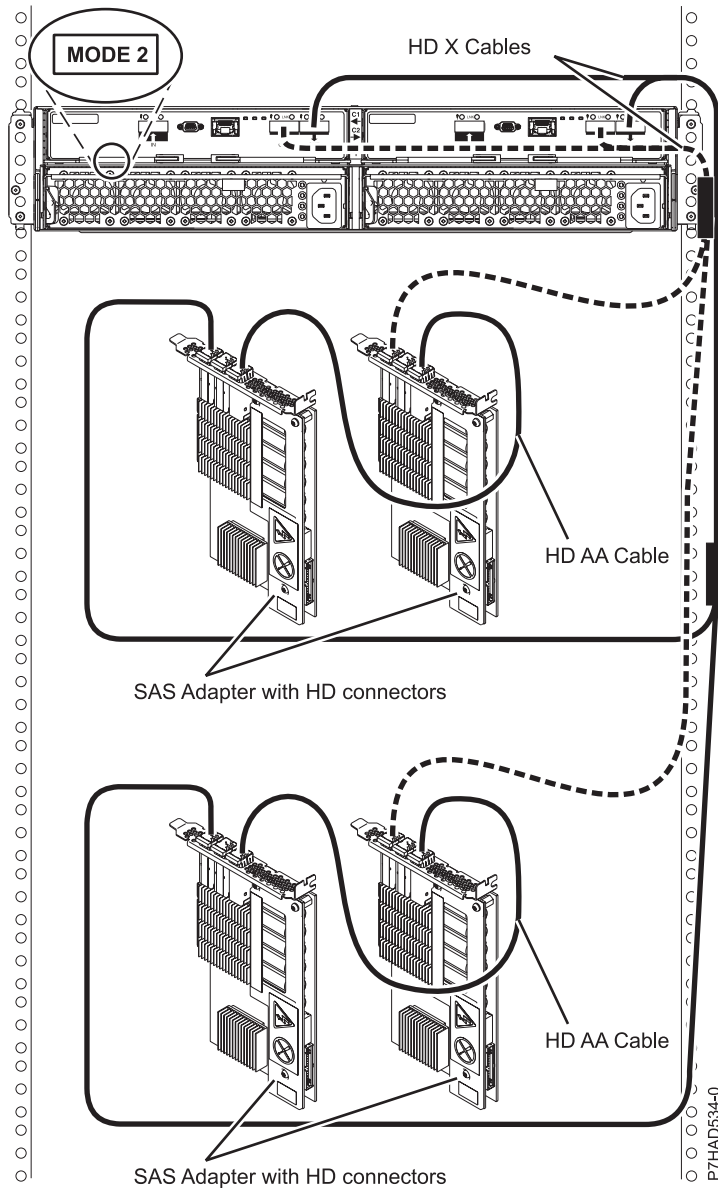

Notes:

- No cascading allowed for the 5887 storage drawer.
- HD AA cable is required.

Figure 209. Two pairs of RAID SAS adapters with HD connectors to a disk expansion drawer – Mode 2 in a multi-initiator HA mode

Two SAS adapters to disk expansion drawer - multi-initiator HA JBOD configuration

Figure 210 on page 249 illustrates connecting two SAS adapters to a disk expansion drawer in a unique JBOD configuration.

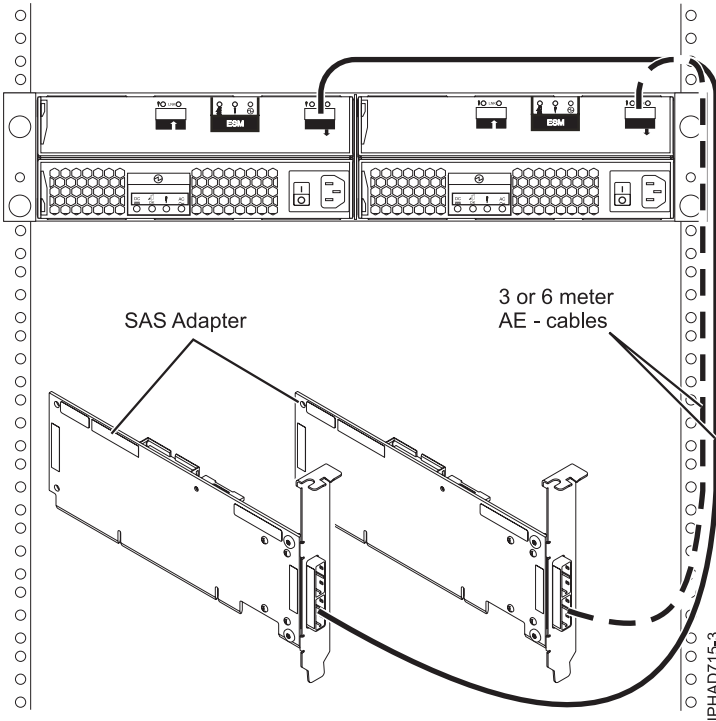

Figure 210. Two RAID SAS adapters to a disk expansion drawer in a multi-initiator HA JBOD configuration

Note: This configuration is only supported by the AIX and Linux operating systems with specific SAS adapters and requires special user configuration setup. See SAS RAID controllers for AIX or SAS RAID controllers for Linux for additional information.

PCIe SAS adapter in PCIe 12x I/O drawer to the internal SAS disk slots

There are several possible configurations for attaching PCIe SAS adapters to the internal SAS disk slots in the PCIe 12X I/O drawer, and multiple ways of setting up the disk layout within the drawer. The disk unit partitions switch setting on the rear of the PCIe 12X I/O drawer controls the grouping of the disk units within the drawer. This will also affect the way the adapter or adapters are cabled to specific ports on the PCIe 12X I/O drawer. The desired switch position should be selected before attaching the AT cables. If the disk unit partitions switch is changed, the PCIe 12X I/O drawer must be powered off and on for the new position to be detected.

All internal disk units are attached using AT cables. There are also options where other external expansion drawers might be connected to these same SAS adapters. External disk expansion drawers are attached using YO cables for single adapter configurations or X cables for two adapter configurations. External media expansion drawers are attached using AE cables for single adapter configurations. External media expansion drawers are not supported for two adapter configurations.

For complete details and examples of these configurations within the PCIe 12X I/O drawer, see *Configuring the 5802 disk-drive subsystem*. Figure 211 on page 250 illustrates the rear view of a typical connection from two PCIe SAS adapters to the PCIe 12X I/O drawer. Use the AT cable to attach from an adapter port to a SAS port on the PCIe 12X I/O drawer.

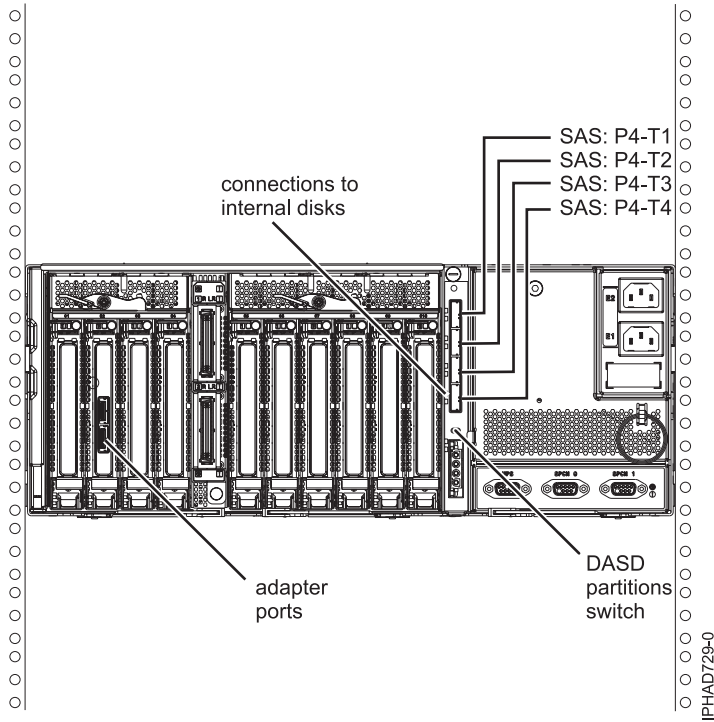

Figure 211. Two RAID SAS adapters to a disk expansion drawer in a multi-initiator HA JBOD configuration

Internal disk drive sharing

The following information is for use after the FC 5901 SAS Storage adapter is installed. Install the adapter and then return here. For more information on the PCI adapters topic, see PCI adapters for the 8233-E8B or 8236-E8C .

Please review the tasks in the Before you begin section before proceeding with the below procedure.

This feature allows you to split the internal disks in the system unit enclosure into groups which you can manage separately.

1. Stop and power off the system. For more information, see Stopping a system or logical partition
2. Cable a single system unit enclosure by doing the following:
 - a. Attach the cable to the SAS port on the rear bulkhead of the system unit enclosure to the top port in the SAS Storage Controller as shown in the following figure.

Restriction: Internal disk drive sharing is only available when internal cable feature FC 1815 is installed from the DASD backplane to the read bulkhead of the system unit enclosure. Also FC 5662 175 MB cache RAID - dual IOA enablement card must not be installed. The SAS Storage Controller may be in any of the other slots that support it.

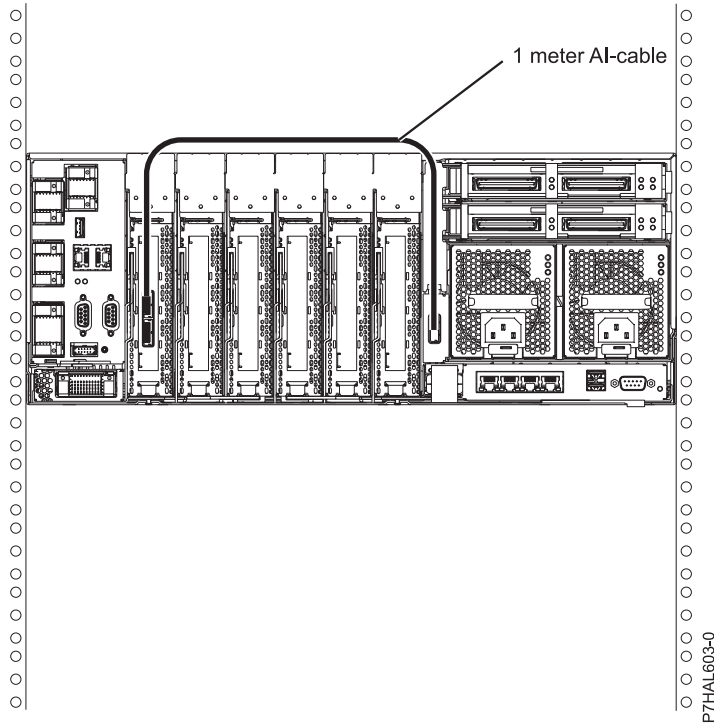

- b. Secure any extra cable.
3. Start the system. For more information, see [Starting the system or logical partition](#).
4. Verify that the feature is installed and is working. For more information, see [Verifying the installed part](#).

With this function installed, 2 of the 6 disks (D3, D6) in the system enclosure will be managed by the SAS Storage Controller adapter.

Note: The Removable Media device is always controlled by the separate embedded SAS controller on the system planar. For more information on installing and removing SAS media devices, see [Removing and replacing media devices](#).

Related information:

- [Installing and configuring Solid State Drives](#)
- [Connecting the SAS adapter to the 5887 disk drive enclosure](#)

SAS cabling for the 5887 drawer

Learn about the different serial-attached SCSI (SAS) cabling configurations available for the 5887 drawer and mixed configurations of the 5886 and 5887 drawers.

- “SAS adaptor (FC 5901) to the 5887” on page 252
- “SAS adaptor (FC 5805 and FC 5903) to the 5887” on page 256
- “SAS adaptor (FC 5904, FC 5906, and FC 5908) to the 5887” on page 257
- “SAS adaptor (FC 5913) to the 5887” on page 260
- “SAS adaptors with high density (HD) connectors” on page 261
- FC EDR1 PCIe storage enclosure to the 5887

SAS adaptor (FC 5901) to the 5887

There are seven supported configurations to connect the FC 5901 adaptor to a 5887.

Notes:

1. No solid-state drives (SSDs) supported with the FC 5901 adaptor.
2. No cascading of 5887 drawers.
3. No mixed configurations of 5886 and 5887 drawers supported.
4. No support for IBM i5.
5. The long end (0.5 m) of the YO cable must be connected to the left side of the drawer (as viewed from the rear) and the short end (0.25 m) must be connected to the right side of drawer (as viewed from the rear).

The following list describes the supported configurations for connecting the FC 5901 adaptor to a 5887:

1. Single FC 5901 adaptor to one 5887 via a mode 1 connection.
 - 5887 drawer with one set of 24 hard disk drives (HDDs).
 - Connection using SAS YO cables to connect to the 5887 drawer.
 - Supported only on AIX and Linux systems.

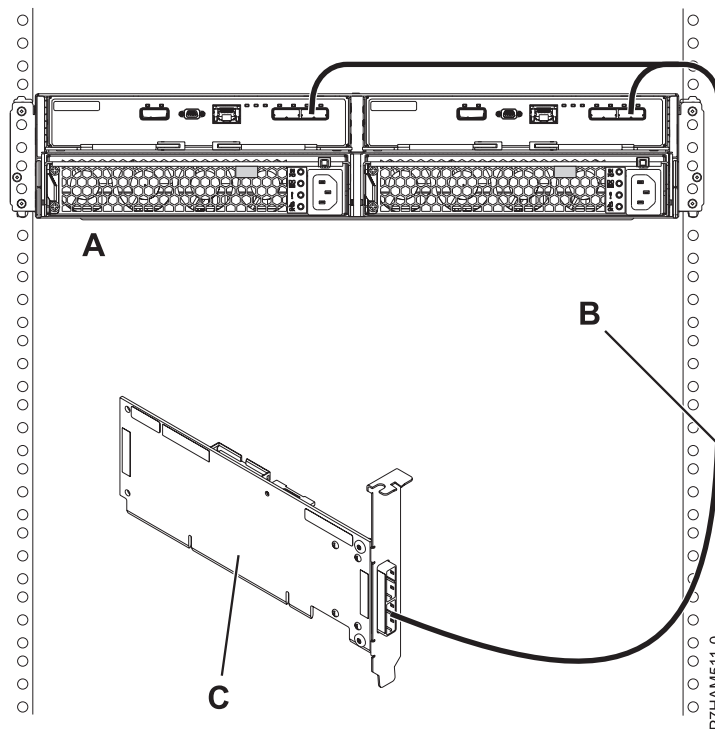

Figure 212. Mode 1 connection of a 58/87 drawer using a YO cable to a single SAS adaptor

2. Single FC 5901 adaptor to two 5887s via a mode 1 connection.
 - 5887 drawers with two sets of 24 hard disk drives (HDDs).
 - Connection using SAS YO cables to connect to the 5887 drawers.
 - Supported only on AIX and Linux systems.
3. Dual FC 5901 adaptors to one 5887 via a mode 1 connection.
 - 5887 drawer with one set of 24 hard disk drives (HDDs).

- Connection using Dual SAS YO cables to connect to the 5887 drawer.
- Supported only on AIX and Linux systems.

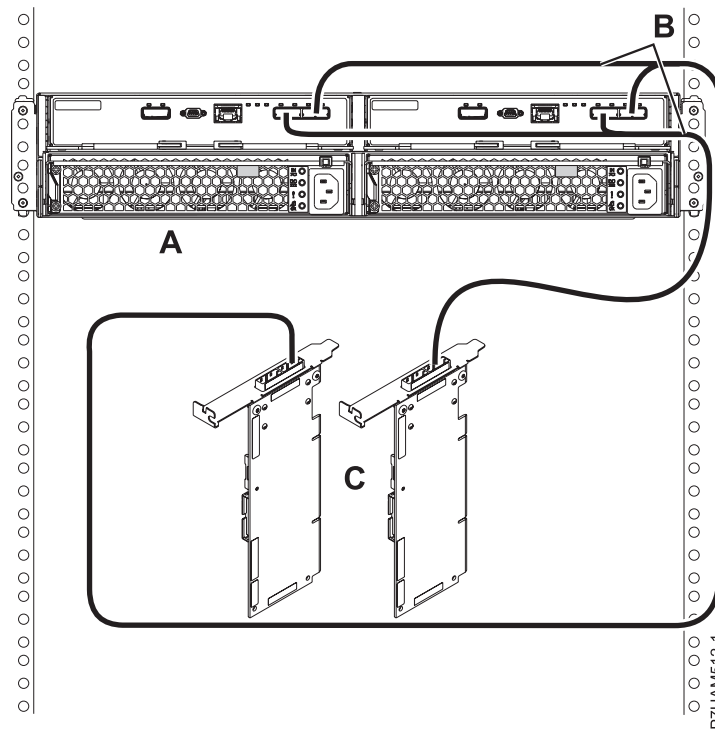

Figure 213. Mode 1 connection of a 58/87 drawer using YO cables to dual SAS adapters

4. Dual FC 5901 adapters to two 5887s via a mode 1 connection.
 - 5887 drawers with two sets of 24 hard disk drives (HDDs).
 - Connection using Dual SAS YO cables to connect to the 5887 drawer.
 - Supported only on AIX and Linux systems.
5. Dual FC 5901 adapters to one 5887 via a mode 2 connection.
 - 5887 drawer with two sets of 12 hard disk drives (HDDs).
 - Connection using Dual SAS YO cables to connect to the 5887 drawer.
 - Supported only on AIX and Linux systems.

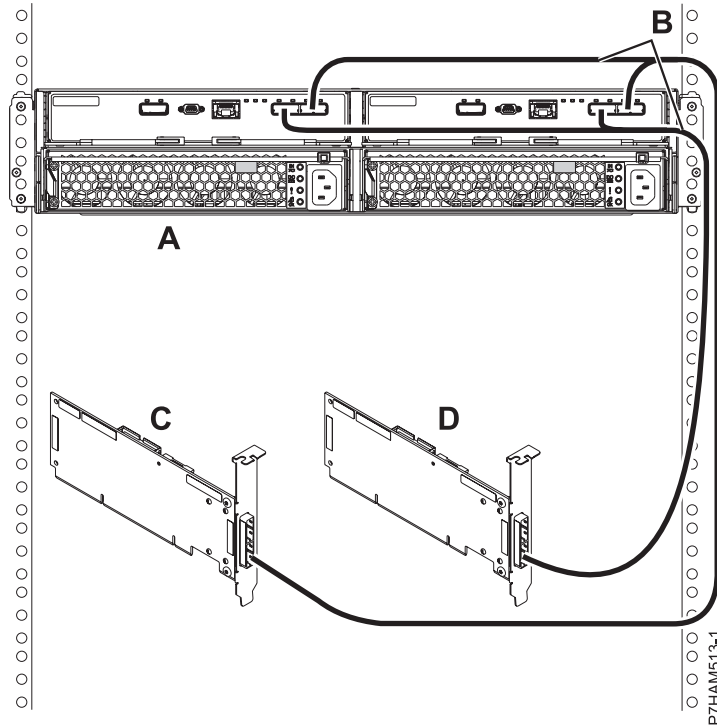

Figure 214. Mode 2 connection of a 58/87 drawer using YO cables to dual SAS adapters

6. Quad FC 5901 (two pair) adapters to one 5887 via a mode 2 connection
 - 5887 drawer with two sets of 12 hard disk drives (HDDs).
 - Connection using Dual SAS X cables to connect to the 5887 drawer.
 - Supported only on AIX and Linux systems.

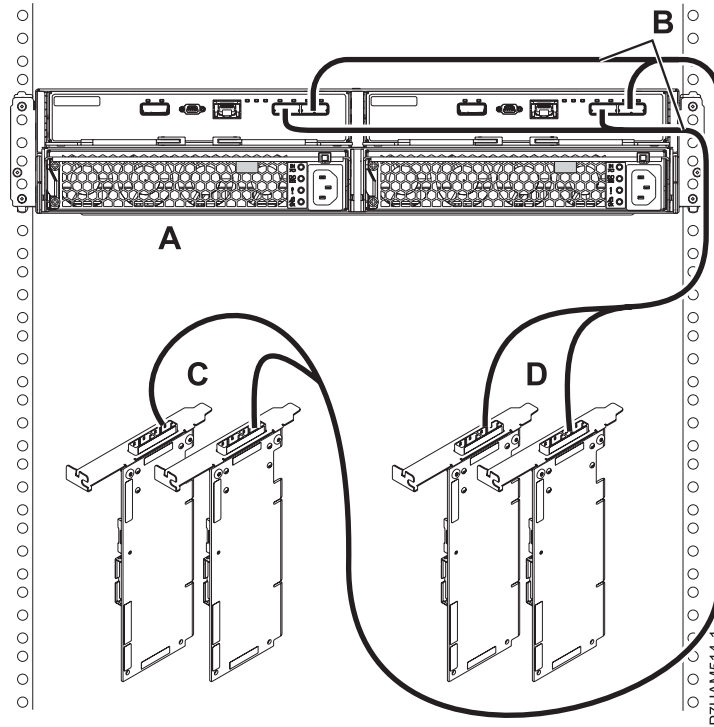

Figure 215. Mode 2 connection of a 58/87 drawer using X cables to quad SAS adapters (two pairs)

7. Quad FC 5901 adapters to one 5887 via a mode 4 connection
 - 5887 drawer with four sets of 6 hard disk drives (HDDs).
 - Connection using Dual SAS X cables to connect to the 5887 drawer.
 - Supported only on AIX and Linux systems.

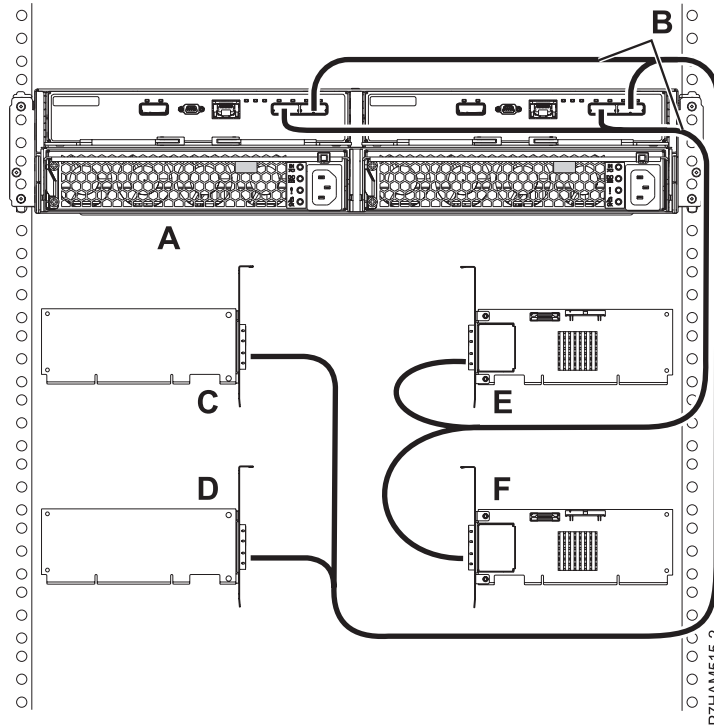

Figure 216. Mode 4 connection of a 58/87 drawer using X cables to quad SAS adapters

SAS adaptor (FC 5805 and FC 5903) to the 5887

There are three supported configurations to connect FC 5805 or FC 5903 adapter to a 5887 and one supported mixed configuration to a 5886 and 5887.

Notes:

1. Maximum of eight SSDs in single drawer configurations.
2. No cascading of 5887 drawers.
3. No cascading of 5886 drawers in mixed configurations.
4. IBM i5 only supports mode 1 connections.
5. The long end (0.5 m) of the YO cable must be connected to the left side of the drawer (as viewed from the rear) and the short end (0.25 m) must be connected to the right side of drawer (as viewed from the rear).

The following list describes the supported configurations:

1. Dual FC 5805 or FC 5903 adapters to one 5887 via a mode 1 connection.
 - 5887 drawer with 1 - 24 HDDs or 1 - 8 SSDs.
 - Connection using Dual SAS YO cables to connect to the 5887 drawer.

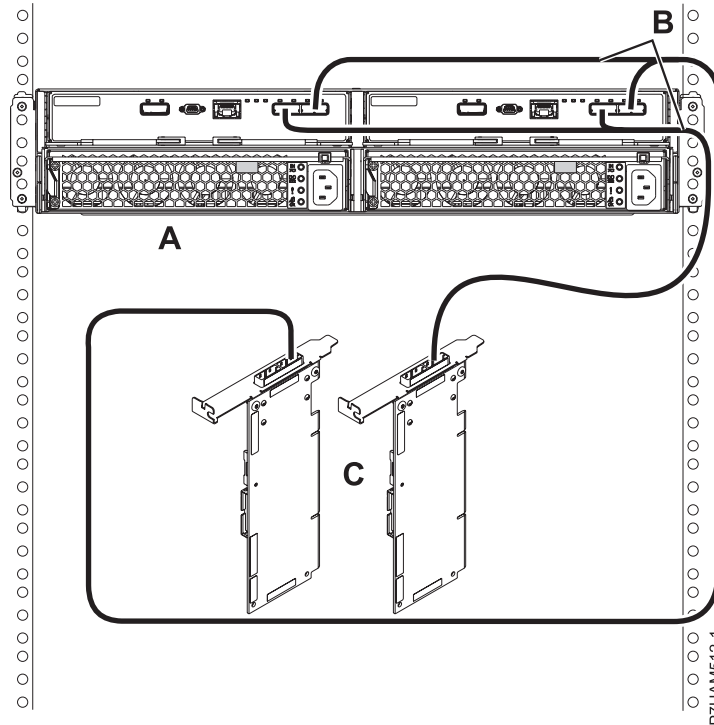

Figure 217. Mode 1 connection of a 58/87 drawer using YO cables to dual SAS adapters

2. Dual FC 5805 or FC 5903 adapters to two 5887s via a mode 1 connection.
 - 5887 drawers with HDDs only.
 - Connection using Dual SAS YO cables to connect to the 5887 drawers.
3. Dual FC 5805 or FC 5903 adapters to one 5886 and one 5887 via a mode 1 connection.
 - 5886 and 5887 drawer with HDDs only.
 - Connection using one SAS X cable to connect to the 5886 drawer and two SAS YO cables to the 5887 drawers.
4. Quad FC 5805 or FC 5903 adapters to one 5887 via a mode 2 connection.
 - 5887 drawer with 1 - 12 HDDs or 1 - 8 SSDs.
 - Connection using Dual SAS X cables to connect to the 5887 drawer.
 - Supported only on AIX and Linux systems. No support for IBM i5.

SAS adaptor (FC 5904, FC 5906, and FC 5908) to the 5887

There are four supported configurations to connect FC 5904, FC 5906, or FC 5908 adapters to a 5887 and six supported mixed configurations to a 5886 and 5887.

Notes:

1. Mode 1 connections only.
2. Maximum of two 5887 drawers on a FC 5904, FC 5906, or FC 5908 adaptor or a pair of FC 5904, FC 5906, or FC 5908 adaptors.
3. No cascading of 5887 drawers.
4. No cascading of 5886 drawers in mixed configurations.
5. Maximum of eight SSDs in single drawer configurations.

6. The long end (0.5 m) of the YO cable must be connected to the left side of the drawer (as viewed from the rear) and the short end (0.25 m) must be connected to the right side of drawer (as viewed from the rear).

The following list describes the supported configurations:

1. Single FC 5904, FC 5906, or FC 5908 adapter to one 5887 via a mode 1 connection.
 - 5887 drawers with 1 - 24 HDDs or 1 - 8 SSDs.
 - Connection using Dual SAS YO cables to connect to the 5887 drawer.

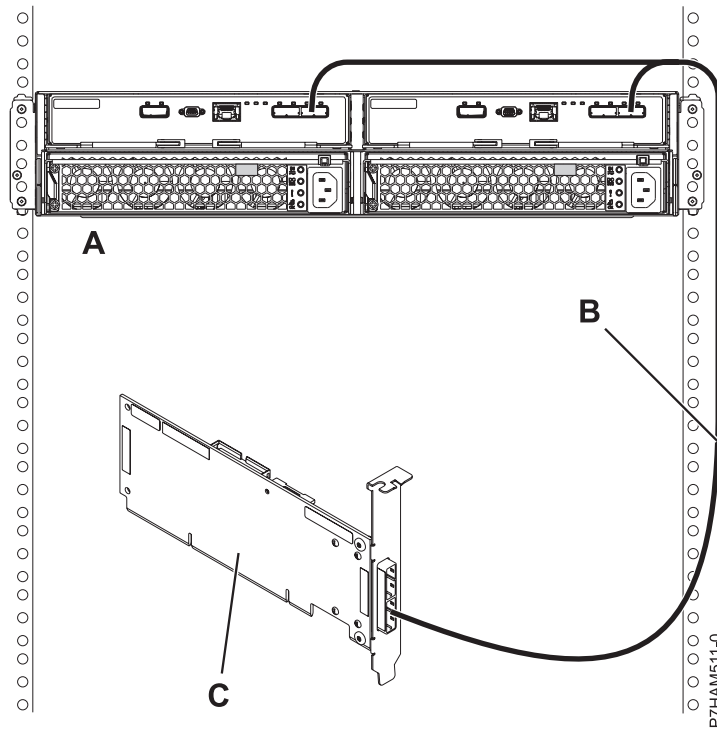

Figure 218. Mode 1 connection of a 58/87 drawer using a YO cable to a single SAS adapter

2. Single FC 5904, FC 5906, or FC 5908 adapter to two 5887s via a mode 1 connection.
 - 5887 drawers with HDDs only.
 - Connection using SAS YO cables to connect to the 5887 drawers.
3. Dual FC 5904, FC 5906, or FC 5908 adapters to one 5887 via a mode 1 connection.
 - 5887 drawers with 1 - 24 HDDs or 1 - 8 SSDs.
 - Connection using Dual SAS YO cables to connect to the 5887 drawer.

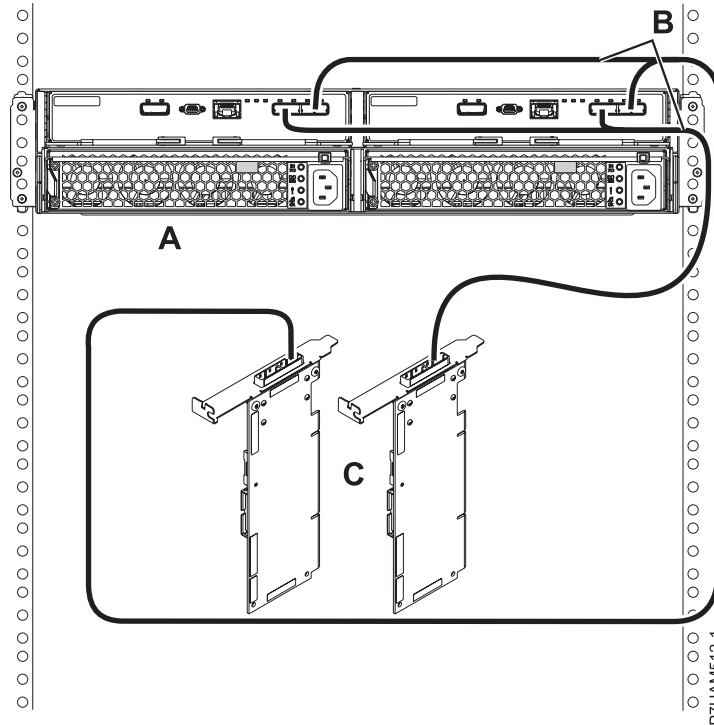

Figure 219. Mode 1 connection of a 58/87 drawer using YO cables to dual SAS adapters

4. Dual FC 5904, FC 5906, or FC 5908 adapters to two 5887s via a mode 1 connection.
 - 5887 drawers with HDDs only.
 - Connection using SAS YO cables to connect to the 5887 drawers.
5. Single FC 5904, FC 5906, or FC 5908 adapter to one 5886 and one 5887 via a mode 1 connection.
 - 5886 and 5887 drawers with HDDs only.
 - Connection using SAS YO cables to connect to both the 5886 drawer and the 5887 drawer.
6. Single FC 5904, FC 5906, or FC 5908 adapter to one 5886 and two 5887s via a mode 1 connection.
 - 5886 and 5887 drawers with HDDs only.
 - Connection using SAS YO cables to connect to both the 5886 drawer and the 5887 drawers.
7. Single FC 5904, FC 5906, or FC 5908 adapter to two 5886s and one 5887 via a mode 1 connection.
 - 5886 and 5887 drawers with HDDs only.
 - Connection using SAS YO cables to connect to both the 5886 drawers and the 5887 drawer.
8. Dual FC 5904, FC 5906, or FC 5908 adapters to one 5886 and one 5887 via a mode 1 connection.
 - 5886 and 5887 drawers with HDDs only.
 - Connection using SAS X cables to connect to the 5886 drawer and SAS YO cables to the 5887 drawer.
9. Dual FC 5904, FC 5906, or FC 5908 adapters to one 5886 and two 5887s via a mode 1 connection.
 - 5886 and 5887 drawers with HDDs only.
 - Connection using SAS X cables to connect to the 5886 drawer and SAS YO cables to the 5887 drawers.
10. Dual FC 5904, FC 5906, or FC 5908 adapters to two 5886s and one 5887 via a mode 1 connection.
 - 5886 and 5887 drawers with HDDs only.
 - Connection using SAS X cables to connect to the 5886 drawers and SAS YO cables to the 5887 drawer.

SAS adapter (FC 5913) to the 5887

There are four supported configurations to connect the FC 5913 adapter to a 5887 and three supported mixed configurations to a 5886 and 5887.

Notes:

1. Maximum of 24 SSDs for a pair of FC 5913s.
2. Allowed to have 24 SSDs in a single drawer or split between two drawers.
3. No cascading of 5887 drawers.
4. No cascading of 5886 drawers in mixed configurations.
5. In mode 2, the 5887 appears as two logical drawers.
6. The long end (0.5 m) of the YO cable must be connected to the left side of the drawer (as viewed from the rear) and the short end (0.25 m) must be connected to the right side of drawer (as viewed from the rear).

The following list describes the supported configurations:

1. Dual FC 5913 adapters to one 5887 via a mode 1 connection.
 - 5887 drawers with 1 - 24 HDDs or SSDs.
 - Connection using SAS 6x YO cables to connect to the 5887 drawer (both cables must be attached to the same port on each adapter).
 - SAS 6x AA cable is required for connecting the pair of FC 5913 adapters.
2. Dual FC 5913 adapters to two 5887s via a mode 1 connection.
 - 5887 drawers with either a maximum of 48 HDDs or 24 SSDs only (cannot have a mix of HDDs and SSDs in the same drawer).
 - Connection using SAS 6x YO cables to connect to the 5887 drawers.
 - SAS 6x AA cable is required for connecting the pair of FC 5913 adapters.
3. Dual FC 5913 adapters to three 5887s via a mode 1 connection.
 - 5887 drawers with either a maximum of 72 HDDs or 24 SSDs only (cannot have a mix of HDDs and SSDs in the same drawer).
 - Connection using SAS 6x YO cables to connect to the 5887 drawers.
4. Quad FC 5913 adapters to one 5887 via a split connection.
 - 1 - 12 SSDs or 1 - 12 HDDs per FC 5913 pair.
 - Connection using SAS 6x X cables to connect to the 5887 drawer (both cables must be attached to the same port on each adapter).
 - SAS 6x AA cable is required for connecting each pair of FC 5913 adapters.
 - Supported only on AIX and Linux systems.
 - No IBM i support.
 - POWER7 only support.
5. Dual FC 5913 adapters to one 5886 and one 5887 via a mode 1 connection.
 - 5886 drawer with 1 - 8 SSDs or 1 - 12 HDDs.
 - 5887 drawer with 1 - 24 SSDs or HDDs.
 - Maximum of 24 SSDs.
 - Connection using SAS 6x X cables to connect to the 5886 drawer.
 - Connection using SAS 6x YO cables to connect to the 5887 drawer.
 - SAS 6x AA cable is required for connecting the pair of FC 5913 adapters.
6. Dual FC 5913 adapters to one 5886 and two 5887s via a mode 1 connection.
 - 5886 drawer with 1 - 8 SSDs or 1 - 12 HDDs.

- 5887 drawers with 1 - 24 SSDs or HDDs.
 - Maximum of 24 SSDs.
 - Connection using SAS 6x X cables to connect to the 5886 drawer.
 - Connection using SAS 6x YO cables to connect to the 5887 drawers.
7. Dual FC 5913 adapters to two 5886s and one 5887 via a mode 1 connection.
 - 5886 drawers with 1 - 8 SSDs or 1 - 12 HDDs.
 - 5887 drawer with 1 - 24 SSDs or HDDs.
 - Maximum of 24 SSDs.
 - Connection using SAS 6x X cables to connect to the 5886 drawers.
 - Connection using SAS 6x YO cables to connect to the 5887 drawer.

SAS adapters with high density (HD) connectors

Learn about the various configurations available using HD connectors.

1. Two SAS adapters with HD connectors to one 5887 via a mode 1 connection.
 - No cascading allowed.
 - HD AA cable is required.

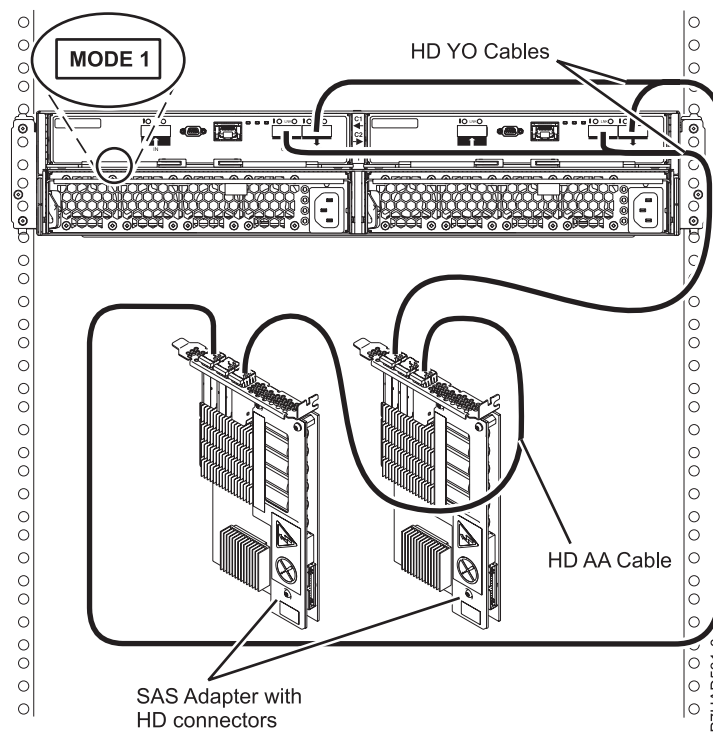

Figure 220. Mode 1 connection of a 58/87 drawer using HD connectors to two SAS adapters

2. Two SAS adapters with HD connectors to two 5887s via a mode 1 connection.
 - No cascading allowed.
 - HD AA cable is required.

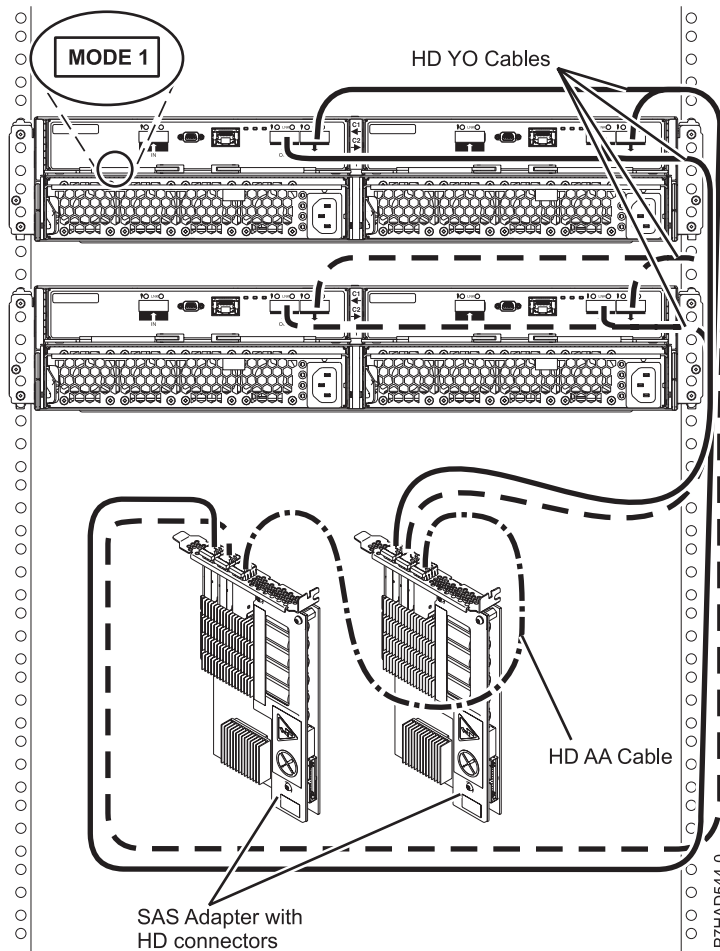

Figure 221. Mode 1 connection of two 58/87 drawers using HD connectors to two SAS adapters

3. Two SAS adapters with HD connectors to three 5887s via a mode 1 connection.
 - No cascading allowed.

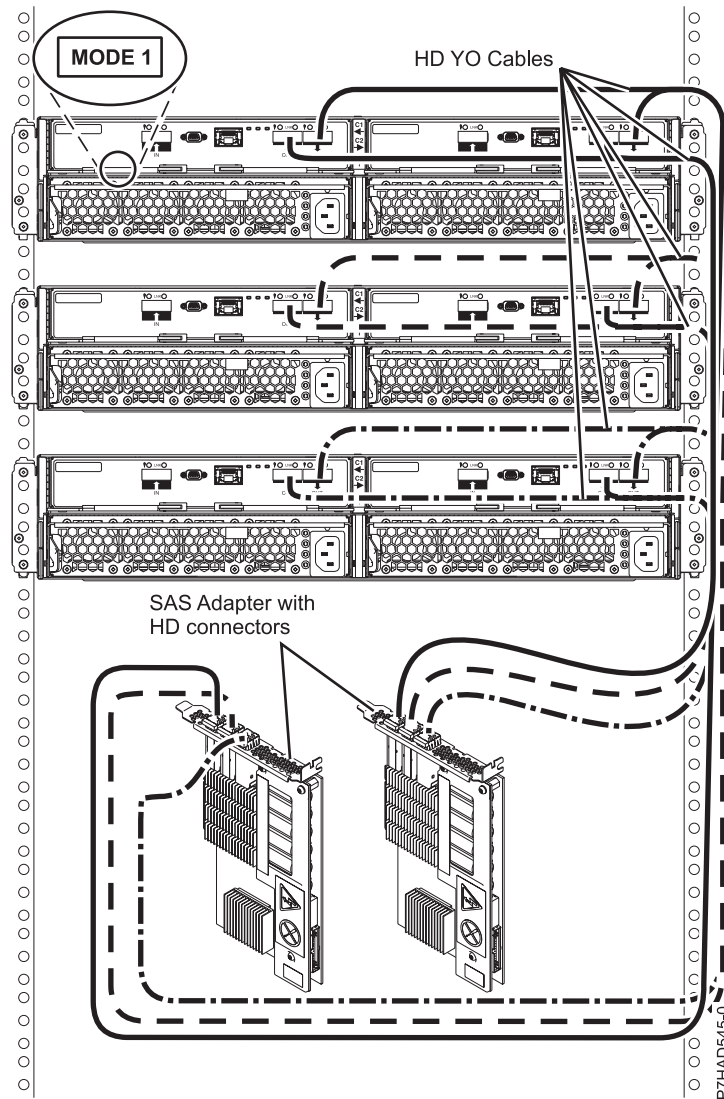

Figure 222. Mode 1 connection of three 58/87 drawers using HD connectors to two SAS adapters

4. Two pairs of SAS adapters with HD connectors to one 5887 via a mode 2 connection
 - No cascading allowed.
 - HD AA cable is required.

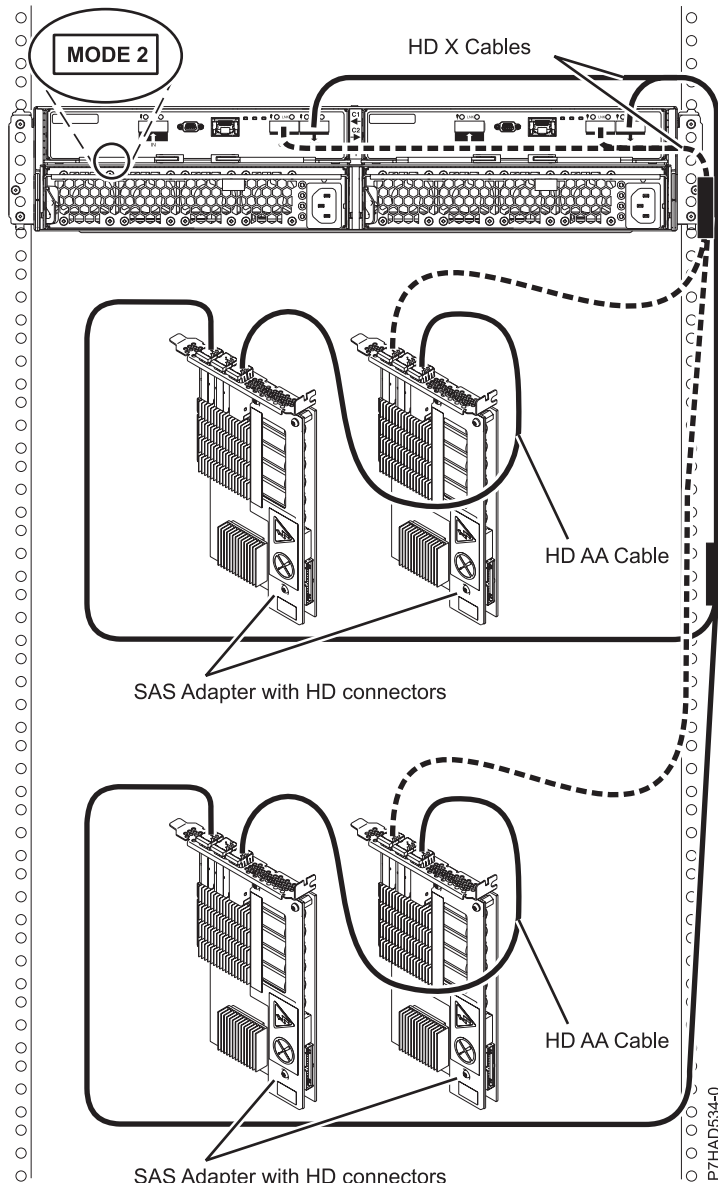

Figure 223. Mode 2 connection of a 58/87 drawer using HD connectors to two pairs of SAS adapters

PCIe storage enclosure (FC EDR1) to the 58/87

The following list describes the supported configurations to connect the EDR1 to the 58/87.

1. One EDR1 to one 58/87 drawer.
 - Both HD EX cables from the 58/87 must be attached to the same numbered port on each EDR1.

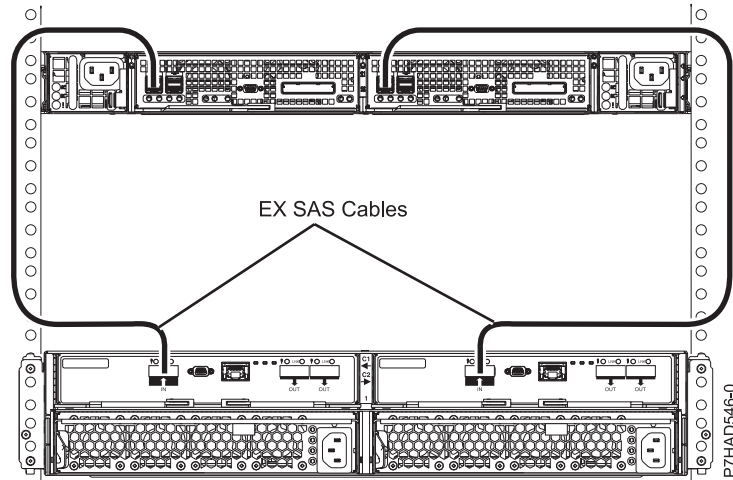

Figure 224. Connection of one 58/87 drawer by using HD EX cables to one EDR1

2. One EDR1 to two 58/87 drawers.

- Both HD EX cables from the same 58/87 must be attached to the same numbered port on each EDR1.

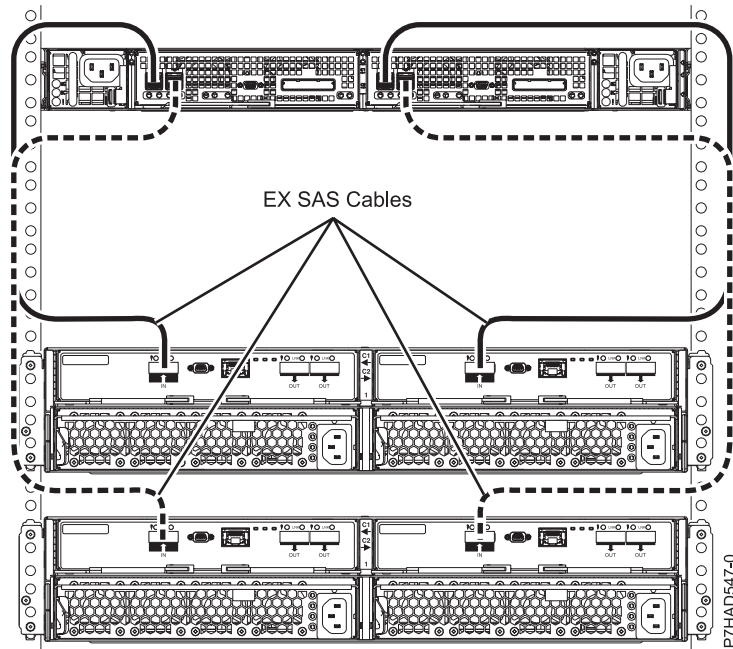

Figure 225. Connection of two 58/87 drawers by using HD EX cables to one EDR1

Rack installation procedures for racks

Learn the requirements and specifications for installing systems into racks .

This topic provides requirements and specifications for 19-inch racks. These requirements and specifications are provided as an aid to help you understand the requirements to install systems into racks. It is your responsibility, working with your rack manufacturer, to ensure that the rack chosen meets the requirements and specifications listed here. Mechanical drawings of the rack, if available from the manufacturer, are recommended for comparison against the requirements and specifications.

IBM maintenance services and installation planning services do not cover verification of non-IBM racks for compliance to Power Systems rack specifications. IBM offers racks for IBM products that are tested and verified by IBM development labs to comply with applicable safety and regulatory requirements. These racks are also tested and verified to fit and function well with IBM products. The customer is responsible for verifying with their rack manufacturer that any non-IBM racks comply with IBM specifications.

Note: The IBM 7014-T00, 7014-T42, 7014-B42, 0551, and 0553 racks meet all the requirements and specifications.

Rack specifications

The general rack specifications are:

- The rack or cabinet must meet the EIA Standard EIA-310-D for 19-inch racks published August 24, 1992. The EIA-310-D standard specifies internal dimensions, for example, the width of the rack opening (width of the chassis), the width of the module mounting flanges, the mounting hole spacing, and the depth of the mounting flanges. The EIA-310-D standard does not control the overall external width of the rack. There are no restrictions on the location of side walls and corner posts relative to the internal mounting space.
- The front rack opening must be 451 mm wide + 0.75 mm (17.75 in. + 0.03 in.), and the rail-mounting holes must be 465 mm + 0.8 mm (18.3 in. + 0.03 in.) apart on center (horizontal width between vertical columns of holes on the two front-mounting flanges and on the two rear-mounting flanges).

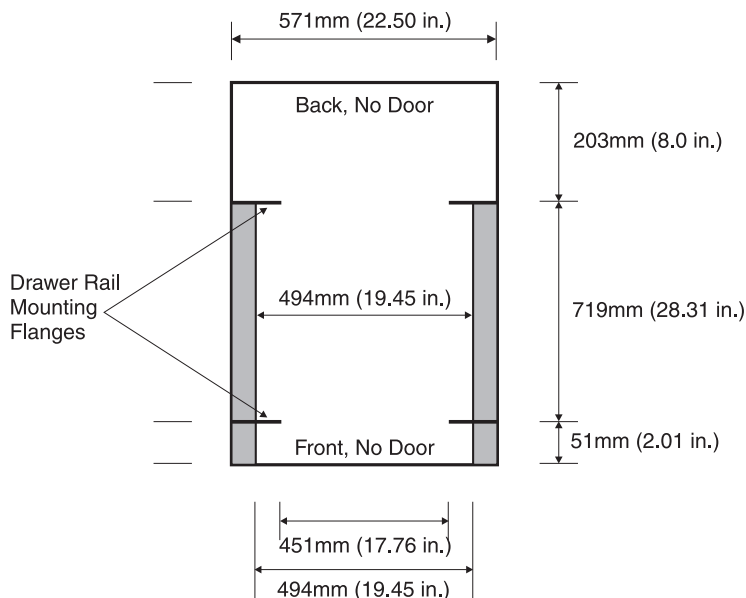

The vertical distance between mounting holes must consist of sets of three holes spaced (from bottom to top) 15.9 mm (0.625 in.), 15.9 mm (0.625 in.), and 12.67 mm (0.5 in.) on center (making each three hole set of vertical hole spacing 44.45 mm (1.75 in.) apart on center). The front and rear mounting flanges in the rack or cabinet must be 719 mm (28.3 in.) apart and the internal width bounded by the mounting flanges at least 494 mm (19.45 in.), for the rails to fit in your rack or cabinet (see the following figure).

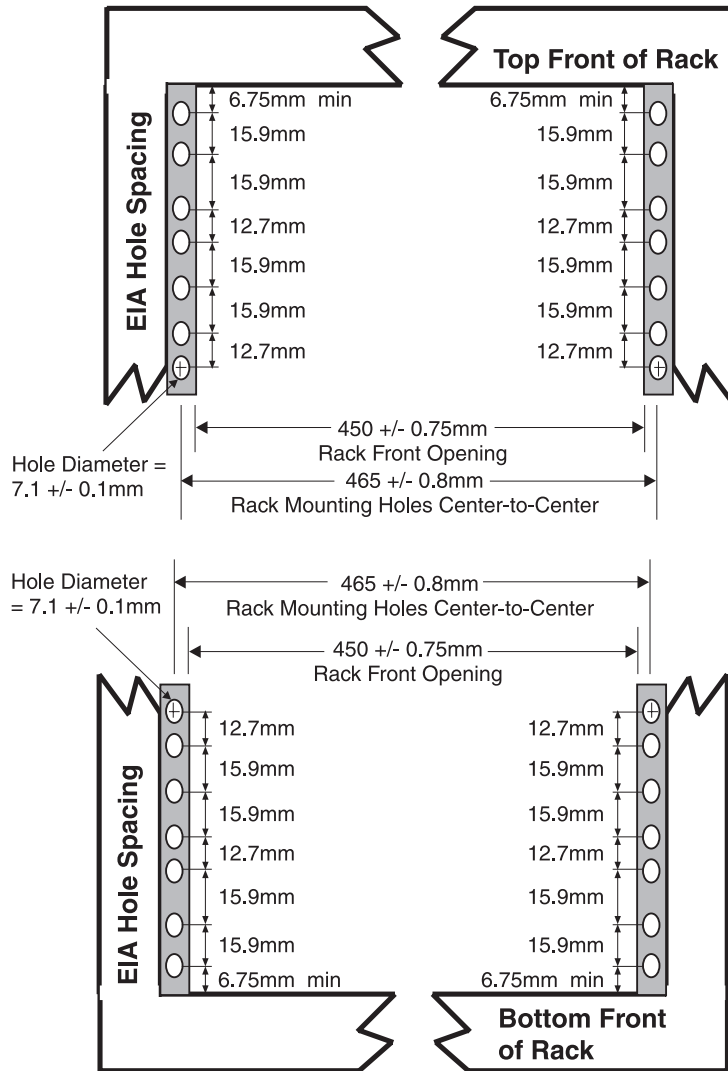

- Models 9117-MMB and 9179-MHB use SMP and FSP flex assemblies that extend beyond the rack mount post width. The front rack opening must be 535 mm (21.06 in.) wide for dimension C (the width between the outsides of the standard mounting flanges, see Figure 100 on page 164). The back rack opening must be 500 mm (19.69 in.) wide for dimension C (the width between the outsides of the standard mounting flanges).

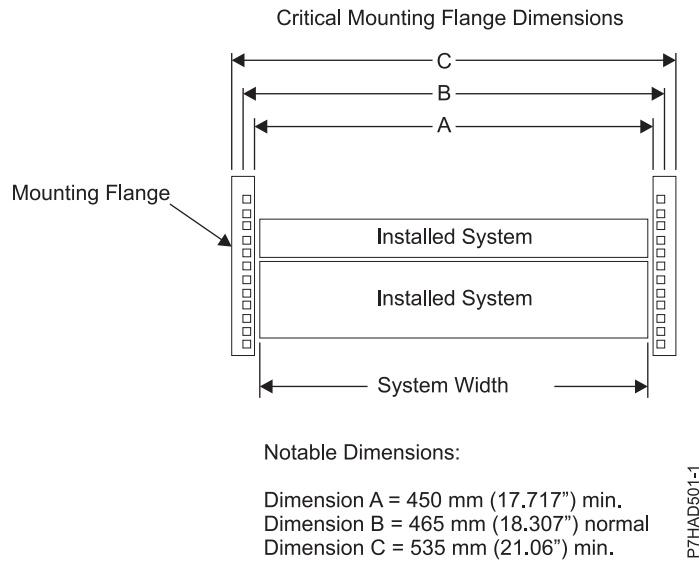
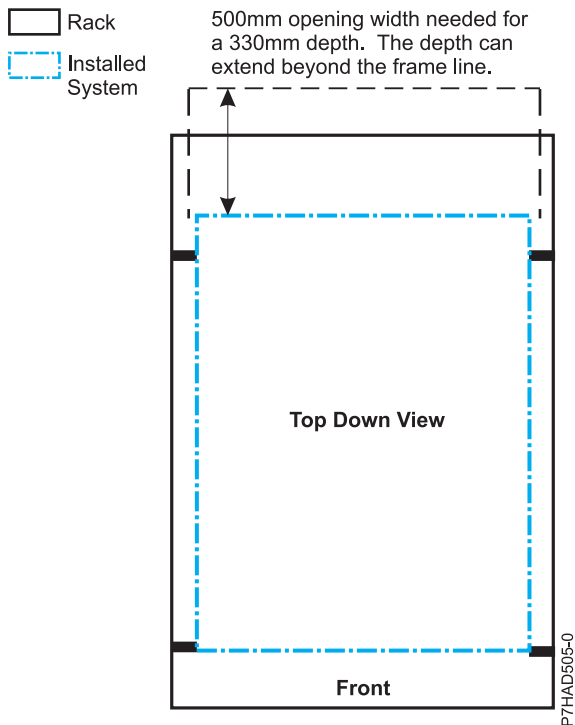

Figure 226. Critical mounting flange dimensions

- A minimum rack opening width of 500 mm (19.69 in.) for a depth of 330 mm (12.99 in.) is needed behind the installed system for maintenance and service. The depth can extend beyond the rack rear door.



- The rack or cabinet must be capable of supporting an average load of 15.9 kg (35 lb) of product weight per EIA unit.
 For example, a four EIA drawer has a maximum drawer weight of 63.6 kg (140 lb).
 - 7.1 mm plus or minus 0.1 mm
 - 9.2 mm plus or minus 0.1 mm
 - 12 mm plus or minus 0.1 mm
- All parts shipped with the Power Systems products must be installed.

- Only ac power drawers are supported in the rack or cabinet. It is strongly recommended to use a power distribution unit that meets the same specifications as power distribution units to supply rack power (for example, feature code 7188). Rack or cabinet power distribution devices must meet the drawer voltage, amperage, and power requirements, as well as that of any additional products that will be connected to the same power distribution device.

The rack or cabinet power receptacle (power distribution unit, uninterruptible power supply, or multi-outlet strip) must have a compatible plug type for your drawer or device.

- The rack or cabinet must be compatible with the drawer-mounting rails. The rail-mounting pins and screws should fit securely and snugly into the rack or cabinet rail-mounting holes. It is strongly recommended that the mounting rails and mounting hardware that are included with the product be used to install it in the rack. The mounting rails and mounting hardware that are provided with products have been designed and tested to safely support the product during operation and service activities as well as to safely support the weight of your drawer or device. The rails must facilitate service access by allowing the drawer to be safely extended, if necessary, forward, backward, or both. Some rails provide drawer specific anti-tip brackets, rear lock-down brackets, and cable management guides that require clearance on the rear side of the rails.

Note: If the rack or cabinet has square holes on the mounting flanges, a plug-in hole adapter might be required.

At a minimum, mounting rails must be able to support four times the maximum rated product weight in its worst-case position (fully-extended front and rear positions) for one full minute without catastrophic failure.

- The rack or cabinet must have stabilization feet or brackets installed both in the front and rear of the rack, or have another means of preventing the rack/cabinet from tipping while the drawer or device is pulled into its extreme front or rear service positions.

Note: Examples of some acceptable alternatives: The rack or cabinet might be securely bolted to the floor, ceiling or walls, or to adjacent racks or cabinets in a long and heavy row of racks or cabinets.

- There must be adequate front and rear service clearances (in and around the rack or cabinet). The rack or cabinet must have sufficient horizontal width clearance in the front and rear to allow the drawer to be fully slid into the front and, if applicable, the rear service access positions (typically this requires 914.4 mm (36 in.) clearance in both the front and rear).
- If present, front and rear doors must be able to open far enough to provide unrestrained access for service or be easily removable. If doors must be removed for service, it is the customer's responsibility to remove them prior to service.
- The rack or cabinet must provide adequate clearance around the rack drawer.
- There must be adequate clearance around the drawer bezel so that it can be opened and closed, according to the product specifications.
- Front or rear doors must also maintain a minimum of 51 mm (2 in.) front, 203 mm (8 in.) rear, door to mounting flange clearance, and 494 mm (19.4 in.) front, 571 mm (22.5 in.) rear, side-to-side clearance for drawer bezels and cables.
- The rack or cabinet must provide adequate front-to-back ventilation.

Note: For optimum ventilation, it is recommended the rack or cabinet not have a front door. If the rack or cabinet has doors, the doors must be fully perforated so that there is proper front-to-back airflow to maintain the required drawer ambient inlet temperature as specified in the server specifications. The perforations should yield at least 34 % minimum open area per square inch.

General safety requirements for products installed in a rack or cabinet

The general safety requirements for products installed in racks are:

- Any product or component that plugs into either an power distribution unit or mains power (via a power cord), or uses any voltage over 42 V ac or 60 V dc (considered to be hazardous voltage) must be Safety Certified by a Nationally Recognized Test Laboratory (NRTL) for the country in which it will be installed.

Some of the items that require safety certification might include: the rack or cabinet (if it contains electrical components integral to the rack or cabinet), fan trays, power distribution unit, uninterruptible power supplies, multi-outlet strips, or any other products installed in the rack or cabinet that connect to hazardous voltage.

Examples of OSHA-approved NRTLs for the U.S.:

- UL
- ETL
- CSA (with CSA NRTL or CSA US mark)

Examples of approved NRTLs for Canada:

- UL (ULc mark)
- ETL (ETLc mark)
- CSA

The European Union requires a CE mark and a Manufacturer's Declaration of Conformity (DOC).

Certified products should have the NRTL logos or marks somewhere on the product or product label. However, proof of certification must be made available upon request. Proof consists of such items as copies of the NRTL license or certificate, a CB Certificate, a Letter of Authorization to apply the NRTL mark, the first few pages of the NRTL certification report, Listing in an NRTL publication, or a copy of the UL Yellow Card. Proof should contain the manufacturers name, product type and model, standard to which it was certified, the NRTL name or logo, the NRTL file number or license number, and a list of any Conditions of Acceptance or Deviations. A Manufacturer's Declaration is not proof of certification by an NRTL.

- The rack or cabinet must meet all electrical and mechanical safety legal requirements for the country in which it is installed. The rack or cabinet must be free of exposed hazards (such as voltages over 60 V dc or 42 V ac, energy over 240 VA, sharp edges, mechanical pinch points, or hot surfaces).
- There must be an accessible and unambiguous disconnect device for each product in the rack, including any power distribution unit.

A disconnect device might consist of either the plug on the power cord (if the power cord is no longer than 1.8 m (6 ft)), the appliance inlet receptacle (if the power cord is of a detachable type), or a power on/off switch, or an Emergency Power Off switch on the rack, provided all power is removed from the rack or product by the disconnect device.

If the rack or cabinet has electrical components (such as fan trays or lights), the rack must have an accessible and unambiguous disconnect device.

- The rack or cabinet, power distribution unit and multi-outlet strips, and products installed in the rack or cabinet must all be properly grounded to the customer facility ground.

There must be no more than 0.1 Ohms between the ground pin of the power distribution unit or rack plug and any touchable metal or conductive surface on the rack and on the products installed in the rack. Grounding method must comply with applicable country's electric code (such as NEC or CEC). Ground continuity can be verified by your service personnel, after the installation is completed, and should be verified prior to the first service activity.

- The voltage rating of the power distribution unit and multi-outlet strips must be compatible with the products plugged into them.

The power distribution unit or multi-outlet strips current and power ratings are rated at 80% of the building supply circuit (as required by the National Electrical Code and the Canadian Electrical Code). The total load connected to the power distribution unit must be less than the rating of the power distribution unit. For example, a power distribution unit with a 30 A connection will be rated for a total load of 24 A (30 A x 80 %). Therefore, the sum of all equipment connected to the power distribution unit in this example must be lower than the 24 A rating.

If an uninterruptible power supply is installed, it must meet all the electrical safety requirements as described for a power distribution unit (including certification by an NRTL).

- The rack or cabinet, power distribution unit, uninterruptible power supply, multi-outlet strips and all products in the rack or cabinet must be installed according to the manufacturer's instructions, and in accordance with all national, state or province, and local codes and laws.

The rack or cabinet, power distribution unit, uninterruptible power supply, multi-outlet strips and all products in the rack or cabinet must be used as intended by the manufacturer (per manufacturer's product documentation and marketing literature).

- All documentation for use and installation of the rack or cabinet, power distribution unit, uninterruptible power supply, and all products in the rack or cabinet, including safety information, must be available on-site.
- If there is more than one source of power in the rack cabinet, there must be clearly visible safety labels for "Multiple Power Source" (in the languages required for the country in which the product is installed).
- If the rack or cabinet or any products installed in the cabinet had safety or weight labels applied by the manufacturer, they must be intact and translated into the languages required for the country in which the product is installed.
- If the rack or cabinet has doors, the rack becomes a fire enclosure by definition and must meet the applicable flammability ratings (V-0 or better). Totally metal enclosures at least 1 mm (0.04 in.) thick are considered to comply.

Nonenclosure (decorative) materials must have a flammability rating of V-1 or better. If glass is used (such as in rack doors) it must be safety glass. If wood shelves are used in the rack/cabinet, they must be treated with a UL Listed flame-retardant coating.

- The rack or cabinet configuration must comply with all requirements for "safe to service" (contact your Installation Planning Representative for assistance in determining if the environment is safe).

There must be no unique maintenance procedures or tools required for service.

Elevated service installations, where the products to be serviced are installed between 1.5 m and 3.7 m (5 ft and 12 ft) above the floor, require the availability of an OSHA- and CSA-approved nonconductive step ladder. If a ladder is required for service, the customer must supply the OSHA- and CSA-approved nonconductive step ladder (unless other arrangements have been made with the local Service Branch Office). Products installed over 2.9 m (9 ft) above the floor require a Special Bid to be completed before they can be serviced by service personnel.

For products not intended for rack-mounting to be serviced, the products and parts that will be replaced as part of that service must not weigh over 11.4 kg (25 lb) Contact your Installation Planning Representative if in doubt.

There must not be any special education or training required for safe servicing of any of the products installed in the racks. Contact your Installation Planning Representative if you are in doubt.

Related reference:

"Rack specifications" on page 127

Rack specifications provide detailed information for your rack, including dimensions, electrical, power, temperature, environment, and service clearances.

Notices

This information was developed for products and services offered in the U.S.A.

The manufacturer may not offer the products, services, or features discussed in this document in other countries. Consult the manufacturer's representative for information on the products and services currently available in your area. Any reference to the manufacturer's product, program, or service is not intended to state or imply that only that product, program, or service may be used. Any functionally equivalent product, program, or service that does not infringe any intellectual property right of the manufacturer may be used instead. However, it is the user's responsibility to evaluate and verify the operation of any product, program, or service.

The manufacturer may have patents or pending patent applications covering subject matter described in this document. The furnishing of this document does not grant you any license to these patents. You can send license inquiries, in writing, to the manufacturer.

The following paragraph does not apply to the United Kingdom or any other country where such provisions are inconsistent with local law: THIS PUBLICATION IS PROVIDED "AS IS" WITHOUT WARRANTY OF ANY KIND, EITHER EXPRESS OR IMPLIED, INCLUDING, BUT NOT LIMITED TO, THE IMPLIED WARRANTIES OF NON-INFRINGEMENT, MERCHANTABILITY OR FITNESS FOR A PARTICULAR PURPOSE. Some states do not allow disclaimer of express or implied warranties in certain transactions, therefore, this statement may not apply to you.

This information could include technical inaccuracies or typographical errors. Changes are periodically made to the information herein; these changes will be incorporated in new editions of the publication. The manufacturer may make improvements and/or changes in the product(s) and/or the program(s) described in this publication at any time without notice.

Any references in this information to websites not owned by the manufacturer are provided for convenience only and do not in any manner serve as an endorsement of those websites. The materials at those websites are not part of the materials for this product and use of those websites is at your own risk.

The manufacturer may use or distribute any of the information you supply in any way it believes appropriate without incurring any obligation to you.

Any performance data contained herein was determined in a controlled environment. Therefore, the results obtained in other operating environments may vary significantly. Some measurements may have been made on development-level systems and there is no guarantee that these measurements will be the same on generally available systems. Furthermore, some measurements may have been estimated through extrapolation. Actual results may vary. Users of this document should verify the applicable data for their specific environment.

Information concerning products not produced by this manufacturer was obtained from the suppliers of those products, their published announcements or other publicly available sources. This manufacturer has not tested those products and cannot confirm the accuracy of performance, compatibility or any other claims related to products not produced by this manufacturer. Questions on the capabilities of products not produced by this manufacturer should be addressed to the suppliers of those products.

All statements regarding the manufacturer's future direction or intent are subject to change or withdrawal without notice, and represent goals and objectives only.

The manufacturer's prices shown are the manufacturer's suggested retail prices, are current and are subject to change without notice. Dealer prices may vary.

This information is for planning purposes only. The information herein is subject to change before the products described become available.

This information contains examples of data and reports used in daily business operations. To illustrate them as completely as possible, the examples include the names of individuals, companies, brands, and products. All of these names are fictitious and any similarity to the names and addresses used by an actual business enterprise is entirely coincidental.

If you are viewing this information in softcopy, the photographs and color illustrations may not appear.

The drawings and specifications contained herein shall not be reproduced in whole or in part without the written permission of the manufacturer.

The manufacturer has prepared this information for use with the specific machines indicated. The manufacturer makes no representations that it is suitable for any other purpose.

The manufacturer's computer systems contain mechanisms designed to reduce the possibility of undetected data corruption or loss. This risk, however, cannot be eliminated. Users who experience unplanned outages, system failures, power fluctuations or outages, or component failures must verify the accuracy of operations performed and data saved or transmitted by the system at or near the time of the outage or failure. In addition, users must establish procedures to ensure that there is independent data verification before relying on such data in sensitive or critical operations. Users should periodically check the manufacturer's support websites for updated information and fixes applicable to the system and related software.

Homologation statement

This product may not be certified in your country for connection by any means whatsoever to interfaces of public telecommunications networks. Further certification may be required by law prior to making any such connection. Contact an IBM representative or reseller for any questions.

Trademarks

IBM, the IBM logo, and ibm.com are trademarks or registered trademarks of International Business Machines Corp., registered in many jurisdictions worldwide. Other product and service names might be trademarks of IBM or other companies. A current list of IBM trademarks is available on the web at Copyright and trademark information at www.ibm.com/legal/copytrade.shtml.

INFINIBAND, InfiniBand Trade Association, and the INFINIBAND design marks are trademarks and/or service marks of the INFINIBAND Trade Association.

Linux is a registered trademark of Linus Torvalds in the United States, other countries, or both.

Electronic emission notices

When attaching a monitor to the equipment, you must use the designated monitor cable and any interference suppression devices supplied with the monitor.

Class A Notices

The following Class A statements apply to the servers.

Federal Communications Commission (FCC) statement

Note: This equipment has been tested and found to comply with the limits for a Class A digital device, pursuant to Part 15 of the FCC Rules. These limits are designed to provide reasonable protection against

harmful interference when the equipment is operated in a commercial environment. This equipment generates, uses, and can radiate radio frequency energy and, if not installed and used in accordance with the instruction manual, may cause harmful interference to radio communications. Operation of this equipment in a residential area is likely to cause harmful interference, in which case the user will be required to correct the interference at his own expense.

Properly shielded and grounded cables and connectors must be used in order to meet FCC emission limits. IBM is not responsible for any radio or television interference caused by using other than recommended cables and connectors or by unauthorized changes or modifications to this equipment. Unauthorized changes or modifications could void the user's authority to operate the equipment.

This device complies with Part 15 of the FCC rules. Operation is subject to the following two conditions: (1) this device may not cause harmful interference, and (2) this device must accept any interference received, including interference that may cause undesired operation.

Industry Canada Compliance Statement

This Class A digital apparatus complies with Canadian ICES-003.

Avis de conformité à la réglementation d'Industrie Canada

Cet appareil numérique de la classe A est conforme à la norme NMB-003 du Canada.

European Community Compliance Statement

This product is in conformity with the protection requirements of EU Council Directive 2004/108/EC on the approximation of the laws of the Member States relating to electromagnetic compatibility. IBM cannot accept responsibility for any failure to satisfy the protection requirements resulting from a non-recommended modification of the product, including the fitting of non-IBM option cards.

This product has been tested and found to comply with the limits for Class A Information Technology Equipment according to European Standard EN 55022. The limits for Class A equipment were derived for commercial and industrial environments to provide reasonable protection against interference with licensed communication equipment.

European Community contact:
IBM Deutschland GmbH
Technical Regulations, Department M372
IBM-Allee 1, 71139 Ehningen, Germany
Tele: +49 7032 15 2941
email: lugi@de.ibm.com

Warning: This is a Class A product. In a domestic environment, this product may cause radio interference, in which case the user may be required to take adequate measures.

VCCI Statement - Japan

この装置は、クラスA 情報技術装置です。この装置を家庭環境で使用すると電波妨害を引き起こすことがあります。この場合には使用者が適切な対策を講ずるよう要求されることがあります。

VCCI-A

The following is a summary of the VCCI Japanese statement in the box above:

This is a Class A product based on the standard of the VCCI Council. If this equipment is used in a domestic environment, radio interference may occur, in which case, the user may be required to take corrective actions.

Japanese Electronics and Information Technology Industries Association (JEITA) Confirmed Harmonics Guideline (products less than or equal to 20 A per phase)

高調波ガイドライン適合品

Japanese Electronics and Information Technology Industries Association (JEITA) Confirmed Harmonics Guideline with Modifications (products greater than 20 A per phase)

高調波ガイドライン準用品

Electromagnetic Interference (EMI) Statement - People's Republic of China

声 明

此为 A 级产品,在生活环境中,
该产品可能会造成无线电干扰。
在这种情况下,可能需要用户对其
干扰采取切实可行的措施。

Declaration: This is a Class A product. In a domestic environment this product may cause radio interference in which case the user may need to perform practical action.

Electromagnetic Interference (EMI) Statement - Taiwan

警告使用者：

這是甲類的資訊產品，在
居住的環境中使用時，可
能會造成射頻干擾，在這
種情況下，使用者會被要
求採取某些適當的對策。

The following is a summary of the EMI Taiwan statement above.

Warning: This is a Class A product. In a domestic environment this product may cause radio interference in which case the user will be required to take adequate measures.

Electromagnetic Interference (EMI) Statement - Korea

이 기기는 업무용(A급)으로 전자파적합기기로서 판매자 또는 사용자는 이 점을 주의하시기 바라며, 가정외의 지역에서 사용하는 것을 목적으로 합니다.

Germany Compliance Statement

Deutschsprachiger EU Hinweis: Hinweis für Geräte der Klasse A EU-Richtlinie zur Elektromagnetischen Verträglichkeit

Dieses Produkt entspricht den Schutzanforderungen der EU-Richtlinie 2004/108/EG zur Angleichung der Rechtsvorschriften über die elektromagnetische Verträglichkeit in den EU-Mitgliedsstaaten und hält die Grenzwerte der EN 55022 Klasse A ein.

Um dieses sicherzustellen, sind die Geräte wie in den Handbüchern beschrieben zu installieren und zu betreiben. Des Weiteren dürfen auch nur von der IBM empfohlene Kabel angeschlossen werden. IBM übernimmt keine Verantwortung für die Einhaltung der Schutzanforderungen, wenn das Produkt ohne Zustimmung von IBM verändert bzw. wenn Erweiterungskomponenten von Fremdherstellern ohne Empfehlung von IBM gesteckt/eingebaut werden.

EN 55022 Klasse A Geräte müssen mit folgendem Warnhinweis versehen werden:

"Warnung: Dieses ist eine Einrichtung der Klasse A. Diese Einrichtung kann im Wohnbereich Funk-Störungen verursachen; in diesem Fall kann vom Betreiber verlangt werden, angemessene Maßnahmen zu ergreifen und dafür aufzukommen."

Deutschland: Einhaltung des Gesetzes über die elektromagnetische Verträglichkeit von Geräten

Dieses Produkt entspricht dem "Gesetz über die elektromagnetische Verträglichkeit von Geräten (EMVG)". Dies ist die Umsetzung der EU-Richtlinie 2004/108/EG in der Bundesrepublik Deutschland.

Zulassungsbescheinigung laut dem Deutschen Gesetz über die elektromagnetische Verträglichkeit von Geräten (EMVG) (bzw. der EMC EG Richtlinie 2004/108/EG) für Geräte der Klasse A

Dieses Gerät ist berechtigt, in Übereinstimmung mit dem Deutschen EMVG das EG-Konformitätszeichen - CE - zu führen.

Verantwortlich für die Einhaltung der EMV Vorschriften ist der Hersteller:

International Business Machines Corp.

New Orchard Road

Armonk, New York 10504

Tel: 914-499-1900

Der verantwortliche Ansprechpartner des Herstellers in der EU ist:

IBM Deutschland GmbH

Technical Regulations, Abteilung M372

IBM-Allee 1, 71139 Ehningen, Germany

Tel: +49 7032 15 2941

email: lugi@de.ibm.com

Generelle Informationen:

Das Gerät erfüllt die Schutzanforderungen nach EN 55024 und EN 55022 Klasse A.

Electromagnetic Interference (EMI) Statement - Russia

ВНИМАНИЕ! Настоящее изделие относится к классу А.
В жилых помещениях оно может создавать радиопомехи, для снижения которых необходимы дополнительные меры

Class B Notices

The following Class B statements apply to features designated as electromagnetic compatibility (EMC) Class B in the feature installation information.

Federal Communications Commission (FCC) statement

This equipment has been tested and found to comply with the limits for a Class B digital device, pursuant to Part 15 of the FCC Rules. These limits are designed to provide reasonable protection against harmful interference in a residential installation.

This equipment generates, uses, and can radiate radio frequency energy and, if not installed and used in accordance with the instructions, may cause harmful interference to radio communications. However, there is no guarantee that interference will not occur in a particular installation.

If this equipment does cause harmful interference to radio or television reception, which can be determined by turning the equipment off and on, the user is encouraged to try to correct the interference by one or more of the following measures:

- Reorient or relocate the receiving antenna.
- Increase the separation between the equipment and receiver.
- Connect the equipment into an outlet on a circuit different from that to which the receiver is connected.
- Consult an IBM-authorized dealer or service representative for help.

Properly shielded and grounded cables and connectors must be used in order to meet FCC emission limits. Proper cables and connectors are available from IBM-authorized dealers. IBM is not responsible for any radio or television interference caused by unauthorized changes or modifications to this equipment. Unauthorized changes or modifications could void the user's authority to operate this equipment.

This device complies with Part 15 of the FCC rules. Operation is subject to the following two conditions: (1) this device may not cause harmful interference, and (2) this device must accept any interference received, including interference that may cause undesired operation.

Industry Canada Compliance Statement

This Class B digital apparatus complies with Canadian ICES-003.

Avis de conformité à la réglementation d'Industrie Canada

Cet appareil numérique de la classe B est conforme à la norme NMB-003 du Canada.

European Community Compliance Statement

This product is in conformity with the protection requirements of EU Council Directive 2004/108/EC on the approximation of the laws of the Member States relating to electromagnetic compatibility. IBM cannot accept responsibility for any failure to satisfy the protection requirements resulting from a non-recommended modification of the product, including the fitting of non-IBM option cards.

This product has been tested and found to comply with the limits for Class B Information Technology Equipment according to European Standard EN 55022. The limits for Class B equipment were derived for typical residential environments to provide reasonable protection against interference with licensed communication equipment.

European Community contact:
IBM Deutschland GmbH
Technical Regulations, Department M372
IBM-Allee 1, 71139 Ehningen, Germany
Tele: +49 7032 15 2941
email: lugi@de.ibm.com

VCCI Statement - Japan

この装置は、クラスB情報技術装置です。この装置は、家庭環境で使用することを目的としていますが、この装置がラジオやテレビジョン受信機に近接して使用されると、受信障害を引き起こすことがあります。

取扱説明書に従って正しい取り扱いをして下さい。 VCCI-B

Japanese Electronics and Information Technology Industries Association (JEITA) Confirmed Harmonics Guideline (products less than or equal to 20 A per phase)

高調波ガイドライン適合品

Japanese Electronics and Information Technology Industries Association (JEITA) Confirmed Harmonics Guideline with Modifications (products greater than 20 A per phase)

高調波ガイドライン準用品

Electromagnetic Interference (EMI) Statement - Korea

이 기기는 가정용(B급)으로 전자파적합기기로서 주로 가정에서 사용하는 것을 목적으로 하며, 모든 지역에서 사용할 수 있습니다.

Germany Compliance Statement

Deutschsprachiger EU Hinweis: Hinweis für Geräte der Klasse B EU-Richtlinie zur Elektromagnetischen Verträglichkeit

Dieses Produkt entspricht den Schutzanforderungen der EU-Richtlinie 2004/108/EG zur Angleichung der Rechtsvorschriften über die elektromagnetische Verträglichkeit in den EU-Mitgliedsstaaten und hält die Grenzwerte der EN 55022 Klasse B ein.

Um dieses sicherzustellen, sind die Geräte wie in den Handbüchern beschrieben zu installieren und zu betreiben. Des Weiteren dürfen auch nur von der IBM empfohlene Kabel angeschlossen werden. IBM übernimmt keine Verantwortung für die Einhaltung der Schutzanforderungen, wenn das Produkt ohne Zustimmung von IBM verändert bzw. wenn Erweiterungskomponenten von Fremdherstellern ohne Empfehlung von IBM gesteckt/eingebaut werden.

Deutschland: Einhaltung des Gesetzes über die elektromagnetische Verträglichkeit von Geräten

Dieses Produkt entspricht dem "Gesetz über die elektromagnetische Verträglichkeit von Geräten (EMVG)". Dies ist die Umsetzung der EU-Richtlinie 2004/108/EG in der Bundesrepublik Deutschland.

Zulassungsbescheinigung laut dem Deutschen Gesetz über die elektromagnetische Verträglichkeit von Geräten (EMVG) (bzw. der EMC EG Richtlinie 2004/108/EG) für Geräte der Klasse B

Dieses Gerät ist berechtigt, in Übereinstimmung mit dem Deutschen EMVG das EG-Konformitätszeichen - CE - zu führen.

Verantwortlich für die Einhaltung der EMV Vorschriften ist der Hersteller:
International Business Machines Corp.
New Orchard Road
Armonk, New York 10504
Tel: 914-499-1900

Der verantwortliche Ansprechpartner des Herstellers in der EU ist:
IBM Deutschland GmbH
Technical Regulations, Abteilung M372
IBM-Allee 1, 71139 Ehningen, Germany
Tel: +49 7032 15 2941
email: lugi@de.ibm.com

Generelle Informationen:

Das Gerät erfüllt die Schutzanforderungen nach EN 55024 und EN 55022 Klasse B.

Terms and conditions

Permissions for the use of these publications are granted subject to the following terms and conditions.

Applicability: These terms and conditions are in addition to any terms of use for the the manufacturer website.

Personal Use: You may reproduce these publications for your personal, noncommercial use provided that all proprietary notices are preserved. You may not distribute, display or make derivative works of these publications, or any portion thereof, without the express consent of the manufacturer.

Commercial Use: You may reproduce, distribute and display these publications solely within your enterprise provided that all proprietary notices are preserved. You may not make derivative works of

these publications, or reproduce, distribute or display these publications or any portion thereof outside your enterprise, without the express consent of the manufacturer.

Rights: Except as expressly granted in this permission, no other permissions, licenses or rights are granted, either express or implied, to the Publications or any information, data, software or other intellectual property contained therein.

The manufacturer reserves the right to withdraw the permissions granted herein whenever, in its discretion, the use of the publications is detrimental to its interest or, as determined by the manufacturer, the above instructions are not being properly followed.

You may not download, export or re-export this information except in full compliance with all applicable laws and regulations, including all United States export laws and regulations.

THE MANUFACTURER MAKES NO GUARANTEE ABOUT THE CONTENT OF THESE PUBLICATIONS. THE PUBLICATIONS ARE PROVIDED "AS-IS" AND WITHOUT WARRANTY OF ANY KIND, EITHER EXPRESSED OR IMPLIED, INCLUDING BUT NOT LIMITED TO IMPLIED WARRANTIES OF MERCHANTABILITY, NON-INFRINGEMENT, AND FITNESS FOR A PARTICULAR PURPOSE.

Printed in USA