

Disk drive backplane for the E5-700

ESCALA Power7



REFERENCE  
86 A1 15FF 05



# ESCALA Power7

## Disk drive backplane for the E5-700

The ESCALA Power7 publications concern the following models:

- Bull Escala E5-700 (Power 750 / 8233-E8B)
- Bull Escala M6-700 (Power 770 / 9117-MMB)
- Bull Escala M6-705 (Power 770 / 9117-MMC)
- Bull Escala M7-700 (Power 780 / 9179-MHB)
- Bull Escala M7-705 (Power 780 / 9179-MHC)
- Bull Escala E1-700 (Power 710 / 8231-E2B)
- Bull Escala E1-705 (Power 710 / 8231-E1C)
- Bull Escala E2-700 / E2-700T (Power 720 / 8202-E4B)
- Bull Escala E2-705 / E2-705T (Power 720 / 8202-E4C)
- Bull Escala E3-700 (Power 730 / 8231-E2B)
- Bull Escala E3-705 (Power 730 / 8231-E2C)
- Bull Escala E4-700 / E4-700T (Power 740 / 8205-E6B)
- Bull Escala E4-705 (Power 740 / 8205-E6C)

References to Power 755 / 8236-E8C models are irrelevant.

## Hardware

May 2012

BULL CEDOC  
357 AVENUE PATTON  
B.P.20845  
49008 ANGERS CEDEX 01  
FRANCE

REFERENCE  
86 A1 15FF 05

The following copyright notice protects this book under Copyright laws which prohibit such actions as, but not limited to, copying, distributing, modifying, and making derivative works.

Copyright © Bull SAS 2012

Printed in France

Suggestions and criticisms concerning the form, content, and presentation of this book are invited. A form is provided at the end of this book for this purpose.

To order additional copies of this book or other Bull Technical Publications, you are invited to use the Ordering Form also provided at the end of this book.

### **Trademarks and Acknowledgements**

We acknowledge the right of proprietors of trademarks mentioned in this book.

*The information in this document is subject to change without notice. Bull will not be liable for errors contained herein, or for incidental or consequential damages in connection with the use of this material.*

---

# Contents

<b>Safety notices</b> . . . . .	<b>v</b>
---------------------------------	----------

---

<b>Disk drive backplane for the 33E/8B or 36E/8C</b> . . . . .	<b>1</b>
--	----------

<b>Removing and replacing the disk drive backplane</b> . . . . .	<b>3</b>
--	----------

Removing the 33E/8B or 36E/8C disk drive backplane . . . . .	3
Replacing the 33E/8B or 36E/8C disk drive backplane . . . . .	10

<b>Common procedures</b> . . . . .	<b>17</b>
------------------------------------	-----------

Before you begin . . . . .	17
----------------------------	----

Identifying a part . . . . .	19
------------------------------	----

Identifying a failing part in an AIX system or logical partition . . . . .	19
--	----

Locating a failing part in an AIX system or logical partition . . . . .	19
---	----

Activating the indicator light for the failing part . . . . .	20
---	----

Deactivating the failing-part indicator light . . . . .	20
---	----

Identifying a failing part in a Linux system or logical partition . . . . .	20
---	----

Locating a failing part in a Linux system or logical partition . . . . .	20
--	----

Finding the location code of a failing part in a Linux system or logical partition . . . . .	21
--	----

Activating the indicator light for the failing part . . . . .	21
---	----

Deactivating the failing-part indicator light . . . . .	21
---	----

Locating a failing part in a Virtual I/O Server system or logical partition . . . . .	21
---	----

Identifying a part by using the Virtual I/O Server . . . . .	22
--	----

Starting the system or logical partition . . . . .	22
--	----

Starting a system that is not managed by a Hardware Management Console or a Systems Director Management Console . . . . .	22
---	----

Starting a system or logical partition by using the HMC . . . . .	24
---	----

Stopping a system or logical partition . . . . .	24
--	----

Stopping a system that is not managed by an HMC or an SDMC . . . . .	24
--	----

Stopping a system by using the HMC . . . . .	26
--	----

Removing and replacing covers on the 33E/8B or 36E/8C system . . . . .	27
--	----

Removing the service access cover from an 33E/8B or 36E/8C system . . . . .	27
---	----

Installing the service access cover on an 33E/8B or 36E/8C system . . . . .	28
---	----

Removing the front cover from an 33E/8B or 36E/8C system . . . . .	28
--	----

Installing the front cover on an 33E/8B or 36E/8C system . . . . .	29
--	----

Installing a part by using the HMC . . . . .	30
--	----

Removing a part by using the HMC . . . . .	31
--	----

Replacing a part by using the HMC . . . . .	31
---	----

Installing a part by using the SDMC . . . . .	31
---	----

Verifying the installed part . . . . .	32
--	----

Verifying an installed feature or replaced part in an AIX system or logical partition . . . . .	32
---	----

Verifying the installed part in a Linux system or logical partition . . . . .	34
---	----

Verifying an installed part by using stand-alone diagnostics . . . . .	35
--	----

Verifying the installed part by using the HMC . . . . .	36
---	----

Activating and deactivating LEDs by using the HMC . . . . .	37
---	----

Deactivating a system attention LED or partition LED . . . . .	37
--	----

Activating or deactivating an identify LED . . . . .	37
--	----

Viewing serviceable events by using the HMC . . . . .	38
---	----

Verifying an installed part or replaced part on a system or logical partition by using Virtual I/O Server tools . . . . .	39
---	----

Verifying the installed part by using VIOS . . . . .	39
--	----

Verify the replacement part by using VIOS . . . . .	39
---	----

<b>Notices</b> . . . . .	<b>43</b>
--------------------------	-----------

Trademarks . . . . .	44
----------------------	----

Electronic emission notices . . . . .	44
---------------------------------------	----

Class A Notices . . . . .	44
Class B Notices . . . . .	48
Terms and conditions . . . . .	50

---

## Safety notices

Safety notices may be printed throughout this guide.

- **DANGER** notices call attention to a situation that is potentially lethal or extremely hazardous to people.
- **CAUTION** notices call attention to a situation that is potentially hazardous to people because of some existing condition.
- **Attention** notices call attention to the possibility of damage to a program, device, system, or data.

### World Trade safety information

Several countries require the safety information contained in product publications to be presented in their national languages. If this requirement applies to your country, a safety information booklet is included in the publications package shipped with the product. The booklet contains the safety information in your national language with references to the U.S. English source. Before using a U.S. English publication to install, operate, or service this product, you must first become familiar with the related safety information in the booklet. You should also refer to the booklet any time you do not clearly understand any safety information in the U.S. English publications.

### Laser safety information

The servers can use I/O cards or features that are fiber-optic based and that utilize lasers or LEDs.

#### Laser compliance

The servers may be installed inside or outside of an IT equipment rack.

## DANGER

When working on or around the system, observe the following precautions:

Electrical voltage and current from power, telephone, and communication cables are hazardous. To avoid a shock hazard:

- Connect power to this unit only with the provided power cord. Do not use the provided power cord for any other product.
- Do not open or service any power supply assembly.
- Do not connect or disconnect any cables or perform installation, maintenance, or reconfiguration of this product during an electrical storm.
- The product might be equipped with multiple power cords. To remove all hazardous voltages, disconnect all power cords.
- Connect all power cords to a properly wired and grounded electrical outlet. Ensure that the outlet supplies proper voltage and phase rotation according to the system rating plate.
- Connect any equipment that will be attached to this product to properly wired outlets.
- When possible, use one hand only to connect or disconnect signal cables.
- Never turn on any equipment when there is evidence of fire, water, or structural damage.
- Disconnect the attached power cords, telecommunications systems, networks, and modems before you open the device covers, unless instructed otherwise in the installation and configuration procedures.
- Connect and disconnect cables as described in the following procedures when installing, moving, or opening covers on this product or attached devices.

To Disconnect:

1. Turn off everything (unless instructed otherwise).
2. Remove the power cords from the outlets.
3. Remove the signal cables from the connectors.
4. Remove all cables from the devices

To Connect:

1. Turn off everything (unless instructed otherwise).
2. Attach all cables to the devices.
3. Attach the signal cables to the connectors.
4. Attach the power cords to the outlets.
5. Turn on the devices.

(D005a)

## DANGER



Observe the following precautions when working on or around your IT rack system:

- Heavy equipment—personal injury or equipment damage might result if mishandled.
- Always lower the leveling pads on the rack cabinet.
- Always install stabilizer brackets on the rack cabinet.
- To avoid hazardous conditions due to uneven mechanical loading, always install the heaviest devices in the bottom of the rack cabinet. Always install servers and optional devices starting from the bottom of the rack cabinet.
- Rack-mounted devices are not to be used as shelves or work spaces. Do not place objects on top of rack-mounted devices.



- Each rack cabinet might have more than one power cord. Be sure to disconnect all power cords in the rack cabinet when directed to disconnect power during servicing.
- Connect all devices installed in a rack cabinet to power devices installed in the same rack cabinet. Do not plug a power cord from a device installed in one rack cabinet into a power device installed in a different rack cabinet.
- An electrical outlet that is not correctly wired could place hazardous voltage on the metal parts of the system or the devices that attach to the system. It is the responsibility of the customer to ensure that the outlet is correctly wired and grounded to prevent an electrical shock.

#### CAUTION

- Do not install a unit in a rack where the internal rack ambient temperatures will exceed the manufacturer's recommended ambient temperature for all your rack-mounted devices.
- Do not install a unit in a rack where the air flow is compromised. Ensure that air flow is not blocked or reduced on any side, front, or back of a unit used for air flow through the unit.
- Consideration should be given to the connection of the equipment to the supply circuit so that overloading of the circuits does not compromise the supply wiring or overcurrent protection. To provide the correct power connection to a rack, refer to the rating labels located on the equipment in the rack to determine the total power requirement of the supply circuit.
- *(For sliding drawers.)* Do not pull out or install any drawer or feature if the rack stabilizer brackets are not attached to the rack. Do not pull out more than one drawer at a time. The rack might become unstable if you pull out more than one drawer at a time.
- *(For fixed drawers.)* This drawer is a fixed drawer and must not be moved for servicing unless specified by the manufacturer. Attempting to move the drawer partially or completely out of the rack might cause the rack to become unstable or cause the drawer to fall out of the rack.

(R001)

**CAUTION:**

Removing components from the upper positions in the rack cabinet improves rack stability during relocation. Follow these general guidelines whenever you relocate a populated rack cabinet within a room or building:

- Reduce the weight of the rack cabinet by removing equipment starting at the top of the rack cabinet. When possible, restore the rack cabinet to the configuration of the rack cabinet as you received it. If this configuration is not known, you must observe the following precautions:
  - Remove all devices in the 32U position and above.
  - Ensure that the heaviest devices are installed in the bottom of the rack cabinet.
  - Ensure that there are no empty U-levels between devices installed in the rack cabinet below the 32U level.
- If the rack cabinet you are relocating is part of a suite of rack cabinets, detach the rack cabinet from the suite.
- Inspect the route that you plan to take to eliminate potential hazards.
- Verify that the route that you choose can support the weight of the loaded rack cabinet. Refer to the documentation that comes with your rack cabinet for the weight of a loaded rack cabinet.
- Verify that all door openings are at least 760 x 230 mm (30 x 80 in.).
- Ensure that all devices, shelves, drawers, doors, and cables are secure.
- Ensure that the four leveling pads are raised to their highest position.
- Ensure that there is no stabilizer bracket installed on the rack cabinet during movement.
- Do not use a ramp inclined at more than 10 degrees.
- When the rack cabinet is in the new location, complete the following steps:
  - Lower the four leveling pads.
  - Install stabilizer brackets on the rack cabinet.
  - If you removed any devices from the rack cabinet, repopulate the rack cabinet from the lowest position to the highest position.
- If a long-distance relocation is required, restore the rack cabinet to the configuration of the rack cabinet as you received it. Pack the rack cabinet in the original packaging material, or equivalent. Also lower the leveling pads to raise the casters off of the pallet and bolt the rack cabinet to the pallet.

(R002)

(L001)



(L002)



(L003)

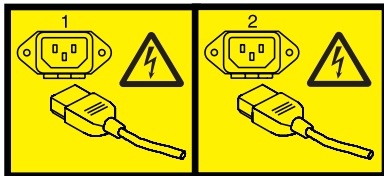

or



All lasers are certified in the U.S. to conform to the requirements of DHHS 21 CFR Subchapter J for class 1 laser products. Outside the U.S., they are certified to be in compliance with IEC 60825 as a class 1 laser product. Consult the label on each part for laser certification numbers and approval information.

**CAUTION:**

This product might contain one or more of the following devices: CD-ROM drive, DVD-ROM drive, DVD-RAM drive, or laser module, which are Class 1 laser products. Note the following information:

- Do not remove the covers. Removing the covers of the laser product could result in exposure to hazardous laser radiation. There are no serviceable parts inside the device.
- Use of the controls or adjustments or performance of procedures other than those specified herein might result in hazardous radiation exposure.

(C026)

**CAUTION:**

Data processing environments can contain equipment transmitting on system links with laser modules that operate at greater than Class 1 power levels. For this reason, never look into the end of an optical fiber cable or open receptacle. (C027)

**CAUTION:**

This product contains a Class 1M laser. Do not view directly with optical instruments. (C028)

**CAUTION:**

Some laser products contain an embedded Class 3A or Class 3B laser diode. Note the following information: laser radiation when open. Do not stare into the beam, do not view directly with optical instruments, and avoid direct exposure to the beam. (C030)

**CAUTION:**

The battery contains lithium. To avoid possible explosion, do not burn or charge the battery.

*Do Not:*

- \_\_\_ Throw or immerse into water
- \_\_\_ Heat to more than 100°C (212°F)
- \_\_\_ Repair or disassemble

Exchange only with the approved part. Recycle or discard the battery as instructed by local regulations. (C003a)

## **Power and cabling information for NEBS (Network Equipment-Building System) GR-1089-CORE**

The following comments apply to the servers that have been designated as conforming to NEBS (Network Equipment-Building System) GR-1089-CORE:

The equipment is suitable for installation in the following:

- Network telecommunications facilities
- Locations where the NEC (National Electrical Code) applies

The intrabuilding ports of this equipment are suitable for connection to intrabuilding or unexposed wiring or cabling only. The intrabuilding ports of this equipment *must not* be metallically connected to the interfaces that connect to the OSP (outside plant) or its wiring. These interfaces are designed for use as intrabuilding interfaces only (Type 2 or Type 4 ports as described in GR-1089-CORE) and require isolation from the exposed OSP cabling. The addition of primary protectors is not sufficient protection to connect these interfaces metallically to OSP wiring.

**Note:** All Ethernet cables must be shielded and grounded at both ends.

The ac-powered system does not require the use of an external surge protection device (SPD).

The dc-powered system employs an isolated DC return (DC-I) design. The DC battery return terminal *shall not* be connected to the chassis or frame ground.

---

## **Disk drive backplane for the 33E/8B or 36E/8C**

Learn about removing and replacing a disk drive backplane in the server.



---

## Removing and replacing the disk drive backplane

Use this procedure to remove, replace, or install the disk drive backplane in the 7/50 (33E/8B) and 7/55 (36E/8C).

Figure 1 shows the 33E/8B and 36E/8C disk drive backplane.

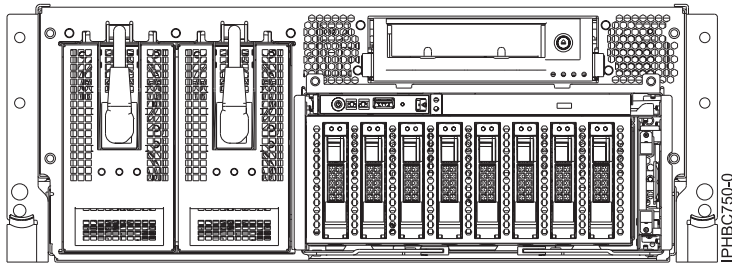

Figure 1. Disk drive backplane

---

## Removing the 33E/8B or 36E/8C disk drive backplane

Learn about removing the disk drive backplane from the server.

### About this task

If your system is managed by the Systems Director Management Console (SDMC), use the SDMC to complete the steps for removing the disk drive backplane from the server. For instructions, see [Removing a part using the Systems Director Management Console](#).

If your system is managed by the Hardware Management Console (HMC), use the HMC to complete the steps for removing the disk drive backplane from the server. For information about using the HMC to remove the disk drive backplane, see [Removing a part using the Hardware Management Console](#).

If you do not have an HMC or SDMC, complete the following steps to remove the disk drive backplane:

### Procedure

1. Perform the prerequisite tasks described in “Before you begin” on page 17.
2. Do one of the following steps, as applicable:
  - a. If you are removing the disk drive backplane for a system upgrade or as part of another procedure, continue to the next step.
  - b. If you are removing the disk drive backplane because of a system failure, use the service action log to help identify the failing part. See “Identifying a part” on page 19.
3. Stop the system or logical partition. For instructions, see [Stopping a system or logical partition](#).
4. Disconnect the power source from the system by unplugging the system.

**Note:** This system has a second power supply. Before continuing with this procedure, ensure that the power source to the system has been completely disconnected.

(L003)

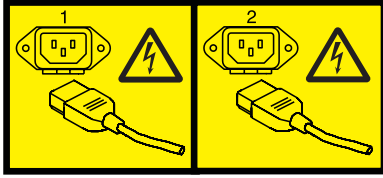

or



5. Remove the front cover. For instructions, see Removing the front cover from a rack-mounted model 33E/8B or 36E/8C.
6. Place the system into the service position. For instructions, see Placing a rack-mounted model 33E/8B or 36E/8C in the service position.
7. Remove the service access cover. For instructions, see Removing the service access cover from a rack-mounted model 33E/8B or 36E/8C.
8. Attach the wrist strap.

**Attention:**

- Attach a wrist strap to an unpainted metal surface of your hardware to prevent electrostatic discharge (ESD) from damaging your hardware.
- When using a wrist strap, follow all electrical safety procedures. A wrist strap is for static control. It does not increase or decrease your risk of receiving electric shock when using or working on electrical equipment.
- If you do not have a wrist strap, just prior to removing the product from ESD packaging and installing or replacing hardware, touch an unpainted metal surface of the system for a minimum of 5 seconds.

9. To remove the fans and the fan cage, complete the following steps:
  - a. To remove the fans, squeeze the tab (A) and lift the fan out of the fan cage as shown in Figure 2 on page 5.

**Note:** If the thumbscrews are too tight, you might need a flat-head screwdriver to complete this step. To pull the fan cage out of the system, you might need to unplug the control panel cable to allow more space.



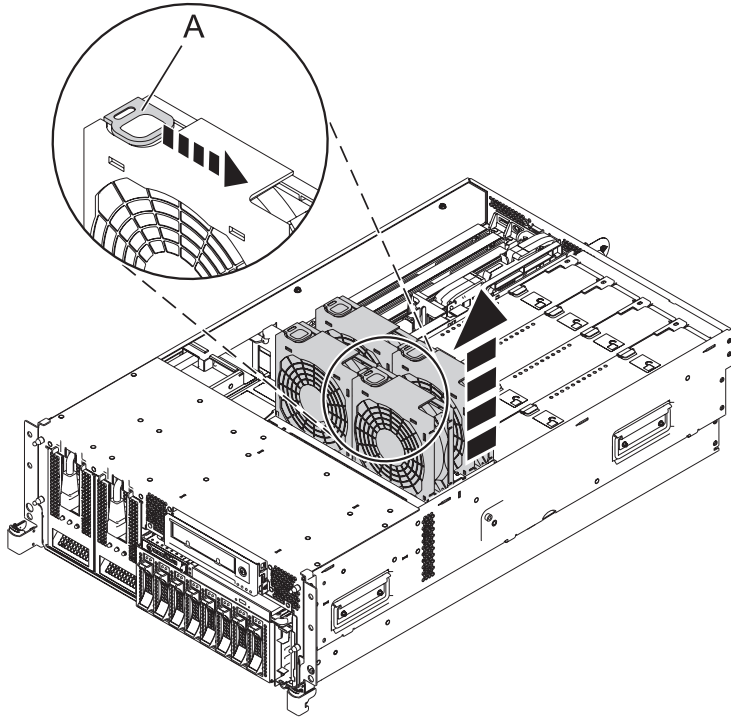

Figure 2. Removing the fan from the fan cage

- b. To remove the air baffles, grasp and pull the air baffle out of the fan cage, as shown in Figure 3.

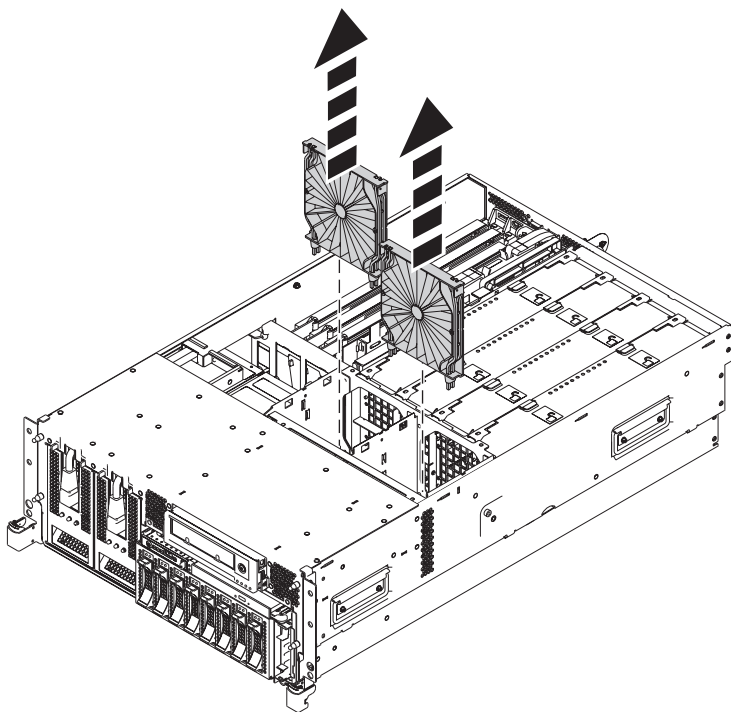

Figure 3. Removing the air baffles from the fan cage

- c. To remove the fan cage, loosen the two thumbscrews (A) and lift the fan cage (B) out of the system as shown in Figure 4.

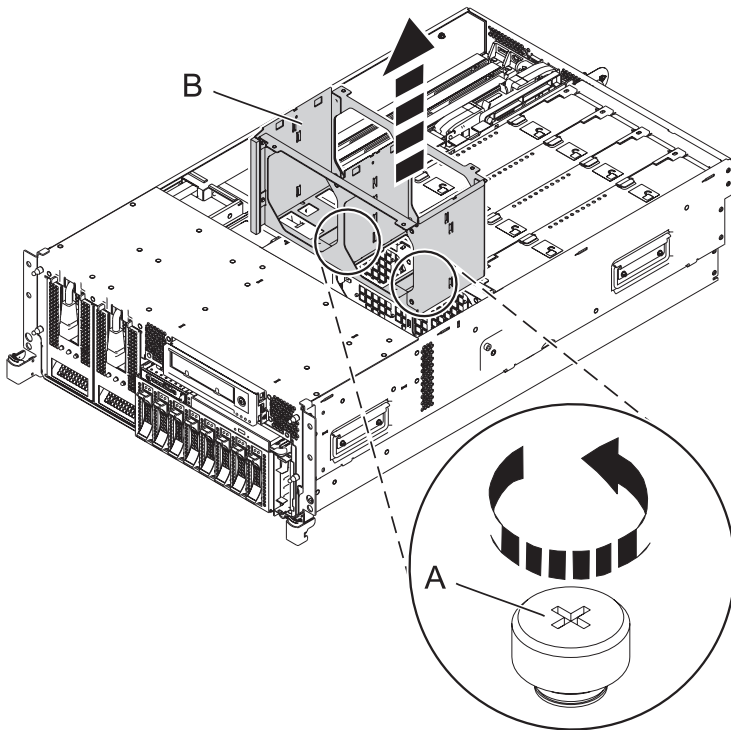

Figure 4. Removing the fan cage from the system

10. Disconnect the cables from the back of the disk drive backplane, as shown in Figure 5 on page 7. If you have connected an external SAS cable, ensure that you disconnect the SAS cable from the disk drive backplane. For more information about external SAS port, refer to Installing the external SAS port on a model 8233-E8B or 8236-E8C.

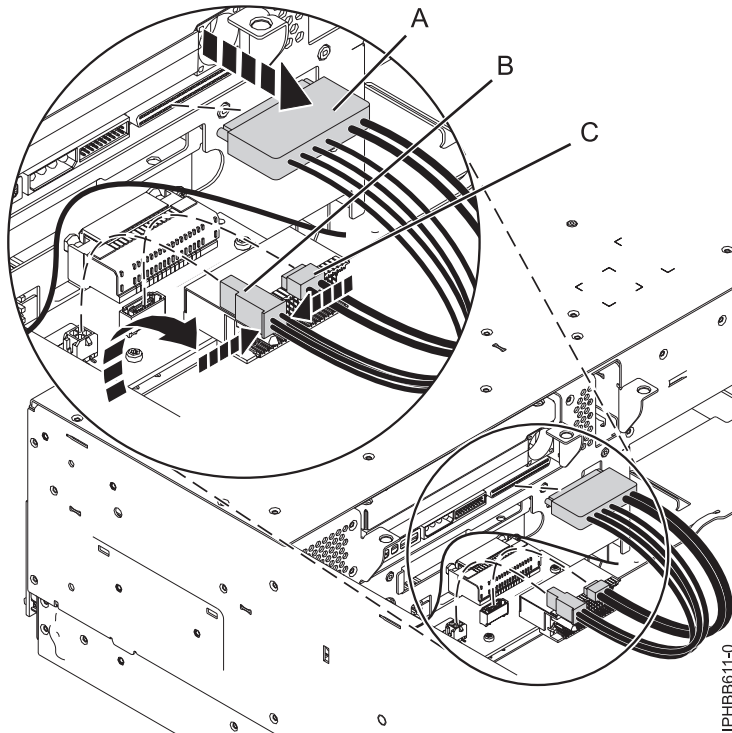

Figure 5. Disconnecting the media device cables from the disk drive backplane

11. If you need to replace the backplane because of an upgrade or system failure, complete the following steps to remove the disk drives, depending on your backplane:

**Note:** If you remove a backplane that is populated with disk drives, the backplane will be heavy. Ensure that you can safely complete the procedure.

- a. To remove the disk drive from the backplane, perform the following steps:

**Note:** Record the location of each disk drive you remove so the disk drive can be replaced into the same location again.

- 1) Unlock the disk drive handle (A) and pull it toward you to unseat the disk drive.
- 2) Place one hand under the disk drive and carefully pull the drive out of the system as shown in Figure 6 on page 8.

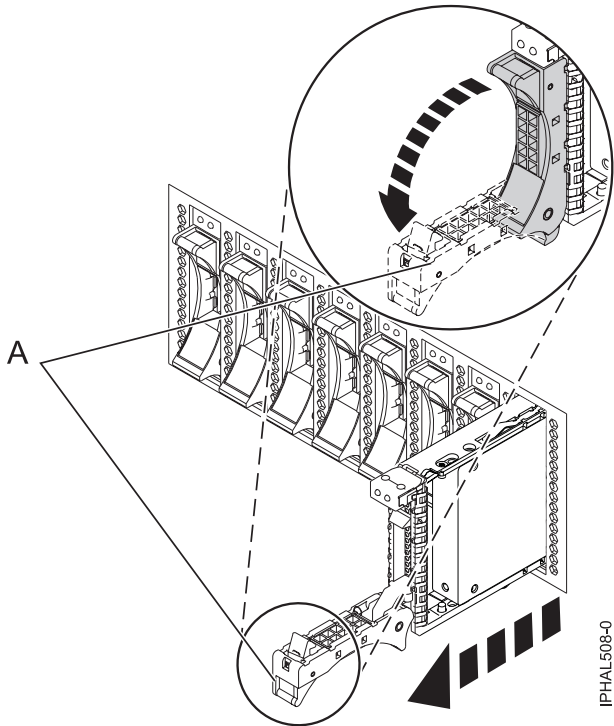

Figure 6. Removing the disk drive from the backplane

12. Remove the media device by pressing in on the latch (A) and sliding the media device out of the system, as shown in the following figure.

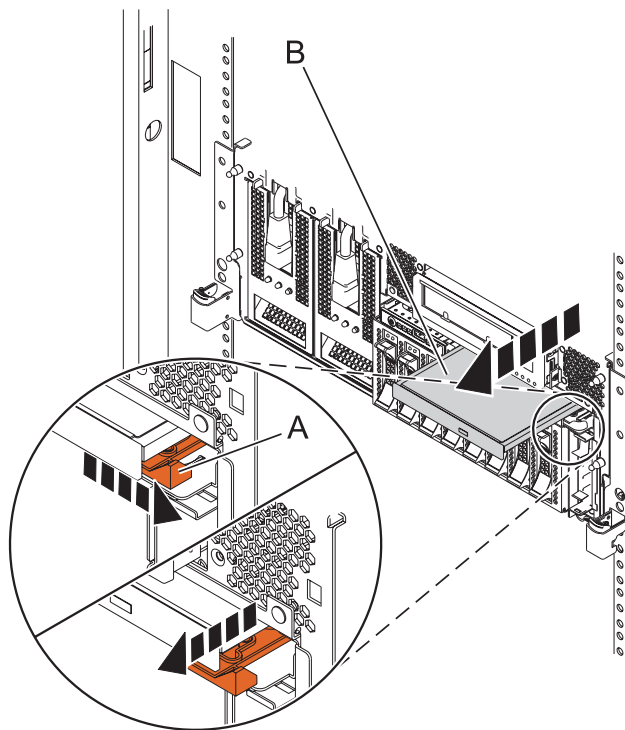
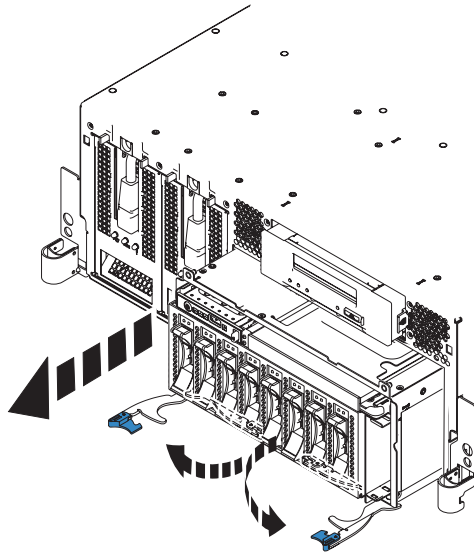

Figure 7. Removing the media device from the disk drive backplane

13. Unlock the disk drive backplane by pulling the handles open from the center of the backplane as shown in Figure 8 and Figure 9.



AREBY515-0

Figure 8. Removing the populated disk drive backplane

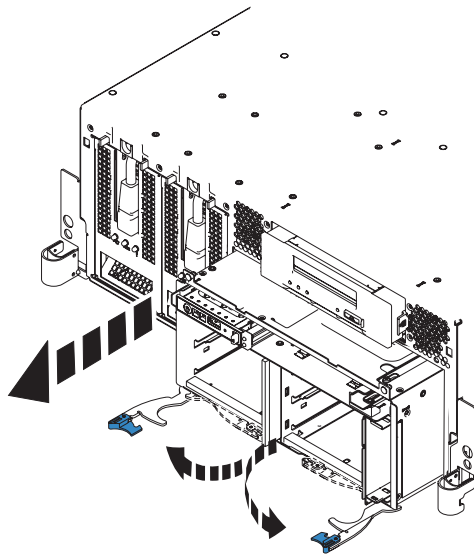

Figure 9. Removing the unpopulated disk drive backplane

14. Pull the backplane out of the server.
15. Remove the control panel and signal cable from the backplane to use in the replacement backplane. For instructions, see Control panel and signal cables.

16. If you removed the backplane as a part of another procedure, continue with that procedure. To replace the backplane or install a new backplane, see Replacing the 33E/8B or 36E/8C disk drive backplane.

---

## Replacing the 33E/8B or 36E/8C disk drive backplane

If you removed the disk drive backplane as a part of another procedure, you might need to use the procedure in this section to replace the disk drive backplane.

### About this task

If your system is managed by the Systems Director Management Console (SDMC), use the SDMC to complete the steps for replacing the disk drive backplane in the server. For instructions, see Replacing a part using the Systems Director Management Console.

If your system is managed by the Hardware Management Console (HMC), use the HMC to complete the steps for replacing the disk drive backplane in the server. For instructions, see Exchanging a part using the Hardware Management Console.

If you do not have an HMC or SDMC, complete the following steps to replace the disk drive backplane:

### Procedure

1. Perform the prerequisite tasks described in “Before you begin” on page 17.
2. Install the control panel and signal cable. For instructions, see Removing and replacing the control panel and control-panel signal cable.
3. Check for a protective cover that might be present on the lower-right connector pins. If a protective cover is present, remove the cover (A), as shown in Figure 10.

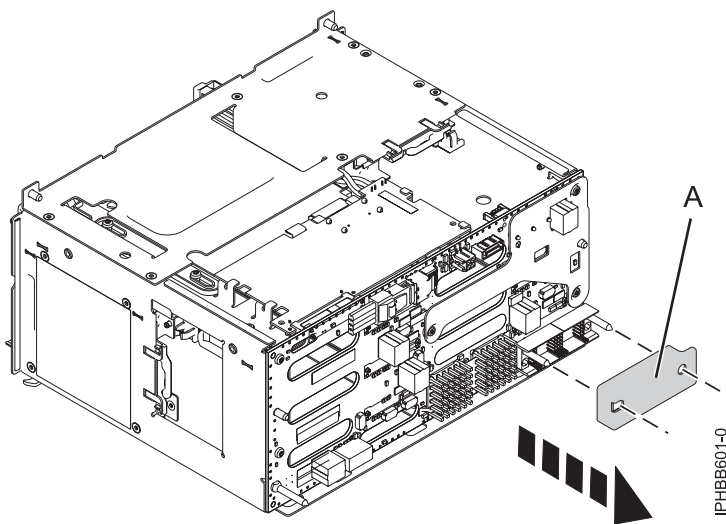

Figure 10. Removing the protective cover from the connector pins

4. Carefully lift the backplane along two sides and align it with the slot in the server.

**Important:** If you remove a backplane that is populated with disk drives, the backplane will be heavy. Ensure that you can safely perform this task before you begin.

5. Insert the backplane firmly into the server, as shown in the following figures.

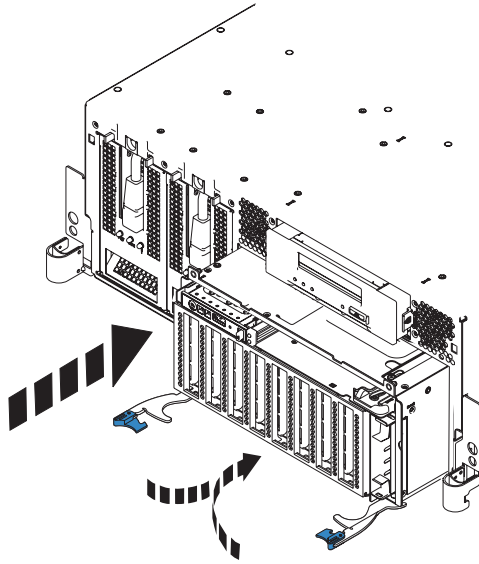
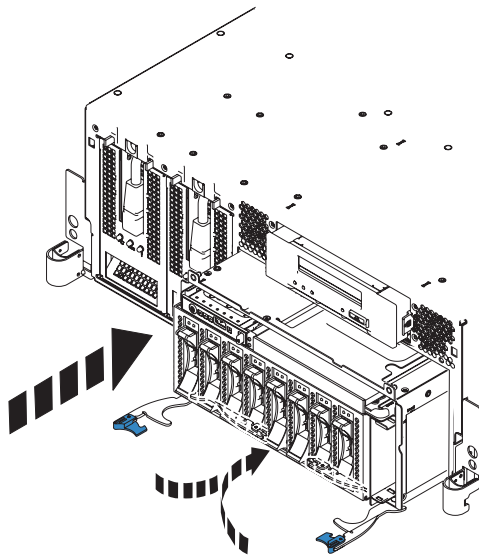

Figure 11. Installing the unpopulated disk drive backplane on a rack-mounted model



AREBY516-0

Figure 12. Installing the populated disk drive backplane on a rack-mounted model

6. Secure the backplane with the locking tabs.
7. Connect the cables to the backplane, as shown in the following figure. You can also connect an external SAS cable to the backplane. For more information about external SAS port, refer to Installing the external SAS port on a model 8233-E8B or 8236-E8C.

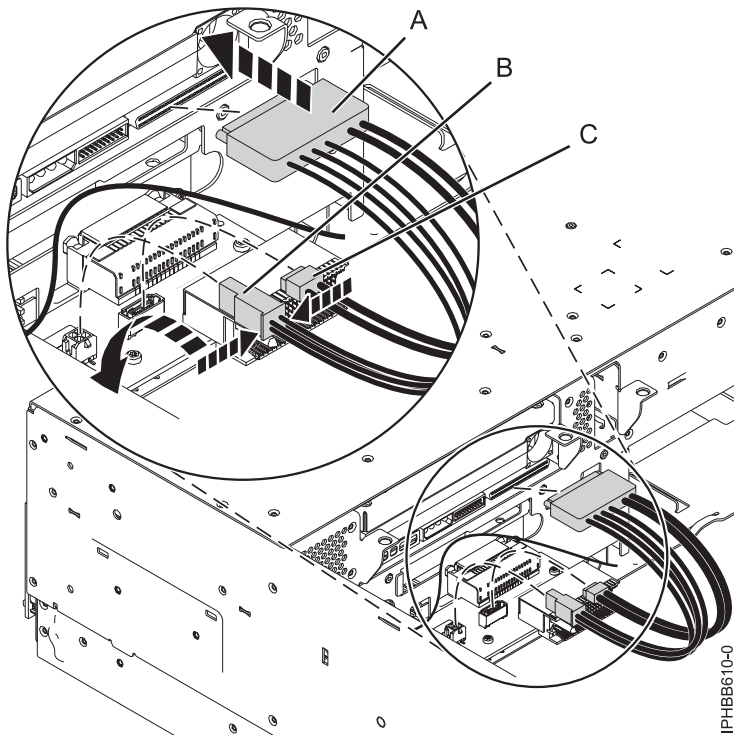

Figure 13. Connecting the cables to the disk drive backplane

8. Replace the disk drives, if you removed them earlier. To replace the disk drives, perform the following steps:
  - a. Hold the disk drive by the top and bottom edge as you position the drive and insert it into the expansion unit. Do not hold the disk drive by the handle.
  - b. Slide the disk drive all the way into the system or expansion unit, and push the disk drive handle (A) in until it locks, as shown in the following figure.



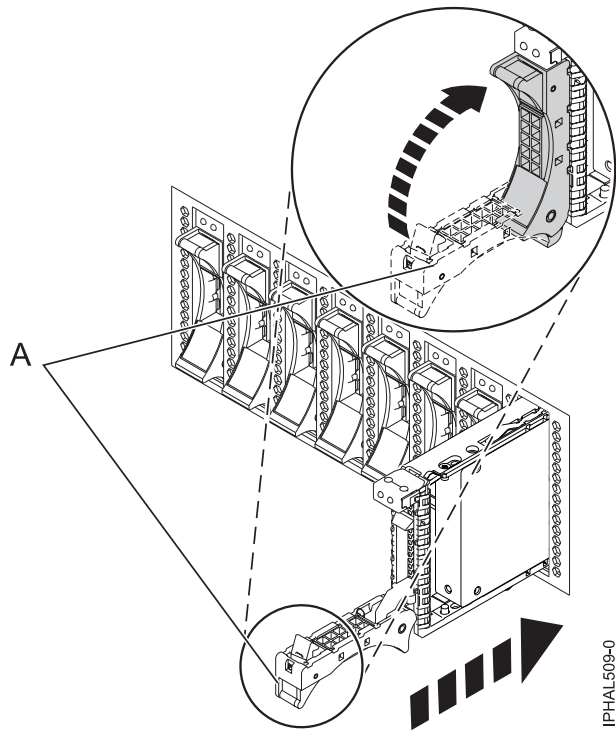
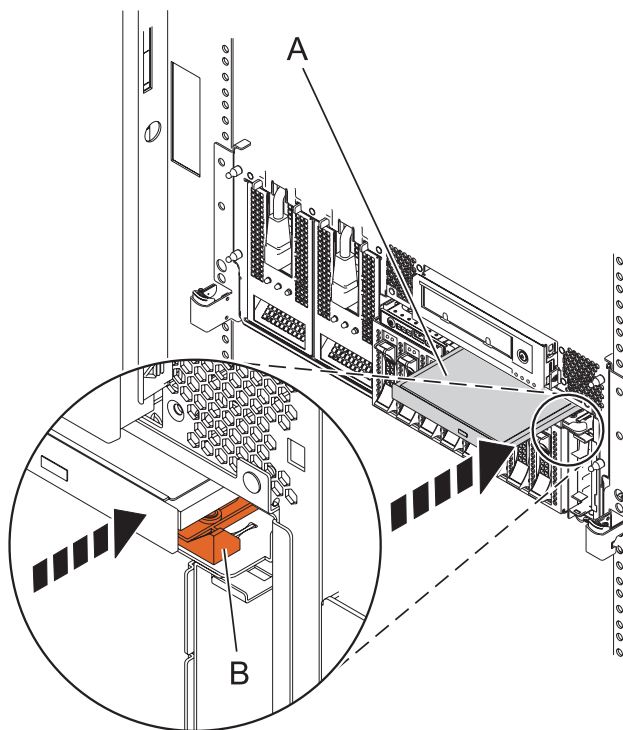

Figure 14. Installing the backplane disk drives

9. Replace the Slimline media device by inserting it into the slot and pushing it in until the lever (**B**) locks into place, as shown in the following figure.



10. Replace the fans, air baffles, and the fan cage.

- a. To replace the fan cage (A), align the locator pins through the holes, and tighten the two thumbscrews (B), as shown in Figure 15.

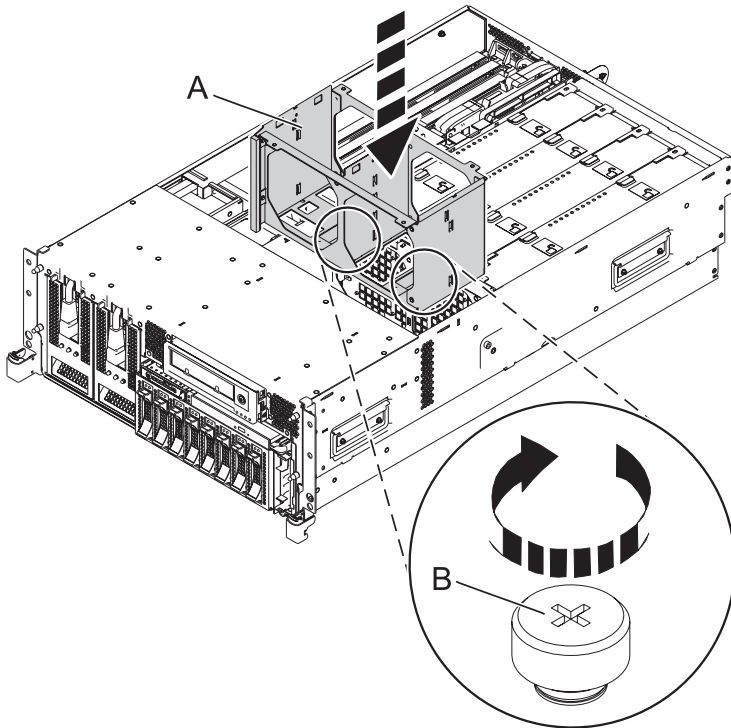

Figure 15. Replacing the fan cage

- b. To install the air baffles, insert the air baffles into their locations in the fan cage, and push down until they lock into place, as shown in Figure 16 on page 15.

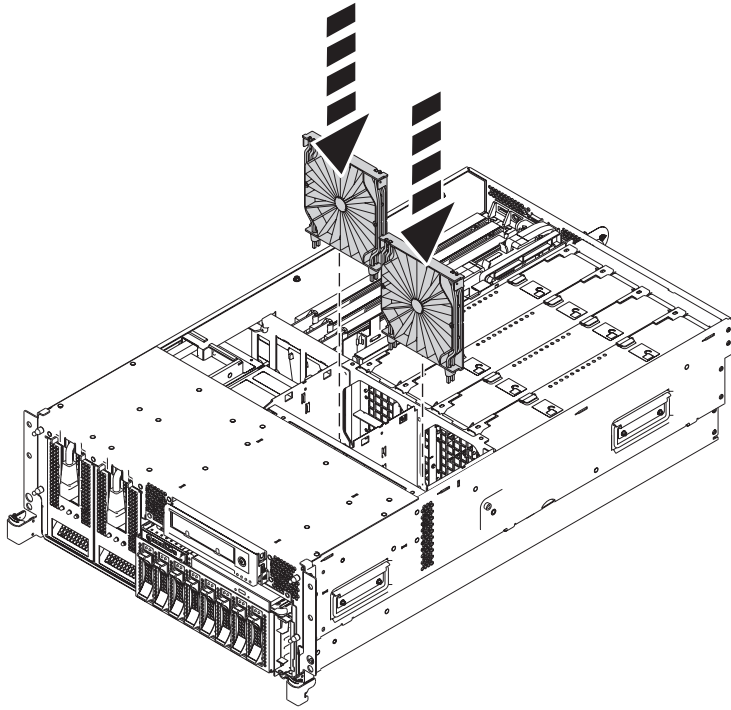

Figure 16. Installing the air baffles in the fan cage

- c. To install the fans, insert the fans into their locations in the fan cage, and push down on each fan until it locks into place, as shown in Figure 17.

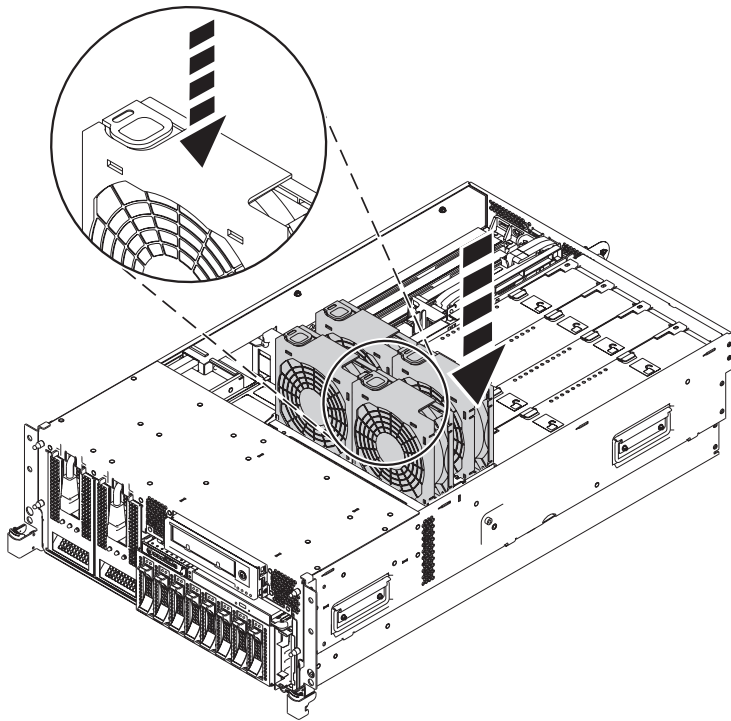

Figure 17. Installing the fans in the fan cage

11. Replace the service access cover. See Installing the service access cover on a rack-mounted model 33E/8B or 36E/8C.
12. Replace the front cover. See Installing the front cover on a rack-mounted model 33E/8B or 36E/8C.
13. Place the system in the operating position. For more information, see Placing the rack-mounted 33E/8B or 36E/8C in the operating position.
14. Start the system or logical partition. See Starting the system or logical partition.
15. Verify the installed part. For instructions, see Verifying the installed part.

---

## Common procedures

This section contains the common procedures related to installing, removing, and replacing the backplane.

---

### Before you begin

Observe these precautions when you are installing, removing, or replacing features and parts.

#### About this task

These precautions are intended to create a safe environment to service your system and do not provide steps for servicing your system. The installation, removal, and replacement procedures provide the step-by-step processes required to service your system.

#### DANGER

When working on or around the system, observe the following precautions:

Electrical voltage and current from power, telephone, and communication cables are hazardous. To avoid a shock hazard:

- Connect power to this unit only with the provided power cord. Do not use the provided power cord for any other product.
- Do not open or service any power supply assembly.
- Do not connect or disconnect any cables or perform installation, maintenance, or reconfiguration of this product during an electrical storm.
- The product might be equipped with multiple power cords. To remove all hazardous voltages, disconnect all power cords.
- Connect all power cords to a properly wired and grounded electrical outlet. Ensure that the outlet supplies proper voltage and phase rotation according to the system rating plate.
- Connect any equipment that will be attached to this product to properly wired outlets.
- When possible, use one hand only to connect or disconnect signal cables.
- Never turn on any equipment when there is evidence of fire, water, or structural damage.
- Disconnect the attached power cords, telecommunications systems, networks, and modems before you open the device covers, unless instructed otherwise in the installation and configuration procedures.
- Connect and disconnect cables as described in the following procedures when installing, moving, or opening covers on this product or attached devices.

##### To Disconnect:

1. Turn off everything (unless instructed otherwise).
2. Remove the power cords from the outlets.
3. Remove the signal cables from the connectors.
4. Remove all cables from the devices

##### To Connect:

1. Turn off everything (unless instructed otherwise).
2. Attach all cables to the devices.
3. Attach the signal cables to the connectors.
4. Attach the power cords to the outlets.
5. Turn on the devices.

(D005a)

## DANGER

Observe the following precautions when working on or around your IT rack system:

- Heavy equipment—personal injury or equipment damage might result if mishandled.
- Always lower the leveling pads on the rack cabinet.
- Always install stabilizer brackets on the rack cabinet.
- To avoid hazardous conditions due to uneven mechanical loading, always install the heaviest devices in the bottom of the rack cabinet. Always install servers and optional devices starting from the bottom of the rack cabinet.
- Rack-mounted devices are not to be used as shelves or work spaces. Do not place objects on top of rack-mounted devices.



- Each rack cabinet might have more than one power cord. Be sure to disconnect all power cords in the rack cabinet when directed to disconnect power during servicing.
- Connect all devices installed in a rack cabinet to power devices installed in the same rack cabinet. Do not plug a power cord from a device installed in one rack cabinet into a power device installed in a different rack cabinet.
- An electrical outlet that is not correctly wired could place hazardous voltage on the metal parts of the system or the devices that attach to the system. It is the responsibility of the customer to ensure that the outlet is correctly wired and grounded to prevent an electrical shock.

## CAUTION

- Do not install a unit in a rack where the internal rack ambient temperatures will exceed the manufacturer's recommended ambient temperature for all your rack-mounted devices.
- Do not install a unit in a rack where the air flow is compromised. Ensure that air flow is not blocked or reduced on any side, front, or back of a unit used for air flow through the unit.
- Consideration should be given to the connection of the equipment to the supply circuit so that overloading of the circuits does not compromise the supply wiring or overcurrent protection. To provide the correct power connection to a rack, refer to the rating labels located on the equipment in the rack to determine the total power requirement of the supply circuit.
- *(For sliding drawers.)* Do not pull out or install any drawer or feature if the rack stabilizer brackets are not attached to the rack. Do not pull out more than one drawer at a time. The rack might become unstable if you pull out more than one drawer at a time.
- *(For fixed drawers.)* This drawer is a fixed drawer and must not be moved for servicing unless specified by the manufacturer. Attempting to move the drawer partially or completely out of the rack might cause the rack to become unstable or cause the drawer to fall out of the rack.

(R001)

Before you begin a replacement or installation procedure, perform these tasks:

## Procedure

1. If you are installing a new feature, ensure that you have the software required to support the new feature.
2. If you are performing an installation or replacement procedure that might put your data at risk, ensure, wherever possible, that you have a current backup of your system or logical partition (including operating systems, licensed programs, and data).
3. Review the installation or replacement procedure for the feature or part.
4. Note the significance of color on your system.

Blue or terra-cotta on a part of the hardware indicates a touch point where you can grip the hardware to remove it from or install it in the system, open or close a latch, and so on. Terra-cotta might also indicate that the part can be removed and replaced with the system or logical partition power on.

5. Ensure that you have access to a medium flat-blade screwdriver, a Phillips screwdriver, and a pair of scissors.
6. If parts are incorrect, missing, or visibly damaged, do the following:
  - If you are replacing a part, contact the provider of your parts or next level of support.
  - If you are installing a feature, contact one of the following service organizations:
    - The provider of your parts or next level of support.
7. If you encounter difficulties during the installation, contact your service provider, or your next level of support.
8. If you are installing new hardware in a logical partition, you need to understand and plan for the implications of partitioning your system. For information, see Logical Partitioning.

---

## Identifying a part

Use these instructions to learn how to identify the location of a failed part, the location of a part to be removed, or the location to install a new part on your system or expansion unit using the appropriate method for your system.

### About this task

For systems servers that contain the POWER7<sup>®</sup> processor, the light-emitting diodes (LEDs) can be used to identify or verify the location of a part that you are removing, servicing, or installing.

The combination identify and fault LED (amber color) shows the location of a field replaceable unit (FRU). When removing a FRU, first verify whether you are working on the correct FRU by using the identify function in the management console or other user interface. When removing a FRU under the direction of the hardware management console, the identify function is activated and deactivated automatically at the correct times.

The identify function causes the amber LED to blink. When you turn off the identify function, the LED returns to the state it was previously. For parts that have a blue service button, the identify function sets LED information for the service button so that when the button is pressed, the correct LEDs on that part blink.

If you need to use the identify function, use the following procedures.

## Identifying a failing part in an AIX system or logical partition

Use these instructions to learn how to locate a failing part, and then activate the indicator light for that part on a system or logical partition running the AIX<sup>®</sup> operating system.

### Locating a failing part in an AIX system or logical partition

You might need to use AIX tools, before activating the indicator light, to locate a part that is failing.

#### Procedure

1. Log in as root user or celogin-.
2. At the command line, type `diag` and press Enter.
3. From the Function Selection menu, select **Task Selection** and press Enter.
4. Select **Display Previous Diagnostic Results** and press Enter.
5. From the Display Previous Diagnostic Results display, select **Display Diagnostic Log Summary**. The Display Diagnostic Log display shows a chronological list of events.

6. Look in the **T** column for the most recent **S** entry. Select this row in the table and press Enter.
7. Select **Commit**. The details of this log entry are shown.
8. Record the location information and the SRN value shown near the end of the entry.
9. Exit to the command line.

### What to do next

Use the location information for the failing part to activate the indicator light that identifies the failing part. See “Activating the indicator light for the failing part.”

### Activating the indicator light for the failing part

Use these instructions to help physically identify the location of a part you are servicing.

#### Procedure

1. Log in as root user.
2. At the command line, type `diag` and press Enter.
3. From the Function Selection menu, select **Task Selection** and press Enter.
4. From the Task Selection menu, select **Identify and Attention Indicators** and press Enter.
5. From the list of lights, select the location code for the failing part and press Enter.
6. Select **Commit**. This turns on the system attention and indicator light for the failing part.
7. Exit to the command line.

### Deactivating the failing-part indicator light

Use this procedure to turn off any indicator light that you turned on as a part of a service action.

#### About this task

To deactivate the indicator light, follow these steps:

#### Procedure

1. Log in as root user.
2. At the command line, type `diag` and press Enter.
3. From the Function Selection menu, select **Task Selection** and press Enter.
4. From the Task Selection menu, select **Identify and Attention Indicators** and press Enter.
5. From the list of lights, select the location code for the failing part and press Enter. When a light is activated for a failing part, an **I** character precedes the location code.
6. Select **Commit**. This turns off the system attention and indicator light for the failing part.
7. Exit to the command line.

### Identifying a failing part in a Linux system or logical partition

If the service aids have been installed on a system or logical partition, you can activate or deactivate the indicator lights to locate a part or complete a service action.

### Locating a failing part in a Linux system or logical partition

If the service aids have been installed on a system or logical partition, you need to activate the indicator lights to locate a part.

#### About this task

To activate the indicator light, follow these steps:



## Procedure

1. Log in as root user.
2. At the command line, type `/usr/sbin/ussysident -s identify -l<location code>` and press Enter.
3. Look for the system attention light to identify the enclosure that contains the failing part.

## Finding the location code of a failing part in a Linux system or logical partition

To retrieve the location code of the failing part, if you do not know the location code, use the procedure in this topic.

### About this task

To locate the failing part in a system or logical partition follow these steps:

## Procedure

1. Log in as root user.
2. At the command line, type `grep diagela /var/log/platform` and press Enter.
3. Look for the most recent entry that contains a system reference code (SRC).
4. Record the location information.

## Activating the indicator light for the failing part

If you know the location code of the failing part, activate the indicator light to help you locate which part to replace.

### About this task

To activate the indicator light, follow these steps:

## Procedure

1. Log in as root user.
2. At the command line, type `/usr/sbin/ussysident -s identify -l<location code>` and press Enter.
3. Look for the system attention light to identify the enclosure that contains the failing part.

## Results

## Deactivating the failing-part indicator light

After you complete a removal and replacement procedure, you must deactivate the failing-part indicator light.

### About this task

To deactivate the indicator light, follow these steps:

## Procedure

1. Log in as root user.
2. At the command line, type `/usr/sbin/ussysident -s normal -l<location code>` and press Enter.

## Locating a failing part in a Virtual I/O Server system or logical partition

You can use Virtual I/O Server (VIOS) tools, before activating the indicator light, to locate a part that is failing.

## Procedure

1. Log in as root user or celogin-.
2. At the command line, type diagmenu and press Enter.
3. From the **Function Selection** menu, select **Task Selection** and press Enter.
4. Select **Display Previous Diagnostic Results** and press Enter.
5. From the **Display Previous Diagnostic Results** display, select **Display Diagnostic Log Summary**. A **Display Diagnostic Log** display appears. This display contains a chronological list of events.
6. Look in the T column for the most recent S entry. Select this row in the table and press Enter.
7. Choose **Commit**. The details of this log entry are shown.
8. Record the location information and the SRN value shown near the end of the entry.
9. Exit to the command line.

## Results

Use the location information for the failing part to activate the indicator light that identifies the failing part. For instructions, see “Identifying a part by using the Virtual I/O Server.”

### Identifying a part by using the Virtual I/O Server

Use these instructions to turn on the indicator light to help you physically locate a part by using the Virtual I/O Server (VIOS).

## Procedure

1. Log in as root user.
2. At the command line, type diagmenu and press Enter.
3. From the Function Selection menu, select **Task Selection**. Press Enter.
4. From the Task Selection menu, select **Identify and Attention Indicators**. Press Enter.
5. From the list of lights, select the location code for the failing part and press Enter.
6. Select **Commit**. This turns on the system attention and indicator light for the failing part.
7. Exit to the command line.

---

## Starting the system or logical partition

Learn how to start a system or logical partition after performing a service action or system upgrade.

### Starting a system that is not managed by a Hardware Management Console or a Systems Director Management Console

You can use the power button or the Advanced System Management Interface to start a system that is not managed by a Hardware Management Console (HMC) or an Systems Director Management Console (SDMC).

#### About this task

To start a system that is not managed by a HMC or SDMC, follow these steps:

## Procedure

1. Open the front rack door, if necessary.
2. Before you press the power button on the control panel, ensure that power is connected to the system unit as follows:
  - All system power cables are connected to a power source.
  - The Power LED, as shown in the following figure, is slowly blinking.

- The top of the display, as shown in the following figure, shows 01 V=F.
3. Press the power button (A), as shown in the following figure, on the control panel.

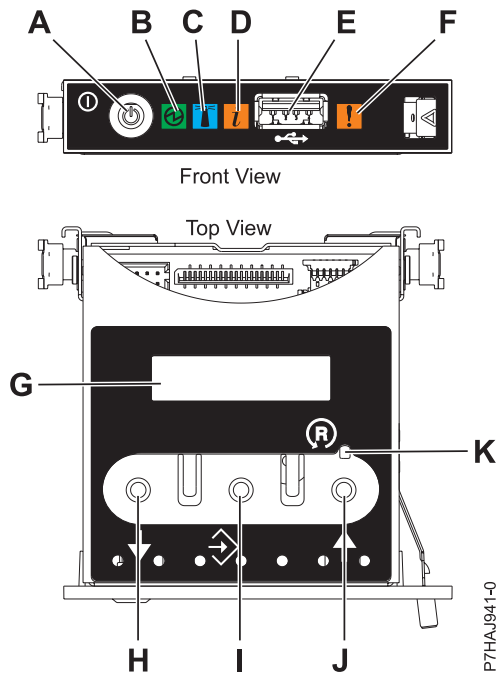

Figure 18. Control panel

- **A:** Power-on button
  - **B:** Power LED
    - A constant light indicates full system power to the unit.
    - A blinking light indicates standby power to the unit.
- Note:** There is approximately a 30-second transition period from the time the power-on button is pressed to when the power LED goes from blinking to solid. During the transition period, the LED might blink faster.
- **C:** Enclosure identify light
    - A constant light indicates the identify state for the enclosure or for a resource within the enclosure.
    - No light indicates that no resources in the enclosure are being identified.
  - **D:** Attention light
    - No light indicates that the system is operating normally.
    - A solid light indicates that the system requires attention.
  - **E:** USB port
  - **F:** Enclosure fault roll-up light
    - A constant light indicates a fault indicator active in the system.
    - No light indicates that the system is operating normally.
  - **G:** Function/Data display
  - **H:** Decrement button
  - **I:** Enter button
  - **J:** Increment button
  - **K:** Pinhole reset button

4. Observe the following after pressing the power button:
  - The power-on light begins to blink faster.
  - The system cooling fans are activated after approximately 30 seconds and begin to accelerate to operating speed.
  - Progress indicators, also referred to as checkpoints, appear on the control panel display while the system is being started. The power-on light on the control panel stops blinking and remains on, indicating that system power is on.

## What to do next

**Tip:** If pressing the power button does not start the system, do the following steps to start the system using the Advanced System Management Interface (ASMI):

1. Access the ASMI. For instructions, see [Accessing the ASMI](#).
2. Start the system using the ASMI. For instructions, see [Powering the system on and off](#).

## Starting a system or logical partition by using the HMC

You can use the Hardware Management Console (HMC) user interface to start the system or logical partition after the required cables are installed and the power cables are connected to a power source.

### About this task

For instructions on working with the HMC, see [Managing the Hardware Management Console](#). For instructions on starting a logical partition, see [Logical partitioning](#). For instructions on starting the system, see [Powering on the managed system](#).

Progress indicators, also referred to as checkpoints, appear on the control panel display while the system is being started. When the power-on light on the control panel stops blinking and remains on, the system power is on.

---

## Stopping a system or logical partition

Learn how to stop a system or logical partition as a part of a system upgrade or service action.

### About this task

**Attention:** Using either the power-on button on the control panel or entering commands at the Hardware Management Console (HMC) to stop the system can cause unpredictable results in the data files. Also, the next time you start the system, it might take longer if all applications are not ended before stopping the system.

To stop the system or logical partition, select the appropriate procedure.

## Stopping a system that is not managed by an HMC or an SDMC

You might need to stop the system to perform another task. If your system is not managed by the Hardware Management Console (HMC) or the Systems Director Management Console (SDMC), use these instructions to stop the system by using the power button or the Advanced System Management Interface (ASMI).

### Before you begin

Before you stop the system, follow these steps:

1. Ensure that all jobs are completed and end all applications.
2. Ensure that the operating system is stopped.

**Attention:** Failure to do so can result in the loss of data.

3. If a Virtual I/O Server (VIOS) logical partition is running, ensure that all clients are shut down or that the clients have access to their devices using an alternate method.

## About this task

The following procedure describes how to stop a system that is not managed by the HMC or the SDMC.

### Procedure

1. Log in to the system as a user with the authority to run the **shutdown** or **pwrdownsys** (Power Down System) command.
2. At the command line, enter one of the following commands:
  - If your system is running the AIX operating system, type **shutdown**.
  - If your system is running the Linux operating system, type **shutdown -h now**.
  - If your system is running the operating system, type **PWRDWN SYS**. If your system is partitioned, use the **PWRDWN SYS** command to power down each of the secondary partitions. Then, use the **PWRDWN SYS** command to power down the primary partition.

The command stops the operating system. The system power turns off, the power-on light begins to slowly flash, and the system goes into a standby state.

3. At the Linux command line, type **shutdown -h now**.

The command stops the operating system. The system power turns off, the power-on light begins to slowly flash, and the system goes into a standby state.
4. At the Linux command line, type **shutdown -h now**.

The command stops the operating system. The system power turns off, the power-on light begins to slowly flash, and the system goes into a standby state.
5. Record the IPL type and the IPL mode from the control panel display to help you return the system to this state when the installation or replacement procedure is completed.
6. Set the power switches of any devices connected to the system to off.
7. Unplug any power cables that are attached to the unit from electrical outlets. Ensure that you unplug power cables from peripheral devices, such as printers and expansion units.

**Important:** The system may be equipped with a second power supply. Before continuing with this procedure, ensure that all power sources to the system have been disconnected.

(L003)

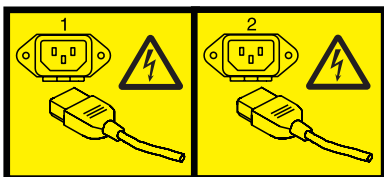

or



## Stopping a system by using the HMC

You can use the Hardware Management Console (HMC) user interface to stop the system or a logical partition.

### About this task

By default, the managed system is set to power off automatically when you shut down the last running logical partition on the managed system. If you set the managed system properties on the HMC so that the managed system does not power off automatically, you must use this procedure to power off your managed system.

**Attention:** If possible, shut down the running logical partitions on the managed system before powering off the managed system. Powering off the managed system without shutting down the logical partitions first causes the logical partitions to shut down abnormally and can cause data loss. If you use a Virtual I/O Server (VIOS) logical partition, ensure that all clients are shut down or that the clients have access to their devices using an alternate method.

To power off a managed system, you must be a member of one of the following roles:

- Super administrator
- Service representative
- Operator
- Product engineer

Use the following steps to stop the system using the HMC.

### Procedure

1. In the navigation area, expand the **Systems Management** folder.
2. Click the **Servers** icon.
3. In the Contents area, select the managed system.
4. Select **Tasks**, then **Operations**, and then **Power Off**
5. Select the appropriate power-off mode and click **OK**.

**Related information:**

 Shutting down and restarting logical partitions

---

## Removing and replacing covers on the 33E/8B or 36E/8C system

Use these instructions to remove, replace, or install covers to access components or perform service.

### Removing the service access cover from an 33E/8B or 36E/8C system

Use this procedure to remove the service access cover to perform service or to gain access to internal components.

#### About this task

To remove the service access cover, follow these steps:

#### Procedure

1. Place the system into the service position. For instructions, see *Placing the 33E/8B or 36E/8C in the service position*.
2. Loosen the two thumbscrews (**A**) located at the back of the cover.
3. Slide the cover (**B**) toward the back of the system unit. When the front of the service access cover clears the upper frame ledge, lift the cover up and off the system unit.

#### Results

**Attention:** For proper cooling and airflow, install the cover before starting the system. Operating the system without the cover for more than 30 minutes could damage the system components.

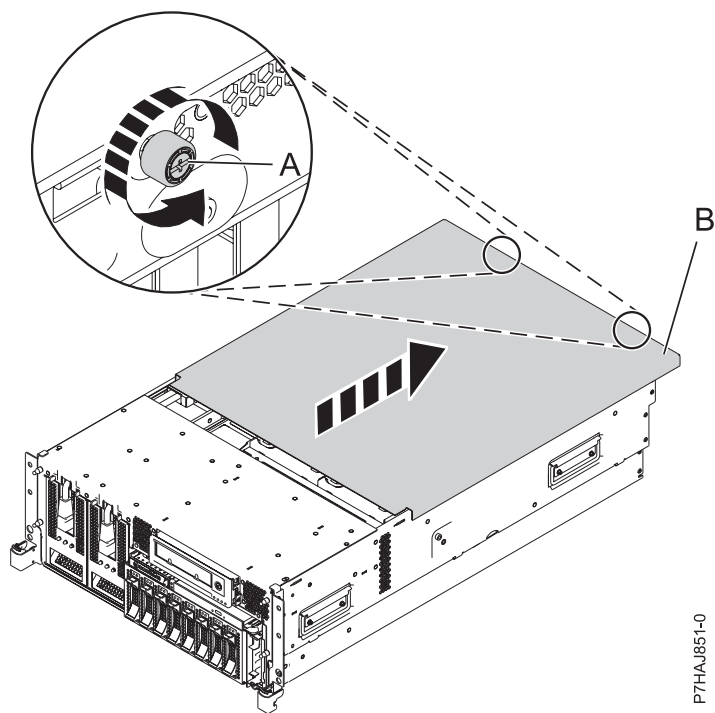

P7HAJ851-0

Figure 19. Removing the service access cover

## Installing the service access cover on an 33E/8B or 36E/8C system

Use this procedure to install the service access cover after performing service or accessing internal components.

### About this task

To install the service access cover, follow these steps:

#### Procedure

1. Place the service access cover (A) on the top of the system unit, approximately 25 mm (1 in.) from the front of the system unit.
2. Hold the service access cover against the system unit, and slide it toward the front of the system.  
The tabs on the service access cover slide beneath the upper chassis ledge, and the two screws align with the screw holes at the back of the system unit.

**Important:** Ensure that the fan LED cables do not get caught on the front edge of the service access cover as you move it forward.

3. Tighten the screws (B) located at the back of the cover.

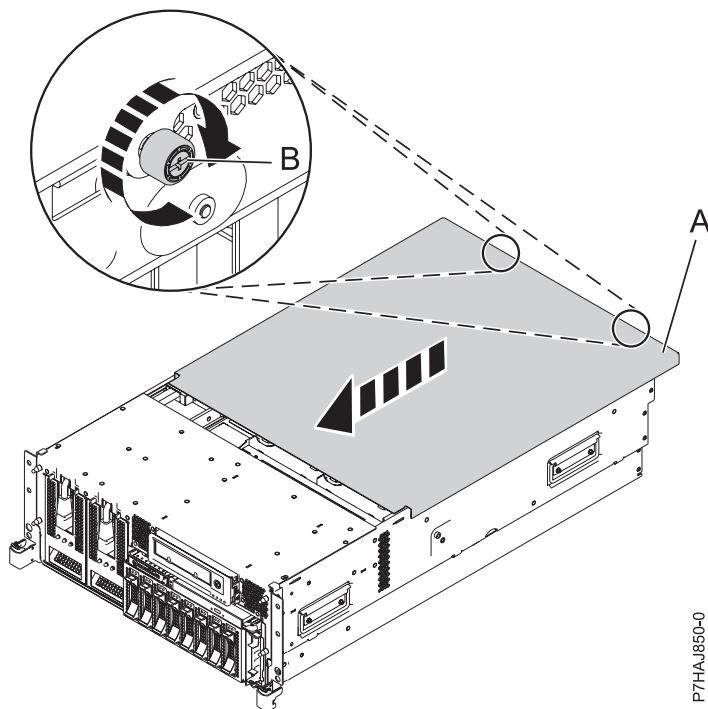

Figure 20. Installing the service access cover

## Removing the front cover from an 33E/8B or 36E/8C system

Use this procedure to remove the cover to access components or perform service.

### About this task

To remove the front cover, follow these steps:

#### Procedure

1. Remove the two screws (A) that secure the system to the rack (B) as shown in the following figure.



2. Pull the cover away from the system. The cover has an indentation where you can hold onto it more easily.

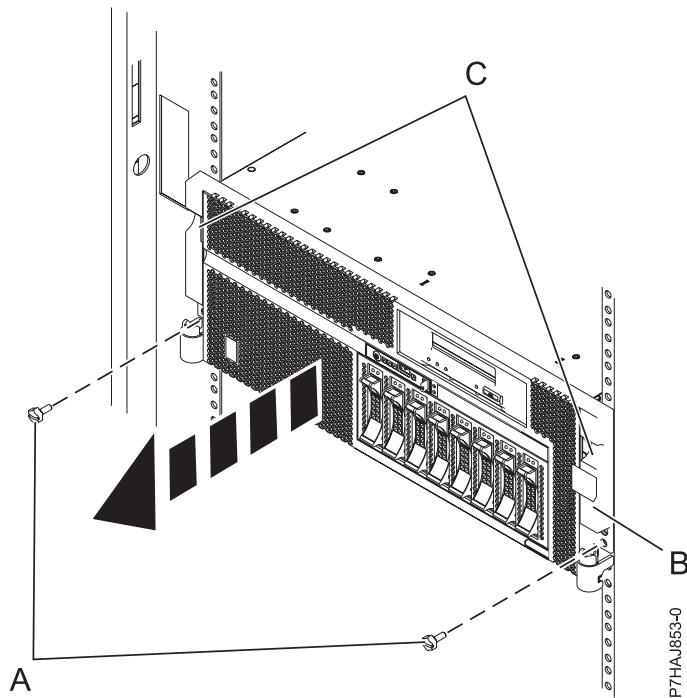

Figure 21. Removing the front cover

## Installing the front cover on an 33E/8B or 36E/8C system

Use this procedure to install the cover after accessing components or performing service.

### About this task

To install the front cover, follow these steps:

### Procedure

1. Align the cover with the system.
2. Gently push the cover in until the four cover clips are seated in their respective mounting posts (B) on the system.
3. Replace the two screws (C) that secure the system to the rack (A).

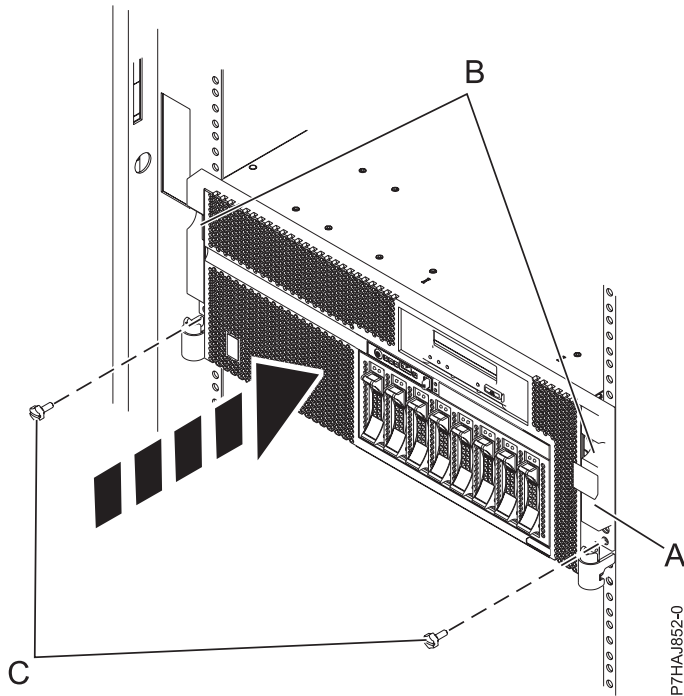

Figure 22. Installing the front cover

## Installing a part by using the HMC

You can use the Hardware Management Console (HMC) to perform many service actions, including the installation of a new feature or part.

### Before you begin

To use the HMC user interface to install a feature or part into a system or expansion unit that is managed by HMC Version 7, or later, complete the following steps:

### Procedure

1. In the navigation area, expand **Systems Management > Servers**.
2. Select the managed system on which you will install the part.
3. In the Tasks area, expand **Serviceability > Hardware > MES Tasks > Open MES**.
4. Click **Add MES Order Number**.
5. Enter the number, and click **OK**.
6. Click the newly created order number, and click **Next**.
7. In the Tasks area, expand **Serviceability > Hardware > MES Tasks**.
8. Select **Add FRU** (field replaceable unit).
9. In the Add/Install/Remove Hardware-Add FRU, Select FRU Type window, select the system or enclosure into which you are installing the feature.
10. From the list, select the type of feature you are installing, and click **Next**.
11. From the list, select the location code where you will install the feature, and click **Add**.
12. After the part is listed in the **Pending Actions** section, click **Launch Procedure** and follow the instructions to install the feature.

**Note:** The HMC might open external instructions for installing the feature. If so, follow those instructions to install the feature.

## Removing a part by using the HMC

You can use the Hardware Management Console (HMC) to perform many service actions, including the removal of a field replaceable unit (FRU) or part.

### About this task

To use the HMC user interface to remove a part in a system or expansion unit that is managed by HMC Version 7, or later, follow these steps:

### Procedure

1. In the navigation area, expand **Systems Management > Servers**.
2. Select the managed system from which you are removing a part.
3. In the **Tasks** area, expand **Serviceability > Hardware > MES Tasks > Remove FRU**
4. In the Add/Install/Remove Hardware - Remove FRU, Select FRU Type window, select the system or enclosure from which you are removing the part.
5. From the list, select the type of part you are removing, and click **Next**.
6. From the list, select the location of the part you are removing, and click **Add**.
7. After the part is listed in the **Pending Actions** section, click **Launch Procedure** and follow the instructions to remove the part.

**Note:** The HMC might open the information center instructions for removing the part. If so, follow those instructions to remove the part.

## Replacing a part by using the HMC

You can use the Hardware Management Console (HMC) to perform many service actions, including exchanging a field replaceable unit (FRU) or part.

### About this task

If you are exchanging a part to repair a serviceable event, follow those instructions. If you are exchanging a part as a part of any other procedure by using HMC Version 7, or later, complete the following steps:

### Procedure

1. In the navigation area, expand **Systems Management > Servers**.
2. Select the managed system in which you are exchanging a part.
3. In the **Tasks** area, expand **Serviceability > Hardware > Exchange FRU**.
4. Select the system or enclosure from which you want to exchange the part.
5. In the Replace Hardware - Replace FRU, Select FRU Type window, select the type of part you will exchange from the menu, and click **Next**
6. From the list, select the location code of the part you will exchange, and click **Add**.
7. After the part is listed in the **Pending Actions** section, click **Launch Procedure** and follow the instructions to exchange the part.

**Note:** The HMC might open external instructions for replacing the part. If so, follow those instructions to replace the part.

---

## Installing a part by using the SDMC

You can use the Systems Director Management Console (SDMC) to perform many service actions, including the installation of a new field-replaceable unit (FRU) or part.

## Before you begin

To use the SDMC user interface to install a part into a system or expansion unit that is managed by an SDMC, follow these steps:

### Procedure

1. In the Power Systems Resources area, select the system on which you want to install a part.
2. From the **Actions** menu, expand **Service and Support > Hardware > MES Tasks > Add FRU**.
3. On the **Add FRU** page, select the system or enclosure type from the **Enclosure type** list.
4. From the list, select the FRU type you are installing, and click **Next**.
5. From the list, select the location code for the location to install, and then click **Add**.
6. After the part is placed in the **Pending Actions** section, click **Launch Procedure** and follow the instructions to install the part.

**Note:** The SDMC might open external instructions for installing the feature. If so, follow those instructions to install the part.

---

## Verifying the installed part

You can verify a newly installed or replaced part on your system, logical partition, or expansion unit using the operating system, stand-alone diagnostics, or the Hardware Management Console (HMC).

## Verifying an installed feature or replaced part in an AIX system or logical partition

If you installed feature or replaced a part, you might want to use the tools in the AIX operating system to verify that the feature or part is recognized by the system or logical partition.

### About this task

To verify the operation of a newly installed feature or replacement part, select the appropriate procedure:

- Verify the installed feature using AIX
- Verifying the replaced part using AIX

Verify the installed feature by using the AIX operating system:

1. Log in as root user.
2. At the command line, type `diag` and press Enter.
3. Select **Advanced Diagnostics Routines** and press Enter.
4. From the **Diagnostic Mode Selection** menu, select **System Verification** and press Enter.
5. When the **Advanced Diagnostic Selection** menu appears, do one of the following:
  - To test a single resource, select the resource that you just installed from the list of resources and press Enter.
  - To test all the resources available to the operating system, select **All Resources** and press Enter.
6. Select **Commit**, and wait until the diagnostic programs run to completion, responding to any prompts that appear.
7. Did the diagnostics run to completion and display the message No trouble was found?
  - **No:** If a service request number (SRN) or other reference code is displayed, suspect a loose adapter or cable connection. Review the installation procedures to ensure that the new feature is installed correctly. If you cannot correct the problem, collect all SRNs or any other reference code information that you see. If the system is running in logical partitioning (LPAR) mode, note the logical partition in which you installed the feature. Contact your service provider for assistance.

- **Yes:** The new device is installed correctly. Exit the diagnostic programs and return the system to normal operations.

Verify the replacement part by using the AIX operating system:

To verify the operation of a newly installed feature or replacement part, follow these steps:

1. Did you use either the AIX operating system or the online diagnostics service aid concurrent (hot-swap) service to replace the part?
  - No:** Go to step 2.
  - Yes:** Go to step 5.
2. Is the system powered off?
  - No:** Go to step 4.
  - Yes:** If the system supports slow boot, set the system to perform a slow boot. For information, see *Performing a slow boot*.
3. Start the system and wait until the AIX operating system login prompt is displayed or until apparent system activity on the operator panel or display has stopped.
 

Did the AIX login prompt display?

  - **No:** If a service request number (SRN) or other reference code is displayed, suspect a loose adapter or cable connection. Review the procedures for the part that you replaced to ensure that the new part is installed correctly. If you cannot correct the problem, collect all SRNs or any other reference code information that you see. If the system does not start or you have no login prompt, see: *Problems with loading and starting the operating system*.  
If the system is partitioned, note the logical partition in which you replaced the part. Contact your service provider for assistance.
  - **Yes:** Go to step 4.
4. At the command prompt, type `diag -a` and press Enter to check for missing resources. If you see a command prompt, go to step 5.
 

If the **Diagnostic selection** menu is shown with **M** appearing next to any resource, follow these steps:

  - a. Select the resource and press Enter.
  - b. Select **Commit**.
  - c. Follow any instructions that are shown.
  - d. If the *Do you want to review the previously displayed error?* message is shown, select **Yes** and press Enter.
  - e. If an SRN is shown, suspect a loose card or connection. If no obvious problem is shown, record the SRN and contact your service provider for assistance..
  - f. If no SRN is shown, go to step 5.
5. Test the part by doing the following steps:
  - a. At the command line, type `diag` and press Enter.
  - b. From the **Function Selection** menu, select **Advanced Diagnostics Routines** and press Enter.
  - c. From the **Diagnostic Mode Selection** menu, select **System Verification** and press Enter.
  - d. Select **All Resources**, or select the diagnostics for the individual part to test only the part you replaced and any devices that are attached to the part you replaced and press Enter.
 

Did the **Resource Repair Action** menu appear?

    - No:** Go to step 6.
    - Yes:** Go to step 7 on page 34.
6. Did the *Testing Complete, No trouble was found* message appear?
  - **No:** There is still a problem. Contact your service provider. **This ends the procedure.**

- **Yes:** Select **Log Repair Action**, if not previously logged, from the **Task Selection** menu to update the AIX error log. If the repair action was reseating a cable or adapter, select the resource associated with that repair action. If the resource associated with your action is not displayed on the resource list, select **sysplanar0** and press Enter.

**Tip:** This action changes the indicator light for the part from the fault state to the normal state. Go to step 9.

7. Select the resource for the replaced part from the **Resource Repair Action** menu. When a test is run on a resource in system verification mode, and that resource has an entry in the AIX error log, if the test on the resource was successful, the **Resource Repair Action** menu appears. Complete the following steps to update the AIX error log to indicate that a system-detectable part has been replaced.

**Note:** On systems with an indicator light for the failing part, this action changes the indicator light to the normal state.

- a. Select the resource that has been replaced from the **Resource Repair Action** menu. If the repair action was reseating a cable or adapter, select the resource associated with that repair action. If the resource associated with your action does not appear on the resource list, select **sysplanar0** and press Enter.
- b. Select **Commit** after you make your selections. Did another **Resource Repair Action** display appear?

**No:** If the **No Trouble Found** display appears, go to step 9

**Yes:** Go to step 8.

8. Select the parent or child of the resource for the replaced part from the **Resource Repair Action** menu if necessary. When a test is run on a resource in system verification mode, and that resource has an entry in the AIX error log, if the test on the resource was successful, the **Resource Repair Action** menu appears. Complete the following steps to update the AIX error log to indicate that a system-detectable part has been replaced.

**Note:** This action changes the indicator light for the part from the fault state to the normal state.

- a. From the **Resource Repair Action** menu, select the parent or child of the resource that has been replaced. If the repair action was to reseat a cable or adapter, select the resource associated with that repair action. If the resource associated with your action does not appear on the resource list, select **sysplanar0** and press Enter.
- b. Select **Commit** after you make your selections.
- c. If the **No Trouble Found** display appears, go to step 9.

9. If you changed the service processor or network settings, as instructed in previous procedures, restore the settings to the values they had prior to servicing the system.

10. Did you do any hot-plug procedures before doing this procedure?

**No:** Go to step 11.

**Yes:** Go to step 12.

11. Start the operating system, with the system or logical partition in normal mode. Were you able to start the operating system?

**No:** Contact your service provider. **This ends the procedure.**

**Yes:** Go to step 12.

12. Are the indicator lights still on?

- **No. This ends the procedure.**
- **Yes.** Turn off the lights. See the following for instructions: Changing service indicators.

## Verifying the installed part in a Linux system or logical partition

If you have installed a new part, learn how to verify that the system recognizes the part.

## About this task

To verify the newly installed or replaced part, continue with “Verifying an installed part by using stand-alone diagnostics.”

## Verifying an installed part by using stand-alone diagnostics

If you have installed or replaced a part, verify that the system recognizes the new part. You can use stand-alone diagnostics to verify an installed part in an AIX or Linux system, expansion unit, or logical partition.

### Before you begin

- If this server is directly attached to another server or attached to a network, ensure communications with the other servers have stopped.
- The stand-alone diagnostics require use of all of the logical partition resources. No other activity can be running on the logical partition.
- The stand-alone diagnostics require access to the system console.

## About this task

You access these diagnostics from a CD-ROM or from the Network Installation Management (NIM) server. This procedure describes how to use the diagnostics from a CD-ROM. For information on running diagnostics from the Network Installation Management (NIM) server, see Running stand-alone diagnostics from a Network Installation Management server.

To use stand-alone diagnostics, follow these steps:

### Procedure

1. Stop all jobs and applications and then stop the operating system on the system or logical partition.
2. Remove all tapes, diskettes, and CD-ROM.
3. Turn off the system unit power. The next step boots the server or logical partition from the stand-alone diagnostics CD-ROM. If the optical drive is not available as the boot device on the server or logical partition on which you are working, follow these steps:
  - a. Access the ASMI. For information on using the ASMI, see Accessing the ASMI for information on using the ASMI.
  - b. On the ASMI main menu, click on **Power/Restart Control**.
  - c. Click Power On/Off System.
  - d. Select the **Service mode boot from default boot list** option in the AIX or Linux logical partition mode boot drop-down menu.
  - e. Click **Save settings and power on**. As soon as the optical drive has power, insert the standalone diagnostic CD-ROM.
  - f. Go to step 5.
4. Turn on the system unit power and immediately insert the diagnostics CD-ROM into the optical drive.
5. After the **keyboard** POST indicator displays on the system console and before the last POST indicator (**speaker**) displays, press the numeric 5 key on the system console to indicate that a service mode boot should be initiated using the default-service mode boot list.
6. Enter any requested password.
7. At the **Diagnostic Operating Instructions** display, press Enter.

**Tip:** If a service request number (SRN) or other reference code is displayed, suspect a loose adapter or cable connection.



**Note:** If you received an SRN or any other reference code when you attempted to start the system, contact your service provider for assistance.

8. If the terminal type is requested, select the **Initialize Terminal** option on the Function Selection menu to initialize the operating system.
9. From the Function Selection menu, select **Advanced Diagnostics Routines** and press Enter.
10. From the Diagnostic Mode Selection menu, select **System Verification** and press Enter.
11. When the Advanced Diagnostic Selection menu appears, select **All Resources**, or test only the part you replaced, and any devices that are attached to the part you replaced, by selecting the diagnostics for the individual part and press Enter.
12. Did the Testing Complete, No trouble was found message appear?
  - **No:** There is still a problem. Contact your service provider.
  - **Yes:** Go to step 13.
13. If you changed the service processor or network settings, as instructed in previous procedures, restore the settings to the value they had prior to servicing the system.
14. If the indicator lights are still on, follow these steps:
  - a. Select **Identify and Attention Indicators** from the Task Selection menu to turn off the system attention and indicator lights and press Enter.
  - b. Select **Set System Attention Indicator to NORMAL** and press Enter.
  - c. Select **Set All Identify Indicators to NORMAL** and press Enter.
  - d. Choose **Commit**.

**Note:** This changes the system attention and identify indicators from the *Fault* state to the *Normal* state.

- e. Exit to the command line.

## Verifying the installed part by using the HMC

If you have installed or replaced a part, use the Hardware Management Console (HMC) to update your HMC records after you have completed a service action on your server. If you have reference codes, symptoms, or location codes that you used during the service action, locate the records for use during this procedure.

### About this task

To verify the installed part, complete these steps:

#### Procedure

1. At the HMC, examine the service action event log for any open service action events. See “Viewing serviceable events by using the HMC” on page 38 for details.
2. Are there any service action events that are open?
  - No:** If the system attention LED is still on, use the HMC to turn off the LED. See “Activating and deactivating LEDs by using the HMC” on page 37. **This ends the procedure.**
  - Yes:** Continue with the next step.
3. Record the list of open service action events.
4. Examine the details of the open service action event. Is the error code associated with this service action event the same as you gathered earlier.
  - **No:** Select one of the following options:
    - Review the other serviceable events, find one that does match, and continue with the next step.
    - If the log does not match what you had gathered earlier, contact your service provider.
  - **Yes:** Continue with the next step.



5. Select and highlight the service action event from the Error Associated With This Serviceable Event window.
6. Click **Close Event**.
7. Add comments for the serviceable event. Include any unique additional information. Click **OK**.
8. Did you replace, add, or modify a field replaceable unit (FRU) of the open service action event?
  - **No:** Select the **No FRU Replaced for this Serviceable Event** option, and click **OK** to close the service action event.
  - **Yes:** Perform the following steps:
    - a. From the FRU list, select a FRU that you need to update.
    - b. Double-click the FRU and update the FRU information.
    - c. Click **OK** to close the service action event.
9. If you continue to have problems, contact your service provider.

## Activating and deactivating LEDs by using the HMC

Use this procedure to activate or deactivate LEDs using Service Focal Point™ for the Hardware Management Console (HMC).

### About this task

Choose from the following:

- “Deactivating a system attention LED or partition LED”
- “Activating or deactivating an identify LED”

### Deactivating a system attention LED or partition LED:

#### About this task

You can deactivate the attention LED for a system or logical partition if you decide that a problem is not a high priority and you decide to repair the problem at a later time. The deactivation also allows the LED to be activated again when another problem occurs. To deactivate a system attention LED by using HMC, complete the following steps:

#### Procedure

1. In the navigation area, open **Systems Management**.
2. Open **Servers** and select the required system.
3. In the content area, select the required partition.
4. Select **Tasks > Operations > Deactivate Attention LED**. A confirmation window is displayed with an indication that there still might be open problems with the system.
5. Click **OK** to continue with the deactivation. A window is displayed that provides the details of the system or partition, and a confirmation that the system or logical partition attention LED was deactivated.

### Activating or deactivating an identify LED:

#### About this task

The system provides several LEDs that help identify various components, such as enclosures or field replaceable units (FRUs), in the system. For this reason, they are called *identify LEDs*.

You can activate or deactivate the following types of identify LEDs:

- **Identify LED for an enclosure** If you want to add an adapter to a specific drawer (enclosure), you need to know the machine type, model, and serial number (MTMS) of the drawer. To determine whether you have the correct MTMS for the drawer that needs the new adapter, you can activate the LED for a drawer and verify that the MTMS corresponds to the drawer that requires the new adapter.

- **Identify LED for a FRU associated with a specified enclosure** If you want to hook up a cable to a specific I/O adapter, you can activate the LED for the adapter which is a field replaceable unit (FRU), and then physically check to see where you should hook up the cable. This is especially useful when you have several adapters with open ports.

To activate or deactivate an identify LED for an enclosure or FRU, follow these steps:

#### Procedure

1. In the navigation area, open **Systems Management**.
2. Select **Servers**.
3. In the content area, check the box for the appropriate System.
4. Select **Tasks > Operations > LED Status > Identify LED**.
5. To activate or deactivate an identify LED for an enclosure, select an enclosure from the table, and click either **Activate LED** or **Deactivate LED**. The associated LED is either turned on or off.
6. To activate or deactivate an identify LED for a FRU, select an enclosure from the table and click **List FRUs**.
7. Select one or more FRUs from the table, and click either **Activate LED** or **Deactivate LED**. The associated LED is either turned on or off.

### Viewing serviceable events by using the HMC

Use this procedure to view a serviceable event, including details, comments, and service history.

#### About this task

To view serviceable events and other information about the events, you must be a member of one of the following roles:

- Super administrator
- Service representative
- Operator
- Product engineer
- Viewer

To view serviceable events, follow these steps:

#### Procedure

1. In the navigation area, select **Service Management**.
2. Select **Manage Serviceable Events**.
3. Select the criteria for the serviceable events that you want to view, and click **OK**. The Serviceable Event Overview window opens. The list shows all serviceable events that match your selection criteria. You can use the menu options to perform actions on the serviceable events.
4. Select a line in the Serviceable Event Overview window, and select **Selected > View Details**. The Serviceable Event Details window opens, showing detailed information about the serviceable event. The upper table shows information, such as problem number and reference code. The lower table shows the field replaceable units (FRUs) associated with this event.
5. Select the error for which you want to view comments and history, and follow these steps:
  - a. Select **Actions > View Comments**.
  - b. When you are finished viewing the comments, click **Close**.
  - c. Select **Actions > View Service History**. The Service History window opens, showing service history associated with the selected error.
  - d. When you are finished viewing the service history, click **Close**.

6. When you are finished, click **Cancel** twice to close the Serviceable Event Details window and the Serviceable Event Overview window.

## Verifying an installed part or replaced part on a system or logical partition by using Virtual I/O Server tools

If you installed or replaced a part, you might want to use the tools in Virtual I/O Server (VIOS) to verify that the part is recognized by the system or logical partition.

### Verifying the installed part by using VIOS

To verify the operation of a newly installed part or replacement part, complete the following steps:

#### Procedure

1. Log in as root user.
2. At the command line, type `diagmenu` and press Enter.
3. Select **Advanced Diagnostics Routines** and press Enter.
4. From the **Diagnostic Mode Selection** menu, select **System Verification** and press Enter.
5. When the **Advanced Diagnostic Selection** menu appears, do one of the following steps:
  - To test a single resource, select the resource that you just installed from the list of resources and press Enter.
  - To test all the resources available to the operating system, select **All Resources** and press Enter.
6. Select **Commit**, and wait until the diagnostic programs run to completion, responding to any prompts that appear.
7. Did the diagnostics run to completion and display the message No trouble was found?
  - **No:** If a service request number (SRN) or other reference code is displayed, suspect a loose adapter or cable connection. Review the installation procedures to ensure that the new part is installed correctly. If you cannot correct the problem, collect all SRNs or any other reference code information that you see. If the system is running in LPAR mode, note the logical partition in which you installed the part. Contact your service provider for assistance.
  - **Yes:** The new device is installed correctly. Exit the diagnostic programs and return the system to normal operations.

### Verify the replacement part by using VIOS

To verify the operation of a newly installed part or replacement part, complete the following steps:

#### Procedure

1. Did you replace the part by using either VIOS or the online diagnostics service aid's concurrent (hot-swap) service operation?
  - **No:** Go to step 2.
  - **Yes:** Go to step 5 on page 40.
2. Is the system powered off?
  - **No:** Go to step 4 on page 40.
  - **Yes:** If the system supports slow boot, set the system to perform a slow boot. For information, see Performing a slow boot.
3. Start the system and wait until the VIOS operating system login prompt displays or until apparent system activity on the operator panel or display has stopped. Did the VIOS login prompt display?
  - **No:** If an SRN or other reference code is displayed, suspect a loose adapter or cable connection. Review the procedures for the part that you replaced to ensure that the new part is installed correctly. If you cannot correct the problem, collect all SRNs or any other reference code information that you see. If the system does not start or you have no login prompt, see: Problems with loading and starting the operating system.

If the system is partitioned, note the logical partition in which you replaced the part. Contact your service provider for assistance.

- **Yes:** Go to step 4.
4. At the command prompt, type `diag -a` and press Enter to check for missing resources. If you see a command prompt, go to step 5.

If the **Diagnostic selection** menu is shown with **M** appearing next to any resource, follow these steps:

- a. Select the resource and press Enter.
  - b. Select **Commit**.
  - c. Follow any instructions that are shown.
  - d. If a *Do you want to review the previously displayed error?* message is shown, select **Yes** and press Enter.
  - e. If an SRN is shown, suspect a loose card or connection. If no obvious problem is shown, record the SRN and contact your service provider for assistance.
  - f. If no SRN is shown, go to 5.
5. Test the part by doing the following:
    - a. At the command line, type `diagmenu` and press Enter.
    - b. From the **Function Selection** menu, select **Advanced Diagnostics Routines** and press Enter.
    - c. From the **Diagnostic Mode Selection** menu, select **System Verification** and press Enter.
    - d. Select **All Resources**, or select the diagnostics for the individual part to test only the part you replaced, and any devices that are attached to the part you replaced and press Enter.  
Did the **Resource Repair Action** menu appear?
      - **No:** Go to step 6.
      - **Yes:** Go to step 7.
  6. Did the *Testing Complete, No trouble was found* message appear?
    - **No:** There is still a problem. Contact your service provider. **This ends the procedure.**
    - **Yes:** Select **Log Repair Action**, if not previously logged, from the **Task Selection** menu to update the error log. If the repair action was reseating a cable or adapter, select the resource associated with that repair action. If the resource associated with your action is not displayed on the Resource List, select `sysplanar0` and press Enter.

**Tip:** This action changes the indicator light for the part from the fault state to the normal state. Go to step 9 on page 41.

7. Select the resource for the replaced part from the **Resource Repair Action** menu. When a test is run on a resource in system verification mode, and that resource has an entry in the error log, if the test on the resource was successful, the **Resource Repair Action** menu appears. Complete the following steps to update the error log to indicate that a system-detectable part has been replaced. On systems with a indicator light for the failing part, this changes the indicator light to the normal state.
  - a. Select the resource that has been replaced from the **Resource Repair Action** menu. If the repair action was reseating a cable or adapter, select the resource associated with that repair action. If the resource associated with your action does not appear on the Resource List, select `sysplanar0`. Press Enter.
  - b. Select **Commit** after you make your selections. Did another **Resource Repair Action** display appear?
    - **No:** If the **No Trouble Found** display appears, go to step 9 on page 41.
    - **Yes:** Go to step 8.
8. Select the parent or child of the resource for the replaced part from the **Resource Repair Action** menu if necessary. When a test is run on a resource in system verification mode, and that resource has an entry in the error log, if the test on the resource was successful, the **Resource Repair Action**

menu appears. Complete the following steps to update the error log to indicate that a system-detectable part has been replaced. This changes the indicator light for the part from the fault state to the normal state.

- a. From the **Resource Repair Action** menu, select the parent or child of the resource that has been replaced. If the repair action was to reseal a cable or adapter, select the resource associated with that repair action. If the resource associated with your action does not appear on the Resource List, select **sysplanar0**. Press Enter.
- b. Select **Commit** after you make your selections.
- a. If the **No Trouble Found** display appears, go to step 9.
9. If you changed the service processor or network settings, as instructed in previous procedures, restore the settings to the values they had prior to servicing the system.
10. Did you do any hot-plug procedures before doing this procedure?
  - **No:** Go to step 11.
  - **Yes:** Go to step 12.
11. Start the operating system, with the system or logical partition in normal mode. Were you able to start the operating system?
  - **No:** Contact your service provider. **This ends the procedure.**
  - **Yes:** Go to step 12.
12. Are the indicator lights still on?
  - **No:** This ends the procedure.
  - **Yes.** Turn off the lights. See one of the following for instructions, see: Changing service indicators.



---

## Notices

This information was developed for products and services offered in the U.S.A.

The manufacturer may not offer the products, services, or features discussed in this document in other countries. Consult the manufacturer's representative for information on the products and services currently available in your area. Any reference to the manufacturer's product, program, or service is not intended to state or imply that only that product, program, or service may be used. Any functionally equivalent product, program, or service that does not infringe any intellectual property right of the manufacturer may be used instead. However, it is the user's responsibility to evaluate and verify the operation of any product, program, or service.

The manufacturer may have patents or pending patent applications covering subject matter described in this document. The furnishing of this document does not grant you any license to these patents. You can send license inquiries, in writing, to the manufacturer.

**The following paragraph does not apply to the United Kingdom or any other country where such provisions are inconsistent with local law:** THIS PUBLICATION IS PROVIDED "AS IS" WITHOUT WARRANTY OF ANY KIND, EITHER EXPRESS OR IMPLIED, INCLUDING, BUT NOT LIMITED TO, THE IMPLIED WARRANTIES OF NON-INFRINGEMENT, MERCHANTABILITY OR FITNESS FOR A PARTICULAR PURPOSE. Some states do not allow disclaimer of express or implied warranties in certain transactions, therefore, this statement may not apply to you.

This information could include technical inaccuracies or typographical errors. Changes are periodically made to the information herein; these changes will be incorporated in new editions of the publication. The manufacturer may make improvements and/or changes in the product(s) and/or the program(s) described in this publication at any time without notice.

Any references in this information to websites not owned by the manufacturer are provided for convenience only and do not in any manner serve as an endorsement of those websites. The materials at those websites are not part of the materials for this product and use of those websites is at your own risk.

The manufacturer may use or distribute any of the information you supply in any way it believes appropriate without incurring any obligation to you.

Any performance data contained herein was determined in a controlled environment. Therefore, the results obtained in other operating environments may vary significantly. Some measurements may have been made on development-level systems and there is no guarantee that these measurements will be the same on generally available systems. Furthermore, some measurements may have been estimated through extrapolation. Actual results may vary. Users of this document should verify the applicable data for their specific environment.

Information concerning products not produced by this manufacturer was obtained from the suppliers of those products, their published announcements or other publicly available sources. This manufacturer has not tested those products and cannot confirm the accuracy of performance, compatibility or any other claims related to products not produced by this manufacturer. Questions on the capabilities of products not produced by this manufacturer should be addressed to the suppliers of those products.

All statements regarding the manufacturer's future direction or intent are subject to change or withdrawal without notice, and represent goals and objectives only.

The manufacturer's prices shown are the manufacturer's suggested retail prices, are current and are subject to change without notice. Dealer prices may vary.

This information is for planning purposes only. The information herein is subject to change before the products described become available.

This information contains examples of data and reports used in daily business operations. To illustrate them as completely as possible, the examples include the names of individuals, companies, brands, and products. All of these names are fictitious and any similarity to the names and addresses used by an actual business enterprise is entirely coincidental.

If you are viewing this information in softcopy, the photographs and color illustrations may not appear.

The drawings and specifications contained herein shall not be reproduced in whole or in part without the written permission of the manufacturer.

The manufacturer has prepared this information for use with the specific machines indicated. The manufacturer makes no representations that it is suitable for any other purpose.

The manufacturer's computer systems contain mechanisms designed to reduce the possibility of undetected data corruption or loss. This risk, however, cannot be eliminated. Users who experience unplanned outages, system failures, power fluctuations or outages, or component failures must verify the accuracy of operations performed and data saved or transmitted by the system at or near the time of the outage or failure. In addition, users must establish procedures to ensure that there is independent data verification before relying on such data in sensitive or critical operations. Users should periodically check the manufacturer's support websites for updated information and fixes applicable to the system and related software.

### **Ethernet connection usage restriction**

This product is not intended to be connected directly or indirectly by any means whatsoever to interfaces of public telecommunications networks.

---

## **Trademarks**

IBM, the IBM logo, and [ibm.com](http://ibm.com) are trademarks or registered trademarks of International Business Machines Corp., registered in many jurisdictions worldwide. Other product and service names might be trademarks of IBM or other companies. A current list of IBM trademarks is available on the web at Copyright and trademark information at [www.ibm.com/legal/copytrade.shtml](http://www.ibm.com/legal/copytrade.shtml).

Linux is a registered trademark of Linus Torvalds in the United States, other countries, or both.

Other product and service names might be trademarks of IBM or other companies.

---

## **Electronic emission notices**

When attaching a monitor to the equipment, you must use the designated monitor cable and any interference suppression devices supplied with the monitor.

## **Class A Notices**

The following Class A statements apply to the servers.

## **Federal Communications Commission (FCC) statement**

**Note:** This equipment has been tested and found to comply with the limits for a Class A digital device, pursuant to Part 15 of the FCC Rules. These limits are designed to provide reasonable protection against harmful interference when the equipment is operated in a commercial environment. This equipment generates, uses, and can radiate radio frequency energy and, if not installed and used in accordance with



the instruction manual, may cause harmful interference to radio communications. Operation of this equipment in a residential area is likely to cause harmful interference, in which case the user will be required to correct the interference at his own expense.

Properly shielded and grounded cables and connectors must be used in order to meet FCC emission limits. IBM is not responsible for any radio or television interference caused by using other than recommended cables and connectors or by unauthorized changes or modifications to this equipment. Unauthorized changes or modifications could void the user's authority to operate the equipment.

This device complies with Part 15 of the FCC rules. Operation is subject to the following two conditions: (1) this device may not cause harmful interference, and (2) this device must accept any interference received, including interference that may cause undesired operation.

### **Industry Canada Compliance Statement**

This Class A digital apparatus complies with Canadian ICES-003.

### **Avis de conformité à la réglementation d'Industrie Canada**

Cet appareil numérique de la classe A est conforme à la norme NMB-003 du Canada.

### **European Community Compliance Statement**

This product is in conformity with the protection requirements of EU Council Directive 2004/108/EC on the approximation of the laws of the Member States relating to electromagnetic compatibility. IBM® cannot accept responsibility for any failure to satisfy the protection requirements resulting from a non-recommended modification of the product, including the fitting of non-IBM option cards.

This product has been tested and found to comply with the limits for Class A Information Technology Equipment according to European Standard EN 55022. The limits for Class A equipment were derived for commercial and industrial environments to provide reasonable protection against interference with licensed communication equipment.

European Community contact:  
IBM Deutschland GmbH  
Technical Regulations, Department M456  
IBM-Allee 1, 71139 Ehningen, Germany  
Tele: +49 7032 15-2937  
email: tjahn@de.ibm.com

**Warning:** This is a Class A product. In a domestic environment, this product may cause radio interference, in which case the user may be required to take adequate measures.

### **VCCI Statement - Japan**

この装置は、クラスA情報技術装置です。この装置を家庭環境で使用すると電波妨害を引き起こすことがあります。この場合には使用者が適切な対策を講ずるよう要求されることがあります。

VCCI-A

The following is a summary of the VCCI Japanese statement in the box above:

This is a Class A product based on the standard of the VCCI Council. If this equipment is used in a domestic environment, radio interference may occur, in which case, the user may be required to take corrective actions.

### **Japanese Electronics and Information Technology Industries Association (JEITA) Confirmed Harmonics Guideline (products less than or equal to 20 A per phase)**

高調波ガイドライン適合品

### **Japanese Electronics and Information Technology Industries Association (JEITA) Confirmed Harmonics Guideline with Modifications (products greater than 20 A per phase)**

高調波ガイドライン準用品

### **Electromagnetic Interference (EMI) Statement - People's Republic of China**

#### **声 明**

此为 A 级产品,在生活环境  
中,该产品可能会造成无线电干  
扰。在这种情况下,可能需要用  
户对其干扰采取切实可行的措  
施。

Declaration: This is a Class A product. In a domestic environment this product may cause radio interference in which case the user may need to perform practical action.

### **Electromagnetic Interference (EMI) Statement - Taiwan**

#### **警告使用者：**

這是甲類的資訊產品，在居住的環境中使用時，可能會造成射頻干擾，在這種情況下，使用者會被要求採取某些適當的對策。

The following is a summary of the EMI Taiwan statement above.

Warning: This is a Class A product. In a domestic environment this product may cause radio interference in which case the user will be required to take adequate measures.

## Electromagnetic Interference (EMI) Statement - Korea

이 기기는 업무용(A급)으로 전자파적합기기로서 판매자 또는 사용자는 이 점을 주의하시기 바라며, 가정외의 지역에서 사용하는 것을 목적으로 합니다.

## Germany Compliance Statement

### Deutschsprachiger EU Hinweis: Hinweis für Geräte der Klasse A EU-Richtlinie zur Elektromagnetischen Verträglichkeit

Dieses Produkt entspricht den Schutzanforderungen der EU-Richtlinie 2004/108/EG zur Angleichung der Rechtsvorschriften über die elektromagnetische Verträglichkeit in den EU-Mitgliedsstaaten und hält die Grenzwerte der EN 55022 Klasse A ein.

Um dieses sicherzustellen, sind die Geräte wie in den Handbüchern beschrieben zu installieren und zu betreiben. Des Weiteren dürfen auch nur von der IBM empfohlene Kabel angeschlossen werden. IBM übernimmt keine Verantwortung für die Einhaltung der Schutzanforderungen, wenn das Produkt ohne Zustimmung von IBM verändert bzw. wenn Erweiterungskomponenten von Fremdherstellern ohne Empfehlung von IBM gesteckt/eingebaut werden.

EN 55022 Klasse A Geräte müssen mit folgendem Warnhinweis versehen werden:

"Warnung: Dieses ist eine Einrichtung der Klasse A. Diese Einrichtung kann im Wohnbereich Funk-Störungen verursachen; in diesem Fall kann vom Betreiber verlangt werden, angemessene Maßnahmen zu ergreifen und dafür aufzukommen."

### Deutschland: Einhaltung des Gesetzes über die elektromagnetische Verträglichkeit von Geräten

Dieses Produkt entspricht dem "Gesetz über die elektromagnetische Verträglichkeit von Geräten (EMVG)". Dies ist die Umsetzung der EU-Richtlinie 2004/108/EG in der Bundesrepublik Deutschland.

### Zulassungsbescheinigung laut dem Deutschen Gesetz über die elektromagnetische Verträglichkeit von Geräten (EMVG) (bzw. der EMC EG Richtlinie 2004/108/EG) für Geräte der Klasse A

Dieses Gerät ist berechtigt, in Übereinstimmung mit dem Deutschen EMVG das EG-Konformitätszeichen - CE - zu führen.

Verantwortlich für die Einhaltung der EMV Vorschriften ist der Hersteller:

International Business Machines Corp.

New Orchard Road

Armonk, New York 10504

Tel: 914-499-1900

Der verantwortliche Ansprechpartner des Herstellers in der EU ist:

IBM Deutschland GmbH

Technical Regulations, Abteilung M456

IBM-Allee 1, 71139 Ehningen, Germany

Tel: +49 7032 15-2937

email: tjahn@de.ibm.com

Generelle Informationen:

Das Gerät erfüllt die Schutzanforderungen nach EN 55024 und EN 55022 Klasse A.

## **Electromagnetic Interference (EMI) Statement - Russia**

**ВНИМАНИЕ!** Настоящее изделие относится к классу А.  
В жилых помещениях оно может создавать радиопомехи, для снижения которых необходимы дополнительные меры

## **Class B Notices**

The following Class B statements apply to features designated as electromagnetic compatibility (EMC) Class B in the feature installation information.

### **Federal Communications Commission (FCC) statement**

This equipment has been tested and found to comply with the limits for a Class B digital device, pursuant to Part 15 of the FCC Rules. These limits are designed to provide reasonable protection against harmful interference in a residential installation.

This equipment generates, uses, and can radiate radio frequency energy and, if not installed and used in accordance with the instructions, may cause harmful interference to radio communications. However, there is no guarantee that interference will not occur in a particular installation.

If this equipment does cause harmful interference to radio or television reception, which can be determined by turning the equipment off and on, the user is encouraged to try to correct the interference by one or more of the following measures:

- Reorient or relocate the receiving antenna.
- Increase the separation between the equipment and receiver.
- Connect the equipment into an outlet on a circuit different from that to which the receiver is connected.
- Consult an IBM-authorized dealer or service representative for help.

Properly shielded and grounded cables and connectors must be used in order to meet FCC emission limits. Proper cables and connectors are available from IBM-authorized dealers. IBM is not responsible for any radio or television interference caused by unauthorized changes or modifications to this equipment. Unauthorized changes or modifications could void the user's authority to operate this equipment.

This device complies with Part 15 of the FCC rules. Operation is subject to the following two conditions: (1) this device may not cause harmful interference, and (2) this device must accept any interference received, including interference that may cause undesired operation.

### **Industry Canada Compliance Statement**

This Class B digital apparatus complies with Canadian ICES-003.

### **Avis de conformité à la réglementation d'Industrie Canada**

Cet appareil numérique de la classe B est conforme à la norme NMB-003 du Canada.

## European Community Compliance Statement

This product is in conformity with the protection requirements of EU Council Directive 2004/108/EC on the approximation of the laws of the Member States relating to electromagnetic compatibility. IBM cannot accept responsibility for any failure to satisfy the protection requirements resulting from a non-recommended modification of the product, including the fitting of non-IBM option cards.

This product has been tested and found to comply with the limits for Class B Information Technology Equipment according to European Standard EN 55022. The limits for Class B equipment were derived for typical residential environments to provide reasonable protection against interference with licensed communication equipment.

European Community contact:  
IBM Deutschland GmbH  
Technical Regulations, Department M456  
IBM-Allee 1, 71139 Ehningen, Germany  
Tele: +49 7032 15-2937  
email: tjahn@de.ibm.com

## VCCI Statement - Japan

この装置は、クラスB情報技術装置です。この装置は、家庭環境で使用することを目的としていますが、この装置がラジオやテレビジョン受信機に近接して使用されると、受信障害を引き起こすことがあります。

取扱説明書に従って正しい取り扱いをして下さい。 VCCI-B

## Japanese Electronics and Information Technology Industries Association (JEITA) Confirmed Harmonics Guideline (products less than or equal to 20 A per phase)

高調波ガイドライン適合品

## Japanese Electronics and Information Technology Industries Association (JEITA) Confirmed Harmonics Guideline with Modifications (products greater than 20 A per phase)

高調波ガイドライン準用品

## Electromagnetic Interference (EMI) Statement - Korea

이 기기는 가정용(B급)으로 전자파적합기기로서 주로 가정에서 사용하는 것을 목적으로 하며, 모든 지역에서 사용할 수 있습니다.

## Germany Compliance Statement

### Deutschsprachiger EU Hinweis: Hinweis für Geräte der Klasse B EU-Richtlinie zur Elektromagnetischen Verträglichkeit

Dieses Produkt entspricht den Schutzanforderungen der EU-Richtlinie 2004/108/EG zur Angleichung der Rechtsvorschriften über die elektromagnetische Verträglichkeit in den EU-Mitgliedsstaaten und hält die Grenzwerte der EN 55022 Klasse B ein.

Um dieses sicherzustellen, sind die Geräte wie in den Handbüchern beschrieben zu installieren und zu betreiben. Des Weiteren dürfen auch nur von der IBM empfohlene Kabel angeschlossen werden. IBM übernimmt keine Verantwortung für die Einhaltung der Schutzanforderungen, wenn das Produkt ohne Zustimmung von IBM verändert bzw. wenn Erweiterungskomponenten von Fremdherstellern ohne Empfehlung von IBM gesteckt/eingebaut werden.

### Deutschland: Einhaltung des Gesetzes über die elektromagnetische Verträglichkeit von Geräten

Dieses Produkt entspricht dem "Gesetz über die elektromagnetische Verträglichkeit von Geräten (EMVG)". Dies ist die Umsetzung der EU-Richtlinie 2004/108/EG in der Bundesrepublik Deutschland.

### Zulassungsbescheinigung laut dem Deutschen Gesetz über die elektromagnetische Verträglichkeit von Geräten (EMVG) (bzw. der EMC EG Richtlinie 2004/108/EG) für Geräte der Klasse B

Dieses Gerät ist berechtigt, in Übereinstimmung mit dem Deutschen EMVG das EG-Konformitätszeichen - CE - zu führen.

Verantwortlich für die Einhaltung der EMV Vorschriften ist der Hersteller:  
International Business Machines Corp.  
New Orchard Road  
Armonk, New York 10504  
Tel: 914-499-1900

Der verantwortliche Ansprechpartner des Herstellers in der EU ist:  
IBM Deutschland GmbH  
Technical Regulations, Abteilung M456  
IBM-Allee 1, 71139 Ehningen, Germany  
Tel: +49 7032 15-2937  
email: tjahn@de.ibm.com

Generelle Informationen:

**Das Gerät erfüllt die Schutzanforderungen nach EN 55024 und EN 55022 Klasse B.**

---

## Terms and conditions

Permissions for the use of these publications are granted subject to the following terms and conditions.

**Applicability:** These terms and conditions are in addition to any terms of use for the the manufacturer website.

**Personal Use:** You may reproduce these publications for your personal, noncommercial use provided that all proprietary notices are preserved. You may not distribute, display or make derivative works of these publications, or any portion thereof, without the express consent of the manufacturer.

**Commercial Use:** You may reproduce, distribute and display these publications solely within your enterprise provided that all proprietary notices are preserved. You may not make derivative works of

these publications, or reproduce, distribute or display these publications or any portion thereof outside your enterprise, without the express consent of the manufacturer.

**Rights:** Except as expressly granted in this permission, no other permissions, licenses or rights are granted, either express or implied, to the Publications or any information, data, software or other intellectual property contained therein.

The manufacturer reserves the right to withdraw the permissions granted herein whenever, in its discretion, the use of the publications is detrimental to its interest or, as determined by the manufacturer, the above instructions are not being properly followed.

You may not download, export or re-export this information except in full compliance with all applicable laws and regulations, including all United States export laws and regulations.

THE MANUFACTURER MAKES NO GUARANTEE ABOUT THE CONTENT OF THESE PUBLICATIONS. THE PUBLICATIONS ARE PROVIDED "AS-IS" AND WITHOUT WARRANTY OF ANY KIND, EITHER EXPRESSED OR IMPLIED, INCLUDING BUT NOT LIMITED TO IMPLIED WARRANTIES OF MERCHANTABILITY, NON-INFRINGEMENT, AND FITNESS FOR A PARTICULAR PURPOSE.

