

Bull ESCALA EPC400

CPU Drawer Service Guide

ORDER REFERENCE
86 A1 21PX 02

Bull ESCALA EPC400

CPU Drawer Service Guide

Hardware

August 1998

BULL ELECTRONICS Angers
CEDOC
34 Rue du Nid de Pie – BP 428
49004 ANGERS CEDEX 01
FRANCE

ORDER REFERENCE
86 A1 21PX 02

The following copyright notice protects this book under the Copyright laws of the United States of America and other countries which prohibit such actions as, but not limited to, copying, distributing, modifying, and making derivative works.

Copyright © Bull S.A. 1992, 1998

Printed in France

Suggestions and criticisms concerning the form, content, and presentation of this book are invited. A form is provided at the end of this book for this purpose.

To order additional copies of this book or other Bull Technical Publications, you are invited to use the Ordering Form also provided at the end of this book.

Trademarks and Acknowledgements

We acknowledge the right of proprietors of trademarks mentioned in this book.

AIX[®] is a registered trademark of International Business Machines Corporation, and is being used under licence.

UNIX is a registered trademark in the United States of America and other countries licensed exclusively through the Open Group

Power Firmware is a trademark of FirmWorks.

Table of Contents

Communication Statements	v
Safety Notices	vi
About This Guide	vii
Chapter 1. CPU Drawer Hardware	1-1
Overview of the CPU Drawer	1-1
Description of the Hardware Components	1-3
3.5-Inch Diskette Drive	1-3
Battery	1-3
CPU Cards	1-3
Device Areas	1-3
Disk Cage	1-4
Disk Devices	1-4
Fan Modules	1-5
KBB Card	1-6
KDK Complex	1-6
Key Mode Switch	1-6
KHS Card	1-7
KP2 / KP3 Back Plane	1-7
KSB Card	1-7
Memory	1-7
Operator Panel	1-8
PCI/ISA Cards	1-8
Power Supply	1-8
System Planar (KPL)	1-8
Internal Connectors	1-10
System Planar (KPL)	1-10
KBB Card	1-13
KDK Card	1-14
KHS Card	1-15
KP2 / KP3 Back Plane	1-16
KSB Card	1-19
Memory Riser	1-20
Chapter 2. Hardware Component Installation	2-1
Preliminary and Restart Operations	2-2
How to Handle Hardware Components	2-2
Preliminary Operations	2-3
Partial Removal / Installation of the CPU Drawer	2-4
Top Cover	2-6
Front Cover	2-7
Restart Operations	2-8
List of Hardware Components	2-9
3.5-Inch Diskette Drive	2-10
Battery	2-13
Disk Cage	2-15
Fan Modules	2-20
KBB Card	2-26

KDK Complex	2-28
Key Mode Switch	2-30
KHS Card	2-33
KSB Card	2-35
Operator Panel	2-38
Power Supply	2-40
System Planar	2-43
VGA Cable	2-45
Video Memory	2-47
Chapter 3. SCSI Cables Description and Connection	3-1
Overview	3-1
SCSI Cables Description	3-2
SCSI Cables Connection	3-3
Appendix A. Spare Parts	A-1
Glossary	G-1
Index	X-1

Communication Statements

The following statements apply to this product. The statements for other products intended for use with this product appears in their accompanying manuals.

Federal Communications Commission (FCC) Statement

Note: This equipment has been tested and found to comply with the limits for a Class A digital device, pursuant to Part 15 of the FCC Rules. These limits are designed to provide reasonable protection against harmful interference when the equipment is operated in a commercial environment. This equipment generates, uses, and can radiate radio frequency energy and, if not installed and used in accordance with the instruction manual, may cause harmful interference to radio communications. Operation of this equipment in a residential area is likely to cause harmful interference in which case the user will be required to correct the interference at his own expense.

Properly shielded and grounded cables and connectors must be used in order to meet FCC emission limits. Neither the provider or the manufacturer are responsible for any radio or television interference caused by using other than recommended cables and connectors or by unauthorized changes or modifications to this equipment. Unauthorized changes or modifications could void the user's authority to operate the equipment.

This device complies with Part 15 of the FCC Rules. Operation is subject to the following two conditions: (1) this device may not cause harmful interference, and (2) this device must accept any interference received, including interference that may cause undesired operation.

EC Council Directive

This product is in conformity with the protection requirements of the following EC Council Directives:

- 89/336/EEC and 92/31/EEC (for the electromagnetic compatibility)
- 73/23/EEC (for the low voltage)
- 93/68/EEC (for CE marking).

Neither the provider nor the manufacturer can accept responsibility for any failure to satisfy the protection requirements resulting from a non-recommended modification of the product, including the fitting of option cards not supplied by the manufacturer.

International Electrotechnical Commission (IEC) Statement

This product has been designed and built to comply with IEC Standard 950.

Avis de conformité aux normes du ministère des Communications du Canada

Cet appareil numérique de la classe A respecte toutes les exigences du Règlement sur le matériel brouilleur du Canada.

Canadian Department of Communications Compliance Statement

This Class A digital apparatus meets all requirements of the Canadian Interference Causing Equipment Regulations.

VCCI Statement

この装置は、情報処理装置等電波障害自主規制協議会（VCCI）の基準に基づくクラス A 情報技術装置です。この装置を家庭環境で使用すると電波妨害を引き起こすことがあります。この場合には使用者が適切な対策を講ずるよう要求されることがあります。

The following is the translation of the VCCI Japanese statement in the box above.

This is a Class A product based on the standard of the Voluntary Control Council for Interferences by Information Technology Equipment (VCCI). If this equipment is used in a domestic environment, radio disturbance may arise. When such trouble occurs, the user may be required to take corrective actions.

Safety Notices

Definitions of Safety Notices

A *danger* notice indicates the presence of a hazard that has the potential of causing death or serious personal injury.

A *caution* notice indicates the presence of a hazard that has the potential of causing moderate or minor personal injury.

A *warning* notice indicates an action that could cause damage to a program, device, system, or data.

Placement of Safety Notices Inside This Manual

System safety notices which do not refer to a specific situation are included in these pages. Any specific safety notices are mentioned inside this manual whenever these must be observed during system operating or handling.

IT Power Systems

This equipment has been designed also for connection to IT Power Systems.

Disconnect Device - Rack (Isolation from Primary Power)

To remove the primary power from the rack, unplug the PDU input plug from the power source.

Disconnect Device - CPU and PCI Expansion Drawers (Isolation from Primary Power)

To remove the primary power from the CPU and PCI expansion drawers, unplug the "Appliance Coupler" from the relevant PDU outlet.

Laser Safety Information

Note: The Optical Link Card (OLC) referred to in this information is part of the Serial Optic Channel Converter assembly.

This system may contain a laser product called the Optical Link Card (OLC). In the U.S., the OLC is certified as a Class 1 laser product that conforms to the requirements contained in the Department of Health and Human Services (DHHS) regulation 21 CFR Subchapter J. Internationally, the OLC is certified as a Class 1 laser product that conforms to the requirements contained in the International Electrotechnical Commission (IEC) standard 825 (1984), the Verband Deutscher Elektrotechniker (VDE) standard 0837 (1986), and the CENELEC (European Committee for Electrotechnical Standardization) Harmonization Document HD 482 S1 (1988). The German testing institute VDE assigned a certificate of conformity to DIN IEC 825/VDE 0837/02.86 and CENELEC HD 482 S1/03.88; the certificate registration number is 3642.

In addition, Statens Provningsanstalt (Swedish National Testing Institute) tested and approved the OLC for use in Sweden as a Class 1 laser product and assigned the approval number SP LA 89:184. The CDRH certification label and the VDE certificate of conformity mark are located on the plastic retainer of the OLC product. The figure shows the system Class 1 information label required by IEC 825.

Class 1 laser products are not considered to be hazardous. The OLC internally contains a gallium aluminum arsenide (GaAlAs) semiconductor laser diode emitting in the wavelength range of 770 to 800 nanometers. This laser diode is a Class 3B laser that is rated at 5.0 milliwatts. The design of the OLC is such that access to laser radiation above a Class 1 level during operation, user maintenance, or service conditions is prevented.

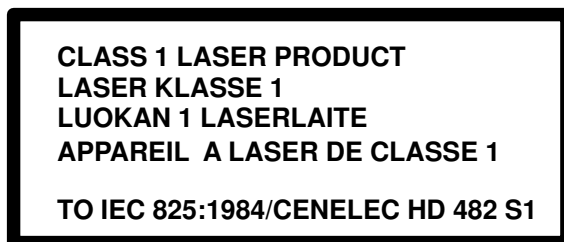

The Optical Link Card (OLC) must only be connected to another OLC or a compatible laser product. Any compatible laser product must contain the open fiber link detection and laser control safety system used in OLC. This is a requirement for correct operation of the optical link. In addition, the OLC product is designed and certified for use in applications with point-to-point optical links only. Using this product in any other type of optical link configuration (for example, links containing optical splitters or star couplers) is considered as not using the product correctly and may require that the user certify the laser product again for conformance to the laser safety regulations.

About This Guide

Audience

This guide is addressed to people in charge of the procedures to remove and/or install CPU drawer hardware components.

Note: The procedures described in this guide must be performed by people trained to perform service tasks on the system and must be executed carefully following the instructions given in this guide.

The system supplier will not be liable for any problems deriving from incorrect handling or wrong installations.

Overview of the Contents

- Chapter 1, **CPU Drawer Hardware**, provides a presentation of the CPU drawer with the name and a brief description of each system component. In addition, it gives detailed information about the location of all the CPU drawer internal connectors.
- Chapter 2, **Hardware Component Installation**, provides instructions for the installation and/or replacement of components in the CPU drawer.
- Chapter 3, **SCSI Cables Description and Connection**, describes the SCSI cables connection rules for the CPU drawer.
- Appendix A, **Spare Parts**, provides the hardware component part number cross-reference.

Related Publications

- *Hardware Tasks: Where do I find the Information I Need?*, is a hardware task roadmap which helps you find the task related information inside the documentation kit.
- *Site Preparation for Rack Systems*, details the environmental and electrical characteristics of the site where the rack must be installed.
- *Setting Up the System*, contains information about system setup, system startup and explains what you should do when the system arrives.
- *Using the System*, provides information about system operability, use of installed devices and maintainability services, both for the CPU drawer and the PCI expansion drawer. Moreover, system upgrading in terms of memory, CPU's, controllers and devices is described.
- *Configuring the System*, provides information about the CPU drawer, the PCI expansion drawer and rack configuration rules. Examples of SCSI configurations are included. This manual is addressed to system administrators and people trained to perform service tasks on the system, in charge of the system configuration.
- *Rack Service Guide*, includes the description of the supported drawers and the procedures to install and remove them. This guide is addressed to people trained to perform service tasks on the system.
- *Maintenance Guide*, provides information about the system initialization process, system firmware and configuration variables, and the system features in terms of reliability, availability and serviceability (RAS). It includes also information about the maintenance tools provided with the system for diagnostic purposes, such as offline tests, system status indicators (tracing and error codes), remote maintenance, both for the CPU drawer and the PCI expansion drawer. This guide is addressed to people trained to perform service tasks on the system.

- *Disks and Tapes Configuration Information*, describes the setting of addresses and switches for both disk and tape drives. It also includes information on CD-ROM drives setting.
- *Bull ESCALA PowerCluster & HA Solutions Setup Guide*, describes how to set up PowerCluster and High Availability solutions; it discuss both the hardware and software aspects.

In addition, if a PCI expansion drawer is connected to the CPU drawer, you can find the relevant information in the PCI expansion drawer specific documentation.

- *PCI Expansion Drawer Quick Set Up*, contains the step by step hardware procedures for a quick set up of the PCI expansion drawer.
- *PCI Expansion Drawer Service Guide*, provides the description of the PCI expansion drawer hardware components and the instructions for their removal and installation. This guide is addressed to people trained to perform service tasks on the system.

Chapter 1. CPU Drawer Hardware

This chapter provides an overview of the CPU drawer hardware.

In particular, it illustrates the location of the hardware components in the CPU drawer, and gives, in alphabetical order, a brief description of each hardware component.

In addition it contains information about all internal connectors.

- **Overview of the CPU Drawer**, below
- **Description of the Hardware Components**, on page 1-3
- **Internal Connectors**, on page 1-10.

Overview of the CPU Drawer

The following figures show both the front and the rear views of the CPU drawer, emphasizing the location of the hardware components contained in it.

Front View

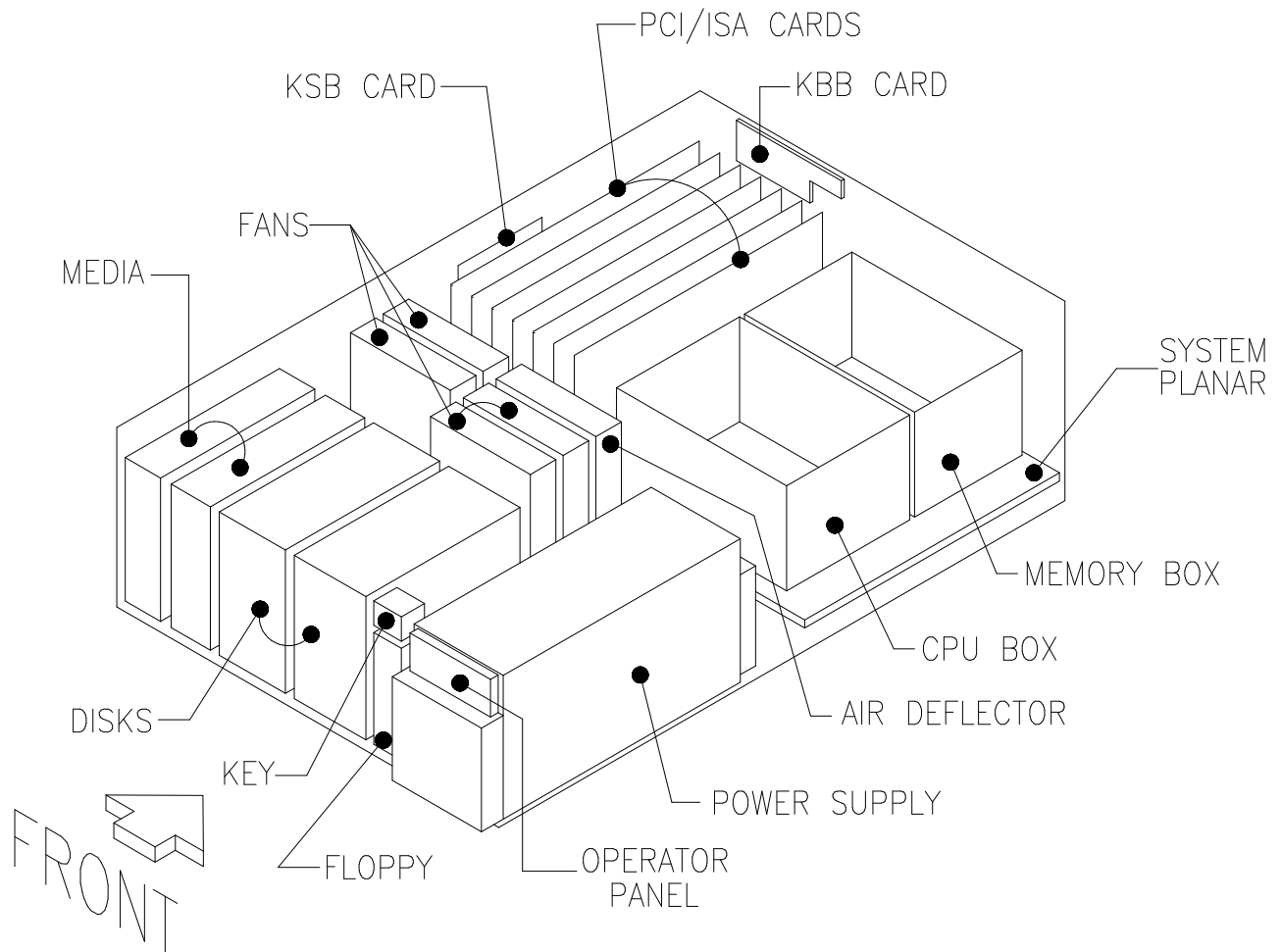

Rear View

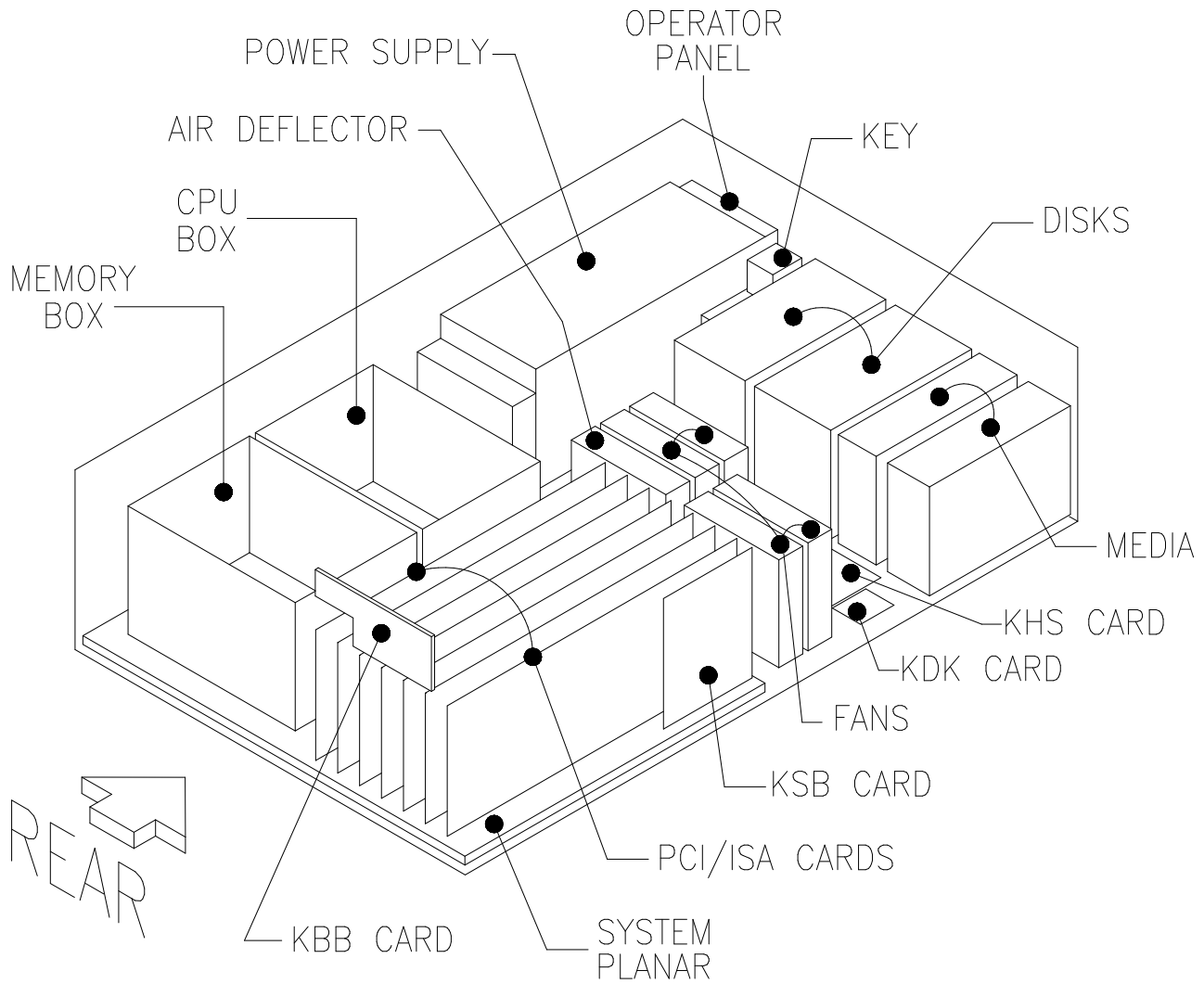

Description of the Hardware Components

3.5-Inch Diskette Drive

This CPU drawer supports the internal 1.44M-byte 3.5-inch diskette drive, which can also read and write 720K-byte diskettes.

Battery

The battery powers the system clock and sustains the NVRAM area (firmware area). It is placed on the KSB card.

CPU Cards

Up to four CPU cards can be installed in the dedicated slots on the system planar.

The CPU drawer supports CPU cards hosting microprocessors based on the RISC PowerPC™ architecture.

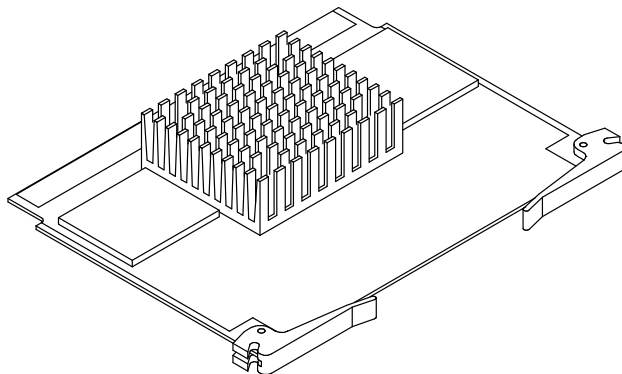

Note: The CPU cards configuration rules are described in the *Configuring the System* guide, while the replacement and upgrading procedures of the CPU cards are included in the *Using the System* guide.

Device Areas

This CPU drawer has three device areas which are located horizontally, on the front side of the CPU drawer itself.

Looking at the CPU drawer front, device areas are identified as follows:

- Area 1, that is the leftmost area, can be used to install up to two media devices, such as a CD-ROM drive, 4 mm tape drive, 8 mm tape drive, or QIC tape drive.
- Area 2 may host a disk cage housing either up to two 1.6 inch hard disk devices or up to three 1 inch hard disk devices.
- Area 3, that is the rightmost area, hosts always a disk cage housing either up to two 1.6 inch hard disk devices or up to three 1 inch hard disk devices. It contains the system disk in the leftmost slot.

Note: The device areas configuration rules are described in the *Configuring the System* guide, while the replacement and upgrading procedures of the devices are included in the *Using the System* guide.

Disk Cage

A disk cage is a metallic box used to install hard disk devices. Each disk cage occupies one device area. There are two types of disk cage:

- KP2 cage, to connect up to two 1.6-inch hard disk devices
- KP3 cage, to connect up to three 1-inch hard disk devices.

The figure illustrates a KP3 disk cage model.

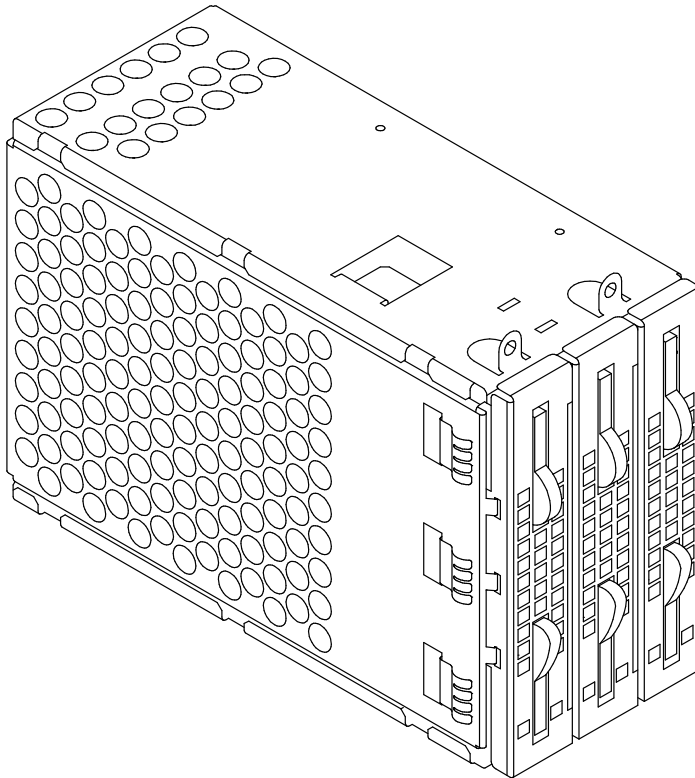

Disk Devices

The CPU drawer houses different kinds of hard disk devices which can be distinguished by:

- Their form factor: 1-inch or 1.6-inch
- Their characteristics, such as storage capacity, operation mode, transfer rate, etc.

Note: For a description of the device configuration rules refer to the *Configuring the System* guide, while for the replacement or the upgrading of a hard disk device refer to the *Using the System* guide.

Fan Modules

The CPU drawer houses four fan modules, which are placed between the device area and the system planar area.

In addition, two other fans are included in the power supply module and are part of the power supply sub-assembly.

Fans are numbered as indicated in the following figure.

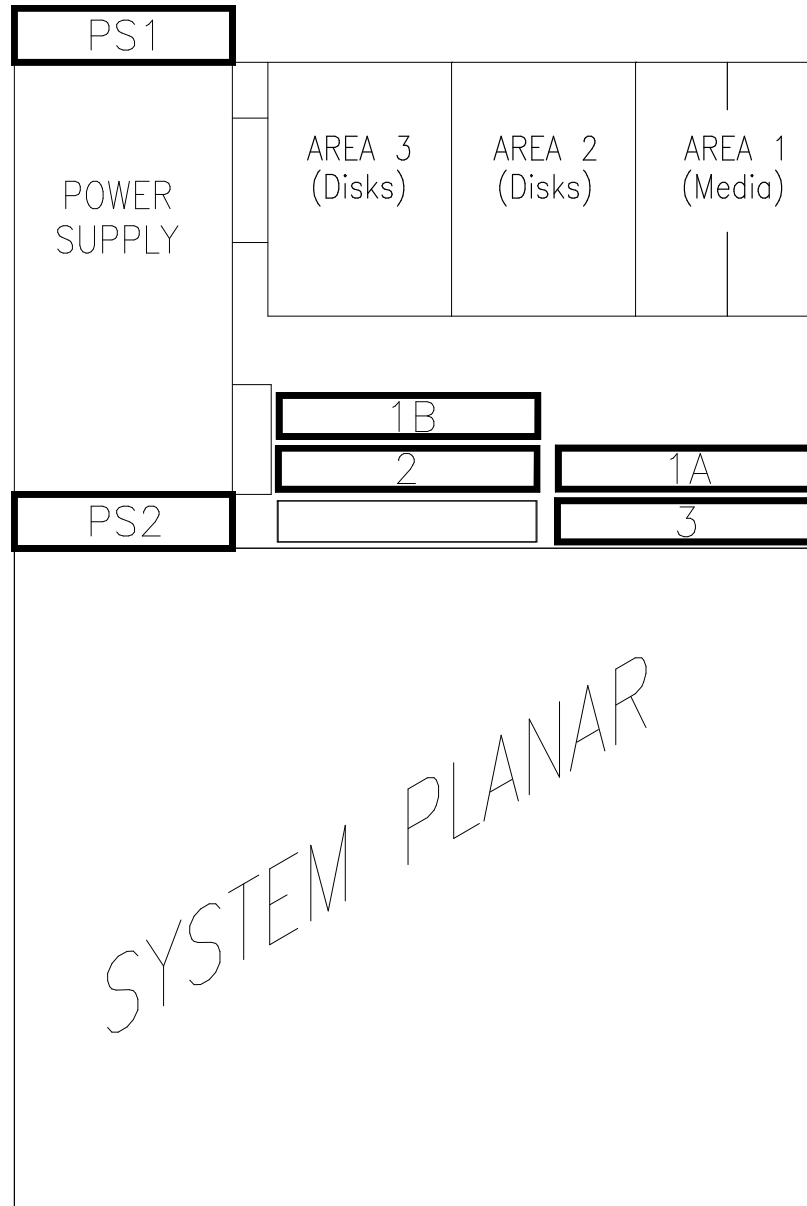

Note that the two fans next to the device area (1A and 1B) are logically seen as one fan (FAN1) by the system.

KBB Card

The KBB card provides:

- Three RS-232 lines (from right to left: COM1, COM2 and COM3) and
- One parallel line.

It dialogues with the system planar through the KSB card.

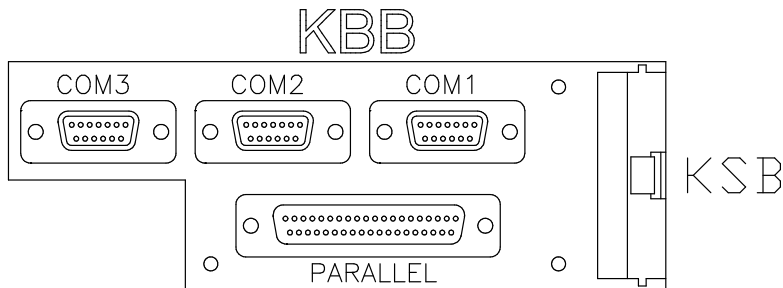

KDK Complex

The KDK complex is composed of the KDK card and two flat cables connected to it. The KDK card is placed at the bottom of the CPU drawer behind the device areas.

The KDK complex main functionalities are the following:

- Interface between the disk cages and the KHS card (if the latter is present)
- Definition of the disk devices SCSI-ID.

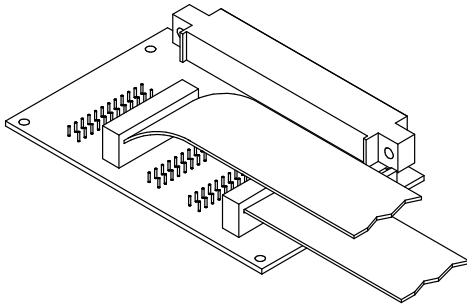

Key Mode Switch

The key mode switch provides four logical functions, which are enabled only when AC power is present in the system.

- ⊙ Power Off
- 🔧 Service
- OK Normal
- 🔒 Secure

Note: Exhaustive information about the use of the key mode switch is given in the *Using the System* guide.

KHS Card

The KHS card is an optional card which is directly plugged in the dedicated connector of the KDK card only in presence of a RAID configuration, as it acts as RAID controller card interface.

It is also connected to the KSB card by means of a dedicated flat cable.

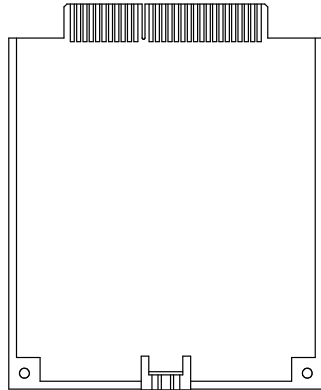

KP2 / KP3 Back Plane

The KP2 / KP3 back plane is a card that is placed on the rear side of the disk cage.

The KP2 back plane supports up to two 1.6-inch hard disk devices, while the KP3 back plane supports up to three 1-inch hard disk devices. Please refer to the disk cage description for further information.

KSB Card

The KSB card houses the BUMP (Bring Up MicroProcessor) logic and holds two dedicated connectors which interconnect the KSB to the KBB card, and to the KHS card if this is installed in the CPU drawer.

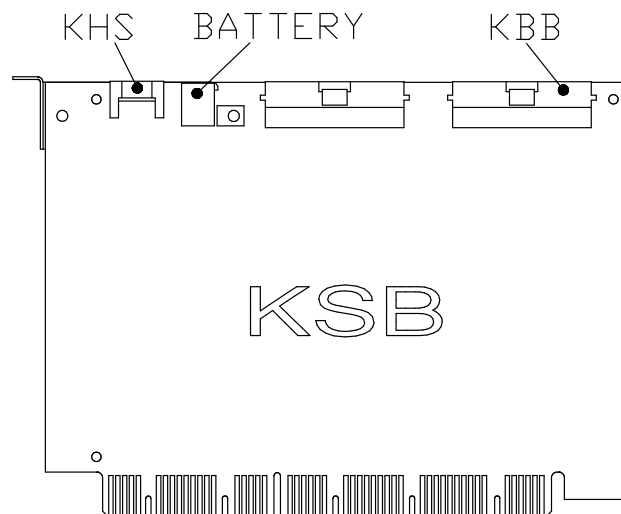

Memory

The system planar houses four memory connectors. They can host either one 4 DIMM memory bank or four memory risers hosting up to six memory banks.

Note: The memory configuration rules are described in the *Configuring the System* guide, while the replacement and upgrading procedures for memory are included in the *Using the System* guide.

Operator Panel

The operator panel houses the following components:

- 3-digit hexadecimal display
- 2 LED's
- Reset button.

Note: For a description of the operator panel functions, refer to the *Using the System* guide.

PCI/ISA Cards

The PCI/ISA controller cards are directly plugged onto the system planar. The CPU drawer can house up to eight controller cards.

Note: The PCI/ISA cards configuration rules are described in the *Configuring the System* guide, while the replacement and upgrading procedures for these controller cards are included in the *Using the System* guide.

Power Supply

Each CPU drawer is equipped with one redundant power supply module. The power supply module provides power and power regulation to all the CPU drawer components.

The power supply module is composed of a mechanical box structure with an AC inlet receptacle, input AC filtering, a power converter card assembly and output cables. The mechanical box structure includes two internal cooling fans.

In addition, as it is a redundant power supply, it contains two cards that share among them the CPU drawer power management. If one of these cards is faulty, the other one takes in charge the power management of the whole CPU drawer, so the system activity continues.

Furthermore, since part of the power supply logic is contained in the PDU (Power Distribution Unit), this power supply must always be connected to a PDU to guarantee correct working.

System Planar (KPL)

The system planar interconnects all CPU drawer resources.

It is capable of connecting the following cards:

- Up to 8 PCI/ISA cards (5 PCI cards + 2 PCI/ISA cards + 1 ISA card)
- Up to 4 CPU cards
- 4 DIMM's or up to 4 memory risers holding each up to 6 DIMM's.

The system planar provides also the connectors to manage the power supply, the diskette drive, the operator panel, the KSB card, the two native SCSI busses, the serial and parallel ports available on the rear side of the CPU drawer, the SVGA port, and the ports used to connect the keyboard, the mouse, the LAN, and the RS-485 interconnection.

Furthermore, it provides 1M byte of integrated video memory, and it is equipped with two sockets used to install two optional DRAM chips that upgrade the video memory to 2M bytes.

The following figure shows the system planar.

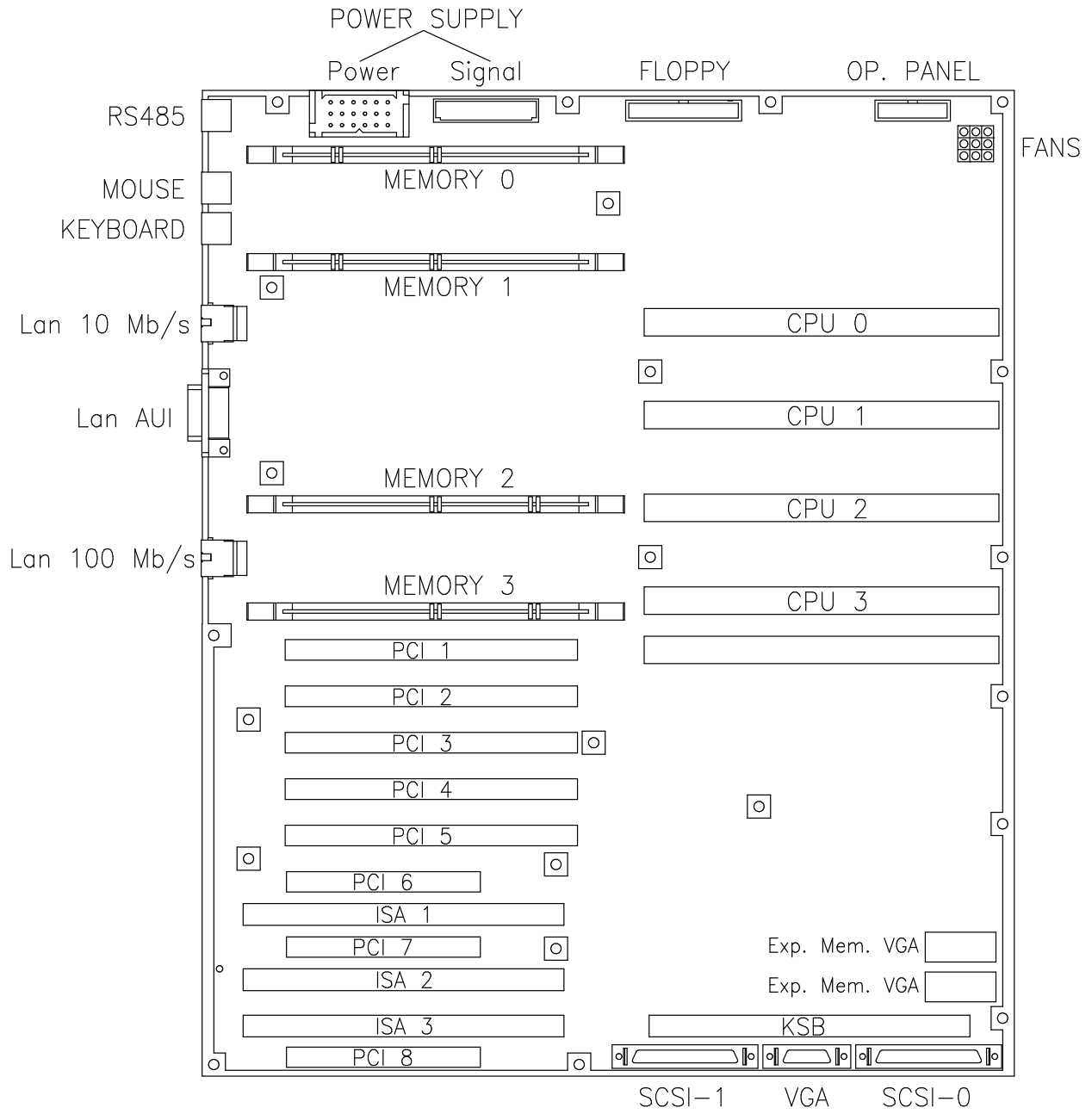

Internal Connectors

This section illustrates all the CPU drawer internal connectors, giving their location in the system and a description of each of them.

System Planar (KPL)

The figure illustrates all connectors present on the system planar.

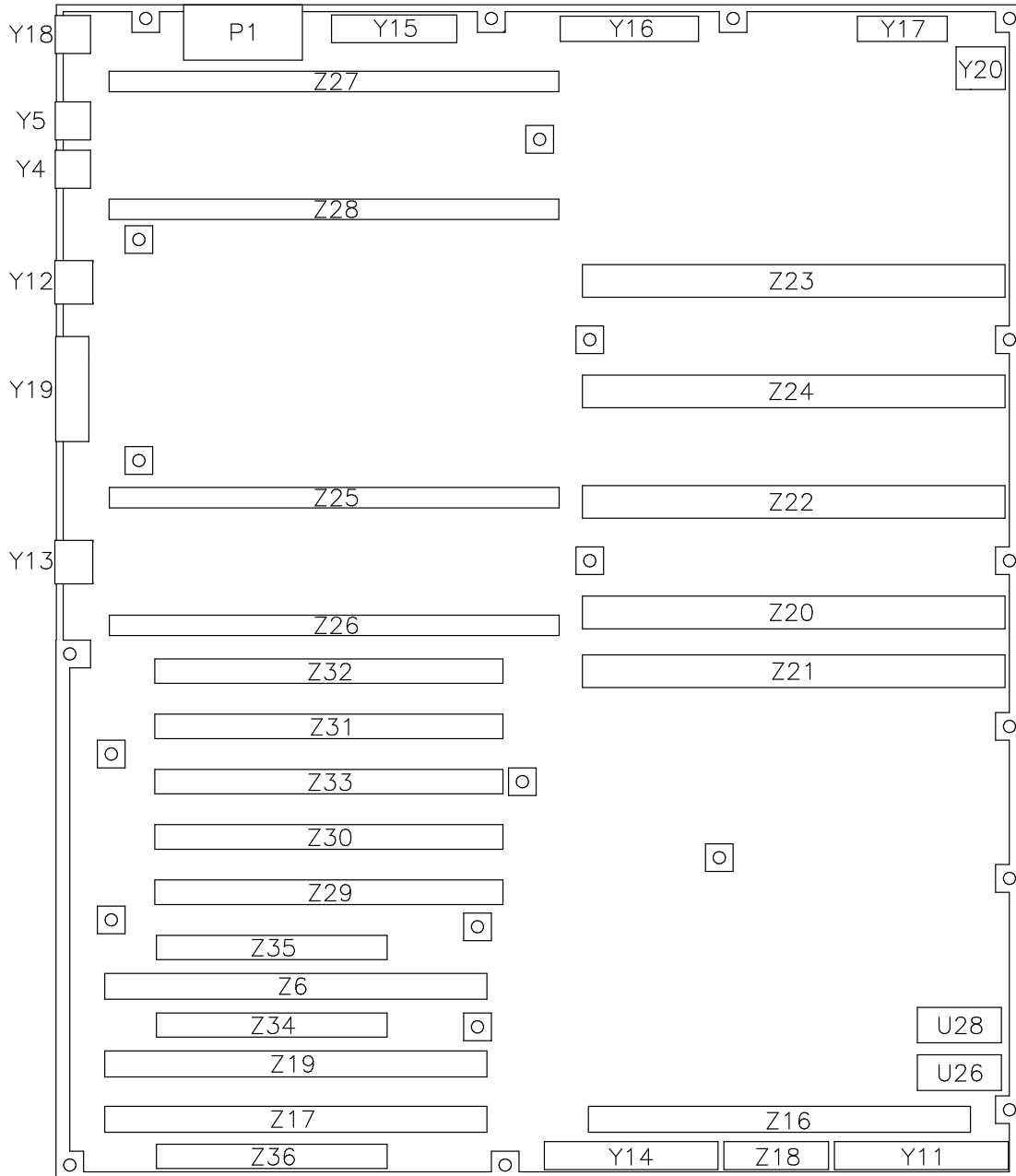

The following table details each connector shown in the previous figure, giving information about the type of connector, and about which function(s) it performs in the CPU drawer.

<i>Reference in the Figure</i>	<i>Type of Connector</i>	<i>Function</i>
P1	<i>18 contacts, power</i>	<i>Power supply interconnection</i>
U26	<i>Socket for DRAM chip</i>	<i>Video memory upgrading</i>
U28	<i>Socket for DRAM chip</i>	<i>Video memory upgrading</i>
Y4	<i>6 contacts, PS/2 type, mini DIN, female</i>	<i>Keyboard interconnection</i>
Y5	<i>6 contacts, PS/2 type, mini DIN, female</i>	<i>Mouse interconnection</i>
Y11	<i>68 contacts, mini DIN, female</i>	<i>SCSI single-ended native controller (SCSI-0)</i>
Y12	<i>8 contacts, RJ-45, female</i>	<i>10M bit per second Ethernet connector (10-base-T)</i>
Y13	<i>8 contacts, RJ-45, female</i>	<i>100M bit per second Ethernet connector (100-base-T)</i>
Y14	<i>68 contacts, mini DIN, female</i>	<i>SCSI single-ended native controller (SCSI-1)</i>
Y15	<i>34 contacts, male</i>	<i>Power supply interconnection</i>
Y16	<i>34 contacts, signal, male</i>	<i>3.5-inch diskette drive interconnection</i>
Y17	<i>20 contacts, male</i>	<i>Operator panel interconnection</i>
Y18	<i>6 contacts, PS/2 type, mini DIN, female</i>	<i>RS-485 port for units interconnection</i>
Y19	<i>15 contacts, DB-15 AUI, female</i>	<i>AUI Ethernet connector (10-base-2 and 10-base-5)</i>
Y20	<i>3x3 contacts, male</i>	<i>Fan modules interconnection</i>
Z6	<i>188 contacts, CARD EDGE</i>	<i>8/16 bit ISA controller card interconnection (Z6 and Z35 are overlapped)</i>
Z16	<i>188 contacts, CARD EDGE</i>	<i>KSB card interconnection</i>
Z18	<i>28 contacts, female</i>	<i>SVGA connector</i>
Z17	<i>188 contacts, CARD EDGE</i>	<i>8/16 bit ISA controller card interconnection (integrated modem card support)</i>
Z19	<i>188 contacts, CARD EDGE</i>	<i>8/16 bit ISA controller card interconnection (Z19 and Z34 are overlapped)</i>
Z20	<i>220 contacts, high speed CARD EDGE</i>	<i>CPU card interconnection</i>
Z21	<i>220 contacts, high speed CARD EDGE</i>	<i>Reserved for future use</i>
Z22	<i>220 contacts, high speed CARD EDGE</i>	<i>CPU card interconnection</i>
Z23	<i>220 contacts, high speed CARD EDGE</i>	<i>CPU card interconnection</i>
Z24	<i>220 contacts, high speed CARD EDGE</i>	<i>CPU card interconnection</i>

<i>Reference in the Figure</i>	<i>Type of Connector</i>	<i>Function</i>
Z25	<i>168 contacts, socket DIMM</i>	<i>Memory DIMM or memory riser interconnection</i>
Z26	<i>168 contacts, socket DIMM</i>	<i>Memory DIMM or memory riser interconnection</i>
Z27	<i>168 contacts, socket DIMM</i>	<i>Memory DIMM or memory riser interconnection</i>
Z28	<i>168 contacts, socket DIMM</i>	<i>Memory DIMM or memory riser interconnection</i>
Z29	<i>184 contacts, CARD EDGE</i>	<i>32/64 bit PCI controller card interconnection</i>
Z30	<i>184 contacts, CARD EDGE</i>	<i>32/64 bit PCI controller card interconnection</i>
Z31	<i>184 contacts, CARD EDGE</i>	<i>32/64 bit PCI controller card interconnection</i>
Z32	<i>184 contacts, CARD EDGE</i>	<i>32/64 bit PCI controller card interconnection</i>
Z33	<i>184 contacts, CARD EDGE</i>	<i>32/64 bit PCI controller card interconnection</i>
Z34	<i>120 contacts, CARD EDGE</i>	<i>32 bit PCI controller card interconnection (Z34 and Z19 are overlapped)</i>
Z35	<i>120 contacts, CARD EDGE</i>	<i>32 bit PCI controller card interconnection (Z35 and Z6 are overlapped)</i>
Z36	<i>120 contacts, CARD EDGE</i>	<i>Not used</i>

KBB Card

The figure illustrates all connectors present on the KBB card.

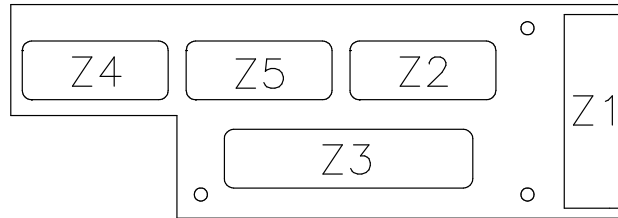

The following table details each connector shown in the above figure, giving information about the type of connector, and about which function(s) it performs in the CPU drawer.

<i>Reference in the Figure</i>	<i>Type of Connector</i>	<i>Function</i>
Z1	<i>60 contacts, male</i>	<i>KSB card interconnection by means of the appropriate flat cable</i>
Z2	<i>9 contacts, DB, male</i>	<i>RS-232 serial line (COM1 port)</i>
Z3	<i>25 contacts, female</i>	<i>Parallel port</i>
Z4	<i>9 contacts, DB, male</i>	<i>RS-232 serial line (COM3 port)</i>
Z5	<i>9 contacts, DB, male</i>	<i>RS-232 serial line (COM2 port)</i>

KDK Card

The figure illustrates all connectors present on the KDK card.

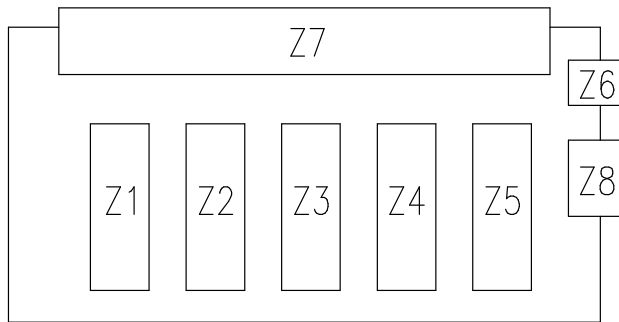

The following table details each connector shown in the above figure, giving information about the type of connector, and about which function(s) it performs in the CPU drawer.

<i>Reference in the Figure</i>	<i>Type of Connector</i>	<i>Function</i>
Z1	<i>20 contacts, male</i>	<i>Not used</i>
Z2	<i>20 contacts, male</i>	<i>Disk cage interconnection by means of the appropriate cable</i>
Z3	<i>20 contacts, male</i>	<i>Not used</i>
Z4	<i>20 contacts, male</i>	<i>Not used</i>
Z5	<i>20 contacts, male</i>	<i>Disk cage interconnection by means of the appropriate cable</i>
Z6	<i>3 contacts, male</i>	<i>Not used</i>
Z7	<i>50 contacts, CARD EDGE, female</i>	<i>KHS card interconnection</i>
Z8	<i>4 contacts, male</i>	<i>Not used</i>

KHS Card

The figure illustrates the connector present on the KHS card.

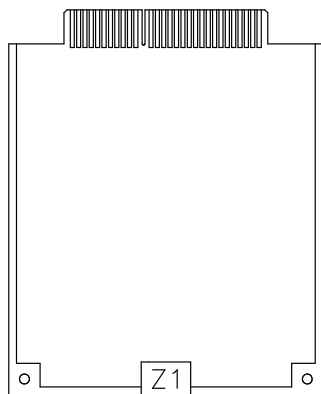

The following table details the connector shown in the above figure, giving information about the type of connector, and about which function(s) it performs in the CPU drawer.

<i>Reference in the Figure</i>	<i>Type of Connector</i>	<i>Function</i>
Z1	<i>10 contacts, male</i>	<i>KSB card interconnection by means of the appropriate cable</i>

KP2 / KP3 Back Plane

KP2 / KP3 back plane houses connectors on both the external and the internal sides.

External Side

The figure illustrates all connectors present on the external side of the KP2 / KP3 back plane.

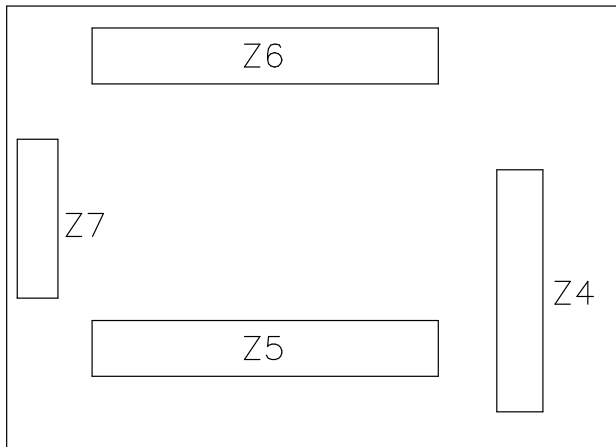

The following table details each connector shown in the above figure, giving information about the type of connector, and about which function(s) it performs in the CPU drawer.

<i>Reference in the Figure</i>	<i>Type of Connector</i>	<i>Function</i>
Z4	<i>20 contacts, male</i>	<i>KDK complex interconnection</i>
Z5	<i>68 contacts, female</i>	<i>SCSI input connector</i>
Z6	<i>68 contacts, female</i>	<i>SCSI output connector</i>
Z7	<i>4 contacts, power, male</i>	<i>Disk cage power connector</i>

KP2 Internal Side

The figure illustrates all connectors present on the internal side of the KP2 back plane.

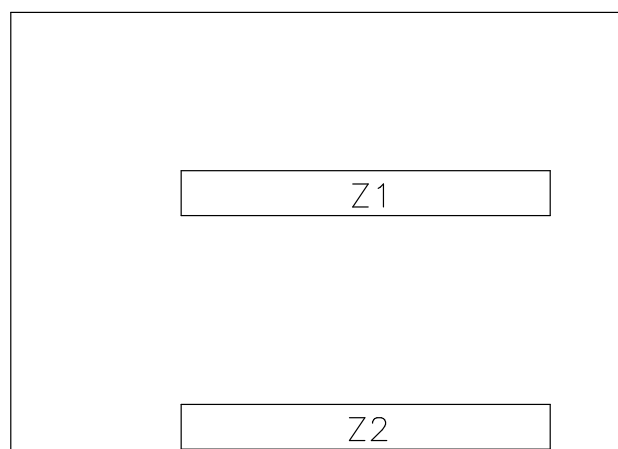

The following table details each connector shown in the above figure, giving information about the type of connector, and about which function(s) it performs in the CPU drawer.

<i>Reference in the Figure</i>	<i>Type of Connector</i>	<i>Function</i>
Z1	<i>80 contacts, SCA, female</i>	<i>1.6-inch hard disk drive interconnection</i>
Z2	<i>80 contacts, SCA, female</i>	<i>1.6-inch hard disk drive interconnection</i>

KP3 Internal Side

The figure illustrates all connectors present on the internal side of the KP3 back plane.

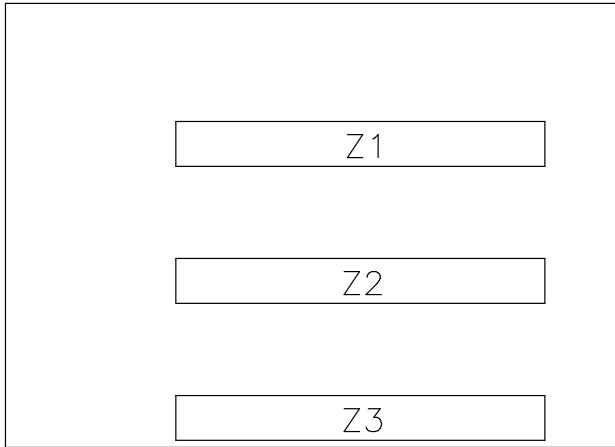

The following table details each connector shown in the above figure, giving information about the type of connector, and about which function(s) it performs in the CPU drawer.

<i>Reference in the Figure</i>	<i>Type of Connector</i>	<i>Function</i>
Z1	<i>80 contacts, SCA, female</i>	<i>1-inch hard disk drive interconnection</i>
Z2	<i>80 contacts, SCA, female</i>	<i>1-inch hard disk drive interconnection</i>
Z3	<i>80 contacts, SCA, female</i>	<i>1-inch hard disk drive interconnection</i>

KSB Card

The figure illustrates all connectors present on the KSB card.

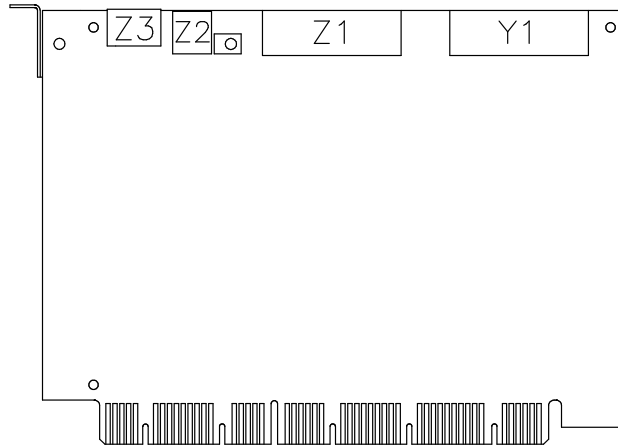

The following table details each connector shown in the above figure, giving information about the type of connector, and about which function(s) it performs in the CPU drawer.

<i>Reference in the Figure</i>	<i>Type of Connector</i>	<i>Function</i>
Y1	<i>60 contacts, male</i>	<i>KBB card interconnection by means of the appropriate cable</i>
Z1	<i>60 contacts, male</i>	<i>Test connector reserved to the manufacturer</i>
Z2	<i>2 contacts, male</i>	<i>Lithium battery interconnection</i>
Z3	<i>10 contacts, male</i>	<i>KHS card interconnection by means of the appropriate cable</i>

Memory Riser

The figure illustrates all connectors present on the memory riser.

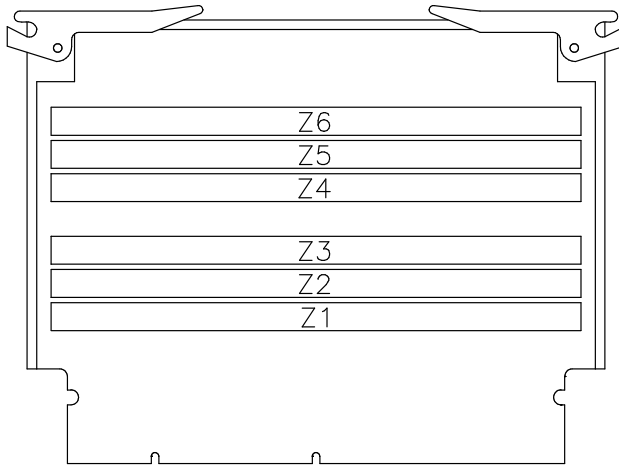

The following table details each connector shown in the above figure, giving information about the type of connector, and about which function(s) it performs in the CPU drawer.

<i>Reference in the Figure</i>	<i>Type of Connector</i>	<i>Function</i>
Z1	<i>168 contacts, socket DIMM</i>	<i>Memory DIMM interconnection</i>
Z2	<i>168 contacts, socket DIMM</i>	<i>Memory DIMM interconnection</i>
Z3	<i>168 contacts, socket DIMM</i>	<i>Memory DIMM interconnection</i>
Z4	<i>168 contacts, socket DIMM</i>	<i>Memory DIMM interconnection</i>
Z5	<i>168 contacts, socket DIMM</i>	<i>Memory DIMM interconnection</i>
Z6	<i>168 contacts, socket DIMM</i>	<i>Memory DIMM interconnection</i>

Chapter 2. Hardware Component Installation

This chapter describes the removal and installation procedures for the CPU drawer hardware components that require the intervention of technicians or trained people. See the **List of Hardware Components**, on page 2-9.

The procedures related to memory, CPU cards, PCI/ISA controllers and devices are not included in this guide. These are described in the *Using the System* guide.

This chapter also describes what to do before handling any hardware component, how to power on/off the system, how to partially remove the CPU drawer from the rack and how to install it, how to remove and re-install the CPU drawer top cover.

Before starting maintenance operations on the CPU drawer, it is recommended to have knowledge of the **Preliminary and Restart Operations**, which include the following sections:

- **How to Handle Hardware Components**, on page 2-2
- **Preliminary Operations**, on page 2-3
- **Partial Removal / Installation of the CPU Drawer**, on page 2-4
- **Top Cover**, on page 2-6
- **Front Cover**, on page 2-7
- **Restart Operations**, on page 2-8.

Preliminary and Restart Operations

A sequence of operations, such as handling hardware components, stopping the system, sliding the CPU drawer out of the rack, removing CPU drawer top cover, removing the CPU drawer front cover, restarting the system, may be required whenever you need to maintain the CPU drawer.

In particular, before starting any maintenance procedure and after having completed it, some specific operations are required for each procedure.

All of these operations are detailed in the following paragraphs, while specific reference-marks to them are included in each procedure.

How to Handle Hardware Components

Tools Needed

You should have the following tools available before you start installation and removal procedures on the CPU drawer.

- A large flat blade screwdriver
- A hex pipe wrench M5 for taptite hex screws M3
- A hex pipe wrench M7 for taptite hex screws M4
- A torx screwdriver for torx screws Ø 2.5 mm
- A torx screwdriver for torx screws Ø 3 mm
- A Phillips screwdriver size 1 for cross-slotted screws
- An antistatic envelope
- An antistatic wrist strap.

How to Use the Antistatic Envelope

Warning: Controllers, memory, cards and devices are sensitive to electrostatic discharge. These components are shipped in antistatic envelopes to prevent this damage.

Take the following precautions when handling any of the above mentioned hardware components:

1. Do not remove the component from the antistatic envelope until you are ready to install it in the CPU drawer.
2. Wear the antistatic wrist strap, refer to **How to Use the Antistatic Wrist Strap**, below.
3. Grip hardware components by the edges. Hold drives by the frame. Avoid touching the soldered joints or pins.
4. If you need to lay the hardware component down while it is out of the antistatic envelope, lay it on the antistatic envelope.
5. Handle the hardware components carefully in order to prevent permanent damage.

How to Use the Antistatic Wrist Strap

The antistatic wrist strap must be used each time you need to handle a controller, memory or CPU card, a media device or a fixed hard disk, because these are sensitive to electrostatic discharge.

The antistatic wrist strap is a band of 1m length providing at one end an adhesive strap which is to be wrapped around your wrist, and at the opposite end a copper clip which is to be attached to a non-varnished metallic frame of the system in a position that does not block your working area or movements.

Preliminary Operations

These preliminary operations must be performed whenever you are going to maintain the CPU drawer.

1. If the system is running, perform a system shutdown.
2. Open the front door of the rack.
3. Power off the system by turning the key mode switch of the CPU drawer to the Power Off position.
4. Open the rear door of the rack, if you need to access the CPU drawer from the rear side.
5. Make sure the power switches for all the external devices and drawers connected to the CPU drawer, if any, are set to OFF.

Note: Do not power off any drawers and external devices included in High Availability configurations.

6. Switch off the circuit-breaker of the PDU outlet where the CPU drawer is connected.
7. Unplug the power cord of the CPU drawer from the dedicated receptacle at the CPU drawer rear.

CAUTION:

To remove the primary power from the CPU drawer, unplug the “Appliance Coupler” on the rear side.

Note: In case any cable connected to the CPU drawer make the drawer sliding operation difficult, record which connector attaches to which cable and disconnect the cables.

CAUTION:

Before proceeding, ensure that these preliminary operations have been performed correctly to prevent a possible hazard.

DANGER

When adding or removing any additional devices to or from the CPU drawer, ensure that the power cables for those devices are unplugged before the signal cables are connected. If possible, disconnect the CPU drawer power cord before you add a device.

Use one hand, when possible, to connect or disconnect signal cables to prevent a possible shock from touching two surfaces with different electrical potentials.

During an electrical storm, do not connect cables for display stations, printers, telephones, or station protectors for communication lines.

Partial Removal / Installation of the CPU Drawer

Removal

1. Accessing the CPU drawer from the rear, loosen the screws securing the CPU drawer to the chassis.

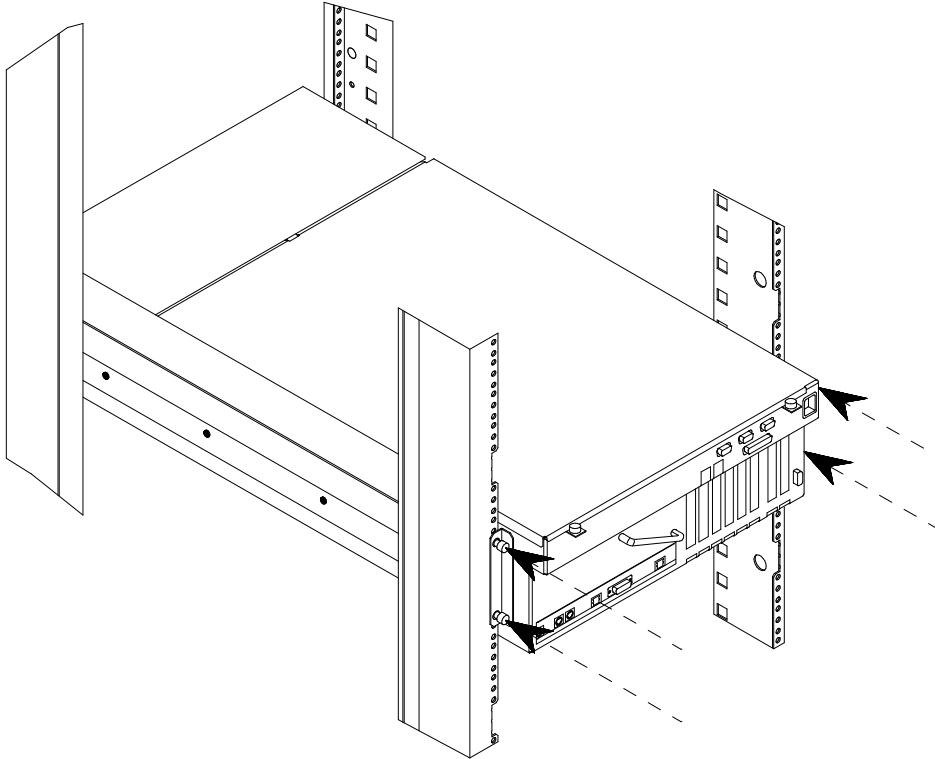

2. Using the handle at the rear of the drawer, slide the drawer out until it is well locked.

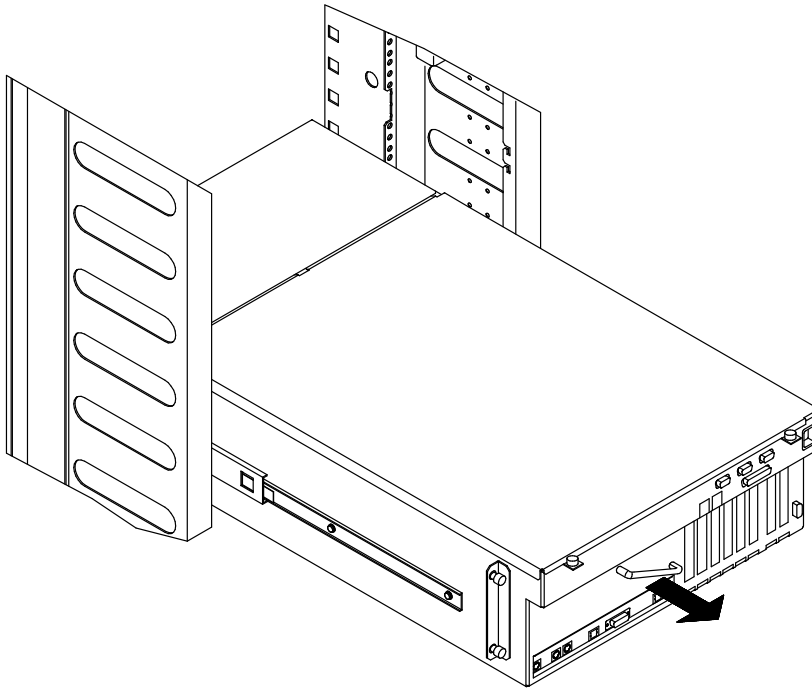

Note: In case cables connected to the drawer make the drawer sliding operation difficult, record which connector attaches to which cable and disconnect the cables.

Installation

1. Unlock the drawer telescopic rails, pushing simultaneously the metal tongues at sides of the drawer (as indicated at A) and firmly push the drawer inside the rack, using the handle, until it is well seated (as indicated at B).

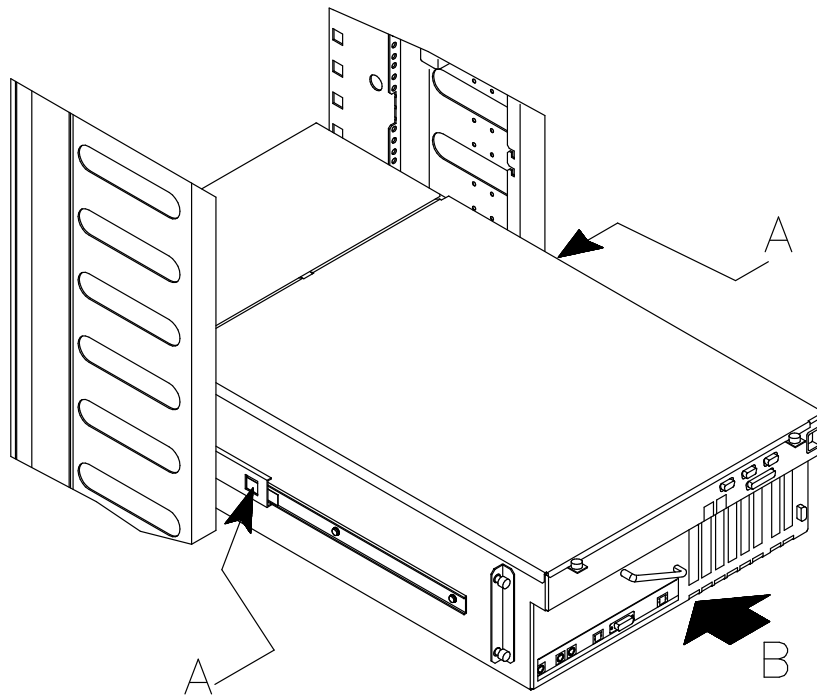

2. Accessing the drawer from the rear, tighten the retaining screws, securing the drawer to the chassis.

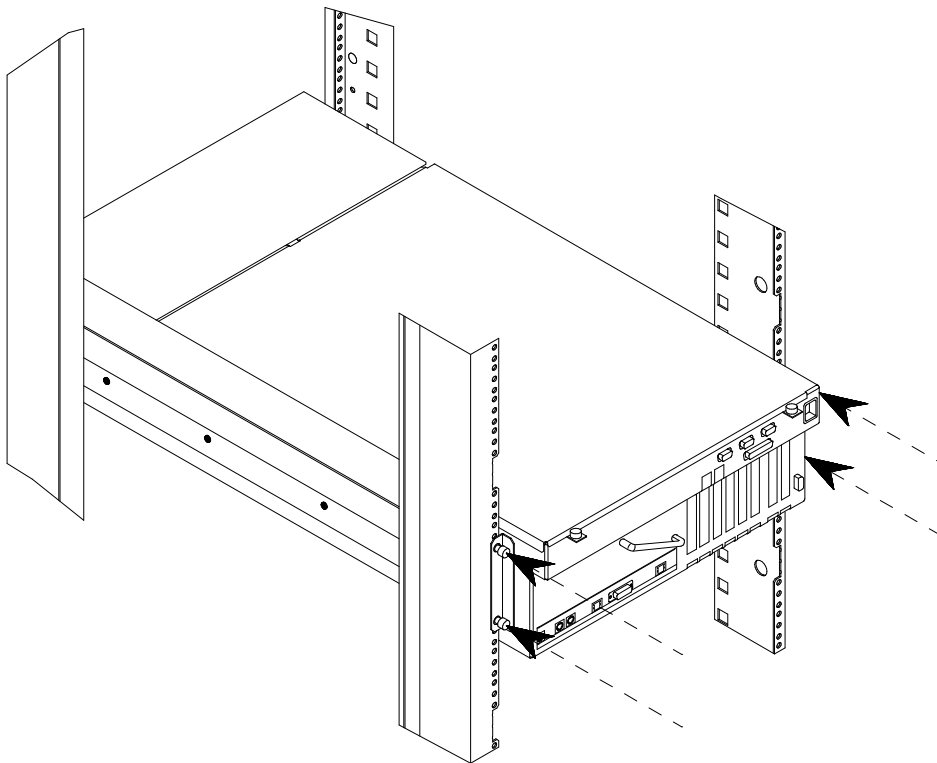

Top Cover

Removal

1. Loosen the retaining screws located on the rear of the drawer top cover, as indicated at A in the figure.
2. Remove the CPU drawer top cover sliding it towards you, as shown at B.

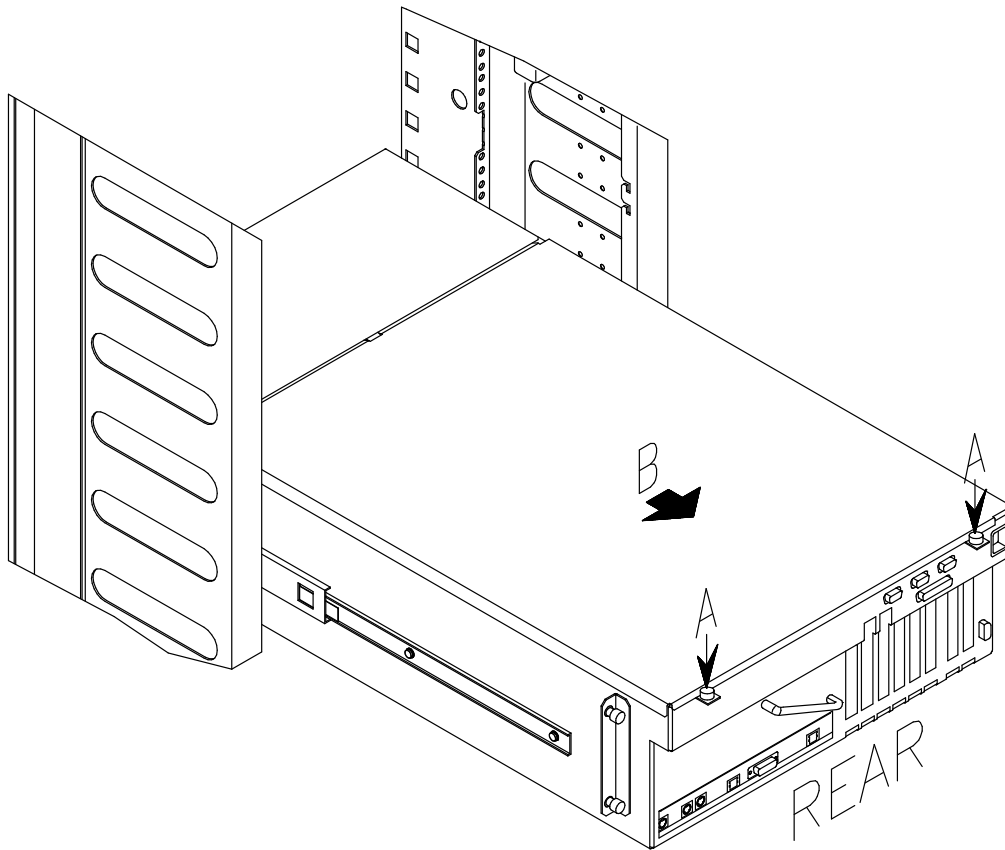

Installation

1. Accessing the CPU drawer from the rear, hook the retaining bracket on the top cover with the corresponding retainer on the CPU drawer chassis.
2. Secure the top cover to the CPU drawer, tightening clockwise its retaining screws.

Front Cover

Removal

1. Loosen the four retaining screws of the front cover and remove it, as shown in the figure.

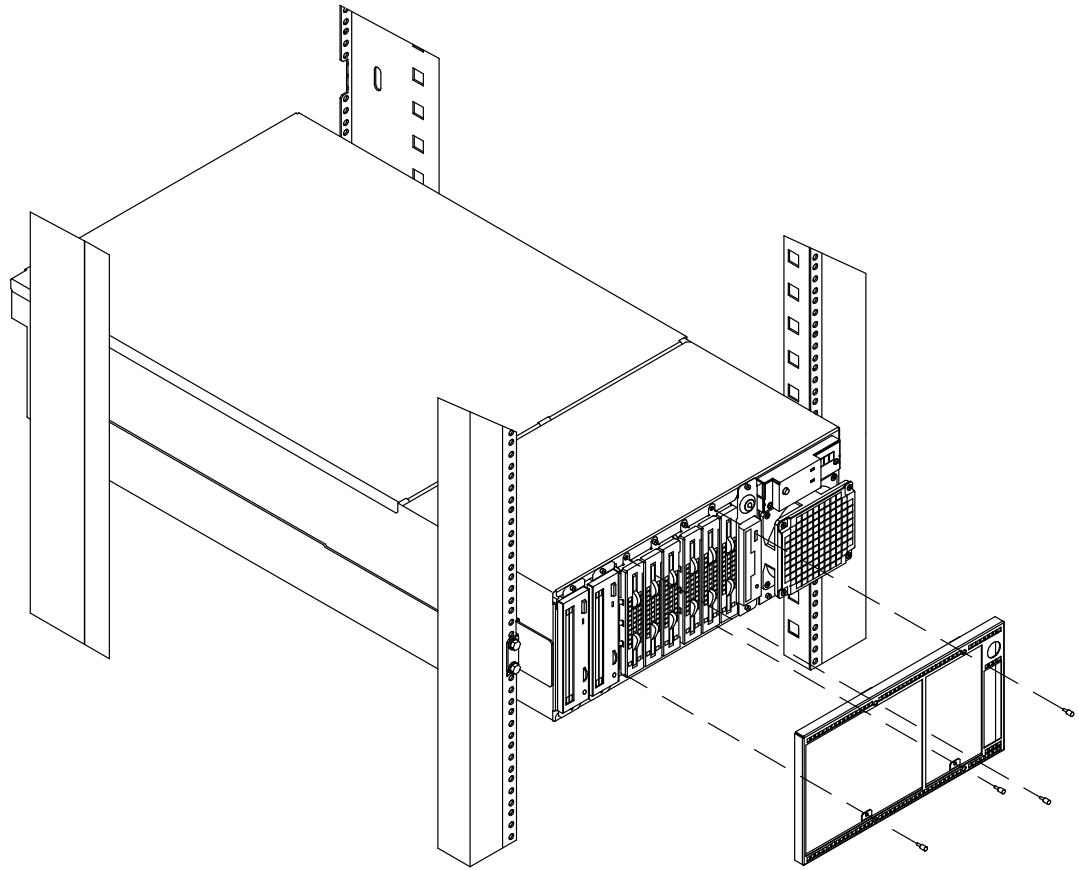

Installation

1. Position the front cover on the CPU drawer front.
2. Fix the front cover screwing the four screws.

Restart Operations

The following operations must be performed after all maintenance operations on the CPU drawer are concluded.

CAUTION:

For proper cooling and safe operation of the system, all the covers must be in place before you power up the system.

1. Connect any external cable to the drawer rear.
2. Connect the CPU drawer power cord.

Warning: Do not connect the CPU drawer to a power source other than the PDU.

3. Switch on the circuit-breaker of the PDU outlet where the drawer is connected.
4. Set the power switches of the external devices and drawers connected to the CPU drawer, if any, to ON.
5. Close the rear door of the rack, if opened.
6. Power on the system by turning the key mode switch of the CPU drawer to the Normal or Service position (use the Service position, if you want to enter the operating system diagnostic mode).
7. Close the front door of the rack.

List of Hardware Components

This section describes the installation and removal procedures of the following hardware components:

- **3.5-Inch Diskette Drive**, on page 2-10
- **Battery**, on page 2-13
- **Disk Cage**, on page 2-15
- **Fan Modules**, on page 2-20
- **KBB Card**, on page 2-26
- **KDK Complex**, on page 2-28
- **Key Mode Switch**, on page 2-30
- **KHS Card**, on page 2-33
- **KSB Card**, on page 2-35
- **Operator Panel**, on page 2-38
- **Power Supply**, on page 2-40
- **System Planar (KPL)**, on page 2-43
- **VGA Cable**, on page 2-45
- **Video Memory**, on page 2-47.

Any hardware components not included in this section are fully covered in the *Using the System* guide, in particular, these components:

- Memories
- CPU cards
- Controllers
- Media drives
- Hard disk drives.

3.5-Inch Diskette Drive

Warning: Before handling any hardware component, read and perform the procedures described in **How to Handle Hardware Components**, on page 2-2 and **Preliminary Operations**, on page 2-3.

Note: The following procedures do not require the CPU drawer to be slid out of the rack.

Removal

1. Open the front door of the rack and access the CPU drawer from the front side.
2. Remove the CPU drawer front cover, following the **Front Cover** procedure, **Removal** steps, on page 2-7.
3. Unscrew the retaining screws needed to secure the 3.5-inch diskette drive metallic frame to the CPU drawer chassis. These are indicated at A in the figure.

Gently slide the metallic frame, that contains the 3.5-inch diskette drive and the key mode switch, out of the CPU drawer, as shown at B.

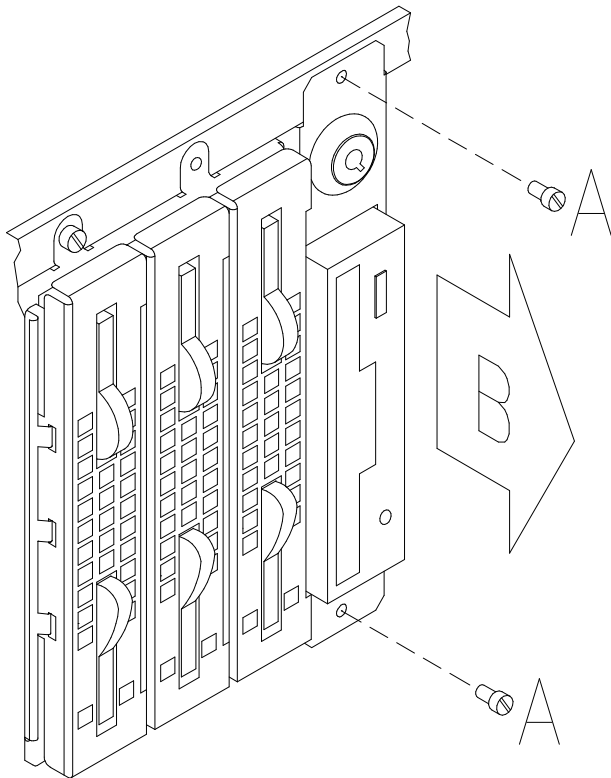

Warning: Handle these components with particular care: all the relevant cables are still connected to them and could be damaged if roughly pulled.

4. Unplug any cable connector from the 3.5-inch diskette drive and from the key mode switch, as shown in the figure.

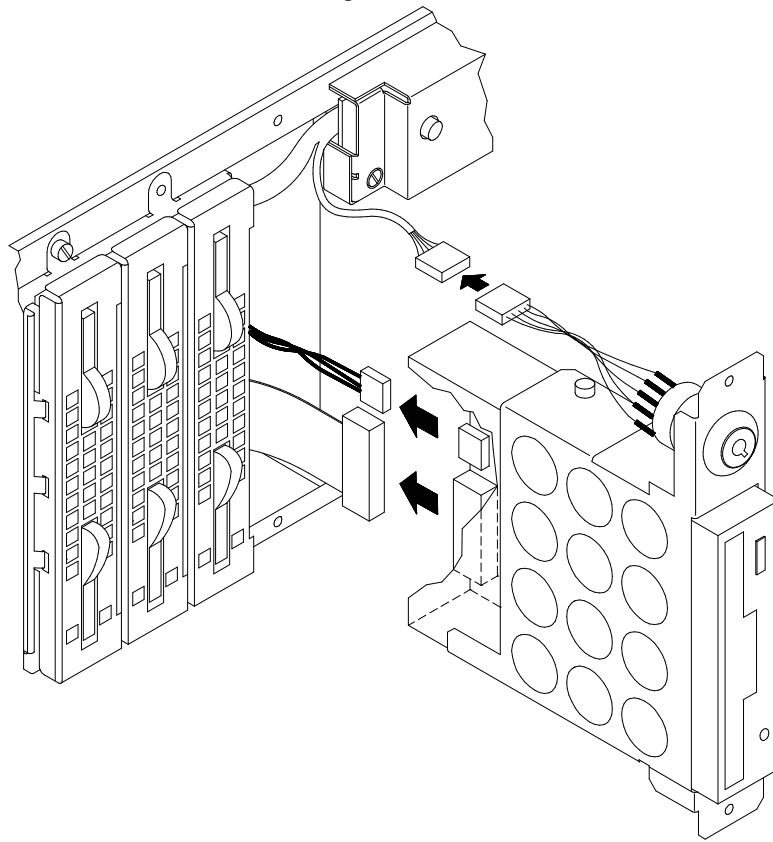

5. Loosen the retaining screws that lock the 3.5-inch diskette drive to its metallic frame, as shown at A in the figure.

Then remove the diskette drive from its metallic frame following the direction indicated at B.

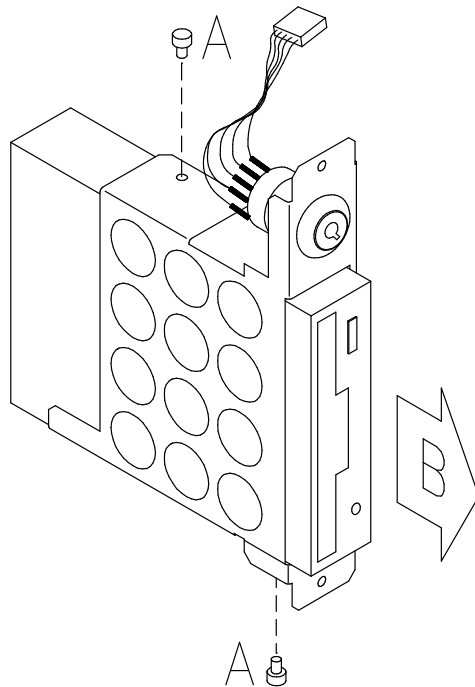

Installation

1. To install the new 3.5-inch diskette drive, follow the steps detailed in the **Removal** procedure in the reverse order.
2. Perform the **Restart Operations**, as described on page 2-8.

Battery

Warning: Before handling any hardware component, read and perform the procedures described in **How to Handle Hardware Components**, on page 2-2 and **Preliminary Operations**, on page 2-3.

CAUTION:

A lithium battery can cause fire, explosion, or a severe burn. Do not recharge, disassemble, heat above 100°C (212°F), solder directly to the cell, incinerate, or expose cell contents to water. Keep away from children.

Danger of explosion if battery is incorrectly replaced. Replace only with the part number specified for your system. Use of another battery may present a risk of fire or explosion.

The battery connector is polarized; do not attempt to reverse the polarity.

Discard used batteries according to the manufacturer instructions.

ATTENTION:

Une batterie au lithium peut occasionner des incendies, des explosions ou de sérieuses brûlures. Ne pas recharger, démonter, chauffer à plus de 100°C, souder directement sur l'élément, incinérer, ou exposer le contenu de l'élément à l'eau. Tenir à l'écart des enfants.

Il y a danger d'explosion s'il y a remplacement incorrect de la batterie. Remplacer uniquement avec une batterie du même type ou d'un type recommandé par le constructeur.

Le connecteur de la batterie est polarisé; ne pas tenter d'inverser la polarité.

Mettre au rebut les batteries usagées conformément aux instructions du fabricant.

Removal

Warning: Before removing the battery, record the values of the NVRAM flags (Open Firmware variables) if these are different from the defaults. Removing the battery causes all NVRAM flags to be reset to the default values. In this case, after having installed the new battery, remember to manually set the NVRAM flags to the required values.

1. Carefully slide the CPU drawer out of the rack, as described in **Partial Removal/Installation of the CPU Drawer, Removal** procedure, on page 2-4.
2. Remove the CPU drawer top cover, following the **Top Cover** procedure, **Removal** steps, on page 2-6.
3. Accessing the CPU drawer from the rear side, identify the KSB card in the right part of the CPU drawer, and locate the battery on it.
4. Unplug the battery cable connector, as indicated at A in the figure.

Remove the battery, pulling it off the Velcro attached to its dedicated support, as shown at B.

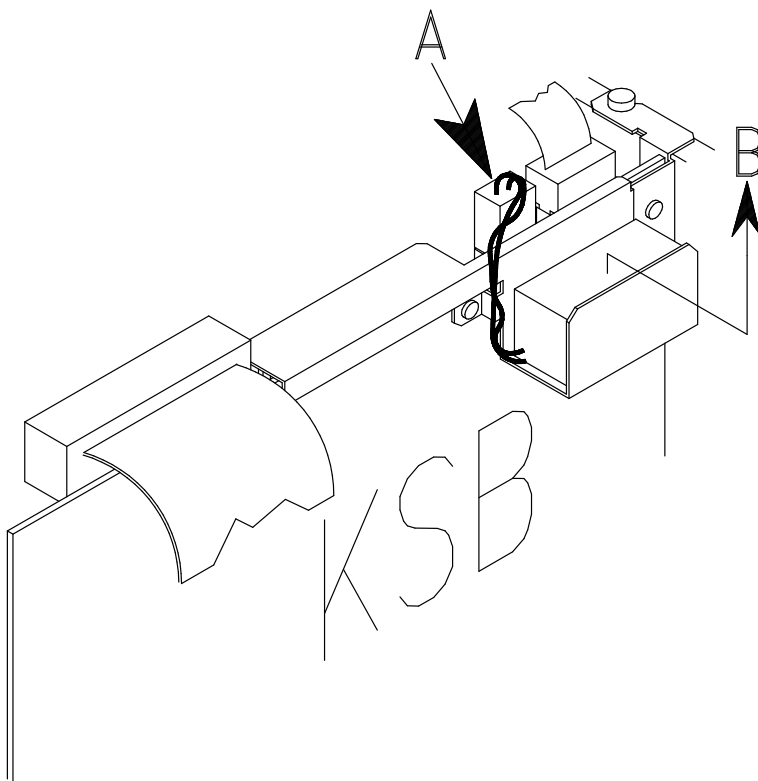

Installation

1. To install the new battery, follow the steps described in the **Removal** procedure in the reverse order.
2. Perform the **Restart Operations**, as described on page 2-8.
3. After the installation procedure of the battery has been completed, remember to:
 - a. Re-load the firmware using the appropriate diskette (see the **Firmware Updating** section, in the *Maintenance Guide*, for more information).
 - b. Manually set the NVRAM flags to the required values if these were different from the defaults.
 - c. Remember to reset the system date and time.

Disk Cage

Warning: Before handling any hardware component, read and perform the procedures described in [How to Handle Hardware Components](#), on page 2-2 and [Preliminary Operations](#), on page 2-3.

Note: The figures illustrate a KP3 disk cage model complete of three disk carriers. The procedures apply to both KP2 and KP3 disk cage models.

Removal

1. Carefully slide the CPU drawer out of the rack, as described in [Partial Removal/Installation of the CPU Drawer, Removal](#) procedure, on page 2-4.
2. Remove the CPU drawer top cover, following the [Top Cover](#) procedure, [Removal](#) steps, on page 2-6.
3. Accessing the CPU drawer from the rear side, disconnect all cables from the disk cage rear connectors shown in the figure.

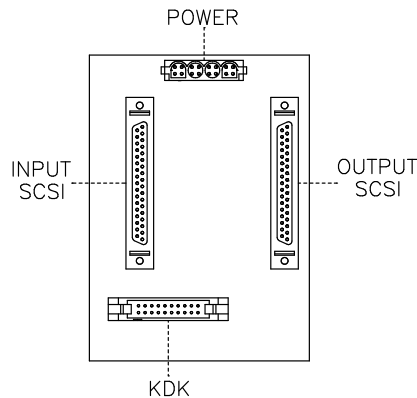

4. Slide the CPU drawer inside the rack, but do not secure it. For details, please refer to [Partial Removal/Installation of the CPU Drawer, Installation](#) steps, on page 2-5.
5. Open the front door of the rack.
6. Remove the CPU drawer front cover, following the [Front Cover](#) procedure, [Removal](#) steps, on page 2-7.
7. Accessing the CPU drawer from the front side, loosen the retaining screws to unlock the disk cage from the chassis, then slide the disk cage out of the slot.

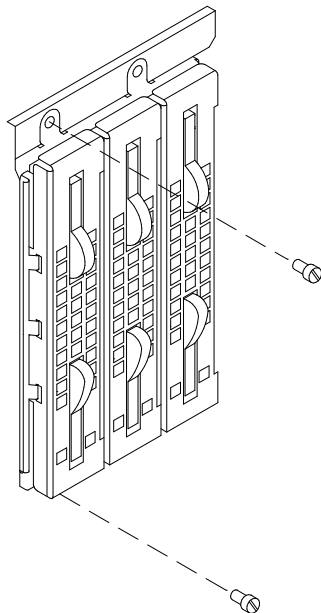

Note: If you have removed the disk cage because you do not need it any more, skip to step 12 of this procedure, otherwise continue with the following steps.

8. Lay the disk cage just removed on a flat surface.
9. Remove the disk carriers, one at a time, from the disk cage. Record their positions to keep the original configuration. The removal and installation procedures of disk carriers are described in the **Expanding Your System Configuration** section, in the *Using the System* guide.
10. Remove the KP2 / KP3 back plane from the disk cage, performing the following steps:
 - a. Loosen the retaining screws used to secure the KP2 / KP3 back plane to the disk cage, as indicated at A in the figure.
 - b. Gently push the KP2 / KP3 back plane towards the front side of the disk cage and slide it out, as indicated at B in the figure.

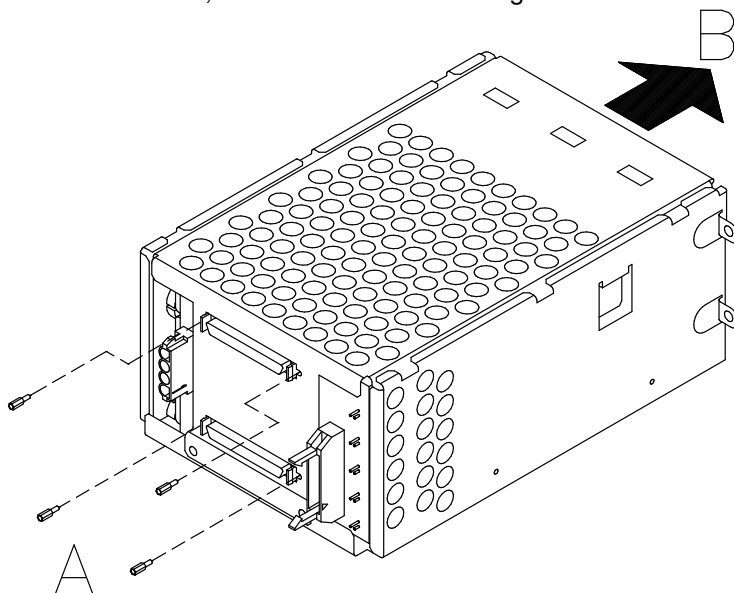

11. At this point skip to the disk cage **Installation** procedure, step 4, on page 2-17 and disregard the following steps.
12. Install the appropriate metal blank on the chassis in the corresponding free slot.

CAUTION:

It is recommended to protect any free device slot with the appropriate metal blanks. This is important for your safety and for the proper functioning of the air cooling system.

13. Slide the CPU drawer out of the rack.
14. Accessing the CPU drawer from the rear side, check and perform the connection of the SCSI cables. For exhaustive information, please refer to the **SCSI Cables Description and Connection** section.
15. Store the removed disk cage in an antistatic envelope.
16. Install the CPU drawer front cover, as described in **Front Cover, Installation** procedure, on page 2-7.
17. Install the CPU drawer top cover, as described in **Top Cover, Installation** procedure, on page 2-6.
18. Carefully slide the CPU drawer inside the rack, following the instructions given in **Partial Removal/Installation of the CPU Drawer, Installation** steps, on page 2-5.
19. Perform the **Restart Operations**, as described on page 2-8.

Installation

1. Open the front door of the rack and access the CPU drawer from the front side.
2. Remove the CPU drawer front cover, as described in **Front Cover, Removal** steps, on page 2-7.
3. Remove the metal blank of the designated slot, by loosening the screws that retain the blank to the CPU drawer chassis.

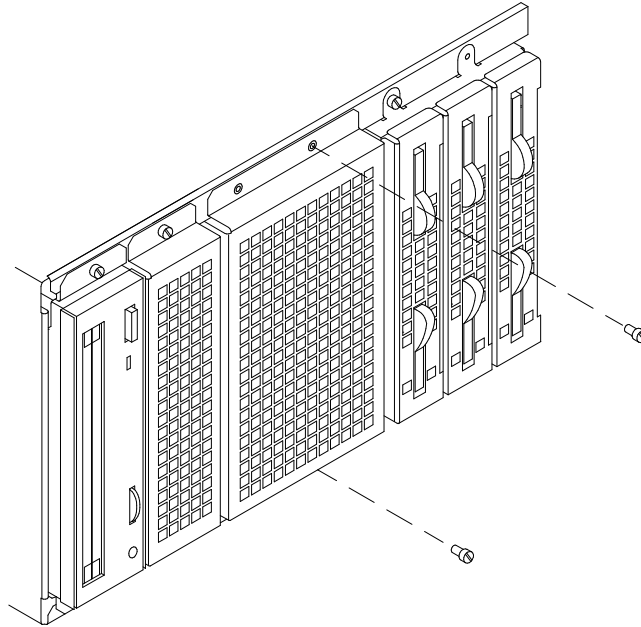

Note: It is recommended to store the metal blank and screws for possible future re-installation.

4. Assemble the KP2 / KP3 back plane and the disk cage metallic box, performing the following steps:
 - a. Accessing the disk cage metallic box from the front, gently slide the KP2 / KP3 back plane inside it keeping the disk carriers connectors towards the internal side of the disk cage. See A in the figure.
 - b. Secure the KP2 / KP3 back plane to the disk cage metallic box, tightening clockwise the retaining screws indicated at B in the figure.

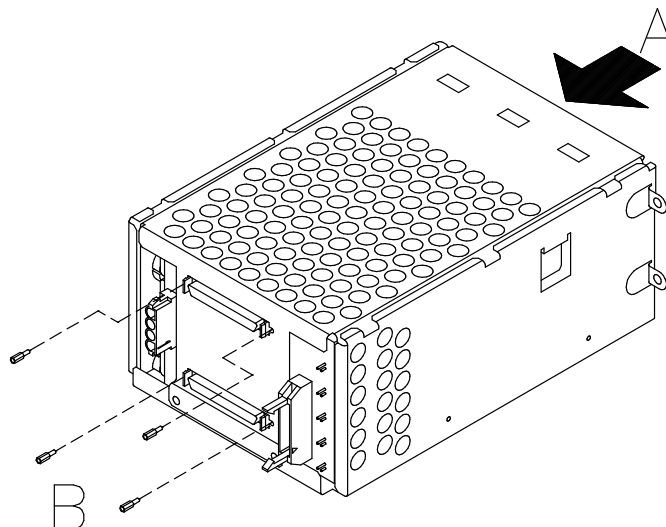

5. Install the required hard disks and disk carriers in the disk cage. For further details about this, please refer to the **Expanding Your System Configuration** section, in the *Using the System* guide.

6. Before installing the disk cage in the CPU drawer, remove the retaining clips, which are pointed out by the arrows in the figure.

Warning: Inserting the disk cage with its retaining clips on, can cause physical damages to the disk cage itself and to the CPU drawer chassis.

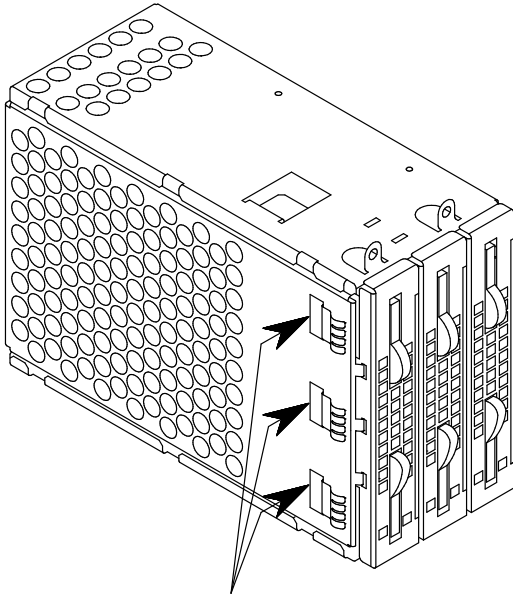

7. Grip the disk cage by the edges and slide it in the slot until it catches the CPU drawer chassis.
8. Tighten the retaining screws to lock the disk cage to the chassis.

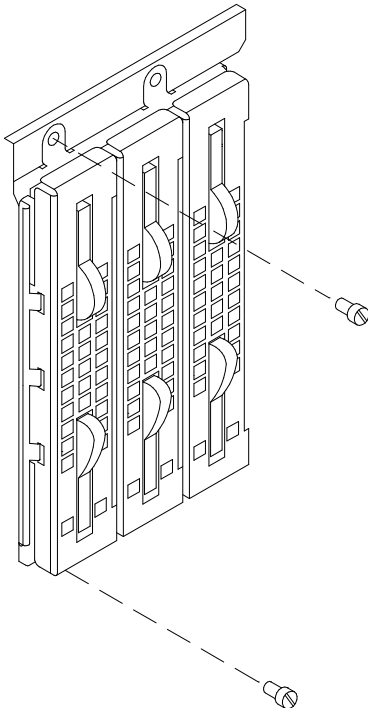

9. If not already done, slide the CPU drawer out of the rack, performing the removal procedures described in **Partial Removal/Installation of the CPU Drawer, Removal** paragraph, on page 2-4.
10. If not already done, remove the CPU drawer top cover, as described in **Top Cover, Removal** steps, on page 2-6.

11. Accessing the CPU drawer from the rear side, connect the cables to the disk cage rear connectors shown in the figure. Check and perform the connection of the SCSI cables, following the rules described in the **SCSI Cables Description and Connection** section.

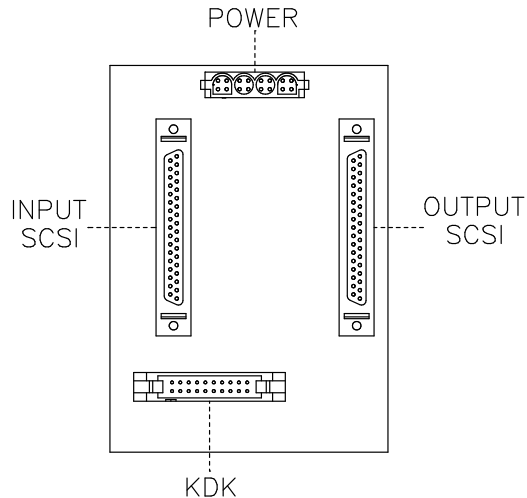

Note: For details about the device area power cables and power distribution, please refer to the **Power Supply** procedure, **Removal** step 7, on page 2-41.

12. Install the CPU drawer front cover, as described in **Front Cover, Installation** steps, on page 2-7.
13. Install the CPU drawer top cover, as described in **Top Cover, Installation** steps, on page 2-6.
14. Carefully slide the CPU drawer inside the rack, following the instructions given in **Partial Removal/Installation of the CPU Drawer, Installation** steps, on page 2-5.
15. Perform the **Restart Operations**, as described on page 2-8.

Fan Modules

Warning: Before handling any hardware component, read and perform the procedures described in **How to Handle Hardware Components**, on page 2-2 and **Preliminary Operations**, on page 2-3.

Removal

1. Carefully slide the CPU drawer out of the rack as described in **Partial Removal/ Installation of the CPU Drawer, Removal** steps, on page 2-4.
2. Remove the CPU drawer top cover, following the **Top Cover** procedure, **Removal** steps, on page 2-6.
3. Identify the faulty fan. Fans are numbered as indicated in the figure.

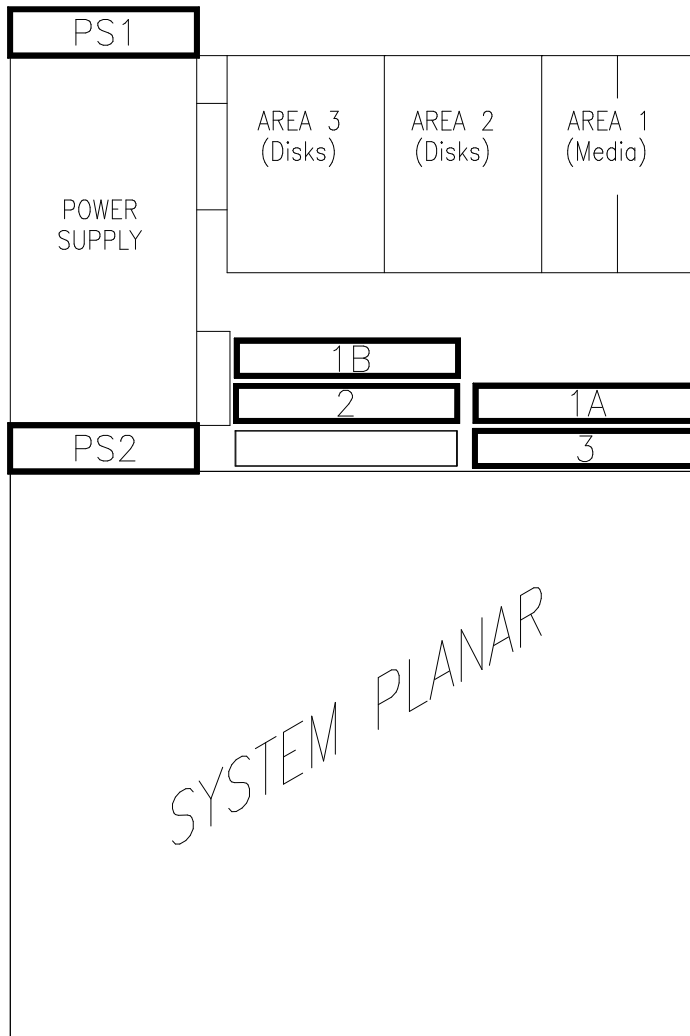

Notes:

- a. PS1 and PS2 fans are part of the power supply sub-assembly. If one of them is faulty, the whole power supply must be replaced. For details, please refer to the **Power Supply** procedure, on page 2-40.
- b. The two fans next to the device area (1A and 1B) are logically seen as one fan (FAN 1) by the system. If an error message indicates FAN 1 as faulty, these two fans must be replaced.
- c. If you need to replace fan 2, first you must remove fan 1B.
- d. If you need to replace fan 3, first you must remove fan 1A.

4. Perform the following steps to remove fans 1A and 1B.
 - a. Unplug the fan module power connector.
 - b. Firmly pull the fan module retaining button out until it unlocks.

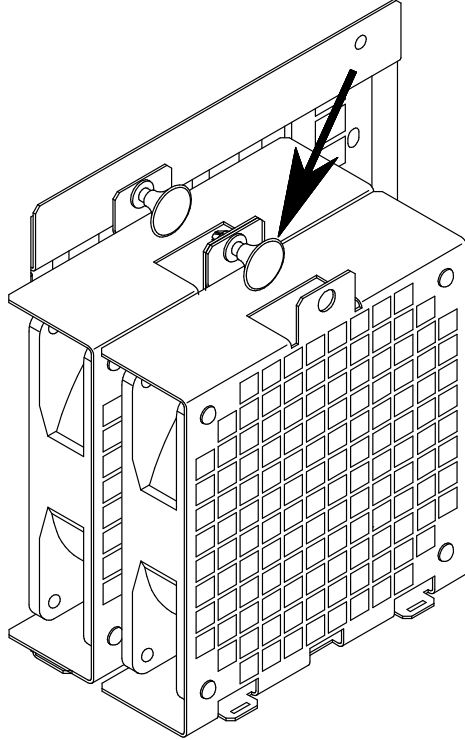

- c. Remove the fan module sliding its lateral metal tongues out of the dedicated slits on the back fan module.

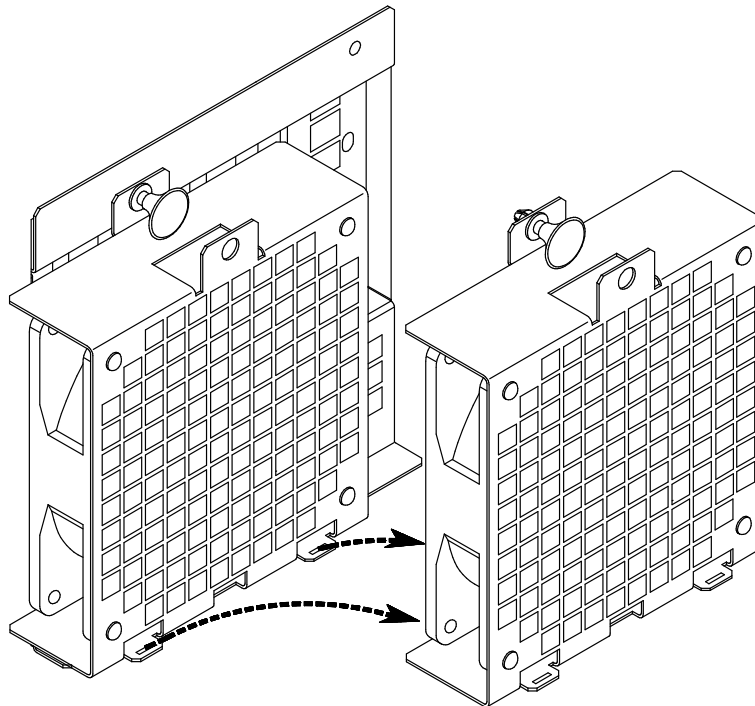

If you need to replace either fan 2 or fan 3, skip to step 5, otherwise disregard it and continue with step d below.

- d. Remove the four rubber fasteners, using pliers, to release the fan from its metallic grid.

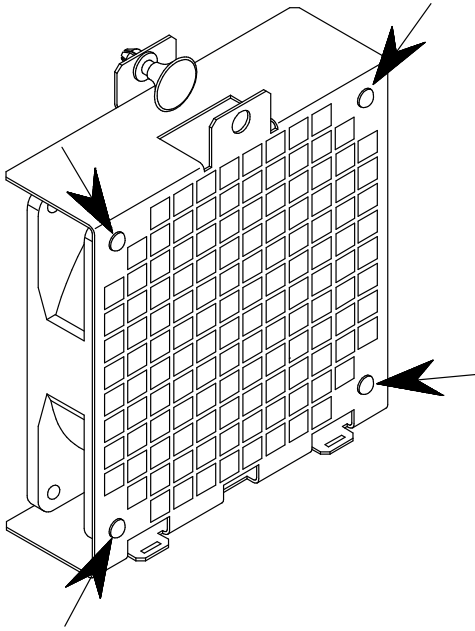

5. Perform the following steps to remove fans 2 and 3.
- Unplug the fan module power connector.
 - Firmly pull the fan module retaining button out, until it unlocks.

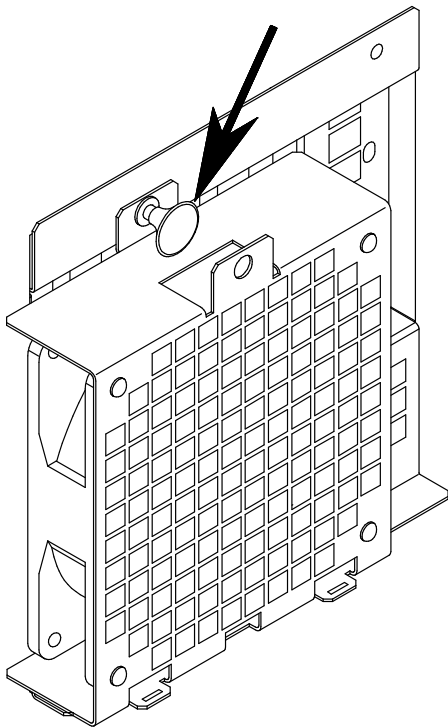

- c. Remove the fan module sliding its central metal tongue out of the dedicated slit on the CPU drawer chassis.

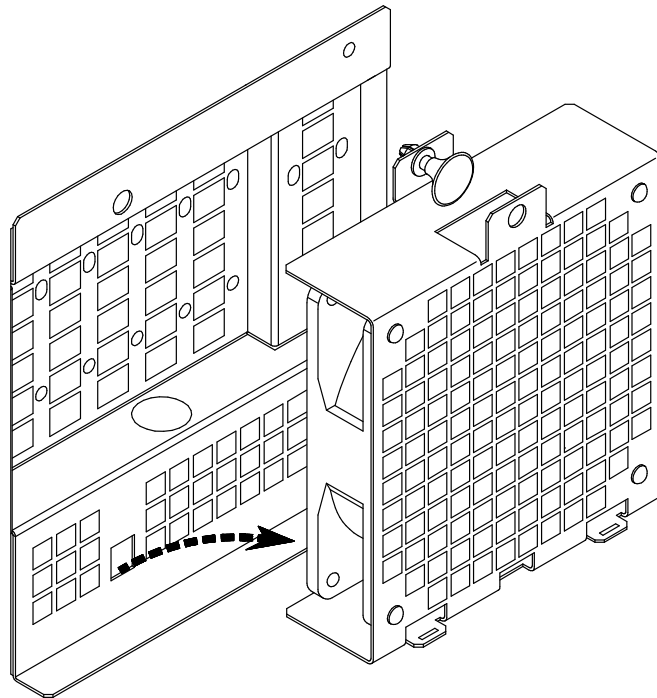

- d. Remove the four rubber fasteners, using pliers, to release the fan from its metallic grid.

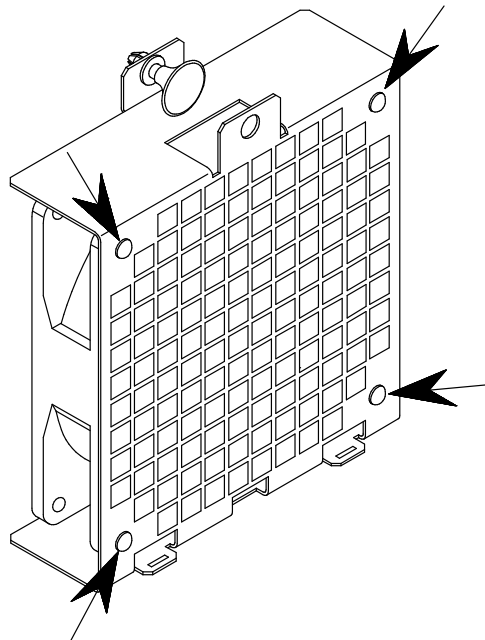

Installation

Perform the following steps for each fan you need to install.

1. Secure the fan to its metallic grid inserting the four rubber fasteners in the dedicated holes.

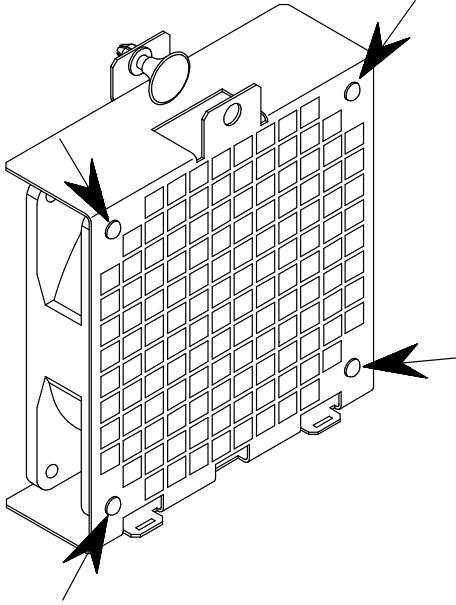

2. Locate the position for the fan module and:

- a. For fans 2 and 3, insert the central metal tongue into the CPU drawer dedicated slit.

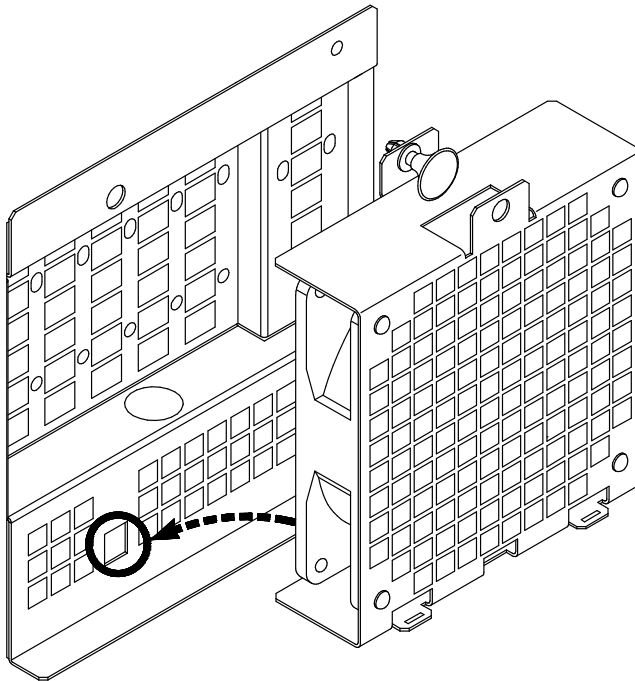

- b. For fans 1A and 1B, insert the lateral metal tongues into the corresponding slits on the back fan module.

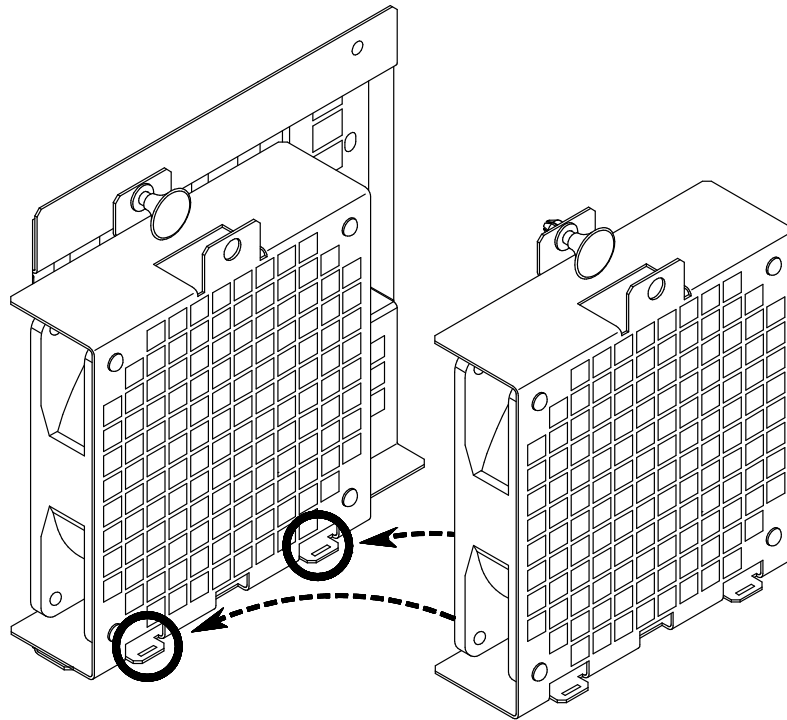

3. Push the fan module retaining button to lock the fan inside the CPU drawer.
4. Plug in the fan module power connector.

Note: Fan 1B is directly powered by the power supply, while the other three fans are powered by the system planar. When plugging the fan power connector, read the fan number written on the label attached to the power cable connector, to avoid wrong connections.

5. Install the CPU drawer top cover as described in the **Top Cover** procedure, **Installation** steps, on page 2-6.
6. Carefully slide the CPU drawer inside the rack, following the instructions given in **Partial Removal/Installation of the CPU Drawer**, **Installation** steps, on page 2-5.
7. Perform the **Restart Operations**, as described on page 2-8.

KBB Card

Warning: Before handling any hardware component, read and perform the procedures described in **How to Handle Hardware Components**, on page 2-2 and **Preliminary Operations**, on page 2-3.

Removal

1. Carefully slide the CPU drawer out of the rack, as described in **Partial Removal/ Installation of the CPU Drawer, Removal** procedure, on page 2-4.
2. Remove the CPU drawer top cover, following the **Top Cover** procedure, **Removal** steps, on page 2-6.
3. Locate the KBB card in the rear side of the CPU drawer.
4. Unplug all external cable connectors attached to the KBB card.
5. Disconnect the KSB-KBB cable from the KSB card.

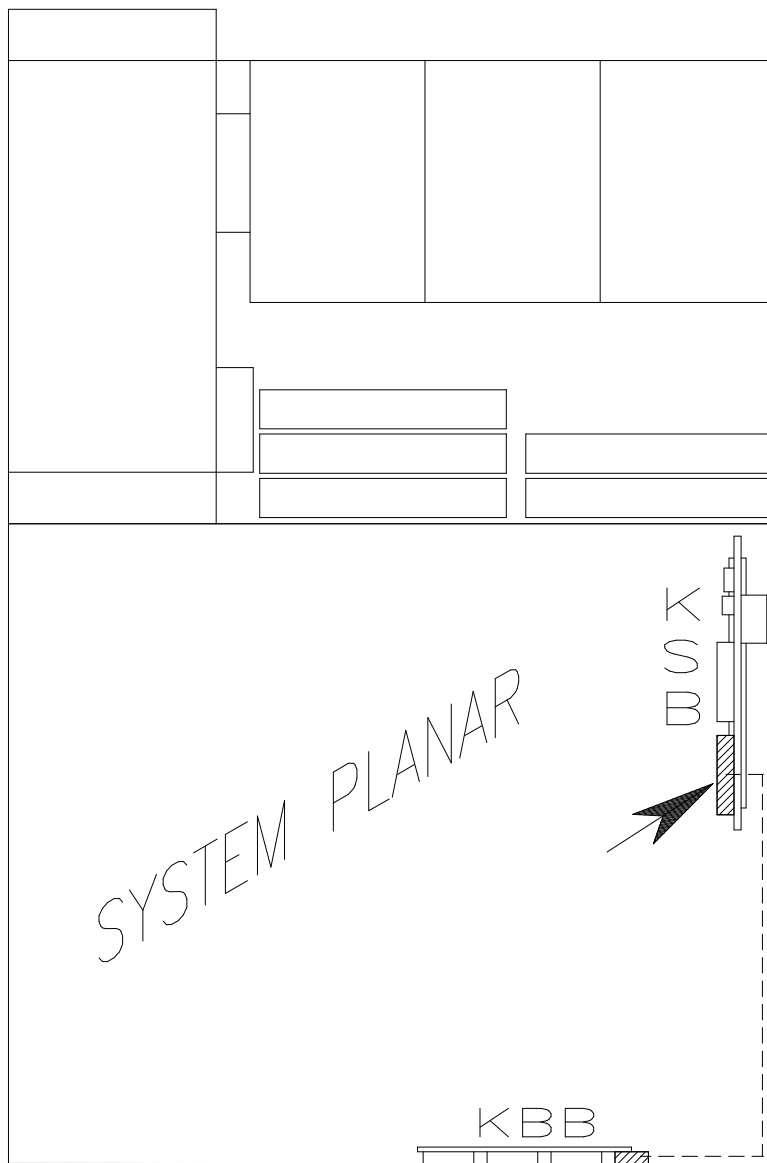

6. Unscrew the indicated standoff screws which secure the KBB card to the rear of the CPU drawer.

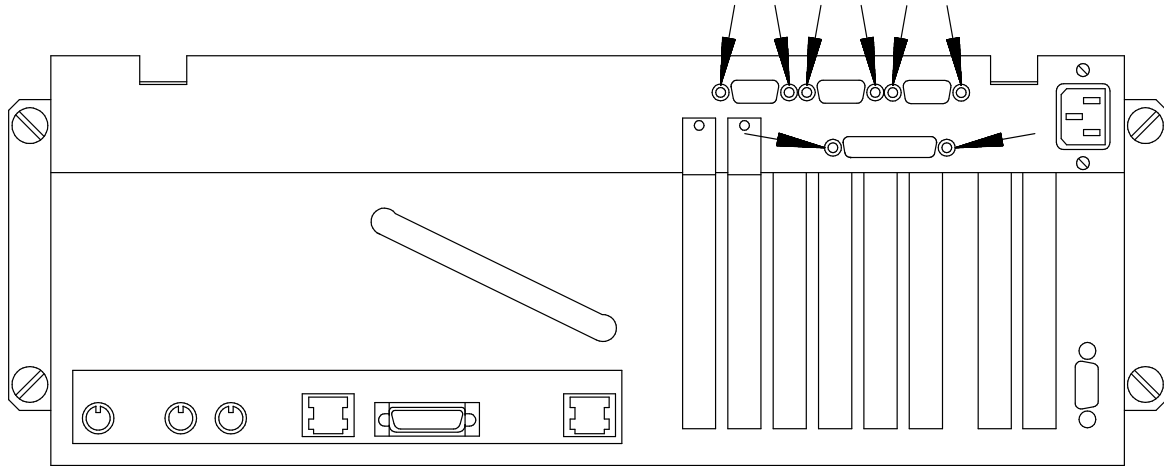

7. Remove the KBB card from the CPU drawer.
8. Disconnect the KSB-KBB cable from the KBB card.

Installation

1. Connect the KSB-KBB cable to the KBB card.
2. Install the KBB card, making sure that the standoff screws fit the related holes at the CPU drawer rear.
3. Secure the KBB to the CPU drawer, tightening clockwise its standoff screws.
4. Connect the KSB-KBB cable to the KSB card.
5. Install the CPU drawer top cover, as described in **Top Cover, Installation** steps, on page 2-6.
6. Carefully slide the CPU drawer inside the rack, following the instructions given in **Partial Removal/Installation of the CPU Drawer, Installation** steps, on page 2-5.
7. Plug in the external cables.
8. Perform the **Restart Operations**, as described on page 2-8.

KDK Complex

Warning: Before handling any hardware component, read and perform the procedures described in **How to Handle Hardware Components**, on page 2-2 and **Preliminary Operations**, on page 2-3.

Note: Further information about the KDK complex and the SCSI cables is given in the **SCSI Cables Description and Connection** section.

Removal

1. Carefully slide the CPU drawer out of the rack, as described in **Partial Removal/ Installation of the CPU Drawer, Removal** procedure, on page 2-4.
2. Remove the CPU drawer top cover, following the **Top Cover** procedure, **Removal** steps, on page 2-6.
3. Accessing the CPU drawer from the rear side, locate the KDK complex behind the device areas.

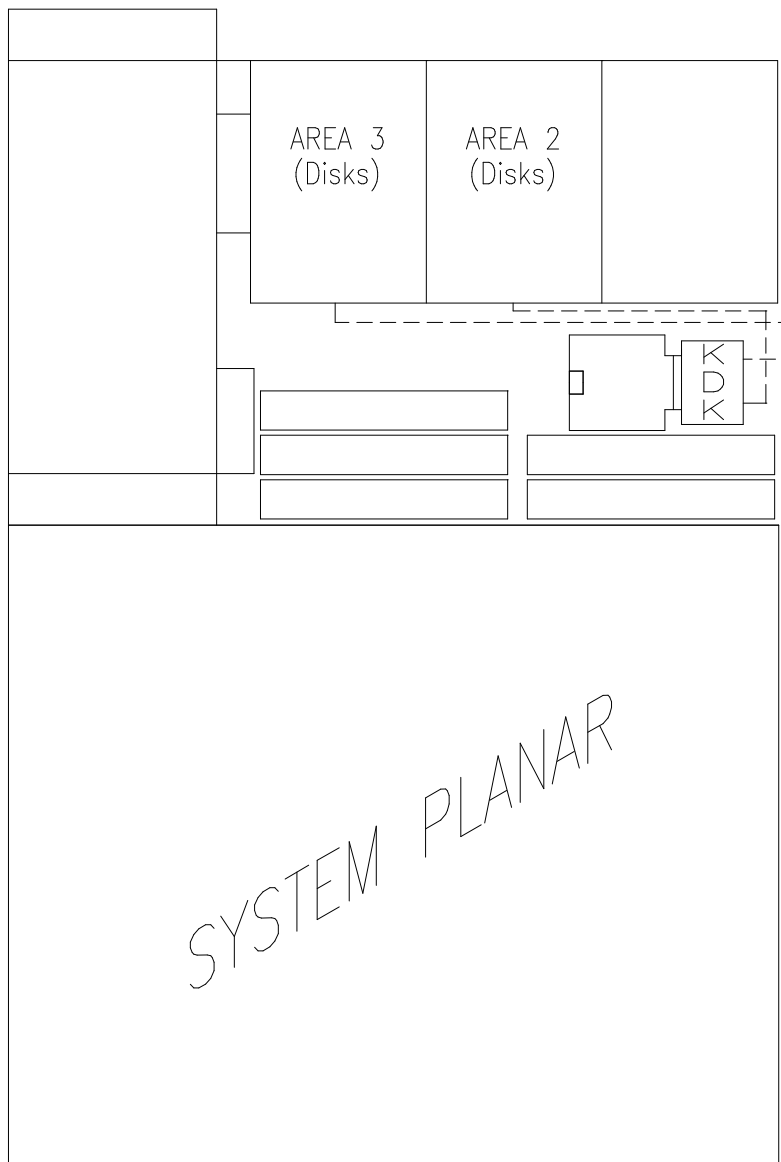

4. Remove the KDK complex from the CPU drawer, performing the following steps:
 - a. Disconnect all the KDK complex cables from the corresponding disk cages installed in the CPU drawer, as indicated at A in the figure.

Note: It is strongly recommended to keep trace of these connections.

- b. Loosen the screws used to secure the KDK card to the CPU drawer chassis, as shown at B.

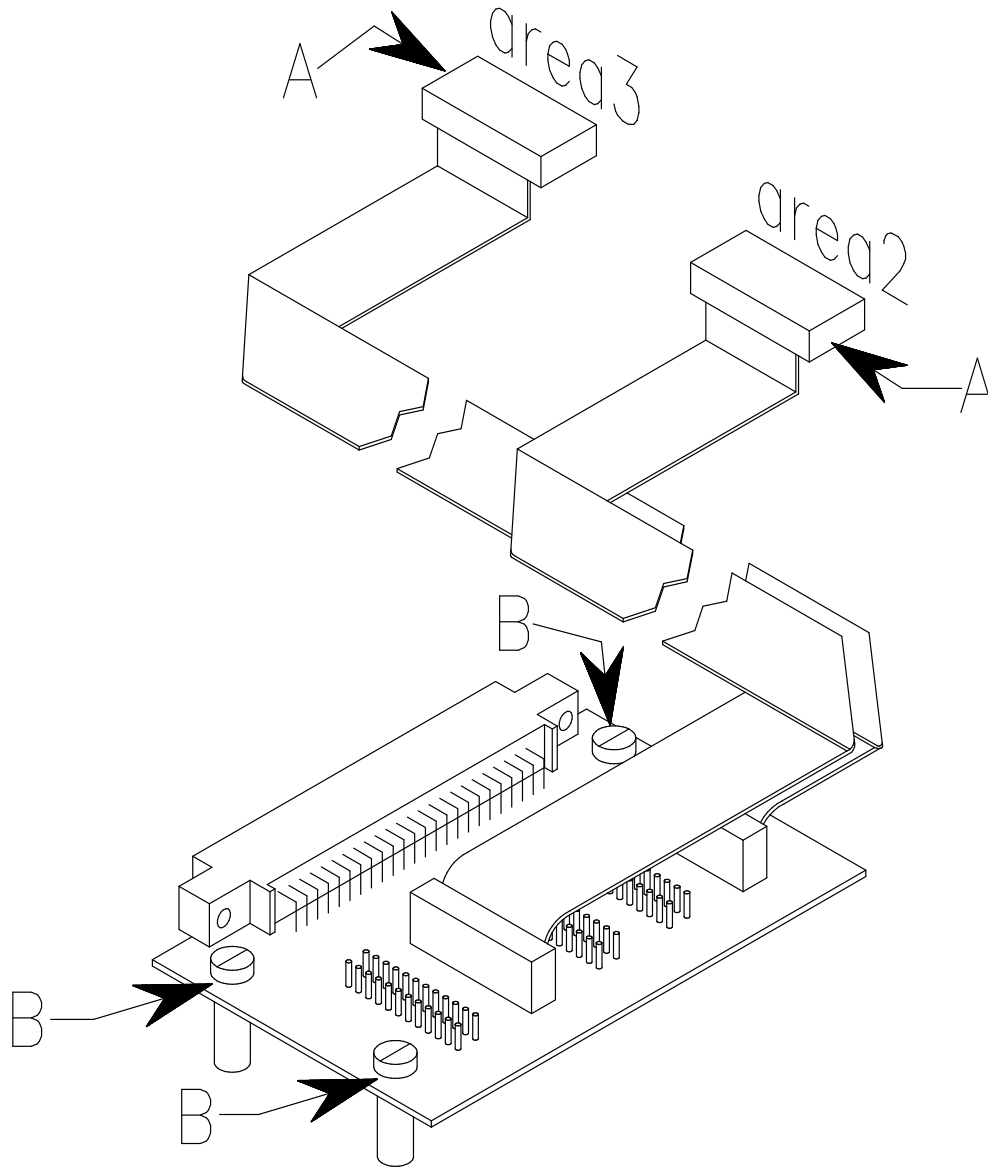

Warning: Handle the KDK complex with care: the relevant cables connected to it could be damaged.

5. If the KHS is present, disconnect the KDK card from it.
6. Carefully remove the KDK complex from the CPU drawer.

Installation

1. To install the KDK complex, follow the steps described in the **Removal** procedure in the reverse order.
2. Perform the **Restart Operations**, as described on page 2-8.

Key Mode Switch

Warning: Before handling any hardware component, read and perform the procedures described in **How to Handle Hardware Components**, on page 2-2 and **Preliminary Operations**, on page 2-3.

Note: The following procedures do not require the CPU drawer to be slid out of the rack.

Removal

1. Open the front door of the rack and access the CPU drawer from the front side.
2. Remove the CPU drawer front cover, following the **Front Cover** procedure, **Removal** steps, on page 2-7.
3. Unscrew the retaining screws needed to secure the metallic frame, that contains the 3.5-inch diskette drive and the key mode switch, to the CPU drawer chassis. These are indicated at A in the figure.

Gently slide the metallic frame, that contains the 3.5-inch diskette drive and the key mode switch, out of the CPU drawer, as shown at B.

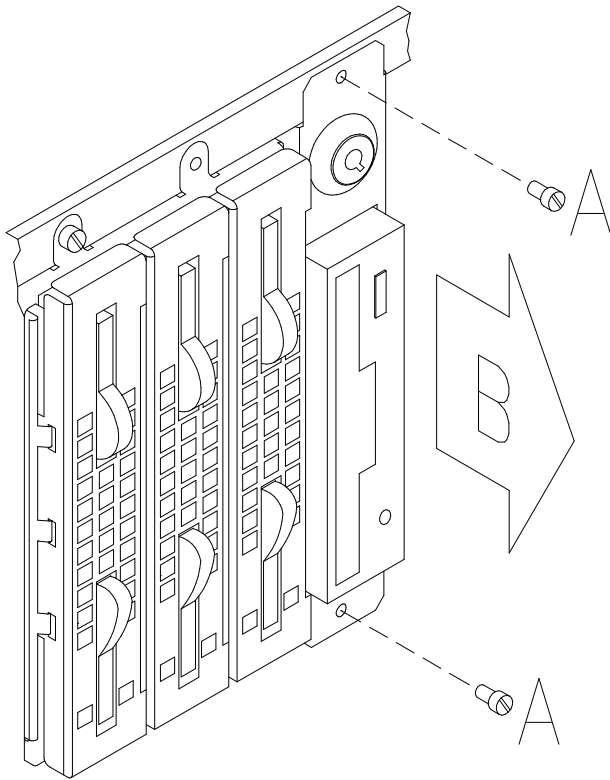

Warning: Handle these components with particular care: all the relevant cables are still connected to them and could be damaged if roughly pulled.

4. Unplug any cable connector from the 3.5-inch diskette drive and from the key mode switch, as shown in the figure.

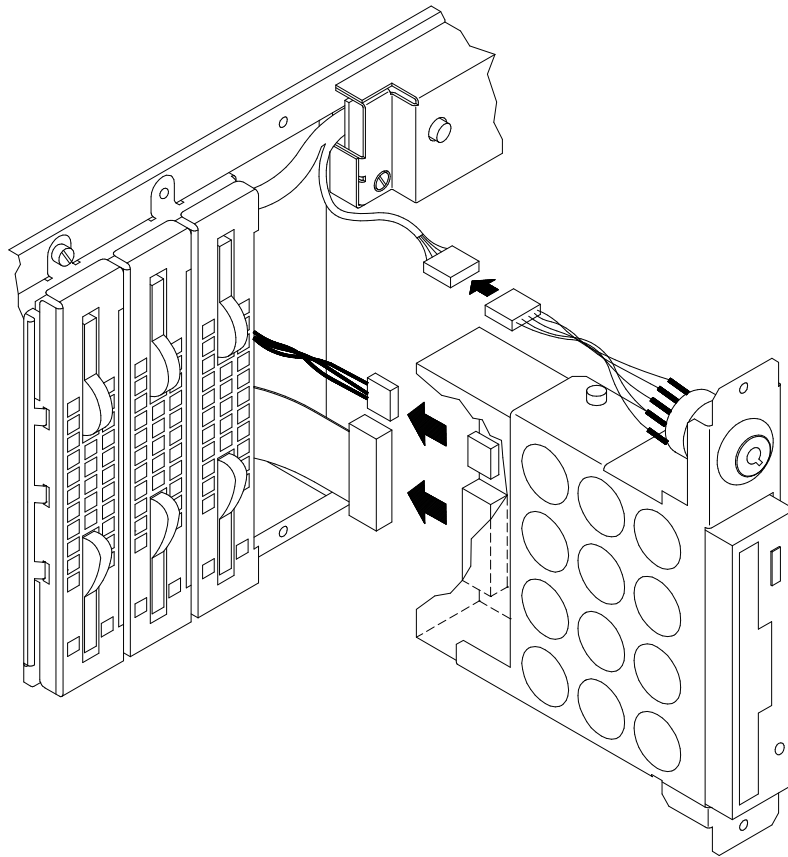

5. Firmly grip the ring nut of the key mode switch and pull it as indicated by the arrow (A). The back of the key mode switch will be released; pull it in the opposite direction and remove it, as shown at B.

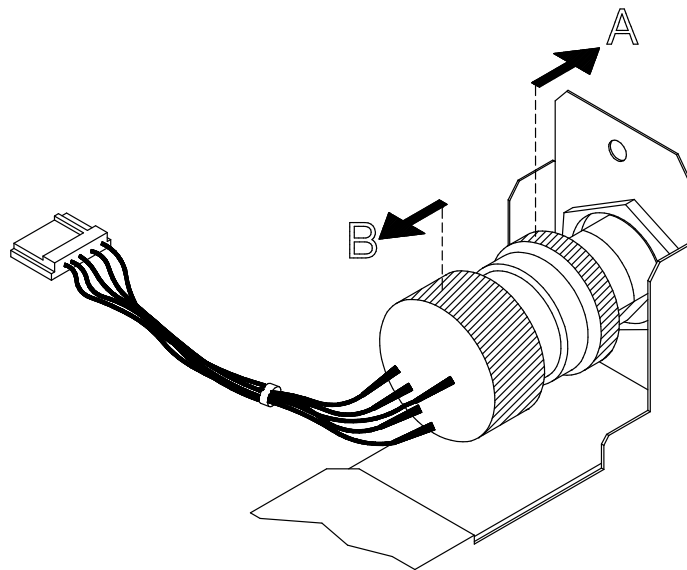

6. Loosen the indicated nut, which secures the key mode switch to the metallic frame, as indicated at A in the figure.
Then pull the key mode switch out of the metallic frame, as shown at B.

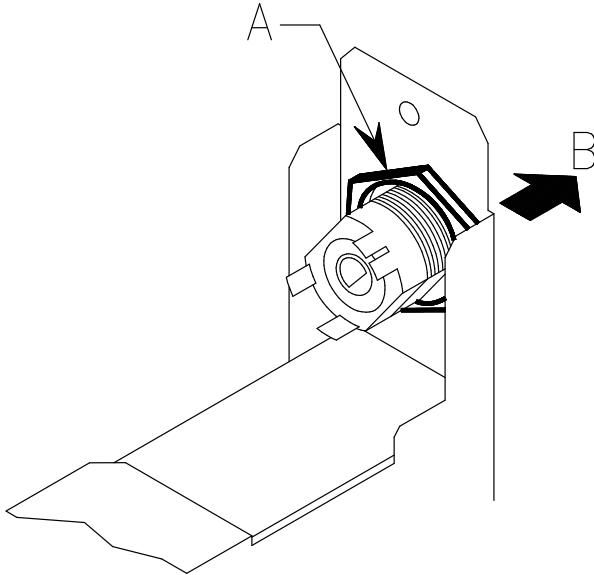

Installation

1. Insert the key mode switch in the dedicated opening, on the metallic frame that also contains the 3.5-inch diskette drive.

The keyhole must be kept in the position indicated in the figure, to install correctly the key mode switch.

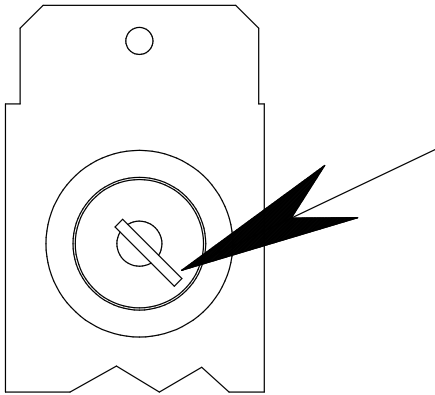

2. Secure the key mode switch to the relevant back part, by means of its ring nut.
3. Connect any cable connector to the 3.5-inch diskette drive and to the key mode switch.
4. Insert the metallic frame that contains the key mode switch and the 3.5-inch diskette drive in the CPU drawer, and secure it to the drawer chassis by means of its retaining screws.
5. Install the CPU drawer front cover, as described in **Front Cover, Installation** procedure, on page 2-7.
6. Close the front door of the rack.
7. Perform the **Restart Operations**, as described on page 2-8.

KHS Card

Warning: Before handling any hardware component, read and perform the procedures described in **How to Handle Hardware Components**, on page 2-2 and **Preliminary Operations**, on page 2-3.

Removal

1. Carefully slide the CPU drawer out of the rack, as described in **Partial Removal/Installation of the CPU Drawer, Removal** procedure, on page 2-4.
2. Remove the CPU drawer top cover, following the **Top Cover** procedure, **Removal** steps, on page 2-6.
3. Accessing the CPU drawer from the rear side, identify the KHS card behind the device areas.

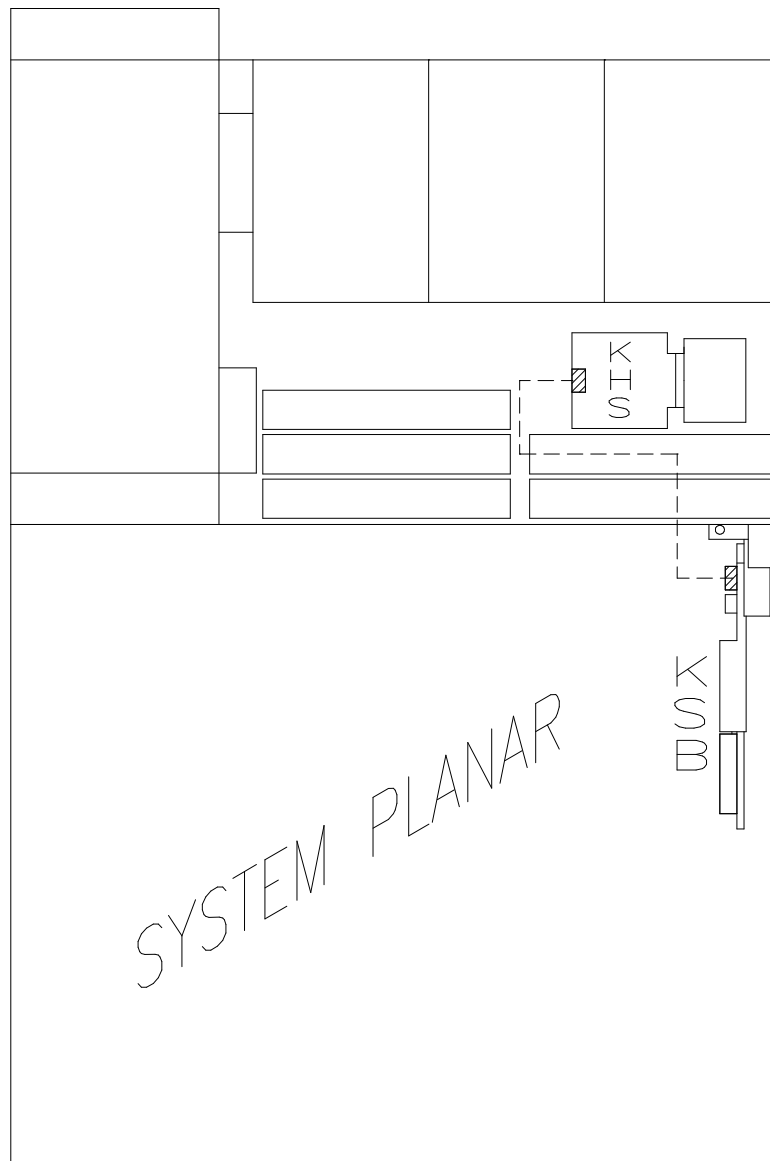

4. Remove the KHS card from the CPU drawer, performing the following steps:
 - a. Disconnect the KHS-KSB cable from the dedicated connector on the KHS card, as indicated at A in the figure.
 - b. Loosen the screw used to secure the KHS card to the CPU drawer chassis, as shown at B.
 - c. Carefully grip the KHS card by its edges and remove it from the KDK card dedicated connector. See C in the figure.

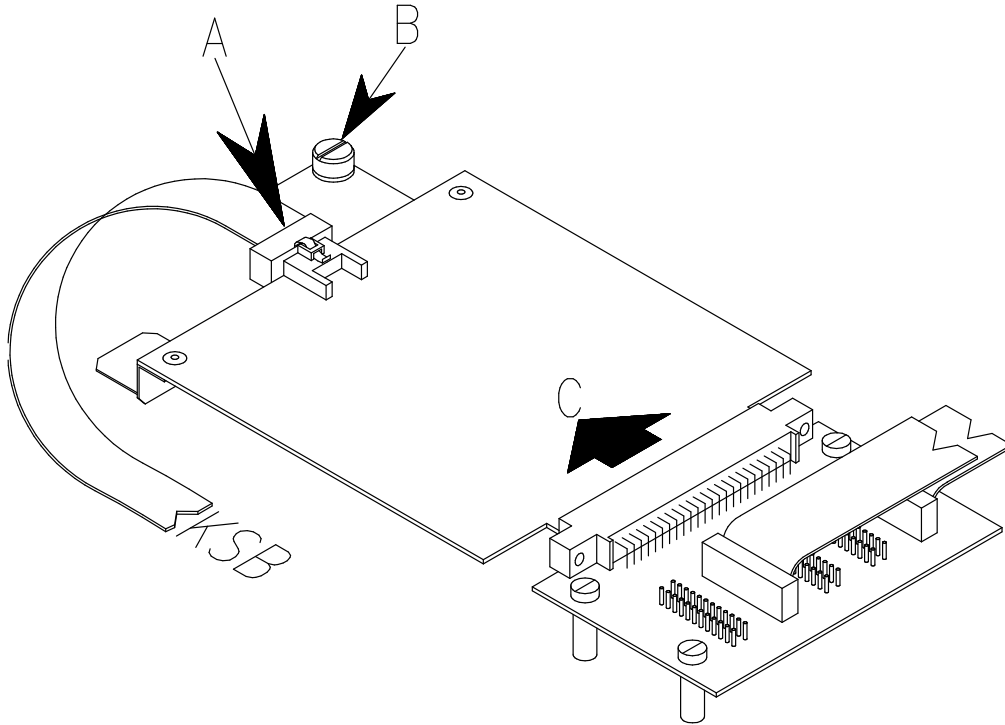

Installation

1. If not already done, slide the CPU drawer out of the rack, as described in **Partial Removal/Installation of the CPU Drawer, Removal** steps, on page 2-4, and remove the CPU drawer top cover, as explained in **Top Cover, Removal** steps, on page 2-6.
2. Accessing the CPU drawer from the rear side, locate the position dedicated to the KHS card, behind the device areas.
3. Align the KHS card with the dedicated connector on the KDK card and firmly push it until its connector is plugged in securely.
4. Secure the KHS card to the CPU drawer chassis, tightening its retaining screw.
5. Interconnect the KHS card to the KSB card by means of the KHS-KSB cable.
6. Carefully slide the CPU drawer inside the rack, following the instructions given in **Partial Removal/Installation of the CPU Drawer, Installation** steps, on page 2-5.
7. Perform the **Restart Operations**, as described on page 2-8.

KSB Card

Note: In case the KSB card must be replaced, the following must be considered.

The KSB card FEPRM and operator panel EEPROM contain the system SYSID (serial number). When one of the two components is to be replaced (for example the KSB card), the SYSID information will be copied from operator panel EEPROM into the new KSB card FEPRM at booting time. To avoid losing this information, it is not possible to replace both of these components at the same time. When both components are to be replaced, proceed as follows:

- a. First replace the operator panel and start up the system: the SYSID information will be copied from the KSB card FEPRM to the operator panel EEPROM.
- b. Replace the KSB card. Then, with the system in standby state, re-load the firmware using the appropriate diskette. For more information, see the **Firmware Updating** section, in the *Maintenance Guide*. The SYSID information will be copied from the operator panel EEPROM to the KSB card FEPRM.

Warning: Before handling any hardware component, read and perform the procedures described in **How to Handle Hardware Components**, on page 2-2 and **Preliminary Operations**, on page 2-3.

Removal

Warning: Before removing the KSB card, record the values of the NVRAM flags (Open Firmware variables) if these are different from the defaults. Since the battery is placed on the KSB card, removing this card causes the NVRAM flags to be reset to the default values. In this case, after having installed the new KSB card, remember to manually set the NVRAM flags to the required values.

1. Carefully slide the CPU drawer out of the rack, as described in **Partial Removal/Installation of the CPU Drawer, Removal** procedure, on page 2-4.
2. Remove the CPU drawer top cover, following the **Top Cover** procedure, **Removal** steps, on page 2-6.
3. Looking at the rear side of the CPU drawer, identify the KSB card in the right part of the system planar.

4. Disconnect the flat cable which connects the KBB card to the KSB card.

If the KHS card is installed inside the CPU drawer, disconnect the flat cable that goes to it from the KSB card.

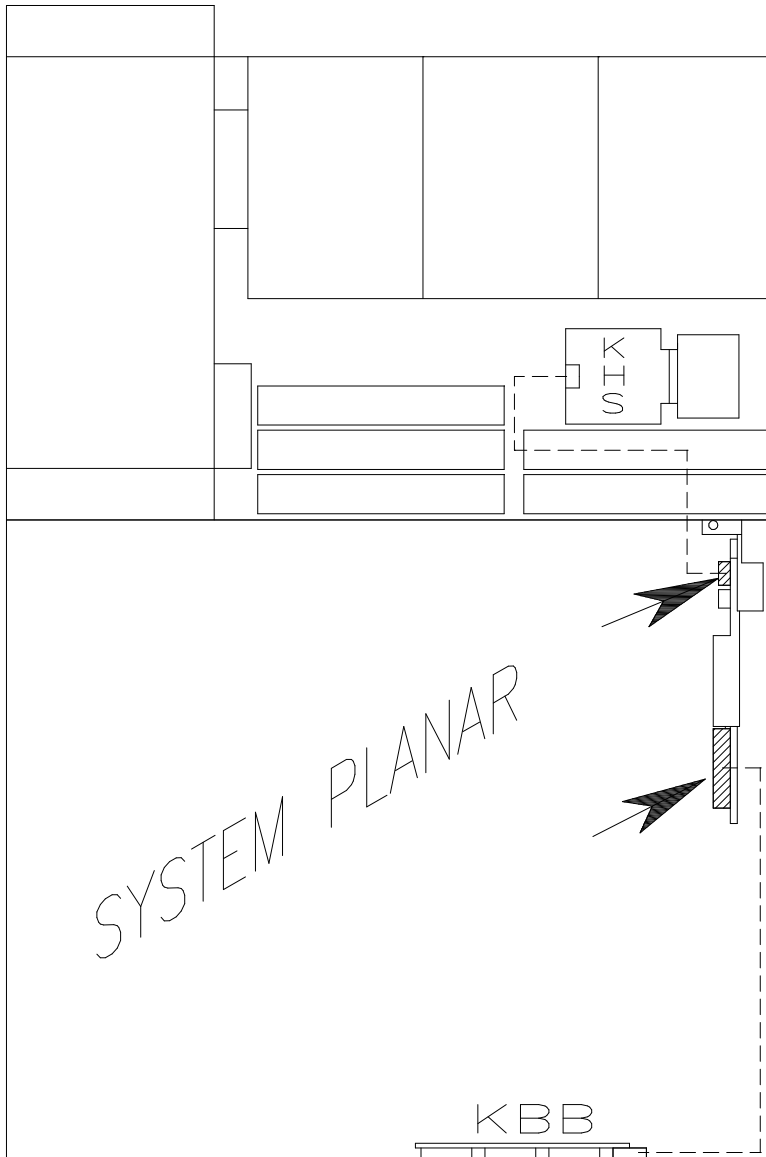

5. Unscrew the retaining screw which secures the KSB card to the CPU drawer chassis, as indicated at A in the figure.

Firmly grip the KSB card and pull it out of the system planar, as shown at B.

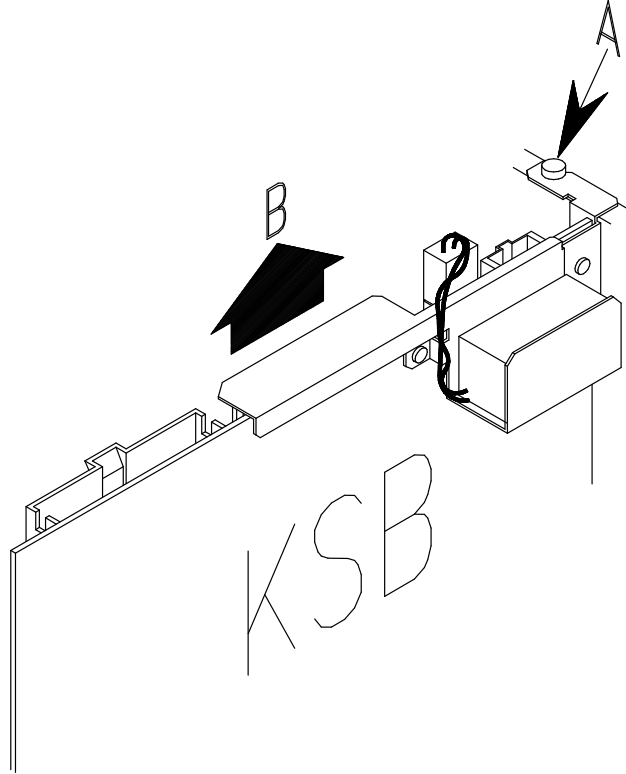

6. Remove the battery from the KSB card: first unplug its connector and then pull the battery off the Velcro attached to its dedicated support. Store this battery as it must be installed on the new KSB card.

Installation

1. To install the new KSB card, follow the steps described in the **Removal** procedure in the reverse order.
2. Perform the **Restart Operations**, as described on page 2-8.
3. After the installation procedure of the KSB card has been completed, remember to:
 - a. Re-load the firmware using the appropriate diskette (see the **Firmware Updating** section, in the *Maintenance Guide*, for more information).
 - b. Manually set the NVRAM flags to the required values, if these were different from the defaults.
 - c. Remember to reset the system date and time.

Operator Panel

Note: In case the operator panel must be replaced, the following must be considered.

The KSB card FEPRM and operator panel EEPROM contain the system SYSID (serial number).

When one of the two components is to be replaced (for example the operator panel), the SYSID information will be copied from the KSB card FEPRM into the new operator panel EEPROM at booting time. To avoid losing this information, it is not possible to replace both of these components at the same time.

When both components are to be replaced, proceed as follows:

1. First replace the operator panel and start up the system: the SYSID information will be copied from the KSB card FEPRM to the operator panel EEPROM.
2. Replace the KSB card. Then, with the system in standby state, re-load the firmware using the appropriate diskette. For more information, see the **Firmware Updating** section, in the *Maintenance Guide*. The SYSID information will be copied from the operator panel EEPROM to the KSB card FEPRM.

Warning: Before handling any hardware component, read and perform the procedures described in **How to Handle Hardware Components**, on page 2-2 and **Preliminary Operations**, on page 2-3.

Note: The following procedures do not require the CPU drawer to be slid out of the rack.

Removal

1. Open the front door of the rack and access the CPU drawer from the front side.
2. Remove the CPU drawer front cover, following the **Front Cover** procedure, **Removal** steps, on page 2-7.
3. Unscrew the retaining screws needed to secure the 3.5-inch diskette drive metallic frame to the CPU drawer chassis. These are indicated at A in the figure.

Gently slide the metallic frame, that contains the 3.5-inch diskette drive and the key mode switch, out of the CPU drawer, as shown at B.

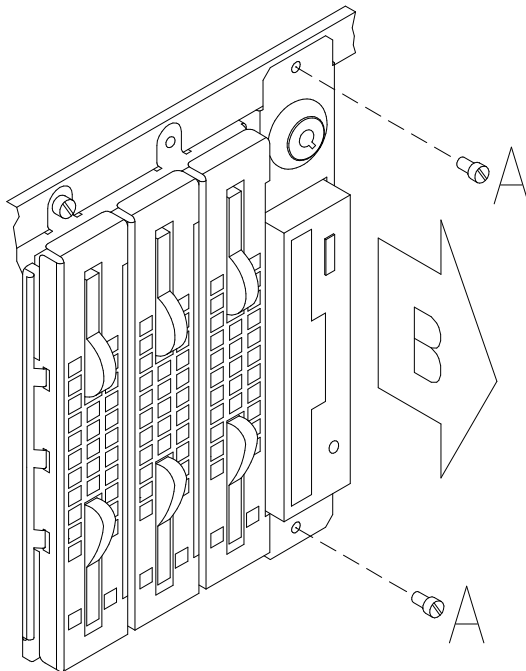

Warning: Handle these components with particular care: all the relevant cables are still connected to them and could be damaged if roughly pulled.

4. Unplug any cable connector from the operator panel, the 3.5-inch diskette drive and the key mode switch, as shown in the figure.

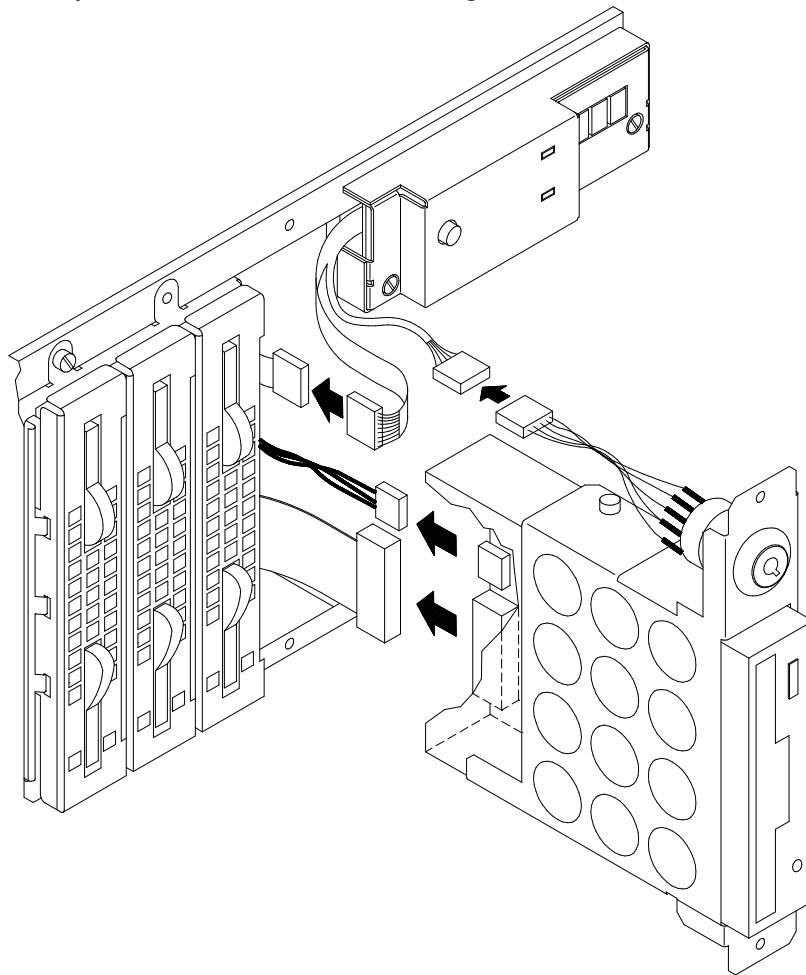

5. Unscrew the retaining screws of the operator panel, to release it from the CPU drawer chassis.

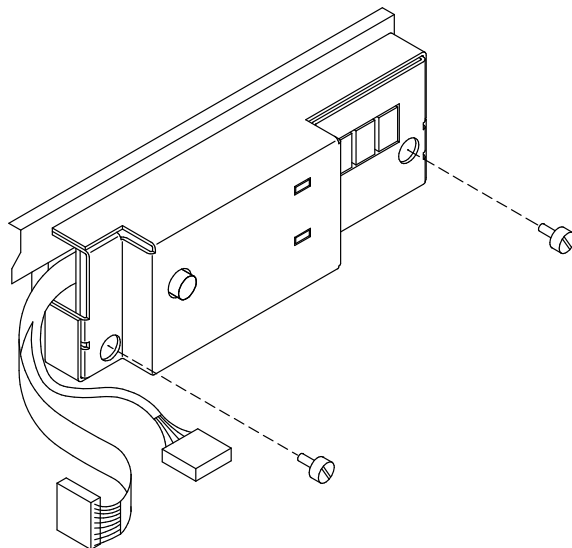

Installation

1. To install the new operator panel, follow the steps detailed in the **Removal** procedure in the reverse order.
2. Perform the **Restart Operations**, as described on page 2-8.

Power Supply

Warning: Before handling any hardware component, read and perform the procedures described in **How to Handle Hardware Components**, on page 2-2 and **Preliminary Operations**, on page 2-3.

DANGER

Do not attempt to open the covers of the power supply. Power supplies are not serviceable and are to be replaced as a unit.

Removal

1. Unplug the CPU drawer power cord from both the PDU and the CPU drawer rear side.
2. Carefully slide the CPU drawer out of the rack, as described in **Partial Removal/ Installation of the CPU Drawer, Removal** steps, on page 2-4.
3. Remove the CPU drawer front cover, following the **Front Cover** procedure, **Removal** steps, on page 2-7.
4. Remove the CPU drawer top cover, following the **Top Cover** procedure, **Removal** steps, on page 2-6.
5. Accessing the CPU drawer from the rear side, unscrew the retaining screws used to secure the power cord receptacle to the drawer chassis. Slide the power cord receptacle towards the internal side of the drawer.

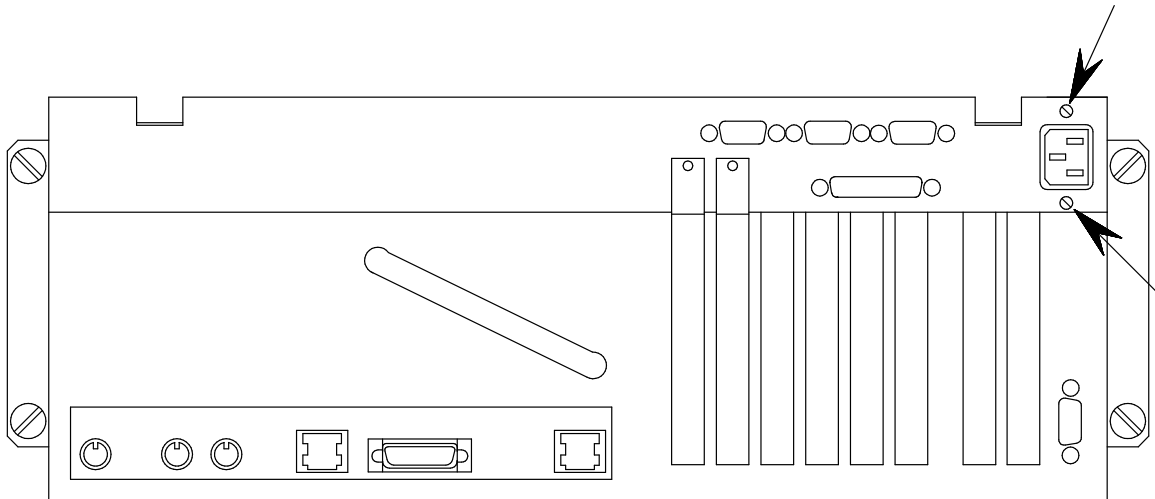

If the power cable ended with the power cord receptacle is retained, by means of fasteners inside the drawer, cut them to release the cable. Then carefully bring it near the power supply.

6. Remove the memory DIMM or riser installed in memory slot 0; if a memory riser is installed in slot 1, remove it to facilitate the access to the power supply connectors on the system planar. If you need information about the memory slots, please see the **system planar** drawing, on page 1-9.

7. Unplug the power supply cable connectors located on the system planar, the device power cable connector of each disk cage and media devices, the fan power cable connector and the floppy power cable connector.

Then carefully bring each cable near the power supply to facilitate the removal operations.

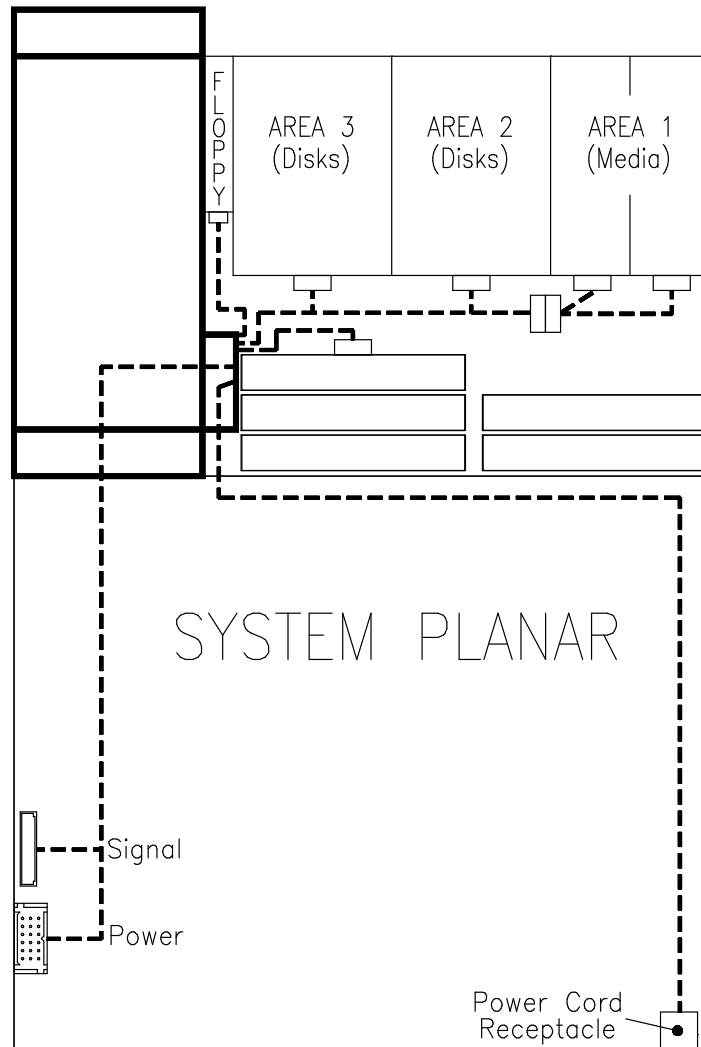

Please note that for the area housing one or more media devices, a split cable is connected to the power cable connector corresponding to that area.

8. Insert the CPU drawer inside the rack.
9. Accessing the CPU drawer from the front side, remove the metallic frame that contains the 3.5-inch diskette drive and the key mode switch. For details, please refer to **3.5-inch Diskette Drive, Removal** steps, on page 2-10.
10. Remove the operator panel, as described in **Operator Panel, Removal** steps, on page 2-38.

11. Remove the disk cage installed in Area 3 because it obstructs the removal of the power supply from the CPU drawer. If you need details, please refer to **Disk Cage, Removal** steps, on page 2-15.
12. Unscrew the retaining screws of the power supply to release it from the CPU drawer chassis.

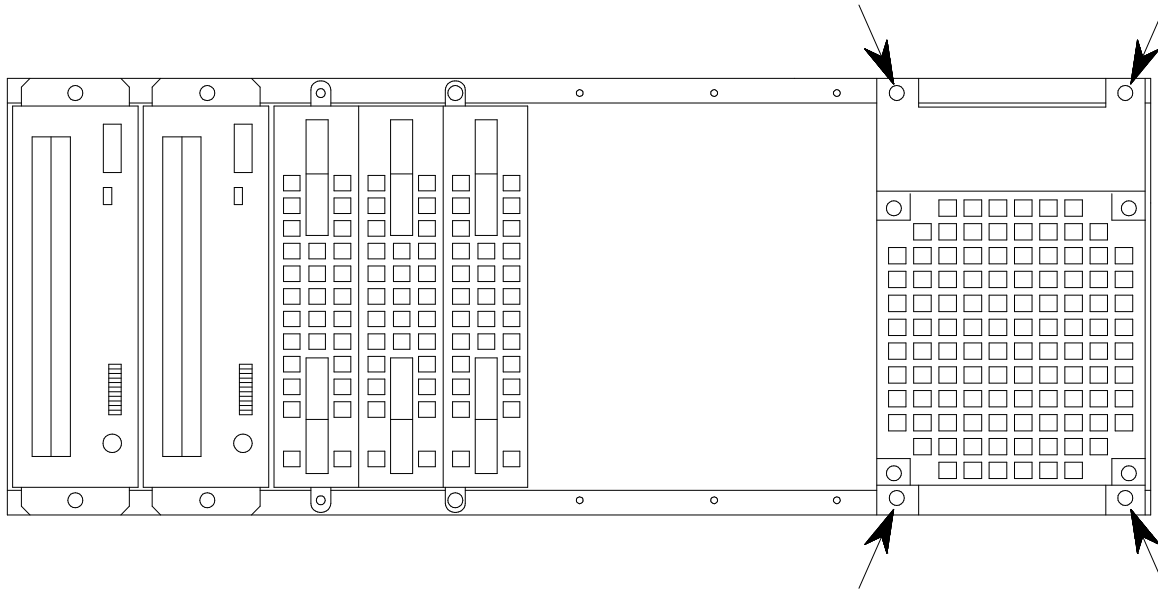

13. Firmly grip the power supply and carefully slide it out of the CPU drawer, towards the front side.

Warning: Be careful when removing the power supply from the CPU drawer. Many cables come from the power supply; these could be damaged, or get entangled and damage something in the CPU drawer.

Installation

1. To install the new power supply, follow the steps described in the **Removal** procedure in the reverse order.
2. Perform the **Restart Operations**, as described on page 2-8.

System Planar

Warning: Before handling any hardware component, read and perform the procedures described in **How to Handle Hardware Components**, on page 2-2 and **Preliminary Operations**, on page 2-3.

Removal

1. Disconnect all external connectors from the rear side of the CPU drawer.
2. Carefully slide the CPU drawer out of the rack, as described in **Partial Removal/ Installation of the CPU Drawer, Removal** steps, on page 2-4.
3. Remove the CPU drawer top cover, following the **Top Cover** procedure, **Removal** steps, on page 2-6.
4. Access the CPU drawer from the rear side.
5. If the KHS card is installed in the CPU drawer, remove the flat cable that connects the KSB card to the KHS one.
6. Disconnect any connector from any cards installed on the system planar and inside the CPU / memory box. Record which connector attaches to which card.
7. Remove all the cards from the system planar and from the CPU / memory box. Record the location of each card.
8. Unplug any internal cable connectors plugged into the system planar.
9. Remove the CPU / Memory box performing the following steps:
 - d. Loosen the retaining screws which secure the box to the system planar.
 - e. Release the box from the metallic frame by unscrewing the retaining nuts, and remove it from the CPU drawer.

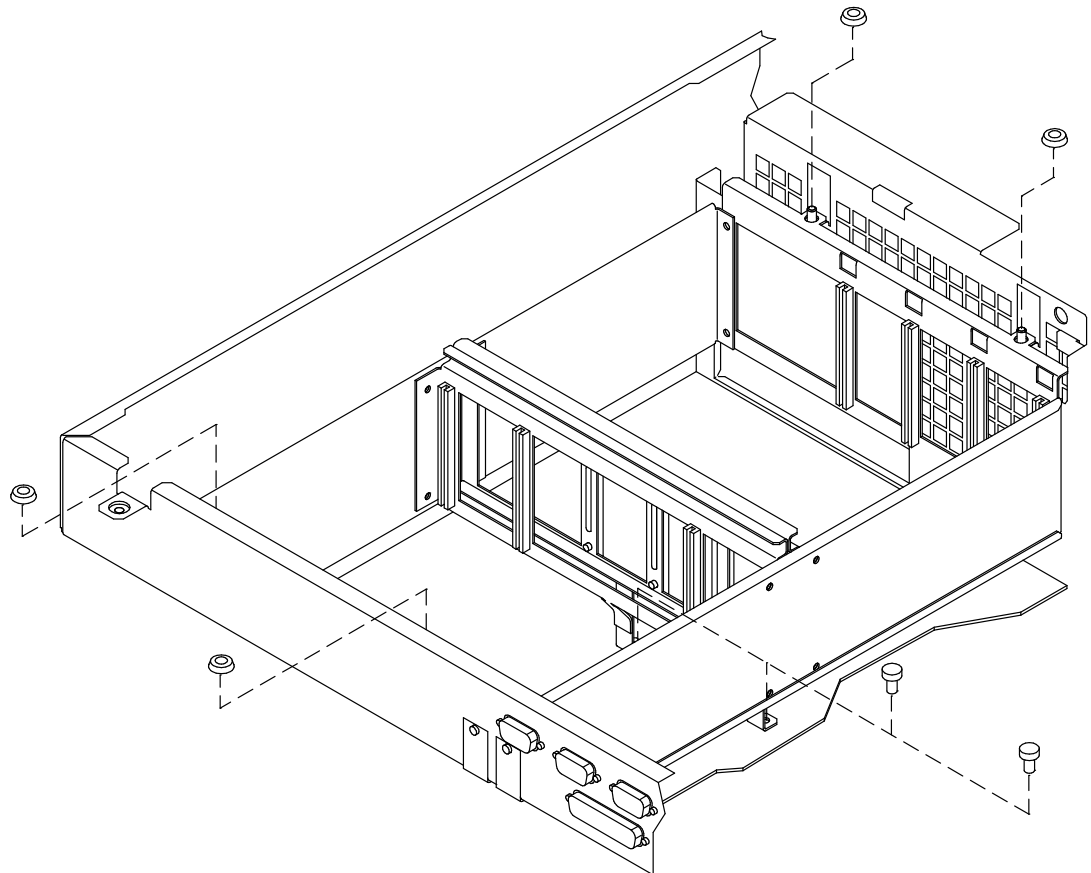

10. Unscrew the retaining screws which secure the system planar to the CPU drawer chassis.
11. Grip the system planar by its edges, on the CPU / memory box side, and carefully remove it, sliding it out of the CPU drawer left side.

Installation

1. To install the system planar, follow the steps described in the **Removal** procedure in the reverse order.
2. Perform the **Restart Operations**, as described on page 2-8.

VGA Cable

Warning: Before handling any hardware component, read and perform the procedures described in **How to Handle Hardware Components**, on page 2-2 and **Preliminary Operations**, on page 2-3.

Removal

1. Carefully slide the CPU drawer out of the rack, as described in **Partial Removal/Installation of the CPU Drawer, Removal** steps, on page 2-4.
2. Remove the CPU drawer top cover, following the **Top Cover** procedure, **Removal** steps, on page 2-6.
3. Locate the VGA connector toward the lower right corner at the CPU drawer rear side. Unplug the external VGA connector, if connected.
4. Loosen the standoff screws which secure the VGA cable connector to the CPU drawer rear.

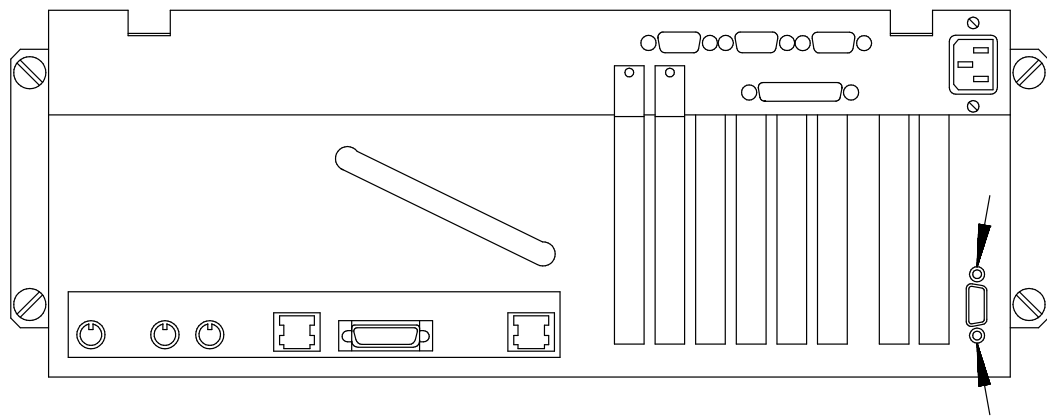

5. Detach the VGA connector and slide it towards the CPU drawer internal side.
Then disconnect the VGA cable connector from the system planar.

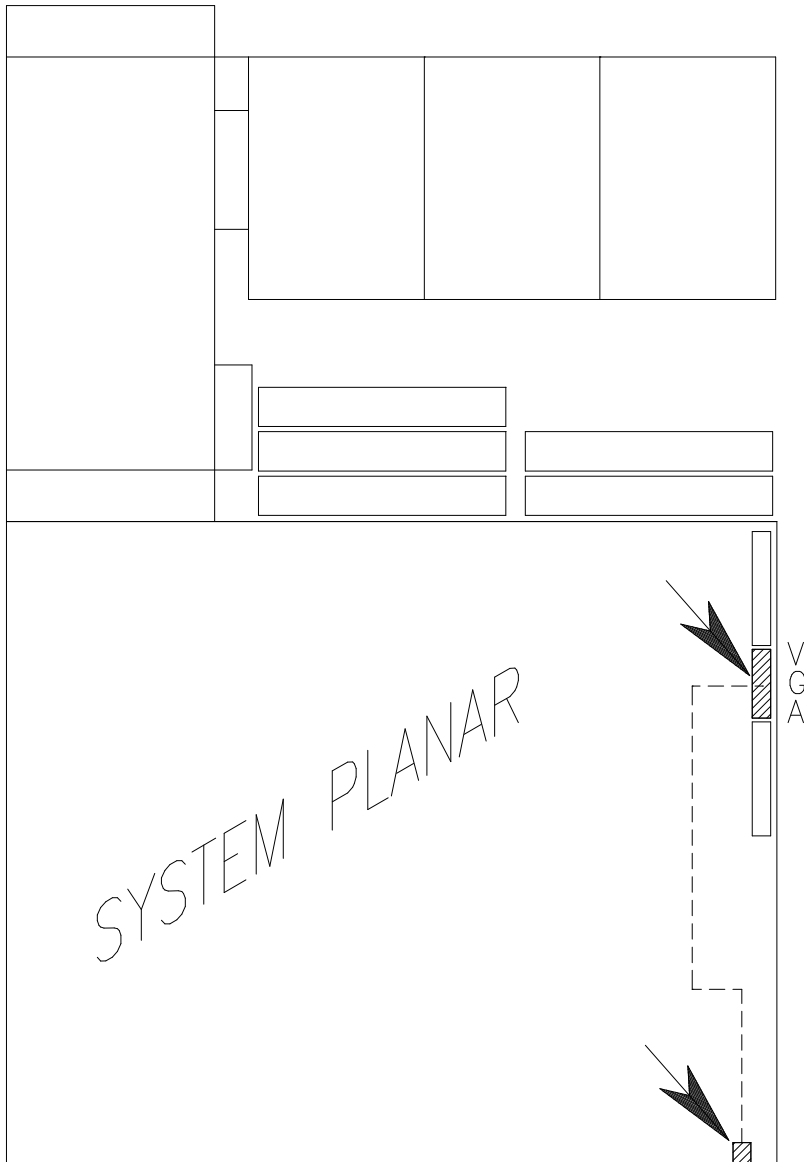

Installation

1. To install the new VGA cable, follow the steps detailed in the **Removal** procedure in the reverse order.
2. Perform the **Restart Operations**, as described on page 2-8.

Video Memory

Warning: Before handling any hardware component, read and perform the procedures described in **How to Handle Hardware Components**, on page 2-2 and **Preliminary Operations**, on page 2-3.

Removal

1. Carefully slide the CPU drawer out of the rack, as described in **Partial Removal/Installation of the CPU Drawer, Removal** steps, on page 2-4.
2. Remove the CPU drawer top cover, following the **Top Cover** procedure, **Removal** steps, on page 2-6.
3. Unplug any requested DRAM chip from the corresponding socket on the system planar.

Installation

1. If not already done, carefully slide the CPU drawer out of the rack, as described in **Partial Removal/Installation of the CPU Drawer, Removal** steps, on page 2-4, and remove the CPU drawer top cover, following the **Top Cover** procedure, **Removal** steps, on page 2-6.
2. Identify the two sockets for the installation of the DRAM chips on the system planar.

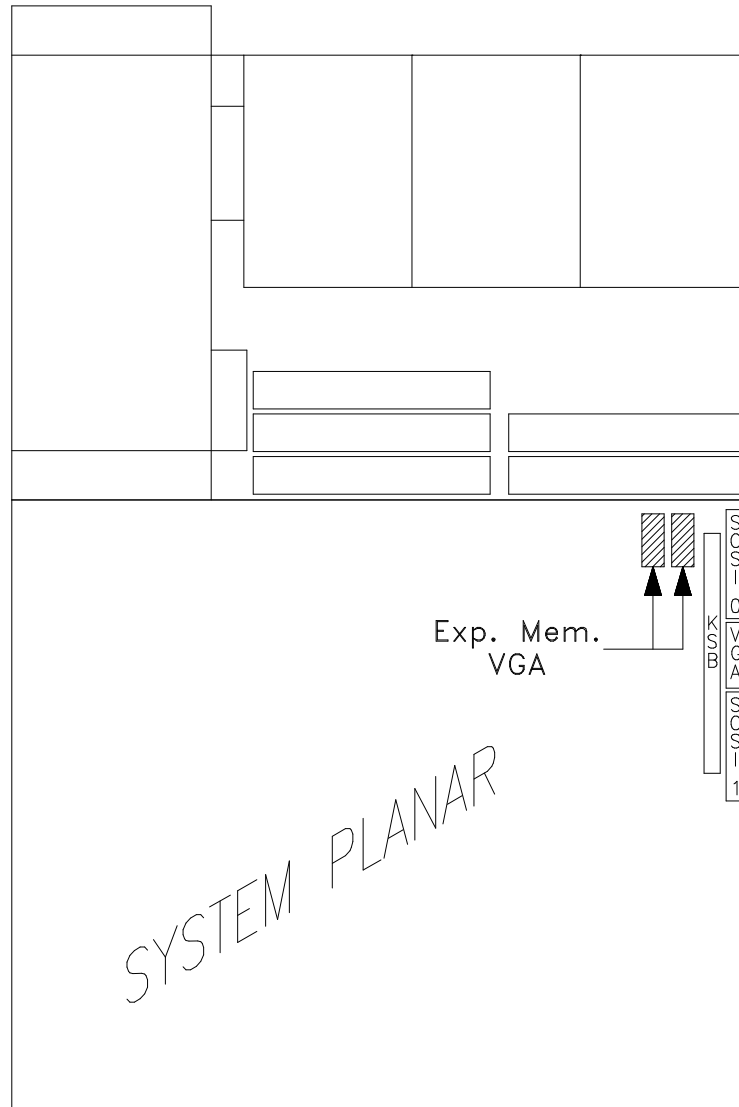

- Put each DRAM chip on the dedicated socket on the system planar taking care of pin 1 position. Push the DRAM chip until it is securely plugged.

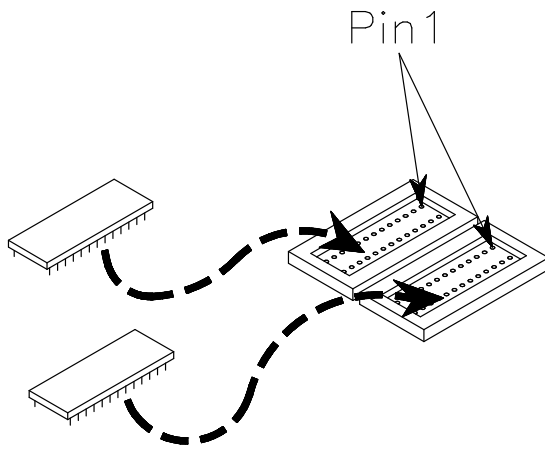

- Re-install the CPU drawer top cover, as described in the **Top Cover** procedure, **Installation** steps, on page 2-6.
- Carefully slide the CPU drawer inside the rack, following the instructions given in **Partial Removal/Installation of the CPU Drawer, Installation** steps, on page 2-5.
- Perform the **Restart Operations**, as described on page 2-8.

Chapter 3. SCSI Cables Description and Connection

- **Overview**, below
- **SCSI Cables Description**, on page 3-2
- **SCSI Cables Connection**, on page 3-3.

Overview

The connection rules of the SCSI cables for the CPU drawer are described in the following pages.

The connections of the various SCSI cables depend on the system configuration, i.e. which disk/media devices and how many of them are installed inside the CPU drawer.

The CPU drawer supports:

- Up to two media devices in Area 1
- Up to two disk cages in Areas 3 and 2, each housing either up to two or up to three SCSI disk devices, according to their form factor (1" or 1.6").

SCSI Cables Description

The following table includes all SCSI cables that can be used for the CPU drawer SCSI connections.

For each SCSI cable of the CPU drawer, a brief description is given.

SCSI Cable	Cable Description
Media Cable for Native Controller	It is used to connect the native SCSI controller 0 (SCSI-0) to the media device(s) installed in Area 1.
Area 3 Disk Cable for Native Controller	It is used to connect the native SCSI controller 1 (SCSI-1) to the disk cage installed in Area 3.
KP2/KP3 Jumper Cable	It is used to connect Area 3 disk cage to Area 2 disk cage.
PCI SCSI Controller Internal Disk Cable	It is used to connect a SCSI controller installed in any PCI slot to one disk cage.
KDK Complex	It is composed by the KDK card and two flat cables connected to the KDK card and to the disk cages.
Internal SCSI Terminating Plug	It is plugged into the dedicated connector on the rear of the last disk cage of a bus, and into the dedicated connector after the last media device, to terminate the media bus.

Some of these cables are pre-installed inside the CPU drawer by the manufacturer according to the required configuration.

SCSI Cables Connection

Disk devices can be installed in Areas 3 and 2. Each of these Areas, can hold either two 1.6-inch disk devices or three 1-inch disk devices. Area 3 houses always the system disk.

Media devices can be installed in Area 1 for a maximum of two media devices.

DRAWER FRONT

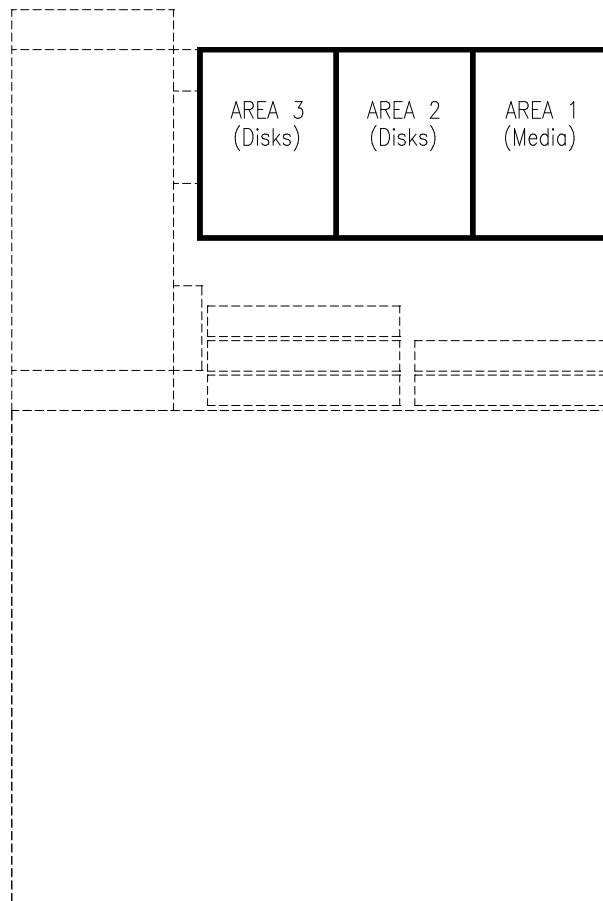

Depending on your system configuration, the disk devices are connected either to one of the native SCSI controllers on the system planar or to a PCI controller card installed on the system planar.

Note: Examples of these connections, as well as examples of RAID configuration, are given in the *Configuring the System* guide.

For the disk devices, the SCSI cables must be connected to the input/output device connectors located on the rear of the disk cage housing the specified disks; in addition, the KDK complex cables must be connected to the rear of the disk cage(s) installed in the CPU drawer, as shown in the figure.

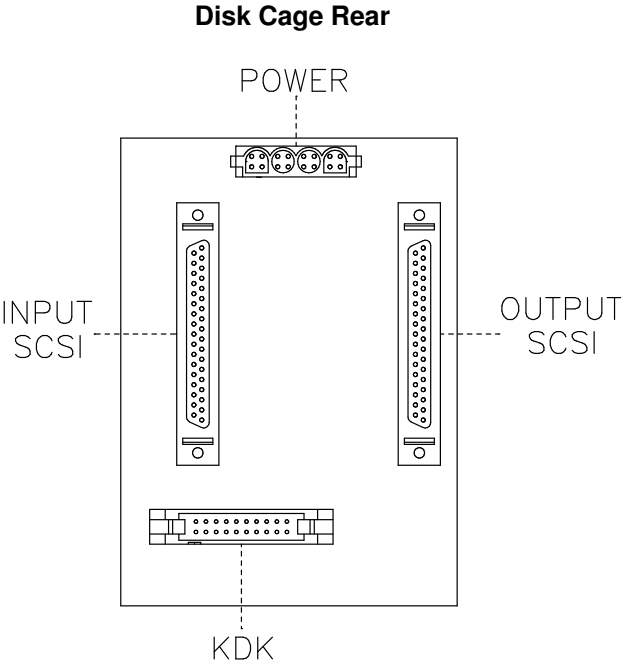

For each media device, the SCSI cables must be connected to the dedicated input/output connectors placed on the rear of the device.

PCI SCSI Controller Internal Disk Cable

The PCI SCSI controller internal disk cable is required whenever you need to connect a non-native PCI controller to a disk cage.

It must be connected in different ways, according to the PCI controller type.

SCSI PCI Controller

If you are installing a SCSI PCI controller, you must connect the relevant cable as shown in the figure.

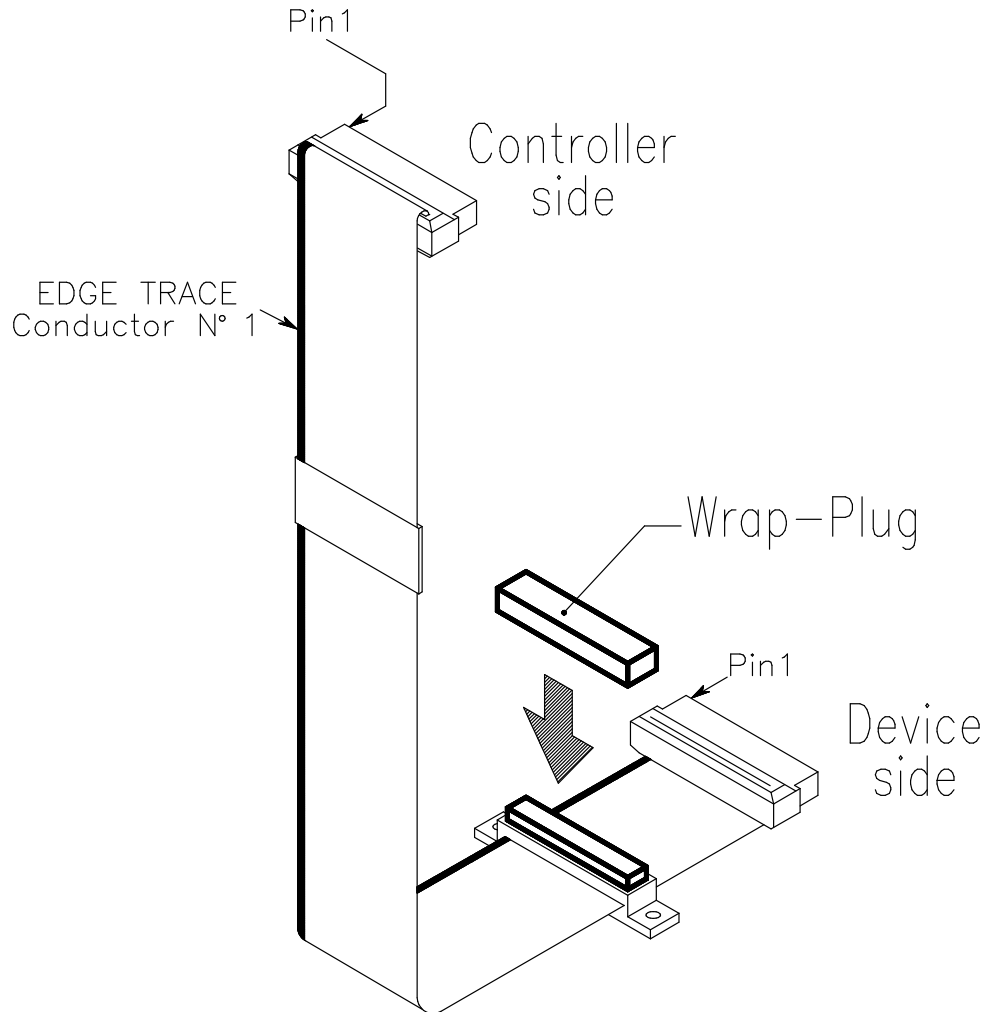

Note: The H.A. Wrap Plug, indicated in the figure, must be installed only in high availability configurations.

RAID Controller

If you are installing a RAID controller, you must fold and connect the relevant cable as shown in the figure.

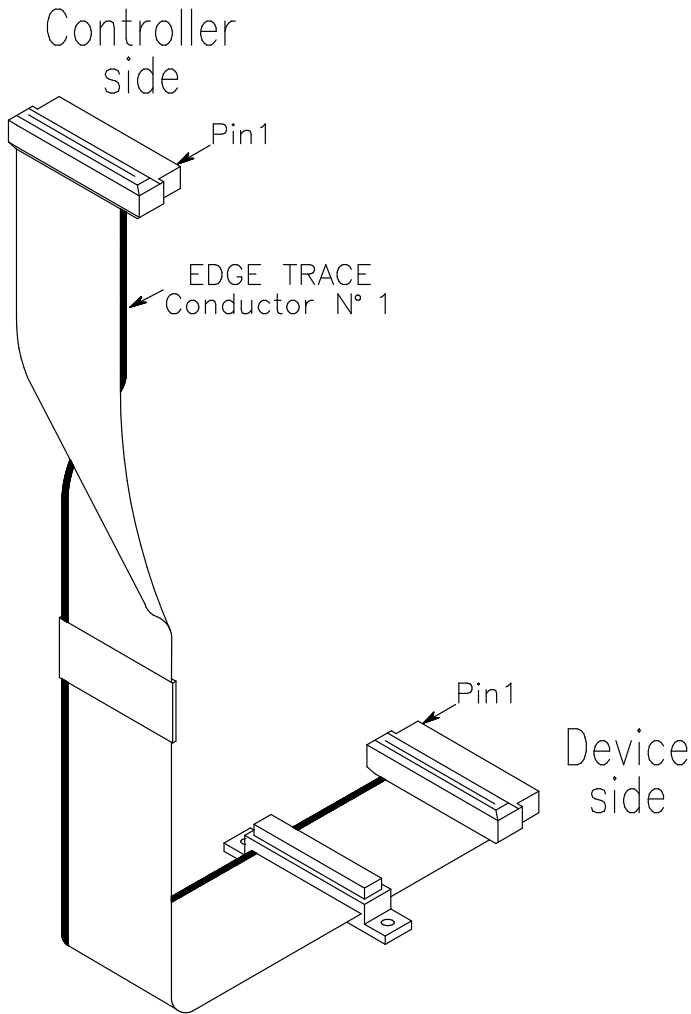

Note: The additional SCSI connector, present on the cable, must not be used. Nothing must be connected to or plugged on it.

Appendix A. Spare Parts

Component - Part Number Cross-Reference

Component	Part Number
3.5-inch diskette drive	MPF920-E
AC cable (CPU drawer to PDU)	90228002
Area 3 disk cable for native controller	78 172 856
Battery	90378001
Cage assembly for 2 disks	78 172 259
Cage assembly for 3 disks	78 172 258
CD-ROM 12x 600 MB (Toshiba 12x XM5701B)	76 666 058
CD-ROM 30x 600 MB (Toshiba 30x XM6201B)	76 703 058
CPU card (K45)	78 172 474
CPU card (KR4)	78 174 948
DAT 4mm 12/24 GB (HP C1537A)	76 666 063
DIMM 32 MB	90678001
DIMM 64 MB	90679001
DIMM128 MB	90680001
Disk 2.1 GB (Seagate ST32171WC) 1"	76 666 023
Disk 4.2 GB (Seagate ST34371WC) 1"	76 666 024
Disk 9.1 GB (Seagate ST19171WC) 1.6"	76 666 025
Disk 9.1 GB (Seagate ST39173WC) 1"	76 703 053
Extender cable for keyboard and mouse	91138001
Extender cable for SVGA	91120001
Fan module	78 173 518
Fan cable	78 172 865
Floppy cable for Sony	78 172 860
H.A. wrap plug	90982001
Internal SCSI terminating plug	90054003
KBB card	78 166 057
KDK complex	78 173 509
Key cable	78 164 146
Key cable extension (system planar to operator panel)	78 173 487
KHS card	78 171 615
KHS-KSB cable	78 170 191
Kit rack mount	78 173 558
KP2 card	78 172 467
KP3 card	78 172 470
KP2/KP3 jumper cable	90171004

Component	Part Number
KSB card	78 173 727
KSB-KBB cable	78 172 869
Media cable for native controller	78 172 858
Media power cable	78 166 951
Memory riser SRC (GX8SRC)	78 165 660
Operator panel	78 172 136
Passthru terminator cable (90 cm)	91076001
PCI SCSI controller internal disk cable	78 173 554
PDU Europe (Rack)	78 173 435
PDU US and Japan (Rack)	78 173 599
Power supply	78 173 434
QIC 16/32 GB (MLR1)	76 666 049
SCSI terminator	92F2566
System planar (KPL)	78 172 708
System planar (KPL)-SVGA cable	78 166 938
VDAT 8mm 7/14 GB (Exabyte EXB8705DX)	76 666 054

Glossary

A

A: Ampere.

AC: Alternating Current.

AIX: IBM's implementation of UNIX operating system.

ANSI: American National Standards Institute.

Appliance Coupler: A standard IEC 320 male plug placed on the drawer rear side.

ASCII: American Standard Code for Information Interchange.

AUI: Attachment Unit Interface.

B

bank: See memory bank.

BUMP: Bring-Up Microprocessor. A low power microprocessor which monitors the system, especially during the various boot phases before the operating system is loaded.

C

CD-ROM: Compact Disc Read-Only Memory. High-capacity read-only memory in the form of an optically readable compact disc.

chip: Synonym for integrated circuit (IC).

CPU: Central Processing Unit.

D

DAS: Disk Array Subsystem. A RAID disk drawer, available in different models.

DC: Direct Current generated by the power supply.

DDS: Digital Data Storage.

device areas: See media and disk device areas.

DIMM: Dual In-line Memory Module. It is the smallest component of the system memory.

disk cage: A metallic box which can host two or three disk carriers.

disk carrier: A sled used to install hard disk drives into the system.

DPCI: Dual Port PCI host bridge.

DRAM: Dynamic Random Access Memory.

drawer: Each system or subsystem installed in a rack is a drawer. There are several types of drawers, such as CPU drawers, expansion drawers, DAS drawers.

E

ECMA: European Computer Manufacturers Association.

EEPROM: Electrically Erasable Programmable Read-Only Memory. An EPROM that can be reprogrammed while it is in the system.

EIA: Electronic Industries Association.

EMI: Electromagnetic Interference.

EPROM: Erasable Programmable Read-Only Memory.

ESD: Electrostatic Discharge. An undesirable discharge of static electricity that can damage equipment and degrade electrical circuitry.

F

FAST-10 WIDE-16: A standard SCSI interface, 16 bits, providing synchronous transfer rate of up to 10 MHz, with a data transfer speed of 20M bytes per second.

FAST-20 WIDE-16: An enhanced standard SCSI interface, 16 bits, providing synchronous transfer rate of up to 20 MHz, with a data transfer speed of up to 40M bytes per second. It is also called ULTRA WIDE.

FEPRM: Flash Erasable Programmable Read-Only Memory. An EPROM containing the system firmware.

firmware: The microcode in read-only memory (ROM). It consists of an ordered set of instructions and data stored in a way that is functionally independent of main storage.

Forth: The Open Firmware based language interpreter.

FW: See firmware.

G

GUI: Graphical User Interface.

H

high availability: A particular configuration which shares resources between two CPU drawers, so that if one CPU drawer fails, the other one takes the control without interrupting any activity.

hot swapping: The operation of removing a faulty hard disk drive and replacing it with a good one without interrupting the system activity.

I

I2C: Inter Integrated Circuit.

ID: A number which uniquely identifies a device on a bus.

IEC: International Electrotechnical Commission.

I/O: Input/Output.

ISA: Industry Standard Architecture (Bus).

J

JBOD: Just a Bunch Of Disks.

K

KBB: It is a card that provides three RS-232 lines and one parallel line. It is also connected to the KSB card by means of a dedicated flat cable.

KBR: A card dedicated to the connection of a PCI expansion drawer.

KDD: A card installed in the PCI expansion drawer and interconnecting all the expansion drawer resources. It manages also the input and output RS-485 connection between the CPU drawer and the PCI expansion drawer.

KDK Complex: It is composed by the KDK card and two flat cables connected to it. Its main functionality is to define the hard disk drive SCSI-ID.

key mode switch: Key controlled switch which controls system operation mode.

KHS: An optional card to be installed in presence of a RAID configuration. It interfaces the RAID controller card.

KP2: The back plane of a disk cage that connects two hard disk drives with 1.6 inch form factor.

KP3: The back plane of a disk cage that connects three hard disk drives with 1 inch form factor.

KPE: The planar hosting the PCI controllers in the PCI expansion drawer. Up to two KPE planars can be installed in each PCI expansion drawer.

KPL: See system planar.

KPS: See power supply.

KSB: It is a card housing the BUMP logic. Also, it holds two dedicated connectors which interconnect the KSB card to the KBB card and to the KHS card, if this is installed.

KXB: A card installed in the PCI expansion drawer, dedicated to the connection to the CPU drawer.

L

LAN: Local Area Network.

LED: Light-Emitting Diode.

M

media and disk device areas: Areas which house the media drives and the hard disk drives.

memory bank: The minimum quantity of memory used by the system. It physically consists of four memory DIMM's. See also DIMM and riser.

MFG: Manufacturing.

MP: MultiProcessor.

multimedia: Information presented through more than one type of media. On computer systems, this media includes sound, graphics, animation and text.

multitasking: The ability to perform several tasks simultaneously. Multitasking allows you to run multiple applications at the same time and exchange information among them.

N

NVRAM: Non Volatile Random Access Memory.

O

OF: See Open Firmware.

OP: See operator panel.

Open Firmware: An architecture for the firmware that controls a computer before the operating system execution. It also provides a user-interface.

operator panel: The system panel where the 3-Digit Hexadecimal Display, two LEDs and the Reset button are located.

operating system: The software which manages the computer's resources and provides the operating environment for application programs.

P

PCI: Peripheral Component Interconnect. A bus architecture that supports high-performance peripherals such as graphic boards, multimedia video cards and high-speed network adapters.

PDU: Power Distribution Unit. The rack power distribution system for the installed drawers.

PowerPC: A standard RISC microprocessor family.

power supply: The CPU drawer and the PCI expansion drawer are equipped with one power supply module. See redundant power supply.

PPI: Parallel Port Interface.

Q

No entries.

R

rack: The metallic frame which houses the drawers and provides them power through its Power Distribution Unit (PDU).

RAID: Redundant Array of Inexpensive Disks. A method of combining hard disk drives into one logical storage unit which offers disk-fault tolerance.

RAM: Random Access Memory.

redundant power supply: The power supply composed by two modules in redundant configuration. They are the same and work in parallel. In case of a power supply fault, the second module takes over automatically providing the needed power.

riser (SRC): A card which can host up to six memory DIMM's. It is used to expand the system memory capacity.

RMS: Recovery Management Support.

ROM: Read Only Memory.

RS-232: An EIA interface standard that defines the physical, electronic and functional characteristics of an interface line.

RS-422: An EIA interface standard that defines the physical, electronic and functional characteristics of an interface line.

RS-485: A line for drawer interconnection. It is used for the connection of expansion drawers.

RSF: Remote Services Facilities.

S

SCSI: Small Computer System Interface. An input and output bus that provides a standard interface used to connect peripherals such as disks or tape drives in a daisy chain.

SID: System Identifier.

slot cover: A metallic plate that covers free PCI/ISA controller card slots.

SRC: Six-DIMM Riser Card.

Stand-By Menu: A menu which is available on the terminal connected to the COM1 port when the system is in standby state. It is used for system maintenance and testing activities.

SYSID: System Identification.

system console: A console, usually equipped with a keyboard and display screen, that is used by an operator to control and communicate with a system.

system planar (KPL): The planar which interconnects all the system resources.

SVGA: Super Video Graphics Array.

T

torx: A special screw with a six-point starlike hollow.

U

U: Unit. Racks and drawers are measured in Units. Each U corresponds to 44.45 mm (1.75 inches).

ULTRA SCSI: See Fast-20 WIDE-16.

UPS: Uninterruptible Power Supply. A device which provides continuous power and sustains the system it is connected to, in case of outages.

V

V: Volt.

VCC: Voltage Continuous Current.

VCCI: Voluntary Control Council for Interference.

VGA: Video Graphics Array.

W

No entries.

X

No entries.

Y

No entries.

Z

No entries.

Index

Numbers

3.5-inch diskette drive
description, 1-3
installation, 2-12
removal, 2-10

A

antistatic envelope, how to use, 2-2
antistatic wrist strap, how to use, 2-2

B

battery
description, 1-3
installation, 2-14
removal, 2-14

C

cables
SCSI, 3-1
VGA cable, 2-45
CPU / memory box, removal, 2-43
CPU card, description, 1-3
CPU drawer
front cover, 2-7
front view, 1-1
overview, 1-1
partial installation, 2-5
partial removal, 2-4
rear view, 1-2
top cover, 2-6

D

device areas, description, 1-3
disk cage
description, 1-4
installation, 2-17
removal, 2-15
disk devices, description, 1-4
diskette drive. *See* 3.5-inch diskette drive

F

fan modules
description, 1-5
installation, 2-24
removal, 2-20
front cover
installation, 2-7
removal, 2-7

H

handling, hardware components, 2-2
hardware components
handling, 2-2
list, 2-9
location, 1-1
preliminary operations, 2-3
restart operations, 2-8
tools needed, 2-2

I

internal connectors
KBB card, 1-13
KDK card, 1-14
KHS card, 1-15
KP2 / KP3 back plane, 1-16
KSB card, 1-19
memory riser, 1-20
system planar, 1-10

K

KBB card
description, 1-6
installation, 2-27
internal connectors, 1-13
removal, 2-26
KDK card, internal connectors, 1-14
KDK complex
description, 1-6
installation, 2-29
removal, 2-28
key mode switch
description, 1-6
installation, 2-32
removal, 2-30
KHS card
description, 1-7
installation, 2-34
internal connectors, 1-15
removal, 2-33
KP2 / KP3. *See* disk cage
KP2 / KP3 back plane
description, 1-7
installation, 2-17
internal connectors, 1-16
removal, 2-15
KPL. *See* system planar
KSB card
description, 1-7
installation, 2-37
internal connectors, 1-19
removal, 2-35

M

maintenance operations
 handling hardware components, 2-2
 preliminary operations, 2-3
 restart operations, 2-8
memory, description, 1-7
memory riser, internal connectors, 1-20
metal blank, removal, 2-17

O

operator panel
 description, 1-8
 installation, 2-39
 removal, 2-38

P

PCI/ISA cards, description, 1-8
power supply
 description, 1-8
 installation, 2-42
 removal, 2-40

S

SCSI cables, 3-1
 connection, 3-3

CPU drawer, 3-2
 description, 3-2
 PCI SCSI controller internal disk cable, 3-5
spare parts, A-1
system planar
 description, 1-8
 installation, 2-44
 internal connectors, 1-10
 removal, 2-43

T

top cover
 installation, 2-6
 removal, 2-6

V

VGA cable
 installation, 2-46
 removal, 2-45
video memory
 installation, 2-47
 removal, 2-47

Vos remarques sur ce document / Technical publication remark form

Titre / Title : Bull ESCALA EPC400 CPU Drawer Service Guide

N° Référence / Reference N° : 86 A1 21PX 02

Daté / Dated : August 1998

ERREURS DETECTEES / ERRORS IN PUBLICATION

AMELIORATIONS SUGGEREES / SUGGESTIONS FOR IMPROVEMENT TO PUBLICATION

Vos remarques et suggestions seront examinées attentivement.

Si vous désirez une réponse écrite, veuillez indiquer ci-après votre adresse postale complète.

Your comments will be promptly investigated by qualified technical personnel and action will be taken as required.

If you require a written reply, please furnish your complete mailing address below.

NOM / NAME : _____ Date : _____

SOCIETE / COMPANY : _____

ADRESSE / ADDRESS : _____

Remettez cet imprimé à un responsable BULL ou envoyez-le directement à :

Please give this technical publication remark form to your BULL representative or mail to:

BULL ELECTRONICS Angers
CEDOC
34 Rue du Nid de Pie – BP 428
49004 ANGERS CEDEX 01
FRANCE

Technical Publications Ordering Form

Bon de Commande de Documents Techniques

To order additional publications, please fill up a copy of this form and send it via mail to:

Pour commander des documents techniques, remplissez une copie de ce formulaire et envoyez-la à :

BULL ELECTRONICS Angers
CEDOC
ATTN / MME DUMOULIN
34 Rue du Nid de Pie – BP 428
49004 ANGERS CEDEX 01
FRANCE

Managers / Gestionnaires :
Mrs. / Mme : C. DUMOULIN +33 (0) 2 41 73 76 65
Mr. / M : L. CHERUBIN +33 (0) 2 41 73 63 96
FAX : +33 (0) 2 41 73 60 19
E-Mail / Courrier Electronique : srv.Cedoc@frnp.bull.fr

CEDOC Reference # N° Référence CEDOC	Qty Qté	CEDOC Reference # N° Référence CEDOC	Qty Qté	CEDOC Reference # N° Référence CEDOC	Qty Qté
____ [__]		____ [__]		____ [__]	
____ [__]		____ [__]		____ [__]	
____ [__]		____ [__]		____ [__]	
____ [__]		____ [__]		____ [__]	
____ [__]		____ [__]		____ [__]	
____ [__]		____ [__]		____ [__]	
____ [__]		____ [__]		____ [__]	
[__] : no revision number means latest revision / pas de numéro de révision signifie révision la plus récente					

NOM / NAME : _____ Date : _____

SOCIETE / COMPANY : _____

ADRESSE / ADDRESS : _____

PHONE / TELEPHONE : _____ FAX : _____

E-MAIL : _____

For Bull Subsidiaries / Pour les Filiales Bull :

Identification: _____

For Bull Affiliated Customers / Pour les Clients Affiliés Bull :

Customer Code / Code Client : _____

For Bull Internal Customers / Pour les Clients Internes Bull :

Budgetary Section / Section Budgétaire : _____

For Others / Pour les Autres :

Please ask your Bull representative. / Merci de demander à votre contact Bull.

BULL ELECTRONICS Angers
CEDOC
34 Rue du Nid de Pie – BP 428
49004 ANGERS CEDEX 01
FRANCE

ORDER REFERENCE
86 A1 21PX 02

PLACE BAR CODE IN LOWER
LEFT CORNER



Utiliser les marques de découpe pour obtenir les étiquettes.
Use the cut marks to get the labels.

┌ ───┐
ESCALA
EPC400
CPU Drawer
Service Guide

86 A1 21PX 02

└ ───┘

┌ ───┐
ESCALA
EPC400
CPU Drawer
Service Guide

86 A1 21PX 02

└ ───┘

┌ ───┐
ESCALA
EPC400
CPU Drawer
Service Guide

86 A1 21PX 02

└ ───┘

