

# Bull ESCALA EPC2400 & EPC2450

User's Guide

ORDER REFERENCE  
86 A1 18KX 01



# Bull ESCALA EPC2400 & EPC2450

## User's Guide

---

### Hardware

October 2000

**BULL CEDOC  
357 AVENUE PATTON  
B.P.20845  
49008 ANGERS CEDEX 01  
FRANCE**

**ORDER REFERENCE  
86 A1 18KX 01**

The following copyright notice protects this book under the Copyright laws of the United States of America and other countries which prohibit such actions as, but not limited to, copying, distributing, modifying, and making derivative works.

Copyright © Bull S.A. 1992, 2000

Printed in France

Suggestions and criticisms concerning the form, content, and presentation of this book are invited. A form is provided at the end of this book for this purpose.

To order additional copies of this book or other Bull Technical Publications, you are invited to use the Ordering Form also provided at the end of this book.

### **Trademarks and Acknowledgements**

We acknowledge the right of proprietors of trademarks mentioned in this book.

AIX<sup>®</sup> is a registered trademark of International Business Machines Corporation, and is being used under licence.

UNIX is a registered trademark in the United States of America and other countries licensed exclusively through the Open Group.

### **Year 2000**

The product documented in this manual is Year 2000 Ready.

*The information in this document is subject to change without notice. Groupe Bull will not be liable for errors contained herein, or for incidental or consequential damages in connection with the use of this material.*

---

# Table of Contents

<b>Communications Statements</b> .....	<b>vii</b>
<b>Safety Notices</b> .....	<b>x</b>
<b>Data Integrity and Verification</b> .....	<b>xii</b>
<b>Environmental Notices</b> .....	<b>xiii</b>
<b>About This Book</b> .....	<b>xv</b>
<b>Chapter 1. System Introduction</b> .....	<b>1-1</b>
Overview .....	1-1
System Rack .....	1-2
I/O Rack .....	1-3
I/O Drawers .....	1-4
10 EIA Unit I/O Drawer .....	1-4
Input/Output Connectors .....	1-5
10 EIA Unit I/O Drawer .....	1-5
<b>Chapter 2. Using the System</b> .....	<b>2-1</b>
Operator Panel and Power Control .....	2-1
Powering On the System .....	2-2
Powering Off the System .....	2-2
POST Indicators .....	2-3
POST Keys .....	2-4
Console Strategy .....	2-5
Reading the System Rack Operator Panel Display .....	2-5
I/O Drawer Indicator Panels .....	2-6
10 EIA Unit I/O Drawer Indicator Panel .....	2-6
Using the Keyboards .....	2-7
Using The Mouse .....	2-8
Handling the Mouse Correctly .....	2-9
Using the 3.5-Inch Diskette Drive .....	2-11
Diskette Compatibility .....	2-11
Using the CD-ROM Drive .....	2-12
Using the Hot Swap Disk Drives .....	2-15
Relationship of AIX Prompts and Physical Drive Location .....	2-15
10 EIA Unit I/O Drawer Locations .....	2-15
Handling Guidelines .....	2-15
Labels .....	2-16
Disk Drive Status Light States .....	2-16
Removing and Inserting Disk Drives .....	2-17
Unconfiguring or Configuring a Disk Drive .....	2-17
Inserting a Disk Drive into the Hot-Swap Bays .....	2-18
Removing Disk Drives from the Hot-Swap Bays .....	2-20
Using the Service Processor Features .....	2-22

<b>Chapter 3. Service Processor Menus</b> .....	<b>3-1</b>
Service Processor Menus .....	3-2
How to access SP menus locally .....	3-2
How to access SP menus remotely .....	3-2
Saving and Restoring Service Processor Settings .....	3-2
How to return to SP menus .....	3-2
Menu Inactivity .....	3-3
General User Menus .....	3-3
Privileged User Menus .....	3-4
Main Menu .....	3-4
Service Processor Setup Menu .....	3-5
Passwords .....	3-6
System Power Control Menu .....	3-7
System Information Menu .....	3-8
Language Selection Menu .....	3-10
Call-In/Call-Out Setup Menu .....	3-10
Modem Configuration Menu .....	3-11
Serial Port Selection Menu .....	3-11
Serial Port Speed Setup Menu .....	3-12
Telephone Number Setup Menu .....	3-12
Call-Out Policy Setup Menu .....	3-14
Customer Account Setup Menu .....	3-15
Reboot/Restart Policy Setup Menu .....	3-15
Boot Mode Menu .....	3-16
Service Processor Procedures in Service Mode .....	3-17
Service Processor Functions .....	3-17
System Power-On Methods .....	3-18
Service Processor Call-In Security .....	3-19
Service Processor Reboot/Restart Recovery .....	3-20
Boot (IPL) Speed .....	3-20
Failure During Boot Process .....	3-20
Failure During Normal System Operation .....	3-20
Service Processor Reboot/Restart Policy Controls .....	3-20
Configure/Deconfigure Processors .....	3-21
Processor Deconfiguration During Boot .....	3-22
Service Processor System Monitoring – Surveillance .....	3-22
System Firmware Surveillance .....	3-22
Operating System Surveillance .....	3-22
Call-Out (Call-Home) .....	3-23
Console Mirroring .....	3-24
System Configuration: .....	3-24
Service Processor Error Logs .....	3-24
System POST Errors .....	3-25
LCD Progress Indicator Log .....	3-25

<b>Chapter 4. System Management Services</b> .....	<b>4-1</b>
Text-Based System Management Services .....	4-1
Password Utilities .....	4-2
Display Error Log .....	4-2
Remote Initial Program Load Setup .....	4-3
SCSI Utilities .....	4-5
Console Select .....	4-6
MultiBoot Menu .....	4-6
Select Boot Devices .....	4-7
Select Language .....	4-8
OK Prompt .....	4-8
Exiting System Management Services .....	4-9
<b>Chapter 5. Using the Online and Standalone Diagnostics</b> .....	<b>5-1</b>
Sources for the Diagnostics .....	5-1
Standalone and Online Diagnostics Operating Considerations .....	5-1
Selecting a Console Display .....	5-1
Identifying the Terminal Type to Diagnostics .....	5-1
Undefined Terminal Types .....	5-1
Running Standalone Diagnostics .....	5-2
Running Online Diagnostics .....	5-2
Running the Diagnostics from a TTY Terminal .....	5-2
Online Diagnostics Modes of Operation .....	5-3
Service Mode .....	5-3
Running the Online Diagnostics in Service Mode .....	5-3
Concurrent Mode .....	5-3
Running the Online Diagnostics in Concurrent Mode .....	5-4
Maintenance Mode .....	5-4
Running the Online Diagnostics in Maintenance Mode .....	5-5
Standalone Diagnostic Operation .....	5-5
Running the Standalone Diagnostics .....	5-5
Logical and Physical Locations .....	5-6
Physical Location Codes .....	5-6
Location Code Format .....	5-6
AIX Location Codes .....	5-6
AIX and Physical Location Code Reference Tables .....	5-9
<b>Chapter 6. Introduction to Tasks and Service Aids</b> .....	<b>6-1</b>
<b>Chapter 7. Using the System Verification Procedure</b> .....	<b>7-1</b>
Step 1. Considerations before Running This Procedure .....	7-1
Step 2. Loading the Diagnostics .....	7-1
Step 3. Running System Verification .....	7-2
Step 4. Additional System Verification .....	7-2
Step 5. Stopping the Diagnostics .....	7-2
<b>Chapter 8. Hardware Problem Determination</b> .....	<b>8-1</b>
Problem Determination Using the Standalone or Online Diagnostics .....	8-1
Problem Determination When Unable to Load Diagnostics .....	8-7
Error Codes .....	8-9

<b>Appendix A. Operator Panel Functions</b> .....	<b>A-1</b>
System Rack Operator Panel .....	A-1
Function Code Table .....	A-2
Operator Panel Function Descriptions .....	A-4
Values for IPL Types and Speeds .....	A-4
<b>Appendix B. Firmware Update Procedures</b> .....	<b>B-1</b>
Determining the Firmware Levels .....	B-1
Obtaining the Firmware Update Package .....	B-2
<b>Appendix C. Service Processor Setup and Test</b> .....	<b>C-1</b>
SP Setup Checklist .....	C-1
Testing the Service Processor Setup .....	C-2
Call-In .....	C-2
Call-Out .....	C-2
Serial Port Configuration .....	C-3
<b>Appendix D. Modem Configurations</b> .....	<b>D-1</b>
Sample Modem Configuration Files .....	D-1
Configuration File Selection .....	D-2
Examples For Using the Generic Sample Modem Configuration Files .....	D-3
Customizing the Modem Configuration Files .....	D-3
Terminal Emulators .....	D-3
Recovery Procedures .....	D-3
Seamless Transfer of a Modem Session .....	D-4
Recovery Strategy .....	D-5
Prevention Strategy .....	D-5
Modem Configuration Samples .....	D-6
<b>Index</b> .....	<b>X-1</b>



---

# Communications Statements

The following statement applies to this product. The statement for other products intended for use with this product will appear in their accompanying manuals.

## Federal Communications Commission (FCC) Statement

**Note:** This equipment has been tested and found to comply with the limits for a Class A digital device, pursuant to Part 15 of the FCC Rules. These limits are designed to provide reasonable protection against harmful interference when the equipment is operated in a commercial environment. This equipment generates, uses, and can radiate radio frequency energy and, if not installed and used in accordance with the instruction manual, may cause harmful interference to radio communications. Operation of this equipment in a residential area is likely to cause harmful interference in which case the user will be required to correct the interference at his own expense.

Properly shielded and grounded cables and connectors must be used in order to meet FCC emission limits. Neither the provider nor the manufacturer are responsible for any radio or television interference caused by using other than recommended cables and connectors or by unauthorized changes or modifications to this equipment. Unauthorized changes or modifications could void the user's authority to operate the equipment.

This device complies with Part 15 of the FCC Rules. Operation is subject to the following two conditions: (1) this device may not cause harmful interference, and (2) this device must accept any interference received, including interference that may cause undesired operation.

## European Union (EU) Statement

This product is in conformity with the protection requirements of EU Council Directive 89/336/EEC on the approximation of the laws of the Member States relating to electromagnetic compatibility. The manufacturer cannot accept responsibility for any failure to satisfy the protection requirements resulting from a non-recommended modification of the product, including the fitting of option cards supplied by third parties. Consult with your dealer or sales representative for details on your specific hardware.

This product has been tested and found to comply with the limits for Class A Information Technology Equipment according to CISPR 22 / European Standard EN 55022. The limits for Class A equipment were derived for commercial and industrial environments to provide reasonable protection against interference with licensed communication equipment.

Attention: This is a Class A product. In a domestic environment this product may cause radio interference in which case the user may be required to take adequate measures.

## International Electrotechnical Commission (IEC) Statement

This product has been designed and built to comply with IEC Standard 950.

## United Kingdom Telecommunications Safety Requirements

This equipment is manufactured to the International Safety Standard EN60950 and as such is approved in the UK under the General Approval Number NS/G/1234/J/100003 for indirect connection to the public telecommunication network.

The network adapter interfaces housed within this equipment are approved separately, each one having its own independent approval number. These interface adapters, supplied by the

manufacturer, do not use or contain excessive voltages. An excessive voltage is one which exceeds 70.7 V peak ac or 120 V dc. They interface with this equipment using Safe Extra Low Voltages only. In order to maintain the separate (independent) approval of the manufacturer's adapters, it is essential that other optional cards, not supplied by the manufacturer, do not use main voltages or any other excessive voltages. Seek advice from a competent engineer before installing other adapters not supplied by the manufacturer.

## **Avis de conformité aux normes du ministère des Communications du Canada**

Cet appareil numérique de la Classe A respecte toutes les exigences du Règlement sur le matériel brouilleur du Canada.

## **Canadian Department of Communications Compliance Statement**

This Class A digital apparatus meets the requirements of the Canadian Interference-Causing Equipment Regulations.

## **VCCI Statement**

この装置は、情報処理装置等電波障害自主規制協議会（VCCI）の基準に基づくクラスB情報技術装置です。この装置は、家庭環境で使用することを目的としていますが、この装置がラジオやテレビジョン受信機に近接して使用されると、受信障害を引き起こすことがあります。  
取扱説明書に従って正しい取り扱いをして下さい。

The following is a summary of the VCCI Japanese statement in the box above.

This is a Class A product based on the standard of the Voluntary Control Council for Interference from Information Technology Equipment (VCCI). If it is used near a radio or television receiver in a domestic environment, it may cause radio interference. Install and use the equipment according to the instruction manual. When used near a radio or a TV receiver, it may become the cause of radio interference.  
Read the instructions for correct handling.

## Radio Protection for Germany

Dieses Gerät ist berechtigt in Übereinstimmung mit dem deutschen EMVG vom 9.Nov.92 das EG-Konformitätszeichen zu führen.

Der Aussteller der Konformitätserklärung ist die IBM Germany.

Dieses Gerät erfüllt die Bedingungen der EN 55022 Klasse A. Für diese von Geräten gilt folgende Bestimmung nach dem EMVG:

Geräte dürfen an Orten, für die sie nicht ausreichend entstört sind, nur mit besonderer Genehmigung des Bundesministers für Post und Telekommunikation oder des Bundesamtes für Post und Telekommunikation betrieben werden. Die Genehmigung wird erteilt, wenn keine elektromagnetischen Störungen zu erwarten sind.

(Auszug aus dem EMVG vom 9.Nov.92, Para.3, Abs.4)

Hinweis

Dieses Genehmigungsverfahren ist von der Deutschen Bundespost noch nicht veröffentlicht worden.

---

# Safety Notices

A *danger* notice indicates the presence of a hazard that has the potential of causing death or serious personal injury.

A *caution* notice indicates the presence of a hazard that has the potential of causing moderate or minor personal injury.

---

## Electrical Safety

Observe the following safety instructions any time you are connecting or disconnecting devices attached to the workstation

### **DANGER**

**An electrical outlet that is not correctly wired could place hazardous voltage on metal parts of the system or the devices that attach to the system. It is the responsibility of the customer to ensure that the outlet is correctly wired and grounded to prevent an electrical shock.**

**Before installing or removing signal cables, ensure that the power cables for the system unit and all attached devices are unplugged.**

**When adding or removing any additional devices to or from the system, ensure that the power cables for those devices are unplugged before the signal cables are connected. If possible, disconnect all power cables from the existing system before you add a device.**

**Use one hand, when possible, to connect or disconnect signal cables to prevent a possible shock from touching two surfaces with different electrical potentials.**

**During an electrical storm, do not connect cables for display stations, printers, telephones, or station protectors for communication lines.**

### **CAUTION:**

**This product is equipped with a three-wire power cable and plug for the user's safety. Use this power cable with a properly grounded electrical outlet to avoid electrical shock.**

### **DANGER**

**To prevent electrical shock hazard, disconnect the power cable from the electrical outlet before relocating the system.**

### **CAUTION:**

**This unit has more than one power supply cord. To reduce the risk of electrical shock, disconnect two power supply cords before servicing.**

---

## Laser Safety Information

The optical drive is a laser product. The optical drive has a label that identifies its classification. The label, located on the drive is shown below.

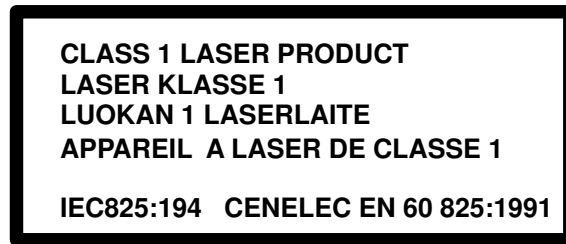

The optical drive is certified in the US to conform to the requirements of the Department of Health and Human Services 21 Code of Federal Regulations (DHHS 21 CFR) Subchapter J for Class 1 laser products. Elsewhere, the drive is certified to conform to the requirements of the International Electrotechnical Commission (IEC), 825 (1st edition 1984) and CENELEC EN 60 825/1991 for Class 1 laser products.

**CAUTION:**

**A class 3 laser is contained in the device. Do not attempt to operate the drive while it is disassembled. Do not attempt to open the covers of the drive as it is not serviceable and is to be replaced as a unit.**

Class 1 laser products are not considered to be hazardous. The optical drive contains internally a Class 3B gallium-arsenide laser that is nominally 0.14 milliwatts at 765 to 815 nanometers. The design incorporates a combination of enclosures, electronics, and redundant interlocks such that there is no exposure to laser radiation above a Class 1 level during normal operation, user maintenance, or servicing conditions.

---

## Data Integrity and Verification

**These computer systems contain mechanisms designed to reduce the possibility of undetected data corruption or loss. This risk, however, cannot be eliminated. Users who experience unplanned outages, system failures, power fluctuations or outages, or component failures must verify the accuracy of operations performed and data saved or transmitted by the system at or near the time of the outage or failure. In addition, users must establish procedures to ensure that there is independent data verification before relying on such data in sensitive or critical operations. Users should periodically check our support websites for updated information and fixes applicable to the system and related software.**

---

# Environmental Notices

---

## Product Recycling and Disposal

Components of the system unit, such as structural parts and circuit cards, can be recycled where recycling facilities exist. Companies are available to disassemble, reutilize, recycle, or dispose of electronics products. This system unit contains batteries and circuit boards with lead solder. Before you dispose of this unit, these batteries and circuit boards must be removed and discarded according to local regulations or recycled where facilities exist. This book contains specific information on each battery type where applicable.

---

## Unit emissions

The unit-related emission value is equal to or lower than 70dB(A).

Der Geräuschpegel der Einheit ist kleiner oder gleich 70 db(A).





---

# About This Book

This book provides information on how to install and remove options, use the system, diagnostics, and service aids, and verify system operation. This book also provides information to help you solve problems that might occur.

If a problem is software related, consult your operating system documentation.

## ISO 9000

ISO 9000 registered quality systems were used in the development and manufacturing of this product.

## Related Publications

The following publications are available:

The *ESCALA EPC2400 & EPC2450 Installation Guide*, order number 86 A1 10EF, contains information on how to set up and cable the system, install and remove options, and verify system operation.

The *ESCALA EPC2400 & EPC2450 Service Guide*, order number 86 A1 19KX, contains reference information, error codes, maintenance analysis procedures (MAPs), removal and replacement procedures, and a parts catalog.

The *ESCALA Site Preparation for Rack Systems*, order number 86 A1 30PX, provides a step-by-step approach to prepare a customer site for the installation of rack-mounted machines together with their subsystems and peripherals.

The *Diagnostics Information for Multiple Bus Systems*, order number 86 A1 26HX, contains information and procedures that are common to all systems.

The *Adapters Information Manual for Multiple Bus Systems*, order number 86 A1 27HX, contains cabling and technical information about some of the adapters and devices available for your system unit.

The *Disks and Tapes Configuration Information*, order number 86 A1 88GX, gives the jumper and switch settings to configure disks and tapes peripherals that use the Small Computer System Interface (SCSI).

The *High Availability Cluster Multi-Processing for AIX, Version 4.3: Enhanced Scalability Installation and Administration Guide Vol.1*, order number 86 A2 62KX, is needed for HACMP/ES planning information.

The *High Availability Cluster Multi-Processing for AIX, Version 4.3: Enhanced Scalability Installation and Administration Guide Vol.2*, order number 86 A2 89KX, is needed for HACMP/ES planning information.

The *High Availability Cluster Multi-Processing for AIX: Planning Guide*, order number 86 A2 55KX, is needed for HACMP/ES planning information.



---

# Chapter 1. System Introduction

---

## Overview

The EPC2400 and EPC2450 systems are 64-bit, symmetric multiprocessing (SMP) enterprise servers. The systems provide the power, capacity and expandability to support evolution of your business into the 64 bit computing environment while still supporting the existing 32 bit applications. The I/O subsystem supports both 32-bit and 64-bit standard PCI adapters.

The systems are multi-processor, multi-bus system packaged in two different rack types. The processor and memory are packaged in the System Rack. A separate I/O rack contains the DASD and I/O devices in drawers. The basic system consists of one System Rack and one I/O Drawer in a separate rack. The systems are expandable to one System Rack and 4 I/O Drawers. See the figure on page 1-1 for an example of the basic system.

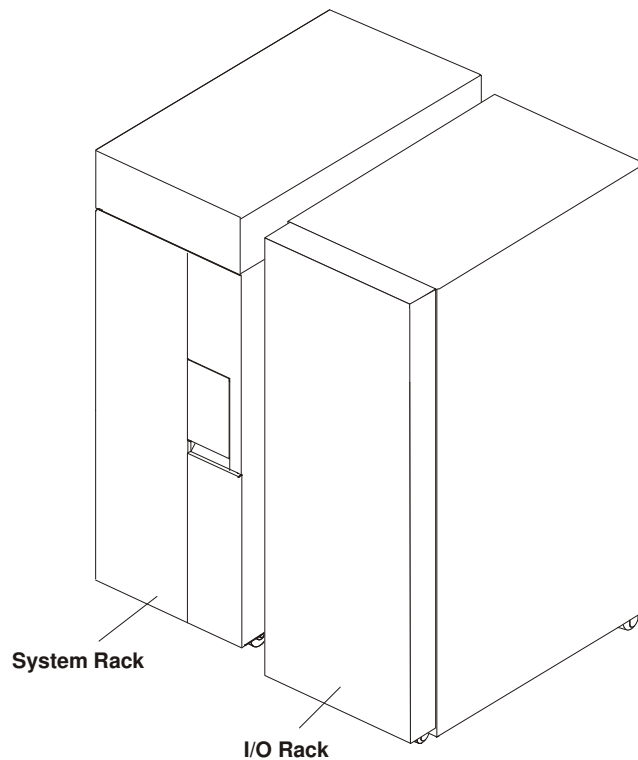

---

## System Rack

The System Rack supports a minimum of one processor card and a maximum of four processor cards. Each processor card has six 64 bit processors. A maximum of 24 processors may be installed in the system which shares a common system memory. The system memory is controlled through a multi-port controller which supports up to 16 memory slots. The total memory available to users is dependent on the memory feature card installed and the number of memory cards. All system memory is contained in the system rack.

Also contained in the System Rack is the operator panel which provides diagnostic support in addition to controlling powering up and down the entire system. The operator panel is shown in the figure on page 1-2 . The System Rack is powered by 200 – 240 V ac.

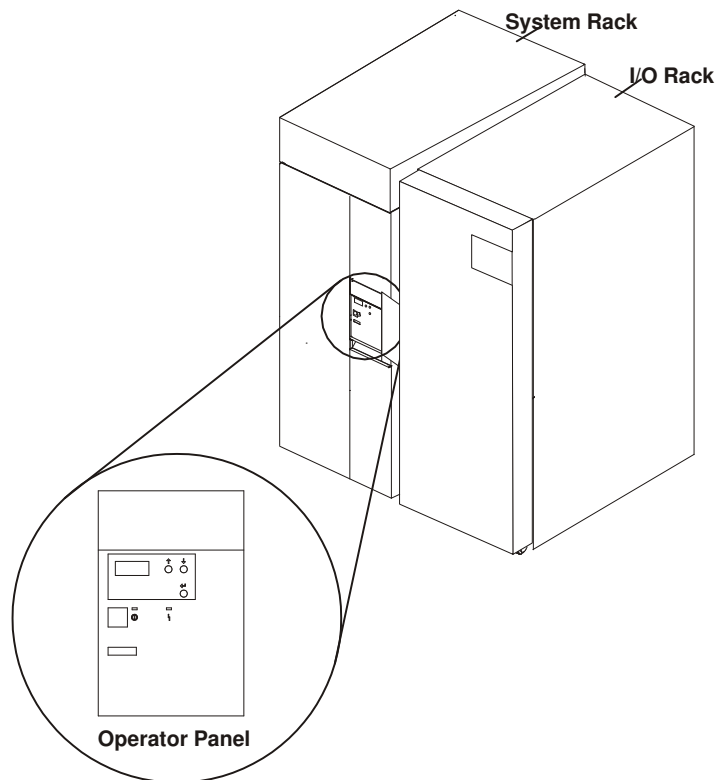

## I/O Rack

Each I/O rack holds up to two I/O Drawers. Each I/O Drawer provides up to 14 PCI adapters per drawer. The primary I/O Drawer (Drawer 0) reserves slots for support of system media, Service Processor and hot-pluggable DASD bays resident in the drawer. For information about PCI adapter slot placement, see Appendix B in the *Installation Guide*). These slots are available in subsequent I/O Drawers 1 through 3 for any supported PCI adapter use. A fully configured system consisting of four I/O Drawers (with a maximum of two I/O Drawers per I/O rack) and one System Rack provides support for up to 55 33Mhz PCI adapters, 48 hot-pluggable SCSI disk bays and up to 8 media bays. The PCI bus supported is 33Mhz with both 32 and 64 bit adapters supported on a per slot basis. Slots 1, 5, 9, 10 and 14 support either 32 or 64 bit PCI adapters. The remaining slots are 32 bits.

The Service Processor (SP), resident in slot 8 of the primary I/O Drawer, provides extended service support. The SP provides facilities for system management, error data collection, remote call-in, remote call-out including surveillance, and numerous other features including password support. The Input/output Rack is powered by 200 – 240 V ac.

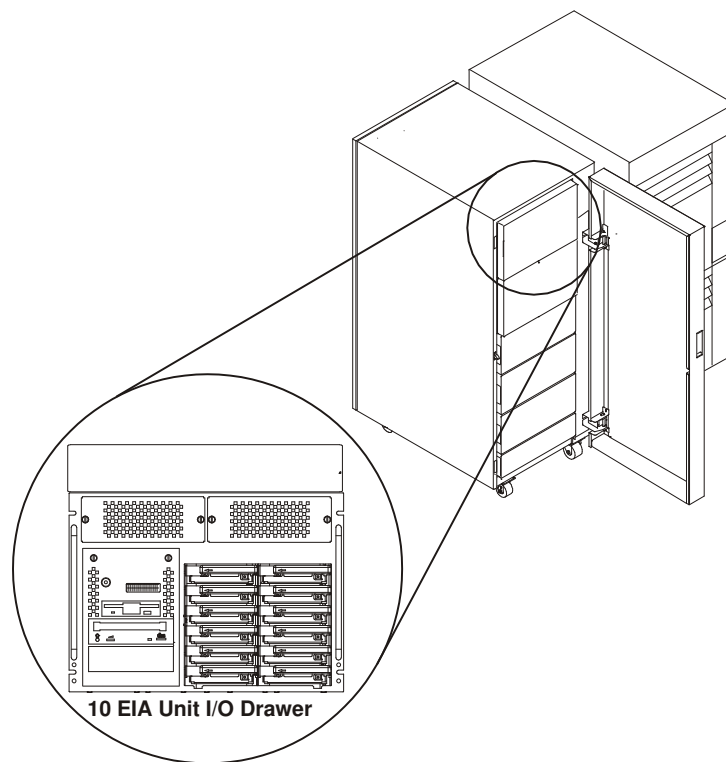

# I/O Drawers

Your system has a 10 EIA Unit I/O Drawer described below.

## 10 EIA Unit I/O Drawer

The 10 EIA Unit I/O Drawer features hot-pluggable disk drive banks shown in the following figure. Disk drive banks allow system users to insert and remove disk drives without performing a power down of the system which increases the availability of the server. The 10 EIA Unit I/O Drawer is powered by 200 – 240 V ac.

The disk drive banks are each able to hold up to six one-inch by 3.5-inch form factor drives, or three 1.6-inch drives.

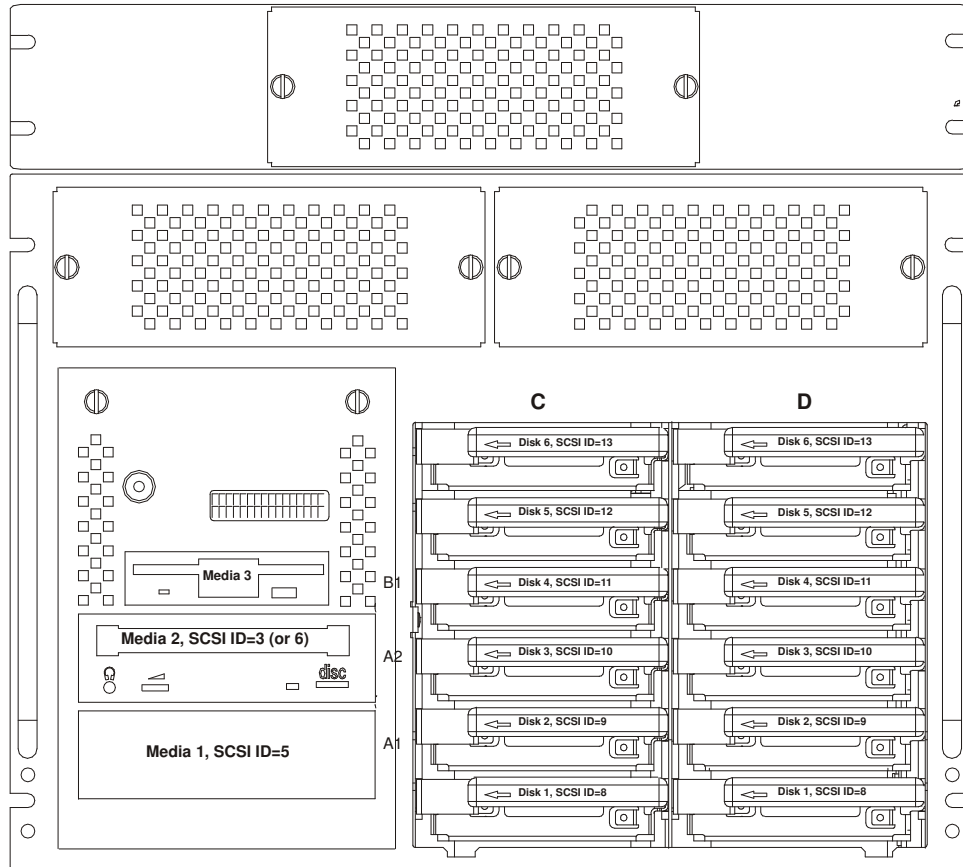

When the drawer has the maximum configuration, it holds up to 12 one-inch by 3.5-inch form factor 16 bit disk drives mounted on carriers and 2 media devices. If the drawer is fully populated with 1.6-inch disk drives, it holds only 6 disk drives. The disk drives are mounted in carriers that are auto docking, auto addressing, and hot swappable.

# Input/Output Connectors

## 10 EIA Unit I/O Drawer

The 10 EIA Unit I/O Drawer Input/Output connectors are shown in the following figure.

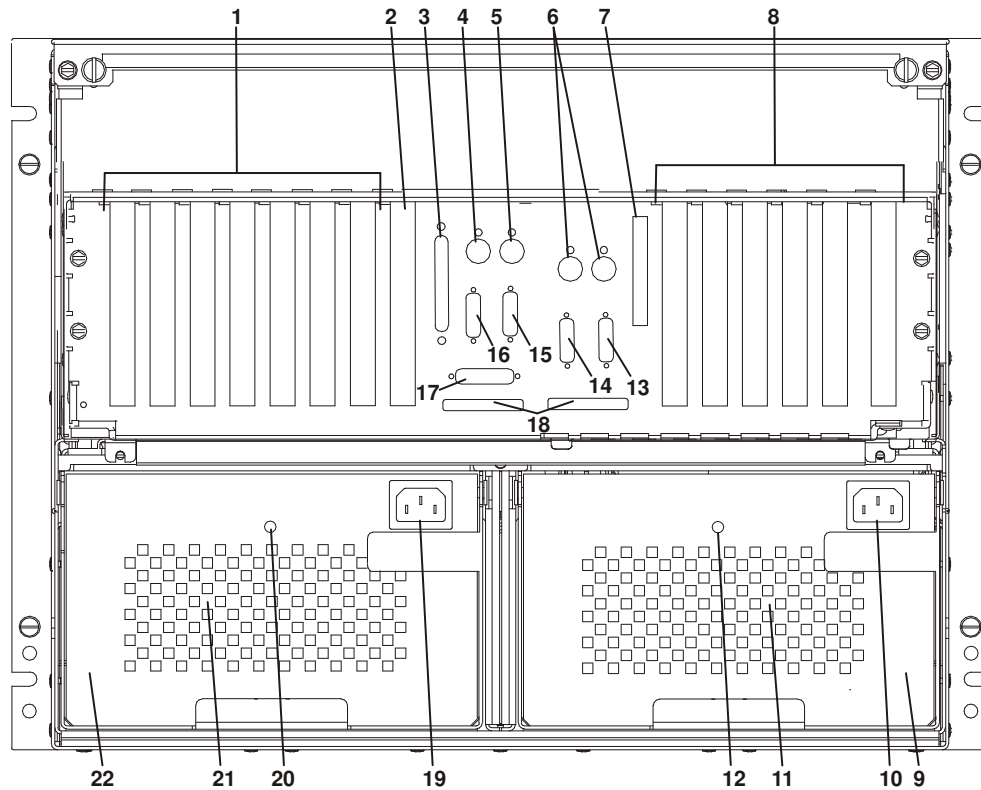

1. PCI adapter slots (1 – 7)
2. PCI adapter slot 8, service processor card and JTAG cable in primary I/O drawer (drawer 0)
3. Parallel connector
4. Keyboard connector
5. Mouse connector
6. Reserved
7. SCSI Redrive card (if installed)
8. PCI adapter slots (9 – 14)
9. Right power supply
10. Power cord connector for right power supply
11. Fans (mounted on front end of right power supply)
12. Right power supply, power good LED
13. SPCN2 connector
14. SPCN1 connector
15. Serial port S2
16. Serial port S1
17. Operator panel (OP) connector

18. RIO 0 and RIO 1 connectors
19. Power cord connector for left power supply
20. Left power supply, power good LED
21. Fans (mounted on front end of left power supply)
22. Left power supply.



---

## Chapter 2. Using the System

System power control and use of options such as the keyboard, mouse, and drives supported by the server are discussed in this section.

---

### Operator Panel and Power Control

The following diagram shows the locations of the operator panel display and the operator panel pushbuttons.

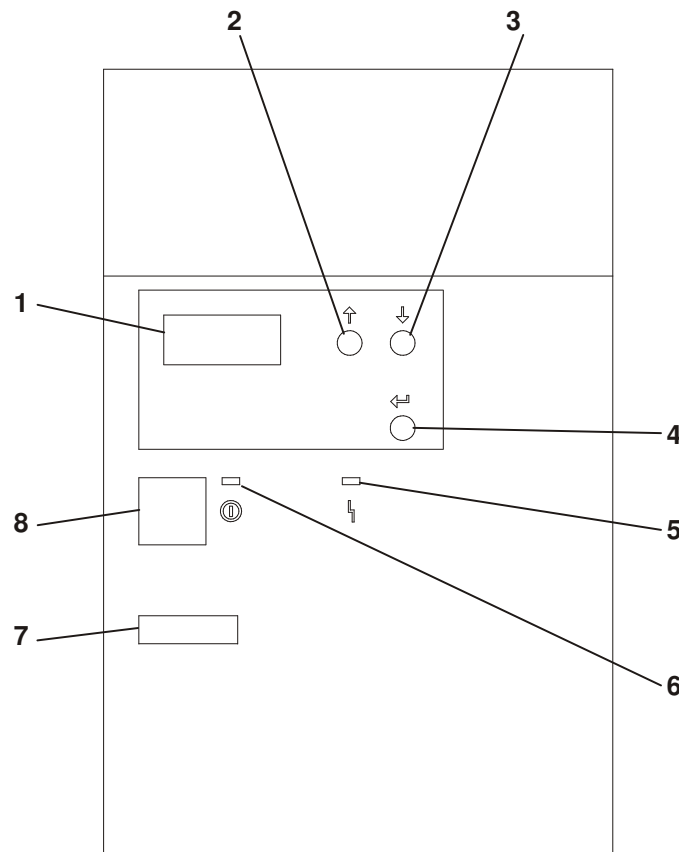

1. Operator Panel Display
2. Scroll Up Pushbutton
3. Scroll Down Pushbutton
4. Enter Pushbutton
5. Attention LED
6. Power On LED
7. Serial Number
8. Power Pushbutton

For more information on operator panel functions, see Appendix A. "Operator Panel Functions".

---

## Powering On the System

Perform the following steps to power on your system rack and I/O Drawer(s):

1. Open the operator panel cover on the system rack.
2. Press the Power (white) pushbutton on the operator panel.
3. The Power On light on the operator panel starts blinking as the system is powered on. The light stops blinking and stays on when power on is complete. Likewise, the green LED on the I/O Drawer(s) starts blinking as the system is powered on. The light stops blinking and stays on when power on is complete.

For more information, see "System Power-On Methods" on page 3-18.

---

## Powering Off the System

If the system is operating under AIX, enter the `shutdown -F` command to power off the system.

If you cannot use this method, you can power off the system by using the following operator panel power Pushbutton procedure.

**Attention:** Using the operator panel Power pushbutton to power off the system without first shutting down the operating system may cause unpredictable results in the data files, and the next IPL takes longer to complete.

1. Open the operator panel cover.
2. Press the Power pushbutton (white) on the operator panel.

The Data/Function display shows **⓪ ?** (the international power-off symbol) with the **?** blinking.

3. Press the Power pushbutton (white) on the operator panel again to confirm.

**Note:** To cancel the power-off operation, do not press the Power pushbutton a second time. Instead, press any other operator panel pushbutton.

4. The operator panel Power On light starts blinking as the system powers off. The operator panel light stops blinking and stays off when the power-off operation is complete. The green LED on the I/O Drawer(s) goes to a slow blink, indicating the I/O Drawer power is now on standby.

Does the system power off successfully?

**NO** Go to step 5

**YES** This ends the procedure

5. Perform the following:
  - a. Press the **↑** or the **↓** pushbutton until function 08 is shown in the operator panel display.
  - b. Press the Enter pushbutton.
  - c. SRC A100 8008 is shown on the Data display.
6. Press the Power pushbutton (white) on the operator panel.

The operator panel display shows **08 ⓪ ?** (the international power-off symbol) with the **?** blinking.

7. Press the Power pushbutton (white) on the operator panel again.

The system powers off, and the Power On light on the system rack operator panel display goes off and remains off. The green LED on the I/O Drawer(s) goes to a slow blink, indicating the I/O Drawer power is now on standby.

**Note:** To cancel the power-off operation, do not select function 08. Instead, press any other operator panel pushbutton.

For additional information on Function 08 – Fast Power Off, see "Function 08 – Fast Power Off" on page A-6.

---

## POST Indicators

During the power-on sequence a series of POST indicators appear on the display.

The following text is displayed on the screen.

- Memory
- Keyboard
- Network
- SCSI
- Speaker

If the POST completes successfully, the text will display "OK".

This section describes the meaning of each of the displayed POST indicators.

**Memory:** Memory test.

**Keyboard:** Initialize the keyboard and mouse. The window for pressing a key to bring up System Management Services is now open. See "POST Keys" on page 2-4 for more information.

**Network:** Self-test on network adapters.

**SCSI:** Adapters are being initialized.

**Speaker:** Sounds an audible tone at the end of POST.

---

# POST Keys

## Numerical 1 Key

The numerical 1 key, when pressed during POST, invokes the System Management Services (SMS) GUI interface.

## Numerical 5 Key

The numerical 5 key, when pressed during POST, invokes the default boot list, located in firmware.

This mode attempts to boot from the first device of each type found in the list. It does not search for other bootable devices of that type if the first device is not bootable. Instead, it continues to the next device type in the list. The firmware supports up to five entries in the boot list.

The default boot order is:

1. Diskette
2. CD ROM
3. Hard File
4. Tape Drive
5. Network
  - a. Token Ring
  - b. Ethernet

## Numerical 6 key

The numerical key 6 works like the numerical key 5 except, firmware looks for a boot record according to the custom bootlist that was setup by System Management Services.

## Numerical 8 key

To enter the Open Firmware command line, you must press the numerical key 8 key *after the keyboard icon appears* and before the last POST indicator appears during the startup power-on sequence. After pressing the numerical key 8, the remaining POST indicators display until initialization completes.

When initialization and power-on self test (POST) are complete, the Open Firmware command line (an "OK" prompt) appears.

The Open Firmware command line is used to set up adapters that are not configurable with the System Management Services. Your adapter documentation directs you to use this option if it is needed.

To exit from the Open Firmware command enter `reset-all` or power the system down and reboot.

---

## Console Strategy

The firmware invokes a console selection sequence at system boot time if any of the following are true:

- A console has not yet been selected
- A previous console selection sequence timed out
- A change in the system configuration affecting the console (keyboard installed/removed, mouse installed/removed, graphics adapter installed/removed or moved to another PCI slot).

The console selection sequence allows the selection (from the appropriate input device) of any one of all the available console devices. If no console is selected within approximately 60 seconds, serial port 1 (com1) is selected as the console and the selection sequence times out.

Once a console has been selected, the console selection sequence is only invoked at boot time if there is a change in the system configuration (as described above), or the contents of the system's non-volatile memory (nvram) is lost.

**Note:** Moving an ASCII terminal from one serial port to another (from com1 to com2) is not detectable by the firmware so it does not constitute a configuration change.

A system console selection sequence can also be initiated from the SMS menus.

---

## Reading the System Rack Operator Panel Display

The operator panel display is used to:

- Track the progress of the system unit self tests and configuration program.
- Display codes when the operating system comes to an abnormal end.
- Display system messages.

During power-on self-test (POST), 4 and 8 characters display indicating the progress of the testing. If an error is detected that requires attention, the system unit halts with up to a 72-digit number shown 8 digits at a time on the operator panel. This number identifies the error (see *ESCALA EPC2400 & EPC2450 Service Guide* for a listing of the error codes). The attention light turns on to indicate an error condition.

4-digit progress codes (checkpoints) are in the form of  $E\ n\ n\ n$ , where E is the first character and n is alphabetic or numeric characters.

8-digit progress codes (checkpoints) are in the form of  $C\ n\ n\ n\ n\ n\ n\ n\ n$ , where C is 'C' and n is alphabetic or numeric.

The diagram on page 2-1 shows the locations of the operator panel display and the operator panel. For details about the operator panel functions and descriptions, see Appendix A. "Operator Panel Functions".

# I/O Drawer Indicator Panels

This section describes the indicator panel located on the left front of the 10 EIA Unit I/O Drawer.

## 10 EIA Unit I/O Drawer Indicator Panel

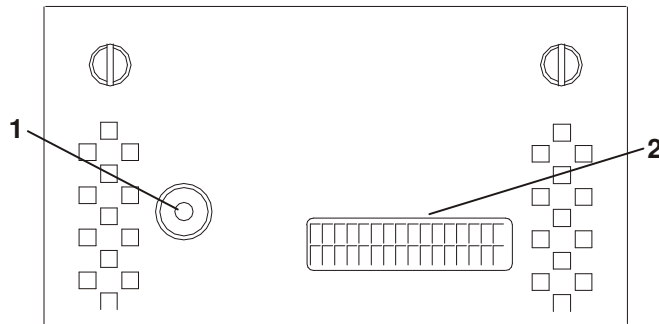

1. Power On LED
2. Drawer Indicator Panel Display

## 10 EIA Unit I/O Drawer and Power Supply LED Status

State of LED	Operator Panel LED	Right Power Supply LED	Left Power Supply LED
Off	No power connected	No power connected	No power connected
On, blinking green	System power connected, not turned on	System power connected, not turned on	System power connected, not turned on
On, steady green	System power connected and turned on	System power connected and turned on	System power connected and turned on

## 10 EIA Unit I/O Drawer Indicator Panel Status

Drawer State	LED	Drawer Indicator Panel
<b>After Connecting AC Power</b>		
Standby	Blinking	Blinking location U??.?
System power	On solid	Blinking location U??.?
Receive Firmware Command	On solid	On solid location Ux.y#
Thereafter	On solid	On solid location Ux.y#
<b>After Power is Removed Because of a Shutdown</b>		
Standby	Blinking	Blinking location Ux.y
System power	Solid	Blinking location Ux.y
Receive Firmware Command	Solid	Solid location Ux.y#
Thereafter	Solid	Solid location Ux.y#
# represents a blinking asterisk (*)		

## Using the Keyboards

There are several keyboards available with the system unit. The keyboards have various keys that enter data and control the cursor location. The keyboards can be engraved for the languages of different countries.

The functions of each keyboard depend on the software used. The character sets for the keyboards are contained and explained in the information for your operating system.

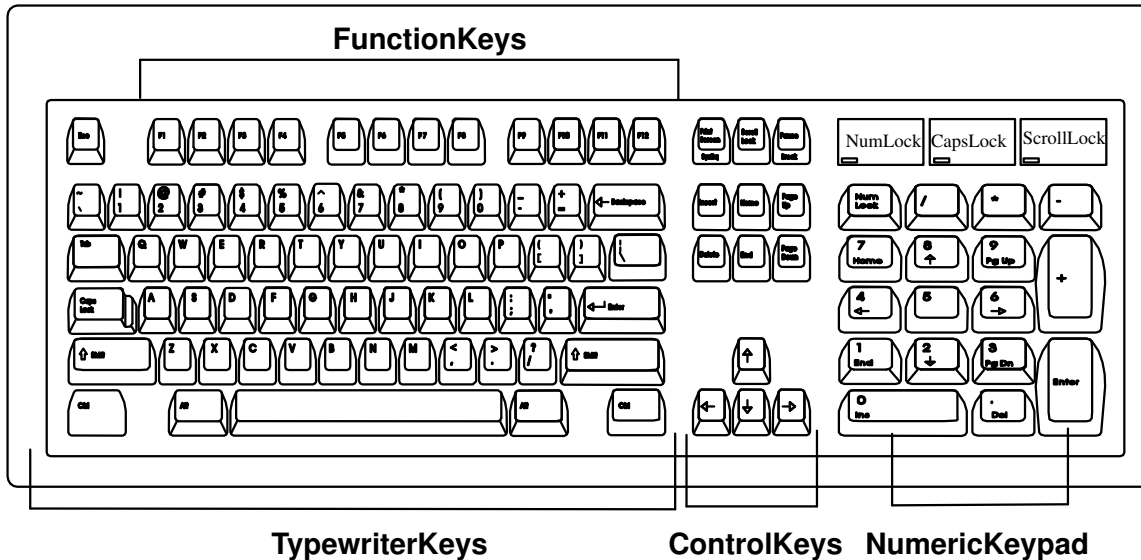

The keyboard is divided into four sections:

- The function keys are multipurpose keys and their function is controlled by the operating system.
- The typewriter keys are similar to a standard typewriter. Their function is controlled by the software.
- The control keys move the cursor on the screen and do programmed control functions. The movement and functions depend upon the application used.
- The numeric keypad is arranged like a calculator to help when typing numbers.

On all of the keyboards, you can adjust the tilt position for typing comfort. To tilt the keyboard, pull out on the keyboard legs. The legs snap into position. To decrease the tilt of the keyboard, rotate the keyboard legs until they snap into the bottom of the keyboard case.

The keyboard cable plugs into the connector at the rear of the system unit.

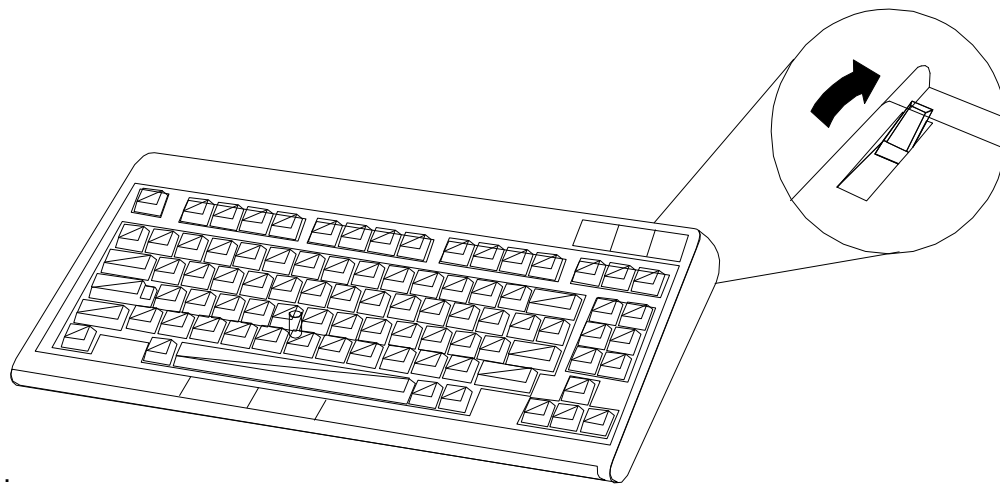

---

## Using The Mouse

The mouse is a hand-operated locating device. Consult your application publication for the exact use of the three-button mouse.

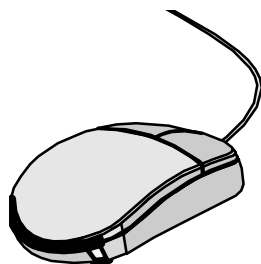

You can use the mouse to perform functions such as positioning a cursor, selecting items from a menu, or moving around in your document much easier and faster than if you used only the keyboard. The cursor moves exactly as you move the mouse on a flat surface, such as a desktop.

When you move the mouse around on a flat surface as shown in the following illustration, the cursor moves on the display screen; the movement changes the position of the cursor.

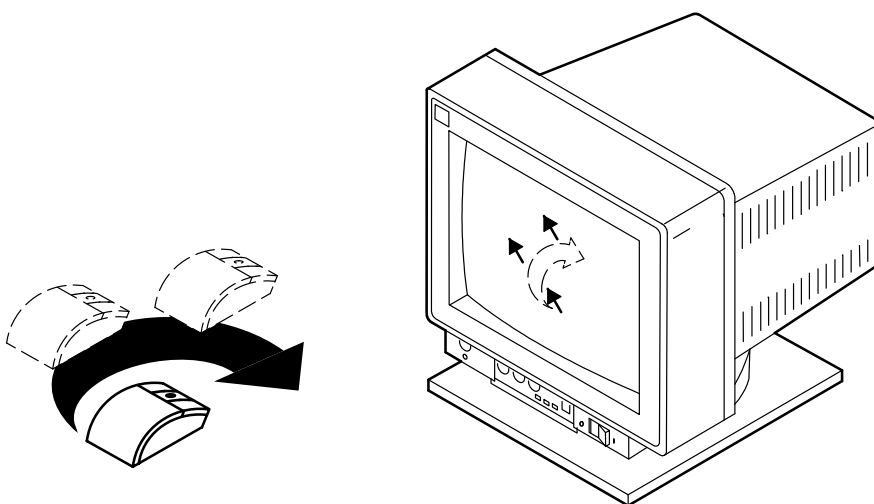

With the mouse buttons, you can perform functions such as selecting and deselecting options, extending your selection, or choosing a command. The precise function of your mouse depends on the software you are using.

The mouse has a cable that plugs into a connector at the rear of the system unit.



## Handling the Mouse Correctly

For best operation, handle the mouse with care. Incorrect handling can damage the mouse.

Do not:

- Operate the mouse on cloth, unfinished wood, newspaper, or carpet.
- Drop or hit the mouse.
- Carry the mouse by holding onto the cable.
- Expose the mouse to extreme temperatures or direct sunlight.
- Place the mouse in liquid spills.

## Care of the Mouse

The operating surface for the mouse should be smooth, clean, and flat. For example, you can operate the mouse on the following surfaces:

- Finished wood
- Glass
- Enamel
- Plastic
- Paper (except newspaper)
- Metal

Rough surfaces collect contaminants that can be transferred to the interior of the mouse by the ball. The surface you use should be free from spills, dirt, dust, lint, wax, eraser dust, and other foreign matter. Rough surfaces can also cause the pads located on the bottom of the mouse to prematurely wear. A deeply pitted surface could cause erratic operation of the mouse.

- Inspect the work surface for spills or other contaminants.
- Dust the work surface.
- If you are using a paper pad, inspect it for wear and replace it if necessary.

## Cleaning the Mouse

1. Remove the retaining ring by turning it counterclockwise, in the direction of the arrow as shown in the illustration.

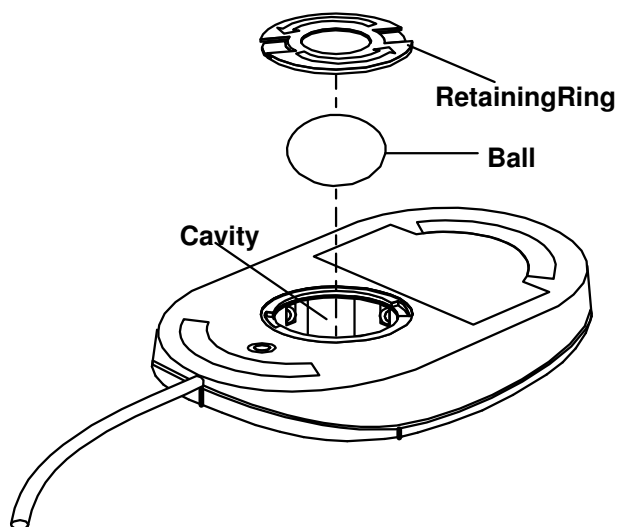

2. Remove the ball.

3. Inspect the ball for contaminants. Wipe it clean with a dry, lint-free cloth.
4. If the ball is dirty, wash it in warm, soapy water. Rinse and wipe the ball with a lint-free cloth until dry
5. Inspect the ball cavity in the mouse for foreign materials. If there are any foreign materials, remove them.
6. Replace the ball.
7. Replace the retaining ring on the mouse and align it with the open slots in the ball cavity.
8. Turn the retaining ring clockwise until the open slots are covered and you hear the ring snap into place.

---

## Using the 3.5-Inch Diskette Drive

### Diskette Compatibility

The system unit has a 1.44MB diskette drive installed.

The 1.44MB diskette drive can format, read, and write diskettes compatible with the following diskette drives:

- 1.0MB diskettes with 720KB formatted data capacity.
- 2.0MB diskettes with 1.44MB formatted data capacity (HD).

Format the diskette according to its specified capacity.

### Write-Protecting 3.5-Inch Diskettes

Write-protecting diskettes is necessary so that important information is not accidentally lost. When diskettes are write-protected, you can read information from the diskettes, but you cannot write information on to them.

There is a write-protect tab on the 3.5-inch diskette.

To locate the write-protect tab, turn the diskette over with the label facing down.

- To prevent writing onto a diskette, slide the write-protect tab to open the protect slot.

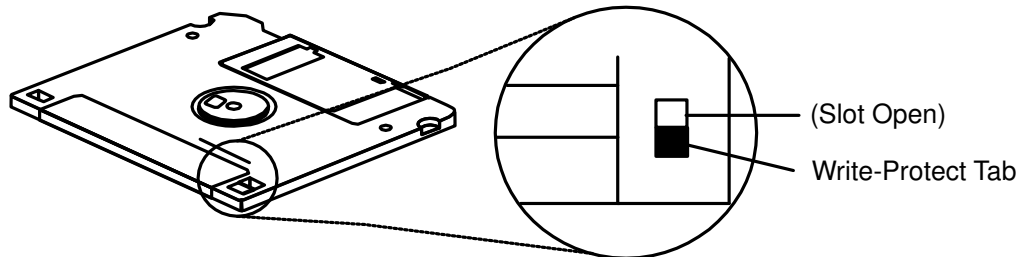

- To allow writing onto a diskette, slide the write-protect tab to cover the protect slot.

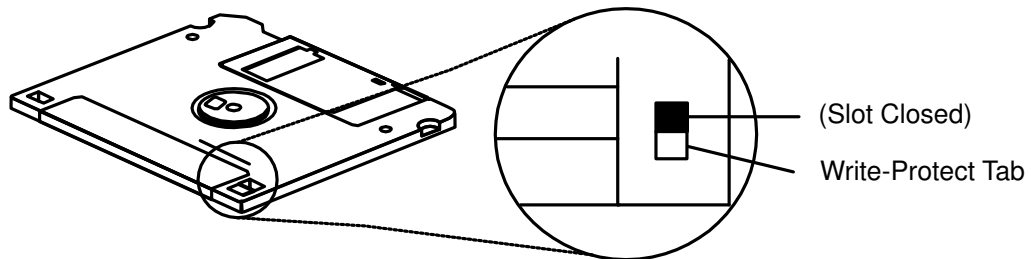

### Loading and Unloading the 3.5-Inch Diskette

To load a diskette into the drive, insert the diskette in the diskette drive with the labeled metal shutter first. Push the diskette into the drive until you hear a click. The click indicates that the diskette is securely in position in the drive.

To unload the diskette, push the diskette-unload button. The diskette unloads partially from the drive. Pull the diskette out.

---

## Using the CD-ROM Drive

**CAUTION:**

**A Class 3 laser is contained in the device. Do not attempt to operate the device while it is disassembled. Do not attempt to open the covers of the device, as it is not serviceable and is to be replaced as a unit.**

The CD-ROM is located in bay 2 of the system unit. Your CD-ROM drive looks like the one shown in the illustration, and the controls are located as indicated.

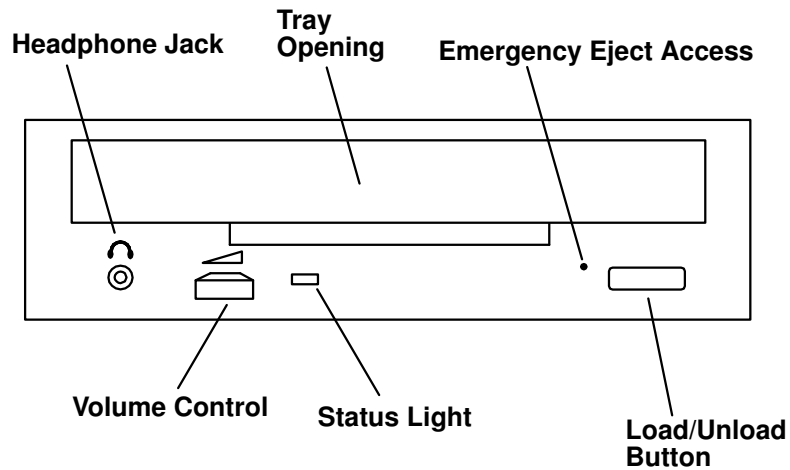

When the CD-ROM is set to On, the status light indicates one of several conditions. The following are status light states and the respective conditions of the CD-ROM drive:

- Off during standby with the CD-ROM loaded or unloaded.
- Blinks from the closing of the tray to completion of initialization.
- Blinks slowly when either the lens or disc is dusty.
- Blinks quickly when in the audio mode.
- Lights during data transfer operations.
- Lights steadily when some condition exists that should be checked.

## Loading the CD-ROM Drive

Press the unload button to open the tray. Place the disc in the tray with the printed side up. Push gently on the load/unload button. The drive automatically pulls the tray into the drive and prepares the disc for reading.

If the CD-ROM drive is in the vertical position, slip out the lower tabs to hold the disc in place.

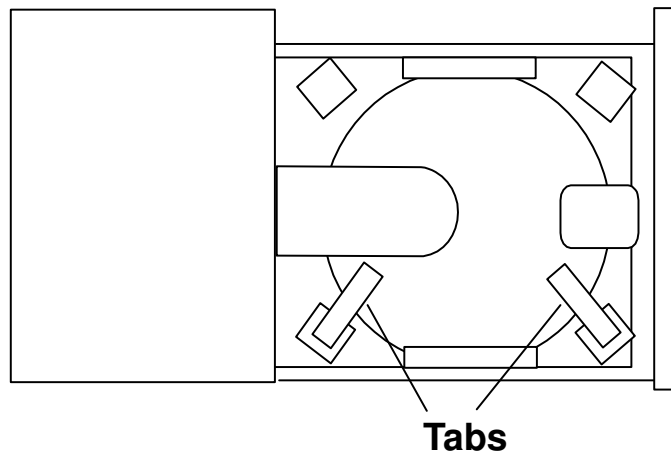

## Unloading the CD-ROM Drive

Push and hold the unload button until the drawer comes out and then remove the disc.

## Cleaning the CD-ROM Drive

This CD-ROM drive has an internal head-cleaning mechanism, and therefore does not require an external cleaning device. The internal cleaning mechanism cleans the head every time the tray is closed with a disc in the tray.

Always handle discs carefully by the edges to avoid leaving fingerprints or scratching them (this helps the disc to maintain good readability.) Wipe discs with a soft, lint-free cloth or lens tissue. Always wipe in a straight line from the inner hub to the outer rim.

## Performing an Emergency Eject

**Note:** Execute the following procedure only in an emergency, such as when the tray does not open if the unload button has been pressed.

1. Insert a small diameter rod, such as a straightened paper clip, into the emergency eject hole. (Refer to the illustration below for the location of the emergency eject access.)
2. Push the tool in until some resistance is felt.
3. Maintain a small amount of pressure on the rod while pulling on the tray with your finger nail.
4. Pull the tray open and remove the disc.

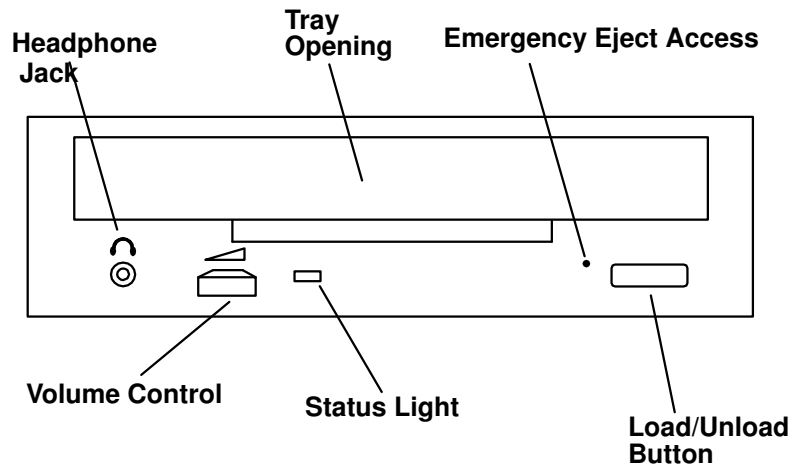

**Note:** Normally the tray makes a ratcheting sound when pulling it open using the above procedure.

# Using the Hot Swap Disk Drives

- For information on inserting a SCSI disk drive, go to "Inserting a Disk Drive into the Hot-Swap Bays" on page 2-18.
- For information on removing a SCSI disk drive, go to "Removing and Inserting Disk Drives" on page 2-20.

## Relationship of AIX Prompts and Physical Drive Location

A SCSI adapter and a SCSI drive address can be displayed on a user display. The AIX command `lsdev -C` returns the attached devices on the system display. For more information, see the documentation for the operating system that controls the system unit. The following diagrams show the physical locations of the drives.

### 10 EIA Unit I/O Drawer Locations

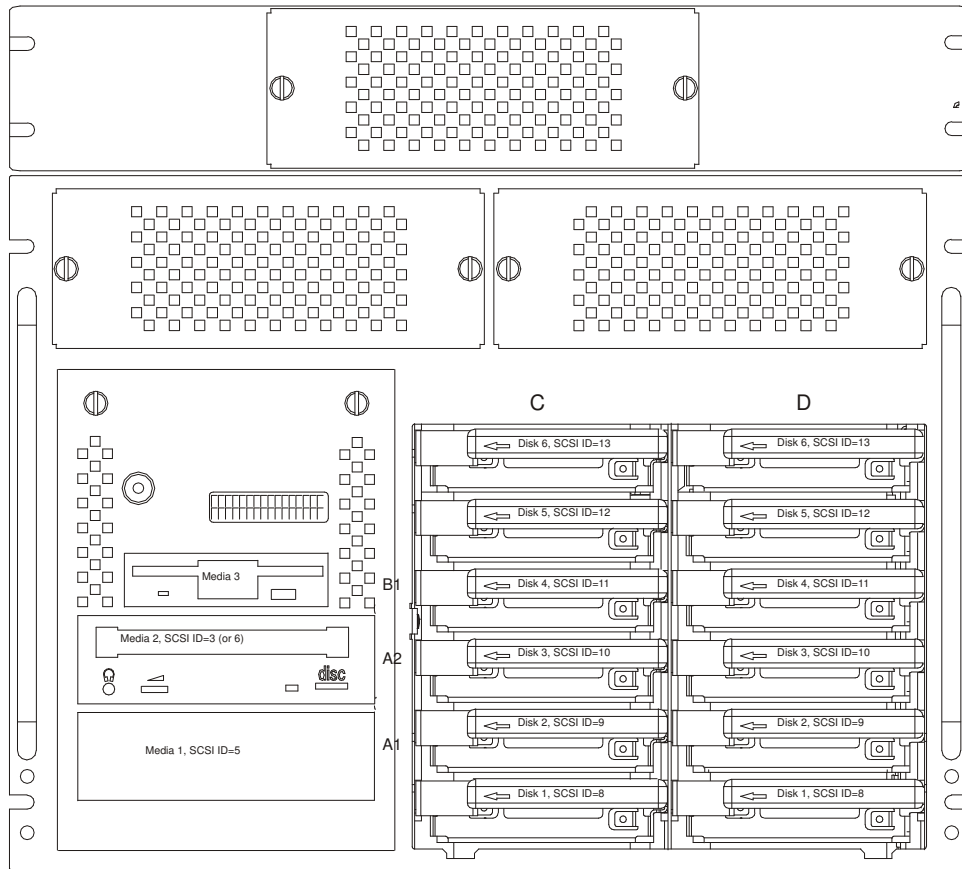

### Handling Guidelines

The hot-swap disk drive is a sensitive device. Handle the hot-swap carrier and disk drive with care.

- Do not drop the disk drive or subject the drive to excessive shock.
- Do not expose the disk drive to temperatures lower than  $-40^{\circ}\text{F}$  ( $-40^{\circ}\text{C}$ ) or higher than  $158^{\circ}\text{F}$  ( $70^{\circ}\text{C}$ ).
- If drive temperature changes, allow approximately one hour of temperature acclimatization for every  $18^{\circ}\text{F}$  ( $10^{\circ}\text{C}$ ) of temperature change.
- Never allow moisture to condense on the drive.

- Static electricity can damage your equipment. Take these precautions to avoid static electricity damage:
  - If you have an antistatic wrist strap available, use it while handling the device.
  - Always handle your disk drive carefully.
  - Handle the drive by the edges and never touch any exposed circuitry.
  - Prevent others from touching the drive.
- Store the hot-swap disk drive in a protective container such as an instrument case or in a protected area.
- Failure to observe these precautions may lead to product failure, damage, and invalidation of all warranties.

## Labels

Several labels are included in your system ship group which may be attached to the handle of the hot-swap drive. The labels may be marked in any way that the user can easily identify the drive for removal or installation.

## Disk Drive Status Light States

### SCSI Disk Drives

The following table explains the meaning of the green and amber status lights and spin down button.

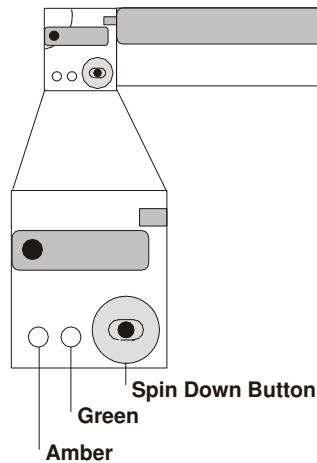

SCSI Disk Drive Status Lights		
Light or Button	Status	Definition
Amber	On	Drive spinning
	Off	Drive not spinning
Green	On	Power On
	Off	Power Off
	Blinking	Power Off/Drive identify
Spin down	Depressed	Spin down drive and remove power



---

## Removing and Inserting Disk Drives

This section provides instructions to help you remove or insert disk drives into hot-swap bays.

### Unconfiguring or Configuring a Disk Drive

This procedure applies to SCSI hot swap disk drives.

**Note:** You do not have to power down the system to remove a hot-swappable assembly from the 10 EIA Unit I/O Drawer. Before you perform these procedures, take the appropriate actions to backup the data for the drive you are removing, and that the drive has been removed from the configuration. Physically removing a hot swap drive from the 10 EIA Unit I/O Drawer before it has been removed from the system configuration, may cause unrecoverable data corruption.

### Unconfiguring (Removing) or Configuring a Disk Drive

There are three conditions where you need to use these procedures:

- You are removing or installing a drive while the system power is turned on.
- You are installing a new drive.
- You are removing a drive from the system.

### Unconfiguring

To unconfigure (remove) a disk drive:

1. Login as root.
2. Enter the **smit** command.
3. Select **Devices**.
4. **SCSI Hot Swap Disk Drives:**
  - a. Select **Fixed Disk**.
  - b. Select **Remove a Fixed Disk**.
  - c. Select the disk you want to remove from the list on the screen.
  - d. When you get to the Keep Definition option, select **Yes**. This retains the details of the drive in the device configuration database.
  - e. Select the **Do** option to remove the drive.
  - f. The drive can now be removed from the drawer, return to the procedure that directed you here.

### Configuring

1. Login as root.
2. Enter the **smit** command.
3. Select **Devices**.
4. Select the type of drive you want to configure.
5. **SCSI Hot Swap Disk Drives**
  - a. Select **Add** for the type of drive you are configuring, then select the type of drive you are adding.
  - b. The drive is ready to use.

## Inserting a Disk Drive into the Hot-Swap Bays

This procedure describes how to insert disk drives into a hot-swap bay while the I/O Drawer is powered on.

**Attention:** Caution should be used when handling all hard drives. Drives are more likely to be damaged during installation and service. Bumping or handling drives roughly causes latent failures. Don't stack drives and always use appropriate ESD practices. A drop of as little as 1/4 inch can cause latent failures. Media can take 30 seconds to spin down, so ensure at least a 30 second delay after switching off the hot-swappable drives for removal.

### Notes:

1. Disk drive banks support hot-swappable disk drives only.
2. This procedure is similar for any hot-swap disk drive that is supported by this drawer. interchangeable.
3. For additional information regarding the operation of the hot-swap disk drives see the installation and user's guide that came with the drives.
4. Remember that each 1.6 inch SCSI disk drive takes two bays.

This section gives the instructions for inserting hot-swap disk drives into the disk drive banks.

1. To insert a hot-swap disk drive, open the door to the Input/output Rack.
2. Loosen the screws that hold the disk drive cover to the drawer and remove the disk drive cover from the drawer, storing it in a safe place.

**Note:** Rack is shown with the door and hinges removed.

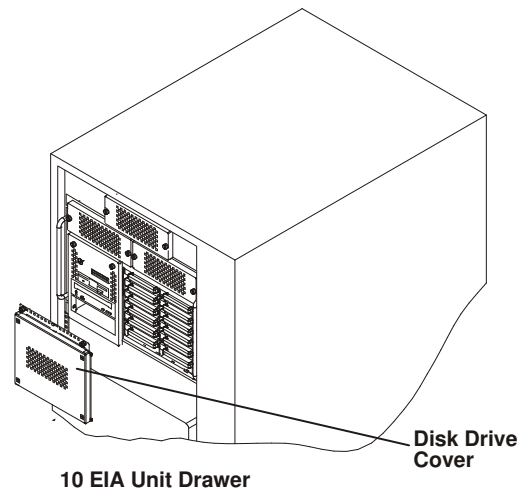

3. Each hot-swap disk drive must have a hot-swap disk drive carrier attached.

**Attention:** Handle the hot-swap disk drive with care as it is very fragile and can be easily damaged if exposed to shock, electrostatic discharge, or rough handling.

4. It is recommended that you insert the hot-swap disk drive in the next unused position of the disk drive banks, going from bottom to top.

**Attention:** Attaching SCSI address jumpers on the hot swap disk drive rather than using the automatic ID furnished by the backplane is not advised. Attaching jumpers can cause service problems, multiple drives at the same address, or confusion locating the correct drive.

- a. Rotate the carrier latch to the open position.

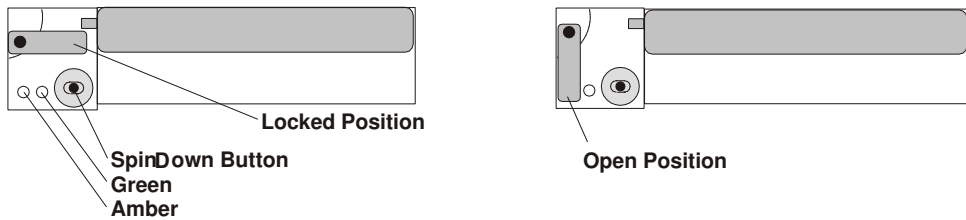

- b. Position the drive carrier assembly horizontally, with the connector facing into the bay.  
c. Align the side of the carrier with the raised guides on the left of the bay.  
d. Slide the carrier into the bay gently to keep from damaging the hot swap disk drive. Slide the carrier to the rear of the bay until it is seated into the connector.

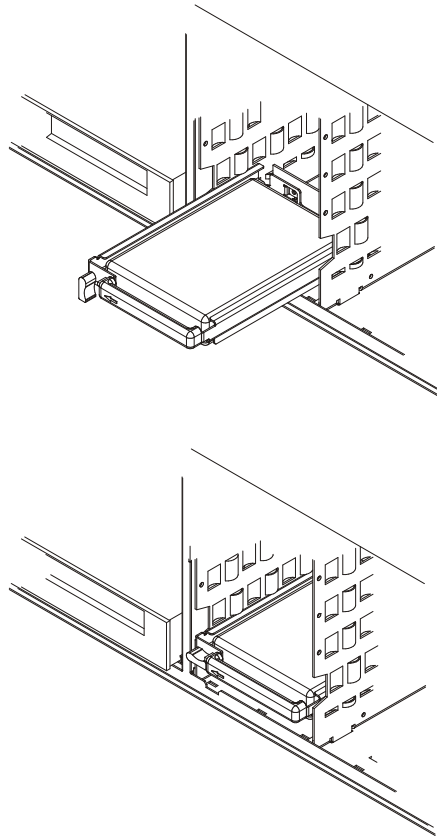

- e. Move the carrier latch to the locked position. If the carrier does not lock, check that the drive carrier is fully seated in the backplane. When the drive carrier is fully seated and power is turned on, the green LED on the drive carrier illuminates.

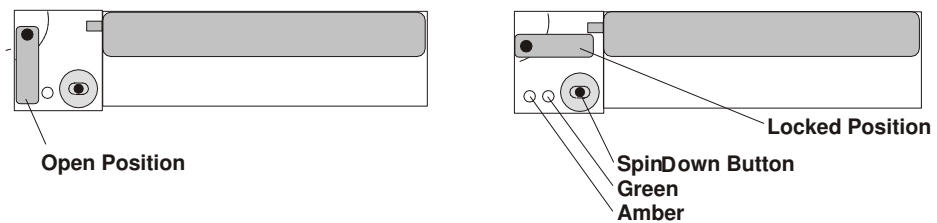

The following table explains the meaning of the green and amber status LEDs and spin down button on a SCSI disk drive.

Status LEDs		
LED or Button	Status	Definition
Amber	On	Drive spinning
	Off	Drive not spinning
Green	On	Power On
	Off	Power Off
	Blinking	Power Off/Drive identify
Spin down	Depressed	Spin down drive and remove power

5. Go to Appendix A. "System Records" in the *Installation Guide* to record the drive location and the ID assigned to the drive; then return here to determine your next step.
6. If you have other hot-swap disk drives to insert, go to page 2-18.
7. If you do not have any other procedures to perform, replace the cover that you removed in step 2 on page 2-18.
8. Close the Input/output Rack door.
9. Go to "Unconfiguring or Configuring a Disk Drive" on page 2-17 and configure the disk drive unit you just inserted.

## Removing Disk Drives from the Hot-Swap Bays

This procedure describes how to remove hot-swap disk drives from a hot swap bay while the I/O Drawer is powered on.

If you remove a hot-swap disk drive when the I/O Drawer power is off, steps 4 on page 2-21 and 5 on page 2-21 do not apply.

**Attention:** Caution should be used when handling all hard disk drives. Drives are more likely to be damaged during installation and service. Bumping or handling drives roughly causes latent failures. Do not stack drives and always use appropriate ESD (Electro-Static Discharge) practices. A drop of as little as 6.5 mm (.25 inches) can cause latent failures. Media can take 30 seconds to spin down, so ensure at least a 30 second delay has passed after switching off hot-swappable drives for removal.

1. Go to "Unconfiguring or Configuring a Disk Drive" on page 2-17 and unconfigure the disk drive unit you are removing.
2. Open the Input/output Rack door.
3. Loosen the screws that hold the disk drive cover to the drawer and remove the disk drive cover from the drawer, storing it in a safe place.

**Note:** Rack is shown with the door and hinges removed.

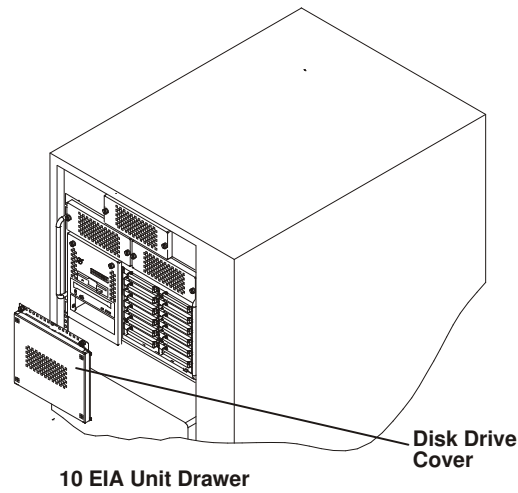

**Attention:** Physically removing a hot-swap drive from the I/O Drawer before it has been removed from the system configuration, may cause unrecoverable data corruption.

4. Verify that the device has been removed from the system configuration; the yellow LED on the hot-swap disk drive should be off.
5. For SCSI disk drives, press the spin down button on the hot swap disk drive; observe the green flashing LED.
6. Unlock the drive by turning the carrier latch 90 degrees clockwise to the open position.

#### SCSI Disk Drives

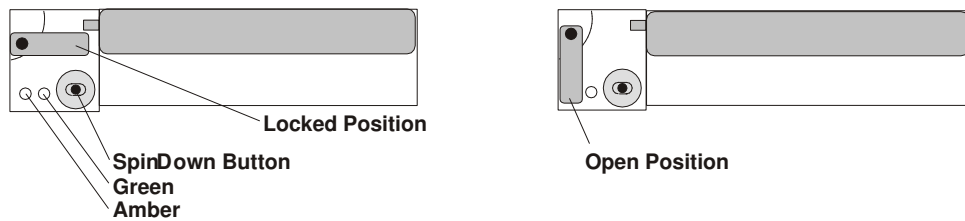

7. Disconnect the drive from the connector on the backplane by grasping the handle on the drive carrier and carefully pulling the drive out of the server.

**Attention:** Do not open the drive; no user adjustments or serviceable parts are inside.

8. Place the hot-swap disk drive in a protective container.
9. Replace the disk drive cover that you removed earlier.
10. Close the Input/output Rack door.

---

## Using the Service Processor Features

The Service Processor features protect users against unnecessary system downtime by keeping support personnel (both internal and external) aware of any unexpected changes in the system environment.

The Service Processor runs on its own power boundary and continually monitors hardware attributes, the AIX Operating System, and the environmental conditions within the system at all times. Any system failure which prevents the system from coming back to an operational state (a fully functional AIX Operating System) is reported by the Service Processor. The Service Processor is controlled by firmware and does not require the AIX Operating System to be operational to perform its tasks. If any system failures are detected, the Service Processor has the ability to take pre-determined corrective actions. The methods of corrective actions are:

- Surveillance
- Call Home
- AIX Operating System Monitoring

Surveillance is a function in which the Service Processor monitors the system through heartbeat communication with the system firmware. During system startup, the firmware surveillance monitor is automatically enabled to check for heartbeats from the firmware. If a heartbeat is not detected within a default period, the Service Processor cycles the system power and attempts to restart until the system either restarts successfully, or a pre-determined retry threshold is reached. In the event the Service Processor is unsuccessful in bringing the system on-line (or in the event that the user asked to be alerted to any Service Processor assisted restarts), the system can call home to report the error.

The Call Home function can be initialized to call either a service center telephone number, a customer administration center, or a digital pager telephone number. The Service Processor can be configured to stop at the first successful call to any of the numbers listed, or can be configured to call every number provided. If connected to the service center, the Service Processor transmits the relevant system information (the system's serial number and model type) and Service Request Number (SRN). If connected to a digital pager service, the Service Processor inputs a Customer Voice Telephone Number defined by the customer. An established sequence of digits or the telephone number to a phone near the failed system could be used to signal a system administrator to a potential system failure.

During normal operations, the Service Processor can also be configured to monitor the AIX Operating System. If AIX does not respond to the Service Processor heartbeat, the Service Processor assumes the Operating System is hung. The Service Processor can automatically initiate a restart and, if enabled, initiate the call home function to alert the appropriate people to the system hang. Enabling Operating System Surveillance also affords AIX the means to detect any Service Processor failures.

The Service Processor cannot be configured in a client/server environment where one system can be used to manage all dial-out functionally for a set of systems.

Prior to installing the Service Processor feature, you need to ensure that you have latest levels of Service Processor microcode and system firmware. You also need a properly configured modem. For more information on configuring a modem, see "Modem Configuration Menu" on page 3-11.

## Chapter 3. Service Processor Menus

The Service Processor menus make it possible for you to configure service processor options, as well as enable and disable functions.

Service Processor menus are available using an ASCII terminal while the system is powering on or when the Service Processor has detected a server problem (such as a surveillance failure).

For a summary of the Service Processor functions and the methods used to invoke them, see Table 3–1.

**Table 3–1. SP Functions**

Service Processor Functions	Service Processor Menus (ASCII terminals)	Service Processor Service Aids (ASCII or graphics terminals)	SMS (ASCII or graphics terminals)
Read VPD image from last system boot	Y <sup>3</sup>		
Read System POST Errors	Y <sup>3</sup>		
Read Service Processor Error Logs	Y <sup>3</sup>		
View Progress Indicators from last Boot	Y <sup>3</sup>		
Power-off System	Y <sup>2</sup>		
Read NVRAM	Y <sup>2</sup>		
Start Talk Mode	Y <sup>2</sup>		
Enable/Disable Console Mirroring	Y <sup>2</sup>		
Setup Reboot/Restart Policy	Y <sup>2</sup>	Y <sup>1</sup>	
Enable/Disable Modem	Y <sup>2</sup>	Y <sup>1</sup>	
Setup Modem Configuration	Y <sup>2</sup>	Y <sup>1</sup>	
Setup Dial-out Phone Numbers	Y <sup>2</sup>	Y <sup>1</sup>	
Setup Surveillance	Y <sup>2</sup>	Y <sup>1</sup>	
Select Modem Line Speed	Y <sup>2</sup>	Y <sup>1</sup>	
Update Service Processor Flash EPROM		Y <sup>1</sup>	
Save/Restore Hardware Maintenance Policies		Y <sup>1</sup>	
Change General Access Password	Y <sup>2</sup>		
Change Privileged Access Password	Y <sup>2</sup>		Y <sup>2</sup>
Select Language	Y <sup>2</sup>		Y <sup>2</sup>
Enable/Disable Unattended Start Mode	Y <sup>2</sup>	Y <sup>1</sup>	Y <sup>2</sup>

Passwords required (if set):

<sup>1</sup> Operating system root password

<sup>2</sup> Privileged access password

<sup>3</sup> General access (power-on) password

---

## Service Processor Menus

The Service Processor (SP) menus are divided into two groups:

- General user menus – the user must know the general access password.
- Privileged user menus – the user must know the privileged access password.

The following section describes these two groups of menus, how to access them, and the functions associated with each option.

If the server is powered on, the SP menus may be accessed locally or remotely as described below.

### How to access SP menus locally

SP menus may be accessed locally by connecting an ASCII terminal to either serial port 1 or 2. Because the presence of the ASCII terminal cannot be confirmed by the SP, you must press a key (any key) on the ASCII terminal to confirm its presence. The key on the ASCII terminal must be pressed during the time when the operator panel display shows the code E07A.

You can recognize when the SP menu access time begins in the following ways:

- The checkpoint prior to the access checkpoint is E043.
- The system beeps three times as it enters checkpoint E07A.

When you gain access, the SP prompts you for a password (if set), and when verified, displays the SP menus.

The SP menu prompt, represented by 1> or 2> indicates the serial port to which the terminal is connected. A 1> indicates serial port 1, and 2> indicates serial port 2.

### How to access SP menus remotely

If your system has a modem connected and configured for call-in (see "Modem Configuration Menu" on page 3-11), SP menus can be accessed remotely as follows:

1. With the system powered off, call in from a remote terminal. Wait for at least two rings and hang up. The system powers on upon detecting ring-indicate, and pauses for a return call if call-in is enabled.
2. Wait five minutes and call-in again. The SP prompts you for a password (if set). When verified, the SP menus display remotely.

### Saving and Restoring Service Processor Settings

All the settings you make (except language) from the service processor menus can be backed up either for recovering from a fault that may corrupt these settings, or for replicating these settings to other servers that include a service processor.

The service aid, Save or Restore Hardware Management Policies, can be used to save your settings after initial setup or whenever the settings must be changed for system operation purposes.

It is strongly recommended that this service aid is used for backing up service processor settings to protect the usefulness of the service processor, and the availability of the server. Refer to "Save or Restore Hardware Management Policies" in Chapter 27 of *"Diagnostics Information for Multiple Bus Systems"* for information about this service aid.

### How to return to SP menus

When exiting SP menu using option "99", there is a 10 second delay before the system continues its boot procedure. During that 10 seconds, you may strike a key on the ASCII terminal to return to the menus and select other options.



During the 10 second delay, an information message appears on the display. After the 10 second delay, SP menus are no longer available until either the next system boot or the SP regains control due to a system failure.

## Menu Inactivity

To prevent loss of control due to power loss or power surges, SP attempts to leave menu mode after 10 minutes of inactivity by simulating the option 99 selection. This attempt is successful on menus containing the "99" option. On the other menus, the attempt is unsuccessful and the following message displays with each attempt:

```
Illegal value entered
Press Return to continue
```

If for some reason you want to hold the server in menu mode, select one of the menus that do not have the "99" option. Boot activity cannot continue if SP is in menu mode, and power losses or surges could result in unpredictable server responses.

## General User Menus

The menu options presented to the General user are a subset of the options available to the Privileged user. The user must know the General Access Password, if set, in order to access these menus.

```
+-----+
|                                     |
|          GENERAL USER MENU        |
|                                     |
|  1. Continue System Boot          |
|                                     |
|  2. Read VPD Image from Last System Boot |
|                                     |
|  3. Read Progress Indicators from Last System Boot |
|                                     |
|  4. Read Service Processor Error Logs |
|                                     |
|  5. Read System POST Errors       |
|                                     |
| 99. Exit from Menus               |
|                                     |
| 1>                                 |
+-----+
```

- **Continue System Boot**

Allows the user to continue with and monitor the system boot already in progress using the current ASCII terminal as the active console.

Make this selection if you wish to monitor the IPL progress messages on your terminal. If you do not wish to monitor the IPL progress messages, select option **99. Exit from Menus**.

- **Read VPD Image from Last System Boot**

Displays manufacturer vital product data, such as serial numbers, part numbers, etc., that were stored from the system boot prior to the one in progress now.

- **Read Progress Indicators from Last System Boot**

Displays the boot progress indicators (check points), up to a maximum of 100, from the system boot prior to the one in progress now. This historical information may be useful to help diagnose system faults.

The progress indicators are displayed in two sections. Above the dashed line are the progress indicators (latest) from the boot that produced the current sessions. Below the dashed line are progress indicators (oldest) from the boot preceding the one that produced the current sessions.

The progress indication codes are listed top (latest) to bottom (oldest). The dashed line merely represents the point where the latest boot started. For an example, refer to "LCD Progress Indicator Log" on page 3-25.

- **Read Service Processor Error Logs**

Displays the SP error logs. For an example, refer to "Service Processor Error Logs" on page 3-24.

- **Read System POST Errors**

Displays the results of the System Firmware POST (Power-On Self Test). Your server may be able to start in the presence of POST errors if there is sufficient working system resources. If POST errors occur during start-up, this error log when used with the diagnostics helps to isolate faults. For an example, refer to "Service Processor Error Logs" on page 3-24.

- **Exit from Menus**

Allows the user to continue with the system boot already in progress using the current ASCII terminal as the active console. Make this selection if you **do not** wish to monitor the IPL progress messages on your terminal. Exiting from the menus causes the modems to disconnect, but the boot process continues.

---

## Privileged User Menus

The following menus are available to privileged users only. The user must know the Privileged Access Password, if set, to access these menus.

### Main Menu

At the top of the MAIN Menu is a listing containing:

- Your Service Processor's current firmware version
- The firmware copyright notice
- The System Name given to your server during setup

You need the firmware version for reference when you either update or repair the functions of your service processor.

The System Name, an optional field, is the name your server reports in problem messages. This name helps your support team, (for example, your system administrator, network administrator, or service representative) to more quickly identify the location, configuration, and history of your server. The System Name is set from the Main Menu using option 6.

**Note:** The information under the Service Processor Firmware heading in the Main Menu illustration that follows is example information only.

```
Service Processor Firmware
VERSION: 19970814
Copyright 1997, IBM Corporation
SYSTEM NAME
```

MAIN MENU

1. Service Processor Setup Menu
  2. System Power Control Menu
  3. System Information Menu
  4. Language Selection Menu
  5. Call-In/Call-Out Setup Menu
  6. Set System Name
  99. Exit from Menus
- 1>

- **Service Processor Setup Menu.** See page 3-5.
- **System Power Control Menu.** See page 3-7.
- **System Information Menu.** See page 3-8.
- **Language Selection Menu.** See page 3-10.
- **Call-In/Call-Out Menu.** See page 3-10.
- **Set System Name.** Allows setting of the system name.

## Service Processor Setup Menu

SERVICE PROCESSOR SETUP MENU

1. Change Privileged Access Password
  2. Change General Access Password
  3. Enable/Disable Console Mirroring:  
Currently Enabled
  4. Start Talk Mode
  5. OS Surveillance Setup Menu
  98. Return to Previous Menu
  99. Exit from Menus
- 1>

**Note:** Unless otherwise stated in menu responses, settings become effective when a menu is exited using option 98 or 99.

## Passwords

Passwords can be any combination of up to 8 alphanumeric characters. You can enter longer passwords, but the entries are truncated to include only the first 8 characters. Privileged Access Password can be set from Service Processor menus or from System Management Services (SMS) utilities (see Chapter 4. "System Management Services"). General Access Password can be set only from Service Processor menus.

For security purposes, Service Processor counts the number of attempts to enter correct passwords. The results of not recognizing a correct password within this error threshold are different, depending on whether the attempts are being made locally (at the server) or remotely (via a modem). The error threshold is 3.

If the error threshold is reached by someone entering passwords at the server, Service Processor commands IPL to resume. This action is taken based on the assumption that the server is in an adequately secure location with only authorized users having access. Such users must still successfully enter a login password to access AIX.

If the error threshold is reached by someone entering passwords remotely, Service Processor commands the server to power down to prevent potential security attacks on the server by unauthorized remote users. The following illustrates what you can access with the Privileged Access Password and the General Access Password.

Privileged Access Password	General Access Password	Resulting Menu
None	None	Service Processor MAIN MENU displayed
None	Set	Users with the password see the GENERAL USER MENU. Users without the password see SP MAIN MENU.
Set	None	Users with the password see the SP MAIN MENU. Users without password see the GENERAL USER MENU.
Set	Set	Users see menus associated with the entered password

- **Change Privileged Access Password**

Set or change the Privileged Access Password. It provides the user with the capability to access all SP functions. This password is usually used by the system administrator or **root** user.

- **Change General Access Password**

Set or change the General Access Password. It provides limited access to SP menus, and is usually available to all users who are allowed to power-on the server, especially remotely.

**Note:** The General Access Password can only be set or changed while the Privileged Access Password is set.

- **Enable/Disable Console Mirroring**

When Console Mirroring is enabled, the SP sends information to both serial ports. This capability may be enabled by local or remote users. This provides local users the capability to monitor remote sessions. Console mirroring may be enabled for the current session only. For more information, see "Console Mirroring" on page 3-24.

- **Start Talk Mode**

In a console mirroring session, it is useful for those that are monitoring the session to be able to communicate with each other. Selecting this menu item activates the keyboards and displays for such communications while console mirroring is established. This is a

full duplex link, so message interference is possible. Alternating messages between users works best.

- **OS Surveillance Setup Menu**

This option may be used to setup operating system (OS) surveillance.

```
-----  
OS Surveillance Setup Menu  
1. Surveillance:  
   Currently Enabled  
2. Surveillance Time Interval:  
   2 minutes  
3. Surveillance Delay:  
   2 minutes  
  
98. Return to Previous Menu  
1>
```

- **Surveillance**

May be set to Enabled or Disabled.

- **Surveillance Time Interval:**

May be set to any number from 2 through 255.

- **Surveillance Delay:**

May be set to any number from 0 through 255.

Refer to "Service Processor System Monitoring – Surveillance" on page 3-22 for more information about surveillance.

## System Power Control Menu

```
-----  
SYSTEM POWER CONTROL MENU  
1. Enable/Disable Unattended Start Mode:  
   Currently Enabled  
2. Reboot/Restart Policy Setup Menu  
3. Continue System Boot  
4. Power-Off System  
5. Boot Mode Menu  
98. Return to Previous Menu  
99. Exit from Menus  
1>
```

- **Enable/Disable Unattended Start Mode**

This option may be used to instruct SP to restore the power-state of the server after a temporary power failure. Unattended Start Mode can also be set via SMS Menus. It is intended to be used on servers that require automatic power-on after a power failure. For more information, see "System Power-On Methods" on page 3-18.

- **Reboot/Restart Policy Setup Menu**

See "Reboot/Restart Policy Setup Menu" on page 3-15.

- **Continue System Boot**

Allows the user to continue with and monitor the system boot already in progress using the current ASCII terminal as the active console.

Make this selection if you wish to monitor the IPL progress messages on your terminal. If you do not wish to monitor the IPL progress messages, select option **99. Exit from Menus**.

- **Power-off System**

Allows the user to power-off the server.

- **Boot Mode Menu**

See "Boot Mode Menu" on page 3-16.

## System Information Menu

```
SYSTEM INFORMATION MENU

1. Read VPD Image from Last System Boot
2. Read Progress Indicators from Last System Boot
3. Read Service Processor Error Logs
4. Read System POST Errors
5. Read NVRAM
6. Read Service Processor Configuration
7. Processor Configuration/Deconfiguration Menu
98. Return to Previous Menu
99. Exit from Menus

1>
```

- **Read VPD Image from Last System Boot**

Displays manufacturer's vital product data (VPD), such as serial numbers, part numbers, etc., that was stored from the system boot prior to the one in progress now.

- **Read Progress Indicators from Last System Boot**

Displays the boot progress indicators (checkpoints), up to a maximum of 100, from the system boot prior to the one in progress now. This historical information may be useful to help diagnose system faults.

The progress indicators are displayed in two sections. Above the dashed line are the progress indicators (latest) from the boot that produced the current sessions. Below the dashed line are progress indicators (oldest) from the boot preceding the one that produced the current sessions.

The progress indication codes are listed top (latest) to bottom (oldest). The dashed line merely represents the point where the latest boot started. For an example, refer to "LCD Progress Indicator Log" on page 3-25.

- **Read Service Processor Error Logs**

Displays error conditions detected by the SP. Refer to "Service Processor Error Logs" on page 3-24 for an example of this error log.

- **Read System POST Errors**

Selecting this item lets you review the results of the POST (Power-On Self Test). Your server may be able to start in the presence of POST errors if there are sufficient working system resources. If POST errors occur during start-up, this error log when used with the diagnostics helps to isolate faults. Refer to "System POST Errors" on page 3-25 for an example of this error log.

- **Read NVRAM**

Displays Non-Volatile Random Access Memory (NVRAM) content.

- **Read Service Processor Configuration**

Displays current service processor configuration.

- **Processor Configuration/Deconfiguration Menu**

This menu allows the user to change the system processor configuration. If it is necessary to take one of the processors offline, this menu allows you to deconfigure a processor, and then reconfigure the processor at a later time. An example of this menu is shown below:

```
+-----+
|                                     |
|          PROCESSOR CONFIGURATION/DECONFIGURATION MENU          |
|                                     |
|   To change the configuration, select the processor number:   |
|                                     |
| 0. Configured   (0x00) 1. Configured   (0xFF) 2. Deconfigured (0x81) |
| 3. Deconfigured (0x21) 4. Deconfigured (0x41) 5. Configured   (0x00) |
| 6. Configured   (0x00) 7. Configured   (0xFF)                    |
|                                     |
| 80. Commit the configuration changes                             |
| 98. Return to Previous Menu                                     |
|                                     |
| 1>                                                                |
+-----+
```

To change the processor configuration, select the processor number first. It will change the processor state from `Configured` to `Deconfigured` or from `Deconfigured` to `Configured`.

Once the configuration has been changed, commit the configuration changes by selecting option 80. The system will reboot after option 80 has been selected.

In the above screen, the four character codes shown are defined as:

<b>0x00</b>	Processor configured by system
<b>0xFF</b>	Processor configured by system
<b>0x81</b>	Processor has been deconfigured manually
<b>0x41</b>	Processor has been deconfigured by system because value of recoverable runtime errors was exceeded.
<b>0x21</b>	Processor has been deconfigured due to repeated fatal internal errors.

### **Processor Card Swapping**

When there is a system failure due to a processor error, the system maintenance procedures direct the replacement of processor cards according to system diagnostic procedures. Do not replace any processor card on a system unless directed to by the

system diagnostic procedures. Never swap processor cards from one system to another in an attempt to isolate a failing card.

## Language Selection Menu

```
LANGUAGE SELECTION MENU

1. English
2. Francais
3. Deutsch
4. Italiano
5. Espanol
6. Svenska
98. Return to Previous Menu
99. Exit from Menus

1>
```

**Note:** Your ASCII terminal must support the ISO-8859 character set in order to properly display languages other than English.

This menu allows selecting languages in which SP and system firmware menus and messages are displayed.

## Call-In/Call-Out Setup Menu

```
CALL-IN/CALL-OUT SETUP MENU

1. Modem Configuration Menu
2. Serial Port Selection Menu
3. Serial Port Speed Setup Menu
4. Telephone Number Setup Menu
5. Call-Out Policy Setup Menu
6. Customer Account Setup Menu
7. Call-Out Test
98. Return to Previous Menu
99. Exit from Menus

1>
```

- **Modem Configuration Menu**, see "Modem Configuration Menu" on page 3-11.
- **Serial Port Selection Menu**, see "Serial Port Selection Menu" on page 3-11.
- **Serial Port Speed Setup Menu**, see "Serial Port Speed Setup Menu" on page 3-12.
- **Telephone Number Setup Menu**, see "Telephone Number Setup Menu" on page 3-12.
- **Call-Out Policy Setup Menu**, see "Call-Out Policy Setup Menu" on page 3-14.



- **Customer Account Setup Menu**, see "Customer Account Setup Menu" on page 3-15.

## Modem Configuration Menu

The first two lines of the Modem Configuration Menu are status lines showing the current selections. Selections are made in the two sections labeled Modem Ports and Modem Configuration File Name. Select the serial port that you want to activate and then select the modem configuration file for the modem on the port. If you want to set up both serial ports with modems, make your selections one port at a time.

```

+-----+
|
|           Modem Configuration Menu
|
|   Port 1 Modem Configuration File Name:
|   Port 2 Modem Configuration File Name:  modem_m0_sp
|
| To make changes, First select the port and then the configuration file name
|
| Modem Ports:
|   1. Serial port 1
|   2. Serial port 2
|
| Modem Configuration File Name:
|   3. none
|   4. modem_f_sp           9. modem_m0_sp
|   5. modem_f0_sp         10. modem_m1_sp
|   6. modem_f1_sp
|   7. modem_z_sp
|   8. modem_z0_sp
|
| 30. Save configuration to NVRAM and Configure modem
| 98. Return to Previous Menu
|
| 1>
+-----+

```

For information on choosing a modem configuration file, see "Sample Modem Configuration Files" on page D-1 and "Seamless Transfer of a Modem Session" on page D-4.

## Serial Port Selection Menu

```

+-----+
|
|           Serial Port Selection Menu
|
|   1. Serial Port 1 Call-Out:
|       Currently Disabled
|
|   2. Serial Port 2 Call-Out:
|       Currently Disabled
|
|   3. Serial Port 1 Call-In:
|       Currently Disabled
|
|   4. Serial Port 2 Call-In:
|       Currently Disabled
|
| 98. Return to Previous Menu
|
| 1>
+-----+

```

You may enable and/or disable the call-in and call-out functions of each serial port in any combination.

**Note:** For security, if the service processor detects an operator panel battery failure, the Serial Port Dial-In capability becomes disabled. See "Service Processor Call-In Security" on page 3-19 for more information.

## Serial Port Speed Setup Menu

```
Serial Port Speed Setup Menu

1. Serial Port 1 Speed:
   Currently 9600

2. Serial Port 2 Speed:
   Currently 9600

98. Return to Previous Menu

1>
```

Serial port speed can be set for terminal performance or to accommodate modem capabilities. A speed of 9600 baud or higher is recommended. Valid serial port speeds are shown below:

50	600	4800
75	1200	7200
110	1800	9600
134	2000	19200
150	2400	38000
300	3600	57600
		115200

## Telephone Number Setup Menu

This menu may be used to set or change the telephone numbers for reporting a system failure. SP allows setting or changing telephone numbers for:

- **Service Center Telephone Number** – The telephone number of the maintenance provider’s computer.
- **Customer Administration Center Telephone Number** – The telephone number of the local system support provider’s computer.
- **Digital Pager Telephone Number** – The telephone number of the digital pager used by the person responsible for problem calls.
- **Customer Voice Telephone Number** – The telephone number service personnel use to reach the system user.
- **Customer System Telephone Number** – The telephone number to which the server’s modem is connected.

Telephone Number Setup Menu

1. Service Center Telephone Number:  
Currently Unassigned
  2. Customer Administration Center Telephone Number:  
Currently Unassigned
  3. Digital Pager Telephone Number:  
Currently Unassigned
  4. Customer Voice Telephone Number:  
Currently Unassigned
  5. Customer System Telephone Number:  
Currently Unassigned
  98. Return to Previous Menu
- 1>

- **Service Center Telephone Number** is the number of the service center computer. The service center usually includes a computer that takes calls from servers with call-out capability. This computer is referred to as "the catcher." The catcher expects messages in a specific format to which SP conforms. For more information about the format and catcher computers, refer to the README file in the AIX `/usr/samples/syscatch` directory. Contact your service provider for the correct telephone number to enter here. Until you have that number, leave this field unassigned.
- **Customer Administration Center Telephone Number** is the number of the System Administration Center computer (catcher) that receives problem calls from servers. Contact your system administrator for the correct telephone number to enter here. Until you have that number, leave this field unassigned.
- **Digital Pager Telephone Number** is the number for a numeric pager carried by someone who responds to problem calls from your server. Contact your administration center representative for the correct telephone number to enter here. For test purposes, enter your telephone number here. You can change it later when testing is complete. See note on page 3-23.
- **Customer Voice Telephone Number** is the telephone number of a phone near the server or answered by someone responsible for the server. This is the telephone number left on the pager for callback. For test purposes, enter your telephone number here. You can change it after testing is completed.
- **Customer System Telephone Number** is the telephone number to which your server's modem is connected. The service or administration center representatives need this number to make direct contact with your server for problem investigation. This is also referred to as the **call-in** phone number.

## Call-Out Policy Setup Menu

```
CALL-OUT POLICY SETUP MENU

1. Call-Out policy (First/All):
   Currently First

2. Remote timeout, (in seconds):
   Currently 120

3. Remote latency, (in seconds):
   Currently 2

4. Number of retries:
   Currently 2

98. Return to Previous Menu

1>
```

- **Call-Out policy** may be set to 'first' or 'all'. If call-out policy is set to 'first', the SP stops at the **first successful** call-out to one of the following numbers in the order listed:

- a. Service Center
- b. Customer Admin Center
- c. Pager

If call-out policy is set to 'all', the SP attempts a call-out to **all** the following numbers in the order listed:

- a. Service Center
- b. Customer Admin Center
- c. Pager

**Remote timeout** and **Remote latency** are functions of your service provider's catcher computer. You should take the defaults or contact your service provider for recommended settings.

**Number of retries** is the number of times you want the server to retry calls that failed to complete.

## Customer Account Setup Menu

```
Customer Account Setup Menu
1. Customer Account Number:
   Currently Unassigned
2. Customer RETAIN Login userid:
   Currently Unassigned
3. Customer RETAIN login password:
   Currently Unassigned
98. Return to Previous Menu
1>
```

- **Customer Account Number** is assigned by your service provider for record keeping and billing. If you have an account number, enter it here. Otherwise, leave this field unassigned.
- **Customer RETAIN Login UserID** and **Customer RETAIN Login Password** apply to a service function to which your service provider may or may not have access. Leave these fields unassigned if your service provider does not use RETAIN.

## Reboot/Restart Policy Setup Menu

```
Reboot/Restart Policy Setup Menu
1. Number of reboot attempts:
   Currently 1
2. Use OS-Defined restart policy?
   Currently Yes
3. Enable supplemental restart policy?
   Currently No
4. Call-Out before restart:
   Currently Disabled
98. Return to Previous Menu
1>
```

**Reboot** is the process of bringing up the system hardware. For example, from a system reset or power on. **Restart** is activating the operating system after the system hardware is re-initialized. Restart must follow a successful reboot.

- **Number of reboot attempts** – If the server fails to successfully complete the boot process, it attempts to reboot the number of times specified. Entry values equal to or greater than 0 are valid. Only successive failed reboot/restart attempts count.
- **Use OS-Defined restart policy** – Allows the SP react or not react the same way as the operating system to major system faults by reading the setting of the operating system parameter **Automatically Restart/Reboot After a System Crash**. This parameter may or may not be defined depending on the operating system or its version/level. If the operating system automatic restart setting is defined, then it may be set to respond to a major fault by restarting or by not restarting. See your operating system documentation for details on setting up operating systems automatic restarts. The default value is YES.

- **Enable supplemental restart policy** – The default setting is NO. If set to YES, the SP restarts the system when the system loses control as detected by SP surveillance, and either:
  - a. The **Use OS–Defined restart policy** is set to NO
 OR
  - b. The **Use OS–Defined restart policy** is set to YES and the operating system has NO automatic restart policy.
 Refer to "Service Processor Reboot/Restart Recovery" on page 3-20.
- **Call–Out before restart (Enabled/Disabled)** If a restart is necessary due to a system fault, you can enable the SP to call out and report the event. This item is valuable if the number of these events becomes excessive, signalling a bigger problem.

## Boot Mode Menu

```

      Boot Mode Menu

    1. Boot to SMS Menu:
      Currently Disabled

    2. Service Mode Boot from Saved List:
      Currently Disabled

    3. Service Mode Boot from Default List:
      Currently Disabled

    4. Boot to Open Firmware Prompt:
      Currently Disabled

    98. Return to Previous Menu

    1>
  
```

To select boot mode, select a number and press Enter. The item corresponding to the selected number toggles from Disabled to Enabled. If the same number is selected again, the item toggles from Enabled to Disabled. If a boot mode is Enabled, the Boot mode selected is performed and the Disabled/Enabled selection is reset to Disabled. Following is a description for each boot mode selection:

- **Boot to SMS Menu**

When enabled, the system boots to the System Management Services (SMS) Menu.
- **Service Mode Boot from Saved List**

This selection causes the system to boot from the saved service mode boot list (saved in NVRAM). This is normally used to try to boot Customer Diagnostics from the CDROM drive. If the system boots AIX from the disk drive and AIX diagnostics are loaded on the disk drive, AIX boots to the diagnostics menu.
- **Service Mode Boot from Default List**

This selection is just like selection 2, "Service Mode Boot from Saved List" above except the system boots from the default boot list that is stored in the system firmware.
- **Boot to Open Firmware**

When this selection is enabled, the system boots to the Open Firmware prompt.

---

## Service Processor Procedures in Service Mode

When the system is in service mode, the following service processor parameters are suspended.

- Unattended Start Mode
- Reboot/Restart Policy
- Call-Out
- Surveillance

When service mode is exited, the service processor parameters revert back to the customer settings.

---

## Service Processor Functions

The following section discusses some of the Service Processor features in greater detail.

The Service Processor supports the following functions:

Built-in Functions	Initialization and Test	SP Basic Instructions Test (BIST)
		System Chip Initialization
	Error Data Collection	BIST/POST errors and status
		Isolation to Field Replaceable Unit (FRU) on fail.
	Configuration	CPU Complex validation
		VPD Collection
	System Management	Reset and Reboot on System Firmware fails
		Reboot on system failure

Local User Function	User Interface	Local async console
		Text based menus with NLS
		Operator Panel messages
	Power and Miscellaneous	Power On/Off
		Configurable Reboot Policy
	Status and Data Access	VPD
		Error data (SP)
		Error data (system)
	Service Processor Setup Utilities	Passwords
		Phone numbers
		Language (NLS) selection
		Call-In/Call-Out enable/disable
		System Name
		Modem Configuration
Remote User Functions	Call-Out (Call Home) Reporting	OS termination
		Boot failure
		Surveillance failure
		Checkstop
		Machine check
		Identify system by name
	Call-In	Power-on via ring-indicate
		Password/security check
		Console mirroring

---

## System Power-On Methods

- Power-on Switch – see "Powering On the System" on page 2-2.
- Remote Power-on via Ring-Indicate Signal

The server automatically powers on when it detects a "ring indicate" signal from a modem attached to one of the integrated serial ports.

A remote user can call the server to activate ring detection by the modem. Listen for a few more rings than the threshold number for starting the system and then hang up. The default threshold is one ring.

Wait 5 minutes for the server to initialize and then call again using an ASCII terminal. The server responds by requesting a password, if set, or presenting the SP menus. The remote user now has control of the server.

**Note:** For security, if the system is powered on by the remote power-on via ring indicate signal and the service processor detects an operator panel battery failure, the service processor causes the system to power off. See "Service Processor Call-In Security" on page 3-19 for more information.



- Unattended start mode – refer to **Enable/Disable Unattended Start Mode** on page 3-7.

The Service Processor can be enabled to recover from the loss of AC power (see **Enable/Disable Unattended Power-On Mode** in the **SYSTEM POWER CONTROL MENU**). When AC power is restored, the system returns to the then current power state at the time AC loss occurred. For example, if the system was powered-on when AC loss occurred, it reboots/restarts when power is restored. If the system was powered-off when AC loss occurred, it remains off when power is restored.

It is recommended that the system rack and I/O rack both receive their AC power from the same building circuit on the same circuit breaker, if not the same electrical outlet box, in such a way that primary power cannot be lost to one rack separately from the other. If such a condition occurs, Unattended Start Mode may not be able to restart system operation when a primary power interruption is restored.

- Timed power-on – refer to the `shutdown -t` command on servers using AIX.

Working in conjunction with AIX, the Service Processor in your server can operate a timer, much like the wake-up timer on your clock radio. You can set the timer so that your server powers on at a certain time after shutting down. The timer is battery operated, so power interruptions occurring while the server is off do not affect its accuracy. Refer to the `shutdown -t` command of AIX for details on setting the timer.

**Note:** If an AC power loss is in progress when the Timed Power-On attempt occurs, the server is not be able to power on when AC power is restored.

- Follow-up to a Failed Boot Attempt

The SP initiates a power-on sequence upon detection of a failed boot attempt (due to a hardware or software failure).

- Fast/Slow Boot (IPL) Capabilities

Using the operator panel functions, you can select the IPL type, mode and speed of your boot capabilities. For more information, refer to operator panel functions 01 and 02 in "Operator Panel Function Descriptions" on page A-4.

**ATTENTION:** Selecting fast IPL results in several diagnostic tests being skipped.

---

## Service Processor Call-In Security

If the service processor detects bad battery-powered storage (indicating that the battery in the Operator Panel has failed or is disconnected), it maintains server security by disabling the call-in capability to both serial ports.

When call-in is disabled, the system can still be powered on by using the ring-indicator signal, but the service processor then causes the system to power down, preventing access to any system facilities or AIX.

Once battery power is restored, the password(s) must be reset and the call-in function(s) enabled. Both of these operations can be performed from Service Processor menus. See "Service Processor Setup Menu" on page 3-5 and "Serial Port Selection Menu" on page 3-11.

---

## Service Processor Reboot/Restart Recovery

**Reboot** describes bringing the system hardware back up. For example, from a system reset or power on. The boot process ends when control passes to the operating system process.

**Restart** describes activating the operating system after the system hardware is reinitialized. Restart must follow a successful reboot.

### Boot (IPL) Speed

When the server enters reboot recovery, slow IPL is automatically invoked. This is to give the POST an opportunity to locate and report any problems that may otherwise be untested. For more information on IPL speed, refer to "Values for IPL Types and Speeds" on page A-4.

### Failure During Boot Process

During the boot process, either initially after system power-on or upon reboot after a system failure, the Service Processor monitors the boot progress. If progress stops, the Service Processor can reinitiate the boot process (reboot) if enabled to do so. Service Processor can re-attempt this process according to the number of retries selected in the Reboot/Restart Policy Setup Menu.

### Failure During Normal System Operation

When the boot process completes and control transfers to the operating system (OS), the Service Processor can monitor operating system activity (see the SERVICE PROCESSOR SETUP MENU item Set Surveillance Parameters). If OS activity stops due to a hardware or software induced failure, the Service Processor can initiate a reboot/restart process based on the settings in the Service Processor Reboot/Restart Policy Setup Menu and the OS automatic restart settings (see OS documentation).

If the operating system is AIX, the menu item under SMIT for setting the restart policy is Automatically Reboot After Crash (True/False), and the default is False. When the setting is True, and if the Service Processor parameter "Use OS-Defined Restart Policy" is Yes (the default), SP takes over for AIX to reboot/restart after a hardware or Surveillance failure.

### Service Processor Reboot/Restart Policy Controls

The operating system's automatic restart policy (see operating system documentation) indicates the OS response to a system crash. The Service Processor can be instructed to refer to that policy, or not, by the Use OS-Defined Restart Policy menu item.

If the operating system has no automatic restart policy, or if it is disabled, then the Service Processor restart policy can be controlled from the Service Processor Menus by using the Enable Supplemental Restart Policy selection.

**Use OS-Defined restart policy** – The default setting is YES. This causes the Service Processor to refer to the OS Automatic Restart Policy setting and take action; the same action the OS would take if it could have responded to the problem causing the restart.

When this setting is NO, or if the OS did not set a policy, the SP refers to Enable supplemental restart policy for its action.

**Enable supplemental restart policy** – The default setting is NO. If set to YES, the SP restarts the server when the OS loses control and either:

1. The **Use OS–Defined restart policy** is set to NO  
OR
2. The **Use OS–Defined restart policy** is set to YES and the operating system has NO automatic restart policy.

Refer to "Service Processor Reboot/Restart Recovery" on page 3-20.

The following provides a more thorough understanding of the relations among the OS and Service Processor restart controls:

OS Automatic reboot/restart after crash setting	Service Processor to use OS–Defined restart policy?	Service Processor Enable supplemental restart policy?	System response
None	No	No <sup>1</sup>	
None	No	Yes	Restarts
None	Yes <sup>1</sup>	No <sup>1</sup>	
None	Yes <sup>1</sup>	Yes	Restarts
False <sup>2</sup>	No	No <sup>1</sup>	
False <sup>2</sup>	No	Yes	Restarts
False <sup>2</sup>	Yes <sup>1</sup>	No <sup>1</sup>	
False <sup>2</sup>	Yes <sup>1</sup>	Yes	
True	No	No <sup>1</sup>	
True	No	Yes	Restarts
True	Yes <sup>1</sup>	No <sup>1</sup>	Restarts
True	Yes <sup>1</sup>	Yes	Restarts

<sup>1</sup> Service Processor default

<sup>2</sup> AIX default

---

## Configure/Deconfigure Processors

The EPC2400 system which has 450MHz processor cards features an enhanced error detection and prevention function called Repeat–Gard. This function allows the system to deconfigure processors from the system configuration if a processor has an unrecoverable error, or repeating recoverable errors. This prevents the system from using a defective processor.

If a processor is deconfigured, it remains off–line for subsequent reboots until the faulty processor hardware is replaced. The Repeat–Gard function also provides the option for users to manually deconfigure a processor, or re–enable a previously deconfigured processor. See page 3-9 for a description of the service processor menus used to configure or deconfigure a processor.

Processor deconfiguration during system boot is a function controlled by the system firmware which enables removal of processors from the system configuration. If a processor has a failure which occurs during tests that are performed during the system boot, or if the processor has had prior unrecoverable or recoverable errors, it will be removed from the system configuration. The system utilize existing hardware Built–in Self–Tests (BIST) and/or the firmware Power–On Self Test (POST) to discover and isolate processor hardware failures during the system boot. The system utilizes the hardware error detection logic in the

processor to capture recoverable and unrecoverable error indications that occurred during prior system operations.

## Processor Deconfiguration During Boot

Repeat–Gard utilizes the error detection and isolation capabilities of the processor card along with the error recording facilities of the Service Processor to provide a method to record key fault information. This information is recorded when a processor has reached a threshold of recoverable errors. It also records information if a critical processor failure ever occurs which allows the affected processor to be identified and removed during the next boot. This function is provided in addition to the services to notify customer support and service support if desired. The service processor is utilized to report critical failures when AIX can not be rebooted.

The Repeat–Gard function provides the capability to remember a specific processor that was experiencing problems during normal operation and automatically deconfigure it during the next boot. This removes the dependency on the system to rely on the processor to fail BIST (Built In Self Test) during the Boot process in order to be removed from the configuration. Processor failures may be intermittent in nature or not recreatable during system boot with BIST, but may fail again during normal operation causing systems to experience a series of system failures and reboots until faulty component processor is replaced.

The customer is given the option to override the default configuration of the processor if so desired during the system boot. In addition, the menu driven interface allows them to selectively deconfigure or configure additional processors which are installed. This provides customers with control over the number of processors which will be made available to the operating system. This is particularly useful for customers performing bench marking runs for their applications on various configurations.

---

## Service Processor System Monitoring – Surveillance

Surveillance is a function in which the Service Processor (SP) monitors the system, and the system monitors the SP. This monitoring is accomplished by periodic samplings called heartbeats.

Surveillance is available during two phases:

1. System firmware bringup (automatic) and
2. Operating system runtime (optional).

### System Firmware Surveillance

Provides the SP with a means to detect boot failures while the system firmware is running.

System firmware surveillance is automatically enabled during system power–on. It cannot be disabled via a user selectable option.

If the SP detects no heartbeats during system IPL (for 7 minutes), it cycles the system power to attempt a reboot. The maximum number of retries is set from the SP menus. If the fail condition persists, the SP leaves the machine powered on, logs an error and offers menus to the user. If Call–out is enabled, the SP calls to report the failure and displays the operating system surveillance failure code on the operator panel.

### Operating System Surveillance

Provides the SP with a means to detect hang conditions, hardware or software failures while the operating system is running. It also provides the operating system with a means to detect SP failure by the lack of a return heartbeat.

Operating system surveillance is not enabled by default. This is to allow the user to run operating systems that do not support this SP option.

Operating system surveillance can be enabled and disabled via:

- SP Menus
- SP Service Aids

Three parameters must be set for operating system surveillance:

1. Surveillance enable/disable
2. Surveillance interval

This is the maximum time SP should wait for a heartbeat from the operating system before timeout.

3. Surveillance delay

This is the length of time to wait from when the operating system is started to when the first heartbeat is expected.

Surveillance does not take effect until the next time the operating system is started after setting the parameters.

If desired, surveillance mode can be initiated immediately from Service Aids. In addition to the three options above, a fourth option is available to allow you to select immediate surveillance and rebooting of the system is not necessarily required.

If operating system surveillance is enabled (and system firmware has passed control to the operating system), and SP does not detect any heartbeats from the operating system, the SP assumes the system is hung and takes action according to the reboot/restart policy settings. See "Service Processor Reboot/Restart Recovery" on page 3-20.

If surveillance is selected from the service processor menus which are only available at bootup, then surveillance is by default enabled as soon as the system boots. From Service Aids the selection is optional.

---

## Call-Out (Call-Home)

The SP can call-out (Call-Home) when it detects one of the following conditions:

- System firmware surveillance failure
- Operating system surveillance failure (if supported by Operating System)
- Restarts
- Critical hardware failure
- Abnormal OS termination

To enable the call-out feature, you need to do the following:

- Have a modem connected to serial port 1 or 2.
- Set up the following using the Service Processor Menus or Diagnostic Service Aids:
  - Enable call-out for the serial port where the modem is connected.
  - Enter the modem configuration filename.
  - Set up site specific parameters (i.e. phone numbers for call-out, call-out policy, number of call-out retries, etc.).
- To Call-Out before restart, set "**call-out before restart**" to ENABLED from the Reboot/Restart Policy Setup menu.

**Note:** Some modems are not designed for the paging function. Although they can be used for paging, they will return an error message when they do not get the expected response from another modem. Therefore, even though the paging was successful, the error message will cause the Service Processor to retry, continuing to place

pager calls for the number of retries specified in the Call-Out Policy Setup Menu. These retries result in redundant pages.

---

## Console Mirroring

Console mirroring allows a person on a local ASCII terminal to monitor the SP activities of a remote user. Console mirroring ends when SP releases control of the serial ports to the system firmware.

### System Configuration:

- Service Processor
- Modem connected to one serial port and enabled for incoming calls
- Local ASCII terminal connected to the other serial port. This local terminal may be connected directly to your server or connected through another modem.

There are two scenarios in which console mirroring can be invoked:

1. Remote session first, then local session added:
  - a. Remote session already in progress.
  - b. Remote user uses SP menus to enable console mirroring, allowing both consoles to be active.
2. Local session first, then remote session added:
  - a. Local session is already in progress.
  - b. The SP receives a call from the remote user.
  - c. The local user selects the option to enable console mirroring. SP immediately begins mirroring SP menus.

---

## Service Processor Error Logs

The Service Processor error logs contain error conditions detected by the SP.

```
-----+-----+
|                                     |
|                                     | Error Log |
|                                     |
| 19970626223337  0. Error detected.. |
|                                     | 4B00F010 |
|                                     | B455440004B007107000013700000000000000000007420A400010000000 |
| 00000000000000 |
|                                     |
| Press "C" to clear error log, any other key to continue. > |
|                                     |
|-----+-----+
```

**Note:** The time stamp in this error log is Coordinated Universal Time (CUT) which is also referred to as Greenwich Mean Time (GMT). AIX error logs have more information available and can time stamp with local time.

---

## System POST Errors

If POST (Power-On Self Test) errors occur during start-up, this error log helps isolate faults when used with the diagnostics.

```
+-----+
|                                               |
|                                               |
|                      Read System POST Errors |
|                                               |
|                                               |
|Version : 1 |
|Severity : 2 |
|Disposition : 0 |
|Initiator : 0 |
|Event being reported : 0 |
|Extended Error Log Data: |
|c2 00 84 09 20 09 06 00 |
|19 97 09 03 00 00 49 42 |
|4d 2c 73 70 00 00 00 00 |
|00 00 2b a0 00 13 00 01 |
|00 00 00 00 00 00 00 00 |
|49 42 4d 00 55 30 2e 31 |
|2d 50 31 2d 58 31 00 |
|                                               |
|                      (Press Return to Continue) |
|                                               |
+-----+
```

---

## LCD Progress Indicator Log

The following is an example of the LCD progress indicator log.

The progress indicators (check points) are displayed in two sections. Above the dashed line are the progress indicators from the boot that produced the current sessions. Below the dashed line are progress indicators from the boot preceding the one that produced the current sessions.

The progress indication codes are chronological from bottom to top. The dashed line merely represents the point where the latest boot started.

```
+-----+
|                                               |
|                      LCD Progress Indicator Log |
|                                               |
|          C33744FE |
|          C33644FE |
|          C33544FE |
|          C33444FE |
|          C33344FE |
|          C33244FE |
|          C33144FE |
|          C33044FE |
|          C1022001 |
|          C13F2090 |
|          C13F2060 |
|          C13F2050 |
|          C1012001 |
|          C1002001 |
|          C100D500 |
|          C100806E |
|          ----- |
|          E075 |
|          E07A |
|          E075 |
|                                               |
|Press Return to continue, or 'x' to return to menu. > |
|                                               |
+-----+
```





---

## Chapter 4. System Management Services

Use the System Management Services menus to view information about your system and to perform such tasks as setting a password. Other tasks, such as accessing and changing adapter and device configurations are performed using system management services.

The text-based open firmware command line (OK prompt) which is available from the System Management Services Utilities menu, allows you to configure certain adapters.

---

### Text-Based System Management Services

The text-based Open Firmware command line allows you to configure some adapters, and the System Management Services makes it possible for you to view information about your system unit and to perform such tasks as setting the password and changing device configurations.

To start the Text-Based System Management Services, turn on or restart the system. After the logo is displayed, the POST indicator words "Memory", "Keyboard", "Network", "SCSI" and "Speaker" appear across the bottom of the screen. Press the 1 key after the word "Keyboard" appears and before the last word "Speaker" appears. For more information on the POST indicator words, refer to "Post Indicators" on page 2-3.

After the text-based System Management Services starts, the following screen appears:

```
|-----|
| System Management Services
|
| 1. Password Utilities
| 2. Display Error Log
| 3. Remote Initial Program Setup
| 4. SCSI Utilities
| 5. Select Console
| 6. MultiBoot
| 7. Select Language
| 8. OK Prompt
|
|
|
|
|
|
|
|
|
|
|
|-----|
| X=Exit |
|-----|
|
|=====>
```

Selecting the numbered options provide capabilities described on the following pages.

After you have finished using the text-based System Management Services, entering **x** (for exit) boots your system. You may also press 8 here to enter the OK prompt.

## Password Utilities

Entering this selection permits access to the following options.

```
-----+-----  
| Password  
|  
| Select  
| 1. Set Privileged Access Password  
| 2. Remove Privileged Access Password  
| 3. Unattended Start Mode  
|  
|                                     |X=Exit|  
|  
|====>
```

**Set Privileged–Access Password:** The privileged–access password protects against the unauthorized starting of the system programs.

Both the Service Processor and System Management Services use this password. If the password is set in System Management Services, the Service Processor automatically uses the same password.

If you previously had set a privileged–access password and want to remove it, select **Remove Privileged–Access Password**.

**Unattended Start Mode <On>:** This selection is used to enable/disable Unattended Start Mode. This option is used to instruct the Service Processor to restore the power–state of the server after a temporary power failure. It is intended to be used on servers that require automatic power–on after a power failure. The default setting is ON.

## Display Error Log

A screen similar to the following is displayed when you select this option. You can view or clear your system’s error log.

```
-----+-----  
|                               System Error Log  
|  
|   Date      Time      ErrorCode Location  
| Entry 1. 10/04/96 02:15:35 25a80011 00-00  
| Entry 2. No Entry  
|  
|   |C=Clear|                               |X=Exit Log|  
|  
|=====>
```

**Note:** The time stamp in this error log is Coordinated Universal Time (CUT) which is also referred to as Greenwich Mean Time (GMT). AIX error logs have more information available and can time stamp with local time.



```

Adapter Parameters

      Device                Slot                Hardware address
1. Gigabit Ethernet      5: U0.1-P1-I5/E1      0004ac7c8628
2. ethernet              3: U0.1-P1-I3/E1      0060949d21db
3. token-ring            11: U0.1-P1-I11/T1    0004ac62a672
4. fddi                  10: U0.1-P1-I10/Q1    00005a40aeff

PRESS ENTER AFTER MAKING A SELECTION ===>

                                     .----- .
                                     |X=Exit|
                                     '-----'

```

Selecting an adapter on this screen displays configuration menus for that adapter. If ethernet is selected, you can set parameters that control how the ethernet adapter communicates with the network. The following screen shows the menu for the ethernet adapter configuration.

```

1. Data Rate "Auto"
2. Full Duplex "No"

```

Selecting the **Data Rate** option allows you the change the media employed by the Ethernet adapter:

```

                                     .----- .
                                     |DATA RATE|
                                     | 1. 10 Mbps|
                                     | 2. 100 Mbps|
                                     | 3. Auto   |
                                     '-----'

===>

```

## Ping

Ping, third option available from the Remote Initial Program Load menu, allows you to test a connection to a remote system unit. After selecting the Ping option, you must choose which adapter communicates with the remote system.

```

Device                Slot                Hardware address
1. Gigabit Ethernet   5: U0.1-P1-I5/E1   0004ac7c8628
2. ethernet           3: U0.1-P1-I3/E1   0060949d21db
3. token-ring         11: U0.1-P1-I11/T1 0004ac62a672
4. fddi               10: U0.1-P1-I10/Q1 00005a40aeff

PRESS ENTER AFTER MAKING A SELECTION ===>

|-----|
|X=Exit|
|-----|

```

After choosing which adapter to use to ping the remote system, you must provide the addresses needed to communicate with the remote system. Select the appropriate device from the Ping menu to display a screen similar to the following:

```

PING IP Address

1. Client IP Address   [9.3.146.162]
2. Server IP Address  [9.3.146.171]
3. Gateway IP Address [0.0.0.0]
4. Subnet Mask        [0.0.0.0]

|-----|
|X=Execute|
|-----|

|-----|
|X=Exit|
|-----|

===>

```

## SCSI Utilities

Allow you to set SCSI hard disk spin up delay times and to set SCSI IDs for SCSI controllers installed in the system.

```

SCSI Utilities

1. Harddisk Spin Up Delay
2. Change SCSI Id

|-----|
| X=exit |
|-----|

```





Selecting any of the **Configure Boot Device** options displays the following screen.

```
-----+
|
|      Configure Nth Boot Device
|
|      Device Number      Current Position      Device Name
|
|          1                1                Diskette
|          2                2                Ethernet
|          3                3                SCSI CD-ROM
|          4                4                SCSI 4.5GB Hard Disk
|          5                -
|
|
|
|
|
|
|      .----- .----- .-----
|      |P=prev-page| |N=next-page| |X=Exit|
|      `----- `----- `-----
|
|====>
|
|-----+
```

## Select Language

This option allows you to change the language used by the text-based System Management Services screens and the Service Processor menus.

```
-----+
|
|      SELECT LANGUAGE
|
|      1. English
|      2. Deutsch
|      3. Espanol
|      4. Francais
|      5. Svenska
|      6. Italiano
|
|
|
|
|
|
|====>
|
|
|
|
|
|
|      .-----
|      |x=Exit|
|      `-----
|
|-----+
```

**Note:** Your ASCII terminal must support the ISO-8859 character set in order to properly display languages other than English

## OK Prompt

This option provides access to the Open Firmware command prompt. The Open Firmware command prompt is used to set up an adapter that is not configurable with the System Management Services. Your adapter documentation directs you to use this option if it is needed. To exit from the Open Firmware command prompt, enter

```
reset-all
```

or power the system down and reboot.



## Exiting System Management Services

After you have finished using the text-based System Management Services, entering **x** (for exit) when the utilities menu is displayed boots your system. Entering **x** on any other screen takes you back to the previous screen.



---

# Chapter 5. Using the Online and Standalone Diagnostics

---

## Sources for the Diagnostics

The diagnostics consist of Standalone Diagnostics and Online Diagnostics. Standalone Diagnostics are packaged on removable media. They must be booted before they can be run. If booted, they have no access to the AIX Error Log or the AIX Configuration Data. Online Diagnostics, when installed, reside with AIX in the file system. They can be booted in single user mode (referred to as service mode), run in maintenance mode (referred to as maintenance mode), or run concurrently (referred to as concurrent mode) with other applications. They have access to the AIX Error Log and the AIX Configuration Data.

---

## Standalone and Online Diagnostics Operating Considerations

**Note:** When possible, run Online Diagnostics in Service Mode. Online Diagnostics perform additional functions, compared to Standalone Diagnostics. This ensures that the error state of the system is captured in NVRAM for your use in fixing the problem. The AIX error log and certain SMIT functions are only available when diagnostics are run from the disk drive.

The following items identify some things to consider before using the diagnostics.

1. When diagnostics are installed, the device support for some devices may not get installed. If this is the case, that device does not appear in the diagnostic test list when running disk based diagnostics.
2. Support for some TTY terminals is optionally installed. If you attach a TTY terminal to a system to run diagnostics be aware that it may not work properly since the AIX support for the terminal may not be installed.

## Selecting a Console Display

When you run Standalone Diagnostics and under some conditions Online Diagnostics, you need to select the console display. The diagnostics display instructions on any graphics display and the terminal attached to the S1 serial port.

## Identifying the Terminal Type to Diagnostics

**Note:** This is not the same as selecting a console display.

When you run diagnostics, the diagnostics must know what type of terminal you are using. If the terminal type is not known when the FUNCTION SELECTION menu is displayed, the diagnostics do not allow you to continue until a terminal is selected from the DEFINE TERMINAL option menu. Select **lft** for graphical displays.

## Undefined Terminal Types

If an undefined terminal type from the DEFINE TERMINAL option menu is entered, the menu prompts the user to enter a valid terminal type, and the menu is redisplayed until either a valid type is entered or the user exits the DEFINE TERMINAL option.

## Resetting the Terminal

If the user enters a terminal type that is valid (according to the DEFINE TERMINAL option menu) but is not the correct type for the ASCII terminal being used, difficulty may be encountered in reading the screen, using the function keys or the Enter key. These difficulties can be bypassed by pressing Ctrl-C to reset the terminal. The screen display

which results from this resetting action varies with the mode in which the system is being run:

- Online Normal or Maintenance Mode – The command prompt appears.
- Standalone Mode or Online Service Mode – The terminal type is reset to "dumb", the Diagnostic Operating Instruction panel is displayed, and the user is required to go through the DEFINE TERMINAL process again.

## Running Standalone Diagnostics

Consider the following when you run Standalone Diagnostics:

- The diagnostic CD must remain in the CD-ROM drive for the entire time that diagnostics are executing.
- The diagnostic CD-ROM cannot be ejected from the CD-ROM drive once the diagnostics have loaded. The CD can only be ejected after the system has been turned off and then turned on (standalone mode) or after the diagnostics program has terminated (Online concurrent mode).
- The CD-ROM drive from which diagnostics were loaded cannot be tested.
- The SCSI adapter (or circuitry) controlling the CD-ROM drive from which diagnostics were loaded cannot be tested.

## Running Online Diagnostics

Consider the following when you run the Online Diagnostics from a server or a disk:

- The diagnostics cannot be loaded and run from a disk until the AIX operating system has been installed and configured. After the AIX operating system has been installed, all three modes of operation are available.
- The diagnostics cannot be loaded on a system (client) from a server if that system is not set up to boot from a server over a network. When the system is set up to boot from a server, the diagnostics are run in the same manner as they are from disk.
- If the diagnostics are loaded from disk or a server, you must shutdown the AIX operating system before turning the system unit off to prevent possible damage to disk data. This is done in one of two ways:
  - If the diagnostics were loaded in standalone mode, press the F3 key until DIAGNOSTIC OPERATING INSTRUCTIONS displays; then press the F3 key once again to shutdown the AIX operating system.
  - If the diagnostics were loaded in maintenance or concurrent mode, enter the `shutdown -F` command.
- Under some conditions the system may stop, with instructions displayed on attached displays and terminals. Follow the instructions to select a console display.

## Running the Diagnostics from a TTY Terminal

Consider the following when you run diagnostics using a TTY-type terminal as the console display:

- See the operator manual for your type of tty terminal to find the key sequences you need to respond to the diagnostics.

Refer to *Terminals and Printers Configuration Guide*, order number 86 A1 22WE, for more information about terminals settings.

---

## Online Diagnostics Modes of Operation

The Online Diagnostics can be run in three modes:

- Service Mode
- Concurrent Mode
- Maintenance Mode

### Service Mode

Service mode provides the most complete checkout of the system resources. This mode also requires that no other programs be running on the system. All system resources except the SCSI adapter, and the disk drives used for paging can be tested. However, note that the memory and processor are only tested during POST and the results of the POST tests are reported by diagnostics.

Error log analysis is done in service mode when you select the Problem Determination option on the DIAGNOSTIC MODE SELECTION menu.

### Running the Online Diagnostics in Service Mode

To run Online Diagnostics in service mode, take the following steps:

1. Stop all programs including the AIX operating system (get help if needed).
2. Turn the power off.
3. Remove all tapes, diskettes, and CD-ROMs.
4. Turn the power on.
  - a. When or after the diskette indicator appears, press F6 on the directly-attached keyboard or 6 on the ASCII terminal keyboard to indicate that diagnostics are to be loaded.
  - b. Enter any requested passwords.
  - c. Follow any instructions to select a console.
5. After the diagnostic controller loads, DIAGNOSTIC OPERATING INSTRUCTIONS appear on the console display.
6. Follow the displayed instructions to checkout the desired resources.
7. When testing is complete; use the F3 key to return to the DIAGNOSTIC OPERATING INSTRUCTIONS.
8. Press the F3 key (from a defined terminal) or press 99 (for an undefined terminal) to shutdown the diagnostics before turning off the system unit.

**Note:** Pressing the F3 key (from a defined terminal) produces a "Confirm Exit" popup menu which offers two options: continuing with the shutdown by pressing F3; or returning to diagnostics by pressing Enter.

For undefined terminals, pressing 99 produces a full screen menu which offers two options: continuing with the shutdown by pressing 99 and then Enter; or returning to diagnostics by pressing Enter.

### Concurrent Mode

Concurrent mode provides a way to run Online Diagnostics on some of the system resources while the system is running normal system activity.

Because the system is running in normal operation, some of the resources cannot be tested in concurrent mode. The following resources cannot be tested in concurrent mode:

- SCSI adapters connected to paging devices
- The disk drive used for paging
- Some display adapters and graphics related devices
- Memory (tested during POST)
- Processor (tested during POST).

There are three levels of testing in concurrent mode:

- The **share-test level** tests a resource while the resource is being shared by programs running in the normal operation. This testing is mostly limited to normal commands that test for the presence of a device or adapter.
- The **sub-test level** tests a portion of a resource while the remaining part of the resource is being used in normal operation. For example, this test could test one port of a multiport device while the other ports are being used in normal operation.
- The **full-test level** requires the device not be assigned to or used by any other operation. This level of testing on a disk drive may require the use of the varyoff command. The diagnostics display menus to allow you to vary off the needed resource.

Error log analysis is done in concurrent mode when you select the Problem Determination option on the DIAGNOSTIC MODE SELECTION menu.

To run the Online Diagnostics in concurrent mode you must be logged onto the AIX operating system and have proper authority to issue the commands (if needed, get help).

The `diag` command loads the diagnostic controller and displays the Online Diagnostic menus.

## Running the Online Diagnostics in Concurrent Mode

To run Online Diagnostics in concurrent mode, take the following steps:

- Log on to the AIX operating system as root or superuser.
- Enter the `diag` command.
- When the DIAGNOSTIC OPERATING INSTRUCTIONS are displayed, follow the instructions to check out the desired resources.
- When testing is complete; use the F3 key to return to the DIAGNOSTIC OPERATING INSTRUCTIONS. Then press the F3 key again to return to the AIX operating system prompt. Be sure to vary on any resource you had varied to off.
- Press the Ctrl-D key sequence to log off from root or superuser.

## Maintenance Mode

Maintenance mode runs the Online Diagnostics using the customer's version of the AIX operating system. This mode requires that all activity on the AIX operating system be stopped so the Online Diagnostics have most of the resources available to check. All of the system resources except the SCSI adapters, memory, processor, and the disk drive used for paging can be checked.

Error log analysis is done in maintenance mode when you select the Problem Determination option on the DIAGNOSTIC MODE SELECTION menu.

The `shutdown -m` command is used to stop all activity on the AIX operating system and put the AIX operating system into maintenance mode. Then the `diag` command is used to invoke the diagnostic controller so you can run the diagnostics. After the diagnostic controller is loaded, follow the normal diagnostic instructions.

## Running the Online Diagnostics in Maintenance Mode

To run the Online Diagnostics in maintenance mode you must be logged on to the customer's version of the AIX operating system as *root* or *superuser* and use the `shutdown -m` and `diag` commands. Use the following steps to run the Online Diagnostics in maintenance mode:

1. Stop all programs except the AIX operating system (get help if needed).
2. Log onto the AIX operating system as *root* or *superuser*.
3. Enter the `shutdown -m` command.
4. When a message indicates the system is in maintenance mode, enter the `diag` command.  
**Note:** It may be necessary to set *TERM* type again.
5. When DIAGNOSTIC OPERATING INSTRUCTIONS is displayed, follow the displayed instructions to checkout the desired resources.
6. When testing is complete; use the F3 key to return to DIAGNOSTIC OPERATING INSTRUCTIONS. Then press the F3 key again to return to the AIX operating system prompt.
7. Press Ctrl-D to log off from *root* or *superuser*.

---

## Standalone Diagnostic Operation

Standalone Diagnostics provide a method to test the system when the Online Diagnostics are not installed and a method of testing the disk drives that cannot be tested by the Online Diagnostics.

No Error Log Analysis is done by the Standalone Diagnostics.

The CD-ROM drive and the SCSI controller that controls it cannot be tested by the Standalone Diagnostics.

## Running the Standalone Diagnostics

To run Standalone Diagnostics in service mode, take the following steps:

1. Verify with the system administrator and system users that the system unit may be shut down, then stop all programs including the AIX operating system. (Refer to the AIX operating system documentation shutdown command information.)
2. Remove all tapes, diskettes, and CD-ROMs.
3. Insert the Diagnostic CD-ROM into the CD-ROM drive.
4. Turn off the system unit.
5. Turn the power on.
  - a. When or after the diskette indicator appears, press F5 on the direct attached keyboard or 5 on the TTY keyboard to indicate that diagnostics are to be loaded.
  - b. Enter any requested passwords.
  - c. Follow any instructions to select a console.
6. After the diagnostic controller loads, DIAGNOSTIC OPERATING INSTRUCTIONS appear on the console display.
7. Follow the displayed instructions to checkout the desired resources.
8. When testing is complete; use the F3 key to return to the DIAGNOSTIC OPERATING INSTRUCTIONS.

---

## Logical and Physical Locations

This system uses Physical Location Codes in conjunction with AIX Location Codes to provide mapping of the failing field replaceable units. The location codes are produced by the system unit's firmware and AIX.

---

## Physical Location Codes

Physical location codes provide a mapping of logical functions in a platform (or expansion sites for logical functions, such as connectors or ports) to their specific locations within the physical structure of the platform.

### Location Code Format

The format for the location code is a string of alphanumeric characters separated by a dash (–), slash (/), pound sign (#) or period (.) character. The base location is all of the information preceding the slash (/) or pound sign (#). The base location identifies a device that is connected to or plugged into the parent. Extended location information follow the slash (/). Extended location information identifies a device that is part of the parent, a connector, or a cable. Cable information follows the pound sign (#). Cable information identifies a cable that is connector to parent. For examples:

- P1–C1 identifies a processor card C1 plugged into planar P1.
- P1–M1 identifies a memory card M1 plugged into planar P1.
- P1–K1 identifies a keyboard attached to K1 on planar P1.
- P1/S1 identifies serial port 1 controller on planar P1, the connector for serial port 1, or the cable attached to serial port 1.
- P1–I2/E3 identifies a Ethernet controller 3 on the card in slot 2 (I2) on planar P1, the connector for Ethernet controller 3 or the cable attached to Ethernet controller 3,
- P1–I2#E3 identifies the cable attached to Ethernet controller 3 on the card in slot 2 (I2) on planar P1.

The period (.) identifies sub–locations (DIMMs on a memory card, SCSI addresses, cables). For examples:

- P1–M1.4 identifies DIMM 4 on memory card 1 on planar P1.
- P1–C1.1 identifies processor 1 on planar P1.
- P2–Z1–A3.1 identifies a SCSI device with SCSI address of LUN 1 at SCSI ID 3 attached to SCSI bus 1 from planar 2.
- P1–I2#E3.2 identifies the second in a series of cables attached to Ethernet controller 3 on the card in slot 2 (I2) on planar P1.

Depending on the AIX and firmware levels, AIX Diagnostics may include the extended location information when identifying a planar or card. The extended location information or cable information is always included when identifying a cable or connector. Location codes with extended location information that are displayed without a description identifying the devices always identify the cable attached to the port.

---

## AIX Location Codes

The basic formats of the AIX location codes are:

- For non–SCSI devices/drives

AB–CD–EF–GH



- For SCSI devices/drives

AB-CD-EF-G, H

For planars, cards, and non-SCSI devices the location code is defined as:

```

AB-CD-EF-GH
|  |  |  |
|  |  |  Device/FRU/Port ID
|  |  Connector ID
|  devfunc Number, Adapter Number or Physical Location
Bus Type or PCI Parent Bus

```

- The AB value identifies a bus type or PCI parent bus as assigned by the firmware.
- The CD value identifies adapter number, adapter's devfunc number, or physical location. The devfunc number is defined as the PCI device number times 8, plus the function number.
- The EF value identifies a connector.
- The GH value identifies a port, address, device, or FRU.

Adapters and cards are identified with just AB-CD.

The possible values for CD depend on the adapter/card.

For pluggable PCI adapters/cards, CD is the device's devfunc number (PCI device number times 8, plus the function number). The C and D are characters in the range of 0-9, and A-F (hex numbers). This allows the location code to uniquely identify multiple adapters on individual PCI cards.

EF is the connector ID. It is used to identify the adapter's connector that a resource is attached to.

GH is used to identify a port, device, or FRU. For example:

- For async devices GH defines the port on the fanout box. The values are 00 to 15.
- For a diskette drive H defines which diskette drive 1 or 2. G is always 0.
- For all other devices GH is equal to 00.

For integrated adapter, EF-GH is the same as the definition for a pluggable adapter. For example, the location code for a diskette drive is 01-D1-00-00. A second diskette drive is 01-D1-00-01.

For SCSI the location code is defined as:

```

AB-CD-EF-G, H
|  |  |  |  |
|  |  |  |  Logical Unit address of the SCSI Device
|  |  |  Control Unit Address of the SCSI Device
|  |  Connector ID
|  devfunc Number, Adapter Number or Physical Location
Bus Type or PCI Parent Bus

```

Where AB-CD-EF are the same as non-SCSI devices.

G defines the control unit address of the device. Values of 0 to 15 are valid.

H defines the logical unit address of the device. Values of 0 to 255 are valid.

There is also a bus location code that is generated as '00-XXXXXXXX' where XXXXXXXX is equivalent to the node's unit address.

Examples of physical location codes and AIX location codes are:

- PCI adapter in drawer 0, Slot 1  
Location Code U0.1-P1-I1  
AIX location Code 20-58
- PCI adapter in drawer 3, Slot 1  
Location Code U0.4-P1-I1  
AIX location Code E0-58

## AIX and Physical Location Code Reference Tables

The following tables contain location codes that are used to identify functional units in the system. Each table below shows the locations for a physical part the system.

### System Rack Locations

FRU Name	Slot Name	Location Code	AIX Location Code	Physical Connection	Logical Connection
<b>System Rack</b>					
System Rack		U1	00-00		
System Backplane		U1.1-P1	00-00		
Memory Controller		U1.1-P1	00-00	On System Backplane	
Operator Panel		U1.1-P1 -L1			
Processor Regulator 21	M04	U1.1-P1-V1			
Processor Regulator 22	M07	U1.1-P1-V2			
I/O Hub Card	M17	U1.1-P1-X1	00-00	On System Backplane	
RIO Port 0 Connector/Cable		U1.1-P1-X1/Q1			
RIO Port 1 Connector/Cable		U1.1-P1-X1/Q2			
RIO Port 2 Connector/Cable		U1.1-P1-X1/Q3			
RIO Port 3 Connector/Cable		U1.1-P1-X1/Q4			
R1 Memory Card Quad A, Front	M01	U1.1-P1-M1	00-00	System Backplane	
R1 Memory Card Quad A, Front	M02	U1.1-P1-M2	00-00	System Backplane	
R1 Memory Card Quad A, Front	M03	U1.1-P1-M3	00-00	System Backplane	
R1 Memory Card Quad B, Front	M08	U1.1-P1-M4	00-00	System Backplane	
R1 Memory Card Quad B, Front	M09	U1.1-P1-M5	00-00	System Backplane	
R1 Memory Card Quad B, Front	M10	U1.1-P1-M6	00-00	System Backplane	
Clock/Processor Regulator 23 Rear	M19	U1.1-P1-X2	00-00	System Backplane	
Processor Card 0 Type 1, Front	M05	U1.1-P1-C1		System Backplane	
Processor Card 0 All Cache		U1.1-P1-C1	00-00	On Processor Card 0	
Processor Card 0 Processor 0		U1.1-P1-C1	00-00	On Processor Card 0	

Processor Card 0 Processor 1		U1.1-P1-C1	00-01	On Processor Card 0	
Processor Card 0 Processor 2		U1.1-P1-C1	00-02	On Processor Card 0	
Processor Card 0 Processor 3		U1.1-P1-C1	00-03	On Processor Card 0	
Processor Card 0 Processor 4		U1.1-P1-C1	00-04	On Processor Card 0	
Processor Card 0 Processor 5		U1.1-P1-C1	00-05	On Processor Card 0	
Processor Card 1 Type 2, Front	M18	U1.1-P1-C2		System Back- plane	
Processor Card 1 All Cache		U1.1-P1-C2	00-00	On Processor Card 1	
Processor Card 1 Processor 6		U1.1-P1-C2	00-06	On Processor Card 1	
Processor Card 1 Processor 7		U1.1-P1-C2	00-07	On Processor Card 1	
Processor Card 1 Processor 8		U1.1-P1-C2	00-08	On Processor Card 1	
Processor Card 1 Processor 9		U1.1-P1-C2	00-09	On Processor Card 1	
Processor Card 1 Processor 10		U1.1-P1-C2	00-10	On Processor Card 1	
Processor Card 1 Processor 11		U1.1-P1-C2	00-11	On Processor Card 1	
R1 Memory Card Quad B, Rear	M11	U1.1-P1-M7	00-00	System Back- plane	
R1 Memory Card Quad C, Rear	M12	U1.1-P1-M8	00-00	System Back- plane	
R1 Memory Card Quad C, Rear	M13	U1.1-P1-M9	00-00	System Back- plane	
R1 Memory Card Quad C, Rear	M14	U1.1-P1-M10	00-00	System Back- plane	
R1 Memory Card Quad C, Rear	M15	U1.1-P1-M11	00-00	System Back- plane	
R1 Memory Card Quad D, Rear	M20	U1.1-P1-M12	00-00	System Back- plane	
R1 Memory Card Quad D, Rear	M21	U1.1-P1-M13	00-00	System Back- plane	
R1 Memory Card Quad D, Rear	M22	U1.1-P1-M14	00-00	System Back- plane	
R1 Memory Card Quad D, Rear	M23	U1.1-P1-M15	00-00	System Back- plane	
R1 Memory Card Quad A, Rear	M24	U1.1-P1-M16	00-00	System Back- plane	
Processor Card 2 Type 2, Rear	M06	U1.1-P1-C3		System Back- plane	

Processor Card 2 All Cache		U1.1-P1-C3	00-00	On Processor Card 2	
Processor Card 2 Processor 12		U1.1-P1-C3	00-12	On Processor Card 2	
Processor Card 2 Processor 13		U1.1-P1-C3	00-13	On Processor Card 2	
Processor Card 2 Processor 14		U1.1-P1-C3	00-14	On Processor Card 2	
Processor Card 2 Processor 15		U1.1-P1-C3	00-15	On Processor Card 2	
Processor Card 2 Processor 16		U1.1-P1-C3	00-16	On Processor Card 2	
Processor Card 2 Processor 17		U1.1-P1-C3	00-17	On Processor Card 2	
Processor Card 3 Type 2, Rear	M16	U1.1-P1-C4		System Back- plane	
Processor Card 3 All Cache		U1.1-P1-C4	00-00	On Processor Card 3	
Processor Card 3 Processor 18		U1.1-P1-C4	00-18	On Processor Card 3	
Processor Card 3 Processor 19		U1.1-P1-C4	00-19	On Processor Card 3	
Processor Card 3 Processor 20		U1.1-P1-C4	00-20	On Processor Card 3	
Processor Card 3 Processor 21		U1.1-P1-C4	00-21	On Processor Card 3	
Processor Card 3 Processor 22		U1.1-P1-C4	00-22	On Processor Card 3	
Processor Card 3 Processor 23		U1.1-P1-C4	00-23	On Processor Card 3	
Power Backplane		U1.1-P2			
Regulator Card Front	R01	U1.1-P2-V1		Power Back- plane	
Regulator Card Front	R02	U1.1-P2-V2		Power Back- plane	
Regulator Card Front	R03	U1.1-P2-V3		Power Back- plane	
Regulator Card Front	R04	U1.1-P2-V4		Power Back- plane	
Regulator Card Front	R05	U1.1-P2-V5		Power Back- plane	
Regulator Card Front	R06	U1.1-P2-V6		Power Back- plane	
Regulator Card Front	R07	U1.1-P2-V7		Power Back- plane	
Regulator Card Front	R08	U1.1-P2-V8		Power Back- plane	

Regulator Card Front	R09	U1.1-P2-V9		Power Back-plane	
Regulator Card Front	R10	U1.1-P2-V10		Power Back-plane	
SPCN Card Rear	R21	U1.1-P2-X1		Power Back-plane	
Blower1 Sense 1		U1.1-P2-X1/F1		On SPCN Card	
Blower2 Sense 2		U1.1-P2-X1/F2		On SPCN Card	
Blower3 Sense 3		U1.1-P2-X1/F3		On SPCN Card	
Blower4 Sense 4		U1.1-P2-X1/F4		On SPCN Card	
Blower1 Front	B01	U1.2-F1		Power Harness, J18	
Blower2 Front	B02	U1.2-F2		Power Harness, J19	
Blower3 Rear	B03	U1.2-F3		Power Harness, J20	
Blower4 Rear	B04	U1.2-F4		Power Harness, J21	
Bulk Power Supply 1 Front	P01	U1.2-V1		Power Harness, P01	
Bulk Power Supply 2 Front	P02	U1.2-V2		Power Harness, P02	
Bulk Power Supply 3 Front	P03	U1.2-V3		Power Harness, P03	
Bulk Power Supply 4 Front	P04	U1.2-V4		Power Harness, P04	
Bulk Power Supply 5 Front	P05	U1.2-V5		Power Harness, P05	
AC Power Rear and 5v standby AC Box	A01	U1.2-V7		Power Harness, P1, P7, P8, P9	

## I/O Drawer 0 Locations

FRU Name	Slot Name	Location Code	AIX Location Code	Physical Connection	Logical Connection
<b>I/O Drawer 0 Locations</b>					
I/O Drawer 0 (of 0 to 3)		U0.1			
I/O planar		U0.1-P1			
RIO Controller 0		U0.1-P1	00-00		
PCI Controller 1		U0.1-P1	00-f850-0000		
PCI slot 1		U0.1-P1-I1	20-58 or 20-58 to 20-5F or 2B-XX	I/O planar J13, 64 bit slot	PCI Controller 1
PCI slot 2		U0.1-P1-I2	20-60 or 20-60 to 20-67 or 2C-XX	I/O planar J4, 32 bit slot	PCI Controller 1
PCI slot 3		U0.1-P1-I3	20-68 or 20-68 to 20-6F or 2D-XX	I/O planar J5, 32 bit slot	PCI Controller 1
PCI slot 4		U0.1-P1-I4	20-70 or 20-70 to 20-77 or 2E-XX	I/O planar J6, 32 bit slot	PCI Controller 1
PCI Controller 0		U0.1-P1	00-f840-0000		
PCI slot 5		U0.1-P1-I5	10-58 or 10-58 to 10-5F or 1B-XX	I/O planar J14, 64 bit slot	PCI Controller 0
PCI slot 6		U0.1-P1-I6	10-60 or 10-60 to 10-67 or 1C-XX	I/O planar J7, 32 bit slot	PCI Controller 0
PCI slot 7		U0.1-P1-I7	10-68 or 10-68 to 10-6F or 1D-XX	I/O planar J8, 32 bit slot	PCI Controller 0
PCI slot 8 Service Processor		U0.1-P1-X1	10-70 or 10-70 to 10-77 or 1E-XX (not used by AIX)	I/O planar J9, 32 bit slot	PCI Controller 0
TOD		U0.1-P1-X1	Not used by AIX	On Service Processor	
BOOT		U0.1-P1-X1	Not used by AIX	On Service Processor	
JTAG		U0.1-P1-X1	Not used by AIX	On Service Processor	

VDISK		U0.1-P1-X1	Not used by AIX	On Service Processor	
NVRAM		U0.1-P1-X1	Not used by AIX	On Service Processor	
PCI slot 8, Service Processor ISA Bridge		U0.1-P1-X1	10-78 or 10-78 to 10-7f or 1F-XX (not used by AIX)	I/O planar J9, 32 bit slot	PCI Controller 0
PCI slot 8 Real Time Clock (RTC)		U0.1-P1-X1	Not used by AIX	On Service Processor	I/O ASIC SIO
PCI slot 8 Timer		U0.1-P1-X1	Not used by AIX	On Service Processor	I/O ASIC SIO
Interrupt Controller		U0.1-P1-X1	Not used by AIX	On Service Processor	I/O ASIC
DMA Controller		U0.1-P1-X1	Not used by AIX	On Service Processor	I/O ASIC
Diskette Controller		U0.1-P1-X1-D1	01-D1	On Service Processor	
Diskette Drive		U0.1-P1-X1/D1	01-D1-00-00	On Service Processor	
Keyboard Mouse Controller		U0.1-P1-X1/K1	01-K1	On Service Processor	
Keyboard		U0.1-P1-X1-K1	01-K1-00-00	On Service Processor	
Mouse Controller		U0.1-P1-X1/K1	01-K1-01	On Service Processor	
Mouse		U0.1-P1-X1-O1	01-K1-01-00	On Service Processor	
Parallel Port		U0.1-P1-X1/R1	01-R1	On Service Processor	
Serial Port 1		U0.1-P1-X1/S1	01-S1	On Service Processor	
Serial Port 2		U0.1-P1-X1/S2	01-S2	On Service Processor	
System Rack Operator Panel Cable				Service Processor J17	
PCI Controller 3		U0.1-P1	00-f870-0000		
PCI Slot 9		U0.1-P1-I9	40-58 or 40-58 to 40-5f or 4B-XX	I/O planar J15, 64 Bit slot	PCI Controller 3
PCI Slot 10		U0.1-P1-I10	40-60 or 40-60 to 40-67 or 4C-XX	I/O planar J16, 64 Bit slot	PCI Controller 3
PCI Controller 2		U0.1-P1	00-f860-0000		



PCI Slot 11		U0.1-P1-I11	30-58 or 30-58 to 30-5f or 3B-XX	I/O planar J10, 32 Bit slot	PCI Controller 2
PCI Slot 12		U0.1-P1-I12	30-60 or 30-60 to 30-67 or 3C-XX	I/O planar J11, 32 Bit slot	PCI Controller 2
PCI Slot 13		U0.1-P1-I13	30-68 or 30-68 to 30-6f or 3D-XX	I/O planar J12, 32 Bit slot	PCI Controller 2
PCI Slot 14		U0.1-P1-I14	30-70 or 30-70 to 30-77 or 3E-XX	I/O planar J17, 64 Bit slot	PCI Controller 2
Local ASIC Control Chip		U0.1-P1	30-78		
Local ASIC Control Chip		U0.1-P1	30-79		
Thermal Sensor		U0.1-P1		On I/O Planar	
RIO 0 Connector		U0.1-P1/Q1		I/O Drawer planar, J1	System Rack
RIO 1 Connector		U0.1-P1/Q2		I/O Drawer planar J2	System Rack
Speaker		U0.1-P1-X1-Q1		Service Processor J3	I/O planar (RL470A and EPC1200A only)
Left Power Supply (10 EIA Unit I/O Drawer when viewed from rear)		U0.1-V1		PDB J1	
Right Power Supply (10 EIA Unit I/O Drawer when viewed from rear)		U0.1-V2		PDB J2	
I/O Drawer Indicator Panel Card (10 EIA Unit I/O Drawer)		U0.1-L1		I/O Drawer Planar, J19 (10 EIA Unit I/O Drawer)	Cable to I/O planar
Fan Monitoring Card		U0.1-X2			Cable to PDB card
DASD Fan Assembly (two-fan assembly on left power supply when viewed from rear) (10 EIA Unit I/O Drawer)		U0.1-F1 U0.1-F2		Fan Monitoring Card J5	Fan Monitoring Card

DASD Fan Assembly (two-fan assembly on right power supply when viewed from rear) (10 EIA Unit I/O Drawer)		U0.1-F3 U0.1-F4		Fan Monitoring Card J5	Fan Monitoring Card
I/O Drawer Left Blower (10 EIA Unit I/O Drawer)		U0.1-F5		Fan Monitoring Card J2	Fan Monitoring Card
I/O Drawer Right Blower (10 EIA Unit I/O Drawer)		U0.1-F6		Fan Monitoring Card J4	Fan Monitoring Card
I/O Drawer Center Blower (10 EIA Unit I/O Drawer)		U0.1-F7		Fan Monitoring Card J3	Fan Monitoring Card
Interface (Bulkhead) Card		U0.1-P1-Q3		I/O planar, J3	
Power Distribution Board (10 EIA Unit I/O Drawer)		U0.1-X3			J22 to I/O Planar

## I/O Drawer 1 Locations

FRU Name	Slot Name	Location Code	AIX Location Code	Physical Connection	Logical Connection
<b>I/O Drawer 1 Locations</b>					
I/O Drawer 1 (of 0 to 3)		U0.2			
I/O planar		U0.2-P1			
RIO Controller 1		U0.2-P1	00-00		
PCI Controller 5		U0.2-P1	00-f8D0-0000		
PCI slot 1		U0.2-P1-I1	60-58 or 60-58 to 60-5F or 6B-XX	I/O planar J13, 64 bit slot	PCI Controller 5
PCI slot 2		U0.2-P1-I2	60-60 or 60-60 to 60-67 or 6C-XX	I/O planar J4, 32 bit slot	PCI Controller 5
PCI slot 3		U0.2-P1-I3	60-68 or 60-68 to 60-6F or 6D-XX	I/O planar J5, 32 bit slot	PCI Controller 5
PCI slot 4		U0.2-P1-I4	60-70 or 60-70 to 60-7f or 6E-XX	I/O planar J6, 32 bit slot	PCI Controller 5
PCI Controller 4		U0.2-P1	00-f8C0-0000		
PCI slot 5		U0.2-P1-I5	50-58 or 50-58 to 50-5F or 5B-XX	I/O planar J14, 64 bit slot	PCI Controller 4
PCI slot 6		U0.2-P1-I6	50-60 or 50-60 to 50-67 or 5C-XX	I/O planar J7, 32 bit slot	PCI Controller 4
PCI slot 7		U0.2-P1-I7	50-68 or 50-68 to 50-6f or 5D-XX	I/O planar J8, 32 bit slot	PCI Controller 4
PCI slot 8		U0.2-P1-I8	50-70 or 50-70 to 50-77 or 5E-XX	I/O planar J9, 32 bit slot	PCI Controller 4
PCI Controller 7		U0.2-P1	00-f8f0-0000		
PCI Slot 9		U0.2-P1-I9	80-58 or 80-58 to 80-5f or 8B-XX	I/O planar J15, 64 Bit slot	PCI Controller 7
PCI Slot 10		U0.2-P1-I10	80-60 or 80-60 to 80-67 or 8C-XX	I/O planar J16, 64 Bit slot	PCI Controller 7

PCI Controller 6		U0.2-P1	00-f8e0-0000		
PCI Slot 11		U0.2-P1-I11	70-58 or 70-58 to 70-5f or 7B-XX	I/O planar J10, 32 Bit slot	PCI Controller 6
PCI Slot 12		U0.2-P1-I12	70-60 or 70-60 to 70-77 or 7C-XX	I/O planar J11, 32 Bit slot	PCI Controller 6
PCI Slot 13		U0.2-P1-I13	70-68 or 70-68 to 70-6f or 7D-XX	I/O planar J12, 32 Bit slot	PCI Controller 6
PCI Slot 14		U0.1-P1-I14	70-70 or 70-70 to 70-77 or 7E-XX	I/O planar J17, 64 Bit slot	PCI Controller 6
Local ASIC control chip		U0.2-P1	70-78		
Local ASIC control chip		U0.2-P1	70-79		
Thermal Sensor		U0.2-P1		On I/O Planar	
RIO 0 Connector		U0.2-P1/Q1		I/O planar, J1	
RIO 1 Connector		U0.2-P1/Q2		I/O planar, J2	
Left Power Supply (10 EIA Unit I/O Drawer when viewed from rear)		U0.2-V1		PDB J1	
Right Power Supply (10 EIA Unit I/O Drawer when viewed from rear)		U0.2-V2		PDB J2	
I/O Drawer Indicator Panel Card (10 EIA Unit I/O Drawer)		U0.2-L1		I/O Drawer Pla- nar, J19 (10 EIA Unit I/O Drawer)	Cable to I/O planar
Fan Monitoring Card		U0.2-X2			Cable to PDB card
DASD Fan Assem- bly (two-fan assem- bly on left power supply when viewed from rear) (10 EIA Unit I/O Drawer)		U0.2-F1 U0.2-F2		Fan Monitoring Card J5	Fan Monitoring Card
DASD Fan Assem- bly (two-fan assem- bly on right power supply when viewed from rear) (10 EIA Unit I/O Drawer)		U0.2-F3 U0.2-F4		Fan Monitoring Card J5	Fan Monitoring Card

I/O Drawer Left Blower (10 EIA Unit I/O Drawer)		U0.2-F5		Fan Monitoring Card J2	Fan Monitoring Card
I/O Drawer Right Blower (10 EIA Unit I/O Drawer)		U0.2-F6		Fan Monitoring Card J4	Fan Monitoring Card
I/O Drawer Center Blower (10 EIA Unit I/O Drawer)		U0.2-F7		Fan Monitoring Card J3	Fan Monitoring Card
Interface (Bulkhead) Card		U0.2-P1-Q3		I/O planar, J3	
Power Distribution Board (10 EIA Unit I/O Drawer)		U0.2-X3			J22 to I/O Planar

## I/O Drawer 2 Locations

FRU Name	Slot Name	Location Code	AIX Location Code	Physical Connection	Logical Connection
<b>I/O Drawer 2 Locations</b>					
I/O Drawer 2 (of 0 to 3)		U0.3			
I/O planar		U0.3-P1			
RIO Controller 2		U0.3-P1	00-00		
PCI Controller 9		U0.3-P1	00-f950-0000		
PCI slot 1		U0.3-P1-I1	A0-58 or A0-58 to A0-5F or AB-XX	I/O planar J13, 64 bit slot	PCI Controller 9
PCI slot 2		U0.3-P1-I2	A0-60 or A0-60 to A0-67 or AC-XX	I/O planar J4, 32 bit slot	PCI Controller 9
PCI slot 3		U0.3-P1-I3	A0-68 or A0-68 to A0-6f or AD-XX	I/O planar J5, 32 bit slot	PCI Controller 9
PCI slot 4		U0.3-P1-I4	A0-70 or A0-70 to A0-77 or AE-XX	I/O planar J6, 32 bit slot	PCI Controller 9
PCI Controller 8		U0.3-P1	00-f940-0000		
PCI slot 5		U0.3-P1-I5	90-58 or 90-58 to 90-5F or 9B-XX	I/O planar J14, 64 bit slot	PCI Controller 8
PCI slot 6		U0.3-P1-I6	90-60 or 90-60 to 90-67 or 9C-XX	I/O planar J7, 32 bit slot	PCI Controller 8
PCI slot 7		U0.3-P1-I7	90-68 or 90-68 to 90-6f or 9D-XX	I/O planar J8, 32 bit slot	PCI Controller 8
PCI slot 8		U0.3-P1-I8	90-70 or 90-70 to 90-77 or 9E-XX	I/O planar J9, 32 bit slot	PCI Controller 8
PCI Controller 11		U0.3-P1	00-f970-0000		
PCI Slot 9		U0.3-P1-I9	C0-58 or C0-58 to C0-5f or CB-XX	I/O planar J15, 64 Bit slot	PCI Controller 9
PCI Slot 10		U0.3-P1-I10	C0-60 or C0-60 to C0-67 or CC-XX	I/O planar J16, 64 Bit slot	PCI Controller 9

PCI Controller 10		U0.3-P1	00-f960-0000		
PCI Slot 11		U0.3-P1-I11	B0-58 or B0-58 to B0-5f or BB-XX	I/O planar J10, 32 Bit slot	PCI Controller 10
PCI Slot 12		U0.3-P1-I12	B0-60 or B0-60 to B0-67 or BC-XX	I/O planar J11, 32 Bit slot	PCI Controller 10
PCI Slot 13		U0.3-P1-I13	B0-68 or B0-68 to B0-6f or BD-XX	I/O planar J12, 32 Bit slot	PCI Controller 10
PCI Slot 14		U0.3-P1-I14	B0-70 or B0-70 to B0-77 or BE-XX	I/O planar J17, 64 Bit slot	PCI Controller 10
Local ASIC Control Chip		U0.3-P1	B0-78		
Local ASIC Control Chip		U0.3-P1	B0-79		
Thermal Sensor		U0.3-P1		On I/O Planar	
RIO 0 Connector		U0.3-P1/Q1		I/O planar, J1	
RIO 1 Connector		U0.3-P1/Q2		I/O planar, J2	
Left Power Supply (10 EIA Unit I/O Drawer when viewed from rear)		U0.3-V1		PDB J1	
Right Power Supply (10 EIA Unit I/O Drawer when viewed from rear)		U0.3-V2		PDB J2	
I/O Drawer Indicator Panel Card (10 EIA Unit I/O Drawer)		U0.3-L1		I/O Drawer Pla- nar, J19 (10 EIA Unit I/O Drawer)	Cable to I/O planar
Fan Monitoring Card		U0.3-X2			Cable to PDB card
DASD Fan Assem- bly (two-fan assem- bly on left power supply when viewed from rear) (10 EIA Unit I/O Drawer)		U0.3-F1 U0.3-F2		Fan Monitoring Card J5	Fan Monitoring Card
DASD Fan Assem- bly (two-fan assem- bly on right power supply when viewed from rear) (10 EIA Unit I/O Drawer)		U0.3-F3 U0.3-F4		Fan Monitoring Card J5	Fan Monitoring Card

I/O Drawer Left Blower (10 EIA Unit I/O Drawer)		U0.3–F5		Fan Monitoring Card J2	Fan Monitoring Card
I/O Drawer Right Blower (10 EIA Unit I/O Drawer)		U0.3–F6		Fan Monitoring Card J4	Fan Monitoring Card
I/O Drawer Center Blower (10 EIA Unit I/O Drawer)		U0.3–F7		Fan Monitoring Card J3	Fan Monitoring Card
Interface (Bulkhead) Card		U0.3–P1–Q3		I/O planar, J3	
Power Distribution Board (10 EIA Unit I/O Drawer)		U0.3–X3			J22 to I/O Planar



## I/O Drawer 3 Locations

FRU Name	Slot Name	Location Code	AIX Location Code	Physical Connection	Logical Connection
<b>I/O Drawer 3 Locations</b>					
I/O Drawer 3 (of 0 to 3)		U0.4			
I/O planar		U0.4-P1			
RIO Controller 3		U0.4-P1	00-00		
PCI Controller 13		U0.4-P1	00-f9D0-0000		
PCI slot 1		U0.4-P1-I1	E0-58 or E0-58 to E0-5F or EB-XX	I/O planar J13, 64 bit slot	PCI Controller 13
PCI slot 2		U0.4-P1-I2	E0-60 or E0-60 to E0-67 or EC-XX	I/O planar J4, 32 bit slot	PCI Controller 13
PCI slot 3		U0.4-P1-I3	E0-68 or E0-68 to E0-6f or ED-XX	I/O planar J5, 32 bit slot	PCI Controller 13
PCI slot 4		U0.4-P1-I4	E0-70 or E0-70 to E0-77 or EE-XX	I/O planar J6, 32 bit slot	PCI Controller 13
PCI Controller 12		U0.4-P1	00-f9c0-0000		
PCI slot 5		U0.4-P1-I5	D0-58 or D0-58 to D0-5f or DB-XX	I/O planar J14, 64 bit slot	PCI Controller 12
PCI slot 6		U0.4-P1-I6	D0-60 or D0-60 to D0-67 or DC-XX	I/O planar J7, 32 bit	PCI Controller 12
PCI slot 7		U0.4-P1-I7	D0-68 or D0-68 to D0-6f or DD-XX	I/O planar J8, 32 bit	PCI Controller 12
PCI slot 8		U0.4-P1-I8	D0-70 or D0-70 to D0-77 or DE-XX	I/O planar J9, 32 bit	PCI Controller 12
PCI Controller 15		U0.4-P1	00-f9f0-0000		
PCI Slot 9		U0.4-P1-I9	G0-58 or G0-58 to G0-5f or GB-XX	I/O planar J15, 64 Bit	PCI Controller 15
PCI Slot 10		U0.4-P1-I10	G0-60 or G0-60 to G0-67 or GC-XX	I/O planar J16, 64 Bit	PCI Controller 15

PCI Controller 14		U0.4-P1	00-f9E0-0000		
PCI Slot 11		U0.4-P1-I11	F0-58 or F0-58 to F0-5f or FB-XX	I/O planar J10, 32 Bit	PCI Controller 14
PCI Slot 12		U0.4-P1-I12	F0-60 or F0-60 to F0-67 or FC-XX	I/O planar J11, 32 Bit	PCI Controller 14
PCI Slot 13		U0.4-P1-I13	F0-68 or F0-68 to F0-6f or FD-XX	I/O planar J12, 32 Bit	PCI Controller 14
PCI Slot 14		U0.4-P1-I14	F0-70 or F0-70 to F0-77 or FE-XX	I/O planar J17, 64 Bit	PCI Controller 14
Local ASIC control chip		U0.4-P1	F0-78		PCI Controller 14
Local ASIC control chip		U0.4-P1	F0-79		PCI Controller 14
Thermal Sensor		U0.4-P1		On I/O Planar	
RIO 0 Connector		U0.4-P1/Q1		I/O planar J1	
RIO 1 Connector		U0.4-P1/Q2		I/O planar J2	
Left Power Supply (10 EIA Unit I/O Drawer when viewed from rear)		U0.4-V1		PDB J1	
Right Power Supply (10 EIA Unit I/O Drawer when viewed from rear)		U0.4-V2		PDB J2	
I/O Drawer Indicator Panel Card (10 EIA Unit I/O Drawer)		U0.4-L1		I/O Drawer Pla- nar, J19 (10 EIA Unit I/O Drawer)	Cable to I/O planar
Fan Monitoring Card		U0.4-X2			Cable to PDB card
DASD Fan Assem- bly (two-fan assem- bly on left power supply when viewed from rear) (10 EIA Unit I/O Drawer)		U0.4-F1 U0.4-F2		Fan Monitoring Card J5	Fan Monitoring Card
DASD Fan Assem- bly (two-fan assem- bly on right power supply when viewed from rear) (10 EIA Unit I/O Drawer)		U0.4-F3 U0.4-F4		Fan Monitoring Card J5	Fan Monitoring Card

I/O Drawer Left Blower (10 EIA Unit I/O Drawer)		U0.4-F5		Fan Monitoring Card J2	Fan Monitoring Card
I/O Drawer Right Blower (10 EIA Unit I/O Drawer)		U0.4-F6		Fan Monitoring Card J4	Fan Monitoring Card
I/O Drawer Center Blower (10 EIA Unit I/O Drawer)		U0.4-F7		Fan Monitoring Card J3	Fan Monitoring Card
Interface (Bulkhead) Card		U0.4-P1-Q3		I/O planar, J3	
Power Distribution Board (10 EIA Unit I/O Drawer)		U0.4-X3			J22 to I/O Planar



---

## Chapter 6. Introduction to Tasks and Service Aids

The AIX Diagnostic Package contains programs that are called Tasks. Tasks can be thought of as "performing a specific function on a resource"; for example, running diagnostics, or performing a service aid on a resource. This chapter refers to the Tasks available in AIX Diagnostics Version 4.2 and later.

**Note:** Many of these programs work on all system model architectures. Some programs are only accessible from Online Diagnostics in Service or Concurrent mode, others may be accessible only from Standalone Diagnostics. While still other programs may only be supported on a particular system architecture, such as CHRP (Common Hardware Reference Platform), or RSPC (PowerPC Reference Platform). ESCALA EPC2400 uses CHRP architecture.

To perform one of these tasks, use the Task Selection option from the FUNCTION SELECTION menu.

Once a task is selected, a resource menu may be presented showing all resources supported by the task.

A fast path method is also available to perform a task by using the diag command and the -T flag. This means the user does not have to go through most of the introductory menus just to get to a particular task. Instead, the user is presented with a list of resources available to support the specified task. The current fast path tasks are:

- Certify – certifies media
- Chkspares – checks for the availability of spare sectors
- Download – downloads microcode to an adapter or device
- Disp\_mcode – displays current level of microcode
- Format – formats media
- Identify – identifies the PCI RAID physical disks

To run these tasks directly from the command line, specify the resource and other task unique flags. Use the descriptions in Chapter 27 of "*Diagnostic Information for Multiple Bus Systems*" to understand which flags are needed for a given task.

For more information about Tasks and Service Aids, refer to "*Diagnostic Information for Multiple Bus Systems*", order number 86 A1 26HX, revision level 07 or higher.

### Tasks

- Add Resource to Resource List
- AIX Shell Prompt
- Analyze Adapter Internal Log
- Backup and Restore Media
- Certify Media
- Change Hardware Vital Product Data
- Configure Dials and LPFKeys
- Configure ISA Adapters
- Configure Reboot Policy
- Configure Remote Maintenance Policy
- Configure Ring Indicate Power On
- Configure Ring Indicate Power On Policy
- Configure Service Processor (RSPC)
- Configure Surveillance Policy
- Create Customized Configuration Diskette
- Delete Resource from Resource List
- Disk Maintenance

Display Configuration and Resource List  
Display Firmware Device Node Information  
Display Hardware Error Report  
Display Hardware Vital Product Data  
Display Machine Check Error Log  
Display Microcode Level  
Display or Change Bootlist  
Display or Change Diagnostic Run Time Options  
Display Previous Diagnostic Results  
Display Resource Attributes  
Display Service Hints  
Display Software Product Data  
Display System Environmental Sensors  
Display Test Patterns  
Download Microcode  
Flash SK-NET FDDI Firmware  
Format Media  
Generic Microcode Download  
Local Area Network Analyzer  
Periodic Diagnostics  
Process Supplemental Media  
Run Diagnostics  
Run Error Log Analysis  
Run Exercisers  
Save or Restore Hardware Management Policies  
Save or Restore Service Processor Configuration  
SCSI Bus Analyzer  
SCSI Device Identification and Removal  
SCSD Tape Drive Service Aid  
Spare Sector Availability  
Update Disk Based Diagnostics  
Update System or Service Processor Flash  
Update System Flash

---

# Chapter 7. Using the System Verification Procedure

The system verification procedure is used to check the system for correct operation. When you are analyzing a hardware problem, you should use Chapter 8. "Hardware Problem Determination".

---

## Step 1. Considerations before Running This Procedure

### Notes:

1. If this system unit is directly attached to another system unit or attached to a network, be sure communications with the other system unit is stopped.
2. This procedure requires use of all of the system resources. No other activity can be running on the system while you are doing this procedure.
  - This procedure requires a display connected to the video port or an ASCII terminal attached to the S1 port.
  - Before starting this procedure, you should stop all programs and the operating system.
  - This procedure runs the Online Diagnostics in Service mode or Standalone Diagnostics. If the Online Diagnostics are installed, they should be run. See the operator manual for your type of ASCII terminal to find the key sequences you need in order to respond to the diagnostics.
  - If you need more information about diagnostics see Chapter 5. "Using the Online and Standalone Diagnostics".
  - If a console display is not selected, the diagnostics stop. The instructions for selecting a console display are displayed on all of the graphic displays and any terminal attached to the S1 port. Follow the displayed instructions to select a console display.
  - Go to Step 2.

---

## Step 2. Loading the Diagnostics

1. Stop all application programs running on the operating system.
2. Stop the operating system.
3. Turn the power off.
4. If you are loading the Standalone Diagnostics and running them from an ASCII terminal:
  - The attributes for the terminal must be set to match the defaults of the diagnostics.
  - If you need to change any settings, record the normal settings, and be sure the terminal attributes are set to work with the diagnostics. If needed, see "Running the Diagnostics from a TTY Terminal" on page 5-2.
  - Return to substep 5 when you finish checking the attributes.
5. Turn the power on.
  - a. When the keyboard indicator appears, press F5 on the direct attached keyboard (5 on the ASCII keyboard) to load the Standalone Diagnostics or F6 on the directly-attached keyboard (6 on the ASCII terminal keyboard) to load the Online Diagnostics.
  - b. Enter any requested passwords.
  - c. Follow any instructions to select a console.

6. When the Diagnostic Operating Instructions display, go to Step 3. If you are unable to load the diagnostics, go to "Problem Determination When Unable to Load Diagnostics" on page 8-7.

---

## Step 3. Running System Verification

The Diagnostic Operating Instructions should be displayed.

1. Press the Enter key.
2. If the terminal type has not been defined, you must use the Initialize Terminal option on the Function Selection menu to initialize the operating system environment before you can continue with the diagnostics.
3. If you want to do a general checkout without much operator action, Select the Diagnostic Routines option on the Function Selection menu.

If you want to do a more complete checkout including the use of wrap plugs, select the Advanced Diagnostics option on the Function Selection menu. The advanced diagnostics are primarily for the service representative; they may instruct you to install wrap plugs to better isolate a problem.

4. Select the System Verification option on the Diagnostic Mode Selection menu.
5. If you want to run a general checkout of all installed resources, Select the All Resource option on the Diagnostic Selection menu.

If you want to check one particular resource, select that resource on the Diagnostic Selection menu.

6. Go to Step 4.

---

## Step 4. Additional System Verification

The checkout programs end with either the Testing Complete menu and a message stating No trouble was found or the A Problem Was Detected On (Time Stamp) menu with an SRN.

1. Press Enter to return to the Diagnostic Selection menu.
2. If you want to check other resources, select the resource. When you have checked all of the resources you need to check, go to Step 5.

---

## Step 5. Stopping the Diagnostics

1. If running Online diagnostics, the system first should be shut down using the following procedure:
  - a. Press F3 repeatedly until you get to the Diagnostic Operating Instructions, then follow the displayed instructions.
  - b. Press F3 once, and then follow the displayed instructions to shut down system.
2. If you changed any attributes on your ASCII terminal to run the diagnostics, change the settings back to normal.
3. This completes the system verification. Report the SRN to the service organization if you received one. To do a normal boot, turn off the system unit and wait 30 seconds, and then set the power switch of the system unit to On.



---

## Chapter 8. Hardware Problem Determination

This chapter provides information on using Standalone or Online Diagnostics. In addition, it also provides a list of error codes and recommended actions the user can perform to resolve the problem before contacting a service representative.

The manufacturer recommends that systems configured with 4GB of memory or greater have access to a 4mm or 8mm tape drive for submission of system dump information if required. This function may be accomplished through locally attached or network attached devices as appropriate.

---

### Problem Determination Using the Standalone or Online Diagnostics

Use this procedure to obtain a service request number (SRN) when you are able to load the Standalone or Online Diagnostics. If you are unable to load the Standalone or Online Diagnostics, go to "Problem Determination When Unable to Load Diagnostics" on page 8-7. The service organization uses the SRN to determine which field replaceable units (FRUs) are needed to restore the system to correct operation.

---

#### Step 1. Considerations before Running This Procedure

**Note:** See the operator manual for your ASCII terminal to find the key sequences you need to respond to the diagnostic programs.

- The diagnostics can use a display connected to a display adapter with the keyboard and mouse connected to the primary I/O Drawer or an ASCII terminal attached to a serial port.
- This procedure asks you to select the type of diagnostics you want to run. If you need more information about the types, see "Standalone and Online Diagnostics Operating Considerations" on page 5-1.
- Go to "Step 2".

---

#### Step 2

**Are the Online Diagnostics installed on this system?**

**NO**            Go to "Step 15".

**YES**            Go to "Step 3".

---

## Step 3

Determine if the operating system is accepting commands.

### Is the operating system accepting commands?

- NO**            The system must be turned off in order to run diagnostics.
1. Verify with the system administration and users that the system may be turned off. If so, then turn off the system unit and go to "Step 6".
- YES**            Go to "Step 4".

---

## Step 4

Diagnostic tests can be run on many resources while the operating system is running. However, more extensive problem isolation is obtained by running Online Diagnostics in Service mode.

### Do you want to run the Online Diagnostics in Service mode?

- NO**            Go to "Step 5".
- YES**            Do the following to shut down your system:
1. At the system prompt, stop the operating system using the proper command for your operating system. For AIX systems, use the shutdown -F command.
  2. After the operating system is stopped, power off the system unit. See "Powering Off the System" on page 2-2.
  3. Go to "Step 6".

---

## Step 5

This step invokes the Online Diagnostics in concurrent mode.

1. Log on as `root` or as `superuser`.
2. Enter the `diag` command.
3. Wait until the Diagnostic Operating Instructions are displayed, or wait for three minutes.

### Are the Diagnostic Operating Instructions displayed without any obvious console display problems?

- NO**            Do the following to shut down your system:
1. At the system prompt, stop the operating system using the proper command for your operating system. For AIX systems, use the `shutdown -F` command.
  2. After the operating system is stopped, power off the system unit. See "Powering Off the System" on page 2-2.
  3. Go to "Step 6".
- YES**            Go to "Step 9".

---

## Step 6

This step loads Online Diagnostics in service mode. If you are unable to load the diagnostics, go to "Step 7".

1. Turn the power on.
2. When the keyboard indicator (icon or text) appears, press F6 on the directly-attached keyboard or 6 on the ASCII terminal keyboard to indicate that diagnostics are to be loaded.
3. Enter any requested passwords.
4. Follow any instructions to select a console.

**Did the Diagnostics Operating Instructions display without any obvious display problem?**

- NO**            Go to "Step 7".  
**YES**            Go to "Step 9".

---

## Step 7

Starting at the top of the following table, find your symptom and follow the instructions given in the Action column.

Symptom	Action
Display problem.	Go to "Step 8".
All other symptoms.	Go to "Problem Determination When Unable to Load Diagnostics" on page 8-7

---

## Step 8

The following steps analyze a console display problem.

Find your type of console display in the following table, then follow the instructions given in the Action column.

Console Display	Action
Display Device	Go to the display documentation for problem determination.
ASCII terminal	Go to the documentation for problem determination for this type of terminal.

---

## Step 9

The diagnostics loaded correctly.

Press the Enter key.

**Is the Function Selection menu displayed?**

- NO**            Go to "Step 10".  
**YES**            Go to "Step 11".

---

## Step 10

There is a problem with the keyboard.

Find the type of keyboard you are using in the following table, then follow the instructions given in the Action column.

Keyboard Type	Action
101–key keyboard. Identify by the type of Enter key used. The Enter key is within one horizontal row of keys.	Record error code M0KBD001 and report the problem to the service organization.
102–key keyboard. Identify by the type of Enter key used. The Enter key extends into two horizontal rows of keys.	Record error code M0KBD002 and report the problem to the service organization.
Kanji keyboard. Identify by the Japanese characters.	Record error code M0KBD003 and report the problem to the service organization.
ASCII–terminal keyboard. This applies to all attached terminals.	Go to the documentation for problem determination for this type terminal.

---

## Step 11

1. If the terminal type has not been defined, you must use the `Initialize Terminal` option on the Function Selection menu to initialize the operating system environment before you can continue with the diagnostics. This is a separate and different operation than selecting the console display.
2. Select `Diagnostic Routines`.
3. Press the Enter key.
4. In the following table, find the menu or system response you received when you selected `Diagnostics`. Follow the instructions given in the Action column.

System Response	Action
The Diagnostic Mode Selection menu is displayed.	Select Problem Determination and go to "Step 12".
The Missing Resource menu is displayed.	Follow the displayed instructions until either the Diagnostic Mode Selection menu or an SRN is displayed.  If the Diagnostic Mode Selection menu is displayed, select Problem Determination and go to "Step 12".  If you get an SRN, record it, and go to "Step 14".

The New Resource menu is displayed.	<p>Follow the displayed instructions.</p> <p>Note: Devices attached to serial ports S1 or S2 will not appear on the New Resource menu.</p> <p>If the Diagnostic Mode Selection menu is displayed, select Problem Determination and go to "Step 12".</p> <p>If you get an SRN, record it, and go to "Step 14".</p> <p>If you do not get an SRN, go to "Step 17".</p>
The system does not respond to selecting diagnostics	Go to "Step 10".

## Step 12

### Did the Diagnostic Selection Menu display?

- NO** If Problem Determination was selected from the Diagnostic Mode Selection menu, and if a recent error has been logged in the error log, the diagnostics automatically begin testing the resource.
- Follow the displayed instructions.
- If the No Trouble Found screen is displayed, press Enter.
- If another resource is tested, repeat this step.
- If the Diagnostic Selection menu is displayed, go to "Step 13".
- If an SRN is displayed, record it, and go to "Step 14".
- YES** Go to "Step 13".

## Step 13

The All Resources option checks most of the configured adapters and devices.

Select and run the diagnostic tests on the resources you are having problems with or select the All Resources option check all of the configured resources. Find the response in the following table and take the Action for it.

Diagnostic Response	Action
An SRN is displayed.	Go to "Step 14".
The system hangs.	Report SRN 109–200.
The Testing Complete menu and the No trouble was found message is displayed, and you have not tested all of the resources.	Press Enter and continue with the testing.
The Testing Complete menu and the No trouble was found message displayed and you have tested all of the resources.	Go to "Step 17".

---

## Step 14

The diagnostics produced an SRN for this problem.

1. Record the SRN and other numbers read out.
2. Report the SRN to the service organization.
3. **STOP.** You have completed these procedures.

---

## Step 15

When you are loading the Standalone Diagnostics, the attributes for the terminal must be set to match the defaults of the diagnostic programs. The ASCII terminal must be attached to serial port 1 on the system unit.

**Are you going to load Standalone Diagnostics and run them from a ASCII terminal?**

- NO**            Go to "Step 16".
- YES**            Go to "Running the Diagnostics from a TTY Terminal" on page 5-2 and be sure your terminal attributes are set to work with the diagnostic programs.
- Return to "Step 16" when you finish checking the attributes. Record any settings that are changed.

---

## Step 16

This step loads the Standalone Diagnostics. If you are unable to load the diagnostics, go to "Step 7".

1. Turn the power on.
2. Insert the diagnostic CD-ROM into the CD-ROM drive in the primary I/O Drawer.
3. When the keyboard indicator appears, press F5 on the direct attached keyboard or 5 on the ASCII keyboard to indicate that diagnostics are to be loaded.
4. Enter any requested passwords.
5. Follow any instructions to select a console.

**Did the Diagnostics Operating Instructions display without any obvious display problem?**

- NO**            Go to "Step 7".
- YES**            Go to "Step 9".

---

## Step 17

The diagnostics did not find a hardware problem. If you still have a problem, contact your software support center.

---

## Problem Determination When Unable to Load Diagnostics

Use this procedure to obtain an error code. The service organization uses the error code to determine which field replaceable units (FRUs) are needed to restore the system to correct operation.

---

### Step 1. Considerations before Running This Procedure

- The diagnostics can use a display connected to a display adapter with the keyboard and mouse connected to the primary I/O Drawer or an ASCII terminal attached to a serial port.
- Go to "Step 2".

---

### Step 2

Are the Online Diagnostics installed on this system?

- NO**            Go to "Step 4".  
**YES**            Go to "Step 3".

---

### Step 3

This step attempts to load Online Diagnostics in service mode.

1. Turn the power off.
2. Turn the power on.
3. If the keyboard indicator appears, press F6 on the direct attached keyboard or 6 on the ASCII keyboard to indicate that diagnostics are to be loaded.
4. Enter any requested passwords.
5. Follow any instructions to select a console.
6. Wait until the diagnostics load or the system appears to stop.

**Did the diagnostics load?**

- NO**            Go to "Step 5".  
**YES**            Go to "Step 6".

---

### Step 4

This step attempts to load the Standalone diagnostics.

1. Turn the power off.
2. Turn the power on.
3. Insert the diagnostic CD-ROM into the CD-ROM drive.
4. If the keyboard indicator appears, press F5 on the direct attached keyboard or 5 on the ASCII keyboard to indicate that diagnostics are to be loaded.
5. Enter any requested passwords.
6. Follow any instructions to select a console.
7. Wait until the diagnostics load or the system appears to stop.

## Did the diagnostics load?

**NO**            Go to "Step 5".

**YES**            Go to "Step 6".

---

## Step 5

Starting at the top of the following table, find your symptom and follow the instructions given in the Action column.

Symptom	Action
The operator panel power LED does not come on, or comes on and does not stay on.	Check the power cable to the outlet. Check the circuit breakers and check for power at the outlet.  Assure the room temperature is within 60 – 90°F.  If you do not find a problem, record error code M0PS0000 and report the problem to the service organization.
The system stops with the Diagnostic Operating Instructions displayed.	Go to "Step 6".
The system stops with a prompt to enter a password.	Enter the password. You are not be allowed to continue until a correct password has been entered. When you have entered a valid password, wait for one of the other conditions to occur.
The system stops with a three, four or eight–digit error code(s) displayed on the console.	Refer to "Error Codes" on page 8-9 and see if your error code is listed. If it is, perform the recommended action. If the error code is not listed, report the error code to your service representative.
The system login prompt is displayed.	You may not have pressed the correct key or you may not have pressed the key soon enough when you were to indicate a Service Mode boot of diagnostic programs. If this was the case, start over at the beginning of this step.  If you are sure you pressed the correct key in a timely manner go to Step 7.
The system does not respond when the password is entered.	Go to Step 7.
The system stopped and an indicator is displayed on the system console and an eight–digit error code is not displayed.	If the indicator (text or icon) represents: <ul style="list-style-type: none"><li>· a keyboard, record error code M0KBD000 and report the problem to the service organization.</li><li>· memory, record error code M0MEM002 and report the problem to the service organization.</li><li>· SCSI, record error code M0CON000 and report the problem to the service organization.</li><li>· Network, record error code M0NET000 and report the problem to the service organization.</li><li>· Speaker/Audio, record error code M0BT0000 and report the problem to the service organization.</li></ul>



The System Management Services menu is displayed.	The device or media you are attempting to boot from may be faulty. 1. Check the SMS error log for any errors. To check the error log: · Choose tools · Choose error log · If an error is logged, check the time stamp. · If the error was logged during the current boot attempt, record it and report it to your service person. · If no recent error is logged in the error log, continue to the next step below. 2. If you are attempting to load the Online Diagnostics, try loading the Standalone Diagnostics. Otherwise, record error code M0SCSI00 and report to the service organization.
The system stops and the message "STARTING SOFTWARE PLEASE WAIT ..." is displayed.	Report error code M0BT0001.
The message "The system will now continue the boot process" is displayed continuously on the system unit's console.	Report error code M0SCSI01.

## Step 6

The diagnostics loaded correctly.

Go to "Problem Determination Using the Standalone or Online Diagnostics" on page 8-1.

## Step 7

There is a problem with the keyboard.

Find the type of keyboard you are using in the following table, then follow the instructions given in the Action column.

Keyboard Type	Action
101-key keyboard. Identify by the type of Enter key used. The Enter key is within one horizontal row of keys.	Record error code M0KBD001 and report the problem to the service organization.
102-key keyboard. Identify by the type of Enter key used. The Enter key extends into two horizontal rows of keys.	Record error code M0KBD002 and report the problem to the service organization.
Kanji keyboard. Identify by the Japanese characters.	Record error code M0KBD003 and report the problem to the service organization.
ASCII-terminal keyboard. This applies to all attached terminals.	Go to the documentation for problem determination for this type terminal.

## Error Codes

The following table lists error codes that you may encounter, and the actions to perform to correct the reported error.

Table 8–1. Firmware Error Codes.

<i>Table 8-1 (Page 1 of 5). Firmware Error Codes.</i>		
<b>Error Code</b>	<b>Description</b>	<b>Action</b>
20A80000	Insufficient information to boot.	Verify the IP address.
20A80001	Client IP address is already in use by other network device	Change IP address.
20A80005	File transmission (TFTP) failed.	Check network connection, try again.
20E00001	Privileged–access password entry error.	The password has been entered incorrectly. Retry installing the password.
20E00009	Invalid password entered – system locked	The password has been entered incorrectly 3 times. Turn off, then turn on the system unit, then enter the password correctly.
20EE0003	IP parameter requires 3 dots "."	Enter valid IP parameter. Example: 000.000.000.000
20EE0004	Invalid IP parameter	Enter valid IP parameter. Example: 000.000.000.000
20EE0005	Invalid IP parameter (255)	Enter valid IP parameter. Example: 255.192.002.000
20EE0007	Keyboard not found	Plug in keyboard.
20EE0008	No configurable adapters found in the system	This warning occurs when the selected SMS function cannot locate any devices/ adapters supported by the function. If a supported device is installed, contact your service representative.
20EE000B	The system was not able to find an operating system on the device list that was attempted.	Modify the Boot Sequence (also known as boot list) to include devices that are known to contain a copy of the Operating System. This can be accomplished by using the System Management Services Menus. For example, select a hard disk known to have a copy of the Operating System as the first and only device in the boot sequence (boot list) and attempt to boot again.

Table 8-1 (Page 2 of 5). Firmware Error Codes.

20EE000C	Pointer to the operating system found in non-volatile storage.	<p>Values normally found in non-volatile storage that point to the location of an Operating System were not found. This can happen for two reasons, either your installed Operating System doesn't support storing the values or some event occurred that caused the system to lose non-volatile storage information (drainage or replacement of the battery). If you are running AIX, this information can be reconstructed by running the bootlist command specifying the device that the Operating System is installed on. Please refer to your AIX documentation for the exact syntax and usage of the bootlist command.</p> <p>In order to boot the Operating System so that the above mentioned values can be reconstructed, power the system down and power it back up again, this should cause the system to look for the Operating System in the devices contained in the custom boot list or in the default boot list, depending on the condition of the system. If this is not successful, modify the Boot Sequence (also known as boot list) to include devices that are known to contain a copy of the Operating System. This can be accomplished by using the System Management Services Menus. For example, select a hard disk known to have a copy of the Operating System as the first and only device in the boot sequence (boot list) and attempt to boot again.</p>
25A80001	Init-nvram invoked, ALL of NVRAM initialized	<p>Errors reported against NVRAM can be caused by low battery voltage and (more rarely) power outages that occur during normal usage. These errors are generally warnings that the NVRAM data content had to be re-established, and do not require any further action unless the error is persistent. When one of these errors occurs, any system customization (for example, boot device list) information may have been lost. The system may need to be reconfigured. Call your service representative if the problem is persistent.</p>
25A80002	Init-nvram invoked, some data partitions may have been preserved.	Refer to Action under error code 25A80001.
25A80011	Data corruption detected, ALL of NVRAM initialized	Refer to Action under error code 25A80001.

25A80012	Data corruption detected, some data partitions may have been preserved.	Refer to Action under error code 25A80001.
25A80100	NVRAM data validation check failed.	Turn off, turn on system unit and retry the operation before replacing any system component.  Refer to Action under error code 25A80001.
25A80210	Setenv/\$Setenv parameter error – name contains a null character.	Refer to Action under error code 25A80001.
25A80211	Setenv/\$Setenv parameter error – value contains a null character.	Refer to Action under error code 25A80001.
25A80998	NVRAMRC script evaluation error – command line execution error	<p>Execution of a command line within the nvram configuration variable "nvramrc" (script) resulted in a "throw" being executed. This script can be modified by the system firmware <b>SMS</b> utilities, the operating system, PCI adapter rom code or utility, or an operator (via the open firmware script editing command "nvedit"). It may not be possible to resolve the problem without a detailed analysis of the nvram script, the current system configuration, and device tree contents.</p> <p>1.The problem can be caused by a SCSI adapter,whose SCSI bus ID has been changed from the default setting, no longer appearing in the system. This can be caused either by removing a SCSI adapter, or a problem with a SCSI adapter.</p> <p style="padding-left: 2em;">a.Select the "SCSI ID" utility from the <b>SMS</b> menu(s).</p> <p style="padding-left: 4em;">1.Verify the list of SCSI controllers/adapters. If the list is not correct, suspect a problem with the adapter(s) installed but not listed.</p> <p style="padding-left: 4em;">2. Select the option to "Save" the configuration information.</p> <p style="padding-left: 4em;">3.Restart the system.</p> <p style="padding-left: 2em;">b.If the problem persists, boot the operating system and verify the SCSI bus IDs of any installed/available SCSI controllers (change as necessary), and restart the system.</p> <p>2.Contact your service support representative for further assistance.</p>

Table 8-1 (Page 4 of 5). Firmware Error Codes.

28030001	RTC not updating – RTC initialization required	Errors reported against the Real Time Clock can be caused by low Battery voltage and (more rarely) power outages that occur during normal system usage. These errors are warnings that the Real Time Clock data content needs to be re-established and do not require any FRU replacement unless the error is persistent. When one of these errors occurs, the Time and Date information has been lost.  · To set/restore the Time and Date, use the Operating System facility.  If the error is persistent, contact your service representative.
28030002	Bad time/date values	Set/restore Time and Date using the Operating System.
28030004	RTC operating mode parameters (eg. data mode) changed	1. Set Time and Date. 2. Refer to Action under error code 28030002.
2BA00013	Service processor reports bad NVRAM CRC	If problem persists, contact your service representative.
40B00000	Operating system surveillance interval exceeded.	1. Surveillance mode control is from the Service Processor(SP) Menus. Verify that the Operating System (OS) Heartbeat Utility is installed and has been activated. 2. Check for errors or unusual conditions that might prevent the OS from reporting Heartbeat messages; such as system dump, machine check or checkstop error. Review the error logs. 3. If the problem persists, call the support center for assistance.
4B00F00F	Call Home fault	Check for: 1. Remote system problem 2. Telephone line problem
4B00F109	Modem on serial port 1 failed to configure	Check modem power and modem connections
4B00F10A	Modem on serial port 2 failed to configure	Check modem power and modem connections
4B00F10F	Modem not detected	Check modem power and modem connections
4B00F110	Call to Service Center failed	Check for: 1. Remote system problem 2. Telephone line problem 3. Remote host problem
4B00F111	Call to System Administrator failed	Check for: 1. Remote system problem 2. Telephone line problem 3. Remote host problem

<i>Table 8-1 (Page 5 of 5). Firmware Error Codes.</i>		
4B00F112	Call to Pager failed	Check for: 1. Remote system problem 2. Telephone line problem
4B00F11B	Operator Panel response failure	If this message persists, re-IPL to clear logs and reset programs.

---

# Appendix A. Operator Panel Functions

---

## System Rack Operator Panel

The following diagram shows the locations of the operator panel display and the operator panel pushbuttons.

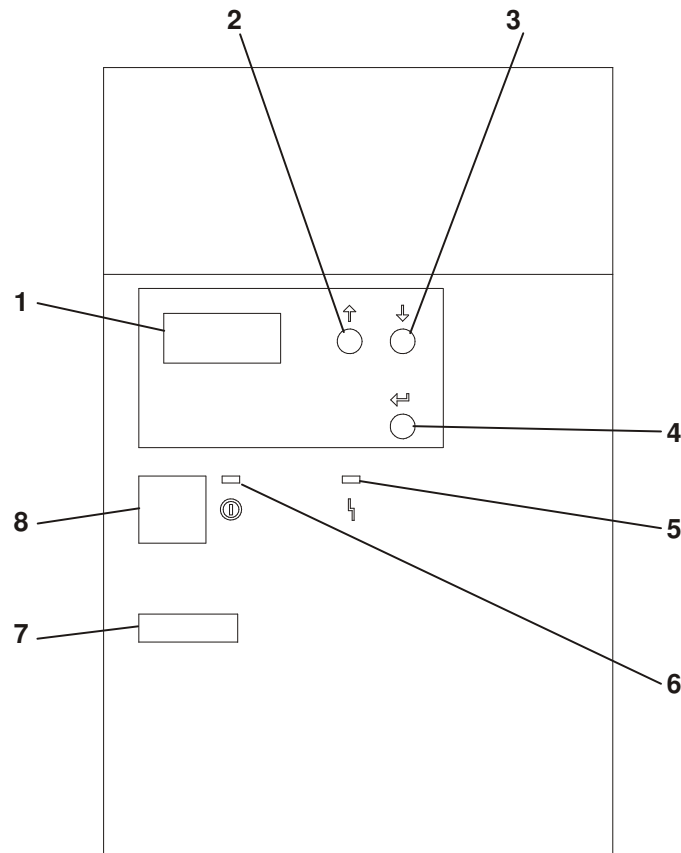

1. Operator Panel Display
2. Scroll Up Pushbutton
3. Scroll Down Pushbutton
4. Enter Pushbutton
5. Attention LED
6. Power On LED
7. Serial Number
8. Power Pushbutton

# Function Code Table

The operator panel functions and descriptions are listed in the following table. For details about the function, see "Operator Panel Function Descriptions" on page A-4.

**Notes:**

1. The x can be any number 0 through 9, any letter A through F, or a blank.
2. Bold function codes indicate user supported codes.

*Table C-1. Operator Panel Function Codes*

<b>Function Code</b>	<b>Function Selected</b>
<b>01 xxxx xxxx</b>	Pressing the Enter button toggles between: <ol style="list-style-type: none"> <li>1. Display the currently selected IPL type.</li> <li>2. Display the currently selected IPL speed override for the next IPL.</li> </ol>
<b>02 xxxx xxxx</b>	<ol style="list-style-type: none"> <li>1. Pressing the Enter button once allows selection of the IPL types A or B  <b>Attention:</b> IPL types C and D are for trained service personnel only and may cause data loss if used improperly.</li> <li>2. Pressing the Enter button twice allows selection of an IPL speed override for the next IPL. Subsequent IPLS are performed at the system selected speed.</li> </ol>
<b>03 xxxx xxxx</b>	Start an IPL and load the system. The IPL uses the selected IPL options. <b>Note:</b> This may cause the system to power off and then back on.
<b>04 xxxx xxxx</b>	Lamp test; all displays and indicators are switched on.
<b>05 xxxx xxxx</b>	Informational System Power Control Network (SPCN) system reference code (SRC); displays an SRC on the operator panel. <b>Note:</b> Function 5 reference codes will only be displayed if the function code is changed from the default function 11 position.
06 xxxx xxxx	Reserved
07 xxxx xxxx	Attention: This function allows concurrent maintenance to be performed by trained service personnel. Inadvertent use may cause system failures.
<b>08 xxxx xxxx</b>	Fast power off.
09 xxxx xxxx through 10 xxxx xxxx	Reserved
<b>11 xxxx xxxx through 19 xxxx xxxx</b>	System reference code (SRC); displays an SRC on the operator panel. <b>Note:</b> Function 12 displays informational status codes and is not used.
20 xxxx xxxx	Reserved
21 xxxx xxxx	Reserved
<b>22 xxxx xxxx</b>	Initiates AIX dump.
23 xxxx xxxx	Reserved
24 xxxx xxxx	Reserved
25 xxxx xxxx	The service representative switch 1 is set; this function is the first step necessary to set the service function range from 50 to 70. <b>Note:</b> This function is for service representatives only and should not be invoked by the user.



Function Code	Function Selected
26 xxxx xxxx	The service representative switch 2 is set; this function is the second step necessary to set the service function range from 50 to 70. <b>Note:</b> This function is for service representatives only and should not be invoked by the user.
27 xxxx xxxx through 31 xxxx xxxx	Reserved
32 xxxx xxxx	Reserved
33 xxxx xxxx	Reserved
34 xxxx xxxx	Reserved
35 xxxx xxxx through 49 xxxx xxxx	Reserved
50 xxxx xxxx	System processing unit stop.
51 xxxx xxxx	System processing unit status.
52 xxxx xxxx	System processing unit start.
53 xxxx xxxx	Path switch and reset.
54 xxxx xxxx	Reserved
55 xxxx xxxx	Display low-level diagnostic service processor log buffer.
56 xxxx xxxx	Display low-level diagnostic service processor code area.
57 xxxx xxxx	Reserved
58 xxxx xxxx	Display low-level diagnostic IPL parameters area.
59 xxxx xxxx	Set first character of base address for function 62 display.
60 xxxx xxxx	Set second character of base address for function 62 display.
61 xxxx xxxx	Set third character of base address for function 62 display.
62 xxxx xxxx	Display service processor control storage.
63 xxxx xxxx	System status SRC trace.
64 xxxx xxxx	Service processor diagnostic status SRC trace.
65 xxxx xxxx	Reserved
66 xxxx xxxx	Reserved
67 xxxx xxxx	Reserved
68 xxxx xxxx	Reserved
69 xxxx xxxx	Reserved
70 xxxx xxxx	Reserved

---

# Operator Panel Function Descriptions

## Values for IPL Types and Speeds

See Table C–2 and Table C–3 for tables of valid IPL types and speeds used in operator panel functions 01 and 02.

Table C–2. IPL Types

IPL Type	Description
A	IPL using copy A of the system firmware.
B	IPL using copy B of the system firmware.
C	<b>Attention:</b> Not supported; may cause data loss if used.
D	<b>Attention:</b> Not supported; may cause data loss if used.

Table C–3. IPL Speeds

IPL Speed	Description	Details
F:	Fast Override	Fast diagnostics run. The following are skipped: <ul style="list-style-type: none"><li>· Mainstorage tests</li><li>· CEC Inter–chip interface tests (wire test)</li><li>· Extended Logical Built–in Self Tests</li><li>· Also, cache data is not provided in mainstorage dumps.</li></ul>
S:	Slow Override	Full hardware diagnostics run. Use whenever hardware is changed, for intermittent hardware failures and on the first install IPL.
V = (F or S):	Use system selected speed	

## Function 01 – Display Selected IPL Type, Mode and Speed

This function allows you to display the IPL type and IPL speed. Pressing the Enter button in Function 01 toggles between:

1. Display IPL type (A or B).
2. Display IPL speed (F, S, or V = F or V = S).

Table C–4. Function 01

Function/Data	Description
01 _ _ _ _ _	Use the scroll up or scroll down buttons and scroll to Function 01.
01 _ _ _ A _ _	Press Enter to enter Function 01 Selected IPL Type display. Valid types, which appear in the sixth character position of the Function/Data display are A or B. See <a href="#">Table C–2</a> for descriptions of IPL types.
01 _ _ V = F _	Use Enter again to toggle to Selected IPL Speed display. Valid speed displays are F, S, V=F or V=S. <ul style="list-style-type: none"> <li>· F: Fast override selected.</li> <li>· S: Slow override selected.</li> <li>· V = (F or S): Use system selected speed.</li> </ul>
01 _ _ _ A _ _	Use Enter to toggle to Selected IPL Type display.

## Function 02 – Select IPL Type, Mode and Speed

This function allows you to select the IPL type and IPL speed. System power must be off to change IPL speed.

1. Pressing Enter once puts you into the change IPL type (A or B) operation.
 

**Attention:** IPL types C and D are not supported and may cause data loss if used.
2. Pressing the Enter button twice puts you into the operation for overriding the system IPL speed (F, S, V) for the next IPL. Subsequent IPLs are performed at the system selected speed.

For example, if you want to select IPL Type, select Function 02. Push the Enter button once, and then use the scroll up or scroll down button to select an IPL type. Pressing Enter again saves that value and exits the Select IPL Type display.

If you want to change the IPL speed, you must have system power off. Select Function 02, push the Enter button twice, use the scroll up or scroll down button to select F, S, or V and then press Enter to activate the override (F or S) or cancel it (V) and exit the Select IPL Speed display. See [Table C–3](#) for recommended speed settings.

Table C–5. Function 02 Select IPL Type

Function/Data	Description
02 _ _ _ _ _	Use the scroll up or scroll down button and scroll to Function 02.
02 _ _ _ A _ _	Press Enter once to enter Function 02. Select IPL Type display. Use the scroll up or scroll down buttons to scroll through the IPL types A and B. See <a href="#">Table C–2</a> for descriptions of IPL types. Pressing Enter saves the selected IPL type and exits Function 02.

## Function 03 – Start IPL

Function 03 is enabled only when the system is powered on.

This function starts an IPL using the selected IPL mode when the Enter button is pressed.

**Note:** The system may power off and then back on as part of the IPL.

## Function 04 – Lamp Test

This function ensures that no indicators are burned out and that characters displayed at the operator panel are valid. When this test is activated, the following lights go on:

- On the system operator panel:
  - The System Attention light
  - The Power On light
  - A 5 x 7 dot pattern for each character in the Function/Data display.

The lamp test continues on the system operator panel until you perform another operator panel function or a power procedure.

## Function 05 – SPCN (System Power Control Network) Informational SRC

Function 05 displays information about power faults and provides informational reference codes during concurrent maintenance procedures. The format for this function is as follows:

```
*-----*      *-----*
| 05 |          | 1RRU rrrr |
*-----*      *-----*
```

RR = Frame number refers to the particular I/O Drawer  
or System Rack

U = Always 1 for information pertaining to the System Rack  
or I/O Drawers other than the primary.

Always C is for the primary I/O Drawer.

rrrr = Service reference code (SRC)

**Note:** Function 5 reference codes are only displayed if the operator panel selection is moved from the default function 11 position.

## Function 07 – Restore System Power and Perform Concurrent Maintenance Repair

**Attention:** This function allows concurrent maintenance to be performed by trained service personnel. Inadvertent use may cause system failures.

## Function 08 – Fast Power Off

Use this function when the system is suspended and a power down cannot be performed.

Initially, an attention SRC (11-x A1xx 8008) is displayed. This indicates that Function 08 has been selected.

**Note:** If the server has Unattended Start Mode (USM) enabled, selecting this function causes the server to power off and then power on again.

## Functions 11 to 19 – System Reference Code

Functions 11 through 19, if enabled, represent the words of the SRC.

**Note:** Function 11 provides the primary SRC. Function 12 is an informational status message only and not used. Functions 14 and 15 provide secondary reference codes in addition to the primary SRC. Function 13 provides status information for service support use. Function 19 provides CCIN information for FRU replacement.

Press Enter to view the SRC. If no SRC is present, press Enter to continue to the next function.

SRC information should be recorded for error reporting. For example, the system processor detected a failure.

1. Look at the four rightmost characters of the operator panel display for function 11. These four characters are the unit reference code.
2. Look at functions 14 and 15 for more reference codes. Each is four characters in length. There may be from zero to four unit reference codes contained in these words. For example:

```
Word 11 - B455 rrrr  
Word 14 - rrrr rrrr  
Word 15 - rrrr 0000  
Word 19 - CCIN CCIN
```

This example shows a total of four reference codes for this failure. The rrrr signifies the reference codes. Each reference code has only one FRU associated with it. The CCIN code is used to determine a failing FRU in some cases.

3. Find the unit reference code in the SRC tables.

**Note:** Depending on the source of the SRC, some functions do not report any SRC status. All SRCs start with information in Function 11.



---

## Appendix B. Firmware Update Procedures

This section applies to all EPC2400 and EPC2450 versions. There is specific System Firmware and Service Processor firmware to support specific machine types and models.

---

### Determining the Firmware Levels

If the server is in operation, the installed firmware versions can be determined using AIX. If the server is about to be initialized, the installed firmware versions can be determined by using the SMS utilities for system firmware levels and Service Processor menus for Service Processor firmware levels.

Use the following procedure to determine your firmware level:

On the system you wish to update, at an AIX command prompt, enter the following command:

```
lscfg -vp | grep -p alterable
```

This command will produce a system configuration report similar to the following:

```
System Firmware:
  ROM Level.(alterable).....19990629 (B) 19990621 (A) *
  Version.....RS6K
  System Info Specific.(YL)...P2

SP_CARD_:
  Part Number.....PART_NUM
  EC Level.....EC_LEVEL
  FRU Number.....FRU_NUM_
  Manufacture ID.....IBM
  Serial Number.....SERIAL_#
  Version.....0000RS6K
  ROM Level.(alterable).....19990630 (B) 19990620 (A) **
  System Info Specific.(YL)...P2
```

\* = System FW levels

\*\* = Service Processor FW levels

The ROM level lines list the level numbers of the system and service processor (SvP) firmware installed. In these examples, the system was booted from type B, because it is listed first. If the most recent level number (A or B) is less than the update levels for your server, you should consider installing the updates.

When an update is performed, the firmware is written to type B only, and "promoted" to type A.

During system initial program load (IPL), an ASCII terminal on serial port 1 or 2 can be used to access the Service Processor menus. The Service Processor level is contained in the heading of the first menu. The following is an example of what the heading looks like:

```
Service Processor Firmware
Version: 19990630
Copyright 1998, IBM Corporation
```

The numbers in the second line show the booted firmware level. If this level is less than the update level available for your server, you should consider installing the update. Similarly, the system firmware level can be accessed from the System Management Services menus.

To determine the level of your system firmware, do the following:

1. Turn your system power on.
2. Watch for the logo screen and the POST indicators to appear on your display.
3. When the word `Keyboard` appears, quickly press the number 1 key. The number 1 key must be pressed before the word `Speaker` appears.

When the tests have completed, and any required passwords have been entered, the System Management Services Utilities menu appears. The System Firmware level is displayed in the top left-hand corner of the display.

When you have read the current firmware level, exit the System Management Services menu as directed on the screen.

If you find the firmware level is less than the update level available for your server, you should consider installing the update.

---

## Obtaining the Firmware Update Package

Contact your marketing representative for information about obtaining Service Processor firmware update packages.



---

## Appendix C. Service Processor Setup and Test

For your convenience, a sample SP setup procedure is provided below. Your setup may include more or less of the available features, so you may wish to adjust this checklist for your own application.

### SP Setup Checklist

1. Ensure the server is powered off.
2. Attach a local ASCII terminal for this setup procedure.
3. Attach a modem (if needed), see "How to access SP menus locally" on page 3-2, and see "Modem Configuration Menu" on page 3-11 for the menus needed to configure your modem.
4. Power on the server, the local terminal, and the modem.
5. Bring up the Service Processor Menus, see Chapter 3. "Service Processor Menus" on page 3-1.

**ATTENTION:** To bring up the Service Processor Menus while the server is booting up, watch the operator panel display for checkpoint E04F. At this checkpoint, a ten second window of time begins with three beeps. Checkpoint E07A is displayed and is visible during the ten second window. During this window, strike any key on the local terminal and the Service Processor menus appear on the local terminal.

6. Set the System Name, see "Privileged User Menus" on page 3-4.
7. Configure Call-In/Call-Out, see "Call-In/Call-Out Setup Menu" on page 3-10.
8. Exit the Service Processor menus
9. Wait until the system offers a logon prompt. Log on and perform an orderly system shutdown using the AIX `shutdown -F` command.
10. Power off the server.
11. Test Call-In, on page C-2.
12. Test Call-Out, on page C-2.
13. Use the "Save or Restore Hardware Management Policies" Service Aid (See Chapter 27 of "Diagnostics Information For Multiple Bus Systems") to backup the service processor settings.

**Note:** This is strongly recommended to protect the usefulness of the service processor and the availability of your server.

Your Service Processor is ready to go to work.

---

## Testing the Service Processor Setup

These tests include communicating with the server's operating system. Be sure the necessary serial port(s) is configured. If you need assistance, refer to "Serial Port Configuration" on page C-3.

Use following procedure to verify your Service Processor setup is working.

The server should still be powered off as a result of the setup checklist steps on page C-1.

### Call-In

1. From any telephone, call the server's telephone number. After you hear three rings, hang up. The server powers on.

**Note:** Although the server powers on during the three rings, you do not receive an indication over the telephone that the server is powering on.

2. Give the server five minutes to boot up and prepare to receive another call.
3. From an ASCII terminal or terminal emulator, call the server again. The server answers and presents the Service Processor Menus on your terminal.
4. If required, enter your privileged access password. If no password is required, the Main Menu displays.
5. From the Main Menu, select `Continue System Boot` to view the IPL progress messages. Depending on your server's configuration, the boot up sequence may take several minutes. Once the boot up completes, the logon prompt displays. You have successfully called into the SP and brought up the server.
6. Log in and then log out to disconnect from the operating system.
7. Call your server again. The operating system answers and offers the login prompt.

If these tests are successful, call-in is working correctly. You must now shut down and power off the server. To do this, perform the following steps:

8. Login in and command your server to shutdown and power off. In AIX, use the `shutdown -F` command.

### Call-Out

During the Service Processor setup, you entered **your** phone number for the Pager (on page 3-13 and Customer Voice (on page 3-13) phone numbers. These entries are used for this test.

1. Power on the server.
2. Bring up the Service Processor Menus, see Chapter 3. "Service Processor Menus".

**ATTENTION:** To bring up the Service Processor Menus while the server is booting up, watch the operator panel display for checkpoint E04F. At this checkpoint, a ten second window of time begins with three beeps. Checkpoint E07A is displayed and is visible during the ten second window. During this window, strike any key on the local terminal and the Service Processor menus appear on the local terminal.

3. At the **SP Main Menu**, select Call-In/Call-Out Setup menu, then select Call-Out test. This causes a simulated error condition for the purposes of this test.
4. When your telephone rings, answer the call. You should hear the sound of a telephone being dialed. This is your system unit trying to page you.

If this test is successful, call-out is working.

You should now select "Telephone Number Setup Menu" on page 3-12 to enter the **actual** telephone numbers your server uses to report problems.

## Serial Port Configuration

To configure the serial port on an AIX system, enter the following commands from an AIX console:

1. Log in as `root`.
2. To find if you have any serial ports already configured, enter:

```
lsdev -Cc tty
```

If no serial ports are configured, none are listed. If you wish to configure serial ports that are not listed, continue with the remaining steps.

3. Identify the serial port(s) with the modem(s).
4. Enter

```
smit tty
```
5. Select `add tty`
6. Select `RS232`
7. Select `Baud rate 9600` or higher.
8. Select `login enable` and set the flow control to `RTS`.
9. Commit the selections and set up any other needed serial ports.
10. Exit SMIT.



---

# Appendix D. Modem Configurations

---

## Sample Modem Configuration Files

With hundreds of modems to choose from, and various modem programming standards, configuring a modem for use with the SP (Service Processor) can be challenging. The SP is designed to place little demand on an attached modem, thereby increasing the setup and connection success rates. Several sample modem configuration files are supplied that will either work directly with your modem, or provide a good starting point for a custom setup, if required.

The sample modem configuration files can be found in your SP firmware and in the /usr/share/modems subdirectory (if your server is using AIX) with the following names. A listing of each file is included at the end of this appendix.

### Generic Modem Configuration Files

AIX File Name	SP Firmware File Name
modem_z_cfg	modem_z_sp
modem_z0_cfg	modem_z0_sp
modem_f_cfg	modem_f_sp
modem_f0_cfg	modem_f0_sp
modem_f1_cfg	modem_f1_sp

### Specific Modem Configuration Files

AIX File Name	SP Firmware File Name
modem_m0.cfg	modem_m0_sp
modem_m1.cfg	modem_m1_sp

With the following selection procedures and your modem manual, one of these configuration files should be suitable for your use.

---

## Configuration File Selection

1. Does your modem respond to the extended command set (prefixed with &)?  
If yes, go to step 3 below.  
If no, continue with step 2 below.
  2. Does your modem respond to:
    - a. ATZ reset command, or
    - b. ATZn reset commands, where n can be 0, 1, etc.?If ATZ, configuration file `modem_z.cfg` is recommended.  
If ATZn, configuration file `modem_z0.cfg` is recommended.  
Go to step 5 below.
  3. Does your modem command set include a test for V.42 error correction at the remote modem (often called "Auto-Reliable Mode")?  
If yes, this test must be disabled. Sample configuration files `/usr/share/modem_m0.cfg` or `/usr/share/modem_m1.cfg` can be used as models to help you create a file for your particular modem. See "Customizing the Modem Configuration Files" on page D-3. Go to step 5.  
If no, go to step 4 below.
  4. Does your modem respond to:
    - a. AT&F reset command, or
    - b. AT&Fn reset commands, where n can be 0, 1, etc.?If AT&F, configuration file `modem_f.cfg` is recommended.  
If AT&Fn, configuration file `modem_f0.cfg` or `modem_f1.cfg` is recommended, depending on which provides the hardware flow control profile.
  5. Selection is complete. If you find it necessary to adjust any of these configuration files, do so with reference to the manual that came with your modem. It is recommended you select settings that enable hardware flow control and respond to DTR.
- Note:** Some older modems do not respond to the commands X0 or &R1. You should edit out these commands from the modem configuration file if yours is such a modem. See your modem manual for more information.

## Examples For Using the Generic Sample Modem Configuration Files

Modem	Setup Z	Setup Z0 (Rare)	Setup F	Setup F0	Setup F1
AT&T DataPort 2001 **				X	
Bocamodem 1440E			X		
Hayes Smart Modem 300	X				
USRobotics 36.6K Sportster					X
Zoom V.32			X		

**Note:** \*\* Ring interrupt only on first ring.

## Customizing the Modem Configuration Files

You can create your own modem configuration file(s) or modify the samples provided. After you customize your modem configuration files, you **MUST** access them via the Configure Remote Maintenance Policy Service Aid rather than from the SP menus.

**Note:** If you have already set up your serial ports, line speeds, authorizations and telephone numbers from the SP menus, specify your customized modem configuration files from the service aid.

If you have not already set up your serial ports, line speeds, authorizations and telephone numbers from the SP menus, you may set them up with the service aids while you specify your customized modem configuration files.

## Terminal Emulators

The SP is compatible with simple ASCII terminals, and therefore compatible with most emulators. It is for the cases when a remote session is handed off from SP to the operating system that agreeing terminal emulators becomes important.

The server's operating system will have some built-in terminal emulators. Your server may also have a commercially available terminal emulation. It is important that the local and host computers select the same or compatible terminal emulators so the key assignments and responses will match. This will assure successful communications and control.

For best formatting, choose line wrap in your terminal emulator setup.

## Recovery Procedures

Line noises, power surges, etc., can sometimes cause your modem to enter an undefined state. When it is being used for dial in, dial out or Ring Indicate Power-On, your modem is initialized each time one of these actions is expected. If one of these environmental conditions occur after your modem has been initialized, it may be necessary to recover your modem to a known state.

If your modem communicates properly with remote users, it is probably in control. It may be wise to occasionally change some of the functional settings and then change them back, just for the sense of security that the modem is communicating, and to assure it has been initialized recently.

Another strategy, particularly if your system is difficult to access physically, is to protect it with an Uninterruptable Power Source (UPS) and a phone-line surge protector.

In case recovery becomes necessary, your system should be shut down as gracefully as possible. Disconnect and reconnect modem power, and power on the system to allow complete reinitialization of your system.

---

## Seamless Transfer of a Modem Session

There are about as many modem command variations as there are modems. The sample modem configuration files have been written to capture the largest number of workable modem settings.

The modem command `&Dn` (where 'n' is a number) generally sets the modem response to the Data Terminal Ready (DTR) signal from the server's serial port. The desired response is that the modem will hold a connection while DTR is enabled, and drop the connection when DTR is released. This is the mechanism by which the server "hangs up" on a connection under normal conditions.

Usually the command `&D2` will work, but not always. The sample modem configuration files take this high percentage position, see the note below. You should consult your modem's manual for its specific response scheme for the `&Dn` command.

There are two methods for dealing with the modem's response to DTR:

1. Recovery
2. Prevention

Before proceeding with one of these strategies, you need to determine if your server's modem is set up properly to respond to DTR.

With the remote terminal connected to serial port 1 and defined as the **primary** console device, there are two tests you can perform:

1. Will the modem **drop** the connection after the "System initialization complete" message appears at the remote terminal?

If yes, this is the correct response. The modem is set up correctly.

If no, try another `&Dn` setting for your server's modem. See your modem manual for this information. The `&Dn` command appears in three places each in three of the sample modem configuration files, see the note below.

2. Will the server's modem **disconnect** when the power drops? You can make this observation at the remote terminal by commanding your server to shutdown and power off. (The AIX command `shutdown -F` will do this.) Watch for the message `NO CARRIER` on your remote terminal.

If yes, this is the correct response. The modem is set up correctly.

If no, try another `&Dn` setting for your server's modem. See your modem manual for this information. The `&Dn` command appears in three places each in three of the sample modem configuration files, see the note below.

**Note:** Only the following sample modem configuration files contain the `&Dn` command (in three places each):

- `modem_f.cfg`
- `modem_f0.cfg`
- `modem_f1.cfg`

If you are using `modem_z.cfg` or `modem_z0.cfg`, you cannot control DTR response. If your remote terminal does not disconnect after logging off, you must command the remote terminal emulator to hang up. This then breaks the connection.



## Recovery Strategy

The recovery strategy consists of making **three** calls to establish a remote session. This is the easiest solution to implement, and allows more freedom for configuring your server's serial ports.

To set up a remote terminal session, dial in to the server and start the system. Wait 5 minutes for the initialization period and call again to gain control via the SP menus. Continue booting the system from the System Power control menu. After the operating system is loaded and initialized, the connection is dropped. At this point, when you call the server back the operating system answers and offers you the login prompt.

## Prevention Strategy

The disconnect is caused by the operating system when it initializes the **primary** console. The tests listed above are conducted with the remote terminal selected as the primary console to manifest the modem's response to DTR transitions.

If a local ASCII terminal or a graphics console is to be a permanent part of your server, then make one of them the primary console. Your remote terminal will no longer experience the connection loss.

If a local console is not a permanent part of your server, you can still assign either the unused graphics console or the unused serial port as the primary console. This gives you the desired seamless connection at your remote terminal.

If you choose to use the unused serial port as the primary console, some initialization traffic will be sent to any serial device attached to that port. As a result, that serial device's connection and function could be affected. These impacts may make that port unattractive for devices other than a temporary local ASCII terminal.

---

# Modem Configuration Samples

## Sample File modem\_z.cfg

```
#
# COMPONENT_NAME: (ESPSETUP) ENTRY SERVICE PROCESSOR SETUP Z
#
# FUNCTIONS: Modem configuration file for many early Hayes* compatible modems.
# This example uses the ATZ reset command to choose the factory defaults.
# This setup will work for many modems, but it is required for early vintage
# modems which respond to neither the ATZ0 reset command nor the extended (&)
# commands. Refer to your modem manual.
#
# * Trademark of Hayes Microcomputer Products, Inc.
#
# (C) COPYRIGHT International Business Machines Corp. 1996
# All Rights Reserved
# Licensed Materials – Property of IBM
#
# US Government Users Restricted Rights – Use, duplication or
# disclosure restricted by GSA ADP Schedule Contract with IBM Corp.
#
#
# If the modem has configuration switches, they should be set to the
# factory default settings.

ICDelay 1
DefaultTO 10
CallDelay 120
# AT Attention Code           , Inserts delay in dialing commands
# Z Reset to factory defaults Q0 Turn on responses
# E0 Turn echo off           Q1 Turn off responses
# V0 Use numeric responses    S0=0 Automatic answer inhibit
# +++ Escape to command mode S0=2 Answer on second ring
# H0 Hang-up                 T = Tone mode. When used as Tr, it is a
#                             no op to maintain program synchronization
#                             when modem may/will echo the commands.
#
# %N Call-Out phone number   %P Paging phone number
# %S Modem speed (available to users)
#
# Following are common responses from a wide range of modems:
# 16, 15, 12, 10, 5 and 1 are connection responses. Add others as required.
# 7=busy; 6=no dial tone; 4=error; 3=no carrier; 2=ring; 0=OK
#
# PROGRAMMING NOTE: No blanks between double quote marks (").

condout: send "ATZQ0Tr"           # Reset to factory defaults.
         ignore "0r" or "OK\r\n" timeout 2 # Ignore modem response.
         send "ATE0Tr"           # Initialize modem: Echo OFF,
         expect "0r" or "OK\r\n" timeout 2 # Enable responses (Numeric),
         send "ATQ0V0Tr"         # Limit response codes.
         expect "0r" timeout 2     # Confirm commands successful.
         send "ATS0=0r"         # Set AutoAnswer OFF
         expect "0r" timeout 2     # Confirm command successful.
         done
```

```

connect:  send "ATDT%N\r"                # Tone dialing command.
                                                # %N from Call Home setup.

                                                # Expect a connection response.
expect "16\r" or "15\r" or "14\r" or "12\r" or "10\r" or "5\r" or "1\r" busy "7\r"
timeout 60
done

retry:    send "A"                        # Repeat the previous command.

                                                # Expect a connection response.
expect "16\r" or "15\r" or "14\r" or "12\r" or "10\r" or "5\r" or "1\r" busy "7\r"
timeout 60
done

disconnect:

delay 2                                     # Separate from previous data.
send "+++"                                # Assure command mode.
delay 2                                     # Allow mode switching delay.
send "ATH0T\r"                             # Set modem switch-hook down
                                                # (i.e., hang up).

ignore "0\r" or "OK\r" timeout 2          # Ignore modem response.
send "ATEOQ1\r"                           # Initialize modem: Echo OFF,
                                                # Disable responses.

ignore "0\r" timeout 1
done

condin:  send "ATZQ0T\r"                  # Reset to factory defaults.
ignore "0\r" or "OK\r\n" timeout 2        # Ignore modem response.
send "ATE0T\r"                             # Initialize modem: Echo OFF,
expect "0\r" or "OK\r\n" timeout 2        # Enable responses (Numeric),
send "ATQ0V0T\r"                           # Limit response codes.
expect "0\r" timeout 2                     # Confirm commands successful.
send "ATS0=2\r"                             # Set AutoAnswer ON
expect "0\r" timeout 2                     # Confirm command successful.
done

waitcall: ignore "2\r" timeout 1            # Ignore first ring.
expect "2\r" timeout 10                   # Pick up second ring
                                                # or timeout.
                                                # Expect a connection response.
expect "16\r" or "15\r" or "14\r" or "12\r" or "10\r" or "5\r" or "1\r"
timeout 60
done

```

```

page:    send "ATDT%N,,,,%R;\r"          # %N = pager call center number
                                                # Add enough commas to wait for
                                                # time to enter paging number.
                                                # %R = paging number

                                                # Confirm successful command.

    expect "0\r" timeout 60
    delay 2                                # Wait before hanging up.
    send "ATH0T\r"                          # Hang up.
    expect "0\r" timeout 2                  # Confirm successful command.
    done

ripo:    send "ATZQ0T\r"                    # Reset to factory defaults.
    ignore "0\r" or "OK\r\n" timeout 2     # Ignore modem response.
    send "ATE0T\r"                          # Initialize modem: Echo OFF,
    expect "0\r" or "OK\r\n" timeout 2     # Enable responses (Numeric),
    send "ATQ0V0T\r"                        # Limit response codes.
    expect "0\r" timeout 2                  # Confirm commands successful.
    send "ATS0=0\r"                          # Set AutoAnswer OFF
    expect "0\r" timeout 2                  # Confirm command successful.
    done                                     # RI Power On enabled.

error:                                       # Handle unexpected modem
                                                # responses.

    expect "8\r" or "7\r" or "6\r" or "4\r" or "3\r"
    delay 2
    done

```

## Sample File modem\_z0.cfg

```

#
# COMPONENT_NAME: (ESPSETUP) ENTRY SERVICE PROCESSOR SETUP Z0
#
# FUNCTIONS: Modem configuration file for some early Hayes* compatible modems.
# This example uses the ATZ0 reset command to choose the factory defaults.
# This setup is recommended for modems that will respond to the ATZ0 command
# and which do not respond to the extended (&) commands. Refer to your modem
# manual.
#
# * Trademark of Hayes Microcomputer Products, Inc.
#
# (C) COPYRIGHT International Business Machines Corp. 1996
# All Rights Reserved
# Licensed Materials – Property of IBM
#
# US Government Users Restricted Rights – Use, duplication or
# disclosure restricted by GSA ADP Schedule Contract with IBM Corp.
#
#
# If the modem has configuration switches, they should be set to the
# factory default settings.

```

```

ICDelay 1
DefaultTO 10
CallDelay 120
# AT Attention Code           , Inserts delay in dialing commands
# Z0 Reset. Restore Profile 0  Q0 Turn on responses
# E0 Turn echo off            Q1 Turn off responses
# V0 Use numeric responses     S0=0 Automatic answer inhibit
# +++ Escape to command mode  S0=2 Answer on second ring
# H0 Hang-up                  X0=0 Limit modem response codes
#                               T = Tone mode. When used as Tr, it is a
#                               no op to maintain program synchronization
#                               when modem may/will echo the commands.
#
#
#
# %N Call-Out phone number  %P Paging phone number
# %S Modem speed (available to users)
#
# Following are common responses from a wide range of modems:
# 16, 15, 12, 10, 5 and 1 are connection responses. Add others as required.
# 7=busy; 6=no dial tone; 4=error; 3=no carrier; 2=ring; 0=OK
#
# PROGRAMMING NOTE: No blanks between double quote marks (").

condout: send "ATZ0Q0Tr"           # Reset modem. Select profile 0
        ignore "0r" or "OK\r\n" timeout 2 # Ignore modem response.
        send "ATE0Tr"             # Initialize modem: Echo OFF,
        expect "0r" or "OK\r\n" timeout 2 # Enable responses (Numeric),
        send "ATQ0V0X0Tr"         # Limit response codes.
        expect "0r" timeout 2      # Confirm commands successful.
        send "ATS0=0r"            # Set AutoAnswer OFF
        expect "0r" timeout 2      # Confirm command successful.
        done

connect: send "ATDT%Nr"           # Tone dialing command.
                                   # %N from Call Home setup.

                                   # Expect a connection response.
expect "16r" or "15r" or "14r" or "12r" or "10r" or "5r" or "1r" busy "7r"
timeout 60
done

retry: send "A"                  # Repeat the previous command.

                                   # Expect a connection response.
expect "16r" or "15r" or "14r" or "12r" or "10r" or "5r" or "1r" busy "7r"
timeout 60
done

disconnect:
        delay 2                   # Separate from previous data.
        send "+++"                # Assure command mode.
        delay 2                   # Allow mode switching delay.
        send "ATH0Tr"             # Set modem switch-hook down
                                   # (i.e., hang up).
        ignore "0r" or "OKr" timeout 2 # Ignore modem response.
        send "ATE0Q1r"           # Initialize modem: Echo OFF,
                                   # Disable responses.

        ignore "0r" timeout 1
        done

```

```

condin: send "ATZ0Q0T\r"           # Reset modem. Select profile 0
      ignore "0\r" or "OK\r\n" timeout 2 # Ignore modem response.
      send "ATE0T\r"               # Initialize modem: Echo OFF,
      expect "0\r" or "OK\r\n" timeout 2 # Enable responses (Numeric),
      send "ATQ0V0X0T\r"          # Limit response codes.
      expect "0\r" timeout 2       # Confirm commands successful.
      send "ATS0=2\r"              # Set AutoAnswer ON
      expect "0\r" timeout 2       # Confirm command successful.
      done

waitcall: ignore "2\r" timeout 1    # Ignore first ring.
      expect "2\r" timeout 10      # Pick up second ring
                                      # or timeout.
                                      # Expect a connection response.
      expect "16\r" or "15\r" or "14\r" or "12\r" or "10\r" or "5\r" or "1\r"
      timeout 60
      done

page:   send "ATDT%N,,,,%R;\r"     # %N = pager call center number
                                      # Add enough commas to wait for
                                      # time to enter paging number.
                                      # %R = paging number

                                      # Confirm successful command.
      expect "0\r" timeout 60
      delay 2                       # Wait before hanging up.
      send "ATH0T\r"                # Hang up.
      expect "0\r" timeout 2       # Confirm successful command.
      done

ripo:   send "ATZ0Q0T\r"           # Reset modem. Select profile 0
      ignore "0\r" or "OK\r\n" timeout 2 # Ignore modem response.
      send "ATE0T\r"               # Initialize modem: Echo OFF,
      expect "0\r" or "OK\r\n" timeout 2 # Enable responses (Numeric),
      send "ATQ0V0X0T\r"          # Limit response codes.
      expect "0\r" timeout 2       # Confirm commands successful.
      send "ATS0=0\r"              # Set AutoAnswer OFF
      expect "0\r" timeout 2       # Confirm command successful.
      done                          # RI Power On enabled.

error:                                     # Handle unexpected modem
                                      # responses.
      expect "8\r" or "7\r" or "6\r" or "4\r" or "3\r"
      delay 2
      done

```

## Sample File modem\_f.cfg

```
#
# COMPONENT_NAME: (ESPSETUP) ENTRY SERVICE PROCESSOR SETUP F
#
# FUNCTIONS: Modem configuration file for many recent Hayes* compatible modems.
# This example uses the AT&F reset command to choose the factory defaults.
# This set up is preferred for modems with extended (&) commands. For early
# vintage modems, setup Z or Z0 is recommended. If your modem responds to
# the extended (&) commands and to factory default choices (&Fn), setup file
# F0 or F1 is recommended.
#
# * Trademark of Hayes Microcomputer Products, Inc.
#
# (C) COPYRIGHT International Business Machines Corp. 1996
# All Rights Reserved
# Licensed Materials – Property of IBM
#
# US Government Users Restricted Rights – Use, duplication or
# disclosure restricted by GSA ADP Schedule Contract with IBM Corp.
#
#
# If the modem has configuration switches, they should be set to the
# factory default settings.

ICDelay 1
DefaultTO 10
CallDelay 120
# AT Attention Code           , Inserts delay in dialing commands
# &F Reset to default profile Q0 Turn on responses
# E0 Turn echo off           Q1 Turn off responses
# V0 Use numeric responses   S0=0 Automatic answer inhibit
# +++ Escape to command mode S0=2 Answer on second ring
# H0 Hang-up                 X0=0 Limit modem response codes
#
#                               T = Tone mode. When used as Tr, it is a
#                               no op to maintain program synchronization
#                               when modem may/will echo the commands.
#
# &C1 Detect CD               &D2 Respond to DTR (often the default)
#
# %N Call-Out phone number   %P Paging phone number
# %S Modem speed (available to users)
#
# Following are common responses from a wide range of modems:
# 16, 15, 12, 10, 5 and 1 are connection responses. Add others as required.
# 7=busy; 6=no dial tone; 4=error; 3=no carrier; 2=ring; 0=OK
#
# PROGRAMMING NOTE: No blanks between double quote marks ("").

condout: send "AT&FQ0Tr"           # Reset to factory defaults.
         ignore "0r" or "OK\r\n" timeout 2 # Ignore modem response.
         send "ATE0Tr"           # Initialize modem: Echo OFF,
         expect "0r" or "OK\r\n" timeout 2 # Enable responses (Numeric),
         send "ATQ0V0X0Tr"       # Limit response codes.
         expect "0r" timeout 2    # Confirm commands successful.
         send "ATS0=0r"          # Set AutoAnswer OFF
         expect "0r" timeout 2    # Confirm command successful.
         send "AT&C1&D2r"       # Detect carrier and DTR.
         expect "0r" timeout 2    # Confirm command successful.
```

```

done

connect:  send "ATDT%N\r"          # Tone dialing command.
                                                # %N from Call Home setup.

                                                # Expect a connection response.
expect "16\r" or "15\r" or "14\r" or "12\r" or "10\r" or "5\r" or "1\r" busy "7\r"
timeout 60
done

retry:    send "A/"                # Repeat the previous command.

                                                # Expect a connection response.
expect "16\r" or "15\r" or "14\r" or "12\r" or "10\r" or "5\r" or "1\r" busy "7\r"
timeout 60
done

disconnect:
delay 2          # Separate from previous data.
send "+++\"      # Assure command mode.
delay 2          # Allow mode switching delay.
send "ATH0T\r"  # Set modem switch-hook down
                                                # (i.e., hang up).

ignore "0\r" or "OK\r" timeout 2 # Ignore modem response.
send "ATE0Q1\r" # Initialize modem: Echo OFF,
                                                # Disable responses.

ignore "0\r" timeout 1
done

condin:  send "AT&FQ0T\r"          # Reset to factory defaults.
ignore "0\r" or "OK\r\n" timeout 2 # Ignore modem response.
send "ATE0T\r"                    # Initialize modem: Echo OFF,
expect "0\r" or "OK\r\n" timeout 2 # Enable responses (Numeric),
send "ATQ0V0X0T\r"               # Limit response codes.
expect "0\r" timeout 2            # Confirm commands successful.
send "ATS0=2\r"                  # Set AutoAnswer ON
expect "0\r" timeout 2            # Confirm command successful.
send "AT&C1&D2\r"                # Detect carrier and DTR.
expect "0\r" timeout 2            # Confirm command successful.
done

waitcall: ignore "2\r" timeout 1    # Ignore first ring.
expect "2\r" timeout 10            # Pick up second ring
                                                # or timeout.
                                                # Expect a connection response.
expect "16\r" or "15\r" or "14\r" or "12\r" or "10\r" or "5\r" or "1\r"
timeout 60
done

page:    send "ATDT%N,,,,%R;\r"    # %N = pager call center number
                                                # Add enough commas to wait for
                                                # time to enter paging number.
                                                # %R = paging number

                                                # Confirm successful command.
expect "0\r" timeout 60
delay 2          # Wait before hanging up.
send "ATH0T\r"  # Hang up.
expect "0\r" timeout 2 # Confirm successful command.
done

```



```

ripo:    send "AT&FQ0T\r"           # Reset to factory defaults.
        ignore "0\r" or "OK\r\n" timeout 2 # Ignore modem response.
        send "ATE0T\r"           # Initialize modem: Echo OFF,
        expect "0\r" or "OK\r\n" timeout 2 # Enable responses (Numeric),
        send "ATQ0V0X0T\r"       # Limit response codes.
        expect "0\r" timeout 2    # Confirm commands successful.
        send "ATS0=0\r"          # Set AutoAnswer OFF
        expect "0\r" timeout 2    # Confirm command successful.
        send "AT&C1&D2\r"        # Detect carrier and DTR.
        expect "0\r" timeout 2    # Confirm command successful.
        done                     # RI Power On enabled.

error:                                     # Handle unexpected modem
                                     # responses.
        expect "8\r" or "7\r" or "6\r" or "4\r" or "3\r"
        delay 2
        done

```

## Sample File modem\_f0.cfg

```

#
# COMPONENT_NAME: (ESPSETUP) ENTRY SERVICE PROCESSOR SETUP F0
#
# FUNCTIONS: Modem configuration file for many recent Hayes* compatible modems.
# This example uses the AT&F0 reset command to choose the factory defaults.
# This set up is preferred for modems with extended (&) commands. For early
# vintage modems, setup Z or Z0 is recommended. If your modem responds to
# the extended (&) commands and to factory default choices (&Fn), but doesn't
# work properly with this setup file, setup F1 is recommended.
#
# * Trademark of Hayes Microcomputer Products, Inc.
#
# (C) COPYRIGHT International Business Machines Corp. 1996
# All Rights Reserved
# Licensed Materials – Property of IBM
#
# US Government Users Restricted Rights – Use, duplication or
# disclosure restricted by GSA ADP Schedule Contract with IBM Corp.
#
#
# If the modem has configuration switches, they should be set to the
# factory default settings.

ICDelay 1
DefaultTO 10
CallDelay 120
# AT Attention Code           , Inserts delay in dialing commands
# &F0 Reset. Restore profile 0 Q0 Turn on responses
# E0 Turn echo off           Q1 Turn off responses
# V0 Use numeric responses    S0=0 Automatic answer inhibit
# +++ Escape to command mode S0=2 Answer on second ring
# H0 Hang-up                 X0=0 Limit modem response codes
#                             T = Tone mode. When used as T\r, it is a
#                             no op to maintain program synchronization
#                             when modem may/will echo the commands.
#
# &C1 Detect CD               &D2 Respond to DTR (often the default)
# &R1 Ignore RTS (CTS)

```

```

#
# %N Call-Out phone number %P Paging phone number
# %S Modem speed (available to users)
#
# Following are common responses from a wide range of modems:
# 16, 15, 12, 10, 5 and 1 are connection responses. Add others as required.
# 7=busy; 6=no dial tone; 4=error; 3=no carrier; 2=ring; 0=OK
#
# PROGRAMMING NOTE: No blanks between double quote marks ("").

condout: send "AT&F0Q0T\r"          # Reset modem. Select profile 0
         ignore "\0\r" or "OK\r\n" timeout 2 # Ignore modem response.
         send "ATE0T\r"              # Initialize modem: Echo OFF,
         expect "\0\r" or "OK\r\n" timeout 2 # Enable responses (Numeric),
         send "ATQ0V0X0T\r"          # Limit response codes.
         expect "\0\r" timeout 2      # Confirm commands successful.
         send "ATS0=0\r"              # Set AutoAnswer OFF
         expect "\0\r" timeout 2      # Confirm command successful.
         send "AT&C1&D2&R1\r"        # Detect carrier and DTR,
                                         # Ignore RTS.
         expect "\0\r" timeout 2      # Confirm command successful.
         done

connect: send "ATDT%N\r"             # Tone dialing command.
                                         # %N from Call Home setup.

                                         # Expect a connection response.
expect "16\r" or "15\r" or "14\r" or "12\r" or "10\r" or "5\r" or "1\r" busy "7\r"
timeout 60
done

retry:  send "A\r"                   # Repeat the previous command.

                                         # Expect a connection response.
expect "16\r" or "15\r" or "14\r" or "12\r" or "10\r" or "5\r" or "1\r" busy "7\r"
timeout 60
done

disconnect:
         delay 2                      # Separate from previous data.
         send "+++\"                 # Assure command mode.
         delay 2                      # Allow mode switching delay.
         send "ATH0T\r"              # Set modem switch-hook down
                                         # (i.e., hang up).
         ignore "\0\r" or "OK\r" timeout 2 # Ignore modem response.
         send "ATE0Q1\r"              # Initialize modem: Echo OFF,
                                         # Disable responses.

         ignore "\0\r" timeout 1
         done

condin:  send "AT&F0Q0T\r"          # Reset modem. Select profile 0
         ignore "\0\r" or "OK\r\n" timeout 2 # Ignore modem response.
         send "ATE0T\r"              # Initialize modem: Echo OFF,
         expect "\0\r" or "OK\r\n" timeout 2 # Enable responses (Numeric),
         send "ATQ0V0X0T\r"          # Limit response codes.
         expect "\0\r" timeout 2      # Confirm commands successful.
         send "ATS0=2\r"              # Set AutoAnswer ON
         expect "\0\r" timeout 2      # Confirm command successful.
         send "AT&C1&D2&R1\r"        # Detect carrier and DTR,
                                         # Ignore RTS.
         expect "\0\r" timeout 2      # Confirm command successful.

```

```

done

waitcall: ignore "2\r" timeout 1          # Ignore first ring.
      expect "2\r" timeout 10           # Pick up second ring
                                          # or timeout.
                                          # Expect a connection response.
expect "16\r" or "15\r" or "14\r" or "12\r" or "10\r" or "5\r" or "1\r"
timeout 60
done

page:   send "ATDT%N,,,,%R;\r"          # %N = pager call center number
                                          # Add enough commas to wait for
                                          # time to enter paging number.
                                          # %R = paging number

                                          # Confirm successful command.

      expect "0\r" timeout 60
      delay 2                            # Wait before hanging up.
      send "ATH0\r"                       # Hang up.
      expect "0\r" timeout 2             # Confirm successful command.
done

ripo:   send "AT&F0Q0\r"                 # Reset modem. Select profile 0
ignore "0\r" or "OK\r\n" timeout 2     # Ignore modem response.
send "ATE0\r"                           # Initialize modem: Echo OFF,
expect "0\r" or "OK\r\n" timeout 2     # Enable responses (Numeric),
send "ATQ0V0X0\r"                       # Limit response codes.
expect "0\r" timeout 2                 # Confirm commands successful.
send "ATS0=0\r"                          # Set AutoAnswer OFF
expect "0\r" timeout 2                 # Confirm command successful.
send "AT&C1&D2&R1\r"                   # Detect carrier and DTR,
                                          # Ignore RTS.
                                          # Confirm command successful.
expect "0\r" timeout 2                 # RI Power On enabled.
done

error:                                     # Handle unexpected modem
                                          # responses.
      expect "8\r" or "7\r" or "6\r" or "4\r" or "3\r"
      delay 2
done

```

## Sample File modem\_f1.cfg

```

#
# COMPONENT_NAME: (ESPSETUP) ENTRY SERVICE PROCESSOR SETUP F1
#
# FUNCTIONS: Modem configuration file for many recent Hayes* compatible modems.
# This example uses the AT&F1 reset command to choose the factory defaults.
# This set up is for modems with extended (&) commands and which do not work
# properly with setup F0. For early vintage modems, setup Z or Z0 is
# recommended.
#
# * Trademark of Hayes Microcomputer Products, Inc.
#
# (C) COPYRIGHT International Business Machines Corp. 1996
# All Rights Reserved
# Licensed Materials – Property of IBM
#

```

```

# US Government Users Restricted Rights – Use, duplication or
# disclosure restricted by GSA ADP Schedule Contract with IBM Corp.
#
#
# If the modem has configuration switches, they should be set to the
# factory default settings.

```

```
ICDelay 1
```

```
DefaultTO 10
```

```
CallDelay 120
```

```

# AT Attention Code           , Inserts delay in dialing commands
# &F1 Reset. Restore profile 1 Q0 Turn on responses
# E0 Turn echo off           Q1 Turn off responses
# V0 Use numeric responses    S0=0 Automatic answer inhibit
# +++ Escape to command mode S0=2 Answer on second ring
# H0 Hang-up                 X0=0 Limit modem response codes
#                             T = Tone mode. When used as Tr, it is a
#                             no op to maintain program synchronization
#                             when modem may/will echo the commands.
#
# &C1 Detect CD               &D2 Respond to DTR (often the default)
# &R1 Ignore RTS (CTS)
#
# %N Call-Out phone number   %P Paging phone number
# %S Modem speed (available to users)
#
# Following are common responses from a wide range of modems:
# 16, 15, 12, 10, 5 and 1 are connection responses. Add others as required.
# 7=busy; 6=no dial tone; 4=error; 3=no carrier; 2=ring; 0=OK
#
# PROGRAMMING NOTE: No blanks between double quote marks ("").

```

```

condout: send "AT&F1Q0Tr"           # Reset modem. Select profile 1
        ignore "0r" or "OK\r\n" timeout 2 # Ignore modem response.
        send "ATE0Tr"               # Initialize modem: Echo OFF,
        expect "0r" or "OK\r\n" timeout 2 # Enable responses (Numeric),
        send "ATQ0V0X0Tr"           # Limit response codes.
        expect "0r" timeout 2        # Confirm commands successful.
        send "ATS0=0r"               # Set AutoAnswer OFF
        expect "0r" timeout 2        # Confirm command successful.
        send "AT&C1&D2&R1r"         # Detect carrier and DTR,
        # Ignore RTS.
        expect "0r" timeout 2        # Confirm command successful.
        done

```

```

connect: send "ATDT%Nr"             # Tone dialing command.
        # %N from Call Home setup.

```

```

        # Expect a connection response.
expect "16r" or "15r" or "14r" or "12r" or "10r" or "5r" or "1r" busy "7r"
timeout 60
done

```

```

retry:  send "A/"                # Repeat the previous command.

                                           # Expect a connection response.
expect "16\r" or "15\r" or "14\r" or "12\r" or "10\r" or "5\r" or "1\r" busy "7\r"
timeout 60
done

disconnect:
  delay 2                          # Separate from previous data.
  send "+++"                        # Assure command mode.
  delay 2                          # Allow mode switching delay.
  send "ATH0T\r"                   # Set modem switch-hook down
                                           # (i.e., hang up).

  ignore "0\r" or "OK\r" timeout 2 # Ignore modem response.
  send "ATE0Q1\r"                 # Initialize modem: Echo OFF,
                                           # Disable responses.

  ignore "0\r" timeout 1
  done

condin:  send "AT&F1Q0T\r"        # Reset modem. Select profile 1
  ignore "0\r" or "OK\r\n" timeout 2 # Ignore modem response.
  send "ATE0T\r"                 # Initialize modem: Echo OFF,
  expect "0\r" or "OK\r\n" timeout 2 # Enable responses (Numeric),
  send "ATQ0V0X0T\r"            # Limit response codes.
  expect "0\r" timeout 2        # Confirm commands successful.
  send "ATS0=2\r"              # Set AutoAnswer ON
  expect "0\r" timeout 2        # Confirm command successful.
  send "AT&C1&D2&R1\r"         # Detect carrier and DTR,
                                           # Ignore RTS.

  expect "0\r" timeout 2        # Confirm command successful.
  done

waitcall: ignore "2\r" timeout 1   # Ignore first ring.
  expect "2\r" timeout 10        # Pick up second ring
                                           # or timeout.
                                           # Expect a connection response.
expect "16\r" or "15\r" or "14\r" or "12\r" or "10\r" or "5\r" or "1\r"
timeout 60
done

page:    send "ATDT%N,,,,%R;\r"   # %N = pager call center number
                                           # Add enough commas to wait for
                                           # time to enter paging number.
                                           # %R = paging number

                                           # Confirm successful command.

  expect "0\r" timeout 60
  delay 2                          # Wait before hanging up.
  send "ATH0T\r"                   # Hang up.
  expect "0\r" timeout 2          # Confirm successful command.
  done

ripo:    send "AT&F1Q0T\r"        # Reset modem. Select profile 1
  ignore "0\r" or "OK\r\n" timeout 2 # Ignore modem response.
  send "ATE0T\r"                 # Initialize modem: Echo OFF,
  expect "0\r" or "OK\r\n" timeout 2 # Enable responses (Numeric),
  send "ATQ0V0X0T\r"            # Limit response codes.
  expect "0\r" timeout 2        # Confirm commands successful.
  send "ATS0=0\r"              # Set AutoAnswer OFF
  expect "0\r" timeout 2        # Confirm command successful.
  send "AT&C1&D2&R1\r"         # Detect carrier and DTR,

```

```

        expect "0\r" timeout 2
        done
        # Ignore RTS.
        # Confirm command successful.
        # RI Power On enabled.

error:
        # Handle unexpected modem
        # responses.
        expect "8\r" or "7\r" or "6\r" or "4\r" or "3\r"
        delay 2
        done

```

## Sample File modem\_m0.cfg

```

#
# COMPONENT_NAME: (ESPSETUP) ENTRY SERVICE PROCESSOR SETUP: modem_m0
#
# FUNCTIONS: Modem configuration file specifically for IBM 7852-400
# modem with Auto-Reliable feature. This feature must be turned off
# for Catcher calls. This example uses the AT&F reset command to
# choose the factory defaults.
#
# (C) COPYRIGHT International Business Machines Corp. 1996
# All Rights Reserved
# Licensed Materials - Property of IBM
#
# US Government Users Restricted Rights - Use, duplication or
# disclosure restricted by GSA ADP Schedule Contract with IBM Corp.
#
#
# The modem has configuration switches. They should be set to the
# factory default settings, except switches 11 and 12. These must be
# to UP ("AT" responses) and DOWN (Asynchronous operation), respectively.

ICDelay 1
DefaultTO 10
CallDelay 120
#
# %N Call-Out phone number %R Return phone number
#
#
# PROGRAMMING NOTE: No blanks between double quote marks ("").

condout: send "AT&F&E2E0T\r"      # Reset to factory defaults
        # Reliable mode
        # Echo off
        ignore "0\r" or "OK\r\n" timeout 2 # Ignore modem response.
        send "AT&E12&E14\r"          # Disable pacing
        # Disable data compression
        expect "0\r" or "OK\r\n" timeout 2 # Confirm commands successful.
        send "AT&SF1&S0S9=1\r"        # DSR independent of CD
        # Force DSR on.
        # CD respond time=100ms
        expect "0\r" or "OK\r\n" timeout 2 # Confirm commands successful.
        send "ATV0S0=0\r"            # Numeric response code
        # Auto-Answer off
        expect "0\r" or "OK\r\n" timeout 2 # Confirm commands successful.
        done

connect: send "ATDT%N\r"          # Tone dialing command.

```

```

# %N from Call Home setup.
# Expect a connection response.
expect "33\r" or "31\r" or "28\r" or "26\r" or "24\r" or "21\r" or
"19\r" or "13\r" or "12\r" or "1\r" busy "7\r"
timeout 60
done

retry: send "A/" # Repeat the previous command.
# Expect a connection response.
expect "33\r" or "31\r" or "28\r" or "26\r" or "24\r" or "21\r" or
"19\r" or "13\r" or "12\r" or "1\r" busy "7\r"
timeout 60
done

disconnect:
delay 2 # Separate from previous data.
send "+++\" # Assure command mode.
delay 2 # Allow mode switching delay.
send "ATH0\r" # Set modem switch-hook down
# (i.e., hang up).
ignore "0\r" or "OK\r" timeout 2 # Ignore modem response.
send "ATEOQ1\r" # Initialize modem: Echo OFF,
# Disable responses.

ignore "0\r" timeout 1
done

condin: send "AT&F&E2E0\r" # Reset to factory defaults.
# Reliable mode
# Echo off
ignore "0\r" or "OK\r\n" timeout 2 # Ignore modem response.
send "AT&E12&E14\r" # Disable pacing
# Disable data compression
expect "0\r" or "OK\r\n" timeout 2 # Confirm commands successful
send "AT&SF1&S0S9=1\r" # DSR independent of CD.
# Force DSR on.
# CD respond time=100ms
expect "0\r" or "OK\r\n" timeout 2 # Confirm commands successful.
send "ATV0S0=2\r" # Numeric response code
# Answer on 2nd ring
expect "0\r" timeout 2 # Confirm commands successful.
done

waitcall: ignore "2\r" timeout 1 # Ignore first ring.
expect "2\r" timeout 10 # Pickup 2nd ring or timeout
# Expect a connection response.
expect "33\r" or "31\r" or "28\r" or "26\r" or "24\r" or "21\r" or
"19\r" or "13\r" or "12\r" or "1\r" busy "7\r"
timeout 60
done

page: send "ATDT%N,,,%R;\r" # %N = pager call center number
# Add enough commas to wait for
# time to enter paging number.
# %R = paging number
expect "0\r" timeout 60 # Confirm successful command.
delay 2 # Wait before hanging up.
send "ATH0\r" # Hang up.
expect "0\r" timeout 2 # Confirm successful command.
done

ripo: send "AT&F&E2E0\r" # Reset to factory defaults.

```

```

                                # Reliable mode
                                # Echo off
ignore "\r" or "OK\r\n" timeout 2 # Ignore modem response.
send "AT&E12&E14\r"              # Disable pacing
                                # Disable data compression
                                # Confirm successful command.
expect "\r" or "OK\r\n" timeout 2 # DSR independent of CD.
send "AT&SF1&S0S9=1\r"          # Force DSR on.
                                # CD respond time=100ms
                                # Confirm commands successful.
expect "\r" or "OK\r\n" timeout 2 # Numeric response code
send "ATV0S0=0\r"                # Auto Answer OFF
                                # Confirm commands successful.
                                #
expect "\r" timeout 2            #
done                              #

error:                             # Handle unexpected modem
                                # responses.
expect "\8\r" or "\7\r" or "\6\r" or "\4\r" or "\3\r"
delay 2
done

```

## Sample File modem\_m1.cfg

```

#
# COMPONENT_NAME: (ESPSETUP) ENTRY SERVICE PROCESSOR SETUP modem_m1
#
# FUNCTIONS: Modem configuration file specifically for IBM 7857-017 modem with
# Auto-Reliable feature. This feature must be turned off for Catcher calls.
# This example uses the AT&F reset command to choose the factory defaults.
#
# To allow dial commands for digital pagers, it is necessary to reduce
# the number of characters in the dial command. Each comma (delay) has
# been set to 6 seconds (S8=6) for that reason.
#
#
# (C) COPYRIGHT International Business Machines Corp. 1996
# All Rights Reserved
# Licensed Materials - Property of IBM
#
# US Government Users Restricted Rights - Use, duplication or
# disclosure restricted by GSA ADP Schedule Contract with IBM Corp.
#

ICDelay 1
DefaultTO 10
CallDelay 120
#
# %N Call-Out phone number %R Return phone number
#
#
# PROGRAMMING NOTE: No blanks between double quote marks ("").

condout: send "AT&F*E0E0\r"      # Reset to factory defaults.
                                # *E0=data compression disabled
                                # E0=echo disabled
                                # Ignore modem response.
ignore "\r" or "OK\r\n" timeout 2 # Trellis modulation disabled
send "AT#F0*Q2S8=6\r"          # Retrain with adaptive rate

```



```

expect "0\r" or "OK\r\n" timeout 2
send "ATV0X0S0=0\r"
# Set ,=6second
# Confirm commands successful
# Numeric response code
# AT compatible messages
# Auto-Answer disabled
# Confirm commands successful.

expect "0\r" or "OK\r\n" timeout 2
done

connect: send "ATDT%N\r"
# Tone dialing command.
# %N from Call Home setup.
# Expect a connection response.

expect "1\r" busy "7\r" timeout 60
done

retry: send "A/"
# Repeat the previous command.
expect "1\r" busy "7\r" timeout 60
done

disconnect:
delay 2
send "+++\" # Assure command mode.
delay 2
send "ATH0\r" # Allow mode switching delay.
# Set modem switch-hook down
# (i.e., hang up).
ignore "0\r" or "OK\r" timeout 2
send "ATE0Q1\r" # Ignore modem response.
# Initialize modem: Echo OFF,
# Disable responses.

ignore "0\r" timeout 1
done

condin: send "AT&F*E0E0\r"
# Reset to factory defaults.
# *E0=data compression disabled
# E0=echo disabled
ignore "0\r" or "OK\r\n" timeout 2
send "AT#F0*Q2\r" # Ignore modem response.
# Trellis modulation disabled
# Retrain with adaptive rate
expect "0\r" or "OK\r\n" timeout 2
send "ATV0X0S0=2\r" # Confirm commands successful
# Numeric response code
# AT compatible messages
# Answer on 2nd ring
# Confirm commands successful.

expect "0\r" timeout 2
done

waitcall: ignore "2\r" timeout 1
# Ignore first ring.
expect "2\r" timeout 10
# Pick up second ring
# or timeout.
# Expect a connection response.

expect "1\r" timeout 60
done

page: send "ATD%N,%R\r"
# %N = pager call center number
# commas=6sec wait time to
# enter paging number.
# %R = return number
expect "0\r" or "3\r" timeout 30
# Confirm successful command.
delay 2
# Wait before hanging up.
send "+++\" # Assure command mode.
delay 2
# Allow mode switching delay.
send "ATH0\r" # Hang up.
expect "0\r" timeout 2
# Confirm successful command.
done

```

```

ripo:    send "AT&F*E0E0\r"          # Reset to factory defaults.
                                               # *E0=data compression disabled
                                               # E0=echo disabled
ignore "0\r" or "OK\r\n" timeout 2      # Ignore modem response.
send "AT#F0*Q2\r"                       # Trellis modulation disabled
                                               # Retrain with adaptive rate
expect "0\r" or "OK\r\n" timeout 2      # Confirm successful command.
send "ATV0X0S0=0\r"                     # Numeric response code
                                               # AT compatible messages
                                               # Auto-Answer disabled
expect "0\r" timeout 2                   # Confirm commands successful.
done                                       #

error:                                     # Handle unexpected modem
                                               # responses.
expect "8\r" or "7\r" or "4\r" or "3\r"
delay 2
done

```

---

# Index

## Numbers

3.5-inch diskette drive, using, 2-11

## A

about this book, xvii

account number, 3-15

AIX location codes, 5-6, 5-9

## B

backup service processor settings, C-1

battery, disposal, recycling, xv

boot mode menu, 3-16

## C

call home. *See* call-out

call-in, testing, C-2

call-in security, 3-19

call-in/call-out setup menu, 3-10

call-out, testing, C-2

call-out (call-home), 3-23

call-out policy setup menu, 3-14

call-out, policy, 3-14

caution, laser compliance statement, xiii

CD-ROM drive, using, 2-12

check points, 3-3, 3-8, 3-25

checklist, setup, C-1

configuration, service processor, 3-9

configuring disk drives, 2-17

console mirroring

enable/disable, 3-6

quick disconnect, 3-24

system configuration, 3-24

control key, 2-7

customer account setup menu, 3-15

customer administration center, 3-12

## D

determining versions of firmware, B-1

Diagnostics, 5-1

diagnostics considerations

running from a TTY terminal, 5-2

running online, 5-2

running standalone, 5-2

diagnostics, sources, 5-1

dial-out telephone numbers, setting, 3-12

disk drive. *See* hot swap disk drive; hot swap disk drives

disk drives, 2-17

configuring, 2-17

unconfiguring, 2-17

display, operator panel, 2-5

## E

entering open firmware, 2-4

error logs, 3-9, 4-2

## F

firmware, B-1

update procedures, B-1

fixed disk. *See* hot swap disk drives

function code table, A-2

function key, 2-7

## G

general access password, changing, 3-6

general user menus, 3-3

## H

hard disk drive. *See* hot swap disk drives

hardfile. *See* hot swap disk drives

hardware problem determination, 8-1

- heartbeat, 3-22
- hot swap disk drives
  - handling, 2-15
  - inserting, 2-18
  - removing, 2-20
  - status lights, 2-16
  - using, 2-15

## I

- I/O Drawer, front view, 1-4
- I/O Drawer, rear view, 1-5
- I/O drawer, indicator panels, 2-6
- I/O drawer locations
  - drawer 0, 5-13
  - drawer 1, 5-17
  - drawer 2, 5-20
  - drawer 3, 5-23
- indicator panel, 10 EIA Unit I/O Drawer, 2-6
- indicator panels, I/O drawer, 2-6
- inserting a SCSI disk drive, 2-18

## K

- keyboards, using, 2-7

## L

- language selection, 3-10
- language selection menu, 3-10
- laser compliance statement, xiii
- laser safety information, xiii
- LCD progress indicator log, 3-25
- LEDs, power, I/O Drawer, 2-6
- location code, format, 5-6
- location codes, 5-6
  - AIX, 5-6
  - physical, 5-6
- locations
  - AIX, 5-9
  - location code reference tables, 5-9
  - logical, 5-6
  - physical, 5-6, 5-9

## M

- menu inactivity, 3-3
- menus
  - general user, 3-3

- privileged user, 3-4
- returning to SP menus, 3-2
- SP, 3-2
- SP boot mode, 3-16
- SP call-in/call-out setup, 3-10
- SP call-out policy setup, 3-14
- SP customer account setup, 3-15
- SP language selection, 3-10
- SP modem configuration, 3-11
- SP reboot policy setup, 3-15
- SP serial port selection, 3-11
- SP serial port speed setup, 3-12
- SP setup, 3-5
- SP system information, 3-8
- SP system power control, 3-7
- SP telephone setup, 3-12
- support menus
  - SMS, 3-1
  - SP menus, 3-1
  - SP service aids, 3-1

- modem
  - configuration file selection, D-2
  - configuration menu, 3-11
  - configuration sample files, D-6
  - configurations, D-1
  - seamless transfer, D-4

- modem configuration menu, 3-11

- mouse, using, 2-8

## N

- notices, laser compliance statement, xiii
- numeric keypad, 2-7
- NVRAM, 3-9

## O

- online diagnostics
  - concurrent mode, 5-3
  - maintenance mode, 5-4
  - service mode, 5-3
- online diagnostics modes of operation, 5-3
- open firmware, entering, 2-4
- operating considerations, standalone and online diagnostics, 5-1
- operator panel
  - display, 2-5
  - functions, A-1
- operator panel display
  - locations, 2-1
  - reading, System Rack, 2-5
- overview, 1-1
  - I/O Connectors, 1-5

I/O Drawers, 1-4  
I/O Rack, 1-3  
System Rack, 1-2

## P

panel, indicator, 2-6  
passwords  
    changing general access password, 3-6  
    changing privileged access password, 3-6  
    overview, 3-6  
physical location codes, 5-6, 5-9  
POST errors, read, 3-4, 3-9  
POST indicators, 2-3  
POST keys, 2-4  
power  
    powering off the system, 2-2  
    powering on the system, 2-2  
power LED, 2-6  
power-on methods, 3-18  
privileged access password, changing, 3-6  
privileged user menus, 3-4  
problem determination  
    using the standalone or online diagnostics, 8-1, 8-7  
    when unable to load diagnostics, 8-7  
procedures, updating firmware, B-1  
processor configuration/deconfiguration, 3-21  
product disposal, xv  
progress indicators, 3-3, 3-8, 3-25

## R

read system POST errors, 3-4, 3-9  
reboot recovery, 3-20  
reboot/restart policy menu, 3-15  
recycling, xv  
reference tables  
    AIX location code, 5-9  
    physical location code, 5-9  
related publications, xvii  
remote latency, 3-14  
remote timeout, 3-14  
removing a hot swap disk drive, 2-20  
restart recovery, 3-20  
restoring service processor settings, 3-2  
RETAIN, 3-15

retries, 3-14  
running the online diagnostics in concurrent mode, 5-4  
running the online diagnostics in maintenance mode, 5-5  
running the online diagnostics in service mode, 5-3  
running the standalone diagnostics, 5-5

## S

safety, laser compliance statement, xiii  
safety notices, xii  
saving service processor settings, 3-2, C-1  
seamless transfer of a modem session, D-4  
security, call-in, 3-19  
serial port selection menu, 3-11  
serial port speed setup menu, 3-12  
service aids, 6-1  
    tasks, 6-1  
service center, 3-13  
service mode, service processor procedures, 3-17  
service processor. *See also* SP  
service processor call-in security, 3-19  
service processor checklist, C-1  
service processor configuration, 3-9  
Service Processor Features, 2-22  
service processor functions, 3-17  
service processor menu, 3-5  
service processor menus. *See* System Management Services  
service processor procedures in service mode, 3-17  
service processor settings, 3-2, C-1  
    restoring, 3-2  
    saving, 3-2  
service processor setup, C-1  
service processor setup checklist, C-1  
service processor test, C-1  
service provider, 3-13  
SP installation, checklist, C-1  
SP menus  
    accessing locally, 3-2  
    accessing remotely, 3-2  
    boot mode, 3-16  
    call-out policy, 3-14  
    call-in/call-out, 3-10  
    customer account, 3-15

- general user, 3-3
- language selection, 3-10
- menu inactivity, 3-3
- modem configuration, 3-11
- privileged user, 3-4
- reboot policy, 3-15
- restart policy, 3-15
- returning to, 3-2
- serial port selection, 3-11
- serial port speed setup, 3-12
- setup menu, 3-5
- supported menu options, 3-1
- system information, 3-8
- system power control, 3-7
- telephone number setup, 3-12

SP setup, C-1

SP test, C-1

standalone and online diagnostics operating considerations, 5-1

standalone diagnostic operation, 5-5

standalone diagnostics, running, 5-5

start talk mode, 3-6

starting system programs, 4-1

surveillance

- operating system, 3-22
- set parameters, 3-7
- system firmware, 3-22

system

- powering off, 2-2
- powering on, 2-2

system administrator, 3-13

system error log, displaying, 4-2

system information menu, 3-8

System Management Services, text-based, 4-1

system management services

- See also* System Management Services text-based, 4-1

system phone number, 3-13

system POST errors, read, 3-4, 3-9

- system power control menu, 3-7
- system power-on methods, 3-18
- System Rack location codes, 5-9
- System Rack operator panel, display, 2-5
- system unit, introduction, 1-1
- system verification procedure, 7-1

## T

- tasks, 6-1
- telephone number setup menu, 3-12
- testing the setup
  - call-in, C-2
  - call-out, C-2
- typewriter key, 2-7

## U

- unattended start mode, enable/disable, 3-7
- unconfiguring disk drives, 2-17
- updating firmware, B-1
- using
  - 3.5-inch diskette drive, 2-11
  - CD-ROM drive, 2-12
  - hot swap disk drives, 2-15
  - keyboards, 2-7
  - mouse, 2-8
  - system verification procedure, 7-1
- using the system, 2-1

## V

- vital product data. *See* VPD
- voice phone number, 3-13
- VPD (vital product data), 3-3

## Vos remarques sur ce document / Technical publication remark form

**Titre / Title :** Bull ESCALA EPC2400 & EPC2450 User's Guide

**N° Référence / Reference N° :** 86 A1 18KX 01

**Daté / Dated :** October 2000

### ERREURS DETECTEES / ERRORS IN PUBLICATION

### AMELIORATIONS SUGGEREES / SUGGESTIONS FOR IMPROVEMENT TO PUBLICATION

Vos remarques et suggestions seront examinées attentivement.

Si vous désirez une réponse écrite, veuillez indiquer ci-après votre adresse postale complète.

Your comments will be promptly investigated by qualified technical personnel and action will be taken as required.

If you require a written reply, please furnish your complete mailing address below.

NOM / NAME : \_\_\_\_\_ Date : \_\_\_\_\_

SOCIETE / COMPANY : \_\_\_\_\_

ADRESSE / ADDRESS : \_\_\_\_\_

Remettez cet imprimé à un responsable BULL ou envoyez-le directement à :

Please give this technical publication remark form to your BULL representative or mail to:

**BULL CEDOC  
357 AVENUE PATTON  
B.P.20845  
49008 ANGERS CEDEX 01  
FRANCE**

# Technical Publications Ordering Form

## Bon de Commande de Documents Techniques

To order additional publications, please fill up a copy of this form and send it via mail to:

Pour commander des documents techniques, remplissez une copie de ce formulaire et envoyez-la à :

**BULL CEDOC**  
**ATTN / MME DUMOULIN**  
**357 AVENUE PATTON**  
**B.P.20845**  
**49008 ANGERS CEDEX 01**  
**FRANCE**

**Managers / Gestionnaires :**  
**Mrs. / Mme :** C. DUMOULIN +33 (0) 2 41 73 76 65  
**Mr. / M :** L. CHERUBIN +33 (0) 2 41 73 63 96  
**FAX :** +33 (0) 2 41 73 60 19  
**E-Mail / Courrier Electronique :** [srv.Cedoc@franp.bull.fr](mailto:srv.Cedoc@franp.bull.fr)

Or visit our web site at: / Ou visitez notre site web à:

<http://www-frec.bull.com> (PUBLICATIONS, Technical Literature, Ordering Form)

CEDOC Reference # N° Référence CEDOC	Qty Qté	CEDOC Reference # N° Référence CEDOC	Qty Qté	CEDOC Reference # N° Référence CEDOC	Qty Qté
____ [__]		____ [__]		____ [__]	
____ [__]		____ [__]		____ [__]	
____ [__]		____ [__]		____ [__]	
____ [__]		____ [__]		____ [__]	
____ [__]		____ [__]		____ [__]	
____ [__]		____ [__]		____ [__]	
____ [__]		____ [__]		____ [__]	
____ [__]		____ [__]		____ [__]	

[\_\_] : **no revision number means latest revision** / pas de numéro de révision signifie révision la plus récente

NOM / NAME : \_\_\_\_\_ Date : \_\_\_\_\_

SOCIETE / COMPANY : \_\_\_\_\_

ADRESSE / ADDRESS : \_\_\_\_\_

PHONE / TELEPHONE : \_\_\_\_\_ FAX : \_\_\_\_\_

E-MAIL : \_\_\_\_\_

**For Bull Subsidiaries / Pour les Filiales Bull :**

Identification: \_\_\_\_\_

**For Bull Affiliated Customers / Pour les Clients Affiliés Bull :**

**Customer Code / Code Client :** \_\_\_\_\_

**For Bull Internal Customers / Pour les Clients Internes Bull :**

**Budgetary Section / Section Budgétaire :** \_\_\_\_\_

**For Others / Pour les Autres :**

**Please ask your Bull representative. / Merci de demander à votre contact Bull.**





**BULL CEDOC**  
**357 AVENUE PATTON**  
**B.P.20845**  
**49008 ANGERS CEDEX 01**  
**FRANCE**

ORDER REFERENCE  
86 A1 18KX 01

PLACE BAR CODE IN LOWER  
LEFT CORNER



Utiliser les marques de découpe pour obtenir les étiquettes.  
Use the cut marks to get the labels.

ESCALA  
EPC2400 &  
EPC2450  
User's Guide

86 A1 18KX 01

ESCALA  
EPC2400 &  
EPC2450  
User's Guide

86 A1 18KX 01

ESCALA  
EPC2400 &  
EPC2450  
User's Guide

86 A1 18KX 01

