



---

**OEM HARD DISK DRIVE SPECIFICATIONS for  
DORS-31080 / DORS-32160  
SCSI-3 FAST-20 68-pin Single-ended Models  
3.5-Inch Hard Disk Drive ( 1080 / 2160 MB )  
Revision (3.0)**

---

---





---

**OEM HARD DISK DRIVE SPECIFICATIONS for**  
**DORS-31080 / DORS-32160**  
**SCSI-3 FAST-20 68-pin Single-ended Models**  
**3.5-Inch Hard Disk Drive ( 1080 / 2160 MB )**  
**Revision (3.0)**

---

---

1st Edition (Rev.1.0) S39H-2859-00 (Dec. 15, 1995)  
2nd Edition (Rev.1.1) S39H-2859-01 (Jan. 22, 1996)  
3rd Edition (Rev.2.0) S39H-2859-02 (Mar. 15, 1996)  
4th Edition (Rev.3.0) S39H-2859-03 (Jun. 13, 1996)

**The following paragraph does not apply to the United Kingdom or any country where such provisions are inconsistent with local law:** INTERNATIONAL BUSINESS MACHINES CORPORATION PROVIDES THIS PUBLICATION “AS IS” WITHOUT WARRANTY OF ANY KIND, EITHER EXPRESS OR IMPLIED, INCLUDING, BUT NOT LIMITED TO, THE IMPLIED WARRANTIES OF MERCHANTABILITY OR FITNESS FOR A PARTICULAR PURPOSE. Some states do not allow disclaimer or express or implied warranties in certain transactions, therefore, this statement may not apply to You.

This publication could include technical inaccuracies or typographical errors. Changes are periodically made to the information herein; these changes will be incorporated in new editions of the publication. IBM may make improvements and/or changes in the product(s) and/or the program(s) described in this publication at any time.

It is possible that this publication may contain reference to, or information about, IBM products (machines and programs), programming, or services that are not announced in your country. Such references or information must not be construed to mean that IBM intends to announce such IBM products, programming, or services in your country.

Technical information about this product is available from your local IBM representative or at <http://www.ibm.com/harddrive>

IBM may have patents or pending patent applications covering subject matter in this document. The furnishing of this document does not give you any license to these patents. You can send license inquiries, in writing, to the IBM Director of Commercial Relations, IBM Corporation, Armonk, NY 10577.

© **Copyright International Business Machines Corporation 1996. All rights reserved.**

Note to U.S. Government Users —Documentation related to restricted rights —Use, duplication or disclosure is subject to restrictions set forth in GSA ADP Schedule Contract with IBM Corp.

---

# Contents

<b>1.0 General</b>	1
1.1 Introduction	1
1.2 References	1
1.3 Glossary	1
1.4 General Caution	1
<b>1.0 Outline of the drive</b>	3
<hr/>	
<b>Part 1. Functional Specification</b>	5
<b>2.0 Fixed Disk Subsystem Description</b>	7
2.1 Control Electronics	7
2.2 Head Disk Assembly	7
2.3 Actuator	7
<b>3.0 Drive Characteristics</b>	9
3.1 Formatted Capacity	9
3.2 Data Sheet	9
3.3 Cylinder Allocation	10
3.4 Performance Characteristics	10
3.4.1 Command overhead	11
3.4.2 Mechanical Positioning	11
3.4.3 Drive Ready Time	13
3.4.4 Data Transfer Speed	13
3.4.5 Buffering Operation (Lookahead/Write Cache)	13
3.4.6 Throughput	14
3.4.7 Operating Mode Definition	15
<b>4.0 Data integrity</b>	17
4.1 Equipment Status	17
4.2 Error Recovery	17
<b>5.0 Physical Format</b>	19
5.1 Shipped Format (PList)	19
5.2 Reassigned Format (GList)	19
<b>6.0 Specification</b>	21
6.1 Electrical Interface Specification	21
6.1.1 Connectors	21
6.1.2 Signal Definition	22
6.1.3 SCSI Cable	23
6.1.4 SCSI Bus Terminator	23
6.1.5 Hot Plug / Unplug	23
6.1.6 SCSI Bus Electrical Characteristics	24
6.1.7 Option Jumper Block	25
6.1.8 Auxiliary Connector	27
6.1.9 Jumper Signal Description	27
6.1.10 Shipping Default	30
6.2 Environment	30
6.3 DC Power Requirements	31

6.3.1 Start Up Current	32
6.4 Reliability	33
6.4.1 Contact Start Stop (CSS)	33
6.4.2 Data Reliability	33
6.4.3 Seek/ID Mis-compare Errors	33
6.4.4 Equipment Errors	33
6.4.5 Failure Prediction ( PFA / S.M.A.R.T.)	33
6.4.6 Automatic Drive Maintenance (ADM)	34
6.4.7 Preventive Maintenance	34
6.5 Mechanical Specifications	35
6.5.1 Outline	35
6.5.2 Mechanical Dimensions	35
6.5.3 Connector Locations	37
6.5.4 Drive Mounting	39
6.5.5 Shipping Zone and Lock	39
6.5.6 Breather Hole	39
6.6 Vibration and Shock	40
6.6.1 Operating Vibration	40
6.6.2 Non-Operating Vibrations	40
6.6.3 Operating Shock	41
6.6.4 Non-Operating Shock	41
6.7 Acoustics	42
6.7.1 Sound Power Levels	42
6.7.2 Sound Power Acceptance Criteria	42
6.7.3 Sound Pressure (Reference)	43
6.8 Identification Labels	44
6.9 Electromagnetic Compatibility	44
6.10 Safety	45
6.10.1 Underwriters Lab (UL) Approval	45
6.10.2 Canadian Standards Authority (CSA) Approval	45
6.10.3 IEC Compliance	45
6.10.4 German Safety Mark	45
6.10.5 Flammability	45
6.10.6 Secondary Circuit Protection	45
6.11 Packaging	45

---

## **Part 2. SCSI Interface Specification** . . . . . 47

<b>7.0 SCSI COMMAND SET</b>	<b>49</b>
7.1 Flag and Link Bits	51
7.2 Abbreviations	51
7.3 Byte ordering conventions	51
7.4 FORMAT UNIT (04)	52
7.4.1 Defect List	53
7.4.2 Defect Descriptor	54
7.5 INQUIRY (12)	56
7.6 Inquiry data	57
7.6.1 INQUIRY Data Format (When Invalid LUN is Specified)	57
7.6.2 Inquiry Data Format - EVPD = 0	59
7.6.3 Inquiry Data Format - EVPD = 1 - Page Code = 00	61
7.6.4 Inquiry Data Format - EVPD = 1 - Page Code = 01	62
7.6.5 Inquiry Data Format - EVPD = 1 - Page Code = 03	63
7.6.6 Inquiry Data Format - EVPD = 1 - Page Code = 80h	64
7.6.7 Inquiry Data Format - EVPD = 1 - Page Code = 82h	65

7.7 LOG SELECT (4C)	67
7.8 LOG SENSE (4D)	68
7.8.1 Log Page Parameters	69
7.8.2 Log Sense Page 0	70
7.8.3 Log Sense Page 2	71
7.8.4 Log Sense Page 3	73
7.8.5 Log Sense Page 5	75
7.8.6 Log Sense Page 6	77
7.8.7 Log Sense Page 3A	77
7.9 MODE SENSE (1A)	78
7.9.2 Mode Parameter List	79
7.10 MODE SELECT (15)	82
7.11 Mode Select Data	84
7.11.1 Page 0 (Vendor Unique Parameters)	85
7.11.2 Page 1 (Read/Write Error Recovery Parameters)	88
7.11.3 Page 2 (Disconnect/Reconnect Parameters)	93
7.11.4 Page 3 (Format Device Parameters)	95
7.11.5 Page 4 (Rigid Disk Drive Geometry Parameters)	97
7.11.6 Page 7 (Verify Error Recovery Parameters)	98
7.11.7 Page 8 (Caching Parameters)	100
7.11.8 Page A (Control Mode Page Parameters)	102
7.11.9 Page 0C (Zone Parameters)	104
7.11.10 Page 1C (Informational Exceptions Control) (PFA / S.M.A.R.T.)	106
7.11.11 Page 38 (Power Control)	109
7.12 PRE-FETCH (34)	110
7.13 READ (08)	111
7.14 READ CAPACITY (25)	112
7.15 READ DEFECT DATA (37)	114
7.15.1 Defect List Header	115
7.15.2 Bytes from Index Format (100b)	115
7.15.3 Physical Sector Format (101b)	115
7.16 READ EXTENDED (28)	117
7.17 READ BUFFER (3C)	118
7.17.1 Combined Header And Data (Mode 000)	118
7.17.2 Read Data (Mode 010b)	119
7.17.3 Descriptor (Mode 011b)	119
7.18 READ LONG (3E)	121
7.19 REASSIGN BLOCKS (07)	122
7.20 RECEIVE DIAGNOSTICS (1C)	124
7.20.1 Receive Diagnostic Page 0	124
7.20.2 Receive Diagnostic Page 40	124
7.21 RELEASE (17)	126
7.22 REQUEST SENSE (03)	127
7.23 RESERVE (16)	128
7.24 REZERO UNIT (01)	129
7.25 SEEK (0B)	130
7.26 SEEK EXTENDED (2B)	131
7.27 SEND DIAGNOSTIC (1D)	132
7.27.1 Send Diagnostic Pages 0	133
7.27.2 Send Diagnostic Pages 40	133
7.28 START/STOP UNIT (1B)	135
7.29 SYNCHRONIZE CACHE (35)	136
7.30 TEST UNIT READY (00)	137
7.31 VERIFY (2F)	138
7.32 WRITE (0A)	139

7.33	WRITE EXTENDED (2A)	140
7.34	WRITE AND VERIFY (2E)	141
7.35	WRITE BUFFER (3B)	142
7.35.1	Combined Header And Data (Mode 000b)	142
7.35.2	Write Data (Mode 010b)	143
7.35.3	Download Microcode (Mode 100b)	143
7.35.4	Download Microcode and Save (Mode 101b)	144
7.36	WRITE LONG (3F)	146
7.37	WRITE SAME (41)	147
<b>8.0</b>	<b>SCSI Status Byte</b>	<b>149</b>
<b>9.0</b>	<b>SCSI MESSAGE SYSTEM</b>	<b>151</b>
9.1	Supported Messages	151
9.1.1	COMMAND COMPLETE (00)	152
9.1.2	WIDE DATA TRANSFER REQUEST (01,02,03H)	152
9.1.3	SYNCHRONOUS DATA TRANSFER REQUEST (01,03,01H)	153
9.1.4	SAVE DATA POINTER (02)	154
9.1.5	RESTORE POINTERS (03)	154
9.1.6	DISCONNECT (04)	154
9.1.7	INITIATOR DETECTED ERROR (05)	155
9.1.8	ABORT (06)	155
9.1.9	MESSAGE REJECT (07)	155
9.1.10	NO OPERATION (08)	155
9.1.11	MESSAGE PARITY ERROR (09)	156
9.1.12	LINKED COMMAND COMPLETE (0A)	156
9.1.13	LINKED COMMAND COMPLETE WITH FLAG (0B)	156
9.1.14	BUS DEVICE RESET (0C)	156
9.1.15	ABORT TAG (0D)	156
9.1.16	CLEAR QUEUE TAG (0E)	156
9.1.17	QUEUE TAG MESSAGES(20h, 21h, 22h)	156
9.1.18	IGNORE WIDE RESIDUE (23,01h)	158
9.1.19	IDENTIFY (80 - FF)	158
9.2	Supported Message Functions	158
9.3	Attention Condition	160
9.4	SCSI Bus Related Error Handling Protocol	160
9.4.1	Unexpected BUS FREE Phase Error Condition	161
9.4.2	MESSAGE OUT Phase Parity Error	161
9.4.3	MESSAGE IN Phase Parity Error (Message Parity Error)	161
9.4.4	COMMAND Phase Parity Error	161
9.4.5	DATA OUT Phase Parity Error	162
9.4.6	INITIATOR DETECTED ERROR Message	162
9.4.7	MESSAGE REJECT Message	162
<b>10.0</b>	<b>SCAM</b>	<b>163</b>
10.1	SCAM Level 1 ( SCAM-1 )	163
10.2	SCAM Level 2 ( SCAM-2 )	164
10.3	Identification string	165
10.4	Function codes	166
10.5	Action codes	167
<b>11.0</b>	<b>Additional Information</b>	<b>169</b>
11.1	SCSI Protocol	169
11.1.1	Priority of SCSI Status Byte Reporting	169
11.1.2	Invalid LUN in Identify Message	169



11.1.3	Incorrect Initiator Connection	170
11.1.4	Command Processing During Execution of Active I/O process	170
11.1.5	Unit Attention Condition	172
11.1.6	Command Processing During Start-up and Format Operations	173
11.1.7	Internal Error Condition	173
11.1.8	Deferred error	173
11.1.9	Degraded Mode	174
11.1.10	Degraded Mode Handling	174
11.1.11	Command Processing While Reserved	175
11.2	Priority Commands	176
11.3	Command Queuing	176
11.3.1	Queue Depth	177
11.3.2	Tagged Queuing	177
11.3.3	Untagged Queuing	177
11.3.4	Command Queuing Rule	177
11.3.5	Queue Full Status	177
11.3.6	Device Behaviour on Command Queuing	178
11.4	Command Reordering	178
11.5	Concurrent I/O Process	178
11.6	Back to Back Write	179
11.7	Write Cache	179
11.8	Power Saving Mode	180
11.8.1	Mode Transition	180
11.9	Automatic Rewrite/Reallocate	181
11.10	Segmented Caching	183
11.10.1	Overview	183
11.10.2	Read Ahead	183
11.11	Reselection Timeout	184
11.12	Single Initiator Selection	185
11.13	Non-arbitrating Systems	185
11.14	Selection without ATN	185
11.15	Multiple Initiator Environment	185
11.15.1	Initiator Sense Data	185
11.15.2	Initiator Mode Select/Mode Sense Parameters	185
11.15.3	Initiator Data Transfer Mode Parameter	185
11.16	Contingent Allegiance Condition	186
11.17	Reset	187
11.17.1	Reset Sources	187
11.17.2	Reset Actions	187
11.18	Diagnostics	188
11.18.1	Power on Diagnostics	188
11.18.2	Diagnostics Command	188
11.18.3	Diagnostics Fault Reporting	188
11.19	Patrol Seek	189
11.20	Automatic Drive Maintenance (ADM)	189
<b>12.0</b>	<b>SCSI SENSE DATA</b>	<b>191</b>
12.1	SCSI Sense Data Format	191
12.1.1	Sense Data Description	192
<b>Index</b>		<b>201</b>



# Figures

1.	Formatted Capacity	9
2.	Data Sheet	9
3.	Command Overhead	11
4.	Mechanical Positioning Performance	11
5.	Full Stroke Seek Time	12
6.	Cylinder Skew	12
7.	Head Skew	12
8.	Latency Time	12
9.	Drive Ready Time	13
10.	Data Transfer Speed	13
11.	Simple Sequential Access Performance	14
12.	Random Access Performance	14
13.	Mode Transition Time	15
14.	Power Connector Pin Assignments	21
15.	Table of Signals	22
16.	Logic Signal Levels	24
17.	Jumper Pins	25
18.	Option Jumper Block Assignment	26
19.	SCSI Device ID	28
20.	Disable Auto Spin Up ,Auto Start Delay & Delay Start	29
21.	LED Circuit	29
22.	Default Jumper Setting	30
23.	Environmental Condition	30
24.	Input Voltage	31
25.	Power Supply Current of DORS-31080 with SCSI Terminator Enabled	31
26.	Power Supply Current of DORS-32160 with SCSI Terminator Enabled	31
27.	Power Supply Generated Ripple at Drive Power Connector	32
28.	Typical Current Wave Form of 12V at Start Up of DORS-32160	32
29.	Outline of DORS-3xxxx	35
30.	Physical Dimension	35
31.	Mechanical Dimension	36
32.	Connector Locations	37
33.	Mounting Positions and Tappings	38
34.	Breather Hole Location	39
35.	Random Vibration PSD Profile Breakpoints (Operating)	40
36.	Random Vibration PSD Profile Breakpoints (Non-Operating)	40
37.	A-weighted Sound Power Levels	42
38.	Sound Pressure Level	43
39.	SCSI Commands Supported	49
40.	SCSI Commands Supported	50
41.	FORMAT UNIT (04)	52
42.	Format of Defect List Header	53
43.	Defect Descriptor - Block Format	54
44.	Defect Descriptor - Bytes From Index Format	55
45.	Defect Descriptor - Physical Sector Format	55
46.	INQUIRY (12)	56
47.	INQUIRY DATA Invalid LUN Specified	57
48.	INQUIRY Data - EVPD = 0	59
49.	INQUIRY DATA - EVPD = 1 (Page Code = 00)	61
50.	INQUIRY DATA - EVPD = 1 (Page Code = 01)	62
51.	INQUIRY DATA - EVPD = 1 (Page Code = 03)	63

52.	INQUIRY DATA - EVPD = 1 (Page Code = 80h)	64
53.	INQUIRY DATA - EVPD = 1 (Page Code = 82h)	65
54.	LOG SELECT (4C)	67
55.	LOG SENSE (4D)	68
56.	MODE SENSE (1A)	78
57.	Page Code Usage	79
58.	MODE Parameter List (Header)	79
59.	MODE Parameter Block Descriptor	80
60.	MODE Parameter Page Format	80
61.	MODE SELECT (15)	82
62.	Page Code Usage	84
63.	Page 0	85
64.	Page 1	88
65.	Page 2	93
66.	Page 3	95
67.	Page 4	97
68.	Page 7	98
69.	Page 8	100
70.	Page A	102
71.	Page 0C	104
72.	Page 1C	106
73.	Page 38h	109
74.	Pre-Fetch (34)	110
75.	READ (08)	111
76.	READ CAPACITY (25)	112
77.	Format of READ CAPACITY command reply	113
78.	Read Defect Data (37)	114
79.	Defect List Header	115
80.	Defect Descriptors of Bytes from Index Format	115
81.	Defect Descriptors of Physical Sector Format	116
82.	Read Extended (28)	117
83.	READ BUFFER (3C)	118
84.	READ BUFFER Header	119
85.	READ BUFFER DESCRIPTOR	120
86.	READ LONG (3E)	121
87.	REASSIGN BLOCKS (07)	122
88.	Format of REASSIGN BLOCKS data	123
89.	RECEIVE DIAGNOSTIC (1C)	124
90.	RELEASE (17)	126
91.	REQUEST SENSE (03)	127
92.	RESERVE (16)	128
93.	REZERO UNIT (01)	129
94.	SEEK (0B)	130
95.	SEEK EXTENDED (2B)	131
96.	SEND DIAGNOSTIC (1D)	132
97.	START/STOP Unit (1B)	135
98.	SYNCHRONIZE CACHE (35)	136
99.	TEST UNIT READY (00)	137
100.	VERIFY (2F)	138
101.	WRITE (0A)	139
102.	WRITE EXTENDED (2A)	140
103.	WRITE AND VERIFY (2E)	141
104.	WRITE BUFFER (3B)	142
105.	WRITE BUFFER Header	143
106.	WRITE LONG (3F)	146

107. WRITE SAME (41)	147
108. SCSI Status Byte	149
109. Supported Messages	151
110. Wide Data Transfer Request.	152
111. Initiator Request / Target Response	152
112. Synchronous Data Transfer Request.	153
113. Initiator Request/Target Response	154
114. Queue Tag Messages	157
115. Ignore Wide Residue	158
116. SCAM Identification string	165
117. SCAM Identification string	166
118. Action codes	167
119. Read Ahead handling per each command	183
120. Format of Sense Data	191
121. Field Pointer Bytes	198
122. Actual Retry Count Bytes	199
123. Format Progress Indication Bytes	199



---

# 1.0 General

---

## 1.1 Introduction

This paper describes functional and interface specifications for SCSI-3 FAST-20 68-Pin Single-ended Models of DORS-3xxxx 3.5 inch hard disk drive.

The drive supports Level-2 SCAM specified in Annex B of ANSI X3T10/855D.

**Note:** The specifications are subject to change without notice.

The interface conforms to the 'draft' ANSI SCSI-2 standard, Revision 10L, Jan 1994 (Document X3.1311-1994), 'draft' ANSI SCSI-3 Fast-20 X3T10/1071D, and Annex B of 'draft' SCSI-3 X3T10/855D. The vendor specific items and options supported by the drive are described in each section.

---

## 1.2 References

- 'draft' ANSI SCSI-2 standard, Revision 10L, Jan 1994 (Document X3.1311-1994)
- 'draft' ANSI SCSI-3 Fast-20, X3T10/1071D
- 'draft' ANSI SCSI-3 SCAM, X3T10/855D Annex B

---

## 1.3 Glossary

<i>Word</i>	<i>Meaning</i>
<b>Kbpi</b>	1,000 Bits Per Inch
<b>Mbps</b>	1,000,000 Bits per second
<b>MB</b>	1,000,000 bytes
<b>KB</b>	1,000 bytes unless otherwise specified
<b>32KB</b>	32 x 1,024 bytes
<b>64KB</b>	64 x 1,024 bytes
<b>Mb/sq.in</b>	1,000,000 bits per square inch
<b>MLC</b>	Machine Level Control
<b>PFA</b>	Predictive Failure Analysis (Trademark of IBM Corp.)
<b>S.M.A.R.T.</b>	Self-Monitoring Analysis and Reporting Technology
<b>ADM</b>	Automatic Drive Maintenance
<b>SCAM</b>	SCSI Configured AutoMatically

---

## 1.4 General Caution

The drive can be easily damaged by shocks or ESD (Electric Static Discharge), so any damages applied to the drive after taking out from shipping package and opening ESD protective bag are user's responsibilities.





---

## 1.0 Outline of the drive

- SCSI 2 Standard
- SCSI-3 FAST-20 WIDE ( up to 40 Mbytes/sec transfer )
- SCSI-3 SCAM Level 2 support
- Queued I/O Process support
- 512 bytes/sector sector format
- Interleave factor 1:1
- Write Cache
- 7 x 64 KBytes segmented sector buffer
- ECC on the fly
- Automatic error recovery procedures for read and write commands
- Self diagnostics on power on and resident diagnostics
- Transparent defect management with ADR ( Automatic Defect Reallocation )
- 8.5 msec seek time in read operation
- 5400rpm spindle rotation.
- Closed loop actuator servo
- Dedicated head landing zone
- Automatic actuator lock
- Informational Exceptions Control Page of SCSI-3 support as **PFA** or **S.M.A.R.T.** function

**Note:** **PFA** is Trademark of IBM corp. which means Predictive Failure Analysis.



---

## Part 1. Functional Specification



---

## 2.0 Fixed Disk Subsystem Description

---

### 2.1 Control Electronics

The drive is electronically controlled by a microprocessor, several logic modules, digital/analogue modules, and various drivers and receivers. The control electronics perform the following major functions.

- Conducts a power-up sequence and calibrates the servo.
- Monitors various timers for head settling, servo failure, etc.
- Analyzes servo signals to provide closed loop control. These include position error signal and estimated velocity.
- Controls the voice coil motor driver to align the actuator onto a desired position.
- Monitors the actuator position and determines the target track for a seek operation.
- Constantly monitors error conditions of the servo and takes corresponding action if an error occurs.
- Controls starting, stopping, and rotating speed of the spindle.
- Controls and interprets all interface signals between the host controller and the drive.
- Controls read write accessing of the disk media, including defect management and error recovery.
- Performs self-checkout (diagnostics).

---

### 2.2 Head Disk Assembly

The head disk assembly (HDA) is assembled in a clean room environment and contain a disk and actuator assembly. Air is constantly circulated and filtered when the drive is operational. Venting of the HDA is accomplished via a breather filter.

The spindle is driven directly by a brushless, sensorless DC drive motor. Dynamic braking is used to stop the spindle quickly.

---

### 2.3 Actuator

The read/write heads are mounted in the actuator. The actuator is a swing-arm assembly driven by a voice coil motor. A closed-loop positioning servo controls the movement of the actuator. An embedded servo pattern supplies feedback to the positioning servo to keep the read/write heads centered over the desired track.

The actuator assembly is balanced to allow vertical or horizontal mounting without adjustment.

When the drive is powered off, the actuator automatically moves the head to a dedicated landing zone outside of the data area, where the actuator is locked.



## 3.0 Drive Characteristics

This chapter provides the characteristics of the drive.

### 3.1 Formatted Capacity

Description	DORS-31080	DORS-32160
Label Capacity (MB)	1080	2160
Bytes per Sector	512	512
Sectors per Track	99-148	99-148
Number of heads	3	5
Number of disks	2	3
Number of LBAs	2,118,144	4,226,725
Total Logical Data Bytes	1,084,489,728	2,164,083,200

Figure 1. Formatted Capacity

### 3.2 Data Sheet

Figure 2. Data Sheet	
Buffer to/from media [Mbit/sec]	47.4 to 71.6
Host to/from buffer ( interface transfer rate ) [Mbyte/sec]	40
Data buffer size	448Kbyte
Number of buffer segments	7 x 64Kbyte
Rotational speed [RPM]	5400
Recording density [Kbpi]	83.5(Ave) / 103.6(Max)
Track density [TPI]	7056
Areal density [Mb/sq.in.]	589(Ave) / 731(Max)
Data zone	8

---

### 3.3 Cylinder Allocation

	Phys. Cyl.	Sectors/Trk
System Area		
Data Zone 0	0-343	148
Data Zone 1	344-1156	143
Data Zone 2	1157-1810	140
Data Zone 3	1811-3959	132
Data Zone 4	3960-4750	121
Data Zone 5	4751-5358	115
Data Zone 6	5359-5907	110
Data Zone 7	5908-6716	99
System Area		

Mode page 03 (Format Device Parameters) and 0C (Zone Parameters) provide methods to determine medium format and zone parameters. See 7.11.4, “Page 3 (Format Device Parameters)” on page 95, and 7.11.9, “Page 0C (Zone Parameters)” on page 104.

---

### 3.4 Performance Characteristics

A drive performance is characterized by the following parameters:

- Command Overhead
- Mechanical Positioning
  - Seek Time
  - Latency
- Data Transfer Speed
- Buffering Operation (Lookahead/Write cache)

**Note:** All the above parameters contribute to drive performance. There are other parameters that contribute to the performance of the actual system. This specification tries to define the bare drive characteristics, not the system throughput which will depend on the system and the application.



### 3.4.1 Command overhead

Command overhead is defined as the time required:

- from last byte of command phase
- to the first byte of data phase
- exclude
  - Physical seek time
  - Latency time
  - Initiator delay with reconnections

Command Case (Drive is in quiescence state)	Time
Cache Not Hit	<0.70msec
Cache Hit	<0.10msec

Figure 3. Command Overhead

### 3.4.2 Mechanical Positioning

#### 3.4.2.1 Average Seek Time (Including Settling)

Figure 4. Mechanical Positioning Performance		
Command Type	Typical	Max
Read	8.5 [msec]	9.5 [msec]
Write	9.5 [msec]	10.5 [msec]

“Typical” and “Max” are given throughout the performance specification by;

**Typical** Average of the drive population tested at nominal environmental and voltage conditions.  
**Max** Maximum value measured on any one drive over the full range of the environmental and voltage conditions. (See 6.2, “Environment” on page 30 and 6.3, “DC Power Requirements” on page 31 for ranges.)

The seek time is measured from the start of actuator's motion to the start of **a reliable read or write operation**. Reliable read or write implies that error correction/recovery is not used to correct arrival problems. The average seek time is measured as the weighted average of all possible seek combinations.

$$\text{Weighted Average} = \frac{\sum_{n=1}^{\max} (\max + 1 - n) (Tn.in + Tn.out)}{(\max + 1) (\max)}$$

Where:

max = Maximum seek length

n = Seek length (1 to max)

Tn.in = Inward measured seek time for an n track seek

Tn.out = Outward measured seek time for an n track seek

### 3.4.2.2 Full Stroke Seek

Figure 5. Full Stroke Seek Time		
Function	Typical	Max.
Read [msec]	15	18
Write [msec]	15.5	19

Full stroke seek is measured as the average of 1000 full stroke seeks with a **random head switch** from both directions (inward and outward).

### 3.4.2.3 Cylinder Switch Time (Cylinder Skew)

Figure 6. Cylinder Skew	
	Typical
Cylinder Skew	3.2 [msec]

A cylinder switch time is defined as the amount of time required by the fixed disk access the next sequential block after reading the last sector in the current cylinder.

The measured method is given in 3.4.6, “Throughput” on page 14.

### 3.4.2.4 Head Switch Time (Head Skew)

Figure 7. Head Skew	
	Typical
Head Skew	1.9 [msec]

### 3.4.2.5 Average Latency

Figure 8. Latency Time		
Rotation	Time for a revolution	Average Latency
5400 [RPM]	11.1 [msec]	5.56 [msec]

### 3.4.3 Drive Ready Time

Figure 9. Drive Ready Time		
Condition	Typical	Max.
Power On to Ready	15 [sec]	20 [sec]

**Ready** The condition in which the drive is able to perform a media access command (eg. read, write) immediately.

**Power On** This includes the time required for the internal self diagnostics.

### 3.4.4 Data Transfer Speed

Figure 10. Data Transfer Speed	
Description	Typical
Disk-Buffer Transfer (Zone 0)	
(Instantaneous)	8.95 [Mbyte/sec]
(Sustained)	5.7 [Mbyte/sec]
Disk-Buffer Transfer (Zone 7)	
(Instantaneous)	5.93 [Mbyte/sec]
(Sustained)	3.8 [Mbyte/sec]
Buffer-Host	
SCSI-3 FAST-20 WIDE	40 [Mbyte/sec]

- Instantaneous disk-buffer transfer rate (Mbyte/sec) is derived by:  
 $(\text{Number of sectors on a track}) * 512 * (\text{revolution/sec})$

**Note:** Number of sectors per track will vary because of the linear density recording.

- Sustained disk-buffer transfer rate (Mbyte/sec) is defined by considering head/cylinder change time. This gives a local average data transfer rate. It is derived by:

$$(\text{Sustained Transfer Rate}) = A / (B + C + D)$$

$$A = (\text{Number of data sectors per cylinder}) * 512$$

$$B = ((\text{\# of Surface per cylinder}) - 1) * (\text{Head switch time})$$

$$C = (\text{Cylinder change time})$$

$$D = (\text{\# of Surface}) * (\text{One revolution time})$$

- Instantaneous Buffer-Host Transfer Rate (Mbyte/sec) defines the maximum data transfer rate on AT Bus. It also depends on the speed of the host.

The measurement method is given in 3.4.6, "Throughput" on page 14.

### 3.4.5 Buffering Operation (Lookahead/Write Cache)

In order to improve the total performance, the drive utilizes its own buffer for lookahead.

Total 448K bytes of the buffer is divided into 7 segmented blocks fixly. These seven segments are managed intelligently to obtain the best performance.

## 3.4.6 Throughput

### 3.4.6.1 Simple Sequential Access

Figure 11. Simple Sequential Access Performance		
Operation	Typical	Max
Sequential Read/Write	Zone 0 3.17 [sec]	Zone 0 3.32 [sec]
	Zone 7 4.68 [sec]	Zone 7 4.90 [sec]

The above table gives the time required to read/write for a total of 8000x consecutive blocks (16,777,216 bytes) accessed by 128 read/write commands. Typical and Max values are given by 105% and 110% of T respectively throughout following performance description.

**Note:** Assumes a host system responds instantaneously.

$$T = (A * 128) + B + C + 16,777,216/D + 512/E \quad (\text{READ})$$

$$T = (A * 128) + B + C + 16,777,216/D \quad (\text{WRITE})$$

where:

T = Calculated Time (sec)

A = Command Process Time (Pre/Post Command overhead)

B = Average Seek Time

C = Average Latency

D = Sustained Disk-Buffer Transfer Rate (Mbyte/sec)

E = Buffer-Host Transfer Rate (Mbyte/sec)

### 3.4.6.2 Random Access

Figure 12. Random Access Performance		
Operation	Typical	Max
Random Read	64 [sec]	67 [sec]
Random Write	64 [sec]	67 [sec]

The above table gives the time required to execute a total of 1000x read/write commands which access a random LBA.

$$T = (A + B + C + 512/D + 512/E) * 4096 \quad (\text{READ})$$

$$T = (A + B + C + 512/D) * 4096 \quad (\text{WRITE})$$

where:

T = Calculated Time (sec)

A = Command Process Time (Pre/Post Command overhead)

B = Average Seek Time

C = Average Latency

D = Sustained Disk-Buffer Transfer Rate (Mbyte/sec)

E = Buffer-Host Transfer Rate (Mbyte/sec)

### 3.4.7 Operating Mode Definition

Operating Mode	Description
<b>Spin-Up</b>	Start up time period from spindle stop or power down.
<b>Seek</b>	Seek operation mode
<b>Write</b>	Write operation mode
<b>Read</b>	Read operation mode
<b>Idle</b>	Spindle motor and servo system are working normally. Commands can be received and processed immediately.
<b>Standby</b>	Spindle motor is stopped. Commands can be received immediately, but write or read operations cannot begin until the spindle is spun-up and the Servo system is ready.

**Note:** Upon Power down or Spindle stopped, a head locking mechanism will secure the heads in the ID parking position.

Recovering from Standby mode does not need soft reset nor hard reset.

#### 3.4.7.1 Mode Transition Time

Figure 13. Mode Transition Time			
From	To	Typical	Max
Standby	Idle	15 [sec]	20 [sec]
Idle	Standby	Immediate (note)	Immediate (note)

**Note:** The actual spin down time will exist, however the command will be processed immediately.



---

## 4.0 Data integrity

The drive retains recorded information under all non-write operations.

No more than one sector can be lost by power down during write operation while write cache is disabled. In case that power down occurs before completion of data transfer from write cache to disk while write cache is enabled, the data remaining in write cache will be lost. To prevent this data loss at power off, the following action is recommended:

- To confirm successful completion of SYNCHRONIZE CACHE (35h) command.

---

## 4.1 Equipment Status

Equipment status is available to the host system any time the drive is not ready to read, write, or seek. This status normally exists at power-on time and will be maintained until the following conditions are satisfied.

- Access recalibration/tuning is complete.
- Spindle speed meets requirements for reliable operations.
- Self-check of drive is complete.

Appropriate error status is made available to the host system if any of the following condition occurs after the drive has become ready:

- Spindle speed goes outside of requirements for reliable operation.
- “Write fault” is detected.

---

## 4.2 Error Recovery

Errors occurring with the drive are handled by the error recovery procedure.

Errors that are uncorrectable after application of the error recovery procedures are reported to the host system as non-recoverable errors.





## 5.0 Physical Format

Media defects are remapped to the next available sector during Format Process in manufacturing. The mapping from LBA to the physical locations is calculated by an internal maintained table.

### 5.1 Shipped Format (PList)

- Data areas are optimally used.
- No extra sector is wasted as a spare throughout user data areas.
- All pushes generated by defects are absorbed by spare tracks of inner zone.  
No spare sector at each track or zone. Spare sectors are reserved after max LBA of data area.

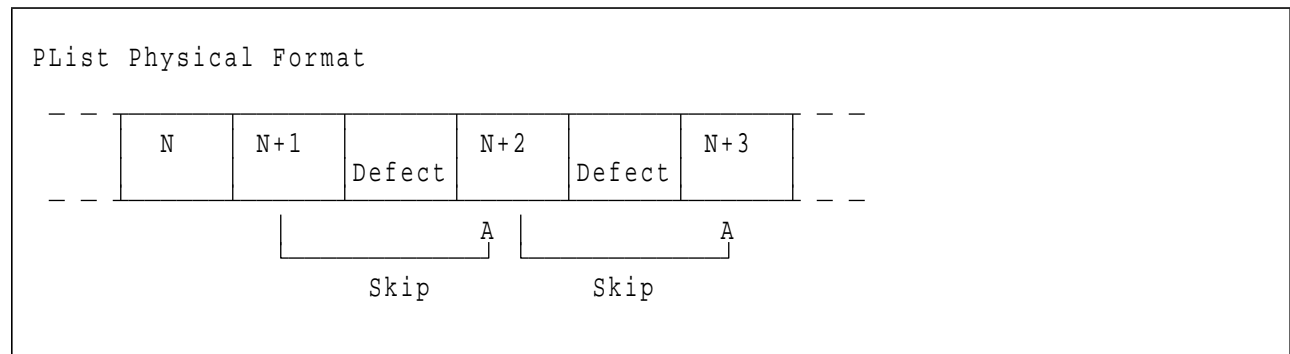

Defects are skipped without any constraint, such as track or cylinder boundary. The calculation from LBA to physical is done automatically by internal table.

### 5.2 Reassigned Format (GList)

- 252 spare sectors are available at shipment following after Max LBA of data area, and are used by Automatic Defect Reallocation and Reassign Block Command.

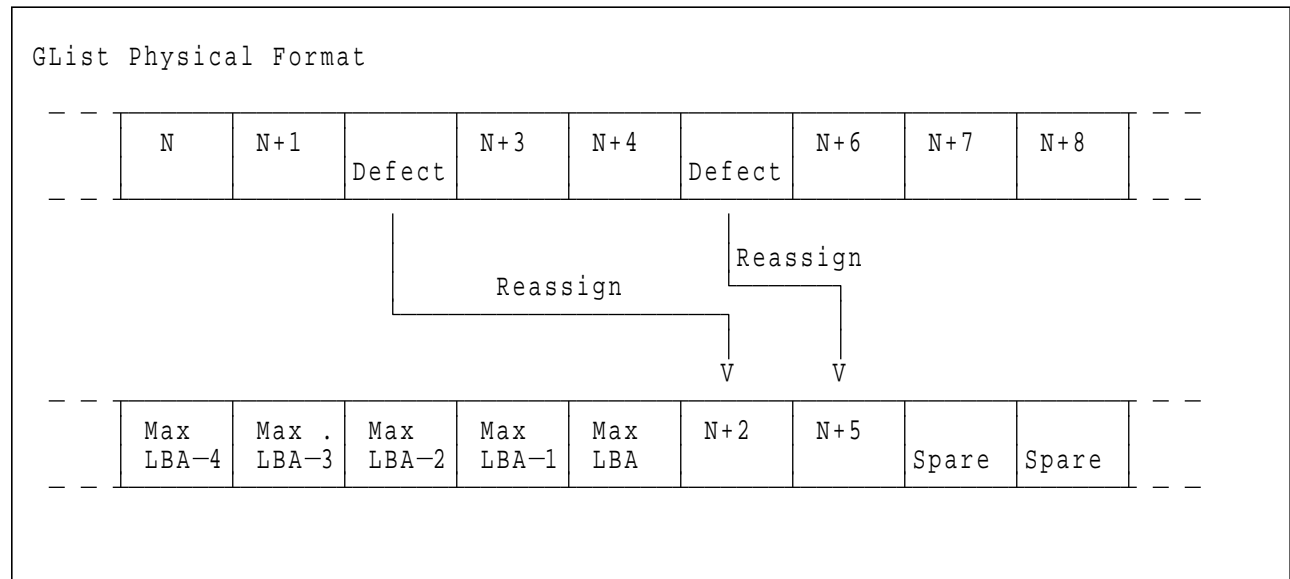

Calculation from LBA to physical is done automatically by internal table.



## 6.0 Specification

### 6.1 Electrical Interface Specification

#### 6.1.1 Connectors

##### 6.1.1.1 Power

The DC power connector is designed to mate with AMP (part 1-480424-0) using AMP pins (part 350078-4) strip or (part 61173-4) loose piece, or their equivalents. Pin assignments are shown below.

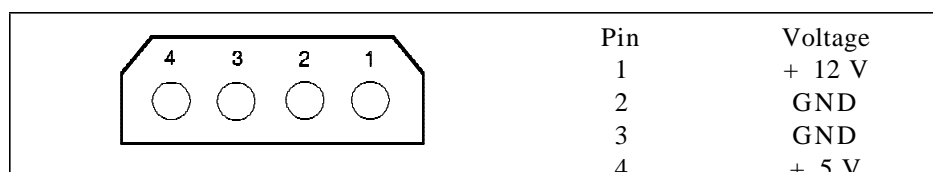

Figure 14. Power Connector Pin Assignments

##### 6.1.1.2 SCSI Signal Connector

The SCSI signal connector is 68-pin connector meeting the ANSI SCSI specification.

## 6.1.2 Signal Definition

The pin assignments of interface signals conforms to ANSI SCSI-3 X3T10/855D as follows.

Figure 15. Table of Signals

Connector Contact Number	Signal Name	Connector Contact Number	Signal Name
01	Ground	35	-DB(12)
02	Ground	36	-DB(13)
03	Ground	37	-DB(14)
04	Ground	38	-DB(15)
05	Ground	39	-DB(P1)
06	Ground	40	-DB(0)
07	Ground	41	-DB(1)
08	Ground	42	-DB(2)
09	Ground	43	-DB(3)
10	Ground	44	-DB(4)
11	Ground	45	-DB(5)
12	Ground	46	-DB(6)
13	Ground	47	-DB(7)
14	Ground	48	-DB(P0)
15	Ground	49	Ground
16	Ground	50	Ground
17	TERMPWR	51	TERMPWR
18	TERMPWR	52	TERMPWR
19	(Reserved)	53	(Reserved)
20	Ground	54	Ground
21	Ground	55	-ATN
22	Ground	56	Ground
23	Ground	57	-BSY
24	Ground	58	-ACK
25	Ground	59	-RST
26	Ground	60	-MSG
27	Ground	61	-SEL
28	Ground	62	-C/D
29	Ground	63	-REQ
30	Ground	64	-I/O
31	Ground	65	-DB(8)
32	Ground	66	-DB(9)
33	Ground	67	-DB(10)
34	Ground	68	-DB(11)

### 6.1.3 SCSI Cable

The drives comply with ANSI X3T10/1071D.

The maximum cumulative signal path length between terminators shall be 3.0 meters when using up to 4 maximum capacitance (25pF) devices.

The maximum cumulative signal path length between terminators shall be 1.5 meters when using from 5 to 8 maximum capacitance devices.

### 6.1.4 SCSI Bus Terminator

The drives comply with ANSI X3T10/1071D.

Active terminator as specified in ANSI X3T10/1071D should be used.

Terminators employing a 220 ohm resistor to 5 Volts and 330 ohm resistor to ground on each signal shall not be used. (**Passive terminators should not be used** for FAST-20.)

**Note : The drive may not spin up while SCSI Bus is disconnected and internal terminator is disabled.**

Internal terminator enabled by jumper plug is equipped in the drive except 80 pin SCA-2 model.

### 6.1.5 Hot Plug / Unplug

Power supply and SCSI bus hot plug and unplug is allowed. There is no special sequence required for connecting 5 or 12 volts. During a hot plug-in event the drive being plugged will draw a large amount of current at the instant of plug-in. This current spike is due to charging the bypass capacitors on the drive. This current pulse may cause the power supply to go out of regulation. If this supply is shared by other drives then a low voltage power on reset may be initiated on those drives. Therefore the recommendation for hot plugging is to have one supply for each drive. Never daisy chain the power leads if hot plugging is planned. Hot plugging should be minimized to prevent wear on the power connector.

Hot plugging the SCSI bus may cause glitches on the bus. To minimize the chance of glitching, it is recommended to plug in the SCSI bus before the power is applied.

During hot plugging, the supplies must not go over the upper voltage limit. In addition proper ESD protection must be used during the plugging event to insure that the SCSI bus ground is at the same potential as the drive ground.

During hot un-plugging if the operating shock limit specification can be exceeded then the drive should be issued a SCSI Stop Unit command that is allowed to complete before un-plugging.

## 6.1.6 SCSI Bus Electrical Characteristics

The interface logic signals has the following electrical specifications. Details should be referred to ANSI X3T10/1071D.

Inputs :	Input High Voltage	=	1.9 Vdc minimum (signal false)
	Input Low Voltage	=	1.0 Vdc maximum (signal true)
Outputs :	Output High Voltage	=	2.5 to 3.7 Vdc (signal asserted)
	Output Low Voltage	=	0.0 to 0.5 Vdc (signal negated)

Figure 16. Logic Signal Levels

## 6.1.7 Option Jumper Block

The 12 positions jumper block shown below is used to select the SCSI device ID, Auto spin up option control, Unit Attention option control, SCSI terminator ON/OFF setting, Auto start delay option control and SCSI parity option control. It also provides an external Light Emitting Diode connection.

Some of the above items can be also controled through Auxiliary Connector as described in 6.1.8, “Auxiliary Connector” on page 27. These controls work as logical OR between Option Jumper Block and Auxiliary Connector.

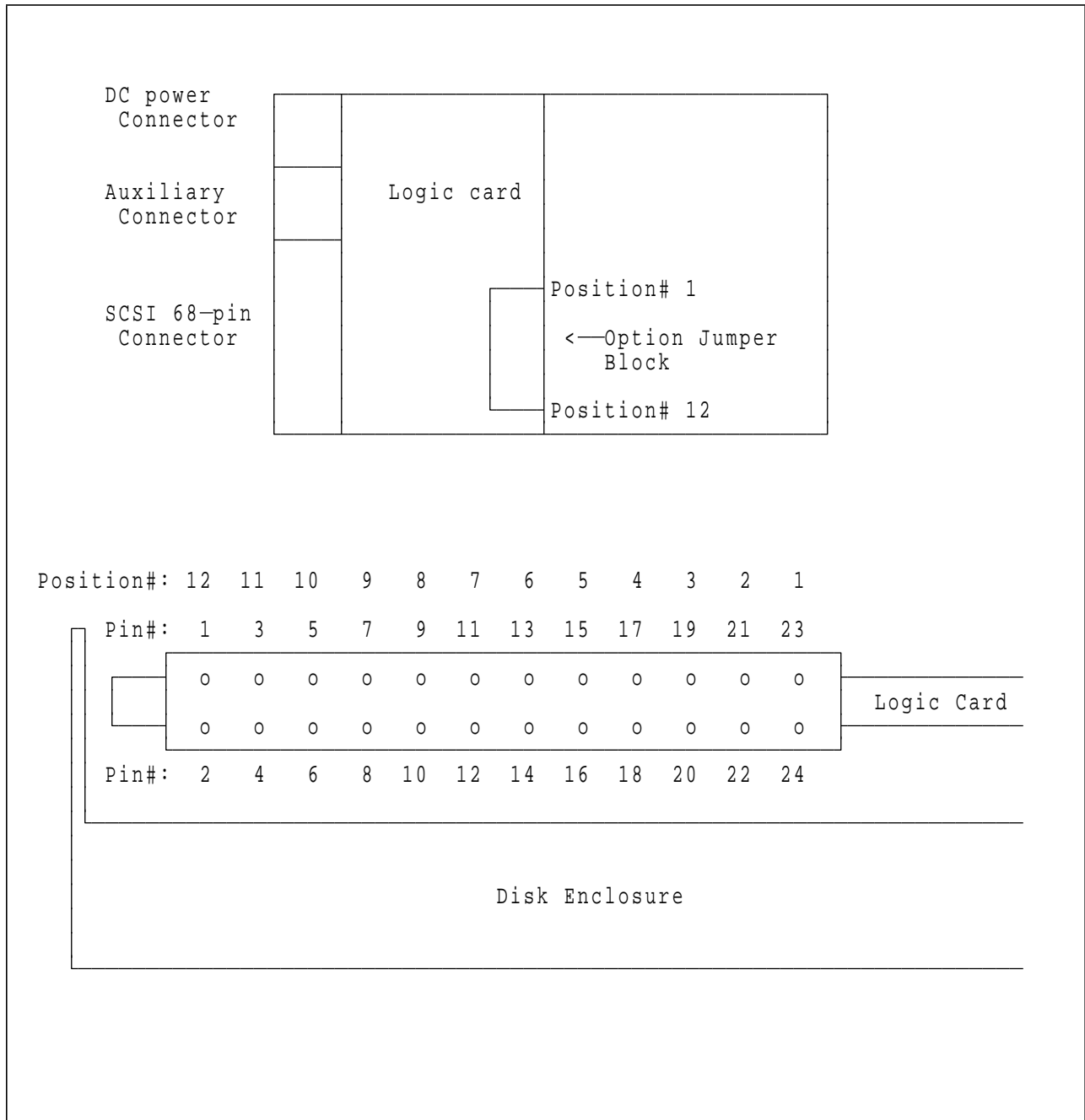
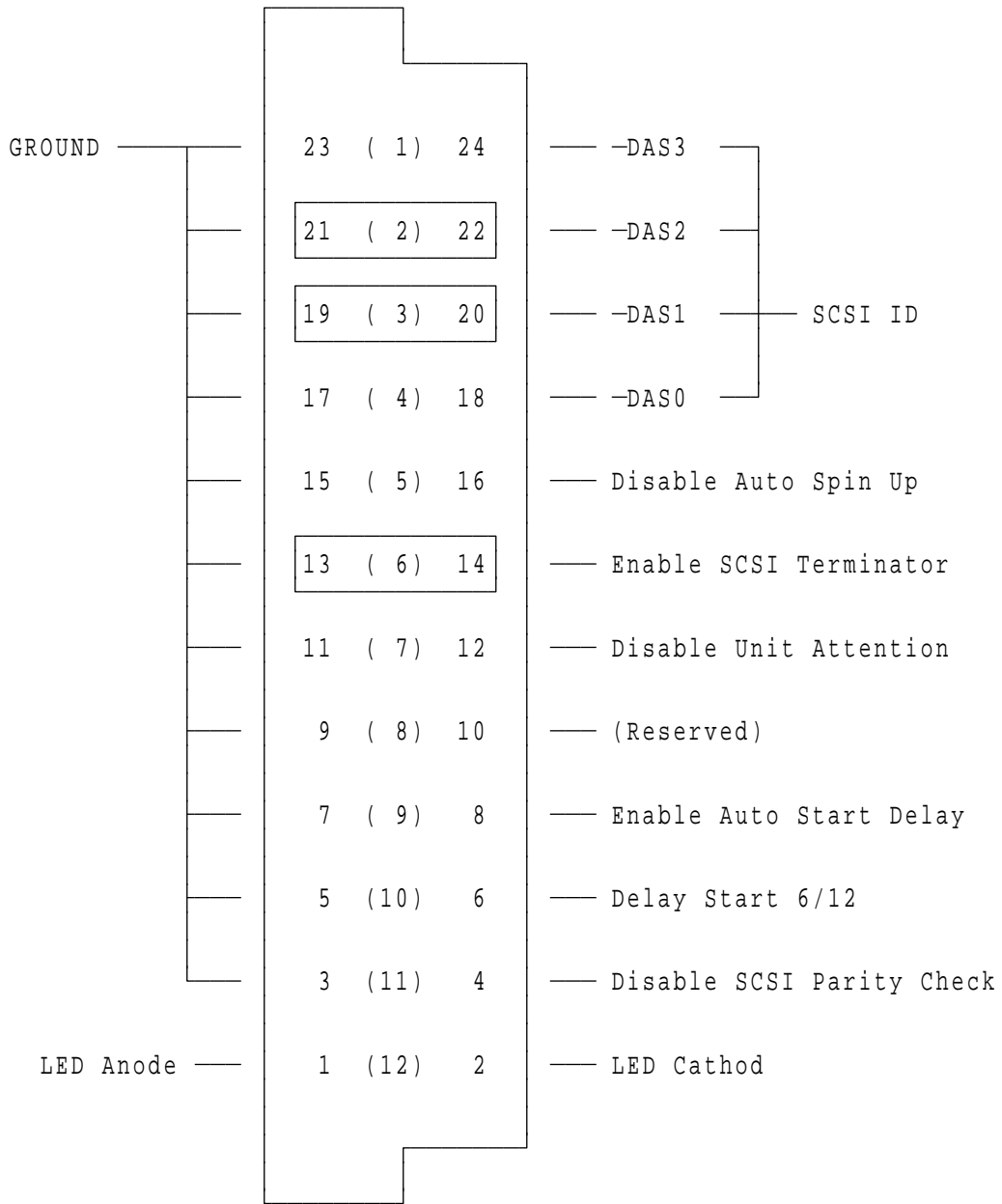

Figure 17. Jumper Pins

**Note :** The pin allocation is not compatible with previous IBM HDDs such as DPES-xxxxx, DALs-xxxxx.

Note : ( x ) shows Position Number



Note : xx ( x ) xx shows default setting at shipment.

Figure 18. Option Jumper Block Assignment



## 6.1.8 Auxiliary Connector

The 68-pin models contain Auxiliary Connector between power connector and 68-pin SCSI connector in addition to Option Jumper Block. The setting at Option Jumper Block and the Auxiliary Connector work as logical OR.

- Pin #1,3,5,7 specify SCSI-ID as -DAS0,1,2,3. Tie-down to the ground is to assert.
- If pin #4 is tied-down to the ground, Auto Spin Up is disabled.
- Pin #8 is for external LED cathod.
- If pin #9 is tied-down to the ground, SCSI Terminator is enabled.

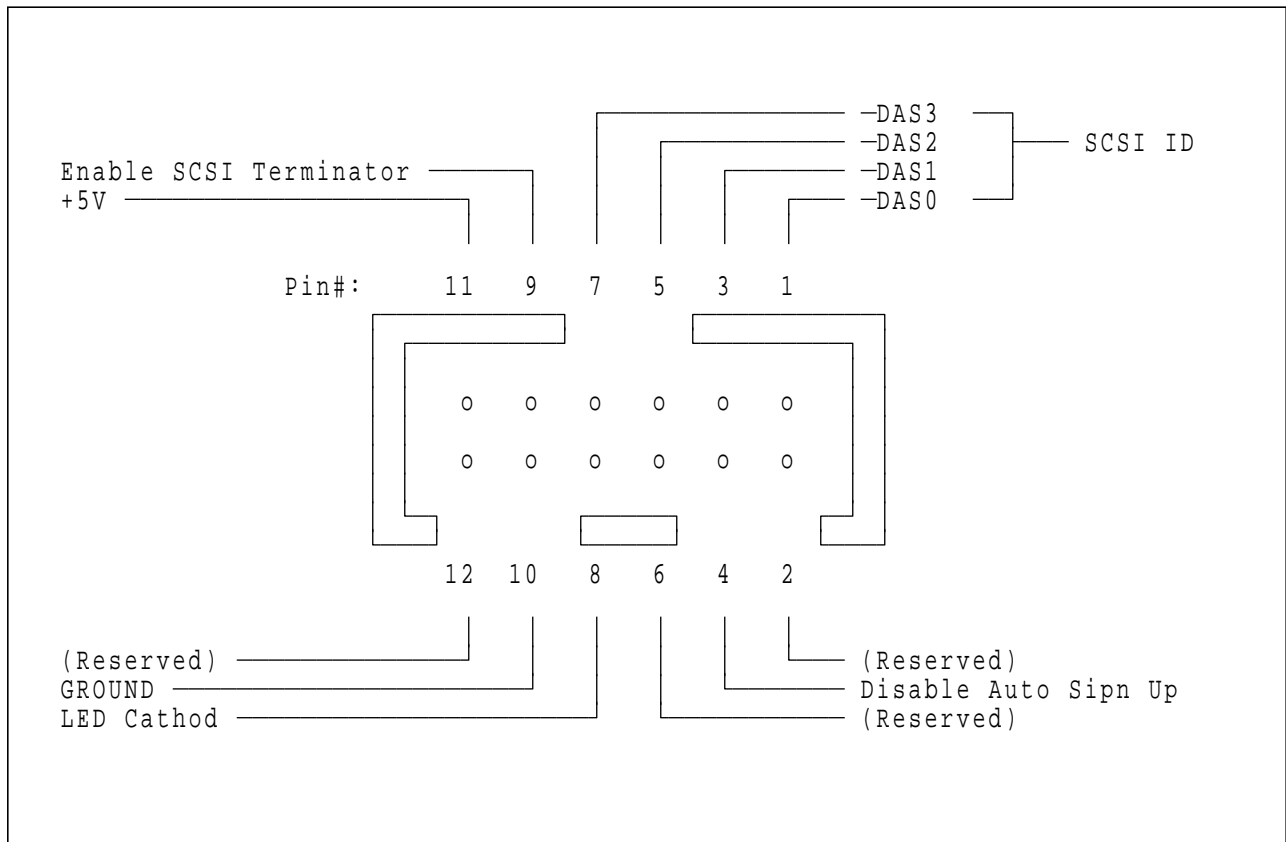

Auxiliary Connector

## 6.1.9 Jumper Signal Description

Throughout this paragraph ON means a shunt jumper is installed and OFF means that no shunt jumper is installed.

### 6.1.9.1 Device address select lines. (-DAS0, -DAS1, -DAS2)

These three lines defines DORS-3xxxx device ID on the SCSI BUS. -DAS0 is the least significant bit and -DAS2 is the most significant bit. Device ID is defined as follows.

Position # →	-DAS3 (1)	-DAS2 (2)	-DAS1 (3)	-DAS0 (4)	Device ID
	off	off	off	off	0
	off	off	off	on	1
	off	off	on	off	2
	off	off	on	on	3
	off	on	off	off	4
	off	on	off	on	5
	off	on	on	off	6 ← Shipping default
	off	on	on	on	7
	on	off	off	off	8
	on	off	off	on	9
	on	off	on	off	10
	on	off	on	on	11
	on	on	off	off	12
	on	on	off	on	13
	on	on	on	off	14
	on	on	on	on	15

Figure 19. SCSI Device ID

### 6.1.9.2 Disable Auto Spin up. (Position 5)

This input defines the drive auto spin up option. If the shunt jumper is not installed(OFF), the drive will spin up automatically after power on reset. If the shunt jumper is installed,the drive will not spin up unless the host system issues the "START COMMAND" to the drive.

**Note : The drive may not spin up while SCSI Bus is disconnected and internal terminator is disabled.**

### 6.1.9.3 SCSI Terminator ON (Position 6)

When this pin is connected to signal ground or jumper on, the internal terminator works.

**Note : The drive may not spin up while SCSI Bus is disconnected and internal terminator is disabled.**

### 6.1.9.4 Disable Unit Attention. (Position 7)

Grounding this pin (jumper on) enables control of UAI (Unit Attention Inhibit) bit in Mode Page 0.

### 6.1.9.5 Auto Start Delay & Delay Start 6/12 (Position 9 & 10)

The Auto Start Delay and Delay Start 6/12 pins control when and how the drive can spin up, with the combination of Disable Auto Spin Up (Position 5). When both Auto Spin up and Auto Start Delays are enabled, the drive start will be delayed by a period of time multiplied by its own SCSI address. If Auto Spin up is disabled, these jumpers will be ignored.

Position #	Disable Auto Spin up (5)	Auto Start Delay (9)	Delay Start 6/12 (10)	Option
	on	any	any	Drive will Not spin up. Requires Start Command
	off	off	off	Spin up immediately after POR.
	off	on	off	Spin up 6 seconds multiplied by SCSI address after POR
	off	on	on	Spin up 12 seconds multiplied by SCSI address after POR

Figure 20. Disable Auto Spin Up ,Auto Start Delay & Delay Start

### 6.1.9.6 Disable SCSI Parity Check (Position 11)

Grounding this pin will disable SCSI Parity checking.

### 6.1.9.7 LED pins (Position 12)

The LED pins are used to drive an external Light Emitting Diode. Up to 8 mA of sink current capability is provided. The LED Anode must be tied to the current limited +5 V source provided on Pin #1 of the Option Jumper Block. The LED Cathode is then connected to the Pin #2 to complete the circuit.

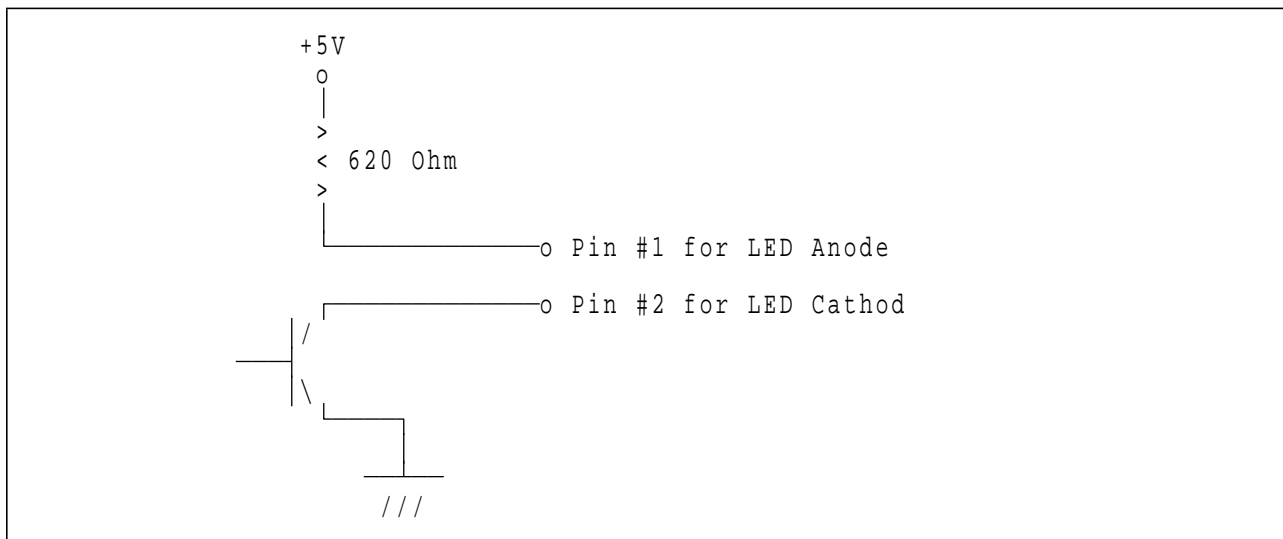

Figure 21. LED Circuit

## 6.1.10 Shipping Default

SCSI ID is set to #6 as shipping default.

SCSI terminator is enabled as shipping default.

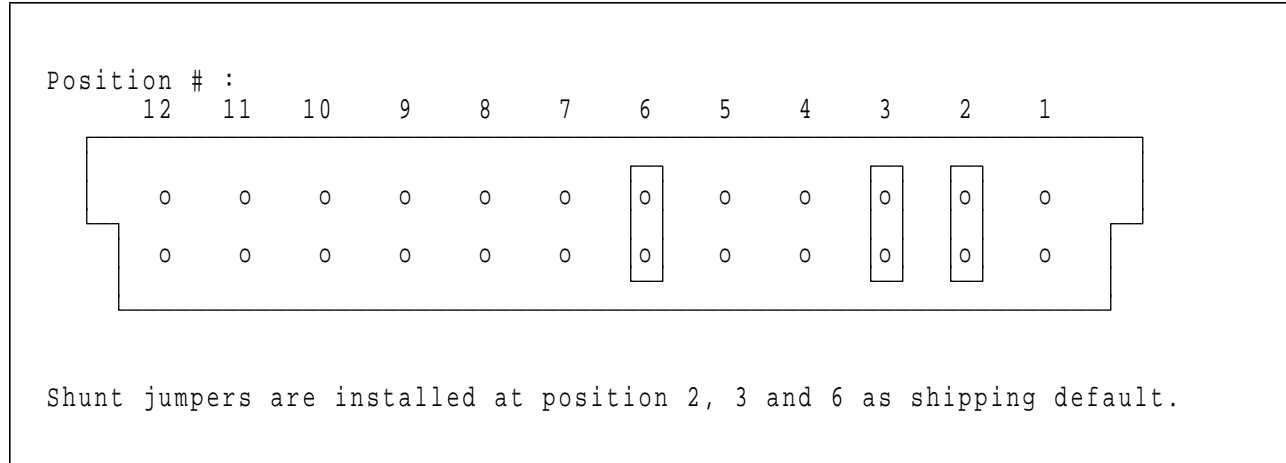

Figure 22. Default Jumper Setting

## 6.2 Environment

Figure 23. Environmental Condition	
<b>Operating Conditions</b>	
Temperature	5 to 55[°C] (See note)
Relative Humidity	8 to 90 [% RH] non-condensing
Maximum Wet Bulb Temperature	29.4[°C] non-condensing
Maximum Temperature Gradient	15[°C / Hour]
Altitude	- 300 to 3048 [m]
<b>Non-Operating Conditions</b>	
Temperature	- 40 to 65[°C]
Relative Humidity	5 to 95 [% RH] non-condensing
Maximum Wet Bulb Temperature	35[°C] non-condensing
Maximum Temperature Gradient	15[°C / Hour]
Altitude	- 300 to 12,000 [m]
<b>Note:</b>	
The system has to provide sufficient ventilation to maintain a surface temperature below 60[°C] at the center of the top cover of the drive.	
Non-Operating Condition should not continue beyond one year.	

## 6.3 DC Power Requirements

Connection to the product should be made in isolated secondary circuits (SELV). The following voltage specification is applied at the power connector of the drive.  
No special power on/off sequencing is required.

Figure 24. Input Voltage		
	During run and spin up	Absolute max voltage
+ 5 Volts Supply	5V +/- 5%	7V
+12 Volts Supply	12V +10% , - 8%	15V

Figure 25. Power Supply Current of DORS-31080 with SCSI Terminator Enabled					
(All values in Amps.)	+5Volts		+12Volts		Total (W)
	Pop Mean	Std.Dev	Pop Mean	Std.Dev	
Idle Average	0.30	0.02	0.15	0.02	3.30
Idle ripple (peak-to-peak)	0.30	0.02	0.21	0.02	
Seek peak (*1)	0.40	0.05	0.80	0.04	
Seek average (*1)	0.30	0.05	0.32	0.02	5.34
Start up (max)	0.46	0.05	1.10	0.10	
Random R/W peak (*2)	0.47	0.03	0.80	0.04	
Random R/W average (*2)	0.30	0.03	0.32	0.02	5.34
Standby/Sleep average	0.13	0.01	0.01	0.01	

Figure 26. Power Supply Current of DORS-32160 with SCSI Terminator Enabled					
(All values in Amps.)	+5Volts		+12Volts		Total (W)
	Pop Mean	Std.Dev	Pop Mean	Std.Dev	
Idle Average	0.30	0.02	0.20	0.02	3.90
Idle ripple (peak-to-peak)	0.30	0.02	0.25	0.02	
Seek peak (*1)	0.40	0.05	0.85	0.06	
Seek average (*1)	0.30	0.05	0.35	0.02	5.70
Start up (max)	0.46	0.05	1.10	0.10	
Random R/W peak (*2)	0.47	0.03	0.85	0.04	
Random R/W average (*2)	0.30	0.03	0.37	0.02	5.70
Standby/Sleep average	0.13	0.01	0.01	0.01	

### Notes:

1. Random Seeks at 40% duty cycle.
2. Seek Duty = 30%, W/R Duty = 45%, Idle Duty = 25%.

Figure 27. Power Supply Generated Ripple at Drive Power Connector		
	Maximum	Notes
+5 V DC	100 [mV pp]	0-10 [MHz]
+12 V DC	150 [mV pp]	0-10 [MHz]

During drive start up and seeking, 12 volt ripple is generated by the drive (referred to as dynamic loading). If several files have their power daisy chained together then the power supply ripple plus other drive's dynamic loading must remain within the regulation tolerance of +10/-8%. A common supply with separate power leads to each drive is a more desirable method of power distribution.

To prevent external electrical noise from interfering with the drive's performance, the drive must be held by four screws in a user system frame which has no electrical level difference at the four screws position, and has less than +/-300 millivolts peak to peak level difference to the drive power connector ground.

### 6.3.1 Start Up Current

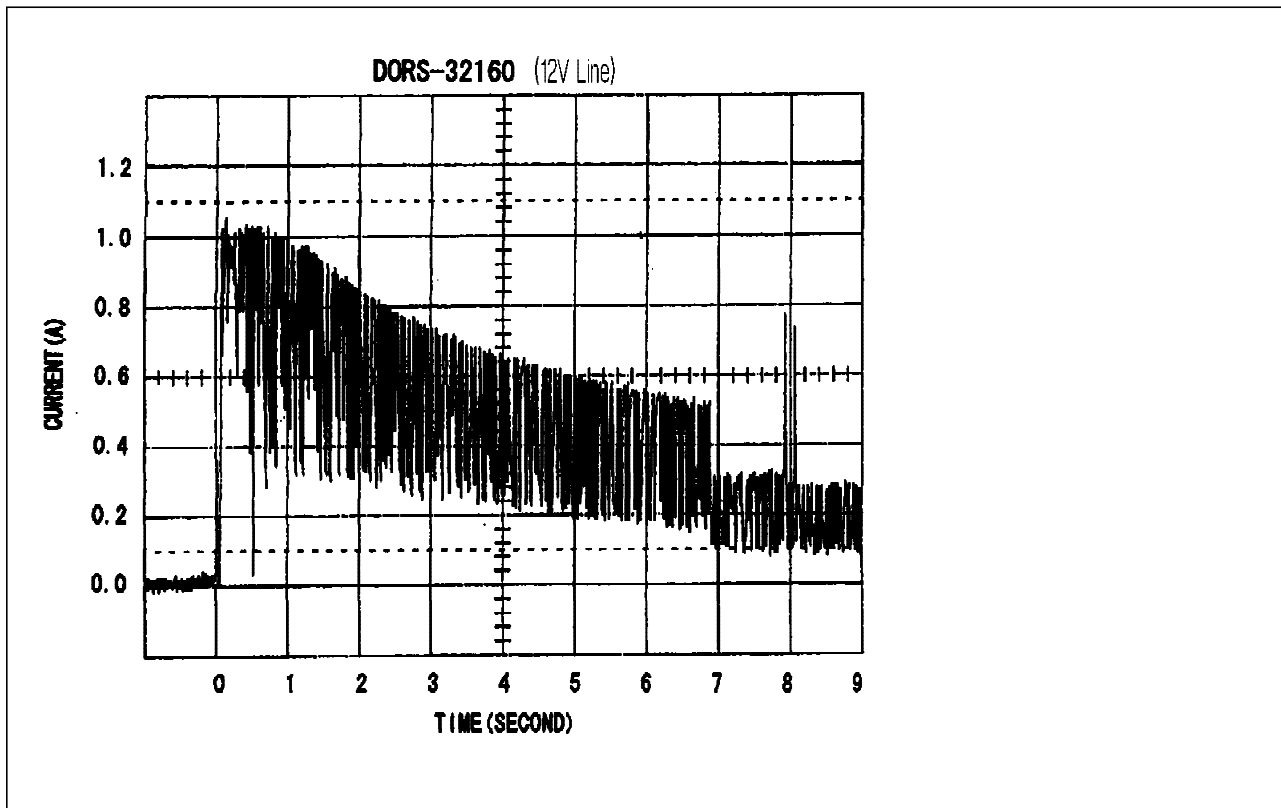

Figure 28. Typical Current Wave Form of 12V at Start Up of DORS-32160

---

## 6.4 Reliability

### 6.4.1 Contact Start Stop (CSS)

The drive is designed to withstand a minimum of 40,000 contact start/stop cycles under 40°C.

### 6.4.2 Data Reliability

- Probability of not recovering data ..... 1 in  $10^{13}$  bits read
- ECC implementation
  - On-The-Fly correction, performed as a part of read channel function, recovers up to 6 symbols of error in 1 sector. (1 symbol is 8 bits.)
  - Off-line correction, performed as a part of retry procedure in the drive, recovers up to 9 symbols of error in 1 sector.

### 6.4.3 Seek/ID Mis-compare Errors

A non-recoverable seek/ID mis-compare error is defined as a seek operation that cannot be corrected by fixed disk error recovery procedure. Seek errors occurring for field format operations are considered to be non-recoverable.

No drive has more than one non-recoverable seek/ID mis-compare error per 5 million seek operations (1 in  $5 \times 10^6$ ) when operated at the full range of voltage and environmental conditions.

Non-recoverable seek/ID mis-compare errors indicate a defective drive.

### 6.4.4 Equipment Errors

A recoverable equipment error is any error other than a seek/ID mis-compare error or read error that is detected and corrected by the drive error recovery procedure. Examples are Write Fault, Drive Not Ready and internal drive errors.

No drive has more than one recoverable equipment error per  $10^8$  reads,  $10^6$  writes or  $10^6$  seeks operations when operated at the full range of voltage and environmental conditions.

Non-recoverable equipment errors indicate a defective drive.

### 6.4.5 Failure Prediction ( PFA / S.M.A.R.T.)

DORS-3xxxx supports Informational Exceptions Control Page (1C) defined in SCSI-3. The function enables the drive to report sense codes of FAILURE PREDICTION THRESHOLD EXCEEDED to the host system.

The page 1C specifies enable/disable, reporting method, and report count.

In case the drive exceeded the failure prediction threshold, the drive returns Check Condition on any command. Then, per specified reporting method in Mode Page 1C, 0/5D/00, 1/5D/00 or 6/5D/00 as sense key/code/qualifire is sent to the host as a response of Request Sense command.

As the default, the function is enabled but no reporting of informational exception condition is made.

The details are described in 7.11.10, “Page 1C (Informational Exceptions Control) (PFA / S.M.A.R.T.)” on page 106.

#### **6.4.6 Automatic Drive Maintenance (ADM)**

| ADM function is equipped to maintain the reliability even in continuous usage beyond one week.

| ADM function is to perform a CSS automatically after detection of idling time for 1 minute plus SCSI-ID offset (SCSI-ID x 10 seconds) at intervals of 1 week.

| The details are described in 11.20, “Automatic Drive Maintenance (ADM)” on page 189.

#### **6.4.7 Preventive Maintenance**

None.



## 6.5 Mechanical Specifications

### 6.5.1 Outline

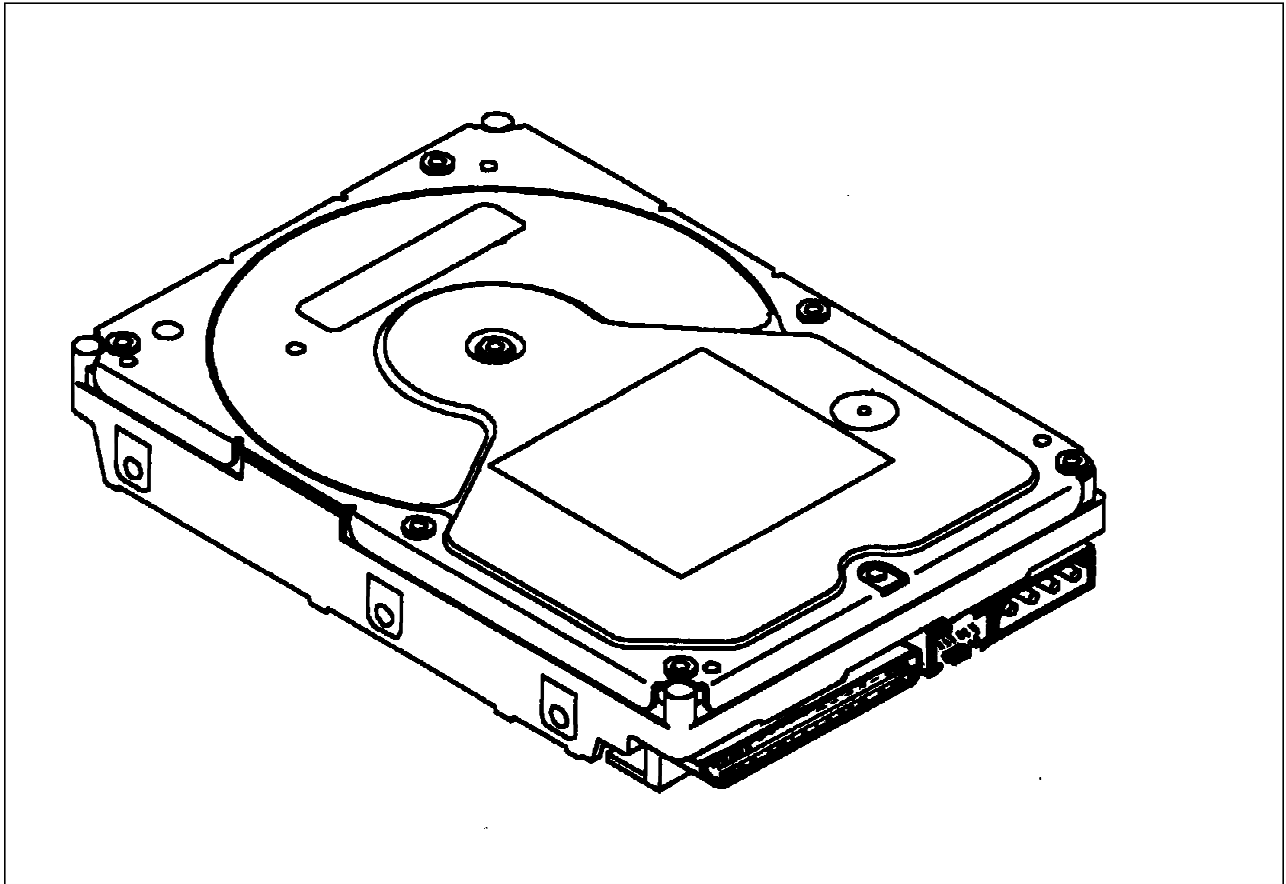

Figure 29. Outline of DORS-3xxxx

### 6.5.2 Mechanical Dimensions

The following chart describes the dimensions and the weight.

Figure 30. Physical Dimension	
Height [mm]	$25.4 \pm 0.4$
Width [mm]	$101.6 \pm 0.4$
Length [mm]	$146.0 \pm 0.6$
Weight [gram]	610 Max.

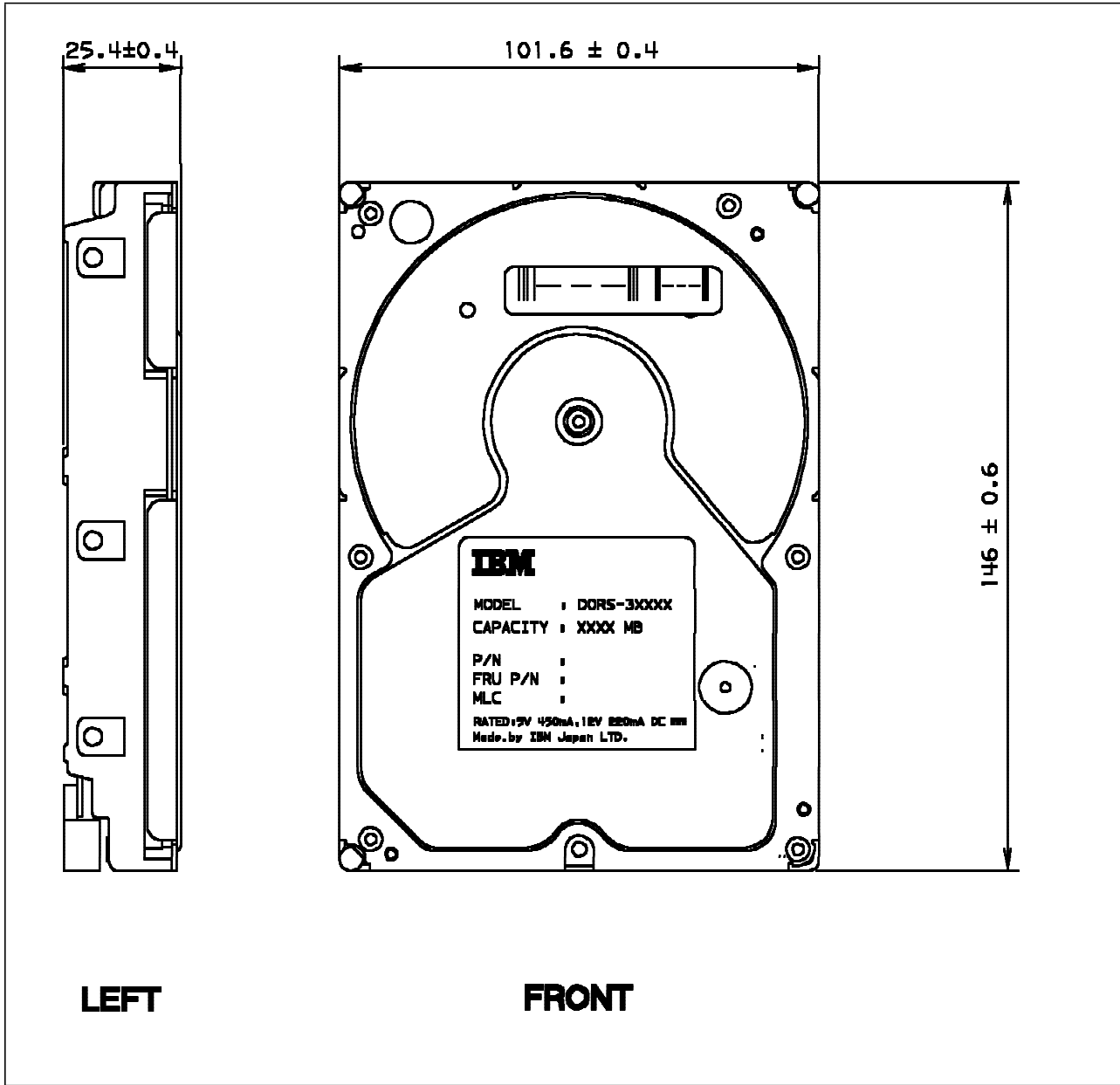

Figure 31. Mechanical Dimension

### 6.5.3 Connector Locations

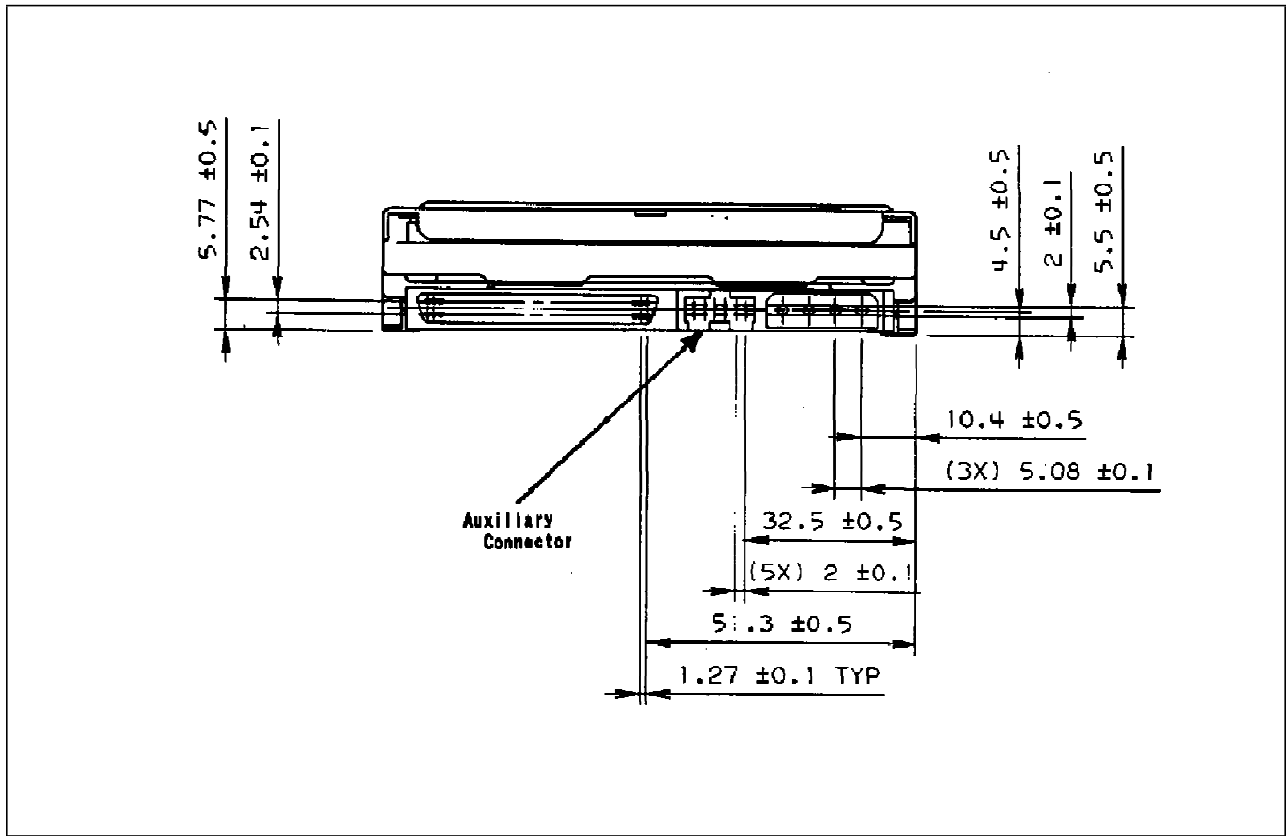

Figure 32. Connector Locations

### 6.5.3.1 Mounting Positions and Tappings

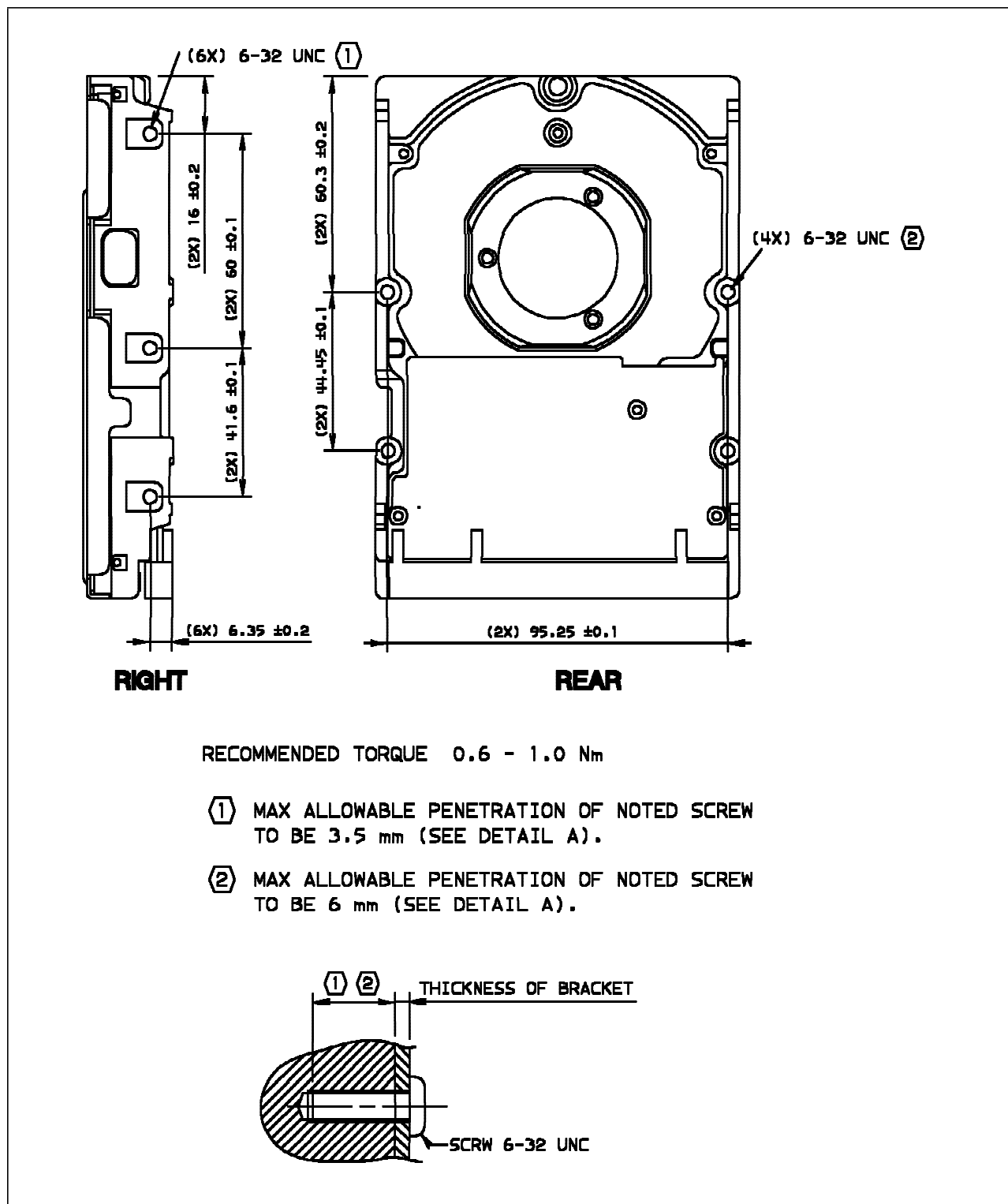

Figure 33. Mounting Positions and Tappings

## 6.5.4 Drive Mounting

The drive will operate in all axes (6 directions). Performance and error rate will stay within specification limits if the drive is operated in the other orientations from which it was formatted.

The recommended mounting screw torque is 0.6 - 1.0 [Nm] (6 - 10 [Kgf.cm]). The recommended mounting screw depth is 6 [mm] Max for bottom and 3.5 [mm] Max for horizontal mounting.

To avoid performance degradation, it is required to mount the drive in the system **securely enough** to prevent from excessive motion or vibration of the drive at seek operation or spindle rotation, with using **appropriate screws** or equivalent mounting hardware. Consult with the issuer of this specification for actual application if necessary.

Drive level vibration test and shock test are to be conducted with mounting the drive to the table using bottom four screws.

## 6.5.5 Shipping Zone and Lock

A dedicated "shipping" (or "landing") zone on the disk, not on the data area of the disk, is provided to protect the disk data during shipping, movement, or storage. Upon power down, a heads are automatically parked and a head locking mechanism will secure the heads in this zone.

## 6.5.6 Breather Hole

The breather hole must be kept clear and unobstructed at all times.

**Do not seal up** the breather hole.

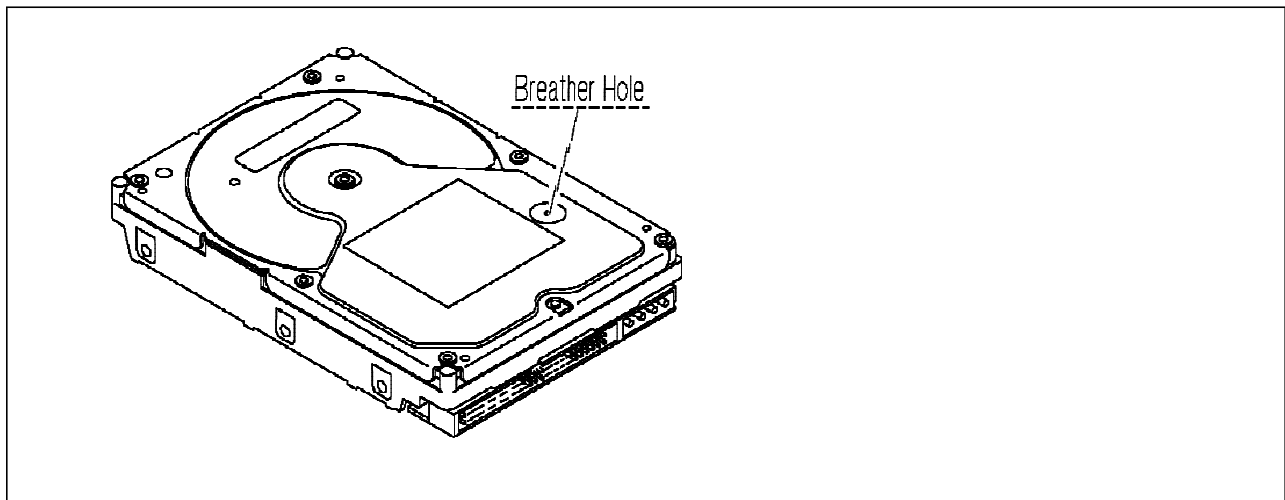

Figure 34. Breather Hole Location

## 6.6 Vibration and Shock

All vibration and shock measurements in this section are made with the drive that has no mounting attachments for the systems. The input power for the measurements is applied to the normal drive mounting points.

### 6.6.1 Operating Vibration

#### 6.6.1.1 Random Vibration

The drive is designed to operate without unrecoverable errors while being subjected to the following vibration levels.

The measurements are carried out during 30 minutes of random vibration using the power spectral density (PSD) levels as following.

Figure 35. Random Vibration PSD Profile Breakpoints (Operating)									
Hz	Random Vibration PSD Profile Breakpoints (Operating)								
[Hz]	5	17	45	48	62	65	150	200	500
$\times 10^{-3}$ [G <sup>2</sup> /Hz]	0.02	1.1	1.1	8.0	8.0	1.0	1.0	0.5	0.5
<b>Note:</b> Overall RMS (root mean square) level of vibration is 0.67G rms.									

**Note:** The specified levels are measured at the mounting points.

#### 6.6.1.2 Swept Sine Vibration

The hard disk drive will meet the criteria shown below while operating in respective conditions.

**No errors**                      0.5 G 0-peak, 5-300-5 Hz sine wave, 0.5 oct/min sweep rate  
with 3 minutes dwells at 2 major resonances

**No data loss**                    1 G 0-peak, 5-300-5 Hz sine wave, 0.5 oct/min sweep rate  
with 3 minutes dwells at 2 major resonances

### 6.6.2 Non-Operating Vibrations

The drive does not sustain permanent damage or loss of recorded data after being subjected to the environment described below.

#### 6.6.2.1 Random Vibration

The test consists of a random vibration applied for each of three mutually perpendicular axes with the time duration of 15 minutes per axis. The PSD levels for the test simulates the shipping and relocation environment which is shown below.

Figure 36. Random Vibration PSD Profile Breakpoints (Non-Operating)							
Hz	Random Vibration PSD Profile Breakpoints (Non-Operating)						
Hz	2	4	8	40	55	70	200
[G <sup>2</sup> /Hz]	0.001	0.03	0.03	0.003	0.01	0.01	0.001

Overall RMS (Root Mean Square) level of vibration is 1.04G (RMS).

### 6.6.2.2 Swept Sine Vibration

- 2 G (Zero to peak), 5 to 500 to 5 Hz sine wave
- 0.5 oct/min sweep rate
- 3 minutes dwell at two major resonances

### 6.6.3 Operating Shock

The drive meets the following criteria.

- No errors within shock pulses of 5G, 11ms half-sine wave.
- No data loss, seek errors, or permanent damages within shock pulses of 10G, 11 ms half-sine wave.
- No data loss or permanent damages at Idle, Seek and Read modes within shock pulses of 30G 4ms, or 15G 5ms half-sine wave.

The shock pulses of each level are applied to the drive, ten pulses for each direction and for all three axes. There must be a minimum of three seconds delay between shock pulses. The input level is applied to a base plate where the drive is attached with four screws.

### 6.6.4 Non-Operating Shock

The drive withstands without damage or degradation of performance, a 75G half-sine wave shock pulse of 11 ms duration on six sides.

The shocks are applied for each direction of the drive for three mutually perpendicular axes and one axis at a time. Input levels are measured on a base plate where the drive is attached with four screws.

The drive withstands without damage or degradation of performance, a 125G half-sine wave shock pulse of 2 ms duration in direction of connector insertion.

**Note:** Actuator is automatically locked at power-off to keep the heads on a landing zone.

## 6.7 Acoustics

The following shows the acoustic levels.

### 6.7.1 Sound Power Levels

The upper limit criteria of the A-weighted sound power levels are given in Bel relative to one pico watt and are shown in the following table. The measurement method is in accordance with ISO7779.

Figure 37. A-weighted Sound Power Levels	
Mode	A-weighted Sound Power Level [Bel]
Idle	4.5
Operating	4.8

Background power levels of the acoustic test chamber for each octave band are to be recorded. Sound power levels are measured with the drive supported by spacers so that the lower surface of the drive is located  $25 \pm 3$ mm height from the chamber desk. No sound absorbing material shall be used. The acoustical characteristics of the drive subsystem are measured under the following conditions.

Idle mode:

Powered on, disks spinning, track following, unit ready to receive and respond to control line commands.

Operating mode:

Continuous random cylinder selection and seek operation of actuator with a delay for a time period achieving the required seek rate  $N_s$  according to the following formula:

$$N_s = 0.4 / (T_t + T_l)$$

where:

$N_s$  = average seek rate in seeks/sec.

$T_t$  = published random seek time.

$T_l$  = time for the drive to rotate by half a revolution.

### 6.7.2 Sound Power Acceptance Criteria

Statistical upper limit  $(L_w)_{stat}$  is calculated with the following formula.

$$(L_w)_{stat} = (L_w)_m + k \times (s_t)_w$$

where:

$(L_w)_m$  is the mean value of the A-weighted sound power level for samples of N drives.

$(s_t)_w$  is the total standard deviation for A-weighted sound power level.

$$(s_t)_w = \text{SQRT}((s_R)_w^2 + (s_p)_w^2)$$

$(s_R)_w$  is the standard deviation for sound power level.

Assume  $(s_R)_w = 0.075$  B.

$(s_p)_w$  is the standard deviation of the samples for A-weighted sound power level.

k is a coefficient determined by number of samples (N) as shown below.



N	3	4	5	6	7	8	9	10	11	12	13	14	15
k	3.19	2.74	2.74	2.49	2.33	2.22	2.13	2.07	2.01	1.97	1.93	1.90	1.87

The calculated left hand side of the criterion equation above is rounded to the nearest 0.05 bel. The individual terms may be rounded to the nearest 0.01 bel before calculation.

### 6.7.3 Sound Pressure (Reference)

#### 6.7.3.1 Unit Sound Pressure Level Measurement

The hard disk drives are measured in a semi-anechoic chamber, with background noise = < 25 dBA. Surfaces to be measured are top cover side and card side. Microphone is set one meter above the drive surface.

Random operation mode is simulated with 40% seek and 60% idle in time.

#### 6.7.3.2 Sound Pressure Level

The hard disk drives meet the following sound pressure level.

Figure 38. Sound Pressure Level		
Mode	Mean	Max
Idle on Track	34 dBA	38 dBA
Random Operation	39 dBA	42 dBA

---

## 6.8 Identification Labels

The following labels are attached to the drive.

1. A label placed on the top of the HDA contains the statement “Made by IBM” or equivalent, Part number, and MLC number.
2. A bar code label placed on the drive is based on user requests. The location is to be designated in the drawing.
3. Labels containing the vendor's name, disk drive model number, serial number, place of manufacture, UL/CSA/TÜV certificates and CE mark when certified.

The labels may be integrated.

---

## 6.9 Electromagnetic Compatibility

The drive, when installed in a suitable enclosure and exercised with a random accessing routine at maximum data rate, meets the worldwide EMC requirements listed below.

IBM will provide technical support to meet the requirements to comply with the EMC specifications.

- United States Federal Communications Commission (FCC) Rules and Regulations (Class B), Part 15.
- European Economic Community (EEC) directive number 76/889 related to the control of radio frequency interference and the Verband Deutscher Elektrotechniker (VDE) requirements of Germany (GOP).
- European Community (EC) directive number 89/336 related EMC.

---

## 6.10 Safety

The following shows the safety standards for different countries.

### 6.10.1 Underwriters Lab (UL) Approval

DORS-3xxxx comply with UL 1950.

### 6.10.2 Canadian Standards Authority (CSA) Approval

DORS-3xxxx comply with CSA C22.2 #950-M89.

### 6.10.3 IEC Compliance

DORS-3xxxx comply with IEC 380, IEC 435 and IEC 950.

### 6.10.4 German Safety Mark

DORS-3xxxx is approved by TÜV on Test Requirements: EN 60 950:1988/A1:1990/A2:1991.

### 6.10.5 Flammability

The printed circuit boards used in this product is made of material with the UL recognized flammability rating of V-1 or better. The flammability rating is marked or etched on the board. All other parts not considered electrical components are made of material with the UL recognized flammability rating of V-1 or better, except small mechanical parts.

### 6.10.6 Secondary Circuit Protection

The drive uses printed circuit wiring that protects the possibility of sustained combustion due to circuit or component failure. Adequate secondary over-current protection is the responsibility of system suppliers.

The host system must protect the drive from any electrical short circuit problem. 10 [A] limit is required for safety purposes.

---

## 6.11 Packaging

The drives are packed in ESD protective bags for shipping.



---

# Part 2. SCSI Interface Specification



## 7.0 SCSI COMMAND SET

Summaries of the SCSI commands supported by the file are listed below. where O=optional, M=mandatory, E=extended, R=reserved and V=vendor unique. The column "SCSI-1" refers to ANSI version 1 standard. The column "CCS" refers to the ANSI sub-committee Common Command Subset for DASD devices. The column "SCSI-2" refers to ANSI version 2 standard.

SCSI-1	CCS	SCSI-2	CODE	COMMAND
M	M	M	04h	FORMAT UNIT
E	M	M	12h	INQUIRY
O	O	O	4Ch	LOG SELECT
O	O	O	4Dh	LOG SENSE
O	O	O	15h	MODE SELECT
O	O	O	1Ah	MODE SENSE
O	O	O	34h	PRE-FETCH
M	M	M	08h	READ
R	O	O	3Ch	READ BUFFER
E	M	M	25h	READ CAPACITY
R	R	O	37h	READ DEFECT DATA
E	M	M	28h	READ EXTENDED
R	R	O	3Eh	READ LONG
O	O	O	07h	REASSIGN BLOCKS
O	O	O	1Ch	RECEIVE DIAGNOSTICS
O	M	M	17h	RELEASE
M	M	M	03h	REQUEST SENSE
O	M	M	16h	RESERVE
O	O	O	01h	REZERO UNIT
O	O	O	0Bh	SEEK
O	O	O	2Bh	SEEK EXTENDED
O	M	M	1Dh	SEND DIAGNOSTICS
O	O	O	1Bh	START/STOP UNIT
R	R	O	35h	SYNCHRONIZE CACHE
O	M	M	00h	TEST UNIT READY
O	O	O	2Fh	VERIFY
M	M	M	0Ah	WRITE
O	O	O	2Eh	WRITE AND VERIFY
R	O	O	3Bh	WRITE BUFFER
E	M	M	2Ah	WRITE EXTENDED
R	R	O	3Fh	WRITE LONG
R	R	O	41h	WRITE SAME

Figure 39. SCSI Commands Supported. (In Alphabetical order)

SCSI-1	CCS	SCSI-2	CODE	COMMAND
O	M	M	00h	TEST UNIT READY
O	O	O	01h	REZERO UNIT
M	M	M	03h	REQUEST SENSE
M	M	M	04h	FORMAT UNIT
O	O	O	07h	REASSIGN BLOCKS
M	M	M	08h	READ
M	M	M	0Ah	WRITE
O	O	O	0Bh	SEEK
E	M	M	12h	INQUIRY
O	O	O	15h	MODE SELECT
O	M	M	16h	RESERVE
O	M	M	17h	RELEASE
O	O	O	1Ah	MODE SENSE
O	O	O	1Bh	START/STOP UNIT
O	O	O	1Ch	RECEIVE DIAGNOSTICS
O	M	M	1Dh	SEND DIAGNOSTICS
E	M	M	25h	READ CAPACITY
E	M	M	28h	READ EXTENDED
E	M	M	2Ah	WRITE EXTENDED
O	O	O	2Bh	SEEK EXTENDED
O	O	O	2Eh	WRITE AND VERIFY
O	O	O	2Fh	VERIFY
O	O	O	34h	PRE-FETCH
R	R	O	35h	SYNCHRONIZE CACHE
R	R	O	37h	READ DEFECT DATA
R	O	O	3Bh	WRITE BUFFER
R	O	O	3Ch	READ BUFFER
R	R	O	3Eh	READ LONG
R	R	O	3Fh	WRITE LONG
R	R	O	41h	WRITE SAME
O	O	O	4Ch	LOG SELECT
O	O	O	4Dh	LOG SENSE

Figure 40. SCSI Commands Supported. (By Command Code)



---

## 7.1 Flag and Link Bits

Many of the structures in this section have fields names FLAG and LINK. The meaning of these fields is defined below.

**FLAG** The Flag bit specifies which message the target shall return to the initiator if the link bit is one and the command completes without any error. If Link is zero, Flag must also be zero. If Link is one and the command terminates successfully, the file will send either the LINKED COMMAND COMPLETE message (FLAG=0) or the LINKED COMMAND COMPLETE WITH FLAG message (FLAG=1). Typically this bit is used to cause an interrupt in the initiator between linked commands.

**LINK** This bit is set to one to indicate that the initiator desires an automatic link to the next command upon successful completion of the current command. Upon successful completion of the command, the file will return INTERMEDIATE GOOD status and then send one of the two messages defined under Flag above.

Upon unsuccessful completion of the command, the file will return CHECK CONDITION status or RESERVATION CONFLICT status and then send the COMMAND COMPLETE message. No further commands in the chain are executed.

---

## 7.2 Abbreviations

These abbreviations are used throughout the following sections:

**LUN.** Logical Unit Number. An encoded three bit identifier for the logical unit.

**VU.** Vendor Unique bits.

**LBA.** Logical Block Address.

**RSVD.** Reserved.

**MSB.** Most Significant bit.

**LSB.** Least Significant bit.

---

## 7.3 Byte ordering conventions

In this specification, where it is not explicitly stated, all multi-byte values are stored with the most significant byte first. For example in a 4 byte field byte 0 will contain the MSB and byte 3 the LSB.

## 7.4 FORMAT UNIT (04)

Byte	Bit							
	7	6	5	4	3	2	1	0
0	Command Code = 04h							
1	LUN			FmtData	CmpList	Defect List Format		
2	VU = 0							
3 4	(MSB)			Interleave Factor				(LSB)
5	VU = 0		Reserved = 0			FLAG	LINK	

Figure 41. FORMAT UNIT (04)

The FORMAT command performs a physical formatting of the file media. This includes handling of defective sectors, and the overwriting of all data areas with a constant data pattern. (Reserved areas of the media are not affected by the FORMAT command.)

- **FmtData** set to one specifies that a Data Out phase follows the Command phase. FmtData set to zero specifies that no Data Out phase follows.
- **CmpList** set to one specifies that the GList (Grown Defect List) existing prior to the format **not** be used and is discarded. The Drive is formatted with PList and DList (if specified). DList becomes the new GList.

**Note:** The file manages two internal defect lists and one external. The primary defect list (“P”List) is created at time of manufacture and cannot be altered. The grown defect list (“G”List) is built after manufacture by the Initiators use of the REASSIGN BLOCK command and the Automatic Reallocate functions. The data defect list (“D”List) is an external list. It is supplied by the initiator in the DATA OUT phase of the FORMAT UNIT command.

- **Defect List Format** specifies the format of the defect descriptor transferred to the Target when FmtData bit is set to one. The Target supports three defect descriptor formats for the Format Unit command as following:

### Format Description

- 000b** Block format
- 100b** Bytes From Index format
- 101b** Physical Sector format

If the FmtData bit is set to zero this field must also be zero otherwise the command will complete with a check condition with a sense key of illegal request and an additional sense code of invalid field in CDB.

- **Interleave Factor** may be zero or one, either of which specifies an interleave of 1:1. Other Interleave Factors are ignored because of the extensive buffering implemented in the file.

## 7.4.1 Defect List

Byte	Bit							
	7	6	5	4	3	2	1	0
0	Reserved = 0							
1	FOV	DPRY	DCRT	STPF	IP = 0	DSP = 0	Immed	0
2 3	(MSB) Defect List Length							(LSB)

Figure 42. Format of Defect List Header. Format of the defect list header sent during the data out phase when FmtData set to one.

The Target has a limited implementation of the Format Option bits located in Bits 2 through 7 of Byte 1 of the Defect List Header (See Figure 42). If the Initiator attempts to select any function not implemented by the Target, the Target terminate the command with *Check Condition Status*. The sense key is set to *Illegal Request* and the additional sense code is set to *Invalid Field in Parameter List*.

- **FOV** (Format Options Valid) bit of zero causes the Target to verify that the setting for the DPRY (Disable Primary), DCRT (Disable Certification), STPF (Stop Format), IP (Initialize Pattern), and DSP (Disable Saving Parameters) bits are zero. If any of these bits are not zero, the Target terminates the command with *Check Condition Status*. The sense key is set to *Illegal Request* and the additional sense code is set to *Invalid Field in Parameter List*.

**Note:** When FOV bit is one there are three combinations of the DPRY, DCRT, STPF, IP and DSP bits allowed. Any other combinations return a *Check Condition Status* With a sense key of *Illegal Request* and an additional sense code of *Invalid Field In Parameter List*. The supported combination are:

DPRY=0	DCRT=1	STPF=1	IP=0	DSP=0
DPRY=1	DCRT=1	STPF=1	IP=0	DSP=0
DPRY=0	DCRT=0	STPF=1	IP=0	DSP=0

- **DPRY** (Disable Primary) bit set to zero indicates that the Target does not use portions of the medium identified as defective in the primary defect PList for Initiator addressable logical blocks. If the Target cannot locate the PList or it cannot determine whether a PList exists, the target terminates the Format Unit command as described for STPF=1. A DPRY bit of one indicates that the Target does not use the Plist to identify defective areas of the medium. The Plist is not deleted.
- **DCRT** (Disable Certification) bit of ZERO indicates that the Target performs a medium certification operation and generates a Certification List (CList) and the Target adds the Clist to the Glist. A DCRT bit of one indicates that the Target does not generate a CList (Certification List) nor perform a certification process while executing the Format Unit Command.
- **STPF** (Stop Format) bit must be set to one. If one or both of the following conditions occurs, the Target terminates the Format Unit command with *Check Condition Status*. The sense key is set to *Medium Error* and the additional sense code is set to either *Defect List Not Found* if the first condition occurred, or *Defect List Error* if the second condition occurred.
  - The Target cannot locate a required defect list nor determine that the list exists.
  - The Target encounters an unrecoverable error while accessing a required defect list.
- **IP** (Initialization Pattern) bit must be set to zero. The Target initializes all data with zeros.

- **DSP** (Disable Saving Parameters) bit must be set to zero. The Target saves all the Mode Select savable parameters during the format operation.
- **Immed** (Immediate) bit set to zero requests that status be returned at the end of the format operation. An immediate bit set to one requests that status be returned immediately. *Good Status* is returned following the CDB validation and transfer of data in the Data Out phase. If the immediate format operation terminates in error, Deferred Error Sense data is generated. With the immediate bit set to one, the Link bit must be set to zero.

## 7.4.2 Defect Descriptor

The Defect List Length field specifies the total length in bytes of the defect descriptors that follow. The Target has an implementation limitation for number of defect descriptors. The number of defect descriptor shall be less than **128**. The defect list length must be equal to four times the number of defect descriptors to follow for the BLOCK format, or eight times the number of defect descriptors to follow for the BYTES FROM INDEX and PHYSICAL SECTOR format, otherwise the command is terminated with *Check Condition Status*. The sense key is set to *Illegal Request* and the additional sense code is set to *Invalid Field In Parameter List*. The defect descriptors must specify the defect based on the current Format Device parameters reported by the Mode Sense command.

The Target supports three Defect List formats.

### 7.4.2.1 Block Format

The Block format of the defect list supported by the file is by logical block where the location of defective sectors is given by their LBA.

Byte	Bit							
	7	6	5	4	3	2	1	0
0	(MSB) Defective Logical Block Address (LSB)							
1								
2								
3								
4n - 4n + 3	Defective Logical Block Address n							

Figure 43. Defect Descriptor - Block Format. Format of the defect list sent during the data out phase when FmtData set to one.

### 7.4.2.2 Bytes From Index Format

Each defect descriptor for the Bytes From Index format specifies that the sector containing this byte be marked defective. The defect descriptor is comprised of the cylinder number of the defect, the head number of the defect, and the defect bytes from index.

Byte	Bit							
	7	6	5	4	3	2	1	0
0	(MSB) Cylinder Number of Defect (LSB)							
1								
2								
3	Head Number of Defect							
4	(MSB) Defect Bytes from Index (LSB)							
5								
6								
7								
8n - 8n + 7	Defect Descriptor n							

Figure 44. Defect Descriptor - Bytes From Index Format. Format of the defect list sent during the data out phase when FmtData set to one.

### 7.4.2.3 Physical Sector Format

Each defect descriptor for the Physical Sector format specifies a defect that is the length of a sector. The defect descriptor is comprised of the cylinder number of the defect, the head number of the defect, and the defect sector number.

Byte	Bit							
	7	6	5	4	3	2	1	0
0	(MSB) Cylinder Number of Defect (LSB)							
1								
2								
3	Head Number of Defect							
4	(MSB) Defective Sector Number (LSB)							
5								
6								
7								
8n - 8n + 7	Defect Descriptor n							

Figure 45. Defect Descriptor - Physical Sector Format. Format of the defect list sent during the data out phase when FmtData set to one.

## 7.5 INQUIRY (12)

Byte	Bit							
	7	6	5	4	3	2	1	0
0	Command Code = 12h							
1	LUN			Reserved = 0				EVPD
2	Page Code							
3	Reserved = 0							
4	Allocation Length							
5	VU = 0	Reserved = 0				FLAG	LINK	

Figure 46. INQUIRY (12)

The INQUIRY command requests the parameters of the target to be sent to the initiator.

An **EVPD bit of one** specifies that the file shall return the vital product data page identified by the Page Code field in the CDB. **Page code** specifies which page of vital product data information the file shall return.

EVPD	PAGE CODE	Description
0	0	The file returns the standard INQUIRY data.
0	Non Zero	The file returns CHECK CONDITION status with the sense key of ILLEGAL REQUEST and the additional sense code of INVALID FIELD IN CDB.
1	Supported	The file returns the vital product data of page code requested.
1	Unsupported	The file returns CHECK CONDITION status with the sense key of ILLEGAL REQUEST and the additional sense code of INVALID FIELD IN CDB.

**Allocation Length** specifies the number of bytes that the initiator has allocated for INQUIRY data to be returned. An allocation length of zero implies that no data is to be returned. The file will terminate the DATA IN phase when all available INQUIRY data has been transferred or when allocation length bytes have been transferred, whichever is less.

If an INQUIRY command is received from an initiator with a pending unit attention condition (before the target reports CHECK CONDITION status), the file processes the INQUIRY command. The unit attention condition is not cleared by this action.

## 7.6 Inquiry data

Two different formats for the INQUIRY data are defined.

- The first format is returned when an invalid LUN is specified by the initiator.
- The second format is returned when a valid LUN is specified by the initiator.

Each of these formats is described in the following sections.

**Note:** Fields with a value shown inside quotes (e.g. Value = 'xyz') are character fields. A value not in quotes is a numeric value. Character fields are alpha-numeric and represented in either ASCII or EBCDIC as stated.

### 7.6.1 INQUIRY Data Format (When Invalid LUN is Specified)

BYTE	BIT							
	7	6	5	4	3	2	1	0
0	Qualifier			Peripheral Dev. Type=1Fh				
1	RMB=0	Device-type Modifier = 0						
2	ISO = 0		ECMA = 0			ANSI = 2		
3	RSVD = 0			RDF = 2				
4	Additional Length = 1F							
5-6	Reserved = 0							
7	REL_A = 0	Wb_32 = 0	Wb_16 = 1	Sync = 1	Link = 1	TTD = 0	CmdQu = 1	SftRe = 0
8-15	Vendor ID = 'IBM' (ASCII)							
16-31	Product ID (ASCII)							
32-35	Product Revision Level (ASCII)							

Figure 47. INQUIRY DATA Invalid LUN Specified

- **Qualifier** is set to 011b. This indicates the LUN specified in the Command Block is not present.<sup>1</sup>
- **Peripheral Dev. Type** is set to 1Fh.
- **Removal Media Bit (RMB)** is always set to zero to indicate no removal media exist.
- **Device-Type Modifier** is set to zero.
- **ISO** is set to zero to indicate that this product does not claim compliance to the International Organization for Standardization (ISO) version of SCSI (ISO DP 9316).

<sup>1</sup> For all commands, except inquiry and request sense, if an invalid lun is specified a check condition will be returned.

- **ECMA** is set to zero to indicate that this product does not claim compliance to the European Computer Manufacturers Association (ECMA) version of SCSI (ECMA-111).
- **ANSI** indicates the level of the ANSI standard that is supported by the product. The file supports ANSI SCSI version 2.
- **RDF** is set to two to indicate that the Inquiry Data Format as specified in ANSI SCSI version 2 is supported by the file.
- **Additional Length** indicates the number of bytes of inquiry information that follows.
- **REL\_A** is set to zero to indicate that the file does not support 'Relative Address Mode'.
- **Wb\_32** is set to zero to indicate that the file does not support 32-bit wide data transfers.
- **Wb\_16** is set to one to indicate that the file supports 16-bit wide data transfers.
- **Sync** is set to one to indicate that the file supports synchronous data transfer.
- **Link** is set to one to indicate that the file supports linked commands.
- **TTD** is set to zero to indicate that the file does not support the CONTINUE I/O PROCESS and TARGET TRANSFER DISABLE message for this logical unit.
- **CmdQu** is set to one to indicate that the file supports command queuing
- **SftRe** is set to zero to indicate that the target supports Hard Reset only.
- **Vendor ID** is 'IBM' padded with ASCII blanks.
- **Product ID** DORS-31080W or DORS-32160W is indicated in ASCII character.
- **Product Revision Level** indicates the level of microcode. It indicates ROM microcode level before the media is available and RAM microcode after available.



## 7.6.2 Inquiry Data Format - EVPD = 0

Figure 48 shows the data format. Actual data for each product is described in the Addendum Spec. for each product.

BYTE	BIT							
	7	6	5	4	3	2	1	0
0	Qualifier = 0			Peripheral Device Type = 0				
1	RMB=0	Device-Type Modifier = 0						
2	ISO = 0		ECMA = 0			ANSI = 2		
3	RSVD = 0			RDF = 2				
4	Additional Length = 143 (8F)							
5-6	Reserved = 0							
7	REL_A = 0	Wb_32 = 0	Wb_16 = 1	Sync = 1	Link = 1	TTD = 0	CmdQu = 1	SftRe = 0
8-15	Vendor ID = 'IBM' (ASCII)							
16-31	Product ID (ASCII)							
32-35	Product Revision Level (ASCII)							
36-43	Drive Serial Number (ASCII)							
43-147	Reserved. Contents are changed without notice.							

Figure 48. INQUIRY Data - EVPD = 0

- **Qualifier** is set to zero to indicate that the LUN specified in the Command Block is currently supported.
- **Peripheral Device Type** is set to zero to indicate that the device is a Direct-Access.
- **Removal Media Bit (RMB)** is always set to zero to indicate no removal media exist.
- **Device-Type Modifier** is set to zero.
- **ISO** is set to zero to indicate that this product does not claim compliance to the International Organization for Standardization (ISO) version of SCSI (ISO DP 9316).
- **ECMA** is set to zero to indicate that this product does not claim compliance to the European Computer Manufacturers Association (ECMA) version of SCSI (ECMA-111).
- **ANSI** indicates the level of the ANSI standard that is supported by the product. The file supports ANSI SCSI version 2.
- **RDF** is set to two to indicate that the Inquiry Data Format as specified in ANSI SCSI version 2 is supported by the file.
- **Additional Length** indicates the number of bytes of inquiry information that follows.
- **REL\_A** is set to zero to indicate that the file does not support 'Relative Address Mode'.

- **Wb\_32** is set to zero to indicate that the file does not support 32-bit wide data transfers.
- **Wb\_16** is set to one to indicate that the file supports 16-bit wide data transfers.
- **Sync** is set to one to indicate that the file supports synchronous data transfer.
- **Link** is set to one to indicate that the file supports linked commands.
- **TTD** is set to zero to indicate that the file does not support the CONTINUE I/O PROCESS and TARGET TRANSFER DISABLE message for this logical unit.
- **CmdQu** is set to one to indicate that the file supports command queuing
- **SftRe** is set to zero to indicate that the target supports Hard Reset only.
- **Vendor ID** is 'IBM' padded with ASCII blanks.
- **Product ID** DORS-31080W or DORS-32160W is indicated in ASCII character.
- **Product Revision Level** indicates the level of microcode. It indicates ROM microcode level before the media is available and RAM microcode after available.
- **Drive Serial Number** indicates serial number of the drive. The serial number is loaded from disk at power on sequence. This field will contain ASCII spaces (20h) until completion of the loading.

### 7.6.3 Inquiry Data Format - EVPD = 1 - Page Code = 00

BYTE	BIT							
	7	6	5	4	3	2	1	0
0	Qualifier = 0				Peripheral Dev Type = 0			
1	Page Code = 00h							
2	Reserved = 0							
3	Page Length = 04h							
4	First Supported Page Code = 01h							
5	Second Supported Page Code = 03h							
6	Third Supported Page Code = 80h							
7	Fourth Supported Page Code = 82h							

Figure 49. INQUIRY DATA - EVPD = 1 (Page Code = 00)

- **Qualifier** is set to zero to indicate that the LUN specified in the Command Block is currently supported.
- **Peripheral Device Type** is set to zero to indicate that the device is a Direct-Access.
- **Page Code** is set to 0, and this field contains the same value as in the page code field of the INQUIRY command descriptor block.
- **Page length** specifies the length of the following page data.
- **The Supported Page Code** field contains the Page Codes supported by the target. The list is ascending order.

## 7.6.4 Inquiry Data Format - EVPD = 1 - Page Code = 01

BYTE	BIT							
	7	6	5	4	3	2	1	0
0	Qualifier = 0				Peripheral Dev Type = 0			
1	Page Code = 01h							
2	Reserved = 0							
3	Page Length = 47 (0x2F)							
4	ASCII Length = 24 (0x18)							
5-16	Reserved							
17	0							
18-27	Reserved							
28	0							
29-40	Reserved							
41-50	Reserved							

Figure 50. INQUIRY DATA - EVPD = 1 (Page Code = 01)

- **Qualifier** is set to zero to indicate that the LUN specified in the Command Block is currently supported.
- **Peripheral Device Type** is set to zero to indicate that the device is a Direct-Access.
- **Page Code** is set to 1, and this field contains the same value as in the page code field of the INQUIRY command descriptor block.
- **Page length** is set to 47, and this field specifies the length of the following page data.
- **ASCII Length** gives the number of bytes of ASCII data to follow.

## 7.6.5 Inquiry Data Format - EVPD = 1 - Page Code = 03

BYTE	BIT							
	7	6	5	4	3	2	1	0
0	Qualifier = 0				Peripheral Dev Type = 0			
1	Page Code = 03h							
2	Reserved = 0							
3	Page Length = 36 (0x24)							
4-7	Reserved = ' ' (ASCII)							
8-39	Reserved							

Figure 51. INQUIRY DATA - EVPD = 1 (Page Code = 03)

- **Qualifier** is set to zero to indicate that the LUN specified in the Command Block is currently supported.
- **Peripheral Device Type** is set to zero to indicate that the device is a Direct-Access.
- **Page Code** is set to 3, and this field contains the same value as in the page code field of the INQUIRY command descriptor block.
- **Page length** is set to 36, and this field specifies the length of the following page data.

## 7.6.6 Inquiry Data Format - EVPD = 1 - Page Code = 80h

---

BYTE	BIT							
	7	6	5	4	3	2	1	0
0	Qualifier = 0				Peripheral Dev Type = 0			
1	Page Code = 80h							
2	Reserved = 0							
3	Page Length = 16 (10h)							
4-19	Serial Number (ASCII)							

---

Figure 52. INQUIRY DATA - EVPD = 1 (Page Code = 80h)

- **Qualifier** is set to zero to indicate that the LUN specified in the Command Block is currently supported.
- **Peripheral Device Type** is set to zero to indicate that the device is a Direct-Access.
- **Page Code** is set to 80h, and this field contains the same value as in the page code field of the INQUIRY command descriptor block.
- **Page length** is set to 16, and this field specifies the length of the following page data.
- **Serial Number** gives the drive serial number.

## 7.6.7 Inquiry Data Format - EVPD = 1 - Page Code = 82h

BYTE	BIT							
	7	6	5	4	3	2	1	0
0	Qualifier = 0				Peripheral Dev Type = 0			
1	Page Code = 82h							
2	Reserved = 0							
3	Page Length = 58 (3Ah)							
4	ASCII Length = 29 (1Dh)							
5-8	Product Type (ASCII)							
9	0							
10-15	Model Number (ASCII)							
16	0							
17-24	Serial Number (ASCII)							
25	0							
26-31	Vendor IBM 'IBM' (ASCII)							
32	0							
33-36	Product Type (EBCDIC)							
37	0							
38-43	Model Number (EBCDIC)							
44	Reserved = 0							
45-52	Serial Number (EBCDIC)							
53-58	Vendor IBM 'IBM' (EBCDIC)							

Figure 53. INQUIRY DATA - EVPD = 1 (Page Code = 82h)

- **Qualifier** is set to zero to indicate that the LUN specified in the Command Block is currently supported.
- **Peripheral Device Type** is set to zero to indicate that the device is a Direct-Access.
- **Page Code** is set to 82h, and this field contains the same value as in the page code field of the INQUIRY command descriptor block.
- **Page length** field specifies the length of the following page data.
- **ASCII Length** gives the number of bytes of ASCII data to follow.

- **Product Type (ASCII)** gives a 4 digit product type code DORS of the drive. The field is left aligned and unused bytes are filled with 20h.
- **Model Number (ASCII)** gives a 5 digit product type code 3xxxx of the drive. The field is left aligned and unused bytes are filled with 20h.
- **Serial Number (ASCII)** gives the file serial number. The field is left aligned and unused bytes are filled with 20h.
- **Vendor ID (ASCII)** gives the vendor as IBM. The field is left aligned and unused bytes are filled with 20h.
- **Product Type (EBCDIC)** gives a 4 digit product type code for the drive. The field is left aligned and unused bytes are filled with 40h.
- **Model Number (EBCDIC)** gives a 5 digit product type code for the drive. The field is left aligned and unused bytes are filled with 40h.
- **Serial Number (EBCDIC)** gives the file serial number. The field is left aligned and unused bytes are filled with 40h.
- **Vendor ID (EBCDIC)** gives the vendor as IBM. The field is left aligned and unused bytes are filled with 40h.



## 7.7 LOG SELECT (4C)

Byte	Bit							
	7	6	5	4	3	2	1	0
0	Command Code = 4Ch							
1	LUN			Reserved = 0			PCR	SP
2	PC		Reserved = 0					
3	Reserved = 0							
4								
5								
6								
7	(MSB) Parameter List Length = 0						(LSB)	
8								
9	Reserved = 0					FLAG	LINK	

Figure 54. LOG SELECT (4C)

The LOG SELECT command provides a means for the initiator to clear statistical information maintained by the drive and reported via the Log Sense command.

- **PCR** The Parameter Code Reset determines whether the Log Sense parameters will be cleared and unit attention posted for all other initiators. A value of 1 indicates that the parameters should be cleared, while a value of zero (except when PC = 11b) indicates that the parameters should not be cleared.
- **SP** The Save Parameters bit value of zero indicates that the page parameters not be saved. A value of 1 indicates that the page parameters that are saveable should be saved after they have been changed.
- **PC** The Page Control field defines the type of parameters to be selected. The PC field set to 11b (and PCR is then a don't care) indicates that the Default Cumulative values are set to their default values of 0. If the PC field is set to 01b and PCR is set to 1 the Current Cumulative values are also set to their default values.

As the file does not support the threshold pages any other value in this field will cause the command to end with a CHECK CONDITION with a sense key of illegal request and an additional sense code of invalid field in CDB.

- **Parameter List Length** The Parameter List Length must be zero to indicate that no data is transferred from the initiator to the target during the potential DATA OUT phase.

If one or more fields of the CDB are not set correctly the command will be terminated with a CHECK CONDITION status. The Sense Key shall be set to Illegal Request and the additional sense code set to Invalid Field in CDB.

The Log Select command will reset the counter variables to their default values of zero. These variables are listed in the Log Sense command.

The target generates a unit attention condition, to indicate that parameters have changed, for all initiators except the one that issued the Log Select command.

## 7.8 LOG SENSE (4D)

Byte	Bit							
	7	6	5	4	3	2	1	0
0	Command Code = 4Dh							
1	LUN			Reserved = 0			PPC = 0	SP
2	PC	Page Code						
3 4	Reserved = 0							
5 6	(MSB)	Parameter Pointer = 0						(LSB)
7 8	(MSB)	Allocation Length						(LSB)
9	Reserved = 0						FLAG	LINK

Figure 55. LOG SENSE (4D)

The LOG SENSE command allows the initiator to retrieve the statistical data about the drive.

- **PPC** (Parameter Pointer Control) bit must be set to zero. This specifies that the drive start transferring data starting from the field specified in the parameter pointer field for the number of bytes specified by the allocation length. If the PPC bit is set to 1, CHECK CONDITION status is returned with a Sense Key of Illegal Request and additional sense code of Invalid Field in CDB.
- **SP** (Save Parameters) bit set to 0 specifies that the drive does not save any log parameters. If set to 1 all page parameters that are savable (those pages denoted by a DS = 0 in the parameter header control byte) are saved.
- **PC** (Page Control) field defines the type of parameters to be selected. This field must be set to 01b to specify the current cumulative values or 11b to specify the default cumulative values.

As the file does not support the threshold pages any other value in this field will cause the command to end with a CHECK CONDITION with a sense key of illegal request and an additional sense code of invalid field in CDB.

- **Page Code** field identifies which page is being requested. This field must be set to the values indicated in Page 0. If the Page Code value is invalid a CHECK CONDITION status is returned with a Sense Key of Illegal Request and additional sense code of Invalid Field in CDB.
- **Parameter Pointer Field** specifies the beginning field for the transfer. This field must be set to 0000h. If the Parameter Pointer Field is not zero a CHECK CONDITION status is returned with a Sense Key of Illegal Request and additional sense code of Invalid Field in CDB.
- **Allocation Length** field specifies the maximum number of bytes the Initiator has allocated for returned Log Sense Data. No bytes are transferred if the length is zero. This condition is not considered an error. The target terminates the Data In phase when all available Log Sense data has been transferred or when the number of bytes equals the allocation length, whichever is less.

## 7.8.1 Log Page Parameters

Each log page begins with a four-byte page header followed by zero or more variable-length log parameters.

- **Page Header** Page Code field identifies which log page is being transferred.

The Page Length field specifies the length in bytes of the following log parameters.

- **Log Parameters** Each log parameter begins with a four-bytes parameter header followed by one or more bytes of parameter value data.

The Parameter Code field identifies which log parameter is being transferred for that log page.

The Parameter Control field, or 3rd byte of each parameter header contains several fields.

- **DU** The Disable Update bit is set to 0 which indicates that the drive updates the log parameter value to reflect events that should be noted by that parameter.
- **DS** The Disable Save bit is set to 1 to indicate the parameter is non-saveable and is set to 0 to indicate the parameter is saveable.
- **TSD** The Target Save Disable bit is set to zero which indicates the drive provides a target defined method for saving log parameters.
- **ETC** The enable Threshold Comparison bit is set to 0 which indicates the drive does not perform comparisons between cumulative and any threshold values.
- **LBIN** The List Binary bit is set to 1 for vendor unique pages whose parameters lists are in binary format, not ASCII. This bit is reserved and set to 0 for all other pages.
- **LP** The List Parameter bit is set to 0 for parameters that are data counters. The LP bit is set to 1 for parameters that are lists.

## 7.8.2 Log Sense Page 0

Byte	7	6	5	4	3	2	1	0
0	Reserved		Page code = 0					
1	Reserved							
2-3	Page Length = 0006h (Number of Pages Supported)							
4	First supported page 0h							
6	Second supported page 2h							
7	Third supported page 3h							
8	Fourth supported page 5h							
9	Fifth supported page 6h							
10	Sixth supported page 3Ah							

Page 0 indicates the supported log sense pages. This page is used to determine which additional pages can be requested by an Initiator.

## 7.8.3 Log Sense Page 2

This page contains counters for write errors

Byte	7	6	5	4	3	2	1	0
0	Reserved		Page code = 02h					
1	Reserved							
2 - 3	PageLength = 38h							
4 - 5	Parameter Code = 00h							
6	DU = 0	DS = 0	TSD = 0	ETC = 0	TMC = 0		LBIN = 0	LP = 0
7	Parameter Length = 04h							
8 - 11	Errors recovered without delay = 0							
12 - 13	Parameter Code = 01h							
14	DU = 0	DS = 0	TSD = 0	ETC = 0	TMC = 0		LBIN = 0	LP = 0
15	Parameter Length = 04h							
16 - 19	Count of LBA's with write fault errors							
20 - 21	Parameter Code = 02h							
22	DU = 0	DS = 0	TSD = 0	ETC = 0	TMC = 0		LBIN = 0	LP = 0
23	Parameter Length = 04h							
24 - 27	Count of LBA's with id type errors							
28 - 29	Parameter Code = 03h							
30	DU = 0	DS = 0	TSD = 0	ETC = 0	TMC = 0		LBIN = 0	LP = 0
31	Parameter Length = 04h							
32 - 35	Total errors recovered							
36 - 37	Parameter Code = 04h							
38	DU = 0	DS = 0	TSD = 0	ETC = 0	TMC = 0		LBIN = 0	LP = 0
39	Parameter Length = 04h							
40 - 43	Times recovery invoked							

Byte	7	6	5	4	3	2	1	0
44 - 45	Parameter Code = 05h							
46	DU = 0	DS = 0	TSD = 0	ETC = 0	TMC = 0		LBIN = 0	LP = 0
47	Parameter Length = 04h							
48 - 51	Total bytes written							
52 - 53	Parameter Code = 06h							
54	DU = 0	DS = 0	TSD = 0	ETC = 0	TMC = 0		LBIN = 0	LP = 0
55	Parameter Length = 04h							
56 - 59	Count of LBA's with hard error							

## 7.8.4 Log Sense Page 3

This page contains counters for read errors

Byte	7	6	5	4	3	2	1	0
0	Reserved		Page code = 03h					
1	Reserved							
2 - 3	PageLength = 38h							
4 - 5	Parameter Code = 00h							
6	DU =0	DS =0	TSD =0	ETC =0	TMC = 0		LBIN =0	LP =0
7	Parameter Length = 04h							
8 - 11	Errors recovered without delay = 0							
12 - 13	Parameter Code = 01h							
14	DU =0	DS =0	TSD =0	ETC =0	TMC = 0		LBIN =0	LP =0
15	Parameter Length = 04h							
16 - 19	Count of LBA's with ECC detected errors							
20 - 21	Parameter Code = 02h							
22	DU =0	DS =0	TSD =0	ETC =0	TMC = 0		LBIN =0	LP =0
23	Parameter Length = 04h							
24 - 27	Count of LBA's with id type errors							
28 - 29	Parameter Code = 03h							
30	DU =0	DS =0	TSD =0	ETC =0	TMC = 0		LBIN =0	LP =0
31	Parameter Length = 04h							
32 - 35	Total errors recovered							
36 - 37	Parameter Code = 04h							
38	DU =0	DS =0	TSD =0	ETC =0	TMC = 0		LBIN =0	LP =0
39	Parameter Length = 04h							
40 - 43	Times recovery invoked							

Byte	7	6	5	4	3	2	1	0
44 - 45	Parameter Code = 05h							
46	DU = 0	DS = 0	TSD = 0	ETC = 0	TMC = 0		LBIN = 0	LP = 0
47	Parameter Length = 04h							
48 - 51	Total bytes read							
52 - 53	Parameter Code = 06h							
54	DU = 0	DS = 0	TSD = 0	ETC = 0	TMC = 0		LBIN = 0	LP = 0
55	Parameter Length = 04h							
56 - 59	Count of LBA's with hard error							

The drive will attempt to read data after a seek before the head has fully settled on track. This is done to aid performance. However as a result there is a high incidence of error recovery invoked which normally uses ECC or a retry to recover the data. As a consequence of this an error recovered by a single retry is not reported by the error counters.

Additionally the drive does not report data recovered by ECC on the fly as it is not possible to distinguish between ECC errors caused by reading before settling and other causes.



## 7.8.5 Log Sense Page 5

This page contains counters for verify errors

Byte	7	6	5	4	3	2	1	0
0	Reserved		Page code = 05h					
1	Reserved							
2 - 3	PageLength = 38h							
4 - 5	Parameter Code = 00h							
6	DU =0	DS =0	TSD =0	ETC =0	TMC = 0		LBIN =0	LP =0
7	Parameter Length = 04h							
8 - 11	Errors recovered without delay = 0							
12 - 13	Parameter Code = 01h							
14	DU =0	DS =0	TSD =0	ETC =0	TMC = 0		LBIN =0	LP =0
15	Parameter Length = 04h							
16 - 19	Count of LBA's with ECC detected errors							
20 - 21	Parameter Code = 02h							
22	DU =0	DS =0	TSD =0	ETC =0	TMC = 0		LBIN =0	LP =0
23	Parameter Length = 04h							
24 - 27	Count of LBA's with id type errors							
28 - 29	Parameter Code = 03h							
30	DU =0	DS =0	TSD =0	ETC =0	TMC = 0		LBIN =0	LP =0
31	Parameter Length = 04h							
32 - 35	Total errors recovered							
36 - 37	Parameter Code = 04h							
38	DU =0	DS =0	TSD =0	ETC =0	TMC = 0		LBIN =0	LP =0
39	Parameter Length = 04h							
40 - 43	Times recovery invoked							

Byte	7	6	5	4	3	2	1	0
44 - 45	Parameter Code = 05h							
46	DU = 0	DS = 0	TSD = 0	ETC = 0	TMC = 0		LBIN = 0	LP = 0
47	Parameter Length = 04h							
48 - 51	Total bytes written							
52 - 53	Parameter Code = 06h							
54	DU = 0	DS = 0	TSD = 0	ETC = 0	TMC = 0		LBIN = 0	LP = 0
55	Parameter Length = 04h							
56 - 59	Count of LBA's with hard error							

The drive will attempt to read data after a seek before the head has fully settled on track. This is done to aid performance. However as a result there is a high incidence of error recovery invoked which normally uses ECC or a retry to recover the data. As a consequence of this an error recovered by a single retry is not reported by the error counters.

Additionally the drive does not report data recovered by ECC on the fly as it is not possible to distinguish between ECC errors caused by reading before settling and other causes.

## 7.8.6 Log Sense Page 6

This page contains counters for non-medium errors. This includes seek errors and other hardware type failures.

Byte	7	6	5	4	3	2	1	0
0	Reserved		Page code = 06h					
1	Reserved							
2 - 3	PageLength = 08h							
4 - 5	Parameter Code = 00h							
6	DU = 0	DS = 0	TSD = 0	ETC = 0	TMC = 0		LBIN = 0	LP = 0
7	Parameter Length = 04h							
8 - 11	Error Count							

## 7.8.7 Log Sense Page 3A

Reserved.

## 7.9 MODE SENSE (1A)

Byte	Bit							
	7	6	5	4	3	2	1	0
0	Command Code = 1Ah							
1	LUN			Reserved = 0				
2	PCF		Page Code					
3	Reserved = 0							
4	Allocation Length							
5	VU = 0		Reserved = 0			FLAG	LINK	

Figure 56. MODE SENSE (1A)

The MODE SENSE command provides a means for the file to report various device parameters to the initiator. It is the complement to the MODE SELECT command.

**Allocation Length** indicates the maximum number of bytes the initiator has set aside for the DATA IN phase. A value of zero is not considered an error. If the allocation length is smaller than the amount available, then that portion of the data up to the allocation length will be sent. It is noted that this may result in only a portion of a multi-byte field being sent.

**7.9.1.1.1 Page Control Field:** PCF (Page Control Field) defines the type of Page Parameter values to be returned.

### PCF Meaning

**0 0 Report current values.** The file returns the current values under which the logical unit is presently configured for the page code specified. The current values returned are:

1. The parameters set in the last successful MODE SELECT command.
2. The saved values if a MODE SELECT command has not been executed since the last power-on, hard RESET condition, or BUS DEVICE RESET message .

**Note:** The file will not process the Mode Select command until the completion of spin-up. Therefore, the initiator cannot modify the current values prior to the saved values being read in.

**0 1 Report changeable value.** The file returns the changeable values for the page code specified. The page requested shall be returned containing information that indicate which fields are changeable. All bits of parameters that are changeable shall be set to one. Parameters that are *defined by the file* shall be set to zero. If any part of a field is changeable all bits in that field shall be set to one.

**Note:** For a value field such as the buffer ratios of page 2, the bit field will not indicate the range of supported values but rather that the field is supported.

**1 0 Report default value.** The file returns the default values for the page code specified. The parameters not supported by the file are set to zero.

**1 1 Report saved value.** The file returns the saved value for the page code specified.

Saved values are one of following :

- the values saved as a result of MODE SELECT command
- identical to the default values
- zero when the parameters are not supported

The Page Length byte value of each page returned by the file indicates up to which fields are supported on that page.

**7.9.1.1.2 Page Code:** This field specifies which page or pages to return. Page code usage is defined in Figure 57.

Page Code	Description
01h – 38h	Return specific page.
3Fh	Return all available pages.

Figure 57. Page Code Usage

## 7.9.2 Mode Parameter List

The mode parameter list contain a header, followed by zero or more block descriptors, followed by zero or more variable-length pages.

### 7.9.2.1 HEADER

---

	7	6	5	4	3	2	1	0
BYTE 0	Mode Data Length							
BYTE 1	Medium Type = 0							
BYTE 2	WP	RSVD = 0						
BYTE 3	Block Descriptor Length (= 0 or 8)							

---

Figure 58. MODE Parameter List (Header)

- **Mode Data Length.** When using the MODE SENSE command, the mode data length field specifies the length in bytes of the following data that is available to be transferred. The mode data length does not include the length byte itself. When using the MODE SELECT command, this field is reserved.
- **Medium Type** field is always set to zero in the file (Default Medium Type).
- **WP.** When used with the MODE SELECT command, the Write Protect (WP) bit is reserved.

When used with the MODE SENSE command, a Write Protect (WP) bit of zero indicates that the medium is write enabled.

- **Block Descriptor Length** specifies the length in bytes of the block descriptors.

When used with the MODE SELECT command, zero or eight are supported by the file.

When used with the MODE SENSE command, the file returns eight to indicate that only a single block descriptor is available.

### 7.9.2.2 Block Descriptor

BYTE 0	Density code = 0
BYTE 1 BYTE 2 BYTE 3	Number of Blocks (MSB)  (LSB)
BYTE 4	RSVD = 0
BYTE 5 BYTE 6 BYTE 7	Block Length

Figure 59. MODE Parameter Block Descriptor

The Block descriptor provides formatting information about the Number of Blocks (user addressable) to format at the specified Block Length.

- **Number of Blocks**

When used with the MODE SELECT command, the **Number of Blocks** field must be;

- Zero to indicate not to change available blocks
- 0xFFFFFFFF to indicate all available blocks
- The exact number of blocks in the data area of the drive, which can be obtained with MODE SENSE
- Number of blocks less than the exact one, in order to **CLIP the number of blocks**

Any other value is invalid, and causes the command to fail with CHECK CONDITION status.

When used with the MODE SENSE command, the field contain exact number of blocks.

- **Block Length**

When used with the MODE SELECT command, the **Block length** field must contain 512 or zero, or the file will terminate the command with CHECK CONDITION status.

When used with the MODE SENSE command, the field will return always contain 512 .

### 7.9.2.3 Page Descriptor

BYTE 0	PS	RSVD=0	Page Code
BYTE 1	Page Length		
BYTE 2-n	Mode Parameters		

Figure 60. MODE Parameter Page Format

Each mode page contains a page code, a page length, and a set of mode parameters.

When using the MODE SENSE command, a Parameter Savable (PS) bit of one indicates that the mode page can be saved by the file in the reserved area of the file.

A PS bit of zero indicates that the supported parameters cannot be saved. When using the MODE SELECT command, the PS bit is reserved (zero).

The pages supported are described in the product specific specification.

## 7.10 MODE SELECT (15)

Byte	Bit							
	7	6	5	4	3	2	1	0
0	Command Code = 15h							
1	LUN			PF = 1	Reserved = 0			SP
2 3	Reserved = 0							
4	Parameter List Length							
5	VU = 0	Reserved = 0				FLAG	LINK	

Figure 61. MODE SELECT (15)

The MODE SELECT command provides a means for the initiator to specify LUN or device parameters to the Target. It also allows an Initiator to specify options the Target uses in error recovery and Caching.

There is a single set of Mode Page parameters shared by all initiators.

**PF** A PF (Page Format) bit value of 1 indicates the data sent by the Initiator after the Mode Select Header and the Block Descriptor, if any, complies to the Page Format. The Target ignores this field since it only accepts mode parameters in the Page Format.

**SP** Save Pages. This indicates;

- 0 The drive shall not save the pages sent during the Data Out phase but will use them for all following commands until the power is removed, a reset is received or a new mode select command is received.
- 1 The drive will save the data in the reserved area of the disk. It will be used for all following commands until another mode select command is issued, this information is maintained over a power cycle or reset of the file.

### Parameter List Length

This specifies the number of bytes to be sent from the initiator. A parameter list length of zero suppresses data transfer and is not considered as an error.

The MODE SELECT parameter list contains a four-byte header, followed by zero or one block descriptor followed by zero or more pages. The pages which are valid with this command are defined in the addendum under the heading **Mode Select Data**. as they vary with the file model.

### 7.10.1.1 Application Note

The initiator should issue a MODE SENSE command requesting all Changeable values (see PCF field in byte two of the CDB in 7.9, “MODE SENSE (1A)” on page 78) prior to issuing a MODE SELECT command. This is necessary to find out which pages are implemented by the file and the length of those pages. The file will return, in the Pages of the MODE SENSE command, the number of bytes supported for each Page. The Page Length set by the initiator in the MODE SELECT command must be the exact value as that returned by the file in MODE SENSE Page Length. If this is not true, the file will return



CHECK CONDITION status with sense key of ILLEGAL REQUEST. See 7.9, “MODE SENSE (1A)” on page 78.

**Note:** If an initiator sends a MODE SELECT command that changes any parameters that apply to other initiators, the file shall generate an unit attention condition for all initiators except the one that issued the MODE SELECT command. The file shall set the additional sense code to PARAMETERS CHANGED (2Ah).

---

## 7.11 Mode Select Data

The file supports the following mode page code:

---

Page	Description	PS
00	Vendor Unique Parameters	1
01	Read-Write Error Recovery Parameters	1
02	Disconnect/Reconnect Control Parameters	1
03	Format Device Parameters	0
04	Rigid Disk Geometry Parameters	0
07	Verify Error Recovery Parameters	1
08	Caching Parameters	1
0A	Control Mode Page	1
0C	Zone Parameters	1
1C	Informational Exceptions Control	1
38	Power Control Parameters	1

---

Figure 62. Page Code Usage

The page length field specifies the length in bytes of the mode parameters that follow. If the initiator does not set this value to the value that is returned for the page by the MODE SENSE command, the file will terminate the command with CHECK CONDITION status.

## 7.11.1 Page 0 (Vendor Unique Parameters)

		BIT							
		7	6	5	4	3	2	1	0
BYTE 0	PS	RSVD=0	Page Code = 00h						
BYTE 1	Page Length = 0Eh								
BYTE 2	QPE	UQE	Ignore	UAI	RSVD=0	SCAM level	DADM		
BYTE 3	RSVD=0	RSVD=0	CMDAC	Ignore	RSVD = 0			CPE	
BYTE 4	RSVD = 0								
BYTE 5	RSVD=0	TCC	DSN	FRDD	DPSDP	RSVD=0	CAEN	Ignore	
BYTE 6	RSVD = 0								
BYTE 7	RSVD = 0								
BYTE 8	RSVD=0	ADC	RSVD=0	DRD	LED Mode				
BYTE 9	RSVD = 0								
BYTE 10	Command Aging Limit (Hi byte)								
BYTE 11	Command Aging Limit (Low byte)								
BYTE 12	QPE Read Threshold								
BYTE 13	QPE Write Threshold								
BYTE 14	DRRT	DNR	RSVD = 0						
BYTE 15	RSVD = 0								

Figure 63. Page 0

Fields marked in the table as 'Ignore' are not used or checked by the file. They will be initialized to zero but may be set as desired. This is for compatibility with older drives.

Changeable Parameter	Default Value
<b>QPE</b>	0
<b>UQE</b>	1
<b>UAI</b>	0
<b>SCAM Level</b>	10
<b>DADM</b>	0
<b>CMDAC</b>	1
<b>CPE</b>	1

<b>TCC</b>	0
<b>DSN</b>	0
<b>FRDD</b>	0
<b>DPSDP</b>	0
<b>CAEN</b>	1
<b>ADC</b>	1
<b>DRD</b>	0
<b>LED Mode</b>	0000b
<b>Command Aging Limit</b>	48
<b>QPE Read Threshold</b>	10
<b>QPE Write Threshold</b>	10
<b>DRRT</b>	0
<b>DNR</b>	0

- **QPE** (Qualify Post Error) bit allows the Initiator to inhibit the reporting of recovered data errors which are recovered under DRP step. A QPE bit of zero causes the Target to report all recovered data errors. A QPE bit of one causes the Target to report only those recovered data errors which exceed the QPE threshold.
- **UQE** (Untagged Queuing Enable) bit controls whether or not untagged queuing is allowed.
- **UAI** (Unit Attention Inhibit) bit is not used during normal operation while the UAI jumper is removed from the drive. It may however be changed by the user with no effects. If the UAI jumper is added to the drive then this bit controls the generation of unit attention conditions.
- **SCAM level**, SCAM level control bits, specify the SCAM function level to be supported.

Bit 2	Bit 1	SCAM function
0	0	Disable
0	1	SCAM level 1
1	0	SCAM level 2

- **DADM**, Disable Automatic Drive Maintenance bit, is set to zero to indicate that the ADM function is enabled to maintain reliability of the drive. The DADM bit of one disables the ADM function.
- **CMDAC** (Command Active) bit determines in conjunction with **LED Mode** bits if an LED on the file is activated while commands are active. If CMDAC bit is one and LED bits are zero, an LED driver is active when a command is queued or executed.
- **CPE** (Concurrent Processing Enable) bit is set to zero to indicate that only untagged and unlinked Request Sense or Inquiry can be executed concurrently. A CPE bit of one indicates that Read(6), Read extend(10), Write(6) and Write extend(10), as well as the above 2 commands, can be executed concurrently.
- **TCC** (Thermal Compensation Control) bit is not used. It is allowed to be modified by the initiator for host system device driver compatibility.
- **DSN** (Disable Target Initiated Synchronous Negotiation) bit is not used and ignored internally.
- **FRDD** (Format/Reassign Degrade Disable) bit is not used and ignored internally.

- **DPSDP** (Data Phase Save Data Pointer) bit is not used and ignored internally.
- **CAEN** When set this bit causes the Command Age Limit timer to be used to avoid commands waiting in the command queue for an indefinite period. When commands have been in the queue for a period of time greater than the timer limit they will be re-ordered to be executed in on a first come first served basis. When this bit is reset commands are always executed based on the queue re-ordering rules.
- **ADC** (Adaptive Cache Enable), when set, allows the drive to modify the read-ahead caching algorithm, ignoring parameters in Page 8. The adaptation is based on analyzing the most recent command history and the current contents of the cache buffers.
- **DRD** (Disable Read Disconnect) bit is not used. It is allowed to be modified by the initiator for host system device driver compatibility.
- **LED Mode** is designed to control the operation of a file LED driver.
  - LED Mode = 0000b
    - The CMDAC bit controls the LED.
    - CMDAC = 1 (Command Active)
    - CMDAC = 0 (Motor Active)
  - LED Mode = 0001b (Motor Active)
    - When the motor is spinning, the LED is high.
  - LED Mode = 0010b (Command Active).
    - When there is a command active or in the queue, the LED is high.
- **Command Aging Limit** This value is used to control the maximum time a command should wait in the command queue when the CAEN bit is set. Each unit of this timer is 50ms.
- **QPE Read Threshold** specifies the error reporting threshold for read operations when the QPE bit is set to one.
- **QPE Write Threshold** specifies the error reporting threshold for write operations when the QPE bit is set to one.
- **DRRT** (Disable Read Reassign Target) bit is not used. It is allowed to be modified by the initiator for host system device driver compatibility.
- **DNR** (Disable Nested Reassigns) bit is not used. It is allowed to be modified by the initiator for host system device driver compatibility.

## 7.11.2 Page 1 (Read/Write Error Recovery Parameters)

	BIT							
	7	6	5	4	3	2	1	0
BYTE 0	PS	RSVD=0	Page Code = 01h					
BYTE 1	Page Length = 0Ah							
BYTE 2	AWRE	ARRE	TB	RC = 0	EER=0	PER	DTE	DCR
BYTE 3	Read Retry Count							
BYTE 4	Correction Span							
BYTE 5	Head Offset Count (Not used)							
BYTE 6	Data Strobe Offset Count (Not used)							
BYTE 7	Reserved							
BYTE 8	Write Retry Count							
BYTE 9	Reserved							
BYTE 10	(MSB)	Recovery Time Limit (Not Used)						
BYTE 11								(LSB)

Figure 64. Page 1

Changeable Parameter	Default Value
<b>AWRE</b>	1
<b>ARRE</b>	1
<b>TB</b>	0
<b>PER</b>	0
<b>DTE</b>	0
<b>DCR</b>	0
<b>Correction Span</b>	0
<b>Read Retry Count</b>	01h
<b>Write Retry Count</b>	01h

The Read-Write recovery parameters that will be used during any command that performs a read or write operation to the medium.

- **AWRE**, an Automatic write reallocation enabled bit is set to zero to indicate that the file shall not perform automatic reallocation of defective data blocks during write operations. A AWRE bit is set to one to indicate that the file shall perform automatic reallocation of defective data blocks during write operations.

- **ARRE**, an Automatic read reallocation enabled bit is set to zero to indicate that the file shall not perform automatic reallocation of defective data blocks during read operations.  
A ARRE bit is set to one to indicate that the file shall perform automatic reallocation of defective data blocks during read operations.
- **TB**, Transfer Block bit, is set to one to indicate that a data block that is not recovered within the recovery limits specified shall be transferred to the initiator before CHECK CONDITION status is returned.  
A TB bit of zero indicates that such a data block shall not be transferred to the initiator. Data blocks that can be recovered within the recovery limits are always transferred, regardless of the value of the bit.
- **RC**, A read continuous bit. **Must be set to zero** , indicating that the error recovery operations that cause delays are acceptable during the data transfer. Data shall not be fabricated.
- **EER**,An enable early recovery bit. **Must be set to zero** , indicating that the file shall use an error recovery procedure that minimizes the risk of mis-detection or mis-correction during the data transfer. Data shall not be fabricated.
- **PER**, Post Error bit, is set to one to indicate that the file reports recovered errors.
- **DTE**, Disable Transfer on Error bit, is set to one to indicate that the file terminates the DATA phase upon detection of a recovered error .
- **DCR**, Disable Correction bit, is set to one to indicate that Error Correction Code is not used for data error recovery.  
A DCR bit of zero indicates that ECC is applied to recover the data.
- **Read Retry Count** sets a limit on the amount of data recovery procedure(DRP) passes the Target attempts when recovering read errors. One pass through DRP involves executing all steps of DRP. Only values of 00h and 01h are valid. A value of zero disables all error recovery procedures.
- **Correction Span** field specifies the size, in bits, of the largest data error burst for which data error correction may be attempted. Any value may be set into this field, including zero. The file will always use it's default correction capabilities.
- **Head Offset Count** is not supported by the file.  
**Note:** Head Offset is implemented in the read error recovery routine. The user can not modify the offset value.
- **Write Retry Count** sets a limit on the amount of data recovery procedure(DRP) passes the Target attempts when recovering write errors. One pass through DRP involves executing all steps of DRP. Only values of 00h and 01h are valid. A value of zero disables all error recovery procedures.

The following summarizes valid modes of operation. If an illegal mode is set the mode select command will complete successfully but the action of the file when an error occurs is undefined.

**PER DTE DCR TB DESCRIPTION**

<b>0</b>	<b>0</b>	<b>0</b>	<b>0</b>	Retries and Error Correction are attempted. Recovered and/or corrected data (if any) is transferred with no CHECK CONDITION status at the end of the transfer.  <b>no err</b> The transfer length is exhausted.  <b>soft err</b> The transfer length is exhausted. Transferred data includes blocks containing recovered errors.  <b>hard err</b> Data transfer stops when an unrecoverable error is encountered. The unrecoverable block is not transferred to the initiator. The file then creates the CHECK CONDITION status with the appropriate Sense Key.
<b>0</b>	<b>0</b>	<b>0</b>	<b>1</b>	Retries and Error Correction are attempted. Recovered and/or corrected data (if any) is transferred with no CHECK CONDITION status at the end of the transfer.  <b>no err</b> The transfer length is exhausted.  <b>soft err</b> The transfer length is exhausted. Transferred data includes blocks containing recovered errors.  <b>hard err</b> Data transfer stops when an unrecoverable error is encountered. The unrecoverable block is transferred to the initiator. The file then creates the CHECK CONDITION status with the appropriate Sense Key.
<b>0</b>	<b>0</b>	<b>1</b>	<b>0</b>	Retries are attempted but no error correction (ECC) is applied. Recovered data (if any) is transferred with no CHECK CONDITION status at the end of the transfer.  <b>no err</b> The transfer length is exhausted.  <b>soft err</b> The transfer length is exhausted. Transferred data includes blocks containing recovered errors.  <b>hard err</b> Data transfer stops when an unrecoverable error is encountered. The unrecoverable block is not transferred to the initiator. The file then creates the CHECK CONDITION status with the appropriate Sense Key.
<b>0</b>	<b>0</b>	<b>1</b>	<b>1</b>	Retries are attempted but no error correction (ECC) is applied. Recovered data (if any) is transferred with no CHECK CONDITION status at the end of the transfer.  <b>no err</b> The transfer length is exhausted.  <b>soft err</b> The transfer length is exhausted. Transferred data includes blocks containing recovered errors.  <b>hard err</b> Data transfer stops when an unrecoverable error is encountered. The unrecoverable block is transferred to the initiator. The file then creates the CHECK CONDITION status with the appropriate Sense Key.
<b>0</b>	<b>1</b>	<b>0</b>	<b>0</b>	Illegal Request-DTE must be zero when PER is zero
<b>0</b>	<b>1</b>	<b>0</b>	<b>1</b>	Illegal Request-DTE must be zero when PER is zero
<b>0</b>	<b>1</b>	<b>1</b>	<b>0</b>	Illegal Request-DTE must be zero when PER is zero
<b>0</b>	<b>1</b>	<b>1</b>	<b>1</b>	Illegal Request-DTE must be zero when PER is zero



- 1 0 0 0** The highest level error is reported at the end of transfer. Retries and error correction are attempted. Recovered and/or corrected data (if any) is transferred with CHECK CONDITION status and RECOVERED ERROR Sense Key set at the end of the transfer.
- no err** The transfer length is exhausted.
  - soft err** The transfer length is exhausted. Transferred data includes blocks containing recovered errors. The information byte in the sense data will contain the logical block address of the last recovered error.
  - hard err** Data transfer stops when an unrecoverable error is encountered. The unrecoverable block is not transferred to the initiator. The file then creates the CHECK CONDITION status with the appropriate Sense Key.
- 1 0 0 1** The highest level error is reported at the end of transfer. Retries and error correction are attempted. Recovered and/or corrected data (if any) is transferred with CHECK CONDITION status and RECOVERED ERROR Sense Key set at the end of the transfer.
- no err** The transfer length is exhausted.
  - soft err** The transfer length is exhausted. Transferred data includes blocks containing recovered errors. The information byte in the sense data will contain the logical block address of the last recovered error.
  - hard err** Data transfer stops when an unrecoverable error is encountered. The unrecoverable block is transferred to the initiator. The file then creates the CHECK CONDITION status with the appropriate Sense Key.
- 1 0 1 0** The highest level error is reported at the end of transfer. Retries are attempted but ECC is not applied. Recovered and/or corrected data (if any) is transferred with CHECK CONDITION status and RECOVERED ERROR Sense Key set at the end of the transfer.
- no err** The transfer length is exhausted.
  - soft err** The transfer length is exhausted. Transferred data includes blocks containing recovered errors. The information byte in the sense data will contain the LBA of the last recovered error.
  - hard err** Data transfer stops when an unrecoverable error is encountered. The unrecoverable block is not transferred to the initiator. The file then creates the CHECK CONDITION status with the appropriate Sense Key.
- 1 0 1 1** The highest level error is reported at the end of transfer. Retries are attempted but ECC is not applied. Recovered and/or corrected data (if any) is transferred with CHECK CONDITION status and RECOVERED ERROR Sense Key set at the end of the transfer.
- no err** The transfer length is exhausted.
  - soft err** The transfer length is exhausted. Transferred data includes blocks containing recovered errors. The information byte in the sense data will contain the LBA of the last recovered error.
  - hard err** Data transfer stops when an unrecoverable error is encountered. The unrecoverable block is transferred to the initiator. The file then creates the CHECK CONDITION status with the appropriate Sense Key.

1	1	0	0	<p>The highest level error is reported at the end of transfer. Retries and error correction are attempted. Recovered and/or corrected data (if any) is transferred with CHECK CONDITION status and RECOVERED ERROR Sense Key set at the end of the transfer.</p> <p><b>no err</b> The transfer length is exhausted.</p> <p><b>soft err</b> The transfer stops on the first soft error detected. The information in the sense data shall contain the LBA of the block in error.</p> <p><b>hard err</b> Data transfer stops on the unrecoverable error. The file then creates the CHECK CONDITION status with the appropriate Sense Key.</p>
1	1	0	1	<p>The highest level error is reported at the end of transfer. Retries and error correction are attempted. Recovered and/or corrected data (if any) is transferred with CHECK CONDITION status and RECOVERED ERROR Sense Key set at the end of the transfer.</p> <p><b>no err</b> The transfer length is exhausted.</p> <p><b>soft err</b> The transfer stops on the first soft error detected. The information in the sense data shall contain the LBA of the block in error.</p> <p><b>hard err</b> Data transfer stops on the unrecoverable error. The unrecoverable error block is returned to the initiator. The file then creates the CHECK CONDITION status with the appropriate Sense Key.</p>
1	1	1	0	<p>The highest level error is reported at the end of transfer. Retries are attempted but ECC is not applied. Recovered data is transferred with CHECK CONDITION status and RECOVERED ERROR Sense Key set at the end of the transfer.</p> <p><b>no err</b> The transfer length is exhausted.</p> <p><b>soft err</b> The transfer stops on the first soft error detected. The recovered error block is returned to the initiator. The information in the sense data shall contain the logical block address of the block in error.</p> <p><b>hard err</b> Data transfer stops on the unrecoverable error. The file then creates the CHECK CONDITION status with the appropriate Sense Key.</p>
1	1	1	1	<p>The highest level error is reported at the end of transfer. Retries are attempted but ECC is not applied. Recovered and/or corrected data (if any) is transferred with CHECK CONDITION status and RECOVERED ERROR Sense Key set at the end of the transfer.</p> <p><b>no err</b> The transfer length is exhausted.</p> <p><b>soft err</b> The transfer stops on the first soft error detected. The information in the sense data shall contain the logical block address of the block in error.</p> <p><b>hard err</b> Data transfer stops on the unrecoverable error. The unrecoverable error block is returned to the initiator. The file then creates the CHECK CONDITION status with the appropriate Sense Key.</p>

### 7.11.3 Page 2 (Disconnect/Reconnect Parameters)

		BIT							
		7	6	5	4	3	2	1	0
BYTE 0	PS	RSVD=0	Page Code = 02h						
BYTE 1	Page Length = 0Ah								
BYTE 2	Read Buffer Full Ratio								
BYTE 3	Write Buffer Empty Ratio								
BYTE 4 – 15	Reserved = 0								

Figure 65. Page 2

Changeable Parameter	Default Value
<b>Read Buffer Full Ratio</b>	00h
<b>Write Buffer Empty Ratio</b>	00h

The disconnect / reconnect page provides the initiator the means to tune the performance of the SCSI bus.

An initiator may use the IDENTIFY message to grant the file the general privilege of disconnecting. (Disconnect requests may still be selectively rejected by the initiator by issuing a MESSAGE REJECT).

The file uses the disconnect/reconnect parameters to control reconnection during READ ( operation code 08h and 28h) and WRITE ( 0Ah , 2Ah and 2E).

- **Read Buffer Full Ratio** is the numerator of a fraction whose denominator is 256. The fraction indicates how full the file data buffer should be before attempting to reconnect to the SCSI bus. If the ratio is set to 0h, the target will calculate and use an optimal ratio based on the negotiated transfer rate.
- **Write Buffer Empty Ratio** is the numerator of a fraction whose denominator is 256. The fraction indicates how empty the file data buffer should be before attempting to reconnect to the SCSI bus. If the ratio is set to 0h, the target will calculate and use an optimal ratio based on the negotiated transfer rate.

Both the Read Buffer Full Ratio and the Write Buffer Empty Ratio pertain to the current active zone. For each active zone, as defined in page 0Ch, there are separate Read Buffer Full Ratios and Write Buffer Empty Ratios. When the active zone is zero, the values are applied across all zones.

#### 7.11.3.1 Reconnection to a disconnected read command

For a read command, the reconnect is delayed relative to the availability of the first block in the file data buffer by the fraction of the file data buffer size. If the remaining data transfer length is less than the fraction of the file data buffer size, the file control program calculates the optimal reconnection point to complete the data transfer as early as possible while minimizing the time connected to the SCSI bus.

### **7.11.3.2 Reconnection to a disconnected write command**

For a write command, the Write Buffer Ratio is significant only if the total data transfer length is greater than the size of the file data buffer. The fraction determines how empty the file data buffer should be before reconnecting to begin filling the buffer again.

### 7.11.4 Page 3 (Format Device Parameters)

		BIT							
		7	6	5	4	3	2	1	0
BYTE 0	PS = 0	RSVD=0	Page Code = 03h						
BYTE 1	Page Length = 16h								
BYTE 2	(MSB)	Tracks per Zone = 3EC7h (DORS31080)							
BYTE 3		82EBh (DORS32160)							(LSB)
BYTE 4	(MSB)	Alternate Sectors per Zone = 0							
BYTE 5									(LSB)
BYTE 6	(MSB)	Alternate Tracks per Zone = 0							
BYTE 7									(LSB)
BYTE 8	(MSB)	Alternate Tracks per Logical Unit = 0							
BYTE 9									(LSB)
BYTE 10	(MSB)	Sectors per Track = 7Dh							
BYTE 11									(LSB)
BYTE 12	(MSB)	Data Bytes per Physical Sector = 0200h							
BYTE 13									(LSB)
BYTE 14	(MSB)	Interleave = 1							
BYTE 15									(LSB)
BYTE 16	(MSB)	Track Skew Factor = 15h							
BYTE 17									(LSB)
BYTE 18	(MSB)	Cylinder Skew Factor = 27h							
BYTE 19									(LSB)
BYTE 20	SSEC	HSEC	RMB	SURF	RESERVED				
BYTE 21-23	RESERVED								

Figure 66. Page 3

The format device page contains parameters which specify the medium format. This page contains no changeable parameters.

**Tracks per Zone** indicates the number of tracks of the zone which is specified by 7.11.9, “Page 0C (Zone Parameters)” on page 104. In case all zone is specified, the mean value of the eight zones is indicated.

Values 0 are indicated in the following items, because all spare sectors are located after data zone.

- Alternate Sectors per Zone
- Alternate Tracks per Zone
- Alternate Tracks per Logical Unit

**Sectors per Track** indicates the number of physical sectors within each track. This field is a function of the active zone which is specified by 7.11.9, "Page 0C (Zone Parameters)" on page 104. In case all zone is specified, the mean value of the eight zones is indicated.

**Track Skew Factor** indicates the number of physical sectors between the last block of one track and the first block on the next sequential track of the same cylinder. This field is a function of the active zone which is specified by 7.11.9, "Page 0C (Zone Parameters)" on page 104. In case all zone is specified, the mean value of the eight zones is indicated.

**Cylinder Skew Factor** indicates the number of physical sectors between the last block of one cylinder and the first block on the next sequential cylinder. This field is a function of the active zone which is specified by 7.11.9, "Page 0C (Zone Parameters)" on page 104. In case all zone is specified, the mean value of the eight zones is indicated.

**SSEC** = Zero indicates that the file does not support soft sector formatting.

**HSEC** = One indicates that the file supports hard sector formatting.

**RMB** = Zero indicates that the media does not support removable. Fixed Disk.

**SURF** = Zero indicates that progressive address are assigned to all logical blocks a cylinder prior to allocating address within the next cylinder.

## 7.11.5 Page 4 (Rigid Disk Drive Geometry Parameters)

		BIT							
		7	6	5	4	3	2	1	0
BYTE 0	RSVD = 0	Page Code = 04h							
BYTE 1	Page Length = 16h								
BYTE 2	(MSB)	Number of Cylinders = 14EDh (DORS31080)							
BYTE 4		= 1A2Fh (DORS32160)							
		(LSB)							
BYTE 5	Number of Heads = 3 (DORS31080)								
		= 5 (DORS32160)							
BYTE 6	(MSB)	Starting Cylinder-Write Precompensation = 0							
BYTE 8		(LSB)							
BYTE 9	(MSB)	Starting Cylinder-Reduced Write Current = 0							
BYTE 11		(LSB)							
BYTE 12	(MSB)	Drive Step Rate (Not used)							
BYTE 13		(LSB)							
BYTE 14	(MSB)	Landing Zone Cylinder (Not used)							
BYTE 16		(LSB)							
BYTE 17	RESERVED							RPL = 0	
BYTE 18	Rotational Offset = 00 (Not used)								
BYTE 19	RESERVED								
BYTE 20	(MSB)	Medium Rotation Rate = 1518h							
BYTE 21		(LSB)							
BYTE 22	RESERVED								
BYTE 23									

Figure 67. Page 4

The rigid disk drive geometric page specifies various parameters for the file.

**RPL** Zero. Indicates that the file does not support spindle synchronization.

## 7.11.6 Page 7 (Verify Error Recovery Parameters)

		BIT							
		7	6	5	4	3	2	1	0
BYTE 0	PS	RSVD=0	Page Code = 07h						
BYTE 1	Page Length = 0Ah								
BYTE 2	Reserved = 0				EER=0	PER	DTE=0	DCR	
BYTE 3	Verify Retry Count								
BYTE 4	Correction Span = 00h								
BYTE 5	Reserved = 0								
BYTE 6	Reserved = 0								
BYTE 7	Reserved = 0								
BYTE 8	Reserved = 0								
BYTE 9	Reserved = 0								
BYTE 10	(MSB)								
BYTE 11	Verify Recovery Time Limit (Not Used)								
									(LSB)

Figure 68. Page 7

Changeable Parameter	Default Value
<b>PER</b>	0
<b>DCR</b>	0
<b>Verify Retry Count</b>	01h

The Verify recovery parameters are used by the Target when recovering from and reporting errors associated with the verification of the initiator's Data for the following commands:

- Verify
- Write and Verify - the verify portion of the command only.

Since bytes 4-11 are not changeable, the Mode Select Commands accepts only the values indicated for bytes 4 - 11.

- **EER**, This bit is 0 since the Target does not support early recovery.
- **PER**, See below for description of bit values.
- **DTE**, This bit is 0 since the Target always continues on recovered verify operation errors.
- **DCR**, See below for description of bit values.



PER, DTE, and DCR bit settings in page 7 override those of page 1 during Verify and the Verify portion of Write and Verify. There are only four valid conditions for the PER, DTE, and DCR bits. All other combinations return Check Condition Status.

PER	DTE	DCR	DESCRIPTION
0	0	0	Soft errors are not reported. ECC is applied to recover the data.
1	0	0	Soft errors are reported. ECC is applied to recover the data.
0	0	1	Soft errors are not reported. ECC is not used to recover the data.
1	0	1	Soft errors are reported. ECC is not used to recover the data.

- **Verify Retry Count** sets a limit on the amount of verify recovery procedure (VRP) passes the Target attempts when recovering verify errors. The Verify Retry Count of one causes the Target to attempt up to one VRP pass per command when a medium error occurs during a verify operation. Only values of 0h and 01h are valid. The value of 0h disables all recovery.
- **Verify Correction Span** field specifies the size, in bits, of the largest data error burst for which data error correction may be attempted. The field may be set to any value but the file will not use offline correction during verify operations.

## 7.11.7 Page 8 (Caching Parameters)

		BIT							
		7	6	5	4	3	2	1	0
BYTE 0	PS	RSVD=0	Page Code = 08h						
BYTE 1	Page Length = 0Ch								
BYTE 2	RESERVED = 0					WCE	MF	RCD	
BYTE 3	Read Retention Priority=0				Write Retention Priority=0				
BYTE 4-5	Disable Pre-fetch Transfer Length								
BYTE 6-7	Minimum Pre-fetch								
BYTE 8-9	Maximum Pre-fetch								
BYTE 10-11	Maximum Pre-fetch Ceiling								
BYTE 12	RESERVED = 0								
BYTE 13	Number of Cache Segments								

Figure 69. Page 8

Changeable Parameter	Default Value
<b>WCE</b>	1
<b>MF</b>	0
<b>RCD</b>	0
<b>Disable Pre-fetch transfer length</b>	0
<b>Minimum Pre-fetch</b>	0
<b>Maximum Pre-fetch</b>	0
<b>Maximum Pre-fetch Ceiling</b>	0
<b>Number of Cache Segments</b>	7

The caching parameters page defines parameters that affect the use of the cache.

- **WCE**, Write Cache Enable bit, is set to zero to indicate that the drive must issue Good Status for Write(6) or Write extend(10) command only after successfully writing the data to the media. A WCE bit of one indicates that the drive may issue Good Status for a Write(6) or Write extend(10) command after successfully receiving the data but before writing it to the media.

**Note:** When WCE = 1, a Synchronize Cache command must be done to assume data is written to the media before powering down the Target.

- **MF**, Multiplication Factor determines how the Maximum Pre-fetch field is interpreted. When this bit is set the data to pre-fetch is given by the command length multiplied by the value in the Maximum Pre-fetch field. When this bit is reset the value in the Maximum pre-fetch field is used as the absolute length to pre-fetch.
- **RCD**, Read Cache Disable bit, of zero indicates that the file may return data requested by a READ command by accessing either the cache or the Read Ahead Buffer, or media. A RCD bit of one indicates that the file shall transfer all data requested by a READ command by accessing the media (i.e., data cannot be transferred from the cache or Read Ahead Buffer).
- **Read Retention Priority**, Demand Read Retention Priority is not supported.
- **Write Retention Priority**, Write Retention Priority is not supported.
- **Disable Pre-fetch Transfer Length** specifies a number of LBA's which if a read command length exceeds will cause the drive not to perform read ahead buffering after the command has completed. A value of zero specifies read ahead is disabled.
- **Minimum Pre-fetch** specifies the minimum number of LBA's that the drive should read ahead after each read command. A value of zero indicates that read ahead should be terminated immediately a new command arrives, except in the case when the new command is on the current head and track.
- **Maximum Pre-fetch** specifies the maximum number of LBA's to read ahead after a read command. This field can either be used as an absolute value, if the MF bit is 0, or else it will be multiplied by the read command length to give the actual length to read ahead.
- **Maximum Pre-fetch ceiling** specifies the maximum number of blocks the drive should attempt to read ahead. It is particularly relevant when the MF bit is set. A value of zero indicates no limit.
- **Number of Cache Segments** This field is used to indicate to the drive how many segments are requested by the initiator. This field is ignored internally. **Number of segments can not be changed. Number of segments are always 7, and the Segment size is 64KB.** However it is allowed to be modified by the initiator for host system device driver compatibility.

## 7.11.8 Page A (Control Mode Page Parameters)

		BIT								
		7	6	5	4	3	2	1	0	
BYTE	0	PS	RSVD=0	Page Code = 0Ah						
BYTE	1	Page Length = 6								
BYTE	2	RESERVED = 0							RLEC = 0	
BYTE	3	Queue Algorithm Modifier			RESERVED = 0		QErr	DQue		
BYTE	4	EECA = 0	RESERVED = 0			RAENP = 0	UAAENP = 0	EAENP = 0		
BYTE	5	RESERVED = 0								
BYTE	6	Ready AEN Holdoff Period = 0								
BYTE	7									

Figure 70. Page A

Changeable Parameter	Default Value
<b>Queue Algorithm Modifier</b>	0
<b>QErr</b>	0
<b>DQue</b>	0

Following are parameter options for Page 0A of MODE SELECT.

- Queue algorithm modifier** specifies restrictions on the algorithm used for re-ordering commands that are tagged with the SIMPLE QUEUE TAG message.
  - 0h : Restricted re-ordering. The target shall re-order the actual execution sequence of the queued commands from each initiator such that data integrity is maintained for that initiator.
  - 1h : Un-restricted re-ordering allowed. The target may re-order the actual execution sequence of the queued commands in any manner it selects. Any data integrity exposures related to command sequence order are explicitly handled by the initiator through the selection of appropriate commands and queue tag messages.
  - 2h-7h : RESERVED.
  - 8 Command re-ordering is disabled
  - 9-Fh : RESERVED
- QErr**, Queue Error Management, bit of zero specifies that the Target suspends execution of queued and active commands from any Initiator which receives a Check Condition Status until pending sense data is cleared. Those commands still queued after the Target has returned Check Condition Status, continue execution in a normal manner when the pending status is cleared. A QErr bit of one specifies that all active commands and all queued commands from all initiators are aborted when the Target returns the Check Condition Status. A unit attention condition will be generated for each initiator which had commands in the queue except the initiator that received the Check Condition Status. The sense key will be set to Unit Attention and the additional sense code will be set to COMMANDS CLEARED BY ANOTHER INITIATOR.

- **DQue**, Disable Queuing, bit of zero specifies that tagged queuing shall be enabled if the target supports tagged queuing. A DQue bit of one specifies that tagged queuing shall be disabled. Any queue commands for that I\_T\_L nexus shall be aborted. Any subsequent queue tag message received shall be rejected with a MESSAGE REJECT message and I/O process shall be executed as an untagged command.

## 7.11.9 Page 0C (Zone Parameters)

		BIT							
		7	6	5	4	3	2	1	0
BYTE 0	PS	RSVD=0	Page Code = 0Ch						
BYTE 1	Page Length = 16h								
BYTE 2	ND = 1	LPN = 0	RSVD = 0						
BYTE 3	Reserved = 0								
BYTE 4	(MSB)	Maximum Number of Zones = 7 (DORS31080)							
BYTE 5		= 8 (DORS32160)							
		(LSB)							
BYTE 6	(MSB)	Active Zone							
BYTE 7		(LSB)							
BYTE 8	(MSB)	Starting Boundary							
BYTE 11		(LSB)							
BYTE 12	(MSB)	Ending Boundary							
BYTE 15		(LSB)							
BYTE 16	(MSB)	Pages Zoned =							
BYTE 23		000000000000100Ch							
		(LSB)							

Figure 71. Page 0C

The zone page contains parameters for direct-access devices which implement a variable number of blocks per cylinder. Each section of the logical unit with a different number of blocks per cylinder is referred as a zone. The only field that is changeable is the **Active Zone** field.

**ND** = ONE meaning that this device is a zoned drive.

**LPN** = ZERO meaning that the zones are based upon physical parameters of the drive (cylinder#), not logical parameters.

**Maximum Number of Zones** is the number of zones the drive can support.

**Active Zone** indicates which zone subsequent Mode Select/Sense command parameters pertain to. A value of 0 is used for parameter values which apply to all zones. Values from 1 to the maximum value depending on the model specify the zone number, where zone 1 is the outer most zone.

Following mode parameters are based on the current active zone:

- Page 2
  - Read Buffer Full Ratio

- Write Buffer Empty Ratio
- Page 3
  - Alternate Sector per Zone
  - Alternate Track per Zone
  - Alternate Track per Logical Unit
  - Sector per Track
  - Track Skew Factor
  - Cylinder Skew Factor

**Starting Boundary** contains the first physical location of the active zone. The first three bytes are the cylinder number and the last byte is the head. The value sent in this field is ignored.

**Ending Boundary** contains the last physical location of the active zone. The first three bytes are the cylinder number and the last byte is the head. The value sent in this field is ignored.

**Pages Zoned** is a bit map of the mode page codes that indicates which pages contain parameters that may be different for different zones. The most significant bit of this field corresponds to page code 3Fh and the least significant bit corresponds to page code 00h. If a bit is one, then the corresponding mode page contains parameters that may be different for different zones. If a bit is zero, then the corresponding mode page contains parameters that are constant for all zones.

## 7.11.10 Page 1C (Informational Exceptions Control) ( PFA / S.M.A.R.T.)

The informational exceptions control page defines the methods used by the target to control the reporting and the operations of specific informational exception conditions. This page shall only apply to informational exceptions that report an additional sense code of FAILURE PREDICTION THRESHOLD EXCEEDED to the application client.

Informational exception conditions occur as the result of vendor specific events within a target. An informational exception condition may occur asynchronous to any commands issued by an application client.

		BIT							
		7	6	5	4	3	2	1	0
BYTE 0	PS	RSVD=0	Page Code = 1Ch						
BYTE 1	Page Length = 0Ah								
BYTE 2	PERF = 0	Reserved = 0			DEXCPT	Reserved = 0		LOGERR = 0	
BYTE 3	Reserved = 0				Method of Reporting				
BYTE 4	(MSB)								
BYTE 5	Interval Timer = 0								
BYTE 6									
BYTE 7									
BYTE 8	(MSB)								
BYTE 9	Report Count								
BYTE 10									
BYTE 11									

Figure 72. Page 1C

Changeable Parameter	Default Value
<b>DEXCPT</b>	0
<b>Method of Reporting</b>	0
<b>Report Count</b>	0

- **LOGERR** (Log Errors) is not used.
- **DEXCPT** (Disable Exception Control) bit of zero indicates information exception operations is enabled. The reporting of information exception conditions when the DEXCPT bit is set to zero is determined from the Method of Reporting field. A DEXCPT bit of one indicates the Target disable all information exception operations including the file idle time function which saves the log select counters. If this bit is set these counters are not written to disk and so will be lost at the next power cycle.



- **PERF** (Performance) bit is not used.
- **Method of Reporting** indicates the methods used by the Target to report informational exception conditions.

**Code Description**

**0h No reporting of informational exception condition.**

This method instructs the target to not report information exception conditions.

**1h Not supported.**

**2h Generate unit attention.**

Key=6, Code=5D, Qualifire=00 are generated for the reporting.

This method instructs the target to report informational exception conditions by returning a CHECK CONDITION stsus on any command. The sense key shall be set to UNIT ATTENTION and the additional sense code shall indicate the cause of the informational exception condition.

The command that has the CHECK CONDITION shall not be excuted before the informational exception condition is reported.

**3h Conditionally generate recovered error.**

Key=1, Code=5D, Qualifire=00 are generated for the reporting.

This method instructs the target to report informational exception conditions, dependent on the value of the **PER** bit of the error recovery parameters mode page, by returning a CHECK CONDITION stsus on any command. The sense key shall be set to RECOVERED ERROR and the additional sense code shall indicate the cause of the informational exception condition.

The command that has the CHECK CONDITION shall complete without error before any informational exception condition may be reported.

**4h Unconditionally generate recovered error.**

Key=1, Code=5D, Qualifire=00 are generated for the reporting.

This method instructs the target to report informational exception conditions, regardless of the value of the **PER** bit of the error recovery parameters mode page, by returning a CHECK CONDITION stsus on any command. The sense key shall be set to RECOVERED ERROR and the additional sense code shall indicate the cause of the informational exception condition.

The command that has the CHECK CONDITION shall complete without error before any informational exception condition may be reported.

**5h Generate no sense.**

Key=0, Code=5D, Qualifire=00 are generated for the reporting.

This method instructs the target to report informational exception conditions, by returning a CHECK CONDITION stsus on any command. The sense key shall be set to NO SENSE and the additional sense code shall indicate the cause of the informational exception condition.

The command that has the CHECK CONDITION shall complete without error before any informational exception condition may be reported.

**6h Only report informational exception condition on request.**

Key=0, Code=5D, Qualifire=00 are generated for the reporting.

This method instructs the target to preserve the informational exception(s) information. To find out about information exception conditions the Application Client polls the target by issuing an unsolicited REQUEST SENSE command. The sense key shall be set to NO SENSE and the additional sense code shall indicate the cause of the informational exception condition.

**7h-Fh Reserved.**

- **Interval Timer** is not supported. Must be zero.
- **Report Count** of ZERO indicates no limits on the number of times the target reports an informational exception condition. Report Count of 1 indicates the target only reports an informational exception condition once.

## 7.11.11 Page 38 (Power Control)

		BIT							
		7	6	5	4	3	2	1	0
BYTE	0	PS	RSVD	Page Code = 038h					
BYTE	1	Page Length = 04h							
BYTE	2	Reserved = 0							
BYTE	3	Automatic Shutdown Time							
BYTE	4	Reserved = 0							
BYTE	5	Reserved = 0							

Figure 73. Page 38h

Changeable Parameter	Default Value
<b>Automatic Shutdown Time</b>	0

- **Automatic Shutdown Time** is the value loaded into the timer after a command completes. If the timer expires before the next command arrives then the drive will enter a **standby mode** with the motor stopped. The next command will restart the motor automatically. A value of zero disables the timer. It is specified in units of minutes.

Drive response during the Automatic Shut Down is as follows.

- Read
  - In case of cache hit, the data is sent.
  - In case of cache not hit, disconnected after the command received.
- Write
  - Data are received till the cache becomes full. Disconnected when the buffer was filled up. (Disconnected time is around 17-18 seconds.)
- Test Unit Ready
  - Ready

## 7.12 PRE-FETCH (34)

Byte	Bit							
	7	6	5	4	3	2	1	0
0	Command Code = 34h							
1	LUN			Reserved = 0			Immed = 0	RelAdr = 0
2 3 4 5	(MSB) Logical Block Address							(LSB)
6	Reserved = 0							
7 8	(MSB) Transfer Length							(LSB)
9	VU = 0	Reserved = 0				FLAG	LINK	

Figure 74. Pre-Fetch (34)

The PRE-FETCH command requests the file to transfer data to the cache. No data is transferred to the initiator.

**Transfer length** The transfer length field specifies the number of contiguous blocks of data that are to be transferred into the cache. A transfer length of zero indicates that blocks are to be transferred into the cache until the segment is filled or there are no more blocks on the media.

**Immed** (Immediate) must be zero. An immediate bit of zero indicates that the status shall not be returned until the operation has completed.

If the Immed bit is set to one, the drive returns a Check Condition status. The sense key shall be set to Illegal Request and the additional sense code shall be set to Invalid Field in CDB.

**RelAdr** Relative Block Address is not supported. Must be set to zero.

---

## 7.13 READ (08)

---

Byte	Bit							
	7	6	5	4	3	2	1	0
0	Command Code = 08h							
1	LUN			(MSB)	LBA			
2	Logical Block Address (LSB)							
3								
4	Transfer Length							
5	VU = 0	Reserved = 0				FLAG	LINK	

---

Figure 75. READ (08)

The READ command requests the file to transfer the specified number of blocks of data to the initiator starting at the specified logical block address.

**Logical block address** This field specifies the logical unit at which the read operation shall begin.

**Transfer length** This field specifies the number of blocks to be transferred. A value of zero implies 256 blocks are to be transferred.<sup>2</sup>

**Note:** Errors are handled by ERP(error recovery procedure). ERPs are controlled by the error recovery parameters specified by MODE SELECT command.

---

<sup>2</sup> Block is 512 bytes in length.

## 7.14 READ CAPACITY (25)

Byte	Bit							
	7	6	5	4	3	2	1	0
0	Command Code = 25h							
1	LUN			Reserved = 0				RelAdr = 0
2	(MSB) Logical Block Address (LSB)							
3								
4								
5								
6	Reserved = 0							
7								
8								
9	VU = 0	Reserved = 0				FLAG	LINK	

Figure 76. READ CAPACITY (25)

The READ CAPACITY command returns information regarding the capacity of the file.

- **Logical Block Address** is used in conjunction with the PMI bit.
- **RelAdr.** A Relative Address is not supported. Must be set to zero.
- **PMI**, Partial Medium Indicator indicates;

PMI	Description
0	The drive returns the last logical block address of the file.
1	The drive returns the last logical block address and block length in bytes are that of the logical block address after which a substantial delay in data transfer will be encountered. This returned logical block address shall be greater than or equal to the logical block address specified by the RelAdr and logical block address fields in the command descriptor block. This option provides the information the initiator needs to determine the amount of space available on the same track which is accessible without a head switch or seek.

### 7.14.1.1 Returned Data Format

The data returned to the initiator in response to the READ CAPACITY command is described here. The data is returned in the DATA IN phase.

---

	7	6	5	4	3	2	1	0
BYTE 0	(MSB)							
BYTE 1								
BYTE 2								
BYTE 3								(LSB)
BYTE 4	(MSB)							
BYTE 5								
BYTE 6								
BYTE 7								(LSB)

---

Figure 77. Format of READ CAPACITY command reply

- **Block Length** specifies the length in bytes of the block. It is set to 512.

## 7.15 READ DEFECT DATA (37)

Byte	Bit							
	7	6	5	4	3	2	1	0
0	Command Code = 37h							
1	LUN			Reserved = 0				0
2	Reserved = 0			Plist	Glist	Defect List Format		
3	Reserved = 0							
4								
5								
6								
7	(MSB)	Allocation Length						(LSB)
8								
9	VU = 0	Reserved = 0				FLAG	LINK	

Figure 78. Read Defect Data (37)

The READ DEFECT DATA command requests that the Target transfers the medium defect data to the initiator.

If the target is unable to access any medium defect data it will return a Check Condition status with the appropriate sense key. The sense key will be set to either Medium Error(03h) if a medium error occurred or No Sense(00h) if the list does not exist and the additional sense code will be set to Defect List Error(19h).

**Plist** The Primary Defect List (Plist) bit set to one indicates that the target returns the primary list of defects. A Plist bit of zero indicates that the target shall not return the Primary Defect list of defects.

**Glist** The Grown Defect List (Glist) bit set to one indicates that the target returns the grown defect list. A Glist bit of zero indicates that the target shall not return the Grown Defect list of defects.

**Note:** With both bits set to one Plist and Glist the target will return both the Primary and Grown defect lists. With both bits set to zero, the target will return only a four-byte Defect List Header.

**Defect List format** The Defect List Format Field is used by the initiator to indicate the preferred format for the defect list.

The Defect List Format of '100 (Bytes from Index Format)' and '101 (Physical Sector Format)' are supported. If the requested format is not supported by the file, it will return the defect list in its default format '101' then terminates the command with Check Condition status. The sense key will be set to Recovered Error (01h) and the additional sense code will be set to Defect List Not Found(1Ch).

The file sends defect list (Defect Descriptors) in a four byte ABA (Absolute Block Address) format which follows a four byte Defect List Header.

The target will transfer all of the Read Defect Data up to the number of bytes allocated by the initiator.



**Note:** The file will terminate the Data In phase when the Allocation Length has been transferred or when all available Defect Data has been transferred to the initiator, whichever is less.

The Read Defect Data contains a four byte header, followed by zero or more defect descriptors.

### 7.15.1 Defect List Header

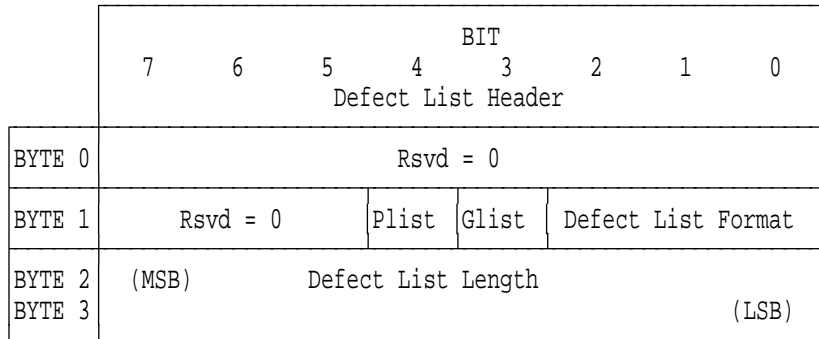

Figure 79. Defect List Header

### 7.15.2 Bytes from Index Format (100b)

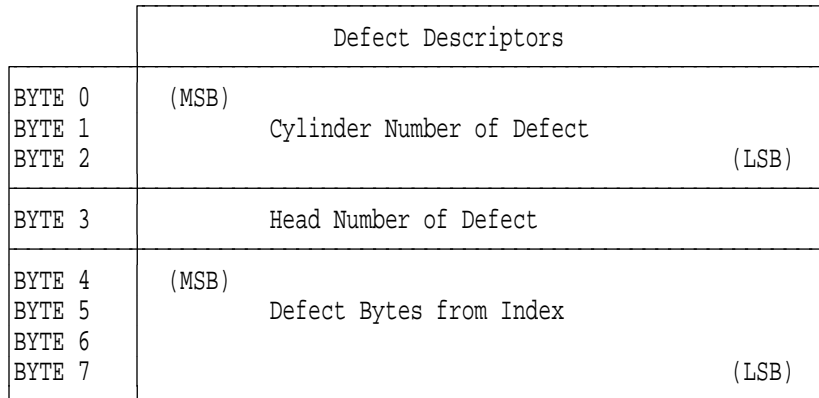

Figure 80. Defect Descriptors of Bytes from Index Format

Defect Bytes from Index is gotten using the following equation:

$$\text{Bytes from Index} = (\text{Physical Sector Number}) * N$$

Where: N = Bytes per sector (512 Bytes)

### 7.15.3 Physical Sector Format (101b)

---

Defect Descriptors	
BYTE 0	(MSB)
BYTE 1	Cylinder Number of Defect
BYTE 2	(LSB)
BYTE 3	Head Number of Defect
BYTE 4	(MSB)
BYTE 5	Defective Sector Number
BYTE 6	
BYTE 7	(LSB)

---

Figure 81. Defect Descriptors of Physical Sector Format

The defect list format field specifies the format of the defect list data returned by the target.

The Defect List Length field specifies the length in bytes of the defect descriptors that follow. The Defect List Length is equal to eight times the number of defect descriptors.

If the Allocation Length is insufficient to transfer all of the defect descriptors, the Defect List Length will not be adjusted to reflect the truncation. The target will not create a CHECK CONDITION status.

## 7.16 READ EXTENDED (28)

Byte	Bit							
	7	6	5	4	3	2	1	0
0	Command Code = 28h							
1	LUN			DPO = 0	FUA = 0	Reserved = 0		RelAdr = 0
2	(MSB) Logical Block Address (LSB)							
3								
4								
5								
6	Reserved = 0							
7	(MSB) Transfer Length (LSB)							
8								
9	VU = 0	Reserved = 0				FLAG	LINK	

Figure 82. Read Extended (28)

The READ EXTENDED command requests the file to transfer data to the initiator. The larger Logical Block Address and Transfer Length fields permit greater quantities of data to be requested per command than with the READ command and are required to access the full LBA range of the larger capacity drives.

**Transfer length** The number of contiguous blocks to be transferred. If the transfer length is zero, the seek occurs, but no data is transferred. This condition is not considered an error. If read ahead is enabled, a read ahead is started after the seek completes.

**DPO** Disable Page Out is not supported. Must be set to zero.

**FUA** Force Unit Access is not supported. Must be set to zero.

**RelAdr** Relative Block Address is not supported. Must be set to zero.

## 7.17 READ BUFFER (3C)

Byte	Bit							
	7	6	5	4	3	2	1	0
0	Command Code = 3Ch							
1	LUN			Reserved = 0		Mode		
2	Buffer ID = 0							
3	(MSB) Buffer Offset (LSB)							
4								
5								
6	(MSB) Allocation Length (LSB)							
7								
8								
9	VU = 0		Reserved = 0			FLAG	LINK	

Figure 83. READ BUFFER (3C)

The READ BUFFER command is used in conjunction with the WRITE BUFFER command as a diagnostic function for testing the file's memory and the SCSI bus integrity. This command does not alter the medium.

The function of this command and the meaning of fields within the command descriptor block depend on the contents of the mode field.

### MODE Description

**000** Read combined header and data

**010** Data

**011** Descriptor

**All others** Not supported.

### 7.17.1 Combined Header And Data (Mode 000)

In this mode, a four byte header followed by data bytes are returned to the initiator during the DATA IN phase. The Buffer ID and the buffer offset field are reserved.

The file terminates the DATA IN phase when allocation length bytes of header plus data have been transferred or when the header and all available data have been transferred to the initiator, whichever is less.

The four-byte READ BUFFER header (Figure 84 on page 119) is followed by data bytes from the file's data buffer.

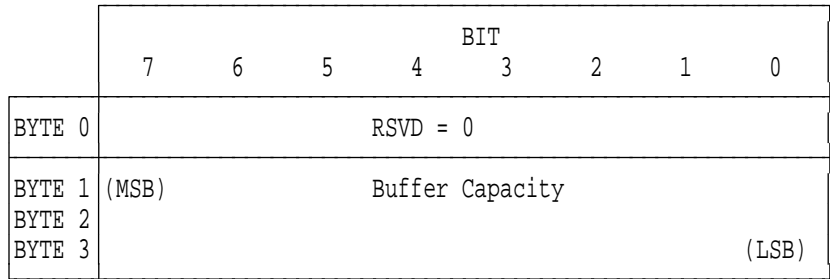

Figure 84. READ BUFFER Header

The buffer capacity specifies the total number of data bytes that are available in the file's data buffer. This number is not reduced to reflect the allocation length nor is it reduced to reflect the actual number of bytes written using the WRITE BUFFER command.

Following the READ BUFFER header, the file will transfer data from its data buffer.

### 7.17.2 Read Data (Mode 010b)

In this mode, the DATA IN phase contains buffer data.

**Buffer ID** field must be set to zero, indicating the data transfer buffer. If another value is specified, the command is terminated with CHECK CONDITION status. File shall set sense key to ILLEGAL REQUEST and additional sense code to ILLEGAL FIELD IN CDB.

**Buffer Offset** specifies the offset of the memory space specified by the Buffer ID. The initiator should conform to the offset boundary requirements returned in the READ BUFFER descriptor. If the value exceeds the buffer specified, the command is terminated with CHECK CONDITION status. File shall set sense key to ILLEGAL REQUEST and additional sense code to ILLEGAL FIELD IN CDB.

**Allocation Length** The file terminates the DATA IN phase when allocation length bytes of data have been transferred or when the header and all available data have been transferred to the initiator, whichever is less.

### 7.17.3 Descriptor (Mode 011b)

In this mode, a maximum of four bytes of READ BUFFER descriptor information are returned. The file returns the descriptor information for the buffer specified by the Buffer ID.

**Buffer ID** field should normally be set to zero indicating the file data transfer buffer. If any other value is specified the file returns all zeros in the READ BUFFER descriptor.

**Buffer Offset** field is reserved.

**Allocation Length** must be set to four or greater. The file transfers the lesser of the allocation length or four bytes of READ BUFFER descriptor. The READ BUFFER descriptor is defined in Figure 85 on page 120.

	7	6	5	4	3	2	1	0
BYTE 0	Offset Boundary							
BYTE 1 (MSB)	Buffer Capacity							
BYTE 2								
BYTE 3	(LSB)							

Figure 85. READ BUFFER DESCRIPTOR

The value contained in the Buffer Offset field of subsequent WRITE BUFFER and READ BUFFER commands should be a multiple of two to the power of the offset boundary. The offset boundary is always set to nine, which indicates Sector(512 bytes) Boundaries.

## 7.18 READ LONG (3E)

Byte	Bit							
	7	6	5	4	3	2	1	0
0	Command Code = 3Eh							
1	LUN			Reserved = 0			CORT = 0	RelAdr = 0
2	(MSB) Logical Block Address (LSB)							
3								
4								
5								
6	Reserved = 0							
7	(MSB) Byte Transfer Length (LSB)							
8								
9	VU = 0	Reserved = 0				FLAG	LINK	

Figure 86. READ LONG (3E)

The READ LONG command requests the file to transfer **one block** of data to the initiator. The transfer data includes 512 bytes of data and ECC field data.

- **CORT** bit of ZERO causes the logical block to be read without any correction made by the file. A CORT bit of one is not supported by the Target (A corrected bit of one causes the data to be corrected by ECC before transferring the data to the initiator).
- **Logical Block Address** field specifies the logical block at which the read operation shall occur.
- **Byte Transfer Length.** This field must exactly specify the number of bytes of data that are available for transfer. If a non-zero byte transfer length does not match the available data length, the target terminates the command with CHECK CONDITION status, the sense key is set to ILLEGAL REQUEST and an additional sense code set to INVALID FIELD IN CDB. The valid and ILI bits is set to one and the information field is set to the difference of the requested length minus the actual length in bytes. Negative values is indicated by two's complement notation.

The transfer length is calculated as follows:

$$\text{transfer length} = \text{logical block size} + 20$$

- **RelAdr** Relative Block Address is not supported by the file.

---

## 7.19 REASSIGN BLOCKS (07)

---

Byte	Bit							
	7	6	5	4	3	2	1	0
0	Command Code = 07h							
1	LUN			Reserved = 0				
2	Reserved = 0							
3								
4								
5	VU = 0	Reserved = 0				FLAG	LINK	

---

Figure 87. REASSIGN BLOCKS (07)

The REASSIGN BLOCKS command requests the file to reassign a logical block to an available spare. The REASSIGN BLOCKS command attempts to allocate spare blocks on a spare track. The logical block address is transferred to the file during the DATA OUT phase. One to four block(s) may be specified for relocation per REASSIGN BLOCKS command.

Reassignment is complete upon the completion of the REASSIGN BLOCKS command. At this time, the defective logical block address has been added to the grown (“G” list) defect list.

Data contained at the logical block address being reassigned is not preserved by the file, and is filled with a constant pattern.

Following is the format of the data sent by the initiator during the DATA OUT phase:



	BIT							
	7	6	5	4	3	2	1	0
BYTE 0	RSVD = 0							
BYTE 1	RSVD = 0							
BYTE 2 BYTE 3	(MSB) Defect list length = 4/8/12/16 (LSB)							
BYTE 4 BYTE 5 BYTE 6 BYTE 7	(MSB) Defective Logical Block Address -1 (LSB)							
BYTE 8 BYTE 9 BYTE 10 BYTE 11	(MSB) Defective Logical Block Address -2 (LSB)							
BYTE 12 BYTE 13 BYTE 14 BYTE 15	(MSB) Defective Logical Block Address -3 (LSB)							
BYTE 16 BYTE 17 BYTE 18 BYTE 19	(MSB) Defective Logical Block Address -4 (LSB)							

Figure 88. Format of REASSIGN BLOCKS data

**Note:** If the file finds a defective block by verifying ECC before it finds a spare, the file will not start the REASSIGN BLOCKS process, but will return CHECK CONDITION status with sense key set to MEDIUM ERROR.

- **Defect List Length** must be 4,8,12 or 16. Otherwise, the drive returns Check Condition with Sense key = Illegal request.
- **Defective Logical Block Address** is 4 bytes in length. The initiator can specify from 1 to 4 Defective Logical Block Address according to the Defect List Length from 4 to 16, respectively. Defective Logical Block Addresses must be ordered in ascending order, or the drive returns Check Condition.

## 7.20 RECEIVE DIAGNOSTICS (1C)

Byte	Bit							
	7	6	5	4	3	2	1	0
0	Command Code = 1Ch							
1	LUN			Reserved = 0				
2	Reserved = 0							
3 4	(MSB) Parameter List Length							(LSB)
5	VU = 0		Reserved = 0			FLAG	LINK	

Figure 89. RECEIVE DIAGNOSTIC (1C)

The Receive Diagnostic command requests that analysis data requested by a Send Diagnostics command be sent to the initiator.

- **Parameter List Length** specifies the amount of data to be returned to the initiator. This value may be zero and this is not considered an error. The target terminates the Data In phase when all available data has been transferred or when the number of bytes transferred equals the Parameter List Length.

### 7.20.1 Receive Diagnostic Page 0

This page contains a list of supported pages.

Byte	7	6	5	4	3	2	1	0
0	Page Code = 0							
1	Reserved = 0							
2 - 3	Page Length = 02h							
4	First supported page 0							
5	Second supported page 40							

### 7.20.2 Receive Diagnostic Page 40

Using the Send Diagnostics command an address, in either physical or logical format, is supplied to the file. This page is then used to retrieve the address translated into the other format.

Byte	7	6	5	4	3	2	1	0
0	Page Code = 40h							
1	Reserved = 0							
2 - 3	Page Length = 0Ah							

Byte	7	6	5	4	3	2	1	0
4	Reserved = 0					Supplied Format		
5	RA	ALTS	ALTT	Reserved = 0		Translate Format		
6 - 13	Translated Address							

- **Supplied Format** is the value supplied by the Send Diagnostic command it may be one of the three following values
  - **000b** Block format
  - **100b** Bytes From Index format
  - **101b** Physical Sector format

It specifies the format in which the address has been supplied.

- **Translate Format** is the value supplied by the Send Diagnostic command and specifies the format that the address has been translated into List. If the supplied format is the Block format, the Translate format must be either Bytes from Index or Physical Sector format. If the supplied format is the Bytes from Index or Physical Sector format, the Translate format must be Block format. Otherwise the Target will terminate the command with Check Condition status.
- **RA (Reserved Area)** is set to 1 if the translated block is a reserved area.
- **ALTS (Alternate Sector)** is set to 1 if the translated block is in alternate sector area.
- **ALTT (Alternate Track)** is set to 1 if the translated block is in alternate track area. This bit is not used by the file.
- **Translated Address** contains the address in the translate format. If it is a logical block address it is contained within the first 4 bytes of the field, i.e. bytes 6 to 9 of the page data. For a physical format it is as follows.

Byte	7	6	5	4	3	2	1	0
6 - 8	Cylinder Number							
9	Head Number							
10 - 13	Sector Number or Bytes from Index							

---

## 7.21 RELEASE (17)

---

Byte	Bit							
	7	6	5	4	3	2	1	0
0	Command Code = 17h							
1	LUN		3rdPty	3rd Party ID			Ext = 0	
2	Reservation Identification							
3	Reserved = 0							
4	Reserved = 0							
5	VU = 0		Reserved = 0			FLAG	LINK	

---

Figure 90. RELEASE (17)

The RELEASE command is used to release a LUN previously reserved.

**Note:** It is not an error for an initiator to release a LUN that is not currently reserved.

- **3rdPty** bit indicates that :
  - 1** This release process is for a third party which is specified by 3rd Party ID.
  - 0** This release process is for the initiator itself.
- **3rd Party ID** specifies the ID of the third party for which the LUN is reserved.<sup>3</sup>
- **Extents** must be 0. Extension is not supported by the file.
- **Reservation Identification** field is ignored.

---

<sup>3</sup> Refer 7.23, “RESERVE (16)” on page 128

---

## 7.22 REQUEST SENSE (03)

---

Byte	Bit							
	7	6	5	4	3	2	1	0
0	Command Code = 03h							
1	LUN			Reserved = 0				
2	Reserved = 0							
3	Reserved = 0							
4	Allocation Length							
5	VU = 0		Reserved = 0			FLAG		LINK

---

Figure 91. REQUEST SENSE (03)

The REQUEST SENSE command requests the file to transfer sense data.

The sense data shall be available when following conditions,

- The previous command to the specified I\_T\_L nexus terminated with CHECK CONDITION status.<sup>4</sup>
- An other information (e.g. medium position ) is available in any fields.
- The previous command to the specified I\_T\_L nexus ended unexpected BUS FREE error.

If REQUEST SENSE command with a invalid LUN is received, file return GOOD status and report a sense key of ILLEGAL REQUEST and an additional sense code of LOGICAL UNIT NOT SUPPORTED.

If the file has no sense data available to return, it shall return a sense key of NO SENSE and an additional sense code of NO ADDITIONAL SENSE INFORMATION.

The sense data shall be preserved by the file for the initiator until retrieved by the REQUEST SENSE command or until any other command for the same I\_T\_L nexus. Sense data shall be cleared upon receipt subsequent command including REQUEST SENSE to the same I\_T\_L nexus.

Separate sense data is maintained by the device for each initiator. Therefore, there is no requirement for an initiator to expeditiously clear a CHECK CONDITION as this will not affect other initiators in a multi-initiator system.

The file will return the number of bytes in the allocation length or 32 bytes whichever is less.

The contents of the sense data is defined in 12.0, “SCSI SENSE DATA” on page 191.

---

<sup>4</sup> I\_T\_L nexus . A nexus which exists between an initiator, a target and a logical unit.

## 7.23 RESERVE (16)

Byte	Bit							
	7	6	5	4	3	2	1	0
0	Command Code = 16h							
1	LUN			3rdPty	3rd Party ID			Ext = 0
2	Reservation Identification							
3	(MSB) Extent List Length = 0 (LSB)							
4								
5	VU = 0	Reserved = 0				FLAG	LINK	

Figure 92. RESERVE (16)

The RESERVE command is used to reserve a LUN for an initiator. This reservation can be either for;

1. The initiator which sends this command.
2. The third party which is specified in this command.

This command results in reserving the entire LUN for the initiator until one of the following occurs:

- The reservation is superseded by another valid RESERVE command from the initiator that made the reservation.
- The LUN is released by a RELEASE command from the same initiator.
- A hard reset condition occurs. (A SCSI bus Reset assertion)
- A BUS DEVICE RESET message is received from any initiator.
- Power off/on occurs.

**3rdPty** bit is to indicates that :

- 1** This reservation is for a third party which is specified by 3rd Party ID.
- 0** This reservation is for the initiator itself.

**3rd Party ID** specifies the ID of the third party for which the LUN is reserved.

**Note:** The LUN may be only released by the initiator who sent the RESERVE command.

**Extents** must be 0. Extension is not supported by the file.

**Reservation Identification** is ignored.

**Extent List** length must be zero. Extent List length is not supported.

---

## 7.24 REZERO UNIT (01)

---

Byte	Bit							
	7	6	5	4	3	2	1	0
0	Command Code = 01h							
1	LUN			Reserved = 0				
2	Reserved = 0							
3								
4								
5	VU = 0	Reserved = 0				FLAG	LINK	

---

Figure 93. REZERO UNIT (01)

The REZERO UNIT command requests that the target seek to logical block address 0.

---

## 7.25 SEEK (0B)

---

Byte	Bit							
	7	6	5	4	3	2	1	0
0	Command Code = 0Bh							
1	LUN			(MSB)	LBA			
2	Logical Block Address (LSB)							
3								
4	Reserved = 0							
5	VU = 0	Reserved = 0				FLAG	LINK	

---

Figure 94. SEEK (0B)

The SEEK command requests the file to seek to the specified logical block address.



---

## 7.26 SEEK EXTENDED (2B)

---

Byte	Bit							
	7	6	5	4	3	2	1	0
0	Command Code = 2Bh							
1	LUN			Reserved = 0				0
2	(MSB) Logical Block Address (LSB)							
3								
4								
5								
6	Reserved = 0							
7								
8								
9	VU = 0	Reserved = 0				FLAG	LINK	

---

Figure 95. SEEK EXTENDED (2B)

The SEEK EXTENDED command requests the file to seek to the specified logical block address.

## 7.27 SEND DIAGNOSTIC (1D)

Byte	Bit							
	7	6	5	4	3	2	1	0
0	Command Code = 1Dh							
1	LUN		PF	RSVD = 0	SlfTst	DevOf1	UntOf1	
2	Reserved = 0							
3 4	(MSB)		Parameter List Length				(LSB)	
5	VU = 0		Reserved = 0			FLAG	LINK	

Figure 96. SEND DIAGNOSTIC (1D)

The SEND DIAGNOSTIC command requests the file to perform its self-diagnostic test, or to perform a function based on a page of information sent in a Data Out phase during the command.

- **PF (Page Format)** bit set to 1 indicates the data sent by the Initiator conform to the page structure as specified in SCSI-2 standard. This bit must be set to 1 if the SlfTst bit is set to 0. This bit is ignored by the Target if the SlfTst bit is set.
- **SlfTst** set to 1 indicates the device performs its internal self test. If set to 0 then a parameter list should be sent by the initiator.
- **DevOf1** this bit is ignored by the target for compatibility.
- **UntOf1** this bit is ignored by the target for compatibility.
- **Parameter List Length** is ignored by the Target if the SlfTst bit is set. Otherwise it should be set to the length of the page to be transferred in the Data Out phase of the command. If it does not match the expected length of the page a CHECK CONDITION status will be generated with a Sense Key of Illegal Request and additional sense of Invalid Field in CDB.

If the SlfTst bit is set upon command completion, the following status is returned:

- GOOD status for successful test completion.
- CHECK CONDITION status for unsuccessful test completions.

The self diagnostics consists of two parts :<sup>5</sup>

- The first part is executed immediately after power up. This test is performed to verify all hardware which is not related to the disk drive. The local microprocessor, RAM (scratchpad and buffer), and control electronics are included here.
- The second part is executed after the spindle motor is started. This includes disk access (seek), R/W channel, and error correction circuitry verification. A reserved area on the disk is used for this test.

<sup>5</sup> See 11.18.2, "Diagnostics Command" on page 188 for a detailed listing of the operations carried out by the Diagnostics Command.

Both tests are performed as a result of the SEND DIAGNOSTIC command. The SEND DIAGNOSTICS will fail with CHECK CONDITION status if it is issued while the spindle motor is not turning. (Such as after STOP command has been received.)

**Note:** The self diagnostic is also performed at Power On Reset time.

**Note:** The SCSI bus signals will not be corrupted when the device is executing the SEND DIAGNOSTIC command.

### 7.27.1 Send Diagnostic Pages 0

This page requests that the file return a list of supported pages on the next receive diagnostics command.

Byte	7	6	5	4	3	2	1	0
0	Page Code = 0							
1	Reserved = 0							
2 - 3	Page Length = 0							

### 7.27.2 Send Diagnostic Pages 40

This allows the initiator to translate a logical block address or physical sector address to the other format. The address to be translated is passed to the target with the Send Diagnostic command and the results are returned to the initiator by the Receive Diagnostics command.

The target will read the parameter list from the initiator and if no errors are detected in the parameter list Good Status will be returned. The data translation will be performed upon receipt of the Receive Diagnostics command.

Byte	7	6	5	4	3	2	1	0
0	Page Code = 40h							
1	Reserved = 0							
2 - 3	Page Length = 0Ah							
4	Reserved = 0					Supplied Format		
5	Reserved = 0					Translate Format		
6 - 13	Address to Translate							

- **Supplied Format** may take either of the following three values:
  - **000b** Block format
  - **100b** Bytes From Index format
  - **101b** Physical Sector format

It specifies the format in which the address has been supplied.

- **Translate Format** specifies that format that the address should be translated into. If the supplied format is the Block format, the Translate format must be either Bytes from Index or Physical Sector format. If the supplied format is the Bytes from Index or Physical Sector format, the Translate format must be Block format. If either of the format fields is invalid or they specify the same format the command will

terminate with CHECK CONDITION status with a Sense of Illegal Request and Illegal Field in Parameter List.

- **Address to Translate** contains the address to translate. If the logical block format is specified then the first 4 bytes of the field, i.e. bytes 6 to 9, contain the LBA and the remainder must be zero. For the physical format the address must be specified as follows.

Byte	7	6	5	4	3	2	1	0
6 - 8	Cylinder Number							
9	Head Number							
10 - 13	Sector Number or Bytes from Index							

---

## 7.28 START/STOP UNIT (1B)

---

Byte	Bit							
	7	6	5	4	3	2	1	0
0	Command Code = 1Bh							
1	LUN			Reserved = 0				Immed
2	Reserved = 0							
3	Reserved = 0							
4	Reserved = 0						Start	
5	VU = 0	Reserved = 0				FLAG	LINK	

---

Figure 97. START/STOP Unit (1B)

The START/STOP UNIT command is used to spin up or stop the spindle motor.

- **Immed** bit is to specify
  - 0** Status is to be returned at the end of the operation.
  - 1** GOOD status shall always be returned immediately after command has been received. The TEST UNIT READY command may be used to determine when the file becomes ready after a spin-up.
- **Start** bit is to specify:
  - 0** Stop the spindle.
  - 1** Start the spindle.

**Note:** Once the drive has become ready (after a power on ) the Start/Stop UNIT command can be used without any errors, regardless of the state of the motor, stopped or spinning.

## 7.29 SYNCHRONIZE CACHE (35)

Byte	Bit							
	7	6	5	4	3	2	1	0
0	Command Code = 35h							
1	LUN			Reserved = 0			Immed = 0	RelAdr = 0
2 3 4 5	(MSB) Logical Block Address							(LSB)
6	Reserved = 0							
7 8	(MSB) Number of Blocks							(LSB)
9	VU = 0	Reserved = 0				FLAG	LINK	

Figure 98. SYNCHRONIZE CACHE (35)

The SYNCHRONIZE CACHE Command ensures that logical blocks in the cache have their most recent data value recorded on the media.

- **Logical Block Address** is to specify:  
where the operation is to begin.
- **Number of Blocks** specifies:  
the total number of contiguous logical blocks within the range. Number of Blocks of zero indicates that all remaining logical blocks on the logical unit shall be within the range.
- **Immed** (immediate) must be zero.  
An immediate bit of zero indicates that the status shall not be returned until the operation has completed.  
If the Immed bit is set to one, the drive returns a Check Condition status. The sense key shall be set to Illegal Request and the additional sense code shall be set to Invalid Field in CDB.
- **RelAdr** (relative address) must be zero.  
The drive does not support the relative addressing.  
If the RelAdr bit is set to one, the drive returns Check Condition status. The sense key shall be set to Illegal Request and the additional sense code shall be set to Invalid Field in CDB.

---

## 7.30 TEST UNIT READY (00)

---

Byte	Bit							
	7	6	5	4	3	2	1	0
0	Command Code = 00h							
1	LUN			Reserved = 0				
2	Reserved = 0							
3								
4								
5	VU = 0	Reserved = 0				FLAG	LINK	

---

Figure 99. TEST UNIT READY (00)

The TEST UNIT READY command allows the initiator to check if the file is READY. The SCSI specification defines READY as the condition where the device will accept a media-access command without returning CHECK CONDITION status.

The file will first verify that the motor is spinning at the correct speed.

- If the spindle motor is not spinning at the correct speed, CHECK CONDITION status is returned with sense key of NOT READY.
- If the motor is spinning at the correct speed, the file accepts normal media access commands.

The TEST UNIT READY command is not intended as a diagnostic. No self diagnostic is performed by the device as a result of this command.

The TEST UNIT READY command has special significance for power sequencing using the START UNIT command with an Immediate bit of 1. In this mode the START UNIT command returns COMMAND COMPLETE status before the completion of motor spin-up and expects the initiator to issue TEST UNIT READY commands to determine when the motor has reached the proper speed.

**Note:** The spindle automatically starts in automatic spin-up Mode. The file does not execute any commands other than TEST UNIT READY, INQUIRY or REQUEST SENSE command until the the Power On sequence is complete. The file will return CHECK CONDITION status with NOT READY sense key and IN PROCESS OF BECOMING READY sense code for all other commands during the Power On period.

## 7.31 VERIFY (2F)

Byte	Bit							
	7	6	5	4	3	2	1	0
0	Command Code = 2Fh							
1	LUN			Reserved = 0			ByteChk = 0	0
2	(MSB) Logical Block Address (LSB)							
3								
4								
5								
6	Reserved = 0							
7	(MSB) Transfer Length (LSB)							
8								
9	VU = 0	Reserved = 0				FLAG	LINK	

Figure 100. VERIFY (2F)

The VERIFY command requests that the file verify the data written on the media. A verification length of zero indicates that no data will be transferred. This condition is not considered an error.

- ByteChk is not supported. Must be set to zero.



---

## 7.32 WRITE (0A)

---

Byte	Bit							
	7	6	5	4	3	2	1	0
0	Command Code = 0Ah							
1	LUN			(MSB)	LBA			
2	Logical Block Address (LSB)							
3								
4	Transfer Length							
5	VU = 0	Reserved = 0				FLAG	LINK	

---

Figure 101. WRITE (0A)

The WRITE command requests the file to write the specified number of blocks of data from the initiator to the medium starting at the specified logical block address.

See 7.13, “READ (08)” on page 111 for the parameters.

## 7.33 WRITE EXTENDED (2A)

Byte	Bit							
	7	6	5	4	3	2	1	0
0	Command Code = 2Ah							
1	LUN		DPO = 0	FUA = 0	Reserved = 0		RelAdr = 0	
2	(MSB) Logical Block Address (LSB)							
3								
4								
5								
6	Reserved = 0							
7	(MSB) Transfer Length (LSB)							
8								
9	VU = 0	Reserved = 0				FLAG	LINK	

Figure 102. WRITE EXTENDED (2A)

The WRITE EXTENDED command requests that the file write the data transferred from the initiator. This command is processed like the standard WRITE command except for the longer transfer length .

**Transfer length** The number of contiguous blocks to be transferred. If the transfer length is zero, the seek occurs, but no data is transferred. This condition is not considered an error.

**DPO** Disable Page Out is not supported. Must be set to zero.

**FUA** Force Unit Access is not supported. Must be set to zero.

**RelAdr** Relative Block Address is not supported. Must be set to zero.

## 7.34 WRITE AND VERIFY (2E)

Byte	Bit							
	7	6	5	4	3	2	1	0
0	Command Code = 2Eh							
1	LUN			DPO = 0	Reserved = 0		ByteChk = 0	RelAdr = 0
2	(MSB) Logical Block Address (LSB)							
3								
4								
5								
6	Reserved = 0							
7	(MSB) Transfer Length (LSB)							
8								
9	VU = 0	Reserved = 0				FLAG	LINK	

Figure 103. WRITE AND VERIFY (2E)

WRITE AND VERIFY command requests that the file writes the data transferred from the initiator to the medium and then verify that the data is correctly written.

- A transfer length of zero indicates that no data is transferred.
- If caching is enabled, the command performs an implied Force Unit Access (FUA) and an implied Synchronize Cache before starting the operation. This insures that the medium, not the cache, is being verified.
- ByteChk is not supported. Must be set to zero.
- DPO (Disable Page Out) is not supported. Must be set to zero.
- Relative Block Address is not supported. Must be set to zero.

## 7.35 WRITE BUFFER (3B)

Byte	Bit							
	7	6	5	4	3	2	1	0
0	Command Code = 3Bh							
1	LUN			Reserved = 0		Mode		
2	Buffer ID							
3	(MSB) Buffer Offset (LSB)							
4								
5								
6	(MSB) Parameter List Length (LSB)							
7								
8								
9	VU = 0	Reserved = 0				FLAG	LINK	

Figure 104. WRITE BUFFER (3B)

The WRITE BUFFER command is used in conjunction with the READ BUFFER command as a diagnostic function for testing the file's memory and the SCSI bus integrity. This command does not alter the medium of the file. Additional modes are provided for downloading microcode and for downloading and saving microcode.

This command will cause the entire cache to be emptied.

The function of this command and the meaning of fields within the command descriptor block depend on the contents of the mode field.

### MODE Description

- 000** Write combined header and data
- 010** Data
- 100** Download Microcode
- 101** Download Microcode and Save
- All other modes are not supported by the file.

### 7.35.1 Combined Header And Data (Mode 000b)

In this mode, the data to be transferred is preceded by a four-byte header.

**Buffer ID** must be zero. If another value is specified, no download function are performed and the command is terminated with CHECK CONDITION status. And File shall set sense key to ILLEGAL REQUEST and additional sense code to ILLEGAL FIELD IN CDB.

**Buffer Offset** must be zero. If another value is specified, no download function are performed and the command is terminated with CHECK CONDITION status. And File shall set sense key to ILLEGAL REQUEST and additional sense code to ILLEGAL FIELD IN CDB.

**Parameter List Length** specifies the number of bytes that shall be transferred during the DATA OUT phase. This number **includes** four bytes of header, so the data length to be stored in the file's buffer is transfer length minus four. If the length exceeds the buffer size, the command is terminated with CHECK CONDITION status. And File shall set sense key to ILLEGAL REQUEST and additional sense code to ILLEGAL FIELD IN CDB.

The four-byte header consists of all reserved bytes.

---

	7	6	5	4	3	2	1	0
BYTE 0	RSVD = 0							
BYTE 1	RSVD = 0							
BYTE 2	RSVD = 0							
BYTE 3	RSVD = 0							

---

Figure 105. WRITE BUFFER Header

### 7.35.2 Write Data (Mode 010b)

In this mode, the DATA OUT phase contains buffer data.

**Buffer ID** must be set to zero, indicating the data transfer buffer. If another value is specified, the command is terminated with CHECK CONDITION status. File shall set sense key to ILLEGAL REQUEST and additional sense code to ILLEGAL FIELD IN CDB.

**Buffer Offset** specifies the offset of the memory space specified by the Buffer ID. The initiator should conform to the offset boundary requirements returned in the READ BUFFER descriptor. If the value exceeds the buffer specified, the command is terminated with CHECK CONDITION status. File shall set sense key to ILLEGAL REQUEST and additional sense code to ILLEGAL FIELD IN CDB.

**Parameter List Length** specifies the Parameter List Length. It must be;

- less than the capacity of the buffer size.
- on a sector boundary. In other words, it must be a multiple of 512.

If a invalid value is specified, the command is terminated with CHECK CONDITION status. File shall set sense key to ILLEGAL REQUEST and additional sense code to ILLEGAL FIELD IN CDB.

### 7.35.3 Download Microcode (Mode 100b)

In this mode, the microcode is transferred to the control memory space of the file. Once downloaded the file will operate with the newly downloaded code until the next power cycle.

**Buffer ID** field is used to indicate which portion of the microcode image is being downloaded. Following Buffer IDs are supported by the Target:

- '00'x : Main Microprocessor Code
- '81'x : Reserved Area Data

Any other value for the Buffer ID except the above will cause the command to terminate with CHECK CONDITION status. The file shall set sense key to ILLEGAL REQUEST and additional sense code to ILLEGAL FIELD IN CDB.

**Buffer Offset** specifies the starting address of the downloaded Microcode. It must be zero. If an invalid value is specified, the command is terminated with CHECK CONDITION status. File shall set sense key to ILLEGAL REQUEST and additional sense code to ILLEGAL FIELD IN CDB.

**Parameter List Length** must be '4000'x for the Buffer ID '00'x. It may also be set to '0000'x in which case no code is updated. For the Buffer ID '81'x it must be the total bytes of Reserved Area Data and the multiple of 512 bytes in length. If an invalid value is specified, the command is terminated with CHECK CONDITION status. File shall set sense key to ILLEGAL REQUEST and additional sense code to ILLEGAL FIELD IN CDB.

This process generates a unit attention condition for MICROCODE HAS BEEN CHANGED for all initiators except the one which sent the write buffer command. Once the write buffer command has been completed the new microcode is immediately ready for operation.

**Note:** This option is documented within this spec to indicate that the file will accept a command of this form though it is not expected that a customer will ever issue such a command. To use the write buffer command in this manner a special microcode version will be required from development. If such a microcode is released from development then it will include appropriate instructions on the function of new microcode and its effect on file operations after downloading.

If the write buffer command is executed with this option and the code downloaded is not valid for this file then it is to be expected that the file will hang on this or a subsequent command. This should normally be recoverable by a power on/off cycle.

## 7.35.4 Download Microcode and Save (Mode 101b)

In this mode, the microcode is transferred to the file and saved into the System reserved area on the disk. The downloaded code becomes effective immediately after download and after each Power On Reset until it is overwritten by another download microcode and save option.

There is no delay required after the completion of the write buffer command before the file can start accepting new commands. However the final write buffer command may take up to 5 seconds to complete.

### 7.35.4.1 Download Main Microprocessor Microcode and Save (starting Buffer ID '00'x)

The code must be downloaded to the file in 9 separate blocks. Each of these being 16KB in size, giving a total code size of 144KB. The 9 blocks must be sent in the correct sequential order but other commands may be interspersed between them, however if power is cycled or a reset occurs the download procedure must be restarted. As the blocks are received they are stored into a reserved area of the file - at this stage they DO NOT overwrite the current microcode. When the last of the 9 blocks is received the download will be checked via checksum and signature for integrity and compatibility with the ROM code. Once these checks have passed the file will overwrite the old code stored on the disk with the new download.

**Buffer ID** must be set to '00'x on the first block, '01'x on the second block etc. The blocks must be sent to the file in the correct logical order, with no omissions or resends of blocks. On all write buffer commands except the final one the file merely stores the code and no action is taken. When the final block is received the file then attempts to use the new microcode. In between downloading the code blocks the file will continue to accept and process other commands from this and any other initiator. In addition it is legal to send

some but not all of the code and then to start sending a different level of code as long as this second level of code is started from the beginning, i.e. Buffer ID '00'x. Any value for the Buffer ID except '00'x or an incrementing value based on the last block sent when downloading the Main Microprocessor Code will cause the command to terminate with CHECK CONDITION status. The file shall set sense key to ILLEGAL REQUEST and additional sense code to ILLEGAL FIELD IN CDB.

**Buffer Offset** specifies the starting address of the downloaded microcode. It must be zero. If an invalid value is specified, the command is terminated with CHECK CONDITION status. File shall set sense key to ILLEGAL REQUEST and additional sense code to ILLEGAL FIELD IN CDB.

**Parameter List Length** must be specified for the total microcode. This value should be '4000'x. It may also be set '0000'x in which case no code is updated. If an invalid value is specified, the command is terminated with CHECK CONDITION status. File shall set sense key to ILLEGAL REQUEST and additional sense code to ILLEGAL FIELD IN CDB.

**Note:** New code to be downloaded to the file will be provided by development either in request to a customer's request for additional function or as a result of a bug fix to a critical file function. Please note however that not all possible fixes or new function can be applied to a file in this manner and that there is a very considerable dependency on the level of ROM code contained within the file. If invalid code or code that is not compatible with the ROM code is downloaded the file will normally reject this code and will continue normal operation. However there is a very small possibility of invalid code being accepted (about 1 in 4E9) and if this occurs the unit will usually become inoperable and have to be returned to the manufacturer to be recovered.

#### 7.35.4.2 Download EEPROM Data and Save

**Buffer ID** must be set to '80'x for the EEPROM data.

**Buffer Offset** must be the even number between '00'x and '7E'x.

**Parameter List Length** specifies the total bytes of EEPROM Data to be saved. It must be less than or equal to '80'x.

#### 7.35.4.3 Download Reserved Area Data and Save

**Buffer ID** must be set to '81'x.

**Buffer Offset** must be zero.

**Parameter List Length** must be the total bytes of Reserved Area Data and the multiple of 512 bytes in length.

## 7.36 WRITE LONG (3F)

Byte	Bit							
	7	6	5	4	3	2	1	0
0	Command Code = 3Fh							
1	LUN			Reserved = 0				RelAdr = 0
2	(MSB) Logical Block Address (LSB)							
3								
4								
5								
6	Reserved = 0							
7	(MSB) Byte Transfer Length (LSB)							
8								
9	VU = 0	Reserved = 0				FLAG	LINK	

Figure 106. WRITE LONG (3F)

The WRITE LONG command requests the file to write **one block** of data transferred from the initiator. The transfer data must include;

- 512 bytes of data
- 20 bytes of ECC data

Parameters are;

- **Logical Block Address** field specifies the logical block at which the write operation shall occur.
- **Byte Transfer Length.** This field must exactly specify the number of bytes of data that are available for transfer. If a non-zero byte transfer length does not match the available data length, the target terminates the command with CHECK CONDITION status, the sense key is set to ILLEGAL REQUEST and an additional sense code set to INVALID FIELD IN CDB. The valid and ILI bits is set to one and the information field is set to the difference of the requested length minus the actual length in bytes. Negative values are indicated by two's complement notation.
- **RelAdr** (Relative Block Address) is not supported. Must be set to ZERO.



## 7.37 WRITE SAME (41)

Byte	Bit							
	7	6	5	4	3	2	1	0
0	Command Code = 41h							
1	LUN			Reserved = 0		PBdata	LBdata	RelAdr = 0
2	(MSB) Logical Block Address (LSB)							
3								
4								
5								
6	Reserved = 0							
7	(MSB) Number of Blocks (LSB)							
8								
9	VU = 0	Reserved = 0				FLAG	LINK	

Figure 107. WRITE SAME (41)

The Write Same command instructs the Target to write a single block of data, transferred to the Target from the Initiator, to a number of sequential logical blocks. This command is useful to write large data areas without sending all of the data over the SCSI bus.

- **Logical Block Address** specifies the address at which the write begins. The Number of Blocks specifies the number of contiguous blocks to be written. If the number is 0, all of the remaining blocks on the specified Logical Unit are written.
- **PBdata** (Physical Block Data) bit of one indicates that the Target replace the first eight bytes of the data to be written to the current physical sector with the physical address of the sector currently being using the physical sector format (refer to Figure 45 on page 55).
- **LBdata** (Logical Block Data) bit of one indicates that the Target replace the first four bytes of the data to be written to the current logical block with the logical block address of the block currently being written.
- **RelAdr** (Relative Block Address) is not supported and must be set to be ZERO.

If both PBdata and LBdata are set to 1, Check Condition Status is returned with a Sense Key of Illegal Request and additional sense code of Invalid Command Operation Code.

The data for this command is not retained in the cache.



## 8.0 SCSI Status Byte

Upon the completion of a command, a status byte is sent to the initiator. Additional sense information may also be available depending on the contents of the status byte. The following section describes the possible values for the status byte and sense data.

---

	BIT							
	7	6	5	4	3	2	1	0
STATUS	Reserved = 0		Status Code				RSVD	

---

Figure 108. SCSI Status Byte. Format of the SCSI STATUS byte. All Reserved fields(R) are set to zero.

### STATUS BYTE Description

- 00h**            **GOOD**  
The command has been successfully completed.
- 02h**            **CHECK CONDITION**  
An error, exception, or abnormal condition has been detected. The sense data is set by the file. The REQUEST SENSE command should be issued to determine the nature of the condition.
- 08h**            **BUSY**  
This condition is returned when disconnect privilege is not granted while the file is BUSY processing the other command for the other initiator. The normal initiator recovery action is to issue the command at a later time, or reissue the command and grant the disconnect privilege.
- 10h**            **INTERMEDIATE/GOOD**  
This status is returned for every command in a series of linked commands (except the last command), unless an error, exception, or abnormal condition causes a CHECK CONDITION status or a RESERVATION CONFLICT status to be set. If this status is not returned, the chain of linked commands is broken, and no further commands in the series are executed.
- 18h**            **RESERVATION CONFLICT**  
This status is returned whenever an SCSI device attempts to access the file, but it has been reserved by another initiator. (See 7.23, “RESERVE (16)” on page 128.)
- 28h**            **QUEUE FULL**  
This status indicates that the target's command queue is full. If tagged command queuing feature is enabled and there is no room on the command queue, this status is returned when the initiator sends a command. For this status, sense is not valid.



## 9.0 SCSI MESSAGE SYSTEM

This chapter details how the message system is implemented on the file. Included is a functional description of the supported messages.

### 9.1 Supported Messages

The message supported by the file is shown in Figure 109.

MESSAGE	CODE (hex)	Direction	Negate ATN Before last ACK
COMMAND COMPLETE	00	IN	—
WIDE DATA TRANSFER REQUEST	010203	IN OUT	Yes
SYNCHRONOUS DATA TRANSFER REQUEST	010301	IN OUT	Yes
SAVE DATA POINTER	02	IN	—
RESTORE POINTERS	03	IN	—
DISCONNECT	04	IN	—
INITIATOR DETECTED ERROR	05	OUT	Yes
ABORT	06	OUT	Yes
MESSAGE REJECT	07	IN OUT	Yes
NO OPERATION	08	OUT	Yes
MESSAGE PARITY ERROR	09	OUT	Yes
LINKED COMMAND COMPLETE	0A	IN	—
LINKED COMMAND COMPLETE (w/FLAG)	0B	IN	—
BUS DEVICE RESET	0C	OUT	Yes
ABORT TAG	0D	OUT	Yes
CLEAR QUEUE TAG	0E	OUT	Yes
SIMPLE QUEUE TAG	20XX	IN OUT	No
HEAD OF QUEUE TAG	21XX	OUT	No
ORDERED QUEUE TAG	22XX	OUT	No
IGNORE WIDE RESIDUE	2301	IN	—
IDENTIFY	80–FF	IN	—
IDENTIFY	80–FF	OUT	No

Key: IN = Target to Initiator, OUT = Initiator to target.  
YES = Initiator shall negate ATN before last ACK of message.  
NO = Initiator may or may not negate ATN before last ACK of message.  
— = Not applicable  
XX = Queue Tag

Figure 109. Supported Messages

If an unsupported message is received, the file will send the *MESSAGE REJECT* message to the initiator. If at the time the unsupported message is received a valid NEXUS exists then the file will continue with the command. If no valid NEXUS exists then the file will go to Bus Free.

## 9.1.1 COMMAND COMPLETE (00)

The file sends this message to the initiator to indicate that the execution of a command has terminated and that valid status has been sent to the initiator. After successfully sending this message, the file releases all bus signals and goes to BUS FREE phase.

## 9.1.2 WIDE DATA TRANSFER REQUEST (01,02,03H)

Byte	Value	Description
0	01H	Extended message
1	02H	Extended message length
2	03H	WIDE DATA TRANSFER REQUEST code
3	E	Transfer Width Exponent

Figure 110. Wide Data Transfer Request.

The data transfer width is two to the transfer width exponent bytes wide. Valid data transfer widths are 8 bits (E=00h) and 16 bits (E=01h). Value of E greater than 01h are reserved.

Target does not initiate the Transfer Width Negotiation.

### 9.1.2.1 Transfer Width Negotiation Started by the Initiator

If the Initiator recognizes that negotiation is required and sends a Wide Data Transfer Request message out, the Target responds by changing to the Message In phase and sending a Wide Data Transfer Request message in to the Initiator prior to transferring any additional message bytes (or any other Information phase bytes) from the Initiator. This provides an interlock during the data transfer width negotiation.

The Drive responds to each Initiator requested transfer width exponent as shown in the following table:

Figure 111. Initiator Request / Target Response		
Initiator Request / Target Response		Target Data Transfer Width
<b>E<sub>i</sub> = 0</b>	<b>E<sub>t</sub> = 0</b>	<b>8 Bit Data Transfer</b>
<b>E<sub>i</sub> &gt; 0</b>	<b>E<sub>t</sub> = 1</b>	<b>16 Bit Data Transfer</b>

If following the Target's response above the Initiator asserts the ATN signal and the first message received is either a Message Parity Error or a Message Reject message, the Target negates the data transfer width agreement and goes to 8 bit mode. For the Message Parity Error case, the implied data transfer width agreement is reinstated if the Target successfully retransmits the Wide Data Transfer Request message to the Initiator. For any other message, the Target completes negotiation and goes to the negotiated data transfer width.

### 9.1.3 SYNCHRONOUS DATA TRANSFER REQUEST (01,03,01H)

Byte	Value	Description
0	01H	Extended message
1	03H	Extended message length
2	01H	SYNCHRONOUS DATA TRANSFER REQUEST code
3	M	Transfer period (M times 4 nanoseconds)
4	X	REQ/ACK offset

Figure 112. Synchronous Data Transfer Request.

A pair of Synchronous Data Transfer Request (SDTR) messages shown in Figure 112 are exchanged between an initiator and a Target to establish the synchronous data transfer mode between the two devices. The message exchange establishes the permissible transfer period and REQ/ACK offset for a synchronous data transfer between the two devices. The initiator may initiate a synchronous data transfer negotiation at any time after the LUN has been identified. A Synchronous Data Transfer Request(SDTR) message exchange shall be initiated by an SCSI device whenever a previously arranged data transfer agreement may have become invalid. *The agreement becomes invalid after any condition which may leave the data transfer agreement in an indeterminate state such as;*

1. after a Power-on Reset
2. after a SCSI Bus "hard" reset condition
3. after a Bus Device Reset message

In addition, a SCSI device may initiate a SDTR message exchange whenever it is appropriate to negotiate a new data transfer agreement(either synchronous or asynchronous).

**M** The transfer period(M above) is the minimum time allowed between leading edges of successive REQ pulses and of successive ACK pulses to meet the device requirements for successful reception of data. The file supports transfer period in the range 100 nSec to 475 nSec in 25 nSec increments.

#### **REQ/ACK Offset**

The ACK/REQ offset(X above) is the maximum number of REQ pulses allowed to be outstanding before the leading edge of its corresponding ACK pulses is received at the file. A REQ/ACK offset value of zero indicate asynchronous data transfer mode. The file supports REQ/ACK offset values in the range 0 through 15.

If ATN is negated before all bytes of a multiple-byte extended message is received, the file will go to **BUS FREE** to signal a catastrophic error.

**Note:** Synchronous Negotiation becomes ineffective after Transfer Width Negotiation.

### 9.1.3.1 Synchronous Negotiation Started by the Initiator

The file responds to each Initiator requested transfer period as shown in the following figure Figure 113:

Initiator Request	Target Response	Target Transfer Period	Maximum Burst Rate
0 ← Mi ← 12	Mt = 12	50 nSec	20.00 MT/s
13 ← Mi ← 18	Mt = Mi	75 nSec	13.33 MT/s
19 ← Mi ← 25	Mt = Mi	100 nSec	10.00 MT/s
26 ← Mi ← 31	Mt = Mi	125 nSec	8.00 MT/s
32 ← Mi ← 37	Mt = Mi	150 nSec	6.67 MT/s
38 ← Mi ← 43	Mt = Mi	175 nSec	5.71 MT/s
44 ← Mi ← 50	Mt = Mi	200 nSec	5.00 MT/s
51 ← Mi ← 56	Mt = Mi	225 nSec	4.44 MT/s
57 ← Mi ← 62	Mt = Mi	250 nSec	4.00 MT/s
63 ← Mi ← 68	Mt = Mi	275 nSec	3.64 MT/s
69 ← Mi ← 75	Mt = Mi	300 nSec	3.33 MT/s
76 ← Mi ← 81	Mt = Mi	325 nSec	3.08 MT/s
82 ← Mi ← 87	Mt = Mi	350 nSec	2.86 MT/s
88 ← Mi ← 93	Mt = Mi	375 nSec	2.67 MT/s
94 ← Mi ← 100	Mt = Mi	400 nSec	2.50 MT/s
101 ← Mi ← 106	Mt = Mi	425 nSec	2.35 MT/s
107 ← Mi ← 255	Mt = Mi	(Asynchronous mode)	N/A

Figure 113. Initiator Request/Target Response

### 9.1.4 SAVE DATA POINTER (02)

This message is sent from the file to direct the initiator to copy the active data pointer to the saved data pointer. The SAVE DATA POINTER message is only sent if the initiator has previously indicated the ability to accommodate disconnection and reconnection via the IDENTIFY message .

The file will send the SAVE DATA POINTER message to the initiator prior to sending a DISCONNECT message to the initiator if a data phase has occurred and another data phase is required to successfully complete the command.

### 9.1.5 RESTORE POINTERS (03)

This message is sent from the file to direct an initiator to copy the most recently saved pointers to the corresponding command, data, and status pointers. Command and status pointers should be restored to the beginning of the present command and status areas. The data pointer should be restored to the value at the beginning of the data area in the absence of a SAVE DATA POINTER message or to the value at the point at which the last SAVE DATA POINTER message occurred. Also see 9.4, “SCSI Bus Related Error Handling Protocol” on page 160.

### 9.1.6 DISCONNECT (04)

This message is sent from the file to inform an initiator that the present connection is going to be broken. A later reconnect will be required in order to complete the current command. The disconnection is to free the SCSI bus while the file performs a relatively long operation that does not require the bus. These messages are only sent if the initiator previously indicated (via the IDENTIFY message) the ability to accommodate disconnection and reconnection.



The DISCONNECT message may also be sent from the initiator to the file to disconnect from the SCSI bus. The file does not support the DISCONNECT message from the initiator. And it always respond by sending MESSAGE REJECT message to the initiator.

### 9.1.7 INITIATOR DETECTED ERROR (05)

This message is sent from an initiator to inform the file that an error has been detected that does not preclude the file from retrying the previous COMMAND, DATA and STATUS phase. The source of the error may be either related to previous activities on the SCSI bus or may be internal to the initiator and unrelated to any previous SCSI bus activity

If the initiator intends to send this message, the initiator must assert the ATN signal prior to its release of ACK for the last byte transferred in the information phase that is to be retried. This provides an interlock so the file can determine which information phase to retry.

After receiving this message, the file may retry the previous phase by sending a RESTORE POINTERS message to the initiator and then repeating the previous COMMAND, DATA, or STATUS phase.

### 9.1.8 ABORT (06)

This message is sent from the initiator to direct the file to clear the present operation for this initiator and logical unit, including queued command(s). If a logical unit has been identified, then all pending data and status for the issuing initiator and this logical unit will be cleared and the file will go to the BUS FREE phase. Pending data and status for other logical unit and initiators will not be cleared. If a logical unit has not been identified, the file will go to the BUS FREE phase without affecting an operation on any logical unit for this initiator or any other initiator. In either case, no status or ending message will be sent to the initiator for this operation. It is not an error to send the ABORT message to a logical unit that is not currently performing an operation for the initiator.

**Note:** It is permissible for an initiator to select the file/LUN after the file has disconnected from the initiator, for the purpose of sending an IDENTIFY message followed by an ABORT message. This will abort the command on the specified logical unit.

### 9.1.9 MESSAGE REJECT (07)

This message is sent from either the initiator or the file to indicate that the last message received was inappropriate or has not been implemented.

If the initiator intends to send this message, the initiator must assert the ATN signal prior to its release of ACK for the REQ/ACK handshake of the message byte that is to be rejected. This provides an interlock so the file can determine which message is rejected.

If the file intends to send this message, the file will change to the MESSAGE IN phase and send the MESSAGE REJECT message to the initiator prior to transferring any additional message bytes (or any other information phase bytes) from the initiator regardless of ATN signal. This provides an interlock so the initiator can determine which message is rejected. After the file sends a MESSAGE REJECT message and if ATN signal is still asserted then it shall return to the MESSAGE OUT phase. The subsequent MESSAGE OUT phase shall begin with the first byte of a message.

### 9.1.10 NO OPERATION (08)

This message is sent from the initiator to the file when the initiator does not currently have any other valid message to send. This message is ignored by the file and will not affect any operation.

### **9.1.11 MESSAGE PARITY ERROR (09)**

This message is sent from the initiator to inform the file that the last message byte received had a parity error.

If the initiator intends to send this message, the initiator must assert the ATN signal prior to its release of ACK for the REQ/ACK handshake of the message byte that has the parity error. This provides an interlock so the file can determine which message byte has the parity error.

If the file receives this message under any other circumstance, the file will change to BUS FREE to signal a catastrophic error. After receiving this message, the file will retry sending the previous message to the initiator.

### **9.1.12 LINKED COMMAND COMPLETE (0A)**

The file sends this message to the initiator to indicate that execution of a linked command (with flag bit equal to zero) has completed and that valid status has been sent to the initiator. After successfully sending this message, the file goes to COMMAND phase to receive the next command.

### **9.1.13 LINKED COMMAND COMPLETE WITH FLAG (0B)**

The file sends this message to the initiator to indicate that the execution of a linked command with flag bit set to one has completed and that valid status has been sent to the initiator. After successfully sending this message, the file goes to COMMAND phase to receive the next command.

### **9.1.14 BUS DEVICE RESET (0C)**

This message is sent from an initiator to direct the file to clear all current commands. This message forces a hard reset condition which will reset the file to an initial state with no operations pending for any initiator. After receiving this message, the file will go to the BUS FREE phase.

### **9.1.15 ABORT TAG (0D)**

When the target receives this message successfully, it clears the current I/O process and go to Bus Free. If the target has already started execution of an I/O process, the execution will be halted. Pending status, data and commands for other active or queued I/O processes shall not be affected.

### **9.1.16 CLEAR QUEUE TAG (0E)**

All I/O processes for all initiators shall be cleared. All active I/O processes shall be terminated. The target shall go to the Bus Free phase following successfully receipt of this message.

### **9.1.17 QUEUE TAG MESSAGES(20h, 21h, 22h)**

Byte	Value	Description
0	20H	Simple Queue Tag message
	21H	Head of Queue Tag message
	22H	Ordered Queue Tag message
1	XXh	Queue Tag

Figure 114. Queue Tag Messages

Queue Tag messages are used to specify an identifier, called a Queue Tag, for an I/O process which establish the I\_T\_L\_Q nexus. The queue tag filed is an 8-bit unsigned integer assigned by the initiator during an initial connection. The Queue Tag for every I/O process for each I\_T\_L nexus must be unique. If the target receives a Queue Tag that is currently in use for the I\_T\_L nexus it will respond as "Incorrect Initiator Response". A Queue Tag becomes available for re-assignment when I/O process ends. The numeric value of a Queue Tag has no effect on the order of execution.

Whenever an initiator connects to the target, the appropriate Queue Tag message must be sent immediately following the Identify message and within the same MESSAGE OUT phase to establish the I\_T\_L\_Q nexus for the I/O process.

Whenever the target reconnects to an initiator to continue a tagged I/O process, the Simple Queue Tag message is sent immediately following the Identify and within the same MESSAGE IN phase to revive the I\_T\_L\_Q nexus for the I/O process.

### 9.1.17.1 SIMPLE QUEUE TAG (20h)

The Simple Queue Tag Message specifies that the current I/O process be placed in the command queue. The order of execution, with respect to other I/O processes received with Simple Queue Tag Messages, is up to the discretion of the target. The target will send a Simple Queue Tag Messages after reselection for I/O processes that were received with either Simple, Ordered, or Head of Queue Tag messages.

### 9.1.17.2 HEAD OF QUEUE TAG (21h)

Commands with this tag should be inserted into the head of the queue. When a command is being executed, this tagged command will be inserted to the head of queue to be executed after the command being currently executed. The previous command being executed will not terminated by this tagged command. This tagged command will wait until the previous command is through. If plural head-of-queue tagged commands are received, those command will be executed in LIFO(Last in First out) order.

### 9.1.17.3 ORDERED QUEUE TAG (22h)

This tagged command is executed in the order received. All commands received before this command should be executed before this command, and all commands received after this commands should be executed after this command.

## 9.1.18 IGNORE WIDE RESIDUE (23,01h)

Byte	Value	Description
0	23h	Message Code
1	01h	Ignore

Figure 115. Ignore Wide Residue

The Ignore Wide Residue Message is sent from the Target to indicate that the number of valid bytes sent during the last REQ/ACK hand shake of a DATA IN phase is less than the negotiated transfer width. The ignore field (always = 01h) indicates that one byte (data bit 8-15) should be ignored. This message is sent immediately following the DATA IN phase and prior to any other messages. Even though a byte is invalid, it's corresponding parity bit is valid for the value transferred.

## 9.1.19 IDENTIFY (80 - FF)

This message is set by either the initiator or the file to establish the logical path connection between the two devices.

The IDENTIFY message is defined as follows:

- Bit 7** This bit is always set to one to distinguish the IDENTIFY message from other messages.
- Bit 6** This bit is only set to one by the initiator to grant the file the privilege of disconnecting. If this bit is zero, the file will not disconnect, unless the initiator instructs the file to disconnect by sending a DISCONNECT Message to the file. This bit is set to zero when the file sends an IDENTIFY message to the initiator.
- Bits 5-3** These bits are reserved and must be zero for an IDENTIFY message.  
**Note:** If an invalid Identify message is received with these bits not equal to zero, then the file sends a MESSAGE REJECT message to the initiator and goes to the Bus Free phase to signal a catastrophic error condition.
- Bits 2-0** These bits specify the logical unit number (LUN).  
Only one LUN may be identified for any one selection sequence. If the file receives an IDENTIFY message with a new LUN after the LUN had previously been identified, the file will go to the BUS FREE phase to signal a catastrophic error. The initiator may send more than one Identify message during a selection sequence in order to toggle disconnect/reconnect permission if the specified LUN remains the same.

When the IDENTIFY message is sent from the file to the initiator during reconnection, an implied RESTORE POINTERS message must be performed by the initiator.

---

## 9.2 Supported Message Functions

The implementation of the supported messages will also include the following functions.

- Retry SCSI Command or STATUS phase  
The retry will be caused by the following error condition.
  - The file detected SCSI bus parity error(Command phase)

- The file receives INITIATOR DETECTED ERROR MESSAGE during or at the conclusion of an information transfer phase (Command Data Out or Status Phase)  
**Note:** The initiator may send the INITIATOR DETECTED ERROR message as a result of an initiator detected SCSI Bus parity error or an internal error.
- Retry MESSAGE IN phase
  - The retry will be caused by the receipt of a MESSAGE PARITY ERROR message immediately following a MESSAGE IN phase.  
**Note:** The Initiator may send the MESSAGE PARITY ERROR message as a result of an Initiator detected SCSI Bus parity error during the Message In phase.
- Receipt of multiple Identify message
  - The initiator is allowed to send multiple IDENTIFY messages out in order to toggle the disconnect/reconnect permission bit. This may be used to selectively enable or disable disconnect/reconnect permission during portions of a command. Note that this function does not effect the operation of the Forced Disconnect function.
- MESSAGE REJECT during Target Disconnection
  - If the Initiator rejects the SAVE DATA POINTER message, the file will disable disconnect/reconnect permission. This is equivalent to receiving an IDENTIFY message with bit 6 equal to zero. This will cause to file to inhibit the pending disconnection.
  - If the initiator rejects the DISCONNECT message, the file will not disconnect but may attempt to disconnect at a later time. This function may be used to selectively disable disconnection during portions of a command.

---

## 9.3 Attention Condition

The attention condition allows an initiator to inform the file that a MESSAGE OUT phase is desired. The initiator may create the attention condition by asserting the ATN signal at any time except during the ARBITRATION or BUS FREE phases.

The initiator must create the attention condition by asserting the ATN signal least two deskew delays before releasing ACK for the last byte transferred in a bus phase to guarantee that the attention condition will be honoured before transition to a new bus phase. This will guarantee a predictable file response to message received during the MESSAGE OUT phase for this attention condition. If the ATN signal is asserted later, it might be honoured in the current bus phase or the next bus phase and then may not result in the expected action.

After the initiator asserts the ATN signal, the file will respond with the MESSAGE OUT phase as follows:

Current Phase	Response
<b>COMMAND</b>	Message Out phase will occur after part or all of the Command Descriptor Block has been transferred to the file. The initiator must continue REQ/ACK handshakes during the Command phase until the file enters the MESSAGE OUT phase.
<b>DATA</b>	The MESSAGE OUT phase will occur after part or all of the data bytes have been transferred and not necessarily on a logical block boundary. The initiator must continue REQ/ACK handshakes (asynchronous transfer) until it detects the phase change.  <b>Note:</b> In synchronous transfer, the initiator must continue sending ACK pulses to reach an offset of zero.
<b>STATUS</b>	The MESSAGE OUT phase will occur after the REQ/ACK handshake of the status byte has been completed.
<b>MESSAGE IN</b>	The MESSAGE OUT phase will occur before the file sends another message.
<b>SELECTION</b>	If ATN occurs during a SELECTION phase and before the initiator releases the BSY signal, the MESSAGE OUT phase will occur immediately after that SELECTION phase.
<b>RESELECTION</b>	The MESSAGE OUT phase will occur after the file has sent its IDENTIFY message for that RESELECTION phase. (First the file tries to complete the reselection.)

The initiator must keep the ATN signal asserted if more than one message byte is to be transferred during the MESSAGE Out phase. The file will process each message byte (multiple-bytes for an extended message) prior to receive the next message from the initiator. The file will continue to handshake and process byte(s) in the MESSAGE OUT phase until ATN goes false unless one of the following condition occurs:

1. The file receives an illegal or inappropriate message and goes to the MESSAGE IN phase to send a MESSAGE REJECT message.
2. The file detects a catastrophic error condition and goes to the BUS FREE phase.

---

## 9.4 SCSI Bus Related Error Handling Protocol

This protocol is used to handle error that threaten the integrity of a connection between the Target and an Initiator.

## 9.4.1 Unexpected BUS FREE Phase Error Condition

There are several error conditions that will cause the file to immediately change to the BUS FREE phase, regardless of the state of the ATN signal. The file will not attempt to reconnect to the initiator to complete the operation that was in progress when the error condition was detected. The initiator should interpret this as a catastrophic error condition.

If the LUN was identified by the file prior to the error condition, then the file will abort the active command for this initiator/LUN and generate sense data for this initiator/LUN to describe the cause of the catastrophic error. The initiator may retrieve this sense data by issuing a REQUEST SENSE command to this LUN. Note however, that the REQUEST SENSE command may fail if the catastrophic error condition persists.

If the LUN was not identified by the file prior to the error condition, then the file will not affect the sense data or the operation of any currently executing command for this initiator or any other initiator.

## 9.4.2 MESSAGE OUT Phase Parity Error

If the file detects a parity error during the MESSAGE OUT phase, the file will retry the MESSAGE OUT phase one time as follows:

1. Continue the REQ/ACK handshakes until the initiator drops ATN. The file will ignore all the remaining MESSAGE OUT phase bytes received after the parity error.
2. Assert the REQ signal prior to changing to any other phase. After detecting this condition, the initiator must resend all of the previous message byte(s) sent during this MESSAGE OUT phase.
3. Repeat the transfer of the MESSAGE OUT phase bytes(s). If the file receives all of the message byte(s) successfully, the file will change to:
  - Any other information transfer phase and transfer at least one byte.
  - BUS FREE phase if the message received was ABORT or BUS DEVICE RESET.

If a second parity error is detected, the target will abort the current command with CHECK CONDITION status and sense data of ABORTED COMMAND / SCSI PARITY ERROR .

## 9.4.3 MESSAGE IN Phase Parity Error (Message Parity Error)

If the file receives a MESSAGE PARITY ERROR message, it is considered a retrievable error. The file will do the following one time if no previous retrievable error and if a MESSAGE IN phase has just occurred:

1. Change phase to MESSAGE IN.
2. Send the last message again.

If this is the second retrievable error, the file will terminate the current command as follows:

1. Change to the BUS FREE phase, regardless of the state of the ATN signal.
2. Abort the active command for this initiator/LUN and set the sense data to ABORTED COMMAND / SCSI PARITY ERROR.

## 9.4.4 COMMAND Phase Parity Error

1. Change phase to MESSAGE IN and send a RESTORE POINTERS message.
2. If RESTORE POINTERS message is accepted, then change phase to COMMAND OUT and receive the command again.

If a second parity error is detected, the file will abort the current command with CHECK CONDITION status and sense data of ABORTED COMMAND / SCSI PARITY ERROR .

## 9.4.5 DATA OUT Phase Parity Error

If the file detects a parity error during DATA OUT phase, the file will abort the current command with CHECK CONDITION status and sense data of ABORTED COMMAND / SCSI PARITY ERROR.

## 9.4.6 INITIATOR DETECTED ERROR Message

An INITIATOR DETECTED ERROR message is valid after a COMMAND, DATA IN/OUT or STATUS phase has occurred. If any other phase has occurred, the message is rejected.

The recovery for COMMAND and STATUS phase consists of:

1. Change phase to MESSAGE IN and send a RESTORE POINTERS message
2. Repeat previous information phase .

If a second INITIATOR DETECTED ERROR message is received in the same selection, the target will abort the current command with CHECK CONDITION status and a Sense key of ABORTED COMMAND with additional sense code of INITIATOR DETECTED ERROR.

If a INITIATOR DETECTED ERROR message is received during a DATA IN/OUT phase, the target will abort the current command with CHECK CONDITION status and a Sense key of ABORTED COMMAND with additional sense code of INITIATOR DETECTED ERROR.

## 9.4.7 MESSAGE REJECT Message

The file will take the following actions after receiving the MESSAGE REJECT message in response to messages listed below.

**DISCONNECT** The file will not disconnect but remains connected.

**COMMAND COMPLETE** No error, continue to bus free.

**IDENTIFY** Command aborted - bus freed - Sense data set to MESSAGE REJECT ERROR.

**LINKED CMD CMLPT** Command aborted - link broken - bus freed - sense data set to MESSAGE REJECT ERROR.

**MESSAGE REJECT** Command aborted - STATUS phase executed with CHECK CONDITION - sense data set to MESSAGE REJECT ERROR.

**RESTORE POINTERS** Command aborted - status set to CHECK CONDITION - sense will be set with the error that caused the RESTORE POINTERS message to be issued. (Assuming that error recovery is in progress)

**SAVE DATA POINTER** The file will not disconnect from the SCSI bus. It will not be considered an error.

**No previous Msg** The command is aborted, the bus freed, and Sense data is set to MESSAGE REJECT ERROR. This occurs when the file has not sent a message, but gets a MESSAGE REJECT from the initiator.



## **10.0 SCAM**

---

### **10.1 SCAM Level 1 ( SCAM-1 )**

- A reset condition shall cause an exit from any state and places the drive in the Reset Delay state.
- When a drive is powered-on, it immediately enters the Power-On Delay state and may perform local initialization. The drive shall leave this state and enter the SCAM Monitor state within a SCAM power-on to SCAM selection delay.
- While in the SCAM Monitor state, a drive shall monitor the SCSI bus for both SCAM selection and normal SCSI selection. If the drive detects the initiation of SCAM protocol, it shall enter the ID Assignable state.
- If a SELECTION phase for the drive's current ID is continuously valid for at least a SCAM unassigned ID selection response delay, the drive shall respond to selection and assert the BSY signal. This response to selection implicitly causes the drive to enter the ID Assigned state just as if an explicit ID assignment had been received. The assigned ID is set to the current ID and the drive now functions as a SCAM tolerant device.
- A drive remains in the ID Assignment state as long as SCAM protocol is maintained until explicit SCAM functions change its state.
- If a drive is isolated and receives an Assign ID action code, the ID specified becomes both the current and assigned ID. The drive releases all SCSI bus signals and enters the Assigned ID state.
- If a drive receives a Configuration Process Complete function code or if SCAM protocol is terminated (the C/D signal is false), it shall release all SCSI bus signals and enter the ID Unassigned state.
- A drive in the ID Unassigned state has not had any SCSI ID explicitly or implicitly assigned and shall not respond to SCSI selections for its current ID regardless of the duration.
- When the exception of a power-on or reset condition, only the detection of SCAM protocol initiation shall cause the drive to leave the ID Unassigned state.
- Once a drive has reached the ID Assigned state it functions as a SCAM tolerant device with the ID assigned. That is, it shall respond to SCSI selection within a SCAM tolerant selection response time and shall not recognize nor respond to SCAM selection.
- A reset condition shall cause a SCAM target to enter the Reset Delay state, in which it may perform local initialization. The drive shall leave this state and enter the SCAM monitor state within a SCAM reset to SCAM selection time.

---

## 10.2 SCAM Level 2 ( SCAM-2 )

- A reset condition shall cause an exit from any state and places the drive in the Reset Delay state.
- When a drive is powered-on, it immediately enters the Power-On Delay state and may perform local initialization. The drive shall leave this state and enter the Initiate SCAM Protocol state within a SCAM power-on to SCAM selection delay.
- In the Initiate SCAM Protocol state, a drive shall arbitrate for the SCSI bus without an ID and perform SCAM selection. After a SCAM selection delay the drive shall examine the SCSI bus to determine the state of the C/D signal. If the C/D signal is true, there is a SCAM initiator present and the drive shall enter the ID Assignable state. If the C/D signal is false, no SCAM initiator is present and the drive shall enter the SCAM Monitor state. Note that a drive make only one attempt to initiate SCAM protocol after power-on.
- While in the SCAM Monitor state, a drive shall monitor the SCSI bus for both SCAM selection and normal SCSI selection. If the drive detects the initiation of SCAM protocol, it shall enter the ID Assignable state.
- If a SELECTION phase for a drive's current ID is continuously valid for at least a SCAM unassigned ID selection response delay, the drive shall respond to selection and assert the BSY signal. This response to selection implicitly causes the drive to enter the ID Assigned state just as if an explicit ID assignment had been received. The assigned ID is set to the current ID and the drive now functions as a SCAM tolerant device.
- A drive remains in the ID Assignment state as long as SCAM protocol is maintained until explicit SCAM functions change its state.
- If a drive is isolated and receives an Assign ID action code, the ID specified becomes both the current and assigned ID. The drive releases all SCSI bus signals and enters the Assigned ID state.
- If a drive receives a Configuration Process Complete function code or if SCAM protocol is terminated (the C/D signal is false), it should release all SCSI bus signals and enter the ID Unassigned state.
- A drive in the ID Unassigned state has not had any SCSI ID explicitly or implicitly assigned and shall not respond to SCSI selections for its current ID regardless of the duration.
- When the exception of a power-on or reset condition, only the detection of SCAM protocol initiation shall cause the drive to leave the ID Unassigned state.
- Once a drive has reached the ID Assigned state it functions as a SCAM tolerant device with the ID assigned. That is, it shall respond to SCSI selection within a SCAM tolerant selection response time and shall not recognize nor respond to SCAM selection.
- A reset condition shall cause a drive to enter the Reset Delay state, in which it may perform local initialization. The SCAM target shall leave this state and enter the SCAM monitor state within a SCAM reset to SCAM selection time.

## 10.3 Identification string

Following string shall be sent out as the Identification string when the Isolation stage.

byte	Note	DORS-31080 50-pin	DORS-32160 50-pin	DORS-31080 68/80-pin	DORS-32160 68/80-pin
0	Type code	A3h		93h	
1		Default ID			
2	vendor identifi- cation			'I'	
3				'B'	
4				'M'	
5				' '	
6				' '	
7				' '	
8				' '	
9				' '	
10	Product ID	'D'	'D'	'D'	'D'
11		'O'	'O'	'O'	'O'
12		'R'	'R'	'R'	'R'
13		'S'	'S'	'S'	'S'
14		'3'	'3'	'3'	'3'
15		'1'	'2'	'1'	'2'
16		'0'	'1'	'0'	'1'
17		'8'	'6'	'8'	'6'
18		'0'	'0'	'0'	'0'
19		' '	' '	'W'	'W'
20		' '	' '	' '	' '
21		' '	' '	' '	' '
22	serial number	serial number (ASCII)			
23					
24					
25					
26					
27					
28					
29					
30	not used	' '			

Figure 116. SCAM Identification string

---

## 10.4 Function codes

The following function codes are supported.

---

Function Code	Description
00000b	Isolate
00001b	Isolate and set priority flag
00011b	Configuration process complete
01111b	Dominant initiator contention
11111b	Synchronization
others	reserved

---

Figure 117. SCAM Identification string

- **Isolate** This function code may be used by SCAM initiators to assign ID's to SCAM device. After the function code, SCAM targets with unassigned ID's participate in an isolation stage. This stage normally terminates with a single SCAM target isolated.
- **Isolate and set priority flag** This function code operates exactly as the Isolate function described above except that the only valid action codes are those that assign an ID to the isolated device(s). This function also causes the device's priority flag to be set to one.
- **Configuration process complete** This function code is issued by the dominant SCAM initiator when the bus configuration is complete and no further ID's are to be assigned. The drive with an unassigned ID that observes this function code shall not respond to selection until a reset condition, power on or the assignment of an ID during a subsequent SCAM protocol invocation.
- **Dominant initiator contention** This function code selects one SCAM initiator, called the dominant SCAM initiator, from possibly multiple SCAM initiators. When this function code is detected, the drive shall do nothing but keep monitoring the bus until next valid function code is detected.
- **Synchronization** This function code is issued to begin a new function sequence. When this function code is detected, SCAM target shall begin a new function sequence regardless of whether the previous function sequence has been completed.

---

## 10.5 Action codes

The following Action codes are supported.

---

First quintet	Second quintet	Description
11000b	ccnnb	Assign ID 00nnb
10001b	ccnnb	Assign ID 01000b
10100b	11000b	Clear priority flag
	10010b	Locate on
	01011b	Locate off
	others	Reserved
others		Reserved

note. cc is the count of zero bits in nnn.

---

Figure 118. Action codes

- **Assign ID** An action code is valid if the check bits are correct and both quintets are received. ID assignment action codes shall also specify an ID that the device can support. Isolated device(s) perform a valid action code when it is received. Transfer cycles after a valid action code and preceding the next synchronization pattern shall be ignored.
- **Clear priority flag** This action code instructs the isolated device(s) to clear the priority flag. This function is typically used when the SCAM initiator wishes to defer the assignment of an ID to the isolated device(s) until a later function sequence.
- **Locate On and Off** These action codes instruct the isolated device(s) to provide assistance for user or service personnel to physically locate the device. Locate on shall make the led turned on and Locate off shall make the led turned off.



---

## 11.0 Additional Information

This chapter provides additional information or descriptions of various functions, features, or operating models supported by the Target that are not fully described in previous chapters.

---

### 11.1 SCSI Protocol

There are various operating conditions that prevent the Target from executing a SCSI command. This section describes each of these operating conditions and their relative priority.

#### 11.1.1 Priority of SCSI Status Byte Reporting

After establishing the I\_T\_L nexus or I\_T\_L\_Q nexus, the Target must first determine whether command execution is allowed. Execution is deferred until a later time if the command must be added to the command queue. Execution may also be prevented by an internal Target condition that requires the reporting of a Check Condition, Queue Full, Busy or Reservation Conflict Status. There are several different internal conditions to be active at the same time. The order in which the Target checks for each of these conditions determines their priority(highest priority first) as follows:

1. Check Condition status for invalid Logical Unit Number. (see 11.1.2, “Invalid LUN in Identify Message”)
2. Check Condition status for Incorrect Initiator Connection(see 11.1.3, “Incorrect Initiator Connection” on page 170)
3. Busy Status or Queue Full Status (see 11.1.4, “Command Processing During Execution of Active I/O process” on page 170)
4. Check Condition status for Unit Attention condition(see 11.1.5, “Unit Attention Condition” on page 172)
5. Check Condition status during Start-up and Format operations(see 11.1.6, “Command Processing During Start-up and Format Operations” on page 173)
6. Check Condition status for Deferred Error Condition(see 11.1.8, “Deferred error” on page 173)
7. Reservation Conflict status(see 11.1.11, “Command Processing While Reserved” on page 175)
8. Check Condition status for invalid command opcode
9. Check Condition status for invalid command descriptor block

The highest priority internal condition that prevents command execution is reported by the Target, provided there is no bus error.

For all Check Conditions, Sense data is built by the target provided a valid LUN address is known. Sense data is cleared by the Target upon receipt of any subsequent command to the LUN from the initiator receiving the Check Condition.

#### 11.1.2 Invalid LUN in Identify Message

There are three different circumstances defined within the SCSI protocol when the response to an invalid LUN will occur. Each of these result in a different response.

### 11.1.2.1 Case 1 - Selection message sequence with Inquiry command

The INQUIRY command is a special case in SCSI. It is used to configure the bus when file IDs and LUNs are not known. The proper response is to return the inquiry data with a peripheral drive type of 1Fh which indicates that the specified LUN is not supported.

### 11.1.2.2 Case 2 - Selection message sequence with any other command

Any other commands, except REQUEST SENSE, return CHECK CONDITION status when an invalid LUN is specified in the message sequence following selection. In response to a REQUEST SENSE command the target shall return sense data. The sense key shall be set to ILLEGAL REQUEST and the additional sense code shall be set to LOGICAL UNIT NOT SUPPORTED.

### 11.1.2.3 Case 3 - After selection message sequence

It is permissible for the initiator to issue multiple IDENTIFY messages during a single command sequence provided to LUN remains the same. If the LUN is altered, the file goes to a Bus Free Phase.

## 11.1.3 Incorrect Initiator Connection

It is an Incorrect Initiator Connection error if any of the following occurs:

- an Initiator attempts to establish an I\_T\_L nexus when an I/O process (either queued or active) with an I\_T\_L nexus already exists from a previous connection with the same initiator.
- an Initiator attempts to establish an I\_T\_L\_Q nexus when an I\_T\_L nexus already exists from a previous connection with the same initiator.
- an Initiator attempts to establish an I\_T\_L nexus when an I\_T\_L\_Q nexus already exists from a previous connection with the same initiator.

**Note:** It is not an Incorrect Initiator Connection to send a command without a Queue tag message when sense is pending on the logical unit for the Initiator that issues the Request Sense command. (If the command is not Request Sense nor Inquiry, sense data is cleared at receipt of the command. )

- an Initiator attempts to establish an I\_T\_L\_Q nexus when an I/O process (either queued or active) with an I\_T\_L\_Q nexus already exists from a previous connection with the same initiator.

If any of the above errors occur, all queued I/O processes and active I/O processes associated with the issuing Initiator on the specified logical unit are terminated. The current I/O process is ended with a CHECK CONDITION status, the sense key is set to ABORTED COMMAND and the additional sense code is set to OVERLAPPED COMMANDS ATTEMPTED. Status is only returned for the current I/O process.

## 11.1.4 Command Processing During Execution of Active I/O process

When the Target is not executing any active I/O processes, a new I/O process is permitted to execute (unless execution is prevented by another internal Target condition listed in 11.1.1, “Priority of SCSI Status Byte Reporting” on page 169).

If an active I/O process does exist when the Target receives a new command, then the Target determines if:

- Check Condition Status with Sense Key = Aborted Command is returned for an Overlapped Commands Attempted error
- the command is permitted to execute
- the command is added to the command queue



- Queue Full Status is returned
- Busy Status is returned

If an active I/O process does exist when the Target receives a new command, then the Target determines how the new command should be handled based on the following rules:

- Check Condition Status is returned with Sense Key set to Aborted Command for an Overlapped Commands Attempted error if:
  - See 11.1.3, “Incorrect Initiator Connection” on page 170
- the command is permitted to execute if
  - the command is an Inquiry or Request Sense command
- Check Condition Status is returned with Sense Key set to Logical Unit Not Ready if:
  - the start-up operation or format operation is an active process.
- the command is permitted to execute if
  - the conditions to execute concurrently are met. (See 11.5, “Concurrent I/O Process” on page 178)
- the command is added to the command queue for an I\_T\_L nexus if:
  - no Queue Tag message was received during the connection which established the I/O process, and
  - disconnection is allowed for the current I/O process, and
  - there is no queued I/O process or active I/O process corresponding to the I\_T\_L nexus for the current I/O process, and
  - the command is not linked to a previous command.
- the command is added to the command queue for an I\_T\_L\_Q nexus if:
  - a Queue Tag message was received during the connection which established the I/O process, and
  - Tagged Queuing is enabled(DQue = 0), and
  - an I/O process(either active or queued) exists at the Target for this Initiator, and
  - disconnection is allowed for the current I/O process, and
  - there is no queued I/O process or active I/O process corresponding to the I\_T\_L\_Q nexus for the current I/O process, and
  - the command is not linked to a previous command.
- Queue Full Status is returned if:
  - the command would otherwise be queued (according to the rules described above) but the command queue is full and all slots are utilized, or
  - the command would otherwise be queued (according to the rules described above) but all of the available command queue slots not reserved for use by another initiator are utilized, or
  - Tagged Queuing is enabled(DQue = 0) and a Format Unit command was previously queued but has not yet begun execution, or
  - Tagged Queuing is enabled(DQue = 0) and a Start Unit command was previously queued but has not yet begun execution.
- Busy Status is returned if:
  - Tagged Queuing is disabled(DQue = 1) and a Format Unit command was previously queued but has not yet begun execution, or
  - Tagged Queuing is disabled(DQue = 1) and a Start Unit command was previously queued but has not yet begun execution, or

- the command would otherwise be queued (according to the rules described above) but disconnection is not allowed for the current I/O process, or

If a command is queued, command execution may still be prevented at a later time when the command is dequeued to become an active I/O process. This occurs if command execution is prevented by another internal Target condition listed in 11.1.1, “Priority of SCSI Status Byte Reporting” on page 169 at the time the command is dequeued.

### 11.1.5 Unit Attention Condition

The file will generate a unit attention condition for each initiator whenever:

- The file has been reset.  
This includes Power On Reset, SCSI Bus Reset, SCSI BUS DEVICE RESET message.
- The mode parameters in effect for this initiator has been changed by another initiator.
- The microcode has been changed.  
WRITE BUFFER command has been executed to download microcode. In this case, a unit attention condition is generated for all initiators except the one that issued the command.
- Commands are cleared by another initiator.  
This condition is generated against the initiator that has queued commands, if ...
  - Clear Queue Message is received.
  - Contingent Allegiance Condition is cleared when QERR (in Mode Page 0A) is 1.
  - DQue is set to 1 while queued command exist.

The unit attention condition persists for each initiator until that initiator clears the condition as described in the following paragraphs.

If the file receives a command from each initiator before reporting a CHECK CONDITION status for a pending unit attention condition for that initiator, the file's response varies with the command as follows.

**INQUIRY** The file executes the command with GOOD status and preserves the unit attention condition.

**REQUEST SENSE**

If the file has an available pending sense data for the initiator, the file sends the pending sense data and preserves the unit attention condition for the initiator.

If the file does not have an available pending sense data for the initiator, the file sends sense data for the unit attention condition and clears the unit attention condition for the initiator.

**ALL OTHER** The file terminates the command with a CHECK CONDITION status and preserves the unit attention condition.

If the file receives a command from each initiator after reporting a CHECK CONDITION status for a pending unit attention condition for that initiator, the file's response varies with the command as follows.

**REQUEST SENSE** The file sends the sense data for a pending unit attention condition and returns GOOD status. And the file clears the unit attention condition for the initiator.

**ALL OTHER** The file executes the command with GOOD status and clears the unit attention condition unless another unit attention condition exists. And then the sense data for the unit attention condition is lost.

## 11.1.6 Command Processing During Start-up and Format Operations

If the Target receives a command from an Initiator while the Target is executing a start-up or format operation, The Target's response varies with the command as follows:

<b>INQUIRY</b>	The file sends inquiry data and returns appropriate status.
<b>REQUEST SENSE</b>	Executes the command, returns a Sense key of NOT READY and an Additional Sense Code of LOGICAL UNIT NOT READY and returns GOOD STATUS.  The Additional Sense Code Qualifier that is returned depends on type of I/O processes that are active:  For the START/STOP UNIT and the Auto-start operation, the qualifier returned is LOGICAL UNIT IS IN PROCESS OF BECOMING READY. For the FORMAT UNIT command, the qualifier returned is LOGICAL UNIT NOT READY,FORMAT IN PROGRESS, and the Sense key specific bytes are set to return the progress indication.
<b>ALL OTHER</b>	The file terminates the command with CHECK CONDITION status. The Sense data generated is described in Request Sense above.

## 11.1.7 Internal Error Condition

The Target generates an Internal Error condition for all Initiators when:

- an internally initiated operation ends with an unrecoverable error. i.e. The start-up sequence for Auto Start enabled terminates after the SCSI bus has been enabled and prior to completion of the bring-up sequence.

An Internal Error condition causes Sense data to be generated and saved for all Initiators. The Error Code field of the Sense is set for a Current Error(70h) and the Sense Key is set to HARDWARE ERROR. Recovered errors are not reported.

The Internal Error condition persists for each Initiator until that Initiator clears the condition from the logical unit as described below. Several commands are handled as special cases during an Internal Error condition. These cases are also discussed.

If the Target receives a command from an Initiator while an Internal Error condition exists for that Initiator, the Target's response varies with the command as follows:

<b>INQUIRY</b>	The file executes the command with GOOD status and do not clear the Internal Error condition.
<b>REQUEST SENSE</b>	The file executes the command, return the sense data generated by the Internal Error condition, return Good Status, and clear the Internal Error condition for that Initiator.
<b>ALL OTHER</b>	The file terminates the command with a CHECK CONDITION status and clear the Internal Error condition.

## 11.1.8 Deferred error

Error code (71h) of sense data indicates that the Check Condition status returned is the result of an error or exception condition that occurred during execution of a previous command for which Good status has already been returned.

The drive creates an Deferred Error condition when :

- Execution of a Start/Stop Unit command with the immediate bit of one ends with an error.

- Execution of a Format Unit command with the immediate bit of one ends with an error.
- Execution of a Write command with WCE (write cache enable) bit of one ends with an error.

### 11.1.9 Degraded Mode

There are certain errors or conditions which may impair the file's ability to function normally. Rather than fail hard, the file is designed to be as responsive as possible. Also, in most cases, some action on the part of the initiator may be used to restore normal operation. This mode of limited operation is called Degraded Mode.

### 11.1.10 Degraded Mode Handling

If any degraded mode condition occurs an initiator will receive a sense key of Hardware error (4h) in the next sense data requested. After clearing the sense key, the drive accepts commands according to the status of the degraded mode.

The following table shows the degraded mode status with acceptable commands and additional sense codes. If a degraded mode exists, the Hardware error condition caused by the degrade mode will be recreated after every POR, SCSI Reset or Bus Device Reset message. The following list shows the various operation modes.

#### 11.1.10.1 Degraded Mode Entry Condition/Consequence State

Degraded Mode	Entry Reason	Accepting Request	Description and sense code
Power on Self Test fail	<ul style="list-style-type: none"> <li>• Failure of a start-up sequence</li> </ul>	<ul style="list-style-type: none"> <li>• Request Sense</li> <li>• Inquiry</li> <li>• Start/Stop unit</li> <li>• Write Buffer(except download and save)</li> </ul>	The integrity of the drive is questionable. Sense code = 4080 (diagnostic fail )

Degraded Mode	Entry Reason	Accepting Request	Description and sense code
Spin-up	Can not start up motor	<ul style="list-style-type: none"> <li>• Request Sense</li> <li>• Inquiry</li> <li>• Start/Stop unit</li> <li>• Write Buffer(except download and save)</li> </ul>	Return Spin-up Degraded Mode. Sense code = 0400
U-code	Can not read u-code	Same as Spin-up Degrade	Return U-code Degraded Mode. Sense code = 4085 (u-code download fail)
Reserved Area	<ul style="list-style-type: none"> <li>• Fail to read drive configuration data</li> <li>• Fail to read Defect list</li> <li>• Fail to read saved Mode Parameter</li> </ul>	All commands.	Reserved area sector valid check failed. Defective sector found in reserved area. (Hard Error) The integrity of the drive is questionable. Sense code = 4080 (diagnostic fail),

### 11.1.11 Command Processing While Reserved

A logical unit is reserved after successful execution of the Reserve command. Each time a Reserve command is executed successfully, the Target records the SCSI ID of the Initiator that made the reservation and the SCSI ID of the Initiator that is to receive the reservation. This information is needed to determine whether subsequent commands should be permitted or if the Reservation Conflict Status should be reported. The Initiator that made the reservation is the Initiator that issued the Reserve command. The Initiator to receive the reservation may be either the same or a different Initiator(third-party reservation).

If the logical unit is reserved when a new command is received, the Target examines the command opcode and the SCSI ID of the issuing Initiator to determine whether a Reservation Conflict Status should be returned based on the following rules:

1. If the issuing Initiator is the one that made the reservation and also the one to receive the reservation then:
  - All commands are permitted.
2. If the issuing Initiator is neither the one that made the reservation nor the one to receive the reservation then:
  - A Request Sense or Inquiry command is permitted.

- A Release command is permitted but is ignored.
  - Any other command results in a Reservation Conflict Status.
3. If the issuing Initiator is the one that made the reservation but is not the one to receive the reservation then:
- An Inquiry, Request Sense, Reserve, or Release command is permitted.
  - Any other command results in a Reservation Conflict Status.
4. If the issuing Initiator is not the one that made the reservation but is the one to receive the reservation then:
- An Reserve command results in a Reservation Conflict Status.
  - A Release command is permitted but is ignored.
  - Any other command is permitted.

If a Reservation Conflict Status is not reported and the command is permitted, then the Target checks the next highest priority internal condition to determine whether execution is allowed. See 11.1.1, “Priority of SCSI Status Byte Reporting” on page 169

---

## 11.2 Priority Commands

Certain SCSI commands always execute without returning a Busy Status, Reservation Conflict Status in response to the command. These commands are:

- Inquiry
- Request Sense

These commands do not disconnect from the SCSI bus prior to completion. They are executed prior to attempting to complete the execution of any other pending command that has disconnected from the SCSI bus. Therefore, a second priority command cannot be received during the execution of a priority command.

These commands are never queued whether or not the command is sent with a queue tag. However, the rule for an Incorrect Initiator Connection still apply to priority commands.(see 11.1.3, “Incorrect Initiator Connection” on page 170)

---

## 11.3 Command Queuing

When the initiator specifies that the file shall disable command queuing, the initiator must send only untagged command. When the initiator specifies that the target shall enable command queuing, the initiator may send either tagged or untagged command, but shall not use both at the same time.

The following commands are never queued and will be immediately executed without Bus disconnection

- Priority Commands(i.e.: Request Sense and Inquiry)
- Commands linked to previous commands. These are defined to be part of a single I/O process. (Linked commands are always executed immediately following the previous command from the same initiator. No other Initiator's command are allowed to be executed between two linked commands.)
- Commands for which disconnection is not allowed.(These may result in a Busy Status.)

- Commands in which a SCSI bus error occurred between selection and first disconnection following the receipt of the CDB.
- Commands for an invalid LUN.
- Commands which cause an OVERLAPPED COMMANDS ATTEMPTED error (see 11.1.3, “Incorrect Initiator Connection” on page 170).

### 11.3.1 Queue Depth

The file has 38 queue elements. Seven of these are reserved for the seven possible initiator's that may connect to the file. This leaves a pool of 31 queue elements which are shared by all initiators on a first come first served basis. Any initiator can queue at least one command at any time irrespective of the actions of any other initiators in the system. A single initiator may queue up to 32 commands, if no other initiator has more than one command in the queue, although at times this maximum may be reduced as the file can reserve command blocks for internal use.

### 11.3.2 Tagged Queuing

Commands with a tag message are saved in the command queue. Queued commands will be reordered by the target defined rule. See the section on Reordering 11.4, “Command Reordering” on page 178 for details.

### 11.3.3 Untagged Queuing

The target supports queuing one I/O process from each initiator. If the target receives an untagged I/O process while executing an I/O process from a different initiator, the untagged I/O process may be queued.

Untagged I/O processes are treated by the target as though they were received with Simple Queue Tag messages for purposes of queuing.

**Note:** There is no guarantee that I/O processes are executed in the order they were received in a multiple initiator environment when Untagged Queuing is enabled.

### 11.3.4 Command Queuing Rule

Commands can be received during an active I/O process if Bus is free. If CPE (concurrent process enable) bit of Mode page 0 is 0, only a single command except 2 commands (Inquiry and Request Sense) can be executed at the same time. In that case, a command starts to be executed after the previous command has completed. If CPE (concurrent process enable) bit of Mode page 0 is 1, I/O processes of Read(6), Read extend(10), Write(6) and Write extend(10) can be active at the same time. See 11.5, “Concurrent I/O Process” on page 178 for details.

### 11.3.5 Queue Full Status

This status is returned when a Simple Queue tag, Ordered Queue tag or Head of Queue tag message is received and the command queue is full. The I/O process is not placed in the command queue. Since one queue element is reserved for each initiator, any untagged command that doesn't cause Incorrect Initiator Connection will not cause Queue Full status.

### 11.3.6 Device Behaviour on Command Queuing

1. Initiators must send a Queue tag immediately after the Identify message in Message Out phase just after Selection. Targets send a simple queue tag immediately after the Identify message in Message In phase just after Reselection.
2. Each initiator can issue either one of tagged command or untagged command exclusively at the same time. There can exist other initiator using the other.
3. When DQue (Disable queue) of mode page 0Ah is 1, if an initiator issues a tagged command, the drive returns "Message Reject" message (07h) and receives that command as an untagged command.
4. Queue Tag number doesn't affect the order to execute.
5. An initiator issues a command with a queue tag which is same as the current I/O process or queued I/O process, the target returns Incorrect Initiator connection.
6. A series of linked commands are a single I/O process, and are assigned the queue tag established in the initial selection. A command received with a Head-of-Queue tag message shall not suspend a series of linked commands for which the target has begun execution.
7. If DQue is changed to 1 while queued commands exist, all queued commands for the all initiators will be aborted. All future commands received, from any initiator, with a queue tag will be processed as untagged commands, with a message reject message being returned immediately after the qtag is received by the target.

---

## 11.4 Command Reordering

Command reordering function is supported under tagged command queuing enabled (DQue = 0). The reorder feature reorders Read/Write commands in order to minimize seek time between commands. This function will improve total thruput of the drive.

---

## 11.5 Concurrent I/O Process

The Concurrent I/O process is that plural I/O processes are active (not queued) on the same logical unit at the same time. The target may start the data phase of an I/O process while another I/O process is not completed. The following I/O processes are allowed to executed concurrently.

- Unlinked and untagged Request Sense and Inquiry during execution of other commands.
- When CPE (Concurrent process enable) bit is 1, one of the following commands can be executed during another one or the same one of the following commands is being executed, if those are untagged or simple tagged commands.
  - Read(6), Read extend(10)
  - Write(6), Write extend(10)

When an I/O process ends in Check Condition Status, the drive enters the Contingent Allegiance Condition and other queued I/O processes from all initiators on the same logical unit will not reconnect and will not complete the execution until the sense data is cleared. See 11.16, "Contingent Allegiance Condition" on page 186 for details. If an I/O process (P-1) encounters an error while another I/O process (P-2) is active, the drive returns Check Condition to P-1 and P-2. The drive may continue P-2 until its convenient point to suspend, but may not send a Status. After the initiator clears the Contingent Allegiance condition, the drive will resume or terminate P-2 according to QErr bit of Control mode page.



If the drive gets an error of P-2 before suspending the execution of P-2, it will keep the sense data separately from the sense data for P-1. The sense data for P-2 will be set after the Contingent Allegiance condition caused by P-1 is cleared.

---

## 11.6 Back to Back Write

Back to Back Write allows plural write commands requesting sequential LBAs to be written without losing a motor revolution.

The target will write back to back under the following conditions:

- Two Write(6) or Write extend(10) commands executed consecutively.
- The write commands address consecutive LBA. The LBA specified by the 2nd write command is the next to the last LBA by the 1st write command.
- The data of the LBA for the 2nd write command is received before the last LBA of the 1st write command is written to the media.
- The CPE (Concurrent process enable) bit is 1 or the WCE (Write Cache enable) bit is 1.

If the CPE (Concurrent process enable) is 1 and the WCE (Write cache enable) is 0, the Data phase of the 2nd write command is started after the Data phase of the 1st write command but before the Status phase of it. After seek complete, the data of both 1st and 2nd write command will be written onto the media. Then the drive reconnects to the nexus of the 1st write command to send Status before sending Status to the 2nd write command.

If the CPE (Concurrent process enable) is 0 and the WCE (Write cache enable) is 1, the drive returns Good Status immediately after the Data phase of the 1st write command but before actually writing the data to the media. The I/O process of the 2nd write command begins after the drive sends Good Status to the 1st write command. And then Good Status is returned to the 2nd write command. After seek complete, the data of both 1st and 2nd write command will be written onto the media.

If the drive returns Check Condition to the 1st write command and enters the contingent allegiance condition, execution of the 2nd write command is suspended. The 2nd write command will resumed execution when the contingent allegiance condition is cleared.

---

## 11.7 Write Cache

If the WCE (Write cache enable) bit is 1, the drive returns Good Status and Command Complete message and goes to Bus Free immediately after receiving the data of the last sector before actually writing the data onto the media.

If the drive detects an error after it returns a Good Status, the drive sets a Differed Error (Error Code of sense data = 71h) and a following command will be returned with Check Condition and the Contingent allegiance condition is established. Under the Contingent allegiance condition, all queued processes including commands from other initiators are suspended.

## 11.8 Power Saving Mode

Power save function will save power consumption while the drive is idle. The drive automatically transfers its operating mode according to the event and timer.

### 11.8.1 Mode Transition

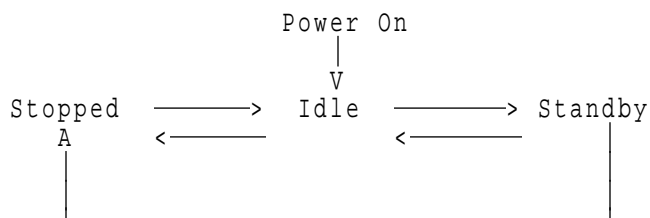

#### Mode Characteristics

Mode Name	Idle	Standby	Stopped
HDC	On	Off	Off
SRV	On	Off	Off
R/W Channel	Off	Off	Off
Content of sector buffer (Write Cache, Look Ahead & etc.)	Kept	Lost	Lost
Spindle motor	On	Off	Off
Status	Good	Good	Not Ready

#### Trigger of Mode Transition

To From	Idle	Standby	Stopped
Idle	---	Expiration of Standby Timer	SCSI Stop Unit Command
Standby	Any SCSI Command	---	SCSI Stop Unit Command
Stopped	SCSI Start Unit Command	Not Applicable	---

#### Action for Mode Transition

To From	Idle	Standby	Stopped
Idle	---	Act_Lock Channel_off VCM_off Stop_spindle	Act_Lock Channel_off VCM_off Stop_spindle
Standby	Channel_on VCM_on HDC_on Start_spindle	---	Not Ready Status
Stopped	Channel_on VCM_on HDC_on Start_spindle	Not Applicable	---

---

## 11.9 Automatic Rewrite/Reallocate

The target supports Auto and Recommended Reallocate for READ, WRITE, WRITE VERIFY and VERIFY.

Automatic and Recommend Reallocate operate from within the read/write command. When an automatic reallocation occurs, the read or write command takes longer to complete.

This operation is sometimes referred to as autoreassignment due to its similarity to the operation performed by the reassign command.

Following is a description of the target behaviour for each setting of ARRE. ARRE setting effects all data errors.(No Sector Found, Data Sync Byte Errors and Data ECC Errors.)

**ARRE=1 :** An error site determined to need rewriting or reallocation during a read is automatically rewritten or reallocated at the conclusion of the read and prior to sending the status. The site will be automatically rewritten or reallocated only if the data has been successfully read.

**ARRE=0 :** An error site determined to need rewriting or reassignment during a read is recommended for rewriting or reassignment at the conclusion of the read.

The setting of the ARRE bit is checked and the target will automatically rewrite/reallocate or recommend rewrite/reassign for the following commands.

- Read(6)
- Read(10)
- Verify
- Verify Portion of Write and Verify

For all other commands the ARRE setting is ignored and the target will not automatically rewrite/reallocate or recommend rewrite/reassign.

Following is a description of the target behaviour for each setting of AWRE. AWRE setting effects only No Sector Found Errors on writes.

**AWRE=1 :** An error site determined to need reassignment during a write is automatically reallocated at the conclusion of the write and prior to sending the status. The site will be automatically reallocated only if the write recovery succeeded at the conclusion of the write.

**AWRE=0 :** An error site determined to need reassignment during a write is recommended for reassignment at the conclusion of the write.

The setting of the AWRE bit is checked and the target will automatically reallocate or recommend reassign for the following commands.

- Write(6)
- Write(10)
- Write portion of Write and Verify

For all other commands the AWRE setting is ignored and the target will not automatically reallocate or recommend reassign.

Auto/Recommend Reallocate information is communicated via the sense data returned following a command during which a site was determined to need rewriting or reassignment. The LBA returned in the sense data is the LBA that determined to need rewriting or reassignment.

The sense data combinations with auto/recommend rewrite/reallocate are listed below.

Key	Code	Qual	Description
1	17	00	Recovered Data without ECC.
1	17	06	Recovered Data without ECC - Auto Reallocated.
1	17	07	Recovered Data without ECC - Recommend Reassign.
1	17	09	Recovered Data without ECC - Data Rewritten.
1	18	00	Recovered Data with ECC.
1	18	02	Recovered Data with ECC - Auto Reallocated.
1	18	05	Recovered Data with ECC - Recommend Reassign.
1	18	07	Recovered Data with ECC - Data Rewritten.

---

## 11.10 Segmented Caching

### 11.10.1 Overview

Segmented Caching divides the data buffer into several smaller buffers. Each buffer is used as Read/Write/Read-Ahead buffer.

### 11.10.2 Read Ahead

The Read Ahead function consists of reading data that the Initiator has not yet requested to the file buffer. This function is intended to improve performance for an initiator that frequently accesses sequential data with successive SCSI read commands. The Read Ahead function works when RCD (the read cache disable) bit of read cache page (page 08h) is set to 0.

The drive initiates the Read ahead function when

- RCD is 0, and
- Read(6), Read extended(10), Read Verify, and Write and Verify is received, and
- The consecutive LBA of the requested LBA is not available on the buffer.

The action of each command for previously started Read ahead function is listed below. If SCSI reset or bus device reset message is received, all contents of segmented buffer is flushed.

Code	Command	Action
00h	Test Unit Ready	No Effect
01h	Rezero Unit	Abort Read Ahead
03h	Request Sense	No Effect
04h	Format Unit	Abort Read ahead and flush all segments
07h	Reassign Blocks	Abort Read ahead and flush all segments
08h	Read(6)	Abort Read ahead if data not in active segment
0Ah	Write(6)	Abort Read ahead
0Bh	Seek(6)	Abort Read Ahead
12h	Inquiry	No Effect
15h	Mode Select(6)	Abort Read ahead and flush all segments
16h	Reserve	No Effect
17h	Release	No Effect
1Ah	Mode Sense(6)	Abort Read ahead and flush all segments
1Bh	Start/Stop Unit	Abort Read ahead and flush all segments

Code	Command	Action
1Dh	Send Diagnostic	Abort Read ahead and flush all segments
25h	Read Capacity	No Effect
28h	Read extended(10)	Abort Read ahead if data not in active segment
2Ah	Write extended(10)	Abort Read ahead
2Bh	Seek extended(10)	Abort Read Ahead
2Eh	Write and Verify	Abort Read ahead
2Fh	Verify	Abort Read ahead
34h	Pre-Fetch	Abort Read ahead if data not in active segment
35h	Synchronize Cache	Abort Read ahead and flush all segments
37h	Read Defect Data	Abort Read ahead and flush all segments
3Bh	Write Buffer	Abort Read ahead and flush all segments
3Ch	Read Buffer	Abort Read Ahead
3Eh	Read Long	Abort Read ahead and flush all segments
3Fh	Write Long	Abort Read ahead and flush all segments
4Dh	Log sense	Abort Read ahead and flush all segments

Figure 119. Read Ahead handling per each command

Even if an error occurs during Read ahead, the error will not be reported to the Initiator. The data read before the error occurs will be stored as a valid data by Read ahead.

---

## 11.11 Reselection Timeout

A reselection timeout error occurs when the target attempts to reselect an initiator and the initiator does not respond within a Selection Timeout delay(250 mSec). If this occurs, the target releases the SCSI bus going to the bus free phase and waits 250ms. It will then retry the reselection up to 16 times. If the initiator still does not respond the command is terminated and the target generates sense data with a Sense Key of Aborted Command and an Additional Sense code of Select/Reselect failure(45h). If any of the reselection attempts is successful then the command is resumed.

---

## 11.12 Single Initiator Selection

For single initiator systems, it is not an error to have only the target ID bit present during selection. Disconnection is not allowed for Single Initiator Selection with only one ID bit present during selection. The initiator must not send an Identify message with the disconnect permission bit(6) on.

---

## 11.13 Non-arbitrating Systems

The Target cannot detect whether other SCSI devices on the SCSI bus use arbitration prior to selection. As a consequence, the Target allows disconnect permission to be enabled by the Identify message independent of the initiators use of arbitration prior to selection. A non-arbitrating initiator must ensure that disconnect permission in the Identify message is disabled (bit 6=0)for proper operation.

---

## 11.14 Selection without ATN

If the target is selected without ATN signal active, no Identify message is received from the initiator. In this case, the LUN is identified from the CDB and disconnect permission is disabled. The target does not perform any phase retries. The target still responds to a subsequent attention condition. However, the LUN is not considered to be known if a fatal error is detected during the Command phase. That is a Command phase parity error or a fatal message error in response to attention condition during Command phase is handled as a Bus Free error with no sense data. The target also knows the use of linked commands if selected without ATN.

Phase retries may be allowed if a subsequent Identify message is received.

---

## 11.15 Multiple Initiator Environment

### 11.15.1 Initiator Sense Data

Separate sense data is reserved for each I-T-L. Each sense data is maintained independent of commands from other initiators.

### 11.15.2 Initiator Mode Select/Mode Sense Parameters

A single shared copy of the Mode Select/Mode Sense parameters is maintained by the file. This includes both the current and saved parameters.

### 11.15.3 Initiator Data Transfer Mode Parameter

A separate data transfer mode parameters area is reserved and maintained for each initiator.

---

## 11.16 Contingent Allegiance Condition

The contingent allegiance condition shall exist following the return of Check Condition, except Check Condition caused by Invalid LUN. Execution of all queued commands shall be suspended until the contingent allegiance condition is cleared.

The contingent allegiance condition can be cleared by the initiator in one of the following ways:

- By issuing a REQUEST SENSE command to the Target and receiving the sense data. This is most recommended way.
- By issuing any other command to the I\_T\_x nexus that reported the fault.
- By issuing an Abort message to the I\_T\_x nexus that reported the fault. This will also abort the current and queued I/O process from that initiator.
- By issuing a Bus Device Reset message to the Target. This will also abort all current and queued I/O processes.
- By generating a RESET condition on the bus. This **MUST** be the last resort.



---

## 11.17 Reset

The Reset condition is used to clear all SCSI devices from the bus. This condition takes precedence over all other phases and conditions. After a reset condition is detected and the reset actions completed, the target returns to a 'SCSI bus enabled' state that allows the target to accept SCSI commands.

This device uses the Hard reset option as defined in the SCSI-2 standard.

### 11.17.1 Reset Sources

There are four sources of resets detected by the target:

Reset Name	Reset Source
<b>Power-On Reset</b>	This is the signal generated by the hardware at initial power-on
<b>Self-Initiated reset</b>	This is a software-generated reset that occurs when a catastrophic error is detected by the microcode.
<b>SCSI Bus Reset</b>	This is a reset generated when the SCSI bus control line RST goes active.
<b>SCSI Bus Device Reset Message</b>	This is the reset generated by the SCSI Bus Device Reset Message(0Ch).

### 11.17.2 Reset Actions

The action taken by the Drive following a reset is dependent on the source of the reset.

#### 11.17.2.1 Power-On reset and Self-Initiated reset

These two reset conditions cause the following to be performed in the order shown.

1. A power-up sequence
2. A start-up sequence is necessary to put the Drive in a ready state

#### 11.17.2.2 SCSI Bus reset and SCSI Bus Device Reset message

These two reset conditions cause the following to be performed.

- If reset goes active while the power-up sequence is in progress, the power-up sequence is started over.
- If the Auto Start pin is grounded and a start-up sequence has not yet completed, a start-up sequence will be re-attempted from the beginning.

**Note:** The power-up sequence, having already completed, is not rerun.

- If reset occurs while a physical sector is being written, the write operation is disabled after the current physical sector is written. Data is not lost as long as power stays valid until the physical sector being written is completed.

---

## 11.18 Diagnostics

The file will execute a self test at power on or when a Send Diagnostics command is issued with the self test bit set.

The diagnostics are to assure the correct operation of the file and to verify that the check circuits detect fault conditions.

### 11.18.1 Power on Diagnostics

At power on time the following tests are executed:

1. Test the microprocessor's internal RAM.
2. Test the HDC.
3. Do a read/write test on sector buffer RAM.
4. Check if the 12 volt line is active.
5. Initialize and check the servo system is functioning correctly.
6. Check the spindle's RPM.
7. Seek to a correct cylinder.

### 11.18.2 Diagnostics Command

The tests executed as a result of the Send Diagnostics command with the self test bit set to a one differs from the tests executed at power on. The spindle motor must be at the correct speed for the Diagnostics command to be executed. If the motor is not at the correct speed, a NOT READY status will be returned in the sense byte.

The Diagnostics command will execute the following tests:

1. Test the adapter section of the file as follows:
  - a. Assure the ECC circuits work correctly.
  - b. Do a read/write test on sector buffer RAM.
2. Check the spindle's RPM.
3. Seek to a correct cylinder.
4. Write the certain area in reserved area.
5. Read from the area.

### 11.18.3 Diagnostics Fault Reporting

Faults detected before successful completion of the adapter section could prevent the file from responding to a selection.

Faults detected after the successful completion of the adapter section will be reported as Check Condition status to the initiator on the first command issued after a fault is detected except for the Inquiry command. The Inquiry command will always respond with good status. Detecting a fault during power on will not terminate execution of the diagnostics nor will it terminate the power on process.

Faults detected during a Send Diagnostics command will report a Check Condition as end status.

---

## 11.19 Patrol Seek

The drive will automatically take a seek motion every 10 minutes of continuous idle mode.

---

## 11.20 Automatic Drive Maintenance (ADM)

ADM function is equipped to maintain reliability even in continuous usage beyond one week.

ADM function is to perform a CSS automatically after detection of idling time for 1 minute plus SCSI-ID offset (SCSI-ID x 10 seconds) at intervals of 1 week.

Enable and disable of ADM function is in control of Mode Page 0, and the shipping default is enable.

See 7.11.1, “Page 0 (Vendor Unique Parameters)” on page 85.

Drive response during the CSS by ADM is as follows.

- Test Unit Ready returns Ready.
- Command with no media access required executes without delay.
- Command with media access required will be completed as quickly as possible (max 10 sec delay over normal execution time) - if drive is spinning down when command received it will go to spin up immediately.

If disconnect is granted by initiator, drive will disconnect immediately and reconnect when ready to complete.

After completion of the command, the CSS is re-started after detection of idle time for 1 minute plus SCSI-ID offset (SCSI-ID x 10 seconds).



## 12.0 SCSI SENSE DATA

### 12.1 SCSI Sense Data Format

Format of the sense data returned by the file in response to the REQUEST SENSE command.

	BIT							
	7	6	5	4	3	2	1	0
BYTE 0	Valid	Error Code (70h or 71h)						
BYTE 1	RSVD = 0							
BYTE 2	0	ILI	0	Sense Key				
BYTE 3 - 6	(MSB) Information Bytes							(LSB)
BYTE 7	Additional Sense Length							
BYTE 8 -11	Reserved							
BYTE 12	Additional Sense Code							
BYTE 13	Additional Sense Code Qualifier							
BYTE 14	FRU = 0							
BYTE 15	SKSV	Sense-Key Specific Bits						
BYTE 16 BYTE 17	Sense-Key Specific Bytes							
BYTE 18 -19	Reserved = 0							
BYTE 20 -23	Vender unique Error information							
BYTE 24 -27	Physical Error Record							
BYTE 28 -31	Reserved = 0							

Figure 120. Format of Sense Data. Format of the Sense Data returned by the file in response to the REQUEST SENSE command

## 12.1.1 Sense Data Description

### 12.1.1.1 Valid Bit

Bit 7 of byte 0

- 0** The Information Bytes are not defined.
- 1** The Information Bytes contain a valid logical block address.

### 12.1.1.2 Error Code

Bit 6 - 0 of byte 0.

- 70h** Current Error. This indicates an error for the current command.
- 71h** Deferred Error. This indicates that the error is for a previous command that has already returned a GOOD status. Such commands are associated with the immediate bit, or write caching. FORMAT UNIT command is an example of a command that may return a deferred error.

### 12.1.1.3 Sense Key

Bit 3 - 0 of byte 2.

The sense key provides generic categories in which error and exception conditions can be reported. Initiators would typically use sense keys for high level error recovery procedures.

<b>0</b>	<b>NO SENSE</b> There is no sense key information to be reported for the logical unit.
<b>1</b>	<b>RECOVERED ERROR</b> The last command completed successfully with some recovery action performed by the file. More detailed information is available in the Additional Sense Code.
<b>2</b>	<b>NOT READY</b> The logical unit addressed cannot be addressed. More detailed information is available in the Additional Sense Code.
<b>3</b>	<b>Medium Error</b> The command terminated with an unrecoverable error condition caused by a flaw in the media or an error in the recorded data. More detailed information is contained in the Additional Sense Code.
<b>4</b>	<b>HARDWARE ERROR</b> The file detected a unrecoverable hardware error while performing a command or during a diagnostic test. More detailed information is contained in the Additional Sense Code.
<b>5</b>	<b>ILLEGAL REQUEST</b> There was an illegal parameter in the command descriptor block or additional parameter supplied as data. If an invalid parameter is found in the CDB, then the command is terminated without altering the medium. If an invalid parameter is found in parameters supplied as data, then the file might have altered the medium.
<b>6</b>	<b>UNIT ATTENTION</b> Indicates that the file entered in the 'Unit Attention Condition'. (See 11.1.5, "Unit Attention Condition" on page 172.)
<b>7-8</b>	Not used
<b>9</b>	Vendor Specific
<b>A</b>	Not used
<b>B</b>	<b>ABORTED COMMAND</b> The file aborted the command.
<b>C-D</b>	Not Implemented
<b>E</b>	Not Used
<b>F</b>	Reserved

#### **12.1.1.4 Information Bytes**

Byte 3 - 6

This field is only valid when Valid Bit is one, and contains the unsigned LBA associated with the sense key.

#### **12.1.1.5 Additional Sense Length**

Byte 7

Indicates the remaining number of bytes in the sense data. (It is set to 18h in the file.)

#### **12.1.1.6 Reserved**

Byte 8 - 11



### 12.1.1.7 Additional Sense Code/Qualifier

Byte 12 / 13

Key	Code	Qual	Description
0	00	00	No error.
0	5D	00	Predictive Failure Analysis Threshold reached
1	01	00	Recovered write error no index
1	02	00	Recovered no seek comp
1	03	00	Recovered write error - write fault
1	14	01	Recovered write error Id not found
1	16	00	Recovered write error DAM not found
1	17	00	Recovered read error without ECC applied.
1	17	01	Recovered read error with retries.
1	17	06	Recovered read error without ECC applied. Auto reallocated.
1	17	07	Recovered read error without ECC applied. Recommended reassign. This value can be returned only when ARRE = 0.
1	17	09	Recovered read error without ECC applied. Data re-written. This value can be returned only when ARRE = 1.
1	18	00	Recovered read error with ECC applied. This value can be returned only when ARRE = 0.
1	18	02	Recovered read error with ECC applied. Auto reallocated. This value can be returned only when ARRE = 1.
1	18	05	Recovered read error with ECC applied. Recommended reassign. This value can be returned only when ARRE = 0.
1	18	07	Recovered read error with ECC applied. Data Rewritten. This value can be returned only when ARRE = 1.
1	1C	01	Primary Defect list Not Found. Requested Defect List Format is not supported. Default Lsi Format is returned.(Read Defect Data Only)
1	1C	02	Grown Defect list Not Found. Requested Defect List Format is not supported. Default Lsi Format is returned.(Read Defect Data Only)
1	44	00	Internal target failure
1	5D	00	Predictive Failure Analysis Threshold reached
2	04	00	Not ready. Start spindle motor fail.
2	04	01	Not ready. In process of becoming ready.
2	04	02	Not ready. Initializing command required. (Start Unit)
2	04	04	Not ready. Format in progress.
2	40	80	Diag Fail - Bring-Up Fail
2	40	85	Diag Fail - RAM Microcode Not Loaded
3	10	00	Medium error. ID CRC error.
3	11	00	Medium error. Unrecovered read error.

Key	Code	Qual	Description
3	14	01	Medium error. Record not found.
3	16	00	Medium error. Data synchronization mark error. (DAM error)
3	19	00	Medium error. Defect list error. A defect list error occurs when a data error is detected while reading the manufacturing defect list or while reading or writing the grown defect list.
3	31	01	Medium error. Medium Format Corrupted Reassign Failed
4	01	00	H/W error. No index or sector.
4	02	00	H/W error. No seek complete.
4	03	00	H/W error. Write fault.
4	09	00	H/W error. Track following error.
4	11	00	H/W error. Unrecovered read error in reserved area.
4	32	00	H/W error. No defect spare location available. A no defect spare location available sense code indicates that the Reassign Block command can not proceed the process because all spare sectors have been used, or it will exceed implementation limitation of defect handling of the file.
4	40	80	Degrade Mode. Diagnostic Fail. Configuration sector valid check fail. Reserved area sector valid check fail.
4	40	85	Degrade Mode. RAM Microcode Not Loaded
4	44	00	H/W error. Internal target failure
5	1A	00	Illegal request. Parameter list length error. The number of parameters supplied is not equal to the value the expected.
5	20	00	Illegal request. Illegal command operation code. This command is also returned when an unsupported command code is received.
5	21	00	Illegal request. Logical block address out of range.
5	24	00	Illegal request. Invalid field in CDB.
5	25	00	Illegal request. Invalid lun.
5	26	00	Illegal request. Invalid fields in the parameter list.
6	28	00	Unit attention. Not ready to ready transition.(Format completed)
6	29	00	Unit attention. Power on reset or Bus device reset occurred.
6	2A	01	Unit attention. Mode select parameter changed.
6	2F	00	Unit attention. Command cleared by another initiator.
6	3F	01	Unit attention. Micro code has been changed.
6	5D	00	Predictive Failure Analysis Threshold reached on
B	1B	00	Aborted command. Synchronous data transfer error. (Extra ack detected)
B	25	00	Aborted command. Unsupported LUN. The drive supports LUN 0 only.
B	43	00	Aborted command. Message reject error. A message reject error occurs when an inappropriate or unexpected message reject is received from the initiator or the initiator rejects a message twice.

<b>Key</b>	<b>Code</b>	<b>Qual</b>	<b>Description</b>
B	45	00	Aborted command. Selection/Reselection failed. A selection/reselection error occurs when the initiator fails to respond to a reselection within 250 milliseconds after the drive starts reselection. The reselection is attempted a second time before setting selection/reselection failed sense code.
B	47	00	Aborted command. SCSI parity error.
B	48	00	Aborted command. Initiator detected error message received. An initiator detected error occurs when the initiator detects an error, sends a message to retry, detects the error again, and sends the retry message a second time. The drive then sets check condition status with Initiator Detected Error.
B	49	00	Aborted command. Inappropriate/illegal message. An inappropriate or illegal message occurs when the initiator sent a message that either is not supported or is not in a logical sequence.
B	4E	00	Aborted command. Overlapped commands attempted.

### 12.1.1.8 FRU (Field Replaceable Unit)

Byte 14

The FRU (Field Replaceable Unit) field value will always be zero.

### 12.1.1.9 Sense Key Specific

Byte 15 - 17

The definition of this field is determined by the value of the sense key field.

**12.1.1.9.1 Illegal Request Case:** Error filed pointer is returned.

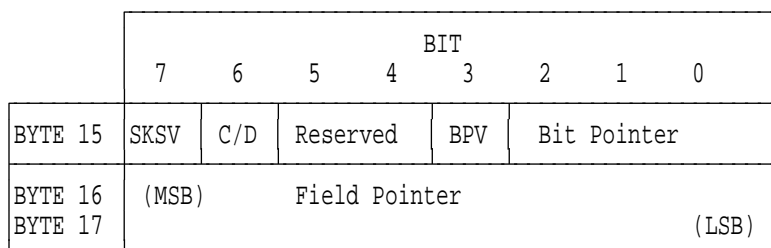

Figure 121. Field Pointer Bytes

**SKSV** Sense-key specific valid

**C/D** Command/Data

0 Indicates that the illegal parameter is in the data parameters sent by the initiator during DATA OUT phase

1 Indicates that the illegal parameter in the command descriptor block.

**BPV** Bit Pointer Valid

0 Indicates the bit pointer field is not valid.

1 Indicates the bit pointer field is significant.

**Bit Pointer** Bit Pointer indicates which bit of the byte number reported in Field Pointer is the bit in error. When a multiple-bit field is in error, the pointer point to the most significant bit of the field.

**Field Pointer** Indicates which bytes of the command descriptor block or of the parameter data was in error. Bytes are numbered starting from zero, as shown in the tables describing the commands and parameters. When a multiple-byte field id in error, the pointer point to the most significant byte of the field.

**12.1.1.9.2 Recovered, Hardware or Medium Error Case:** Actual Retry Count is reported.

		BIT							
		7	6	5	4	3	2	1	0
BYTE 15	SKSV	Reserved							
BYTE 16	(MSB)	Actual Retry Count						(LSB)	
BYTE 17									

Figure 122. Actual Retry Count Bytes

**SKSV** Sense-key specific valid

0 Indicates that Actual Retry Count is not valid.

1 Indicates that Actual Retry Count is valid.

**Actual Retry Count** Actual number of retries used in attempting to recover from the error condition.

**12.1.1.9.3 Not Ready Case:** Progress indication is returned. These fields are only defined for the FORMAT UNIT command with the Immediate bit set to one.

		BIT							
		7	6	5	4	3	2	1	0
BYTE 15	SKSV	Reserved							
BYTE 16	(MSB)	Progress Indication						(LSB)	
BYTE 17									

Figure 123. Format Progress Indication Bytes

**SKSV** Sense-key specific valid

0 Indicates that Progress Indication is not valid.

1 Indicates that Progress Indication is valid.

**Progress Indication** Indicates a percent complete in which the returned value is the numerator that has 10000h as its denominator.

**12.1.1.10 Reserved**

Byte 18 - 19

**12.1.1.11 Vender unique error information**

Byte 20 - 23

Reserved.

### 12.1.1.12 Physical Error Record

Byte 24 - 27

- ILI = 1 - This field contains zeros.
- ILI = 0 - These bytes contain the physical location of the error in cylinder, head and sector. Byte 24 and 25 are Cylinder high and cylinder low respectively. Byte 26 is the head number and byte 27 is the sector. If the head and/or sector is undetermined, the value is set to FFh. If the Cylinder value is undetermined, both bytes 24 and 25 are set to FFh. This field is valid with Sense Key 1, 3 and 4 only.

### 12.1.1.13 Reserved

Byte 28 - 31

# Index

## A

ABORT 155  
ABORT TAG 156  
Attention Condition 160  
Automatic rewrite/reallocate 181

## B

Back to Back Write 179  
BUS DEVICE RESET 156

## C

CLEAR QUEUE TAG 156  
Command 47  
    FORMAT UNIT 52  
    INQUIRY 56  
    LOG SELECT 67  
    LOG SENSE 68  
    MODE SELECT 82  
    MODE SENSE 78  
    PRE-FETCH 110  
    READ 111  
    READ BUFFER 118  
    READ CAPACITY 112  
    READ DEFECT DATA(37) 114  
    READ EXTENDED 117  
    READ LONG 121  
    REASSIGN BLOCKS 122  
    RECEIVE DIAGNOSTICS 124  
    RELEASE 126  
    REQUEST SENSE (03) 127  
    RESERVE 128  
    REZERO 129  
    SEEK 130  
    SEEK EXTENDED 131  
    SEND DIAGNOSTIC 132  
    START/STOP 135  
    SYNCHRONIZE CACHE 136  
    TEST UNIT READY 137  
    VERIFY 138  
    WRITE 139  
    WRITE AND VERIFY 141  
    WRITE BUFFER 142  
    WRITE EXTENDED 140  
    WRITE LONG 146  
    WRITE SAME 147  
COMMAND COMPLETE 151  
Command Processing During Execution of Active I/O  
    process 170  
Command Processing While Reserved 175  
Command Queuing 176  
Command Reordering 178

Concurrent I/O process 178  
Contingent Allegiance Condition 186

## D

Deferred error 173  
Degraded Mode 174  
DIAGNOSTICS 132  
DISCONNECT 154

## F

FORMAT UNIT 52  
    Defect Descriptor 54  
    Defect List 53

## I

I\_T\_L nexus 127  
IDENTIFY 158  
IGNORE WIDE RESIDUE 158  
Incorrect Initiator Connection 170  
INITIATOR DETECTED ERROR 155, 162  
INQUIRY 56  
Inquiry data 57  
Internal Error 173  
Invalid LUN 57, 169

## L

LBA 51  
Link Command 51  
    Flag Bits 51  
LINKED COMMAND COMPLETE 156  
LINKED COMMAND COMPLETE WITH  
    FLAG 156  
LOG SELECT 67  
LOG SENSE 68  
Log Sense Data 69  
LSB 51  
LUN 51

## M

MESSAGE PARITY ERROR 155  
MESSAGE REJECT 155, 162  
MESSAGE SYSTEM 150  
    ABORT 155  
    ABORT TAG 156  
    BUS DEVICE RESET 156  
    CLEAR QUEUE TAG 156  
    COMMAND COMPLETE 151  
    DISCONNECT 154  
    IDENTIFY 158  
    IGNORE WIDE RESIDUE 158

## MESSAGE SYSTEM *(continued)*

- INITIATOR DETECTED ERROR 155
- LINKED COMMAND COMPLETE 156
- LINKED COMMAND COMPLETE WITH FLAG 156
- MESSAGE PARITY ERROR 155
- MESSAGE REJECT 155
- NO OPERATION 155
- QUEUE TAG MESSAGES(20h, 21h, 22h) 156
- RESTORE POINTERS 154
- SAVE DATA POINTER 154
- SYNCHRONOUS DATA TRANSFER REQUEST 153
- WIDE DATA TRANSFER REQUEST 152

Mode Parameter

- Caching Parameters 100
- Control Mode Page 102
- Disconnect Parameters 93
- Format Device Parameters 95
- Informational Exceptions Control 106
- Power Condition Parameters 109
- Read-Write Error Recover Parameter 88
- Reconnect Parameters 93
- Rigid Disk Drive Geometry Parameters 97
- Vendor Unique Parameters 85
- Verify Error Recover Parameter 98
- Zone Parameters 104

MODE SELECT 82

- Parameter List 79

Mode Select Data 84

MODE SENSE 78

- Page Control Field. 78
- Parameter List 79

MSB 51

Multiple Initiator 185

## N

- NO OPERATION 155
- Non-arbitrating Systems 185

## P

- Page Format (PF) 82
- Parity Error
  - COMMAND Phase Parity Error 161
  - DATA OUT Phase Parity Error 161
  - MESSAGE IN Phase Parity Error 161
  - MESSAGE OUT Phase Parity Error 161
- Power saving mode 180
- PRE-FETCH 110
- Priority Commands 176

## Q

- QUEUE TAG MESSAGES(20h, 21h, 22h) 156

## R

- READ 111
  - Read Ahead 183
- READ BUFFER 118
- READ CAPACITY 112
- READ DEFECT DATA(37) 114
- READ EXTENDED 117
- READ LONG 121
- REASSIGN BLOCKS 122
- RECEIVE DIAGNOSTICS 124
- RELEASE 126
- REQUEST SENSE 127
- Reselection
  - Time Out 184
- RESERVE 128
- RESTORE POINTERS 154
- REZERO 129
- RSVD 51

## S

- SAVE DATA POINTER 154
- Save Pages (SP) 82
- Saveable Page 82
- SCAM 162
- SCSI Bus Related Error 160
  - Unexpected Bus Free Error 160
- SEEK 130
- SEEK EXTENDED 131
- Segmented caching 183
- Selection without ATN 185
- SEND DIAGNOSTIC 132
- Sense Data 189
- Single Initiator Selection 184
- START 135
- Status Byte 147
- STOP 135
- SYNCHRONIZE CACHE 136
- SYNCHRONOUS DATA TRANSFER REQUEST 153

## T

- TEST UNIT READY 137
- Third Party Release 126

## U

- Unit Attention Condition 172

## V

- VERIFY 138
- VU 51



## **W**

WIDE DATA TRANSFER REQUEST 152  
WRITE 139  
WRITE AND VERIFY 141  
WRITE BUFFER 142  
Write Cache 179  
WRITE EXTENDED 140  
WRITE LONG 146  
WRITE SAME 147



Part Number  
39H2859

S39H-2859-03