



Technical Reference

January 2007

www.lexmark.com

Lexmark and Lexmark with diamond design are trademarks of Lexmark International, Inc., registered in the United States and/or other countries.

© 2007 Lexmark International, Inc.

740 West New Circle Road

Lexington, Kentucky 40550

Edition: January 2007

The following paragraph does not apply to any country where such provisions are inconsistent with local law: LEXMARK INTERNATIONAL, INC., PROVIDES THIS PUBLICATION "AS IS" WITHOUT WARRANTY OF ANY KIND, EITHER EXPRESS OR IMPLIED, INCLUDING, BUT NOT LIMITED TO, THE IMPLIED WARRANTIES OF MERCHANTABILITY OR FITNESS FOR A PARTICULAR PURPOSE. Some states do not allow disclaimer of express or implied warranties in certain transactions; therefore, this statement may not apply to you.

This publication could include technical inaccuracies or typographical errors. Changes are periodically made to the information herein; these changes will be incorporated in later editions. Improvements or changes in the products or the programs described may be made at any time. Comments about this publication may be addressed to Lexmark International, Inc., Department F95/032-2, 740 West New Circle Road, Lexington, Kentucky 40550, U.S.A. In the United Kingdom and Eire, send to Lexmark International Ltd., Marketing and Services Department, Westhorpe House, Westhorpe, Marlow Bucks SL7 3RQ. Lexmark may use or distribute any of the information you supply in any way it believes appropriate without incurring any obligation to you. To obtain additional copies of publications related to this product, visit the Lexmark Web site at www.lexmark.com.

References in this publication to products, programs, or services do not imply that the manufacturer intends to make these available in all countries in which it operates. Any reference to a product, program, or service is not intended to state or imply that only that product, program, or service may be used. Any functionally equivalent product, program, or service that does not infringe any existing intellectual property right may be used instead. Evaluation and verification of operation in conjunction with other products, programs, or services, except those expressly designated by the manufacturer, are the user's responsibility.

Lexmark, Lexmark with diamond design, MarkNet, MarkVision, and Optra are trademarks of Lexmark International, Inc., registered in the United States and/or other countries. ColorGrade, PerfectFinish, and PictureGrade are trademarks of Lexmark International, Inc.

The following terms are trademarks or registered trademarks of other companies:

Albertus	The Monotype Corporation plc	ITC Avant Garde Gothic	International Typeface Corporation
Antique Olive	Monsieur Marcel OLIVE	ITC Bookman	International Typeface Corporation
Apple-Chancery	Apple Computer, Inc.	ITC Lubalin Graph	International Typeface Corporation
Arial	The Monotype Corporation plc	ITC Mona Lisa	International Typeface Corporation
Candid	Agfa Corporation	ITC Zapf Chancery	International Typeface Corporation
CG Omega	Product of Agfa Corporation	Joanna	The Monotype Corporation plc
CG Times license	Based on Times New Roman under from The Monotype Corporation plc, is a product of Agfa Corporation	Marigold Monaco New York	Arthur Baker Apple Computer, Inc. Apple Computer, Inc.
Chicago	Apple Computer, Inc.	Oxford	Arthur Baker
Clarendon	Linotype-Hell AG and/or its subsidiaries	Palatino	Linotype-Hell AG and/or its subsidiaries
Eurostile	Nebiolo	Stempel Garamond	Linotype-Hell AG and/or its subsidiaries
Geneva	Apple Computer, Inc.	Taffy	Agfa Corporation
GillSans	The Monotype Corporation plc	Times New Roman	The Monotype Corporation plc
Helvetica	Linotype-Hell AG and/or its subsidiaries	TrueType	Apple Computer, Inc.
Hoefler	Jonathan Hoefler Type Foundry	Univers	Linotype-Hell AG and/or its subsidiaries
		Wingdings	Microsoft Corporation

PCL® is a registered trademark of the Hewlett-Packard Company. PCL 5 and PCL 6 are Hewlett-Packard Company's designations of a set of printer commands (language) and functions included in its printer products. These printers are intended to be compatible with the PCL 5 and PCL 6 languages. This means these printers recognize PCL 5 and PCL 6 commands used in various application programs, and that the printer emulates the functions corresponding to the commands.

Other trademarks are the property of their respective owners.

© 1998, 2007 Lexmark International, Inc.

All rights reserved.

UNITED STATES GOVERNMENT RIGHTS

This software and any accompanying documentation provided under this agreement are commercial computer software and documentation developed exclusively at private expense.

Contents

Introduction	1-1
Overview.....	1-1
Navigational Tips.....	1-4
Printing the File.....	1-4
Bibliography.....	1-5
PCL Emulation.....	2-1
Selecting PCL Emulation.....	2-1
Using SmartSwitch.....	2-1
Using the Operator Panel or MarkVision Professional.....	2-1
Using Your Software Program	2-2
Page Formatting.....	2-3
Printable Areas.....	2-3
Lexmark™ C520, C522n, C524, C524n, C524dn, C530dn, C532n, C532dn, C534n, C534dn, C534dtn, C770, C770n, C772, C772n, C920, C920n, C920dn, and C920dnf	2-4
Print Area Menu Item.....	2-6
Font and Symbol Set Support for the Lexmark C520, C522n, C524, C524n, C524dn, C530dn, C532n, C532dn, C534n, C534dn, C534dtn, C770, C770n, C772, C772n, C920, C920n, C920dn, C920dnf.....	2-8
Forward and Backward Compatibility Modes for the Lexmark C520, C522n, C524, C524n, C524dn, C530dn, C532n, C534n, C534dn, C534dn, C534dtn, C770, C770n, C772, C772n, C920, C920n, C920dn, C920dnf	2-9
Selecting Symbol Sets for Lexmark C520, C522n, C524m C542b C524dn, C530dn, C532n, C532dn, C534n, C534dn, C534dtn, C770, C770n, C772, C772n, C920, C920n, C920dn, C920dnt	2-14
Command Structure	2-48
Control Codes.....	2-49
Commands.....	2-49
PCL Emulation Commands	2-51
PCL Emulation Commands by Function	2-52
GL/2 Commands	2-74

Raster Image Graphics.....	2-78
Raster Compression Mode	2-78
Macros.....	2-85

Printer Job Language3-1

PJL Command Notation	3-1
Kernel Commands.....	3-2
Job Separation Commands.....	3-4
Environment Commands and Variables.....	3-7
Common Variables for PCL Emulation	3-48
Status Readback Commands.....	3-54
Status Message Format	3-61
Information Messages.....	3-61
Auto-Continuable Conditions	3-63
Attendance Conditions.....	3-67
Operator Intervention - Paper Handling	3-72
Operator Intervention - Paper Jams.....	3-75
Service Errors	3-80
Device Attendance Commands.....	3-80
Unique PJL Commands.....	3-82
File Commands for Flash or Disk.....	3-86
File and Device Protection Commands	3-93
Protecting a File or Device	3-93
Unlocking a Protected File or Device.....	3-95
Re-Locking a Protected File or Device.....	3-96
Unlocking a Protected File or Device for the Current Job.....	3-97
Recovering Lost Passwords.....	3-98

PostScript Emulation4-1

Selecting PostScript Emulation	4-1
Using SmartSwitch.....	4-1
Using the Operator Panel or MarkVision Professional.....	4-1
Using Your Software Program	4-2
Paper Tray Support.....	4-5
Envelope Size Support.....	4-10
Envelope Tray Support	4-12

Supplemental Operator Summary..... 4-14

Page Device Parameters..... 4-49

Interpreter Parameters 4-63

 User Parameters..... 4-63

 System Parameters..... 4-66

 Device Parameters..... 4-72

Status and Error Messages 4-93

 Tagged Binary Not Active 4-93

 Tagged Binary Active 4-93

 Status Messages..... 4-94

Switching Languages5-1

SmartSwitch 5-1

 Setting SmartSwitch for Different Interfaces 5-2

Printer Job Language 5-2

Sniffing..... 5-3

Flash Memory and Disk6-1

Resource Data Collection (Download Target)..... 6-2

 Storing Resources on Flash Memory or Disk..... 6-3

Viewing the Contents of Flash Memory and Disk..... 6-3

Password Protection..... 6-7

Rewriting the Flash Content 6-8

Accessing Files with PostScript Emulation..... 6-9

 File Naming Conventions 6-9

 Device Search Order..... 6-12

Performance 6-13

Job Buffering 6-13

 Creating a Partition 6-14

 Enabling Job Buffering 6-14

 Disabling Job Buffering 6-15

 Recovering from a Power Loss 6-15

Printer Specifications7-1

Airflow Requirement.....	7-1
Noise Emission Levels	7-1
Electrical Specifications	7-2
Power Requirements.....	7-3
.Physical Specifications.....	7-5
Clearance Requirements	7-8
Environmental Conditions	7-9
Altitude Specifications	7-9
Atmospheric Pressure.....	7-9

Printer Interfaces.....8-1

Setting Up the Communications Port	8-2
Setting Up the Communications Port Using Windows 95/98/Me	8-2
Setting Up the Communications Port Using Windows NT 4.0	8-3
Setting Up the Communications Port Using Windows 2000	8-4
Setting Up the Communications Port Using Windows XP	8-5
Deciding Which Interface to Use	8-6
Parallel Interface.....	8-7
Standard Parallel Connector	8-8
Using the INIT* Signal to Initialize.....	8-8
Computer-to-Printer Communications.....	8-8
Printer-to-Computer Communication (Advanced Status).....	8-13
Parallel Mode 1	8-14
Parallel Mode 2	8-15
Signal Descriptions	8-15
Using the RS-232C Serial Interface	8-18
Network Support.....	8-28
Input Buffer	8-29

PCL Support A-1

PJL Support..... B-1

PostScript Support C-1

Index..... X-1

CHAPTER 1: Introduction

Overview

The following edition of the Technical Reference contains information about printer commands and printer languages supported by the following Lexmark printers:

- Lexmark™ C520, C522n, C524, C524n, C524dn, C770, C770n, C772, C772n, C920, C920n, C920dn, and C920dnf.

Acronym	Meaning
n	network
d	duplex
dn	duplex and network
dnf	duplex network finisher

To determine which commands and languages your printer supports, see the appendixes in the back of this document or see your printer documentation.

If your printer is not included in this edition of the *Technical Reference*, it may be available in another version. Visit the Lexmark Web site at www.lexmark.com/publications for more information.

Table 1-1: *Technical Reference* Documentation Available in Hard Copy

If you need a <i>Technical Reference</i> for the...	Order Lexmark part number...
Optra™ K	11A4079
Optra N	11A9979
Optra SC	11C0905
Optra E310	12A2194

The *Technical Reference* is divided into the following:

Chapter 2: “PCL Emulation”

Shows how to select PCL emulation and discusses PCL emulation commands, GL/2 commands, and resident font and symbol set support.

Chapter 3: “Printer Job Language”

Contains detailed information about certain commands that cause the printer to enter PCL emulation, PostScript emulation, and Personal Printer Data Stream (PPDS), and many other types of commands.

Chapter 4: “PostScript Emulation”

Provides information about PostScript emulation and explains PostScript emulation supplemental operators.

Chapter 5: “Switching Languages”

Describes ways to switch printer languages and explains when you may want to choose one method over another.

Chapter 6: “Flash Memory and Disk”

Provides information about using the flash memory and hard disk. It describes how to manage printer memory, store resources (such as fonts and macros), and manage files.

Chapter 7: “Printer Specifications”

Lists printer specifications, including information about hardware and environmental conditions.

Chapter 8: “Printer Interfaces”

Provides information on printer interfaces, including information about parallel and serial interface, network support, and communication protocols.

See the tables in the three appendixes to determine if your printer supports a particular PCL emulation, PJI, or PostScript emulation command. The appendixes are:

Appendix A: “PCL Support”

Appendix B: “PJM Support”

Appendix C: “PostScript Support”

Navigational Tips

If you are not familiar with PDF files, the following tips may help you find the information you need.

- To move forward and backward through this document:
 - Select an option under View in the menu bar at the top of the page.
 - Use the arrows in the toolbar at the top of the page, or the up arrow and down arrow keys on the keyboard.
 - Press the Page Up and Page Down keys on the keyboard.
 - Use the scroll bar to the right of the page.
 - Click the page number box on the status bar at the bottom of the page and type the page you want.
- To increase or decrease the magnification of the pages:
 - Select the magnifying glass icon on the toolbar at the top of the page and then draw a box around the area you want to view.
 - Click the magnification box on the status bar and select an option from the drop-down menu.
- To jump directly to a particular section or key word in this document:
 - Click one of the bookmarks in the overview window to the left of the page.
 - Click a topic in the table of contents.
 - Select Tools from the menu bar and then choose Find or Search.
 - Click the binoculars icon on the toolbar and then type a word in the text box.
 - Click a cross-reference to a figure, page number, or heading in the document itself.

Printing the File

Although this book was designed primarily for online viewing, you can print a hard copy by clicking File on the toolbar, and then choosing Print. Make sure you've selected the correct printer, range of pages, and number of copies before you click OK. You should be aware that if you print this document on a color printer, the color you see on the paper may not match the color you see on your computer monitor.

Bibliography

For detailed information about PCL emulation printer commands, PostScript emulation printer commands and operators, and interfaces, see the following documentation:

- *Hewlett-Packard DeskJet Printer Family Technical Reference*, C2121-90101
- *Hewlett-Packard LaserJet 4 Typography and Graphics*, Random House Electronic Publishing
- *Hewlett-Packard PCL 5 Color Technical Reference Manual*, 5961-0635
- *Hewlett-Packard PCL 5 Printer Language Technical Reference Manual*, 5961-0509
- *Hewlett-Packard PostScript SIMM Technical Reference, I/O Device Operators and Parameters*, C2080-90921
- *Hewlett-Packard Printer Job Language Technical Reference Manual*, 5961H0512
- *IBM Personal System/2 Hardware Interface Technical Reference*, S68X-2330
- *Interface between Data Terminal Equipment and Data Communications Equipment Employing Serial Binary Data Interchange*, Electronic Industries Association, publications EIA RS-232C and EIA/TIA-232-E
- *Network Printing Alliance Protocol, A Printer/Host Control Specification Developed by the NPA*, Level 1, Revision N
- *PostScript Language Reference Manual (Third Edition)*, Adobe Systems Incorporated, Addison-Wesley Publishing

CHAPTER 2: PCL Emulation

When you select PCL emulation as the printer language, the printer supports the Hewlett-Packard Company's LaserJet Printer Command Language. This chapter shows how to select PCL emulation and discusses PCL emulation commands, along with resident PCL emulation font and symbol set support.

To determine which commands your printer supports, see Appendix A: "PCL Support" on page A-1.

Selecting PCL Emulation

Using SmartSwitch

When SmartSwitch is enabled for both printer languages on an interface (for example, Parallel, USB, Serial Option 1, or Network Option 1), the printer automatically switches to the printer language being sent by your software program. The printer is shipped with SmartSwitch enabled for both printer languages in all interfaces. The printer examines all print jobs and switches dynamically between PostScript emulation and PCL emulation.

Using the Operator Panel or MarkVision Professional

If **SmartSwitch** is set to **Off** for both printer languages, you can select PCL emulation from your printer operator panel or from MarkVision™ Professional. See your printer documentation for information on changing menu settings.

Using Your Software Program

To select PCL emulation, use the Printer Job Language (PCL) Enter Language Command. See “ENTER LANGUAGE Command” on page 3-3 for more information. See “Printer Job Language” on page 3-1 for the syntax and use of PCL.

Warning: When you change printer languages, you may lose some or all previously downloaded resources, unless **Resource Save** is set to **On** or the resources are stored in flash memory or on disk.

Page Formatting

The printable areas and logical pages for PCL emulation (both portrait and landscape orientation) are illustrated below. See the Legend that follows for definitions of areas A through I.

Printable Areas

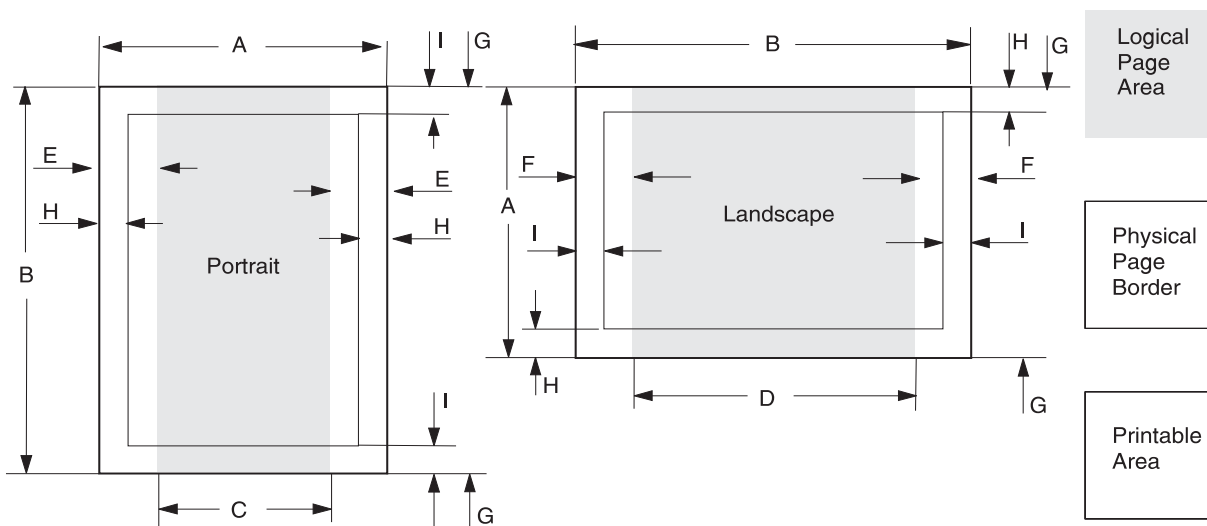

Legend:

- A** Portrait physical page width and landscape physical page length
- B** Portrait physical page length and landscape physical page width
- C** Portrait logical page width
- D** Landscape logical page width
- E** Distance between the side edge of the physical page and the logical page in portrait
- F** Distance between the side edge of the physical page and the logical page in landscape
- G** Distance between the top and bottom edge of the physical page and logical page
- H** Distance between the left and right edge of the physical page and the printable area in portrait, or distance between the top and bottom edge of the physical page and printable area in landscape
- I** Distance between the top and bottom edge of the physical page and the printable area in portrait, or distance between the left and right edge of the physical page and the printable area in landscape

Note: The tables beginning on page 2-4 list the page sizes and dimensions of each area labeled on the preceding diagram for all paper and envelope sizes your printer supports. If information about your printer is not included in the following tables, see page 1-1 for information on how to get a *Technical Reference* for your printer.

Lexmark™ C520, C522n, C524, C524n, C524dn, C530dn, C532n, C532dn, C534n, C534dn, C534dtn, C770, C770n, C772, C772n, C920, C920n, C920dn, and C920dnf

The following table lists page sizes and print area dimensions for all paper and envelope sizes the Lexmark™ C520, C522n, C524, C524n, C524dn, C530dn, C532n, C532dn, C534n, C534dn, C534dtn, C770, C770n, C772, C772n, C920, C920n, C920dn, and C920dnf printers support. For more information about the printable areas and logical pages for PCL emulation, see “Printable Areas” on page 2-3.

Table 2-1: Lexmark C520, C522n, C524, C524n, C524dn, C530dn, C532n, C534n, C534dn, C534dtn, C770, C770n, C772, C772n, C920, C920n, C920dn, C920dnf Paper and Envelope Dimensions

Selection		Paper/Envelope Dimensions		Dimensions by Area (pels) ¹								
Page Size Parameters ²	Name	mm	inches	A	B	C	D	E	F	G	H	I
Paper												
13, 613	A5	148 x 210	5.83 x 8.27	3496	4960	3196	4720	142	118	0	100	100
12, 45, 612	JIS B5 Paper	182 x 257	7.2 x 10.1	4300	6070	4000	5830	150	120	0	100	100
26, 626	A4 (198 mm) ³	210 x 297	8.3 x 11.7	4960	7014	4676	6778	142	118	0	80	80
26, 626	A4 (203 mm) ³	210 x 297	8.3 x 11.7	4960	7014	4800	6778	80	118	0	80	80
1, 601	Executive	184 x 267	7.25 x 10.5	4350	6300	4050	6060	150	120	0	100	100
2, 602	Letter	216 x 279	8.5 x 11	5100	6600	4800	6360	150	120	0	100	100
3, 603	Legal	216 x 356	8.5 x 14	5100	8400	4800	8160	150	120	0	100	100
4 or 10	Folio	216 x 330	8.5 x 13	5100	7800	4800	7560	150	120	0	100	100
15	Statement	139.7 x 215.9	5.5 x 8.5	3300	5100	3000	4860	150	120	0	100	100
101	Universal	216 x 356	8.5 x 14					150	120	0	100	100

¹ Pel dimensions are for 600 dpi.

² Page Size Parameters are explained in Table 2-16 on page 2-54.

³ The width of the logical page for A4 paper can be changed from the printer operator panel or your software application.

⁴ Paper ID 99 will be supported for backward compatibility with other Lexmark printers. Paper ID 99 has the same logical paper size as ID 100 (compatible with HP LaserJet 5Si/5SiMx) but is 8 pels wider than the Lexmark 4039.

Note: The explanation of the printable area assumes the **Print Area** menu item is set to **Normal**. For more information, see “Print Area Menu Item” on page 2-6.

Table 2-1: Lexmark C520, C522n, C524, C524n, C524dn, C530dn, C532n, C534n, C534dn, C534dtn, C770, C770n, C772, C772n, C920, C920n, C920dn, C920dnfPaper and Envelope Dimensions (Continued)

Selection		Paper/Envelope Dimensions		Dimensions by Area (pels) ¹								
Page Size Parameters ²	Name	mm	inches	A	B	C	D	E	F	G	H	I
Envelope												
90	DL	220 x 110	8.66 x 4.33	2598	5196	2314	4960	142	118	0	100	100
91	C5	229 x 162	9.02 x 6.38	3826	5408	2542	5172	142	118	0	100	100
99 ⁴ , 100	B5 Envelope	250 x 176	9.84 x 6.93	4156	5904	3872	5668	142	118	0	100	100
600	Other Envelope	216 x 356	8.5 x 14	5100	8400	4800	8160	150	120	0	100	100
89	9 (Com 9)	225 x 98	8.875 x 3.875	2326	5324	2024	5084	150	120	0	100	100
81	10 (Com 10)	241 x 105	9.5 x 4.125	2474	5700	2174	5460	150	120	0	100	100
80	7 3/4 (Monarch)	98 x 191	3.875 x 7.5	2326	4300	2024	4260	150	120	0	100	100

¹ Pel dimensions are for 600 dpi.

² Page Size Parameters are explained in Table 2-16 on page 2-54.

³ The width of the logical page for A4 paper can be changed from the printer operator panel or your software application.

⁴ Paper ID 99 will be supported for backward compatibility with other Lexmark printers. Paper ID 99 has the same logical paper size as ID 100 (compatible with HP LaserJet 5Si/5SiMx) but is 8 pels wider than the Lexmark 4039.

Note: The explanation of the printable area assumes the **Print Area** menu item is set to **Normal**. For more information, see "Print Area Menu Item" on page 2-6.

Print Area Menu Item

The *printable area* is the area on a sheet of paper within which a pel can be printed. *Logical page* is a conceptual entity that defines the area in which margins (top, bottom, left, right) may be set and the area in which the PCL cursor may be positioned.

The *physical page border* is the actual physical boundaries of a page.

The **Print Area** menu item is available from the printer operator panel or through MarkVision Professional. For some printers, Print Area supports three values: Normal, Whole Page, and Fit to Page. See your printer documentation for more information

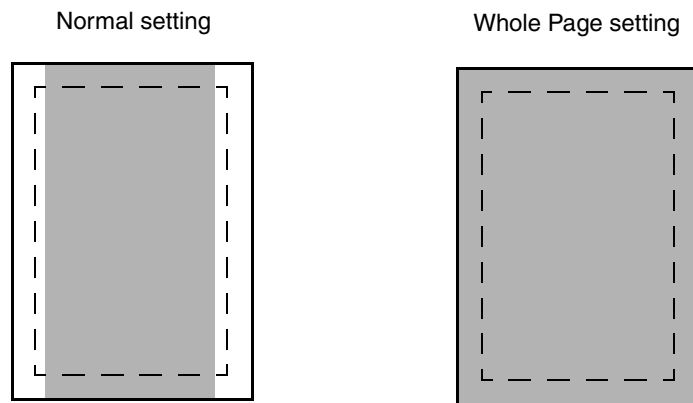

Legend:

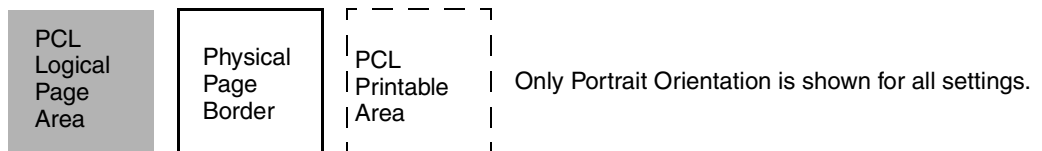

The *Normal setting*, which is the factory default, means the printable area includes the entire page except the narrow border around the edge of the page. This is the nonprintable area. The printer measures margin settings relative to the logical page.

For a more detailed explanation of the Normal setting, see “Printable Areas” on page 2-3.

The *Whole Page setting* only affects pages printed when using PCL emulation. If Whole Page is selected, the PCL language sets the logical page area equal to the physical page dimensions. Since the logical page dimensions and the physical page dimensions are the same, in theory, the cursor may be positioned anywhere on the page. However, the PCL language clips the image to the printable area. So, the Whole Page setting is useful for printing scanned images that extend from edge to edge of a page.

Some printers offer the *Fit to Page setting*. When Fit to Page is selected, PCL emulation or PostScript emulation formats a page using a printable area equal to the physical page, which is from one edge of the page to the other edge of the page. If you use this setting, no clipping occurs. In Fit to Page, the PCL emulation logical page dimensions are equal to the physical page dimensions, as in the Whole Page setting.

The printer holds this formatted image in memory, but when the page prints, the image is compressed a small amount in both horizontal and vertical directions, and then centered on the physical page for letter-size paper only. This process creates a small margin around the image. This artificial margin prevents printing from one edge to the other, since doing so could contaminate the printer and cause printing problems.

The following illustrations show an image held in memory for printing from one edge to the other and how the image would actually print based on the Fit to Page setting. Notice that a small border appears at the edges of the printed page, and the image is slightly compressed.

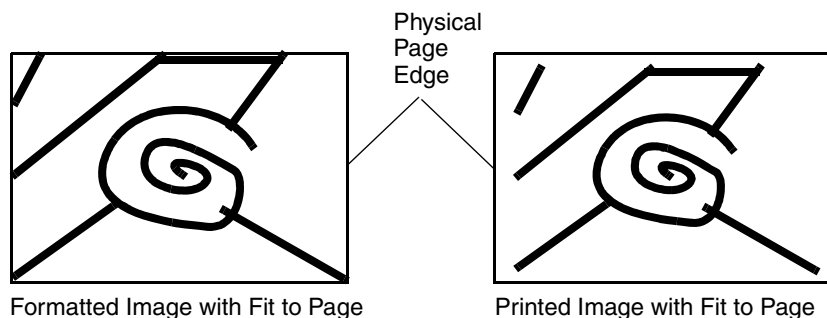

Font and Symbol Set Support for the Lexmark C520, C522n, C524, C524n, C524dn, C530dn, C532n, C532dn, C534n, C534dn, C534dtn, C770, C770n, C772, C772n, C920, C920n, C920dn, C920dnf

Your printer has 91 resident fonts in PCL emulation, including 89 scalable fonts and two bitmapped fonts.

Several parameters are used to select a font from the data stream. These include symbol set, spacing, point or pitch, style, weight, and typeface number. For scalable fonts, you can vary the size of a font by specifying pitch or point size. For bitmapped fonts, you must choose the pitch or point size listed on the font sample pages. You can print the font sample pages using a PJL command (see “LPRINTPCLFONTS” on page 3-83.), or through MarkVision Professional (network models only). See your printer documentation for more information.

A *symbol set* defines which characters are available for a font and the code point for each of these characters. Your printer supports 88 resident symbol sets. The tables beginning on page 2-10 show the symbol sets available for each font in PCL emulation. Not all fonts support all symbol sets.

You can select a font as the PCL emulation default through MarkVision Professional (network models only). See your printer documentation for more information.

The fonts are divided into three major groups. The first 47 fonts (R0 to R46) shown on the font sample pages are the standard PCL emulation fonts. The next 39 fonts (R47 to R85) are called Type 1 fonts and were originally defined for PostScript emulation, but now also work in the PCL emulation. The final five fonts (R86 to R90) are additional specialty PCL emulation fonts. For a list of the 47 standard PCL emulation fonts, see Table 2-2 on page 2-9. For a list of the 39 Type 1 fonts, see Table 2-3 on page 2-11. For a list of the five additional specialty PCL emulation fonts, see Table 2-11 on page 2-43. These tables list both the forward and backward compatibility font selection commands. For more information on forward and backward compatibility, see page 2-9. For more information on selecting symbol sets, see page 2-38.

For compatibility purposes, you can disable Type 1 fonts with the Printer Job Language (PJL) LTYPE1FONTS command. The factory default for these fonts is Enabled. See LTYPE1FONTS on page 3-48 for more information.

You can also select fonts using PJP commands. The selection parameter is the number portion from the font identifier shown on the font sample pages, such as 0 or 76 from font identifiers R0 or R76. Use the PJP values shown in the tables beginning on page 2-9 to select a symbol set. If a symbol set does not have a PJP value, use the symbol set ID to select the symbol set. A font selection can be either temporary or set as the default.

Use the following PJP commands to select fonts: FONTSOURCE, FONTNUMBER, PITCH, PTSIZE, SYMSET, SET, DEFAULT. See “Table 3-5: Common Variables for PCL Emulation” on page 3-48 for more information about these commands.

Forward and Backward Compatibility Modes for the Lexmark C520, C522n, C524, C524n, C524dn, C530dn, C532n, C534n, C534dn, C534dn, C534dtn, C770, C770n, C772, C772n, C920, C920n, C920dn, C920dnf

Your PCL emulation has forward and backward compatibility modes. The *forward compatibility mode* is used to emulate the fonts in the Hewlett-Packard Company’s LaserJet 4050. The *backward compatibility mode* is used for compatibility with the Hewlett-Packard Company’s LaserJet 5 and the Lexmark family of printers.

Standard PCL Emulation Fonts

The following table lists the font selection commands for forward and backward compatibility mode for each of the 47 standard PCL emulation fonts. Since the font selection commands for the forward and backward compatibility modes are identical, they are listed together in the table.

Table 2-2: Forward and Backward Compatibility Font Selection Commands

Standard PCL Emulation Font Name	Forward and Backward Compatibility Mode			
	Spacing	Style	Weight	Typeface
Courier	0	0	0	4099
Courier Italic	0	1	0	4099
Courier Bold	0	0	3	4099
Courier Bold Italic	0	1	3	4099
CG Times	1	0	0	4101
CG Times Italic	1	1	0	4101

¹This font is not implemented in the Hewlett-Packard Company’s LaserJet 4050.

Table 2-2: Forward and Backward Compatibility Font Selection Commands (Continued)

Standard PCL Emulation Font Name	Forward and Backward Compatibility Mode			
	Spacing	Style	Weight	Typeface
CG Times Bold	1	0	3	4101
CG Times Bold Italic	1	1	3	4101
Univers Medium	1	0	0	4148
Univers Medium Italic	1	1	0	4148
Univers Bold	1	0	3	4148
Univers Bold Italic	1	1	3	4148
Times New Roman	1	0	0	16901
Times New Roman Italic	1	1	0	16901
Times New Roman Bold	1	0	3	16901
Times New Roman Bold Italic	1	1	3	16901
Arial	1	0	0	16602
Arial Italic	1	1	0	16602
Arial Bold	1	0	3	16602
Arial Bold Italic	1	1	3	16602
Letter Gothic	0	0	0	4102
Letter Gothic Italic	0	1	0	4102
Letter Gothic Bold	0	0	3	4102
Univers Condensed Medium	1	4	0	4148
Univers Condensed Medium Italic	1	5	0	4148
Univers Condensed Bold	1	4	3	4148
Univers Condensed Bold Italic	1	5	3	4148
Garamond Antiqua	1	0	0	4197
Garamond Kursiv	1	1	0	4197
Garamond Halbfett	1	0	3	4197
Garamond Kursiv Halbfett	1	1	3	4197
CG Omega	1	0	0	4113
CG Omega Italic	1	1	0	4113
CG Omega Bold	1	0	3	4113
CG Omega Bold Italic	1	1	3	4113
Antique Olive	1	0	0	4168
Antique Olive Italic	1	1	0	4168
Antique Olive Bold	1	0	3	4168
Albertus Medium	1	0	1	4362

¹This font is not implemented in the Hewlett-Packard Company's LaserJet 4050.

Table 2-2: Forward and Backward Compatibility Font Selection Commands (Continued)

Standard PCL Emulation Font Name	Forward and Backward Compatibility Mode			
	Spacing	Style	Weight	Typeface
Albertus Extra Bold	1	0	4	4362
Clarendon Condensed Bold	1	4	3	4140
Marigold	1	0	0	4297
Coronet	1	1	0	4116
Line Printer 16	0	0	0	0
POSTNET Barcode ¹	1	0	0	0
Wingdings	1	0	0	31402
Symbol	1	0	0	16686

¹This font is not implemented in the Hewlett-Packard Company's LaserJet 4050.

Type 1 Fonts

Thirty of the Type 1 fonts have different font selection parameters in the forward and backward compatibility modes and nine of the fonts work only in the forward compatibility mode. With the appropriate printer driver installed and selected, your software program selects these fonts.

The following table shows the font selection commands for forward and backward compatibility modes and indicates the font group for each font. All Type 1 fonts are supported by both the Hewlett-Packard Company's LaserJet 4050 and the Lexmark family of printers unless otherwise noted.

Table 2-3: Forward and Backward Compatibility Font Selection Commands

Type 1 Font name	Forward Compatibility Mode				Backward Compatibility Mode			
	Spacing	Style	Weight	Typeface	Spacing	Style	Weight	Typeface
Helvetica	1	0	0	24580	1	0	0	61444
Helvetica Italic	1	1	0	24580	1	1	0	61444
Helvetica Bold	1	0	3	24580	1	0	3	61444
Helvetica Bold Italic	1	1	3	24580	1	1	3	61444
Helvetica Narrow	1	4	0	24580	1	4	0	61444
Helvetica Narrow Italic	1	5	0	24580	1	5	0	61444
Helvetica Narrow Bold	1	4	3	24580	1	4	3	61444

¹ Notice the values for forward and backward compatibility modes differ slightly for Bold.
² This font is not implemented in the Hewlett-Packard Company's LaserJet 4050.
³ This font is not implemented in the Lexmark family of printers.

Table 2-3: Forward and Backward Compatibility Font Selection Commands (Continued)

Type 1 Font name	Forward Compatibility Mode				Backward Compatibility Mode			
	Spacing	Style	Weight	Typeface	Spacing	Style	Weight	Typeface
Helvetica Narrow Bold Italic	1	5	3	24580	1	5	3	61444
Palatino Roman	1	0	0	24591	1	0	0	61455
Palatino Italic	1	1	0	24591	1	1	0	61455
Palatino Bold	1	0	3	24591	1	0	3	61455
Palatino Bold Italic	1	1	3	24591	1	1	3	61455
ITC Bookman Light	1	0	-3	24623	1	0	-3	61487
ITC Bookman Light Italic	1	1	-3	24623	1	1	-3	61487
ITC Bookman Demi	1	0	2	24623	1	0	2	61487
ITC Bookman Demi Italic	1	1	2	24623	1	1	2	61487
ITC Avant Garde Book	1	0	0	24607	1	0	0	61471
ITC Avant Garde Book Oblique	1	1	0	24607	1	1	0	61471
ITC Avant Garde Demi ¹	1	0	2	24607	1	0	3	61471
ITC Avant Garde Demi Oblique ¹	1	1	2	24607	1	1	3	61471
Century Schoolbook Roman	1	0	0	24703	1	0	0	61463
Century Schoolbook Italic	1	1	0	24703	1	1	0	61463
Century Schoolbook Bold	1	0	3	24703	1	0	3	61463
Century Schoolbook Bold Italic	1	1	3	24703	1	1	3	61463
ITC Zapf Chancery Medium Italic	1	1	0	45099	1	1	0	61483
CourierPS ³	0	0	0	24579				
CourierPS Oblique ³	0	1	0	24579				
CourierPS Bold ³	0	0	3	24579				
CourierPS Bold Oblique ³	0	1	3	24579				
Times Roman ³	1	0	0	25093				
Times Italic ³	1	1	0	25093				
Times Bold ³	1	0	3	25093				
Times Bold Italic ³	1	1	3	25093				
Helvetica Light ²	1	0	-3	24580	1	0	-3	61444
Helvetica Light Oblique ²	1	1	-3	24580	1	1	-3	61444
Helvetica Black ²	1	0	5	24580	1	0	5	61444
Helvetica Black Oblique ²	1	1	5	24580	1	1	5	61444

¹ Notice the values for forward and backward compatibility modes differ slightly for Bold.

² This font is not implemented in the Hewlett-Packard Company's LaserJet 4050.

³ This font is not implemented in the Lexmark family of printers.

Table 2-3: Forward and Backward Compatibility Font Selection Commands (Continued)

Type 1 Font name	Forward Compatibility Mode				Backward Compatibility Mode			
	Spacing	Style	Weight	Typeface	Spacing	Style	Weight	Typeface
SymbolPS ³	1	0	0	45358				
ITC Zapf Dingbats	1	0	0	45101	1	0	0	61485

¹ Notice the values for forward and backward compatibility modes differ slightly for Bold.
² This font is not implemented in the Hewlett-Packard Company's LaserJet 4050.
³ This font is not implemented in the Lexmark family of printers.

Your Lexmark printer defaults to the forward compatibility mode to enable a Hewlett-Packard Company's driver to select the forward compatibility fonts. The Lexmark PCL emulation driver uses the backward compatibility mode and temporarily switches the printer to this mode. The PCL (PJM) emulation commands to switch the default compatibility modes are:

```
Forward  ESC%-12345X@PJM DEFAULT LPARM:PCL LFONTCOMPATIBILITY=PCL6
         @PJM RESET
         ESC%-12345X
```

```
Backward ESC%-12345X@PJM DEFAULT LPARM:PCL LFONTCOMPATIBILITY=PCL5
         @PJM RESET
         ESC%-12345X
```

Specialty PCL Fonts

The following table lists the font selection commands for forward and backward compatibility mode for each of the five specialty PCL emulation fonts. Since the font selection commands for the forward and backward compatibility modes are identical, they are listed together in the table. These fonts are supported only in PCL 5 emulation, not in PCL XL.

Table 2-4: Forward and Backward Compatibility Font Selection Commands

Standard PCL Emulation Font Name	Forward and Backward Compatibility Mode			
	Spacing	Style	Weight	Typeface
C39 Narrow ¹	1	0	0	32774
C39 Regular ¹	1	0	0	32772
C39 Wide ¹	1	0	0	32777
OCR-A ¹	0	0	0	23584
OCR-B ¹	0	0	0	23590

¹ This font is not implemented in the Hewlett-Packard Company's LaserJet 4050.

Selecting Symbol Sets for Lexmark C520, C522n, C524m C542b C524dn, C530dn, C532n, C532dn, C534n, C534dn, C534dtn, C770, C770n, C772, C772n, C920, C920n, C920dn, C920dnt

To determine if a font or typeface supports a symbol set, see the complete listing of PCL emulation fonts and symbol sets in the following tables: “Table 2-7: TC520, C522n, C524, C524n, C524dn, C530dn, C532n, C532dn, C534n, C534dn, C534dtn, C770, C770n, C772, C772n, C920, C920n, C920dn, and C920dnf PCL Emulation Symbol Sets - Specials” on page 2-26, “Table 2-9: TC520, C522n, C524, C524n, C524dn, C530dn, C532n, C532dn, C534n, C534dn, C534dtn, C770, C770n, C772, C772n, C920, C920n, C920dn, and C920dnf PCL Emulation Symbol Sets - Latin 1” on page 2-32, and “Table 2-11: TC520, C522n, C524, C524n, C524dn, C530dn, C532n, C532dn, C534n, C534dn, C534dtn, C770, C770n, C772, C772n, C920, C920n, C920dn, and C920dnf PCL Emulation Symbol Sets - Specials” on page 2-43.

Selecting Symbol Sets for the Lexmark C520, C522n, C524, C524n, C524dn, C530dn, C532n, C532dn, C534n, C534dn, C534dtn, C770, C770n, C772, C772n, C920, C920n, C920dn, C920dnf

To determine if a font or typeface supports a symbol set, see the complete listing of PCL emulation fonts and symbol sets in the following tables: “Table 2-7: TC520, C522n, C524, C524n, C524dn, C530dn, C532n, C532dn, C534n, C534dn, C534dtn, C770, C770n, C772, C772n, C920, C920n, C920dn, and C920dnf PCL Emulation Symbol Sets - Specials” on page 2-26, “Table 2-10: C520, C522n, C524, C524n, C530dn, C532n, C532dn, C534n, C534dn, C534dtn, C524dn, C770, C770n, C772n, C772n, C920, C920n, C920dn, and C920dnf PCL Emulation Symbol Sets - Latin 2, Latin 5, Latin 6, Cyrillic, Greek” on page 2-37, and “Table 2-11: TC520, C522n, C524,

C524n, C524dn, C530dn, C532n, C532dn, C534n, C534dn, C534dtn, C770, C770n, C772, C772n, C920, C920n, C920dn, and C920dnf PCL Emulation Symbol Sets - Specials” on page 2-43

Table 2-5: C520, C522n, C524, C524n, C524dn, C530dn, C532n, C532dn, C534n, C534dn, C534dtn, C770, C770n, C772, C772n, C920, C920n, C920dn, C920dnf PCL Emulation Symbol Sets - Latin 1

Typeface / Symbol Set	Latin 1																							
	Legal	Windows 3.0 Latin 1	Windows 98 Latin 1	ISO 8859-1 Latin 1 (ECMA-94)	ISO 8859-15 Latin 9	PC-8, Code Page 437	PC-8 Danish/Norwegian (437N)	PC-850 Multilingual	PC-858 Multilingual Euro	PC-860 Portugal	PC-861 Iceland	PC-863 Canadian French	PC-865 Nordic	PC-1004 OS/2	ABICOMP Brazil/Portugal	ABICOMP International	Roman-8	Roman-9	Roman Extension	PS Text	MC Text	Desk Top	Ventura International	Ventura US
PJL Value	LEGAL	WIN30	WINL1	ISOL1	ISOL9	PC8	PC8DN	PC850	PC858							ROMAN8			PSTEXT		DESKTOP	VNINTL	VNUS	
Symbol Set ID	1U	9U	19U	0N	9N	10U	11U	12U	13U	20U	21U	23U	25U	9J	13P	14P	8U	4U	0E	10J	12J	7J	13J	14J
Courier	✓	✓	✓	✓	✓	✓	✓	✓	✓	✓	✓	✓	✓	✓	✓	✓	✓	✓	✓	✓	✓	✓	✓	✓
Courier Italic	✓	✓	✓	✓	✓	✓	✓	✓	✓	✓	✓	✓	✓	✓	✓	✓	✓	✓	✓	✓	✓	✓	✓	✓
Courier Bold	✓	✓	✓	✓	✓	✓	✓	✓	✓	✓	✓	✓	✓	✓	✓	✓	✓	✓	✓	✓	✓	✓	✓	✓
Courier Bold Italic	✓	✓	✓	✓	✓	✓	✓	✓	✓	✓	✓	✓	✓	✓	✓	✓	✓	✓	✓	✓	✓	✓	✓	✓
CG Times	✓	✓	✓	✓	✓	✓	✓	✓	✓	✓	✓	✓	✓	✓	✓	✓	✓	✓	✓	✓	✓	✓	✓	✓
CG Times Italic	✓	✓	✓	✓	✓	✓	✓	✓	✓	✓	✓	✓	✓	✓	✓	✓	✓	✓	✓	✓	✓	✓	✓	✓
CG Times Bold	✓	✓	✓	✓	✓	✓	✓	✓	✓	✓	✓	✓	✓	✓	✓	✓	✓	✓	✓	✓	✓	✓	✓	✓
CG Times Bold Italic	✓	✓	✓	✓	✓	✓	✓	✓	✓	✓	✓	✓	✓	✓	✓	✓	✓	✓	✓	✓	✓	✓	✓	✓
Univers Medium	✓	✓	✓	✓	✓	✓	✓	✓	✓	✓	✓	✓	✓	✓	✓	✓	✓	✓	✓	✓	✓	✓	✓	✓
Univers Medium Italic	✓	✓	✓	✓	✓	✓	✓	✓	✓	✓	✓	✓	✓	✓	✓	✓	✓	✓	✓	✓	✓	✓	✓	✓
Univers Bold	✓	✓	✓	✓	✓	✓	✓	✓	✓	✓	✓	✓	✓	✓	✓	✓	✓	✓	✓	✓	✓	✓	✓	✓
Univers Bold Italic	✓	✓	✓	✓	✓	✓	✓	✓	✓	✓	✓	✓	✓	✓	✓	✓	✓	✓	✓	✓	✓	✓	✓	✓
Times New Roman	✓	✓	✓	✓	✓	✓	✓	✓	✓	✓	✓	✓	✓	✓	✓	✓	✓	✓	✓	✓	✓	✓	✓	✓
Times New Roman Italic	✓	✓	✓	✓	✓	✓	✓	✓	✓	✓	✓	✓	✓	✓	✓	✓	✓	✓	✓	✓	✓	✓	✓	✓
Times New Roman Bold	✓	✓	✓	✓	✓	✓	✓	✓	✓	✓	✓	✓	✓	✓	✓	✓	✓	✓	✓	✓	✓	✓	✓	✓

✓ Indicates Typeface supports the specified Symbol Set.
 ✗ Indicates Typeface does not support the specified Symbol Set.

Table 2-5: C520, C522n, C524, C524n, C524dn, C530dn, C532n, C532dn, C534n, C534dn, C534dn, C770, C770n, C772, C772n, C920, C920n, C920dn, C920dnf PCL Emulation Symbol Sets - Latin 1 (Continued)

Typeface / Symbol Set	Latin 1																							
	Legal	Windows 3.0 Latin 1	Windows 98 Latin 1	ISO 8859-1 Latin 1 (ECMA-94)	ISO 8859-15 Latin 9	PC-8, Code Page 437	PC-8 Danish/Norwegian (437N)	PC-850 Multilingual	PC-858 Multilingual Euro	PC-860 Portugal	PC-861 Iceland	PC-863 Canadian French	PC-865 Nordic	PC-1004 OS/2	ABICOMP Brazil/Portugal	ABICOMP International	Roman-8	Roman-9	Roman Extension	PS Text	MC Text	Desk Top	Ventura International	Ventura US
PJL Value	LEGAL	WIN30	WINL1	ISOL1	ISOL9	PC8	PC8DN	PC850	PC858								ROMAN8			PSTEXT		DESKTOP	VNINTL	VNUS
Symbol Set ID	1U	9U	19U	0N	9N	10U	11U	12U	13U	20U	21U	23U	25U	9J	13P	14P	8U	4U	0E	10J	12J	7J	13J	14J
Times New Roman Bold Italic	✓	✓	✓	✓	✓	✓	✓	✓	✓	✓	✓	✓	✓	✓	✓	✓	✓	✓	✓	✓	✓	✓	✓	✓
Arial	✓	✓	✓	✓	✓	✓	✓	✓	✓	✓	✓	✓	✓	✓	✓	✓	✓	✓	✓	✓	✓	✓	✓	✓
Arial Italic	✓	✓	✓	✓	✓	✓	✓	✓	✓	✓	✓	✓	✓	✓	✓	✓	✓	✓	✓	✓	✓	✓	✓	✓
Arial Bold	✓	✓	✓	✓	✓	✓	✓	✓	✓	✓	✓	✓	✓	✓	✓	✓	✓	✓	✓	✓	✓	✓	✓	✓
Arial Bold Italic	✓	✓	✓	✓	✓	✓	✓	✓	✓	✓	✓	✓	✓	✓	✓	✓	✓	✓	✓	✓	✓	✓	✓	✓
Letter Gothic	✓	✓	✓	✓	✓	✓	✓	✓	✓	✓	✓	✓	✓	✓	✓	✓	✓	✓	✓	✓	✓	✓	✓	✓
Letter Gothic Italic	✓	✓	✓	✓	✓	✓	✓	✓	✓	✓	✓	✓	✓	✓	✓	✓	✓	✓	✓	✓	✓	✓	✓	✓
Letter Gothic Bold	✓	✓	✓	✓	✓	✓	✓	✓	✓	✓	✓	✓	✓	✓	✓	✓	✓	✓	✓	✓	✓	✓	✓	✓
Univers Condensed Medium	✓	✓	✓	✓	✓	✓	✓	✓	✓	✓	✓	✓	✓	✓	✓	✓	✓	✓	✓	✓	✓	✓	✓	✓
Univers Condensed Medium Italic	✓	✓	✓	✓	✓	✓	✓	✓	✓	✓	✓	✓	✓	✓	✓	✓	✓	✓	✓	✓	✓	✓	✓	✓
Univers Condensed Bold	✓	✓	✓	✓	✓	✓	✓	✓	✓	✓	✓	✓	✓	✓	✓	✓	✓	✓	✓	✓	✓	✓	✓	✓
Univers Condensed Bold Italic	✓	✓	✓	✓	✓	✓	✓	✓	✓	✓	✓	✓	✓	✓	✓	✓	✓	✓	✓	✓	✓	✓	✓	✓
Garamond Antiqua	✓	✓	✓	✓	✓	✓	✓	✓	✓	✓	✓	✓	✓	✓	✓	✓	✓	✓	✓	✓	✓	✓	✓	✓
Garamond Kursiv	✓	✓	✓	✓	✓	✓	✓	✓	✓	✓	✓	✓	✓	✓	✓	✓	✓	✓	✓	✓	✓	✓	✓	✓
Garamond Halbfett	✓	✓	✓	✓	✓	✓	✓	✓	✓	✓	✓	✓	✓	✓	✓	✓	✓	✓	✓	✓	✓	✓	✓	✓
Garamond Kursiv Halbfett	✓	✓	✓	✓	✓	✓	✓	✓	✓	✓	✓	✓	✓	✓	✓	✓	✓	✓	✓	✓	✓	✓	✓	✓
CG Omega	✓	✓	✓	✓	✓	✓	✓	✓	✓	✓	✓	✓	✓	✓	✓	✓	✓	✓	✓	✓	✓	✓	✓	✓
CG Omega Italic	✓	✓	✓	✓	✓	✓	✓	✓	✓	✓	✓	✓	✓	✓	✓	✓	✓	✓	✓	✓	✓	✓	✓	✓
CG Omega Bold	✓	✓	✓	✓	✓	✓	✓	✓	✓	✓	✓	✓	✓	✓	✓	✓	✓	✓	✓	✓	✓	✓	✓	✓

✓ Indicates Typeface supports the specified Symbol Set.
 ✗ Indicates Typeface does not support the specified Symbol Set.

Table 2-5: C520, C522n, C524, C524n, C524dn, C530dn, C532n, C532dn, C534n, C534dn, C534dn, C770, C770n, C772, C772n, C920, C920n, C920dn, C920dnf PCL Emulation Symbol Sets - Latin 1 (Continued)

Typeface / Symbol Set	Latin 1																							
	Legal	Windows 3.0 Latin 1	Windows 98 Latin 1	ISO 8859-1 Latin 1 (ECMA-94)	ISO 8859-15 Latin 9	PC-8, Code Page 437	PC-8 Danish/Norwegian (437N)	PC-850 Multilingual	PC-858 Multilingual Euro	PC-860 Portugal	PC-861 Iceland	PC-863 Canadian French	PC-865 Nordic	PC-1004 OS/2	ABICOMP Brazil/Portugal	ABICOMP International	Roman-8	Roman-9	Roman Extension	PS Text	MC Text	Desk Top	Ventura International	Ventura US
PJL Value	LEGAL	WIN30	WINL1	ISOL1	ISOL9	PC8	PC8DN	PC850	PC858								ROMAN8			PSTEXT		DESKTOP	VNINTL	VNUS
Symbol Set ID	1U	9U	19U	0N	9N	10U	11U	12U	13U	20U	21U	23U	25U	9J	13P	14P	8U	4U	0E	10J	12J	7J	13J	14J
CG Omega Bold Italic	✓	✓	✓	✓	✓	✓	✓	✓	✓	✓	✓	✓	✓	✓	✓	✓	✓	✓	✓	✓	✓	✓	✓	✓
Antique Olive	✓	✓	✓	✓	✓	✓	✓	✓	✓	✓	✓	✓	✓	✓	✓	✓	✓	✓	✓	✓	✓	✓	✓	✓
Antique Olive Italic	✓	✓	✓	✓	✓	✓	✓	✓	✓	✓	✓	✓	✓	✓	✓	✓	✓	✓	✓	✓	✓	✓	✓	✓
Antique Olive Bold	✓	✓	✓	✓	✓	✓	✓	✓	✓	✓	✓	✓	✓	✓	✓	✓	✓	✓	✓	✓	✓	✓	✓	✓
Albertus Medium	✓	✓	✓	✓	✓	✓	✓	✓	✓	✓	✓	✓	✓	✓	✓	✓	✓	✓	✓	✓	✓	✓	✓	✓
Albertus Extra Bold	✓	✓	✓	✓	✓	✓	✓	✓	✓	✓	✓	✓	✓	✓	✓	✓	✓	✓	✓	✓	✓	✓	✓	✓
Clarendon Condensed Bold	✓	✓	✓	✓	✓	✓	✓	✓	✓	✓	✓	✓	✓	✓	✓	✓	✓	✓	✓	✓	✓	✓	✓	✓
Marigold	✓	✓	✓	✓	✓	✓	✓	✓	✓	✓	✓	✓	✓	✓	✓	✓	✓	✓	✓	✓	✓	✓	✓	✓
Coronet	✓	✓	✓	✓	✓	✓	✓	✓	✓	✓	✓	✓	✓	✓	✓	✓	✓	✓	✓	✓	✓	✓	✓	✓
Helvetica	✓	✓	✓	✓	✓	✓	✓	✓	✓	✓	✓	✓	✓	✓	✓	✓	✓	✓	✓	✓	✓	✓	✓	✓
Helvetica Italic	✓	✓	✓	✓	✓	✓	✓	✓	✓	✓	✓	✓	✓	✓	✓	✓	✓	✓	✓	✓	✓	✓	✓	✓
Helvetica Bold	✓	✓	✓	✓	✓	✓	✓	✓	✓	✓	✓	✓	✓	✓	✓	✓	✓	✓	✓	✓	✓	✓	✓	✓
Helvetica Bold Italic	✓	✓	✓	✓	✓	✓	✓	✓	✓	✓	✓	✓	✓	✓	✓	✓	✓	✓	✓	✓	✓	✓	✓	✓
Helvetica Narrow	✓	✓	✓	✓	✓	✓	✓	✓	✓	✓	✓	✓	✓	✓	✓	✓	✓	✓	✓	✓	✓	✓	✓	✓
Helvetica Narrow Italic	✓	✓	✓	✓	✓	✓	✓	✓	✓	✓	✓	✓	✓	✓	✓	✓	✓	✓	✓	✓	✓	✓	✓	✓
Helvetica Narrow Bold	✓	✓	✓	✓	✓	✓	✓	✓	✓	✓	✓	✓	✓	✓	✓	✓	✓	✓	✓	✓	✓	✓	✓	✓
Helvetica Narrow Bold Italic	✓	✓	✓	✓	✓	✓	✓	✓	✓	✓	✓	✓	✓	✓	✓	✓	✓	✓	✓	✓	✓	✓	✓	✓
Palatino Roman	✓	✓	✓	✓	✓	✓	✓	✓	✓	✓	✓	✓	✓	✓	✓	✓	✓	✓	✓	✓	✓	✓	✓	✓
Palatino Italic	✓	✓	✓	✓	✓	✓	✓	✓	✓	✓	✓	✓	✓	✓	✓	✓	✓	✓	✓	✓	✓	✓	✓	✓

✓ Indicates Typeface supports the specified Symbol Set.
 ✗ Indicates Typeface does not support the specified Symbol Set.

Table 2-5: C520, C522n, C524, C524n, C524dn, C530dn, C532n, C532dn, C534n, C534dn, C534dn, C770, C770n, C772, C772n, C920, C920n, C920dn, C920dnf PCL Emulation Symbol Sets - Latin 1 (Continued)

Typeface / Symbol Set	Latin 1																							
	Legal	Windows 3.0 Latin 1	Windows 98 Latin 1	ISO 8859-1 Latin 1 (ECMA-94)	ISO 8859-15 Latin 9	PC-8, Code Page 437	PC-8 Danish/Norwegian (437N)	PC-850 Multilingual	PC-858 Multilingual Euro	PC-860 Portugal	PC-861 Iceland	PC-863 Canadian French	PC-865 Nordic	PC-1004 OS/2	ABICOMP Brazil/Portugal	ABICOMP International	Roman-8	Roman-9	Roman Extension	PS Text	MC Text	Desk Top	Ventura International	Ventura US
PJL Value	LEGAL	WIN30	WINL1	ISOL1	ISOL9	PC8	PC8DN	PC850	PC858								ROMAN8			PSTEXT		DESKTOP	VNINTL	VNUS
Symbol Set ID	1U	9U	19U	0N	9N	10U	11U	12U	13U	20U	21U	23U	25U	9J	13P	14P	8U	4U	0E	10J	12J	7J	13J	14J
Palatino Bold	✓	✓	✓	✓	✓	✓	✓	✓	✓	✓	✓	✓	✓	✓	✓	✓	✓	✓	✓	✓	✓	✓	✓	✓
Palatino Bold Italic	✓	✓	✓	✓	✓	✓	✓	✓	✓	✓	✓	✓	✓	✓	✓	✓	✓	✓	✓	✓	✓	✓	✓	✓
ITC Bookman Light	✓	✓	✓	✓	✓	✓	✓	✓	✓	✓	✓	✓	✓	✓	✓	✓	✓	✓	✓	✓	✓	✓	✓	✓
ITC Bookman Light Italic	✓	✓	✓	✓	✓	✓	✓	✓	✓	✓	✓	✓	✓	✓	✓	✓	✓	✓	✓	✓	✓	✓	✓	✓
ITC Bookman Demi	✓	✓	✓	✓	✓	✓	✓	✓	✓	✓	✓	✓	✓	✓	✓	✓	✓	✓	✓	✓	✓	✓	✓	✓
ITC Bookman Demi Italic	✓	✓	✓	✓	✓	✓	✓	✓	✓	✓	✓	✓	✓	✓	✓	✓	✓	✓	✓	✓	✓	✓	✓	✓
ITC Avant Garde Book	✓	✓	✓	✓	✓	✓	✓	✓	✓	✓	✓	✓	✓	✓	✓	✓	✓	✓	✓	✓	✓	✓	✓	✓
ITC Avant Garde Book Oblique	✓	✓	✓	✓	✓	✓	✓	✓	✓	✓	✓	✓	✓	✓	✓	✓	✓	✓	✓	✓	✓	✓	✓	✓
ITC Avant Garde Demi	✓	✓	✓	✓	✓	✓	✓	✓	✓	✓	✓	✓	✓	✓	✓	✓	✓	✓	✓	✓	✓	✓	✓	✓
ITC Avant Garde Demi Oblique	✓	✓	✓	✓	✓	✓	✓	✓	✓	✓	✓	✓	✓	✓	✓	✓	✓	✓	✓	✓	✓	✓	✓	✓
Century Schoolbook Roman	✓	✓	✓	✓	✓	✓	✓	✓	✓	✓	✓	✓	✓	✓	✓	✓	✓	✓	✓	✓	✓	✓	✓	✓
Century Schoolbook Italic	✓	✓	✓	✓	✓	✓	✓	✓	✓	✓	✓	✓	✓	✓	✓	✓	✓	✓	✓	✓	✓	✓	✓	✓
Century Schoolbook Bold	✓	✓	✓	✓	✓	✓	✓	✓	✓	✓	✓	✓	✓	✓	✓	✓	✓	✓	✓	✓	✓	✓	✓	✓
Century Schoolbook Bold Italic	✓	✓	✓	✓	✓	✓	✓	✓	✓	✓	✓	✓	✓	✓	✓	✓	✓	✓	✓	✓	✓	✓	✓	✓
ITC Zapf Chancery Medium Italic	✓	✓	✓	✓	✓	✓	✓	✓	✓	✓	✓	✓	✓	✓	✓	✓	✓	✓	✓	✓	✓	✓	✓	✓
CourierPS	✓	✓	✓	✓	✓	✓	✓	✓	✓	✓	✓	✓	✓	✓	✓	✓	✓	✓	✓	✓	✓	✓	✓	✓
CourierPS Oblique	✓	✓	✓	✓	✓	✓	✓	✓	✓	✓	✓	✓	✓	✓	✓	✓	✓	✓	✓	✓	✓	✓	✓	✓
CourierPS Bold	✓	✓	✓	✓	✓	✓	✓	✓	✓	✓	✓	✓	✓	✓	✓	✓	✓	✓	✓	✓	✓	✓	✓	✓
CourierPS Bold Oblique	✓	✓	✓	✓	✓	✓	✓	✓	✓	✓	✓	✓	✓	✓	✓	✓	✓	✓	✓	✓	✓	✓	✓	✓

✓ Indicates Typeface supports the specified Symbol Set.
 ✗ Indicates Typeface does not support the specified Symbol Set.

Table 2-5: C520, C522n, C524, C524n, C524dn, C530dn, C532n, C532dn, C534n, C534dn, C534dn, C770, C770n, C772, C772n, C920, C920n, C920dn, C920dnf PCL Emulation Symbol Sets - Latin 1 (Continued)

Typeface / Symbol Set	Latin 1																							
	Legal	Windows 3.0 Latin 1	Windows 98 Latin 1	ISO 8859-1 Latin 1 (ECMA-94)	ISO 8859-15 Latin 9	PC-8, Code Page 437	PC-8 Danish/Norwegian (437N)	PC-850 Multilingual	PC-858 Multilingual Euro	PC-860 Portugal	PC-861 Iceland	PC-863 Canadian French	PC-865 Nordic	PC-1004 OS/2	ABICOMP Brazil/Portugal	ABICOMP International	Roman-8	Roman-9	Roman Extension	PS Text	MC Text	Desk Top	Ventura International	Ventura US
PJL Value	LEGAL	WIN30	WINL1	ISOL1	ISOL9	PC8	PC8DN	PC850	PC858							ROMAN8			PSTEXT		DESKTOP	VNINTL	VNUS	
Symbol Set ID	1U	9U	19U	0N	9N	10U	11U	12U	13U	20U	21U	23U	25U	9J	13P	14P	8U	4U	0E	10J	12J	7J	13J	14J
Times Roman	✓	✓	✓	✓	✓	✓	✓	✓	✓	✓	✓	✓	✓	✓	✓	✓	✓	✓	✓	✓	✓	✓	✓	✓
Times Italic	✓	✓	✓	✓	✓	✓	✓	✓	✓	✓	✓	✓	✓	✓	✓	✓	✓	✓	✓	✓	✓	✓	✓	✓
Times Bold	✓	✓	✓	✓	✓	✓	✓	✓	✓	✓	✓	✓	✓	✓	✓	✓	✓	✓	✓	✓	✓	✓	✓	✓
Times Bold Italic	✓	✓	✓	✓	✓	✓	✓	✓	✓	✓	✓	✓	✓	✓	✓	✓	✓	✓	✓	✓	✓	✓	✓	✓
Helvetica Light	✗	✓	✓	✓	✓	✓	✗	✓	✓	✓	✗	✓	✓	✓	✓	✓	✓	✓	✓	✓	✓	✗	✓	✓
Helvetica Light Oblique	✗	✓	✓	✓	✓	✓	✗	✓	✓	✓	✗	✓	✓	✓	✓	✓	✓	✓	✓	✓	✓	✗	✓	✓
Helvetica Black	✗	✓	✓	✓	✓	✓	✗	✓	✓	✓	✗	✓	✓	✓	✓	✓	✓	✓	✓	✓	✓	✗	✓	✓
Helvetica Black Oblique	✗	✓	✓	✓	✓	✓	✗	✓	✓	✓	✗	✓	✓	✓	✓	✓	✓	✓	✓	✓	✓	✗	✓	✓
Line Printer 16	✓	✓	✓	✓	✓	✓	✓	✓	✓	✓	✓	✓	✓	✓	✓	✓	✓	✓	✓	✓	✓	✓	✓	✓
POSTNET Barcode	✗	✗	✗	✗	✗	✗	✗	✗	✗	✗	✗	✗	✗	✗	✗	✗	✗	✗	✗	✗	✗	✗	✗	✗
C39 Narrow	✗	✗	✗	✗	✗	✗	✗	✗	✗	✗	✗	✗	✗	✗	✗	✗	✗	✗	✗	✗	✗	✗	✗	✗
C39 Regular	✗	✗	✗	✗	✗	✗	✗	✗	✗	✗	✗	✗	✗	✗	✗	✗	✗	✗	✗	✗	✗	✗	✗	✗
C39 Wide	✗	✗	✗	✗	✗	✗	✗	✗	✗	✗	✗	✗	✗	✗	✗	✗	✗	✗	✗	✗	✗	✗	✗	✗
OCR-A	✗	✗	✗	✗	✗	✗	✗	✗	✗	✗	✗	✗	✗	✗	✗	✗	✗	✗	✗	✗	✗	✗	✗	✗
OCR-B	✓	✓	✓	✓	✓	✓	✓	✓	✓	✓	✓	✓	✓	✓	✓	✓	✓	✓	✓	✗	✗	✗	✓	✓
Wingdings	✗	✗	✗	✗	✗	✗	✗	✗	✗	✗	✗	✗	✗	✗	✗	✗	✗	✗	✗	✗	✗	✗	✗	✗
Symbol	✗	✗	✗	✗	✗	✗	✗	✗	✗	✗	✗	✗	✗	✗	✗	✗	✗	✗	✗	✗	✗	✗	✗	✗
SymbolPS	✗	✗	✗	✗	✗	✗	✗	✗	✗	✗	✗	✗	✗	✗	✗	✗	✗	✗	✗	✗	✗	✗	✗	✗
ITC Zapf Dingbats	✗	✗	✗	✗	✗	✗	✗	✗	✗	✗	✗	✗	✗	✗	✗	✗	✗	✗	✗	✗	✗	✗	✗	✗

✓ Indicates Typeface supports the specified Symbol Set.
✗ Indicates Typeface does not support the specified Symbol Set.

Table 2-6: C520, C522n, C 524, C524n, C524dn, C530dn, C532n, C532dn, C534n, C534dn, C534dtn, C770, C770n, C772, C772n, C920, C920n, C920dn, and C920dnf PCL Emulation Symbol Sets - Latin 2, Latin 5, Latin 6, Cyrillic, Greek

Typeface / Symbol Set	Latin 2					Latin 5					Latin 6			Cyrillic						Greek								
	Windows 98 Latin 2	ISO 8859-2 Latin 2	PC-852 Latin 2	PC-8 Polish Mazovia	PC-8 PC Nova	Windows 98 Latin 5	ISO 8859-9 Latin 5	PC-857 Latin 5 (Turkish)	PC-853 Latin 3 (Turkish)	PC-Turkish (437T)	Turkish-8	Windows 98 Latin 6 (Baltic)	ISO 8859-10 Latin 6	PC-775 Baltic (PC-8 Latin 6)	Windows 98 Cyrillic	ISO 8859-5 Latin/Cyrillic	PC-866 Cyrillic	PC-855 Cyrillic	Russian-GOST	PC-8 Bulgarian	Ukrainian	Windows 98 Greek	ISO 8859-7 Latin/Greek	PC-869 Greece	PC-851 Greece	PC-8 Latin/Greek	PC-8 Greek Alternate (437G)	Greek-8
PJL Value	WINL2	ISOL2	PC852			WINL5	ISOL5			PC8TK																		
Symbol Set ID	9E	2N	17U	24Q	27Q	5T	5N	16U	18U	9T	8T	19L	6N	26U	9R	10N	3R	10R	12R	13R	14R	9G	12N	11G	10G	12G	14G	8G
Courier	✓	✓	✓	✓	✓	✓	✓	✓	✓	✓	✓	✓	✓	✓	✓	✓	✓	✓	✓	✓	✓	✓	✓	✓	✓	✓	✓	✓
Courier Italic	✓	✓	✓	✓	✓	✓	✓	✓	✓	✓	✓	✓	✓	✓	✓	✓	✓	✓	✓	✓	✓	✓	✓	✓	✓	✓	✓	✓
Courier Bold	✓	✓	✓	✓	✓	✓	✓	✓	✓	✓	✓	✓	✓	✓	✓	✓	✓	✓	✓	✓	✓	✓	✓	✓	✓	✓	✓	✓
Courier Bold Italic	✓	✓	✓	✓	✓	✓	✓	✓	✓	✓	✓	✓	✓	✓	✓	✓	✓	✓	✓	✓	✓	✓	✓	✓	✓	✓	✓	✓
CG Times	✓	✓	✓	✓	✓	✓	✓	✓	✓	✓	✓	✓	✓	✓	✓	✓	✓	✓	✓	✓	✓	✓	✓	✓	✓	✓	✓	✓
CG Times Italic	✓	✓	✓	✓	✓	✓	✓	✓	✓	✓	✓	✓	✓	✓	✓	✓	✓	✓	✓	✓	✓	✓	✓	✓	✓	✓	✓	✓
CG Times Bold	✓	✓	✓	✓	✓	✓	✓	✓	✓	✓	✓	✓	✓	✓	✓	✓	✓	✓	✓	✓	✓	✓	✓	✓	✓	✓	✓	✓
CG Times Bold Italic	✓	✓	✓	✓	✓	✓	✓	✓	✓	✓	✓	✓	✓	✓	✓	✓	✓	✓	✓	✓	✓	✓	✓	✓	✓	✓	✓	✓
Univers Medium	✓	✓	✓	✓	✓	✓	✓	✓	✓	✓	✓	✓	✓	✓	✓	✓	✓	✓	✓	✓	✓	✓	✓	✓	✓	✓	✓	✓
Univers Medium Italic	✓	✓	✓	✓	✓	✓	✓	✓	✓	✓	✓	✓	✓	✓	✓	✓	✓	✓	✓	✓	✓	✓	✓	✓	✓	✓	✓	✓
Univers Bold	✓	✓	✓	✓	✓	✓	✓	✓	✓	✓	✓	✓	✓	✓	✓	✓	✓	✓	✓	✓	✓	✓	✓	✓	✓	✓	✓	✓
Univers Bold Italic	✓	✓	✓	✓	✓	✓	✓	✓	✓	✓	✓	✓	✓	✓	✓	✓	✓	✓	✓	✓	✓	✓	✓	✓	✓	✓	✓	✓
Times New Roman	✓	✓	✓	✗	✓	✓	✓	✓	✗	✓	✓	✓	✓	✓	✗	✗	✗	✗	✗	✗	✗	✗	✗	✗	✗	✗	✗	✗
Times New Roman Italic	✓	✓	✓	✗	✓	✓	✓	✓	✗	✓	✓	✓	✓	✓	✗	✗	✗	✗	✗	✗	✗	✗	✗	✗	✗	✗	✗	✗
Times New Roman Bold	✓	✓	✓	✗	✓	✓	✓	✓	✗	✓	✓	✓	✓	✓	✗	✗	✗	✗	✗	✗	✗	✗	✗	✗	✗	✗	✗	✗
Times New Roman Bold Italic	✓	✓	✓	✗	✓	✓	✓	✓	✗	✓	✓	✓	✓	✓	✗	✗	✗	✗	✗	✗	✗	✗	✗	✗	✗	✗	✗	✗
Arial	✓	✓	✓	✗	✓	✓	✓	✓	✗	✓	✓	✓	✓	✓	✗	✗	✗	✗	✗	✗	✗	✗	✗	✗	✗	✗	✗	✗
Arial Italic	✓	✓	✓	✗	✓	✓	✓	✓	✗	✓	✓	✓	✓	✓	✗	✗	✗	✗	✗	✗	✗	✗	✗	✗	✗	✗	✗	✗

✓ Indicates Typeface supports the specified Symbol Set.
✗ Indicates Typeface does not support the specified Symbol Set.

Table 2-6: C520, C522n, C 524, C524n, C524dn, C530dn, C532n, C532dn, C534n, C534dn, C534dtn, C770, C770n, C772, C772n, C920, C920n, C920dn, and C920dnf PCL Emulation Symbol Sets - Latin 2, Latin 5, Latin 6, Cyrillic, Greek (Continued)

Typeface / Symbol Set	Latin 2					Latin 5					Latin 6			Cyrillic						Greek								
	Windows 98 Latin 2	ISO 8859-2 Latin 2	PC-852 Latin 2	PC-8 Polish Mazovia	PC-8 PC Nova	Windows 98 Latin 5	ISO 8859-9 Latin 5	PC-857 Latin 5 (Turkish)	PC-853 Latin 3 (Turkish)	PC-Turkish (437T)	Turkish-8	Windows 98 Latin 6 (Baltic)	ISO 8859-10 Latin 6	PC-775 Baltic (PC-8 Latin 6)	Windows 98 Cyrillic	ISO 8859-5 Latin/Cyrillic	PC-866 Cyrillic	PC-855 Cyrillic	Russian-GOST	PC-8 Bulgarian	Ukrainian	Windows 98 Greek	ISO 8859-7 Latin/Greek	PC-869 Greece	PC-851 Greece	PC-8 Latin/Greek	PC-8 Greek Alternate (437G)	Greek-8
PJL Value	WINL2	ISOL2	PC852			WINL5	ISOL5			PC8TK																		
Symbol Set ID	9E	2N	17U	24Q	27Q	5T	5N	16U	18U	9T	8T	19L	6N	26U	9R	10N	3R	10R	12R	13R	14R	9G	12N	11G	10G	12G	14G	8G
Arial Bold	✓	✓	✓	✗	✓	✓	✓	✓	✗	✓	✓	✓	✓	✓	✗	✗	✗	✗	✗	✗	✗	✗	✗	✗	✗	✗	✗	✗
Arial Bold Italic	✓	✓	✓	✗	✓	✓	✓	✓	✗	✓	✓	✓	✓	✓	✗	✗	✗	✗	✗	✗	✗	✗	✗	✗	✗	✗	✗	✗
Letter Gothic	✓	✓	✓	✗	✓	✓	✓	✓	✗	✓	✓	✓	✓	✓	✗	✗	✗	✗	✗	✗	✗	✗	✗	✗	✗	✗	✗	✗
Letter Gothic Italic	✓	✓	✓	✗	✓	✓	✓	✓	✗	✓	✓	✓	✓	✓	✗	✗	✗	✗	✗	✗	✗	✗	✗	✗	✗	✗	✗	✗
Letter Gothic Bold	✓	✓	✓	✗	✓	✓	✓	✓	✗	✓	✓	✓	✓	✓	✗	✗	✗	✗	✗	✗	✗	✗	✗	✗	✗	✗	✗	✗
Univers Condensed Medium	✓	✓	✓	✗	✓	✓	✓	✓	✗	✓	✓	✓	✓	✓	✗	✗	✗	✗	✗	✗	✗	✗	✗	✗	✗	✗	✗	✗
Univers Condensed Medium Italic	✓	✓	✓	✗	✓	✓	✓	✓	✗	✓	✓	✓	✓	✓	✗	✗	✗	✗	✗	✗	✗	✗	✗	✗	✗	✗	✗	✗
Univers Condensed Bold	✓	✓	✓	✗	✓	✓	✓	✓	✗	✓	✓	✓	✓	✓	✗	✗	✗	✗	✗	✗	✗	✗	✗	✗	✗	✗	✗	✗
Univers Condensed Bold Italic	✓	✓	✓	✗	✓	✓	✓	✓	✗	✓	✓	✓	✓	✓	✗	✗	✗	✗	✗	✗	✗	✗	✗	✗	✗	✗	✗	✗
Garamond Antiqua	✓	✓	✓	✗	✓	✓	✓	✓	✗	✓	✓	✓	✓	✓	✗	✗	✗	✗	✗	✗	✗	✗	✗	✗	✗	✗	✗	✗
Garamond Kursiv	✓	✓	✓	✗	✓	✓	✓	✓	✗	✓	✓	✓	✓	✓	✗	✗	✗	✗	✗	✗	✗	✗	✗	✗	✗	✗	✗	✗
Garamond Halbfett	✓	✓	✓	✗	✓	✓	✓	✓	✗	✓	✓	✓	✓	✓	✗	✗	✗	✗	✗	✗	✗	✗	✗	✗	✗	✗	✗	✗
Garamond Kursiv Halbfett	✓	✓	✓	✗	✓	✓	✓	✓	✗	✓	✓	✓	✓	✓	✗	✗	✗	✗	✗	✗	✗	✗	✗	✗	✗	✗	✗	✗
CG Omega	✓	✓	✓	✗	✓	✓	✓	✓	✗	✓	✓	✓	✓	✓	✗	✗	✗	✗	✗	✗	✗	✗	✗	✗	✗	✗	✗	✗
CG Omega Italic	✓	✓	✓	✗	✓	✓	✓	✓	✗	✓	✓	✓	✓	✓	✗	✗	✗	✗	✗	✗	✗	✗	✗	✗	✗	✗	✗	✗
CG Omega Bold	✓	✓	✓	✗	✓	✓	✓	✓	✗	✓	✓	✓	✓	✓	✗	✗	✗	✗	✗	✗	✗	✗	✗	✗	✗	✗	✗	✗

✓ Indicates Typeface supports the specified Symbol Set.

✗ Indicates Typeface does not support the specified Symbol Set.

Table 2-6: C520, C522n, C 524, C524n, C524dn, C530dn, C532n, C532dn, C534n, C534dn, C534dtn, C770, C770n, C772, C772n, C920, C920n, C920dn, and C920dnf PCL Emulation Symbol Sets - Latin 2, Latin 5, Latin 6, Cyrillic, Greek (Continued)

Typeface / Symbol Set	Latin 2					Latin 5					Latin 6			Cyrillic						Greek								
	Windows 98 Latin 2	ISO 8859-2 Latin 2	PC-852 Latin 2	PC-8 Polish Mazovia	PC-8 PC Nova	Windows 98 Latin 5	ISO 8859-9 Latin 5	PC-857 Latin 5 (Turkish)	PC-853 Latin 3 (Turkish)	PC-Turkish (437T)	Turkish-8	Windows 98 Latin 6 (Baltic)	ISO 8859-10 Latin 6	PC-775 Baltic (PC-8 Latin 6)	Windows 98 Cyrillic	ISO 8859-5 Latin/Cyrillic	PC-866 Cyrillic	PC-855 Cyrillic	Russian-GOST	PC-8 Bulgarian	Ukrainian	Windows 98 Greek	ISO 8859-7 Latin/Greek	PC-869 Greece	PC-851 Greece	PC-8 Latin/Greek	PC-8 Greek Alternate (437G)	Greek-8
PJL Value	WINL2	ISOL2	PC852			WINL5	ISOL5			PC8TK																		
Symbol Set ID	9E	2N	17U	24Q	27Q	5T	5N	16U	18U	9T	8T	19L	6N	26U	9R	10N	3R	10R	12R	13R	14R	9G	12N	11G	10G	12G	14G	8G
CG Omega Bold Italic	✓	✓	✓	✗	✓	✓	✓	✓	✗	✓	✓	✓	✓	✓	✗	✗	✗	✗	✗	✗	✗	✗	✗	✗	✗	✗	✗	✗
Antique Olive	✓	✓	✓	✗	✓	✓	✓	✓	✗	✓	✓	✓	✓	✓	✗	✗	✗	✗	✗	✗	✗	✗	✗	✗	✗	✗	✗	✗
Antique Olive Italic	✓	✓	✓	✗	✓	✓	✓	✓	✗	✓	✓	✓	✓	✓	✗	✗	✗	✗	✗	✗	✗	✗	✗	✗	✗	✗	✗	✗
Antique Olive Bold	✓	✓	✓	✗	✓	✓	✓	✓	✗	✓	✓	✓	✓	✓	✗	✗	✗	✗	✗	✗	✗	✗	✗	✗	✗	✗	✗	✗
Albertus Medium	✓	✓	✓	✗	✓	✓	✓	✓	✗	✓	✓	✓	✓	✓	✗	✗	✗	✗	✗	✗	✗	✗	✗	✗	✗	✗	✗	✗
Albertus Extra Bold	✓	✓	✓	✗	✓	✓	✓	✓	✗	✓	✓	✓	✓	✓	✗	✗	✗	✗	✗	✗	✗	✗	✗	✗	✗	✗	✗	✗
Clarendon Condensed Bold	✓	✓	✓	✗	✓	✓	✓	✓	✗	✓	✓	✓	✓	✓	✗	✗	✗	✗	✗	✗	✗	✗	✗	✗	✗	✗	✗	✗
Marigold	✓	✓	✓	✗	✓	✓	✓	✓	✗	✓	✓	✓	✓	✓	✗	✗	✗	✗	✗	✗	✗	✗	✗	✗	✗	✗	✗	✗
Coronet	✓	✓	✓	✗	✓	✓	✓	✓	✗	✓	✓	✓	✓	✓	✗	✗	✗	✗	✗	✗	✗	✗	✗	✗	✗	✗	✗	✗
Helvetica	✓	✓	✓	✗	✓	✓	✓	✓	✗	✓	✓	✓	✓	✓	✗	✗	✗	✗	✗	✗	✗	✗	✗	✗	✗	✗	✗	✗
Helvetica Italic	✓	✓	✓	✗	✓	✓	✓	✓	✗	✓	✓	✓	✓	✓	✗	✗	✗	✗	✗	✗	✗	✗	✗	✗	✗	✗	✗	✗
Helvetica Bold	✓	✓	✓	✗	✓	✓	✓	✓	✗	✓	✓	✓	✓	✓	✗	✗	✗	✗	✗	✗	✗	✗	✗	✗	✗	✗	✗	✗
Helvetica Bold Italic	✓	✓	✓	✗	✓	✓	✓	✓	✗	✓	✓	✓	✓	✓	✗	✗	✗	✗	✗	✗	✗	✗	✗	✗	✗	✗	✗	✗
Helvetica Narrow	✓	✓	✓	✗	✓	✓	✓	✓	✗	✓	✓	✓	✓	✓	✗	✗	✗	✗	✗	✗	✗	✗	✗	✗	✗	✗	✗	✗
Helvetica Narrow Italic	✓	✓	✓	✗	✓	✓	✓	✓	✗	✓	✓	✓	✓	✓	✗	✗	✗	✗	✗	✗	✗	✗	✗	✗	✗	✗	✗	✗
Helvetica Narrow Bold	✓	✓	✓	✗	✓	✓	✓	✓	✗	✓	✓	✓	✓	✓	✗	✗	✗	✗	✗	✗	✗	✗	✗	✗	✗	✗	✗	✗
Helvetica Narrow Bold Italic	✓	✓	✓	✗	✓	✓	✓	✓	✗	✓	✓	✓	✓	✓	✗	✗	✗	✗	✗	✗	✗	✗	✗	✗	✗	✗	✗	✗

✓ Indicates Typeface supports the specified Symbol Set.
✗ Indicates Typeface does not support the specified Symbol Set.

Table 2-6: C520, C522n, C 524, C524n, C524dn, C530dn, C532n, C532dn, C534n, C534dn, C534dtn, C770, C770n, C772, C772n, C920, C920n, C920dn, and C920dnf PCL Emulation Symbol Sets - Latin 2, Latin 5, Latin 6, Cyrillic, Greek (Continued)

Typeface / Symbol Set	Latin 2					Latin 5					Latin 6			Cyrillic						Greek								
	Windows 98 Latin 2	ISO 8859-2 Latin 2	PC-852 Latin 2	PC-8 Polish Mazovia	PC-8 PC Nova	Windows 98 Latin 5	ISO 8859-9 Latin 5	PC-857 Latin 5 (Turkish)	PC-853 Latin 3 (Turkish)	PC-Turkish (437T)	Turkish-8	Windows 98 Latin 6 (Baltic)	ISO 8859-10 Latin 6	PC-775 Baltic (PC-8 Latin 6)	Windows 98 Cyrillic	ISO 8859-5 Latin/Cyrillic	PC-866 Cyrillic	PC-855 Cyrillic	Russian-GOST	PC-8 Bulgarian	Ukrainian	Windows 98 Greek	ISO 8859-7 Latin/Greek	PC-869 Greece	PC-851 Greece	PC-8 Latin/Greek	PC-8 Greek Alternate (437G)	Greek-8
PJL Value	WINL2	ISOL2	PC852			WINL5	ISOL5			PC8TK																		
Symbol Set ID	9E	2N	17U	24Q	27Q	5T	5N	16U	18U	9T	8T	19L	6N	26U	9R	10N	3R	10R	12R	13R	14R	9G	12N	11G	10G	12G	14G	8G
Palatino Roman	✓	✓	✓	✗	✓	✓	✓	✓	✗	✓	✓	✓	✓	✓	✗	✗	✗	✗	✗	✗	✗	✗	✗	✗	✗	✗	✗	✗
Palatino Italic	✓	✓	✓	✗	✓	✓	✓	✓	✗	✓	✓	✓	✓	✓	✗	✗	✗	✗	✗	✗	✗	✗	✗	✗	✗	✗	✗	✗
Palatino Bold	✓	✓	✓	✗	✓	✓	✓	✓	✗	✓	✓	✓	✓	✓	✗	✗	✗	✗	✗	✗	✗	✗	✗	✗	✗	✗	✗	✗
Palatino Bold Italic	✓	✓	✓	✗	✓	✓	✓	✓	✗	✓	✓	✓	✓	✓	✗	✗	✗	✗	✗	✗	✗	✗	✗	✗	✗	✗	✗	✗
ITC Bookman Light	✓	✓	✓	✗	✓	✓	✓	✓	✗	✓	✓	✓	✓	✓	✗	✗	✗	✗	✗	✗	✗	✗	✗	✗	✗	✗	✗	✗
ITC Bookman Light Italic	✓	✓	✓	✗	✓	✓	✓	✓	✗	✓	✓	✓	✓	✓	✗	✗	✗	✗	✗	✗	✗	✗	✗	✗	✗	✗	✗	✗
ITC Bookman Demi	✓	✓	✓	✗	✓	✓	✓	✓	✗	✓	✓	✓	✓	✓	✗	✗	✗	✗	✗	✗	✗	✗	✗	✗	✗	✗	✗	✗
ITC Bookman Demi Italic	✓	✓	✓	✗	✓	✓	✓	✓	✗	✓	✓	✓	✓	✓	✗	✗	✗	✗	✗	✗	✗	✗	✗	✗	✗	✗	✗	✗
ITC Avant Garde Book	✓	✓	✓	✗	✓	✓	✓	✓	✗	✓	✓	✓	✓	✓	✗	✗	✗	✗	✗	✗	✗	✗	✗	✗	✗	✗	✗	✗
ITC Avant Garde Book Oblique	✓	✓	✓	✗	✓	✓	✓	✓	✗	✓	✓	✓	✓	✓	✗	✗	✗	✗	✗	✗	✗	✗	✗	✗	✗	✗	✗	✗
ITC Avant Garde Demi	✓	✓	✓	✗	✓	✓	✓	✓	✗	✓	✓	✓	✓	✓	✗	✗	✗	✗	✗	✗	✗	✗	✗	✗	✗	✗	✗	✗
ITC Avant Garde Demi Oblique	✓	✓	✓	✗	✓	✓	✓	✓	✗	✓	✓	✓	✓	✓	✗	✗	✗	✗	✗	✗	✗	✗	✗	✗	✗	✗	✗	✗
Century Schoolbook Roman	✓	✓	✓	✗	✓	✓	✓	✓	✗	✓	✓	✓	✓	✓	✗	✗	✗	✗	✗	✗	✗	✗	✗	✗	✗	✗	✗	✗
Century Schoolbook Italic	✓	✓	✓	✗	✓	✓	✓	✓	✗	✓	✓	✓	✓	✓	✗	✗	✗	✗	✗	✗	✗	✗	✗	✗	✗	✗	✗	✗

✓ Indicates Typeface supports the specified Symbol Set.

✗ Indicates Typeface does not support the specified Symbol Set.

Table 2-6: C520, C522n, C 524, C524n, C524dn, C530dn, C532n, C532dn, C534n, C534dn, C534dtn, C770, C770n, C772, C772n, C920, C920n, C920dn, and C920dnf PCL Emulation Symbol Sets - Latin 2, Latin 5, Latin 6, Cyrillic, Greek (Continued)

Typeface / Symbol Set	Latin 2					Latin 5					Latin 6			Cyrillic						Greek								
	Windows 98 Latin 2	ISO 8859-2 Latin 2	PC-852 Latin 2	PC-8 Polish Mazovia	PC-8 PC Nova	Windows 98 Latin 5	ISO 8859-9 Latin 5	PC-857 Latin 5 (Turkish)	PC-853 Latin 3 (Turkish)	PC-Turkish (437T)	Turkish-8	Windows 98 Latin 6 (Baltic)	ISO 8859-10 Latin 6	PC-775 Baltic (PC-8 Latin 6)	Windows 98 Cyrillic	ISO 8859-5 Latin/Cyrillic	PC-866 Cyrillic	PC-855 Cyrillic	Russian-GOST	PC-8 Bulgarian	Ukrainian	Windows 98 Greek	ISO 8859-7 Latin/Greek	PC-869 Greece	PC-851 Greece	PC-8 Latin/Greek	PC-8 Greek Alternate (437G)	Greek-8
PJL Value	WINL2	ISOL2	PC852			WINL5	ISOL5			PC8TK																		
Symbol Set ID	9E	2N	17U	24Q	27Q	5T	5N	16U	18U	9T	8T	19L	6N	26U	9R	10N	3R	10R	12R	13R	14R	9G	12N	11G	10G	12G	14G	8G
Century Schoolbook Bold	✓	✓	✓	✗	✓	✓	✓	✓	✗	✓	✓	✓	✓	✓	✗	✗	✗	✗	✗	✗	✗	✗	✗	✗	✗	✗	✗	✗
Century Schoolbook Bold Italic	✓	✓	✓	✗	✓	✓	✓	✓	✗	✓	✓	✓	✓	✓	✗	✗	✗	✗	✗	✗	✗	✗	✗	✗	✗	✗	✗	✗
ITC Zapf Chancery Medium Italic	✓	✓	✓	✗	✓	✓	✓	✓	✗	✓	✓	✓	✓	✓	✗	✗	✗	✗	✗	✗	✗	✗	✗	✗	✗	✗	✗	✗
CourierPS	✓	✓	✓	✗	✓	✓	✓	✓	✗	✓	✓	✓	✓	✓	✗	✗	✗	✗	✗	✗	✗	✗	✗	✗	✗	✗	✗	✗
CourierPS Oblique	✓	✓	✓	✗	✓	✓	✓	✓	✗	✓	✓	✓	✓	✓	✗	✗	✗	✗	✗	✗	✗	✗	✗	✗	✗	✗	✗	✗
CourierPS Bold	✓	✓	✓	✗	✓	✓	✓	✓	✗	✓	✓	✓	✓	✓	✗	✗	✗	✗	✗	✗	✗	✗	✗	✗	✗	✗	✗	✗
CourierPS Bold Oblique	✓	✓	✓	✗	✓	✓	✓	✓	✗	✓	✓	✓	✓	✓	✗	✗	✗	✗	✗	✗	✗	✗	✗	✗	✗	✗	✗	✗
Times Roman	✓	✓	✓	✗	✓	✓	✓	✓	✗	✓	✓	✓	✓	✓	✗	✗	✗	✗	✗	✗	✗	✗	✗	✗	✗	✗	✗	✗
Times Italic	✓	✓	✓	✗	✓	✓	✓	✓	✗	✓	✓	✓	✓	✓	✗	✗	✗	✗	✗	✗	✗	✗	✗	✗	✗	✗	✗	✗
Times Bold	✓	✓	✓	✗	✓	✓	✓	✓	✗	✓	✓	✓	✓	✓	✗	✗	✗	✗	✗	✗	✗	✗	✗	✗	✗	✗	✗	✗
Times Bold Italic	✓	✓	✓	✗	✓	✓	✓	✓	✗	✓	✓	✓	✓	✓	✗	✗	✗	✗	✗	✗	✗	✗	✗	✗	✗	✗	✗	✗
Helvetica Light	✗	✗	✗	✗	✗	✗	✗	✗	✗	✗	✗	✗	✗	✗	✗	✗	✗	✗	✗	✗	✗	✗	✗	✗	✗	✗	✗	✗
Helvetica Light Oblique	✗	✗	✗	✗	✗	✗	✗	✗	✗	✗	✗	✗	✗	✗	✗	✗	✗	✗	✗	✗	✗	✗	✗	✗	✗	✗	✗	✗
Helvetica Black	✗	✗	✗	✗	✗	✗	✗	✗	✗	✗	✗	✗	✗	✗	✗	✗	✗	✗	✗	✗	✗	✗	✗	✗	✗	✗	✗	✗
Helvetica Black Oblique	✗	✗	✗	✗	✗	✗	✗	✗	✗	✗	✗	✗	✗	✗	✗	✗	✗	✗	✗	✗	✗	✗	✗	✗	✗	✗	✗	✗
Line Printer 16	✓	✓	✓	✓	✓	✓	✓	✓	✓	✓	✓	✓	✓	✓	✓	✓	✓	✓	✓	✓	✓	✓	✓	✓	✓	✓	✓	✓

✓ Indicates Typeface supports the specified Symbol Set.
✗ Indicates Typeface does not support the specified Symbol Set.

Table 2-6: C520, C522n, C 524, C524n, C524dn, C530dn, C532n, C532dn, C534n, C534dn, C534dtn, C770, C770n, C772, C772n, C920, C920n, C920dn, and C920dnf PCL Emulation Symbol Sets - Latin 2, Latin 5, Latin 6, Cyrillic, Greek (Continued)

Typeface / Symbol Set	Latin 2					Latin 5					Latin 6			Cyrillic						Greek								
	Windows 98 Latin 2	ISO 8859-2 Latin 2	PC-852 Latin 2	PC-8 Polish Mazovia	PC-8 PC Nova	Windows 98 Latin 5	ISO 8859-9 Latin 5	PC-857 Latin 5 (Turkish)	PC-853 Latin 3 (Turkish)	PC-Turkish (437T)	Turkish-8	Windows 98 Latin 6 (Baltic)	ISO 8859-10 Latin 6	PC-775 Baltic (PC-8 Latin 6)	Windows 98 Cyrillic	ISO 8859-5 Latin/Cyrillic	PC-866 Cyrillic	PC-855 Cyrillic	Russian-GOST	PC-8 Bulgarian	Ukrainian	Windows 98 Greek	ISO 8859-7 Latin/Greek	PC-869 Greece	PC-851 Greece	PC-8 Latin/Greek	PC-8 Greek Alternate (437G)	Greek-8
PJL Value	WINL2	ISOL2	PC852			WINL5	ISOL5			PC8TK																		
Symbol Set ID	9E	2N	17U	24Q	27Q	5T	5N	16U	18U	9T	8T	19L	6N	26U	9R	10N	3R	10R	12R	13R	14R	9G	12N	11G	10G	12G	14G	8G
POSTNET Barcode	x	x	x	x	x	x	x	x	x	x	x	x	x	x	x	x	x	x	x	x	x	x	x	x	x	x	x	x
C39 Narrow	x	x	x	x	x	x	x	x	x	x	x	x	x	x	x	x	x	x	x	x	x	x	x	x	x	x	x	x
C39 Regular	x	x	x	x	x	x	x	x	x	x	x	x	x	x	x	x	x	x	x	x	x	x	x	x	x	x	x	x
C39 Wide	x	x	x	x	x	x	x	x	x	x	x	x	x	x	x	x	x	x	x	x	x	x	x	x	x	x	x	x
OCR-A	x	x	x	x	x	x	x	x	x	x	x	x	x	x	x	x	x	x	x	x	x	x	x	x	x	x	x	x
OCR-B	✓	✓	✓	✓	✓	x	x	x	x	x	x	x	x	x	x	x	x	x	x	x	x	x	x	x	x	x	x	x
Wingdings	x	x	x	x	x	x	x	x	x	x	x	x	x	x	x	x	x	x	x	x	x	x	x	x	x	x	x	x
Symbol	x	x	x	x	x	x	x	x	x	x	x	x	x	x	x	x	x	x	x	x	x	x	x	x	x	x	x	x
SymbolIPS	x	x	x	x	x	x	x	x	x	x	x	x	x	x	x	x	x	x	x	x	x	x	x	x	x	x	x	x
ITC Zapf Dingbats	x	x	x	x	x	x	x	x	x	x	x	x	x	x	x	x	x	x	x	x	x	x	x	x	x	x	x	x

✓ Indicates Typeface supports the specified Symbol Set.
x Indicates Typeface does not support the specified Symbol Set.

Table 2-7: TC520, C522n, C524, C524n, C524dn, C530dn, C532n, C532dn, C534n, C534dn, C534dtn, C770, C770n, C772, C772n, C920, C920n, C920dn, and C920dnf PCL Emulation Symbol Sets - Specials

Typeface / Symbol Set	Specials																
	Ventura Math	PS Math	Math-8	Pi font	Microsoft Publishing	PC-911 Katakana	POSTNET Barcode	OCR-A	OCR-B	C39 Bar Code (Upper Case)	C39 Bar Code (plus Lower Case)	C39 Bar Code (plus Human Readable)	Symbol	Wingdings	Ventura ITC Zapf Dingbats	PS ITC Zapf Dingbats	PCL ITC Zapf Dingbats
PJL Value	VNMATH	PSMATH	MATH8	PIFONT	MSPUBL												
Symbol Set ID	6M	5M	8M	15U	6J	3K	15Y	00	10	9Y	109Y	209Y	19M	579L	9L	10L	14L
Courier	✓	✓	✓	✓	✓	✗	✗	✗	✗	✗	✗	✗	✗	✗	✗	✗	✗
Courier Italic	✓	✓	✓	✓	✓	✗	✗	✗	✗	✗	✗	✗	✗	✗	✗	✗	✗
Courier Bold	✓	✓	✓	✓	✓	✗	✗	✗	✗	✗	✗	✗	✗	✗	✗	✗	✗
Courier Bold Italic	✓	✓	✓	✓	✓	✗	✗	✗	✗	✗	✗	✗	✗	✗	✗	✗	✗
CG Times	✓	✓	✓	✓	✓	✗	✗	✗	✗	✗	✗	✗	✗	✗	✗	✗	✗
CG Times Italic	✓	✓	✓	✓	✓	✗	✗	✗	✗	✗	✗	✗	✗	✗	✗	✗	✗
CG Times Bold	✓	✓	✓	✓	✓	✗	✗	✗	✗	✗	✗	✗	✗	✗	✗	✗	✗
CG Times Bold Italic	✓	✓	✓	✓	✓	✗	✗	✗	✗	✗	✗	✗	✗	✗	✗	✗	✗
Univers Medium	✓	✓	✓	✓	✓	✗	✗	✗	✗	✗	✗	✗	✗	✗	✗	✗	✗
Univers Medium Italic	✓	✓	✓	✓	✓	✗	✗	✗	✗	✗	✗	✗	✗	✗	✗	✗	✗
Univers Bold	✓	✓	✓	✓	✓	✗	✗	✗	✗	✗	✗	✗	✗	✗	✗	✗	✗
Univers Bold Italic	✓	✓	✓	✓	✓	✗	✗	✗	✗	✗	✗	✗	✗	✗	✗	✗	✗
Times New Roman	✓	✓	✓	✓	✓	✗	✗	✗	✗	✗	✗	✗	✗	✗	✗	✗	✗
Times New Roman Italic	✓	✓	✓	✓	✓	✗	✗	✗	✗	✗	✗	✗	✗	✗	✗	✗	✗
Times New Roman Bold	✓	✓	✓	✓	✓	✗	✗	✗	✗	✗	✗	✗	✗	✗	✗	✗	✗
Times New Roman BoldItalic	✓	✓	✓	✓	✓	✗	✗	✗	✗	✗	✗	✗	✗	✗	✗	✗	✗
Arial	✓	✓	✓	✓	✓	✗	✗	✗	✗	✗	✗	✗	✗	✗	✗	✗	✗
Arial Italic	✓	✓	✓	✓	✓	✗	✗	✗	✗	✗	✗	✗	✗	✗	✗	✗	✗
Arial Bold	✓	✓	✓	✓	✓	✗	✗	✗	✗	✗	✗	✗	✗	✗	✗	✗	✗
Arial Bold Italic	✓	✓	✓	✓	✓	✗	✗	✗	✗	✗	✗	✗	✗	✗	✗	✗	✗

✓ Indicates Typeface supports the specified Symbol Set.
✗ Indicates Typeface does not support the specified Symbol Set.

Table 2-7: TC520, C522n, C524, C524n, C524dn, C530dn, C532n, C532dn, C534n, C534dn, C534dtn, C770, C770n, C772, C772n, C920, C920n, C920dn, and C920dnf PCL Emulation Symbol Sets - Specials (Continued)

Typeface / Symbol Set	Specials																
	Ventura Math	PS Math	Math-8	Pi font	Microsoft Publishing	PC-911 Katakana	POSTNET Barcode	OCR-A	OCR-B	C39 Bar Code (Upper Case)	C39 Bar Code (plus Lower Case)	C39 Bar Code (plus Human Readable)	Symbol	Wingdings	Ventura ITC Zapf Dingbats	PS ITC Zapf Dingbats	PCL ITC Zapf Dingbats
PJL Value	VNMATH	PSMATH	MATH8	PIFONT	MSPUBL												
Symbol Set ID	6M	5M	8M	15U	6J	3K	15Y	00	10	9Y	109Y	209Y	19M	579L	9L	10L	14L
Letter Gothic	✓	✓	✓	✓	✓	✗	✗	✗	✗	✗	✗	✗	✗	✗	✗	✗	✗
Letter Gothic Italic	✓	✓	✓	✓	✓	✗	✗	✗	✗	✗	✗	✗	✗	✗	✗	✗	✗
Letter Gothic Bold	✓	✓	✓	✓	✓	✗	✗	✗	✗	✗	✗	✗	✗	✗	✗	✗	✗
Univers Condensed Medium	✓	✓	✓	✓	✓	✗	✗	✗	✗	✗	✗	✗	✗	✗	✗	✗	✗
Univers Condensed Medium Italic	✓	✓	✓	✓	✓	✗	✗	✗	✗	✗	✗	✗	✗	✗	✗	✗	✗
Univers Condensed Bold	✓	✓	✓	✓	✓	✗	✗	✗	✗	✗	✗	✗	✗	✗	✗	✗	✗
Univers Condensed Bold Italic	✓	✓	✓	✓	✓	✗	✗	✗	✗	✗	✗	✗	✗	✗	✗	✗	✗
Garamond Antiqua	✓	✓	✓	✓	✓	✗	✗	✗	✗	✗	✗	✗	✗	✗	✗	✗	✗
Garamond Kursiv	✓	✓	✓	✓	✓	✗	✗	✗	✗	✗	✗	✗	✗	✗	✗	✗	✗
Garamond Halbfett	✓	✓	✓	✓	✓	✗	✗	✗	✗	✗	✗	✗	✗	✗	✗	✗	✗
Garamond Kursiv Halbfett	✓	✓	✓	✓	✓	✗	✗	✗	✗	✗	✗	✗	✗	✗	✗	✗	✗
CG Omega	✓	✓	✓	✓	✓	✗	✗	✗	✗	✗	✗	✗	✗	✗	✗	✗	✗
CG Omega Italic	✓	✓	✓	✓	✓	✗	✗	✗	✗	✗	✗	✗	✗	✗	✗	✗	✗
CG Omega Bold	✓	✓	✓	✓	✓	✗	✗	✗	✗	✗	✗	✗	✗	✗	✗	✗	✗
CG Omega Bold Italic	✓	✓	✓	✓	✓	✗	✗	✗	✗	✗	✗	✗	✗	✗	✗	✗	✗
Antique Olive	✓	✓	✓	✓	✓	✗	✗	✗	✗	✗	✗	✗	✗	✗	✗	✗	✗
Antique Olive Italic	✓	✓	✓	✓	✓	✗	✗	✗	✗	✗	✗	✗	✗	✗	✗	✗	✗
Antique Olive Bold	✓	✓	✓	✓	✓	✗	✗	✗	✗	✗	✗	✗	✗	✗	✗	✗	✗
Albertus Medium	✓	✓	✓	✓	✓	✗	✗	✗	✗	✗	✗	✗	✗	✗	✗	✗	✗
Albertus Extra Bold	✓	✓	✓	✓	✓	✗	✗	✗	✗	✗	✗	✗	✗	✗	✗	✗	✗

✓ Indicates Typeface supports the specified Symbol Set.
✗ Indicates Typeface does not support the specified Symbol Set.

Table 2-7: TC520, C522n, C524, C524n, C524dn, C530dn, C532n, C532dn, C534n, C534dn, C534dtn, C770, C770n, C772, C772n, C920, C920n, C920dn, and C920dnf PCL Emulation Symbol Sets - Specials (Continued)

Typeface / Symbol Set	Specials																
	Ventura Math	PS Math	Math-8	Pi font	Microsoft Publishing	PC-911 Katakana	POSTNET Barcode	OCR-A	OCR-B	C39 Bar Code (Upper Case)	C39 Bar Code (plus Lower Case)	C39 Bar Code (plus Human Readable)	Symbol	Wingdings	Ventura ITC Zapf Dingbats	PS ITC Zapf Dingbats	PCL ITC Zapf Dingbats
PJL Value	VNMATH	PSMATH	MATH8	PIFONT	MSPUBL												
Symbol Set ID	6M	5M	8M	15U	6J	3K	15Y	00	10	9Y	109Y	209Y	19M	579L	9L	10L	14L
Clarendon Condensed Bold	✓	✓	✓	✓	✓	✗	✗	✗	✗	✗	✗	✗	✗	✗	✗	✗	✗
Marigold	✓	✓	✓	✓	✓	✗	✗	✗	✗	✗	✗	✗	✗	✗	✗	✗	✗
Coronet	✓	✓	✓	✓	✓	✗	✗	✗	✗	✗	✗	✗	✗	✗	✗	✗	✗
Helvetica	✓	✓	✓	✓	✓	✗	✗	✗	✗	✗	✗	✗	✗	✗	✗	✗	✗
Helvetica Italic	✓	✓	✓	✓	✓	✗	✗	✗	✗	✗	✗	✗	✗	✗	✗	✗	✗
Helvetica Bold	✓	✓	✓	✓	✓	✗	✗	✗	✗	✗	✗	✗	✗	✗	✗	✗	✗
Helvetica Bold Italic	✓	✓	✓	✓	✓	✗	✗	✗	✗	✗	✗	✗	✗	✗	✗	✗	✗
Helvetica Narrow	✓	✓	✓	✓	✓	✗	✗	✗	✗	✗	✗	✗	✗	✗	✗	✗	✗
Helvetica Narrow Italic	✓	✓	✓	✓	✓	✗	✗	✗	✗	✗	✗	✗	✗	✗	✗	✗	✗
Helvetica Narrow Bold	✓	✓	✓	✓	✓	✗	✗	✗	✗	✗	✗	✗	✗	✗	✗	✗	✗
Helvetica Narrow Bold Italic	✓	✓	✓	✓	✓	✗	✗	✗	✗	✗	✗	✗	✗	✗	✗	✗	✗
Palatino Roman	✓	✓	✓	✓	✓	✗	✗	✗	✗	✗	✗	✗	✗	✗	✗	✗	✗
Palatino Italic	✓	✓	✓	✓	✓	✗	✗	✗	✗	✗	✗	✗	✗	✗	✗	✗	✗
Palatino Bold	✓	✓	✓	✓	✓	✗	✗	✗	✗	✗	✗	✗	✗	✗	✗	✗	✗
Palatino Bold Italic	✓	✓	✓	✓	✓	✗	✗	✗	✗	✗	✗	✗	✗	✗	✗	✗	✗
ITC Bookman Light	✓	✓	✓	✓	✓	✗	✗	✗	✗	✗	✗	✗	✗	✗	✗	✗	✗
ITC Bookman Light Italic	✓	✓	✓	✓	✓	✗	✗	✗	✗	✗	✗	✗	✗	✗	✗	✗	✗
ITC Bookman Demi	✓	✓	✓	✓	✓	✗	✗	✗	✗	✗	✗	✗	✗	✗	✗	✗	✗
ITC Bookman Demi Italic	✓	✓	✓	✓	✓	✗	✗	✗	✗	✗	✗	✗	✗	✗	✗	✗	✗
ITC Avant Garde Book	✓	✓	✓	✓	✓	✗	✗	✗	✗	✗	✗	✗	✗	✗	✗	✗	✗

✓ Indicates Typeface supports the specified Symbol Set.
✗ Indicates Typeface does not support the specified Symbol Set.

Table 2-7: TC520, C522n, C524, C524n, C524dn, C530dn, C532n, C532dn, C534n, C534dn, C534dtn, C770, C770n, C772, C772n, C920, C920n, C920dn, and C920dnf PCL Emulation Symbol Sets - Specials (Continued)

Typeface / Symbol Set	Specials																
	Ventura Math	PS Math	Math-8	Pi font	Microsoft Publishing	PC-911 Katakana	POSTNET Barcode	OCR-A	OCR-B	C39 Bar Code (Upper Case)	C39 Bar Code (plus Lower Case)	C39 Bar Code (plus Human Readable)	Symbol	Wingdings	Ventura ITC Zapf Dingbats	PS ITC Zapf Dingbats	PCL ITC Zapf Dingbats
PJL Value	VNMATH	PSMATH	MATH8	PIFONT	MSPUBL												
Symbol Set ID	6M	5M	8M	15U	6J	3K	15Y	00	10	9Y	109Y	209Y	19M	579L	9L	10L	14L
ITC Avant Garde Book Oblique	✓	✓	✓	✓	✓	✗	✗	✗	✗	✗	✗	✗	✗	✗	✗	✗	✗
ITC Avant Garde Demi	✓	✓	✓	✓	✓	✗	✗	✗	✗	✗	✗	✗	✗	✗	✗	✗	✗
ITC Avant Garde Demi Oblique	✓	✓	✓	✓	✓	✗	✗	✗	✗	✗	✗	✗	✗	✗	✗	✗	✗
Century Schoolbook Roman	✓	✓	✓	✓	✓	✗	✗	✗	✗	✗	✗	✗	✗	✗	✗	✗	✗
Century Schoolbook Italic	✓	✓	✓	✓	✓	✗	✗	✗	✗	✗	✗	✗	✗	✗	✗	✗	✗
Century Schoolbook Bold	✓	✓	✓	✓	✓	✗	✗	✗	✗	✗	✗	✗	✗	✗	✗	✗	✗
Century Schoolbook Bold Italic	✓	✓	✓	✓	✓	✗	✗	✗	✗	✗	✗	✗	✗	✗	✗	✗	✗
ITC Zapf Chancery Medium Italic	✓	✓	✓	✓	✓	✗	✗	✗	✗	✗	✗	✗	✗	✗	✗	✗	✗
CourierPS	✓	✓	✓	✓	✓	✗	✗	✗	✗	✗	✗	✗	✗	✗	✗	✗	✗
CourierPS Oblique	✓	✓	✓	✓	✓	✗	✗	✗	✗	✗	✗	✗	✗	✗	✗	✗	✗
CourierPS Bold	✓	✓	✓	✓	✓	✗	✗	✗	✗	✗	✗	✗	✗	✗	✗	✗	✗
CourierPS Bold Oblique	✓	✓	✓	✓	✓	✗	✗	✗	✗	✗	✗	✗	✗	✗	✗	✗	✗
Times Roman	✓	✓	✓	✓	✓	✗	✗	✗	✗	✗	✗	✗	✗	✗	✗	✗	✗
Times Italic	✓	✓	✓	✓	✓	✗	✗	✗	✗	✗	✗	✗	✗	✗	✗	✗	✗
Times Bold	✓	✓	✓	✓	✓	✗	✗	✗	✗	✗	✗	✗	✗	✗	✗	✗	✗
Times Bold Italic	✓	✓	✓	✓	✓	✗	✗	✗	✗	✗	✗	✗	✗	✗	✗	✗	✗
Helvetica Light	✗	✗	✗	✗	✗	✗	✗	✗	✗	✗	✗	✗	✗	✗	✗	✗	✗
Helvetica Light Oblique	✗	✗	✗	✗	✗	✗	✗	✗	✗	✗	✗	✗	✗	✗	✗	✗	✗
Helvetica Black	✗	✗	✗	✗	✗	✗	✗	✗	✗	✗	✗	✗	✗	✗	✗	✗	✗
Helvetica Black Oblique	✗	✗	✗	✗	✗	✗	✗	✗	✗	✗	✗	✗	✗	✗	✗	✗	✗

✓ Indicates Typeface supports the specified Symbol Set.
✗ Indicates Typeface does not support the specified Symbol Set.

Table 2-7: TC520, C522n, C524, C524n, C524dn, C530dn, C532n, C532dn, C534n, C534dn, C534dtn, C770, C770n, C772, C772n, C920, C920n, C920dn, and C920dnf PCL Emulation Symbol Sets - Specials (Continued)

Typeface / Symbol Set	Specials																
	Ventura Math	PS Math	Math-8	Pi font	Microsoft Publishing	PC-911 Katakana	POSTNET Barcode	OCR-A	OCR-B	C39 Bar Code (Upper Case)	C39 Bar Code (plus Lower Case)	C39 Bar Code (plus Human Readable)	Symbol	Wingdings	Ventura ITC Zapf Dingbats	PS ITC Zapf Dingbats	PCL ITC Zapf Dingbats
PJL Value	VNMATH	PSMATH	MATH8	PIFONT	MSPUBL												
Symbol Set ID	6M	5M	8M	15U	6J	3K	15Y	00	10	9Y	109Y	209Y	19M	579L	9L	10L	14L
Line Printer 16	✓	✓	✓	✓	✓	✓	✗	✗	✗	✗	✗	✗	✗	✗	✗	✗	✗
POSTNET Barcode	✗	✗	✗	✗	✗	✗	✓	✗	✗	✗	✗	✗	✗	✗	✗	✗	✗
C39 Narrow	✗	✗	✗	✗	✗	✗	✗	✗	✗	✓	✓	✓	✗	✗	✗	✗	✗
C39 Regular	✗	✗	✗	✗	✗	✗	✗	✗	✗	✓	✓	✓	✗	✗	✗	✗	✗
C39 Wide	✗	✗	✗	✗	✗	✗	✗	✗	✗	✓	✓	✓	✗	✗	✗	✗	✗
OCR-A	✗	✗	✗	✗	✗	✗	✗	✓	✗	✗	✗	✗	✗	✗	✗	✗	✗
OCR-B	✗	✗	✗	✗	✗	✗	✗	✗	✓	✗	✗	✗	✗	✗	✗	✗	✗
Wingdings	✗	✗	✗	✗	✗	✗	✗	✗	✗	✗	✗	✗	✗	✓	✗	✗	✗
Symbol	✗	✗	✗	✗	✗	✗	✗	✗	✗	✗	✗	✗	✓	✗	✗	✗	✗
SymbolPS	✗	✗	✗	✗	✗	✗	✗	✗	✗	✗	✗	✗	✓	✗	✗	✗	✗
ITC Zapf Dingbats	✗	✗	✗	✗	✗	✗	✗	✗	✗	✗	✗	✗	✗	✗	✓	✓	✓

✓ Indicates Typeface supports the specified Symbol Set.
✗ Indicates Typeface does not support the specified Symbol Set.

Table 2-8: C520, C522n, C524, C524n, C524dn, C530dn, C532n, C532dn, C534n, C534dn, C534dtn, C770, C770n, C772, C772n, C920, C920n, C920dn, and C920dnf ISO PCL Emulation Symbol Sets

Symbol Set ID	Symbol Set / Typeface
1E	ISO 4: United Kingdom
0U	ISO 6: ASCII
0S	ISO 11: Swedish for Names

Table 2-8: C520, C522n, C524, C524n, C524dn, C530dn, C532n, C532dn, C534n, C534dn, C534dtn, C770, C770n, C772, C772n, C920, C920n, C920dn, and C920dnf ISO PCL Emulation Symbol Sets (Continued)

Symbol Set ID	Symbol Set / Typeface
0I	ISO 15: Italian
2S	ISO 17: Spanish
1G	ISO 21: German
0D	ISO 60: Norwegian Version 1
1F	ISO 69: French
2U	ISO 2: IRV (International Ref Version)
0F	ISO 25: French
0G	ISO: HP German
0K	ISO 14: JIS ASCII
2K	ISO 57: Chinese
3S	ISO 10: Swedish
1S	ISO: HP Spanish
6S	ISO 85: Spanish
4S	ISO 16: Portuguese
5S	ISO 84: Portuguese
1D	ISO 61: Norwegian Version 2

Table 2-9: TC520, C522n, C524, C524n, C524dn, C530dn, C532n, C532dn, C534n, C534dn, C534dtn, C770, C770n, C772, C772n, C920, C920n, C920dn, and C920dnf PCL Emulation Symbol Sets - Latin 1

Typeface / Symbol Set	Latin 1																							
	Legal	Windows 3.0 Latin 1	Windows 98 Latin 1	ISO 8859-1 Latin 1 (ECMA-94)	ISO 8859-15 Latin 9	PC-8, Code Page 437	PC-8 Danish/Norwegian (437N)	PC-850 Multilingual	PC-858 Multilingual Euro	PC-860 Portugal	PC-861 Iceland	PC-863 Canadian French	PC-865 Nordic	PC-1004 OS/2	ABICOMP Brazil/Portugal	ABICOMP International	Roman-8	Roman-9	Roman Extension	PS Text	MC Text	Desk Top	Ventura International	Ventura US
PJL Value	LEGAL	WIN30	WINL1	ISOL1	ISOL9	PC8	PC8DN	PC850	PC858							ROMAN8			PSTEXT		DESKTOP	VNINTL	VNUS	
Symbol Set ID	1U	9U	19U	0N	9N	10U	11U	12U	13U	20U	21U	23U	25U	9J	13P	14P	8U	4U	0E	10J	12J	7J	13J	14J
Courier	✓	✓	✓	✓	✓	✓	✓	✓	✓	✓	✓	✓	✓	✓	✓	✓	✓	✓	✓	✓	✓	✓	✓	✓
Courier Italic	✓	✓	✓	✓	✓	✓	✓	✓	✓	✓	✓	✓	✓	✓	✓	✓	✓	✓	✓	✓	✓	✓	✓	✓
Courier Bold	✓	✓	✓	✓	✓	✓	✓	✓	✓	✓	✓	✓	✓	✓	✓	✓	✓	✓	✓	✓	✓	✓	✓	✓
Courier Bold Italic	✓	✓	✓	✓	✓	✓	✓	✓	✓	✓	✓	✓	✓	✓	✓	✓	✓	✓	✓	✓	✓	✓	✓	✓
CG Times	✓	✓	✓	✓	✓	✓	✓	✓	✓	✓	✓	✓	✓	✓	✓	✓	✓	✓	✓	✓	✓	✓	✓	✓
CG Times Italic	✓	✓	✓	✓	✓	✓	✓	✓	✓	✓	✓	✓	✓	✓	✓	✓	✓	✓	✓	✓	✓	✓	✓	✓
CG Times Bold	✓	✓	✓	✓	✓	✓	✓	✓	✓	✓	✓	✓	✓	✓	✓	✓	✓	✓	✓	✓	✓	✓	✓	✓
CG Times Bold Italic	✓	✓	✓	✓	✓	✓	✓	✓	✓	✓	✓	✓	✓	✓	✓	✓	✓	✓	✓	✓	✓	✓	✓	✓
Univers Medium	✓	✓	✓	✓	✓	✓	✓	✓	✓	✓	✓	✓	✓	✓	✓	✓	✓	✓	✓	✓	✓	✓	✓	✓
Univers Medium Italic	✓	✓	✓	✓	✓	✓	✓	✓	✓	✓	✓	✓	✓	✓	✓	✓	✓	✓	✓	✓	✓	✓	✓	✓
Univers Bold	✓	✓	✓	✓	✓	✓	✓	✓	✓	✓	✓	✓	✓	✓	✓	✓	✓	✓	✓	✓	✓	✓	✓	✓
Univers Bold Italic	✓	✓	✓	✓	✓	✓	✓	✓	✓	✓	✓	✓	✓	✓	✓	✓	✓	✓	✓	✓	✓	✓	✓	✓
Times New Roman	✓	✓	✓	✓	✓	✓	✓	✓	✓	✓	✓	✓	✓	✓	✓	✓	✓	✓	✓	✓	✓	✓	✓	✓
Times New Roman Italic	✓	✓	✓	✓	✓	✓	✓	✓	✓	✓	✓	✓	✓	✓	✓	✓	✓	✓	✓	✓	✓	✓	✓	✓
Times New Roman Bold	✓	✓	✓	✓	✓	✓	✓	✓	✓	✓	✓	✓	✓	✓	✓	✓	✓	✓	✓	✓	✓	✓	✓	✓
Times New Roman Bold Italic	✓	✓	✓	✓	✓	✓	✓	✓	✓	✓	✓	✓	✓	✓	✓	✓	✓	✓	✓	✓	✓	✓	✓	✓
Arial	✓	✓	✓	✓	✓	✓	✓	✓	✓	✓	✓	✓	✓	✓	✓	✓	✓	✓	✓	✓	✓	✓	✓	✓

✓ Indicates Typeface supports the specified Symbol Set.
 ✗ Indicates Typeface does not support the specified Symbol Set.

Table 2-9: TC520, C522n, C524, C524n, C524dn, C530dn, C532n, C532dn, C534n, C534dn, C534dtn, C770, C770n, C772, C772n, C920, C920n, C920dn, and C920dnf PCL Emulation Symbol Sets - Latin 1 (Continued)

Typeface / Symbol Set	Latin 1																							
	Legal	Windows 3.0 Latin 1	Windows 98 Latin 1	ISO 8859-1 Latin 1 (ECMA-94)	ISO 8859-15 Latin 9	PC-8, Code Page 437	PC-8 Danish/Norwegian (437N)	PC-850 Multilingual	PC-858 Multilingual Euro	PC-860 Portugal	PC-861 Iceland	PC-863 Canadian French	PC-865 Nordic	PC-1004 OS/2	ABICOMP Brazil/Portugal	ABICOMP International	Roman-8	Roman-9	Roman Extension	PS Text	MC Text	Desk Top	Ventura International	Ventura US
PJL Value	LEGAL	WIN30	WINL1	ISOL1	ISOL9	PC8	PC8DN	PC850	PC858								ROMAN8			PSTEXT		DESKTOP	VNINTL	VNUS
Symbol Set ID	1U	9U	19U	0N	9N	10U	11U	12U	13U	20U	21U	23U	25U	9J	13P	14P	8U	4U	0E	10J	12J	7J	13J	14J
Arial Italic	✓	✓	✓	✓	✓	✓	✓	✓	✓	✓	✓	✓	✓	✓	✓	✓	✓	✓	✓	✓	✓	✓	✓	✓
Arial Bold	✓	✓	✓	✓	✓	✓	✓	✓	✓	✓	✓	✓	✓	✓	✓	✓	✓	✓	✓	✓	✓	✓	✓	✓
Arial Bold Italic	✓	✓	✓	✓	✓	✓	✓	✓	✓	✓	✓	✓	✓	✓	✓	✓	✓	✓	✓	✓	✓	✓	✓	✓
Letter Gothic	✓	✓	✓	✓	✓	✓	✓	✓	✓	✓	✓	✓	✓	✓	✓	✓	✓	✓	✓	✓	✓	✓	✓	✓
Letter Gothic Italic	✓	✓	✓	✓	✓	✓	✓	✓	✓	✓	✓	✓	✓	✓	✓	✓	✓	✓	✓	✓	✓	✓	✓	✓
Letter Gothic Bold	✓	✓	✓	✓	✓	✓	✓	✓	✓	✓	✓	✓	✓	✓	✓	✓	✓	✓	✓	✓	✓	✓	✓	✓
Univers Condensed Medium	✓	✓	✓	✓	✓	✓	✓	✓	✓	✓	✓	✓	✓	✓	✓	✓	✓	✓	✓	✓	✓	✓	✓	✓
Univers Condensed Medium Italic	✓	✓	✓	✓	✓	✓	✓	✓	✓	✓	✓	✓	✓	✓	✓	✓	✓	✓	✓	✓	✓	✓	✓	✓
Univers Condensed Bold	✓	✓	✓	✓	✓	✓	✓	✓	✓	✓	✓	✓	✓	✓	✓	✓	✓	✓	✓	✓	✓	✓	✓	✓
Univers Condensed Bold Italic	✓	✓	✓	✓	✓	✓	✓	✓	✓	✓	✓	✓	✓	✓	✓	✓	✓	✓	✓	✓	✓	✓	✓	✓
Garamond Antiqua	✓	✓	✓	✓	✓	✓	✓	✓	✓	✓	✓	✓	✓	✓	✓	✓	✓	✓	✓	✓	✓	✓	✓	✓
Garamond Kursiv	✓	✓	✓	✓	✓	✓	✓	✓	✓	✓	✓	✓	✓	✓	✓	✓	✓	✓	✓	✓	✓	✓	✓	✓
Garamond Halbfett	✓	✓	✓	✓	✓	✓	✓	✓	✓	✓	✓	✓	✓	✓	✓	✓	✓	✓	✓	✓	✓	✓	✓	✓
Garamond Kursiv Halbfett	✓	✓	✓	✓	✓	✓	✓	✓	✓	✓	✓	✓	✓	✓	✓	✓	✓	✓	✓	✓	✓	✓	✓	✓
CG Omega	✓	✓	✓	✓	✓	✓	✓	✓	✓	✓	✓	✓	✓	✓	✓	✓	✓	✓	✓	✓	✓	✓	✓	✓
CG Omega Italic	✓	✓	✓	✓	✓	✓	✓	✓	✓	✓	✓	✓	✓	✓	✓	✓	✓	✓	✓	✓	✓	✓	✓	✓
CG Omega Bold	✓	✓	✓	✓	✓	✓	✓	✓	✓	✓	✓	✓	✓	✓	✓	✓	✓	✓	✓	✓	✓	✓	✓	✓
CG Omega Bold Italic	✓	✓	✓	✓	✓	✓	✓	✓	✓	✓	✓	✓	✓	✓	✓	✓	✓	✓	✓	✓	✓	✓	✓	✓
Antique Olive	✓	✓	✓	✓	✓	✓	✓	✓	✓	✓	✓	✓	✓	✓	✓	✓	✓	✓	✓	✓	✓	✓	✓	✓

✓ Indicates Typeface supports the specified Symbol Set.
 ✗ Indicates Typeface does not support the specified Symbol Set.

Table 2-9: TC520, C522n, C524, C524n, C524dn, C530dn, C532n, C532dn, C534n, C534dn, C534dtn, C770, C770n, C772, C772n, C920, C920n, C920dn, and C920dnf PCL Emulation Symbol Sets - Latin 1 (Continued)

Typeface / Symbol Set	Latin 1																							
	Legal	Windows 3.0 Latin 1	Windows 98 Latin 1	ISO 8859-1 Latin 1 (ECMA-94)	ISO 8859-15 Latin 9	PC-8, Code Page 437	PC-8 Danish/Norwegian (437N)	PC-850 Multilingual	PC-858 Multilingual Euro	PC-860 Portugal	PC-861 Iceland	PC-863 Canadian French	PC-865 Nordic	PC-1004 OS/2	ABICOMP Brazil/Portugal	ABICOMP International	Roman-8	Roman-9	Roman Extension	PS Text	MC Text	Desk Top	Ventura International	Ventura US
PJL Value	LEGAL	WIN30	WINL1	ISOL1	ISOL9	PC8	PC8DN	PC850	PC858							ROMAN8			PSTEXT		DESKTOP	VNINTL	VNUS	
Symbol Set ID	1U	9U	19U	0N	9N	10U	11U	12U	13U	20U	21U	23U	25U	9J	13P	14P	8U	4U	0E	10J	12J	7J	13J	14J
Antique Olive Italic	✓	✓	✓	✓	✓	✓	✓	✓	✓	✓	✓	✓	✓	✓	✓	✓	✓	✓	✓	✓	✓	✓	✓	✓
Antique Olive Bold	✓	✓	✓	✓	✓	✓	✓	✓	✓	✓	✓	✓	✓	✓	✓	✓	✓	✓	✓	✓	✓	✓	✓	✓
Albertus Medium	✓	✓	✓	✓	✓	✓	✓	✓	✓	✓	✓	✓	✓	✓	✓	✓	✓	✓	✓	✓	✓	✓	✓	✓
Albertus Extra Bold	✓	✓	✓	✓	✓	✓	✓	✓	✓	✓	✓	✓	✓	✓	✓	✓	✓	✓	✓	✓	✓	✓	✓	✓
Clarendon Condensed Bold	✓	✓	✓	✓	✓	✓	✓	✓	✓	✓	✓	✓	✓	✓	✓	✓	✓	✓	✓	✓	✓	✓	✓	✓
Marigold	✓	✓	✓	✓	✓	✓	✓	✓	✓	✓	✓	✓	✓	✓	✓	✓	✓	✓	✓	✓	✓	✓	✓	✓
Coronet	✓	✓	✓	✓	✓	✓	✓	✓	✓	✓	✓	✓	✓	✓	✓	✓	✓	✓	✓	✓	✓	✓	✓	✓
Helvetica	✓	✓	✓	✓	✓	✓	✓	✓	✓	✓	✓	✓	✓	✓	✓	✓	✓	✓	✓	✓	✓	✓	✓	✓
Helvetica Italic	✓	✓	✓	✓	✓	✓	✓	✓	✓	✓	✓	✓	✓	✓	✓	✓	✓	✓	✓	✓	✓	✓	✓	✓
Helvetica Bold	✓	✓	✓	✓	✓	✓	✓	✓	✓	✓	✓	✓	✓	✓	✓	✓	✓	✓	✓	✓	✓	✓	✓	✓
Helvetica Bold Italic	✓	✓	✓	✓	✓	✓	✓	✓	✓	✓	✓	✓	✓	✓	✓	✓	✓	✓	✓	✓	✓	✓	✓	✓
Helvetica Narrow	✓	✓	✓	✓	✓	✓	✓	✓	✓	✓	✓	✓	✓	✓	✓	✓	✓	✓	✓	✓	✓	✓	✓	✓
Helvetica Narrow Italic	✓	✓	✓	✓	✓	✓	✓	✓	✓	✓	✓	✓	✓	✓	✓	✓	✓	✓	✓	✓	✓	✓	✓	✓
Helvetica Narrow Bold	✓	✓	✓	✓	✓	✓	✓	✓	✓	✓	✓	✓	✓	✓	✓	✓	✓	✓	✓	✓	✓	✓	✓	✓
Helvetica Narrow Bold Italic	✓	✓	✓	✓	✓	✓	✓	✓	✓	✓	✓	✓	✓	✓	✓	✓	✓	✓	✓	✓	✓	✓	✓	✓
Palatino Roman	✓	✓	✓	✓	✓	✓	✓	✓	✓	✓	✓	✓	✓	✓	✓	✓	✓	✓	✓	✓	✓	✓	✓	✓
Palatino Italic	✓	✓	✓	✓	✓	✓	✓	✓	✓	✓	✓	✓	✓	✓	✓	✓	✓	✓	✓	✓	✓	✓	✓	✓
Palatino Bold	✓	✓	✓	✓	✓	✓	✓	✓	✓	✓	✓	✓	✓	✓	✓	✓	✓	✓	✓	✓	✓	✓	✓	✓
Palatino Bold Italic	✓	✓	✓	✓	✓	✓	✓	✓	✓	✓	✓	✓	✓	✓	✓	✓	✓	✓	✓	✓	✓	✓	✓	✓

✓ Indicates Typeface supports the specified Symbol Set.
 ✗ Indicates Typeface does not support the specified Symbol Set.

Table 2-9: TC520, C522n, C524, C524n, C524dn, C530dn, C532n, C532dn, C534n, C534dn, C534dtn, C770, C770n, C772, C772n, C920, C920n, C920dn, and C920dnf PCL Emulation Symbol Sets - Latin 1 (Continued)

Typeface / Symbol Set	Latin 1																							
	Legal	Windows 3.0 Latin 1	Windows 98 Latin 1	ISO 8859-1 Latin 1 (ECMA-94)	ISO 8859-15 Latin 9	PC-8, Code Page 437	PC-8 Danish/Norwegian (437N)	PC-850 Multilingual	PC-858 Multilingual Euro	PC-860 Portugal	PC-861 Iceland	PC-863 Canadian French	PC-865 Nordic	PC-1004 OS/2	ABICOMP Brazil/Portugal	ABICOMP International	Roman-8	Roman-9	Roman Extension	PS Text	MC Text	Desk Top	Ventura International	Ventura US
PJL Value	LEGAL	WIN30	WINL1	ISOL1	ISOL9	PC8	PC8DN	PC850	PC858							ROMAN8			PSTEXT		DESKTOP	VNINTL	VNUS	
Symbol Set ID	1U	9U	19U	0N	9N	10U	11U	12U	13U	20U	21U	23U	25U	9J	13P	14P	8U	4U	0E	10J	12J	7J	13J	14J
ITC Bookman Light	✓	✓	✓	✓	✓	✓	✓	✓	✓	✓	✓	✓	✓	✓	✓	✓	✓	✓	✓	✓	✓	✓	✓	✓
ITC Bookman Light Italic	✓	✓	✓	✓	✓	✓	✓	✓	✓	✓	✓	✓	✓	✓	✓	✓	✓	✓	✓	✓	✓	✓	✓	✓
ITC Bookman Demi	✓	✓	✓	✓	✓	✓	✓	✓	✓	✓	✓	✓	✓	✓	✓	✓	✓	✓	✓	✓	✓	✓	✓	✓
ITC Bookman Demi Italic	✓	✓	✓	✓	✓	✓	✓	✓	✓	✓	✓	✓	✓	✓	✓	✓	✓	✓	✓	✓	✓	✓	✓	✓
ITC Avant Garde Book	✓	✓	✓	✓	✓	✓	✓	✓	✓	✓	✓	✓	✓	✓	✓	✓	✓	✓	✓	✓	✓	✓	✓	✓
ITC Avant Garde Book Oblique	✓	✓	✓	✓	✓	✓	✓	✓	✓	✓	✓	✓	✓	✓	✓	✓	✓	✓	✓	✓	✓	✓	✓	✓
ITC Avant Garde Demi	✓	✓	✓	✓	✓	✓	✓	✓	✓	✓	✓	✓	✓	✓	✓	✓	✓	✓	✓	✓	✓	✓	✓	✓
ITC Avant Garde Demi Oblique	✓	✓	✓	✓	✓	✓	✓	✓	✓	✓	✓	✓	✓	✓	✓	✓	✓	✓	✓	✓	✓	✓	✓	✓
Century Schoolbook Roman	✓	✓	✓	✓	✓	✓	✓	✓	✓	✓	✓	✓	✓	✓	✓	✓	✓	✓	✓	✓	✓	✓	✓	✓
Century Schoolbook Italic	✓	✓	✓	✓	✓	✓	✓	✓	✓	✓	✓	✓	✓	✓	✓	✓	✓	✓	✓	✓	✓	✓	✓	✓
Century Schoolbook Bold	✓	✓	✓	✓	✓	✓	✓	✓	✓	✓	✓	✓	✓	✓	✓	✓	✓	✓	✓	✓	✓	✓	✓	✓
Century Schoolbook Bold Italic	✓	✓	✓	✓	✓	✓	✓	✓	✓	✓	✓	✓	✓	✓	✓	✓	✓	✓	✓	✓	✓	✓	✓	✓
ITC Zapf Chancery Medium Italic	✓	✓	✓	✓	✓	✓	✓	✓	✓	✓	✓	✓	✓	✓	✓	✓	✓	✓	✓	✓	✓	✓	✓	✓
CourierPS	✓	✓	✓	✓	✓	✓	✓	✓	✓	✓	✓	✓	✓	✓	✓	✓	✓	✓	✓	✓	✓	✓	✓	✓
CourierPS Oblique	✓	✓	✓	✓	✓	✓	✓	✓	✓	✓	✓	✓	✓	✓	✓	✓	✓	✓	✓	✓	✓	✓	✓	✓
CourierPS Bold	✓	✓	✓	✓	✓	✓	✓	✓	✓	✓	✓	✓	✓	✓	✓	✓	✓	✓	✓	✓	✓	✓	✓	✓
CourierPS Bold Oblique	✓	✓	✓	✓	✓	✓	✓	✓	✓	✓	✓	✓	✓	✓	✓	✓	✓	✓	✓	✓	✓	✓	✓	✓
Times Roman	✓	✓	✓	✓	✓	✓	✓	✓	✓	✓	✓	✓	✓	✓	✓	✓	✓	✓	✓	✓	✓	✓	✓	✓
Times Italic	✓	✓	✓	✓	✓	✓	✓	✓	✓	✓	✓	✓	✓	✓	✓	✓	✓	✓	✓	✓	✓	✓	✓	✓

✓ Indicates Typeface supports the specified Symbol Set.
 ✗ Indicates Typeface does not support the specified Symbol Set.

Table 2-9: TC520, C522n, C524, C524n, C524dn, C530dn, C532n, C532dn, C534n, C534dn, C534dtn, C770, C770n, C772, C772n, C920, C920n, C920dn, and C920dnf PCL Emulation Symbol Sets - Latin 1 (Continued)

Typeface / Symbol Set	Latin 1																							
	Legal	Windows 3.0 Latin 1	Windows 98 Latin 1	ISO 8859-1 Latin 1 (ECMA-94)	ISO 8859-15 Latin 9	PC-8, Code Page 437	PC-8 Danish/Norwegian (437N)	PC-850 Multilingual	PC-858 Multilingual Euro	PC-860 Portugal	PC-861 Iceland	PC-863 Canadian French	PC-865 Nordic	PC-1004 OS/2	ABICOMP Brazil/Portugal	ABICOMP International	Roman-8	Roman-9	Roman Extension	PS Text	MC Text	Desk Top	Ventura International	Ventura US
PJL Value	LEGAL	WIN30	WINL1	ISOL1	ISOL9	PC8	PC8DN	PC850	PC858								ROMAN8			PSTEXT		DESKTOP	VNINTL	VNUS
Symbol Set ID	1U	9U	19U	0N	9N	10U	11U	12U	13U	20U	21U	23U	25U	9J	13P	14P	8U	4U	0E	10J	12J	7J	13J	14J
Times Bold	✓	✓	✓	✓	✓	✓	✓	✓	✓	✓	✓	✓	✓	✓	✓	✓	✓	✓	✓	✓	✓	✓	✓	✓
Times Bold Italic	✓	✓	✓	✓	✓	✓	✓	✓	✓	✓	✓	✓	✓	✓	✓	✓	✓	✓	✓	✓	✓	✓	✓	✓
Helvetica Light	✗	✓	✓	✓	✓	✓	✗	✓	✓	✓	✗	✓	✓	✓	✓	✓	✓	✓	✓	✓	✓	✗	✓	✓
Helvetica Light Oblique	✗	✓	✓	✓	✓	✓	✗	✓	✓	✓	✗	✓	✓	✓	✓	✓	✓	✓	✓	✓	✓	✗	✓	✓
Helvetica Black	✗	✓	✓	✓	✓	✓	✗	✓	✓	✓	✗	✓	✓	✓	✓	✓	✓	✓	✓	✓	✓	✗	✓	✓
Helvetica Black Oblique	✗	✓	✓	✓	✓	✓	✗	✓	✓	✓	✗	✓	✓	✓	✓	✓	✓	✓	✓	✓	✓	✗	✓	✓
Line Printer 16	✓	✓	✓	✓	✓	✓	✓	✓	✓	✓	✓	✓	✓	✓	✓	✓	✓	✓	✓	✓	✓	✓	✓	✓
POSTNET Barcode	✗	✗	✗	✗	✗	✗	✗	✗	✗	✗	✗	✗	✗	✗	✗	✗	✗	✗	✗	✗	✗	✗	✗	✗
C39 Narrow	✗	✗	✗	✗	✗	✗	✗	✗	✗	✗	✗	✗	✗	✗	✗	✗	✗	✗	✗	✗	✗	✗	✗	✗
C39 Regular	✗	✗	✗	✗	✗	✗	✗	✗	✗	✗	✗	✗	✗	✗	✗	✗	✗	✗	✗	✗	✗	✗	✗	✗
C39 Wide	✗	✗	✗	✗	✗	✗	✗	✗	✗	✗	✗	✗	✗	✗	✗	✗	✗	✗	✗	✗	✗	✗	✗	✗
OCR-A	✗	✗	✗	✗	✗	✗	✗	✗	✗	✗	✗	✗	✗	✗	✗	✗	✗	✗	✗	✗	✗	✗	✗	✗
OCR-B	✓	✓	✓	✓	✓	✓	✓	✓	✓	✓	✓	✓	✓	✓	✓	✓	✓	✓	✓	✗	✗	✗	✓	✓
Wingdings	✗	✗	✗	✗	✗	✗	✗	✗	✗	✗	✗	✗	✗	✗	✗	✗	✗	✗	✗	✗	✗	✗	✗	✗
Symbol	✗	✗	✗	✗	✗	✗	✗	✗	✗	✗	✗	✗	✗	✗	✗	✗	✗	✗	✗	✗	✗	✗	✗	✗
SymbolPS	✗	✗	✗	✗	✗	✗	✗	✗	✗	✗	✗	✗	✗	✗	✗	✗	✗	✗	✗	✗	✗	✗	✗	✗
ITC Zapf Dingbats	✗	✗	✗	✗	✗	✗	✗	✗	✗	✗	✗	✗	✗	✗	✗	✗	✗	✗	✗	✗	✗	✗	✗	✗

✓ Indicates Typeface supports the specified Symbol Set.
✗ Indicates Typeface does not support the specified Symbol Set.

Table 2-10: C520, C522n, C524, C524n, C530dn, C532n, C532dn, C534n, C534dn, C534dtn, C524dn, C770, C770n, C772n, C772n, C920, C920n, C920dn, and C920dnf PCL Emulation Symbol Sets - Latin 2, Latin 5, Latin 6, Cyrillic, Greek

Typeface / Symbol Set	Latin 2					Latin 5					Latin 6			Cyrillic					Greek									
	Windows 98 Latin 2	ISO 8859-2 Latin 2	PC-852 Latin 2	PC-8 Polish Mazovia	PC-8 PC Nova	Windows 98 Latin 5	ISO 8859-9 Latin 5	PC-857 Latin 5 (Turkish)	PC-853 Latin 3 (Turkish)	PC-Turkish (437T)	Turkish-8	Windows 98 Latin 6 (Baltic)	ISO 8859-10 Latin 6	PC-775 Baltic (PC-8 Latin 6)	Windows 98 Cyrillic	ISO 8859-5 Latin/Cyrillic	PC-866 Cyrillic	PC-855 Cyrillic	Russian-GOST	PC-8 Bulgarian	Ukrainian	Windows 98 Greek	ISO 8859-7 Latin/Greek	PC-869 Greece	PC-851 Greece	PC-8 Latin/Greek	PC-8 Greek Alternate (437G)	Greek-8
PJL Value	WINL2	ISOL2	PC852			WINL5	ISOL5			PC8TK																		
Symbol Set ID	9E	2N	17U	24Q	27Q	5T	5N	16U	18U	9T	8T	19L	6N	26U	9R	10N	3R	10R	12R	13R	14R	9G	12N	11G	10G	12G	14G	8G
Courier	✓	✓	✓	✓	✓	✓	✓	✓	✓	✓	✓	✓	✓	✓	✓	✓	✓	✓	✓	✓	✓	✓	✓	✓	✓	✓	✓	
Courier Italic	✓	✓	✓	✓	✓	✓	✓	✓	✓	✓	✓	✓	✓	✓	✓	✓	✓	✓	✓	✓	✓	✓	✓	✓	✓	✓	✓	
Courier Bold	✓	✓	✓	✓	✓	✓	✓	✓	✓	✓	✓	✓	✓	✓	✓	✓	✓	✓	✓	✓	✓	✓	✓	✓	✓	✓	✓	
Courier Bold Italic	✓	✓	✓	✓	✓	✓	✓	✓	✓	✓	✓	✓	✓	✓	✓	✓	✓	✓	✓	✓	✓	✓	✓	✓	✓	✓	✓	
CG Times	✓	✓	✓	✓	✓	✓	✓	✓	✓	✓	✓	✓	✓	✓	✓	✓	✓	✓	✓	✓	✓	✓	✓	✓	✓	✓	✓	
CG Times Italic	✓	✓	✓	✓	✓	✓	✓	✓	✓	✓	✓	✓	✓	✓	✓	✓	✓	✓	✓	✓	✓	✓	✓	✓	✓	✓	✓	
CG Times Bold	✓	✓	✓	✓	✓	✓	✓	✓	✓	✓	✓	✓	✓	✓	✓	✓	✓	✓	✓	✓	✓	✓	✓	✓	✓	✓	✓	
CG Times Bold Italic	✓	✓	✓	✓	✓	✓	✓	✓	✓	✓	✓	✓	✓	✓	✓	✓	✓	✓	✓	✓	✓	✓	✓	✓	✓	✓	✓	
Univers Medium	✓	✓	✓	✓	✓	✓	✓	✓	✓	✓	✓	✓	✓	✓	✓	✓	✓	✓	✓	✓	✓	✓	✓	✓	✓	✓	✓	
Univers Medium Italic	✓	✓	✓	✓	✓	✓	✓	✓	✓	✓	✓	✓	✓	✓	✓	✓	✓	✓	✓	✓	✓	✓	✓	✓	✓	✓	✓	
Univers Bold	✓	✓	✓	✓	✓	✓	✓	✓	✓	✓	✓	✓	✓	✓	✓	✓	✓	✓	✓	✓	✓	✓	✓	✓	✓	✓	✓	
Univers Bold Italic	✓	✓	✓	✓	✓	✓	✓	✓	✓	✓	✓	✓	✓	✓	✓	✓	✓	✓	✓	✓	✓	✓	✓	✓	✓	✓	✓	
Times New Roman	✓	✓	✓	✓	✓	✓	✓	✓	✓	✓	✓	✓	✓	✓	✓	✓	✓	✓	✓	✓	✓	✓	✓	✓	✓	✓	✓	
Times New Roman Italic	✓	✓	✓	✓	✓	✓	✓	✓	✓	✓	✓	✓	✓	✓	✓	✓	✓	✓	✓	✓	✓	✓	✓	✓	✓	✓	✓	
Times New Roman Bold	✓	✓	✓	✓	✓	✓	✓	✓	✓	✓	✓	✓	✓	✓	✓	✓	✓	✓	✓	✓	✓	✓	✓	✓	✓	✓	✓	
Times New Roman Bold Italic	✓	✓	✓	✓	✓	✓	✓	✓	✓	✓	✓	✓	✓	✓	✓	✓	✓	✓	✓	✓	✓	✓	✓	✓	✓	✓	✓	
Arial	✓	✓	✓	✓	✓	✓	✓	✓	✓	✓	✓	✓	✓	✓	✓	✓	✓	✓	✓	✓	✓	✓	✓	✓	✓	✓	✓	

✓ Indicates Typeface supports the specified Symbol Set.
 ✗ Indicates Typeface does not support the specified Symbol Set.

Table 2-10: C520, C522n, C524, C524n, C530dn, C532n, C532dn, C534n, C534dn, C534dtn, C524dn, C770, C770n, C772n, C772n, C920, C920n, C920dn, and C920dnf PCL Emulation Symbol Sets - Latin 2, Latin 5, Latin 6, Cyrillic, Greek (Continued)

Typeface / Symbol Set	Latin 2					Latin 5					Latin 6			Cyrillic					Greek									
	Windows 98 Latin 2	ISO 8859-2 Latin 2	PC-852 Latin 2	PC-8 Polish Mazovia	PC-8 PC Nova	Windows 98 Latin 5	ISO 8859-9 Latin 5	PC-857 Latin 5 (Turkish)	PC-853 Latin 3 (Turkish)	PC-Turkish (437T)	Turkish-8	Windows 98 Latin 6 (Baltic)	ISO 8859-10 Latin 6	PC-775 Baltic (PC-8 Latin 6)	Windows 98 Cyrillic	ISO 8859-5 Latin/Cyrillic	PC-866 Cyrillic	PC-855 Cyrillic	Russian-GOST	PC-8 Bulgarian	Ukrainian	Windows 98 Greek	ISO 8859-7 Latin/Greek	PC-869 Greece	PC-851 Greece	PC-8 Latin/Greek	PC-8 Greek Alternate (437G)	Greek-8
PJL Value	WINL2	ISOL2	PC852			WINL5	ISOL5			PC8TK																		
Symbol Set ID	9E	2N	17U	24Q	27Q	5T	5N	16U	18U	9T	8T	19L	6N	26U	9R	10N	3R	10R	12R	13R	14R	9G	12N	11G	10G	12G	14G	8G
Arial Italic	✓	✓	✓	✓	✓	✓	✓	✓	✓	✓	✓	✓	✓	✓	✓	✓	✓	✓	✓	✓	✓	✓	✓	✓	✓	✓	✓	✓
Arial Bold	✓	✓	✓	✓	✓	✓	✓	✓	✓	✓	✓	✓	✓	✓	✓	✓	✓	✓	✓	✓	✓	✓	✓	✓	✓	✓	✓	✓
Arial Bold Italic	✓	✓	✓	✓	✓	✓	✓	✓	✓	✓	✓	✓	✓	✓	✓	✓	✓	✓	✓	✓	✓	✓	✓	✓	✓	✓	✓	✓
Letter Gothic	✓	✓	✓	✗	✓	✓	✓	✓	✗	✓	✓	✓	✓	✓	✗	✗	✗	✗	✗	✗	✗	✗	✗	✗	✗	✗	✗	✗
Letter Gothic Italic	✓	✓	✓	✗	✓	✓	✓	✓	✗	✓	✓	✓	✓	✓	✗	✗	✗	✗	✗	✗	✗	✗	✗	✗	✗	✗	✗	✗
Letter Gothic Bold	✓	✓	✓	✗	✓	✓	✓	✓	✗	✓	✓	✓	✓	✓	✗	✗	✗	✗	✗	✗	✗	✗	✗	✗	✗	✗	✗	✗
Univers Condensed Medium	✓	✓	✓	✗	✓	✓	✓	✓	✗	✓	✓	✓	✓	✓	✗	✗	✗	✗	✗	✗	✗	✗	✗	✗	✗	✗	✗	✗
Univers Condensed Medium Italic	✓	✓	✓	✗	✓	✓	✓	✓	✗	✓	✓	✓	✓	✓	✗	✗	✗	✗	✗	✗	✗	✗	✗	✗	✗	✗	✗	✗
Univers Condensed Bold	✓	✓	✓	✗	✓	✓	✓	✓	✗	✓	✓	✓	✓	✓	✗	✗	✗	✗	✗	✗	✗	✗	✗	✗	✗	✗	✗	✗
Univers Condensed Bold Italic	✓	✓	✓	✗	✓	✓	✓	✓	✗	✓	✓	✓	✓	✓	✗	✗	✗	✗	✗	✗	✗	✗	✗	✗	✗	✗	✗	✗
Garamond Antiqua	✓	✓	✓	✗	✓	✓	✓	✓	✗	✓	✓	✓	✓	✓	✗	✗	✗	✗	✗	✗	✗	✗	✗	✗	✗	✗	✗	✗
Garamond Kursiv	✓	✓	✓	✗	✓	✓	✓	✓	✗	✓	✓	✓	✓	✓	✗	✗	✗	✗	✗	✗	✗	✗	✗	✗	✗	✗	✗	✗
Garamond Halbfett	✓	✓	✓	✗	✓	✓	✓	✓	✗	✓	✓	✓	✓	✓	✗	✗	✗	✗	✗	✗	✗	✗	✗	✗	✗	✗	✗	✗
Garamond Kursiv Halbfett	✓	✓	✓	✗	✓	✓	✓	✓	✗	✓	✓	✓	✓	✓	✗	✗	✗	✗	✗	✗	✗	✗	✗	✗	✗	✗	✗	✗
CG Omega	✓	✓	✓	✗	✓	✓	✓	✓	✗	✓	✓	✓	✓	✓	✗	✗	✗	✗	✗	✗	✗	✗	✗	✗	✗	✗	✗	✗
CG Omega Italic	✓	✓	✓	✗	✓	✓	✓	✓	✗	✓	✓	✓	✓	✓	✗	✗	✗	✗	✗	✗	✗	✗	✗	✗	✗	✗	✗	✗
CG Omega Bold	✓	✓	✓	✗	✓	✓	✓	✓	✗	✓	✓	✓	✓	✓	✗	✗	✗	✗	✗	✗	✗	✗	✗	✗	✗	✗	✗	✗

✓ Indicates Typeface supports the specified Symbol Set.
✗ Indicates Typeface does not support the specified Symbol Set.

Table 2-10: C520, C522n, C524, C524n, C530dn, C532n, C532dn, C534n, C534dn, C534dn, C524dn, C770, C770n, C772n, C772n, C920, C920n, C920dn, and C920dnf PCL Emulation Symbol Sets - Latin 2, Latin 5, Latin 6, Cyrillic, Greek (Continued)

Typeface / Symbol Set	Latin 2					Latin 5					Latin 6			Cyrillic						Greek								
	Windows 98 Latin 2	ISO 8859-2 Latin 2	PC-852 Latin 2	PC-8 Polish Mazovia	PC-8 PC Nova	Windows 98 Latin 5	ISO 8859-9 Latin 5	PC-857 Latin 5 (Turkish)	PC-853 Latin 3 (Turkish)	PC-Turkish (437T)	Turkish-8	Windows 98 Latin 6 (Baltic)	ISO 8859-10 Latin 6	PC-775 Baltic (PC-8 Latin 6)	Windows 98 Cyrillic	ISO 8859-5 Latin/Cyrillic	PC-866 Cyrillic	PC-855 Cyrillic	Russian-GOST	PC-8 Bulgarian	Ukrainian	Windows 98 Greek	ISO 8859-7 Latin/Greek	PC-869 Greece	PC-851 Greece	PC-8 Latin/Greek	PC-8 Greek Alternate (437G)	Greek-8
PJL Value	WINL2	ISOL2	PC852			WINL5	ISOL5			PC8TK																		
Symbol Set ID	9E	2N	17U	24Q	27Q	5T	5N	16U	18U	9T	8T	19L	6N	26U	9R	10N	3R	10R	12R	13R	14R	9G	12N	11G	10G	12G	14G	8G
CG Omega Bold Italic	✓	✓	✓	✗	✓	✓	✓	✓	✗	✓	✓	✓	✓	✓	✗	✗	✗	✗	✗	✗	✗	✗	✗	✗	✗	✗	✗	✗
Antique Olive	✓	✓	✓	✗	✓	✓	✓	✓	✗	✓	✓	✓	✓	✓	✗	✗	✗	✗	✗	✗	✗	✗	✗	✗	✗	✗	✗	✗
Antique Olive Italic	✓	✓	✓	✗	✓	✓	✓	✓	✗	✓	✓	✓	✓	✓	✗	✗	✗	✗	✗	✗	✗	✗	✗	✗	✗	✗	✗	✗
Antique Olive Bold	✓	✓	✓	✗	✓	✓	✓	✓	✗	✓	✓	✓	✓	✓	✗	✗	✗	✗	✗	✗	✗	✗	✗	✗	✗	✗	✗	✗
Albertus Medium	✓	✓	✓	✗	✓	✓	✓	✓	✗	✓	✓	✓	✓	✓	✗	✗	✗	✗	✗	✗	✗	✗	✗	✗	✗	✗	✗	✗
Albertus Extra Bold	✓	✓	✓	✗	✓	✓	✓	✓	✗	✓	✓	✓	✓	✓	✗	✗	✗	✗	✗	✗	✗	✗	✗	✗	✗	✗	✗	✗
Clarendon Condensed Bold	✓	✓	✓	✗	✓	✓	✓	✓	✗	✓	✓	✓	✓	✓	✗	✗	✗	✗	✗	✗	✗	✗	✗	✗	✗	✗	✗	✗
Marigold	✓	✓	✓	✗	✓	✓	✓	✓	✗	✓	✓	✓	✓	✓	✗	✗	✗	✗	✗	✗	✗	✗	✗	✗	✗	✗	✗	✗
Coronet	✓	✓	✓	✗	✓	✓	✓	✓	✗	✓	✓	✓	✓	✓	✗	✗	✗	✗	✗	✗	✗	✗	✗	✗	✗	✗	✗	✗
Helvetica	✓	✓	✓	✗	✓	✓	✓	✓	✗	✓	✓	✓	✓	✓	✗	✗	✗	✗	✗	✗	✗	✗	✗	✗	✗	✗	✗	✗
Helvetica Italic	✓	✓	✓	✗	✓	✓	✓	✓	✗	✓	✓	✓	✓	✓	✗	✗	✗	✗	✗	✗	✗	✗	✗	✗	✗	✗	✗	✗
Helvetica Bold	✓	✓	✓	✗	✓	✓	✓	✓	✗	✓	✓	✓	✓	✓	✗	✗	✗	✗	✗	✗	✗	✗	✗	✗	✗	✗	✗	✗
Helvetica Bold Italic	✓	✓	✓	✗	✓	✓	✓	✓	✗	✓	✓	✓	✓	✓	✗	✗	✗	✗	✗	✗	✗	✗	✗	✗	✗	✗	✗	✗
Helvetica Narrow	✓	✓	✓	✗	✓	✓	✓	✓	✗	✓	✓	✓	✓	✓	✗	✗	✗	✗	✗	✗	✗	✗	✗	✗	✗	✗	✗	✗
Helvetica Narrow Italic	✓	✓	✓	✗	✓	✓	✓	✓	✗	✓	✓	✓	✓	✓	✗	✗	✗	✗	✗	✗	✗	✗	✗	✗	✗	✗	✗	✗
Helvetica Narrow Bold	✓	✓	✓	✗	✓	✓	✓	✓	✗	✓	✓	✓	✓	✓	✗	✗	✗	✗	✗	✗	✗	✗	✗	✗	✗	✗	✗	✗
Helvetica Narrow Bold Italic	✓	✓	✓	✗	✓	✓	✓	✓	✗	✓	✓	✓	✓	✓	✗	✗	✗	✗	✗	✗	✗	✗	✗	✗	✗	✗	✗	✗

✓ Indicates Typeface supports the specified Symbol Set.
 ✗ Indicates Typeface does not support the specified Symbol Set.

Table 2-10: C520, C522n, C524, C524n, C530dn, C532n, C532dn, C534n, C534dn, C534dn, C524dn, C770, C770n, C772n, C772n, C920, C920n, C920dn, and C920dnf PCL Emulation Symbol Sets - Latin 2, Latin 5, Latin 6, Cyrillic, Greek (Continued)

Typeface / Symbol Set	Latin 2					Latin 5					Latin 6			Cyrillic					Greek									
	Windows 98 Latin 2	ISO 8859-2 Latin 2	PC-852 Latin 2	PC-8 Polish Mazovia	PC-8 PC Nova	Windows 98 Latin 5	ISO 8859-9 Latin 5	PC-857 Latin 5 (Turkish)	PC-853 Latin 3 (Turkish)	PC-Turkish (437T)	Turkish-8	Windows 98 Latin 6 (Baltic)	ISO 8859-10 Latin 6	PC-775 Baltic (PC-8 Latin 6)	Windows 98 Cyrillic	ISO 8859-5 Latin/Cyrillic	PC-866 Cyrillic	PC-855 Cyrillic	Russian-GOST	PC-8 Bulgarian	Ukrainian	Windows 98 Greek	ISO 8859-7 Latin/Greek	PC-869 Greece	PC-851 Greece	PC-8 Latin/Greek	PC-8 Greek Alternate (437G)	Greek-8
PJL Value	WINL2	ISOL2	PC852			WINL5	ISOL5			PC8TK																		
Symbol Set ID	9E	2N	17U	24Q	27Q	5T	5N	16U	18U	9T	8T	19L	6N	26U	9R	10N	3R	10R	12R	13R	14R	9G	12N	11G	10G	12G	14G	8G
Palatino Roman	✓	✓	✓	✗	✓	✓	✓	✓	✗	✓	✓	✓	✓	✓	✗	✗	✗	✗	✗	✗	✗	✗	✗	✗	✗	✗	✗	✗
Palatino Italic	✓	✓	✓	✗	✓	✓	✓	✓	✗	✓	✓	✓	✓	✓	✗	✗	✗	✗	✗	✗	✗	✗	✗	✗	✗	✗	✗	✗
Palatino Bold	✓	✓	✓	✗	✓	✓	✓	✓	✗	✓	✓	✓	✓	✓	✗	✗	✗	✗	✗	✗	✗	✗	✗	✗	✗	✗	✗	✗
Palatino Bold Italic	✓	✓	✓	✗	✓	✓	✓	✓	✗	✓	✓	✓	✓	✓	✗	✗	✗	✗	✗	✗	✗	✗	✗	✗	✗	✗	✗	✗
ITC Bookman Light	✓	✓	✓	✗	✓	✓	✓	✓	✗	✓	✓	✓	✓	✓	✗	✗	✗	✗	✗	✗	✗	✗	✗	✗	✗	✗	✗	✗
ITC Bookman Light Italic	✓	✓	✓	✗	✓	✓	✓	✓	✗	✓	✓	✓	✓	✓	✗	✗	✗	✗	✗	✗	✗	✗	✗	✗	✗	✗	✗	✗
ITC Bookman Demi	✓	✓	✓	✗	✓	✓	✓	✓	✗	✓	✓	✓	✓	✓	✗	✗	✗	✗	✗	✗	✗	✗	✗	✗	✗	✗	✗	✗
ITC Bookman Demi Italic	✓	✓	✓	✗	✓	✓	✓	✓	✗	✓	✓	✓	✓	✓	✗	✗	✗	✗	✗	✗	✗	✗	✗	✗	✗	✗	✗	✗
ITC Avant Garde Book	✓	✓	✓	✗	✓	✓	✓	✓	✗	✓	✓	✓	✓	✓	✗	✗	✗	✗	✗	✗	✗	✗	✗	✗	✗	✗	✗	✗
ITC Avant Garde Book Oblique	✓	✓	✓	✗	✓	✓	✓	✓	✗	✓	✓	✓	✓	✓	✗	✗	✗	✗	✗	✗	✗	✗	✗	✗	✗	✗	✗	✗
ITC Avant Garde Demi	✓	✓	✓	✗	✓	✓	✓	✓	✗	✓	✓	✓	✓	✓	✗	✗	✗	✗	✗	✗	✗	✗	✗	✗	✗	✗	✗	✗
ITC Avant Garde Demi Oblique	✓	✓	✓	✗	✓	✓	✓	✓	✗	✓	✓	✓	✓	✓	✗	✗	✗	✗	✗	✗	✗	✗	✗	✗	✗	✗	✗	✗
Century Schoolbook Roman	✓	✓	✓	✗	✓	✓	✓	✓	✗	✓	✓	✓	✓	✓	✗	✗	✗	✗	✗	✗	✗	✗	✗	✗	✗	✗	✗	✗
Century Schoolbook Italic	✓	✓	✓	✗	✓	✓	✓	✓	✗	✓	✓	✓	✓	✓	✗	✗	✗	✗	✗	✗	✗	✗	✗	✗	✗	✗	✗	✗

✓ Indicates Typeface supports the specified Symbol Set.

✗ Indicates Typeface does not support the specified Symbol Set.

Table 2-10: C520, C522n, C524, C524n, C530dn, C532n, C532dn, C534n, C534dn, C534dtn, C524dn, C770, C770n, C772n, C772n, C920, C920n, C920dn, and C920dnf PCL Emulation Symbol Sets - Latin 2, Latin 5, Latin 6, Cyrillic, Greek (Continued)

Typeface / Symbol Set	Latin 2					Latin 5					Latin 6			Cyrillic						Greek								
	Windows 98 Latin 2	ISO 8859-2 Latin 2	PC-852 Latin 2	PC-8 Polish Mazovia	PC-8 PC Nova	Windows 98 Latin 5	ISO 8859-9 Latin 5	PC-857 Latin 5 (Turkish)	PC-853 Latin 3 (Turkish)	PC-Turkish (437T)	Turkish-8	Windows 98 Latin 6 (Baltic)	ISO 8859-10 Latin 6	PC-775 Baltic (PC-8 Latin 6)	Windows 98 Cyrillic	ISO 8859-5 Latin/Cyrillic	PC-866 Cyrillic	PC-855 Cyrillic	Russian-GOST	PC-8 Bulgarian	Ukrainian	Windows 98 Greek	ISO 8859-7 Latin/Greek	PC-869 Greece	PC-851 Greece	PC-8 Latin/Greek	PC-8 Greek Alternate (437G)	Greek-8
PJL Value	WINL2	ISOL2	PC852			WINL5	ISOL5			PC8TK																		
Symbol Set ID	9E	2N	17U	24Q	27Q	5T	5N	16U	18U	9T	8T	19L	6N	26U	9R	10N	3R	10R	12R	13R	14R	9G	12N	11G	10G	12G	14G	8G
Century Schoolbook Bold	✓	✓	✓	✗	✓	✓	✓	✓	✗	✓	✓	✓	✓	✓	✗	✗	✗	✗	✗	✗	✗	✗	✗	✗	✗	✗	✗	✗
Century Schoolbook Bold Italic	✓	✓	✓	✗	✓	✓	✓	✓	✗	✓	✓	✓	✓	✓	✗	✗	✗	✗	✗	✗	✗	✗	✗	✗	✗	✗	✗	✗
ITC Zapf Chancery Medium Italic	✓	✓	✓	✗	✓	✓	✓	✓	✗	✓	✓	✓	✓	✓	✗	✗	✗	✗	✗	✗	✗	✗	✗	✗	✗	✗	✗	✗
CourierPS	✓	✓	✓	✗	✓	✓	✓	✓	✗	✓	✓	✓	✓	✓	✗	✗	✗	✗	✗	✗	✗	✗	✗	✗	✗	✗	✗	✗
CourierPS Oblique	✓	✓	✓	✗	✓	✓	✓	✓	✗	✓	✓	✓	✓	✓	✗	✗	✗	✗	✗	✗	✗	✗	✗	✗	✗	✗	✗	✗
CourierPS Bold	✓	✓	✓	✗	✓	✓	✓	✓	✗	✓	✓	✓	✓	✓	✗	✗	✗	✗	✗	✗	✗	✗	✗	✗	✗	✗	✗	✗
CourierPS Bold Oblique	✓	✓	✓	✗	✓	✓	✓	✓	✗	✓	✓	✓	✓	✓	✗	✗	✗	✗	✗	✗	✗	✗	✗	✗	✗	✗	✗	✗
Times Roman	✓	✓	✓	✗	✓	✓	✓	✓	✗	✓	✓	✓	✓	✓	✗	✗	✗	✗	✗	✗	✗	✗	✗	✗	✗	✗	✗	✗
Times Italic	✓	✓	✓	✗	✓	✓	✓	✓	✗	✓	✓	✓	✓	✓	✗	✗	✗	✗	✗	✗	✗	✗	✗	✗	✗	✗	✗	✗
Times Bold	✓	✓	✓	✗	✓	✓	✓	✓	✗	✓	✓	✓	✓	✓	✗	✗	✗	✗	✗	✗	✗	✗	✗	✗	✗	✗	✗	✗
Times Bold Italic	✓	✓	✓	✗	✓	✓	✓	✓	✗	✓	✓	✓	✓	✓	✗	✗	✗	✗	✗	✗	✗	✗	✗	✗	✗	✗	✗	✗
Helvetica Light	✗	✗	✗	✗	✗	✗	✗	✗	✗	✗	✗	✗	✗	✗	✗	✗	✗	✗	✗	✗	✗	✗	✗	✗	✗	✗	✗	✗
Helvetica Light Oblique	✗	✗	✗	✗	✗	✗	✗	✗	✗	✗	✗	✗	✗	✗	✗	✗	✗	✗	✗	✗	✗	✗	✗	✗	✗	✗	✗	✗
Helvetica Black	✗	✗	✗	✗	✗	✗	✗	✗	✗	✗	✗	✗	✗	✗	✗	✗	✗	✗	✗	✗	✗	✗	✗	✗	✗	✗	✗	✗
Helvetica Black Oblique	✗	✗	✗	✗	✗	✗	✗	✗	✗	✗	✗	✗	✗	✗	✗	✗	✗	✗	✗	✗	✗	✗	✗	✗	✗	✗	✗	✗
Line Printer 16	✓	✓	✓	✓	✓	✓	✓	✓	✓	✓	✓	✓	✓	✓	✓	✓	✓	✓	✓	✓	✓	✓	✓	✓	✓	✓	✓	✓

✓ Indicates Typeface supports the specified Symbol Set.
✗ Indicates Typeface does not support the specified Symbol Set.

Table 2-10: C520, C522n, C524, C524n, C530dn, C532n, C532dn, C534n, C534dn, C534dtn, C524dn, C770, C770n, C772n, C772n, C920, C920n, C920dn, and C920dnf PCL Emulation Symbol Sets - Latin 2, Latin 5, Latin 6, Cyrillic, Greek (Continued)

Typeface / Symbol Set	Latin 2					Latin 5					Latin 6			Cyrillic						Greek								
	Windows 98 Latin 2	ISO 8859-2 Latin 2	PC-852 Latin 2	PC-8 Polish Mazovia	PC-8 PC Nova	Windows 98 Latin 5	ISO 8859-9 Latin 5	PC-857 Latin 5 (Turkish)	PC-853 Latin 3 (Turkish)	PC-Turkish (437T)	Turkish-8	Windows 98 Latin 6 (Baltic)	ISO 8859-10 Latin 6	PC-775 Baltic (PC-8 Latin 6)	Windows 98 Cyrillic	ISO 8859-5 Latin/Cyrillic	PC-866 Cyrillic	PC-855 Cyrillic	Russian-GOST	PC-8 Bulgarian	Ukrainian	Windows 98 Greek	ISO 8859-7 Latin/Greek	PC-869 Greece	PC-851 Greece	PC-8 Latin/Greek	PC-8 Greek Alternate (437G)	Greek-8
PJL Value	WINL2	ISOL2	PC852			WINL5	ISOL5			PC8TK																		
Symbol Set ID	9E	2N	17U	24Q	27Q	5T	5N	16U	18U	9T	8T	19L	6N	26U	9R	10N	3R	10R	12R	13R	14R	9G	12N	11G	10G	12G	14G	8G
POSTNET Barcode	x	x	x	x	x	x	x	x	x	x	x	x	x	x	x	x	x	x	x	x	x	x	x	x	x	x	x	x
C39 Narrow	x	x	x	x	x	x	x	x	x	x	x	x	x	x	x	x	x	x	x	x	x	x	x	x	x	x	x	x
C39 Regular	x	x	x	x	x	x	x	x	x	x	x	x	x	x	x	x	x	x	x	x	x	x	x	x	x	x	x	x
C39 Wide	x	x	x	x	x	x	x	x	x	x	x	x	x	x	x	x	x	x	x	x	x	x	x	x	x	x	x	x
OCR-A	x	x	x	x	x	x	x	x	x	x	x	x	x	x	x	x	x	x	x	x	x	x	x	x	x	x	x	x
OCR-B	✓	✓	✓	✓	✓	x	x	x	x	x	x	x	x	x	x	x	x	x	x	x	x	x	x	x	x	x	x	x
Wingdings	x	x	x	x	x	x	x	x	x	x	x	x	x	x	x	x	x	x	x	x	x	x	x	x	x	x	x	x
Symbol	x	x	x	x	x	x	x	x	x	x	x	x	x	x	x	x	x	x	x	x	x	x	x	x	x	x	x	x
SymbolIPS	x	x	x	x	x	x	x	x	x	x	x	x	x	x	x	x	x	x	x	x	x	x	x	x	x	x	x	x
ITC Zapf Dingbats	x	x	x	x	x	x	x	x	x	x	x	x	x	x	x	x	x	x	x	x	x	x	x	x	x	x	x	x

✓ Indicates Typeface supports the specified Symbol Set.
x Indicates Typeface does not support the specified Symbol Set.

Table 2-11: TC520, C522n, C524, C524n, C524dn, C530dn, C532n, C532dn, C534n, C534dn, C534dtn, C770, C770n, C772, C772n, C920, C920n, C920dn, and C920dnf PCL Emulation Symbol Sets - Specials

Typeface / Symbol Set	Specials																
	Ventura Math	PS Math	Math-8	Pi font	Microsoft Publishing	PC-911 Katakana	POSTNET Barcode	OCR-A	OCR-B	C39 Bar Code (Upper Case)	C39 Bar Code (plus Lower Case)	C39 Bar Code (plus Human Readable)	Symbol	Wingdings	Ventura ITC Zapf Dingbats	PS ITC Zapf Dingbats	PCL ITC Zapf Dingbats
PJL Value	VNMATH	PSMATH	MATH8	PIFONT	MSPUBL												
Symbol Set ID	6M	5M	8M	15U	6J	3K	15Y	00	10	9Y	109Y	209Y	19M	579L	9L	10L	14L
Courier	✓	✓	✓	✓	✓	✗	✗	✗	✗	✗	✗	✗	✗	✗	✗	✗	✗
Courier Italic	✓	✓	✓	✓	✓	✗	✗	✗	✗	✗	✗	✗	✗	✗	✗	✗	✗
Courier Bold	✓	✓	✓	✓	✓	✗	✗	✗	✗	✗	✗	✗	✗	✗	✗	✗	✗
Courier Bold Italic	✓	✓	✓	✓	✓	✗	✗	✗	✗	✗	✗	✗	✗	✗	✗	✗	✗
CG Times	✓	✓	✓	✓	✓	✗	✗	✗	✗	✗	✗	✗	✗	✗	✗	✗	✗
CG Times Italic	✓	✓	✓	✓	✓	✗	✗	✗	✗	✗	✗	✗	✗	✗	✗	✗	✗
CG Times Bold	✓	✓	✓	✓	✓	✗	✗	✗	✗	✗	✗	✗	✗	✗	✗	✗	✗
CG Times Bold Italic	✓	✓	✓	✓	✓	✗	✗	✗	✗	✗	✗	✗	✗	✗	✗	✗	✗
Univers Medium	✓	✓	✓	✓	✓	✗	✗	✗	✗	✗	✗	✗	✗	✗	✗	✗	✗
Univers Medium Italic	✓	✓	✓	✓	✓	✗	✗	✗	✗	✗	✗	✗	✗	✗	✗	✗	✗
Univers Bold	✓	✓	✓	✓	✓	✗	✗	✗	✗	✗	✗	✗	✗	✗	✗	✗	✗
Univers Bold Italic	✓	✓	✓	✓	✓	✗	✗	✗	✗	✗	✗	✗	✗	✗	✗	✗	✗
Times New Roman	✓	✓	✓	✓	✓	✗	✗	✗	✗	✗	✗	✗	✗	✗	✗	✗	✗
Times New Roman Italic	✓	✓	✓	✓	✓	✗	✗	✗	✗	✗	✗	✗	✗	✗	✗	✗	✗
Times New Roman Bold	✓	✓	✓	✓	✓	✗	✗	✗	✗	✗	✗	✗	✗	✗	✗	✗	✗
Times New Roman BoldItalic	✓	✓	✓	✓	✓	✗	✗	✗	✗	✗	✗	✗	✗	✗	✗	✗	✗
Arial	✓	✓	✓	✓	✓	✗	✗	✗	✗	✗	✗	✗	✗	✗	✗	✗	✗
Arial Italic	✓	✓	✓	✓	✓	✗	✗	✗	✗	✗	✗	✗	✗	✗	✗	✗	✗
Arial Bold	✓	✓	✓	✓	✓	✗	✗	✗	✗	✗	✗	✗	✗	✗	✗	✗	✗
Arial Bold Italic	✓	✓	✓	✓	✓	✗	✗	✗	✗	✗	✗	✗	✗	✗	✗	✗	✗

✓ Indicates Typeface supports the specified Symbol Set.
✗ Indicates Typeface does not support the specified Symbol Set.

Table 2-11: TC520, C522n, C524, C524n, C524dn, C530dn, C532n, C532dn, C534n, C534dn, C534dtn, C770, C770n, C772, C772n, C920, C920n, C920dn, and C920dnf PCL Emulation Symbol Sets - Specials (Continued)

Typeface / Symbol Set	Specials																
	Ventura Math	PS Math	Math-8	Pi font	Microsoft Publishing	PC-911 Katakana	POSTNET Barcode	OCR-A	OCR-B	C39 Bar Code (Upper Case)	C39 Bar Code (plus Lower Case)	C39 Bar Code (plus Human Readable)	Symbol	Wingdings	Ventura ITC Zapf Dingbats	PS ITC Zapf Dingbats	PCL ITC Zapf Dingbats
PJL Value	VNMATH	PSMATH	MATH8	PIFONT	MSPUBL												
Symbol Set ID	6M	5M	8M	15U	6J	3K	15Y	00	10	9Y	109Y	209Y	19M	579L	9L	10L	14L
Letter Gothic	✓	✓	✓	✓	✓	✗	✗	✗	✗	✗	✗	✗	✗	✗	✗	✗	✗
Letter Gothic Italic	✓	✓	✓	✓	✓	✗	✗	✗	✗	✗	✗	✗	✗	✗	✗	✗	✗
Letter Gothic Bold	✓	✓	✓	✓	✓	✗	✗	✗	✗	✗	✗	✗	✗	✗	✗	✗	✗
Univers Condensed Medium	✓	✓	✓	✓	✓	✗	✗	✗	✗	✗	✗	✗	✗	✗	✗	✗	✗
Univers Condensed Medium Italic	✓	✓	✓	✓	✓	✗	✗	✗	✗	✗	✗	✗	✗	✗	✗	✗	✗
Univers Condensed Bold	✓	✓	✓	✓	✓	✗	✗	✗	✗	✗	✗	✗	✗	✗	✗	✗	✗
Univers Condensed Bold Italic	✓	✓	✓	✓	✓	✗	✗	✗	✗	✗	✗	✗	✗	✗	✗	✗	✗
Garamond Antiqua	✓	✓	✓	✓	✓	✗	✗	✗	✗	✗	✗	✗	✗	✗	✗	✗	✗
Garamond Kursiv	✓	✓	✓	✓	✓	✗	✗	✗	✗	✗	✗	✗	✗	✗	✗	✗	✗
Garamond Halbfett	✓	✓	✓	✓	✓	✗	✗	✗	✗	✗	✗	✗	✗	✗	✗	✗	✗
Garamond Kursiv Halbfett	✓	✓	✓	✓	✓	✗	✗	✗	✗	✗	✗	✗	✗	✗	✗	✗	✗
CG Omega	✓	✓	✓	✓	✓	✗	✗	✗	✗	✗	✗	✗	✗	✗	✗	✗	✗
CG Omega Italic	✓	✓	✓	✓	✓	✗	✗	✗	✗	✗	✗	✗	✗	✗	✗	✗	✗
CG Omega Bold	✓	✓	✓	✓	✓	✗	✗	✗	✗	✗	✗	✗	✗	✗	✗	✗	✗
CG Omega Bold Italic	✓	✓	✓	✓	✓	✗	✗	✗	✗	✗	✗	✗	✗	✗	✗	✗	✗
Antique Olive	✓	✓	✓	✓	✓	✗	✗	✗	✗	✗	✗	✗	✗	✗	✗	✗	✗
Antique Olive Italic	✓	✓	✓	✓	✓	✗	✗	✗	✗	✗	✗	✗	✗	✗	✗	✗	✗
Antique Olive Bold	✓	✓	✓	✓	✓	✗	✗	✗	✗	✗	✗	✗	✗	✗	✗	✗	✗
Albertus Medium	✓	✓	✓	✓	✓	✗	✗	✗	✗	✗	✗	✗	✗	✗	✗	✗	✗
Albertus Extra Bold	✓	✓	✓	✓	✓	✗	✗	✗	✗	✗	✗	✗	✗	✗	✗	✗	✗

✓ Indicates Typeface supports the specified Symbol Set.
✗ Indicates Typeface does not support the specified Symbol Set.

Table 2-11: TC520, C522n, C524, C524n, C524dn, C530dn, C532n, C532dn, C534n, C534dn, C534dtn, C770, C770n, C772, C772n, C920, C920n, C920dn, and C920dnf PCL Emulation Symbol Sets - Specials (Continued)

Typeface / Symbol Set	Specials																
	Ventura Math	PS Math	Math-8	Pi font	Microsoft Publishing	PC-911 Katakana	POSTNET Barcode	OCR-A	OCR-B	C39 Bar Code (Upper Case)	C39 Bar Code (plus Lower Case)	C39 Bar Code (plus Human Readable)	Symbol	Wingdings	Ventura ITC Zapf Dingbats	PS ITC Zapf Dingbats	PCL ITC Zapf Dingbats
PJL Value	VNMATH	PSMATH	MATH8	PIFONT	MSPUBL												
Symbol Set ID	6M	5M	8M	15U	6J	3K	15Y	00	10	9Y	109Y	209Y	19M	579L	9L	10L	14L
Clarendon Condensed Bold	✓	✓	✓	✓	✓	✗	✗	✗	✗	✗	✗	✗	✗	✗	✗	✗	✗
Marigold	✓	✓	✓	✓	✓	✗	✗	✗	✗	✗	✗	✗	✗	✗	✗	✗	✗
Coronet	✓	✓	✓	✓	✓	✗	✗	✗	✗	✗	✗	✗	✗	✗	✗	✗	✗
Helvetica	✓	✓	✓	✓	✓	✗	✗	✗	✗	✗	✗	✗	✗	✗	✗	✗	✗
Helvetica Italic	✓	✓	✓	✓	✓	✗	✗	✗	✗	✗	✗	✗	✗	✗	✗	✗	✗
Helvetica Bold	✓	✓	✓	✓	✓	✗	✗	✗	✗	✗	✗	✗	✗	✗	✗	✗	✗
Helvetica Bold Italic	✓	✓	✓	✓	✓	✗	✗	✗	✗	✗	✗	✗	✗	✗	✗	✗	✗
Helvetica Narrow	✓	✓	✓	✓	✓	✗	✗	✗	✗	✗	✗	✗	✗	✗	✗	✗	✗
Helvetica Narrow Italic	✓	✓	✓	✓	✓	✗	✗	✗	✗	✗	✗	✗	✗	✗	✗	✗	✗
Helvetica Narrow Bold	✓	✓	✓	✓	✓	✗	✗	✗	✗	✗	✗	✗	✗	✗	✗	✗	✗
Helvetica Narrow Bold Italic	✓	✓	✓	✓	✓	✗	✗	✗	✗	✗	✗	✗	✗	✗	✗	✗	✗
Palatino Roman	✓	✓	✓	✓	✓	✗	✗	✗	✗	✗	✗	✗	✗	✗	✗	✗	✗
Palatino Italic	✓	✓	✓	✓	✓	✗	✗	✗	✗	✗	✗	✗	✗	✗	✗	✗	✗
Palatino Bold	✓	✓	✓	✓	✓	✗	✗	✗	✗	✗	✗	✗	✗	✗	✗	✗	✗
Palatino Bold Italic	✓	✓	✓	✓	✓	✗	✗	✗	✗	✗	✗	✗	✗	✗	✗	✗	✗
ITC Bookman Light	✓	✓	✓	✓	✓	✗	✗	✗	✗	✗	✗	✗	✗	✗	✗	✗	✗
ITC Bookman Light Italic	✓	✓	✓	✓	✓	✗	✗	✗	✗	✗	✗	✗	✗	✗	✗	✗	✗
ITC Bookman Demi	✓	✓	✓	✓	✓	✗	✗	✗	✗	✗	✗	✗	✗	✗	✗	✗	✗
ITC Bookman Demi Italic	✓	✓	✓	✓	✓	✗	✗	✗	✗	✗	✗	✗	✗	✗	✗	✗	✗
ITC Avant Garde Book	✓	✓	✓	✓	✓	✗	✗	✗	✗	✗	✗	✗	✗	✗	✗	✗	✗

✓ Indicates Typeface supports the specified Symbol Set.
✗ Indicates Typeface does not support the specified Symbol Set.

Table 2-11: TC520, C522n, C524, C524n, C524dn, C530dn, C532n, C532dn, C534n, C534dn, C534dtn, C770, C770n, C772, C772n, C920, C920n, C920dn, and C920dnf PCL Emulation Symbol Sets - Specials (Continued)

Typeface / Symbol Set	Specials																
	Ventura Math	PS Math	Math-8	Pi font	Microsoft Publishing	PC-911 Katakana	POSTNET Barcode	OCR-A	OCR-B	C39 Bar Code (Upper Case)	C39 Bar Code (plus Lower Case)	C39 Bar Code (plus Human Readable)	Symbol	Wingdings	Ventura ITC Zapf Dingbats	PS ITC Zapf Dingbats	PCL ITC Zapf Dingbats
PJL Value	VNMATH	PSMATH	MATH8	PIFONT	MSPUBL												
Symbol Set ID	6M	5M	8M	15U	6J	3K	15Y	00	10	9Y	109Y	209Y	19M	579L	9L	10L	14L
ITC Avant Garde Book Oblique	✓	✓	✓	✓	✓	✗	✗	✗	✗	✗	✗	✗	✗	✗	✗	✗	✗
ITC Avant Garde Demi	✓	✓	✓	✓	✓	✗	✗	✗	✗	✗	✗	✗	✗	✗	✗	✗	✗
ITC Avant Garde Demi Oblique	✓	✓	✓	✓	✓	✗	✗	✗	✗	✗	✗	✗	✗	✗	✗	✗	✗
Century Schoolbook Roman	✓	✓	✓	✓	✓	✗	✗	✗	✗	✗	✗	✗	✗	✗	✗	✗	✗
Century Schoolbook Italic	✓	✓	✓	✓	✓	✗	✗	✗	✗	✗	✗	✗	✗	✗	✗	✗	✗
Century Schoolbook Bold	✓	✓	✓	✓	✓	✗	✗	✗	✗	✗	✗	✗	✗	✗	✗	✗	✗
Century Schoolbook Bold Italic	✓	✓	✓	✓	✓	✗	✗	✗	✗	✗	✗	✗	✗	✗	✗	✗	✗
ITC Zapf Chancery Medium Italic	✓	✓	✓	✓	✓	✗	✗	✗	✗	✗	✗	✗	✗	✗	✗	✗	✗
CourierPS	✓	✓	✓	✓	✓	✗	✗	✗	✗	✗	✗	✗	✗	✗	✗	✗	✗
CourierPS Oblique	✓	✓	✓	✓	✓	✗	✗	✗	✗	✗	✗	✗	✗	✗	✗	✗	✗
CourierPS Bold	✓	✓	✓	✓	✓	✗	✗	✗	✗	✗	✗	✗	✗	✗	✗	✗	✗
CourierPS Bold Oblique	✓	✓	✓	✓	✓	✗	✗	✗	✗	✗	✗	✗	✗	✗	✗	✗	✗
Times Roman	✓	✓	✓	✓	✓	✗	✗	✗	✗	✗	✗	✗	✗	✗	✗	✗	✗
Times Italic	✓	✓	✓	✓	✓	✗	✗	✗	✗	✗	✗	✗	✗	✗	✗	✗	✗
Times Bold	✓	✓	✓	✓	✓	✗	✗	✗	✗	✗	✗	✗	✗	✗	✗	✗	✗
Times Bold Italic	✓	✓	✓	✓	✓	✗	✗	✗	✗	✗	✗	✗	✗	✗	✗	✗	✗
Helvetica Light	✗	✗	✗	✗	✗	✗	✗	✗	✗	✗	✗	✗	✗	✗	✗	✗	✗
Helvetica Light Oblique	✗	✗	✗	✗	✗	✗	✗	✗	✗	✗	✗	✗	✗	✗	✗	✗	✗
Helvetica Black	✗	✗	✗	✗	✗	✗	✗	✗	✗	✗	✗	✗	✗	✗	✗	✗	✗
Helvetica Black Oblique	✗	✗	✗	✗	✗	✗	✗	✗	✗	✗	✗	✗	✗	✗	✗	✗	✗

✓ Indicates Typeface supports the specified Symbol Set.
✗ Indicates Typeface does not support the specified Symbol Set.

Table 2-11: TC520, C522n, C524, C524n, C524dn, C530dn, C532n, C532dn, C534n, C534dn, C534dtn, C770, C770n, C772, C772n, C920, C920n, C920dn, and C920dnf PCL Emulation Symbol Sets - Specials (Continued)

Typeface / Symbol Set	Specials																
	Ventura Math	PS Math	Math-8	Pi font	Microsoft Publishing	PC-911 Katakana	POSTNET Barcode	OCR-A	OCR-B	C39 Bar Code (Upper Case)	C39 Bar Code (plus Lower Case)	C39 Bar Code (plus Human Readable)	Symbol	Wingdings	Ventura ITC Zapf Dingbats	PS ITC Zapf Dingbats	PCL ITC Zapf Dingbats
PJL Value	VNMATH	PSMATH	MATH8	PIFONT	MSPUBL												
Symbol Set ID	6M	5M	8M	15U	6J	3K	15Y	00	10	9Y	109Y	209Y	19M	579L	9L	10L	14L
Line Printer 16	✓	✓	✓	✓	✓	✓	✗	✗	✗	✗	✗	✗	✗	✗	✗	✗	✗
POSTNET Barcode	✗	✗	✗	✗	✗	✗	✓	✗	✗	✗	✗	✗	✗	✗	✗	✗	✗
C39 Narrow	✗	✗	✗	✗	✗	✗	✗	✗	✗	✓	✓	✓	✗	✗	✗	✗	✗
C39 Regular	✗	✗	✗	✗	✗	✗	✗	✗	✗	✓	✓	✓	✗	✗	✗	✗	✗
C39 Wide	✗	✗	✗	✗	✗	✗	✗	✗	✗	✓	✓	✓	✗	✗	✗	✗	✗
OCR-A	✗	✗	✗	✗	✗	✗	✗	✓	✗	✗	✗	✗	✗	✗	✗	✗	✗
OCR-B	✗	✗	✗	✗	✗	✗	✗	✗	✓	✗	✗	✗	✗	✗	✗	✗	✗
Wingdings	✗	✗	✗	✗	✗	✗	✗	✗	✗	✗	✗	✗	✗	✓	✗	✗	✗
Symbol	✗	✗	✗	✗	✗	✗	✗	✗	✗	✗	✗	✗	✓	✗	✗	✗	✗
SymbolPS	✗	✗	✗	✗	✗	✗	✗	✗	✗	✗	✗	✗	✓	✗	✗	✗	✗
ITC Zapf Dingbats	✗	✗	✗	✗	✗	✗	✗	✗	✗	✗	✗	✗	✗	✗	✓	✓	✓

✓ Indicates Typeface supports the specified Symbol Set.
✗ Indicates Typeface does not support the specified Symbol Set.

All fonts that support the Roman-8 (8U) symbol set also support the following 19 symbol sets.

Table 2-12: C520, C522n, C524, C524n, C524dn, C530dn, C532n, C532dn, C534n, C534dn, C534dtn, C770, C770n, C772, C772n, C920, C920n, C920dn, and C920dnf ISO PCL Emulation Symbol Sets

Symbol Set ID	Symbol Set / Typeface
1E	ISO 4: United Kingdom
0U	ISO 6: ASCII

Table 2-12: C520, C522n, C524, C524n, C524dn, C530dn, C532n, C532dn, C534n, C534dn, C534dtn, C770, C770n, C772, C772n, C920, C920n, C920dn, and C920dnf ISO PCL Emulation Symbol Sets (Continued)

Symbol Set ID	Symbol Set / Typeface
0S	ISO 11: Swedish for Names
0I	ISO 15: Italian
2S	ISO 17: Spanish
1G	ISO 21: German
0D	ISO 60: Norwegian Version 1
1F	ISO 69: French
2U	ISO 2: IRV (International Ref Version)
0F	ISO 25: French
0G	ISO: HP German
0K	ISO 14: JIS ASCII
2K	ISO 57: Chinese
3S	ISO 10: Swedish
1S	ISO: HP Spanish
6S	ISO 85: Spanish
4S	ISO 16: Portuguese
5S	ISO 84: Portuguese
1D	ISO 61: Norwegian Version 2

Command Structure

This section introduces the different types of PCL emulation commands and their structure, or syntax. It also demonstrates how you can link commands to abbreviate them.

Control Codes

Control Codes are single-character instructions.

Table 2-13: Control Codes

Code	Dec	Hex	Function	Result
BS	8	08	Backspace	Moves the cursor toward the left margin one horizontal space equal to the last printed character
HT	9	09	Horizontal Tab	Moves the cursor to the next defined tab stop
LF	10	0A	Line Feed	Advances the cursor to the same horizontal position on the following line as determined by either the Vertical Motion Index (VMI) or Set Line Spacing command
FF	12	0C	Form Feed	Advances the cursor to the same horizontal position at the top margin of the next page
CR	13	0D	Carriage Return	Moves the cursor to the left margin
SP	32	20	Space	Moves the cursor to the right one column
SI	15	0F	Primary Font	Selects the primary font
SO	14	0E	Secondary Font	Selects the secondary font

Commands

PCL emulation commands are multibyte strings (also known as “escape sequences”) that begin with the Escape control code (^{ESC}, ←, decimal 27, or hexadecimal 1B). The ^{ESC} control code notifies the printer that the characters that follow are to be interpreted as part of a command and are not control codes or data to be printed.

Command Structure

Most PCL emulation commands have the following structure:

^{ESC} & a # C

Spaces have been added to this example for readability. The command parameter variables are indicated by a number sign (#).

Table 2-14: Description of Command Structure

Element	Description
^{ESC}	Decimal 27 or hex 1B
&	Parameterized character from American National Standard Code for Information Interchange (ASCII) table (ranging from 33 to 47 decimal)

Table 2-14: Description of Command Structure (Continued)

Element	Description
a	Group character from ASCII table (ranging from 96 to 126 decimal) that specifies a group type of control
#	Decimal character string value within specified numeric ranges; may be preceded by a + or - sign and contain a decimal point
C	Termination character from ASCII table (ranging from 64 to 94 decimal)

Command Parameters

A command parameter sets the value for a command. This value stays constant until either a different value resets the command or a command resets the printer to the default values. For example, after the printer receives a command that selects a right margin beginning at column 63, the right margin of each printed page begins at column 63. That margin stays constant until a right margin command with a different value resets it or until the printer is reset.

Parameters for each command are listed in the command tables beginning on page 2-52. Use the Symbol Set Tables to determine the decimal or hexadecimal value for each parameter. To determine a decimal or hex value, first locate the value of the parameter you require in the Symbol Set Table. The decimal value is the value shown in the bottom of the cell or box with that parameter. To find a hex value, go straight up the grid from the desired parameter and read the value in the top heading. This is the first character of the hex value. Next, go straight across the grid to the left of the parameter and read the value in the left column heading. This is the second character of the hex value. For example, $\text{ESC} (\leftarrow)$ is coded 1B in Hex and 27 in decimal. (Any one of the three values \leftarrow , 1B, or 27 might be used in your application. Read your documentation to determine which to use.) The example on the following page sets the pitch of the primary font to 16.66 characters per inch.

Example:

$\text{ESC} (\text{s}16.66\text{H}$

- **Decimal:** 27 40 115 49 54 46 54 54 72
- **Hex:** 1B 28 73 31 36 2E 36 36 48

Use the plus symbol (+) or the minus symbol (-) to select a position relative to the current cursor position. For example:

$\text{ESC}\&a6\text{C}$	Move to horizontal cursor position, column six
$\text{ESC}\&a+6\text{C}$	Move six columns to the right of the current position
$\text{ESC}\&a-6\text{C}$	Move six columns to the left of the current position

Linking Commands

You can combine PCL emulation commands by linking them *if* the first 3 bytes of the commands are identical. The combined, short form sends the first 3 bytes only once in the string. To combine commands:

- Use the first 3 bytes (characters) of the command only once at the start of the command string.
- Make the last letter of each command in the string lowercase.
- Capitalize the last letter of the string.

For example, notice that the first 3 bytes of these two commands are the same:

```
ESC (s10H      Select 10 characters per inch
ESC (s4099T    Select Courier typeface
```

To combine these two commands, use this form:

```
ESC (s10h4099T
```

which is 3 bytes shorter than the long form:

```
ESC (s10HESC (s4099T
```

You can combine more than two commands; for example, you can add Select Stroke Weight Bold (^{ESC}(s3B) to the previous two commands:

```
ESC (s10h3b4099T
```

or in the long form:

```
ESC (s10HESC (s3BESC (s4099T
```

PCL Emulation Commands

See the following tables for a listing of the commands grouped by function.

To determine which commands your printer supports, see “Table A-1: PCL Emulation Commands” on page A-1.

PCL Emulation Commands by Function

Table 2-15: Job Control

Command / Parameters	Function / Result
ESC E	Printer Reset <ul style="list-style-type: none"> Prints any partial pages. Resets printer environment to defaults. Deletes all temporary downloaded resources.
ESC &d#A 0 = Collation off 1 ... 999 (number of Copies)	Number of Collated Copies Turns collation of pages off or sets the number of collated copies.
ESC &l#X # = number of Copies (1 to 32767) Default = 1	Number of Copies Affects the page currently in process and subsequent pages.
ESC &l#S 0 Single-Sided (Default) 1 Duplex Long-Edge Binding 2 Duplex Short-Edge Binding 100 Manual Duplex First Sides 101 Manual Duplex Second Sides	Simplex/Duplex Print Long-edge or short-edge binding refers to the side of the physical page where binding occurs.
ESC &l#U # = number of Decipoints Range = -32767 to 32767 (1 Decipoint = 1/720 inch) Default = 0	Long-Edge Offset Registration Also known as Left Offset. Adjusts placement of logical page along the width of the physical page.
ESC &l#Z # = number of Decipoints Range = -32767 to 32767 (1 Decipoint = 1/720 inch) Default = 0	Short-Edge Offset Registration Also known as Top Offset. Adjusts placement of logical page along the length of the physical page.

Table 2-15: Job Control (Continued)

Command / Parameters	Function / Result
<p>$\text{ESC}\&u\#D$</p> <p>Range = (96, 100, 120, 144, 150, 160, 180, 200, 225, 240, 288, 300, 360, 400, 450, 480, 600, 720, 800, 900, 1200, 1440, 1800, 2400, 3600, 7200)</p> <p>Default = 300 units per inch</p>	<p>Unit of Measure</p> <p>Sets the size for the PCL Unit (units per inch).</p> <p>The Unit of Measure defines the unit used in the following commands:</p> <ul style="list-style-type: none"> • Horizontal Cursor Position by PCL Unit ($\text{ESC}^*p\#X$) • Vertical Cursor Position by PCL Unit ($\text{ESC}^*p\#Y$) • Horizontal Rectangle Size by PCL Unit ($\text{ESC}^*c\#A$) • Vertical Rectangle Size by PCL Unit ($\text{ESC}^*c\#B$) <p>The Unit of Measure also affects the rounding of character escapements and the Horizontal Motion Index.</p> <p>Note: This command does not affect the interpretation of binary raster data for bitmapped fonts, raster graphics, or user defined fill patterns.</p>
<p>$\text{ESC}\% - 12345X$</p>	<p>Universal Exit Language (UEL) / Start of PJJ</p> <p>This command terminates the current printer language and allows switching into PJJ. For more information, see "UNIVERSAL EXIT LANGUAGE Command" on page 3-2.</p>

Table 2-16: Page Control

Command / Parameters	Function / Result																																						
<p>ESC&l#A</p> <p>Paper</p> <table> <tr><td>1</td><td>Executive</td></tr> <tr><td>2</td><td>Letter</td></tr> <tr><td>3</td><td>Legal</td></tr> <tr><td>4, 10</td><td>Folio</td></tr> <tr><td>6, 11</td><td>Ledger (11 x 17)</td></tr> <tr><td>13, 25</td><td>A5 Paper</td></tr> <tr><td>15</td><td>Statement</td></tr> <tr><td>26</td><td>A4 Paper</td></tr> <tr><td>27</td><td>A3 Paper</td></tr> <tr><td>12, 45</td><td>B5 Paper</td></tr> <tr><td>46</td><td>B4 Paper</td></tr> <tr><td>101</td><td>Custom Paper/Universal</td></tr> </table> <p>Envelopes</p> <table> <tr><td>80</td><td>Monarch 7 3/4</td></tr> <tr><td>81</td><td>Commercial 10</td></tr> <tr><td>89</td><td>Commercial 9</td></tr> <tr><td>90</td><td>DL</td></tr> <tr><td>91</td><td>C5</td></tr> <tr><td>99, 100</td><td>B5 Envelope</td></tr> <tr><td>600</td><td>Other Envelope</td></tr> </table>	1	Executive	2	Letter	3	Legal	4, 10	Folio	6, 11	Ledger (11 x 17)	13, 25	A5 Paper	15	Statement	26	A4 Paper	27	A3 Paper	12, 45	B5 Paper	46	B4 Paper	101	Custom Paper/Universal	80	Monarch 7 3/4	81	Commercial 10	89	Commercial 9	90	DL	91	C5	99, 100	B5 Envelope	600	Other Envelope	<p>Set Page Size</p> <p>Selects the physical size of the paper, which also determines the logical page dimensions. See the tables beginning on page 2-1 for the paper and envelope dimensions your printer supports.</p> <p>If the requested page size is not in the requested source or if no source is requested, sources are checked for the requested size in the following order: multipurpose feeder, tray 1, tray 2, tray 3, tray 4, tray 5, and envelope feeder.</p> <p>Notes:</p> <ul style="list-style-type: none"> • When the printer receives the page size command, any partially formatted pages are printed, and the cursor position and margins are reset. • Duplex printing is not supported on any envelope. • The size loaded in the active source is checked to see if it matches the requested size. If the multipurpose feeder is configured as Cassette or Manual, the same applies; however, if the multipurpose feeder is configured as First and media is loaded in the multipurpose feeder, then, regardless of media size, it is the source used until it is empty.
1	Executive																																						
2	Letter																																						
3	Legal																																						
4, 10	Folio																																						
6, 11	Ledger (11 x 17)																																						
13, 25	A5 Paper																																						
15	Statement																																						
26	A4 Paper																																						
27	A3 Paper																																						
12, 45	B5 Paper																																						
46	B4 Paper																																						
101	Custom Paper/Universal																																						
80	Monarch 7 3/4																																						
81	Commercial 10																																						
89	Commercial 9																																						
90	DL																																						
91	C5																																						
99, 100	B5 Envelope																																						
600	Other Envelope																																						
<p>ESC&l#H</p> <table> <tr><td>0</td><td>Active Source or Eject Page</td></tr> <tr><td>1</td><td>Tray 1 (Default)</td></tr> <tr><td>2</td><td>Manual Paper Feed</td></tr> <tr><td>3</td><td>Manual Envelope Feed</td></tr> <tr><td>4</td><td>Tray 2</td></tr> <tr><td>5</td><td>Tray 3</td></tr> <tr><td>6</td><td>Optional Envelope Feeder</td></tr> <tr><td>7</td><td>Auto Select</td></tr> <tr><td>8</td><td>Multipurpose Feeder</td></tr> <tr><td>20</td><td>Tray 4</td></tr> <tr><td>21</td><td>Tray 5</td></tr> <tr><td>62</td><td>Optional Paper Source</td></tr> </table>	0	Active Source or Eject Page	1	Tray 1 (Default)	2	Manual Paper Feed	3	Manual Envelope Feed	4	Tray 2	5	Tray 3	6	Optional Envelope Feeder	7	Auto Select	8	Multipurpose Feeder	20	Tray 4	21	Tray 5	62	Optional Paper Source	<p>Paper Source</p> <p>Selects the paper feed source.</p> <p>Note: If the paper source is changed for the back of a duplexed page, a blank back page prints, the paper source changes, and the information for the back side of the page is printed on the front side of a page sent from the new paper source.</p>														
0	Active Source or Eject Page																																						
1	Tray 1 (Default)																																						
2	Manual Paper Feed																																						
3	Manual Envelope Feed																																						
4	Tray 2																																						
5	Tray 3																																						
6	Optional Envelope Feeder																																						
7	Auto Select																																						
8	Multipurpose Feeder																																						
20	Tray 4																																						
21	Tray 5																																						
62	Optional Paper Source																																						
<p>ESC&f#G</p> <p># = number of Decipoints (1 Decipoint = 1/720 inch)</p>	<p>Set Universal Width</p> <p>Sets the width of the Universal size in decipoints.</p>																																						
<p>ESC&f#F</p> <p># = number of Decipoints (1 Decipoint = 1/720 inch)</p>	<p>Set Universal Height</p> <p>Sets the height of the Universal size in decipoints.</p>																																						

Table 2-16: Page Control (Continued)

Command / Parameters	Function / Result
$ESC \&f\#O$ 0 Short-edge 1 Long-edge	Set Universal Feed Direction Sets the feed direction of Universal size. Feed direction means which side of the print media, either the short edge or the long edge, feeds through the printer first.
$ESC \&f\#W$ [custom name] # = number of bytes in the custom name	Set Universal Custom Name Sets the user-specified custom name for the Universal paper size being used.
$ESC \&l\#O$ 0 Portrait (Default) 1 Landscape 2 Reverse Portrait 3 Reverse Landscape	Select Orientation Specifies the position of the logical page with respect to the physical page. Note: This setting resets margins, the number of printable lines per page, and the cursor position.
$ESC \&a\#P$ # = Degrees (0, 90, 180, 270) Default = 0	Print Direction Rotates the coordinate system counter-clockwise in 90° increments with respect to the current orientation. Note: Margins are not rotated or cleared.
$ESC \&c\#T$ 0 Horizontal Printing -1 Vertical Rotated Printing	Character Text Path Direction Vertically rotates text for use in vertical writing, such as printing Japanese text.
$ESC \&a\#L$ # = Column Default = 0	Set Left Margin Sets the left margin to the left edge of the designated column. Note: The column width is defined by the space character of the active font and the Horizontal Motion Index (HMI).
$ESC \&a\#M$ # = Column Default = Logical Page Width	Set Right Margin Sets the right margin to the right edge of the designated column. Note: The column width is defined by the space character of the active font and the HMI.
$ESC g$	Clear Horizontal Margins Clears left and right margins.
$ESC \&l\#E$ # = number of lines Default = 3 (1/2 inch)	Set Top Margin Sets the number of lines between the top of the physical page and first line of print. Line height is determined by the current Vertical Motion Index (VMI) and/or line spacing value. Note: Setting a top margin of 0 results in the first line of text falling outside of the printable area.
$ESC \&l1T$	Job Separation This command is parsed and ignored.

Table 2-16: Page Control (Continued)

Command / Parameters	Function / Result
$\text{ESC}\&l\#F$ # = number of lines Default = 60 or 64 (Country specific)	Set Text Length Sets the bottom margin length in lines, measured from the first line of the page. Text Length equals Logical Page Length –1 inch (–1/2 inch for top and –1/2 inch for bottom).
$\text{ESC}\&l\#G$ 0 Auto Select (uses the active bin) 1 Standard Bin 2 Bin 1 <i>or</i> Rear Bin 3 Bin 1 <i>or</i> Rear Bin 4 Bin 2 5 Bin 3 6 Bin 4 7 Bin 5 8 Bin 6 9 Bin 7 10 Bin 8 11 Bin 9 12 Bin 10	Set Output Bin Sets the exit path to direct paper to one of the output bins.
$\text{ESC}\&l\#L$ 0 Off 1 On (Default)	Skip Perforation Perforation area includes the area from the bottom margin of the current page to the top margin of the next page. When skipping perforations, a line feed past the bottom margin ejects a page and places the cursor at the top margin of the next page.
$\text{ESC}\&k\#H$ # = number of 1/120 inch increments (Valid to 4 decimal places)	Set Horizontal Motion Index (HMI) Sets the width of all characters for fixed-space fonts. Sets only the width of the space for proportional spaced fonts.
$\text{ESC}\&l\#C$ # = number of 1/48 inch increments (Valid to 4 decimal places) Default = 8	Set Vertical Motion Index (VMI) Sets Vertical Motion Index in 1/48 inch increments. The VMI determines the vertical distance between lines. Notes: <ul style="list-style-type: none"> For some printers, you can change the default VMI from the printer operator panel or through MarkVision Professional by using the Lines Per Page menu item. See your printer documentation for more information. Use of this command alters any previous Set Line Spacing command settings.

Table 2-16: Page Control (Continued)

Command / Parameters	Function / Result
$\text{ESC}\&\ell\#D$ 1 1 line/inch 2 2 lines/inch 3 3 lines/inch 4 4 lines/inch 6 6 lines/inch (Default) 8 8 lines/inch 12 12 lines/inch 16 16 lines/inch 24 24 lines/inch 48 48 lines/inch	Set Line Spacing (Alternative Method) Specifies VMI in lines per inch. Notes: <ul style="list-style-type: none"> For some printers, you can change the default VMI from the printer operator panel or through MarkVision Professional by using the Lines Per Page menu item. See your printer documentation for more information. Unsupported values are ignored. Use of this command alters any earlier VMI setting.
$\text{ESC}\&a\#G$ 0 Next Side 1 Front Side 2 Back Side	Duplex Page Side Selection Specifies which physical page side to print next when duplex printing. Note: When the duplex option is not installed, this command causes a conditional page eject.
$\text{ESC}\&\ell\#P$ # = number from 0 to 14 0 = default page length is used (1 to 14 = new page length is set)	Set Page Length Sets the logical page length in number of lines. Notes: <ul style="list-style-type: none"> This command is sent at the beginning of a page in a print job and prior to any printable data. When the command is sent, the current page is closed and printed. Unsupported values are ignored.
$\text{ESC}\&k\#W$ 5 Turn Text Scale Mode OFF 6 Turn Text Scale Mode ON	Text Scale Mode Allows 66 lines of text at six lines per inch to print on an effective page length of 10 1/2 inches. Notes: <ul style="list-style-type: none"> Unsupported values are ignored. The command is ignored when the printer is in landscape mode.

Table 2-17: Alphanumeric ID

Command / Parameters	Function / Result																																
<p><code>ESC&n#W [operation] [string]</code></p> <p># = number of data bytes that make up the operation and string</p> <p>Operation</p> <p>operation = 100 or 1 byte = 0x64 or 'd' ascii</p> <p>For example:</p> <p>100 Media Select</p> <p>String</p> <p>string = See Alphanumeric String list at right</p>	<p>Alphanumeric ID</p> <p>Selects the media type using a character string. The string ID is case sensitive and may be up to 511 bytes long.</p> <p>The string ID specifies the media type requested.</p> <table border="1"> <thead> <tr> <th>Media Type</th> <th>Alphanumeric String</th> </tr> </thead> <tbody> <tr><td>Plain Paper</td><td>Plain</td></tr> <tr><td>Bond</td><td>Bond</td></tr> <tr><td>Transparency</td><td>Transparency</td></tr> <tr><td>Card Stock</td><td>Card Stock</td></tr> <tr><td>Labels</td><td>Labels</td></tr> <tr><td>Letterhead</td><td>Letterhead</td></tr> <tr><td>Pre-printed</td><td>Preprinted</td></tr> <tr><td>Colored Paper</td><td>Color</td></tr> <tr><td>Envelope</td><td>Envelope</td></tr> <tr><td>Custom Type 1</td><td>Custom Type 1 or User Type 1</td></tr> <tr><td>Custom Type 2</td><td>Custom Type 2 or User Type 2</td></tr> <tr><td>Custom Type 3</td><td>Custom Type 3 or User Type 3</td></tr> <tr><td>Custom Type 4</td><td>Custom Type 4 or User Type 4</td></tr> <tr><td>Custom Type 5</td><td>Custom Type 5 or User Type 5</td></tr> <tr><td>Custom Type 6</td><td>Custom Type 6 or User Type 6</td></tr> </tbody> </table> <p>For example, the following shows the command and parameters used to select bond paper: <code>ESC&n5WdBond</code></p> <p>To select letterhead paper: <code>ESC&n11WdLetterhead</code></p>	Media Type	Alphanumeric String	Plain Paper	Plain	Bond	Bond	Transparency	Transparency	Card Stock	Card Stock	Labels	Labels	Letterhead	Letterhead	Pre-printed	Preprinted	Colored Paper	Color	Envelope	Envelope	Custom Type 1	Custom Type 1 or User Type 1	Custom Type 2	Custom Type 2 or User Type 2	Custom Type 3	Custom Type 3 or User Type 3	Custom Type 4	Custom Type 4 or User Type 4	Custom Type 5	Custom Type 5 or User Type 5	Custom Type 6	Custom Type 6 or User Type 6
Media Type	Alphanumeric String																																
Plain Paper	Plain																																
Bond	Bond																																
Transparency	Transparency																																
Card Stock	Card Stock																																
Labels	Labels																																
Letterhead	Letterhead																																
Pre-printed	Preprinted																																
Colored Paper	Color																																
Envelope	Envelope																																
Custom Type 1	Custom Type 1 or User Type 1																																
Custom Type 2	Custom Type 2 or User Type 2																																
Custom Type 3	Custom Type 3 or User Type 3																																
Custom Type 4	Custom Type 4 or User Type 4																																
Custom Type 5	Custom Type 5 or User Type 5																																
Custom Type 6	Custom Type 6 or User Type 6																																

Table 2-18: Cursor Positioning

Command / Parameters	Function / Result
<p><code>ESC&a#C</code></p> <p># = number of Columns¹</p>	<p>Horizontal Cursor Position (in Columns)</p> <p>Moves the cursor to a new position along the horizontal axis.</p> <p>Note: The column width is determined by the space character width of the active font or the Horizontal Motion Index (HMI), if set.</p>
<p><code>ESC&a#H</code></p> <p># = number of Decipoints¹</p> <p>(1 Decipoint = 1/720 inch)</p>	<p>Horizontal Cursor Position (in Decipoints)</p> <p>Moves the cursor to a new position along the horizontal axis.</p>
<p><code>ESC*p#X</code></p> <p># = number of PCL Units¹</p>	<p>Horizontal Cursor Position (in PCL Units)</p> <p>Moves the cursor to a new position along the horizontal axis.</p> <p>Note: PCL units are set by the Unit-of-Measure Command.</p>

¹ Parameter preceded by + or - sign denotes a relative cursor move from the current cursor position. Parameter without a sign denotes an absolute cursor move from the top left margin.

Table 2-18: Cursor Positioning (Continued)

Command / Parameters	Function / Result
$\text{ESC}\&\text{a}\#\text{R}$ # = number of Rows ¹	Vertical Cursor Position (in Rows) Moves the cursor to a new position along the vertical axis. Note: Row height is determined by either the Vertical Motion Index (VMI) or the Set Line Spacing Command.
$\text{ESC}\&\text{a}\#\text{V}$ # = number of Decipoints ¹ (1 Decipoint = 1/720 inch)	Vertical Cursor Position (in Decipoints) Moves the cursor to a new position along the vertical axis.
$\text{ESC}^+\text{p}\#\text{Y}$ # = number of PCL Units ¹	Vertical Cursor Position (in PCL Units) Moves the cursor to a new position along the vertical axis. Note: PCL units are set by the Unit-of-Measure Command.
$\text{ESC}=\text{}$	Half Line-Feed Moves the cursor down 1/2 line (1/2 of the current VMI).
$\text{ESC}\&\text{k}\#\text{G}$ 0 CR=CR, LF=LF, FF=FF (Default) 1 CR=CR+LF, LF=LF, FF=FF 2 CR=CR, LF=CR+LF, FF=CR+FF 3 CR=CR+LF, LF=CR+LF, FF=CR+FF	Set Line Termination Controls how the printer responds to the Carriage Return (CR), Line Feed (LF), and Form Feed (FF) control codes.
$\text{ESC}\&\text{f}\#\text{S}$ 0 Push 1 Pop	Push / Pop Cursor Position Sets up a cursor position stack for storing and recalling various cursor positions. The stack can store up to 20 cursor positions.
¹ Parameter preceded by + or - sign denotes a relative cursor move from the current cursor position. Parameter without a sign denotes an absolute cursor move from the top left margin.	

Note: For the commands listed in Table 2-19, font selection is based on all parameters set following the best fit selection rules.

Table 2-19: Font Selection

Command / Parameters	Function / Result
$^{ESC}(\#$ (primary) $^{ESC})\#$ (secondary) # = symbol set ID Default = 10U (PC-8) or 12U (PC-850), [Country specific]	Select Symbol Set The line-draw characters are contained in the symbol set ID 10U, PC-8. The non-U.S. characters are contained in symbol set ID 12U, PC-850.
$^{ESC}(s\#P$ (primary) $^{ESC})s\#P$ (secondary) 0 Fixed (Default) 1 Proportional	Select Spacing Selects a font with proportional or fixed spacing.
$^{ESC}(s\#H$ (primary) $^{ESC})s\#H$ (secondary) # = characters per inch Default = 10	Select Pitch Selects the number of characters per inch (cpi) for a fixed-space bitmapped or monospaced scalable font. Valid to 2 decimal places. Note: Pitch is not needed for proportional spaced fonts.
$^{ESC}(s\#V$ (primary) $^{ESC})s\#V$ (secondary) # = height in points (.25 to 999.75) Default = 12	Height (Select Point Size) Sets the font height in points. Valid to 2 decimal places. Note: Point size is not needed for monospaced fonts. For fonts larger than 12 points, it may be necessary to change the line spacing.
$^{ESC}(s\#S$ (primary) $^{ESC})s\#S$ (secondary) 0 Upright (Default) 1 Italic 4 Condensed 5 Condensed Italic 8 Compressed 24 Expanded 32 Outline 64 Inline 128 Shadowed 160 Outline Shadowed	Select Style Identifies the physical traits of a character and the composition of the font symbols. Note: You can only use this command to select fonts currently available in the printer. It cannot alter the appearance of the available fonts.

Table 2-19: Font Selection (Continued)

Command / Parameters	Function / Result
ESC(s#B (primary) ESC)s#B (secondary) -7 Ultra Thin -6 Extra Thin -5 Thin -4 Extra Light -3 Light -2 Demi Light -1 Semi Light 0 Medium (Default) 1 Semi Bold 2 Demi Bold 3 Bold 4 Extra Bold 5 Black 6 Extra Black 7 Ultra Black	Select Stroke Weight Selects a font with a particular thickness. Note: This command will not alter the stroke weight of an available font.
ESC(s#T (primary) ESC)s#T (secondary) # Typeface identifier (0 - 65535) Note: For a list of typeface numbers, see Table 2-2 on page 2-9 and "Font and Symbol Set Support for the Lexmark C520, C522n, C524, C524n, C524dn, C530dn, C532n, C532dn, C534n, C534dn, C534dtn, C770, C770n, C772, C772n, C920, C920n, C920dn, C920dnf" on page 2-8.	Select Typeface Selects the best fit font design. To obtain the typeface values for downloaded fonts, print the font list from the printer operator panel or through MarkVision Professional. See your printer documentation for more information. On the printout, the typeface number is the last number on the font selection command example line. The example line is below the name of the font. In the following example, the typeface number is underlined: RO Courier <<ESC>><<symset>><<ESC>>(s0p<<pitch>>h0s0b <u>4099</u> T
ESC(#X (primary) ESC)#X (secondary) # = Font ID (0 - 32767)	Select Font by Font ID Selects the font by the identification number.
ESC(3@ (primary) ESC)3@ (secondary)	Select Default Font Sets all font selection characteristics to the Default Font.
ESC&p#X[data] # = number of data of bytes to print as text	Transparent Print Data Prints the next number of bytes as text.
ESC&d#D 0,1 Fixed 2 Fixed - double 3 Floating 4 Floating - double	Select Underline Type (Enable) Notes: <ul style="list-style-type: none"> Fixed underline is drawn 5 pels below cursor position. Floating underline position is determined by all the positions of the characters with descenders in the fonts that are to be underlined. Underline thickness is 1/100 inch.
ESC&d@	Underline - Disable

Table 2-19: Font Selection (Continued)

Command / Parameters	Function / Result
ESC&t#P 0, 1 1 byte characters 21 1 or 2 byte characters 31 1 or 2 byte characters 38 1 or 2 byte characters 1008 1, 2, or 3 byte characters (UTF-8)	Text Parsing Method Communicates to the PCL parser whether character codes are interpreted as 1-byte or 2-byte character codes.
ESC&k#S 0 10.00 cpi 2 16.66 cpi 4 12.00 cpi	Select Primary and Secondary Pitch Selects the pitch for the primary and secondary font.

Table 2-20: User-Defined Symbol Set

Command / Parameters	Function / Result
ESC*c#R # = Symbol Set ID (0 - 32767) Default = 0	Symbol Set ID Code Sets the symbol set identification for the symbol set downloaded.
ESC(f#W[data] # = number of data bytes	Define Symbol Set Contains the data for the user-defined symbol sets.
ESC*c#S 0 Delete all (temporary and permanent) 1 Delete all temporary 2 Delete current (ID) 4 Make current temporary 5 Make current permanent	Symbol Set Control Manages user-defined symbol sets.

Table 2-21: Font Creation

Command / Parameters	Function / Result
ESC*c#D # = Font ID # (0 - 32767) Default = 0	Set Font ID Sets the identification number for the font being downloaded.
ESC)s#W[data] # = number of data bytes	Load Font Header Downloads soft font header information. Note: Set Font ID before using this command.
ESC*c#F 0 Delete all (temporary and permanent) 1 Delete all temporary 2 Delete previous font ID 3 Delete previous specified character 4 Make previous font ID temporary 5 Make previous font ID permanent 6 Copy current font	 Font Control Manages soft fonts.
ESC*c#E # = Code Point (0 - 65536) Default = 0	Set Character Code Sets the decimal code point associated with the next character downloaded or deleted.
ESC(s#W[data] # = number of data bytes	Load Character Downloads character descriptor and data to the current character code.

Table 2-22: Macros

Command / Parameters	Function / Result
ESC&f#Y # = Macro ID (0 - 32767) Default = 0	Set Macro ID Sets the ID for the macro you have created on flash or disk.
ESC&f#X 0 Start definition 1 End definition 2 Execute macro (previous macro ID) 3 Call macro (previous macro ID) 4 Enable overlay (previous macro ID) 5 Disable overlay 6 Delete all macros 7 Delete all temporary macros 8 Delete current macro ID 9 Make last ID temporary 10 Make last ID permanent	Macro Control Manages use of macros. Notes: <ul style="list-style-type: none"> GL/2 commands are supported inside macros. Only call and execute macro commands are allowed within a macro. A macro may call or execute another macro. This is called nesting. A maximum of two nesting levels are allowed, for a total of three levels. See "Macros" on page 2-85 for additional information.

Table 2-23: Print Model

Command / Parameters	Function / Result																														
<p>ESC*c#G</p> <p>Gray Scale Fills</p> <table> <tr><td>0</td><td>White (default)</td></tr> <tr><td>1-2</td><td>2% gray</td></tr> <tr><td>3-10</td><td>10% gray</td></tr> <tr><td>11-20</td><td>15% gray</td></tr> <tr><td>21-35</td><td>30% gray</td></tr> <tr><td>36-55</td><td>45% gray</td></tr> <tr><td>56-80</td><td>70% gray</td></tr> <tr><td>81-99</td><td>90% gray</td></tr> <tr><td>100</td><td>100% gray (Black)</td></tr> </table> <p>Cross-Hatch Fills</p> <table> <tr><td>1</td><td>Horizontal line</td></tr> <tr><td>2</td><td>Vertical line</td></tr> <tr><td>3</td><td>Diagonal line</td></tr> <tr><td>4</td><td>Diagonal line</td></tr> <tr><td>5</td><td>Square grid</td></tr> <tr><td>6</td><td>Diagonal grid</td></tr> </table> <p>User-Defined Patterns</p> <p># = User-Defined Pattern ID</p>	0	White (default)	1-2	2% gray	3-10	10% gray	11-20	15% gray	21-35	30% gray	36-55	45% gray	56-80	70% gray	81-99	90% gray	100	100% gray (Black)	1	Horizontal line	2	Vertical line	3	Diagonal line	4	Diagonal line	5	Square grid	6	Diagonal grid	<p>Area Fill ID</p> <p>Selects pattern used to fill a rectangular area.</p> <p>Note: This command is also used to set the user-defined pattern ID.</p>
0	White (default)																														
1-2	2% gray																														
3-10	10% gray																														
11-20	15% gray																														
21-35	30% gray																														
36-55	45% gray																														
56-80	70% gray																														
81-99	90% gray																														
100	100% gray (Black)																														
1	Horizontal line																														
2	Vertical line																														
3	Diagonal line																														
4	Diagonal line																														
5	Square grid																														
6	Diagonal grid																														
<p>ESC*v#N</p> <table> <tr><td>0</td><td>Transparent (Default)</td></tr> <tr><td>1</td><td>Opaque</td></tr> </table>	0	Transparent (Default)	1	Opaque	<p>Source Transparency Mode</p> <p>Affects copying of white pixels from the source onto the destination image.</p>																										
0	Transparent (Default)																														
1	Opaque																														
<p>ESC*v#O</p> <table> <tr><td>0</td><td>Transparent (Default)</td></tr> <tr><td>1</td><td>Opaque</td></tr> </table>	0	Transparent (Default)	1	Opaque	<p>Pattern Transparency Mode</p> <p>Affects copying of white pixels from the pattern onto the destination image.</p>																										
0	Transparent (Default)																														
1	Opaque																														
<p>ESC*<i>l</i>#O</p> <p># = logical operation, value (0 to 255)</p> <p>Default = 252</p>	<p>Logical Operation</p> <p>Defines boolean operations to be performed on data already printed and data about to be printed.</p>																														
<p>ESC*<i>l</i>#R</p> <table> <tr><td>0</td><td>Grid Intersection (Default)</td></tr> <tr><td>1</td><td>Grid Centered</td></tr> </table>	0	Grid Intersection (Default)	1	Grid Centered	<p>Pixel Placement</p> <p>Determines how pixels are placed for a rectangular area fill and GL/2 objects.</p> <p>Pixel Placement does not affect text or raster images.</p>																										
0	Grid Intersection (Default)																														
1	Grid Centered																														
<p>ESC*v#T</p> <table> <tr><td>0</td><td>Solid Black (Default)</td></tr> <tr><td>1</td><td>Solid White</td></tr> <tr><td>2</td><td>Gray Shading Pattern</td></tr> <tr><td>3</td><td>Cross-Hatch Pattern</td></tr> <tr><td>4</td><td>User Defined Pattern</td></tr> <tr><td>9</td><td>True gray Level Fill</td></tr> </table>	0	Solid Black (Default)	1	Solid White	2	Gray Shading Pattern	3	Cross-Hatch Pattern	4	User Defined Pattern	9	True gray Level Fill	<p>Select Current Pattern</p> <p>Selects pattern used when printing text and raster images.</p>																		
0	Solid Black (Default)																														
1	Solid White																														
2	Gray Shading Pattern																														
3	Cross-Hatch Pattern																														
4	User Defined Pattern																														
9	True gray Level Fill																														

Table 2-24: User-Defined Pattern

Command / Parameters	Function / Result
ESC*c#W[data] # = number of data bytes	User-Defined Pattern Downloads binary pattern data.
ESC*p#R 0 Rotate with print (Default) 1 Fixed	Set Pattern Reference Point Sets the pattern reference point to the current cursor position for user-defined patterns. Note: Default pattern reference point is the upper left corner of the logical page.
ESC*c#Q 0 Delete all patterns (temporary and permanent) 1 Delete all temporary patterns 2 Delete pattern (last ID specified) 4 Make pattern of last ID # temporary 5 Make pattern of last ID # permanent	 Pattern Control Manages the use of user-defined patterns. Note: Use the Area Fill ID command (ESC*c#G) to set the ID.

Table 2-25: Rectangular Area Fill Graphics

Command / Parameters	Function / Result
ESC*c#H # = Number of Decipoints (0 - 32767) (1 Decipoint = 1/720 inch) Default = 0, valid to 4 decimal places	Horizontal Rectangle Size (in Decipoints) Specifies the rectangle width in decipoints.
ESC*c#A # = Number of PCL Units (0 - 32767) Default = 0	Horizontal Rectangle Size (in PCL Units) Specifies the rectangle width in PCL units. Note: The size of PCL Units is set by the Unit-of-Measure command.
ESC*c#V # = Number of Decipoints (0 - 32767) (1 Decipoint = 1/720 inch) Default = 0, valid to 4 decimal places	Vertical Rectangle Size (in Decipoints) Specifies the rectangle height in decipoints.
ESC*c#B # = Number of PCL Units (0 - 32767) Default = 0	Vertical Rectangle Size (in PCL Units) Specifies the rectangle height in PCL units. Note: The size of PCL Units is set by the Unit-of-Measure command.

Table 2-25: Rectangular Area Fill Graphics (Continued)

Command / Parameters	Function / Result																														
<p>ESC*c#G</p> <p>Gray Scale Fills</p> <table border="0"> <tr><td>0</td><td>White (default)</td></tr> <tr><td>1-2</td><td>2% Gray</td></tr> <tr><td>3-10</td><td>10% Gray</td></tr> <tr><td>11-20</td><td>15% Gray</td></tr> <tr><td>21-35</td><td>30% Gray</td></tr> <tr><td>36-55</td><td>45% Gray</td></tr> <tr><td>56-80</td><td>70% Gray</td></tr> <tr><td>81-99</td><td>90% Gray</td></tr> <tr><td>100</td><td>100% Gray (Black)</td></tr> </table> <p>Cross-Hatch Fills</p> <table border="0"> <tr><td>1</td><td>Horizontal Line</td></tr> <tr><td>2</td><td>Vertical Line</td></tr> <tr><td>3</td><td>Diagonal Line</td></tr> <tr><td>4</td><td>Diagonal Line</td></tr> <tr><td>5</td><td>Square Grid</td></tr> <tr><td>6</td><td>Diagonal Grid</td></tr> </table> <p>User-Defined Patterns</p> <p># = User-Defined Pattern ID</p>	0	White (default)	1-2	2% Gray	3-10	10% Gray	11-20	15% Gray	21-35	30% Gray	36-55	45% Gray	56-80	70% Gray	81-99	90% Gray	100	100% Gray (Black)	1	Horizontal Line	2	Vertical Line	3	Diagonal Line	4	Diagonal Line	5	Square Grid	6	Diagonal Grid	<p>Area Fill ID</p> <p>Selects the pattern used to fill the rectangular area.</p> <p>Note: This command is also used to set the user-defined pattern ID.</p>
0	White (default)																														
1-2	2% Gray																														
3-10	10% Gray																														
11-20	15% Gray																														
21-35	30% Gray																														
36-55	45% Gray																														
56-80	70% Gray																														
81-99	90% Gray																														
100	100% Gray (Black)																														
1	Horizontal Line																														
2	Vertical Line																														
3	Diagonal Line																														
4	Diagonal Line																														
5	Square Grid																														
6	Diagonal Grid																														
<p>ESC*c#P</p> <table border="0"> <tr><td>0</td><td>Black Fill (Default)</td></tr> <tr><td>1</td><td>White Fill</td></tr> <tr><td>2</td><td>Gray Fill</td></tr> <tr><td>3</td><td>Pre-Defined Cross-Hatch Pattern Fill</td></tr> <tr><td>4</td><td>User-Defined Pattern</td></tr> <tr><td>5</td><td>Current Pattern Fill</td></tr> <tr><td>9</td><td>True gray Level Fill</td></tr> </table>	0	Black Fill (Default)	1	White Fill	2	Gray Fill	3	Pre-Defined Cross-Hatch Pattern Fill	4	User-Defined Pattern	5	Current Pattern Fill	9	True gray Level Fill	<p>Fill Rectangular Area</p> <p>Fills a rectangular area defined by Horizontal and Vertical Rectangle Sizes with the selected pattern.</p>																
0	Black Fill (Default)																														
1	White Fill																														
2	Gray Fill																														
3	Pre-Defined Cross-Hatch Pattern Fill																														
4	User-Defined Pattern																														
5	Current Pattern Fill																														
9	True gray Level Fill																														

Table 2-26: Raster Graphics

Command / Parameters	Function / Result
ESC*t#R 75 75 dpi 100 100 dpi 150 150 dpi 200 200 dpi 300 300 dpi 600 600 dpi 1200 1200 dpi	Raster Resolution Note: 200 dpi is only supported when the printer is operating in 600 dpi or 1200 dpi mode.
ESC*r#F 0 Rotate with print 3 Fixed (Default)	Raster Graphics Presentation Sets the Raster Image Orientation in relation to the logical page.
ESC*r#S # = Number of Input Pixels	Raster Width (Source) Sets the width of the clip window for raster graphics.
ESC*r#T # = Number of Raster Lines	Raster Height (Source) Sets the height of the clip window for raster graphics.
ESC*r#A 0 Left Graphics Margin at 0 (Default) 1 Current Cursor Position 2 At logical left page limit with scaling On 3 At current cursor position with scaling On	Start Raster Graphics Sets the left margin for raster graphics.
ESC*b#V[data] # = Number of Data Bytes	Transfer Raster Data by Plane This command is used when the raster data is encoded by plane as specified by the Simple Color command or the Configure Image Data command. The command sends each plane in the row except the last.
ESC*b#Y # = Number of Raster Lines	Y Offset Moves the cursor position down by the specified number of raster lines.

Table 2-26: Raster Graphics (Continued)

Command / Parameters	Function / Result
ESC*b#M 0 Uncoded (Default) 1 Run-Length Encoded 2 Tagged Image File Format (TIFF) byte 3 Delta Row 5 Adaptive Compression 9 Replacement Delta Row 999 Zlib 1002 Group 4 1003 Group 3 one dimensional 1004 Group 3 two dimensional K=2 1005 Group 3 two dimensional K=4 1006 TIFF word (16 bit) 1007 TIFF double-word (32 bit) 1008 Adaptive compression (includes TIFF word and TIFF double-word)	Set Raster Compression Mode Identifies the compression mode the host uses to transfer RIG data. For instance, this command can be run-length encoding or TIFF encoding. Note: For further information, see “Raster Compression Mode” on page 2-78 and “Group 3 and Group 4 Raster Compression” on page 2-83.
ESC*b#W[data] # = Number of Data Bytes	Transfer Raster Data by Row/Block Transfers RIG data. Note: After each command, the cursor position is moved to the beginning of the next raster row.
ESC*rB	End Raster Graphics (Version B) Signals the end of the raster graphics transfer. If a Raster Height is specified, the cursor is moved to the first raster row past the Raster Height.
ESC*rC	End Raster Graphics (Version C) Same as Version B, but: <ul style="list-style-type: none"> • Resets the compression mode to uncoded. • Sets the left graphics margin to 0.
ESC*t#H	Raster Width (Destination) Sets the width of the destination raster.

Table 2-26: Raster Graphics (Continued)

Command / Parameters	Function / Result
ESC*t#V	Raster Height (Destination) Sets the height of the destination raster.
ESC*g#W[data] # - 8 (K-only) or 26 (KCMY) Data Byte 0 - 0x02 (constant) Byte 1 - number of colors 0x01 - K only 0x04 - CMYK Byte 2,3 - X res for K plane 0x012C (300) or 0x0258 (600) Byte 4,5 - Y res for K plane 0x012C (300) or 0x0258 (600) Byte 6,7 - K plane intensity levels 0x02 (1 bit/plane) or 0x04 (2 bits/plane) Byte 8,9 - X res for C plane 0x012C (300) or 0x0258 (600) Byte 10,11 - Y res for C plane 0x012C (300) or 0x0258 (600) Byte 12,13 - C plane intensity levels 0x02 (1 bit/plane) or 0x04 (2 bits/plane) Byte 14,15 - X res for M plane 0x012C (300) or 0x0258 (600) Byte 16,17 - Y res for M plane 0x012C (300) or 0x0258 (600) Byte 18,19 - M plane intensity levels 0x02 (1 bit/plane) or 0x04 (2 bits/plane) Byte 20,21 - X res for Y plane 0x012C (300) or 0x0258 (600) Byte 22,23 - Y res for Y plane 0x012C (300) or 0x0258 (600) Byte 24,25 - Y plane intensity levels 0x02 (1 bit/plane) or 0x04 (2 bits/plane)	Set Raster Configuration Sets the configuration of the destination raster.

Table 2-27: Color Extensions

Command / Parameters		Function / Result
ESC&b#M 0 Print in mixed render algorithm mode 1 Print using gray scale equivalent		Monochrome Print Mode Changes each color value to its gray scale equivalent.
ESC&p#C 0 Delete all palettes except those in stack (active palette is deleted) 1 Delete all palettes in stack (active palette not affected) 2 Delete palette specified by Palette Control ID 6 Copy active palette to ID specified by Palette Control ID		Palette Control Provides palette management.
ESC&p#I 0 to 32767 Palette ID number		Palette Control ID Indicates the ID number used by the Palette Control command.
ESC&p#S 0 to 32767 Palette ID number		Select Palette Selects a new active palette by indicating the ID number.
ESC* <i>l</i> #W[data] 0 Resets or initializes the color lookup tables for each primary color to the unity curve 770, Data Data for color lookup table		Color Lookup Tables Enables the color lookup tables and specifies the table to use.
ESC* <i>m</i> #W[data] 7 to 32767, Data Data size and data of byte-aligned binary data that specifies a matrix or matrices for the primary colors		Download Dither Matrix Downloads a device dependent user-defined dither matrix.
ESC* <i>o</i> #W[data] 1 to 32767, Data Specifies lightness, saturation, and image scaling		Driver Configuration Command Indicates the lightness, saturation, and scaling algorithm to be applied to a job.
ESC* <i>p</i> #P 0 Push (Save) Palette 1 Pop (Restore) Palette		Push/Pop Palette Saves (push) the current palette and then restores (pop) it from the palette stack.
ESC* <i>r</i> #U -4 4 planes, device CMYK palette -3 3 planes, device CMY palette 1 Single plane, K (black) palette 3 3 planes, device RGB palette		Simple Color Creates a fixed-size palette. The color specification of the palette cannot be modified.

Table 2-27: Color Extensions (Continued)

Command / Parameters	Function / Result
ESC*t# 0 Gamma Correction Off 0.0 to 4.0 Gamma Number	Gamma Correction Improves the perceptual correctness of color data sent from the monitor to any other non-linear device by adjusting the brightness and darkness.
ESC*t#J	Render Algorithm Selects the algorithm used for dithering images and fills.
ESC*v#A -32767.0 to 32767.0	Color Component One Indicates the first primary color specified by the Assign Color Index command.
ESC*v#B -32767.0 to 32767.0	Color Component Two Indicates the second primary color specified by the Assign Color Index command.
ESC*v#C -32767.0 to 32767.0	Color Component Three Indicates the third primary color specified by the Assign Color Index command.
ESC*v# # = Palette Index 0 to $2^n - 1$ = Palette Index	Assign Color Index Designates the three current color components to the specified palette index number. n represents the number of bits per index.
ESC*v#S # = Palette Index 0 to $2^n - 1$ = Palette Index	Foreground Color Sets the foreground color to the specified index in the current palette. n represents the current palette size.
ESC*v#W[data]	Configure Image Data Creates programmable palettes.
ESC*i#W[data]	Viewing Illuminant 8, Data Designates the relative white point used in determining a viewing illuminant condition.

Table 2-28: Status Readback

Command / Parameters	Function / Result
ESC*s#T 0 Invalid location (Default) 1 Use currently selected location 2 All locations 3 Internal (resident) 4 Downloaded entity 5 Cartridge 7 User-installable flash 200 Disk	Set Status Readback Location Type Sets the status location type to the specified value. The 5 value for Cartridge may be specified, but since your printer does not support font cards or cartridges, the command is ignored. The 7 value for User-installable flash is only valid when flash memory is installed. The 200 value is only valid when a hard disk is installed.
ESC*s#U 0 All 1 If download, temporary; otherwise, highest priority 2 If download, permanent; otherwise, next higher priority	Set Status Readback Location Unit Sets the status location unit to the specified value. The location unit is used along with the location type to identify a location for the Inquire Status Readback Entity command. Note: The unit value is interpreted differently, depending on the location type specified.
ESC*s#I 0 Font 1 Macro 2 User-defined pattern 3 Symbol set (for unbound scalable fonts) 4 Font extended	Inquire Status Readback Entity Returns the requested information set by Set Status Readback Location Type and Set Status Readback Location Unit.
ESC*s1M	Free Space Returns the total available memory and the largest available block of memory.
ESC&r#F 0 Flush all complete pages 1 Flush all pages	Flush All Pages Holds print jobs in the print buffer until the current job finishes printing.
ESC*s#X -32767 to 32767 Default = 0	Echo Returns # back to host computer.

Table 2-29: Picture Frame

Command / Parameters	Function / Result
ESC*c#X # of Decipoints: 0 to 32767 (1 Decipoint = 1/720 inch)	Picture Frame Horizontal Size (in Decipoints) Specifies the horizontal dimension of the picture frame used when printing a GL/2 plot.
ESC*c#Y # of Decipoints: 0 to 32767 (1 Decipoint = 1/720 inch)	Picture Frame Vertical Size (in Decipoints) Specifies the vertical dimension of the picture frame used when printing a GL/2 plot.
ESC*c0T 0 Set Anchor Point to Cursor Position	Set Picture Frame Anchor Point Sets the position of the picture frame anchor point to the cursor position. The picture frame anchor point defines the location of the upper left corner of the picture frame.
ESC*c#K Size in inches: 0 to 32767	GL/2 Horizontal Plot Size Specifies the horizontal scaling factor used when importing an image into the picture frame.
ESC*c#L Size in inches: 0 to 32767	GL/2 Vertical Plot Size Specifies the vertical scaling factor used when importing an image into the picture frame.
ESC%#B 0 Use Previous GL/2 Pen Position 1 Use Current PCL Cursor Position	Enter GL/2 Language Exits PCL emulation and uses GL/2 commands to print.
ESC%#A 0 Use Previous PCL Cursor Position 1 Use Current GL/2 Pen Position	Enter PCL Emulation Exits GL/2 mode and uses PCL emulation commands to print.

Table 2-30: Miscellaneous Commands

Command / Parameters	Function / Result
ESC&s#C 0 Enable 1 Disable (Default)	End-Of-Line Text Wrap Enabling End-Of-Line Text Wrap moves portions of lines that extend into the unprintable area to the next line. Disabling drops the portion extending into the unprintable area.
ESCY	Display Functions On Prints all control codes and escape sequences rather than executing them. Notes: <ul style="list-style-type: none"> To prevent characters from falling outside the right margin (and not printing), enable End-Of-Line Text Wrap (ESC&s0C). To see the control characters and other blank codepoints in symbol set Roman8 (8U), set the symbol set to PC-8 (10U).

Table 2-30: Miscellaneous Commands (Continued)

Command / Parameters	Function / Result
ESCZ	Display Functions Off Turns off Display Functions; resumes normal command processing.
ESCz	Print Test Page Causes a test page to print.
ESC*o#M(b) -1 Ink Saver 0 Normal 1 Best	Print Quality Selects the print quality setting for the page.
ESC&l#M(b) 0 Plain Paper 1 Bond 2 Coated Paper 3 Glossy Paper 4 Transparency 101 Photo Paper 102 Card Stock 103 Labels 104 Envelope 105 Letterhead 106 Preprinted 107 Colored Paper 108 Iron On	Paper Type Selects the paper type setting for the page.

GL/2 Commands

Note: GL/2 is not a stand-alone plotter emulation. It can only be entered from within PCL emulation and cannot be used with software without a unique printer driver written explicitly for GL/2.

The following tables list the GL/2 commands by group. To determine which GL/2 commands your printer supports, see “Table A-2: GL/2 Commands” on page A-7.

Table 2-31: Configuration Group

Command / Parameter	Command Name
CO "text"	Comment
DF;	Default Values
IN (n);	Initialize
IP (X _{P1} , Y _{P1} (, X _{P2} , Y _{P2}));	Input P1 and P2

Table 2-31: Configuration Group (Continued)

Command / Parameter	Command Name
IR (X_{P1} , Y_{P1} , X_{P2} , Y_{P2});	Input Relative P1 and P2
IW (X_1 , Y_1 , X_2 , Y_2);	Input Window
MC (mode(, opcode));	Logical Operation
PP (mode);	Pixel Placement
RO (angle);	Rotate Coordinate System
SC (X_{min} , X_{max} , Y_{min} , Y_{max} (, type(, left, bottom)));	Scale

Table 2-32: Vector Group

Command / Parameter	Command Name
AA X_{center} , Y_{center} , sweep_angle(, chord_angle);	Arc Absolute
AR X_{center} , Y_{center} , sweep_angle(, chord_angle);	Arc Relative
AT X_{inter} , Y_{inter} , X_{end} , Y_{end} (, chord_angle);	Absolute Arc Three Point
BR X_1 , Y_1 , X_2 , Y_2 , X_3 , Y_3 (,...);	Bezier Relative
BZ X_1 , Y_1 , X_2 , Y_2 , X_3 , Y_3 (,...);	Bezier Absolute
CI radius(, chord_angle);	Circle
PA (X , Y (,...));	Plot Absolute
PD (X , Y (,...));	Pen Down
PE (flag(value) coordinates (...));	Polyline Encoded
PR (X , Y (,...));	Plot Relative
PU (X , Y (,...));	Pen Up
RT $X_{incr\ inter}$, $Y_{incr\ inter}$, $X_{incr\ end}$, $Y_{incr\ end}$ (, chord_angle);	Arc Relative Three Point
WU (type);	Pen Width Units

Table 2-33: Polygon Group

Command / Parameter	Command Name
EA X , Y ;	Edge Rectangle Absolute
EP;	Edge Polygon
ER X , Y ;	Edge Rectangle Relative
EW radius, start_angle, sweep_angle(, chord_angle);	Edge Wedge
FP (0);	Fill Polygon, Odd/Even
FP 1;	Fill Polygon, Non-Zero Winding
PM (mode);	Polygon Mode

Table 2-33: Polygon Group (Continued)

Command / Parameter	Command Name
RA X, Y;	Fill Rectangle Absolute
RR X, Y;	Fill Rectangle Relative
WG radius, start_angle, sweep_angle(, chord_angle);	Fill Wedge

Table 2-34: Character Group

Command / Parameter	Command Name
AD (kind, value(...));	Define Alternate Font
CF (mode(, pen));	Character Fill
CP (spaces, lines);	Character Plot
DI (run, rise);	Absolute Direction
DR (run, rise);	Relative Direction
DT (label_terminator(, mode));	Define Label Terminator
DV (path(, line));	Define Variable Text Path
ES (width(, height));	Extra Space
FI font_ID;	Primary Font
FN font_ID;	Secondary Font
LB char...char label_terminator;	Label
LM (mode,[row number])	Label Mode
LO (position);	Label Origin
LO 21;	Uses PCL Label Origin
SA;	Select Alternate Font
SB (mode);	Scalable or Bitmapped Fonts
SD (kind, value(...));	Define Standard Font
SI (width, height);	Absolute Character Size
SL (tangent);	Character Slant
SR (width, height);	Relative Character Size
SS;	Select Standard Font
TD (mode);	Transparent Data

Table 2-35: Line and Fill Attributes Group

Command / Parameter	Command Name
AC (X, Y);	Anchor Corner
CR (red _{black ref.} , red _{white ref.} , green _{black ref.} , green _{white ref.} , blue _{black ref.} , blue _{white ref.});	Color Range
FT (fill_type(, option1(, option2));	Fill Type
FT22, (PCL User-Defined Pattern ID);	Fill Type
FT 9, level;	Fill Type
LA (kind, value(...));	Line Attributes
LT (pattern_number(, pattern_length(, mode)));	Line Type
NP (number);	Number of Pens
PC (pen (, red, green, blue));	Pen Color
PW (width(, pen));	Pen Width
RF (index(, width, height(, pen, ...)));	Define Raster Fill
SM (character);	Symbol Mode
SP (pen);	Select Pen
SV (screen_type(, option1(, option2)));	Screened Vectors
SV (9, level,)	Screened Vectors
TM (width, height(, number...));	Threshold Matrix
TR (mode);	Transparency Mode
UL (index(, gap,...gap));	User Defined Line
WU (type);	Pen Width Units

Raster Image Graphics

These commands utilize the raster area. Before sending data, set the presentation mode, the resolution, the compression mode, the raster height and width, and start raster graphics. These parameters are in effect until you overwrite them with a different command or there is a printer reset.

To ensure that the printed image appears in the expected area, set width and height parameters.

Raster Compression Mode

The Raster Compression Mode command determines how raster data is coded. It affects the amount of code required to create an image, and the efficiency of image printing.

Syntax:

ESC*b#M

Parameters:

0	Uncoded (default)
1	Run-Length Encoded
2	Tagged Image File Format (TIFF) Byte
3	Delta Row
5	Adaptive Compression
9	Replacement Delta Row
999	Zlib
1002	Group 4
1003	Group 3 one dimensional
1004	Group 3 two dimensional K=2
1005	Group 3 two dimensional K=4
1006	TIFF word (16 bit)
1007	TIFF double-word (32 bit)
1008	Adaptive Compression (includes TIFF word and TIFF double-word)

Descriptions and examples of the different parameters appear on the following pages. Each example draws the same square outline 64 bits (8 bytes) wide by 64 scan lines long.

Uncoded Data

Uncoded Data is not compressed. Only those bytes needed to form the image are sent. Each bit represents a single dot. In the first byte, bit 7 corresponds to the first dot in the raster row, bit 5 to the third dot, and so forth.

Example:

ESC*p300x300Y	I Move the cursor to 1" x 1" (1 in. from top margin and 1 in. from left edge of logical page)
ESC*t100R	I Set resolution to 100 dots per inch
ESC*r0F	I Rotate image to match current orientation
ESC*b0M	I Set compression mode to Uncoded
ESC*r1A	I Start raster graphics at current position
ESC*b8W 'FF FF FF FF FF FF FF FF'x	I Raster data uncompressed
ESC*b8W '80 00 00 00 00 00 00 01'x	
ESC*b8W '80 00 00 00 00 00 00 01'x	
...	
ESC*b8W '80 00 00 00 00 00 00 01'x	I Repeat to provide 64 total scan lines
ESC*b8W 'FF FF FF FF FF FF FF FF'x	
ESC*rB	I End graphics

Run-Length Encoded Data

Run-Length Encoded Data is interpreted in pairs of bytes. The first byte:

- Acts as a counter, or control byte.
- Indicates how many times to repeat the data in the second byte.
- Can be from 0 (no repetition) to 255.
- The second byte is the data byte.

Example:

ESC*p300x600Y	I Move cursor to 1" x 2"
ESC*b1M	I Set compression to Run-Length
ESC*r1A	I Start raster graphics at current position
ESC*b2W '07FF'x	I Run-Length: 8xFF'x
ESC*b6W '0080 0500 0001'x	I 1x'80'x, 6x'00'x, 1x'01'x
ESC*b6W '0080 0500 0001'x	I 1x'80'x, 6x'00'x, 1x'01'x
...	I ...
ESC*b6W '0080 0500 0001'x	I 1x'80'x, 6x'00'x, 1x'01'x
ESC*b2W '07FF'x	I 8xFF'x
ESC*rB	I End graphics

Tagged Image File Format

TIFF "Packbits" contain a control byte (a signed number) that indicates whether the raster data bytes are to be repeated (up to 127 times) or printed as encoded data.

- For control values of 0 through 127, the next (Control+1) byte(s) is uncoded.
- For control values of -1 through -127 ('FF'x - '81'x), the next byte is repeated (Abs(Control)+1) times.

Example:

ESC*p300x900Y	I Move cursor to 1" x 3"
ESC*b2M	I Set compression to TIFF
ESC*r1A	I Start Raster Graphics at current position
ESC*b2W 'F9FF'x	I TIFF: 8xFF'x
ESC*b6W '0080 FB00 0001'x	I 1:'80'x, 6x'00'x, 1:'01'x or
ESC*b9W '078000000000000001'x	I 8:'8000000000000001'x
...	I ...
ESC*b6W '0080 FB00 0001'x	I 1:'80'x, 6x'00'x, 1:'01'x
ESC*b2W 'F9FF'x	I 8xFF'x
ESC*rB	I End graphics

Delta Row

Delta Row is a compression mode that identifies and transmits only those bytes different from the ones in a preceding row. The control byte consists of two parts:

- High 3 bits: Number of bytes to replace +1 (1 to 8).
- Low 5 bits: Offset from last unmodified byte (0-30); if the offset is 31, the next byte(s) is added to the offset until the next byte is not 255.

Example:

ESC*p300x1200Y

ESC*b3M

ESC*r1A

ESC*b9W 'E0FFFFFFFFFFFFFFFF'x

ESC*b9W 'E08000000000000001'x

ESC*b0W

...

ESC*b0W

ESC*b9W 'E0FFFFFFFFFFFFFFFF'x

ESC*rB

I Move cursor to 1" x 4"

I Set compression to Delta Row

I Start raster graphics at current position

I Num Offset

I '111 0000'b=8 at 0: 'FFFFFFFFFFFFFFFF'x

I 8 at 0: '8000000000000001'x

I No bytes change

I No bytes change

I 8 at 0: '8FFFFFFFFFFFFFFFF'x

I End graphics

Adaptive Compression

Adaptive compression allows the combined use of compression methods 0 through 3 (Uncoded, Run-Length Encoded, TIFF, and Delta Row). It also allows the printing of empty rows (all zeros) or duplicate rows.

- The Transfer Raster Data command size includes all rows (scan lines).
- Scan Mode and SizeH,L are three-byte primary control strings: CountH and CountL.

Table 2-36: Adaptive Compression Control Strings

Scan Mode	CountH,CountL	Data
0	Data sizeH,L	Uncoded raster scan data
1	Data sizeH,L	Size of Run-length encoded data (high,low)
2	Data sizeH,L	Size of Tagged Image File Format (TIFF) data (high,low)
3	Data SizeH,L	Size of Delta Row data (high,low)
4	NumberH,L of empty rows	None
5	NumberH,L of duplicate rows	None
254	Data SizeH,L	TIFF word
255	Data SizeH,L	TIFF double-word

Example:

```

ESC*p300x1500Y           |Move cursor to 1" x 5"
ESC*b5M                  |Set the compression to Adaptive Compression
ESC*b29W                 |Raster Data: 29 bytes follow
'03 0009'x 'E0FFFFFFFFFFFFFF'x | Delta Row: 8 at 0: 'FFFFFFFFFFFFFFh'x
'01 0006'x '0080 FB00 0001'x   | Run Length: 1:'80'x, 6x'00'x, 1:'01'x
'05 0035'x               | Duplicate rows: 61 times
'02 0002'x 'F9FF 'x        | TIFF: 8x'FF'x
ESC*rB                   |End graphics
    
```

Zlib

Zlib is a generic compression method. It refers to a standard for compression as well as the library that implements the standard.

The zlib compression method uses the deflate algorithm. This same algorithm is used by more widely known compression utilities such as PKZIP and GZIP.

Compressed data is a series of variably-sized blocks. An encoder determines how to break the data into blocks and finds the best compression method to use for each block.

An encoder works based on the following principles. The encoder creates a dictionary containing different characters in a set of data. Short strings of bits represent more commonly occurring characters, and long strings of bits represent less frequently used characters. A probability tree determines which characters are frequently used. Repeated patterns in a string of characters are identified and stored, so the string doesn't have to be stored multiple times.

A three-bit zlib header is added to the beginning of a block to describe the type of compression used and indicates whether the block is a final block. Other information in the header includes checksums, compression algorithm used, and the level of compression. In compression all checksums are set to zero and in decompression the checksums are ignored.

The memory required for zlib compression and decompression is independent of the size of the data to be compressed or decompressed.

The number 999 does not conflict with other compression types, so it is used to represent zlib compression. See page 2-78 for more information.

Group 3 and Group 4 Raster Compression

Since Group 4 images do not use line endings, the width of the image must be specified using the Raster Width command (`ESC*r#S`).

The compressed image data is sent to the printer using the Transfer Raster Data command (`ESC*b#W`). The maximum number of bytes that can be sent using the Transfer Raster Data command is 32K bytes. Images larger than 32K bytes must be broken up and sent using multiple commands. It does not matter where the image is broken, or how many Transfer Raster Data commands are used. Once the image is started (with a Transfer Raster Data command), no other commands are allowed until the entire image has been sent.

The following example prints a Group 4 image file that is 256 bits wide and 9,645 bytes long:

```
ESC*b1002M           ISet Raster Compression to Group 4
ESC*r256S            IDefine width of image in input bits
ESC*r1A             IStart Raster Graphics at current position
ESC*b9645W          I9,645 bytes of a Group 4 image
...[Group 4 image data]...
ESC*rB             IEnd Raster Graphics
```

All lines of data must be the same length. If they are not, zeroes (0) must be added to attain the same length.

Note: If the uncompressed image extends beyond the logical page dimensions or beyond the raster width specified in the Raster Width command (`ESC*r#S`), the image is clipped at print time.

Additional Compression Modes

When the compression mode is 1008 (Lexmark Adaptive), TIFF word and double-word can be printed using compression scan modes 254 and 255 respectively. This compression method sends a raster image as a block of raster data.

Macros

When creating a macro, first assign it an ID number. If this number is identical to an existing macro ID in RAM, the old macro is deleted when you specify the Macro Control Start Definition. Next, start the macro definition, send the contents of the macro, and stop the macro definition.

Note: Although a macro may be called or executed from within another macro (nesting), a macro cannot be defined within another macro definition. Each macro must be defined separately.

Example:

This example creates a macro to print the Wigit Corp. logo, then calls the logo macro in the body of a letter.

ESC&f1Y	ISet the macro ID to 1
ESC&f0X	IStart the macro definition
ESC&a+72H	IRelative move right 1/10 inch (+72/720th)
ESC(8U	ISelect Roman-8 symbol set
ESC(s1p18v0s3b4101T	ISelect CG Times 18 point bold
W	IPrint W
ESC&a-21.6H	IRelative move left 0.03 inch
ESC(s12v1S	ISelect (CG Times) 12 point (bold) italic
igit	IPrint igit
ESC&a+72H	IRelative move right 1/10 inch
ESC(s18v0S	ISelect 18 point and turn off italic
C	IPrint C
ESC(s12v1S	ISelect 12 point italic
orp.	IPrint orp.
ESC&a+72H	IRelative move right 1/10 inch
ESC&f1X	IEnd of macro definition
ESC&f10X	IMake Macro ID 1 permanent
...	
...	
From:	IPrint the header From:
ESC&f1y3X	ISet the macro ID to 1 and call the macro
...	IPrint the letter
Thank you for ...	IPrint the closing
ESC&f1y3X	ISet the macro ID to 1 and call the macro
...	

CHAPTER 3: Printer Job Language

Your printer supports complete Printer Job Language (PJL) commands, including certain commands that cause the printer to enter PCL emulation, PostScript emulation, and Personal Printer Data Stream (PPDS).

To determine which commands your printer supports, see Appendix B: “PJL Support” on page B-1.

PJL Command Notation

The syntax for each supported PJL command is listed in this chapter. The following character codes are used throughout the chapter to illustrate the syntax of each PJL command.

Table 3-1: PJL Command Notation

Character Code	Description	Hex Code	Decimal Code
<ESC>	Escape Character	0x1B	27
<LF>	Line Feed Character	0x0A	10
<CR>	Carriage Return Character	0x0D	13
<FF>	Form Feed Character	0x0C	12
<HT>	Horizontal Tab	0x09	9
<UEL>	Universal Exit Language	0x1B 25 2D 31 32 33 34 35 58	

Notes:

- Parameters enclosed in square brackets ([]) are optional and not required for command execution.
- The PJL interpreter requires uppercase for the @PJL prefix for all PJL commands *except* the Universal Exit Language (UEL) command. The rest of the PJL command is not case sensitive. The UEL command is case sensitive.
- All PJL commands except UEL must be terminated with a line feed character (<LF>).

Kernel Commands

UNIVERSAL EXIT LANGUAGE Command

The Universal Exit Language (UEL) command terminates the current printer language and allows dynamic switching into PJL.

Syntax:

```
<ESC>%-12345X
```

Notes:

- If the printer receives this command while in PCL emulation, it performs a Printer Language Reset (^{ESC}E) before exiting PCL emulation.
- If the printer receives this command while in PostScript emulation, it performs an End-of-Job (EOJ) command before exiting PostScript emulation (Ctrl-D).

The PJL commands must immediately follow the UEL command (that is, the X in the UEL syntax must be immediately followed by the @PJL of the next PJL command).

ENTER LANGUAGE Command

This command causes the printer to enter the specified language, such as PCL emulation, PostScript emulation, or PPDS.

Syntax:

```
@PJL ENTER LANGUAGE = language[<CR>]<LF>
```

Notes:

- *language* is *PCL*, *PCLXL*, *PostScript*, or *PPDS*.
- You can use uppercase, lowercase, or mixed case. (@PJL must be uppercase; all others can be mixed or lowercase.)

Example:

```
@PJL ENTER LANGUAGE = PostScript[<CR>]<LF>
```

enters PostScript emulation.

COMMENT Command

This command lets you add descriptive comments to your PJL job.

Syntax:

```
@PJL COMMENT words[<CR>]<LF>
```

Notes:

- When the printer receives this command, it is ignored.
- The *words* parameter can be any combination of printable characters, spaces, and horizontal tabs.
- The COMMENT command is terminated by the line feed character (<LF>).

Job Separation Commands

Your printer supports the PJL JOB and EOJ commands. When the printer receives a JOB command, the print timeout is multiplied by 10; when the printer receives a PJL EOJ command, the print timeout is reset to the user default. The **Waiting** message appears on the printer operator panel display or through MarkVision Professional until an EOJ command is received or until the print timeout expires.

Your printer also supports the PASSWORD parameter for the PJL JOB command.

JOB Command

The host computer can use the JOB command to separate print data into various parts or jobs. Specifically, the JOB command signifies to the printer the start of a print job. Use the EOJ command to signify the end of a job. In addition, use the JOB/EOJ pair to accomplish the following:

- Provide a job name (the name displays on the printer operator panel or through MarkVision Professional).
- Indicate which pages of the job should be printed.
- Monitor the job status as it prints.

Syntax:

```
@PJL JOB [NAME = "job name"] [START = first page]  
[END = last page] [PASSWORD = number][<CR>]<LF>
```

Notes:

- The JOB command should only be used in conjunction with the EOJ command.
- After receiving a JOB command, the printer does not process a UEL command as a PJL job boundary until it receives the corresponding EOJ. Instead, UELs occurring within a JOB/EOJ pair are processed as printer language resets (for example, PCL ^{ESC}E).

Parameters:

NAME = "*job name*"

Use the NAME parameter to assign a character string name to a particular job. The name may be any combination of printable characters, spaces or horizontal tabs up to a maximum of 80 characters, spaces, or tabs. The *job name* must be enclosed in double quotes, as indicated by the command syntax.

START = *first page*

Use the START parameter in conjunction with the END parameter to skip the printing of a particular portion of the job. The emulator discards pages of a job until the page specified by this parameter is reached. The *first page* range is from 1 to 2,147,483,647. Omission of the START parameter causes the printer to start printing with page 1 of the job.

END = *last page*

Use the END parameter in conjunction with the START parameter to skip the printing of a particular portion of the job. The emulator discards all pages of a job after the *last page* has been printed. The specification of *last page* is relative to page 1 of the print job and its range is from 1 to 2,147,483,647. Omission of the END parameter causes the printer to print all pages to the end of the job.

PASSWORD = *number*

A system administrator can control which jobs, and therefore which users, are allowed to modify the printer default or NVRAM variables by declaring a PJL password. With a PJL password declared, the PASSWORD parameter with the correct PASSWORD number must be specified in order to modify the default printer environment.

A PJL JOB command with the correct PASSWORD must be issued before any PJL command can modify an NVRAM setting. The PJL EOJ command terminates the job and disables any further modification of NVRAM. If a PJL password is declared and the wrong PASSWORD number is specified on the PJL JOB command, the printer will delay one half of a second before processing the next command.

For detailed information on PJL password protection, see “File and Device Protection Commands” on page 3-93.

Note: Setting a default PJL password disables the use of PJL DEFAULT and INITIALIZE commands. (See “DEFAULT Command” on page 3-8 and “INITIALIZE Command” on page 3-11.)

EOJ Command

The EOJ command signifies the end of a print job.

Syntax:

```
@PJL EOJ [NAME = "job name"]<CR><LF>
```

Note:

Only use the EOJ command in conjunction with the JOB command.

Parameter:

```
NAME = "job name"
```

Use the NAME parameter to assign a character string name to a particular job. The name may be any combination of printable characters, spaces, or horizontal tabs up to a maximum of 80 characters, spaces, or tabs. The NAME string may be different from the NAME string specified in the JOB command. The *job name* must be enclosed in double quotes.

Environment Commands and Variables

This section describes the printer environment variables and the PJL commands used to modify or query the variables.

Note: The word *common* applies to those variables common to both your printer and the Hewlett-Packard Company's LaserJet printers.

Table 3-2: Environment Variable Categories

Categories	Beginning on Page ...
Common Variables for Both Printer Languages	3-12
Printer Unique Variables for Both Printer Languages	3-19
Common Variables for PCL emulation	3-48
Printer Unique Variables for PCL emulation	3-49
Common Variables for PostScript emulation	3-51
Printer Unique Variables for PostScript emulation	3-52
Printer Unique LRESOURCE Variables	3-53

The following commands modify the environment variables, and are described in this section:

- DEFAULT
- SET
- INITIALIZE
- RESET

The following commands query the environment variables, and are described in "Status Readback Commands" on page 3-54.

- INQUIRE
- DINQUIRE
- INFO
- ECHO

DEFAULT Command

This command modifies the default setting for the specified environment variable and stores the setting in the printer NVRAM. The new setting is activated with the occurrence of the next PJL reset condition.

Syntax:

```
@PJL DEFAULT [command modifier:value] variable=value<CR><LF>
```

```
[command modifier:value]
```

The [command modifier:*value*] parameter specifies the type of PJL variables to be modified. The variables supported are listed in the tables beginning on page 3-12.

- A [command modifier:*value*] parameter is not required for variables listed in the tables “Common Variables for Both Printer Languages” on page 3-12, and “Printer Unique Variables for Both Printer Languages” on page 3-19.
- LPARM:*PCL* is used with variables specific to PCL emulation. (See the tables “Common Variables for PCL Emulation” on page 3-48, and “Printer Unique Variables for PCL Emulation” on page 3-49.)
- LPARM:*POSTSCRIPT* is used for variables specific to PostScript emulation. (See the tables “Common Variables for PostScript Emulation” on page 3-51, and “Printer Unique Variables for PostScript Emulation” on page 3-52.)
- LRESOURCE:"*device:filename.filetype*" is required for LRESOURCE variables. (See the table “Printer Unique LRESOURCE Variables” on page 3-53.)

Values for "*device:filename.filetype*" are:

<i>device</i>	<i>flash, flash1, disk, or disk1</i> (case insensitive)
<i>filename</i>	A unique identifier for a file, such as the macro ID for a PCL macro, the symbol set ID for a PCL symbol set, the font ID for a PCL font, and so on. The <i>filename</i> is case sensitive.
<i>filetype</i>	An identifier that categorizes the file, such as <i>p5macro</i> for PCL macros or <i>p5symset</i> for PCL symbol sets. See “Table 3-22: Variables for Flash and Disk File and Password Commands” on page 3-87 for a complete list of the supported file types. The <i>filetype</i> is case sensitive.

`variable=value`

The supported variables and values are listed in the tables beginning on page 3-12.

Note: Variables may be modified by the DEFAULT command, except those marked Read Only. Some variables may only be modified using the PJL SET command. These variables cannot be modified using the DEFAULT command. They are marked Set Only.

SET Command

This command modifies the current setting for the specified environment variable. The new setting is active immediately, and remains active until the next occurrence of a PJL reset condition.

Use the SET command to modify any currently defined environment variable that cannot be set using the desired printer language. For example, use the PJL SET command to set Print Quality Enhancement Technology (PQET) or Page Protect, which cannot be set within a printer language such as PCL emulation.

Syntax:

```
@PJL SET [command modifier:value] variable=value[<CR>]<LF>
```

where

[command modifier:value]

The [command modifier:value] parameter specifies the type of PJL variables to be modified. The variables supported are listed in the tables beginning on page 3-12.

- A [command modifier:value] is not required for variables listed in the tables “Common Variables for Both Printer Languages” on page 3-12, and “Printer Unique Variables for Both Printer Languages” on page 3-19.
- LPARM: PCL is used with variables specific to PCL emulation. (See the tables “Common Variables for PCL Emulation” on page 3-48, and “Printer Unique Variables for PCL Emulation” on page 3-49.)
- LPARM: POSTSCRIPT is used for variables specific for PostScript emulation. (See the tables “Common Variables for PostScript Emulation” on page 3-51, and “Printer Unique Variables for PostScript Emulation” on page 3-52.)

- LRESOURCE:"*device:filename.filetype*" is required for LRESOURCE variables. (See "Table 3-9: Printer Unique LRESOURCE Variables" on page 3-53.)

Values for "*device:filename.filetype*" are:

<i>device</i>	<i>flash, flash1, disk, or disk1</i> (case insensitive)
<i>filename</i>	A unique identifier for a file, such as the macro ID for a PCL macro, the symbol set ID for a PCL symbol set, the font ID for a PCL font, and so on. The <i>filename</i> is case sensitive.
<i>filetype</i>	An identifier that categorizes the file, such as <i>p5macro</i> for PCL macros or <i>p5symset</i> for PCL symbol sets. See the table beginning on page 3-87 for a complete list of the supported file types. The <i>filetype</i> is case sensitive.

`variable=value`

The supported variables and values are listed in the tables beginning on page 3-12.

Note: Variables may be modified by the DEFAULT command, except those marked Read Only. Some variables may only be modified using the PJL SET command. These variables cannot be modified using the DEFAULT command. They are marked Set Only.

INITIALIZE Command

This command restores both the current and default environment variables to their factory default values and updates the printer NVRAM. This command affects all of the variables listed in “Table 3-3: Common Variables for Both Printer Languages” on page 3-12 through “Table 3-8: Printer Unique Variables for PostScript Emulation” on page 3-52, except the following:

- All read only variables
- PASSWORD
- LANG
- LRESOURCESAVE
- LDOWNLOADTARGET
- LPPDS
- LHONORINIT
- LUSDEFAULTS
- PARALLEL
- RESOURCESAVE

Note: This command does not affect LRESOURCE variables listed in “Table 3-9: Printer Unique LRESOURCE Variables” on page 3-53.

Syntax:

```
@PJL INITIALIZE[<CR>]<LF>
```

RESET Command

This command resets the current environment variables to the settings stored in the printer NVRAM. Therefore, any variables modified by the PJL SET command are returned to their default value after execution of the PJL RESET command.

Syntax:

```
@PJL RESET[<CR>]<LF>
```

Common Variables for Both Printer Languages

Note: The word *common* applies to those variables common to both your printer and the Hewlett-Packard Company's LaserJet printers.

The following common variables are supported for both PCL emulation and PostScript emulation, unless otherwise noted. Therefore, the [command modifier: value] parameter should not be specified.

To determine which variables your printer supports, see "Table B-1: Common Variables for Both Printer Languages" on page B-1.

Table 3-3: Common Variables for Both Printer Languages

Variable	Function	Selections	Factory Default
AUTOCONT (DEFAULT only)	Auto Continue	0, 5 to 255, OFF, ON A value of 0 or OFF indicates Auto Continue is disabled. A value of ON indicates Auto Continue is set to 30. INQUIRE or DINQUIRE on the Auto Continue variable returns a numeric value. Note: If a value greater than 255 is specified by a SET or DEFAULT command, the value is changed to 255.	0
BINDING	Duplex Bind	LONGEDGE, SHORTEGE	LONGEDGE
BITSPERPIXEL	Image Enhancement Technology and Image Enhancement Technology Type	1, 2, 4, Auto A value of 1 indicates the Image Enhancement Technology setting is set to Off. A value of 2 or 4 indicates the Image Enhancement Technology setting is set to On. INQUIRE or DINQUIRE returns the value of Image Enhancement Technology as follows: <ul style="list-style-type: none"> • If Image Enhancement Technology is set to Off, 1 is returned. • If Image Enhancement Technology is set to On, 2 or 4 is returned depending on the Image Enhancement Technology Type setting. If Image Enhancement Technology Type is set to On, the numerical value of BITSPERPIXEL is returned. If Image Enhancement Technology Type is set to Auto, a value of 2 or 4 is returned depending on the amount of total memory installed. 	1
CLEARABLEWARNINGS (READ only)	Auto Continue from operator panel non-fatal warning messages	JOB, ON If Auto Continue is set to On, JOB is returned. If Auto Continue is set to Off, ON is returned.	ON
COPIES	Number of copies of each page	1 to 999 Note: If a value greater than 999 is specified by a SET or DEFAULT command, the value is changed to 999.	1

Table 3-3: Common Variables for Both Printer Languages (Continued)

Variable	Function	Selections	Factory Default
CPLOCK (DEFAULT only)	Disables menus	ON, OFF ON disables the printer operator panel menus. OFF enables menus.	OFF
DENSITY	Print Darkness	1 to 5 <ul style="list-style-type: none"> • 1 = Lightest • 2 = Lighter • 3 = Normal • 4 = Darker • 5 = Darkest To determine the default value of your printer, see "Table B-1: Common Variables for Both Printer Languages" on page B-1.	2, 3, 4 (Model specific)
DUPLEX	Duplex	ON, OFF	OFF
ECONOMODE	Toner Saver	ON, OFF	OFF
FORMATTERNUMBER (READ only)	Unique printer identifier	The value of the NVRAM serial number field is returned. The NVRAM serial number field is set to the printer serial number. In order to guarantee that a unique identifier exists in this field, the printer writes a random alphanumeric string into this field whenever the critical byte area in NVRAM is re-initialized.	Set by printer manufacturer
FORMLINES	Lines per page	1 to 255 Note: If a value greater than 255 is specified by a SET or DEFAULT command, the value is changed to 255.	60, 64 (Country specific)
HOLD (SET only)	Print and Hold	ON, OFF, STORE, PROOF The HOLD variable interacts with the HOLDKEY and HOLDTYPE variables. For more information, see HOLDTYPE on page 3-14.	OFF
HOLDKEY (SET only)	Print and Hold PIN	"PIN" <i>PIN</i> is a text string consisting of exactly four numerals. Only the numerals 1 through 6 are valid. Note: A null (" ") string is an acceptable value and indicates no PIN is specified. The HOLDKEY variable interacts with the HOLD and HOLDTYPE variables. For more information, see HOLDTYPE as follows.	NULL (no PIN)

Table 3-3: Common Variables for Both Printer Languages (Continued)

Variable	Function	Selections	Factory Default
HOLDTYPE (SET only)	Print and Hold Type	PUBLIC, PRIVATE The HOLD, HOLDKEY, and HOLDTYPE variables interact with each other as follows: <ul style="list-style-type: none"> When HOLD is set to On, HOLDKEY is set to a valid PIN, and HOLDTYPE is set to Private, Confidential Print capability is available. When HOLD is set to On, HOLDKEY is set to “ ”, and HOLDTYPE is set to Public, Repeat Print capability is available. When HOLD is set to Store, HOLDKEY is set to “ ”, and HOLDTYPE is set to Public, Reserve Print capability is available. When HOLD is set to Proof, HOLDKEY is set to “ ”, and HOLDTYPE is set to Public, Verify Print capability is available. Print and Hold capabilities are not available with any other possible combination of HOLD, HOLDKEY, and HOLDTYPE settings. 	PUBLIC
IMAGEADAPT (DEFAULT only)	Resolution reduction	ON, OFF	ON
INTRAY2	Tray lock - Tray 2	UNLOCKED, LOCKED	UNLOCKED
INTRAY3	Tray lock - Tray 3	UNLOCKED, LOCKED	UNLOCKED
INTRAY4	Tray lock - Tray 4	UNLOCKED, LOCKED	UNLOCKED
INTRAY5	Tray lock - Tray 5	UNLOCKED, LOCKED	UNLOCKED
INTRAY1SIZE (SET only)	Tray 1 installed size, default formatting size	A3, A3+, A4, A5, B4, B4PAPER, B5PAPER, JISB4, JISB5, CUSTOM, EXECUTIVE, FOLIO, LEDGER, LEGAL, LETTER, 11X17, COM10, COM9, MONARCH, DL, C5, B5, OTHERENVELOPE, STATEMENT	LETTER, A4 (Country specific)
INTRAY2SIZE (SET only)	Tray 2 installed size, default formatting size	A3, A3+, A4, A5, B4, B4PAPER, B5PAPER, JISB4, JISB5, CUSTOM, EXECUTIVE, FOLIO, LEDGER, LEGAL, LETTER, 11X17, STATEMENT	LETTER, A4 (Country specific)
INTRAY3SIZE (SET only)	Tray 3 installed size, default formatting size	A3, A3+, A4, A5, B4, B4PAPER, B5PAPER, JISB4, JISB5, CUSTOM, EXECUTIVE, FOLIO, LEDGER, LEGAL, LETTER, 11X17, STATEMENT	LETTER, A4 (Country specific)
INTRAY4SIZE (SET only)	Tray 4 installed size, default formatting size	A3, A3+, A4, A5, B4, B4PAPER, B5PAPER, JISB4, JISB5, CUSTOM, EXECUTIVE, FOLIO, LEDGER, LEGAL, LETTER, 11X17, STATEMENT	LETTER, A4 (Country specific)
INTRAY5SIZE (SET only)	Tray 5 installed size, default formatting size	A3, A3+, A4, A5, B4, B4PAPER, B5PAPER, JISB4, JISB5, CUSTOM, EXECUTIVE, FOLIO, LEDGER, LEGAL, LETTER, 11X17, STATEMENT	LETTER, A4 (Country specific)
JOBNAME (SET only)	Print and Hold Jobname	“jobname” <i>jobname</i> is a text string truncated to 24 characters. Note: A null (“ ”) string is an acceptable value and indicates no Print and Hold Jobname is specified.	NULL (No jobname)

Table 3-3: Common Variables for Both Printer Languages (Continued)

Variable	Function	Selections	Factory Default
JOB OFFSET	Offset Pages	ON, OFF, BETWEENJOBS, BETWEENCOPIES INQUIRE or DINQUIRE returns the value of Offset Pages as follows: <ul style="list-style-type: none"> If Offset Pages is set to Off, OFF is returned. If Offset Pages is set to Between Jobs or Between Copies, ON is returned. Offset refers to stacking entire print jobs or copies of the same print job in two separate groups in an output bin.	OFF
LANG (DEFAULT only)	Default display language	DANISH, GERMAN, ENGLISH, SPANISH, FRENCH, ITALIAN, DUTCH, NORWEGIAN, SWEDISH, PORTUGUESE, FINNISH, JAPANESE, RUSSIAN, POLISH, HUNGARIAN, TURKISH, CZECH	Country specific
LOW TONER (DEFAULT only)	Toner Alarm	ON, OFF, CONTINUE, STOP A value of ON or CONTINUE indicates the Toner Alarm setting is set Off. The value of OFF or STOP indicates the Toner Alarm setting is Single. INQUIRE or DINQUIRE returns the value of the Toner Alarm as follows: <ul style="list-style-type: none"> If Toner Alarm is set to Off, CONTINUE is returned. If Toner Alarm is set to Single, STOP is returned. If Toner Alarm is set to Continuous, STOP is returned. 	ON, CONTINUE (Model specific)
MANUAL FEED (READ only)	Manual feed selection	OFF Printer always returns OFF.	OFF
MEDIA TYPE	Default paper source, default formatting size	PLAIN, COATED, GLOSSY, PHOTO, GREETINGCARD, IRONON, BOND, TRANSPARENCY, CARDSTOCK, LABELS, LETTERHEAD, PREPRINTED, COLORED, ENVELOPE, CUSTOMTYPE1, CUSTOMTYPE2, CUSTOMTYPE3, CUSTOMTYPE4, CUSTOMTYPE5, CUSTOMTYPE6, "name" <i>name</i> is a variable that allows for custom naming of custom print material types. The text string is truncated to 24 characters.	PLAIN
MP TRAY (DEFAULT only)	Multipurpose feeder configuration	CASSETTE, MANUAL, FIRST Sets the configuration of the Multipurpose Feeder.	CASSETTE
ORIENTATION	Print orientation	PORTRAIT, LANDSCAPE This variable does not affect PostScript emulation.	PORTRAIT

Table 3-3: Common Variables for Both Printer Languages (Continued)

Variable	Function	Selections	Factory Default																										
OUTBIN	Output Bin	<p>UPPER, LOWER, OPTIONALOUTBIN1, OPTIONALOUTBIN2, OPTIONALOUTBIN3, OPTIONALOUTBIN4, OPTIONALOUTBIN5, OPTIONALOUTBIN6, OPTIONALOUTBIN7, OPTIONALOUTBIN8, OPTIONALOUTBIN9, OPTIONALOUTBIN10, "name"</p> <p><i>name</i> is a variable that allows for custom naming of optional output bins. The text string is truncated to 24 characters.</p> <p>A DINQUIRE or INQUIRE on the Output Bin setting returns:</p> <table border="0"> <thead> <tr> <th>Output Bin setting</th> <th>DINQUIRE or INQUIRE value</th> </tr> </thead> <tbody> <tr> <td>Standard Bin</td> <td>UPPER</td> </tr> <tr> <td>Bin 1</td> <td>OPTIONALOUTBIN1</td> </tr> <tr> <td>Bin 2</td> <td>OPTIONALOUTBIN2</td> </tr> <tr> <td>Bin 3</td> <td>OPTIONALOUTBIN3</td> </tr> <tr> <td>Bin 4</td> <td>OPTIONALOUTBIN4</td> </tr> <tr> <td>Bin 5</td> <td>OPTIONALOUTBIN5</td> </tr> <tr> <td>Bin 6</td> <td>OPTIONALOUTBIN6</td> </tr> <tr> <td>Bin 7</td> <td>OPTIONALOUTBIN7</td> </tr> <tr> <td>Bin 8</td> <td>OPTIONALOUTBIN8</td> </tr> <tr> <td>Bin 9</td> <td>OPTIONALOUTBIN9</td> </tr> <tr> <td>Bin 10</td> <td>OPTIONALOUTBIN10</td> </tr> <tr> <td>"name"</td> <td>"name"</td> </tr> </tbody> </table>	Output Bin setting	DINQUIRE or INQUIRE value	Standard Bin	UPPER	Bin 1	OPTIONALOUTBIN1	Bin 2	OPTIONALOUTBIN2	Bin 3	OPTIONALOUTBIN3	Bin 4	OPTIONALOUTBIN4	Bin 5	OPTIONALOUTBIN5	Bin 6	OPTIONALOUTBIN6	Bin 7	OPTIONALOUTBIN7	Bin 8	OPTIONALOUTBIN8	Bin 9	OPTIONALOUTBIN9	Bin 10	OPTIONALOUTBIN10	"name"	"name"	UPPER
Output Bin setting	DINQUIRE or INQUIRE value																												
Standard Bin	UPPER																												
Bin 1	OPTIONALOUTBIN1																												
Bin 2	OPTIONALOUTBIN2																												
Bin 3	OPTIONALOUTBIN3																												
Bin 4	OPTIONALOUTBIN4																												
Bin 5	OPTIONALOUTBIN5																												
Bin 6	OPTIONALOUTBIN6																												
Bin 7	OPTIONALOUTBIN7																												
Bin 8	OPTIONALOUTBIN8																												
Bin 9	OPTIONALOUTBIN9																												
Bin 10	OPTIONALOUTBIN10																												
"name"	"name"																												
PAGEPROTECT	Page Protect	<p>AUTO, ON</p> <p>A value of ON indicates the Page Protect setting is set On. The value of AUTO indicates the Page Protect setting is set Off.</p> <p>INQUIRE or DINQUIRE returns the value of the Page Protect as follows:</p> <ul style="list-style-type: none"> • If Page Protect is set Off, AUTO is returned. • If Page Protect is set On, ON is returned. 	AUTO																										
PAPER	Default paper source, default formatting size	<p>Paper: A3, A3+, A4, A5, B4, B4PAPER, B5PAPER, JISB4, JISB5, CUSTOM, EXECUTIVE, FOLIO, LEDGER, LEGAL, LETTER, STATEMENT, 11X17</p> <p>Envelopes: COM10, COM9, MONARCH, DL, C5, B5, OTHERENVELOPE</p>	LETTER, A4 (Country specific)																										

Table 3-3: Common Variables for Both Printer Languages (Continued)

Variable	Function	Selections	Factory Default
PARALLEL (DEFAULT only) (Port Specific)	Parallel Protocol	SLOW, FAST A value of SLOW indicates the Parallel Protocol setting is Standard. The value of FAST indicates the Parallel Protocol setting is FASTBYTES. INQUIRE or DINQUIRE returns the value of the Parallel Protocol as follows: <ul style="list-style-type: none"> • If Parallel Protocol is set as Standard, SLOW is returned. • If Parallel Protocol is set as Fastbytes, FAST is returned. 	FAST
PASSWORD (DEFAULT only)	Default password for PJL NVRAM security	0 to 65535 Locks the printer operator panel to keep the user defaults from changing. See your printer documentation for more information. The Default PJL password is 0. If the PJL password is not equal to 0, a DINQUIRE or INQUIRE on the PASSWORD variable returns ENABLED. If the PJL password is equal to 0, a DINQUIRE or INQUIRE on the PASSWORD variable returns DISABLED. See the PASSWORD parameter of the JOB command on page 3-5 for more information.	0
PERSONALITY (Port specific)	SmartSwitch settings	PCL, POSTSCRIPT, AUTO PERSONALITY controls the SmartSwitch settings for the interface link on which the PJL command is received. If AUTO is sent, both PS SmartSwitch and PCL Smartswitch menu settings are set to ON. If PCL is sent, PS SmartSwitch is set to OFF and PCL SmartSwitch is set to ON. If POSTSCRIPT is sent, PCL SmartSwitch is set to OFF and PS SmartSwitch is set to ON. When queried, AUTO is returned if both SmartSwitch settings are ON. If one SmartSwitch setting is OFF, the printer language whose SmartSwitch setting is ON is returned. If both SmartSwitch settings are OFF, the default printer language is returned.	AUTO
POWERSAVE (DEFAULT only)	Power Save feature	ON, OFF ON enables the power-saving feature. OFF disables the power-saving feature. Note: Some printer models released in the year 2000 or later designated as Energy Star printers cannot have Power Saver disabled.	ON

Table 3-3: Common Variables for Both Printer Languages (Continued)

Variable	Function	Selections	Factory Default
POWERSAVETIME (DEFAULT only)	Power Save time, in minutes	0 to 120 (Model specific) 0 to 240 (Model specific) (0 indicates the Power Saver Time feature is disabled.) The time the printer remains idle before it enters Power Save mode when POWERSAVE is On. Note: If a value greater than 120 or 240 is specified by a SET or DEFAULT command, the value is changed to 120 or 240 based on the printer model.	20
QTY (SET only)	Collation - Collated Copies (QTY)	0 to 999 Used to request the number of collated copies of a print job. If Collation - Collated Copies (QTY) is not equal to 0, a DINKQUIRE or INQUIRE returns the numerical setting for QTY. If Collation - Collated Copies (QTY) is set to Off, a DINKQUIRE or INQUIRE returns 0. Note: If a value greater than 999 is specified by a SET or DEFAULT command, the value is changed to 999.	0
REPRINT	Jam Recovery	ON, OFF, AUTO	AUTO
RESOLUTION	Print Resolution	300, 600, 1200	600
RESOURCESAVE (DEFAULT only)	Resource Save	ON, OFF, AUTO ON indicates Resource Save is set On. OFF and AUTO indicate Resource Save is set to Off. See "Table B-1: Common Variables for Both Printer Languages" on page B-1 for the default value of your printer.	OFF, AUTO (Model specific)
RET	Print Quality Enhancement Technology (PQET)	OFF, DARK, MEDIUM, LIGHT, ON If this value is set through PJL, the same value is returned on a PJL inquiry. DARK, MEDIUM, LIGHT, and ON values indicate that PQET is On. OFF indicates PQET is Off.	ON
TIMEOUT	Print timeout, in seconds	0 to 255 The time the printer remains idle before the job is forced to print. Note: If a value greater than 255 is specified by a SET or DEFAULT command, the value is changed to 255.	90

Table 3-3: Common Variables for Both Printer Languages (Continued)

Variable	Function	Selections	Factory Default
USERNAME (SET only)	Print and Hold Username	“username” <i>username</i> is a text string truncated to 24 characters. Note: A null (“ ”) string is an acceptable value and indicates no Print and Hold Username is specified.	NULL (No username)
WIDEA4	A4 width	NO, YES NO indicates the A4 width is 198 mm. YES indicates the A4 width is 203 mm.	NO

Printer Unique Variables for Both Printer Languages

The following variables are unique to some Lexmark printers and are supported for both PCL emulation and PostScript emulation. Therefore, the [command modifier: *value*] parameter should not be specified.

To determine which variables your printer supports, see “Table B-2: Printer Unique PJP Variables for Both Printer Languages” on page B-4.

Table 3-4: Printer Unique Variables for Both Printer Languages

Variable	Function	Selections	Factory Default
LACTIVEBINRESET (DEFAULT only)	Active Bin Reset	MANUAL, AUTOMATIC	MANUAL
LADVANCEDSTATUS (DEFAULT only) (Port specific)	Advanced Status	ON, OFF ON enables parallel bidirectional support. OFF disables parallel bidirectional support.	ON
LALARMCONTROL (DEFAULT only)	Alarm Control	OFF, SINGLE, CONTINUOUS	SINGLE
LAUROCRLF	Auto CR after LF	ON, OFF	OFF
LAUTOLFCR	Auto LF after CR	ON, OFF	OFF
LBLANKPAGES	Blank Pages	DONOTPRINT, PRINT Note: Some printers have a fixed value of DONOTPRINT.	DONOTPRINT
LBONDLENGTH (DEFAULT only)	Bond Length	NORMAL, SHORT	NORMAL
LBONDLOADING (DEFAULT only)	Bond Paper Loading	OFF, DUPLEX	OFF

Table 3-4: Printer Unique Variables for Both Printer Languages (Continued)

Variable	Function	Selections	Factory Default																										
LBONDOUTBIN (DEFAULT only)	Assign Type/Bin - Bond	<p>UPPER, LOWER, DISABLED, OPTIONALOUTBIN1, OPTIONALOUTBIN2, OPTIONALOUTBIN3, OPTIONALOUTBIN4, OPTIONALOUTBIN5, OPTIONALOUTBIN6, OPTIONALOUTBIN7, OPTIONALOUTBIN8, OPTIONALOUTBIN9, OPTIONALOUTBIN10, "name"</p> <p><i>name</i> is a variable that allows for custom naming of optional output bins. The text string is truncated to 24 characters.</p> <p>Specifies a selected output bin for jobs printed on bond paper.</p> <p>A DINKQUIRE or INQUIRE on the Assign Type/Bin - Bond setting returns:</p> <table border="0"> <tr> <td style="text-align: center;">Assign Type/Bin - Bond setting</td> <td style="text-align: center;">DINKQUIRE or INQUIRE value</td> </tr> <tr> <td>Standard Bin</td> <td>UPPER</td> </tr> <tr> <td>Bin 1</td> <td>OPTIONALOUTBIN1</td> </tr> <tr> <td>Bin 2</td> <td>OPTIONALOUTBIN2</td> </tr> <tr> <td>Bin 3</td> <td>OPTIONALOUTBIN3</td> </tr> <tr> <td>Bin 4</td> <td>OPTIONALOUTBIN4</td> </tr> <tr> <td>Bin 5</td> <td>OPTIONALOUTBIN5</td> </tr> <tr> <td>Bin 6</td> <td>OPTIONALOUTBIN6</td> </tr> <tr> <td>Bin 7</td> <td>OPTIONALOUTBIN7</td> </tr> <tr> <td>Bin 8</td> <td>OPTIONALOUTBIN8</td> </tr> <tr> <td>Bin 9</td> <td>OPTIONALOUTBIN9</td> </tr> <tr> <td>Bin 10</td> <td>OPTIONALOUTBIN10</td> </tr> <tr> <td>"name"</td> <td>"name"</td> </tr> </table>	Assign Type/Bin - Bond setting	DINKQUIRE or INQUIRE value	Standard Bin	UPPER	Bin 1	OPTIONALOUTBIN1	Bin 2	OPTIONALOUTBIN2	Bin 3	OPTIONALOUTBIN3	Bin 4	OPTIONALOUTBIN4	Bin 5	OPTIONALOUTBIN5	Bin 6	OPTIONALOUTBIN6	Bin 7	OPTIONALOUTBIN7	Bin 8	OPTIONALOUTBIN8	Bin 9	OPTIONALOUTBIN9	Bin 10	OPTIONALOUTBIN10	"name"	"name"	UPPER, DISABLED (Model specific)
Assign Type/Bin - Bond setting	DINKQUIRE or INQUIRE value																												
Standard Bin	UPPER																												
Bin 1	OPTIONALOUTBIN1																												
Bin 2	OPTIONALOUTBIN2																												
Bin 3	OPTIONALOUTBIN3																												
Bin 4	OPTIONALOUTBIN4																												
Bin 5	OPTIONALOUTBIN5																												
Bin 6	OPTIONALOUTBIN6																												
Bin 7	OPTIONALOUTBIN7																												
Bin 8	OPTIONALOUTBIN8																												
Bin 9	OPTIONALOUTBIN9																												
Bin 10	OPTIONALOUTBIN10																												
"name"	"name"																												
LBONDTEXTURE (DEFAULT only)	Bond Texture	SMOOTH, NORMAL, ROUGH	ROUGH																										
LBONDWEIGHT (DEFAULT only)	Bond Weight	LIGHT, NORMAL, HEAVY	NORMAL																										
LBWLOCK	Black & White Lock	ON, OFF	OFF																										
LCANCEL	Cancel Control	ON, OFF	ON																										
LCARDSTOCKLENGTH (DEFAULT only)	Card Stock Length	NORMAL, SHORT	NORMAL																										
LCARDSTOCKLOADING (DEFAULT only)	Card Stock Paper Loading	OFF, DUPLEX	OFF																										

Table 3-4: Printer Unique Variables for Both Printer Languages (Continued)

Variable	Function	Selections	Factory Default																										
LCARDSTOCKOUTBIN (DEFAULT only)	Assign Type/Bin - Card Stock	UPPER, LOWER, DISABLED, OPTIONALOUTBIN1, OPTIONALOUTBIN2, OPTIONALOUTBIN3, OPTIONALOUTBIN4, OPTIONALOUTBIN5, OPTIONALOUTBIN6, OPTIONALOUTBIN7, OPTIONALOUTBIN8, OPTIONALOUTBIN9, OPTIONALOUTBIN10, "name" <i>name</i> is a variable that allows for custom naming of optional output bins. The text string is truncated to 24 characters. Specifies a selected output bin for jobs printed on card stock. A DINKQUIRE or INQUIRE on the Assign Type/Bin - Card Stock setting returns: <table border="0"> <tr> <td>Assign Type/Bin - Card Stock setting</td> <td>DINKQUIRE or INQUIRE value</td> </tr> <tr> <td>Standard Bin</td> <td>UPPER</td> </tr> <tr> <td>Bin 1</td> <td>OPTIONALOUTBIN1</td> </tr> <tr> <td>Bin 2</td> <td>OPTIONALOUTBIN2</td> </tr> <tr> <td>Bin 3</td> <td>OPTIONALOUTBIN3</td> </tr> <tr> <td>Bin 4</td> <td>OPTIONALOUTBIN4</td> </tr> <tr> <td>Bin 5</td> <td>OPTIONALOUTBIN5</td> </tr> <tr> <td>Bin 6</td> <td>OPTIONALOUTBIN6</td> </tr> <tr> <td>Bin 7</td> <td>OPTIONALOUTBIN7</td> </tr> <tr> <td>Bin 8</td> <td>OPTIONALOUTBIN8</td> </tr> <tr> <td>Bin 9</td> <td>OPTIONALOUTBIN9</td> </tr> <tr> <td>Bin 10</td> <td>OPTIONALOUTBIN10</td> </tr> <tr> <td>"name"</td> <td>"name"</td> </tr> </table>	Assign Type/Bin - Card Stock setting	DINKQUIRE or INQUIRE value	Standard Bin	UPPER	Bin 1	OPTIONALOUTBIN1	Bin 2	OPTIONALOUTBIN2	Bin 3	OPTIONALOUTBIN3	Bin 4	OPTIONALOUTBIN4	Bin 5	OPTIONALOUTBIN5	Bin 6	OPTIONALOUTBIN6	Bin 7	OPTIONALOUTBIN7	Bin 8	OPTIONALOUTBIN8	Bin 9	OPTIONALOUTBIN9	Bin 10	OPTIONALOUTBIN10	"name"	"name"	UPPER, DISABLED (Model specific)
Assign Type/Bin - Card Stock setting	DINKQUIRE or INQUIRE value																												
Standard Bin	UPPER																												
Bin 1	OPTIONALOUTBIN1																												
Bin 2	OPTIONALOUTBIN2																												
Bin 3	OPTIONALOUTBIN3																												
Bin 4	OPTIONALOUTBIN4																												
Bin 5	OPTIONALOUTBIN5																												
Bin 6	OPTIONALOUTBIN6																												
Bin 7	OPTIONALOUTBIN7																												
Bin 8	OPTIONALOUTBIN8																												
Bin 9	OPTIONALOUTBIN9																												
Bin 10	OPTIONALOUTBIN10																												
"name"	"name"																												
LCARDSTOCKTEXTURE (DEFAULT only)	Card Stock Texture	SMOOTH, NORMAL, ROUGH	NORMAL																										
LCARDSTOCKWEIGHT (DEFAULT only)	Card Stock Weight	LIGHT, NORMAL, HEAVY	NORMAL																										
LCOLLATION	Collation Mode	ON, OFF If Collation is ON, the pages of the print job are collated. For example, if the job contains three pages and two copies are requested, collated output prints pages 1, 2, 3, 1, 2, 3. If collation is set to OFF, uncollated output prints pages 1, 1, 2, 2, 3, 3.	OFF																										
LCOLORCORRECTION	Indicates which color target the printer emulates	NONE, DISPLAY, SWOP, OFF, AUTO, VIVID, DUOTONE, MANUAL See "Table B-2: Printer Unique PJL Variables for Both Printer Languages" on page B-4 for the default value of your printer.	AUTO, VIVID (Model specific)																										
LCOLOREDLENGTH (DEFAULT only)	Colored Paper Length	NORMAL, SHORT	NORMAL																										

Table 3-4: Printer Unique Variables for Both Printer Languages (Continued)

Variable	Function	Selections	Factory Default																										
LCOLOREDLOADING (DEFAULT only)	Colored Paper Loading	OFF, DUPLEX	OFF																										
LCOLOREDOUTBIN (DEFAULT only)	Assign Type/Bin - Colored Paper	<p>UPPER, LOWER, DISABLED, OPTIONALOUTBIN1, OPTIONALOUTBIN2, OPTIONALOUTBIN3, OPTIONALOUTBIN4, OPTIONALOUTBIN5, OPTIONALOUTBIN6, OPTIONALOUTBIN7, OPTIONALOUTBIN8, OPTIONALOUTBIN9, OPTIONALOUTBIN10, "name"</p> <p><i>name</i> is a variable that allows for custom naming of optional output bins. The text string is truncated to 24 characters.</p> <p>Specifies a selected output bin for jobs printed on colored paper.</p> <p>A DINQUIRE or INQUIRE on the Assign Type/Bin - Colored Paper setting returns:</p> <table border="0"> <tr> <td>Assign Type/Bin - Colored Paper setting</td> <td>DINQUIRE or INQUIRE value</td> </tr> <tr> <td>Standard Bin</td> <td>UPPER</td> </tr> <tr> <td>Bin 1</td> <td>OPTIONALOUTBIN1</td> </tr> <tr> <td>Bin 2</td> <td>OPTIONALOUTBIN2</td> </tr> <tr> <td>Bin 3</td> <td>OPTIONALOUTBIN3</td> </tr> <tr> <td>Bin 4</td> <td>OPTIONALOUTBIN4</td> </tr> <tr> <td>Bin 5</td> <td>OPTIONALOUTBIN5</td> </tr> <tr> <td>Bin 6</td> <td>OPTIONALOUTBIN6</td> </tr> <tr> <td>Bin 7</td> <td>OPTIONALOUTBIN7</td> </tr> <tr> <td>Bin 8</td> <td>OPTIONALOUTBIN8</td> </tr> <tr> <td>Bin 9</td> <td>OPTIONALOUTBIN9</td> </tr> <tr> <td>Bin 10</td> <td>OPTIONALOUTBIN10</td> </tr> <tr> <td>"name"</td> <td>"name"</td> </tr> </table>	Assign Type/Bin - Colored Paper setting	DINQUIRE or INQUIRE value	Standard Bin	UPPER	Bin 1	OPTIONALOUTBIN1	Bin 2	OPTIONALOUTBIN2	Bin 3	OPTIONALOUTBIN3	Bin 4	OPTIONALOUTBIN4	Bin 5	OPTIONALOUTBIN5	Bin 6	OPTIONALOUTBIN6	Bin 7	OPTIONALOUTBIN7	Bin 8	OPTIONALOUTBIN8	Bin 9	OPTIONALOUTBIN9	Bin 10	OPTIONALOUTBIN10	"name"	"name"	UPPER, DISABLED (Model specific)
Assign Type/Bin - Colored Paper setting	DINQUIRE or INQUIRE value																												
Standard Bin	UPPER																												
Bin 1	OPTIONALOUTBIN1																												
Bin 2	OPTIONALOUTBIN2																												
Bin 3	OPTIONALOUTBIN3																												
Bin 4	OPTIONALOUTBIN4																												
Bin 5	OPTIONALOUTBIN5																												
Bin 6	OPTIONALOUTBIN6																												
Bin 7	OPTIONALOUTBIN7																												
Bin 8	OPTIONALOUTBIN8																												
Bin 9	OPTIONALOUTBIN9																												
Bin 10	OPTIONALOUTBIN10																												
"name"	"name"																												
LCOLOREDTEXTURE (DEFAULT only)	Colored Paper Texture	SMOOTH, NORMAL, ROUGH	NORMAL																										
LCOLOREDWEIGHT (DEFAULT only)	Colored Paper Weight	LIGHT, NORMAL, HEAVY	NORMAL																										
LCOLORMODEL	Color Model	CMYK, RGB, BLACK	RGB, CMYK (Model specific)																										
LCUSTOMPAPERUNITS	Universal Units of Measure	INCHES, MILLIMETERS	INCHES, MILLIMETERS (Country specific)																										
LCUSTOMPAPERWIDTH	Universal Width	<p>76 to 915 in increments of 1 mm 3 to 36.01 in increments of 0.01 in.</p> <p>Note: Values are determined to be inches or millimeters based on the LCUSTOMPAPERUNITS setting.</p>	216, 305 mm 8.5, 12 in. (Model and country specific)																										

Table 3-4: Printer Unique Variables for Both Printer Languages (Continued)

Variable	Function	Selections	Factory Default
LCUSTOMPAPERHEIGHT	Universal Height	76 to 915 in increments of 1 mm 3 to 36.01 in increments of 0.01 in. Note: Values are determined to be inches or millimeters based on the LCUSTOMPAPERUNITS setting.	356, 360, 457 mm 14, 14.17, 18 in. (Model and country specific)
LCUSTOMPAPERFEED	Universal Feed Direction	SHORTEDGE, LONGEDGE	SHORTEDGE
LCUSTOMTYPE1LENGTH (DEFAULT only)	Custom Type 1 Length	NORMAL, SHORT	NORMAL
LCUSTOMTYPE1LOADING (DEFAULT only)	Custom Type 1 Paper Loading	OFF, DUPLEX	OFF
LCUSTOMTYPE1MEDIA (DEFAULT only)	Custom Type 1 Media	PAPER, COATED, GLOSSY, TRANSPARENCY, LABELS, CARDSTOCK, ENVELOPE, COTTONPAPER	PAPER
LCUSTOMTYPE1NAME (DEFAULT only)	Custom Type 1 Name	"name" <i>name</i> is a variable that allows for custom naming of print material types. The text string is truncated to 24 characters. When queried, the quotes are not returned around the string name. The default name is returned unless you have specified a custom name.	CUSTOMTYPE1

Table 3-4: Printer Unique Variables for Both Printer Languages (Continued)

Variable	Function	Selections	Factory Default																										
LCUSTOMTYPE1OUTBIN (DEFAULT only)	Assign Type/Bin - Custom Type 1	UPPER, LOWER, DISABLED, OPTIONALOUTBIN1, OPTIONALOUTBIN2, OPTIONALOUTBIN3, OPTIONALOUTBIN4, OPTIONALOUTBIN5, OPTIONALOUTBIN6, OPTIONALOUTBIN7, OPTIONALOUTBIN8, OPTIONALOUTBIN9, OPTIONALOUTBIN10, "name" <i>name</i> is a variable that allows for custom naming of optional output bins. The text string is truncated to 24 characters. Specifies a selected output bin for jobs printed on custom type 1 paper. A DINQUIRE or INQUIRE on the Assign Type/Bin - Custom Type 1 setting returns: <table border="0"> <tr> <td style="text-align: center;">Assign Type/Bin - Custom Type 1 setting</td> <td style="text-align: center;">DINQUIRE or INQUIRE value</td> </tr> <tr> <td>Standard Bin</td> <td>UPPER</td> </tr> <tr> <td>Bin 1</td> <td>OPTIONALOUTBIN1</td> </tr> <tr> <td>Bin 2</td> <td>OPTIONALOUTBIN2</td> </tr> <tr> <td>Bin 3</td> <td>OPTIONALOUTBIN3</td> </tr> <tr> <td>Bin 4</td> <td>OPTIONALOUTBIN4</td> </tr> <tr> <td>Bin 5</td> <td>OPTIONALOUTBIN5</td> </tr> <tr> <td>Bin 6</td> <td>OPTIONALOUTBIN6</td> </tr> <tr> <td>Bin 7</td> <td>OPTIONALOUTBIN7</td> </tr> <tr> <td>Bin 8</td> <td>OPTIONALOUTBIN8</td> </tr> <tr> <td>Bin 9</td> <td>OPTIONALOUTBIN9</td> </tr> <tr> <td>Bin 10</td> <td>OPTIONALOUTBIN10</td> </tr> <tr> <td>"name"</td> <td>"name"</td> </tr> </table>	Assign Type/Bin - Custom Type 1 setting	DINQUIRE or INQUIRE value	Standard Bin	UPPER	Bin 1	OPTIONALOUTBIN1	Bin 2	OPTIONALOUTBIN2	Bin 3	OPTIONALOUTBIN3	Bin 4	OPTIONALOUTBIN4	Bin 5	OPTIONALOUTBIN5	Bin 6	OPTIONALOUTBIN6	Bin 7	OPTIONALOUTBIN7	Bin 8	OPTIONALOUTBIN8	Bin 9	OPTIONALOUTBIN9	Bin 10	OPTIONALOUTBIN10	"name"	"name"	UPPER, DISABLED (Model specific)
Assign Type/Bin - Custom Type 1 setting	DINQUIRE or INQUIRE value																												
Standard Bin	UPPER																												
Bin 1	OPTIONALOUTBIN1																												
Bin 2	OPTIONALOUTBIN2																												
Bin 3	OPTIONALOUTBIN3																												
Bin 4	OPTIONALOUTBIN4																												
Bin 5	OPTIONALOUTBIN5																												
Bin 6	OPTIONALOUTBIN6																												
Bin 7	OPTIONALOUTBIN7																												
Bin 8	OPTIONALOUTBIN8																												
Bin 9	OPTIONALOUTBIN9																												
Bin 10	OPTIONALOUTBIN10																												
"name"	"name"																												
LCUSTOMTYPE1TEXTURE (DEFAULT only)	Custom Type 1 Texture	SMOOTH, NORMAL, ROUGH	NORMAL																										
LCUSTOMTYPE1WEIGHT (DEFAULT only)	Custom Type 1 Weight	LIGHT, NORMAL, HEAVY	NORMAL																										
LCUSTOMTYPE2LENGTH (DEFAULT only)	Custom Type 2 Length	NORMAL, SHORT	NORMAL																										
LCUSTOMTYPE2LOADING (DEFAULT only)	Custom Type 2 Paper Loading	OFF, DUPLEX	OFF																										
LCUSTOMTYPE2MEDIA (DEFAULT only)	Custom Type 2 Media	PAPER, COATED, GLOSSY, TRANSPARENCY, LABELS, CARDSTOCK, ENVELOPE, COTTONPAPER	PAPER																										

Table 3-4: Printer Unique Variables for Both Printer Languages (Continued)

Variable	Function	Selections	Factory Default																										
LCUSTOMTYPE2NAME (DEFAULT only)	Custom Type 2 Name	"name" <i>name</i> is a variable that allows for custom naming of print material types. The text string is truncated to 24 characters. When queried, the quotes are not returned around the string name. The default name is returned unless you have specified a custom name.	CUSTOMTYPE2																										
LCUSTOMTYPE2OUTBIN (DEFAULT only)	Assign Type/Bin - Custom Type 2	UPPER, LOWER, DISABLED, OPTIONALOUTBIN1, OPTIONALOUTBIN2, OPTIONALOUTBIN3, OPTIONALOUTBIN4, OPTIONALOUTBIN5, OPTIONALOUTBIN6, OPTIONALOUTBIN7, OPTIONALOUTBIN8, OPTIONALOUTBIN9, OPTIONALOUTBIN10, "name" <i>name</i> is a variable that allows for custom naming of optional output bins. The text string is truncated to 24 characters. Specifies a selected output bin for jobs printed on custom type 2 paper. A DINQUIRE or INQUIRE on the Assign Type/Bin - Custom Type 2 setting returns: <table border="0"> <tr> <td>Assign Type/Bin Custom Type 2 setting</td> <td>DINQUIRE or INQUIRE value</td> </tr> <tr> <td>Standard Bin</td> <td>UPPER</td> </tr> <tr> <td>Bin 1</td> <td>OPTIONALOUTBIN1</td> </tr> <tr> <td>Bin 2</td> <td>OPTIONALOUTBIN2</td> </tr> <tr> <td>Bin 3</td> <td>OPTIONALOUTBIN3</td> </tr> <tr> <td>Bin 4</td> <td>OPTIONALOUTBIN4</td> </tr> <tr> <td>Bin 5</td> <td>OPTIONALOUTBIN5</td> </tr> <tr> <td>Bin 6</td> <td>OPTIONALOUTBIN6</td> </tr> <tr> <td>Bin 7</td> <td>OPTIONALOUTBIN7</td> </tr> <tr> <td>Bin 8</td> <td>OPTIONALOUTBIN8</td> </tr> <tr> <td>Bin 9</td> <td>OPTIONALOUTBIN9</td> </tr> <tr> <td>Bin 10</td> <td>OPTIONALOUTBIN10</td> </tr> <tr> <td>"name"</td> <td>"name"</td> </tr> </table>	Assign Type/Bin Custom Type 2 setting	DINQUIRE or INQUIRE value	Standard Bin	UPPER	Bin 1	OPTIONALOUTBIN1	Bin 2	OPTIONALOUTBIN2	Bin 3	OPTIONALOUTBIN3	Bin 4	OPTIONALOUTBIN4	Bin 5	OPTIONALOUTBIN5	Bin 6	OPTIONALOUTBIN6	Bin 7	OPTIONALOUTBIN7	Bin 8	OPTIONALOUTBIN8	Bin 9	OPTIONALOUTBIN9	Bin 10	OPTIONALOUTBIN10	"name"	"name"	UPPER, DISABLED (Model specific)
Assign Type/Bin Custom Type 2 setting	DINQUIRE or INQUIRE value																												
Standard Bin	UPPER																												
Bin 1	OPTIONALOUTBIN1																												
Bin 2	OPTIONALOUTBIN2																												
Bin 3	OPTIONALOUTBIN3																												
Bin 4	OPTIONALOUTBIN4																												
Bin 5	OPTIONALOUTBIN5																												
Bin 6	OPTIONALOUTBIN6																												
Bin 7	OPTIONALOUTBIN7																												
Bin 8	OPTIONALOUTBIN8																												
Bin 9	OPTIONALOUTBIN9																												
Bin 10	OPTIONALOUTBIN10																												
"name"	"name"																												
LCUSTOMTYPE2TEXTURE (DEFAULT only)	Custom Type 2 Texture	SMOOTH, NORMAL, ROUGH	NORMAL																										
LCUSTOMTYPE2WEIGHT (DEFAULT only)	Custom Type 2 Weight	LIGHT, NORMAL, HEAVY	NORMAL																										
LCUSTOMTYPE3LENGTH (DEFAULT only)	Custom Type 3 Length	NORMAL, SHORT	NORMAL																										
LCUSTOMTYPE3LOADING (DEFAULT only)	Custom Type 3 Paper Loading	OFF, DUPLEX	OFF																										

Table 3-4: Printer Unique Variables for Both Printer Languages (Continued)

Variable	Function	Selections	Factory Default																										
LCUSTOMTYPE3MEDIA (DEFAULT only)	Custom Type 3 Media	PAPER, COATED, GLOSSY, TRANSPARENCY, LABELS, CARDSTOCK, ENVELOPE, COTTONPAPER	PAPER																										
LCUSTOMTYPE3NAME (DEFAULT only)	Custom Type 3 Name	"name" <i>name</i> is a variable that allows for custom naming of print material types. The text string is truncated to 24 characters. When queried, the quotes are not returned around the string name. The default name is returned unless you have specified a custom name.	CUSTOMTYPE3																										
LCUSTOMTYPE3OUTBIN (DEFAULT only)	Assign Type/Bin - Custom Type 3	UPPER, LOWER, DISABLED, OPTIONALOUTBIN1, OPTIONALOUTBIN2, OPTIONALOUTBIN3, OPTIONALOUTBIN4, OPTIONALOUTBIN5, OPTIONALOUTBIN6, OPTIONALOUTBIN7, OPTIONALOUTBIN8, OPTIONALOUTBIN9, OPTIONALOUTBIN10, "name" <i>name</i> is a variable that allows for custom naming of optional output bins. The text string is truncated to 24 characters. Specifies a selected output bin for jobs printed on custom type 3 paper. A DINQUIRE or INQUIRE on the Assign Type/Bin - Custom Type 3 setting returns: <table border="0"> <tr> <td>Assign Type/Bin - Custom Type 3 setting</td> <td>DINQUIRE or INQUIRE value</td> </tr> <tr> <td>Standard Bin</td> <td>UPPER</td> </tr> <tr> <td>Bin 1</td> <td>OPTIONALOUTBIN1</td> </tr> <tr> <td>Bin 2</td> <td>OPTIONALOUTBIN2</td> </tr> <tr> <td>Bin 3</td> <td>OPTIONALOUTBIN3</td> </tr> <tr> <td>Bin 4</td> <td>OPTIONALOUTBIN4</td> </tr> <tr> <td>Bin 5</td> <td>OPTIONALOUTBIN5</td> </tr> <tr> <td>Bin 6</td> <td>OPTIONALOUTBIN6</td> </tr> <tr> <td>Bin 7</td> <td>OPTIONALOUTBIN7</td> </tr> <tr> <td>Bin 8</td> <td>OPTIONALOUTBIN8</td> </tr> <tr> <td>Bin 9</td> <td>OPTIONALOUTBIN9</td> </tr> <tr> <td>Bin 10</td> <td>OPTIONALOUTBIN10</td> </tr> <tr> <td>"name"</td> <td>"name"</td> </tr> </table>	Assign Type/Bin - Custom Type 3 setting	DINQUIRE or INQUIRE value	Standard Bin	UPPER	Bin 1	OPTIONALOUTBIN1	Bin 2	OPTIONALOUTBIN2	Bin 3	OPTIONALOUTBIN3	Bin 4	OPTIONALOUTBIN4	Bin 5	OPTIONALOUTBIN5	Bin 6	OPTIONALOUTBIN6	Bin 7	OPTIONALOUTBIN7	Bin 8	OPTIONALOUTBIN8	Bin 9	OPTIONALOUTBIN9	Bin 10	OPTIONALOUTBIN10	"name"	"name"	UPPER, DISABLED (Model specific)
Assign Type/Bin - Custom Type 3 setting	DINQUIRE or INQUIRE value																												
Standard Bin	UPPER																												
Bin 1	OPTIONALOUTBIN1																												
Bin 2	OPTIONALOUTBIN2																												
Bin 3	OPTIONALOUTBIN3																												
Bin 4	OPTIONALOUTBIN4																												
Bin 5	OPTIONALOUTBIN5																												
Bin 6	OPTIONALOUTBIN6																												
Bin 7	OPTIONALOUTBIN7																												
Bin 8	OPTIONALOUTBIN8																												
Bin 9	OPTIONALOUTBIN9																												
Bin 10	OPTIONALOUTBIN10																												
"name"	"name"																												
LCUSTOMTYPE3TEXTURE (DEFAULT only)	Custom Type 3 Texture	SMOOTH, NORMAL, ROUGH	NORMAL																										
LCUSTOMTYPE3WEIGHT (DEFAULT only)	Custom Type 3 Weight	LIGHT, NORMAL, HEAVY	NORMAL																										
LCUSTOMTYPE4LENGTH (DEFAULT only)	Custom Type 4 Length	NORMAL, SHORT	NORMAL																										

Table 3-4: Printer Unique Variables for Both Printer Languages (Continued)

Variable	Function	Selections	Factory Default																										
LCUSTOMTYPE4LOADING (DEFAULT only)	Custom Type 4 Paper Loading	OFF, DUPLEX	OFF																										
LCUSTOMTYPE4MEDIA (DEFAULT only)	Custom Type 4 Media	PAPER, COATED, GLOSSY, TRANSPARENCY, LABELS, CARDSTOCK, ENVELOPE, COTTONPAPER	PAPER																										
LCUSTOMTYPE4NAME (DEFAULT only)	Custom Type 4 Name	"name" <i>name</i> is a variable that allows for custom naming of print material types. The text string is truncated to 24 characters. When queried, the quotes are not returned around the string name. The default name is returned unless you have specified a custom name.	CUSTOMTYPE4																										
LCUSTOMTYPE4OUTBIN (DEFAULT only)	Assign Type/Bin - Custom Type 4	UPPER, LOWER, DISABLED, OPTIONALOUTBIN1, OPTIONALOUTBIN2, OPTIONALOUTBIN3, OPTIONALOUTBIN4, OPTIONALOUTBIN5, OPTIONALOUTBIN6, OPTIONALOUTBIN7, OPTIONALOUTBIN8, OPTIONALOUTBIN9, OPTIONALOUTBIN10, "name" <i>name</i> is a variable that allows for custom naming of optional output bins. The text string is truncated to 24 characters. Specifies a selected output bin for jobs printed on custom type 4 paper. A DINQUIRE or INQUIRE on the Assign Type/Bin - Custom Type 4 setting returns: <table border="0"> <tr> <td style="text-align: center;">Assign Type/Bin Custom Type 4 setting</td> <td style="text-align: center;">DINQUIRE or INQUIRE value</td> </tr> <tr> <td>Standard Bin</td> <td>UPPER</td> </tr> <tr> <td>Bin 1</td> <td>OPTIONALOUTBIN1</td> </tr> <tr> <td>Bin 2</td> <td>OPTIONALOUTBIN2</td> </tr> <tr> <td>Bin 3</td> <td>OPTIONALOUTBIN3</td> </tr> <tr> <td>Bin 4</td> <td>OPTIONALOUTBIN4</td> </tr> <tr> <td>Bin 5</td> <td>OPTIONALOUTBIN5</td> </tr> <tr> <td>Bin 6</td> <td>OPTIONALOUTBIN6</td> </tr> <tr> <td>Bin 7</td> <td>OPTIONALOUTBIN7</td> </tr> <tr> <td>Bin 8</td> <td>OPTIONALOUTBIN8</td> </tr> <tr> <td>Bin 9</td> <td>OPTIONALOUTBIN9</td> </tr> <tr> <td>Bin 10</td> <td>OPTIONALOUTBIN10</td> </tr> <tr> <td>"name"</td> <td>"name"</td> </tr> </table>	Assign Type/Bin Custom Type 4 setting	DINQUIRE or INQUIRE value	Standard Bin	UPPER	Bin 1	OPTIONALOUTBIN1	Bin 2	OPTIONALOUTBIN2	Bin 3	OPTIONALOUTBIN3	Bin 4	OPTIONALOUTBIN4	Bin 5	OPTIONALOUTBIN5	Bin 6	OPTIONALOUTBIN6	Bin 7	OPTIONALOUTBIN7	Bin 8	OPTIONALOUTBIN8	Bin 9	OPTIONALOUTBIN9	Bin 10	OPTIONALOUTBIN10	"name"	"name"	UPPER, DISABLED (Model specific)
Assign Type/Bin Custom Type 4 setting	DINQUIRE or INQUIRE value																												
Standard Bin	UPPER																												
Bin 1	OPTIONALOUTBIN1																												
Bin 2	OPTIONALOUTBIN2																												
Bin 3	OPTIONALOUTBIN3																												
Bin 4	OPTIONALOUTBIN4																												
Bin 5	OPTIONALOUTBIN5																												
Bin 6	OPTIONALOUTBIN6																												
Bin 7	OPTIONALOUTBIN7																												
Bin 8	OPTIONALOUTBIN8																												
Bin 9	OPTIONALOUTBIN9																												
Bin 10	OPTIONALOUTBIN10																												
"name"	"name"																												
LCUSTOMTYPE4TEXTURE (DEFAULT only)	Custom Type 4 Texture	SMOOTH, NORMAL, ROUGH	NORMAL																										
LCUSTOMTYPE4WEIGHT (DEFAULT only)	Custom Type 4 Weight	LIGHT, NORMAL, HEAVY	NORMAL																										

Table 3-4: Printer Unique Variables for Both Printer Languages (Continued)

Variable	Function	Selections	Factory Default																										
LCUSTOMTYPE5LENGTH (DEFAULT only)	Custom Type 5 Length	NORMAL, SHORT	NORMAL																										
LCUSTOMTYPE5LOADING (DEFAULT only)	Custom Type 5 Paper Loading	OFF, DUPLEX	OFF																										
LCUSTOMTYPE5MEDIA (DEFAULT only)	Custom Type 5 Media	PAPER, COATED, GLOSSY, TRANSPARENCY, LABELS, CARDSTOCK, ENVELOPE, COTTONPAPER	PAPER																										
LCUSTOMTYPE5NAME (DEFAULT only)	Custom Type 5 Name	"name" <i>name</i> is a variable that allows for custom naming of print material types. The text string is truncated to 24 characters. When queried, the quotes are not returned around the string name. The default name is returned unless you have specified a custom name.	CUSTOMTYPE5																										
LCUSTOMTYPE5OUTBIN (DEFAULT only)	Assign Type/Bin - Custom Type 5	UPPER, LOWER, DISABLED, OPTIONALOUTBIN1, OPTIONALOUTBIN2, OPTIONALOUTBIN3, OPTIONALOUTBIN4, OPTIONALOUTBIN5, OPTIONALOUTBIN6, OPTIONALOUTBIN7, OPTIONALOUTBIN8, OPTIONALOUTBIN9, OPTIONALOUTBIN10, "name" <i>name</i> is a variable that allows for custom naming of optional output bins. The text string is truncated to 24 characters. Specifies a selected output bin for jobs printed on custom type 5 paper. A DINQUIRE or INQUIRE on the Assign Type/Bin - Custom Type 5 setting returns: <table border="0"> <tr> <td>Assign Type/Bin - Custom Type 5 setting</td> <td>DINQUIRE or INQUIRE value</td> </tr> <tr> <td>Standard Bin</td> <td>UPPER</td> </tr> <tr> <td>Bin 1</td> <td>OPTIONALOUTBIN1</td> </tr> <tr> <td>Bin 2</td> <td>OPTIONALOUTBIN2</td> </tr> <tr> <td>Bin 3</td> <td>OPTIONALOUTBIN3</td> </tr> <tr> <td>Bin 4</td> <td>OPTIONALOUTBIN4</td> </tr> <tr> <td>Bin 5</td> <td>OPTIONALOUTBIN5</td> </tr> <tr> <td>Bin 6</td> <td>OPTIONALOUTBIN6</td> </tr> <tr> <td>Bin 7</td> <td>OPTIONALOUTBIN7</td> </tr> <tr> <td>Bin 8</td> <td>OPTIONALOUTBIN8</td> </tr> <tr> <td>Bin 9</td> <td>OPTIONALOUTBIN9</td> </tr> <tr> <td>Bin 10</td> <td>OPTIONALOUTBIN10</td> </tr> <tr> <td>"name"</td> <td>"name"</td> </tr> </table>	Assign Type/Bin - Custom Type 5 setting	DINQUIRE or INQUIRE value	Standard Bin	UPPER	Bin 1	OPTIONALOUTBIN1	Bin 2	OPTIONALOUTBIN2	Bin 3	OPTIONALOUTBIN3	Bin 4	OPTIONALOUTBIN4	Bin 5	OPTIONALOUTBIN5	Bin 6	OPTIONALOUTBIN6	Bin 7	OPTIONALOUTBIN7	Bin 8	OPTIONALOUTBIN8	Bin 9	OPTIONALOUTBIN9	Bin 10	OPTIONALOUTBIN10	"name"	"name"	UPPER, DISABLED (Model specific)
Assign Type/Bin - Custom Type 5 setting	DINQUIRE or INQUIRE value																												
Standard Bin	UPPER																												
Bin 1	OPTIONALOUTBIN1																												
Bin 2	OPTIONALOUTBIN2																												
Bin 3	OPTIONALOUTBIN3																												
Bin 4	OPTIONALOUTBIN4																												
Bin 5	OPTIONALOUTBIN5																												
Bin 6	OPTIONALOUTBIN6																												
Bin 7	OPTIONALOUTBIN7																												
Bin 8	OPTIONALOUTBIN8																												
Bin 9	OPTIONALOUTBIN9																												
Bin 10	OPTIONALOUTBIN10																												
"name"	"name"																												
LCUSTOMTYPE5TEXTURE (DEFAULT only)	Custom Type 5 Texture	SMOOTH, NORMAL, ROUGH	NORMAL																										

Table 3-4: Printer Unique Variables for Both Printer Languages (Continued)

Variable	Function	Selections	Factory Default																										
LCUSTOMTYPE5WEIGHT (DEFAULT only)	Custom Type 5 Weight	LIGHT, NORMAL, HEAVY	NORMAL																										
LCUSTOMTYPE6LENGTH (DEFAULT only)	Custom Type 6 Length	NORMAL, SHORT	NORMAL																										
LCUSTOMTYPE6LOADING (DEFAULT only)	Custom Type 6 Paper Loading	OFF, DUPLEX	OFF																										
LCUSTOMTYPE6MEDIA (DEFAULT only)	Custom Type 6 Media	PAPER, COATED, GLOSSY, TRANSPARENCY, LABELS, CARDSTOCK, ENVELOPE, COTTONPAPER	PAPER																										
LCUSTOMTYPE6NAME (DEFAULT only)	Custom Type 6 Name	"name" <i>name</i> is a variable that allows for custom naming of print material types. The text string is truncated to 24 characters. When queried, the quotes are not returned around the string name. The default name is returned unless you have specified a custom name.	CUSTOMTYPE6																										
LCUSTOMTYPE6OUTBIN (DEFAULT only)	Assign Type/Bin - Custom Type 6	UPPER, LOWER, DISABLED, OPTIONALOUTBIN1, OPTIONALOUTBIN2, OPTIONALOUTBIN3, OPTIONALOUTBIN4, OPTIONALOUTBIN5, OPTIONALOUTBIN6, OPTIONALOUTBIN7, OPTIONALOUTBIN8, OPTIONALOUTBIN9, OPTIONALOUTBIN10, "name" <i>name</i> is a variable that allows for custom naming of optional output bins. The text string is truncated to 24 characters. Specifies a selected output bin for jobs printed on custom type 6 paper. A DINQUIRE or INQUIRE on the Assign Type/Bin - Custom Type 6 setting returns: <table border="0"> <tr> <td>Assign Type/Bin - Custom Type 6 setting</td> <td>DINQUIRE or INQUIRE value</td> </tr> <tr> <td>Standard Bin</td> <td>UPPER</td> </tr> <tr> <td>Bin 1</td> <td>OPTIONALOUTBIN1</td> </tr> <tr> <td>Bin 2</td> <td>OPTIONALOUTBIN2</td> </tr> <tr> <td>Bin 3</td> <td>OPTIONALOUTBIN3</td> </tr> <tr> <td>Bin 4</td> <td>OPTIONALOUTBIN4</td> </tr> <tr> <td>Bin 5</td> <td>OPTIONALOUTBIN5</td> </tr> <tr> <td>Bin 6</td> <td>OPTIONALOUTBIN6</td> </tr> <tr> <td>Bin 7</td> <td>OPTIONALOUTBIN7</td> </tr> <tr> <td>Bin 8</td> <td>OPTIONALOUTBIN8</td> </tr> <tr> <td>Bin 9</td> <td>OPTIONALOUTBIN9</td> </tr> <tr> <td>Bin 10</td> <td>OPTIONALOUTBIN10</td> </tr> <tr> <td>"name"</td> <td>"name"</td> </tr> </table>	Assign Type/Bin - Custom Type 6 setting	DINQUIRE or INQUIRE value	Standard Bin	UPPER	Bin 1	OPTIONALOUTBIN1	Bin 2	OPTIONALOUTBIN2	Bin 3	OPTIONALOUTBIN3	Bin 4	OPTIONALOUTBIN4	Bin 5	OPTIONALOUTBIN5	Bin 6	OPTIONALOUTBIN6	Bin 7	OPTIONALOUTBIN7	Bin 8	OPTIONALOUTBIN8	Bin 9	OPTIONALOUTBIN9	Bin 10	OPTIONALOUTBIN10	"name"	"name"	UPPER, DISABLED (Model specific)
Assign Type/Bin - Custom Type 6 setting	DINQUIRE or INQUIRE value																												
Standard Bin	UPPER																												
Bin 1	OPTIONALOUTBIN1																												
Bin 2	OPTIONALOUTBIN2																												
Bin 3	OPTIONALOUTBIN3																												
Bin 4	OPTIONALOUTBIN4																												
Bin 5	OPTIONALOUTBIN5																												
Bin 6	OPTIONALOUTBIN6																												
Bin 7	OPTIONALOUTBIN7																												
Bin 8	OPTIONALOUTBIN8																												
Bin 9	OPTIONALOUTBIN9																												
Bin 10	OPTIONALOUTBIN10																												
"name"	"name"																												

Table 3-4: Printer Unique Variables for Both Printer Languages (Continued)

Variable	Function	Selections	Factory Default																										
LCUSTOMTYPE6TEXTURE (DEFAULT only)	Custom Type 6 Texture	SMOOTH, NORMAL, ROUGH	NORMAL																										
LCUSTOMTYPE6WEIGHT (DEFAULT only)	Custom Type 6 Weight	LIGHT, NORMAL, HEAVY	NORMAL																										
LDOWNLOADTARGET (SET only)	Download Target	RAM, FLASH, FLASH1, DISK, DISK1 If the device specified as the download target is write or read/write password protected, the download target will not be changed.	RAM																										
LDRYTIMEDELAY	Dry Time Delay	0, 3 ... 30, OFF, AUTO	OFF																										
LDUPLICATEHELDJOBS	Delete or Save Print and Hold Jobs	DELETE, SAVE	DELETE																										
LENVELOPEENHANCE (DEFAULT only)	Envelope Enhance	ON, OFF	ON																										
LENVELOPELENGTH (DEFAULT only)	Envelope Length	NORMAL, SHORT	NORMAL																										
LENVELOPEOUTBIN (DEFAULT only)	Assign Type/Bin - Envelope	UPPER, LOWER, DISABLED, OPTIONALOUTBIN1, OPTIONALOUTBIN2, OPTIONALOUTBIN3, OPTIONALOUTBIN4, OPTIONALOUTBIN5, OPTIONALOUTBIN6, OPTIONALOUTBIN7, OPTIONALOUTBIN8, OPTIONALOUTBIN9, OPTIONALOUTBIN10, "name" <i>name</i> is a variable that allows for custom naming of optional output bins. The text string is truncated to 24 characters. Specifies a selected output bin for jobs printed on envelopes. A DINQUIRE or INQUIRE on the Assign Type/Bin - Envelope setting returns: <table border="0"> <tr> <td>Assign Type/Bin - Envelope setting</td> <td>DINQUIRE or INQUIRE value</td> </tr> <tr> <td>Standard Bin</td> <td>UPPER</td> </tr> <tr> <td>Bin 1</td> <td>OPTIONALOUTBIN1</td> </tr> <tr> <td>Bin 2</td> <td>OPTIONALOUTBIN2</td> </tr> <tr> <td>Bin 3</td> <td>OPTIONALOUTBIN3</td> </tr> <tr> <td>Bin 4</td> <td>OPTIONALOUTBIN4</td> </tr> <tr> <td>Bin 5</td> <td>OPTIONALOUTBIN5</td> </tr> <tr> <td>Bin 6</td> <td>OPTIONALOUTBIN6</td> </tr> <tr> <td>Bin 7</td> <td>OPTIONALOUTBIN7</td> </tr> <tr> <td>Bin 8</td> <td>OPTIONALOUTBIN8</td> </tr> <tr> <td>Bin 9</td> <td>OPTIONALOUTBIN9</td> </tr> <tr> <td>Bin 10</td> <td>OPTIONALOUTBIN10</td> </tr> <tr> <td>"name"</td> <td>"name"</td> </tr> </table>	Assign Type/Bin - Envelope setting	DINQUIRE or INQUIRE value	Standard Bin	UPPER	Bin 1	OPTIONALOUTBIN1	Bin 2	OPTIONALOUTBIN2	Bin 3	OPTIONALOUTBIN3	Bin 4	OPTIONALOUTBIN4	Bin 5	OPTIONALOUTBIN5	Bin 6	OPTIONALOUTBIN6	Bin 7	OPTIONALOUTBIN7	Bin 8	OPTIONALOUTBIN8	Bin 9	OPTIONALOUTBIN9	Bin 10	OPTIONALOUTBIN10	"name"	"name"	UPPER, DISABLED (Model specific)
Assign Type/Bin - Envelope setting	DINQUIRE or INQUIRE value																												
Standard Bin	UPPER																												
Bin 1	OPTIONALOUTBIN1																												
Bin 2	OPTIONALOUTBIN2																												
Bin 3	OPTIONALOUTBIN3																												
Bin 4	OPTIONALOUTBIN4																												
Bin 5	OPTIONALOUTBIN5																												
Bin 6	OPTIONALOUTBIN6																												
Bin 7	OPTIONALOUTBIN7																												
Bin 8	OPTIONALOUTBIN8																												
Bin 9	OPTIONALOUTBIN9																												
Bin 10	OPTIONALOUTBIN10																												
"name"	"name"																												

Table 3-4: Printer Unique Variables for Both Printer Languages (Continued)

Variable	Function	Selections	Factory Default
LENVELOPETEXTURE (DEFAULT only)	Envelope Texture	SMOOTH, NORMAL, ROUGH	NORMAL
LENVELOPEWEIGHT (DEFAULT only)	Envelope Weight	LIGHT, NORMAL, HEAVY	NORMAL
LESCCHAR (READ only) (Port specific)	ESC Character Substitution	0 to 255	27
LFAXRESOLUTION (SET only)	Fax Resolution	STANDARD, FINE, SUPERFINE, ULTRAFINE Note: Status Readback commands return a ? when no SET command has modified the LFAXRESOLUTION variable. For more information, see "Status Readback Commands" on page 3-54.	STANDARD
LFAXREDIAL (SET only)	Fax Redial	0 to 14 Note: Status Readback commands return a ? when no SET command has modified the LFAXREDIAL variable. For more information, see "Status Readback Commands" on page 3-54.	5
LFAXREDIALFREQUENCY (SET only)	Fax Redial Frequency	1 to 200 Note: Status Readback commands return a ? when no SET command has modified the LFAXREDIALFREQUENCY variable. For more information, see "Status Readback Commands" on page 3-54.	3
LFAXTRANSMISSIONLOG (SET only)	Fax Transmission Log	PRINT, DONOTPRINT, PRINTERERROR Note: Status Readback commands return a ? when no SET command has modified the LFAXTRANSMISSIONLOG variable. For more information, see "Status Readback Commands" on page 3-54.	PRINTERERROR
LFEEDERPAPERSTYPE	Envelope Feeder Paper Type	ENVELOPE, CUSTOMTYPE1, CUSTOMTYPE2, CUSTOMTYPE3, CUSTOMTYPE4, CUSTOMTYPE5, CUSTOMTYPE6, "name" <i>name</i> is a variable that allows for custom naming of print material types. The text string is truncated to 24 characters.	ENVELOPE
LGLOSSYLOADING	Glossy Paper Loading	OFF, DUPLEX	OFF

Table 3-4: Printer Unique Variables for Both Printer Languages (Continued)

Variable	Function	Selections	Factory Default																										
LGLOSSYOUTPUTBIN	Assign Type/Bin - Glossy	<p>UPPER, LOWER, OPTIONALOUTBIN1, OPTIONALOUTBIN2, OPTIONALOUTBIN3, OPTIONALOUTBIN4, OPTIONALOUTBIN5, OPTIONALOUTBIN6, OPTIONALOUTBIN7, OPTIONALOUTBIN8, OPTIONALOUTBIN9, OPTIONALOUTBIN10, "name"</p> <p><i>name</i> is a variable that allows for custom naming of optional output bins. The text string is truncated to 24 characters.</p> <p>Specifies a selected output bin for jobs printed on Glossy paper.</p> <p>A DINKQUIRE or INQUIRE on the Assign Type/Bin - Glossy setting returns:</p> <table border="1"> <thead> <tr> <th>Assign Type/Bin - Glossy setting</th> <th>DINKQUIRE or INQUIRE value</th> </tr> </thead> <tbody> <tr> <td>Standard Bin</td> <td>UPPER</td> </tr> <tr> <td>Bin 1</td> <td>OPTIONALOUTBIN1</td> </tr> <tr> <td>Bin 2</td> <td>OPTIONALOUTBIN2</td> </tr> <tr> <td>Bin 3</td> <td>OPTIONALOUTBIN3</td> </tr> <tr> <td>Bin 4</td> <td>OPTIONALOUTBIN4</td> </tr> <tr> <td>Bin 5</td> <td>OPTIONALOUTBIN5</td> </tr> <tr> <td>Bin 6</td> <td>OPTIONALOUTBIN6</td> </tr> <tr> <td>Bin 7</td> <td>OPTIONALOUTBIN7</td> </tr> <tr> <td>Bin 8</td> <td>OPTIONALOUTBIN8</td> </tr> <tr> <td>Bin 9</td> <td>OPTIONALOUTBIN9</td> </tr> <tr> <td>Bin 10</td> <td>OPTIONALOUTBIN10</td> </tr> <tr> <td>"name"</td> <td>"name"</td> </tr> </tbody> </table>	Assign Type/Bin - Glossy setting	DINKQUIRE or INQUIRE value	Standard Bin	UPPER	Bin 1	OPTIONALOUTBIN1	Bin 2	OPTIONALOUTBIN2	Bin 3	OPTIONALOUTBIN3	Bin 4	OPTIONALOUTBIN4	Bin 5	OPTIONALOUTBIN5	Bin 6	OPTIONALOUTBIN6	Bin 7	OPTIONALOUTBIN7	Bin 8	OPTIONALOUTBIN8	Bin 9	OPTIONALOUTBIN9	Bin 10	OPTIONALOUTBIN10	"name"	"name"	UPPER
Assign Type/Bin - Glossy setting	DINKQUIRE or INQUIRE value																												
Standard Bin	UPPER																												
Bin 1	OPTIONALOUTBIN1																												
Bin 2	OPTIONALOUTBIN2																												
Bin 3	OPTIONALOUTBIN3																												
Bin 4	OPTIONALOUTBIN4																												
Bin 5	OPTIONALOUTBIN5																												
Bin 6	OPTIONALOUTBIN6																												
Bin 7	OPTIONALOUTBIN7																												
Bin 8	OPTIONALOUTBIN8																												
Bin 9	OPTIONALOUTBIN9																												
Bin 10	OPTIONALOUTBIN10																												
"name"	"name"																												
LGLOSSYTEXTURE	Glossy Paper Texture	SMOOTH, NORMAL, ROUGH	NORMAL																										
LGLOSSYWEIGHT	Glossy Paper Weight	LIGHT, NORMAL, HEAVY	NORMAL																										
LHOLEPUNCHALARM	Hole Punch Alarm	OFF, SINGLE, CONTINUOUS	OFF																										
LHOLEPUNCHMODE	Hole Punch Mode	2HOLE, 3HOLE, 4HOLE	3HOLE (US) 4HOLE (non-US)																										
LHONORINIT (DEFAULT only) (Port specific)	Honor INIT Signal	HONORSIGNAL, DONOTHONORSIGNAL	DONOTHONOR SIGNAL																										
LIMAGEBRIGHTNESS	Image Brightness	-100 to 100	0																										
LIMAGECONTRAST	Image Contrast	-100 to 100	0																										
LIMAGEENHANCE	Image Enhancement Technology	ON, OFF	OFF																										

Table 3-4: Printer Unique Variables for Both Printer Languages (Continued)

Variable	Function	Selections	Factory Default
LIMAGEENHANCETYPE	Image Enhancement Technology Type	2, 4, AUTO	2, 4 (Model specific)
LIMAGEORIENTATION	Page Image Orientation	DONOTROTATE, ROTATEPAPER, ROTATEENVELOPES, ROTATESTAPLED, ROTATESTAPLEDANDENVELOPES, ROTATEALL	DONOTROTATE Note: The factory default is ROTATEPAPER if an optional finisher is installed.
LIMAGESMOOTHING	Image Smoothing for PostScript	ON, OFF	OFF
LINFEDERSIZE	Envelope feeder installed size, default formatting size	COM10, COM9, MONARCH, DL, C5, B5, OTHERENVELOPE	COM10, DL (Country specific)
LINKALERT	Ink Alert	ON, OFF Displays a printer attendance message when an ink cartridge is low.	OFF
LINMPFEEDERSIZE	Multipurpose feeder installed size, default formatting size	Paper: A3, A3+, A4, A5, JISB4, B5PAPER, JISB5, CUSTOM, EXECUTIVE, FOLIO, LEDGER, LEGAL, LETTER, STATEMENT, 11X17 Envelopes: COM10, COM9, MONARCH, DL, C5, B5, OTHERENVELOPE	LETTER, A4 (Country specific)
LJAMRECOVERY	Jam Recovery	ON, OFF, AUTO	AUTO
LLABELSLENGTH (DEFAULT only)	Labels Length	NORMAL, SHORT	NORMAL
LLABELSLOADING (DEFAULT only)	Labels Paper Loading	OFF, DUPLEX	OFF

Table 3-4: Printer Unique Variables for Both Printer Languages (Continued)

Variable	Function	Selections	Factory Default																										
LLABELSOUTBIN (DEFAULT only)	Assign Type/Bin - Labels	<p>UPPER, LOWER, DISABLED, OPTIONALOUTBIN1, OPTIONALOUTBIN2, OPTIONALOUTBIN3, OPTIONALOUTBIN4, OPTIONALOUTBIN5, OPTIONALOUTBIN6, OPTIONALOUTBIN7, OPTIONALOUTBIN8, OPTIONALOUTBIN9, OPTIONALOUTBIN10, "name"</p> <p><i>name</i> is a variable that allows for custom naming of optional output bins. The text string is truncated to 24 characters.</p> <p>Specifies a selected output bin for jobs printed on labels.</p> <p>A DINKQUIRE or INQUIRE on the Assign Type/Bin - Labels setting returns:</p> <table border="0"> <tr> <td style="text-align: center;">Assign Type/Bin - Labels setting</td> <td style="text-align: center;">DINKQUIRE or INQUIRE value</td> </tr> <tr> <td>Standard Bin</td> <td>UPPER</td> </tr> <tr> <td>Bin 1</td> <td>OPTIONALOUTBIN1</td> </tr> <tr> <td>Bin 2</td> <td>OPTIONALOUTBIN2</td> </tr> <tr> <td>Bin 3</td> <td>OPTIONALOUTBIN3</td> </tr> <tr> <td>Bin 4</td> <td>OPTIONALOUTBIN4</td> </tr> <tr> <td>Bin 5</td> <td>OPTIONALOUTBIN5</td> </tr> <tr> <td>Bin 6</td> <td>OPTIONALOUTBIN6</td> </tr> <tr> <td>Bin 7</td> <td>OPTIONALOUTBIN7</td> </tr> <tr> <td>Bin 8</td> <td>OPTIONALOUTBIN8</td> </tr> <tr> <td>Bin 9</td> <td>OPTIONALOUTBIN9</td> </tr> <tr> <td>Bin 10</td> <td>OPTIONALOUTBIN10</td> </tr> <tr> <td>"name"</td> <td>"name"</td> </tr> </table>	Assign Type/Bin - Labels setting	DINKQUIRE or INQUIRE value	Standard Bin	UPPER	Bin 1	OPTIONALOUTBIN1	Bin 2	OPTIONALOUTBIN2	Bin 3	OPTIONALOUTBIN3	Bin 4	OPTIONALOUTBIN4	Bin 5	OPTIONALOUTBIN5	Bin 6	OPTIONALOUTBIN6	Bin 7	OPTIONALOUTBIN7	Bin 8	OPTIONALOUTBIN8	Bin 9	OPTIONALOUTBIN9	Bin 10	OPTIONALOUTBIN10	"name"	"name"	UPPER, DISABLED (Model specific)
Assign Type/Bin - Labels setting	DINKQUIRE or INQUIRE value																												
Standard Bin	UPPER																												
Bin 1	OPTIONALOUTBIN1																												
Bin 2	OPTIONALOUTBIN2																												
Bin 3	OPTIONALOUTBIN3																												
Bin 4	OPTIONALOUTBIN4																												
Bin 5	OPTIONALOUTBIN5																												
Bin 6	OPTIONALOUTBIN6																												
Bin 7	OPTIONALOUTBIN7																												
Bin 8	OPTIONALOUTBIN8																												
Bin 9	OPTIONALOUTBIN9																												
Bin 10	OPTIONALOUTBIN10																												
"name"	"name"																												
LLABELSTEXTURE (DEFAULT only)	Labels Texture	SMOOTH, NORMAL, ROUGH	NORMAL																										
LLABELSWEIGHT (DEFAULT only)	Labels Weight	LIGHT, NORMAL, HEAVY	NORMAL																										
LLASTTRAYRENUMBER	Last Tray Renumber	OFF, TRAY1, TRAY2, TRAY3, TRAY4, TRAY5, MPFEEDER	OFF																										
LLEFTMARGINOFFSET	Left Margin Offset	-128 to 127	0																										
LLETTERHEADLENGTH (DEFAULT only)	Letterhead Length	NORMAL, SHORT	NORMAL																										
LLETTERHEADLOADING (DEFAULT only)	Letterhead Paper Loading	OFF, DUPLEX	OFF																										

Table 3-4: Printer Unique Variables for Both Printer Languages (Continued)

Variable	Function	Selections	Factory Default																										
LLETTERHEADOUTBIN (DEFAULT only)	Assign Type/Bin - Letterhead	UPPER, LOWER, DISABLED, OPTIONALOUTBIN1, OPTIONALOUTBIN2, OPTIONALOUTBIN3, OPTIONALOUTBIN4, OPTIONALOUTBIN5, OPTIONALOUTBIN6, OPTIONALOUTBIN7, OPTIONALOUTBIN8, OPTIONALOUTBIN9, OPTIONALOUTBIN10, "name" <i>name</i> is a variable that allows for custom naming of optional output bins. The text string is truncated to 24 characters. Specifies a selected output bin for jobs printed on letterhead paper. A DINKQUIRE or INQUIRE on the Assign Type/Bin - Letterhead setting returns: <table border="0"> <tr> <td>Assign Type/Bin - Letterhead setting</td> <td>DINKQUIRE or INQUIRE value</td> </tr> <tr> <td>Standard Bin</td> <td>UPPER</td> </tr> <tr> <td>Bin 1</td> <td>OPTIONALOUTBIN1</td> </tr> <tr> <td>Bin 2</td> <td>OPTIONALOUTBIN2</td> </tr> <tr> <td>Bin 3</td> <td>OPTIONALOUTBIN3</td> </tr> <tr> <td>Bin 4</td> <td>OPTIONALOUTBIN4</td> </tr> <tr> <td>Bin 5</td> <td>OPTIONALOUTBIN5</td> </tr> <tr> <td>Bin 6</td> <td>OPTIONALOUTBIN6</td> </tr> <tr> <td>Bin 7</td> <td>OPTIONALOUTBIN7</td> </tr> <tr> <td>Bin 8</td> <td>OPTIONALOUTBIN8</td> </tr> <tr> <td>Bin 9</td> <td>OPTIONALOUTBIN9</td> </tr> <tr> <td>Bin 10</td> <td>OPTIONALOUTBIN10</td> </tr> <tr> <td>"name"</td> <td>"name"</td> </tr> </table>	Assign Type/Bin - Letterhead setting	DINKQUIRE or INQUIRE value	Standard Bin	UPPER	Bin 1	OPTIONALOUTBIN1	Bin 2	OPTIONALOUTBIN2	Bin 3	OPTIONALOUTBIN3	Bin 4	OPTIONALOUTBIN4	Bin 5	OPTIONALOUTBIN5	Bin 6	OPTIONALOUTBIN6	Bin 7	OPTIONALOUTBIN7	Bin 8	OPTIONALOUTBIN8	Bin 9	OPTIONALOUTBIN9	Bin 10	OPTIONALOUTBIN10	"name"	"name"	UPPER, DISABLED (Model specific)
Assign Type/Bin - Letterhead setting	DINKQUIRE or INQUIRE value																												
Standard Bin	UPPER																												
Bin 1	OPTIONALOUTBIN1																												
Bin 2	OPTIONALOUTBIN2																												
Bin 3	OPTIONALOUTBIN3																												
Bin 4	OPTIONALOUTBIN4																												
Bin 5	OPTIONALOUTBIN5																												
Bin 6	OPTIONALOUTBIN6																												
Bin 7	OPTIONALOUTBIN7																												
Bin 8	OPTIONALOUTBIN8																												
Bin 9	OPTIONALOUTBIN9																												
Bin 10	OPTIONALOUTBIN10																												
"name"	"name"																												
LLETTERHEADTEXTURE (DEFAULT only)	Letterhead Texture	SMOOTH, NORMAL, ROUGH	NORMAL																										
LLETTERHEADWEIGHT (DEFAULT only)	Letterhead Weight	LIGHT, NORMAL, HEAVY	NORMAL																										
LMANUALCOLORRGBTEXT	Manual Color - RGB Text	OFF, VIVID, SRGBVIVID, SRGBDISPLAY	SRGBVIVID																										
LMANUALCOLORRGB- GRAPHICS	Manual Color - RGB Graphics	OFF, VIVID, SRGBVIVID, SRGBDISPLAY	SRGBVIVID																										
LMANUALCOLORRGB- IMAGE	Manual Color - RGB Image	OFF, VIVID, SRGBVIVID, SRGBDISPLAY	SRGBDISPLAY																										
LMANUALCOLORCMYK- TEXT	Manual Color - CMYK Text	OFF, VIVID, VIVIDCMYK, USCMYK, EUROCMYK	USCMYK (US) EUROCMYK (non-US)																										
LMANUALCOLORCMYK- GRAPHICS	Manual Color - CMYK Graphics	OFF, VIVID, VIVIDCMYK, USCMYK, EUROCMYK	USCMYK (US) EUROCMYK (non-US)																										

Table 3-4: Printer Unique Variables for Both Printer Languages (Continued)

Variable	Function	Selections	Factory Default
LMANUALCOLORCMYK-IMAGE	Manual Color - CMYK Image	OFF, VIVID, VIVIDCMYK, USCMYK, EUROCMYK	USCMYK (US) EUROCMYK (non-US)
LMANUALENVELOPESIZE	Manual Envelope, default formatting size	COM10, COM9, MONARCH, DL, C5, B5, OTHERENVELOPE	COM10, DL (Country specific)
LMANUALENVELOPETYPE	Manual Envelope Type	ENVELOPE, CUSTOMTYPE1, CUSTOMTYPE2, CUSTOMTYPE3, CUSTOMTYPE4, CUSTOMTYPE5, CUSTOMTYPE6, "name" <i>name</i> is a variable that allows for custom naming of custom print material types. The text string is truncated to 24 characters.	ENVELOPE
LMANUALPAPERSIZE	Manual Paper, default formatting size	A3, A3+, A4, A5, B4, B4PAPER, B5PAPER, CUSTOM, EXECUTIVE, FOLIO, JISB4, JISB5, LEDGER, LEGAL, LETTER, STATEMENT, 11X17	LETTER, A4 (Country specific)
LMANUALPAPERTYPE	Manual Paper Type	PLAIN, COATED, GLOSSY, PHOTO, GREETINGCARD, IRONON, BOND, TRANSPARENCY, CARDSTOCK, LABELS, LETTERHEAD, PREPRINTED, COLORED, ENVELOPE, CUSTOMTYPE1, CUSTOMTYPE2, CUSTOMTYPE3, CUSTOMTYPE4, CUSTOMTYPE5, CUSTOMTYPE6, "name" <i>name</i> is a variable that allows for custom naming of print material types. The text string is truncated to 24 characters. When queried, the quotes are not returned around the string name. The default name is returned unless you have specified a custom name.	PLAIN, CUSTOMTYPE3 (Model specific)
LMPFEEDERPAPERTYPE	Multipurpose Feeder Paper Type	PLAIN, COATED, GLOSSY, PHOTO, GREETINGCARD, IRONON, BOND, TRANSPARENCY, CARDSTOCK, LABELS, LETTERHEAD, PREPRINTED, COLORED, ENVELOPE, CUSTOMTYPE1, CUSTOMTYPE2, CUSTOMTYPE3, CUSTOMTYPE4, CUSTOMTYPE5, CUSTOMTYPE6, "name" <i>name</i> is a variable that allows for custom naming of print material types. The text string is truncated to 24 characters. When queried, the quotes are not returned around the string name. The default name is returned unless you have specified a custom name.	CUSTOMTYPE3, CUSTOMTYPE4, CUSTOMTYPE6 PLAIN (Model specific)
LMULTIPAGEBORDER	Multipage Border	NONE, SOLID	NONE
LMULTIPAGEORDER	Multipage Order	HORIZONTAL, VERTICAL, REVHORIZONTAL, REVVERTICAL	HORIZONTAL

Table 3-4: Printer Unique Variables for Both Printer Languages (Continued)

Variable	Function	Selections	Factory Default
LMULTIPAGEPRINT	Multipage Printing	OFF, 2UP, 3UP, 4UP, 6UP, 9UP, 12UP, 16UP	OFF
LMULTIPAGEVIEW	Multipage View	AUTO, SHORTEEDGE, LONGEDGE	AUTO
LNPAP (READ only) (Port specific)	NPA Protocol Setting	ON, OFF, AUTO This value is reported for the interface link that the command is received.	AUTO
LOPTIONALOUTBIN1NAME (DEFAULT only)	Optional Output Bin 1 Name	"name" <i>name</i> is a variable that allows for custom naming of optional output bins. The text string is truncated to 24 characters. When queried, the quotes are not returned around the string name. The default name is returned unless you have specified a custom name.	OPTIONAL OUTBIN1
LOPTIONALOUTBIN2NAME (DEFAULT only)	Optional Output Bin 2 Name	"name" <i>name</i> is a variable that allows for custom naming of optional output bins. The text string is truncated to 24 characters. When queried, the quotes are not returned around the string name. The default name is returned unless you have specified a custom name.	OPTIONAL OUTBIN2
LOPTIONALOUTBIN3NAME (DEFAULT only)	Optional Output Bin 3 Name	"name" <i>name</i> is a variable that allows for custom naming of optional output bins. The text string is truncated to 24 characters. When queried, the quotes are not returned around the string name. The default name is returned unless you have specified a custom name.	OPTIONAL OUTBIN3
LOPTIONALOUTBIN4NAME (DEFAULT only)	Optional Output Bin 4 Name	"name" <i>name</i> is a variable that allows for custom naming of optional output bins. The text string is truncated to 24 characters. When queried, the quotes are not returned around the string name. The default name is returned unless you have specified a custom name.	OPTIONAL OUTBIN4
LOPTIONALOUTBIN5NAME (DEFAULT only)	Optional Output Bin 5 Name	"name" <i>name</i> is a variable that allows for custom naming of optional output bins. The text string is truncated to 24 characters. When queried, the quotes are not returned around the string name. The default name is returned unless you have specified a custom name.	OPTIONAL OUTBIN5

Table 3-4: Printer Unique Variables for Both Printer Languages (Continued)

Variable	Function	Selections	Factory Default
LOPTIONALOUTBIN6NAME (DEFAULT only)	Optional Output Bin 6 Name	"name" <i>name</i> is a variable that allows for custom naming of optional output bins. The text string is truncated to 24 characters. When queried, the quotes are not returned around the string name. The default name is returned unless you have specified a custom name.	OPTIONAL OUTBIN6
LOPTIONALOUTBIN7NAME (DEFAULT only)	Optional Output Bin 7 Name	"name" <i>name</i> is a variable that allows for custom naming of optional output bins. The text string is truncated to 24 characters. When queried, the quotes are not returned around the string name. The default name is returned unless you have specified a custom name.	OPTIONAL OUTBIN7
LOPTIONALOUTBIN8NAME (DEFAULT only)	Optional Output Bin 8 Name	"name" <i>name</i> is a variable that allows for custom naming of optional output bins. The text string is truncated to 24 characters. When queried, the quotes are not returned around the string name. The default name is returned unless you have specified a custom name.	OPTIONAL OUTBIN8
LOPTIONALOUTBIN9NAME (DEFAULT only)	Optional Output Bin 9 Name	"name" <i>name</i> is a variable that allows for custom naming of optional output bins. The text string is truncated to 24 characters. When queried, the quotes are not returned around the string name. The default name is returned unless you have specified a custom name.	OPTIONAL OUTBIN9
LOPTIONALOUTBIN10NAME (DEFAULT only)	Optional Output Bin 10 Name	"name" <i>name</i> is a variable that allows for custom naming of optional output bins. The text string is truncated to 24 characters. When queried, the quotes are not returned around the string name. The default name is returned unless you have specified a custom name.	OPTIONAL OUTBIN10
LOUTBINCONFIG (DEFAULT only)	Configure Output Bins	MAILBOX, LINK, MAILBOXOVERFLOW, LINKOPTIONAL, TYPEASSIGNMENT	MAILBOX

Table 3-4: Printer Unique Variables for Both Printer Languages (Continued)

Variable	Function	Selections	Factory Default																										
LOVERFLOWOUTBIN (DEFAULT only)	Overflow Bin	<p>UPPER, LOWER, OPTIONALOUTBIN1, OPTIONALOUTBIN2, OPTIONALOUTBIN3, OPTIONALOUTBIN4, OPTIONALOUTBIN5, OPTIONALOUTBIN6, OPTIONALOUTBIN7, OPTIONALOUTBIN8, OPTIONALOUTBIN9, OPTIONALOUTBIN10, "name"</p> <p><i>name</i> is a variable that allows for custom naming of optional output bins. The text string is truncated to 24 characters.</p> <p>If an output bin is full, print jobs assigned to that output bin exit to the assigned overflow output bin.</p> <p>A DINQUIRE or INQUIRE on the Overflow Bin setting returns:</p> <table border="0"> <thead> <tr> <th>Overflow Bin setting</th> <th>DINQUIRE or INQUIRE value</th> </tr> </thead> <tbody> <tr> <td>Standard Bin</td> <td>UPPER</td> </tr> <tr> <td>Bin 1</td> <td>OPTIONALOUTBIN1</td> </tr> <tr> <td>Bin 2</td> <td>OPTIONALOUTBIN2</td> </tr> <tr> <td>Bin 3</td> <td>OPTIONALOUTBIN3</td> </tr> <tr> <td>Bin 4</td> <td>OPTIONALOUTBIN4</td> </tr> <tr> <td>Bin 5</td> <td>OPTIONALOUTBIN5</td> </tr> <tr> <td>Bin 6</td> <td>OPTIONALOUTBIN6</td> </tr> <tr> <td>Bin 7</td> <td>OPTIONALOUTBIN7</td> </tr> <tr> <td>Bin 8</td> <td>OPTIONALOUTBIN8</td> </tr> <tr> <td>Bin 9</td> <td>OPTIONALOUTBIN9</td> </tr> <tr> <td>Bin 10</td> <td>OPTIONALOUTBIN10</td> </tr> <tr> <td>"name"</td> <td>"name"</td> </tr> </tbody> </table>	Overflow Bin setting	DINQUIRE or INQUIRE value	Standard Bin	UPPER	Bin 1	OPTIONALOUTBIN1	Bin 2	OPTIONALOUTBIN2	Bin 3	OPTIONALOUTBIN3	Bin 4	OPTIONALOUTBIN4	Bin 5	OPTIONALOUTBIN5	Bin 6	OPTIONALOUTBIN6	Bin 7	OPTIONALOUTBIN7	Bin 8	OPTIONALOUTBIN8	Bin 9	OPTIONALOUTBIN9	Bin 10	OPTIONALOUTBIN10	"name"	"name"	UPPER
Overflow Bin setting	DINQUIRE or INQUIRE value																												
Standard Bin	UPPER																												
Bin 1	OPTIONALOUTBIN1																												
Bin 2	OPTIONALOUTBIN2																												
Bin 3	OPTIONALOUTBIN3																												
Bin 4	OPTIONALOUTBIN4																												
Bin 5	OPTIONALOUTBIN5																												
Bin 6	OPTIONALOUTBIN6																												
Bin 7	OPTIONALOUTBIN7																												
Bin 8	OPTIONALOUTBIN8																												
Bin 9	OPTIONALOUTBIN9																												
Bin 10	OPTIONALOUTBIN10																												
"name"	"name"																												
LOVERFLOWTIMER (DEFAULT only)	Overflow Timer, in minutes	<p>0 to 255</p> <p>A value of 0 (zero) indicates Overflow Timer is set to Disabled.</p> <p>If Overflow Timer is set to Disabled, a DINQUIRE or INQUIRE on the Overflow Timer setting returns zero.</p> <p>If Overflow Timer is set to a numeric value, a DINQUIRE or INQUIRE on the Overflow Timer setting returns that value.</p>	0																										
LPAGECOUNT (READ only)	Page Count	0 to 999999	0																										
LPAGEMODE	Print Area	NORMAL, WHOLEPAGE, FULLPAGE	NORMAL																										
LPAPERSOURCE	Default paper source	<p>TRAY1, TRAY2, TRAY3, TRAY4, TRAY5, FEEDER, MPFEEDER, MANUALPAPER, MANUALEVELOPE</p> <p>Note: If any optional source is specified, but it is not installed, the default paper source is not changed.</p> <p>See "Table B-2: Printer Unique PJL Variables for Both Printer Languages" on page B-4 for the default value of your printer.</p>	TRAY1, TRAY2 (Model specific)																										

Table 3-4: Printer Unique Variables for Both Printer Languages (Continued)

Variable	Function	Selections	Factory Default																										
LPICTUREGRADE™	PictureGrade™	ON, OFF	ON																										
LPLAINLENGTH (DEFAULT only)	Plain Paper Length	NORMAL, SHORT	NORMAL																										
LPLAINOUTBIN (DEFAULT only)	Assign Type/Bin - Plain Paper	<p>UPPER, LOWER, DISABLED, OPTIONALOUTBIN1, OPTIONALOUTBIN2, OPTIONALOUTBIN3, OPTIONALOUTBIN4, OPTIONALOUTBIN5, OPTIONALOUTBIN6, OPTIONALOUTBIN7, OPTIONALOUTBIN8, OPTIONALOUTBIN9, OPTIONALOUTBIN10, "name"</p> <p><i>name</i> is a variable that allows for custom naming of optional output bins. The text string is truncated to 24 characters.</p> <p>Specifies a selected output bin for jobs printed on plain paper.</p> <p>A DINQUIRE or INQUIRE on the Assign Type/Bin - Plain setting returns:</p> <table border="1"> <thead> <tr> <th>Assign Type/Bin - Plain setting</th> <th>DINQUIRE or INQUIRE value</th> </tr> </thead> <tbody> <tr> <td>Standard Bin</td> <td>UPPER</td> </tr> <tr> <td>Bin 1</td> <td>OPTIONALOUTBIN1</td> </tr> <tr> <td>Bin 2</td> <td>OPTIONALOUTBIN2</td> </tr> <tr> <td>Bin 3</td> <td>OPTIONALOUTBIN3</td> </tr> <tr> <td>Bin 4</td> <td>OPTIONALOUTBIN4</td> </tr> <tr> <td>Bin 5</td> <td>OPTIONALOUTBIN5</td> </tr> <tr> <td>Bin 6</td> <td>OPTIONALOUTBIN6</td> </tr> <tr> <td>Bin 7</td> <td>OPTIONALOUTBIN7</td> </tr> <tr> <td>Bin 8</td> <td>OPTIONALOUTBIN8</td> </tr> <tr> <td>Bin 9</td> <td>OPTIONALOUTBIN9</td> </tr> <tr> <td>Bin 10</td> <td>OPTIONALOUTBIN10</td> </tr> <tr> <td>"name"</td> <td>"name"</td> </tr> </tbody> </table>	Assign Type/Bin - Plain setting	DINQUIRE or INQUIRE value	Standard Bin	UPPER	Bin 1	OPTIONALOUTBIN1	Bin 2	OPTIONALOUTBIN2	Bin 3	OPTIONALOUTBIN3	Bin 4	OPTIONALOUTBIN4	Bin 5	OPTIONALOUTBIN5	Bin 6	OPTIONALOUTBIN6	Bin 7	OPTIONALOUTBIN7	Bin 8	OPTIONALOUTBIN8	Bin 9	OPTIONALOUTBIN9	Bin 10	OPTIONALOUTBIN10	"name"	"name"	UPPER, DISABLED (Model specific)
Assign Type/Bin - Plain setting	DINQUIRE or INQUIRE value																												
Standard Bin	UPPER																												
Bin 1	OPTIONALOUTBIN1																												
Bin 2	OPTIONALOUTBIN2																												
Bin 3	OPTIONALOUTBIN3																												
Bin 4	OPTIONALOUTBIN4																												
Bin 5	OPTIONALOUTBIN5																												
Bin 6	OPTIONALOUTBIN6																												
Bin 7	OPTIONALOUTBIN7																												
Bin 8	OPTIONALOUTBIN8																												
Bin 9	OPTIONALOUTBIN9																												
Bin 10	OPTIONALOUTBIN10																												
"name"	"name"																												
LPLAINTEXTURE (DEFAULT only)	Plain Paper Texture	SMOOTH, NORMAL, ROUGH	NORMAL																										
LPLAINWEIGHT (DEFAULT only)	Plain Paper Weight	LIGHT, NORMAL, HEAVY	NORMAL																										
LPOWERSAVER (DEFAULT only)	Power Saver time, in minutes	<p>0 to 120 (Model specific)</p> <p>0 to 240 (Model specific)</p> <p>(0 indicates the Power Saver feature is disabled.)</p> <p>Note: If a value outside the possible value range is specified by a SET or DEFAULT command, the value is changed to the closest value within the possible value range.</p> <p>Some printer models released in the year 2000 or later designated as Energy Star printers cannot have Power Saver disabled.</p>	20																										

Table 3-4: Printer Unique Variables for Both Printer Languages (Continued)

Variable	Function	Selections	Factory Default
LPPDS (DEFAULT only)	Activate Personal Printer Data Stream (PPDS) printer language	ON, OFF Use ON to enable PPDS printer language and OFF to disable PPDS printer language. After this command is processed, the printer performs a Power On Reset (POR) to activate the changes. Note: The following printer settings in NVRAM are changed when PPDS is activated: <ul style="list-style-type: none"> • PCL and PS SmartSwitch settings for each port are turned off. • Printer Language is set to PPDS. 	OFF
LPPDSFORMLINES (DEFAULT only)	Lines Per Page (PPDS)	1 to 255	64, 68 (Country specific)
LPPDSLINESPERINCH (DEFAULT only)	Lines Per Inch	0.25 to 30.00 in increments of 0.25 Note: If a Lines Per Inch setting outside this range is specified, the printer defaults to the closest number in the range.	6.00
LPREPRINTEDLENGTH (DEFAULT only)	Preprinted Paper Length	NORMAL, SHORT	NORMAL
LPREPRINTEDLOADING (DEFAULT only)	Preprinted Paper Loading	OFF, DUPLEX	OFF

Table 3-4: Printer Unique Variables for Both Printer Languages (Continued)

Variable	Function	Selections	Factory Default																										
LPREPRINTEDOUTBIN	Assign Type/Bin - Preprinted Paper	<p>UPPER, LOWER, DISABLED, OPTIONALOUTBIN1, OPTIONALOUTBIN2, OPTIONALOUTBIN3, OPTIONALOUTBIN4, OPTIONALOUTBIN5, OPTIONALOUTBIN6, OPTIONALOUTBIN7, OPTIONALOUTBIN8, OPTIONALOUTBIN9, OPTIONALOUTBIN10, "name"</p> <p><i>name</i> is a variable that allows for custom naming of optional output bins. The text string is truncated to 24 characters.</p> <p>Specifies a selected output bin for jobs printed on preprinted paper.</p> <p>A DINKQUIRE or INQUIRE on the Assign Type/Bin - Preprinted Paper setting returns:</p> <table border="0"> <tr> <td style="text-align: center;">Assign Type/Bin - Preprinted paper setting</td> <td style="text-align: center;">DINKQUIRE or INQUIRE value</td> </tr> <tr> <td>Standard Bin</td> <td>UPPER</td> </tr> <tr> <td>Bin 1</td> <td>OPTIONALOUTBIN1</td> </tr> <tr> <td>Bin 2</td> <td>OPTIONALOUTBIN2</td> </tr> <tr> <td>Bin 3</td> <td>OPTIONALOUTBIN3</td> </tr> <tr> <td>Bin 4</td> <td>OPTIONALOUTBIN4</td> </tr> <tr> <td>Bin 5</td> <td>OPTIONALOUTBIN5</td> </tr> <tr> <td>Bin 6</td> <td>OPTIONALOUTBIN6</td> </tr> <tr> <td>Bin 7</td> <td>OPTIONALOUTBIN7</td> </tr> <tr> <td>Bin 8</td> <td>OPTIONALOUTBIN8</td> </tr> <tr> <td>Bin 9</td> <td>OPTIONALOUTBIN9</td> </tr> <tr> <td>Bin 10</td> <td>OPTIONALOUTBIN10</td> </tr> <tr> <td>"name"</td> <td>"name"</td> </tr> </table>	Assign Type/Bin - Preprinted paper setting	DINKQUIRE or INQUIRE value	Standard Bin	UPPER	Bin 1	OPTIONALOUTBIN1	Bin 2	OPTIONALOUTBIN2	Bin 3	OPTIONALOUTBIN3	Bin 4	OPTIONALOUTBIN4	Bin 5	OPTIONALOUTBIN5	Bin 6	OPTIONALOUTBIN6	Bin 7	OPTIONALOUTBIN7	Bin 8	OPTIONALOUTBIN8	Bin 9	OPTIONALOUTBIN9	Bin 10	OPTIONALOUTBIN10	"name"	"name"	UPPER, DISABLED (Model specific)
Assign Type/Bin - Preprinted paper setting	DINKQUIRE or INQUIRE value																												
Standard Bin	UPPER																												
Bin 1	OPTIONALOUTBIN1																												
Bin 2	OPTIONALOUTBIN2																												
Bin 3	OPTIONALOUTBIN3																												
Bin 4	OPTIONALOUTBIN4																												
Bin 5	OPTIONALOUTBIN5																												
Bin 6	OPTIONALOUTBIN6																												
Bin 7	OPTIONALOUTBIN7																												
Bin 8	OPTIONALOUTBIN8																												
Bin 9	OPTIONALOUTBIN9																												
Bin 10	OPTIONALOUTBIN10																												
"name"	"name"																												
LPREPRINTEDTEXTURE (DEFAULT only)	Preprinted Paper Texture	SMOOTH, NORMAL, ROUGH	NORMAL																										
LPREPRINTEDWEIGHT (DEFAULT only)	Preprinted Paper Weight	LIGHT, NORMAL, HEAVY	NORMAL																										
LPRINTBUFFER	Print Buffer control	<p>ON, OFF</p> <p>If ON is selected, Print Buffer displays with the Waiting message.</p> <p>If OFF is selected, Print Buffer does not display with the Waiting message.</p>	ON																										
LPRINTHEADIDLETIME (SET only)	Printhead Idle Time	0 to 15 seconds	0																										
LPRINTERUSAGE	Printer Usage	MAXSPEED, MAXYIELD	MAXSPEED, MAXYIELD (Model specific)																										
LPRINTMENUSBUTTON (DEFAULT only)	Disable Print Menus from front panel	ON, OFF	ON																										

Table 3-4: Printer Unique Variables for Both Printer Languages (Continued)

Variable	Function	Selections	Factory Default
LPRINTQUALITY	Print Quality Mode	QUICKPRINT, NORMAL, PRESENTATION, GRAPHICS, IMAGES, 1200IMAGEQ, INKSAVER, NORMAL, BEST	NORMAL
LPUNCH	Hole Punch	ON, OFF	OFF
LREAROUTBINNAME	Rear Output Bin Name	"name" <i>name</i> is a variable that allows for custom naming of optional output bins. The text string is truncated to 24 characters. When queried, the quotes are not returned around the string name. The default name is returned unless you have specified a custom name.	REAROUTBIN
LREPEATPRINTLIMIT (DEFAULT only)	Print and Hold Repeat Print Job Limit	0 to 50 jobs Specifies the number of Repeat Print jobs that can be held in printer memory. If the Repeat Print Job Limit setting is not equal to 0, a DINKQUIRE or INQUIRE returns the numerical setting for LREPEATPRINTLIMIT. If Repeat Print Job Limit setting is set to Disabled, a DINKQUIRE or INQUIRE returns 0.	5
LRESET	Reset Control	ON, OFF When the LRESET variable is set to ON, RESET PRINTER is available in the JOB MENU when the printer is in the Busy or Waiting state. This is true for most printers with a printer operator panel. If this variable is set to OFF, RESET PRINTER is not available.	ON
LRESOURCESAVE (DEFAULT only)	Resource Save	ON, OFF	OFF
LRIGHTMARGINOFFSET	Right Margin Offset	-10 to 10	0
LSCREENING	Color Screening Selections	COLORGRADE, IMAGESONLY, IET	COLORGRADE
LSEPARATORSHEETS	Indicates where separator sheets are placed within the print job	NONE, BETWEENCOPIES, BETWEENJOBS, BETWEENPAGES	NONE
LSEPARATORSOURCE	Indicates which source contains the separator sheets	TRAY1, TRAY2, TRAY3, TRAY4, TRAY5, FEEDER, MPFEEDER, MANUALPAPER, MANUALEVELOPE	TRAY1

Table 3-4: Printer Unique Variables for Both Printer Languages (Continued)

Variable	Function	Selections	Factory Default
LSTANDARDOUTBINNAME (DEFAULT only)	Standard Output Bin Name	"name" <i>name</i> is a variable that allows for custom naming of output bins. The text string is truncated to 24 characters. When queried, the quotes are not returned around the string name. The default name is returned unless you have specified a custom name.	UPPER
LSTROKEWIDTH	PostScript minimum stroke width	1 to 255 The width of a line or a stroke between two points.	1 pel or 1/600th inch
LSTAPLE	Staple Job	ON, OFF, AUTO, FRONT, BACK, DUAL, 0, 1, 2	OFF
LSTAPLEEMPTYALARM (DEFAULT only)	Staples Empty Alarm	OFF, SINGLE, CONTINUOUS	OFF
LSTAPLETESTBIN (DEFAULT only)	Staple Priming Bin	OPTIONALOUTBIN1, OPTIONALOUTBIN2, OPTIONALOUTBIN3, OPTIONALOUTBIN4, OPTIONALOUTBIN5, OPTIONALOUTBIN6, OPTIONALOUTBIN7, OPTIONALOUTBIN8, OPTIONALOUTBIN9, OPTIONALOUTBIN10	OPTIONALOUTBIN1, OPTIONALOUTBIN2 (Model specific)
LSTAPLETESTSOURCE (DEFAULT only)	Staple Priming Source	TRAY1, TRAY2, TRAY3, TRAY4, TRAY5, MPFEEDER	TRAY1
LSUBSTITUTESIZE	Substitute Size	OFF, LETTERA4, STATEMENTA5, 11X17A3, ALLLISTED	OFF, LETTERA4, ALLLISTED (Model specific)
LTOPBINROTATE (DEFAULT only)	Top Bin Timeout, in minutes	0 to 255 A DINKQUIRE or INQUIRE on LTOPBINROTATE returns the numeric value.	0
LTOPMARGINOFFSET	Top Margin Offset	-128 to 127	0
LTRANSPARENCYLENGTH (DEFAULT only)	Transparency Length	NORMAL, SHORT	NORMAL

Table 3-4: Printer Unique Variables for Both Printer Languages (Continued)

Variable	Function	Selections	Factory Default
LTRANSPARENCYOUTBIN (DEFAULT only)	Assign Type/Bin - Transparency	UPPER, LOWER, DISABLED, OPTIONALOUTBIN1, OPTIONALOUTBIN2, OPTIONALOUTBIN3, OPTIONALOUTBIN4, OPTIONALOUTBIN5, OPTIONALOUTBIN6, OPTIONALOUTBIN7, OPTIONALOUTBIN8, OPTIONALOUTBIN9, OPTIONALOUTBIN10, "name" <i>name</i> is a variable that allows for custom naming of optional output bins. The text string is truncated to 24 characters. Specifies a selected output bin for jobs printed on transparencies. A DINQUIRE or INQUIRE on the Assign Type/Bin - Transparency setting returns: Assign Type/Bin - DINQUIRE or Transparency setting INQUIRE value Standard Bin UPPER Bin 1 OPTIONALOUTBIN1 Bin 2 OPTIONALOUTBIN2 Bin 3 OPTIONALOUTBIN3 Bin 4 OPTIONALOUTBIN4 Bin 5 OPTIONALOUTBIN5 Bin 6 OPTIONALOUTBIN6 Bin 7 OPTIONALOUTBIN7 Bin 8 OPTIONALOUTBIN8 Bin 9 OPTIONALOUTBIN9 Bin 10 OPTIONALOUTBIN10 "name" "name"	UPPER, DISABLED (Model specific)
LTRANSPARENCYTEXTURE (DEFAULT only)	Transparency Texture	SMOOTH, NORMAL, ROUGH	NORMAL
LTRANSPARENCYWEIGHT (DEFAULT only)	Transparency Weight	LIGHT, NORMAL, HEAVY	NORMAL
LTRAY1SENSEDTYPE PAPER	Detected Type for Paper - Tray 1	PLAIN, BOND, GLOSSY, CARDSTOCK, LABELS, LETTERHEAD, PREPRINTED, COLORED, CUSTOMTYPE1, CUSTOMTYPE2, CUSTOMTYPE3, CUSTOMTYPE4, CUSTOMTYPE6	PLAIN
LTRAY1SENSEDTYPE TRANSPARENCY	Detected Type for Trans- parency- Tray 1	TRANSPARENCY, CUSTOMTYPE5	TRANSPARENCY
LTRAY2SENSEDTYPE PAPER	Detected Type for Paper - Tray 2	PLAIN, BOND, GLOSSY, CARDSTOCK, LABELS, LETTERHEAD, PREPRINTED, COLORED, CUSTOMTYPE1, CUSTOMTYPE2, CUSTOMTYPE3, CUSTOMTYPE4, CUSTOMTYPE6	PLAIN, CUSTOMTYPE2
LTRAY2SENSEDTYPE TRANSPARENCY	Detected Type for Trans- parency - Tray 2	TRANSPARENCY, CUSTOMTYPE5	TRANSPARENCY

Table 3-4: Printer Unique Variables for Both Printer Languages (Continued)

Variable	Function	Selections	Factory Default
LTRAY3SENSEDTYPE PAPER	Detected Type for Paper - Tray 3	PLAIN, BOND, GLOSSY, CARDSTOCK, LABELS, LETTERHEAD, PREPRINTED, COLORED, CUSTOMTYPE1, CUSTOMTYPE2, CUSTOMTYPE3, CUSTOMTYPE4, CUSTOMTYPE6	PLAIN, CUSTOMTYPE3
LTRAY3SENSEDTYPE TRANSPARENCY	Detected Type for Trans- parency - Tray 3	TRANSPARENCY, CUSTOMTYPE5	TRANSPARENCY
LTRAY4SENSEDTYPE PAPER	Detected Type for Paper - Tray 4	PLAIN, BOND, GLOSSY, CARDSTOCK, LABELS, LETTERHEAD, PREPRINTED, COLORED, CUSTOMTYPE1, CUSTOMTYPE2, CUSTOMTYPE3, CUSTOMTYPE4, CUSTOMTYPE6	PLAIN, CUSTOMTYPE4
LTRAY4SENSEDTYPE TRANSPARENCY	Detected Type for Trans- parency - Tray 4	TRANSPARENCY, CUSTOMTYPE5	TRANSPARENCY
LTRAY1AUTOSIZE (DEFAULT only)	Auto Size Sensing for Tray 1	ON, OFF	ON
LTRAY2AUTOSIZE (DEFAULT only)	Auto Size Sensing for Tray 2	ON, OFF	ON
LTRAY3AUTOSIZE (DEFAULT only)	Auto Size Sensing for Tray 3	ON, OFF	ON
LTRAY4AUTOSIZE (DEFAULT only)	Auto Size Sensing for Tray 4	ON, OFF	ON
LTRAY5AUTOSIZE (DEFAULT only)	Auto Size Sensing for Tray 5	ON, OFF	ON
LTRAY1PAPERTYPE	Tray 1 Paper Type	PLAIN, COATED, GLOSSY, PHOTO, GREETINGCARD, IRONON, BOND, TRANSPARENCY, CARDSTOCK, LABELS, LETTERHEAD, PREPRINTED, COLORED, ENVELOPE, CUSTOMTYPE1, CUSTOMTYPE2, CUSTOMTYPE3, CUSTOMTYPE4, CUSTOMTYPE5, CUSTOMTYPE6, "name" <i>name</i> is a text string that is truncated to 24 characters.	PLAIN

Table 3-4: Printer Unique Variables for Both Printer Languages (Continued)

Variable	Function	Selections	Factory Default
LTRAY2PAPERTYPE	Tray 2 Paper Type	<p>PLAIN, COATED, GLOSSY, PHOTO, GREETINGCARD, IRONON, BOND, TRANSPARENCY, CARDSTOCK, LABELS, LETTERHEAD, PREPRINTED, COLORED, ENVELOPE, CUSTOMTYPE1, CUSTOMTYPE2, CUSTOMTYPE3, CUSTOMTYPE4, CUSTOMTYPE5, CUSTOMTYPE6, "name"</p> <p><i>name</i> is a text string that is truncated to 24 characters.</p> <p>See "Table B-2: Printer Unique PJL Variables for Both Printer Languages" on page B-4 for the default value for your printer.</p>	PLAIN, CUSTOMTYPE2 (Model specific)
LTRAY3PAPERTYPE	Tray 3 Paper Type	<p>PLAIN, COATED, GLOSSY, PHOTO, GREETINGCARD, IRONON, BOND, TRANSPARENCY, CARDSTOCK, LABELS, LETTERHEAD, PREPRINTED, COLORED, ENVELOPE, CUSTOMTYPE1, CUSTOMTYPE2, CUSTOMTYPE3, CUSTOMTYPE4, CUSTOMTYPE5, CUSTOMTYPE6, "name"</p> <p><i>name</i> is a text string that is truncated to 24 characters.</p> <p>See "Table B-2: Printer Unique PJL Variables for Both Printer Languages" on page B-4 for the default value for your printer.</p>	PLAIN, CUSTOMTYPE3 (Model specific)
LTRAY4PAPERTYPE	Tray 4 Paper Type	<p>PLAIN, COATED, GLOSSY, PHOTO, GREETINGCARD, IRONON, BOND, TRANSPARENCY, CARDSTOCK, LABELS, LETTERHEAD, PREPRINTED, COLORED, ENVELOPE, CUSTOMTYPE1, CUSTOMTYPE2, CUSTOMTYPE3, CUSTOMTYPE4, CUSTOMTYPE5, CUSTOMTYPE6, "name"</p> <p><i>name</i> is a text string that is truncated to 24 characters.</p>	PLAIN, CUSTOMTYPE4 (Model specific)
LTRAY5PAPERTYPE	Tray 5 Paper Type	<p>PLAIN, COATED, GLOSSY, PHOTO, GREETINGCARD, IRONON, BOND, TRANSPARENCY, CARDSTOCK, LABELS, LETTERHEAD, PREPRINTED, COLORED, ENVELOPE, CUSTOMTYPE1, CUSTOMTYPE2, CUSTOMTYPE3, CUSTOMTYPE4, CUSTOMTYPE5, CUSTOMTYPE6, "name"</p> <p><i>name</i> is a text string that is truncated to 24 characters.</p>	PLAIN, CUSTOMTYPE5 (Model specific)
LTRAY1RENUMBER	Tray 1 Renumber	OFF, TRAY2, TRAY3, TRAY4, TRAY5, MPFEEDER	OFF

Table 3-4: Printer Unique Variables for Both Printer Languages (Continued)

Variable	Function	Selections	Factory Default
LTYPE1FONTS	Enables Type 1 fonts for PCL emulation	OFF, ON	ON
LUSDEFAULTS (DEFAULT only)	US/non-US defaults	US, NONUS	US, NONUS (Country specific)

Common Variables for PCL Emulation

Note: The word *common* applies to those variables common to both your printer and the Hewlett-Packard Company's LaserJet printers.

Use these variables only for PCL emulation. The [command modifier: *value*] parameter should be specified as LPARM:PCL. For example:

```
@PJL SET LPARM:PCL FONTSOURCE=I<CR><LF>
```

To determine which variables your printer supports, see "Table B-3: Common Variables for PCL Emulation" on page B-12.

Table 3-5: Common Variables for PCL Emulation

Variable	Function	Selections	Factory Default
FONTSOURCE	Font Source	I, S, M1, M2, M3, M4, D1 I Internal font source S Permanent download fonts M1, M2, M3, M4 Flash font source D1 Disk font source All other values default to internal font source.	I
FONTSOURCE	Font Source	I, S, M1, M2, M3, M4, D1	I
PITCH	Default pitch (fixed-pitch fonts)	0.08 to 100 (in increments of 0.01) Note: If an invalid pitch is requested, the printer selects the closest pitch.	10.00
PTSIZE	Default point size (proportional spaced fonts)	1 to 1008 (in increments of 0.25) Note: If an invalid point size is requested, the printer selects the closest point size.	12.00
SYMSET	Symbol set for the default font	If a symbol set is requested that is not resident in the printer, the symbol set is not changed.	PC8, PC850 (Country specific)

Printer Unique Variables for PCL Emulation

The following variables are unique to your printer and are supported in PCL emulation only. The [command modifier: *value*] parameter should be specified as LPARM:PCL. For example:

```
@PJL SET LPARM:PCL LBITMAPROUNDING=OFF[<CR>]<LF>
```

To determine which variables your printer supports, see “Table B-4: Printer Unique Variables for PCL Emulation” on page B-12.

Table 3-6: Printer Unique Variables for PCL Emulation

Variable	Function	Selections	Factory Default
LA4WIDTH	A4 Width in millimeters	198, 203	198
LASSIGNFEEDER	Tray Renumber Assign Envelope Feeder	OFF, 0 to 199 Variable used with PJL SET or DEFAULT command.	OFF
		OFF, 0 to 199, NONE Variable used with PJL INQUIRE or DINQUIRE command.	OFF
LASSIGNMANUALENVELOPE	Tray Renumber Assign Manual Envelope	OFF, 0 to 199 Variable used with PJL SET or DEFAULT command.	OFF
		OFF, 0 to 199, NONE Variable used with PJL INQUIRE or DINQUIRE command.	OFF
LASSIGNMANUALPAPER	Tray Renumber Assign Manual Paper	OFF, 0 to 199 Variable used with PJL SET or DEFAULT command.	OFF
		OFF, 0 to 199, NONE Variable used with PJL INQUIRE or DINQUIRE command.	OFF
LASSIGNMPFEEDER	Tray Renumber Assign Multipurpose Feeder	OFF, 0 to 199 Variable used with PJL SET or DEFAULT command.	OFF
		OFF, 0 to 199, NONE Variable used with PJL INQUIRE or DINQUIRE command.	OFF

Table 3-6: Printer Unique Variables for PCL Emulation (Continued)

Variable	Function	Selections	Factory Default
LASSIGNTRAY1	Tray Renumber Assign Tray 1	OFF, 0 to 199 Variable used with PJL SET or DEFAULT command.	OFF
		OFF, 0 to 199, NONE Variable used with PJL INQUIRE or DINQUIRE command.	OFF
LASSIGNTRAY2	Tray Renumber Assign Tray 2	OFF, 0 to 199 Variable used with PJL SET or DEFAULT command.	OFF
		OFF, 0 to 199, NONE Variable used with PJL INQUIRE or DINQUIRE command.	OFF
LASSIGNTRAY3	Tray Renumber Assign Tray 3	OFF, 0 to 199 Variable used with PJL SET or DEFAULT command.	OFF
		OFF, 0 to 199, NONE Variable used with PJL INQUIRE or DINQUIRE command.	OFF
LASSIGNTRAY4	Tray Renumber Assign Tray 4	OFF, 0 to 199 Variable used with PJL SET or DEFAULT command.	OFF
		OFF, 0 to 199, NONE Variable used with PJL INQUIRE or DINQUIRE command.	OFF
LASSIGNTRAY5	Tray Renumber Assign Tray 5	OFF, 0 to 199 Variable used with PJL SET or DEFAULT command.	OFF
		OFF, 0 to 199, NONE Variable used with PJL INQUIRE or DINQUIRE command.	OFF
LBITMAPROUNDING	Bitmap Font Partial Pel Rounding	ON, OFF Some printers handle partial pel character escapement rounding of bitmap fonts differently. LBITMAPROUNDING offers a way of instructing the printer how to handle partial pel rounding of bitmap fonts. Bitmap rounding is compatible with the Hewlett-Packard Company's LaserJet printers.	ON
LCOLOREXTENSIONS	Color Extensions	ON, OFF, HPCLJ5	ON

Table 3-6: Printer Unique Variables for PCL Emulation (Continued)

Variable	Function	Selections	Factory Default
LFONTCOMPATIBILITY	Font Compatibility Level	PCL5, PCL6	PCL6
LFONTPRIORITY (SET only)	Font Priority Search	RESOLUTION, NORESOLUTION When RESOLUTION is specified, your printer is compatible with the Hewlett-Packard Company's LaserJet printers. When NORESOLUTION is specified, font resolution is removed from the font selection priority criteria.	RESOLUTION

Common Variables for PostScript Emulation

Note: The word *common* applies to those variables common to both your printer and the Hewlett-Packard Company's LaserJet printers.

Use these variables only for PostScript emulation. The [command modifier: *value*] parameter should be specified as LPARM:POSTSCRIPT. For example:

```
@PJL SET LPARM:POSTSCRIPT JAMRECOVERY=OFF[<CR>]<LF>
```

To determine which variables your printer supports, see "Table B-5: Common Variables for PostScript Emulation" on page B-13.

Table 3-7: Common Variables for PostScript Emulation

Variable	Function	Selections	Factory Default
JAMRECOVERY	Jam Recovery	ON, OFF For queries, when the Jam Recovery setting is set to Auto, PJL returns the value of OFF. The remaining two Jam Recovery values, On and Off are returned by PJL as ON and OFF respectively. When PJL is used to set Jam Recovery OFF, the setting is actually set to Auto. When PJL is used to set Jam Recovery ON, the setting is set to ON. Changing this variable also affects PCL emulation.	OFF
PRTPSERRS	Print PS Errors	ON, OFF	OFF

Printer Unique Variables for PostScript Emulation

The following variables are unique in some printers and are supported in PostScript emulation only.

The [command modifier: *value*] parameter should be specified as LPARM:POSTSCRIPT. For example:

```
@PJL SET LPARM:POSTSCRIPT LPICTUREGRADE=ON[<CR>]<LF>
```

To determine which variables your printer supports, see Table B-6 on page B-14.

Table 3-8: Printer Unique Variables for PostScript Emulation

Variable	Function	Selections	Factory Default
LPICTUREGRADE™	PictureGrade™	ON, OFF	ON
LPSFONTPRIORITY	Font Priority	RESIDENT, FLASHDISK	RESIDENT

Printer Unique LRESOURCE Variables

Use the following variables when additional storage devices are installed.

The [command modifier: *value*] parameter of the DEFAULT, INQUIRE, DINQUIRE, and SET commands must be specified as LRESOURCE:"*device:filename.filetype*". For example:

```
@PJL DEFAULT LRESOURCE : "device:filename.filetype" LDESCRIPTION="my description"[<CR>]<LF>
```

Values for "*device:filename.filetype*" are:

<i>device</i>	<i>flash, flash1, disk, or disk1</i> (case insensitive)
<i>filename</i>	A unique identifier for a file, such as the macro ID for a PCL macro, the symbol set ID for a PCL symbol set, the font ID for a PCL font, or the actual file name for data, Type 1 fonts, and demo files as shown on the Directory. The <i>filename</i> is case sensitive.
<i>filetype</i>	The identifier that categorizes the file, such as <i>p5macro</i> for PCL macros or <i>p5symset</i> for PCL symbol sets.

Using the DEFAULT command to modify any of these variables forces a write to flash or disk if resource collection mode is set to On before the command is executed. The DEFAULT command causes a PJL Reset.

To determine which variables your printer supports, see “Table B-7: Printer Unique LRESOURCE Variables” on page B-14.

Table 3-9: Printer Unique LRESOURCE Variables

Variable	Function	Selections	Factory Default
LDESCRIPTION (DEFAULT only)	Macro or Symbol Set Description ¹	"alphanumeric string" The description is limited to 16 characters and must be enclosed in double quotes. If more than 16 characters are specified by the DEFAULT command, the first 16 characters are used and a PjL parser warning is issued. The DINQUIRE command can be used to query the file description. The description is returned in the response.	NULL (no description)
LRWLOCK (DEFAULT only)	Read/Write Lock (password) for an entire device or a particular file on the device ²	"alphanumeric string" This variable can be used with other PjL commands: <ul style="list-style-type: none"> • DEFAULT command The Read/Write password is limited to eight characters. If more than eight characters are specified by the PjL DEFAULT command, the password is truncated and a PjL warning is issued. If a null (" ") password is given, password protection is removed from the specified device or file. • DINQUIRE or INQUIRE commands Use these commands to determine if a password has been specified for a device or specific file. The response is one of the following: NOTSET The password has not been set or has been reset to zero. SET The password is defined and active. EXPIRED The password is reset to zero (flash memory only). The LDECLARE command can be used to temporarily unlock access to a device or particular file. See “File and Device Protection Commands” on page 3-93 for additional information about using passwords on these devices.	NULL (no password) NOTSET
LWLOCK (DEFAULT only)	Write Lock (password) for an entire device or particular file on the device ²	"alphanumeric string" Same as LRWLOCK, except the password limits write-only access instead of read-write access.	NULL (no password)

¹ The macro or symbol set description is printed in the Description field of the Print Directory listing.
² To password-protect a device, the command modifier:value should be LRESOURCE : "device:". The colon (;) and double quotes (" ") must be specified.

Status Readback Commands

Applications can request configuration and status information from the printer using the Status Readback commands. In addition, the printer can also be instructed to send unsolicited status information back to the host computer when asynchronous events occur, such as a memory error or a paper jam.

To determine which commands your printer supports, see “Table B-8: Status Readback Commands” on page B-15.

DINQUIRE Command

This command is used to query the default setting (NVRAM) of the specified environment variable.

Syntax:

```
@PJL DINQUIRE [command modifier:value] variable[<CR>]<LF>
```

Response Syntax:

```
@PJL DINQUIRE [command modifier:value] variable<CR><LF>  
value<CR><LF>  
<FF>
```

where:

[command modifier:*value*]

The [command modifier:*value*] parameter specifies the type of PJL variable to be queried. The variables supported are listed in the tables beginning on page 3-12.

- A [command modifier:*value*] parameter is not required for variables listed in the tables “Common Variables for Both Printer Languages” on page 3-12, and “Printer Unique Variables for Both Printer Languages” on page 3-19.
- LPARM: *PCL* is used with variables specific to PCL emulation. (See the tables “Common Variables for PCL Emulation” on page 3-48, and “Printer Unique Variables for PCL Emulation” on page 3-49.)

- LPARM: *POSTSCRIPT* is used for variables specific for PostScript emulation. (See the tables “Common Variables for PostScript Emulation” on page 3-51, and “Printer Unique Variables for PostScript Emulation” on page 3-52.)
- LRESOURCE: "*device:filename.filetype*" is required for LRESOURCE variables. (See the table “Printer Unique LRESOURCE Variables” on page 3-53.)

Values for "*device:filename.filetype*" are:

<i>device</i>	<i>flash, flash1, disk, or disk1</i> (case insensitive)
<i>filename</i>	A unique identifier for a file, such as the macro ID for a PCL macro, the symbol set ID for a PCL symbol set, the font ID for a PCL font, and so on. The <i>filename</i> is case sensitive.
<i>filetype</i>	An identifier that categorizes the file, such as <i>p5macro</i> for PCL macros or <i>p5symset</i> for PCL symbol sets. See the table beginning on page 3-87 for a complete list of the supported file types. The <i>filetype</i> is case sensitive.

`variable=value`

The supported variables are listed in the tables beginning on page 3-12.

This printer returns a ? for inquiries of an unsupported variable, or inquiries of a variable associated with an option that is not installed.

ECHO Command

The ECHO command instructs the printer to return the specified words after the command is parsed. This command provides a method of capturing the status information returned by a specific print job.

Syntax:

```
@PJL ECHO [words][<CR>]<LF>
```

Response Syntax:

```
@PJL ECHO [words]<CR><LF>
<FF>
```

words parameter

The *words* parameter must start with a printable character and can consist of a combination of printable characters, spaces, and horizontal tabs.

Note: The ECHO command is terminated by the line feed character.

INFO Command

The INFO command is used to query status information from the printer.

“Table 3-10: INFO Category Parameter Values” on page 3-56 lists the categories of information that can be queried.

See “Status Message Format” on page 3-61 for additional information about the messages returned by the INFO STATUS, USTATUS DEVICE, and USTATUS TIMED commands.

Syntax:

```
@PJL INFO category[<CR>]<LF>
```

Response Syntax:

```
@PJL INFO category<CR><LF>
[one or more lines of printable characters, spaces, or tabs]<CR><LF>
<FF>
```

category

Table 3-10 lists the supported categories.

Table 3-10: INFO Category Parameter Values

Category Values	Description
ID	Returns the model name or the model number stored in the printer NVRAM.
CONFIG	Returns the printer configuration, including paper sources, paper sizes, and installed options.
MEMORY	Returns the printer available memory.
PAGECOUNT	Returns the printer page count.
STATUS	Returns the printer current status.
VARIABLES	Returns the printer environment variables and values.
USTATUS	Returns the printer unsolicited status variables and values.

INFO CONFIG Response Syntax (An Example):

```
@PJL INFO CONFIG<CR><LF>
  IN TRAYS [2 ENUMERATED] <CR><LF>
    INTRAY1<CR><LF>
    INTRAY2<CR><LF>
  MANUAL FEED<CR><LF>
  OUT TRAYS [1 ENUMERATED] <CR><LF>
    UPPER FACEDOWN<CR><LF>
  PAPERS [13 ENUMERATED] <CR><LF>
    LETTER<CR><LF>
    LEGAL<CR><LF>
    A4<CR><LF>
    A5<CR><LF>
    B5PAPER<CR><LF>
    EXECUTIVE<CR><LF>
    COM10<CR><LF>
    COM9<CR><LF>
    MONARCH<CR><LF>
    DL<CR><LF>
    C5<CR><LF>
    B5<CR><LF>
    OTHERENVELOPE<CR><LF>
  LANGUAGES [1 ENUMERATED] <CR><LF>
    PCL<CR><LF>
  USTATUS [4 ENUMERATED] <CR><LF>
    DEVICE<CR><LF>
    JOB<CR><LF>
    PAGE<CR><LF>
    TIMED<CR><LF>
  FLASH=1048576<CR><LF>
  DISK=543283200
  MEMORY=2097152<CR><LF>
  DISPLAY LINES=2<CR><LF>
  SYSTEM FIRMWARE VERSION=250A<CR><LF>
  ENGINE FIRMWARE VERSION=0<CR><LF>
<FF>
```

INQUIRE Command

This command is used to query the current setting of the specified environment variable.

Syntax:

```
@PJL INQUIRE [command modifier:value] variable[<CR>]<LF>
```

Response Syntax:

```
@PJL INQUIRE [command modifier:value] variable<CR><LF>
value<CR><LF>
<FF>
```

```
[command modifier:value]
```

The [command modifier:*value*] parameter specifies the type of PJL variables to be queried. The variables supported are listed in the tables beginning on page 3-12.

- A [command modifier:*value*] parameter is not required for variables listed in the tables “Common Variables for Both Printer Languages” on page 3-12, and “Printer Unique Variables for Both Printer Languages” on page 3-19.
- LPARM:*PCL* is used with variables specific to PCL emulation. (See the tables “Common Variables for PCL Emulation” on page 3-48, and “Printer Unique Variables for PCL Emulation” on page 3-49.)
- LPARM:*POSTSCRIPT* is used for variables specific for PostScript emulation. (See the tables “Common Variables for PostScript Emulation” on page 3-51, and “Printer Unique Variables for PostScript Emulation” on page 3-52.)
- LRESOURCE:"*device:filename.filetype*" is required for LRESOURCE variables. (See the table “Printer Unique LRESOURCE Variables” on page 3-53.)

Values for "*device:filename.filetype*" are:

<i>device</i>	<i>flash, flash1, disk, or disk1</i> (case insensitive)
<i>filename</i>	A unique identifier for a file, such as the macro ID for a PCL macro, the symbol set ID for a PCL symbol set, the font ID for a PCL font, and so on. The <i>filename</i> is case sensitive.
<i>filetype</i>	An identifier that categorizes the file, such as <i>p5macro</i> for PCL macros or <i>p5symset</i> for PCL symbol sets. See the table beginning on page 3-87 for a complete list of the supported file types. The <i>filetype</i> is case sensitive.

`variable=value`

The supported variables are listed in the tables beginning on page 3-12.

This printer returns a ? for inquiries of an unsupported variable, or inquiries of a variable associated with an option that is not installed.

USTATUS Command

This command is used to enable and disable unsolicited status from the printer. Unsolicited status information is sent automatically when an asynchronous event occurs. “Table 3-11: USTATUS Unsolicited Status Variable Values” on page 3-60 lists the asynchronous information that can be enabled and disabled.

Syntax:

```
@PJL USTATUS ustatus variable=value[<CR>]<LF>
```

Response Syntax:

```
@PJL USTATUS ustatus variable<CR><LF>  
[one or more lines of printable characters, spaces, or tabs]<CR><LF>  
<FF>
```

To determine which variables your printer supports, see “Table B-9: USTATUS Unsolicited Status Variables” on page B-15.

See “Status Message Format” on page 3-61 for additional information about the messages returned by the INFO STATUS, USTATUS DEVICE, and USTATUS TIMED commands.

`ustatus variable=value`

The following values are supported for the `ustatus variable=value` parameter.

Table 3-11: USTATUS Unsolicited Status Variable Values

Ustatus Variable	Value	Description
DEVICE	ON	Enables unsolicited status for device changes.
	VERBOSE	Enables unsolicited status for all device changes. Also enables warnings from the PjL parser.
	OFF	Disables unsolicited status for device changes.
JOB	ON	Enables unsolicited status for job changes. The printer sends a status message when a job begins and ends.
	OFF	Disables unsolicited status for job changes.
PAGE	ON	Enables unsolicited status for page changes. The printer sends a status message when a printed sheet reaches the standard output bin.
	OFF	Disables unsolicited status for page changes.
TIMED	5 to 300 in seconds	Enables timed unsolicited status. The printer automatically sends status at a specified time interval.
	0	Disables timed unsolicited status.

USTATUSOFF Command

This command turns off unsolicited status. Unsolicited status may also be turned off by using the USTATUS command on each variable.

Syntax:

```
@PJL USTATUSOFF[<CR>]<LF>
```

Status Message Format

The format of the returned information from the INFO STATUS, USTATUS DEVICE, and USTATUS TIMED commands is described in this section.

Information Messages

Information messages are returned in this form:

CODE=status code
 DISPLAY=display string (in double quotes)
 ONLINE=online status

Table 3-12: PJL Information Messages

Printer State	Status Code	Display String	Online Status
Ready	10001	Ready	TRUE
Ready	10001	RDYMSG	TRUE
Ready with Ink Low	10006	88 Ink Low	TRUE
Not Ready	10002	Not Ready	FALSE
In the Menu	10002	Not Ready	FALSE
Printer reset	10005	Resetting the Printer	FALSE
Ready with Toner Low	10006	88 Toner Low	TRUE
Ready with Toner Low	10006	88 Yellow Toner Low	TRUE
Ready with Toner Low	10006	88 Magenta Toner Low	TRUE
Ready with Toner Low	10006	88 Cyan Toner Low	TRUE
Ready with Toner Low	10006	88 Black Toner Low	TRUE
Ready with Toner Low	10006	88 Color Print Cartridge Low	TRUE
Ready with Toner Low	10006	88 Black Print Cartridge Low	TRUE
Ready with Toner Low	10006	88 Photo Print Cartridge Low	TRUE
Ready with Replace Toner	10006	Replace Toner	TRUE
Ready with Replace PC Kit	10006	Replace PC Kit	TRUE
Ready with Replace Fuser	10006	Replace Fuser	TRUE

x represents an input source code. For more information on input source codes, see “Table 3-16: Tray Values” on page 3-74.

yy represents a size code. For more information on size codes, see “Table 3-17: Media Size Values” on page 3-74.

ww represents the bin code. For more information on bin codes, see “Table 3-18: Output Bin Values” on page 3-75.

Note: The Display String is returned in the current language. A display message longer than one line shows only the first line of the message.

Table 3-12: PJL Information Messages

Printer State	Status Code	Display String	Online Status
Ready with Replace Transfer	10006	Replace Transfer	TRUE
Power Saver with Ink Low	10006	88 Ink Low	TRUE
Power Saver mode with Toner Low	10006	88 Toner Low	TRUE
Power Saver mode with Replace Toner	10006	Replace Toner	TRUE
Power Saver mode with Replace PC Kit	10006	Replace PC Kit	TRUE
Power Saver mode with Replace Fuser	10006	Replace Fuser	TRUE
Power Saver mode with Replace Transfer	10006	Replace Transfer	TRUE
Canceling Job	10007	Cancelling Job	TRUE
Busy	10023	Busy	TRUE
Waiting	10024	Waiting	TRUE
Input Source Empty	11xyy	Tray <source #> Empty	TRUE
Input Source Missing	12xyy	Tray <source #> Missing	TRUE
Output Bin Full	15ww1	Bin <bin #> Full	TRUE
Resolution Reduced	35029	Res Reduced	TRUE
Power Saver	35078	Powersaver	TRUE

x represents an input source code. For more information on input source codes, see "Table 3-16: Tray Values" on page 3-74.

yy represents a size code. For more information on size codes, see "Table 3-17: Media Size Values" on page 3-74.

ww represents the bin code. For more information on bin codes, see "Table 3-18: Output Bin Values" on page 3-75.

Note: The Display String is returned in the current language. A display message longer than one line shows only the first line of the message.

Auto-Continuable Conditions

These status messages are returned independent of the state of the **Auto Continue** menu item. Auto-continuable messages are returned in this form:

CODE=status code
 DISPLAY=display string (in double quotes)
 ONLINE=online status

To determine which messages your printer supports, see “Table B-10: PJL Messages for Auto-Continuable Conditions” on page B-16.

Table 3-13: PJL Messages for Auto-Continuable Conditions

Printer State	Status Code	Display String	Online Status
Intervention required: PPDS font error	30014	50 PPDS Font Error	FALSE
Intervention required: insufficient collation area	30016	37 Insufficient Collation Area	FALSE
Intervention required: insufficient defragment memory	30016	37 Insufficient Defrag Memory	FALSE
Intervention required: insufficient memory	30016	37 Insufficient Memory	FALSE
Intervention required: memory full	30016	38 Memory Full	FALSE
Intervention required: held jobs may not be restored	30016	Held Jobs May Not Be Restored	FALSE
Intervention required: configuration change	30016	57 Configuration Change	FALSE
Intervention required: complex page	30017	39 Complex Page	FALSE
Intervention required: standard serial error	30018	54 Standard Serial Error	FALSE
Intervention required: serial option error	30018	54 Serial Option 1 Error	FALSE
Intervention required: parallel error	30018	54 Parallel Error	FALSE
Intervention required: network software error	30018	54 Std Network Software Error	FALSE
Intervention required: standard serial fax connection lost	30018	54 Std Ser Fax Connection Lost	FALSE

¹ x equals the number of the parallel, serial or network port or option installed.

Note: The Display String is returned in the current language. A display string longer than one line shows only the first line of the message.

Table 3-13: PJL Messages for Auto-Continuable Conditions (Continued)

Printer State	Status Code	Display String	Online Status
Intervention required: standard serial disabled	30018	56 Standard Serial Disabled	FALSE
Intervention required: serial option disabled	30018	56 Serial 1 Port Disabled	FALSE
Intervention required: standard parallel port disabled	30018	56 Standard Parallel Port Disabled	FALSE
Intervention required: parallel port disabled	30018	56 Parallel Port Disabled	FALSE
Intervention required: parallel port error	30018	56 Parallel Port x Disabled	FALSE
Intervention required: standard USB port disabled	30018	56 Standard USB Port Disabled	FALSE
Intervention required: resource save off deficient memory	30019	35 Res Save Off Deficient Memory	FALSE
Intervention required: insufficient fax buffer	30026	55 Insufficient Fax Buffer	FALSE
Intervention required: standard parallel ENA connection lost	30027	54 Std Par ENA Connection Lost	FALSE
Intervention required: standard parallel port disabled	30027	56 Std Parallel Port Disabled	FALSE
Intervention required: resolution reduced	30029	36 Resolution Reduced	FALSE
Intervention required: print jobs on disk request	30031	Print Jobs on Disk? or Print Jobs on Disk. Go/Stop?	FALSE
Intervention required: printer powered off, disk installed with Print and Hold jobs on the disk	30031	Restore Held Jobs. Go/Stop?	FALSE
Intervention required: short paper	30034	34 Short Paper	FALSE
Intervention required: flash full	30035	52 Flash Full	FALSE
Intervention required: disk full	30035	62 Disk Full	FALSE
Intervention required: defective flash	30036	51 Defective Flash	FALSE
Intervention required: unformatted flash	30036	53 Unformatted Flash	FALSE
Intervention required: defective disk	30036	61 Defective Disk	FALSE

¹ x equals the number of the parallel, serial or network port or option installed.

Note: The Display String is returned in the current language. A display string longer than one line shows only the first line of the message.

Table 3-13: PJL Messages for Auto-Continuable Conditions (Continued)

Printer State	Status Code	Display String	Online Status
Intervention required: unformatted disk	30036	63 Unformatted Disk	FALSE
Intervention required: scheduled maintenance	30075	80 Scheduled Maintenance	FALSE
Intervention required: resource save off deficient memory	30076	35 Res Save Off Deficient Memory	FALSE
Intervention required: insufficient collation area	30076	37 Insufficient Collation Area	FALSE
Intervention required: hole punch box full	30107	Empty Hole Punch Box	FALSE
Intervention required: hole punch box full	30107	Empty Box M	FALSE
Intervention required: hole punch box missing	30107	Insert Box M	FALSE
Intervention required: staple cartridge missing	30107	Insert Staple Cartridge	FALSE
Intervention required: insert stapler	30107	Insert Stapler	FALSE
Intervention required: priming failed	30107	Priming Failed, Retry. Go/Stop?	FALSE
Intervention required: network x software error	30112	54 Network x Software Error	FALSE
Intervention required: serial port x disabled	30112	56 Serial Port x Disabled	FALSE
Intervention required: serial option x error	30112	54 Serial Option x Error	FALSE
Intervention required: serial x fax connection lost	30112	54 Ser x Fax Connection Lost	FALSE
Intervention required: USB port disabled	30112	56 USB Port x Disabled	FALSE
Intervention required: parallel x ENA connection lost	30113	54 Par x ENA Connection Lost	FALSE
Intervention required: parallel x port disabled	30113	56 Parallel Port x Disabled	FALSE
Intervention required: disk operation failed jobs on disk	32001	Operation Failed Jobs on Disk	FALSE
Intervention required: disk operation failed faxes on disk	32001	Operation Failed Faxes on Disk	FALSE

¹ x equals the number of the parallel, serial or network port or option installed.

Note: The Display String is returned in the current language. A display string longer than one line shows only the first line of the message.

Table 3-13: PJL Messages for Auto-Continuable Conditions (Continued)

Printer State	Status Code	Display String	Online Status
Intervention required: flash full	32002	52 Flash Full	FALSE
Intervention required: disk full	32002	62 Disk Full	FALSE
Intervention required: disk corrupted	32015	Disk Corrupted. Reformat?	FALSE
Intervention required: too many flash options installed	32030	58 Too Many Flash Options	FALSE
Intervention required: unformatted flash	32052	53 Unformatted Flash	FALSE
Intervention required: unformatted disk	32052	63 Unformatted Disk	FALSE
Intervention required: unsupported disk format	32052	64 Unsupported Disk Format	FALSE
Intervention required: defective flash	32056	51 Defective Flash	FALSE
Intervention required: defective disk	32056	61 Defective Disk	FALSE
Intervention required: scheduled maintenance	35075	80 Scheduled Maintenance	FALSE
Intervention required: scheduled maintenance	35075	81 Scheduled Maintenance	FALSE
Intervention required: fuser maintenance	40038	80 Fuser Maintenance	FALSE
Intervention required: fuser maintenance	40038	80 Fuser Life Warning	FALSE
Intervention required: belt maintenance	40038	80 Belt Life Warning	FALSE
Intervention required: fuser/belt maintenance	40038	80 Fuser/Belt Life Warning	FALSE
Intervention required: fuser maintenance	40038	80 Fuser Exhausted	FALSE
Intervention required: belt maintenance	40038	80 Belt Exhausted	FALSE
Intervention required: fuser/belt maintenance	40038	80 Fuser/Belt Exhausted	FALSE
Intervention required: ITU maintenance	40038	83 ITU Maintenance	FALSE

¹ x equals the number of the parallel, serial or network port or option installed.
Note: The Display String is returned in the current language. A display string longer than one line shows only the first line of the message.

Attendance Conditions

Attendance conditions require operator intervention. Attendance messages are returned in this form:

CODE=status code
 DISPLAY=display string (in double quotes)
 ONLINE=online status

To determine which messages your printer supports, see “Table B-11: PJL Messages for Attendance Conditions” on page B-21.

Table 3-14: PJL Message for Attendance Conditions

Printer State	Status Code	Display String	Online Status
Intervention required: insert coating roll	40010	30 Coating Roll Missing	FALSE
Intervention required: insert print unit	40010	30 XXXX¹ Print Unit Missing	FALSE
Intervention required: insert hole punch box	40010	Insert Hole Punch Box	FALSE
Intervention required: insert photoconductor cartridge	40010	Insert PC Cartridge	FALSE
Intervention required: printer upper door open	40021	Cover Open or Close Top Covers or Insert Cartridge or Close Door	FALSE
Intervention required: close toner box cover	40021	Close Cover A	FALSE
Intervention required: defective print cartridge or defective ink cartridge	40021	31 Defective Print Cartridge 31 Defective Cartridge XXXX	FALSE
Intervention required: unsupported print cartridge	40021	32 Unsupported Print Cartridge	FALSE
Intervention required: unsupported print cartridge	40021	32 Unsupported XXXX Cartridge	FALSE
Intervention required: unsupported cartridge	40021	32 Unsupported Cartridge	FALSE
Intervention required: change cartridge invalid refill	40021	Change Cartridge Invalid Refill	FALSE
Intervention required: cartridge life expired	40021	Cartridge Life Expired XXXX	FALSE

¹ XXXX represents a subset of letters CMYK, where CMYK denotes Cyan, Magenta, Yellow, and Black cartridges, respectively. For this message, the values for XXXX are returned to indicate which ink cartridges are defective.

² <d> represents a one-letter designator for each door labeled on the printer.

³ <c> represents a one-letter designator for each cover labeled on the printer.

Note: The Display String is returned in the current language. A display string that is returned is truncated to the DISPLAY CHARACTER SIZE returned in INFO CONFIG.

Table 3-14: PJL Message for Attendance Conditions

Printer State	Status Code	Display String	Online Status
Intervention required: cartridge life warning	40021	Cartridge Life Warning XXXX	FALSE
Intervention required: missing cartridge	40021	31 Missing Cartridge XXXX	FALSE
Intervention required: missing printhead	40021	31 Missing Printhead	FALSE
Intervention required: unsupported printhead	40021	32 Unsupported Printhead	FALSE
Intervention required: size sense error	40021	40 Tray x Size Sense Error	FALSE
Intervention required: open bin exit tray	40021	41 Open Bin 1 Exit Tray	FALSE
Intervention required: printer cover open	40021	Close Cover	FALSE
Intervention required: open cover	40021	Open Cover	FALSE
Intervention required: deflector open	40021	Close Deflector G	FALSE
Intervention required: open rear door	40021	Open Rear Door	FALSE
Intervention required: close front door	40021	Close Front Door	FALSE
Intervention required: close side door	40021	Close Side Door	FALSE
Intervention required: close finisher door	40021	Close Finisher Door	FALSE
Intervention required: close finisher side door	40021	Close Finisher Side Door	FALSE
Intervention required: close finisher top cover	40021	Close Finisher Top Cover	FALSE
Intervention required: close door <d> ²	40021	Close Door <d>	FALSE
Intervention required: close cover <c> ³	40021	Close Cover <c>	FALSE
Intervention required: close tray top cover	40021	Close Tray x Top Cover	FALSE

¹ XXXX represents a subset of letters CMYK, where CMYK denotes Cyan, Magenta, Yellow, and Black cartridges, respectively. For this message, the values for XXXX are returned to indicate which ink cartridges are defective.

² <d> represents a one-letter designator for each door labeled on the printer.

³ <c> represents a one-letter designator for each cover labeled on the printer.

Note: The Display String is returned in the current language. A display string that is returned is truncated to the DISPLAY CHARACTER SIZE returned in INFO CONFIG.

Table 3-14: PJL Message for Attendance Conditions

Printer State	Status Code	Display String	Online Status
Intervention required: print cartridge missing	40021	Insert Print Cartridge	FALSE
Intervention required: paper jam	40022	2xx Paper Jam	FALSE
Intervention required: check tray connection	40027	Check Tray <source #> Connection	FALSE
Intervention required: install tray x or cancel job	40027	Install Tray x or Cancel Job	FALSE
Intervention required: envelope feeder detached	40028	Reattach Envelope Feeder	FALSE
Intervention required: multipurpose feeder detached	40028	Reattach MP Feeder	FALSE
Intervention required: install envelope feeder or cancel job	40028	Install Env Feed or Cancel Job	FALSE
Intervention required: reattach output bin	40029	Reattach Output Bin <bin #>	FALSE
Intervention required: reattach bins	40029	Reattach Bins <bin #x - bin #y>	FALSE
Intervention required: install bin x or cancel job	40029	Install Bin x or Cancel Job	FALSE
Intervention required: check finisher installation	40029	Check Finisher Installation	FALSE
Intervention required: check mailbox installation	40029	Check Mailbox Installation	FALSE
Intervention required: tray configuration error	40030	33 Tray x Config Error	FALSE
Intervention required: input configuration error	40030	58 Input Config Error	FALSE
Intervention required: too many trays attached	40030	58 Too Many Trays Attached	FALSE
Intervention required: too many bins attached	40030	58 Too Many Bins Attached	FALSE
Intervention required: too many disks installed	40030	58 Too Many Disks Installed	FALSE
Intervention required: too many disks installed	40036	58 Too Many Disks Installed	FALSE

¹ XXXX represents a subset of letters CMYK, where CMYK denotes Cyan, Magenta, Yellow, and Black cartridges, respectively. For this message, the values for XXXX are returned to indicate which ink cartridges are defective.

² <d> represents a one-letter designator for each door labeled on the printer.

³ <c> represents a one-letter designator for each cover labeled on the printer.

Note: The Display String is returned in the current language. A display string that is returned is truncated to the DISPLAY CHARACTER SIZE returned in INFO CONFIG.

Table 3-14: PJL Message for Attendance Conditions

Printer State	Status Code	Display String	Online Status
Intervention required: PerfectFinish™ missing	40037	31 PerfectFinish Missing	FALSE
Intervention required: PerfectFinish empty	40037	87 PerfectFinish Empty	FALSE
Intervention required: photo developer nearly exhausted	40038	84 Black Photo Dev Life Warning	FALSE
Intervention required: photo developer nearly exhausted	40038	84 Color Photo Dev Life Warning	FALSE
Intervention required: color photo developer exhausted	40038	84 All Photo Devs Exhausted	FALSE
Intervention required: black photo developer exhausted	40038	84 Black Photo Dev Exhausted	FALSE
Intervention required: toner low	40038	88 Toner Low	FALSE
Intervention required: toner low	40038	88 Yellow Toner Low	FALSE
Intervention required: toner low	40038	88 Magenta Toner Low	FALSE
Intervention required: toner low	40038	88 Cyan Toner Low	FALSE
Intervention required: toner low	40038	88 Black Toner Low	FALSE
Intervention required: toner empty	40038	88 Yellow Toner Empty	FALSE
Intervention required: toner empty	40038	88 Cyan Toner Empty	FALSE
Intervention required: toner empty	40038	88 Magenta Toner Empty	FALSE
Intervention required: toner empty	40038	88 Black Toner Empty	FALSE
Intervention required: toner low	40038	88 Color Print Cartridge Low	FALSE
Intervention required: toner low	40038	88 Black Print Cartridge Low	FALSE
Intervention required: toner low	40038	88 Photo Print Cartridge Low	FALSE

¹ XXXX represents a subset of letters CMYK, where CMYK denotes Cyan, Magenta, Yellow, and Black cartridges, respectively. For this message, the values for XXXX are returned to indicate which ink cartridges are defective.

² <d> represents a one-letter designator for each door labeled on the printer.

³ <c> represents a one-letter designator for each cover labeled on the printer.

Note: The Display String is returned in the current language. A display string that is returned is truncated to the DISPLAY CHARACTER SIZE returned in INFO CONFIG.

Table 3-14: PJL Message for Attendance Conditions

Printer State	Status Code	Display String	Online Status
Intervention required: cartridge low	40038	88 Cartridge Low <CMYK>	FALSE
Intervention required: replace photoconductor kit	40038	Replace PC Kit	FALSE
Intervention required: replace photoconductor kit to continue	40038	Replace PC Kit To Continue	FALSE
Intervention required: replace toner cartridge	40038	Replace Toner Cartridge	FALSE
Intervention required: replace toner cartridge to continue	40038	Replace Toner To Continue	FALSE
Intervention required: replace oil coating roll	40038	Replace Oil Coating Roll	FALSE
Intervention required: cartridge empty	40039	89 Cartridge Empty <CMYK>	FALSE
Intervention required: load staples	40040	Load Staples	FALSE
Intervention required: priming failed. retry?	40041	Priming Failed. Retry?	FALSE
Intervention required: OPMSG	40048	Message specified by OPMSG	FALSE
Intervention required: STMSG	40049	Message specified by STMSG	FALSE
Intervention required: replace fuser	40050	Replace Fuser	FALSE
Intervention required: replace transfer kit	40050	Replace Transfer Kit	FALSE
Intervention required: incompatible bin x	40087	59 Incompatible Bin x	FALSE
Intervention required: incompatible duplex	40088	59 Incompatible Duplex	FALSE
Intervention required: incompatible tray x	40089	59 Incompatible Tray x	FALSE
Intervention required: incompatible envelope feeder	40090	59 Incompatible Envelope Feeder	FALSE
Intervention required: check duplex connection	40095	Check Duplex Connection	FALSE

¹ XXXX represents a subset of letters CMYK, where CMYK denotes Cyan, Magenta, Yellow, and Black cartridges, respectively. For this message, the values for XXXX are returned to indicate which ink cartridges are defective.

² <d> represents a one-letter designator for each door labeled on the printer.

³ <c> represents a one-letter designator for each cover labeled on the printer.

Note: The Display String is returned in the current language. A display string that is returned is truncated to the DISPLAY CHARACTER SIZE returned in INFO CONFIG.

Table 3-14: PJL Message for Attendance Conditions

Printer State	Status Code	Display String	Online Status
Intervention required: install duplex or cancel job	40095	Install Duplex or Cancel Job	FALSE
Intervention required: duplex cover open	40096	Close Duplex Door	FALSE
Intervention required: insert duplex option	40096	Insert Duplex Option	FALSE
Intervention required: load staples	40101	Load Staples	FALSE

¹ XXXX represents a subset of letters CMYK, where CMYK denotes Cyan, Magenta, Yellow, and Black cartridges, respectively. For this message, the values for XXXX are returned to indicate which ink cartridges are defective.

² <d> represents a one-letter designator for each door labeled on the printer.

³ <c> represents a one-letter designator for each cover labeled on the printer.

Note: The Display String is returned in the current language. A display string that is returned is truncated to the DISPLAY CHARACTER SIZE returned in INFO CONFIG.

Operator Intervention - Paper Handling

When a **Load <tray>**, **Load Manual**, or **Change <tray>** message appears on the printer operator panel display or through MarkVision Professional, a message is returned to the host computer indicating the paper source and size for the prompt.

Attendance (operator intervention) messages are returned in this form:

```
CODE=status code
DISPLAY="display string (in double quotes)"
ONLINE=online status
```

The display string is the first line of the message that displays.

To determine which messages your printer supports, see “Table B-12: PJL Messages for Paper Handling” on page B-28.

Table 3-15: PJL Messages for Paper Handling

Printer State	Status Code	Display String*	Online Status
Intervention required: wrong paper size in tray x	30034	34 Wrong Paper Size in Tray x	FALSE
Intervention required: wrong paper size manual feed	30034	34 Wrong Paper Size Manual Feed	FALSE
Intervention required: remove paper standard bin	40019	Remove Paper Standard Bin	FALSE
Intervention required: remove paper output bin	40019	Remove Paper Output Bin <bin #>	FALSE
Intervention required: remove paper all output bins	40019	Remove Paper All Output Bins	FALSE
Intervention required: remove paper	40019	Remove Paper <linked set bin name>	FALSE
Intervention required: check <source> paper guide	4100x	Check <source> Paper Guide	FALSE
Intervention required: incorrect media	41xyy	34 Incorrect Media	FALSE
Intervention required: load request	41xyy	Load <source>... <Custom Type Name> <Custom String> <size> <type> <size>	FALSE
Intervention required: load manual request	41xyy	Load Manual <Custom Type Name> <Custom String> <size> <type> <size>	FALSE
Intervention required: change request	41xyy	Change <source>... <Custom Type Name> <Custom String> <size> <type> <size>	FALSE
Intervention required: insert duplex pages & press Go.	412yy	Insert Duplex Pages & Press Go.	FALSE
Intervention required: insert tray request	4300x	Insert Tray <source #>	FALSE

x represents an input source code. For more information, see “Table 3-16: Tray Values” on page 3-74.

yy represents a media size code. For more information, see “Table 3-17: Media Size Values” on page 3-74.

* See your printer See your printer documentation for more information on printer messages.

Table 3-16: Tray Values

X Value	Tray
0	Multipurpose Feeder
1	Manual Feed
2	Tray 1
3	Tray 2
4	Envelope Feeder
5	Tray 3
6	Tray 4
7	Tray 5

Table 3-17: Media Size Values

YY Value	Media Size
00	Universal
01	Other Envelope
02	Letter Paper
03	Legal Paper
04	A4 Paper
05	Executive Paper
06	11 x 17 (Ledger)
07	A3
08	Com 10 Envelope
09	7 3/4 Envelope (Monarch)
10	C5 Envelope
11	DL Envelope
12	JIS B4
13	JIS B5 Paper
14	B5 Envelope
15	Custom Media
16	A3+, JB4 Paper (Model specific)
17	JB5 Paper
18	JPostcard
19	JDoublePostcard

Table 3-17: Media Size Values

YY Value	Media Size
20	A5
21	Folio
22	Statement
90	Com 9 Envelope

Table 3-18: Output Bin Values

WW Value	Output Bin
00	Standard Bin
01	Bin 1
02	Bin 2
03	Bin 3
04	Bin 4
05	Bin 5
06	Bin 6
07	Bin 7
08	Bin 8
09	Bin 9
10	Bin 10

Operator Intervention - Paper Jams

When a **<#> Paper Jam** message appears on the printer operator panel display or through MarkVision Professional, a message is returned to the host computer indicating the type and location for the prompt.

Attendance (operator intervention) messages are returned in this form:

CODE=status code
 DISPLAY=display string (in double quotes)
 ONLINE=online status

To determine which messages your printer supports, see Table B-13 on page B-30.

Table 3-19: PJL Messages for Paper Jams

Printer State	Status Code	Display String*	Online Status
Intervention required: paper jam	4200x	200 Paper Jam	FALSE
Intervention required: paper jam	4201x	201 Paper Jam	FALSE
Intervention required: paper jam	4202x	202 Paper Jam	FALSE
Intervention required: paper jam	4203x	203 Paper Jam	FALSE
Intervention required: paper jam	4204x	204 Paper Jam	FALSE
Intervention required: paper jam	4205x	205 Paper Jam	FALSE
Intervention required: paper jam	4206x	206 Paper Jam	FALSE
Intervention required: paper jam	4207x	207 Paper Jam	FALSE
Intervention required: paper jam	4208x	208 Paper Jam	FALSE
Intervention required: paper jam	4209x	209 Paper Jam	FALSE
Intervention required: paper jam	4210x	210 Paper Jam	FALSE
Intervention required: paper jam	4211x	211 Paper Jam	FALSE
Intervention required: paper jam	4220x	220 Paper Jam	FALSE
Intervention required: paper jam	4221x	221 Paper Jam	FALSE
Intervention required: paper jam	4222x	222 Paper Jam	FALSE
Intervention required: paper jam	4230x	230 Paper Jam	FALSE
Intervention required: paper jam	4231x	231 Paper Jam	FALSE

w indicates this message includes a letter indicating a door or cover. The door or cover needs to be opened.

x represents the number of jammed pages in the printer.

y represents the tray number.

z represents the bin number.

* See your printer documentation for more information on printer messages.

Table 3-19: PJL Messages for Paper Jams (Continued)

Printer State	Status Code	Display String*	Online Status
Intervention required: paper jam	4232x	232 Paper Jam	FALSE
Intervention required: paper jam	4233x	233 Paper Jam	FALSE
Intervention required: paper jam	4234x	234 Paper Jam	FALSE
Intervention required: paper jam	424yx	24y Paper Jam	FALSE
Intervention required: paper jam	4241wy	241 Paper Jam	FALSE
Intervention required: paper jam	4242wy	242 Paper Jam	FALSE
Intervention required: paper jam	4243w	243 Paper Jam	FALSE
Intervention required: paper jam	4244wy	244 Paper Jam	FALSE
Intervention required: paper jam	4245w	245 Paper Jam	FALSE
Intervention required: paper jam	4246w	246 Paper Jam	FALSE
Intervention required: paper jam	4247wy	247 Paper Jam	FALSE
Intervention required: paper jam	4248w	248 Paper Jam	FALSE
Intervention required: paper jam	4249w	249 Paper Jam	FALSE
Intervention required: paper jam	4250w	250 Paper Jam	FALSE
Intervention required: paper jam	4250x	250 Paper Jam	FALSE
Intervention required: paper jam	4251wy	251 Paper Jam	FALSE
Intervention required: paper jam	4251x	251 Paper Jam	FALSE
Intervention required: paper jam	4252w	252 Paper Jam	FALSE

w indicates this message includes a letter indicating a door or cover. The door or cover needs to be opened.

x represents the number of jammed pages in the printer.

y represents the tray number.

z represents the bin number.

* See your printer documentation for more information on printer messages.

Table 3-19: PJL Messages for Paper Jams (Continued)

Printer State	Status Code	Display String*	Online Status
Intervention required: paper jam	4253w	253 Paper Jam	FALSE
Intervention required: paper jam	4254wy	254 Paper Jam	FALSE
Intervention required: paper jam	4255	255 Paper Jam	FALSE
Intervention required: paper jam	4256w	256 Paper Jam	FALSE
Intervention required: paper jam	4257w	257 Paper Jam	FALSE
Intervention required: paper jam	4258w	258 Paper Jam	FALSE
Intervention required: paper jam	4259wy	259 Paper Jam	FALSE
Intervention required: paper jam	4260w	260 Paper Jam	FALSE
Intervention required: paper jam	4260x	260 Paper Jam	FALSE
Intervention required: paper jam	4261w	261 Paper Jam	FALSE
Intervention required: paper jam	4261x	261 Paper Jam	FALSE
Intervention required: paper jam	427zx	27z Paper Jam	FALSE
Intervention required: paper jam	4271	271 Paper Jam	FALSE
Intervention required: paper jam	4272	272 Paper Jam	FALSE
Intervention required: paper jam	4273	273 Paper Jam	FALSE
Intervention required: paper jam	4280x	280 Paper Jam	FALSE
Intervention required: paper jam	4280x	Clear Staple Job from Finisher	FALSE
Intervention required: paper jam	4280w	280 Paper Jam	FALSE

w indicates this message includes a letter indicating a door or cover. The door or cover needs to be opened.

x represents the number of jammed pages in the printer.

y represents the tray number.

z represents the bin number.

* See your printer documentation for more information on printer messages.

Table 3-19: PJL Messages for Paper Jams (Continued)

Printer State	Status Code	Display String*	Online Status
Intervention required: paper jam	4281w	281 Paper Jam	FALSE
Intervention required: paper jam	4281x	281 Paper Jam	FALSE
Intervention required: paper jam	4282w	282 Paper Jam	FALSE
Intervention required: paper jam	4282x	282 Paper Jam	FALSE
Intervention required: paper jam	4283w	283 Paper Jam	FALSE
Intervention required: paper jam	4283x	283 Paper Jam	FALSE
Intervention required: paper jam	4284w	284 Paper Jam	FALSE
Intervention required: paper jam	4284x	284 Paper Jam	FALSE
Intervention required: paper jam	4285w	285 Paper Jam	FALSE
Intervention required: paper jam	4286w	286 Paper Jam	FALSE
Intervention required: paper jam	4287	287 Paper Jam	FALSE
Intervention required: paper jam	4288	288 Paper Jam	FALSE
Intervention required: paper jam	4289	289 Paper Jam	FALSE
Intervention required: paper jam	4290	290 Paper Jam	FALSE
Intervention required: paper jam	4291	291 Paper Jam	FALSE
Intervention required: paper jam	4292	292 Paper Jam	FALSE
Intervention required: paper jam	4293	293 Paper Jam	FALSE

w indicates this message includes a letter indicating a door or cover. The door or cover needs to be opened.

x represents the number of jammed pages in the printer.

y represents the tray number.

z represents the bin number.

* See your printer documentation for more information on printer messages.

Table 3-19: PJL Messages for Paper Jams (Continued)

Printer State	Status Code	Display String*	Online Status
Intervention required: paper jam	4294	294 Paper Jam	FALSE
Intervention required: paper jam	4295	295 Paper Jam	FALSE
<p>w indicates this message includes a letter indicating a door or cover. The door or cover needs to be opened. x represents the number of jammed pages in the printer. y represents the tray number. z represents the bin number. * See your printer documentation for more information on printer messages.</p>			

Service Errors

Error Code 50000 is returned for all 9xx Service Errors when the printer can return a status code.

To determine whether your printer supports returning service messages, see “Table B-14: Service Errors” on page B-35.

Device Attendance Commands

To determine which commands your printer supports, see “Table B-15: Device Attendance Messages” on page B-36.

RDYMSG Command

The RDYMSG command is used to specify a message that appears on the first line of the printer operator panel display or through MarkVision Professional whenever the printer is ONLINE (in the **Ready** or **Busy** state). This message displays instead of the **Ready** or **Busy** message.

Syntax:

```
@PJL RDYMSG DISPLAY = "message" [<CR>] <LF>
```

OPMSG Command

When an OPMSG command is received, the message appears and is allotted both lines of the display. The printer is taken OFFLINE. This message, along with the STMSG command, is the lowest priority, so if another intervention occurs, it displays instead.

Note: See your printer documentation for information about how to return your printer to the ONLINE state. Once in the ONLINE state, the **Ready**, **Busy**, or **Waiting** message appears on the printer operator panel display or through MarkVision Professional.

A printer reset is not available from the printer operator panel or through MarkVision Professional while **OPMSG** displays.

Syntax:

```
@PJL OPMSG DISPLAY = "message" [<CR>] <LF>
```

STMSG Command

When a STMSG command is received, the message appears and is allotted both lines of the display. The printer is taken OFFLINE. This message, along with the OPMSG command, is the lowest priority, so if another intervention occurs, it displays instead.

Note: See your printer documentation for information about how to return your printer to the ONLINE state. Once in the ONLINE state, the **Ready**, **Busy**, or **Waiting** message appears on the printer operator panel display or through MarkVision Professional.

A printer reset is not available from the printer operator panel or through MarkVision Professional while **STMSG** displays.

Syntax:

```
@PJL STMSG DISPLAY = "message" [<CR>] <LF>
```

Unique PJL Commands

To determine which commands your printer supports, see “Table B-16: Lexmark Unique PJL Commands” on page B-36.

LBEEP Command

This command causes the printer to beep three times.

Syntax:

```
@PJL LBEEP[<CR>]<LF>
```

LPORTROTATE Command

This command causes the printer to rotate ports at the next job boundary. The information to rotate ports is specified in the job header. For example, the printer could switch from parallel interface to serial interface between jobs.

Syntax:

```
@PJL LPORTROTATE[<CR>]<LF>
```

LPRINT Commands (Information Pages)

Use these commands to print one of the internal information pages.

```
@PJL testpage[<CR>]<LF>
```

The supported `testpage` values are listed in the following table.

Table 3-20: LPRINT testpage Commands

testpage Value	Description
LPRINTDIRECTORY	Prints both the flash and disk directory listings. If neither flash memory or a disk is installed, the command is ignored.
LPRINTTESTPAGE	Prints the test page.
LPRINTMENUS	Prints the menu settings page.
LPRINTPCLFONTS	Prints the PCL font listing.
LPRINTPSFONTS	Prints the PostScript font listing.

For example, to print a menu settings page:

Syntax:

```
@PJL LPRINTMENUS[<CR>]<LF>
```

LESCAPECHAR Command

This command modifies the code point of the escape character for the host computer specified by the `PORT` parameter. The escape character is mapped to code point 0x1B for each host interface port.

Syntax:

```
@PJL LESCAPECHAR CHAR=byte PORT=port [<CR>]<LF>
```

`CHAR` parameter

The `byte` value for the `CHAR` parameter is the code point of the ASCII character used for the escape character.

For example, at the factory, the printer uses 0x1B (character <Esc>) for the escape character. If `CHAR = 65` is specified with this command, the printer uses 0x41 (character 'A') as the escape character for the host interface port specified via the `PORT` parameter.

PORT parameter

The following ports are valid parameters for LESCAPECHAR:

- INA
- INA1
- INA2
- INA3
- LOCALTALK1
- LOCALTALK2
- LOCALTALK3
- PARALLEL
- PARALLEL1
- PARALLEL2
- PARALLEL 3
- USB
- USB1
- USB2
- USB3
- SERIAL
- SERIAL1
- SERIAL2
- SERIAL3
- IR
- IR1
- IR2
- IR3

LFX PHONENUMBER Command

This command tells the printer that the output resulting from the current job is being sent to the fax processing device instead of to the printer. The current job is printed and is not sent to the fax processing device if one of the following occurs:

- The printer is not configured for fax send capability
- The command is received with a command that selects an interpreter that does not support formatting functionality for sending faxes

Syntax:

```
@PJL LFX PHONENUMBER="number" [STATIONID="station name"]<CR><LF>
```

```
PHONENUMBER="number"
```

The PHONENUMBER parameter is a text string up to 60 characters long. If an unsupported character is supplied in the PHONENUMBER parameter, the entire LFX PHONENUMBER command is ignored.

Table 3-21: LFX PHONENUMBER “number” Values

Character	Description
0 - 9	DTMF ¹ digits 0 to 9
*	DTMF ¹ character *
#	DTMF ¹ character #
A - D	DTMF ¹ characters A, B, C, and D
!	Flash
W	Wait for dial tone
@	Wait for silence
&	Wait for credit card tone
, (comma)	Pause
^	Toggles between tone and pulse modes
¹ DTMF, Dual Tone Multi-Frequency, is the system used by touch-tone telephones which assigns a specific frequency, or tone, to each key so it can easily be identified by a microprocessor.	

```
[STATIONID="station name"]
```

The STATIONID parameter specifies a station name that is sent to the receiving fax machine to indicate the origin of an incoming fax. The “station name” is a text string which is truncated to 20 characters. A null value (“”) indicates no station ID is specified. If no station name is specified, the default station name of the printer is used.

LDOWNLOADTARGET Command

This command specifies which device is the target for downloaded files. The target can be RAM, flash, or disk.

Syntax:

```
@PJL SET LDOWNLOADTARGET=variable [<CR>]<LF>
```

File Commands for Flash or Disk

Use the following commands to manage resources on flash and disk devices:

- LOPENFILE
- LCLOSEFILE
- LREADFILE
- LWRITEFILE
- LRUNFILE
- LRENAMEFILE
- LDELETEFILE
- LFORMAT
- LDEFRAG

Syntax:

```
@PJL LOPENFILE DEVICE=filedevice FILENAME=fname ACCESS=accesstype  
[<CR>]<LF>
```

See Chapter 6: “Flash Memory and Disk” for more information.

Table 3-22 lists the parameters used with most of the commands. Additional parameters are noted in the description of each command.

Table 3-22: Variables for Flash and Disk File and Password Commands

Parameter	Syntax	Description
<i>accesstype</i>	ACCESS = <i>accesstype</i>	<p>One of the following access types must be specified when a file is opened:</p> <ul style="list-style-type: none"> <i>RO</i> Open for read only. The file must already exist on the specified device. <i>WO</i> Create a new file. If the file already exists, its contents will be discarded and a new file will be created. <i>RW</i> Open for reading and writing. The file must already exist. <i>AP</i> Open for reading and writing, and position the file pointer to the end of the file. The file must already exist. <p>Access types are case sensitive.</p> <p>The LREADFILE command is ignored if the file was not opened with an <i>accesstype</i> of <i>RO</i>, <i>RW</i>, or <i>AP</i>. The LWRITEFILE command is ignored if the file was not opened with an <i>accesstype</i> of <i>WO</i>, <i>RW</i>, or <i>AP</i>.</p>
<i>bytecount</i>	LENGTH = <i>bytecount</i>	<p>The amount of data in bytes to be read or written. The parameter is optional for both the LREADFILE and LWRITEFILE commands.</p> <p>If the LENGTH parameter is omitted from the LREADFILE command, <i>bytecount</i> is assumed to be equal to the entire file beginning at the START location. If the LENGTH parameter is omitted from the LWRITEFILE command, an @PJL END DATA command must be placed at the <i>end</i> of the data. All data up to '@' in @PJL END DATA is written to the file.</p> <p>Note: The LWRITEFILE command requires that <i>either</i> the LENGTH parameter or the @PJL END DATA command be specified, but not both.</p> <p>If the LENGTH is greater than the file size on a LREADFILE command, it is assumed to be the entire file beginning at the START location.</p>

Table 3-22: Variables for Flash and Disk File and Password Commands (Continued)

Parameter	Syntax	Description																																		
<i>filedevice</i>	DEVICE = <i>filedevice</i>	<p>File storage media. Case insensitive.</p> <p><i>flash</i> <i>flash1</i> <i>disk</i> <i>disk1</i> <i>rom</i></p> <p>The <i>rom</i> value is used for the LRUNFILE command only.</p> <p>Note: The command is ignored if the device is not installed.</p>																																		
<i>flashdevice</i>	DEVICE = <i>flashdevice</i>	<p>File storage media.</p> <p><i>flash</i> <i>flash1</i></p>																																		
<i>filename</i>	FILENAME = "fname" OLDFILENAME = "fname" NEWFILENAME = "fname"	<p>"Fname" is comprised of a filename, a unique identifier for a file, and a filetype, which specifies the type of file. The format is <i>filename.filetype</i>.</p> <p>The <i>filename</i> must be one of the following:</p> <table> <tr> <td><i>macro ID</i></td> <td>PCL macros</td> </tr> <tr> <td><i>symbol set ID</i></td> <td>PCL symbol sets</td> </tr> <tr> <td><i>font ID</i></td> <td>PCL fonts</td> </tr> <tr> <td><i>actual filename</i></td> <td>data, Type 1 fonts, demo files (case sensitive)</td> </tr> </table> <p>The <i>filetype</i> must be one of the following:</p> <table> <tr> <td><i>t1</i></td> <td>PostScript font</td> </tr> <tr> <td><i>sFnt5</i></td> <td>PCL scalable font</td> </tr> <tr> <td><i>bFnt5</i></td> <td>PCL bitmap font</td> </tr> <tr> <td><i>MAC5</i></td> <td>PCL macro</td> </tr> <tr> <td><i>data</i></td> <td>User Data</td> </tr> <tr> <td><i>type1</i></td> <td>PostScript font</td> </tr> <tr> <td><i>demo</i></td> <td>Demo</td> </tr> <tr> <td><i>p5scalable</i></td> <td>PCL scalable font</td> </tr> <tr> <td><i>p5bitmap</i></td> <td>PCL bitmap font</td> </tr> <tr> <td><i>p5macro</i></td> <td>PCL macro</td> </tr> <tr> <td><i>p5symset</i></td> <td>PCL symbol set</td> </tr> <tr> <td><i>ppdsbm</i></td> <td>PPDS bitmap font</td> </tr> <tr> <td><i>xlmacro</i></td> <td>PCL XL user stream</td> </tr> </table> <p>All <i>fname</i> specifications must be enclosed in quotation marks and cannot exceed 127 characters.</p> <p>If the file is password-protected, the password must be provided in order to unlock the file.</p> <p>For additional information about passwords, see "File and Device Protection Commands" on page 3-93.</p>	<i>macro ID</i>	PCL macros	<i>symbol set ID</i>	PCL symbol sets	<i>font ID</i>	PCL fonts	<i>actual filename</i>	data, Type 1 fonts, demo files (case sensitive)	<i>t1</i>	PostScript font	<i>sFnt5</i>	PCL scalable font	<i>bFnt5</i>	PCL bitmap font	<i>MAC5</i>	PCL macro	<i>data</i>	User Data	<i>type1</i>	PostScript font	<i>demo</i>	Demo	<i>p5scalable</i>	PCL scalable font	<i>p5bitmap</i>	PCL bitmap font	<i>p5macro</i>	PCL macro	<i>p5symset</i>	PCL symbol set	<i>ppdsbm</i>	PPDS bitmap font	<i>xlmacro</i>	PCL XL user stream
<i>macro ID</i>	PCL macros																																			
<i>symbol set ID</i>	PCL symbol sets																																			
<i>font ID</i>	PCL fonts																																			
<i>actual filename</i>	data, Type 1 fonts, demo files (case sensitive)																																			
<i>t1</i>	PostScript font																																			
<i>sFnt5</i>	PCL scalable font																																			
<i>bFnt5</i>	PCL bitmap font																																			
<i>MAC5</i>	PCL macro																																			
<i>data</i>	User Data																																			
<i>type1</i>	PostScript font																																			
<i>demo</i>	Demo																																			
<i>p5scalable</i>	PCL scalable font																																			
<i>p5bitmap</i>	PCL bitmap font																																			
<i>p5macro</i>	PCL macro																																			
<i>p5symset</i>	PCL symbol set																																			
<i>ppdsbm</i>	PPDS bitmap font																																			
<i>xlmacro</i>	PCL XL user stream																																			

Table 3-22: Variables for Flash and Disk File and Password Commands (Continued)

Parameter	Syntax	Description
<i>location</i>	START = <i>location</i>	<p>The location in the file to begin writing or reading. Use an integer that represents an offset in bytes from the beginning of the file.</p> <p>Optional for both LREADFILE and LWRITEFILE commands. If this parameter is omitted from an LREADFILE command, a <i>location</i> of 0 (beginning of the file) is assumed. If it is omitted from a LWRITEFILE command with an <i>accesstype</i> of <i>RW</i>, a <i>location</i> of 0 is also assumed.</p> <p>If a START location is provided but it is greater than the file size, the LREADFILE command response will contain no file data. Similarly, an LWRITEFILE command with an <i>accesstype</i> of <i>RW</i> functions like an LWRITEFILE command with an <i>accesstype</i> of <i>AP</i>.</p>

Note: If PostScript emulation is used to create the file on the device, it may automatically attach a *.data* extension to the *fname*. See “Filename Extensions” on page 6-10 for more information. For example, if “*myfile*” is downloaded to flash through PostScript emulation, the *fname* on the PJL commands is “*myfile.data*”.

LOPENFILE Command

Use this command to open a file on a storage device.

Syntax:

```
@PJL LOPENFILE DEVICE = filedevice FILENAME = "fname"
ACCESS = accesstype[<CR>]<LF>
```

LCLOSEFILE Command

Use this command to close a file on a storage device. The command is ignored if the file doesn't exist on the device or if the file is not open.

Syntax:

```
@PJL LCLOSEFILE DEVICE = filedevice FILENAME = "fname"[<CR>]<LF>
```

LREADFILE Command

Use this command to read data from a file on a storage device.

Syntax:

```
@PJL LREADFILE DEVICE = filedevice FILENAME = "fname"  
[START = location] [LENGTH = bytecount][<CR>]<LF>
```

Response Syntax:

```
@PJL LREADFILE DEVICE = filedevice FILENAME = "fname"  
START = location LENGTH = bytecount<CR><LF>  
<requested data from the file>@PJL END DATA<CR><LF><FF>
```

Notes:

- The file must be closed using the LCLOSEFILE command once all operations are complete.
- The command is ignored if the file doesn't exist on the device or has not already been opened with LOPENFILE with an *accesstype* of *RO*, *RW*, or *AP*.
- If the START = *location* parameter is omitted, location 0 (beginning of the file) is assumed.
- If a START location is provided but it is greater than the file size, the response will contain no file data.
- If the LENGTH parameter is omitted, *bytecount* is assumed to be equal to the entire file beginning at the START location.
- If the LENGTH is greater than the file size on a LREADFILE command, it is assumed to be the entire file beginning at the START location.

LWRITEFILE Command

Use this command to write data to a file on a storage device.

Syntax:

```
@PJL LWRITEFILE DEVICE = filedevice FILENAME = "fname"  
[START = location] [LENGTH = bytecount][<CR>]<LF><data>  
[@PJL END DATA][<CR>]<LF>
```

Notes:

- The file must be closed using the LCLOSEFILE command once all operations are complete.
- The command is ignored if the file doesn't exist on the device. The command is ignored if the file isn't already open with a write *accesstype*.
- If START = *location* is omitted on a file with an *accesstype* of *RW*, location 0 is assumed.
- If START = *location* is greater than file size and the *accesstype* is *RW*, it positions the file pointer at the end of the file.
- If the LENGTH is omitted from a LWRITEFILE command, an @PJL END DATA must be placed at the *end* of the data. All data up to '@' in @PJL END DATA is written to the file. The command requires *either* the LENGTH parameter or the @PJL END DATA be specified, but not both.

LRUNFILE Command

Use this command to load and execute a file on a storage device. For example, use this command to run the resident demo file or a demo file stored on flash or disk.

Syntax:

```
@PJL LRUNFILE DEVICE = filedevice FILENAME = "fname"[<CR>]<LF>
```

LRENAMEFILE Command

Use this command to rename a file on a storage device. The command is ignored if the filename specified as OLDFILENAME doesn't exist on the device, or if the filename specified as NEWFILENAME already exists on the device.

Syntax:

```
@PJL LRENAMEFILE DEVICE = filedevice OLDFILENAME = "fname"  
NEWFILENAME = "fname"[<CR>]<LF>
```

LDELETEFILE Command

Use this command to delete a file on a storage device. The command is ignored if the file doesn't exist on the device.

Syntax:

```
@PJL LDELETEFILE DEVICE = filedevice FILENAME = "fname"[<CR>]<LF>
```

LFORMAT Command

Use this command to format a device for storage.

Syntax:

```
@PJL LFORMAT DEVICE = filedevice[<CR>]<LF>
```

LDEFRAG Command

Use this command to recover storage space on a flash device.

Syntax:

```
@PJL LDEFRAG DEVICE = flashdevice[<CR>]<LF>
```

File and Device Protection Commands

The following information applies to password protection.

- You can set both read/write and write passwords for a resource. If both passwords are set, the read/write password has precedence over the write password.
- If you attempt to password-protect a non-existing resource, the PJL interpreter will return a warning (CODE = 25001).
- If a resource has already been password protected, the resource must be “unlocked” before you can specify a different password for that resource.
- Several restrictions with passwords apply to flash due to the nature of the technology:
 - You can create/change passwords for the whole flash multiple times, but each change uses up free space in the flash that can only be recovered by reformatting the whole flash.
 - You can create passwords for individual resources on the flash only once. You can also delete this password once. If this is done, you must recreate the resource before using the password feature again.

Protecting a File or Device

Use the DEFAULT command to set a password on the entire flash or disk or on an individual macro or font in flash.

Password Protection for a File

LRWLOCK with DEFAULT specified locks a file or device for reading and writing.
LWLOCK with DEFAULT specified locks a file or device for writing only.

Syntax:

```
@PJL DEFAULT LRESOURCE:"device:filename.filetype"
LRWLOCK="password" [<CR>]<LF>
```

```
@PJL DEFAULT LRESOURCE:"device:filename.filetype"
LWLOCK="password" [<CR>]<LF>
```

The filename used depends on whether you wish to put a password on a font or a macro.

The filename for a font is a five digit ID from the print directory page (add zeros to the left of the ID to fill the five digits) followed by a three digit instance number. The first time a font is downloaded after a flash has been formatted, the instance number is 0. Filetypes are described under *filename* in “Table 3-9: Printer Unique LRESOURCE Variables” on page 3-53. For example, to write password protect a PCL emulation bitmapped font (filetype of *p5bitmap*) with an ID of *127*, which has not been downloaded since flash was formatted:

```
@PJL DEFAULT LRESOURCE:"flash:00127000.p5bitmap"
LWLOCK="password" [<CR>]<LF>
```

To password protect a macro, the filename is the ID taken from the print directory page, followed by the filetype. For example, to read/write password protect a PCL emulation macro (filetype is *p5macro*) saved to flash with an ID of 1023:

```
@PJL DEFAULT LRESOURCE:"flash:1023.p5macro"
LRWLOCK="password" [<CR>]<LF>
```

Note: If the filename is incorrect, the printer applies the password to the entire device.

Password for an Entire Device

If you want to set a password on a device, not just a single file, omit the filename. LRWLOCK with DEFAULT specified locks a device for reading and writing. LWLOCK with DEFAULT specified locks a device for writing only.

Syntax:

```
@PJL DEFAULT LRESOURCE:"device:" LRWLOCK="password" [<CR>]<LF>
```

```
@PJL DEFAULT LRESOURCE:"device:" LWLOCK="password" [<CR>]<LF>
```

Unlocking a Protected File or Device

Use the LDECLARE command to specify a password so a protected file or device may be accessed or “unlocked.” The LDECLARE command is only allowed within a JOB/EOJ combination.

LRWLOCK with LDECLARE specified unlocks a file or device for reading and writing. LWLOCK with LDECLARE specified unlocks a file or device for writing only. The file or device *must* be re-locked using the LDELETEPASSWORD command after the job is completed. The file or device is not automatically re-locked with the EOJ command.

Syntax:

```
@PJL LDECLARE LRESOURCE : "device:filename.filetype"
LRWLOCK = "password" [<CR>]<LF>
```

```
@PJL LDECLARE LRESOURCE : "device:filename.filetype"
LWLOCK = "password" [<CR>]<LF>
```

```
LRESOURCE : "device:filename.filetype"
```

Values for "device:filename.filetype" are:

<i>device</i>	<i>flash, flash1, disk, or disk1</i> (case insensitive)
<i>filename</i>	A unique identifier for a file, such as the macro ID for a PCL macro, the symbol set ID for a PCL symbol set, the font ID for a PCL font, or the actual file name for data, Type 1 fonts, and demo files as shown on the Directory. The <i>filename</i> is case sensitive.
<i>filetype</i>	An identifier that categorizes the file, such as <i>p5macro</i> for PCL macros or <i>p5symset</i> for PCL symbol sets. See the table beginning on page 3-87 for a complete list of the supported file types. The <i>filetype</i> is case sensitive.

```
LRWLOCK = "password" or LWLOCK = "password"
```

See “Printer Unique LRESOURCE Variables” on page 3-52 for information about values for LRWLOCK = "password" and LWLOCK = "password" parameters.

Note: This should be the same password that was defined in the DEFAULT command. See “Password Protection for a File” on page 3-93 and “Password for an Entire Device” on page 3-94 for examples.

Re-Locking a Protected File or Device

Use the LDELETEPASSWORD command to re-lock a password-protected file or device that has been unlocked using the LDECLARE command.

If an LRESOURCE is not specified, all unlocked files or devices are re-locked.

Syntax:

```
@PJL LDELETEPASSWORD [LRESOURCE : "device:filename.filetype"] [<CR>]<LF>  
LRESOURCE : "device:filename.filetype"
```

Values for "*device:filename.filetype*" are:

<i>device</i>	<i>flash, flash1, disk, or disk1</i> (case insensitive)
<i>filename</i>	A unique identifier for a file, such as the macro ID for a PCL macro, the symbol set ID for a PCL symbol set, the font ID for a PCL font, or the actual file name for data, Type 1 fonts, and demo files as shown on the Directory. The <i>filename</i> is case sensitive.
<i>filetype</i>	An identifier that categorizes the file, such as <i>p5macro</i> for PCL macros or <i>p5symset</i> for PCL symbol sets. See the table beginning on page 3-87 for a complete list of the supported filetypes. The <i>filetype</i> is case sensitive.

Unlocking a Protected File or Device for the Current Job

The file or device unlocked by the execution of this command is automatically re-locked upon execution of the EOJ command or by a printer language change.

Syntax:

```
@PJL LDECLARE LRESOURCE : "device:filename.filetype"
LRWLOCKJ = "password" [<CR>]<LF>
```

```
@PJL LDECLARE LRESOURCE : "device:filename.filetype"
LWLOCKJ = "password" [<CR>]<LF>
```

```
LRESOURCE : "device:filename.filetype"
```

Values for "device:filename.filetype" are:

<i>device</i>	<i>flash, flash1, disk, or disk1</i> (case insensitive)
<i>filename</i>	A unique identifier for a file, such as the macro ID for a PCL macro, the symbol set ID for a PCL symbol set, the font ID for a PCL font, or the actual file name for data, Type 1 fonts, and demo files as shown on the Directory. The <i>filename</i> is case sensitive.
<i>filetype</i>	An identifier that categorizes the file, such as <i>p5macro</i> for PCL macros or <i>p5symset</i> for PCL symbol sets. See the table beginning on page 3-87 for a complete list of the supported file types. The <i>filetype</i> is case sensitive.

```
LRWLOCK = "password" or LWLOCK = "password" Parameters
```

See "Printer Unique LRESOURCE Variables" on page 3-52 for information about values for LRWLOCK = "password" and LWLOCK = "password" parameters.

Recovering Lost Passwords

Use the LQUERYSEED and LBYPASSPASSWORD commands to recover lost passwords.

Syntax:

```
@PJL LQUERYSEED[<CR>]<LF>
```

```
@PJL LBYPASSPASSWORD KEY = "key"[<CR>]<LF>
```

Use the following steps to retrieve lost passwords:

- 1 Send the LQUERYSEED command to the printer by one of the host computer interfaces.

This command causes a value, the “seed,” to display on the printer operator panel, through MarkVision Professional or, if there isn’t an LCD panel, to print on the Menu Settings Page. The value of the “seed” determines the *key*.

- 2 Obtain the *key* from the Lexmark Customer Support Center.

You must have the “seed” value.

- 3 Send the @PJL LBYPASSPASSWORD command to the printer by any port.

If the correct *key* is specified, a modified version of the directory is produced. The directory indicates the appropriate passwords for the flash or disk.

CHAPTER 4: PostScript Emulation

This section explains PostScript emulation supplemental operators in detail. For more information, refer to the *PostScript Language Reference Manual (Third Edition)* by Adobe Systems, Inc.

To determine which commands your printer supports, see Appendix C: “PostScript Support” on page C-1.

Selecting PostScript Emulation

Using SmartSwitch

When SmartSwitch is enabled for both printer languages on an interface, the printer automatically switches to the printer language being sent by your software program. The printer is shipped with SmartSwitch enabled for both printer languages and all interfaces. The printer examines all print jobs and switches dynamically between PostScript emulation and PCL emulation.

Using the Operator Panel or MarkVision Professional

You may select PostScript emulation from the printer operator panel or through MarkVision Professional. To disable the automatic switching and have all input interpreted as PostScript language, turn PCL SmartSwitch **Off** and set the printer language default to PostScript emulation. See your printer documentation for information on changing menu settings.

Using Your Software Program

To select PostScript emulation, use the ENTER LANGUAGE command, which is a Printer Job Language (PJM) command. For more information, see “ENTER LANGUAGE Command” on page 3-3. See “Printer Job Language” on page 3-1 for information about syntax and the use of PJL.

Warning: When you change printer languages, you may lose all previously downloaded fonts and macros, unless **Resource Save** is set to **On** or the resources are stored in flash memory or on disk.

Table 4-1: Paper Sizes Supported

✓ Supported ✗ Not Supported							
Paper Sizes				Printer Models			
Literal Name	Size (mm)	Size (inches)	Size (points)	C520, C522n, C524, C524n, C524dn	C530dn, C532n, C532dn, C534n, C534dn, C534dtn	C770, C770n, C772, C772n	C920, C920n, C920dn, C920dnf
letter	215.9 x 279.4	8.5 x 11.0	612 x 792	✓	✓	✓	✓
legal ¹	215.9 x 355.6	8.5 x 14.0	612 x 1008	✓	✓	✓	✓
JIS b5 ²	182.0 x 257.0	7.17 x 10.1	516 x 729	✓	✓	✓	✓
a4	210.0 x 297.0	8.27 x 11.7	595 x 842	✓	✓	✓	✓
executivepage	184.2 x 266.7	7.25 x 10.5	522 x 756	✓	✓	✓	✓
a5 ³	148.0 x 210.0	5.83 x 8.27	419 x 595	✓	✓	✓	✓
b4	257 x 364	10.12 x 14.33	729 x 1032	✓	✓	✓	✗
a3	297 x 420	11.7 x 16.54	842 x 1191	✓	✓	✓	✗
a3+	328 x 453	12.91 x 17.83	930 x 1284	✗	✗	✓	✗
11x17	279.4 x 431.8	11 x 17	792 x 1224	✓	✓	✓	✓
ledger	431.8 x 279.4	17 x 11	1224 x 792	✓	✗	✓	✓
folio ¹	216 x 330	8.5 x 13	612 x 936	✓	✓	✓	✓

¹The Lexmark C510(n) supports this size media only with an optional legal tray.
² B5 is a Japanese Industry Standard (JIS) paper size. The same B5 designation is used by JIS and International Standards Organization (ISO) for different paper sizes.
³The Lexmark C770, C770n, C772, C772n requires more than 1 sheet of A5 for test print job.
⁴The Lexmark C530dn, C532n, C532dn, C534n, C534dn, C534dtn supports Statement with MPF only. The 250-sheet tray and 500-sheet tray do not support statement.

Table 4-1: Paper Sizes Supported (Continued)

✓ Supported ✗ Not Supported							
Paper Sizes				Printer Models			
Literal Name	Size (mm)	Size (inches)	Size (points)	C520, C522n, C524, C524dn	C530dn, C532n, C532dn, C534n, C534dn, C534dtn	C770, C770n, C772, C772n	C920, C920n, C920dn, C920dnf
statement ⁴	140 x 216	5.5 x 8.5	396 x 612	✓	✗	✓	✓
custom ¹	215.9 x 355.6	8.5 x 14.0	612 x 1020	✗	✗	✗	✓
custom	297 x 431.8	11.7 x 17	842 x 1224	✗	✗	✗	✓
custom	320 x 559	12.6 x 22	908 x 1584	✗	✗	✗	✗
custom	297 x 914	11.7 x 36	842 x 2592	✗	✗	✗	✗

¹The Lexmark C510(n) supports this size media only with an optional legal tray.

² B5 is a Japanese Industry Standard (JIS) paper size. The same B5 designation is used by JIS and International Standards Organization (ISO) for different paper sizes.

³The Lexmark C770, C770n, C772, C772n requires more than 1 sheet of A5 for test print job.

⁴The Lexmark C530dn, C532n, C532dn, C534n, C534dn, C534dtn supports Statement with MPF only. The 250-sheet tray and 500-sheet tray do not support statement.

currentuniversalsize

– `currentuniversalsize integer integer integer (string)`

queries the current settings for the Universal paper size. Three *integers* and one *string* are returned on the stack:

Universal Width
 Universal Height
 Universal Feed Direction
 Custom Universal Prompt String

Error: **stackoverflow**

ignoresize

– `ignoresize integer`

queries whether or not text is being oriented based on page size.

An *integer* value is returned on the stack:

- 0 perform automatic orientation of text based on page size
- 1 treat the page size as an envelope
- 2 treat the page size as paper

Error: **stackoverflow**

setignoresize

integer `setignoresize` –

overrides the automatic page orientation selected by the printer to support custom media sizes. This operator determines whether or not to adjust the text based on the page size.

integer value may be:

- 0 perform automatic orientation of text based on page size (default)
- 1 treat the page size as an envelope
- 2 treat the page size as paper

A value set by this operator takes effect on a subsequent **setpagedevice** only if **PageSize Policy** is set to 7.

Errors: **rangecheck, stackunderflow, typecheck**

setuniversalsize

– *integer integer integer (string)* setuniversalsize

changes the current settings for the Universal paper size. Each parameter on the stack indicates:

Universal Width	minimum to maximum width in points
Universal Height	minimum to maximum height in points
Universal Feed Direction	
0	short edge
1	long edge
Custom Universal Prompt String	String must be 16 characters or less.

Error: **rangecheck, stackunderflow, typecheck**

Paper Tray Support

When the printer receives one of the operators listed in “Table 4-2: Tray Selected with Tray Operators” on page 4-7, it performs the actions listed as follows. This paper tray selection process ends as soon as a suitable paper source is chosen and paper is fed from this tray.

- The printer checks the value of **manualfeed** in **statusdict** and the **ManualFeed** page device parameter. If either one is true, the printer sends a message to load the requested size in the manual feed tray or multipurpose feeder.
- The **PageSize Policy** is set to 0 by means of **setpagedevice**.
- The printer checks the paper size loaded in the current active source to determine if it matches the requested size. If the sizes match, the paper is fed from the active source.

Note: The current active tray is the last source that was selected from the printer operator panel or by the printer language.

- If the requested size and the size loaded in the active source do not match, the sources are searched in the order defined by the Priority array in the **InputAttributes** dictionary in the pagedevice dictionary.

- If the requested media size is not found by the previous search, the following search order is used:
 - Tray 1
 - Tray 2
 - Tray 3
 - Multipurpose Feeder
 - Tray 4
 - Tray 5
- If the requested size cannot be located in any automatic source, a **configurationerror** is issued and the job is flushed.

For printers that support automatic duplexing:

- Automatic duplexing is not supported for custom-size paper or for envelopes in the multipurpose feeder. Automatic duplexing is supported from the multipurpose feeder for all other papers.
- If the paper source is changed before the back side of a duplexed page prints, a blank back page prints, the paper source changes, and the information for the back side of the page is printed on the front side of a page sent from the new paper source.

When these operators are used, it is equivalent to executing the following PostScript emulation sequence:

```
<< /PageSize [x y] /ImagingBBox null /Policies << /PageSize 0>> >>  
  setpagedevice
```

where x y are the `PageSize` in points.

Table 4-2: Tray Selected with Tray Operators

✓ Supported ✗ Not Supported		Printer Models			
Operator	Tray Selected (Corresponding image size is set)	C520, C522n, C524, C524n, C524dn	C530dn, C532n, C532dn, C534n, C534dn, C534dtn	C770, C770n C772, C772n	C920, C920n, C920dn, C920dnf
a3tray	tray with A3-size paper	✗	✗	✓	✓
a4tray	tray with A4-size paper	✓	✓	✓	✓
a5tray	tray with A5-size paper	✓	✓	✓	✓
b4tray	tray with B4-size paper	✓	✓	✓	✗
b5tray	tray with B5-size paper	✓	✓	✓	✓
customtray	tray with custom-size paper	✗	✗	✗	✗
executivetray	tray with executive-size paper	✓	✓	✓	✓
foliotray	tray with folio-size paper	✓	✓	✓	✓
ledgertray	tray with ledger-size paper	✓	✓	✓	✗
legaltray	tray with legal-size paper	✓	✓	✓	✓
lettertray	tray with letter-size paper	✓	✓	✓	✓
statementtray	tray with statement-size paper	✓	✓	✓	✓
11x17tray	tray with 11 x 17-size paper	✓	✓	✓	✗

manualfeed

`/manualfeed` *boolean def*

in **statusdict** indicates if a manual feed source has been selected. The boolean value can be:

true prints from a manual feed source (default)
false prints from an automatic feed source

This boolean key can be redefined to affect manual feed for the current job.

If the value of the **manualfeed** operator or the **ManualFeed** page device parameter is *true* when `showpage` or `copypage` is executed, the page is fed manually. If both have a value of *false* when `showpage` or `copypage` is executed, the page is fed from an automatic source. These two values are independent of each other.

Note: If `manualfeed` is redefined between printing the front and back page of a duplexed page, the information for the front and back pages is printed on the same page.

Error: **stackoverflow**

papertray

– `papertray` *integer*

queries the paper tray that is currently selected. An *integer* is returned on the stack indicating which paper tray is currently in use. Valid *integers* are:

0 Tray 1
1 Tray 2
2 Multipurpose Feeder *or* Envelope Feeder
3 Manual Paper
4 Manual Envelope
5 Tray 3
7 Multipurpose Feeder
8 Tray 4
9 Tray 5

Error: **stackoverflow**

setpapertray

integer setpapertray –

changes the active paper source for the next page through the end of job by setting the PageSize entry in the page device to the size loaded in the selected source and by setting MediaPosition to the selected source. This operator executes a **setpagedevice**.

The **PageSize Policy** page device parameter is not altered by this operator.

Use the following *integers* to set the paper tray:

0	Tray 1
1	Tray 2
2	Multipurpose Feeder <i>or</i> Envelope Feeder
3	Manual Paper
4	Manual Envelope
5	Tray 3
7	Multipurpose Feeder
8	Tray 4
9	Tray 5

Notes:

- If the Manual Paper or Manual Envelope source is selected, the **Manual-Feed** page device parameter is set to *true*.
- A **rangecheck** error is returned if a paper source that is not installed is selected.
- If a **setpapertray** operator is issued for the back of a duplexed page, the printer ejects a blank back page, changes the paper source, and prints the information for the back side of the page on the front side of a page from the new paper source.

The setting returns to the user default setting for the **Paper Source** menu item at the end of the print job.

Errors: **rangecheck**, **stackunderflow**, **typecheck**

Envelope Size Support

The literal names in Table 4-3 are also supported as operators in **userdict**. These operators change the image size, but do not change the active paper source. Therefore, when these operators are used, part of the image may be clipped.

When these literal names are used as operators, it is equivalent to executing the following PostScript emulation sequence. The following example uses a 3.875 x 7.5 envelope.

```
<</Policies <</PageSize 7>> /PageSize [279 540]>> >>setpagedevice
```

Table 4-3: Envelope Sizes Supported

✓ Supported ✗ Not Supported							
Envelope Sizes				Printer Models			
Literal Name	Size (mm)	Size (inches)	Size (points)	C520, C522n, C524, C524dn	C530dn, C532n, C532dn, C534n, C534dn, C534dtn	C770, C770n, C772, C772n	C920, C920n, C920dn, C920dnf
3.875x7.5envelope	98.4 x 190.5	3.875 x 7.5	[279 540]	✓	✓	✓	✓
3.875x8.875envelope	98.4 x 225.4	3.875 x 8.875	[279 639]	✓	✓	✓	✓
4.125x9.5envelope	104.8 x 241.3	4.125 x 9.5	[297 684]	✓	✓	✓	✓
110x220envelope	110 x 220	4.33 x 8.66	[312 624]	✓	✓	✓	✓
162x229envelope	162 x 229	6.38 x 9.01	[459 649]	✓	✓	✓	✓
176x250envelope	176 x 250	6.93 x 9.84	[499 708]	✓	✓	✓	✓
otherenvelope ¹	Other		[612 996]	✓	✓	✓	✓
otherenvelope	Other		[841 842]	✗	✗	✗	✗

¹ For other envelopes, the page is formatted to 216 x 356 mm (8.5 x 14 in.) unless a size is specified by your software program.

The literal names in Table 4-4 are supported as PostScript emulation compatible operators.

Table 4-4: Literal Names Supported

✓ Supported ✗ Not Supported					
Literal Names		Printer Models			
Literal Name	Compatible Literal Name	C520, C522n, C524, C524dn	C530dn, C532n, C532dn, C534n, C534dn, C534dtn	C770, C770n, C772, C772n	C920, C920n, C920dn, C920dnf
monarcenvelope	3.875x7.5envelope	✓	✓	✓	✓
com10envelope	4.125x9.5envelope	✓	✓	✓	✓
dlenvelope	110x220envelope	✓	✓	✓	✓
c5envelope	162x229envelope	✓	✓	✓	✓
b5envelope	176x250envelope	✗	✗	✗	✗

Note: Duplexing is not supported on any envelope size. If duplex printing is requested and one of the envelope size operators is sent to the printer, duplexing is suspended until a paper size is requested that is supported for duplex printing.

Envelope Tray Support

If **manualfeed** in **statusdict** and the **ManualFeed** page device parameter are *false* when the printer receives one of the **envelopetray** operators listed in “Table 4-5: Envelopetray Operator Selections” on page 4-13, the printer:

- Sets the PageSize Policy to 0.
- Checks the active source to see if it matches the requested envelope size. If the sizes match, the envelope is fed from the active source.

Note: The active source is the last source selected from the printer operator panel or data stream.
- If the requested size and the size loaded in the active source do not match, the sources are searched in the order defined by the Priority array in the **InputAttributes** dictionary in the pagedevice dictionary.
- If the requested media size is not found by the previous search, the following search order is used:
 - Envelope Feeder
 - Multipurpose Feeder
- If the requested size and type are not available from any automatic source, you are prompted to load the requested envelope size and type in the manual feed source.
- If the size is still not available, a **configurationerror** is issued and the print job is flushed.

If **manualfeed** or **ManualFeed** is *true*, the printer prompts you to load the requested size manually. If no manual feed exists on the printer, a **rangecheck** error message is generated.

The envelope tray the printer selects when it receives an **envelopetray** operator is listed in Table 4-5. These operators are equivalent to executing the following PostScript emulation sequence:

```
<</PageSize [x y] /ImagingBBox null /Policies<</PageSize 0>> >>
  setpagedevice
```

where *x y* are the PageSize in points.

Table 4-5: Envelopetray Operator Selections

✓ Supported ✗ Not Supported					
Tray Operators		Printer Models			
Operator	Tray Selected (Corresponding image size is set)	C520, C522n, C524, C524n, C524dn	C530dn, C532n, C532dn, C534n, C534dn, C534dtn	C770, C770n, C772, C772n	C920, C920n, C920dn, C920dnf
110x220envelopetray	tray with 110 x 220 size envelopes	✓	✓	✓	✓
dlenvelopetray	tray with 110 x 220 size envelopes	✓	✓	✓	✓
162x229envelopetray	tray with 162 x 229 size envelopes	✓	✓	✓	✓
c5envelopetray	tray with 162 x 229 size envelopes	✓	✓	✓	✓
176x250envelopetray	tray with 176 x 250 size envelopes	✓	✓	✓	✓
b5envelopetray	tray with 176 x 250 size envelopes	✓	✓	✓	✓
3.875x7.5envelopetray	tray with 3.875 x 7.5 size envelopes	✓	✓	✓	✓
monarcenvelopetray	tray with 3.875 x 7.5 size envelopes	✓	✓	✓	✓
3.875x8.875envelopetray	tray with 3.875 x 8.875 size envelopes	✓	✓	✓	✓
4.125x9.5envelopetray	tray with 4.125 x 9.5 size envelopes	✓	✓	✓	✓
com10envelopetray	tray with 4.125 x 9.5 size envelopes	✓	✓	✓	✓
otherenvelopetray	tray with other size envelopes	✓	✓	✓	✓

Supplemental Operator Summary

To determine which operators your printer supports, see Table C-1 on page C-1.

appletalktype

– `appletalktype` *(string)*

in **statusdict**, this string reflects the current value of the **LocalTalkType** device parameter from the %LocalTalk% device. The default *string* is *LaserWriter*. To change the *type* portion (`appletalktype`) of the AppleTalk network name and redefine the string, execute the following:

```
/appletalktype (string) def
```

When you redefine a string inside the normal server loop, it is reset to the default value at the end of the print job. When you define it outside the normal server loop, it is reset to the default value when the printer is switched to a printer language other than PostScript emulation or when a power-on reset occurs.

Errors: **rangecheck**, **stackoverflow**, **typecheck**

buildtime

– `buildtime` *integer*

returns the **BuildTime** system parameter, which is a timestamp that identifies the specific build of the PostScript emulation interpreter.

Error: **stackoverflow**

byteorder

`byteorder` *boolean*

returns a boolean on the stack with the same value as the system parameter **ByteOrder**. Indicates the printer microprocessor native byte order. The boolean values indicate:

```
true    low-order byte first  
false  high-order byte first
```

Error: **stackoverflow**

checkpassword

integer checkpassword or
(string) checkpassword

checks the passwords for both the **SystemParamsPassword** system parameter and the **StartJobPassword** system parameter stored in the printer.

If the *integer* form is used, the integer is converted into a string before the password check occurs. A *boolean* is returned on the stack to indicate if the specified password matches either password. The boolean value can be:

true correct password
false incorrect password

After the *boolean* is returned, the printer waits 1 second before it continues processing.

Errors: **stackunderflow**, **typecheck**

Note: The password is defined as a 4-byte number.

currentfilenameextend

currentfilenameextend *boolean*

returns a boolean on the stack to indicate whether the extension should be automatically added to any filename. The boolean value is either:

true adds the extension
false does not add the extension

See “Filename Extensions” on page 6-10.

Error: **stackoverflow**

currentmanualduplexmode

integer currentmanualduplexmode

queries the current value of the manual duplex mode. An integer is returned on the stack:

0 current job manual duplex mode is no manual duplex
1 current job manual duplex mode is printing first sides of job
2 current job manual duplex mode is printing second sides of job

Error: **stackoverflow**

defaulttimeouts

– `defaulttimeouts job manualfeed wait`

queries the user default settings of all timeouts. Three integers are returned on the stack:

- **JobTimeout** system parameter
0 disabled (default)
15...65535 seconds
- **ManualFeedTimeout** page device parameter
0 disabled
1...65535 seconds (default is device dependent)

To find the default for your printer, see Table C-2 on page C-5.

- **WaitTimeout** system parameter
0 disabled
15...65535 seconds (default is 40 seconds)

Error: **stackoverflow**

deletefile

`filename deletefile`

deletes the specified file from the disk. This operator is in **systemdict**.

Errors: **invalidfileaccess**, **ioerror**, **stackunderflow**, **typecheck**,
undefinedfilename

Note: An **undefinedfilename** error occurs if the file does not exist.

devcontrol

string integer devcontrol boolean

allows a host computer utility to manage resources on the flash or disk. It requires a string device name parameter, an integer command name parameter, and two command argument parameters. The device control operator performs a specified command on the specified device. The return values on the stack indicate:

true the command is successful
false the command is unsuccessful and returns an error code

Table 4-6: devcontrol Operator Parameters

Integer Command Name Parameter	Argument Parameter	Description
1	null null	Park disk heads
5	file null	Make contiguous flash file
8	filename description	Set description of file
9	password null	Set device read/write password
10	password null	Set device write password
11	filename password	Set file read/write password
12	filename password	Set file write password
13	password null	Declare device read/write password
14	password null	Declare device write password
15	filename password	Declare file read/write password
16	filename password	Declare file write password
17	null null	Reset device password list
18	null null	Reset file password list
19	devicename password	Get device password
19	filename password	Get file password
20	devicename null	Determine if device password is properly declared
20	filename null	Determine if file password is properly declared
21	null null	Scan for bad block
22	null null	Abort bad block scan
23	null null	Quick bad block scan
24	null null	Flush the disk cache
27	file null	Be quiet when writing to disk

Table 4-7: Unsuccessful devcontrol Parameter Error Codes

Code	Meaning
1	File system access has not been initialized
2	Could not allocate file descriptor
3	Some invalid argument was passed
4	No such device
5	Invalid access to file requested
6	Argument too large (filename, buffer)
7	Invalid file descriptor or filename
8	Catch all error or device error
9	Unable to allocate memory for buffer, data structure
10	Device busy
11	Device not currently mounted
12	Attempt to perform illegal IO operation
13	No space to update or create file
14	Major change in file system for findnext() to function properly
15	Corrupted file system on device
16	Device already mounted
17	Could not initialize file system
18	Device not mounted
19	No file entry located
20	Bad file system on device
21	Password required
22	Aborted by callback

Errors: **invalidaccess**, **rangecheck**, **typecheck**

devdismount

device devdismount -

dismounts the specified device by setting the **Mounted** device parameter for the specified device to *false*. This operator is in **systemdict**.

Errors: **invalidaccess**, **stackunderflow**, **undefinedfilename**

Note: An **undefinedfilename** error occurs when an invalid device name is used.

devforall

proc scratchstring devforall –

executes the specified *proc* procedure for each storage device after pushing a substring on the stack that is the portion of the scratch string containing the device name. This operator is in **systemdict**.

Errors: **invalidaccess**, **rangecheck**, **stackoverflow**, **stackunderflow**, **typecheck**, **undefined**

devformat

devicename pages action devformat –

formats (erases all data from) the specified device. This operator is in **systemdict**.

pages Sets the **LogicalSize** device parameter for the specified device:
0 entire device is formatted
1,2,3 an **ioerror** occurs

action 1 is added to the action argument. The result is used for the **InitializeAction** device parameter for the same device.

A **devformat** on a flash device formats the entire device regardless of the **LogicalSize** specified.

Errors: **invalidaccess**, **ioerror**, **limitcheck**, **rangecheck**, **stackunderflow**, **typecheck**, **undefined**, **undefinedfilename**

Note: An **invalidaccess** error occurs if **devformat** is not executed through **exitserver** or **startjob**.

devmount

device devmount boolean

sets the **Mounted** device parameter for the specified device to *true*. It also returns the value of the **Mounted** device parameter for the specified device. This operator is in **systemdict**.

The boolean values indicate:

true device successfully mounted, or was already mounted
false device not mounted

If a device with the specified device name is not installed, an **undefinedfilename** error occurs.

This operator may change the search order. See “Device Search Order” on page 6-12.

Errors: **invalidaccess**, **stackunderflow**, **undefinedfilename**

devstatus

devicename devstatus false or
devicename devstatus searchable writeable hasnames mounted removable searchorder free size true

returns on the stack the status of a specified device. This operator is in **systemdict**. A value of *false* is returned if the device is not present. If the device is present, five boolean values and three integers (see the following description) followed by a value of *true* are returned.

The five boolean values are:

searchable

true, if the device is included in the search order and is to be searched for the file operators that do not specify a device name. Same as the value of the **Searchable** device parameter from the specified IODevice.

writeable

true, if the device can be written to. This value is the same as the **Writeable** device parameter from the specified IODevice.

hasnames

true, if the device supports named files. This value is the same as the **HasNames** device parameter from the specified IODevice.

mounted

true, if the device is mounted. This value is the same as the **Mounted** device parameter from the specified IODevice.

removable

true, if the device is removable and must be mounted before it is referenced. This value is the same as the **Removable** device parameter from the specified IODevice.

The three integers are:

searchorder

The position in the search order. This value is the same as the **SearchOrder** device parameter from the specified IODevice.

free

The number of free bytes on the device. This value is the same as the **Free** device parameter from the specified IODevice.

size

The total number of bytes on the device. This value is the same as the **LogicalSize** device parameter from the specified IODevice.

Error: **typecheck**

diskonline

– `diskonline` *boolean*

returns the value of the **Writeable** device parameter (which is a boolean) for the %disk1% IODevice.

This operator is equivalent to executing the following PostScript emulation sequence:

```
(%disk1%) currentdevparams /Writeable get
```

Error: **stackoverflow**

diskstatus

– `diskstatus free logicalsize`

returns on the stack the following two integers:

- Number of pages that are free on the optional disk. The value of the **Free** device parameter from the `%disk1%` IODevice.
- Total number of pages (1024 bytes) that are on the optional disk. The value of the **LogicalSize** device parameter from the `%disk1%` IODevice.

This operator is equivalent to executing the following PostScript emulation sequence:

```
(%disk1%) currentdevparams dup /Free get exch /LogicalSize get
```

Error: **stackoverflow**

displayoperatormsg

(string) `displayoperatormsg`

sets a custom paper message. The string parameter is used as a prompt string when a page prints. The `string` value can be any string up to 16 characters. The string is cleared at the end of a print job.

Errors: **stackunderflow, typecheck**

doidlefonts

– `doidlefonts false`

returns a constant boolean value of `false`.

Error: **stackoverflow**

dojamrecovery

– dojamrecovery *boolean*

queries the user default setting of the **Jam Recovery** menu item. A boolean value is returned on the stack:

true reprint jammed page (**Jam Recovery** is set to **On**) (default)
false do not reprint jammed page (**Jam Recovery** is set to **Off**)

This operator is equivalent to executing the following PostScript emulation sequence:

```
currentpagedevice /ExitJamRecovery get
```

Error: **stackoverflow**

doprinterrors

– doprinterrors *boolean*

returns a boolean with the same value as the system parameter **DoPrintErrors**. It also indicates the current value of the **Print PS Error** printer setting. The **DoPrintErrors** system parameter must be present for the **doprinterrors** operator to be present.

Error: **stackoverflow**

doret

– doret *integer*

returns the PQET setting for the current print job. An integer value is returned on the stack:

0 Off
1 On

Note: For printers that do not support PQET, **doret** returns a *0*.

This operator is equivalent to executing the following PostScript emulation sequence:

```
currentpagedevice /PostRenderingEnhanceDetails get /REValue get
```

Error: **stackoverflow**

dostartpage

– dostartpage *boolean*

returns a boolean with the same value as the system parameter **DoStartPage**. The **DoStartPage** system parameter must be present for the compatibility operator **dostartpage** to be present.

Error: **stackoverflow**

dosysstart

– dosysstart *boolean*

returns the current value of the **StartupMode** system parameter. A boolean value is returned:

true StartupMode set to 1 or 11
false StartupMode other than 1 or 11

This operator is equivalent to executing the following PostScript emulation sequence:

```
currentsystemparams /StartupMode get
```

Error: **stackoverflow**

duplexer

– duplexer *boolean*

queries if a duplex unit is installed. A boolean value is returned on the stack:

true duplex unit is installed
false duplex unit is not installed

Note: For printers that do not support duplexing, this value is always *false*.

Error: **stackoverflow**

duplexmode

– duplexmode *boolean*

queries the current value for the **Duplex** page device parameter.

true printing mode is duplex

false printing mode is simplex

Note: For printers that do not support duplexing, this value is always *false*.

This operator is equivalent to executing the following PostScript emulation sequence:

```
currentpagedevice /Duplex get
```

Error: **stackoverflow**

enginesync

– enginesync *boolean*

indicates if the printer waits for the last page of a job to print before returning a Ctrl-D to the host computer.

Error: **stackoverflow**

file

filename access file file

creates a file object with specified filename and access. The *access* values are:

- r* open the file for reading only
- w* create a file if one does not already exist, or truncate and overwrite it if it does exist. File is opened for writing only.
- a* create a file if one does not already exist or append it if it does exist. File is opened for writing only.
- r+* open the file for reading and writing. An **undefinedfilename** error occurs if the file does not exist.
- w+* create a file if it does not already exist, or truncate and overwrite if it does exist. File is opened for reading and writing.
- a+* create a file if it does not exist or append it if it does exist. File is opened for reading and writing.

This operator is in **systemdict**.

Errors: **invalidfileaccess, ioerror, limitcheck, stackunderflow, typecheck, undefinedfilename**

Note: An **undefinedfilename** error occurs if the file does not exist.

filenameforall

pattern proc scratchstring filenameforall

lists all the files with names that match a specified pattern string, copies the filename for each of these files into a specified scratch string, and calls a specified *proc* procedure. This operator is in **systemdict**.

Errors: **ioerror, stackoverflow, stackunderflow, typecheck**

fileposition

file fileposition position

indicates the current position on an open file. This operator is in **systemdict**.

Errors: **ioerror, stackunderflow, typecheck, undefinedfilename**

Note: An **undefinedfilename** error occurs if the file does not exist.

firstside

– `firstside` *boolean*

indicates whether the current imaging area is on the front side of the page.

true front side is currently being imaged
false back side is currently being imaged

Error: **stackoverflow**

fontnonzerowinding

– *boolean* `fontnonzerowinding`

sets the winding rule for Type 1 fonts. No query operation is performed since the winding rule is reset to *true* at the beginning of each print job. The boolean value can be:

true non-zero winding used by the interpreter
false even or odd winding rule used by interpreter

Error: **stackoverflow**

hardwareiomode

– `hardwareiomode` *boolean*

queries the user default setting of the **Parallel Protocol** menu item. This operator returns the value of the Parallel Protocol, either Standard or Fastbytes. An *integer* value is returned on the stack:

1 Parallel Fastbytes Off (Standard)
2 Parallel Fastbytes On (Fastbytes)

Error: **stackoverflow**

idlefonts

– `idlefonts` *mark*

supports compatibility with the IBM LaserPrinters 4019, 4029, and 4039. It is parsed and returns a mark on the stack.

Error: **stackoverflow**

ignoresize

See page 4-4.

initializedisk

pages action initializedisk –

initializes the disk with the page count and action as integer arguments. The arguments set the (%disk1%) **IO** device parameters as follows:

- **LogicalSize** parameter is set to *pages*.
- If a value of 0 is set as *pages*, the entire disk is formatted.
- If a value of 1, 2, or 3 is set as *pages*, an **ioerror** is generated.
- **InitializeAction** parameter is set to *action* plus 1.

Errors: **invalidaccess**, **ioerror**, **rangecheck**, **stackunderflow**, **typecheck**

jobname

– jobname (*string*)

identifies each print job selection. This string in **statusdict** queries and changes the current setting of the **JobName** user parameter. Originally, *jobname* is set to null.

- To query **jobname**: *jobname* or
currentuserparams /JobName get.
A string indicating the job name is returned on the stack.
- To change **jobname**: /*jobname* (*string*) def or
<< /JobName (*string*) >> setuserparams
where *string* is the new job name.

Error: **stackoverflow**

jobsource

– jobsource (*string*)

indicates the current value of the **CurlInputDevice** system parameter. A string is returned on the stack indicating the job source. Valid values are:

- %LocalTalk%
- %SerialA%
- %SerialB%
- %SerialC%
- %SerialD%
- %ParallelA%
- %ParallelB%
- %ParallelC%
- %ParallelD%
- %IR_A%
- %IR_B%
- %IR_C%
- %IR_D%
- %USB_A%
- %USB_B%
- %USB_C%
- %USB_D%
- %EtherTalkB%
- %EtherTalkC%
- %EtherTalkD%
- %TokenTalkB%
- %TokenTalkC%
- %TokenTalkD%
- %LexLinkB%
- %LexLinkC%
- %LexLinkD%
- %PrintServerB%
- %PrintServerC%
- %PrintServerD%
- %RemotePrinterB%
- %RemotePrinterC%
- %RemotePrinterD%
- %AppSocketB%
- %AppSocketC%
- %AppSocketD%

```
%LPR_B%  
%LPR_C%  
%LPR_D%  
%UnknownDevice%
```

This operator is equivalent to executing the following PostScript emulation sequence:

```
currentsystemparams /CurInputDevice get
```

Error: **stackoverflow**

jobtimeout

– `jobtimeout` *integer*

queries the current user default setting for the **JobTimeout** parameter. An integer is returned on the stack:

```
0    disabled  
15...65355 seconds
```

This operator is equivalent to executing the following PostScript emulation sequence:

```
currentuserparams /JobTimeout get
```

Error: **stackoverflow**

manualfeed

See page 4-8.

manualfeedtimeout

`/manualfeedtimeout integer def`

is an integer key in **statusdict** that works with the **ManualFeedTimeout** page device parameter to determine the manualfeed timeout for a given page.

If during a print job, `manualfeedtimeout` is defined as an integer value in **statusdict**, that value is used instead of the **ManualFeedTimeout** page device parameter.

The value of the **ManualFeedTimeout** page device parameter and **manualfeedtimeout** key in **statusdict** are independent of each other; the value of one does not affect the value of the other.

`0` disabled
`1...65355` seconds

An **undefined** error results if **manualfeedtimeout** is queried before the value is set.

Errors: **stackoverflow**, **undefined**

newsheet

– `newsheet` –

causes the current page to start on the front side of a new sheet.

Error: **none**

pagecount

– `pagecount integer`

queries the value of the **PageCount** system parameter. An integer is returned on the stack indicating the current page count.

This operator is equivalent to executing the following PostScript emulation sequence:

```
currentsystemparams /PageCount get
```

Error: **stackoverflow**

pagesprinted

- pagesprinted

queries the number of pages of the current job submitted by the PostScript interpreter to the printer.

Error: **stackoverflow**

papertray

See page 4-8.

printername

(string) printername *(substring)*

returns the value of the **PrinterName** system parameter that is defined by the `setprintername` operator. The value of the string defines the printer name. A maximum of 32 characters are returned on the stack.

This operator is equivalent to executing the following PostScript emulation sequence:

```
currentsystemparams /PrinterName get
```

Errors: **rangecheck, stackunderflow, typecheck**

product

- product *(string)*

queries the name of the product that is defined in **statusdict**. A string is returned on the stack indicating the name of the product. The product string in **systemdict** cannot be changed.

To change this product string in **statusdict**:

```
/product (string) def
```

Error: **stackoverflow**

PS2fonts

- PS2fonts

redefines the following PostScript resident fonts to match the character designs and metrics defined in PostScript Level 2. The font names in parentheses are the equivalent PostScript 3 font names for the associated PostScript Level 2 names.

Antique Olive	(Antique Olive Roman)
Antique Olive Bold	
Antique Olive Italic	
Letter Gothic	
Letter Gothic Bold	
Letter Gothic Italic	(Letter Gothic Slanted)
Marigold	
Univers Bold	

Error: **none**

PS3fonts

- PS3fonts

restores the font compatibility to PostScript 3.

Error: **none**

quiet

- quiet *integer*

queries the **PowerSave** page device parameter. An integer is returned on the stack:

0 Power Saver is Off

1 to 120 or 1 to 240 (Model specific)

Number of minutes elapsed after last page prints before
Power Saver is invoked.

Power Saver reduces power consumption when the printer is idle. When `quiet` is enabled, it takes longer to print the first page after the printer has been idle.

Note: Some printer models released in the year 2000 or later designated as Energy Star printers cannot have Power Saver disabled.

This operator is equivalent to executing the following PostScript emulation sequence:

```
currentpagedevice /PowerSave get
```

Error: **stackoverflow**

ramsize

– `ramsize` *integer*

queries the current setting of the **RamSize** system parameter. An integer is returned on the stack showing total RAM in bytes.

This operator is equivalent to executing the following PostScript emulation sequence:

```
currentsystemparams /RamSize get
```

Error: **stackoverflow**

realformat

– `realformat` *boolean*

returns a boolean with the same value as the **RealFormat** system parameter. It indicates the printer microprocessor native real number representation. A query determines if the printer real number representation matches the application real number representation and compensates if necessary.

Error: **stackoverflow**

renamefile

oldfilename newfilename `renamefile`

renames the `oldfilename` to the `newfilename`. This operator is in **systemdict**.

Errors: **invalidfileaccess**, **ioerror**, **stackunderflow**, **typecheck**, **undefinedfilename**

Note: An **undefinedfilename** error occurs if the file does not exist.

resolution

– resolution *integer*

queries the resolution for the current print job. An integer is returned on the stack:

```
300 300 dpi is set to On
600 600 dpi is set to On
1200 1200 dpi is set to On
```

This operator is equivalent to executing the following PostScript emulation sequence:

```
currentpagedevice /HWResolution get 0 get
```

Error: **stackoverflow**

revision

– revision *integer*

queries the **Revision** system parameter. An integer is returned on the stack to indicate the revision level.

Error: **stackoverflow**

sccbatch

channel sccbatch *baud* *option*

returns the user default settings for serial communication parameters.

channel has the following valid integer values:

9

25

If only one serial interface port is available on the printer, both *9* and *25* return the same values. Baud and option values are returned on the stack.

baud returns the value of the **Baud** menu item.

option returns an 8 bit value as defined in the following illustration:

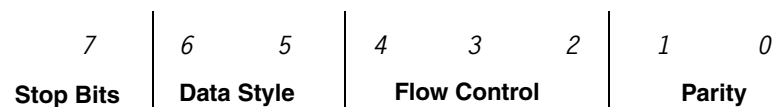
**Stop Bits**

This bit is always set to zero.

Data Style

01 7 data bits

11 8 data bits

Flow Control

000 XON/XOFF

001 DTR/DSR

101 DTR

110 XON/XOFF/DTR

111 XON/XOFF/DTR/DSR

Parity

00 ignore

01 odd

10 even

11 none

Errors: **rangecheck**, **stackoverflow**, **stackunderflow**, **typecheck**

sccinteractive

channel sccinteractive *baud options*

provided for parsing compatibility purposes. A value of *0* is returned.

Errors: **invalidaccess**, **rangecheck**, **stackoverflow**, **stackunderflow**,
typecheck

setcoverpage

boolean setcoverpage –

specifies a cover page for a fax job. The default value is *false*.

The *boolean* values indicate:

true the current page that is processing is moved to the first page of the
current fax job

false the current page that is processing is unaffected

Errors: **stackunderflow**, **typecheck**

setdefaulttimeouts

job manualfeed wait setdefaulttimeouts –

changes the values for all timeouts. Valid values are:

JobTimeout system parameter

0 disabled

15...65355 seconds

ManualFeedTimeout page device parameter

0 disabled

1...65355 seconds

WaitTimeout system parameter

0 disabled

15...65355 seconds

Errors: **invalidaccess**, **rangecheck**, **stackunderflow**, **typecheck**

setdoidlefonts

boolean setdoidlefonts –

is parsed and discarded. A boolean value is required.

Errors: **stackunderflow**, **typecheck**

setdojamrecovery

boolean setdojamrecovery –

changes the user default setting of the **Jam Recovery** menu item. The changes are not effective until the end of the print job.

The *boolean* values indicate:

<i>true</i>	reprint jammed page (Jam Recovery is set to On)
<i>false</i>	do not reprint jammed page (Jam Recovery is set to Off or Auto [model dependent])

This operator is equivalent to executing the following PostScript emulation sequence:

```
%Go into exitserver or startjob context
<< /ExitJamRecovery boolean >> setpagedevice
```

Errors: **invalidaccess**, **stackunderflow**, **typecheck**

setdoprinterrors

boolean setdoprinterrors

sets the system parameter **DoPrintErrors** to the value of *boolean*. It also indicates the current value of the **Print PS Error** printer setting. The **DoPrintErrors** system parameter must be present for the **setdoprinterrors** operator to be present.

The *boolean* values indicate:

<i>true</i>	Print PS Error is set to On
<i>false</i>	Print PS Error is set to Off

Errors: **invalidaccess**, **stackunderflow**, **typecheck**

setdoret

integer setdoret –

changes the PQET setting for the next page through the end of the print job.

The integer values allowed are:

- 0 turn PQET Off
- 1 turn PQET On
- 2 turn PQET On
- 3 turn PQET On
- 4 turn PQET On

The value you select for PQET returns to the user default setting when the print job is finished.

This operator is equivalent to executing the following PostScript emulation sequence:

```
<< //PostRenderingEnhanceDetails << /REValue integer >> >>  
setpagedevice
```

Errors: **rangecheck**, **stackunderflow**, **typecheck**

setdostartpage

boolean setdostartpage

sets the **DoStartPage** system parameter to the value of *boolean*. The **DoStartPage** system parameter must be present for the **setdostartpage** operator to be present. For more information, see “DoStartPage” on page 4-68.

Errors: **invalidaccess**, **stackunderflow**, **typecheck**

setdosysstart

boolean setdosysstart –

modifies the value of the **StartupMode** system parameter.

true StartupMode set to 1
false StartupMode set to 0 (default)

- If *true*, the printer executes a Sys/Start file from flash or disk when the PostScript emulation interpreter is initialized. If no flash or disk is installed, no action occurs.
- If a Sys/Start file is on both flash and disk, the search order for the devices determines which one is executed.
- If *false*, the printer does not execute a Sys/Start file.

Errors: **invalidaccess, stackunderflow, typecheck**

setduplexmode

boolean setduplexmode –

sets the value of the **Duplex** page device parameter for the current print job.

true sets printing mode to duplex
false sets printing mode to simplex

At the start of the next print job, the value is reset to the user default setting.

This operator is equivalent to executing the following PostScript emulation sequence:

```
<< /Duplex boolean >> setpagedevice
```

Errors: **configurationerror, stackunderflow, typecheck**

Notes:

- If simplex printing is requested between the front side and back side of a sheet, a blank back side is printed and information for the back side is printed on the front side of the next sheet.
- For printers that do not support duplexing, this value is always set to *false*.

setenginesync

boolean setenginesync –

changes the setting that indicates whether the printer waits for the last page of a job to print before returning a Ctrl-D to the host computer.

The boolean values indicate:

true printer waits for the last page of the job to print
false printer does not wait for the last page of the job to print

Errors: **invalidaccess, stackunderflow, typecheck**

setethernetaddress

string setethernetaddress

sets the **EthernetAddress** parameter in the **EtherTalk** communication parameter set. The **EthernetAddress** parameter is the Ethernet address of the Ethernet internal print server (also called an internal network adapter or INA). The string value can be any string up to 17 characters.

Errors: **stackunderflow, typecheck**

setfilenameextend

boolean setfilenameextend

sets whether the extension should be automatically added to any filename.

true adds the extension
false does not add the extension

The default setting is *true*.

See “Filename Extensions” on page 6-10.

Errors: **stackunderflow, typecheck**

setfileposition

file position setfileposition

moves the read pointer in an open file to the new specified file position. This is defined as the number of bytes from the start of the file. The next read operation starts at the new file position. This operator is in **systemdict**.

Errors: **ioerror**, **stackunderflow**, **typecheck**, **undefinedfilename**

Note: An **undefinedfilename** error occurs if the file does not exist.

sethardwareiomode

integer sethardwareiomode –

is parsed and discarded. In addition, one integer is removed from the stack. It supports compatibility with the IBM LaserPrinters 4019, 4029, and 4039.

Errors: **invalidaccess**, **stackunderflow**, **typecheck**

setidlefonts

mark... setildefonts –

supports compatibility with the IBM LaserPrinters 4019, 4029, and 4039. It is parsed and pulls items from the stack until a mark is reached.

Error: **unmatchedmark**

setignoresize

See page 4-4.

setjobtimeout

integer setjobtimeout –

changes the value of the **JobTimeout** user parameter for the next page through the end of the print job. Valid integers are:

0 disabled
15...65355 seconds

The value returns to the **JobTimeout** system parameter setting at the end of the print job.

This operator is equivalent to executing the following PostScript emulation sequence:

```
<</JobTimeout integer >> setuserparams
```

Errors: **rangecheck**, **stackunderflow**, **typecheck**

setmanualduplexmode

int setmanualduplexmode

changes the current job's setting of manualduplexmode. Valid *int* values are:

0 no manual duplexing
1 printing the first sides of the job
2 printing the second sides of the job.

When printing second sides of the job is specified, a load manual duplex side 2 operator intervention condition will occur after the last page of the first sides is printed, and prior to the first page of the second sides being printed. While printing the second sides the printer's available paper sources are restricted to the automatic tray (tray1) and the manual paper feeder for the remainder of the job or until the manual duplex mode value is changed.

Error: **stackunderflow**, **typecheck**

setpapertray

See page 4-9.

setprintername

string setprintername –

changes the **PrinterName** system parameter to the value of the *string*. The string value can be any string up to 32 characters.

This operator is equivalent to executing the following PostScript emulation sequence:

```
<< /PrinterName (string) >> setsystemparams
```

Errors: **invalidaccess, limitcheck, stackunderflow, typecheck**

setquiet

integer setquiet –

changes the user default setting of the **PowerSave** page device parameter.

The following integers are valid:

0 Power Saver Off

1 to 120 or 1 to 240 (Model specific)

Number of minutes elapsed after last page prints before
Power Saver is invoked.

Any changes made by this operator are not active until the end of the print job.

Note: Some printer models released in the year 2000 or later designated as Energy Star printers cannot have Power Saver disabled.

This operator is equivalent to executing the following PostScript emulation sequence:

```
%Go into exitserver or startjob context  
<< /PowerSave integer >> setpagedevice
```

Errors: **rangecheck, stackunderflow, typecheck**

setresolution

integer setresolution –

changes the resolution for the current print job and discards unprinted data. See your printer documentation for a list of supported resolutions. The following integers are valid:

<i>300</i>	300 dpi is set to On
<i>600</i>	600 dpi is set to On
<i>1200</i>	1200 dpi is set to On

Notes:

- For some printers, the resolution value returns to the user default setting for the **Print Resolution** menu item at the end of the print job.
- The printer waits for the paper path to clear before changing the resolution.
- If the resolution is changed for the back side of a duplexed sheet, the printer ejects a blank back page, changes the resolution, and prints the information for the page where the resolution was changed on the front side of the next sheet.

This operator is equivalent to executing the following PostScript emulation sequence:

```
<< /HWResolution [xres yres] >> setpagedevice  
where xres = yres.
```

Errors: **rangecheck**, **stackunderflow**, **typecheck**

setscbatch

integer integer integer setscbatch –

supports compatibility with the IBM LaserPrinters 4019, 4029, and 4039. It is parsed, and three integers are removed from the stack and discarded.

Error: **stackunderflow**

setscinteractive

channel baud options setscinteractive

supports compatibility with the IBM LaserPrinters 4019, 4029, and 4039. It is parsed, and three integers are removed from the stack and discarded.

Errors: **invalidaccess, rangecheck, stackunderflow, typecheck**

setsoftwareiomode

integer setsoftwareiomode –

supports compatibility with the IBM LaserPrinters 4019, 4029, and 4039. It is parsed, and an integer is removed from the stack and discarded.

This command validates that the integer value provided is an Adobe-supported value of 0, 1, 2, 3, 4, 5, or 100, and then discards the operator and value.

Errors: **stackunderflow, typecheck, invalidaccess, rangecheck**

settumble

boolean settumble –

sets the value of the **Tumble** page device parameter for the current print job.

- true* sets the tumble setting to short-edge binding (back side of the duplexed page prints upside down in relation to the front side)
- false* sets the tumble setting to long-edge binding (back side of the duplexed page prints in the same orientation as the front) (default)

No error is generated if a duplex unit is not installed.

Notes:

- At the start of the next print job, the setting for tumble is reset to the user default setting for the **Duplex Bind** menu item.
- If tumble is changed between the printing of a front and back side of a duplexed sheet, a blank back side is not ejected.

This operator is equivalent to executing the following PostScript emulation sequence:

```
<< /Tumble boolean >> setpagedevice
```

Errors: **stackunderflow, typecheck**

setuserdiskpercent

integer setuserdiskpercent –

removes an integer from the stack and discards it.

Errors: **stackunderflow**, **rangecheck**, **invalidaccess**, **typecheck**

softwareiomode

– softwareiomode *0*

supports compatibility with the IBM LaserPrinters 4019, 4029, and 4039. It is parsed and returns a *0* (zero, Binary Mode Off) on the stack.

Software IO mode defines the data stream you are using.

Errors: **stackoverflow**, **stackunderflow**

tumble

– tumble *boolean*

returns the current value of the **Tumble** page device parameter.

true the back side of the duplexed page prints upside down in relation to the front side (short-edge binding)

false the back side of the duplexed page prints in the same orientation as the front side (long-edge binding) (default)

Note: No error is generated if a duplex unit is not installed.

This operator is equivalent to executing the following PostScript emulation sequence:

```
currentpagedevice /Tumble get
```

Errors: **stackunderflow**, **stackoverflow**

userdiskpercent

– userdiskpercent *0*

returns a *0* (zero) on the stack.

Errors: **stackoverflow**, **invalidaccess**

waittimeout

– waittimeout *integer*

queries the current value for the **WaitTimeout** user parameter. An integer is returned on the stack:

0 disabled

15...65355 seconds

This operator is equivalent to executing the following PostScript emulation sequence:

```
currentuserparams /WaitTimeout get
```

Error: **stackoverflow**

Page Device Parameters

In addition to the page device parameters described in Section 4.11 of the *PostScript Language Reference Manual (Third Edition)* by Adobe Systems, Inc., the following page device parameters are used by **setpagedevice** and **currentpagedevice**. Certain parameters, such as **Policies**, **Priority**, and **ManualFeed** are listed here since more information about the parameters is given in Table 4-8 than in the *PostScript Language Reference Manual (Third Edition)* by Adobe Systems, Inc.

To determine which parameters and default values your printer supports, see Table C-2 on page C-5.

Table 4-8: Page Device Parameters

Key	Type	Definition
BeginPage	procedure	Executes at the beginning of each page and returns an integer which indicates how many times showpage has been invoked.
Collate	boolean	Indicates if the printer is set to collate multi-copy print jobs. If a print job consists of three pages and two copies are requested, then the collated output is 1, 2, 3, 1, 2, 3. The non-collated output is 1, 1, 2, 2, 3, 3.
DeferredMediaSelection	boolean	Determines if the printer uses the printer's own internal algorithms or Adobe PostScript algorithms to select print media. The following values are supported: True Uses the printer's algorithms False Uses Adobe PostScript algorithms (default)
DeviceRenderingInfo	dictionary	Specifies the following unique printer rendering parameters: Screening , TonerSaver , PictureGrade , ImageEnhancement , PrintDarkness , AutoMediaType , EdgeToEdge , DefaultPoliciesPageSize , SubstituteSize , Type , ColorCorrection , ImageBrightness , ImageContrast , and PrintQuality . <i>Screening</i> controls which halftone dictionary is installed at the beginning of each print job. The value is set at the start of a job according to the print quality settings selected from the printer operator panel. The following names are valid: ColorGrade™ 600 dpi printing PictureGrade 300 dpi, 600 dpi, or 1200 dpi printing with PictureGrade On IET 1200 Image Quality printing or 2400 Print Quality IETImagesOnly 1200 Image Quality printing for images; 600 dpi printing for text and graphics or maps to IET and sets Print Quality to either 1200 Image Quality or 2400 Print Quality IETPictureGrade 1200 Image Quality printing with PictureGrade On None 300 dpi or 600 dpi printing with PictureGrade Off

Table 4-8: Page Device Parameters (Continued)

Key	Type	Definition
DeviceRenderingInfo (continued)	dictionary	<p><i>TonerSaver</i> is a boolean that controls the Toner Saver feature.</p> <p>True Starts the printer toner saver mechanism False Stops the printer toner saver mechanism</p> <p>Notes:</p> <ul style="list-style-type: none"> • A PostScript job can override the effect of Screening by using sethalftone, setscreen, or setcolorscreen operators, unless Screening is set to IET or IETPictureGrade. • A PostScript job can enter or exit IET or PictureGrade using the Screening parameter in a setpagedevice call. This does not change the user default printer settings for print quality, which are read and used by the interpreter for the next print job unless the setpagedevice is issued in a startjob context. • If Screening is set to IET or IETPictureGrade, TonerSaver is set to False. This is true for all models except the Opra C710, Opra M410, Opra T family, and Opra W810. <p><i>PictureGrade</i> is an integer that provides compatibility with previous Lexmark printer drivers. PictureGrade works in conjunction with Screening.</p> <p>If Screening is set to None or PictureGrade, the values for PictureGrade affect Screening in the following way:</p> <p>0 Changes Screening to None 1 Changes Screening to PictureGrade</p> <p>If Screening is set to IET or IETPictureGrade, the values for PictureGrade affect Screening in the following way:</p> <p>0 Changes Screening to IET 1 Changes Screening to IETPictureGrade</p> <p>For more information on Screening, see page 4-49.</p> <p><i>ImageEnhancement</i> is an integer that provides compatibility with previous Lexmark printer drivers. ImageEnhancement works in conjunction with Screening.</p> <p>If Screening is set to None or IET, the values for ImageEnhancement affect Screening in the following way:</p> <p>0 Changes Screening to None 1 Changes Screening to IET</p> <p>If Screening is set to PictureGrade or IETPictureGrade, the values for ImageEnhancement affect Screening in the following way:</p> <p>0 Changes Screening to PictureGrade 1 Changes Screening to IETPictureGrade</p> <p>For more information on Screening, see page 4-49.</p> <p><i>PrintDarkness</i> specifies the value of the Print Darkness printer setting. Legal values are:</p> <p>1 Lightest 2 Lighter 3 Normal 4 Darker 5 Darkest</p>

Table 4-8: Page Device Parameters (Continued)

Key	Type	Definition
DeviceRenderingInfo (continued)	dictionary	<p><i>AutoMediaType</i> is a boolean that controls the <i>MediaType</i> entries in the InputAttributes dictionary in the <i>pagedevice</i> dictionary.</p> <p>True <i>MediaType</i> entries in the <i>InputAttributes</i> dictionaries cannot be modified by the user. The values are confined to values known by the printer operating system.</p> <p>False <i>MediaType</i> entries in the <i>InputAttributes</i> dictionaries can be modified by the user.</p> <p><i>EdgeToEdge</i> is a boolean which determines if there should be an unprintable area on the page.</p> <p>True Print to the edge of the paper.</p> <p>False Do not print to the edge of the paper (default).</p> <p><i>DefaultPoliciesPageSize</i> is an integer which equals the PageSize parameter in the Policies dictionary unless PageSize is set to 23; in that case, <i>DefaultPoliciesPageSize</i> equals the PageSize parameter value before it was set to 23 or equals 0 if the PageSize parameter is initialized to 23. For more information on PageSize, see page 4-59.</p> <p><i>SubstituteSize</i> allows for the substitution of A4- and Letter-size print materials, and A3- and 11x17 inch-size print materials for each other when one size is not installed.</p> <p>Note: For size substitution to occur, the substituted print material and the requested print material must be of the same paper type.</p> <p>The following values are supported:</p> <p>/Off No size substitution is performed.</p> <p>/A4-Letter If A4 is requested but not installed and Letter is installed, Letter is substituted for A4. Or, if Letter is requested but not installed and A4 is installed, A4 is substituted for Letter.</p> <p>/A3-11x17 If A3 is requested but not installed and 11x17 is installed, 11x17 is substituted for A3. Or, if 11x17 is requested but not installed and A3 is installed, A3 is substituted for 11x17.</p> <p>/All Both size substitutions are permitted.</p> <p>Note: When the size substitution occurs, the page is scaled to the size of the requested print material.</p> <p>The <i>DefaultPoliciesPageSize</i> value is used as the effective policy when:</p> <ul style="list-style-type: none"> • The SubstituteSize parameter is not set to /Off and a size substitution cannot be performed. • The PageSize parameter in the Policies dictionary is set to 23. <p>Notes:</p> <ul style="list-style-type: none"> • If SubstituteSize is set to /Off, the effective policy is the value of PageSize. • If SubstituteSize is not set to /Off and a size substitution is possible, the effective policy is 3.

Table 4-8: Page Device Parameters (Continued)

Key	Type	Definition
DeviceRenderingInfo (continued)	dictionary	<p><i>Type</i> is a constant value. To find the value of <i>Type</i> for your printer, see Table C-2 on page C-5.</p> <p><i>ColorCorrection</i> is a null, string, or name object that controls the appearance of colors. The value is determined by the user default setting in the Color Correction menu item. The following values are supported:</p> <ul style="list-style-type: none"> -null- /Display /Vivid <p><i>ImageBrightness</i> is an integer that controls the brightness of images. The following values are supported:</p> <ul style="list-style-type: none"> -100 ... 100 0 (default) <p><i>ImageContrast</i> is an integer that controls the contrast of images. The following values are supported:</p> <ul style="list-style-type: none"> -100 ... 100 0 (default) <p><i>PrintQuality</i> is an integer that controls the print quality settings. The following values are supported:</p> <ul style="list-style-type: none"> 0 Quick Print 1 Normal 2 Presentation 3 1200 Image Q
Duplex	boolean	<p>Indicates if printed pages are duplexed (printed on both sides of the page) or simplex (printed on one side of the page).</p> <ul style="list-style-type: none"> True Print duplex mode False Print simplex mode (default)
EndPage	procedure	<p>Executes at the end of each printed page to indicate if the contents of raster memory should be printed. <i>EndPage</i> gets two integer arguments through the operand stack: one is a count of the previous <i>showpage</i> executions and the other is the code that indicates the execution condition.</p> <p>The code is 0 (zero) if it is called from <i>showpage</i>, 1 if it is called from <i>copypage</i>, and 2 if it is called during device deactivation. The procedure must return a boolean value.</p>
ExitJamRecovery	boolean	<p>Indicates the setting of the Jam Recovery menu item.</p> <ul style="list-style-type: none"> True Jam Recovery is set to On. False Jam Recovery is set to Off or Auto (model specific).
HWResolution	integer	<p>Indicates the resolution of the printer (in pixels per inch) along the <i>x</i> and <i>y</i> dimensions of the device space. <i>x</i> and <i>y</i> are always equal. The following resolutions are supported:</p> <ul style="list-style-type: none"> 300 dpi 600 dpi 1200 dpi

Table 4-8: Page Device Parameters (Continued)

Key	Type	Definition																
ImagingBBox	array or null	<p>Defines a rectangle that lies within the boundaries of the page specified by PageSize. ImagingBBox may be either a value of null or an array of four numbers.</p> <p>A value of null indicates the bounding box is the largest imageable area possible for a given page size.</p>																
InputAttributes	dictionary	<p>Contains information about the various installed input sources. There is a numeric key, which is a dictionary, for each installed input source.</p> <p>Input sources</p> <p>The numeric keys are:</p> <table border="0"> <thead> <tr> <th>Key</th> <th>Source</th> </tr> </thead> <tbody> <tr> <td>0</td> <td>Tray 1</td> </tr> <tr> <td>1</td> <td>Tray 2</td> </tr> <tr> <td>2</td> <td>Envelope feeder</td> </tr> <tr> <td>3</td> <td>Tray 3</td> </tr> <tr> <td>4</td> <td>Multipurpose feeder</td> </tr> <tr> <td>5</td> <td>Tray 4</td> </tr> <tr> <td>6</td> <td>Tray 5</td> </tr> </tbody> </table> <p>The entries in each input source dictionary describe the media that is currently available in the source. The allowable keys in each source dictionary are:</p> <ul style="list-style-type: none"> PageSize MediaColor MediaType (See “AutoMediaType” on page 4-51.) MediaWeight MatchAll InputLocation Read only string which indicates the physical tray corresponding to the source. 	Key	Source	0	Tray 1	1	Tray 2	2	Envelope feeder	3	Tray 3	4	Multipurpose feeder	5	Tray 4	6	Tray 5
Key	Source																	
0	Tray 1																	
1	Tray 2																	
2	Envelope feeder																	
3	Tray 3																	
4	Multipurpose feeder																	
5	Tray 4																	
6	Tray 5																	

Table 4-8: Page Device Parameters (Continued)

Key	Type	Definition
InputAttributes (continued)	dictionary	<p><i>Mode</i> is a key within the InputAttributes dictionary, and its value is a name that determines the mapping of the physical input sources to the input sources listed in InputAttributes. The allowable values are:</p> <p>/Default Printer's default source assignment</p> <p>/Opra Specifies the following ordering used in InputAttributes: 0 - Tray 1 1 - Tray 2 2 - Envelope Feeder 1 or Multipurpose feeder 3 - Tray 3 4 - Multipurpose feeder 5 - Tray 4 6 - Tray 5 7 - Feeder 2</p> <p>/HPLJFamily1 Specifies the following ordering used by the Hewlett-Packard Company's printers: 0 - Tray 1 1 - Tray 2 2 - Envelope Feeder 1 or Multipurpose feeder 3 - Multipurpose feeder (see Note) 4 - Tray 3 5 - Tray 4 6 - Tray 5 7 - Feeder 2</p> <p>Note: Values 3 and 4 for the Hewlett Packard Company's LaserJet printers are switched relative to the /Opra values 3 and 4.</p> <p><i>Priority</i> is an array of integers that describes the order in which the input sources are searched. The first integer represents the highest priority source and so on. If no array exists or none of the matching sources is in the array, then the priority order is arbitrary.</p>
Install	procedure	Installs device dependent parameters into the graphics state. This procedure can modify any parameter in the graphics state.
Jog	integer	<p>Specifies which Offset Pages setting is used. The following values are supported:</p> <p>0 Offset Pages is disabled. 1 Offset Pages is disabled. 2 Offset Pages is set to Between Jobs. 3 Offset Pages is set to Between Copies.</p> <p>Offset refers to stacking entire print jobs or copies of the same print job in two separate groups in an output bin.</p>

Table 4-8: Page Device Parameters (Continued)

Key	Type	Definition
ManualFeed	boolean	<p>Indicates if the current (or active) source is a manual source. The following values are supported:</p> <p>True Manual feed False Automatic feed</p> <p>If ManualFeed is set to True, and a change is made to PageSize, MediaWeight, MediaColor, or MediaType parameters, no matching occurs. It is assumed that the correct page is fed.</p> <p>Note: ManualFeed is initialized at the start of each print job according to the default paper source set by the operator panel menus or through PjL. If the default paper source is a manual source, ManualFeed is set to True. If the default paper source is not a manual paper source, ManualFeed is set to False.</p>
ManualFeedTimeout	integer	<p>Indicates the amount of time that the printer waits for you to manually load a sheet of paper.</p> <p>0 infinite wait or no timeout</p> <p>If the timeout expires, a timeout error is generated.</p> <p>This is initialized at the start of each PostScript emulation job to the value of the Feed Timeout menu item value.</p>
MediaColor	string name or null	Specifies the color of the current media.
MediaPosition	integer	<p>Specifies the tray to select, if possible, whether it is the best match or not. Policies may be consulted to determine the selection. For example, assume there is legal-size paper in Tray 1 and letter-size paper in all the other trays, and the Policy for the PageSize page device parameter is 1. The command</p> <pre><< /PageSize [612 1008]/MediaPosition 1 >> setpagedevice</pre> <p>selects Tray 2 even though Tray 1 is a perfect match, because the PageSize Policy of 1 allows the PageSize to be ignored.</p>
MediaType	string name or null	Indicates the type of the current media. The value of the string is arbitrary and may describe any attribute not already defined by size, color, or weight.
MediaWeight	integer or null	Specifies the weight of the current media in g/m ² . The value is either null or a number.
NumCopies	integer or null	Specifies the number of copies of each page that should be printed. If the value is null, the current value of #copies determines the number of copies to print.
Nup	boolean	<p>Determines if Nup is On or Off. Use the Nup function to print multiple page images on a single page, where the value of <i>N</i> refers to the number of pages. For example, 2-Up means two page images are printed on one page.</p> <p>True Nup is On and the NupDetails parameters are active. False Nup is Off.</p> <p>For some printers, the value of Nup is set through the Multipage Printing menu item. For more information about multipage printing (Nup), see your printer documentation.</p>

Table 4-8: Page Device Parameters (Continued)

Key	Type	Definition																																																																																				
NupDetails	dictionary	<p>Describes the specific actions performed when the Nup function is active.</p> <p><i>Rows</i> is an integer that specifies the number of rows to print on a portrait-oriented page.</p> <p><i>Columns</i> is an integer that specifies the number of columns to print on a portrait-oriented page.</p> <p>Rows and Columns are limited to these values:</p> <table border="1"> <thead> <tr> <th>Rows</th> <th>Columns</th> </tr> </thead> <tbody> <tr><td>2</td><td>1</td></tr> <tr><td>3</td><td>1</td></tr> <tr><td>2</td><td>2</td></tr> <tr><td>3</td><td>2</td></tr> <tr><td>3</td><td>3</td></tr> <tr><td>4</td><td>3</td></tr> <tr><td>4</td><td>4</td></tr> </tbody> </table> <p><i>Orientation</i> specifies the orientation of the individual Nup pages on the printed page. Supported values are:</p> <table border="1"> <tbody> <tr><td>0</td><td>Portrait</td></tr> <tr><td>1</td><td>Landscape</td></tr> </tbody> </table> <p>Orientation determines the positioning of multiple page images on pages printed using NupDetails. You may choose one of four different orders. The positioning of page images depends on whether they are sent to the printer as portrait or landscape images. The following examples show the result of using each setting on a 2-row, 2-column page:</p> <table border="1"> <thead> <tr> <th colspan="4">Horizontal</th> <th colspan="4">Vertical</th> </tr> <tr> <th colspan="2">Portrait</th> <th colspan="2">Landscape</th> <th colspan="2">Portrait</th> <th colspan="2">Landscape</th> </tr> </thead> <tbody> <tr> <td>Page 1</td><td>Page 2</td><td>Page 2</td><td>Page 4</td><td>Page 1</td><td>Page 3</td><td>Page 3</td><td>Page 4</td> </tr> <tr> <td>Page 3</td><td>Page 4</td><td>Page 1</td><td>Page 3</td><td>Page 2</td><td>Page 4</td><td>Page 1</td><td>Page 2</td> </tr> </tbody> </table> <table border="1"> <thead> <tr> <th colspan="4">Reverse Horizontal</th> <th colspan="4">Reverse Vertical</th> </tr> <tr> <th colspan="2">Portrait</th> <th colspan="2">Landscape</th> <th colspan="2">Portrait</th> <th colspan="2">Landscape</th> </tr> </thead> <tbody> <tr> <td>Page 2</td><td>Page 1</td><td>Page 1</td><td>Page 3</td><td>Page 3</td><td>Page 1</td><td>Page 1</td><td>Page 2</td> </tr> <tr> <td>Page 4</td><td>Page 3</td><td>Page 2</td><td>Page 4</td><td>Page 4</td><td>Page 2</td><td>Page 3</td><td>Page 4</td> </tr> </tbody> </table>	Rows	Columns	2	1	3	1	2	2	3	2	3	3	4	3	4	4	0	Portrait	1	Landscape	Horizontal				Vertical				Portrait		Landscape		Portrait		Landscape		Page 1	Page 2	Page 2	Page 4	Page 1	Page 3	Page 3	Page 4	Page 3	Page 4	Page 1	Page 3	Page 2	Page 4	Page 1	Page 2	Reverse Horizontal				Reverse Vertical				Portrait		Landscape		Portrait		Landscape		Page 2	Page 1	Page 1	Page 3	Page 3	Page 1	Page 1	Page 2	Page 4	Page 3	Page 2	Page 4	Page 4	Page 2	Page 3	Page 4
Rows	Columns																																																																																					
2	1																																																																																					
3	1																																																																																					
2	2																																																																																					
3	2																																																																																					
3	3																																																																																					
4	3																																																																																					
4	4																																																																																					
0	Portrait																																																																																					
1	Landscape																																																																																					
Horizontal				Vertical																																																																																		
Portrait		Landscape		Portrait		Landscape																																																																																
Page 1	Page 2	Page 2	Page 4	Page 1	Page 3	Page 3	Page 4																																																																															
Page 3	Page 4	Page 1	Page 3	Page 2	Page 4	Page 1	Page 2																																																																															
Reverse Horizontal				Reverse Vertical																																																																																		
Portrait		Landscape		Portrait		Landscape																																																																																
Page 2	Page 1	Page 1	Page 3	Page 3	Page 1	Page 1	Page 2																																																																															
Page 4	Page 3	Page 2	Page 4	Page 4	Page 2	Page 3	Page 4																																																																															

Table 4-8: Page Device Parameters (Continued)

Key	Type	Definition
NupDetails (continued)	dictionary	<p><i>Border</i> specifies the type of border to draw around the individual Nup pages. Supported values are:</p> <ul style="list-style-type: none"> 0 No border 1 A solid black line <p><i>Order</i> is an integer that specifies how the Nup pages are placed on the printed page. Supported values are as follows, with first the value, the orientation, and the description:</p> <ul style="list-style-type: none"> 0 H The first page is placed at the upper left corner of the printed page and subsequent pages are placed across and then down. 1 V The first page is placed at the upper left corner of the printed page and subsequent pages are placed down and then across. 2 RH The first page is placed at the upper right corner of the printed page and subsequent pages are placed across and then down. 3 RV The first page is placed at the upper right corner of the printed page and subsequent pages are placed down and then across. <p><i>Type</i> is a constant value. To find the value of <i>Type</i> for your printer, see Table C-2 on page C-5.</p> <p><i>LandscapeOverride</i> is a boolean which specifies the orientation of Nup pages. Supported values are:</p> <ul style="list-style-type: none"> False Orientation is specified by the <i>PageSize</i> parameter. True Orientation is assumed to be Landscape regardless of the orientation specified by the <i>PageSize</i> parameter. <p>Note: The PostScript emulation interpreter has to know the orientation of Nup pages to position the pages correctly on a hostpage. However, during the translation process, many landscape pages are created in portrait orientation by using the <i>PageSize</i> parameter. Then, the page is rotated to create the appearance of landscape orientation. When this happens, the PostScript emulation interpreter cannot place the Nup page correctly on the hostpage unless the <i>PageSize</i> parameter is set correctly.</p>

Table 4-8: Page Device Parameters (Continued)

Key	Type	Definition
OutputAttributes	dictionary	<p>Contains information about the output bin targets. There is a numeric key, which is a dictionary, for each installed output bin. OutputType and OutputLocation are the allowable keys in each output dictionary. OutputType is used in the search algorithm to determine which output bin is used as the exit path.</p> <p>The numeric keys are:</p> <ul style="list-style-type: none"> 0 Standard Output Bin or Top Output Bin 1 Optional Output Bin 1 or Rear Output Bin 2 Optional Output Bin 2 3 Optional Output Bin 3 4 Optional Output Bin 4 5 Optional Output Bin 5 6 Optional Output Bin 6 7 Optional Output Bin 7 8 Optional Output Bin 8 9 Optional Output Bin 9 10 Optional Output Bin 10 <p><i>OutputType</i> fields can be assigned strings to specify the output destination.</p> <p>For example:</p> <pre><< /OutputAttributes << 0 << /OutputType (Standard Bin) >> >> >> setpagedevice << /OutputAttributes << 1 << /OutputType (Optional Output Bin 1 Exit) >> >> >> setpagedevice</pre> <p>For more information, see “OutputType” on page 4-58.</p> <p><i>OutputLocation</i> key is a read-only string that represents the name of the associated destination.</p> <p>The OutputAttributes dictionary contains a Priority Array. If an OutputType string does not match, the priority array is searched in order for a valid output bin.</p> <p>The initial value of the priority array is set at the beginning of a job and is equal to the value of the menu item for OutputBin. The array can be changed using this setpagedevice operator:</p> <pre><< /OutputAttributes << /Priority [1 0] >> >> setpagedevice</pre> <p>This command gives the Optional Output Bin 1 (1) a higher priority than the Standard Bin (0). Once the command is issued, if no match is found for the OutputType string, the paper exits into the standard output bin.</p>
OutputPage	boolean	<p>Specifies if pages are actually printed. Supported values are:</p> <ul style="list-style-type: none"> True Job is processed as usual (default). False No page is printed, but all other job processing occurs.
OutputType	string	<p>Specifies the output bin destination for the current page. If the destination is not null, setpagedevice compares it with the OutputType values in the OutputAttributes dictionary during the search algorithm. If a match is found, this output bin is the target output for the current page.</p>
PageDeviceName	string name or null	<p>Assigns or names a page device by using a string parameter. This is used by the findcolorrendering operator.</p>

Table 4-8: Page Device Parameters (Continued)

Key	Type	Definition
PageSize	array	Specifies the size (width and height) of the current page in 1/72 inch units. A value of [0 0] is assumed to be the lower left corner of the physical page and [width height] is the upper right corner.
Policies	dictionary	<p>Uses entries to describe the actions to perform when a particular function cannot be completed. The entries are as follows:</p> <p><i>PageSize</i> is an integer that specifies what recovery action to use when <i>PageSize</i> cannot be matched with any available media (paper, envelope, or other print materials). The actions are:</p> <ul style="list-style-type: none"> 0 Generate a configurationerror. (default) 1 Ignore the requested <i>PageSize</i>. 2 Interact with a human operator or print manager. 3 Select the next larger or smaller available media and adjust the page to fit. 4 Select the next larger available media and adjust the page to fit. 5 Select the next larger or smaller available media, but do not adjust the page. 6 Select the next larger available media, but do not adjust the page. 7 Disable media selection. Implement the requested <i>PageSize</i> on the previously selected media without making adjustments. The way the image is positioned on the media is printer-dependent and may result in part of the image being clipped. 23 If the SubstituteSize parameter from the DeviceRenderingInfo dictionary is set to Off, the effective policy executed is the value of the DefaultPageSizePolicy key in the DeviceRenderingInfo dictionary. If the SubstituteSize parameter from the DeviceRenderingInfo dictionary is set to a value other than Off and an installed source has installed media which may be substituted for the requested media, the effective policy executed is 3. If the SubstituteSize parameter from the DeviceRenderingInfo dictionary is set to a value other than Off and a media substitution cannot be made, the effective policy executed is the value of the DefaultPageSizePolicy key in the DeviceRenderingInfo dictionary. <p><i>PolicyNotFound</i> is an integer that specifies which recovery action to use when a requested feature other than <i>PageSize</i> cannot be matched with any key in the Policies dictionary.</p> <p>The actions are:</p> <ul style="list-style-type: none"> 0 Generate a configurationerror. 1 Ignore the requested feature (default). 2 Interact with a person or print manager. <p><i>PolicyReport</i> is a procedure that is called when a successful <i>setpagedevice</i> is finished. The procedure consults policies to process unsatisfied feature requests if needed. Default value is {pop}.</p>
PostRenderingEnhance	boolean	Always True to indicate that PostRenderingEnhanceDetails is enabled.

Table 4-8: Page Device Parameters (Continued)

Key	Type	Definition
PostRenderingEnhance Details	dictionary	<p>Describes enhancements that are made to the output after the page has been held in memory.</p> <p><i>REValue</i> is an integer that specifies the current value of the PQET menu item. Supported values are:</p> <p>0 PQET is Off. 1 to 4 PQET is On (default is 1).</p> <p><i>Type</i> is a constant value. To find the value of Type for your printer, see "PostRenderingEnhanceDetails" on page C-8.</p>
PowerSave	integer	<p>A value of 1–120 or 1–240 (model specific) indicates the number of minutes that elapses after the last page prints and before the Power Saver feature is invoked. A value of 0 (zero) indicates the Power Saver feature is turned Off on some printer models.</p> <p>Note: Some printer models released in the year 2000 or later designated as Energy Star printers cannot have Power Saver disabled.</p> <p>This value is initialized at the start of each PostScript emulation job to the value of the Power Saver menu item.</p> <p>Note: This parameter can only be modified within a system administration job.</p>
ProcessColorModel	name or string	<p>Specifies the color model to use for rendering process colors in the printer. Supported values are:</p> <p>DeviceGray DeviceRGB DeviceCMYK DeviceCMY</p>
Punch	integer	<p>Requests holes to be punched in the output page. The format for setting the Punch key is:</p> <pre><</Punch n>> setpagedevice</pre> <p>where <i>n</i> is one of the following values:</p> <p>0 Do not punch holes in the output page. 3 Punch holes in the output page.</p>
SlipSheet	integer	<p>Specifies where blank separator sheets should be inserted in the output. Supported values are:</p> <p>0 Do not insert separator sheets. 1 Insert a separator sheet at device deactivation. 2 Insert a separator sheet at the end of the print job. 3 Insert a separator sheet at the end of each set in a multicopy job. If Collate is set to True, a set consists of one copy of each page of the document. For example, if a print job is five pages long, a set is one copy of pages one to five. If Collate is set to False, a set is all the copies of a single page of the job. For example, if a print job is three copies of a five page job, a set is three copies of the first page. 4 Insert a separator sheet after each showpage or copypage.</p>

Table 4-8: Page Device Parameters (Continued)

Key	Type	Definition																
SlipSheetDetails	dictionary	<p>Specifies the following two unique separator sheet parameters: SlipSheetSource and Type.</p> <p><i>SlipSheetSource</i> is an integer type parameter which identifies the source used for separator sheets. Supported values are:</p> <table> <tr> <td>Null</td> <td>Use current source (default)</td> </tr> <tr> <td>0</td> <td>Tray 1</td> </tr> <tr> <td>1</td> <td>Tray 2</td> </tr> <tr> <td>2</td> <td>Envelope Feeder</td> </tr> <tr> <td>3</td> <td>Tray 3</td> </tr> <tr> <td>4</td> <td>Multipurpose feeder</td> </tr> <tr> <td>5</td> <td>Tray 4</td> </tr> <tr> <td>6</td> <td>Tray 5</td> </tr> </table> <p>The key is found in the DeviceRenderingInfo dictionary within pagedevice. It can be altered using a setpagedevice operator.</p> <pre>/SlipSheetDetails << /Type 96 /SlipSheetSource n>> >> setpagedevice</pre> <p><i>Type</i> is a constant value. To find the value of Type for your printer, see Table C-2 on page C-5.</p>	Null	Use current source (default)	0	Tray 1	1	Tray 2	2	Envelope Feeder	3	Tray 3	4	Multipurpose feeder	5	Tray 4	6	Tray 5
Null	Use current source (default)																	
0	Tray 1																	
1	Tray 2																	
2	Envelope Feeder																	
3	Tray 3																	
4	Multipurpose feeder																	
5	Tray 4																	
6	Tray 5																	
Staple	integer	<p>Specifies whether to staple the current print job.</p> <p>Supported values are:</p> <table> <tr> <td>0</td> <td>Do not staple the print job.</td> </tr> <tr> <td>1</td> <td>Staple each set in the front position.</td> </tr> <tr> <td>2</td> <td>Staple each set in the rear position.</td> </tr> <tr> <td>3</td> <td>Staple each set according to the Auto setting.</td> </tr> <tr> <td>4</td> <td>Staple each set in the dual position.</td> </tr> </table> <p>The format for setting the Staple key is:</p> <pre><</Staple n>> setpagedevice</pre>	0	Do not staple the print job.	1	Staple each set in the front position.	2	Staple each set in the rear position.	3	Staple each set according to the Auto setting.	4	Staple each set in the dual position.						
0	Do not staple the print job.																	
1	Staple each set in the front position.																	
2	Staple each set in the rear position.																	
3	Staple each set according to the Auto setting.																	
4	Staple each set in the dual position.																	
TraySwitch	boolean	<p>Indicates tray linking is always active. When the media in one input source is depleted, other input sources are searched to determine if the same media can be found in another source. If another source is found, the alternate source is selected. The media in both input sources must be the same size and type for tray linking to occur.</p>																

Table 4-8: Page Device Parameters (Continued)

Key	Type	Definition
Tumble	boolean	<p>Indicates the orientation of the second side of a duplexed page with respect to the first side. Supported values are:</p> <p>True Causes pages to print as if they are to be bound across the top of the page (image is rotated 180° on the back side of the page)</p> <p>False Causes pages to print as if they are to be side bound (as in a book)</p>
UniversalDetails	dictionary	<p>Controls the variable Universal paper size feature. The entries are as follows:</p> <p><i>Type</i> is a constant value. To find the value of <i>Type</i> for your printer, see Table C-2 on page C-5.</p> <p><i>PageSize</i> is an array of two numbers (real or integer) that defines the x and y values (in points) for Universal.</p> <p><i>Orientation</i> is an integer that defines how the Universal paper will be fed through the printer. Supported values are:</p> <p>0 Paper is fed short edge first.</p> <p>1 Paper is fed long edge first.</p> <p><i>Prompt</i> defines a string to be displayed on the operator panel when the printer prompts a user to load Universal.</p>

Interpreter Parameters

This section describes the PostScript emulation interpreter parameters. There are three types of interpreter parameters:

- User parameters
- System parameters
- Device parameters

To determine which parameters your printer supports, see Appendix C: “PostScript Support” on page C-1.

User Parameters

The following user parameters are used by **setuserparams** and **currentuserparams**.

If a value is requested that is not within the range for the requested parameter, the minimum (or maximum) value is used.

If a **setuserparams** value does not match the type of the specified parameter, a **typecheck** error occurs. If a parameter is not supported by the printer, it is ignored. An attempt to change the value of a read-only parameter has no effect on the parameter.

To determine which parameters your printer supports, see Table C-3 on page C-9.

Table 4-9: PostScript Emulation User Parameters

Key	Type	Definition
AccurateScreens	boolean	Controls whether the accurate screen algorithm is used during subsequent executions of the setscreen and setcolorscreen operators.
CollatedCopies	integer	Requests the number of collated copies to print for the job. The CollatedCopies parameter must be set before the first page of the job has been sent. If CollatedCopies is set to zero, the parameter has no effect on the job. If CollatedCopies is set to a number other than zero, the value of #copies and of the NumCopies and Collate pagedevice parameters are ignored for the job. Legal values: Any integer between 0 and 999, inclusive.

Table 4-9: PostScript Emulation User Parameters (Continued)

Key	Type	Definition
HalftoneMode	integer	Affects the results of subsequent halftone setting operators such as <code>setscreen</code> , <code>setcolorscreen</code> , and <code>sethalftone</code> . The HalftoneMode parameter has no effect on the current halftone. Legal values: <ul style="list-style-type: none"> 0 Normal mode of operation. The operators setscreen, setcolorscreen, and sethalftone are not affected. 1 Execution of <code>setscreen</code>, <code>setcolorscreen</code>, or <code>sethalftone</code> causes a default screen to be used rather than the screen given by the job. The default screen depends on the current resolution and parameters in the DeviceRenderingInfo dictionary in the <code>pagedevice</code> dictionary that is in affect at the time the halftone operator is executed. 2 Not supported. HalftoneMode is set to 1.
IdiomRegnition	boolean	Legal values: <ul style="list-style-type: none"> True Procedure substitution is enabled during execution of the bind operator. False Idiom recognition is disabled.
JobName	string	Name of the current job for status responses. Legal values: Any alphanumeric characters in the ASCII printable range (X'20' through X'FE') excluding the characters ; and]. Maximum length is 80 characters (characters beyond 80 characters are truncated).
JobTimeout	integer	Number of seconds a print job executes before it is terminated and a PostScript emulation timeout error is generated. Set to 0 to disable job timeout. JobTimeout is initialized to the value of the JobTimeout system parameter at the beginning of each job. Legal value: Any non-negative integer.
MaxDictStack	integer	Maximum elements in a dictionary stack. Legal value: Any integer between 40 and 255, inclusive.
MaxExecStack	integer	Maximum elements in the execution stack. Legal value: Any integer greater than or equal to 75.
MaxFontItem	integer	Maximum number of bytes occupied by the pixel array of a single character in the font cache. There is an upper limit dependent on the MaxFontCache system parameter and the amount of printer memory. Legal values: Any non-negative integer.
MaxFormItem	integer	Maximum number of bytes occupied by a single cached form. Legal value: Any integer between zero and half of <code>RamSize</code> .
MaxLocalVM	integer	Maximum bytes occupied by values in local VM. Legal value: Any integer greater than or equal to 76800 or the amount of local VM currently in use plus a small margin.

Table 4-9: PostScript Emulation User Parameters (Continued)

Key	Type	Definition
MaxOpStack	integer	Maximum elements in the operand stack. Legal value: Any integer greater than or equal to 75.
MaxPatternItem	integer	Maximum bytes occupied by a single cached pattern. Legal value: Any integer between zero and half of RamSize.
MaxScreenItem	integer	Maximum bytes occupied by a single halftone screen. Legal value: Any non-negative integer.
MaxSuperScreen	integer	Establishes an upper limit for the number of pixels in the supercell. Supercells affect Type 1 and Type 2 halftones. If MaxSuperScreen is set to zero, the use of supercells is prevented. Legal value: Any integer between zero and half of RamSize.
MaxUPathItem	integer	Maximum bytes occupied by a single user path. Legal value: Any integer between zero and half of RamSize.
MinFontCompress	integer	(Read-only) This value is always the value of MAXINTEGER .
PageCount	integer	(Read-only) This value is a running sum of the number of pages submitted by the PostScript interpreter to the print engine for printing. Note: This value is reset to 0 (zero) during PostScript initialization. Since PostScript initialization by the printer cannot be known, we recommend querying the value of PageCount at the beginning of a job and at the end of a job, and then calculating the difference to determine how many pages are submitted to the printer for a specific job. This parameter is not valid for tracking pages between jobs.
UseOldcopypage	boolean	Legal values: True Indicates the copypage command is processed as defined in the PostScript Level 2 description. False Indicates the copypage command is processed as defined in the PostScript 3 description.
VMReclaim	integer	Legal values: 0 Enables automatic garbage collection -1 Disables automatic garbage collection for local Virtual Memory (VM) -2 Disables automatic garbage collection for both local and global VM
VMThreshold	integer	Frequency of automatic garbage collection, which occurs when the specified number of bytes have been allocated since the previous collection. Legal value: Any integer from 8192 to 500000, inclusive.
WaitTimeout	integer	Number of seconds the interpreter waits to receive additional characters from the host before it terminates the current print job by executing a PostScript emulation timeout error. A value of 0 indicates an infinite timeout. WaitTimeout is initialized to the value of the WaitTimeout system parameter at the beginning of each print job. Legal value: Any non-negative integer.

System Parameters

The **setsystemparams** operator sets the values of the specified system parameters. This operator requires a password if one is set. The **currentsystemparams** operator returns a dictionary of the current values of the system parameters.

Values supplied to **setsystemparams** that are outside the range or limits for the specified integer parameter do not cause **rangecheck** or **limitcheck** errors. An appropriate value is used. For example, if you set **JobTimeout** to 14, it is actually set to 15, and no error is generated. The exceptions are noted in Table 4-10.

Values supplied to **setsystemparams** that do not match the type of the specified parameter cause **typecheck** errors. Parameters that are not supported by the printer are ignored. An attempt to change the value of a read-only parameter has no effect on the parameter. Write-only parameters are not returned by **currentsystemparams**.

To determine which parameters your printer supports, see Table C-4 on page C-11.

Table 4-10: PostScript Emulation System Parameters

Key	Type	Definition
BuildTime	integer	(Read-only) Timestamp identifying the specific build of the PostScript emulation interpreter.
ByteOrder	boolean	(Read-only) Native (preferred) order of multiple-byte numbers in binary encoded tokens. False high-order first True low-order first
CurDisplayList	integer	(Read-only) This value is always zero.
CurFontCache	integer	(Read-only) Bytes currently occupied by the font cache.
CurFormCache	integer	(Read-only) Bytes currently occupied by the form cache.
¹ These parameters are Lexmark-specific and are in addition to the Adobe PostScript Language Supplement 2016. ² These parameters are available with the Adobe PostScript Language Supplement 3010. ³ These parameters are Lexmark-specific and are in addition to the Adobe PostScript Language Supplement 3010.		

Table 4-10: PostScript Emulation System Parameters (Continued)

Key	Type	Definition
CurInputDevice	string	<p>(Read-only) The name of the communications device corresponding to the current input file for the PostScript emulation program which is currently executing. Possible values are:</p> <p>%LocalTalkA% %TokenTalkD% %LocalTalkB% %LexLinkB% %LocalTalkC% %LexLinkC% %LocalTalkD% %LexLinkD% %SerialA% %PrintServerB% %SerialB% %PrintServerC% %SerialC% %PrintServerD% %SerialD% %RemotePrinterB% %ParallelA% %RemotePrinterC% %ParallelB% %RemotePrinterD% %ParallelC% %AppSocketB% %ParallelD% %AppSocketC% %IR_A% %AppSocketD% %IR_B% %LPR_B% %IR_C% %LPR_C% %IR_D% %LPR_D% %EtherTalkB% %UnknownDevice% %EtherTalkC% %USB_A% %EtherTalkD% %USB_B% %TokenTalkB% %USB_C% %TokenTalkC% %USB_D%</p>
CurOutlineCache	integer	(Read-only) This value is always zero.
CurOutputDevice	string	(Read-only) The name of the communications device corresponding to the current output file for the PostScript emulation program which is currently executing. This string is the same as CurInputDevice .
CurPatternCache	integer	(Read-only) Bytes currently occupied by the pattern cache.
CurScreenStorage	integer	(Read-only) This value is always zero.
CurSourceList	integer	(Read-only) This value is always zero.
CurUPathCache	integer	(Read-only) Bytes currently occupied by the user path cache.
DisableFastProcs	integer	This bit field allows precompiled PostScript procedures to be selectively disabled. These precompiled procedures speed the execution time of some application-generated print jobs by substituting PostScript procedures in the job's ProcSet with fast functions that are built into the printer firmware.

¹ These parameters are Lexmark-specific and are in addition to the Adobe PostScript Language Supplement 2016.

² These parameters are available with the Adobe PostScript Language Supplement 3010.

³ These parameters are Lexmark-specific and are in addition to the Adobe PostScript Language Supplement 3010.

Table 4-10: PostScript Emulation System Parameters (Continued)

Key	Type	Definition
DoPrintErrors	boolean	Specifies whether to print an error page using a built-in error handler when a PostScript emulation error occurs. True Print PS Error user default value is set to On. False Print PS Error user default value is set to Off.
DoStartPage	boolean	(Read only) Always returns False.
EnableExtraFonts ¹	boolean	True All 75 resident fonts are enabled. False Original 39 PostScript fonts are available. Note: Changes to this parameter take effect when PostScript is restarted.
EngineBoot ¹	string	(Read-only) Specifies the version of the boot code.
EngineCode ¹	string	(Read-only) Specifies the version of the engine code.
EngineSpeed ¹	integer	(Read-only) Maximum speed of the print engine in pages per minute.
EnvironmentSave ²	boolean	Indicates or modifies the Resource Save user default value. True Resource Save user default value is set to On. False Resource Save user default value is set to Off. Note: When a job changes this parameter from False to True, all interpreter tasks such as PostScript and PCL are terminated and restarted at the end of the current job.
FactoryDefaults	boolean	If set to True and the printer is then immediately powered off, all non-volatile parameters revert to factory default values at the next power-on. The print job that sets FactoryDefaults to True must be the last job executed before power-off; otherwise, the request is ignored.
FatalErrorAddress	integer	The address at which a fatal system software error occurred. It is stored in this parameter before execution is stopped. It is also transmitted to the host over the communications channel.
FontResourceDir	string	Specifies the location in the file system for font resource files.
FontVersion ¹	string	(Read-only) The version of the font read-only memory (ROM).
GenericResourceDir	string	Specifies the location in the file system for resource files.
GenericResourcePathSep	string	Concatenated to the GenericResourceDir and the category name. It is followed by the resource name to get the external location of the resource. Example: If GenericResourceDir and GenericResourcePathSep were (Resource/) and (/), respectively, the LexmarkLogo resource of the Pattern category would be in Resource/Pattern/LexmarkLogo.

¹ These parameters are Lexmark-specific and are in addition to the Adobe PostScript Language Supplement 2016.² These parameters are available with the Adobe PostScript Language Supplement 3010.³ These parameters are Lexmark-specific and are in addition to the Adobe PostScript Language Supplement 3010.

Table 4-10: PostScript Emulation System Parameters (Continued)

Key	Type	Definition
InstalledRam	integer	(Read-only) Indicated, in bytes, the total amount of installed printer memory (RAM) in the system. Note: InstalledRam should not be confused with RamSize which is the amount of memory (RAM) available to the formatting interpreters and the graphics engine.
JobTimeout	integer	The value in seconds to which the user parameter JobTimeout is initialized at the beginning of each print job. If you set the system parameter JobTimeout to a negative value, it is ignored and the previous setting of JobTimeout is used. A value of 0 (zero) indicates that the timeout is infinite. If you set a number between 1 and 14, 15 is set. Legal values: x = 0, 15 <= x <= 65355
languagelevel	integer	The value of languagelevel integer in systemdict always matches the value of this system parameter. If set to 2, the printer will behave as though /UseOldcopypage and /UseOldfonts are both true (regardless of their actual values). The latter two parameters will return their actual values when queried. Legal Values: 2, 3
MaxDisplayAndSourceList ²	integer	(Read-only) This value is always the same value as InstalledRam .
MaxDisplayList	integer	(Read-only) See Table C-4 on page C-11 for the default value of your printer.
MaxFontCache	integer	(Read-only) See Table C-4 on page C-11 for the default value of your printer.
MaxFormCache	integer	Maximum bytes occupied by the form cache. Legal value: Any non-negative integer.
MaxImageBuffer	integer	(Read-only) See Table C-4 on page C-11 for the default value of your printer.
MaxOutlineCache	integer	(Read-only) See Table C-4 on page C-11 for the default value of your printer.
MaxPatternCache	integer	Maximum bytes occupied by the pattern cache. Legal value: Any non-negative integer.
MaxPermanentVM ²	integer	(Read-only) See Table C-4 on page C-11 for the default value of your printer.
MaxRasterMemory	integer	(Read-only) See Table C-4 on page C-11 for the default value of your printer.
MaxScreenStorage	integer	(Read-only) See Table C-4 on page C-11 for the default value of your printer.

¹ These parameters are Lexmark-specific and are in addition to the Adobe PostScript Language Supplement 2016.

² These parameters are available with the Adobe PostScript Language Supplement 3010.

³ These parameters are Lexmark-specific and are in addition to the Adobe PostScript Language Supplement 3010.

Table 4-10: PostScript Emulation System Parameters (Continued)

Key	Type	Definition
MaxSourceList	integer	(Read-only) See Table C-4 on page C-11 for the default value of your printer.
MaxUPathCache	integer	Maximum bytes occupied by the user path cache. Legal value: Any non-negative integer.
PageCount	integer	(Read-only) Total number of pages that have been printed.
PanelCode ¹	string	(Read-only) Version of the operator panel code.
PrinterCode ¹	string	(Read-only) Firmware version of the printer controller card.
PrinterName	string	Initialized from the printer name stored in NVRAM (the default name of the printer). If this parameter is set to a zero length string, the PrinterName is set to the value of the product string in statusdict . Legal value: Any string of 32 or fewer non-null characters.
RamSize	integer	(Read-only) Total amount of memory (in bytes) installed in the printer.
RealFormat	string	(Read-only) Preferred representation for real numbers in binary encoded tokens.
Revision	integer	(Read-only) The current revision level of the machine-dependent portion of PostScript emulation.
SearchBuiltinFontsFirst ¹	boolean	Controls the device search order the interpreter uses to locate fonts.
SerialNumber ¹	string	(Read-only) Serial number of your printer.
StartJobPassword	string	(Write-only) Controls the ability of the startjob operator to alter initial Virtual Memory (VM). Legal value: Any integer or string of 32 or fewer non-null characters. An integer is converted to a string.
StartupMode	integer	Controls the system start file (Sys/Start) during PostScript emulation initialization. Also, controls the job start file (Job/Start) before each print job. <ul style="list-style-type: none"> 0 Disable use of Sys/Start file and Job/Start file. 1 Sys/Start file executes (if present on disk or flash). 10 Job/Start file executes before each user job. 11 Both files run (a combination of 1 and 10). Legal Values: $0 \leq x \leq 255$. Values other than the four listed are equivalent to 0. Note: If both flash and disk have a Sys/Start file and Job/Start file, the value of the SearchOrder for the two devices determines which file is executed.
StaticRamSize ¹	integer	(Read-only) Amount of static memory (in bytes) on the controller board.

¹ These parameters are Lexmark-specific and are in addition to the Adobe PostScript Language Supplement 2016.

² These parameters are available with the Adobe PostScript Language Supplement 3010.

³ These parameters are Lexmark-specific and are in addition to the Adobe PostScript Language Supplement 3010.

Table 4-10: PostScript Emulation System Parameters (Continued)

Key	Type	Definition
SystemParamsPassword	string	(Write-only) Controls the ability of setsystemparams to change the values of system parameters and setdevparams to change the values of device parameters. Legal value: Any integer or string of 32 or fewer non-null characters. An integer is converted to a string.
UseOldcopypage ³	boolean	True indicates the copypage command is processed as defined in PostScript Level 2 description. False indicates the copypage command is processed as defined in PostScript 3 description.
UseOldFonts ³	boolean	True redefines the following PostScript resident fonts to match the character designs and metrics defined in PostScript Level 2. The font names in parentheses are the equivalent PostScript 3 font names for the associated PostScript Level 2 names. Antique Olive (Antique Olive Roman) Antique Olive Bold Antique Olive Italic Letter Gothic Letter Gothic Bold Letter Gothic Italic (Letter Gothic Slanted) Marigold Univers Bold False restores the font compatibility to PostScript 3.
ValidNV	boolean	(Read-only) Indicates if non-volatile memory is currently used to store persistent parameters. If this memory is found defective during system initialization, factory defaults are used. If further testing reveals this memory is defective, it is not used and ValidNV is False. Otherwise, ValidNV is True.
WaitTimeout	integer	The value, in seconds, to which the user parameter WaitTimeout is initialized at the beginning of each print job. Negative values are ignored and the previous setting is used. A value of zero indicates an infinite timeout. If you select a number between 1 and 14, 15 is set. Legal values: $x = 0$, $15 \leq x \leq 65355$

¹ These parameters are Lexmark-specific and are in addition to the Adobe PostScript Language Supplement 2016.

² These parameters are available with the Adobe PostScript Language Supplement 3010.

³ These parameters are Lexmark-specific and are in addition to the Adobe PostScript Language Supplement 3010.

Device Parameters

The **currentdevparams** operator returns a dictionary of the current values of the system parameters.

The **setdevparams** operator sets the values of the specified device parameters.

- This operator requires a password if one is set.
- Values supplied to **setdevparams** that are outside the range or limits for the specified integer parameter do not cause **rangecheck** or **limitcheck** errors. The appropriate value is used.
- Values supplied to **setdevparams** that do not match the type of the specified parameter cause **typecheck** errors.
- If a parameter name is not known, an **undefined** error occurs.
- An attempt to change the value of a read-only parameter has no effect on the parameter.
- To specify the parameters for a specific communications channel, use the appropriate suffix. For example, the serial channels are:
 - %SerialA%
 - %SerialB%
 - %SerialC%
 - %SerialD%

For some printers, no “A” channel exists. If %Serial% is specified, it refers to the channel where the print job is sent.

For additional information on flash memory and disk, see Chapter 6: “Flash Memory and Disk” on page 6-1.

To determine which devices your printer supports, see Table C-5 on page C-14.

To determine which device parameters your printer supports, see Table C-6 on page C-16.

Table 4-11: PostScript Emulation Device Parameters

Key	Type	Definition
Device Parameters for the Communication Device %Parallel%, %ParallelA%, %ParallelB%, %ParallelC%, %ParallelD% (%Parallel_NV% and %Parallel_Pending% contain the same parameters)		
DelayedOutputClose	boolean	Selects how the printer manages the port at the end of each print job. Supported values are: True An end-of-file message is not sent until the current job and all preceding jobs finish printing. False An end-of-file message is sent as soon as a job finishes executing in the interpreter, whether or not that job has finished printing. This value is set independently for each port.
Enabled	boolean	(Read-only) Supported values are: True False
Filtering	name	Indicates if the input needs further filtering before the data can be correctly processed. Supported values are: InterpreterBased None
Handshake	integer	(Read-only) Always returns a value of 2.
HasNames	boolean	(Read-only) Always returns False.
Interpreter	name	(Read-only) Supported values are: PostScript AutoSelect PCL PPDS
On	boolean	Designates if the communication channel is On and able to receive and send data. Supported values are: True Data is sent and processed False Data is lost
OutputDevice	string	(Read-only)
PCLSmartSwitch	boolean	Supported values are: True PCL SmartSwitch is set to On . False PCL SmartSwitch is set to Off . For more information, see "Using SmartSwitch" on page 2-1.
PortLocation	string	(Read-only) Designates the physical location of the port related to the parameter set. Supported values are: Standard Port Option Slot 1 Option Slot 2 Option Slot 3 Option Slot 4

Table 4-11: PostScript Emulation Device Parameters (Continued)

Key	Type	Definition
PSSmartSwitch	boolean	Supported values are: True PS SmartSwitch is set to On . False PS SmartSwitch is set to Off . For more information, see “Using SmartSwitch” on page 4-1.
Type	name	(Read-only) Always returns the value of /Communications.
Device Parameters for the Communication Device %Serial%, %SerialA%, %SerialB%, %SerialC%, %SerialD% (%Serial_NV% and %Serial_Pending% contain the same parameters)		
Baud	integer	Returns the value of the Baud menu item.
CheckParity	boolean	(Read-only) Designates whether parity checking is done on the incoming data. Supported values are: True Parity menu item set to Even or Odd. False Parity menu item set to None or Ignore.
DataBits	integer	Returns the value of the Data Bits menu item.
DelayedOutputClose	boolean	Selects how the printer manages the port at the end of each print job. Supported values are: True An end-of-file message is not sent until the current job and all preceding jobs finish printing. False An end-of-file message is sent as soon as a job finishes executing in the interpreter, whether or not that job has finished printing. This value is set independently for each port.
Enabled	boolean	(Read-only) Supported values are: True False
Filtering	name	Indicates if the input needs further filtering before the data can be correctly processed. Supported values are: InterpreterBased None
FlowControl	name	Designates the serial flow control method between the host computer and the device. Returns a value corresponding to the Serial Protocol menu item. Supported values are: Dtr DtrDsr XonXoff XonXoffDtr XonXoffDtrDsr
HasNames	boolean	(Read-only) Always returns False.
HonorDSR	boolean	Serial - Honor DSR. Supported values are: True Honor DSR is set to On . False Honor DSR is set to Off .

Table 4-11: PostScript Emulation Device Parameters (Continued)

Key	Type	Definition
Interpreter	name	(Read-only) Supported values are: PostScript AutoSelect PCL PPDS
On	boolean	Designates if the communication channel is On and able to receive and send data. Supported values are: True Data is sent and processed. False Data is lost.
Parity	name	Designates the parity to be used between the host computer and the device. Returns the value of the Parity menu item. Supported values are: Even Odd None Ignore If Parity is set to Ignore, CheckParity is set to False and Parity becomes Even.
PCLSmartSwitch	boolean	Supported values are: True PCL SmartSwitch is set to On . False PCL SmartSwitch is set to Off . For more information, see "Using SmartSwitch" on page 2-1.
PortLocation	string	(Read-only) Designates the physical location of the port related to the parameter set. Supported values are: Standard Port Option Slot 1 Option Slot 2 Option Slot 3
PSSmartSwitch	boolean	Supported values are: True PS SmartSwitch is set to On . False PS SmartSwitch is set to Off . For more information, see "Using SmartSwitch" on page 4-1.
RobustXon	boolean	Supported values are: True RobustXon is set to On . False RobustXon is set to Off .
SerialMode	name	Designates the serial communication configuration: RS232C or RS422. Returns the value of the Serial RS-232/RS-422 menu item. Supported values are: RS232 RS422 Returns RS232 on a printer that is attached with a cable that does not support RS-422.

Table 4-11: PostScript Emulation Device Parameters (Continued)

Key	Type	Definition
StopBits	integer	(Read-only) Supported values are: 1 2
Type	name	(Read-only) Always returns the value of /Communications.
Device Parameters for the Communication Device %LocalTalk%, %LocalTalkA%, %LocalTalkB%, %LocalTalkC%, %LocalTalkD% (%LocalTalk_NV% and %LocalTalk_Pending% contain the same parameters)		
DelayedOutputClose	boolean	Selects how the printer manages the port at the end of each print job. Supported values are: True An end-of-file message is not sent until the current job and all preceding jobs finish printing. False An end-of-file message is sent as soon as a job finishes executing in the interpreter, whether or not that job has finished printing. This value is set independently for each port.
Enabled	boolean	(Read-only) Supported values are: True False
Filtering	name	Indicates if the input needs further filtering before the data can be correctly processed. Supported values are: InterpreterBased None
HasNames	boolean	(Read-only) Always returns False.
Interpreter	name	(Read-only) Supported values are: PostScript AutoSelect PCL PPDS
LocalTalkType	string	The “type” of the AppleTalk network entity name. This parameter also sets the Type parameter to the same value. The new value is returned by the appletalktype compatibility operator. Legal value: Any string of 32 or fewer non-null characters. Default value is LaserWriter. Note: Setting this variable does not affect the value for other physical internal print servers. The statusdict string appletalktype is correct for the current job port.
NodeID	integer	(Read-only)
On	boolean	Designates if the communication channel is On and able to receive and send data. Supported values are: True Data is sent and processed. False Data is lost.

Table 4-11: PostScript Emulation Device Parameters (Continued)

Key	Type	Definition
PCLSmartSwitch	boolean	Supported values are: True PCL SmartSwitch is On. False PCL SmartSwitch is Off. For more information, see “Using SmartSwitch” on page 2-1.
PortLocation	string	(Read-only) Designates the physical location of the port related to the parameter set. Supported values are: Standard Port Option Slot 1 Option Slot 2 Option Slot 3
PSSmartSwitch	boolean	Supported values are: True PS SmartSwitch is On. False PS SmartSwitch is Off. For more information, see “Using SmartSwitch” on page 4-1.
Type	name	(Read-only) Always returns the value of /Communications.
Device Parameters for the Communication Device %EtherTalk%, %EtherTalkA%, %EtherTalkB%, %EtherTalkC%, %EtherTalkD% (%EtherTalk_NV% and %EtherTalk_Pending% contain the same parameters)		
DelayedOutputClose	boolean	Selects how the printer manages the port at the end of each print job. Supported values are: True An end-of-file message is not sent until the current job and all preceding jobs finish printing. False An end-of-file message is sent as soon as a job finishes executing in the interpreter, whether or not that job has finished printing. This value is set independently for each port.
Enabled	boolean	(Read-only) Supported values are: True False
EthernetAddress	string	(Read only) The Ethernet address of the Ethernet internal print server. Legal value: Any string of 17 or fewer non-null characters.
EtherTalkType	string	The “type” of the EtherTalk interface entity name. This parameter also sets the LocalTalkType parameter to the same value. The new value is returned by the appletalktype compatibility operator. Legal value: Any string of 32 or fewer non-null characters. Default value is LaserWriter. Note: Setting this variable does not affect the value for other physical internal print servers. The statusdict string appletalktype is correct for the current job port.
EtherTalkZone	string	The “zone” of the EtherTalk interface entity name. EtherTalkZone is read/write only to RAM. There is no NVRAM variable for EtherTalkZone. Legal value: Any string of 32 or fewer non-null characters.

Table 4-11: PostScript Emulation Device Parameters (Continued)

Key	Type	Definition
Filtering	name	Indicates if the input needs further filtering before the data can be correctly processed. Supported values are: InterpreterBased None
HasNames	boolean	(Read-only) Always returns False.
Interpreter	name	(Read-only) Supported values are: PostScript AutoSelect PCL PPDS
NodeID	integer	(Read-only)
On	boolean	Designates if the communication channel is On and able to receive and send data. Supported values are: True Data is sent and processed. False Data is lost.
PCLSmartSwitch	boolean	Supported values are: True PCL SmartSwitch is On. False PCL SmartSwitch is Off. For more information, see "Using SmartSwitch" on page 2-1.
PortLocation	string	(Read-only) Designates the physical location of the port related to the parameter set. Supported values are: Standard Port Option Slot 1 Option Slot 2 Option Slot 3
PSSmartSwitch	boolean	Supported values are: True PS SmartSwitch is On. False PS SmartSwitch is Off. For more information, see "Using SmartSwitch" on page 4-1.
Type	name	(Read-only) Always returns the value of /Communications.
Device Parameters for the Communication Device %IR%, %IR_A%, %IR_B%, %IR_C%, %IR_D% (%IR_NV% and %IR_Pending% contain the same parameters)		
DelayedOutputClose	boolean	Selects how the printer manages the port at the end of each print job. Supported values are: True An end-of-file message is not sent until the current job and all preceding jobs finish printing. False An end-of-file message is sent as soon as a job finishes executing in the interpreter, whether or not that job has finished printing. This value is set independently for each port.

Table 4-11: PostScript Emulation Device Parameters (Continued)

Key	Type	Definition
Enabled	boolean	(Read-only) Supported values are: True False
Filtering	name	Indicates if the input needs further filtering before the data can be correctly processed. Supported values are: InterpreterBased None
HasNames	boolean	(Read-only) Always returns False.
Interpreter	name	(Read-only) Supported values are: PostScript AutoSelect PCL PPDS
On	boolean	Designates if the communication channel is On and able to receive and send data. Supported values are: True Data is sent and processed. False Data is lost.
PCLSmartSwitch	boolean	Supported values are: True PCL SmartSwitch is On. False PCL SmartSwitch is Off. For more information, see "Using SmartSwitch" on page 2-1.
PortLocation	string	(Read-only) Designates the physical location of the port related to the parameter set. Supported values are: Standard Port Option Slot 1 Option Slot 2 Option Slot 3
PSSmartSwitch	boolean	Supported values are: True PS SmartSwitch is set to On. False PS SmartSwitch is set to Off. For more information, see "Using SmartSwitch" on page 4-1.
Type	name	(Read-only) Always returns the value of /Communications.
Device Parameters for the Communication Device %USB%, %USB_A%, %USB_B%, %USB_C%, %USB_D% (%USB_NV% and %USB_Pending% contain the same parameters)		
DelayedOutputClose	boolean	Selects how the printer manages the port at the end of each print job. Supported values are: True An end-of-file message is not sent until the current job and all preceding jobs finish printing. False An end-of-file message is sent as soon as a job finishes executing in the interpreter, whether or not that job has finished printing.

Table 4-11: PostScript Emulation Device Parameters (Continued)

Key	Type	Definition
Enabled	boolean	(Read-only) Supported values are: True False
Filtering	name	Indicates if the input needs further filtering before the data can be correctly processed. Supported values are: InterpreterBased None
HasNames	boolean	(Read-only) Always returns False.
Interpreter	name	(Read-only) Supported values are: PostScript AutoSelect PCL PPDS
On	boolean	Designates if the communication channel is On and able to receive and send data. Supported values are: True Data is sent and processed. False Data is lost.
PCLSmartSwitch	boolean	Supported values are: True PCL SmartSwitch is On. False PCL SmartSwitch is Off. For more information, see "Using SmartSwitch" on page 2-1.
PortLocation	string	(Read-only) Designates the physical location of the port related to the parameter set. Supported values are: Standard Port Option Slot 1, 2, and 3 (Model specific)
PSSmartSwitch	boolean	Supported values are: True PS SmartSwitch is set to On. False PS SmartSwitch is set to Off. For more information, see "Using SmartSwitch" on page 4-1.
Type	name	(Read-only) Always returns the value of /Communications.
Device Parameters for the Communication Device %TokenTalk%, %TokenTalkA%, %TokenTalkB%, %TokenTalkC%, %TokenTalkD%		
(%TokenTalk_NV% and %TokenTalk_Pending% contain the same parameters)		
Address	string	(Read-only)
Bridging	name	(Read-only) Adaptive

Table 4-11: PostScript Emulation Device Parameters (Continued)

Key	Type	Definition
DelayedOutputClose	boolean	Selects how the printer manages the port at the end of each print job. Supported values are: True An end-of-file message is not sent until the current job and all preceding jobs finish printing. False An end-of-file message is sent as soon as a job finishes executing in the interpreter, whether or not that job has finished printing. This value is set independently for each port.
Enabled	boolean	(Read-only) Supported values are: True False
Filtering	name	Indicates if the input needs further filtering before the data can be correctly processed. Supported values are: InterpreterBased None
HasNames	boolean	(Read-only) Always returns False.
Interpreter	name	(Read-only) Supported values are: PostScript AutoSelect PCL PPDS
NodeID	integer	(Read-only)
On	boolean	Designates if the communication channel is On and able to receive and send data. Supported values are: True Data is sent and processed. False Data is lost.
PCLSmartSwitch	boolean	Supported values are: True PCL SmartSwitch is On. False PCL SmartSwitch is Off. For more information, see "Using SmartSwitch" on page 2-1.
PortLocation	string	(Read-only) Designates the physical location of the port related to the parameter set. Supported values are: Standard Port Option Slot 1 Option Slot 2 Option Slot 3
PSSmartSwitch	boolean	Supported values are: True PS SmartSwitch is set to On. False PS SmartSwitch is set to Off. For more information, see "Using SmartSwitch" on page 4-1.

Table 4-11: PostScript Emulation Device Parameters (Continued)

Key	Type	Definition
TokenTalkType	string	Setting this variable does not affect the value of other physical internal print servers. Note: The statusdict string appletalktype is correct for the current job port.
Type	name	(Read-only) Always returns the value of /Communications.
Zone	string	Returns the value identified when the printer makes connection to the network at power on.
Device Parameters for the Communication Device %AppSocket%, %AppSocketA%, %AppSocketB%, %AppSocketC%, %AppSocketD% (%AppSocket_NV% and %AppSocket_Pending% contain the same parameters)		
DelayedOutputClose	boolean	Selects how the printer manages the port at the end of each print job. Supported values are: True An end-of-file message is not sent until the current job and all preceding jobs finish printing. False An end-of-file message is sent as soon as a job finishes executing in the interpreter, whether or not that job has finished printing. This value is set independently for each port.
Enabled	boolean	(Read-only) Supported values are: True False
Filtering	name	Indicates if the input needs further filtering before the data can be correctly processed. Supported values are: InterpreterBased None
HasNames	boolean	(Read-only) Always returns False.
Interpreter	name	(Read-only) Supported values are: PostScript AutoSelect PCL PPDS
On	boolean	Designates if the communication channel is On and able to receive and send data. Supported values are: True Data is sent and processed. False Data is lost.
PortLocation	string	(Read-only) Designates the physical location of the port related to the parameter set. Supported values are: Standard Port Option Slot 1 Option Slot 2 Option Slot 3
Type	name	(Read-only) Always returns the value of /Communications.

Table 4-11: PostScript Emulation Device Parameters (Continued)

Key	Type	Definition
Device Parameters for the Communication Device %RemotePrinter%, %RemotePrinterA%, %RemotePrinterB%, %RemotePrinterC%, %RemotePrinterD% (%RemotePrinter_NV% and %RemotePrinter_Pending% contain the same parameters)		
DelayedOutputClose	boolean	Selects how the printer manages the port at the end of each print job. Supported values are: True An end-of-file message is not sent until the current job and all preceding jobs finish printing. False An end-of-file message is sent as soon as a job finishes executing in the interpreter, whether or not that job has finished printing. This value is set independently for each port.
Enabled	boolean	(Read-only) Supported values are: True False
Filtering	name	Indicates if the input needs further filtering before the data can be correctly processed. Supported values are: InterpreterBased None Note: Setting this variable changes the value of the corresponding %PrintServer% device.
HasNames	boolean	(Read-only) Always returns False.
Interpreter	name	(Read-only) Supported values are: PostScript AutoSelect PCL PPDS
On	boolean	Designates if the communication channel is On and able to receive and send data. Supported values are: True Data is sent and processed. False Data is lost.
PortLocation	string	(Read-only) Designates the physical location of the port related to the parameter set. Supported values are: Standard Port Option Slot 1 Option Slot 2 Option Slot 3
Type	name	(Read-only) Always returns the value of /Communications.

Table 4-11: PostScript Emulation Device Parameters (Continued)

Key	Type	Definition
Device Parameters for the Communication Device %PrintServer%, %PrintServerA%, %PrintServerB%, %PrintServerC%, %PrintServerD% (%PrintServer_NV% and %PrintServer_Pending% contain the same parameters)		
DelayedOutputClose	boolean	Selects how the printer manages the port at the end of each print job. Supported values are: True An end-of-file message is not sent until the current job and all preceding jobs finish printing. False An end-of-file message is sent as soon as a job finishes executing in the interpreter, whether or not that job has finished printing. This value is set independently for each port.
Enabled	boolean	(Read-only) Supported values are: True False
Filtering	name	Indicates if the input needs further filtering before the data can be correctly processed. Supported values are: InterpreterBased None Note: Setting this variable changes the value of the corresponding %RemotePrinter% device.
HasNames	boolean	(Read-only) Always returns False.
Interpreter	name	(Read-only) Supported values are: PostScript AutoSelect PCL PPDS
On	boolean	Designates if the communication channel is On and able to receive and send data. Supported values are: True Data is sent and processed. False Data is lost.
PortLocation	string	(Read-only) Designates the physical location of the port related to the parameter set. Supported values are: Standard Port Option Slot 1 Option Slot 2 Option Slot 3
Type	name	(Read-only) Always returns the value of /Communications.

Table 4-11: PostScript Emulation Device Parameters (Continued)

Key	Type	Definition
Device Parameters for the Communication Device %LPR%, %LPR_A%, %LPR_B%, %LPR_C%, %LPR_D% (%LPR_NV% and %LPR_Pending% contain the same parameters)		
Enabled	boolean	(Read-only) Supported values are: True False
Filtering	name	Indicates if the input needs further filtering before the data can be correctly processed. Supported values are: InterpreterBased None
HasNames	boolean	(Read-only) Always returns False.
Interpreter	name	(Read-only) Supported values are: PostScript AutoSelect PCL PPDS
On	boolean	Designates if the communication channel is On and able to receive and send data. Supported values are: True Data is sent and processed. False Data is lost.
PortLocation	string	(Read-only) Designates the physical location of the port related to the parameter set. Supported values are: Standard Port Option Slot 1 Option Slot 2 Option Slot 3
Type	name	(Read-only) Always returns the value of /Communications.
Device Parameters for the Communication Device %LexLink%, %LexLinkA%, %LexLinkB%, %LexLinkC%, %LexLinkD% (%LexLink_NV% and %LexLink_Pending% contain the same parameters)		
DelayedOutputClose	boolean	Selects how the printer manages the port at the end of each print job. Supported values are: True An end-of-file message is not sent until the current job and all preceding jobs finish printing. False An end-of-file message is sent as soon as a job finishes executing in the interpreter, whether or not that job has finished printing. This value is set independently for each port.
Enabled	boolean	(Read-only) Supported values are: True False

Table 4-11: PostScript Emulation Device Parameters (Continued)

Key	Type	Definition
HasNames	boolean	(Read-only) Always returns False.
Interpreter	name	(Read-only) Supported values are: PostScript AutoSelect PCL PPDS
On	boolean	Designates if the communication channel is On and able to receive and send data. Supported values are: True Data is sent and processed. False Data is lost.
PortLocation	string	(Read-only) Designates the physical location of the port related to the parameter set. Supported values are: Standard Port Option Slot 1 Option Slot 2 Option Slot 3
Type	name	(Read-only) Always returns the value of /Communications.
Device Parameters for the Parameters Device %IP%, %IP_A%, %IP_B%, %IP_C%, %IP_D%		
GatewayAddress	string	(Read-only)
IPAddress	string	(Read-only)
IPAddressDynamic	boolean	(Read-only) Supported values are: True False
NetworkMask	string	(Read-only)
On	boolean	Designates if the communication channel is On and able to receive and send data. Supported values are: True Data is sent and processed. False Data is lost.
Physical	string	(Read-only)
PortLocation	string	(Read-only) Designates the physical location of the port related to the parameter set. Supported values are: Standard Port Option Slot 1 Option Slot 2 Option Slot 3
Type	name	(Read-only) Always returns the value of /Parameters.

Table 4-11: PostScript Emulation Device Parameters (Continued)

Key	Type	Definition
Device Parameters for the Parameters Device %EthernetPhysical%, %EthernetPhysicalA%, %EthernetPhysicalB%, %EthernetPhysicalC%, %EthernetPhysicalD%		
EthernetAddress	string	(Read-only)
On	boolean	Designates if the communication channel is On and able to receive and send data. Supported values are: True Data is sent and processed. False Data is lost.
PortLocation	string	(Read-only) Designates the physical location of the port related to the parameter set. Supported values are: Standard Port Option Slot 1 Option Slot 2 Option Slot 3
Type	name	(Read-only) Always returns the value of /Parameters.
Device Parameters for the Parameters Device %TokenRingPhysical%, %TokenRingPhysicalA%, %TokenRingPhysicalB%, %TokenRingPhysicalC%, %TokenRingPhysicalD%		
Address	string	(Read-only)
On	boolean	Designates if the communication channel is On and able to receive and send data. Supported values are: True Data is sent and processed. False Data is lost.
PortLocation	string	(Read-only) Designates the physical location of the port related to the parameter set. Supported values are: Standard Port Option Slot 1 Option Slot 2 Option Slot 3
Speed	integer	Supported values are: 4 16
Type	name	(Read-only) Always returns the value of /Parameters.
Device Parameters for the Parameters Device %Engine%		
BSizeStandard	name	(Read-only) Value of JIS

Table 4-11: PostScript Emulation Device Parameters (Continued)

Key	Type	Definition																																																																																						
Darkness	real	<p>Print Darkness and Toner Saver Setting</p> <p>Designates the print darkness and toner saver setting (model specific).</p> <p>Legal value: Any non-negative real number from 0.0 to 1.0, inclusive.</p> <p>For queries, the Print Darkness setting is returned as a real value:</p> <table border="1"> <thead> <tr> <th>Print Darkness Setting</th> <th>Toner Saver Setting Value</th> <th>Darkness Value Returned</th> </tr> </thead> <tbody> <tr><td>Lightest</td><td>On</td><td>0.1</td></tr> <tr><td>Lighter</td><td>On</td><td>0.2</td></tr> <tr><td>Normal</td><td>On</td><td>0.3</td></tr> <tr><td>Darker</td><td>On</td><td>0.4</td></tr> <tr><td>Darkest</td><td>On</td><td>0.5</td></tr> <tr><td>Lightest</td><td>Off</td><td>0.6</td></tr> <tr><td>Lighter</td><td>Off</td><td>0.7</td></tr> <tr><td>Normal</td><td>Off</td><td>0.8</td></tr> <tr><td>Darker</td><td>Off</td><td>0.9</td></tr> <tr><td>Darkest</td><td>Off</td><td>1.0</td></tr> </tbody> </table> <p>When the Darkness value is changed, the following ranges determine the Print Darkness and Toner Saver setting values:</p> <table border="1"> <thead> <tr> <th>Darkness Value</th> <th>Print Darkness Setting Value</th> <th>Toner Saver Setting Value</th> </tr> </thead> <tbody> <tr><td>0.0 <=value<=0.15</td><td>Lightest</td><td>On</td></tr> <tr><td>0.15 <=value<=0.25</td><td>Lighter</td><td>On</td></tr> <tr><td>0.25 <=value<=0.35</td><td>Normal</td><td>On</td></tr> <tr><td>0.35 <=value<=0.45</td><td>Darker</td><td>On</td></tr> <tr><td>0.45 <=value<=0.55</td><td>Darkest</td><td>On</td></tr> <tr><td>0.55 <=value<=0.65</td><td>Lightest</td><td>Off</td></tr> <tr><td>0.65 <=value<=0.75</td><td>Lighter</td><td>Off</td></tr> <tr><td>0.75 <=value<=0.85</td><td>Normal</td><td>Off</td></tr> <tr><td>0.85 <=value<=0.95</td><td>Darker</td><td>Off</td></tr> <tr><td>0.95 <=value<=1.0</td><td>Darkest</td><td>Off</td></tr> </tbody> </table> <p>Print Darkness Setting</p> <p>Designates the print darkness (model specific).</p> <p>Legal value: Any non-negative real number from 0.0 to 1.0, inclusive.</p> <p>For queries, the Print Darkness setting is returned as a real value:</p> <table border="1"> <tbody> <tr><td>0.1</td><td>Lightest</td></tr> <tr><td>0.3</td><td>Lighter</td></tr> <tr><td>0.5</td><td>Normal</td></tr> <tr><td>0.7</td><td>Darker</td></tr> <tr><td>0.9</td><td>Darkest</td></tr> </tbody> </table> <p>When the Darkness value is modified, the following ranges are used to determine the Print Darkness setting:</p> <table border="1"> <tbody> <tr><td>0.0 - 0.2</td><td>Lightest</td></tr> <tr><td>>0.2 - 0.4</td><td>Lighter</td></tr> <tr><td>>0.4 - 0.6</td><td>Normal</td></tr> <tr><td>>0.6 - 0.8</td><td>Darker</td></tr> <tr><td>>0.8 - 1.0</td><td>Darkest</td></tr> </tbody> </table>	Print Darkness Setting	Toner Saver Setting Value	Darkness Value Returned	Lightest	On	0.1	Lighter	On	0.2	Normal	On	0.3	Darker	On	0.4	Darkest	On	0.5	Lightest	Off	0.6	Lighter	Off	0.7	Normal	Off	0.8	Darker	Off	0.9	Darkest	Off	1.0	Darkness Value	Print Darkness Setting Value	Toner Saver Setting Value	0.0 <=value<=0.15	Lightest	On	0.15 <=value<=0.25	Lighter	On	0.25 <=value<=0.35	Normal	On	0.35 <=value<=0.45	Darker	On	0.45 <=value<=0.55	Darkest	On	0.55 <=value<=0.65	Lightest	Off	0.65 <=value<=0.75	Lighter	Off	0.75 <=value<=0.85	Normal	Off	0.85 <=value<=0.95	Darker	Off	0.95 <=value<=1.0	Darkest	Off	0.1	Lightest	0.3	Lighter	0.5	Normal	0.7	Darker	0.9	Darkest	0.0 - 0.2	Lightest	>0.2 - 0.4	Lighter	>0.4 - 0.6	Normal	>0.6 - 0.8	Darker	>0.8 - 1.0	Darkest
Print Darkness Setting	Toner Saver Setting Value	Darkness Value Returned																																																																																						
Lightest	On	0.1																																																																																						
Lighter	On	0.2																																																																																						
Normal	On	0.3																																																																																						
Darker	On	0.4																																																																																						
Darkest	On	0.5																																																																																						
Lightest	Off	0.6																																																																																						
Lighter	Off	0.7																																																																																						
Normal	Off	0.8																																																																																						
Darker	Off	0.9																																																																																						
Darkest	Off	1.0																																																																																						
Darkness Value	Print Darkness Setting Value	Toner Saver Setting Value																																																																																						
0.0 <=value<=0.15	Lightest	On																																																																																						
0.15 <=value<=0.25	Lighter	On																																																																																						
0.25 <=value<=0.35	Normal	On																																																																																						
0.35 <=value<=0.45	Darker	On																																																																																						
0.45 <=value<=0.55	Darkest	On																																																																																						
0.55 <=value<=0.65	Lightest	Off																																																																																						
0.65 <=value<=0.75	Lighter	Off																																																																																						
0.75 <=value<=0.85	Normal	Off																																																																																						
0.85 <=value<=0.95	Darker	Off																																																																																						
0.95 <=value<=1.0	Darkest	Off																																																																																						
0.1	Lightest																																																																																							
0.3	Lighter																																																																																							
0.5	Normal																																																																																							
0.7	Darker																																																																																							
0.9	Darkest																																																																																							
0.0 - 0.2	Lightest																																																																																							
>0.2 - 0.4	Lighter																																																																																							
>0.4 - 0.6	Normal																																																																																							
>0.6 - 0.8	Darker																																																																																							
>0.8 - 1.0	Darkest																																																																																							

Table 4-11: PostScript Emulation Device Parameters (Continued)

Key	Type	Definition
PageCount	integer	(Read-only) Page Count
TimeToStandby	integer	Power Saver. Supported values are: 0 to 120, in minutes
Type	name	(Read-only) Always returns the value of /Parameters.
Device Parameters for the Parameters Device %Console%		
Language	name	Display Language
Type	name	(Read-only) Always returns the value of /Parameters.
Device Parameters for the Parameters Device %Calendar%, %CalendarA%, %CalendarB%, %CalendarC%, %CalendarD%		
Day	integer	Supported values are: 1–31
Hour	integer	Supported values are: 0–23
Minute	integer	Supported values are: 0–59
Month	integer	Supported values are: 1–12
Running	boolean	Signifies whether time is available for this device.
Second	integer	Supported values are: 0–59
Type	name	(Read-only) Value of /Parameters
Year	integer	
DateTime	string	Date and Time in the format: YYYY-MM-DD HH:MM
DayOfWeekLong	string	Long day name (for example, "Wednesday")
DayOfWeekNum	integer	Supported values are: 0–6 (0=Sunday)
DayOfWeekShort	string	Short day name (for example, "Wed")
Device Parameters for the IODevice Device %disk1%		
BlockSize	integer	(Read-only)
Free	integer	(Read-only) Indicates the amount of free space available (in pages) on the disk. Valid only if the disk is mounted (mounted is set to True). A value of 0 (zero) indicates that either the disk is not mounted or is full.
HasNames	boolean	(Read-only) Indicates if the disk supports named files. Valid only if the disk is mounted (mounted is set to True). If the disk is not mounted, the parameter has a value of False.

Table 4-11: PostScript Emulation Device Parameters (Continued)

Key	Type	Definition
InitializeAction	integer	Specifies an action for initializing the disk. Supported values are: <ul style="list-style-type: none"> 0 Indicates no action; the value returned when the parameter is read. 1 Indicates that the current file system (if any) should be deleted and a new one of LogicalSize created (the disk is assumed to have been formatted already). The disk must first be mounted; otherwise, an ioerror results. 2 Reformats the entire disk before creating a new file system of size LogicalSize. 3 (or greater) has the same effect as the value 2 and also tests the disk x - 2 times. <p>Note: The current file system refers to /FileSystem. See Type as follows for more information.</p>
LogicalSize	integer	Specifies the size of the file system to be created and is as an argument by InitializeAction. <ul style="list-style-type: none"> • If 0 (zero), InitializeAction uses the size of the entire disk. When queried, indicates the current size of the file system on the device (in pages). A value of 0 indicates that the device is not mounted. • If set with a certain value and the device is reformatted, a query returns the value that was set. If queried before the disk is reformatted, a different value from the one set may be returned because it may return the current size. • If set to 1, 2, or 3, an ioerror occurs. <p>Legal value: Any non-negative integer, including 0. The value must be less than or equal to the value of PhysicalSize. If set to a value greater than PhysicalSize, or less than zero, a rangecheck error occurs.</p>
Mounted	boolean	<p>True System attempts to mount the disk. False System attempts to dismount the disk.</p> <p>A device must contain a valid file system to mount successfully. When a device is mounted, it is known to the system and is readable. To verify if the device is currently mounted, query this parameter immediately after setting it.</p>
PhysicalSize	integer	(Read-only) Indicates the size of the disk (in pages). Valid only when the disk is mounted. A value of 0 (zero) indicates that the device is not mounted.
Removable	boolean	(Read-only) Indicates if the drive supports removable disks. Always returns False.
Searchable	boolean	(Read-only) Indicates if the disk participates in searches in the file system operations that specify a filename without specifying a device.
SearchOrder	integer	(Read-only) If the Searchable parameter is True, indicates the priority assigned to the disk when searching for a file and no device has been specified. A lower integer indicates a higher priority. If the Searchable parameter is False, this value is ignored.
Type	name	(Read-only) Always returns the value of /FileSystem.
Writeable	boolean	(Read-only) Indicates if the files on the disk can be opened for write access. If the disk is write protected, this parameter is a constant equal to False. When the disk is not mounted, this parameter indicates if the drive supports writeable media.
Device Parameters for the IODevice %flash1%		
BlockSize	integer	(Read-only)
Free	integer	(Read-only) Indicates the amount of free space available (in pages) on the flash. Valid if the flash is mounted (mounted is set to True). A value of 0 (zero) indicates that either the flash is not mounted or is full.

Table 4-11: PostScript Emulation Device Parameters (Continued)

Key	Type	Definition
HasNames	boolean	(Read-only) Indicates if the flash parameter is only valid when flash is mounted (mounted is set to True). If flash is not mounted, the parameter has a value of False.
InitializeAction	integer	Specifies an action for initializing flash: <ul style="list-style-type: none"> 0 Indicates no action; the value is returned when the parameter is read. 1 Indicates that the current file system should be deleted and a new one of PhysicalSize created (the flash must be formatted already). The flash must first be mounted; otherwise, an ioerror results. 2 Reformats the entire flash before creating a new file system of PhysicalSize 3 (or greater) has the same effect as the value 2 and also tests the flash x – 2 times Legal value: Any non-negative integer.
LogicalSize	integer	This parameter is not used for InitializeAction . InitializeAction always formats to PhysicalSize, regardless of what is specified in LogicalSize. A query returns the current size (in pages) of the file system on the device. A value of 0 (zero) indicates that the device is not mounted. Legal value: Any non-negative integer, including 0 (zero). The value of LogicalSize must be less than or equal to the value of PhysicalSize. A rangecheck error occurs if you try to set a larger value or set the value to 0 (zero).
Mounted	boolean	<ul style="list-style-type: none"> True System attempts to mount the flash. False System attempts to dismount the flash. When a device is mounted, it becomes known to the system and is readable, depending on the nature of the device. A device must contain a valid file system or it will not mount successfully. To verify if the device is currently mounted, query this parameter immediately after setting it.
PhysicalSize	integer	(Read-only) Indicates the size of the flash (in pages) for a flash that is mounted. A value of 0 indicates that the device is not mounted.
Removable	boolean	(Read-only) Indicates if the drive supports removable flash.
Searchable	boolean	(Read-only) Indicates if the flash participates in searches in file system operations that specify a filename without specifying a device.
SearchOrder	integer	(Read-only) If the Searchable parameter is True, indicates the priority at which the flash is searched for a file in operations where no device has been specified. A lower integer indicates a high priority. If the Searchable parameter is False, the value of this integer has no meaning.
Type	name	(Read-only) This constant always returns the value of /FileSystem.
Writeable	boolean	(Read-only) Indicates if the files on the flash can be opened for write access. A write-protected flash returns False. When the flash is not mounted, this parameter indicates if the device supports writeable media.

Table 4-11: PostScript Emulation Device Parameters (Continued)

Key	Type	Definition
Device Parameters for theIODevice %rom%		
BlockSize	integer	(Read-only)
Free	integer	(Read-only) Indicates the amount (in pages) of free space available in ROM. Valid only if the ROM is mounted (mounted is set to True). A value of 0 (zero) indicates that either the ROM is not mounted or it is full.
HasNames	boolean	(Read-only) Indicates if ROM supports named files. Valid only if ROM is mounted (mounted is set to True). If ROM is not mounted, this parameter has a value of False.
InitializeAction	integer	(Read-only) Always returns a value of 0 (zero), which indicates no action.
LogicalSize	integer	(Read-only)
Mounted	boolean	<p>True System attempts to mount the ROM. False System attempts to dismount the ROM.</p> <p>When a device is mounted, it becomes known to the system and is readable, depending on the nature of the device.</p> <p>A device must contain a valid file system or it will not mount successfully. To verify if the device is currently mounted, query this parameter immediately after setting it.</p> <p>If the ROM device is dismounted, unpredictable results occur.</p>
PhysicalSize	integer	(Read-only) Indicates the size of the ROM (in pages) that is mounted. A value of 0 (zero) indicates that the device is not mounted. This parameter is only valid when ROM is mounted.
Removable	boolean	(Read-only) Always False.
Searchable	boolean	(Read-only) Indicates if ROM participates in searches in file system operations that specify a filename without specifying a device.
SearchOrder	integer	(Read-only) If the Searchable parameter is True, indicates the priority assigned to the ROM when searching for a file and no device has been specified. A lower integer indicates a higher priority. If the Searchable parameter is False, the value of this integer has no meaning.
Type	name	(Read-only) Always returns the value of /FileSystem.
Writeable	boolean	(Read-only) Indicates if the files on the ROM can be opened for write access. Always False.

Status and Error Messages

Printers return PostScript emulation error messages and status information to the computer through any active interface. To send information to the computer through the parallel interface, configure the interface as bidirectional.

Tagged Binary Not Active

Your printer responds and processes a Ctrl+T (x'14') command as a status query when:

- The PostScript emulation interpreter is processing a print job.
- The printer is idle and the PostScript emulation interpreter is the selected interpreter.

Your printer responds and processes a Ctrl+T (x'14') command as normal data and *not* a status query when:

- Another interpreter is processing a print job.
- The printer is idle and another interpreter is the selected interpreter.

Notes:

- Status queries cannot be received while the printer is in an error state.
- Your printer *always* selects the PostScript emulation interpreter and processes a Ctrl+T (x'14') command as a status query when data is received through the LocalTalk interface.

Tagged Binary Active

When Tagged Binary is active, your printer *always* responds to a Ctrl+T (x'14') command as a status query and selects the PostScript emulation interpreter to process the current print job. Tagged Binary mode is immediately exited at the end of the print job.

Note: Status queries cannot be received while the printer is in an error state.

Status Messages

Your printer responds to a Ctrl+T (x'14') status query on an interface by sending a one-line status message back to the host computer over the same interface. If the status query is received between print jobs and the printer is idle with no error conditions, an idle response is returned to the host computer.

Status messages are bracketed by the characters `%%[` and `]%%`, so the computer software can extract them from other data generated by the current print job. They follow a standard syntax, consisting of one or more key-value pairs, separated by semicolons. For example:

```
%%[ job: Project Report; status: busy; source: Parallel ]%%
```

The following table lists the possible keys and value descriptions.

To determine which status message keys your printer supports, see Table C-7 on page C-26.

Table 4-12: Status Message Keys and Value Descriptions

Key	Value Description
job	The name of the print job, as stored in the JobName entry in statusdict . This field is omitted if the current print job has no defined JobName .
status	Printer activity at the time the message is sent: <ul style="list-style-type: none"> Idle No job in progress Busy Executing a PostScript emulation program and/or printing pages Waiting I/O wait in mid-job Initializing During startup Not ready Printer menus display or Not Ready displays.
source	Source of the job the server is executing: <ul style="list-style-type: none"> Serial Parallel Network USB LocalTalk Infrared Internal <p>This field is omitted if the server is idle.</p>

CHAPTER 5: Switching Languages

Your printer may support both PCL emulation and PostScript emulation. See your printer documentation for more information. This chapter describes ways to switch printer languages and explains when you may want to choose one method over another. SmartSwitch is provided with the printer to switch languages. Other methods of switching languages are:

- PJI ENTER LANGUAGE command
- Sniffing

SmartSwitch

The SmartSwitch feature lets the printer switch to either PCL emulation or PostScript emulation for each interface (parallel, serial, USB, or network). Your printer is shipped from the factory with **SmartSwitch** set to **On** for all languages and all interfaces. Consequently, the printer examines all print jobs coming into all its interfaces and switches between PostScript emulation and PCL emulation dynamically.

If a software program explicitly tells the printer which language to use by a PJI command, the printer always accepts and uses that explicit command, regardless of how SmartSwitch has been set from the printer operator panel.

If a software program does not explicitly tell the printer which language to use, the printer examines the incoming data stream and selects the language.

Setting SmartSwitch for Different Interfaces

You can customize your printer so that particular print jobs are sent to particular interfaces. For example, you may want to send all PostScript emulation jobs to the network interface and all PCL emulation jobs to the parallel interface. You can do so by choosing different languages for each interface from the printer operator panel or through MarkVision Professional and setting the selected language to On for the interface you want. See your printer documentation for more information.

If you have turned off a particular language for an interface, but then decide to send a job to that interface using that language, you *must* begin the job with a PJP command to override the settings you made from the printer operator panel or through MarkVision Professional. For example, if you set **PCL emulation** to **Off** for the serial interface and later decide to send a job in that language through that interface, you must preface the job with a PJP command to override the Off setting. Be sure to end the job with a Universal Exit Language (UEL) command, which is described on page 3-2.

Printer Job Language

For details on Printer Job Language (PJP) and the PJP ENTER LANGUAGE command, see “ENTER LANGUAGE Command” on page 3-3.

Sniffing

Sniffing is:

- Enabled when any End-of-Job point occurs.
- Disabled when a SIC or PJJL command within a valid printer language is received.

The printer examines the received data stream, attempts to determine the type of data stream, and automatically switches to the proper language.

The printer examines the active printer language and decides when an End-of-Job point occurs. End-of-Job points are:

- SIC command
- UEL command
- Print timeout
- Wait timeout
- PostScript timeout due to erasing the contents of an internal link
- Ctrl+D in PostScript or tagged binary
- INIT*
- Network Protocol Alliance Protocol job boundary

CHAPTER 6: Flash Memory and Disk

Flash memory and disk devices are used to store permanent fonts, macros, and symbol sets. The disk device is also used to buffer print jobs, collate large jobs, and store job statistics. Unlike RAM memory, these devices retain the following information when the printer is powered off, or when the printer switches languages:

- PCL emulation permanent bitmapped and scalable fonts
- PCL emulation permanent macros
- PCL emulation symbol sets
- PostScript Type 1 fonts
- Files created using the PostScript emulation file operators
- Demonstration files

Some printers have connectors that let you install optional flash memory or a disk device; other printers may offer one or the other of these devices as a standard feature. See your printer documentation for more information.

When first installed in the printer, the flash memory or disk may be unformatted. You must format the device before you download resources. A message displays on the printer operator panel or through MarkVision Professional if the device is unformatted.

Warning: When you format flash memory or a disk, all information currently stored on the device is lost.

If flash memory or a disk becomes full while downloading resources, a message displays on the printer operator panel or through MarkVision Professional. The file being downloaded is not saved unless room is available to store the entire file.

Resource Data Collection (Download Target)

Use the Resource Data Collection (Download Target) mode to save the following information to flash memory or disk:

- Permanent bitmapped and scalable fonts for PCL emulation
- Permanent macros for PCL emulation macros
- Permanent symbol sets for PCL emulation
- Type 1 fonts for PostScript emulation
- Other PostScript resources

Resource Data Collection can be turned On and Off by using:

- The operator panel menus to select **Download Target**.
- The MarkVision Professional printer utility. You can also download resources to flash memory and disk or format the flash memory or disk using this printer utility.
- A PJL command (see “LDOWNLOADTARGET” on page 3-30 and “LDOWNLOADTARGET Command” on page 3-86).

The download target (the destination for the resource data collection) may be RAM (the default), flash memory, or disk.

If you store resources (fonts, macros, or symbol sets) in RAM, the resources can be lost if the printer is reset or if the printer language changes while **Resource Save** is set to **Off**. In each case, the resources must be downloaded again. By storing resources on flash memory or disk, the resources become permanent in the printer.

Storing Resources on Flash Memory or Disk

Complete the following steps to download resources to flash memory or disk using the printer operator panel, MarkVision Professional, or a PJP command.

- 1 Set the download target to flash memory or disk.

Resource Data Collection mode is enabled to the device selected.

- 2 Download the resources to flash memory or disk using PCL emulation or PostScript emulation.

- PCL emulation collects and stores the currently defined font, macro, or symbol set information in printer RAM memory. These resources are written to flash memory or disk when Resource Data Collection is disabled (see step 3). Stored resources are also copied to flash memory or disk when a printer language switch occurs.
- PostScript emulation writes Type 1 fonts or other resources to flash memory or disk after successfully parsing a **definefont** operator.

- 3 Set Download Target to RAM.

Resource Data Collection mode is disabled.

Viewing the Contents of Flash Memory and Disk

There are three ways to view the contents of flash memory and disk:

- Send the PJP LPRINTDIRECTORY command (see “LPRINT Commands (Information Pages)” on page 3-83).
- Select **Print Directory** from the printer operator panel menus.
- Use the MarkVision Professional utility.

The directory lists the storage device (flash or disk), the names of the files, and the file size. See page 6-4 for a sample directory.

Example of Directory

The Directory that prints appears similar to the one below. An explanation of the parts of the Directory follows the example.

```

Optional Font Memory Size 1048576 bytes
Part Name:  FLASH
Part Number: (none)
Write password protected

```

ID	Type	Size	Prot.	Description
1000	PCL bitmap font	32140	W	ITClublnGrphBkOb
1002	PCL bitmap font	52550		Courier
1003	PCL scalable font	254491		CG Times
	PostScript font	134572		Courier
	User data	1000		My Program
	Demo	1000		My Demo
	Unknown file type	1000		My Unknown
248	PCL macro	10	R/W	
249	PCL macro	10		mydescription
9 files		476773 bytes used		
		0 bytes unavailable		
		571803 bytes free		

Optional Font Memory

Expression used to indicate flash memory or disk is installed.

Part Name

Part Name as it is stored in the flash memory card header. If flash memory is formatted by the printer, the part name field is shown as **FLASH**. The part name field for the disk is not printed.

Part Number

Part Number as it is stored in the flash memory card header. If the flash memory is formatted by the printer, the part number field is shown as (`none`). The part number field for the disk is not printed.

Write Password Protected

Indicates the entire flash memory or disk is write-protected.

If the device is read/write protected, "`Read/Write password protected`" is printed. If the device is write-protected, "`Write protected`" is printed. If the device is not protected, this line is blank.

For more information, see "File and Device Protection Commands" on page 3-93 and "Password Protection" on page 6-7.

ID

Valid for PCL emulation macros, fonts, and symbol sets only. The ID must be used when adding a description to a macro or a symbol set. If two files with the same file type have duplicate IDs, the following occurs:

- If multiple macros or symbol sets have been created with duplicate download IDs, only the last macro or symbol set is listed. It is the only one that can be selected. On flash memory, the number listed for `bytes unavailable` includes the unlisted macros and symbol sets. The `bytes unavailable` field is not applicable for the disk device.
- PostScript emulation fonts, and files created by PostScript emulation file operators, do not have IDs.

Type

File types that can be stored on flash memory or disk have unique extensions. The following file types are recognized by the flash format used on earlier printer models; the name of the file type printed in the directory appears in parenthesis.

- .t1 (PostScript font)
- .sFnt5 (PCL scalable font)
- .bFnt5 (PCL bitmap font)
- .Mac5 (PCL macro)

Except as noted below, file types listed above are recognized by the flash format used in your printer. In addition, the flash format in your printer also recognizes the following formats:

- .data (user data) - any file written with PostScript operators
- .type1 (PostScript font) - replaces the earlier .t1 extension
- .demo (demo) - used for demonstration printouts or forms
- .p5scalable (PCL scalable font)
- .p5bitmap (PCL bitmapped font)
- .p5macro (PCL macro) - replaces the earlier .Mac5 extension
- .p5symset (PCL symbol set)

Usually the PostScript file operators can only read/write files with the extension *.data*. Use the **setfilenameextend** operator to read/write other file types, including *.demo*. Any other file type appears in the list as Unknown File Type. The description column then contains the full filename with the file type (extension).

Size

The size listed for each resource includes the size of the file header.

Prot.

Indicates if the file is password protected.

- R/W** - read/write protection
- w** - write protection

If this field is blank, then this resource in flash memory or disk is not password protected.

For more information on file protection, see “File and Device Protection Commands” on page 3-93 and “Password Protection” on page 6-7.

Description

The description field for fonts comes from the font header. The description field for macros or symbol sets is blank unless the description field in the file header is set by the P_JL LRESOURCE command. See “Printer Unique LRESOURCE Variables” on page 3-52.

The description for macros or symbol sets can be set only once for files stored in flash memory. The description can be set any number of times for macros or symbol sets stored on a disk. The limitation for flash files is due to flash technology. See the “LDESCRIPTION” variable in “Table 3-9: Printer Unique LRESOURCE Variables” on page 3-53 for more information.

Password Protection

You can password protect either the entire flash memory or disk, or files stored on the flash memory or disk.

There are two levels of password protection:

Read/Write

Ensures that the file or device is protected against reading and writing unless the password has been appropriately specified (applies only to actual file data).

Write

Ensures that data cannot be changed on a file or device unless the password has been appropriately specified. A Read/Write password takes precedence over a Write password.

Each file or device can have a separate password. Write passwords ensure that files cannot be deleted, renamed, or updated and a device cannot be formatted or specified as a download target. Read/Write password protection provides the same protection as Write, but additionally ensures that data cannot be read from the file or device.

By using passwords, administrators can ensure data integrity and proper authorization. If flash memory is write password protected, for example, users cannot delete existing files, format the device, or download new files to the device (without first specifying the password). A specific example might be a macro file of an authorizing signature that is stored on flash memory with a Read/Write password. This password ensures that only those authorized can use the signature. All other files (fonts, letterhead, macros) can be unprotected for general use.

Passwords are set, declared, retracted, and deleted using the PjL commands or the MarkVision Professional utility. See “Protecting a File or Device” on page 3-93.

Rewriting the Flash Content

Be aware that once a bit on the flash memory is turned from 1 (binary 1) to 0 (binary 0), it cannot be changed back to binary 1 without a complete flash memory format. As PostScript emulation file operators write data to flash memory, the printer microcode software verifies that none of the bits being set to binary 1 is binary 0. If any attempt is made to change a 0 bit back to 1, a PostScript emulation **ioerror** occurs.

When a device is formatted, all locations are set to binary 1. This is also the reason descriptions and passwords can be set only once for files on flash memory.

Accessing Files with PostScript Emulation

File Naming Conventions

For any PostScript emulation operator that requires a filename parameter, the filename can be one of the following:

`%device%filename`

Specifically references a file on a particular device. If the filename does not exist on `%device%`, no other `%device%` is accessed for a duplicate filename.

`filename`

Does not specifically reference a device. The following action occurs:

- For the PostScript emulation operator **deletefile**, only the first device in the search order is checked for filename.
- For all other PostScript emulation operators, and all other combinations of search order and available devices, each installed `%device%` is checked in the search order for the existence of filename. The operator acts upon the first filename that it finds.

Device Names

The term *device* refers to flash memory, disk, or ROM. For PostScript emulation, some of the operators require or return device names. These operators are: **deletefile**, **filenameforall**, **devforall**, **devdismount**, **devmount**, **devformat**, **devstatus**. The device always begins and optionally ends with a `%` character. The following are the valid device names:

```
%rom%
%flash%
%flash1%
%disk%
%disk1%
```

The same filename can exist on more than one device. The device prefix determines the actual file to use. For example, `%rom%myfile` and `%flash%myfile` designate, respectively, a file called `myfile` both on the ROM and on flash memory. The device name distinguishes which file to use.

Device names are case sensitive. They must appear exactly as shown.

Each device (except the disk) has one synonym. For example, the flash memory can be referred to as `%flash%` or `%flash1%`. The name with the `1` is a unique identifier. This system allows for future expansion of multiple flash memory or disk devices. The disk device name provides for multiple physical units and multiple logical units. Thus, `%disk1_0%` indicates the first physical unit and the first (`0`) logical partition on the device. Currently, one physical device (for ROM, flash memory, and disk) is supported. The disk supports only the first (`0`) logical partition.

Filenames

Each file on a device has a unique name to identify the information contained within the file. The name may be up to 127 characters in length. All character codes from X'01' to X'FF' are valid (X'00' is not valid). Filenames are case sensitive: for example, `%flash%myfile` and `%flash%MYFILE` indicate different files on the flash memory.

Filename Extensions

By default, all files referenced when using the PostScript emulation file operators are given a `.data` extension. For example, if the following PostScript emulation command occurs,

```
(%flash%myfile) (w) file
```

the file `myfile.data` is opened on flash memory. The `.data` extension is added to:

- Enable the Print Directory feature to identify files as PostScript emulation data files.
- Ensure the integrity of files, such as resource collection files and demonstration files.

However, it is sometimes necessary to access files by their *real* name through PostScript emulation. For example, you may want to remove old versions of PCL language resource collection fonts (without formatting the entire device).

To do this, use the PostScript emulation **setfilenameextend** operator. This operator is in the **statusdict** dictionary.

The value of this operator adds the extension *.data* to all filenames referenced when using PostScript emulation file operators. To prevent the *.data* extension from being added, issue the following PostScript emulation command:

```
statusdict begin
  false setfilenameextend
end
```

To add the *.data* extension automatically again, issue:

```
statusdict begin
  true setfilenameextend
end
```

The following example shows how to remove a file for the font *myfont* from the disk. The PostScript emulation resource collection filename is *myfont.type1*. The PostScript emulation command to remove the file is:

```
statusdict begin
  false setfilenameextend
  (%disk%myfont.type1) deletefile
  true setfilenameextend
end
```

For other file types, see page 6-6.

Note: We recommend that you enable **setfilenameextend** as soon as possible after you disable it. For example, the following PostScript emulation commands generate an **undefinedfilename** error:

```
(%disk%iconimage) (w) file dup
(0f0606060686c6ff) writestring closefile
statusdict begin
false setfilenameextend
end
(%disk%iconimage) (r) file
%%[ Error: undefinedfilename; OffendingCommand: file ]%%
```

This occurs because the filename actually written to disk is *iconimage.data*. When **setfilenameextend** is enabled (the default), all PostScript emulation file operators treat filename operands as *filename.data*; when disabled, they treat filename operands literally.

If you receive unexpected **undefinedfilename** or similar errors, try toggling **setfilenameextend** and sending your print job again.

Device Search Order

If you are using the PostScript emulation operators **run**, **file**, **renamefile**, **status** or **eexec**, you do not need to specify the device. If you omit the device name, devices are searched in the default order: disk and then flash memory. If the following PostScript emulation code is encountered,

```
(myfile) (w) file
```

the file on disk is used (since disk occurs before flash memory in the default search order), and files cannot be created in ROM.

The operator **deletefile** searches only the first device in the default search order if a device is not specified.

Use the PostScript emulation operators **devmount**, **devdismount** to change the order. The default search order is determined by the order the devices are mounted. For example, if you want to place the disk device after the flash memory in the default search order, use the following command sequence:

```
(%disk%) devdismount
(%disk%) devmount
```

To change the order so the devices are searched as disk, flash memory, and then ROM, use the following PostScript emulation command sequence:

```
(%rom%) devdismount
(%flash%) devdismount
(%disk%) devdismount
(%disk%) devmount
(%flash%) devmount
(%rom%) devmount
```

If the device is already mounted, the following operators may change the search order:

- **initializedisk**
- **devformat**
- `<</InitializeAction>>setdevparams`

Sending these operators has the following effect on the devices in the search order:

- 1** If mounted, `(%device%) devdismount`
- 2** Formats the device
- 3** If dismounted in step 1, `(%device%) devmount`

If you do not want a device searched, dismount it and leave it dismounted.

Note: *Do not* leave the ROM device unmounted. All internal fonts are contained on the ROM device.

In the previous examples, the **devmount**, **devdismount** operators must be used outside the server loop. We recommend that you place the requests in a **stop** context so that if the devices do not exist, error recovery can take place.

Previous search orders are not retained. Once a change is made, it remains in effect.

Performance

Some performance degradation may occur during initial access to a resource on a disk (as opposed to flash memory or RAM). However, the information is put in cache, and further references to that resource occur at RAM speed.

Table 6-1: Device Performance Retrieval Speeds

Device	Retrieval Speed	Write
Disk	70KB/second	70KB/second
Flash Memory	1MB/second	200KB/second

Job Buffering

Job buffering to the disk lets you store incoming print jobs on a disk installed on your printer. Although job buffering is designed for individual workstations and networks using MarkVision Professional as the primary tool to control printer operations, you can handle some job buffering functions from the printer operator panel. See your printer documentation for more details.

Job buffering requires a minimum of 10 percent of disk storage space. For example, if you have an 840MB hard disk installed, you must partition a minimum of 84MB of the disk for job buffering. You must define the size of the job buffer area before you enable buffering for any link ports.

For minimum acceptable job buffering performance, the hard disk should be able to read and write files at a sustained rate of 600Kb/sec. The Lexmark hard disk option supports this requirement.

Some advantages of job buffering include:

- The printer accepts print jobs more quickly.
- The printer accepts print jobs from all ports as long as the disk is not filled.
- The printer continues to print even after the host computer, network connection, or printer server goes down.
- Buffered jobs print when power is restored after a printer power loss.
- The printer manages print jobs from multiple sources.

Keep in mind that job buffering may also:

- Slow system performance.
- Restrict the amount of memory available on the disk for other uses.
- Increase the time required for a printer reset or recovery after a power loss.
- Reprint jobs after a power-on reset (POR).

Creating a Partition

Before job buffering is enabled for a port, you must allocate a portion of the disk for job buffering functions. The minimum size for a job buffering partition is 10 percent of the disk storage space. When a new partition is created, the entire disk is formatted and all resources previously downloaded to the disk are lost.

Once a partition is defined, this disk space is reserved for job buffering.

Enabling Job Buffering

Once a partition is allocated, job buffering to a disk may be enabled for each active link port. You can enable job buffering from the operator panel menus, if available, or through MarkVision Professional. You cannot enable a port before the partition is allocated. When buffering is enabled from the printer operator panel, a power-on reset (POR) automatically occurs. If buffering is enabled through MarkVision Professional, you must perform a full power-on reset before job buffering can occur.

Disabling Job Buffering

When you disable job buffering, it takes effect immediately on the port you disabled. A POR is automatically performed when job buffering is disabled for any port from the printer operator panel or through MarkVision Professional, so the unused memory resources can be reallocated. When buffering is disabled on a port, any jobs on the disk are printed before normal processing of incoming jobs continues.

To delete or resize a job buffer partition, first delete or print all jobs. Then, disable job buffering on all ports. Finally, delete or resize the job buffer partition.

Recovering from a Power Loss

If the printer loses power, the job being spooled to the disk may be lost. Jobs already stored on the disk remain intact. When power is restored, you are asked if you want to print the jobs held in the buffer. See your printer documentation for information on how to cancel the jobs or print the jobs held in the buffer.

Jobs that were partially printed during the loss of power are printed again in their entirety when power is restored.

CHAPTER 7: Printer Specifications

This chapter lists printer specifications and information about hardware, environmental conditions, and power requirements.

Airflow Requirement

Room should meet ASHRAE 62–1989 standards.

Noise Emission Levels

The following measurements were made in accordance with ISO 7779 and reported in conformance with ISO 9296.

Table 7-1: Noise Emission Levels

Status	1-Meter Average Sound Pressure, dBA			
	C520, C522n, C524, C524n, C524dn	C530dn, C532n, C534n, C534n, C534dn, C534dtn	C770, C770n C772, C772n	C920, C920n, C920dn, C920dnf
Printing	51 dBA	53 dBA (mono) 51 dBA (color)	52 dBA	53, 55, 55
Duplex printing	52dBA	53 dBA	57 dBA	55, 58, 58
Standby (Idle without Power Saver)	32 dBA	31 dBA	30 dBA	30
Status	Declared Sound Power Level, Bels			
	C520, C522n, C524, C524n, C524dn	C530dn, C532n, C534n, C534n, C534dn, C534dtn	C770, C770n C772, C772n	C920, C920n, C920dn, C920dnf
Printing	6.5B	6.7B (mono) 6.6B (color)	6.5 B	55
Duplex printing	6.6B	6.7B		58

Electrical Specifications

Table 7-2: Printer Electrical Specifications

Printer Model	Electrical Specification
C520, C522n, C524, C524n, and C524dn (low voltage model)	110–127 VAC at 47-63Hz, nominal 99–137 V, extreme
C520, C522n, C524, C524n, and C524dn (high voltage model)	220–240 V at 47-63 Hz, nominal 198–259 V, extreme
C530dn, C532n, C532dn, C534n, C534dn, and C524dtn (low voltage model)	110-127 V at 47-63 HZ 99-137 V extreme
C530dn, C532n, C532dn, C534n, C534dn, and C534dtn (high voltage model)	220-240 V at 47-63 Hz 198-259 V extreme
C770, C770n, C772, C772n (low voltage model)	110-127 VAC at 47-63 Hz 99-137 VAC, extreme
C770, C770n, C772, C772n (high voltage model)	220-240 VAC at 47-63 Hz 198-259 VAC, extreme
C920, C920n, C920dn, C929dnf (low voltage model)	110-127 V at 50-60 Hz nominal 99-135 V, extreme
C920, C920n, C920dn, C929dnf (high voltage model) ¹	220-240 V at 50-60 Hz nominal 198-254 V, extreme
¹ Using 220-110 power converter with 110 V printer is not recommended.	

Warning: Lexmark recommends that you do not use voltage converters with printers.

Power Requirements

The following tables list the nominal average power requirements (including fuser power).

Table 7-3: C520n, C522n, C524, C524n, C524dn, C524dtn average power requirements

Printing states	C520n, C522n	C524	C524n, C524dn	C524dtn
Average power while printing				
Base printer	350 W	350 W	350 W	350 W
All options	350 W	350 W	350 W	350 W
Average power while idle				
Power Saver on	<16 W	<18 W	18 W	18 W
Power Saver off	105 W	105 W	105 W	105 W
Max current while printing				
100 V	2 A	4.5 A	4.5 A	4.5 A
110 V	4 A	4 A	4 A	4 A
2210 V	4.5 A	2 A	2 A	2 A

Table 7-4: C530dn, C532n C532dn, C534n, C534dtn nominal average power requirement

Printing states	C530n	C532n	C534n, C534dn	C534dtn
Average power while printing				
Base printer	350 W	350 W	350 W	350 W
All options	350 W	350 W	375 W	375 W
Average power while idle				
Power Saver on	<16 W	<16 W	<18 W	<18 W
Power Saver off	105 W	105 W	105 W	105 W
Max current while printing				
100 V	4.5 A	4.5 A	4.5 A	4.5 A
110 V	4 A	4 A	4 A	4 A
2210 V	2 A	2 A	2 A	2 A

Table 7-5: C770, C770n, C772, C772n nominal average power requirements

Printing states	C770	C770n	C772	C772n
Average power while printing				
Base printer	650 W	650 W	650 W	650 W
All options	700 W	700 W	700 W	700 W
Average power while idle				
Power Saver on	30 W	30 W	30 W	30 W
Power Saver off	190 W	190 W	190 W	190 W
Max current while printing				
100 V	12.3 A	12.3 A	12.3 A	12.3 A
110 V	10.2 A	10.2 A	10.2 A	10.2 A
220 V	5.2 A	5.2 A	5.2 A	5.2 A

Table 7-6: C920, C920n, C922, C922n Nominal Average Power Requirements

Printing states	C920b	C920n	C920dn	C920dnf
Average power while printing				
Continuous mono	400W	400W	410W	410W
Continuous color	290W	290W	300W	300W
Average power while idle				
Power Saver on	13W	14W	15W	15W
Power Saver off	125W	125W	125W	125W
Max current while printing				
120 V	11A	11A	11A	11A
230 V	6A	6A	6A	6A

.Physical Specifications

Table 7-7: C520, C522n, C524, C524n, C524dn, C530dn, C532n, C532dn, C534n, C534dn, C534dtn, C770, C770n, C772, C772n Dimensions

	Height	Width	Depth	Weight
C520n, C522n, C524, C524n C524dn Basic printer (no extensions)	484mm (19 in.)	440mm (17.3 in.)	408mm (16.1 in.)	57.0 lbs 58.75lbs for dn model only
Printer with output bin installed	484mm (19 in.)	440mm (17.3 in.)	512mm (20.2 in.)	
Printer without toner cartridges	484mm (19 in.)	440mm (17.3 in.)	408mm (16.1 in.)	49.5 lbs
C524dtn Printer, Duplex Unit, 500-Sheet Drawer	610mm (24 in.)	440mm (17.3 in.)	558mm (22 in.)	64.0 lbs
500-Sheet Drawer Drawer only - no printer	127mm (5 in.)	420mm (16.5 in.)	518mm 20.4"	7.0 lbs
Printer with 500 sheet drawer (same as dtn model)	610mm (24 in.)	440mm (17.3 in.)	558mm (22 in.)	64.0 lbs
MPF Configuration Printer with Multipurpose feeder extended (& output bin installed)	484mm (19 in.)	440mm (17.3in.)	676mm (26.6 in.)	
Primary Tray Configuration Printer with paper adjuster extended in the back (& output bin installed)				2.1 lbs
A4/letter size media	484mm (19 in.)	440mm (17.3 in.)	512mm (20.2 in.)	
Legal size media	484mm (19 in.)	440mm (17.3 in.)	540mm (21.3 in.)	
Note: A buffer of 12 inches is needed on the back of the printer				

Table 7-7: C520, C522n, C524, C524n, C524dn, C530dn, C532n, C532dn, C534n, C534dn, C534dtn, C770, C770n, C772, C772n Dimensions

	Height	Width	Depth	Weight
C530n, C532n, C532dn, C5324n, c534dn basic (no extensions)	484 mm (19 in.)	40 mm (17.3 in.)	408 mm (16.1 in.)	57 lb (58.75 lbs C532dn and C534dn)
C530n, C532n, C532dn, C534n, c534dn output bin installed	484 mm (19 in.)	40 mm (17.3 in.)	512 mm (20.1 in.)	49.5 lb
C530n, C532n, C532dn, C534n, c534dn without toner cartridges	484 mm (19 in.)	440 mm (17.3 in.)	408 mm (16.1 in.)	49.5 lb
C534dtn duplex unit, 550-sheet drawer	610 mm (24 in.)	440 mm (17.3 in.)	558 mm (22 in.)	64 lbs
C770, C770n, C772, C772n	528.3 mm (20.8 in.)	604.5 mm (23.8 in.)	469.9 mm (18.5 in.)	47.7 kg (105 lb)
C770n, C772n (including duplex option)	617.2 mm (24.3 in.)	604.5 mm (23.8 in.)	469.9 mm (18.5 in.)	47.7 kg (105 lb)
C770n, C772n (including duplex unit and optional 500-sheet drawer)	734.1 mm (28.9 in.)	604.5 mm (23.8 in.)	469.9 mm 18.5 in.	60 kg (132 lb)
C772, C772n (maximum input trays including duplex unit, three optional 500-sheet drawers, and printer stand)	1051.6 mm (41.4 in.)	604.5 mm (23.8 in.)	649.9 mm (18.5 in.)	81.4 kg (179.0 lb)
C772 (with maximum input sheets including duplex unit, optional 500-sheet drawer, and 2000-sheet drawer)	1104.9 mm (43.5 in.)	604.5 mm (23.8 in.)	604.5 mm) (23.8 in.)	82.3 kg (181 lb)
Options				
500-sheet drawer	127 mm 5 in.	604.5 mm (23.8 in.)	649.9 mm (18.5 in.)	6.1 kg (13.5 lb)
500-sheet tray	96.5 mm (3.8 in.)	396.2 mm (15.6 in.)	386.1 mm (15.5 in.)	1.2 kg (2.6 lb)
Duplex option	88.9 mm (3.5 in.)	604.5 mm 23.8 in.	669.9 mm (18.5 in.)	6.1 kg (13.5 lb)

Table 7-7: C520, C522n, C524, C524n, C524dn, C530dn, C532n, C532dn, C534n, C534dn, C534dtn, C770, C770n, C772, C772n Dimensions

	Height	Width	Depth	Weight
2,000-sheet tray (including stabilizer bars)	391.2 mm (15.4 in.)	660.4 mm (26 in.)	604.5 mm (23.8 in.)	22.3 kg (49 lb)
Outdoor media drawer	127 mm (5 in.)	604.5 mm (23.8 in.)	469.9 mm (18.5 in.)	6.1 kg (13.5 lb)
Banner Tray (including output bail)	228.6 mm (9 in.)	304.8 mm (12 in.)	774.7 mm (30.5 in.)	3.3 kg (7.2 lb)
Envelope drawer	127 mm (5 in.)	604.5 mm (23.8 in.)	649.9 mm (18.5 in.)	6.1 kg (13.5 lb)
Output xpander	177.8 mm (7 in.)	368.3 mm (14.5 in.)	649.9 mm (18.5 in.)	2.5 kg (5.4 lb)
5-bin mailbox	292.1 mm (11.5 in.)	368.3 mm (14.5 in.)	469.9 mm (18.5 in.)	4.0 kg (8.7 lb)
StapleSmart Finisher	228.6 mm (9 in.)	447.7 mm (17.6 in.)	495.3 mm (19.5 in.)	5.6 kg (13 lb)
Printer stand (including stabilizer bars)	101.6 mm (4 in.)	673.1 mm (26.5 in.)	609 mm (24 in.)	9.1 kg 20 lb

Table 7-8: C920, C920n, C920dn, C920dtn Dimensions

	Height	Width	Depth	Weight
C920, C920n	512 mm (20.2 in.)	695 mm (27.4 in.)	705 mm (28.in.)	80.5 kg (177.1 lb)
C920dn	512 mm (20.2 in.)	695 mm (27.4 in.)	705 mm (28.in.)	86.4 kg (190.2 lb)
C920dtn	641 mm (25.2 in.)	695 mm (27.4 in.)	705 mm (28.in)	104.9 kg (231 lb)

Clearance Requirements

Table 7-9: C520, C522n, C524, C524n, C524dn, C770, C770n, C772, C772n C920, C920n, C920dn, C920dtn

	Left side	Right Side	Front	Rear	Top
C520, C522n, C524, C524n	565 mm (22.24 in.)	565 mm (22.24 in.)	644 mm (25.35 in.)	644 mm (25.35 in.)	565 mm (22.24 in.)
C524dn	565 mm (22.24 in.)	565 mm (22.24 in.)	644 mm (25.35 in.)	644 mm (25.35 in.)	565 mm (22.24 in.)
C524dtn	565 mm (22.24 in.)	565 mm (22.24 in.)	644 mm (25.35 in.)	644 mm (25.35 in.)	775 mm (30.5 in.)
C530dn, C532n, C532dn, C534n, C534dn, C534dtn	565 mm (22.24 in.)	565 mm (22.24 in.)	644 mm (25.35 in.)	644 mm (25.35 in.)	565 mm (22.24 in.)
C770, C770n C772, C772n	609.6 mm (24 in.)	381 mm (15 in.) ¹	508 mm (20 in.)	304.8 mm (12 in.)	1,0668 mm ² (42 in.)
C920, C920n, C922, C922n Printer	330 mm (13 in.)	330 mm (13 in.)	686 mm (27 in.)	127 mm (5 in.)	229 mm (9 in.)
C920, C920n, C922, C922n Duplex	330 mm (13 in.)	330 mm (13 in.)	686 mm (27in.)	127 mm (5 in.)	229 mm (9 in.)
C920, C920n, C922, C922n High capacity feeder ³	330 mm (13 in.)	153 mm (6 in.)	762 mm (30 in.)	127 mm (5 in.)	229 mm (9 in.)
C920, C920n, C922, C922n Finisher	330 mm (13 in.)	153 mm (6. in.)	686 mm (27 in.)	127 mm (5 in.)	686 mm (27 in.)
C920, C920n, C922, C922n Banner media tray ³	330 mm (13 in.)	1168 mm (46 in.)	686 mm (27 in.)	127 mm (5 in.)	229 mm (9 in.)
C920, C920n, C922, C922n					

¹Allow 1,219.2 mm (48 in.) clearance to the left for banner option to C772.

²Allow clearance above the printer for front door clearance and for adding options such as additional input drawers, output expander, StapleSmart finisher, or 5-bin mailbox.

³Required clearance is 330 mm (13 in.) without HCF and 762 mm (30 in.) with HCF.

Environmental Conditions

Note: When shipping or storing printers, always pack the printer supplies (cartridges and photoconductors, for example) separately.

Table 7-10: Air Temperature Ranges

Printer Model	Operating Value	Shipping/Storage Value
C520, C522n, C524, C524n, C524dn	15.6–32.20°C (60–90°F)	10-32.20°C (50-110°F)
C530dn, C532n, C532dn, C534n, C534dn, C534dtn	10-43.3° C (50-110°)	-40-40°C (-40-104° F)
C770, C770n, C772, C772n	15.6-32.2° C (60-90° F)	-40-40°C (-40-104° F)
C920, C920n, C920dn, C920dnf	10–30°C (50–91°F)	0 to 35°C (32 to 92°F)

Table 7-11: Humidity Ranges

Printer Model	Operating Value	Shipping/Storage Value
C520, C522n, C524, C524n, C524dn	8–80%	5–95%
C530dn, C532n, C532dn, C534n, C534dn, C534dtn	8-80%	8-80%
C770, C770n, C772, C772n	8-80%	8-80%
C920, C920n, C920dn, C920dnf	20-80%	20-90%

Altitude Specifications

Table 7-12: Printer Altitude Specifications

Printer Model	Altitude (Above Sea Level)
C520, C522n, C524, C524n, C524dn	10,300 meters (34,000 ft.)
C530dn, C532n, C532dn, C534n, C534dn, C534dnt	10,300 meters (34,000 ft.)
C770, C770n, C772, C772n	10,300 meters (34,000 ft.)
C920, C920n, C920dn, C920dnf	0-2300 meters (7,545 ft)

Atmospheric Pressure

74.6 kPa

CHAPTER 8: Printer Interfaces

Interfaces connect your printer to other devices, such as a computer. Some Lexmark printers have a standard parallel connector (also referred to as a *Centronics*-type interface) and/or a USB connector. Some Lexmark printers have an internal print server and a USB connector. Some printers also offer a parallel interface option. See your printer documentation for more information. See page 8-7 for more information about parallel interface.

If a serial connector is required, you may be able to install an RS-232C Serial/Parallel 1284-C Interface Card. See page 8-18 for more information about serial interface.

Some printers have standard print servers, but you can also buy optional print servers that connect the printer to Token-Ring or Ethernet networks. For detailed installation or setup instructions, see your printer documentation or the *Software and Documentation* CD. See “Network Support” on page 8-28 for more information about print servers.

See your printer documentation for information on which printer interface options your printer supports and for detailed installation instructions.

Note: All print servers are capable of supporting AppleTalk.

Setting Up the Communications Port

You must establish communication between your printer and computer. To do this, you define your communications port in the application you are using. Instructions for several applications or operating systems are as follows.

Setting Up the Communications Port Using Windows 95/98/Me

In your Windows 95/98/Me application:

- 1 On the Menu bar, click **Start**.
- 2 Click **Settings**.
- 3 Click **Control Panel**. The Control Panel screen appears.
- 4 Double-click the **System** icon. The System Properties screen appears.
- 5 Click the **Device Manager** tab.
- 6 Scroll down to Ports and click the + once to expand the list of available Ports.
- 7 Double-click the communications port you want to configure.
- 8 Click the **Properties** button at the bottom of the screen.

The Communications Port Properties screen for this specific port displays. For example, if you select the COM1 port, then the Communications Port [COM1] Properties screen displays.

- 9 Click the **Port Settings** tab.
- 10 Fill out the fields for the following printer settings to make them match your printer settings:
 - Bits per second
 - Data bits
 - Parity
 - Stop bits
 - Flow Control

Note: For Flow Control, select Hardware if you want DTR protocol or Xon/Xoff for Xon/Xoff protocol.

- 11 Click **OK**.
- 12 Close all windows now that the port is set up.

Setting Up the Communications Port Using Windows NT 4.0

In your Windows NT 4.0 application:

- 1 On the Menu bar, click **Start**.
- 2 Click **Settings**.
- 3 Click **Control Panel**. The Control Panel screen appears.
- 4 Double-click the **Ports** icon. The Ports screen appears.
- 5 Select the communications port you want to configure.
- 6 Click the **Settings** button.

The Settings screen for this specific port displays. For example, if you select the COM1 port, then the Settings for COM1 screen displays.

- 7 Fill out the fields for the following printer settings to make them match your printer settings:
 - Baud Rate
 - Parity
 - Stop bits
 - Flow Control

Note: For Flow Control, select Hardware if you want DTR protocol or Xon/Xoff for Xon/Xoff protocol.

- 8 Click **OK**.
- 9 Close all screens now that the port is set up.

Setting Up the Communications Port Using Windows 2000

In your Windows 2000 application:

- 1 On the Menu bar, click **Start**.
- 2 Click **Settings**.
- 3 Click **Control Panel**. The Control Panel screen appears.
- 4 Double-click the **System** icon. The System Properties screen appears.
- 5 Select the **Hardware** tab.
- 6 In the Device Manager area of the Hardware tab screen, click the **Device Manager** button. The Device Manager screen appears.
- 7 Scroll down to Ports and click the + once to expand the list of available Ports.
- 8 Select the communications port you want to configure and double-click.

The Communications Port Properties screen for this specific port displays. For example, if you select the COM1 port, then the Communications Port [COM1] Properties screen displays.

- 9 Click the **Port Settings** tab.
- 10 Fill out the fields for the following printer settings to make them match your printer settings:
 - Bits per second
 - Data bits
 - Parity
 - Stop bits
 - Flow Control

Note: For Flow Control, select Hardware if you want DTR protocol or Xon/Xoff for Xon/Xoff protocol.
- 11 Click **OK**.
- 12 Close all windows now that the port is set up.

Setting Up the Communications Port Using Windows XP

In your Windows XP application:

- 1 On the Menu bar, click **Start**.
- 2 Click **Control Panel**. The Control Panel screen appears.
- 3 Switch the Control Panel to Classic View.
- 4 Click the **Hardware** tab.
- 5 In the Device Manager area of the Hardware tab screen, click the **Device Manager** button. The Device Manager screen appears.
- 6 Scroll down to Ports and click the + once to expand the list of available Ports.
- 7 Select the communications port you want to configure and double-click.

The Communications Port Properties screen for this specific port displays. For example, if you select the COM1 port, then the Communications Port [COM1] Properties screen displays.

- 8 Click the **Port Settings** tab.
- 9 Fill out the fields for the following printer settings to make them match your printer settings:
 - Bits per second
 - Data bits
 - Parity
 - Stop bits
 - Flow Control

Note: For Flow Control, select Hardware if you want DTR protocol or Xon/Xoff for Xon/Xoff protocol.
- 10 Click **OK**.
- 11 Close all windows now that the port is set up.

Deciding Which Interface to Use

On some printers, you can attach multiple interface cables to the printer at the same time. The printer automatically switches to the interface receiving a job. Then it prints the job and begins searching the interfaces for the next job.

One or more of the following is built into your printer: a standard parallel connector, a USB connector, or a network connector. To use a port, connect a cable from the printer to the computer, then set the appropriate values from the printer operator panel or, for network connected printers only, through MarkVision Professional. See your printer documentation for more information.

Use a parallel interface when you:

- Attach your printer to a personal computer.
- Attach your printer to a host system with a Centronics-compatible parallel port.
- Attach your printer to a Lexmark external print server.

Use a USB interface when you:

- Attach your printer to a personal computer, iMac, Sun Ray, or Sun Blade.
- Need to connect the printer to a computer that does not have an available parallel port.

Use a serial interface when you:

- Require an interface cable more than 10 feet in length.

Note: Lexmark also offers a 20-ft parallel interface cable (part number 1427498).

- Need to connect the printer to a computer that does not have an available parallel port.

Attach network cables to the Token-Ring or Ethernet print servers installed in your printer. Refer to the *MarkNet™ Quick Start* book or your user documentation for additional setup information.

Parallel Interface

Use the Lexmark 3.04 m (10 ft) parallel cable part number 1021231, or a cable that is IEEE 1284 compliant, to connect your printer to a personal computer or to a host system with a Centronics-compatible parallel port. See your printer documentation for the location of the printer parallel connector.

Note: To reset your printer with an INIT* signal, set **Honor Init** to **On** from the printer operator panel or through MarkVision Professional. See your printer documentation for more information.

Your printer can communicate with a computer across the parallel interface in three ways:

Computer to Printer

This is typically how a computer and printer communicate. When the printer is receiving data from the computer, it can use either *Standard* or *Fastbytes* protocol. The burst transfer rate in Fastbytes is faster than in Standard protocol. For best throughput, use Fastbytes protocol.

Printer to Computer (Advanced Status)

Your printer can send data to the computer. This capability lets the printer send status messages to the computer on the parallel interface.

Parallel Modes 1 and 2

These are printer features that enhance reliability of data transfer from the host computer to the printer. See “Parallel Mode 1” on page 8-14 and “Parallel Mode 2” on page 8-15 for more information.

Standard Parallel Connector

The standard IEEE 1284-B compliant parallel connector on the printer is a 36-pin D-shell female receptacle, as shown.

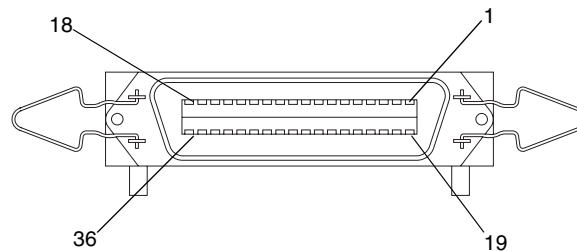

Using the INIT* Signal to Initialize

When the printer is using the parallel interface and it receives an INIT* signal, it initializes as follows (unless INIT* is disabled by a variable default setting):

- It prints data received before INIT*, and then initializes.
- It returns variable defaults to the values stored in the user default settings.
- It returns fixed default settings to the factory values.
- It retains permanent downloaded fonts and macros, but deletes temporary downloaded fonts and macros.
- The link buffer remains intact.
- Variable default paper size settings become the active paper formatting size.
- If paper is loaded in a tray with auto size sensing, the printer resets the active default paper formatting size to the size of the paper in the tray.
- INIT* is not honored when Hex Print is active.
- INIT* causes the parallel interface to go busy. The printer processes INIT* when the parallel interface becomes active and all preceding characters have been processed.

Computer-to-Printer Communications

This section describes how the parallel interface receives data from the computer.

Standard Parallel Connector

The cabling in the following illustration supports Standard and Fastbytes protocols and IEEE 1284 Nibble, Byte, and ECP protocols.

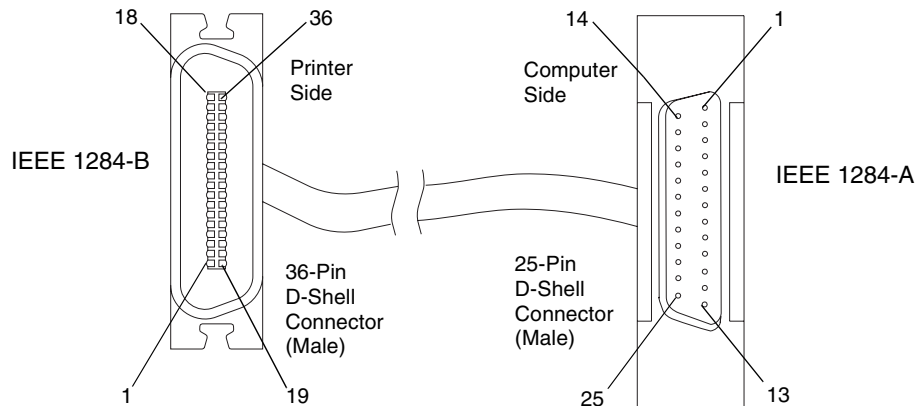

The following illustration shows the pin assignments for connecting the 25-pin connector to the 36-pin connector. The symbol * indicates an active low signal.

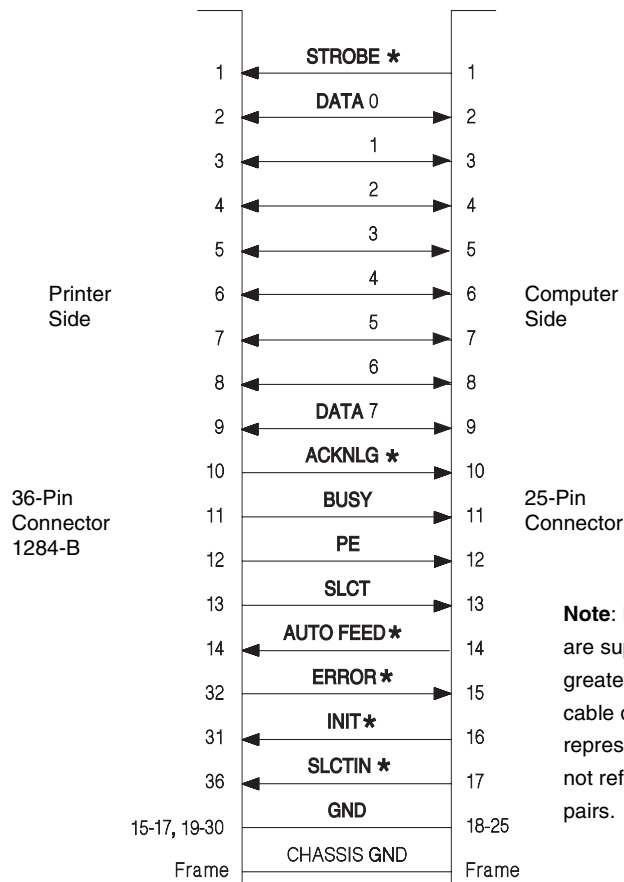

Note: Lexmark IEEE 1284 compliant cables are supported up to 20 feet. Cable lengths greater than 20 feet are not supported. The cable drawing to the left is a functional representation of the Lexmark cables; it does not reflect correct pairing of leads or unused pairs.

The parallel interface consists of an 8-bit parallel data bus with the following characteristics:

- Uses 17 of the 36 positions on the printer connector, as follows:
 - The host system controls 12 lines, which it uses to send data and commands to the printer.
 - The printer controls five lines. The printer uses two lines to notify the computer when data is transferred successfully and three lines to report printer status.
- Controls synchronization with an externally supplied STROBE* pulse.
- Controls data flow control with BUSY and ACKNLG* signals. Does not carry out data transfer by ignoring the BUSY or ACKNLG* signal. (The system can carry out data transfer to the printer only when the level of the BUSY signal is low and after confirming the ACKNLG* signal is high.)
- Uses standard transistor-transistor logic (TTL) levels for all interface control signals and input data. Interface conditions are based on TTL levels. All printer outputs are totem-pole TTL devices. All printer input/output (I/O) are devices with an internal pull-up resistor to 5 V. Rise and fall times of each signal must be less than 1,500 nanoseconds (ns) without slope reversal.

Note: For best results, use the Lexmark 1.83 m (6 ft) parallel cable, part number 11K4078.

Standard Protocol Data Transfer Sequence

The following illustration shows the typical data transfer sequence on the parallel interface. See Table 8-1 for typical parallel interface timings on the parallel interface.

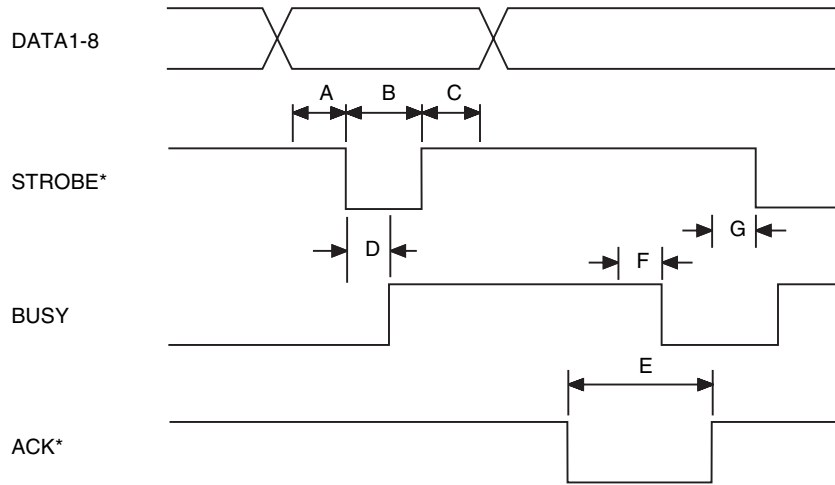

Table 8-1 shows all protocol timings in nanoseconds.

Table 8-1: Typical Parallel Interface Timings

Time	Name	Minimum/Maximum
A	Data setup to STROBE* low	500 min.
B	STROBE* width	500 min.
C	Data hold after STROBE*	500 min.
D	STROBE* low to BUSY high	500 max.
E	ACKNLG* low until ACKNLG* high	500 min.
F	ACKNLG* high to BUSY low ¹	—
G	BUSY low and ACKNLG* high to STROBE* low	500 min.
¹ Relationship of ACKNLG* and BUSY is not consistent		

Fastbytes Protocol Data Transfer Sequence

Your printer is equipped with *Fastbytes* protocol, which is an enhanced parallel interface protocol. Fastbytes protocol may give you a faster data transfer time on some personal computers and operating systems. Fastbytes protocol is the printer default.

If you have data transmission problems between your personal computer and the printer, change the parallel protocol to *Standard*. This causes the printer to operate in IEEE-compliant compatibility mode.

The following illustration shows the typical timing sequence.

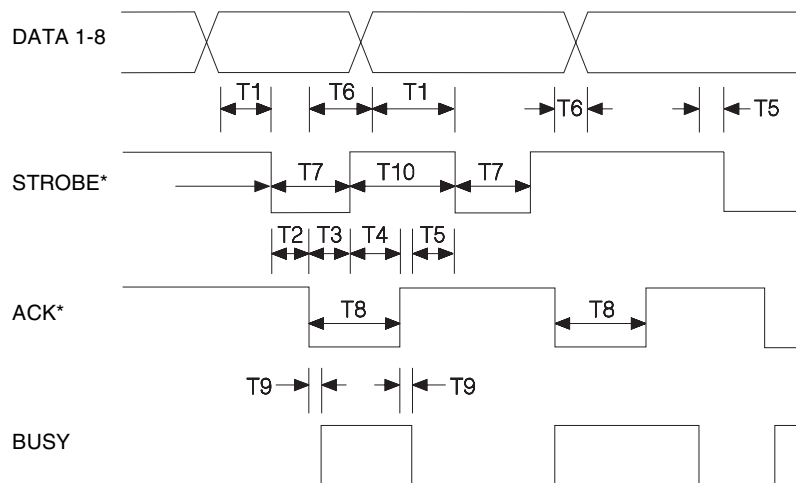

Table 8-2 shows all protocol timings in nanoseconds

Table 8-2: Fastbytes Timing Sequence

Time	Name	Minimum/Maximum
T1	Data setup to STROBE* low	400 min.
T2	STROBE* low to ACKNLG* low	0
T3	ACKNLG* low to STROBE* high	0
T4	STROBE* high to ACKNLG* high	0
T5	ACKNLG* high and BUSY low to STROBE* low	0
T6	ACKNLG* low to change data	50 min.
T7	STROBE* Timeout Max based on Auto Strobe Timer	500 min.
T8	ACKNLG* width Equal to Data Setup Time	400 min.
T9	ACKNLG* to BUSY Skew	+/- 20 max.
T10	STROBE* high time Equal to Data Setup Time	400 min.

Printer-to-Computer Communication (Advanced Status)

The printer has a standard IEEE 1284-B compliant connector and is an IEEE 1284-I compliant device. The optional RS-232C Serial/Parallel 1284-C Interface Card has an IEEE 1284-C compliant connector and is an IEEE 1284-I compliant device.

Your printer could be considered an IEEE 1284-II compliant device if the “C” to “B” style connector converter were used. The printer exceeds the maximum allowable circuit capacitance for Level II interfaces. Compliance with IEEE 1284-II may slow data flow control time slightly; however, all minimum and maximum criteria set forth in IEEE 1284 documentation will be met.

The printer supports:

- Compatibility mode
- Nibble mode
- Byte mode
- ECP mode

The printer also supports a Device ID function. When queried for its ID, the printer returns the following information:

- Manufacturer
- Command set
- Model of printer

The LEXPARAL.EXE file is available from [ftp.lexmark.com](ftp://ftp.lexmark.com/pub/driver/technical_brief/LEXPARAL.EXE) as /pub/driver/technical_brief/LEXPARAL.EXE. Use your web browser to access ftp://ftp.lexmark.com/pub/driver/technical_brief/LEXPARAL.EXE.

When the **Advanced Status** menu item is set to **On**, the printer supports IEEE 1284 communication. If the attached host computer does not support IEEE 1284 communication, you can turn **Advanced Status** to **Off** from the printer operator panel or through MarkVision Professional, and SLCTIN* and AUTO FD XT* will be ignored.

Note: Excessive device queries and status checks (Nibble and Byte modes) will slow printer performance.

You can get IEEE 1284 documentation by calling 1-800-678-IEEE (order number DS02709).

Parallel Mode 1

Parallel Mode 1 is a feature available for many Lexmark printers. The factory default setting is **On** or **Off** depending on your printer model. See your printer documentation for the factory default for your printer.

If the host side of the parallel interface is using open collector drivers to transmit data to the printer, **Parallel Mode 1** should be set to **Off** to increase reliability of data transfer. Turning this mode **Off** equalizes all parallel interface signal impedances. On some printer models, you can set **Parallel Mode 1** to **Off** from the printer operator panel, through MarkVision Professional, or through a PJL command. See your printer documentation for more information.

Parallel Mode 2

Parallel Mode 2 is a feature available for many Lexmark printers. The factory default setting is **On**.

The timing required by the printer is clearly indicated in “Standard Protocol Data Transfer Sequence” on page 8-11. This is the classic Centronics interface timing.

By setting **Parallel Mode 2** to **Off** from the printer operator panel, through MarkVision Professional, or through a PJI command, the printer changes when data is valid. Once **Parallel Mode 2** is set to **Off**, the printer takes data from the host computer at the trailing edge of STROBE. This is the last possible host driven transition where data should be valid.

If **Parallel Mode 2** is **Off**, the printer automatically turns **Advanced Status** to **Off**, eliminating any IEEE 1284 data flow control.

Note: You may find this feature helpful when having data transfer reliability problems.

Signal Descriptions

STROBE Receiver for the Lexmark T640x

The following diagram illustrates the STROBE receiver for the Lexmark T640x.

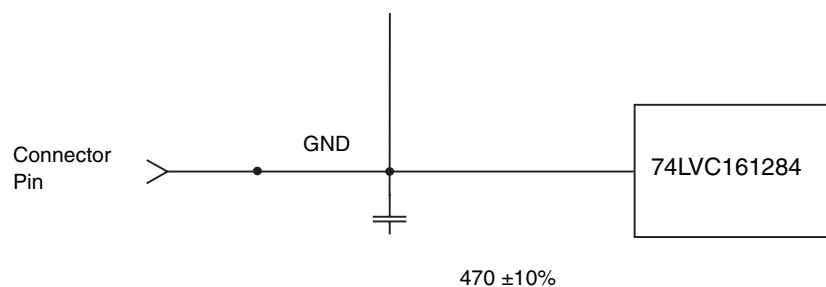

AUTOFD* Receiver for the Lexmark T640x

The following diagram illustrates the AUTOFD* receiver for the Lexmark T640x.

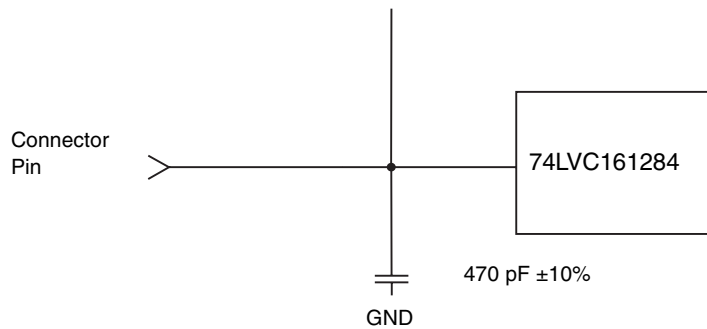

DATA 1-8 Signal Driver/Receivers for the Lexmark T640x

The following diagram illustrates the DATA 1-8 signal driver/receivers for the Lexmark T640x.

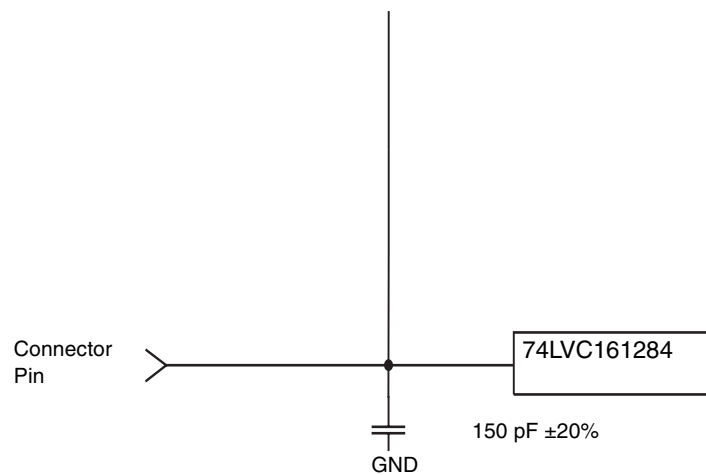

ACKNLG*, ERROR*, SLCT, PE Drivers for the Lexmark T640x

The following diagram illustrates the ACKNLG*, ERROR*, SLCT, PE drivers for the Lexmark T640x.

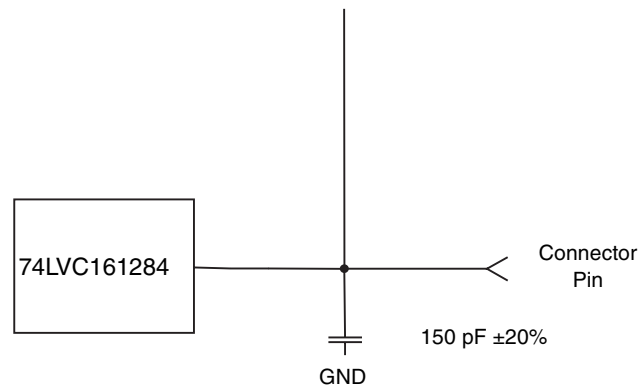

BUSY Driver and INIT* Receiver for the Lexmark T640x

The following diagram illustrates the BUSY driver and the INIT* receiver for the Lexmark T640x.

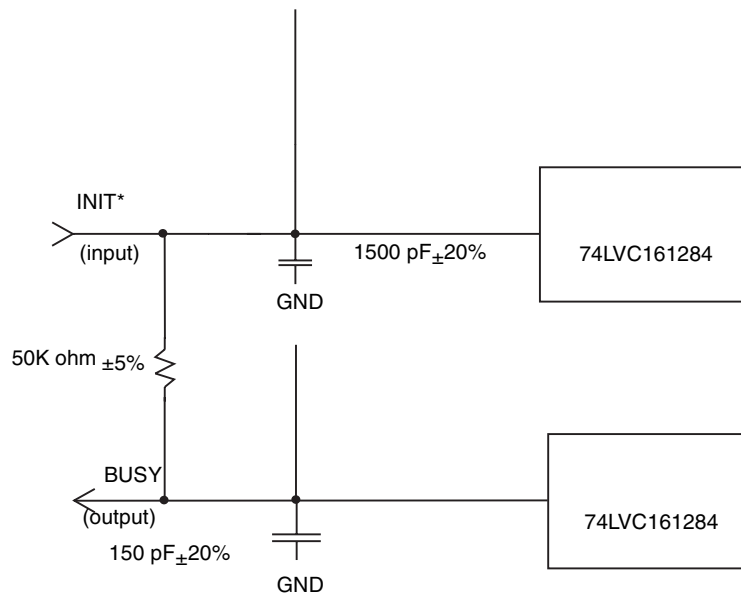

SLCTIN* Receiver for the Lexmark T640x

The following diagram illustrates the SLCTIN* receiver for the Lexmark T640x.

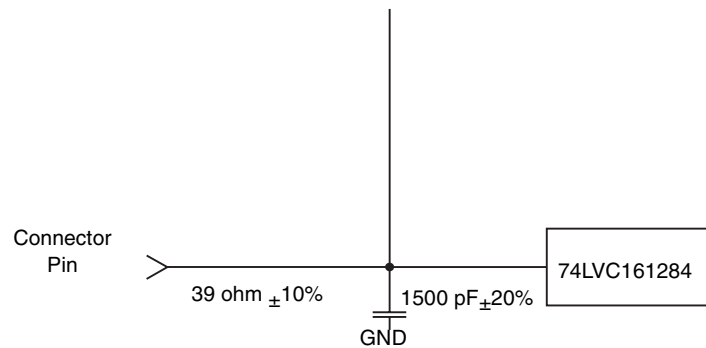

Serial Interface

The serial interface allows data to flow back and forth between the computer and the printer. However, the serial interface transfers data at a slower rate than the parallel interface.

If a serial connector is required, you may be able to install an RS-232C Serial Interface Card, an External Serial Adapter, or an RS-232C Serial/Parallel 1284-C Interface Card. See your printer documentation for more information.

Use RS-232C serial interface if the printer is more than 3.04 m (10 ft) from the computer but less than 15.24 m (50 ft) away. (You can also use a 6.1 m (20 ft) Lexmark cable to connect a printer and a computer located up to 20 feet apart.)

When using the serial interface, your printer has the following differences from the serial interface on some other printers:

- The printer returns XON/XOFF with 2 stop bits in all cases.
- The printer does not support DTR inversion.

Using the RS-232C Serial Interface

This section describes how to use the RS-232C serial interface.

How to Connect the RS-232C Serial Interface

Use Lexmark serial cable P/N 1038693 (15.24 m or 50 ft) to connect the serial interface.

RS-232C Serial Cable Pin Assignments

The RS-232C serial cable appears as follows:

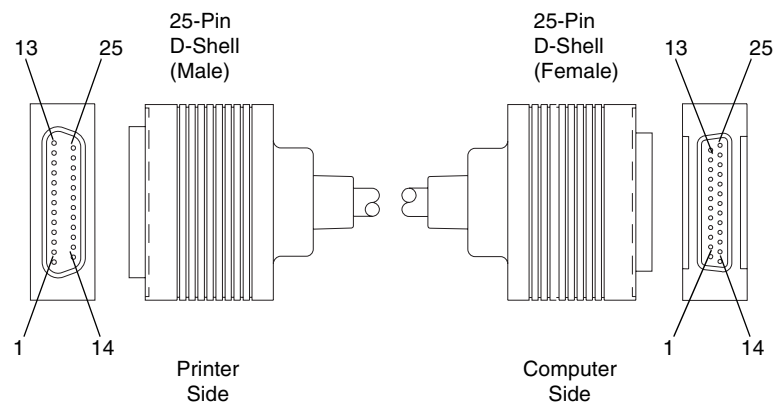

Table 8-3: Dedicated Serial Connector Pin Assignments (RS-232C)

Pin	Signal	Direction	Description
1	GND		Frame Ground
2	TXD	Out	Transmit Data. The pin transmits data to your computer or terminal.
3	RXD	In	Receive Data. The pin receives data from your computer or terminal.
4	RTS	Out	Request to Send. The printer sets this signal high and the signal remains high while the printer is on.
5	CTS	In	Clear to Send. This pin is optionally used for serial data flow control protocol when in serial mode.
6	DSR	In	Data Set Ready. This pin is optionally used for data validation, depending on the Honor DSR setting, or flow control, depending on the Serial Protocol setting.
7	GND		Logic Ground
20	DTR	Out	Data Terminal Ready. This pin is optionally used for serial data flow control protocol when in serial mode.

Using an IBM-Compatible Personal Computer with Serial Interface RS-232C

Note: These instructions are for connecting the printer to an IBM-compatible personal computer using a dual asynchronous adapter or an external print server.

If you are using any of the above products, or if your computer has a 9-pin D shell connector that conforms to the IBM designed 9-pin serial port, use a 9-pin to 25-pin cable, such as IBM Part Number 6450242 (254 mm or 10 in.).

Null modem cables, such as Lexmark part number 1038693 [15.24 m (50 ft)], will connect the converter cable to the printer. The illustration below represents the 25-pin connectors for the RS-232C cable (1038693).

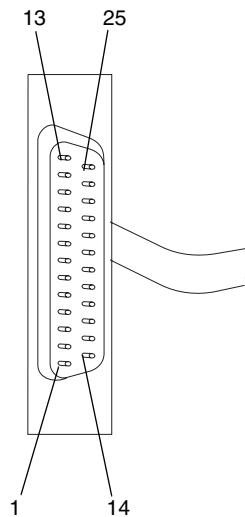

The following illustration shows the pin assignments for the 9-pin to 25-pin IBM EIA RS-232C serial cables.

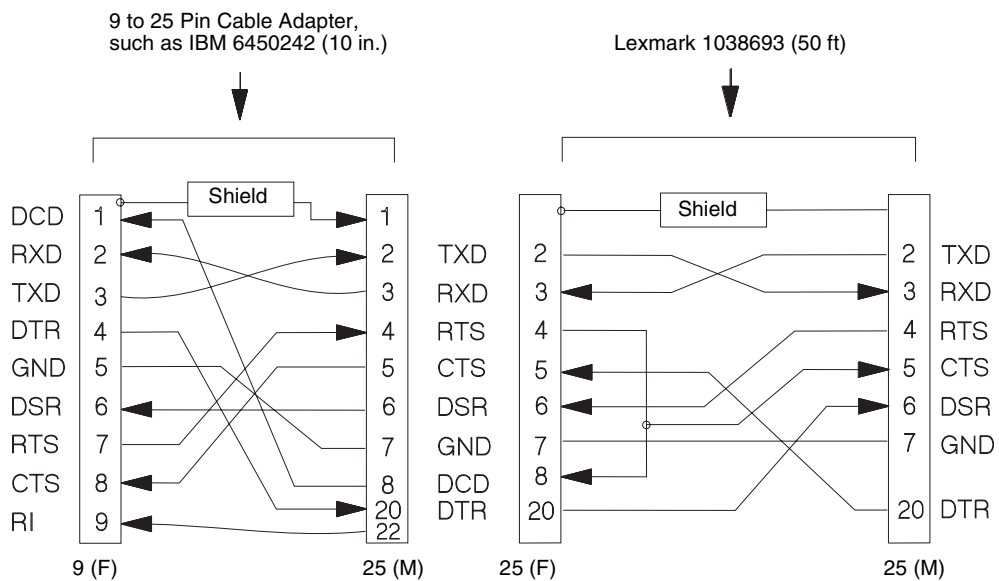

Serial Communication Parameters (RS-232C)

The following paragraphs show acceptable values for serial communication parameters.

Voltage Level Range

The maximum voltage level for control lines or data lines is +/- 25 positive V dc and +/- 25 negative V dc. A timing or control line is active if the voltage is more than +3 V, or inactive if the voltage is less than -3 V. The voltage reference point is the signal ground on pin 7.

A data signal greater than +3 V means that the bit is a logical 0. A signal less than -3 V means that the bit is logical 1.

For additional information, refer to *Interface between Data Terminal Equipment and Data Communications Equipment Employing Serial Binary Data Interchange*, published by the Electronic Industries Association, publications EIA RS-232C and EIA/TIA-232-E.

Serial Data Frame Considerations (RS-232C)

The computer sends serial data in data frames (also known as packets). You can create 10-bit, 11-bit, and 12-bit data frames and set the serial data transfer parameter so that each data frame contains 7 or 8 data bits. However, your printer is an 8-bit printer; characters, controls, and all points addressable (APA) graphics need 8 bits of data. If you select 7-bit data transfer, some unexpected characters might print.

Data Transmission

The list of acceptable data transfer rates (in bits per second) can be accessed from the printer operator panel or through MarkVision Professional. See your printer documentation for more information.

Data Bits

The printer sends or receives 7 or 8 data bits in each transmission frame, depending on which one is selected.

Start and Stop Bits

The printer receives data with 1 start bit and either 1 or 2 stop bits. The printer always sends 1 start and 2 stop bits.

Parity

There are four possible parity settings: Odd, Even, None, and Ignore.

Odd	The port expects to receive data frames with an odd number of logical 1's per byte. The printer transmits XOFF and XON with odd parity. If the printer detects a parity error, the port sends X'5F' to the printer instead of the character sent by the host system.
Even	The port expects to receive data frames with an even number of logical 1's per byte. The port transmits XOFF and XON with even parity. If the port detects a parity error, the port sends an inverted question mark to the printer instead of the character sent by the host system.
None	The port expects no parity bit when it receives data. The port transmits XON and XOFF without parity bits.
Ignore	The port expects a parity bit when the port receives a data frame. The port ignores the parity bit. The port uses even parity when it transmits XON and XOFF.

Some printers post a **54 Standard Serial Error** or a **54 Serial Option x Error** (x represents the number of the serial port) the first time they detect a transmission error (parity, overrun, or framing). The **54 Standard Serial Error** or the **54 Serial Option x Error** can be reset from the printer operator panel or through MarkVision Professional. See your printer documentation for more information.

If repeated serial errors occur, power the printer off and then back on to restore proper serial operation.

Data Flow Control

Data flow control is accomplished through the following lines:

- Data Set Ready (DSR)
- Data Terminal Ready (DTR)

Five data flow control protocols are available:

- DTR pacing
- DTR/DSR
- XON/XOFF
- XON/XOFF/DTR
- XON/XOFF/DTR/DSR

Your printer supports two modes in which both hardware and software data flow control protocols are performed. In XON/XOFF/DTR mode, the printer uses both XON/XOFF and DTR pacing. When XON/XOFF/DTR/DSR mode is active, the printer uses both XON/XOFF and DTR/DSR pacing.

Robust XON may be selected when the data flow control protocol for the serial port is set to XON/XOFF, XON/XOFF/DTR, or XON/XOFF/DTR/DSR pacing. The printer sends a continuous stream of XON signals to the host computer to indicate that the serial port is ready to receive additional data. The signals continue as long as one of the following conditions exist:

- No data has been received across the serial port in the last second.
- The last XON was accepted by the host computer.
- The printer is ready to receive data.

See your printer documentation for more information about selecting the protocol from the printer operator panel or through MarkVision Professional.

Protocol (RS-232C)

Table 8-4 shows the state or function of each serial interface signal in the three data flow control protocols when the Honor DSR setting is On.

Table 8-4: Serial Link (All Protocols) with Honor DSR On

Printer	XON/XOFF Protocol (Honor DSR On)	DTR Protocol (Honor DSR On)	DTR/DSR Protocol (Honor DSR On)
DTR	Always active	Flow control to computer	Flow control to computer
DSR	Data validity	Data validity	Flow control (transmit mode) to computer (receive mode)
CTS	Ignored	Flow control from computer	Ignored

Table 8-5 shows the state of each serial interface signal in the three data flow control protocols when the Honor DSR setting is Off.

Table 8-5: Serial Link (All Protocols) with Honor DSR Off

Printer Signal	XON/XOFF Protocol (Honor DSR Off)	DTR Protocol (Honor DSR Off)	DTR/DSR Protocol (Honor DSR Off)
DTR (Output)	Always active	Flow control to computer	Flow control to computer
DSR (Input)	Ignored	Ignored ¹	Flow control to computer
CTS (Input)	Ignored	Flow control from computer ¹	Ignored

¹ These values are compatible with Hewlett-Packard Company's LaserJet printers.

DTR and DTR/DSR Protocol Timing (RS-232C)

Use DTR to pace the data flow from the computer. DTR goes from high to low to indicate to the computer that the printer cannot receive more data when it detects the following BUSY conditions:

- Buffer full
- Attendance error
- Printer not in ready state

The following diagram illustrates DTR Protocol Timing.

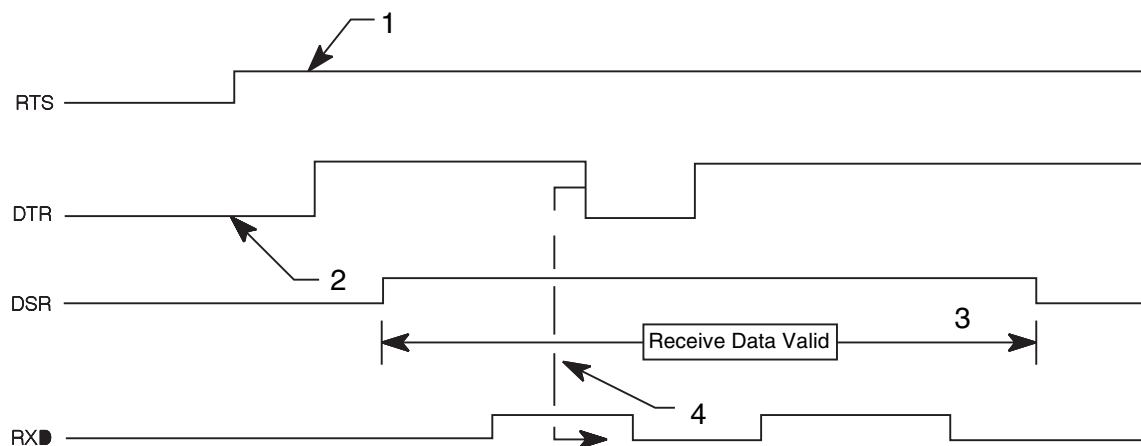

Legend:

- 1 The RTS signal is driven active as long as power is supplied to the printer.
- 2 The DTR signal becomes active when initialization is complete, telling the computer that the printer is ready to receive data.
- 3 When Honor DSR is On, the printer considers data received invalid when DSR is low and discards the data. Only DTR/DSR is used for flow control from the printer to the host computer.
- 4 DTR drops to tell the computer that the receive buffer is nearly full or that the printer is busy and that data transmission should stop. About 640 free bytes remain in the buffer at this time. If the computer continues to send data after the printer has sent a low DTR signal, data could be lost.

XON/XOFF Protocol Timing (RS-232C)

When you select this data flow control protocol, the printer sends an XOFF signal when it detects the following BUSY conditions:

- Buffer full
- Attendance error
- Printer not in ready state

The following diagram illustrates XON/XOFF Protocol Timing.

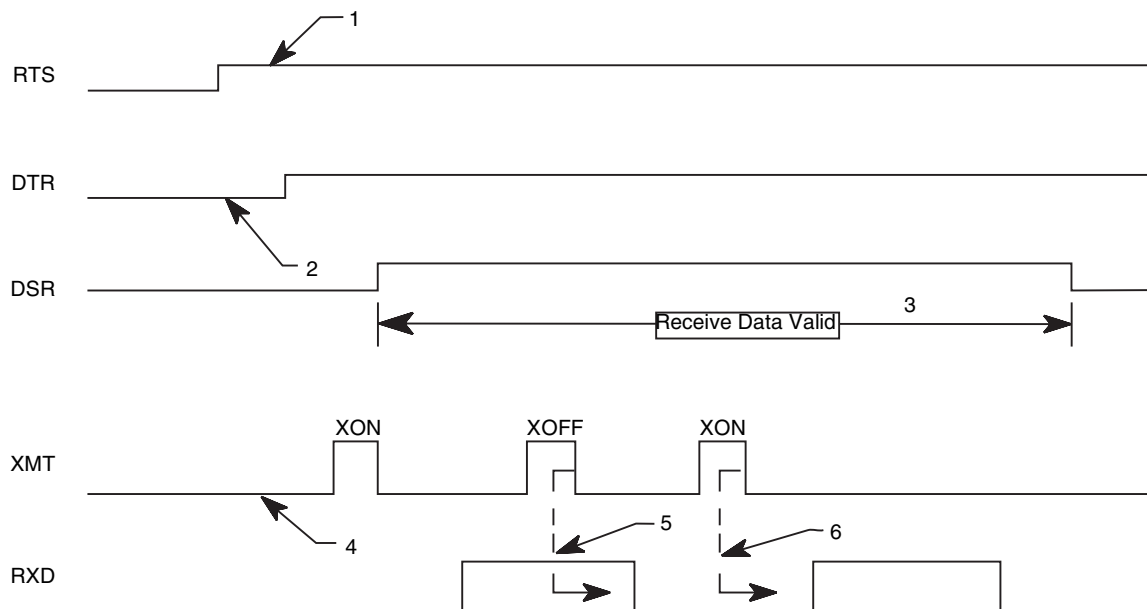

Legend:

- 1 The RTS signal is driven active as long as power is supplied to the printer.
- 2 The DTR signal becomes active at the completion of initialization.
- 3 The printer considers data received invalid when DSR is low and discards the data. (This is conditional depending on the setting of Honor DSR.)
- 4 After you power on the printer and DTR is active, the printer sends an XON signal to the computer (DC1 control or X'11'). However, the computer does not need to detect this initial XON before sending data to the printer, because the printer can be powered on before the computer or terminal.
- 5 The printer sends an XOFF signal (DC3 control or X'13') to request that data transmission end until the buffer clears. About 640 free bytes remain in the buffer at this time. If the computer continues to send data after the printer sent an XOFF signal, data could be lost.
- 6 The printer sends an XON signal to the computer when the buffer space is again available. The serial interface is ready to receive more data.

Serial Errors

The printer places an underscore character in the link buffer when it detects an error. Some printers also display serial errors on the printer operator panel or through MarkVision Professional as attendance messages, such as a **54 Standard Serial Error** or **54 Serial Option x Error** (x represents the number of the serial port). Serial errors that do *not* generate such an error message are:

- Serial Break
- Framing error received simultaneously as a Break
- Powering on an IBM-compatible personal computer connected to the printer

Serial Computer Configuration Recommendations (RS-232C)

For correct operation of the serial interface, your printer and your computer operating system must be configured identically. The following is an example of how to configure DOS for the printer using serial DTR protocol:

DOS:

From the DOS prompt, enter the following commands:

```
mode comy:9600,n,8,1,p
mode lptx :=comy
```

where x equals 1, 2, or 3, and y equals 1 or 2

Include these two command statements in the AUTOEXEC.BAT file on the computer so they run each time your system starts operating.

Once this is set, to copy to the communications port again use the copy command:

```
copy 'filename' lptx
```

Windows 95/98/Me/2000, Windows NT 4.0, and Windows XP:

For correct operation of the RS-232C serial interface, while setting up your communications port, make sure you selected Hardware in the Flow Control field. Selecting Hardware sets the communication to DTR protocol. See the following sections for more information:

- “Setting Up the Communications Port Using Windows 95/98/Me” on page 8-2
- “Setting Up the Communications Port Using Windows NT 4.0” on page 8-3
- “Setting Up the Communications Port Using Windows 2000” on page 8-4
- “Setting Up the Communications Port Using Windows XP” on page 8-5

RS-232C Port Compatibility

The RS-232C port (on the RS-232C Serial Interface Card or the RS-232C Serial/Parallel 1284-C Interface Card) is compatible with the Plug and Play External COM Device Draft Specification, Rev. 0.86.

Devices that are compatible with Plug and Play COM can:

- Detect attachment of serial devices.
- Identify the device.
- Locate a driver for the device.
- Detect detachment of serial devices.

Network Support

Installing an internal print server enables you to connect your printer to a local area network (LAN). The print server supports these network interfaces:

- The Token-Ring print server conforms to IEEE 802.5 using either IBM Cabling System (STP) or unshielded twisted-pair cable, which meets the IBM Cabling System Type 3 Media Specification (UTP).
- The Ethernet Combined 10BaseT and 10Base2 print server conforms to IEEE 802.3 with a Category 3, 4, or 5 unshielded twisted-pair (UTP) cable for the 10BaseT and conforms to IEEE 802.3 with an RG58 coaxial cable for the 10Base2.

- The Ethernet 10/100BaseTX print server conforms to the IEEE 802.3 standard for 10BaseT networks using Category 3, 4, or 5 unshielded twisted-pair (UTP) cabling, and to the IEEE 802.3u Fast Ethernet standard for 100BaseTX networks using Category 5 UTP cabling.

For information on installing a print server in your printer, see your printer documentation.

You may also connect your printer to a LAN by using an external print server. Use one of the following:

- Lexmark MarkNet print servers
- IBM LAN Connection for Printers and Plotters (IBM 4033)

Note: Network capabilities are standard on some printer models. See your printer documentation for more information.

Input Buffer

Your printer has an input (link) buffer for each interface. The maximum size of the input buffer depends upon the amount of RAM memory installed. The input buffers serve the same purpose as a print spooler and can be allocated automatically by the printer. The size of the input buffer may be modified or disabled from the operator panel menus or through MarkVision Professional.

If NPAP is active on a port, two-thirds of the buffer memory is reserved for NPAP and one-third is set aside for the input buffer. If NPAP is not active, all the memory is available for the input buffer.

Table 8-8 shows the sizes automatically selected for the buffers when the buffer size is set to **Auto** in the menus.

Table 8-6: Input Buffer Sizes in Bytes

Memory Size	Parallel Buffer Size	Serial Buffer Size	Network Buffer Size	LocalTalk	USB	Fax
2MB	12K	12K	12K	12K	12K	N/A
4MB	12K	12K	48K	12K	12K	350K
6MB	24K	12K	48K	24K	12K	350K

Note: MB represents 1,048,576 bytes. K represents 1024 bytes. N/A means non-applicable.

Table 8-6: Input Buffer Sizes in Bytes (Continued)

Memory Size	Parallel Buffer Size	Serial Buffer Size	Network Buffer Size	LocalTalk	USB	Fax
8, 10, or 12MB	48K	24K	48K	48K	24K	350K
16, 18, or 20MB	48K (1MB if no optional adapter is installed)	24K	1MB	1MB	24K	1MB
24, 28, 32, or 34MB	192K (1MB if no optional adapter is installed)	150K	1MB	1MB	150K	1MB
36, 38, or 40MB	384K (1MB if no optional adapter is installed)	300K	1MB	1MB	300K	1MB
44MB or larger	2MB	300K	2MB	2MB	300K	1MB

Note: MB represents 1,048,576 bytes. K represents 1024 bytes. N/A means non-applicable.

Note: When using serial communication, the printer signals the host computer to stop transmitting bytes when the serial input buffer is within 640 bytes. In addition, when XON/XOFF protocol is used, the printer signals the host computer to stop transmitting when the serial input buffer is 384, 256, and 128 bytes from full.

APPENDIX A: PCL Support

Table A-1 lists PCL emulation commands and identifies printers that support them.

For detailed information about PCL emulation commands and how to select them, see “PCL Emulation” on page 2-1.

Table A-2 on page A-7 identifies printer support for the GL/2 commands.

Table A-1: PCL Emulation Commands

Command	Function	Page	✓ Supported ✗ Not Supported	Page numbers reference command descriptions	Printer Model		
			C520, C522n, C524, C524n, C524dn	C530dn, C532n, C532dn C534n, C534dn, C534dtn	C770, C770n C772, C772n	C920, 920n 920dn, 920dnf	
ESC E	Printer Reset	2-52	✓		✓	✓	✓
ESC Y	Display Functions-On	2-73	✓		✓	✓	✓
ESC Z	Display Functions-Off	2-74	✓		✓	✓	✓
ESC z	Print Test Page	2-74	✗		✗	✗	✗
ESC &a#C	Horizontal Cursor Position (in Columns)	2-58	✓		✓	✓	✓
ESC &a#G	Duplex Page Side Selection	2-57	✓		✓	✓	✓
ESC &a#H	Horizontal Cursor Position (in Decipoints)	2-58	✓		✓	✓	✓
ESC &a#L	Set Left Margin	2-55	✓		✓	✓	✓
ESC &a#M	Set Right Margin	2-55	✓		✓	✓	✓
ESC &a#P	Print Direction	2-55	✓		✓	✓	✓
ESC &a#R	Vertical Cursor Position (in Rows)	2-59	✓		✓	✓	✓
ESC &a#V	Vertical Cursor Position (in Decipoints)	2-59	✓		✓	✓	✓
ESC &b#M	Monochrome Print Mode	2-70	✓		✓	✓	✓
ESC &c#T	Character Text Path Direction	2-55	✓		✓	✓	✓
ESC &d@	Underline-Disable	2-61	✓		✓	✓	✓

Table A-1: PCL Emulation Commands (Continued)

Command	Function	Page	✓ Supported ✗ Not Supported	Page numbers reference command descriptions	Printer Model			
					C520, C522n, C524, C524n, C524dn	C530dn, C532n, C532dn, C534n, C534dn, C534dtn	C770, C770n, C772, C772n	C920, 920n, 920dn, 920dnf
ESC&d#A	Number of Collated Copies	2-52	✓		✓	✓	✓	✓
ESC&d#D	Underline-Enable	2-61	✓		✓	✓	✓	✓
ESC&f#F	Set Universal Height	2-54	✓		✓	✓	✓	✓
ESC&f#G	Set Universal Width	2-54	✓		✓	✓	✓	✓
ESC&f#O	Set Universal Feed Direction	2-55	✓		✓	✓	✓	✓
ESC&f#W	Set Universal Custom Name	2-55	✓		✓	✓	✓	✓
ESC&f#S	Push / Pop Cursor Position	2-59	✓		✓	✓	✓	✓
ESC&f#X	Macro Control	2-63	✓		✓	✓	✓	✓
ESC&f#Y	Set Macro ID	2-63	✓		✓	✓	✓	✓
ESC&k#G	Set Line Termination	2-59	✓		✓	✓	✓	✓
ESC&k#H	Set Horizontal Motion Index	2-56	✓		✓	✓	✓	✓
ESC&k#S	Select Primary and Secondary Pitch	2-62	✓		✓	✓	✓	✓
ESC&k#W	Text Scale Mode	2-57	✗		✗	✗	✗	✗
ESC&l#A	Page Size	2-54	✓		✓	✓	✓	✓
ESC&l#C	Set Vertical Motion Index	2-56	✓		✓	✓	✓	✓
ESC&l#D	Set Line Spacing	2-57	✓		✓	✓	✓	✓
ESC&l#E	Set Top Margin	2-55	✓		✓	✓	✓	✓
ESC&l#F	Set Text Length	2-56	✓		✓	✓	✓	✓
ESC&l#G	Set Output Bin	2-56	✓		✓	✓	✓	✓
ESC&l#H	Paper Source	2-54	✓		✓	✓	✓	✓
ESC&l#L	Skip Perforation	2-56	✓		✓	✓	✓	✓
ESC&l#O	Select Orientation	2-55	✓		✓	✓	✓	✓
ESC&l#M(b)	Paper Type	2-74	✗		✗	✗	✗	✗
ESC&l#P	Set Page Length	2-57	✓		✓	✓	✓	✓
ESC&l#S	Simplex/Duplex Print	2-52	✓		✓	✓	✓	✓
ESC&l1T	Job Separation	2-55	✗		✗	✗	✗	✗
ESC&l#U	Long-Edge Offset Registration	2-52	✓		✓	✓	✓	✓

Table A-1: PCL Emulation Commands (Continued)

Command	Function	Page	✓ Supported ✗ Not Supported	Page numbers reference command descriptions	Printer Model		
					C520, C522n, C524, C524n, C524dn	C530dn, C532n, C532dn, C534n, C534dn, C534dtn	C770, C770n, C772, C772n
ESC&l#X	Number of Copies	2-52	✓		✓	✓	✓
ESC&l#Z	Short-Edge Offset Registration	2-52	✓		✓	✓	✓
ESC&n#W [operation] [string id]	Alphanumeric ID	2-58	✓		✓	✓	✓
ESC&p#C	Palette Control	2-70	✓		✓	✓	✓
ESC&p#I	Palette Control ID	2-70	✓		✓	✓	✓
ESC&p#S	Select Palette	2-70	✓		✓	✓	✓
ESC&p#X[data]	Transparent Print Data	2-61	✓		✓	✓	✓
ESC&r#F	Flush All Pages	2-72	✓		✓	✓	✓
ESC&s#C	End-Of-Line Text Wrap	2-73	✓		✓	✓	✓
ESC&t#P	Text Parsing Method	2-62	✓		✓	✓	✓
ESC&u#D	Unit of Measure	2-53	✓		✓	✓	✓
ESC(#	Primary Font Symbol Set	2-60	✓		✓	✓	✓
ESC(#X	Select Primary Download Font (by Font ID)	2-61	✓		✓	✓	✓
ESC(3@	Select Default Primary Font	2-61	✓		✓	✓	✓
ESC(f#W[data]	Define Symbol Set	2-62	✓		✓	✓	✓
ESC(s#B	Primary Font Stroke Weight	2-61	✓		✓	✓	✓
ESC(s#H	Primary Font Pitch	2-60	✓		✓	✓	✓
ESC(s#P	Primary Font Spacing	2-60	✓		✓	✓	✓
ESC(s#S	Primary Font Style	2-60	✓		✓	✓	✓
ESC(s#T	Primary Font Typeface Selection	2-61	✓		✓	✓	✓
ESC(s#V	Primary Font Height (Point Size)	2-60	✓		✓	✓	✓
ESC(s#W[data]	Load Character	2-63	✓		✓	✓	✓
ESC)#	Secondary Font Symbol Set	2-60	✗		✗	✗	✗
ESC)#X	Select Secondary Download Font (by Font ID)	2-61	✗		✗	✗	✗
ESC)3@	Select Default Secondary Font	2-61	✓		✓	✓	✓
ESC)s#B	Secondary Font Stroke Weight	2-61	✗		✗	✗	✗

Table A-1: PCL Emulation Commands (Continued)

Command	Function	Page	✓ Supported ✗ Not Supported	Page numbers reference command descriptions	Printer Model			
					C520, C522n, C524, C524n, C524dn	C530dn, C532n, C532dn, C534n, C534dn, C534dtn	C770, C770n, C772, C772n	C920, 920n, 920dn, 920dnf
ESC)s#H	Secondary Font Pitch	2-60	✗		✗	✗	✗	✗
ESC)s#P	Secondary Font Spacing	2-60	✗		✗	✗	✗	✗
ESC)s#S	Secondary Font Style	2-60	✗		✗	✗	✗	✗
ESC)s#T	Secondary Font Typeface Selection	2-61	✗		✗	✗	✗	✗
ESC)s#V	Secondary Font Height (Point Size)	2-60	✗		✗	✗	✗	✗
ESC)s#W[data]	Load Font Header	2-63	✓		✓	✓	✓	✓
ESC*b#M	Set Raster Compression Mode	2-68	✓		✓	✓	✓	✓
ESC*b#V[data]	Transfer Raster Data (by Plane)	2-67	✓		✓	✓	✓	✓
ESC*b#W[data]	Transfer Raster Data (by Row / Block)	2-68	✓		✓	✓	✓	✓
ESC*b#Y	Y Offset	2-67	✓		✓	✓	✓	✓
ESC*c#A	Horizontal Rectangle Size (in PCL Units)	2-65	✓		✓	✓	✓	✓
ESC*c#B	Vertical Rectangle Size (in PCL Units)	2-65	✓		✓	✓	✓	✓
ESC*c#D	Set Font ID	2-63	✓		✓	✓	✓	✓
ESC*c#E	Set Character Code	2-63	✓		✓	✓	✓	✓
ESC*c#F	Font Control	2-63	✓		✓	✓	✓	✓
ESC*c#G	Area Fill ID	2-64, 2-66	✓		✓	✓	✓	✓
ESC*c#H	Horizontal Rectangle Size (in Decipoints)	2-65	✓		✓	✓	✓	✓
ESC*c#K	GL/2 Horizontal Plot Size (in Inches)	2-73	✓		✓	✓	✓	✓
ESC*c#L	GL/2 Vertical Plot Size (in Inches)	2-73	✓		✓	✓	✓	✓
ESC*c#P	Fill Rectangular Area	2-66	✓		✓	✓	✓	✓
ESC*c#Q	Pattern Control	2-65	✓		✓	✓	✓	✓
ESC*c#R	Symbol Set ID Code	2-62	✓		✓	✓	✓	✓
ESC*c#S	Symbol Set Control	2-62	✓		✓	✓	✓	✓
ESC*c0T	Set Picture Frame Anchor Point	2-73	✓		✓	✓	✓	✓
ESC*c#V	Vertical Rectangle Size (in Decipoints)	2-65	✓		✓	✓	✓	✓
ESC*c#W[data]	User-Defined Pattern	2-65	✓		✓	✓	✓	✓

Table A-1: PCL Emulation Commands (Continued)

Command	Function	Page	✓ Supported ✗ Not Supported	Page numbers reference command descriptions	Printer Model			
					C520, C522n, C524, C524n, C524dn	C530dn, C532n, C532dn, C534n, C534dn, C534dtn	C770, C770n, C772, C772n	C920, 920n, 920dnf, 920dnf
ESC*c#X	Picture Frame Horizontal Size (in Decipoints)	2-73	✓		✓	✓	✓	✓
ESC*c#Y	Picture Frame Vertical Size (in Decipoints)	2-73	✓		✓	✓	✓	✓
ESC* <i>l</i> #O	Logical Operation	2-64	✓		✓	✓	✓	✓
ESC* <i>l</i> #R	Pixel Placement	2-64	✓		✓	✓	✓	✓
ESC* <i>l</i> #W[data]	Color Lookup Tables	2-70	✓		✓	✓	✓	✓
ESC*m#W[data]	Download Dither Matrix	2-70	✓		✓	✓	✓	✓
ESC*o#M(b)	Print Quality	2-74	✗		✗	✗	✗	✗
ESC*o#W[data]	Driver Configuration Command	2-70	✓		✓	✓	✓	✓
ESC*p#P	Push / Pop Palette	2-70	✓		✓	✓	✓	✓
ESC*p#R	Set Pattern Reference Point	2-65	✓		✓	✓	✓	✓
ESC*p#X	Horizontal Cursor Position (in PCL Units)	2-58	✓		✓	✓	✓	✓
ESC*p#Y	Vertical Cursor Position (in PCL Units)	2-59	✓		✓	✓	✓	✓
ESC*r#A	Start Raster Graphics	2-67	✓		✓	✓	✓	✓
ESC*r#F	Raster Graphics Presentation Mode	2-67	✓		✓	✓	✓	✓
ESC*r#S	Raster Width (Source)	2-67	✓		✓	✓	✓	✓
ESC*r#T	Raster Height (Source)	2-67	✓		✓	✓	✓	✓
ESC*r#U	Simple Color	2-70	✓		✓	✓	✓	✓
ESC*rB	End Raster Graphics (Version B)	2-68	✓		✓	✓	✓	✓
ESC*rC	End Raster Graphics (Version C)	2-68	✓		✓	✓	✓	✓
ESC*s#I	Inquire Status Readback Entity	2-72	✓		✓	✓	✓	✓
ESC*s1M	Free Space	2-72	✓		✓	✓	✓	✓
ESC*s#T	Set Status Readback Location Type	2-72	✓		✓	✓	✓	✓
ESC*s#U	Set Status Readback Location Unit	2-72	✓		✓	✓	✓	✓
ESC*s#X	Echo	2-72	✓		✓	✓	✓	✓
ESC*t#H	Raster Width Destination	2-68	✓		✓	✓	✓	✓
ESC*t#I	Gamma Correction	2-71	✓		✓	✓	✓	✓

Table A-1: PCL Emulation Commands (Continued)

Command	Function	Page	✓ Supported ✗ Not Supported	Page numbers reference command descriptions	Printer Model		
					C520, C522n, C524, C524n, C524dn	C530dn, C532n, C532dn C534n, C534dn, C534dtn	C770, C770n C772, C772n
ESC*t#J	Render Algorithm	2-71	✓		✓	✓	✓
ESC*t#R	Raster Resolution	2-67	✓		✓	✓	✓
ESC*t#V	Raster Height Destination	2-69	✓		✓	✓	✓
ESC*g#W	Set Raster Configuration	2-69	✗		✗	✗	✗
ESC*v#A	Color Component One	2-71	✓		✓	✓	✓
ESC*v#B	Color Component Two	2-71	✓		✓	✓	✓
ESC*v#C	Color Component Three	2-71	✓		✓	✓	✓
ESC*v#I	Assign Color Index	2-71	✓		✓	✓	✓
ESC*v#N	Source Transparency Mode	2-64	✓		✓	✓	✓
ESC*v#O	Pattern Transparency Mode	2-64	✓		✓	✓	✓
ESC*v#S	Foreground Color	2-71	✓		✓	✓	✓
ESC*v#T	Select Current Pattern	2-64	✓		✓	✓	✓
ESC*v#W[data]	Configure Image Data	2-71	✓		✓	✓	✓
ESC*i#W[data]	Viewing Illuminant	2-71	✗		✗	✗	✗
ESCg	Clear Horizontal Margins	2-55	✓		✓	✓	✓
ESC=	Half Line-Feed	2-59	✓		✓	✓	✓
ESC%#A	Enter PCL Emulation	2-73	✓		✓	✓	✓
ESC%#B	Enter GL/2 Language Note: The values of -1, 2, and 3 are not supported by any of the printers included in this document.	2-73	✓		✓	✓	✓
ESC%–12345X	Universal Exit Language (UEL) / Start of PJL	2-53	✓		✓	✓	✓

Table A-2 lists GL/2 commands and identifies the printers that support them.

Table A-2: GL/2 Commands

Command	Function	Page	Printer Model			
			C520, C522n, C524, C524n, C524dn	C530dn, C532n, C534n, C534dn, C534dtn	C770, C770n, C772, C772n	C920, 920n, 920dn, 920dnf
✓ Supported ✗ Not Supported	Page numbers reference command descriptions.					
AA	Arc Absolute	2-75	✓	✓	✓	✓
AC	Anchor Corner	2-77	✓	✓	✓	✓
AD	Define Alternate Font	2-76	✓	✓	✓	✓
AR	Arc Relative	2-75	✓	✓	✓	✓
AT	Arc Absolute Three Point	2-75	✓	✓	✓	✓
BR	Bezier Relative	2-75	✓	✓	✓	✓
BZ	Bezier Absolute	2-75	✓	✓	✓	✓
CF	Character Fill	2-76	✓	✓	✓	✓
CI	Circle	2-75	✓	✓	✓	✓
CO	Comment	2-74	✓	✓	✓	✓
CP	Character Plot	2-76	✓	✓	✓	✓
CR	Color Range	2-77	✓	✓	✓	✓
DF	Default	2-74	✓	✓	✓	✓
DI	Absolute Direction	2-76	✓	✓	✓	✓
DR	Relative Direction	2-76	✓	✓	✓	✓
DT	Define Label Terminator	2-76	✓	✓	✓	✓
DV	Define Variable Text Path	2-76	✓	✓	✓	✓
EA	Edge Rectangle Absolute	2-75	✓	✓	✓	✓
EP	Edge Polygon	2-75	✓	✓	✓	✓
ER	Edge Rectangle Relative	2-75	✓	✓	✓	✓
ES	Extra Space	2-76	✓	✓	✓	✓
EW	Edge Wedge	2-75	✓	✓	✓	✓
FI	Primary Font	2-76	✓	✓	✓	✓
FN	Secondary Font	2-76	✓	✓	✓	✓
FP	Fill Polygon, Odd/Even	2-75	✓	✓	✓	✓
FP	Fill Polygon, Non-Zero Winding	2-75	✓	✓	✓	✓

Table A-2: GL/2 Commands (Continued)

✓ Supported ✗ Not Supported		Page numbers reference command descriptions.	Printer Model			
			C520, C522n, C524, C524n, C524dn	C530dn, C532n, C534n, C534dn, C534dtn	C770, C770n, C772, C772n	C920, 920n, 920dnf, 920dnf
Command	Function	Page				
FT	Fill Type	2-77	✓	✓	✓	✓
FT	Fill Type - 22	2-77	✓	✓	✓	✓
FT	Fill Type - 9	2-77	✓	✓	✓	✓
IN	Initialize	2-74	✓	✓	✓	✓
IP	Input P1 and P2	2-74	✓	✓	✓	✓
IR	Input Relative P1 and P2	2-75	✓	✓	✓	✓
IW	Input Window	2-75	✓	✓	✓	✓
LA	Line Attributes	2-77	✓	✓	✓	✓
LB	Label, Default Terminator = '03'x	2-76	✓	✓	✓	✓
LO	Label Origin	2-76	✓	✓	✓	✓
LO	Uses PCL Label Origin	2-76	✓	✓	✓	✓
LT	Line Type	2-77	✓	✓	✓	✓
LM	Label Mode	2-76	✗	✗	✗	✗
MC	Logical Operation	2-75	✓	✓	✓	✓
NP	Number of Pens	2-77	✓	✓	✓	✓
PA	Plot Absolute	2-75	✓	✓	✓	✓
PC	Pen Color	2-77	✓	✓	✓	✓
PD	Pen Down	2-75	✓	✓	✓	✓
PE	Polyline Encoded	2-75	✓	✓	✓	✓
PM	Polygon Mode	2-75	✓	✓	✓	✓
PP	Pixel Placement	2-75	✓	✓	✓	✓
PR	Plot Relative	2-75	✓	✓	✓	✓
PU	Pen Up	2-75	✓	✓	✓	✓
PW	Pen Width	2-77	✓	✓	✓	✓
RA	Fill Rectangle Absolute	2-76	✓	✓	✓	✓
RF	Define Raster Fill	2-77	✓	✓	✓	✓
RO	Rotate Coordinate System	2-75	✓	✓	✓	✓
RR	Fill Rectangle Relative	2-76	✓	✓	✓	✓

Table A-2: GL/2 Commands (Continued)

✓ Supported ✗ Not Supported		Page numbers reference command descriptions.	Printer Model			
Command	Function	Page	C520, C522n, C524, C524n, C524dn	C530dn, C532n, C534n, C534dn, C534dtn	C770, C770n, C772, C772n	C920, 920n, 920dnf
RT	Arc Relative Three Point	2-75	✓	✓	✓	✓
SA	Select Alternate Font	2-76	✓	✓	✓	✓
SB	Scalable/Bitmapped Fonts	2-76	✓	✓	✓	✓
SC	Scale	2-75	✓	✓	✓	✓
SD	Define Standard Font	2-76	✓	✓	✓	✓
SI	Absolute Character Size	2-76	✓	✓	✓	✓
SL	Character Slant	2-76	✓	✓	✓	✓
SM	Symbol Mode	2-77	✓	✓	✓	✓
SP	Select Pen	2-77	✓	✓	✓	✓
SR	Relative Character Size	2-76	✓	✓	✓	✓
SS	Select Standard Font	2-76	✓	✓	✓	✓
SV	Screened Vectors	2-77	✓	✓	✓	✓
SV	Screened Vectors - 9, level	2-77	✓	✓	✓	✓
TD	Transparent Data	2-76	✓	✓	✓	✓
TM	Threshold Matrix	2-77	✓	✓	✓	✓
TR	Transparency Mode	2-77	✓	✓	✓	✓
UL	User Defined Line	2-77	✓	✓	✓	✓
WG	Fill Wedge	2-76	✓	✓	✓	✓
WU	Pen Width Units	2-77	✓	✓	✓	✓

APPENDIX B: PJL Support

The following tables list PJL commands and identify printers that support them.

For detailed information about PJL commands, see “Printer Job Language” on page 3-1. All commands may not have a full description.

Note: The word *common* applies to those variables common to both your Lexmark printer and the Hewlett-Packard Company’s LaserJet printers.

Table B-1: Common Variables for Both Printer Languages

✓ Supported ✗ Not Supported Page numbers reference variable descriptions and are listed for supported variables only. Default values are listed for exceptions only.		Printer Model			
		C520, C522n, C524 C524n,	C530dn, C532n, C532dn, C534n, C534dtn.	C770, C770n, C772, C772n	C920, C920n C920dn, C920dnf
Variable Name	Page				
AUTOCONT	3-12	✓	✓	✓	✓
AUTOSELECT		✗	✗	✗	✗
BINDING	3-12	✓	✓	✓	✓
BITSPERPIXEL	3-12	✗	✗	✗	✗
CLEARABLEWARNINGS	3-12	✗	✗	✗	✗
CONTEXTSWITCH		✗	✗	✗	✗
COPIES	3-12	✓	✓	✓	✓
CPLOCK	3-13	✓	✓	✓	✓
DENSITY	3-13	✓	✓	✓	✓
DISKLOCK		✓	✓	✓	✓
DUPLEX	3-13	✓	✓	✓	✓
ECONOMODE	3-13	✓	✓	✓	✓

Table B-1: Common Variables for Both Printer Languages (Continued)

✓ Supported ✗ Not Supported Page numbers reference variable descriptions and are listed for supported variables only. Default values are listed for exceptions only.		Printer Model			
		C-520, C522n, C524 C524n,	C-530dn, C532n, C532dn, C534n, C534dtn.	C770, C770n, C772, C772n	C920, C920n C920dn, C920dnf
Variable Name	Page				
FORMATTERNUMBER	3-13	✓	✓	✓	✓
FORMLINES	3-13	✓	✓	✓	✓
HOLD	3-13	✗	✗	✗	✗
HOLDKEY	3-13	✗	✗	✗	✗
HOLDTYPE	3-14	✗	✗	✗	✗
IMAGEADAPT	3-14	✗	✗	✗	✗
INTRAY1		✗	✗	✗	✗
INTRAY2	3-14	✗	✗	✗	✗
INTRAY3	3-14	✗	✗	✗	✗
INTRAY4	3-14	✗	✗	✗	✗
INTRAY5	3-14	✗	✗	✗	✗
INTRAY1SIZE	3-14	✓	✓	✓	✓
INTRAY2SIZE	3-14	✓	✓	✓	✓
INTRAY3SIZE	3-14	✗	✗	✗	✗
INTRAY4SIZE	3-14	✗	✗	✗	✗
INTRAY5SIZE	3-14	✗	✗	✗	✗
IOBUFFER		✗	✗	✗	✗
IOSIZE		✗	✗	✗	✗
JOBATTR		✗	✗	✗	✗
JOBNAME	3-14	✗	✗	✗	✗
JOBOFFSET	3-15	✗	✗	✗	✗
LANG	3-15	✓	✓	✓	✓
LOWTONER	3-15	✓	✓	✓	✓
MANUALFEED	3-15	✓	✓	✓	✓
MEDIASOURCE		✗	✗	✗	✗

Table B-1: Common Variables for Both Printer Languages (Continued)

✓ Supported ✗ Not Supported Page numbers reference variable descriptions and are listed for supported variables only. Default values are listed for exceptions only.		Printer Model			
		C-520, C522n, C524 C524n,	C-530dn, C532n, C532dn, C534n, C534dtn.	C-770, C770n, C772, C772n	C-920, C920n C920dn, C920dnf
Variable Name	Page				
MEDIATYPE	3-15	✓	✓	✓	✓
MPTRAY	3-15	✗	✗	✗	✗
ORIENTATION	3-15	✓	✓	✓	✓
OUTBIN	3-16	✓	✓	✓	✓
PAGEPROTECT	3-16	✓	✓	✓	✓
PAPER	3-16	✓	✓	✓	✓
PARALLEL	3-17	✗	✗	✗	✗
PASSWORD	3-17	✓	✓	✓	✓
PERSONALITY	3-17	✓	✓	✓	✓
POWERSAVE	3-17	✓	✓	✓	✓
POWERSAVETIME	3-18	✓	✓	✓	✓
PRINTQUALITY		✗	✗	✗	✗
QTY	3-18	✗	✗	✗	✗
RENDERMODE		✗	✗	✗	✗
REPRINT	3-18	✓	✓	✓	✓
RESOLUTION	3-18	✓	✓	✓	✓
RESOURCESAVE	3-18				
RESOURCESAVESIZE		✗	✗	✗	✗
RET	3-18	✗	✗	✗	✗
TIMEOUT	3-18	✓	✓	✓	✓
USERNAME	3-19	✗	✗	✗	✗
WIDEA4	3-19	✗	✗	✗	✗

Table B-2: Printer Unique PJJ Variables for Both Printer Languages

✓ Supported ✗ Not Supported Page numbers reference variable descriptions and are listed for supported variables only. Default values are listed for exceptions only.		Printer Model			
		C520, C522n, C524 C524n,	C530dn, C532n, C532dn, C534n, C534dtn.	C770, C770n, C772, C772n	C920, C920n C920dn, C920dnf
		Variable Name	Page		
LACTIVEBINRESET	3-19	✗	✗	✗	✗
LADVANCEDSTATUS	3-19	✓	✓	✓	✓
LALARMCONTROL	3-19	✗	✗	✗	✗
LAUTOCRLF	3-19	✓	✓	✓	✓
LAUTOLFCR	3-19	✓	✓	✓	✓
LBLANKPAGES	3-19	✓	✓	✓	✓
LBONDLENGTH	3-19	✗	✗	✗	✗
LBONDLOADING	3-19	✗	✗	✗	✗
LBONDOUTBIN	3-20	✗	✗	✗	✗
LBONDTEXTURE	3-20	✓	✓	✓	✓
LBONDWEIGHT	3-20	✓	✓	✓	✓
LBWLOCK	3-20	✗	✗	✗	✗
LCANCEL	3-20	✓	✓	✓	✓
LCARDSTOCKLENGTH	3-20	✗	✗	✗	✗
LCARDSTOCKLOADING	3-20	✗	✗	✗	✗
LCARDSTOCKOUTBIN	3-21	✗	✗	✗	✗
LCARDSTOCKTEXTURE	3-21	✓	✓	✓	✓
LCARDSTOCKWEIGHT	3-21	✓	✓	✓	✓
LCOLLATION	3-21	✓	✓	✓	✓
LCOLORCORRECTION	3-21	✗	✗	✗	✗
LCOLOREDLENGTH	3-21	✗	✗	✗	✗
LCOLOREDLOADING	3-22	✗	✗	✗	✗
LCOLOREDOUTBIN	3-22	✗	✗	✗	✗
LCOLOREDTEXTURE	3-22	✓	✓	✓	✓
LCOLOREDWEIGHT	3-22	✓	✓	✓	✓

Table B-2: Printer Unique PJL Variables for Both Printer Languages (Continued)

✓ Supported ✗ Not Supported Page numbers reference variable descriptions and are listed for supported variables only. Default values are listed for exceptions only.		Printer Model			
		C520, C522n, C524 C524n,	C530dn, C532n, C532dn, C534n, C534dtn.	C770, C770n, C772, C772n	C920, C920n C920dn, C920dnf
LCOLORMODEL	3-22	✗	✗	✗	✗
LCUSTOMPAPERUNITS	3-22	✓	✓	✓	✓
LCUSTOMPAPERWIDTH	3-22	✓	✓	✓	✓
LCUSTOMPAPERHEIGHT	3-23	✓	✓	✓	✓
LCUSTOMPAPERFEED	3-23	✓	✓	✓	✓
LCUSTOMTYPE1LENGTH	3-23	✗	✗	✗	✗
LCUSTOMTYPE1LOADING	3-23	✓	✓	✓	✓
LCUSTOMTYPE1MEDIA	3-23	✓	✓	✓	✓
LCUSTOMTYPE1NAME	3-23	✓	✓	✓	✓
LCUSTOMTYPE1OUTBIN	3-24	✗	✗	✗	✗
LCUSTOMTYPE1TEXTURE	3-24	✓	✓	✓	✓
LCUSTOMTYPE1WEIGHT	3-24	✓	✓	✓	✓
LCUSTOMTYPE2LENGTH	3-24	✗	✗	✗	✗
LCUSTOMTYPE2LOADING	3-24	✓	✓	✓	✓
LCUSTOMTYPE2MEDIA	3-24	✓	✓	✓	✓
LCUSTOMTYPE2NAME	3-25	✓	✓	✓	✓
LCUSTOMTYPE2OUTBIN	3-25	✗	✗	✗	✗
LCUSTOMTYPE2TEXTURE	3-25	✓	✓	✓	✓
LCUSTOMTYPE2WEIGHT	3-25	✓	✓	✓	✓
LCUSTOMTYPE3LENGTH	3-25	✗	✗	✗	✗
LCUSTOMTYPE3LOADING	3-25	✗	✗	✗	✗
LCUSTOMTYPE3MEDIA	3-26	✓	✓	✓	✓
LCUSTOMTYPE3NAME	3-26	✓	✓	✓	✓
LCUSTOMTYPE3OUTBIN	3-26	✗	✗	✗	✗
LCUSTOMTYPE3TEXTURE	3-26	✓	✓	✓	✓
LCUSTOMTYPE3WEIGHT	3-26	✓	✓	✓	✓
LCUSTOMTYPE4LENGTH	3-26	✗	✗	✗	✗

Table B-2: Printer Unique PJJ Variables for Both Printer Languages (Continued)

✓ Supported ✗ Not Supported Page numbers reference variable descriptions and are listed for supported variables only. Default values are listed for exceptions only.		Printer Model			
		C520, C522n, C524 C524n,	C530dn, C532n, C532dn, C534n, C534dtn.	C770, C770n, C772, C772n	C920, C920n C920dn, C920dnf
LCUSTOMTYPE4LOADING	3-27	✗	✗	✗	✗
LCUSTOMTYPE4MEDIA	3-27	✓	✓	✓	✓
LCUSTOMTYPE4NAME	3-27	✓	✓	✓	✓
LCUSTOMTYPE4OUTBIN	3-27	✗	✗	✗	✗
LCUSTOMTYPE4TEXTURE	3-27	✓	✓	✓	✓
LCUSTOMTYPE4WEIGHT	3-27	✓	✓	✓	✓
LCUSTOMTYPE5LENGTH	3-28	✗	✗	✗	✗
LCUSTOMTYPE5LOADING	3-28	✗	✗	✗	✗
LCUSTOMTYPE5MEDIA	3-28	✓	✓	✓	✓
LCUSTOMTYPE5NAME	3-28	✓	✓	✓	✓
LCUSTOMTYPE5OUTBIN	3-28	✗	✗	✗	✗
LCUSTOMTYPE5TEXTURE	3-28	✓	✓	✓	✓
LCUSTOMTYPE5WEIGHT	3-29	✓	✓	✓	✓
LCUSTOMTYPE6LENGTH	3-29	✗	✗	✗	✗
LCUSTOMTYPE6LOADING	3-29	✗	✗	✗	✗
LCUSTOMTYPE6MEDIA	3-29	✓	✓	✓	✓
LCUSTOMTYPE6NAME	3-29	✓	✓	✓	✓
LCUSTOMTYPE6OUTBIN	3-29	✗	✗	✗	✗
LCUSTOMTYPE6TEXTURE	3-30	✓	✓	✓	✓
LCUSTOMTYPE6WEIGHT	3-30	✓	✓	✓	✓
LDOWNLOADTARGET	3-30	✓	✓	✓	✓
LDRYTIMEDELAY	3-30	✗	✗	✗	✗
LDUPLICATEHELDJOBS	3-30	✓	✓	✓	✓
LENVELOPEENHANCE	3-30	✗	✗	✗	✗
LENVELOPELENGTH	3-30	✗	✗	✗	✗
LENVELOPEOUTBIN	3-30	✗	✗	✗	✗
LENVELOPETEXTURE	3-31	✓	✓	✓	✓

Table B-2: Printer Unique PJL Variables for Both Printer Languages (Continued)

✓ Supported ✗ Not Supported Page numbers reference variable descriptions and are listed for supported variables only. Default values are listed for exceptions only.		Printer Model			
		C520, C522n, C524 C524n,	C530dn, C532n, C532dn, C534n, C534dtn.	C770, C770n, C772, C772n	C920, C920n C920dn, C920dnf
LENVELOPEWEIGHT	3-31	✓	✓	✓	✓
LESCCHAR	3-31	✓	✓	✓	✓
LFAXRESOLUTION	3-31	✗	✗	✗	✗
LFAXREDIAL	3-31	✗	✗	✗	✗
LFAXREDIALFREQUENCY	3-31	✗	✗	✗	✗
LFAXTRANSMISSIONLOG	3-31	✗	✗	✗	✗
LFEEDERPAPERTYPE	3-31	✗	✗	✗	✗
LGLOSSYLOADING	3-31	✗	✗	✗	✗
LGLOSSYOUTPUTBIN	3-32	✗	✗	✗	✗
LGLOSSYTEXTURE	3-32	✗	✗	✗	✗
LGLOSSYWEIGHT	3-32	✗	✗	✗	✗
LHOLEPUNCHALARM	3-32	✗	✗	✗	✗
LHOLEPUNCHMODE	3-32	✗	✗	✗	✗
LHONORINIT	3-32	✓	✓	✓	✓
LIMAGEBRIGHTNESS	3-32	✗	✗	✗	✗
LIMAGECONTRAST	3-32	✗	✗	✗	✗
LIMAGEENHANCE	3-32	✓	✓	✓	✓
LIMAGEENHANCETYPE	3-33	✓	✓	✓	✓
LIMAGEORIENTATION	3-33	✓	✓	✓	✓
LIMAGESMOOTHING	3-33	✗	✗	✗	✗
LINFEDER		✗	✗	✗	✗
LINFEDERSIZE	3-33	✗	✗	✗	✗
LINKALERT	3-33	✗	✗	✗	✗
LINMPFEEDERSIZE	3-33	✓	✓	✓	✓
LJAMRECOVERY	3-33	✓	✓	✓	✓
LLABELSLENGTH	3-33	✗	✗	✗	✗
LLABELSLOADING	3-33	✓	✓	✓	✓

Table B-2: Printer Unique PJL Variables for Both Printer Languages (Continued)

✓ Supported ✗ Not Supported Page numbers reference variable descriptions and are listed for supported variables only. Default values are listed for exceptions only.		Printer Model			
		C520, C522n, C524 C524n,	C530dn, C532n, C532dn, C534n, C534dtn.	C770, C770n, C772, C772n	C920, C920n C920dn, C920dnf
LLABELSOUTBIN	3-34	✗	✗	✗	✗
LLABELSTEXTURE	3-34	✓	✓	✓	✓
LLABELSWEIGHT	3-34	✓	✓	✓	✓
LLEFTMARGINOFFSET	3-34	✓	✓	✓	✓
LLETTERHEADLENGTH	3-34	✗	✗	✗	✗
LLETTERHEADLOADING	3-34	✗	✗	✗	✗
LLETTERHEADOUTBIN	3-35	✗	✗	✗	✗
LLETTERHEADTEXTURE	3-35	✓	✓	✓	✓
LLETTERHEADWEIGHT	3-35	✓	✓	✓	✓
LMANUALCOLORRGBTEXT	3-35	✗	✗	✗	✗
LMANUALCOLORRGBGRAPHICS	3-35	✗	✗	✗	✗
LMANUALCOLORRGBIMAGE	3-35	✗	✗	✗	✗
LMANUALCOLORCMYKTEXT	3-35	✗	✗	✗	✗
LMANUALCOLORCMYKGRAPHICS	3-35	✗	✗	✗	✗
LMANUALCOLORCMYKIMAGE	3-36	✗	✗	✗	✗
LMANUALENVELOPESIZE	3-36	✓	✓	✓	✓
LMANUALENVELOPETYPE	3-36	✓	✓	✓	✓
LMANUALPAPERSIZE	3-36	✓	✓	✓	✓
LMANUALPAPERTYPE	3-36	✓	✓	✓	✓
LMAXSTATUSMSG		✗	✗	✗	✗
LMPFEEDERPAPERTYPE	3-36	✗	✗	✗	✗
LMULTIPAGEBORDER	3-36	✓	✓	✓	✓
LMULTIPAGEORDER	3-36	✓	✓	✓	✓
LMULTIPAGEPRINT	3-37	✓	✓	✓	✓
LMULTIPAGEVIEW	3-37	✓	✓	✓	✓
LNPAP	3-37	✓	✓	✓	✓
LOPTIONALOUTBIN1NAME	3-37	✗	✗	✗	✗

Table B-2: Printer Unique PJL Variables for Both Printer Languages (Continued)

✓ Supported ✗ Not Supported Page numbers reference variable descriptions and are listed for supported variables only. Default values are listed for exceptions only.		Printer Model			
		C520, C522n, C524 C524n,	C530dn, C532n, C532dn, C534n, C534dtn.	C770, C770n, C772, C772n	C920, C920n C920dn, C920dnf
LOPTIONALOUTBIN2NAME	3-37	✗	✗	✗	✗
LOPTIONALOUTBIN3NAME	3-37	✗	✗	✗	✗
LOPTIONALOUTBIN4NAME	3-37	✗	✗	✗	✗
LOPTIONALOUTBIN5NAME	3-37	✗	✗	✗	✗
LOPTIONALOUTBIN6NAME	3-38	✗	✗	✗	✗
LOPTIONALOUTBIN7NAME	3-38	✗	✗	✗	✗
LOPTIONALOUTBIN8NAME	3-38	✗	✗	✗	✗
LOPTIONALOUTBIN9NAME	3-38	✗	✗	✗	✗
LOPTIONALOUTBIN10NAME	3-38	✗	✗	✗	✗
LOUTBINCONFIG	3-38	✗	✗	✗	✗
LOVERFLOWOUTBIN	3-39	✗	✗	✗	✗
LOVERFLOWTIMER	3-39	✗	✗	✗	✗
LPAGECOUNT	3-39	✓	✓	✓	✓
LPAGEMODE	3-39	✓	✓	✓	✓
LPAPERSOURCE	3-39				
LPICTUREGRADE	3-40	✓	✓	✓	✓
LPLAINLENGTH	3-40	✗	✗	✗	✗
LPLAINOUTBIN	3-40	✗	✗	✗	✗
LPLAINTEXTURE	3-40	✓	✓	✓	✓
LPLAINWEIGHT	3-40	✓	✓	✓	✓
LPOWERSAVER	3-40	✓	✓	✓	✓
LPPDS	3-41	✓	✓	✓	✓
LPPDSFORMLINES	3-41	✓	✓	✓	✓
LPPDSLINESPERINCH	3-41	✓	✓	✓	✓
LPREPRINTEDLENGTH	3-41	✗	✗	✗	✗
LPREPRINTEDLOADING	3-41	✗	✗	✗	✗
LPREPRINTEDOUTBIN	3-42	✗	✗	✗	✗

Table B-2: Printer Unique PJJ Variables for Both Printer Languages (Continued)

✓ Supported ✗ Not Supported Page numbers reference variable descriptions and are listed for supported variables only. Default values are listed for exceptions only.		Printer Model			
		C520, C522n, C524 C524n,	C530dn, C532n, C532dn, C534n, C534dtn.	C770, C770n, C772, C772n	C920, C920n C920dn, C920dnf
LPREPRINTEDTEXTURE	3-42	✓	✓	✓	✓
LPREPRINTEDWEIGHT	3-42	✓	✓	✓	✓
LPRINTBUFFER	3-42	✓	✓	✓	✓
LPRINtheadIDLETIME	3-42	✗	✗	✗	✗
LPRINTERUSAGE	3-42	✗	✗	✗	✗
LPRINTMENUSBUTTON	3-42	✗	✗	✗	✗
LPRINTQUALITY	3-43	✗	✗	✗	✗
LPUNCH	3-43	✗	✗	✗	✗
LREAROUTBINNAME	3-43	✗	✗	✗	✗
LREPEATPRINTLIMIT	3-43	✗	✗	✗	✗
LRESET	3-43	✓	✓	✓	✓
LRESOURCESAVE	3-43	✓	✓	✓	✓
LRIGHTMARGINOFFSET	3-43	✓	✓	✓	✓
LSCREENING	3-43	✗	✗	✗	✗
LSEPARATORSHEETS	3-43	✓	✓	✓	✓
LSEPARATORSOURCE	3-43	✓	✓	✓	✓
LSTANDARDOUTBINNAME	3-44	✗	✗	✗	✗
LSTAPLE	3-44	✗	✗	✗	✗
LSTAPLEEMPTYALARM	3-44	✗	✗	✗	✗
LSTAPLETESTBIN	3-44	✗	✗	✗	✗
LSTAPLETESTSOURCE	3-44	✗	✗	✗	✗
LSTROKEWIDTH	3-44	✗	✗	✗	✗
LSUBSTITUTESIZE	3-44				
LTOPBINROTATE	3-44	✗	✗	✗	✗
LTOPMARGINOFFSET	3-44	✗	✗	✗	✗
LTRANSPARENCYLENGTH	3-44	✗	✗	✗	✗
LTRANSPARENCYOUTBIN	3-45	✗	✗	✗	✗

Table B-2: Printer Unique PJJ Variables for Both Printer Languages (Continued)

✓ Supported ✗ Not Supported Page numbers reference variable descriptions and are listed for supported variables only. Default values are listed for exceptions only.		Printer Model			
		C520, C522n, C524 C524n,	C530dn, C532n, C532dn, C534n, C534dtn.	C770, C770n, C772, C772n	C920, C920n C920dn, C920dnf
LTRANSPARENCYTEXTURE	3-45	✓	✓	✓	✓
LTRANSPARENCYWEIGHT	3-45	✓	✓	✓	✓
LTRAY1SENSEDTYPEPAPER	3-45	✗	✗	✗	✗
LTRAY1SENSEDTYPETRANSPARENCY	3-45	✗	✗	✗	✗
LTRAY2SENSEDTYPEPAPER	3-45	✗	✗	✗	✗
LTRAY2SENSEDTYPETRANSPARENCY	3-45	✗	✗	✗	✗
LTRAY3SENSEDTYPEPAPER	3-46	✗	✗	✗	✗
LTRAY3SENSEDTYPETRANSPARENCY	3-46	✗	✗	✗	✗
LTRAY4SENSEDTYPEPAPER	3-46	✗	✗	✗	✗
LTRAY4SENSEDTYPETRANSPARENCY	3-46	✗	✗	✗	✗
LTRAY1AUTOSIZE	3-46	✗	✗	✗	✗
LTRAY2AUTOSIZE	3-46	✗	✗	✗	✗
LTRAY3AUTOSIZE	3-46	✗	✗	✗	✗
LTRAY4AUTOSIZE	3-46	✗	✗	✗	✗
LTRAY5AUTOSIZE	3-46	✗	✗	✗	✗
LTRAY1PAPERTYPE	3-46				
LTRAY2PAPERTYPE	3-47				
LTRAY3PAPERTYPE	3-47	✗	✗	✗	✗
LTRAY4PAPERTYPE	3-47	✗	✗	✗	✗
LTRAY5PAPERTYPE	3-47	✗	✗	✗	✗
LTRAY1RENUMBER	3-47	✓	✓	✓	✓
LTYPE1FONTS	3-48	✓	✓	✓	✓
LUSDEFAULTS	3-48	✓	✓	✓	✓

Table B-3: Common Variables for PCL Emulation

✓ Supported ✗ Not Supported Page numbers reference variable descriptions.		Printer Model			
		C520, C522n, C524 C524n,	C530dn, C532n, C532dn, C534n, C534dtn.	C770, C770n, C772, C772n	C920, C920n C920dn, C920dnf
Variable Name	Page				
FONTNUMBER	3-48	✓	✓	✓	✓
FONTSOURCE	3-48	✓	✓	✓	✓
PITCH	3-48	✓	✓	✓	✓
PTSIZE	3-48	✓	✓	✓	✓
SYMSET	3-48	✓	✓	✓	✓

Table B-4: Printer Unique Variables for PCL Emulation

✓ Supported ✗ Not Supported Page numbers reference variable descriptions.		Printer Model			
		C520, C522n, C524 C524n,	C530dn, C532n, C532dn, C534n, C534dtn.	C770, C770n, C772, C772n	C920, C920n C920dn, C920dnf
Variable Name	Page				
LA4WIDTH	3-49	✓	✓	✓	✓
LASSIGNFEEDER	3-49	✗	✗	✗	✗
LASSIGNMANUALENVELOPE	3-49	✓	✓	✓	✓
LASSIGNMANUALPAPER	3-49	✓	✓	✓	✓
LASSIGNMPFEEDER	3-49	✗	✗	✗	✗
LASSIGNTRAY1	3-50	✓	✓	✓	✓
LASSIGNTRAY2	3-50	✓	✓	✓	✓
LASSIGNTRAY3	3-50	✗	✗	✗	✗
LASSIGNTRAY4	3-50	✗	✗	✗	✗
LASSIGNTRAY5	3-50	✗	✗	✗	✗

Table B-4: Printer Unique Variables for PCL Emulation (Continued)

✓ Supported ✗ Not Supported Page numbers reference variable descriptions.		Printer Model			
		C520, C522n, C524 C524n,	C530dn, C532n, C532dn, C534n, C534dtn.	C770, C770n, C772, C772n	C920, C920n C920dn, C920dnf
Variable Name	Page				
LBITMAPROUNDING	3-50	✓	✓	✓	✓
LCOLOREXTENSIONS	3-50	✓	✓	✓	✓
LFONTCOMPATIBILITY	3-51	✓	✓	✓	✓
LFONTPRIORITY	3-51	✓	✓	✓	✓

Table B-5: Common Variables for PostScript Emulation

✓ Supported ✗ Not Supported Page numbers reference variable descriptions and are listed for supported variables only.		Printer Model			
		C520, C522n, C524 C524n,	C530dn, C532n, C532dn, C534n, C534dtn.	C770, C770n, C772, C772n	C920, C920n C920dn, C920dnf
Variable Name	Page				
JAMRECOVERY	3-51	✓	✓	✓	✓
PRTPSERRS	3-51	✓	✓	✓	✓
ADOBEMBT		✗	✗	✗	✗

Table B-6: Printer Unique Variables for PostScript Emulation

✓ Supported ✗ Not Supported Page numbers reference variable descriptions.		Printer Model			
		C520, C522n, C524 C524n, C524dm	C53-dm, C532m, C532dm C534m, C534dm, C534dtn	C770, C770n, C772, C772n	C920, C920n, C922, C922n
Variable Name	Page				
LPICTUREGRADE	3-52	✓	✓	✓	✓
LPSFONTPRIORITY	3-52	✓	✓	✓	✓

Table B-7: Printer Unique LRESOURCE Variables

✓ Supported ✗ Not Supported Page numbers reference variable descriptions.		Printer Model			
		C520, C522n, C524 C524n, C524dm	C53-dm, C532m, C532dm C534m, C534dm, C534dtn	C770, C770n, C772, C772n	C920, C920n, C922, C922n
Variable Name	Page				
LDESCRIPTION	3-53	✓	✓	✓	✓
LRWLOCK	3-53	✓	✓	✓	✓
LWLOCK	3-53	✓	✓	✓	✓

Table B-8: Status Readback Commands

✓ Supported ✗ Not Supported Page numbers reference command descriptions.		Printer Model			
		C520, C522n, C524 C524n, C524dmi	C53-dm. C532m. C532dmi C534m. C534dm. C534dtn	C770, C770n, C772, C772n	C920, C920n, C922, C922n
Command Name	Page				
Dinquire	3-54	✓	✓	✓	✓
Echo	3-55	✓	✓	✓	✓
Info	3-56	✓	✓	✓	✓
Inquire	3-58	✓	✓	✓	✓
Ustatus	3-59	✓	✓	✓	✓
Ustatusoff	3-60	✓	✓	✓	✓

Table B-9: USTATUS Unsolicited Status Variables

✓ Supported ✗ Not Supported Page numbers reference variable descriptions.		Printer Model			
		C520, C522n, C524 C524n, C524dmi	C53-dm. C532m. C532dmi C534m. C534dm. C534dtn	C770, C770n, C772, C772n	C920, C920n, C922, C922n
Variable Name	Page				
DEVICE	3-60	✓	✓	✓	✓
JOB	3-60	✓	✓	✓	✓
PAGE	3-60	✓	✓	✓	✓
TIMED	3-60	✓	✓	✓	✓

Table B-10: PJL Messages for Auto-Continuable Conditions

✓ Supported ✗ Not Supported Page numbers reference message descriptions.				Printer Model			
				C520, C522n, C524 C524n, C524dmi	C53-dm, C532m, C532dm, C534m, C534dm, C534dtn	C770, C770n, C772, C772n	C920, C920n, C922, C922n
Message	Page	Status Code	Return String				
Intervention Required - PPDS Font Error	3-63	30014	50 PPDS Font Error	✓	✓	✓	✓
Intervention Required - Insufficient Collation Area	3-63	30016	37 Insufficient Collation Area	✓	✓	✓	✓
Intervention Required - Insufficient Defragment Memory	3-63	30016	37 Insufficient Defrag Memory	✓	✓	✓	✓
Intervention Required - Insufficient Memory	3-63	30016	37 Insufficient Memory	✗	✗	✗	✗
Intervention Required - Memory Full	3-63	30016	38 Memory Full	✓	✓	✓	✓
Intervention Required - Held Jobs May Not Be Restored	3-63	30016	Held Jobs May Not Be Restored	✗	✗	✗	✗
Intervention Required - Configuration Change	3-63	30016	57 Configuration Change	✗	✗	✗	✗
Intervention Required - Complex Page	3-63	30017	39 Complex Page	✓	✓	✓	✓
Intervention Required - Standard Serial Error	3-63	30018	54 Standard Serial Error	✗	✗	✗	✗
Intervention Required - Serial Option Error	3-63	30018	54 Serial Option <slot #> error	✗	✗	✗	✗
Intervention Required - Parallel Error	3-63	30018	54 Parallel Error	✗	✗	✗	✗
Intervention Required - Network Software Error	3-65	30018	54 Std Network Software Error	✓	✓	✓	✓
Intervention Required - Standard Serial Fax Connection Lost	3-63	30018	54 Std Ser Fax Connection Lost	✗	✗	✗	✗
Intervention Required - Standard Serial Disabled	3-64	30018	56 Standard Serial Disabled	✗	✗	✗	✗

Table B-10: PJL Messages for Auto-Continuable Conditions (Continued)

✓ Supported ✗ Not Supported Page numbers reference message descriptions.				Printer Model			
				C520, C522n, C524 C524n, C524dmi	C53-dm. C532m. C532dmi C534m. C534dmi. C534dtn	C770, C770n, C772, C772n	C920, C920n, C922, C922n
Message	Page	Status Code	Return String				
Intervention Required - Serial Option Disabled	3-64	30018	56 Serial <slot #> Port Disabled	✗	✗	✗	✗
Intervention Required - Std Parallel Port Disabled	3-64	30018	56 Std Parallel Port Disabled	✗	✗	✗	✗
Intervention Required - Parallel Port Disabled	3-64	30018	56 Parallel Port Disabled	✗	✗	✗	✗
Intervention Required - Parallel Port Error	3-64	30018	56 Parallel Port x Disabled	✗	✗	✗	✗
Intervention Required - Standard USB Disabled	3-64	30018	56 Standard USB Port Disabled	✓	✓	✓	✓
Intervention Required - Resource Save Off Deficient Memory	3-64	30019	35 Res Save Off Deficient Memory	✗	✗	✗	✗
Intervention Required - Insufficient Fax Buffer	3-64	30026	55 Insufficient Fax Buffer	✗	✗	✗	✗
Intervention Required - Std Par ENA Connection Lost	3-64	30027	54 Std Par ENA Connection Lost	✗	✗	✗	✗
Intervention Required - Std Parallel Port Disabled	3-64	30027	56 Std Parallel Port Disabled	✗	✗	✗	✗
Intervention Required - Resolution Reduced	3-64	30029	36 Resolution Reduced	✗	✗	✗	✗
Intervention Required - Print Jobs on Disk Request	3-64	30031	Print Jobs on Disk? or Print Jobs on Disk. Go/Stop?	✗	✗	✗	✗
Intervention Required - Restore Held Jobs. Go/Stop?	3-64	30031	Restore Held Jobs. Go/Stop?	✗	✗	✗	✗
Intervention Required - Short Paper	3-64	30034	34 Short Paper	✓	✓	✓	✓
Intervention Required - Flash Full	3-64	30035	52 Flash Full	✗	✗	✗	✗
Intervention Required - Disk Full	3-64	30035	62 Disk Full	✗	✗	✗	✗

Table B-10: PJL Messages for Auto-Continuable Conditions (Continued)

✓ Supported ✗ Not Supported Page numbers reference message descriptions.				Printer Model			
				C520, C522n, C524 C524n, C524dmi	C53-dm, C532m, C532dmi C534m, C534dmi, C534dtn	C770, C770n, C772, C772n	C920, C920n, C922, C922n
Message	Page	Status Code	Return String				
Intervention Required - Defective Flash	3-64	30036	51 Defective Flash	✗	✗	✗	✗
Intervention Required - Unformatted Flash	3-64	30036	53 Unformatted Flash	✗	✗	✗	✗
Intervention Required - Defective Disk	3-64	30036	61 Defective Disk	✗	✗	✗	✗
Intervention Required - Unformatted Disk	3-65	30036	63 Unformatted Disk	✗	✗	✗	✗
Intervention Required - Scheduled Maintenance	3-65	30075	80 Scheduled Maintenance	✓	✓	✓	✓
Intervention Required - Resource Save Off Deficient Memory	3-65	30076	35 Res Save Off Deficient Memory	✓	✓	✓	✓
Intervention Required - Insufficient Collation Area	3-65	30076	37 Insufficient Collation Area	✗	✗	✗	✗
Intervention Required - Empty Hole Punch Box	3-65	30107	Empty Hole Punch Box	✗	✗	✗	✗
Intervention Required - Empty Box M	3-65	30107	Empty Box M	✗	✗	✗	✗
Intervention Required - Insert Box M	3-65	30107	Insert Box M	✗	✗	✗	✗
Intervention Required - Insert Staple Cartridge	3-65	30107	Insert Staple Cartridge	✗	✗	✗	✗
Intervention Required - Insert Stapler	3-65	30107	Insert Stapler	✗	✗	✗	✗
Intervention Required - Priming Failed	3-65	30107	Priming Failed, Retry. Go/ Stop?	✗	✗	✗	✗
Intervention Required - Network x Software Error	3-65	30112	54 Network x Software Error	✗	✗	✗	✗
Intervention Required - Serial Port x Disabled	3-65	30112	56 Serial Port x Disabled	✗	✗	✗	✗

Table B-10: PJI Messages for Auto-Continuable Conditions (Continued)

✓ Supported ✗ Not Supported Page numbers reference message descriptions.				Printer Model			
				C520, C522n, C524 C524n, C524dmi	C53-dm. C532m. C532dmi C534m. C534dmi. C534dtn	C770, C770n, C772, C772n	C920, C920n, C922, C922n
Message	Page	Status Code	Return String				
Intervention Required - Serial Option x Error	3-65	30112	54 Serial Option x Error	✗	✗	✗	✗
Intervention Required - Serial x Fax Connection Lost	3-65	30112	54 Ser x Fax Connection Lost	✗	✗	✗	✗
Intervention Required - USB Port Disabled	3-65	30112	56 USB Port x Disabled	✗	✗	✗	✗
Intervention Required - Parallel x ENA Connection Lost	3-65	30113	54 Par x ENA Connection Lost	✗	✗	✗	✗
Intervention Required - Parallel x Port Disabled	3-65	30113	56 Parallel Port x Disabled	✗	✗	✗	✗
Intervention Required - Disk Operation Failed Jobs on Disk	3-65	32001	Operation Failed Jobs on Disk	✗	✗	✗	✗
Intervention Required - Disk Operation Failed Faxes on Disk	3-65	32001	Operation Failed Faxes on Disk	✗	✗	✗	✗
Intervention Required - Flash Full	3-66	32002	52 Flash Full	✓	✓	✓	✓
Intervention Required - Disk Full	3-66	32002	62 Disk Full	✗	✗	✗	✗
Intervention required: Disk Corrupted. Reformat?	3-66	32015	Disk Corrupted. Reformat?	✗	✗	✗	✗
Intervention Required - Too Many Flash Options Installed	3-66	32030	58 Too Many Flash Options	✗	✗	✗	✗
Intervention Required - Unformatted Flash	3-66	32052	53 Unformatted Flash	✓	✓	✓	✓
Intervention Required - Unformatted Disk	3-66	32052	63 Unformatted Disk	✗	✗	✗	✗
Intervention Required: Unsupported Disk Format	3-66	32052	64 Unsupported Disk Format	✗	✗	✗	✗

Table B-10: PJL Messages for Auto-Continuable Conditions (Continued)

✓ Supported ✗ Not Supported Page numbers reference message descriptions.				Printer Model			
				C520, C522n, C524 C524n, C524dmi	C53-dm. C532m. C532dmi C534m. C534dmi. C534dtn	C770, C770n, C772, C772n	C920, C920n, C922, C922n
Message	Page	Status Code	Return String				
Intervention Required - Defective Flash	3-66	32056	51 Defective Flash	✓	✓	✓	✓
Intervention Required - Defective Disk	3-66	32056	61 Defective Disk	✗	✗	✗	✗
Intervention Required - Scheduled Maintenance	3-66	35075	80 Scheduled Maintenance	✗	✗	✗	✗
Intervention Required - Scheduled Maintenance	3-66	35075	81 Scheduled Maintenance	✗	✗	✗	✗
Intervention Required - Fuser Maintenance	3-66	40038	80 Fuser Maintenance	✗	✗	✗	✗
Intervention Required - Fuser Life Warning	3-66	40038	80 Fuser Life Warning	✗	✗	✗	✗
Intervention Required - Belt Life Warning	3-66	40038	80 Belt Life Warning	✗	✗	✗	✗
Intervention Required - Fuser/Belt Life Warning	3-66	40038	80 Fuser/Belt Life Warning	✗	✗	✗	✗
Intervention Required - Fuser Exhausted	3-66	40038	80 Fuser Exhausted	✗	✗	✗	✗
Intervention Required - Belt Exhausted	3-66	40038	80 Belt Exhausted	✗	✗	✗	✗
Intervention Required - Fuser/Belt Exhausted	3-66	40038	80 Fuser/Belt Exhausted	✗	✗	✗	✗
Intervention Required - ITU Maintenance	3-66	40038	83 ITU Maintenance	✗	✗	✗	✗

Table B-11: PJL Messages for Attendance Conditions

✓ Supported ✗ Not Supported Page numbers reference message descriptions.				Printer Model			
				C520, C522n, C524 C524n, C524dmi	C53-dm, C532m, C532dm C534m, C534dm, C534dtn	C770, C770n, C772, C772n	C920, C920n, C922, C922n
Message	Page	Status Code	Return String				
Intervention Required - 30 Coating Roll Missing	3-67	40010	30 Coating Roll Missing	✗	✗	✗	✗
Intervention Required - 30 XXXX ¹ Print Unit Missing	3-67	40010	30 XXXX¹ Print Unit Missing	✗	✗	✗	✗
Intervention Required - Insert Hole Punch Box	3-67	40010	Insert Hole Punch Box	✗	✗	✗	✗
Intervention Required - Insert PC Cartridge	3-67	40010	Insert PC Cartridge	✗	✗	✗	✗
Intervention Required - Cartridge Life Expired	3-67	40021	Cartridge Life Expired XXXX¹	✗	✗	✗	✗
Intervention Required - Cartridge Life Warning	3-68	40021	Cartridge Life Warning XXXX¹	✗	✗	✗	✗
Intervention Required - Printer Upper Door Open	3-67	40021	Cover Open, Close Top Covers, Close Door, or Insert Cartridge	✓	✓	✓	✓
Intervention Required - Printer Cover Open	3-68	40021	Close Cover	✗	✗	✗	✗
Intervention Required - Close Toner Box Cover	3-67	40021	Close Cover A	✗	✗	✗	✗
Intervention Required - Close Deflector G	3-68	40021	Close Deflector G	✗	✗	✗	✗
Intervention Required - Defective Print Cartridge	3-67	40021	31 Defective Print Cartridge	✓	✓	✓	✓
Intervention Required - Defective Ink Cartridge	3-67	40021	31 Defective Cartridge XXXX¹	✗	✗	✗	✗
Intervention Required - Missing Cartridge	3-68	40021	31 Missing Cartridge XXXX¹	✗	✗	✗	✗
¹ XXXX represents a subset of letters CMYK, where CMYK denotes Cyan, Magenta, Yellow, and Black cartridges, respectively.							

Table B-11: PJL Messages for Attendance Conditions (Continued)

✓ Supported ✗ Not Supported Page numbers reference message descriptions.				Printer Model			
				C520, C522n, C524 C524n, C524dmi	C53-dm, C532m, C532dmi C534m, C534dmi, C534dtn	C770, C770n, C772, C772n	C920, C920n, C922, C922n
Message	Page	Status Code	Return String				
Intervention Required - Missing Printhead	3-68	40021	31 Missing Printhead	✗	✗	✗	✗
Intervention Required - Unsupported Print Cartridge	3-67	40021	32 Unsupported Print Cartridge	✓	✓	✓	✓
Intervention Required - Unsupported XXXX ¹ Cartridge	3-67	40021	32 Unsupported XXXX¹ Cartridge	✗	✗	✗	✗
Intervention Required - Unsupported Cartridge	3-67	40021	32 Unsupported Cartridge	✗	✗	✗	✗
Intervention Required - Unsupported Printhead	3-68	40021	32 Unsupported Printhead	✗	✗	✗	✗
Intervention Required - Tray Size Sense Error	3-68	40021	40 Tray x Size Sense Error	✗	✗	✗	✗
Intervention Required - Open Bin Exit Tray	3-68	40021	41 Open Bin 1 Exit Tray	✗	✗	✗	✗
Intervention Required - Change Cartridge Invalid Refill	3-67	40021	Change Cartridge Invalid Refill	✓	✓	✓	✓
Intervention Required - Open Cover	3-68	40021	Open Cover	✗	✗	✗	✗
Intervention Required - Open Rear Door	3-68	40021	Open Rear Door	✗	✗	✗	✗
Intervention Required - Close Front Door	3-68	40021	Close Front Door	✗	✗	✗	✗
Intervention Required - Close Side Door	3-68	40021	Close Side Door	✗	✗	✗	✗
Intervention Required - Close Finisher Door	3-68	40021	Close Finisher Door	✗	✗	✗	✗
Intervention Required - Close Finisher Side Door	3-68	40021	Close Finisher Side Door	✗	✗	✗	✗
¹ XXXX represents a subset of letters CMYK, where CMYK denotes Cyan, Magenta, Yellow, and Black cartridges, respectively.							

Table B-11: PJL Messages for Attendance Conditions (Continued)

✓ Supported ✗ Not Supported Page numbers reference message descriptions.				Printer Model			
				C520, C522n, C524 C524n, C524dmi	C53-dm, C532m, C532dmi C534m, C534dmi, C534dtn	C770, C770n, C772, C772n	C920, C920n, C922, C922n
Message	Page	Status Code	Return String				
Intervention Required - Close Finisher Top Cover	3-68	40021	Close Finisher Top Cover	✗	✗	✗	✗
Intervention Required - Close Door <d>	3-68	40021	Close Door <d>	✓	✓	✓	✓
Intervention Required - Close Cover <c>	3-68	40021	Close Cover <c>	✗	✗	✗	✗
Intervention Required - Close Tray x Top Cover	3-68	40021	Close Tray x Top Cover	✗	✗	✗	✗
Intervention Required - Insert Print Cartridge	3-69	40021	Insert Print Cartridge	✗	✗	✗	✗
Intervention Required - Paper Jam	3-69	40022	2xx Paper Jam	✗	✗	✗	✗
Intervention Required - Check Tray Connection	3-69	40027	Check Tray <source #> Connection	✗	✗	✗	✗
Intervention Required - Install Tray x or Cancel Job	3-69	40027	Install Tray x or Cancel Job	✗	✗	✗	✗
Intervention Required - Reattach Envelope Feeder	3-69	40028	Reattach Envelope Feeder	✗	✗	✗	✗
Intervention Required - Install Env Feeder or Cancel Job	3-69	40028	Install Env Feed or Cancel Job	✗	✗	✗	✗
Intervention Required - Reattach MP Feeder	3-69	40028	Reattach MP Feeder	✗	✗	✗	✗
Intervention Required - Reattach Output Bin	3-69	40029	Reattach Output Bin <bin #>	✗	✗	✗	✗
Intervention Required - Reattach Bins	3-69	40029	Reattach Bins <bin #x - bin #y>	✗	✗	✗	✗
Intervention Required - Install Bin x or Cancel Job	3-69	40029	Install Bin x or Cancel Job	✗	✗	✗	✗
¹ XXXX represents a subset of letters CMYK, where CMYK denotes Cyan, Magenta, Yellow, and Black cartridges, respectively.							

Table B-11: PJL Messages for Attendance Conditions (Continued)

✓ Supported ✗ Not Supported Page numbers reference message descriptions.				Printer Model			
				C520, C522n, C524 C524n, C524dmi	C53-dm, C532m, C532dmi C534m, C534dmi, C534dtn	C770, C770n, C772, C772n	C920, C920n, C922, C922n
Message	Page	Status Code	Return String				
Intervention Required - Check Finisher Installation	3-69	40029	Check Finisher Installation	✗	✗	✗	✗
Intervention Required - Check Mailbox Installation	3-69	40029	Check Mailbox Installation	✗	✗	✗	✗
Intervention Required - Tray Config Error	3-69	40030	33 Tray x Config Error	✗	✗	✗	✗
Intervention Required - Input Config Error	3-69	40030	58 Input Config Error	✗	✗	✗	✗
Intervention Required - Too Many Trays Attached	3-69	40030	58 Too Many Trays Attached	✗	✗	✗	✗
Intervention Required - Too Many Bins Attached	3-69	40030	58 Too Many Bins Attached	✗	✗	✗	✗
Intervention Required - Too Many Disks Installed	3-69	40030	58 Too Many Disks Installed	✗	✗	✗	✗
Intervention Required - Too Many Disks Installed	3-69	40036	58 Too Many Disks Installed	✗	✗	✗	✗
Intervention Required - PerfectFinish Missing	3-70	40037	31 PerfectFinish Missing	✗	✗	✗	✗
Intervention Required - PerfectFinish Empty	3-70	40037	87 PerfectFinish Empty	✗	✗	✗	✗
Intervention Required - Toner Low	3-70	40038	88 Toner Low	✓	✓	✓	✓
¹ XXXX represents a subset of letters CMYK, where CMYK denotes Cyan, Magenta, Yellow, and Black cartridges, respectively.							

Table B-11: PJI Messages for Attendance Conditions (Continued)

✓ Supported ✗ Not Supported Page numbers reference message descriptions.				Printer Model			
				C520, C522n, C524 C524n, C524dtn	C53-dm, C532m, C532dln C534m, C534dm, C534dtn	C770, C770n, C772, C772n	C920, C920n, C922, C922n
Message	Page	Status Code	Return String				
Intervention Required - Toner Low	3-70	40038	88 Yellow Toner Low 88 Magenta Toner Low 88 Cyan Toner Low 88 Black Toner Low	✗	✗	✗	✗
	3-70		88 Color Print Cartridge Low 88 Black Print Cartridge Low 88 Photo Print Cartridge Low	✗	✗	✗	✗
	3-70		88 Yellow Toner Empty 88 Magenta Toner Empty 88 Cyan Toner Empty 88 Black Toner Empty	✗	✗	✗	✗
Intervention Required - 84 Black Photo Dev Life Warning	3-70	40038	84 Black Photo Dev Life Warning	✗	✗	✗	✗
Intervention Required - 84 Color Photo Dev Life Warning	3-70	40038	84 Color Photo Dev Life Warning	✗	✗	✗	✗
Intervention Required - 84 All Photo Devs Exhausted	3-70	40038	84 All Photo Devs Exhausted	✗	✗	✗	✗
Intervention Required - 84 Black Photo Dev Exhausted	3-70	40038	84 Black Photo Dev Exhausted	✗	✗	✗	✗
Intervention Required - Cartridge Low	3-71	40038	88 Cartridge Low <CMYK>	✗	✗	✗	✗
Intervention Required - Replace PC Kit	3-71	40038	Replace PC Kit	✗	✗	✗	✗
Intervention Required - Replace PC Kit To Continue	3-71	40038	Replace PC Kit To Continue	✗	✗	✗	✗
Intervention Required - Replace Toner Cartridge	3-71	40038	Replace Toner Cartridge	✗	✗	✗	✗
¹ XXXX represents a subset of letters CMYK, where CMYK denotes Cyan, Magenta, Yellow, and Black cartridges, respectively.							

Table B-11: PJL Messages for Attendance Conditions (Continued)

✓ Supported ✗ Not Supported Page numbers reference message descriptions.				Printer Model			
				C520, C522n, C524 C524n, C524dmi	C53-dm, C532m, C532dmi C534m, C534dmi, C534dtn	C770, C770n, C772, C772n	C920, C920n, C922, C922n
Message	Page	Status Code	Return String				
Intervention Required - Replace Toner Cartridge To Continue	3-71	40038	Replace Toner To Continue	✗	✗	✗	✗
Intervention Required - Replace Oil Coating Roll	3-71	40038	Replace Oil Coating Roll	✗	✗	✗	✗
Intervention Required - Cartridge Empty	3-71	40039	89 Cartridge Empty <CMYK>	✗	✗	✗	✗
Intervention Required - Load Staples	3-71	40040	Load Staples	✗	✗	✗	✗
Intervention Required - Priming Failed. Retry?	3-71	40041	Priming Failed. Retry?	✗	✗	✗	✗
Intervention Required - OPMSG	3-71	40048	OPMSG message	✓	✓	✓	✓
Intervention Required - STMSG	3-71	40049	STMSG message	✓	✓	✓	✓
Intervention Required - Replace Fuser	3-71	40050	Replace Fuser	✗	✗	✗	✗
Intervention Required - Replace Transfer Kit	3-71	40050	Replace Transfer Kit	✗	✗	✗	✗
Intervention Required - Incompatible Bin x	3-71	40087	59 Incompatible Bin x	✗	✗	✗	✗
Intervention Required - Incompatible Duplex	3-71	40088	59 Incompatible Duplex	✗	✗	✗	✗
Intervention Required - Incompatible Tray x	3-71	40089	59 Incompatible Tray x	✗	✗	✗	✗
Intervention Required - Incompatible Envelope Feeder	3-71	40090	59 Incompatible Envelope Feeder	✗	✗	✗	✗
Intervention Required - Check Duplex Connection	3-71	40095	Check Duplex Connection	✗	✗	✗	✗
¹ XXXX represents a subset of letters CMYK, where CMYK denotes Cyan, Magenta, Yellow, and Black cartridges, respectively.							

Table B-11: PJL Messages for Attendance Conditions (Continued)

✓ Supported ✗ Not Supported Page numbers reference message descriptions.				Printer Model			
				C520, C522n, C524 C524n, C524dmi	C53-dm, C532m, C532dmi C534m, C534dmi, C534dtn	C770, C770n, C772, C772n	C920, C920n, C922, C922n
Message	Page	Status Code	Return String				
Intervention Required - Install Duplex or Cancel Job	3-72	40095	Install Duplex or Cancel Job	✗	✗	✗	✗
Intervention Required - Duplex Cover Open	3-72	40096	Close Duplex Door	✗	✗	✗	✗
Intervention Required - Insert Duplex Option	3-72	40096	Insert Duplex Option	✗	✗	✗	✗
Intervention Required - Load Staples	3-72	40101	Load Staples	✗	✗	✗	✗
¹ XXXX represents a subset of letters CMYK, where CMYK denotes Cyan, Magenta, Yellow, and Black cartridges, respectively.							

Table B-12: PJL Messages for Paper Handling

✓ Supported ✗ Not Supported Page numbers reference message descriptions.				Printer Model			
				C520, C522n, C524 C524n, C524dmi	C53-dm, C532dm, C534dm, C534dtn	C770, C770n, C772, C772n	C920, C920n, C922, C922n
Message	Page	Status Code	Return String*				
Intervention Required - Wrong Paper Size in Tray x	3-73	30034	34 Wrong Paper Size in Tray x	✗	✗	✗	✗
Intervention Required - Wrong Paper Size Manual Feed	3-73	30034	34 Wrong Paper Size Manual Feed	✗	✗	✗	✗
Intervention Required - Remove Paper Standard Bin	3-73	40019	Remove Paper Standard Bin	✓	✓	✓	✓
Intervention Required - Remove Paper Outbin <bin #>	3-73	40019	Remove Paper Output Bin <bin #>	✗	✗	✗	✗
Intervention Required - Remove Paper All Output Bins	3-73	40019	Remove Paper All Output Bins	✗	✗	✗	✗
Intervention Required - Remove Paper <linked set bin name>	3-73	40019	Remove Paper <linked set bin name>	✗	✗	✗	✗
Intervention Required - Check <Source> Paper Guide	3-73	4100x	Check <source> Paper Guide	✗	✗	✗	✗
Intervention Required - Incorrect Media	3-73	41xyy	34 Incorrect Media	✗	✗	✗	✗
Intervention Required - Load Request	3-73	41xyy	Load <source> <Custom Type Name> <Custom String> <size> <type> <size>	✓	✓	✓	✓
Intervention Required - Load Manual Request	3-73	41xyy	Load Manual <Custom Type Name> <Custom String> <size> <type> <size>	✓	✓	✓	✓
x represents an input source code. For more information, see "Table 3-16: Tray Values" on page 3-74. yy represents a media size code. For more information, see "Table 3-17: Media Size Values" on page 3-74. * See your printer documentation for return string messages.							

Table B-12: PJL Messages for Paper Handling (Continued)

✓ Supported ✗ Not Supported Page numbers reference message descriptions.				Printer Model			
Message	Page	Status Code	Return String*	C520, C522n, C524 C524n, C524dim	C53-dm, C532m, C532dim C534m, C534dm, C534dtn	C770, C770n, C772, C772n	C920, C920n, C922, C922n
Intervention Required - Change Request	3-73	41xyy	Change <source> <Custom Type Name> <Custom String> <size> <type> <size>	✓	✓	✓	✓
Intervention Required - Insert Duplex Pages & Press Go.	3-73	412yy	Insert Duplex Pages & Press Go.	✗	✗	✗	✗
Intervention Required - Insert Tray Request	3-73	4300x	Insert Tray <source #>	✓	✓	✓	✓
x represents an input source code. For more information, see “Table 3-16: Tray Values” on page 3-74. yy represents a media size code. For more information, see “Table 3-17: Media Size Values” on page 3-74. * See your printer documentation for return string messages.							

Table B-13: PJL Messages for Paper Jams

✓ Supported ✗ Not Supported Page numbers reference message descriptions.			Printer Model			
			C520, C522n, C524 C524n, C524dmi	C53-dm, C532m, C532dmi C534m, C534dm, C534dtn	C770, C770n, C772, C772n	C920, C920n, C922, C922n
Message	Page	Status Code				
Intervention Required - Paper Jam	3-76	4200x	✗	✗	✗	✗
Intervention Required - Paper Jam	3-76	4201x	✗	✗	✗	✗
Intervention Required - Paper Jam	3-76	4202x	✗	✗	✗	✗
Intervention Required - Paper Jam	3-76	4203x	✗	✗	✗	✗
Intervention Required - Paper Jam	3-76	4204x	✗	✗	✗	✗
Intervention Required - Paper Jam	3-76	4205x	✗	✗	✗	✗
Intervention Required - Paper Jam	3-76	4206x	✗	✗	✗	✗
Intervention Required - Paper Jam	3-76	4207x	✗	✗	✗	✗
Intervention Required - Paper Jam	3-76	4208x	✗	✗	✗	✗
Intervention Required - Paper Jam	3-76	4209x	✗	✗	✗	✗
Intervention Required - Paper Jam	3-76	4210x	✗	✗	✗	✗
Intervention Required - Paper Jam	3-76	4211x	✗	✗	✗	✗
w indicates this message includes a letter indicating a door or cover. The door or cover needs to be opened. x represents the number of jammed pages in the printer. y represents the tray number. z represents the bin number.						

Table B-13: PJL Messages for Paper Jams (Continued)

✓ Supported ✗ Not Supported Page numbers reference message descriptions.			Printer Model			
			C520, C522n, C524 C524n, C524dmi	C53-dm, C532m, C532dmi C534m, C534dmi, C534dtn	C770, C770n, C772, C772n	C920, C920n, C922, C922n
Message	Page	Status Code				
Intervention Required - Paper Jam	3-76	4220x	✗	✗	✗	✗
Intervention Required - Paper Jam	3-76	4221x	✗	✗	✗	✗
Intervention Required - Paper Jam	3-76	4222x	✗	✗	✗	✗
Intervention Required - Paper Jam	3-76	4230x	✗	✗	✗	✗
Intervention Required - Paper Jam	3-76	4231x	✗	✗	✗	✗
Intervention Required - Paper Jam	3-77	4232x	✗	✗	✗	✗
Intervention Required - Paper Jam	3-77	4233x	✗	✗	✗	✗
Intervention Required - Paper Jam	3-77	4234	✗	✗	✗	✗
Intervention Required - Paper Jam	3-77	424yx	✗	✗	✗	✗
Intervention Required - Paper Jam	3-77	4241wy	✗	✗	✗	✗
Intervention Required - Paper Jam	3-77	4242wy	✗	✗	✗	✗
Intervention Required - Paper Jam	3-77	4243w	✗	✗	✗	✗
Intervention Required - Paper Jam	3-77	4244wy	✗	✗	✗	✗
w indicates this message includes a letter indicating a door or cover. The door or cover needs to be opened. x represents the number of jammed pages in the printer. y represents the tray number. z represents the bin number.						

Table B-13: PJL Messages for Paper Jams (Continued)

✓ Supported ✗ Not Supported Page numbers reference message descriptions.			Printer Model			
			C520, C522n, C524 C524n, C524dm	C53-dm, C532m, C532dmm C534m, C534dm, C534dtn	C770, C770n, C772, C772n	C920, C920n, C922, C922n
Message	Page	Status Code				
Intervention Required - Paper Jam	3-77	4245w	✗	✗	✗	✗
Intervention Required - Paper Jam	3-77	4246w	✗	✗	✗	✗
Intervention Required - Paper Jam	3-77	4247wy	✗	✗	✗	✗
Intervention Required - Paper Jam	3-77	4248w	✗	✗	✗	✗
Intervention Required - Paper Jam	3-77	4249w	✗	✗	✗	✗
Intervention Required - Paper Jam	3-77	4250w	✗	✗	✗	✗
Intervention Required - Paper Jam	3-77	4250x	✗	✗	✗	✗
Intervention Required - Paper Jam	3-77	4251 wy	✗	✗	✗	✗
Intervention Required - Paper Jam	3-77	4251x	✗	✗	✗	✗
Intervention Required - Paper Jam	3-77	4252w	✗	✗	✗	✗
Intervention Required - Paper Jam	3-78	4253w	✗	✗	✗	✗
Intervention Required - Paper Jam	3-78	4254wy	✗	✗	✗	✗
Intervention Required - Paper Jam	3-78	4255	✗	✗	✗	✗
w indicates this message includes a letter indicating a door or cover. The door or cover needs to be opened. x represents the number of jammed pages in the printer. y represents the tray number. z represents the bin number.						

Table B-13: PJL Messages for Paper Jams (Continued)

✓ Supported ✗ Not Supported Page numbers reference message descriptions.			Printer Model			
			C520, C522n, C524 C524n, C524dm	C53-dm, C532m, C532dmm C534m, C534dm, C534dtn	C770, C770n, C772, C772n	C920, C920n, C922, C922n
Message	Page	Status Code				
Intervention Required - Paper Jam	3-78	4256w	✗	✗	✗	✗
Intervention Required - Paper Jam	3-78	4257w	✗	✗	✗	✗
Intervention Required - Paper Jam	3-78	4258w	✗	✗	✗	✗
Intervention Required - Paper Jam	3-78	4259wy	✗	✗	✗	✗
Intervention Required - Paper Jam	3-78	4260w	✗	✗	✗	✗
Intervention Required - Paper Jam	3-78	4260x	✗	✗	✗	✗
Intervention Required - Paper Jam	3-78	4261w	✗	✗	✗	✗
Intervention Required - Paper Jam	3-78	4261x	✗	✗	✗	✗
Intervention Required - Paper Jam	3-78	427zx	✗	✗	✗	✗
Intervention Required - Paper Jam	3-78	4271	✗	✗	✗	✗
Intervention Required - Paper Jam	3-78	4272	✗	✗	✗	✗
Intervention Required - Paper Jam	3-78	4273	✗	✗	✗	✗
Intervention Required - Paper Jam	3-78	4280w	✗	✗	✗	✗
w indicates this message includes a letter indicating a door or cover. The door or cover needs to be opened. x represents the number of jammed pages in the printer. y represents the tray number. z represents the bin number.						

Table B-13: PJL Messages for Paper Jams (Continued)

✓ Supported ✗ Not Supported Page numbers reference message descriptions.			Printer Model			
			C520, C522n, C524 C524n, C524dmi	C53-dm, C532m, C532dmi C534m, C534dmi, C534dtn	C770, C770n, C772, C772n	C920, C920n, C922, C922n
Message	Page	Status Code				
Intervention Required - Paper Jam	3-78	4280x	✗	✗	✗	✗
Intervention Required - Paper Jam	3-79	4281w	✗	✗	✗	✗
Intervention Required - Paper Jam	3-79	4281x	✗	✗	✗	✗
Intervention Required - Paper Jam	3-79	4282w	✗	✗	✗	✗
Intervention Required - Paper Jam	3-79	4282x	✗	✗	✗	✗
Intervention Required - Paper Jam	3-79	4283w	✗	✗	✗	✗
Intervention Required - Paper Jam	3-79	4283x	✗	✗	✗	✗
Intervention Required - Paper Jam	3-79	4284w	✗	✗	✗	✗
Intervention Required - Paper Jam	3-79	4284x	✗	✗	✗	✗
Intervention Required - Paper Jam	3-79	4285w	✗	✗	✗	✗
Intervention Required - Paper Jam	3-79	4286w	✗	✗	✗	✗
Intervention Required - Paper Jam	3-79	4287	✗	✗	✗	✗
Intervention Required - Paper Jam	3-79	4288	✗	✗	✗	✗
w indicates this message includes a letter indicating a door or cover. The door or cover needs to be opened. x represents the number of jammed pages in the printer. y represents the tray number. z represents the bin number.						

Table B-13: PJL Messages for Paper Jams (Continued)

✓ Supported ✗ Not Supported Page numbers reference message descriptions.			Printer Model			
			C520, C522n, C524 C524n, C524dm	C53-dm, C532m, C532dmm C534m, C534dm, C534dmm	C770, C770n, C772, C772n	C920, C920n, C922, C922n
Message	Page	Status Code				
Intervention Required - Paper Jam	3-79	4289	✗	✗	✗	✗
Intervention Required - Paper Jam	3-79	4290	✗	✗	✗	✗
Intervention Required - Paper Jam	3-79	4291	✗	✗	✗	✗
Intervention Required - Paper Jam	3-79	4292	✗	✗	✗	✗
Intervention Required - Paper Jam	3-79	4293	✗	✗	✗	✗
Intervention Required - Paper Jam	3-80	4294	✗	✗	✗	✗
Intervention Required - Paper Jam	3-80	4295	✗	✗	✗	✗
w indicates this message includes a letter indicating a door or cover. The door or cover needs to be opened. x represents the number of jammed pages in the printer. y represents the tray number. z represents the bin number.						

Table B-14: Service Errors

✓ Supported ✗ Not Supported Page numbers reference message description.			Printer Model		
			C520, C524	C522n, C524n	C524dn
Message	Page	Error Code			
ALL SERVICE MESSAGES	3-80	50000	✗	✗	✗

Table B-15: Device Attendance Messages

✓ Supported ✗ Not Supported Page numbers reference message descriptions.		Printer Model			
		C520, C522n, C524 C524n, C524dm	C53-dm. C532m. C532dm C534m. C534dm. C534dtn	C770, C770n, C772, C772n	C920, C920n, C922, C922n
Message	Page				
RDYMSG	3-80	✓	✓	✓	✓
OPMSG	3-81	✓	✓	✓	✓
STMSG	3-81	✓	✓	✓	✓

Table B-16: Lexmark Unique PjL Commands

✓ Supported ✗ Not Supported Page numbers reference command descriptions.		Printer Model			
		C520, C522n, C524 C524n, C524dm	C53-dm. C532m. C532dm C534m. C534dm. C534dtn	C770, C770n, C772, C772n	C920, C920n, C922, C922n
Command	Page				
LBEEP	3-82	✓	✓	✓	✓
LDOWNLOADTARGET	3-30	✓	✓	✓	✓
LPORTROTATE	3-82	✓	✓	✓	✓
LPRINT testpage	3-83	✓	✓	✓	✓
• LPRINTDIRECTORY	3-83	✓	✓	✓	✓
• LPRINTTESTPAGE	3-83	✓	✓	✓	✓
• LPRINTMENUS	3-83	✓	✓	✓	✓
• LPRINTPCLFONTS	3-83	✓	✓	✓	✓

Table B-16: Lexmark Unique PjL Commands (Continued)

✓ Supported ✗ Not Supported Page numbers reference command descriptions.		Printer Model			
		C-520, C522n, C524 C524n, C524dm	C-53-dm, C532m, C532dmm C534m, C534dm, C534dtn	C770, C770n, C772, C772n	C920, C920n, C922, C922n
Command	Page				
• LPRINTPSFONTS	3-83	✓	✓	✓	✓
LESCAPECHAR	3-83	✓	✓	✓	✓
LFAX PHONENUMBER	3-85	✓	✓	✓	✓
LOPENFILE	3-89	✓	✓	✓	✓
LCLOSEFILE	3-89	✓	✓	✓	✓
LREADFILE	3-90	✓	✓	✓	✓
LWRITEFILE	3-91	✓	✓	✓	✓
LRUNFILE	3-91	✓	✓	✓	✓
LRENAMEFILE	3-92	✓	✓	✓	✓
LDELETEFILE	3-92	✓	✓	✓	✓
LFORMAT	3-92	✓	✓	✓	✓
LDEFRAG	3-92	✓	✓	✓	✓

Table B-17: File and Device Protection Commands

✓ Supported ✗ Not Supported Page numbers reference command descriptions.		Printer Model			
		C520, C522n, C524 C524n, C524dm	C53-dm. C532m. C532dm C534m. C534dm. C534dtn	C770, C770n, C772, C772n	C920, C920n, C922, C922n
Command	Page				
LDECLARE LRESOURCE	3-95	✓	✓	✓	✓
LDELETEPASSWORD	3-96	✓	✓	✓	✓
LQUERYSEED LBYPASSPASSWORD KEY	3-98	✓	✓	✓	✓

APPENDIX C: PostScript Support

The following tables list PostScript commands and identify printers that support them.

For detailed information about PostScript emulation, see “PostScript Emulation” on page 4-1.

Table C-1: Supplemental Operators

✓ Supported ✗ Not Supported Page numbers reference operator descriptions.		Printer Model			
		C520, C522n, C524 C524n, C524dim	C53-dm, C532m, C532dim C534m, C534dim, C534dtn	C770, C770n, C772, C772n	C920, C920n, C922, C922n
Operator Name	Page				
appletalktype	4-14	✓	✓	✓	✓
buildtime	4-14	✓	✓	✓	✓
byteorder	4-14	✓	✓	✓	✓
checkpassword	4-15	✓	✓	✓	✓
currentfilenameextend	4-15	✓	✓	✓	✓
currentmanualduplexmode	4-15	✗	✗	✗	✗
currentuniversalsize	4-3	✓	✓	✓	✓
defaulttimeouts	4-16	✓	✓	✓	✓
deletefile	4-16	✓	✓	✓	✓
devcontrol	4-17	✓	✓	✓	✓
devdismount	4-18	✓	✓	✓	✓
devforall	4-19	✓	✓	✓	✓
devformat	4-19	✓	✓	✓	✓
devmount	4-20	✓	✓	✓	✓
devstatus	4-20	✓	✓	✓	✓
diskonline	4-21	✓	✓	✓	✓

Table C-1: Supplemental Operators (Continued)

✓ Supported ✗ Not Supported Page numbers reference operator descriptions.		Printer Model			
		C520, C522n, C524 C524n, C524dm	C53-dm, C532m, C532dm C534m, C534dm, C534dtn	C770, C770n, C772, C772n	C920, C920n, C922, C922n
Operator Name	Page				
diskstatus	4-22	✓	✓	✓	✓
displayoperatormsg	4-22	✓	✓	✓	✓
doidlefonts	4-22	✓	✓	✓	✓
dojamrecovery	4-23	✓	✓	✓	✓
doprinterrors	4-23	✓	✓	✓	✓
doret	4-23	✓	✓	✓	✓
dostartpage	4-24	✓	✓	✓	✓
dosysstart	4-24	✓	✓	✓	✓
duplexer	4-24	✓	✓	✓	✓
duplexmode	4-25	✓	✓	✓	✓
enginesync	4-25	✓	✓	✓	✓
file	4-26	✓	✓	✓	✓
filenameforall	4-26	✓	✓	✓	✓
fileposition	4-26	✓	✓	✓	✓
firstside	4-27	✓	✓	✓	✓
fontnonzerowinding	4-27	✓	✓	✓	✓
hardwareiomode	4-27	✓	✓	✓	✓
idlefonts	4-27	✓	✓	✓	✓
ignoresize	4-4	✓	✓	✓	✓
initializedisk	4-28	✓	✓	✓	✓
jobname	4-28	✓	✓	✓	✓
jobsource	4-29	✓	✓	✓	✓
jobtimeout	4-30	✓	✓	✓	✓
manualfeed	4-8	✓	✓	✓	✓
manualfeedtimeout	4-31	✓	✓	✓	✓
newsheet	4-31	✓	✓	✓	✓

Table C-1: Supplemental Operators (Continued)

✓ Supported ✗ Not Supported Page numbers reference operator descriptions.		Printer Model			
		C520, C522n, C524 C524n, C524dln	C53-dm, C532m, C532dln C534m, C534dln, C534dtn	C770, C770n, C772, C772n	C920, C920n, C922, C922n
Operator Name	Page				
pagecount	4-31	✓	✓	✓	✓
pagesprinted	4-32	✓	✓	✓	✓
papertray	4-8	✓	✓	✓	✓
printrname	4-32	✓	✓	✓	✓
product	4-32	✓	✓	✓	✓
PS2fonts	4-33	✓	✓	✓	✓
PS3fonts	4-33	✓	✓	✓	✓
quiet	4-33	✓	✓	✓	✓
ramsize	4-34	✓	✓	✓	✓
realformat	4-34	✓	✓	✓	✓
renamefile	4-34	✓	✓	✓	✓
resolution	4-35	✓	✓	✓	✓
revision	4-35	✓	✓	✓	✓
sccbatch	4-36	✓	✓	✓	✓
sccinteractive	4-37	✓	✓	✓	✓
setcoverpage	4-37	✓	✓	✓	✓
setdefaulttimeouts	4-37	✓	✓	✓	✓
setdoidlefonts	4-38	✓	✓	✓	✓
setdojamrecovery	4-38	✓	✓	✓	✓
setdoprinterrors	4-38	✓	✓	✓	✓
setdoret	4-39	✓	✓	✓	✓
setdostartpage	4-39	✓	✓	✓	✓
setdosysstart	4-40	✓	✓	✓	✓
setduplexmode	4-40	✓	✓	✓	✓
setenginesync	4-41	✓	✓	✓	✓
setethernetaddress	4-41	✓	✓	✓	✓

Table C-1: Supplemental Operators (Continued)

✓ Supported ✗ Not Supported Page numbers reference operator descriptions.		Printer Model			
		C520, C522n, C524 C524n, C524dm	C53-dm, C532m, C532dm C534m, C534dm, C534dtn	C770, C770n, C772, C772n	C920, C920n, C922, C922n
Operator Name	Page				
setfilenameextend	4-41	✓	✓	✓	✓
setfileposition	4-42	✓	✓	✓	✓
sethardwareiomode	4-42	✓	✓	✓	✓
setidlefonts	4-42	✓	✓	✓	✓
setignoresize	4-4	✓	✓	✓	✓
setjobtimeout	4-43	✓	✓	✓	✓
setmanualduplexmode	4-43	✗	✗	✗	✗
setpapertray	4-9	✓	✓	✓	✓
setprintername	4-44	✓	✓	✓	✓
setquiet	4-44	✓	✓	✓	✓
setresolution	4-45	✓	✓	✓	✓
setscbatch	4-45	✓	✓	✓	✓
setscinteractive	4-46	✓	✓	✓	✓
setsoftwareiomode	4-46	✓	✓	✓	✓
settumble	4-46	✓	✓	✓	✓
setuniversalsize	4-5	✓	✓	✓	✓
setuserdiskpercent	4-47	✓	✓	✓	✓
softwareiomode	4-47	✓	✓	✓	✓
tumble	4-47	✓	✓	✓	✓
userdiskpercent	4-48	✓	✓	✓	✓
waittimeout	4-48	✓	✓	✓	✓

Table C-2: Page Device Parameters

✓ Supported ✗ Not Supported Page numbers reference parameter descriptions. Default values are listed.		Printer Model			
		C520, C522n, C524 C524n, C524dln	C53-dm. C532m. C532dm C534m. C534dm. C534dtn	C770, C770n, C772, C772n	C920, C920n, C922, C922n
Key	Page				
BeginPage	4-49	✓	✓	✓	✓
Collate	4-49				
DeferredMediaSelection	4-49				
DeviceRenderingInfo	4-49	✓	✓	✓	✓
• Screening	4-49				
– ColorGrade	4-49	✗	✗	✗	✗
– PictureGrade	4-49	✓	✓	✓	✓
– IET	4-49	✓	✓	✓	✓
– IETImagesOnly	4-49	✗	✗	✗	✗
– IETPictureGrade	4-49	✓	✓	✓	✓
– None	4-49	✓	✓	✓	✓
• TonerSaver	4-50				
• PictureGrade	4-50	✓	✓	✓	✓
• ImageEnhancement	4-50	✓	✓	✓	✓
• PrintDarkness	4-50	✓	✓	✓	✓
• AutoMediaType	4-51				
• EdgeToEdge	4-51	✓	✓	✓	✓
• DefaultPoliciesPageSize	4-51	✗	✗	✗	✗
• SubstituteSize	4-51	✓	✓	✓	✓
• Type	4-52				
• ColorCorrection	4-52	✗	✗	✗	✗
• ImageBrightness	4-52	✗	✗	✗	✗
• ImageContrast	4-52	✗	✗	✗	✗
• PrintQuality	4-52	✗	✗	✗	✗

Table C-2: Page Device Parameters (Continued)

✓ Supported ✗ Not Supported Page numbers reference parameter descriptions. Default values are listed.		Printer Model			
		C520, C522n, C524 C524n, C524dmi	C53-dm, C532m, C532dm C534m, C534dm, C534dtn	C770, C770n, C772, C772n	C920, C920n, C922, C922n
Key	Page				
Duplex	4-52	✓	✓	✓	✓
EndPage	4-52	✓	✓	✓	✓
ExitJamRecovery	4-52	✓	✓	✓	✓
HWRResolution	4-52	✓	✓	✓	✓
ImagingBBox	4-53	✓	✓	✓	✓
InputAttributes	4-53	✓	✓	✓	✓
• 0 - Tray 1	4-53	✓	✓	✓	✓
• 1 - Tray 2	4-53	✓	✓	✓	✓
• 2 - Envelope Feeder	4-53	✓	✓	✓	✓
• 3 - Tray 3	4-53	✓	✓	✓	✓
• 4 - Multipurpose Feeder	4-53	✓	✓	✓	✓
• 5 - Tray 4	4-53	✓	✓	✓	✓
• 6 - Tray 5	4-53	✓	✓	✓	✓
– PageSize	4-53	✓	✓	✓	✓
– MatchAll	4-53	✓	✓	✓	✓
– MediaColor	4-53	✓	✓	✓	✓
– MediaType	4-53	✓	✓	✓	✓
– MediaWeight	4-53	✓	✓	✓	✓
– InputLocation	4-53	✓	✓	✓	✓
• Mode	4-54	✓	✓	✓	✓
• Priority	4-54	✓	✓	✓	✓
Install	4-54	✓	✓	✓	✓
Jog	4-54	✗	✗	✗	✗
ManualFeed	4-55	✓	✓	✓	✓
ManualFeedTimeout	4-55	✓	✓	✓	✓

Table C-2: Page Device Parameters (Continued)

✓ Supported ✗ Not Supported Page numbers reference parameter descriptions. Default values are listed.		Printer Model			
		Key	Page	C520, C522n, C524 C524n, C524dm	C53-dm, C532m, C532dm C534m, C534dm, C534dtn
MediaColor	4-55	✓	✓	✓	✓
MediaPosition	4-55				
MediaType	4-55	✓	✓	✓	✓
MediaWeight	4-55	✓	✓	✓	✓
NumCopies	4-55	✓	✓	✓	✓
Nup	4-55	✓	✓	✓	✓
NupDetails	4-56	✓	✓	✓	✓
• Rows	4-56				
• Columns	4-56				
• Orientation	4-56				
• Border	4-57				
• Order	4-57				
• Type	4-57				
• LandscapeOverride	4-57				
OutputAttributes	4-58	✓	✓	✓	✓
• 0 - Standard Bin	4-58	✓	✓	✓	✓
• 1 - Optional Bin 1	4-58	✓	✓	✓	✓
• 2 - Optional Bin 2	4-58	✓	✓	✓	✓
• 3 - Optional Bin 3	4-58	✓	✓	✓	✓
• 4 - Optional Bin 4	4-58	✓	✓	✓	✓
• 5 - Optional Bin 5	4-58	✓	✓	✓	✓
• 6 - Optional Bin 6	4-58	✓	✓	✓	✓
• 7 - Optional Bin 7	4-58	✓	✓	✓	✓
• 8 - Optional Bin 8	4-58	✓	✓	✓	✓
• 9 - Optional Bin 9	4-58	✓	✓	✓	✓

Table C-2: Page Device Parameters (Continued)

✓ Supported ✗ Not Supported Page numbers reference parameter descriptions. Default values are listed.		Printer Model			
		C520, C522n, C524 C524n, C524dmi	C53-dm, C532m, C532dmi C534m, C534dm, C534dtn	C770, C770n, C772, C772n	C920, C920n, C922, C922n
Key	Page				
<ul style="list-style-type: none"> • 10 - Optional Bin 10 	4-58	✓	✓	✓	✓
<ul style="list-style-type: none"> – OutputType 	4-58	✓	✓	✓	✓
<ul style="list-style-type: none"> – OutputLocation 	4-58	✓	✓	✓	✓
OutputPage	4-58				
OutputType	4-58	✓	✓	✓	✓
PageDeviceName	4-58	✓	✓	✓	✓
PageSize	4-59	✓	✓	✓	✓
Policies	4-59	✓	✓	✓	✓
<ul style="list-style-type: none"> • PolicyNotFound 	4-59				
<ul style="list-style-type: none"> • PolicyReport 	4-59				
<ul style="list-style-type: none"> • PageSize 	4-59				
PostRenderingEnhance	4-59				
PostRenderingEnhanceDetails	4-60	✓	✓	✓	✓
<ul style="list-style-type: none"> • REValue 	4-60				
<ul style="list-style-type: none"> • Type 	4-60				
PowerSave	4-60				
ProcessColorModel	4-60	✗	✗	✗	✗
Punch	4-60	✗	✗	✗	✗
SlipSheet	4-60	✗	✗	✗	✗
SlipSheetDetails	4-61	✓	✓	✓	✓
<ul style="list-style-type: none"> • SlipSheetSource 	4-61				
<ul style="list-style-type: none"> • Type 	4-61				
Staple	4-61	✗	✗	✗	✗
TraySwitch	4-61	✓	✓	✓	✓
Tumble	4-62	✓	✓	✓	✓

Table C-2: Page Device Parameters (Continued)

Key		Page	Printer Model			
			C520, C522n, C524 C524n, C524dmi	C53-dm, C532m, C532dm C534m, C534dm, C534dtn	C770, C770n, C772, C772n	C920, C920n, C922, C922n
✓ Supported ✗ Not Supported Page numbers reference parameter descriptions. Default values are listed.						
UniversalDetails		4-62	✓	✓	✓	✓
• Type		4-62				
• PageSize		4-62	✓	✓	✓	✓
• Orientation		4-62	✓	✓	✓	✓
• Prompt		4-62	✓	✓	✓	✓

Table C-3: User Interpreter Parameters

Key			Printer Model			
			C520, C522n, C524 C524n, C524dmi	C53-dm, C532m, C532dm C534m, C534dm, C534dtn	C770, C770n, C772, C772n	C920, C920n, C922, C922n
✓ Supported ✗ Not Supported Page numbers reference parameter descriptions.						
AccurateScreens	4-63	false	✓	✓	✓	✓
CollatedCopies	4-63	Collation - Collated Copies (QTY) value	✓	✓	✓	✓
HalftoneMode	4-64	0	✓	✓	✓	✓
IdiomRecognition	4-64	true	✓	✓	✓	✓
JobName	4-64	()	✓	✓	✓	✓
JobTimeout	4-64	JobTimeout system parameter	✓	✓	✓	✓

Table C-3: User Interpreter Parameters (Continued)

✓ Supported ✗ Not Supported Page numbers reference parameter descriptions.			Printer Model			
			C520, C522n, C524 C524n, C524dln	C53-dm, C532m, C532dlm C534m, C534dlm, C534dln	C770, C770n, C772, C772n	C920, C920n, C922, C922n
Key	Page	Default				
MaxDictStack	4-64	255	✓	✓	✓	✓
MaxExecStack	4-64	10015	✓	✓	✓	✓
MaxFontItem	4-64	12500	✓	✓	✓	✓
MaxFormItem	4-64	100000	✓	✓	✓	✓
MaxLocalVM	4-64	2147483647	✓	✓	✓	✓
MaxOpStack	4-65	100000	✓	✓	✓	✓
MaxPatternItem	4-65	20000	✓	✓	✓	✓
MaxScreenItem	4-65	48000	✓	✓	✓	✓
MaxSuperScreen	4-65	1024	✓	✓	✓	✓
MaxUPathItem	4-65	5000	✓	✓	✓	✓
MinFontCompress	4-65	2147483647	✓	✓	✓	✓
PageCount	4-65	0	✓	✓	✓	✓
UseOldcopypage	4-65	false	✓	✓	✓	✓
VMReclaim	4-65	0	✓	✓	✓	✓
VMThreshold	4-65	25000 per MB of RAM	✓	✓	✓	✓
WaitTimeout	4-65	WaitTimeout system parameter	✓	✓	✓	✓

Table C-4: System Interpreter Parameters

✓ Supported ✗ Not Supported Page numbers reference parameter descriptions. Default values are listed.		Printer Model			
		C520, C522n, C524 C524n, C524dim	C53-dim. C532dm. C534m. C534dim. C534dtn	C770, C770n, C772, C772n	C920, C920n, C922, C922n
Key	Page				
BuildTime	4-66	✓	✓	✓	✓
ByteOrder	4-66				
CurDisplayList	4-66				
CurFontCache	4-66				
CurFormCache	4-66				
CurInputDevice	4-67	✓	✓	✓	✓
CurOutlineCache	4-67				
CurOutputDevice	4-67	✓	✓	✓	✓
CurPatternCache	4-67				
CurScreenStorage	4-67				
CurSourceList	4-67				
CurUPathCache	4-67				
DisableFastProcs	4-67				
DoPrintErrors	4-68				
DoStartPage	4-68				
EnableExtraFonts	4-68				
EngineBoot	4-68	✓	✓	✓	✓
EngineCode	4-68	✓	✓	✓	✓
EngineSpeed	4-68	✓	✓	✓	✓
EnvironmentSave	4-68				
FactoryDefaults	4-68				
FatalErrorAddress	4-68				
FontResourceDir	4-68				
FontVersion	4-68	✓	✓	✓	✓

Table C-4: System Interpreter Parameters (Continued)

✓ Supported ✗ Not Supported Page numbers reference parameter descriptions. Default values are listed.		Printer Model			
		C520, C522n, C524 C524n, C524dm	C53-dm, C532m, C532dm C534m, C534dm, C534dtn	C770, C770n, C772, C772n	C920, C920n, C922, C922n
Key	Page				
GenericResourceDir	4-68				
GenericResourcePathSep	4-68				
InstalledRam	4-69	✓	✓	✓	✓
JobTimeout	4-69				
languagelevel	4-69				
MaxDisplayList	4-69				
MaxFontCache	4-69				
MaxFormCache	4-69				
MaxImageBuffer	4-69				
MaxOutlineCache	4-69				
MaxPatternCache	4-69				
MaxPermanentVM	4-69				
MaxRasterMemory	4-69				
MaxScreenStorage	4-69				
MaxSourceList	4-70				
MaxUPathCache	4-70				
PageCount	4-70				
PanelCode	4-70	✓	✓	✓	✓
PrinterCode	4-70	✓	✓	✓	✓
PrinterName	4-70	✓	✓	✓	✓
RamSize	4-70	✓	✓	✓	✓
RealFormat	4-70				
Revision	4-70	✓	✓	✓	✓
SearchBuiltinFontsFirst	4-70				
SerialNumber	4-70	✓	✓	✓	✓

Table C-4: System Interpreter Parameters (Continued)

✓ Supported ✗ Not Supported Page numbers reference parameter descriptions. Default values are listed.		Printer Model			
		C520, C522n, C524 C524n, C524dm	C53-dm, C532dm, C532dtn C534dm, C534dtn	C770, C770n, C772, C772n	C920, C920n, C922, C922n
Key	Page				
StartJobPassword	4-70				
StartupMode	4-70				
StaticRamSize	4-70	✓	✓	✓	✓
SystemParamsPassword	4-71				
UseOldcopypage	4-71				
UseOldfonts	4-71				
ValidNV	4-71				
WaitTimeout	4-65				

Table C-5: Devices Supported

Device	Page	Printer Model			
		C520, C522n, C524 C524n, C524dtn	C53-dm, C532m, C532dtn C534m, C534dm, C534dtn	C770, C770n, C772, C772n	C920, C920n, C922, C922n
%ParallelA%	4-66	✓	✓	✓	✓
%ParallelB%		✗	✗	✗	✗
%ParallelC%		✗	✗	✗	✗
%ParallelD%		✗	✗	✗	✗
%SerialA%		✓	✓	✓	✓
%SerialB%		✗	✗	✗	✗
%SerialC%		✗	✗	✗	✗
%SerialD%		✗	✗	✗	✗
%LocalTalkA%		✗	✗	✗	✗
%LocalTalkB%		✗	✗	✗	✗
%LocalTalkC%		✗	✗	✗	✗
%LocalTalkD%		✗	✗	✗	✗
%EtherTalkA%		✓	✓	✓	✓
%EtherTalkB%		✗	✗	✗	✗
%EtherTalkC%		✗	✗	✗	✗
%EtherTalkD%		✗	✗	✗	✗
%IR_A%		✗	✗	✗	✗
%IR_B%		✗	✗	✗	✗
%IR_C%		✗	✗	✗	✗
%IR_D%		✗	✗	✗	✗
%USB_A%		✓	✓	✓	✓
%USB_B%		✗	✗	✗	✗
%USB_C%		✗	✗	✗	✗
%USB_D%		✗	✗	✗	✗
%TokenTalkA%		✗	✗	✗	✗
%TokenTalkB%		✗	✗	✗	✗

Table C-5: Devices Supported (Continued)

Device	Page	Printer Model			
		C520, C522n, C524 C524n, C524dtn	C53-dm, C532m, C532dtn C534m, C534dm, C534dtn	C770, C770n, C772, C772n	C920, C920n, C922, C922n
%AppSocketC%	4-66	x	x	x	x
%AppSocketD%		x	x	x	x
%RemotePrinterA%		x	x	x	x
%RemotePrinterB%		x	x	x	x
%RemotePrinterC%		x	x	x	x
%RemotePrinterD%		x	x	x	x
%PrintServerA%		x	x	x	x
%PrintServerB%		x	x	x	x
%PrintServerC%		x	x	x	x
%PrintServerD%		x	x	x	x
%LPR_A%		✓	✓	✓	✓
%LPR_B%		x	x	x	x
%LPR_C%		x	x	x	x
%LPR_D%		x	x	x	x
%LexLinkA%		x	x	x	x
%LexLinkB%		x	x	x	x
%LexLinkC%		x	x	x	x
%LexLinkD%		x	x	x	x
%IP_A%		✓	✓	✓	✓
%IP_B%		x	x	x	x
%IP_C%	x	x	x	x	
%IP_D%	x	x	x	x	
%EthernetPhysicalA%	x	x	x	x	
%EthernetPhysicalB%	x	x	x	x	
%EthernetPhysicalC%	x	x	x	x	
%EthernetPhysicalD%	x	x	x	x	

Table C-6: Device Parameters

✓ Supported ✗ Not Supported Page numbers reference parameter descriptions.		Printer Model			
		Key	Page	C-520, C-522n, C-524 C-524n, C-524dm	C-53-dm, C-532dm C-534dm, C-534dtn
Device Parameters for the Communication Device %Parallel%, %ParallelA%, %ParallelB%, %ParallelC%, %ParallelD%					
DelayedOutputClose	4-73	✓	✓	✓	✓
Enabled	4-73	✓	✓	✓	✓
Filtering	4-73	✓	✓	✓	✓
Handshake	4-73	✓	✓	✓	✓
HasNames	4-73	✓	✓	✓	✓
Interpreter	4-73	✓	✓	✓	✓
On	4-73	✓	✓	✓	✓
OutputDevice	4-73	✓	✓	✓	✓
PCLSmartSwitch	4-73	✓	✓	✓	✓
PortLocation	4-73	✓	✓	✓	✓
PSSmartSwitch	4-74	✓	✓	✓	✓
Type	4-74	✓	✓	✓	✓
Device Parameters for the Communication Device %Serial%, %SerialA%, %SerialB%, %SerialC%, %SerialD%					
Baud	4-74	✓	✓	✓	✓
CheckParity	4-74	✓	✓	✓	✓
DataBits	4-74	✓	✓	✓	✓
DelayedOutputClose	4-74	✓	✓	✓	✓
Enabled	4-74	✓	✓	✓	✓
Filtering	4-74	✓	✓	✓	✓
FlowControl	4-74	✓	✓	✓	✓
HasNames	4-74	✓	✓	✓	✓

Table C-6: Device Parameters (Continued)

✓ Supported ✗ Not Supported Page numbers reference parameter descriptions.		Printer Model			
		Key	Page	C-520, C522n, C524 C524n, C524dtn	C53-dm. C532m. C532dtn C534m. C534dm. C534dtn
HonorDSR	4-74	✓	✓	✓	✓
Interpreter	4-75	✓	✓	✓	✓
On	4-75	✓	✓	✓	✓
Parity	4-75	✓	✓	✓	✓
PCLSmartSwitch	4-75	✓	✓	✓	✓
PortLocation	4-75	✓	✓	✓	✓
PSSmartSwitch	4-75	✓	✓	✓	✓
RobustXon	4-75	✓	✓	✓	✓
SerialMode	4-75	✓	✓	✓	✓
StopBits	4-76	✓	✓	✓	✓
Type	4-76	✓	✓	✓	✓
Device Parameters for the Communication Device %LocalTalk%, %LocalTalkA%, %LocalTalkB%, %LocalTalkC%, %LocalTalkD%					
DelayedOutputClose	4-76	✓	✓	✓	✓
Enabled	4-76	✓	✓	✓	✓
Filtering	4-76	✓	✓	✓	✓
HasNames	4-76	✓	✓	✓	✓
Interpreter	4-76	✓	✓	✓	✓
LocalTalkType	4-76	✓	✓	✓	✓
NodeID	4-76	✓	✓	✓	✓
On	4-76	✓	✓	✓	✓
PCLSmartSwitch	4-77	✓	✓	✓	✓
PortLocation	4-77	✓	✓	✓	✓
PSSmartSwitch	4-77	✓	✓	✓	✓
Type	4-77	✓	✓	✓	✓

Table C-6: Device Parameters (Continued)

✓ Supported ✗ Not Supported Page numbers reference parameter descriptions.		Printer Model			
		C-520, C-522n, C-524 C-524n, C-524dm	C-53-dm. C-532m. C-532dm C-534m. C-534dm. C-534dtn	C-770, C-770n, C-772, C-772n	C-920, C-920n, C-922, C-922n
Key	Page				
Device Parameters for the Communication Device %EtherTalk%, %EtherTalkA%, %EtherTalkB%, %EtherTalkC%, %EtherTalkD%					
DelayedOutputClose	4-77	✓	✓	✓	✓
Enabled	4-77	✓	✓	✓	✓
EthernetAddress	4-77	✓	✓	✓	✓
EtherTalkType	4-77	✓	✓	✓	✓
EtherTalkZone	4-77	✓	✓	✓	✓
Filtering	4-78	✓	✓	✓	✓
HasNames	4-78	✓	✓	✓	✓
Interpreter	4-78	✓	✓	✓	✓
NodeID	4-78	✓	✓	✓	✓
On	4-78	✓	✓	✓	✓
PCLSmartSwitch	4-78	✓	✓	✓	✓
PortLocation	4-78	✓	✓	✓	✓
PSSmartSwitch	4-78	✓	✓	✓	✓
Type	4-78	✓	✓	✓	✓
Device Parameters for the Communication Device %IR%, %IR_A%, %IR_B%, %IR_C%, %IR_D%					
DelayedOutputClose	4-78	✓	✓	✓	✓
Enabled	4-79	✓	✓	✓	✓
Filtering	4-79	✓	✓	✓	✓
HasNames	4-79	✓	✓	✓	✓
Interpreter	4-79	✓	✓	✓	✓
On	4-79	✓	✓	✓	✓
PCLSmartSwitch	4-79	✓	✓	✓	✓
PortLocation	4-79	✓	✓	✓	✓

Table C-6: Device Parameters (Continued)

✓ Supported ✗ Not Supported Page numbers reference parameter descriptions.		Printer Model			
		C-520, C-522n, C-524 C-524n, C-524dm	C-53-dm. C-532m. C-532dm C-534m. C-534dm. C-534dtn	C-770, C-770n, C-772, C-772n	C-920, C-920n, C-922, C-922n
Key	Page				
PSSmartSwitch	4-79	✓	✓	✓	✓
Type	4-79	✓	✓	✓	✓
Device Parameters for the Communication Device %USB%, %USB_A%, %USB_B%, %USB_C%, %USB_D%					
DelayedOutputClose	4-79	✓	✓	✓	✓
Enabled	4-80	✓	✓	✓	✓
Filtering	4-80	✓	✓	✓	✓
HasNames	4-80	✓	✓	✓	✓
Interpreter	4-80	✓	✓	✓	✓
On	4-80	✓	✓	✓	✓
PCLSmartSwitch	4-80	✓	✓	✓	✓
PortLocation	4-80	✓	✓	✓	✓
PSSmartSwitch	4-80	✓	✓	✓	✓
Type	4-80	✓	✓	✓	✓
Device Parameters for the Communication Device %TokenTalk%, %TokenTalkA%, %TokenTalkB%, %TokenTalkC%, %TokenTalkD%					
Address	4-80	✓	✓	✓	✓
Bridging	4-80	✓	✓	✓	✓
DelayedOutputClose	4-81	✓	✓	✓	✓
Enabled	4-81	✓	✓	✓	✓
Filtering	4-81	✓	✓	✓	✓
HasNames	4-81	✓	✓	✓	✓
Interpreter	4-81	✓	✓	✓	✓
NodeID	4-81	✓	✓	✓	✓
On	4-81	✓	✓	✓	✓
PCLSmartSwitch	4-81	✓	✓	✓	✓

Table C-6: Device Parameters (Continued)

✓ Supported ✗ Not Supported Page numbers reference parameter descriptions.		Printer Model			
		C-520, C522n, C524 C524n, C524dm	C-53-dm. C532m. C532dm C534m. C534dm. C534dtn	C770, C770n, C772, C772n	C-920, C920n, C922, C922n
Key	Page				
PortLocation	4-81	✓	✓	✓	✓
PSSmartSwitch	4-81	✓	✓	✓	✓
TokenTalkType	4-82	✓	✓	✓	✓
Type	4-82	✓	✓	✓	✓
Zone	4-82	✗	✗	✗	✗

Table C-6: Device Parameters (Continued)

✓ Supported ✗ Not Supported Page numbers reference parameter descriptions.		Printer Model			
		C-520, C522n, C524 C524n, C524dm	C53-dm. C532m. C532dm C534m. C534dm. C534dtn	C770, C770n, C772, C772n	C920, C920n, C922, C922n
Key	Page				
Device Parameters for the Communication Device %AppSocket%, %AppSocketA%, %AppSocketB%, %AppSocketC%, %AppSocketD%					
DelayedOutputClose	4-82	✓	✓	✓	✓
Enabled	4-82	✓	✓	✓	✓
Filtering	4-82	✓	✓	✓	✓
HasNames	4-82	✓	✓	✓	✓
Interpreter	4-82	✓	✓	✓	✓
On	4-82	✓	✓	✓	✓
PortLocation	4-82	✓	✓	✓	✓
Type	4-82	✓	✓	✓	✓
Device Parameters for the Communication Device %RemotePrinter%, %RemotePrinterA%, %RemotePrinterB%, %RemotePrinterC%, %RemotePrinterD%					
DelayedOutputClose	4-83	✓	✓	✓	✓
Enabled	4-83	✓	✓	✓	✓
Filtering	4-83	✓	✓	✓	✓
HasNames	4-83	✓	✓	✓	✓
Interpreter	4-83	✓	✓	✓	✓
On	4-83	✓	✓	✓	✓
PortLocation	4-83	✓	✓	✓	✓
Type	4-83	✓	✓	✓	✓
Device Parameters for the Communication Device %PrintServer%, PrintServerA%, PrintServerB%, %PrintServerC%, %PrintServerD%					
DelayedOutputClose	4-84	✓	✓	✓	✓
Enabled	4-84	✓	✓	✓	✓

Table C-6: Device Parameters (Continued)

✓ Supported ✗ Not Supported Page numbers reference parameter descriptions.		Printer Model			
		C-520, C-522n, C-524 C-524n, C-524dm	C-53-dm, C-532m, C-532dm C-534m, C-534dm, C-534dtn	C-770, C-770n, C-772, C-772n	C-920, C-920n, C-922, C-922n
Key	Page				
Filtering	4-84	✓	✓	✓	✓
HasNames	4-84	✓	✓	✓	✓
Interpreter	4-84	✓	✓	✓	✓
On	4-84	✓	✓	✓	✓
PortLocation	4-84	✓	✓	✓	✓
Type	4-84	✓	✓	✓	✓
Device Parameters for the Communication Device %LPR%, %LPR_A%, %LPR_B%, %LPR_C%, %LPR_D%					
Enabled	4-85	✓	✓	✓	✓
Filtering	4-85	✓	✓	✓	✓
HasNames	4-85	✓	✓	✓	✓
Interpreter	4-85	✓	✓	✓	✓
On	4-85	✓	✓	✓	✓
PortLocation	4-85	✓	✓	✓	✓
Type	4-85	✓	✓	✓	✓
Device Parameters for the Communication Device %LexLink%, %LexLinkA%, %LexLinkB%, %LexLinkC%, %LexLinkD%					
DelayedOutputClose	4-85	✓	✓	✓	✓
Enabled	4-85	✓	✓	✓	✓
HasNames	4-86	✓	✓	✓	✓
Interpreter	4-86	✓	✓	✓	✓
On	4-86	✓	✓	✓	✓
PortLocation	4-86	✓	✓	✓	✓
Type	4-86	✓	✓	✓	✓

Table C-6: Device Parameters (Continued)

✓ Supported ✗ Not Supported Page numbers reference parameter descriptions.		Printer Model			
		C-520, C-522n, C-524 C-524n, C-524dm	C-53-dm, C-532m, C-532dm C-534m, C-534dm, C-534dtn	C-770, C-770n, C-772, C-772n	C-920, C-920n, C-922, C-922n
Key	Page				
Device Parameters for the Communication Device %IP%, %IP_A%, %IP_B%, %IP_C%, %IP_D%					
GatewayAddress	4-86	✓	✓	✓	✓
IPAddress	4-86	✓	✓	✓	✓
IPAddressDynamic	4-86	✓	✓	✓	✓
NetworkMask	4-86	✓	✓	✓	✓
On	4-86	✓	✓	✓	✓
Physical	4-86	✓	✓	✓	✓
PortLocation	4-86	✓	✓	✓	✓
Type	4-86	✓	✓	✓	✓
Device Parameters for the Communication Device %EthernetPhysical%, %EthernetPhysicalA%, %EthernetPhysicalB%, %EthernetPhysicalC%, %EthernetPhysicalD%					
EthernetAddress	4-87	✓	✓	✓	✓
On	4-87	✓	✓	✓	✓
PortLocation	4-87	✓	✓	✓	✓
Type	4-87	✓	✓	✓	✓
Device Parameters for the Communication Device %TokenRingPhysical%, %TokenRingPhysicalA%, %TokenRingPhysicalB%, %TokenRingPhysicalC%, %TokenRingPhysicalD%					
Address	4-87	✓	✓	✓	✓
On	4-87	✓	✓	✓	✓
PortLocation	4-87	✓	✓	✓	✓
Speed	4-87	✓	✓	✓	✓
Type	4-87	✓	✓	✓	✓

Table C-6: Device Parameters (Continued)

✓ Supported ✗ Not Supported Page numbers reference parameter descriptions.		Printer Model			
		C-520, C-522n, C-524 C-524n, C-524dm	C-53-dm, C-532m, C-532dm C-534m, C-534dm, C-534dtn	C-770, C-770n, C-772, C-772n	C-920, C-920n, C-922, C-922n
Key	Page				
Device Parameters for the Parameters Device %Engine%					
BSizeStandard	4-87	✓	✓	✓	✓
Darkness	4-88	✓	✓	✓	✓
PageCount	4-89	✓	✓	✓	✓
TimeToStandby	4-89	✓	✓	✓	✓
Type	4-89	✓	✓	✓	✓
Device Parameters for the Parameters Device %Console%					
Language	4-89	✓	✓	✓	✓
Type	4-89	✓	✓	✓	✓
Device Parameters for the Parameters Device %Calendar%, %CalendarA%, %CalendarB%, %CalendarC%, %CalendarD%					
Day	4-89	✓	✓	✓	✓
Hour	4-89	✓	✓	✓	✓
Minute	4-89	✓	✓	✓	✓
Month	4-89	✓	✓	✓	✓
Running	4-89	✓	✓	✓	✓
Second	4-89	✓	✓	✓	✓
Type	4-89	✓	✓	✓	✓
Year	4-89	✓	✓	✓	✓
DateTime	4-89	✓	✓	✓	✓
DayOfWeekLong	4-89	✓	✓	✓	✓
DayOfWeekNum	4-89	✓	✓	✓	✓
DayOfWeekShort	4-89	✓	✓	✓	✓

Table C-6: Device Parameters (Continued)

✓ Supported ✗ Not Supported Page numbers reference parameter descriptions.		Printer Model			
		C-520, C522n, C524 C524n, C524dm	C53-dm. C532m. C532dm C534m. C534dm. C534dtn	C770, C770n, C772, C772n	C920, C920n, C922, C922n
Key	Page				
Device Parameters for the Parameters Device %disk1%					
BlockSize	4-89	✓	✓	✓	✓
Free	4-89	✓	✓	✓	✓
HasNames	4-89	✓	✓	✓	✓
InitializeAction	4-90	✓	✓	✓	✓
LogicalSize	4-90	✓	✓	✓	✓
Mounted	4-90	✓	✓	✓	✓
PhysicalSize	4-90	✓	✓	✓	✓
Removable	4-90	✓	✓	✓	✓
Searchable	4-90	✓	✓	✓	✓
SearchOrder	4-90	✓	✓	✓	✓
Type	4-90	✓	✓	✓	✓
Writeable	4-90	✓	✓	✓	✓
Device Parameters for the Parameters Device %flash1%					
BlockSize	4-90	✓	✓	✓	✓
Free	4-90	✓	✓	✓	✓
HasNames	4-91	✓	✓	✓	✓
InitializeAction	4-91	✓	✓	✓	✓
LogicalSize	4-91	✓	✓	✓	✓
Mounted	4-91	✓	✓	✓	✓
PhysicalSize	4-91	✓	✓	✓	✓
Removable	4-91	✓	✓	✓	✓
Searchable	4-91	✓	✓	✓	✓
SearchOrder	4-91	✓	✓	✓	✓
Type	4-91	✓	✓	✓	✓
Writeable	4-91	✓	✓	✓	✓

Table C-6: Device Parameters (Continued)

✓ Supported ✗ Not Supported Page numbers reference parameter descriptions.		Printer Model			
		C-520, C-522n, C-524 C-524n, C-524dtn	C-53-dm, C-532m, C-532dtn C-534m, C-534dm, C-534dtn	C-770, C-770n, C-772, C-772n	C-920, C-920n, C-922, C-922n
Key	Page				
Device Parameters for the Parameters Device %rom%					
BlockSize	4-92	✓	✓	✓	✓
Free	4-92	✓	✓	✓	✓
HasNames	4-92	✓	✓	✓	✓
InitializeAction	4-92	✓	✓	✓	✓
LogicalSize	4-92	✓	✓	✓	✓
Mounted	4-92	✓	✓	✓	✓
PhysicalSize	4-92	✓	✓	✓	✓
Removable	4-92	✓	✓	✓	✓
Searchable	4-92	✓	✓	✓	✓
SearchOrder	4-92	✓	✓	✓	✓
Type	4-92	✓	✓	✓	✓
Writeable	4-92	✓	✓	✓	✓

Table C-7: PostScript Commands: Message Keys

✓ Supported ✗ Not Supported Page numbers reference status message key and value descriptions.		Printer Model			
		C-520, C-522n, C-524 C-524n, C-524dtn	C-53-dm, C-532m, C-532dtn C-534m, C-534dm, C-534dtn	C-770, C-770n, C-772, C-772n	C-920, C-920n, C-922, C-922n
Key	Page				
job	4-94	✓	✓	✓	✓

Table C-7: PostScript Commands: Message Keys

✓ Supported ✗ Not Supported Page numbers reference status message key and value descriptions.		Printer Model			
		C520, C522n, C524 C524n, C524dim	C53-dm. C532m. C532dm C534m. C534dm. C534dtn	C770, C770n, C772, C772n	C920, C920n, C922, C922n
		Key	Page		
status	4-94	✓	✓	✓	✓
source	4-94	✓	✓	✓	✓

Index

A

airflow requirement 7-1
altitude specifications 7-9
atmospheric pressure 7-9
attendance messages (PJL) 3-63, 3-67, 3-72, 3-75

B

bibliography 1-5

C

clearance requirements 7-8
communications
 computer-to-printer 8-8
 ports, setting up 8-2
 Windows 2000 8-4
 Windows 95/98/Me 8-2
 Windows NT 4.0 8-3
 Windows XP 8-5
 printer-to-computer 8-13
 protocols 8-23
compatibility modes
 backward and forward
 Lexmark E323 2-9
 Lexmark T634 2-9
compression
 description, raster image graphics 2-78
 raster compression mode command 2-78
 set raster compression mode 2-68
connectors 8-1

D

device (flash memory or disk)
 names (PostScript emulation) 6-9
 search order 6-12
dimensions, printer 7-5
directory
 description 6-4
 example 6-4
 printing
 MarkVision Professional 6-3

 operator panel 6-3
 PJL 3-83
disk
 description 6-1
 directory of contents 6-4
 job buffering 6-13
 password protection 6-7
 performance 6-13
 Resource Data Collection mode 6-2
 retrieval speed 6-13
 storing fonts, macros, and symbol sets 6-2
 viewing the contents 6-3
disk option, download target (PJL) 3-30
drivers
 ACKNLG*
 Lexmark C510 8-17
 ERROR*
 Lexmark C510 8-17
 PE
 Lexmark C510 8-17
 SLCT
 Lexmark C510 8-17
DSR protocol 8-24
DTR protocol 8-23, 8-24
DTR/DSR protocol 8-23, 8-24

E

edge to edge printing
 See whole page setting
electrical specifications 7-2
envelope sizes supported 4-10
 Lexmark C510(n) 2-4
environmental commands and variables (PJL) 3-7
environmental conditions 7-9
errors, service 3-80
escape commands (PCL emulation)
 categorized by function
 color extensions 2-70
 cursor positioning 2-58
 font creation 2-63
 font selection 2-60
 job control 2-52

- macros 2-63
- miscellaneous commands 2-73
- page control 2-54
- picture frame 2-73
- print model 2-64
- raster graphics 2-67
- rectangular area fill graphics 2-65
- status readback 2-72
- user-defined pattern 2-65
- user-defined symbol set 2-62

external network adapter
See external print server

external print server
 MarkNet Pro 8-29
 MarkNet XLe 8-29

F

fastbytes protocol 8-12

file (flash memory or disk)
 close 3-89
 delete 3-92
 format device 3-92
 open 3-89
 read 3-90
 rename 3-92
 run 3-91
 write 3-91

filenames
 file types 6-6
 filename parameter (PJL) 3-88
 macros, font, and symbol set ID 6-5
 PostScript emulation conventions 6-9
 searching 6-12

fit to page printing 2-6, 2-7

flash memory
 description 6-1
 directory of contents 6-4
 download target (PJL) 3-30
 password protection 6-7
 performance 6-13
 Resource Data Collection mode 6-2
 retrieval speed 6-13
 rewriting contents 6-8
 storing fonts, macros, and symbol sets 6-2
 viewing the contents 6-3

fonts
 PCL emulation

- Lexmark X422 2-8
- printing directory list for flash or disk 3-83, 6-3
- saving on flash memory or disk 6-3
- setting password protection 3-93

formatting flash or disk, PJL 3-92

G

GL/2 commands
 character group 2-76
 configuration group 2-74
 line and fill attributes group 2-77
 polygon group 2-75
 vector group 2-75

H

hard disk
See disk

hardware specifications 7-1, 8-1

Honor DSR setting 8-24

I

information messages
 status messages (PJL) 3-61

interface
 parallel 8-7
 selecting 8-6
 serial 8-18
 SmartSwitch 5-2

internal network adapter
See internal print server

internal print server
 MarkNet S 8-28

J

job buffering 6-13
 creating a partition 6-14
 disabling 6-15
 enabling 6-14
 recovering from a power loss 6-15

L

language switching
 PCL emulation

- MarkVision Professional 2-1
 - operator panel 2-1
 - software program 2-2
- PostScript emulation 4-1
 - operator panel 4-1
 - software program 4-2
- Printer Job Language (PJL) 3-3
 - setting for different interfaces 5-2
- SmartSwitch 5-1
- logical page
 - PCL emulation 2-3, 2-6

M

- macros
 - printing directory list
 - flash memory or disk 6-3
 - setting password protection 3-93
 - storing on flash memory or disk 6-3
- MarkNet Pro external print server 8-29
- MarkNet S internal print server 8-28
- MarkNet XLe external print server 8-29
- MarkVision Professional
 - job buffering 6-13
 - passwords 6-8
 - Resource Data Collection mode 6-2
 - viewing contents of flash memory and disk 6-3
- media sizes
 - status message codes 3-74
- menus, printing settings from PJL 3-83
- multipurpose feeder
 - paper source
 - PCL emulation 2-54
 - Printer Job Language (PJL) 3-39

N

- network support 8-28
- noise emission levels 7-1
- nonprintable areas 2-6
- notation, commands
 - PCL emulation 2-49
 - Printer Job Language (PJL) 3-1

O

- operator intervention
 - status messages (PJL) 3-72, 3-75

- output bins
 - status message codes 3-75

P

- page, printable
 - PCL emulation 2-3
- paper handling 3-72
- paper sizes
 - status message codes 3-74
- paper sizes supported
 - Lexmark C510(n) 2-4
- paper trays
 - PCL emulation
 - paper size 2-54
 - paper source 2-54
 - PostScript emulation
 - automatic size sensing search order 4-5
 - operators 4-7
 - Printer Job Language (PJL)
 - paper size 3-14
 - paper source 3-39
 - status message codes 3-74
- parallel interface 8-7
 - connector pin assignments 8-8
 - signal descriptions 8-15
 - standard connector 8-8
- parallel modes 8-14
- parameters, PostScript emulation
 - interpreter 4-63
 - device 4-72
 - system 4-66
 - user 4-63
 - page device 4-49
- password 6-7
 - directory of flash memory or disk 6-6
 - general notes 3-93
 - locking entire flash or disk 3-94
 - lost file or device password 3-98
 - read/write protection 6-7
 - relocking file or device 3-96
 - setting job password 3-5, 3-6
 - setting password for a file 3-93
 - unlocking file or device for current job 3-97
 - unlocking protection for flash or disk 3-95
 - write protection 6-7
- PCL emulation
 - command structure 2-50

- control codes 2-49
- escape control code 2-49
- linking commands 2-51
- parameters 2-50
- relative positioning 2-50
- syntax 2-49
- commands
 - alphabetic 2-51
 - alphanumeric ID 2-58
 - color extensions
 - assign color index 2-71
 - color component one 2-71
 - color component three 2-71
 - color component two 2-71
 - color lookup tables 2-70
 - configure image data 2-71
 - driver configuration command 2-70
 - foreground color 2-71
 - gamma correction 2-71
 - monochrome print mode 2-70
 - palette control 2-70
 - palette ID 2-70
 - push/pop palette 2-70
 - render algorithm 2-71
 - select palette by ID 2-70
 - simple color 2-70
 - user-defined dither matrix 2-70
 - viewing illuminant 2-71
 - cursor positioning
 - half line-feed 2-59
 - horizontal (columns) 2-58
 - horizontal (decipoints) 2-58
 - horizontal (PCL units) 2-58
 - line termination 2-59
 - push/pop cursor position 2-59
 - vertical (decipoints) 2-59
 - vertical (PCL units) 2-59
 - vertical (rows) 2-59
 - font creation
 - character code 2-63
 - font control 2-63
 - font descriptor 2-63
 - font ID 2-63
 - load character 2-63
 - font selection
 - height (primary) 2-60
 - height (secondary) 2-60
 - pitch (primary) 2-60
 - pitch (secondary) 2-60
 - primary and secondary pitch 2-62
 - select default font (primary) 2-61
 - select default font (secondary) 2-61
 - select download font (primary) 2-61
 - select download font (secondary) 2-61
 - spacing (primary) 2-60
 - spacing (secondary) 2-60
 - stroke weight (primary) 2-61
 - stroke weight (secondary) 2-61
 - style (primary) 2-60
 - style (secondary) 2-60
 - symbol set (primary) 2-60
 - symbol set (secondary) 2-60
 - text parsing method 2-62
 - transparent print data 2-61
 - typeface selection (primary) 2-61
 - typeface selection (secondary) 2-61
 - underline disable 2-61
 - underline enable 2-61
- job control
 - job separation 2-55
 - long-edge offset registration 2-52
 - number of collated copies 2-52
 - number of copies 2-52
 - output bin 2-56
 - printer reset 2-52
 - short-edge offset registration 2-52
 - simplex/duplex print 2-52
 - unit of measure 2-53
 - Universal Exit Language 2-53
- macros
 - macro control 2-63
 - macro ID 2-63
- miscellaneous commands
 - display functions off 2-74
 - display functions on 2-73
 - end-of-line wrap 2-73
 - paper type 2-74
 - print quality 2-74
 - print test page 2-74
- page control
 - character text path 2-55
 - clear horizontal margins 2-55
 - duplex page side selection 2-57
 - horizontal motion index 2-56
 - left margin 2-55
 - line spacing (alternative method) 2-57

- page orientation 2-55
- page size 2-54
- paper source 2-54
- print direction 2-55
- right margin 2-55
- set page length 2-57
- set universal custom name 2-55
- set universal feed direction 2-55
- set universal height 2-54
- set universal width 2-54
- skip perforation 2-56
- text length 2-56
- text scale mode 2-57
- top margin 2-55
- vertical motion index 2-56
- picture frame
 - enter GL/2 language 2-73
 - enter PCL emulation 2-73
 - GL/2 plot horizontal size 2-73
 - GL/2 plot vertical size 2-73
 - picture frame horizontal size 2-73
 - picture frame vertical size 2-73
 - set picture frame anchor point 2-73
- print model
 - area fill ID 2-64
 - logical operation 2-64
 - pattern control 2-65
 - pattern transparency mode 2-64
 - pixel placement 2-64
 - select current pattern 2-64
 - set pattern reference point 2-65
 - source transparency mode 2-64
 - user-defined pattern 2-65
- raster graphics
 - destination raster height 2-69
 - destination raster width 2-68
 - end raster graphics (version B) 2-68
 - end raster graphics (version C) 2-68
 - raster graphics presentation 2-67
 - raster resolution 2-67
 - set raster compression mode 2-68
 - set raster configuration 2-69
 - source raster height 2-67
 - source raster width 2-67
 - start raster graphics 2-67
 - transfer raster data by plane 2-67
 - transfer raster data by row/block 2-68
 - Y offset 2-67
 - rectangular area fill graphics
 - area fill ID 2-66
 - fill rectangular area 2-66
 - horizontal rectangle size 2-65
 - vertical rectangle size (decipoints) 2-65
 - vertical rectangle size (PCL Units) 2-65
 - status readback
 - echo 2-72
 - flush all pages 2-72
 - free space 2-72
 - inquire status readback entity 2-72
 - set status readback location type 2-72
 - set status readback location unit 2-72
 - user-defined symbol set
 - define symbol set 2-62
 - symbol set control 2-62
 - symbol set ID code 2-62
 - control codes 2-49
 - font and symbol set support
 - Lexmark X422 2-8
 - GL/2 Language 2-74
 - linking commands 2-50
 - paper and envelope dimensions
 - Lexmark C510(n) 2-4
 - password protection 3-93
 - saving files on flash memory or disk 6-3
 - selecting
 - MarkVision Professional 2-1
 - operator panel 2-1
 - SmartSwitch 2-1
 - software program 2-2
 - SmartSwitch 2-1
 - specialty fonts 2-13
 - standard fonts 2-9
 - Type 1 fonts 2-11
 - variables, PJI
 - common 3-48
 - printer unique 3-49
- physical page
 - PCL emulation 2-3
- physical page border 2-6
- physical specifications 7-5
- ports, communication 8-2
 - Windows 2000 8-4
 - Windows 95/98/Me 8-2
 - Windows NT 4.0 8-3
 - Windows XP 8-5
- PostScript emulation

- accessing files 6-9
- device names 6-9
- device parameters 4-72
- device search order 6-12
- envelope size support 4-10
- filenames 6-9
- interpreter parameters 4-63
- page device parameters 4-49
- paper size commands
 - currentuniversalsize 4-3
 - ignoresize 4-4
 - setignoresize 4-4
 - setuniversalsize 4-5
- paper tray commands
 - manualfeed 4-8
 - papertray 4-8
 - setpapertray 4-9
- paper tray support 4-5
- password protecting
 - Type 1 fonts on flash memory or disk 3-93
- saving fonts on flash memory or disk 6-3
- selecting language 4-1
- SmartSwitch 4-1
- status and error messages 4-93, 4-94
- supplemental operators 4-14
 - appletalktype 4-14
 - buildtime 4-14
 - byteorder 4-14
 - checkpassword 4-15
 - currentfilenameextend 4-15
 - currentmanualduplexmode 4-15
 - defaulttimeouts 4-16
 - deletefile 4-16
 - devcontrol 4-17
 - devdismount 4-18
 - devforall 4-19
 - devformat 4-19
 - devmount 4-20
 - devstatus 4-20
 - diskonline 4-21
 - diskstatus 4-22
 - displayoperatormsg 4-22
 - doidlefonts 4-22
 - dojamrecovery 4-23
 - doprinterrors 4-23
 - doret 4-23
 - dostartpage 4-24
 - dosysstart 4-24
 - duplexer 4-24
 - duplexmode 4-25
 - enginesync 4-25
 - file 4-26
 - filenameforall 4-26
 - fileposition 4-26
 - firstside 4-27
 - fontnonzerowinding 4-27
 - hardwareiomode 4-27
 - idlefonts 4-27
 - ignoresize 4-28
 - initializedisk 4-28
 - jobname 4-28
 - jobsources 4-29
 - jobtimeout 4-30
 - manualfeed 4-30
 - manualfeedtimeout 4-31
 - newsheet 4-31
 - pagecount 4-31
 - pagesprinted 4-32
 - papertray 4-32
 - printername 4-32
 - product 4-32
 - PS2fonts 4-33
 - PS3fonts 4-33
 - quiet 4-33
 - ramsize 4-34
 - realformat 4-34
 - renamefile 4-34
 - resolution 4-35
 - revision 4-35
 - sccbatch 4-36
 - sccinteractive 4-37
 - setcoverpage 4-37
 - setdefaulttimeouts 4-37
 - setdoidlefonts 4-38
 - setdojamrecovery 4-38
 - setdoprinterrors 4-38
 - setdoret 4-39
 - setdostartpage 4-39
 - setdosysstart 4-40
 - setduplexmode 4-40
 - setenginesync 4-41
 - setethernetaddress 4-41
 - setfilenameextend 4-41
 - setfileposition 4-42
 - sethardwareiomode 4-42
 - setidlefonts 4-42

- setignoresize 4-42
- setjobtimeout 4-43
- setmanualduplexmode 4-43
- setpapertray 4-43
- setprintername 4-44
- setquiet 4-44
- setresolution 4-45
- setscbatch 4-45
- setscinteractive 4-46
- setsoftwareiomode 4-46
- settumble 4-46
- setuserdiskpercent 4-47
- softwareiomode 4-47
- tumble 4-47
- userdiskpercent 4-48
- waittimeout 4-48
- system parameters 4-66
- user parameters 4-63
- using the operator panel 4-1
- power requirements 7-3
- printable areas 2-3, 2-6
- Printer Job Language (PJL)
 - attendance messages 3-67
 - 30 Print Unit Missing 3-67
 - 30 Coating Roll Missing 3-67
 - 31 Defective Cartridge XXXX 3-67
 - 31 Defective Print Cartridge 3-67
 - 31 Missing Cartridge XXXX 3-68
 - 31 Missing Printhead 3-68
 - 31 PerfectFinish Missing 3-70
 - 32 Unsupported Cartridge 3-67
 - 32 Unsupported Cartridge 3-67
 - 32 Unsupported Print Cartridge 3-67
 - 32 Unsupported Printhead 3-68
 - 33 Tray x Config Error 3-69
 - 40 Tray x Size Sense Error 3-68
 - 41 Open Bin 1 Exit Tray 3-68
 - 58 Input Config Error 3-69
 - 58 Too Many Bins Attached 3-69
 - 58 Too Many Disks Installed 3-69
 - 58 Too Many Trays Attached 3-69
 - 59 Incompatible Bin x 3-71
 - 84 All Photo Devs Exhausted 3-70
 - 84 Black Photo Dev Exhausted 3-70
 - 84 Black Photo Dev Life Warning 3-70
 - 84 Color Photo Dev Life Warning 3-70
 - 87 PerfectFinish Empty 3-70
 - 88 Black Print Cartridge Low 3-70
 - 88 Black Toner Empty 3-70
 - 88 Black Toner Low 3-70
 - 88 Cartridge Low <CMYK> 3-71
 - 88 Color Print Cartridge Low 3-70
 - 88 Cyan Toner Empty 3-70
 - 88 Cyan Toner Low 3-70
 - 88 Magenta Toner Empty 3-70
 - 88 Magenta Toner Low 3-70
 - 88 Photo Print Cartridge Low 3-70
 - 88 Toner Low 3-70
 - 88 Yellow Toner Empty 3-70
 - 88 Yellow Toner Low 3-70
 - 89 Cartridge Empty <CMYK> 3-71
 - 2xx Paper Jam 3-69
 - Cartridge Life Expired XXXX 3-67
 - Cartridge Life Warning XXXX 3-68
 - Change Cartridge Invalid Refill 3-67
 - Check Duplex Connection 3-71
 - Check Finisher Installation 3-69
 - Check Mailbox Installation 3-69
 - Check Tray <source #> Connection 3-69
 - Close Cover 3-68
 - Close Cover <c> 3-68
 - Close Cover A 3-67
 - Close Deflector G 3-68
 - Close Door 3-67
 - Close Door <d> 3-68
 - Close Duplex Door 3-72
 - Close Finisher Door 3-68
 - Close Finisher Side Door 3-68
 - Close Finisher Top Cover 3-68
 - Close Front Door 3-68
 - Close Side Door 3-68
 - Close Top Covers 3-67
 - Close Tray x Top Cover 3-68
 - Cover Open 3-67
 - Incompatible Duplex 3-71
 - Incompatible Envelope Feeder 3-71
 - Incompatible Tray x 3-71
 - Insert Cartridge 3-67
 - Insert Duplex Option 3-72
 - Insert Hole Punch Box 3-67
 - Insert PC Cartridge 3-67
 - Insert Print Cartridge 3-69
 - Install Bin x or Cancel Job 3-69
 - Install Duplex or Cancel Job 3-72
 - Install Env Feed or Cancel Job 3-69
 - Install Tray x or Cancel Job 3-69

- Load Staples 3-71, 3-72
- Open Cover 3-68
- Open Rear Door 3-68
- OPMSG message 3-71
- paper handling
 - 34 Incorrect Media 3-73
 - 34 Wrong Paper Size in Tray x 3-73
 - 34 Wrong Paper Size Manual Feed 3-73
 - Change <source> 3-73
 - Check <source> Paper Guide 3-73
 - Insert Duplex Pages & Press Go. 3-73
 - Insert Tray <source #> 3-73
 - Load <source> 3-73
 - Load Manual 3-73
 - Remove Paper <linked set bin name> 3-73
 - Remove Paper All Output Bins 3-73
 - Remove Paper Output Bin <bin #> 3-73
 - Remove Paper Standard Bin 3-73
- paper jams
 - 200 Paper Jam 3-76
 - 201 Paper Jam 3-76
 - 202 Paper Jam 3-76
 - 203 Paper Jam 3-76
 - 204 Paper Jam 3-76
 - 205 Paper Jam 3-76
 - 206 Paper Jam 3-76
 - 207 Paper Jam 3-76
 - 208 Paper Jam 3-76
 - 220 Paper Jam 3-76
 - 221 Paper Jam 3-76
 - 222 Paper Jam 3-76
 - 230 Paper Jam 3-76
 - 231 Paper Jam 3-76
 - 232 Paper Jam 3-77
 - 241 Paper Jam 3-77
 - 242 Paper Jam 3-77
 - 243 Paper Jam 3-77
 - 244 Paper Jam 3-77
 - 245 Paper Jam 3-77
 - 246 Paper Jam 3-77
 - 247 Paper Jam 3-77
 - 248 Paper Jam 3-77
 - 249 Paper Jam 3-77
 - 24y Paper Jam 3-77
 - 250 Paper Jam 3-77
 - 251 Paper Jam 3-77
 - 252 Paper Jam 3-77
 - 253 Paper Jam 3-78
 - 254 Paper Jam 3-78
 - 255 Paper Jam 3-78
 - 256 Paper Jam 3-78
 - 257 Paper Jam 3-78
 - 258 Paper Jam 3-78
 - 259 Paper Jam 3-78
 - 260 Paper Jam 3-78
 - 261 Paper Jam 3-78
 - 271 Paper Jam 3-78
 - 272 Paper Jam 3-78
 - 273 Paper Jam 3-78
 - 27z Paper Jam 3-78
 - 280 Paper Jam 3-78
 - 281 Paper Jam 3-79
 - 282 Paper Jam 3-79
 - 283 Paper Jam 3-79
 - 284 Paper Jam 3-79
 - 285 Paper Jam 3-79
 - 286 Paper Jam 3-79
 - 287 Paper Jam 3-79
 - 288 Paper Jam 3-79
 - 289 Paper Jam 3-79
 - 290 Paper Jam 3-79
 - 291 Paper Jam 3-79
 - 292 Paper Jam 3-79
 - 293 Paper Jam 3-79
 - 294 Paper Jam 3-80
 - 295 Paper Jam 3-80
- Priming Failed. Retry? 3-71
- Reattach Bins <bin #x - bin #y> 3-69
- Reattach Envelope Feeder 3-69
- Reattach MP Feeder 3-69
- Reattach Output Bin <bin #> 3-69
- Replace Fuser 3-71
- Replace Oil Coating Roll 3-71
- Replace PC Kit 3-71
- Replace PC Kit To Continue 3-71
- Replace Toner Cartridge 3-71
- Replace Toner Cartridge To Continue 3-71
- Replace Transfer Kit 3-71
- STMSG message 3-71
- auto-continuable messages 3-63
 - 34 Short Paper 3-64
 - 35 Res Save Off Deficient Memory 3-64, 3-65
 - 36 Resolution Reduced 3-64

- 37 Insufficient Collation Area 3-63, 3-65
- 37 Insufficient Defrag Memory 3-63
- 37 Insufficient Memory 3-63
- 38 Memory Full 3-63
- 39 Complex Page 3-63
- 50 PPDS Font Error 3-63
- 51 Defective Flash 3-64, 3-66
- 52 Flash Full 3-64, 3-66
- 53 Unformatted Flash 3-64, 3-66
- 54 Network x Software Error 3-65
- 54 Par x ENA Connection Lost 3-65
- 54 Parallel Error 3-63
- 54 Ser x Fax Connection Lost 3-65
- 54 Serial Option 1 Error 3-63
- 54 Serial Option x Error 3-65
- 54 Standard Serial Error 3-63
- 54 Std Network Software Error 3-63
- 54 Std Par ENA Connection Lost 3-64
- 54 Std Ser Fax Connection Lost 3-63
- 55 Insufficient Fax Buffer 3-64
- 56 Parallel Port Disabled 3-64
- 56 Parallel Port x Disabled 3-65
- 56 Serial Port 1 Disabled 3-64
- 56 Serial Port x Disabled 3-65
- 56 Standard Parallel Port Disabled 3-64
- 56 Standard Serial Disabled 3-64
- 56 Standard USB Port Disabled 3-64
- 56 Std Parallel Port Disabled 3-64
- 56 USB Port x Disabled 3-65
- 57 Configuration Change 3-63
- 58 Too Many Flash Options 3-66
- 61 Defective Disk 3-64, 3-66
- 61 Unformatted Disk 3-65
- 62 Disk Full 3-64, 3-66
- 63 Unformatted Disk 3-66
- 64 Unsupported Disk Format 3-66
- 80 Belt Exhausted 3-66
- 80 Belt Life Warning 3-66
- 80 Fuser Exhausted 3-66
- 80 Fuser Life Warning 3-66
- 80 Fuser Maintenance 3-66
- 80 Fuser/Belt Exhausted 3-66
- 80 Fuser/Belt Life Warning 3-66
- 80 Scheduled Maintenance 3-65, 3-66
- 81 Scheduled Maintenance 3-66
- 83 ITU Maintenance 3-66
- Disk Corrupted. Reformat? 3-66
- Empty Box M 3-65
- Held Jobs May Not Be Restored 3-63
- Insert Box M 3-65
- Insert Staple Cartridge 3-65
- Insert Stapler 3-65
- Operation Failed Faxes on Disk 3-65
- Operation Failed Jobs on Disk 3-65
- Priming Failed, Retry. Go/Stop? 3-65
- Print Jobs on Disk. Go/Stop? 3-64
- Print Jobs on Disk? 3-64
- Restore Held Jobs. Go/Stop? 3-64
- command categories
 - device attendance 3-80
 - file and device protection 3-93
 - file commands for flash and disk 3-86
 - job separation commands 3-4
 - kernel commands 3-2
 - miscellaneous 3-82
 - status readback 3-53, 3-54
- command syntax
 - command codes 3-1
 - optional parameters 3-2
- commands
 - COMMENT 3-3
 - DEFAULT 3-8, 3-94
 - DINQUIRE 3-54
 - ECHO 3-55
 - ENTER LANGUAGE 3-3
 - EOJ 3-6
 - INFO 3-56
 - INITIALIZE 3-11
 - INQUIRE 3-58
 - JOB 3-4
 - LBEEP 3-82
 - LBYPASSPASSWORD 3-97
 - LCLOSEFILE 3-89
 - LDECLARE 3-95, 3-97
 - LDELETEFILE 3-92
 - LDELETEPASSWORD 3-96
 - LDOWNLOADTARGET 3-86
 - LESCAPECHAR 3-83
 - LFAX PHONENUMBER 3-85
 - LFORMAT 3-92
 - LOPENFILE 3-89
 - LPORTROTATE 3-82
 - LPRINTDIRECTORY 3-83, 6-4
 - LPRINTMENUS 3-83
 - LPRINTPSFONTS 3-83
 - LPRINTTESTPAGE 3-83

- LREADFILE 3-90
- LRENAMEFILE 3-92
- LRUNFILE 3-91
- LWRITEFILE 3-91
- OPMSG 3-81
- RDYMSG 3-80
- RESET 3-11
- SET 3-9
- STMSG 3-81
- USTATUS 3-59
- USTATUSOFF 3-60
- information messages
 - 88 Black Print Cartridge Low 3-61
 - 88 Black Toner Low 3-61
 - 88 Color Print Cartridge Low 3-61
 - 88 Cyan Toner Low 3-61
 - 88 Magenta Toner Low 3-61
 - 88 Photo Print Cartridge Low 3-61
 - 88 Toner Low 3-61, 3-62
 - 88 Yellow Toner Low 3-61
 - Bin <bin #> Full 3-62
 - Busy 3-62
 - Cancelling Job 3-62
 - Not Ready 3-61
 - Power Saver with 88 Ink Low 3-62
 - Powersaver 3-62
 - RDYMSG 3-61
 - Ready 3-61
 - Ready with 88 Ink Low 3-61
 - Replace Fuser 3-61, 3-62
 - Replace PC Kit 3-61, 3-62
 - Replace Toner 3-61, 3-62
 - Replace Transfer 3-62
 - Res Reduced 3-62
 - Resetting the Printer 3-61
 - Tray <source #> Empty 3-62
 - Tray <source #> Missing 3-62
 - Waiting 3-62
- status messages and codes 3-61
- variable categories 3-7
 - common variables
 - all printer languages 3-12
 - PCL emulation 3-48
 - PostScript emulation 3-51
 - printer unique
 - all printer languages 3-19
 - LRESOURCE 3-52
 - PCL emulation 3-49
 - PostScript emulation 3-52
 - variables
 - AUTOCONT 3-12
 - BINDING 3-12
 - BITSPERPIXEL 3-12
 - CLEARABLEWARNINGS 3-12
 - COPIES 3-12
 - CPLOCK 3-13
 - DENSITY 3-13
 - DUPLEX 3-13
 - ECONOMODE 3-13
 - FONTNUMBER 3-48
 - FONTSOURCE 3-48
 - FORMATTERNUMBER 3-13
 - FORMLINES 3-13
 - HOLD 3-13
 - HOLDKEY 3-13
 - HOLDTYPE 3-14
 - IMAGEADAPT 3-14
 - INTRAY1SIZE 3-14
 - INTRAY2 3-14
 - INTRAY2SIZE 3-14
 - INTRAY3 3-14
 - INTRAY3SIZE 3-14
 - INTRAY4 3-14
 - INTRAY4SIZE 3-14
 - INTRAY5 3-14
 - INTRAY5SIZE 3-14
 - JAMRECOVERY 3-51
 - JOBNAME 3-14
 - JOBOFFSET 3-15
 - LA4WIDTH 3-49
 - LACTIVEBINRESET 3-19
 - LADVANCEDSTATUS 3-19
 - LALARMCONTROL 3-19
 - LANG 3-15
 - LASSIGNFEEDER 3-49
 - LASSIGNMANUALENEVELOPE 3-49
 - LASSIGNMANUALPAPER 3-49
 - LASSIGNMPFEEDER 3-49
 - LASSIGNTRAY1 3-50
 - LASSIGNTRAY2 3-50
 - LASSIGNTRAY3 3-50
 - LASSIGNTRAY4 3-50
 - LASSIGNTRAY5 3-50
 - LAUTOCRLF 3-19
 - LAUTOLFCR 3-19
 - LBITMAPROUNDING 3-50

LBLANKPAGES 3-19
LBONDLENGTH 3-19
LBONDLOADING 3-19
LBONDOUTBIN 3-20
LBONDTEXTURE 3-20
LBONDWEIGHT 3-20
LBWLOCK 3-20
LCANCEL 3-20
LCARDSTOCKLENGTH 3-20
LCARDSTOCKLOADING 3-20
LCARDSTOCKOUTBIN 3-21
LCARDSTOCKTEXTURE 3-21
LCARDSTOCKWEIGHT 3-21
LCOLLATION 3-21
LCOLORCORRECTION 3-21
LCOLOREDLENGTH 3-21
LCOLOREDLOADING 3-22
LCOLOREDOUTBIN 3-22
LCOLOREDTEXTURE 3-22
LCOLOREDWEIGHT 3-22
LCOLOREXTENSIONS 3-50
LCOLORMODEL 3-22
LCUSTOMPAPERFEED 3-23
LCUSTOMPAPERHEIGHT 3-23
LCUSTOMPAPERUNITS 3-22
LCUSTOMPAPERWIDTH 3-22
LCUSTOMTYPE1LENGTH 3-23
LCUSTOMTYPE1LOADING 3-23
LCUSTOMTYPE1MEDIA 3-23
LCUSTOMTYPE1NAME 3-23
LCUSTOMTYPE1OUTBIN 3-24
LCUSTOMTYPE1TEXTURE 3-24
LCUSTOMTYPE1WEIGHT 3-24
LCUSTOMTYPE2LENGTH 3-24
LCUSTOMTYPE2LOADING 3-24
LCUSTOMTYPE2MEDIA 3-24
LCUSTOMTYPE2NAME 3-25
LCUSTOMTYPE2OUTBIN 3-25
LCUSTOMTYPE2TEXTURE 3-25
LCUSTOMTYPE2WEIGHT 3-25
LCUSTOMTYPE3LENGTH 3-25
LCUSTOMTYPE3LOADING 3-25
LCUSTOMTYPE3MEDIA 3-26
LCUSTOMTYPE3NAME 3-26
LCUSTOMTYPE3OUTBIN 3-26
LCUSTOMTYPE3TEXTURE 3-26
LCUSTOMTYPE3WEIGHT 3-26
LCUSTOMTYPE4LENGTH 3-26
LCUSTOMTYPE4LOADING 3-27
LCUSTOMTYPE4MEDIA 3-27
LCUSTOMTYPE4NAME 3-27
LCUSTOMTYPE4OUTBIN 3-27
LCUSTOMTYPE4TEXTURE 3-27
LCUSTOMTYPE4WEIGHT 3-27
LCUSTOMTYPE5LENGTH 3-28
LCUSTOMTYPE5LOADING 3-28
LCUSTOMTYPE5MEDIA 3-28
LCUSTOMTYPE5NAME 3-28
LCUSTOMTYPE5OUTBIN 3-28
LCUSTOMTYPE5TEXTURE 3-28
LCUSTOMTYPE5WEIGHT 3-29
LCUSTOMTYPE6LENGTH 3-29
LCUSTOMTYPE6MEDIA 3-29
LCUSTOMTYPE6NAME 3-29
LCUSTOMTYPE6OUTBIN 3-29
LCUSTOMTYPE6TEXTURE 3-30
LCUSTOMTYPE6WEIGHT 3-30
LDESCRIPTION 3-53
LDOWNLOADTARGET 3-30
LDRYTIMEDELAY 3-30
LDUPLICATEHELDJOBS 3-30
LENVELOPEENHANCE 3-30
LENVELOPELENGTH 3-30
LENVELOPEOUTBIN 3-30
LENVELOPETEXTURE 3-31
LENVELOPEWEIGHT 3-31
LESCCHAR 3-31
LFAXREDIAL 3-31
LFAXREDIALFREQUENCY 3-31
LFAXRESOLUTION 3-31
LFAXTRANSMISSIONLOG 3-31
LFEEDERPAPERTYPE 3-31
LFONTCOMPATIBILITY 3-51
LFONTPRIORITY 3-51
LGLOSSYLOADING 3-31
LGLOSSYOUTPUTBIN 3-32
LGLOSSYTEXTURE 3-32
LGLOSSYWEIGHT 3-32
LHOLEPUNCHALARM 3-32
LHOLEPUNCHMODE 3-32
LHONORINIT 3-32
LIMAGEBRIGHTNESS 3-32
LIMAGECONTRAST 3-32
LIMAGEENHANCE 3-32
LIMAGEENHANCETYPE 3-33
LIMAGEORIENTATION 3-33

- LIMAGESMOOTHING 3-33
- LINFEDERSIZE 3-33
- LINKALERT 3-33
- LINMPFEEDERSIZE 3-33
- LJAMRECOVERY 3-33
- LLABELSLENGTH 3-33
- LLABELSLOADING 3-33
- LLABELSOUTBIN 3-34
- LLABELSTEXTURE 3-34
- LLABELSWEIGHT 3-34
- LLASTTRAYRENUMBER 3-34
- LLEFTMARGINOFFSET 3-34
- LLETTERHEADLENGTH 3-34
- LLETTERHEADLOADING 3-34
- LLETTERHEADOUTBIN 3-35
- LLETTERHEADTEXTURE 3-35
- LLETTERHEADWEIGHT 3-35
- LMANUALENVELOPESIZE 3-36
- LMANUALENVELOPETYPE 3-36
- LMANUALPAPERSIZE 3-36
- LMANUALPAPERTYPE 3-36
- LMPFEEDERPAPERTYPE 3-36
- LMULTIPAGEBORDER 3-36
- LMULTIPAGEORDER 3-36
- LMULTIPAGEPRINT 3-37
- LMULTIPAGEVIEW 3-37
- LNPAP 3-37
- LOPTIONALOUTBIN1NAME 3-37
- LOPTIONALOUTBIN2NAME 3-37
- LOPTIONALOUTBIN3NAME 3-37
- LOPTIONALOUTBIN4NAME 3-37
- LOPTIONALOUTBIN5NAME 3-37
- LOPTIONALOUTBIN6NAME 3-38
- LOPTIONALOUTBIN7NAME 3-38
- LOPTIONALOUTBIN8NAME 3-38
- LOPTIONALOUTBIN9NAME 3-38
- LOPTIONALOUTBIN10NAME 3-38
- LOUTBINCONFIG 3-38
- LOVERFLOWOUTBIN 3-39
- LOVERFLOWTIMER 3-39
- LOWTONER 3-15
- LPAGECOUNT 3-39
- LPAGEMODE 3-39
- LPAPERSOURCE 3-39
- LPICTUREGRADE 3-40, 3-52
- LPLAINLENGTH 3-40
- LPLAINOUTBIN 3-40
- LPLAINTEXTURE 3-40
- LPLAINWEIGHT 3-40
- LPOWERSAVER 3-40
- LPPDS 3-41
- LPPDSFORMLINES 3-41
- LPPDSLINESPERINCH 3-41
- LPREPRINTEDLENGTH 3-41
- LPREPRINTEDLOADING 3-41
- LPREPRINTEDOUTBIN 3-42
- LPREPRINTEDTEXTURE 3-42
- LPREPRINTEDWEIGHT 3-42
- LPRINTBUFFER 3-42, B-10
- LPRINTERUSAGE 3-42
- LPRINTHEADIDLETIME 3-42
- LPRINTMENUSBUTTON 3-42, B-10
- LPRINTQUALITY 3-43
- LPSFONTPRIORITY 3-52
- LPUNCH 3-43
- LREAROUTBINNAME 3-43
- LREPEATLIMIT 3-43
- LRESET 3-43
- LRESOURCESAVE 3-43, B-10
- LRIGHTMARGINOFFSET 3-43
- LRWLOCK 3-53
- LSCREENING 3-43
- LSEPARATORSHEETS 3-43
- LSEPARATORSOURCE 3-43
- LSTANDARDOUTBINNAME 3-44
- LSTAPLE 3-44
- LSTAPLEEMPTYALARM 3-44
- LSTAPLETESTBIN 3-44
- LSTAPLETESTSOURCE 3-44
- LSTROKEWIDTH 3-44
- LSUBSTITUTESIZE 3-44
- LTOPBINROTATE 3-44
- LTOPMARGINOFFSET 3-44
- LTRANSPARENCYLENGTH 3-44
- LTRANSPARENCYOUTBIN 3-45
- LTRANSPARENCYTEXTURE 3-45
- LTRANSPARENCYWEIGHT 3-45
- LTRAY1AUTOSIZE 3-46
- LTRAY1PAPERTYPE 3-46
- LTRAY1RENUMBER 3-47
- LTRAY1SENSEDTYPEPAPER 3-45
- LTRAY1SENSEDTYPETRANSPARENCY 3-45
- LTRAY2AUTOSIZE 3-46
- LTRAY2PAPERTYPE 3-47
- LTRAY2SENSEDTYPEPAPER 3-45

LTRAY2SENSEDTYPETRANS PareNCY
 3-45
 LTRAY3AUTOSIZE 3-46
 LTRAY3PAPERTYPE 3-47
 LTRAY3SENSEDTYPEPAPER 3-46
 LTRAY3SENSEDTYPETRANS PareNCY
 3-46
 LTRAY4AUTOSIZE 3-46
 LTRAY4PAPERTYPE 3-47
 LTRAY4SENSEDTYPEPAPER 3-46
 LTRAY4SENSEDTYPETRANS PareNCY
 3-46
 LTRAY5AUTOSIZE 3-46
 LTRAY5PAPERTYPE 3-47
 LTYPE1FONTS 3-48
 LUSDEFAULTS 3-48
 LWLOCK 3-53
 MANUALFEED 3-15
 MEDIATYPE 3-15
 MPTRAY 3-15
 ORIENTATION 3-15
 OUTBIN 3-16
 PAGEPROTECT 3-16
 PAPER 3-16
 PARALLEL 3-17
 PASSWORD 3-17
 PERSONALITY 3-17
 PITCH 3-48
 POWERSAVE 3-17
 POWERSAVETIME 3-18
 PRTPSERRS 3-51
 PTSIZE 3-48
 QTY 3-18
 REPRINT 3-18
 RESOLUTION 3-18
 RESOURCESAVE 3-18
 RET 3-18
 SYMSET 3-48
 TIMEOUT 3-18
 USERNAME 3-19
 WIDEA4 3-19
 printer languages, selecting
 MarkVision Professional 2-1
 methods 5-1
 operator panel 2-1, 4-1
 PCL emulation 2-1
 Printer Job Language (P JL) 3-3
 setting for different interfaces 5-2

SmartSwitch 5-1
 software program 2-2
 switching 5-1
 printer specifications
 airflow requirement 7-1
 altitude 7-9
 atmospheric pressure 7-9
 clearance requirements 7-8
 dimensions 7-5
 electrical 7-2
 environmental conditions 7-9
 flash memory and disk retrieval speeds 6-13
 interfaces 8-1
 noise emission levels 7-1
 power requirements 7-3
 size 7-5
 weight 7-5
 protocol
 DTR/DSR 8-24
 fastbytes data transfer sequence 8-12
 Robust XON 8-23
 RS-232C 8-25
 standard data transfer sequence 8-11
 XON/XOFF 8-26

R

raster compression mode 2-78
 adaptive compression 2-82
 delta row 2-81
 group 3 and 4 2-83
 Lexmark adaptive 2-84
 run-length encoded data 2-80
 Tagged Image File Format (TIFF) 2-80
 unencoded data 2-79
 raster image graphics 2-78
 receivers
 AUTOFD*
 Lexmark C510 8-16
 BUSY driver
 Lexmark C510 8-17
 DATA 1-8 Signal
 Lexmark C510 8-16
 INIT*
 Lexmark C510 8-17
 SLCTIN*
 Lexmark C510 8-18
 required clearance 7-8

- Resource Data Collection 6-2, 6-3
- Robust XON protocol 8-23
- RS-232C
 - cable pin assignments 8-19
 - connecting 8-19
 - port compatibility 8-28
 - protocol timing 8-25
 - XON/XOFF protocol timing 8-26

S

- selecting printer languages
 - setting for different interfaces 5-2
 - SmartSwitch 5-1
- serial interface
 - network support 8-28
 - RS-232C
 - cable pin assignments 8-19
 - communication parameters 8-21
 - DTR and DTR/DSR protocol timing 8-25
 - port compatibility 8-28
 - protocol 8-24
 - serial configuration recommendations 8-27
 - using RS-232C 8-18
 - when to use 8-18
- service errors 3-80
- signal descriptions 8-15
- size, printer 7-5
- SmartSwitch 5-1
 - setting for different interfaces 5-2
 - switching printer languages 5-1
- sniffing 5-3
- specialty PCL emulation fonts
 - forward/backward compatibility modes 2-13
- specialty PCL fonts 2-13
- specifications
 - See printer specifications
- standard PCL emulation fonts 2-9
 - forward/backward compatibility modes 2-9
- standard protocol 8-11
- status messages
 - attendance conditions 3-67
 - auto-continuable conditions 3-63
 - information messages 3-61
 - operator intervention - paper handling 3-72
 - operator intervention - paper jams 3-75
 - PostScript emulation 4-94
- switching printer languages

- MarkVision Professional 2-1
 - methods 5-1
 - operator panel 2-1, 4-1
 - PCL emulation 2-1
 - PostScript emulation 4-1
 - Printer Job Language (PJL) 3-3
 - setting for different interfaces 5-2
 - SmartSwitch 5-1
 - software program 2-2, 4-2
- Symbol Set Tables, locating ID values 2-50
- symbol sets
 - printing directory list
 - flash memory or disk 6-3
 - setting password protection 3-93
 - storing on flash memory or disk 6-3
 - support
 - ISO fonts 2-30, 2-47
- syntax, commands
 - PCL emulation 2-49
 - Printer Job Language 3-1

T

- test page, printing from PJL
 - flash memory and disk directory 3-83, 6-4
 - menu settings page 3-83
 - PostScript emulation font list 3-83
 - printer test page 3-83
- trays
 - PCL emulation
 - page size 2-54
 - paper source 2-54
 - PostScript emulation
 - automatic size sensing search order 4-5
 - operators 4-7
 - Printer Job Language (PJL)
 - paper size 3-14
 - paper source 3-39
 - status message codes 3-74
- Type 1 fonts
 - description 2-11
 - forward/backward compatibility modes 2-11

U

- Universal Exit Language 3-2

V

- variables, PJJ
 - common for all printer languages 3-12
 - common for PCL emulation 3-48
 - common for PostScript emulation 3-51
 - environment 3-7
 - printer unique for all printer languages 3-19
 - printer unique for PCL emulation 3-49

W

- weight, printer 7-5
- whole page setting 2-7

X

- XON/XOFF protocol 8-23
 - RS-232C 8-26