



pSeries 615 Model 6C3 and Model 6E3

User's Guide

SA38-0629-00





@server

pSeries 615 Model 6C3 and Model 6E3

User's Guide

SA38-0629-00

First Edition (May 2003)

Before using this information and the product it supports, read the information in "Safety Notices" on page ix, Appendix A, "Environmental Notices", on page 141, and Appendix B, "Notices", on page 143.

A reader's comment form is provided at the back of this publication. If the form has been removed, address comments to Information Development, Department H6DS-905-6C006, 11501 Burnet Road, Austin, Texas 78758-3493. To send comments electronically, use this commercial internet address: aix6kpub@austin.ibm.com. Any information that you supply may be used without incurring any obligation to you.

© **International Business Machines Corporation, 2003. All rights reserved.** Note to U.S. Government Users -- Documentation related to restricted rights -- Use, duplication or disclosure is subject to restrictions set forth in GSA ADP Schedule Contract with IBM Corp.

Contents

Safety Notices	ix
Rack Safety Instructions	ix
Electrical Safety	x
Laser Safety Information	xi
Laser Compliance	xi
Data Integrity and Verification	xiii
About This Book	xv
ISO 9000	xv
Highlighting	xv
Accessing Information	xv
References to AIX Operating System	xv
Related Publications	xv
Ergonomic Information	xvii
Trademarks	xvii
Chapter 1. Reference Materials	1
Documentation Overview	3
Chapter 2. Introducing the System	7
System Features	8
Chapter 3. Using the System	11
Starting the System	11
Starting the System without an HMC Attached	11
Starting the System with an HMC Attached	11
Stopping the System	12
Stopping the System without an HMC Attached	12
Stopping the System with an HMC Attached and AIX Installed	12
Stopping the System with an HMC Attached and Linux Installed	12
Reading the Operator Panel Display	13
Operator Panel	14
Disturbance or System Attention LED	15
Component LEDs	16
Using the Keyboards	18
Using the Three-Button Mouse	19
Handling the Mouse Correctly	19
Caring for the Mouse	19
Cleaning the Mouse	19
Using a 3.5-Inch Diskette Drive	21
Write-Protecting 3.5-Inch Diskettes	21
Loading and Unloading the 3.5-Inch Diskette	22
Using a CD-ROM Drive	22
Front View of CD-ROM Drive	23
Understanding the Status Lights	23
Handling Compact Discs	24
Other Handling Considerations	24
Loading a Compact Disc	25
Opening the Tray Manually	25
Playing an Audio CD	25
Chapter 4. Using the Service Processor	27

Service Processor Menus	27
Accessing the Service Processor Menus Locally	27
Accessing the Service Processor Menus Remotely	28
Saving and Restoring Service Processor Settings	28
Menu Inactivity	28
General User Menu.	29
Privileged User Menus	29
Main Menu	29
Service Processor Setup Menu	32
Passwords	33
System Power Control Menu	37
System Information Menu	40
Language Selection Menu	45
Call-In/Call-Out Setup Menu	46
Modem Configuration Menu.	47
Serial Port Selection Menu	47
Serial Port Speed Setup Menu	48
Telephone Number Setup Menu	48
Call-Out Policy Setup Menu.	50
Customer Account Setup Menu	50
Call-out Test Menu	51
Service Processor Parameters in Service Mode	51
System Power-On Methods.	51
Service Processor Reboot/Restart Recovery	52
Boot (IPL) Speed	52
Failure During Boot Process	52
Failure During Normal System Operation.	52
Service Processor Reboot/Restart Policy Controls	52
System Firmware Updates	54
General Information on System Firmware Updates	54
Determining the Level of Firmware on the System	55
System Firmware Update Using a Locally Available Image	55
Updating System Firmware from the Service Processor Menus.	56
Updating System Firmware from the AIX Service Aids	56
Updating System Firmware from the AIX Command Line	56
Updating System Firmware from a NIM Server.	56
Recovery Mode	56
Configuring and Deconfiguring Processors or Memory	58
Run-Time CPU Deconfiguration (CPU Gard)	59
Service Processor System Monitoring - Surveillance	59
System Firmware Surveillance.	59
Operating System Surveillance	60
Call-Out (Call-Home)	60
Console Mirroring	61
System Configuration	61
Service Processor Error Logs	62
LCD Progress Indicator Log	63
Service Processor Operational Phases	64
Pre-Standby Phase.	64
Standby Phase	64
Bring-Up Phase	65
Runtime Phase	65
Chapter 5. Using System Management Services	67
Select Language.	69
Change Password Options	69

Set Privileged-Access Password	69
View Error Log	70
Setup Remote IPL (Initial Program Load)	71
Change SCSI Settings	73
Select Console	73
Select Boot Options	74
Select Boot Devices	77
Display Current Settings	79
Restore Default Settings	79
Multiboot Startup	80
Exiting System Management Services	80
Chapter 6. Using the Online and Standalone Diagnostics	81
Operating Considerations for Online and Standalone Diagnostics	81
Identifying the Terminal Type to the Diagnostics	82
Undefined Terminal Types	82
Resetting the Terminal.	82
Online Diagnostics Modes of Operation	82
Service Mode	82
Concurrent Mode	84
Maintenance Mode	85
Standalone Diagnostic Operation	86
Considerations for Running Standalone Diagnostics from CD-ROM	86
Running Standalone Diagnostics from a Network Installation Management (NIM) Server	87
Booting Standalone Diagnostics from the NIM Server on a System with an HMC Attached	88
Booting Standalone Diagnostics from the NIM Server on a System with No HMC Attached	89
Chapter 7. Introducing Tasks and Service Aids	91
Tasks	91
Add Resource to Resource List	92
AIX Shell Prompt	92
Analyze Adapter Internal Log	93
Backup and Restore Media	93
Certify Media	93
Change Hardware Vital Product Data	96
Configure Dials and LPF Keys.	96
Configure ISA Adapter.	97
Configure Reboot Policy	97
Configure Remote Maintenance Policy.	98
Configure Ring Indicate Power-On Policy.	99
Configure Scan Dump Policy.	100
Configure Surveillance Policy	100
Create Customized Configuration Diskette	100
Delete Resource from Resource List	101
Disk Maintenance	101
Disk to Disk Copy	101
Display/Alter Sector	102
Display Configuration and Resource List	102
Display Firmware Device Node Information	102
Display Hardware Error Report	102
Display Hardware Vital Product Data	102
Display Machine Check Error Log	102
Display Microcode Level	103
Display MultiPath I/O (MPIO) Device Configuration.	103
Display or Change Bootlist	103
Display or Change Diagnostic Run-Time Options	103

Display Previous Diagnostic Results	105
Display Resource Attributes	105
Display Service Hints	105
Display Software Product Data	105
Display System Environmental Sensors	106
Examples	106
Display Test Patterns.	107
Display USB Devices	107
Download Microcode	107
Download Microcode to PCI SCSI RAID Adapter	107
Download Microcode to a PCI-X Dual Channel Adapter	107
Download Microcode to Disk Drive Attached to a PCI SCSI RAID Adapter	108
Download Microcode to a Fiber Channel Adapter	108
Download Microcode to DVD-RAM Attached to a PCI SCSI Adapter	108
Download Microcode to Disk Attached to PCI SCSI Adapter	109
Download Microcode to Other Devices	109
Fault Indicators	109
Fibre Channel RAID Service Aids	110
Flash SK-NET FDDI Firmware	110
Format Media	111
Hardfile Attached to SCSI Adapter (non-RAID)	111
Hardfile Attached to PCI SCSI RAID Adapter	112
Optical Media	112
Diskette Format.	112
Gather System Information	112
Generic Microcode Download	113
Hot Plug Task	113
PCI Hot Plug Manager	113
SCSI Hot Swap Manager	115
RAID Hot Plug Devices	116
Identify Indicators	116
Identify and System Attention Indicators	117
Local Area Network Analyzer	117
Log Repair Action	117
Periodic Diagnostics	118
PCI RAID Physical Disk Identify.	118
Process Supplemental Media.	118
Run Diagnostics	118
Run Error Log Analysis	118
Run Exercisers	119
Exerciser Commands (CMD)	119
Abbreviations	120
Memory Exerciser	120
Tape Exerciser	120
Diskette Exerciser	120
CD-ROM Exerciser	120
Floating Point Exerciser.	121
Save or Restore Hardware Management Policies	121
SCSI Bus Analyzer	121
SCSI RAID Physical Disk Status and Vital Product Data.	122
SCSD Tape Drive Service Aid	122
Spare Sector Availability	123
SSA Service Aid	123
System Fault Indicator	123
System Identify Indicator	123
Update Disk-Based Diagnostics.	123

Update System or Service Processor Flash	124
7135 RAIDiant Array Service Aid	125
Command Examples	125
7318 Serial Communications Network Server Service Aid	125
Chapter 8. Verifying the Hardware Operation	127
Considerations Before Running This Procedure	127
Using the HMC to Load the Online Diagnostics in Service Mode.	127
Using the HMC to Load the Standalone Diagnostics from CD-ROM	128
Loading the Online Diagnostics on a System without an HMC Attached	128
Loading the Standalone Diagnostics on a System without an HMC Attached	129
Running System Verification	129
Performing Additional System Verification	129
Stopping the Diagnostics	129
Chapter 9. Hardware Problem Determination	131
Problem Determination Using the Standalone or Online Diagnostics	131
Problem Determination When Unable to Load Diagnostics	137
Appendix A. Environmental Notices	141
Product Recycling and Disposal.	141
Environmental Design	141
Acoustical Noise Emissions	142
Declared Acoustical Noise Emissions.	142
Appendix B. Notices	143
Appendix C. General Attributes Required When Using a TTY Terminal	145
Additional Communication Attributes	146
Additional Keyboard Attributes	146
Additional Printer Attributes	147
Appendix D. Service Processor Setup and Test	149
Service Processor Setup Checklist.	149
Testing the Setup	150
Testing Call-In	150
Testing Call-Out	150
Serial Port Configuration	150
Appendix E. Modem Configurations	153
Sample Modem Configuration Files	153
Generic Modem Configuration Files	153
Specific Modem Configuration Files	153
Configuration File Selection	154
Examples for Using the Generic Sample Modem Configuration Files	155
Customizing the Modem Configuration Files	156
IBM 7852-400 DIP Switch Settings	157
Xon/Xoff Modems	157
Ring Detection	158
Terminal Emulators	158
Recovery Procedures	158
Transfer of a Modem Session	159
Recovery Strategy.	160
Prevention Strategy	160
Modem Configuration Sample Files	161
Sample File modem_m0.cfg	161

Sample File modem_m1.cfg	164
Sample File modem_z.cfg	166
Sample File modem_z0.cfg	169
Sample File modem_f.cfg	172
Sample File modem_f0.cfg	174
Sample File modem_f1.cfg	176
Index	179

Safety Notices

A *danger* notice indicates the presence of a hazard that has the potential of causing death or serious personal injury. Danger notices appear on the following pages:

- x

A *caution* notice indicates the presence of a hazard that has the potential of causing moderate or minor personal injury. Caution notices appear on the following pages:

- x
- xi
- 22

Note: For a translation of these notices, see *System Unit Safety Information*, order number SA23-2652.

Rack Safety Instructions

- Do not install this unit in a rack where the internal rack ambient temperatures will exceed 35 degrees C.
- Do not install this unit in a rack where the air flow is compromised. Any side, front or back of the unit used for air flow through the unit must not be in direct contact with the rack.
- Care should be taken to ensure that a hazardous condition is not created due to uneven mechanical loading when installing this unit in a rack. If the rack has a stabilizer it must be firmly attached before installing or removing this unit.
- Consideration should be given to the connection of the equipment to the supply circuit so that overloading of circuits does not compromise the supply wiring or overcurrent protection. To provide the correct power connection to the rack, refer to the rating labels located on the equipment in the rack to determine the total power requirement for the supply circuit.
- An electrical outlet that is not correctly wired could place hazardous voltage on the metal parts of the system or the devices that attach to the system. It is the responsibility of the customer to ensure that the outlet is correctly wired and grounded to prevent an electrical shock.

Electrical Safety

Observe the following safety instructions any time you are connecting or disconnecting devices attached to the workstation.

When using or servicing your system keep the following in mind:

- The ac power interface connector is considered the main power disconnect device.
- This system has redundant power supply capabilities, meaning that it has the capability of having two power supplies running simultaneously in the same system unit. When instructed to disconnect the power source, ensure that all power cables have been unplugged.

DANGER

An electrical outlet that is not correctly wired could place hazardous voltage on metal parts of the system or the devices that attach to the system. It is the responsibility of the customer to ensure that the outlet is correctly wired and grounded to prevent an electrical shock.

Before installing or removing signal cables, ensure that the power cables for the system unit and all attached devices are unplugged.

When adding or removing any additional devices to or from the system, ensure that the power cables for those devices are unplugged before the signal cables are connected. If possible, disconnect all power cables from the existing system before you add a device.

Use one hand, when possible, to connect or disconnect signal cables to prevent a possible shock from touching two surfaces with different electrical potentials.

During an electrical storm, do not connect cables for display stations, printers, telephones, or station protectors for communications lines.

D05

CAUTION:

This product is equipped with a three-wire power cable and plug for the user's safety. Use this power cable with a properly grounded electrical outlet to avoid electrical shock.

C01

DANGER

To prevent electrical shock hazard, disconnect all power cables from the electrical outlet before relocating the system.

D01

Laser Safety Information

CAUTION:

This product may contain a CD-ROM, DVD-ROM, or laser module on a PCI card, which are class 1 laser products.

C30

Laser Compliance

All lasers are certified in the U.S. to conform to the requirements of DHHS 21 CFR Subchapter J for class 1 laser products. Outside the U.S., they are certified to be in compliance with the IEC 825 (first edition 1984) as a class 1 laser product. Consult the label on each part for laser certification numbers and approval information.

CAUTION:

All IBM laser modules are designed so that there is never any human access to laser radiation above a class 1 level during normal operation, user maintenance, or prescribed service conditions. Data processing environments can contain equipment transmitting on system links with laser modules that operate at greater than class 1 power levels. For this reason, never look into the end of an optical fiber cable or open receptacle. Only trained service personnel should perform the inspection or repair of optical fiber cable assemblies and receptacles.

C25, C26

Data Integrity and Verification

IBM computer systems contain mechanisms designed to reduce the possibility of undetected data corruption or loss. This risk, however, cannot be eliminated. Users who experience unplanned outages, system failures, power fluctuations or outages, or component failures must verify the accuracy of operations performed and data saved or transmitted by the system at or near the time of the outage or failure. In addition, users must establish procedures to ensure that there is independent data verification before relying on such data in sensitive or critical operations. Users should periodically check the IBM support websites for updated information and fixes applicable to the system and related software.

About This Book

This book provides information about the pSeries 615 Model 6C3 and Model 6E3, specifically how to use the system, use diagnostics and service aids, and verify system operation. In this book, the pSeries 615 Model 6C3 and Model 6E3 are hereafter referred to as the "system."

ISO 9000

ISO 9000 registered quality systems were used in the development and manufacturing of this product.

Highlighting

The following highlighting conventions are used in this book:

Bold	Identifies commands, subroutines, keywords, files, structures, directories, and other items whose names are predefined by the system. Also identifies graphical objects such as buttons, labels, and icons that the user selects.
<i>Italics</i>	Identifies parameters whose actual names or values are to be supplied by the user.
Monospace	Identifies examples of specific data values, examples of text similar to what you might see displayed, examples of portions of program code similar to what you might write as a programmer, messages from the system, or information you should actually type.

Accessing Information

Documentation for the IBM @server pSeries is available online. Visit the IBM @server pSeries Information Center at http://publib16.boulder.ibm.com/pseries/en_US/infocenter/base.

- To access the pSeries publications, click **Hardware documentation**.
- To view information about the accessibility features of @server pSeries hardware and the AIX operating system, click **AIX and pSeries accessibility**.

References to AIX Operating System

This document may contain references to the AIX operating system. If you are using another operating system, consult the appropriate documentation for that operating system.

This document may describe hardware features and functions. While the hardware supports them, the realization of these features and functions depends upon support from the operating system. AIX provides this support. If you are using another operating system, consult the appropriate documentation for that operating system regarding support for those features and functions. Documentation for the AIX operating system is available from the IBM @server pSeries Information Center at http://publib16.boulder.ibm.com/pseries/en_US/infocenter/base. Select **AIX documentation**. The *AIX Documentation* CD contains the base set of publications for the operating system, including system-management and end-user documentation.

Related Publications

The following publications provide additional information about your system unit:

- The *pSeries 610 Model 6C3 and Model 6E3 User's Guide*, order number SA38-0606, contains information to help users use the system, use the service aids, and solve minor problems.
- The *pSeries 610 Model 6C3 and Model 6E3 Service Guide*, order number SA38-0604, contains reference information, maintenance analysis procedures (MAPs), error codes, removal and replacement procedures, and a parts catalog.

- The *RS/6000 @server pSeries Diagnostic Information for Multiple Bus Systems*, order number SA38-0509, contains diagnostic information, service request numbers (SRNs), and failing function codes (FFCs).
- The *RS/6000 @server pSeries Adapters, Devices, and Cable Information for Multiple Bus Systems*, order number SA38-0516, contains information about adapters, devices, and cables for your system. This manual is intended to supplement the service information found in the *RS/6000 @server pSeries Diagnostic Information for Multiple Bus Systems*.
- The *Site and Hardware Planning Guide*, order number SA38-0508, contains information to help you plan your installation.
- The *System Unit Safety Information*, order number SA23-2652, contains translations of safety information used throughout this book.
- The *PCI Adapter Placement Reference*, order number SA38-0538, contains information regarding slot restrictions for adapters that can be used in this system.
- The *7014 Model T00 and T42 Rack Installation and Service Guide*, order number SA38-0577, contains information regarding the 7014 Model T00 and T42 Rack, in which this server may be installed.

Ergonomic Information

After you have set up your system, we encourage you to visit the Healthy Computing Web site. Good ergonomic practice is important to get the most from your workstation and to avoid discomfort. This means that the equipment and the workplace should be arranged to suit your individual needs and the kind of work you do.

The Healthy Computing Web site gives ergonomic guidelines to help you understand the ergonomic considerations that you should know when working at a computer workstation. The address is:
<http://www.us.pc.ibm.com/healthycomputing>

Trademarks

The following terms are trademarks of International Business Machines Corporation in the United States, other countries, or both:

- AIX
- @server
- IBM
- PowerPC
- pSeries

Other company, product, and service names may be trademarks or service marks of others.

Chapter 1. Reference Materials

Note: This document may contain references to the AIX operating system. If you are using another operating system, consult the appropriate documentation for that operating system.

This document may describe hardware features and functions. While the hardware supports them, the implementation of these features and functions depends on support from the operating system. AIX provides this support. If you are using another operating system, consult the appropriate documentation for that operating system regarding support for those features and functions.

This chapter helps you get started with installing and configuring the @server pSeries environment. The following information is included in the chapter:

- @server pSeries Roadmap
- Documentation Overview - Brief description of the printed and softcopy documentation shipped including targeted audience

The @server pSeries Roadmap helps you locate marketing, service, and customer task information. The roadmap guides you through the tasks and the publications that document those tasks.

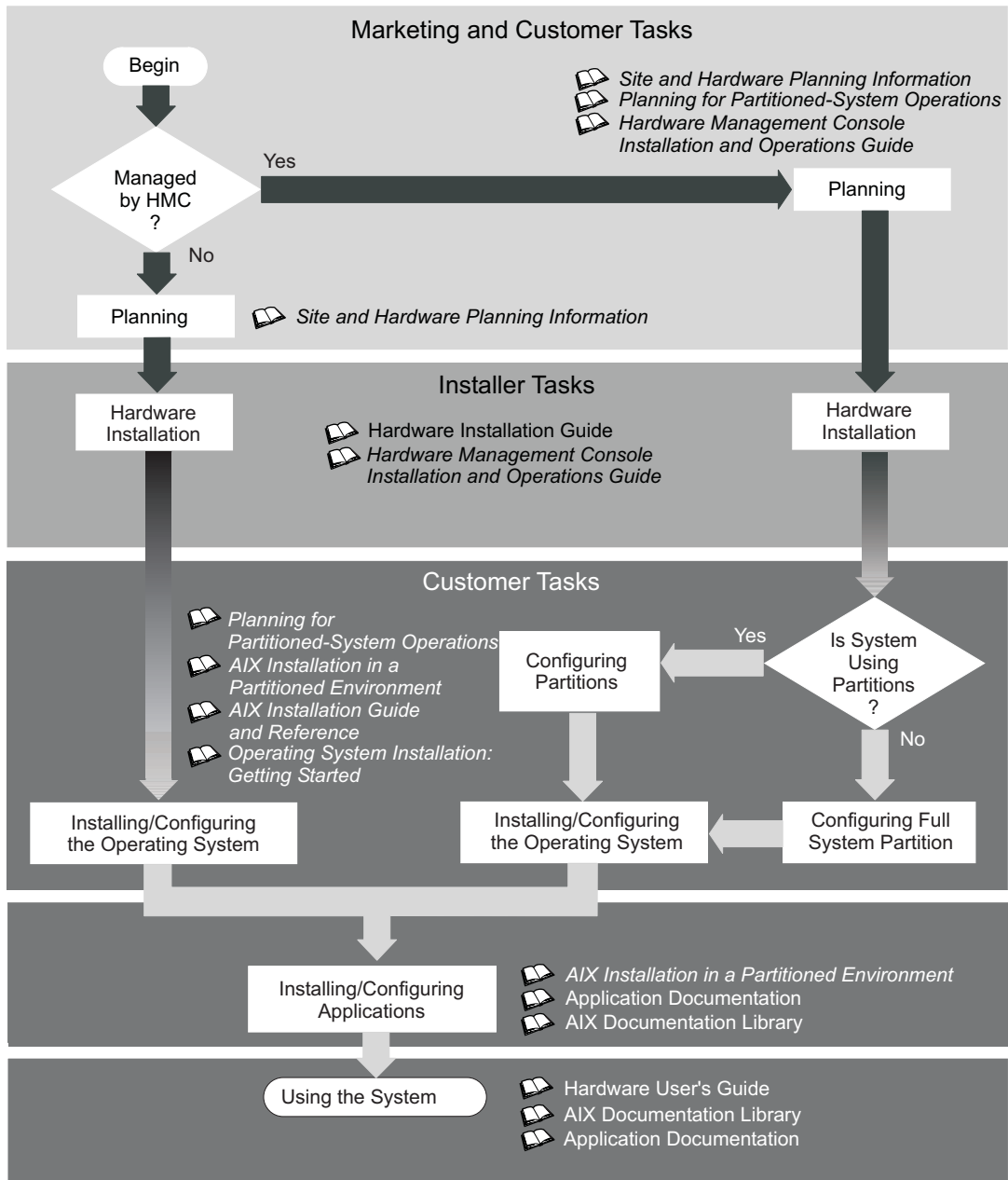

The publications listed in this section are available online. To access the online books, visit our IBM @server pSeries Information Center at http://publib16.boulder.ibm.com/pseries/en_US/infocenter/base.

Documentation Overview

This section provides descriptions and target audience information for the @server pSeries and AIX 5L documentation libraries. Some of the documentation may only be available in printed form or in softcopy form. Based on the documentation content, the books are divided into the following categories: **Planning**, **Installing and Configuring**, and **Using the System**.

Table 1. Planning

Documentation Title	Description	Audience	Type
<i>Site and Hardware Planning Information</i>	Contains information to help plan for site preparation tasks, such as floor-planning, electrical needs, air conditioning, and other site-planning considerations.	Marketing, system administrators	softcopy
<i>Planning for Partitioned-System Operations</i>	Describes planning considerations for partitioned systems, including information on dynamic partitioning and Capacity Upgrade on Demand.	System administrators	printed and softcopy
<i>Hardware Management Console for pSeries Installation and Operations Guide</i>	Provides information on how to install, configure, and use a Hardware Management Console (HMC). Logical partition (LPAR) tasks, such as configuring and managing partitions on multiple host servers, are included.	System administrators	printed and softcopy

Table 2. Installing and Configuring

Documentation Title	Description	Audience	Type
Hardware Installation Guide	Provides information on how to install system hardware, cable the system, and verify operations.	System installer	printed and softcopy
<i>Planning for Partitioned-System Operations</i>	Describes planning considerations for partitioned systems, including information on dynamic partitioning and Capacity Upgrade on Demand.	System administrators	printed and softcopy
<i>Hardware Management Console for pSeries Installation and Operations Guide</i>	Provides information on how to install, configure, and use a Hardware Management Console (HMC). Logical partition (LPAR) tasks, such as configuring and managing partitions on multiple host servers, are included.	System administrators	printed and softcopy
<i>AIX Installation in a Partitioned Environment</i>	Provides information on how to install the AIX operating system in an LPAR environment.	System administrators	printed and softcopy
<i>AIX Operating System Installation: Getting Started</i>	Provides information on how to install and configure the AIX operating system on a standalone system using a CD-ROM device.	System administrators	printed and softcopy
<i>AIX 5L Installation Guide and Reference</i>	Provides information on installing the AIX 5L operating system on standalone systems, as well as on client systems using the Network Installation Management (NIM) interface.	System administrators	printed and softcopy
<i>PCI Adapter Placement Reference</i>	Outlines system-specific PCI adapter slot placement and adapter support configurations.	System administrators, service personnel	softcopy
<i>AIX 5L Release Notes</i>	Provides late-breaking information for a specific AIX release.	System administrators	printed and softcopy
<i>AIX 5L Documentation CD</i>	AIX documentation library (system management guides, user guides, application programmer guides, commands and files references, AIX man pages, and so on).	System administrators	softcopy

Table 3. Using the System

Documentation Title	Description	Audience	Type
<i>Hardware Management Console for pSeries Installation and Operations Guide</i>	Provides information on how to install, configure, and use a Hardware Management Console (HMC). Logical partition (LPAR) tasks, such as configuring and managing partitions on multiple host servers, are included.	System administrators	printed and softcopy
Hardware User's Guide	Provides using, problem determination, and service processor information.	System administrators	printed and softcopy
<i>Diagnostic Information for Multiple Bus Systems</i>	Combines operating instructions for hardware diagnostic programs with common MAPs and SRNs (Service Request Numbers).	Service personnel	printed and softcopy
<i>PCI Adapter Placement Reference</i>	Outlines system-specific PCI adapter slot placement and adapter support configurations.	System administrators, service personnel	printed
<i>Hardware Management Console for pSeries Maintenance Guide</i>	Contains MAPs, removal and replacement, error code, and parts information to help diagnose and repair the system.	Service personnel	printed and softcopy
<i>Adapters, Devices, and Cable Information for Multiple Bus Systems</i>	Provides information about adapters, devices, and cables that are attached to or used within the system.	System administrators	printed and softcopy
<i>System Unit Safety Information</i>	Contains the English version of safety notices, as well as translations of those safety notices into other languages.	System administrators, service personnel	printed and softcopy
<i>AIX 5L Documentation CD</i>	AIX documentation library (system management guides, user guides, application programmer guides, commands and files references, AIX man pages, and so on).	System administrators	softcopy

Chapter 2. Introducing the System

This chapter provides information about the system features of the pSeries 615 Model 6C3 and Model 6E3. The Model 6C3 is a rack mount system and the Model 6E3 is a deskside system.

The pSeries 615 Model 6C3 and Model 6E3 have similar operational capabilities but are packaged differently.

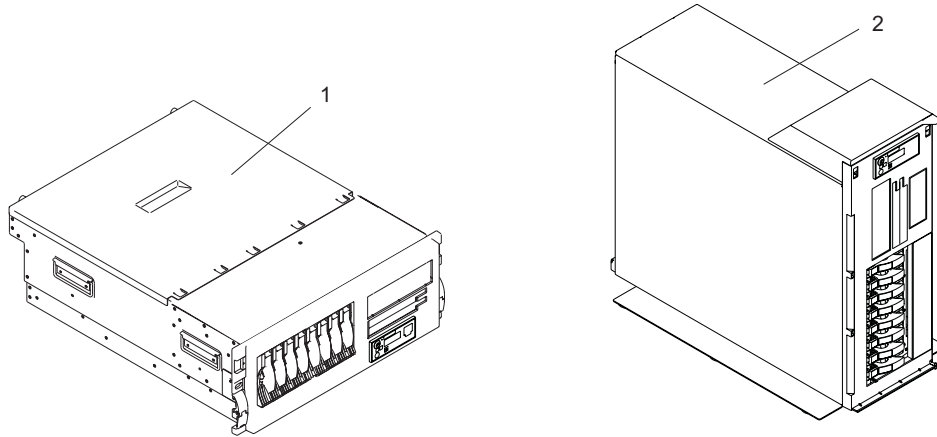

The Model 6C3 is a 4 EIA-unit drawer designed to be housed in a 19-inch rack while the Model 6E3 is a deskside system. Both models can be configured as a 1-way to 2-way symmetric multiprocessing (SMP) system; each can have up to 8 hot-plug disk drives and 6 hot-plug PCI adapters. Both models support redundant hot-plug power supplies and cooling fans.

Power is provided through ac power cords. Either model can be set up to use 100-127 V ac or 200-240 V ac power.

The two media slimline bays can be used to accommodate any of the following drives:

- IDE DVD-ROM drive
- IDE CD-ROM drive
- Diskette drive (special mounting carriage needed)

Another full height (1 inch) media bay supports a SCSI tape drive or DVD-RAM drive.

Note: A CD-ROM is recommended for use in the base configuration of either model.

System Features

The Model 6C3 and Model 6E3 support many of the same features. The following figure shows the rear of the two system units. Both system units have the same layout from the rear. When the features are described in this section, the descriptions apply to both models.

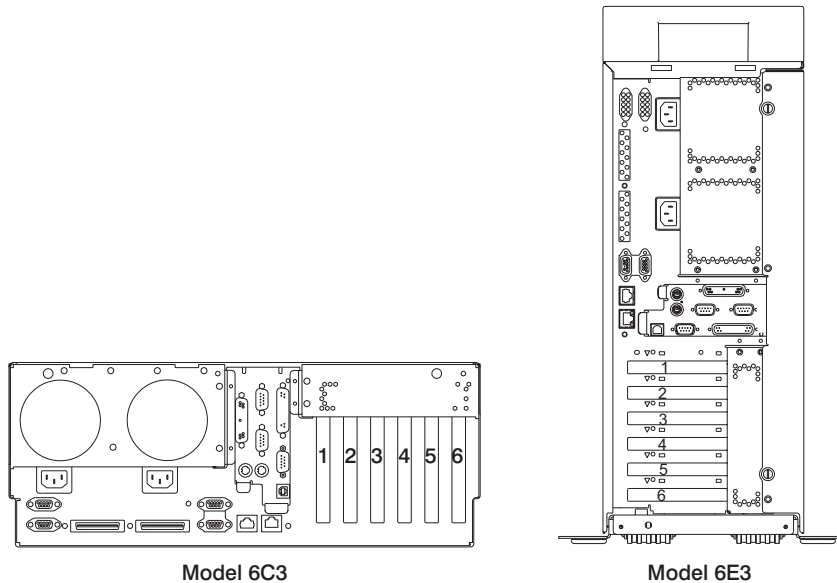

Bus Architecture

Six PCI-X slots are available. Four of these slots (1, 4, 5, and 6) are 64-bit capable at 133 MHz, 3.3 volts. The remaining PCI-X slots (2 and 3) are 32-bit capable at 66 MHz, 3.3 volts. The slots are numbered on the rear of the chassis from left to right or top to bottom, 1 through 6.

All 64-bit PCI-X slots are capable of running either 64-bit or 32-bit adapters. However, a 32-bit adapter operates in a 32-bit mode and shows no performance advantage while running in a 64-bit slot. The preceding illustration shows the PCI adapter slot locations when viewing from the rear of the systems.

Processors

- One-way and two-way processor DCMs (double chip modules) are available.
- An 8 MB L3 cache is contained in the processor DCM.

Memory

- 1 GB to 16 GB ECC (error code correction) DDR (double data rate) SDRAM (synchronous dynamic random-access memory)
- Memory DIMMs plug into the system backplane (8 DIMM slots).
- DIMMs must be populated in quads (a single memory feature contains four DIMMs).
- Memory quads can be different memory sizes.
- A system can have a maximum of 16 GB of memory.

Media Bays and Media Backplane

Two slimline media bays and one full-height media bay are provided. The slimline media bays are for IDE optical devices or diskette drives. The full-height bay is for a SCSI tape drive or DVD-RAM drive.

Note: The following restrictions apply to the media drives:

1. Media devices are not hot-pluggable.

2. The first optical device such as a CD ROM or DVD ROM can only be plugged into Bay #3. Bay #3 is the top slimline bay in a rack configuration.
3. Bay #2, the bottom slimline bay in a rack configuration, will accept a second optical device or the single, supported, floppy drive.
4. An error occurs if 2 diskette drives are installed in the slimline bays simultaneously.

The media backplane plugs into the system backplane and provides connections for the operator panel as well as the devices in the media bays.

- Media bay 1 is for the operator panel.
- Media bay 2 can accommodate an IDE CD-ROM, IDE DVD-ROM, or a diskette drive.
- Media bay 3 can accommodate an IDE CD-ROM or IDE DVD-ROM.
- Media bay 4 can accommodate a SCSI DVD-RAM or tape drive.

Note: A built-in external SCSI port is not provided. Customers can use an optional SCSI adapter for connections to an external SCSI subsystem.

The system supports up to two DASD backplanes that support 4 hot-plug disk drives each. The first backplane is standard on the system and is located next to the media backplane. The second DASD backplane is optional and is located next to the first. Supported hot-plug disk-drive are as follows:

- 36.4 GB Ultra3 10K RPM 1 inch
- 73.4 GB Ultra3 10K RPM 1 inch
- 146.8 GB Ultra3 10K RPM 1 inch
- 36.4 GB Ultra3 15K RPM 1 inch
- 73.4 GB Ultra3 15K RPM 1 inch
- 146.8 GB Ultra3 15K RPM 1 inch

For an updated listing of hot-plug disk-drive sizes, contact your sales representative .

Power Supplies

Up to two power supplies maximum per system; the second power supply is for redundant power.

- AC input type 100-127 V ac or 200-240 V ac
- Single phase

Keyboard

- Standard: 101-key enhanced keyboard
- 101/102 or 106-key enhanced keyboard is also available

Mouse

- Three-button

Operator Panel

- 32-character LED diagnostics display
- LEDs for power on and attention
- Buttons for power on and system reset
- Service processor reset switch

System Reset Button

Dumps AIX (if dump is enabled) and reboots.

Service Processor Reset Switch

Resets the service processor into standby mode. The service processor reset switch is the pinhole located above the system reset button on the operator panel.

- RJ-45 Serial port

Chapter 3. Using the System

This chapter provides information on how to start and use the system.

Starting the System

This section discusses the various ways to start the system.

Starting the System without an HMC Attached

To power on the system, perform the following steps in sequence.

1. On a Model 6C3, open the front rack door.
On a Model 6E3, open the bezel door.
2. Ensure that the power is connected to the system unit.
Before you press the power-on button on your operator panel, observe the following:
 - The power LED is slowly blinking.
 - An OK prompt is visible in the operator panel display.

3. Press the power-on button on the operator panel.

After pressing the power-on button located on the operator panel, observe the following:

- a. The power LED begins to blink visibly faster.
- b. The system cooling fans are activated and begin to accelerate up to operating speed.

Note: There is approximately a 30-second transition period between the time the power-on button is pressed and the power LED remains on solid (no longer blinking).

- c. The power LED stays on solid and progress indicators, also referred to as *checkpoints*, are visible on the operator panel display.

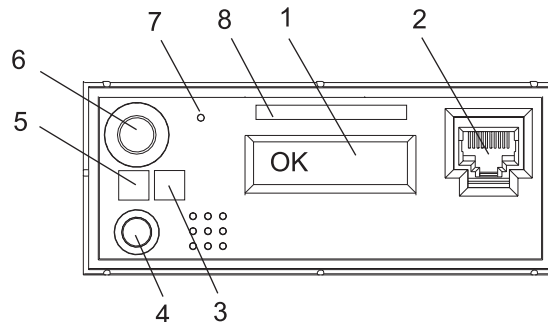

- | | |
|---|--|
| 1 Operator Panel Display | 5 Power LED |
| 2 Front Serial Connector (FS1) (Model 6C3 Only) | 6 Power-On Button |
| 3 Attention LED | 7 Service Processor Reset Switch (Pinhole) |
| 4 System Reset Button | 8 Serial Number Label |

Starting the System with an HMC Attached

After the required cables are installed and the power cables are connected, the HMC user interface provides a power-on function to turn on the power to the system. The power-on button on the operator panel can be pushed to initialize the system but the preferred method is to use the HMC. Progress

indicators, also referred to as *checkpoints*, are visible on the operator panel display as the system power is turned on. The power LED on the system stops blinking and stays on, indicating the system power is on.

The system unit is powered on through an internal system power control network (SPCN). When power is applied, the power LEDs on the system unit go from blinking to continuous. This indicates that the system power levels are satisfactory.

Stopping the System

This section discusses the various ways to stop the system.

Stopping the System without an HMC Attached

Attention: When shutting down your system to install options, shut down all applications first and then shut down the operating system. The system power turns off and the system goes into standby mode when the operating system is shut down. Before removing power from the system, ensure that the shutdown process is complete. Failure to do so can result in the loss of data.

1. Log in to the system as root user.
2. Have your system administrator stop all applications that are running on the system.
3. At the command line, ask the administrator to type one of the following commands:
 - If your system is running AIX, type `shutdown`
 - If your system is running Linux, type `shutdown now -h`
4. After you shut down the operating system, set the power switches of any attached devices to Off.

Stopping the System with an HMC Attached and AIX Installed

The HMC user interface provides a power-off function to turn off the power to the system.

AIX provides hot-swap procedures for adapters and devices that support hot-swap removal and installation. You do not have to shut down the system to change an adapter or device that supports hot-swap. Individual power components and fans can be serviced with the power on for power systems equipped with redundant power and cooling. Before servicing the system, check removal and installation procedures.

If the system is running AIX, typing the **shutdown** command causes the system to shut down and power off. The **-F** flag shuts down the system without warning system users. Check with the system administrator before using this command. If you cannot use this method, you can power off the system by pressing the power-on button on the operator panel or typing the appropriate command at the HMC.

Attention: Using the power-on button on the operator panel or commands at the HMC to power off the system can cause unpredictable results in the data files. The next IPL will also take longer to complete if all applications in all partitions are not stopped beforehand.

Stopping the System with an HMC Attached and Linux Installed

The HMC user interface provides a power-off function to turn off the power to the system.

Linux does not provide hot-swap procedures for adapter and device removal and installation. You must shut down the system and the power must be turned off to service an adapter or device. Individual power components and fans may be serviced with power on for systems equipped with redundant power and cooling. Before servicing this system, check removal and installation procedures.

If the system is running Linux, typing the **shutdown now -h** command causes the system to shut down and power off. Check with the system administrator before using this command. If you cannot use this method, you can power off the system by pressing the power-on button on the operator panel or typing the appropriate command at the HMC.

Attention: Using the power-on button on the operator panel or commands at the HMC to power off the system can cause unpredictable results in the data files. The next IPL will also take longer to complete if all applications are not stopped beforehand.

Reading the Operator Panel Display

The operator panel display is used to:

- Track the progress of the system unit self-tests and configuration program
- Display codes when the operating system comes to an abnormal end
- Display system messages

Operator Panel

The following illustration shows the component location on the operator panel.

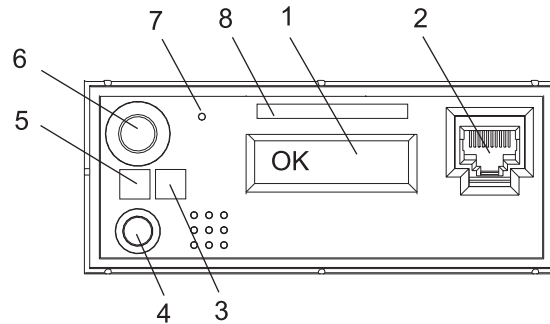

Number	Component Name	Component Description
1	Operator Panel Display	Displays current status of system startup, or diagnostic information in the event of a hardware problem.
2	Front Serial Connector (FS1) (Model 6C3 Only)	Serial port uses RJ-45 connector. Use to plug in external devices at the front of the system unit.
3	Attention LED	Normal State - LED is off
4	System Reset Button	Resets the system
5	Power LED	Blinking - When connected to the power source (System is in standby mode). Solid - When power button has been pressed. Note: There is approximately a 30-second transition period from the time the power button is pressed to when the power LED goes from blinking to on solid. During the transition period, you may observe the blinking intervals speed up.
6	Power-On Button	Turns the system power on and off.
7	Service Processor Reset Switch (Pinhole)	Service Personnel Use
8	Serial Number Label	Displays the system serial number

For more information about other system LEDs, see “Component LEDs” on page 16.

Disturbance or System Attention LED

The system attention LED on the operator panel is turned on when an entry is made in the service processor error log that is transmitted to the system-level error logs (the AIX error log and the service action event log in the Service Focal Point application). When the attention light comes on, examine these error logs to see if user intervention is required.

If a hardware problem is indicated, call service support. If no intervention is required, the system attention LED can be turned off by either of the following methods:

- On the HMC's graphical interface, as follows:
 1. Click on the **Service Applications** icon.
 2. Double-click the **Service Focal Point** icon.
 3. In the **Contents** area, select **Hardware Service Functions**. The LED Management window opens.
 4. In the LED Management window, select one or more managed systems from the table.
 5. Select **Deactivate LED**. The associated system attention LED is turned off.

For more information about the operator panel as it relates to the HMC, see the *IBM Hardware Management Console for pSeries Installation and Operations Guide*, order number SA38-0590.

- As a user with root authority, enter `diag` on an AIX command line and do the following:
 1. Select **Task Selection**.
 2. On the task selection menu, select **Identify and Attention Indicators**.
 3. When the list of LEDs displays, use the cursor to highlight **Set System Attention Indicator to Normal**.
 4. Press Enter, and then press F7 to commit. This action turns off the LED.
- If the system is powered off, access the service processor menus and from the main menu, do the following:
 1. Select **System Information Menu**.
 2. Select **LED Control Menu**.
 3. Select **Clear System Attention Indicator**. This action turns off the LED.

For more information regarding the LED, refer to "Component LEDs" on page 16.

Component LEDs

Individual LEDs are located on or near the failing components. The LEDs are located either on the component itself or on the carrier of the component (for example, memory card, fan, memory module, CPU). LEDs are either green or amber.

Green LEDs indicate either of the following:

- Electrical power is present.
- Activity is occurring on a link. (The system could be sending or receiving information.)

Amber LEDs indicate a fault or identify condition. If your system or one of the components on your system has an amber LED turned on or blinking, identify the problem and take the appropriate action to restore the system to normal.

The following table identifies the location, color and status of your system component LEDs.

Unit (FRU)	LED Function	Location	Viewable Location	LED Color	OFF	ON	Blink
Power and Packaging LEDs							
System	Attention	Operator Panel and Rear	External Front and Rear	Amber	Normal	Fault	Identify
	Power ¹			Green	No ac	System On	Standby
Fan	Identify ¹	FRU)	Internal	Amber	Normal	N/A	Identify
Power Supply	AC Input Good ¹	FRU	External	Green	No Input	Input Good	N/A
	Fault ¹ /Identify	FRU	External	Amber	Normal	Fault	1. Identify 2.Comm. Fault
	DC Output Good	FRU	External	Green	All Pwr Sup Outs Off	All PS Outputs On	Blink if PS micro or comm link failed
Disk Drives (DASD)	Power ¹	DASD Cage	Chassis	Green	Off	Power	N/A
	Activity ¹	DASD	Chassis	Green	No Activity	N/A	Activity
	Activity Repl	DASD	Chassis	Amber	Meets RPA Hot Swap Requirement		
CARD LEDs							
PCI Slots	Power ¹	Socket	External	Green	PCI Hot Swap Standards		
	Identify	Socket	External ³	Amber	PCI Hot Swap Standards		
RIO-G	Identify	Socket	External	Amber	Normal	N/A	Identify
Memory DIMMs	Identify	Memory Connector	Internal Only	Amber	Normal	N/A	Identify
System Backplane	Identify	Planar	Internal Only	Amber	Normal	N/A	Identify
DASD Backplane	Identify	Card	Internal	Amber	Normal	N/A	Identify
Media Backplane	Identify	Card	Internal	Amber	Normal	N/A	Identify
Service Processor Card	Identify	Card	Internal	Amber	Normal	N/A	Identify
Voltage Regulator Module	Identify	Card	Internal	Amber	Normal	N/A	Identify

Unit (FRU)	LED Function	Location	Viewable Location	LED Color	OFF	ON	Blink
Power and Packaging LEDs							
RAID Adapter Card	Identify	Card	External	Amber	Normal	N/A	Identify

Using the Keyboards

There are several keyboards available for the system. The keyboards have various keys that enter data and control the cursor location. The keyboards can be engraved for the languages of various countries.

The functions of each keyboard depend on the software used. The character sets for the keyboards are contained and explained in the documentation for your operating system.

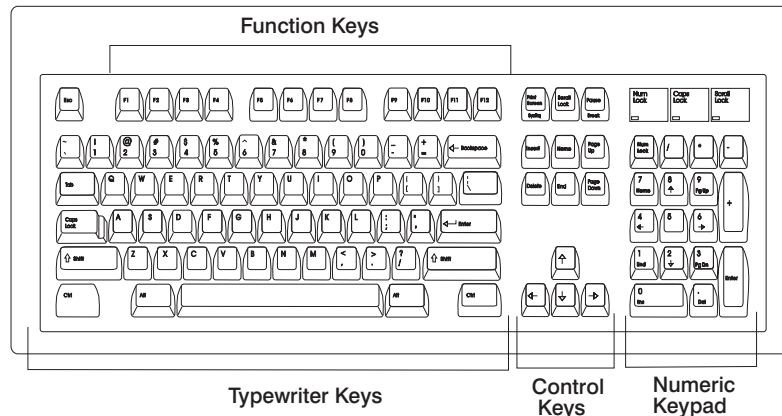

The keyboard is divided into four sections:

- *Function keys* are multipurpose keys and their function is controlled by the operating system.
- *Typewriter keys* are similar to a standard typewriter. Their function is controlled by the software.
- *Control keys* move the cursor on the screen and do programmed control functions. The movement and functions depend upon the application used.
- *Numeric keypad* is arranged like a calculator to help when typing numbers.

On all of the keyboards, you can adjust the tilt position for typing comfort. To tilt the keyboard, pull out on the keyboard legs. The legs snap into position. To decrease the tilt of the keyboard, rotate the keyboard legs until they snap into the bottom of the keyboard case.

The keyboard cable plugs into the keyboard connector at the rear of the system.

Using the Three-Button Mouse

The mouse is a hand-operated locating device. A three-button mouse is available for use with the system. Consult your application publication for the exact use of the three-button mouse.

You can use the mouse to perform such functions as positioning a cursor, selecting items from a menu, or moving around in your document much easier and faster than if you used only the keyboard. The cursor moves exactly as you move the mouse on a flat surface, such as a desktop.

With the mouse buttons, you can perform functions such as selecting and deselecting options, extending your selection, or choosing a command. The precise function of your mouse depends on the software you are using.

The mouse cable plugs into the mouse connector at the rear of the system.

Handling the Mouse Correctly

For best operation, handle the mouse with care. Incorrect handling can damage the mouse.

Do not:

- Operate the mouse on cloth, unfinished wood, newspaper, or carpet.
- Drop or hit the mouse.
- Carry the mouse by holding onto the cable.
- Expose the mouse to extreme temperatures or direct sunlight.
- Place the mouse in liquid spills.

Caring for the Mouse

The operating surface for the mouse should be smooth, clean, and flat. For example, you can operate the mouse on the following surfaces:

- Finished wood
- Glass
- Enamel
- Plastic
- Paper (except newspaper)
- Metal

Rough surfaces collect contaminants that can be transferred to the interior of the mouse by the ball. Rough surfaces can also cause the pads located on the bottom of the mouse to prematurely wear. A deeply pitted surface could cause erratic operation of the mouse. The surface you use should be free from spills, dirt, dust, lint, wax, eraser dust, and other foreign matter.

To care for the mouse:

- Inspect the work surface for spills or other contaminants.
- Dust the work surface.
- If you are using a paper pad, inspect it for wear and replace it if necessary.

Cleaning the Mouse

Use the following steps to clean the mouse:

1. Remove the retaining ring by turning it counterclockwise, in the direction of the arrow, as shown in the illustration.

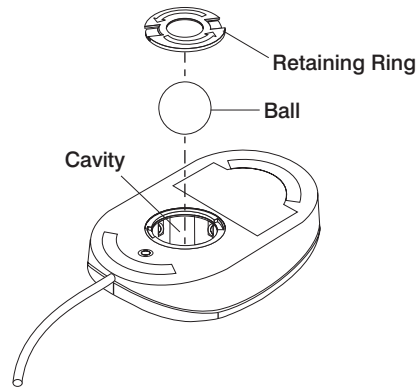

2. Remove the ball.
3. Inspect the ball for contaminants. Wipe it clean with a dry, lint-free cloth.
4. If the ball is dirty, wash it in warm, soapy water. Rinse and wipe the ball with a lint-free cloth until dry.
5. Inspect the ball cavity in the mouse for foreign materials. If there are any foreign materials, remove them.
6. Replace the ball.
7. Replace the retaining ring on the mouse and align it with the open slots in the ball cavity.
8. Turn the retaining ring clockwise until the open slots are covered and you hear the ring snap into place.

Using a 3.5-Inch Diskette Drive

A 1.44 MB diskette drive is an optional feature for this system. Contact your sales representative before purchasing a diskette drive for this system.

The 1.44 MB diskette drive can format, read, and write diskettes compatible with the following diskette drives:

- 1.0 MB diskettes with 720 KB formatted data capacity
- 2.0 MB diskettes with 1.44 MB formatted data capacity (High Density)

Format the diskette according to its specified capacity.

Write-Protecting 3.5-Inch Diskettes

Write-protecting diskettes is necessary so that important information is not accidentally lost. When diskettes are write-protected, you can read information from the diskettes, but you cannot write information to them.

There is a write-protect tab on the 3.5-inch diskette. To locate the write-protect tab, turn the diskette over with the label facing down.

To prevent writing onto a diskette, slide the write-protect tab to open the protect slot, as shown in the illustration.

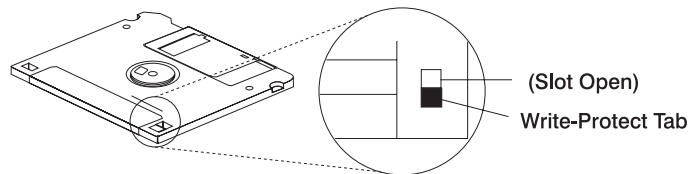

To allow writing onto a diskette, slide the write-protect tab to cover the protect slot, as shown in the illustration.

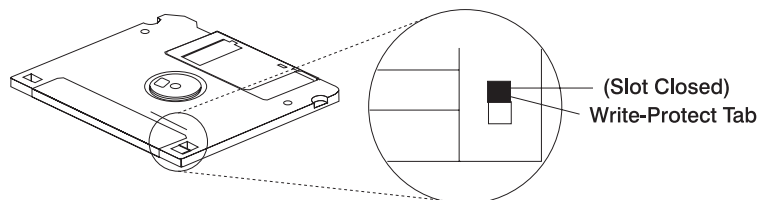

Loading and Unloading the 3.5-Inch Diskette

To load a diskette into the drive, insert the diskette in the diskette drive with the labeled metal shutter first. Push the diskette into the drive until you hear a click. The click indicates that the diskette is securely in position in the drive.

To unload the diskette, push the diskette-unload button. The diskette unloads partially from the drive. Remove the diskette.

Using a CD-ROM Drive

CAUTION:

A class 1 laser is contained in the device. Do not attempt to operate the drive while it is disassembled. Do not attempt to open the covers of the drive as it is not serviceable and is replaced as a unit.

C07

This section describes the features of the 40X SCSI-2 CD-ROM drive and provides instructions for handling the drive and CD-ROM discs. The CD-ROM is a half-high, 5.25-inch, 8-bit, single-ended, tray-loading drive. Its features include the following:

- SCSI-2 interface supports both synchronous and asynchronous data transfer
- High-speed data transfer rate of 2100 KB per second (14X) at inner diameter and 4800 KB per second (32X) at outer diameter due to constant RPM spin rate
- High-speed synchronous burst rate of 10 MB per second
- Average random access time of 90 ms
- Loading tray accommodates both 8-cm discs (in the horizontal orientation only) and 12-cm discs
- Reads multi-session discs
- Reads CD-recordable discs
- Reads CD-RW discs
- Supports all major CD-ROM formats: Mode 1, Mode 2, XA, CDDA, and audio
- Headphone output and line output for audio

Front View of CD-ROM Drive

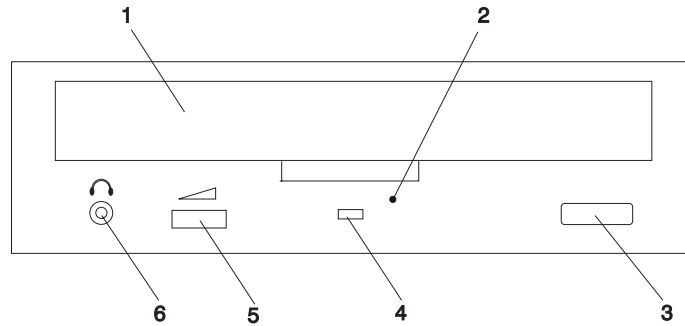

- 1 Compact Disc Tray
- 2 Emergency Eject Hole
- 3 Load/Unload Button
- 4 Status Light
- 5 Volume Control
- 6 Headphone Jack

Understanding the Status Lights

The status lights indicate the operational status of the drive. The various conditions are as follows:

If light is:	Condition is:
Off	Drive is in standby mode with or without a disc loaded.
Blinking (green)	Any of the following: <ul style="list-style-type: none">• Drive tray is inserted. The light blinks while the drive completes the initialization checkout.• Drive is reading data. The light blinks while data is being read.• Drive is in Play Audio Mode. The light blinks while the audio is playing.
On (amber)	Hardware error condition found during initialization. Note: If this occurs, contact your service representative.

Handling Compact Discs

Compact discs are high-density media that must be handled with care and kept clean to ensure that they remain readable. Use the following precautions to ensure reliability:

- Hold the compact disc by the edges. Do not touch the surface of the compact disc.
- To remove dust or fingerprints, wipe the compact disc from the center to the outside of the compact disc as shown, using a lint-free cloth.

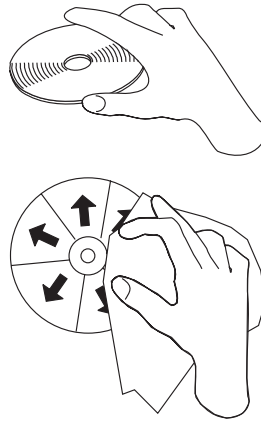

Attention: Wiping the compact disc in a circular direction can cause loss of data.

- Do not write on the surface.
- Do not store or place the compact disc in direct sunlight.
- Do not use benzene, thinners, or other cleaners to clean the compact disc.
- Do not bend the compact disc.

Other Handling Considerations

Be sure to take the following additional precautions when you use the CD-ROM drive:

- Remove compact discs from the tray before you move the drive anywhere.
- Do not place the drive where any of the following conditions exist:
 - High temperature
 - High humidity
 - Excessive dust
 - Excessive vibration or sudden shock
 - Inclined surface
 - Direct sunlight
- Do not insert foreign objects into the drive.
- Do not remove the drive covers or attempt to service the drive yourself.

Loading a Compact Disc

To load a compact disc into the drive, do the following:

1. Press the Load/Unload button to open the tray. The tray slides out of the drive.
2. Place the compact disc in the tray with the label facing up.
3. Press the Load/Unload button, or gently push in the tray, to close the tray.

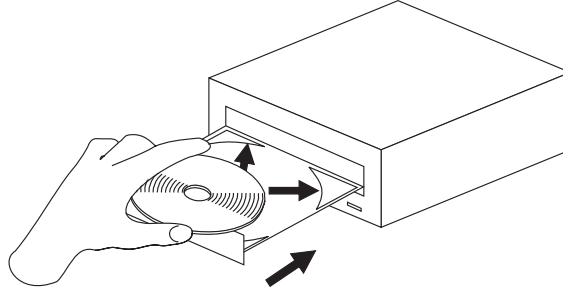

Note: Be sure that none of the vertical retaining tabs are extended when you use the drive in the horizontal position.

Opening the Tray Manually

The compact disc tray automatically opens when you press the Load/Unload button. If it does not automatically open, follow these steps to force it open manually:

1. Shut down and turn off the power to your system.
2. Insert the straightened end of a paper clip into the emergency eject hole until you feel some resistance. If you are not sure where the emergency eject hole is located, see “Front View of CD-ROM Drive” on page 23.
3. Continue to push in the paper clip while you pull out the tray with your fingernail.
4. Pull the tray completely open and remove the disc. It is normal for the tray to make a clicking sound while you are pulling it open.

Playing an Audio CD

To play an audio CD, you must have headphones connected to the headphone jack located on the front of the drive, or connected to the line-out connector located on the back of the system. You must also have an audio software application installed.

The headphone jack provides the connection for headphones using a 3.5-mm (1/8 inch) stereo mini-plug. The volume control adjusts the audio output level for the headphones.

Chapter 4. Using the Service Processor

Notes:

1. On some of the system management services (or service processor) screens, you will see the term *LPAR*, which is equivalent to the term *logical partition*. This system does not support logical partitions.
2. The information in this chapter regarding the configuring of serial ports, and modems attached to those serial ports, applies only to the serial ports (S1, S2 and S3) on the service processor(location U0.1-P1). None of this information is applicable to the serial ports, or modems attached to those serial ports on the HMC.

The service processor runs on its own power boundary and continually monitors hardware attributes and the environmental conditions within the system. The service processor is controlled by firmware and does not require the operating system to be operational to perform its tasks.

The service processor menus allow you to configure service processor options, as well as enable and disable functions.

Service processor menus are available using an ASCII terminal or an HMC virtual terminal window when OK is displayed on the operator panel or when the service processor has detected a system problem (such as a surveillance failure).

Service Processor Menus

The service processor menus are divided into the following groups:

- General user menu - the user must know the general-access password.
- Privileged user menus - the user must know the privileged-access password.

If the system is powered off, the service processor menus can be accessed locally or remotely on the following:

- Serial port 1 (S1)
- Serial port 2 (S2)
- HMC

Accessing the Service Processor Menus Locally

Service processor menus can be accessed by opening a virtual terminal window on the HMC, or by attaching an ASCII terminal to serial port 1 (S1) or serial port 2 (S2). After OK displays in the operator panel, press any key on the keyboard to signal the service processor.

Notes:

1. The service processor menus cannot be accessed simultaneously on a virtual terminal window on the HMC and on an ASCII terminal. Accessing the menus on the HMC locks out access to the ASCII terminals and vice versa.
2. When the system is connected to an HMC and a virtual terminal window is open, providing a connection to the managed system, serial port 1 is used by the HMC and is not available to the functions that are normally provided by the service processor. Those functions include the ring-indicate power-on, console mirroring, serial port snooping and call-in/call-out.

When you gain access, the service processor prompts you for a password (if one is set), and when verified, displays the service processor menus.

The service processor menu prompt, represented by 0> or 1>, indicates the serial port to which the terminal is connected.

- An ASCII terminal can have the following prompts:

- 0> indicates serial port 1 (S1)
- 1> indicates serial port 2 (S2)
- The HMC always displays a prompt of 0>

Accessing the Service Processor Menus Remotely

If your system has a modem connected to serial port 1 or serial port 2 and is configured for call-in (see “Modem Configuration Menu” on page 47), the service processor menus can be accessed remotely as follows:

1. With the system powered off, call in from a remote terminal.
2. The service processor detects ring-indicate and prompts you for a password (if one is set). When verified, the service processor menus display remotely.

Saving and Restoring Service Processor Settings

All the settings that you make (except language) from the service processor menu can be backed up either for recovering from a fault that may corrupt these settings, or for replicating these settings to other servers that include a service processor.

The service aid, Save or Restore Hardware Management Policies, can be used to save your settings after initial setup or whenever the settings must be changed for system operation purposes.

It is strongly recommended that you use this service aid for backing up service processor settings to protect the usefulness of the service processor and the availability of the system. Refer to “Save or Restore Hardware Management Policies,” in “Introduction to Tasks and Service Aids” for information about this service aid.

Menu Inactivity

The service processor exits menu mode after ten minutes of inactivity and displays a message indicating that it has done so. Pressing any key on the virtual terminal window causes the main menu to display.

General User Menu

The menu options presented to the general user are a subset of the options available to the privileged user. The user must know the general-access password, if one is set, to access this menu.

```
GENERAL USER MENU

1. Power-on System

2. Power-off System

3. Read VPD Image from Last System Boot

4. Read Progress Indicators from Last System Boot

5. Read Service Processor Error Logs

6. Read System POST Errors

99. Exit from Menus

0>
```

- **Power-on System**

Allows the user to start the system using the current virtual terminal window as the active console.

- **Power-off System**

This option is not available on this system.

- **Read VPD Image from Last System Boot**

Displays manufacturer vital product data, such as serial numbers, part numbers, and so on, that were stored from the system boot prior to the one in progress now, for the entire system.

- **Read Progress Indicators from Last System Boot**

Displays a number of the boot progress indicators, which may include service processor checkpoints, IPL checkpoints, or AIX configuration codes, from the previous system boot. This information can be useful in diagnosing system faults.

The progress indicator codes are listed from top (latest) to bottom (oldest).

This information is not stored in nonvolatile storage. If the system is powered off using the power-on button on the operator panel, this information is retained. If the ac power is disconnected from the system, this information will be lost. For an example, refer to “LCD Progress Indicator Log” on page 63.

- **Read Service Processor Error Logs**

Displays the service processor error logs. For an example, refer to “Service Processor Error Logs” on page 62.

- **Read System POST Errors**

Displays additional error log information (this option is only for service personnel).

- **Exit from Menus**

Selecting this option will exit the service processor menus. You can re-enter the menus by pressing any key on the console.

Privileged User Menus

The following menus are available to privileged users only. The user must know the privileged-access password, if one is set, to access these menus.

Main Menu

A listing at the top of the main menu contains the following:

- Your system’s current firmware version

- The firmware copyright notice
- The system name given to your system during setup

You need the firmware version for reference when you either update or repair the functions of your service processor.

The system name, an optional field, is the name that your system reports in problem messages. This name helps your support team (for example, your system administrator, network administrator, or service representative) to more quickly identify the location, configuration, and history of your system. Set the system name, from the main menu, using option 6.

Note: When the system is connected to an HMC and a virtual terminal window is open, providing a connection to the managed system, serial port 1 is used by the HMC and is not available to the functions that are normally provided by the service processor. Those functions include the ring-indicate power-on, console mirroring, serial port snooping and call-in/call-out.

Note: The information under the Service Processor Firmware heading in the following Main Menu illustration is example information only.

```
Service Processor Firmware
VERSION: 1F030521
Copyright 2003 IBM Corporation
SYSTEM NAME
```

MAIN MENU

1. Service Processor Setup Menu
 2. System Power Control Menu
 3. System Information Menu
 4. Language Selection Menu
 5. Call-In/Call-Out Setup Menu
 6. Set System Name
 99. Exit from Menus
- 0>

- **Service Processor Setup Menu**
See “Service Processor Setup Menu” on page 32 for more information.
- **System Power Control Menu**
See “System Power Control Menu” on page 37 for more information.
- **System Information Menu**
See “System Information Menu” on page 40 for more information.
- **Language Selection Menu**
See “Language Selection Menu” on page 45 for more information.
- **Call-In/Call-Out Setup Menu**
See “Call-In/Call-Out Setup Menu” on page 46 for more information.
- **Set System Name**
Allows setting of the system name.

Service Processor Setup Menu

The following Service Processor Setup Menu is accessed from the Main Menu:

```
SERVICE PROCESSOR SETUP MENU

1. Change Privileged Access Password
2. Change General Access Password
3. Enable/Disable Console Mirroring:
   Currently Enabled
4. Start Talk Mode
5. OS Surveillance Setup Menu
   NOT supported in LPAR mode
6. Reset Service Processor
7. Reprogram Flash EPROM Menu
8. Serial Port Snoop Setup Menu
   NOT supported in LPAR mode
9. Scan Log Dump Setup Menu:
   Currently As Needed
98. Return to Previous Menu
99. Exit from Menus
0>
```

Note: Unless otherwise stated in menu responses, settings become effective when a menu is exited using option 98 or 99.

Passwords

Passwords can be any combination of up to eight alphanumeric characters. You can enter longer passwords, but the entries are truncated to include only the first eight characters. The privileged-access password can be set from service processor menus or from System Management Services (SMS) utilities (see Chapter 5, “Using System Management Services”, on page 67). The general-access password can be set only from service processor menus.

For security purposes, the service processor counts the number of attempts to enter passwords. The results of not recognizing a password within this error threshold are different, depending on whether the attempts are being made locally (at the system) or remotely (through a modem). The error threshold is three attempts.

If the error threshold is reached by someone entering passwords at the system, the service processor commands the system to resume the initial program load (IPL). This action is taken based on the assumption that the system is in an adequately secure location with only authorized users having access. Such users must still successfully enter a login password to access the operating system.

If the error threshold is reached by someone entering passwords remotely, the service processor commands the system to power off to prevent potential security attacks on the system by unauthorized remote users. The following table lists what you can access with the privileged-access password and the general-access password.

Privileged Access Password	General Access Password	Resulting Menu
None	None	Service processor MAIN MENU displays.
Set	None	Users with the password see the service processor MAIN MENU. Users without password cannot log in.
Set	Set	Users see menus associated with the entered password.

- **Change Privileged-Access Password**

Set or change the privileged-access password. It provides the user with the capability to access all service processor functions. This password is usually used by the system administrator or root user.

- **Change General-Access Password**

Set or change the general-access password. It provides limited access to service processor menus, and is usually available to all users who are allowed to power on the system, especially remotely.

Note: The general-access password can only be set or changed after the privileged-access password is set.

- **Enable/Disable Console Mirroring**

Note: Console mirroring is not available on serial port 1 when the system is connected to an HMC and a virtual terminal window is open providing a connection to the managed system.

Console mirroring is supported on serial port 1 (S1) and serial port 2 (S2). When console mirroring is enabled, the service processor sends information to all serial ports. The serial port from which console mirroring is enabled is referred to as the *active port*. The *mirror port* is determined when keyboard input is detected from one of the other ports. From this point on, the service processor sends information only to the active port and the mirror port. This capability can be enabled by local or remote users, providing local users with the capability to monitor remote sessions. Console mirroring can be enabled for the current session only. For more information, see “Console Mirroring” on page 61.

- **Start Talk Mode**

In a console-mirroring session, it is useful for those who are monitoring the session to be able to communicate with each other. Selecting **Start Talk Mode** activates the keyboards and displays for such communications while console mirroring is established. This is a full duplex link, so message interference is possible. Alternating messages between users works best.

- **OS Surveillance Setup Menu**

This menu can be used to set up operating system (OS) surveillance.

```
OS Surveillance Setup Menu

1. Surveillance:
   Currently Enabled

2. Surveillance Time Interval:
   2 minutes

3. Surveillance Delay:
   2 minutes

98. Return to Previous Menu

0>
```

- **Surveillance**

Can be set to Enabled or Disabled.

- **Surveillance Time Interval**

Can be set to any number from 2 through 255.

- **Surveillance Delay**

Can be set to any number from 0 through 255.

For more information about surveillance, refer to “Service Processor System Monitoring - Surveillance” on page 59.

- **Reset Service Processor**

If this option is selected, entering Y causes the service processor to reboot.

- **Reprogram Flash EPROM Menu**

This option requires a diskette drive to be installed in the system. If this option is selected, and no diskette drive is present in the system, the service processor will indicate Not Supported on the screen.

This option updates the system EPROMs. After entering Y to indicate that you want to continue, you are prompted to enter the update diskettes. Follow the instructions on the screen. When the update is complete, the service processor reboots.

All system EPROMs that can be reprogrammed are updated at the same time and are as follows:

- System power control network programming
- Service processor programming
- System firmware programming
- Run-Time Abstraction Services

- **Serial Port Snoop Setup Menu**

Note: Serial port snooping is not available when the system is connected to an HMC and a virtual terminal window is open providing a connection to the managed system.

This menu can be used to set up serial port snooping, in which the user can configure serial port 1 as a "catch-all" reset device.

From the service processor main menu, select option 1, service processor setup menu, then select option 8 (Serial Port Snoop Setup Menu).

```
SERIAL PORT SNOOP SETUP MENU

1. System reset string:
   Currently Unassigned

2. Snoop Serial Port:
   Currently Unassigned

98. Return to Previous Menu

1>
```

Use the **Snoop Serial Port** option to select the serial port to snoop.

Note: Only serial port 1 is supported.

Use the system reset string option to enter the system reset string, which resets the machine when it is detected on the main console on Serial Port 1.

After serial port snooping is correctly configured, at any point after the system is booted to the operating system, whenever the reset string is typed on the main console, the system uses the service processor reboot policy to restart.

Because pressing Enter after the reset string is not required, make sure that the string is not common or trivial. A mixed-case string is recommended.

- **Scan Log Dump Policy**

A scan dump is the collection of chip data that the service processor gathers after a system malfunction, such as a checkstop or hang. The scan dump data may contain chip scan rings, chip trace arrays, and SCOM contents.

The scan dump data are stored in the system control store. The size of the scan dump area is approximately 4 MB.

During the scan log dump, A8xx (in the range A810 to A8FF) displays in the operator panel. The xx characters will change as the scan log dump progresses. If the xx characters do not change after five minutes, the service processor is hung and must be reset.

When the scan log dump is complete, depending on how the reboot policy is set, the system will either:

- Go to the standby state (and the service processor menus will be available), indicated by OK or STBY in the operator panel

OR

- Attempt to reboot.

```
Scan Log Dump Setup Menu

  1. Scan Log Dump Policy:
      Currently As Needed

  2. Scan Log Dump Content:
      Currently As Requested

  3. Immediate Dump

 98. Return to Previous Menu

0> 1
Select from the following options:
(As Needed=2, Always=3)

Enter New Option:

0>
```

The scan log dump policy can be set to the following:

2 = As Needed

The processor run-time diagnostics record the dump data based on the error type. This is the default value.

3 = Always

Selecting this option allows the service processor to record a scan log dump for all error types.

The scan log dump policy can also be set from the Tasks menu in the AIX diagnostic service aids.

Option 2 displays the following screen:

```
Scan Log Dump Setup Menu

  1. Scan Log Dump Policy:
      Currently As Needed

  2. Scan Log Dump Content:
      Currently As Requested

  3. Immediate Dump

 98. Return to Previous Menu

0> 2
Select from the following options:
(As Requested=1, Optimum=2, Complete=3, Minimum=4)

Enter New Option:

0>
```

The scan log dump content can be set to the following:

1 = As Requested

The processor run-time diagnostics will select the contents of the dump file based on the type of error that occurs. This is the default.

2 = Optimum

The dump will include the smallest amount of information to diagnose a hardware error.

3 = Complete

The dump will include as much information as possible to allow the complete analysis of hardware and software errors.

4 = Minimum

The dump will include the smallest amount of information possible (a minimum number of hardware scan log rings).

The complete dump will take the longest time to finish; it may take as long as 1.5 hours on a fully configured system.

Option 3, **Immediate Dump**, can only be used when the system is in the standby state with power on. It is used to dump the system data after a checkstop or machine check occurs when the system firmware is running, or when the operating system is booting or running.

The scan log dump content can also be set from the Tasks menu in the AIX diagnostic service aids.

If a valid dump file already exists, the dump control code will stop because the contents of the prior dump must be protected.

System Power Control Menu

This menu is used to set power control options. Other menus that control boot options are available from this menu.

```
SYSTEM POWER CONTROL MENU

1. Enable/Disable Unattended Start Mode:
   Currently Enabled

2. Ring Indicate Power-On Menu

3. Reboot/Restart Policy Setup Menu

4. Power-On System

5. Power-Off System

6. Enable/Disable Fast System Boot
   Currently Fast Boot

7. Boot Mode Menu

98. Return to Previous Menu

99. Exit from Menus

0>
```

- **Enable/Disable Unattended Start Mode**

Use this option to instruct the service processor to restore the power state of the system after a temporary power failure. Unattended start mode can also be set through the System Management Services (SMS) menus. This option is intended to be used on systems that require automatic power-on after a power failure. For more information, see “System Power-On Methods” on page 51.

- **Ring Indicate Power-On Menu**

```
RING INDICATE POWER-ON MENU

1. Ring indicate power-on :
   Currently Enabled

2. Number of rings:
   Currently 3

30. Refresh Modem Settings

98. Return to Previous Menu
```

Note: Ring-indicate power-on is not available on serial port 1 when the system is connected to an HMC and a virtual terminal window is open providing a connection to the managed system.

Ring indicate power-on is enabled by default on both serial port 1 (S1) and serial port 2 (S2). When ring indicate power-on is enabled, call-in is disabled.

If ring indicate power-on is enabled and call-in is already enabled, you will be asked to confirm your choice. Refer to the message displayed on your screen.

If the ring indicate power-on setting is changed, you must select option 30, **Refresh Modem Settings** to update the modem settings. If **Refresh Modem Settings** is selected, and the modem(s) have not been configured, you will be asked to configure the modems first. See “Call-In/Call-Out Setup Menu” on page 46 for information on configuring modems.

Option 2 is used to set the number of rings.

- **Reboot/Restart Policy Setup Menu**

The following menu controls the Reboot/Restart Policy:

```
Reboot/Restart Policy Setup Menu

1. Number of reboot attempts:
   Currently 1

2. Use OS-Defined restart policy?
   Currently No

3. Enable supplemental restart policy?
   Currently Yes

4. Call-Out before restart:
   Currently Disabled

98. Return to Previous Menu

0>
```

Reboot is the process of bringing up the system hardware; for example, from a system reset or power on. *Restart* is activating the operating system after the system hardware is reinitialized. Restart must follow a successful reboot.

- **Number of reboot attempts** - If the system fails to successfully complete the boot process, it attempts to reboot the number of times specified. Entry values equal to or greater than 0 are valid. Only successive failed reboot/restart attempts are counted.
- **Use OS-Defined restart policy** - This allows the service processor to react in the same way that the operating system does to major system faults by reading the setting of the operating system parameter **Automatically Restart/Reboot After a System Crash**. This parameter might already be defined, depending on the operating system or its version or level. If the operating system automatic

restart setting is defined, it can be set to respond to a major fault by restarting or by not restarting. See your operating system documentation for details on setting up operating system automatic restarts. The default value is No.

- **Enable supplemental restart policy** - The default setting is Yes. When set to Yes, the service processor restarts the system when the system loses control as detected by service processor surveillance, and either:

The **Use OS-Defined restart policy** is set to No.

OR

The **Use OS-Defined restart policy** is set to Yes, and the operating system has no automatic restart policy.

- **Call-Out before restart (Enabled/Disabled)** - If a restart is necessary due to a system fault, you can enable the service processor to call out and report the event. This option can be valuable if the number of these events becomes excessive, which might signal a bigger problem.

- **Power-On System**

Allows immediate power-on of the system.

- **Power-Off System**

This option is not available on this system.

- **Enable/Disable Fast System Boot**

Allows the user to select the IPL type, mode, and speed of the system boot.

Attention: Selecting the fast IPL results in several diagnostic tests being skipped and a shorter memory test being run.

- **Boot Mode Menu**

The Boot Mode Menu allows you to select a boot mode.

```
Boot Mode Menu

1. Boot to SMS Menu:
   Currently Disabled

2. Service Mode Boot from Saved List:
   Currently Disabled

3. Service Mode Boot from Default List:
   Currently Disabled

4. Boot to Open Firmware Prompt:
   Currently Disabled

98. Return to Previous Menu

0>
```

To select a boot mode, select a number and press Enter. The item corresponding to the selected number toggles between Disabled to Enabled. If a boot mode is Enabled, the boot mode selected is performed, and the Disabled/Enabled selection is reset to Disabled. The following describes each boot mode:

- **Boot to SMS Menu**

When this selection is enabled, the system boots to the System Management Services (SMS) Menu.

- **Service Mode Boot from Saved List**

This selection causes the system to perform a service mode boot using the service mode boot list saved in NVRAM. If the system boots AIX from the disk drive and AIX diagnostics are loaded on the disk drive, AIX boots to the diagnostics menu.

Using this option to boot the system is the preferred way to run online diagnostics.

- **Service Mode Boot from Default List**

This selection is similar to *Service Mode Boot from Saved List*, except the system boots using the default boot list that is stored in the system firmware. This is normally used to try to boot customer diagnostics from the CD-ROM drive.

Using this option to boot the system is the preferred way to run standalone diagnostics.

– **Boot to Open Firmware Prompt**

This option should only be used by service personnel to obtain additional debug information. When this selection is enabled, the system boots to the open firmware prompt.

System Information Menu

This menu provides access to system configuration information, error logs, system resources, and processor configuration.

```
SYSTEM INFORMATION MENU

1. Read VPD Image from Last System Boot
2. Read Progress Indicators from Last System Boot
3. Read Service Processor Error Logs
4. Read System POST Errors
5. Read NVRAM
6. Read Service Processor Configuration
7. Processor Configuration/Deconfiguration Menu
8. Memory Configuration/Deconfiguration Menu
9. Power Control Network Utilities Menu
10. LED Control Menu
11. MCM/L3 Interposer Plug Count Menu
    Not Supported
12. Performance Mode Setup Menu
13. L3 Mode Menu
    Not Applicable
14. Remote I/O (RIO) Link Speed Set Up Menu
98. Return to Previous Menu
99. Exit from Menus
0>
```

• **Read VPD Image from Last System Boot**

Displays manufacturer's vital product data (VPD), such as serial numbers, part numbers, and so on, that was stored from the system boot prior to the one in progress now. VPD from all devices in the system is displayed.

• **Read Progress Indicators from Last System Boot**

Displays a number of the boot progress indicators, which may include Service Processor checkpoints, IPL checkpoints, or AIX configuration codes, from the previous system boot. This information can be useful in diagnosing system faults.

The progress indicator codes are listed from top (latest) to bottom (oldest).

This information is not stored in nonvolatile storage. If the system is powered off using the power-on button on the operator panel, this information is retained. If the ac power is disconnected from the system, this information will be lost. For an example, refer to "LCD Progress Indicator Log" on page 63.

- **Read Service Processor Error Logs**

Displays error conditions detected by the service processor. Refer to “Service Processor Error Logs” on page 62 for an example of this error log.

- **Read System POST Errors**

This option should only be used by service personnel to obtain additional debug information.

- **Read NVRAM**

Displays Non Volatile Random Access Memory (NVRAM) content.

- **Read Service Processor Configuration**

Displays current service processor configuration.

- **Processor Configuration/Deconfiguration Menu**

Enable/Disable CPU Repeat Gard

CPU repeat gard will automatically deconfigure a CPU during a system boot if a processor has failed BIST (built-in self-test), caused a machine check or check stop, or has reached a threshold of recoverable errors. The processor will remain deconfigured until repeat gard is disabled or the processor is replaced.

The default is enabled.

For more information, see “Configuring and Deconfiguring Processors or Memory” on page 58.

Dynamic Processor Sparing

This option is not available on this system.

This menu allows the user to change the system processor configuration. If it is necessary to take one of the processors offline, use this menu to deconfigure a processor, and then reconfigure the processor at a later time. An example of this menu follows:

```
PROCESSOR CONFIGURATION/DECONFIGURATION MENU
77. Enable/Disable CPU Repeat Gard: Currently Enabled
78. Enable/Disable Dynamic Processor Sparing (if available): Currently Disabled

  1. 0  3.0 (00) Configured by system    2. 1  3.1 (00) Deconfigured by system

98. Return to Previous Menu

0>
```

Note: This table is built from vital product data collected during the last boot sequence. The first time the system is powered on, or after the system’s nonvolatile RAM (NVRAM) has been erased, this table may be empty. The table is rebuilt during the next boot into AIX.

The fields of the previous table represent the following:

Column 1

(1.) Menu selection index.

Column 2

(0) Logical processor device number assigned by AIX. You can display these logical device numbers by issuing the following command on the AIX command line:

```
lsdev -C | grep proc
```

Column 3

(3.0) Processor address list used by the service processor.

Column 4

(00) Error status of the processors.

The error status of each processor is indicated by AB, where B indicates the number of errors and A indicates the type of error according to the following:

1. Bring-up failure
2. Run-time non-recoverable failure
3. Run-time recoverable failure
4. Group integrity failure
5. Non-repeat-gardable error. The resource may be reconfigured on the next boot.

A status of 00 indicates that the CPU has not had any errors logged against it by the service processor.

To enable or disable CPU repeat gard, use menu option 77. CPU repeat gard is enabled by default.

If CPU repeat gard is disabled, processors that are in the "deconfigured by system" state will be reconfigured. These reconfigured processors are then tested during the boot process, and if they pass, they remain online. If they fail the boot testing, they are deconfigured even though CPU repeat gard is disabled.

The failure history of each CPU is retained. If a processor with a history of failures is brought back online by disabling repeat gard, it remains online if it passes testing during the boot process. However, if repeat gard is enabled, the processor is taken offline again because of its history of failures.

Notes:

1. The processor numbering scheme used by the service processor is different from the numbering scheme used by AIX. Consult the AIX documentation before configuring or deconfiguring a processor to ensure that the correct processor is selected.
2. The number of processors available to AIX can be determined by issuing the following command on the AIX command line: `bindprocessor -q`

Note: The number of processors available to Linux can be determined by issuing the following command on the Linux command line:

```
cat /proc/cpuinfo | grep POWER
```

• **Memory Configuration/Deconfiguration Menu**

Enable/Disable Memory Repeat Gard

Memory repeat gard will automatically deconfigure a quad of memory during a system boot if a memory DIMM has failed BIST (built-in self-test), caused a machine check or check stop, or has reached a threshold of recoverable errors. The quad will remain deconfigured until repeat gard is disabled or the memory is replaced.

The default is enabled.

For more information, see "Configuring and Deconfiguring Processors or Memory" on page 58.

Runtime Recoverable Error Repeat Gard

The runtime recoverable error repeat gard flag controls the deallocation of the memory if a recoverable error occurs during runtime. If a recoverable memory error occurs, and runtime recoverable error repeat gard is disabled, the system will continue running with no change in the memory configuration. If a recoverable memory error occurs, and runtime recoverable error repeat gard is enabled, the memory quad in which the error occurred will be garded out (taken offline).

The default is disabled.

These menus allow the user to change the system memory configuration. If it is necessary to take one of the memory DIMMs offline, this menu allows you to deconfigure a DIMM, and then reconfigure the DIMM at a later time.

When this option is selected, a menu displays. The following is an example of this menu:

```
MEMORY CONFIGURATION/DECONFIGURATION MENU

77. Enable/Disable Memory Repeat Gard: Currently Enabled

78. Runtime Recoverable Error Repeat Gard: Currently Disabled

    1. Memory card

98. Return to Previous Menu
```

After you select the memory card option by entering 1, a menu displays, allowing the selection of a memory DIMM. The following is an example of this menu.

```
MEMORY CONFIGURATION/DECONFIGURATION MENU

1. 3.16(00) Configured by system  2. 3.17(00) Configured by system
3. 3.18(00) Configured by system  4. 3.19(00) Configured by system
5. 4.24(00) Configured by system  6. 4.25(00) Configured by system
7. 4.26(00) Configured by system  8. 4.27(00) Configured by system

98. Return to Previous Menu
```

Note: This table is built from vital product data collected during the last boot sequence. The first time the system is powered on, or after the system's nonvolatile RAM (NVRAM) has been erased, this table may be empty. The table is rebuilt during the next boot into AIX.

The fields in the previous table represent the following:

Column 1

1. Menu selection index/DIMM number

Column 2

xx.xx : DIMM address used by service processor

Column 3

(00) Error status

The error status of the each memory DIMM is indicated by AB, where B indicates the number of errors and A indicates the type of error according to the following table:

1. Bring-up failure
2. Run-time non-recoverable failure
3. Run-time recoverable failure
4. Group integrity failure
5. Non-repeat-gardable error. The resource may be reconfigured on the next boot.

An error status of 00 (for example, 3.16(00)) indicates that the memory DIMM has not had any errors logged against it by the service processor.

To change the memory configuration, select the number of the memory DIMM. The memory DIMM state will change from configured to deconfigured or from deconfigured to configured.

In the previous example menu, each line shows two DIMMs and indicates whether they are configured.

To enable or disable Memory Repeat Gard, use menu option 77 of the Memory Configuration/Deconfiguration Menu.

To enable or disable runtime recoverable error repeat gard, use option 78 of the Memory Configuration/Deconfiguration Menu.

The failure history of each DIMM is retained. If a DIMM with a history of failures is brought back online by disabling Repeat Gard, it remains online if it passes testing during the boot process. However, if Repeat Gard is enabled, the DIMM is taken offline again because of its history of failures.

- **Power Control Network Utilities Menu**

```
POWER CONTROL NETWORK UTILITIES MENU

1. Lamp Test for all Operator Panels
2. Display I/O Type
3. Change I/O Type
4. Collect & Display SPCN Trace Data
98. Return to Previous Menu

0>
```

- **Lamp Test for All Operator Panels**

Selecting this option tests the media drawer operator panel's indicators by causing them to blink on and off for approximately 30 seconds.

- **Display I/O Type**

This option is not available on this system.

- **Change I/O Type**

Use this option to change the I/O type after a service action or configuration change, if the I/O type is incorrect. If this option is chosen, you will be asked to make the following entries:

1. For the I/O drawer address, type 1.
2. For the I/O type, type A8.

If either value is not valid, a failure message displays on the console. Press Enter to return to the Power Control Network Utilities Menu.

- **Collect & Display SPCN Trace Data**

This option is used by service personnel to dump the SPCN trace data from the system unit to gather additional debug information. If this option is selected, enter 1 when prompted for the SPCN drawer number and enter d0 when prompted for the unit address. The following is an example of this menu and its output:

Enter the SPCN drawer number: 0

Enter the Unit Address: d0

The SPCN trace data will be displayed on the screen. The following is an example of this output:

Please wait....

```
***** Power Trace Data Start ***** 00000000ffffffff0006158800a000061574a00000
060200353700060210031300060242000000060241040b0006110a00400006110902000006110208040
000000000061102080b000604100000006d0e38500006110300000061109020000604020000006
040200010006041000010006d0e385010006041000020000000006d0e385020006041000030006d0e
385030006158010000006154003180006101116000006101116010006158010010007158156a0000711
0000100000000000091012000000910120001
***** Power Trace data End *****
```

(Press Return to Continue)

- **LED Indicator Menu**

This menu displays the state of the processor subsystem disturbance/system attention LED. Use this menu to toggle the attention/fault LED between identify (blinking) and off. Option 1 is only available when the system is in the error state (the CEC is powered on and the service processor menus are available). It is not available when the system is in standby. An example of this menu follows:

```
LED Indicator

1. Set/Reset Identify LED state
2. Clear System Attention Indicator
98. Return to Previous Menu

Enter LED index

0 >
```

Option 2, Clear System Attention Indicator, clears the attention indicator on the operator panel.

The processor subsystem disturbance/LED is on the operator panel.

- **MCM/L3 Interposer Plug Count Menu**

This option is not available on this system.

- **Performance Mode Setup Menu**

This option is not available on this system.

Notes:

1. Some processor card changes cause the default performance mode to change. This new setting is not reflected in the menu until after the system is rebooted with the new configuration.
2. If the NVRAM has been cleared, the default performance mode and the current performance mode will indicate uninitialized.

If you want to override the default setting, a brief description of each performance mode follows:

- Large Commercial System Optimization is the setting for systems that do not fall into the other two categories, standard operation and turbo database mode. This setting provides the best performance for most applications.
- Standard Operation optimizes the system for large memory bandwidth applications where minimal sharing of data occurs and the likelihood of significant hardware data-prefetching exists.
- Turbo Database Mode optimizes system operation for environments where there is a large amount of data sharing among processes running concurrently on the system.

Language Selection Menu

The service processor menus and messages are available in various languages. This menu allows selecting languages in which the service processor and system firmware menus and messages are displayed.

LANGUAGE SELECTION MENU

1. English
 2. Francais
 3. Deutsch
 4. Italiano
 5. Espanol
 98. Return to Previous Menu
 99. Exit from Menus
- 0>

Note: Your virtual terminal window must support the ISO-8859 character set to correctly display languages other than English.

Call-In/Call-Out Setup Menu

Note: The information in this section regarding the configuring of serial ports, and modems attached to those serial ports, applies only to the serial ports (S1 and S2) on the system backplane (location U0.1-P1). These serial ports are normally used for call-in and call-out.

The call-out function is normally handled by the Service Focal Point application running on the HMC.

None of these menus are applicable to the serial ports, or modems attached to those serial ports, on the HMC.

Call-in/call-out is not available on serial port 1 when the system is connected to and HMC and a virtual terminal window is open providing a connection to the managed system.

CALL-IN/CALL-OUT SETUP MENU

1. Modem Configuration Menu
 2. Serial Port Selection Menu
 3. Serial Port Speed Setup Menu
 4. Telephone Number Setup Menu
 5. Call-Out Policy Setup Menu
 6. Customer Account Setup Menu
 7. Call-Out Test
NOT supported in LPAR mode
 98. Return to Previous Menu
 99. Exit from Menus
- 0>

- **Modem Configuration Menu**, see “Modem Configuration Menu” on page 47.
- **Serial Port Selection Menu**, see “Serial Port Selection Menu” on page 47.
- **Serial Port Speed Setup Menu**, see “Serial Port Speed Setup Menu” on page 48.

- **Telephone Number Setup Menu**, see “Telephone Number Setup Menu” on page 48.
- **Call-Out Policy Setup Menu**, see “Call-Out Policy Setup Menu” on page 50.
- **Customer Account Setup Menu**, see “Customer Account Setup Menu” on page 50.
- **Call-Out Test** tests the configuration after the modem is installed and configured correctly.

Modem Configuration Menu

Note: This option applies only to a modem attached to serial port 1 (S1) or serial port 2 (S2) on the CEC backplane.

The first two lines of the Modem Configuration Menu contain status of the current selections. Selections are made in the sections labeled Modem Ports and Modem Configuration File Name. Select the serial port that you want to activate and then select the modem configuration file for the modem on the port. If you want to set up all of the serial ports with modems, make your selections one port at a time.

```

Modem Configuration Menu

Port 1 Modem Configuration File Name:
Port 2 Modem Configuration File Name:

To make changes, First select the port and then the configuration file
name

Modem Ports:
  1. Serial port 1
  2. Serial port 2

Modem Configuration File Name:
  5. none9. modem_z_sp
  6. modem_f_sp          10. modem_m1_sp
  7. modem_f0_sp         11. modem_m0_sp
  8. modem_f1_sp         12. modem_m1_sp

 30. Save configuration to NVRAM and Configure modem
 98. Return to Previous Menu

0>

```

For information on choosing a modem configuration file, see “Sample Modem Configuration Files” on page 153 and “Transfer of a Modem Session” on page 159.

Serial Port Selection Menu

This menu allows you to enable or disable the call-in and call-out functions of each serial port in any combination.

Serial Port Selection Menu

- 1. Serial Port 1 Call-Out:
Currently Disabled
NOT supported in LPAR mode
 - 2. Serial Port 2 Call-Out:
Currently Disabled
NOT supported in LPAR mode
 - 3. Serial Port 1 Call-In:
Currently Disabled
 - 4. Serial Port 2 Call-In:
Currently Disabled
 - 98. Return to Previous Menu
- 0>

Call-in and ring indicate power-on cannot be enabled at the same time. If ring-indicate power-on is already enabled and you try to enable call-in, a message prompts you for confirmation. Refer to the message displayed on the screen.

Serial Port Speed Setup Menu

This menu allows you to set serial port speed to enhance terminal performance or to accommodate modem capabilities.

Serial Port Speed Setup Menu

- 1. Serial Port 1 Speed:
Currently 9600
 - 2. Serial Port 2 Speed:
Currently 9600
 - 98. Return to Previous Menu
- 0>

A serial port speed of 9600 baud or higher is recommended. The following are valid serial port speeds:

50	600	4800
75	1200	7200
110	1800	9600
134	2000	19200
150	2400	38000
300	3600	57600
		115200

Telephone Number Setup Menu

Note: These menus are available, however, the function of calling out to report a system failure is normally handled by the Service Focal Point application running on the HMC.

Use this menu to set or change the telephone numbers for reporting a system failure.

Telephone Number Setup Menu

1. Service Center Telephone Number:
Currently Unassigned
 2. Customer Administration Center Telephone Number:
Currently Unassigned
 3. Digital Pager Telephone Number:
Currently Unassigned
 4. Customer Voice Telephone Number:
Currently Unassigned
 5. Customer System Telephone Number:
Currently Unassigned
98. Return to Previous Menu
- 0>

- **Service Center Telephone Number** is the number of the service center computer. The service center usually includes a computer that takes calls from servers with call-out capability. This computer is referred to as the *catcher*. The catcher expects messages in a specific format to which the service processor conforms.
For more information about the format and catcher computers, refer to the readme file in the AIX `/usr/samples/syscatch` directory. Contact your service provider for the correct service center telephone number to enter. Until you have that number, leave this field unassigned.
- **Customer Administration Center Telephone Number** is the number of the System Administration Center computer (catcher) that receives problem calls from servers. Contact your system administrator for the correct telephone number to enter here. Until you have that number, leave this field unassigned.
- **Digital Pager Telephone Number** is the number for a numeric pager carried by someone who responds to problem calls from your system. Contact your administration center representative for the correct telephone number to enter. For test purposes, use a test number, which you can change later (see the note on page 60).
- **Customer Voice Telephone Number** is the telephone number of a phone near the system or answered by someone responsible for the system. This is the telephone number left on the pager for callback. For test purposes, use a test number, which you can change later.
- **Customer System Telephone Number** is the telephone number to which your system's modem is connected. The service or administrative center representatives need this number to make direct contact with your system for problem investigation. This is also referred to as the *call-in* phone number.

Call-Out Policy Setup Menu

Call out settings can be set using the following menu:

```
CALL-OUT POLICY SETUP MENU

1. Call-Out policy (First/All):
   Currently First

2. Remote timeout, (in seconds):
   Currently 120

3. Remote latency, (in seconds):
   Currently 2

4. Number of retries:
   Currently 2

98. Return to Previous Menu

0>
```

- **Call-Out policy** can be set to first or all. If call-out policy is set to first, the service processor stops at the first successful call-out to one of the following numbers in the order listed:

1. Service Center
2. Customer Administrative Center
3. Pager

If call-out policy is set to all, the service processor attempts a call-out to all of the following numbers in the order listed:

1. Service Center
2. Customer Administrative Center
3. Pager

- **Remote timeout** and **remote latency** are functions of your service provider's catcher computer. Either use the defaults or contact your service provider for recommended settings.
- **Number of retries** is the number of times you want the system to retry calls that failed to complete.

Customer Account Setup Menu

This menu allows users to enter information that is specific to their account.

```
Customer Account Setup Menu

1. Customer Account Number:
   Currently Unassigned

2. Customer RETAIN Login userid:
   Currently Unassigned

3. Customer RETAIN login password:
   Currently Unassigned

98. Return to Previous Menu

0>
```

- **Customer Account Number** is assigned by your service provider for record-keeping and billing. If you have an account number, enter it. Otherwise, leave this field unassigned.
- **Customer RETAIN Login User ID** and **Customer RETAIN Login Password** apply to a service function to which your service provider might have access. If your service provider does not use RETAIN, leave these fields unassigned.

Call-out Test Menu

Tests the configuration after the modem is installed and configured. In order for this test to execute successfully, at least one of the following numbers must be assigned:

- Service center telephone number
- Customer administration center telephone number
- Digital pager telephone number

Service Processor Parameters in Service Mode

When the system is in service mode, the following service-processor parameters are suspended:

- Unattended Start Mode
- Reboot/Restart Policy
- Call-Out
- Surveillance

When service mode is exited, the service processor functions are reactivated.

System Power-On Methods

This section discusses the following system power-on methods:

- Power-on Switch

- Service Processor Menus

Privileged users can power on the system by selecting the **System Control Power Menu** option from the main menu and then selecting the **Power-on System** option from the System Power Control Menu. General users should select **Power-on System** on the General User Menu.

- Remote Power-on via Ring-Indicate Signal

The system automatically powers on when it detects a "ring indicate" signal from a modem attached to serial port 1 (S1) or serial port 2 (S2).

A remote user can call the system to activate ring detection by the modem. Listen for a few more rings than the threshold number for starting the system. The system powers on without answering the call.

- Unattended start mode - refer to **Enable/Disable Unattended Start Mode** on page 37.

The service processor can be enabled to recover from the loss of ac power (see Enable/Disable Unattended Power-On Mode in the SYSTEM POWER CONTROL MENU). When ac power is restored, the system returns to the power state at the time ac loss occurred. For example, if the system was powered on when ac loss occurred, it reboots/restarts when power is restored. If the system was powered off when ac loss occurred, it remains off when power is restored.

- Timed power-on - refer to the **shutdown -t** command on servers using AIX.

Working in conjunction with AIX, the service processor in your system can operate a timer, much like the wake-up timer on your clock radio. You can set the timer so that your system powers on at a certain time after shutting down. The timer is battery-operated, so power interruptions that occur while the system is off do not affect its accuracy. Refer to the AIX **shutdown -t** command for details on setting the timer.

Note: If an ac power loss is in progress when the timed power-on attempt occurs, the system cannot power on when ac power is restored.

- Follow-up to a Failed Boot Attempt

The service processor initiates a power-on sequence if a failed boot attempt is detected (due to a hardware or software failure).

- Fast or Slow Boot (IPL)

Using the service processor menus, you can select the IPL type, mode, and speed of your system.

Attention: Selecting fast IPL results in several diagnostic tests being skipped and a shorter memory test being run.

Service Processor Reboot/Restart Recovery

Reboot describes bringing the system hardware back up; for example, from a system reset or power-on. The boot process ends when control passes to the operating system process.

Restart describes activating the operating system after the system hardware is reinitialized. Restart must follow a successful reboot.

Boot (IPL) Speed

When the system enters reboot recovery, slow IPL is automatically started, which gives the POST an opportunity to locate and report any problems that might otherwise be unreported.

Failure During Boot Process

During the boot process, either initially after system power-on or upon reboot after a system failure, the service processor monitors the boot progress. If progress stops, the service processor can reinitiate the boot process (reboot) if enabled to do so. The service processor can re-attempt this process according to the number of retries selected in the Reboot/Restart Policy Setup Menu.

Failure During Normal System Operation

When the boot process completes and control transfers to the operating system (OS), the service processor can monitor operating system activity (see the Set Surveillance Parameters option in the SERVICE PROCESSOR SETUP MENU). If OS activity stops due to a hardware- or software-induced failure, the service processor can initiate a reboot/restart process based on the settings in the Service Processor Reboot/Restart Policy Setup Menu and the OS automatic restart settings (see the operating system documentation).

If you are using the AIX operating system, the menu item under SMIT for setting the restart policy is **Automatically Reboot After Crash**. The default is false. When the setting is true, and if the service processor parameter "Use OS-Defined Restart Policy" is yes (the default), the service processor takes over for AIX to reboot/restart after a hardware or surveillance failure.

Service Processor Reboot/Restart Policy Controls

The operating system's automatic restart policy (see operating system documentation) indicates the operating system response to a system crash. The service processor can be instructed to refer to that policy by the Use OS-Defined Restart Policy setup menu.

If the operating system has no automatic restart policy, or if it is disabled, then the service processor-restart policy can be controlled from the service processor menus. Use the Enable Supplemental Restart Policy selection.

Use OS-Defined restart policy - The default setting is no. This causes the service processor to refer to the OS Automatic Restart Policy setting and take action (the same action the operating system would take if it could have responded to the problem causing the restart).

When this setting is no, or if the operating system did not set a policy, the service processor refers to enable supplemental restart policy for its action.

Enable supplemental restart policy - The default setting is yes. When set to yes, the service processor restarts the server when the operating system loses control and either:

The **Use OS-Defined restart policy** is set to No.

OR

The **Use OS-Defined restart policy** is set to Yes and the operating system has no automatic restart policy.

If set to Yes, the service processor restarts the system when the system loses control and it is detected by service processor surveillance. Refer to “Service Processor Reboot/Restart Recovery” on page 52.

The following table describes the relationship among the operating system and service processor restart controls:

OS Automatic reboot/restart after crash setting	Service processor to use OS-Defined restart policy?	Service Processor Enable supplemental restart policy?	System response
None	No ¹	No	
None	No ¹	Yes ¹	Restarts
None	Yes	No	
None	Yes	Yes ¹	Restarts
False ²	No ¹	No	
False ²	No ¹	Yes ¹	Restarts
False ²	Yes	No	
False ²	Yes	Yes ¹	
True	No ¹	No	
True	No ¹	Yes ¹	Restarts
True	Yes	No	Restarts
True	Yes	Yes ¹	Restarts

¹ Service processor default

² AIX default

System Firmware Updates

This section provides information and instructions for updating the system firmware. You may need to perform these steps if you are installing an option or if your support representative has instructed you to update your firmware.

Downloading the firmware update image and update instructions from the Web is preferred.

Always check the pSeries and RS/6000 Support Web site for the latest firmware images and update instructions. The Web address is: <http://techsupport.services.ibm.com/server/mdownload2>

If you cannot download from the Web, do the following:

- If the system is running, but access to the Web is not available, see “System Firmware Update Using a Locally Available Image” on page 55.
- If the system cannot be powered on, but the service processor menus are available, see “Updating System Firmware from the Service Processor Menus” on page 56.
- If the service processor programming has been corrupted, the service processor will automatically enter recovery mode when power is applied to the system. For more information about recovery mode, see “Recovery Mode” on page 56.

To check the level of firmware that is currently on the system, see “Determining the Level of Firmware on the System” on page 55.

General Information on System Firmware Updates

All the system firmware types that can be reprogrammed are updated at the same time. They are:

- System power control network programming
- Service processor programming
- IPL programming
- Run-time abstraction services

It is strongly recommended that you create a set of firmware update diskettes from the Web site as soon as possible after a system is installed. The diskette images can be downloaded to any personal computer, pSeries, or RS/6000 system with Internet access. This method and contacting your service representative are the only two ways to acquire a set of firmware update diskettes; they cannot be created by using the service processor menus or by using the operating system.

Retain and store the latest firmware diskettes each time the firmware gets updated in the event that the firmware becomes corrupted and must be reloaded.

Download the detailed instructions, as well as the latest flash images, from the following Web address: <http://techsupport.services.ibm.com/server/mdownload2>. Before doing a system firmware update, check the Web site for the latest code and images. Do not attempt a firmware update if you are unsure of the image you have, or of the procedure required for the update.

The images are available on the Web site in either DOS format or AIX (backup) format:

- If downloading to a PC, download the DOS image and follow the instructions. The diskettes that are created will be in AIX (backup) format.
- If downloading to a pSeries or RS/6000 system, follow the instructions to create an image on a disk drive or on diskettes.

Determining the Level of Firmware on the System

Note: This information may be superseded by information that is available on the following Web site. Always check the Web site for the latest images and instructions for checking the firmware level. The Web address is: <http://www.rs6000.ibm.com/support/micro>

The firmware level is denoted by vFyymmdd, where:

- v = version number
- F = the p615's firmware designation
- yy = year
- mm = month
- dd = day

of the release.

If the system is running AIX, the firmware level can be determined by either of the following methods:

- On the AIX command line, by typing:

```
lscfg -vp|grep -p Platform
```

A line that begins with ROM level (alterable).. displays the firmware level that is currently on the system.

- Looking at the top of the service processor main menu.

If the system is running Linux, the platform firmware level can be determined by the following methods:

- On the Linux command line, type:

```
/usr/sbin/ibmras/nvram/ --print-vpd | grep 3F
```

A line similar to the following displays the firmware level that is currently on the system:

```
Alterable ROM Level 3F030504
```

- Looking at the top of the service processor main menu.

System Firmware Update Using a Locally Available Image

To update the system firmware using a locally available image, perform the following steps:

1. Log in as root user.
2. If the **/tmp/fwupdate** directory does not exist, create it by issuing the following command:

```
mkdir /tmp/fwupdate
```

3. The firmware update file must be downloaded or copied into the **/tmp/fwupdate** directory on the system. This can be done by using the **ftp** command to get the image from an ftp server or NFS-mounting the directory on the host system.

The firmware updated file can also be transferred to the target system by backing up the image onto diskettes from another server and restoring it into the **/tmp/fwupdate** directory.

After the firmware update file has been downloaded or copied into the **/tmp/fwupdate** directory, verify its existence by entering the following command:

```
ls /tmp/fwupdate/3F*.img
```

The update file will have the format 3Fyymmdd.img. The 3F indicates that this is an update image for your system: yy is the year, mm is the month, and dd is the day of the update file.

4. If the system is running AIX:
After the firmware update file has been written to the **/tmp/fwupdate** directory, enter the following commands:

```
cd /usr/lpp/diagnostics/bin
./update_flash -f /tmp/fwupdate/3Fyymmdd.img
```

Attention: Do not overlook the periods (.) in the commands shown above. AIX commands are case-sensitive. Type them exactly as shown.

The firmware update is complete.

If the system is running Linux, refer to the detailed instructions with the latest image that are provided on CORE or the Web

You will be asked for confirmation to proceed with the firmware update and the required reboot. If you confirm, the system will apply the new firmware, reboot, and return to the AIX prompt. This may take up to ten minutes depending on the configuration of the system.

Attention: On some systems, the message `Wait for rebooting before stopping` may display on the system console. Do not turn off the system until the system has fully rebooted to the AIX login prompt. If a shutdown is necessary at that time, log in as root user and issue the **shutdown** command.

While the update is in progress, you will see `Rebooting...` on the display for several minutes.

The firmware update is complete.

Updating System Firmware from the Service Processor Menus

This procedure requires a diskette drive to be installed in the system. This procedure also requires a set of firmware update diskettes in backup format.

The service processor menus are available while the system is powered off. As a privileged user, from the service processor main menu, select **Service Processor Setup**, then select **Reprogram Flash EPROM Menu**. The update process requests update diskettes as needed.

Updating System Firmware from the AIX Service Aids

Note: This service aid is supported only in online diagnostics.

Refer to the detailed instructions that are provided on CORE or the web with the latest image.

Note: Because the system always reboots itself during this type of firmware update process, the update process can take from 20 to 60 minutes.

Updating System Firmware from the AIX Command Line

Refer to the detailed instructions that are provided on the Web site with the latest image.

Note: The update process can take up to 60 minutes, and the system reboots itself during the update process.

Updating System Firmware from a NIM Server

Refer to “Running Standalone Diagnostics from a Network Installation Management (NIM) Server” on page 87.

Recovery Mode

If the service processor detects that its programming has been corrupted when it is powering up to standby mode, it will enter recovery mode. In recovery mode, it will ask for the firmware update diskettes by putting eight-digit codes on the operator panel.

The eight-digit codes are as follows:

Code	Action
A1FD 0000	System firmware has been corrupted and must be reflashed.
A1FD 0001	Insert update diskette 1.
A1FD 0002	Insert update diskette 2.
A1FD 0003	Insert update diskette 3.
A1FD 000n	Insert update diskette n.

Notes:

1. If the wrong diskette is inserted at any time, or if the diskette is left in the drive after it has been read, B1FD 001F is displayed, indicating that the wrong diskette is in the drive.
2. If B1FD 001A is displayed at any time during the process, the service processor must be reset by activating the pinhole reset switch on the primary drawer operator panel.

After the update process is complete, the service processor resets itself and goes through a complete reboot.

Configuring and Deconfiguring Processors or Memory

All failures that crash the system with a machine check or check stop, even if intermittent, are reported as a diagnostic callout for service repair. To prevent the recurrence of intermittent problems and improve the availability of the system until a scheduled maintenance window, processors and memory DIMMs with a failure history are marked "bad" to prevent their being configured on subsequent boots. This function is called *repeat guard*.

A processor or memory DIMM is marked "bad" under the following circumstances:

- A processor or memory DIMM fails built-in self-test (BIST) or power-on self-test (POST) testing during boot (as determined by the service processor).
- A processor or memory DIMM causes a machine check or check stop during runtime, and the failure can be isolated specifically to that processor or memory DIMM (as determined by the processor runtime diagnostics in the service processor).
- A processor or memory DIMM reaches a threshold of recovered failures that results in a predictive callout (as determined by the processor run-time diagnostics in the service processor).

During boot time, the service processor does not configure processors or memory DIMMs that are marked “bad.”

If a processor or memory DIMM is deconfigured, the processor or memory DIMM remains offline for subsequent reboots until it is replaced or repeat guard is disabled. The repeat guard function also provides the user with the option of manually deconfiguring a processor or memory DIMM, or re-enabling a previously deconfigured processor or memory DIMM.

For information about configuring or deconfiguring a processor, see the Processor Configuration/Deconfiguration Menu on page 41. For information about configuring or deconfiguring a memory DIMM, see the Memory Configuration/Deconfiguration Menu on page 42. Both of these menus are submenus under the System Information Menu. You can enable or disable CPU Repeat Gard or Memory Repeat Gard using the Processor Configuration/Deconfiguration Menu.

Run-Time CPU Deconfiguration (CPU Gard)

L1 instruction cache recoverable errors, L1 data cache correctable errors, and L2 cache correctable errors are monitored by the processor run-time diagnostics (PRD) code running in the service processor. When a predefined error threshold is met, an error log with warning severity and threshold exceeded status is returned to AIX. At the same time, PRD marks the CPU for deconfiguration at the next boot. AIX will attempt to migrate all resources associated with that processor to another processor and then stop the defective processor.

Service Processor System Monitoring - Surveillance

Surveillance is a function in which the service processor monitors the system, and the system monitors the service processor. This monitoring is accomplished by periodic samplings called *heartbeats*.

Surveillance is available during the following phases:

- System firmware bringup (automatic)
- Operating system run-time (optional)

Note: Operating system surveillance is disabled in partitioned systems.

System Firmware Surveillance

System firmware surveillance is automatically enabled during system power-on. It cannot be disabled by the user, and the surveillance interval and surveillance delay cannot be changed by the user.

If the service processor detects no heartbeats during system IPL (for a set period of time), it cycles the system power to attempt a reboot. The maximum number of retries is set from the service processor menus. If the fail condition persists, the service processor leaves the machine powered on, logs an error, and displays menus to the user. If Call-out is enabled, the service processor calls to report the failure and displays the operating-system surveillance failure code on the operator panel.

Operating System Surveillance

Operating system surveillance provides the service processor with a means to detect hang conditions, as well as hardware or software failures, while the operating system is running. It also provides the operating system with a means to detect a service processor failure caused by the lack of a return heartbeat.

Operating system surveillance is not enabled by default, allowing you to run operating systems that do not support this service processor option.

You can also use service processor menus and AIX service aids to enable or disable operating system surveillance.

For operating system surveillance to work correctly, you must set these parameters:

- Surveillance enable/disable
- Surveillance interval

The maximum time the service processor should wait for a heartbeat from the operating system before timeout.

- Surveillance delay

The length of time to wait from the time the operating system is started to when the first heartbeat is expected.

Surveillance does not take effect until the next time the operating system is started after the parameters have been set.

If desired, you can initiate surveillance mode immediately from service aids. In addition to the three options above, a fourth option allows you to select immediate surveillance, and rebooting of the system is not necessarily required.

If operating system surveillance is enabled (and system firmware has passed control to the operating system), and the service processor does not detect any heartbeats from the operating system, the service processor assumes the system is hung and takes action according to the reboot/restart policy settings. See “Service Processor Reboot/Restart Recovery” on page 52.

If surveillance is selected from the service processor menus which are only available at system boot, then surveillance is enabled by default as soon as the system boots. From service aids, the selection is optional.

Call-Out (Call-Home)

Note: The call-out function is handled by the Service Focal point application on the Hardware Management Console (HMC).

The service processor can call out (call-home) when it detects one of the following conditions:

- System firmware surveillance failure
- Operating system surveillance failure (if supported by operating system)
- Restarts
- Critical hardware failure
- Abnormal operating system termination

To enable the call-out feature, do the following:

1. Connect a modem to any serial port.
2. Set up the following using the service processor menus or diagnostic service aids:
 - Enable call-out for the serial port where the modem is connected.

- Enter the modem configuration file name.
 - Set up site-specific parameters (phone numbers for call-out, call-out policy, number of call-out retries, and so on).
3. To call out before restart, set **Call-out before restart** to ENABLED from the Reboot/Restart Policy Setup menu.

Note: Some modems, such as the IBM 7857-017, are not designed for the paging function. Although they can be used for paging, they will return an error message when they do not get the expected response from another modem. Therefore, even though the paging was successful, the error message will cause the service processor to retry, continuing to place pager calls for the number of retries specified in the call-out policy setup menu. These retries result in redundant pages.

Console Mirroring

Console mirroring allows a user on one serial port to monitor the service processor activities on another serial port. This can be done on the locally attached HMC virtual terminal window or windows remotely attached through modems. Console mirroring is supported on any combination of locally or remotely attached monitors.

The serial port from which console mirroring is enabled is called the *primary port*. The mirror port is determined when keyboard input is detected from one of the other two serial ports. From this point forward, the service processor sends information to the active port and the mirror port only. Console mirroring ends when the service processor releases control of the serial ports to the system firmware.

Console mirroring is supported on serial port 1 (S1), serial port 2 (S2), and serial port 3 (S3). Remote attachment through modem is supported on serial port 1 (S1) and serial port 2 (S2).

System Configuration

The following describes the configuration for console mirroring:

- Service processor
- Modem connected to one serial port and enabled for incoming calls
- Local HMC virtual terminal window connected to the other serial port. This local terminal can be connected directly to your system or connected through another modem.

Console mirroring can be started by either of the following methods:

- Remote session first, then local session added:
 1. Remote session is already in progress.
 2. Remote user uses service processor menus to enable console mirroring, allowing both consoles to be active.
- Local session first, then remote session added:
 1. Local session is already in progress.
 2. The service processor receives a call from the remote user.
 3. The local user selects the option to enable console mirroring. The service processor immediately begins mirroring service processor menus.

Service Processor Error Logs

The service processor error logs, an example of which follows, contain error conditions detected by the service processor.

```

                                Error Log

1. 11/30/99   19:41:56 Service Processor Firmware Failure
   B1004999

Enter error number for more details.
Press Return to continue, or 'x' to return to menu.
Press "C" to clear error log, any other key to continue. >
```

Note: The time stamp in this error log is coordinated universal time (UTC), which is also referred to as Greenwich mean time (GMT). Operating system error logs have additional information available and can time stamp with local time.

Entering an error number provides nine words of system reference code (SRC) data; an example menu follows.

```

Detail:   6005

SRC
-----
word11:B1004999   word12:0110005D   word13:00000000
word14:00000000   word15:00001111   word16:00000000
word17:B1004AAA   word18:0114005D   word19:A4F1E909

B1004999

Press Return to continue, or 'x' to return to menu.
```

If Return is pressed, the contents of NVRAM will be dumped 320 bytes at a time, starting at address 0000.

LCD Progress Indicator Log

The following is an example of the LCD progress indicator log. It shows the types of entries that can appear in the log and is for example purposes only.

The progress indicator codes are listed from top (latest) to bottom (oldest).

```
                LCD Progress Indicator Log
B0FF
0539..17
0538..17
0539..17
0538..17
0539..17
0581
0538..17
0539..12
0538..12
0539..
0821..01-K1-00
0539..
0728..01-R1-00-00
0539..
0664..40-60-00-1,0
0539..
0777..U0.1-P2-I1/E1
0539..
0742..U0.1-P2-I2/E1
0539..
0776..U0.1-P2-I3/T1
E139
E1FB
E139
E183
Press Return to continue, or 'x' to return to menu. >
EAA1..U0.1-P1-I4
E172..U0.1-P1
E172..U0.1-P1-I4
E172..U0.1-P1
94BB
9109
9380
9108
9107
9106
9105
9118
9104
9103
9102
90FD
```

Service Processor Operational Phases

This section provides a high-level flow of the phases of the service processor.

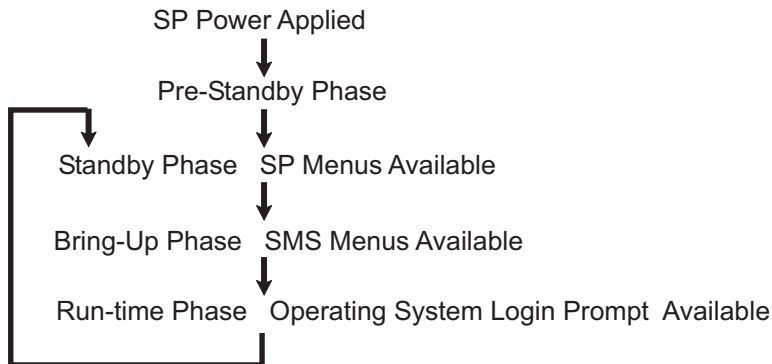

Pre-Standby Phase

This phase is entered when the system is connected to a power source. The system may or may not be fully powered on. This phase is exited when the power-on self-tests (POSTs) and configuration tasks are completed.

The pre-standby phase components are:

- Service Processor Initialization - Service processor performs any necessary hardware and software initialization.
- Service Processor POST - Service processor conducts Power-on self-tests on its various work and code areas.
- Service Processor Unattended Start Mode Checks - To assist fault recovery. If unattended start mode is set, the service processor automatically reboots the system. The service processor does not wait for user input or power-on command, but moves through the phase and into the bring-up phase. Access the SMS menus or the service processor menus to reset the unattended start mode.

Standby Phase

The standby phase can be reached in either of the following ways:

- With the system off and power connected (the normal path), recognized by 0K in the LCD display.
OR
- With the system on after an operating system fault, recognized by an 8-digit code in the LCD display.

In the standby phase, the service processor takes care of some automatic duties and is available for menus operation. The service processor remains in the standby phase until a power-on request is detected.

The standby phase components are as follows:

- Modem Configuration
The service processor configures the modem (if installed) so that incoming calls can be received, or outgoing calls can be placed.
- Dial In
Monitor incoming phone line to answer calls, prompt for a password, verify the password, and remotely display the standby menu. The remote session can be mirrored on the local HMC virtual terminal window if the system is so equipped and if the user enables this function.
- Menus

The service processor menus are password-protected. Before you can access them, you need either the general user-password or privileged-user password.

Service processor menus are available on ASCII terminals attached to the serial ports on the system, and on terminal emulators. On HMC-managed systems, service processor menus are also available on the HMC graphical user interface.

Bring-Up Phase

This phase is entered upon power-on, and exited upon loading of the operating system.

The bring-up phase components are as follows:

- **Retry Request Check**

The service processor checks to see if the previous boot attempt failed. If the specified number of failures are detected, the service processor displays an error code and places an outgoing call to notify an external party if the user has enabled this option.

- **Dial Out**

The service processor can dial a preprogrammed telephone number in the event of an IPL failure. The service processor issues an error report with the last reported IPL status indicated and any other available error information.

- **Update Operator Panel**

The service processor displays operator panel data on the HMC virtual terminal window if a remote connection is active.

- **Environmental Monitoring**

The service processor provides expanded error recording and reporting.

- **System Firmware Surveillance (Heartbeat Monitoring)**

The service processor monitors and times the interval between system firmware heartbeats.

- **Responding to System Processor Commands**

The service processor responds to any command issued by the system processor.

Runtime Phase

This phase includes the tasks that the service processor performs during steady-state execution of the operating system.

- **Environmental Monitoring**

The service processor monitors voltages, temperatures, and fan speeds (on some servers).

- **Responding to System Processor Commands**

The service processor responds to any command issued by the system processor.

- **Run-Time Surveillance**

If the device driver is installed and surveillance enabled, the service processor monitors the system heartbeat. If the heartbeat times out, the service processor places an outgoing call. This is different from the bring-up phase scenario, where the specified number of reboot attempts are made before placing an outgoing call.

- **HMC surveillance**

On an HMC-managed system, the service processor monitors the communication link between the managed system and the HMC. If the service processor detects that this communication link has been broken, it will post an error to the operating system running on the managed system.

Chapter 5. Using System Management Services

Use the system management services menus to view information about your system , and to perform tasks such as setting a password, changing the boot list, and setting the network parameters.

Note: On some of the system management services (or service processor) screens, you will see the term *LPAR* which is equivalent to the term *logical partition*. This system does not support logical partitions.

To start the system management services, do the following:

1. For a partitioned system, use the Hardware Management Console for pSeries (HMC) to restart the partition.
For a full system partition, restart the system.
2. For a partitioned system, watch the virtual terminal window on the HMC.
For a full system partition, watch the firmware console.
3. Look for the POST indicators **memory**, **keyboard**, **network**, **scsi**, **speaker**, which appear across the bottom of the screen.
Press the numeric 1 key after the word **keyboard** appears, and before the word **speaker** appears.

After the system management services starts, the following screen displays:

```
Main Menu
1  Select Language
2  Change Password Options NOT available in LPAR mode
3  View Error Log
4  Setup Remote IPL (Initial Program Load)
5  Change SCSI Settings
6  Select Console NOT available in LPAR mode
7  Select Boot Options

-----
Navigation keys:

                                     X = eXit System Management Services
-----
Type the number of the menu item and press Enter or Select a Navigation key: _
```

Note: The System Management Services can also be started using the Service Processor Boot Mode Menu. See page 39.

On all menus except the Main Menu, there are several navigation keys:

M Return to the main menu.

ESC Return to the previous menu.

X Exit the System Management Services and start the operating system.

If X is entered, you are asked to confirm your choice to exit the SMS menus and start the operating system.

When there is more than one page of information to display, there are two additional navigation keys:

N Display the next page of the list.

P Display the previous page of the list.

Note: The lowercase navigation key has the same effect as the uppercase key that is shown on the screen. For example, *m* or *M* returns you to the main menu.

On each menu screen, you are given the option of choosing a menu item and pressing enter (if applicable), or selecting a navigation key.

Select Language

Note: Your TTY must support the ISO-8859 character set to properly display languages other than English.

This option allows you to change the language used by the text-based System Management Services menus.

```
SELECT LANGUAGE
```

1. English
2. Francais
3. Deutsch
4. Italiano
5. Espanol

Navigation keys:

M = return to main menu

ESC key = return to previous screen

X = eXit System Management Services

Type the number of the menu item and press Enter or Select a Navigation key: _

Change Password Options

The Change Password Options menu enables you to select from password utilities.

Note: This option is not available when the system is booted in LPAR mode.

```
Password Utilities
```

- 1 Set Privileged-Access Password
- 2 Remove Privileged-Access Password

Navigation keys:

M = return to main menu

ESC key = return to previous screen

X = eXit System Management Services

Type the number of the menu item and press Enter or Select a Navigation key: _

Set Privileged-Access Password

The privileged-access password protects against the unauthorized starting of the system programs.

Note: If the privileged-access password has been enabled, you are asked for the privileged-access password at startup every time you boot your system.

If you previously had set a privileged-access password and want to remove it, select **Remove Privileged-Access Password**.

View Error Log

Use this option to view or clear your system's error log. A menu similar to the following displays when you select this option.

```
Error Log

      Date      Time      Error Code      Location
Entry 1. 01/04/96 12:13:22 25A80011      00-00
Entry 2. no error logged

1. Clear error log

-----
Navigation keys:
M = return to main menu
ESC key = return to previous screen          X = eXit System Management Services
-----
Type the number of the menu item and press Enter or Select a Navigation key: _
```

Note: The time stamp in his error log is coordinated universal time (UTC), which is also referred to as Greenwich mean time (GMT). Operating system error logs have more information available and can time stamp with your local time.

Setup Remote IPL (Initial Program Load)

This option allows you to enable and set up the remote startup capability of your system. A list of NIC (network interface card) adapters in the system displays first. The following is an example of this screen.

```
NIC Adapters
  Device                               Slot      Hardware Address
1.  10/100 Mbps Ethernet PCI Adapt    Integ:  U0.1-P1/E1    00096baeac10
2.  IBM 10/100/1000 Base-TX PCI       Integ:  U0.1-P1/E2    0009cbce0fde

-----
Navigation keys:
M = return to main menu
ESC key = return to previous screen          X = eXit System Management Services
-----
Type the number of the menu item and press Enter or Select a Navigation key: _
```

When an adapter is selected, the network parameters menu displays:

```
Network Parameters
10/100 Mbps Ethernet PCI Adapter II:  U0.1-P1/E1
 1. IP Parameters
 2. Adapter Parameters
 3. Ping Test

-----
Navigation keys:
M = return to main menu
ESC key = return to previous screen          X = eXit System Management Services
-----
Type the number of the menu item and press Enter or Select a Navigation key: _
```

Selecting the IP (Internet Protocol) parameters option displays the following menu:

```
IP Parameters
10/100 Mbps Ethernet PCI Adapter II:  U0.1-P1/E1
 1. Client IP Address   [000.000.000.000]
 2. Server IP Address   [000.000.000.000]
 3. Gateway IP Address  [000.000.000.000]
 4. Subnet Mask         [255.255.255.000]

-----
Navigation keys:
M = return to main menu
ESC key = return to previous screen          X = eXit System Management Services
-----
Type the number of the menu item and press Enter or Select a Navigation key: _
```

To change IP parameters, type the number of the parameters for which you want to change the value. Entering IP parameters on this screen will automatically update the parameters on the ping test screen.

Attention: If the client system and the server are on the same subnet, set the gateway IP address to [0.0.0.0].

Selecting **Adapter Configuration** allows the setting of the network speed, enabling or disabling spanning tree, and setting the protocol as shown in the following example menu :

```
Adapter Configuration
10/100 Mbps Ethernet PCI Adapter II: U0.1-P1/E1
1. Speed, Duplex
2. Spanning Tree Enabled
3. Protocol
```

Navigation keys:

M = return to main menu

ESC key = return to previous screen

X = eXit System Management Services

Type the number of the menu item and press Enter or Select a Navigation key: _

Selecting the **Speed, Duplex** option allows you to set the interface speed at which the card will run at half versus full duplex. The current setting is indicated by "<===".

```
Adapter Configuration
10/100 Mbps Ethernet PCI Adapter II: U0.1-P1/E1
```

1. auto, auto
2. 10, half
3. 10, full
4. 100, half
5. 100, full

Navigation keys:

M = return to main menu

ESC key = return to previous screen

X = eXit System Management Services

Type the number of the menu item and press Enter or Select a Navigation key: _

Selecting the **Spanning Tree Enabled** menu allows you to enable or disable the spanning tree flag. If this flag is enabled (because the network the system is being attached to supports spanning trees), the firmware will impose a waiting period of 60 seconds before the adapter is allowed to communicate with the network. If this flag is disabled, the network adapter will be able to access the network immediately after the system is connected.

```
Spanning Tree Enabled
10/100 Mbps Ethernet PCI Adapter II: U0.1-P1/E1
```

1. Yes <===
2. No

Navigation keys:

M = return to main menu

ESC key = return to previous screen

X = eXit System Management Services

Type the number of the menu item and press Enter or Select a Navigation key: _

The **Protocol** option allows you to set the appropriate protocol for your network as shown.

```
Protocol
10/100 Mbps Ethernet PCI Adapter II: U0.1-P1/E1
```

1. Standard <===
2. IEEE802.3

Navigation keys:

M = return to main menu

ESC key = return to previous screen

X = eXit System Management Services

Type the number of the menu item and press Enter or Select a Navigation key: _

Select the **ping test** option from the network parameters menu to test an adapter's network connection to a remote system. After the ping test option is selected, the same series of screens will take you through setting up the IP parameters and the adapter configuration before attempting the ping test.

Notes:

1. After the ping test is initiated, it may take 60 seconds or longer to return a result.
2. If the ping test passes or fails, the firmware will stop and wait for a key to be pressed before continuing.

Change SCSI Settings

This option allows you to view and change the addresses of the SCSI controllers attached to your system.

```
SCSI Utilities
```

1. Hardware Spin Up Delay
2. Change SCSI Id

Navigation keys:

M = return to main menu

ESC key = return to previous screen

X = eXit System Management Services

Type the number of the menu item and press Enter or Select a Navigation key: _

Select Console

The Select Console Utility allows the user to select which console the user would like to use to display the SMS menus. This selection is only for the SMS menus and does not affect the display used by the operating system.

Follow the instructions that display on the screen. The firmware automatically returns to the SMS main menu.

Note: This option is not available if an HMC is attached. A virtual terminal window on the HMC is the default firmware console if an HMC is attached.

Select Boot Options

Use this menu to view and set various options regarding the installation devices and boot devices.

1. Select Install or Boot a Device
2. Select Boot Devices
3. Multiboot Startup

Navigation keys:

M = return to main menu

ESC key = return to previous screen

X = eXit System Management Services

Type the number of the menu item and press Enter or Select a Navigation key: _

Option 1

Select Install or Boot a Device allows you to select a device to boot from or install the operating system from. This selection is for the current boot only.

Option 2

Select Boot Devices allows you to set the boot list.

Option 3

Multiboot Startup toggles the multiboot startup flag, which controls whether the multiboot menu is invoked automatically on startup.

If option 1 is selected, the following menu is displayed:

- ```
Select Device Type
1. Diskette
2. Tape
3. CD/DVD
4. IDE
5. Hard Drive
6. Network
7. None
8. List All Devices
```

-----  
Navigation keys:

M = return to main menu

ESC key = return to previous screen

X = eXit System Management Services

-----  
Type the number of the menu item and press Enter or Select a Navigation key: \_

If a device is selected that does not reside in the system, a menu with the following message displays:

```

| THE SELECTED DEVICES WERE NOT DETECTED IN THE SYSTEM ! |
Press any key to continue.
```

If hard drive is selected, the following menu displays:

- ```
Select Hard Drive Type
1. SCSI
2. SSA
3. SAN
4. None
5. List All Devices
```

Navigation keys:

M = return to main menu

ESC key = return to previous screen

X = eXit System Management Services

Type the number of the menu item and press Enter or Select a Navigation key: _

If **List All Devices** is selected, a menu similar to the following displays, depending on the devices that are installed in the system:

```
Select Device
Device Current Device
Number Position Name
1.      1      SCSI 18200 MB Harddisk (loc=U0.1-P2/Z1-A8,0)
2.      -      SCSI 18200 MB Harddisk (loc=U0.1-P2/Z1-A9,0)
3.      -      SCSI 18200 MB Harddisk (loc=U0.1-P2/Z1-Aa,0)
4.      None
5.      List all devices

-----
Navigation keys:
M = return to main menu
ESC key = return to previous screen                X = eXit System Management Services
-----
Type the number of the menu item and press Enter or Select a Navigation key: _
```

The appropriate device can then be selected for this boot or installation.

When a device is selected for installing the operating system, or to boot from, the **Select Task** menu allows you to get more information about the device, or to boot from that device in normal mode or service mode. The following is an example of this menu.

```
Select Task
SCSI 18200 MB Harddisk (loc=U0.1-P2/Z1-A8,0)
1. Information
2. Normal Mode Boot
3. Service Mode Boot

-----
Navigation keys:
M = return to main menu
ESC key = return to previous screen                X = eXit System Management Services
-----
Type the number of the menu item and press Enter or Select a Navigation key: _
```

If either **Normal Mode Boot** or **Service Mode Boot** is selected, the next screen will ask, "Are you sure?". If you answer yes, the device will be booted in the appropriate mode. If you answer no, the firmware will return to the **Select Task** menu.

Select Boot Devices

Select this option to view and change the customized boot list, which is the sequence of devices read at startup.

- ```
Configure Boot Device Order
1. Select 1st Boot Device
2. Select 2nd Boot Device
3. Select 3rd Boot Device
4. Select 4th Boot Device
5. Select 5th Boot Device
6. Display Current Setting
7. Restore Default Setting
```

-----  
Navigation keys:

M = return to main menu

ESC key = return to previous screen

X = eXit System Management Services

-----  
Type the number of the menu item and press Enter or Select a Navigation key: \_

When any of the options 1-5 is selected, the Device Type screen will be displayed, which will be similar to the following.

- ```
Select Device Type
1. Diskette
2. Tape
3. CD/DVD
4. IDE
5. Hard Drive
6. Network
7. None
8. List All Devices
```

Navigation keys:

M = return to main menu

ESC key = return to previous screen

X = eXit System Management Services

Type the number of the menu item and press Enter or Select a Navigation key: _

When a device type is selected, such as item 1, a Select Task menu will be displayed. The following is an example of that menu for a hard disk.

```
Select Task
SCSI 18200 MB Harddisk (loc=U0.1-P2/Z1-A8,0)

1. Information
2. Set Boot Sequence: Configure as 1st Boot Device

-----
Navigation keys:
M = return to main menu
ESC key = return to previous screen                X = eXit System Management Services
-----
Type the number of the menu item and press Enter or Select a Navigation key: _
```

Selecting **Information** will display a menu similar to the following for a hard disk.

```
Device Information
 /pci@3ffffdf0a000/pci@2,4/scsi@1/sd@8,0
      : (Integrated)      (Bootable)
DEVICE      : SCSI 18200 MB Harddisk ( loc=U0.1-P2/Z1-A8,0)
NAME        : sd
DEVICE-TYPE : block

-----
Navigation keys:
M = return to main menu
ESC key = return to previous screen                X = eXit System Management Services
-----
Type the number of the menu item and press Enter or Select a Navigation key: _
```

The Set Boot Sequence option allows you to set the location of the device in the boot list.

Display Current Settings

This option displays the current setting of the customized boot list. An example of this menu, with one device in the boot list, follows.

```
Current Boot Sequence
1.  SCSI 18200 MB Harddisk (1oc=U0.1-P1/Z1-A8,0)
2.  None
3.  None
4.  None
5.  None

-----
Navigation keys:
M = return to main menu
ESC key = return to previous screen          X = eXit System Management Services
-----
Type the number of the menu item and press Enter or Select a Navigation key: _
```

Restore Default Settings

This option restores the boot list to the default boot list. The default boot list will vary depending on the devices that are installed in the system.

The default boot list is:

1. Primary diskette drive (if installed)
2. CD-ROM drive (if installed)
3. Tape drive (in installed)
4. Hard disk drive (if installed)
5. Network adapter

Multiboot Startup

Multiboot Startup toggles the multiboot startup flag, which controls whether the multiboot menu is invoked automatically on startup.

Exiting System Management Services

After you have finished using the system management services, type **x** (for exit) to boot your system.

Chapter 6. Using the Online and Standalone Diagnostics

The AIX diagnostics consist of online diagnostics and standalone diagnostics.

Attention: The AIX operating system must be installed in a partition in order to run online diagnostics on that partition. If the AIX operating system is not installed, use the standalone diagnostic procedures.

Online diagnostics, when they are installed, reside with AIX in the file system. They can be booted:

- In single user mode (referred to as *service mode*)
- To run in maintenance mode (referred to as *maintenance mode*)
- To run concurrently with other applications (referred to as *concurrent mode*)

Standalone diagnostics must be booted before they can be run. If booted, the diagnostics have no access to the AIX error log or the AIX configuration data.

Does the system have AIX diagnostics preinstalled?

- Yes** If there is an HMC attached to the system, go to “Operating Considerations for Online and Standalone Diagnostics”.
- If an HMC is not attached to the system, go to “Running the Online Diagnostics with No HMC Attached” on page 84.
- No** If there is an HMC attached to the system, go to “Loading the Standalone Diagnostics from CD-ROM Using an HMC” on page 86.
- If an HMC is not attached to the system, go to “Running the Standalone Diagnostics with CD-ROM with No HMC Attached” on page 86.
- If standalone diagnostics will be run from a NIM server, go to “Running Standalone Diagnostics from a Network Installation Management (NIM) Server” on page 87. If an HMC is not attached to the system, follow the directions for a full system partition.

Operating Considerations for Online and Standalone Diagnostics

Note: When possible, run online diagnostics in service mode. Online diagnostics perform additional functions compared to standalone diagnostics. Running online diagnostics in service mode ensures that the error state of the system that has been captured in NVRAM is available for your use in analyzing the problem. The AIX error log and certain SMIT functions are only available when diagnostics are run from the disk drive.

Consider the following items before using the diagnostics:

- Standalone diagnostics can run on systems configured for either a full (or single) system partition or a multiple partitioned system. When running in a partitioned system, the device from which you are booting standalone diagnostics must be made available to the partition dedicated to running standalone diagnostics. This may require moving the device from the partition that currently contains the boot device (for example, the CD-ROM or network adapter connected to the NIM server that has a standalone diagnostic image) to the partition used to run standalone diagnostics. For partitions running AIX levels under 5.2, if you move devices, reboot both source and destination partitions. For more information, see “Standalone Diagnostic Operation” on page 86.
- When diagnostics are installed, the device support for some devices might not get installed. If this is the case, that device does not display in the diagnostic test list when running disk-based diagnostics.
- When running diagnostics in a partitioned system, diagnostics will work only with the resources that were assigned to that partition. You must run diagnostics in the partition containing the resource that you want to test.

Identifying the Terminal Type to the Diagnostics

When you run diagnostics, you must identify which type of terminal you are using. If the terminal type is not known when the FUNCTION SELECTION menu is displayed, the diagnostics do not allow you to continue until a terminal is selected from the DEFINE TERMINAL option menu. Choose the "lft" selection when running diagnostics from a Hardware Management Console for pSeries (HMC).

Undefined Terminal Types

If you specify an undefined terminal type from the DEFINE TERMINAL option menu, the menu prompts the user to enter a valid terminal type. The menu redisplay until either a valid type is entered or you exit the DEFINE TERMINAL option. For a system attached to an HMC use VT320 emulation. If the AIX operating system is being used, from the command line, type: `export term=vt320`

Resetting the Terminal

If you enter a terminal type that is valid (according to the DEFINE TERMINAL option menu) but is not the correct type for the Hardware Management Console for pSeries (HMC) virtual terminal window being used, you may be unable to read the screen, use the function keys, or use the Enter key. Bypass these difficulties by pressing Ctrl-C to reset the terminal. The screen display that results from this reset depends on the mode in which the system is being run:

- Online Normal or Maintenance Mode - The command prompt displays.
- Standalone Mode or Online Service Mode - The terminal type is reset to dumb, the Diagnostic Operating Instruction panel displays, and you are required to go through the DEFINE TERMINAL process again.

Online Diagnostics Modes of Operation

Notes:

1. When running online diagnostics on a partition in a partitioned system, diagnostics can be run only on resources that are allocated to that partition.
2. Online diagnostics can only be run in a partition with AIX installed.

The online diagnostics can be run in the following modes:

- Service Mode
- Concurrent Mode
- Maintenance Mode

Service Mode

Service mode provides the most complete checkout of the system resources. This mode also requires that no other programs be running on the partition or on a full system partition. Except for the SCSI adapter and the disk drives used for paging, resources on all partitions or systems on a full system partition can be tested. However, note that the memory and processor are only tested during POST, and the results of the POST tests are reported by diagnostics.

Error-log analysis is done in service mode when you select the **Problem Determination** option on the DIAGNOSTIC MODE SELECTION menu.

Consider the following when you run the online diagnostics from a server or a disk:

- The diagnostics cannot be loaded and run from a disk until the AIX operating system has been installed and configured.
- The diagnostics cannot be loaded on a system (client) from a server if that system is not set up to boot from a server over a network. When the system is set up to boot from a server, the diagnostics are run in the same manner as they are from disk.

- On a full system partition, if the diagnostics are loaded from disk or a server, you must shut down the AIX operating system before turning off the system unit to prevent possible damage to disk data. Do this in either of the following ways:
 - If the diagnostics were loaded in standalone mode, press the F3 key until DIAGNOSTIC OPERATING INSTRUCTIONS displays. Then press the F3 key once again to shut down the AIX operating system.
 - If the diagnostics were loaded in maintenance or concurrent mode, type the shutdown -F command.
- Under some conditions, the system might stop, with instructions displayed on attached displays and terminals. Follow the instructions to select a console display.

Running Online Diagnostics in Service Mode with an HMC Attached to the System

To run the online diagnostics in service mode from the boot hard disk, do the following:

1. From the HMC, select **Partition Manager**.
2. Right-click on the mouse and select **Open Terminal Window**.
3. From the Service Processor Menu on the VTERM, select Option 2 **System Power Control**.
4. Select option 6. Verify that the state changes to currently disabled. Disabling fast system boot automatically enables slow boot.
5. Select Option 98 to exit the system power control menu.
6. Use the HMC to power on the managed system in a full system partition by selecting the managed system in the Contents area.
7. Right-click or select the desired system in the Contents area. Next, on the menu, choose **Selected**.
8. Select **Power On**.
9. Select the **Power on Diagnostic Stored Boot list** option (refer to “Full System Management Tasks” in the *IBM Hardware Management Console for pSeries Installation and Operations Guide*, order number SA38-0590, for more information on full system partitions).
10. Make sure that there is no media in the devices in the media drive.
11. Enter any passwords, if requested.

Note: If you are unable to load the diagnostics to the point when the DIAGNOSTIC OPERATING INSTRUCTIONS display, go to “Using the HMC to Load the Standalone Diagnostics from CD-ROM” on page 128.

Running the Online Diagnostics with No HMC Attached

Online diagnostics can be loaded by booting from a hard file in the custom boot list by pressing the numeric 6 key on the keyboard.

To boot from the devices listed in the service mode boot list, perform the following procedure:

1. Verify with the system administrator and users that all programs may be stopped, then do so.
2. Turn off the system.

Note: If AIX is running, type the shutdown command.

3. Wait until the Power-on LED stops flashing and remains off, then press the power button to turn the system on.
4. When the **keyboard** indicator appears during startup, press the numeric 6 key on the keyboard.
5. Enter any requested passwords.

After any requested passwords have been entered, the system attempts to boot from the first device of each type found on the list. If no bootable image is found on the first device of each type on the list, the system does not search through the other devices of that type for a bootable image; instead, it polls the first device of the next type.

If all types of devices in the boot list have been polled without finding a bootable image, the system restarts. This action gives the user the opportunity to start the System Management Services (by pressing the number 1 key on a directly attached keyboard or the number 1 on an ASCII terminal) before the system attempts to boot again.

Concurrent Mode

Running the online diagnostics in concurrent mode is started by entering **diag** at an AIX prompt. Use concurrent mode to run online diagnostics on some of the system resources while the system is running normal activity.

Because the system is running in normal operation, the following resources cannot be tested in concurrent mode:

- SCSI adapters connected to paging devices
- Disk drive used for paging
- Some display adapters and graphics related devices
- Memory (tested during POST)
- Processor (tested during POST)

The following levels of testing exist in concurrent mode:

- The **share-test level** tests a resource while the resource is being shared by programs running in the normal operation. This testing is mostly limited to normal commands that test for the presence of a device or adapter.
- The **sub-test level** tests a portion of a resource while the remaining part of the resource is being used in normal operation. For example, this test could test one port of a multiport device while the other ports are being used in normal operation.
- The **full-test level** requires the device not be assigned to or used by any other operation. This level of testing on a disk drive might require the use of the **varyoff** command. The diagnostics display menus to allow you to vary off the needed resource.

Error-log analysis is done in concurrent mode when you select the **Problem Determination** option on the DIAGNOSTIC MODE SELECTION menu.

To run the online diagnostics in concurrent mode, you must be logged in to the AIX operating system and have proper authority to issue the commands (if help is needed, see the system operator).

The **diag** command loads the diagnostic controller and displays the online diagnostic menus.

Running the Online Diagnostics in Concurrent Mode

To run online diagnostics in concurrent mode, do the following:

1. Log in to the AIX operating system as root user, or use CE Login.
2. Enter the **diag** command.
3. When the DIAGNOSTIC OPERATING INSTRUCTIONS display, follow the instructions to check out the desired resources.
4. When testing is complete, use the F3 key to return to the DIAGNOSTIC OPERATING INSTRUCTIONS. Press the F3 key again to return to the AIX operating system prompt. Be sure to vary on any resource that you had varied to off.
5. Press Ctrl-D to log off from root user or CE Login.

Maintenance Mode

Maintenance mode runs the online diagnostics using the customer's version of the AIX operating system. This mode requires that all activity on the partition running the AIX operating system be stopped so that the online diagnostics have most of the resources available to check. All of the system resources, except the SCSI adapters, memory, processor, and the disk drive used for paging, can be checked.

Error log analysis is done in maintenance mode when you select the **Problem Determination** option on the DIAGNOSTIC MODE SELECTION menu.

Use the **shutdown -m** command to stop all activity on the AIX operating system and put the AIX operating system into maintenance mode. The **diag** command is then used to invoke the diagnostic controller so you can run the diagnostics. After the diagnostic controller is loaded, follow the normal diagnostic instructions.

Documentation for the AIX operating system is available from the IBM @server pSeries Information Center at http://publib16.boulder.ibm.com/pseries/en_US/infocenter/base. Select **AIX documentation**. The *AIX Documentation* CD contains the base set of publications for the operating system, including system-management and end-user documentation.

Running the Online Diagnostics in Maintenance Mode

To run the online diagnostics in maintenance mode, do the following:

1. Stop all programs running on the partition except the AIX operating system (if help is needed, see the system operator).
2. Log in to the AIX operating system as root user, or use CE Login.
3. Type the **shutdown -m** command.
4. When a message indicates the system is in maintenance mode, enter the **diag** command.

Note: It might be necessary to set *TERM* type again.

5. When DIAGNOSTIC OPERATING INSTRUCTIONS screen displays, follow the displayed instructions to check out the desired resources.
6. When testing is complete, use the F3 key to return to DIAGNOSTIC OPERATING INSTRUCTIONS. Press the F3 key again to return to the AIX operating system prompt.
7. Press Ctrl-D to log off from root user or CE Login.

Standalone Diagnostic Operation

Use standalone diagnostics to test the system when the online diagnostics are not installed and as a method of testing the disk drives that cannot be tested by the online diagnostics.

Note: No error log analysis is done by the standalone diagnostics. The CD-ROM drive and the SCSI controller that controls it cannot be tested by the standalone diagnostics. Standalone diagnostics:

- Are resident on CD-ROM or a Network Installation Management (NIM) server
- Provide a method to test the system when the online diagnostics are not installed or cannot be loaded from the disk drive
- Allow testing of the disk drives and other resources that cannot be tested by the online diagnostics
- Do not have access to the AIX configuration data
- Do not have access to the AIX error log
- Do not allow for running of error log analysis

Considerations for Running Standalone Diagnostics from CD-ROM

Consider the following when you run standalone diagnostics:

- The diagnostic CD must remain in the CD-ROM drive for the entire time that diagnostics are running.
- The diagnostic CD cannot be ejected from the CD-ROM drive after the diagnostics have loaded. The CD can only be ejected after the system has been turned off and then turned on (standalone mode) or after the diagnostics program has terminated (online concurrent mode).
- The CD-ROM drive from which diagnostics were loaded cannot be tested.
- The SCSI adapter (or circuitry) controlling the CD-ROM drive from which diagnostics were loaded cannot be tested.

Loading the Standalone Diagnostics from CD-ROM Using an HMC

To run standalone diagnostics in service mode from CD-ROM, do the following:

1. Stop all programs including the AIX operating system (get help if needed).
2. Remove all tapes, diskettes, and CD-ROMs.
3. Power off the pSeries 650 (refer to Full System Management Tasks in the *IBM Hardware Management Console for pSeries Installation and Operations Guide*, order number SA38-0590).
4. Right-click the mouse and select **Open Terminal Window**.
5. From the service processor menu on the VTERM, select option 2, **System Power Control Menu**.
6. Select option 6. Verify that the state changes to currently disabled. Disabling fast system boot automatically enables slow boot.
7. Select option 98 to exit the system power control menu.
8. Use the HMC to power on the managed server in a full system partition. Select the **Power on Diagnostic Default Boot List** (refer to Full System Management Tasks in the *IBM Hardware Management Console for pSeries Installation and Operations Guide*, order number SA38-0590).
9. Insert the CD-ROM into the system's CD-ROM drive (not into the HMC's CD-ROM drive).

Running the Standalone Diagnostics with CD-ROM with No HMC Attached

To load **standalone diagnostics** from the default boot list, perform the following procedure:

1. Verify with the system administrator and users that all programs may be stopped, then do so.
2. Turn off the system.

Note: If AIX is running, type the shutdown command. If Linux is running, type the shutdown now -h command.

3. Wait until the Power-on LED stops flashing and remains off, then press the power button to turn on the system.
4. Immediately insert the diagnostic CD-ROM into the CD-ROM drive.
5. When or after the word **keyboard** appears during startup, press the numeric 5 key on the keyboard.
6. Enter any requested passwords.

Running Standalone Diagnostics from a Network Installation Management (NIM) Server

A client system connected to a network with a Network Installation Management (NIM) server can boot standalone diagnostics from the NIM server if the client-specific settings on both the NIM server and client are correct.

Notes:

1. All operations to configure the NIM server require root user authority.
2. If you replace the network adapter in the client, the network adapter hardware address settings for the client must be updated on the NIM server.
3. The **Cstate** for each standalone diagnostics client on the NIM server should be kept in the *diagnostic boot has been enabled* state.
4. On the client system, the NIM server network adapter should be put in the bootlist after the boot disk drive. This allows the system to boot in standalone diagnostics from the NIM server if there is a problem booting from the disk drive. Refer to the **Multiboot** section under “SMS” in the client system’s service guide for information on setting the bootlist.

NIM Server Configuration

Refer to the “Advanced NIM Configuration Tasks” chapter of the *AIX Installation Guide and Reference*, order number SC23-4389 for information on doing the following:

- Registering a client on the NIM server
- Enabling a client to run diagnostics from the NIM server

Documentation for the AIX operating system is available from the IBM @server pSeries Information Center at http://publib16.boulder.ibm.com/pseries/en_US/infocenter/base. Select **AIX documentation**. The *AIX Documentation* CD contains the base set of publications for the operating system, including system-management and end-user documentation.

To verify that the client system is registered on the NIM server and the diagnostic boot is enabled, run the command **lsnim -a Cstate -Z ClientName** from the command line on the NIM server. Refer to the following table for system responses.

Note: The *ClientName* is the name of the system on which you want to run standalone diagnostics.

System Response	Client Status
#name:Cstate: ClientName:diagnostic boot has been enabled:	The client system is registered on the NIM server and enabled to run diagnostics from the NIM server.
#name:Cstate: ClientName:ready for a NIM operation: or #name:Cstate: ClientName:BOS installation has been enabled:	The client is registered on the NIM server but not enabled to run diagnostics from the NIM server. Note: If the client system is registered on the NIM server but Cstate has not been set, no data will be returned.
0042-053 lsnim: there is no NIM object named "ClientName"	The client is not registered on the NIM server.

Booting Standalone Diagnostics from the NIM Server on a System with an HMC Attached

To run standalone diagnostics on a client from the NIM server, do the following:

1. Remove any removable media (tape or CD-ROM).
2. Stop all programs including the AIX operating system (get help if needed).
3. If you are running standalone diagnostics in a full system partition, verify with the system administrator and system users that the system unit can shut down. Stop all programs, including the AIX operating system. Refer to the AIX operating system documentation for **shutdown** command information.

In a partitioned system, make the CD-ROM drive available to the partition used to run standalone diagnostics (refer to the *IBM Hardware Management Console for pSeries Installation and Operations Guide*, order number SA38-0590 for more information). Verify with the system administrator and system users using that partition that all applications on that partition must be stopped, and that the partition will be rebooted. Stop all programs on that partition, including the operating system.
4. If you are in a full system partition, power on the system unit to run standalone diagnostics. In a partitioned system, reboot the partition to run standalone diagnostics.
5. When the keyboard indicator is displayed (the word **keyboard** on a HMC virtual terminal window or the keyboard icon on a graphical display), press the number 1 key on the keyboard to display the SMS menu.
6. Enter any requested passwords.
7. Select **Set Up Remote IPL** (Indicial Program Load).
8. Enter the client address, server address, gateway address (if applicable), and subnet mask.
9. If the NIM server is set up to allow pinging from the client system, use the **ping** utility in the RIPL utility to verify that the client system can ping the NIM server. Under the **ping** utility, choose the network adapter that provides the attachment to the NIM server to do the ping operation. If the ping returns with an OK prompt, the client is prepared to boot from the NIM server. If ping returns with a FAILED prompt, the client cannot proceed with the NIM boot.

Note: If the ping fails, contact your service representative.

To do a one-time boot of the network adapter attach to the NIM server network, do the following:

1. Exit to the SMS Main screen.
2. Select **Select Boot Options**.
3. Select **Install or Boot a Device**.
4. On the Select Device Type screen, select **Network**.
5. Set the network parameters for the adapter from which you want to boot.
6. Exit completely from SMS. The system starts loading packets while doing a **bootp** from the network.

Follow the instructions on the screen to select the system console.

- If Diagnostics Operating Instructions Version x.x.x displays, standalone diagnostics have loaded successfully.
- If the AIX login prompt displays, standalone diagnostics did not load. Check the following items:
 - The network parameters on the client may be incorrect.
 - Cstate on the NIM server may be incorrect.
 - Network problems might be preventing you from connecting to the NIM server.

Verify the settings and the status of the network. If you continue to have problems, contact your service representative.

Booting Standalone Diagnostics from the NIM Server on a System with No HMC Attached

Chapter 7. Introducing Tasks and Service Aids

The AIX Diagnostic Package contains programs that are called *Tasks*. Tasks can be thought of as performing a specific function on a resource; for example, running diagnostics or performing a service aid on a resource.

Note: Many of these programs work on all system model architectures. Some programs are only accessible from online diagnostics in service or concurrent mode, while others might be accessible only from standalone diagnostics.

To perform one of these tasks, use the **Task Selection** option from the FUNCTION SELECTION menu.

After a task is selected, a resource menu may be presented showing all resources supported by the task.

A fast-path method is also available to perform a task by using the **diag** command and the **-T** flag. By using the fast path, the user can bypass most of the introductory menus to access a particular task. The user is presented with a list of resources available to support the specified task. The fast-path tasks are as follows:

- Certify - Certifies media
- Chkspares - Checks for the availability of spare sectors
- Download - Downloads microcode to an adapter or device
- Disp_mcode - Displays current level of microcode
- Format - Formats media
- Identify - Identifies the PCI RAID physical disks
- IdentifyRemove - Identifies and removes devices (Hot Plug)

To run these tasks directly from the command line, specify the resource and other task-unique flags. Use the descriptions in this chapter to understand which flags are needed for a given task.

Tasks

The following tasks are described in this chapter:

- Add Resource to Resource List
- AIX Shell Prompt
- Analyze Adapter Internal Log
- Backup and Restore Media
- Certify Media
- Change Hardware Vital Product Data
- Configure Dials and LPF Keys
- Configure ISA Adapters
- Configure Reboot Policy
- Configure Remote Maintenance Policy
- Configure Ring Indicate Power-On Policy
- Configure Scan Dump Policy
- Configure Surveillance Policy
- Create Customized Configuration Diskette
- Delete Resource from Resource List
- Disk Maintenance
- Display Configuration and Resource List
- Display Firmware Device Node Information
- Display Hardware Error Report
- Display Hardware Vital Product Data
- Display Machine Check Error Log
- Display Microcode Level
- Display Multipath I/O (MPIO) Device Configuration

- Display or Change Bootlist
- Display or Change Diagnostic Run Time Options
- Display Previous Diagnostic Results
- Display Resource Attributes
- Display Service Hints
- Display Software Product Data
- Display System Environmental Sensors
- Display Test Patterns
- Display USB Devices
- Download Microcode
- Fibre Channel RAID Service Aids
- Flash SK-NET FDDI Firmware
- Format Media
- Gather System Information
- Generic Microcode Download
- Hot Plug Task
- Identify Indicators
- Identify and System Attention Indicators
- Local Area Network Analyzer
- Log Repair Action
- Periodic Diagnostics
- PCI RAID Physical Disk Identify
- Process Supplemental Media
- Run Diagnostics
- Run Error Log Analysis
- Run Exercisers
- Save or Restore Hardware Management Policies
- SCSI Bus Analyzer
- SCSI RAID Physical Disk Status and Vital Product Data
- SCSD Tape Drive Service Aid
- Spare Sector Availability
- SSA Service Aid
- System Fault Indicator
- System Identify Indicator
- Update Disk-Based Diagnostics
- Update System or Service Processor Flash
- 7135 RAIDiant Array Service Aids
- 7318 Serial Communication Network Server

Add Resource to Resource List

Use this task to add resources back to the resource list.

Note: Only resources that were previously detected by the diagnostics and deleted from the Diagnostic Test List are listed. If no resources are available to be added, then none are listed.

AIX Shell Prompt

Note: Use this service aid in Online Service Mode only.

This service aid allows access to the AIX command line. To use this service aid, the user must know the root password (when a root password has been established).

Note: Do not use this task to install code or to change the configuration of the system. This task is intended to view files, configuration records, and data. Using this service aid to change the system configuration or install code can produce unexplained system problems after exiting the diagnostics.

Analyze Adapter Internal Log

The PCI RAID adapter has an internal log that logs information about the adapter and the disk drives attached to the adapter. Whenever data is logged in the internal log, the device driver copies the entries to the AIX system error log and clears the internal log.

The Analyze Adapter Internal Log service aid analyzes these entries in the AIX system error log. The service aid displays the errors and the associated service actions. Entries that do not require any service actions are ignored.

When running this service aid, a menu is presented to enter the start time, the end time, and the file name. The start time and end time have the following format: *[mmd dHHMMyy]*. (where *mm* is the month (1-12), *dd* is the date (1-31) *HH* is the hour (00-23) *MM* is the minute (00-59), and *yy* is the last two digits of the year (00-99). The file name is the location where the user wants to store the output data.

To invoke the service aid task from the command line, type:

```
diag -c -d devicename -T "adapela [-s start date -e end date]
```

Flag	Description
-c	Specifies not console mode.
-d devicename	Specifies the device whose internal log you want to analyze (for example, SCRAID0)
-s start date	Specifies all errors after this date are analyzed.
-e end date	Specifies all errors before this date are analyzed.
-T	Specifies the Analyze Adapter Internal Log task

Note: To specify a file name from the command line, use the redirection operator at the end of the command to specify where the output of the command is to be sent, for example *> filename* (where *filename* is the name and location where the user wants to store the output data (for example, */tmp/adaptlog*).

Backup and Restore Media

This service aid allows verification of backup media and devices. It presents a menu of tape and diskette devices available for testing and prompts for selecting the desired device. It then presents a menu of available backup formats and prompts for selecting the desired format. The supported formats are **tar**, **backup**, and **cpio**. After the device and format are selected, the service aid backs up a known file to the selected device, restores that file to **/tmp**, and compares the original file to the restored file. The restored file remains in **/tmp** to allow for visual comparison. All errors are reported.

Certify Media

This task allows the selection of diskette, DVD-RAM media, or hard files to be certified. Normally, this is done under the following conditions:

- To determine the condition of the drive and media
- To verify that the media is error free after a Format Service Aid has been run on the media

Normally, run certify if after running diagnostics on a drive and its media, no problem is found, but you suspect that a problem still exists.

Hard files can be connected either to a SCSI adapter (non-RAID) or a PCI SCSI RAID adapter. The usage and criteria for a hard file connected to a non-RAID SCSI adapter are different from those for a hard file connected to a PCI SCSI RAID adapter.

Certify Media can be used in the following ways:

- Certify Diskette

This selection enables you to verify the data written on a diskette. When you select this service aid, a menu asks you to select the type of diskette being verified. The program then reads all of the ID and data fields on the diskette one time and displays the total number of bad sectors found.

- Certify DVD-RAM media

This selection reads all of the ID and data fields. It checks for bad data and counts all errors encountered. If an unrecovered error occurs, or recovered errors exceed the threshold value, the data on the media should be transferred to other media and the original media should be discarded.

The Certify service aid will display the following information:

- Capacity in bytes
- Number of Data Errors Not Recovered
- Number of Equipment Check Errors
- Number of Recovered Errors

If the drive is reset during a certify operation, the operation is restarted.

If the drive is reset again, the certify operation is terminated, and the user is asked to run diagnostics on the drive.

This task can be run directly from the AIX command line. See the following command syntax: `diag -c -d -T certify`

Flag	Description
-------------	--------------------

- | | |
|-----------|----------------------------|
| -c | No console mode |
| -d | Specifies a device |
| -T | Specifies the certify task |

- Certify Hardfile Attached to a Non-RAID SCSI Adapter

This selection reads all of the ID and data fields. It checks for bad data and counts all errors encountered. If there are unrecovered data errors that do not exceed the threshold value, the hard file must be formatted and certified. If the unrecovered data errors, recovered data errors, recovered and unrecovered equipment errors exceed the threshold values, the disk must be replaced.

It also makes 2000 random seeks after the read certify of the surface completes. If a disk times out before finishing the random seeks, then the disk needs to be replaced. The random seeks also count all errors encountered.

The Certify service aid will display the following information:

- Drive capacity in megabytes.
- Number of Data Errors Recovered.
- Number of Data Errors Not Recovered.
- Number of Equipment Checks Recovered.
- Number of Equipment Checks Not Recovered.

This task can be run directly from the AIX command line. See the following command syntax: `diag -c -d deviceName -T "certify"`

Flag	Description
-------------	--------------------

- | | |
|-----------|----------------------------|
| -c | No console mode |
| -d | Specifies a device |
| -T | Specifies the certify task |

- Format and/or Erase Hardfile Attached to a Non-RAID SCSI Adapter

Attention: The following commands *will* change the content of the hardfile. Be sure to back up data prior to running the command, and take care in choosing the hardfile upon which you run this task.

- Hardfile Format

Writes all of the disk. The pattern written on the disk is device-dependant; for example, some drives may write all 0s, while some may write the hexadecimal number 5F. No bad-block reassignment occurs.

- Hardfile Format and Certify

Performs the same function as Hardfile Format. After the format is completed, Certify is run. Certify then reassigns all bad blocks encountered.

- Hardfile Erase Disk

This option can be used to overwrite (remove) all data currently stored in user-accessible blocks of the disk. The Erase Disk option writes one or more patterns to the disk. An additional option allows data in a selectable block to be read and displayed on the system console.

To use the Erase Disk option, specify the number (0-3) of patterns to be written. The patterns are written serially; that is, the first pattern is written to all blocks. Then the next pattern is written to all blocks, overlaying the previous pattern. A random pattern is written by selecting **Write Random Pattern**.

Note: The Erase Disk service aid has not been certified as meeting the Department of Defense or any other organization's security guidelines.

To overwrite the data on the drive, use the following steps:

1. Select **Erase Disk**.
2. Do a format without certify.
3. Select **Erase Disk** to run it a second time.

For a newly installed drive, you can ensure that all blocks on the drive are overwritten with your pattern if you use the following procedure:

1. Format the drive.
2. Check the defect MAP by running the Erase Disk selection.

Note: If you use Format and Certify option, there may be some blocks which get placed into the grown defect MAP.

3. If there are bad blocks in the defect MAP, record the information presented and ensure that this information is kept with the drive. This data is used later when the drive is to be overwritten.
4. Use you drive as you would normally.
5. When the drive is no longer needed and is to be erased, run the same version of the Erase Disk selection which was used in step 2.

Note: Using the same version of the service aid is only critical if any bad blocks were found in step 3.

6. Compare the bad blocks which were recorded for the drive in step 3 with those that now appear in the grown defect MAP.

Note: If there are differences between the saved data and the newly obtained data, then all sectors on this drive cannot be overwritten. The new bad blocks are not overwritten.

7. If the bad block list is the same, continue running the service aid to overwrite the disk with the chosen pattern(s).

This task can be run directly from the AIX command line. See the command syntax: `diag -c -d deviceName -T "format [-s* fmtcert | erase -a {read | write}] [-F]*`

Flag	Description
fmtcert	Formats and certifies the disk.
erase	Overwrites the data on the disk.
*	Available in no-console mode only.
-F	Force the disk erasure even if all blocks cannot be erased due to errors accessing the grown defect map.

Note: The Erase Disk option in command line mode uses default values. To selectively read or write, use the **diag** command in console mode.

- Certify Hardfile attached to a PCI SCSI RAID Adapter

This selection is used to certify physical disks attached to a PCI SCSI RAID adapter. Certify reads the entire disk and checks for recovered errors, unrecovered errors, and reassigned errors. If these errors exceed the threshold values, the user is prompted to replace the physical disk.

This task can be run directly from the AIX command line. See the following command syntax: `diag -c -d RAIDadapterName -T "certify {-l chID | -A}"`

Flag	Description
-c	No console mode
-d	Specifies the RAID adapter to which the disk is attached
-T	Specifies the certify task and its parameters
-l	Specifies physical Disk channel/ID (for example: -l 27)
-A	All disks

Change Hardware Vital Product Data

Use this service aid to display the Display/Alter VPD Selection Menu. The menu lists all resources installed on the system. When a resource is selected, a menu displays that lists all the VPD for that resource.

Note: The user cannot alter the VPD for a specific resource unless the VPD is not machine-readable.

Configure Dials and LPF Keys

Note: The Dials and LPF Keys service aid is not supported in standalone mode (CD-ROM and NIM) on systems with 32 MB or less memory. If you have problems in standalone mode, use the hardfile-based diagnostics.

This service aid provides a tool for configuring and removing dials and LPF keys to the asynchronous serial ports.

This selection invokes the SMIT utility to allow Dials and LPF keys configuration. A TTY must be in the available state on the async port before the Dials and LPF keys can be configured on the port. The task allows an async adapter to be configured, then a TTY port defined on the adapter. Dials and LPF keys can then be defined on the port.

Before configuring Dials or LPF keys on a serial port, you must remove all defined TTYs. To determine if there are any defined TTYs, select **List All Defined TTYs**. Once all defined TTYs have been removed, then add a new TTY and configure the Dials or LPF keys.

Configure ISA Adapter

This task uses SMIT to identify and configure ISA adapters on systems that have an ISA bus and adapters.

Diagnostic support for ISA adapters not shown in the list may be supported from a supplemental diskette. You can use the Process Supplemental Media task to add ISA adapter support from a supplemental diskette.

Whenever an ISA adapter is installed, this service aid must be run and the adapter configured before the adapter can be tested. You must also run this service aid to remove an ISA adapter from the system whenever an ISA adapter is physically removed from the system.

If diagnostics are run on an ISA adapter that has been removed from the system, the diagnostics fail because the system cannot detect the ISA adapter.

Configure Reboot Policy

This service aid controls how the system tries to recover from a system crash.

Use this service aid to display and change the following settings for the Reboot Policy.

Note: Because of system capability, some of the following settings might not be displayed by this service aid.

- Maximum Number of Reboot Attempts
Enter a number that is 0 or greater.

Note: A value of 0 indicates 'do not attempt to reboot' to a crashed system.

This number is the maximum number of consecutive attempts to reboot the system. The term *reboot*, in the context of this service aid, describes bringing system hardware back up from scratch; for example, from a system reset or power-on.

When the reboot process completes successfully, the reboot-attempts count is reset to 0, and a restart begins. The term *restart*, in the context of this service aid, is used to describe the operating system activation process. Restart always follows a successful reboot.

When a restart fails, and a restart policy is enabled, the system attempts to reboot for the maximum number of attempts.

- Use the O/S Defined Restart Policy (1=Yes, 0=No)

When 'Use the O/S Defined Restart Policy' is set to Yes, the system attempts to reboot from a crash if the operating system has an enabled Defined Restart or Reboot Policy.

When 'Use the O/S Defined Restart Policy' is set to No, or the operating system restart policy is undefined, then the restart policy is determined by the 'Supplemental Restart Policy'.

- Enable Supplemental Restart Policy (1=Yes, 0=No)

The 'Supplemental Restart Policy', if enabled, is used when the O/S Defined Restart Policy is undefined, or is set to False.

When surveillance detects operating system inactivity during restart, an enabled 'Supplemental Restart Policy' causes a system reset and the reboot process begins.

- Call-Out Before Restart (on/off)

When enabled, Call-Out Before Restart allows the system to call out (on a serial port that is enabled for call-out) when an operating system restart is initiated. Such calls can be valuable if the number of these events becomes excessive, thus signalling bigger problems.

- Enable Unattended Start Mode (1=Yes, 0=No)

When enabled, 'Unattended Start Mode' allows the system to recover from the loss of ac power.

If the system was powered-on when the ac loss occurred, the system reboots when power is restored. If the system was powered-off when the ac loss occurred, the system remains off when power is restored.

You can access this service aid directly from the AIX command line, by typing:

```
/usr/lpp/diagnostics/bin/uspchrp -b
```

Configure Remote Maintenance Policy

The Remote Maintenance Policy includes modem configurations and phone numbers to use for remote maintenance support.

Use this service aid to display and change the following settings for the Remote Maintenance Policy.

Note: Because of system capability, some of the following settings might not be displayed by this service aid.

- Configuration File for Modem on serial port 1 (S1)

Configuration File for Modem on serial port 2 (S2).

Enter the name of a modem configuration file to load on either S1 or S2. The modem configuration files are located in the directory **/usr/share/modems**. If a modem file is already loaded, it is indicated by Modem file currently loaded.

- Modem file currently loaded on S1

Modem file currently loaded on S2

This is the name of the file that is currently loaded on serial port 1 or serial port 2.

Note: These settings are only shown when a modem file is loaded for a serial port.

- Call In Authorized on S1 (on/off)

Call In Authorized on S2 (on/off)

Call In allows the Service Processor to receive a call from a remote terminal.

- Call Out Authorized on S1 (on/off)

Call Out Authorized on S2 (on/off)

Call Out allows the Service Processor to place calls for maintenance.

- S1 Line Speed

S2 Line Speed

A list of line speeds is available by using **List** on the screen.

- Service Center Phone Number

This is the number of the service center computer. The service center usually includes a computer that takes calls from systems with call-out capability. This computer is referred to as "the catcher." The catcher expects messages in a specific format to which the Service Processor conforms. For more information about the format and catcher computers, refer to the README file in the AIX **/usr/samples/syscatch** directory. Contact the service provider for the correct telephone number to enter here.

- Customer Administration Center Phone Number

This is the number of the System Administration Center computer (catcher) that receives problem calls from systems. Contact the system administrator for the correct telephone number to enter here.

- Digital Pager Phone Number In Event of Emergency

This is the number for a pager carried by someone who responds to problem calls from your system.

- Customer Voice Phone Number

This is the number for a telephone near the system, or answered by someone responsible for the system. This is the telephone number left on the pager for callback.

- Customer System Phone Number

This is the number to which your system's modem is connected. The service or administration center representatives need this number to make direct contact with your system for problem investigation. This is also referred to as the Call In phone number.

- Customer Account Number

This number is available for service providers to use for record-keeping and billing.

- Call Out Policy Numbers to call if failure

This is set to either First or All. If the call-out policy is set to First, call out stops at the first successful call to one of the following numbers in the order listed:

1. Service Center
2. Customer Administration Center
3. Pager

If Call Out Policy is set to All, call-out attempts to call all of the following numbers in the order listed:

1. Service Center
2. Customer Administration Center
3. Pager

- Customer RETAIN Login ID Customer RETAIN Login Password

These settings apply to the RETAIN service function.

- Remote Timeout, in seconds Remote Latency, in seconds

These settings are functions of the service provider's catcher computer.

- Number of Retries While Busy

This is the number of times the system should retry calls that resulted in busy signals.

- System Name (System Administrator Aid)

This is the name given to the system and is used when reporting problem messages.

Note: Knowing the system name aids the support team in quickly identifying the location, configuration, history, and so on of your system.

You can access this service aid directly from the AIX command line, by typing:

```
/usr/lpp/diagnostics/bin/uspchrp -m
```

Configure Ring Indicate Power-On Policy

This service aid allows the user to power-on a system by telephone from a remote location. If the system is powered off, and Ring Indicate Power On is enabled, the system powers on at a predetermined number of rings. If the system is already on, no action is taken. In either case, the telephone call is not answered, and the caller receives no feedback that the system has powered on.

Use this service aid to display and change the following settings for the Ring Indicate Power-On Policy:

Because of system capability, some of the following settings might not be displayed by this service aid.

- Power On Via Ring Indicate (on/off)
- Number of Rings Before Power On

You can access this service aid directly from the AIX command line, by typing:

```
/usr/lpp/diagnostics/bin/uspchrp -r
```

Configure Scan Dump Policy

Configure Scan Dump Policy allows the user to set or view the scan dump policy (scan dump control and size) in NVRAM. Scan Dump data is a set of chip data that the service processor gathers after a system malfunction. It consists of chip scan rings, chip trace arrays, and Scan COM (SCOM) registers. This data is stored in the scan-log partition of the system's Nonvolatile Random Access Memory (NVRAM).

Use this service aid to display and change the following settings for the Scan Dump Policy at run time:

- Scan Dump Control (how often the dump is taken)
- Scan Dump Size (size and content of the dump)

The Scan Dump Control (SDC) settings are as follows:

- As Needed: This setting allows the platform firmware to determine whether a scan dump is performed. This is the default setting for the dump policy.
- Always: This setting overrides the firmware recommendations and always performs a dump after a system failure.

The Scan Dump Size (SDS) settings are as follows:

- As Requested - Dump content is determined by the platform firmware.
- Minimum - Dump content collected provides the minimum debug information, enabling the platform to reboot as quickly as possible.
- Optimum - Dump content collected provides a moderate amount of debug information.
- Complete - Dump data provides the most complete error coverage at the expense of reboot speed.

You can access this service aid directly from the AIX command line by typing:

```
/usr/lpp/diagnostics/bin/uspchrp -d
```

Configure Surveillance Policy

This service aid monitors the system for hang conditions; that is, hardware or software failures that cause operating system inactivity. When enabled, and surveillance detects operating system inactivity, a call is placed to report the failure.

Use this service aid to display and change the following settings for the Surveillance Policy:

Note: Because of system capability, some of the following settings might not be displayed by this service aid:

- Surveillance (on/off)
- Surveillance Time Interval - This is the maximum time between heartbeats from the operating system.
- Surveillance Time Delay - This is the time to delay between when the operating system is in control and when to begin operating system surveillance.
- Changes are to Take Effect Immediately - Set this to Yes if the changes made to the settings in this menu are to take place immediately. Otherwise, the changes take effect beginning with the next system boot.

You can access this service aid directly from the AIX command line, by typing:

```
/usr/lpp/diagnostics/bin/uspchrp -s
```

Create Customized Configuration Diskette

This selection invokes the Diagnostic Package Utility Service Aid, which allows the user to create a standalone diagnostic package configuration diskette.

The Standalone Diagnostic Package Configuration Diskette allows the following to be changed from the console:

- Default refresh rate for a low function terminal (LFT)

The refresh rate used by the standalone diagnostic package is 60 Hz. If the display's refresh rate is 77 Hz, set the refresh rate to 77.

- Different async terminal console

You can create a console configuration file that allows a terminal attached to any RS232 or RS422 adapter to be selected as a console device. The default device is an RS232 TTY device attached to the first standard serial port (S1).

Delete Resource from Resource List

Use this task to delete resources from the resource list.

Note: Only resources that were previously detected by the diagnostics and have not been deleted from the Diagnostic Test List are listed. If no resources are available to be deleted, then none are listed.

Disk Maintenance

This service aid provides the following options for the fixed-disk maintenance:

- Disk to Disk Copy
- Display/Alter Sector

Disk to Disk Copy

Notes:

1. This service aid cannot be used to update to a different size drive. The service aid only supports copying from a SCSI drive to another SCSI drive of similar size.
2. Use the **migratepv** command when copying the contents to other disk drive types. This command also works when copying SCSI disk drives or when copying to a different size SCSI disk drive. Refer to *System Management Guide: Operating System and Devices* for a procedure on migrating the contents of a physical volume.

This publication is located on the *AIX Documentation CD*. The documentation information is made accessible by loading the documentation CD onto the hard disk or by mounting the CD in the CD-ROM drive.

This selection allows you to recover data from an old drive when replacing it with a new drive. The service aid recovers all logical volume manager (LVM) software reassigned blocks. To prevent corrupted data from being copied to the new drive, the service aid stops if an unrecoverable read error is detected. To help prevent possible problems with the new drive, the service aid stops if the number of bad blocks being reassigned reaches a threshold.

To use this service aid, both the old and new disks must be installed in or attached to the system with unique SCSI addresses. This requires that the new disk drive SCSI address must be set to an address that is not currently in use and the drive be installed in an empty location. If there are no empty locations, then one of the other drives must be removed. When the copy is complete, only one drive can remain installed. Either remove the target drive to return to the original configuration, or perform the following procedure to complete the replacement of the old drive with the new drive:

1. Remove both drives.
2. Set the SCSI address of the new drive to the SCSI address of the old drive.
3. Install the new drive in the old drive's location.
4. Install any other drives (that were removed) into their original location.

To prevent problems that can occur when running this service aid from disk, it is suggested that this service aid be run, when possible, from the diagnostics that are loaded from removable media.

Display/Alter Sector

Note: Use caution when you use this service aid because inappropriate modification to some disk sectors can result in the total loss of all data on the disk.

This selection allows the user to display and alter information on a disk sector. Sectors are addressed by their decimal sector number. Data is displayed both in hex and in ASCII. To prevent corrupted data from being incorrectly corrected, the service aid does not display information that cannot be read correctly.

Display Configuration and Resource List

If a device is not included in the Test List or if you think a Diagnostic Package for a device is not loaded, check by using the Display Configuration and Resource List task. If the device you want to test has a plus (+) sign or a minus (-) sign preceding its name, the Diagnostic Package is loaded. If the device has an asterisk (*) preceding its name, the Diagnostic Package for the device is not loaded or is not available.

This service aid displays the item header only for all installed resources. Use this service aid when there is no need to see the vital product data (VPD). (No VPD is displayed.)

Display Firmware Device Node Information

This task displays the firmware device node information. This service aid is intended to gather more information about individual or particular devices on the system. The format of the output data may differ depending on which level of the AIX operating system is installed.

Display Hardware Error Report

This service aid uses the **errpt** command to view the hardware error log.

The Display Error Summary and Display Error Detail selection provide the same type of report as the **errpt** command. The Display Error Analysis Summary and Display Error Analysis Detail selection provide additional analysis.

Display Hardware Vital Product Data

This service aid displays all installed resources, along with any VPD for those resources. Use this service aid when you want to look at the VPD for a specific resource.

Display Machine Check Error Log

Note: The Machine Check Error Log Service Aid is available only on Standalone Diagnostics.

When a machine check occurs, information is collected and logged in an NVRAM error log before the system unit shuts down. This information is logged in the AIX error log and cleared from NVRAM when the system is rebooted from the hard disk, LAN, or standalone media. When booting from Standalone Diagnostics, this service aid converts the logged information into a readable format that can be used to isolate the problem. When booting from the hard disk or LAN, the information can be viewed from the AIX error log using the Hardware Error Report Service Aid. In either case, the information is analyzed when the **sysplanar0** diagnostics are running in Problem Determination Mode.

Display Microcode Level

This task is used to display the microcode or firmware levels of currently installed resources. When the **sys0** resource is selected, the task displays the levels of both the system firmware and service processor firmware. **sys0** may not be available in all cases.

You can display the current level of the microcode on an adapter, the system, or a device by using the AIX **diag** command. See the following command syntax: `diag -c -d device -T "disp_mcode"`

Flag	Description
-c	No console mode.
-d	Used to specify a device.
-T	Use the disp_mcode option to display microcode.

The AIX **ismcode** command serves as a command line interface to the Display Microcode Level task. For information on the **ismcode** command, refer to the *AIX Commands Reference* manual.

Display MultiPath I/O (MPIO) Device Configuration

This service aid displays the status of MPIO devices and their connections to their parent devices.

This service aid is capable of sending SCSI commands on each available path regardless of the default MPIO path algorithm. Therefore, it is useful for testing the unused path for integrity.

Run this service aid if it is suspected that there is a problem with the path between MPIO devices and their parent devices.

This service aid is capable of:

- Listing MPIO devices
- Listing the parents of MPIO devices
- Displaying the status and location of specified MPIO devices
- Displaying the hierarchy of MPIO adapters and devices.

If there are no devices with multiple paths, this service aid will not be shown on the "Task Selection" menu.

Access this service aid directly from the AIX command line, by typing:

```
/usr/lpp/diagnostics/bin/umpio
```

Display or Change Bootlist

This service aid allows the bootlist to be displayed, altered, or erased.

The system attempts to perform an IPL from the first device in the list. If the device is not a valid IPL device or if the IPL fails, the system proceeds in turn to the other devices in the list to attempt an IPL.

Display or Change Diagnostic Run-Time Options

The Display or Change Diagnostic Run-Time Options task allows the diagnostic run-time options to be set.

Note: The run-time options are used only when selecting the Run Diagnostic task.

The run-time options are:

- Display Diagnostic Mode Selection Menus

This option allows the user to turn on or off displaying the DIAGNOSTIC MODE SELECTION MENU (the default is on).

- Run Tests Multiple Times

This option allows the user to turn on or off, or specify a loop count, for diagnostic loop mode (the default is off).

Note: This option is only displayed when you run the Online Diagnostics in Service Mode.

- Include Advanced Diagnostics

This option allows the user to turn on or off including the Advanced Diagnostics (the default is off).

- Include Error Log Analysis (not available in diagnostics 5.2.0 or later)

This option allows the user to turn on or off including the Error Log Analysis (ELA) (the default is off).

- Number of Days Used to Search Error Log

This option allows the user to select the number of days for which to search the AIX error log for errors when running the Error Log Analysis. The default is seven days, but it can be changed from one to sixty days.

- Display Progress Indicators

This option allows the user to turn on or off the progress indicators when running the Diagnostic Applications. The progress indicators, in a box at the bottom of the screen, indicate that the test is being run (the default is on).

- Diagnostic Event Logging

This option allows the user to turn on or off logging information to the Diagnostic Event Log (the default is on).

- Diagnostic Event Log File Size

This option allows the user to select the maximum size of the Diagnostic Event Log. The default size for the Diagnostic Event Log is 100 KB. The size can be increased in 100 KB increments to a maximum of 1 MB.

Use the **diaggetrto** command to display one or more diagnostic run-time options. Use the following AIX command line syntax:

```
/usr/lpp/diagnostics/bin/diaggetrto [-a] [-d] [-l] [-m] [-n] [-p] [-s]
```

Use the **diagsetrto** command to change one or more diagnostic run-time options. Use the following AIX command line syntax:

```
/usr/lpp/diagnostics/bin/diagsetrto [-a on|off] [-d on|off] [-l size] [-m on|off] [-n days] [-p on|off]
```

Flag descriptions for the **diaggetrto** and **diagsetrto** commands are as follows:

Flag	Description
------	-------------

-a	Displays or changes the value of the Include Advanced Diagnostics option.
-d	Displays or changes the value of the Diagnostic Event Logging option.
-l	Displays or changes the value of the Diagnostic Event Log File Size. Allowable size are between 100K and 1000K in increments of 100K. The size may never be decreased.
-m	Displays or changes the value of the Display Diagnostic Mode Selection Menu option.
-n	Displays or changes the value of the Number of Days Used To Search the Error Log option. Allowable values are between 1 and 60 days. 7 days is the default.
-p	Displays or changes the value of the Display Progress Indicators option.
-s	Displays all of the diagnostic run-time options.

Display Previous Diagnostic Results

Note: This service aid is not available when you load the diagnostics from a source other than a hard disk drive or a network.

This service aid allows a service representative to display results from a previous diagnostic session. When the Display Previous Diagnostic Results option is selected, the user can view up to 25 no trouble found (NTF) and service request number (SRN) results.

This service aid displays Diagnostic Event Log information. You can display the Diagnostic Event Log in a short version or a long version. The Diagnostic Event Log contains information about events logged by a diagnostic session.

This service aid displays the information in reverse chronological order.

This information is not from the AIX operating system error log. This information is stored in the **/var/adm/ras** directory.

You can run the command from the AIX command line by typing: `/usr/lpp/diagnostics/bin/diagrpt` `[[-o] | [-s mmddyy] | [-a] | [-r]]`

Flag	Description
-o	Displays the last diagnostic results file stored in the /etc/lpp/diagnostics/data directory
-s mmddyy	Displays all diagnostic result files logged since the date specified
-a	Displays the long version of the Diagnostic Event Log
-r	Displays the short version of the Diagnostic Event Log

Display Resource Attributes

This task displays the Customized Device Attributes associated with a selected resource. This task is similar to running the **lsattr -E -l resource** command.

Display Service Hints

This service aid reads and displays the information in the CEREADME file from the diagnostics media. This file contains information that is not contained in the publications for this version of the diagnostics. The file also contains information about using this particular version of diagnostics.

Display Software Product Data

This task uses SMIT to display information about the installed software and provides the following functions:

- List Installed Software
- List Applied but Not Committed Software Updates
- Show Software Installation History
- Show Fix (APAR) Installation Status
- List Fileset Requisites
- List Fileset Dependents
- List Files Included in a Fileset
- List File Owner by Fileset

Display System Environmental Sensors

This service aid displays the environmental sensor information for the system. The information displayed is the sensor name, physical location code, literal value of the sensor status, and the literal value of the sensor reading.

The sensor status can be any one of the following:

- **Normal** - The sensor reading is within the normal operating range.
- **Critical High** - The sensor reading indicates a serious problem with the device. Run diagnostics on `sysplanar0` to determine what repair action is needed.
- **Critical Low** - The sensor reading indicates a serious problem with the device. Run diagnostics on `sysplanar0` to determine what repair action is needed.
- **Warning High** - The sensor reading indicates a problem with the device. This could become a critical problem if action is not taken. Run diagnostics on `sysplanar0` to determine what repair action is needed.
- **Warning Low** - The sensor reading indicates a problem with the device. This could become a critical problem if action is not taken. Run diagnostics on `sysplanar0` to determine what repair action is needed.
- **Hardware Error** - The sensor could not be read because of a hardware error. Run diagnostics on `sysplanar0` in problem-determination mode to determine what repair action is needed.
- **Hardware Busy** - The system has repeatedly returned a busy indication, and a reading is not available. Try the service aid again. If the problem continues, run diagnostics on `sysplanar0` in problem-determination mode to determine what repair action is needed.

This service aid can also be run as a command. You can use the command to list the sensors and their values in a text format, list the sensors and their values in numerical format, or a specific sensor can be queried to return either the sensor status or sensor value.

Run the command by entering one of the following: `/usr/lpp/diagnostics/bin/uesensor -l | -a /usr/lpp/diagnostics/bin/uesensor -t token -i index [-v]`

Flag	Description
<code>-l</code>	List the sensors and their values in a text format.
<code>-a</code>	List the sensors and their values in a numerical format. For each sensor, the numerical values are displayed as: <i>token index status measured value location code</i>
<code>-t <i>token</i></code>	Specifies the sensor token to query.
<code>-i <i>index</i></code>	Specifies the sensor index to query.
<code>-v</code>	Indicates to return the sensor measured value. The sensor status is returned by default.

Examples

The following are examples from this command:

1. Display a list of the environmental sensors: `/usr/lpp/diagnostics/bin/uesensor -l`

```
Sensor = Fan Speed
Status = Normal
Value = 2436 RPM
Location Code = F1
Sensor = Power Supply
Status = Normal
Value = Present and operational
Location Code = V1
Sensor = Power Supply
Status = Critical low
Value = Present and not operational
Location Code = V2
```

2. Display a list of the environmental sensors in a numerical list: `/usr/lpp/diagnostics/bin/uesensor -a`

```
3 0 11 87 P1
9001 0 11 2345 F1
9004 0 11 2 V1
9004 1 9 2 V2
```

3. Return the status of sensor 9004, index 1: `/usr/lpp/diagnostics/bin/uesensor -t 9004 -i 1`

9

4. Return the value of sensor 9004, index 1: `/usr/lpp/diagnostics/bin/uesensor -t 9004 -i 1 -v`

2

Display Test Patterns

This service aid provides a means of adjusting system display units by providing test patterns that can be displayed. The user works through a series of menus to select the display type and test pattern. After the selections are made, the test pattern displays.

Display USB Devices

The following are the main functions of this service aid:

- Display a list of USB controllers on an adapter.
- Display a list of USB devices that are connected to the selected controller.

To run the USB devices service aid, go to the diagnostics "TASKS SELECTION" menu, select "*Display USB Devices*". From the controller list that displayed on the screen, select one of the items that begins with "OHCDX", where "X" is a number. A list of devices attached to the controller displays.

Download Microcode

This service aid provides a way to copy microcode to an adapter or device. The service aid presents a list of adapters and devices that use microcode. After the adapter or device is selected, the service aid provides menus to guide you in checking the current level and downloading the needed microcode.

This task can be run directly from the AIX command line. See the following sections for instructions on downloading to a particular type adapter or device.

Download Microcode to PCI SCSI RAID Adapter

See the following command syntax for a PCI SCSI RAID Adapter:

```
diag -c -d RAIDadapterName -T "download [-B] [-D] [-P]"
```

Flag	Description
------	-------------

- | | |
|----|---|
| -B | Download boot block microcode (default to functional microcode) |
| -D | Microcode is on diskette (default to /etc/microcode directory) |
| -P | Download the previous level of microcode (default to latest level) |

Download Microcode to a PCI-X Dual Channel Adapter

Microcode installation occurs while the adapter and attached drives are available for use. Before installation of the microcode, ensure that there is a current backup of the system available. It is recommended that the installation be scheduled during a non-peak production time period.

Notes:

1. If the source is **/etc/microcode**, the image must be stored in the **/etc/microcode** directory on the system. If the system is booted from a NIM server, the image must be stored in the **usr/lib/microcode** directory of the SPOT the client is booted from.

2. If the source is diskette, the diskette must be in a backup format and the image stored in the **/etc/microcode** directory.

See the following command syntax for a PCI-X Adapter:

```
diag -c -d device_name -T "download [-s {/etc/microcode|diskette}]
[-l {latest|previous}] [-f]"
```

Flag	Description
------	-------------

-c	No console mode. Run without user interaction.
-d	Device name is the name of the adapter.
-f	Force the installation even if the current level of microcode is not on the source.
-l	Level of microcode to install. The default is the latest.
-s	Source of the new microcode image. The default is /etc/microcode .
-T	Use the download option to download microcode.

Download Microcode to Disk Drive Attached to a PCI SCSI RAID Adapter

See the following command syntax for a disk drive attached to a PCI SCSI RAID Adapter:

```
diag -c -d RAIDAdapterName -T "download {-l chID | -A} [-D] [-P]"
```

Flag	Description
------	-------------

-A	All disk drives
-D	Microcode is on diskette (default to /etc/microcode directory)
-l	RAID disk drive-physical disk channel/ID (for example, 27)
-P	Download the previous level of microcode (default to latest level)

Download Microcode to a Fiber Channel Adapter

Microcode installation occurs while the adapter and attached drives are available for use. Before installation of the microcode, ensure that a current backup of the system is available. It is recommended that the installation be scheduled during a non-peak production time period.

Notes:

1. If the source is **/etc/microcode**, the image must be stored in the **/etc/microcode** directory on the system. If the system is booted from a NIM server, the image must be stored in the **usr/lib/microcode** directory of the SPOT the client is booted from.
2. If the source is diskette, the diskette must be in backup format and the image stored in the **/etc/microcode** directory.

See the following command syntax for a Fiber Channel Adapter. `diag -c -d device_name -T "download [-s {/etc/microcode|diskette}] [-l {latest|previous}] [-f]"`

Flag	Description
------	-------------

-c	No console mode. Run without user interaction.
-d	Device name is the name of the adapter.
-T	Use the download option to download microcode.
-s	Source of the new microcode image. Default is /etc/microcode .
-l	Level of microcode to install. The default is the latest.
-f	Force the installation even if the current level of microcode is not on the source.

Download Microcode to DVD-RAM Attached to a PCI SCSI Adapter

See the following command syntax for a DVD-RAM attached to a PCI SCSI Adapter:

```
diag [-c] -d cdX -T "download [-s {/etc/microcode|diskette}]
[-l {latest|previous}] [-f]"
```

Flag	Description
-c	No console mode. Run without user interaction
cdX	Device selected, for example, cd0.
-s	Source of the new microcode. The default is <i>/etc/microcode</i> .
-l	Level of microcode image to be installed. Latest in default
-f	Install the microcode on the device even if the current level is unavailable on the source.

Download Microcode to Disk Attached to PCI SCSI Adapter

See following command syntax for a disk drive attached to a PCI SCSI adapter:

```
diag [-c] -d hdiskX -T "download [-s {/etc/microcode|diskette}]
[-l {latest|previous}] [-f]"
```

Flag	Description
-c	No console mode. Run without user interaction
-d <i>hdiskX</i>	Selected device, for example, <i>hdisk0</i> .
-T <i>download</i>	Download microcode task.
-s	Source of the new microcode. The default is <i>/etc/microcode</i> .
-l	Level of microcode image to be installed. Latest in default
-f	Install the microcode on the device even if the current level is unavailable on the source.

Download Microcode to Other Devices

See the following command syntax: `diag -c -d device_name -T "download [-s diskette] [-l previous] [-F]"`

Flag	Description
-F	Force the download microcode even if the current level is unavailable on the source.
-l	Microcode level. Latest is default.
-s	Source of the new microcode. The default is <i>/etc/microcode</i> . Default source device is disk.

Fault Indicators

Note: Prior to Diagnostics version 5.1.0.35, this task was also known as the System Fault Indicator task.

This task is used to display or reset the Fault Indicators on the systems that support this function. This task may also be used to set the Fault Indicators for testing purposes, but the Indicators are not set back to normal when you exit this task.

The Fault Indicators are used to identify a fault with the system. These indicators may be set automatically by hardware, firmware, or diagnostics when a fault is detected in the system.

The Fault Indicators are turned off when a Log Repair Action is performed. After a serviceable event is complete, do a System Verification to verify the fix. Also do a Log Repair Action if the test on the resource was good, and that resource had an entry in the error log. If the serviceable event was not a result of an error log entry, use the Log Repair Action Task to turn off the system fault indicator.

For additional information concerning the use of these indicators, refer to the system guide.

Note: The AIX command does not allow you to set the fault indicators to the Fault state.

Use the following command syntax:

```
/usr/lpp/diagnostics/bin/usysfault [-s normal] [-l location code]
```

Flag	Description
-s <i>normal</i>	Sets the Fault Indicator to the normal state.
-l <i>location code</i>	Identifies the resource by physical location code.

When the command is used without the **-s** flag, the current state of the indicator is displayed as normal or attention.

When the command is used without the **-I** flag, the Primary Enclosure resource is used.

Use the **-I** flag only in systems that have more than one fault indicator.

Note: See also the "Identify and System Attention Indicators" on page 117. Some systems that do not support Fault Indicators have a similar System Attention Indicator.

Fibre Channel RAID Service Aids

The Fibre Channel RAID service aids contain the following functions:

Certify LUN

This selection reads and checks each block of data in the logical unit number (LUN). If excessive errors are encountered, the user is notified.

You can run this task from the AIX command line. Use the following fast-path command:

```
diag -T "certify"
```

Certify Spare Physical Disk

This selection allows the user to certify (check integrity of the data) drives that are designated as spares.

You can run this task from the AIX command line. Use the following fast-path command:

```
diag -T "certify"
```

Format Physical Disk

This selection is used to format a selected disk drive.

You can run this task from the AIX command line. Use the following fast-path command:

```
diag -T "format"
```

Array Controller Microcode Download

This selection allows the microcode on the Fibre Channel RAID controller to be updated when required.

You can run this task from the AIX command line. Use the following fast-path command:

```
diag -T "download"
```

Physical Disk Microcode Download

This selection is used to update the microcode on any of the disk drives in the array.

You can run this task from the AIX command line. Use the following fast-path command:

```
diag -T "download"
```

Update EEPROM

This selection is used to update the contents of the electronically erasable programmable read-only memory (EEPROM) on a selected controller.

Replace Controller

Use this selection when it is necessary to replace a controller in the array.

Flash SK-NET FDDI Firmware

This task allows the Flash firmware on the SysKconnect SK-NET FDDI adapter to be updated.

Format Media

This task allows the selection of diskettes, hardfiles, or optical media to be formatted. Each selection is described below.

Hardfile Attached to SCSI Adapter (non-RAID)

- Hardfile Format

Writes all of the disk. The pattern written on the disk is device-dependent; for example some drives may write all 0s, while some may write the hexadecimal number 5F. No bad block reassignment occurs

- Hardfile Format and Certify

Performs the same function as Hardfile Format. After the format is completed, Certify is run. Certify then reassigns all bad blocks encountered.

- Hardfile Erase Disk

This option can be used to overwrite (remove) all data currently stored in user-accessible blocks of the disk. The **Erase Disk** option writes one or more patterns to the disk. An additional option allows data in a selectable block to be read and displayed on the system console.

To use the **Erase Disk** option, specify the number (0-3) of patterns to be written. The patterns are written serially; that is, the first pattern is written to all blocks. The next pattern is written to all blocks, overlaying the previous pattern. A random pattern is written by selecting the **Write Random Pattern?** option.

Note: The Erase Disk service aid has not been certified as meeting the Department of Defense or any other organization's security guidelines.

To overwrite the data on the drive, use the following steps :

1. Select **Erase Disk**.
2. Do a format without certify.
3. Select **Erase Disk** to run it a second time.

For a newly installed drive, you can ensure that all blocks on the drive are overwritten with your pattern by using the following procedure:

1. Format the drive.
2. Check the defect MAP by running the **Erase Disk** option.

Note: If you use the **Format and Certify** option, there may be some blocks which get placed into the grown defect MAP.

3. If there are bad blocks in the defect MAP, record the information presented and ensure that this information is kept with the drive. This data is used later when the drive is to be overwritten.
4. Use the drive as you would normally.
5. When the drive is no longer needed and is to be erased, run the same version of the **Erase Disk** option which was used in step 2.

Note: Using the same version of the service aid is only critical if any bad blocks were found in step 3.

6. Compare the bad blocks which were recorded for the drive in step 3 with those that now appear in the grown defect MAP.

Note: If there are differences between the saved data and the newly obtained data, all sectors on this drive cannot be overwritten. The new bad blocks are not overwritten.

7. If the bad block list is the same, continue running the service aid to overwrite the disk with the chosen pattern(s).

This task can be run directly from the AIX command line. See the command syntax: `diag -c -d deviceName -T "format [-s* ffmtcert | erase -a {read | write}] [-F]"`

Flag	Description
ffmtcert	Formats and certifies the disk.
*	Available in no-console mode only.
-F	Force the disk erasure even if all blocks cannot be erased due to errors accessing grown defect map.

Note: The Erase Disk option in command line mode uses default values. To selectively read or write, use the **diag** command in console mode.

Hardfile Attached to PCI SCSI RAID Adapter

This function formats the physical disks attached to a PCI SCSI RAID adapter. This task can be run directly from the AIX command line. See the following command syntax: `diag -c -d RAIDadapterName -T "format {-l chld | -A }"`

Flag	Description
-l	Physical disk channel/ID (An example of a physical disk channel/ID is 27, where the channel is 2 and the ID is 7.)
-A	All disks

Optical Media

Use the following functions to check and verify optical media:

- **Optical Media Initialize**
Formats the media without certifying. This function does not reassign the defective blocks or erase the data on the media. This option provides a quick way of formatting the media and cleaning the disk.
Note: It takes approximately one minute to format the media.
- **Optical Media Format and Certify**
Formats and certifies the media. This function reassigns the defective blocks and erases all data on the media.

This task can be run directly from the AIX command line. See the following command syntax: `diag -c -d deviceName -T "format [-s {initialize | ffmtcert}]"`

Option	Description
initialize	Formats media without certifying
ffmtcert	Formats and certifies the media

Diskette Format

This selection formats a diskette by writing patterns to it.

Gather System Information

This service aid uses the AIX snap command to collect configuration information on networks, file systems, security, the kernel, the ODM, and other system components. You can also collect SSA adapter and disk drive configuration data, or AIX trace information for software debugging.

The output of the SNAP service aid can be used by field service personnel, or it can be put on removable media and transferred to remote locations for more extensive analysis.

To use the SNAP task, select **Gather System Information** from the task list. You can select which components you want to collect information for, and where to store the data (hard disk or removable media).

Generic Microcode Download

The Generic Microcode Download service aid provides a means of executing a gencode script from a diskette or tape. The purpose of this generic script is to load microcode to a supported resource.

The gencode program should be downloaded onto diskette or tape in **tar** format while the microcode image itself goes onto another one in **restore** format. Running the Generic Microcode Download task will search for the gencode script on diskette or tape and execute it. It will ask for a Gencode media to be inserted into the drive. The service aid moves the gencode script file to the **/tmp** directory and runs the program that downloads the microcode to the adapter or device.

This service aid is supported in both concurrent and standalone modes from disk, LAN, or loadable media.

Hot Plug Task

The Hot Plug Task provides software function for those devices that support hot-plug or hot-swap capability. This includes PCI adapters, SCSI devices, and some RAID devices. This task was previously known as "SCSI Device Identification and Removal" or "Identify and Remove Resource."

The Hot Plug Task has a restriction when running in Standalone or Online Service mode; new devices cannot be added to the system unless there is already a device with the same FRU part number installed in the system. This restriction is in place because the device software package for the new device cannot be installed in Standalone or Online Service mode.

Depending on the environment and the software packages installed, selecting this task displays the following subtasks:

- PCI Hot Plug Manager
- SCSI Hot Swap Manager
- RAID Hot Plug Devices

To run the Hot Plug Task directly from the command line, type the following: `diag -T"identifyRemove"`

If you are running the diagnostics in Online Concurrent mode, run the Missing Options Resolution Procedure immediately after removing any device.

If the Missing Options Resolution Procedure runs with no menus or prompts, device configuration is complete. Otherwise, work through the missing options menu to complete device configuration in diagnostics prior to version 5.2.0. In diagnostics version 5.2.0 and later, select the device that has an uppercase M in front of it in the resource list so that missing options processing can be done on that resource.

PCI Hot Plug Manager

The PCI Hot Plug Manager task is a SMIT menu that allows you to identify, add, remove, or replace PCI adapters that are hot-pluggable. The following functions are available under this task:

- List PCI Hot Plug Slots
- Add a PCI Hot Plug Adapter
- Replace/Remove a PCI Hot Plug Adapter
- Identify a PCI Hot Plug Slot
- Unconfigure Devices
- Configure Devices
- Install/Configure Devices Added After IPL

The **List PCI Hot Plug Slots** function lists all PCI hot-plug slots. Empty slots and populated slots are listed. Populated slot information includes the connected logical device. The slot name consists of the physical location code and the description of the physical characteristics for the slot.

The **Add a PCI Hot Plug Adapter** function is used to prepare a slot for the addition of a new adapter. The function lists all the empty slots that support hot plug. When a slot is selected, the visual indicator for the slot blinks at the Identify rate. After the slot location is confirmed, the visual indicator for the specified PCI slot is set to the Action state. This means the power for the PCI slot is off and the new adapter can be plugged in.

The **Replace/Remove a PCI Hot Plug Adapter** function is used to prepare a slot for adapter exchange. The function lists all the PCI slots that support hot plug and are occupied. The list includes the slot's physical location code and the device name of the resource installed in the slot. The adapter must be in the Defined state before it can be prepared for hot-plug removal. When a slot is selected, the visual indicator for the slot is set to the Identify state. After the slot location is confirmed, the visual indicator for the specified PCI slot is set to the Action state. This means the power for the PCI slot is off, and the adapter can be removed or replaced.

The **Identify a PCI Hot Plug Slot** function is used to help identify the location of a PCI hot-plug adapter. The function lists all the PCI slots that are occupied or empty and support hot plug. When a slot is selected for identification, the visual indicator for the slot is set to the Identify state.

The **Unconfigure Devices** function attempts to put the selected device, in the PCI hot-plug slot, into the Defined state. This action must be done before any attempted hot-plug function. If the unconfigure function fails, it is possible that the device is still in use by another application. In this case, the customer or system administrator must be notified to quiesce the device.

The **Configure Devices** function allows a newly added adapter to be configured into the system for use. This function should also be done when a new adapter is added to the system.

The **Install/Configure Devices Added After IPL** function attempts to install the necessary software packages for any newly added devices. The software installation media or packages are required for this function.

Standalone Diagnostics has restrictions on using the PCI Hot-Plug Manager. For example:

- Adapters that are replaced must be exactly the same FRU part number as the adapter being replaced.
- New adapters cannot be added unless a device of the same FRU part number already exists in the system, because the configuration information for the new adapter is not known after the Standalone Diagnostics are booted.
- The following functions are not available from the Standalone Diagnostics and will not display in the list:
 - Add a PCI Hot Plug Adapter
 - Configure Devices
 - Install/Configure Devices Added After IPL

You can run this task directly from the command line by typing the following command: `diag -d device -T"identifyRemove"`

However, note that some devices support both the PCI Hot-Plug task and the RAID Hot-Plug Devices task. If this is the case for the *device* specified, then the Hot Plug Task displays instead of the PCI Hot Plug Manager menu.

More detailed information concerning PCI Hot-Plug Manager can be found in the AIX Operating System, System Management Guide.

SCSI Hot Swap Manager

This task was known as "SCSI Device Identification and Removal" or "Identify and Remove Resources" in previous releases. This task allows the user to identify, add, remove, and replace a SCSI device in a system unit that uses a SCSI Enclosure Services (SES) device. The following functions are available:

- List the SES Devices
- Identify a Device Attached to an SES Device
- Attach a Device to an SES Device
- Replace/Remove a Device Attached to an SES Device
- Configure Added/Replaced Devices

The **List the SES Devices** function lists all the SCSI hot-swap slots and their contents. Status information about each slot is also available. The status information available includes the slot number, device name, whether the slot is populated and configured, and location.

The **Identify a Device Attached to an SES Device** function is used to help identify the location of a device attached to an SES device. This function lists all the slots that support hot swap that are occupied or empty. When a slot is selected for identification, the visual indicator for the slot is set to the Identify state.

The **Attach a Device to an SES Device** function lists all empty hot-swap slots that are available for the insertion of a new device. After a slot is selected, the power is removed. If available, the visual indicator for the selected slot is set to the Remove state. After the device is added, the visual indicator for the selected slot is set to the Normal state, and power is restored.

The **Replace/Remove a Device Attached to an SES Device** function lists all populated hot-swap slots that are available for removal or replacement of the devices. After a slot is selected, the device populating that slot is Unconfigured; then the power is removed from that slot. If the Unconfigure operation fails, it is possible that the device is in use by another application. In this case, the customer or system administrator must be notified to quiesce the device. If the Unconfigure operation is successful, the visual indicator for the selected slot is set to the Remove state. After the device is removed or replaced, the visual indicator, if available for the selected slot, is set to the Normal state, and power is restored.

Note: Before you remove the device, be sure that no other host is using it.

The **Configure Added/Replaced Devices** function runs the configuration manager on the parent adapters that had child devices added or removed. This function ensures that the devices in the configuration database are configured correctly.

Standalone Diagnostics has restrictions on using the SCSI Hot Plug Manager. For example:

- Devices being used as replacement devices must be exactly the same type of device as the device being replaced.
- New devices may not be added unless a device of the same FRU part number already exists in the system, because the configuration information for the new device is not known after the Standalone Diagnostics are booted.

You can run this task directly from the command line. See the following command syntax:

```
diag -d device-T"identifyRemove"  
OR  
diag [-c] -d device -T"identifyRemove -a [identify|remove]"
```

Flag	Description
------	-------------

- | | |
|----|--|
| -a | Specifies the option under the task. |
| -c | Run the task without displaying menus. Only command line prompts are used. This flag is only applicable when running an option such as identify or remove. |
| -d | Indicates the SCSI device. |

-T Specifies the task to run.

RAID Hot Plug Devices

This task allows the user to identify, or remove a RAID device in a system unit that uses a SCSI Enclosure Services (SES) device. The following subtasks are available:

- **Normal**
- **Identify**
- **Remove**

The **Normal** subtask is used to return a RAID hot plug device to its normal state. This subtask is used after a device has been identified or replaced. This subtask lists all channel/IDs of the RAID and the status of the devices that are connected. A device in its normal state has power and the check light is off.

The **Identify** subtask is used to identify the physical location of a device or an empty position in the RAID enclosure. This subtask lists all channel/IDs of the RAID and the status of the devices that are connected to the RAID enclosure. If a device is attached to the selected channel/ID, the check light on the device will begin to flash. If the channel/ID does not have a device attached, the light associated with the empty position on the enclosure will begin to flash.

The **Remove** subtask is used to put the RAID hot plug device in a state where it can be removed or replaced. This subtask lists all channel/IDs of the RAID adapter that have devices that can be removed. Only devices with a status of Failed, Spare, Warning, or Non Existent can be removed. A device's status can be changed with the AIX **smitty pdam** command. After a device is selected for removal, the check light on the device will begin to flash, indicating that you may physically remove that device.

Standalone Diagnostics has restrictions on using the RAID Hot Plug Manager:

- Devices being used as replacement devices must be exactly the same type of device as the device being replaced.
- New devices may not be added unless a device of the same FRU part number already exists in the system because the configuration information for the new device is not known after the Standalone Diagnostics are booted.

You can run this task directly from the command line. See the following command syntax:

```
diag -c -d <device name> -T "identifyRemove -l <ChId> -s {identify|remove|normal}
```

Flags Description

- c** Run the task without displaying menus. Only command line prompts are used.
- d** Raid adapter device name (for example, scraid0).
- s** Subtask to execute such as identify, remove, or normal.
- l** *ChId* is the channel number of the RAID adapter and SCSI ID number of the position in the enclosure concatenated together (for example, 27 for channel 2, device 7).
- T** Task to run.

Identify Indicators

See the "Identify and System Attention Indicators" on page 117 for a description of the Identify Indicators task.

Identify and System Attention Indicators

Note: Prior to Diagnostics version 5.1.0.35, this task may also have been known as the System Identify Indicator or Identify Indicators task.

This task is used to display or set the Identify Indicators and the single system attention indicator on the systems that support this function.

Some systems may support the Identify Indicators or the Attention Indicators. The Identify Indicator is used to help physically identify the system in a large equipment room. The Attention Indicator is used to help physically identify a system with a fault in a large equipment room.

When a fault has been detected on a system that supports the Attention Indicator, the Indicator is set to an Attention condition. After the failing system has been identified and the problem fixed, the Attention Indicator changes back to normal. This should be done by the Log Repair Action Task.

Note: It is important to run the Log Repair Action function. This action keeps the Fault Indicator from going back to the Fault state due to a previous error in the error log that has already been serviced.

For additional information concerning the use of this indicator, refer to the service guide.

This task can also be run directly from the command line by typing
`/usr/lpp/diagnostics/bin/usysident [-s {normal | identify}] [-l location code]`

Flag	Description
-s {normal identify}	Sets the state of the System Identify Indicator to either normal or identify.
-l <i>location code</i>	Identifies the resource by physical location code.

When this command is used without the **-l** flag, the Primary Enclosure resource is used.

Use the **-l** flag only in systems that have more than one Identify and System attention indicator.

When this command is used without **-s** flag, the current state of the identify indicator is displayed.

For more information on the tasks, see Chapter 7, "Introducing Tasks and Service Aids", on page 91.

Local Area Network Analyzer

This selection is used to exercise the LAN communications adapters (Token Ring, Ethernet, and (FDDI) Fiber Distributed Data Interface). The following services are available:

- Connectivity testing between two network stations. Data is transferred between the two stations, requiring the user to provide the Internet addresses of both stations.
- Monitoring ring (Token Ring only). The ring is monitored for a specified period of time. Soft and hard errors are analyzed.

Log Repair Action

The Log Repair Action task logs a repair action in the AIX Error Log. A Repair Action log indicates that a FRU has been replaced, and error log analysis should not be done for any errors logged before the repair action. The Log Repair Action task lists all resources. Replaced resources can be selected from the list, and when **commit** (F7 key) is selected, a repair action is logged for each selected resource.

Periodic Diagnostics

This selection provides a tool for configuring periodic diagnostics and automatic error log analysis. You can select a hardware resource to be tested once a day, at a user-specified time.

Hardware errors logged against a resource can also be monitored by enabling automatic error log analysis. This allows error log analysis to be performed every time a hardware error is put into the error log. If a problem is detected, a message is posted to the system console and either sent to the Service Focal Point when there is an attached HMC, or a mail message to the users belonging to the system group containing information about the failure, such as the service request number.

The service aid provides the following functions:

- Add or delete a resource to the periodic test list
- Modify the time to test a resource
- Display the periodic test list
- Modify the error notification mailing list
- Disable or enable automatic error log analysis

PCI RAID Physical Disk Identify

For a description of the PCI RAID Physical Disk Identify task, see “SCSI RAID Physical Disk Status and Vital Product Data” on page 122.

Process Supplemental Media

Process Supplemental Media contains all the necessary diagnostic programs and files required to test a particular resource. The supplemental media is normally released and shipped with the resource as indicated on the diskette label. Diagnostic Supplemental Media must be used when the device support has not been incorporated into the latest diagnostic CD-ROM.

This task processes the Diagnostic Supplemental Media. Insert the supplemental media when you are prompted; then press Enter. After processing has completed, go to the Resource Selection list to find the resource to test.

Notes:

1. This task is supported in Standalone Diagnostics only.
2. Process and test one resource at a time. Run diagnostics after each supplemental media is processed. (for example; If you need to process two supplemental media, run diagnostics twice, once after each supplement media is processed.)

Run Diagnostics

The Run Diagnostics task invokes the Resource Selection List menu. When the commit key is pressed, diagnostics are run on all selected resources.

The procedures for running the diagnostics depend on the state of the diagnostics run-time options. See “Display or Change Diagnostic Run-Time Options” on page 103.

Run Error Log Analysis

The Run Error Log Analysis task invokes the Resource Selection List menu. When the commit key is pressed, Error Log Analysis is run on all selected resources.

Run Exercisers

The Run Exercisers task provides a tool to troubleshoot intermittent system problems, to test hardware, and to verify replacement parts. When AIX error logging is enabled, the Run Error Log Analysis task can be used to analyze errors after the exerciser completes. Hardware errors are logged in the AIX Error Log. Miscompares and recoverable errors are not reported. However, they may be logged in the AIX Error Log when logging thresholds are exceeded.

The diagnostic supervisor typically sets up temporary work files in the **/tmp** directory to log messages and device statistics. These files are deleted before an exerciser session begins. In addition to individual exerciser requirements, the following requirements pertain to all exercisers:

- Only supported in concurrent or service modes
- Not supported from standalone diagnostics
- System performance will be degraded while running the exerciser, so it is recommended that customer applications be shut down before it is run.
- At least 1 MB of free storage in the **/tmp** directory is available

From the TASK SELECTION LIST menu select **Run Exercisers**. The RESOURCES SELECTION LIST menu displays. From this menu, choose the resources you want to exercise, and then select **commit** to start the **Run Exerciser** task. An intermediate pop-up window might display, stating system performance will be degraded. (The pop-up window does not display if the task had previously been selected). Press Enter and the EXERCISER OPTIONS menu prompts for the type of test to run.

The EXERCISER OPTIONS menu displays the following options:

- **Option 1 - Short Exercise.** Exercises the resources within a relatively short time and exits.
- **Option 2 - Extended Exercise.** Allows greater flexibility and control over resources and test duration.

After choosing the **Short Exercise** option, additional menus, pop-up windows and prompts may display for each resource. Read any text and carefully complete any prompts before committing. The exercisers start, and the **Device Status Screen** displays. The exercisers runs 5 to 10 minutes depending on the number of processors, processor speed, memory size, and I/O configuration.

After choosing the **Extended Exercise** option, additional menus, pop-up windows and prompts may display for each resource. Read any text and carefully fill out any prompts before committing. The **System Exerciser Main Menu** displays. From this menu, the exercisers can be activated through:

- Option 1 - Short Exercise
- Option 2 - Extended Exercise
- Option x (where exercises are exited)

For information about using other available options, see the help text.

When the task completes, any errors that were encountered are displayed for review. Finally, an **Exerciser Complete** pop-up window displays.

To continue, press Enter. The TASK SELECTION LIST menu displays.

If miscompare errors were encountered, run diagnostics on the resource. If the problem is not reported, contact your service support structure. If any other error were encountered, select and run the Error Log Analysis task. If Error Log Analysis does not report a problem, contact your service support structure.

Exerciser Commands (CMD)

Use the following commands as needed in the exerciser menus and reports. Not all commands are available in each menu or report.

CMD Description

a	Acknowledge an error
b	Back one page
c	Toggle between cycle count and last error
e	View the AIX error log
f	Page forward one page
q	Return to Main Menu
r	Refresh screen
s	Enable or disable beep on error
x	Exit system exerciser

Abbreviations

The following list describes abbreviations used in the exerciser reports.

Acronym	Description
COE	Continue on error (use number to select).
CP	Device has run the specified number of cycles and is not running.
DD	The exerciser has been terminated by a signal.
ER	Device has stopped with an error.
HG	The device is hung.
HOE	Halt on error (use number to select).
RN	Device is running.
ST	Device is stopped.

Memory Exerciser

The memory exerciser is labeled mem0. The exerciser requests as many memory buffers as possible from AIX. The exerciser fills these buffers with specified bit patterns and then compares them to the original bit patterns. If memory is removed as a result of processors being reconfigured dynamically, the exerciser terminates.

On systems with multiple processors, a process is started for each processor. The free memory space is split evenly between the available processors, thus reducing the time required to exercise all of the memory.

Running this service aid requires 128 KB of free space in **/etc/lpp/diagnostics/data**.

Tape Exerciser

The tape exerciser is labeled rmt x , where x is the number of a specific device. The exerciser performs read, write, and compare operations using known data patterns. A tape device and Test Diagnostic Cartridge are required to run this exerciser. The actual Test Diagnostics Cartridge depends upon the specific tape device being tested. The exerciser automatically rewinds the tape. Test Requirements are:

- Tape device
- Test Diagnostic Cartridge (the part number depends upon tape device)

Diskette Exerciser

The diskette exerciser is labeled fd x , where x is the number of a specific device. The exerciser performs read, write, and compare operations using known data patterns. A scratch diskette is required to run this exerciser, data on the scratch diskette is destroyed. Test requirements are:

- Diskette device
- Scratch diskette (data on diskette is destroyed)

CD-ROM Exerciser

The CD-ROM exerciser is labeled cd x , where x is the number of a specific device. The exerciser performs read and compare operations using known data patterns. A CD-ROM device and a Test Disc is required to run this exerciser. Test requirements are:

- CD-ROM device
- Test Disc P/N 81F8902

Floating Point Exerciser

The floating point exerciser is labeled `procx`, where `x` is the number of the processor containing the floating point unit. The exerciser performs load/store and arithmetic operations using floating point registers and instructions. The floating point instructions are executed using static values and the outcome of the operation is compared with the expected result. Any mismatch results in an error condition. If the processor is in use by the exerciser and is removed as a result of dynamic logical partitioning, the exerciser terminates.

Save or Restore Hardware Management Policies

Use this service aid to save or restore the settings from Ring Indicate Power-On Policy, Surveillance Policy, Remote Maintenance Policy and Reboot Policy. The following options are available:

- Save Hardware Management Policies

This selection writes all of the settings for the hardware-management policies to the following file:
`/etc/lpp/diagnostics/data/hmpolicies`

- Restore Hardware Management Policies

This selection restores all of the settings for the hardware-management policies from the contents of the following file: **`/etc/lpp/diagnostics/data/hmpolicies`**

You can access this service aid directly from the AIX command line, by typing:

```
/usr/lpp/diagnostics/bin/uspchrp -a
```

SCSI Bus Analyzer

This service aid allows you to diagnose a SCSI bus problem in a freelance mode.

To use this service aid, the user should understand how a SCSI bus works. Use this service aid when the diagnostics cannot communicate with anything on the SCSI bus and cannot isolate the problem. Normally the procedure for finding a problem on the SCSI bus with this service aid is to start with a single device attached, ensure that it is working, then start adding additional devices and cables to the bus, ensuring that each one works. This service aid works with any valid SCSI bus configuration.

The SCSI Bus Service Aid transmits a SCSI Inquiry command to a selectable SCSI Address. The service aid then waits for a response. If no response is received within a defined amount of time, the service aid displays a timeout message. If an error occurs or a response is received, the service aid then displays one of the following messages:

- The service aid transmitted a SCSI Inquiry Command and received a valid response back without any errors being detected.
- The service aid transmitted a SCSI Inquiry Command and did not receive any response or error status back.
- The service aid transmitted a SCSI Inquiry Command and the adapter indicated a SCSI bus error.
- The service aid transmitted a SCSI Inquiry Command and an adapter error occurred.
- The service aid transmitted a SCSI Inquiry Command and a check condition occur.

When the SCSI Bus Service Aid is started a description of the service aid displays.

Pressing the Enter key displays the Adapter Selection menu. Use this menu to enter the address to transmit the SCSI Inquiry Command.

When the adapter is selected, the SCSI Bus Address Selection menu displays. Use this menu to enter the address to transmit the SCSI Inquiry Command.

After the address is selected, the SCSI Bus Test Run menu displays. Use this menu to transmit the SCSI Inquiry Command by pressing Enter. The service aid then indicates the status of the transmission. When the transmission is completed, the results of the transmission displays.

Notes:

1. A Check Condition can be returned when the bus or device is working correctly.
2. If the device is in use by another process, AIX does not send the command.

SCSI RAID Physical Disk Status and Vital Product Data

Note: This task was previously known as the PCI RAID Physical Disk Identify task.

Use this service aid when you want to look at the vital product data for a specific disk attached to a RAID adapter. This service aid displays all disks that are recognized by the PCI RAID adapter, along with their status, physical location, microcode level, and other vital product data. The physical location of a disk consists of the channel number of the RAID adapter and the SCSI ID number of the position in the enclosure. The microcode level is listed next to the physical location of the disk.

You can run this task directly from the command line with the following command syntax:

```
diag -c -d < device name > -T "identify"
```

Flags Description

- c Run the task without displaying menus. Only command line prompts are used.
- d RAID adapter device name (for example, sccraid0).
- T Task to run.

SCSD Tape Drive Service Aid

This service aid allows you to obtain the status or maintenance information from a SCSD tape drive. Not all models of SCSD tape drive are supported.

The service aid provides the following options:

- Display time since a tape drive was last cleaned. The time since the drive was last cleaned displays on the screen, as well as a message regarding whether the drive is recommended to be cleaned.
- Copy a tape drive's trace table. The trace table of the tape drive is written to diskettes or a file. The diskettes must be formatted for DOS. Writing the trace table may require several diskettes. The actual number of diskettes is determined by the size of the trace table. Label the diskettes as follows: TRACE x .DAT (where x is a sequential diskette number). The complete trace table consists of the sequential concatenation of all the diskette data files.
When the trace table is written to a disk file, the service aid prompts for a file name. The default name is: /tmp/TRACE. x , where x is the AIX name of the SCSD tape drive being tested.
- Display or copy a tape drive's log sense information. The service aid provides options to display the log sense information to the screen, to copy it to a DOS formatted diskette, or to copy it to a file. The file name LOGSENSE.DAT is used when the log sense data is written to the diskette. The service aid prompts for a file name when you have selected that the log sense data is to be copied to a file.

This service aid can be run directly from the AIX command line. See the following command syntax (path is /usr/lpp/diagnostics/bin/utape):

```
utape [-h | -?] [-d device] [-n | -l | -t]
OR
utape -c -d device [-v] {-n | {-l | -t} { -D | -f [ filename]}}
```

Flag	Description
------	-------------

- | | |
|---------------|---|
| -c | Run the service aid without displaying menus. The return code indicates success or failure. The output is suppressed except for the usage statement and the numeric value for hours since cleaning (if -n and -D flags are used). |
| -D | Copy data to diskette. |
| -f | Copy data to the file name given after this flag or to a default file name if no name is specified. |
| -h, -? | Display a usage statement and/or return code. If the -c flag is present, only the return code displays to indicate the service aid did not run. If the -c is not used, a usage statement displays and the service aid exits. |
| -l | Display or copy log sense information. |
| -n | Display time since drive was last cleaned. |
| -t | Copy trace table. |
| -v | Verbose mode. If the -c flag is present, the information displays on the screen. If the -n flag is present, the information about tape-head cleaning is printed. |

Spare Sector Availability

This selection checks the number of spare sectors available on the optical disk. The spare sectors are used to reassign when defective sectors are encountered during normal usage or during a format and certify operation. Low availability of spare sectors indicates that the disk must be backed up and replaced. Formatting the disk does not improve the availability of spare sectors.

You can run this task directly from the AIX command line. See the following command syntax: `diag -c -d deviceName -T chkspares`

SSA Service Aid

This service aid provides tools for diagnosing and resolving problems on SSA-attached devices. The following tools are provided:

- Set Service Mode
- Link Verification
- Configuration Verification
- Format and Certify Disk

System Fault Indicator

For a description of the System Fault Indicator task, see “Fault Indicators” on page 109.

System Identify Indicator

For a description of the System Fault Indicator task, see “Identify and System Attention Indicators” on page 117.

Update Disk-Based Diagnostics

This service aid allows fixes (APARs) to be applied.

This task invokes the SMIT Update Software by Fix (APAR) task. The task allows the input device and APARs to be selected. You can install any APAR using this task.

Update System or Service Processor Flash

This selection updates the system or service processor flash.

Look for additional update and recovery instructions with the update kit. You need to know the fully qualified path and file name of the flash update image file provided in the kit. If the update image file is on a diskette, the service aid can list the files on the diskette for selection. The diskette must be a valid backup format diskette.

Refer to the update instructions with the kit, or the service guide for the system unit to determine the current level of the system unit or service processor flash memory.

When this service aid is run from online diagnostics, the flash update image file is copied to the **/var** file system. It is recommended that the source of the microcode that you want to download be put into the **/etc/microcode** directory on the system. If there is not enough space in the **/var** file system for the new flash update image file, an error is reported. If this error occurs, exit the service aid, increase the size of the **/var** file system, and retry the service aid. After the file is copied, a screen requests confirmation before continuing with the flash update. When you continue the update flash, the system reboots using the **shutdown -u** command. The system does not return to the diagnostics, and the current flash image is not saved. After the reboot, you can remove the **/var/update_flash_image** file.

When this service aid is run from standalone diagnostics, the flash update image file is copied to the file system from diskette or from the NIM server. Using a diskette, the user must provide the image on backup format diskette because the user does not have access to remote file systems or any other files that are on the system. If using the NIM server, the microcode image must first be copied onto the NIM server in the **/usr/lib/microcode** directory pointed to the NIM SPOT (from which you plan to have the NIM client boot standalone diagnostics) prior to performing the NIM boot of diagnostics. Next, a NIM check operation must be run on the SPOT containing the microcode image on the NIM server. After performing the NIM boot of diagnostics one can use this service aid to update the microcode from the NIM server by choosing the **/usr/lib/microcode** directory when prompted for the source of the microcode that you want to update. If not enough space is available, an error is reported, stating additional system memory is needed. After the file is copied, a screen requests confirmation before continuing with the flash update. When you continue with the update, the system reboots using the **reboot -u** command. You may receive a Caution: some process(es) wouldn't die message during the reboot process, you can ignore this message. The current flash image is not saved.

You can use the **update_flash** command in place of this service aid. The command is located in the **/usr/lpp/diagnostics/bin** directory. The command syntax is as follows:

```
update_flash [-q] -f file_name
update_flash [-q] -D device_name -f file_name
update_flash [-q] -D update_flash [-q] -D device_name -l
```

Attention: The **update_flash** command reboots the entire system. Do not use this command if more than one user is logged in to the system.

Flag Description

- D** Specifies that the flash update image file is on diskette. The *device_name* variable specifies the diskette drive. The default *device_name* is **/dev/fd0**.
- f** Flash update image file source. The *file_name* variable specifies the fully qualified path of the flash update image file.
- l** Lists the files on a diskette, from which the user can choose a flash update image file.

- q Forces the **update_flash** command to update the flash EPROM and reboot the system without asking for confirmation.

7135 RAIDiant Array Service Aid

The 7135 RAIDiant Array service aids contain the following functions:

- Certify LUN
Reads and checks each block of data in the logical unit number (LUN). If excessive errors are encountered, the user is notified.
- Certify Spare Physical Disk
Allows the user to certify (check the integrity of the data) on drives designated as spares.
- Format Physical Disk
Formats a selected disk drive.
- Array Controller Microcode Download
Allows the microcode on the 7135 controller to be updated when required.
- Physical Disk Microcode Download
Updates the microcode on any of the disk drives in the array.
- Update EEPROM
Updates the contents of the EEPROM on a selected controller.
- Replace Controller
Replaces a controller in the array.

Command Examples

To download the adapter microcode, use this command syntax: `diag -c -d deviceName -T "download [-B] [-D] [-P]"`

Flag	Description
------	-------------

- | | |
|----|---|
| -B | Download boot block microcode (default to functional microcode) |
| -D | Microcode is on diskette (default to /etc/microcode directory) |
| -P | Download the previous level of microcode (default to latest level) |

To download physical disk microcode, use this command syntax : `diag -c -d deviceName -T "download -l Chld [-D] [-P]"`

Flag	Description
------	-------------

- | | |
|----|---|
| -D | Microcode is on diskette (default to /etc/microcode directory) |
| -l | Physical disk channel/ID (for example, 27) |
| -P | Download the previous level of microcode (default to latest level) |

To format a physical disk, use this command syntax: `diag -c -d deviceName -T "format -l Chld"`

Flag	Description
------	-------------

- | | |
|----|--|
| -l | Physical disk channel/ID (for example, 27) |
|----|--|

To certify a physical disk, use this command syntax: `diag -c -d deviceName -T "certify -l Chld"`

Flag	Description
------	-------------

- | | |
|----|--|
| -l | Physical disk channel/ID (for example, 23) |
|----|--|

To identify a physical disk, use this command syntax: `diag -c -d deviceName -T "identify"`

7318 Serial Communications Network Server Service Aid

This service aid provides a tool for diagnosing terminal server problems.

Chapter 8. Verifying the Hardware Operation

To check the system for correct hardware operation, use the system verification procedure discussed in this chapter.

Considerations Before Running This Procedure

Read the following before using this procedure:

- The AIX operating system must be installed on your system before you attempt to perform this procedure.
- If this system unit is directly attached to another system unit or attached to a network, be sure communications with the other systems are stopped.
- This procedure requires use of all of the system resources. No other activity can be running on the system while you are performing this procedure.
- This procedure requires a Hardware Management Console for pSeries (HMC), a display attached to a graphics adapter, or an ASCII terminal attached to the S1 or S2 port.
- This procedure runs the AIX online diagnostics in service mode on a system booted in full system partition mode.

Does the system have AIX diagnostics preinstalled?

- YES** If there is an HMC attached to the system, go to “Using the HMC to Load the Online Diagnostics in Service Mode”.
- If an HMC is not attached to the system, go to “Loading the Online Diagnostics on a System without an HMC Attached” on page 128.
- NO** If there is an HMC attached to the system, go to “Using the HMC to Load the Standalone Diagnostics from CD-ROM” on page 128.
- If an HMC is not attached to the system, go to “Loading the Standalone Diagnostics on a System without an HMC Attached” on page 129.

Using the HMC to Load the Online Diagnostics in Service Mode

To run the online diagnostics in service mode from the boot hard disk, do the following from the HMC:

1. Select **Server and Partition**.
2. Select **Partition Management**.
For more information about full system partitions, refer to the *IBM Hardware Management Console for pSeries Installation and Operations Guide*.
3. From the HMC, select **Server Management**.
4. In the Contents area, select the pSeries 650. Right-click on the mouse, and select **Open Terminal Window**.
5. From the Service Processor menu on the VTERM, select Option 2 **System Power Control**.
6. Select option 6. Verify that the state changes to currently disabled. Disabling fast system boot automatically enables slow boot.
7. Select Option 98 to exit the system power control menu.
8. Use the HMC to power on the pSeries 650 in full system partition mode by selecting the managed system in the Contents area.
9. Highlight the desired system by right-clicking on or selecting the system in the Contents area. On the menu, choose **Selected**.
10. Select **Power On**.

11. Select the **Power on Diagnostics Stored Boot List** option.
12. Ensure that the media subsystem contains no media devices.
13. Enter any passwords, if requested.

Note: If you are unable to load the diagnostics to the point when the DIAGNOSTIC OPERATING INSTRUCTIONS display, go to “Using the HMC to Load the Standalone Diagnostics from CD-ROM”.

Go to “Running System Verification” on page 129.

Using the HMC to Load the Standalone Diagnostics from CD-ROM

To run the standalone diagnostics in service mode from CD-ROM, use the following steps:

1. Stop all programs, including the AIX operating system (get help if needed).
2. Remove all tapes, diskettes, and CD-ROMs.
3. Power off the pSeries 650 (refer to the *IBM Hardware Management Console for pSeries Installation and Operations Guide*, for more information).
4. In your desktop area, right-click on the mouse, and select **Open Terminal Window**.
5. From the service processor menu on the VTERM, select option 2, **System Power Control Menu**.
6. Select option 6. Verify that the state changes to currently disabled. Disabling fast system boot automatically enables slow boot.
7. Select option 98 to exit the system power control menu.
8. Use the HMC to power on the pSeries 650 in full system partition mode. Select **Power on Diagnostic Default Boot List**.
9. Insert the CD-ROM into the CD-ROM drive in the media subsystem in the pSeries 650 (*not* into the HMC CD-ROM drive).

Go to “Running System Verification” on page 129.

Note: If you are unable to load standalone diagnostics, call your support center for assistance.

Loading the Online Diagnostics on a System without an HMC Attached

To run the online diagnostics in service mode from the boot hard disk, do the following:

1. Stop all programs including the AIX operating system (get help if needed).
2. Remove all tapes, diskettes, and CD-ROM discs.
3. Turn off the system unit power.
4. Turn on the system unit power.
5. After the **keyboard** POST indicator displays on the firmware console and before the last POST indicator (**speaker**) displays, press the numeric 6 key on either the directly attached keyboard or the ASCII terminal to indicate that a service mode boot should be initiated using the customized service mode boot list.
6. Enter any requested password.

Note: If you are unable to load the diagnostics to the point when the DIAGNOSTIC OPERATING INSTRUCTIONS display, call your support center for assistance.

Loading the Standalone Diagnostics on a System without an HMC Attached

To run the standalone diagnostics in service mode from the boot hard disk, do the following:

1. Stop all programs including the AIX operating system (get help if needed).
2. Remove all tapes, diskettes, and CD-ROM discs.
3. Turn off the system unit power.
4. Turn on the system unit power and immediately insert the diagnostics CD-ROM into the CD-ROM drive.
5. After the **keyboard** POST indicator displays on the firmware console and before the last POST indicator (**speaker**) displays, press the numeric 5 key on either the directly attached keyboard or the ASCII terminal to indicate that a service mode boot should be initiated using the default service mode boot list.
6. Enter any requested password.

Note: If you are unable to load the diagnostics to the point when the DIAGNOSTIC OPERATING INSTRUCTIONS display, call your support center for assistance.

Running System Verification

When the Diagnostic Operating Instructions display, do the following to run system verification:

1. Press Enter.
2. If the terminal type is requested, you must use the **Initialize Terminal** option on the Function Selection menu to initialize the operating system before you can continue with the diagnostics.
3. Select the **System Verification** option on the Diagnostic Mode Selection menu.
4. To run a general checkout of all installed resources, select the **All Resource** option on the Diagnostic Selection menu. Follow the instructions on the screen to complete the checkout procedure.
To check one particular resource, select that resource on the Diagnostic Selection menu.

The checkout program ends with either of the following results:

- The Testing Complete screen displays a message stating No trouble was found.
- The A Problem Was Detected On (Time Stamp) menu displays, with either a service request number (SRN) or an error code. Make a note of any codes displayed on the display or operator panel.

To perform additional system verification, go to “Performing Additional System Verification”. To exit diagnostics, go to “Stopping the Diagnostics”.

Performing Additional System Verification

To perform additional system verification, do the following:

1. Press Enter to return to the Diagnostic Selection menu.
2. To check other resources, select the resource. When you have checked all of the resources you need to check, go to “Stopping the Diagnostics”.

Stopping the Diagnostics

To stop the diagnostics, do the following:

1. To exit the diagnostics, press the F3 key (from a defined terminal) or press 99 (from an undefined terminal).
2. If you changed any attributes on your terminal to run the diagnostics, change the settings back to normal.

This completes the system verification.

If the server passed all the diagnostic tests, the verification process is complete and your server is ready to use.

If you received an error code, record the code and go to the [@server pSeries 650 Service Guide](#).

Chapter 9. Hardware Problem Determination

This chapter provides information on using standalone or online diagnostics to help you solve hardware problems.

You may obtain more extensive problem isolation by running online diagnostics in service mode. This requires that the partition be rebooted (in a logical partitioned system) with no other users on that partition or that the system be rebooted (in a full system partition) with no other users on the system. Alternatively, if AIX online diagnostics are installed on the partition or system, you can run online diagnostics in concurrent mode. If the system or partition does not have AIX diagnostics installed, or if you cannot boot AIX or online diagnostics in service mode, run standalone diagnostics instead.

Attention: On systems with external I/O drawers attached, environmental conditions resulting from loss of system AC power may cause a machine check if I/O in one of the external I/O drawers was being accessed at the same time the loss of AC (momentary or permanent) occurred.

Problem Determination Using the Standalone or Online Diagnostics

Use this procedure to obtain a service request number (SRN) when you load the standalone or online diagnostics. If you are unable to load the standalone or online diagnostics, go to “Problem Determination When Unable to Load Diagnostics” on page 137. The service organization uses the SRN to determine which field replaceable units (FRUs) are needed to restore the system to correct operation.

Step 1. Considerations before Running This Procedure

Note: See the *IBM Hardware Management Console for pSeries Installation and Operations Guide* to find the key sequences you need for your Hardware Management Console for pSeries (HMC) virtual terminal window to respond to the diagnostic programs.

- The diagnostics may be run within a virtual terminal window on the HMC connected to the system.
- This procedure requires that you select the type of diagnostics you want to run.
- Go to “Step 2”.

Step 2

Are the online diagnostics installed on this system?

NO Go to “Step 15” on page 136.

YES Go to “Step 3” on page 132.

Step 3

Determine if the partition is accepting commands.

Is the operating system accepting commands?

NO Run standalone diagnostics. Go to “Step 15” on page 136.

YES Go to “Step 4”.

Step 4

Diagnostic tests can be run on many resources while the operating system is running. However, you can obtain more extensive problem isolation by running online diagnostics in service mode.

Do you want to run the online diagnostics in service mode?

NO Go to “Step 5”.

YES Go to “Step 6” on page 133.

Step 5

This step starts the online diagnostics in concurrent mode.

Note: The AIX operating system must be installed on the partition on which you want to run online diagnostics.

1. Log in as root user or use CE Login.
2. Enter the diag command.
3. Wait until the diagnostic operating instructions display, or wait for three minutes.

Are the diagnostic operating instructions displayed without any obvious console display problems?

NO If the diagnostics operating instructions are not displayed on the partition, reboot that partition.

Note: Do not turn off the system unit if the system is running one or more logical partitions.

Go to “Step 6” on page 133.

YES Go to “Step 9” on page 133.

Step 6

This step loads online diagnostics in service mode.

1. Reboot the system.
2. At the SMS menu, press the numeric 6 key on the keyboard to indicate that diagnostics are to be loaded.
3. Type the requested passwords.
4. Follow the instructions to select a console.

Did the diagnostics operating instructions display without any obvious display problem?

NO Go to “Step 7”.

YES Go to “Step 9”.

Step 7

Is the problem a display problem?

NO Go to “Problem Determination When Unable to Load Diagnostics” on page 137.

YES Go to “Step 8”.

Step 8

This step analyzes a console display problem.

Go to the problem-determination documentation for this type of terminal. For more information, refer to the *Hardware Management Console for pSeries Maintenance Guide*.

Step 9

The diagnostics loaded correctly.

Press Enter.

Is the Function Selection menu displayed?

NO Go to “Step 10” on page 134.

YES Go to “Step 11” on page 134.

Step 10

There is a problem with the keyboard.

Go to the problem-determination documentation for this type of terminal. For more information, refer to the *Hardware Management Console for pSeries Maintenance Guide*.

Step 11

1. If the terminal type has not been defined, use the **Initialize Terminal** option on the Function Selection menu to initialize the operating system environment before you can continue with the diagnostics. This is a separate and different operation from selecting the console display.
2. Select **Diagnostic Routines**.
3. Press Enter.
4. In the following table, find the menu or system response you received when you selected **Diagnostics**. Perform the action listed in the Action column.

System Response	Action
The Diagnostic Mode Selection menu is displayed.	Select Problem Determination and go to "Step 12" on page 135.
The Missing Resource menu is displayed.	Follow the displayed instructions until either the Diagnostic Mode Selection menu or an SRN is displayed. If the Diagnostic Mode Selection menu is displayed, select Problem Determination and go to "Step 12" on page 135. If you get an SRN, record it, and go to "Step 14" on page 135.
The New Resource menu is displayed.	Follow the displayed instructions. Note: Devices attached to serial ports S1 or S2 do not appear on the New Resource menu. If the Diagnostic Mode Selection menu is displayed, select Problem Determination and go to "Step 12" on page 135. If you get an SRN, record it, and go to "Step 14" on page 135. If you do not get an SRN, go to "Step 16" on page 136.
The system does not respond to selecting diagnostics .	Go to "Step 10".

Step 12

Did the Diagnostic Selection Menu display?

NO If **Problem Determination** was selected from the Diagnostic Mode Selection menu, and if a recent error has been logged in the error log, the diagnostics automatically begin testing the resource.

Follow the displayed instructions.

- If the No Trouble Found screen is displayed, press Enter.
- If another resource is tested, repeat this step.
- If the Diagnostic Selection menu is displayed, go to “Step 13”.

If an SRN is displayed, record it, and go to “Step 14”.

YES Go to “Step 13”.

Step 13

The All Resources option checks most of the configured adapters and devices.

Select and run the diagnostic tests on the resources you are having problems with, or select the **All Resources** option to check all of the configured resources. Find the response in the following table and perform the action listed in the Action column.

Diagnostic Response	Action
An SRN is displayed.	Go to “Step 14”.
The system hangs.	Report SRN 109-200.
The Testing Complete menu and the No trouble was found message is displayed, and you have not tested all of the resources.	Press Enter and continue with the testing.
The Testing Complete menu and the No trouble was found message displayed and you have tested all of the resources.	Go to “Step 16” on page 136.

Step 14

The diagnostics produced an SRN for this problem. Do the following:

1. Record the SRN.
2. Report the SRN to the service organization.
3. **STOP.** You have completed these procedures.

Step 15

This step loads the standalone diagnostics.

1. If you are running one or more logical partitions, reboot the partition.

Note: Standalone diagnostics may be run with a CD-ROM or from a NIM server. If run from CD-ROM, the CD-ROM drive must be made available to the partition upon which you want to run standalone diagnostics. After this is done, go to step 2. If running from NIM, the NIM server must be set up to allow a diagnostic boot from that partition (both NIM server and client partition must have network adapters).

2. Insert the diagnostic CD into the CD-ROM drive.
3. When the **keyboard** POST indicator displays, press the numeric 5 key on the keyboard to indicate that diagnostics are to be loaded.
4. Type the requested passwords.
5. Follow the instructions to select a console.

Did the Diagnostics Operating Instructions display without any obvious display problem?

NO Go to "Step 7" on page 133.

YES Go to "Step 9" on page 133.

Step 16

The diagnostics did not detect a hardware problem. If you still have a problem, contact your service organization.

Problem Determination When Unable to Load Diagnostics

Use the following procedure to obtain an error code. The service organization uses the error code to determine which field replaceable units (FRUs) are needed to restore the system to correct operation.

Step 1

Are the online diagnostics installed on this system?

NO Go to "Step 3" on page 138.

YES Go to "Step 2".

Step 2

This step attempts to load online diagnostics in service mode.

1. Reboot the partition.
2. If the **keyboard** POST indicator displays, press the numeric 6 key on the keyboard to indicate that diagnostics are to be loaded from the hard disk.
3. Type the requested passwords.
4. Follow the instructions to select a console.
5. Wait until the diagnostics load or the system appears to stop.

Did the diagnostics load?

NO Go to "Step 4" on page 138.

YES Go to "Step 5" on page 140.

Step 3

This step attempts to load the standalone diagnostics.

1. Reboot the partition.

Note: Standalone diagnostics may be run with a CD-ROM or from a NIM server. If run from CD-ROM, the CD-ROM drive must be made available to the partition upon which you want to run standalone diagnostics. After this is done, go to step 2 on page 136. If running from NIM, the NIM server must be set up to allow a diagnostic boot from that partition (both NIM server and client partition must have network adapters).

2. Insert the diagnostic CD into the CD-ROM drive.
3. If the **keyboard** POST indicator displays, press the numeric 5 key on the keyboard to indicate that diagnostics are to be loaded from CD-ROM.
4. Type the requested passwords.
5. Follow the instructions to select a console.
6. Wait until the diagnostics load or the system appears to stop.

Did the diagnostics load?

NO Go to "Step 4".

YES Go to "Step 5" on page 140.

Step 4

Starting at the top of the following table, locate your symptom and perform the action listed in the Action column.

Symptom	Action
The power LED does not come on, or comes on and does not stay on.	Check the power cable to the outlet. Check the circuit breakers and check for power at the outlet. Ensure that the room temperature is within 60 - 90°F. If you do not find a problem, record error code MOPS0000 and report the problem to the service organization.
The diagnostics are loaded and there was NO beep heard from the system unit during the IPL sequence.	Record error code M0SPK001.
The system stops with the diagnostic operating instructions displayed.	Go to "Step 5" on page 140.
The system stops with a prompt to enter a password.	Enter the password. You are not allowed to continue until a correct password has been entered. When you have entered a valid password, wait for one of the other conditions to occur.
The system stops with a three-, four- or eight-digit error code(s) displayed on the console.	Record the error code(s) and report the problem to the service organization.
The system login prompt is displayed.	You may not have pressed the correct key or you may not have pressed the key soon enough when you were to indicate a service mode boot of diagnostic programs. If this was the case, start over at the beginning of this step. If you are sure that you pressed the correct key in a timely manner, go to "Step 6" on page 140.
The system does not respond when the password is entered.	Go to "Step 6" on page 140.

Symptom	Action
The system stopped and an indicator is displayed on the system console and an eight-digit error code is not displayed.	<p>If the indicator represents:</p> <ul style="list-style-type: none"> • A keyboard: record error code M0KBD000 and report the problem to the service organization. • Memory: record error code M0MEM002 and report the problem to the service organization. • SCSI: record error code M0CON000 and report the problem to the service organization. • Network: record error code M0NET000 and report the problem to the service organization. • Speaker/audio: record error code M0BT0000 and report the problem to the service organization.
The System Management Services menu is displayed.	<p>The device or media that you are attempting to boot from might be faulty.</p> <ol style="list-style-type: none"> 1. Check the SMS error log for any errors. To check the error log: <ul style="list-style-type: none"> • Select View Error Log. • If an error is logged, check the time stamp. • If the error was logged during the current boot attempt, record it and report it to your service representative. • If no recent error is logged in the error log, continue to the next step. 2. If you are attempting to load the online diagnostics, try loading the standalone diagnostics. Otherwise, record error code M0SCSI01 and report to the service organization.
The system appears to be stopped, the disk activity light is on continuously, and a beep was heard from the system unit.	Record error code M0MEM001 and report the problem to the service organization.
The system stops and the message STARTING SOFTWARE PLEASE WAIT ... is displayed.	Report error code M0BT0000.
The message The system will now continue the boot process is displayed continuously on the system unit's console.	Report error code M0SCSI01.

Step 5

The diagnostics loaded correctly.

Go to “Problem Determination Using the Standalone or Online Diagnostics” on page 131.

Step 6

There is a problem with the keyboard.

Go to the problem-determination documentation for this type of terminal. For more information, refer to the *Hardware Management Console for pSeries Maintenance Guide*.

Appendix A. Environmental Notices

Product Recycling and Disposal

This unit contains materials such as circuit boards, cables, electromagnetic compatibility gaskets and connectors which may contain lead and copper/beryllium alloys that require special handling and disposal at end of life. Before this unit is disposed of, these materials must be removed and recycled or discarded according to applicable regulations. IBM offers product-return programs in several countries. For country specific instructions refer to the following web site: <http://www.ibm.com/ibm/environment/products/prp.phtml>

This product may contain a sealed lead acid, nickel cadmium, nickel metal hydride, lithium, or lithium ion battery. Consult your user manual or service manual for specific battery information. The battery must be recycled or disposed of properly. Recycling facilities may not be available in your area. For information on disposal of batteries, contact your local waste disposal facility.

In the United States, IBM has established a collection process for reuse, recycling, or proper disposal of used IBM sealed lead acid, nickel cadmium, nickel metal hydride, and other battery packs from IBM Equipment. For information on proper disposal of these batteries, please contact IBM at 1-800-426-4333. Have the IBM part number listed on the battery available prior to your call.

Environmental Design

The environmental efforts that have gone into the design of this system signify IBM's commitment to improve the quality of its products and processes. Some of these accomplishments include the elimination of the use of Class 1 ozone-depleting chemicals in the manufacturing process and reductions in manufacturing wastes. For more information, contact an IBM account representative.

Acoustical Noise Emissions

The equivalent continuous A-weighted sound pressure level at workstations (emission sound pressure level at the 1-meter bystander positions) does not exceed 70 dB(A).

Declared Acoustical Noise Emissions

Product Configuration	Declared A-Weighted Sound Power Level, $LWAd$ (B)		Declared A-Weighted Sound Pressure Level, $\langle LpAm \rangle$ (dB) at 1 meter Bystander Position	
	Operating	Idling	Operating	Idling
6E3 (Deskside)	6.0	5.9	42	41
6C3 (Rack Drawer)	6.1	6.0	44	43

Notes:

1. $LWAd$ is the declared (upper limit) sound power level for a random sample of machines. (1B = 10dB)
2. $LpAm$ is the mean value of the A-weighted sound pressure level at the 1-meter bystander positions for a random sample of machines.
3. 7029 Model 6E3 levels apply to the following system configurations: 2 way 1 gigahertz processor, 2 disk drives, 2048 GB of RAM, non-redundant power supply (One power supply, 1 processor fan).
4. 7029 Model 6C3 levels apply to the following hardware configurations: 2 way 1 gigahertz processor, 2 disk drives, 2048 GB of RAM, redundant power supply (Two 645 watt power supplies, 2 processor fans).
5. All measurements made in conformance with ISO 7779 and declared in conformance with ISO 9296.

Appendix B. Notices

This information was developed for products and services offered in the U.S.A.

The manufacturer may not offer the products, services, or features discussed in this document in other countries. Consult the manufacturer's representative for information on the products and services currently available in your area. Any reference to the manufacturer's product, program, or service is not intended to state or imply that only that product, program, or service may be used. Any functionally equivalent product, program, or service that does not infringe any intellectual property right of the manufacturer may be used instead. However, it is the user's responsibility to evaluate and verify the operation of any product, program, or service.

The manufacturer may have patents or pending patent applications covering subject matter described in this document. The furnishing of this document does not give you any license to these patents. You can send license inquiries, in writing, to the manufacturer.

The following paragraph does not apply to the United Kingdom or any country where such provisions are inconsistent with local law: THIS MANUAL IS PROVIDED "AS IS" WITHOUT WARRANTY OF ANY KIND, EITHER EXPRESSED OR IMPLIED, INCLUDING, BUT NOT LIMITED TO, THE IMPLIED WARRANTIES OF NON-INFRINGEMENT, MERCHANTABILITY OR FITNESS FOR A PARTICULAR PURPOSE. Some states do not allow disclaimer of express or implied warranties in certain transactions; therefore, this statement may not apply to you.

This information could include technical inaccuracies or typographical errors. Changes are periodically made to the information herein; these changes will be incorporated in new editions of the publication. The manufacturer may make improvements and/or changes in the product(s) and/or the program(s) described in this publication at any time without notice.

Information concerning products made by other than the manufacturer was obtained from the suppliers of those products, their published announcements, or other publicly available sources. The manufacturer has not tested those products and cannot confirm the accuracy of performance, compatibility or any other claims related to products made by other than the manufacturer. Questions on the capabilities of products made by other than the manufacturer should be addressed to the suppliers of those products.

Appendix C. General Attributes Required When Using a TTY Terminal

The following general attributes are the default settings for the diagnostic programs. Be sure your terminal is set to these attributes.

Note: Set these attributes before the diagnostic programs are loaded.

General Setup Attributes	3151 /11/31/41 Settings	3151 /51/61 Settings	3161 /3164 Settings	Description
Machine mode	3151	3151 PC	3161 or 3164	The diagnostic programs are set to emulate use of the 3161 ASCII Display Terminal. If your terminal can emulate a 5085, 3161 or 3164 terminal, use these attribute settings. Otherwise, refer to your operator's manual, compare the attribute descriptions with those of your terminal, and set your attributes accordingly.
Generated Code Set		ASCII		
Screen	Normal	Normal		Uses the EIA-232 interface protocol.
Row and Column	24 x 80	24 x 80		Uses the EIA-232 interface protocol.
Scroll	Jump	Jump	Jump	When the last character on the bottom line is entered, the screen moves down one line.
Auto LF	Off	Off	Off	For the "On" setting, pressing the Return key moves the cursor to the first character position of the next line. For the "Off" setting, pressing the Return key moves the cursor to the first character position of the current line. The CR and LF characters are generated by the New line setting.
CRT saver	Off	Off	10	The "10" setting causes the display screen to go blank if there is no activity for 10 minutes. When the system unit sends data or a key is pressed, the screen contents display again.
Line wrap	On	On	On	The cursor moves to the first character position of the next line in the page after it reaches the last character position of the current line in the page.
Forcing insert	Off	Off		
Tab	Field	Field	Field	The column tab stops are ignored, and the tab operation depends on the field attribute character positions.
Trace			All	Both inbound data (data to the system unit) and outbound data (data from the system unit) to and from the main port can be transferred to the auxiliary port without disturbing communications with the system unit when the Trace key is pressed.

Additional Communication Attributes

The following communication attributes are for the 3151, 3161, and 3164 terminals.

Communication Setup Attributes	3151/11 /31/41) Settings	3151 /51/61, Settings	3161 /3164 Settings	Description
Operating mode	Echo	Echo	Echo	Data entered from the keyboard on the terminal is sent to the system unit for translation and then sent back to the display screen. Sometimes called <i>conversational mode</i> .
Line speed	9600 bps	9600 bps	9600 bps	Uses the 9600 bps (bits per second) line speed to communicate with the system unit.
Word length (bits)	8	8	8	Selects eight bits as a data word length (byte).
Parity	No	No	No	Does not add a parity bit and is used together with the word length attribute to form the 8-bit data word (byte).
Stop bit	1	1	1	Places a bit after a data word (byte).
Turnaround character	CR	CR	CR	Selects the carriage return (CR) character as the line turnaround character.
Interface	EIA-232	EIA-232	EIA-232	Uses the EIA-232 interface protocol.
Line control	IPRTS	IPRTS	IPRTS	Uses the 'permanent request to send' (IPRTS) signal to communicate with system unit.
Break signal (ms)	500	500	500	The terminal sends a break signal to the system unit within 500 ms after the Break key is pressed.
Send null suppress	On	On		Trailing null characters are not sent to the system unit.
Send null			On	Trailing null characters are sent to the system unit.
Response delay (ms)	100	100	100	The terminal waits for 100 ms for the system unit to respond.

Additional Keyboard Attributes

The following keyboard attributes are for the keyboard attached to the 3151, 3161, and 3164 terminals.

Keyboard Setup Attributes	3151/11 /31/41) Settings	3151 /51/61) Settings	3161 /3164 Settings	Description
Enter	Return	Return	Return	The Enter key functions as the Return key.
Return	New line	New line	New line	The cursor moves to the next line when the Return key is pressed.

Keyboard Setup Attributes	3151/11 /31/41 Settings	3151 /51/61 Settings	3161 /3164 Settings	Description
New line	CR	CR	CR	The Return key generates the carriage return (CR) and the line feed (LF) characters. The line turnaround occurs after the CR and LF characters are generated.
Send	Page	Page	Page	The contents of the current page are sent to the system unit when the Send key is pressed.
Insert character	Space	Space	Space	A blank character is inserted when the Insert key is pressed.

Additional Printer Attributes

The following printer attributes are for a printer attached to the 3151, 3161, and 3164 terminals.

Printer Setup Attributes	3151/11 /31/41 Settings	3151 /51/61 Settings	3161 /3164 Settings	Description
Line speed	9600	9600	9600	Uses 19200 or 9600 bps (bits per second) line speed to communicate with the system unit.
Word length (bits)	8	8	8	Selects eight bits as a data word length (byte).
Parity	Even	Even	No	
Stop bit	1	1	1	Places a bit after a data word (byte).
Characters	ALL	ALL		
Line end			CR-LF	
Print			View port	
Print EOL			Off	
Print null			Off	

Appendix D. Service Processor Setup and Test

For your convenience, an example of a basic service processor setup checklist is included here. Your setup may include more or fewer of the available features, so you can adjust this checklist for your own application so that it is helpful to you.

Service Processor Setup Checklist

1. Unplug the power cord from the server.
2. Attach a local terminal for this setup procedure.
3. Plug in the system and power on the local terminal.
Attention: Make sure that system power remains off.
4. Start the service processor menus. See Chapter 4, “Using the Service Processor”, on page 27.
5. Set the system name. See “Privileged User Menus” on page 29.
6. Enable surveillance. See 34.
7. Configure Call-In/Call-Out. See “Call-In/Call-Out Setup Menu” on page 46.
8. Exit the service processor menus.
9. Unplug the power cord from the system.
10. Attach modems (if needed). See “Accessing the Service Processor Menus Remotely” on page 28.
11. Plug in the system.
Attention: Make sure that the system power remains off.
12. Test both of the following:
 - Call-In, see “Testing Call-In” on page 150
 - Call-Out, see “Testing Call-Out” on page 150

Your service processor is now ready for use.

Testing the Setup

This section contains sample testing procedures to help ensure that your setup is working.

These tests include communicating with the server operating system. Before you start, ensure that the necessary serial port(s) is configured. If you need assistance, refer to “Serial Port Configuration”.

The server should be powered off as a result of the “Service Processor Setup Checklist” on page 149.

Testing Call-In

1. At your remote terminal, call in to your server. Your server answers and offers you the Service Processor Main Menu after requesting your privileged access password.
2. Select **System Power Control**.
3. Select **Power-On System**.
When you are asked if you wish to continue powering on the system, type **Y**.
4. After the system firmware and operating system have initialized the server, the login prompt displays at your remote terminal if you set up Seamless Modem Transfer (refer to “Transfer of a Modem Session” on page 159 for more information). This may take several minutes. When the login prompt displays, you have successfully called the service processor.
5. Type `logout` to disconnect from the operating system. The message `No Carrier` displays on your remote terminal.
6. Call your server again. The operating system answers and offers you the login prompt. If these tests are successful, call-in is working.
7. Log in and type `shutdown` to shut down your server.
8. The message `No Carrier` displays on your remote terminal.

Testing Call-Out

During the setup, you entered your phone numbers for the pager (on page 49) and customer voice (on page 49). These numbers are used for this test.

1. Your remote terminal is disconnected as a result of the Call-In test.
2. Call your server again.
3. At the service processor main menu, select **Call-In/Call-Out Setup** menu, then select **Call-Out** test. This action causes a simulated error condition for the purposes of this test.
4. After a few moments, a message displays, regarding an illegal entry. Press `Enter` to clear the message and return to the main menu.
5. When your telephone rings, answer the call. You should hear the sound of a telephone being dialed. Your computer is trying to page you.

If this test is successful, call-out is working correctly.

Return to the “Telephone Number Setup Menu” on page 48 to enter the actual telephone numbers your server will use for reporting problems.

Serial Port Configuration

To configure the serial port on an AIX system, run the following from an AIX console:

1. Log in as root user.
2. To determine if you have any serial ports already configured, type:
`lsdev -Cc tty`

If no serial ports are configured, none are listed. If you want to configure serial ports that are not listed, continue with the remaining steps.

3. Identify the serial port(s) with the modem(s).
4. Type `smit tty`
5. Select **add tty**
6. Select **RS232**
7. Select **Baud rate 9600** or higher.
8. Select **login enable** and set the flow control to RTS.
9. Commit the selections and set up any other needed serial ports.
10. Exit SMIT.

Appendix E. Modem Configurations

The service processor is designed to place little demand on an attached modem, thereby increasing the setup and connection success rates.

Sample Modem Configuration Files

This appendix contains information about several sample modem configuration files that either work directly with your modem or provide a good starting point for a custom setup.

The sample modem configuration files are located in your service processor firmware in the **/usr/share/modems** subdirectory (if your system or server is running AIX) with the following names. A listing of each specific file is included in this appendix.

Generic Modem Configuration Files

AIX File Name	Service Processor Firmware File Name
modem_z.cfg	modem_z_sp
modem_z0.cfg	modem_z0_sp
modem_f.cfg	modem_f_sp
modem_f0.cfg	modem_f0_sp
modem_f1.cfg	modem_f1_sp

Specific Modem Configuration Files

AIX File Name	Service Processor Firmware File Name
modem_m0.cfg	modem_m0_sp
modem_m1.cfg	modem_m1_sp

Use the following selection procedures and your modem manual to determine which of the configuration files is suitable for your use.

Configuration File Selection

Use the following steps to select a configuration file:

1. Is your modem an IBM 7852-400?

If Yes, use modem configuration file **modem_m0.cfg** and go to step 7.

Note: The IBM 7852-400 modem has DIP switches on the right side of the unit. See “IBM 7852-400 DIP Switch Settings” on page 157 for the correct switch settings.

If No, continue with step 2.

2. Is your modem an IBM 7857-017?

If Yes, use modem configuration file **modem_m1.cfg** and go to step 7.

Note: The IBM 7857-017 modem has two telephone line connections on the back of the unit. One is marked **LL** (for Leased Line), and the other is marked **PTSN** (for Public Telephone Switched Network). The service processor expects to use the modem on the public network, so the telephone line should attach to the PTSN connector.

If No, continue with step 3.

3. Does your modem respond to the extended command set (prefixed with &)?

If Yes, go to step 5.

If No, continue with step 4.

4. Does your modem respond to:

- ATZ reset command
or
- ATZ n reset commands, where n can be 0, 1, and so on?
If ATZ, configuration file **modem_z.cfg** is recommended.
If ATZ n , configuration file **modem_z0.cfg** is recommended.

Go to step 7.

5. Does your modem command set include a test for V.42 error correction at the remote modem (often called “Auto-Reliable Mode”)?

If Yes, disable this test. You can use sample configuration files **/usr/share/modem_m0.cfg** or **/usr/share/modem_m1.cfg** as models to help you create a file for your particular modem. See “Customizing the Modem Configuration Files” on page 156 for more information. Go to step 7.

If No, go to step 6.

6. Does your modem respond to:

- AT&F reset command
or
- AT&F n reset commands, where n can be 0, 1, and so on?

If AT&F, configuration file **modem_f.cfg** is recommended.

If AT&F n , configuration file **modem_f0.cfg** or **modem_f1.cfg** is recommended, depending on which provides the hardware flow control profile.

7. You have completed selection of the configuration file.

If your modem configuration selection is not available in the Service Processor Modem Configuration Menu, you must access it through the Configure Remote Maintenance Policy Service Aid.

If you find it necessary to adjust any of these configuration files, use the manual provided with your modem to accomplish that task. It is recommended you select settings that enable hardware flow control and respond to DTR.

Note: Some older modems do not respond to the **X0** or **&R1** commands. Edit out these commands from the modem configuration file if yours is such a modem. See your modem manual for more information.

Some modems, such as the IBM 7857-017, are not designed for the paging function. Although they can be used for paging, they return an error message when they do not get the expected response from another modem. Therefore, even though the paging was successful, the error message causes the service processor to retry, continuing to place pager calls for the number of retries specified in the Call-Out Policy Setup Menu. These retries result in redundant pages.

Examples for Using the Generic Sample Modem Configuration Files

The following table contains information to help you determine which modem configuration file to use with various modems.

Modem	Setup Z	Setup Z0 (Rare)	Setup F	Setup F0	Setup F1
AT&T DataPort 2001 (Ring interrupt only on first ring)				X	
Bocamodem 1440E			X		
Hayes Smart Modem 300	X				
IBM 5841	X				
IBM 5843	X				
IBM 7851				X	
IBM 7852-10				X	
IBM 7855					X
USRobotics 36.6K Sportster					X
Zoom V.32			X		

Customizing the Modem Configuration Files

You can create your own modem configuration files or modify the samples provided. After you customize your modem configuration files, you *must* access them through the Configure Remote Maintenance Policy Service Aid rather than from the service processor menus.

Note: If you have already set up your serial ports, line speeds, authorizations, and telephone numbers from the service processor menus, use the service aid to specify your customized modem configuration files.

If you have not already set up your serial ports, line speeds, authorizations, and telephone numbers from the service processor menus, use the service aids to set them while you specify your customized modem configuration files.

To disable Auto-Reliable Mode testing of the remote modem, use the sample modem configuration file **/usr/share/modems/modem_f.cfg** as a model that you can modify, as follows:

1. Find the necessary command in your modem manual.
2. Copy the **/usr/share/modems/modem_f.cfg** file to a new file with a different name (for example, **modem_fx.cfg**).
3. In the new file (**modem_fx.cfg**), change the line Send "ATE0T\r" to Send "ATcccE0T\r" where ccc is the added command as specified in your modem manual, as follows:

Change the third line of each of the following stanzas:

- condout
- condin
- ripo

4. Save the changes.

IBM 7852-400 DIP Switch Settings

If you are using a 7852-400 modem to enable service processor communications, for proper operation, the dual inline package (DIP) switches must be set according to the following table:

Switch	Position	Function
1	Up	Force DTR
2	Up	Flow Control &E4
3	Down	Result Codes Enabled
4	Down	Modem Emulation Disabled
5	Up	Auto Answer Enabled
6	Up	Maximum Throughput Enabled
7	Up	RTS Normal Functions
8	Down	Enable Command Mode
9	Down	Remote Digital Loopback Test Enabled
10	Up	Dial-Up Line Enabled
11	*Up	AT Responses Enabled (Extended Responses Disabled)
12	*Down	Asynchronous Operation
13	Up	28.8KB Line Speed
14	Up	
15	Up	CD and DSR Normal Functions
16	Up	2-Wire Leased Line Enabled

* Only switches 11 and 12 are changed from the factory default settings.

Xon/Xoff Modems

Some early modems assume software flow control (Xon/Xoff) between the computer and the modem. Modems with this design send extra characters during and after the transmitted data. The service processor cannot accept these extra characters. If your configuration includes such a modem, your functional results may be unpredictable.

The sample modem configuration files included in this appendix do not support these modems, so custom configuration files are necessary. Anchor Automation 2400E is an example of such a modem.

If you experience unexplainable performance problems that may be due to Xon/Xoff characters, it is recommended that you upgrade your modem.

Ring Detection

Most modems produce an interrupt request each time they detect a ring signal. Some modems generate an interrupt only on the first ring signal that they receive. AT&T DataPort 2001 is an example of such a modem.

The service processor uses the ring interrupt request to count the number of rings when Ring Indicate Power-On (RIPO) is enabled. If your modem produces an interrupt on only the first ring, set Ring Indicate Power-On to start on the first ring. Otherwise, you can choose to start Ring Indicate Power-On on any ring count.

Terminal Emulators

The service processor is compatible with simple ASCII terminals, and therefore compatible with most emulators. When a remote session is handed off from the service processor to the operating system, agreement between terminal emulators becomes important.

The server's operating system will have some built-in terminal emulators. You may also have a commercially available terminal emulation. It is important that the local and host computers select the same or compatible terminal emulators so that the key assignments and responses match, ensuring successful communications and control.

For best formatting, choose line wrap in your terminal emulator setup.

Recovery Procedures

Situations such as line noises and power surges can sometimes cause your modem to enter an undefined state. When it is being used for dial-in, dial-out or ring indicate power-on, your modem is initialized each time one of these actions is expected. If one of these environmental conditions occur after your modem has been initialized, it might be necessary to recover your modem to a known state.

If your modem communicates correctly with remote users, it is probably in control. It may be wise to occasionally change some of the functional settings and then change them back, just for the sense of security that the modem is communicating, and to ensure it has been initialized recently.

If your system is particularly difficult to access physically, another strategy is to protect it with an Uninterruptible Power Source (UPS) and a phone-line surge protector.

In case recovery becomes necessary, shut down your system using established procedures. Disconnect the power cable and press the power button to drain capacitance while power is disconnected. Disconnect and reconnect modem power, and then reconnect system power to completely reinitialize your system.

Transfer of a Modem Session

Because many modem command variations exist, the sample modem configuration files located at the end of this appendix have been written to capture the largest number of workable modem settings.

The modem command **&Dn** (where *n* is a number) generally sets the modem response to the Data Terminal Ready (DTR) signal from the server's serial port. The desired response is that the modem will hold a connection while DTR is enabled, and drop the connection when DTR is released. Using this mechanism, the server hangs up on a connection under normal conditions.

Consult your modem manual for its specific response scheme for the **&Dn** command.

Two strategies are available for dealing with the modem's response to DTR:

- Recovery
- Prevention

Before you use one of these strategies, determine if your server's modem is set up correctly to respond to DTR.

With the remote terminal connected to serial port 1 and defined as the Primary Console Device, there are two tests you can perform:

1. Will the modem drop the connection after the System initialization complete message displays at the remote terminal?

If Yes, the modem is set up correctly.

If No, try another **&Dn** setting for your server's modem. See your modem manual for this information. The **&Dn** command appears in three places each in three of the sample modem configuration files, as follows:

2. Will the server's modem disconnect when the power drops? You can make this observation at the remote terminal by commanding your server to shut down and power off. (Use the AIX command **shutdown -F**.) Watch for the message NO CARRIER on your remote terminal.

If Yes, this is the correct response. The modem is set up correctly.

If No, try another **&Dn** setting for your server's modem. See your model manual for this information. The **&Dn** command appears in three places each in three of the sample modem configuration files. Only the following sample modem configuration files contain the **&Dn** command (in three places each):

- modem_f.cfg
- modem_f0.cfg
- modem_f1.cfg

If you are using modem_z.cfg or modem_z0.cfg, you cannot control DTR response. If your remote terminal does not disconnect after logging off, you must command the remote terminal emulator to hang up. This then breaks the connection.

Recovery Strategy

The recovery strategy consists of making two calls to establish a remote session. This solution is the easiest to implement and allows more freedom for configuring your server's serial ports.

To set up a remote terminal session, dial into the service processor and start the system. After the operating system is loaded and initialized, the connection will be dropped. At this point, call the server back and the operating system will answer and offer you the login prompt.

Prevention Strategy

The disconnect is caused by the operating system when it initializes the Primary Console. The tests listed in "Transfer of a Modem Session" on page 159 are conducted with the remote terminal selected as the primary console to manifest the modem's response to DTR transitions.

- If a local ASCII terminal or a graphics console is to be a permanent part of your server, then make one of them the primary console. Your remote terminal will no longer experience the connection loss.
- If a local console is not a permanent part of your server, you can still assign either the unused graphics console or the unused serial port as the primary console. This gives you the desired seamless connection at your remote terminal.
- If you choose to use the unused serial port as the primary console, some initialization traffic will be sent to any serial device attached to that port. As a result, that serial device's connection and function could be affected. These impacts may make that port unattractive for devices other than a temporary local ASCII terminal.

Modem Configuration Sample Files

Sample File modem_m0.cfg

```
#
# COMPONENT_NAME: (ESPSETUP) ENTRY SERVICE PROCESSOR SETUP: modem_m0
#
# FUNCTIONS: Modem configuration file specifically for IBM 7852-400
# modem with Auto-Reliable feature. This feature must be turned off
# for Catcher calls. This example uses the AT&F reset command to
# choose the factory defaults.
#
# (C) COPYRIGHT International Business Machines Corp. 1996
# All Rights Reserved
# Licensed Materials - Property of IBM
#
# US Government Users Restricted Rights - Use, duplication or
# disclosure restricted by GSA ADP Schedule Contract with IBM Corp.
#
#
# The modem has configuration switches. They should be set to the
# factory default settings, except switches 11 and 12. These must be
# to UP ("AT" responses) and DOWN (Asynchronous operation), respectively.

ICDelay 1
DefaultTO 10
CallDelay 120
#
# %N Call-Out phone number %R Return phone number
#
# PROGRAMMING NOTE: No blanks between double quote marks (").

condout: send "AT&F&E2E0T\r" # Reset to factory defaults
# Reliable mode
# Echo off
ignore "0\r" or "OK\r\n" timeout 2 # Ignore modem response.
send "AT&E12&E14\r" # Disable pacing
# Disable data compression
expect "0\r" or "OK\r\n" timeout 2 # Confirm commands successful.
send "AT&SF1&S0S9=1\r" # DSR independent of CD
# Force DSR on.
# CD respond time=100ms
expect "0\r" or "OK\r\n" timeout 2 # Confirm commands successful.
send "ATV0S0=0\r" # Numeric response code
# Auto-Answer off
expect "0\r" or "OK\r\n" timeout 2 # Confirm commands successful.
done

connect: send "ATDT%N\r" # Tone dialing command.
# %N from Call Home setup.
# Expect a connection response.
expect "33\r" or "31\r" or "28\r" or "26\r" or "24\r" or "21\r" or
"19\r" or "13\r" or "12\r" or "1\r" busy "7\r"
timeout 60
done

retry: send "A/" # Repeat the previous command.
# Expect a connection response.
expect "33\r" or "31\r" or "28\r" or "26\r" or "24\r" or "21\r" or
```

```

"19\r" or "13\r" or "12\r" or "1\r" busy "7\r"
    timeout 60
    done

disconnect:
    delay 2                # Separate from previous data.
    send "+++"            # Assure command mode.
    delay 2                # Allow mode switching delay.
    send "ATH0\r"        # Set modem switch-hook down
                        # (i.e., hang up).
    ignore "0\r" or "OK\r" timeout 2 # Ignore modem response.
    send "ATE0Q1\r"      # Initialize modem: Echo OFF,
                        # Disable responses.

    ignore "0\r" timeout 1
    done

condin:
    send "AT&F&E2E0T\r"  # Reset to factory defaults.
                        # Reliable mode
                        # Echo off
    ignore "0\r" or "OK\r\n" timeout 2 # Ignore modem response.
    send "AT&E12&E14\r"  # Disable pacing
                        # Disable data compression
    expect "0\r" or "OK\r\n" timeout 2 # Confirm commands successful
    send "AT&SF1&S0S9=1\r" # DSR independent of CD.
                        # Force DSR on.
                        # CD respond time=100ms
    expect "0\r" or "OK\r\n" timeout 2 # Confirm commands successful.
    send "ATV0S0=2\r"    # Numeric response code
                        # Answer on 2nd ring
    expect "0\r" timeout 2 # Confirm commands successful.
    done

waitcall:
    ignore "2\r" timeout 1 # Ignore first ring.
    expect "2\r" timeout 10 # Pickup 2nd ring or timeout
                        # Expect a connection response.
    expect "33\r" or "31\r" or "28\r" or "26\r" or "24\r" or "21\r" or
"19\r" or "13\r" or "12\r" or "1\r" busy "7\r"
    timeout 60
    done

page:
    send "ATDT%N,,,,%R;\r" # %N = pager call center number
                        # Add enough commas to wait for
                        # time to enter paging number.
                        # %R = paging number
    expect "0\r" timeout 60 # Confirm successful command.
    delay 2                 # Wait before hanging up.
    send "ATH0\r"          # Hang up.
    expect "0\r" timeout 2 # Confirm successful command.
    done

ripos:
    send "AT&F&E2E0T\r"  # Reset to factory defaults.
                        # Reliable mode
                        # Echo off
    ignore "0\r" or "OK\r\n" timeout 2 # Ignore modem response.
    send "AT&E12&E14\r"  # Disable pacing
                        # Disable data compression
    expect "0\r" or "OK\r\n" timeout 2 # Confirm successful command.
    send "AT&SF1&S0S9=1\r" # DSR independent of CD.
                        # Force DSR on.
                        # CD respond time=100ms

```

```
expect "0\r" or "OK\r\n" timeout 2 # Confirm commands successful.
send "ATV0S0=0\r"                  # Numeric response code
                                     # Auto Answer OFF
expect "0\r" timeout 2              # Confirm commands successful.
done                                 #

error:                               # Handle unexpected modem
                                     # responses.
expect "8\r" or "7\r" or "6\r" or "4\r" or "3\r"
delay 2
done
```

Sample File modem_m1.cfg

```
#
# COMPONENT_NAME: (ESPSETUP) ENTRY SERVICE PROCESSOR SETUP modem_m1
#
# FUNCTIONS: Modem configuration file specifically for IBM 7857-017 modem with
# Auto-Reliable feature. This feature must be turned off for Catcher calls.
# This example uses the AT&F reset command to choose the factory defaults.
#
# To allow dial commands for digital pagers, it is necessary to reduce
# the number of characters in the dial command. Each comma (delay) has
# been set to 6 seconds (S8=6) for that reason.
#
#
# (C) COPYRIGHT International Business Machines Corp. 1996
# All Rights Reserved
# Licensed Materials - Property of IBM
#
# US Government Users Restricted Rights - Use, duplication or
# disclosure restricted by GSA ADP Schedule Contract with IBM Corp.
#

ICDelay 1
DefaultT0 10
CallDelay 120
#
# %N Call-Out phone number %R Return phone number
#
#
# PROGRAMMING NOTE: No blanks between double quote marks (").

condout: send "AT&F*E0E0\r" # Reset to factory defaults.
# *E0=data compression disabled
# E0=echo disabled
ignore "0\r" or "OK\r\n" timeout 2 # Ignore modem response.
send "AT#F0*Q2S8=6\r" # Trellis modulation disabled
# Retrain with adaptive rate
# Set ,=6second
expect "0\r" or "OK\r\n" timeout 2 # Confirm commands successful
send "ATV0X0S0=0\r" # Numeric response code
# AT compatible messages
# Auto-Answer disabled
expect "0\r" or "OK\r\n" timeout 2 # Confirm commands successful.
done

connect: send "ATDT%N\r" # Tone dialing command.
# %N from Call Home setup.
expect "1\r" busy "7\r" timeout 60 # Expect a connection response.
done

retry: send "A/" # Repeat the previous command.
expect "1\r" busy "7\r" timeout 60 # Expect a connection response.
done

disconnect:
delay 2 # Separate from previous data.
send "+++" # Assure command mode.
delay 2 # Allow mode switching delay.
send "ATH0\r" # Set modem switch-hook down
# (i.e., hang up).
ignore "0\r" or "OK\r" timeout 2 # Ignore modem response.
```



```

send "ATE0Q1\r" # Initialize modem: Echo OFF,
# Disable responses.

ignore "\0\r" timeout 1
done

condin: send "AT&F*E0E0\r" # Reset to factory defaults.
# *E0=data compression disabled
# E0=echo disabled

ignore "\0\r" or "OK\r\n" timeout 2 # Ignore modem response.
send "AT#F0*Q2\r" # Trellis modulation disabled
# Retrain with adaptive rate

expect "\0\r" or "OK\r\n" timeout 2 # Confirm commands successful
send "ATV0X0S0=2\r" # Numeric response code
# AT compatible messages
# Answer on 2nd ring

expect "\0\r" timeout 2 # Confirm commands successful.
done

waitcall: ignore "2\r" timeout 1 # Ignore first ring.
expect "2\r" timeout 10 # Pick up second ring
# or timeout.
# Expect a connection response.

expect "1\r" timeout 60
done

page: send "ATD%N,%R\r" # %N = pager call center number
# commas=6sec wait time to
# enter paging number.
# %R = return number

expect "\0\r" or "3\r" timeout 30 # Confirm successful command.
delay 2 # Wait before hanging up.
send "+++" # Assure command mode.
delay 2 # Allow mode switching delay.
send "ATH0\r" # Hang up.
expect "\0\r" timeout 2 # Confirm successful command.
done

ripos: send "AT&F*E0E0\r" # Reset to factory defaults.
# *E0=data compression disabled
# E0=echo disabled

ignore "\0\r" or "OK\r\n" timeout 2 # Ignore modem response.
send "AT#F0*Q2\r" # Trellis modulation disabled
# Retrain with adaptive rate

expect "\0\r" or "OK\r\n" timeout 2 # Confirm successful command.
send "ATV0X0S0=0\r" # Numeric response code
# AT compatible messages
# Auto-Answer disabled

expect "\0\r" timeout 2 # Confirm commands successful.
done

error: # Handle unexpected modem
# responses.

expect "8\r" or "7\r" or "4\r" or "3\r"
delay 2
done

```

Sample File modem_z.cfg

```
#
# COMPONENT_NAME: (ESPSETUP) ENTRY SERVICE PROCESSOR SETUP Z
#
# FUNCTIONS: Modem configuration file for many early Hayes* compatible modems.
# This example uses the ATZ reset command to choose the factory defaults.
# This setup will work for many modems, but it is required for early vintage
# modems which respond to neither the ATZ0 reset command nor the extended (&)
# commands. Refer to your modem manual.
#
# * Trademark of Hayes Microcomputer Products, Inc.
#
# (C) COPYRIGHT International Business Machines Corp. 1996
# All Rights Reserved
# Licensed Materials - Property of IBM
#
# US Government Users Restricted Rights - Use, duplication or
# disclosure restricted by GSA ADP Schedule Contract with IBM Corp.
#
#
# If the modem has configuration switches, they should be set to the
# factory default settings.

ICDelay 1
DefaultT0 10
CallDelay 120
# AT Attention Code , Inserts delay in dialing commands
# Z Reset to factory defaults Q0 Turn on responses
# E0 Turn echo off Q1 Turn off responses
# V0 Use numeric responses S0=0 Automatic answer inhibit
# +++ Escape to command mode S0=2 Answer on second ring
# H0 Hang-up T = Tone mode. When used as T\r, it is a
# no op to maintain program synchronization
# when modem may/will echo the commands.
#
#
# %N Call-Out phone number %P Paging phone number
# %S Modem speed (available to users)
#
# Following are common responses from a wide range of modems:
# 16, 15, 12, 10, 5 and 1 are connection responses. Add others as required.
# 7=busy; 6=no dial tone; 4=error; 3=no carrier; 2=ring; 0=OK
#
# PROGRAMMING NOTE: No blanks between double quote marks (").

condout: send "ATZQ0T\r" # Reset to factory defaults.
ignore "0\r" or "OK\r\n" timeout 2 # Ignore modem response.
send "ATE0T\r" # Initialize modem: Echo OFF,
expect "0\r" or "OK\r\n" timeout 2 # Enable responses (Numeric),
send "ATQ0V0T\r" # Limit response codes.
expect "0\r" timeout 2 # Confirm commands successful.
send "ATS0=0\r" # Set AutoAnswer OFF
expect "0\r" timeout 2 # Confirm command successful.
done

connect: send "ATDT%N\r" # Tone dialing command.
# %N from Call Home setup.

# Expect a connection response.
expect "16\r" or "15\r" or "14\r" or "12\r" or "10\r" or "5\r" or "1\r" busy "7\r"
timeout 60
```

```

done

retry:    send "A/"                                # Repeat the previous command.

                                                # Expect a connection response.
expect "16\r" or "15\r" or "14\r" or "12\r" or "10\r" or "5\r" or "1\r" busy "7\r"
timeout 60
done

disconnect:
delay 2                                         # Separate from previous data.
send "+++"                                     # Assure command mode.
delay 2                                         # Allow mode switching delay.
send "ATH0T\r"                                 # Set modem switch-hook down
                                                # (i.e., hang up).

ignore "0\r" or "OK\r" timeout 2              # Ignore modem response.
send "ATE0Q1\r"                                # Initialize modem: Echo OFF,
                                                # Disable responses.

ignore "0\r" timeout 1
done

condin:   send "ATZQ0T\r"                       # Reset to factory defaults.
ignore "0\r" or "OK\r\n" timeout 2           # Ignore modem response.
send "ATE0T\r"                                # Initialize modem: Echo OFF,
expect "0\r" or "OK\r\n" timeout 2          # Enable responses (Numeric),
send "ATQ0V0T\r"                             # Limit response codes.
expect "0\r" timeout 2                       # Confirm commands successful.
send "ATS0=2\r"                              # Set AutoAnswer ON
expect "0\r" timeout 2                       # Confirm command successful.
done

waitcall: ignore "2\r" timeout 1              # Ignore first ring.
expect "2\r" timeout 10                      # Pick up second ring
                                                # or timeout.
                                                # Expect a connection response.
expect "16\r" or "15\r" or "14\r" or "12\r" or "10\r" or "5\r" or "1\r"
timeout 60
done

page:     send "ATDT%N,,,,,%R;\r"             # %N = pager call center number
                                                # Add enough commas to wait for
                                                # time to enter paging number.
                                                # %R = paging number

                                                # Confirm successful command.
expect "0\r" timeout 60
delay 2                                         # Wait before hanging up.
send "ATH0T\r"                                 # Hang up.
expect "0\r" timeout 2                         # Confirm successful command.
done

ripo:    send "ATZQ0T\r"                       # Reset to factory defaults.
ignore "0\r" or "OK\r\n" timeout 2           # Ignore modem response.
send "ATE0T\r"                                # Initialize modem: Echo OFF,
expect "0\r" or "OK\r\n" timeout 2          # Enable responses (Numeric),
send "ATQ0V0T\r"                             # Limit response codes.
expect "0\r" timeout 2                       # Confirm commands successful.
send "ATS0=0\r"                              # Set AutoAnswer OFF
expect "0\r" timeout 2                       # Confirm command successful.
done                                           # RI Power On enabled.

```

```
error:                                     # Handle unexpected modem
                                           # responses.
expect "8\r" or "7\r" or "6\r" or "4\r" or "3\r"
delay 2
done
```

Sample File modem_z0.cfg

```
#
# COMPONENT_NAME: (ESPSETUP) ENTRY SERVICE PROCESSOR SETUP Z0
#
# FUNCTIONS: Modem configuration file for some early Hayes* compatible modems.
# This example uses the ATZ0 reset command to choose the factory defaults.
# This setup is recommended for modems that will respond to the ATZ0 command
# and which do not respond to the extended (&) commands. Refer to your modem
# manual.
#
# * Trademark of Hayes Microcomputer Products, Inc.
#
# (C) COPYRIGHT International Business Machines Corp. 1996
# All Rights Reserved
# Licensed Materials - Property of IBM
#
# US Government Users Restricted Rights - Use, duplication or
# disclosure restricted by GSA ADP Schedule Contract with IBM Corp.
#
#
# If the modem has configuration switches, they should be set to the
# factory default settings.

ICDelay 1
DefaultT0 10
CallDelay 120
# AT Attention Code           , Inserts delay in dialing commands
# Z0 Reset. Restore Profile 0 Q0 Turn on responses
# E0 Turn echo off           Q1 Turn off responses
# V0 Use numeric responses    S0=0 Automatic answer inhibit
# +++ Escape to command mode S0=2 Answer on second ring
# H0 Hang-up                 X0=0 Limit modem response codes
#                             T = Tone mode. When used as T\r, it is a
#                             no op to maintain program synchronization
#                             when modem may/will echo the commands.
#
# %N Call-Out phone number    %P Paging phone number
# %S Modem speed (available to users)
#
# Following are common responses from a wide range of modems:
# 16, 15, 12, 10, 5 and 1 are connection responses. Add others as required.
# 7=busy; 6=no dial tone; 4=error; 3=no carrier; 2=ring; 0=OK
#
# PROGRAMMING NOTE: No blanks between double quote marks (").

condout:    send "ATZ0Q0T\r"           # Reset modem. Select profile 0
            ignore "0\r" or "OK\r\n" timeout 2 # Ignore modem response.
            send "ATE0T\r"           # Initialize modem: Echo OFF,
            expect "0\r" or "OK\r\n" timeout 2 # Enable responses (Numeric),
            send "ATQ0V0X0T\r"       # Limit response codes.
            expect "0\r" timeout 2    # Confirm commands successful.
            send "ATS0=0\r"          # Set AutoAnswer OFF
            expect "0\r" timeout 2    # Confirm command successful.
            done

connect:    send "ATDT%N\r"           # Tone dialing command.
            # %N from Call Home setup.

            # Expect a connection response.
            expect "16\r" or "15\r" or "14\r" or "12\r" or "10\r" or "5\r" or "1\r" busy "7\r"
```

```

timeout 60
done

retry:    send "A/"                                # Repeat the previous command.

                                                # Expect a connection response.
expect "16\r" or "15\r" or "14\r" or "12\r" or "10\r" or "5\r" or "1\r" busy "7\r"
timeout 60
done

disconnect:
delay 2                                         # Separate from previous data.
send "+++"                                     # Assure command mode.
delay 2                                         # Allow mode switching delay.
send "ATH0T\r"                                 # Set modem switch-hook down
                                                # (i.e., hang up).

ignore "0\r" or "OK\r" timeout 2              # Ignore modem response.
send "ATE0Q1\r"                                # Initialize modem: Echo OFF,
                                                # Disable responses.

ignore "0\r" timeout 1
done

condin:   send "ATZ0Q0T\r"                      # Reset modem. Select profile 0
ignore "0\r" or "OK\r\n" timeout 2           # Ignore modem response.
send "ATE0T\r"                                # Initialize modem: Echo OFF,
expect "0\r" or "OK\r\n" timeout 2           # Enable responses (Numeric),
send "ATQ0V0X0T\r"                           # Limit response codes.
expect "0\r" timeout 2                       # Confirm commands successful.
send "ATS0=2\r"                               # Set AutoAnswer ON
expect "0\r" timeout 2                       # Confirm command successful.
done

waitcall: ignore "2\r" timeout 1              # Ignore first ring.
         expect "2\r" timeout 10              # Pick up second ring
                                                # or timeout.
                                                # Expect a connection response.
expect "16\r" or "15\r" or "14\r" or "12\r" or "10\r" or "5\r" or "1\r"
timeout 60
done

page:     send "ATDT%N,,,,%R;\r"              # %N = pager call center number
                                                # Add enough commas to wait for
                                                # time to enter paging number.
                                                # %R = paging number

                                                # Confirm successful command.
expect "0\r" timeout 60
delay 2                                         # Wait before hanging up.
send "ATH0T\r"                                 # Hang up.
expect "0\r" timeout 2                         # Confirm successful command.
done

ripo:    send "ATZ0Q0T\r"                      # Reset modem. Select profile 0
ignore "0\r" or "OK\r\n" timeout 2           # Ignore modem response.
send "ATE0T\r"                                # Initialize modem: Echo OFF,
expect "0\r" or "OK\r\n" timeout 2           # Enable responses (Numeric),
send "ATQ0V0X0T\r"                           # Limit response codes.
expect "0\r" timeout 2                       # Confirm commands successful.
send "ATS0=0\r"                               # Set AutoAnswer OFF
expect "0\r" timeout 2                       # Confirm command successful.

```

```
done                                # RI Power On enabled.
error:                               # Handle unexpected modem
                                     # responses.
expect "8\r" or "7\r" or "6\r" or "4\r" or "3\r"
delay 2
done
```

Sample File modem_f.cfg

```
#
# COMPONENT_NAME: (ESPSETUP) ENTRY SERVICE PROCESSOR SETUP F
#
# FUNCTIONS: Modem configuration file for many recent Hayes* compatible modems.
# This example uses the AT&F reset command to choose the factory defaults.
# This set up is preferred for modems with extended (&) commands. For early
# vintage modems, setup Z or Z0 is recommended. If your modem responds to
# the extended (&) commands and to factory default choices (&Fn), setup file
# F0 or F1 is recommended.
#
# * Trademark of Hayes Microcomputer Products, Inc.
#
# (C) COPYRIGHT International Business Machines Corp. 1996
# All Rights Reserved
# Licensed Materials - Property of IBM
#
# US Government Users Restricted Rights - Use, duplication or
# disclosure restricted by GSA ADP Schedule Contract with IBM Corp.
#
#
# If the modem has configuration switches, they should be set to the
# factory default settings.

ICDelay 1
DefaultT0 10
CallDelay 120
# AT Attention Code , Inserts delay in dialing commands
# &F Reset to default profile Q0 Turn on responses
# E0 Turn echo off Q1 Turn off responses
# V0 Use numeric responses S0=0 Automatic answer inhibit
# +++ Escape to command mode S0=2 Answer on second ring
# H0 Hang-up X0=0 Limit modem response codes
# T = Tone mode. When used as T\r, it is a
# no op to maintain program synchronization
# when modem may/will echo the commands.
#
# &C1 Detect CD &D2 Respond to DTR (often the default)
#
# %N Call-Out phone number %P Paging phone number
# %S Modem speed (available to users)
#
# Following are common responses from a wide range of modems:
# 16, 15, 12, 10, 5 and 1 are connection responses. Add others as required.
# 7=busy; 6=no dial tone; 4=error; 3=no carrier; 2=ring; 0=OK
#
# PROGRAMMING NOTE: No blanks between double quote marks (").

condout: send "AT&FQ0T\r" # Reset to factory defaults.
         ignore "0\r" or "OK\r\n" timeout 2 # Ignore modem response.
         send "ATE0T\r" # Initialize modem: Echo OFF,
         expect "0\r" or "OK\r\n" timeout 2 # Enable responses (Numeric),
         send "ATQ0V0X0T\r" # Limit response codes.
         expect "0\r" timeout 2 # Confirm commands successful.
         send "ATS0=0\r" # Set AutoAnswer OFF
         expect "0\r" timeout 2 # Confirm command successful.
         send "AT&C1&D2\r" # Detect carrier and DTR.
         expect "0\r" timeout 2 # Confirm command successful.
         done
```



```

connect:    send "ATDT%N\r"                # Tone dialing command.
                                                # %N from Call Home setup.

                                                # Expect a connection response.
expect "16\r" or "15\r" or "14\r" or "12\r" or "10\r" or "5\r" or "1\r" busy "7\r"
timeout 60
done

retry:     send "A/"                      # Repeat the previous command.

                                                # Expect a connection response.
expect "16\r" or "15\r" or "14\r" or "12\r" or "10\r" or "5\r" or "1\r" busy "7\r"
timeout 60
done

disconnect:
delay 2                                         # Separate from previous data.
send "+++"                                     # Assure command mode.
delay 2                                         # Allow mode switching delay.
send "ATH0T\r"                                 # Set modem switch-hook down
                                                # (i.e., hang up).
ignore "0\r" or "OK\r" timeout 2              # Ignore modem response.
send "ATE0Q1\r"                                # Initialize modem: Echo OFF,
                                                # Disable responses.

ignore "0\r" timeout 1
done

condin:    send "AT&FQ0T\r"                 # Reset to factory defaults.
ignore "0\r" or "OK\r\n" timeout 2            # Ignore modem response.
send "ATE0T\r"                                 # Initialize modem: Echo OFF,
expect "0\r" or "OK\r\n" timeout 2            # Enable responses (Numeric),
send "ATQ0V0X0T\r"                            # Limit response codes.
expect "0\r" timeout 2                        # Confirm commands successful.
send "ATS0=2\r"                                # Set AutoAnswer ON
expect "0\r" timeout 2                        # Confirm command successful.
send "AT&C1&D2\r"                            # Detect carrier and DTR.
expect "0\r" timeout 2                        # Confirm command successful.
done

waitcall:  ignore "2\r" timeout 1              # Ignore first ring.
expect "2\r" timeout 10                       # Pick up second ring
                                                # or timeout.
                                                # Expect a connection response.
expect "16\r" or "15\r" or "14\r" or "12\r" or "10\r" or "5\r" or "1\r"
timeout 60
done

page:      send "ATDT%N,,,,%R;\r"           # %N = pager call center number
                                                # Add enough commas to wait for
                                                # time to enter paging number.
                                                # %R = paging number

                                                # Confirm successful command.
expect "0\r" timeout 60
delay 2                                         # Wait before hanging up.
send "ATH0T\r"                                 # Hang up.
expect "0\r" timeout 2                        # Confirm successful command.
done

ripo:      send "AT&FQ0T\r"                 # Reset to factory defaults.

```

```

        ignore "0\r" or "OK\r\n" timeout 2 # Ignore modem response.
        send "ATE0T\r" # Initialize modem: Echo OFF,
        expect "0\r" or "OK\r\n" timeout 2 # Enable responses (Numeric),
        send "ATQ0V0X0T\r" # Limit response codes.
        expect "0\r" timeout 2 # Confirm commands successful.
        send "ATS0=0\r" # Set AutoAnswer OFF
        expect "0\r" timeout 2 # Confirm command successful.
        send "AT&C1&D2\r" # Detect carrier and DTR.
        expect "0\r" timeout 2 # Confirm command successful.
        done # RI Power On enabled.

error: # Handle unexpected modem
        # responses.
        expect "8\r" or "7\r" or "6\r" or "4\r" or "3\r"
        delay 2
        done

```

Sample File modem_f0.cfg

```

#
# COMPONENT_NAME: (ESPSETUP) ENTRY SERVICE PROCESSOR SETUP F0
#
# FUNCTIONS: Modem configuration file for many recent Hayes* compatible modems.
# This example uses the AT&F0 reset command to choose the factory defaults.
# This set up is preferred for modems with extended (&) commands. For early
# vintage modems, setup Z or Z0 is recommended. If your modem responds to
# the extended (&) commands and to factory default choices (&Fn), but doesn't
# work properly with this setup file, setup F1 is recommended.
#
# * Trademark of Hayes Microcomputer Products, Inc.
#
# (C) COPYRIGHT International Business Machines Corp. 1996
# All Rights Reserved
# Licensed Materials - Property of IBM
#
# US Government Users Restricted Rights - Use, duplication or
# disclosure restricted by GSA ADP Schedule Contract with IBM Corp.
#
# If the modem has configuration switches, they should be set to the
# factory default settings.

ICDelay 1
DefaultT0 10
CallDelay 120
# AT Attention Code , Inserts delay in dialing commands
# &F0 Reset. Restore profile 0 Q0 Turn on responses
# E0 Turn echo off Q1 Turn off responses
# V0 Use numeric responses S0=0 Automatic answer inhibit
# +++ Escape to command mode S0=2 Answer on second ring
# H0 Hang-up X0=0 Limit modem response codes
# T = Tone mode. When used as T\r, it is a
# no op to maintain program synchronization
# when modem may/will echo the commands.
#
# &C1 Detect CD &D2 Respond to DTR (often the default)
# &R1 Ignore RTS (CTS)
#
# %N Call-Out phone number %P Paging phone number
# %S Modem speed (available to users)
#

```

```

# Following are common responses from a wide range of modems:
# 16, 15, 12, 10, 5 and 1 are connection responses. Add others as required.
# 7=busy; 6=no dial tone; 4=error; 3=no carrier; 2=ring; 0=OK
#
# PROGRAMMING NOTE: No blanks between double quote marks (").

condout:  send "AT&F0Q0T\r"          # Reset modem. Select profile 0
          ignore "\0\r" or "OK\r\n" timeout 2 # Ignore modem response.
          send "ATE0T\r"            # Initialize modem: Echo OFF,
          expect "\0\r" or "OK\r\n" timeout 2 # Enable responses (Numeric),
          send "ATQ0V0X0T\r"        # Limit response codes.
          expect "\0\r" timeout 2    # Confirm commands successful.
          send "ATS0=0\r"            # Set AutoAnswer OFF
          expect "\0\r" timeout 2    # Confirm command successful.
          send "AT&C1&D2&R1\r"      # Detect carrier and DTR,
                                     # Ignore RTS.
          expect "\0\r" timeout 2    # Confirm command successful.
          done

connect:  send "ATDT%N\r"           # Tone dialing command.
                                     # %N from Call Home setup.

          # Expect a connection response.
          expect "16\r" or "15\r" or "14\r" or "12\r" or "10\r" or "5\r" or "1\r" busy "7\r"
          timeout 60
          done

retry:    send "A/"                 # Repeat the previous command.

          # Expect a connection response.
          expect "16\r" or "15\r" or "14\r" or "12\r" or "10\r" or "5\r" or "1\r" busy "7\r"
          timeout 60
          done

disconnect:
          delay 2                    # Separate from previous data.
          send "+++"                 # Assure command mode.
          delay 2                    # Allow mode switching delay.
          send "ATH0T\r"            # Set modem switch-hook down
                                     # (i.e., hang up).
          ignore "\0\r" or "OK\r" timeout 2 # Ignore modem response.
          send "ATE0Q1\r"           # Initialize modem: Echo OFF,
                                     # Disable responses.
          ignore "\0\r" timeout 1
          done

condin:   send "AT&F0Q0T\r"          # Reset modem. Select profile 0
          ignore "\0\r" or "OK\r\n" timeout 2 # Ignore modem response.
          send "ATE0T\r"            # Initialize modem: Echo OFF,
          expect "\0\r" or "OK\r\n" timeout 2 # Enable responses (Numeric),
          send "ATQ0V0X0T\r"        # Limit response codes.
          expect "\0\r" timeout 2    # Confirm commands successful.
          send "ATS0=2\r"            # Set AutoAnswer ON
          expect "\0\r" timeout 2    # Confirm command successful.
          send "AT&C1&D2&R1\r"      # Detect carrier and DTR,
                                     # Ignore RTS.
          expect "\0\r" timeout 2    # Confirm command successful.
          done

waitcall: ignore "2\r" timeout 1    # Ignore first ring.

```

```

        expect "2\r" timeout 10                # Pick up second ring
                                                # or timeout.
                                                # Expect a connection response.
expect "16\r" or "15\r" or "14\r" or "12\r" or "10\r" or "5\r" or "1\r"
timeout 60
done

page:      send "ATDT%N,,,,%R;\r"            # %N = pager call center number
                                                # Add enough commas to wait for
                                                # time to enter paging number.
                                                # %R = paging number

                                                # Confirm successful command.

        expect "0\r" timeout 60
        delay 2                               # Wait before hanging up.
        send "ATH0T\r"                       # Hang up.
        expect "0\r" timeout 2               # Confirm successful command.
done

ripo:      send "AT&F0Q0T\r"                 # Reset modem. Select profile 0
        ignore "0\r" or "OK\r\n" timeout 2 # Ignore modem response.
        send "ATE0T\r"                       # Initialize modem: Echo OFF,
        expect "0\r" or "OK\r\n" timeout 2 # Enable responses (Numeric),
        send "ATQ0V0X0T\r"                   # Limit response codes.
        expect "0\r" timeout 2               # Confirm commands successful.
        send "ATS0=0\r"                       # Set AutoAnswer OFF
        expect "0\r" timeout 2               # Confirm command successful.
        send "AT&C1&D2&R1\r"                 # Detect carrier and DTR,
                                                # Ignore RTS.

        expect "0\r" timeout 2               # Confirm command successful.
done                                             # RI Power On enabled.

error:                                           # Handle unexpected modem
                                                # responses.

        expect "8\r" or "7\r" or "6\r" or "4\r" or "3\r"
        delay 2
done

```

Sample File modem_f1.cfg

```

#
# COMPONENT_NAME: (ESPSETUP) ENTRY SERVICE PROCESSOR SETUP F1
#
# FUNCTIONS: Modem configuration file for many recent Hayes* compatible modems.
# This example uses the AT&F1 reset command to choose the factory defaults.
# This set up is for modems with extended (&) commands and which do not work
# properly with setup F0. For early vintage modems, setup Z or Z0 is
# recommended.
#
# * Trademark of Hayes Microcomputer Products, Inc.
#
# (C) COPYRIGHT International Business Machines Corp. 1996
# All Rights Reserved
# Licensed Materials - Property of IBM
#
# US Government Users Restricted Rights - Use, duplication or
# disclosure restricted by GSA ADP Schedule Contract with IBM Corp.
#
#
# If the modem has configuration switches, they should be set to the
# factory default settings.

```

```

ICDelay 1
DefaultT0 10
CallDelay 120
# AT Attention Code , Inserts delay in dialing commands
# &F1 Reset. Restore profile 1 Q0 Turn on responses
# E0 Turn echo off Q1 Turn off responses
# V0 Use numeric responses S0=0 Automatic answer inhibit
# +++ Escape to command mode S0=2 Answer on second ring
# H0 Hang-up X0=0 Limit modem response codes
# T = Tone mode. When used as T\r, it is a
# no op to maintain program synchronization
# when modem may/will echo the commands.
#
# &C1 Detect CD &D2 Respond to DTR (often the default)
# &R1 Ignore RTS (CTS)
#
# %N Call-Out phone number %P Paging phone number
# %S Modem speed (available to users)
#
# Following are common responses from a wide range of modems:
# 16, 15, 12, 10, 5 and 1 are connection responses. Add others as required.
# 7=busy; 6=no dial tone; 4=error; 3=no carrier; 2=ring; 0=OK
#
# PROGRAMMING NOTE: No blanks between double quote marks (").

condout: send "AT&F1Q0T\r" # Reset modem. Select profile 1
         ignore "0\r" or "OK\r\n" timeout 2 # Ignore modem response.
         send "ATE0T\r" # Initialize modem: Echo OFF,
         expect "0\r" or "OK\r\n" timeout 2 # Enable responses (Numeric),
         send "ATQ0V0X0T\r" # Limit response codes.
         expect "0\r" timeout 2 # Confirm commands successful.
         send "ATS0=0\r" # Set AutoAnswer OFF
         expect "0\r" timeout 2 # Confirm command successful.
         send "AT&C1&D2&R1\r" # Detect carrier and DTR,
         # Ignore RTS.
         expect "0\r" timeout 2 # Confirm command successful.
         done

connect: send "ATDT%N\r" # Tone dialing command.
         # %N from Call Home setup.

         # Expect a connection response.
         expect "16\r" or "15\r" or "14\r" or "12\r" or "10\r" or "5\r" or "1\r" busy "7\r"
         timeout 60
         done

retry: send "A/" # Repeat the previous command.

         # Expect a connection response.
         expect "16\r" or "15\r" or "14\r" or "12\r" or "10\r" or "5\r" or "1\r" busy "7\r"
         timeout 60
         done

disconnect:
         delay 2 # Separate from previous data.
         send "+++" # Assure command mode.
         delay 2 # Allow mode switching delay.
         send "ATH0T\r" # Set modem switch-hook down
         # (i.e., hang up).

```

```

        ignore "0\r" or "OK\r" timeout 2 # Ignore modem response.
        send "ATE0Q1\r" # Initialize modem: Echo OFF,
        # Disable responses.

        ignore "0\r" timeout 1
        done

condin:  send "AT&F1Q0T\r" # Reset modem. Select profile 1
        ignore "0\r" or "OK\r\n" timeout 2 # Ignore modem response.
        send "ATE0T\r" # Initialize modem: Echo OFF,
        expect "0\r" or "OK\r\n" timeout 2 # Enable responses (Numeric),
        send "ATQ0V0X0T\r" # Limit response codes.
        expect "0\r" timeout 2 # Confirm commands successful.
        send "ATS0=2\r" # Set AutoAnswer ON
        expect "0\r" timeout 2 # Confirm command successful.
        send "AT&C1&D2&R1\r" # Detect carrier and DTR,
        # Ignore RTS.

        expect "0\r" timeout 2 # Confirm command successful.
        done

waitcall: ignore "2\r" timeout 1 # Ignore first ring.
        expect "2\r" timeout 10 # Pick up second ring
        # or timeout.
        # Expect a connection response.

        expect "16\r" or "15\r" or "14\r" or "12\r" or "10\r" or "5\r" or "1\r"
        timeout 60
        done

page:    send "ATDT%N,,,,%R;\r" # %N = pager call center number
        # Add enough commas to wait for
        # time to enter paging number.
        # %R = paging number

        # Confirm successful command.

        expect "0\r" timeout 60
        delay 2 # Wait before hanging up.
        send "ATH0T\r" # Hang up.
        expect "0\r" timeout 2 # Confirm successful command.
        done

ripo:   send "AT&F1Q0T\r" # Reset modem. Select profile 1
        ignore "0\r" or "OK\r\n" timeout 2 # Ignore modem response.
        send "ATE0T\r" # Initialize modem: Echo OFF,
        expect "0\r" or "OK\r\n" timeout 2 # Enable responses (Numeric),
        send "ATQ0V0X0T\r" # Limit response codes.
        expect "0\r" timeout 2 # Confirm commands successful.
        send "ATS0=0\r" # Set AutoAnswer OFF
        expect "0\r" timeout 2 # Confirm command successful.
        send "AT&C1&D2&R1\r" # Detect carrier and DTR,
        # Ignore RTS.

        expect "0\r" timeout 2 # Confirm command successful.
        done # RI Power On enabled.

error:  # Handle unexpected modem
        # responses.

        expect "8\r" or "7\r" or "6\r" or "4\r" or "3\r"
        delay 2
        done

```

Index

Numerics

- 3.5-inch diskette drive
 - using 21
- 7135 RAIDiant array 125
- 7318 server service aid 125

A

- accessing information xv
- acoustical
 - noise
 - emissions 142
- AIX documentation xv, 85, 87
- alter/display bootlist 103
- attention LED 15
- attributes required for TTY terminal 145

B

- battery
 - disposal, recycling 141
- boot devices
 - select 77
- boot list 84
- boot mode menu 39
- boot options
 - select 74
- bus 8

C

- call-in
 - testing 150
- call-in/call-out setup menu 46
- call-out
 - testing 150
- call-out (call-home) 60
- call-out policy setup menu 50
- CD-ROM drive
 - using 22
- change diagnostic run-time 104
- configuration
 - client 88
 - NIM server 87
- configure
 - memory 58
 - processor 58
- configure scan dump policy 100
- console mirroring 61
 - enable/disable 34
- customer account setup menu 50

D

- deconfigure
 - memory 58

- deconfigure (*continued*)
 - processor 58
- diaggetrto command 104
- diagnostic run-time
 - change 104
 - display 104
- diagnostics
 - considerations 81
 - loading 86, 128, 129
 - online 82
 - concurrent mode 84, 85
 - loading 127
 - maintenance mode 85
 - problem determination
 - loading 137
 - running
 - service mode 83
 - service mode 82
 - standalone 86
 - considerations 86
 - loading 128
 - NIM server 87
 - stopping 129
 - using 81
- diagsetrto command 104
- display diagnostic run-time 104
- display fault indicators 109
- display identify indicators 117
- display/alter bootlist 103
- documentation
 - AIX xv, 85, 87
- documentation overview 3
- drive
 - 3.5-inch diskette
 - using 21
 - CD-ROM
 - using 22

E

- electrical safety ix
 - laser compliance statement xi
- emissions
 - noise 142
- ergonomic information xvii
- error log
 - view 70
- error logs
 - service processor 62

F

- fault indicators 109
- features
 - keyboard 9
 - media drives 8
 - mouse 9

- features *(continued)*
 - operator panel 9
 - power supply 9
- firmware 55
 - level 55
 - update 55
- firmware updates
 - system 54
- flash SK-NET FDDI firmware 110

G

- general user menu 29

H

- hardware
 - operation
 - verifying 127
 - problem determination 131
 - verification
 - considerations 127
- highlighting xv
- HMC
 - Linux system
 - stopping 12
 - running online diagnostics with no attached HMC 84
 - running standalone diagnostics with no attached HMC 86
 - system
 - starting 11
 - stopping 12

I

- identify indicators 116, 117
- indicators
 - fault 109
- information, accessing xv

K

- keyboard 9
- keyboards
 - using 18

L

- language
 - select 69
- language selection menu 45
- laser compliance statement xi
- laser safety information xi
- LCD progress indicator log 63
- LED
 - indicator
 - menu 45
- LEDs
 - attention 15

- LEDs *(continued)*
 - component 16
 - disturbance 15
- lights
 - status
 - understanding 23
- loading
 - online diagnostics 127
 - standalone diagnostic 128
- local area network service aid 117
- log repair action service aid 117

M

- media bays and backplane 8
- memory 8
 - configure 58
 - deconfigure 58
- memory configuration/deconfiguration menu 43
- menu
 - boot mode 39
 - call-in/call-out 46
 - call-out policy setup 50
 - customer account setup 50
 - general
 - user 29
 - language selection 45
 - LED indicator 45
 - main 29
 - memory configuration/deconfiguration 43
 - modem configuration 47
 - OS surveillance
 - setup 34
 - power control network utilities 44
 - processor configuration/deconfiguration 41
 - reboot/restart policy setup 38
 - ring indicate 38
 - serial port selection 47
 - serial port speed setup 48
 - setup 32
 - system information 40
 - system power control 37
 - telephone setup 48
 - user
 - privileged 29
- modem
 - configuration file selection 154
 - configurations 153
 - transfer 159
- modem_f.cfg, sample file 172
- modem_f0.cfg, sample file 174
- modem_f1.cfg, sample file 176
- modem_m0.cfg, sample file 161
- modem_m1.cfg, sample file 164
- modem_z.cfg, sample file 166
- modem_z0.cfg, sample file 169
- mouse 9
 - three-button
 - caring for 19
 - cleaning 19
 - using 19

N

- network service aid 117
- NIM server
 - configuration 87
 - client 88
 - standalone diagnostics 87
- noise
 - emissions 142

O

- online diagnostics
 - concurrent mode 84, 85
 - loading 127
 - maintenance mode 85
 - modes of operation 82
 - service mode 82
- online publications xv, 2
- operating considerations
 - online and standalone diagnostics 81
- operation
 - hardware
 - verifying 127
- operational phases
 - service processor 64
- operator panel 9, 14
 - reading 13
- overview
 - documentation 3

P

- parameters
 - service processor
 - service mode 51
- password
 - options
 - changing 69
- passwords 33
 - general
 - change 34
 - privileged
 - change 34
- physical disk status
 - SCSI RAID 122
- power control network utilities menu 44
- power supplies 9
- power-on
 - methods 51
- primary console 160
- privileged user menus 29
- problem determination
 - diagnostics
 - loading 137
 - hardware 131
 - online
 - diagnostics 137
 - standalone
 - diagnostics 137
 - using online diagnostics 131

- problem determination (*continued*)
 - using standalone diagnostics 131
- processor
 - configure 58
 - deconfigure 58
- processor configuration/deconfiguration menu 41
- processors 8
- product disposal 141
- publications
 - accessing xv
 - online xv, 2

R

- reading the operator panel display 13
- reboot/restart policy setup menu 38
- recycling 141
- related publications xv
- remote IPL (Initial Program Load)
 - setup 71
- repair log service aid 117
- reset fault indicators 109
- restart recovery 52
- RETAIN 50
- retries 50
- ring indicate power-on menu 38
- run exercisers 119

S

- safety notices ix
- scan dump policy 100
- scsi
 - change settings 73
- SCSI bus analyzer
 - bus analyzer 121
- SCSI RAID physical disk status and vital product data 122
- select console 73
- serial port
 - selection menu 47
 - snoop setup menu 35
 - speed setup menu 48
- Service Aids
 - 7135 RAIDiant array 125
 - 7318 service aid 125
 - add resource 92
 - analyze adapter internal log 93
 - backup/restore media 93
 - certify media 93
 - change hardware VPD 96
 - configure dials and LPF Keys 96
 - configure ISA adapter 97
 - configure reboot policy 97
 - configure remote maintenance policy 98
 - configure surveillance policy 100
 - create customized configuration diskette 100
 - delete resource 101
 - disk to disk copy 101
 - disk-based diagnostic 123
 - display configuration and resource list 102

Service Aids *(continued)*

- display firmware device node information 102
- display hardware error report 102
- display hardware VPD 102
- display microcode level 107
- display or change diagnostic run-time options 103
- display previous diagnostic results 105
- display resource attributes 105
- display service hints 105
- display software product data 105
- display system environmental sensors 106
- display test patterns 107
- display USB Devices 107
- display/alter bootlist 103
- display/alter sector 102
- download microcode 107
- fibre channel RAID service aids 110
- flash SK-NET FDDI firmware 110
- format media 111
- generic microcode download 113
- introduction 91
- local area network 117
- log repair action 117
- machine check error log 102
- PCI RAID physical disk identify 118
- periodic diagnostics 118
- process supplemental media 118
- ring indicate power on policy 99
- run diagnostics 118
- run error log analysis 118
- run exercisers 119
- save or restore hardware management policies 121
- SCSD tape drive 122
- spare sector availability 123
- SSA service aid 123
- update system or service processor flash 124

service processor

- access
 - local 27
 - remote 28
- boot mode menu 39
- call-in/call-out setup menu 46
- call-out call-home 60
- call-out policy setup menu 50
- checklist 149
- console mirroring 61
- customer account setup menu 50
- error logs 62
- general user menu 29
- language selection menu 45
- main menu 29
- memory configuration/deconfiguration menu 43
- menus 27
- modem configuration menu 47
- monitoring - surveillance 59
- operational phases 64
- OS surveillance setup menu 34
- parameters
 - service mode 51
- passwords 33
- power control network utilities menu 44

service processor *(continued)*

- privileged user menus 29
- procedures in service mode 51
- processor configuration/deconfiguration menu 41
- reboot/restart policy setup menu 38
- reboot/restart recovery 52
 - boot speed 52
 - failure 52
 - policy controls 52
- ring indicate power-on menu 38
- serial port selection menu 47
- serial port snoop setup menu 35
- serial port speed setup menu 48
- settings
 - saving and restoring 28
- setup 149
- setup checklist 149
- setup menu 32
- system information menu 40
- system power control menu 37
- telephone setup menu 48
- test 149
- using 27

set identify indicators 117

settings

- display current 79
- restore default 79

setup menu 32

SMS

- exiting 80

SSA service aid 123

standalone diagnostics 86

- loading 128
- NIM server 87, 88

startup

- multiboot 80

status lights

- understanding 23

stopping

- diagnostics 129

stopping the system with an HMC 12

stopping the system with an HMC and Linux 12

stopping the system without an HMC 12

surveillance

- monitoring 59

system

- starting with an HMC 11
- starting without an HMC 11
- stopping with an HMC 12
- stopping with an HMC and Linux 12
- stopping without an HMC 12
- using 11
- verification
 - additional 129
 - running 129

system attention indicators 117

system features 7

- bus 8
- memory 8
- processors 8

system firmware updates 54

- system information menu 40
- system management services 67
 - boot devices
 - select 77
 - boot options, select 74
 - error log
 - view 70
 - exiting SMS 80
 - IPL, remote setup 71
 - IPL, setup 71
 - multiboot startup 80
 - password
 - change options 69
 - privileged-access 69
 - SCSI settings, change 73
 - select console 73
 - select language 69
 - settings
 - display current 79
 - settings, restore default 79
- system power-on methods 51

T

- telephone setup menu 48
- terminal type
 - identifying 82
- testing the setup
 - call-in 150
 - call-out 150
- trademarks xvii
- transfer of a modem session 159
- TTY terminal attributes
 - general 145
- TTY terminal attributes required for diagnostics 145

V

- verification
 - system
 - additional 129
- verification, system 129
- verifying, hardware operation 127
- vital product data
 - SCSI RAID 122

W

- Web sites
 - AIX documentation xv, 85, 87
 - ergonomic information xvii
 - firmware updates 54, 55
 - microcode updates 54, 55

Readers' Comments — We'd Like to Hear from You

pSeries 615 Model 6C3 and Model 6E3
User's Guide

Publication No. SA38-0629-00

Overall, how satisfied are you with the information in this book?

	Very Satisfied	Satisfied	Neutral	Dissatisfied	Very Dissatisfied
Overall satisfaction	<input type="checkbox"/>	<input type="checkbox"/>	<input type="checkbox"/>	<input type="checkbox"/>	<input type="checkbox"/>

How satisfied are you that the information in this book is:

	Very Satisfied	Satisfied	Neutral	Dissatisfied	Very Dissatisfied
Accurate	<input type="checkbox"/>	<input type="checkbox"/>	<input type="checkbox"/>	<input type="checkbox"/>	<input type="checkbox"/>
Complete	<input type="checkbox"/>	<input type="checkbox"/>	<input type="checkbox"/>	<input type="checkbox"/>	<input type="checkbox"/>
Easy to find	<input type="checkbox"/>	<input type="checkbox"/>	<input type="checkbox"/>	<input type="checkbox"/>	<input type="checkbox"/>
Easy to understand	<input type="checkbox"/>	<input type="checkbox"/>	<input type="checkbox"/>	<input type="checkbox"/>	<input type="checkbox"/>
Well organized	<input type="checkbox"/>	<input type="checkbox"/>	<input type="checkbox"/>	<input type="checkbox"/>	<input type="checkbox"/>
Applicable to your tasks	<input type="checkbox"/>	<input type="checkbox"/>	<input type="checkbox"/>	<input type="checkbox"/>	<input type="checkbox"/>

Please tell us how we can improve this book:

Thank you for your responses. May we contact you? Yes No

When you send comments to IBM, you grant IBM a nonexclusive right to use or distribute your comments in any way it believes appropriate without incurring any obligation to you.

Name

Address

Company or Organization

Phone No.



Fold and Tape

Please do not staple

Fold and Tape



NO POSTAGE
NECESSARY
IF MAILED IN THE
UNITED STATES

BUSINESS REPLY MAIL

FIRST-CLASS MAIL PERMIT NO. 40 ARMONK, NEW YORK

POSTAGE WILL BE PAID BY ADDRESSEE

Information Development
Department H6DS-905-6C006
11400 Burnet Road
Austin, TX 78758-3493

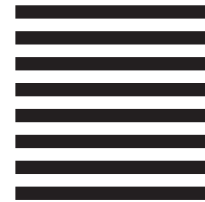

Fold and Tape

Please do not staple

Fold and Tape



Printed in U.S.A.

May 2003

SA38-0629-00

