

Exabyte Mammoth-2 Tape Drive

---

# Product Specification

## Copyright

---

Copyright 2001 by Exabyte Corporation. All rights reserved. This item and the information contained herein are the property of Exabyte Corporation. No part of this document may be reproduced, transmitted, transcribed, stored in a retrieval system, or translated into any language or computer language in any form or by any means, electronic, mechanical, magnetic, optical, chemical, manual, or otherwise, without the express written permission of Exabyte Corporation, 1685 38th Street, Boulder, Colorado 80301.

## Disclaimer

---

Exabyte Corporation makes no representation or warranties with respect to the contents of this document and specifically disclaims any implied warranties of merchantability or fitness for any particular purpose. Further, Exabyte Corporation reserves the right to revise this publication without obligation to notify any person or organization of such revision or changes.

## Trademark Notices

---

Exabyte and Exapak are U.S. registered trademarks of Exabyte Corporation. M2, MammothTape, SmartClean, EZ17, and NetStorM are trademarks of Exabyte Corporation. People Working for You and SupportSuite are service marks of Exabyte Corporation. All other product names are trademarks or registered trademarks of their respective owners.

## Revision History

---

Revision	Date	Description
000	March 1999	Preliminary release
001	December 1999	Initial release. Added information about SmartClean and updated specifications.
002	September 2001	Added HVD, Fibre Channel, and E-copy command information.

**Note:** The most current information about this product is available at Exabyte's World Wide Web site ([www.exabyte.com](http://www.exabyte.com)).

Exabyte Corporation  
1685 38th Street  
Boulder, Colorado 80301  
(303) 442-4333

330874-002

## Product Warranty Caution

---

The Exabyte® Mammoth-2 Tape Drive is warranted to be free from defects in materials, parts, and workmanship and will conform to the current product specification upon delivery. **For the specific details of your warranty, refer to your sales contract or contact the company from which the tape drive was purchased.**

The warranty for the tape drive shall not apply to failures caused by:

- Physical abuse or use not consistent with the operating instructions or product specifications provided by Exabyte's personnel or agent for the applicable equipment.
- Use of any type of cleaning material other than an Exabyte AME SmartClean cartridge or an Exabyte Mammoth Cleaning Cartridge (or a cleaning cartridge approved by Exabyte for the Mammoth-2 tape drive).
- Modifications by other than Exabyte's personnel or agent in any way other than those approved by Exabyte, provided the warranty shall not be voided by the repair or replacement of parts or the attachment of items in the manner described in maintenance or installation instructions provided by Exabyte.
- Repair by other than Exabyte's personnel or agent in a manner contrary to the maintenance instructions provided by Exabyte.
- Removal of the Exabyte serial number tag.
- Physical abuse due to improper packaging of returns.

### CAUTION

Returning the tape drive in unauthorized packaging may damage the unit and void the warranty.

If you are returning the tape drive for repair, package it in its original packaging (or in replacement packaging obtained from your vendor). Refer to the packing instructions in this manual.

If problems with the tape drive occur, contact your maintenance organization; do not void the product warranty by allowing untrained or unauthorized personnel to attempt repairs.

# Notes

---

# Contents

## About This Specification xiii

---

How This Manual is Organized . . . . .	xiii
Conventions . . . . .	xiii
Related Publications . . . . .	xiv

## 1 Mammoth-2 Features

---

Internal or Tabletop Models . . . . .	1-3
Components . . . . .	1-4
Front Panel Controls and Indicators . . . . .	1-4
Back Panel Components . . . . .	1-5
Internal Components . . . . .	1-6
Labels . . . . .	1-9
Communication Interface . . . . .	1-10
SCSI Configurations . . . . .	1-11
Fibre Channel Configuration . . . . .	1-12

## 2 Installation and Operation

---

ESD Precautions . . . . .	2-1
Installation (Internal Tape Drive) . . . . .	2-2
Power . . . . .	2-3
Chassis Grounding . . . . .	2-4
Communication Interface Connections . . . . .	2-4
Device Addressing . . . . .	2-12
Monitor Port . . . . .	2-14
Tape Drive Mounting Requirements . . . . .	2-14
Operating Environment Requirements . . . . .	2-16
Operation . . . . .	2-17
Monitoring the LEDs and LCD . . . . .	2-17
Selecting Data Cartridges . . . . .	2-23
Loading and Unloading Cartridges . . . . .	2-24
Cleaning the Tape Drive . . . . .	2-25
Resetting the Tape Drive . . . . .	2-25
Serverless Backup . . . . .	2-26

## 3 Technical Description

---

Write Operations .....	3-1
Data Flow .....	3-2
Data Compression .....	3-3
Error Detection, Correction, and Recovery Procedures .....	3-3
Read Operations .....	3-5
Data Flow .....	3-5
Data Decompression .....	3-6
PRML Read Channel Signal Processing .....	3-6
Adaptive Data Buffering Function .....	3-7
Streaming Mode .....	3-8
Start/Stop Mode .....	3-8
Helical-Scan Recording Technology .....	3-9
Physical Track Structure .....	3-10
Tape Format .....	3-11
Format Determination .....	3-11
SmartClean Cleaning Material .....	3-12
Physical Beginning and End of Tape .....	3-13
Tape History Log (THL) .....	3-14
Partitions .....	3-14
Data Area .....	3-15
Read/Write Compatibility .....	3-19

## 4 Overview of the SCSI Command Protocol

---

Communication Interface versus Command Protocol .....	4-1
SCSI-2 Command Protocol .....	4-2
SCSI-2 Command Set .....	4-3
Status Bytes .....	4-5
Sense Keys .....	4-5
TapeAlert .....	4-6
Tape History Log .....	4-9
EXTENDED COPY (Fibre Channel Only) .....	4-9
RECEIVE COPY RESULTS (Fibre Channel Only) .....	4-10

## 5 Overview of the Communication Interface

---

SCSI Communication Interface .....	5-1
Single-ended, HVD, or LVD .....	5-2
Device Addressing .....	5-3
SCSI Bus Phases .....	5-4
SCSI Message System .....	5-5
Fibre Channel Communication Interface .....	5-6
Fibre Channel topologies .....	5-6
Fibre Channel Network Components .....	5-9
Device Addressing .....	5-10
Loop Initialization .....	5-13
Fabric Login (FLOGI) .....	5-14

## 6 Specifications and Standards

---

Size and Weight .....	6-2
Storage Capacity .....	6-4
Performance Specifications .....	6-5
Data Transfer Rates .....	6-5
Read and Write Access Times .....	6-5
Reselection Phase Timeout .....	6-6
Tape Speeds .....	6-6
Drive Ready States .....	6-7
Reliability Specifications .....	6-8
Hardware Service Life .....	6-9
Head and Cartridge Loader Life .....	6-9
Mean Time Between Failures (MTBF) .....	6-9
Mean Time to Repair (Tabletop Model Only) .....	6-10
Data Integrity .....	6-11
Data Reliability .....	6-11
Power Specifications .....	6-13
Internal Tape Drive .....	6-13
Tabletop Tape Drive .....	6-14
Acoustic Noise Specification (Tabletop Model Only) .....	6-16
Environmental Specifications .....	6-16
Operating Environment .....	6-17
Particulate Contamination Limits .....	6-20
Shock Specifications .....	6-21
Vibration Specifications .....	6-21
Shipping Specifications .....	6-22
Packing Materials .....	6-22
Shipping Cartons (Internal Tape Drive) .....	6-23
Shipping Carton (Tabletop Tape Drive) .....	6-24

Safety and Regulatory Agency Compliance .....	6-25
Domestic and International Standards .....	6-25
Electromagnetic Compatibility (EMC) .....	6-25
Agency Compliance (Tabletop Model Only) .....	6-26

## **A The Tabletop M2 Tape Drive**

---

Components .....	A-2
Front Panel Components .....	A-2
Back Panel Components .....	A-3
Optical GBICs .....	A-5
Enclosure Color .....	A-5
Labels .....	A-6
Installation Requirements .....	A-7
ESD Precautions .....	A-7
Device IDs .....	A-7
SCSI Cable and Terminator Requirements .....	A-9
Fibre Channel Cable and GBIC Requirements .....	A-10
Power Cord Requirements .....	A-11

## **B Glossary B-1**

---

## **Index I-1**

---

## **Contacting Exabyte Inside back cover**

---



# Tables

## Installation and Operation

---

Table 2-1	Pin assignments for the SCSI power connector. . . . .	2-3
Table 2-2	Ideal characteristic impedances for SCSI cables . . . . .	2-5
Table 2-3	LVD SCSI connector pin assignments . . . . .	2-6
Table 2-4	HVD SCSI connector pin assignments . . . . .	2-7
Table 2-5	Single-ended wide SCSI connector pin assignments . . . . .	2-9
Table 2-6	Fibre Channel 80-pin SCA-2 connector pin assignments. . . . .	2-11
Table 2-7	Monitor port pin assignments . . . . .	2-14
Table 2-8	LED states. . . . .	2-18
Table 2-9	LCD message descriptions . . . . .	2-19
Table 2-10	LCD messages in the available languages . . . . .	2-21

## Overview of the SCSI Command Protocol

---

Table 4-1	M2 SCSI command set. . . . .	4-3
Table 4-2	Status byte descriptions . . . . .	4-5
Table 4-3	Supported sense keys. . . . .	4-6
Table 4-4	TapeAlert flags used by the tape drive . . . . .	4-7

## Overview of the Communication Interface

---

Table 5-1	SCSI bus phases. . . . .	5-4
Table 5-2	SCSI messages . . . . .	5-5

## Specifications and Standards

---

Table 6-1	Size and weight of the tape drive. . . . .	6-2
Table 6-2	Data capacities of Exabyte SmartClean AME cartridges . . . . .	6-4
Table 6-3	Data capacities of Exatape AME data cartridges . . . . .	6-4
Table 6-4	Maximum data transfer rates . . . . .	6-5
Table 6-5	Read/write access times . . . . .	6-6
Table 6-6	Search times (in seconds). . . . .	6-7
Table 6-7	Sleep states (in seconds). . . . .	6-8
Table 6-8	Power specifications (internal tape drive). . . . .	6-13
Table 6-9	Power consumption (internal tape drive). . . . .	6-14
Table 6-10	Power supply specifications (tabletop tape drive). . . . .	6-14
Table 6-11	AC power characteristics (tabletop tape drive) . . . . .	6-15
Table 6-12	AC power consumption (tabletop tape drive). . . . .	6-15

<b>Table 6-13</b>	Acoustic noise (tabletop tape drive) .....	6-16
<b>Table 6-14</b>	Environmental specifications .....	6-16
<b>Table 6-15</b>	Temperature and humidity points (internal tape drive).....	6-18
<b>Table 6-16</b>	Temperature and humidity points (tabletop tape drive) .....	6-19
<b>Table 6-17</b>	Particulate contamination limits .....	6-20
<b>Table 6-18</b>	Shock specifications .....	6-21
<b>Table 6-19</b>	Vibration specifications.....	6-21
<b>Table 6-20</b>	Shipping carton dimensions and weights (internal tape drive) .....	6-23
<b>Table 6-21</b>	Shipping carton dimensions and weights (tabletop tape drive) .....	6-24
<b>Table 6-22</b>	EMC standards.....	6-25

## **The Tabletop M2 Tape Drive**

---

<b>Table A-1</b>	External SCSI cable lengths .....	A-9
<b>Table A-2</b>	Terminator recommendations .....	A-10

# Figures

## Mammoth-2 Features

---

<b>Figure 1-1</b>	Exabyte Mammoth-2 (M2) tape drive. . . . .	1-1
<b>Figure 1-2</b>	Tabletop and internal models of the tape drive . . . . .	1-3
<b>Figure 1-3</b>	Front panel components. . . . .	1-4
<b>Figure 1-4</b>	Back panel components of the internal SCSI M2 tape drive . . . . .	1-5
<b>Figure 1-5</b>	Back panel components of the internal Fibre Channel M2 drive . . . . .	1-5
<b>Figure 1-6</b>	Internal components of the M2 tape drive (SCSI tape drive shown) . . . . .	1-6
<b>Figure 1-7</b>	Dynamic Head Cleaning action. . . . .	1-7
<b>Figure 1-9</b>	Product ID label location for the internal model (LVD SCSI label shown) . .	1-9
<b>Figure 1-8</b>	M2's air bearing and conditioning head . . . . .	1-9
<b>Figure 1-10</b>	SCSI ID label location for the internal model . . . . .	1-10

## Installation and Operation

---

<b>Figure 2-1</b>	SCSI tape drive back-panel connector and pin locations (in millimeters) . . .	2-2
<b>Figure 2-2</b>	Fibre Channel tape drive back-panel connector locations (in millimeters) . .	2-3
<b>Figure 2-3</b>	SCSI ID jumper settings . . . . .	2-13
<b>Figure 2-4</b>	Mounting holes . . . . .	2-15
<b>Figure 2-5</b>	Mounting holes in inches and millimeters (three sets of four). . . . .	2-15
<b>Figure 2-6</b>	Front panel components. . . . .	2-17
<b>Figure 2-7</b>	Exabyte AME media with SmartClean . . . . .	2-23

## Technical Description

---

<b>Figure 3-1</b>	Write operations. . . . .	3-2
<b>Figure 3-2</b>	Sophisticated ECC3 provides error checking over 40 tracks of data. . . . .	3-4
<b>Figure 3-3</b>	Read operations . . . . .	3-5
<b>Figure 3-4</b>	Comparison of PR4 and EPR4 peak sampling . . . . .	3-7
<b>Figure 3-5</b>	Helical-scan recording. . . . .	3-9
<b>Figure 3-6</b>	Physical block format . . . . .	3-10
<b>Figure 3-7</b>	Tape format . . . . .	3-11
<b>Figure 3-8</b>	Cleaning material and window at the beginning of the Exabyte AME Data Cartridge with SmartClean . . . . .	3-12

## Overview of the Communication Interface

---

<b>Figure 5-1</b>	Point-to-point topology. . . . .	5-6
<b>Figure 5-2</b>	Arbitrated loop topology . . . . .	5-7
<b>Figure 5-3</b>	Switched fabric topology . . . . .	5-8

## Specifications and Standards

---

<b>Figure 6-1</b>	Dimensions of the internal tape drive in inches (and centimeters) . . . . .	6-3
<b>Figure 6-2</b>	Dimensions of the tabletop tape drive in inches (and centimeters). . . . .	6-3
<b>Figure 6-3</b>	Tape path temperature and humidity ranges for operation (internal tape drive) . . . . .	6-18
<b>Figure 6-4</b>	Ambient operating environment (tabletop tape drive) . . . . .	6-19
<b>Figure 6-5</b>	Particulate contamination specification vs. typical office . . . . .	6-20

## The Tabletop M2 Tape Drive

---

<b>Figure A-1</b>	Tabletop M2 tape drive . . . . .	A-1
<b>Figure A-2</b>	Front panel components on the tabletop tape drive . . . . .	A-2
<b>Figure A-3</b>	Back panel components for the SCSI tabletop model . . . . .	A-3
<b>Figure A-4</b>	Back panel components for the Fibre Channel tabletop model . . . . .	A-4
<b>Figure A-5</b>	Standard optical GBIC . . . . .	A-5
<b>Figure A-6</b>	Label location for the tabletop model (LVD label shown) . . . . .	A-6

# About This Specification

This product specification provides functional, performance, and environmental specifications for the Exabyte® Mammoth-2 (M2™) tape drive. It is intended for engineering, marketing, or purchasing personnel who are evaluating the tape drive to determine the feasibility of integrating it into product lines.

## How This Manual is Organized

[Chapter 1](#) describes the features and components of the internal and tabletop drive.

[Chapter 2](#) describes the requirements for installing and operating the tape drive, including information about installing the tape drive into an enclosure.

[Chapter 3](#) contains a technical description of the tape drive.

[Chapter 4](#) provides an overview of the SCSI command protocol used by the tape drive.

[Chapter 5](#) provides an overview of the SCSI and Fibre Channel communication interfaces.

[Chapter 6](#) provides performance, reliability, power, environmental, and shipping specifications for the tape drive. It also contains agency compliance information for the tape drive.

[Appendix A](#) provides installation instructions and specifications for the tabletop model of the tape drive.

[Appendix B](#) is a glossary of terms used in this specification.

## Conventions

This manual uses the conventions shown below to highlight notes, important information, and cautions. Take special note of boxed text. Failure to follow cautions can result in equipment damage.

**Note:** Read *Notes* for additional information or suggestions about the topic or procedure being discussed.

---

► **Important** Read the information in *Important* notices to learn crucial information about the topic being discussed.

---

**CAUTION**

Read the information in *CAUTION* boxes to learn how to avoid damaging the tape drive or losing data.

## Related Publications

### Exabyte Mammoth-2 Tape Drive

- *Exabyte Mammoth-2 Tape Drive Installation and Operation*, 330875
- *Exabyte Mammoth-2 Tape Drive SCSI Reference*, 330876
- *Exabyte AME 8mm Data Cartridge Specification*, 300652

### Standards

- *ANSI Small Computer System Interface-2 (SCSI-2)*, X3.131 – 1994
- *ANSI SCSI-3 Fast20 Parallel Interface (Fast-20)*, X3.277 – 1996
- *ANSI SCSI Parallel Interface-2 (SPI-2)*, X3T10/1142D, Rev. 11
- *ANSI Helical-Scan Digital Computer Tape Cartridge*, X3B5/89-136, Rev. 6
- *Standard ECMA-249, 8mm Wide Magnetic Tape Cartridge for Information Interchange – Helical Scan Recording – DA-2 Format*, June 1998
- *Standard ECMA-293, 8 mm Wide Magnetic Tape Cartridge for Information Interchange – Helical Scan Recording – MammothTape-2 Format*, December 1999
- *TapeAlert Specification*, Version 2.0, November, 1997
- *IEEE 802.3 Carrier Sense Multiple Access with Collision Detection (CSMA/CD) Access Method and Physical Layer Specifications*, 1985
- *ANSI Information Technology SCSI Primary Commands-2 (SPC-2)*, T10/1236-D, Revision 18

- *Extended Copy Command, T10/99-143r1 Proposal*
- *ANSI Information Technology SCSI-3 Stream Device Commands (SSC), X3T10 / 997D, Revision 22*
- *ANSI Information Technology Fibre Channel Protocol for SCSI (FCP), X3.269- 1996*
- *ANSI Information Technology Fibre Channel Protocol for SCSI, Second Revision 2 (FCP- 2), T10/ Project 1144-D/ Rev 4, December 1999*
- *ANSI Information Technology Fibre Channel Physical and Signaling Standard (FC- PH), X3.230- 1994*
- *ANSI Information Technology Fibre Channel 2nd Generation Physical and Signaling Standard (FC-PH-2), X3. 303- 1998*
- *ANSI Information Technology Fibre Channel Arbitrated Loop (FC- AL), X3.272- 1996*
- *ANSI Information Technology Fibre Channel Arbitrated Loop (FC-AL-2), NCITS 332- 1999*
- *Information Technology Fibre Channel Fabric Loop Attachment (FC-FLA), T11/ Project 1235- DT/ Rev 2.7*
- *Fibre Channel FC-Tape Standard, T11/ 99 – 069v4, 1999*
- *Fibre Channel Tape Connector Profile Using 80-pin SCA-2 Connector, T11/99 – 234v2*
- *Specification for 40-pin SCA- 2 Connector w/Bidirectional ESI, SFF-8067*
- *Specification for 40-pin SCA- 2 Connector w/Parallel Selection, SFF-8045*
- *SCA-2 Unshielded Connections, EIA-700A0AE (SFF-8451)*
- *Gigabit Interface Converter (GBIC), Small Form Factor, SFF-8053, Revision 5.x*
- *Common FC-PH Feature Sets Profiles, Fibre Channel Systems Initiative, FCSI-101-Rev. 3.1*
- *SCSI Profile, Fibre Channel System Initiative, FCSI-201-Rev. 2. 2*
- *FCSI IP Profile, Fibre Channel System Initiative, FCSI-202-Rev. 2.1*

# Notes

---



---

# 1

## Mammoth-2 Features

---

The Exabyte® Mammoth-2 (M2™) tape drive, shown in [Figure 1-1](#), is a high-speed, high-capacity tape drive ideally suited to meet the demanding requirements of the network server industry and the data-intensive applications in the health care, video, and banking industries. Built on the solid technology foundation of the first generation MammothTape technology tape drives, M2 improves on the earlier drives by combining technological advances in the data recording format with improvements in head design, media, data compression, and error correction to provide dramatically increased performance, capacity, and reliability.

The M2 tape drive transfers uncompressed data at a rate of up to 43.2 gigabytes per hour (GB/hr) or up to 108 GB/hr of compressed data. A single cartridge can store up to 150 GB of compressed data. Data compression is accomplished using the industry-standard Adaptive Lossless Data Compression (ALDC) algorithm to provide a 2.5:1 compression ratio. Enhanced Partial Response Maximum Likelihood (PRML) signal processing and sophisticated error correction code (ECC3) algorithms ensure data integrity.

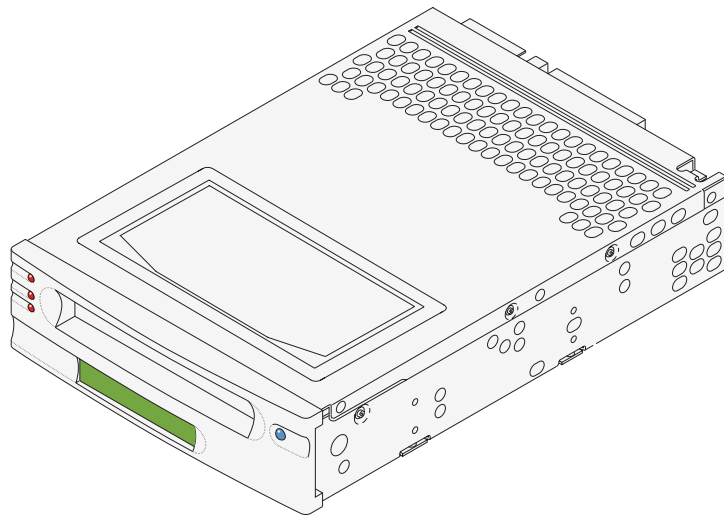

**Figure 1-1** Exabyte Mammoth-2 (M2) tape drive

The M2 tape drive is available with the following communication interfaces:

- Low voltage differential (LVD) Ultra2 SCSI
- High voltage differential (HVD) SCSI-2
- Native Fibre Channel

The SCSI versions of the M2 tape drive provide full compatibility with traditional computing environments. The LVD tape drive supports connection to LVD and single-ended wide SCSI buses. The native Fibre Channel version of M2 includes built-in support for the new EXTENDED COPY (E-copy) SCSI command, making it ideal for use in a storage area network (SAN) environment that uses serverless backup.

The M2 tape drive is designed to take advantage of an improved formulation of advanced metal evaporated (AME) tape. In addition to improved data capacity, the SmartClean™ media includes a short segment of cleaning tape at the beginning of each cartridge. SmartClean media is part of an innovative approach to making M2 a truly self-cleaning, maintenance free tape drive.

The M2 tape drive uses a highly efficient M2 data format that writes narrow, closely spaced tracks that contain more data than the original Mammoth format. The AME media and data format result in higher capacities than were possible with the original Mammoth media and format. At the same time, the tape drive retains the ability to read AME tapes written in the original Mammoth format.

## Internal or Tabletop Models

The M2 tape drive is available in either a self-contained tabletop model or an internal model ready for installation into an enclosure. The tabletop model is an external peripheral housed in an Exabyte enclosure, complete with power supply and cooling fan. The internal model of the tape drive conforms to a 5.25-inch, half-high form factor and can easily be integrated into your own system. [Figure 1-2](#) shows the tabletop and internal models.

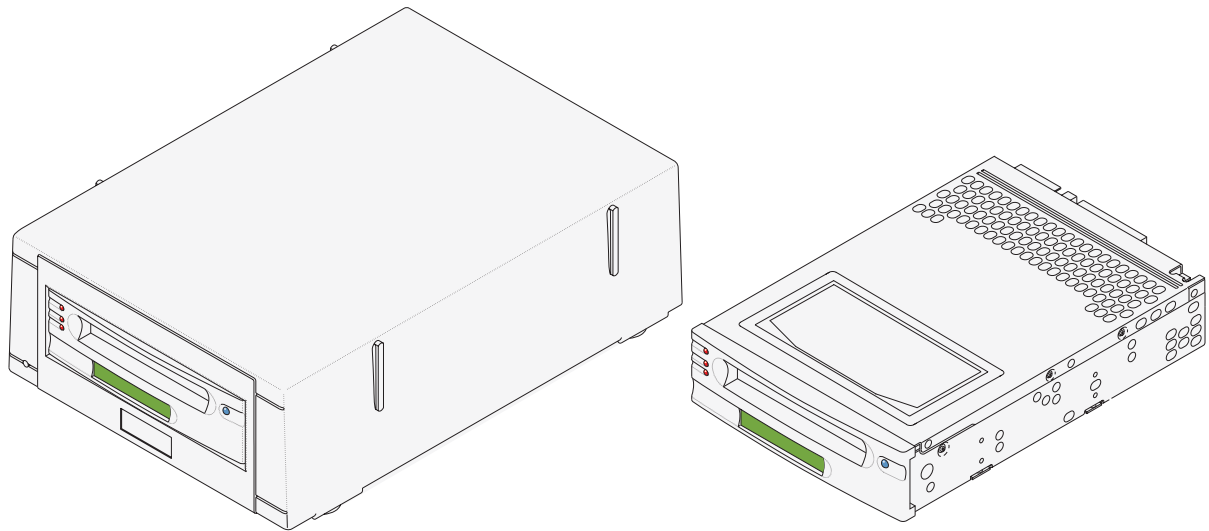

**Figure 1-2** Tabletop and internal models of the tape drive

## Components

This section describes the major components of the tape drive. For a description of the components that are unique to the tabletop model, see [Appendix A](#). Unless otherwise noted, the components of the SCSI and Fibre Channel models of the tape drive are identical.

### Front Panel Controls and Indicators

[Figure 1-3](#) shows the controls and indicators on the front panel of the tape drive. For more information about using these controls and indicators, see [Chapter 2](#).

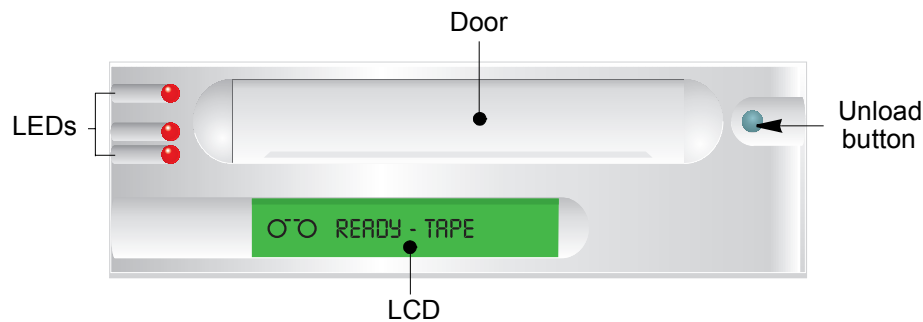

**Figure 1-3** Front panel components

**Door and faceplate** The cartridge door is where the data cartridge is inserted into the tape drive. The standard color for the door and faceplate of the SCSI version of the tape drive is pearl white; for the Fibre Channel version the standard color is black. Other available colors include pebble gray, platinum, and gray.

**Unload button** Pushing the unload button causes the tape drive to unload the tape and eject the data cartridge. Pushing and holding the unload button for 10 seconds causes the tape drive to initiate an internal reset.

**LCD (standard)** Both the Fibre Channel and SCSI models of M2 include a liquid crystal display (LCD) that provides alphanumeric information about the tape drive's operational status. The LCD exhibits messages consisting of up to 16 alphanumeric characters. The display can be configured to show the messages in one of six different languages (English, Spanish, French, German, Portuguese, or Italian).

**LEDs** Three light emitting diodes (LEDs) on the front panel provide status information.

## Back Panel Components

Figure 1-4 shows the location and appearance of the back panel components of the internal SCSI M2 tape drive.

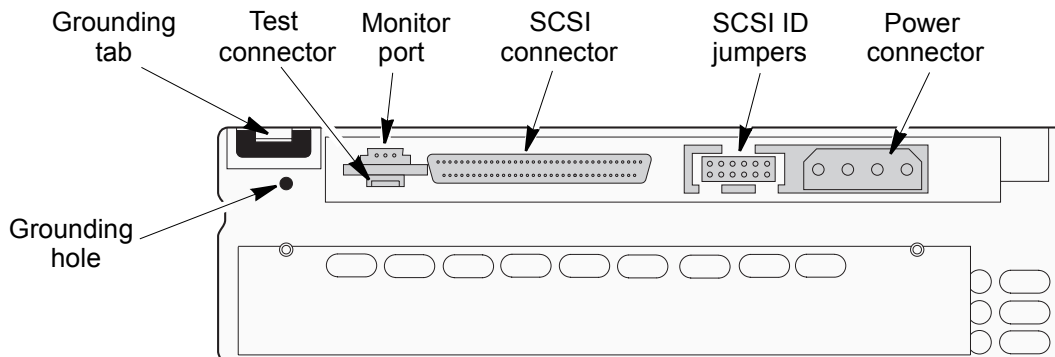

**Figure 1-4** Back panel components of the internal SCSI M2 tape drive

Figure 1-5 shows the location and appearance of the back panel components of the internal Fibre Channel M2 tape drive.

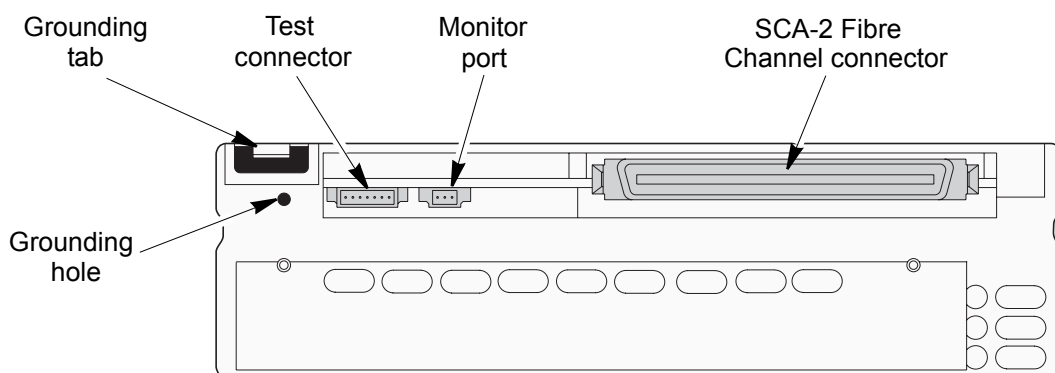

**Figure 1-5** Back panel components of the internal Fibre Channel M2 drive

**Ground tab and grounding hole** Both the SCSI and Fibre Channel tape drives include a ground tab and grounding hole to provide additional, optional grounding for the tape drive.

**Monitor port** The Monitor port provides a serial interface to the tape drive's microprocessor. You can load code and perform diagnostics through a 3-pin serial cable attached to this port using a custom Exabyte diagnostic program. Both the SCSI and Fibre Channel versions of the tape drive include a monitor port.

**Test connector** The test connector is for Exabyte internal use only.

**SCSI connector (SCSI drive only)** The SCSI connector allows you to connect the tape drive to the SCSI bus. The tape drive uses a 68-pin, wide SCSI connector.

**SCSI ID connector (SCSI drive only)** The SCSIID connector consists of the eight (four pairs) jumper posts closest to the power connector (the remaining two pairs are reserved). The jumper posts have 2mm center points. You set the SCSI ID by placing jumpers or a remote switch over the jumper posts.

**Power connector (SCSI drive only)** The 4-pin power connector on the SCSI model of the M2 is compatible with the power connector used for standard 5.25-inch half-high devices.

**SCA-2 Fibre Channel connector (Fibre Channel drive only)** The 80-pin SCA-2 connector allows you to connect the internal tape drive's Fibre Channel ports to a separate interface board or system backplane. In addition to lines carrying data, this connector provides the power input for the tape drive and provisions for setting the Fibre ID.

## Internal Components

Figure 1-6 shows the internal components of the M2 tape drive.

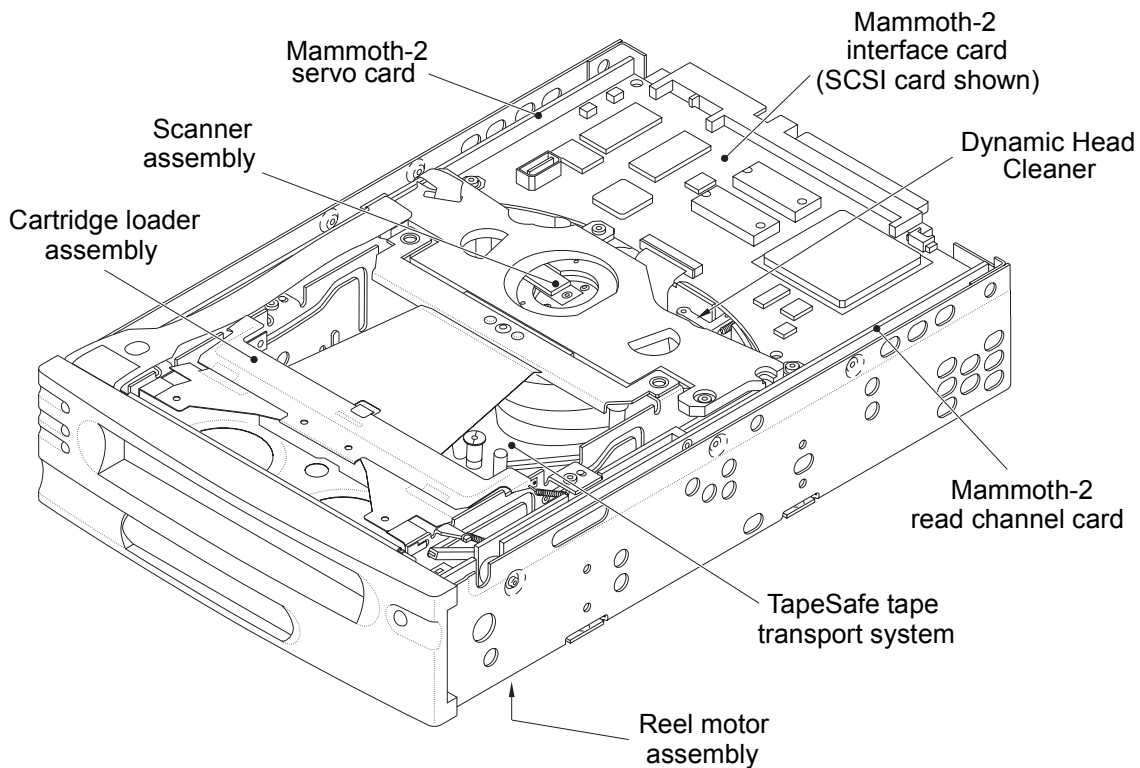

**Figure 1-6** Internal components of the M2 tape drive (SCSI tape drive shown)

## Printed Circuit Cards

**Mammoth-2 interface card** The interface card includes the microprocessor system that controls the data path and system interface. Also included on the card are a controller chip (either SCSI or Fibre Channel), the compression engine, buffer controller, ECC3, and track formatting circuits.

**Mammoth-2 read channel card** The read channel card contains equalizer and data synchronizing circuits.

**Mammoth-2 servo card** The servo card contains the sensor interface circuits, as well as the servo and driver circuitry for the tape path, drum, and cartridge loader motors.

## Mechanical Components

**Dynamic Head Cleaner** The Dynamic Head Cleaner, or cleaning wheel, includes a small, cloth-covered wheel attached to the end of a mechanical arm, as shown in [Figure 1-7](#). The Dynamic Head Cleaner reduces the amount of media residue buildup on the heads, increasing the life of the heads and reducing the potential for soft errors that may occur during normal read and write operations.

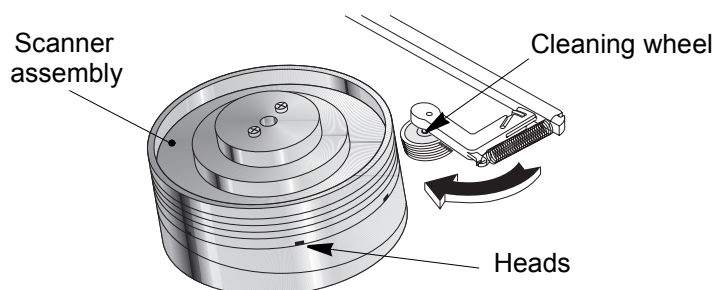

**Figure 1-7** Dynamic Head Cleaning action

The Dynamic Head Cleaner is activated and makes contact with the scanner and heads every time a tape is loaded. It is also activated the next time a rewind operation occurs following 100 hours of tape motion. In addition, a sophisticated algorithm contained in the tape drive's firmware can invoke the Dynamic Head Cleaner if cleaning is needed during extended backup or restore operations.

**TapeSafe tape transport system** The patented TapeSafe tape transport system is comprised of the tape loading and guiding elements, shock mounts, and card mounts. TapeSafe combines a dual-reel tape transport system, low tape speed, low tape tension, and an air-cushioned head-to-tape interface with the Dynamic Head Cleaner to provide the most gentle and most reliable tape transport system in the industry.

**Reel motor assembly** The reel motor assembly contains the reel motor card, the reel motors, and the cartridge recognition sensors. These components make up the reel-to-reel, direct-drive tape transport system. This capstan-free tape transport enlists a sophisticated algorithm contained in the drive's firmware to measure the diameter of tape on each hub of the tape cartridge at all times. As the diameter increases on one reel and decreases on the other, the motor driving the reels speeds one up and slows the other down to maintain a constant tape speed.

**Cartridge loader assembly** The cartridge loader assembly includes the cartridge load mechanism and the cartridge load motor. M2's cartridge loader is specifically designed to withstand the rigors of robotic cartridge loading and unloading in the demanding storage automation environment.

**Scanner assembly** M2's power-on-rotor scanner assembly consists of a spinning upper rotor that contains four read and four write heads and a stationary lower drum that contains the rotary transformers and scanner motor.

The implementation of power-on-rotor technology moves signal amplification and write driver circuitry for both the read and write heads onto the spinning portion of the scanner. Because the signals are already amplified to approximately equal levels before they reach the rotary transformer, the crosstalk between the read and write signals is eliminated and the signal-to-noise ratio is greatly improved. Power-on-rotor technology makes it possible to increase the number of channels on the scanner and allows M2 to perform read-while-write data verification.

A conditioning head placed immediately in front of each read or write head produces a very stable air flow over the read or write heads. This stable air flow reduces or eliminates any potential for drag at the head-to-tape interface. As a result, the tape touches the heads with only enough force to allow data to be reliably written or read. Reducing the drag helps reduce head wear and prolongs the life of the write and read heads. The reduced drag also eliminates another potential source of tape wear.



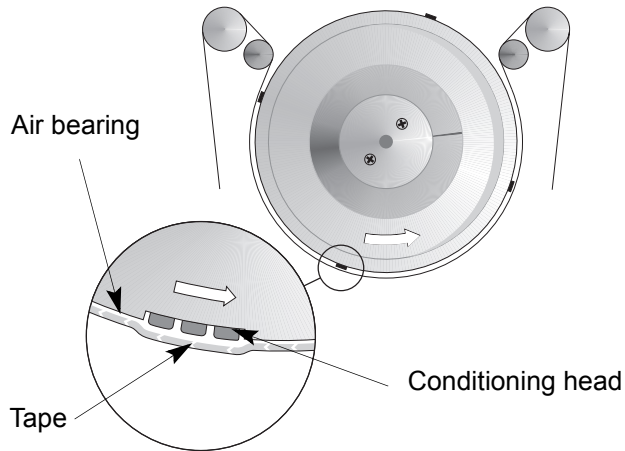

**Figure 1-8** M2's air bearing and conditioning head

## Labels

The tape drive labels provide product identification and configuration information. See [Appendix A](#) for the tabletop model's label locations.

The product ID label on the internal tape drive, shown in [Figure 1-9](#), shows the machine level change history (MLCH), serial number, and SCSI configuration.

**Note:** The labels for LVD, HVD, and Fibre Channel are slightly different.

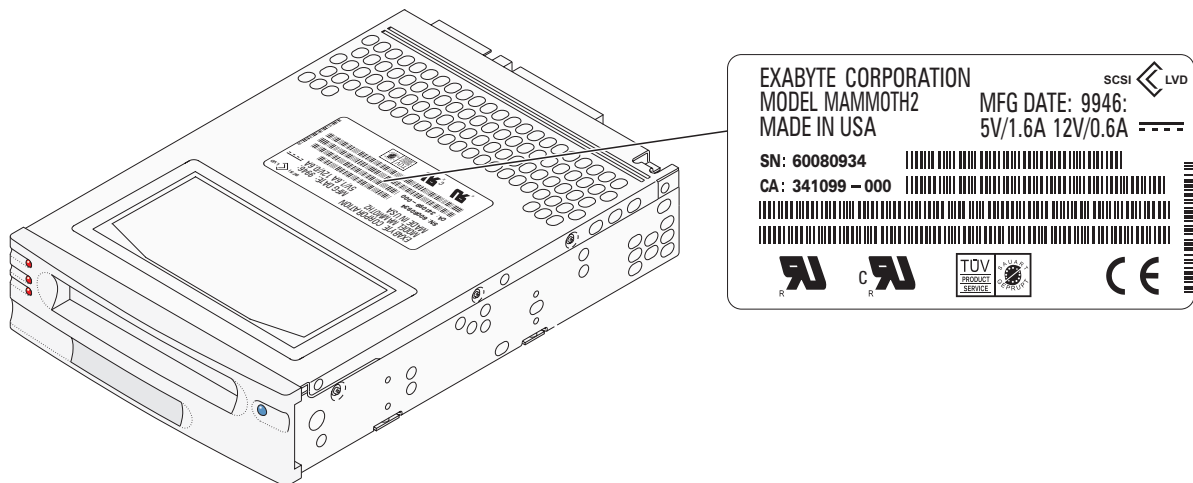

**Figure 1-9** Product ID label location for the internal model (LVD SCSI label shown)

The SCSI ID label on the bottom of the SCSI tape drive, shown in [Figure 1-10](#), illustrates the tape drive SCSI ID settings.

**Note:** The SCSI ID label shown in [Figure 1-10](#) appears on both the SCSI and Fibre Channel models of the tape drive. The information on this label is not pertinent to the Fibre Channel drive and should be ignored.

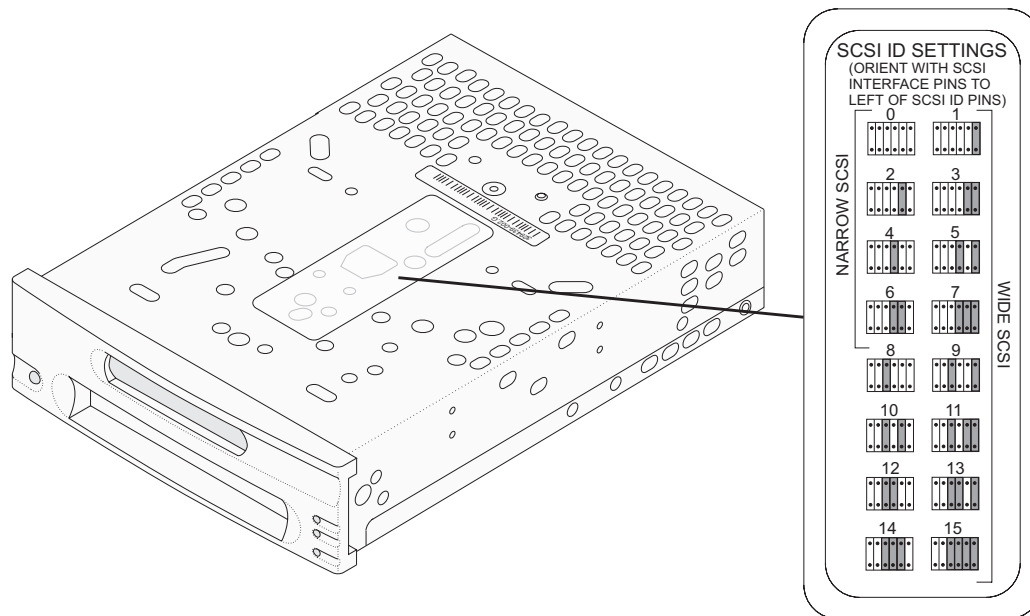

**Figure 1-10** SCSI ID label location for the internal model

## Communication Interface

The M2 tape drive is available with either a parallel SCSI bus communication interface or a Fibre Channel communication interface. Regardless of the communication interface used, the host (or initiator) controls the operation of the tape drive (the target) by issuing commands, transferring data, and responding to status information based on the SCSI command protocol.

The differences between the SCSI bus communication interface (LVD or HVD) and the Fibre Channel communication interface arise primarily from how device addressing is handled and how the SCSI commands, status messages, and data are transmitted between the host or server storage device and the tape drive. [Chapter 5](#) provides an overview of the SCSI and Fibre Channel communication interfaces used by the tape drive.

## SCSI Configurations

The SCSI version of the tape drive is available in the following SCSI configurations:

- Low-voltage differential (LVD) wide Ultra2 SCSI
- High-voltage differential (HVD) wide SCSI-2

### CAUTION

All wide SCSI configurations, single-ended (SE), low-voltage differential (LVD), and high-voltage differential (HVD), use the same 68-pin connector. Do not attach an HVD drive to an LVD SCSI bus. Doing so may cause the bus to hang.

The LVD tape drive supports connection to LVD and single-ended wide SCSI buses. Circuitry in the tape drive detects the SCSI environment (LVD or single-ended) and automatically configures the tape drive's operation to the appropriate bus capability.

In wide SCSI configurations, up to 16 devices (including one or more initiators) can be attached to a single SCSI bus. SCSI IDs can range from 0 to 15 on a single bus.

The tape drive supports fast synchronous transfer mode in all SCSI configurations. See [Chapter 5](#) for more information about the SCSI interface.

## Fibre Channel Configuration

The Fibre Channel version of the M2 tape drive conforms to the Fibre Channel Arbitrated Loop standards and specifications listed under [“Related Publications.”](#)

A Fibre Channel network supports data rates that are comparable to or better than SCSI (up to 200 MB per second versus 160 MB per second for Ultra160 SCSI). The Fibre Channel protocol provides addressing for up to 126 ports on an arbitrated loop or 16 million ports on a switched fabric.

---

➤ **Important** Although the arbitrated loop protocol provides addressing for 126 ports, in practical application, the number of ports that can share the available bandwidth without degrading performance is much smaller.

A Fibre Channel loop on a hub currently has a maximum transfer rate of 200 MB per second. Each Fibre Channel tape drive can transfer data at up to 30 MB per second. Be aware that connecting multiple devices that have a combined transfer rate greater than 200 MB per second on a single loop may reduce the performance of the tape drives.

---

---

# 2 Installation and Operation

---

This chapter provides installation and operation requirements for the M2 tape drive.

**Note:** The requirements for installing the SCSI tape drive and the Fibre Channel tape drive differ somewhat. Where they differ, the information for the SCSI tape drive appears first, followed by the information for the Fibre Channel tape drive.

## ESD Precautions

Before beginning installation of the internal tape drive, make sure that the location is free of conditions that could cause electrostatic discharge (ESD). Discharge any static electricity by touching a known grounded surface.

### CAUTION

To avoid interrupting tape drive operation and potential ESD damage to the tape drive, discharge static electricity from your body before you touch the tape drive front panel or interface connector for any reason. (Touch a known grounded surface, such as your computer's metal chassis or the rear of the drive enclosure.)

## Installation (Internal Tape Drive)

**Note:** See [Appendix A](#) for the installation requirements for the tabletop model of the tape drive.

The internal tape drive must be installed in an enclosure that provides the following:

- Power
- Chassis grounding
- Communication interface connections
- Provisions for setting the device address
- Secure mounting
- Proper operating environment

In addition to these basic requirements, you may want to include provisions for making a connection to the tape drive's monitor port. The monitor port allows you to perform the following operations:

- Load code
- Upload a diagnostic listing (dump) from the tape drive's buffer
- Access the tape drive firmware using the M2 Monitor program

[Figure 2-1](#) shows the dimensional locations of the back-panel connectors on the SCSI tape drive. [Figure 2-2](#) show the same information for the Fibre Channel tape drive.

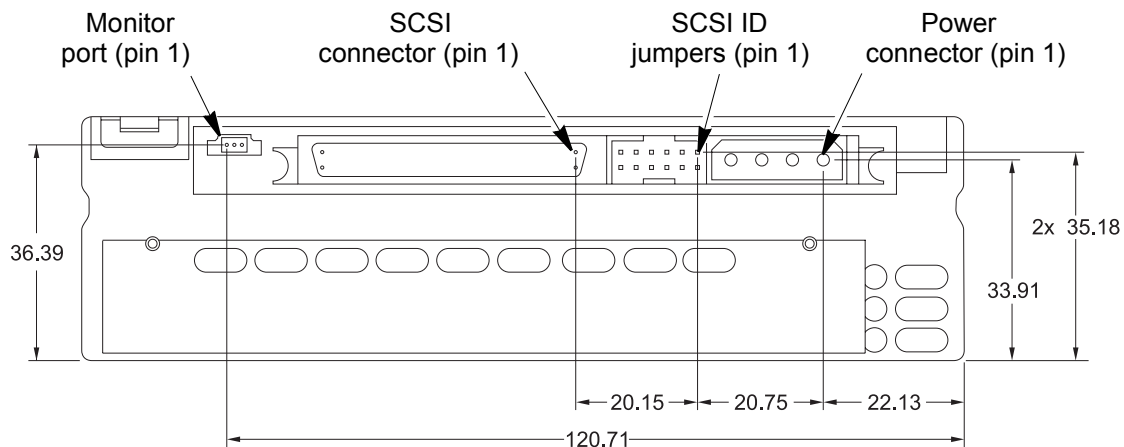

**Figure 2-1** SCSi tape drive back-panel connector and pin locations (in millimeters)

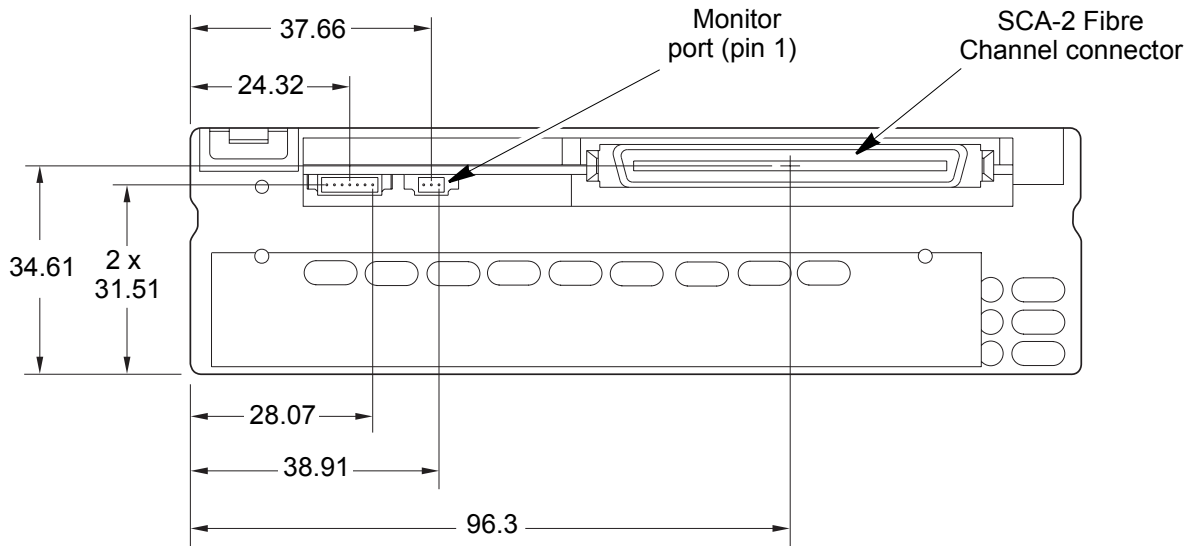

**Figure 2-2** Fibre Channel tape drive back-panel connector locations (in millimeters)

## Power

This section describes the power connector requirements for the SCSI tape drive and the Fibre Channel tape drive.

### SCSI Tape Drive Power Connector

The internal SCSI tape drive’s power connector is compatible with power connectors used for standard 5.25-inch, half-high devices. Use an AMP 1-480424-0 series or equivalent female power connector. [Figure 2-1](#) shows the location of the power connector on the tape drive.

[Table 2-1](#) lists the pin assignments for the power connector on the SCSI tape drive.

**Table 2-1** Pin assignments for the SCSI power connector

Pin number	Assignment
1	+12 VDC
2	Ground, 12 VDC return
3	Ground, 5 VDC return
4	+5 VDC

## Fibre Channel Tape Drive Power Connector

The internal Fibre Channel tape drive's power is supplied through the 80-pin SCA-2 Fibre Channel connector shown in [Figure 2-2](#). Refer to [Table 2-6 on page 2-11](#) for the pin-out of this connector.

## Chassis Grounding

**Note:** The power supply returns are connected to the chassis and do not isolate logic common ground from chassis ground.

When you secure the tape drive to the enclosure's metal chassis (using the mounting holes shown in [Figure 2-4 on page 2-15](#)), the tape drive is grounded. If desired, you can use *one* of the following methods to provide additional chassis grounding for the tape drive:

- Connect the enclosure's grounding wire to the grounding tab using a 1/4-inch female spade connector.

or

- Connect the enclosure's grounding wire to the grounding hole using an M2 × 0.4 × 6 mm self-tapping screw (available from Exabyte).

**Note:** The location of the grounding tab and the grounding hole are the same for both the SCSI and Fibre Channel tape drives (see [Figure 1-4 on page 1-5](#)).

## Communication Interface Connections

This section describes the communication interface connection requirements for the SCSI tape drive and the Fibre Channel tape drive.

### SCSI Interface Requirements

This section describes the SCSI interface connection requirements, including:

- SCSI cable requirements
- SCSI connector requirements
- Terminator requirements



**SCSI Cable Requirements** The cable connected to the tape drive SCSI connector must have a minimum primary conductor size of 28 AWG. This size minimizes noise effects and ensures proper distribution of terminator power. Ideally, to match the cable terminators, the cable should have the characteristic impedance shown in [Table 2-2](#).

**Note:** If you will be using an external SCSI cable to connect the tape drive to a SCSI bus, the cable must conform to the SCSI-3 cable specifications described on [page A-9](#).

**Table 2-2** Ideal characteristic impedances for SCSI cables

Single-ended	Low-voltage Differential (LVD)	High-voltage Differential (HVD)
132 ohms	110 ohms	88 ohms

---

➤ **Important** To minimize discontinuities and signal reflections, Exabyte recommends that cables used on the same bus have the same impedances.

---

**SCSI Connector Requirements** The SCSI connector on the back of the tape drive is a 68-pin male, shielded, AMP 7860190-7.

### CAUTION

All wide SCSI configurations (single-ended, LVD, and HVD) use the same 68-pin connector. The pin assignments on the connector are different for each SCSI configuration. Do not attach an HVD drive to an LVD or single-ended SCSI bus. Doing so may cause the bus to hang.

Table 2-3 shows the pin assignments for the LVD SCSI connector.

**Table 2-3** LVD SCSI connector pin assignments

Pin #	Signal	Pin #	Signal
1	+DB (12)	35	-DB (12)
2	+DB(13)	36	-DB(13)
3	+DB(14)	37	-DB(14)
4	+DB(15)	38	-DB(15)
5	+DB(P1)	39	-DB(P1)
6	+DB(0)	40	-DB(0)
7	+DB(1)	41	-DB(1)
8	+DB(2)	42	-DB(2)
9	+DB(3)	43	-DB(3)
10	+DB(4)	44	-DB(4)
11	+DB(5)	45	-DB(5)
12	+DB(6)	46	-DB(6)
13	+DB(7)	47	-DB(7)
14	+DB(P)	48	-DB(P)
15	GROUND	49	GROUND
16	DIFFSENS	50	GROUND
17	TERMPWR	51	TERMPWR
18	TERMPWR	52	TERMPWR
19	OPEN	53	OPEN
20	GROUND	54	GROUND
21	+ATN	55	-ATN
22	GROUND	56	GROUND
23	+BSY	57	-BSY
24	+ACK	58	-ACK
25	+RST	59	-RST
26	+MSG	60	-MSG
27	+SEL	61	-SEL
28	+C/D	62	-C/D

**Table 2-3** LVD SCSI connector pin assignments *(continued)*

Pin #	Signal	Pin #	Signal
29	+REQ	63	-REQ
30	+I/O	64	-I/O
31	+DB(8)	65	-DB(8)
32	+DB(9)	66	-DB(9)
33	+DB(10)	67	-DB(10)
34	+DB(11)	68	-DB(11)

Table 2-4 shows the pin assignments for the HVD SCSI connector.

**Table 2-4** HVD SCSI connector pin assignments

Pin #	Signal	Pin #	Signal
1	+DB(12)	35	-DB(12)
2	+DB(13)	36	-DB(13)
3	+DB(14)	37	-DB(14)
4	+DB(15)	38	-DB(15)
5	+DB(P1)	39	-DB(P1)
6	GROUND	40	GROUND
7	+DB(0)	41	-DB(0)
8	+DB(1)	42	-DB(1)
9	+DB(2)	43	-DB(2)
10	+DB(3)	44	-DB(3)
11	+DB(4)	45	-DB(4)
12	+DB(5)	46	-DB(5)
13	+DB(6)	47	-DB(6)
14	+DB(7)	48	-DB(7)
15	+DBP	49	-DBP
16	DSSENS.IO	50	GROUND
17	TERMPWR	51	TERMPWR
18	TERMPWR	52	TERMPWR
19	OPEN	53	OPEN
20	+ATN	54	-ATN
21	GROUND	55	GROUND
22	+BSY	56	-BSY
23	+ACK	57	-ACK

**Table 2-4** HVD SCSI connector pin assignments *(continued)*

Pin #	Signal	Pin #	Signal
24	+RST	58	-RST
25	+MSG	59	-MSG
26	+SEL	60	-SEL
27	+CD	61	-CD
28	+REQ	62	-REQ
29	+IO	63	-IO
30	GROUND	64	GROUND
31	+DB(8)	65	-DB(8)
32	+DB(9)	66	-DB(9)
33	+DB(10)	67	-DB(10)
34	+DB(11)	68	-DB(11)

Table 2-5 shows the connector pin assignments for the tape drive when attached to a single-ended wide SCSI bus.

---

➤ **Important** Although you can attach an M2 LVD SCSI tape drive to a single-ended SCSI bus, doing so will result in the tape drive operating as a single-ended device. The tape drive will provide a maximum data transfer rate of 20 MB/second when attached to a single-ended wide bus. In addition, although the LVD SCSI interface is compatible with narrow SCSI buses, Exabyte does not support using the M2 tape drive in a single-ended narrow SCSI environment.

---

**Table 2-5** Single-ended wide SCSI connector pin assignments

Pin #	Signal	Pin #	Signal
1	GROUND	35	-DB (12)
2	GROUND	36	-DB(13)
3	GROUND	37	-DB(14)
4	GROUND	38	-DB(15)
5	GROUND	39	-DB(P1)
6	GROUND	40	-DB(0)
7	GROUND	41	-DB(1)
8	GROUND	42	-DB(2)
9	GROUND	43	-DB(3)
10	GROUND	44	-DB(4)
11	GROUND	45	-DB(5)
12	GROUND	46	-DB(6)
13	GROUND	47	-DB(7)
14	GROUND	48	-DB(P)
15	GROUND	49	GROUND
16	GROUND	50	GROUND
17	TERMPWR	51	TERMPWR
18	TERMPWR	52	TERMPWR
19	OPEN	53	OPEN
20	GROUND	54	GROUND
21	GROUND	55	-ATN
22	GROUND	56	GROUND
23	GROUND	57	-BSY
24	GROUND	58	-ACK
25	GROUND	59	-RST
26	GROUND	60	-MSG
27	GROUND	61	-SEL
28	GROUND	62	-C/D
29	GROUND	63	-REQ
30	GROUND	64	-I/O
31	GROUND	65	-DB(8)
32	GROUND	66	-DB(9)
33	GROUND	67	-DB(10)
34	GROUND	68	-DB(11)

**SCSI Terminator Requirements** If the internal tape drive is the last device on the SCSI bus, you must terminate the bus by installing a pass-through terminator on the tape drive's SCSI connector. Or, if there is an unused connector at the end of the SCSI cable, you can terminate the bus there. The tape drive does not supply terminator power.

---

➤ **Important** Exabyte recommends using active termination. Exabyte testing has shown that older passive termination does not provide rising edge transitions that are fast or clean enough at fast SCSI speeds.

---

**Note:** If you will be using an external terminator on the tape drive enclosure, the terminator must conform to the requirements described on [page A-10](#).

### Fibre Channel Requirements

The Fibre Channel connector on the back of the tape drive is an 80-pin, copper SCA-2 connector. When integrating the internal drive into an enclosure, this connector must be attached to a separate interface board or system backplane that provides the following:

- Power
- Provisions for setting the hard address (the Fibre ID)
- Connection to the two Fibre Channel ports

[Table 2-6](#) shows the connector pin assignments for the Fibre Channel tape drive. Unless otherwise noted, all signals are defined in the SCA-2 connector specifications (see "[Related Publications](#)").

**Table 2-6** Fibre Channel 80-pin SCA-2 connector pin assignments

Pin #	Pin length <sup>a</sup>	80-pin connector contact and signal name	Pin #	Pin length <sup>a</sup>	80-pin connector contact and signal name
1	L	12 V CHARGE	41	L	GROUND (12 V)
2	S	12 V	42	L	GROUND (12 V)
3	S	12 V	43	L	GROUND (12 V)
4	S	12 V	44	S	MATED 2 (not connected)
5	S	12 V	45	L	OPT 12 V GROUND (not connected)
6	S	12 V	46	L	GROUND (12 V)
7	S	OPT 12 V (not connected)	47	S	-DRIVE_ATN (not connected)
8	S	OPT 12 V (not connected)	48	S	-LIB_RST (not connected)
9	S	OPT 12 V (not connected)	49	S	-LIB_SEN (not connected)
10	S	Reserved	50	S	-LIB_DRV_SEN (not connected)
11	S		51	S	+LIB_TX (not connected)
12	S		52	S	-LIB_TX (not connected)
13	S		53	S	-LIB+RX (not connected)
14	S		54	S	+LIB_RX (not connected)
15	S		55	S	Reserved
16	S	-ENBL BYP CH1 (not connected)	56	S	OPT 12 V GROUND (not connected)
17	S	-PARALLEL ESI (not connected)	57	S	+PORT 1_IN
18	S	READY LED (not connected)	58	S	-PORT 1_IN
19	S	POWER CONTROL (not connected)	59	S	GROUND (12 V)
20	S	-ENBL BYP CH2 (not connected)	60	S	+PORT 2_IN
21	S	SEL_6	61	S	-PORT 2_IN
22	S	SEL_5	62	S	GROUND (12 V)
23	S	SEL_4	63	S	+PORT 1_OUT
24	S	SEL_3	64	S	-PORT 1_OUT
25	S	FAULT LED (not connected)	65	S	GROUND (5 V)
26	S	DEVICE CONT 2 (not connected)	66	S	+PORT 2_OUT
27	S	DEVICE CONT 1 (not connected)	67	S	-PORT 2_OUT
28	S	5 V	68	S	GROUND (5 V)
29	S	5 V	69	S	SEL_2
30	S	5 V	70	S	SEL_1
31	S	5 V	71	S	SEL_0
32	S	5 V	72	S	DEVICE CONT 0 (not connected)
33	S	5 V	73	S	GROUND (5 V)
34	S	5 V	74	S	MATED 1 (not connected)

**Table 2-6** Fibre Channel 80-pin SCA-2 connector pin assignments (*continued*)

Pin #	Pin length <sup>a</sup>	80-pin connector contact and signal name	Pin #	Pin length <sup>a</sup>	80-pin connector contact and signal name
35	S	5 V	75	L	GROUND (5 V)
36	L	5 V CHARGE	76	L	GROUND (5 V)
37	L	Reserved	77	L	Reserved
38	L	RMT_START (not connected)	78	L	DLYD_START (not connected)
39	L	GROUND (5 V)	79	L	GROUND (5 V)
40	L	GROUND (5 V)	80	L	GROUND (5 V)

<sup>a</sup> L – Long backplane pin length  
S – Short backplane pin length

## Device Addressing

This section describes the requirements for setting the tape drive's device address. The parallel SCSI and Fibre Channel interfaces employ different methods of setting the device address.

**Note:** Both the SCSI drive and the Fibre Channel drive have the SCSI ID label shown in [Figure 1-10](#). The SCSI ID information on this label is not pertinent to the Fibre Channel drive; you should ignore it if you have a Fibre Channel tape drive.

### SCSI ID (SCSI Tape Drive Only)

The SCSI tape drive uses six 2 mm jumper posts on the back of the tape drive to set the SCSI ID. SCSI IDs of 0 through 15 are set using a binary value determined by the four right-most pins. The presence of a jumper represents a one; the absence of a jumper represents a zero. For replacement jumpers, use AMP 382575-2 or equivalent. Jumper 5 is reserved and jumper 6 is TERMPOWER. [Figure 2-3](#) shows the SCSI ID jumper settings. See [Figure 2-1 on page 2-2](#) for the location of pin 1.



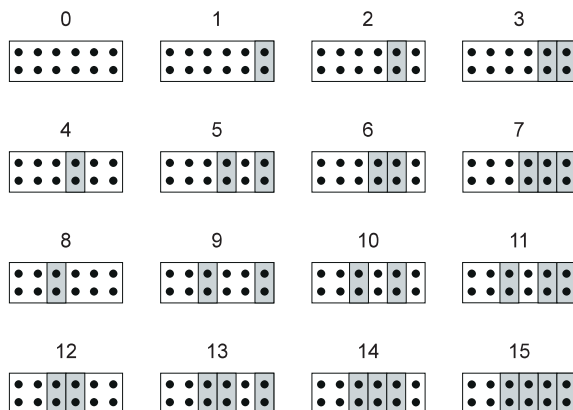

**Figure 2-3** SCSI ID jumper settings

If desired, you can set the SCSI ID by removing all of the jumpers and connecting a remote switch to the SCSI ID connector. Use an AMP part number 1-111623-7. This AMP part is used with a ribbon cable; AMP does not currently offer a discrete wire version. The connector mates to all of the pins on the connector; however, only the four right-most pins are used for the SCSI ID.

### Fibre ID (Fibre Channel Tape Drive Only)

The Fibre ID (hard address) for the internal Fibre Channel tape drive is set through the address bits (pins 21 – 24 and 69 – 71) on the 80-SCA-2 connector (see [Table 2-6](#)). Addresses are selectable from 00h to FFh. However, within this range, the addresses 7Eh and 7Fh are reserved and should not be used. Using either of these addresses will immediately cause the tape drive to use soft addressing (see the *Exabyte Mammoth-2 Fibre Channel Supplement* for more information).

---

➤ **Important** The valid address range for the Loop ID is 00h through FFh. However, within this range, the addresses 7Eh and 7Fh are reserved. If you select either 7Eh or 7Fh as the address, the tape drive automatically uses soft addressing when obtaining an arbitrated loop physical address (AL\_PA). See [page 5-13](#) for more information.

Furthermore, if you select an address higher than 7Fh, the tape drive ignores the most significant bit of the binary representation of the address, resulting in an address that is different from the one selected. See [“Device Addressing” on page 5-10](#) for more information about Fibre Channel device addressing.

---

## Monitor Port

The Monitor port, shown in [Figure 1-4 on page 1-5](#), allows you to perform the following:

- Load code
- Upload a diagnostic listing (dump) from the tape drive's buffer
- Access the tape drive firmware using the M2 Monitor program

Use a 3-pin header (Molex 53261-0310) connected to the active monitor cable (Exabyte 33-01-00015). The level translator is included in the cable.

The connector pin definitions are listed in [Table 2-7](#). See [Figure 2-1](#) and [Figure 2-2](#) for the location of the Monitor port pin 1 on the SCSI tape drive and Fibre Channel tape drive, respectively.

**Table 2-7** Monitor port pin assignments

Pin number	Name	Level
1	Gnd	Gnd
2	- TXD	TTL
3	- RXD	TTL

## Tape Drive Mounting Requirements

The tape drive can be mounted either horizontally or vertically and in a stationary or sliding position. The requirements are the same for the SCSI and Fibre Channel versions of the tape drive.

---

➤ **Important** In early versions of M2, the LVD SCSI connector extends approximately 0.36 inches (9.2 mm) beyond the industry-standard length for a 5.25-inch, half-high form factor.

---

As shown in [Figure 2-4](#), the tape drive chassis includes three sets of four mounting holes to allow for a number of mounting positions (two sets on the sides, set A and set B, and one set on the bottom, set C). [Figure 2-5](#) shows the dimensional locations of the mounting holes.

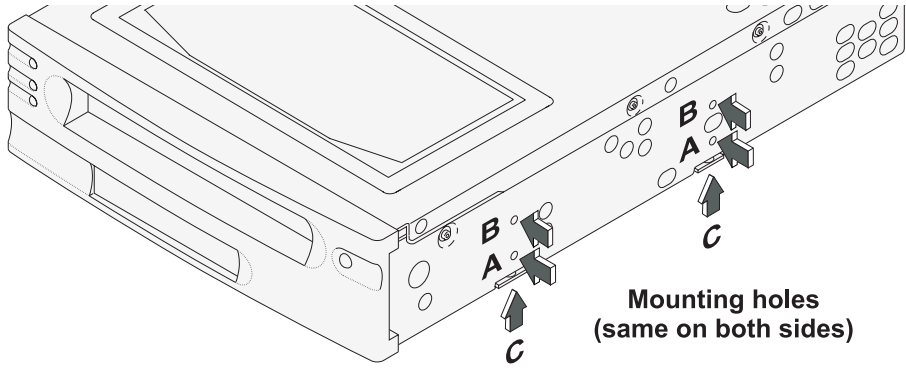

Figure 2-4 Mounting holes

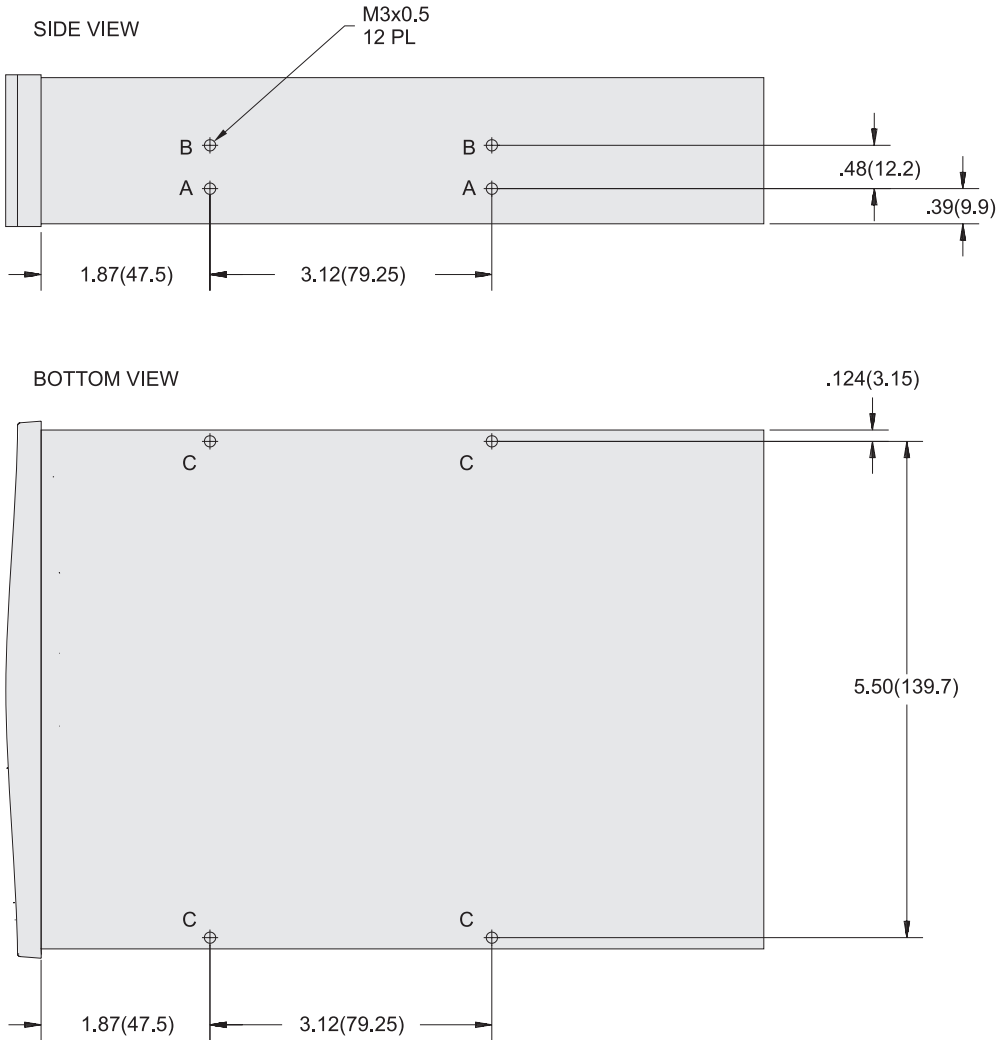

Figure 2-5 Mounting holes in inches and millimeters (three sets of four)

When mounting the tape drive, follow these guidelines:

- Use *one* set of mounting holes. (Use all four holes in whichever set you choose; do not use combinations of mounting holes from different sets.)
- Use M3 × 0.5 × 6 mm screws. **For proper mounting, use the correct screw length.**
- Ensure that no objects such as screw heads, cables, or adjacent devices are pressing against the frame.
- Do not obstruct the ventilation slots on the bottom and at the rear of the tape drive.
- Allow sufficient space for accessing the tape drive's front panel controls.

## Operating Environment Requirements

You can design your own enclosure, or you can purchase the tape drive already integrated into an Exabyte tabletop enclosure (see [Appendix A](#)). If you design your own enclosure or incorporate the tape drive into an existing enclosure, the design must maintain the tape drive's operating environment requirements as described in [Chapter 6](#).

# Operation

The operation of the SCSI and Fibre Channel models of the M2 tape drive is identical. Tape drive operation involves these types of activities:

- Monitoring the LEDs and LCD
- Selecting data cartridges
- Loading and unloading cartridges
- Cleaning the tape drive (automatic with SmartClean AME cartridges)
- Resetting the tape drive (if an error occurs)

**Note:** The M2 tape drive is compatible with numerous software applications. For the latest information about device drivers and software compatibility, go to Exabyte's web site at [www.exabyte.com](http://www.exabyte.com). If your software application is not listed, contact Exabyte Technical Support (see [Contacting Exabyte](#) on the inside back cover).

## Monitoring the LEDs and LCD

Figure 2-6 shows the controls and indicators for operating the tape drive.

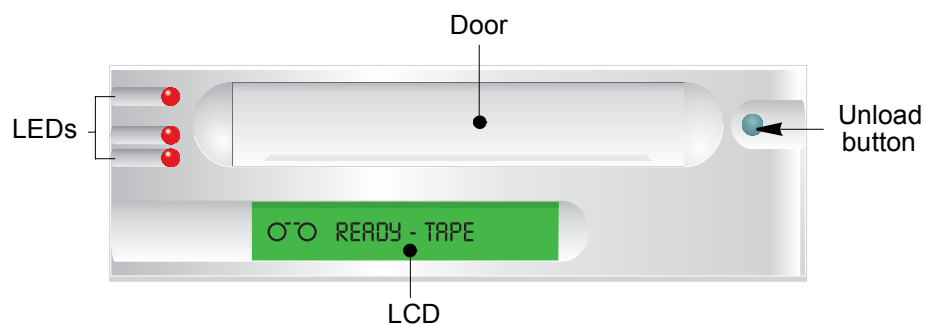

**Figure 2-6** Front panel components

## LED Status Indicators

The tape drive front panel includes three LEDs for indicating its operational status. The LEDs operate the same for both the SCSI model tape drive and the Fibre Channel tape drive. The LEDs have the following, general meanings:

- **Top LED (amber).** When this LED is flashing, an error has occurred. After extensive use of standard AME media, this LED may stay illuminated, indicating that the tape drive needs to be cleaned using a Mammoth cleaning cartridge (see [page 2-25](#)). The LED also turns on when the tape drive is performing a cleaning operation.
- **Middle LED (green).** When this LED is on, tape is loaded and the tape drive is ready to begin operations.
- **Bottom LED (green).** When this LED is flashing, tape motion is occurring. When this LED is on, the tape drive is performing a reset.

[Table 2-8](#) shows the LED combinations that occur during normal tape drive operation.

**Note:** You may occasionally observe LED combinations and sequences not described in the table. These other combinations represent special or unusual conditions that are beyond the scope of this table.

**Table 2-8** LED states

	Tape drive state <sup>a</sup>							
	POST or reset	Error or failed POST	Ready (no tape loaded)	Ready (tape loaded)	Normal tape motion	High speed motion	Time to clean <sup>b</sup>	Clean in progress
<b>Top LED (Error/Clean)</b>	●	*	n/a	n/a	n/a	n/a	●	●
<b>Middle LED (Tape Ready)</b>	●	○	○	●	●	●	n/a	●
<b>Bottom LED (Tape Motion)</b>	●	○	○	○	*	* fast	n/a	*

<sup>a</sup> Legend: ○ = off ● = on \* = flash n/a = not applicable (may be any state)

<sup>b</sup> Only when standard AME media has been used extensively in the drive. Cleaning is automatic when AME with SmartClean cartridges are used.

## LCD Messages

The M2 tape drive includes a liquid crystal display (LCD) that displays alphanumeric information about the tape drive's operational status.

[Table 2-9](#) provides a detailed list of the messages that may appear on the LCD.

**Table 2-9** LCD message descriptions

LCD message	Description
<b>Reset messages (When the tape drive is reset, the LCD cycles through the following messages.)</b>	
*** RESETTING	The first message to appear during the power-on sequence.
MODEL:	The model number of the tape drive.
SUBMOD:	The submodel number of the tape drive.
SN:	The serial number of the tape drive.
CODE:	The level of the tape drive's firmware.
LAST CLN: <i>nn</i> hrs	The number of hours since the tape drive has last been cleaned.
COMPRESS: ON <i>or</i> COMPRESS: OFF	Compression is turned on (the default) or compression is turned off.
DIFFERENTIAL <i>or</i> LV DIFFERENTIAL <i>or</i> FIBRE CHANNEL	The tape drive has a HVD (Differential) SCSI, LVD (LV Differential) SCSI or Fibre Channel configuration.
WIDE	The tape drive has a wide SCSI configuration.
SCSI ID <i>or</i> Fibre Channel ID:	The SCSI ID or Fibre Channel ID of the tape drive.
<i>LANGUAGE:</i>	<p>The available non-English languages for the LCD appear when you perform the following steps:</p> <ol style="list-style-type: none"> <li>1. Press and hold the unload button during the reset sequence. After the SCSI ID message appears, the LCD cycles through the languages.</li> <li>2. When the desired language displays, release the button and the messages appear in that language.</li> </ol> <p>For a list of non-English language LCD messages, refer to <a href="#">Table 2-10</a>.</p>
<b>Tape drive status messages</b>	
READY-NOTAPE	The tape drive is ready to accept a cartridge.
○ ○ LOADING . . . . .	The tape drive is loading the tape.
○ ○ READY-TAPE	The tape drive has successfully loaded the tape and is ready for read/write operations.

**Table 2-9** LCD message descriptions (*continued*)

LCD message	Description
<b>Tape drive status messages (<i>continued</i>)</b>	
EJECT ■■■=====	The unload button was pressed. The tape drive ejects the cartridge as soon as it has finished its current operation. The icon to the left or right of the EJECT message indicates the current operation.
○ <sup>-</sup> ○ EJECT-PREVENT	The software has disabled the eject function with the PREVENT/ALLOW MEDIA REMOVAL command. The tape drive will rewind and unload the tape, but will not eject the cartridge.
○ <sup>-</sup> ○ ILLEGAL TAPE	The tape drive detected an incompatible cartridge and ejected it.
<b>Tape motion messages</b>	
○ <sup>↑</sup> ○ READ +■■■=====	The tape drive is reading or writing data. The + sign appears when the tape drive is in compression mode. The boxes show the amount of tape used.
○ <sup>↓</sup> ○ WRITE+■■■=====	
○/○ PROTECTED	The tape drive cannot write data because the data cartridge is write-protected.
○/○ ILLEGAL WRT	The tape drive cannot write to the type of data cartridge inserted. This message remains until an unload/eject operation is performed.
>> SEARCH ■■=====	High-speed search is in progress. The arrows indicate the direction of the search.
<< SEARCH ■■=====	
<< REWIND ■■=====	Rewind is in progress.
○X○ ERASE ■■=====	The tape drive is erasing data on the tape.
○X○ FORMAT =====	The tape drive is repartitioning the tape to the requested format. The icon to the left of the message displays the current operation.
○ <sup>-</sup> ○ WORN TAPE	The tape currently in the tape drive has exceeded the tape drive's maximum tape passes threshold and must be replaced.
<b>Cleaning messages</b>	
○*○ CLEAN SOON	The tape drive should be cleaned at the next convenient time.
○*○ CLEANING . . . .	Cleaning is in progress.
○*○ DEPLETED	The cleaning tape in the cartridge is depleted and the tape drive will eject it. Use a new cleaning cartridge.
<b>Error conditions</b> (When a hardware error occurs, the LCD cycles through the current error code and the previous two error codes.)	
ERR 1: xx yy zz ERR 2: xx yy zz ERR 3: xx yy zz	In the error display, xx indicates the fault symptom code, and yy and zz indicate secondary errors (if any). If an error appears, contact Exabyte Technical Support.



**Table 2-9** LCD message descriptions (*continued*)

LCD message	Description
<b>Diagnostics and code load messages</b>	
DIAG-TESTING . . . .	The tape drive is beginning the diagnostic tests.
○*○ TESTING	Tape motion is occurring during diagnostic tests.
DIAG-PASSED	This message appears for 15 seconds when the test completes successfully.
DIAG-FAILED	The test failed. The LCD then cycles through three statistics messages: DIAG-WRITE, DIAG-READ, DIAG-ECC.
LOADING CODE . . . .	This message displays when code is loading from a code load tape, through SCSI, or through the Monitor port. If the code load is successful, the tape drive automatically resets. If the code load fails, the LCD displays CODE LOAD FAIL.
CODE LOAD FAIL	These messages appear in sequence after the code load failed.
RETRY CODE LOAD	
MAKE CODELOAD TP	The tape drive is making a code load tape.

[Table 2-10](#) provides a list of LCD messages in all the available languages.

**Table 2-10** LCD messages in the available languages

Full message	English	French	German	Spanish	Italian	Portuguese
RESETTING	RESETTING	R.A.Z.	RUECKSETZEN	RESTAURANDO	INIZIALIZZA	RESTAURANDO
MODEL	MODEL:	MODELE:	TYP:	MODELO:	MOD:	MODELO:
SUBMODEL	SUBMOD:	SOUSMOD:	MODELL:	SUBMOD:	SUBMOD:	SUBMOD:
SERIAL NUMBER	SN:	NS:	SN:	N.S.:	S/N:	N/S:
CODE	CODE:	CODE:	CODE:	CODIGO:	CODICE:	CODIGO:
LAST CLEANED	LASTCLN: XXXX HRS	DERN NET:XXXX H	LTZT REI:XXXXSTD	ULT LIMP:XXXXHRS	ULT PUL:XXXX ORE	ULT LIMP:XXXXHRS
DATA COMPRESSION ON	COMPRESSION: ON	COMPRESSION: ON	KOMPRESSN: EIN	COMPRESION: SI	COMPRESS.: SI	COMPRESSAO: SIM
DATA COMPRESSION OFF	COMPRESSION: OFF	COMPRESSION: OFF	KOMPRESSN: AUS	COMPRESION: NO	COMPRESS.: NO	COMPRESSAO: NAO
SINGLE ENDED	SINGLE ENDED	SINGLE ENDED	SINGLE ENDED	SINGLE ENDED	SINGLE ENDED	SINGLE ENDED
DIFFERENTIAL	DIFFERENTIAL	DIFFERENTIEL	DIFFERENTIELL	DIFERENCIAL	DIFFERENTIAL	DIFERENCIAL
LV DIFFERENTIAL	LV DIFFERENTIAL	LV DIFFERENTIEL	LV DIFFERENTIELL	LV DIFERENCIAL	LV DIFFERENTIAL	LV DIFERENCIAL
FIBRE CHANNEL	FIBRE CHANNEL	FIBRE CHANNEL	FIBRE CHANNEL	FIBRE CHANNEL	FIBRE CHANNEL	FIBRE CHANNEL

## 2 Installation and Operation

**Table 2-10** LCD messages in the available languages (*continued*)

Full message	English	French	German	Spanish	Italian	Portuguese
WIDE	WIDE	16-BITS	16 BIT BREIT	16 BIT	16 BIT	16 BIT
SCSI ID	SCSI ID:	SCSI ID:	SCSI ID:	ID SCSI:	ID SCSI:	ID. SCSI:
FIBRE ID	FIBRE ID:	FIBRE ID:	FIBRE ID:	FIBRE ID:	FIBRE ID:	FIBRE ID:
LANGUAGE	LANGUAGE:	LANGUE:	SPRACHE:	IDIOMA:	LINGUA:	LINGUA:
ENGLISH	ENGLISH	FRANCAIS	DEUTSCH	ESPAÑOL	ITALIANO	PORTUGUES
READY-NO TAPE	READY-NO TAPE	PRET-SANSBDE	BEREIT-LEER	LST SN CINTA	PRONT.NO NAS	PRONT-S/FITA
LOADING	LOADING	CHARGEMENT	LADEN	CARGANDO	CARICANDO	CARREGANDO
READY-TAPE	READY-TAPE	PRET-BANDE	BEREIT-BAND	LST CN CINTA	PRONT. NAS	PRONT-C/FITA
EJECT	EJECT	EJECT.	AUSWRF	SACAR	EJECT	EJETAR
EJECT PREVENTED	EJECT PREVNT	EJECT.INHIBE	AUSWRF VERH	SACAR PREVEN	EJECT INATT.	EJECÃO EVIT.
ILLEGAL TAPE	ILLEGAL TAPE	BANDE INVAL	BAND UNGUELT	CINTA INVAL	NASTRO INV.	FITA INVAL
READ	READ	LECT.	LESEN	LEER	LEGGI	LER
WRITE	WRITE	ESCR.	SCHR.	ESCR.	SCRIVI	ESCR.
WRITE PROTECTED	PROTECTED	PROTEC ECR	SCHREIBGESCH	ESCR PROTEGI	PROT. SCRIT.	ESCR PROTEGI
ILLEGAL WRITE	ILLEGAL WRT	ECRIT. INVAL	SCHR. UNGUELT	ESCR INVAL	SCRITT.INV.	ESCR. INVAL
SEARCH	SEARCH	RCHER.	SUCHEN	BUSCAR	CERCA	PROCUR
REWIND	REWIND	REBOB.	RUCKSP	REGRE	RIAVV.	REGRE
ERASE	ERASE	EFFAC.	LOESCH	BORRAR	CANC.	APAGAR
FORMAT	FORMAT	FORMAT	FORMAT	FORMAT	FORMAT	FORMAT
WORN TAPE	WORN TAPE	BANDE USEE	RAND ABGENUTZT	CINTA GASTADA	NASTRO CONSUMATO	FITA GASTA
CLEANING RECOMMENDED	CLEAN SOON	NETT. RECOM.	BALD REINIG.	LIMP PRONTO	PULIZ. RACC.	LIMP. RECOM.
CLEANING	CLEANING	NETTOYAGE	REINIGUNG	LIMPIANDO	PULIZANDO	LIMPANDO
DEPLETED CLEANING CARTRIDGE	DEPLETED	EPUISE	AUFGEBRAUCHT	VACIADO	NASTRO USATO	ESVAZIADO
DIAGNOSTICS-TESTING	DIAG-TESTING	DIAG-TEST	DIAG-TEST	DIAG-PRUEBA	DIAG-TEST	DIAG.-TESTE
TESTING	TESTING	TEST	TEST	PRUEBA	TEST	TESTE
DIAGNOSTICS-PASSED	DIAG-PASSED	DIAG-FINI-OK	DIAG-ENDE-OK	DIAG-APROV	DIAG-PASSATA	DIAG.-APROV.
DIAGNOSTICS FAILED	DIAG-FAILED	DIAG-DEFAILL	DIAG-FEHLER	DIAG-FALLA	DIAG-FALLITA	DIAG.-FALHA
DIAGNOSTICS WRITE	DIAG-WRITE	DIAG-ECRIT	DIAG-SCHR.	DIAG-ESCR	DIAG-SCRIT	DIAG.-ESCR.

**Table 2-10** LCD messages in the available languages (*continued*)

Full message	English	French	German	Spanish	Italian	Portuguese
DIAGNOSTICS READ	DIAG-READ	DIAG-LECT	DIAG-LESEN	DIAG-LEER	DIAG-LETT.	DIAG. LER
DIAGNOSTICS ECC	DIAG-ECC	DIAG-ECC	DIAG-ECC	DIAG-ECC	DIAG-ECC	DIAG.-ECC
LOADING CODE	LOADING CODE...	CHARGEM DE CODE	CODE LADEN	CARGANDO COD	CAR. CODICE	CARREG. CODIGO
CODE LOAD FAILED	CODE LOAD FAIL	ERR. CHARG. CODE	CODE NICHT ANGEN	FALLA-CARG COD	CAR.COD. FALLITO	FALHA CARR. COD.
RETRY CODE LOAD	RETRY CODE LOAD	RECHARGEZ CODE	CODE NEU LADEN	REINT CG COD	RIPROVA CAR COD	TENT NOV COD CAR
MAKING CODE LOAD TAPE	MAKE CODELOAD TP	CHARGEMENT CODE	FW BAND ERSTELLN	PRO CG COD CINTA	PREP. LOAD TAPE	PRO CAR COD FITA
LAST 3 ERRORS	LAST 3 ERRORS	3 DERN ERR	3 LETZTE FEHLER	ULTIMOS 3 ERR	ULTIMI 3 ERR	ULTIMOS 3 ERROS
ERROR 1	ERR 1:	ERR 1:	ERR 1:	ERR 1:	ERR 1:	ERRO 1:
ERROR 2	ERR 2:	ERR 2:	ERR 2:	ERR 2:	ERR 2:	ERRO 2:
ERROR 3	ERR 3:	ERR 3:	ERR 3:	ERR 3:	ERR 3:	ERRO 3:

## Selecting Data Cartridges

The M2 tape drive reads and writes to Advanced Metal Evaporated (AME) data cartridges with Exabyte SmartClean™ technology. SmartClean cartridges, shown in [Figure 2-7](#), are a technology exclusive to MammothTape technology tape drives. The cartridges combine the extremely reliable AME recording media with a short segment of tape drive head cleaning material. The SmartClean cartridges are easily identified by their cobalt-blue color.

**Figure 2-7** Exabyte AME media with SmartClean

The SmartClean hybrid data cartridges enable the tape drive to perform self-maintenance, ensuring a superior head-to-tape interface by using its own cleaning material before, during, or after reading and writing data. AME cartridges with SmartClean significantly decrease user-required maintenance of the tape drive, making these cartridges ideal for use in drives operating in 7x24 automated environments.

### Reading Mammoth Format Cartridges

To ensure backward compatibility with data written by Mammoth and Mammoth-LT, M2 can read, but not write AME cartridges written using the original Mammoth format. Cartridges previously recorded using the original Mammoth format can be overwritten using the new Mammoth-2 format.

### Using Metal Particle Tapes

The M2 tape drive cannot write data to or read data from metal particle (MP) tape. If you insert an MP cartridge, the tape drive immediately ejects it. If you need to retrieve data from MP tape, contact Exabyte Technical Support for information about data conversion services.

## Loading and Unloading Cartridges

To load a cartridge, insert it into the tape drive door. The tape drive loads the tape in approximately 20 seconds. When the middle LED is on, the tape drive is ready for read and write operations.

To unload a cartridge, press the unload button. **Do not press and hold the unload button for more than 10 seconds; this can cause a reset under certain conditions.** If the tape drive is free of errors, it performs the following actions within approximately one minute:

- Completes any command in process
- Writes any buffered information to tape
- Rewinds the tape to the beginning
- Unloads the tape and ejects the cartridge

**Note:** If an error occurs before or during the unload procedure, the tape drive suspends the unload sequence. To clear the error, press the unload button again. The tape drive reattempts the unload sequence, but does not write data in the buffer.

## Cleaning the Tape Drive

The TapeSafe tape handling system's Dynamic Head Cleaner (described on [page 1-7](#)) and Exabyte's AME with SmartClean™ media makes M2 a completely self-maintaining tape drive under normal operating conditions. When M2 is used with standard AME media, the self-cleaning action of the Dynamic Head Cleaner extends the interval for required manual cleaning to 100 tape motion hours. When cleaning is required, the top LED turns on and the LCD displays the message, "CLEAN SOON." To help maintain data integrity and reliability, you should use an Exabyte-approved cleaning cartridge to clean the tape drive as soon as possible after the LED illuminates and the message appears.

## Resetting the Tape Drive

You can use either of the following methods to reset the tape drive:

- Power the tape drive off and back on again.
- Press and hold the unload button for at least 10 seconds, then release the button. This clears any error, resets the tape drive, and ejects any cartridge that is in the tape drive (unless a hardware or servo error occurred).
- Send a RST pulse on the SCSI bus for a minimum of 25  $\mu$ sec (*SCSI bus reset*). A SCSI bus reset immediately clears all devices from the bus, resets their associated equipment, and terminates all pending I/O processes.
- Issue a Bus Device Reset (0Ch) message to the tape drive (*device reset*). A device reset clears the tape drive from the bus, causes all commands sent to it to be cleared, and terminates all pending I/O processes.

**Note:** If a SCSI bus or device reset occurs during a power-on reset, the power-on reset operation will restart.

## Serverless Backup

**Note:** This feature is only available with the Fibre Channel tape drive. Implementing serverless backup on a storage area network (SAN) requires specially enabled application software.

The native Fibre Channel M2 tape drive supports serverless backup in SANs by providing a function called E-copy. E-copy is the name used for the M2's implementation of the SCSI EXTENDED COPY command. The EXTENDED COPY command permits data transfer to occur between the tape drive and any magnetic disk or other tape drive connected to the Fibre Channel SAN, without the data passing through an intermediate server. For more information on serverless backup and the EXTENDED COPY command, see [“EXTENDED COPY \(Fibre Channel Only\)” on page 4-9](#).

### Example of E-copy

An E-copy backup from a disk to a tape drive might take place as follows:

1. Through its application software, a server issues an EXTENDED COPY command to the tape drive. This command includes parameters that specify how much data is to be backed up and where it is located.
2. The tape drive interprets the command parameters and then acts as the SCSI initiator to issue Read commands to the specified disk across the Fibre Channel SAN.
3. The disk sends the requested data to the tape drive across the SAN.
4. The tape drive writes the data to tape. If desired, the application software can request that the tape drive report status information about the operation.

During a restore operation, the process is reversed. The tape drive receives an EXTENDED COPY command from the application software that specifies blocks of data on a tape as the data source. When the tape drive receives the command, it first reads the specified data from tape and then issues WRITE commands to the target disk drive to transfer the data to disk.

---

# 3 Technical Description

---

This chapter provides the following information about the tape drive:

- Write operations
- Read operations
- Adaptive data buffering function
- Helical-scan technology
- Physical track structure
- Tape format
- Read/write compatibility

## Write Operations

This section describes the following features of write operations:

- Data flow
- Data compression
- Error detection, correction, and recovery

## Data Flow

Figure 3-1 provides a high-level overview of the flow of data during a write operation.

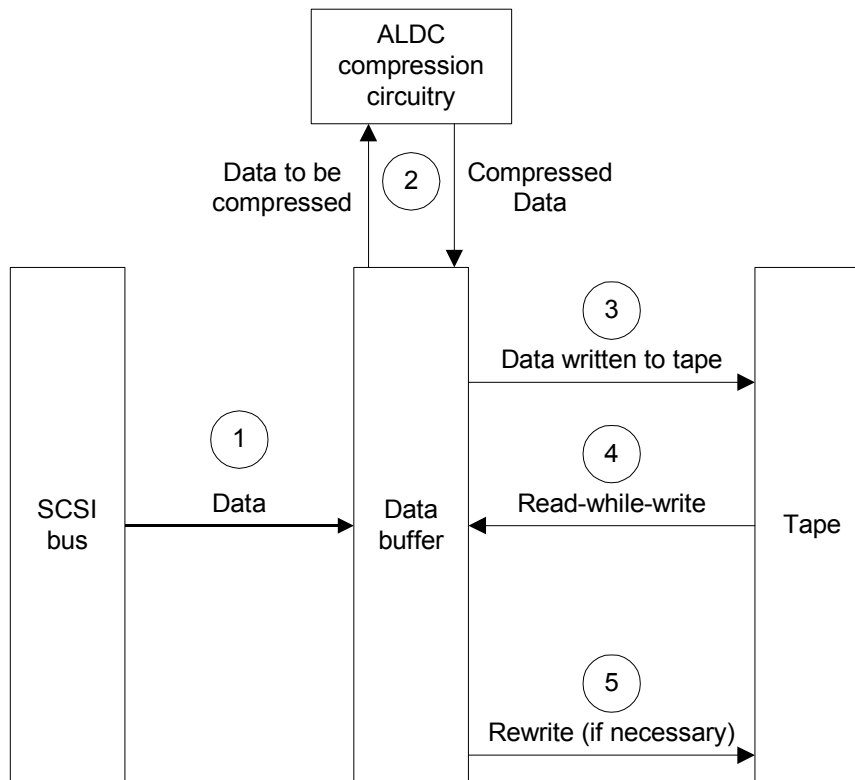

**Figure 3-1** Write operations

The following steps outline the data flow process during a write operation. (The steps below correspond to the circled numbers in Figure 3-1.)

1. Data goes directly from the SCSI bus to the tape drive's data buffer. (Data transfers between the SCSI bus and the buffer occur asynchronously or synchronously.)
2. If you select compressed format for the tape at the logical beginning of a partition (LBOP), the data goes from the data buffer to the Adaptive Lossless Data Compression (ALDC) compression circuit where it is compressed. A 16-bit checksum value is calculated on the original (uncompressed) data and appended to the compressed data. The compressed data is then returned to the data buffer.



After compression, the tape drive performs a data integrity check by decompressing the data, recalculating the checksum, and comparing it with the original checksum. After the check, the tape drive transfers the compressed data back to its data buffer.

3. When the motion threshold (see [page 3-8](#)) is exceeded in the data buffer, tape motion begins, error correction codes (ECC) and physical-block CRC bytes are integrated with each physical block, and data is written to tape.
4. The tape drive performs read-while-write verification of the recorded data to ensure that it was transferred to tape accurately.
5. If necessary, the tape drive rewrites the data.

## Data Compression

By default, the tape drive writes compressed data using an Adaptive Lossless Data Compression (ALDC) algorithm with a 1 KB compression buffer. The tape drive provides an average compression ratio of 2.5:1, which can be higher or lower depending on the type of data. Compression can be enabled and disabled through SCSI.

The ALDC algorithm operates in a look-aside mode where data is transferred from the data buffer to the compression circuitry and then returned to the buffer in such a way that the data flow between the host to the tape drive is uninterrupted.

## Error Detection, Correction, and Recovery Procedures

As the tape drive writes data to tape, it integrates physical-block cyclic redundancy check (CRC) bytes and error correction codes with each physical block. After it writes data, the tape drive uses the ECC and CRC to perform a read-after-write check to ensure data reliability.

### Cyclic Redundancy Check (CRC)

The tape drive adds eight bytes of CRC data to every physical block on tape. The CRC data is used in the read-after-write check used to validate data after it is written to tape.

## Error Correction Codes (ECC)

M2 integrates powerful two-dimensional Reed-Solomon error correction codes (ECC1 and ECC2) into each data block. Unlike first-generation MammothTape technology tape drives, each Mammoth-2 physical data block occupies an entire track. As a result, the ECC1 and ECC2 error correction codes operate over the entire track, making error correction much more powerful than in the first-generation drives. The improved implementation of ECC1 and ECC2 also requires significantly less ECC overhead (35% overhead in first-generation versus 16% overhead in Mammoth-2). Because of the improvements to ECC1 and ECC2, M2 obtains a bit error rate of  $1.0 \times 10^{-17}$  in environments where the raw bit error rate is worse than  $1.0 \times 10^{-4}$ .

In addition to ECC1 and ECC2, M2 uses sophisticated new multi-track ECC3 error correction algorithms to further ensure data integrity. During a write operation, the ECC3 hardware reads a group of 38 tracks (one physical block occupies one track) from the buffer and generates error correction information for the whole group. The ECC3 firmware then writes this error correction information to tape in two tracks immediately after the data tracks (see [Figure 3-2](#)).

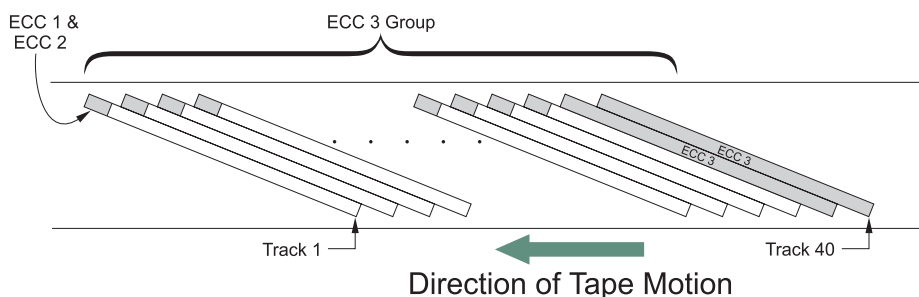

**Figure 3-2** Sophisticated ECC3 provides error checking over 40 tracks of data

The powerful ECC3 algorithm allows M2 to recover up to two full tracks of data out of a 40-track group. ECC3 is used only when a raw data error cannot be corrected by ECC1 and ECC2. The ECC3 information is stored in the last two tracks of each 40-track group.

## Read-While-Write Checking

The tape drive performs a read-while-write check of the recorded user data to ensure full data reliability. If the tape drive determines that any data blocks should be rewritten, it rewrites the data in a later track without requiring host intervention or repositioning of the tape.

# Read Operations

This section describes the following features of read operations:

- Data flow
- Data decompression
- PRML read channel signal processing

## Data Flow

Figure 3-3 provides a high-level overview of the flow of data during a read operation.

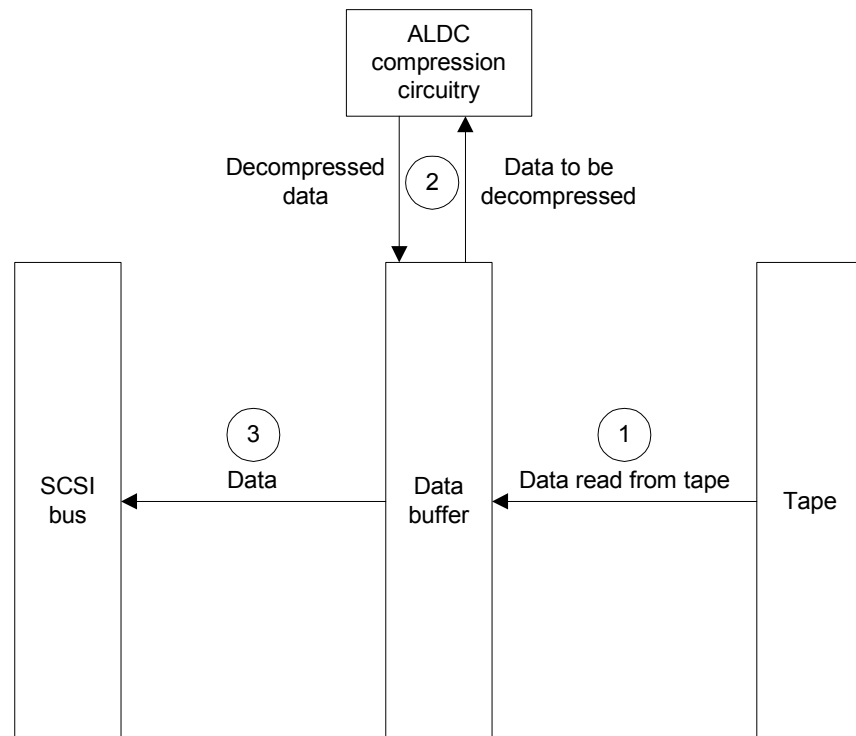

**Figure 3-3** Read operations

The following steps outline the process for reading logical blocks of user data. (The steps below correspond to the circled numbers in Figure 3-3.)

1. The tape drive reads data from tape, uses EPR4 read channel processing and ECC to correct errors as necessary for each physical block, and transfers data to the data buffer. The read operation continues until the buffer is full and tape motion stops.

2. If the data has been compressed, the data goes from the data buffer to the decompression circuit (ALDC or IDRC) to be decompressed. The decompressed data is then returned to the data buffer.
3. From the data buffer the data is transferred to the SCSI bus.

If the data has not been compressed, the data goes directly from the data buffer to the SCSI bus. In either case, the 8-byte logical block CRC, which was appended when the data was written, is again verified. This final integrity check ensures that all block reconstruction and decompression was successful.

## Data Decompression

By default, the tape drive reads compressed data using an Adaptive Lossless Data Compression (ALDC) algorithm with a 1 KB compression buffer. To ensure compatibility with data recorded using first-generation MammothTape technology drives, M2 also reads compressed data written in the original Mammoth format using the Improved Data Recording Capability (IDRC) algorithm.

The ALDC algorithm operates in a look-aside mode where data is transferred from the data buffer to the decompression circuitry and then returned to the buffer in such a way that the data flow between the host to the tape drive is uninterrupted.

## PRML Read Channel Signal Processing

To maximize both efficiency and reliability of signal detection at high bit densities, M2 uses an enhanced implementation of Partial Response Maximum Likelihood (PRML) technology called EPR4 to process the electrical signal from the read heads.

PRML significantly improves peak detection accuracy by sampling entire waveforms instead of just peaks in isolation. Within these waveforms, PRML uses advanced digital signal processing techniques to differentiate a valid signal from noise and reconstruct the original data.

Because PRML can correct many errors on the basis of “context,” it can compensate for overlapping peaks and valleys. As a result, it can handle more tightly packed bits better than the analog peak detection traditionally used in tape drives. The advanced digital filtering techniques used in PRML signal processing also allow it to overcome interference.

The EPR4 implementation of PRML increases the number of times and levels at which each transition is sampled to improve detection of fast, closely spaced peaks. Figure 3-4 compares the peak sampling for Class IV Partial Response PRML (PR4) with EPR4.

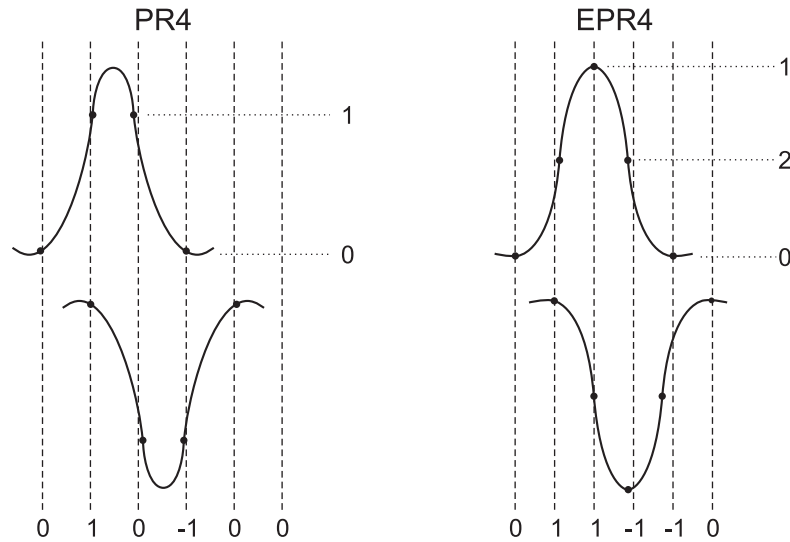

Figure 3-4 Comparison of PR4 and EPR4 peak sampling

## Adaptive Data Buffering Function

Mammoth-2 features a 32 MB adaptive data buffer, which enables the tape drive to optimize throughput by matching its buffer “fill” requirements to the host data transfer rate.

By default, M2 continually monitors the data flow from the host and automatically adjusts both the reconnect and motion thresholds to match variations in the host data transfer rate (*auto-thresholding*). By adapting to the host’s transfer rate, the tape drive is able to minimize the need for stopping and starting the tape.

The mode of operation (streaming or start/stop) depends on the rate that data can be transferred between the initiator and tape drive, as follows:

- **The tape drive operates in streaming mode** if the initiator can sustain a minimum transfer rate of 12 MB per second in uncompressed format or 30 MB per second in compressed format (with a 2.5:1 compression ratio).
- **The tape drive operates in start/stop mode** if the initiator cannot sustain this minimum transfer rate; starting and stopping occur automatically.

## Streaming Mode

When operating in streaming mode, the tape drive adapts to the host's data transfer rate by disconnecting from and reconnecting to the SCSI bus. The tape drive determines when to reconnect to the SCSI bus by comparing how full the buffer is to the reconnect threshold, as follows:

- During a write operation, if the tape drive's buffer fills with data from the host faster than the tape drive can write the data to tape, the tape drive disconnects from the SCSI bus while continuing to write data until the amount of space available in the buffer is equal to the reconnect threshold. The tape drive then reconnects to the SCSI bus to accept more data.
- During a read operation, if the host can accept data from the tape drive's buffer faster than the tape drive can fill the buffer with data from the tape, the tape drive disconnects from the SCSI bus until it has filled the buffer back up to a level equal to the reconnect threshold. Then the tape drive reconnects to the SCSI bus to transfer more data.

## Start/Stop Mode

When operating in start/stop mode, the tape drive adapts to the host's data transfer rate by starting and stopping tape motion. The tape drive determines when to restart tape motion by comparing how full the buffer is to the motion threshold, as follows:

- During a write operation, the tape drive waits until the buffer is filled to a certain level (the motion threshold), starts the tape, records the buffered data, then stops the tape until the buffer can be filled to that level again by the host.
- During a read operation, the tape drive fills the buffer with data from the tape, stops the tape, waits for the host to accept enough data to empty the buffer to the motion threshold, then starts the tape and fills the buffer again.

# Helical-Scan Recording Technology

For high density recording, the tape drive implements advanced helical-scan recording technology. Helical-scan recorders write very narrow tracks on the tape. The combination of the helical wrap of the tape around the scanner, the rotation of the scanner assembly, and the linear motion of the tape causes the heads to trace a track across the tape at an acute angle to the bottom edge of the tape, as shown in [Figure 3-5](#).

This recording method creates a track length that is several times longer than the width of the tape. Tracks can be accurately positioned with precise minimal tolerances, resulting in a very high number of tracks per inch.

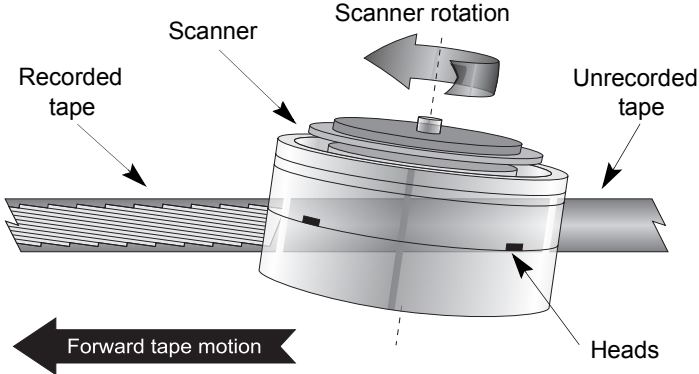

**Figure 3-5** Helical-scan recording

## Physical Track Structure

The Exabyte Mammoth-2 tape drive writes tracks of data using the Mammoth-2 physical track structure, shown in Figure 3-6. A track is the format recorded by a given write head as the tape travels over it. Each track contains fixed areas for sync, physical blocks, search fields, and servo zones (even tracks) or servo pads (odd tracks). Mammoth-2 writes two track pairs (four tracks) for each drum rotation.

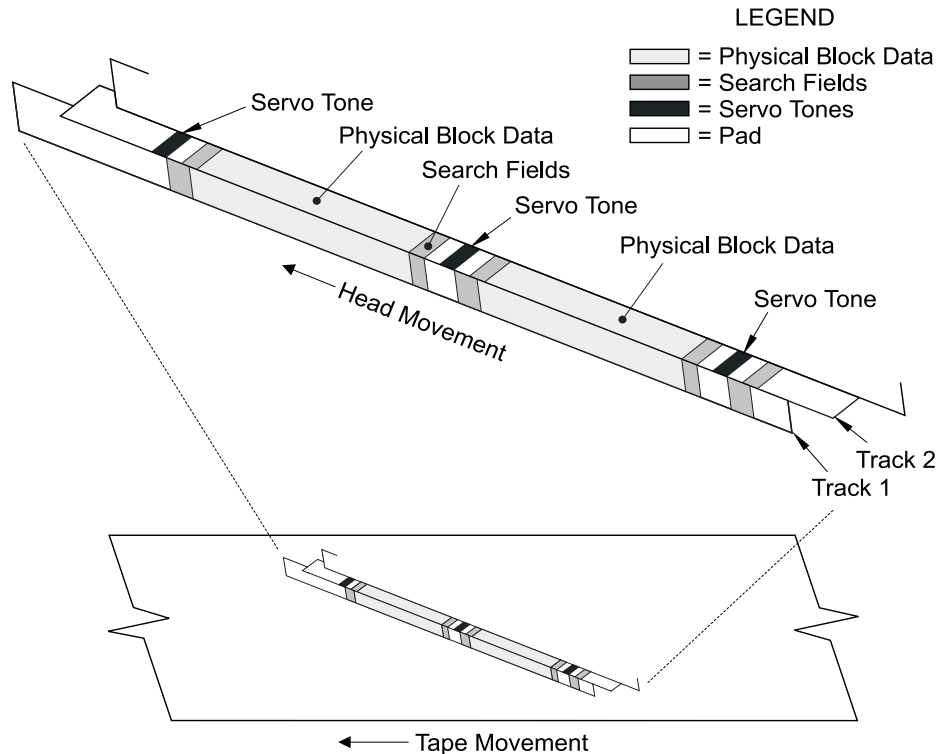

**Figure 3-6** Physical block format (**Note:** Although the physical block data is physically split into two sections, it is treated as a single data block by the ECC algorithms.)

The data area of each track is comprised of one physical block, which is approximately 33 KB in size. Each physical block contains the following information:

- 8 bytes of cyclic redundancy check (CRC) data
- 5,272 bytes of error correction code (ECC1 and ECC2) data
- 33,392 bytes of user data (data may be compressed)
- 48 bytes of header information and checksum data

**Note:** The physical block header, ECC1 and ECC2 data, and physical block CRC data do not affect the data capacity of the tape.



# Tape Format

M2 records data to tape using the highly efficient Mammoth-2 format. The basic structure of this format is shown in [Figure 3-7](#).

**Note:** An Exabyte AME cartridge with SmartClean includes a 2-meter section of cleaning material at the beginning of the tape. This cleaning material is separated from the AME media by the clear leader or “window” shown at the left end of the tape in [Figure 3-7](#).

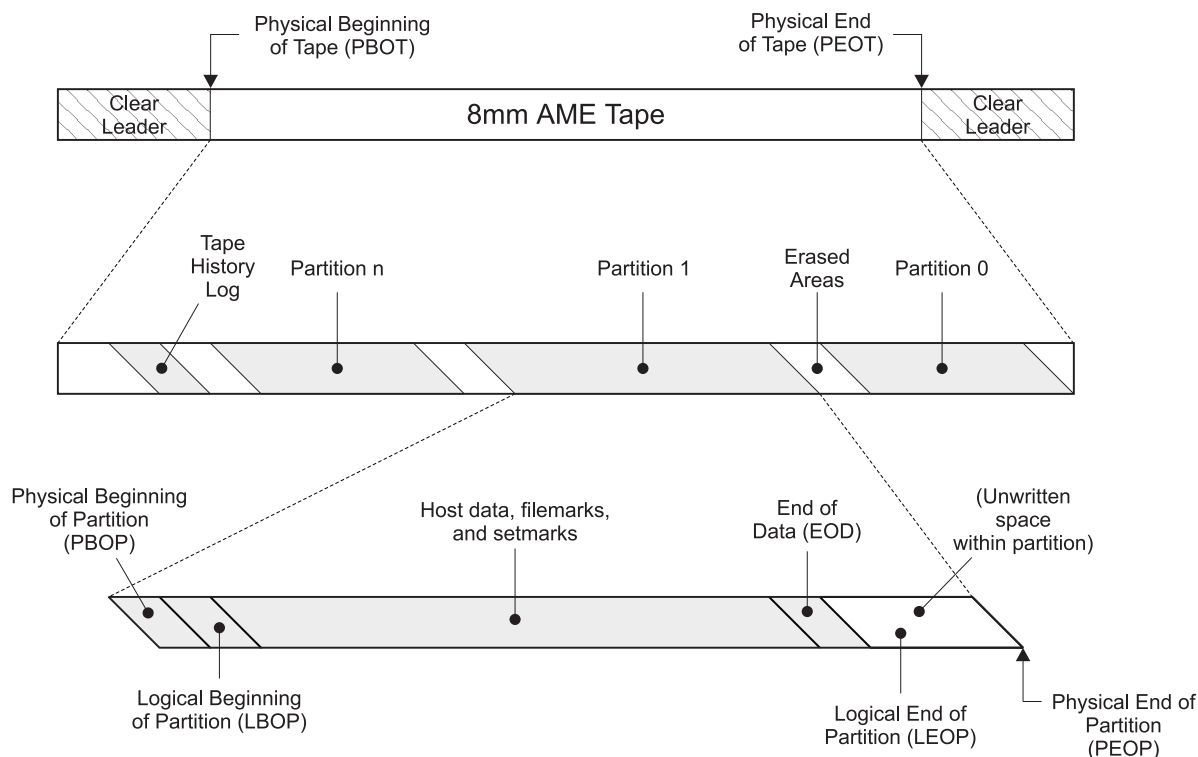

**Figure 3-7** Tape format

## Format Determination

The tape drive uses a combination of recognition holes in the cartridge, sizing algorithm, and tape characteristics (for example, the clear leader separating the cleaning material from the AME media in a SmartClean cartridge) to automatically determine the following:

- Media type (SmartClean, AME, or MP)
- Tape length
- Data format (Mammoth-2 or Mammoth)

If the tape drive detects data on the tape but cannot identify it as either Mammoth-2 or Mammoth format, it returns an error indicating an unknown format (Fault Symptom Code 1Ch). If the tape drive does not detect any data on the tape, it treats the tape as blank.

**Note:** When you insert an MP tape, the tape drive immediately ejects the cartridge.

## SmartClean Cleaning Material

Each SmartClean cartridge contains a 2-meter length of cleaning material at the beginning of the tape. A clear tape “window” separates the cleaning material from the AME media (see [Figure 3-8](#)). The window is part of the Exabyte Recognition System that identifies the cartridge as certified for use in Mammoth-2. The window allows the drive to position the tape correctly at the beginning of the AME media and locate the cleaning material when needed.

The SmartClean cleaning material has a slightly abrasive surface specifically formulated for Mammoth-2’s recording heads. It effectively removes tape lubricant staining without causing wear to the heads.

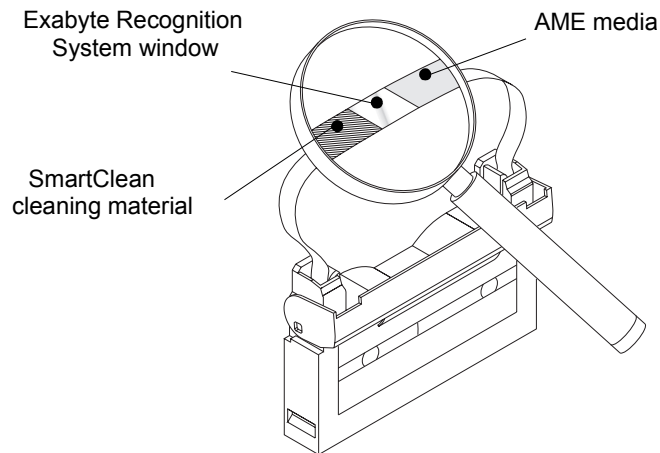

**Figure 3-8** Cleaning material and window at the beginning of the Exabyte AME Data Cartridge with SmartClean

Mammoth-2 performs automatic cleanings with SmartClean for preventive purposes. When debris and staining are removed early, the chance of a serious read or write error is greatly reduced. The tape drive contains an internal monitoring system that determines when cleaning is required and performs the cleanings automatically. The M2 requires cleaning under the following circumstances:

- **After every 100 tape motion hours** — Mammoth-2 tracks its operations internally and registers the need for a cleaning after every 100 tape motion hours.
- **When “soft” error thresholds are exceeded** — Soft errors are read or write errors that have been successfully corrected by M2’s internal error correction methods. M2 registers the need for a cleaning whenever these errors exceed certain thresholds for a specific length of time.

The cleaning material in a SmartClean cartridge is designed to be effective throughout the typical lifetime of the cartridge. Each SmartClean operation uses a randomly chosen section of the cleaning material, so even after repeated usage it still retains a degree of abrasivity and can clean effectively.

If the cleaning media in a SmartClean cartridge ever becomes ineffective for sufficiently cleaning the tape drive heads, data can still be written and read on the AME media. The tape drive would just require cleaning with another SmartClean cartridge or a standard Mammoth cleaning cartridge.

## Physical Beginning and End of Tape

As shown in [Figure 3-7](#), each tape has a physical beginning and a physical end. The physical beginning of tape (PBOT) is located at the point on the tape where the clear leader material is attached to the media. This position is detected by an optical sensor.

The physical end of tape (PEOT) is located at the point on the tape where the clear trailer material is attached to the media. This position is detected by an optical sensor.

## Tape History Log (THL)

If enabled, the tape drive writes a Tape History Log (THL) in a special partition located between the physical beginning of tape (PBOT) and the physical beginning of partition (PBOP) mark for the first user partition. See [page 4-9](#) for more information about the Tape History Log.

## Partitions

As shown in [Figure 3-7](#), a tape in Mammoth-2 format can be divided into *partitions*. A partition is a self-contained area on the tape that can be written and read independently. Partitions provide an effective way to maintain a directory on the tape.

Each partition can contain multiple data sets and files. The default is one partition per tape (in which case, the entire tape is a single partition), but the tape drive can support as many as 64 partitions on a tape. You can use the MODE SELECT command to specify the number of partitions and the partition sizes.

For each partition, the tape drive places the following markers on the tape to help manage the data:

- Physical beginning of partition
- Logical beginning of partition
- Logical end of partition
- Physical end of partition

### Physical Beginning of Partition (PBOP)

The physical beginning of partition (PBOP) mark consists of a fixed number of PBOP blocks. These blocks are recorded at the beginning of each partition when you format the tape for partitions using the MODE SELECT command. Each PBOP must have an associated logical beginning of partition (LBOP).

If you do not partition the tape, the tape drive automatically records these blocks during the first WRITE command. PBOP blocks can only be overwritten by another MODE SELECT command.

## Logical Beginning of Partition (LBOP)

The logical beginning of partition (LBOP) mark consists of a fixed number of LBOP blocks, which are blocks of internal drive information recorded on the tape directly following the PBOP. The tape drive uses LBOP blocks to record the most current information about the partitions and to form a splice point when rewriting a partition. These blocks contain data concerning the size, location, and format of every partition on the tape.

## Logical End of Partition (LEOP)

Logical end of partition (LEOP) is a virtual mark used to provide early warning to the host that physical end of partition (PEOP) is near. The tape drive calculates the LEOP based on the size of the partition.

---

➤ **Important** If you ignore LEOP and keep writing data to the tape, data can be written all the way to PEOP, leaving no room in the partition for an end of data (EOD) mark.

---

## Physical End of Partition (PEOP)

Physical end of partition (PEOP) is also a virtual mark. When the tape is formatted and the tape drive determines the size of each partition, the tape drive calculates the location of PEOP and stores that information in the LBOP blocks. When the tape drive detects PEOP, the tape drive stops recording to prevent overwriting data in the next partition.

The last partition on the tape uses the physical end of tape (PEOT) instead of PEOP.

## Data Area

Each partition contains a data area, which lies between LBOP and the end of data (EOD) mark. The tape drive determines the maximum size of the data area when the tape is partitioned, taking into account the length of the tape and the number of partitions you specify with MODE SELECT. The actual size of the data area is determined by the amount of data actually written by the host.

The data area consists of compressed or uncompressed user data, filemarks, and setmarks.

## Compressed and Uncompressed Formats

Both uncompressed and compressed formats are allowed on the same tape. You can specify the format at the logical beginning of partition (LBOP) with the SCSI MODE SELECT command. If no MODE SELECT command is received, the tape drive uses the default format (compressed mode).

**Note:** If the tape is at a valid position for writing data other than LBOP, the tape drive writes data in the same logical format as the data already in that partition. When reading a data cartridge, the tape drive automatically determines the tape's format.

## Logical Blocks

A logical block contains user data that is transferred from the host to the tape drive. Logical blocks can have either fixed or variable lengths, which can be intermixed on the tape. The tape drive supports uncompressed logical block sizes from 4 bytes to 240 kilobytes, which can be controlled with the MODE SELECT command. The number of logical blocks that can be written in a partition depends on the size of the partition and the logical block size.

**Note:** Using logical block sizes of less than 80 bytes will significantly impact tape drive performance and capacity.

**Logical block compression** When compression is turned on, the tape drive compresses logical blocks of user data before placing them in the physical blocks. Thus, each physical block contains a compressed representation of the original user data.

**Logical block packing** To optimize tape capacity when writing tapes, the tape drive packs logical blocks of user data into physical blocks. Each physical block on tape can contain multiple logical blocks. To prevent losing data capacity when small logical block sizes are used, the tape drive can begin writing a logical block in one physical block and end in a subsequent physical block. To keep track of logical blocks, the tape drive uses logical block headers.

## Gap Bytes

A gap byte is a byte containing undefined data that the tape drive uses to fill empty space in a physical block. The tape drive may automatically write gap bytes in the following cases:

- At the end of a write operation.
- Before writing a filemark or setmark.
- When it is physically impossible to start the next logical block in the physical block because less than three bytes are available. (This is because the two-byte logical block header and at least one data byte must be present in the first physical block before the logical block can spill over to a second physical block.)

Gap bytes cannot be accessed by any SCSI command.

## Gap Blocks and Gap Tracks

A gap block is a physical block containing only gap bytes. A gap track is a track containing only gap blocks. When the tape drive stops at the end of a write operation, it writes gap tracks following the last track pair containing data blocks.

The gap tracks provide the track orientation required to append data. When a subsequent write operation begins, the controller repositions the tape and records the data on a track adjacent to a gap track.

Gap blocks cannot be accessed by any SCSI command.

## Filemarks

Filemarks enable you to locate particular blocks of data on the tape quickly during a high-speed search. You use the WRITE FILEMARK command to write long or short filemarks. By using a SPACE or LOCATE command, you can position the tape to the data marked by long or short filemarks using a high speed search.

**Long filemarks** A long filemark in Mammoth-2 format is 200 KB long and consists of six tracks of information:

- Two gap tracks at the beginning
- Two tracks of filemark physical blocks
- Two gap tracks at the end

There is no logical limit to the number of filemarks you can write on a tape, but the physical limit is determined by the file sizes.

The information in the filemark physical blocks identifies the filemark's number and location on the tape. This information cannot be accessed or changed by the user. The gap tracks at the beginning and end allow file append and file splice operations. The tape drive may write additional gap tracks and gap blocks before the filemark to ensure that all data has been written to tape correctly or to complete tracks that are not completely filled with data blocks.

**Short filemarks** A short filemark consists of a single physical block (approximately 33 KB). This block contains information identifying the filemark's number and location on the tape. Short filemarks are not splice points.

### **Setmarks**

You can issue a WRITE FILEMARK command to write one or more setmarks to tape. Setmarks, which are the same length as long filemarks, provide an additional way to indicate data boundaries on the tape. In a sense, they can be thought of as "hierarchically superior" filemarks. You can issue a LOCATE command to locate setmarks; however, you can also use a MODE SELECT command to suppress setmark detection during read, verify, space block, and space filemark operations.

### **End of Data (EOD)**

The end of data (EOD) mark consists of EOD blocks. These blocks are recorded directly after the last data or filemark block in a single partition. All EOD blocks contain the same information, which can be overwritten when new data is appended to existing data in the partition. The tape drive then records a new EOD mark at the end of the appended data.



## Read/Write Compatibility

The M2 tape drive reads and writes Exabyte AME with SmartClean and standard Exabyte AME cartridges written in Mammoth-2 format. The tape drive can read, but not write, AME cartridges in the original Mammoth format.

Mammoth and Mammoth-LT tape drives cannot read AME cartridges written in Mammoth-2 format. Instead, the drives identify the tape as formatted but blank, allowing Mammoth-2 formatted data to be overwritten. These first-generation MammothTape technology drives automatically eject AME with SmartClean cartridges.

The tape drive cannot write data to or read data from metal particle (MP) tape. If you insert an MP cartridge, the tape drive immediately ejects it.

## Notes

---

---

# 4 Overview of the SCSI Command Protocol

---

This chapter provides an overview of the SCSI command protocol used by both the SCSI and Fibre Channel models of the tape drive. It includes the following topics:

- Command protocol versus communication interface
- SCSI-2 command protocol

## Communication Interface versus Command Protocol

When two devices are connected across a bus or a network, their interaction is accomplished via a *communication interface* (for example, a parallel SCSI bus, a Fibre Channel arbitrated loop, or an Ethernet network). The communication interface allows multiple devices to share connections, yet operate and exchange data independently. The communication interface is comprised of the physical interface and the signaling protocol used during communication.

The physical interface determines the number of devices that can be attached to a bus or network loop, the maximum length of the cables, and the physical characteristics of the cable itself (for example, the number of wires, shielding, and so forth). The signaling protocol defines the electrical characteristics and timing of signals carried by the cable, the message system requirements, transmission speeds and maximum data transfer rates, as well as the encoding and decoding of the individual bit patterns representing commands passing between the individual devices.

The format and content of the information carried over the communication interface, as well as how each device uses and responds to the information, is governed by a *command protocol*. The command protocol determines how the host (or initiator) interacts with the target device (for example, the tape drive) by issuing commands to control its operation, transferring data, and responding to status information. The target device responds to commands from the host by performing the requested operation (for example, writing or reading data on magnetic tape) and returning status information.

The M2 tape drive is available with either a parallel SCSI bus communication interface or a Fibre Channel communication interface. The differences between the two interfaces arise primarily from how each interface handles device addressing and how each handles transmitting SCSI commands, data, and status between the host and the tape drive. Regardless of the communication interface, the operation of the tape drive is governed by the SCSI command protocol.

The following sections describe how the SCSI command protocol is implemented. Refer to the *Exabyte Mammoth-2 SCSI Reference* for detailed information about the SCSI command protocol. [Chapter 5](#) provides information about both the parallel bus and Fibre Channel communication interfaces.

## SCSI-2 Command Protocol

This section provides an overview of the SCSI-2 command protocol supported by both the SCSI and Fibre Channel versions of the M2 tape drive.

The tape drive SCSI command protocol includes the following special features:

- Support for the TapeAlert tape drive status monitoring and messaging utility (see [page 4-6](#) for more information)
- Support for writing a Tape History Log at the beginning of each tape (see [page 4-9](#) for more information)
- Support for the EXTENDED COPY (E-copy) and RECEIVE COPY RESULTS commands (Fibre Channel only; see [page 4-9](#) and [page 4-10](#) for more information)

Refer to the *Exabyte Mammoth-2 Tape Drive SCSI Reference* and the *Exabyte Mammoth-2 Fibre Channel Interface Supplement* for detailed information about the SCSI command protocol.

## SCSI-2 Command Set

Table 4-1 lists and briefly describes the SCSI-2 command set supported by the tape drive.

**Table 4-1** M2 SCSI command set

Command	OP code	Description
ERASE	19h	Causes the tape drive to erase all data from the current tape position to the physical end of partition.
EXTENDED COPY	83h	Allows the tape drive to copy one or more logical blocks of data from one location to another without an intervening server. See <a href="#">page 4-9</a> for more information. <b>Note:</b> This command is only applicable to the Fibre Channel tape drive.
INQUIRY	12h	Requests that general tape drive information be sent to the initiator. In the Fibre Channel tape drive, this command also allows the tape drive to report its world-wide names as specified for the Fibre Channel protocol (FCP).
LOAD/UNLOAD	1Bh	Causes the tape drive to load or unload the data cartridge.
LOCATE	2Bh	Positions the tape at a specified logical position. (Typically, this position is determined by data that was obtained through a previous READ POSITION command.)
LOG SELECT	4Ch	Manages a set of internal counters regarding read and write error recovery operations and amounts of data compressed. The initiator can set threshold and cumulative values for the counters or reset the counters.
LOG SENSE	4Dh	Returns the values of the counters managed by the LOG SELECT command.
MODE SELECT	15h or 55h	Allows you to specify medium, logical unit, and device parameters. In the Fibre Channel tape drive, this command also allows you to modify and control the behavior of the tape drive within the Fibre Channel protocol (FCP).
MODE SENSE	1Ah or 5Ah	Enables the tape drive to report medium, logical unit, or device parameters. In the Fibre Channel tape drive, this command also allows you to report the behavior of the tape drive within the Fibre Channel protocol (FCP).
PREVENT/ALLOW MEDIUM REMOVAL	1Eh	Allows or disallows the removal of the data cartridge from the tape drive.
READ	08h	Transfers one or more bytes or blocks of data from the tape to the initiator.
READ BLOCK LIMITS	05h	Requests that the tape drive return data identifying the maximum and minimum logical block lengths supported.

**Table 4-1** M2 SCSI command set (*continued*)

Command	OP code	Description
READ BUFFER	3Ch	Creates a diagnostic listing of the tape drive's current state or the contents of the tape drive's data buffer.
READ POSITION	34h	Reports the tape drive's current logical position but does not cause tape motion to occur. Used in conjunction with the LOCATE command.
RECEIVE COPY RESULTS	84h	Returns the results of a previous (or current) EXTENDED COPY command. See <a href="#">page 4-10</a> for more information. <b>Note:</b> This command is only applicable to the Fibre Channel tape drive.
RECEIVE DIAGNOSTIC RESULTS	1Ch	Reports the results of the tests requested by a previous SEND DIAGNOSTIC command.
RELEASE UNIT	17h and 57h	Releases the tape drive from exclusive use by the initiator that had previously reserved it with a RESERVE UNIT command.
REPORT LUNS	A0h	Requests that the tape drive report its LUN (Logical Unit Number) to the initiator. <b>Note:</b> This command is only applicable to the Fibre Channel tape drive.
REQUEST SENSE	03h	Requests that the tape drive transfer sense data to the initiator.
RESERVE UNIT	16h and 56h	Reserves the tape drive for exclusive use by the initiator that issued the command.
REWIND	01h	Causes the tape drive to rewind the tape to the logical beginning of partition.
SEND DIAGNOSTICS	1Dh	Causes the tape drive to perform certain self-diagnostic tests.
SPACE	11h	Enables the tape drive to perform forward or backward searches using logical blocks, filemarks, or setmarks. Also allows spacing to end of data (EOD).
TEST UNIT READY	00h	Allows you to determine if the tape drive is ready to accept an appropriate medium access command.

**Table 4-1** M2 SCSI command set (*continued*)

Command	OP code	Description
VERIFY	13h	Enables the tape drive to verify one or more logical blocks of data on the tape.
WRITE	0Ah	Transfers one or more bytes or blocks of data from the initiator to the tape drive.
WRITE BUFFER	3Bh	Transfers new microcode from the initiator into the tape drive's control memory.
WRITE FILEMARKS	10h	Causes the tape drive to write any data remaining in its buffer, then to write one or more filemarks or setmarks to tape.

## Status Bytes

After the tape drive executes a command, it issues a status byte to the initiator that indicates whether it performed the command successfully. [Table 4-2](#) describes the four status bytes supported by the tape drive. Refer to the *Exabyte Mammoth-2 Tape Drive SCSI Reference* for more information about status bytes.

**Table 4-2** Status byte descriptions

Status byte	Hex value	Description
Good	00h	Indicates that the tape drive successfully completed the operation.
Check Condition	02h	Indicates that an error, exception, or abnormal condition has caused sense information to be set. The initiator can issue a REQUEST SENSE command to access this information.
Busy	08h	Indicates that the tape drive is busy. This status is sent whenever the tape drive is unable to accept a command from an initiator.
Reservation Conflict	18h	Indicates that the tape drive is reserved for the exclusive use of another initiator.

## Sense Keys

When the tape drive returns Check Condition status to the initiator, the initiator can issue a REQUEST SENSE (03h) command to receive information about the error, exception, or abnormal condition. This information includes a sense key, which describes the general error or change of state. [Table 4-3](#) describes the sense keys supported by the tape drive.

For more information about these sense keys and sense data returned by the tape drive, refer to the *Exabyte Mammoth-2 Tape Drive SCSI Reference*.

**Table 4-3** Supported sense keys

Sense key	Hex value	Description
No Sense	0h	Indicates that there is no specific sense key information to be reported.
Not Ready	2h	Indicates that the tape drive cannot accept any motion commands.
Hardware Error	4h	Indicates that the tape drive detected a hardware failure.
Illegal Request	5h	Indicates that there was an illegal parameter in the command descriptor block (CDB) or in the additional parameters supplied as data for some command.
Unit Attention	6h	Indicates that the state of the tape drive may have changed.
Aborted Command	Bh	Indicates that the tape drive aborted the last command.

## TapeAlert

TapeAlert provides a standardized method for reporting errors and potential difficulties with the tape drive and media. The tape drive's internal TapeAlert firmware constantly monitors the tape drive and the media for errors and potential difficulties that could have an impact on backup quality. Any problems identified are flagged on the TapeAlert page returned by the LOG SENSE SCSI command.

When the tape drive is used with TapeAlert-compatible backup software, the software automatically reads the log page after the completion of each backup. If an error is flagged, the backup software displays a clear warning message, suggests a course of action to remedy the problem, and adds the TapeAlert message to its logs.

[Table 4-4](#) lists the TapeAlert flags used by the tape drive. Each parameter is one byte long. The bit 0 contains the value for the flag, as follows:

- 0 – The flag is not currently set.
- 1 – The flag is currently set.

The remaining seven bits of the flag are not used.

**Note:** Issuing a LOG SENSE command that returns the TapeAlert page resets all of the flags to 0. The flags are also reset whenever the tape drive is reset and by the condition indicated by the flag being corrected.



**Table 4-4** TapeAlert flags used by the tape drive

Flag name	Type <sup>a</sup>	Description
Read	W	The tape drive is having problems reading data. No data has been lost, but there has been a reduction in the performance of the tape.
Write	W	The tape drive is having problems writing data. No data has been lost, but there has been a reduction in the capacity of the tape.
Hard Error	W	A hard read/write error has occurred. The current operation has stopped because the tape drive cannot correct an error that occurred while the tape drive was reading or writing data.
Media	C	Media performance is severely degraded. The data is at risk. To safe guard the data on this tape, do the following: <ul style="list-style-type: none"> <li>▪ Copy any data you want to preserve to another tape.</li> <li>▪ Do not use this tape again.</li> <li>▪ Restart the current operation using a different tape.</li> </ul> <b>Note:</b> The Tape History Log (THL) option must be enabled in the tape drive's EEPROM.
Read Failure	C	The tape drive can no longer read data from the tape. Either the tape is damaged or the tape drive is not operating correctly. <ul style="list-style-type: none"> <li>▪ Try reading data from a known good tape. If you can read this tape, replace the damaged tape.</li> <li>▪ If the problem persists, contact Exabyte Technical Support.</li> </ul>
Write Failure	C	The tape drive can no longer write data to the tape. Either the tape is damaged or the tape drive is not operating correctly. <ul style="list-style-type: none"> <li>▪ Try writing data from a known good tape. If you can write data to this tape, replace the damaged tape.</li> <li>▪ If the problem persists, contact Exabyte Technical Support.</li> </ul>
Media Life	W	The tape is past its specified life cycle. The data cartridge has reached the end of its useful life. <ul style="list-style-type: none"> <li>▪ Copy any data you want to preserve to another tape.</li> <li>▪ Do not use this tape again.</li> </ul> <b>Note:</b> The Tape History Log (THL) option must be enabled in the tape drive's EEPROM.
Not Data Grade	W	The tape drive cannot read the MRS stripes on the tape. The tape is not data grade. Any data you back up onto the tape is at risk. Replace the cartridge with one containing data-grade tape (for example, Exatape).
Write Protect	C	The initiator attempted to write to a write-protected data cartridge. Remove the write protection or use another cartridge.
No Removal	I	A data cartridge unload operation was attempted while the initiator was preventing media removal.
Cleaning Media	I	A cleaning cartridge is currently in the tape drive. If you want to back up or restore, insert a data cartridge.

**Table 4-4** TapeAlert flags used by the tape drive (*continued*)

Flag name	Type <sup>a</sup>	Description
Unsupported Format	I	The loaded tape contains data in an unsupported format.
Snapped Tape	C	The data cartridge in the tape drive contains a broken tape. <ul style="list-style-type: none"> <li>▪ Discard the data cartridge.</li> <li>▪ Restart the current operation with a different tape.</li> </ul>
Clean Now	C	The tape drive needs cleaning. <ul style="list-style-type: none"> <li>▪ If the tape drive is not currently in use, eject any data cartridge and insert a cleaning cartridge to clean the tape drive.</li> <li>▪ If the tape drive is in use, wait until the current operation is complete, then insert a cleaning cartridge to clean the tape drive.</li> </ul>
Clean Periodic	W	The tape drive needs to be cleaned at the next opportunity.
Expired Cleaning Media	C	The cleaning cartridge that was inserted into the tape drive is used up. Use a new cleaning cartridge to clean the tape drive.
Hardware A	C	The tape drive has a problem that is not read/write related. <ul style="list-style-type: none"> <li>▪ Reset the tape drive.</li> <li>▪ Restart the operation.</li> <li>▪ If the problem persists, contact Exabyte Technical Support.</li> </ul>
Hardware B	C	The tape drive has a problem that is not read/write related. <ul style="list-style-type: none"> <li>▪ Turn the tape drive off and then on again.</li> <li>▪ Restart the operation.</li> <li>▪ If the problem persists, contact Exabyte Technical Support.</li> </ul>
Interface	W	There is a problem in the SCSI interface between the initiator and the tape drive. <ul style="list-style-type: none"> <li>▪ Check all of the SCSI cables and connections.</li> <li>▪ Restart the operation.</li> </ul>
Eject Media	C	The current operation has failed. <ul style="list-style-type: none"> <li>▪ Eject the current data cartridge, then reload it.</li> <li>▪ Restart the operation.</li> </ul>
Download Fail	W	The last attempt to download new firmware has failed. Obtain the correct firmware and try again.

<sup>a</sup> I = Informational suggestion to user.

W = Warning. Remedial action is advised. Performance of data may be at risk.

C = Critical. Immediate remedial action is required.

## Tape History Log

If enabled, the tape drive writes a Tape History Log (THL) in a special partition located between the physical beginning of tape (PBOT) and the physical beginning of partition (PBOP) of the first user partition. This log is used to store tape history and diagnostic data. The log is normally updated each time a tape is unloaded and provides a running history of the tape condition and the tape drives in which it has been used. Applications can read this log to determine tape condition before performing a write or read operation.

Warning thresholds can be set using the LOG SELECT command and returned using the LOG SENSE command. When these thresholds are exceeded, the tape drive returns Check Condition status with the sense key set to Unit Attention (6h).

For example, if the tape drive detects that the tape pass threshold of 20,000 has been exceeded, the tape drive sets the Media Life flag on the TapeAlert Log Sense page. The number of passes is recorded in the Tape History Log. See [page 4-6](#) for more information about TapeAlert.

To determine the current statistics for a tape, issue a LOG SENSE command to read the Tape History Log.

## EXTENDED COPY (Fibre Channel Only)

The EXTENDED COPY command permits data transfer to occur between the tape drive and any magnetic disk or other tape drive connected to the Fibre Channel SAN, without the data passing through an intermediate server. The only server involvement during an EXTENDED COPY operation is to issue the initial EXTENDED COPY command to the tape drive and prepare the tape drive and targeted disks for the operation. The preparatory steps may include issuing commands to move a tape in a library to the tape drive, load and position the tape, and determine tape drive and disk status. The server does not interact with the data in any way.

E-copy is the M2 implementation of the EXTENDED COPY command. The E-copy functionality in the M2 tape drive firmware is initialized during its power-on self-test (POST). When POST is complete, the tape drive is ready to receive EXTENDED COPY commands from the server. When it receives and processes an EXTENDED COPY command, the tape drive assumes control of the data transfer process. The tape drive takes over the role of copy manager from the server and acts as a SCSI initiator. It establishes a connection with a target disk and issues READ, WRITE, and other SCSI commands to the disk. It accepts data directly from the disk for backup, writes data to the disk when recovery is required, and obtains status information from the disk.

One EXTENDED COPY command can specify multiple copy sessions. Each session copies a specific block of data. A group of sessions requested in an EXTENDED COPY command can be equivalent to an entire file or a group of files.

### **RECEIVE COPY RESULTS (Fibre Channel Only)**

The RECEIVE COPY RESULTS command is used to return the results of a previous (or current) EXTENDED COPY command to the server that issued the EXTENDED COPY command. The results that can be returned from the previous (or current) EXTENDED COPY command are either tape drive (copy manager) status information, inline data from read operations, or information about the order in which the segments were processed during the EXTENDED COPY command.

---

# 5 Overview of the Communication Interface

---

This chapter provides an overview of the parallel SCSI and native Fibre Channel communication interfaces available for the M2 tape drive. See [Chapter 4](#) for information about the SCSI command protocol used by the tape drive. The *Exabyte Mammoth-2 SCSI Reference* provides detailed information about the parallel SCSI communication interface.

## 5.1 SCSI Communication Interface

This section provides an overview of the SCSI communication interface used by the tape drive. The tape drive's parallel SCSI communication interface includes the following features:

- Support for single-ended wide, Ultra2 low-voltage differential (LVD) wide, or high-voltage differential (HVD) wide SCSI configurations (see [page 5-2](#) for more information)
- Support for standard SCSI-2 bus phases and messaging (see [page 5-4](#) for more information)
- Support for parity checking configurable through the MODE SELECT command
- Support for multiple SCSI hosts

## Single-ended, HVD, or LVD

A single-ended SCSI bus uses one signal line to transmit information between devices. Single-ended SCSI configurations have always been popular because of their low cost, but they are vulnerable to signal noise and as a result, have bus-length limitations (6 meters).

High-voltage differential (HVD) SCSI buses use the signal differential between two lines to transmit information between devices. Because HVD configurations use a relatively high voltage on the signal lines, HVD buses are resistant to signal noise and allow greater cable lengths (up to 25 meters), but are expensive to implement. HVD devices cannot be mixed with single-ended or LVD devices on the same bus.

LVD is an alternative to the HVD interface. Like HVD, low-voltage differential SCSI buses use the signal differential between two lines to transmit information between devices. LVD has the same advantages (better signal noise resistance and greater bus lengths than single-ended), but is less expensive than HVD.

LVD devices are compatible with single-ended devices. You can add an LVD device to an existing single-ended SCSI bus without altering the bus configuration. Circuitry in the LVD tape drive determines whether the tape drive is being used on an LVD or single-ended SCSI bus and automatically configures the tape drive's operation to the appropriate bus capability.

---

➤ **Important** Be aware that if you connect single-ended and LVD devices on the same bus, all devices on the bus operate as single-ended devices. This eliminates the performance advantages provided by the differential interface.

---

### SCSI-2 versus Ultra2 SCSI

Until relatively recently, SCSI-2 or Fast SCSI has been the predominant signaling protocol used in tape storage devices. It provides a burst data transfer rate of up to 10 MB/second on a narrow bus or 20 MB/second on a wide bus. SCSI-2 is available as either single-ended or high-voltage differential.

Ultra2 SCSI is the next step in the SCSI evolution. It provides burst data rates of up to 80 MB/second. Ultra2 uses an LVD physical interface, which allows for longer cable lengths and more devices per bus than the earlier single-ended standards, with a lower cost and complexity than HVD.

When operating on an Ultra2 SCSI bus, the LVD SCSI M2 tape drive can transfer uncompressed data at up to 12 MB/sec (43.2 GB/hr) or up to 30 MB/sec of compressed data. When attached to a single-ended SCSI bus, the tape drive can transfer data at up to the maximum rate supported by the bus.

### **Narrow or Wide SCSI**

A wide SCSI bus uses 68 parallel lines to transmit signals between devices on the bus. A narrow SCSI bus uses 50 parallel lines. The tape drive is available in a wide configuration only. Exabyte does not support operating the tape drive on a narrow SCSI bus.

## **Device Addressing**

The wide SCSI bus provides addressing for up to 16 devices, including the host bus adapter, on a single bus. Each device attached to the SCSI bus must have a unique SCSI ID. This SCSI ID, which can be a value from 0 through 15, allows the host computer to communicate with each device attached to the bus.

## SCSI Bus Phases

[Table 5-1](#) describes the SCSI bus phases used by the tape drive during communication over the bus.

**Table 5-1** SCSI bus phases

SCSI bus phase	Explanation
Bus Free	BSY and SEL are false. The SCSI bus is idle and available for arbitration.
Arbitration	BSY and SCSI ID assertion (highest ID wins).
Selection	Winning ID asserts SEL. The initiator releases I/O and BSY. The tape drive sets BSY. The initiator releases SEL and asserts ATN.
Message Out	The initiator sends the Identify message and indicates whether disconnects are permitted. See <a href="#">Table 5-2</a> for other messages supported during the Message Out phase.
Command	The tape drive switches to Command phase. The initiator sends the command CDB. See <a href="#">Chapter 4</a> for information about the commands supported by the tape drive.
Data In/Out	The tape drive sets the bus to one of the Data phases and sends or receives data.
Status	The tape drive returns one byte of status information, as described in <a href="#">Table 4-2 on page 4-5</a> .
Message In	The tape drive returns one byte of message information, as described in <a href="#">Table 5-2</a> .



## SCSI Message System

Table 5-2 lists the SCSI messages supported by the tape drive. Refer to the *Exabyte Mammoth-2 Tape Drive SCSI Reference* for more information.

**Table 5-2** SCSI messages

Hex value	Description	In (tape drive to initiator)	Out (initiator to tape drive)
00h	Command Complete	✓	
01h	Extended Messages: <ul style="list-style-type: none"> <li>▪ Synchronous Data Transfer Request</li> <li>▪ Wide Data Transfer Request</li> </ul>	✓	✓
02h	Save Data Pointers	✓	
03h	Restore Pointers	✓	
04h	Disconnect	✓	
05h	Initiator Detected Error		✓
06h	Abort		✓
07h	Message Reject	✓	✓
08h	No Operation		✓
09h	Message Parity Error		✓
0Ch	Bus Device Reset		✓
23h	Ignore Wide Residue	✓	
80h or C0h	Identify	✓	✓

## 5.2 Fibre Channel Communication Interface

This section provides an overview of the Fibre Channel communication interface. The Fibre Channel version of the M2 tape drive conforms to the Fibre Channel standards listed under “[Related Publications](#)” at the beginning of this specification.

Fibre Channel is a highly reliable gigabit interconnect technology that allows simultaneous communications among workstations, mainframes, servers, data storage systems, and other peripherals using SCSI and IP protocols. The M2 tape drive’s native Fibre Channel interface allows it to be connected directly to a Fibre Channel network or fabric, without an intermediate Fibre Channel to SCSI bridge.

### Fibre Channel topologies

The Fibre Channel protocol defines three different logical or physical arrangements (topologies) for connecting the devices into a network: point-to-point, arbitrated loop, and switched fabric. In all of these topologies, a transmitter node in one device sends information to a receiver node in another device. The physical connection between devices varies from one topology to another. The M2 tape drive can be used with arbitrated loop and switched fabric topologies.

- Point-to-point topology, illustrated in [Figure 5-1](#), is the simplest interconnect method. The connection is not shared with any other devices. Simplicity and use of the full data transfer rate make this Fibre Channel topology an ideal extension to the standard SCSI bus interface.

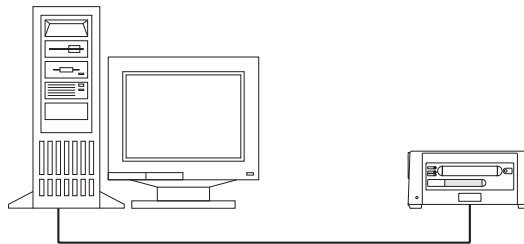

**Figure 5-1** Point-to-point topology

- The arbitrated loop (FC-AL) topology, illustrated in [Figure 5-2](#), provides a relatively simple method of connecting and sharing resources. FC-AL connects up to 126 devices or nodes in a single, continuous loop or ring. Each device is identified by a unique, world-wide name. The loop is constructed by daisy-chaining the transmit and receive cables from one device to the next or by using a hub or switch to create a star-connected virtual loop. The loop can be self-contained or incorporated as an element in a larger network.

**Note:** An arbitrated loop can also be used to make a point-to-point connection between a single device and a host bus adapter that supports the arbitrated loop topology.

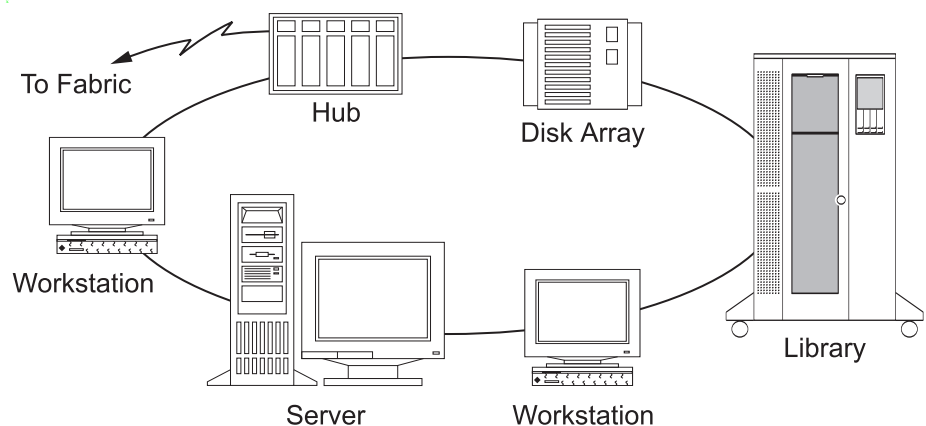

**Figure 5-2** Arbitrated loop topology

All the devices in an FC-AL network share the available data transfer capacity of the Fibre Channel interface. When the loop is initialized, each device attached to the loop identifies itself. The devices use an arbitration protocol to determine which device controls the loop for data transfer.

After a device gains control of the loop, it establishes a point-to-point connection with the recipient device and can then use the full data transfer capacity. Until the transmitting device releases the connection, no other devices can use the loop for data transfer. As a result, increasing the number of devices on the loop can reduce the overall performance of the loop because the amount of time each device can use the loop is reduced.

Because multiple devices cannot transfer data over the network at the same time, errors resulting from packet collisions and data loss are relatively infrequent and can be handled by the hardware. When transmission errors do occur, it is possible to retransmit just the affected frames; retransmitting the entire data stream is not required.

- A switched fabric, illustrated in [Figure 5-3](#), is the most complex topology. It can be used to connect up to 16 million nodes, each of which is identified by a unique, world-wide name. In much the same way as a telephone call is routed from one side of the country to the other, the data passes from the originator, through a switch and into a “cloud” of interconnected networks.

The path each data frame takes through the cloud is determined by switches throughout the cloud. When the frame reaches its destination, it moves out of the cloud to the recipient, where the frames that make up the data stream are reassembled and decoded.

In a switched fabric, each data frame is transferred over a virtual point-to-point connection. There can be any number of full-bandwidth transfers occurring through the switch. Devices do not have to arbitrate for control of the network; each device can use the full available bandwidth.

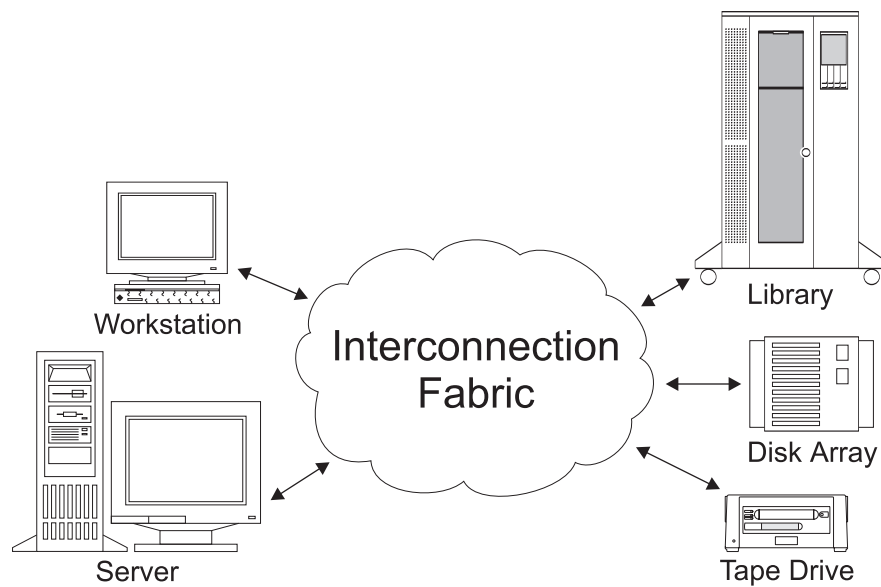

**Figure 5-3** Switched fabric topology

## Fibre Channel Network Components

**Note:** For simplicity, the following discussion refers to the Fibre Channel environment as a “network,” regardless of the topology in use.

A Fibre Channel network consists of the following components:

- **Initiator.** The host computer system typically acts as the initiator of commands. The host system includes the application software, the operating system, the device drivers, and the Fibre Channel host bus adapter (a node) with one or more ports.
- **Domain.** A Fibre Channel domain consists of two or more devices (nodes) connected by fibre cables (optical or copper) attached to Fibre Channel ports. The domain provides a pathway for passing commands, status, and messages. Depending on the topology used, the domain may include one or more hubs, switches, or both.
- **Targets.** The targets are devices (nodes) that are capable of receiving and processing commands from the host. Each node has at least one port associated with it.

### Nodes

A Fibre Channel device consists of a node and one or more ports. The node is the source (or destination) of information being transported. Each Fibre Channel node must support at least one upper-level command protocol that allows it to interact with other nodes. The tape drive is a node that supports the SCSI command protocol.

### Ports

Each node has at least one port (an N\_Port, NL\_Port, F\_Port, or FL\_Port) that provides the physical connection between the node and the network. The port transports information to or from other ports. When a node has multiple ports, all the ports can connect to the same network or to different networks. Multiple ports allow a node to take advantage of the cumulative bandwidth of all the ports, provide redundancy, or both.

The M2 tape drive is a node with two NL\_Ports (the Port A and Port B connectors on the tabletop model). Each port can be attached to either an arbitrated loop or a switched fabric.

NL\_Ports include functionality that allows data from one port to be routed through intermediate ports on an arbitrated loop before reaching the destination port. The routing and repeating functions, which are unique to the arbitrated loop topology, are provided by the NL\_Port.

---

➤ **Important** Although the tape drive can operate on two separate loops, it does not support active data transfers on both loops simultaneously. If one loop is actively transferring data, data transfer on the other loop cannot be initiated until the current transfer is complete. This restriction does not preclude the ability to issue commands over the second loop to determine drive status.

---

## Device Addressing

Fibre Channel and the parallel SCSI interfaces employ different methods of addressing devices. Unlike a parallel SCSI interface, which uses a limited number of fixed SCSI IDs, the Fibre Channel protocol assigns addresses dynamically at the time each port connects to the network. The protocol provides addressing for up to 126 ports on an arbitrated loop or 16 million ports on a switched fabric.

---

➤ **Important** Although the arbitrated loop protocol provides addressing for 126 ports, in practical application, the number of ports that can share the available bandwidth without degrading performance is much smaller.

For example, three M2 tape drives, each capable of a sustained data transfer rate of 30 MB/second, consume the available bandwidth on a 100 MB/second arbitrated loop. Attaching additional devices results in diminished performance for all devices.

---

The process for assigning the addresses depends on the topology being used (point-to-point, arbitrated loop, or switched fabric). One consequence of this topology-based address assignment is that if the device is relocated or the topology is reconfigured, the address may change. To provide positive identification of a device, the dynamically assigned address is associated with the port's world-wide name (WWN) for the duration of the connection.

## World-wide names

The manufacturer assigns each Fibre Channel device one or more unique identifiers or world-wide names at the time it is built. These names stay with the device for its lifetime.

**Note:** In the case of the Fibre Channel tape drive, the "device" is actually the Fibre Channel interface card inside the tape drive. If this card is replaced, the WWNs assigned to the tape drive change.

Each tape drive has three unique, 48-bit world-wide names, as follows:

- One world-wide name is assigned to the tape drive (the node).
- Two world-wide names are assigned to the tape drive's two Fibre Channel ports (one for NL\_Port A and one for NL\_Port B).

The tape drive reports these world-wide names to the device server on the Vital Product Data Device Identification Page (Page Code 83h) of the INQUIRY command (see the *Exabyte Mammoth-2 Fibre Channel Interface Supplement* for information).

## Fibre ID and Loop ID

In addition to the world-wide name, each of the tape drive's two NL\_Ports has a 7-bit Fibre ID or hard address set on the tape drive (see [page 2-12](#) and [page A-7](#)). During the loop initialization process (LIP) on an arbitrated loop, the tape drive obtains two Loop IDs, one for each Fibre Channel port (Loop A and Loop B). If possible, this Loop ID is the same as the Fibre ID (see ["Hard addressing versus soft addressing" on page 5-12](#)).

**Note:** If the tape drive ports are connected to multiple loops, the Loop IDs obtained during loop initialization may be different for each loop, depending on the host bus adapter, hub, or switch being used in the Fibre Channel network.

## Hard addressing versus soft addressing

When the tape drive (the device) connects to an arbitrated loop, it can use either hard or soft addressing when obtaining the Loop ID during loop initialization, as follows:

- If the device was previously on a fabric, the device first attempts to get the Loop ID previously assigned by the fabric.
- If a Loop ID was not previously assigned to the device or if the previously assigned Loop ID is no longer available, the device attempts to obtain a Loop ID based on its Fibre ID (the hard address). If all of the devices on the loop have unique hard addresses, then the Loop ID for each device is the same as the hard address.

---

➤ **Important** Setting the Fibre ID for the tape drive does not guarantee that the selected ID will be used as the Loop ID when the tape drive logs onto a Fibre Channel network.

---

- If the hard address is already in use by another device on the network, the device attempts to use soft addressing to obtain a Loop ID. When soft addressing is used, the Loop ID for the device is determined during initialization and is dynamically set to the lowest available value within the range from 01h to E8h.
- Setting the Require Hard Address (RHA) bit to 1 on the MODE SELECT Fibre Channel Port Control Mode page prevents the tape drive from using soft addressing. If the specified hard address (Fibre ID) is already in use, the tape drive cannot log onto the network and will not be able to participate on the loop.

---

➤ **Important** If the tape drive is unable to obtain a Loop ID, it enters a non-participating state on the loop.

---



## Arbitrated Loop Physical Address (AL\_PA)

When a device is on an arbitrated loop, it uses a lookup table to associate the Loop ID with an arbitrated loop physical address (AL\_PA) for each port. AL\_PAs are unique one-byte values dynamically assigned each time the loop is initialized.

## Loop Initialization

Loop Initialization is a logical procedure used by an L\_Port or NL\_Port to determine its environment and to assign an AL\_PA prior to beginning loop operations. The tape drive performs Loop Initialization procedures as specified in the *Fibre Channel Arbitrated Loop Standard*, with the exception of the Loop Initialization Select Master (LISM) procedure.

### Loop Initialization Primitive (LIP)

To begin the Loop Initialization process, a device (the tape drive) issues a Loop Initialization Primitive (LIP) sequence. When a device issues a LIP sequence on an active loop, any exchange operations in progress over the loop are temporarily suspended while the loop is initialized. Whenever possible, the suspended exchanges resume after initialization is complete.

### Loop Initialization Select Master (LISM)

Loop initialization requires a temporary master to manage the process. The process of selecting a temporary loop master is called Loop Initialization Select Master (LISM). During LISM, each device entering the loop transmits a LISM frame containing its world-wide name (WWN).

Each device on the loop compares the WWN in the LISM frame transmitted from the previous device on the loop with its own WWN. If the received WWN is lower, the receiving device stops transmitting its own LISM frame and forwards the received LISM frame. This process continues until one device on the loop receives its own LISM frame, meaning that the frame has propagated completely around the loop. That device becomes loop master until another device with a lower WWN enters the loop.

The M2 tape drive always forwards any received LISM frames instead of transmitting its own LISM frame, even if the WWN in the received LISM frame is higher. This behavior prevents the tape drive from becoming loop master and allows the host to control the Loop Initialization sequence.

### **Fabric Login (FLOGI)**

Fabric Login is the mechanism used to assign Loop IDs to the tape drive when it is attached to a switched fabric. The M2 tape drive uses Fabric Login to detect whether a fabric is present. If a fabric is detected, the tape drive establishes a session with the fabric by communicating its world-wide names and exchanging service parameters. If a fabric is present, the tape drive attempts a Fabric Login after Loop Initialization is complete.

During the Fabric Login process, the fabric assigns the upper 16 bits of the 24-bit port address. (The lower 8 bits of the port address are the device's AL\_PA in both fabric and non-fabric environments.) If no fabric is detected, the upper 24 bits of the port address are set to 0. In addition to obtaining the Loop IDs, the tape drive sets service parameters to require that frames must be delivered in the same order that they were sent.

---

# 6 Specifications and Standards

---

This chapter provides the following specifications for the internal and tabletop models of the tape drive:

- Size and weight
- Storage capacity
- Performance specifications
- Reliability specifications
- Power specifications
- Environmental requirements
- Shipping specifications
- Safety and regulatory agency compliance

## Size and Weight

Table 6-1 provides the dimensions and weight of the internal and tabletop tape drive models. Figure 6-1 shows the internal tape drive dimensions. Figure 6-2 shows the tabletop tape drive dimensions.

**Table 6-1** Size and weight of the tape drive

<b>Height</b> <b>Internal without faceplate</b> <b>Internal with faceplate (LCD or LED)</b> <b>Tabletop model</b>	1.63 inches (4.13 cm) 1.68 inches (4.28 cm) 3.9 inches (10.02 cm)
<b>Width</b> <b>Internal without faceplate</b> <b>Internal with faceplate (LCD or LED)</b> <b>Tabletop model</b>	5.75 inches (14.60 cm) 5.87 inches (14.92 cm) 8.5 inches (21.67 cm)
<b>Depth<sup>a</sup></b> <b>Internal without faceplate</b> <b>Internal with LCD faceplate</b> <b>Internal with LED faceplate</b> <b>Tabletop model</b>	8.00 inches (20.32 cm) A = 8.39 inches (21.31 cm) A = 8.20 inches (20.82 cm) 12.2 inches (30.90 cm)
<b>Weight</b> <b>Internal model</b> <b>Tabletop model</b>	2.9 pounds (1.3 kilograms) 8.0 pounds (3.6 kilograms)

<sup>a</sup> On early models of the LVD tape drive, the SCSI connector extends an additional 0.36 inches (9.2 mm) beyond the back edge of the tape drive chassis.

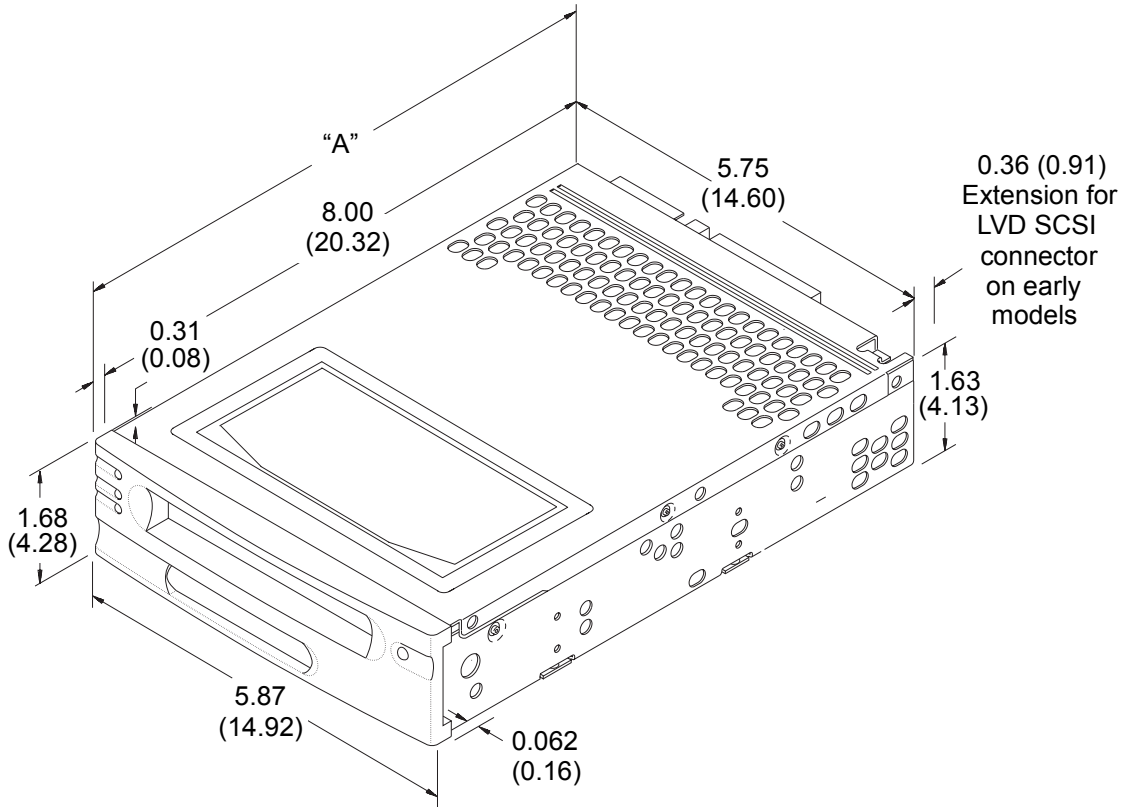

**Figure 6-1** Dimensions of the internal tape drive in inches (and centimeters)

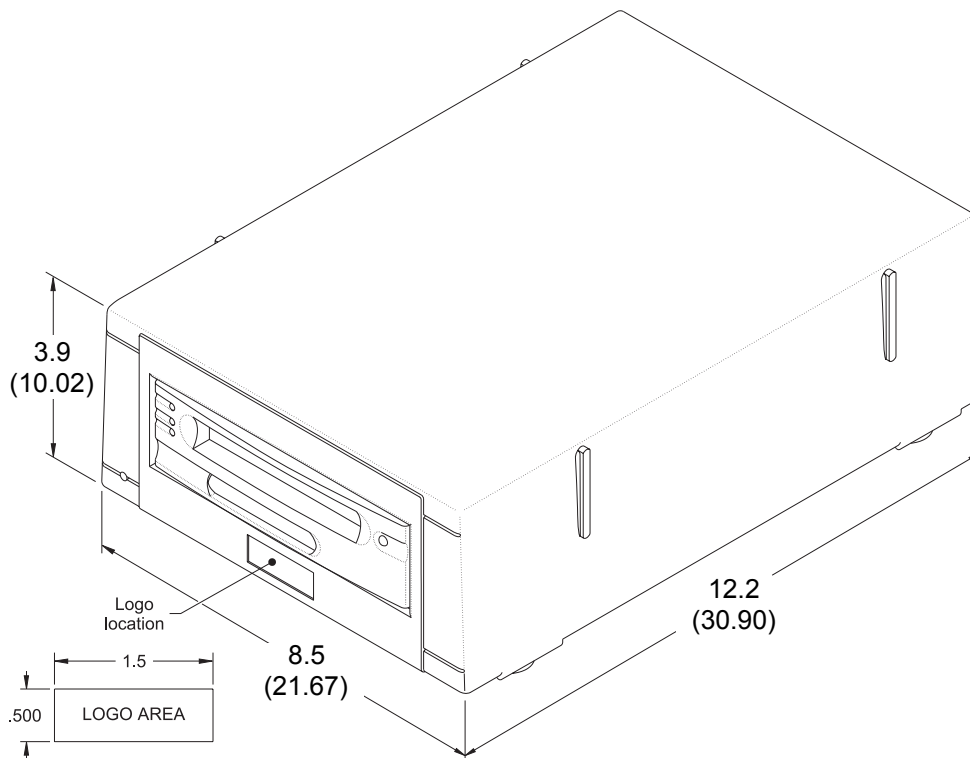

**Figure 6-2** Dimensions of the tabletop tape drive in inches (and centimeters)

## Storage Capacity

[Table 6-2](#) provides the approximate data capacities in gigabytes (GB) for each length of SmartClean cartridge, when used with M2.

**Table 6-2** Data capacities of Exabyte SmartClean AME cartridges

Tape length (meters of AME media)	Native recording capacity	Compressed recording capacity <sup>a</sup>
225m	60 GB	150 GB
150m	40 GB	100 GB
75m	20 GB	50 GB

<sup>a</sup> Assumes a 2.5:1 compression ratio. Actual compressed capacity varies depending on the type of data being recorded.

Although not recommended, M2 can also read and write standard AME cartridges designed for Mammoth and Mammoth-LT. When these cartridges are used, M2 will require regularly scheduled manual cleaning using a MammothTape cleaning cartridge. Such maintenance is eliminated or greatly reduced by using only SmartClean media.

[Table 6-3](#) provides the approximate data capacities in gigabytes (GB) for each length of standard AME cartridge when used with M2.

**Table 6-3** Data capacities of Exatape AME data cartridges

Tape length (meters of AME media)	Native recording capacity	Compressed recording capacity <sup>a</sup>
170m	45 GB	112.5 GB
125m	30 GB	75 GB
45m	12 GB	25 GB
22m	5.5 GB	12.5 GB

<sup>a</sup> Assumes a 2.5:1 compression ratio. Actual compressed capacity varies depending on the type of data being recorded.

# Performance Specifications

This section describes the performance specifications for the tape drive. The tape drives are factory tested to these specifications using Exabyte AME media.

## Data Transfer Rates

Table 6-4 lists the maximum data transfer rates in megabytes per second (MB/sec.) that the tape drive can achieve.

**Table 6-4** Maximum data transfer rates

<b>Data transfer rate</b>	12 MB/sec. 30 MB/sec. (compressed; assuming a 2.5:1 ratio)
<b>Burst transfer rate</b>	80 MB/sec. – synchronous (Ultra2 wide) 20 MB/sec. – synchronous (single-ended wide) 14 MB/sec. – asynchronous (single-ended wide with 1-foot cable) <sup>a</sup> 106 MB/sec. – asynchronous (Fibre Channel)

<sup>a</sup> The asynchronous transfer rate degrades as the cable length increases. For example, a 6-meter cable can achieve a maximum transfer rate of 4 MB/sec., depending on the cable impedance and termination quality.

## Read and Write Access Times

Read access time starts when the tape drive receives the last byte of the READ command (that is, when the initiator de-asserts ACK) and ends when the tape drive asserts REQ to indicate that it is ready to transfer the first data byte across the SCSI bus to the initiator.

Write access time starts when the tape drive receives the last byte of the WRITE command (that is, when the initiator de-asserts ACK) and ends when the tape drive asserts REQ to request that the initiator transfer the first data byte across the SCSI bus.

Table 6-5 lists typical read and write access times in microseconds ( $\mu\text{sec}$ ) for the tape drive. Access time depends on whether the tape drive is operating in start/stop mode or streaming mode.

**Table 6-5** Read/write access times

Mode	Typical ( $\mu\text{sec}$ )	Maximum ( $\mu\text{sec}$ )
Start/stop	300	600
Streaming <sup>a</sup>	400	900

<sup>a</sup> In streaming mode, access times are slightly higher because there are additional performance demands on the microprocessor.

**Note:** The measurement of access time does not include the initial READ or WRITE command received after the mode is changed (from write to read, or from read to write).

## Reselection Phase Timeout

If the initiator fails to respond to a device reselection sequence, the tape drive times out after 250 milliseconds. The tape drive continues to repeat the reselection process until it is reset, until the initiator finally responds, or until the reselection attempts exceed the specified number of retries.

## Tape Speeds

The speed at which the tape drive moves tape through the tape path depends on the operation being performed.

### Read and Write Speed

During normal read or write operations, the tape drive moves the tape at approximately 1.8 inches per second (4.6 cm per second) and exerts only 12 grams of tension on the tape.



## File-Search Speed

The maximum search speed is 410 MB per second (1.6 meters per second). The average search speed depends on the length of the search. [Table 6-6](#) outlines the total search time required to locate to a file 20 GB away on the tape.

**Table 6-6** Search times (in seconds)

Function	Description	Time (sec.)
<b>Load</b>	Insert cartridge to ready state	17
<b>Search</b>	Search 20 GB (75 m at 1.6 m/sec), including acceleration and deceleration	47
	Reposition to start of file	5
<b>Total search and load time (for 20 GB)</b>		<b>69</b>

## Rewind Tape Speed

The rewind speed is 34 times the read/write speed (approximately 62 inches per second). Rewind time starts when the initiator issues a REWIND command and ends when the tape drive returns a Command Complete message (for a non-immediate rewind). The times assume the following:

- The tape is positioned at LEOT when REWIND is issued.
- The tape has only one partition.
- The scanner has not stopped rotating.
- Tape tension has not been released.
- The cartridge is not ejected. (Add 10 seconds for cartridge eject.)

## Drive Ready States

To save power and reduce wear on the tape and the internal mechanisms, the tape drive automatically moves through various states of inactivity based on the time since the last activity took place. As the tape drive proceeds from a ready state into inactivity, it progresses through the following states:

- Active
- Sleep 1
- Sleep 2

Sleep states enable the tape drive to return to an active state faster than if it was powered off and then back on, because the tape remains loaded and is not repositioned to logical beginning of partition (LBOP). When the tape is positioned at LBOP, the tape drive untensions (enters the Sleep 1 state) immediately.

Table 6-7 defines sleep states, including SCSI response time for each state.

**Table 6-7** Sleep states (in seconds)

	Active <sup>a</sup>	Sleep 1 <sup>b</sup>	Sleep 2
<b>Time since last activity</b>	<5 sec.	>5 sec. <30 sec.	>30 sec.
<b>SCSI information command response time</b>	normal <sup>c</sup>	normal	normal
<b>SCSI tape motion command response time</b>	normal	+ 1.5 sec.	+ 5 sec.

<sup>a</sup> The tape is tensioned and the scanner is spinning.

<sup>b</sup> The tape is untensioned and the scanner is spinning.

<sup>c</sup> The tape drive responds to the command within the time defined by the SCSI standard.

The tape drive releases tape tension and goes into Sleep 1 state if the tape drive has not received a command to move the tape in the last 5 seconds. After releasing tape tension, the tape drive goes into Sleep 2 state and stops scanner rotation if it does not receive a tape motion command within 30 seconds of the last command.

## Reliability Specifications

This section lists the reliability specifications for the tape drive, including the following:

- Hardware service life
- Head and cartridge loader life
- Mean time between failures (MTBF)
- Mean time to repair (tabletop model only)
- Data integrity
- Data reliability

The tape drive attempts to provide a warning on wear items and the need for preventive maintenance. This type of maintenance is not considered a failure.

## Hardware Service Life

The tape drive has been designed to exceed a useful service life of five years, during which time all performance and reliability specifications are applicable.

## Head and Cartridge Loader Life

The tape drive scanner, including all of the heads, is rated at 50,000 hours. The cartridge loader is rated for 100,000 load/unload cycles.

## Mean Time Between Failures (MTBF)

The predicted MTBF value for either the internal tape drive or the tabletop tape drive (in an Exabyte enclosure including the power supply, fan, and cables) is 300,000 hours. The MTBF is defined as follows:

$$\text{MTBF} = \frac{\text{Total Power-on Hours}}{\text{Number of Relevant Equipment Failures}}$$

where:

- **Total Power-on Hours** is the total time the tape drive is drawing current from the input power supply system.
- **Relevant Equipment Failures** are those failures that cannot be corrected by the operating personnel and require the intervention of maintenance personnel.

## Test Conditions

The MTBF value for the tape drive is determined under the following conditions:

- The tape drive is tested at an ambient temperature of  $23^{\circ}\text{C} \pm 2^{\circ}$  and a relative humidity of 45% relative humidity  $\pm 10\%$  (non-condensing).
- The tape drive is operated in accordance with operating specifications.

## Conditions for the MTBF Value

Conditions under which the specifications for MTBF apply are as follows:

- The Exatape AME with SmartClean data cartridges used must comply with any existing media standards.
- Environmental conditions for the tape drive and the 8mm data cartridges must be maintained as specified in this chapter.
- If the tape drive is used with an AME cartridge without SmartClean, it must be cleaned with an Exabyte Mammoth Cleaning Cartridge (or a cleaning cartridge approved by Exabyte for Mammoth-2) using the recommended cleaning procedure.

## Restrictions for the MTBF Value

The following types of failures are excluded from the calculation of MTBF:

- Failures arising from incorrect operating procedures.
- Cable failures, power supply failures, or other failures not caused by equipment.
- Failures caused by incorrect grounding procedures or by interference from external sources.
- Media failures, or any failures or degraded performance caused by use of faulty or damaged media.
- New failures that arise from continued use of a failed, misaligned, or damaged tape drive.
- Failures caused by incorrect maintenance procedures.
- Failures for which early warnings have been provided.

## Mean Time to Repair (Tabletop Model Only)

The internal tape drive is not field repairable; it must be returned to the factory.

For the tabletop model, if the enclosed tape drive is treated as a field replaceable unit, the mean time required to remove and replace the enclosed tape drive is less than 15 minutes.

## Data Integrity

Conditions under which data integrity is maintained are as follows:

- If there is a power loss while the tape drive is reading, no recorded data will be lost.
- If there is a power loss while the tape drive is writing, any data remaining in the buffer will be lost.
- The tape drive will not record incorrect data to tape without posting an error condition.
- The tape drive will not return incorrect data to the system without posting an error condition.

## Data Reliability

Data reliability is specified as a bit error rate (BER) in units of errors per total number of bits transferred to the host.

### Conditions for Data Reliability

The conditions under which the specifications for data reliability apply are as follows:

- The Exatape AME with SmartClean or standard AME data cartridges used must comply with any existing media standards.
- Data cartridges must be written and read on a tape drive that is in good operating condition and properly grounded.
- Environmental conditions for the tape drive and the 8mm data cartridges must be maintained as specified in this chapter.
- If the tape drive is used with AME media without SmartClean technology, the drive must be cleaned with an Exabyte Mammoth cleaning cartridge (or a cleaning cartridge approved by Exabyte for M2) using the recommended cleaning procedure (see [page 2-25](#)).

### Restrictions for Data Reliability

The following types of errors are not included in the determination of data reliability:

- Errors caused by a failure of the tape drive.
- Errors caused by faulty or damaged cartridges or media.

- Errors caused by failure to comply with input power and grounding requirements, interference from external sources, or incorrect system operation or failure.
- Errors corrected by the tape drive's ECC.
- Errors occurring in blocks other than blocks containing user data.

### **Write Reliability**

Write reliability is determined by the rate of permanent write errors. During a write operation, the tape drive uses read-after-write checking to determine whether physical data blocks are correctly written to tape. When the read-after-write check criteria are not met for a data block, the tape drive rewrites the block. The tape drive keeps track of the number of times blocks are rewritten and stores this number internally. The number is available through the LOG SENSE command.

If the tape drive can rewrite the data block correctly, the error is a temporary write error, which does not affect write reliability. However, if the tape drive cannot write the data block correctly after completing the write recovery procedures, the error is a permanent write error. When a permanent write error occurs, the tape drive returns Check Condition status.

The bit error rate for permanent write errors is less than  $1.0 \times 10^{-17}$ .

### **Read Reliability**

Read reliability is determined by the rate of permanent read errors. If, during a read operation, the tape drive cannot read a block that has been correctly written, it attempts to reread the block. The tape drive keeps track of the number of times it attempts to reread a block and stores this number internally. This number is available through the LOG SENSE command.

If the tape drive can reread the data block correctly, the error is a temporary read error, which does not affect read reliability. If, however, the tape drive cannot reread the data block correctly after completing the read recovery procedures, the error is a permanent read error. When a permanent read error occurs, the drive returns Check Condition status. The bit error rate for permanent read errors is less than  $1.0 \times 10^{-17}$ .

# Power Specifications

This section provides power specifications for the tape drive.

## Internal Tape Drive

**Note:** The power specifications for the internal tape drive are in addition to any requirements for the enclosure into which it is installed.

### DC Voltages

The internal model of the tape drive operates from standard +5 VDC and +12 VDC supply voltages, as specified in [Table 6-8](#). (All specified voltages are DC; no external AC power is used.)

**Table 6-8** Power specifications (internal tape drive)

Specification	+5 Volts	+12 Volts
<b>Nominal tolerance:</b> <sup>a</sup> Ripple and noise <sup>b</sup> (60 Hz to 20 MHz)	± 5% 125 mVpp max	± 10% 125 mVpp max
<b>Operating current (in amps):</b> Nominal <sup>c</sup>		
Single-ended wide SCSI	1.5	0.5
LVD wide SCSI	1.5	0.5
HVD wide SCSI	1.5	0.5
Fibre Channel	1.5	0.5
Peak <sup>d</sup>		
Single-ended wide SCSI	2.1	2.5
LVD wide SCSI	2.1	2.5
HVD wide SCSI	2.1	2.5
Fibre Channel	2.1	2.5

<sup>a</sup> The tolerance is limited by some digital parts having a 5% tolerance specification.

<sup>b</sup> The ripple voltage is included in the total voltage tolerance.

<sup>c</sup> Nominal current occurs during streaming write or read operation.

<sup>d</sup> The peak current occurs during load, drum spin-up, unload, or at the start of search or rewind operations, and lasts for less than 5 seconds.

**Note:** The tape drive does not provide overvoltage or overcurrent protection. Safety agency certification requires that the supplied voltages be from a Safety Extra-Low Voltage source (per IEC 950).

## Power Consumption

Table 6-9 shows the internal tape drive's power consumption when operating and when idle.

**Table 6-9** Power consumption (internal tape drive)

	SCSI configuration			Fibre Channel
	Single-ended wide	Low-voltage differential (LVD) wide	High-voltage differential (HVD) wide	
<b>Power consumption (operating)<sup>a</sup></b>	18 watts	18 watts	13 watts	18 watts
<b>Power consumption (idle)<sup>b</sup></b>	6.5 watts	7 watts	7 watts	7 watts

<sup>a</sup> Assumes that the tape drive is reading data 50% of the time and writing data 50% of the time.

<sup>b</sup> Sleep 2 state (see [page 6-7](#)).

## Tabletop Tape Drive

The power specifications for the tabletop tape drive include both the requirements for the tape drive and the enclosure components.

### Power Supply

The tabletop tape drive uses an internal switching power supply. You do not need to change any input settings. The power supply automatically adjusts for changes in voltages and frequency within the specified range. An AC line filter minimizes interference.

Table 6-10 lists the general specifications for the power supply.

**Table 6-10** Power supply specifications (tabletop tape drive)

<b>Type</b>	25 watts, switching
<b>Efficiency</b>	70% @ 25 watts, 120 VAC, 60 Hz
<b>Input voltage<sup>a</sup></b>	85 to 264 VAC
<b>Frequency<sup>a</sup></b>	50 or 60 Hz ± 5%
<b>Switching frequency</b>	100 KHz, typical

<sup>a</sup> Autoswitching input selection—no user selection required.



## AC Power Characteristics

The tabletop tape drive continues to operate when the AC power experiences intermittent operations, voltage surges, and voltage spikes. [Table 6-11](#) shows the AC power characteristics acceptable to the tabletop tape drive.

**Table 6-11** AC power characteristics (tabletop tape drive)

<b>Intermittent operation</b>	<ul style="list-style-type: none"> <li>▪ 100% line dropout for 1/2 cycle at nominal line voltage.</li> <li>▪ 50% line reduction for 1 1/2 cycles at nominal line voltage.</li> <li>▪ 20% line reduction for 2 1/2 cycles at nominal line voltage.</li> </ul>
<b>Line discontinuities</b> <b>Voltage surges</b>  <b>Voltage spikes</b>	500 volts at nominal line voltage <ul style="list-style-type: none"> <li>▪ Pulse width: 100 ns</li> <li>▪ Rise time: 5 ns</li> <li>▪ Repetition time: 1 Hz</li> </ul> Common and differential mode, positive and negative polarity  1 to 5 KV at nominal line voltage <ul style="list-style-type: none"> <li>▪ Pulse width: 1 s</li> <li>▪ Rise time: 25 ns</li> <li>▪ Repetition time: 1 Hz</li> </ul> Common and differential mode, positive and negative polarity

## Power Consumption

[Table 6-12](#) provides power consumption specifications.

**Table 6-12** AC power consumption (tabletop tape drive)

<b>AC input current (average)</b>	0.8 amps (rms) for 120 VAC 0.4 amps (rms) for 240 VAC
<b>AC input current (cold)</b>	30 amps, maximum for 120 VAC 60 amps, maximum for 240 VAC

## Acoustic Noise Specification (Tabletop Model Only)

The overall, averaged A-weighted sound pressure levels (decibels) for the tape drive, when measured in the Mammoth-2 tabletop enclosure, do not exceed the upper limits specified in [Table 6-13](#).

**Table 6-13** Acoustic noise (tabletop tape drive)

Operating mode	LpA <sup>a</sup>
The tape drive is powered on and idle.	45
The tape drive is fully operational and operating in streaming mode for a read or write operation.	48
The tape drive is performing a high-speed search or rewind operation (less than 2 minutes duration).	49

<sup>a</sup> LpA is the 30 second sustained average A-weighted sound pressure level over the following frequency range: 5 Hz to 12.5 KHz.

## Environmental Specifications

[Table 6-14](#) summarizes the environmental requirements for the tape path in either the internal or tabletop model of the tape drive. The following sections provide additional detail about these requirements.

**Table 6-14** Environmental specifications

	Operating (cartridge inserted)	In storage <sup>a</sup> or not operating <sup>b</sup>	Being shipped <sup>c</sup>
<b>Tape path temperature range<sup>d</sup></b>	+5° C to +45° C (+41° F to +113° F)	-40° C to +60° C (-40° F to +140° F)	
<b>Temperature variation<sup>e</sup></b>	1° C per minute; max 13° C per hour (2° F per minute; max 23° F per hour)	1° C per minute; max 20° C per hour (2° F per minute; max 36° F per hour)	
<b>Relative humidity<sup>a</sup></b>	20% to 80% Non-condensing	10% to 90% Non-condensing	
<b>Wet bulb</b>	26° C (79° F) max		
<b>Altitude</b>	-304.8 m to +3,048 m (-1,000 ft to +10,000 ft)		-304.8 m to +12,192 m (-1,000 ft to +40,000 ft)

<sup>a</sup> The tape drive is in its original packaging; no cartridge is inserted.

<sup>b</sup> The tape drive is unpacked; no cartridge is inserted.

<sup>c</sup> The tape drive is in its original packaging; transportation period does not exceed six months.

<sup>d</sup> All temperature specifications assume that measurements are made at the tape path. An internal thermistor located near the exit side of the tape path measures the temperature.

<sup>e</sup> The data cartridge's temperature and humidity must be allowed to stabilize in the specified ambient environment for 24 hours.

## Operating Environment

The tape drive design optimizes the air flow from front to back. The flow impedance is such that a minimal negative pressure in the enclosure will draw sufficient air through the drive's front faceplate. This air is then directed through the drive and exhausted through the rear panel. The design minimizes air flow through the tape path and minimizes tape path contamination.

When the tape drive is incorporated into an enclosure, adequate air flow must be provided to dissipate heat resulting from approximately 12 watts of power consumption. The air flow around the entire tape drive must be sufficient to prevent the tape path temperature from exceeding 45° C (113° F), as measured near the scanner using a thermocouple. The onboard thermistor may also be used; however, this device has an accuracy of  $\pm 2^{\circ}$  C.

### Internal Tape Drive

[Figure 6-3](#) shows the temperature and humidity requirements for the internal tape drive, as measured at the tape path. The area within the dotted line represents the operating environment. [Table 6-15](#) defines the points in the chart.

---

► **Important** The operating temperature and humidity specifications are for the tape path. When the tape drive is in an enclosure, the ambient temperature typically must be lower than the maximum temperature to avoid exceeding the maximum at the tape path.

---

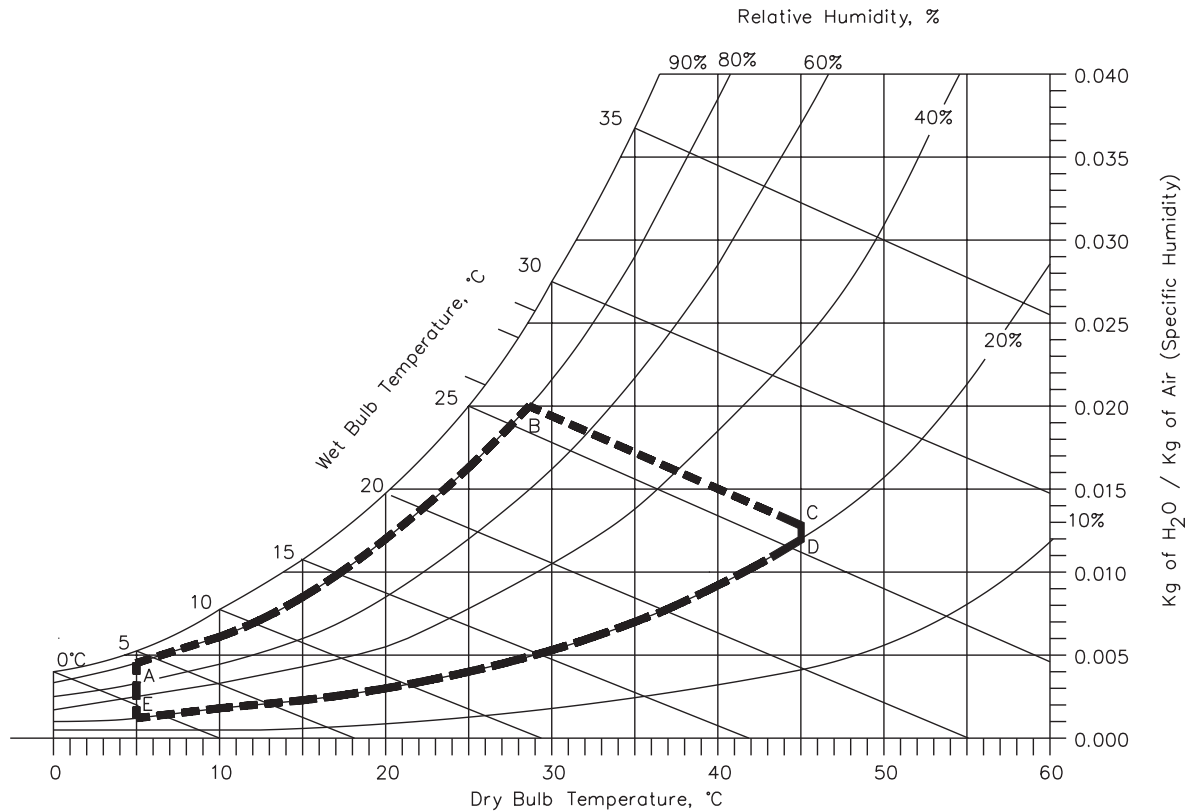

**Figure 6-3** Tape path temperature and humidity ranges for operation (internal tape drive)

**Table 6-15** Temperature and humidity points (internal tape drive)

Point	Temperature	Humidity
A	5° C	80%
B	29° C	80%
C	45° C	22%
D	45° C	20%
E	5° C	20%

## Tabletop Tape Drive

Because the tabletop tape drive includes an enclosure, ambient temperature and humidity must be maintained at the levels described in this section to achieve the tape path requirements described on [page 6-16](#). To meet tape path temperature and humidity requirements, maintain the tabletop tape drive's ambient operating environment within the area defined by the dotted lines in [Figure 6-4](#). [Table 6-16](#) defines the points in the chart.

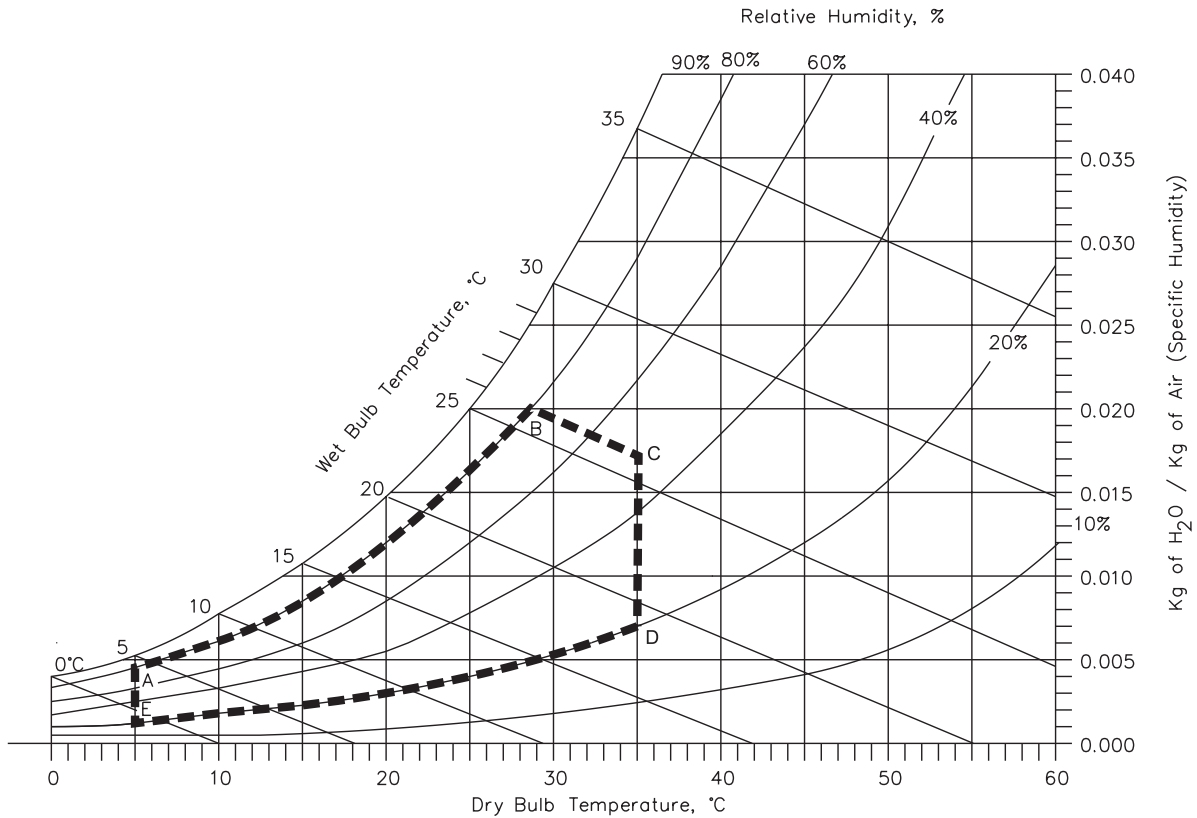

**Figure 6-4** Ambient operating environment (tabletop tape drive)

**Table 6-16** Temperature and humidity points (tabletop tape drive)

Point	Temperature	Humidity
A	5° C	80%
B	29° C	80%
C	35° C	50%
D	35° C	20%
E	5° C	20%

## Particulate Contamination Limits

The ambient operating environment should not exceed the particulate counts shown in [Table 6-17](#).

**Table 6-17** Particulate contamination limits

Particle size (microns)	Number of particles $\geq$ particle size per cubic meter	Number of particles $\geq$ particle size per cubic foot
0.1	$8.8 \times 10^7$	$2.5 \times 10^6$
0.5	$3.5 \times 10^7$	$1.0 \times 10^6$
5.0	$2.5 \times 10^5$	$7.0 \times 10^3$

[Figure 6-5](#) shows the particulate contamination profile of a typical office compared to the specifications for the tape drive. Contamination profiles of individual office areas vary.

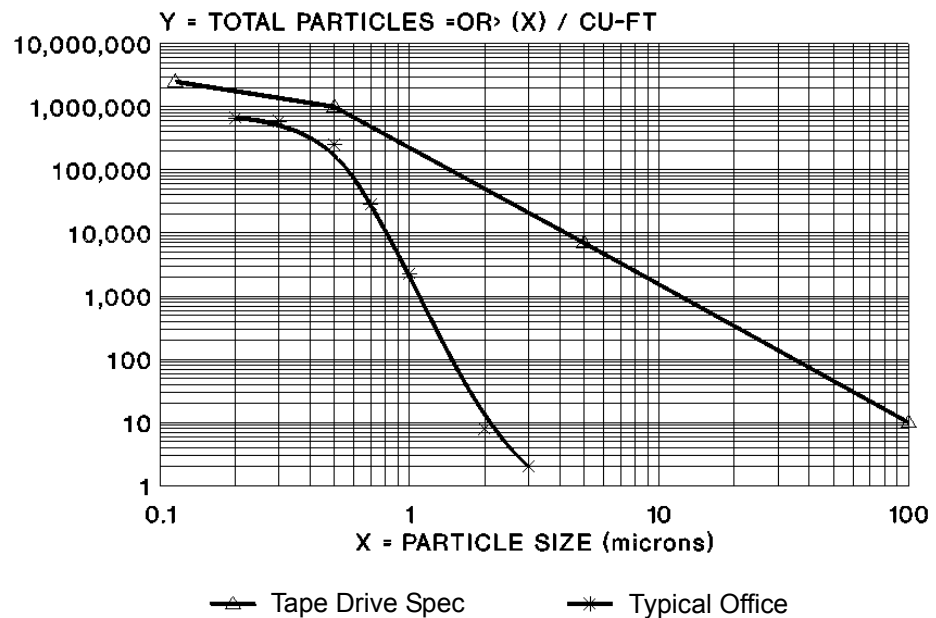

**Figure 6-5** Particulate contamination specification vs. typical office

## Shock Specifications

Table 6-18 lists the shock specifications for the tape drive. The operating shock levels indicate how much shock the tape drive can withstand while it is reading and writing data. The non-operating and storage shock levels indicate how much shock the tape drive can withstand when it is not operating. After withstanding this amount of shock, the tape drive will operate normally.

**Table 6-18** Shock specifications

Operating	Stored <sup>a</sup> or not operating <sup>b</sup>	Being shipped <sup>a</sup>	During handling
3 g for 5 ms <sup>c</sup>	<b>Internal model:</b> 45 g at a velocity change of 192 inch/sec <sup>d</sup>  <b>Tabletop model:</b> 45 g at a velocity change of 167 inch/sec	ISTA Procedure 2A	Drop and Topple per IEC 68-2-31

<sup>a</sup> Tape drive is in original packaging with no cartridge inserted.

<sup>b</sup> Tape drive is unpacked, with no power applied.

<sup>c</sup> A minimum of 20 shock pulses were applied to each of the three orthogonal axes. The shock pulses were half-sine waves and were applied at a rate not exceeding one shock per second.

<sup>d</sup> A minimum of three trapezoidal shock pulses of 45 g were applied to each of the tape drive's six sides at a velocity change of 192 inches per second (equivalent height equals 48 inches).

## Vibration Specifications

Table 6-19 lists the vibration specifications for the tape drive during operation, non-operation, storage, and transportation. The operating specifications listed in this table indicate the amount of vibration that the tape drive can withstand while reading and writing data.

**Table 6-19** Vibration specifications

Random vibration <sup>a</sup> applied during operation (reading and writing)	
1 Hz	PSD = 0.0000040 g <sup>2</sup> /Hz
5 Hz	PSD = 0.0000270 g <sup>2</sup> /Hz
10 to 150 Hz	PSD = 0.0004048 g <sup>2</sup> /Hz
200 to 400 Hz	PSD = 0.0001079 g <sup>2</sup> /Hz
Random vibration <sup>b</sup> applied during non-operation (unpacked) and storage (in original packaging)	
1 Hz	PSD = 0.0003 g <sup>2</sup> /Hz
3 Hz	PSD = 0.00055 g <sup>2</sup> /Hz

**Table 6-19** Vibration specifications (*continued*)

<b>Random vibration<sup>a</sup> applied during operation (reading and writing)</b>	
12 to 100 Hz	PSD = 0.01 g <sup>2</sup> /Hz
400 Hz	PSD = 0.000003 g <sup>2</sup> /Hz
<b>Vibration applied during shipping (in original packaging)</b>	
ISTA Procedure 2A	
<b>Swept sine applied during non-operation<sup>c</sup> and operating<sup>d</sup></b>	
5 to 500 to 5 Hz	

<sup>a</sup> A 0.30 G RMS random vibration spectrum is applied to each of three orthogonal axes for a minimum of 20 minutes per axis.

<sup>b</sup> A 1.06 G RMS random vibration spectrum is applied to each of three orthogonal axes for a minimum of 20 minutes per axis.

<sup>c</sup> Three sweeps at one octave per minute are applied to each axis at 0.75 g (peak) input.

<sup>d</sup> Three sweeps at one octave per minute are applied to each axis at 0.3 g (peak) input.

## Shipping Specifications

This section describes the shipping requirements for the internal tape drive. See [Appendix A](#) for the tabletop tape drive shipping requirements where they differ from those for the internal tape drive.

## Packing Materials

The packing materials used to ship the internal and tabletop models of the tape drive are unbleached, reusable, recyclable, and environmentally safe. The materials contain no chlorofluorocarbons (CFCs) or heavy metals.

To avoid damaging the tape drive, use the original shipping carton and packing materials (or replacement packaging obtained from the vendor) when repacking and shipping the tape drive. The shipping carton and packing materials are not intended to be used for shipping items other than the original Exabyte tape drive.



## Shipping Cartons (Internal Tape Drive)

The internal tape drive is sealed in a static protection bag and is shipped with either one drive per carton (single pack) or with from two to five drives per carton (multi-pack). [Table 6-20](#) shows shipping dimensions and weights for the tape drive.

**Table 6-20** Shipping carton dimensions and weights (internal tape drive)

	Dimensions (L × W × H)	Weight
<b>Single-pack</b>	13.5 inches × 10.75 inches × 5.62 inches (34.3 × 27.3 × 14.3 cm)	<b>1 tape drive:</b> 4.1 lbs (1.8 kg)
<b>Multi-pack</b>	23.25 inches × 13.5 inches × 11.5 inches (59.1 × 34.3 × 29.2 cm)	3 tape drives: 12 lbs (5.4 kg) 4 tape drives: 15 lbs (6.5 kg) 5 tape drives: 18 lbs (8.2 kg)

Both the single-pack and the multi-pack shipping cartons and internal packing materials are designed so that an enclosed tape drive does not receive a shock greater than 45 g when the carton is dropped on any surface, corner, or edge from the following heights:

- 48 inches (121.9 cm) at a velocity change of 192 inches per second (488 cm/sec) for the single-pack carton
- 36 inches (91.4 cm) at a velocity change of 167 inches per second (424 cm/sec) for the multi-pack carton

Both sizes of shipping carton pass the tests described in the International Safe Transit Association (ISTA) Procedure 2A — Performance Test for Individual Packaged Products — for products weighing less than 150 pounds.

**Note:** Do not use a multi-pack shipping carton when shipping a single tape drive. If you use a multi-pack shipping carton, you must place from three to five tape drives in the carton.

## Shipping Carton (Tabletop Tape Drive)

When shipped, the tabletop tape drive is sealed in a static protection bag and is shipped with one unit per carton.

The shipping cartons and internal packing materials are designed so that the enclosed tabletop tape drive does not receive a shock greater than 45 g when the carton is dropped on any surface, corner, or edge from 36 inches (91.4 cm) at a velocity change of 167 inches per second (424 cm/sec).

The shipping carton passes the tests described in the International Safe Transit Association (ISTA) Procedure 2A — Performance Test for Individual Packaged Products — for products weighing less than 150 pounds.

Table 6-21 provides the shipping carton's outside dimensions and weight.

**Table 6-21** Shipping carton dimensions and weights (tabletop tape drive)

<b>Length</b>	17.75 inches (45 cm)
<b>Width</b>	16.25 inches (41 cm)
<b>Height</b>	10.75 inches (27 cm)
<b>Weight (with tape drive)</b>	11.5 pounds (4.3 kg)

When repacking and shipping the tabletop tape drive, use the original shipping carton and packing materials (or replacement packaging obtained from the vendor) to avoid damaging the tape drive. The shipping carton and packing materials are not intended to be used for shipping items other than a tabletop tape drive.

# Safety and Regulatory Agency Compliance

This section lists the safety and regulatory agency compliance information for both the internal and tabletop models of the tape drive.

**Note:** For the tabletop tape drive, the requirement for a shielded cabinet is met by the tabletop enclosure.

## Domestic and International Standards

When purchased from Exabyte Corporation, both the internal and tabletop models of the tape drive comply with the following domestic and international product safety standards.

- UL Standard 1950, 3rd Edition, Information Technology Equipment
- CSA Standard C22.2 No. 950-95, Safety of Information Technology Equipment
- IEC 950/EN60950, Safety of Information Technology Equipment including Electrical Business Equipment

**Note:** The internal model of the tape drive is certified as a component only. Certification of the final integrated product is the responsibility of the system integrator.

## Electromagnetic Compatibility (EMC)

When properly installed in a shielded cabinet and used with shielded cables and adequate grounding of the SCSI bus and input power, the tape drive meets the requirements for radiated and conducted emissions as defined by the standards listed in [Table 6-22](#). For the tabletop tape drive, the requirement for a shielded cabinet is met by the enclosure.

**Table 6-22** EMC standards

Country	Safety standard
USA	FCC, CFR 47, Ch. I, Part 15, Subpart B, Class A
Canada	ICES-003, Class A
Australia	AS/NZ 3548, Class A
Taiwan	CNS-13438, Class A
Europe	EN55022/CISPR 22, Class A EN55024:1998, Information Technology Equipment

## Agency Compliance (Tabletop Model Only)

This section lists the agency compliance for the tabletop tape drive. This information is in addition to the safety standards listed in [Chapter 6](#).

**Note:** For the tabletop tape drive, the requirement for a shielded cabinet is met by the tabletop enclosure.

### Laser Safety Standards

The tabletop Fibre Channel M2 tape drive must be used with an 850 nm shortwave laser and optical multi-mode GBIC transceiver modules. To maintain a Class 1 laser classification for the Fibre Channel tape drive, the GBICs must meet the Class 1 laser device classification as defined by the following list of laser safety standards:

- DHHS regulation 21 CFR 1010.10 and 1040.11, Class 1 laser products
- EN 60825-1 (IEC 60825-1), Safety of Laser Products, Part 1, Equipment Classifications, Requirements and User's Guides
- EN 60825-2 (IEC 60825-2), Safety of Laser Products, Part 2: Safety of Optical Fibre Communication Systems
- EN 60950 (IEC 60950), 2nd Edition, 1991, including Amendments 1 (1992), 2 (1993), 3 (1995), and 4 (1996)
- CB Scheme Report and Certificate valid and conforming with IEC 60950 2nd Edition, including Amendments 1 (1992), 2 (1993), 3 (1995), 4 (1996) and all group deviations listed in latest revision of CB Bulletin No. 86A I
- UL Approved to UL 1950 3rd. Edition
- CSA Approval through the use of the UL marking in compliance with CSA C22.2 950 1995 3rd. Edition
- TUV Approval for the "GS" mark in compliance with EN 60950 2nd Edition 1991 including Amendments 1 (1992), 2 (1993), 3 (1995), 4 (1996)

## **Electrostatic Discharge (ESD) Limits**

When properly installed in a shielded cabinet with shielded cables and adequate grounding of the SCSI bus and input power, the tape drive complies with EN61000-4-2: 1995, Electromagnetic Compatibility (EMC), Part 4: Testing and Measurement Techniques, Section 2: Electrostatic Discharge (ESD) Immunity, which includes the following standard values:

- Contact discharges, 4 kV
- Air-gap discharges, 8 kV

Exabyte tests to the following increased test values:

- Up to 15 kilovolts air-gap discharge applied to all non-metallic or non-conductive surfaces
- Up to 8 kilovolts direct discharge applied to all metallic or conductive surfaces

No errors will occur or damage be caused to the tape drive when a cartridge charged to a maximum of 20,000 volts is inserted.

In each case, there is no degradation or non-recoverable loss of function due to damaged equipment or firmware.

## **Radiated Radio Frequency Field Immunity**

When properly installed in a shielded cabinet with shielded cables and adequate grounding of the SCSI bus and input power, the tape drive complies with ENV 50204: 1995 and EN 61000-4-3: 1996, Electromagnetic Compatibility (EMC), Part 4: Testing and Measurement Techniques, Section 3: Radiated Electromagnetic Field Requirements.

The tape drive will continue to operate without error when subjected to a radiated RF field of 3 volts/meter. The field is 80% amplitude modulated (AM) with a 1 kHz signal. Additionally, a 3 volts/meter field at 900 MHz is pulse modulated (PM) at 200 Hz.

## **Electrical Fast Transient/Burst (EFT) Immunity**

When properly installed in a shielded cabinet with shielded cables and adequate grounding of the SCSI bus and input power, the tape drive complies with EN 61000-4-4: 1995, Electromagnetic Compatibility (EMC), Part 4: Testing and Measurement Techniques, Section 4: Electrical Fast Transient/Burst Immunity.

The tape drive will continue to operate without error when subjected to EFT  $\pm 2,000$  volts (V) on the AC power ports and  $\pm 1,000$  V on the I/O ports.

### **Surge Immunity**

When properly installed in a shielded cabinet with shielded cables and adequate grounding of the SCSI bus and input power, the tape drive complies with EN 61000-4-4: 1995, Electromagnetic Compatibility (EMC), Part 4: Testing and Measurement Techniques, Section: Surge Immunity.

The tape drive will continue to operate without error when subjected to a surge of up to  $\pm 2,000$  V.

### **Conducted Radio Frequency Field Immunity**

When properly installed in a shielded cabinet with shielded cables and adequate grounding of the SCSI bus and input power, the tape drive complies with EN 61000-4-4: 1995, Electromagnetic Compatibility (EMC), Part 4: Testing and Measurement Techniques, Section 6: Conducted Radio Frequency Immunity.

The tape drive will continue to operate without error while subjected to a field of  $3 V_{(rms)}$ . The field is 80% amplitude modulated (AM) with a 1 kHz signal.

### **Voltage Dips, Interruptions, and Variations Immunity**

When properly installed in a shielded cabinet with shielded cables and adequate grounding of the SCSI bus and input power, the tape drive complies with EN 61000-4-4: 1995, Electromagnetic Compatibility (EMC), Part 4: Testing and Measurement Techniques, Section 11: Voltage Dips, Short Interruptions, and Voltage Variations Immunity.

The tape drive will continue to operate without error after being exposed to a 70% voltage dip for 10 milliseconds (ms). The tape drive will be self-recoverable or can be restored by the operator after being exposed to a 40% voltage dip for 100 ms and after a power interruption of 5 seconds.

---

# A The Tabletop M2 Tape Drive

---

This appendix provides the information about the tabletop M2 tape drive where it differs from the internal tape drive, including the following:

- Components
- Installation requirements

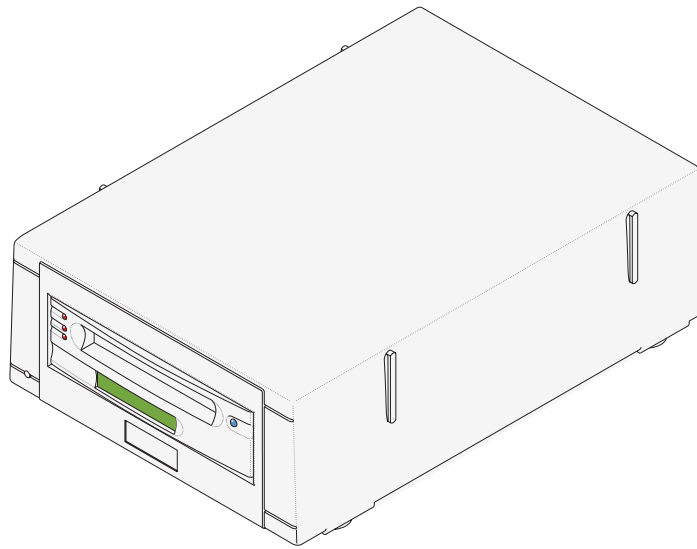

**Figure A-1** Tabletop M2 tape drive

The tabletop M2 tape drive is a fully integrated standalone data storage system that includes the following features:

- An internal, self-switching power supply
- A variable-speed thermistor-controlled fan
- A switch for setting the device address
- Two communication interface connectors
- Maximum EMI/RFI shielding that meets all applicable regulatory and safety agency requirements

## Components

This section describes the major components of the tape drive that are unique to the tabletop model. See [Chapter 1](#) for a description of the components not described in this appendix.

### Front Panel Components

[Figure A-2](#) shows the main components of the tabletop tape drive's front panel.

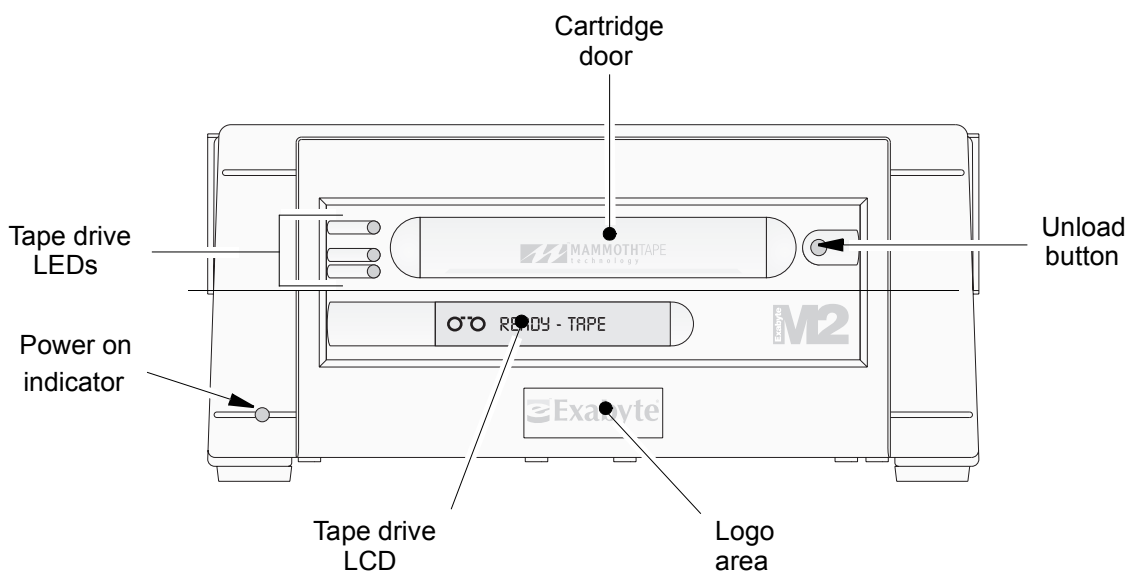

**Figure A-2** Front panel components on the tabletop tape drive

**Power-On Indicator** When you turn on the tabletop tape drive's power, the green power-on LED on the lower left corner of the faceplate lights up. When power is off or disconnected, the LED turns off.

**Tape Drive LEDs** The functions of the LEDs for the tabletop tape drive are the same as for the internal model. See ["Monitoring the LEDs and LCD" on page 2-17](#) for detailed information about the LEDs.

**Logo Area** The tabletop tape drive provides a recessed area in the bottom center of the faceplate for a company logo. For custom label information, contact your Exabyte account manager.

**Tape Drive LCD (standard)** The function of the LCD for the tabletop tape drive is the same as for the internal model. See ["Monitoring the LEDs and LCD" on page 2-17](#) for detailed information about the LCD.



**Cartridge Door** The function of the cartridge door for the tabletop tape drive is the same as for the internal model.

**Unload Button** The function of the unload button for the tabletop tape drive are the same as for the internal model. (See [“Unload button” on page 1-4.](#))

## Back Panel Components

Figure A-3 shows the main components of the SCSI tabletop tape drive’s back panel. Figure A-4 shows the main components of the Fibre Channel tabletop tape drive’s back panel. The back panel components are the same for the SCSI tape drive and the Fibre Channel tape drive, unless otherwise noted.

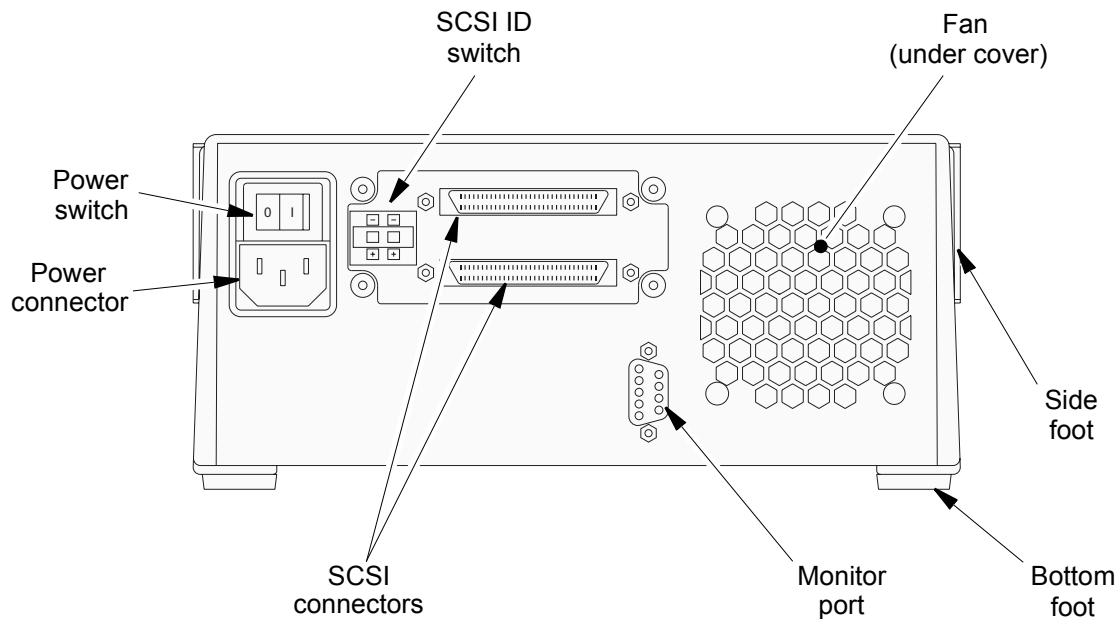

**Figure A-3** Back panel components for the SCSI tabletop model

## A The Tabletop M2 Tape Drive

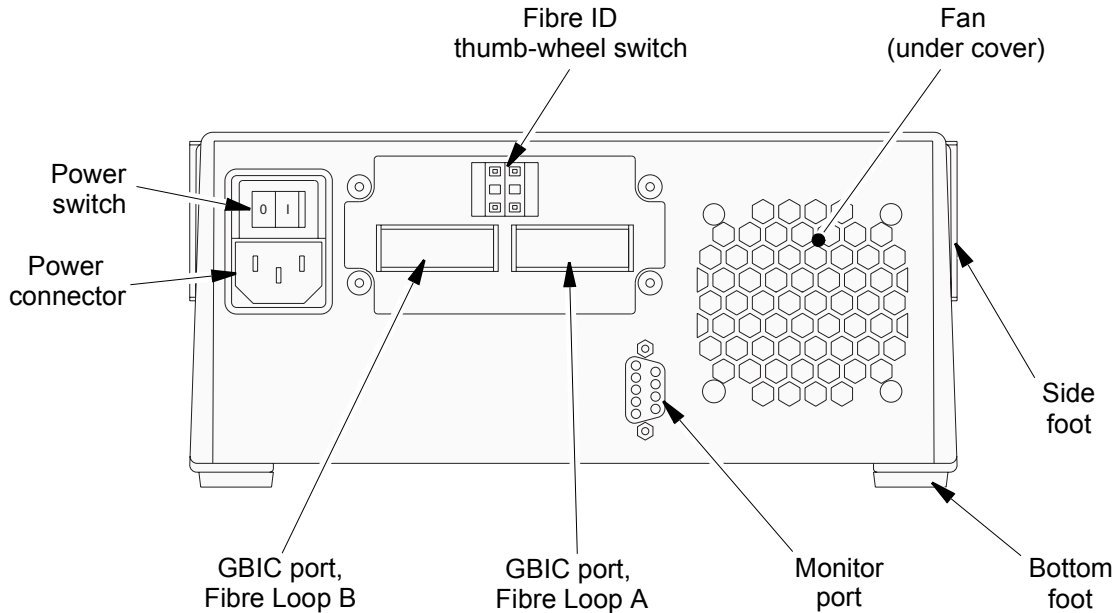

**Figure A-4** Back panel components for the Fibre Channel tabletop model

**Power Switch** The power switch allows you to turn power on and off for the enclosed tape drive.

**Power Connector** The power cord connector provides access to the internal AC power supply for the enclosed tape drive. See [page A-11](#) for power cord specifications.

**SCSI ID Switch (SCSI tape drive only)** The SCSI ID switch is a push wheel switch that enables you to set the address of the tape drive on the SCSI bus. The SCSI ID switch is recessed to prevent accidental selection.

**Fiber ID Switch (Fibre Channel tape drive only)** The thumb-wheel switch allows you to set the hexadecimal Fibre ID for the tabletop tape drive. Addresses are selectable from 00h to 7Fh. The factory default is set to 0Dh. The switch is recessed to prevent accidental changes.

**Fan** A thermistor-controlled fan increases or decreases airflow through the enclosure as environmental temperatures change. The unique design of the enclosure provides air circulation throughout the tape drive. The fan also features locked rotor protection. If a foreign object becomes lodged in the fan, the fan motor automatically shuts off. The fan restarts automatically when the object is removed.

**Feet** Feet located on the bottom and sides of the enclosure allow the tape drive to be used in either a vertical or horizontal position.

**Monitor Port** The Monitor port provides a serial interface to the tape drive's microprocessor. You can load code and perform diagnostics through a serial cable attached to this port using a custom Exabyte diagnostic program. Both the SCSI and Fibre Channel versions of the tape drive include a Monitor port.

**Note:** The Monitor port may not be present on all tabletop models of the tape drive. Contact Exabyte Technical Support (see the inside back cover) for assistance if you need to use this port.

**SCSI Connectors (SCSI tape drive only)** Two 68-pin male SCSI connectors enable you to connect the tape drive to a wide SCSI bus. See [page A-9](#) for more information.

**GBIC Ports (Fibre Channel tape drive only)** Two GBIC (gigabit interface converter) ports on the back of the tabletop tape drive provide the connections to two Fibre Channel loops.

## Optical GBICs

GBICs, similar to the one shown in [Figure A-5](#), are installed in each tape drive GBIC port to provide the connection between the tape drive and the Fibre Channel network. See [page A-10](#) for GBIC requirements. GBICs are not included with the tabletop tape drive. GBICs are available from Exabyte (see "[Contacting Exabyte](#)" on the inside back cover).

---

► **Important** The tape drives only support the use of optical GBICs and cables. Do not install copper GBICs or cables.

---

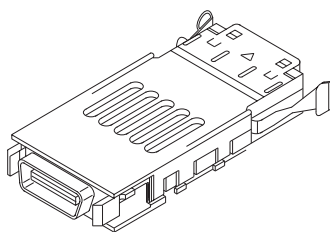

**Figure A-5** Standard optical GBIC

## Enclosure Color

The standard color of the enclosure for the tabletop tape drive, including the faceplate and door, is pearl white.

## Labels

The tabletop tape drive includes a single agency label on the bottom of the enclosure (Figure A-6). This label provides component, serial number, part number revision, and agency compliance information. It also provides the manufacture date, electrical information, and indicates whether the drive is SCSI or Fibre Channel.

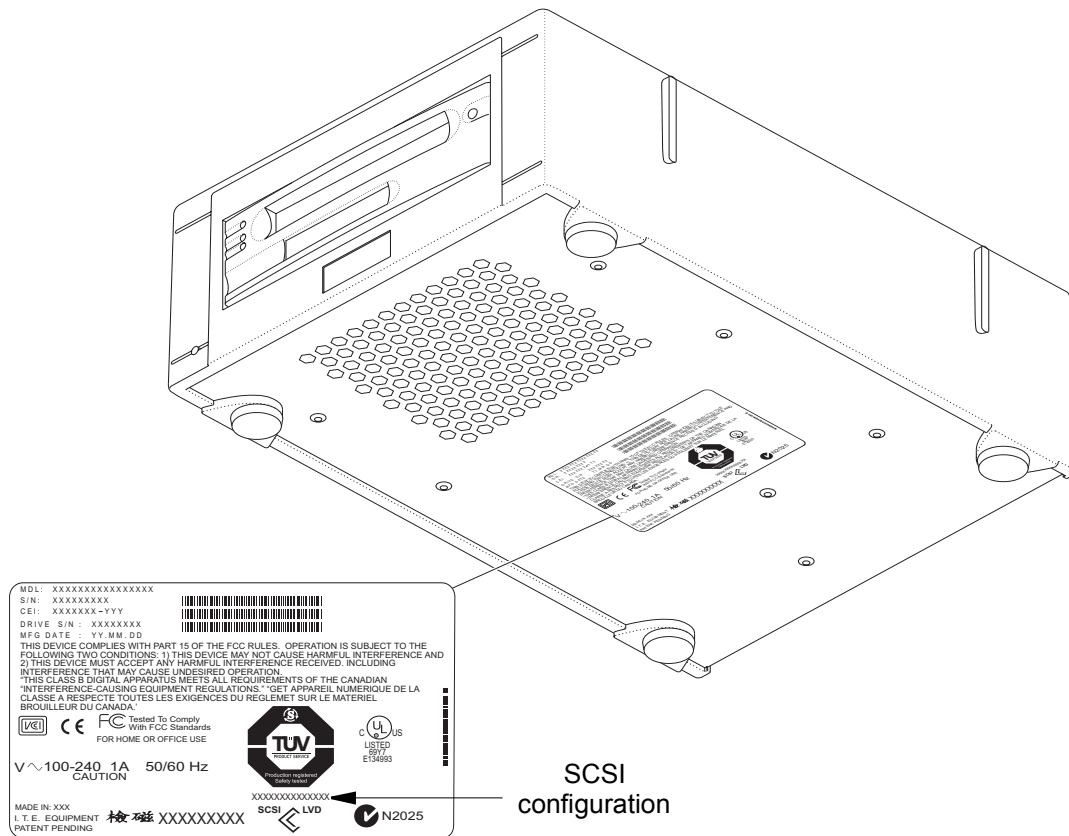

Figure A-6 Label location for the tabletop model (LVD label shown)

# Installation Requirements

This section describes the following installation requirements for the tabletop tape drive:

- ESD precautions
- Device IDs
- SCSI cable and terminator requirements
- Fibre Channel cable and GBIC requirements
- Power cable requirements

For detailed instructions for completing the installation tasks, refer to the *Exabyte Mammoth-2 Tape Drive Installation and Operation* manual.

## ESD Precautions

The Fibre Channel tape drive's front panel and Fibre Channel port connectors are sensitive to ESD.

### CAUTION

To avoid interrupting tape drive operation and potential ESD damage to the tape drive, discharge static electricity from your body before you touch the tape drive front panel or interface connectors for any reason. (Touch a known grounded surface, such as your computer's metal chassis or the rear of the drive enclosure.)

## Device IDs

This section describes how to set the device IDs for both the SCSI and Fibre Channel models of the tabletop tape drive. For the SCSI tape drive, the device ID is the SCSI ID the tape drive uses during arbitration on the SCSI bus. For the Fibre Channel tape drive, the device ID is the Fibre ID, which is mapped to a Loop ID when the tape drive is participating on a Fibre Channel arbitrated loop or fabric.

## Setting the SCSI ID (SCSI Tape Drive Only)

If you are setting up the SCSI tabletop tape drive, use the SCSI ID switch (see [Figure A-3](#)) to set the device address for the tape drive on the SCSI bus. You can set the ID to an address of 0 through 15. The factory default address setting is 15. If necessary, use a pen or other fine-tipped instrument to change the SCSI ID switch on the back of the tabletop tape drive.

## Setting the Fibre ID (Fibre Channel Tape Drive Only)

If you are setting up the Fibre Channel tabletop tape drive, use the Fibre ID thumb-wheel switches (see [Figure A-4](#)) to set the two-digit hexadecimal address. The factory default Fibre ID is set to 0Fh.

---

► **Important** The Fibre ID thumb-wheel switches physically allow selection of addresses 00h through FFh. However, if you select an address higher than 7Fh, the tape drive ignores the most significant bit of the binary representation of the address, resulting in a different address.

Furthermore, within this range, the addresses 7Eh and 7Fh are reserved. If you select either 7Eh or 7Fh as the address, the tape drive automatically uses soft addressing when obtaining a Loop ID.

---

## SCSI Cable and Terminator Requirements

This section provides the requirements for the cables and terminators used with the SCSI model of the tabletop tape drive.

### SCSI Cables

#### CAUTION

All wide SCSI configurations (single-ended, LVD, and HVD) use the same 68-pin connector. Do not attach an HVD drive to an LVD SCSI bus; doing so may cause the bus to hang.

The tabletop tape drive does not include a SCSI cable. Select a cable that complies with the SCSI-3 specification and meets the maximum length requirements listed in [Table A-1](#). The maximum length of the SCSI cable depends on whether you are using a single-ended, LVD, or HVD SCSI configuration.

---

► **Important** Although LVD SCSI is compatible with narrow SCSI interfaces, Exabyte does not support using the M2 tape drive in a narrow SCSI environment.

---

**Table A-1** External SCSI cable lengths

SCSI configuration	Maximum cable length <sup>a b</sup>	Notes
Single-ended wide	3 meters (9.8 feet), terminator to terminator	A maximum cable length of 6 meters is acceptable if the transfer rate is less than 10 MB/second for wide SCSI configurations.
Ultra2 LVD	12 meters (39 feet)	If the bus is a point-to-point configuration (two devices, the target and the initiator), the bus length can be up to 25 meters (82 feet).
HVD	25 meters (82 feet)	

<sup>a</sup> Each tabletop tape drive attached to the SCSI bus uses 0.4 meters (1.31 feet) of the total allowable bus length internally. To determine the total length, add this amount to the length of cable used on the bus for each tabletop tape drive.

<sup>b</sup> A stub length of no more than 0.1 meters (4 inches) is allowed off the mainline interconnection within any connected equipment.

## SCSI Terminators

If the tabletop tape drive is the last device on the SCSI bus, use one of the terminator types listed in [Table A-2](#) or an equivalent. Terminators for single-ended, LVD, and HVD buses have different electrical characteristics and are not interchangeable; do not mix them.

**Table A-2** Terminator recommendations

	Wide SCSI configuration
Single-ended	AMP 869516-1
LVD	AMP 796051-1 (SE/LVD Multi-mode)
HVD	AMP 869515-1

## Fibre Channel Cable and GBIC Requirements

This section provides the requirements for the optical fiber cables and GBICs used with the Fibre Channel model of the tabletop tape drive.

The tabletop Fibre Channel M2 tape drive must be used with an 850 nm shortwave laser and optical multi-mode GBIC transceiver modules. The optical GBICs and fiber cables you choose must comply with the 100-M5-SN-1 classification as specified in the Fibre Channel standard (FC-PI).

**Note:** The tape drive can also be used with optical cables that meet the 100-M6-SN1 classification, with the limitation that operation with a cable length over 275 meters cannot be guaranteed.

Optical fiber cables and GBICs are available from Exabyte (see [“Contacting Exabyte”](#) on the inside back cover).



## Power Cord Requirements

The tabletop tape drive includes a 120 VAC three-conductor power cord for use in the United States and Canada. The three-conductor, 18AWG, SVT or SJT type AC power cord has a molded NEMA 5-15P male connector on one end and a molded IEC type CEE-22 female connector on the other end. The power cord is UL Listed and CSA Certified.

The tabletop tape drive can operate from 100 to 240 VAC, with a frequency of 50 or 60 Hz, without manual intervention. As described below, you must supply power cords for other input voltages or when using the tabletop tape drive outside of the United States and Canada.

### 220 VAC Power Cord for the United States and Canada

A 220 VAC power for the tabletop tape drive must meet the following requirements:

- The power cord must have a NEMA 6-15P male connector on one end.
- The power cord must have an IEC type CEE-22 female connector on the other end.
- The cordage used must be an SVT or SJT type, three conductor, 18 AWG minimum.
- The power cord must comply with local electrical code.

### International 220 VAC Power Cord

An international 220 VAC power cord for the tabletop tape drive must meet the following requirements:

- The power cord must have an attachment plug of the proper type, rating, and safety approval for the intended country.
- The power cord must have an IEC type CEE-22 female connector on one end.
- The cordage must be adequately rated and harmonized to CENELEC publication HD-21.

## Notes

---

---

# B Glossary

---

**Adapter** See *Host bus adapter*.

**ALDC** Advaptive Lossless Data Compression. An advanced data compression algorithm that provides an average compression ratio of 2.5:1 across multiple data types. See also *IDRC*.

**AME** Advanced Metal Evaporated. A state-of-the-art tape technology designed for data storage. AME media consists of a film of metallic recording material deposited on a thin substrate by an evaporative process.

**Application** Any type of computer program that performs a function or processes data for a user. For example, a backup application sends files to storage devices based on criteria specified by a user.

**Arbitrated loop topology** One of the three Fibre Channel network topologies. Up to 126 devices can be connected serially in an arbitrated loop, but only two can communicate at one time.

A port on an Arbitrated Loop includes functionality that allows data from one port to be routed through intermediate ports on an arbitrated loop before reaching the destination port. The routing and repeating functions, which are unique to the arbitrated loop topology, are provided by an NL\_Port.

See also *Point-to-point topology* and *Switched fabric topology*.

**AL\_PA** Arbitrated Loop Physical Address. A unique one-byte value used to identify a port in an Arbitrated Loop topology. AL\_PAs are dynamically assigned each time the loop is initialized.

**Bandwidth** The maximum information carrying capacity of a network connection. Bandwidth is usually expressed in bits per second (bps) or bytes per second (Bps).

**Baud** A measurement of the signalling rate of a transmission line equal to the maximum number of voltage or frequency changes that can take place on the line in one second. For Fibre Channel, a signal change is equal to a single transmission bit, so baud equals bits per second.

**Bit** Binary digit. A bit is the smallest unit of computer storage. It can be one of two values: 0 or 1. Transmission rates are often expressed in bits per second (bps).

**BER** Bit Error Rate. The probability that a transmitted bit will be received in error. The bit error rate is expressed as a ratio of error bits to total number of bits.

**bps** Bits per second.

**BOP** Beginning of Partition. On tapes partitioned into logical volumes, the BOP is treated as the Beginning of Tape (BOT) for that volume. A tape has only one BOT, but has as many BOPs as it has partitions.

**BOT** Beginning of Tape. A physical location at the beginning of the recordable portion on a tape. For MammothTape technology, BOT is the region of clear leader between the leader splice to the magnetic medium and the data cartridge recognition stripe. MammothTape technology drives identify BOT optically.

**Buffer** A temporary storage area, usually in RAM. The tape drive read and write buffers act as holding areas that enable the tape drive to balance the rate at which it transfers data to or from tape with the data transfer rate of the host.

**Bus** In a network, the electrical pathway between a computer and other devices. A SCSI bus supports up to 8 or 16 devices, depending on the type of bus.

**Byte** A group of eight data bits with the most significant bit denoted as 7 and the least significant bit denoted as 0. A byte is equivalent to one alphanumeric character.

**CDB** Command Descriptor Block.

**Cleaning wheel** See *Dynamic Head Cleaner*.

**Compression** The reduction in size of data to save space. For data recorded to tape, compression can be performed either by a backup application (software compression) or by the tape drive itself (hardware compression).

**Compression ratio** The relationship between the size of the original data and its size on tape. If 100 MB of data is compressed to 50 MB on tape, its compression ratio is 2:1.

**CRC** Cyclic Redundancy Check. A complex mathematical method used to check that the data written to tape is error-free. CRC is used during the read-back check process to determine accuracy of data written to or recovered from tape.

**Data transfer rate** The transmission speed of a communications line. Tape drive transfer rates are measured in megabytes per second (MB/sec).

**Differential SCSI** See *HVD SCSI*.

**Domain** Two or more devices (nodes) connected by cables (optical or copper) that are attached to ports. The domain provides a pathway for passing commands, status, and messages. Depending on the topology used, the domain may include one or more hubs, switches, or both.

**Driver** A program that works with a computer's operating system to operate a peripheral device. A driver is required for each peripheral attached to a computer. Also referred to as a device driver.

**Dynamic Head Cleaner** A cleaning system used by MammothTape technology drives that consists of a set of stacked cloth disks attached to the end of a mechanical arm. The mechanical arm swings in toward the scanner during drive operation to allow the disks to make contact with the recording heads. The disks pull debris from the recording surface as well as debris that might travel from the sides of the heads to the recording surface.

**ECC** Error Correction Code. The incorporation of extra parity bits in stored data as it is written to tape. This error information is used during read operations to detect and correct errors. M2 integrates powerful two-dimensional Reed-Solomon error correction codes (ECC1 and ECC2) into each data block. In addition to ECC1 and ECC2, M2 uses sophisticated new multi-track ECC3 error correction algorithms to further ensure data integrity. See also *CRC*.

**E-copy** See *EXTENDED COPY*.

**EOD mark** End of Data. The end of data (EOD) mark consists of EOD blocks. These blocks are recorded directly after the last data or filemark block in a single partition to indicate that no more valid data is beyond this point on the tape.

**EPR4** Extended Partial Response Level 4. An advanced implementation of PRML that uses sophisticated mathematical models to further improve detection of closely spaced peaks in a data stream. See also *PRML*.

**Exabyte** (1) A network storage backup company that designs, manufactures, and markets industry-leading data storage products including tape drives and automated tape libraries. Exabyte is focused on the midrange application and database server market, manufacturing tape backup solutions and storage area network solutions for small, medium, and large businesses.

(2) measurement of data:

One Exabyte =

1,000 Petabytes, or

1,000,000 Terabytes, or

1,000,000,000 Gigabytes, or

1,000,000,000,000 Megabytes, or

1,000,000,000,000,000 Kilobytes, or

1,000,000,000,000,000,000 bytes

**EXTENDED COPY** A SCSI command that permits data transfer to occur between the tape drive and any magnetic disk or other tape drive connected to the Fibre Channel SAN, without the data passing through an intermediate server.

**F\_Port** See *Fabric Port*.

**Fabric** A collection of devices that provides switching and routing functions in a Fibre Channel network. See also *Switched fabric*.

**Fabric port** The port within a fabric topology that provides Fibre Channel attachment.

**Fast SCSI** A standardized SCSI signaling protocol that transfers data at up to 10 MB per second on an 8-bit bus (narrow SCSI) or up to 20 MB per second on a 16-bit bus (wide SCSI).

**FC-AL** The Fibre Channel Arbitrated Loop. The standard that governs the operation of Fibre Channel devices in an arbitrated loop topology.

**FCP** Fibre Channel Protocol. The protocol that maps SCSI-3 operations to Fibre Channel.

**Fibre Channel** A set of standards for the high speed transfer of large amounts of information. Fibre Channel supports multiple network protocols over both copper and fiber optic cabling. Fibre Channel is capable of transmitting data at 200 MB per seconds over distances of up to 10 kilometers.

**Fibre Channel port** A connection on a device that allows it to be connected to a Fibre Channel network.

**Fibre Channel to SCSI router** A device that translates between Fibre Channel and SCSI protocols so that devices on these two types of networks can communicate with each other.

**Fibre ID** See *Loop ID*.

**FLOGI** Fabric Login (FLOGI) is the mechanism used to assign Loop IDs to the tape drive when it is operating in a switched fabric.

**FL\_Port** A port within a fabric that provides attachment to an Arbitrated Loop.

**Format** Defines how data is written to the tape, including the number and position of tracks, number of bits per inch, and the recording code to be used.

**Gigabaud** In Fibre Channel, equivalent to gigabits per second.

**Gigabit interface converter (GBIC)** A standard, internal Fibre Channel connector that is hot-pluggable.

**Gigabyte (GB)** One billion bytes.

**Hard address** The AL\_PA that an NL\_Port attempts to acquire during Loop Initialization. The hard address is set using the Fibre ID switches on the back of the tabletop M2 tape drive or by setting the address bits on the SCA-2 connector on the internal tape drive.

**HBA** See *Host bus adapter*.

**Heads** See *Recording head*.

**Helical-scan recording** A magnetic tape technology developed by Exabyte Corporation. 8mm tape drives use helical-scan recording in which very narrow overlapping tracks of data are written at an acute angle to the edge of the tape. The tape moves slowly past a high-speed rotating drum containing the recording heads, resulting in gentle tape handling and a high data transfer rate.

**Host** Any type of computer that sends information or commands to a peripheral device, client, or another computer. A host typically functions as an initiator.

**Host bus adapter** A controller installed in a host computer that allows the host to communicate with a peripheral device. The adapter translates information between the peripheral and the host's internal bus. Computers require host bus adapters to communicate with SCSI and Fibre Channel devices.

**Hub** A device that acts as the central connection between other devices in a network. In a Fibre Channel network, hubs form the basis of an arbitrated loop.

**HVD SCSI** High Voltage Differential SCSI; commonly referred to as "differential" SCSI. A physical interface for a SCSI bus that allows for cable lengths of up to 82 feet (25 meters) with up to 16 devices on the bus. Unlike LVD SCSI, HVD SCSI requires additional power circuitry that makes it incompatible with single-ended or LVD SCSI devices. HVD SCSI is also more expensive to implement. See also *LVD SCSI*.

**IDRC** Improved Data Recording Capability data compression algorithms for compressing data as it is recorded. These algorithms typically offer an average compression ratio of 2:1. See also *ALDC*.

**Initiator** A SCSI device containing application clients that originate device service requests to be processed in a device server. The host computer system typically acts as the initiator of commands. It consists of the application software, the operating system, the device drivers, and a host bus adapter consisting of a node with one or more ports.

**Kilobyte (KB)** 1,024 bytes. (Also accepted as one thousand bytes.)

**LCD** Liquid Crystal Display.

**LED** Light Emitting Diode.

**LIP** Loop Initialization Primitive sequence. To begin the Loop Initialization process, a device (the tape drive) issues a Loop Initialization Primitive (LIP) sequence. When a device issues a LIP sequence on an active loop, any exchange operations in progress over the loop are temporarily suspended while the loop is initialized. Whenever possible, the suspended exchanges resume after initialization is complete.



**LISM** Loop Initialization Select Master. Loop initialization requires a temporary master to manage the process. The process of selecting a temporary loop master is called Loop Initialization Select Master (LISM).

**LBOP** Logical Beginning of Partition. On tapes partitioned into logical volumes, the LBOP is treated as the Beginning of Partition (BOP) for that volume.

**Loop** See *Arbitrated loop topology*.

**Loop ID** A 7-bit value ranging from zero to 126. The Loop ID is used to represent a port's AL\_PA on a loop. During the loop initialization process (LIP) on an arbitrated loop, the M2 tape drive obtains two Loop IDs, one for each Fibre Channel port (Loop A and Loop B). If possible, this Loop ID is the same as the hard address. See also *Hard address*.

**Loop port** A node or fabric port capable of performing Arbitrated Loop functions and protocols. FL\_Ports and NL\_Ports are examples of loop-capable ports.

**LVD SCSI** Low Voltage Differential SCSI. A physical interface for a SCSI bus that allows for cable lengths of up to 82 feet (25 meters) with two devices on the bus or 39 feet (12 meters) with up to 16 devices on the bus.

Unlike HVD SCSI, LVD SCSI does not require additional power circuitry to operate. LVD allows devices using different SCSI protocols (for example, fast SCSI and Ultra2 SCSI) to operate on the same bus. If a single-ended device is detected anywhere on the bus, all of the devices switch to single-ended mode. This capability is called "multi-mode."

See also *single-ended SCSI*, *HVD SCSI*, and *Ultra2 SCSI*.

**L\_Port** Logical Port. A logical entity that performs Arbitrated Loop specific protocols.

**Mammoth-2 (M2)** The second generation of Mammoth tape drives that provides data capacities of up to 150 GB and transfer rates of up to 30 MB per second (assuming 2.5:1 compression).

**MammothTape technology** An integrated system encompassing both tape drive design and the state-of-the-art AME media used in the tape drive. All aspects of the technology work together to optimize recording performance and data integrity.

**Megabyte (MB)** One million bytes.

**Microsecond ( $\mu$ sec)** One millionth of a second.

**Millisecond** One thousandth of a second.

**MP tape** Metal Particle tape. A media technology designed for data storage. MP tape's recording surface consists of tiny, capsule-shaped, pure metallic particles that are aligned parallel to the tape surface and secured with a binder.

**Multi-mode fiber optic** A type of fiber optic cable that uses multiple concurrent beams of light to transmit data. Multimode fiber optic cabling allows distances of up to 500 meters between devices.

**MTBF** Mean Time Between Failures. A quantitative measure used to specify the reliability of a tape drive's mechanics and electronics as a whole under specific environmental conditions, cleanings, and duty cycle. MTBF does not usually include a tape drive's head life or failures due to media problems. The duty cycle is often included in the MTBF specification.

**μm** Micrometer or micron (0.00003937 inches).

**μsec** See *Microsecond*.

**Narrow SCSI** SCSI devices can be either narrow or wide. Narrow SCSI supports 8-bit data transfers. Up to 8 devices can be connected on a narrow SCSI bus.

You can identify a narrow or wide SCSI device by its SCSI connector. A narrow device has a 50-pin connector, while a wide device has a 68-pin connector. See also *Wide SCSI*.

**Native Fibre Channel** Describes a device that can be attached directly to a Fibre Channel network. Native Fibre Channel devices have built-in Fibre Channel host bus adapters.

**N\_Port** A port within a node that provides Fibre Channel attachment.

**NL\_Port** A node port with Arbitrated Loop capabilities.

**Node** The node is the source (or destination) of information being transported. Each Fibre Channel node must support at least one upper-level command protocol that allows it to interact with other nodes. Each node must have one or more N\_Ports or NL\_Ports. The tape drive is a node that supports the SCSI command protocol.

**Non-participating mode** A mode within an NL\_Port that prevents the port from participating in loop activities. The port continues to transmit received data, but cannot arbitrate for control of the loop or originate data.

**Optical fiber** A cable with a thin glass wire core that is capable of transmitting data in the form of light pulses.

**Participating mode** A mode within an NL\_Port that allows the port to participate in loop activities. A port must have a valid AL\_PA before it can enter participating mode.

**Partition** A self-contained area on a tape that can be written and read independently. Partitions allow you to create multiple logical tapes from a single large-capacity cartridge, making for more efficient use of the media. The tape drive can quickly position to the partition containing the data you want without having to search the entire tape. MammothTape technology drives can write and read tapes containing up to 64 partitions.

**PBOP mark** Physical Beginning of Partition. The physical beginning of partition (PBOP) mark consists of a fixed number of PBOP blocks. These blocks are recorded at the beginning of each partition when you format the tape for partitions using the MODE SELECT command. Each PBOP must have an associated logical beginning of partition (LBOP).

**PEOP** Physical End of Partition. Physical end of partition (PEOP) is a virtual mark. When the tape is formatted and the tape drive determines the size of each partition, the tape drive calculates the location of PEOP and stores that information in the LBOP blocks. When the tape drive detects PEOP, the tape drive stops recording to prevent overwriting data in the next partition.

**PBOT** Physical Beginning of Tape. The point at the beginning of a tape where the clear leader is attached to the magnetic media. MammothTape technology drives use an optical sensor to detect PBOT.

**PEOT** Physical End of Tape. The point at the end of a tape at which the magnetic media is attached to the clear leader. MammothTape technology drives use an optical sensor to detect PBOT.

**Point-to-point topology** One of the three Fibre Channel network topologies. A point-to-point connection is simply two devices, such as a server and disk array, connected directly together.

See also *Arbitrated loop topology* and *Switched fabric topology*.

**Port** The socket or adapter in a device that allows connection to networks or other devices.

**Port\_Name** A unique 64-bit identifier assigned to each Fibre Channel port. See also *World-wide name*.

**PRML** Partial Response Maximum Likelihood. An advanced signal processing technology that significantly improves the accuracy and efficiency of peak detection when reading data from tape.

**Protocol** A set of rules governing transmissions that enables devices to communicate with each other. Network protocols define how data must be packaged for transmission between devices on the network.

**Read** The process of transferring data from tape to the tape drive's data buffer and from the buffer to the host.

**Recording head** A device that uses induction to "write" a data pattern onto magnetic media and then uses either inductance or magnetoresistance to "read" the data back.

**RECEIVE COPY RESULTS** A SCSI command used to return the results of a previous (or current) EXTENDED COPY command to the server that issued the EXTENDED COPY command.

**Recording format** The definition of how data is written to the tape. It defines such things as the number and position of tracks, bits per inch, and the recording code to be used

**REQ/ACK** Request/Acknowledge. A bus message sequence in which one device requests data, and the other device receiving the request acknowledges the request.

**Router** See *Fibre Channel to SCSI router*.

**SAN** Storage Area Network. A secondary network dedicated to backup and storage functions. The main purpose of a SAN is to centralize the storage function and relieve the primary network of the massive data transfers that can slow it down.

**Scanner** A drum containing the recording heads in a helical-scan tape drive. To read and write data, the scanner rotates at a high speed while the tape moves slowly past it.

**SCSI** Small Computer System Interface. A widely used set of standards for controlling computer peripherals such as disk drives, CD-ROM drives, and tape drives. SCSI is a parallel data transfer technology (8 or 16 bits are transferred simultaneously). SCSI comes in several variations that support either 8-bit (narrow) or 16-bit (wide) buses and data transfer rates from 5 to 80 MB per second.

**SCSI ID** A unique address (0–7 for narrow or 0–15 for wide) assigned to each device attached to a SCSI bus.

**Server** A program or computer that provides specific services to other programs or users. A computer that functions as a server may perform multiple functions such as delivering data to users, providing applications, and managing print jobs. A server can also be dedicated to a single function such as backing up data (backup server), delivering files (file server), managing a database (database server), or handling e-mail (mail server).

**Serverless backup** A backup operation that does not require data to be routed through a server. Serverless backup requires a network configuration, such as a SAN, in which storage and backup devices are not tied to specific servers. Intelligence built into routers or other connecting devices in the SAN query servers for information on which data needs to be backed up. These devices then initiate the movement of that data directly from storage devices to backup devices through the SAN.

**Single-ended SCSI** A physical interface for a SCSI bus that allows for cable lengths of up to 20 feet (6 meters) with up to eight devices on the bus. See also *HVD SCSI* and *LVD SCSI*.

**Single-mode fiber optic** A type of fiber optic cable that uses a single, highly focused beam of light to transmit data. Single-mode fiber optic cabling allows distances of up to 10 kilometers between devices.

**Start/stop mode** An operational mode that occurs if the host can't supply data fast enough to keep the tape drive operating in streaming mode, the drive's performance suffers. Under these conditions, the drive must operate in stop/start mode. Each time the tape drive has to wait for data from the host, it must perform a "backhitch" operation before resuming operation.

**Streaming** An operational mode that occurs when the data transfer rate to or from the host closely matches the tape drive's data transfer rate, allowing the drive to read or write data in a continuous stream.

**Switch** A device that provides multiple routes for data in a network. In Fibre Channel, switches form the basis of a switched fabric topology.

**Switched fabric topology** One of the three Fibre Channel network topologies. A switched fabric establishes multiple pathways for data across a network. Any number of devices on the network can communicate simultaneously. Bandwidth in the switched fabric network is cumulative.

See also *Arbitrated loop topology* and *Point-to-point topology*.

**TapeAlert** A standardized method for reporting errors and potential difficulties with the tape drive and media. The tape drive's internal TapeAlert firmware constantly monitors the tape drive and the media for errors and potential difficulties that could have an impact on backup quality. Any problems identified are flagged on the TapeAlert page returned by the LOG SENSE SCSI command.

**THL** Tape History Log. A special partition located between the physical beginning of tape (PBOT) and the physical beginning of partition (PBOP) of the first user partition. This log is used to store tape history and diagnostic data. The log is normally updated each time a tape is unloaded and provides a running history of the tape condition and the tape drives in which it has been used. Applications can read this log to determine tape condition before performing a write or read operation.

**Target** A SCSI device that receives SCSI commands and directs such commands to one or more logical units. The targets are devices (nodes) that are capable of receiving and processing commands from the host. Each node has at least one port associated with it.

**Terabyte (TB)** One trillion bytes.

**Termination** In SCSI, termination refers to placing a resistor (terminator) at both physical ends of the SCSI bus to prevent signal reflection.

**Topology** An interconnection scheme that allows multiple devices to communicate. For example, point-to-point, Arbitrated Loop, and switched fabric are all Fibre Channel topologies.

**Track** Linear area of media on which data is written.

**Throughput** The speed at which data can be transmitted through a network or to and from a device.

**Transfer rate** The speed that a device or computer system can transfer data.

**Ultra2 SCSI** An advanced SCSI signaling protocol that significantly increases the distance and speed at which data traveling on a SCSI bus can be transmitted. Ultra2 SCSI provides for transfer rates of up to 80 MB per second.

**Wide SCSI** SCSI devices can be either wide or narrow. Wide SCSI supports 16-bit data transfers. Up to 16 devices can be connected on a wide SCSI bus.

You can identify a wide or narrow SCSI device by its SCSI connector. A wide device has a 68-pin connector, while a narrow device has a 50-pin connector. See also *Narrow SCSI*.

**World-wide Name (WWN)** A 64-bit world-wide unique identifier assigned to Fibre Channel entities. Each Fibre Channel device is assigned one or more unique identifiers or world-wide names at the time it is built. These names stay with the device for its lifetime.

## Notes

---



# Index

---

## A

- AC power specifications
  - internal model 6-13
  - tabletop model 6-15
- access times 6-5
- acoustic noise specifications 6-16
- adaptive data buffering 3-7
- addressing, about 5-10 to 5-13
- agency standards
  - internal model 6-25
  - tabletop model 6-26 to 6-28
- air bearing, description 1-8
- air flow requirements
  - external model A-4
  - internal model 6-17
- AL\_PA
  - description 5-13
  - during loop initialization 5-13
  - in fabric Port ID 5-14
- ALDC data compression, description 3-3
- altitude specifications 6-16
- AME cartridges
  - capacities 6-4
  - cleaning requirements when used 2-25
  - compatibility 2-24
  - format determination 3-11
  - using 6-4
- AME with SmartClean cartridges
  - available lengths 6-4
  - data capacities 6-4
  - description 2-23, 3-12
  - Exabyte Recognition System 3-12
  - format determination 3-11
  - location of cleaning material 3-12
  - recognizing 2-23
  - use characteristics 3-13
  - using 3-12, 6-4
- arbitrated loop
  - addressing 5-11 to 5-13
  - description 5-7
  - dual loop support 5-10
  - maximum number of devices 1-12
  - maximum transfer rate 1-12
- asynchronous transfers 6-5
- auto-thresholding 3-7

## B

- back panel components
  - dimensional locations 2-2 to 2-3
  - internal model 1-5 to 1-6
  - tabletop model A-3 to A-5
- bit error rate 6-12
- block size 3-10
- blocks
  - gap 3-17
  - logical 3-16
  - physical 3-9
- buffering data 3-7
- bus phases (SCSI) 5-4

## C

- cables
  - requirements, internal model 2-4 to 2-5, 2-10 to 2-12
  - requirements, tabletop model A-10
  - See also* Fibre Channel cable
  - See also* SCSI cable
- capacity of the tape drive 6-4
- cartridge loader life 6-9
- cartridges
  - cleaning 2-25
  - data capacities 6-4
  - loading and unloading 2-24
  - types to use 2-23
  - using metal particle tape 2-24
  - See also* AME cartridges
  - See also* AME with SmartClean cartridges
- cleaning LED indicator 2-18
- cleaning the tape drive 2-25
- cleaning wheel
  - See* dynamic head cleaner
- code level, displayed on LCD 2-19
- color
  - internal model 1-4
  - tabletop model A-5
- command protocol 4-1
- commands supported, SCSI-2 4-2 to 4-5
  - See also* SCSI commands
- communication interface 4-1

compatibility, data format 3-19  
 compression mode, displayed on LCD 2-19  
 conditioning heads, description 1-8  
 conducted radio frequency field  
   immunity 6-28  
 connectors  
   dimensional locations 2-2 to 2-3  
   internal tape drive 1-5 to 1-6  
   monitor port 2-14  
   tabletop tape drive A-3 to A-5  
 cooling requirements 6-16 to 6-19  
 cyclic redundancy check (CRC) 3-3

## D

data block structure, Mammoth-2  
   format 3-10  
 data buffering 3-7  
 data cartridges  
   *See* cartridges  
 data compression  
   ALDC 3-3  
   average compression ratio 3-3  
   data flow 3-2  
   default algorithm 3-3  
 data decompression  
   ALDC 3-6  
   data flow 3-5  
   default algorithm 3-6  
   IDRC 3-6  
 data flow 3-2 to 3-3  
 data formats, read/write compatibility 3-19  
 data integrity 6-11  
 data recording, helical scan 3-9  
 data reliability 6-11  
 data transfer rate 6-5  
 DC voltages 6-13  
 device addressing 5-10 to 5-13  
 differential SCSI interface 1-11, 5-1 to 5-3  
 dimensions  
   internal model 6-2 to 6-3  
   shipping cartons 6-23 to 6-24  
   tabletop model 6-2 to 6-3  
 domain 5-9  
 drive ready states 6-7  
 dual loop support 5-10  
 dynamic head cleaner  
   affect on manual cleaning cycle 2-25  
   description 1-7  
   operation 2-25

## E

E-copy, M2 implementation 2-26, 4-9  
 electrical fast transient/burst (EFT)  
   immunity 6-27  
 electromagnetic interference  
   *See* radiated emissions standards  
 electrostatic discharge (ESD) 6-27  
 enclosure for the tape drive  
   cooling requirements 6-17  
   description A-1 to A-6  
   specifications 6-14 to 6-28  
 end of data (EOD) 3-18  
 environmental specifications  
   internal model 6-16 to 6-22  
   tabletop model 6-19  
 EPR4 signal processing, description 3-7  
 error conditions  
   displayed on LCD 2-20  
   displayed on LEDs 2-18  
 error correction codes (ECC), description 3-4  
 error detection and recovery 3-3  
 error rate 6-12  
 ESD  
   limits, tabletop model 6-27  
   precautions for Fibre Channel front panel  
     and GBICs 2-1  
   protection provided by mounting 2-4  
 EXTENDED COPY command 4-9  
 external tape drive  
   *See* tabletop tape drive

## F

fabric login 5-14  
 fan, tabletop model A-4  
 features 1-1 to 1-8  
 feet, tabletop model A-4  
 Fibre Channel  
   description 1-12  
   device addressing 5-10 to 5-13  
   dual loop support 5-10  
   fabric login 5-14  
   interface description 5-6 to 5-14  
   loop initialization 5-13  
   SCA-2 connector 1-6  
   topologies 5-6 to 5-8  
   world-wide names 5-11  
 Fibre Channel cable  
   pinout for SCA-2 connector 2-10 to 2-12  
   requirements, tabletop model A-10

Fibre ID  
 reserved addresses [A-8](#)  
 setting for the internal tape drive [2-13](#)  
 setting for the tabletop tape drive [A-8](#)  
 switch location [A-4](#)  
*See also* Loop ID  
 file search speed [6-7](#)  
 filemarks [3-17](#)  
 format of tape [3-11](#)  
 formats  
*See* data formats  
 front panel  
 internal model [1-4](#)  
 tabletop model [A-2](#)  
 front panel precautions for ESD, Fibre Channel [2-1](#)

## G

gap bytes [3-17](#)  
 GBIC (gigabit interface converter)  
 description [A-5](#)  
 optical specifications [A-10](#)  
 precautions for ESD [2-1](#)  
 glossary [B-1](#) to [B-13](#)  
 grounding tab or hole  
 location [1-5](#)  
 using [2-4](#)  
 grounding the tape drive [2-4](#)

## H

hard addressing [5-12](#)  
 head life [6-9](#)  
 heat dissipation requirements [6-17](#)  
 helical scan technology  
 air bearing [1-8](#)  
 description [3-9](#)  
 high-speed search [6-7](#)  
 high-voltage differential (HVD) SCSI  
 description [1-11](#), [5-2](#)  
 maximum cable length [A-9](#)  
 terminator [A-10](#)  
 host computer [5-9](#)  
 hosts, support for multiple [5-1](#)  
 humidity specifications  
 internal model [6-16](#)  
 tabletop model [6-19](#)

## I

IDRC compressed data, read  
 compatibility [3-6](#)  
 initiator [5-9](#)  
 installation requirements  
 internal model [2-2](#) to [2-16](#)  
 tabletop model [A-7](#) to [A-11](#)  
 internal components [1-6](#) to [1-8](#)  
 internal tape drive  
 description [1-3](#)  
 labels [1-9](#)  
 operating environment [6-17](#) to [6-18](#)  
 power specifications [6-13](#) to [6-14](#)  
 shipping specifications [6-22](#) to [6-23](#)  
 size and weight [6-2](#)  
 specifications [6-1](#) to [6-25](#)

## J

jumpers, SCSI ID [2-12](#)

## L

labels  
 internal model [1-9](#)  
 tabletop model [A-6](#)  
 LCD  
 changing the displayed language [2-19](#)  
 description of messages [2-19](#) to [2-21](#)  
 list of foreign language  
 messages [2-21](#) to [2-23](#)  
 location and description [2-19](#)  
 LEDs  
 general description [1-4](#)  
 location on tabletop drive [A-2](#)  
 power-on indicator, tabletop model [A-2](#)  
 tape drive states [2-17](#) to [2-18](#)  
 loading cartridges [2-24](#)  
 logical beginning of partition (LBOP) [3-15](#)  
 logical blocks [3-16](#)  
 logical end of partition (LEOP) [3-15](#)  
 logo area for tabletop model [A-2](#)  
 Loop ID  
 definition [5-11](#)  
 reserved addresses [2-13](#)  
 loop initialization [5-13](#)  
 Loop Initialization Primitive (LIP) [5-13](#)  
 Loop Initialization Select Master (LISM) [5-13](#)

- loop topology
  - See* arbitrated loop
- low-voltage differential (LVD) SCSI
  - description 1-11, 5-2
  - maximum cable length A-9
  - terminator A-10
  - using with single-ended SCSI 5-2

## M

- Mammoth-2 format
  - data block structure 3-10
  - description 3-11 to 3-18
  - track structure 3-10
- maximum transfer rate 6-5
- mean time between failures 6-9
- mean time to repair for tabletop model 6-10
- mechanical components 1-7 to 1-8
- messages supported, SCSI 5-5
- monitor port
  - connector 2-14
  - description 1-5
  - internal model 1-5
  - tabletop model A-5
- motion threshold 3-8
- mounting holes
  - description 2-14
  - location 2-15
  - using 2-16
- mounting the tape drive 2-14 to 2-16
- multi-track ECC3, description 3-4

## N

- narrow SCSI, description 5-3
- network, topologies supported 5-6 to 5-8
- NL\_Port, characteristics 5-10
- node, definition 5-9
- noise specifications, tabletop model 6-16

## O

- operating environment
  - internal model 6-17 to 6-18
  - tabletop model 6-19
- operating the tape drive 2-17 to 2-25

## P

- packing materials 6-22
- parity checking, SCSI bus 5-1
- particulate contamination limits 6-20
- partitions
  - data area 3-15
  - formats 3-16
  - markers 3-14 to 3-15
- PC cards in the tape drive 1-6 to 1-7
- performance specifications 6-5 to 6-8
- physical beginning of partition (PBOP) 3-14
- physical block size 3-10
- physical end of partition (PEOP) 3-15
- pin assignments
  - SCA-2 Fibre Channel
    - connector 2-10 to 2-12
  - SCSI connectors 2-6 to 2-9
- point-to-point topology 5-6
- port, definition 5-9
- power connector
  - internal model 1-6, 2-3 to 2-4
  - tabletop model A-4
- power consumption
  - internal model 6-14
  - tabletop model 6-15
- power cord, tabletop model A-11
- power specifications
  - internal model 6-13 to 6-14
  - tabletop model 6-14 to 6-15
- power switch, tabletop model A-4
- printed circuit cards 1-7
- PRML signal processing, description 3-6

## R

- radiated emissions standards 6-25
- radiated field (RF) immunity 6-27
- read access time 6-5
- read compatibility 3-19
- read operations 3-5
- read reliability 6-12
- read-after-write checking 3-4
- RECEIVE COPY RESULTS command 4-10
- reconnect threshold 3-8
- Reed-Solomon error correction,
  - description 3-4
- regulatory agency standards and
  - compliance 6-25 to 6-28
- related publications xiv to xv

- reliability specifications
  - cartridge loader life 6-9
  - data integrity 6-11
  - data reliability 6-11
  - head life 6-9
  - MTBF 6-9
  - service life 6-9
- reselection timeout 6-6
- resetting the tape drive 2-25
- rewind tape speed 6-7

## S

- safety agency notices and standards
  - internal tape drive 6-25
  - tabletop model 6-26 to 6-28
- scanner design features 1-8
- screws for mounting 2-16
- SCSI
  - bus phases 5-4
  - command protocol
    - overview 4-2 to 4-10
  - commands supported 4-2
  - communication interface
    - overview 5-1 to 5-5
  - fast synchronous mode 1-11
  - high-voltage differential (HVD),
    - wide 1-11, 5-2
  - low-voltage differential (LVD), Ultra2,
    - wide 1-11, 5-2 to 5-3
  - single-ended 5-2
- SCSI bus
  - narrow 5-3
  - physical interface 5-1 to 5-3
  - wide 5-3
- SCSI cable
  - impedance 2-5
  - primary conductor 2-5
  - specifications for internal
    - model 2-4 to 2-5
  - specifications for tabletop model A-9
- SCSI commands
  - all supported commands 4-3 to 4-5
  - EXTENDED COPY 4-9
  - RECEIVE COPY RESULTS 4-10
- SCSI configuration
  - available 1-10
  - displayed on LCD 2-19
  - label 1-9, A-6
  - supported 5-1
- SCSI connector
  - internal model 1-6, 2-5 to 2-9
  - pin assignments 2-6 to 2-9
  - tabletop model A-5
- SCSI ID
  - connector 1-6
  - displayed on LCD 2-19
  - jumpers 2-12
  - label 1-10
  - remote switch requirements 2-13
  - setting for internal model 2-12 to 2-13
  - setting for tabletop model A-8
  - switch description for tabletop
    - model A-4
- SCSI interface description 5-1 to 5-5
- SCSI terminator
  - internal model 2-10
  - tabletop model A-10
- SCSI-2, description 5-2
- serial interface 1-5
- serial number of tape drive
  - displayed on LCD 2-19
  - label 1-9
- serial port
  - internal model 1-5
  - tabletop model A-5
- serverless backup 2-26
- service life 6-9
- setmarks 3-18
- shipping specifications
  - internal model 6-22 to 6-23
  - tabletop model 6-24
- shock specifications 6-21
- short filemarks 3-18
- single-ended SCSI interface
  - data transfer rates 6-5
  - impact on performance 2-8
  - maximum cable length A-9
  - terminator A-10
  - using a narrow bus 2-8
  - wide 5-2
- sleep states 6-8
- SmartClean cartridge
  - See AME with SmartClean cartridges
- soft addressing 5-12
- speed of tape
  - file search 6-7
  - read or write 6-6
  - rewind 6-7
  - search 6-7
- start/stop mode 3-8
- storage capacity 6-4

storage specifications 6-22  
 streaming mode 3-7  
 surge immunity 6-28  
 switched fabric topology 5-8  
 synchronous transfers 6-5

**T**

tabletop tape drive  
   description 1-3  
   features A-1  
   operating environment 6-19  
   power specifications 6-14 to 6-15  
   shipping specifications 6-24  
   size and weight 6-2  
   specifications 6-1 to 6-28

tape  
  *See* cartridges

tape drive  
  *See* internal tape drive  
  *See* tabletop tape drive

tape format  
  determined by tape drive 3-11  
  logical 3-11  
  physical 3-10  
  *See also* Mammoth-2 format

tape history log 4-9

tape path, environmental requirements 6-17

tape speed  
  during read or write 6-6  
  during rewind 6-7  
  during search 6-7

TapeAlert  
  description 4-6 to 4-8  
  flags used 4-7 to 4-8  
  Log Sense page 4-9

TapeSafe, description 1-8

target 5-9

temperature specifications  
  cooling requirements 6-16 to 6-19  
  internal model 6-16  
  tabletop model 6-19

terminator requirements  
  internal model 2-10  
  tabletop model A-10

timeout for reselection 6-6

topologies supported 5-6 to 5-8

track structure 3-11

transfer rate 6-5

transportation specifications 6-22

**U**

Ultra2 SCSI interface  
   data transfer rates 6-5  
   description 1-11, 5-2 to 5-3  
   performance impact of a single-ended bus 2-8

unload button  
  description 1-4  
  using to eject cartridge 2-24  
  using to reset the tape drive 2-25

**V**

vibration specifications 6-21

voltage dips, interruptions, and variations  
  immunity 6-28

voltage specifications  
  internal model 6-13  
  tabletop model 6-14

**W**

watts consumed 6-14

weight  
  internal model 6-2  
  shipping 6-23 to 6-24  
  tabletop model 6-2

wide SCSI, description 5-3

world-wide names  
  description 5-11

write access time 6-5

write compatibility 3-19

write operations 3-1 to 3-4

write reliability 6-12

# Contacting Exabyte

You can contact Exabyte using any of the following methods:

<b>For technical support</b>	
Exabyte Technical Support	1-800-445-7736
	1-303-417-7792
	1-303-417-7160 (fax)
e-mail	support@exabyte.com
World Wide Web	www.exabyte.com
<b>To order supplies and accessories</b>	
	1-800-774-7172 or 1-800-392-8273
<b>To return equipment for service</b>	
Exabyte Service	1-800-445-7736
	Scotland: +44-1324-564564
e-mail	service@exabyte.com

**Note:** If it is more convenient to your location, contact Exabyte Technical Support in Europe at the following numbers:

Phone: +31-30-254-8890

Fax: +31-30-258-1582