

Magstar MP 3570 Tape Subsystem



Introduction and Planning Guide

C-Series Models

Magstar MP 3570 Tape Subsystem



Introduction and Planning Guide

C-Series Models

Note

Before using this information and the product that it supports, be sure to read the general information under "Appendix. Notices" on page 55.

Third Edition (September 1999)

| This edition, GA32-0392-02, is a revision to GA32-0392-01, which is now obsolete. Changes or additions are indicated by a vertical line to the left of the change.

© **Copyright International Business Machines Corporation 1998, 1999. All rights reserved.**

US Government Users Restricted Rights – Use, duplication or disclosure restricted by GSA ADP Schedule Contract with IBM Corp.

Contents

Figures	vii
Preface	ix
How to send your comments	ix
Organization	ix
Magstar MP Publications	x
RISC System/6000 Publications	x
AS/400 Publications.	xi
Netfinity and PC Server Publications	xi
Related Information	xi
Related Software Information	xi
Web Site Information	xi
Summary of Changes	xiii
Third Edition	xiii
Chapter 1. Introduction	1
Magstar MP (Multi-Purpose) Tape Subsystem	1
Compatibility with other Magstar MP Tape Drives	5
Model Conversions	6
Magstar MP Bar Code Reader	6
Magstar MP Fast Access Linear Tape Cartridges	7
Bar Code Format.	9
Cartridge Magazine	10
Operator and Service Message Interface	11
Model C00	11
Models C01, C02, C11, C12, C21, and C22	11
Library Modes of Operation	13
Random Mode.	13
Automatic (Sequential) Mode	13
Manual (Sequential) Mode	14
Library Configurations	15
Base Configuration Modes of Operation	15
Split Configuration Modes of Operation	15
SCSI Medium Changer Addressing for Base and Split Configuration	16
Performance	17
Software Support.	18
Chapter 2. Standard Functions and Features	19
Standard Functions	19
Feature Codes	20
Device Orientation	21
Chapter 3. Planning Considerations	23
Planning for Supplies and Equipment	23
Planning for Software Support	25
Planning for Operator Training	25
Planning for Installation	25
End of Life (EOL) Plan.	26
Special Application Considerations	27
Status and Sense Bytes	27
Update in Place	27
Read/Write Buffering	27

Device-Dependent Parameters	28
Forward/Backward Space File	28
Data Security Erase Operation	28
Data Compression	28
Planning for Operations	29
Data Compression Capability	29
Planning for Data Migration	30
Developing a Data-Migration Sequence	31
Developing a Data-Migration Strategy	32
Data Migration Tasks	32
Verifying Data Migration	33
Chapter 4. Site Planning	35
Physical Specifications	35
Subsystem Component Specifications	36
Model C00	36
Model C01 or C02	37
Model C11 or C12 (Rack Mount)	38
Model C21 or C22 Rack Mount (Netfinity)	38
Power Characteristics	39
In-Rush Current	39
Power Control	39
Power Cords, Plugs, and Receptacles	40
Environmental Specifications	44
Cooling Requirements	44
Product Environment	44
Acoustical Characteristics	44
Chapter 5. SCSI Configuration	45
SCSI Physical Interface Characteristics	45
Bus Termination	45
SCSI Bus Jumper	45
SCSI Features and Cables	46
RISC System/6000 Controller Features 2409, 6207, or 6209	48
RISC System/6000 Controller Feature 2412 or 2416	48
RISC System/6000 Controller Feature 2420	48
AS/400 System Feature 2729, 6501, or 6534	50
IBM Netfinity and PC Servers	50
Other Intel-Based Systems	50
Hewlett Packard	50
Sun Solaris	50
Connecting the Magstar MP to Multiple Systems	51
RS/6000	51
AS/400	51
Chapter 6. Planning Tasks and Checklists	53
Planning Personnel	53
Task Assignments	53
Checklists	54
Configuration Planning	54
Site Planning	54
Appendix. Notices	55
Safety Notices	56
Danger Notices	56
Caution Notices	57

Attention Notices	57
Possible Safety Hazards	57
Environmental Notices	58
Product Recycling	58
Environmental Design	58
End of Life (EOL) Plan.	58
Terminology.	58
Trademarks.	58
IBM Agreement for Licensed Internal Code	59
Actions You May Not Take	60
Communications Statements	61
Statement of Limited Warranty	63
Glossary	67
Index	71
Readers' Comments — We'd Like to Hear from You.	75

Figures

1. Magstar MP Model C00	2
2. Magstar MP Models C01, C02, C11, C12, C21, and C22	2
3. Magstar MP Fast Access Linear Tape Cartridge	7
4. Magstar MP C-Format XL Tape Cartridge Labels	9
5. Magstar MP Cartridge Magazine (Viewed from the Operator Side).	10
6. Model C00 Operator Panel	11
7. Magstar MP Library Front Panel Assembly	12
8. Receptacle Connector for RussellStoll 3743U-2 or 3913U-2	40
9. Power Plugs	43
10. RISC System/6000 SCSI Cable Attachment to Host Systems.	46
11. AS/400 SCSI Cable Attachment to Host Systems	46

Preface

This publication contains planning, installation, and migration information for the IBM® Magstar® MP (Multipurpose) 3570 Tape Subsystem.

How to send your comments

Request for IBM publications should be made to your IBM representative or to the IBM branch office serving your locality. If you request publications from the address given below, your order will be delayed because publications are not stocked there.

Your feedback is important in helping to provide the most accurate and high-quality information. A Reader's Comment Form is provided at the back of this publication. Either mail the form, or fax it to 520-799-2906. If the form has been removed, comments may be addressed to:

IBM Corporation
Department 61C
9000 South Rita Road
Tucson, Arizona 85744-0001, U.S.A.

Or you can send your comments by email to:

- IBMLink from U.S.A.: STARPUBS at SJEVM5
- IBMLink from Canada: STARPUBS at TORIBM
- IBM Mail Exchange: USIB3VVD at IBMMAIL
- Internet: starpubs@vnet.ibm.com

Be sure to include the name of the book, the part number of the book, the version of the product, and, if applicable, the specific location of the text you are commenting on (for example, a page number or table).

When you send information to IBM, you grant IBM a nonexclusive right to use or distribute the information in any way it believes appropriate without incurring any obligation to you.

Organization

The information in this book is organized as follows:

- "Chapter 1. Introduction" on page 1 provides an overview of the Magstar MP 3570 Tape Subsystem, summarizes its primary applications, available models, and components, describes the Magstar MP Fast Access Linear Tape cartridges, and outlines the cartridge magazine, library modes of operation, library configurations, performance considerations and software support available for the subsystems.
- "Chapter 2. Standard Functions and Features" on page 19 describes standard functions and feature codes of the Magstar MP 3570 Tape Subsystem.
- "Chapter 3. Planning Considerations" on page 23 discusses supplies and equipment, software support, operator training, application-related topics, operation-related topics, and data migration to the Magstar MP 3570 Tape Subsystem.

- “Chapter 4. Site Planning” on page 35 describes physical specifications, power characteristics, environmental specifications, cooling requirements, and acoustical considerations.
- “Chapter 5. SCSI Configuration” on page 45 discusses the SCSI physical interface characteristics, configuration, and cabling issues.
- “Chapter 6. Planning Tasks and Checklists” on page 53 discusses task assignments, configuration planning, and site planning.
- “Statement of Limited Warranty” on page 63 contains the IBM warranty statement for IBM Magstar MP 3570 Tape Subsystem.
- “Glossary” on page 67 defines the terms, abbreviations, and acronyms that are used in this publication.
- “Index” on page 71 includes keywords and terms to help retrieve information in this publication.

Magstar MP Publications

For additional information about the Magstar MP 3570 Tape Subsystem, see:

- *IBM Magstar MP 3570 Tape Subsystem Operator Guide C-Series Models*, GA32-0393
- *IBM Magstar MP 3570 Tape Subsystem Hardware Reference C-Series Models*, GA32-0394
- *Magstar MP 3570 Tape Subsystem Maintenance Information C-Series Models*

For related information about the Magstar MP 3575 Tape Library Dataserver, see:

- *Magstar MP 3575 Tape Library Dataserver, Introduction and Planning Guide*, GA32-0380
- *Magstar MP 3575 Tape Library Dataserver, Operator Guide*, GA32-0381
- *Magstar MP 3575 Tape Library Dataserver, Hardware Reference*, GA32-0382
- *Magstar MP 3575 Tape Library Dataserver, Maintenance Information for Model L06*
- *Magstar MP 3575 Tape Library Dataserver, Maintenance Information for Models, L12, L18, L24, and L32*

RISC System/6000 Publications

For additional information about RISC System/6000 systems, see:

- *RISC System/6000 Getting Started: Using RISC System/6000*, GC23-2521
- *RISC System/6000 Getting Started: Managing RISC/6000*, GC23-2378
- *RISC System/6000 V4 Problem Solving Guide*, SC23-2606
- *RISC System/6000 V4 Message Guide, & Reference*, SC23-2641
- *RISC System/6000 Planning for System Installation*, SA38-0508
- *RISC System/6000 Adapters, Devices, and Cable Information for Multiple Bus Systems*, SA38-0516
- *Adapters, Devices, and Cable Information for Micro Channel[®] Bus Systems*, SA23-2764

AS/400 Publications

For additional information about AS/400 systems, see:

- *AS/400 Physical Planning Guide and Reference*, GA41-9571
- *AS/400 Control Language Reference*, SC41-0030
- *AS/400 Service: Service Functions*, SY44-3902
- *AS/400 System Operation*, SC41-3203
- *AS/400 Physical Planning Reference*, SA41-3109
- *AS/400 Physical Planning Summary*, SX41-3108
- *AS/400 Control Language Reference*, SC41-0030
- *AS/400 Security Concepts and Planning*, SC41-8083
- *AS/400 System/370™ Connectivity*, GG24-3336
- *Automated Tape Library Planning and Management Guide* Version 3, SC41-3309
- *Automated Tape Library Planning and Management Guide* Version 4, SC41-5309

Netfinity and PC Server Publications

- *Netfinity Rack Planning Installation Guide*, S24L-8055
- *IBM Netfinity Rack Solutions*, G221-6110
- *IBM Netfinity Systems Management*, G221-6111
- *IBM PC Servers Rack HMM Type 9306*, S83H-9585

Related Information

For related information about the Magstar MP 3570 Tape Subsystem, see:

- *American National Standard Institute (ANSI) Small Computer System Interface-2 (SCSI-2)*, X3.131-1994
- *Care and Handling of Computer Magnetic Storage Media* by S. G. Geller, National Bureau of Standards Special Publication 500-101, for sale by the Superintendent of Documents, U.S.A. Government Printing Office, Washington, DC 20402
- *External Devices Translated Safety Notices*, SA26-7192
- *IBM General Information Installation Manual—Physical Planning*, GC22-7072
- *9309 Rack Enclosure General Information and Site Preparation*, GA24-4103
- *7015 Installation and Service Guide*, SA23-2628

Related Software Information

For information about software related to the Magstar MP 3570 Tape Subsystem, see:

- *IBM SCSI Tape Drive, Medium Changer, and Library Device Drivers Installation and User's Guide*, GC35-0154

Additional publications may be ordered as required for training.

Web Site Information

The following Web sites can be used as an alternate resource for questions and/or comments.

<http://www.pc.ibm.com>

<http://www.pc.ibm.com/support/>

<http://www.storage.ibm.com/>

Summary of Changes

The summary of changes contains specific release updates to this book. All significant changes are marked in the text by revision bars (|) in the left margin. The following sections describe the specific publication updates made to the book.

Third Edition

This edition contains information on the Magstar 3570 Tape Subsystem which has been enhanced to deliver extended length higher cartridge capacity. Magstar MP Model C drives now have the capability to use not only the C-Format and B-Format cartridges, but also the C-Format XL cartridges. This makes the Magstar MP Model C drives capable of 7 GB native capacity (21 GB with 3:1 compression).

Chapter 1. Introduction

This section provides an overview of the IBM® Magstar® MP 3570 Tape Subsystem, summarizes its primary applications, available models, and components, describes the Magstar MP Fast Access Linear Tape cartridges, and outlines the cartridge magazine, library modes of operation, and performance considerations.

Magstar MP (Multi-Purpose) Tape Subsystem

The Magstar MP 3570 Tape Subsystem models are compact, high-capacity, integrated storage devices that are available as stand-alone or rack-mounted units. The subsystems are well-suited for a variety of applications and are thus referred to as Magstar MP (Multi-Purpose) units.

Note: The 3570 Models C21 and C22 emulate 3570 Models C11 and C12.

The Magstar MP 3570 Tape Subsystem is attached to host processors that use the Small Computer System Interface (SCSI-2). It is intended for use on mid-range systems that require reliable tape storage support for backup, restore, archive, and data interchange operations, as well as applications that require rapid data access or high data capacity. These systems include, but are not limited to the RISC System/6000®, RS/6000® SP™, AS/400® systems, Sun systems, HP-UX systems, IBM PC Servers, Netfinity systems, and other Windows NT® systems.

In addition, the Magstar MP 3570 Tape Subsystem may be used on a variety of systems through support of leading storage management offerings. See “Software Support” on page 18.

The technology in the Magstar MP 3570 Tape Subsystem is designed to fit current and emerging tape applications primarily when automatic tape handling is desired.

The Magstar MP 3570 Tape Subsystem may be used to:

- Create tape archive and retrieve files
- Back up and restore systems
- Store large, sequential application data sets
- Store temporary data sets
- Satisfy off-site data storage requirements for disaster recovery
- Support hierarchical storage
- Function as network server storage
- Store mixed digital libraries
- Support image processing
- Support I/O intensive data recall operations when multi-user access is required

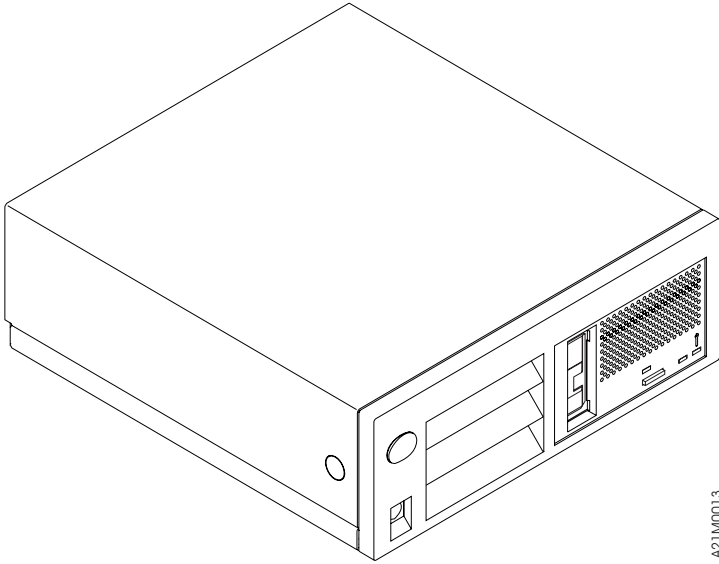

A21M0013

Figure 1. Magstar MP Model C00

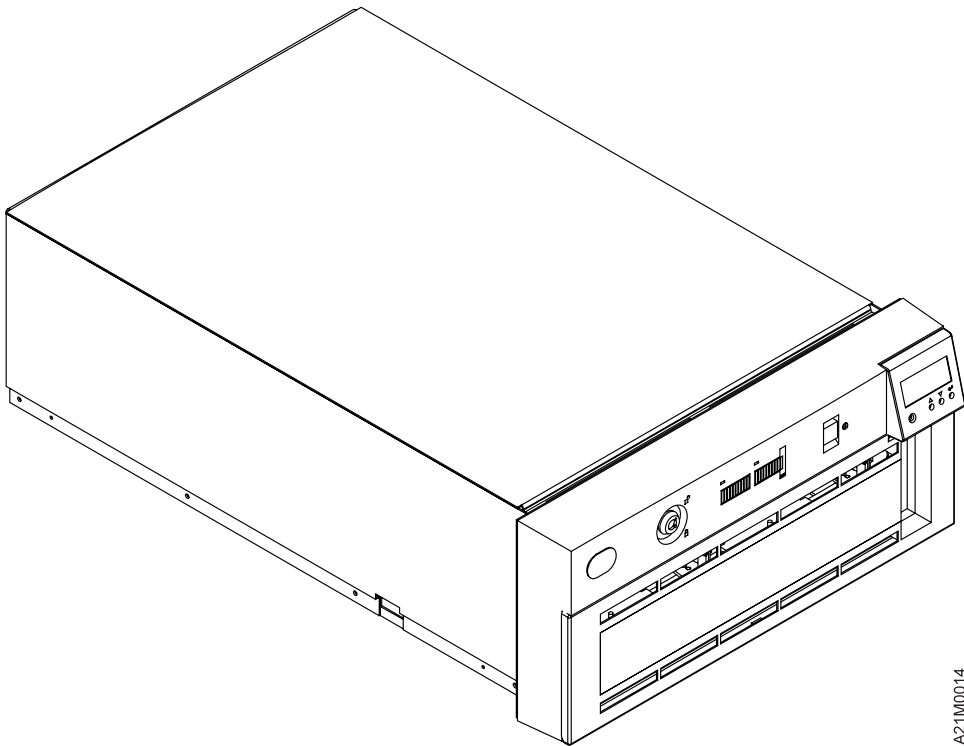

A21M0014

Note: Model C21 and C22 are modified to fit in the Netfinity rack.

Figure 2. Magstar MP Models C01, C02, C11, C12, C21, and C22

Each tape drive in a Magstar MP Tape Subsystem provides:

- High speed data transfer. (See “Performance” on page 17.)
- Block level access to data
- Automatic data buffering to balance system read/write speed
- High streaming and start/stop performance

Low-cost external storage of data allows for random retrieval of infrequently used data. These applications require access to archived data, such as financial and medical records where large storage facilities are costly. The Magstar MP Tape Subsystem allows users to keep more data available for longer periods. It also supports automated backup storage for mid-range systems or UNIX® (or AIX) LAN (local area network) servers that have large disk capacity or need unattended storage capacity for multiple volume backup. It is designed to be an efficient, low-cost storage solution by using the cost advantages of tape over disk and optical media.

The Magstar MP Tape Subsystem is available as a table-top, stand-alone, drive-only unit (Model C00) (see Figure 1) or as library Models C01, C02, C11, C12, C21, and C22 (see Figure 2). Models C01 and C02 are stand-alone library units, and Models C11, C12, C21, and C22 are rack-mounted library units. Models C01, C11, and C21 have a single tape drive, and Models C02, C12, and C22 have two tape drives.

Note: The Magstar MP Tape Subsystem Models C21 and C22 are designed only for installation in the IBM Netfinity rack or the NETBAY22 rack.

All of the Magstar MP units use the Magstar MP Fast Access Linear Tape cartridges with longitudinal serpentine recording. These cartridges use a unique design that is approximately one half the size of IBM 3480, 3490, or 3590 tape cartridges. This cartridge style provides two tape spools with mid-point load for fast access to the metal particle media. See “Magstar MP Fast Access Linear Tape Cartridges” on page 7 for additional details.

There are three version, or formats, of 3570 tape cartridges:

- B-Format (original)
- C-Format
- C-Format XL (eXtended Length)

The B-Format cartridge is fully read/write compatible between all Magstar MP tape drives. The C-Format cartridge enables the performance features of the Magstar MP 3570 C-Series Tape Subsystem. The C-Format XL cartridge increases the data capacity from 5GB to 7GB native, and 21GB with 3:1 data compression (1 gigabyte equals 1 000 000 000 bytes). See “Compatibility with other Magstar MP Tape Drives” on page 5 and “Performance” on page 17 for additional details.

Model C00 consists of one tape drive, the integrated microprocessor control unit, and all necessary power and cooling components. The unit attaches to a host processor through a differential SCSI-2 channel adapter. The integrated control unit contains the electronics and microcode for reading and writing data. The control unit functions include management of the data buffer, error recovery procedures, and the control of all tape drive operations and some channel operations. The Model C00 tape drive contains a compact loading mechanism that handles the Magstar MP Fast Access Linear Tape cartridges. The operator communications and the message interface are handled by a combination of three LED indicators.

Models C01, C02, C11, C12, C21, and C22 each contain two removable 10-cartridge magazines and use a cartridge loading and transport mechanism to move the tapes to and from the storage magazines and the tape drive. Each library unit has an operator panel with buttons and a display. The operator panel is the interface for all operator functions. Each library unit can operate in automatic, manual, or random mode (see “Library Modes of Operation” on page 13). Models C02, C12, and C22 may operate in Base Configuration or Split Configuration as selected in the operator menu (see “Library Configurations” on page 15). With two magazines of cartridges, the Magstar MP can provide up to 420GB of online data capacity with a data transfer rate of up to 54GB per hour at maximum compression. Dual-drive Models C02, C12, and C22 can provide up to double this data transfer rate (up to 108GB per hour at maximum compression).

A standard bar code reader can improve application performance for library models. When the host re-inventories the cartridges, it can take several minutes for the host to mount each cartridge in a drive and read the volume serial number identification from the tape in a full library. A bar code reader eliminates the need to load each cartridge in a drive. This feature is included on all Magstar MP C-Series libraries and provides an efficient way to inventory cartridges in the library.

The cleaning function allows the Magstar MP to maintain drive operating efficiency. The need to clean the tape head is determined by microcode. For Model C00, the Clean LED flashes to prompt the operator to load the cleaning cartridge (see Figure 6 on page 11). The cleaning cartridge is automatically ejected when cleaning is complete. For the library models, the cleaning cartridge is stored inside the unit. Options are available on the operator panel to use the cleaning cartridge.

Table 8 on page 35 shows the physical specifications of the Magstar MP 3570 Tape Subsystem. Table 1 lists the available Magstar MP models (device type 3570).

Table 1. Magstar MP Tape Subsystem Models (Device Type 3570)

Model	Type	Drives	Color	Cartridges
C00	Stand-alone, drive-only unit (see Figure 1)	1	Black	1
C01	Stand-alone library unit (see Figure 2)	1	Black	Up to 20
C02	Stand-alone library unit (see Figure 2)	2	Black	Up to 20
C11	Rack-mounted library unit (see Figure 2)	1	Black	Up to 20
C12	Rack-mounted library unit (see Figure 2)	2	Black	Up to 20
C21	Rack-mounted library unit (Netfinity only) (see Figure 2)	1	Black	Up to 20
C22	Rack-mounted library unit (Netfinity only) (see Figure 2)	2	Black	Up to 20

Compatibility with other Magstar MP Tape Drives

The Magstar MP C-Series tape drive can be distinguished from the Magstar MP B-Series tape drive by the color of the unload button on the drive front panel. The C-Series unload button is green while the B-Series unload button is blue. In order to distinguish between the different versions of tape cartridges, see “Magstar MP Fast Access Linear Tape Cartridges” on page 7.

The original B-Format tape cartridges can be written, read, and interchanged between Magstar MP 3570 B-Series Tape Subsystems, Magstar MP 3570 C-Series Tape Subsystems, and all tape drives in the Magstar MP Tape Library Dataserver.

The C-Format and C-Format XL tape cartridges can only be written, read, and interchanged between Magstar MP 3570 C-Series Tape Subsystems and the Magstar MP Model C Tape Drives feature of the Magstar MP Tape Library Dataserver. The C-Format and C-Format XL tape cartridges cannot be used in Magstar MP 3570 B-Series Tape Subsystems or in Magstar MP 3570 Model B1A tape drives in a Tape Library Dataserver.

Note: A particular level of microcode or higher is required to be able to use the C-Format XL cartridges. If the required level of microcode is loaded, a label, which reads XL READY, will be posted on the rear of the unit (next to the serial number label).

When B-Format cartridges are used in the C-Series tape drives, the tape drives operate with better performance than the B-Series tape drives. Even higher performance is achieved by using C-Format or C-Format XL tape cartridges (see “Performance” on page 17).

Table 2. Compatibility with other Magstar MP Tape Drives

Description	B-Format Cartridge	C-Format Cartridge	C-Format XL Cartridge
3570 B-Series Tape Drive	Supported	Not supported	Not supported
3570 C-Series Tape Drives	Supported	Supported	Supported if Feature Code 2007 or 9007 is installed
3575 with 3570 Model B1A Tape Drive(s)	Supported	Not supported	Not supported
3575 with Magstar MP Model C Tape Drive(s)	Supported	Supported	Supported if Feature Code 2007 or 9007 is installed

Note: If a cartridge is loaded into a drive which does not support it, the drive will respond to Test Unit Ready and other SCSI commands with CHECK CONDITION status and associated sense data of 3/3000 (Medium Error, Incompatible Medium Installed).

Model Conversions

The following model conversions are allowed for the Magstar MP 3570 Tape Subsystem:

- Model C01 to Model C02
- Model C01 to Model C11
- Model C11 to Model C12
- Model C02 to Model C12

Note: A second drive for Model C21 may be ordered as part number 08L6480.

Magstar MP Bar Code Reader

The Bar Code Reader enables the host application software to inventory cartridges efficiently. It is part of the cartridge picker sub-assembly. It reads the bar code portion of the top cartridge label as the cartridges enter the picker. The host can issue SCSI commands to read the bar code volser.

The Bar Code Reader is provided to enhance application performance using the Magstar MP 3570 Tape Subsystem. For Standard Label tape processing, the bar code labels and internally recorded VOLSER must match. Most IBM tape management systems, like ADSM and BRMS/400, use Standard Label tape processing. For further information, see “Bar Code Format” on page 9.

The Bar Code Reader is included on all Models C01, C02, C11, C12, C21, and C22 Magstar Tape Subsystems.

Magstar MP Fast Access Linear Tape Cartridges

Using the Magstar MP C-Format or C-Format XL cartridges, the Magstar MP 3570 Tape Subsystem drive reads and writes data on 128 tracks per cartridge, eight tracks at a time. The subsystem uses an interleaved serpentine longitudinal recording format. The first set of eight tracks is written from the mid-point along the length of the tape to near the end of the tape, where the head is indexed to the next set of eight tracks for return to the tape mid-point. This process continues until all 128 tracks are written, and then is repeated for the other half of the medium until the tape is full. Operation using the Magstar MP B-Format cartridges is similar to the C-Format or C-Format XL cartridge operation; except that four tracks, instead of eight tracks, are written at a time until all 128 tracks have been written.

Data is written on or read from metal particle tape that is enclosed in a tape cartridge (Figure 3). The Magstar MP Fast Access Linear Tape cartridges are different from cartridges that are used in other IBM tape storage products, and cannot be interchanged with the media that is used in other IBM tape products.

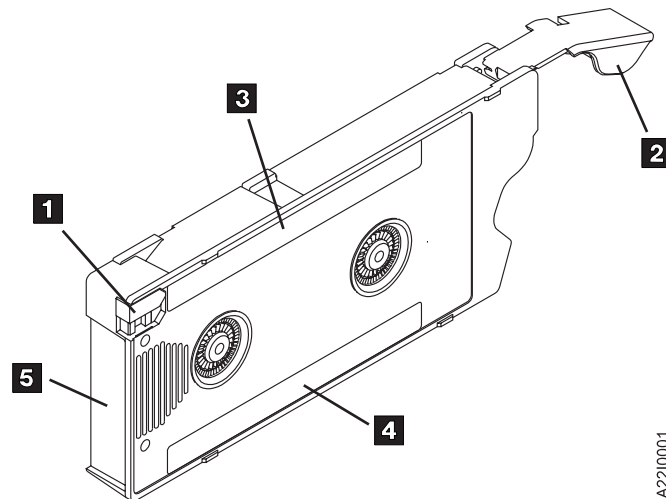

Figure 3. Magstar MP Fast Access Linear Tape Cartridge

Each tape cartridge includes a file-protect selector **1** that, when placed in the upward position as indicated, file protects the tape and prevents data from being written on it. The cartridge can be written on when the file-protect selector is in the downward position. The automatic cartridge loader in the drive opens the cartridge door **2** and allows the read/write element to access the tape path.

The Magstar MP Tape Subsystem design provides faster data access than other tape technologies by eliminating the time that is spent threading the tape before it can be used to read or write data. In addition, the load point for the tape is near the mid-point of the tape length, with half the media wound onto each of two spools. As a result, the average distance that must be traveled to access data is one quarter of the length of the tape, which shortens the data acquisition time and reduces the head wear.

The Magstar MP Fast Access Linear Tape cartridge contains major enhancements over conventional data recording cartridges. It has a rugged case that is designed for repetitive handling by automated pickers and protects the medium in an enclosed environment. The cartridge contains advanced metal-particle tape media

that is developed for high capacity and durability. The tape never leaves the cartridge, and maintains a self-enclosed tape path that allows the medium to avoid being handled by external pickers, rollers, or external guides. The unique tape path eliminates tape thread time, reduces complexity, and provides higher reliability. The new tape path also permits quick loading and, combined with the mid-point load position, provides unparalleled tape performance.

The cartridge door remains closed during storage and handling to protect the medium and tape path from contamination.

A data cartridge has a blue, green, or red file-protect selector (see Table 3) and is marked IBM Magstar MP Fast Access Linear Tape. A cleaning cartridge has a gray file-protect selector and is marked IBM Magstar MP Cleaning Cartridge.

Each data cartridge is identified by a factory-applied volume serial (volser) number and a bar code. The volser and bar code appear on a label (see **3** in Figure 3) along the edges of both the data and cleaning cartridges that face the operator as the cartridge goes into the Magstar MP. Label **3** also has a small space in which the operator may write a note.

Note: Do not write on, mark over, or otherwise obscure either of the bar codes on a cartridge; doing so may cause the system to malfunction.

Another label is placed on the cartridge along the bottom of the plastic face (see **4** in Figure 3). It is marked IBM Magstar MP Fast Access Linear Tape (or IBM Magstar MP Cleaning Cartridge in the case of a cleaning cartridge). The C-Format cartridge includes the words “C-Format” on this label and the label for the C-Format XL cartridge includes the words “C-Format XL 7GB”.

Table 3. Magstar MP Cartridge Differences

Description	Native Capacity	BarCode/Volser Label	File Protect Switch
Magstar MP Cleaning Cartridge	N/A	FCLNxxx	Gray
Magstar MP B-Format Data Cartridge	5GB	Fxxxxxx	Blue
Magstar MP C-Format Data Cartridge	5GB	Gxxxxxx	Green
Magstar MP C-Format XL Data Cartridge	7GB	Hxxxxxx	Red

User-supplied labels should not be affixed to the cartridge because they may interfere with the proper handling of the cartridge in either the drive or the library transport mechanism.

Label **5** is located on the end of the cartridge, opposite the cartridge door, and contains a bar code identical to the one that is located on the top label.

If a cartridge label needs to be replaced, a kit containing enough labels for 10 cartridges can be ordered. See “Planning for Supplies and Equipment” on page 23 for ordering information.

Bar Code Format

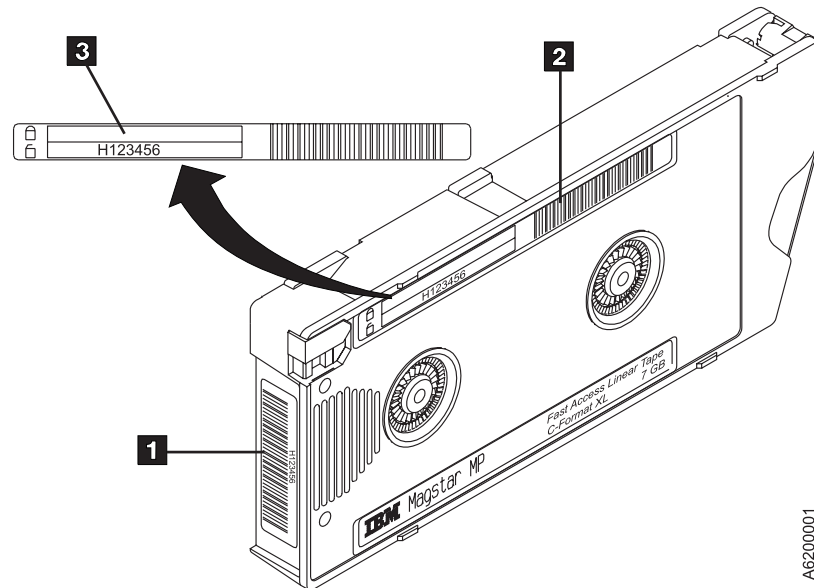

Figure 4. Magstar MP C-Format XL Tape Cartridge Labels

The bar code is seven characters in length not including the start/stop characters.

- The first character (left-most character) is the media type character and is an uppercase "H" for all Magstar MP C-Format XL cartridges (see **3** in Figure 4), "G" for C-Format cartridges, and "F" for B-Format cartridges and for the cleaning cartridge.

- The remaining six (right-most) characters are used to uniquely identify the cartridges. The valid bar code characters are as follows:
 - Uppercase Alpha - A through Z.
 - Numeric - 0 through 9.
 - Blanks (or Spaces) - Trailing only.

The bar code can be any mixture of alpha and numeric characters such as the following :

- "HABC123" "HABC2C3" "H123ABC".
- "H12345 " (with a trailing blank character).
- "HA3B " (with 3 trailing blank characters).
- The bar code is located on two labels on the Magstar MP cartridge, (see **1** and **2** in Figure 4).
- Some operating systems or applications, like ADSM and BRMS/400, only display the last six characters. (The media type "F", "G", or "H" is not displayed.)
- For Standard Label tape processing using the Bar Code Reader, the bar code labels and internally recorded VOLSER must match. If there are existing cartridges where there is a mismatch between the Bar Code Label and the VOLSER with which the tape was initialized, a set of custom cartridge labels can be ordered to match the Bar Code Label to the internal VOLSER. To receive the custom labels, order part number 05H9643 for B-Format cartridges, 08L6192 for C-Format cartridges, or 08L6666 for C-Format XL cartridges from IBM Supply Fulfillment Operations:
 - 1-888-IBM-MEDIA in the United States, or
 - +31 433 502 576 in Europe.

Cartridge Magazine

Model C00 can hold only one cartridge at a time. Models C01, C02, C11, C12, C21, and C22 can each contain two 10-cartridge tape magazines, which give these models the capability of holding up to 20 cartridges.

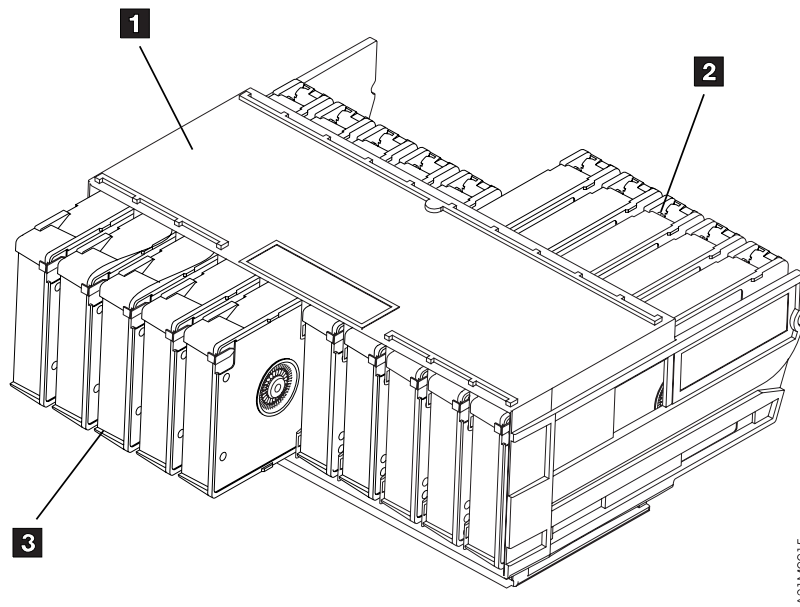

Figure 5. Magstar MP Cartridge Magazine (Viewed from the Operator Side)

As shown in Figure 5, each magazine **1** stores tape cartridges in one of 10 storage cells in two possible physical positions: the *import* position **2** or the *export* position **3**. In the import position, the cartridge transport mechanism can access the cartridge. The transport in each library unit moves processed cartridges to the export position in automatic and manual modes where they are accessible for removal by the operator.

Operator and Service Message Interface

This section describes the operator and service message interface facilities for Model C00 and Models C01, C02, C11, C12, C21, and C22.

Model C00

Figure 6 shows the operator panel for Model C00.

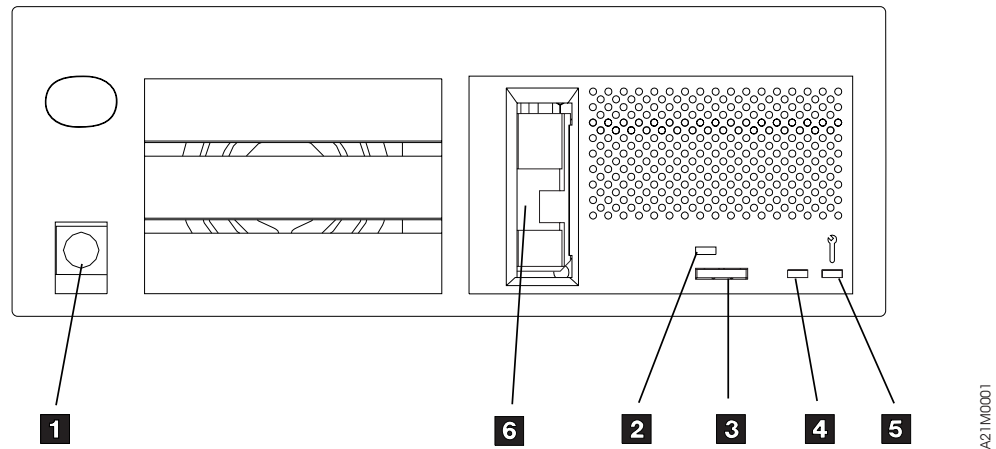

Figure 6. Model C00 Operator Panel

- | | |
|----------------------------------|------------------------------------|
| 1 Power On/Off Switch | 4 Clean LED Indicator |
| 2 Tape Busy LED Indicator | 5 Maintenance LED Indicator |
| 3 Tape Unload Button | 6 Drive Door |

Model C00 uses the three LEDs in various combinations to indicate operator messages and error conditions. See *IBM Magstar MP 3570 Tape Subsystem Operator Guide C-Series Models* for additional information.

Models C01, C02, C11, C12, C21, and C22

The LCD display screen on the front panel assembly (see **1** in Figure 7) of the library models, along with the three LEDs (see **7**, **8**, and **9** in Figure 7) on the front assembly, provides operator and service messages.

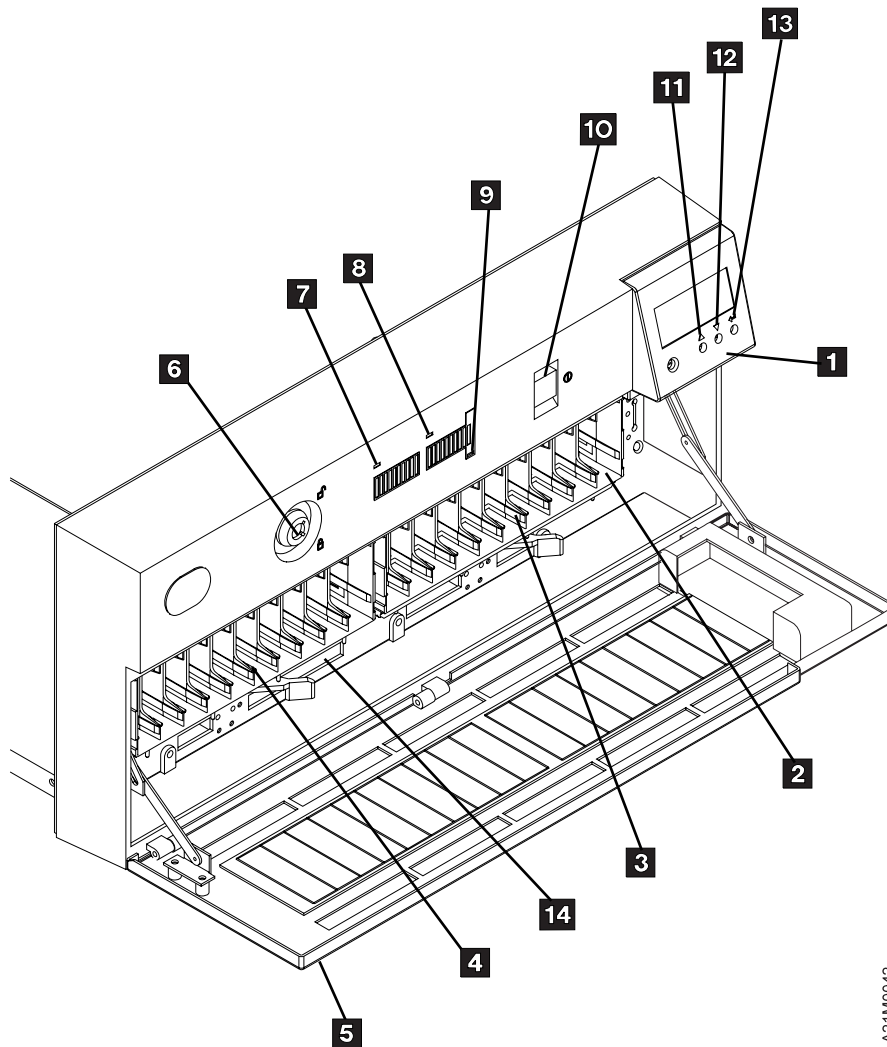

A21M0042

Figure 7. Magstar MP Library Front Panel Assembly

- | | |
|--------------------------------------|---|
| 1 Operator Panel | 8 Magazine 1 in use indicator |
| 2 Priority Cell | 9 Priority Cell in use indicator |
| 3 Magazine 1 location | 10 Power On/Off switch |
| 4 Magazine 2 location | 11 Scroll Up |
| 5 Door | 12 Scroll Down |
| 6 Security key lock | 13 Enter |
| 7 Magazine 2 in use indicator | 14 Serial number label |

Models C01, C02, C11, C12, C21, and C22 have a priority cell **2** that can be used to load or unload cartridges from the subsystem without removing the cartridge magazine. Because cartridges can be inserted without opening the door, the integrity of the tape inventory is not violated. To use this feature, the rightmost cartridge cell **3** in magazine 1 must be unused. Magazine 1 must always be present if the priority cell is to be used.

Library Modes of Operation

The library processes cartridges either sequentially or non-sequentially. For sequential processing, the library is capable of operating in either automatic or manual modes, selectable at the operator panel. These two modes are identical except that following each unload operation in manual mode the operator must push a button to initiate the next load operation.

In order to process cartridges in a non-sequential manner, the library must be set to random mode at the operator panel.

The mode selected by the operator is stored in non-volatile memory and becomes the default mode during subsequent power-on cycles.

Note: When using ADSM with a Magstar MP model C02, C12, or C22, it is recommended the Magstar MP be configured to operate in Random Mode and Base Configuration. This allows ADSM to use the second drive for reclamation.

Random Mode

Random mode allows the Magstar MP to act as a self-contained library of up to 19 cartridges, controlled entirely by SCSI hosts. In addition, access is provided to a 20th cartridge through the priority cell. The host uses SCSI commands to a Medium Changer device to select a cartridge from a source element and move it to its destination element. Control of the source and destination elements is left entirely to the host.

A request for an external cartridge to be mounted can be satisfied by inserting the cartridge into the priority cell in the import position. The Magstar MP notifies hosts of the presence of a cartridge in the priority cell, but the host must specifically address that cell to access the cartridge.

When the destination of a move is a magazine cell, the transport mechanism places the cartridge in the cell in the import position for possible later re-use. However, if the destination is the priority cell, the transport mechanism places the cartridge in the cell in the export position.

Because the library door must be closed while in random mode, the priority cell is used as an import/export station to add or remove cartridges from the library without violating the integrity of the magazine inventory. A host can cause cartridges from the priority cell to be moved to any empty magazine cell or to a device. It can also cause cartridges from a magazine or a device to be moved to the priority cell. Requests for external cartridges to be mounted can only be satisfied when magazine 1 (the rightmost magazine) is present. Library inventory and control is entirely the responsibility of the hosts. If the library door is opened while in random mode, the drive responds to the next command with a Unit Attention condition.

Automatic (Sequential) Mode

Automatic mode provides the customer the ability to operate the library as a sequential autoloader, keeping the tape drive continually fed with cartridges. The initiator controls only the unload of a cartridge from the tape drive. The library will

automatically load the next available cartridge into the drive after the ejected cartridge is put back into the magazine. All media changer operations are effectively hidden from the system.

When automatic mode is selected, the cartridges are automatically processed according to their positions in the magazines. The library processes all cartridges that are in import positions sequentially, beginning at the rightmost cell position and then proceeding from right to left as viewed from the front of the library. After processing a cartridge, the library returns it to its original magazine cell and places it in the export position.

The operator can supply external cartridges to an application by inserting a cartridge in the priority cell in the import position. Any cartridge inserted in the priority cell will automatically be the next cartridge that is loaded into the drive. When that specific cartridge is unloaded, the library returns the cartridge to the priority cell in the export position and resumes processing cartridges from the magazine. The library continues to search for cartridges until it has searched all cells without finding a cartridge in the import position.

The operator can remove cartridges that are in the export position from magazines and add cartridges in the import position to the magazine while the library is in automatic mode. The library stops when the door is opened and resumes operation when the door is closed. If a cartridge is in a drive when the door is opened, processing continues until complete. When the door is closed, the cartridge is returned to the cell from which it was removed. An operator may also insert full magazines into the library when it is in automatic mode.

If the operator unloads a cartridge from the tape drive by using the operator panel on the Magstar MP 3570 Tape Subsystem, the operator must select START on the operator panel to load the next cartridge. If the cartridge is unloaded from the tape drive by the host, the next cartridge is automatically loaded in the tape drive. There is no need for the operator to select START on the operator panel.

Manual (Sequential) Mode

In manual mode, the library functions the same as in the automatic mode, except the operator initiates each load operation. Each time the operator selects START from the **Options Menu**, the library selects the cartridge from the next unprocessed magazine cell and mounts it in the drive. Manual mode operation is also activated by placing a cartridge in the import position of the priority cell and selecting START. Only one cartridge is processed for each operator action. After being unloaded, each cartridge is returned to the magazine location from which it was taken and placed in the export position.

The library starts processing cartridges beginning at the rightmost cell in the library. The search for unprocessed cartridges is from right to left across the magazine(s) as viewed from the front of the library.

Library Configurations

Models C02 , C12, and C22 may operate in Base Configuration or Split Configuration as selected in the operator menus. Models C01, C11, and C21 do not support Split Configuration.

Note: If attached to an AS/400 system, when switching between Base and Split configuration, the I/O processor must be reloaded. To reload the I/O processor, vary off and on with reset, or use STRSST to IPL the I/O processor.

Base Configuration Modes of Operation

In a Base Configuration, all magazine cells are accessible to all initiators on the bus. This is the default configuration for all library models. The library mode of operation is selected at the operator panel for drive 1 only, but it applies to the entire library.

Random Mode - Base Configuration

See “Random Mode” on page 13 for an overview of this mode. Magstar MP acts as a self-contained library of up to 19 cartridges with additional access to a 20th cartridge through the priority cell. In models with 2 drives, the source and destination elements of a move can indicate either drive. See “SCSI Medium Changer Addressing for Base and Split Configuration” on page 16.

Automatic Mode - Base Configuration

See “Automatic (Sequential) Mode” on page 13 for an overview of this mode. In models with 2 drives, only drive 1 is used for this mode. Drive 2 is unused. The library processes all cartridges that are in import positions sequentially, beginning at the rightmost priority cell position, then proceeding from right to left across both magazines as viewed from the library front.

Manual Mode - Base Configuration

See “Manual (Sequential) Mode” on page 14 for an overview of this mode. In models with 2 drives, only drive 1 is used for this mode. Drive 2 is unused. The library processes all cartridges that are in import positions sequentially, beginning at the rightmost priority cell position, then proceeding from right to left across both magazines as viewed from the library front.

Split Configuration Modes of Operation

It is advantageous to be able to share a single library between host systems. Unfortunately, some applications (and some systems) do not allow for sharing devices between systems. Split Configuration allows for a single library to be used by multiple systems by having the library manage this ‘sharing’. This is accomplished by having the library appear as two separate half-size libraries on one or two SCSI busses. Two SCSI busses are created when the SCSI Bus Jumper is removed between the drive 1 and drive 2 SCSI ports.

Split Configuration is created by logically dividing one physical library into two logical libraries.

Logical Library 1 consists of:

- Drive 1,
- Magazine 1 (including the priority cell), and
- The transport mechanism.

Logical Library 2 consists of:

- Drive 2,
- Magazine 2, and
- The transport mechanism.

Logical Library 1 is available to host systems via the drive 1 SCSI port, and Logical Library 2 is available to host systems via the drive 2 SCSI port. Cartridges not in the logical library associated with a port are not accessible to commands received on that port.

In a Split Configuration, the library mode of operation is selected separately for drive 1 (Logical Library 1) and drive 2 (Logical Library 2). All possible combinations of modes of operation are allowed in Split Configuration.

Random Mode - Split Configuration

See “Random Mode” on page 13 for an overview of this mode. All operations for the priority cell are associated with Logical Library 1 only. For Logical Library 1, Magstar MP acts as a self-contained library of up to 9 cartridges with additional access to a 10th cartridge through the priority cell. For Logical Library 2, the Magstar MP acts as a self-contained library of up to 10 cartridges, with no host access to the priority cell.

Automatic Mode - Split Configuration

See “Automatic (Sequential) Mode” on page 13 for an overview of this mode. All operations for the priority cell are associated with Logical Library 1 only. For Logical Library 1, the operation begins at the right-most priority cell position, then proceeds from right to left across magazine 1. For Logical Library 2, the operation begins at the right-most cell in magazine 2, then proceeds from right to left across magazine 2.

Manual Mode - Split Configuration

See “Manual (Sequential) Mode” on page 14 for an overview of this mode. All operations for the priority cell are associated with Logical Library 1 only. For Logical Library 1, the operation begins at the right-most priority cell position, then proceeds from right to left across magazine 1. For Logical Library 2, the operation begins at the right-most cell in magazine 2, then proceeds from right to left across magazine 2.

SCSI Medium Changer Addressing for Base and Split Configuration

Magstar MP library models are consistent with the SCSI standard for Sequential Access and Medium Changer devices. Each tape drive in a Magstar MP library has a unique SCSI device ID. In Random mode, the library control interface consists of a SCSI Medium Changer device available as a logical unit through one or both drive ports, depending on the library configuration.

For a Base Configuration, a Medium Changer device is available through the drive 1 SCSI port only.

For Split configuration, the transport mechanism is shared, but it appears as two Medium Changer devices, one for each drive SCSI port.

Performance

Users who run applications that are highly dependent on tape processing speed can take advantage of the significant performance improvements that are provided by the Magstar MP Tape Subsystem.

Each Magstar MP Model C tape drive has the following performance characteristics:

- 7MB/sec sustained data rate for C-Format or C-Format XL media (native)
- 15MB/sec sustained data rate for C-Format or C-Format XL media with maximum compression
- 3.5MB/sec sustained data rate for B-Format media (native)
- 10.5MB/sec sustained data rate for B-Format media with 3:1 compression
- 20MB/sec burst data rate
- 8 sec average load-to-ready time
- 14 sec average search time to first byte of data for C-Format XL media
- 5 sec average unload time

Because data transfer rates and throughput are enhanced with data compression, users can process more tape applications and run tape-related workloads faster. Users with limited time for system backup or with large amounts of disk storage can use these tape subsystems efficiently to back up their systems. The Magstar MP Tape Subsystem provides efficient tape operations and provides relief to users who have difficulty completing tape activities in the time available. In the event of loss or damage to files on disk storage, the high performance of the subsystem permits faster system recovery.

By using the built-in data-compression capability, the user can achieve greater data rates than the native data rate. However, the actual throughput is a function of many components, such as the host system processor, disk data rate, block size, data compression ratio, SCSI bus capabilities, and system or application software. Optimum performance can be achieved by using the largest block size available. Although the Magstar MP drive is capable of up to a 15MB/sec sustained data rate, other components of the system may limit the actual effective data rate.

Software Support

Program support for the Magstar MP 3570 Tape Subsystem is provided in the AS/400 environment by OS/400 V3R1 or later.

AS/400 Note:

PTFs (Program Temporary Fixes) are required prior to attaching a Magstar MP 3570 Tape Subsystem to an AS/400 system. The PTFs for all supported AS/400 releases are listed in INFO APAR II10363. This information APAR contains the most current PTF information for all supported releases and important information concerning attachment of the Magstar MP 3570 Tape Subsystem to the AS/400.

After installing the appropriate PTFs, a SAVSYS must be done to ensure that the new IOP code is available during a system recovery.

Specific Magstar MP device support is provided by a device driver shipped with the unit for the following operating environments:

- HP-X/Open Company Limited UNIX systems
- RS/6000 systems
- Sun systems
- Windows NT systems

The 3570 Tape Subsystem is supported in the following environments:

- AIX/6000[®] 3.2.5, 4.1.1 and later, or 4.2.0 and later releases.
- RISC System/6000
- Hewlett Packard: 9000 Series 800, /T, and /K class servers running HP-UX 10.0X through 10.3X.
- Sun Solaris: Solaris 2.3, 2.4, 2.51, and 2.6 for Sun and Sun Sparc
- Windows NT: Microsoft[®] Windows NT Server Version 4.0 with service pack 3 or greater
- Netfinity attach Model C21 and C22 only

The following software products support the IBM Magstar MP 3570 subsystems:

- Computer Associates - ARCserveIT
- Help/Systems - Robot/SAVE
- IBM ADSM
- IBM Backup Recovery and Media Services/400 (BRMS/400)
- IBM Sysback/6000
- Legato Systems NetWorker
- RDARS
- SCH Technologies REELlibrarian and REELbackup
- Sterling Software - Alexandria
- Veritas Media Librarian and NetBackup

Additional software support is available from many industry-leading tape application vendors. A complete list of compatible software, and the minimum level required for each, is available from <http://www.storage.ibm.com/hardsoft/tape/>

Chapter 2. Standard Functions and Features

This section describes the following information about the Magstar MP 3570 C-Series Tape Subsystem:

- Standard functions
- Feature codes
- Device orientation

Standard Functions

The Magstar MP 3570 C-Series Tape Subsystem has the following functions:

- Support for SCSI-2, the ANSI standard command set for sequential access and medium changer devices, plus several SCSI-3 extensions.
- 2-byte wide differential SCSI-3 connector and electrical system (P cable)
- Support for initiators, such as the RISC System/6000, RS/6000 SP, AS/400 systems, Sun systems, HP-UX systems, and Windows NT systems.
- 5MB buffer
- Read/write data flow with error checking code and cyclic redundancy checking
- Cartridge capacity of 5GB uncompressed and 15GB compressed data (C-Format cartridge)
- Cartridge capacity of 7GB uncompressed and 21GB compressed data (C-Format XL cartridge)
- Support for data compression (LZ-1)
- Timing-based track-following servo system
- Cartridge with dual reels that eliminate threading and pneumatics
- Bar code reader
- Data security (lock and key) for Models C01, C02, C11, C12, C21, and C22.
- RAS (Reliability, Availability, Serviceability) features including:
 - Real-time diagnostics
 - Real-time failure isolation
 - Hardware/media isolation
 - Service information messages (SIMs)
 - Media information messages (MIMs)
 - Online microcode update capability

Also, the subsystem design permits:

- Complete self-testing when the subsystem is powered on.
- Operator notification when a failure is detected.
- Pre-mounting and automatic feeding of 20 cartridges in either automatic or random mode on Models C01, C02, C11, C12, C21, and C22.
- Low power and cooling requirements as a result of using small size components and advanced logic technology.
- Fast data access. The cartridge's normal load/unload point is in the center of the media with an equal amount of media on each reel.
- Write and read compatibility, with cartridges from 3570 B-Series models.

Feature Codes

Features and specific codes are used to:

- Identify the tape media technology
- Provide greater configuration flexibility
- Identify the specific attachment type

Several features are available for the Magstar MP models. Some features are standard on a particular model while other features are optional. The feature codes are listed in Table 4. For additional information, see Table 13 on page 41 for power cords and Table 17 on page 47 for SCSI cables.

Table 4. Features (All Features Not Available for All Models)

Feature Code	Description	Magstar MP Models
2007	Field Installed C-Format XL Data Cartridge Support	C00, C01, C02, C11, and C12
2891	Interposer HD68/HD50 Fast/Narrow (F/N) for RISC System/6000 SCSI-2 Differential High-Performance External I/O Controller (FC 2420)	C00, C01, C02, C11, and C12
2892	Interposer HD68/CC68 for RISC System/6000 Enhanced SCSI-2 Differential Fast/Wide (F/W) Adapter/A (FC 2412) or the SCSI-2 Differential Fast/Wide (F/W) Adapter/A (FC 2416)	C00, C01, C02, C11, and C12
2895	Interposer for AS/400 Magnetic Media Subsystem Controller (FC 6501 only)	C00, C01, C02, C11, and C12
5205	0.5 m (2 ft) SCSI Cable	C00, C01, C02, C11, and C12
5212	12 m (39 ft) SCSI Cable	C00, C01, C02, C11, and C12
5218	18 m (59 ft) SCSI Cable	C00, C01, C02, C11, and C12
5225	25 m (81 ft) SCSI Cable	C00, C01, C02, C11, and C12
6480 (part number 08L6480)	Second C Drive For Model C21	C21
6517 (part number 08L6517)	3570 Adapter Card Kit (for second SCSI bus)	C21, C22
5245	4.5 m (15 ft) SCSI Cable	C00, C01, C02, C11, and C12
8703	20 C-Format Data Cartridges	C00, C01, C02, C11, and C12
8705	10 C-Format Data Cartridges	C00, C01, C02, C11, and C12
8708	10 C-Format XL Data Cartridges	C00, C01, C02, C11, and C12
8750	1 Cleaner Cartridge	C00, C01, C02, C11, and C12
8752	10 B-Format Data Cartridges	C00, C01, C02, C11, and C12
8753	1 Magazine	C01, C02, C11, and C12
8758	10 C-Format Data Cartridges	C00, C01, C02, C11, and C12

Table 4. Features (All Features Not Available for All Models) (continued)

Feature Code	Description	Magstar MP Models
9007	Plant Installed C-Format XL Data Cartridge Support	C00, C01, C02, C11, and C12
9080	Watertight Plug for Power Cord	C00, C01, and C02
9200	Open Systems Device Drivers	C00, C01, C02, C11, and C12
9210	Attached to Sun	C00, C01, C02, C11, and C12
9211	Attached to HP-UX	C00, C01, C02, C11, and C12
9212	Attached to Windows NT	C00, C01, C02, C11, and C12
9400	Attached to AS/400	C00, C01, C02, C11, and C12
9571	1 C-Format Data Cartridge and 1 Cleaner Cartridge	C00, C01, C02, C11, and C12
9600	Attached to RS/6000	C00, C01, C02, C11, and C12
9800	9 ft Power Cord, 125V, 10A U.S.A./Canada	C00, C01, and C02
9820	2.7 m Power Cord, 250V, 10A France	C00, C01, and C02
9821	2.7 m Power Cord, 250V, 10A Denmark	C00, C01, and C02
9825	2.7 m Power Cord, 250V, 10A U.K.	C00, C01, and C02
9827	2.7 m Power Cord, 250V, 10A Israel	C00, C01, and C02
9828	2.7 m Power Cord, 250V, 10A Switzerland	C00, C01, and C02
9829	2.7 m Power Cord, 250V, 10A South Africa	C00, C01, and C02
9830	2.7 m Power Cord, 250V, 10A Italy	C00, C01, and C02
9831	2.7 m Power Cord, 250V, 10A Australia	C00, C01, and C02
9833	9 ft Power Cord, 250V, 10A U.S.A./Canada	C00, C01, and C02
9986	6 ft Power Cord, 125V, 10A Chicago	C00, C01, and C02
Notes:		
1. Two power cords are required for two-drive Models C02 and C12 and provided for Model C22.		

Device Orientation

Model C00 operates two orientations.

- Horizontal when the cartridge loader cell is vertical.
- Vertical when the cartridge loader cell is horizontal and the power switch is near the bottom.

Models C01, C02, C11, C12, C21, or C22 operate in horizontal orientation only.

Chapter 3. Planning Considerations

Planning considerations for the IBM Magstar MP 3570 Tape Subsystem include:

- “Planning for Supplies and Equipment”
- “Planning for Software Support” on page 25
- “Planning for Operator Training” on page 25
- “Planning for Installation” on page 25
- “Special Application Considerations” on page 27
- “Planning for Operations” on page 29
- “Planning for Data Migration” on page 30
- “Verifying Data Migration” on page 33

Planning for Supplies and Equipment

Magstar MP Fast Access Linear Tapes, cleaner cartridges, and magazines can be specified with feature codes (not available for all models) on the initial Magstar MP order or for field installation.

One data cartridge and one cleaner cartridge are supplied with each Magstar MP Model C00 unit. For the Magstar MP library units, the ship group includes either one data cartridge and one cleaner cartridge (FC 9571), 10 data cartridges and one cleaner cartridge (FC 8705), or 20 data cartridges and one cleaner cartridge (FC 8703). Two 10-cartridge magazines are also supplied with each Models C01, C02, C11, C12, C21, and C22.

At the time of order, Model C00 users must specify one and only one FC 9571. Model C01, C02, C11, and C12 library users must specify one and only one of FC 9571, FC 8705, or FC 8703.

The following additional supplies and equipment are recommended:

- A supply of tape cartridges for storing data
- Storage shelves for storing shelf-resident tape cartridges
- Additional library magazines for transporting and loading tape cartridges
- For Standard Label tape processing using the Bar Code Reader, the bar code labels and internally recorded VOLSER must match. If there are existing cartridges where there is a mismatch between the Bar Code Label and the VOLSER with which the tape was initialized, a set of custom cartridge labels can be ordered to match the Bar Code Label to the internal VOLSER. To receive the custom labels, order part number 05H9643 for B-Format cartridges, 08L6192 for C-Format cartridges, or 08L6666 for C-Format XL cartridges from IBM Supply Fulfillment Operations:
 - 1-888-IBM-MEDIA in the United States, or
 - +31 433 502 576 in Europe.

Table 5 shows additional supply items available from IBM Supply Fulfillment Operations. For additional Magstar MP Cartridges, cleaning cartridges, and magazines, contact the appropriate distributor for your location as given in Table 6 on page 24.

Table 5. Magstar MP Media Supply Items

Description	IBM Part Number
Cleaner Cartridge	P/N 05H2463
Cartridge Magazine	P/N 49G6598
B-Format Data Cartridge	P/N 05H2462
B-Format Replacement Label Kit - 10 Sets of Labels	P/N 05H9393
B-Format Custom VOLSER Label Kit - 10 Set of Labels	P/N 05H9643*
C-Format Data Cartridge	P/N 08L6187
C-Format Replacement Label Kit - 10 Sets of Labels	P/N 08L6191
C-Format Custom VOLSER Label Kit - 10 Sets of Labels	P/N 08L6192*
C-Format XL Data Cartridge	P/N 08L6663
C-Format XL Replacement Label Kit - 10 Sets of Labels	P/N 08L6665
C-Format XL Custom VOLSER Label Kit - 10 Sets of Labels	P/N 08L6666*
*The bar code label and the internally recorded VOLSER must match. If there are existing cartridges where there is a mismatch between the bar code label and the VOLSER with which the tape was initialized, a set of custom cartridge labels can be ordered to match the bar code label to the internal VOLSER.	

Table 6. Magstar MP Media Supply Distributors

Location	Contact	Telephone Number
United States, Canada, Puerto Rico	IBM Media Distribution North America	888-IBM-MEDIA
Central America	General Business Machines	+1-305-539-3470
Spain	IBM Supplies Distribution Europe	900 983131
Italy	IBM Supplies Distribution Europe	1678 78349
France	IBM Supplies Distribution Europe	0590 5871
Germany	IBM Supplies Distribution Europe	0130 818 005
Sweden	IBM Supplies Distribution Europe	0207 94270
Norway	IBM Supplies Distribution Europe	800 11389
Denmark	IBM Supplies Distribution Europe	800 15534
Finland	IBM Supplies Distribution Europe	08001 13110
United Kingdom	IBM Supplies Distribution Europe	0800 968679
Elsewhere in Europe, Middle East, and Africa	IBM Supplies Distribution Europe	+31 433 502 756 (voice) +31 433 262 292 (fax)
Japan	Supply Services, IBM Japan, Ltd.	03-3546-7611

Planning for Software Support

Most software that supports current IBM magnetic tape subsystems also supports the Magstar MP Tape Subsystem.

See “Software Support” on page 18 for software that supports the Magstar MP 3570 Tape Subsystem. Refer to the system software manuals for additional information.

If the Magstar MP Tape Subsystem is to be used in an AS/400 environment, it is recommended the *Automated Tape Library Planning and Management Guide*, SC41-3309 be reviewed prior to installation.

Planning for Operator Training

Before the tape subsystem is installed, the tape subsystem operators should be trained. Typical tasks for tape subsystem operators are:

- Switching the tape subsystem on or off
- Setting options on the operator panel
- Inserting or removing tape cartridges from the library
- Inserting or removing cartridge magazines from the library
- Setting or resetting the file-protect selector on the tape cartridge
- Initializing a tape volume
- Disposing of tape cartridges
- Performing problem determination

See *IBM Magstar MP 3570 Tape Subsystem Operator Guide C-Series Models* for more information about operator tasks.

Planning for Installation

- Consider the following items when placing the Magstar MP 3570 Tape Subsystem anywhere that is convenient to the host system:



The weight caution symbol indicates that Magstar MP Library Model C01 weighs approximately 35 kilograms (77 pounds), Model C02 weighs approximately 40 kilograms (88 pounds), Model C11 and C21 weigh approximately 24 kilograms (53 pounds), and Model C12 and C22 weigh approximately 29 kilograms (64 pounds). It takes two persons to safely lift a C01, and three to lift a C02.

- The power cord(s) and the SCSI cable(s) must be the appropriate length (see Table 17 on page 47).
 - The unit should not be placed in a dusty location.
 - Do not stack more than one Magstar MP tape subsystem on top of another.
 - The orientation of Model C00 may be either horizontal (when the cartridge loader cell is vertical) or vertical (when the cartridge loader cell is horizontal and the power switch is near the bottom).
 - The orientation of Models C01, C02, C11, C12, C21, and C22 must be horizontal with the slots arrayed vertically and the priority cell on the right.
- Consider the following issues when installing the Magstar MP 3570 Tape Subsystem:

Note: It is recommended that a service representative install rack-mounted libraries.

- Model C00, C01, C02, C21, or C22 may be installed either by the customer or by a service representative. When the service representative installs these models, it is a customer billable service call. Refer to *IBM Magstar MP 3570 Tape Subsystem Operator Guide C-Series Models* for installation procedures.
- Model C11 or C12 requires installation by a service representative. Installation is described in *Magstar MP 3570 Tape Subsystem Maintenance Information C-Series Models*.
- Conversion from a one-drive model to a two-drive model requires installation by the service representative.
- Consider the following conditions when installing Model C11, C12, C21, or C22 in a rack:

Note: The Magstar MP Tape Subsystem Models C21 and C22 are designed only for installation in the IBM Netfinity rack or the NETBAY22 rack.

- The Magstar MP should be installed as low as possible in the rack because of its weight.

Note: Models C21 and C22 should be installed no higher than EIA unit 28.

- Elevated operating ambient temperature
Install this model in an environment compatible with the manufacturer's maximum rated ambient temperature. See Table 15 on page 44.
- Reduced air flow
Proper air flow is required to avoid compromising the safe operation of the equipment. Ensure that the rack does not impede air flow.
- Mechanical loading
Mounting of this equipment should not create a hazard due to uneven mechanical loading.
- Circuit overloading and reliable grounding
Proper over-current protection and grounding are required when installing this model in a rack environment. See Table 11 on page 39 for additional information.

End of Life (EOL) Plan

Each Magstar MP is a purchased unit. Therefore, it is the sole responsibility of the purchaser to dispose of it in accordance with local laws and regulations at the time of disposal.

Special Application Considerations

The following topics apply to tape programming unique to applications.

Status and Sense Bytes

The subsystem provides additional sense bytes to support the device-specific error-recovery procedures. Many procedures are handled by the drive instead of the initiator. Programs that refer to sense bytes may require modification. See *IBM Magstar MP 3570 Tape Subsystem Hardware Reference C-Series Models* for a description of the status and sense bytes.

Update in Place

Programs that attempt to update a block in place require a special error handling routine. The subsystem does not support update in place operations. This type of program is not recommended. If such a program already exists, it will require modification before being used with the Magstar MP 3570 Tape Subsystem. The following Magstar MP characteristics are applicable:

- The Magstar MP checks the blocks during read, write, and space block operations. These programs fail if the block sequence is altered.
- Block ID is not transferred to the system during a read operation. It is only transferred explicitly by a special command.

Note: Most operating systems provide a macro level interface for this function (if it is supported).

Read/Write Buffering

The integrated control unit contains a 5MB storage area that is used to buffer the flow of read and write data. This buffering action permits the subsystem to respond rapidly to read and write data requests.

Buffered read mode is always used for reading data. It permits the rapid transfer of data from the buffer to the host processor. The buffered read operation allows the drive to anticipate demands for data by reading ahead and storing multiple blocks of data in the buffer. Data, when written on the subsystem tape, can only be read forward (never backward).

The modes of operation for writing data are buffered write and unbuffered write modes. Each mode can be selected by a command from the host processor. The buffered write mode is the default mode of operation.

Buffered write mode permits data to be transferred at full channel speeds into the buffer. After the complete data block is transferred to the buffer, the drive signals normal completion before the data is written to tape. The drive transfers the data to the tape medium without further initiator assistance.

Unbuffered write mode differs from buffered write mode in that the data is written on tape and verified before the next block of data can be transferred from the initiator to the drive buffer.

Device-Dependent Parameters

Programs that perform certain functions may not give the expected results when they are used with the Magstar MP 3570 Tape Subsystem. Program functions that may depend on the device type and may need alteration include:

- Dynamic device allocation
- Accounting routines
- Stand-alone programs
- Interrupt routines
- Programs that call data security erase

Forward/Backward Space File

Forward space file is performed by the Magstar MP 3570 Tape Subsystem.

Data Security Erase Operation

In the subsystem, data security erase writes random data on the tape. Any command that attempts to read over the random data created by the data security erase can receive an indication of permanent error.

Data Compression

The control unit provides a data-compression function, LZ-1. Data compression is not recommended for encrypted data because the resulting compression ratio may be less than one (that is, the block expands). In general, data compression achieves a higher ratio when a logical block from an initiator is not processed by a compression or transformation cipher algorithm (within the host).

Planning for Operations

Planning requirements include modifications in physical layout, subsystem operations, and operator procedures. The changes involve understanding the architecture of the subsystem, tape cartridge handling, the cartridge transport mechanism, storage requirements for the cartridges, and accompanying modifications to the operating system.

Operations personnel play a significant role in subsystem migration. Operations and production control personnel perform many of the tasks that are described in other sections of this guide, including data migration and media conversion.

Operations requirements include equipment removal, installation, drive assignment schedules, and cartridge initialization. Additional tasks include managing tape cartridges in the computer room, developing or modifying procedures where required, and providing training.

Data Compression Capability

To enhance data transfer rates, the Magstar MP is preset with LZ-1 compression enabled.

Device drivers that support the data-compression function and perform device allocation automatically recognize when data compression is enabled. Other controls, such as system defaults and operator commands, allow the device driver to determine the format of an output tape and to allocate it to a compatible subsystem. Consequently, there are no additional requirements for generating output tapes, except during setup of new device support that involves software installation.

To process an input tape, the volume must be mounted on a device that supports the tape format. To allocate compatible devices for a given job, the initiator must be told the format on the volume or the program must be provided with a device type for allocation purposes. In cases where tapes are premounted, the operator must select a compatible subsystem, or move the tape to an appropriate subsystem when the tape cannot be processed.

When tapes are allocated or mounted on incompatible devices, the control program may detect the situation from information in the volume label (if present).

Planning for Data Migration

For the following discussion, data migration is defined as the movement of data to tape cartridges during the normal processing of jobs.

The following topics explain techniques to categorize tape subsystem use, determine a data movement schedule, balance tape drive requirements, and explore alternatives for forming a general migration strategy.

Most tape libraries are composed of common categories of tapes that are defined by the characteristics of how they are used. Determining the common categories is the first step in developing a migration strategy.

Each category is unique because of special criteria applied to its use and handling in a data-processing environment. The criteria can include life cycle, security requirements, special handling, or various application dependencies. Table 7 describes some standard tape categories.

Table 7. Tape Characteristics by Tape Category

Category	Tape Characteristics
Archive	<ul style="list-style-type: none">• Contain records held for historical, legal, regulatory, or disaster recovery purposes.• Have a retention period usually more than a year and are often stored off-site.• Processing of these tapes can be done in locations other than the site where they were created. This off-site processing can occur as a part of a comprehensive disaster plan or for various legal or regulatory requirements.
Digital Library	<ul style="list-style-type: none">• Fast random file retrieval and storage.
Hierarchical Storage Management	<ul style="list-style-type: none">• Involves movement of infrequently accessed data to lowest cost medium.• Cost-managed storage.
Interchange	<ul style="list-style-type: none">• Prepared for use in other locations.• May be used in other computer systems or for special purposes like microfilm production.• May be tapes prepared at another location to be used on the local system (for example, tapes created on data collection equipment).
Disk Backup	<ul style="list-style-type: none">• Created in normal disk backup jobs.• Represents several generations of disk files stored in a subsystem at any given time.• Used to recover files in the event of a program or system error or other malfunction. The restore function is seldom used, but when it is, the integrity of the copied data is critical.• Files usually have a high turnover rate and may require interchange with other sites.

Table 7. Tape Characteristics by Tape Category (continued)

Category	Tape Characteristics
Journal	<ul style="list-style-type: none"> • Contain transactions recorded against another dataset. • Allow their companion datasets to be reconstructed by applying the journal data to a previous version of the companion datasets. • Used in data base and online systems applications.
Scratch	<ul style="list-style-type: none"> • Called the scratch pool. It contains no active data. It often consists of a regular flow of new, unused tapes entering a subsystem to be used for growth and replacement of old tapes. This may be important in determining the number of tape cartridges to order. • Used for the creation of new files during normal processing when the data is to be kept.
Process	<ul style="list-style-type: none"> • Created during periodic execution of an installation's application programs. • Represent the highest volume of files in a subsystem. For example, multiple generations of a tape master file can be considered process tapes. • Range of criteria and time frames, most commonly, the daily, weekly, or monthly processing cycle.

Developing a Data-Migration Sequence

Another aspect of planning involves the sequence to follow during the migration. Specific considerations for each category of a subsystem determine where to begin and the preferred sequence. Some considerations are:

Disk backup tapes: These tapes can be converted easily during the first phase of the plan. They quickly reduce subsystem space requirements and improve performance. Large-scale data transfer is involved that lends itself to device and data-transfer verification with familiar utilities.

Process tapes: These tapes can be converted either selectively or at the normal process rate. Application programming personnel or operations staff who normally audit application job flow may monitor the transition. This category should account for most of the migration workload.

Archive tapes: All new archive volumes can be created on the tape cartridges.

Note: Existing archive tapes can be converted to take advantage of space and data-integrity improvements.

Journal tapes: Unbuffered mode is typically used for journal tapes after each record is written to ensure the accuracy of the data. Because the subsystem is buffered, the unbuffered mode option can be used for these journal tapes. Journal tapes that do require a high level of integrity could remain on the existing media type until the application is modified accordingly. Although the subsystem is a high performance, batch-mode device, it can be used in unbuffered mode for those

applications that require low logging activity. It is not recommended for high-activity logging, such as journal tapes, because the effective data rate is lowered.

Interchange tapes: These tapes cannot be migrated initially. They require selective conversion based on the ability of the interchange system to operate with the Magstar MP tape cartridge and its format.

To develop a migration sequence, you should plan for complete migration and conversion of all possible tapes, except interchange and journal tapes. The total number of cartridges required is equal to the sum of process, disk backup, scratch, and archive tapes in the current inventory plus possible additions for growth. Enough of your existing drive types must be kept to process the interchange and critical journal tapes.

Developing a Data-Migration Strategy

The Magstar MP 3570 Tape Subsystem writes and reads data in a format that is not compatible with subsystems that write data in other formats. The discussion that follows may serve as a starting point as you develop your migration strategy.

Our assumption is that you will want to replace your existing drives at a pace that allows you to convert your applications and that you will keep one or more existing drives for data interchange and journaling. Possible strategies include:

- Old file in and new file out
- Copy files

The determining factors will be the time that you allot for migration and the number of cataloged datasets in your existing library.

Old File In and New File Out

With this migration technique, files written in other formats are read in and newly created files are written on Magstar MP cartridges. At any given library turnover rate, a given percentage of library cartridges will be written in Magstar MP format. This method involves the gradual transition to Magstar MP hardware from existing hardware.

Copy Files

With this strategy, data can be copied to the Magstar MP tape cartridge. This works best for multiple cartridge read-only files that can benefit from the increased capacity of the Magstar MP format. Presumably, this would be a last step to convert the remaining files that are not processed by using one of the other strategies.

Data Migration Tasks

Migration to the Magstar MP 3570 Tape Subsystem involves the following basic tasks:

1. Modifying the system to identify the SCSI adapter paths as required.
2. Installing the tape units and testing them under control of the operating system.
3. Testing applications by using the operating system, magnetic tape subsystem, application programs, and Magstar MP Fast Access Linear Tape cartridges.
4. Modifying datasets (if required) and application programs that are used with the subsystem.

5. Moving existing data (if necessary) from the current tape format to IBM Magstar MP tape format.

A migration strategy must include a consideration of multiple tape format, the choice of cartridge system tapes, and the available magnetic tape subsystems and features.

Verifying Data Migration

Application programming personnel may need to perform several tasks when transferring data to the subsystem. Ensuring that the data is correctly transferred is the highest priority in the overall migration. Tape programming that was written at the device level may require modifications to take advantage of functions available with the subsystem. Typical tasks for application personnel are:

- Setting up a data test plan so that project control personnel can monitor the migration.
- Producing file copies with a special copy program or another utility that provides similar functions. The copies can be used in the early stages of the migration to ensure device and medium integrity before production-controlled migration begins.
- Processing test jobs with test data.
- Verifying results with a production run of the same application.
- Running a tape-compare utility.

Chapter 4. Site Planning

The Magstar MP models are integrated tape subsystems. They contain both SCSI controller and tape drives in single units and do not require interconnection to other tape subsystem units.

This section lists the following information about the Magstar MP 3570 Tape Subsystem:

- Physical specifications
- Subsystem component specifications
- Power characteristics
- Environmental specifications
- Cooling requirements
- Product environment
- Acoustical characteristics

Physical Specifications

Table 8 shows the physical specifications of the Magstar MP 3570 Tape Subsystem.

Table 8. Physical Specifications

Dimensions	Model C00	Model C01 (horizontal)	Model C02 (horizontal)	Model C11 (rack mounted)	Model C12 (rack mounted)	Model C21 (rack mounted)	Model C22 (rack mounted)
Height	112 mm (4.4 in)	217 mm (8.5 in)	217 mm (8.5 in)	217 mm (8.5 in)	217 mm (8.5 in)	217 mm (8.5 in)	217 mm (8.5 in)
Width	320 mm (12.6 in)	483 mm (19.0 in)	483 mm (19.0 in)	444 mm (17.5 in)	444 mm (17.5 in)	444 mm (17.5 in)	444 mm (17.5 in)
Depth	338 mm (13.3 in)	771 mm (30.4 in)	771 mm (30.4 in)	714 mm (28.1 in)	714 mm (28.1 in)	714 mm (28.1 in)	714 mm (28.1 in)
Weight	8.4 kg (18.5 lb)	35 kg (77.1 lb)	40 kg (88.2 lb)	24 kg (52.8 lb)	29 kg (63.9 lb)	24 kg (52.8 lb)	29 kg (63.9 lb)
Weight with Pedestal	8.5 kg (18.7 lb) (see note)	39.8 kg (87.7 lb) (see note)	44.8 kg (98.7 lb) (see note)	N/A	N/A	N/A	N/A
Display Panel	No	Yes	Yes	Yes	Yes	Yes	Yes
Magstar MP Media	One cartridge	Up to 20 cartridges	Up to 20 cartridges	Up to 20 cartridges	Up to 20 cartridges	Up to 20 cartridges	Up to 20 cartridges

Notes:

1. Model C00, C01, or C02 stands on a pedestal that raises each unit by 25 mm (1 in) above the table surface.
2. Models C21 and C22 are Netfinity rack-mount only.
3. Models C11, C12, C21, and C22 use slides and require 6 EIA units in a rack.

Subsystem Component Specifications

Table 9 shows a representative configuration of Model C00 in plan view. Table 10 shows a representative configuration of Model C01 or C02 in plan view.

Model C00

Measurements are in millimeters and inches.

English measurements are shown in parentheses.

Table 9. Plan View of Model C00

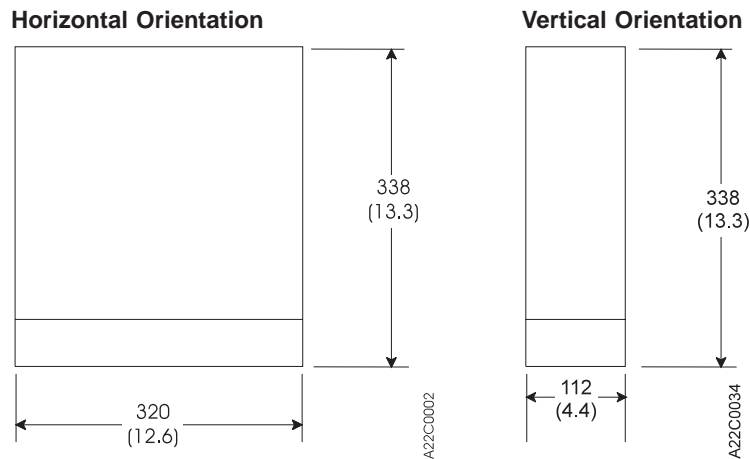

Dimensions:

Front: 320 mm (12.6 in.)

Side: 338 mm (13.3 in.)

Height: 112 mm (4.4 in.)

Dimensions:

Front: 112 mm (4.4 in.)

Side: 338 mm (13.3 in.)

Height: 320 mm (12.6 in.)

Service Clearance

No additional clearance is needed for service.

Weight

8.4 kg (18.5 lb)

Weight

8.5 kg (18.7 lb) with pedestal

Note: Model C00 stands on a pedestal that raises the unit by 25 mm (1 in.) above the table surface.

Model C01 or C02

Measurements are in millimeters and inches.

English measurements are shown in parentheses.

Table 10. Plan View of Model C01 or C02

Horizontal Orientation

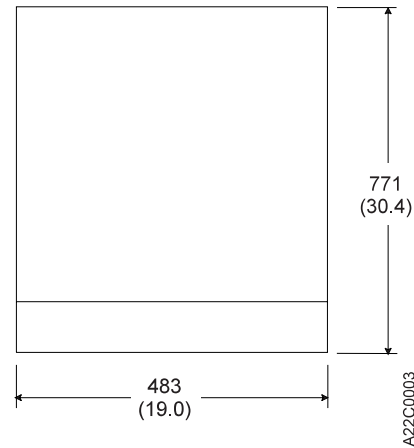

Dimensions

Front: 483 mm (19.0 in.)

Side: 771 mm (30.4 in.)

Height: 217 mm (8.5 in.)

Service Clearance: No additional clearance is needed for service.



Weight for Model C01

35.0 kg (77.1 lb)

Weight for Model C01

39.8 kg (87.7 lb) with pedestal

Weight for Model C02

40.0 kg (88.2 lb)

Weight for Model C02

44.8 kg (98.7 lb) with pedestal

Note: Model C01 or C02 stands on a pedestal that raises each unit by 25 mm (1 in) above the table surface.

Model C11 or C12 (Rack Mount)

Refer to the appropriate rack specification for service clearances. See *Magstar MP 3570 Tape Subsystem Maintenance Information C-Series Models* or *9309 Rack Enclosure General Information and Site Preparation* for general information about rack installation.

For installation in RISC System/6000-type racks, see *7015 Installation and Service Guide*.

Model C11 or C12 uses slides and requires 6 EIA units in a rack. These units may be installed in an IBM rack 9309 Model 002 or an IBM rack 7015 Model R00. Model C11 or C12 will also fit into a non-IBM 19-inch rack if it meets all of the following criteria:

1. EIA standard 19-inch rack with a panel size of 19 in (482.6 mm)
2. Enclosure depth of 915 mm (30.0 in.)
3. Width of 452 mm (17.8 in.) with a center mounting hole of 465.1 mm (18.3 in.)
4. EIA mounting holes must not be threaded.

Note: A RS/6000 rack-mounted unit (Model C11 or C12) must be installed by a service representative. It cannot be installed directly by the customer.

Model C21 or C22 Rack Mount (Netfinity)

Note: The Magstar MP Tape Subsystem Models C21 and C22 are designed only for installation in the IBM Netfinity rack or the NETBAY22 rack.



The weight caution symbol indicates that Magstar MP Library Model C21 weighs approximately 24 kilograms (53 pounds), and Model C22 weighs approximately 29 kilograms (64 pounds). It takes two persons to safely lift Models C21 and C22.

Note: Install height in rack is 28 maximum EIA units.

Model C21 and C22 each requires 6 EIA units in the rack.

Power Characteristics

The ac power to the Magstar MP power supply is supplied from a wall outlet, rack enclosure, or other ac source. Table 11 lists the electrical requirements for the device. (All line voltages are nominal.) The power supply adjusts itself automatically for any combination of voltages and frequencies shown in Table 11.

Table 11. Electrical Requirements

Magstar MP Model	Line Voltage (Vac)	Line Frequency (Hz)	Nominal Power Use (W)	Line Current (amps at 100–127 Vac)	Line Current (amps at 200–240 Vac)	kVA
C00 (note 1)	100–127 Nominal or 200–240 Nominal	50–60	65 watts (222 BTU/hr)	0.60 (note 2)	0.30	0.065
C01, C11, or C21 (note 1)	100–127 Nominal or 200–240 Nominal	50–60	75 watts (256 BTU/hr)	0.70 (note 2)	0.35	0.075
C02, C12, or C22 (note 3)	100–127 Nominal or 200–240 Nominal	50–60	140 watts (478 BTU/hr)	1.30 (note 2)	0.65	0.14
Notes:						
1. All Magstar MP models are single-phase systems.						
2. The readings are in amps (RMS).						
3. Two power outlets are required for two-drive Models C02, C12, and C22.						

Table 12 shows the heat output values for the device.

Table 12. Heat Output

Model	Calorific Value	kCal/hr Value
C00	15.6	0.056
C01, C11, or C21	17.9	0.065
C02, C12, or C22	33.4	0.120

In-Rush Current

The in-rush current is 30 amps peak for 1/2 cycle at 100-127 volts and 50 amps peak for 1/2 cycle at 200-240 volts.

Power Control

A power switch is on the front of each Magstar MP model.

There is no power-on indicator on the device. All models have indicator LEDs on the front that are illuminated for a short time when the device is turned on. Model C01, C02, C11, C12, C21 or C22 has operator panels where power-on status is displayed after the LEDs have been turned off.

Remote power control is not provided by the Magstar MP unit. If required, it is provided by the enclosure or higher level subassembly.

Power Cords, Plugs, and Receptacles



The ship group provides the appropriate power cord(s) for all electrical environments in which the device is expected to operate. An appliance coupler is at the device end of the cord. The other end of the cord is determined by application and country. A customer can also order a power cord separately.

Note: Two power cords are required for two-drive Model C02 or C12.

Power cords used in the United States and Canada are listed by the Underwriter's Laboratories (UL) and certified by the Canadian Standards Association (CSA). These power cords consist of electrical cords, either type SVT or SJT, terminated by attachment plugs complying with the National Electrical Manufacturer's Association (NEMA).

U.S.A. and Canada models require one of the following plug and receptacle pairs:

- Plug type NEMA 5-15P (100–127 V ac)
- Receptacle NEMA 5-15R (100–127 V ac)
- Plug type NEMA 6-15P (200–240 V ac)
- Receptacle NEMA 6-15R (200–240 V ac)

Check local electrical codes. Ensure that adequate electrical service is available for the device. If it is necessary that the device power cord be plugged into a receptacle that is below a raised floor, the following may be required:

- Plug type RussellStoll 3720DPU2
- Receptacle RussellStoll 3743U-2 (see Figure 8)
- Connector housing RussellStoll 3913U-2 (see Figure 8)
- Power cord style: A8

Service ratings for plug type 3720DPU2 are as follows:

- Maximum voltage: 208–240 V ac
- Current: 15 A
- Phases: 1
- Wires: 3

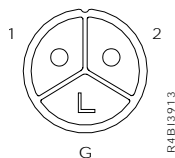

Figure 8. Receptacle Connector for RussellStoll 3743U-2 or 3913U-2

A RussellStoll inline connector used with flexible metal conduit or liquid-tight flexible metal conduit requires a RussellStoll FSA adapter.

Power cords used in countries outside of North America conform to the electrical codes established by that country. These power cords consist of electrical cords, type HD21, terminated by attachment plugs approved by the testing organizations for each specific country.

Table 13 lists power cord specifications, part numbers, countries of use, and index numbers to match with the receptacle illustrations shown in Figure 9 on page 43.

Table 13. Power Cord Specifications for Models C00, C01, and C02

Country	Voltage / Amperes	Length	Power Cord Plug	Feature Code and P/N
Bahamas, Barbados, Bolivia, Brazil, Canada, Costa Rica, Dominican Republic, El Salvador, Guatemala, Guyana, Haiti, Honduras, Jamaica, Japan, Netherland Antilles, Panama, Peru, Philippines, Taiwan, Tobago, U.S.A. (except Chicago), Venezuela	250 V / 10 A	2.7 m (9 ft)	1	FC 9833 P/N 1838574
Bahamas, Barbados, Bermuda, Bolivia, Brazil, Canada, Cayman Islands, Colombia, Costa Rica, Dominican Republic, Ecuador, El Salvador, Guatemala, Guyana, Haiti, Honduras, Jamaica, Japan, Korea (South), Mexico, Netherlands Antilles, Nicaragua, Panama, Peru, Philippines, Puerto Rico, Saudi Arabia, Suriname, Taiwan, Trinidad, U.S.A. (except Chicago), Venezuela, Vietnam	125 V / 10 A	2.7 m (9 ft)	2	FC 9800 P/N 6952300
U.S.A. Chicago	125 V / 10 A	1.8 m (6 ft)	2	FC 9986 P/N 6952301
U.S.A.-Watertight	125 V / 10 A	4.3 m (14 ft)	12	FC 9080 and FC 9800 P/N 46F5894
U.S.A.-Chicago Watertight	125 V / 10 A	1.8 m (6 ft)	12	FC 9080 and FC 9986 P/N 46F5893
Argentina, Australia, New Zealand	250 V / 10 A	2.7 m (9 ft)	3	FC 9831 P/N 13F9940

Table 13. Power Cord Specifications for Models C00, C01, and C02 (continued)

Country	Voltage / Amperes	Length	Power Cord Plug	Feature Code and P/N
Abu Dhabi, Angola, Antigua, Austria, Belgium, Bosnia, Botswana, Bulgaria, Cameroon, Croatia, Czech Republic, Egypt, Finland, France, Germany, Greece, Hungary, Iceland, Indonesia, Iran, Ivory Coast, Korea (South), Lebanon, Liberia, Luxembourg, Macao, Madagascar, Morocco, Mozambique, Netherlands, Netherlands Antilles, Norway, Paraguay, Poland, Portugal, Rhodesia, Romania, Russia, Saudi Arabia, Serbia, Slovakia, Slovenia, Spain, Sudan, Sweden, Syria, Swaziland, Tunisia, Turkey, Yugoslavia, Zaire	250 V / 10 A	2.7 m (9 ft)	4	FC 9820 P/N 13F9979
Denmark	250 V / 10 A	2.7 m (9 ft)	5	FC 9821 P/N 13F9997
Bangladesh, Burma, Pakistan, South Africa, Sri Lanka	250 V / 10 A	2.7 m (9 ft)	6	FC 9829 P/N 14F0015
Bahrain, Bermuda, Bosnia, Brunei, Channel Islands, Cyprus, Ghana, Hong Kong, India, Iraq, Ireland, Jordan, Kenya, Kuwait, Malawi, Malaysia, Nigeria, Oman, People's Republic of China, Qatar, Sierra Leone, Singapore, Tanzania, Uganda, United Arab Emirates (Dubai), United Kingdom, Zambia	250 V / 10 A	2.7 m (9 ft)	7	FC 9825 P/N 14F0033
Liechtenstein, Switzerland	250 V / 10 A	2.7 m (9 ft)	8	FC 9828 P/N 14F0051
Chile, Ethiopia, Italy, Libya, Malta, Sierra Leone, Somalia	250 V / 10 A	2.7 m (9 ft)	9	FC 9830 P/N 14F0069
Israel	250 V / 10 A	2.7 m (9 ft)	10	FC 9827 P/N 14F0087

Note: Two power cords are shipped for Model C21 and four power cords are shipped for Model C22. These cords fit in the Netfinity and NETBAY22 racks.

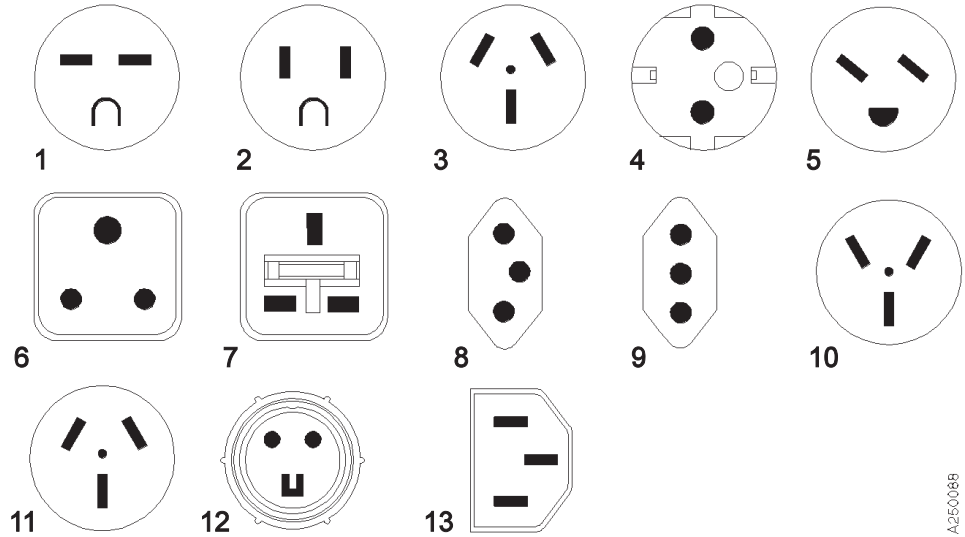

Figure 9. Power Plugs

Table 14 lists the applicable country standard for the plugs shown in Figure 9.

Table 14. Power Cord Plug Country Standards

Plug Number	Standard
1	NEMA WD-1 6-15P
2	NEMA WD-1 5-15P
3	AS 3112=1964 IVZS 198
4	CEE7 VII
5	NORMBLAD 4
6	SABS 164, BS 546
7	BS 1363
8	SEV SN 416534
9	CEI 23-16
10	SII-32-1971
11	CEE7 XVII
12	See note
13	IEC 320 Sheet C14

Note: The applicable plug is RussellStoll 3720DPU1 (or equivalent).

A250065

Environmental Specifications

Table 15 shows the operating and shipping environment allowed for the Magstar MP Tape Subsystem. These parameters describe a Class B Extended operating and shipping environment.

Table 15. Magstar MP Environmental Specifications

Condition	Temperature (dry bulb)	Relative Humidity	Maximum Wet Bulb	Maximum Elevation (above sea level)
Operating	16 to 32°C (61 to 90°F)	8 to 80% (noncondensing)	26°C (79°F)	2133 m (6975 ft)
Nonoperating	10 to 43°C (50 to 109°F)	8 to 80% (noncondensing)	27°C (81°F)	2133 m (6975 ft)
Storage	1 to 60°C (34 to 140°F)	5 to 80% (noncondensing)	29°C (84°F)	2133 m (6975 ft)
Shipping	-40 to 60°C (-40 to 140°F)	5 to 100% (noncondensing)	29°C (84°F)	No restrictions

Cooling Requirements

The Magstar MP requires ambient room temperatures that are consistent with the environmental specifications. One cooling fan is used to cool the drive and another fan cools the power supply. The air flow for these fans must not be obstructed.

Product Environment

The Magstar MP devices are designed to operate in an office environment. To ensure maximum longevity and reliability of your unit:

- Keep the unit away from high-traffic areas, especially if the floor is carpeted.
- Keep the unit out of computer-printer rooms because of toner and paper dust. Do not store paper supplies next to any unit.
- Keep the unit away from moving air such as doorways, open windows, fans, and air conditioners.

Isolate your unit from heavy traffic and dust to avoid unnecessary contamination. Ensure that the machine covers are always kept closed to minimize any contamination from airborne particles.

Acoustical Characteristics

Models C00, C01, and C02 meet a Class B Extended operating and shipping environment. The noise levels for the Magstar MP 3570 Tape Subsystem are 5.5 bels idle and 5.8 bels operating.

Chapter 5. SCSI Configuration

A Magstar MP 3570 Tape Subsystem can be integrated with any host that supports a SCSI-2 interface and has the proper drivers installed.

SCSI Physical Interface Characteristics

The Magstar MP Tape Subsystem operates as a SCSI-2 device with SCSI-3 features. The instruction set is SCSI-2, but includes SCSI-3 commands and mode sense data.

The Magstar MP Tape Subsystem attaches to host processors through the Magstar MP Fast/wide (16-bit) differential SCSI interface. It uses a shielded high-density SCSI-3 68-pin P connector that accommodates 16 bus addresses. The Magstar MP attaches directly to a differentially driven, wide (16 bit) SCSI-3 P-cable.

Under the SCSI-2 protocol, this type of attachment allows cable lengths of up to 25 m (81 ft) with the appropriate cable and terminator selection. The stub length at each device must not exceed 0.2 m (0.66 ft).

Magstar MP Tape Subsystems also logically support the narrow (8-bit) protocol. An interposer is required to connect a Magstar MP subsystem to an 8-bit SCSI-2 bus.

Note: Only 8 bus addresses (0 to 7) are valid for an 8-bit SCSI bus.

Bus Termination

The SCSI bus and all of the wires in the SCSI cable must be properly terminated according to the SCSI standard. This termination is especially important if a system mixes devices or initiators with 68-pin connectors with those of the older 50-pin style.

An external terminator may be mounted into a socket that is a part of the SCSI cable connector. A terminator must be installed on the last device on each end of a string of multiple devices. In a single-device installation, the terminator is installed in the socket of this device. The Magstar MP 3570 Tape Subsystem is delivered with an external differential terminator included, but it is not installed.

SCSI Bus Jumper

Dual-drive models include a 0.5 meter SCSI Bus Jumper cable which is attached or removed depending on the library configuration.

Base Configuration

For dual-drive models, set up in a Base Configuration, the SCSI Bus Jumper is attached between the two drives so the drives are on the same SCSI bus.

Split Configuration

For dual-drive models, set up in a Split Configuration, the 0.5 meter SCSI Bus Jumper is removed so each drive port is attached to a separate SCSI bus. Thus, each drive port in a Split Configuration has the same cable and termination requirements as a single-drive model C01, C11, or C21.

SCSI Features and Cables

The following section describes the feature codes for host system attachment (see Figure 10, Figure 11, Table 16, and Table 17).

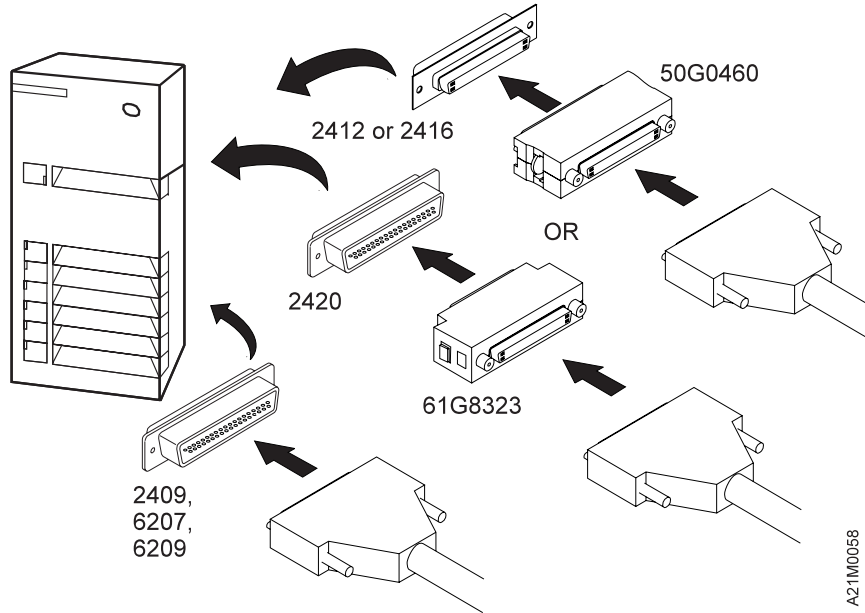

Figure 10. RISC System/6000 SCSI Cable Attachment to Host Systems

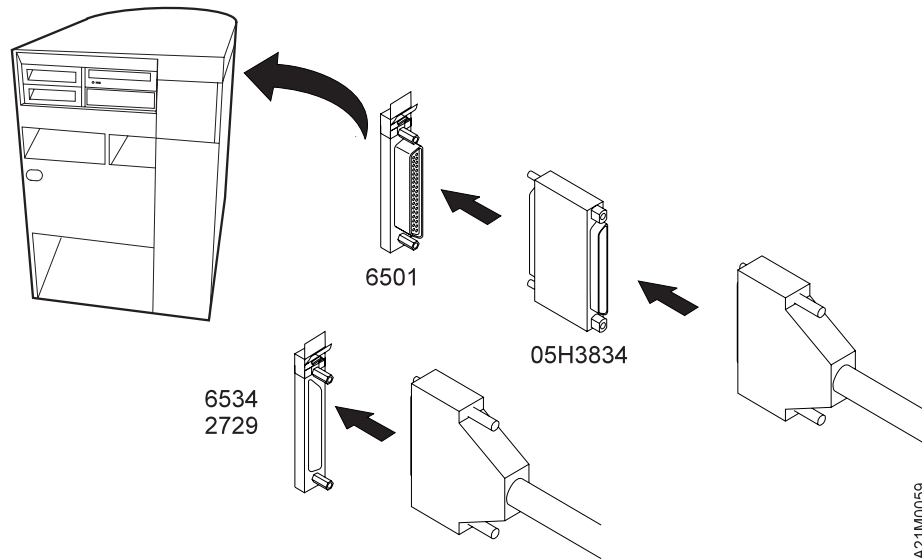

Figure 11. AS/400 SCSI Cable Attachment to Host Systems

Notes:

1. For RISC System/6000, use the host-provided SCSI connectors at the host end to provide the daisy chain for multi-device applications.

2. For Model C02 or C12 set up in the Base Configuration, use the supplied 0.5 meter SCSI Bus Jumper to connect drive 1 to drive 2; select a single SCSI cable feature and a single interposer feature to attach the Magstar MP to one SCSI bus.
3. For Netfinity Model C22 set up in the Base Configuration, and use the supplied 0.5 meter SCSI Bus Jumper to connect drive 1 to drive 2; the host SCSI cable is included and there is no interposer required.
4. For Models C02, C12, set up in the Split Configuration, and select 2 SCSI cable features and 2 interposer features for attachment of the Magstar MP to two SCSI busses. The supplied 0.5 meter SCSI Bus Jumper is not used for this configuration.
5. For Netfinity Model C22 set up in the Split Configuration, and order the 3570 Adapter Card Kit (PN 08L6517). The supplied 0.5 meter SCSI Bus Jumper is not used for this configuration.

Table 16. RISC System/6000, AS/400, and Netfinity

Host	Host Connection (Feature Codes Are for the Host)	Interposer P/N and Feature Code (Feature Codes Are for Magstar MP)
RS/6000	PCI SCSI-2 Differential Fast/Wide Adapter (FC 2409, identifier 4-B)	None required
RS/6000	PCI SCSI-2 Differential Fast/Wide Adapter (FC 2407, identifier 4-L)	None required
RS/6000	PCI SCSI-2 Fast/Wide Differential Adapter (FC 6209, identifier 4-B)	None required
RS/6000	SCSI-2 Differential Fast/Wide Adapter/A (FC, 2416 identifier 4-6)	50G0460 (FC 2892)
RS/6000	Enhanced SCSI-2 Differential Fast/Wide Adapter/A (FC 2412, identifier 4-C)	50G0460 (FC 2892)
RS/6000	SCSI-2 Differential Fast/Narrow High-Performance External I/O Controller (FC 2420, identifier 4-2)	61G8323 (FC 2891)
AS/400	Magnetic Media Subsystem Controller (FC 6501)	05H3834 (FC 2895)
AS/400	Magnetic Media Subsystem Controller (FC 6534)	None Required
AS/400	Magnetic Media Subsystem Controller (FC 2729)	None Required
Netfinity	P/N 08L6517 Differential SCSI Adapter 2944/UW	None required

Table 17. Magstar MP SCSI Cable Feature Codes

Feature Code (for Magstar MP)	IBM Part Number	Cable Length (see notes 1, 2, and 3)
FC 5205	P/N 49G6456	0.5 m (2 ft)
FC 5212	P/N 49G6458	12 m (39 ft)
FC 5218	P/N 49G6459	18 m (59 ft)
FC 5225	P/N 08L6201	25 m (81 ft)
FC 5245	P/N 49G6457	4.5 m (15 ft)

Table 17. Magstar MP SCSI Cable Feature Codes (continued)

Feature Code (for Magstar MP)	IBM Part Number	Cable Length (see notes 1, 2, and 3)
<p>Notes:</p> <ol style="list-style-type: none"> On RS/6000 systems, cable lengths greater than 18 m (59 ft) are not permitted with feature code 2420. Cable lengths up to 25 m (81 ft) can be used with feature code 2409, 6207, 6209, 2412, or 2416. On AS/400 systems, cable lengths up to 25 m (81 ft) can be used with feature code 2729, 6501, and 6534. For Models C21 and C22 the part number of the SCSI cables are: 0.5 meter SCSI jumper cable, part number 05H9527 and host to device 4.5 meter cable, part number 05H9651. These cables are shipped with the library. 		

RISC System/6000 Controller Features 2409, 6207, or 6209

Any combination of initiators and targets up to a total of 16 is allowed if:

- The SCSI bus is terminated properly at each end.
- Cable restrictions are followed according to SCSI-2 specification. With RISC System/6000 SCSI controller feature codes 2409, 6207, or 6209, the maximum cable length is 25 m (81 ft). Table 17 lists the available cables used to attach the Magstar MP 3570 Tape Subsystem to a RISC System/6000 system.

Multiple RISC System/6000 systems may be linked to the Magstar MP 3570 Tape Subsystem. For maximum performance, the Magstar MP Tape Subsystem may need to be the only target on the SCSI bus.

RISC System/6000 Controller Feature 2412 or 2416

An interposer, feature code 2892 (see Table 16), is required to attach the Magstar MP 3570 Tape Subsystem to RISC System/6000 controller feature 2412 or 2416. Any combination of initiators and targets up to a total of 16 is allowed if:

- The SCSI bus is terminated properly at each end.
- Cable restrictions are followed according to SCSI-2 specification. With RISC System/6000 SCSI controller feature code 2412 or 2416, the maximum cable length is 25 m (81 ft). Table 17 on page 47 lists available cables used to attach the Magstar MP Tape Subsystem to RISC System/6000.

Multiple RISC System/6000 systems may be linked to the Magstar MP Tape Subsystem. For maximum performance, the Magstar MP Tape Subsystem may need to be the only target on the SCSI bus.

RISC System/6000 Controller Feature 2420

A 1-byte to 2-byte interposer, feature code 2891 (see Table 16), is required to attach the Magstar MP Tape Subsystem to RISC System/6000 controller or RS/6000 SP feature 2420. If feature 2420 is used, the Magstar MP must be attached at the end of the SCSI bus. Any combination of initiators and targets up to a total of eight is allowed if:

- A Magstar MP is the last device on the SCSI bus.
- The SCSI bus is properly terminated at each end.

- Cable restrictions are followed according to RISC/6000 requirements. With SCSI controller feature 2420, the maximum cable length is 18 m (59 ft). Table 17 on page 47 lists the available cables used to attach the Magstar MP Tape Subsystem to RISC System/6000.

Multiple RISC System/6000 systems may be linked to the Magstar MP Tape Subsystem. For maximum performance, the Magstar MP Tape Subsystem may need to be the only target on the SCSI bus.

RS/6000 Note:

Check that the flash memory on the SCSI adapter in the system contains the proper level of microcode. Affected machine types include any system that contains a SCSI-2 Differential F/W adapter (4-6) or SCSI-2 Enhanced Differential F/W adapter (4-C).

To determine if your machine has an adapter with downlevel microcode, type this command on an AIX prompt: **lscfg -vl ascsi* | pg**

To determine if you have a 4-6 or 4-C SCSI adapter, look at the lines labeled **Displayable Message** and **Loadable Microcode Level**.

The **4-6** adapter will indicate:

```
Displayable Message.....SCSI-2FWSD
Loadable Microcode Level.....0010
```

The **4-C** adapter will indicate:

```
Displayable Message.....SCSI-2FWSD
Loadable Microcode Level.....0080
```

Look for the line **ROS Level and ID** which should show as:

```
ROS Level and ID .....XX
```

- For the 4-6:
 - XX** should be either 67, 68, 70, 72, 73, 74, or higher.
 - If 74 or higher is displayed, there is no need to apply any update to the 4-6.
- For the 4-C:
 - XX** should be either C4, C5, C6, or higher.
 - If C6 or higher is displayed, there is no need to apply any update.

Level 74 & C6 or higher microcode is strongly recommended for use with IBM Magstar MP tape drives, to ensure optimum performance and reduced errors. It may also resolve problems with other sequential SCSI devices (or devices that do not support command queueing) that are attached to dedicated F/W controllers and used in systems with multiple F/W adapters.

AS/400 System Feature 2729, 6501, or 6534

An interposer, feature code 2895 (see Table 16), is required to connect the Magstar MP 3570 Tape Subsystem to system feature 6501. No interposers are required to connect the Magstar MP 3570 Tape Subsystem to system feature 6534 or 2729.

The following condition applies to AS/400 9404 and 9406 SCSI bus attachment of system feature code 6501 to the Magstar MP Tape Subsystem:

- Feature code 6534 and 2729 provide one port.
- Feature code 6501 provides two ports.
- Each port can support one Magstar MP 3570 Tape Subsystem. For optimum performance, there should only be one Magstar MP subsystem attached to each AS/400 feature 6501.
- No other devices can be supported on a feature 2729, 6501, or 6534 port with the Magstar MP 3570 Tape Subsystem attached.
- An AS/400 system cannot be interconnected with any other system (including another AS/400) on the same SCSI bus. See “Connecting the Magstar MP to Multiple Systems” on page 51.
- When the subsystem is attached to AS/400 with feature code 2729, 6501, or 6534, one of the SCSI addresses on the Magstar MP must be set to 0 if the Magstar MP is to be used as an alternate IPL device.

Table 17 on page 47 lists the available cables of the proper length for attaching the Magstar MP 3570 Tape Subsystem to AS/400 with feature code 2729, 6501, or 6534.

IBM Netfinity and PC Servers

A differential SCSI adapter 2944/UW is included with each Model C21 or C22. Part number 08L6517 supplies an additional SCSI Differential adapter 2944/UW for Models C21 or C22. The adapter is designed for a 32-bit PCI bus in an Intel-based computer using the Microsoft Windows NT operating system and is equipped with a 68-pin high-density connector. Included with the adapter card is a 4.5 meter SCSI cable and a terminator.

Other Intel-Based Systems

Requires SCSI F/W or U/W differential to single ended adapter: Adaptec 2944 U/W Differential.

Hewlett Packard

Requires servers that support HP Precision Bus (HP-PB) fast/wide (F/W) Differential Adapter 28696A.

Sun Solaris

Requires SCSI F/W differential adapter.

Connecting the Magstar MP to Multiple Systems

RS/6000

Multiple RS/6000 systems may be attached to a Magstar MP 3570 Tape Subsystem. For more cabling information, see the "RISC System/6000 Publications" on page x.

AS/400

An AS/400 system cannot be interconnected with any other system (including another AS/400) on the same SCSI bus. Therefore, a Model C02 or C12 in a Split Configuration is the only Magstar MP 3570 Tape Subsystem that can be attached to an AS/400 system and another system at the same time (on separate SCSI busses).

Chapter 6. Planning Tasks and Checklists

Migration from a non-tape environment or from an existing non-compatible tape environment to the Magstar MP 3570 Tape Subsystem involves the following tasks:

- Ensuring completion of pre-installation planning and migration tasks.
- Selecting the appropriate model and features to satisfy the performance requirements for the applications used.
- Planning the physical environment for installation.
- Determining the software required to support applications.
- Planning for application and operational changes that may be required in a tape subsystem environment.
- Planning for data migration from a non-tape or non-compatible tape environment to the Magstar MP 3570 Tape Subsystem.
- Determining required supplies and equipment.

Planning Personnel

To ensure an efficient installation, define tasks of planning personnel to do the following:

- Ensure that planning and ordering activities proceed on schedule.
- Determine the location of the subsystem, and ensure that environmental, electrical, and space requirements are met.
- Choose, install, and test the licensed programs for the system.
- Define a storage management policy and plan for data migration.

Task Assignments

Before ordering:

- Determine required licensed programs.
- Determine cable requirements.
- Determine location requirements.
- Determine electrical requirements.
- Determine the required number of Magstar MP Fast Access Linear Tapes
- Determine if extra cleaner cartridges are required.

On order date:

- Order the Magstar MP 3570 Tape Subsystem.
- Order supplies.
- Order any necessary licensed programs.
- Prepare the physical layout.
- Confirm the Magstar MP 3570 Tape Subsystem and supplies orders.

Approximately 10 weeks before delivery:

- Begin the software installation.
- Arrange for the installation of electrical wiring and outlets.

Approximately 6 weeks before delivery:

- Review the progress of the installation.
- Identify and resolve any scheduling problems.

Approximately 4 weeks before delivery:

- Complete site preparation and installation and testing of the electrical wiring and outlets.
- See “Planning for Installation” on page 25 for installation considerations.

At delivery:

“Planning for Installation” on page 25 specifies the models that can be installed by the customer and those that require installation by the service representative. See *IBM Magstar MP 3570 Tape Subsystem Operator Guide C-Series Models* for installation information.

Checklists

The following checklists are provided to aid in identifying all required tasks before installation of or migration to the Magstar MP 3570 Tape Subsystem.

Configuration Planning

Determine the Subsystem Configuration

- ___ 1. Determine the number and length of required cables.
- ___ 2. Determine adapters and interposers.
- ___ 3. Determine data security requirements.
- ___ 4. Identify SCSI IDs.

Site Planning

Ordering Equipment and Consumables

- ___ 1. Order machines and features.
- ___ 2. Order additional cartridge system tapes (if required).
- ___ 3. Order additional magazines if ordering a library model.
- ___ 4. Order additional cleaner cartridges (if required).
- ___ 5. Order custom cartridge labels (if required).

Additional supply items are available from IBM Supply Fulfillment Operations at **1-888-IBM-MEDIA (426-6334)**.

Appendix. Notices

This information was developed for products and services offered in the U.S.A.

IBM may not offer the products, services, or features discussed in this document in other countries. Consult your local IBM representative for information on the products and services currently available in your area. Any reference to an IBM product, program, or service is not intended to state or imply that only that IBM product, program, or service may be used. Any functionally equivalent product, program, or service that does not infringe any IBM intellectual property right may be used instead. However, it is the user's responsibility to evaluate and verify the operation of any non-IBM product, program, or service.

IBM may have patents or pending patent applications covering subject matter described in this document. The furnishing of this document does not give you any license to these patents. You can send license inquiries, in writing, to:

IBM Director of Licensing
IBM Corporation
North Castle Drive
Armonk, NY 10504-1785
U.S.A.

For license inquiries regarding double-byte (DBCS) information, contact the IBM Intellectual Property Department in your country or send inquiries, in writing, to:

IBM World Trade Asia Corporation
Licensing
2-31 Roppongi 3-chome, Minato-ku
Tokyo 106, Japan

The following paragraph does not apply to the United Kingdom or any other country where such provisions are inconsistent with local law:

INTERNATIONAL BUSINESS MACHINES CORPORATION PROVIDES THIS PUBLICATION "AS IS" WITHOUT WARRANTY OF ANY KIND, EITHER EXPRESS OR IMPLIED, INCLUDING, BUT NOT LIMITED TO, THE IMPLIED WARRANTIES OF NON-INFRINGEMENT, MERCHANTABILITY OR FITNESS FOR A PARTICULAR PURPOSE. Some states do not allow disclaimer of express or implied warranties in certain transactions, therefore, this statement may not apply to you.

This information could include technical inaccuracies or typographical errors. Changes are periodically made to the information herein; these changes will be incorporated in new editions of the publication. IBM may make improvements and/or changes in the product(s) and/or the program(s) described in this publication at any time without notice.

Any references in this information to non-IBM Web sites are provided for convenience only and do not in any manner serve as an endorsement of those Web sites. The materials at those Web sites are not part of the materials for this IBM product and use of those Web sites is at your own risk.

IBM may use or distribute any of the information you supply in any way it believes appropriate without incurring any obligation to you

Any performance data contained herein was determined in a controlled environment. Therefore, the results obtained in other operating environments may vary significantly. Some measurements may have been made on development-level systems and there is no guarantee that these measurements will be the same on generally available systems. Furthermore, some measurement may have been estimated through extrapolation. Actual results may vary. Users of this document should verify the applicable data for their specific environment.

Information concerning non-IBM products was obtained from the suppliers of those products, their published announcements or other publicly available sources. IBM has not tested those products and cannot confirm the accuracy of performance, compatibility or any other claims related to non-IBM products. Questions on the capabilities of non-IBM products should be addressed to the suppliers of those products.

All statements regarding IBM's future direction or intent are subject to change or withdrawal without notice, and represent goals and objectives only.

All IBM prices shown are IBM's suggested retail prices, are current and are subject to change without notice. Dealer prices may vary.

This information is for planning purposes only. The information herein is subject to change before the products described become available.

This information contains examples of data and reports used in daily business operations. To illustrate them as completely as possible, the examples include the names of individuals, companies, brands, and products. All of these names are fictitious and any similarity to the names and addresses used by an actual business enterprise is entirely coincidental.

If you are viewing this information softcopy, the photographs and color illustrations may not appear.

Safety Notices

Listed below are the safety requirements for operating this product.

Each danger and caution notice contains a reference number (RSFTxxxx). Use the reference number to check the translation in *External Devices Translated Safety Notices*, SA26-7192.

Danger Notices

A danger notice calls attention to a situation that is potentially lethal or extremely hazardous to people.

The following danger notices appear in this publication:

DANGER

To prevent a possible electrical shock from touching two surfaces with different electrical grounds, use one hand, when possible, to connect or disconnect signal cables. (RSFTD004)

DANGER

An electrical outlet that is not correctly wired could place hazardous voltage on metal parts of the system or the products that attach to the system. It is the customer's responsibility to ensure that the outlet is correctly wired and grounded to prevent an electrical shock. (RSFTD201)

DANGER

To prevent a possible electrical shock when adding or removing any devices to or from the system, ensure that the power cords for those devices are unplugged before the signal cables are connected or disconnected. If possible, disconnect all power cords from the existing system before you add or remove a device.(RSFTD203)

DANGER

To prevent a possible electrical shock when installing the device, ensure that the power cord for that device is unplugged before installing signal cables. (RSFTD204)

Caution Notices

A caution notice calls attention to a situation that is potentially hazardous to people because of some existing condition.



The general caution symbol identifies conditions where caution must be used.



The electrical caution symbol identifies electrical hazards where extreme caution must be used.



The weight caution symbol indicates that Magstar MP Library Model C01 weighs approximately 35 kilograms (77 pounds), Model C02 weighs approximately 40 kilograms (88 pounds), Models C11 and C21 weigh approximately 24 kilograms (53 pounds), and Models C12 and C22 weigh approximately 29 kilograms (64 pounds). It takes two persons to safely lift a C01, and three to lift a C02.

Attention Notices

An attention notice indicates the possibility of damage to a program, device, system, or data.

Possible Safety Hazards

Possible safety hazards are:

Electrical

An electrically charged frame can cause serious or lethal electrical shock.

Mechanical

Hazards, such as a safety cover missing, are potentially harmful to people.

Chemical

Do not use solvents, cleaners, or other chemicals not approved for use on this product.

Any of the problems listed above must be repaired before you use the Magstar MP 3570 Tape Subsystem.

Environmental Notices

The following environmental information pertains to this product.

Product Recycling

This unit contains recyclable materials. The materials should be recycled where facilities are available and according to local regulations. In some areas IBM will provide a product take-back program that ensures proper handling of the product. Contact your IBM representative for more information.

Environmental Design

The environmental efforts that have gone into the design of this unit signifies IBM's commitment to improve the quality of its products and processes. Some of these activities include elimination of the use of CFCs, development of reusable or recyclable packaging, and reduction of manufacturing wastes.

End of Life (EOL) Plan

This box is a purchased unit. Therefore, it is the sole responsibility of the purchaser to dispose of it in accordance with local laws and regulations at the time of disposal.

Terminology

See "Glossary" on page 67 for definitions of terms, abbreviations, and acronyms used in this publication.

Trademarks

The following terms are trademarks of the IBM Corporation in the United States or other countries or both:

AIX
AIX/6000
AIX/ESA
Application System/400
AS/400
ESCON
IBM
IBMLink
Magstar

Micro Channel
RISC System/6000
RS/6000
SP
System/370

Microsoft and Windows NT are registered trademarks of Microsoft Corporation.

UNIX is a registered trademark in the U.S.A. and other countries licensed exclusively through X/Open Company Limited.

Other company, product, and service names may be trademarks or service marks of others.

IBM Agreement for Licensed Internal Code

You accept the terms of this Agreement by your initial use of a machine that contains IBM Licensed Internal Code (called "Code").

These terms apply to Code used by certain machines IBM or your reseller specifies (called "Specific Machines"). International Business Machines Corporation or one of its subsidiaries ("IBM") owns copyrights in Code or has the right to license Code. IBM or a third party owns all copies of Code, including all copies made from them.

If you are the rightful possessor of a Specific Machine, IBM grants you a license to use the Code (or any replacement IBM provides) on, or in conjunction with, only the Specific Machine for which the Code is provided. IBM licenses the Code to only one rightful possessor at a time.

Under each license, IBM authorizes you to do only the following:

1. Execute the Code to enable the Specific Machine to function according to its Official Published Specifications (called "Specifications");
2. Make a backup or archival copy of the Code (unless IBM makes one available for your use), provided you reproduce the copyright notice and any other legend of ownership on the copy. You may use the copy only to replace the original, when necessary; and
3. Execute and display the Code as necessary to maintain the Specific Machine.

You agree to acquire any replacement for, or additional copy of, Code directly from IBM in accordance with IBM's standard policies and practices. You also agree to use that Code under these terms.

You may transfer possession of the Code to another party only with the transfer of the Specific Machine. If you do so, you must 1) destroy all your copies of the Code that were not provided by IBM, 2) either give the other party all your IBM-provided copies of the Code or destroy them, and 3) notify the other party of these terms. IBM licenses the other party when it accepts these terms. These terms apply to all Code you acquire from any source.

Your license terminates when you no longer rightfully possess the Specific Machine.

Actions You May Not Take

You agree to use the Code only as authorized above. You may not do, for example, any of the following:

1. Otherwise copy, display, transfer, adapt, modify, or distribute the Code (electronically or otherwise), except as IBM may authorize in the Specific Machine's Specifications or in writing to you;
2. Reverse assemble, reverse compile, or otherwise translate the Code unless expressly permitted by applicable law without the possibility of contractual waiver;
3. Sublicense or assign the license for the Code; or
4. Lease the Code or any copy of it.

Communications Statements

Federal Communications Commission (FCC) Statement

This equipment has been tested and found to comply with the limits for a Class A digital device, pursuant to Part 15 of the FCC Rules. These limits are designed to provide reasonable protection against harmful interference when the equipment is operated in a commercial environment. This equipment generates, uses, and can radiate radio frequency energy and, if not installed and used in accordance with the instruction manual, may cause harmful interference to radio communications. Operation of this equipment in a residential area is likely to cause harmful interference, in which case the user will be required to correct the interference at his own expense.

Properly shielded, grounded and terminated cables and connectors must be used in order to meet FCC emission limits. IBM is not responsible for any radio or television interference caused by using other than recommended cables and connectors or by unauthorized changes or modifications to this equipment. Unauthorized changes or modifications could void the user's authority to operate the equipment.

This device complies with Part 15 of the FCC Rules. Operation is subject to the following two conditions: (1) this device may not cause harmful interference, and (2) this device must accept any interference received, including interference that may cause undesired operation.

European Union (EU) Electromagnetic Compatibility Directive

This product has been tested and found to comply with the limits for Class A Information Technology Equipment according to European Standard EN55022. The limits for Class A Equipment were derived for commercial and industrial environments to provide reasonable protection against interference with licensed communication equipment.

Attention

This is a Class A product. In a domestic environment this product may cause interference in which case the user may be required to take adequate measures.

Properly shielded and grounded cables and connectors must be used in order to reduce the potential for causing interference to radio and television communications and to other electrical or electronic equipment. Such cables and connectors are available from IBM authorized dealers. IBM cannot accept the responsibility for any interference caused by using other than recommended cables and connectors.

Germany Electromagnetic Compatibility Directive

Dieses Gerät ist berechtigt in Übereinstimmung mit dem deutschen EMVG vom 9.Nov.92 das EG-Konformitätszeichen zu führen. Der AuBteller der Konformitätserklärung ist die IBM.

Dieses Gerät erfüllt die Bedingungen der EN 55022 Klasse A. Für diese Klasse von Geräten gilt folgende Bestimmung nach dem EMVG: Geräte dürfen an Orten, für

die sie nicht ausreichend entstört sind, nur mit besonderer Genehmigung des Bundesministers für Post und Telekommunikation oder des Bundesamtes für Post und Telekommunikation betrieben werden. Die Genehmigung wird erteilt, wenn keine elektromagnetischen Störungen zu erwarten sind. (Auszug aus dem EMVG vom 9.Nov.92, Para.3, Abs.4)

Hinweis:

Dieses Genehmigungsverfahren ist von der Deutschen Bundespost noch nicht veröffentlicht worden.

Japan Voluntary Control Council Information

この装置は、情報処理装置等電波障害自主規制協議会（VCCI）の基準に基づく第一種情報技術装置です。この装置を家庭環境で使用すると電波妨害を引き起こすことがあります。この場合には使用者が適切な対策を講ずるよう要求されることがあります。

Taiwan Class A Statement

警告使用者：
這是甲類B 資訊產品，在居住的環境中使用時，可能會造成射頻干擾，在這種情況下，使用者會被要求採取某些適當的對策。

New Zealand, Australia (from AS/NZ 3548:1995)

Attention - This is a Class A product. In a domestic environment this product may cause radio interference, in which case the user may be required to take adequate measures.

Canada

This Class A digital apparatus complies with ICES-003.

Cet appareil numérique de la classe a est conform à la norme NMB-003 du Canada.

Statement of Limited Warranty

The warranties provided by IBM in this Statement of Limited Warranty apply only to Machines you originally purchase for your use, and not for resale, from IBM or your reseller. The term "Machine" means an IBM machine, its features, conversions, upgrades, elements, or accessories, or any combination of them. Unless IBM specifies otherwise, the following warranties apply only in the country where you acquire the Machine. If you have any questions, contact IBM or your reseller.

Machine: IBM Magstar MP 3570 Tape Subsystem

Warranty Period*: Three years

**Contact your place of purchase for warranty service information.*

Production Status

Each Machine is manufactured from new parts, or new and used parts. In some cases, the Machine may not be new and may have been previously installed. Regardless of the Machine's production status, IBM's warranty terms apply.

The IBM Warranty for Machines

IBM warrants that each Machine 1) is free from defects in materials and workmanship and 2) conforms to IBM's Official Published Specifications. The warranty period for a Machine is a specified, fixed period commencing on its Date of Installation. The date on your receipt is the Date of Installation, unless IBM or your reseller informs you otherwise.

During the warranty period, IBM or your reseller, if authorized by IBM, will provide warranty service under the type of service designated for the Machine and will manage and install engineering changes that apply to the Machine.

For IBM or your reseller to provide warranty service for a feature, conversion, or upgrade, IBM or your reseller may require that the Machine on which it is installed be 1) for certain Machines, the designated, serial-numbered Machine and 2) at an engineering-change level compatible with the feature, conversion, or upgrade. Many of these transactions involve the removal of parts and their return to IBM. A part that replaces a removed part will assume the remaining warranty service status of the replaced part. You represent that all removed items are genuine and unaltered. When a type of service involves the exchange of a Machine or part, the item IBM or your reseller replaces becomes its property and the replacement becomes yours.

If a Machine does not function as warranted during the warranty period, IBM or your reseller will repair it or replace it with one that is at least functionally equivalent, without charge. The replacement may not be new, but will be in good working order. If IBM or your reseller is unable to repair or replace the Machine, you may return it to your place of purchase and your money will be refunded.

If you transfer a Machine to another user, warranty service is available to that user for the remainder of the warranty period. You should give your proof of purchase and this Statement to that user. However, for Machines which have a life-time warranty, this warranty is not transferable.

Warranty Service

To obtain warranty service for the Machine, you should contact your reseller or call IBM. In the United States, call IBM at **1-800-IBM-SERV (426-7378)**. In Canada, call IBM at **1-800-465-6666**. You may be required to present proof of purchase.

IBM or your reseller will provide certain types of repair and exchange service, either at your location or at IBM's or your reseller's service center, to restore a Machine to good working order.

When a type of service involves the exchange of a Machine or part, the item IBM or your reseller replaces becomes its property and the replacement becomes yours. The replacement may not be new, but will be in good working order and at least functionally equivalent to the item replaced. Before IBM or your reseller exchanges a Machine or part, you agree to remove all features, parts, options, alterations, and attachments not under warranty service. You also agree to ensure that the Machine is free of any legal obligations or restrictions that prevent its exchange. You agree to:

1. obtain authorization from the owner to have IBM or your reseller service a Machine that you do not own; and
2. where applicable, before service is provided —
 - a. follow the problem determination, problem analysis, and service request procedures that IBM or your reseller provide,
 - b. secure all programs, data, and funds contained in a Machine, and
 - c. inform IBM or your reseller of changes in a Machine's location.

IBM is responsible for loss of, or damage to, your Machine while it is 1) in IBM's possession or 2) in transit in those cases where IBM is responsible for the transportation charges.

Extent of Warranty

IBM does not warrant uninterrupted or error-free operation of a Machine.

The warranties may be voided by misuse, accident, modification, unsuitable physical or operating environment, improper maintenance by you, removal or alteration of Machine or parts identification labels, or failure caused by a product for which IBM is not responsible.

THESE WARRANTIES REPLACE ALL OTHER WARRANTIES OR CONDITIONS, EXPRESS OR IMPLIED, INCLUDING, BUT NOT LIMITED TO, THE IMPLIED WARRANTIES OR CONDITIONS OF MERCHANTABILITY AND FITNESS FOR A PARTICULAR PURPOSE. THESE WARRANTIES GIVE YOU SPECIFIC LEGAL RIGHTS AND YOU MAY ALSO HAVE OTHER RIGHTS WHICH VARY FROM JURISDICTION TO JURISDICTION. SOME JURISDICTIONS DO NOT ALLOW THE EXCLUSION OR LIMITATION OF EXPRESS OR IMPLIED WARRANTIES, SO THE ABOVE EXCLUSION OR LIMITATION MAY NOT APPLY TO YOU. IN THAT EVENT SUCH WARRANTIES ARE LIMITED IN DURATION TO THE WARRANTY PERIOD. NO WARRANTIES APPLY AFTER THAT PERIOD.

Limitation of Liability

Circumstances may arise where, because of a default on IBM's part or other liability you are entitled to recover damages from IBM. In each such instance, regardless of the basis on which you are entitled to claim damages from IBM (including fundamental breach of contract, negligence, misrepresentation, or other contract or tort claim), IBM is liable only for:

1. damages for bodily injury (including death) and damage to real property and tangible personal property; and
2. the amount of any other actual direct damages or loss, up to the greater of U.S. \$100,000 or the charges (if recurring, 12 months' charges apply) for the Machine that is the subject of the claim.

UNDER NO CIRCUMSTANCES IS IBM LIABLE FOR ANY OF THE FOLLOWING: 1) THIRD-PARTY CLAIMS AGAINST YOU FOR LOSSES OR DAMAGES (OTHER THAN THOSE UNDER THE FIRST ITEM LISTED ABOVE); 2) LOSS OF, OR DAMAGE TO, YOUR RECORDS OR DATA; OR 3) SPECIAL, INCIDENTAL, OR INDIRECT DAMAGES OR FOR ANY ECONOMIC CONSEQUENTIAL DAMAGES (INCLUDING LOST PROFITS OR SAVINGS), EVEN IF IBM OR YOUR RESELLER IS INFORMED OF THEIR POSSIBILITY. SOME JURISDICTIONS DO NOT ALLOW THE EXCLUSION OR LIMITATION OF INCIDENTAL OR CONSEQUENTIAL DAMAGES, SO THE ABOVE EXCLUSION OR LIMITATION MAY NOT APPLY TO YOU.

International Business Machines Corporation

Armonk, New York 10504, U.S.A.

Glossary

This glossary defines the special terms, abbreviations, and acronyms that are used in this publication. If you do not find the term you are looking for, refer to the *Dictionary of Computing*, New York: McGraw-Hill, 1994.

A

AEN. See *asynchronous event notification*.

archiving. The storage of backup files and associated journals, usually for a given period.

archiving application. The retention of records, in machine-readable form, for historical purposes.

asynchronous event notification (AEN). The ability of a device to initiate communications with attached hosts.

automatic mode. A mode of operation that can be selected on the cartridge loader. This mode allows the automatic feeding and loading of premounted tape cartridges requiring no operator action.

B

backup and recovery application. The short-term retention of records used for restoring essential business and system files when vital data has been lost because of program or system errors or malfunctions.

bit. A binary digit that may have the value of either 0 or 1.

block. A collection of contiguous data recorded as a unit.

buffer. A routine or storage used to compensate for a difference in the rate of flow of data, or time of occurrence of events, when transferring data from one device to another.

buffered mode. A mode that allows some logical blocks to accumulate in a buffer before the data is transferred to the device or bus.

byte. A binary number containing exactly eight bits.

C

capacity of media. The amount of data that can be contained on storage media and expressed in bytes of data.

cartridge loader. A standard function for the tape drive. It allows the automatic loading of premounted tape cartridges or the manual loading of single tape cartridges.

command. Control information that initiates an action or the beginning of a sequence of actions.

conversion. The process of changing from one method of data processing to another or from one data-processing system to another.

D

data. Any representations such as characters or analog quantities to which meaning is, or might be, assigned.

data base. A set of data, consisting of at least one file, that is sufficient for a given purpose or for a given data-processing system.

data compression. A technique or algorithm used to encode a quantity of data such that the encoded result can normally be stored in less space than the original data and such that the original data can be recovered from the encoded result through a reverse technique or reverse algorithm.

device driver. A technique for moving data between processor storage and input/output devices.

drive ready. A condition of a tape drive in which a tape cartridge has been inserted in the drive, and the tape has been positioned to the logical beginning-of-tape/load point position.

dump. To write the contents of storage, or a part of storage, usually from an internal storage to an external medium, for a specific purpose such as to allow other use of storage, as a safeguard against faults or errors, or with debugging.

E

effective data rate. The average number of bits, bytes, characters, or blocks per unit time transferred from a data source to a data sink and accepted as valid. The rate is expressed in bits, bytes, characters, or blocks per second, minute, or hour.

EIA. A unit of measure established by the Electronics Industry Association equal to 44.45 mm (1.75 in).

enable. To provide the means or opportunity. The modification of system, control unit, or device action through the change of a software module or a hardware switch (circuit jumper) position.

error-recovery procedures (ERP). Procedures designed to help isolate and, where possible, to recover from errors in equipment. The procedures are often used with programs that record the statistics of machine malfunctions.

F

FC. Feature code.

FID. Field Replaceable Unit (FRU) Identifier. FIDs are codes that are associated with error messages and each one indicates a specific problem condition. When a service call is made, the FID code should be given to your service representative.

file. A set of related records, treated as a unit. For example, in stock control, a file could consist of a set of invoices.

file protected. Pertaining to a tape volume from which data can be read only. Data cannot be written on the tape.

format. The arrangement or layout of data on a data medium.

formatted tape volume. A tape volume that has been initialized with certain formatting information (servo tracks) that is required to exist for the recording technique used on the volume before any data can be recorded. Depending on the format and media, formatting may or may not be required to use the media for data-recording purposes.

G

GB. Gigabyte; 1 000 000 000 bytes of storage.

I

index. A function performed by the cartridge loader that moves cartridges down the input or output stack one cartridge position. A loader can perform multiple consecutive indexes.

initiator. A SCSI device that requests an I/O process to be performed by another SCSI device (a target). In many cases, an initiator can also be a target.

install. To set up for use or service. The act of adding a product, feature, or function to a system or device either by a singular change or by the addition of multiple components or devices.

interchange. The ability to process (read or write) a given tape volume on any one of a set of tape devices that support the form factor and recording format on the tape volume.

interchange application. The preparation of tapes for use on other systems or devices, either local or remote, or the use of tape data prepared by another system.

interposer. An interposer is a part used to convert a 68-pin connector to a 50-pin D-shell connector.

I/O. Input/output.

L

label. A label is a control file that is associated with a data file that provides volume and file identification information. The label is a software construct that appears as any other file to the I/O subsystem.

loader. A standard function for the tape drive. It allows the automatic loading of premounted tape cartridges or the manual loading of single tape cartridges.

load point. The beginning of the recording area on magnetic tape.

logical block. A logical block is an independently accessible unit of information created by the program within a file. A logical block may be either a data logical block or a mark logical block.

logical record. A logical record is a string of concatenated data bytes that is passed between an application program and a control program or access method as the result of an I/O request.

LZ-1. Lempel-Ziv data compression program.

M

magnetic recording. A technique of storing data by selectively magnetizing portions of a magnetizable material.

magnetic tape. A tape with a magnetizable surface layer on which data can be stored by magnetic recording.

magnetic tape drive. A mechanism for moving magnetic tape and controlling its movement.

manual (sequential) mode. A mode of operation that can be selected on the cartridge loader. This mode allows a single tape cartridge feed performed by the operator.

MB. Megabyte; 1 000 000 bytes of storage.

media capacity. The amount of data that can be contained on storage media and expressed in bytes of data.

microprocessor. An integrated circuit that accepts coded instructions for execution. The instructions may be entered, integrated, or stored internally.

microprogram. (1) A sequence of elementary instructions that correspond to a specific computer operation, that is maintained in special storage, and whose execution is initiated by the introduction of a computer instruction into the instruction register of a computer. (2) A group of micro instructions that when executed perform a preplanned function.

migration. The process of changing from one method of data processing to another or from one data-processing system to another.

mount. The act of making a tape volume available for processing by a specific tape device.

mounted. The state of a tape volume while it is available for processing by a specific tape device.

MP. Multipurpose. Designates the suitability of the Magstar MP 3570 Tape Subsystem for a wide variety of applications beyond those for which tape subsystems are ordinarily used. This designation is based on the high-performance characteristics, of the Magstar MP system, the most notable being the unit's high speed.

P

physical-write protection. A facility provided by the mechanical housing of the tape volume that allows a human being or robotics device to write protect a tape volume. Physical-write protection persists until the state of the facility on the tape volume is changed.

processing application. The execution of a systematic sequence of operations performed on data to accomplish a specific purpose.

Q

quiesce. To bring a device or system to a halt by a rejection of new requests for work.

R

random access. Random access refers to the processing of information on a volume in a manner that requires the device to access nonconsecutive storage locations on the medium.

removable media. Recording media that can be added to or removed from a recording device.

S

SCSI. Small computer system interface.

SCSI address. The hexadecimal representation of the unique address (0–F) assigned to a SCSI device. This address would normally be assigned and set in the SCSI device during system installation.

SCSI device. A host adapter or a target controller that can be attached to a SCSI bus.

sequential access. Refers to the processing of information on a volume in a manner that requires the device to access consecutive storage locations (logical blocks) on the medium.

sequential mode. See *automatic mode* or *manual mode*.

ship group. The group of supplies, cords, or documentation that is shipped with the machine.

special feature. A specific design addition to an IBM product that is quoted in the IBM Sales Manual and ordered separately.

standard function. The significant design elements of an IBM product that are included as part of the basic standard product.

T

tape cartridge. A container holding magnetic tape that can be processed without separating it from the container.

tape volume. The recording medium and associated mechanical package that houses the media used by a tape device. See also *volume*.

target. A SCSI device that performs an operation requested by the initiator. A target can also be an initiator.

terminator. A part used to end a SCSI bus.

V

volume. (1) A certain portion of data, together with its data carrier, that can be handled conveniently as a unit. (2) A data carrier that is mounted and demounted as a unit, for example, a tape cartridge.

W

write protected. A tape volume is write protected if some logical or physical mechanism causes the device processing the tape volume to prevent the program from writing on the volume.

Index

A

acoustical characteristics 44
applications
 journal 30
 overview 27
 process 31
 programming 33
AS/400 system 1, 18, 19, 50
assignments, task 53
attention notice 57
automatic (sequential) mode 13

B

Base Configuration 15, 45
buffered read and write modes 27
bus termination 45

C

cables
 power cord 41
 power plug 42
 SCSI 45, 47
cartridge, tape
 cleaning 4, 8
 file-protect selector 7
 label 23
 load point 19
 magazine 10
 ordering 23
 part number 23
 recording format 7
caution notice 57
checklist, planning 54
cleaning cartridge 8
clearance, service 36
code, feature 47, 50
compression, data 17, 28
configuration 54
controller, RISC System/6000 48
conversion, model 6
cooling requirement 44
copy files 32
current, in-rush 39

D

danger notice 56
data rate 3, 17
device-dependent parameter 28
dimensions
 Model C00 35
 Model C01 35
 Model C02 35
 Model C11 35
 Model C12 35
 Model C21 35

dimensions (*continued*)
 Model C22 35

E

effective data rate 17
end of life (EOL) plan 26, 58
environmental design 58
environmental notice 58
environmental specifications 44
erase, data security 28
export position, cartridge magazine 10

F

fast access linear tape cartridge, Magstar MP 7
feature code 20, 46, 47, 50
file-protect selector 7
floor plan 36, 37
forward space file 28

H

hazard, safety 57
heat output 39
horizontal orientation, device 21

I

import position, cartridge magazine 10
in-rush current 39
installation
 conversion 26
 customer 25
 floor plan 36
 rack mount 38
interposer, RISC System/6000 48

L

LED indicator 39
limited warranty 63
LZ-1, data compression 28, 29

M

magazine, cartridge 10
manual (sequential) mode 14
migration
 list of tasks 32
 planning 30
 sequence of events 31
 strategy 32
 verifying 33
mode of operation 13, 14
Model C00
 data transfer rate 3
 dimensions 35

Model C00 (continued)

- floor plan 36
- horizontal 21
- installation 25
- operator panel 11
- overview 1
- power supply 39
- vertical 21
- weight 35

Model C01

- conversion (to Model C02) 6
- data transfer rate 3
- dimensions 35
- floor plan 37
- front panel assembly 11
- horizontal 21
- installation 25
- overview 1
- power supply 39
- vertical 21
- weight 35

Model C02

- conversion (from Model C00) 6
- data transfer rate 3
- dimensions 35
- floor plan 37
- front panel assembly 11
- horizontal 21
- installation 25
- overview 1
- power supply 39
- vertical 21
- weight 35

Model C11

- conversion (to Model C12) 6
- data transfer rate 3
- dimensions 35
- front panel assembly 11
- horizontal 21
- installation 25
- overview 1
- power supply 39
- rack mount 38
- weight 35

Model C12

- conversion (from Model C02) 6
- data transfer rate 3
- dimensions 35
- front panel assembly 11
- horizontal 21
- installation 25
- overview 1
- power supply 39
- rack mount 38
- weight 35

Model C1A

- conversion 6
- reference 1

Model C21

- dimensions 35
- horizontal 21

Model C21 (continued)

- overview 1
- power supply 39
- rack mount 38
- vertical 21
- weight 35

Model C22

- dimensions 35
- horizontal 21
- overview 1
- power supply 39
- rack mount 38
- vertical 21
- weight 35

N

- NETBAY22 42
- Netfinity 1, 2, 3, 4, 18, 35, 38, 42, 47, 50
- notice, caution 57
- number for cartridge, part 23
- number for SCSI cable, part 47

O

- operation, mode of 13, 14
- operator tasks 25
- ordering supplies 23, 54
- orientation, horizontal or vertical 21
- overview, Magstar MP 3570 Tape Subsystem 1

P

- parameter, device-dependent 28
- plan, floor 36
- planning
 - checklist 54
 - equipment 23
 - installation 25
 - operations 29
 - operator training 25
 - site 35
 - software support 25
 - supplies 23
 - tasks 53
- position, cartridge import or export 10
- power
 - control switch 39
 - cord 40
 - plug 41, 42
 - receptacle 40
 - supply 39
- processing speed, tape 17
- product recycling 58
- program support 18
- protect selector, file 7

R

- rack mount 38
- random mode 13

- rate, data 3, 17
- read and write buffered modes 27
- recording format, cartridge 7
- recycling, product 58
- RISC System/6000
 - cabling 46
 - controller 48
 - interposer 48
 - SCSI attachment 46

S

- safety notice 56
- scratch pool cartridges 31
- SCSI
 - attachment 45
 - bus jumper 45
 - bus termination 45
 - cable feature code 47
 - configuration 45
 - device type 45
 - feature code 46
 - physical interface 45
 - status and sense bytes 27
- security erase, data 28
- selector, file-protect 7
- sequential mode 14
- service clearance 36
- ship group 23
- site planning 35
- space file, forward 28
- specifications
 - cooling 44
 - environmental 44
 - floor plan 36
 - physical 35
 - power cord 41
 - power supply 39
 - rack mount 38
- speed, tape processing 17
- Split Configuration 15, 45
- status and sense bytes 27
- support
 - AS/400 18
 - RISC System/6000 18

T

- tape
 - archive 30
 - interchange 30
 - journal 30
 - migration strategy 32
 - process 31
 - scratch 31
- tape cartridge, fast access linear
 - cleaning 8
 - magazine 10
 - recording format 7
- task assignments 53

- temperature
 - nonoperating 44
 - operating 44
 - shipping 44
- termination, bus 45
- trademarks 58
- training, operator 25
- transfer rate, data 3, 17

U

- unbuffered write mode 27
- update in place 27

V

- verifying data migration 33
- vertical orientation, device 21

W

- weight 35
- write mode, buffered or unbuffered 27

Readers' Comments — We'd Like to Hear from You

**Magstar MP 3570 Tape Subsystem
Introduction and Planning Guide
C-Series Models**

Publication No. GA32-0392-02

Overall, how satisfied are you with the information in this book?

	Very Satisfied	Satisfied	Neutral	Dissatisfied	Very Dissatisfied
Overall satisfaction	<input type="checkbox"/>	<input type="checkbox"/>	<input type="checkbox"/>	<input type="checkbox"/>	<input type="checkbox"/>

How satisfied are you that the information in this book is:

	Very Satisfied	Satisfied	Neutral	Dissatisfied	Very Dissatisfied
Accurate	<input type="checkbox"/>	<input type="checkbox"/>	<input type="checkbox"/>	<input type="checkbox"/>	<input type="checkbox"/>
Complete	<input type="checkbox"/>	<input type="checkbox"/>	<input type="checkbox"/>	<input type="checkbox"/>	<input type="checkbox"/>
Easy to find	<input type="checkbox"/>	<input type="checkbox"/>	<input type="checkbox"/>	<input type="checkbox"/>	<input type="checkbox"/>
Easy to understand	<input type="checkbox"/>	<input type="checkbox"/>	<input type="checkbox"/>	<input type="checkbox"/>	<input type="checkbox"/>
Well organized	<input type="checkbox"/>	<input type="checkbox"/>	<input type="checkbox"/>	<input type="checkbox"/>	<input type="checkbox"/>
Applicable to your tasks	<input type="checkbox"/>	<input type="checkbox"/>	<input type="checkbox"/>	<input type="checkbox"/>	<input type="checkbox"/>

Please tell us how we can improve this book:

Thank you for your responses. May we contact you? Yes No

When you send comments to IBM, you grant IBM a nonexclusive right to use or distribute your comments in any way it believes appropriate without incurring any obligation to you.

Name

Address

Company or Organization

Phone No.



Fold and Tape

Please do not staple

Fold and Tape



NO POSTAGE
NECESSARY
IF MAILED IN THE
UNITED STATES

BUSINESS REPLY MAIL

FIRST-CLASS MAIL PERMIT NO. 40 ARMONK, NEW YORK

POSTAGE WILL BE PAID BY ADDRESSEE

International Business Machine Corporation
Department 61C 9000 South Rita Road
TUCSON AZ 85775-4401



Fold and Tape

Please do not staple

Fold and Tape



Printed in the United States of America
on recycled paper containing 10%
recovered post-consumer fiber.

GA32-0392-02

