

IBM TotalStorage DS300  
and DS400



# Hardware Maintenance Manual



IBM TotalStorage DS300  
and DS400



# Hardware Maintenance Manual

**Note**

Before using this information and the product it supports, be sure to read the general information in Appendix C, "Notices," on page 55

**Fourth Edition (April 2005)**

**© Copyright International Business Machines Corporation 2004, 2005. All rights reserved.**

US Government Users Restricted Rights – Use, duplication or disclosure restricted by GSA ADP Schedule Contract with IBM Corp.

# Safety

Before installing this product, read the Safety Information.

قبل تركيب هذا المنتج، يجب قراءة الملاحظات الأمنية

Antes de instalar este produto, leia as Informações de Segurança.

在安装本产品之前，请仔细阅读 **Safety Information** (安全信息)。

安裝本產品之前，請先閱讀「安全資訊」。

Prije instalacije ovog produkta obavezno pročitajte Sigurnosne Upute.

Před instalací tohoto produktu si přečtěte příručku bezpečnostních instrukcí.

Læs sikkerhedsforskrifterne, før du installerer dette produkt.

Lees voordat u dit product installeert eerst de veiligheidsvoorschriften.

Ennen kuin asennat tämän tuotteen, lue turvaohjeet kohdasta Safety Information.

Avant d'installer ce produit, lisez les consignes de sécurité.

Vor der Installation dieses Produkts die Sicherheitshinweise lesen.

Πριν εγκαταστήσετε το προϊόν αυτό, διαβάστε τις πληροφορίες ασφάλειας (safety information).

לפני שתתקינו מוצר זה, קראו את הוראות הבטיחות.

A termék telepítése előtt olvassa el a Biztonsági előírásokat!

Prima di installare questo prodotto, leggere le Informazioni sulla Sicurezza.

製品の設置の前に、安全情報をお読みください。

본 제품을 설치하기 전에 안전 정보를 읽으십시오.

Пред да се инсталира овој продукт, прочитајте информацијата за безбедност.

Les sikkerhetsinformasjonen (Safety Information) før du installerer dette produktet.

Przed zainstalowaniem tego produktu, należy zapoznać się z książką "Informacje dotyczące bezpieczeństwa" (Safety Information).

Antes de instalar este produto, leia as Informações sobre Segurança.

Перед установкой продукта прочтите инструкции по технике безопасности.

Pred inštaláciou tohto zariadenia si pečítajte Bezpečnostné predpisy.

Pred namestitvijo tega proizvoda preberite Varnostne informacije.

Antes de instalar este producto, lea la información de seguridad.

Läs säkerhetsinformationen innan du installerar den här produkten.

## Important:

All caution and danger statements in this documentation begin with a number. This number is used to cross reference an English caution or danger statement with translated versions of the caution or danger statement in the *IBM Safety Information* book.

For example, if a caution statement begins with a number 1, translations for that caution statement appear in the *IBM Safety Information* book under statement 1.

Be sure to read all caution and danger statements in this documentation before performing the instructions. Read any additional safety information that comes with your server or optional device before you install the device.

### Statement 1:



### DANGER

**Electrical current from power, telephone, and communication cables is hazardous.**

**To avoid a shock hazard:**

- **Do not connect or disconnect any cables or perform installation, maintenance, or reconfiguration of this product during an electrical storm.**
- **Connect all power cords to a properly wired and grounded electrical outlet.**
- **Connect to properly wired outlets any equipment that will be attached to this product.**
- **When possible, use one hand only to connect or disconnect signal cables.**
- **Never turn on any equipment when there is evidence of fire, water, or structural damage.**
- **Disconnect the attached power cords, telecommunications systems, networks, and modems before you open the device covers, unless instructed otherwise in the installation and configuration procedures.**
- **Connect and disconnect cables as described in the following table when installing, moving, or opening covers on this product or attached devices.**

**To Connect:**

1. Turn everything OFF.
2. First, attach all cables to devices.
3. Attach signal cables to connectors.
4. Attach power cords to outlet.
5. Turn device ON.

**To Disconnect:**

1. Turn everything OFF.
2. First, remove power cords from outlet.
3. Remove signal cables from connectors.
4. Remove all cables from devices.





**Statement 2:**



**CAUTION:**

**When replacing the lithium battery, use only IBM Part Number 33F8354 or an equivalent type battery recommended by the manufacturer. If your system has a module containing a lithium battery, replace it only with the same module type made by the same manufacturer. The battery contains lithium and can explode if not properly used, handled, or disposed of.**

*Do not:*

- **Throw or immerse into water**
- **Heat to more than 100°C (212°F)**
- **Repair or disassemble**

**Dispose of the battery as required by local ordinances or regulations.**

**Statement 3:**



**CAUTION:**

When laser products (such as CD-ROMs, DVD drives, fiber optic devices, or transmitters) are installed, note the following:

- Do not remove the covers. Removing the covers of the laser product could result in exposure to hazardous laser radiation. There are no serviceable parts inside the device.
- Use of controls or adjustments or performance of procedures other than those specified herein might result in hazardous radiation exposure.



**DANGER**

Some laser products contain an embedded Class 3A or Class 3B laser diode. Note the following.

Laser radiation when open. Do not stare into the beam, do not view directly with optical instruments, and avoid direct exposure to the beam.



Class 1 Laser Product  
Laser Klasse 1  
Laser Klass 1  
Luokan 1 Laserlaite  
Appareil À Laser de Classe 1

**Statement 4:**



≥ 18 kg (39.7 lb)



≥ 32 kg (70.5 lb)



≥ 55 kg (121.2 lb)

**CAUTION:**  
Use safe practices when lifting.

**Statement 5:**



**CAUTION:**  
The power control button on the device and the power switch on the power supply do not turn off the electrical current supplied to the device. The device also might have more than one power cord. To remove all electrical current from the device, ensure that all power cords are disconnected from the power source.

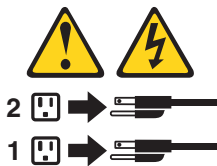

Statement 8:



**CAUTION:**

Never remove the cover on a power supply or any part that has the following label attached.



Hazardous voltage, current, and energy levels are present inside any component that has this label attached. There are no serviceable parts inside these components. If you suspect a problem with one of these parts, contact a service technician.

Statement 10:



**CAUTION:**

Do not place any object weighing more than 82 kg (180 lb) on top of rack-mounted devices.



>82 kg (180 lb)

**WARNING:** Handling the cord on this product or cords associated with accessories sold with this product, will expose you to lead, a chemical known to the State of California to cause cancer, and birth defects or other reproductive harm. **Wash hands after handling.**

**ADVERTENCIA:** El contacto con el cable de este producto o con cables de accesorios que se venden junto con este producto, pueden exponerle al plomo, un elemento químico que en el estado de California de los Estados Unidos está considerado como un causante de cáncer y de defectos congénitos, además de otros riesgos reproductivos. **Lávese las manos después de usar el producto.**

---

# Contents

<b>Safety</b> . . . . .	iii
<b>Chapter 1. Introduction</b> . . . . .	1
About this document . . . . .	1
Who should read this document . . . . .	1
How this document is organized . . . . .	2
Where to start. . . . .	2
Notices and statements used in this document. . . . .	2
The IBM Documentation CD . . . . .	3
Hardware and software requirements . . . . .	3
Using the Documentation Browser . . . . .	3
Related documentation . . . . .	4
<b>Chapter 2. IBM TotalStorage DS300 storage subsystem type 1701 (models 1RL, 1RS, 2RD)</b> . . . . .	5
General checkout . . . . .	5
General information . . . . .	5
Additional service information . . . . .	6
Specifications . . . . .	6
Storage subsystem components . . . . .	6
Storage subsystem controls and LEDs . . . . .	10
Cache memory and RAID controller battery . . . . .	12
Diagnostics . . . . .	12
Monitoring status through software . . . . .	12
Using the diagnostic hardware . . . . .	12
Symptom-to-FRU index. . . . .	13
Parts listing . . . . .	17
<b>Chapter 3. IBM TotalStorage DS400 type 1700 (models 1RS, 2RD) storage subsystem</b> . . . . .	21
General checkout . . . . .	21
General information . . . . .	21
Additional service information . . . . .	21
Specifications . . . . .	21
Storage subsystem components . . . . .	22
Storage subsystem controls and LEDs . . . . .	24
Cache memory and RAID controller battery . . . . .	26
Diagnostics . . . . .	26
Monitoring status through software . . . . .	27
Using the diagnostic hardware . . . . .	27
Symptom-to-FRU index. . . . .	27
Parts listing . . . . .	31
<b>Appendix A. Installing and replacing components</b> . . . . .	33
Installation guidelines . . . . .	33
System reliability guidelines . . . . .	33
Handling static-sensitive devices . . . . .	33
Installing and removing the bezel on DS300 Models 1700-1RS and 1700-2RD, and DS400 . . . . .	34
Installing and removing the bezel on the DS300 type 1701 (model 1RL) . . . . .	35
Installing a hot-swap hard disk drive . . . . .	36
Replacing a hot-swap hard disk drive . . . . .	37
Replacing the real-time clock battery in the RAID controller . . . . .	38

Replacing the cache battery in the RAID controller . . . . .	41
Replacing a cache memory module . . . . .	44
Replacing a RAID controller . . . . .	46
Replacing a hot-swap power supply . . . . .	50
<b>Appendix B. Getting help and technical assistance . . . . .</b>	<b>53</b>
Before you call . . . . .	53
Using the documentation . . . . .	53
Getting help and information from the World Wide Web . . . . .	53
Software service and support . . . . .	54
Hardware service and support . . . . .	54
<b>Appendix C. Notices . . . . .</b>	<b>55</b>
Edition notice . . . . .	55
Trademarks . . . . .	56
Important notes. . . . .	56
Product recycling and disposal . . . . .	57
Battery return program . . . . .	57
Electronic emission notices . . . . .	57
Federal Communications Commission (FCC) statement . . . . .	57
Chinese Class A warning statement . . . . .	58
Industry Canada Class A emission compliance statement . . . . .	58
Australia and New Zealand Class A statement . . . . .	58
United Kingdom telecommunications safety requirement. . . . .	58
European Union EMC Directive conformance statement. . . . .	58
Taiwan Class A warning statement. . . . .	59
Japanese Voluntary Control Council for Interference (VCCI) statement . . . . .	59
Power cords . . . . .	59
<b>Index . . . . .</b>	<b>63</b>

---

## Chapter 1. Introduction

The *IBM® TotalStorage® DS300 and DS400 Hardware Maintenance Manual* contains basic information, such as specifications and symptom lists, about the IBM TotalStorage DS300 and DS400 storage subsystems. You can use this information to perform basic hardware maintenance and resolve problems on your storage subsystem. You can also use this information to complete the tasks given in the problem determination procedures provided in the *IBM TotalStorage DS300 Problem Determination Guide* and *DS400 Problem Determination Guide*. Each Problem Determination Guide is an interactive document that is available on the IBM support Web site:

<http://www.ibm.com/pc/support/site.wss/document.do?Indocid=MIGR-56887>

**Note:** The component information that is provided in the maintenance portion of this document has been extracted from the individual installation and user's guides for each component. Therefore, you might find it helpful to see the individual installation and user's guides for specific components.

The storage subsystem documentation might be updated occasionally to include information about new features, a translated version of the documentation might be available in your language, or technical updates might be available to provide additional information that is not included in the storage subsystem documentation. These updates are available from the IBM Web site. Complete the following steps to check for updated documentation and technical updates:

1. Go to <http://www.ibm.com/pc/support/>.
2. In the **Browse by topic** section, click **Publications**.
3. On the Publications page, in the **Brand** field, select **Servers**.
4. In the **Family** field, select **TotalStorage DS300** or **TotalStorage DS400**.
5. Click **Continue**.

For a list of supported options for the storage subsystem, go to the ServerProven® Web site at <http://www.ibm.com/pc/compat/>.

See the *Rack Installation Instructions* that comes with the storage subsystem for complete rack installation and removal instructions.

---

### About this document

This document provides information about hardware maintenance for the IBM TotalStorage DS300 and DS400 storage subsystems. Use this document for the following tasks:

- Diagnose and troubleshoot system faults
- Configure and service hardware
- Determine system specifications
- Interpret system data

### Who should read this document

This document is intended for system operators and service technicians who have extensive knowledge of Fibre Channel, iSCSI, and network technology.

## How this document is organized

This document contains the following chapters:

Chapter 1, "Introduction," on page 1 provides a brief overview on how to use the hardware maintenance, diagnostic, and test information provided in this document.

Chapter 2, "IBM TotalStorage DS300 storage subsystem type 1701 (models 1RL, 1RS, 2RD)," on page 5 provides service and diagnostic information for the TotalStorage DS300 storage subsystem.

Chapter 3, "IBM TotalStorage DS400 type 1700 (models 1RS, 2RD) storage subsystem," on page 21 provides service and diagnostic information for the TotalStorage DS400 storage subsystem.

Appendix A, "Installing and replacing components," on page 33 provides instructions for installing and replacing hardware components in the storage subsystem.

"Power cords" on page 59 lists required power cords for the storage subsystems discussed in this document by country and region.

## Where to start

Start with the General Checkout sections in each chapter to help you to diagnose problems with the IBM fibre channel and iSCSI products that this document describes.

To diagnose problems, see the Symptom-to-FRU index for the applicable storage subsystem.

## Notices and statements used in this document

The caution and danger statements that appear in this document are also in the multilingual *Safety Information* document, which is on the IBM *Documentation CD*. Each statement is numbered for reference to the corresponding statement in the *Safety Information* document.

The following notices and statements are used in this document:

- **Note:** These notices provide important tips, guidance, or advice.
- **Important:** These notices provide information that might help you avoid inconvenient or problem situations.
- **Attention:** These notices indicate possible damage to programs, devices, or data. An attention notice is placed just before the instruction or situation in which damage could occur.
- **Caution:** These statements indicate situations that can be potentially hazardous to you. A caution statement is placed just before the description of a potentially hazardous procedure step or situation.
- **Danger:** These statements indicate situations that can be potentially lethal or extremely hazardous to you. A danger statement is placed just before the description of a potentially lethal or extremely hazardous procedure step or situation.



---

## The IBM Documentation CD

The IBM *Documentation* CD contains documentation for your storage subsystem in Portable Document Format (PDF) and includes the IBM Documentation Browser to help you find information quickly.

### Hardware and software requirements

The IBM *Documentation* CD requires the following minimum hardware and software:

- Microsoft® Windows® 2000, or Red Hat Linux.
- 100 MHz microprocessor.
- 32 MB of RAM.
- Adobe Acrobat Reader 3.0 (or later) or xpdf, which comes with Linux operating systems. Acrobat Reader software is included on the CD, and you can install it when you run the Documentation Browser.

### Using the Documentation Browser

Use the Documentation Browser to browse the contents of the CD, read brief descriptions of the documents, and view documents using Adobe Acrobat Reader or xpdf. The Documentation Browser automatically detects the regional settings in use in your system and displays the documents in the language for that region (if available). If a document is not available in the language for that region, the English version is displayed.

Use one of the following procedures to start the Documentation Browser:

- If Autostart is enabled, insert the CD into your CD-ROM drive. The Documentation Browser starts automatically.
- If Autostart is disabled or is not enabled for all users, use one of the following procedures:
  - If you are using a Windows operating system, insert the CD into the CD-ROM drive and click **Start --> Run**. In the **Open** field, type  
`e:\win32.bat`  
  
where *e* is the drive letter of the CD-ROM drive, and click **OK**.
  - If you are using Red Hat Linux, insert the CD into the CD-ROM drive; then, run the following command from the `/mnt/cdrom` directory:  
`sh runlinux.sh`

Select your storage subsystem from the **Product** menu. The **Available Topics** list displays all the documents for the storage subsystem. Some documents might be in folders. A plus sign (+) indicates each folder or document that has additional documents under it. Click the plus sign to display the additional documents.

When you select a document, a description of the document appears under **Topic Description**. To select more than one document, press and hold the Ctrl key while you select the documents. Click **View Book** to view the selected document or documents in Acrobat Reader or xpdf. If you selected more than one document, all the selected documents are opened in Acrobat Reader or xpdf.

To search all the documents, type a word or word string in the **Search** field and click **Search**. The documents in which the word or word string appears are listed in

order of the most occurrences. Click a document to view it, and press Ctrl+F to use the Acrobat search function or Alt+F to use the xpdf search function within the document.

Click **Help** for detailed information about using the Documentation Browser.

---

## Related documentation

This *Hardware Maintenance Manual* contains information to help you solve problems yourself, and it contains information for service technicians.

- *IBM TotalStorage DS300 and DS400 Hardware Installation and User's Guide*  
This document is in PDF on the IBM *Documentation CD*. This document provides general information about the storage subsystem, including information about features, how to configure the storage subsystem, and how to get help.
- *IBM TotalStorage DS300 and DS400 Quick Installation Guide*  
This printed document contains the basic information you need to get the storage subsystem installed and running.
- *IBM TotalStorage DS300 and DS400 Software Installation Guide*  
This document is in PDF on the IBM *Documentation CD*. It contains information about installing the IBM ServeRAID™ Manager program and the using the FlashCopy® Management Command Line Tool.
- *Safety Information*  
This document is in PDF on the IBM *Documentation CD*. It contains translated caution and danger statements. Each caution and danger statement that appears in the documentation has a number that you can use to locate the corresponding statement in your language in the *Safety Information* document.
- *Rack Installation Instructions*  
This printed document contains instructions for installing the storage subsystem in a rack.
- *IBM TotalStorage DS300 Problem Determination Guide* and *IBM TotalStorage DS400 Problem Determination Guide*  
Each Problem Determination Guide is an interactive document that is available on the IBM Support Web site:  
<http://www.ibm.com/pc/support/site.wss/document.do?Indocid=MIGR-56887>  
The guide addresses problems that you might encounter with the DS300 or DS400 storage subsystem during and after installation. It uses flowcharting techniques to guide you in the isolation and correction of problems.

---

## Chapter 2. IBM TotalStorage DS300 storage subsystem type 1701 (models 1RL, 1RS, 2RD)

This chapter covers basic hardware maintenance information for the DS300 storage subsystem type 1701 (models 1RL, 1RS, 2RD). For more detailed information on the installation and use of the DS300 storage subsystem, refer to the *DS300 and DS400 Hardware Installation and User's Guide*.

**Note:** The problem determination maps found in the *DS300 and DS400 Problem Determination Guides* provide you with additional diagnostic aids.

---

### General checkout

Use the status LEDs, ServerRAID Manager software, and the Symptom-to-FRU index to diagnose problems. See “Storage subsystem controls and LEDs” on page 10, “Monitoring status through software” on page 12, and “Symptom-to-FRU index” on page 13.

To diagnose problems with the DS300 storage subsystem, you can also refer to the *DS300 and DS400 Problem Determination Guides*.

The guide addresses problems that you might encounter with the DS300 or DS400 storage subsystem during and after installation. It uses flowcharting techniques to guide you in the isolation and correction of problems.

### General information

There are three models of the DS300 storage subsystem type 1701 (models 1RL, 1RS, 2RD).

- The IBM TotalStorage DS300 storage subsystem model 1RL comes with the following components:
  - One iSCSI RAID controller
  - 7 hard disk drive filler panels
  - One power supply
  - One or more power cords
- The IBM TotalStorage DS300 storage subsystem model 1RS comes with the following components:
  - One iSCSI RAID controller
  - 14 hard disk drive filler panels
  - Two power supplies
  - One or more power cords
- The IBM TotalStorage DS300 storage subsystem model 2RD comes with the following components:
  - Two iSCSI RAID controller
  - 14 hard disk drive filler panels
  - Two power supplies
  - One or more power cords

## Additional service information

This section provides additional service information about the DS300 storage subsystem.

## Specifications

The following information is a summary of the specifications of the storage subsystem. Depending on the storage subsystem model, some specifications might not apply.

Racks are marked in vertical increments of 1.75 inches. Each increment is referred to as a unit, or “U.” A 1-U-high device is 1.75 inches tall.

Table 1. DS300 storage subsystems operating specifications

<p><b>Size (measured from front of hard disk drive to rear of unit)</b></p> <ul style="list-style-type: none"> <li>• Depth: 584 mm (23.0 in.)</li> <li>• Height: 128 mm (5.0 in)</li> <li>• Width: 442 mm (17.4 in)</li> </ul> <p><b>Heat output</b></p> <ul style="list-style-type: none"> <li>• 558 watts (1903.96 Btu/hr)</li> </ul> <p><b>Weight</b></p> <ul style="list-style-type: none"> <li>• Standard storage server as shipped (without hard disk drives): 48.2 kg (106 lb)</li> <li>• Standard storage server as shipped (with 14 hard disk drives): 62.2 kg (137 lb)</li> <li>• Unit weight (without hard disk drives): 25.9 kg (57 lb)</li> <li>• Unit weight (with hard disk drives): 39 kg (86 lb)</li> </ul> <p><b>Electrical input</b></p> <ul style="list-style-type: none"> <li>• Sine-wave input (50 to 60 Hz) is required</li> <li>• Input voltage: <ul style="list-style-type: none"> <li>– Low range: <ul style="list-style-type: none"> <li>- Minimum: 90 V ac</li> <li>- Maximum: 136 V ac</li> </ul> </li> <li>– High range: <ul style="list-style-type: none"> <li>- Minimum: 198 V ac</li> <li>- Maximum: 264 V ac</li> </ul> </li> <li>– Approximate input kilovolt-amperes (kVA): <ul style="list-style-type: none"> <li>- Minimum configuration: 0.06 kVA</li> <li>- Maximum configuration: 0.56 kVA</li> </ul> </li> </ul> </li> </ul>	<p><b>Environment</b></p> <ul style="list-style-type: none"> <li>• Air temperature: <ul style="list-style-type: none"> <li>– Storage server on: <ul style="list-style-type: none"> <li>10° to 35°C (50° to 95°F)</li> <li>Altitude: 0 to 914 m (3000 ft)</li> </ul> </li> <li>– Storage server on: <ul style="list-style-type: none"> <li>10° to 32°C (50° to 90°F)</li> <li>Altitude: 914 m (3000 ft) to 2133 m (7000 ft)</li> </ul> </li> </ul> </li> <li>• Humidity: <ul style="list-style-type: none"> <li>– 8% to 80%</li> </ul> </li> </ul>	<p><b>Acoustical noise emissions:</b> For maximum system configurations (14 hard disk drives installed).</p> <ul style="list-style-type: none"> <li>• Sound power (operating): 5.7 bels (typical)</li> <li>• Sound pressure (operating): 42 dBA (typical)</li> </ul> <p><b>Note:</b> These levels were measured in controlled acoustical environments according to the procedures specified by the American National Standards Institute (ANSI) S12.10 and ISO 7779 and are reported in accordance with ISO 9296. Actual sound-pressure levels in a given location might exceed the average values stated because of room reflections and other nearby noise sources. The declared sound-power levels indicate an upper limit, below which a large number of computers will operate</p>
--	---	---

## Storage subsystem components

The following sections show the components of the storage subsystem.

The hot-swap features of the storage subsystem enable you to remove and replace hard disk drives and power supplies without turning off the storage subsystem. Therefore, you can maintain the availability of the system while a hot-swap device is removed, installed, or replaced.

## Front view

The following illustration shows the components and controls on the front of the DS300 type 1701 (models 1RS, 2RD) storage subsystem.

**Note:** The illustrations in this document might differ slightly from your hardware.

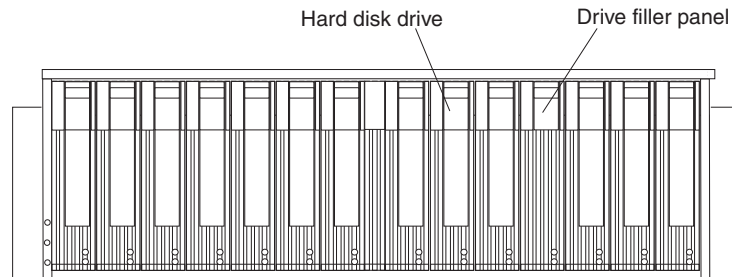

Figure 1. DS300 (type 1701 (models 1RS, 2RD) storage subsystem front components

### Hard disk drive

You can install up to 14 Ultra320 hot-swap hard disk drive *customer replaceable units* (CRUs) in the storage subsystem. Each hard disk drive CRU contains a hard disk drive and tray.

### Drive filler panel

The storage subsystem comes without installed hard disk drives and contains filler panels in the unused drive bays. Before installing new drives, you must remove the filler panels and save them. Each of the 14 bays must always contain either a filler panel or a hard disk drive to maintain proper cooling and airflow.

### Tray handle and latch

Use the blue latch on the tray handle to release or lock the hard disk drive in place.

For information about installing and replacing a hard disk drive, see “Installing a hot-swap hard disk drive” on page 36 and “Replacing a hot-swap hard disk drive” on page 37.

The following illustration shows the components and controls on the front of the DS300 (model 1RL) storage subsystem.

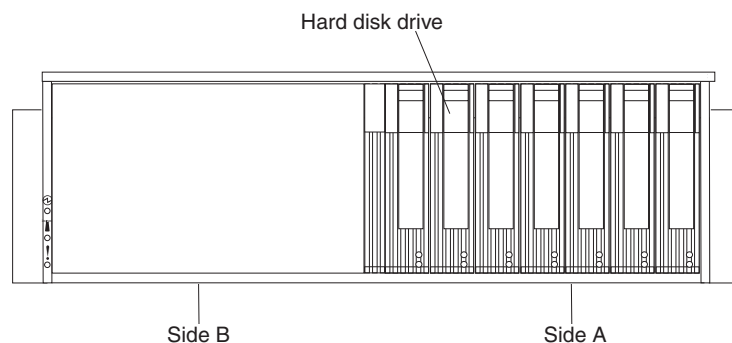

Figure 2. DS300 (model 1RL) storage subsystem front components

The DS300 (model 1RL) storage subsystem supports seven hard disk drives. You can add seven more hard disk drives with the purchase of a second power supply.

### Rear view

The following illustrations show the components at the rear of the two DS300 storage subsystem models.

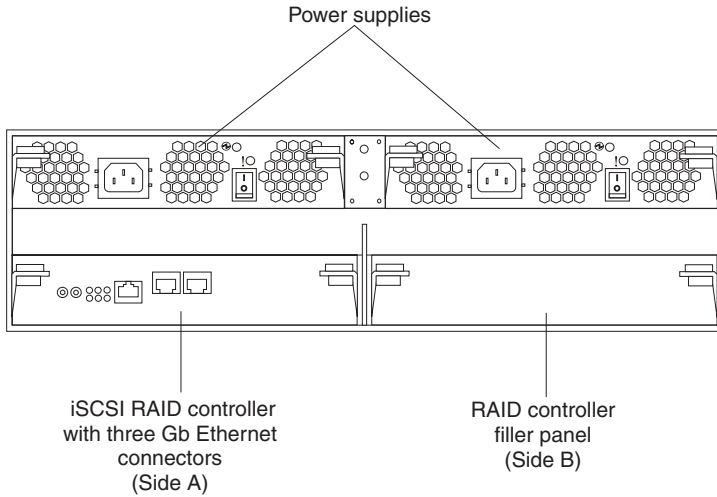

Figure 3. DS300 storage subsystem model 1RS rear view

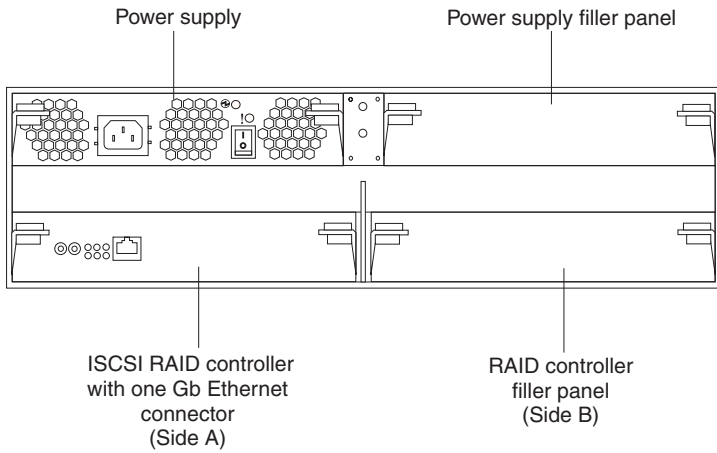

Figure 4. DS300 storage subsystem model 1RL rear view

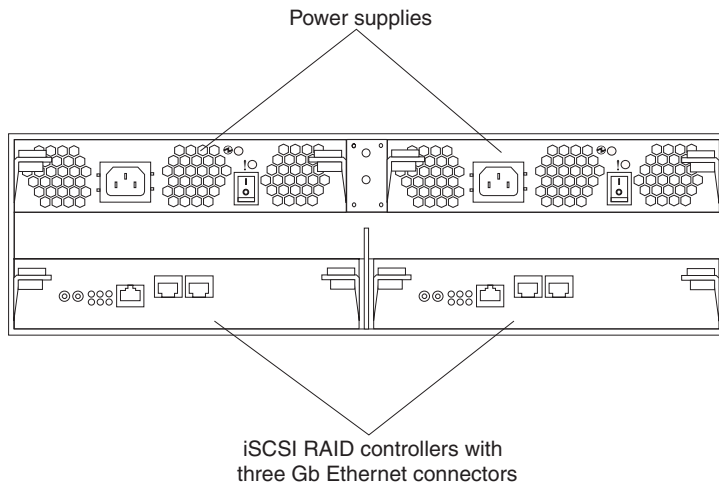

Figure 5. DS300 storage subsystem model 2RD rear view

### iSCSI RAID controller

The DS300 storage subsystem models come with one iSCSI RAID controller. There is a filler panel in the right RAID controller bay (side B), which must remain in place to maintain proper cooling.

The DS300 storage subsystem model 1RL contains one iSCSI RAID controller with one 1 Gb/sec (gigabit per second) Ethernet input connector for data and management and eight LEDs.

#### Notes:

1. Make sure that you always install a power supply above a controller.
2. The RAID controller in model 1RL does not contain a cache battery.

The DS300 storage subsystem model 1RS contains one iSCSI RAID controller with one 1 Gb/sec Ethernet input connector for management, two 1 Gb/sec Ethernet input connectors for data, and 12 LEDs.

The DS300 storage subsystem model 2RD contains two iSCSI RAID controller with one 1 Gb/sec Ethernet input connector for management, two 1 Gb/sec Ethernet input connectors for data, and 12 LEDs.

Each RAID controller also contains a cache battery to maintain cache data in the event of a power failure. For more information, see “Cache memory and RAID controller battery” on page 12.

### Power supply

The DS300 storage subsystem comes with either one or two hot-swap power supplies. Each unit is a self-contained power supply with three integral cooling fans, a power switch, and two status LEDs.

If the storage subsystem comes with only one power supply, there is a filler panel in the right power supply bay (side B). The filler panel must remain in place to maintain proper cooling.

**Note:** If storage subsystem model 1RL has only one power supply installed, both the RAID controller and the power supply must be installed in side A.

## Storage subsystem controls and LEDs

The following sections show the DS300 storage subsystem controls and LEDs.

### Front view

The following illustration shows the LEDs on the front of the DS300 storage subsystem.

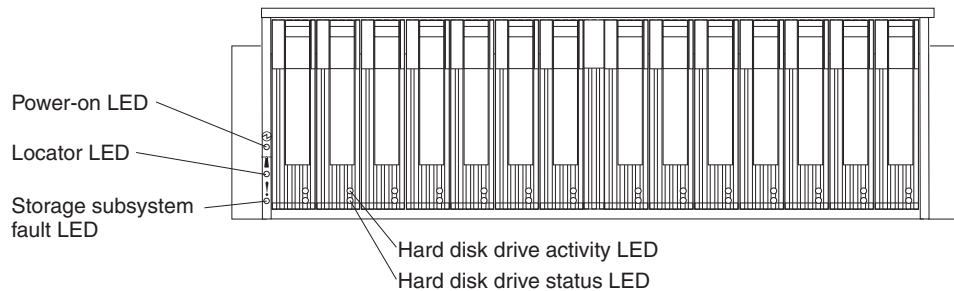

Figure 6. DS300 storage subsystem front LEDs

For information about installing and replacing hard disk drives, see “Installing a hot-swap hard disk drive” on page 36 and “Replacing a hot-swap hard disk drive” on page 37. For more information about the LEDs, see “Front view.”

### Rear view

The following sections show the LEDs, controls, and connectors on the components at the rear of the storage subsystem.

**Power supply:** The following illustration shows the LEDs, controls, and connectors on the power supply.

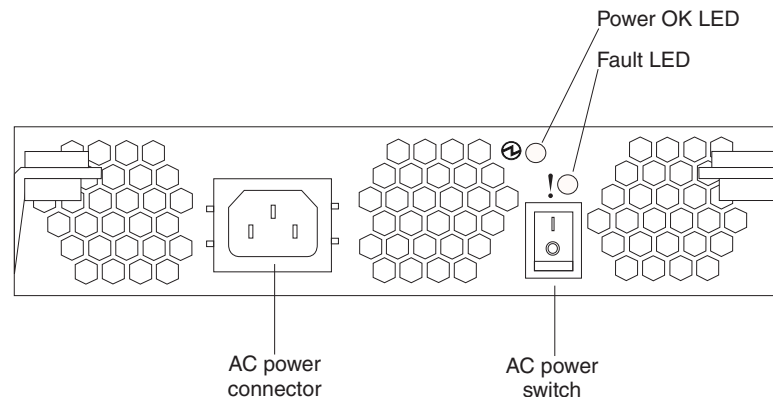

Figure 7. DS300 power supply LEDs, controls, and connectors

#### Power cord connector

Connect the power cord to this connector.

#### AC power on/off switch

Use this switch to turn the power supply on and off.

#### Power OK LED (green)

When this LED is lit, it indicates that the power supply is turned on.

#### Fault LED (amber)

When this LED is lit, there is a fault with either the power supply or a fan.



**iSCSI RAID controller with one Ethernet connector (type 1701 (model 1RL)):**  
 The following illustration shows an iSCSI RAID controller with one Ethernet connector (model 1RL).

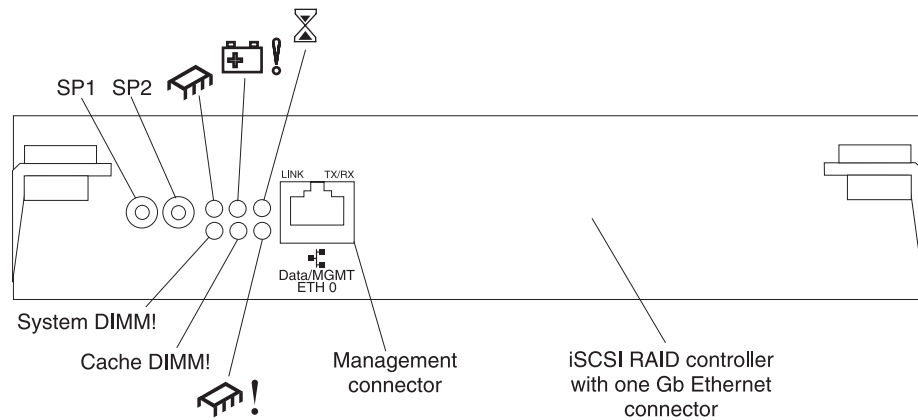

Figure 8. iSCSI RAID controller (model 1RL) LEDs, controls, and connectors

**Serial connectors (SP1 and SP2)**

The serial connectors are for diagnostic purposes only.

**Data and management iSCSI connector**

The data and management connector is for ServeRAID Manager function and iSCSI data traffic.

**iSCSI RAID controller with three Ethernet connectors type 1701 (models 1RS, 2RD):** The iSCSI RAID controller with three Ethernet connectors has 12 LEDs and several connectors, depending on the storage subsystem model. The following illustration shows the LEDs and connectors on the DS300 storage subsystem iSCSI RAID controller.

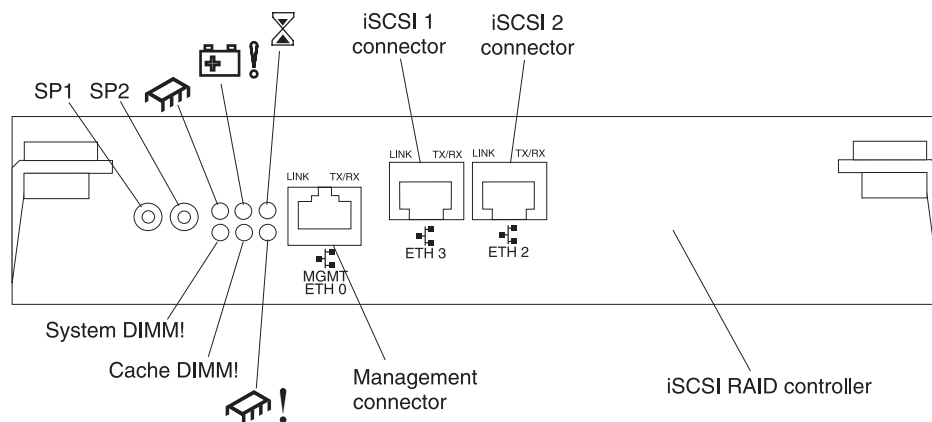

Figure 9. iSCSI RAID controller (models 1RS, 2RD) LEDs, connectors, and controls

**Serial connectors (SP1 and SP2)**

The serial connectors are for diagnostic purposes only.

**Management connector**

The management connector is for ServeRAID Manager function.

**ETH 3 connector**

The ETH 3 connector is for iSCSI data transfer.

### ETH 2 connector

The ETH 2 connector is for iSCSI data transfer.

## Cache memory and RAID controller battery

Each RAID controller contains 256 MB of cache memory. It also contains a sealed, rechargeable lithium ion battery that maintains data in the cache for up to three days in the event of a power failure. The service life of the battery is 36 months, after which time the battery should be replaced. For information about replacing the battery, see “Replacing the cache battery in the RAID controller” on page 41.

---

## Diagnostics

To diagnose problems on the DS300 storage subsystem type 1701 (models 1RL, 1RS, 2RD), use the following diagnostic tools:

- ServeRAID Manager software
- LEDs and the “Symptom-to-FRU index” on page 13

For additional help when diagnosing problems with the DS400 storage subsystem, refer to the *DS300 and DS400 Problem Determination Guides*.

## Monitoring status through software

Use the ServeRAID Manager program to monitor the status of the storage subsystem. Run the software constantly, and check it frequently. ServeRAID Manager provides the best way to diagnose and repair storage subsystem failures. The software can help you:

- Determine the nature of the failure
- Locate the failed component
- Determine the recovery procedures to repair the failure

For example, the recovery procedure for an IBM Predictive Failure Analysis® (PFA) flag (impending drive failure) on a drive varies depending on the drive status (hot spare, unassigned, RAID level, current logical drive status, and so on). Depending on the circumstances, a PFA flag on a drive can indicate a high risk of data loss (if the drive is in a RAID 0 volume) or a minimal risk (if the drive is unassigned). Only the ServeRAID Manager software can identify the risk level and provide the necessary recovery procedures.

**Note:** For PFA flags, the General-system-error LED and Drive fault LEDs do not turn on, so checking the LEDs will not notify you of the failure, even if the risk of data loss is high.

Recovering from a storage subsystem failure might require you to perform procedures other than replacing the component (such as backing up the logical drive or failing a drive before you remove it). The ServeRAID Manager software gives these procedures.

**Attention:** You might lose data if you do not follow the software recovery procedures.

## Using the diagnostic hardware

A wrap-plug can be ordered as a IBM CRU option (Part Number 00G2380). The wrap-plug is used to perform the wrap test and to identify ethernet path problems.

See the DS300 and DS400 Problem Determination Guide for more information. See the *DS300 and DS400 Problem Determination Guides* for more information.

## Symptom-to-FRU index

Use the ServeRAID Manager software to diagnose and repair storage subsystem failures. You can also use the following symptom-to-FRU index tables to find solutions to problems that have definite symptoms.

- Table 2
- Table 3 on page 14
- Table 4 on page 15

**Attention:** Except in an emergency, never turn off the power if any storage subsystem fault LEDs are lit. Make sure you collect the logs from the ServeRAID Manager (Save Support Archive) to capture the state of the controllers at the time of the failure. You can now correct the fault before you turn off the power.

See the problem determination maps in the *DS300 and DS400 Problem Determination Guide* for more detailed procedures for problem isolation.

Table 2. Symptom-to-FRU index for front view LEDs



Symbol	Problem Indicator	Action
	Green Power LED is off.  When this LED is off, it indicates that dc power is not present, or that the power supply or the LED itself has failed. A power LED is also on the power supply.	Check Power Supply LEDs. Refer to power supply LEDs table. <b>Note:</b> To remove all electrical power from the storage subsystem, you must disconnect the power cord from the electrical outlet.
	Blue Locator LED is lit.  When this LED is lit, it has been remotely lit by the ServeRAID Manager program (running on the system that is the management station for the storage subsystem), to aid in visually locating the storage subsystem.	None required <b>Note:</b> The LED can be turned off by selecting <b>Identify Enclosure</b> from the ServeRAID Manager program.

Table 2. Symptom-to-FRU index for front view LEDs (continued)

Symbol	Problem Indicator	Action
!	<p>Amber Storage Subsystem Fault LED is lit solidly.</p> <p>If the fault LED is lit continuously (not flashing), there is a problem with the storage subsystem. Use the ServeRAID Manager program to diagnose and repair the problem. For more information, see the <i>DS300 and DS400 Problem Determination Guide</i>.</p> <p>One of more of the following conditions might exist:</p> <ul style="list-style-type: none"> <li>• Power supply fault</li> <li>• Fan fault</li> <li>• Overtemperature fault</li> <li>• RAID controller module fault</li> <li>• Battery fault</li> <li>• Cache DIMM fault</li> <li>• XScale DIMM fault</li> <li>• Disk drive fault</li> <li>• Turned ON through SES control page</li> </ul>	<ol style="list-style-type: none"> <li>1. Check the LEDs for all components on enclosure (disk drives, power supplies, controllers) and follow the solution instructions provided for the respective illuminated LED.</li> <li>2. If no other fault LED is on, replace the controller:                             <ul style="list-style-type: none"> <li>• DS300 1-RS (p/n 13N1860)</li> <li>• DS300 1-RL (p/n 13N1861)</li> </ul> </li> <li>3. If replacing the controller does not resolve the issue, replace the chassis/backplane assembly (p/n 13N1786).</li> </ol>
	<p>Amber Storage Subsystem Fault LED is lit flashing.</p> <p>When this LED is lit flashing, it indicates that an illegal hardware configuration is detected.</p>	<p>Verify that the RAID controller and power supply are both installed in the slot A side.</p> <p><b>Note:</b> This should only occur with the DS300 type 1701 (model 1RL).</p>
No label	<p>Green Hard disk drive activity LED is off.</p> <p>No drive activity is being detected.</p>	<p>Start your application and verify that the activity LED flashes as the drive is accessed.</p>
No label	<p>Amber Hard Disk Drive Status LED is lit solidly.</p> <p>Each hard disk drive has a status LED. When this LED is lit solidly, it indicates that the drive has failed.</p> <p><b>Note:</b> When this LED is flashing slowly (one flash per second), it indicates that the drive is being rebuilt. When the LED is flashing rapidly (three flashes per second), it indicates that the RAID controller is identifying the drive.</p>	<p>For a single drive failure, replace the failed drive.</p> <p>For a multiple drive failure, attempt to determine the order in which the drives failed and then follow the appropriate recovery process for their RAID level. For additional information on troubleshooting drive-side issues, refer to the Drive Side PD Map in the <i>DS300 and DS400 Problem Determination Guide</i>.</p>

Table 3. Symptom-to-FRU index for power supply LEDs

Symbol	Problem Indicator	Action
	<p>Green Power Supply Power LED is off.</p>	<p>Verify that the power cord is plugged in and that the storage subsystem power is on.</p>

Table 3. Symptom-to-FRU index for power supply LEDs (continued)

Symbol	Problem Indicator	Action
!	<p>Amber Fault LED is lit solidly.</p> <p>The amber Fault LED will be ON solid when the enclosure services module detects a fault, such as one or more of the following conditions:</p> <ul style="list-style-type: none"> <li>• DC output fault</li> <li>• AC input fault</li> <li>• Fan fault</li> <li>• Turned ON through SES control page</li> </ul> <p><b>Note:</b> The amber Fault LED flashes when the power/cooling module locate feature is selected.</p>	<p>Replace the power supply (p/n 13N1784).</p>

Table 4. Symptom-to-FRU index for iSCSI-iSCSI RAID controller LEDs



LED symbol or label	Problem Indicator	Action
	<p>Green Controller Ready LED is off.</p>	<p>If the Controller Ready LED is off, one or more of the RAID controller fault LEDs will be lit. Follow the recovery procedure for the Fault LED that is lit.</p>
	<p>Amber Battery Fault LED is lit.</p> <p>When this LED is lit, it indicates that the battery cannot sustain the RAID controller memory in case of power loss. This might be caused by any of the following conditions:</p> <ul style="list-style-type: none"> <li>• The battery is removed.</li> <li>• There is a battery-charger circuit failure.</li> <li>• The battery temperature is too high.</li> <li>• The battery voltage is out of range.</li> <li>• The battery charge current is out of range.</li> </ul>	<ol style="list-style-type: none"> <li>1. Determine whether any other amber LEDs are lit and follow the appropriate recovery process for that component.</li> <li>2. Remove the controller and replace the battery (p/n 13N1785). Then reinsert the controller.</li> </ol> <p><b>Note:</b> This action is not applicable to the type 1701 (model 1RL) because it does not have a battery.</p>

Table 4. Symptom-to-FRU index for iSCSI-iSCSI RAID controller LEDs (continued)



LED symbol or label	Problem Indicator	Action
	<p>Amber Cache Dirty LED is lit.</p> <p>When this LED is lit, it indicates that there is data in the cache that has not been written to a disk or synchronized to the redundant controller cache.</p>	<p>The Cache Dirty LED will go on and off at varying rates and durations during normal operation. No action is required when this LED goes on.</p> <p>If the Cache Dirty LED lit solidly, it indicates an improper controller shutdown during the controller initialization. Restart the controller from ServeRAID Manager to flush the cache. The Cache Dirty LED will turn off before the Controller Ready LED turns on and the server logins start.</p> <p><b>Attention:</b> Do <i>not</i> turn off power to the enclosure or remove the controller from the enclosure when the Cache Dirty LED is illuminated. Doing so could cause loss of any data in the cache that is not mirrored.</p> <p><b>Notes:</b></p> <ol style="list-style-type: none"> <li>1. This is not a FRU.</li> <li>2. This action is not applicable to the DS300 type 1701 (model 1RL because it does not support a cache.</li> </ol>
System DIMM!	<p>Amber XScale (Processor) DIMM Fault LED is lit.</p> <p>When this LED is lit, it indicates that the XScale memory has failed. This is the result of one the following conditions:</p> <ul style="list-style-type: none"> <li>• Cannot read the DIMM configuration data</li> <li>• Nonrecoverable ECC failure</li> </ul>	<p>Replace the controller:</p> <ul style="list-style-type: none"> <li>• DS300 1-RS (p/n 13N1860)</li> <li>• DS300 1-RL (p/n 13N1861)</li> </ul>
Cache DIMM!	<p>Amber Cache DIMM Fault LED is lit.</p> <p>When this LED is lit, it indicates that the cache memory has failed. This is based on one of the following conditions:</p> <ul style="list-style-type: none"> <li>• Cannot read the DIMM configuration data</li> <li>• Nonrecoverable ECC failure</li> </ul>	<ol style="list-style-type: none"> <li>1. Replace the DIMM 256MB (p/n 73P4026).</li> <li>2. If the DIMM replacement does not fix the problem, replace the controller: <ul style="list-style-type: none"> <li>• DS300 1-RS (p/n 13N1860)</li> <li>• DS300 1-RL (p/n 13N1861)</li> </ul> </li> </ol>
	<p>Amber Controller Not Ready LED is lit.</p> <p>When this LED is lit, it indicates that the controller is not ready.</p>	<p>This LED might be lit because the controller did not finish POST. Contact your IBM support representative to attempt to recover the controller.</p> <p><b>IBM personnel only:</b> Refer to the <i>DS300 and DS400 Problem Determination Guide</i>.</p>
ETH0 Link	<p>Green GbE Link Status LED is off.</p> <p>When this LED is lit, it indicates that the Gb Ethernet link is operational.</p>	<p>If this LED is off, perform the following actions:</p> <ul style="list-style-type: none"> <li>• Check the status on the Ethernet switch.</li> <li>• Replace the Ethernet cable.</li> <li>• Switch the Ethernet cable to another port on the same switch in the same network segment.</li> </ul> <p>If these actions fail to light the Green GbE link status LED, refer to the <i>DS300 and DS400 Problem Determination Guides</i>.</p>

Table 4. Symptom-to-FRU index for iSCSI-iSCSI RAID controller LEDs (continued)

LED symbol or label	Problem Indicator	Action
ETH0 TX/RX	Green GbE Activity LED is off.  This LED will flicker continuously between on and off. When this LED is lit, it indicates that data packets are being transmitted or received.	If this LED is off, then no data is being sent or received. Establish a connection and start passing data.
ETH3 Link	Green GbE Link Status LED is off.  When this LED is lit, it indicates that the Gb Ethernet link is operational.	If this LED is off, perform the following actions: <ul style="list-style-type: none"> <li>• Check the status on the Ethernet switch.</li> <li>• Replace the Ethernet cable.</li> <li>• Switch the Ethernet cable to another port on the same switch in the same network segment.</li> </ul> If these actions fail to light the Green GbE link status LED, refer to the <i>DS300 and DS400 Problem Determination Guide</i> .
ETH3 TX/RX	Green GbE Activity LED is off.  This LED will flicker continuously between on and off. When this LED is lit, it indicates that data packets are being transmitted or received.	If this LED is off, then no data is being sent or received. Establish a connection and start passing data.
ETH2 Link	Green GbE Link Status LED is off.  When this LED is lit, it indicates that the Gb Ethernet link is operational.	If this LED is off, perform the following actions: <ul style="list-style-type: none"> <li>• Check the status on the Ethernet switch.</li> <li>• Replace the Ethernet cable.</li> <li>• Switch the Ethernet cable to another port on the same switch in the same network segment.</li> </ul> If these actions fail to light the Green GbE link status LED, refer to the <i>DS300 and DS400 Problem Determination Guide</i> .
ETH2 TX/RX	Green GbE Activity LED is off.  This LED will flicker continuously between on and off. When this LED is lit, it indicates that data packets are being transmitted or received.	If this LED is off, then no data is being sent or received. Establish a connection and start passing data.

**Note:** If you cannot find the problem in the Symptom-to-FRU index, refer to the *DS300 and DS400 Problem Determination Guide*.

## Parts listing

The following figures and table provide a parts listing for the DS300 storage subsystem type 1701 (models 1RL, 1RS, 2RD).

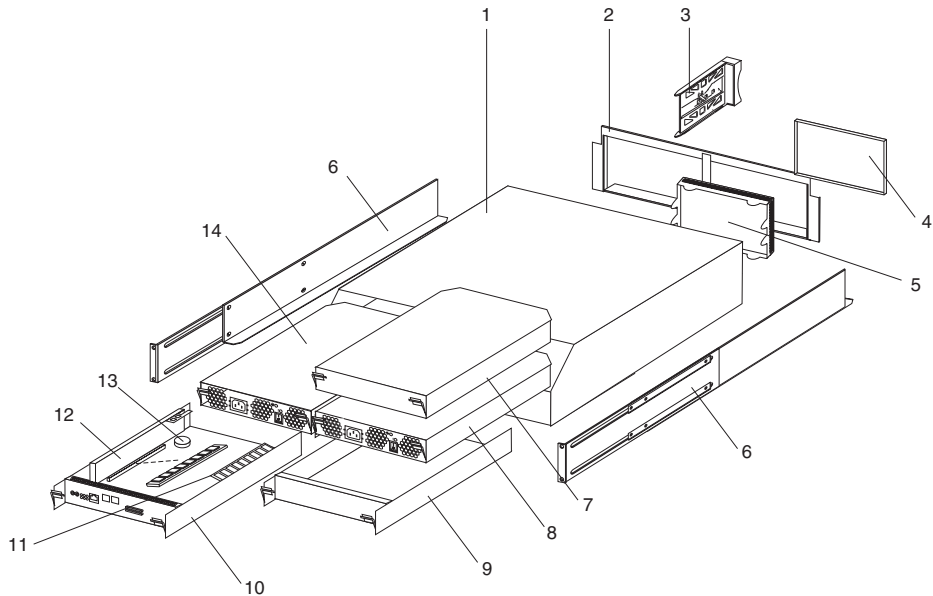

Figure 10. DS300 type 1701 (models 1RL, 1RS, 2RD) storage subsystem parts list

Index	DS300 storage subsystem (models 1RL, 1RS, 2RD)	Part number	CRU/ FRU
1	Chassis and midplane assembly (all models)	13N1786	FRU
2	Chassis bezel (all models)	13N1787	CRU
3	Blank drive bay cover (HDD carrier) (all models)	19K1291	CRU
4 and 5	EMC cover and appearance cover (model 1RL only) <b>Note:</b> The appearance cover must be installed in the chassis before the chassis bezel is installed. The chassis bezel must be removed before the appearance cover can be removed or replaced.	13N1790	CRU
6	Rail kit (left/right) (all models)	37L0067	CRU
7	Panel, blank: power supply cover (model 1RL only)	13N1789	CRU
8	Power supply (models 1RS, 2RD)	13N1784	CRU
9	Panel, blank: controller cover (all models)	13N1793	CRU
10	iSCSI controller (model 1RS) (shipped without battery and memory cache) (all models)	13N1860	CRU
10	iSCSI controller, 7-drive (models 1RL, 2RD) (shipped without battery and memory cache)	13N1861	CRU
11	Memory, Cache-DIMM: 256 MB (all models)	73P4026	CRU
12	Battery, cache (models 1RS, 2RD)	13N1785	CRU
13	Battery, (real-time clock, CR1220) (all models)	46H4132	CRU
14	Power supply (all models)	13N1784	CRU
	Cable, serial (For use by IBM service personnel only) (all models)	13N1792	FRU
	Line cord jumper, high voltage (all models)	36L8886	CRU



Index	DS300 storage subsystem (models 1RL, 1RS, 2RD)	Part number	CRU/ FRU
	Miscellaneous hardware kit, including: (all models) <ul style="list-style-type: none"> <li>• Ethernet wrap plug (00G2380)</li> <li>• 2 M6 hex screws</li> <li>• 2 M6 cage nuts</li> <li>• 2 M6 nut clips</li> </ul>	13N1791	CRU
	Wrap plug, ethernet (for diagnostics) (all models)	00G2380	CRU

“Power cords” on page 59 lists required power cords for the storage components discussed in this document by country and region.



---

## Chapter 3. IBM TotalStorage DS400 type 1700 (models 1RS, 2RD) storage subsystem

The following chapter covers basic hardware maintenance information for the DS400 storage subsystem Type 1701 (models 1RS, 2RD). For more detailed information on the installation and use of the DS400 storage subsystem, refer to the *DS300 and DS400 Hardware Installation and User's Guide*.

**Note:** The problem determination maps found in the *DS300 and DS400 Problem Determination Guides* provide you with additional diagnostic aids.

---

### General checkout

Use the status LEDs, ServeRAID Manager software, and the Symptom-to-FRU index to diagnose problems. See “Monitoring status through software” on page 27, “Storage subsystem controls and LEDs” on page 24, and “Symptom-to-FRU index” on page 27.

To diagnose problems with the DS400 storage subsystem, you can also refer to *DS300 and DS400 Problem Determination Guides*.

The guide addresses problems that you might encounter with the DS300 or DS400 storage subsystem during and after installation. It uses flowcharting techniques to guide you in the isolation and correction of problems.

### General information

The IBM TotalStorage DS400 storage subsystem model 1700-1RS comes with the following components:

- One Fibre Channel RAID controller
- 14 hard disk drive filler panels
- Two power supplies

The IBM TotalStorage DS400 storage subsystem model 1700-2RD comes with the following components:

- Two Fibre Channel RAID controllers
- 14 hard disk drive filler panels
- Two power supplies

---

### Additional service information

This section provides additional service information about the DS400 storage subsystem.

### Specifications

The following information is a summary of the specifications of the storage subsystem. Depending on the storage subsystem model, some specifications might not apply.

Racks are marked in vertical increments of 1.75 inches. Each increment is referred to as a unit, or “U.” A 1-U-high device is 1.75 inches tall.

Table 5. DS400 storage subsystems operating specifications

<p><b>Size (measured from front of hard disk drive to rear of unit)</b></p> <ul style="list-style-type: none"> <li>• Depth: 584 mm (23.0 in.)</li> <li>• Height: 128 mm (5.0 in)</li> <li>• Width: 442 mm (17.4 in)</li> </ul> <p><b>Heat output</b></p> <ul style="list-style-type: none"> <li>• 558 watts (1903.96 Btu/hr)</li> </ul> <p><b>Weight</b></p> <ul style="list-style-type: none"> <li>• Standard storage server as shipped (without hard disk drives): 48.2 kg (106 lb)</li> <li>• Standard storage server as shipped (with 14 hard disk drives): 62.2 kg (137 lb)</li> <li>• Unit weight (without hard disk drives): 25.9 kg (57 lb)</li> <li>• Unit weight (with hard disk drives): 39 kg (86 lb)</li> </ul> <p><b>Electrical input</b></p> <ul style="list-style-type: none"> <li>• Sine-wave input (50 to 60 Hz) is required</li> <li>• Input voltage:             <ul style="list-style-type: none"> <li>– Low range:                 <ul style="list-style-type: none"> <li>- Minimum: 90 V ac</li> <li>- Maximum: 136 V ac</li> </ul> </li> <li>– High range:                 <ul style="list-style-type: none"> <li>- Minimum: 198 V ac</li> <li>- Maximum: 264 V ac</li> </ul> </li> <li>– Approximate input kilovolt-amperes (kVA):                 <ul style="list-style-type: none"> <li>- Minimum configuration: 0.06 kVA</li> <li>- Maximum configuration: 0.56 kVA</li> </ul> </li> </ul> </li> </ul>	<p><b>Environment</b></p> <ul style="list-style-type: none"> <li>• Air temperature:             <ul style="list-style-type: none"> <li>– Storage server on: 10° to 35°C (50° to 95°F) Altitude: 0 to 914 m (3000 ft)</li> <li>– Storage server on: 10° to 32°C (50° to 90°F) Altitude: 914 m (3000 ft) to 2133 m (7000 ft)</li> </ul> </li> <li>• Humidity:             <ul style="list-style-type: none"> <li>– 8% to 80%</li> </ul> </li> </ul>	<p><b>Acoustical noise emissions:</b> For maximum system configurations (14 hard disk drives installed).</p> <ul style="list-style-type: none"> <li>• Sound power (operating): 5.7 bels (typical)</li> <li>• Sound pressure (operating): 42 dBA (typical)</li> </ul> <p><b>Note:</b> These levels were measured in controlled acoustical environments according to the procedures specified by the American National Standards Institute (ANSI) S12.10 and ISO 7779 and are reported in accordance with ISO 9296. Actual sound-pressure levels in a given location might exceed the average values stated because of room reflections and other nearby noise sources. The declared sound-power levels indicate an upper limit, below which a large number of computers will operate</p>
--	---	---

## Storage subsystem components

The following sections show the components of the storage subsystem.

The hot-swap features of the storage subsystem enable you to remove and replace hard disk drives and power supplies without turning off the storage subsystem. Therefore, you can maintain the availability of the system while a hot-swap device is removed, installed, or replaced.

### Front view

The following illustration shows the components and controls on the front of the DS400 storage subsystem.

**Note:** The illustrations in this document might differ slightly from your hardware.

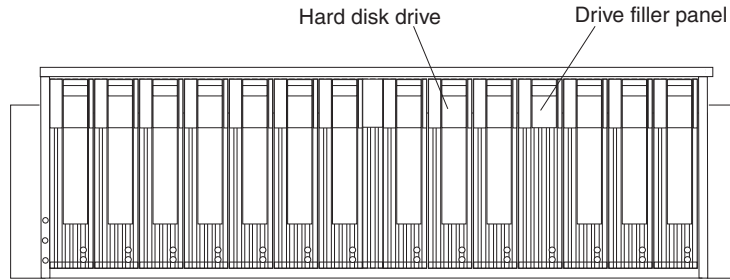

Figure 11. DS400 storage subsystem front components

### Hard disk drive

You can install up to 14 Ultra320 hot-swap hard disk drive *customer replaceable units* (CRUs) in the storage subsystem. Each hard disk drive CRU contains a hard disk drive and tray.

### Drive filler panel

The storage subsystem comes without installed hard disk drives and contains filler panels in the unused drive bays. Before installing new drives, you must remove the filler panels and save them. Each of the 14 bays must always contain either a filler panel or a hard disk drive to maintain proper cooling and airflow.

### Tray handle and latch

Use the blue latch on the tray handle to release or lock the hard disk drive in place.

For information about installing and replacing a hard disk drive, see “Installing a hot-swap hard disk drive” on page 36 and “Replacing a hot-swap hard disk drive” on page 37.

### Rear view

The following illustrations show the components at the rear of the DS400 storage subsystem.

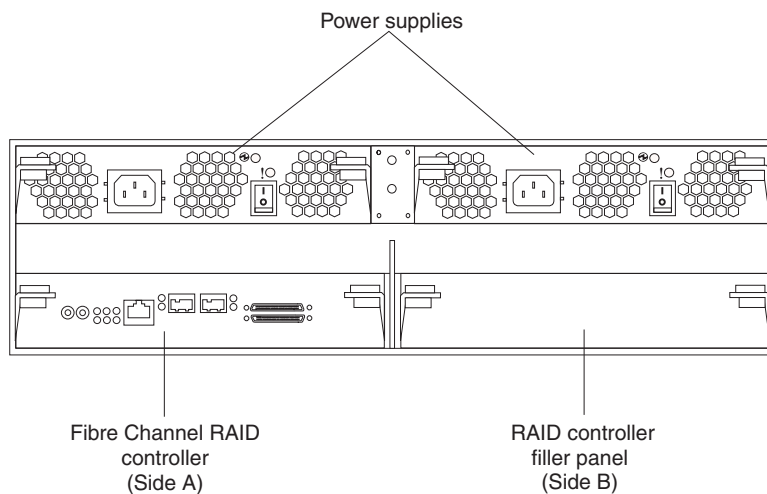

Figure 12. DS400 storage subsystem model 1700-1RS rear view

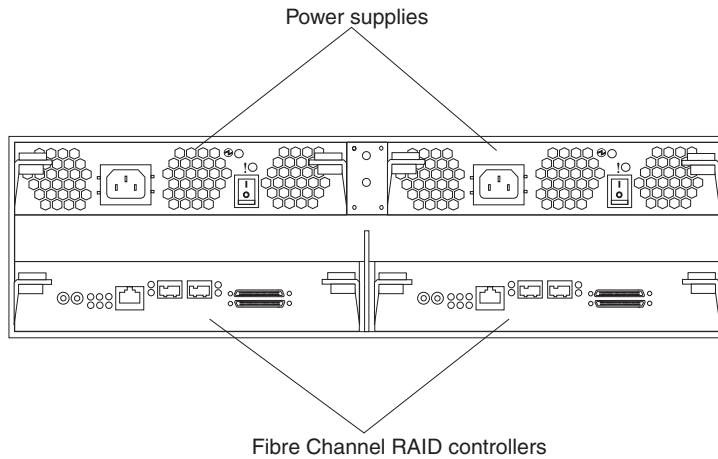

Figure 13. DS400 storage subsystem model 1700-2RD rear view

### Fibre Channel RAID controller

The DS400 storage subsystem comes with one or two Fibre Channel RAID controllers. Each Fibre Channel RAID controller has one 1 Gb/sec (gigabit per second) Ethernet connector for management, two 2 Gb/sec Fibre Channel host ports, and 12 LEDs.

If the storage subsystem comes with only one RAID controller, there is a filler panel in the right RAID controller bay (side B). The filler panel must remain in place to maintain proper cooling.

Each RAID controller also contains a battery to maintain cache data in the event of a power failure. For more information, see “Cache memory and RAID controller battery” on page 26..

### Power supply

The DS400 storage subsystem contains two hot-swap power supplies. Each unit is a self-contained power supply with three integral cooling fans, a power switch, and two status LEDs.

## Storage subsystem controls and LEDs

The following sections show the DS400 storage subsystem controls and LEDs.

### Front view

The following illustration shows the LEDs on the front of the DS400 storage subsystem.

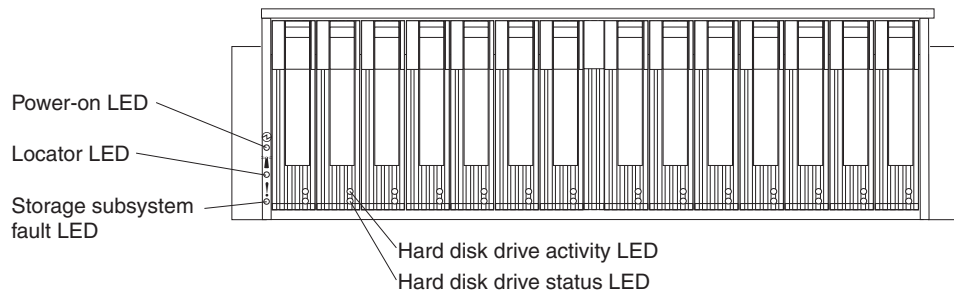

Figure 14. DS400 storage subsystem front LEDs

For information about installing and replacing hard disk drives, see “Installing a hot-swap hard disk drive” on page 36 and “Replacing a hot-swap hard disk drive” on page 37. For more information about the LEDs, see “Front view” on page 24.

## Rear view

The following sections show the LEDs, controls, and connectors on the components at the rear of the storage subsystem.

**Power supply:** The following illustration shows the LEDs, controls, and connectors on the power supply.

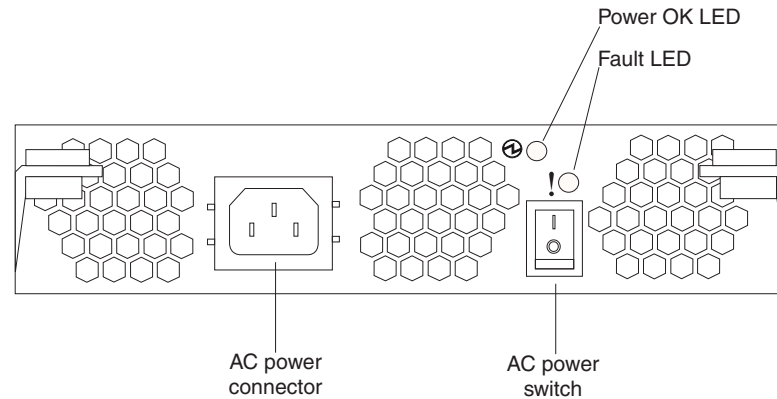

Figure 15. DS400 power supply LEDs, controls, and connectors

### Power cord connector

Connect the power cord to this connector.

### AC power on/off switch

Use this switch to turn the power supply on and off.

### Power OK LED (green)

When this LED is lit, it indicates that the power supply is turned on.

### Fault LED (amber)

When this LED is lit, there is a fault with either the power supply or a fan.

**Fibre Channel RAID controller:** The Fibre Channel RAID controller has 12 LEDs and several connectors, depending on the storage subsystem model. The following illustration shows the LEDs and connectors on the DS400 storage subsystem Fibre Channel RAID controller.

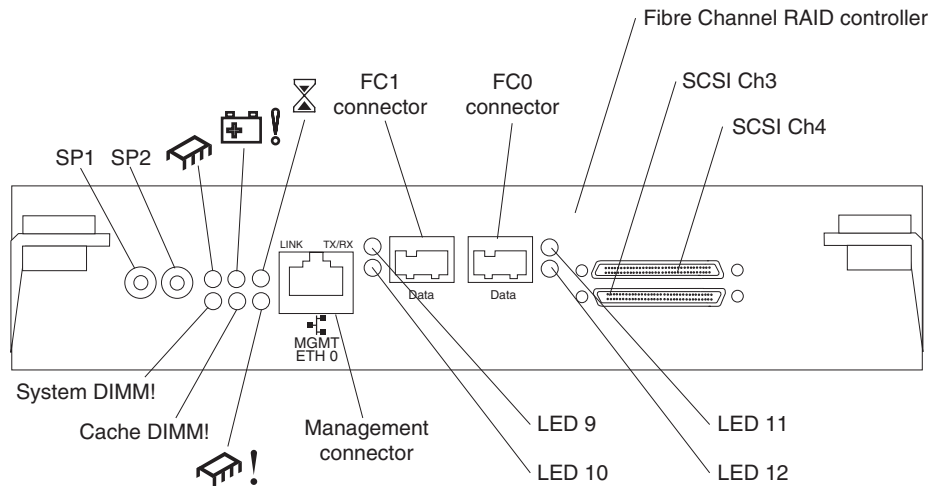

Figure 16. Fibre Channel RAID controller LEDs and connectors

### Serial connectors (SP1 and SP2)

The serial connectors are for diagnostic purposes only.

### Management connector

The management connector is for ServeRAID Manager function.

### FC 1 connector

The FC 1 connector is for Fibre Channel data transfer.

### FC 0 connector

The FC 0 connector is for Fibre Channel data transfer.

### SCSI channel 4

SCSI channel 4 can be connected to an IBM EXP400 Storage Expansion Unit.

### SCSI channel 3

SCSI channel 3 can be connected to an IBM EXP400 Storage Expansion Unit.

The Fibre Channel RAID controller has two status LEDs on each of the two Fiber Channel host connectors.

## Cache memory and RAID controller battery

Each RAID controller contains 256 MB of cache memory. It also contains a sealed, rechargeable lithium ion battery that maintains data in the cache for up to three days in the event of a power failure. The service life of the battery is 36 months, after which time the battery should be replaced. For information about replacing the battery, see “Replacing the cache battery in the RAID controller” on page 41..

## Diagnostics

To diagnose problems on the DS400 storage subsystem, use the following diagnostic tools:

- ServeRAID Manager software
- LEDs and the “Symptom-to-FRU index” on page 27
- FASiT MSJ (see the *DS300 and DS400 Problem Determination Guide*)



For additional help when diagnosing problems with the DS400 storage subsystem, refer to the *DS300 and DS400 Problem Determination Guide*.

## Monitoring status through software

Use the ServeRAID Manager program to monitor the status of the storage subsystem. Run the software constantly, and check it frequently. The ServeRAID Manager software provides the best way to diagnose and repair storage subsystem failures. The software can help you:

- Determine the nature of the failure
- Locate the failed component
- Determine the recovery procedures to repair the failure

For example, the recovery procedure for an IBM Predictive Failure Analysis (PFA) flag (impending drive failure) on a drive varies depending on the drive status (hot spare, unassigned, RAID level, current logical drive status, and so on). Depending on the circumstances, a PFA flag on a drive can indicate a high risk of data loss (if the drive is in a RAID 0 volume) or a minimal risk (if the drive is unassigned). Only the ServeRAID Manager software can identify the risk level and provide the necessary recovery procedures.

**Note:** For PFA flags, the General-system-error LED and Drive fault LEDs do not turn on, so checking the LEDs will not notify you of the failure, even if the risk of data loss is high.

Recovering from a storage subsystem failure might require you to perform procedures other than replacing the component (such as backing up the logical drive or failing a drive before you remove it). The ServeRAID Manager software gives these procedures.

**Attention:** You might lose data if you do not follow the software recovery procedures.

## Using the diagnostic hardware

You can order an ethernet wrap plug IBM CRU option (Part Number 00G2380). This wrap plug is used to perform the wrap-plug test and to identify DS300 and DS400 ethernet path problems. You can also order the fibre channel wrap plug kit (IBM Part Number 24P0950). This wrap plug kit is used to identify DS400 fibre channel path problems. See the *DS300 and DS400 Problem Determination Guide* for more information.

---

## Symptom-to-FRU index

Use the ServeRAID Manager software to diagnose and repair storage subsystem failures. You can also use the following symptom-to-FRU index tables to find solutions to problems that have definite symptoms.

- Table 6 on page 28
- Table 7 on page 29
- Table 8 on page 29
- Table 9 on page 31

**Attention:** Except in an emergency, never turn off the power if any storage subsystem fault LEDs are lit. Make sure you collect the logs from the ServeRAID Manager (Save Support Archive) to capture the state of the controllers at the time of the failure. You can now correct the fault before you turn off the power.

See the problem determination maps in the *DS300 and DS400 Problem Determination Guide* for more detailed procedures for problem isolation.

Table 6. Symptom-to-FRU index for front view LEDs



Symbol	Problem Indicator	Action
	<p>Green Power LED is off</p> <p>When this LED is off, it indicates that dc power is not present, or that the power supply or the LED itself has failed. A power LED is also on the power supply.</p>	<p>Check Power Supply LEDs. Refer to power supply LEDs table.</p> <p><b>Note:</b> To remove all electrical power from the storage subsystem, you must disconnect the power cord from the electrical outlet.</p>
	<p>Blue Locator LED is lit.</p> <p>When this LED is lit, it has been remotely lit by the ServeRAID Manager program (running on the system that is the management station for the storage subsystem), to aid in visually locating the storage subsystem.</p>	<p>None required</p> <p><b>Note:</b> The LED can be turned off by selecting <b>Identify Enclosure</b> from the ServeRAID Manager program.</p>
	<p>Amber Storage Subsystem Fault LED is lit.</p> <p>If the fault LED is lit continuously (not flashing), there is a problem with the storage subsystem. Use the ServeRAID Manager program to diagnose and repair the problem. For more information, see the <i>DS300 and DS400 Problem Determination Guide</i>.</p> <p>One of more of the following conditions might exist:</p> <ul style="list-style-type: none"> <li>• Power supply fault</li> <li>• Fan fault</li> <li>• Overtemperature fault</li> <li>• RAID controller module fault</li> <li>• Battery fault</li> <li>• Cache DIMM fault</li> <li>• XScale DIMM fault</li> <li>• Disk drive fault</li> <li>• Turned ON through SES control page</li> </ul>	<ol style="list-style-type: none"> <li>1. Check the LEDs for all components on enclosure (disk drives, power supplies, controllers) and follow the solution instructions provided for the respective illuminated LED.</li> <li>2. If no other fault LED is on, replace the DS400 controller (p/n 13N1859).</li> <li>3. If replacing the controller does not resolve the issue, replace the chassis/backplane assembly (p/n 13N1786).</li> </ol>
No label	<p>Green Hard Disk Drive Activity LED is off.</p> <p>No drive activity is being detected.</p>	<p>Start your application and verify that the activity LED flashes as the drive is accessed.</p>

Table 6. Symptom-to-FRU index for front view LEDs (continued)

Symbol	Problem Indicator	Action
No label	<p>Amber Hard Disk Drive Status LED is lit.</p> <p>Each hard disk drive has a status LED. When this LED is lit solidly, it indicates that the drive has failed.</p> <p><b>Note:</b> When this LED is flashing slowly (one flash per second), it indicates that the drive is being rebuilt. When the LED is flashing rapidly (three flashes per second), it indicates that the RAID controller is identifying the drive.</p>	<p>For a single drive failure, replace the failed drive.</p> <p>For a multiple drive failure, attempt to determine the order in which the drives failed and then follow the appropriate recovery process for their RAID level. For additional information on troubleshooting drive-side issues, refer to the Drive Side PD Map in the <i>DS300 and DS400 Problem Determination Guide</i>.</p>

Table 7. Symptom-to-FRU index for power supply LEDs



Symbol	Problem Indicator	Action
	Green Power Supply Power LED is off.	Verify that the power cord is plugged in and that the storage subsystem power is on.
	<p>Amber Fault LED is lit solidly.</p> <p>The amber Fault LED will be ON solid when the enclosure services module detects a fault, such as one or more of the following conditions:</p> <ul style="list-style-type: none"> <li>• DC output fault</li> <li>• AC input fault</li> <li>• Fan fault</li> <li>• Turned ON through SES control page</li> </ul> <p><b>Note:</b> The amber Fault LED flashes when the power/cooling module locate feature is selected.</p>	Replace the power supply (p/n 13N1784).

Table 8. Symptom-to-FRU index for FC-SCSI RAID controller LEDs



LED symbol or label	Problem Indicator	Action
	Green Controller Ready LED is off	If the Controller Ready LED is off, one or more of the RAID controller fault LEDs will be lit. Follow the recovery procedure for the Fault LED that is lit.
	<p>Amber Battery Fault LED is lit.</p> <p>When this LED is lit, it indicates that the battery cannot sustain the RAID controller memory in case of power loss. This might be caused by any of the following conditions:</p> <ul style="list-style-type: none"> <li>• The battery is removed.</li> <li>• There is a battery-charger circuit failure.</li> <li>• The battery temperature is too high.</li> <li>• The battery voltage is out of range.</li> <li>• The battery charge current is out of range.</li> </ul>	<ol style="list-style-type: none"> <li>1. Determine whether any other amber LEDs are lit and follow the appropriate recovery process for that component.</li> <li>2. Remove the controller and replace the battery (p/n 46H4132). Then reinsert the controller.</li> </ol>

Table 8. Symptom-to-FRU index for FC-SCSI RAID controller LEDs (continued)



LED symbol or label	Problem Indicator	Action
	<p>Amber Cache Dirty LED is lit.</p> <p>When this LED is lit, it indicates that there is data in the cache that has not been written to a disk or synchronized to the redundant controller cache.</p>	<p>The Cache Dirty LED will go on and off at varying rates and durations during normal operation. No action is required when this LED goes on.</p> <p>If the Cache Dirty LED lit solidly, it indicates an improper controller shutdown during the controller initialization. Restart the controller from ServeRAID Manager to flush the cache. The Cache Dirty LED will turn off before the Controller Ready LED turns on and the server logins start.</p> <p><b>Attention:</b> Do <i>not</i> turn off power to the enclosure or remove the controller from the enclosure when the Cache Dirty LED is illuminated. Doing so could cause loss of any data in the cache that is not mirrored.</p> <p><b>Note:</b> This is not a FRU.</p>
System DIMM!	<p>Amber XScale (Processor) DIMM Fault LED is lit.</p> <p>When this LED is lit, it indicates that the XScale memory has failed. This is the result of one the following conditions:</p> <ul style="list-style-type: none"> <li>• Cannot read the DIMM configuration data</li> <li>• Nonrecoverable ECC failure</li> </ul>	<p>Replace the controller (p/n 13N1859).</p>
Cache DIMM!	<p>Amber Cache DIMM Fault LED is lit.</p> <p>When this LED is lit, it indicates that the cache memory has failed. This is based on one of the following conditions:</p> <ul style="list-style-type: none"> <li>• Cannot read the DIMM configuration data</li> <li>• Nonrecoverable ECC failure</li> </ul>	<ol style="list-style-type: none"> <li>1. Replace the DIMM 256MB DIMM (p/n 73P4026).</li> <li>2. If the DIMM replacement does not fix the problem, replace the controller (p/n 13N1859).</li> </ol>
	<p>Amber Controller Not Ready LED is lit.</p> <p>When this LED is lit, it indicates that the controller is not ready.</p>	<p>This LED might be lit because the controller did not finish POST. Contact your IBM support representative to attempt to recover the controller.</p> <p><b>IBM personnel only:</b> Refer to the <i>DS300 and DS400 Problem Determination Guide</i>.</p>
ETH0 Link	<p>Green GbE Link Status LED is off.</p> <p>When this LED is lit, it indicates that the Gb Ethernet link is operational.</p>	<p>If this LED is off, perform the following actions:</p> <ul style="list-style-type: none"> <li>• Check the status on the Ethernet switch.</li> <li>• Replace the Ethernet cable.</li> <li>• Switch the Ethernet cable to another port on the same switch in the same network segment.</li> </ul> <p>If these actions fail to light the Green GbE link status LED, refer to the <i>DS300 and DS400 Problem Determination Guide</i>.</p>
ETH0 TX/RX	<p>Green GbE Activity LED is off.</p> <p>This LED will flicker continuously between on and off. When this LED is lit, it indicates that data packets are being transmitted or received.</p>	<p>If this LED is off, then no data is being sent or received. Establish a connection and start passing data.</p>

Table 9. Symptom-to-FRU index for FC-SCSI RAID controller FC host port status LEDs

Green LEDs		Amber LEDs		Indication
FC 1 (LED 9)	FC 0 (LED 11)	FC 1 (LED 10)	FC 0 (LED 12)	
On		On		Power On
On		Off		Online (normal operation)
Off		On		Link established (transitory condition)
Off		Flashing twice per second.		Loss of synchronization. Refer to the <i>DS300 and DS400 Problem Determination Guide</i> .
The green and amber LEDs alternate flashing twice per second.				FC chip fault. Refer to the <i>DS300 and DS400 Problem Determination Guide</i> .
Off		Flashing once per second.		Beacon. Refer to the <i>DS300 and DS400 Problem Determination Guide</i> .

**Note:** If you cannot find the problem in the Symptom-to-FRU index, refer to the *DS300 and DS400 Problem Determination Guides*.

## Parts listing

Figure 17 and the following table provide a parts listing for the DS400 storage subsystem type 1701 (models 1RS, 2RD).

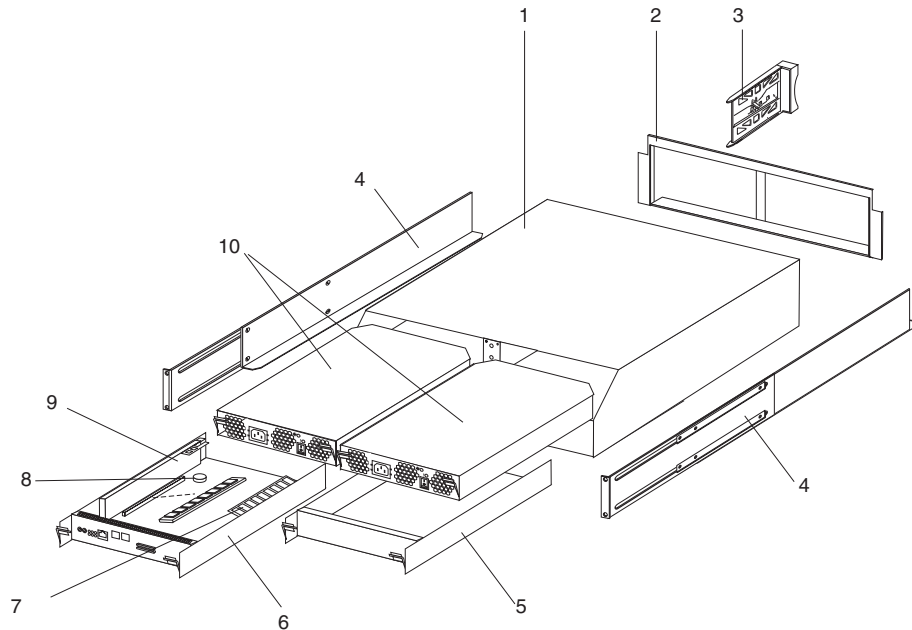

Figure 17. DS400 storage subsystem parts list

Index	DS400 storage subsystem	Part number	CRU/ FRU
1	Chassis and midplane assembly (all models)	13N1786	FRU

Index	DS400 storage subsystem	Part number	CRU/ FRU
2	Chassis bezel (all models)	13N1787	CRU
3	Blank drive bay cover (HDD carrier) (models 1RS, 2RD)	19K1291	CRU
4	Rail kit (left/right) (all models)	37L0067	CRU
5	Panel, blank: controller cover (model 1RS)	13N1793	CRU
6	FC controller (all models) (shipped without battery and memory cache)	13N1859	CRU
7	Memory, Cache-DIMM: 256 MB (all models)	73P4026	CRU
8	Battery (real-time clock, CR1220 (all models)	46H4132	CRU
9	Battery, cache (all models)	13N1785	CRU
10	Power supply (all models)	13N1784	CRU
	Cable, serial (For use by IBM service personnel only) (all models)	13N1792	FRU
	Line cord jumper, high voltage (all models)	36L8886	CRU
	Cable, SCSI LVD, 2 m (all models)	09N7276	CRU
	Cable, SCSI LVD, 4 m (all models)	09N7278	CRU
	Cable, Fiber-optic, 1 m (all models)	19K1265	CRU
	Cable, Fiber-optic, 5 m (all models)	19K1266	CRU
	Cable, Fiber-optic, 25 m (all models)	19K1267	CRU
	Short-wave SFP	19K1280	CRU
	Miscellaneous hardware kit, including: (all models) <ul style="list-style-type: none"> <li>• Ethernet wrap plug (00G2380)</li> <li>• 2 M6 hex screws</li> <li>• 2 M6 cage nuts</li> <li>• 2 M6 nut clips</li> </ul>	13N1791	CRU
	Wrap plug, ethernet (for diagnostics) (all models)	00G2380	CRU
	Wrap plug kit, fibre channel (for diagnostics) (all models)	24P0950	CRU

“Power cords” on page 59 lists required power cords for the storage components discussed in this document by country and region.

---

## Appendix A. Installing and replacing components

This appendix provides instructions for installing and replacing hardware components in the storage subsystem.

---

### Installation guidelines

Before you begin installing options, read the following information:

- Read the safety information beginning on page iii and the guidelines in “Handling static-sensitive devices.” This information will help you work safely with the server and options.
- Make sure that you have an adequate number of properly grounded electrical outlets for your server, external storage subsystem, and other devices.
- Back up all important data before you make changes to disk drives.
- Have a small flat-blade screwdriver available.
- You do not have to turn off the storage subsystem to install or replace a hard disk drive or power supply.
- Blue on a component indicates touch points, where you can grip the component to remove it from or install it in the storage subsystem, open or close a latch, and so on.
- Orange on a component or an orange label on or near a component indicates that the component can be hot-swapped, which means that you can remove or install the component while the storage subsystem is running. (Orange can also indicate touch points on hot-swap components.) See the instructions for removing or installing a specific hot-swap component for any additional procedures that you might have to perform before you remove or install the component.
- For a list of supported options for the storage subsystem, go to <http://www.ibm.com/pc/compat/>.

### System reliability guidelines

To help ensure proper cooling and system reliability, make sure that:

- Each of the drive bays has a drive or a filler panel and electromagnetic compatibility (EMC) shield installed in it.
- If the storage subsystem has redundant power, each of the power-supply bays has a power supply installed in it.
- There is adequate space around the storage subsystem to allow the storage subsystem cooling system to work properly. Leave approximately 50 mm (2.0 in.) of open space around the front and rear of the storage subsystem. Do not place objects in front of the fans.
- You have replaced a failed power supply within 10 minutes of removal.
- You have replaced a hot-swap drive within 2 minutes of removal.

### Handling static-sensitive devices

**Attention:** Static electricity can damage the server and other electronic devices. To avoid damage, keep static-sensitive devices in their static-protective packages until you are ready to install them.

To reduce the possibility of damage from electrostatic discharge, observe the following precautions:

- Limit your movement. Movement can cause static electricity to build up around you.
- Wear an electrostatic-discharge wrist strap, if one is available.
- Handle the device carefully, holding it by its edges or its frame.
- Do not touch solder joints, pins, or exposed circuitry.
- Do not leave the device where others can handle and damage it.
- While the device is still in its static-protective package, touch it to an unpainted metal part of the storage subsystem for at least 2 seconds. This drains static electricity from the package and from your body.
- Remove the device from its package and install it directly into the storage subsystem without setting down the device. If it is necessary to set down the device, put it back into its static-protective package. Do not place the device on the storage subsystem cover or on a metal surface.
- Take additional care when handling devices during cold weather. Heating reduces indoor humidity and increases static electricity.

---

## Installing and removing the bezel on DS300 Models 1700-1RS and 1700-2RD, and DS400

**Note:** Before installing the bezel on the storage subsystem, install it in the rack. For more information, see the *Rack Mounting Instructions* that come with the storage subsystem.

Complete the following steps to install the storage subsystem bezel:

1. Position the bezel directly in front of the storage subsystem.
2. Insert the three tabs on the bottom of the bezel into the matching holes on the storage subsystem chassis.

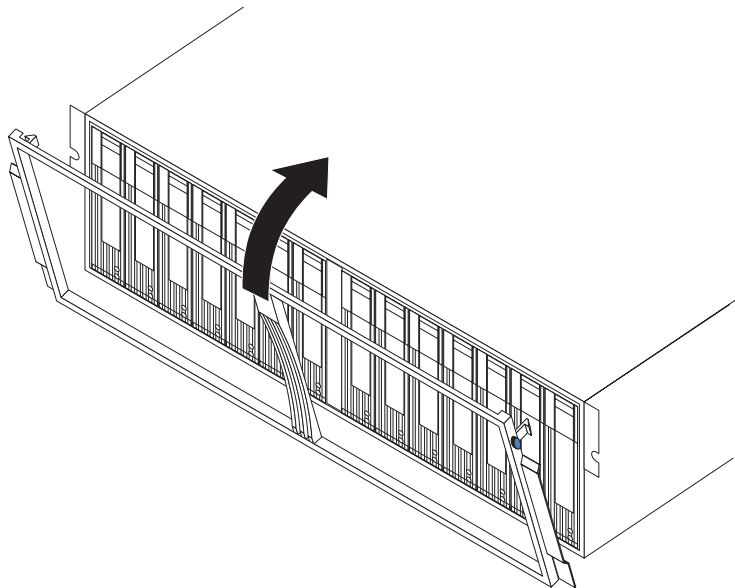

Figure 18. Installing the bezel on the DS300 and DS400

3. Rotate the top of the bezel toward the storage subsystem until the two tabs on the top of the bezel snap into place.
4. To remove the bezel:



- a. Press in on the blue tab on the top outside edge of both sides of the bezel, and pull the top of the bezel slightly away from the storage subsystem.
- b. Pull the bezel up to release the three tabs at the bottom edge of the bezel. Store the bezel in a safe place.

---

## Installing and removing the bezel on the DS300 type 1701 (model 1RL)

**Note:** Before installing the bezel on the storage subsystem, install it in the rack. For more information, see the *Rack Mounting Instructions* that come with the storage subsystem.

Complete the following steps to install the storage subsystem bezel:

1. Make sure that the EMI panel on the left side of the storage subsystem remains in place for proper cooling.

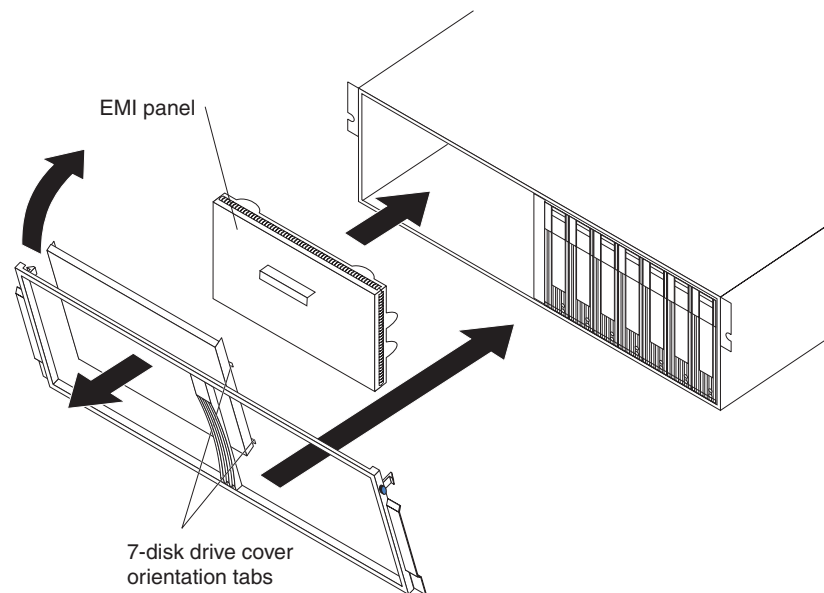

Figure 19. Installing the bezel on the DS300 model 1RL

2. Place the 7-hard disk drive cover insert into the left side of the bezel. Make sure that the cover insert tabs are flush with the bezel frame.
3. Position the bezel directly in front of the storage subsystem.
4. Insert the three tabs on the bottom of the bezel into the matching holes on the storage subsystem chassis.
5. Rotate the top of the bezel toward the storage subsystem until the two tabs at the top of the bezel snap into place.
6. To remove the bezel:
  - a. Press in on the blue tab on the top outside edge on both sides of the bezel, and pull the top of the bezel slightly away from the storage subsystem.
  - b. Pull the bezel up to release the three tabs at the bottom edge of the bezel. Store the bezel in a safe place.

---

## Installing a hot-swap hard disk drive

The storage subsystem supports up to 14 IBM Ultra320 SCSI hard disk drives. These IBM drives come preassembled in a drive tray, ready for installation. (Do not detach the drive from the tray.) Be sure to record the location information for each drive in Appendix A of the *DS300 and DS400 Hardware Installation and User's Guide*.

The storage subsystem comes with filler panels in the drive bays. Before installing a new hard disk drive, remove the filler panel and save it for future use. Each of the 14 bays must contain either a filler panel or a hard disk drive.

Complete the following steps to install a hard disk drive in the storage subsystem. You can install drives while the storage subsystem is turned on.

**Note:** If you are replacing a drive, see “Replacing a hot-swap hard disk drive” on page 37 for more information.

1. Read the instructions that come with the hard disk drive.
2. Read the safety information beginning on page iii and “Installation guidelines” on page 33.
3. Determine the bay into which you want to install the hard disk drive.
4. Remove the filler panel:
  - a. Insert a finger into the square hole at the top of the filler panel to grip and pull the filler panel out of the drive bay.
  - b. Save the filler panel for future use.
5. Install the hard disk drive.

**Note:** The hard disk drive comes with a tray already attached. Do not attempt to detach the drive from the tray.

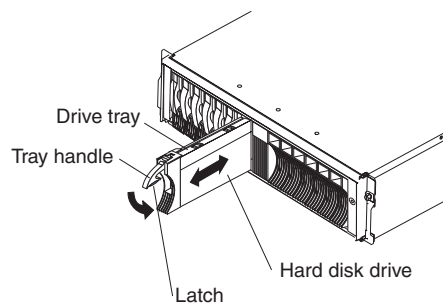

Figure 20. Installing a hard disk drive

- a. Press the latch on the bottom of the tray handle to release it.
  - b. Pull out the tray handle to the open position.
  - c. Gently slide the drive into the empty bay until the tray handle touches the expansion-unit bezel.
  - d. Push down the tray handle into the closed (latched) position.
6. Check the hard disk drive LEDs:
    - When a drive is ready for use, the green activity LED is off and the amber drive-fault LED is off.
    - If the amber drive-fault LED is lit and not flashing, remove the drive from the unit and wait 10 seconds; then, reinstall the drive.

**ServeRAID information:** In some cases, the ServeRAID Manager program will automatically reset the drive to the Hot Spare or Rebuild state. If the drive-state change does not occur automatically (amber LED stays lit), see the ServeRAID Manager program online help for information about changing the state of the drive from the current state to another state, such as Hot Spare or Ready. The amber LED turns off within 10 seconds after the drive-state change.

7. Configure the hard disk drive using the appropriate software.

---

## Replacing a hot-swap hard disk drive

Hard disk drive problems include any malfunctions that delay, interrupt, or prevent successful I/O activity between the hosts and the hard disk drives in the storage subsystem. This includes transmission problems between the host controllers and the drives. This section explains how to replace a failed drive.

**Attention:** Failure to replace a hard disk drive in the correct bay might result in loss of data. If data is stored on the hard disk, label the drive before you remove it. Then, when you replace the drive, install it in the same drive bay from which you removed it.

Check the hardware and software documentation that comes with your server to see whether there are restrictions regarding hard disk drive configurations. Some system SCSI configurations might not allow mixing different hard disk drive capacities or types within an array.

Complete the following steps to replace a hot-swap hard disk drive:

1. Read the instructions that come with the hard disk drive.
2. Read the safety information beginning on page iii and “Installation guidelines” on page 33.
3. Find the hard disk drive that you want to remove.

**Attention:** Never hot-swap a hard disk drive when its green activity LED is flashing. Hot-swap a drive only when its amber status LED is lit (not flashing) or when the drive is inactive (activity LED is off).

4. Remove the hard disk drive.

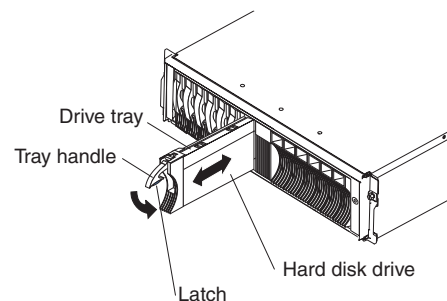

Figure 21. Removing a hard disk drive

- a. Press the latch on the bottom of the tray handle to release it.
- b. Pull out the tray handle to the open position.

- c. Lift the drive partially out of the bay and wait at least 20 seconds before fully removing the drive from the storage subsystem. This enables the drive to spin down and avoids possible damage to the drive.
  - d. Make sure that there is proper identification (such as a label) on the hard disk drive; then, gently slide it completely out of the storage subsystem.
5. Install the new hard disk drive:
    - a. Gently push the drive into the empty bay until the tray handle touches the storage subsystem tray.
    - b. Push down the tray handle into the closed (latched) position.
  6. Check the hard disk drive LEDs.
    - When a drive is ready for use, the green activity LED and the amber status LED are off.
    - If the amber status LED is lit and not flashing, remove the drive from the unit and wait 10 seconds; then, reinstall the drive. If the amber LED is flashing, the drive is being rebuilt.

**ServeRAID information:** In some cases, the ServeRAID Manager program will automatically reset the drive to the Hot Spare or Rebuild state. If the drive-state change does not occur automatically (amber LED stays lit), see the ServeRAID Manager program online help for information about changing the state of the drive from the current state to another state, such as Hot Spare or Ready. The amber LED turns off within 10 seconds after the drive-state change.

---

## Replacing the real-time clock battery in the RAID controller

When replacing the real-time clock lithium battery, you must replace it with a lithium battery of the same type.

To order replacement batteries, call 1-800-426-7378 within the United States, and 1-800-465-7999 or 1-800-465-6666 within Canada. Outside the U.S. and Canada, call your IBM reseller or IBM marketing representative.

### Statement 2:



### CAUTION:

**When replacing the lithium battery, use only IBM Part Number 46H4132 or an equivalent type battery. If your system has a module containing a lithium battery, replace it only with the same module type. The battery contains lithium and can explode if not properly used, handled, or disposed of.**

*Do not:*

- **Throw or immerse into water**
- **Heat to more than 100°C (212°F)**
- **Repair or disassemble**

**Dispose of the battery as required by local ordinances or regulations.**

**Attention:** For storage subsystems with only one controller installed: To prevent data loss, you must shut down the system before you replace the battery. For the correct shutdown sequence, see the *DS300 and DS400 Hardware Installation and User's Guide*.

1. Read the safety information beginning on page iii and "Installation guidelines" on page 33.
2. Label each cable that is connected to the RAID controller so that you can correctly reconnect them to the RAID controller after you replace the battery.
3. **For storage subsystems with only one controller installed:** Stop the host I/O data to the storage subsystem; then, turn off the power-supply switches on the rear of the storage subsystem.
4. **For storage subsystems with two controllers installed:** Move the I/O data to the alternate controller:
  - a. Open a Telnet session and connect to the alternate controller management port IP address.
  - b. At the command prompt, enter admin.
  - c. Enter the administrator password.
  - d. Enter controller peer disable.The controller that you are removing will shut down and all I/O data will have moved to the alternate controller.
5. Remove the Ethernet cables from the RAID controller.
6. **For a Fibre Channel RAID controller only:** Remove the fiber-optic cables and the SFP modules from the RAID controller. For more information, see the *DS300 and DS400 Hardware Installation and User's Guide*.

**Attention:** When you handle static-sensitive devices, take precautions to avoid damage from static electricity. For details about handling static-sensitive devices, see "Handling static-sensitive devices" on page 33.

7. Remove the RAID controller that contains the battery that you want to replace:
  - a. While squeezing together the latch and lever that are on each side of the controller, press down on the orange area on each latch. The controller will slide out of the bay a short distance.

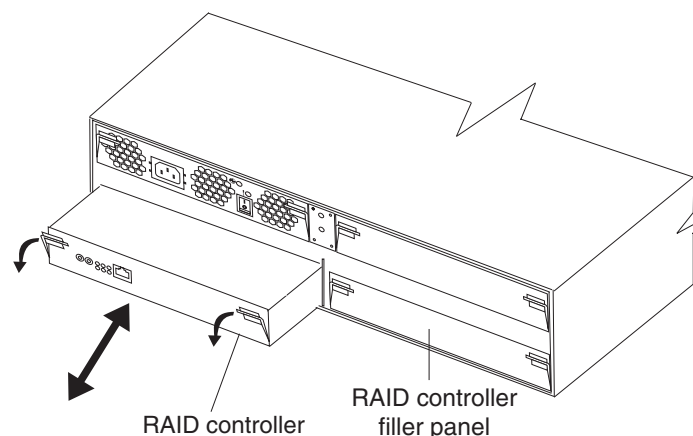
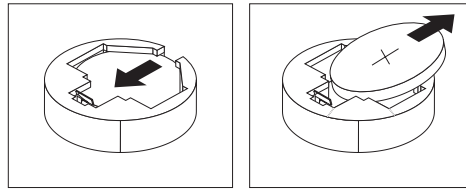

Figure 22. Removing a RAID controller

- b. Grasp both latches and pull the controller out of the bay.
  - c. Place the controller on a dry, level surface.
8. Remove the battery:

- a. Use a blunt object to press the side of the battery in the direction of the battery socket spring. The battery pops up when released.
- b. Use your thumb and index finger to lift the battery from the socket.



9. Insert the new battery:
  - a. Tilt the battery so that you can insert it into the socket on the side opposite the battery clip.
  - b. Press the battery down into the socket until it clicks into place. Make sure the battery socket holds the battery securely.
10. Install the RAID controller:
  - a. Make sure that the lever on each side of the controller is down as far as it will go.
  - b. Push the controller into the bay until it meets resistance (about 6 mm [0.25 in.] from the end of the chassis).
  - c. While squeezing together the latch and lever, push both latches up as far as they will go. The controller will slide the rest of the way into the bay.
11. Reconnect the Ethernet cables that you removed in step 7 on page 41 to the RAID controller.
12. **For a Fibre Channel RAID controller only:** Install the SFP modules and the fiber-optic cables that you removed in step 8 on page 41.
13. **For a storage subsystem with only one controller installed:** Turn on the power-supply switches on the rear of the storage subsystem.
14. **For a storage subsystem with two controllers installed:** Move the I/O data back to the original controller:
  - a. Open a Telnet session and connect to the alternate controller management port IP address. If the Telnet session is open from step 4 on page 39, go to step 14d.
  - b. At the command prompt, enter `admin`.
  - c. Enter the administrator password.
  - d. Enter `controller peer enable`.
  - e. Enter `controller info`.  
Information about the controller is displayed on the screen. If the information shows that the peer controller status is Not Ready, repeat this step until the status is Ready.
  - f. Enter `array failback`.  
The I/O data is moved back to the original controller.
15. Wait approximately 10 minutes for the ServeRAID Manager program to come back online.
16. Use the ServeRAID Manager program to monitor the status of the storage subsystem.

---

## Replacing the cache battery in the RAID controller

**Note:** The iSCSI RAID controller in the DS300 model 1RL does not contain a cache battery.

Each RAID controller contains a rechargeable battery that maintains the data in the cache memory for three days without power to the unit.

Complete the following steps if the ServeRAID Manager program instructs you to replace the battery because the current battery has failed or is nearing its expiration date. You can also use the ServeRAID Manager program to check the status of the battery.

**Attention:** For storage subsystems with only one controller installed: To prevent data loss, you must shut down the system before you replace the RAID controller battery. For the correct shutdown sequence, see the *DS300 and DS400 Hardware Installation and User's Guide*.

1. Read the safety information beginning on page iii and "Installation guidelines" on page 33.
2. Label each cable that is connected to the RAID controller so that you can correctly reconnect them to the RAID controller after you replace the battery.
3. **For a storage subsystem with only one controller installed:** Stop the host I/O data to the storage subsystem.
4. **For storage subsystems with two controllers installed:** Move the I/O data to the alternate controller:
  - a. Open a Telnet session and connect to the alternate controller management port IP address.
  - b. At the command prompt, enter admin.
  - c. Enter the administrator password.
  - d. Enter controller peer disable.

The controller that you are removing will shut down and all I/O data will have moved to the alternate controller.

5. If you are not using write-cache mirroring, you might have to clear cache memory on the RAID controller that contains the battery that has failed. To clear the cache, either shut down the controller before removing it from the storage subsystem or turn off caching in the storage subsystem by using the ServeRAID Manager program. Follow the steps in the ServeRAID Manager program before you continue with this procedure.
6. **For a storage subsystem with one controller installed:** Turn off the power-supply switches on the rear of the storage subsystem.
7. Remove the Ethernet cables from the RAID controller.
8. **For a Fibre Channel RAID controller only:** Remove the fiber-optic cables and the SFP modules from the RAID controller. For more information, see the *DS300 and DS400 Hardware Installation and User's Guide*.

**Attention:** When you handle static-sensitive devices, take precautions to avoid damage from static electricity. For details about handling static-sensitive devices, see "Handling static-sensitive devices" on page 33.

9. Remove the RAID controller that contains the battery that you want to replace:
  - a. While squeezing together the latch and lever that are on each side of the controller, press down on the orange area on each latch. The controller will slide out of the bay a short distance.

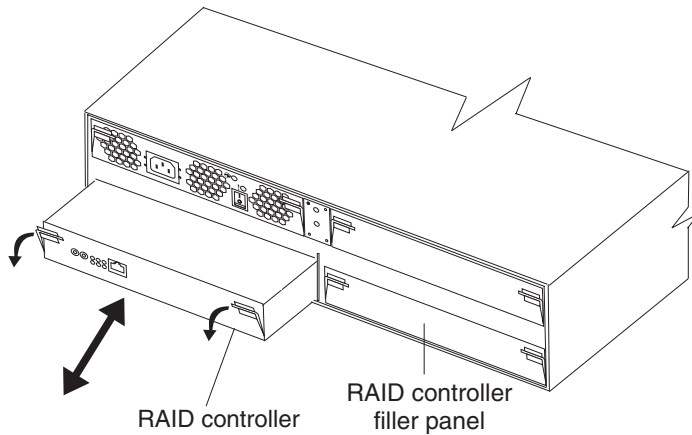

Figure 23. Removing a RAID controller

- b. Grasp both latches and pull the controller out of the bay.
  - c. Place the controller on a dry, level surface.
10. Remove the cache battery from the controller:
- a. Loosen the thumbscrew that holds the battery in place.

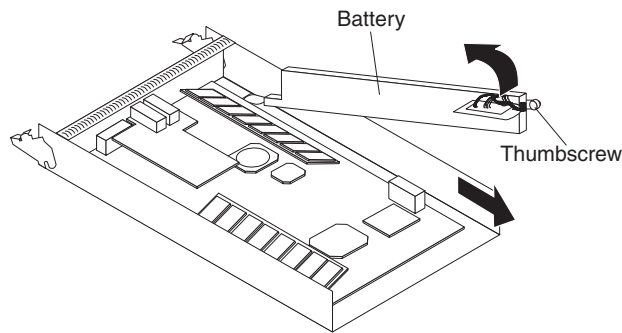

Figure 24. Removing the RAID controller battery

- b. Hold down the edge of the controller base on the battery side (near the thumbscrew).
  - c. Pull up on the blue lift tab on the battery to remove it from the connector.
  - d. Slide the battery toward the open end of the controller to remove it.
  - e. Dispose of the used battery according to local and federal regulations, which might include hazardous material handling procedures. For more information, see “Battery return program” on page 57.
11. Unpack the replacement battery and set it on a dry, level surface. Save the packing material and documentation in case you have to return the battery.
12. Install the new cache battery into the RAID controller:
- a. Slide the battery under the tab near the front of the RAID controller.



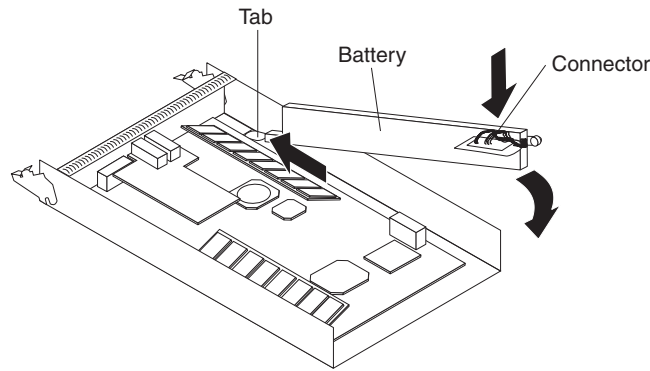

Figure 25. Installing a cache battery in the RAID controller

- b. Press down on the blue lift tab to secure the battery to the connector.
  - c. Tighten the thumbscrew.
13. Install the RAID controller:
  - a. Make sure that the lever on each side of the controller is down as far as it will go.
  - b. Push the controller into the bay until it meets resistance (about 6 mm [0.25 in.] from the end of the chassis).
  - c. While squeezing together the latch and lever, push both latches up as far as they will go. The controller will slide the rest of the way into the bay.
14. Reconnect the Ethernet cables that you removed in step 7 on page 41 to the RAID controller.
15. **For a Fibre Channel RAID controller only:** Install the SFP modules and the fiber-optic cables that you removed in step 8 on page 41.
16. **For a storage subsystem with one controller installed:** Turn on the power supply switches on the rear of the storage subsystem.
17. **For a storage subsystem with two controllers installed:** Move the I/O data back to the original controller:
  - a. Open a Telnet session and connect to the alternate controller management port IP address. If the Telnet session is open from step 4a on page 41, go to step 17d.
  - b. At the command prompt, enter `admin`.
  - c. Enter the administrator password.
  - d. Enter `controller peer enable`.
  - e. Enter `controller info`.  
Information about the controller is displayed on the screen. If the information shows that the peer controller status is Not Ready, repeat this step until the status is Ready.
  - f. Enter `array failback`.  
The I/O data is moved back to the original controller.
18. Wait approximately 10 minutes for the ServeRAID Manager program to come back online.

**Note:** It might take from 15 minutes to a few hours for a new battery to become fully charged. The ServeRAID Manager program might show the battery as failed until it is fully charged. Controller caching is automatically disabled until the new battery becomes fully charged.

19. Use the ServeRAID Manager program to monitor the status of the storage subsystem.

---

## Replacing a cache memory module

Complete the following steps to replace a cache dual inline memory module (DIMM). The Cache DIMM amber LED is lit.

1. Read the safety information beginning on page iii and “Installation guidelines” on page 33.
2. Label each cable that is connected to the RAID controller so that you can correctly reconnect them to the RAID controller after you replace the cache DIMM.
3. **For a storage subsystem with only one controller installed:** Stop the host I/O data to the storage subsystem.
4. **For a storage subsystem with only one controller installed:** Use the ServeRAID Manager program to shut down the RAID controller; then, turn off the power-supply switches on the rear of the storage subsystem.
5. **For storage subsystems with two controllers installed:** Move the I/O data to the alternate controller:
  - a. Open a Telnet session and connect to the alternate controller management port IP address.
  - b. At the command prompt, enter admin.
  - c. Enter the administrator password.
  - d. Enter controller peer disable.  
The controller that you are removing will shut down and all I/O data will have moved to the alternate controller.
6. Remove the Ethernet cables from the RAID controller.
7. **For a Fibre Channel RAID controller only:** Remove the fiber-optic cables and the SFP modules from the RAID controller. For more information, see the *DS300 and DS400 Hardware Installation and User's Guide*.  
**Attention:** When you handle static-sensitive devices, take precautions to avoid damage from static electricity. For details about handling static-sensitive devices, see “Handling static-sensitive devices” on page 33.
8. Remove the RAID controller that contains the RAID cache DIMM that you want to replace:
  - a. While squeezing together the latch and lever that are on each side of the controller, press down on the orange area on each latch. The controller will slide out of the bay a short distance.

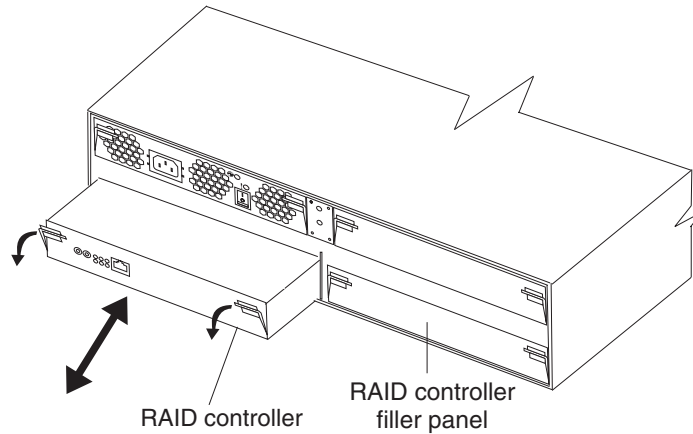

Figure 26. Removing a RAID controller

- b. Grasp both latches and pull the controller out of the bay.
- c. Place the controller on a dry, level surface.

**Attention:** To avoid breaking the retaining clips or damaging the DIMM connectors, open and close the clips gently.

9. Remove the RAID cache DIMM from the RAID controller:
  - a. Open the retaining clip on each end of the RAID cache DIMM connector. Figure 27 shows the cache DIMM you will replace.

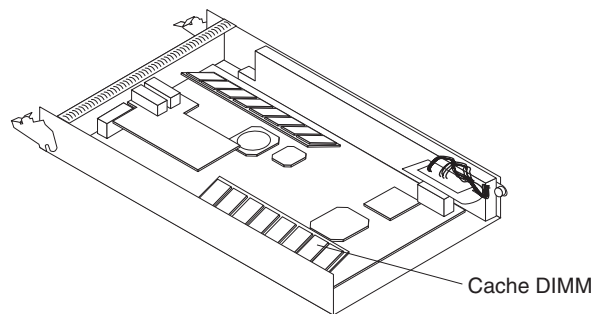

Figure 27. Removing the RAID cache DIMM

- b. Remove the cache DIMM.
- c. Touch the static-protective package that contains the new RAID cache DIMM to any unpainted metal surface on the storage subsystem. Then, remove the DIMM from the package.
- d. Angle the DIMM so that the DIMM keys align correctly with the slot.

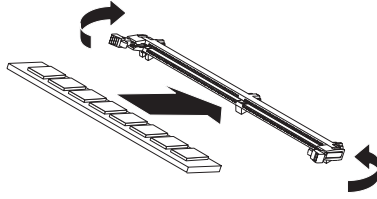

Figure 28. Inserting a DIMM into the connector

- e. Insert the DIMM into the connector by aligning the edges of the DIMM with the slots at the ends of the DIMM connector. Firmly press the DIMM into the connector by applying pressure on both ends of the DIMM simultaneously. The retaining clips snap into the locked position when the DIMM is firmly seated in the connector. If there is a gap between the DIMM and the retaining clips, the DIMM has not been correctly inserted; open the retaining clips, remove the DIMM, and then reinsert it.
10. Install the RAID controller in the storage subsystem:
    - a. Make sure that the lever on each side of the controller is down as far as it will go.
    - b. Push the controller into the bay until it meets resistance (about 6 mm [0.25 in.] from the end of the chassis).
    - c. While squeezing together the latch and lever, push both latches up as far as they will go. The controller will slide the rest of the way into the bay.
  11. Reconnect the Ethernet cables that you removed in step 6 on page 44.
  12. **For a Fibre Channel RAID controller only:** Install the SFP modules and the fiber-optic cables that you removed in step 7 on page 44.
  13. **For a storage subsystem with only one controller installed:** Turn on the power-supply switches on the rear of the storage subsystem.
  14. **For a storage subsystem with two controllers installed:** Move the I/O data back to the original controller:
    - a. Open a Telnet session and connect to the alternate controller management port IP address. If the Telnet session is open from step 5a on page 44, go to step 14d.
    - b. At the command prompt, enter `admin`.
    - c. Enter the administrator password.
    - d. Enter `controller peer enable`.
    - e. Enter `controller info`.  
Information about the controller is displayed on the screen. If the information shows that the peer controller status is Not Ready, repeat this step until the status is Ready.
    - f. Enter `array failback`.  
The I/O data is moved back to the original controller.

---

## Replacing a RAID controller

**Important:** If the storage subsystem has two controllers installed, *do not* use the procedure in this section. See the Technical Update about replacing a controller that comes with the replacement controller and is available on the IBM Support Web site (<http://www.ibm.com/pc/support/>).

When instructed to do so by the ServeRAID Manager program, replace a RAID controller that has failed.

**Notes:**

1. The replacement RAID controller does not come with a cache battery or RAID cache DIMM installed. You must remove the cache battery and cache DIMM that are inside the RAID controller that you are replacing, and install them in the replacement RAID controller. The steps to remove and install the battery and DIMM are included in the following procedure.
2. The RAID controller in the DS300 model 1RL does not contain a cache battery.

Complete the following steps to replace a RAID controller:

1. Read the safety information beginning on page iii and “Installation guidelines” on page 33.
2. Check the ServeRAID Manager program for instructions for recovering from a RAID controller failure. Follow the instructions in the software documentation before continuing with step 4.
3. Turn off the power supply switches on the rear of the storage subsystem.
4. Label each cable that is connected to the RAID controller that has failed. This ensures that all cables will be correctly reconnected to the new RAID controller.
5. Remove all Ethernet cables from the RAID controller.
6. **For a Fibre Channel RAID controller only:** Remove the fiber-optic cables and the SFP modules from the RAID controller. For more information, see the *DS300 and DS400 Hardware Installation and User’s Guide*.

**Attention:** When you handle static-sensitive devices, take precautions to avoid damage from static electricity. For details about handling static-sensitive devices, see “Handling static-sensitive devices” on page 33.

7. Remove the failed RAID controller (the fault LED is on):
  - a. While squeezing together the latch and lever that are on each side of the controller, press down on the orange area on each latch. The controller will slide out of the bay a short distance.

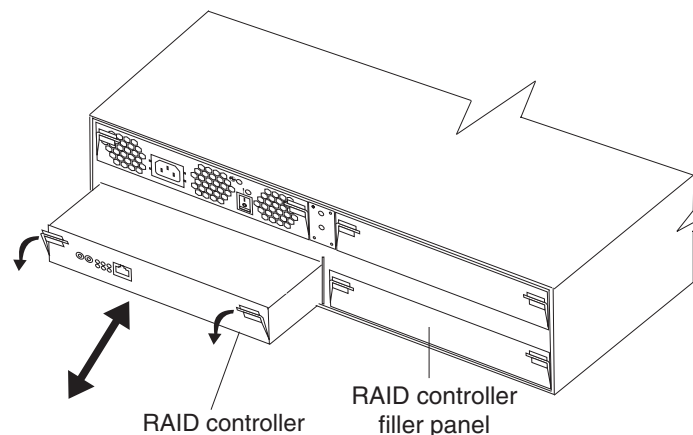

Figure 29. Removing a RAID controller

- b. Grasp both latches and pull the controller out of the bay.
  - c. Place the controller on a dry, level surface.
8. Remove the cache battery (**DS300 Model 1700-1RS and DS400 only**):

- a. Loosen the thumbscrew that holds the battery in place.

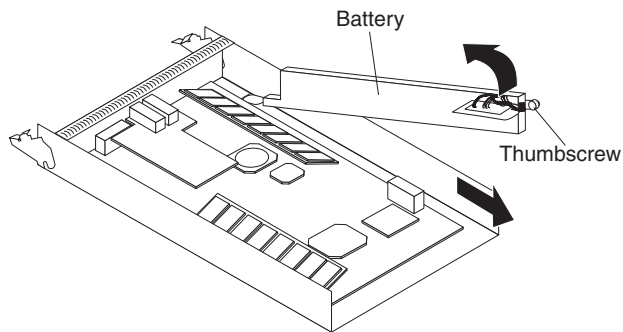

Figure 30. Removing the RAID controller battery

- b. Hold down the edge of the controller base on the battery side (near the thumbscrew).
  - c. Pull up on the blue lift tab on the battery to remove it from the connector.
  - d. Slide the battery toward the open end of the controller to remove it.
  - e. Place the battery on a dry, level surface.
9. Unpack the replacement RAID controller and set it on a dry, level surface. Save the packing material and documentation in case you have to return the RAID controller.
  10. Install the battery (that you removed in step 8 on page 47) into the replacement RAID controller:
    - a. Slide the battery under the tab near the front of the RAID controller.

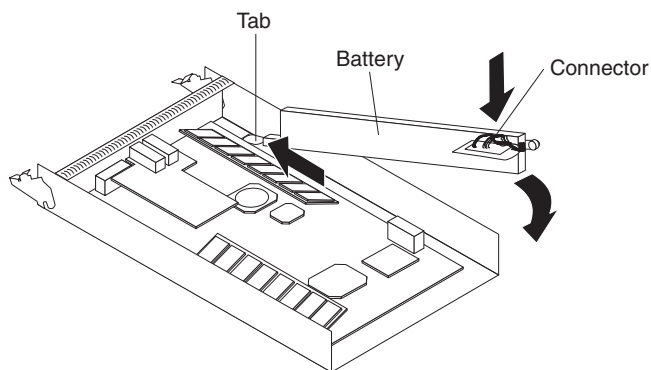

Figure 31. Installing a cache battery in the RAID controller

- b. Press down on the blue lift tab to secure the battery to the connector.
  - c. Tighten the thumbscrew.
11. Remove the RAID cache DIMM from the failed RAID controller:
    - a. Open the retaining clip on each end of the cache DIMM connector. Figure 27 on page 45 shows the cache DIMM that you will remove.

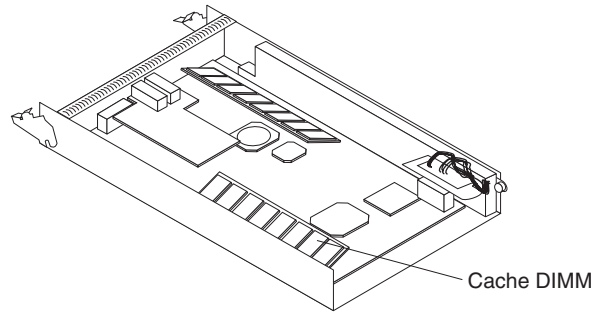

Figure 32. Removing the RAID cache DIMM

- b. Carefully remove the cache DIMM.
12. Install the RAID cache DIMM in the new RAID controller:
  - a. Open the retaining clip on each end of the RAID cache DIMM connector.
  - b. Angle the DIMM so that the DIMM keys align correctly with the slot.

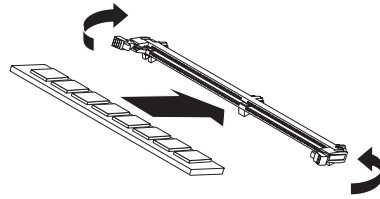

Figure 33. Inserting a DIMM into the connector

- c. Insert the DIMM into the connector by aligning the edges of the DIMM with the slots at the ends of the DIMM connector. Firmly press the DIMM into the connector by applying pressure on both ends of the DIMM simultaneously. The retaining clips snap into the locked position when the DIMM is firmly seated in the connector. If there is a gap between the DIMM and the retaining clips, the DIMM has not been correctly inserted; open the retaining clips, remove the DIMM, and then reinsert it.
13. Install the replacement RAID controller in the storage subsystem:
  - a. Make sure that the lever on each side of the controller is down as far as it will go.
  - b. Push the controller into the bay until it meets resistance (about 6 mm [0.25 in.] from the end of the chassis).
  - c. While squeezing together the latch and lever, push both latches up as far as they will go. The controller will slide the rest of the way into the bay.
14. Reconnect the Ethernet cables that you removed in step 5 on page 47.
15. **For a Fibre Channel RAID controller only:** Insert the SFP modules and fiber-optic cables that you removed in step 6 on page 47.
16. Turn on the power supply switches on the rear of the storage subsystem.
17. Wait approximately 10 minutes and then check the status LEDs on the RAID controller. Make sure that:
  - The Ethernet link green LEDs are lit.
  - The Fibre Channel port green LEDs are lit.
  - The Controller ready green LED is lit.
  - The Controller not ready amber LED is off.

For more information about network configuration, see the *DS300 and DS400 Hardware Installation and User's Guide* and the *DS300 and DS400 Software Installation Guide*.

---

## Replacing a hot-swap power supply

Before replacing a power supply, read the following important information:

- The power supply does not require preventive maintenance.
- The unit must be installed in the correct place to maintain proper expansion unit cooling.
- Use only power supplies that are supported for your specific storage subsystem.

Complete the following steps to replace a hot-swap power supply:

1. Read the safety information beginning on page iii and “Installation guidelines” on page 33.
2. Turn off the power supply.
3. Disconnect the power cord from the electrical outlet and from the power supply.
4. Remove the power supply from the storage subsystem:
  - a. While squeezing together the latch and lever that are on each side of the power supply, press down on the orange area on each latch. The power supply will slide out of the bay a short distance.

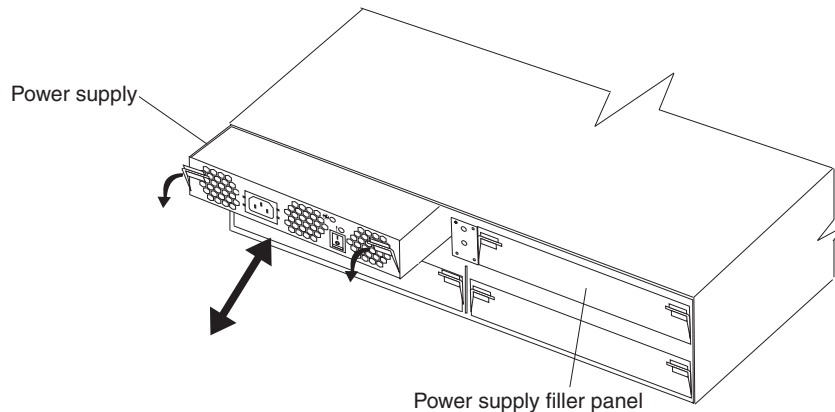

Figure 34. Removing a power supply

- b. Grasp both latches and pull the power supply out of the bay.
  - c. Place the power supply on a dry, level surface.
5. Make sure that the power switch on the replacement power supply is turned off.
  6. Install the replacement power supply in the storage subsystem:
    - a. Make sure that the lever on each side of the power supply is down as far as it will go.
    - b. Push the power supply into the bay until it meets resistance (about 6 mm [0.25 in.] from the end of the chassis).
    - c. While squeezing together the latch and lever, push both latches up as far as they will go. The power supply will slide the rest of the way into the bay.
  7. Connect the power cord to the power supply.



8. Untwist the power cord strain-relief plastic tie (located below and to the right of the ac power switch).
9. Wrap the strain-relief tie around the power cord approximately 10 cm (4 in.) from the ac power connector end; then, twist the tie.
10. Connect the power-supply cord into a properly grounded electrical outlet.

**Note:** The fault (amber) LED is lit on the new power supply because its power switch is turned off.

11. Turn on the power supply.

After you turn on the power, the fault (amber) LED is off and the Power OK (green) LEDs are lit.



---

## Appendix B. Getting help and technical assistance

If you need help, service, or technical assistance or just want more information about IBM products, you will find a wide variety of sources available from IBM to assist you. This appendix contains information about where to go for additional information about IBM and IBM products, what to do if you experience a problem with your xSeries or IntelliStation® system, and whom to call for service, if it is necessary.

---

### Before you call

Before you call, make sure that you have taken these steps to try to solve the problem yourself:

- Check all cables to make sure that they are connected.
- Check the power switches to make sure that the system is turned on.
- Use the troubleshooting information in your system documentation, and use the diagnostic tools that come with your system. Information about diagnostic tools is in the *DS300 and DS400 Problem Determination Guides* and the *Hardware Maintenance Manual* at the IBM Support Web site.
- Go to the IBM Support Web site at <http://www.ibm.com/pc/support/> to check for technical information, hints, tips, and new device drivers or to submit a request for information.

You can solve many problems without outside assistance by following the troubleshooting procedures that IBM provides in the online help or in the publications that are provided with your system and software. The information that comes with your system also describes the diagnostic tests that you can perform. Most xSeries and IntelliStation systems, operating systems, and programs come with information that contains troubleshooting procedures and explanations of error messages and error codes. If you suspect a software problem, see the information for the operating system or program.

---

### Using the documentation

Information about your IBM xSeries or IntelliStation system and preinstalled software, if any, is available in the documentation that comes with your system. That documentation includes printed books, online books, readme files, and help files. See the troubleshooting information in your system documentation for instructions for using the diagnostic programs. The troubleshooting information or the diagnostic programs might tell you that you need additional or updated device drivers or other software. IBM maintains pages on the World Wide Web where you can get the latest technical information and download device drivers and updates. To access these pages, go to <http://www.ibm.com/pc/support/> and follow the instructions. Also, you can order publications through the IBM Publications Ordering System at <http://www.elink.ibm.com/public/applications/publications/cgibin/pbi.cgi>.

---

### Getting help and information from the World Wide Web

On the World Wide Web, the IBM Web site has up-to-date information about IBM xSeries and IntelliStation products, services, and support. The address for IBM xSeries information is <http://www.ibm.com/eserver/xseries/>. The address for IBM IntelliStation information is <http://www.ibm.com/pc/intellistation/>.

You can find service information for your IBM products, including supported options, at <http://www.ibm.com/pc/support/>.

---

## Software service and support

Through IBM Support Line, you can get telephone assistance, for a fee, with usage, configuration, and software problems with xSeries servers, IntelliStation workstations, and appliances. For information about which products are supported by Support Line in your country or region, go to <http://www.ibm.com/services/sl/products/>.

For more information about Support Line and other IBM services, go to <http://www.ibm.com/services/>, or go to <http://www.ibm.com/planetwide/> for support telephone numbers. In the U.S. and Canada, call 1-800-IBM-SERV (1-800-426-7378).

---

## Hardware service and support

You can receive hardware service through IBM Services or through your IBM reseller, if your reseller is authorized by IBM to provide warranty service. Go to <http://www.ibm.com/planetwide/> for support telephone numbers, or in the U.S. and Canada, call 1-800-IBM-SERV (1-800-426-7378).

In the U.S. and Canada, hardware service and support is available 24 hours a day, 7 days a week. In the U.K., these services are available Monday through Friday, from 9 a.m. to 6 p.m.

---

## Appendix C. Notices

This publication was developed for products and services offered in the U.S.A.

IBM may not offer the products, services, or features discussed in this document in other countries. Consult your local IBM representative for information on the products and services currently available in your area. Any reference to an IBM product, program, or service is not intended to state or imply that only that IBM product, program, or service may be used. Any functionally equivalent product, program, or service that does not infringe any IBM intellectual property right may be used instead. However, it is the user's responsibility to evaluate and verify the operation of any non-IBM product, program, or service.

IBM may have patents or pending patent applications covering subject matter described in this document. The furnishing of this document does not give you any license to these patents. You can send license inquiries, in writing, to:

*IBM Director of Licensing  
IBM Corporation  
North Castle Drive  
Armonk, NY 10504-1785  
U.S.A.*

INTERNATIONAL BUSINESS MACHINES CORPORATION PROVIDES THIS PUBLICATION "AS IS" WITHOUT WARRANTY OF ANY KIND, EITHER EXPRESS OR IMPLIED, INCLUDING, BUT NOT LIMITED TO, THE IMPLIED WARRANTIES OF NON-INFRINGEMENT, MERCHANTABILITY OR FITNESS FOR A PARTICULAR PURPOSE. Some states do not allow disclaimer of express or implied warranties in certain transactions, therefore, this statement may not apply to you.

This information could include technical inaccuracies or typographical errors. Changes are periodically made to the information herein; these changes will be incorporated in new editions of the publication. IBM may make improvements and/or changes in the product(s) and/or the program(s) described in this publication at any time without notice.

Any references in this publication to non-IBM Web sites are provided for convenience only and do not in any manner serve as an endorsement of those Web sites. The materials at those Web sites are not part of the materials for this IBM product, and use of those Web sites is at your own risk.

IBM may use or distribute any of the information you supply in any way it believes appropriate without incurring any obligation to you.

---

### Edition notice

**© Copyright International Business Machines Corporation 2004, 2005. All rights reserved.**

U.S. Government Users Restricted Rights — Use, duplication, or disclosure restricted by GSA ADP Schedule Contract with IBM Corp.

---

## Trademarks

The following terms are trademarks of International Business Machines Corporation in the United States, other countries, or both:

IBM  
e (logo) server  
FlashCopy  
Predictive Failure Analysis  
ServeRAID  
ServerProven  
TotalStorage

Intel™ and Pentium® III are trademarks of Intel Corporation in the United States, other countries, or both.

Microsoft, Windows, and Windows NT® are trademarks of Microsoft Corporation in the United States, other countries, or both.

Other company, product, or service names may be the trademarks or service marks of others.

---

## Important notes

Processor speeds indicate the internal clock speed of the microprocessor; other factors also affect application performance.

CD-ROM drive speeds list the variable read rate. Actual speeds vary and are often less than the maximum possible.

When referring to processor storage, real and virtual storage, or channel volume, KB stands for approximately 1000 bytes, MB stands for approximately 1000000 bytes, and GB stands for approximately 1000000000 bytes.

When referring to hard disk drive capacity or communications volume, MB stands for 1 000 000 bytes, and GB stands for 1 000 000 000 bytes. Total user-accessible capacity may vary depending on operating environments.

Maximum internal hard disk drive capacities assume the replacement of any standard hard disk drives and population of all hard disk drive bays with the largest currently supported drives available from IBM.

Maximum memory may require replacement of the standard memory with an optional memory module.

IBM makes no representation or warranties regarding non-IBM products and services that are ServerProven®, including but not limited to the implied warranties of merchantability and fitness for a particular purpose. These products are offered and warranted solely by third parties.

Unless otherwise stated, IBM makes no representations or warranties with respect to non-IBM products. Support (if any) for the non-IBM products is provided by the third party, not IBM.

Some software may differ from its retail version (if available), and may not include user manuals or all program functionality.

---

## Product recycling and disposal

This unit contains materials such as circuit boards, cables, electromagnetic compatibility gaskets, and connectors which may contain lead and copper/beryllium alloys that require special handling and disposal at end of life. Before this unit is disposed of, these materials must be removed and recycled or discarded according to applicable regulations. IBM offers product-return programs in several countries. Information on product recycling offerings can be found on IBM's Internet site at <http://www.ibm.com/ibm/environment/products/prp.shtml>.

---

## Battery return program

This product may contain a sealed lead acid, nickel cadmium, nickel metal hydride, lithium, or lithium ion battery. Consult your user manual or service manual for specific battery information. The battery must be recycled or disposed of properly. Recycling facilities may not be available in your area. For information on disposal of batteries outside the United States, go to <http://www.ibm.com/ibm/environment/products/batteryrecycle.shtml> or contact your local waste disposal facility.

In the United States, IBM has established a collection process for reuse, recycling, or proper disposal of used IBM sealed lead acid, nickel cadmium, nickel metal hydride, and battery packs from IBM equipment. For information on proper disposal of these batteries, contact IBM at 1-800-426-4333. Have the IBM part number listed on the battery available prior to your call.

In the Netherlands, the following applies.



---

## Electronic emission notices

### Federal Communications Commission (FCC) statement

**Note:** This equipment has been tested and found to comply with the limits for a Class A digital device, pursuant to Part 15 of the FCC Rules. These limits are designed to provide reasonable protection against harmful interference when the equipment is operated in a commercial environment. This equipment generates, uses, and can radiate radio frequency energy and, if not installed and used in accordance with the instruction manual, may cause harmful interference to radio communications. Operation of this equipment in a residential area is likely to cause harmful interference, in which case the user will be required to correct the interference at his own expense.

Properly shielded and grounded cables and connectors must be used in order to meet FCC emission limits. IBM is not responsible for any radio or television interference caused by using other than recommended cables and connectors or by unauthorized changes or modifications to this equipment. Unauthorized changes or modifications could void the user's authority to operate the equipment.

This device complies with Part 15 of the FCC Rules. Operation is subject to the following two conditions: (1) this device may not cause harmful interference, and (2) this device must accept any interference received, including interference that may cause undesired operation.

## Chinese Class A warning statement

**Attention:** This is a class A statement. In a domestic environment, this product might cause radio interference in which case the user might be required to take adequate measures.

**声 明**  
此为 A 级产品。在生活环境中，  
该产品可能会造成无线电干扰。  
在这种情况下，可能需要用户对其  
干扰采取切实可行的措施。

## Industry Canada Class A emission compliance statement

This Class A digital apparatus complies with Canadian ICES-003.

### Avis de conformité à la réglementation d'Industrie Canada

Cet appareil numérique de la classe A est conforme à la norme NMB-003 du Canada.

## Australia and New Zealand Class A statement

**Attention:** This is a Class A product. In a domestic environment this product may cause radio interference in which case the user may be required to take adequate measures.

## United Kingdom telecommunications safety requirement

### Notice to Customers

This apparatus is approved under approval number NS/G/1234/J/100003 for indirect connection to public telecommunication systems in the United Kingdom.

## European Union EMC Directive conformance statement

This product is in conformity with the protection requirements of EU Council Directive 89/336/EEC on the approximation of the laws of the Member States relating to electromagnetic compatibility. IBM cannot accept responsibility for any failure to satisfy the protection requirements resulting from a nonrecommended modification of the product, including the fitting of non-IBM option cards.

This product has been tested and found to comply with the limits for Class A Information Technology Equipment according to CISPR 22/European Standard EN 55022. The Limits for Class A equipment were derived for commercial and industrial environments to provide reasonable protection against interference with licensed communication equipment.



**Attention:** This is a Class A product. In a domestic environment this product may cause radio interference in which case the user may be required to take adequate measures.

## Taiwan Class A warning statement

警告使用者:  
這是甲類的資訊產品，在居住的環境中使用時，可能會造成射頻干擾，在這種情況下，使用者會被要求採取某些適當的對策。

## Japanese Voluntary Control Council for Interference (VCCI) statement

この装置は、情報処理装置等電波障害自主規制協議会（VCCI）の基準に基づくクラスA情報技術装置です。この装置を家庭環境で使用すると電波妨害を引き起こすことがあります。この場合には使用者が適切な対策を講ずるよう要求されることがあります。

---

## Power cords

For your safety, IBM provides a power cord with a grounded attachment plug to use with this IBM product. To avoid electrical shock, always use the power cord and plug with a properly grounded outlet.

IBM power cords used in the United States and Canada are listed by Underwriter's Laboratories (UL) and certified by the Canadian Standards Association (CSA).

For units intended to be operated at 115 volts: Use a UL-listed and CSA-certified cord set consisting of a minimum 18 AWG, Type SVT or SJT, three-conductor cord, a maximum of 15 feet in length and a parallel blade, grounding-type attachment plug rated 15 amperes, 125 volts.

For units intended to be operated at 230 volts (U.S. use): Use a UL-listed and CSA-certified cord set consisting of a minimum 18 AWG, Type SVT or SJT, three-conductor cord, a maximum of 15 feet in length and a tandem blade, grounding-type attachment plug rated 15 amperes, 250 volts.

For units intended to be operated at 230 volts (outside the U.S.): Use a cord set with a grounding-type attachment plug. The cord set should have the appropriate safety approvals for the country in which the equipment will be installed.

IBM power cords for a specific country or region are usually available only in that country or region.

<b>IBM power cord part number</b>	<b>Used in these countries and regions</b>
02K0546	China
13F9940	Australia, Fiji, Kiribati, Nauru, New Zealand, Papua New Guinea
13F9979	Afghanistan, Albania, Algeria, Andorra, Angola, Armenia, Austria, Azerbaijan, Belarus, Belgium, Benin, Bosnia and Herzegovina, Bulgaria, Burkina Faso, Burundi, Cambodia, Cameroon, Cape Verde, Central African Republic, Chad, Comoros, Congo (Democratic Republic of), Congo (Republic of), Cote D'Ivoire (Ivory Coast), Croatia (Republic of), Czech Republic, Dahomey, Djibouti, Egypt, Equatorial Guinea, Eritrea, Estonia, Ethiopia, Finland, France, French Guyana, French Polynesia, Germany, Greece, Guadeloupe, Guinea, Guinea Bissau, Hungary, Iceland, Indonesia, Iran, Kazakhstan, Kyrgyzstan, Laos (People's Democratic Republic of), Latvia, Lebanon, Lithuania, Luxembourg, Macedonia (former Yugoslav Republic of), Madagascar, Mali, Martinique, Mauritania, Mauritius, Mayotte, Moldova (Republic of), Monaco, Mongolia, Morocco, Mozambique, Netherlands, New Caledonia, Niger, Norway, Poland, Portugal, Reunion, Romania, Russian Federation, Rwanda, Sao Tome and Principe, Saudi Arabia, Senegal, Serbia, Slovakia, Slovenia (Republic of), Somalia, Spain, Suriname, Sweden, Syrian Arab Republic, Tajikistan, Tahiti, Togo, Tunisia, Turkey, Turkmenistan, Ukraine, Upper Volta, Uzbekistan, Vanuatu, Vietnam, Wallis and Futuna, Yugoslavia (Federal Republic of), Zaire
13F9997	Denmark
14F0015	Bangladesh, Lesotho, Macao, Maldives, Namibia, Nepal, Pakistan, Samoa, South Africa, Sri Lanka, Swaziland, Uganda
14F0033	Abu Dhabi, Bahrain, Botswana, Brunei Darussalam, Channel Islands, China (Hong Kong S.A.R.), Cyprus, Dominica, Gambia, Ghana, Grenada, Iraq, Ireland, Jordan, Kenya, Kuwait, Liberia, Malawi, Malaysia, Malta, Myanmar (Burma), Nigeria, Oman, Polynesia, Qatar, Saint Kitts and Nevis, Saint Lucia, Saint Vincent and the Grenadines, Seychelles, Sierra Leone, Singapore, Sudan, Tanzania (United Republic of), Trinidad and Tobago, United Arab Emirates (Dubai), United Kingdom, Yemen, Zambia, Zimbabwe
14F0051	Liechtenstein, Switzerland
14F0069	Chile, Italy, Libyan Arab Jamahiriya
14F0087	Israel
1838574	Antigua and Barbuda, Aruba, Bahamas, Barbados, Belize, Bermuda, Bolivia, Brazil, Caicos Islands, Canada, Cayman Islands, Costa Rica, Colombia, Cuba, Dominican Republic, Ecuador, El Salvador, Guam, Guatemala, Haiti, Honduras, Jamaica, Japan, Mexico, Micronesia (Federal States of), Netherlands Antilles, Nicaragua, Panama, Peru, Philippines, Taiwan, United States of America, Venezuela
24P6858	Korea (Democratic People's Republic of), Korea (Republic of)
34G0232	Japan
36L8880	Argentina, Paraguay, Uruguay
49P2078	India
49P2110	Brazil

<b>IBM power cord part number</b>	<b>Used in these countries and regions</b>
6952300	Antigua and Barbuda, Aruba, Bahamas, Barbados, Belize, Bermuda, Bolivia, Caicos Islands, Canada, Cayman Islands, Colombia, Costa Rica, Cuba, Dominican Republic, Ecuador, El Salvador, Guam, Guatemala, Haiti, Honduras, Jamaica, Mexico, Micronesia (Federal States of), Netherlands Antilles, Nicaragua, Panama, Peru, Philippines, Saudi Arabia, Thailand, Taiwan, United States of America, Venezuela



---

# Index

## A

- acoustical noise emissions specifications of storage subsystem 6, 22
- air temperature specifications of storage subsystem 6, 22
- attention notices 2

## B

- battery
  - replacing 41
- battery return program 57
- battery, real-time clock 38
- bezel assembly
  - installing on DS300 model 1701-1RL 35
  - installing on DS300 models 1700-1RS and 1700-2RD, and DS400 34

## C

- cache memory
  - DS300 storage subsystem 12
  - DS400 storage subsystem 26
- caution statements 2
- Class A electronic emission notice 57
- components
  - DS300 (1701-1RL) storage subsystem 5, 6
  - DS300 (1701-1RS) storage subsystem 5, 6
  - DS400 storage subsystem 22
- customer replaceable units (CRU) 7, 23

## D

- danger statements 2
- diagnostic hardware
  - DS300 storage subsystem 12
  - DS400 storage subsystem 27
- diagnostics
  - DS300 storage subsystem 12
  - DS400 storage subsystem 26
- DIMM, replacing cache 44
- documentation browser 3
  - autostart 3
- documentation CD 3
- drive, hard disk
  - installing 36
  - replacing 37
- DS300 (1701-1RL) storage subsystem
  - back view 9
  - components 5
  - front view 7
- DS300 (1701-1RS) storage subsystem
  - back view 8
  - components 5
  - front view 7
- DS300 storage subsystem
  - additional service information 6

- DS300 storage subsystem (*continued*)
  - back view LEDs 10
  - cache memory 12
  - components 6
  - diagnostic hardware 12
  - diagnostics 12
  - front view LEDs 10
  - general checkout 5
  - iSCSI RAID controller 9
  - iSCSI RAID controller (Model 1701-1RL) 11
  - iSCSI RAID controller (Model 1701-1RS) 11
  - parts listing 17
  - power supply 9
  - specifications 6
  - symptom-to-FRU indices 13
  - troubleshooting 13
- DS400 storage subsystem
  - additional service information 21
  - back view 23
  - back view LEDs 25
  - cache memory 26
  - components 21, 22
  - diagnostic hardware 27
  - diagnostics 26
  - fibre channel RAID controller 24, 25
  - front view 22
  - front view LEDs 24
  - general checkout 21
  - monitoring status through software 12, 27
  - parts listing 31
  - power supply 24
  - specifications 21
  - symptom-to-FRU indices 27
  - troubleshooting 27

## E

- electrical input specifications of storage subsystem 6, 22
- electronic emission Class A notice 57
- electrostatic discharge, handling 33
- environmental specifications of storage subsystem 6, 22

## F

- family field 1
- FCC Class A notice 57
- fibre channel RAID controller
  - DS400 storage subsystem 24
  - FC host port status LEDs 26
  - LEDs and connectors 26
- filler panels 7, 23

## G

- general checkout
  - DS300 storage subsystem 5
  - DS400 storage subsystem 21

## H

- hard disk drive
  - installing 36
  - replacing 37
- hardware and software requirements 3
- hardware components
  - installing and replacing 33
- hardware maintenance, overview 1
- hot-swap hard disk drive, Ultra320 7, 23
- hot-swap power supply, replacing 50
- humidity specifications of storage subsystem 6, 22

## I

- important notices 2
- installation guidelines 33
- installing components
  - hot-swap hard disk drive 36
- iSCSI RAID controller (Model 1701-1RL) 11

## M

- memory, cache
  - replacing 44
- monitoring status through software
  - DS400 storage subsystem 12, 27

## N

- noise emissions specifications of storage subsystem 6, 22
- notes, important 56
- notices
  - electronic emission 57
  - FCC, Class A 57
- notices and statements 2

## O

- online publications 1
- options, supported 1

## P

- parts listing
  - DS300 storage subsystem 17
  - DS400 storage subsystem 31
- power cords 59
- power supply
  - DS300 storage subsystem 9
  - DS400 storage subsystem 24
  - replacing 50
- publications 4

## R

- rack installation and removal instructions 1
- RAID controller
  - replacing 47
- recycling and disposal 57
- removing components
  - DIMM 44
- replacing components
  - cache battery 41
  - hard disk drive 37
  - power supply 50
  - RAID controller 47

## S

- ServeRAID Manager 12, 27
- software requirements 3
- specifications
  - DS300 storage subsystem 6
  - DS400 storage subsystem 21
- statements and notices 2
- static-sensitive devices, handling 33
- storage subsystem
  - components
    - replacing RAID controller 47
- symptom-to-FRU indices
  - DS300 storage subsystem
    - front view LEDs 13
    - iSCSI-iSCSI RAID controller LEDs 15
    - power supply RAID controller LEDs 14
  - DS400 storage subsystem
    - fibre channel host port status LEDs 31
    - front view LEDs 28
    - power supply LEDs 29
    - RAID controller LEDs 29

## T

- temperature specifications of storage subsystem 6, 22
- TotalStorage DS400 components 21
- trademarks 56
- troubleshooting
  - DS300 storage subsystem 13
  - DS400 storage subsystem 27

## U

- Ultra320 7, 23
- United States electronic emission Class A notice 57
- United States FCC Class A notice 57

## W

- weight specifications of storage subsystem 6, 22





Part Number: 25K8190

Printed in USA

(1P) P/N: 25K8190

