



Hardware Management Console for pSeries
Maintenance Guide

SA38-0603-04





@server

Hardware Management Console for pSeries
Maintenance Guide

SA38-0603-04

Sixth Edition (December 2003)Fifth Edition (December 2003)

Before using this information and the product it supports, read the information in “Safety Notices” on page v, Appendix B, “Environmental Notices,” on page 121, and Appendix C, “Notices,” on page 123.

A reader’s comment form is provided at the back of this publication. If the form has been removed, address comments to Publications Department, Internal Zip 905-6C006, 11501 Burnet Road, Austin, Texas 78758-3493. To send comments electronically, use this commercial internet address: aix6kpub@austin.ibm.com. Any information that you supply may be used without incurring any obligation to you.

©**International Business Machines Corporation, 2001, 2003. All rights reserved.** Note to U.S. Government Users - Documentation related to restricted rights - Use, duplication, or disclosure is subject to the restrictions set forth in the GSA ADP Schedule Contract with IBM Corp.

Contents

Safety Notices	v
Electrical Safety	v
Laser Safety Information	v
Laser Compliance	v
Data Integrity and Verification	vii
About This Book	ix
ISO 9000	ix
Highlighting	ix
Accessing Information	x
Related Publications	x
Trademarks	xi
Chapter 1. Reference Information	1
Hardware Management Console Overview	1
Managed System Operation	2
HMC to Managed System Cabling	2
Powering On and Off	4
Power-On Self-Test	4
Specifications and System Unit Locations	4
External AC Power Cable	5
Service Inspection Guide	5
Chapter 2. Diagnostics Overview	7
MAPs	7
Diagnostics, Test, and Recovery	7
Chapter 3. HMC Software Support	9
Viewing the HMC Console Logs	9
Chapter 4. Maintenance Analysis Procedures	11
Entry MAP	12
MAP 1020 Problem Determination	13
MAP 1520 Power	15
MAP 1530: Testing the HMC	15
Diagnostic Procedures	15
System Unit Testing	16
Managed System Connection	17
Modem MAP	19
Ethernet MAP	22
Disk Drive MAP	23
DVD RAM MAP	24
Diskette Drive MAP	26
Display Problems	27
Chapter 5. Error Code to FRU Index	29
Symptom to Action	29
Error Messages and Recovery Information	29
Chapter 6. Removal and Replacement Procedures	87
Service Procedures	87
General Information	87

Restoring the HMC Image	88
Removals and Replacements	89
Installing or Removing the 8-Port ASYNC Adapter	89
Installing or Removing the 128-Port ASYNC Adapter	92
Removing an Adapter	93
Exchanging a Disk Drive	93
Replacing the Planar and Performing the Flash (BIOS/VPD) update procedure	94
Chapter 7. Hardware Management Console Parts	95
Parts Listing for a 6578-KLU	96
Parts Listing for a 7315-C01	99
Parts Listing for a 7315-C02	103
Parts Listing for a 7315-CR2	106
Parts Listing for a 7315-C03	110
Power Cords	113
Appendix A. Service Focal Point.	115
Getting Started	115
Testing Error Reporting	115
Service Focal Point Settings	116
Automatic Call-Home Feature	116
Setting Up Surveillance	116
Enabling Surveillance Notifications	117
Working With Serviceable Events	117
Viewing Serviceable Events	117
Viewing Serviceable Event Details	118
Saving and Managing Extended Error Data	118
Viewing and Adding Serviceable Event Comments	118
Closing a Serviceable Event	119
Updating Field Replaceable Unit (FRU) Information	119
Replacing an Existing FRU	119
Adding a New FRU	120
Viewing Serviceable Event Partition Information	120
Hardware Service Functions	120
Activating and Deactivating FRU Identity LEDs	120
Appendix B. Environmental Notices	121
Product Recycling and Disposal.	121
Environmental Design	121
Acoustical Noise Emissions	121
Appendix C. Notices	123
Index	125

Safety Notices

A *danger* notice indicates the presence of a hazard that has the potential of causing death or serious personal injury.

Danger notices appear on the following pages:

- v

A *caution* notice indicates the presence of a hazard that has the potential of causing moderate or minor personal injury.

Caution notices appear on the following pages:

- v

Note: For a translation of these notices, see the *System Unit Safety Information* manual, order number SA23-2652.

Electrical Safety

Observe the following safety instructions any time you are connecting or disconnecting devices attached to the system.

CAUTION:

This product is equipped with a three-wire power cable and plug for the user's safety. Use this power cable with a properly grounded electrical outlet to avoid electrical shock.

C01

Laser Safety Information

CAUTION:

This product may contain a CD-ROM, DVD-ROM, or laser module on a PCI card, which are class 1 laser products.

C30

Laser Compliance

All lasers are certified in the U.S. to conform to the requirements of DHHS 21 CFR Subchapter J for class 1 laser products. Outside the U.S., they are certified to be in compliance with the IEC 825 (first edition 1984) as a class 1 laser product. Consult the label on each part for laser certification numbers and approval information.

CAUTION:

All IBM laser modules are designed so that there is never any human access to laser radiation above a class 1 level during normal operation, user maintenance, or prescribed service conditions. Data processing environments can contain equipment transmitting on system links with laser modules that operate at greater than class 1 power levels. For this reason, never look into the end of an optical fiber cable or open receptacle. Only trained service personnel should perform the inspection or repair of optical fiber cable assemblies and receptacles.

C25, C26

Data Integrity and Verification

IBM computer systems contain mechanisms designed to reduce the possibility of undetected data corruption or loss. This risk, however, cannot be eliminated. Users who experience unplanned outages, system failures, power fluctuations or outages, or component failures must verify the accuracy of operations performed and data saved or transmitted by the system at or near the time of the outage or failure. In addition, users must establish procedures to ensure that there is independent data verification before relying on such data in sensitive or critical operations. Users should periodically check the IBM support websites for updated information and fixes applicable to the system and related software.

About This Book

This book is used by the service representative to help repair hardware management console (HMC) hardware failures. This book assumes that the service representative is trained to service the HMC system hardware and the managed systems that are supported by the HMC.

This book provides maintenance information to help diagnose and repair problems that may occur on the HMC. The HMC consists of a personal computer that runs software that is used to manage the configurations of one or more other systems. *Managed system* is the term used in the book to refer to systems that are managed by the HMC.

The HMC is connected to one or more managed system through a serial port. The managed systems are capable of running logically partitioned configurations (LPAR) or symmetric multi-processor configurations. The HMC provides the tools and interfaces to enable system administrators and service representatives to perform installation, configuration, problem determination, and service tasks on the managed system. Because the HMC can be connected to multiple managed systems, only one console is needed to perform these tasks on numerous managed systems.

This book refers to other service documentation that is available for the HMC. The system-hardware part of the HMC is based on the following personal computers:

- 6578 Model KLU
- 6792 Model 31U
- 8305 Model 41U
- 8676 Model 22X

The maintenance documentation for the personal computers listed above is used to service the system as a standalone system.

This book provides maintenance information for specific configurations of the HMC, including adapters and devices that have been added to the configuration to provide communication between the HMC and the managed system.

This book should be used if you have been directed to perform HMC tasks from the managed system's service documentation.

ISO 9000

ISO 9000 registered quality systems were used in the development and manufacturing of this product.

Highlighting

The following highlighting conventions are used in this book:

Bold	Identifies commands, subroutines, keywords, files, structures, directories, and other items whose names are predefined by the system. Also identifies graphical objects such as buttons, labels, and icons that the user selects.
<i>Italics</i>	Identifies parameters whose actual names or values are to be supplied by the user.
Monospace	Identifies examples of specific data values, examples of text similar to what you might see displayed, examples of portions of program code similar to what you might write as a programmer, messages from the system, or information you should actually type.

Accessing Information

Documentation for the IBM @server pSeries is available online. Visit the IBM @server pSeries Information Center at http://publib16.boulder.ibm.com/pseries/en_US/infocenter/base.

- To access the pSeries publications, click **Hardware documentation**.
- To view information about the accessibility features of @server pSeries hardware and the AIX operating system, click **AIX and pSeries accessibility**.

Related Publications

The following publications provide additional information about the system:

Note: Each PC hardware maintenance manual, listed below, may reference more than one machine type in the actual title of the publication. The title given in this section identifies only the PC machine types and models crossed referenced in the following table:

pSeries HMC Machine Type and Model Number	Personal Computer Machine Type and Model Number	Supporting Hardware Maintenance Manual Part Number
7040 (FC 7315)	6578 Model KLU	06P1504
7040 (FC 7316)	6792 Model 31U	24P2934
7315 Model C01 (FC 7316)	6792 Model 31U	24P2934
7315 Model C02	8305 Model 41U	24P2969
7315 Model CR2	8676 Model 22X	48P9908

- The *IBM Hardware Management Console for pSeries Installation and Operations Guide*, order number SA38-0590, contains information to help users to operate the HMC and manage partitions on the attached host systems.
- The managed system's service guide contains information about the system that is connected to the HMC. The managed system's service guide directs the service representative to this book in the event that the HMC and the managed system cannot communicate because of a problem with the HMC or the cabling between the two systems.
- The *Diagnostic Information for Multiple Bus Systems*, order number SA38-0509, contains common diagnostic procedures, error codes, service request numbers, and failing function codes for a managed system. This manual is intended for trained service representatives. If a problem is related to the Hardware Management Console, the *Diagnostic Information for Multiple Bus Systems* book directs the service representative to the appropriate book for the HMC.
- The *Hardware Maintenance Manual for IBM NetVista Computer types 6578* (available through <http://www.pc.ibm.com>), part number 06P1504, contains information about servicing the HMC personal computer.
- The *Hardware Maintenance Manual for IBM NetVista Computer types 6792* (available through <http://www.pc.ibm.com>), part number 24P2934, contains information about servicing the HMC personal computer.
- The *Hardware Maintenance Manual for IBM NetVista Computer types 8676* (available through <http://www.pc.ibm.com>), part number 48P9908, contains information about servicing the HMC personal computer.
- The *Hardware Maintenance Manual for IBM NetVista Computer types 8305* (available through <http://www.pc.ibm.com>), part number 24P2969, contains information about servicing the HMC personal computer.
- The *Site and Hardware Planning Information*, order number SA38-0508, contains information to help you plan your installation.

- The *Electronic Service Agent for RS/6000 User's Guide*, contains information for use by the service representative to help set up and use the Electronic Service Agent. The book is available on the CD that is delivered with the HMC.
- The *System Unit Safety Information*, order number SA23-2652, contains translations of safety information used in this book.

Trademarks

The following terms are trademarks of the International Business Machines Corporation in the United States, other countries, or both:

- AIX
- Electronic Service Agent
- @server
- IBM
- NetVista
- pSeries

Other company, product, and service names may be trademarks or service marks of others.

Chapter 1. Reference Information

This chapter provides reference information for the HMC.

Hardware Management Console Overview

The hardware management console (HMC) system is delivered with its software preinstalled on the disk drive. After the system is installed and connected to a managed system, system management tasks can begin.

The HMC uses its serial connection to one or more managed systems to perform various functions. The HMC's main functions include the following:

- Providing a console for system administrators and service representatives to manage system hardware
- Creating and maintaining a multiple partitioned environment on a managed system
- Detecting, reporting, and storing changes in hardware conditions.
- Acting as a service focal point for service representatives to determine an appropriate service strategy (Ethernet connection required)
- Displaying a virtual operating system session terminal for each partition

The HMC software does not have provisions for loading or running additional applications that are not related to hardware management. All the tasks you need to maintain the managed system, the underlying operating system, and the HMC's application code are available by using the HMC's management applications.

Managed System Operation

The HMC's graphical user interface provides the functions needed to create and maintain a partitioned environment on a managed system. Using the interface allows for direct manipulation of HMC-defined objects and increased information regarding detected changes in hardware conditions.

The managed system can be run as a partitioned system, sometimes referred to as *logically partitioned* (LPAR). This means that the managed system can run multiple operating systems simultaneously. The system can also run as a large single partition, also referred to as a *Full System Partition*.

Partitioning provides users with the ability to divide a single managed system into several systems. Each of these systems, running in a partition, is capable of running applications in multiple, independent environments simultaneously. Logical partitioning makes it possible for a user to run a single application using different sets of data on separate partitions, as if that application were running independently on separate physical systems. By creating partitions, for example, a company can test its program in one partition while developing the same program in another, at the same time, all using the same system. This "same system" partitioning method is more cost-effective, potentially eliminating the need for a separate test system.

The Full System Partition is no different from the traditional way of using a system. The single system uses all of its resources as one system.

HMC to Managed System Cabling

To connect your HMC to a managed system, connect the serial cable into serial port 1 located on the back of the HMC. Connect the other end of the serial cable into the HMC 1 connector located on the primary I/O book of the managed system.

The managed system has two HMC ports that support connection of one HMC each. Two HMCs can be connected to the same managed system for redundancy and convenience.

The following illustration shows the location of the serial ports on the back of the HMC and the HMC connectors located on the system I/O book. As shown in this example, two HMCs are connected.

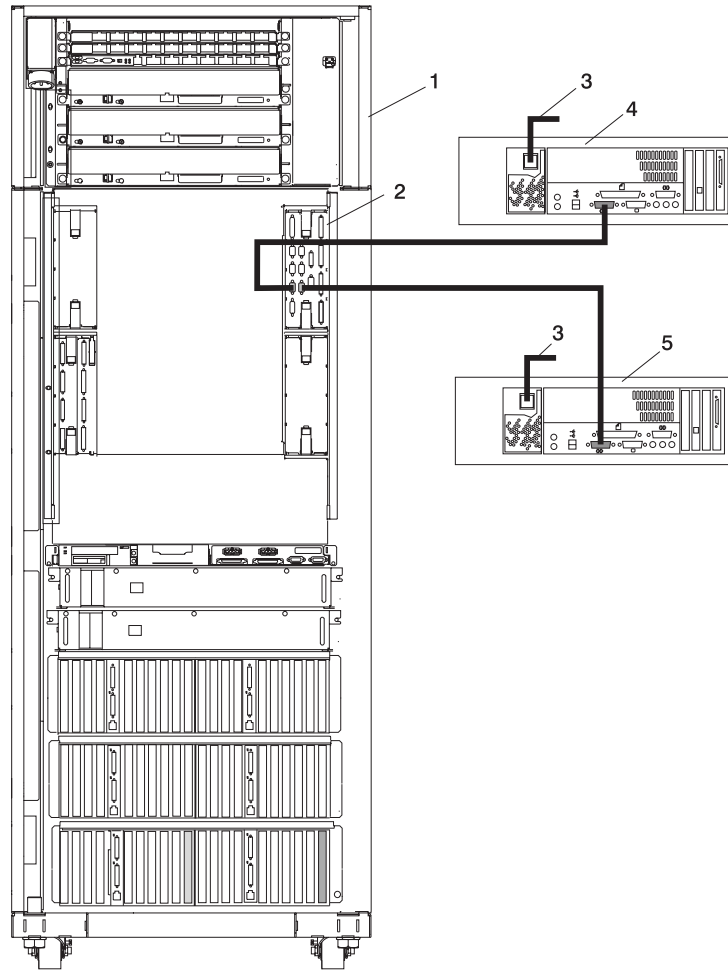

- 1 Primary Rack
- 2 Primary I/O Book
- 3 Power Plug to External Power Source (wall plug)
- 4 Primary HMC Connected to the Primary I/O Book
- 5 Optional Second HMC Connected to the Primary I/O Book

Powering On and Off

During the process of powering on, the HMC checks to see which managed systems are available and communicating with the console. To ensure that each managed system is available before you power on the HMC, managed systems must be in "standby mode" or actively operating. Standby mode is indicated by the OK shown in the operator panel after the managed system has the power connected and the initial tests are complete.

Note: If the managed system is in an emergency power off (EPOW) condition, the managed system must be brought to "standby mode" before the HMC can be used to power on the system.

To power on the HMC, do the following:

1. Press the Power button once to turn on the power.
2. When the system has finished the power-on self-test (POST), log in to the HMC by using your service representative name and password.

To power off the HMC, do the following:

1. Log in to the HMC and select **Power Off**.
2. The HMC shuts down any applications that are running, and then turns off the HMC.

Note: If the HMC fails to respond and will not shut down and turn off the power, call for HMC software support.

Power-On Self-Test

After power is turned on and before the operating system is loaded, the system does a power-on self-test (POST). This test performs checks to ensure that the hardware is functioning correctly before the operating system is loaded. During the POST, codes indicating the progress of the POST might appear on the display. After the POST is complete, the HMC operating software loads and a login prompt appears.

Specifications and System Unit Locations

Your HMC system is based on one of the following listed PC machine types and models. Use the following table when cross referencing between a PC and pSeries HMC Machine Type and Model Number.

pSeries HMC Machine Type and Model Number	Personal Computer (PC) Machine Type and Model Number	Supporting Hardware Maintenance Manual Part Number
7040 (FC 7315)	6578 Model KLU	06P1504
7040 (FC 7316)	6792 Model 31U	24P2934
7315 Model C01 (FC 7316)	6792 Model 31U	24P2934
7315 Model C02	8305 Model 41U	24P2969
7315 Model CR2	8676 Model 22X	48P9908

For information about system specifications and system unit locations, refer to "Related Publications" on page x for a listing of PC hardware maintenance manuals. The publications are available through the following web site:

<http://www.pc.ibm.com>

External AC Power Cable

To avoid electrical shock, a power cable with a grounded attachment plug is provided. Use only properly grounded outlets.

Power cables used in the United States and Canada are listed by Underwriter's Laboratories (UL) and certified by the Canadian Standards Association (CSA). These power cords consist of the following:

- Electrical cables, type ST
- Attachment plugs complying with National Electrical Manufacturers Association (NEMA) L6-30P
- Appliance couplers complying with International Electrotechnical Commission (IEC) Standard 320, Sheet C13 and C14

Power cables used in other countries consist of the following:

- Electrical cables, type HD21 or HD22
- Attachment plugs approved by the appropriate testing organization for the specific countries where they are used
- Appliance couplers complying with the International Electrotechnical Commission (IEC) Standard 320, Sheet C13 and C14

Service Inspection Guide

Perform a service inspection on the server when the following are true:

- The server is inspected for a maintenance agreement.
- Service is requested and service has not recently been performed.
- An alterations and attachments review is performed.
- Changes have been made to the equipment that may affect the safe operation of the equipment.
- External devices with their own power cables have those cables attached.

If the inspection indicates an unacceptable safety condition, the condition must be corrected before anyone can service the machine.

Note: The owner of the server is responsible to correct any unsafe condition.

Perform the following checks:

1. Check the covers for sharp edges and for damage or alterations that expose the internal parts of the server unit.
2. Check the covers for proper fit to the server unit. They should be in place and secure.
3. Perform the appropriate power-off procedures.
4. Open the covers.
5. Check for alterations or attachments. If there are any, check for obvious safety hazards, such as broken wires, sharp edges, or broken insulation.
6. Check the internal cables for damage.
7. Check for dirt, water, and any other contamination within the server unit.
8. Check the voltage label on the back of the server unit to ensure that it matches the voltage at the outlet.
9. Check the external power cable for damage.
10. With the external power cable connected to the server unit, check for 0.1 ohm or less resistance between the ground lug on the external power cable plug and the metal frame.

11. Perform the following checks on each device that has its own power cables:
 - a. Check for damage to the power cord.
 - b. Check for the correct grounded power cable.
 - c. With the external power cable connected to the device, check for 0.1 ohm or less resistance between the ground lug on the external power cable plug and the metal frame of the device.
12. Close the doors.
13. Perform the appropriate power-on procedures.

Chapter 2. Diagnostics Overview

The first step to service a managed system and the attached HMC (HMC) is to begin in the *Diagnostic Information for Multiple Bus Systems* maintenance analysis procedures (MAPs). The *Diagnostic Information for Multiple Bus Systems*, order number SA38-0509 directs the service representative to the appropriate documentation depending on the type of problem that is to be isolated and repaired.

If a problem is determined to be in the HMC, see “Entry MAP” on page 12 for information about diagnosing and repairing the HMC.

MAPs

The MAPs for the HMC are the starting point for diagnosing and repairing the HMC. The MAPs guide the service representative to a specific repair action. There are occasions where the MAPs direct the service representative directly to the service documentation for the personal computer. When this occurs, the service documentation for the personal computer is used to complete the repair action.

Diagnostics, Test, and Recovery

The following tools are available to help identify and resolve hardware-related problems:

- Power-on self-test (POST)
 - POST beep codes
 - Error code format
- PC Doctor

When you are referred to the PC service documentation, refer to “Related Publications” on page x for a listing of PC hardware maintenance manuals. The publications are available through the following web site:

<http://www.pc.ibm.com>

Note: Use the table located at the beginning of the related publications section to cross reference the PC machine type and model number to the HMC machine type and model number.

Chapter 3. HMC Software Support

The software support organization uses the Problem Determination application to look at the HMC's internal code and determine how to fix a software problem.

Only a service representative or support representative can access this feature. When the **hscpe** user selects the Microcode Maintenance feature, the system prompts the service representative for a password. The service representative must contact software support to obtain this password.

Viewing the HMC Console Logs

The console logs display error and information messages that the console has logged while running commands. The service representative can use this information to learn more about what caused an error and how to resolve it. The HMC classifies log entries as either an informational message or an error message. Log entries are identified with an *I* or *E*, respectively. The HMC lists these log entries chronologically, with the most recent shown at the top of the list.

Use the HMC Console Log to view a record of HMC system events. System events are activities that indicate when processes begin and end. These events also indicate whether the attempted action was successful.

To view the HMC log, do the following:

1. To allow access to the HMC Microcode Maintenance as the **hscpe** user, contact software support and request the password.
2. In the Navigation area, click **Problem Determination**.
3. In the Contents area, click **Microcode Maintenance**. The User Authentication window opens.
4. Enter the HMC system unit's serial number and the password provided by software support. The Microcode Maintenance Menu window opens.
5. Select **View Console Logs** to open the HMC Log window.

The log includes the following information:

- The event's unique ID code
- The date the event occurred
- The time the event occurred
- The log's type
- The name of the attempted action
- The log's reference code
- The status of the log

To view a particular event, do the following:

1. Select an event by clicking once on it.
2. Press Enter to get to a summary of the log you selected. From here, you must select a Block ID to display. The blocks are listed next to the buttons and include the following options:
 - Standard Data Block
 - Secondary Data Block
 - Microcode Reason / ID Error Information
3. Select the data block you want to view.

4. Press Enter. The extended information shown for the data block you selected includes the following:
 - Program name
 - Current process ID
 - Parent process ID
 - Current thread priority
 - Current thread ID
 - Screen group
 - Subscreen group
 - Current foreground screen process group
 - Current background screen process group

For information about error messages displayed and recovery for these messages, see “Error Messages and Recovery Information” on page 29.

Chapter 4. Maintenance Analysis Procedures

Use the information in this chapter to diagnose and repair problems that are related to the hardware management console (HMC). You should use these maintenance analysis procedures (MAPs) when directed from the managed system's service documentation, or when a problem with the HMC is suspected.

Note: If you are looking for procedures that are related to servicing the HMC, see the following for:

- Diagnostic information and service tips, go to Chapter 2, "Diagnostics Overview," on page 7.
- Removing and replacing parts, go to Chapter 6, "Removal and Replacement Procedures," on page 87.
- Backing up disk drive information on the HMC, refer to the *IBM Hardware Management Console for pSeries Installation and Operations Guide*, form number SA38-0590, for backup procedures.
- Restoring disk drive information on the HMC, refer to the *IBM Hardware Management Console for pSeries Installation and Operations Guide*, form number SA38-0590, for backup procedures.
- Checking modem settings. Refer to the *IBM Hardware Management Console for pSeries Installation and Operations Guide*, form number SA38-0590.
- For additional PC maintenance information, refer to "Related Publications" on page x for a listing of PC hardware maintenance manuals. The publications are available through the following web site:

<http://www.pc.ibm.com>

Entry MAP

To start, find the symptom in the Symptom column of the following table. Then, perform the action described in the Action column.

Symptom	Action
Operator reported that the HMC did not start, but no other problems were reported.	Go to "MAP 1020 Problem Determination" on page 13.
Operator reported "Communication not active" on the HMC.	Go to "Managed System Connection" on page 17.
Operator reported communication problems with a remotely connected HMC or a managed system.	Go to "Managed System Connection" on page 17.
Power Problems	Go to "MAP 1520 Power" on page 15.
HMC Boot Problems	Go to "MAP 1020 Problem Determination" on page 13.
Display problem	Go to "Display Problems" on page 27.
DVD-RAM drive problem	Go to "DVD RAM MAP" on page 24.
Disk drive problem	Go to "Disk Drive MAP" on page 23.
Diskette drive problem	Go to "Diskette Drive MAP" on page 26.
Ethernet LAN problem	Go to "Ethernet MAP" on page 22.
You need to test the system to verify a problem with any of the following: <ul style="list-style-type: none"> • display • diskette drive • DVD-RAM Drive • disk drive • Ethernet LAN 	Go to "System Unit Testing" on page 16.
Eight character error code beginning with <i>HMC</i> received when using the HMC graphical user interface.	Go to Chapter 5, "Error Code to FRU Index," on page 29.
HMC does not communicate through the modem.	Go to "Modem MAP" on page 19.
PC Doctor diagnostic tests detected an error.	Refer to "Related Publications" on page x for a listing of PC hardware maintenance manuals. The publications are available through the following web site: http://www.pc.ibm.com If a part is called out for replacement, see Chapter 7, "Hardware Management Console Parts," on page 95 for parts that are not included in the personal computer service documentation.
Problems understanding the usage of the HMC.	Go to <i>IBM Hardware Management Console for pSeries Installation and Operations Guide</i> .
All other problems (for example: HMC graphical user interface unresponsive, parity errors, power, POST codes, blank display, mouse, or keyboard).	Go to "MAP 1020 Problem Determination" on page 13.
Symptoms not in this list.	Go to "MAP 1020 Problem Determination" on page 13.

MAP 1020 Problem Determination

Use this MAP to determine if there is a problem with the HMC hardware. This MAP might direct you to procedures in different sections of this book or to other books.

Step 1020-1

Note: If the HMC is running, shut down the console by exiting the graphical user interface, the PC should turn off the power automatically. If the PC cannot turn off the power, then turn the power switch off.

1. Turn on the HMC power.
2. Watch the console and allow enough time for the system to complete the POST and load the HMC software.
3. Watch and listen for the following failing symptoms during power-on:
 - POST error condition.
 - A series of beeps that indicate an error condition.
 - The HMC login screen and user interface fails to start.
 - A reference code or any other error information is displayed.

Do you have any of the failing symptoms during power on?

No Go to "Step 1020-2."

Yes Go to the "General Checkout" section of the hardware maintenance manual for your machine type, refer to "Related Publications" on page x for a listing of hardware maintenance manuals. The hardware maintenance manuals can be accessed at the following web site:

<http://www.pc.ibm.com>

Step 1020-2

Follow the procedures in "System Unit Testing" on page 16 to run the PC diagnostic software (PC Doctor).

Does the PC Doctor diagnostics diskette boot and allow tests to be run on the PC system unit?

No Go to "MAP 1520 Power" on page 15.

Yes Go to "Step 1020-3."

Step 1020-3

Follow the procedures in "System Unit Testing" on page 16 to test the PC hardware for the HMC. Select **System Unit** problem area and run the test for **Run All Selected**.

Did the system unit tests detect any errors?

No Go to "Step 1020-4" on page 14.

Yes Go to "Step 1020-5" on page 14.

Step 1020-4

Attention: This step requires software support assistance. Contact software support before continuing.

You might need to reload the HMC from the recovery DVD and reload the customer's backup profile and configuration data (see "Reloading the Hardware Management Console Image" on page 89 for more information).

After reloading the software from the recovery DVD, does the HMC start correctly?

No Call your support representative.

Yes This ends the procedure. Go to MAP 0410 in the *Diagnostic Information for Multiple Bus Systems*.

Step 1020-5

Use the PC Doctor diagnostics and the maintenance procedures for the type of PC that you are working on to isolate the failure and exchange FRUs. Refer to "Related Publications" on page x for a listing of PC hardware maintenance manuals. The publications are available through the following web site:

<http://www.pc.ibm.com>

When the problem is repaired, or if the problem cannot be isolated, continue with "Step 1020-6."

Step 1020-6

Note: If you reach this step and you have not been able to isolate a failure, call your next level of support for assistance.

Reinstall all FRUs that did not fix the problem.

You must have performed a repair action to continue. If you have not already done so, verify the repair. For instructions, see "System Unit Testing" on page 16.

Did the system unit tests run without errors?

No Return to "System Unit Testing" on page 16 to troubleshoot the error. Return here and continue when the problem is resolved. Continue with "Step 1020-7."

Yes Go to "Step 1020-7."

Step 1020-7

Does the HMC communicate with all connected managed systems?

No Go to "Managed System Connection" on page 17.

Yes Go to "Step 1020-8" on page 15.

Step 1020-8

Did you exchange the system board or the system board battery?

No This ends the procedure.

Yes Go to “Step 1020-9”

Step 1020-9

If you have not already done so, configure the system board. Refer to “Configuring the System” on page 88.

This ends the procedure.

MAP 1520 Power

To troubleshoot a power problem on the PC, refer to the service documentation for the PC, refer to “Related Publications” on page x for a listing of PC hardware maintenance manuals. The publications are available through the following web site:

<http://www.pc.ibm.com>

MAP 1530: Testing the HMC

This MAP tests each of the base parts of the HMC. If a failure is detected, you will be instructed to fix the failing part and then close out the service call.

This section describes diagnostics tests for the HMC. Use the information in this section when you are directed to test the HMC to isolate a problem or verify a repair.

To help identify adapters, use “Specifications and System Unit Locations” on page 4.

Diagnostic Procedures

You should have been directed here to test a specific part of the HMC. See “System Unit Testing” on page 16. for the following problem areas:

- Display
- Keyboard
- Mouse
- Floppy Drive
- DVD-RAM
- DASD (disk drive)
- Memory
- Power
- Run All Selected
- SCSI
- Serial Port/Modem
- 16/4 Port Serial
- Ethernet

System Unit Testing

This section provides information to help you use the PC Doctor diagnostic diskette to test the PC hardware parts of the HMC. The PC Doctor diagnostic diskette is bootable.

Note: Performing procedures other than those specified in the following procedures may cause errors.

1. If you know which device is failing or you were sent here by another procedure, do the following:
 - a. Shut down the HMC, and ensure that the PC power is off.
 - b. Insert the PC Doctor diagnostic diskette into drive A.
 - c. Power on the PC.
 - d. Wait until a diagnostic selection menu is displayed.
2. Select either **Diagnostics** or **Interactive Tests** for a list of devices to test.
 - Devices that require manual intervention (keyboard, video, mouse, diskette, CD-ROM) may be selected from the Interactive Tests task bar.
 - Devices that do not require manual intervention (processor, system board, I/O ports, fixed disks, memory) and predefined test sequences (Run Normal/Quick Test) can be selected from the Diagnostic task bar.

Select the task containing the device(s) or test(s) and follow the instructions. If you were instructed to **Run All Selected**, continue with that selection.

3. If the diagnostics report a failure on the PC hardware, refer to “Related Publications” on page x for a listing of PC hardware maintenance manuals. The publications are available through the following web site:
<http://www.pc.ibm.com>
4. If the diagnostics do not report a failure, the HMC PC hardware is functioning correctly. If you still have a problem, go to “MAP 1020 Problem Determination” on page 13.

Managed System Connection

Use this procedure to test the modem connection to the PC for the HMC.

1. **Is the managed system currently communicating with the HMC?**

No Go to step 2.

Yes This procedure is complete.

2. **Is the managed system attached to serial (COM) port 2 on the HMC?**

No Go to step 4.

Yes Go to step 3.

3. The HMC's serial port 2 is reserved for modem use only. Move the serial cable from the HMC's serial port 2 to another HMC serial port. Go to step 1.

4. **Is the managed system attached to serial (COM) port 1 on the HMC?**

No Go to step 5.

Yes Go to step 7 on page 18.

5. Do the following:

- a. Move the serial cable to serial port 1 (HMC1) of the HMC to aid in debugging. (The assumption is that this cable is on a multi-port serial adapter. Note the position of the port that the cable was moved from, for reinstallation after debugging.)
- b. Reinitialize the HMC to have it attempt communication with the managed system.

Is the managed system communicating with the HMC?

No Go to step 7 on page 18.

Yes Go to step 6.

6. Do the following:

- a. Replace the multi-port serial adapter card and its cable.
- b. Return the serial cable to its original location.

(If the replacement hardware is delayed, use another, vacant serial connector port on the adapter card as an attempt to restore HMC-managed system communication until the replacement hardware arrives.) Go to step 1.

7. Do the following:
 - a. Place a loopback plug on the far end of the serial port connector that is attached to the managed system.
 - b. Insert the PC Doctor diskette into the HMC's drive A: (floppy drive).
 - c. Reboot the HMC and wait until the PC Doctor main menu appears.
 - d. Click **Diagnostics > Serial Ports** to open the serial port diagnostics screen.
 - e. On the serial port diagnostics screen, select only the following tests for COM 1:
 - Register and Interrupts
 - Internal Loopback
 - External Loopback

Note: Do not select External Loopback if loopback plug is not used.

 - FIFO Buffers (16550A)

Did all the COM 1 tests pass?

No Go to step 8.

Yes Go to step 11.

8. Did the external loopback test fail?

No Go to step 10.

Yes Go to step 9.

9. Replace the serial port cable. Go to step 1 on page 17.
10. The problem appears to be in the serial port 1 of the HMC. Replace the hardware (system board) that contains this port. Go to step 1 on page 17.
11. The problem appears to be with the serial port in the managed system. Refer to the MAPs for the managed system.

Modem MAP

Use this procedure to test the modem connection to the PC for the HMC.

1. Verify that the modem and phone line are functioning properly.
To verify, do the following:
 - a. On the HMC console, open the Service Agent application.
 - b. Select **Test Tools**.
 - c. Initiate a Test PMR.
 - d. Monitor the call log to verify that the call is completed successfully. If the call is completed successfully, the modem is functioning correctly.

Is the installed modem currently functioning on the HMC?

No Go to step 2.

Yes The problem is not in the modem. This is the end of this procedure.

2. **Are the HMC configurations, relating to the modem operation, correct?**

No Go to step 3.

Yes Go to step 4.

3. Correct the HMC configuration arguments. Go to step 1.

4. **Is the modem powered on? (Are any indicators lit?)**

No Go to step 5.

Yes Go to step 6.

5. **Ensure the modem is powered on.**

Go to step 1.

6. **Is the serial cable, between the HMC's serial (COM) port connector (HMC2) and the modem, attached?**

No Go to step 7.

Yes Go to step 8.

7. Attach the serial cable (as indicated by the preceding step).

Go to step 1.

8. Install the PC Doctor diskette into the HMC's drive A: (floppy drive). Reboot the HMC and wait until the PC Doctor main menu appears. Click **Diagnostics > Other Devices > Modem** to perform the modem diagnostic test.

Did the diagnostic pass?

No Go to step 9 on page 20.

Yes Go to step 17 on page 21.

9. **Is the modem properly connected to a working telephone line (or equivalent)?**

Note: This can be checked by connecting a known good telephone to the line in place of the modem and making a phone call.

No Go to step 18 on page 21.

Yes Locate a serial port loopback plug for the next step. Go to step 10.

10. Do the following:

- a. Place a loopback plug on the end of the serial port connector that is attached to the modem.
- b. Return to PC Doctor main menu.
- c. Click **Diagnostics > Serial Ports** to access the serial port diagnostics screen.
- d. On the serial port diagnostics screen, select only the following tests for COM 2:
 - Register and Interrupts
 - Internal Loopback
 - External Loopback

Note: Do not select External Loopback if loopback plug is not used.

- FIFO Buffers (16550A)

Did all the COM 2 tests pass?

No Go to step 11.

Yes Go to step 14 on page 21.

11. **Did the external loopback test fail?**

No Go to step 12.

Yes Go to step 13.

12. The COM 2 port is defective. Replace the HMC hardware for COM 2 on your HMC.

Go to step 1 on page 19.

13. Replace the serial port cable. Go to step 1 on page 19.

14. The fault appears to be within the modem operation.

Are the modem's internal settings (for example, switches) correct?

Note: If you are using a 7852-400 modem to enable communications, for proper operation, the dual inline package (DIP) switches must be set according to the following table:

Switch	Position	Function
1	Up	Force DTR
2	Up	Flow Control &E4
3	Down	Result Codes Enabled
4	Down	Modem Emulation Disabled
5	Down*	Auto Answer Enabled
6	Up	Maximum Throughput Enabled
7	Up	RTS Normal Functions
8	Down	Enable Command Mode
9	Down	Remote Digital Loopback Test Enabled
10	Up	Dial-Up Line Enabled
11	Down	AT Responses Enabled (Extended Responses Disabled)
12	Down*	Asynchronous Operation
13	Up	28.8KB Line Speed
14	Up	
15	Up	CD and DSR Normal Functions
16	Up	2-Wire Leased Line Enabled

* Only switches 5 and 12 are changed from the factory default settings.

No Go to step 15.

Yes Go to step 16.

15. Correct the modem's internal settings. Go to step 1 on page 19.

16. The modem appears to be faulty. Replace the modem. Go to step 1 on page 19.

17. **Is the modem properly connected to a working telephone line (or equivalent)?**

Note: This can be checked by connecting a known good telephone to the line in place of the modem and making a telephone call.

No Go to step 18.

Yes Go to step 19.

18. Properly connect the telephone line (or equivalent) to the modem. Go to step 1 on page 19.

19. The failure mode is undetermined. Call service support.

Ethernet MAP

Use this procedure to test the Ethernet adapter in the PC for the HMC.

1. **Is the Ethernet port currently functioning though normal operation of the HMC?**
 - No** Go to step 2.
 - Yes** This is the end of the procedure.
2. **Are the Ethernet configuration values set correctly? (IP address, Subnet Mask, and so on.)**
 - No** Go to step 3.
 - Yes** Go to step 4.
3. Set the Ethernet configuration values to their proper settings. Go to step 1.
4. **Can the HMC's IP address be 'pinged' by another system that should be able to 'see' the HMC on the customer's network?**
 - No** Go to step 5.
 - Yes** Go to step 13.
5. **Is the Ethernet cable properly attached to the HMC and the customer's network?**
 - No** Go to step 6.
 - Yes** Go to step 7.
6. Attach the HMC to the customer's network using an Ethernet cable with the correct pinout. Go to step 1.
7. **Is the Ethernet cable the proper pinout? (There are two types of Ethernet cables in use, which are distinguished by different pinouts. The customer's network will determine which version of cable to use.)**
 - No** Go to step 8.
 - Yes** Go to step 9.
8. Replace the Ethernet cable with the correct version. Go to step 1.
9. Install the PC Doctor diskette into the HMC's drive A: (floppy drive). Reboot the HMC and wait until the PC Doctor main menu appears.

Click **Diagnostics > Other Devices > Intel Ethernet** to run the Ethernet diagnostic.

Did the diagnostic pass?
 - No** Go to step 10.
 - Yes** Go to step 13.
10. Refer to the Ethernet hardware's hardware maintenance manual to determine if there are any internal settings/jumpers that may disable the Ethernet port.

Are there any internal settings/jumpers?

 - No** Go to step 11.
 - Yes** Go to step 12.
11. Replace the Ethernet hardware in the HMC. (This may be a PCI card or system board replacement, depending on the HMC hardware.) Go to step 1.
12. Set the internal settings/jumpers to enable the HMC's Ethernet port. Go to step 1.
13. The failure appears not to be in the HMC.

Disk Drive MAP

Use this procedure to test the disk drive in the PC for the HMC.

1. Use the information in "System Unit Testing" on page 16 to test the PC. Select **Hard Disk Drive** problem area.

Return here when the test is complete.

2. **Did the disk drive test fail?**

No Go to step 6.

Yes Continue with the next step.

3. Exchange the FRUs called by the diagnostics one at a time. For FRU removal and replacement instructions, refer to the "Related Publications" on page x for a listing of PC hardware maintenance manuals. The publications are available through the following web site:

<http://www.pc.ibm.com>

When each FRU is exchanged, test the repair using the information in "System Unit Testing" on page 16. Select **Hard Disk Drive** problem area.

Did the disk drive test fail?

No Continue with the next step.

Yes Call for assistance.

4. If you exchanged the disk drive and there are jumpers or tab settings on the new disk drive, ensure they are set the same as the old drive. If there is a SCSI cable-terminating resistor device, ensure it is secured to the cable and (if necessary) reattached to its original location on the PC.

Go to "Hard Disk Jumper Settings" in the PC hardware maintenance manual. Refer to "Related Publications" on page x for a listing of PC hardware maintenance manuals. The publications are available through the following web site:

<http://www.pc.ibm.com>

Continue with the next step.

5. If you exchanged the disk drive, restore the HMC image to the new disk drive. Refer to "Reloading the Hardware Management Console Image" on page 89.

6. Use the information in "System Unit Testing" on page 16 to test the PC. Select **Run All Selected** problem area.

- If the tests fail, go to "MAP 1020 Problem Determination" on page 13 to isolate the problem.
- If the tests run without errors, turn off the PC power and then turn on the power. Ensure that the system boots and the HMC screen displays.

This ends the procedure. Go to MAP 0410 in the *Diagnostic Information for Multiple Bus Systems*.

DVD RAM MAP

Use this procedure to test the DVD drive in the PC for the HMC.

1. Determine the media in the DVD RAM drive:
 - Compact Disk Recordable (CD-R) similar to a CD
 - DVD-RAM media cartridge

Is the media a CD-R?

No Go to step 4.

Yes Continue with the next step.

2. Clean the compact disk as follows:
 - Hold the disk by its edges. Do not touch the surface.
 - Remove dust and fingerprints from the surface by wiping from the center to the outside using a dry, soft cloth.

Reinstall the CD, with the label-side facing up.

Continue with the next step.

3. Retry the failing task using the original media.

Does the failure occur again?

No Continue with the next step.

Yes Go to step 5.

This ends the procedure. Go to MAP 0410 in the *Diagnostic Information for Multiple Bus Systems*.

4. Ensure the write protect tab is in the "disabled" (down) position.

Was the write protect tab in the "disabled" (down) position?

No Go to step 3.

Yes Continue with the next step.

5. Leave the original media in the drive.
 - If you are attempting a restore procedure, turn off the PC power.
 - For any other operation, shut down the HMC, and then turn off the PC power.

Note: For shutdown procedures, see "Powering On and Off" on page 4.

Turn on the PC power and test the DVD-RAM drive using the information in "System Unit Testing" on page 16. Select **DVD-RAM Drive** problem area.

When the test is complete, return here and continue with the next step.

6. **Did the DVD-RAM test fail while testing with the original media?**

No Go to step 11 on page 25.

Yes Continue with the next step.

7. Exchange the original media with a new one.

Note: If you are replacing DVD-RAM media, the new cartridge must be formatted. If possible, use another HMC to format the new cartridge.

Turn off the PC power.

Turn on the PC power, and test the DVD-RAM drive with the new media. Use the information in “System Unit Testing” on page 16 to test the PC. Select **DVD-RAM Drive** problem area.

8. **Did the DVD-RAM test fail while testing with the new media?**

No The original media was defective. This ends the procedure. Go to MAP 0410 in the *Diagnostic Information for Multiple Bus Systems*.

Yes Continue with the next step.

9. Verify the following:

- All DVD-RAM drive data and power cables are secure.
- The DVD-RAM drive is jumpered as “Master” and is cabled to the Secondary IDE Bus.

If the diagnostics continue to fail, exchange the DVD-RAM drive. When complete, run the DVD-RAM test again.

Note: If there are any jumpers or tab settings on the new drive, ensure they have the same settings as the old drive.

Did the DVD-RAM Drive test continue to fail?

No The original DVD-RAM drive was defective. This ends the procedure. Go to MAP 0410 in the *Diagnostic Information for Multiple Bus Systems*.

Yes Continue with the next step.

10. Continue exchanging FRUs from the FRU list and running the DVD-RAM drive tests.

- If the FRUs fix the problem, this ends the procedure. Go to MAP 0410 in the *Diagnostic Information for Multiple Bus Systems*.
- If you cannot isolate the problem, call your next level of support for assistance.

11. The PC resources (for example: interrupt, I/O address) may be configured incorrectly. Verify the PC resources are correctly configured, using the procedure in “PC Configuration” on page 89.

Select **System Unit** for the configuration area, and verify configuration for the system unit and all adapters.

When you complete the verification, retry the failing procedure and continue with the next step.

12. **Does the failing procedure continue to fail?**

No The resource settings were incorrect. This ends the procedure. Go to MAP 0410 in the *Diagnostic Information for Multiple Bus Systems*.

Yes If you cannot isolate the problem, call your next level of support for assistance.

This ends the procedure. Go to MAP 0410 in the *Diagnostic Information for Multiple Bus Systems*.

Diskette Drive MAP

Use this procedure to test the diskette drive in the PC for the HMC.

1. Turn on the PC power and test the diskette drive using the information in "System Unit Testing" on page 16. Select **System Unit** problem area and the test of **Diskette Drive**.

Note: Do not test with the diskette on which the errors occurred. Use a new diskette.

When the test is complete, continue with the next step.

2. **Did the diskette test fail while testing with a new diskette?**

Note: Answer "Yes" if you were not able to run the test because of the diskette errors.

No Go to step 5.

Yes Continue with the next step.

3. Exchange the diskette drive.

When complete, run the diskette test again.

Did the diskette test fail again?

No The original diskette drive was failing. This ends the procedure. Go to MAP 0410 in the *Diagnostic Information for Multiple Bus Systems*.

Yes Continue with the next step.

4. Continue exchanging FRUs from the FRU list and running tests. If the FRUs fix the problem, this ends the procedure. Go to MAP 0410 in the *Diagnostic Information for Multiple Bus Systems*.

If you cannot resolve the problem, call your next level of support for assistance.

5. **Did the original failure occur while writing to a diskette?**

No Go to step 7.

Yes Continue with the next step.

6. Retry the original task using a new diskette.

- If the failure occurs again, go to step 8.
- If no failures occur, the original diskette was failing. This ends the procedure. Go to MAP 0410 in the *Diagnostic Information for Multiple Bus Systems*.

7. Re-create the information on the diskette, or get a new diskette with the information.

Retry the original task.

- If the failure occurs again, continue with the next step.
- If no failures occur, the original diskette was failing, this ends the procedure. Go to MAP 0410 in the *Diagnostic Information for Multiple Bus Systems*.

8. Test the diskette drive, using the information in "System Unit Testing" on page 16. Select **System Unit** problem area and the test of **Diskette Drive**.

- If the tests fail, isolate the problem using the procedures found in the PC hardware maintenance manual. Refer to "Related Publications" on page x for a listing of PC related hardware maintenance manuals. The publications are available through the following web site:

<http://www.pc.ibm.com>

When complete, go to MAP 0410 in the *Diagnostic Information for Multiple Bus Systems*.

- If the tests do not or if you cannot isolate the problem, call your next level of support for assistance.

Display Problems

Use this procedure when the customer reports a display problem.

1. Is the display type a 95xx (17P, 17X, 21P)?

No Continue with the next step.

Yes 95xx-xxx repairs may require replacing internal display FRUs.

Repair and test the display using the procedures in *Monitor Hardware Maintenance Manual Vol 2*, S41G-3317.

2. Is the display type a 65xx (P70, P200)?

No Continue with the next step.

Yes 65xx-xxx repairs may require replacing the entire display. There are no internal display FRUs. Repair and test the display using the procedures in *Monitor Hardware Maintenance Manual Vol 3, P and G series*, S52H-3679.

When the test and repair are complete, continue with step 5.

3. Is the display type a 65xx (P72, P202)?

No Continue with the next step.

Yes 65xx-xxx repairs may require replacing the entire display. There are no internal display FRUs. Repair and test the display using the procedures in *Color Monitor Operating Instructions*.

When the test and repair are complete, continue with step 5.

4. Repair and test the display using the documentation shipped with the display.

When the test and repair are complete, continue with step 6.

5. Verify the repair using the information in "System Unit Testing" on page 16. Select **System Unit** for the problem area and the **Test for Display**.

When the test and repair are complete, return to step 6.

6. Close out the service call.

Chapter 5. Error Code to FRU Index

Symptom to Action

Error Messages and Recovery Information

The following tables contain information about error messages that can be displayed by the HMC during system configuration and operations.

Use this appendix to learn more about a specific error or information message. The table also includes recovery information (if applicable) to help you determine a recovery strategy.

Console Events Error Codes	Message	Recovery Action
HSCE2066	A scheduled backup of critical console data failed with a return code of {0}.	<p>The possible return code values are:</p> <ul style="list-style-type: none"> • 4 - A return code of 4 indicates the removable media could not be mounted. Recovery Action - Verify that the media is inserted properly in the drive and try the operation again. • 5 - A return code of 5 indicates that the removable media is write protected. Recovery Action - Remove the write protection and try the operation again. • Any value except 4 or 5 is an Internal HMC Error Recovery Action: <ol style="list-style-type: none"> 1. Perform Backup Critical Data task. 2. Call for HMC software support.

Inventory Scout Error Codes	Message	Recovery Action
HSCI0100	No managed systems were detected that are attached to this system console.	None
HSCI0101	No partitions have been defined for this managed system.	None
HSCI0102	A blank or invalid entry was entered in the partition password field.	Enter a valid password value.
HSCI0103	A blank or invalid entry was entered in the listening port field.	Enter a valid port value.
HSCI0104	A blank or invalid entry was entered in the IP address field.	Enter a valid IP address value.
HSCI0110	The Inventory Scout command completed successfully.	None
HSCI0111	The Inventory Scout command request failed	<ol style="list-style-type: none"> 1. Verify that the removable media is properly inserted in the drive and try the operation again. 2. Try the operation with different media. 3. Run PC Doctor to determine if there is a problem with the hardware. 4. Call for HMC software support.

Inventory Scout Error Codes	Message	Recovery Action
HSCI0112	The removable media cannot be mounted. Please make sure the media is inserted properly in the drive and retry the operation	<ol style="list-style-type: none"> 1. Verify that the removable media is properly inserted in the drive and try the operation again. 2. Try the operation with different media. 3. Run PC Doctor to determine if there is a problem with the hardware. 4. Call for HMC software support.
HSCI0113	The media specified is write protected. Please adjust the media and retry.	Remove the write protection and try the operation again.
HSCI0114	The Inventory Scout request failed. Ensure the removable media is properly inserted in the drive.	<ol style="list-style-type: none"> 1. Verify that the removable media is properly inserted in the drive and try the operation again. 2. Try the operation with different media. 3. Run PC Doctor to determine if there is a problem with the hardware. 4. Call for HMC software support.
HSCI0115	An error occurred while copying the Inventory Scout data. Verify that a blank formatted diskette is inserted properly in the drive and retry the operation.	<ol style="list-style-type: none"> 1. Verify that the removable media is properly inserted in the drive and try the operation again. 2. Try the operation with different media. 3. Run PC Doctor to determine if there is a problem with the hardware. 4. Call for HMC software support.
HSCI0116	An error occurred while compressing the Inventory Scout data. Please retry the operation.	<ol style="list-style-type: none"> 1. Verify that the removable media is properly inserted in the drive and try the operation again. 2. Try the operation with different media. 3. Run PC Doctor to determine if there is a problem with the hardware. 4. Call for HMC software support.
HSCI0117	An error occurred while trying to unmount the media.	<ol style="list-style-type: none"> 1. Verify that the removable media is properly inserted in the drive and try the operation again. 2. Try the operation with different media. 3. Run PC Doctor to determine if there is a problem with the hardware. 4. Call for HMC software support.
HSCI0118	The Inventory Scout daemon was restarted successfully.	None
HSCI0119	The Inventory Scout daemon could not be restarted.	<ol style="list-style-type: none"> 1. Verify that the removable media is properly inserted in the drive and try the operation again. 2. Try the operation with different media. 3. Run PC Doctor to determine if there is a problem with the hardware. 4. Call for HMC software support.

Inventory Scout Error Codes	Message	Recovery Action
HSCI0120	The internal managed system name is malformed. Please exit this task and retry the operation.	<ol style="list-style-type: none"> 1. Verify that the removable media is properly inserted in the drive and try the operation again. 2. Try the operation with different media. 3. Run PC Doctor to determine if there is a problem with the hardware. 4. Call for HMC software support.
HSCI0121	The Inventory Scout request failed. An error occurred while copying data to removable media.	<ol style="list-style-type: none"> 1. Verify that the removable media is properly inserted in the drive and try the operation again. 2. Try the operation with different media. 3. Run PC Doctor to determine if there is a problem with the hardware. 4. Call for HMC software support. <p>After collecting all necessary data for L3 support, try the following steps to fix the problem:</p> <ol style="list-style-type: none"> 1. Reboot the HMC. If the reboot does not correct the problem, continue with the next step. 2. Run the following:: <ol style="list-style-type: none"> a. <code>/usr/sbin/rsct/bin/rmcctrl -z ctrmc -</code> b. <code>rm /var/ct/IW/registry/local_tree</code> c. <code>rm /var/ct/IW/register/SfpCl</code> 3. Reboot the HMC again.

Inventory Scout Error Codes	Message	Recovery Action
HSCI0122	The system partition(s) did not respond to query attempts.	<ol style="list-style-type: none"> 1. Check that the HMC host name and the host name of the partition are fully qualified domain name (not a short host name). If they are not, this must be corrected for remote security to work. 2. Verify the network routing is set up so the HMC can use ping to reach the partition and vice versa. If one or both cannot be reached from the other, correct the routing. 3. Check to make sure /var is not full on the partition, which would prevent certain processes from running correctly. 4. Verify that the following filesets have been installed properly on the AIX partitions: <ul style="list-style-type: none"> • rsct.core • csm.client • devices.chrp.base.ServiceRM 5. Log in to one of the partitions and issue the following command: <code>lssrc -s ctcas</code>. If the output shows <code>ctcas</code> is inoperative, run an <code>ls -l</code> command on the /var/ct/cfg/ directory. If the files ct_has.pkf and ct_has.qkf are zero-length, there was an (AIX) installation configuration problem. These zero-length files should be removed and then issue the command <code>startsrc -s ctcas</code>. If the <code>startsrc -s ctcas</code> command does not work, the AIX lpp may not have been installed. 6. If the output is still blank, reboot the HMC. After the reboot occurs, wait at least 10 minutes before trying again, to make sure all the partitions have resynchronized their information with the HMC. 7. If the problem persists, contact your software service support representative.

Profile Data Error Codes	Message	Recovery Action
HSQL0001	There is no more space for a new profile name. Reuse profile names being used by other profiles or remove the profiles that are no longer needed.	No more space for a new profile name is available. Reuse the profile names that are already used by other profiles, or remove the profiles that are no longer needed. This is a customer action.
HSQL0002	Too many drawers are being used in profiles. Remove the drawers that no longer exist or are not needed.	Remove the drawers that no longer exist or are no longer needed. This is a customer action.
HSQL0003	The profile data save area is full. Remove any profiles that are no longer needed.	Remove the profiles that are no longer needed. This is a customer action.

Profile Data Error Codes	Message	Recovery Action
HSCL0004	A profile with name {0} already exists in the partition with ID {1} in profile data of the managed system. Provide another name for this profile.	Rename the profile to names that are not already in use in this partition. This is a customer action.
HSCL0005	Cannot find information regarding profile data of the managed system. Execute a rebuild managed system operation.	<ol style="list-style-type: none"> 1. Perform a rebuild managed system operation. 2. If the problem persists, contact your software service support representative.
HSCL0006	The managed system's profile data has been corrupted. You must either restore or reinitialize the profile data.	You must either restore or initialize the profile data. This is a customer action.
HSCL0007	The profile data of the managed system cannot be accessed or modified. Execute a rebuild managed system operation	<ol style="list-style-type: none"> 1. Perform a rebuild managed system operation. 2. If the problem persists, contact your software service support representative.
HSCL0008	Could not construct or initialize profile data. Perform a Rebuild Managed System operation.	If the customer has not done so, perform a Rebuild Managed System operation. Follow the procedures in "Rebuild is Indicated for Managed System" on page 83 to perform this action. If the problem persists, check the state of the system and perform the procedures in "Operating States" on page 79 to return the managed system to ready state.
HSCL0009	Could not construct or initialize the profile data from the backup file, {0}. Repeat the operation.	Repeat the operation. Direct customers to follow the procedures in their <i>IBM Hardware Management Console for pSeries Installation and Operations Guide</i> . If the problem persists, call for HMC software support.
HSCL000B	Could not get the activated LPAR profile from the profile data. Perform a Rebuild Managed System operation.	If the customer has not done so, perform a Rebuild Managed System operation. Follow the procedures in "Rebuild is Indicated for Managed System" on page 83 to perform this action. If the problem persists, check the state of the system and perform the procedures in "Operating States" on page 79 to return the managed system to ready state.
HSCL000C	Could not get the activated system profile from the profile data. Perform a Rebuild Managed System operation.	If the customer has not done so, perform a Rebuild Managed System operation. Follow the procedures in "Rebuild is Indicated for Managed System" on page 83 to perform this action. If the problem persists, check the state of the system and perform the procedures in "Operating States" on page 79 to return the managed system to ready state.
HSCL000D	Could not get all the system profiles from the profile data. Perform a Rebuild Managed System operation.	If the customer has not done so, perform a Rebuild Managed System operation. Follow the procedures in "Rebuild is Indicated for Managed System" on page 83 to perform this action. If the problem persists, check the state of the system and perform the procedures in "Operating States" on page 79 to return the managed system to ready state.

Profile Data Error Codes	Message	Recovery Action
HSCL000E	Could not get the default LPAR profile from the profile data. Perform a Rebuild Managed System operation.	If the customer has not done so, perform a Rebuild Managed System operation. Follow the procedures in "Rebuild is Indicated for Managed System" on page 83 to perform this action. If the problem persists, check the state of the system and perform the procedures in "Operating States" on page 79 to return the managed system to ready state.
HSCL000F	Could not get the default system profile from the profile data. Perform a Rebuild Managed System operation.	If the customer has not done so, perform a Rebuild Managed System operation. Follow the procedures in "Rebuild is Indicated for Managed System" on page 83 to perform this action. If the problem persists, check the state of the system and perform the procedures in "Operating States" on page 79 to return the managed system to ready state.
HSCL0010	Could not get the LPAR profiles for the partition from the profile data. Perform a Rebuild Managed System operation.	If the customer has not done so, perform a Rebuild Managed System operation. Follow the procedures in "Rebuild is Indicated for Managed System" on page 83 to perform this action. If the problem persists, check the state of the system and perform the procedures in "Operating States" on page 79 to return the managed system to ready state.
HSCL0011	Could not get the LPAR profiles at this partition from the profile data. Perform a Rebuild Managed System operation.	If the customer has not done so, perform a Rebuild Managed System operation. Follow the procedures in "Rebuild is Indicated for Managed System" on page 83 to perform this action. If the problem persists, check the state of the system and perform the procedures in "Operating States" on page 79 to return the managed system to ready state.
HSCL0012	Could not get the system profile from the profile data. Perform a Rebuild Managed System operation.	If the customer has not done so, perform a Rebuild Managed System operation. Follow the procedures in "Rebuild is Indicated for Managed System" on page 83 to perform this action. If the problem persists, check the state of the system and perform the procedures in "Operating States" on page 79 to return the managed system to ready state.
HSCL0013	Could not remove the LPAR profile from the profile data. Perform a Rebuild Managed System operation.	If the customer has not done so, perform a Rebuild Managed System operation. Follow the procedures in "Rebuild is Indicated for Managed System" on page 83 to perform this action. If the problem persists, check the state of the system and perform the procedures in "Operating States" on page 79 to return the managed system to ready state.

Profile Data Error Codes	Message	Recovery Action
HSCL0014	Could not remove the system profile from the profile data. Perform a Rebuild Managed System operation.	If the customer has not done so, perform a Rebuild Managed System operation. Follow the procedures in “Rebuild is Indicated for Managed System” on page 83 to perform this action. If the problem persists, check the state of the system and perform the procedures in “Operating States” on page 79 to return the managed system to ready state.
HSCL0015	Could not save the LPAR profile to the profile data. Perform a Rebuild Managed System operation.	If the customer has not done so, perform a Rebuild Managed System operation. Follow the procedures in “Rebuild is Indicated for Managed System” on page 83 to perform this action. If the problem persists, check the state of the system and perform the procedures in “Operating States” on page 79 to return the managed system to ready state.
HSCL0016	Could not save the system profile to the profile data. Perform a Rebuild Managed System operation.	If the customer has not done so, perform a Rebuild Managed System operation. Follow the procedures in “Rebuild is Indicated for Managed System” on page 83 to perform this action. If the problem persists, check the state of the system and perform the procedures in “Operating States” on page 79 to return the managed system to ready state.
HSCL0017	Could not create the LPAR profile in the profile data. Perform a Rebuild Managed System operation.	If the customer has not done so, perform a Rebuild Managed System operation. Follow the procedures in “Rebuild is Indicated for Managed System” on page 83 to perform this action. If the problem persists, check the state of the system and perform the procedures in “Operating States” on page 79 to return the managed system to ready state.
HSCL0018	Could not create the system profile in the profile data. Perform a Rebuild Managed System operation.	If the customer has not done so, perform a Rebuild Managed System operation. Follow the procedures in “Rebuild is Indicated for Managed System” on page 83 to perform this action. If the problem persists, check the state of the system and perform the procedures in “Operating States” on page 79 to return the managed system to ready state.
HSCL0019	Could not set the activated LPAR profile in the profile data. Perform a Rebuild Managed System operation.	If the customer has not done so, perform a Rebuild Managed System operation. Follow the procedures in “Rebuild is Indicated for Managed System” on page 83 to perform this action. If the problem persists, check the state of the system and perform the procedures in “Operating States” on page 79 to return the managed system to ready state.

Profile Data Error Codes	Message	Recovery Action
HSCL001A	Could not set the activated system profile in the profile data. Perform a Rebuild Managed System operation.	If the customer has not done so, perform a Rebuild Managed System operation. Follow the procedures in "Rebuild is Indicated for Managed System" on page 83 to perform this action. If the problem persists, check the state of the system and perform the procedures in "Operating States" on page 79 to return the managed system to ready state.
HSCL001B	Could not set the default LPAR profile in the profile data. Perform a Rebuild Managed System operation.	If the customer has not done so, perform a Rebuild Managed System operation. Follow the procedures in "Rebuild is Indicated for Managed System" on page 83 to perform this action. If the problem persists, check the state of the system and perform the procedures in "Operating States" on page 79 to return the managed system to ready state.
HSCL001C	Could not set the default system profile in the profile data. Perform a Rebuild Managed System operation.	If the customer has not done so, perform a Rebuild Managed System operation. Follow the procedures in "Rebuild is Indicated for Managed System" on page 83 to perform this action. If the problem persists, check the state of the system and perform the procedures in "Operating States" on page 79 to return the managed system to ready state.
HSCL001D	Could not clean up the profile data. Perform a Rebuild Managed System operation.	If the customer has not done so, perform a Rebuild Managed System operation. Follow the procedures in "Rebuild is Indicated for Managed System" on page 83 to perform this action. If the problem persists, check the state of the system and perform the procedures in "Operating States" on page 79 to return the managed system to ready state.
HSCL001E	Could not update the profile data cache. Perform a Rebuild Managed System operation.	If the customer has not done so, perform a Rebuild Managed System operation. Follow the procedures in "Rebuild is Indicated for Managed System" on page 83 to perform this action. If the problem persists, check the state of the system and perform the procedures in "Operating States" on page 79 to return the managed system to ready state.
HSCL001F	Could not check for duplicate LPAR name. Perform a Rebuild Managed System operation.	If the customer has not done so, perform a Rebuild Managed System operation. Follow the procedures in "Rebuild is Indicated for Managed System" on page 83 to perform this action. If the problem persists, check the state of the system and perform the procedures in "Operating States" on page 79 to return the managed system to ready state.

Profile Data Error Codes	Message	Recovery Action
HSCL0020	Could not remove the LPAR profile from the system profile content in the profile data. Perform a Rebuild Managed System operation.	If the customer has not done so, perform a Rebuild Managed System operation. Follow the procedures in "Rebuild is Indicated for Managed System" on page 83 to perform this action. If the problem persists, check the state of the system and perform the procedures in "Operating States" on page 79 to return the managed system to ready state.
HSCL0021	Could not add the LPAR profile to the system profile in the profile data. Perform a Rebuild Managed System operation.	If the customer has not done so, perform a Rebuild Managed System operation. Follow the procedures in "Rebuild is Indicated for Managed System" on page 83 to perform this action. If the problem persists, check the state of the system and perform the procedures in "Operating States" on page 79 to return the managed system to ready state.
HSCL0022	Could not get the partition name from the profile data. Perform a Rebuild Managed System operation.	If the customer has not done so, perform a Rebuild Managed System operation. Follow the procedures in "Rebuild is Indicated for Managed System" on page 83 to perform this action. If the problem persists, check the state of the system and perform the procedures in "Operating States" on page 79 to return the managed system to ready state.
HSCL0023	Could not get all the partition names from the profile data. Perform a Rebuild Managed System operation.	If the customer has not done so, perform a Rebuild Managed System operation. Follow the procedures in "Rebuild is Indicated for Managed System" on page 83 to perform this action. If the problem persists, check the state of the system and perform the procedures in "Operating States" on page 79 to return the managed system to ready state.
HSCL0024	Could not set the partition name in the profile data. Perform a Rebuild Managed System operation.	If the customer has not done so, perform a Rebuild Managed System operation. Follow the procedures in "Rebuild is Indicated for Managed System" on page 83 to perform this action. If the problem persists, check the state of the system and perform the procedures in "Operating States" on page 79 to return the managed system to ready state.
HSCL0025	Could not build the profile data from the local file, {0}. Perform a Rebuild Managed System operation.	If the customer has not done so, perform a Rebuild Managed System operation. Follow the procedures in "Rebuild is Indicated for Managed System" on page 83 to perform this action. If the problem persists, check the state of the system and perform the procedures in "Operating States" on page 79 to return the managed system to ready state.

Profile Data Error Codes	Message	Recovery Action
HSCL0026	Could not write the data to the managed system. Perform a Rebuild Managed System operation.	If the customer has not done so, perform a Rebuild Managed System operation. Follow the procedures in "Rebuild is Indicated for Managed System" on page 83 to perform this action. If the problem persists, check the state of the system and perform the procedures in "Operating States" on page 79 to return the managed system to ready state.
HSCL0027	Could not backup the profile data to a file. Perform a Rebuild Managed System operation.	If the customer has not done so, perform a Rebuild Managed System operation. Follow the procedures in "Rebuild is Indicated for Managed System" on page 83 to perform this action. If the problem persists, check the state of the system and perform the procedures in "Operating States" on page 79 to return the managed system to ready state.
HSCL0028	Could not read profile data from the managed system. Perform a Rebuild Managed System operation.	If the customer has not done so, perform a Rebuild Managed System operation. Follow the procedures in "Rebuild is Indicated for Managed System" on page 83 to perform this action. If the problem persists, check the state of the system and perform the procedures in "Operating States" on page 79 to return the managed system to ready state.
HSCL0029	Could not delete profiles at the partition with ID of {0} in the profile data. Perform a Rebuild Managed System operation.	If the customer has not done so, perform a Rebuild Managed System operation. Follow the procedures in "Rebuild is Indicated for Managed System" on page 83 to perform this action. If the problem persists, check the state of the system and perform the procedures in "Operating States" on page 79 to return the managed system to ready state.
HSCL002A	Could not modify the system profiles containing the LPAR slot ID of {0} in the profile data. Perform a Rebuild Managed System operation.	If the customer has not done so, perform a Rebuild Managed System operation. Follow the procedures in "Rebuild is Indicated for Managed System" on page 83 to perform this action. If the problem persists, check the state of the system and perform the procedures in "Operating States" on page 79 to return the managed system to ready state.
HSCL002B	Could not do a priority restore on the profile data. Perform a Rebuild Managed System operation.	If the customer has not done so, perform a Rebuild Managed System operation. Follow the procedures in "Rebuild is Indicated for Managed System" on page 83 to perform this action. If the problem persists, check the state of the system and perform the procedures in "Operating States" on page 79 to return the managed system to ready state.

Profile Data Error Codes	Message	Recovery Action
HSCL002C	Could not merge the profile information in profile data. Perform a Rebuild Managed System operation.	If the customer has not done so, perform a Rebuild Managed System operation. Follow the procedures in "Rebuild is Indicated for Managed System" on page 83 to perform this action. If the problem persists, check the state of the system and perform the procedures in "Operating States" on page 79 to return the managed system to ready state.
HSCL002D	Could not merge partition name data in the profile data. Perform a Rebuild Managed System operation.	If the customer has not done so, perform a Rebuild Managed System operation. Follow the procedures in "Rebuild is Indicated for Managed System" on page 83 to perform this action. If the problem persists, check the state of the system and perform the procedures in "Operating States" on page 79 to return the managed system to ready state.
HSCL002E	Could not merge default and activated list data in profile data. Perform a Rebuild Managed System operation.	If the customer has not done so, perform a Rebuild Managed System operation. Follow the procedures in "Rebuild is Indicated for Managed System" on page 83 to perform this action. If the problem persists, check the state of the system and perform the procedures in "Operating States" on page 79 to return the managed system to ready state.
HSCL002F	Could not merge drawer and profile information data in profile data. Perform a Rebuild Managed System operation.	If the customer has not done so, perform a Rebuild Managed System operation. Follow the procedures in "Rebuild is Indicated for Managed System" on page 83 to perform this action. If the problem persists, check the state of the system and perform the procedures in "Operating States" on page 79 to return the managed system to ready state.
HSCL0030	Unable to initialize the profile data. Perform a Rebuild Managed System operation.	If the customer has not done so, perform a Rebuild Managed System operation. Follow the procedures in "Rebuild is Indicated for Managed System" on page 83 to perform this action. If the problem persists, check the state of the system and perform the procedures in "Operating States" on page 79 to return the managed system to ready state.
HSCL0031	The profile data has been cleared. Either restore or reinitialize the profile data save area.	Perform restore profile data task or reinitialize the profile data. Refer to the <i>IBM Hardware Management Console for pSeries Installation and Operations Guide</i> , order number SA38-0590 for these procedures.
HSCL0032	Could not set the system profile's user defined name to the profile data. Perform a Rebuild Managed System operation.	If the customer has not done so, perform a Rebuild Managed System operation. Follow the procedures in "Rebuild is Indicated for Managed System" on page 83 to perform this action. If the problem persists, check the state of the system and perform the procedures in "Operating States" on page 79 to return the managed system to ready state.

Profile Data Error Codes	Message	Recovery Action
HSCL0033	This managed system version, {0}, is unknown to HMC. Update to an HMC release that can handle this version of managed system.	<ol style="list-style-type: none"> 1. Perform the rebuild managed system operation. 2. If the same error occurs, update to an HMC release that supports this version of managed system. 3. If you are not sure what version to use, contact software support.
HSCL0034	The levels of managed system and profile data area are not matching up. Managed system version: {0}, profile data area version: {1}. Upgrade the managed system version "to proper level."	<ol style="list-style-type: none"> 1. Perform the rebuild managed system operation. 2. If the same error occurs, update the managed system to the correct version. 3. If you are not sure what version to use, contact software support.
HSCL0035	Cannot restore profile data with 2 different versions of profile save data.	<ol style="list-style-type: none"> 1. Perform the operation again. 2. If the same error occurs, restore using another profile data file.
HSCL0036	Migrate profile data failed.	<ol style="list-style-type: none"> 1. Perform the operation again. 2. If the problem persists, contact your software service support representative.
HSCL0037	This level of profile data, {0}, is unknown to this HMC. Please update to an HMC version that can handle this level of profile data.	<ol style="list-style-type: none"> 1. Perform the operation again. 2. If the problem persists, update to an HMC version that supports this level of profile data. 3. If you are not sure what version to use, contact software support.
HSCL0038	Creation of affinity logical partition profiles failed in profile data save area.	<ol style="list-style-type: none"> 1. Perform the rebuild managed system operation. 2. Retry the operation again. 3. If the problem persists, contact your software service support representative.
HSCL0039	Deletion of affinity logical partitions failed in profile data save area.	<ol style="list-style-type: none"> 1. Perform the rebuild managed system operation. 2. Retry the operation again. 3. If the problem persists, contact your software service support representative.
HSCL003A	Removal system profiles failed at profile data save area.	<ol style="list-style-type: none"> 1. Perform the rebuild managed system operation. 2. Retry the operation again. 3. If the problem persists, contact your software service support representative.
HSCL003B	Setting of partition information failed in profile data save area.	<ol style="list-style-type: none"> 1. Perform the rebuild managed system operation. 2. Retry the operation again. 3. If the problem persists, contact your software service support representative.

Profile Data Error Codes	Message	Recovery Action
HSCL003C	Retrieval of all affinity logical partition information failed in profile data save area.	<ol style="list-style-type: none"> 1. Perform the rebuild managed system operation. 2. Retry the operation again. 3. If the problem persists, contact your software service support representative.
HSCL003D	Retrieval of partition information failed in profile data save area.	<ol style="list-style-type: none"> 1. Perform the rebuild managed system operation. 2. Retry the operation again. 3. If the problem persists, call for HMC software support.
HSCL003E	Cannot build LPAR information from profile data save area when the managed system is not LPAR capable.	The capabilities of your managed system are listed on the Machine tab of the properties panel.
HSCL003F	Cannot build affinity logical partition information from profile data save area when the managed system is not Affinity LPAR capable.	The capabilities of your managed system are listed on the Machine tab of the properties panel.
HSCL0040	No more space for physical location code in the profile data save area.	<ol style="list-style-type: none"> 1. Perform the rebuild managed system operation 2. Retry the operation again. 3. If the problem persists, call for HMC software support.
HSCL0041	Migration of partition information failed in profile data save area	<ol style="list-style-type: none"> 1. Perform the rebuild managed system operation. 2. If the problem persists, call for HMC software support.
HSCL0042	Migration of profile names failed in profile data save area	<ol style="list-style-type: none"> 1. Perform the rebuild managed system operation. 2. If the problem persists, call for HMC software support.
HSCL0043	Migration of default profile list failed in profile data save area	<ol style="list-style-type: none"> 1. Perform the rebuild managed system operation. 2. If the problem persists, call for HMC software support.
HSCL0044	Migration of activated profile list failed in profile data save area	<ol style="list-style-type: none"> 1. Perform the rebuild managed system operation. 2. If the problem persists, call for HMC software support.
HSCL0045	Migration of physical location code information failed in profile data save area	<ol style="list-style-type: none"> 1. Perform the rebuild managed system operation. 2. If the problem persists, call for HMC software support.
HSCL0046	Migration of drawer and profile information failed in profile data save area	<ol style="list-style-type: none"> 1. Perform the rebuild managed system operation. 2. If the problem persists, call for HMC software support.

Profile Data Error Codes	Message	Recovery Action
HSCL0047	Migration of time stamps of profile data save area failed	<ol style="list-style-type: none"> 1. Perform the rebuild managed system operation. 2. If the problem persists, call for HMC software support.
HSCL0048	Migration of checksums of profile data save area failed	<ol style="list-style-type: none"> 1. Perform the rebuild managed system operation. 2. If the problem persists, call for HMC software support.

Managed System Error Codes	Message	Recovery Action
HSCL01F5	Unable to lock the Service Processor. Perform one of the following steps: (1) Check serial cable connection; (2) Check if another Console is communicating with the Service Processor; (3) Perform the Release Lock task; (4) Perform Rebuild task to re-establish the connection.	<ol style="list-style-type: none"> 1. Wait for three minutes and retry the task. 2. If the problem persists, make sure other HMCs and remote login sessions of the HMCs are not performing any task. Then perform the Release HMC Lock task to unlock the service processor, and then try the task again. 3. Rebuild the managed system. Follow the procedures in "Rebuild is Indicated for Managed System" on page 83 to perform this action. <p>This is a customer action.</p>
HSCL01F6	Unable to unlock the managed system lock. Perform the Release Hardware Management Console Lock to unlock the managed system.	<p>This is a customer action.</p> <ol style="list-style-type: none"> 1. Perform the Release HMC lock to unlock the service processor, and try the task again. 2. If the task still fails and a redundant HMC is present, turn off the redundant HMC power and try the task again. 3. If the problem persists, refer to "Managed System States for the HMC" on page 84 and check the state of the managed system. Perform the appropriate actions to recover.
HSCL01F7	Unable to get the current time from the managed system.	<ol style="list-style-type: none"> 1. Try the task again. 2. Perform a Rebuild Managed System operation. Follow the procedures in "Rebuild is Indicated for Managed System" on page 83 to perform this action. 3. If the problem persists, refer to "Managed System States for the HMC" on page 84 and check the state of the managed system. Perform the appropriate actions to recover.
HSCL01F8	This property cannot be altered.	None.

Managed System Error Codes	Message	Recovery Action
HSCL01F9	Unable to create managed system instance in object manager.	This is a customer action. 1. Try the task again. 2. Shut down and restart the HMC. 3. Try the task again.
HSCL01FA	The managed system is already powered off.	None.
HSCL01FC	The parameter specified is not valid. Specify a different value.	None.
HSCL01FD	Power on failed. Try again.	Retry the Power On task. This is a customer action.
HSCL01FE	The managed system is already powered on.	None.
HSCL01FF	Could not rebuild. Shut down and restart the Hardware Management Console.	This is a customer action. 1. Before rebooting, try the task again. 2. Reboot the HMC. 3. Refer to "Managed System States for the HMC" on page 84 and check the state of the managed system. Perform the appropriate actions to recover. 4. Try the task again. 5. Verify the customer has performed the appropriate recovery action, If the problem persists, call for HMC software support.
HSCL0200	Unable to communicate with Service Processor. Check serial cable connection.	1. Check the serial cable connection from the HMC to the managed system. 2. Refer to "Managed System States for the HMC" on page 84 and check the state of the managed system. Perform the appropriate actions to put the managed system in the correct state.
HSCL0201	Service Processor Command failed after {0} attempts: Invalid Response.	Wait several minutes and try the task again.
HSCL0202	Service Processor Socket is corrupted.	1. Wait two minutes and retry the command. 2. If the command still fails, wait an additional two minutes and try again. 3. If both tries fail, rebuild the managed system to re-establish the socket connection. Follow the procedures in "Rebuild is Indicated for Managed System" on page 83 to perform this action, then try the task again.
HSCL0203	Command sent to Service Processor failed. Error Response {0}	1. Try the task again. 2. Refer to "Managed System States for the HMC" on page 84 and check the state of the managed system. Perform the appropriate actions to put the managed system in the correct state.

Managed System Error Codes	Message	Recovery Action
HSCL0204	Command failed. Unknown error.	<ol style="list-style-type: none"> 1. Try the task again. 2. Refer to “Managed System States for the HMC” on page 84 and check the state of the managed system. Perform the appropriate actions to put the managed system in the correct state.
HSCL0205	The Managed System is in the Error State and is unable to continue with the Recover Partition Data Task.	<p>The recovery partition data task cannot be run until the managed system is no longer in error state.</p> <ol style="list-style-type: none"> 1. Record the error message. 2. Refer to the recovery procedures for the managed system.
HSCL0206	Failed to Power On the Managed System. Unable to continue with the Power On Task	<ol style="list-style-type: none"> 1. Check the operator panel value of the managed system to verify it is in the no power state and that the managed system is not in the error state. 2. Verify that no other task is being performed while executing this task, then retry the task. 3. If problem persists, call HMC software support.
HSCL0207	Failed to Power Off the Managed System. Unable to continue with the Recover Partition Data Task.	<ol style="list-style-type: none"> 1. Check the operator panel value of the managed system to verify it is powered on and that the managed system is not in the error state. 2. Verify that no other task is being performed while executing this task, then retry the task 3. If problem persists, call HMC software support.
HSCL0209	Remote virtual terminal sessions are not allowed. Please check the remote virtual terminal settings.	Virtual terminal cannot open remotely at this point. If opening the virtual terminal remotely is needed, enable your remote virtual terminal setting. Use the Enable/Disable Remote Virtual Terminal task in the System Configuration menu to enable remote connections.
HSCL020A	The power on system profile operation timed out. Activate the system profile manually once the managed system is powered on.	Activate the system profile manually after the managed system is powered on.
HSCL020B	The CUoD activation code you entered is incorrect. Please check the activation code and retry.	Make sure the key is correct, and enter it again. If it still fails, contact your service representative.
HSCL020C	The managed system does not allow Activation Codes for CUoD operations.	None
HSCL020D	The command you issued contained incorrect data.	Contact your next level of software support.
HSCL020E	The sequence number of this activation code indicates it has been used before. Please enter in a newer activation code.	Make sure the key is correct, and enter it again. If it still fails, contact your service representative.

Managed System Error Codes	Message	Recovery Action
HSCLO20F	The activation code was not entered correctly. Re-enter your activation code.	Make sure the key is correct, and enter it again. If it still fails, contact your service representative.
HSCLO210	The managed system cannot currently process an activation code. This condition is temporary, please retry this operation.	The system is processing another CUoD function. Retry the operation.
HSCLO211	The requested function is currently disabled.	Power off the managed system, and power it back on.
HSCLO212	The managed system is not CUoD capable at the present time.	Make sure that the managed system is powered on. If it is powered on, check the managed system's properties panel to verify that the system is not CUoD capable. Contact your representative for more information about this feature.
HSCLO213	The managed system does not support CUoD upgrades for processors.	Contact your representative for more information about this feature.
HSCLO214	The managed system does not support CUoD upgrades for memory.	Contact your representative for more information about this feature.
HSCLO215	There was an error trying to save processor order information to a diskette. Verify the diskette is writable, and retry the operation. If the error persists, contact your service representative.	Verify the diskette is writable, and retry the operation again. If the error persists, contact your service representative.
HSCLO216	There was an error trying to send processor order information to the remote system. Verify the network connection to the remote system and that the user has access to the remote system and directory where the file will be copied. If the problem persists, contact your software support representative.	Verify the network connection to the remote system and that user has access to the remote system and directory where the file will be copied. If the problem persists, contact your software support representative.
HSCLO216	The managed system cannot process the CUoD task at this time. The function has been disabled. You must power off and then power on the managed system to enable this task.	To enable the CUoD task, power off and then power on the managed system.

Managed System Resource Error Codes	Message	Recovery Action
HSCL03EA	There is an insufficient number of processors: Obtained - {0}, Required - {1}. Check that there are enough processors available to activate the partition. If not, create a new profile or modify the existing profile with the available resources, then activate the partition. If the partition must be activated with the specified number of processors, deactivate any active partitions using the resource, then activate the partition.	<ol style="list-style-type: none"> 1. Check the managed system properties panel to make sure that enough processors are available to activate the partition. 2. If there are not enough processors available, create a new profile or modify the existing profile with the available resources. Then, activate the partition. 3. If the partition must be activated at any cost, deactivate any running partition that is using the resource and then activate the partition. <p>This is a customer action.</p>
HSCL03EB	Unable to allocate the I/O slot for activation in {0}. Check that the specified I/O is available to activate the partition. If not, create a new profile or modify the existing profile with the available resources, then activate the partition. If the partition must be activated with these resources, deactivate any running partition(s) using the resource then activate this partition.	<p>This is a customer action.</p> <ol style="list-style-type: none"> 1. Check the managed system properties panel to make sure that enough I/O slots are available to activate the partition. 2. If there are not enough I/O slots available, create a new profile or modify the existing profile with the available resources. Then activate the partition. 3. If the partition must be activated at any cost, deactivate any running partition that is using the resource and then activate the partition. <p>Note: If you have tried to recover using the above actions and you are not successful, and you must activate the partition, edit the profile for the partition you are activating and remove all slots that are associated with the identified slot's PHB. See the <i>PCI Adapter Placement Reference</i>, order number SA38-0538 for information on PHB slot associations.</p>
HSCL03EC	There is not enough memory: Obtained - {0}, Required - {1}. Check that there is enough memory available to activate the partition. If not, create a new profile or modify the existing profile with the available resources, then activate the partition. If the partition must be activated with these resources, deactivate any running partition(s) using the resource then activate this partition.	<ol style="list-style-type: none"> 1. Check the managed system properties panel to make sure that enough memory is available to activate the partition. 2. If there is not enough available memory, create a new profile or modify the existing profile with the available resources and then activate the partition. 3. Check the Memory Planning section of the <i>IBM Hardware Management Console for pSeries Installation and Operations Guide</i>, order number SA38-0590. 4. If the partition must be activated at any cost, deactivate any running partition using the resource and activate the partition. <p>This is a customer action.</p>

Managed System Resource Error Codes	Message	Recovery Action
HSCLO3ED	The I/O Drawer specified by this ID cannot be found and may have been deleted from the managed system. Modify the profile.	The I/O drawer defined in the profile may have been removed from the server. Check to verify that the I/O drawers defined in the profile are installed. Then, modify the profile to match the server configuration. This is a customer action.
HSCLO3EE	The specified slot number cannot be found. Make sure the profile is not using I/O drawer slots that do not exist in the managed system.	An I/O slot defined in the profile may have been removed from the server. Verify that the I/O slots defined in the profile are installed. Then, modify the profile to match the server configuration. This is a customer action.
HSCLO3EF	The number of drawers, slots, and I/O required/desired information stored in the properties do not match. The profile may be corrupted. Perform the Restore Profile Data task.	This is a customer action. <ol style="list-style-type: none"> 1. The profile may be corrupted. Perform the Restore Profile Data task. 2. If problem persists, delete the profile and create a new profile. 3. If the problem persists, refer to “Managed System States for the HMC” on page 84 and check the state of the managed system. Perform the appropriate actions to recover.
HSCLO3F0	Unable to allocate the I/O slot for activation in I/O drawer {0}. Slot {1} is currently being used by another partition. Perform one of the following three actions 1) remove this I/O slot from the profile or 2) change the I/O slot from Required to Desired in the profile or 3) remove the I/O slot from the other partition.	Perform one of the following actions: <ul style="list-style-type: none"> • Remove this I/O slot from the profile. • Change the I/O slot from Required to Desired in the profile. • Remove the I/O slot from the other partition.
HSCLO3F1	Unable to allocate one or more I/O slots. The following slots are in error state: {0} slot {1}. Please complete one of the following actions: Remove this I/O slot from the profile, or change the I/O slot from required to desired in the profile, or reboot the managed system to restore the PCI slots in error to normal state.	Perform one of the following options: <ul style="list-style-type: none"> • Remove this I/O slot from the profile. • Change the I/O slot from required to desired in the profile. • Reboot the managed system to restore the PCI slots in error to normal state. • Consult the hardware documentation for the managed system to determine the cause of the error state.
HSCLO3F2	Unable to allocate the I/O slot for activation in I/O drawer {0}. Slot {1} is not present. Remove this I/O slot from the profile or change the I/O slot from Required to Desired in the profile.	Remove this I/O slot from the profile or change the I/O slot from Required to Desired in the profile.
HSCLO3F3	Unable to allocate the I/O slot for activation in I/O drawer {0}. Slot {1} is system deconfigured. Remove this I/O slot from the profile or change the I/O slot from Required to Desired in the profile.	Remove this I/O slot from the profile or change the I/O slot from Required to Desired in the profile.

Partition Error Codes	Message	Recovery Action
HSCL0591	Cannot activate logical partition when an affinity logical partition has already been activated since powering on	Activation of logical partitions is not allowed at this point. To activate this partition, do the following: <ol style="list-style-type: none"> 1. Power off the managed system. 2. Power on the managed system to partition standby. 3. Try the activation operation again.
HSCL0592	Cannot activate a 8-processor affinity logical partition when a logical partition or other type of affinity logical partition has already been activated since powering on	Activation of an 8-way affinity logical partition is not allowed at this point. To activate this partition, do the following: <ol style="list-style-type: none"> 1. Power off the managed system. 2. Power on the managed system to partition standby. 3. Try the activation operation again.
HSCL0593	Cannot activate a 4-processor affinity logical partition when a logical partition or other type of affinity logical partition has already been activated since powering on	Activation of a 4-way affinity logical partition is not allowed at this point. If you need to activate this partition, do the following: <ol style="list-style-type: none"> 1. Power off the managed system. 2. Power on the managed system to partition standby. 3. Retry the activation operation.
HSCL0594	Managed system is not capable of activating a 4-processor affinity logical partition	The capabilities of your managed system are listed on the Machine tab of the properties panel.
HSCL0595	Managed system is not capable of activating a 8-processor affinity logical partition	The capabilities of your managed system are listed on the Machine tab of the properties panel.
HSCL0596	Cannot activate a Full Machine Partition in a non-SMP capable managed system	The capabilities of your managed system are listed on the Machine tab of the properties panel.
HSCL0597	Cannot activate a logical partition in a non-LPAR capable managed system	The capabilities of your managed system are listed on the Machine tab of the properties panel.
HSCL0598	Cannot activate an affinity logical partition in a non-Affinity-LPAR capable managed system	The capabilities of your managed system are listed on the Machine tab of the properties panel.
HSCL059A	Cannot activate the partition. The profile's maximum memory amount exceeds the managed system's memory limit. Please change the profile's maximum memory amount.	Change the profile's maximum memory amount, and retry the operation.
HSCL05DD	Unable to get partition state. Repeat the operation.	Repeat the operation. If the problem persists, refer to "Managed System States for the HMC" on page 84 and check the state of the managed system. Perform the appropriate actions to recover.
HSCL05DE	A partition in the managed system already uses the name {0}. Provide another name for this partition.	Rename the partition to another name that is not yet used by other partitions in the same managed system. This is a customer action.

Partition Error Codes	Message	Recovery Action
HSCL05DF	The partition is not in a state under which this operation can be performed. Check the state of the partition.	Verify that the operation is allowable under this partition state. This is a customer action.
HSCL05E0	The partition {0} is in an undefined state. Rebuild the managed system.	If the customer has not done so, perform a Rebuild Managed System operation. Follow the procedures in “Rebuild is Indicated for Managed System” on page 83 to perform this action. If the problem persists, check the state of the system and perform the procedures in “Operating States” on page 79 to return the managed system to ready state.
HSCL05E1	Only 16 partitions per managed system can be allocated. There are no more unallocated partitions available. Delete unused or unwanted partitions for this managed system and retry the operation. Partitions in the ready state are currently not in use.	This is a customer action. Delete unused or unwanted partitions. Partitions in the ready state are currently not in use.
HSCL05E4	Unable to delete a full system partition. You do not have the necessary permission to delete a full system partition.	This is a customer action. You do not have the necessary permission to delete a full system partition. Contact your user administrator to give you the appropriate access.
HSCL05E5	Unable to create partition when the managed system is in {0} state. Make sure that the managed system is in the ready state and was powered on with Partition Standby.	This is a customer action. Verify the managed system is in the ready state and in Partition Standby. If the problem persists, refer to “Managed System States for the HMC” on page 84 and check the state of the managed system. Perform the appropriate actions to recover.
HSCL05E6	Partition {0} delete failed. Cannot delete a partition when its state is in {1}. If the partition is not in the ready error state, perform a hard reset operation then delete the partition.	This is a customer action. Verify the partition is not in running or booting state. If the state is in ready or error state, perform a Rebuild Managed System operation. Follow the procedures in “Rebuild is Indicated for Managed System” on page 83 to perform this action, then try the task again.
HSCL05E7	The profile you tried to activate does not belong to the partition {0} you specified. Select the correct LPAR profile.	Verify that you selected the correct LPAR profile to activate.
HSCL05E8	Cannot delete partition {0}. A partition cannot be deleted when the managed system is at the {1} state. Delete the LPAR when the managed system is in the Ready state and in Partition Standby.	This is a customer action. If the managed system is in the Ready state and Partition Standby, rebuild the managed system. Follow the procedures in “Rebuild is Indicated for Managed System” on page 83 to perform this action, and then try the task again. Also refer to partition error message HSCL05H6. Verify the customer has performed the appropriate recovery actions. If the problem persists, call for HMC software support. If the problem persists, refer to “Managed System States for the HMC” on page 84 and check the state of the managed system. Perform the appropriate actions to recover.

Partition Error Codes	Message	Recovery Action
HSCL05E9	Could not activate the partition. Make sure that the partition is not already activated and that the managed system is running.	Verify that the partition is not already activated, and the state and power-on condition of the managed system are correct, try the operation again.
HSCL05EA	Cannot activate the partition when it is in state {0}. Make sure the partition is not running, booting or in the open firmware state.	Verify the LPAR is not in the running, booting, or open firmware state. This is a customer action.
HSCL05EB	Could not create partition. Make sure that all requirements are met for creating a logical partition.	Cannot create a partition. To verify that all the requirements for creating a logical partition are met, refer to Create Partitions, in Partition Management Tasks, in the <i>IBM Hardware Management Console for pSeries Installation and Operations Guide</i> , order number SA38-0590. If all requirements are met, do a rebuild of the managed system, follow the procedures in “Rebuild is Indicated for Managed System” on page 83 to perform this action, and try the task again. If the failure still occurs, call for HMC software support.
HSCL05EC	Could not delete partition {0}. Make sure that all requirements are met for deleting a logical partition.	Cannot delete a partition. Verify that all the requirements for deleting a partition are met, refer to “Deleting Partitions”, in “Partition Management Tasks”, in the <i>IBM Hardware Management Console for pSeries Installation and Operations Guide</i> , order number SA38-0590. If all requirements are met, rebuild the managed system. Follow the procedures in “Rebuild is Indicated for Managed System” on page 83 to perform this action, and try the task again.
HSCL05ED	Could not set the properties for partition {0}. Try again	Repeat the operation. If the operation still fails, call for HMC software support. If the problem persists, refer to “Managed System States for the HMC” on page 84 and check the state of the managed system. Perform the appropriate actions to recover.
HSCL05EE	Could not get the managed system’s service processor log entry. Try again	Repeat the operation. If the problem persists, refer to “Managed System States for the HMC” on page 84 and check the state of the managed system. Perform the appropriate actions to recover.
HSCL05EF	This new partition does not have a user defined name. Specify a name for the partition.	Set the user-defined name for this partition. This is a customer action.
HSCL05F0	Cannot create the partition when the managed system was powered on with {0}. Make sure the managed system is powered on with Partition Standby.	Verify that the managed system is in Partition Standby. This is a customer action.
HSCL05F1	Could not delete partition {0}. A partition cannot be deleted when the managed system was power on with {1}. Make sure that the managed system was powered on with Partition Standby.	This is a customer action. Verify that the managed system is in Partition Standby.

Partition Error Codes	Message	Recovery Action
HSCL05F2	No port or session number information for opening a virtual terminal partition on {0} with id {1}. Try again.	<ol style="list-style-type: none"> 1. Wait for two minutes and then try the task again. 2. If the problem persists, refer to “Managed System States for the HMC” on page 84 to check the state of the managed system. Perform the appropriate actions to recover. 3. If the operation still fails, call for HMC software support.
HSCL05F3	Could not display the OS reset dialog for partition {0}. Try again.	<ol style="list-style-type: none"> 1. Log off and then log back into the HMC and try the operation again. 2. If this does not correct the problem, call for HMC software support.
HSCL05F4	Could not display the partition activate dialog for partition {0}. Try again.	<ol style="list-style-type: none"> 1. Log off and then log back in to the HMC and try the operation again. 2. If this does not correct the problem, call for HMC software support.
HSCL05F5	Could not display the create partition dialog for the managed system: {0}. Try again.	<ol style="list-style-type: none"> 1. Log off and then log back in to the HMC and try the operation again. 2. If this does not correct the problem, call for HMC software support.
HSCL05F6	Could not create the partition on the managed system {0} with partition name {1}. Refresh the interface and check whether the operation was performed. If not, try the operation again.	Verify the newly created partition displays on the graphical user interface. If not, retry the create partition task and check the graphical user interface again. If the task still fails, log off and log back in to the HMC, and try the task again.
HSCL05F7	Could not open the virtual terminal for partition {0} with ID {1}.	<ol style="list-style-type: none"> 1. Refresh the interface and check whether the operation was performed. 2. Reboot the HMC, and try the task again. <p>Verify that the customer has performed the appropriate recovery actions.</p>
HSCL05F8	Could not perform the OS reset {0} reset on partition {1} with ID {2}.	<ol style="list-style-type: none"> 1. Refresh the interface and check whether the operation was performed. If not, try the operation again. 2. If the partition has been reset. (If you performed a soft reset, check to see if the partition rebooted. If you performed a hard reset, verify that the partition state changed to ready.) 3. Retry the OS reset operation. 4. If a hard reset was performed, rebuild the managed system. See “Rebuild is Indicated for Managed System” on page 83 and check the state. See “Managed System States for the HMC” on page 84. <p>Verify the customer has performed the appropriate recovery actions.</p>

Partition Error Codes	Message	Recovery Action
HSCL05F9	Could not delete partition {0}. Refresh the interface and check whether the operation was performed. If not, try the operation again.	<ol style="list-style-type: none"> 1. Verify that the partition displays on the graphical user interface. 2. Retry the delete partition and check the graphical user interface to see if it is updated appropriately. 3. Log off and log back in to the HMC. <p>Verify that the customer has performed the appropriate recovery actions.</p>
HSCL058A	Could not activate the partition on partition {0} with ID {1}. Refresh the interface and check whether the operation was performed. If not, try the operation again.	<ol style="list-style-type: none"> 1. Refresh the graphical user interface. 2. Perform a rebuild of the managed system, following the procedures in "Rebuild is Indicated for Managed System" on page 83 to perform this action 3. Try the task again. 4. Call for HMC software support. <p>Verify that the customer has performed the appropriate recovery actions.</p>
HSCL058B	Could not read the boot error value task on partition {0} with ID {1}. Refresh the interface and check whether the operation was performed. If not, try the operation again.	<ol style="list-style-type: none"> 1. Try the task again. 2. Perform a Rebuild Managed System operation. Follow the procedures in "Rebuild is Indicated for Managed System" on page 83 to perform this action, then try the task again.

Profile Error Codes	Message	Recovery Action
HSCL07D1	This partition profile is currently active in its logical partition and cannot be modified or deleted. To make the profile inactive, perform a hard operating system reset on the partition to bring it to the Ready state, then repeat the operation.	Partition profiles that are active in a logical partition cannot be modified or deleted. Perform a Hard Operating System Reset on the Partition to bring it to the Ready state, at which time the profile will no longer be active. This is a customer action.
HSCL07D2	This partition profile is the logical partition's default profile and cannot be deleted. If you still want to delete it, change the default profile for this logical partition or, if necessary, create another partition profile to be the default profile.	All logical partition s must have at least one partition profile, which is designated as the Default Profile because it is the profile implicitly used when the Partition is activated with no profile specified. If you still wish to delete it, change the Default Profile for this logical partition (create another partition profile if necessary). This is a customer action.
HSCL07D3	The partition profile could not be found in the Hardware Management Console save area. The Hardware Management Console is either out of sync with the console save area or the console save area has been corrupted. Rebuild this partition profile's managed system.	<ol style="list-style-type: none"> 1. The HMC is out of sync with the profile data. 2. The profile data has been corrupted. This might cause the loss of the partition profile. 3. Rebuild the partition profiles for the managed system. <p>This is a customer action.</p>

Profile Error Codes	Message	Recovery Action
HSCL07D4	A profile named {0} already exists for this partition in the Hardware Management Console save area. Choose a different name for the new system profile.	All partition profiles for a logical partition must have unique names. Choose a different name for the new profile. This is a customer action.
HSCL07D5	Creation of partition profiles for the full system partition is not allowed. You must use one of the predefined partition profiles for the full system partition.	You must use one of the predefined partition profiles for the full system partition. This is a customer action.
HSCL07D6	You cannot delete full system partition profiles.	
HSCL07D7	You cannot modify the full system partition profile's properties.	None
HSCL07D8	Deleting default profile associations within the current context is not allowed.	This is a customer action. You can delete the default partition profile association only by: <ol style="list-style-type: none"> 1. Deleting the Partition CIMInstance to which the association connects. This will also delete the partition profile CIMInstance to which the association connects the partition. 2. Use createInstance to change the DefaultLparProfile Association to overwrite the previous association you intended to delete.
HSCL07D9	Setting a default profile association is only allowed during create.	This is a customer action. You can alter the DefaultLparProfile Association only through createInstance, which overwrites the previous association.
HSCL07DA	The partition profile used for the operation cannot be found in the profile data.	Verify that you entered the correct information. This is a customer action.
HSCL07DB	An attempt to create a profile failed.	Try the task again.
HSCL07DC	An attempt to modify a profile failed.	Try the task again.

System Profile Error Codes	Message	Recovery Action
HSCL09C6	Could not find the system profile in memory. It may be corrupted. Restore the profile data.	The system profile may be corrupted. <ol style="list-style-type: none"> 1. Perform the Restore Profile Data task. 2. If problem persists, delete and re-create a new system profile. This is a customer action.
HSCL09C7	A system profile named {0} already exists for this managed system in the Hardware Management Console save area. Choose a different name for the new system profile.	Every system profile created for an individual managed system must have a unique name. Choose a different name for the new system profile. This is a customer action. If the problem persists, refer to "Managed System States for the HMC" on page 84 and check the state of the managed system. Perform the appropriate actions to recover.

System Profile Error Codes	Message	Recovery Action
HSCL09C8	Could not open the Copy System Profile dialog. Try again.	<ol style="list-style-type: none"> 1. Try the task again. 2. Log off the HMC, and log back in. 3. Try the task again. <p>This is a customer action. Verify that the customer has performed the appropriate recovery actions.</p>
HSCL09C9	Could not copy the system profile {0}. Try again.	<ol style="list-style-type: none"> 1. Try the task again. 2. Log off the HMC, and log back in. 3. Try the task again. <p>This is a customer action. Verify that the customer has performed the appropriate recovery actions.</p>
HSCL09CA	Could not delete the system profile. Try again.	<ol style="list-style-type: none"> 1. Try the task again. 2. Log off the HMC, and log back in. 3. Try the task again. <p>This is a customer action. Verify that the customer has performed the appropriate recovery actions.</p>
HSCL09CC	Cannot activate a Full System Partition profile when the managed system is powered on with Partition Standby.	Check the status of the Managed System from the properties panel and verify that the system was powered on as Full System Partition. If not in Full System Partition, switch the managed system from Partition Standby to Full System Partition. To switch these power-on options, turn off the power for the managed system. Then, the power on and select Full System Partition during the power-on process.
HSCL09CD	Cannot activate user defined partition profiles when the managed system is powered on with Full System Partition.	Check the status of the managed system from the properties panel and verify that the system was powered-on as Partition Standby. If not in Partition Standby, switch the managed system from Full System partition to Partition Standby. To switch these power-on options, turn off the power to the managed system. Then, turn on the power and select Partition Standby during the power-on process.
HSCL09CE	You cannot have LPAR and affinity LPAR profiles in the same System Profile.	Ensure the system profile contains only profiles that belong to the same partition type. To determine the partition type, select the logical partition and view its properties.
HSCL09CF	Validation of system profile failed. Retry the operation.	Retry the operation. If the problem persists, contact HMC software support.
HSCL09D0	Cannot validate system profile if the managed system is not in ready state.	Retry the operation with the managed system in the Ready state.
HSCL09D1	Cannot validate system when the managed system is powered-on with the Full System Partition	None

Operating System Reset Error Codes	Message	Recovery Action
HSCL0DAE	The Hardware Management Console was unable to successfully issue an Operating System Reset request to the managed system or Logical Partition	<ol style="list-style-type: none"> 1. Try the task again. 2. Perform a Rebuild Managed System operation. Follow the procedures in “Rebuild is Indicated for Managed System” on page 83 to perform this action, then try the task again.
HSCL0DAF	A Hard Operating System Reset can be issued only on a logical partition, not on the managed system.	None
HSCL0DB0	A Soft Operating System Reset can be issued for the managed system when it is in the Ready state only if it was powered on in Full System Partition.	<p>If the managed system was not powered on in Full System Partition, turn off the power to the managed system, and then turn on the power in Full System Partition. If the managed system is in the No-Power state, perform only the power-on operation. The managed system should transition to the Initializing state, then to the Ready state.</p> <p>If the managed system is in the Error state, or No-Communication state, refer to “Managed System States for the HMC” on page 84 and check the state of the managed system. Perform the appropriate actions to recover.</p>
HSCL0DB1	A Soft Operating System Reset can be issued for the managed system only if it is in the Initializing or Ready state.	<p>If the managed system is in the No-Power state, apply power to the system. The managed system should transition to the Initializing state then to the Ready state.</p> <p>If the managed system is in an Error state or No-Communication state, refer to “Managed System States for the HMC” on page 84 and check the state of the managed system. Perform the appropriate actions to recover.</p>
HSCL0DB2	An Operating System Reset can be issued for a logical partition only if the partition is in the Running or Starting state.	<ol style="list-style-type: none"> 1. Refresh the graphical user interface. 2. Try the task again. 3. Perform a Rebuild Managed System operation. Follow the procedures in “Rebuild is Indicated for Managed System” on page 83 to perform this action, then try the task again. <p>This is a customer action.</p>

Virtual Terminal Error Codes	Message	Recovery Action
HSCL0FA1	The managed system's service processor could not open a virtual terminal session.	<ol style="list-style-type: none"> 1. Verify that the managed system is connected and has power. 2. Try the task again. 3. Perform a Rebuild Managed System operation. Follow the procedures in "Rebuild is Indicated for Managed System" on page 83 to perform this action, then try the task again. 4. If the problem persists, call for HMC software support. This is a customer action.
HSCL0FA2	All available virtual terminal sessions have been opened and are in use. To force a new open session, perform a Close Terminal Session operation which frees up the session.	This is a customer action.No virtual terminal sessions are available. Perform a Close Terminal Session to forcefully close an open session and free it up to be opened.
HSCL0FA3	Unable to close the virtual terminal session. Issue a Close Virtual Terminal Connection operation.	<ol style="list-style-type: none"> 1. Perform Backup Critical Data task. 2. Call for HMC software support.
HSCL0FA4	There is no virtual terminal session with session number {0} open.	None

Backup and Restore Error Codes	Message	Recovery Action
HSCL1195	Unable to back up the profile data to the backup file. Try again.	<ol style="list-style-type: none"> 1. Try the task again. 2. Reboot the HMC, and then try the task again. 3. If the operation still fails, call for HMC software support. <p>Verify that the customer has performed the appropriate recovery actions.</p>
HSCL1196	You do not have read access permission on the backup file, {0}. Try the operation again.	<ol style="list-style-type: none"> 1. Try the task again. <p>Verify that the customer has performed the appropriate recovery actions.</p>
HSCL1197	Unable to read the profile data's backup file, {0}. Try the operation again.	<ol style="list-style-type: none"> 1. Try the task again. 2. Reboot the HMC, and then try the task again. <p>Verify that the customer has performed the appropriate recovery actions.</p>
HSCL1198	Cannot find backup file, {0}, for profile data. Select a valid, existing backup file.	<ol style="list-style-type: none"> 1. Try the task again. <p>Verify that the customer has performed the appropriate recovery actions.</p>
HSCL1199	A full restore is not permitted when there are logical partitions in the {0} state. A full restore can only be issued when the managed system was powered on with Partition Standby and there are no partitions running, booting, or in the open firmware state.	<ol style="list-style-type: none"> 1. Verify the managed system was powered-on to run in Partition Standby. 2. Try the task again. <p>Verify that the customer has performed the appropriate recovery actions.</p>

Backup and Restore Error Codes	Message	Recovery Action
HSCL119A	There was an I/O error while backing up the profile data. Try again.	<ol style="list-style-type: none"> 1. Try the task again. 2. Reboot the HMC, and then try the task again. <p>Verify that the customer has performed the appropriate recovery actions.</p>
HSCL119B	The restore profile data operation failed. Try again.	<ol style="list-style-type: none"> 1. Try the task again. 2. Reboot the HMC, and then try the task again. <p>Verify that the customer has performed the appropriate recovery actions.</p>
HSCL119C	Cannot initialize profile data when a partition is in the {0} state and when the managed system is not powered on with Partition Standby, or when there are partitions running, booting, or in the open firmware state.	Cannot initialize the profile data when managed system is not running logical partitions and in the ready state. Also, there should be no partition in running, booting, or open firmware state. This is a customer action.
HSCL119D	Cannot restore the profile data if the managed system is in the {0} state.	<ol style="list-style-type: none"> 1. Verify the managed system is in ready state and running logical partitions or Partition Standby. 2. Try the task again. <p>This is a customer action.</p>
HSCL119E	Cannot initialize the profile data if the managed system is in the {0} state.	<ol style="list-style-type: none"> 1. Verify the managed system is in ready state and running logical partitions or partition standby. 2. Try the task again. <p>This is a customer action.</p>
HSCL119F	The backup file {0} used to restore the profile data is not valid. Its file size ({1}) is not correct. Select a valid backup file.	<p>The backup file selected is not valid. The file may be damaged.</p> <ol style="list-style-type: none"> 1. Try the task again. 2. Select another backup file and try the task again. 3. If the problem persists, call for HMC software support
HSCL11A0	Cannot restore the profile data if the managed system is in the {0} state. The managed system must be in the Ready state and powered on with Partition Standby.	<ol style="list-style-type: none"> 1. Verify the managed system is in ready state and running logical partitions or Partition Standby. 2. Try the task again. <p>This is a customer action.</p>
HSCL11A1	Cannot initialize the profile data if the managed system is in the {0} state. The managed system must be in the Ready state and powered on with Partition Standby.	<ol style="list-style-type: none"> 1. Verify the managed system is in ready state and running logical partitions or partition standby. 2. Try the task again. <p>This is a customer action.</p>

Backup and Restore Error Codes	Message	Recovery Action
HSCL11A2	Could not display the backup dialog for the managed system: {0}. Try again.	<ol style="list-style-type: none"> 1. Try the task again. 2. Log off the HMC, then log back in. 3. Try the task again. <p>This is a customer action. Verify that the customer has performed the appropriate recovery actions.</p>
HSCL11A3	Could not back up the profile data for the managed system: {0} to file: {1}.	<ol style="list-style-type: none"> 1. Refresh the graphical user interface. 2. Try the task again. 3. Reboot the HMC, then try the task again. 4. If the problem persists, call for HMC software support.
HSCL11A4	Cannot back up profile data to the default backup file name: {0}.	Choose a different backup file name. This is a customer action.
HSCL11A5	Could not display the remove backup dialog for the managed system: {0}. Try again.	<ol style="list-style-type: none"> 1. Try the task again. 2. Log off the HMC, and log back in. 3. Try the task again. <p>This is a customer action. Verify that the customer has performed the appropriate recovery actions.</p>
HSCL11A6	Could not remove the backup file {0} from the managed system {1}.	<ol style="list-style-type: none"> 1. Refresh the graphical user interface. 2. Try the task again. 3. Reboot the HMC, then try the task again. 4. If the problem persists, call for HMC software support.
HSCL11A7	No backup file has been selected for the operation. Select a backup file.	This is a customer action.
HSCL11A8	Could not display the restore profile data dialog for the managed system: {0}. Try again.	<ol style="list-style-type: none"> 1. Try the task again. 2. Log off the HMC, then log back in. 3. Try the task again. <p>This is a customer action. Verify that the customer has performed the appropriate recovery actions.</p>
HSCL11A9	Could not initialize the profile data task on the managed system {0}. Refresh the interface and check whether the operation was performed. If not, try the operation again.	Refresh the graphical user interface. Check whether the operation has been performed and displays on the graphical user interface. If not, repeat the operation. If the problem persists, refer to "Managed System States for the HMC" on page 84 and check the state of the managed system. Perform the appropriate actions to recover.

Backup and Restore Error Codes	Message	Recovery Action
HSCL11AA	Could not restore the profile data task on the managed system {0} with backup file {1} of {2} option. Refresh the interface and check whether the operation was performed. If not, try the operation again.	<ol style="list-style-type: none"> 1. Refresh the graphical user interface. 2. Try the task again. 3. Perform a Rebuild Managed System operation. Follow the procedures in "Rebuild is Indicated for Managed System" on page 83 to perform this action, then try the task again. 4. If the problem persists, call for HMC software support.
HSCL11AB	Could not display the recover partition data dialog for the managed system {0}.	<ol style="list-style-type: none"> 1. Try the task again. 2. Log off the HMC, then log back in. 3. Try the task again. <p>This is a customer action. Verify that the customer has performed the appropriate recovery actions.</p>
HSCL11AC	Could not perform the recover partition data task on the managed system {0}.	<ol style="list-style-type: none"> 1. Refresh the graphical user interface. 2. Try the task again. 3. Perform a Rebuild Managed System operation. Follow the procedures in "Rebuild is Indicated for Managed System" on page 83 to perform this action, then try the task again. 4. If the problem persists, call for HMC software support.
HSCL11AD	Could not display the Rebuild the Managed System dialog for the managed system {0}.	None
HSCL11AE	The backup profile data name must start with a numeric or alphabetic character.	Specify the name correctly.
HSCL11AF	The backup profile data name must not contain / \ ' or " characters.	Specify the name correctly.

Utility Class Error Codes	Message	Recovery Action
HSCL138A	Unable to a get the socket connection to the managed system. Shut down and restart the Hardware Management Console.	Shut down and restart the HMC. This is a customer action.
HSCL138C	Unable to find the machine type, model, serial number of this HMC.	Reboot the HMC. This is a customer action.
HSCL138D	Could not release the management framework socket.	Reboot the HMC. This is a customer action.
HSCL138F	Unable to get the Hardware Management Console host name. Check the network settings within the system configuration.	Check the network setting under system configuration, then try the task again. This is a customer action.
HSCL1390	The managed system is not registered in the management framework. Shut down and restart the Hardware Management Console.	Shut down and restart the HMC. This is a customer action.

Utility Class Error Codes	Message	Recovery Action
HSCL1391	The management framework socket is not registered. Make sure to not attempt any operations while the delete, rebuild, or restore profile data tasks are being performed. Perform the Rebuild Managed System task.	<ol style="list-style-type: none"> 1. Make sure not to perform any operation while the Delete, Rebuild and Restore Profile Data tasks are performed. 2. Perform the Rebuild Managed System task. <p>This is a customer action.</p>
HSCL1392	The management framework socket is either deleted or changed. Do not perform any operations while the delete, rebuild, or restore profile data tasks are being performed. Perform the Rebuild Managed System task.	Make sure not to perform any operation while the Delete, Rebuild, and Restore Profile Data tasks are performed. This is a customer action.
HSCL1393	Unable to load the list of IBM PC product names.	<ol style="list-style-type: none"> 1. Reboot the HMC. 2. If the problem persists, call for HMC software support.
HSCL1395	Unable to launch the confirmation dialog. Try again.	<ol style="list-style-type: none"> 1. Refresh the graphical user interface. 2. Try the task again. 3. Perform a Rebuild Managed System operation. Follow the procedures in "Rebuild is Indicated for Managed System" on page 83 to perform this action, then try the task again. 4. If the problem persists, call for HMC software support.
HSCL1396	Unable to initialize the HMC-CSP Version compatibility table.	Retry the operation. If it fails, contact HMC Software Support.
HSCL1397	Unable to determine what version of firmware is loaded on the service processor.	Try the operation again. If it fails, contact HMC Software Support.
HSCL1398	Unable to determine what versions of service processor firmware is compatible with this version of the Hardware Management Console.	Retry the operation. If the error persists, contact HMC software support.

CIMOM Error Codes	Message	Recovery Action
HSCL157F	Cannot find an instance of the object specified.	<ol style="list-style-type: none"> 1. Perform a Rebuild Managed System operation. Follow the procedures in "Rebuild is Indicated for Managed System" on page 83 to perform this action, then try the task again. 2. If the problem persists, call for HMC software support.
HSCL1584	You do not have the proper authorization or permission to perform this task. Log in as the proper user and try again.	Log in with appropriate permissions to perform the task. This is a customer action.
HSCL1585	There was an unknown error while querying the object manager database.	<ol style="list-style-type: none"> 1. Try the task again. 2. Reboot the HMC. 3. If the problem persists, call for HMC software support.

CIMOM Error Codes	Message	Recovery Action
HSCL1586	Cannot find an Instance with object manager of {0}.	<ol style="list-style-type: none"> 1. Perform a Rebuild Managed System operation. Follow the procedures in “Rebuild is Indicated for Managed System” on page 83 to perform this action, then try the task again. 2. If the problem persists, call for HMC software support.

HMC Console Error Codes	Message	Recovery Action
HSCL1771	Unable to create console information and set it with the managed system. Perform the Rebuild Managed System operation.	If the customer has not done so, perform a Rebuild Managed System operation. Follow the procedures in “Rebuild is Indicated for Managed System” on page 83 to perform this action. If the problem persists, check the state of the system and perform the procedures in “Operating States” on page 79 to return the managed system to ready state.
HSCL1772	Could not set Hardware Management Console information. Perform the Rebuild Managed System operation.	If the customer has not done so, perform a Rebuild Managed System operation. Follow the procedures in “Rebuild is Indicated for Managed System” on page 83 to perform this action. If the problem persists, check the state of the system and perform the procedures in “Operating States” on page 79 to return the managed system to ready state.
HSCL1773	Invocation of the Hardware Management Console information method failed. Perform the Rebuild Managed System operation.	If the customer has not done so, perform a Rebuild Managed System operation. Follow the procedures in “Rebuild is Indicated for Managed System” on page 83 to perform this action. If the problem persists, check the state of the system and perform the procedures in “Operating States” on page 79 to return the managed system to ready state.
HSCL1774	Unable to get the defined slot number for Hardware Management Console information slots. Perform the Rebuild Managed System operation.	If the customer has not done so, perform a Rebuild Managed System operation. Follow the procedures in “Rebuild is Indicated for Managed System” on page 83 to perform this action. If the problem persists, check the state of the system and perform the procedures in “Operating States” on page 79 to return the managed system to ready state.
HSCL1775	Could not get host Hardware Management Console information slot ID. Perform the Rebuild Managed System operation.	If the customer has not done so, perform a Rebuild Managed System operation. Follow the procedures in “Rebuild is Indicated for Managed System” on page 83 to perform this action. If the problem persists, check the state of the system and perform the procedures in “Operating States” on page 79 to return the managed system to ready state.

HMC Console Error Codes	Message	Recovery Action
HSCL1776	Could not get the Hardware Management Console information. Perform the Rebuild Managed System operation.	If the customer has not done so, perform a Rebuild Managed System operation. Follow the procedures in "Rebuild is Indicated for Managed System" on page 83 to perform this action. If the problem persists, check the state of the system and perform the procedures in "Operating States" on page 79 to return the managed system to ready state.
HSCL1777	Failed to construct the Hardware Management Console information string. Perform the Rebuild Managed System operation.	If the customer has not done so, perform a Rebuild Managed System operation. Follow the procedures in "Rebuild is Indicated for Managed System" on page 83 to perform this action. If the problem persists, check the state of the system and perform the procedures in "Operating States" on page 79 to return the managed system to ready state.
HSCL177F	Could not delete the Hardware Management Console instance.	<ol style="list-style-type: none"> 1. Perform a Rebuild Managed System operation. Follow the procedures in "Rebuild is Indicated for Managed System" on page 83 to perform this action, then try the task again. 2. Reboot the HMC and then try the task again. 3. If the problem persists, call for HMC software support.

WEBSM/AUIML Error Codes	Message	Recovery Action
HSCL1965	Unable to determine the Hardware Management Console server's host name. Check the Hardware Management Console network settings under System Configuration and verify that they are correct.	Check the HMC Network Settings under System Configuration and verify the settings are correct, and that you have a valid host name for the HMC. Contact your System/Network Administrator for network settings help. This is a customer action.
HSCL1966	You must select one profile for powering on the Full System Partition or select Cancel.	Select a profile from the Power-on window or select Cancel to close the window. This is a customer action.
HSCL1967	You must select one system profile to power on with or select Cancel.	Select a system profile from the window or select Cancel to close the window. This is a customer action.
HSCL1968	You must select a power on option or select Cancel.	Select either Full System Partition or Partition Standby to turn on the power or select Cancel to close the window. This is a customer action.
HSCL1969	Could not retrieve information from the GUI server. Check your network configuration and connection.	Check the HMC network settings under System Configuration and verify the settings are correct. This is a customer action.
HSCL196A	Choose a new default profile from the list or select Cancel.	None

WEBSM/AUIML Error Codes	Message	Recovery Action
HSCL196B	The object is not found in the data area. Please refresh the interface.	<ol style="list-style-type: none"> 1. Perform the refresh task. 2. If the problem persists, call for HMC software support.
HSCL196C	Problem obtaining object information. Please refresh the interface	<ol style="list-style-type: none"> 1. Perform the refresh task. 2. If the same error occurs, perform the rebuild managed system operation. 3. If the problem persists, call for HMC software support.

User Management Error Codes	Message	Recovery Action
HSCL2329	The following characters cannot be used in the login name: space , : () [] ' & ; * \$ "	Specify a login name using valid characters. This is a customer action.
HSCL232A	The user name already exists or may be a user name reserved by the Hardware Management Console. Choose another user name.	User names must be unique. Choose a different user name. This is a customer action.
HSCL232B	The user login name cannot be longer than 32 characters. Choose another login name with less than 32 characters.	Choose a new login name that uses less than 32 characters. This is a customer action.
HSCL232C	The user must have a role. Select a role from the list.	User must have a role assigned. Choose a role from the menu list. This is a customer action.
HSCL232D	Could not modify user's property.	<ol style="list-style-type: none"> 1. Try the task again. 2. If the problem persists, call for HMC software support. <p>This is a customer action.</p>
HSCL232E	Could not create user.	Check to see the create command in debug print. This is a customer action.
HSCL232F	The Hardware Management Console user cannot be deleted.	None
HSCL2330	The new password and confirmation password do not match. Try again.	New password and confirmation password must match. Enter the new password again.
HSCL2331	Change user password failed.	<ol style="list-style-type: none"> 1. Try the task again. 2. If the problem persists, call for HMC software support. <p>This is a customer action.</p>
HSCL2332	The Hardware Management Console user properties cannot be changed.	Cannot change the HMC special user properties. This is a customer action.
HSCL2333	Multiple roles are not allowed. Select only one role from the role list.	Select only one role from the role list. This is a customer action.

User Management Error Codes	Message	Recovery Action
HSCL2334	<p>Cannot create or modify the user due to the following reasons:</p> <ol style="list-style-type: none"> 1. May not be able to locate the file 'rmcadduser' in /opt/hsc/bin directory. 2. May not be able to locate the file "ctrmc.acls" file in /var/ct/cfg directory. 3. Service Focal Point functionality may not be installed. 	<p>This is a customer action. If the problem persists, call for HMC software support.</p>
HSCL2336	<p>The user name is not valid. The user name cannot start with: space, !, @, #, \$, %, ^, &, *, (,), -, +, =.</p>	<p>Specify a user name that contains valid characters. This is a customer action.</p>
HSCL2337	<p>Cannot delete the user due to the following reasons:</p> <ol style="list-style-type: none"> 1. May not be able to locate the file 'rmcremoveuser' in /opt/hsc/bin directory. 2. May not be able to locate the file 'ctrmc.acls' in /var/ct/cfg directory. 3. Service Focal Point functionality may not be installed. 	<p>This is a customer action. If the problem persists, call for HMC software support.</p>
HSCL251E	<p>Failed to set the 'enable remote virtual terminal' option</p>	<ol style="list-style-type: none"> 1. Retry the operation again. 2. If the problem persists, call for HMC software support.
HSCL251F	<p>The following error was encountered: \n{0}\n. Retry the operation.</p>	<ol style="list-style-type: none"> 1. Wait 5-7 minutes. 2. Retry the operation again. 3. Reboot the HMC. 4. If the problem persists, call for HMC software support.
HSCL2726	<p>An affinity LPAR configuration already exists. You must remove this configuration before setting up a new affinity LPAR configuration.</p>	<ol style="list-style-type: none"> 1. Verify that affinity LPARs display on the graphical user interface. If no affinity LPARs can be seen, refresh the console. If the affinity LPARs do not display, rebuild the managed system. 2. Make sure that no affinity logical partitions are in the Running or Initializing state. 3. Remove the existing affinity LPAR configuration. 4. Retry the operation. 5. If problem persists, contact HMC software support.
HSCL2727	<p>The operation failed. It is possible that another user is in the process of creating or updating affinity logical partitions. If this is not the case, restore profile data and retry the operation.</p>	<ol style="list-style-type: none"> 1. Make sure that another user is not in the process of creating or updating affinity LPARs. 2. If another user is not creating affinity LPARs, restore the profile data. Choose the Managed System Priority option, and restore from the file labeled backupFile. 3. Retry the operation.

User Management Error Codes	Message	Recovery Action
HSCL2728	Your partition names are not all unique. No partitions have been created. Make sure that all partition names are different from each other and those of already created partitions.	Try setting up an affinity LPAR configuration again, using unique names for every partition, both LPAR and affinity LPAR.
HSCL2729	Affinity LPAR creation failed. Retry the operation.	<ol style="list-style-type: none"> 1. Ensure affinity partitions do not already exist. 2. Retry the operation.
HSCL272A	An error occurred in partition creation. Default profiles and the system profile may have to be created manually. First, rebuild the managed system, and then create items if needed.	<ol style="list-style-type: none"> 1. Rebuild the managed system. 2. You may have to manually create missing items (default profiles, system profile).
HSCL272B	An error occurred in default profile creation. Default profiles and the system profile will have to be created manually. First rebuild the managed system, and then create the needed items.	<ol style="list-style-type: none"> 1. Rebuild the managed system. 2. Create the missing affinity LPAR default profiles manually. Create a system profile that includes each affinity partition's default profile.
HSCL272D	An error occurred in default profile creation. The system profile will have to be created manually. First rebuild the managed system, and then create the missing system profile.	<ol style="list-style-type: none"> 1. Rebuild the managed system. 2. Create a system profile that includes each affinity partition's default profile.
HSCL272E	An unknown error occurred during partition creation.	<ol style="list-style-type: none"> 1. Retry the operation. 2. If the problem persists, contact HMC software support.
HSCL272F	An error occurred in partition creation. Affinity partitions have been created, but default profiles and the system profile may have to be created manually. First, recover partition data, and then create items if needed.	<ol style="list-style-type: none"> 1. Recover partition data - choose the Restore option. 2. Manually create any missing affinity LPAR items.
HSCL2730	Unable to get the resources of the partition since it is not an affinity logical partition	<ol style="list-style-type: none"> 1. Retry the task. 2. Rebuild the managed system.
HSCL2731	The addition of affinity logical partitions exceeds the maximum limit. Delete other partitions and retry the task.	Delete enough logical partitions to satisfy limit requirements and then retry the task.
HSCL2734	Cannot create only one affinity logical partition.	The user must create as many affinity LPAR partitions as resources will allow at the same time. To create an affinity LPAR configuration, use the Affinity Partition option.
HSCL2735	Cannot delete only one affinity logical partition.	The user must delete all affinity LPAR partitions at the same time. To delete an affinity LPAR configuration, use the Affinity Partition option.
HSCL2736	The update operation cannot be performed since there are no affinity logical partitions	<ol style="list-style-type: none"> 1. Refresh the interface and check if affinity logical partitions exist. If so, retry the operation. 2. If the problem persists, call HMC software support.

User Management Error Codes	Message	Recovery Action
HSCL2737	The operation failed since the update parameter is invalid.	<ol style="list-style-type: none"> 1. Retry the task. 2. If the problem persists, call HMC software support.
HSCL2738	The operation failed since the cluster size parameter is invalid.	<ol style="list-style-type: none"> 1. Retry the task. 2. If the problem persists, call HMC software support.
HSCL2739	The update operation failed since the hardware resources have not changed.	<ol style="list-style-type: none"> 1. If the hardware resources (processor and memory) have changed, retry the task. 2. If the problem persists, call the HMC software support.
HSCL273A	The managed system is not affinity LPAR capable.	None. If you are certain that the managed system is or should be affinity LPAR-capable, contact software support.
HSCL273B	The managed system cannot handle the creation of partitions with the specified cluster size.	None. If you are certain that the managed system supports partitions of the specified cluster size, contact software support.
HSCL273C	Affinity LPAR deletion failed. Rebuild the managed system and retry the operation.	<ol style="list-style-type: none"> 1. Rebuild the managed system. 2. Retry the operation. 3. If problem persists, contact HMC software support.
HSCL273D	Deletion of affinity logical partitions failed. Recover partition data and retry the operation.	<ol style="list-style-type: none"> 1. Recover partition data - choose the Restore option. 2. Retry the operation. 3. If problem persists, contact HMC software support.
HSCL273E	Deletion of partition {0} failed. The partition cannot be deleted in the Running or Initializing state. Stop the partition and retry the task.	<ol style="list-style-type: none"> 1. Make sure that all partitions are stopped. 2. Retry the deletion operation.
HSCL2901	This partition is not capable of adding, removing, or moving processors dynamically.	If you know that this partition is capable of processor DLPAR operations, make sure the managed system is powered on, then wait and retry the task. If this does not work, rebuild the managed system, or reboot the HMC if necessary. Contact your representative for more information about this feature.
HSCL2902	The destination partition is not capable of adding, removing, or moving processors dynamically.	If you know that this partition is capable of processor DLPAR operations, make sure the managed system is powered on, then wait and retry the task. If this does not work, rebuild the managed system, or reboot the HMC if necessary. Contact your representative for more information about this feature.
HSCL2903	Your processor request goes below the profile's Required processor limit. You can remove or move {0} or fewer processors. Retry the operation.	Retry the operation, entering a smaller number of processors.

User Management Error Codes	Message	Recovery Action
HSCL2904	Your processor request exceeds the profile's Maximum processor limit. You can add or move up to {0} processors. Retry the operation.	Retry the operation, entering a smaller number of processors.
HSCL2905	This partition is not capable of adding, removing, or moving memory dynamically.	If you know that this partition is capable of DLPAR memory operations, make sure the managed system is powered on, then wait and retry the task. If this does not work, rebuild the managed system, or reboot the HMC if necessary. Contact your representative for more information about this feature.
HSCL2906	The destination partition is not capable of adding, removing, or moving memory dynamically.	If you know that this partition is capable of DLPAR memory operations, make sure the managed system is powered on, then wait and retry the task. If this does not work, rebuild the managed system, or reboot the HMC if necessary. Contact your representative for more information about this feature.
HSCL2907	Your memory request exceeds the profile's Maximum memory limit. You can add or move up to {0} MBs of memory. Retry the operation.	<ol style="list-style-type: none"> 1. Retry the task and request a smaller memory amount. 2. Reset the partition, then reactivate the partition and then retry the operation. 3. If the problem persists, contact your software support representative.
HSCL2908	Your memory request goes below the the profile's Minimum memory limit. You can remove or move up to {0} MB of memory. Retry the operation.	<ol style="list-style-type: none"> 1. Retry the task and request a smaller memory amount. 2. Reset the partition, then reactivate the partition and then retry the operation. 3. If the problem persists, contact your software support representative.
HSCL2909	Your memory request exceeds the total available memory of the managed system. You can add up to {0} MB of memory. Retry the operation.	<ol style="list-style-type: none"> 1. Check the available memory of the managed system, then retry the task and request a smaller memory amount. 2. Reset the partition, then reactivate the partition and then retry the operation. 3. If the problem persists, contact your software support representative.
HSCL290B	This partition is not capable of adding, removing, or moving I/O slots dynamically.	If you know that this partition is capable of DLPAR memory operations, make sure the managed system is powered on, then wait and retry the task. If the problem persists, rebuild the managed system, or reboot the HMC if necessary. Contact your representative for more information about this feature.

User Management Error Codes	Message	Recovery Action
HSCL290C	The destination partition is not capable of adding, removing, or moving I/O slots dynamically.	If you know that this partition is capable of DLPAR memory operations, make sure the managed system is powered on, then wait and retry the task. If the problem persists, rebuild the managed system, or reboot the HMC if necessary. Contact your representative for more information about this feature.
HSCL290D	Since the managed system is not capable of dynamic logical partitioning, you cannot unassign resources.	None
HSCL290E	Since the managed system is not capable of dynamic logical partitioning, you cannot correct requested memory values.	None
HSCL290F	The partition cannot be activated because there are not enough free processors to satisfy the partition's requirements. However, there are stopped processors available which are still assigned to running partitions that you may unassign.	Attempt to restore the lost processors. For more information, see "Restoring Processor Resources" on page 81. When you are finished, try to activate partition again.
HSCL2907	Your memory request exceeds the profile's Maximum memory limit. You can add or move up to {0} MB's of memory. Retry the operation.	<ol style="list-style-type: none"> 1. Retry the task with the smaller amount of memory. 2. Reset the partition and reactivate the partition and then retry the task. 3. If problem persists, call software support.
HSCL2908	Your memory request goes below the the profile's Minimum memory limit. You can remove or move up to {0} MB of memory. Retry the operation.	<ol style="list-style-type: none"> 1. Retry the task with the smaller amount of memory. 2. Reset the partition and reactivate the partition and then retry the task. 3. If problem persists, call software support.
HSCL2909	Your memory request exceeds the total available memory of the managed system. You can add up to {0} MB of memory. Retry the operation.	<ol style="list-style-type: none"> 1. Check the available memory of the managed system and retry the task with a smaller amount of memory. 2. Reset the partition and reactivate the partition and then retry the task. 3. If problem persists, call software support.
HSCL2910	The partition cannot be activated because there are not enough free adapters to satisfy the partition's requirements. However, there are stopped adapters available which are still assigned to running partitions that you may unassign.	Attempt to restore lost adapters. For more information, see "Restoring Adapter Resources" on page 82. When you are finished, activate the partition again.
HSCL2911	The partition cannot be activated because there is not enough available system memory to satisfy the profile's required amount. However, there is some memory available which was requested by running partitions but is not being used that you may unassign.	Correct the requested memory value. For more information, see "Restoring Memory Resources" on page 82. When you are finished, activate the partition again.
HSCL3001	LED operations are not supported with this CSP version. For LED operations, please upgrade to CSP version 3.0 or greater.	To upgrade to a later version of CSP, contact your service representative.

User Management Error Codes	Message	Recovery Action
HSCL3002	The LED operation failed.	Retry the operation. If the problem persists, contact hardware support.
HSCL3051	An error occurred during frame initialization. Not all I/O may have been powered on. Retry the operation.	Retry the operation. If the problem persists, contact HMC software support.
HSCL3052	An error occurred during frame initialization. Not all managed systems could be powered on. Retry the operation.	Retry the operation. If the problem persists, contact HMC software support
HSCL3053	An unknown error occurred during frame initialization. Retry the operation.	Retry the operation. If the problem persists, contact HMC software support.
HSCL3054	An error occurred during frame initialization. Retry the operation.	Retry the operation. If the problem persists, contact HMC software support.
HSCL3055	An error occurred while deactivating CSPs. Retry the operation.	Retry the operation. If the problem persists, contact HMC software support.
HSCL3056	An error occurred during the pinhole reset. Retry the operation.	Retry the operation. If the problem persists, contact HMC software support.
HSCL3057	An error occurred while deactivating I/O drawers. Retry the operation.	Retry the operation. If the problem persists, contact HMC software support.
HSCL3058	Frame information retrieval failed. Retry the operation.	Retry the operation. If the problem persists, contact HMC software support.
HSCL3059	The refresh operation failed. Retry the operation.	Retry the operation. If the problem persists, contact HMC software support.
HSCL305A	The wrong number of cages was received. The I/O cages must be specified in pairs. Retry the operation.	Retry the operation, specifying the adapter drawers in pairs. There should be an even number of drawers specified. If the problem persists, contact HMC software support.
HSCL305B	The list of I/O drawers to deactivate was not sent correctly. Please send the cage numbers of the I/O drawers in pairs.	Retry the operation, sending the cage numbers of the adapter drawers in pairs.
HSCL3200	Unknown lock error.	Contact HMC software support.
HSCL3201	Invalid lock type.	Contact HMC software support.
HSCL3202	Failed to acquire lock because of timeout.	Retry the operation. If the problem persists, contact HMC software support.
HSCL3203	Illegal nested lock type requested.	Contact HMC software support.
HSCL3204	Lock not held.	Contact HMC software support.

Platform Management Error Codes	Message	Recovery Action
HSCP0001	The Backup Critical Data request completed successfully.	None
HSCP0002	Please make sure that the media is inserted properly in the drive and retry the operation.	Verify that the media is inserted correctly in the drive and try the operation again.
HSCP0003	The Backup Critical Data request failed.	Internal HMC Error. 1. Perform Backup Critical Data task. 2. Call for HMC software support.

Platform Management Error Codes	Message	Recovery Action
HSCP0004	The media is write protected. Remove the write protection and retry the operation.	Remove the write protection and try the operation again.
HSCP0005	The Backup Critical Data request is in progress. Please wait.	None
HSCP0010	The Format Removable Media request completed successfully.	None
HSCP0011	Please make sure the media is inserted properly in the drive and retry the operation.	None
HSCP0012	The media is write protected. Remove the write protection and retry the operation.	None
HSCP0013	An unknown error occurred. Replace the media and retry the operation.	Replace the media and try the operation again. If the error persists, call for HMC software support.
HSCP0014	The Format Removable Media request failed.	<ol style="list-style-type: none"> 1. Verify that the removable media is properly inserted in the drive and try the operation again. 2. Try the operation with different media. 3. Run PC Doctor to determine if there is a problem with the hardware. 4. If the error persists, call for HMC software support.
HSCP0015	Please wait while the media is being formatted.	None
HSCP0020	The Save Upgrade Data request completed successfully.	None
HSCP0021	The Save Upgrade Data request failed.	<ol style="list-style-type: none"> 1. Verify that the removable media is properly inserted in the drive and try the operation again. 2. Try the operation with different media. 3. Run PC Doctor to determine if there is a problem with the hardware. 4. If the problem persists, call for HMC software support.
HSCP0022	The Save Upgrade Data request failed. Ensure the removable media is properly inserted in the drive.	Verify the removable media is properly inserted in the drive and try the operation again. If the error persists, call for HMC software support.
HSCP0023	The media is write protected. Remove the write protection and retry the operation.	None
HSCP0024	An error occurred while copying the upgrade data. Ensure the removable media is properly inserted in the drive and retry the operation.	Verify the removable media is properly inserted in the drive and try the operation again. If the error persists, call for HMC software support.

Platform Management Error Codes	Message	Recovery Action
HSCP0025	An error occurred while compressing the upgrade data. Please retry the operation.	<ol style="list-style-type: none"> 1. Verify that the removable media is properly inserted in the drive and try the operation again. 2. Try the operation with different media. 3. Run PC Doctor to determine if there is a problem with the hardware. 4. If the problem persists, call for HMC software support.
HSCP0026	An error occurred while trying to mount the media. Ensure the removable media is properly inserted in the drive.	<ol style="list-style-type: none"> 1. Verify that the removable media is properly inserted in the drive and try the operation again. 2. Try the operation with different media. 3. Run PC Doctor to determine if there is a problem with the hardware. 4. If the problem persists, call for HMC software support.
HSCP0027	An error occurred while trying to unmount the media.	<ol style="list-style-type: none"> 1. Verify that the removable media is properly inserted in the drive and try the operation again. 2. Try the operation with different media. 3. Run PC Doctor to determine if there is a problem with the hardware. 4. If the problem persists, call for HMC software support.
HSCP0028	An error occurred while creating the list of files to save.	<ol style="list-style-type: none"> 1. Verify that the removable media is properly inserted in the drive and try the operation again. 2. Try the operation with different media. 3. Run PC Doctor to determine if there is a problem with the hardware. 4. If the problem persists, call for HMC software support.
HSCP0029	An error occurred while instantiating the save upgrade data target class.	<ol style="list-style-type: none"> 1. Verify that the removable media is properly inserted in the drive and try the operation again. 2. Try the operation with different media. 3. Run PC Doctor to determine if there is a problem with the hardware. 4. If the problem persists, call for HMC software support.
HSCP0030	An error occurred while attempting to create the restore trigger file.	<ol style="list-style-type: none"> 1. Verify that the removable media is properly inserted in the drive and try the operation again. 2. Try the operation with different media. 3. Run PC Doctor to determine if there is a problem with the hardware. 4. If the problem persists, call for HMC software support.

Platform Management Error Codes	Message	Recovery Action
HSCP0040	The corrective service file was successfully downloaded to this system console. Press OK to continue and install this update.	None
HSCP0041	The corrective service file was successfully applied. Please quiesce the system console and reboot for the changes to take effect.	None
HSCP0042	An unrecoverable error occurred during the corrective service file download. Retry the operation. If the operation fails again, contact your support representative.	Try the operation again. If the error persists, call for HMC software support.
HSCP0043	An unrecoverable error occurred during the corrective service installation. Retry the operation. If the operation fails again, contact your service representative.	Try the operation again. If the error persists, call for HMC software support.
HSCP0044	The removable media cannot be mounted. Please make sure the media is inserted properly in the drive and retry the operation.	<ol style="list-style-type: none"> 1. Verify that the removable media is properly inserted in the drive and try the operation again. 2. Try the operation with different media. 3. Run PC Doctor to determine if there is a problem with the hardware. 4. If the error persists, call software support.
HSCP0045	The corrective service data is corrupt. Please ensure the correct media is inserted properly in the drive and retry the operation.	Verify the removable media is properly inserted in the drive and try the operation again. If the error persists, call for HMC software support.
HSCP0046	An error occurred while attempting to remotely connect to the server. Please try the operation again. If the operation fails again, contact your service representative.	Verify that the remote site is operational and try the operation again. If the error persists, call for HMC software support.
HSCP0047	An error occurred while downloading the corrective service file. Please try the operation again. If the operation fails again, contact your service representative.	Verify that the remote site is operational and try the operation again. If the error persists, call for HMC software support.
HSCP0048	An unknown error occurred. Retry the operation. If the operation fails again, contact your support representative.	Try the operation again. If the error persists, call for HMC software support.
HSCP0049	The Install Corrective Service request is in progress. Please wait.	None
HSCP0060	The Customize Date/Time request completed successfully.	None
HSCP0061	The Customize Date/Time request failed.	<ol style="list-style-type: none"> 1. Verify that the removable media is properly inserted in the drive and try the operation again. 2. Try the operation with different media. 3. Run PC Doctor to determine if there is a problem with the hardware. 4. If the problem persists, call for HMC software support.

Platform Management Error Codes	Message	Recovery Action
HSCP0070	Please enter an integer value between 1 and 99.	None
HSCP0080	There are no system events.	None
HSCP0081	Unable to display the log data.	<ol style="list-style-type: none"> 1. Verify that the removable media is properly inserted in the drive and try the operation again. 2. Try the operation with different media. 3. Run PC Doctor to determine if there is a problem with the hardware. 4. If the problem persists, call for HMC software support.
HSCP0082	Unable to retrieve log data.	<ol style="list-style-type: none"> 1. Verify that the removable media is properly inserted in the drive and try the operation again. 2. Try the operation with different media. 3. Run PC Doctor to determine if there is a problem with the hardware. 4. If the problem persists, call for HMC software support.
HSCP0083	An error occurred while processing the exit request.	<ol style="list-style-type: none"> 1. Verify that the removable media is properly inserted in the drive and try the operation again. 2. Try the operation with different media. 3. Run PC Doctor to determine if there is a problem with the hardware. 4. If the problem persists, call for HMC software support.
HSCP0090	Cannot check both the 'Export default gateway' and 'Silent' options for 'routed'.	Select either the Export default gateway or Silent for the Routed options.
HSCP0091	You may need to reboot for all Network Settings changes to take effect.	Restart the HMC.

Service Focal Point Error Codes	Message	Recovery Action
HSCS0001	Unable to access RMC to obtain Serviceable Events.	The HMC could not retrieve the serviceable events. Wait and try the previous function again. If error continues, shut down and restart the HMC. If the error persists, call for HMC software support.
HSCS0002	Unable to process request.	The HMC could not process your request. Wait and try the previous function again. If error continues, shut down and restart the HMC. If the error persists, call for HMC software support.

Service Focal Point Error Codes	Message	Recovery Action
HSCS0003	Unable to update the attribute on the Serviceable Event.	The HMC could not process your request to make changes to the Serviceable Event. Wait and try the previous function again. If error continues, shut down and restart the HMC. If the error persists, call for HMC software support.
HSCS0004	Unable to locate Serviceable Event to update.	The HMC could not locate the Serviceable Event you are trying to view or update. It may have expired or otherwise been closed. Exit the Select Serviceable Event dialog and retry.
HSCS0005	Function Failed: Error occurred attempting to display a Serviceable Event panel.	The HMC was unable to locate or launch a window you have requested. This is an internal HMC error. 1. Perform Backup Critical Data task. 2. Call for HMC software support.
HSCS0006	This Serviceable Event may contain more information that this version of the HMC can display. You may wish to upgrade your HMC to the latest version.	To see Serviceable Event data made available in more recent HMC versions, upgrade this HMC to the most recent version, or switch to an HMC that has already been upgraded.
HSCS0008	Function Failed: An error occurred when retrieving machine names.	Not all functions may be operating. Wait and try the previous function again. If error continues, shut down and restart the HMC. If the error persists, call for HMC software support.
HSCS0020	Function Failed: An error occurred when launching the Service Focal Point Settings panel.	Not all functions may be operating. Wait and try the previous function again. If error continues, shut down and restart the HMC. If the error persists, call for HMC software support.
HSCS0021	Function Failed: Error occurred getting information to display the Service Focal Point settings.	Not all functions may be operating. Wait and try the previous function again. If error continues, shut down and restart the HMC. If the error persists, call for HMC software support.
HSCS0022	Function Failed: An error occurred when updating Service Focal Point settings.	Not all functions may be operating. Wait and try the previous function again. If error continues, shut down and restart the HMC. If the error persists, call for HMC software support.
HSCS0023	Function Failed: Error occurred processing button for the Service Focal Point Settings Panel.	Not all functions may be operating. Wait and try the previous function again. If error continues, shut down and restart the HMC. If the error persists, call for HMC software support.
HSCS0024	Function Failed: Error occurred processing sort for the Service Focal Point Settings Panel.	Not all functions may be operating. Wait and try the previous function again. If error continues, shut down and restart the HMC. If the error persists, call for HMC software support.

Service Focal Point Error Codes	Message	Recovery Action
HSCS0025	Function Failed: Error occurred processing Double Click for the Service Focal Point Settings Panel.	Not all functions may be operating. Wait and try the previous function again. If error continues, shut down and restart the HMC. If the error persists, call for HMC software support.
HSCS0026	Service Focal Point settings have been saved successfully.	None.
HSCS0032	Function Failed: An error occurred when updating Extended Error Enable/Disable settings.	Not all functions may be operating. Wait and try the previous function again. If error continues, shut down and restart the HMC. If the error persists, call for HMC software support.
HSCS0040	New FRU Location Code and Part Number must be entered.	Enter the requested Location Code and Part Number.
HSCS0041	A New FRU Part Number must be entered.	Enter the requested Part Number.
HSCS0042	There was nothing to apply.	There were no changes to the FRU list to be added to the Serviceable Event.
HSCS0043	The No FRUs to Update box was checked but there are updated FRUs in the in the pending table. If there are no FRUs to update, remove the ones from the pending table. If you want to update the FRUs from the pending table, uncheck the check box.	None
HSCS0044	The No FRUs to Update box was unchecked and there are no updated FRUs in the in the pending table. If there are no FRUs to update, check the check box to indicate this.	None
HSCS0045	Function Failed: An error occurred when updating FRU information for the Serviceable Event.	Not all functions may be operating. Wait and try the previous function again. If error continues, shut down and restart the HMC. If the error persists, call for HMC software support.
HSCS0046	Function Failed: An error occurred when attempting to remove an item from the list.	Not all functions may be operating. Wait and try the previous function again. If error continues, shut down and restart the HMC. If the error persists, call for HMC software support.
HSCS0047	Function Failed: An error occurred when attempting to Close the Serviceable Event	Not all functions may be operating. Wait and try the previous function again. If error continues, shut down and restart the HMC. If the error persists, call for HMC software support.
HSCS0048	Function Failed: An error occurred when adding FRU information for the Serviceable Event.	Not all functions may be operating. Wait and try the previous function again. If error continues, shut down and restart the HMC. If the error persists, call for HMC software support.
HSCS0049	Function Failed: An error occurred when processing the panel.	Not all functions may be operating. Wait and try the previous function again. If error continues, shut down and restart the HMC. If the error persists, call for HMC software support.

Service Focal Point Error Codes	Message	Recovery Action
HSCS0050	Function Failed: An error occurred when launching panel.	Not all functions may be operating. Wait and try the previous function again. If error continues, shut down and restart the HMC. If the error persists, call for HMC software support.
HSCS0060	Cannot change state from Unknown for machine	The requested machine state is not allowed at this time. Close and then restart the Enable/Disable windows for updated machine information.
HSCS0061	Insert scratch diskette number {0} of {1}.	Insert a scratch diskette and select the appropriate button.
HSCS0062	Insert DVD cartridge and press the {0} button.	Insert a formatted DVD cartridge and push the appropriate button.
HSCS0064	No extended error data available.	Select a serviceable event that has extended error data associated with it.
HSCS0065	Error writing to floppy diskette: {0}	Make sure there is a floppy diskette in the diskette drive. Try the operation again.
HSCS0066	Error writing to DVD cartridge: {0}	Make sure there is a formatted DVD cartridge in the DVD drive. Try the operation again.
HSCS0067	Error reading extended error data: {0}	Not all functions may be operating. Wait and try the previous function again. If error continues, shut down and restart the HMC. If the error persists, call for HMC software support.
HSCS0068	Error creating temporary file: {0}	<ol style="list-style-type: none"> 1. Verify that the removable media is properly inserted in the drive and try the operation again. 2. Try the operation with different media. 3. Run PC Doctor to determine if there is a problem with the hardware. 4. If the problem persists, call for HMC software support.
HSCS0069	Error writing to temporary file: {0}	<ol style="list-style-type: none"> 1. Verify that the removable media is properly inserted in the drive and try the operation again. 2. Try the operation with different media. 3. Run PC Doctor to determine if there is a problem with the hardware. 4. If the problem persists, call for HMC software support.
HSCS0070	Error formatting floppy diskette: {0}	Make sure there is a floppy diskette in the diskette drive. Try the operation again.
HSCS0071	Extended error data has been saved successfully.	None
HSCS0072	The saving of extended error data has been canceled.	No action. The operation was cancelled as a result of your request.

Service Focal Point Error Codes	Message	Recovery Action
HSCS0080	Error encountered while getting the partition information.	Not all functions may be operating. Wait and try the previous function again. If error continues, shut down and restart the HMC. If the error persists, call for HMC software support.
HSCS0081	Error encountered while reading the partition information.	Not all functions may be operating. Wait and try the previous function again. If error continues, shut down and restart the HMC. If the error persists, call for HMC software support.
HSCS0082	Error encountered while getting the extended error data.	Not all functions may be operating. Wait and try the previous function again. If error continues, shut down and restart the HMC. If the error persists, call for HMC software support.
HSCS0083	Unexpected error encountered while saving the extended error data.	<ol style="list-style-type: none"> 1. Verify that the removable media is properly inserted in the drive and try the operation again. 2. Try the operation with different media. 3. Run PC Doctor to determine if there is a problem with the hardware. 4. If the problem persists, call for HMC software support.
HSCS0084	Error encountered while attempting to call home with the extended error information.	Not all functions may be operating. Wait and try the previous function again. If error continues, shut down and restart the HMC. If the error persists, call for HMC software support.
HSCS0085	Error encountered while attempting to call home with the extended error information. The call program returned a value of {0}.	Not all functions may be operating. Wait and try the previous function again. If error continues, shut down and restart the HMC. If the error persists, call for HMC software support.
HSCS0086	Request to call home the extended error information has been successfully submitted. See the Service Agent application to monitor the progress of the request.	The operation was successful. Use the Service Agent application to monitor the progress of the request.
HSCS0087	Error encountered while attempting to call home the Serviceable Event.	Not all functions may be operating. Wait and try the previous function again. If error continues, shut down and restart the HMC. If the error persists, call for HMC software support.
HSCS0088	Error encountered while attempting to call home the Serviceable Event. The callsa program returned a value of {0}.	Not all functions may be operating. Wait and try the previous function again. If error continues, shut down and restart the HMC. If the error persists, call for HMC software support.
HSCS0089	Request to call home the Serviceable Event has been successfully submitted. See the Service Agent application to monitor the progress of the request.	Not all functions may be operating. Wait and try the previous function again. If error continues, shut down and restart the HMC. If the error persists, call for HMC software support.

Service Focal Point Error Codes	Message	Recovery Action
HSCS0090	Unexpected return code encountered while creating a temporary packaging file: {0}	Not all functions may be operating. Wait and try the previous function again. If error continues, shut down and restart the HMC. If the error persists, call for HMC software support.
HSCS0096	No items selected when button was pressed.	Not all functions may be operating. Wait and try the previous function again. If error continues, shut down and restart the HMC. If the error persists, call for HMC software support.
HSCS0100	Please wait while the extended error data is being saved.	The extended error data is being saved to the appropriate removable media.
HSCS0101	Error writing to DVD cartridge.	Ensure there is a formatted DVD cartridge in the DVD drive. Try the operation again.
HSCS0102	Error unmounting DVD cartridge after writing data successfully.	Ensure there is a formatted DVD cartridge in the DVD drive. Try the operation again.
HSCS0103	DVD drive is already mounted.	None
HSCS0104	The LED request did not complete successfully.	<ol style="list-style-type: none"> 1. Retry the task. 2. Log off and then back in to the HMC interface. 3. Reboot the HMC. 4. If the problem persists, call HMC software support.
HSCS0105	The LED request completed successfully.	None.
HSCS0106	Function failed: An error occurred attempting to display the LED Management panel.	<ol style="list-style-type: none"> 1. Retry the task. 2. Log off and then back in to the HMC interface. 3. Reboot the HMC. 4. If the problem persists, call HMC software support.
HSCS0122	Function failed: An error occurred attempting to display the Hardware Services panel.	<ol style="list-style-type: none"> 1. Retry the task. 2. Log off and then back in to the HMC interface. 3. Reboot the HMC. 4. If the problem persists, call HMC software support.
HSCS0123	The System Attention LED for the selected machine is not supported. The system LED will not be activated	None.
HSCS0124	The Identify LED for the selected FRU is not supported. The FRU LED will not be activated.	None.

Virtual Terminal Errors

When using a virtual terminal (VTERM), you might see an error code displayed in the bottom-left corner of the VTERM window. The following table lists the error codes and the recovery actions for each.

Virtual Terminal (VTERM) Error Codes	Message	Recovery Action
Comm 654	The virtual terminal server is unable to process this type of request. An unknown error occurred during virtual terminal device-type negotiations.	If the error persists, contact the system administrator for help.
Comm 655	The socket connection to the Virtual Terminal server has been established and the session is waiting for negotiation to finish.	If the error persists, contact the system administrator for help.
Comm 657	The session is in the process of establishing the TCP/IP connection to the virtual terminal server. When you close a session that displays COMM 657, there may be some delay before it closes.	The delay varies. You can close the browser.
Comm 658	The session is initializing the TCP/IP connection to the HMC.	If the error persists, contact the system administrator for help.
Comm 659	The Virtual Terminal TCP connection to the session has not succeeded or has failed.	<ul style="list-style-type: none"> • The TCP/IP connection to the virtual terminal server could not be established. • You clicked Disconnect on the Communication menu. • The virtual terminal server closed the TCP/IP connection either by application control or because it detected an error.

Operating States

In the Contents area, an operating state is listed next to your managed system. This section describes what each of these states mean, and the actions you should take to recover.

Managed System Operating States: The following operating states apply to the managed system itself.

State	Description	Recovery Action
<i>Initializing</i>	The managed system is powered on and is initializing.	Wait for initialization to complete. Initialization can take up to an hour, depending on the managed system's hardware and boot configuration.
<i>Ready</i>	The managed system is powered on and functioning normally.	None
<i>No Power</i>	The managed system is powered off.	None
<i>Error</i>	The managed system's operating system or hardware is experiencing errors.	If the managed system is set up to run as a Full System Partition, the system will also indicate an Error state. Read the managed system operator panel.
<i>Incomplete</i>	The HMC cannot gather complete partition, profile, and resource information from the managed system.	In the Contents area, highlight the managed system icon and select Rebuild the Managed System from the menu.

State	Description	Recovery Action
<i>No Connection</i>	HMC cannot contact the managed system.	<ol style="list-style-type: none"> 1. Delete the managed system from the Navigation area by highlighting the managed system icon and selecting Delete from the menu. 2. Follow the instructions to delete the managed system from the Navigation area. 3. Reconnect to the managed system by checking that the cable connections are secure.
<i>Recovery</i>	The partition and profile data stored in the managed system is corrupted.	<p>In the Contents area, select the managed system icon and choose Recover Partition Data from the menu.</p> <ul style="list-style-type: none"> • If you want to restore the data from a backup, select Restore from the menu. If your system is not currently powered on in Partition Standby, restoring data can take up to an hour. When the data is restored, the managed system powers on to Partition Standby. <p>OR</p> <ul style="list-style-type: none"> • If you do not want to restore data from a backup source, select Initialize from the menu.
<i>Version Mismatch</i>	Your managed system's service processor level is higher than your HMC's code level.	Contact your service representative to upgrade your HMC's level so that the levels match.
<i>CUoD CTA</i>	You must accept the CUoD license.	<p>To accept the license, do any of the following:</p> <ul style="list-style-type: none"> • When you boot the HMC and managed system, click Accept on the License Agreement window. • If you have already booted the HMC and managed system, select the managed system in the Contents area. Select CUoD → Accept License. Click Accept. • Power off the managed system, remove all CUoD resources from the managed system, and then power your managed system back on again.

Partition Operating States: The following operating states describe the logical partition you have created.

State	Description	Recovery Action
<i>Ready</i>	The partition is not yet active but is ready for activation.	None
<i>Starting</i>	The partition is activated and is going through its booting routines.	None
<i>Running</i>	The partition has finished its booting routines. The operating system can be performing its booting routines or is in its normal running state.	None

State	Description	Recovery Action
<i>Error</i>	Activation of this partition failed due to a hardware or operating system error.	Select the partition and choose the Read Boot Error Value task from the menu to see the reasons for the activation failure. "Boot Error Values" on page 85 You can also try to activate the partition again.
<i>Not Available</i>	This partition is not available for use. Reasons can include: <ul style="list-style-type: none"> • The managed system is powered off. • The Full System Partition is not available when the managed system is powered on with the Partition Standby power-on option. • Logical partitions are not available when the managed system is powered on with the Full System Partition power-on option. • Affinity partitions are not available when the managed system is powered on and non-affinity partitions are activated first. • Non-affinity partitions are not available when the managed system is powered on and affinity partitions are powered on first. 	Turn on the power to the managed system and select either Full System Partition or Partition Standby during the power-on process.
<i>Open Firmware</i>	The partition was activated by a profile that specified an OPEN_FIRMWARE boot mode.	None

Restoring Partition Resources

This section has procedures to help you restore partition resources that are stopped but are still assigned to a partition, as a result of a failed dynamic logical partitioning operation. These resources are lost, or are unusable by any other partition until they have been unassigned.

Restoring Processor Resources: When you are dynamically adding processor resources to a partition, the HMC determines if there are any stopped processors in a running partition. If the HMC finds stopped, unused processors, a **Processor Information** button appears on the window. When you click this button, the **Processor Recovery** window opens. This window displays each stopped processor's states, statuses, and the partitions to which they are currently assigned.

If no partition is performing dynamic logical partitioning processor operations, you can unassign stopped processors from their partitions and release them for system use.

Note: If another user is currently performing a dynamic logical partitioning processor operation on any partition, and you unassign stopped processors from that partition, that user's dynamic logical partitioning operation will fail.

To unassign stopped processors, do the following:

1. Log in to the HMC, using either the System Administrator or Advanced Operator roles.
2. In the Navigation area, click the console's icon to expand the tree.
3. In the Navigation area, click the **Server and Partition** folder.
4. In the Contents area, click the **Server Management** icon.
5. In the Contents area, click the managed system's icon to expand the tree.
6. Select the partition to which you want to add the processors.
7. From the Selected menu, select **Dynamic Logical Partitioning**.
8. Select **Processors**.
9. The **Dynamic Logical Partitioning** window opens. Click **Add resources to this partition**.

10. If the **Processor Information** button appears underneath the **Number of CPUs to add** field, the HMC has discovered stopped processors on running partitions that you might be able to unassign, or that are release for system use. If the **Processor Information** button appears, click it. If it does not, you do not have processor resources to restore.
11. The **Restore Processors** window opens. This window displays each lost processor, along with the processor's state, status, and partition assignment. Select the processor you want to release and click **Unassign**. The processors you selected are then unassigned and released for other partitions to use.

Restoring Adapter Resources: When you are dynamically adding adapter resources to a partition, the HMC determines if there are any stopped adapters in any running partition. If the HMC finds stopped, unused adapters, an **Adapter Information** button appears on the window. When you click this button, the Restore Adapters window opens. This window displays each stopped adapter's state, status, and the partition to which it is assigned. If another user is not performing a dynamic logical partition operation, you can unassign stopped adapters from their partitions and release them for system use.

Note: If another user is currently performing a dynamic logical partitioning adapter operation on any partition, and you unassign stopped adapters from that partition, that user's dynamic logical partitioning operation will fail.

To unassign stopped adapters from a running partition, do the following:

1. Log in to the HMC using either the System Administrator or Advanced Operator roles.
2. In the Navigation area, click the console's icon to expand the tree.
3. In the Navigation area, click the **Server and Partition** folder.
4. In the Contents area, click the **Server Management** icon.
5. In the Contents area, click the managed system's icon to expand the tree.
6. Select the partition to which you want to add the processors.
7. From the Selected menu, select **Dynamic Logical Partitioning**.
8. Select **Adapters**.
9. The Dynamic Logical Partitioning window opens. Click **Add resources to this partition**.
10. If the **Adapter Information** button appears underneath the **Adapters to add** field, the HMC has discovered stopped processors on running partitions that you might be able to unassign, or release for system use. If the **Adapter Information** button appears, click it. If it does not, you do not have adapter resources to restore.
11. The Adapter Recovery window opens. This window displays each lost adapter, along with the adapter's drawer, slot, type, state, and partition assignment. If you are sure that another user is not currently performing a dynamic logical partitioning operation, select the adapter you want to release and click **Unassign**. The adapters you selected are then unassigned and released for system use.

Restoring Memory Resources: When you are dynamically adding, removing, or moving memory resources to a partition, the HMC determines if there is an inconsistency between the amount of memory being used by the partition and the amount of memory requested by the partition for pending memory changes.

If these amounts are not equal, a **Memory Information** button appears on the window. When you click this button, the Restore Memory window opens. This window displays each running partition's amount of memory in use, requested memory amount, the maximum and minimum profile memory values, and the total available system memory. If another user is not performing any dynamic logical partitioning memory operations, you can correct a partition's requested memory value amount so that it is equal to the memory amount currently in use. If the requested memory value is greater than the amount of memory actually in use, a correction of the requested memory amount will result in some memory being released for other partitions to use. If another user is currently performing a dynamic logical partitioning memory operation on a partition, and you correct the requested memory amount for that partition, that user's dynamic logical partitioning operation will fail.

To correct requested memory amounts, do the following:

1. Log in to the HMC using either the System Administrator or Advanced Operator roles.
2. In the Navigation area, click the console's icon to expand the tree.
3. In the Navigation area, click the **Server and Partition** folder.
4. In the Contents area, click the **Server Management** icon.
5. In the Contents area, click the managed system's icon to expand the tree.
6. Select the partition to which you want to add the processors.
7. From the Selected menu, select **Dynamic Logical Partitioning**.
8. Select **Memory**.
9. The Dynamic Logical Partitioning window opens. Click **Add resources to this partition**.
10. If the **Memory Information** button appears underneath the **Destination Partition Details** field, the HMC has discovered memory inconsistencies. If the **Memory Information** button appears, click it. If it does not appear, you do not have memory resources to restore.
11. The Restore Memory window opens. This window displays the name of the partition that has the inconsistency, the amount of memory in use by this partition, the requested memory amount, this partition's minimum and maximum memory amounts, and the amount of free (system available) memory. Select the partition or partitions you want to correct, and click **Correct Requested Value**. The memory amount is then corrected, and the Dynamic Memory Configuration window is updated with the new values.

Error Recovery Actions

The recovery action for many error messages is to perform a rebuild managed system operation. This section has procedures to help rebuild a managed system. References to this procedure are indicated throughout the error message tables as appropriate.

Rebuild is Indicated for Managed System: For messages that indicate that a rebuild managed system operation is needed, do the following to be sure that the operation is necessary:

1. Verify you have the correct authority to perform the task.
 - If you do not, log in with the correct user authority and try the task again.
 - If you do have the correct authority, retry the task. If it still fails, continue with step 2.
2. Perform the Rebuild Managed System task (see "Steps to Rebuild a Managed System") then retry the failing task. If the task still fails, continue with step 3.
3. Reboot the HMC, then verify that the managed system is in *Ready* state.
 - If the managed system is in *Ready* state, retry the failing task. If the task still fails, call for HMC software support.
 - If the managed system is in any state other than *Ready*, (for example, not in *Connection* state, *Error* state, or another state) refer to "Managed System States for the HMC" on page 84 for the recovery procedure for the current state.

Steps to Rebuild a Managed System: To rebuild a managed system, do the following:

1. In the HMC contents area, select the managed system that you want to rebuild.
2. Select **Rebuild Managed System** from the Select menu or by clicking the right mouse button in the content area.
3. A confirmation window displays a message, asking you to confirm whether you want to perform this task.

While this task is running, you cannot perform any other HMC functions. This task can take up to several minutes to complete.

Steps for Rebooting the HMC: To reboot the HMC, do the following:

1. From the Select menu, select **Console**.

2. Select **Exit**.
3. When you exit from your HMC session, you can choose to shut down, reboot, or logout from your session. Select **reboot**.
4. Select **Exit**. The HMC reboots.

Performing a File System Check on HMC Reboot: In the event of an unexpected power loss or if the white reset button on the HMC is pressed, the system runs a file system check (fsck) on the next system reboot. If the automatic file system check fails, the HMC prompts the user to enter the HMC's root password so that it can perform a manual file system maintenance operation. If the following message displays: Enter the root password or hit Control-D to reboot., do the following to recover the HMC:

1. Type the following root password: `passwd`
2. To run a file-system check, type `fsck file system` where *file system* is the name of the file system that fails the file-system check, such as `/` and `/var` in the field. When the checking is completed, a prompt window opens.
3. Type `reboot`
OR
Press Ctrl-D to reboot the HMC interface.

Changing a Partition Host Name Manually

To change the host name of the partition manually, before changing the host name of the partition, do the following:

1. Perform this step only if you are running AIX 5L for POWER Version 5.1 with the 5100-02 Recommended Maintenance package (or later). Run the following command:

```
/usr/sbin/rsct/bin/runact -c IBM.ManagementServer
SetRTASPollingInterval Seconds=0
```

2. Run the following command:

```
/usr/sbin/rsct/bin/lsrc IBM.ManagementServer Hostname
```

The output displayed will be similar to the following: (If the partition is managed by multiple HMCs, there may be multiple entries, because each HMC has its own entry).

```
resource 1: Hostname = "hmc1.mydomain.mycompany.com"
```

3. For each entry, remove the resource using the host name shown. For example, type the following:

```
/usr/sbin/rsct/bin/rmrsrc -s'Hostname =
"hmc1.mydomain.mycompany.com"' IBM.ManagementServer
```

You can verify that all entries have been removed by performing Step 2 again.

4. Run the following command:
`/usr/sbin/rsct/bin/rmctrl -z`
5. Change the host name of the partition.
6. Run the following command:
`/usr/sbin/rsct/bin/rmctrl -A`

Managed System States for the HMC

This section describes the states for a managed system that display on the HMC. Follow the procedures in this section to restore management of a system in one of the listed states.

No Connection State: The HMC has lost contact with the managed system, or power to the service processor has been removed. Do the following:

1. Check the operator panel on the managed system to verify that the power is on.
 - a. If the power light indicates that there is no power on the managed system operator panel, refer to the *pSeries 690 User's Guide* for problem-determination procedures.

- b. After power is restored, wait 5 minutes for the service processor to re-IPL and the HMC to reestablish contact. If the HMC can access partitions using a virtual terminal (VTERM) but the state is still *No Connection*, call for HMC support.
2. If the power indicator is on, wait 5 minutes for the HMC to attempt to reestablish contact. The service processor in the managed system may be in the process of turning power on. If partitions no longer respond, the system power is off.
3. From a telnet session from another system, attempt to ping or contact active partitions on this managed system.
If the partitions are active, do the following:
 - a. Verify that the serial cable on the HMC is firmly connected and that it is not damaged.
 - b. Reboot the HMC.
 - c. Reset the Service Processor.
4. If the managed system is running and restarting the HMC did not resolve the problem, call for HMC support.

Incomplete State: The HMC is unable to collect information required to build a complete representation of the managed system. Do the following:

1. Select **Rebuild Managed System** from the managed system task list. If the state goes to *Recovery*, see "Recovery State". If the state does not go to *Recovery*, continue with the next step.

Note: This operation performed in the next step may take up to ten minutes to complete.

2. Reboot the HMC. If state goes to *Recovery*, see "Recovery State."
If the status remains *Incomplete*, verify whether there is a redundant HMC and verify that no one is entering commands from the alternate HMC.
Repeat step 1. If it still fails, go to the next step.
3. Restore the profile data. The profile data restore task is a full restore from a backup copy.
4. Verify that the HMC serial cable is securely attached to the HMC and that it is not damaged.
5. Reset the service processor.
6. If the problem persists, call for hardware service.

Recovery State: Profile data stored in the managed server has been cleared or damaged. Do the following:

1. Select **Recover partition data** from the managed system task list to restore or initialize profile data.
2. If the state changes to *Incomplete*, see "Incomplete State" for recovery procedures.
If the state changes to *No Connection*, go to "No Connection State" on page 84 for recovery procedures.
3. If the restore fails, reset the service processor.
4. Clear NVRAM (nonvolatile memory), and retry the recovery partition data task.
5. If the problem persists, call for HMC software support.

Error State: *Error* state automatically generates a call to the service support center if the function is enabled. If the function is not enabled, call for HMC software support.

Open Firmware State: The partition has been activated and is in the Open Firmware state. You can open a virtual terminal to the partition and enter open firmware commands.

Boot Error Values

The following table contains the boot error values and messages that might display on the HMC if a problem occurs during the boot process and initial loading of the console software.

Boot Error Values	Message
0x00	NO_ERROR
0x01	NO_GLOBAL_SERVER
0x02	NO_CONTIGUOUS_PAGE_TABLE_MEMORY
0x03	NO_CONTIGUOUS_REAL_MODE_MEMORY
0x04	NOT_ENOUGH_PARTITION_LOGICAL_MEMORY
0x05	ALL_ASSIGNED_PROCESORS_ARE_NOT_WORKING
0x06	NO_PROCESSORS_ASSIGNED
0x07	INVALID_PROCESSOR_ASSIGNED_FOR_ALPAR_PARTITION
0x08	NO_MEMORY_AVAILABLE_FOR_ALPAR_PARTITIONS
0x60	ANOTHER_SERVICE_AUTHORITY_PARTITION_IS_ACTIVE
0x7F	FAIL_TO_BOOT
0x80	I/O_SLOT_ASSIGNMENT_ERROR
0xAC	AIX_OS_TERM_WITH_CRASH_CODE

HMC Recovery Procedure

If attempts to recover the HMC were not successful, do the following:

1. Verify that the serial cable is securely attached to the managed system and is not damaged.
2. There are two dedicated HMC serial ports on the managed system. Move the cable to the second port. If this does not resolve the problem, continue with the next step.
3. Back up the customer profile data.
4. Shut down the HMC.
5. Run hardware diagnostics (PC Doctor). If an error is detected, repair the HMC.
6. Move the serial cable on the HMC PC to the alternate serial port.
7. Turn on the power to the HMC.
8. If there is still no connection and the managed system is still running, review the HMC logs for errors. Save the logs and core files. Call HMC software support.

Releasing an HMC Lock on the Managed System

If you have two HMCs connected to your managed system, one HMC temporarily locks out the other while it is performing operations. This action prevents the other HMC from operating on the managed system because simultaneous operations could cause conflicting results. If the interface is locked, most console operations automatically wait for the lock to release.

However, in the event that an HMC has a problem that prevents the lock from being properly released, you may need to manually unlock the connection to the managed system. Typically, if one HMC has locked the connection, you must unlock it from the other HMC, which then allows other HMCs to communicate with the managed system and run further commands.

To release a lock on a managed system, you must be a member of one of the following roles:

- System Administrator
- Advanced Operator

To release an HMC lock, do the following:

1. In the Contents area, select the managed system.
2. In the menu, click **Selected**.
3. Select **Release Console Lock**.

Chapter 6. Removal and Replacement Procedures

This chapter contains service procedures and procedures to help remove and replace parts that are part of the HMC.

Depending on the system configuration, when you are directed to exchange FRUs, run tests, or change configuration data, the customer's interface to the managed system may not be available. Before starting any of these tasks, notify the customer.

When you exchange a system board, battery, or adapter, follow the configuration procedures in this manual to ensure correct operation.

Attention: Removing power from a HMC may cause loss of data on the disk drives. If power must be removed, select **Power Off** from the HMC user interface. This action shuts down the operating system and turns off the power to the HMC. See "Powering On and Off" on page 4.

Service Procedures

The service procedures in this section help in performing maintenance tasks and installing updates to the HMC.

General Information

Attention: The system board, adapters, memory modules, and processor modules can be damaged by electrostatic discharge. If you are directed to exchange FRUs in a HMC, refer to the "Handling Electro-Static Discharge (ESD) Sensitive Devices" in the 6578, 6792, 8305 or 8187 maintenance information manuals.

When you are referred to the hardware maintenance manual for the personal computer, use the hardware maintenance manual for the appropriate personal computer machine type.

Depending on the system configuration, when you are directed to exchange FRUs, run tests, or change configuration data, the customer's interface to the system hardware may not be available. Before starting any of these tasks, notify the customer.

When you exchange a system board, battery, or adapter, follow the configuration procedures in this manual to ensure correct operation.

When you exchange a disk drive, ensure the licensed internal code is loaded on the new drive. Use the "Restore the Hard Disk" procedures in the hardware maintenance manual for the personal computer machine type.

Removing power from the HMC may cause loss of data on the disk drive. If power must be removed, shut down the HMC. See "Powering On and Off" on page 4.

Restoring the HMC Image

Attention: This procedure will restore the HMC image onto the disk drive in the HMC PC. Before performing this procedure, contact HMC software support and also ensure that the customer has backups for all critical console data.

Refer to the *IBM Hardware Management Console for pSeries Installation and Operations Guide*, order number SA38-0590 when performing the following procedures:

1. Correct any error conditions on the HMC hardware.
2. Reload the HMC system image, as follows:
 - a. Turn on the HMC power.
 - b. Locate the HMC system image DVD and insert it into the DVD drive on the HMC personal computer.
 - c. Turn the HMC power off and then on, and allow the system to boot from the DVD.
 - d. When the boot stops, follow the instructions on the screen to install the HMC system image.
3. Restore the customer's critical console data.
4. Reboot the HMC.

Backup Profiles

Refer to the *IBM Hardware Management Console for pSeries Installation and Operations Guide*, form number SA38-0590.

System Board Configuration

Your HMC system is based on one of the following listed PC machine types and models. Use the following table when cross referencing between a PC and pSeries HMC Machine Type and Model Number.

pSeries HMC Machine Type and Model Number	Personal Computer (PC) Machine Type and Model Number	Supporting Hardware Maintenance Manual Part Number
7040 (FC 7315)	6578 Model KLU	06P1504
7040 (FC 7316)	6792 Model 31U	24P2934
7315 Model C01 (FC 7316)	6792 Model 31U	24P2934
7315 Model C02	8305 Model 41U	24P2969
7315 Model CR2	8676 Model 22X	48P9908
7315 Model C03	8187 Model F4U	74P2661

For information about system board specifications, refer to "Related Publications" on page x for a listing of PC hardware maintenance manuals. The publications are available through the following web site:

<http://www.pc.ibm.com>

Configuring the System

Refer to the *IBM Hardware Management Console for pSeries Installation and Operations Guide*, form number SA38-0590, when performing the following procedures.

Update Device Microcode

Refer to the *IBM Hardware Management Console for pSeries Installation and Operations Guide*, form number SA38-0590, when performing the following procedures.

Updating HMC Code

Refer to the *IBM Hardware Management Console for pSeries Installation and Operations Guide*, form number SA38-0590. If there are upgrades to the HMC hardware, ensure that the hardware updates are performed first.

Obtaining HMC Image: Refer to the *IBM Hardware Management Console for pSeries Installation and Operations Guide*, form number SA38-0590.

Reloading the Hardware Management Console Image:

1. Locate the Hardware Management Console Backup CD. The customer should have this CD stored in a safe place in the event it is needed to recover the HMC.
2. Insert the CD into the DVD-RAM, and close the drive.
3. If the power is on, exit the HMC, and turn off the console power.
4. Turn on the HMC power. When the system loads from the Hardware Management Console Backup CD, the HMC automatically loads itself onto the disk drive of the HMC.

Note: If the HMC does not load the HMC Backup CD, it may be because the DVD-RAM drive is not set to be a boot device. Use the Setup Utility program to make the DVD-RAM a boot device, as follows:

- a. Turn off the power to the HMC and watch the in-use lights until they go off.
- b. Turn on the power to the HMC.
- c. When the Setup Utility prompt displays on the screen during start-up, press F1. The Setup Utility menu displays.
- d. Follow the instructions on the screen to change the Start Options to make the DVD-RAM the boot device. Additional information about the Setup Utility Program can be found in the PC hardware maintenance manual. Refer to “Related Publications” on page x for a listing of PC hardware maintenance manuals. The publications are available through the following web site:

<http://www.pc.ibm.com>

When you complete this procedure, if you changed the boot device list, be sure to reset the boot device list to enable the system to boot from the disk drive.

5. When the installation is complete, remove the CD from the DVD-RAM drive and reboot the system.
6. Instruct the customer to restore their console data from their backup copies. The customer can find the procedure under “Restoring Console Data” in the *IBM Hardware Management Console for pSeries Installation and Operations Guide*, order number SA38-0590.

PC Configuration

Refer to the *IBM Hardware Management Console for pSeries Installation and Operations Guide*, form number SA38-0590, when performing the following procedures.

Removals and Replacements

For removal and replacement procedures that are not described here, refer to “Related Publications” on page x for a listing of PC hardware maintenance manuals. The publications are available through the following web site:

<http://www.pc.ibm.com>

Installing or Removing the 8-Port ASYNC Adapter

When an 8-Port ASYNC Adapter is installed in the HMC, the adapter must be configured using the following procedure.

Configuring a Serial Adapter

You can use your HMC to configure adapters that are installed in your HMC. When performing this task, all serial adapters in the system must be configured at the same time. When adding an additional adapter, the original adapter must also be reconfigured. If you do not reconfigure the original adapter, its original definition will be lost.

To configure serial adapters, do the following:

1. In the Navigation area, click the **HMC Maintenance** icon.
2. In the Contents area, double-click the **System Configuration** icon.
3. In the Contents area, click **Configure Serial Adapter**.
4. The Working window opens. Type 1 to select Configure Serial Adapter(s)
5. The configuration utility guides you through a series of questions.

For an 8-port adapter, you must provide the following questions with the following answers:

- a. Question: How many boards would you like to install? Answer: Type the total number of 8-Port and/or 128-Port async adapters in the system.
- b. Question: Board #1. What type of board is this? (L for list) Answer: Board type 15
- c. Question: Do you want to set Altpin on this board? (y or n) Answer: No

If two 8-port adapters are installed in the system, the HMC asks the following questions:

- a. Question: Board #2. What type of board is this? (L for list) Answer: Board type 15
- b. Question: Do you want to set Altpin on this board? (y or n) Answer: No

For a 128-port adapter, you must provide the following questions with the following answers:

- a. Question: How many boards would you like to install? Answer: The total number of 8-Port and/or 128-Port async adapters that are installed in the HMC PC.
- b. Question: Board #1. What type of board is this? (L for list) Answer: Board type 16 (IBM 128-Port async PCI)
- c. Question: How many ports does this digiBoard have? Possible values:

- 1) 8
- 2) 16
- 3) 24
- 4) 32
- 5) 40
- 6) 48
- 7) 56
- 8) 64
- 9) 72
- 10) 80
- 11) 88
- 12) 96
- 13) 104
- 14) 112
- 15) 120
- 16) 128

Board #1 How many ports? (1-16) Answer: Count the total number of Enhanced RANs you are attaching to the 128-Port async adapter and multiply by 2. Type the selection number 4), for 32 in this example, at the prompt.

d. Question: Do you want to set Altpin on this board? (y or n) Answer: No

If two 128-Port async adapters are installed in the system, the utility repeats the previous sequence of questions for each. The configuration utility guides you through a series of questions.

Note: The term C/CON is synonymous with Enhanced RAN or RAN.

- a. Question: How many C/X cards do you have? Answer: Type the total number of 128-Port async adapters installed in the HMC PC.
- b. Question: How many C/CONs (RANs) are connected to card 1 line 1? Answer: Type the total number of RANs on line 1. For this example, two concentrators (RANs) are connected to line 1.
- c. Question: What type of wiring scheme are you going to use for card 1, line 1? Answer: A
- d. Enter the type of communication mode to use on line 1. (Type L for a list) Answer: 14
- e. Question: How many ports does this C/CON (RAN) support? (conc #1) Answer: 16
- f. Question: How many C/CONs (RANs) are connected to card 1, line 2? Answer: Type the number of RANs connected to line 2.

Reboot your HMC to load the adapter device driver.

Configuring RS422 Ports on an 8-Port Adapter: This task allows you to switch a port from RS232 to RS422. Use this task for ports that are connected to a frame's power supply.

Note: Managed systems should continue to use the default RS232 port type.

To configure RS422 ports on an 8-Port adapter connected to the HMC, do the following:

1. In the Navigation area, click the **HMC Maintenance** icon.
2. In the Contents area, double-click the **System Configuration** icon.
3. In the Contents area, click **Configure Serial Adapter**.
4. The Working window opens. Select **Configure RS422 ports on an 8-port Adapter**.
5. From the menu, select the 8-port adapter you want to configure.
6. From the menu, select the port change.

Removing the 8-Port ASYNC Adapter: To remove an 8-port ASYNC adapter, do the following:

1. Obtain the root password from the customer.
2. Log in with the ID **hscpe** and open a command prompt window.
3. Type `su -`, then log in with the root password.
4. At the command prompt, type `/usr/sbin/digiConf`
5. When prompted, set the configuration to the correct number of adapters in the HMC.

Installing or Removing the 128-Port ASYNC Adapter

The 128-Port ASYNC adapter is an option for the HMC. It must be configured by the service representative when the HMC is installed. The 128-Port ASYNC adapter software is installed in the HMC base software installation package.

128-Port ASYNC Adapter Connector

The HMC 128-Port ASYNC adapter installation differs from the installation in AIX. The 128-Port ASYNC adapter has two 15-pin D-shell connectors on it. The connector that is closest to the edge connector that plugs into the HMC PC is line 1. The remote access nodes (RANs) are cabled in a daisy chain and are terminated using a line terminator. The following figure shows the adapter.

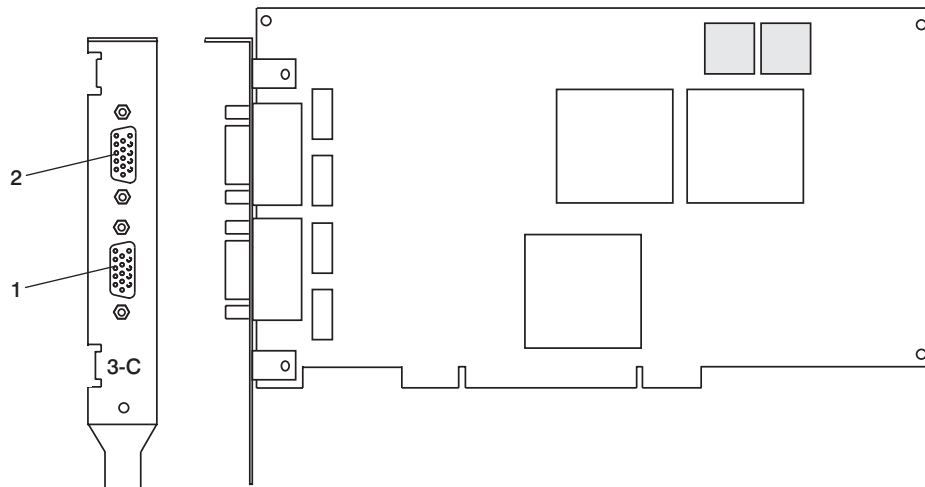

The following figure shows an example of a typical RAN configuration. RANs are connected to both line 1 and line 2 of the adapter in this example.

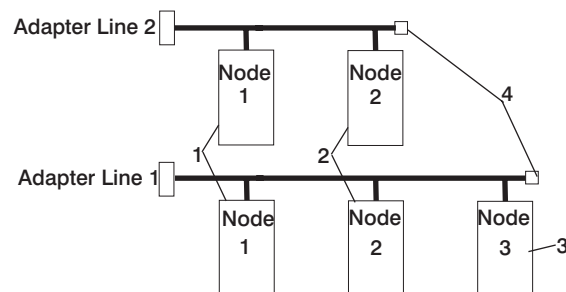

- 1 RAN Nodes
- 2 RAN Nodes
- 3 RAN Node
- 4 Terminators

- Up to eight RANS can be attached to one adapter. If four are attached to line one, only four more can be attached to line 2.
- RANs *must* be numbered in ascending order. The RAN closest to the adapter is assigned as node 1. No gaps in the numbering should occur. Example, numbering RANs as 1, 3, 4 in a line will cause configuration problems.

Setting a RAN Node Number

The *AIX Asynchronous Communications Guide* provides information about configuring and running diagnostics on the 128-Port ASYNC Adapter and associated RANs. To access the *AIX Asynchronous Communications Guide*, see the IBM eServer pSeries Information Center at http://publib16.boulder.ibm.com/pseries/en_US/infocenter/base. Click **AIX documentation**. The 128-Port ASYNC adapter identifies RANs by their node numbers. Each RAN in a daisy chain must have a unique node number ($1n-4n$), which must be set during installation. The node numbers must be assigned in ascending order with the lowest number assigned to the RAN closest to the 128-Port ASYNC adapter. The following figure shows the front panel of a RAN.

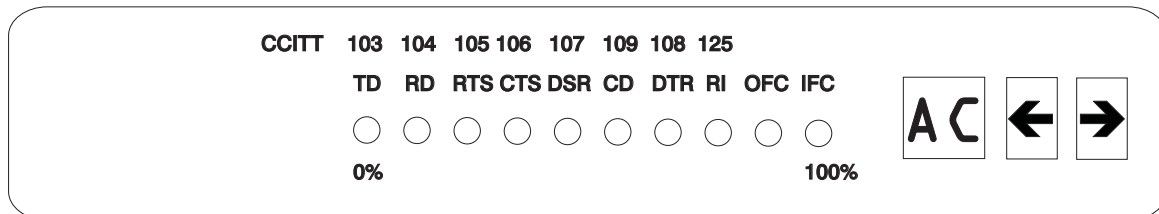

To set the RAN node number, do the following:

1. Turn the RAN on and wait for the power-on self-test (POST) to complete.
2. When P1 is displayed on the front panel seven-segment LED display, press the Left Arrow button once. The current node number is displayed, for example, $1n$ for node 1.
3. Press the Right Arrow button to advance the node number through the eight possible settings ($1n-8n$).
4. When the desired node number is displayed, press the Left Arrow button again to select the number. The display should now read Pn (indicating a pass condition). If there was an error, the display reads En .

In the case of duplicate node numbers, the RAN farthest from the host adapter displays En , instead of AC , when the system is started.

Removing an Adapter

After you remove a 128-Port ASYNC adapter, do the following:

1. Obtain the root password from the customer.
2. Log in with the ID **hscpe** and open a command prompt window.
3. Type `su -`, then login with the root password.
4. At the command prompt, type `/usr/sbin/digiConf`.
5. When prompted, set the configuration to the correct number of adapters in the HMC.

Exchanging a Disk Drive

When you exchange a disk drive, ensure that the licensed internal code is installed on the new drive. Use the "Restore Hard Disk" procedures, refer to "Related Publications" on page x for a listing of PC hardware maintenance manuals. The publications are available through the following web site:

<http://www.pc.ibm.com>

Replacing the Planar and Performing the Flash (BIOS/VPD) update procedure

After replacing the system planar, you should perform the flash BIOS/VPD update.

Attention: Refer to the information label located inside the system unit cover for any model-specific information.

To perform the flash (BIOS/VPD) update procedure, do the following:

1. Power off the computer.
2. Insert the flash update diskette into drive A.
3. Power on the computer.
4. When the Update Utility window opens, select the country/keyboard, then press Enter.
5. If the computer serial number was previously recorded, the number is displayed with an option to update it. Press **Y** to update the serial number.
6. Type the 7-digit serial number of the computer you are servicing, then press Enter.
7. Follow the instructions on the screen to complete the flash (BIOS/VPD) update procedure.

Chapter 7. Hardware Management Console Parts

This section contains part number information for parts that are added to the base personal computer. These additional parts when added to one of the following listed personal computers makeup your HMC. For personal computer parts information not listed, refer to the hardware maintenance manual for the personal computer on which you are servicing. To access the personal computer hardware maintenance manuals, go to the following web address:

<http://www.pc.ibm.com>

The following table contains a cross reference equivalent of the HMC machine type and model number to the personal computer machine type and model number.

pSeries HMC Machine Type and Model Number	Personal Computer (PC) Machine Type and Model Number	Supporting Hardware Maintenance Manual Part Number
7040 (FC 7315)	6578 Model KLU	06P1504
7040 (FC 7316)	6792 Model 31U	24P2934
7315 Model C01 (FC 7316)	6792 Model 31U	24P2934
7315 Model C02	8305 Model 41U	24P2969
7315 Model CR2	8676 Model 22X	48P9908
7315 Model C03	8187 Model F4U	74P2661

Parts Listing for a 6578-KLU

Feature code 7315 was released as HMC machine type 7040 and used the PC machine type 6578-KLU for its base configuration. If necessary, to cross reference to the original PC hardware maintenance manuals, go to "Related Publications" on page x.

Note: Each PC hardware maintenance manual may reference more than one machine type in the title of the pub. The title given in the Related Publications section of this publication only identifies the PC machine types cross referenced in the following table. Use the part number to reference the correct manual.

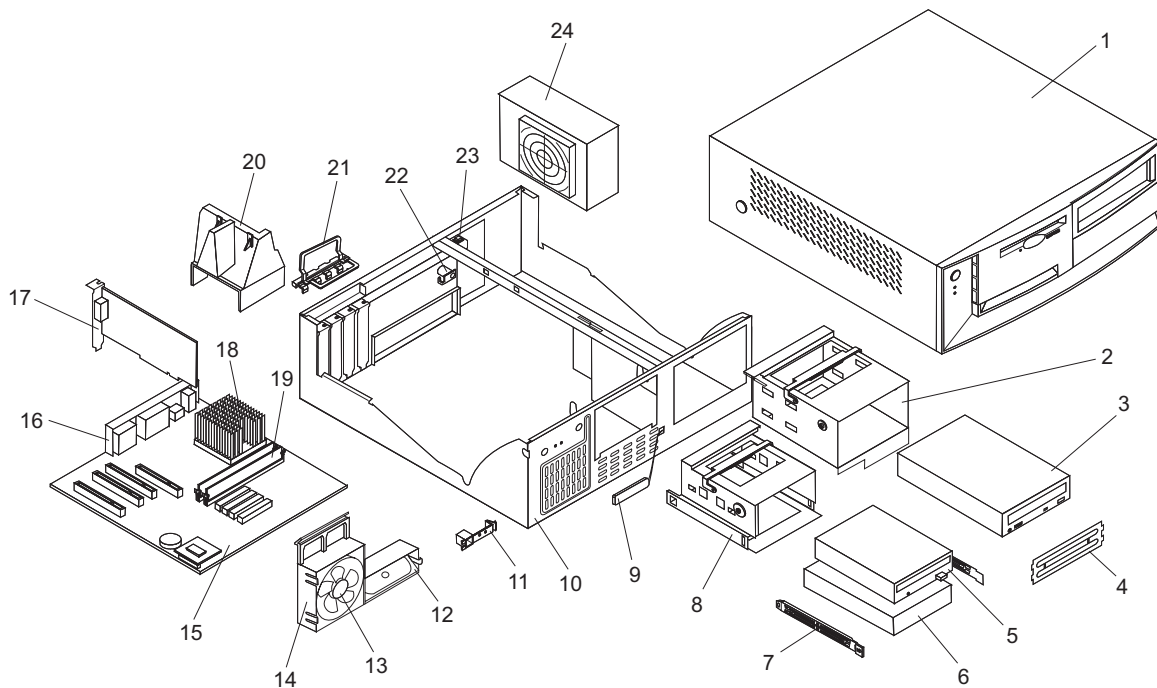

Index	Description	Units	Part Numbers
1	Top cover assembly stealth black	1	49P4367
2	DASD Bracket		09N5746
3	DVD-RAM Drive (Black)		24P3615
	DVD-RAM Drive (White)		19K1537
4	Bezel Kit		09N5732
5	FDD 3.5" 1.44MB (w/o bezel)		75H9550
	Diskette Drive (Japan)		75H9552
6	HDD 40GB 7200RPM		19K1568
	HDD 30GB 7200RPM		19K1567
	IDE: Hard Drive Cable		37L4525
7	DASD Rail Kit		19K5331
8	3.5 DASD Bracket		06P2734
9	RFID Antenna		03K9654
10	Chassis assembly		49P4369
11	Control panel assembly		37L5092
12	Speaker assembly		01K4909
			00N5151
13	Fan assembly		33L2594
14	Fan Sink	1	06P2458
12-14	Fan/Speaker/Power Switch Assembly		01K4909
15	Planar (Spartan-G 10/100/1000 POV)	1	02R4085
16	Planar EMC shield		09N5770
17	PCI: nVidia Vanta (16MB)		25P4058
18	Processor P4 2.4 GHz	1	48P7684
			59P1991
			02R4517
19	Memory 256MB NP SDRAM		33L3305
20	Air Baffle Duct		06P2733
21	I/O cam bracket		09N5734
22	Keylock Assembly		09K9829
23	C2 Switch Assembly		09K9827
24	Power Supply		00N7685
	Power Supply (Japan)		00N7687
	Power Supply (China)		00N7689
	Power Supply (China)		24P6883
	Power Supply (China)		24P6885

The following table contains part descriptions and part numbers for parts not shown in the 6578 Model KLU illustration.

Description	Units	Part Numbers
5.25 locking handle		09N5747
5.25 EMC Shield		19K5548
3.5 locking handle		09N5748
PS/2 2 Button Mouse (black)		24P0383
Bezel kit (black)		49P4371
50-foot 9-9 pin serial cable, connects HMC to system		44P0206
10/100 Ethernet Adapter (FC 4962)		09P5023
Token Ring Adapter Cable (9 Pin D-Shell to STP)		6339098
PCI: 16/4 Token Ring Mngt		34L5009
Battery		33F8354
COM Port to Modem Async Cable		21L4322
PC Doctor Diagnostic Diskette		21G4251
US Power Cord		93F2364
Mouse, Three-Button USB		09N5532
Mouse, Three-Button USB (ScrollPoint-white)		12J4546
Mouse, Three-Button USB (ScrollPoint-black)		28L1865
128 port async adapter		93H6545
Wrap plug		43G0928
Terminator		43G0926
9-25 pin serial cable connects from fanout cable to system HMC 1		31L7196
8 port async adapter		93H6541
Fanout cable		07L9822
Wrap plug		6298964
Bracket		03K8992
9-25 pin serial cable connects from fanout cable to system HMC 1		31L7196

Parts Listing for a 7315-C01

HMC machine type 7315 Model C01 or HMC machine type 7040 feature code 7316 uses the PC machine type 6792 Model 31U for its base configuration. If necessary, to cross reference to the original PC hardware maintenance manuals, go to “Related Publications” on page x.

Note: Each PC hardware maintenance manual may reference more than one machine type in the title of the pub. The title given in the Related Publications section of this publication only identifies the PC machine types cross referenced in the following table. Use the part number to reference the correct manual.

pSeries HMC Machine Type and Model Number	Personal Computer (PC) Machine Type and Model Number	Supporting Hardware Maintenance Manual Part Number
7040 (FC 7315)	6578 Model KLU	06P1504
7040 (FC 7316)	6792 Model 31U	24P2934
7315 Model C01 (FC 7316)	6792 Model 31U	24P2934
7315 Model C02	8305 Model 41U	24P2969
7315 Model CR2	8676 Model 22X	48P9908
7315 Model C03	8187 Model F4U	74P2661

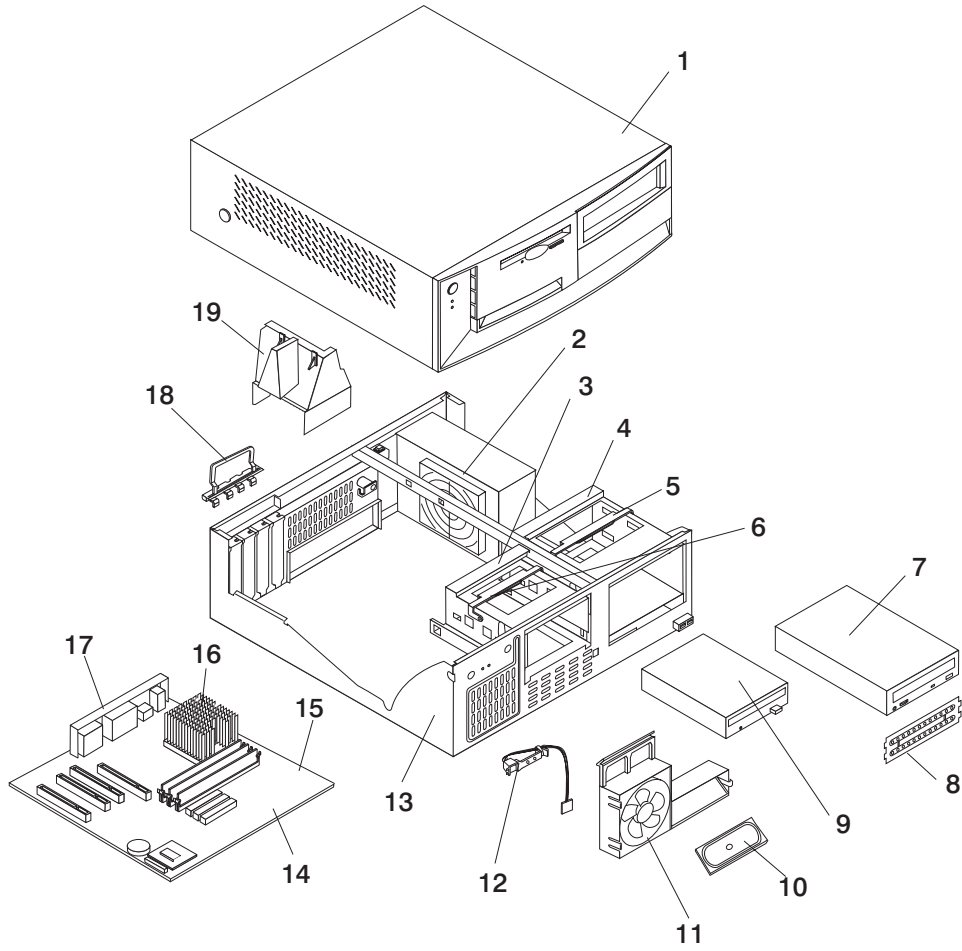

Index	Description	Units	Part Numbers
1	Top cover assembly stealth black	1	49P4367
2	185W Power Supply		24P6883
2	Power Supply (China)		24P6885
3	DASD Bracket		06P2734
4	DASD Bracket		09N5746
5	5.25 Locking Handle		09N5747
6	3.5 Locking Handle		09N5748
7	DVD-RAM Drive (Panasonic-Black)		24P3615 33P3243
	DVD-RAM Drive (Hitachi -Black)		37L5098
	DVD Cable		19P0484 (1)
	DVD Media (Blank)		19P0862 (5 pack)
8	Shield 5.25 EMC		19K5548
9	Diskette Drive		75H9550
	Diskette Drive (Japan)		75H9552
	Diskette Cable		33L2596
10	Speaker assembly		01K4909
			00N5151
11	92mm Fan w/Grommets		33L2594
12	Control Panel Power switch		37L5092
13	Chassis assembly		49P4369
14	Planar: 10/100 EtherNet		25P5090
15	Processor P4 2.0 GHz	1	48P7205
16	Memory 512MB DIMM, EDO ECC		33L3307
17	I/O cam bracket		09N5734
19	Air Baffle Duct		06P2733
			32P4707

The following table contains part descriptions and part numbers for parts not shown in the 7315 Model C01 illustration.

Description	Units	Part Numbers
Planar (Spartan-G 10/100/1000 POV)	1	02R4085
Bezel kit stealth black		49P4371
Mouse PS/2 2 button stealth black		24P0383
Battery		33F8354
COM2 Port to Modem Async Cable		21L4322
ASYNC 8 Way Adapter		93H6541
ASYNC 128 Way Adapter		93H6545
10/100 Ethernet Adapter		09P5023
Mouse		24P0507
HDD 40GB 7200RPM		19K1568
IDE: Hard Drive Cable		37L4525

Parts Listing for a 7315-C02

Machine type 7315-C02 uses a personal computer machine type of 8305 Model 41U for its base configuration. If necessary, to cross reference to the original PC hardware maintenance manuals, go to “Related Publications” on page x.

Note: Each PC hardware maintenance manual may reference more than one machine type in the title of the pub. The title given in the Related Publications section of this publication only identifies the PC machine types cross referenced in the following table. Use the part number to reference the correct manual.

pSeries HMC Machine Type and Model Number	Personal Computer (PC) Machine Type and Model Number	Supporting Hardware Maintenance Manual Part Number
7040 (FC 7315)	6578 Model KLU	06P1504
7040 (FC 7316)	6792 Model 31U	24P2934
7315 Model C01 (FC 7316)	6792 Model 31U	24P2934
7315 Model C02	8305 Model 41U	24P2969
7315 Model CR2	8676 Model 22X	48P9908
7315 Model C03	8187 Model F4U	74P2661

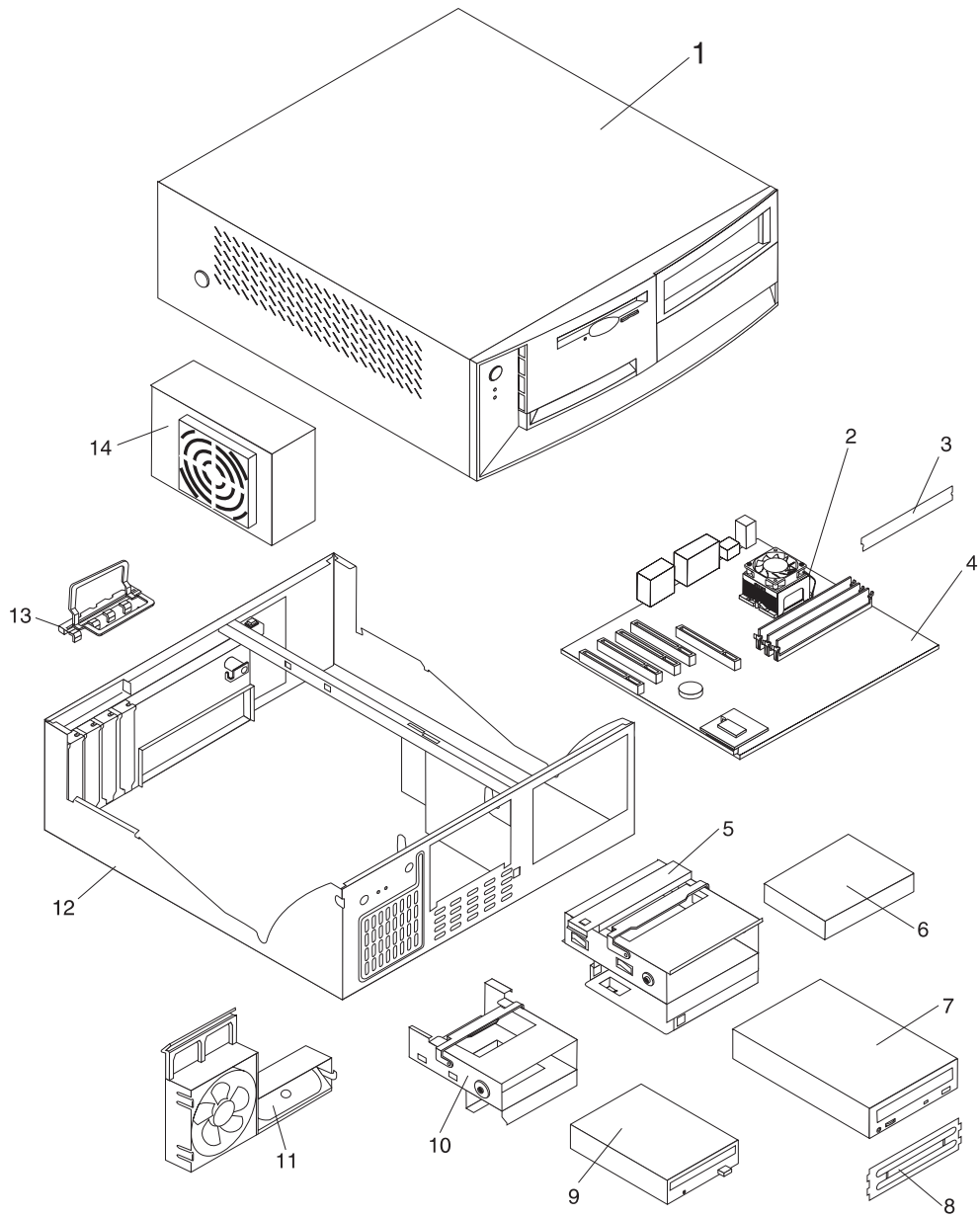

Index	Description	Units	Part Numbers
1	Top cover assembly stealth black	1	49P4367
2	Processor P4 2.4 GHz	1	48P7684
	Fan Sink	1	32P4004
3	Memory 512MB SDRAM, NP		33L3307
4	Planar (10/100/1000)	1	49P1602
5	5.25 locking handle		09N5747
6	HDD 40GB 7200RPM		19K1568
7	DVD RAM Drive (Panasonic -Black)		24P3615
			33P3243
	DVD RAM Drive (Hitachi -Black)		37L5098
	CD-ROM/DVD Cable		19P0484
	DVD R/W Media (blank)		19P0862 (5 pack)
8	Shield 5.25 EMC		19K5548
9	Diskette Drive		75H9550
	Diskette Drive (Japan)		75H9549
	Diskette Cable		49P4764
10	3.5 locking handle		09N5748
11	Speaker assembly		01K4909
			00N5151
12	Power Supply		24P6883
	Power Supply (China)		24P6885
13	Chassis assembly		49P4369
14	I/O cam bracket		09N5734

The following table contains part descriptions and part numbers for parts not shown in the 7315 Model C02 illustration.

Description	Units	Part Numbers
Mouse PS/2 2 button stealth black		24P0383
Bezel kit stealth black		49P4371
Battery		33F8354
System Board		49P1602
COM2 Port to Modem Async Cable		21L4322
ASYNC 8 Way Adapter		93H6541
ASYNC 128 Way Adapter		93H6545
10/100 Ethernet Adapter		09P5023
Mouse (USB)		24P0507

Parts Listing for a 7315-CR2

Machine type 7315-CR2 uses a personal computer machine type of 8676 Model 22X for its base configuration. If necessary, to cross reference to the original PC hardware maintenance manuals, go to “Related Publications” on page x.

Note: Each PC hardware maintenance manual may reference more than one machine type in the title of the pub. The title given in the Related Publications section of this publication only identifies the PC machine types cross referenced in the following table. Use the part number to reference the correct manual.

pSeries HMC Machine Type and Model Number	Personal Computer (PC) Machine Type and Model Number	Supporting Hardware Maintenance Manual Part Number
7040 (FC 7315)	6578 Model KLU	06P1504
7040 (FC 7316)	6792 Model 31U	24P2934
7315 Model C01 (FC 7316)	6792 Model 31U	24P2934
7315 Model C02	8305 Model 41U	24P2969
7315 Model CR2	8676 Model 22X	48P9908
7315 Model C03	8187 Model F4U	74P2661

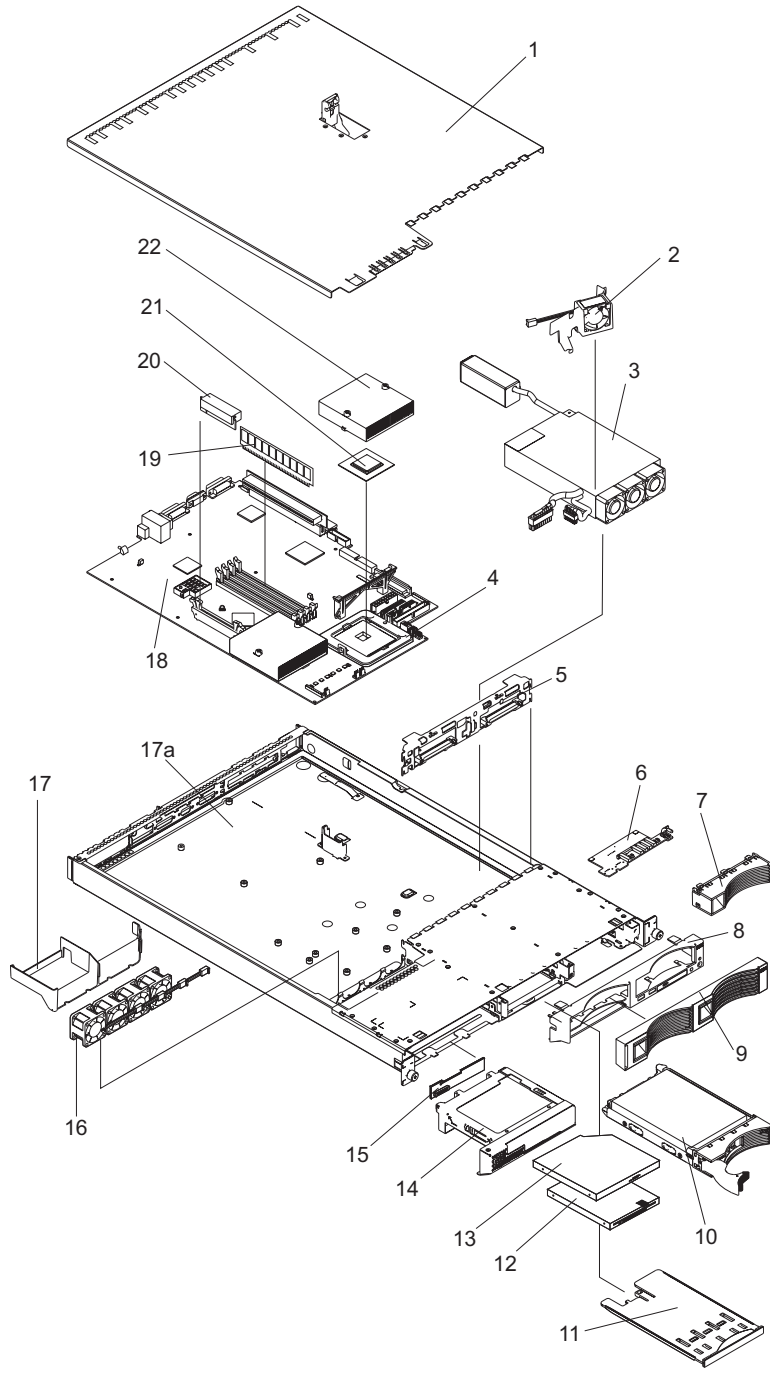

Index	Description	Units	Part Numbers
1	Top cover assembly	1	24P0708
2	Fan, DASD	1	00N6991
3	Power Supply (331W)		49P2013
3	Power Supply (332W)		93H7091
4	Heatsink Retention Module	1	24P0836
5	Hot-Swap SCSI Backplane		32P1932
6	Operator Information Card		48P9086
7	Bezel Filler		06P6245
8	Bezel, Hot Swap Trim		24P0720
9	Bezel, Non-Hot Swap Trim		24P0723
10	40GB IDE Drive (7200 RPM)		19K1568
11	USB Tray		32P0580
12	12.7, 3 MODE Diskette Drive		36L8645
13	24X CD-ROM drive (primary)		06P5263
13	24X CD-ROM drive		33P3231
13	DVD-RAM		33P3307
14	Bracket, CD-ROM Drive/Diskette Drive		32P1925
15	Interposer Card		48P9028
16	Microprocessor Fan		24P1118
17	Baffle		24P0742
17a	Chassis		32P1924
18	System Board		88P9728
19	256 PC2100 ECC Memory DIMM		09N4306
19	1 GB Memory DIMM		09N4308
20	9.0 1U/13A VRM Card,		74P4407
21	533/3.06-0K L3 Microprocessor		02R8908
22	533 Heatsink		24P0891

The following table contains part descriptions and part numbers for parts not shown in the 7315 Model CR2 illustration.

Description	Units	Part Numbers
3.0V Battery		33F8354
Mouse		24P0507
Mouse Cable		00N6954
-48V Connector		01R1199
40x20 Fan Assembly Duct		24P0892
1U Tool-less Rail Kit		24P1121
Service Label		90P4244
Eserver xSeries Nameplate		33P2205
Non-Hot Swap Hard Disk Drive Rail Kit		32P1928
3.5V Riser Assembly		25P3359
Jumper Cord		36L8886
CD-ROM Drive Power Cable		24P0867
CD-ROM Signal Cable		24P0851
Hard Disk Drive Power Fixed 2-Drop Cable		24P0865
Cable, switch and USB		24P0853
Cable, diskette drive signal		24P0790
Cable, IDE drive		24P0788
Hot-Swap SCSI Assembly Cable		24P0786
Cable, hard disk drive 4-pin power		24P0622
Hard Disk Drive Backplane to System Board Cable		00N6988
Power cord		6952300
Miscellaneous parts kit - contains: CD-ROM drive spring rod (1); diskette drive spring rod (1); screws (10); PCI card support bracket (1); icon light pipe (1); rear light pipe (1); CD-ROM drive blank bezel (1); diskette drive blank bezel (1); slotted M3x5 screws (18); I/O bracket (2) fan bracket (1); 40 mm by 20 mm fan bracket (1) (all models) FRU		32P1926

Parts Listing for a 7315-C03

Machine type 7315-C03 uses a personal computer machine type of 8187 Model F4U for its base configuration. If necessary, to cross reference to the original PC hardware maintenance manuals, go to “Related Publications” on page x.

Note: Each PC hardware maintenance manual may reference more than one machine type in the title of the pub. The title given in the Related Publications section of this publication only identifies the PC machine types cross referenced in the following table. Use the part number to reference the correct manual.

pSeries HMC Machine Type and Model Number	Personal Computer (PC) Machine Type and Model Number	Supporting Hardware Maintenance Manual Part Number
7040 (FC 7315)	6578 Model KLU	06P1504
7040 (FC 7316)	6792 Model 31U	24P2934
7315 Model C01 (FC 7316)	6792 Model 31U	24P2934
7315 Model C02	8305 Model 41U	24P2969
7315 Model CR2	8676 Model 22X	48P9908
7315 Model C03	8187 Model F4U	74P2661

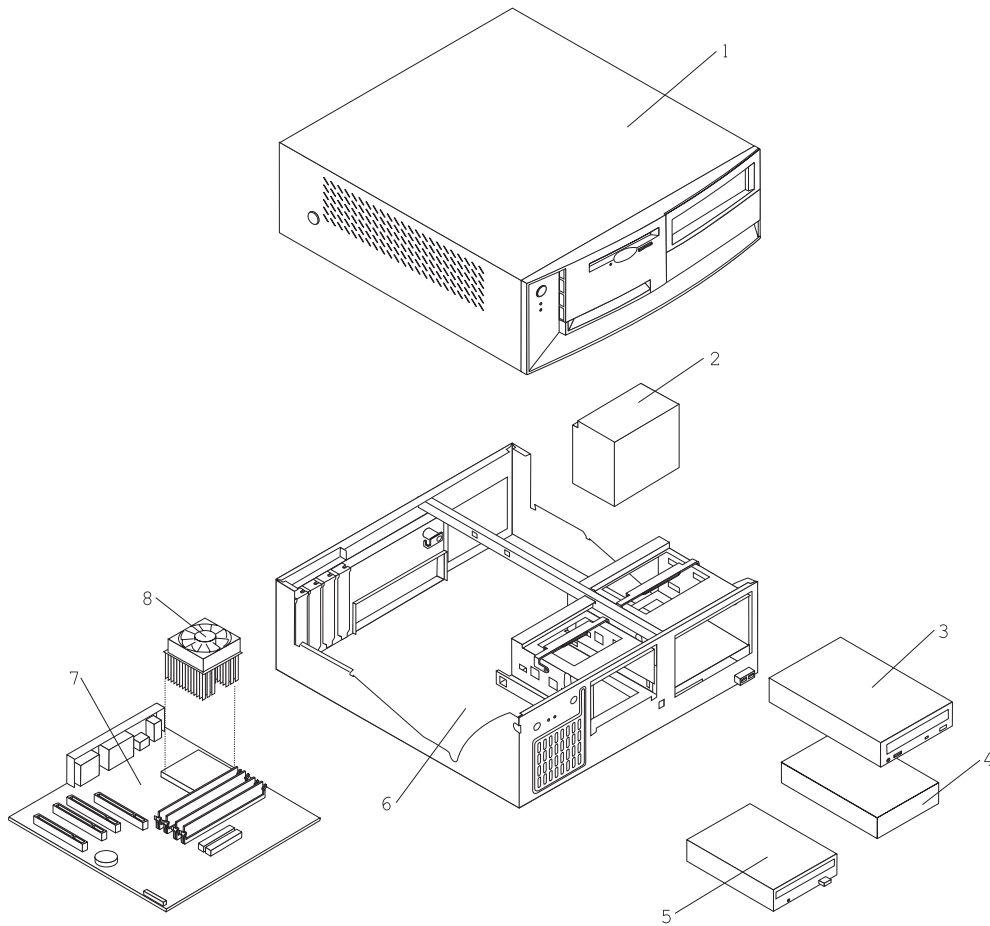

Index	Description	Units	Part Numbers
1	Top cover assembly	1	88P5962
2	Power supply, 230W	1	74P4300
3	DVD-RAM		24P3615 33P3243 33P3309
4	HDD, 40 GB EIDE	1	19K1568
5	FDD, 3.5 1.44 MB		76H4091
6	Chassis/top cover kit		88P5963
7	System board, Gigabit E-net, POV		73P0596 13R8930
8	Intel P4 3.0 GHz		88P5870
8	Fan sink		01R3330 32P4004

The following table contains part descriptions and part numbers for parts not shown in the 7315 Model C03 illustration.

Description	Units	Part Numbers
256 MB SDRAM		31P9121
RFID antenna - velcro		03K9654
Cable, C2 assembly		09K9827
5.25 EMC shield		19K5548
Retention kit		88P5915
Planar shield kit		88P5931
Cable, FDD		88P6515
Cable, ATA66 1 drop		88P5967
Cable, ATA66 2 drop		88P5971
Cable, SATA		88P5927
Service label		88P5964
Bezel kit		49P4371
Pivot lock, 3.5 FDD		09N5748
Pivot lock, 5.25 DASD		09N5747
Fan bracket assembly		88P6700
Misc. hardware kit		88P5965
Cable, CD-ROM audio		75H9219
Keylock assembly, random		88P5920
HDD mounting bracket assembly		88P5916
Cable assembly, power/LED		37L5092
Cable, second serial port		49P4530
Cable, dual USB 2.0		49P4365
Battery, 3.0 V		33F8354
ASYNC 8 Way Adapter		93H6541
ASYNC 128 Way Adapter		93H6545
10/100 Ethernet Adapter		09P5023

Power Cords

For your safety, the manufacturer provides a power cord with a grounded attachment plug to use with this product. To avoid electrical shock, always use the power cord and plug with a properly grounded outlet.

Power cords used in the United States and Canada are listed by Underwriter's Laboratories (UL) and certified by the Canadian Standards Association (CSA).

For units intended to be operated at 115 volts: Use a UL-listed and CSA-certified cord set consisting of a minimum 18 AWG, Type SVT or SJT, three-conductor cord, a maximum of 15 feet in length and a parallel blade, grounding-type attachment plug rated 15 amperes, 125 volts.

For units intended to be operated at 230 volts (U.S. use): Use a UL-listed and CSA-certified cord set consisting of a minimum 18 AWG, Type SVT or SJT, three-conductor cord, a maximum of 15 feet in length and a tandem blade, grounding-type attachment plug rated 15 amperes, 250 volts.

For units intended to be operated at 230 volts (outside the U.S.): Use a cord set with a grounding-type attachment plug. The cord set should have the appropriate safety approvals for the country in which the equipment will be installed.

The power cords listed in the following table are specifically designed for a country or region and are usually available only in that country or region.

Power Cord Part Number	Used in these Countries and Regions
13F9940	Argentina, Australia, China (PRC), New Zealand, Papua New Guinea, Paraguay, Uruguay, Western Samoa
13F9979	Afghanistan, Algeria, Andorra, Angola, Austria, Belgium, Benin, Bulgaria, Burkina Faso, Burundi, Cameroon, Central African Rep., Chad, China (Macau S.A.R.), Czech Republic, Egypt, Finland, France, French Guiana, Germany, Greece, Guinea, Hungary, Iceland, Indonesia, Iran, Ivory Coast, Jordan, Lebanon, Luxembourg, Malagasy, Mali, Martinique, Mauritania, Mauritius, Monaco, Morocco, Mozambique, Netherlands, New Caledonia, Niger, Norway, Poland, Portugal, Romania, Senegal, Slovakia, Spain, Sudan, Sweden, Syria, Togo, Tunisia, Turkey, former USSR, Vietnam, former Yugoslavia, Zaire, Zimbabwe
13F9997	Denmark
14F0015	Bangladesh, Burma, Pakistan, South Africa, Sri Lanka
14F0033	Antigua, Bahrain, Brunei, Channel Islands, China (Hong Kong S.A.R.), Cyprus, Dubai, Fiji, Ghana, India, Iraq, Ireland, Kenya, Kuwait, Malawi, Malaysia, Malta, Nepal, Nigeria, Polynesia, Qatar, Sierra Leone, Singapore, Tanzania, Uganda, United Kingdom, Yemen, Zambia
14F0051	Liechtenstein, Switzerland
14F0069	Chile, Ethiopia, Italy, Libya, Somalia
14F0087	Israel
1838574	Thailand
6952301	Bahamas, Barbados, Bermuda, Bolivia, Brazil, Canada, Cayman Islands, Colombia, Costa Rica, Dominican Republic, Ecuador, El Salvador, Guatemala, Guyana, Haiti, Honduras, Jamaica, Japan, Korea (South), Liberia, Mexico, Netherlands Antilles, Nicaragua, Panama, Peru, Philippines, Saudi Arabia, Suriname, Taiwan, Trinidad (West Indies), United States of America, Venezuela

Appendix A. Service Focal Point

This chapter provides information about using the Service Focal Point application.

Service representatives use the HMC as the starting point for all service issues. The HMC groups various system management issues at one control point, allowing service representatives to use the Service Focal Point application to determine an appropriate service strategy.

Traditional service strategies become more complicated in a partitioned environment. Each partition runs on its own, unaware that other partitions exist on the same system. If one partition reports an error for a shared resource, such as a managed system power supply, other active partitions report the same error. The Service Focal Point application enables service representatives to avoid long lists of repetitive call-home information by recognizing that these errors repeat, and the filtering them into one error code.

Errors that require service are reported to the HMC as *serviceable events*. Because the HMC stores these serviceable events for 90 days and then discards them, it is important to have the partition and HMC date and time set correctly. For instance, if the date on a partition's software is set 90 days *behind* the HMC's set time, the serviceable events reported from this partition are immediately discarded. For more information about setting the HMC's date and time, see the *IBM Hardware Management Console for pSeries Installation and Operations Guide*, order number SA38-0590. To set the partition's date and time, see the documentation provided with the operating system that is running on that partition.

Getting Started

When you are setting up Service Focal Point, keep the following in mind:

- If the time configured on a partition is 90 days older than time configured on the HMC, serviceable events cannot be reported.
- Verify that the HMC host names are defined. For more information on using fully qualified and short host names, see the *IBM Hardware Management Console for pSeries Installation and Operations Guide*, order number SA38-0590.
- If you need to add or change a partition name, see *IBM Hardware Management Console for pSeries Installation and Operations Guide*.

Testing Error Reporting

To ensure that Service Focal Point is configured properly, generate a test error by doing the following:

1. In the partition, run diagnostics to test the managed system's operator panel.
2. When the diagnostics window asks you if you see **0000** on the managed system's operator panel, select **NO**. This action generates an error.
3. In the SRN window, type **Enter** to proceed.
4. When the system asks you if you want the error sent to Service Focal Point, select **YES**.
5. Type **F3** to exit diagnostics.
6. Wait for one minute while the managed system sends the error to Service Focal Point.
7. Check the Serviceable Event window to ensure that the error was sent to Service Focal Point and that Service Focal Point reported the error. For more information about working with serviceable events, see "Working With Serviceable Events" on page 117.

Service Focal Point Settings

The Service Focal Point Settings task in the Contents area allows you to configure your HMC's Service Focal Point application.

Note: The Advanced Operator, Operator and Viewer roles have read-only access to the following tasks.

Automatic Call-Home Feature

You can configure the HMC to automatically call an appropriate service center when it identifies a serviceable event.

To enable or disable the call-home feature, you must be a member of one of the following roles:

- System Administrator
- Service Representative

To enable or disable the call-home feature for one or more systems, do the following:

Note: It is strongly recommended that you not disable the call-home feature. When you disable the call-home feature, serviceable events are not automatically reported to your service representative.

1. In the Navigation area, click the **Service Applications** icon.
2. In the Navigation area, double-click the **Service Focal Point** icon.
3. In the Contents area, click **Service Focal Point Settings**.
4. The Service Focal Point Settings window opens. Select the **CEC Call Home** tab on the top of the window.
5. Click on the managed system you want to enable or disable.
6. Click **Enable** to enable call-home for the selected system, or click **Disable** to disable call-home for the selected system.
7. Click **OK**.

Setting Up Surveillance

Service Focal Point surveillance generates serviceable events when it detects communication problems between the HMC and its managed systems.

You can configure how you want the HMC to survey the following:

- The number of disconnected minutes considered an outage
- The number of connected minutes you want the HMC to consider a recovery
- The number of minutes between outages considered a new incident

To set up surveillance, you must be a member of one of the following roles:

- System Administrator
- Service Representative

To set up surveillance, do the following:

1. In the Navigation area, click the **Service Applications** icon.
2. In the Navigation area, double-click the **Service Focal Point** icon.
3. In the Contents area, select **Service Focal Point Settings**.
4. The Service Focal Point Settings window opens. Select the **Surveillance Setup** tab on the top of the window.
5. In the first field, select the number of minutes you want the HMC to wait before sending a disconnection error message.

6. In the second field, select the amount of connection time that the HMC is considered to be recovered. This amount is expressed in minutes.
7. In the third field, select the number of minutes between outages that you want the HMC to wait before sending a new incident report.
8. Select one or more managed systems from the table in the lower part of the window and then click **Enable** or **Disable**. Surveillance is then either enabled or disabled for the selected managed systems.

Enabling Surveillance Notifications

You can enable or disable surveillance-error notification from this HMC to connected managed systems. Enabling this notification causes errors to be passed to the Service Agent application for notification.

To set up surveillance, you must be a member of one of the following roles:

- System Administrator
- Service Representative

To set up surveillance-error notification, do the following:

1. In the Navigation area, click the **Service Applications** icon.
2. In the Navigation area, double-click the **Service Focal Point** icon.
3. In the Contents area, select **Service Focal Point Settings**.
4. The **Service Focal Point Settings** window opens. Select the **Surveillance Notification** tab on the top of the window.
5. Select one or more managed systems from the list and then click **Enable** or **Disable**. Surveillance notification is then either enabled or disabled for the selected managed systems.

Working With Serviceable Events

You can view, add, or update serviceable event information, including error details.

Viewing Serviceable Events

To view serviceable events, you must be a member of one of the following roles:

- System Administrator
- Service Representative
- Advanced Operator
- Operator
- Viewer

To view a serviceable event, do the following:

1. In the Navigation area, click the **Service Applications** icon.
2. In the Navigation area, double-click the **Service Focal Point** icon.
3. In the Contents area, click **Select Serviceable Event**.
4. Designate the set of serviceable events you want to view. Click **OK** when you are finished.
5. The Serviceable Event Overview window opens, and the entries displayed are ordered by time stamp. Each line in the Serviceable Event Overview window corresponds to one error within a serviceable event. On this window, designate the set of serviceable events you want to view by specifying your search criteria (such as event status or error class).

Note: Only events that match *all* of the criteria that you specify are shown. When you are finished, click **OK**.

When you select a line in the Serviceable Event Overview window, all lines in the same serviceable event are selected. To open the Serviceable Event Details window for the selected event, select the event and click **Event Details**.

Viewing Serviceable Event Details

To view serviceable event details, do the following:

1. Perform the steps in “Viewing Serviceable Events” on page 117.
2. The Serviceable Event Details window opens, showing extended serviceable event information, including the following:
 - Status
 - Earliest original time stamp of any managed object
 - AIX error log
 - Should this error ever get called home?
 - Error was called home
 - Pointer to extended error-data collection on the HMC

The window’s lower table displays all of the errors associated with the selected serviceable event. The information is shown in the following sequence:

- Failing device system name
- Failing device machine type/model/serial
- Error class
- Descriptive error text

Viewing Serviceable Event Error Details

To view serviceable event error details, do the following:

1. Perform the steps in “Viewing Serviceable Event Details.”
2. Select an error in the lower table, and click **Error Details**.

Viewing Service Processor Error Details

To view service processor error details, do the following:

1. Perform the steps in “Viewing Serviceable Event Error Details.”
2. If the serviceable event error details you are viewing are for a service processor-class error, the lower table on the resulting window contains service processor errors. Select a service processor error from the lower table, and click **Service Processor Error Details** to see further details.

Saving and Managing Extended Error Data

To save extended error (EE) data, do the following:

1. Perform the steps in “Viewing Serviceable Event Details.”
2. Click **Save EE Data**. To save extended error data for only *one* error associated with the serviceable event (rather than for the entire serviceable event), select the error from the lower table and then click **Error Details**. In the next menu, click **Manage EE Data**.

Viewing and Adding Serviceable Event Comments

To add comments to a serviceable event, you must be a member of the Service Representative role.

To add comments to a serviceable event, do the following:

Note: You cannot edit or delete previous comments.

1. Perform the steps in “Viewing Serviceable Event Details.”

2. Select the error to which you want to add comments to and click **Comments....** If you want to close the event and add comments, click **Close Event** from this window. The Serviceable Event Comments window opens.
3. Type your name and add comments as appropriate. You can also review previous comments, but you cannot edit this information.
4. If you clicked **Comments** on the Serviceable Event Details window, clicking **OK** commits your entry and returns you to the Serviceable Event Details window.

If you clicked **Close Event** on the Serviceable Event Details window, clicking **OK** commits all changes and opens the Update FRU Information window. For more information about updating field replaceable unit information, see “Updating Field Replaceable Unit (FRU) Information.”

Closing a Serviceable Event

To close a serviceable event, do the following:

1. Perform the steps in “Viewing Serviceable Event Details” on page 118.
2. Select the error to which you want to add comments and click **Comments....**
3. Click **Close Event** from this window. The Serviceable Event Comments window opens.
4. Click **OK** to commit your comments. The **Update FRU Information** window displays. See “Updating Field Replaceable Unit (FRU) Information” for information on completing this window. Click **OK** on the **Update FRU Information** window to close the serviceable event.

Note: You must close a serviceable event after it has been serviced to ensure that if a similar error is reported later, it is called home. If an old problem remains open, the new similar problem is reported as a duplicate. Duplicate errors are neither reported nor called home to a service center. Close a serviceable event when the partition that reports the error is active. Closing the event causes the new status of the serviceable event to be properly sent to the partition.

Updating Field Replaceable Unit (FRU) Information

This task allows you to update the FRU information you changed or modified as a result of this serviceable event. From this panel, you can also activate and deactivate LEDs and search for other serviceable events that contain the same FRU entries.

To update FRU information, do the following:

1. Perform the steps in “Viewing Serviceable Event Details” on page 118.
2. Click **FRU Information...** . The Update FRU Information window opens.

The lower table shows any parts that you have replaced or added during your current update session but that have not been committed to the serviceable event. The changes from the lower table are committed by clicking the **OK** or **Apply**.

From this window, you can also activate and deactivate LEDs and search for other Serviceable Events that contain the same FRU entries.

Replacing an Existing FRU

To replace a part already listed for this serviceable event, do the following:

1. Perform the steps in “Updating Field Replaceable Unit (FRU) Information.”
2. In the upper table, double-click the part you want to replace.
3. If the FRU has a new part number, type it in the **New FRU Part Number** field.
4. Click **Replace FRU**. The Update FRU Information window displays the FRU replacement information in the lower table. Click **OK** or **Apply** to commit the changes to the serviceable event.

Adding a New FRU

You can add a part to the serviceable event that was not listed in the upper table of the Update FRU Information window. To add a new FRU for this serviceable event, do the following:

1. Perform the steps in “Updating Field Replaceable Unit (FRU) Information” on page 119.
2. Click **Add New FRU to List**.
3. Type the FRU’s location code and its part number in the appropriate fields.
4. Click **Add to List**. The Update FRU Information window opens and displays the newly added FRU in the lower table.
5. Click **OK** or **Apply** to commit these changes to the serviceable event.

Note: After you click **OK** or **Apply**, you cannot change this information. If you clicked the **Close Event** button in the Serviceable Event Details window, then clicking **OK** also completes the close dialog and changes the status of the serviceable event to *Closed*.

Viewing Serviceable Event Partition Information

You can view partition information associated with this serviceable event. This information includes each affected partition’s state and resource use.

1. Perform the steps in “Viewing Serviceable Event Details” on page 118.
2. Click **Partition Info...**

Hardware Service Functions

The following section describes the Hardware Service Functions tool for the HMC.

Activating and Deactivating FRU Identity LEDs

This task allows you to activate or deactivate a managed system’s system attention LED or any FRU identity LED. FRU identity LEDs are helpful in determining which FRUs need servicing.

To activate or deactivate a managed system’s System Attention LED, do the following:

1. In the Navigation area, click the **Service Applications** icon.
2. In the Navigation area, double-click the **Service Focal Point** icon.
3. In the Contents area, select **Hardware Service Functions**. The **LED Management** window opens.
4. In the LED Management window, select one or more managed systems from the table.
5. Select either **Activate LED** or **Deactivate LED**. The associated System Attention LED is then either turned on or off.

To activate or deactivate a FRU associated with a particular managed system, do the following:

1. In the Navigation area, click the **Service Applications** icon.
2. In the Navigation area, double-click the **Service Focal Point** icon.
3. In the Contents area, click **Hardware Service Functions**. The **LED Management** window opens.
4. In the **LED Management** window, select one managed system from the table.
5. Click the **List FRUs...** button. The list of FRU slot indices and their respective current LED states display.
6. Select one or more FRU slot indexes.
7. Click either the **Activate LED** or the **Deactivate LED** button.

The associated FRU Identity LEDs are now either enabled (blinking) or off.

Appendix B. Environmental Notices

Product Recycling and Disposal

This unit contains materials such as circuit boards, cables, electromagnetic compatibility gaskets and connectors which may contain lead and copper/beryllium alloys that require special handling and disposal at end of life. Before this unit is disposed of, these materials must be removed and recycled or discarded according to applicable regulations. IBM offers product-return programs in several countries. For country specific instructions refer to the following web site: <http://www.ibm.com/ibm/environment/products/prp.phtml>

This product may contain a sealed lead acid, nickel cadmium, nickel metal hydride, lithium, or lithium ion battery. Consult your user manual or service manual for specific battery information. The battery must be recycled or disposed of properly. Recycling facilities may not be available in your area. For information on disposal of batteries, contact your local waste disposal facility.

In the United States, IBM has established a collection process for reuse, recycling, or proper disposal of used IBM sealed lead acid, nickel cadmium, nickel metal hydride, and other battery packs from IBM Equipment. For information on proper disposal of these batteries, please contact IBM at 1-800-426-4333. Have the IBM part number listed on the battery available prior to your call.

Environmental Design

The environmental efforts that have gone into the design of this system signify IBM's commitment to improve the quality of its products and processes. Some of these accomplishments include the elimination of the use of Class 1 ozone-depleting chemicals in the manufacturing process and reductions in manufacturing wastes. For more information, contact an IBM account representative.

Acoustical Noise Emissions

The equivalent continuous A-weighted sound pressure level at workstations (emission sound pressure level at the 1-meter bystander positions) does not exceed 70 dB(A).

Der Geräuschpegel der Einheit ist kleiner oder gleich 70 db(A).

Appendix C. Notices

This information was developed for products and services offered in the U.S.A.

The manufacturer may not offer the products, services, or features discussed in this document in other countries. Consult the manufacturer's representative for information on the products and services currently available in your area. Any reference to the manufacturer's product, program, or service is not intended to state or imply that only that product, program, or service may be used. Any functionally equivalent product, program, or service that does not infringe any intellectual property right of the manufacturer may be used instead. However, it is the user's responsibility to evaluate and verify the operation of any product, program, or service.

The manufacturer may have patents or pending patent applications covering subject matter described in this document. The furnishing of this document does not give you any license to these patents. You can send license inquiries, in writing, to the manufacturer.

The following paragraph does not apply to the United Kingdom or any country where such provisions are inconsistent with local law: THIS MANUAL IS PROVIDED "AS IS" WITHOUT WARRANTY OF ANY KIND, EITHER EXPRESSED OR IMPLIED, INCLUDING, BUT NOT LIMITED TO, THE IMPLIED WARRANTIES OF NON-INFRINGEMENT, MERCHANTABILITY OR FITNESS FOR A PARTICULAR PURPOSE. Some states do not allow disclaimer of express or implied warranties in certain transactions; therefore, this statement may not apply to you.

This information could include technical inaccuracies or typographical errors. Changes are periodically made to the information herein; these changes will be incorporated in new editions of the publication. The manufacturer may make improvements and/or changes in the product(s) and/or the program(s) described in this publication at any time without notice.

Information concerning products made by other than the manufacturer was obtained from the suppliers of those products, their published announcements, or other publicly available sources. The manufacturer has not tested those products and cannot confirm the accuracy of performance, compatibility or any other claims related to products made by other than the manufacturer. Questions on the capabilities of products made by other than the manufacturer should be addressed to the suppliers of those products.

Index

A

- about this book ix
- ac, power cables 5
- accessing information x
- acoustical
 - noise
 - emissions 121
- adapters
 - configuring RS422 ports on an 8-port 91
 - configuring serial 89
- adding
 - FRUs 120
 - serviceable event comments 118
- automatic call home
 - overview 116

B

- backup profiles 88
- battery
 - disposal, recycling 121
- boot error values 85

C

- cables
 - ac power 5
- cabling, HMC 2
- cabling, managed system 2
- configuration, system 88
- configuration, system board 88
- console hardware logs, viewing 9

D

- diagnostic procedures 15
- diagnostics 7
- diskette drive MAP 23
- diskette MAP 26
- display problems MAP 27
- DVD RAM MAP 24

E

- emissions
 - noise 121
- entry MAP 12
- error code to FRU index 29
- error messages 29
 - perform a file system check* indicated 84
 - reboot the HMC* indicated 83
 - rebuild managed system* indicated 83
 - backup and restore 56
 - CIMOM 60
 - HMC 61
 - inventory scout 29

- error messages (*continued*)
 - managed system 42, 69
 - managed system resource 46
 - operating system reset 55
 - partition 48
 - profile 52
 - profile data 32
 - recovery actions 83
 - service focal point 73
 - system profile 53
 - unity class 59
 - user management 63
 - virtual terminal 56, 78
 - window 62
- errors
 - virtual terminal 78
- Ethernet MAP 22
- extended error data
 - managing 118

F

- flow, diagnostic 7
- FRU
 - updating information 119
- FRU identity LEDs
 - activating 120
 - deactivating 120
- FRU index, error code 29
- FRUs
 - adding 120
 - replacing 119

H

- hardware service functions 120
 - activating and deactivating FRU identity LEDs 120
- highlighting ix
- HMC
 - viewing the software log 9
- HMC cabling 2
- HMC code update 89
- HMC lock
 - releasing 86
- HMC software support 9
- HMC, overview 1

I

- image, restoring the HMC 88
- information, accessing x
- inspection guide, service 5
- installing 128-port ASYNC adapter 92
- installing 8-port ASYNC adapter 89

L

- laser compliance statement v
- laser safety information v
- locations 4
- logical partitions
 - operating states 80

M

- maintenance analysis procedures 7
- managed system
 - error state 85
 - incomplete state 85
 - no connection state 84
 - open firmware state 85
 - recovery state 85
 - error messages 69
 - operating states 79
 - states 84
- managed system cabling 2
- managed system testing 17
- managed system, operation 2
- managing
 - extended error data 118
- MAP 1020 problem determination 13
- MAP 1520 problem determination 15
- MAP 1530 testing the HMC 15
- MAP, disk drive 23
- MAP, diskette 26
- MAP, display problems 27
- MAP, DVD MAP 24
- MAP, entry 12
- MAP, Ethernet 22
- MAP, modem 19
- MAPs 7, 10
- microcode update 88
- modem MAP 19

N

- noise
 - emissions 121

O

- on/off, power 4
- online publications x
- operating states
 - error 85
 - HMC 84
 - incomplete 85
 - managed system 79
 - no connection 84
 - partition 80
 - recovery 85
 - recovery information 79
- operation, managed system 2
- overview
 - service focal point 115
- Overview, diagnostic 7

- overview, HMC 1

P

- partition
 - operating states 80
- parts list 95
 - 6578-KLU 96
 - 7315-C01 99
 - 7315-C02 103
 - 7315-C03 110
 - 7315-CR2 106
 - console parts 95
 - power cords 113
- PC configuration 89
- power cables, ac 5
- power-on self-test 4
- powering off 4
- powering on 4
- preface ix
- problem determination 13, 15
 - application overview 9
 - viewing the HMC console log 9
- procedures, diagnostic 15
- procedures, maintenance analysis 10
- procedures, removal and replacement 87
- procedures, service 87
- product disposal 121
- profiles, backup 88
- publications
 - accessing x
 - online x

R

- recover information
 - incomplete state 85
- recovery 7
- recovery information 29
 - error 83
 - error state 85
 - managed system operating states 79
 - operating states 79, 80
 - rebooting the HMC 83
 - rebuilding a managed system 83
 - recovery procedure 86
 - recovery state 85
 - virtual terminal errors 78
- recycling 121
- removal and replacement procedures 87
- removal and replacements 89
- replacing
 - FRUs 119
- restore information
 - operating states 84
- restorey information
 - no connection state 84
- restoring the HMC image 88
- RS422 ports
 - configuring on an 8-port adapter 91

S

- safety notices v
 - laser compliance statement v
- self-test, power-on 4
- serial adapters
 - configuring 89
- service focal point
 - activating and deactivating FRU identity LEDs 120
 - adding FRUs 120
 - call home overview 116
 - closing a serviceable event 119
 - enabling surveillance notifications 117
 - error messages 73
 - hardware service functions 120
 - overview 115
 - replacing FRUs 119
 - saving and managing extended error data 118
 - serviceable events 117
 - setting up surveillance 116
 - settings 116
 - testing error reporting 115
 - updating FRU information 119
 - viewing and adding serviceable event comments 118
 - viewing error details 118
 - viewing service processor error details 118
 - viewing serviceable event details 118
 - viewing serviceable event partition information 120
 - viewing serviceable events 117
- service inspection guide 5
- service procedures 87
- serviceable event
 - viewing partition information 120
- serviceable events
 - adding comments 118
 - selecting and viewing 117
 - updating FRU information 119
 - viewing comments 118
 - viewing details 118
 - viewing error details 118
 - viewing service processor error details 118
 - working with 117
- software support 9
- specifications 4
- support, HMC software 9
- symptom to action list 29
- system board configuration 88
- system configuration 88
- system connection, managed 17
- system unit locations 4
- system unit testing 16

T

- test 7
- testing system unit 16
- testing the HMC 15

U

- update device microcode 88
- update HMC ocode 89
- updating
 - FRU information 119
- user
 - error messages 63

V

- viewing
 - serviceable event comments 118
 - serviceable event details 118
 - serviceable event error details 118
 - serviceable event partition information 120
- viewing hardware console logs 9
- virtual terminal
 - errors 78

Readers' Comments — We'd Like to Hear from You

Hardware Management Console for pSeries
Maintenance Guide

Publication No. SA38-0603-04

Overall, how satisfied are you with the information in this book?

	Very Satisfied	Satisfied	Neutral	Dissatisfied	Very Dissatisfied
Overall satisfaction	<input type="checkbox"/>	<input type="checkbox"/>	<input type="checkbox"/>	<input type="checkbox"/>	<input type="checkbox"/>

How satisfied are you that the information in this book is:

	Very Satisfied	Satisfied	Neutral	Dissatisfied	Very Dissatisfied
Accurate	<input type="checkbox"/>	<input type="checkbox"/>	<input type="checkbox"/>	<input type="checkbox"/>	<input type="checkbox"/>
Complete	<input type="checkbox"/>	<input type="checkbox"/>	<input type="checkbox"/>	<input type="checkbox"/>	<input type="checkbox"/>
Easy to find	<input type="checkbox"/>	<input type="checkbox"/>	<input type="checkbox"/>	<input type="checkbox"/>	<input type="checkbox"/>
Easy to understand	<input type="checkbox"/>	<input type="checkbox"/>	<input type="checkbox"/>	<input type="checkbox"/>	<input type="checkbox"/>
Well organized	<input type="checkbox"/>	<input type="checkbox"/>	<input type="checkbox"/>	<input type="checkbox"/>	<input type="checkbox"/>
Applicable to your tasks	<input type="checkbox"/>	<input type="checkbox"/>	<input type="checkbox"/>	<input type="checkbox"/>	<input type="checkbox"/>

Please tell us how we can improve this book:

Thank you for your responses. May we contact you? Yes No

When you send comments to IBM, you grant IBM a nonexclusive right to use or distribute your comments in any way it believes appropriate without incurring any obligation to you.

Name

Address

Company or Organization

Phone No.



Fold and Tape

Please do not staple

Fold and Tape



NO POSTAGE
NECESSARY
IF MAILED IN THE
UNITED STATES

BUSINESS REPLY MAIL

FIRST-CLASS MAIL PERMIT NO. 40 ARMONK, NEW YORK

POSTAGE WILL BE PAID BY ADDRESSEE

Information Development
Department H6DS-905-6C006
11501 Burnet Road
Austin, TX 78758-3493



Fold and Tape

Please do not staple

Fold and Tape



Printed in USA

December 2003

SA38-0603-04

