

Expandable Storage Plus

# 2104 Model DU3 Installation Guide



Expandable Storage Plus

# 2104 Model DU3 Installation Guide

**Second Edition (December 2000)**

| This revision supersedes GA33-3311-00. Technical changes are shown by a vertical line to the left of each change.

**The following paragraph does not apply to any country where such provisions are inconsistent with local law:**

THIS PUBLICATION IS PRINTED "AS IS" WITHOUT WARRANTY OF ANY KIND, EITHER EXPRESS OR IMPLIED, INCLUDING, BUT NOT LIMITED TO, THE IMPLIED WARRANTIES OF MERCHANTABILITY OR FITNESS FOR A PARTICULAR PURPOSE. Some states do not allow disclaimer of express or implied warranties in certain transactions; therefore, this statement may not apply to you.

This publication could contain technical inaccuracies or typographical errors. Changes are periodically made to the information herein; these changes will be incorporated in new editions of the publication.

It is possible that this publication may contain reference to, or information about, products (machines and programs), programming, or services that are not announced in your country. Such references or information must not be construed to mean that such products, programming, or services will be offered in your country. Any reference to a licensed program in this publication is not intended to state or imply that you can use only the licensed program indicated. You can use any functionally equivalent program instead.

© Copyright International Business Machines Corporation, 2000. All rights reserved.

Note to U.S. Government Users – Documentation related to restricted rights – Use, duplication, or disclosure is subject to restrictions set forth in the GSA ADP Schedule Contract.



---

# Contents

<b>Communications Statements</b> . . . . .	v
Federal Communications Commission (FCC) Statement . . . . .	v
Japanese Voluntary Control Council for Interference (VCCI) Statement. . . . .	v
Korean Government Ministry of Communication (MOC) Statement . . . . .	v
New Zealand Compliance Statement . . . . .	v
International Electrotechnical Commission (IEC) Statement . . . . .	vi
Avis de conformité à la réglementation d'Industrie Canada . . . . .	vi
Industry Canada Compliance Statement. . . . .	vi
United Kingdom Telecommunications Requirements . . . . .	vi
European Union (EU) Statement . . . . .	vi
Radio Protection for Germany . . . . .	vi
Taiwan Class A Compliance Statement . . . . .	vii
<b>Safety Notices</b> . . . . .	ix
Definitions of Safety Notices. . . . .	ix
Safety Notice for Installing, Relocating, or Servicing . . . . .	ix
<b>Electrostatic Discharge (ESD)</b> . . . . .	xi
<b>About This Book</b> . . . . .	xiii
Numbering Convention . . . . .	xiii
Related Publications . . . . .	xiii
Trademarks . . . . .	xiii
<b>Installing a 2104 Model DU3</b> . . . . .	1
Installing a 2104 Model DU3 into a Rack . . . . .	3
Checking the Items for a 2104 Model DU3 . . . . .	4
Preparing the Rack (System or Expansion) . . . . .	5
Removing the Disk Drive Modules and Dummy Disk Drive Modules. . . . .	8
Installing the 2104 Model DU3 into the Rack . . . . .	13
Reinstalling the Disk Drive Modules and Dummy Disk Drive Modules. . . . .	16
Setting the Options on the 2104 Model DU3 . . . . .	19
Connecting the 2104 Model DU3 to the Power Source . . . . .	30
Connecting the 2104 to the Using System. . . . .	32
Switching On and Testing the 2104 . . . . .	34
<b>Appendix A. Operating with RISC Systems</b> . . . . .	37
SCSI Service Aids. . . . .	37
Identifying 2104s and Disk Drive Modules . . . . .	37
Configuring a 2104 to the using system . . . . .	37
Unconfiguring a 2104 from the using system . . . . .	38
Valid 2104 Model DU3 Configurations . . . . .	39
Summary of Valid 2104 Model DU3 Configurations . . . . .	40
Single-Bus Mode Configurations . . . . .	41
Dual-Bus Mode Configurations . . . . .	48
Configurations That are Not Valid. . . . .	54
Two Adapters in One Using System Connected to One 2104 . . . . .	54

One Adapter in One Using System Connected to Two 2104s via the SCSI Interface Cards . . . . .	55
One Adapter in One Using System Connected to 2104s via a Y-Cable (1) . . . . .	56
One Adapter in One Using System Connected to 2104s via a Y-Cable (2) . . . . .	57
One Dual-Channel Non-RAID Adapter in One Using System Connected to Two 2104s and Internal Disk Drives. . . . .	58
One RAID Adapter in Each of Two Using Systems Connected to Two 2104s . . . . .	59
Collecting Errors . . . . .	60
Web Support Pages . . . . .	60
Related Publications . . . . .	61
<b>Appendix B. Translated Safety Notices . . . . .</b>	<b>63</b>

---

## **Communications Statements**

The following statements apply to this product. The statements for other products intended for use with this product appear in their accompanying manuals.

---

### **Federal Communications Commission (FCC) Statement**

This equipment has been tested and found to comply with the limits for a Class A digital device, pursuant to Part 15 of the FCC Rules. These limits are designed to provide reasonable protection against harmful interference when the equipment is operated in a commercial environment. This equipment generates, uses, and can radiate radio frequency energy and, if not installed and used in accordance with the instruction manual, may cause interference to radio communications. Operation of this equipment in a residential area is likely to cause harmful interference, in which case the user will be required to correct the interference at his own expense.

Properly shielded and grounded cables and connectors must be used in order to meet FCC emission limits. Neither the provider nor the manufacturer is responsible for any radio or television interference caused by using other than recommended cables and connectors or by unauthorized changes or modifications to this equipment. Unauthorized changes or modifications could void the user's authority to operate the equipment.

This device complies with Part 15 of FCC Rules. Operation is subject to the following two conditions: (1) this device may not cause harmful interference, and (2) this device must accept any interference received, including interference that may cause undesired operation.

---

### **Japanese Voluntary Control Council for Interference (VCCI) Statement**

This product is a Class A Information Technology Equipment and conforms to the standards set by the Voluntary Control Council for Interference by Information Technology Equipment (VCCI). In a domestic environment, this product might cause radio interference, in which event the user might be required to take adequate measures.

---

### **Korean Government Ministry of Communication (MOC) Statement**

Please note that this device has been approved for business purposes with regard to electromagnetic interference. If you find that this device is not suitable for your use, you can exchange it for one that is approved for non-business purposes.

---

### **New Zealand Compliance Statement**

This is a Class A product. In a domestic environment this product might cause radio interference, in which event the user might be required to take adequate measures.

---

## International Electrotechnical Commission (IEC) Statement

This product has been designed and built to comply with (IEC) Standard 60950.

---

## Avis de conformité à la réglementation d'Industrie Canada

Cet appareil numérique de la classe A est conforme à la norme NMB-003 du Canada.

---

## Industry Canada Compliance Statement

This Class A digital apparatus complies with IECS-003.

---

## United Kingdom Telecommunications Requirements

This apparatus is manufactured to the International Safety Standard EN60950 and as such is approved in the U.K. under approval number NS/G/1234/J/100003 for indirect connection to public telecommunications systems in the United Kingdom.

---

## European Union (EU) Statement

This product is in conformity with the protection requirements of EU council directive 89/336/EEC on the approximation of the laws of the Member States relating to electromagnetic compatibility. Neither the provider nor the manufacturer can accept responsibility for any failure to satisfy the protection requirements resulting from a non-recommended modification of the product, including the fitting of option cards not supplied by the manufacturer.

This product is in conformity with the EU council directive 73/23/EEC on the approximation of the laws of the Member States relating to electrical equipment designed for use within certain voltage limits. This conformity is based on compliance with the following harmonized standard: EN60950.

---

## Radio Protection for Germany

**Zulassungsbescheinigung laut dem Deutschen Gesetz über die elektromagnetische Verträglichkeit von Geräten (EMVG) vom 30. August 1995 (bzw. der EMC EG Richtlinie 89/336):**

Dieses Gerät ist berechtigt in Übereinstimmung mit dem Deutschen EMVG das EG-Konformitätszeichen - CE - zu führen. Verantwortlich für die Konformitätserklärung nach Paragraph 5 des EMVG ist die:

IBM Deutschland Informationssysteme GmbH, 70548 Stuttgart.

Informationen in Hinsicht EMVG Paragraph 3 Abs. (2) :

Das Gerät erfüllt die Schutzerfordernungen nach EN 50082-1 und EN 55022 Klasse A.
---

EN 55022 Klasse A Geräte müssen mit folgendem Warnhinweis versehen werden:  
"Warnung: dies ist eine Einrichtung der Klasse A. Diese Einrichtung kann im

Wohnbereich Funkstörungen verursachen; in diesem Fall kann vom Betreiber verlangt werden, angemessene Massnahmen durchzuführen und dafür aufzukommen."

EN 50082-1 Hinweis:

"Wird dieses Gerät in einer industriellen Umgebung betrieben (wie in EN 50082-2 festgelegt), dann kann es dabei eventuell gestört werden. In solch einem Fall ist der Abstand bzw. die Abschirmung zu der industriellen Störquelle zu vergrössern."

Anmerkung:

Um die Einhaltung des EMVG sicherzustellen sind die Geräte, wie in den Handbüchern angegeben, zu installieren und zu betreiben.

---

## Taiwan Class A Compliance Statement

### 警告使用者:

這是甲類的資訊產品，在居住的環境中使用時，可能會造成射頻干擾，在這種情況下，使用者會被要求採取某些適當的對策。



---

## Safety Notices

---

### Definitions of Safety Notices

A *danger* notice indicates the presence of a hazard that has the potential of causing death or serious personal injury.

This book contains no *danger* notices.

A *caution* notice indicates the presence of a hazard that has the potential of causing moderate or minor personal injury.

This book contains *caution* notices on pages 8, 13, 24, and 27.

An *attention* notice indicates an action that could cause damage to a program, device, system, or data.

---

### Safety Notice for Installing, Relocating, or Servicing

Before connecting or removing any cables to or from connectors at the using system, be sure to follow the steps in the installation or relocation checklist specified in the *Installation and Service Guide*, or equivalent, for your using system.

For safety checks when servicing the Expandable Storage Plus, refer to “Service Inspection Guide” in the *Expandable Storage Plus: 2104 Models DU3 and TU3 Service Guide*.





---

## Electrostatic Discharge (ESD)

**Attention:**

**When you handle field-replaceable units (FRUs) and other computer parts, take these precautions to avoid static damage:**

- **Limit your movement. Movement can cause static electricity to build up around you.**
- **Always touch computer parts carefully. Hold adapters and memory-modules by their edges. Never touch any exposed circuits.**
- **Prevent people who are not correctly grounded from touching computer parts.**
- **Before you install a new part, touch the static-protective package that contains the part against an unpainted metal part of the 2104 or using system for at least two seconds. This action reduces static electricity in the package and in your body.**
- **Remove the part from its package and, if possible, install it directly into the 2104 without putting the part down. If you need to put the part down, first place the static-protective package that contained the part onto a smooth, level surface, then place the part onto the package. Do not place the part onto any metal surface.**



---

## About This Book

This book provides installation instructions for any person who is required to install a 2104 Model DU3, which is a rack-mounted Small Computer Systems Interface (SCSI) disk enclosure.

**Important**

The installation of this product is a customer responsibility.

---

## Numbering Convention

In this book, one gigabyte (GB) equals 1 000 000 000 bytes.

---

## Related Publications

Publications that are related to the Expandable Storage Plus: 2104 Model DU3:

*Expandable Storage Plus: 2104 Models DU3 and TU3 Operator's Guide*, SA33-3310

*Expandable Storage Plus: 2104 Models DU3 and TU3 Service Guide*, GY33-0198

*Expandable Storage Plus: 2104 Models DU3 and TU3 Hardware Technical Information*, SA33-3309

For publications that are related to RISC systems, see "Appendix A. Operating with RISC Systems" on page 37.

---

## Trademarks

The following items are trademarks of International Business Machines Corporation in the United States, or other countries, or both:

- AIX
- IBM
- RS/6000
- @server



---

## Installing a 2104 Model DU3

### Important

The installation of this product is a customer responsibility.

### Attention:

**Before continuing with any of the actions described in this book, please refer to “Appendix B. Translated Safety Notices” on page 63.**

These instructions describe how to:

- Install a 2104 Model DU3 into an RS/6000™ or IBM® server pSeries rack (system rack or expansion rack)
- Connect the 2104 Model DU3 to a power source
- Connect the 2104 Model DU3 to the using system
- Switch on and test the installation

The instructions assume that:

- The rack has already been set up
- A stabilizer has been correctly attached to the bottom front of the rack to prevent the rack from tipping forward while the 2104 Model DU3 is being installed into the rack. (If necessary, see the *Installation and Service Guide*, or equivalent, for the rack.)
- You have access to:
  - Preinstallation planning information for the system
  - 2104 configuration information

If the 2104 Model DU3 has already been installed in the rack:

- Go to “Connecting the 2104 Model DU3 to the Power Source” on page 30 if the power cables for the 2104 have not been installed.
- Go to “Connecting the 2104 to the Using System” on page 32 if the power cables for the 2104 have been installed.

### Notes:

1. Each rack-mounted 2104 requires an airflow of 1.1 m<sup>3</sup> per minute (40 ft<sup>3</sup> per minute). When racks containing many 2104s are to be installed together, the following requirements must be met to ensure that the 2104s are adequately cooled:
  - The airflow enters at the front of the rack and leaves at the back. To prevent the air that is leaving the rack from entering the intake of another piece of equipment, racks should be positioned in alternate rows, back-to-back and front-to-front.
  - The front of racks should be positioned on floor-tile seams, with a full line of perforated tiles immediately in front of the racks. Each perforated tile should have an air flow of at least 11.34 m<sup>3</sup> per minute (400 ft<sup>3</sup> per minute). The underfloor temperature must not exceed 15°C (60°F).

- Where racks are in rows front-to-front or back-to-back, there should be a gap of at least 1220 mm (48 in) separating the rows.
  - To ensure correct air flow within each rack, the rack filler plates must be installed in unused positions. Also, all the gaps in the front of the racks must be sealed, including the gaps between the 2104s.
2. The recommended operating temperature is 22°C (72°F) or lower.

---

## Installing a 2104 Model DU3 into a Rack

Installing a 2104 Model DU3 into an RS/6000 or IBM@server pSeries rack is done by:

1. Preparing the rack
2. Removing the disk drive modules from the 2104 Model DU3
3. Installing the 2104 Model DU3 into the rack
4. Reinstalling the disk drive modules into the 2104 Model DU3

The procedure that is recommended is described in the next four sections of this book, but first you need to check whether you have received all the parts required for your 2104 Model DU3.

## Checking the Items for a 2104 Model DU3

1. Refer to Figure 1.

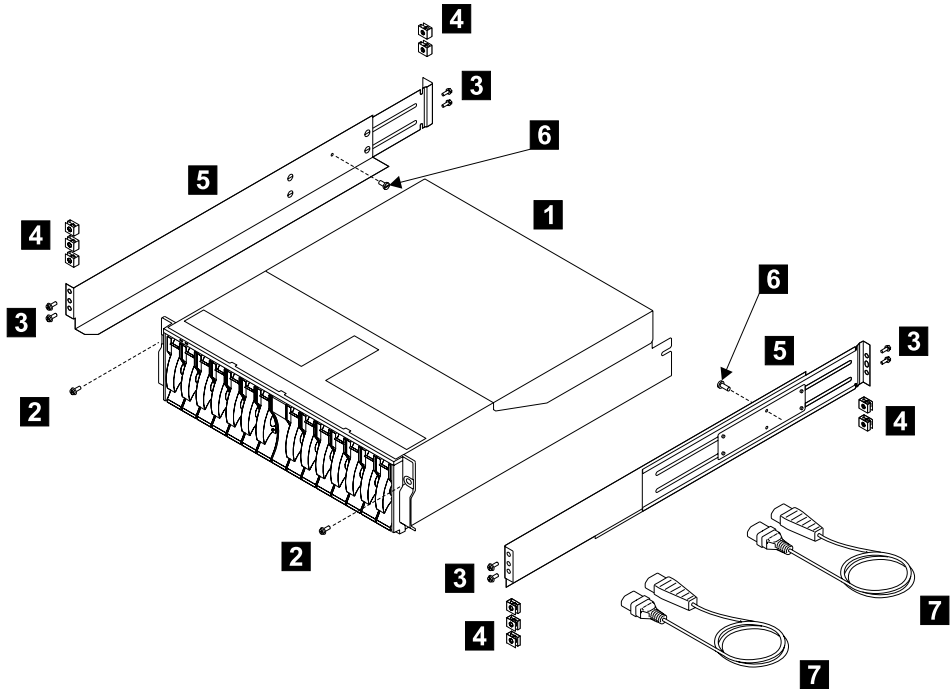

Figure 1. Items for the 2104 Model DU3

<b>1</b>	2104 Model DU3	<b>5</b>	Support rails
<b>2</b>	Mounting screws (front)	<b>6</b>	Mounting screws (back)
<b>3</b>	Rail mounting screws	<b>7</b>	Power cable(s)
<b>4</b>	Nut clips		

**Note:** If your 2104 Model DU3 has only one fan-and-power-supply assembly, only one power cable is supplied.

2. Ensure that you have all the items that are shown on the list.  
In addition to the items shown there is also a sheet of labels. Use these to label your disk enclosure (see 4 on page 19).
3. Refer to the Web site described at “Web Support Pages” on page 60 for the latest microcode and system software levels. When you have completed the installation, you will be asked to ensure that the latest levels of software and microcode have been installed.



## Preparing the Rack (System or Expansion)

1. Find the two support rails ( **5** in Figure 1 on page 4) that are supplied with the 2104.
2. The 2104 Model DU3 is three Electronics Industries Association (EIA) units high. Using the preinstallation planning information, or other relevant information, determine where you are going to locate the 2104 Model DU3 in the rack.

**Notes:**

- If you are installing the 2104 Model DU3 into an empty rack, install it into the lowest available position so that the rack does not become unstable.
  - If you are installing more than one 2104 Model DU3 into the rack, start at the lowest available position, and work upward.
  - You might need to remove the rack power distribution unit before you install the support rails (see the *Installation and Service Guide*, or equivalent, for the rack).
3. Refer to the EIA markings on the rack and decide where you are going to install the support rails. If appropriate, allow for possible future installation of other disk enclosures.

4. Refer to Figure 2.

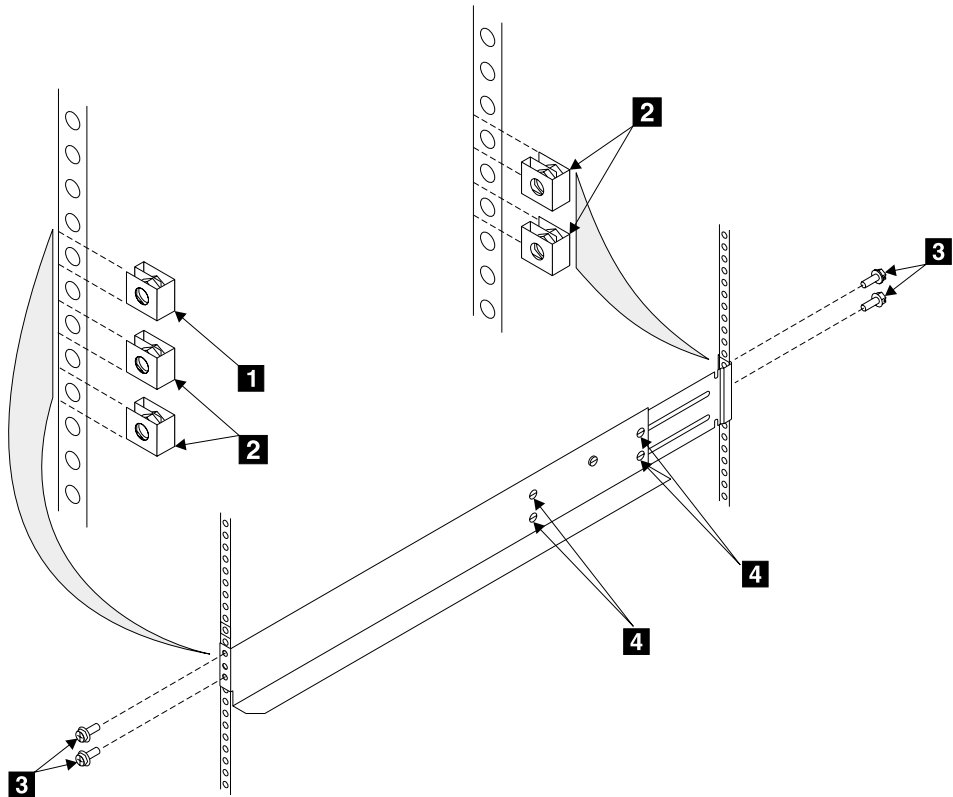

Figure 2. Installing the Support Rails

5. For each support rail:
  - a. Attach nut clips **2** at the selected holes in the front of the rack. These nut clips must align with the upper and lower holes in the support rail.
  - b. Count two holes upward from the upper nut clip, and attach a nut clip **1**.
  - c. At the back of the rack, install two nut clips **3** at the selected holes.
  - d. Loosen the four adjustment screws **4** so that you can adjust the length of the support rail.
  - e. At the front of the rack, locate the support rail so that its mounting lug is **outside** the nut clips **2**.
  - f. Insert the rail screws **5** through the holes in the lug and into the nut clips.
  - g. Partially tighten the screws.
  - h. At the back of the rack, locate the support rail so that its mounting lug is **outside** the nut clips **3**.
  - i. Insert the rail screws **6** through the holes in the lug and into the nut clips.
  - j. Partially tighten the screws.

- k. Check whether the support rail is horizontal (a spirit level might be useful here).  
If the rail is not horizontal, relocate it as necessary.
  - l. Fully tighten the front and back rail screws.
  - m. Fully tighten the four adjustment screws **4**.
6. Go to “Removing the Disk Drive Modules and Dummy Disk Drive Modules” on page 8.

## Removing the Disk Drive Modules and Dummy Disk Drive Modules

### CAUTION:

A 2104 Model DU3 weighs up to 38.5 kg (85 lb) with disk drive modules installed. Do not attempt to lift the 2104 Model DU3 into the rack unless all the disk drive modules have been removed.

**Attention:** Disk drive modules are fragile. Handle them with care, and keep them well away from strong magnetic fields.

1. Refer to Figure 3.

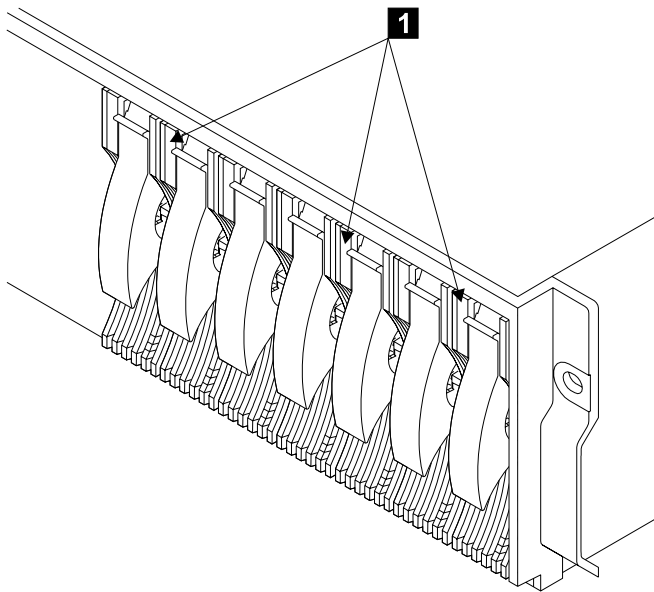

Figure 3. Disk Drive Modules showing position of the Serial Number Label

2. Before you start to remove any modules, make a list of which disk drive modules are in which slots in the 2104 Model DU3. This action helps you to reinstall the modules into their correct slots after you have installed the 2104 Model DU3 into the rack.

Disk drive modules have a serial number label **1**. This label carries the last 8 to 10 digits of the serial number of the disk drive, and also the disk drive type (SCSI) and capacity (for example, 18.2 GB).

**Note:** Each disk drive module also has a SCSI address that is related to its position in the 2104 Model DU3. Disk drive modules **must** be reinstalled into the same slots from which they were removed.

3. Refer to Figure 4.

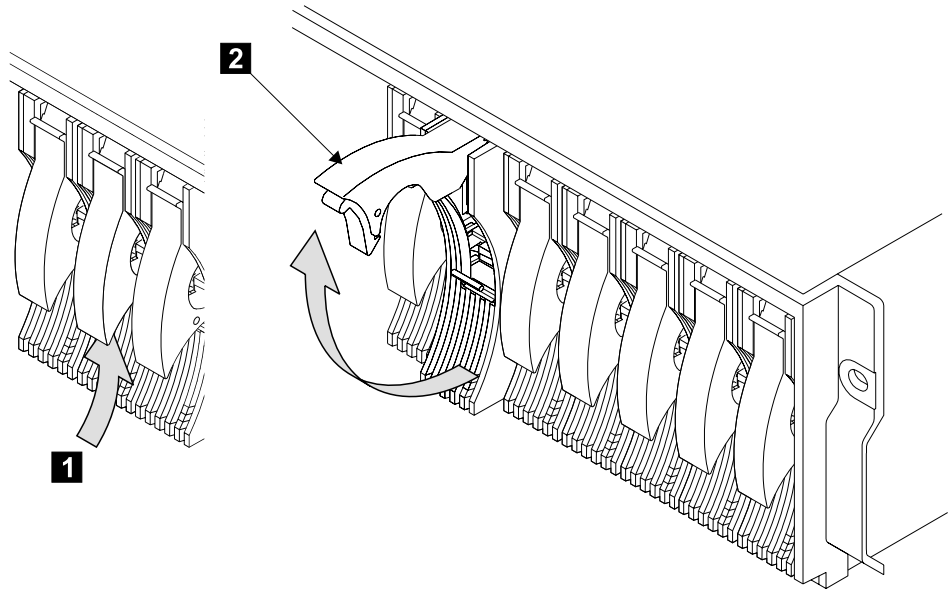

*Figure 4. Opening the Handle of a Disk Drive Module*

4. Press the blue latch **1**, and pull the handle **2** fully up. This action pulls the disk drive module partially out of its slot.

5. Refer to Figure 5.

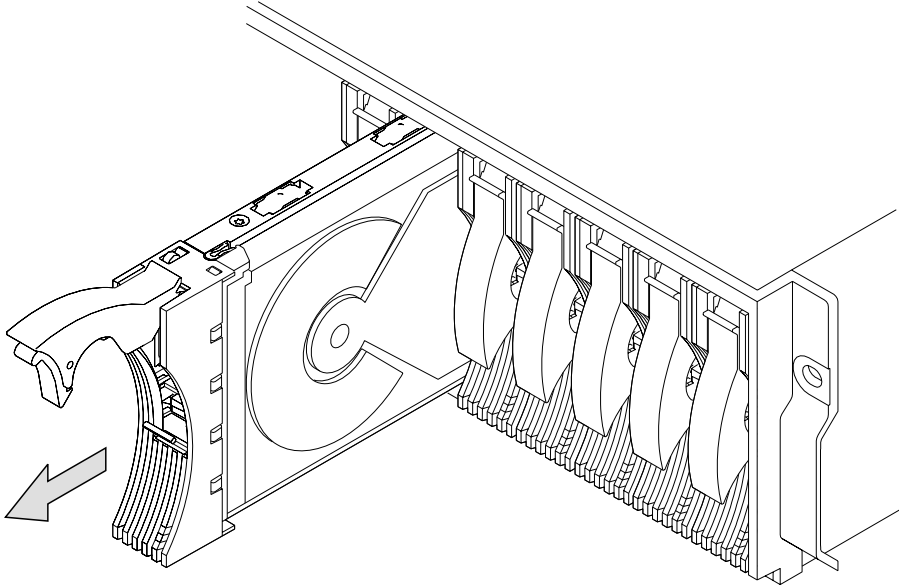

*Figure 5. Removing a Disk Drive Module*

6. Grip the handle, and carefully pull out the disk drive module. As the module comes out, put one hand under its base to prevent it from falling.

7. Lay the disk drive module on its side as shown in Figure 6. It rests on four blue supports (not visible in the figure) on the bottom of the disk drive module. This prevents the disk drive module from falling over and becoming damaged.

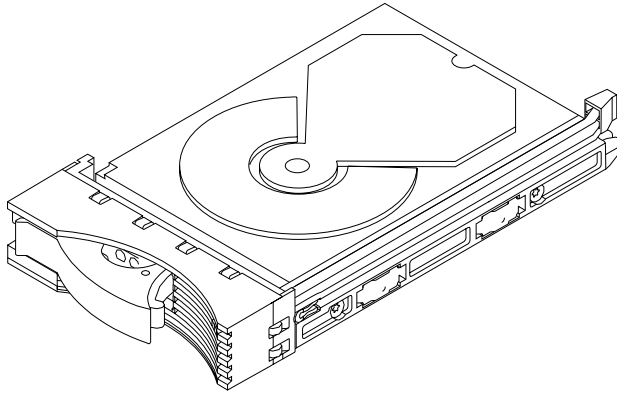

*Figure 6. Disk Drive Module on its Side for Safe Storage*

- Note:** It is recommended that the removed disk drive modules be kept in the sequence they were in before they were removed from the 2104 Model DU3.
8. Repeat steps 3 through 7 for each disk drive module. Ensure that you remove all the disk drive modules from the 2104 Model DU3.

9. You might also want to remove the dummy disk drive modules. A dummy disk drive module has a simple handle. There is no latch to be pulled upward. Refer to Figure 7.

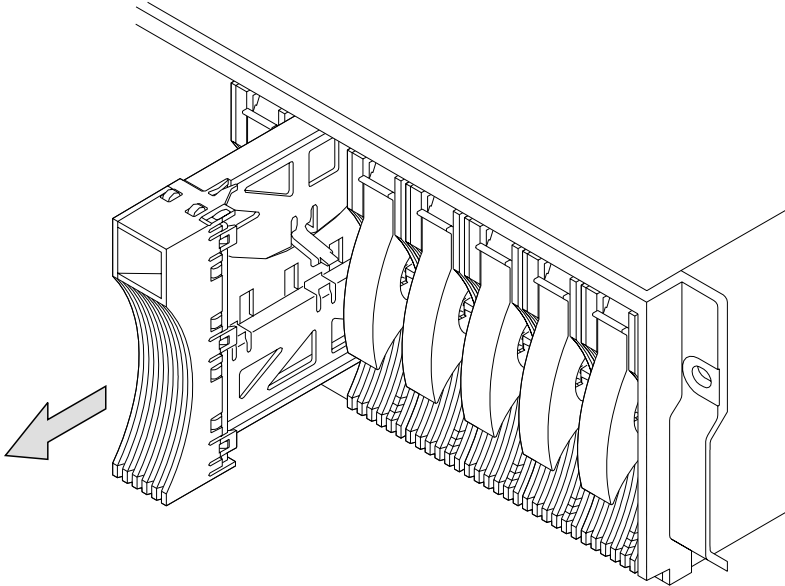

*Figure 7. Removing a Dummy Disk Drive Module*



## Installing the 2104 Model DU3 into the Rack

### CAUTION:

- A 2104 Model DU3 weighs up to 38.5 kg (85 lb) with disk drive modules installed. Do not attempt to lift the 2104 Model DU3 into the rack unless all the disk drive modules have been removed.
- Do not attempt to lift the 2104 by yourself. Ask another person for aid.
- Do not use the handles of the fan or fan-and-power-supply assemblies to carry the 2104. These handles are not intended to support the weight of the 2104.
- The stabilizer must be correctly attached to the bottom front of the rack to prevent the rack from tipping forward while the 2104 Model DU3 is being installed into the rack. Do not pull out or install any unit if the stabilizer is not attached to the rack.
- 

**Note:** If you are going to install the 2104 Model DU3 into a Model T00 or T42 rack, you must also observe the safety notices for those racks before you start. You can find the safety notices in the System Installation chapter of the *7014 Model T00 and T42 Rack Installation and Service Guide*, SA33-0577, or at web page:

[http://www.rs6000.ibm.com/resource/hardware\\_docs/sa38-0577/a4aw9bas.html](http://www.rs6000.ibm.com/resource/hardware_docs/sa38-0577/a4aw9bas.html)

1. If you have not already done so, remove all the disk drive modules from the 2104 Model DU3 (see “Removing the Disk Drive Modules and Dummy Disk Drive Modules” on page 8).
2. Stand at the front of the rack and, with help from another person, place the back of the 2104 Model DU3 onto the support rails, then slide the 2104 Model DU3 into the rack.

3. Refer to Figure 8.

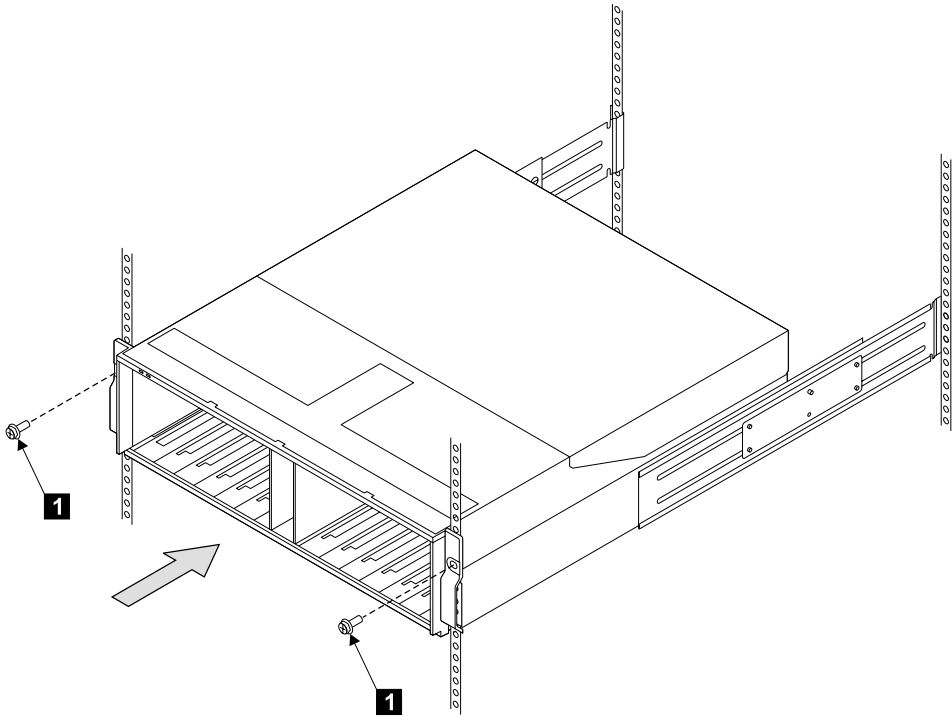

*Figure 8. Installing the Front Mounting Screws*

4. Install the two front mounting screws **1** and tighten them.

5. Refer to Figure 9.

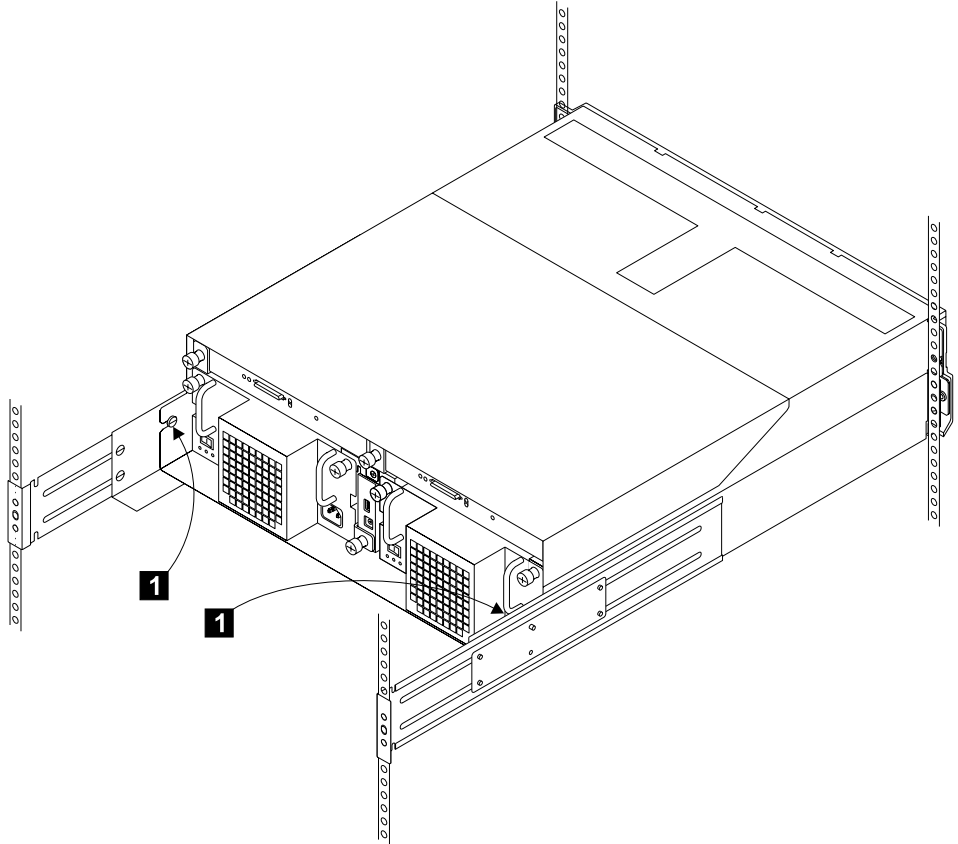

*Figure 9. Installing the Back Mounting Screws*

6. At the back of the rack, install and tighten the two screws **1**.

**Note:** These are the screws identified as **6** in Figure 1 on page 4.

7. Go to “Reinstalling the Disk Drive Modules and Dummy Disk Drive Modules” on page 16.

## Reinstalling the Disk Drive Modules and Dummy Disk Drive Modules

### Attention:

- Disk drive modules are fragile. Handle them with care, and keep them well away from strong magnetic fields.
  - Any slot that has no disk drive module installed *must* contain a dummy disk drive module. The dummy disk drive module ensures that the correct airflow is maintained around the disk drive modules in the other slots.
1. Referring to the note that you made about the original locations of the disk drive modules, reinstall the disk drive modules (in the same sequence that they were removed) as described in the following steps.
  2. Refer to Figure 10.

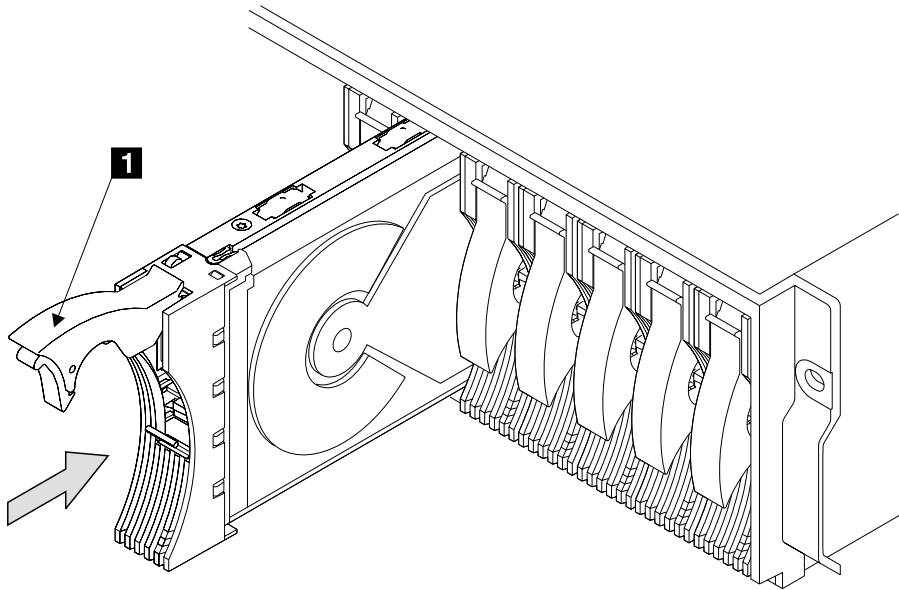

Figure 10. Reinstalling a Disk Drive Module

3. Ensure that the handle **1** is fully open on the disk drive module that you are going to install.
4. With one hand giving support to the base of the disk drive module and the other hand holding the handle **1**, insert the disk drive module and push it into the slot. When the handle touches the front surface of the enclosure, the module stops. Note that the disk drive module is not yet fully home.

5. Refer to Figure 11.

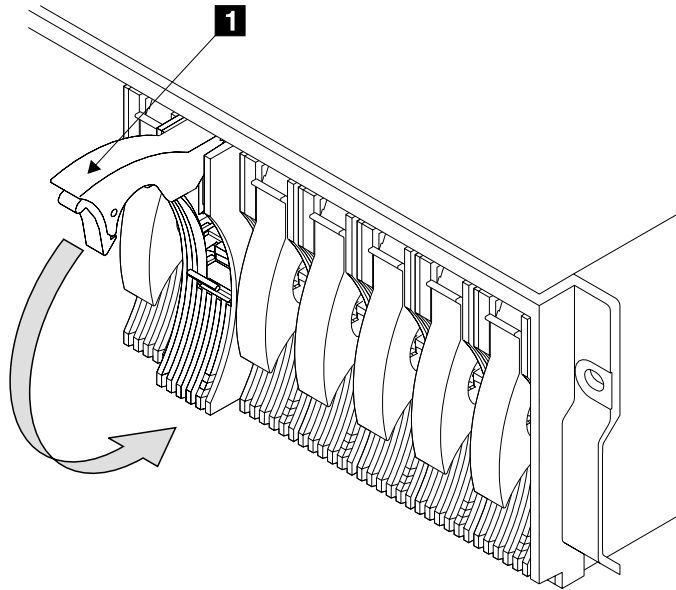

Figure 11. Closing the Handle of a Disk Drive Module

6. While continuing to push the disk drive module into the slot, slowly close the handle **1** until it stops with a click. This action pushes the module fully home.
7. Verify that the disk drive module that you have just installed is aligned with the sides of the 2104 and that no gap exists between this module and the modules that are next to it.

Verify also that the front edge of this disk drive module aligns with the front edges of the modules that are next to it.

If the disk drive module is not correctly aligned, remove it (see “Removing the Disk Drive Modules and Dummy Disk Drive Modules” on page 8) and reinstall it (steps 2 through 6 above).

8. Repeat steps 2 through 7 for each disk drive module.

**Attention:** Any slot that has no disk drive module installed *must* contain a dummy disk drive module. The dummy disk drive module ensures that the correct airflow is maintained around the disk drive modules in the other slots.

9. Ensure that the 2104 Model DU3 has no empty slots. Install dummy disk drive modules if necessary.
10. Refer to Figure 12.

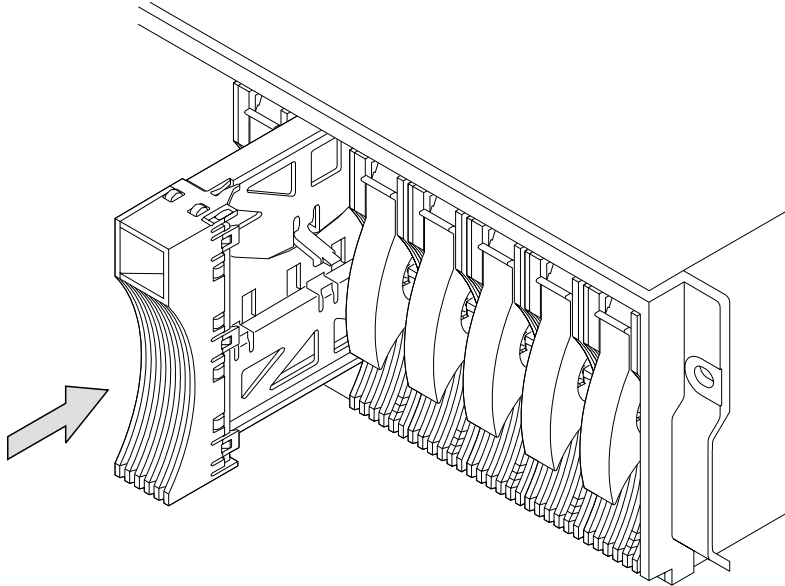

*Figure 12. Reinstalling a Dummy Disk Drive Module*

11. Go to “Connecting the 2104 Model DU3 to the Power Source” on page 30.

---

## Setting the Options on the 2104 Model DU3

1. Refer to your 2104 configuration information for details of how the options are to be set.
2. Refer to Figure 13.

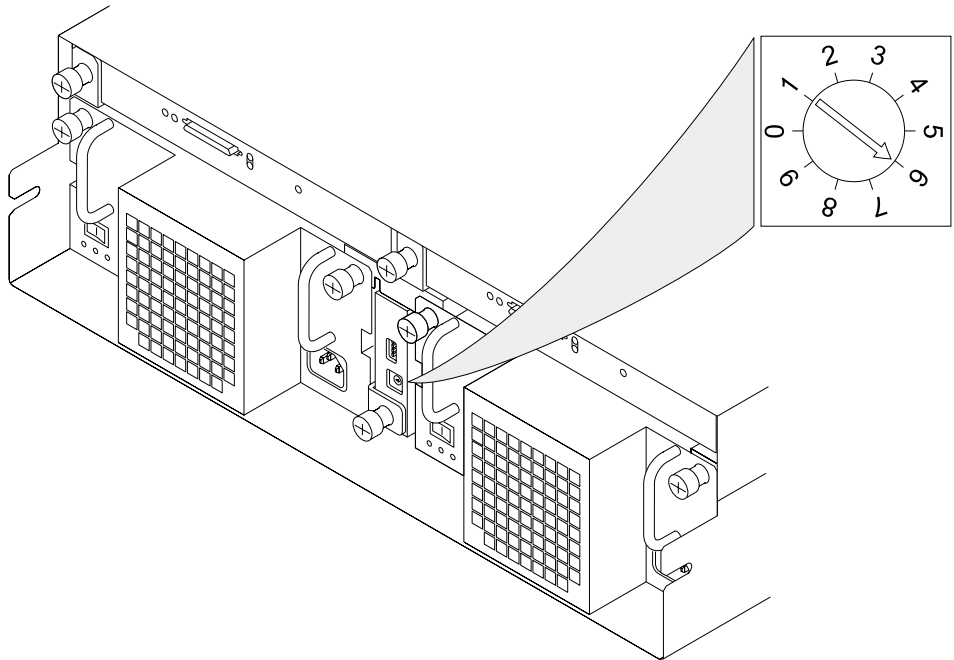

*Figure 13. Setting the Box ID*

3. Rotate the Box ID rotary switch to the ID you have chosen for this 2104 disk enclosure. You need a small screwdriver to do this.
4. Find the sheet of labels supplied with your 2104. These are numbers 0 through 9. Select the one that represents your setting of the Box ID rotary switch and attach it to the front of the 2104.

5. Now look at the option switches. Refer to Figure 14.

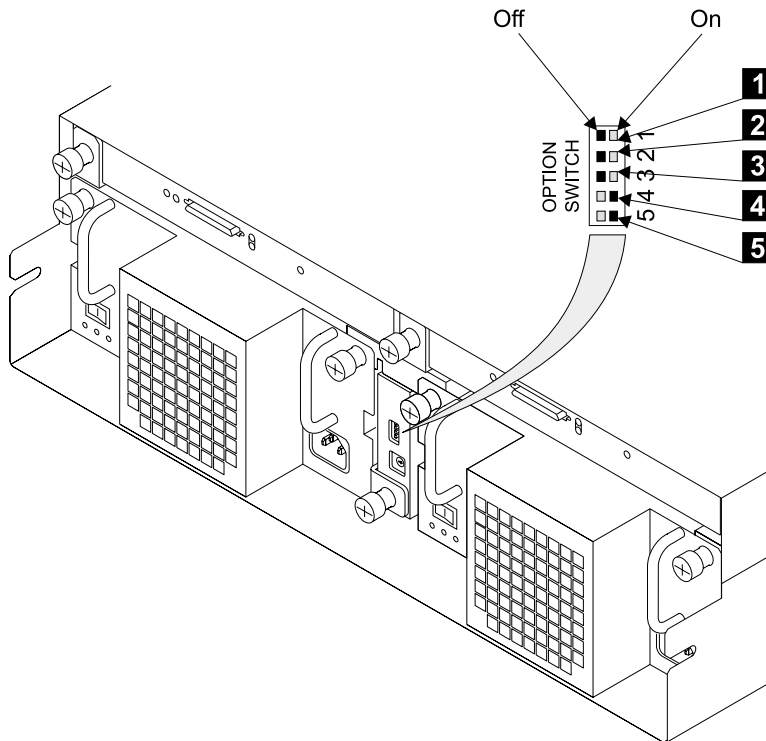

Figure 14. Option Switches

6. When the Power Control switch **1** is set to On, the 2104 does not automatically switch on or off when the using system is switched on or off.  
If you want the 2104 to switch on and off automatically with the using system, ensure that this switch is set to Off.
7. The Drive Autostart switch **2** is set to On at the factory. Do not change this setting unless the customer requires it to be changed (see Notes).  
Similarly, the Delay Motor Start Mode switch **5** is set to Off at the factory. Do not change this setting unless the customer requires it to be changed (see Notes).



**Notes:**

- a. When the Drive Autostart switch **2** is set to On (the default setting), the motors of the disk drive modules do not start until a **Start Motor** command is issued. The timing sequence of startup is under the control of the using-system software.

When the Drive Autostart switch **2** is set to Off, the disk drive modules are set to Delay Motor Start mode.

The delay time before motor startup is specified by the disk drive modules. After power is switched on, the delay time is usually SCSI ID x 12 seconds. For example, the delay for a disk drive module whose SCSI ID is 2 is 2x12 seconds (24 seconds).

- b. The Delay Motor Start Mode switch **5** selects either Delay Motor Start Mode or Normal Start Mode when the Drive Autostart switch **2** is set to Off .

When the Delay Motor Start Mode switch **5** is set to On, Delay Motor Start mode is selected.

The delay time before motor startup is specified for each disk drive module. After power is switched on, the delay time is usually SCSI ID x 12 seconds. For example, the delay for a disk drive module whose SCSI ID is 2 is 2x12 seconds (24 seconds).

When the Delay Motor Start Mode switch **5** is set to Off, Normal Start Mode is selected. Immediately after power is switched on, the motors of the disk drive modules start.

8. Ensure that the Enable Enclosure Services switch **3** and the Select Enclosure Services switch **4** are both set to On to allow ANSI SCSI-3 Enclosure Services (SES) to operate.

9. Now you must remove the switch card assembly so that you can check and, if necessary, change the settings of the internal switches. To remove the switch card assembly:
  - a. Refer to Figure 15.

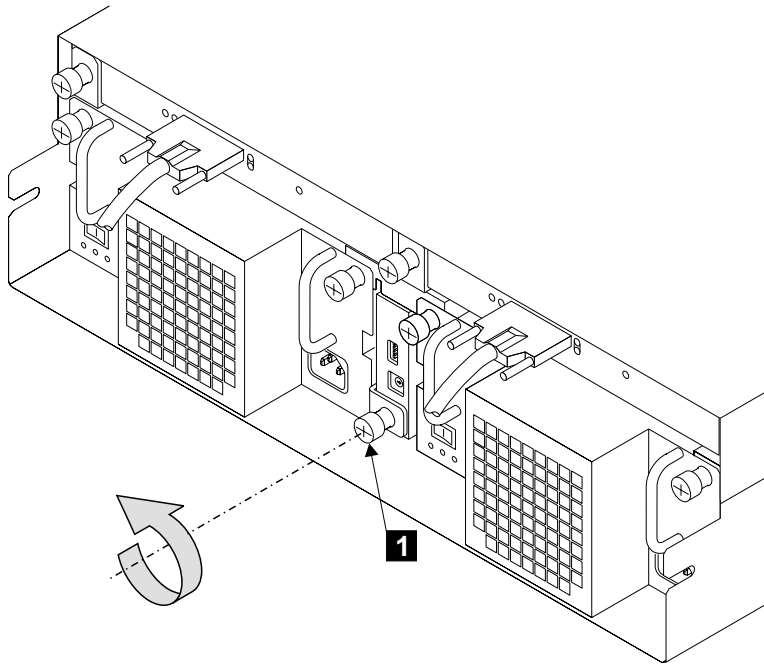

*Figure 15. Unscrewing the Thumbscrew on the Switch Card Assembly*

- b. Unscrew the thumbscrew **1**.

c. Refer to Figure 16.

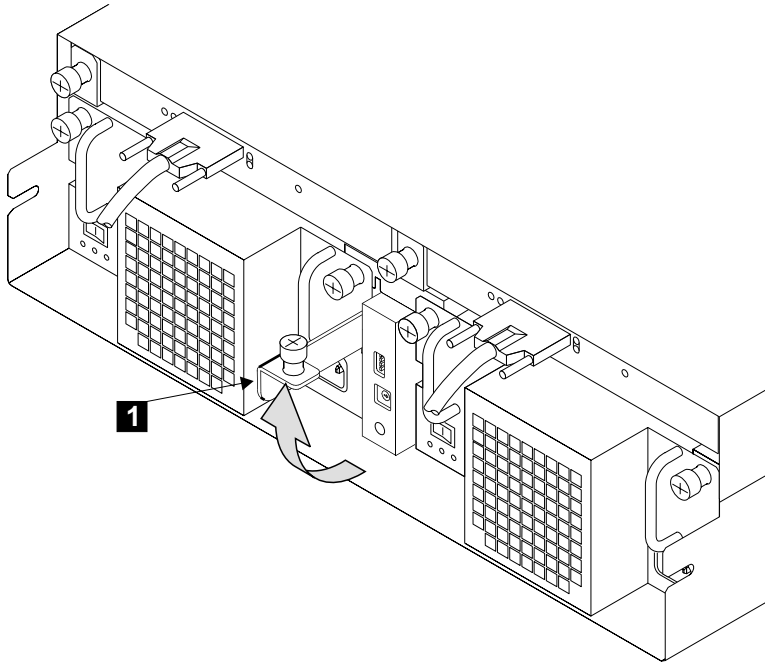

*Figure 16. Opening the Lever on the Switch Card Assembly*

d. Pull the lever **1** upward. This action unplugs the switch card assembly from the 2104.

e. Refer to Figure 17.

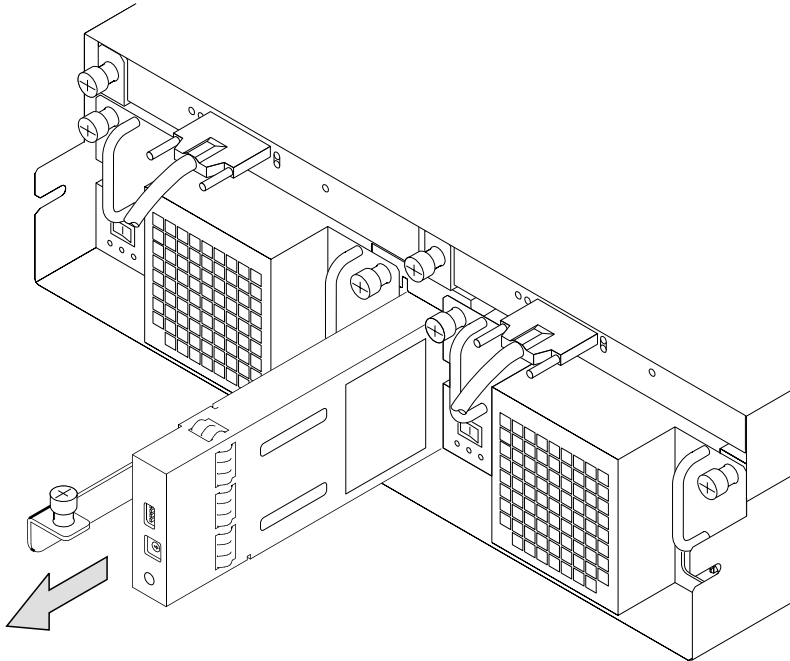

*Figure 17. Removing the Switch Card Assembly*

f. Pull the switch card assembly out from the 2104.

**CAUTION:**

**Do not insert hands or tools into the space that contained the switch card assembly.**

10. Refer to Figure 18.

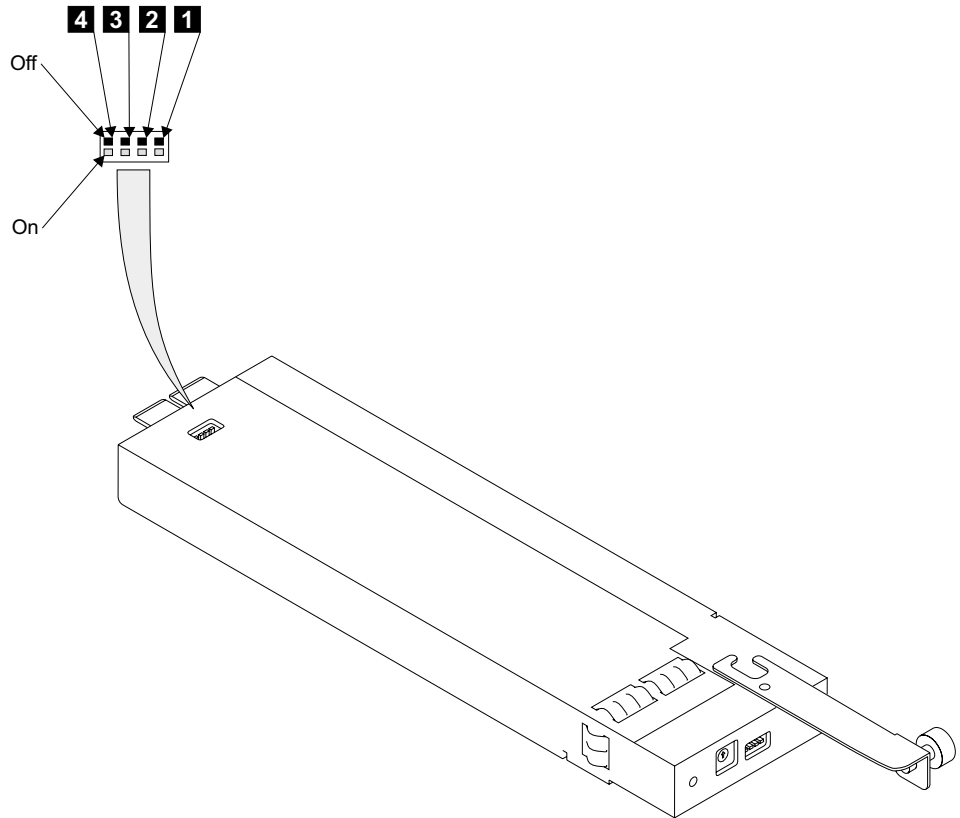

Figure 18. Switch Card Assembly Internal Switches

11. Each disk drive module is identified to the using system by a SCSI address. This address is related to the slot in which the disk drive module is installed. The SCSI address switch **1** allows you to reverse the addresses of the slots, if required.

Table 1 shows the normal and reversed SCSI addresses of the slots.

**Note:** On the 2104 Model DU3, the **physical** numbers of the disk drive module slots are always 1 through 14, from left to right.

Table 1. SCSI Addresses of Disk Drive Module Slots

Disk drive module slot	1	2	3	4	5	6	7	8	9	10	11	12	13	14
SCSI address	0	1	2	3	4	5	6	8	9	10	11	12	13	14

**Note:** If the 2104 is configured for single SCSI bus mode with two SCSI attachments (for example, SCSI adapters), SCSI addresses 5 and 6 cannot be used. The disk drive module slots with SCSI addresses 5 and 6 must contain dummy disk drive modules.

The SCSI enclosure services (SES) use address 15 if the Enable Enclosure Services switch is set to On.

**Attention:** The SCSI address of the SCSI attachment that is connected to the 2104 must be different from the addresses of the installed disk drive modules. When a second SCSI attachment is connected to a 2104, the SCSI address of that SCSI attachment must be different from the address of the first SCSI attachment and different from the addresses of the installed disk drive modules.

12. The 2104 Orientation switch **2** configures the Power and Check lights that are on the front of the 2104. Ensure that this switch is set to Off so that the lights are correct for your 2104 Model DU3.
13. The SCSI Bus Split switch **3** controls the SCSI bus configuration of your 2104. When the switch is set to Off, the 2104 is configured in single SCSI bus mode. When the switch is set to On, the 2104 is configured in dual SCSI bus (split bus) mode.

If a 2104 Model DU3 is in dual SCSI bus mode and the SCSI address switch **1** is set to Off, the SCSI addresses of one SCSI bus are 0 through 6 from left to center, and the SCSI addresses of the other SCSI bus are 8 through 14 from center to right.

Refer to the 2104 configuration information, and set the switch as required.

14. Switch **4** is reserved. Ensure that it is set to Off.

15. Reinstall the switch card assembly:
  - a. Refer to Figure 19.

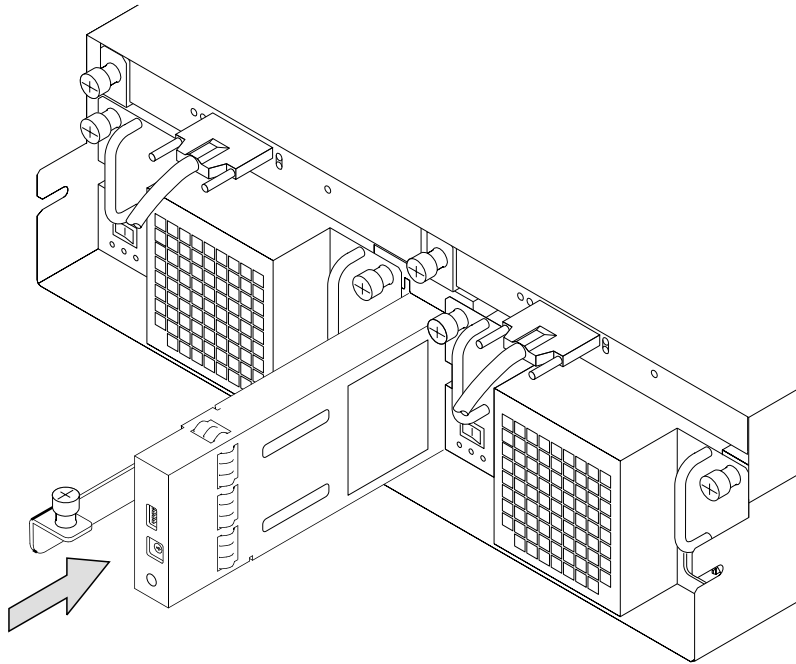

*Figure 19. Inserting the Switch Card Assembly*

- b. Insert the switch card assembly into the 2104. Push the assembly in until it stops.

**CAUTION:**

**As you push the assembly fully home, the lever automatically moves toward its closed position. Ensure that your fingers do not become pinched between the lever and the assembly.**

c. Refer to Figure 20.

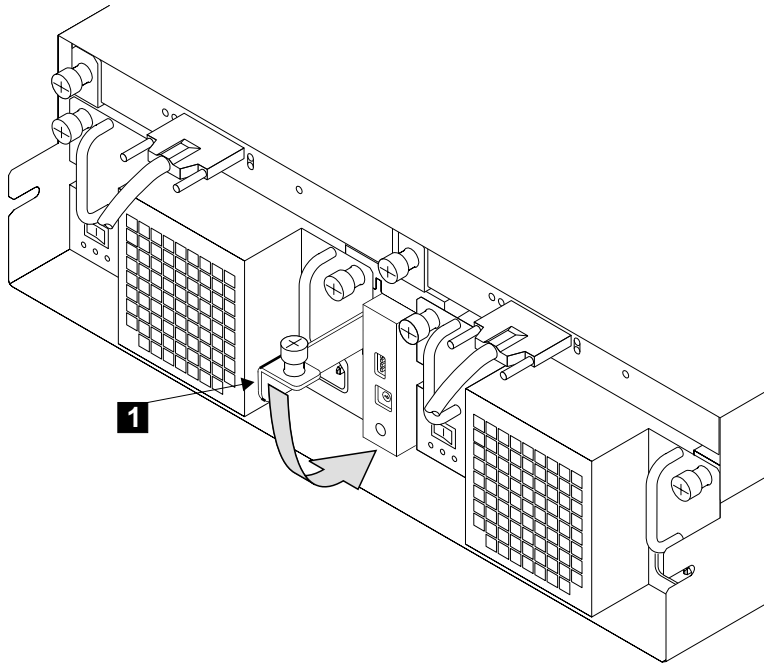
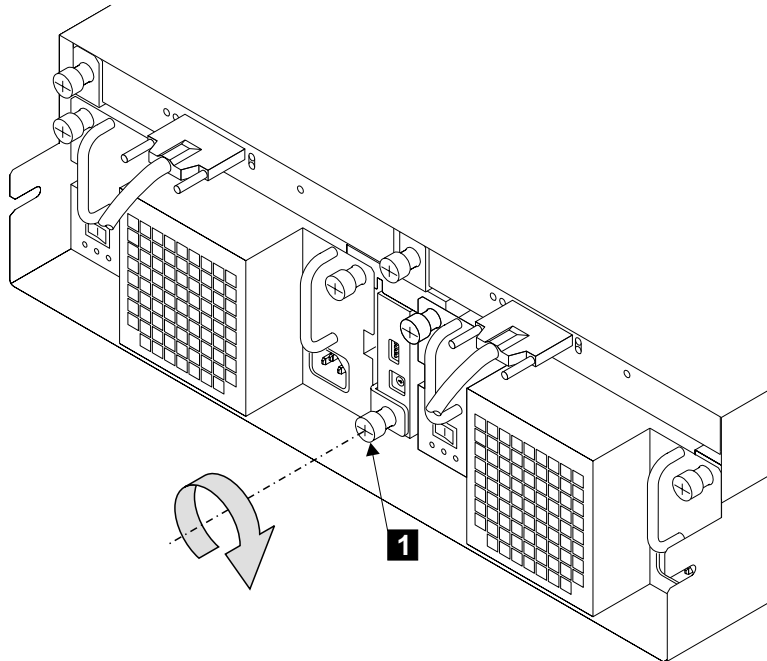

*Figure 20. Closing the Lever on the Switch Card Assembly*

d. Push the lever **1** downward until it is fully closed. This action plugs the switch card assembly into the 2104 .



e. Refer to Figure 21.



*Figure 21. Tightening the Thumbscrew on the Switch Card Assembly*

f. Tighten the thumbscrew **1** fully.

---

## Connecting the 2104 Model DU3 to the Power Source

1. Refer to Figure 22.

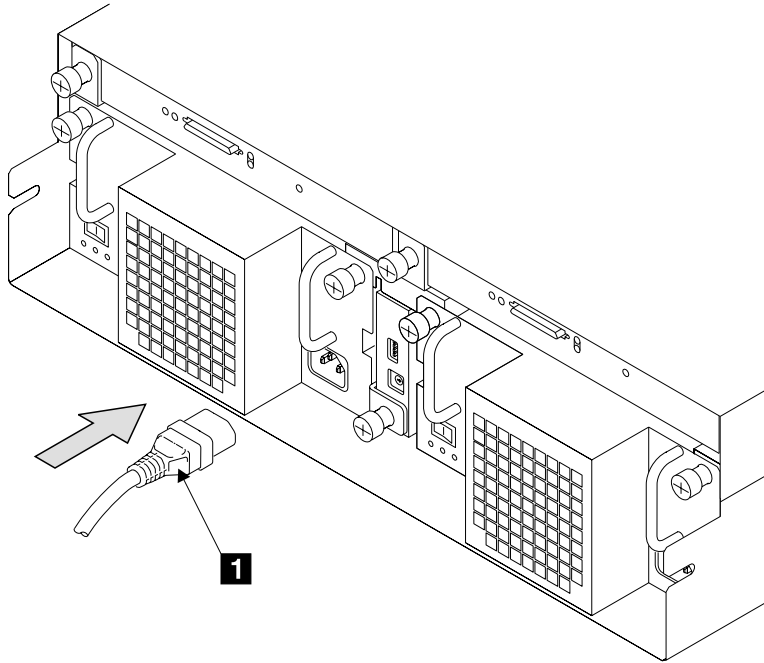

Figure 22. Connecting the Power Plugs

2. At the back of the 2104, plug a power cable into the mainline power connector **1** on each fan-and-power-supply assembly.

**Attention:** *Never use power cables from another drawer to connect a 2104 to the mainline power outlet. Use only the shielded power cables that are supplied with the 2104.*

3. Refer to Figure 23.

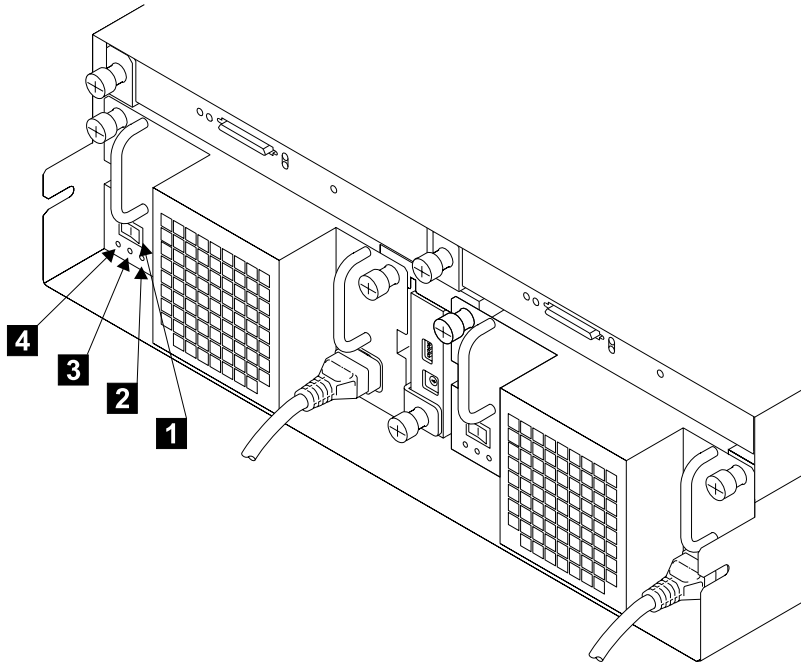

Figure 23. Check Power Supply Switch and Lights

4. Ensure that the DC On/Standby switch **1** is set to Standby.
5. Ensure that all power is removed from the rack.
6. Plug the other end of the power cable into the power source in the rack (see the *Installation and Service Guide*, or equivalent, for the rack).
7. Perform the grounding checks described in the *Expandable Storage Plus: 2104 Models DU3 and TU3 Service Guide*.
8. If the grounding check is satisfactory, switch on power to the rack. The green AC PWR light **4** comes on.
9. Switch on the DC On/Standby switch **1** on each power supply. If option switch 1 (see Figure 14 on page 20) is on, the green DC PWR light **3** comes on. If option switch 1 (see Figure 14 on page 20) is off, the green DC PWR light **3** stays off. It will come on when the 2104 is connected to the using system.
10. Go to “Connecting the 2104 to the Using System” on page 32.

---

## Connecting the 2104 to the Using System

1. Referring to your preinstallation planning information or 2104 configuration information, check how the 2104 is to be connected to the using system. Verify your configuration by referring to “Valid 2104 Model DU3 Configurations” on page 39.
2. Attach identification labels to the external SCSI signal cables (see the appropriate *Adapters, Devices and Cables Information* manual for details).
3. Refer to Figure 24.

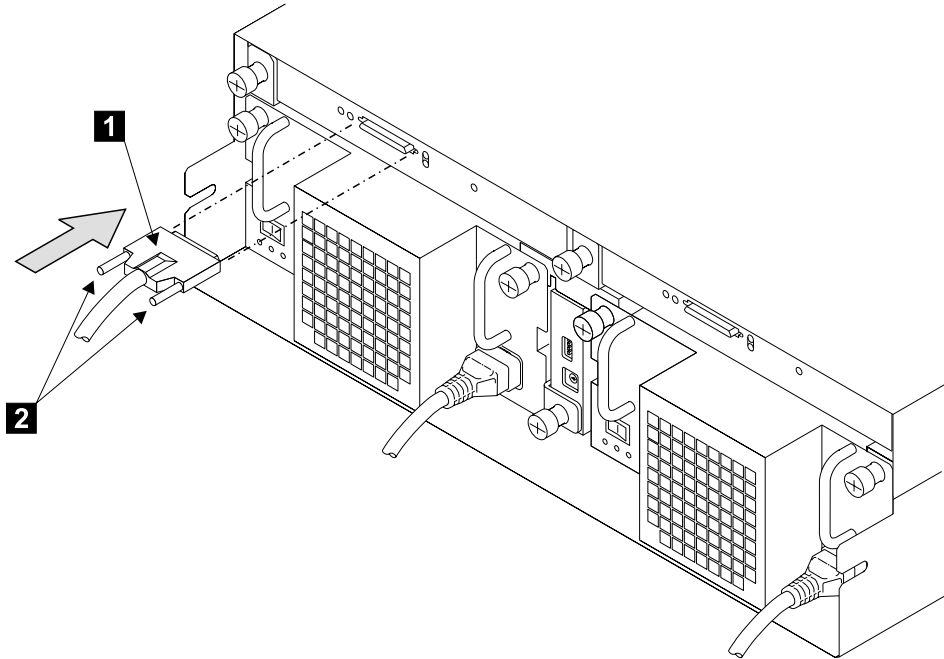
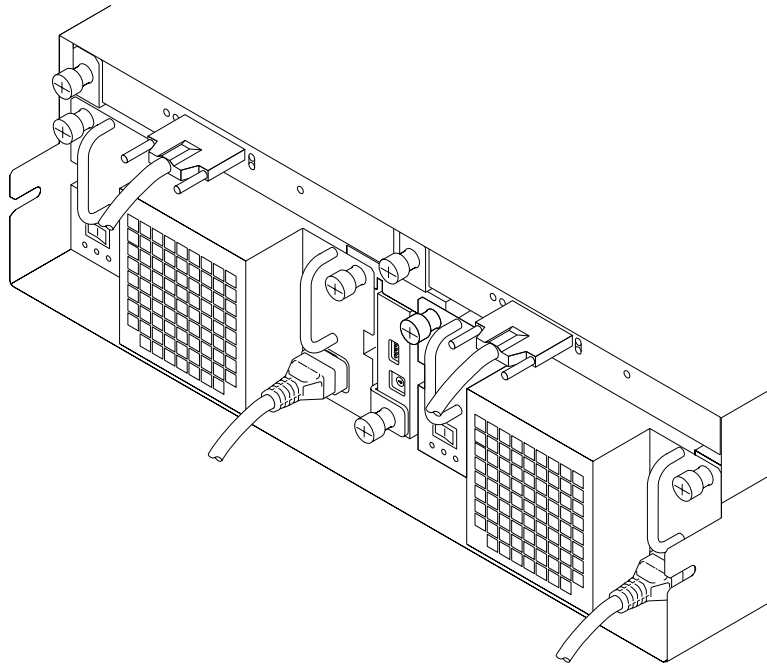

Figure 24. Plug in the SCSI Signal Cable

4. Plug the SCSI signal cables into the connectors **1** on the SCSI interface cards.
5. Tighten the retaining screws **2**. You might need a small screwdriver to do this. **DO NOT USE A POWER-DRIVEN SCREWDRIVER.**
6. Ensure that all signal cables are correctly connected. An incorrect connection can prevent the 2104 from becoming ready.



*Figure 25. Back of Fully Configured 2104 Model DU3 After Connection to the Using System*

---

## Switching On and Testing the 2104

1. If the power to the using system is switched off, switch it on.
2. Refer to Figure 26.

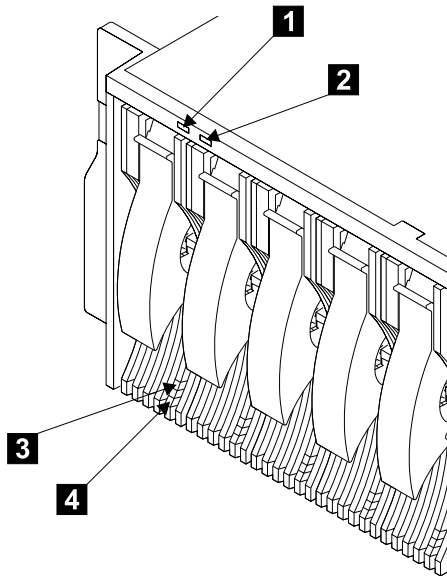

Figure 26. Checking the Lights

The 2104 has two lights. The green Power light **1** comes on and stays on. The amber Check light **2** comes on for approximately two seconds and goes off.

Each disk drive module has two lights. The green Activity light **3** comes on for approximately two seconds when power is first supplied to the disk drive; it then goes off. The amber Check light **4** then comes on for approximately two seconds and then goes off.

**Note:** Dummy disk drive modules have no lights.

Configuration is complete when the lights on the 2104, and its installed disk drive modules, are as described here (refer to Figure 26):

2104 Power light **1** : On

2104 Check light **2** : Off

Activity light **3** on each installed disk drive module: Off

Check light **4** on each installed disk drive module: Off

If the lights are correct:

- a. Refer to the Web site described at “Web Support Pages” on page 60 for the latest microcode and system software levels. Ensure that the using-system

software is at the correct level for the 2104, and that the correct level of microcode for the disk drive modules has been loaded.

- b. Go to “Appendix A. Operating with RISC Systems” on page 37, which gives information about how to configure your 2104 to the using system, what service aids are available, and how to collect statistics during the operation of your 2104.

If the lights are not as described here, refer to the *Expandable Storage Plus: 2104 Models DU3 and TU3 Service Guide*, for help in identifying the cause of this fault.





---

## Appendix A. Operating with RISC Systems

This appendix gives advice for operating an RS/6000 or IBM @serverpSeries computer to which one or more Expandable Storage Plus 2104 Model DU3 is attached.

---

### SCSI Service Aids

Service aids are available on the using system to help you service the 2104 Model DU3. Service aids described in the *Expandable Storage Plus: 2104 Models DU3 and TU3 Service Guide* are:

- Format Media
- Certify Media
- SCSI Device Identification and Removal
- Download Microcode

---

### Identifying 2104s and Disk Drive Modules

You can identify an Expandable Storage Plus 2104 Model DU3 and the disk drive modules installed in it either by the location code contained in system messages that refer to that unit, or by using the SCSI Device Identification and Removal service aid.

See “Location Codes” in the operator guide for your system for general information about location codes.

---

### Configuring a 2104 to the using system

Use the **cfgmgr** command to configure or reconfigure a 2104 to the using system.

**Note:** This command might not be valid for your RAID adapter.

---

## Unconfiguring a 2104 from the using system

To remove a 2104 from the using system, use the following command:

```
rmdev -l [enclosurenumber] -d
```

where [enclosurenumber] is the enclosure device that was generated by the **cfgmgr** command (for example, [ses0], [ses1], [ses2]).

Remove the ses\_healthcheck job from the system cron table.

---

## Valid 2104 Model DU3 Configurations

Only point-to-point connections are allowed between the SCSI interface cards in a 2104 and the SCSI adapter or integrated SCSI port in a using system.

A 2104 Model DU3 that has only one SCSI interface card can be attached to only one SCSI adapter or integrated SCSI port. A 2104 Model DU3 that has two SCSI interface cards can be attached to two SCSI adapters or integrated SCSI ports.

When an internal connector on the adapter is used, the corresponding external connector must not be used to connect to a 2104 Model DU3.

A 2104 Model DU3 can be configured to support either a single SCSI bus or a dual SCSI bus. The setting of the SCSI Bus Split switch on the switch card in the 2104 Model DU3 defines which configuration is to be used.

An RS/6000 or IBM @server pSeries computer uses one of the following SCSI adapters to connect to the 2104:

- PCI SCSI-2 Single-Ended Fast/Wide Adapter (type 4-A, feature 6208)
  - This adapter has one external SCSI connector and one internal SCSI connector. Both connectors are connected to the same shared SCSI channel.
- PCI Single-Ended Ultra SCSI Adapter (type 4-K, feature 6206)
  - This adapter has one external SCSI connector and one internal SCSI connector. The two connectors are connected to the same shared SCSI channel.
- PCI Dual Channel Ultra2 SCSI Adapter (type 4-R, feature 6205)
  - This dual-channel adapter has two external SCSI connectors and two internal SCSI connectors. Each pair, consisting of one external and one internal connector, is connected to a separate SCSI channel.
- PCI 3-Channel Ultra2 SCSI RAID Adapter (type 4-T feature 2494)
  - This 3-Channel adapter has two external SCSI connectors and one internal SCSI connector. Each connector is connected to a separate SCSI channel.
- PCI 4-Channel Ultra3 SCSI RAID Adapter (type 4-X, feature 2498)
  - This 4-Channel adapter has four external SCSI connectors and two internal SCSI connectors. The Channel 1 and Channel 2 external connectors share the same SCSI bus as the corresponding Channel 1 and Channel 2 internal connectors. The Channel 3 and Channel 4 external connectors have their own non-shared SCSI bus.

## Summary of Valid 2104 Model DU3 Configurations

A summary of valid configurations and SCSI ID assignments is shown in the following table:

Table 2. Summary of Valid Configurations

SCSI Bus Mode	Number of Connected Adapters	SCSI IDs of Adapters	Maximum Number of Disk Drive Modules	SCSI IDs of Disk Drive Modules	SCSI ID of Enclosure Services Processor	Adapters Supported
Single Bus	1	7	14	0,1,2,3,4,5,6,8,9,10,11,12,13,14	15	All adapters listed on page 39.
Single Bus	2	5, 6	12	0,1,2,3,4,8,9,10,11,12,13,14	15	See Notes 1 and 2.
Dual Bus						
• SCSI Bus 1	1	7	7	0,1,2,3,4,5,6 (See Note 3.)	15	All adapters listed on page 39.
• SCSI Bus 2	1	7	7	8,9,10,11,12,13,14 (See Note 4.)	15	All adapters listed on page 39.

### Notes:

1. In HACMP configurations: PCI Dual Channel Ultra2 SCSI Adapter (type 4-R), in separate using systems
2. In non-HACMP configurations : PCI Dual Channel Ultra2 SCSI Adapter (type 4-R) or Ultra2 SCSI Integrated Port, either in the same, or in separate using systems, but **not** sharing access to the disk drive modules.
3. Left hand half of the 2104 Model DU3, viewed from the front
4. Right hand half of the 2104 Model DU3, viewed from the front

## Single-Bus Mode Configurations

For a single-bus mode configuration, the SCSI Bus Split switch on the switch card of a 2104 Model DU3 must be set to Off.

Each 2104 Model DU3 can be connected to one external SCSI connector on a SCSI adapter card, or to one integrated SCSI port, in a using system. If an adapter card has four external SCSI connectors, it can be connected to up to four 2104s (Model DU3 or TU3).

For High Availability Cluster Multi-Processing (HACMP) configurations, the two SCSI interface cards in a 2104 are connected either to external SCSI connectors on adapter cards, or to integrated Ultra2 SCSI ports, in two different using systems. The adapter cards must be PCI Dual-Channel Ultra2 SCSI Adapters (Type 4-R, feature 6205).

For non-HACMP configurations, the SCSI interface cards in a 2104 can be connected either to an external SCSI connector on an adapter card, or to an Ultra2 SCSI integrated port, in a using system. The adapter cards must be PCI Dual-Channel Ultra2 SCSI Adapters (Type 4-R, feature 6205), and may be in the same using system or in two different using systems. However, they must not share access to the disk drives in the 2104.

## One Adapter in One Using System Connected to One 2104 Model DU3

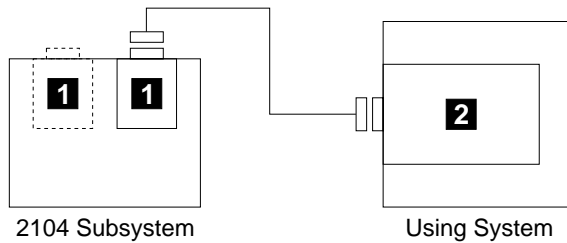

Figure 27. One Adapter in One Using System connected to One 2104 (Single-Bus Mode)

<b>1</b>	<p>SCSI interface card</p> <p><b>Note:</b> The second SCSI interface card that is in the 2104 is optional.</p>
<b>2</b>	<p>SCSI adapter of one of these types:</p> <ul style="list-style-type: none"> <li>• PCI SCSI-2 Single-Ended Fast/Wide Adapter (type 4-A, feature 6208)</li> <li>• PCI Single-Ended Ultra SCSI Adapter (type 4-K, feature 6206)</li> <li>• PCI Dual Channel Ultra2 SCSI Adapter (type 4-R, feature 6205)</li> <li>• PCI 3-Channel Ultra2 SCSI RAID Adapter (type 4-T feature 2494)</li> <li>• PCI 4-Channel Ultra3 SCSI RAID Adapter (type 4-X, feature 2498)</li> </ul> <p><b>Note:</b> The 2104 can be connected to an integrated SCSI port instead of to one of these adapters</p>

**Attention:** The SCSI address of the adapter that is connected to the 2104 must be different from the addresses of the installed disk drive modules.

## Two Adapters in One Using System Connected to Two 2104s (Model DU3)

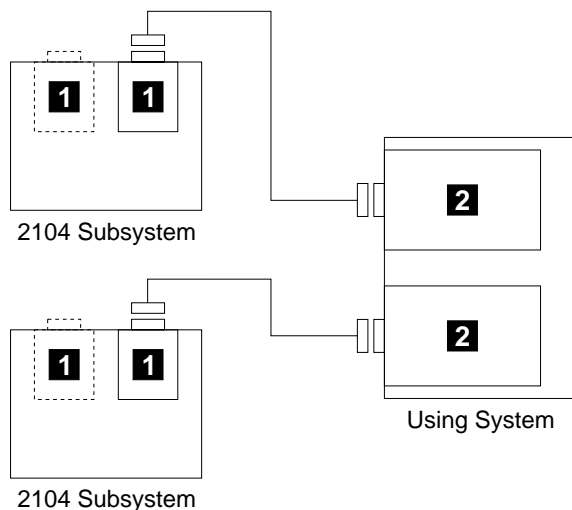

Figure 28. Two Adapters in One Using System Connected to Two 2104s (Single-Bus Mode)

<b>1</b>	<p>SCSI interface card</p> <p><b>Note:</b> The second SCSI interface card that is in the 2104 is optional.</p>
<b>2</b>	<p>SCSI adapter of one of these types:</p> <ul style="list-style-type: none"> <li>• PCI SCSI-2 Single-Ended Fast/Wide Adapter (type 4-A, feature 6208)</li> <li>• PCI Single-Ended Ultra SCSI Adapter (type 4-K, feature 6206)</li> <li>• PCI Dual Channel Ultra2 SCSI Adapter (type 4-R, feature 6205)</li> <li>• PCI 3-Channel Ultra2 SCSI RAID Adapter (type 4-T feature 2494)</li> <li>• PCI 4-Channel Ultra3 SCSI RAID Adapter (type 4-X, feature 2498)</li> </ul> <p><b>Note:</b> The 2104 can be connected to an integrated SCSI port instead of to one of these adapters</p>

**Attention:** The SCSI address of the adapter that is connected to the 2104 must be different from the addresses of the installed disk drive modules.

## One Adapter in Each of Two Using Systems Connected to Two 2104s (Model DU3)

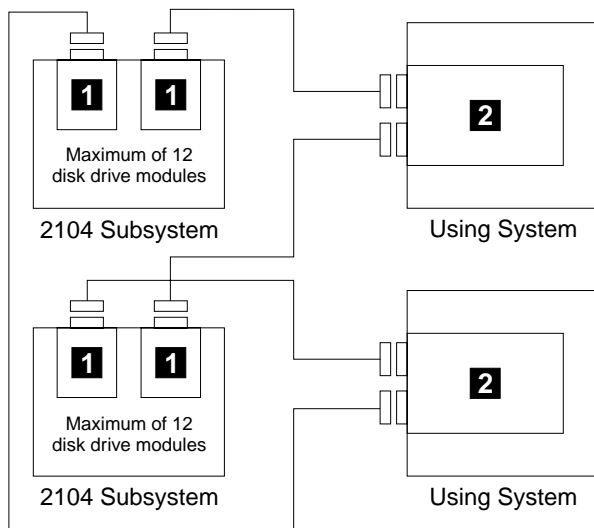

Figure 29. One Adapter in Each of Two Using Systems Connected to Two 2104s (Single-Bus Mode)

<b>1</b>	SCSI interface card
<b>2</b>	<p>For HACMP configurations in standby and mutual takeover mode:</p> <ul style="list-style-type: none"> <li>• PCI Dual Channel Ultra2 SCSI Adapter (type 4-R, feature 6205)</li> </ul> <p>The adapters must be in two separate using systems.</p> <p>For non-HACMP configurations, the connections can be to either two different using systems or to the same using system, but disk drive modules must not be shared:</p> <ul style="list-style-type: none"> <li>• PCI Dual Channel Ultra2 SCSI Adapter (type 4-R, feature 6205)</li> <li>• Ultra2 SCSI Integrated port</li> </ul>

**Attention:** The SCSI address of the adapter that is connected to the 2104 must be different from the addresses of the installed disk drive modules. When a second adapter is connected to a 2104, the SCSI address of that adapter must be different from the address of the first adapter and the addresses of the disk drive modules installed in the 2104.

In each 2104, slots 6 and 7 (SCSI addresses 5 and 6) must contain dummy disk drive modules. Each 2104 can contain no more than 12 disk drive modules.



## One Adapter in One Using System Connected to Two 2104s (Model DU3)

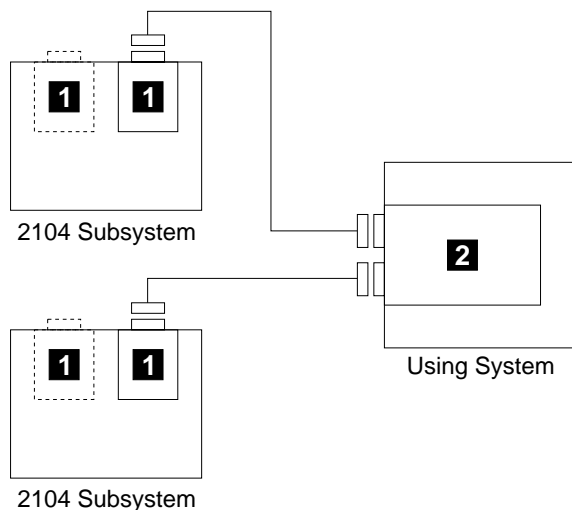

Figure 30. One Adapter in One Using System Connected to Two 2104s - Single-Bus Mode

<b>1</b>	SCSI interface card <b>Note:</b> The second SCSI interface card that is in the 2104 is optional.
<b>2</b>	SCSI adapter of one of these types: <ul style="list-style-type: none"> <li>• PCI SCSI-2 Single-Ended Fast/Wide Adapter (type 4-A, feature 6208)</li> <li>• PCI Single-Ended Ultra SCSI Adapter (type 4-K, feature 6206)</li> <li>• PCI Dual Channel Ultra2 SCSI Adapter (type 4-R, feature 6205)</li> <li>• PCI 3-Channel Ultra2 SCSI RAID Adapter (type 4-T feature 2494)</li> <li>• PCI 4-Channel Ultra3 SCSI RAID Adapter (type 4-X, feature 2498)</li> </ul> <p><b>Note:</b> The 2104 can be connected to an integrated SCSI port instead of to one of these adapters</p>

**Attention:** The SCSI address of the adapter that is connected to the 2104 must be different from the addresses of the installed disk drive modules.

**Note:** These configurations are valid with or without an additional integrated port.

## One Adapter in One Using System Connected to Two 2104s (Model DU3) and an Internal RAID Array

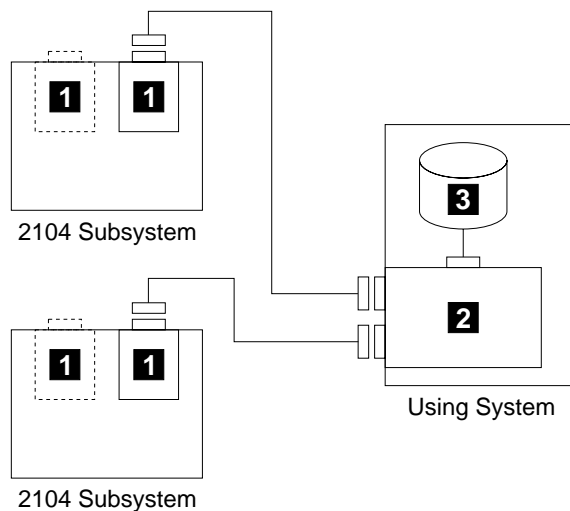

Figure 31. One Adapter, One Using System with Internal RAID Array, and Two 2104s (Single-Bus Mode)

<b>1</b>	SCSI interface card <b>Note:</b> The second SCSI interface card that is in the 2104 is optional.
<b>2</b>	SCSI adapter of one of these types: <ul style="list-style-type: none"> <li>• PCI 3-Channel Ultra2 SCSI RAID Adapter (type 4-T, feature 2494)</li> <li>• PCI 4-Channel Ultra3 SCSI RAID Adapter (type 4-X, feature 2498)</li> </ul>
<b>3</b>	Internal RAID array

### Attention:

- The SCSI address of the adapter that is connected to the 2104 must be different from the addresses of the installed disk drive modules.
- The external connectors of the SCSI RAID adapter must not share a SCSI bus with the internal RAID array.

## One Adapter in Each of Two Using Systems Connected to One 2104 Model DU3

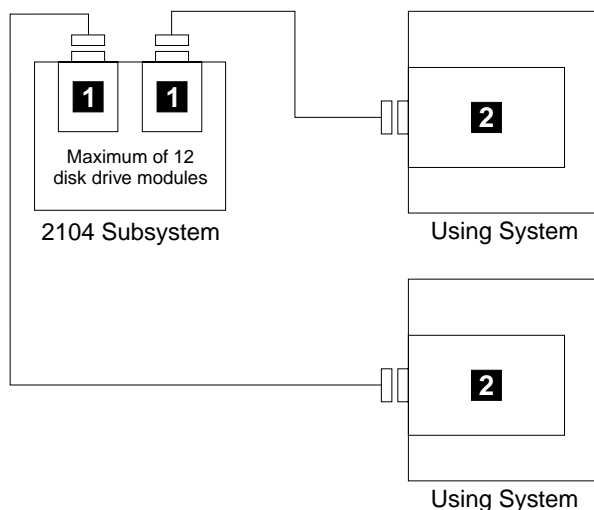

Figure 32. One Adapter in Each of Two Using Systems Connected to One 2104 Model DU3 (Single-Bus Mode)

<b>1</b>	SCSI interface card
<b>2</b>	<p>For HACMP configurations in standby or mutual takeover mode:</p> <ul style="list-style-type: none"> <li>• PCI Dual Channel Ultra2 SCSI Adapter (type 4-R, feature 6205)</li> </ul> <p><b>Note:</b> The two adapters must not be in the same using system.</p> <p>For non-HACMP configurations:</p> <ul style="list-style-type: none"> <li>• PCI Dual Channel Ultra2 SCSI Adapter (type 4-R, feature 6205)</li> <li>• Ultra2 SCSI Integrated Port</li> </ul> <p><b>Note:</b> In non-HACMP configurations, connections can be made to two separate using systems, or to the same using system. Connection can be to an Ultra2 SCSI integrated port or to an Ultra2 SCSI connector on the SCSI adapters listed. Access to the disks in the 2104 cannot be shared.</p>

### Attention:

- The SCSI address of the adapter that is connected to the 2104 must be different from the addresses of the installed disk drive modules. When a second adapter is connected to a 2104, the SCSI address of that adapter must be different from the address of the first adapter and the addresses of the installed disk drive modules.
- In each 2104, slots 6 and 7 (SCSI addresses 5 and 6) must contain **dummy** disk drive modules.
- Each 2104 can contain no more than 12 disk drive modules.

## Dual-Bus Mode Configurations

For a dual-bus mode configuration, the SCSI Bus Split switches on the switch card of a 2104 Model DU3 must be set to On.

Each 2104 Model DU3 in the configuration is connected either to one external SCSI connector on an adapter card, or to an integrated SCSI port. If an adapter card has four external SCSI connectors, it can be connected to up to four 2104s (Model DU3).

The external SCSI connectors can be either on the same adapter card, or on two separate adapter cards. If the connectors are on two separate adapter cards, these adapter cards can be either both be in the same using system or be in two separate using systems.

## Two Adapters in One Non-HACMP Using System Connected to One 2104 Model DU3

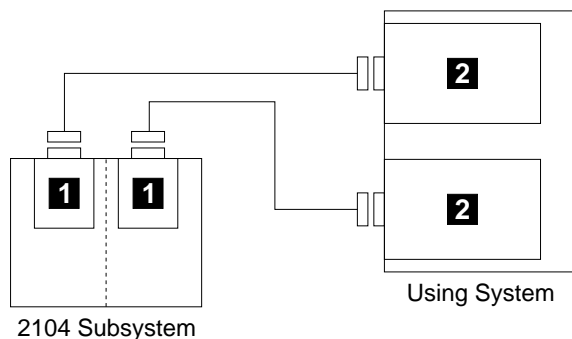

Figure 33. Two Adapters in One Non-HACMP Using System Connected to One 2104 (Dual-Bus Mode)

<b>1</b>	SCSI interface card
<b>2</b>	<p>SCSI or SCSI RAID adapter of one of these types:</p> <ul style="list-style-type: none"> <li>• PCI SCSI-2 Single-Ended Fast/Wide Adapter (type 4-A, feature 6208)</li> <li>• PCI Single-Ended Ultra SCSI Adapter (type 4-K, feature 6206)</li> <li>• PCI Dual Channel Ultra2 SCSI Adapter (type 4-R, feature 6205)</li> <li>• PCI 3-Channel Ultra2 SCSI RAID Adapter (type 4-T feature 2494)</li> <li>• PCI 4-Channel Ultra3 SCSI RAID Adapter (type 4-X, feature 2498)</li> </ul> <p><b>Note:</b> Connection can be to an integrated SCSI port instead of to a SCSI connector on one of the listed SCSI adapters</p>

**Attention:** The SCSI addresses of the adapters that are connected to the 2104 must be different from each other and from the addresses of the installed disk drive modules.

**Note:** A similar configuration that has one adapter with two external SCSI connectors, instead of the two single-connector SCSI adapters, is also a valid configuration.

## Three Adapters in Two Non-HACMP Using Systems Connected to Two 2104 Model DU3s

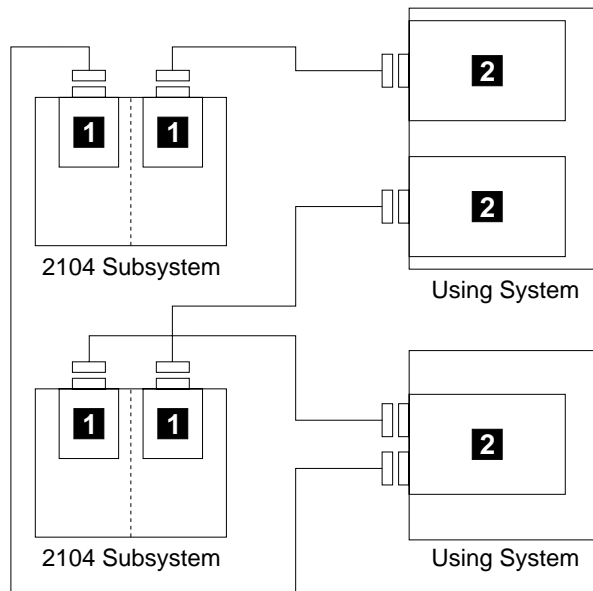

Figure 34. Three Adapters in Two Non-HACMP Using Systems Connected to Two 2104 Model DU3s (Dual-Bus Mode)

<b>1</b>	SCSI interface card
<b>2</b>	<p>SCSI or SCSI RAID adapter of one of these types:</p> <ul style="list-style-type: none"> <li>• PCI SCSI-2 Single-Ended Fast/Wide Adapter (type 4-A, feature 6208)</li> <li>• PCI Single-Ended Ultra SCSI Adapter (type 4-K, feature 6206)</li> <li>• PCI Dual Channel Ultra2 SCSI Adapter (type 4-R, feature 6205)</li> <li>• PCI 3-Channel Ultra2 SCSI RAID Adapter (type 4-T feature 2494)</li> <li>• PCI 4-Channel Ultra3 SCSI RAID Adapter (type 4-X, feature 2498)</li> </ul> <p><b>Note:</b> Connection can be to an integrated SCSI port instead of to a SCSI connector on one of the listed SCSI adapters</p>

**Attention:** The SCSI address of the adapter that is connected to the 2104 must be different from the addresses of the installed disk drive modules. When a second adapter is connected to a 2104, the SCSI address of that adapter must be different from the address of the first adapter and the addresses of the installed disk drive modules.

**Note:** A similar valid configuration can have two adapters, each with one external SCSI connector, instead of the adapter with two external SCSI connectors.

## One Adapter in One Non-HACMP Using System Connected to One 2104 Model DU3 and an Internal RAID Array

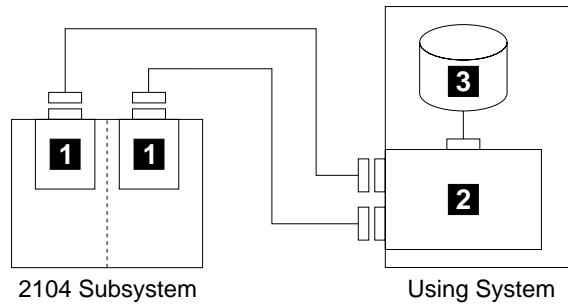

Figure 35. One Adapter in One Non-HACMP Using System Connected to One 2104 Model DU3 and an Internal RAID Array (Dual-Bus Mode)

<b>1</b>	SCSI interface card
<b>2</b>	SCSI adapter of one of these types: <ul style="list-style-type: none"> <li>• PCI 3-Channel Ultra2 SCSI RAID Adapter (type 4-T feature 2494)</li> <li>• PCI 4-Channel Ultra3 SCSI RAID Adapter (type 4-X, feature 2498)</li> </ul>
<b>3</b>	Internal RAID array

**Attention:** The SCSI address of the adapter that is connected to the 2104 must be different from the addresses of the installed disk drive modules.

## One Adapter in Each of Two Non-HACMP Using Systems Connected to One 2104 Model DU3

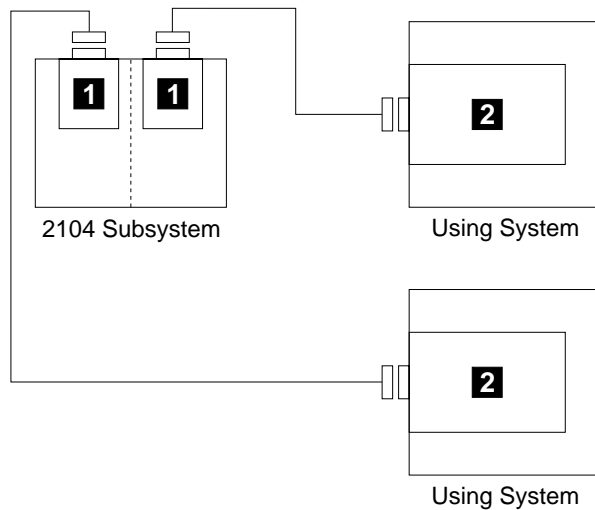

Figure 36. One Adapter in Each of Two Non-HACMP Using Systems Connected to One 2104 Model DU3 (Dual-Bus Mode)

<b>1</b>	SCSI interface card
<b>2</b>	<p>SCSI or SCSI RAID adapter of one of these types:</p> <ul style="list-style-type: none"> <li>• PCI SCSI-2 Single-Ended Fast/Wide Adapter (type 4-A, feature 6208)</li> <li>• PCI Single-Ended Ultra SCSI Adapter (type 4-K, feature 6206)</li> <li>• PCI Dual Channel Ultra2 SCSI Adapter (type 4-R, feature 6205)</li> <li>• PCI 3-Channel Ultra2 SCSI RAID Adapter (type 4-T feature 2494)</li> <li>• PCI 4-Channel Ultra3 SCSI RAID Adapter (type 4-X, feature 2498)</li> </ul> <p><b>Note:</b> Connection can be to an integrated SCSI port instead of to a SCSI connector on one of the listed SCSI adapters</p>

**Attention:** The SCSI address of the adapter that is connected to the 2104 must be different from the addresses of the installed disk drive modules. When a second adapter is connected to a 2104, the SCSI address of that adapter must be different from the address of the first adapter and the addresses of the installed disk drive modules.



## One RAID Adapter in Each of Two Non-HACMP Using Systems Connected to Two 2104s (Model DU3)

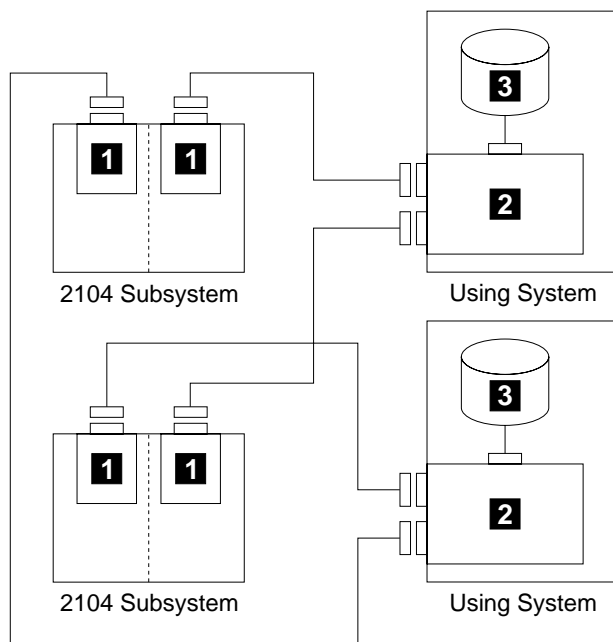

Figure 37. One RAID Adapter in Each of Two Non-HACMP Using Systems Connected to Two 2104s (Dual-Bus Mode)

<b>1</b>	SCSI interface card
<b>2</b>	SCSI RAID adapter of one of these types: <ul style="list-style-type: none"> <li>• PCI 3-Channel Ultra2 SCSI RAID Adapter (type 4-T feature 2494)</li> <li>• PCI 4-Channel Ultra3 SCSI RAID Adapter (type 4-X, feature 2498)</li> </ul>

### Attention:

- The SCSI address of the adapter that is connected to the 2104 must be different from the addresses of the installed disk drive modules.
- The external connectors on the SCSI RAID adapter cards and the internal RAID connector must not share a SCSI bus.

---

## Configurations That are Not Valid

This section gives some examples of configurations that are not valid.

### Two Adapters in One Using System Connected to One 2104

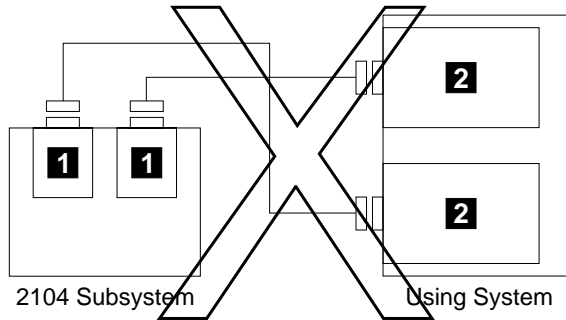

Figure 38. Two Adapters in One Using System Connected to One 2104 (Single-Bus Mode).. **This configuration is not valid.**

<b>1</b>	SCSI interface card
<b>2</b>	SCSI adapter. This configuration is not valid for any type of adapter.

**Note:** This configuration is not valid when the 2104 is configured in single-bus mode, but is valid when the 2104 is configured in dual-bus mode. See page 49.

## One Adapter in One Using System Connected to Two 2104s via the SCSI Interface Cards

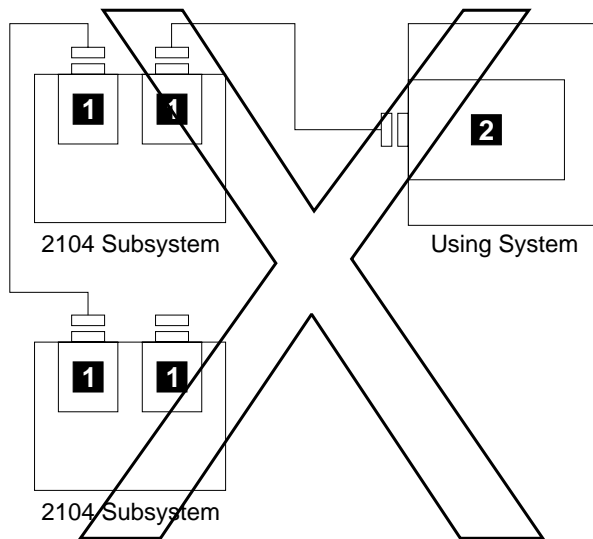

Figure 39. One Adapter in One Using System Connected to Two 2104s via the SCSI Interface Cards. **This configuration is not valid.**

<b>1</b>	SCSI interface card
<b>2</b>	SCSI adapter. This configuration is not valid for any type of adapter.

## One Adapter in One Using System Connected to 2104s via a Y-Cable (1)

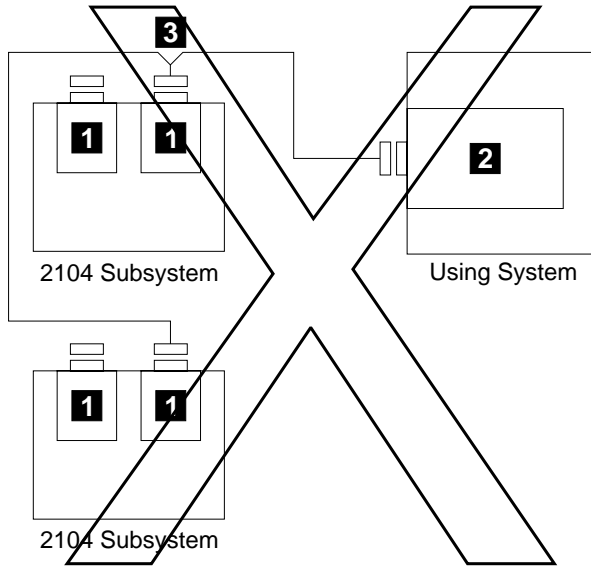

Figure 40. One Adapter in One Using System Connected to 2104s via a Y-Cable (1).  
**This configuration is not valid.**

<b>1</b>	SCSI interface card
<b>2</b>	SCSI adapter. This configuration is not valid for any type of adapter.
<b>3</b>	Y-cable. Not supported for any type of adapter that is used with the 2104.

## One Adapter in One Using System Connected to 2104s via a Y-Cable (2)

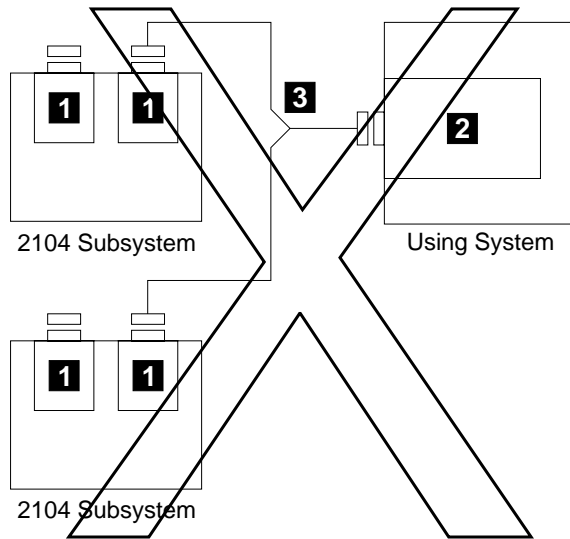

Figure 41. One Adapter in One Using System Connected to 2104s via a Y-Cable (2).  
**This configuration is not valid.**

<b>1</b>	SCSI interface card
<b>2</b>	SCSI adapter. This configuration is not valid for any type of adapter.
<b>3</b>	Y-cable. Not supported for any type of adapter that is used with the 2104.

## One Dual-Channel Non-RAID Adapter in One Using System Connected to Two 2104s and Internal Disk Drives

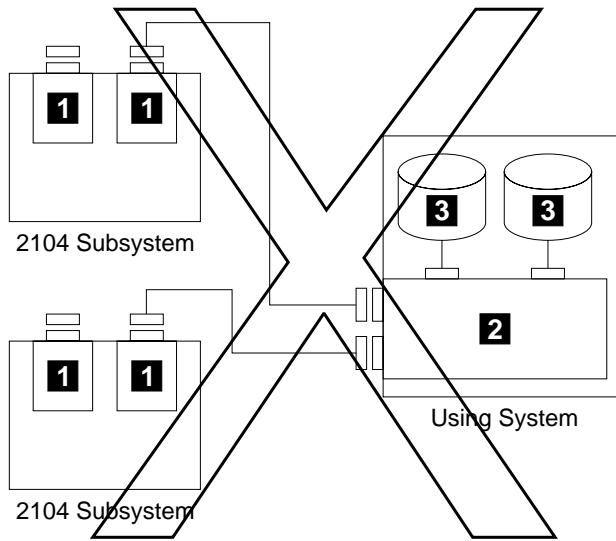
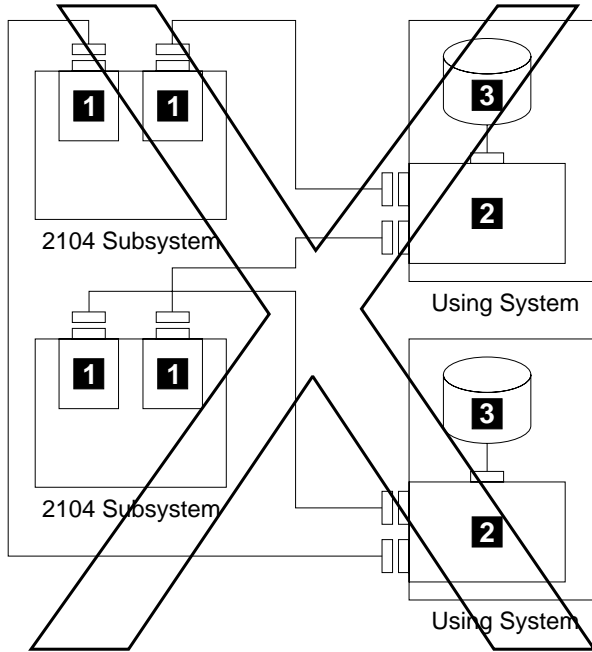

Figure 42. One Dual-Channel Non-RAID Adapter in One Using System Connected to Two 2104s and Internal Disk Drives. **This configuration is not valid.**

<b>1</b>	SCSI interface card
<b>2</b>	PCI Dual Channel Ultra2 SCSI Adapter (type 4-R, feature 6205). This configuration is not valid on this adapter because two internal and two external attachments that are on the same SCSI bus exceed the capacity of the adapter.
<b>3</b>	Internal disk drives.

## One RAID Adapter in Each of Two Using Systems Connected to Two 2104s



**Figure 43. One RAID Adapter in Each of Two Using Systems Connected to Two 2104s. This configuration is not valid.**

<b>1</b>	SCSI interface card
<b>2</b>	This configuration is not valid for RAID adapters, including the PCI 3-Channel Ultra2 SCSI RAID Adapter (type 4-T, feature 2494) because it cannot use high-availability cluster multiprogramming (HACMP).
<b>3</b>	Internal RAID disk drive array

---

## Collecting Errors

To enable the collection of 2104 disk enclosure errors, add this cron job SES Healthcheck to the system cron table.

**Note:** Root permissions will be required to perform this update.

Edit the system crons with the **crontab -e** command. At the bottom of the file, enter:

```
15 * * * * /usr/lpp/diagnostics/bin/run_ses_healthcheck 1>/dev/null 2>/dev/null
```

For details of the **crontab** command, go to the following Web site:

**[www.rs6000.ibm.com/doc\\_link/en\\_US/a\\_doc\\_lib/cmds/aixcmds1/crontab.htm#A1599114e](http://www.rs6000.ibm.com/doc_link/en_US/a_doc_lib/cmds/aixcmds1/crontab.htm#A1599114e)**

This cron runs at 15 minutes after each hour, and sends mail to the "root user" with details of any errors that are present in the enclosure. It also presents a console message indicating which enclosure has a problem.

The cron requires a script. To create this script, generate a file named `run_ses_healthcheck` in directory `/usr/lpp/diagnostics/bin`. The contents of the file must be:

```
#!/bin/ksh
#Name: run_ses_healthcheck
#Location: /usr/lpp/diagnostics/bin
#Function: SCSI SES hourly healthcheck

/usr/sbin/lssdev -Cc container -t ses -s scsi -F name -S available |
    /usr/bin/xargs -n1 -i /bin/nice --10 /usr/lpp/diagnostics/bin/diagela -t {}
```

**Note:** Although, because of page width, the final line of the contents is shown here split between two lines, you must enter it all on one line.

Give the following command so that the script can be run:

```
chmod 544 /usr/lpp/diagnostics/bin/run_ses_healthcheck
```

---

## Web Support Pages

Adapter microcode is available from the following Web site:

**[www.rs6000.ibm.com/support/micro/download.html](http://www.rs6000.ibm.com/support/micro/download.html)**

PTFs are required for AIX 4.3.3 and AIX 4.2.1. These PTFs are available from the following Web site:

**[service.boulder.ibm.com/cgi-bin/support/rs6000.support/downloads](http://service.boulder.ibm.com/cgi-bin/support/rs6000.support/downloads)**



---

## Related Publications

- *Diagnostic Information for Micro Channel Bus Systems, SA23-2765*
- *Diagnostic Information for Multiple Bus Systems, SA38-0509*
- *Site and Hardware Planning Information, SA38-0508*
- *Adapters, Devices and Cable Information for Micro Channel Bus Systems, SA23-2764*
- *Adapters, Devices and Cable Information for Multiple Bus Systems, SA38-0516*



---

## Appendix B. Translated Safety Notices

This appendix contains the danger and caution notices that are used in the various books relating to the Expandable Storage Plus: 2104 Models DU3 and TU3.

The notices are shown in English and in various other languages.

### **Danger notice**

A danger notice calls attention to a situation that is potentially lethal or extremely hazardous to people.

### **Caution notice**

A caution notice calls attention to a situation that is potentially hazardous to people because of some existing condition.

Always use safe working procedures whenever you work on machines. Use your own judgment to identify safety conditions that these notices do not describe.

### **Danger Notices**

#### **DANGER**

In the following step you are going to remove the power cables. These cables are live if the rack power distribution unit or uninterruptable power supply (UPS) unit is still switched on.

#### **DANGER**

Do not try to open the covers of the fan-and-power-supply assembly.

#### **DANGER**

Do not plug a power cable into the fan-and-power-supply assembly until the assembly is fully home and its thumbscrews are fully tightened.

#### **DANGER**

An electrical outlet that is not correctly wired could place hazardous voltage on metal parts of the system or the devices that attach to that system. It is the customers's responsibility to ensure that the outlet is correctly wired and grounded to prevent an electrical shock. During an electrical storm, do not disconnect cables for display stations, printers, telephones, or station protectors for communication lines.

## Caution Notices

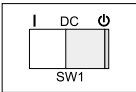
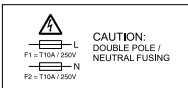
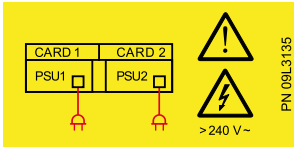

**CAUTION:**  
This unit may have two linecords. To remove all power, disconnect both linecords.

**CAUTION:**  
This unit weighs 38.5 kg.

**CAUTION:**  
Do not remove cover, do not service, no serviceable parts.

**CAUTION:**  
Double pole/neutral fusing

**CAUTION:**  
A "Standby" condition is indicated by the symbol to the right of "DC" directly above the switch, SW1. When SW1 is toggled to the right position directly under the "Standby" symbol, the unit's AC-power is not shut off.

**CAUTION:**  
The stabilizer must be correctly attached to the bottom front of the rack to prevent the rack from tipping forward while the 2104 Model DU3 is being removed from the rack. Do not pull out or install any unit if a stabilizer is not attached to the rack.

**CAUTION:**  
The stabilizer must be correctly attached to the bottom front of the rack to prevent the rack from tipping forward while the 2104 Model DU3 is being installed into the rack. Do not remove or install any unit if a stabilizer is not attached to the rack.

**CAUTION:**  
A 2104 Model DU3 weighs up to 38.5 kg (85 lb) with the maximum number of disk drive modules installed. Do not attempt to lift the 2104 into the rack unless all the disk drive modules have been removed.

**CAUTION:**  
A 2104 Model DU3 weighs up to 38.5 kg (85 lb) with the maximum number of disk drive modules installed. Do not attempt to remove the 2104 from the rack unless all the disk drive modules have been removed.

**CAUTION:**  
Do not attempt to lift the 2104 by yourself. Ask another person for aid.

**CAUTION:**  
Do not insert hands or tools into the empty space that contained the fan assembly.

**CAUTION:**  
Do not insert hands or tools into the empty space that contained the fan-and-power-supply assembly.

**CAUTION:**  
Do not insert hands or tools into the empty space that contained the switch card assembly.

**CAUTION:**  
Do not insert hands or tools into the empty space that contained the SCSI interface card assembly.

**CAUTION:**  
This product is equipped with a 3-wire power cable and plug for the user's safety. Use this power cable in conjunction with a correctly grounded electrical outlet to avoid an electrical shock.

**CAUTION:**  
Do not touch the power outlet or the power outlet face plate with anything other than test probes before you have completed this safety check.

**CAUTION:**  
If the reading is not infinity, do not proceed. Make the necessary corrections to the wiring before you continue. Do not switch on the branch circuit CB until all the above steps are satisfactorily completed.

**CAUTION:**  
A 2104 Model TU3 can weigh up to 54.5 kg (120 lb) with the maximum number of disk drive modules installed. Do not attempt to lift one without help from a second person.

**CAUTION:**  
Do not use the handles of the fan or fan-and-power-supply assemblies to carry the 2104. These handles are not intended to support the weight of the unit.

**CAUTION:**  
As you push the assembly fully home, the lever automatically moves toward its closed position. Ensure that your fingers do not become pinched between the lever and the assembly.

---

## Consignes de sécurité

Cette annexe contient les consignes de sécurité Danger et Attention qui sont utilisées dans les différents manuels relatifs à l'unité de stockage Expandable Storage Plus: 2104 modèles DU3 et TU3.

Ces consignes apparaissent en anglais et dans diverses autres langues.

**Consigne Danger**

Indique la présence d'un risque de blessures graves, voire mortelles.

**Consigne Attention**

Indique la présence d'un risque de blessures légères.

Respectez toujours les consignes de sécurité lorsque vous travaillez sur des machines. Mettez vous-même en place les conditions de sécurité nécessaires dans les cas non prévus par ces consignes.

### Consignes Danger

---

#### DANGER

Dans l'étape qui suit, vous allez débrancher les cordons d'alimentation. Ces cordons sont toujours alimentés si le cordon d'alimentation de l'armoire ou l'unité d'alimentation de secours sont en fonction.

---

---

#### DANGER

N'essayez pas d'ouvrir le bloc ventilateur-alimentation.

---

---

#### DANGER

Ne connectez pas le câble d'alimentation dans le bloc ventilateur-alimentation avant d'avoir complètement enfoncé ce dernier dans son logement et serré ses vis à fond.

---

---

#### DANGER

Un mauvais câblage électrique peut provoquer une mise sous tension dangereuse des parties métalliques du système ou des unités qui lui sont raccordées.  
Il appartient au client de s'assurer que le socle de prise de courant est correctement câblé et mis à la terre afin d'éviter tout risque de choc électrique.  
Ne déconnectez pas les cordons téléphoniques, d'interface ou d'alimentation, ni les dispositifs de protection électrique des lignes de transmission pendant un orage.

---

## Consignes Attention

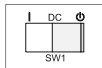
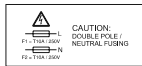
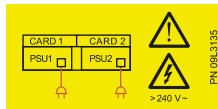

### ATTENTION :

Cette unité peut posséder deux cordons d'alimentation. Pour supprimer toutes les tensions dans l'unité, débranchez les deux cordons.

### ATTENTION :

Cette unité pèse 38.5 kg.

### ATTENTION :

Ne pas ouvrir. Ne tenter aucune réparation. Aucune pièce n'est réparable en clientèle.

### ATTENTION :

L'un des deux fusibles est sur le neutre.

### ATTENTION :

Un état "Attente" est indiqué par le symbole droite de "DC" au-dessus de l'interrupteur SW1. Lorsque SW1 bascule dans la bonne position sous le symbole "Attente", l'alimentation (courant alternatif) de l'unité n'est pas coupée.

### ATTENTION :

Le stabilisateur doit être solidement fixé au bas de la face avant de l'armoire pour empêcher cette dernière de basculer lorsqu'on en retire le 2104 modèle DU3.

Ne retirez pas ou n'installez pas d'unité avant d'avoir vérifié que le stabilisateur est bien fixé à l'armoire.

### ATTENTION :

Le stabilisateur doit être solidement fixé au bas de la face avant de l'armoire pour empêcher cette dernière de basculer lorsqu'on installe le 2104 modèle DU3.

Ne retirez pas ou n'installez pas d'unité avant d'avoir vérifié que le stabilisateur est bien fixé à l'armoire.

### ATTENTION :

Un 2104 modèle DU3 pèse au moins 38.5 Kg lorsque le nombre maximal de modules de disque est installé. N'essayez pas de soulever le modèle 2104 dans l'armoire avant d'avoir retiré tous les modules de disque.

### ATTENTION :

Un 2104 modèle DU3 pèse au moins 38.5 Kg lorsque le nombre maximal de modules de disque est installé. N'essayez pas de retirer le modèle 2104 avant d'avoir retiré tous les modules de disque.

### ATTENTION :

N'essayez pas de soulever seul le modèle 2104. Faites-vous aider pour la déplacer en toute sécurité.

### ATTENTION :

N'insérez pas vos mains ou des outils dans l'emplacement qu'occupait le bloc de ventilation.

### ATTENTION :

N'insérez pas vos mains ou des outils dans l'emplacement qu'occupait le bloc ventilateur-alimentation.

### ATTENTION :

N'insérez pas vos mains ou des outils dans l'emplacement qu'occupait le bloc de la carte à commutateurs.

**ATTENTION :**

N'insérez pas vos mains ou des outils dans l'emplacement qu'occupait la carte d'interface SCSI.

**ATTENTION :**

Pour votre sécurité, ce produit est équipé d'un cordon d'alimentation à trois fils et d'une fiche de prise de courant à trois broches. Pour éviter tout risque de choc électrique, branchez ce cordon sur un socle de prise de courant correctement mis à la terre.

**ATTENTION :**

Tant que vous n'avez pas terminé le contrôle de sécurité, ne touchez le socle et la plaque de prise de courant qu'avec des sondes de test.

**ATTENTION :**

Si vous obtenez un résultat autre que l'infini, arrêtez-vous. Révissez l'installation électrique. Ne remettez pas le disjoncteur du circuit de dérivation sous tension avant d'avoir passé toutes les étapes ci-dessus.

**ATTENTION :**

Un 2104 modèle TU3 pèse au moins 54.5 Kg lorsque le nombre maximal de modules de disque est installé. Ne tentez pas de la soulever seul. Faites-vous aider pour la déplacer en toute sécurité.

**ATTENTION :**

N'utilisez pas les poignées fixées sur le ventilateur ou le bloc ventilateur-alimentation pour porter le modèle 2104. Ces poignées ne sont pas prévues pour supporter le poids de l'unité.

**ATTENTION :**

Lorsque vous enfoncez complètement le bloc dans son logement, le levier se place automatiquement en position fermée. Veillez à ne pas vous coincer les doigts entre le levier et le bloc.



---

## Sicherheitshinweise

Dieser Anhang enthält die Hinweise VORSICHT und ACHTUNG, die in den verschiedenen zu Expandable Storage Plus: 2104 Modelle DU3 und TU3 gehörenden Büchern vorkommen.

Die Hinweise werden in Englisch und in weiteren Sprachen gezeigt.

### Hinweis VORSICHT

Der Hinweis VORSICHT macht auf eine Gefahr aufmerksam, die tödliche oder schwere Verletzungen zur Folge haben kann.

### Hinweis ACHTUNG

Der Hinweis ACHTUNG macht auf mögliche Probleme aufmerksam, die zu einer Personengefährdung führen können.

Achten Sie beim Arbeiten mit Maschinen immer auf sichere Arbeitsbedingungen. Es liegt in der Verantwortung jedes einzelnen, mögliche Sicherheitsrisiken zu erkennen, die in diesen Hinweisen nicht aufgeführt sind.

### Hinweise VORSICHT

#### Vorsicht

Im folgenden Schritt werden die Netzkabel entfernt. Ist die Stromversorgungseinheit des Gehäuses oder die unterbrechungsfreie Stromversorgung noch eingeschaltet, führen diese Kabel Strom.

#### Vorsicht

Die Abdeckungen der aus Ventilator und Netzteil bestehenden Baugruppe nicht öffnen.

#### Vorsicht

Kein Netzkabel in die aus Ventilator und Netzteil bestehende Baugruppe einstecken, bis die Baugruppe vollständig eingeschoben ist und die Rändelschrauben fest angezogen sind.

#### Vorsicht

Bei nicht ordnungsgemäß angeschlossener Netzsteckdose können an offenliegenden Metallteilen dieses Systems oder an angeschlossenen Einheiten gefährliche Berührungsspannungen auftreten.  
Für den ordnungsgemäßen Zustand der Steckdose ist der Betreiber verantwortlich.  
Während eines Gewitters keine Kabel von Bildschirmeinheiten, Druckern, Telefonapparaten oder Blitzschutzeinheiten lösen.

## Hinweise ACHTUNG

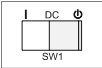
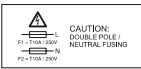
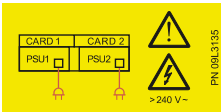

**Achtung:**  
Diese Einheit könnte zwei Stromversorgungskabel haben. Um die Einheit ganz von der Netzspannung zu trennen, beide Stromversorgungskabel lösen.

**Achtung:**  
Diese Einheit wiegt 38.5 kg.

**Achtung:**  
Abdeckung nicht entfernen. Nicht reparieren. Keine wartungsbedürftigen Teile.

**Achtung:**  
Zweipolige bzw. Neutralleiter-Sicherung

**Achtung:**  
Durch das Symbol rechts von "DC", direkt über dem Schalter SW1, wird eine Bereitschaftsbedingung angegeben. Wird der Schalter SW1 nach rechts, direkt unter das Bereitschaftssymbol, gelegt, ist die Wechselstromversorgung der Einheit nicht ausgeschaltet.

**Achtung:**  
Der Stabilisator muss ordnungsgemäß unten an der Vorderseite des Gehäuses angebracht werden, um ein Vorkippen des Gehäuses beim Entfernen des 2104 Modells DU3 zu verhindern. Keine Einheiten herausziehen oder installieren, wenn kein Stabilisator am Gehäuse montiert ist.

**Achtung:**  
Der Stabilisator muss ordnungsgemäß unten an der Vorderseite des Gehäuses angebracht werden, um ein Vorkippen des Gehäuses beim Installieren des 2104 Modells DU3 zu verhindern. Keine Einheiten entfernen oder installieren, wenn kein Stabilisator am Gehäuse montiert ist.

**Achtung:**  
Ein 2104 Modell DU3 wiegt bis zu 38.5 kg, wenn die maximale Anzahl von Plattenlaufwerkmodulen installiert ist. Die Einheit 2104 nicht in das Gehäuse heben, bevor alle Plattenlaufwerkmodule entfernt wurden.

**Achtung:**  
Ein 2104 Modell DU3 wiegt bis zu 38.5 kg, wenn die maximale Anzahl von Plattenlaufwerkmodulen installiert ist. Die Einheit 2104 nicht aus dem Gehäuse entfernen, bevor alle Plattenlaufwerkmodule entfernt wurden.

**Achtung:**  
Nicht versuchen, die Einheit 2104 alleine anzuheben. Zum Transport sind zwei Personen erforderlich.

**Achtung:**  
Keine Hand oder Werkzeuge in den leeren Bereich einführen, in dem sich die Ventilatorbaugruppe befand.

**Achtung:**  
Keine Hand oder Werkzeuge in den leeren Bereich einführen, in dem sich die aus Ventilator und Netzteil bestehende Baugruppe befand.

**Achtung:**

Keine Hand oder Werkzeuge in den leeren Bereich einführen, in dem sich die Schalterkartenbaugruppe befand.

**Achtung:**

Keine Hand oder Werkzeuge in den leeren Bereich einführen, in dem sich die SCSI-Schnittstellenkarte befand.

**Achtung:**

Netzkabel und Netzstecker dieses Gerätes entsprechen den einschlägigen Sicherheitsbestimmungen. Dieses Gerät nur an eine Schutzkontaktsteckdose mit ordnungsgemäßer Schutzleiterverbindung anschließen.

**Achtung:**

Die Netzsteckdose und die Abdeckplatte der Netzsteckdose nicht mit etwas anderem als den Prüfspitzen berühren, bevor diese Sicherheitsüberprüfung beendet ist.

**Achtung:**

Wird nicht 'Unendlich' gemessen, nicht weiterarbeiten. Die entsprechenden Korrekturen an der Verkabelung vornehmen, bevor weitergearbeitet wird. Netzstromkreis erst einschalten, wenn alle genannten Schritte richtig ausgeführt wurden.

**Achtung:**

Ein 2104 Modell TU3 wiegt bis zu 54.5 kg, wenn die maximale Anzahl von Plattenlaufwerkmodulen installiert ist. Zum Anheben der Einheit sind zwei Personen erforderlich.

**Achtung:**

Nicht die Griffe des Ventilators oder der aus Ventilator und Netzteil bestehenden Baugruppe benutzen, um die Einheit 2104 zu tragen. Diese Griffe sind nicht zum Tragen der Einheit vorgesehen.

**Achtung:**

Wird die Baugruppe in Grundstellung gebracht, bewegt sich der Hebel automatisch in die geschlossene Position. Darauf achten, dass die Finger nicht zwischen dem Hebel und der Baugruppe gequetscht werden.

## Προειδοποιήσεις ασφάλειας

Το παράρτημα αυτό περιέχει τις σημειώσεις κινδύνου και προσοχής που χρησιμοποιούνται στα διάφορα εγχειρίδια που σχετίζονται με το προϊόν Expandable Storage Plus: 2104 Μοντέλα DU3 και TU3.

Οι σημειώσεις εμφανίζονται στα αγγλικά και σε διάφορες άλλες γλώσσες.

<b>Σημείωση κινδύνου</b>	Μια σημείωση κινδύνου επισημαίνει μια κατάσταση που μπορεί να είναι πολύ επικίνδυνη ή και θανατηφόρος για τους ανθρώπους.
<b>Σημείωση προσοχής</b>	Μια σημείωση προσοχής επισημαίνει μια κατάσταση που μπορεί να είναι επικίνδυνη για τους ανθρώπους λόγω ορισμένων συνθηκών.

Ακολουθείτε πάντα ασφαλείς διαδικασίες εργασίας όταν εργάζεστε με μηχανές. Χρησιμοποιείτε τη δική σας κρίση για να αναγνωρίζετε άλλες συνθήκες που τυχόν επηρεάζουν την ασφάλεια και δεν περιγράφονται σε αυτές τις σημειώσεις.

### Σημειώσεις κινδύνου

#### ΚΙΝΔΥΝΟΣ

Στο ακόλουθο βήμα θα αφαιρέσετε τα καλώδια ρεύματος. Στα καλώδια αυτά υπάρχει ηλεκτρικό ρεύμα αν η μονάδα διανομής ρεύματος του ικρίωματος (rack) ή η μονάδα αδιάλειπτης παροχής ρεύματος (UPS) είναι ακόμα σε λειτουργία.

#### ΚΙΝΔΥΝΟΣ

Μην επιχειρήσετε να ανοίξετε τα καλύμματα της συσκευής που περικλείει την πηγή ρεύματος και τον ανεμιστήρα.

#### ΚΙΝΔΥΝΟΣ

Μην συνδέσετε καλώδιο ρεύματος στη συσκευή που περικλείει την πηγή ρεύματος και τον ανεμιστήρα πριν η συσκευή τοποθετηθεί στη θέση της και σφίξετε τις βίδες στήριξης.

#### ΚΙΝΔΥΝΟΣ

Μια ηλεκτρική πρίζα που δεν είναι καλωδιωμένη σωστά θα μπορούσε να προκαλέσει την παρουσία επικίνδυνης τάσης σε μεταλλικά εξαρτήματα του συστήματος ή στις συσκευές που προσαρτώνται στο σύστημα. Είναι ευθύνη του πελάτη να βεβαιωθεί ότι η πρίζα παροχής ρεύματος είναι σωστά καλωδιωμένη και γειωμένη ώστε να μην υπάρχει κίνδυνος ηλεκτροπληξίας. Κατά τη διάρκεια καταιγίδας, μην αποσυνδέετε καλώδια σταθμών εμφάνισης, εκτυπωτών, τηλεφώνων ή προστατευτικά σταθμών για γραμμές επικοινωνίας.

## Σημειώσεις προσοχής

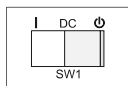
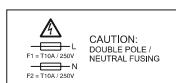
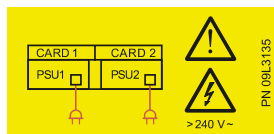

### ΠΡΟΣΟΧΗ:

Αυτή η μονάδα μπορεί να έχει δύο καλώδια γραμμής. Για να διακόψετε πλήρως την παροχή ρεύματος, αποσυνδέστε και τα δύο καλώδια γραμμής.

### ΠΡΟΣΟΧΗ:

Το βάρος αυτής της μονάδας είναι 38.5 Kg.

### ΠΡΟΣΟΧΗ:

Μην αφαιρέσετε το κάλυμμα, μην επιχειρήσετε να κάνετε συντήρηση της μονάδας, δεν υπάρχουν εξαρτήματα των οποίων μπορεί να γίνει συντήρηση.

### ΠΡΟΣΟΧΗ:

Ασφάλεια δύο πόλων/ουδέτερου

### ΠΡΟΣΟΧΗ:

Η κατάσταση "Standby" σημειώνεται με το σύμβολο που βρίσκεται στα δεξιά της σήμανσης "DC" πάνω από το διακόπτη SW1. Αν ο διακόπτης SW1 είναι στη δεξιά θέση, κάτω ακριβώς από το σύμβολο "Standby", η παροχή εναλλασσόμενου ρεύματος της μονάδας δεν έχει διακοπεί.

### ΠΡΟΣΟΧΗ:

Ο σταθεροποιητής πρέπει να προσαρτηθεί σωστά στο κάτω εμπρόσθιο μέρος του ικρίωματος ώστε να μην γείρει προς τα εμπρός το ικρίωμα κατά την αφαίρεση της μονάδας 2104 Μοντέλο DU3 από το ικρίωμα. Μην αφαιρέσετε ή εγκαταστήσετε καμία μονάδα αν δεν έχει προσαρτηθεί σταθεροποιητής στο ικρίωμα.

### ΠΡΟΣΟΧΗ:

Ο σταθεροποιητής πρέπει να προσαρτηθεί σωστά στο κάτω εμπρόσθιο μέρος του ικρίωματος ώστε να μην γείρει προς τα εμπρός το ικρίωμα κατά την εγκατάσταση της μονάδας 2104 Μοντέλο DU3 στο ικρίωμα. Μην αφαιρέσετε ή εγκαταστήσετε καμία μονάδα αν δεν έχει προσαρτηθεί σταθεροποιητής στο ικρίωμα.

### ΠΡΟΣΟΧΗ:

Μια μονάδα 2104 Μοντέλο DU3 έχει βάρος τουλάχιστον 38.5 Kg όταν είναι εγκατεστημένος ο μέγιστος αριθμός μονάδων δίσκων. Μην επιχειρήσετε να ανυψώσετε τη μονάδα 2104 για να την εγκαταστήσετε στο ικρίωμα αν δεν έχουν αφαιρεθεί όλες οι μονάδες δίσκων.

### ΠΡΟΣΟΧΗ:

Μια μονάδα 2104 Μοντέλο DU3 έχει βάρος τουλάχιστον 38.5 Kg όταν είναι εγκατεστημένος ο μέγιστος αριθμός μονάδων δίσκων. Μην επιχειρήσετε να αφαιρέσετε τη μονάδα 2104 από το ικρίωμα αν δεν έχουν αφαιρεθεί όλες οι μονάδες δίσκων.

**ΠΡΟΣΟΧΗ:**

Μην επιχειρήσετε να ανυψώσετε τη μονάδα 2104 μόνος σας. Ζητήστε τη βοήθεια ενός ακόμα ατόμου.

**ΠΡΟΣΟΧΗ:**

Μην εισάγετε χέρια ή εργαλεία στον κενό χώρο όπου βρισκόταν η συσκευή που περικλείει τον ανεμιστήρα.

**ΠΡΟΣΟΧΗ:**

Μην εισάγετε χέρια ή εργαλεία στον κενό χώρο όπου βρισκόταν η συσκευή που περικλείει την πηγή ρεύματος και τον ανεμιστήρα.

**ΠΡΟΣΟΧΗ:**

Μην εισάγετε χέρια ή εργαλεία στον κενό χώρο όπου βρισκόταν η συσκευή που περικλείει την κάρτα διακοπών (switch card).

**ΠΡΟΣΟΧΗ:**

Μην εισάγετε χέρια ή εργαλεία στον κενό χώρο όπου βρισκόταν η συσκευή που περικλείει την κάρτα διεπαφής SCSI.

**ΠΡΟΣΟΧΗ:**

Για την ασφάλεια του χρήστη, το προϊόν αυτό είναι εξοπλισμένο με καλώδιο 3 αγωγών και φως. Χρησιμοποιείτε το καλώδιο ρεύματος μαζί με σωστά γειωμένη ηλεκτρική πρίζα για να αποφύγετε τον κίνδυνο ηλεκτροπληξίας.

**ΠΡΟΣΟΧΗ:**

Μην αγγίξετε την πρίζα ρεύματος ή το κάλυμμα της πρίζας με οτιδήποτε άλλο πλην των ηλεκτροδίων δοκιμών έως ότου ολοκληρώσετε αυτό τον έλεγχο ασφάλειας.

**ΠΡΟΣΟΧΗ:**

Αν η ένδειξη δεν είναι άπειρο, μην προχωρήσετε. Πριν συνεχίσετε, κάντε τις απαραίτητες διορθώσεις στην καλώδιωση. Μην ανάψετε το κύκλωμα διακλάδωσης CB πριν ολοκληρωθούν ικανοποιητικά όλα τα παραπάνω βήματα.

**ΠΡΟΣΟΧΗ:**

Μια μονάδα 2104 Μοντέλο TU3 μπορεί να έχει βάρος έως και 38.5 Kg όταν είναι εγκατεστημένος ο μέγιστος αριθμός μονάδων δίσκων. Μην επιχειρήσετε να την ανυψώσετε χωρίς τη βοήθεια ενός ακόμα ατόμου.

**ΠΡΟΣΟΧΗ:**

Μη χρησιμοποιείτε τις λαβές του ανεμιστήρα ή της συσκευής που περικλείει την πηγή ρεύματος και τον ανεμιστήρα για να μεταφέρετε τη μονάδα 2104. Οι λαβές αυτές δεν είναι σχεδιασμένες να υποστηρίζουν το βάρος της μονάδας.

**ΠΡΟΣΟΧΗ:**

Καθώς ωθείτε τη συσκευή στη θέση της, ο μοχλός επαναφέρεται αυτόματα στην κλειστή θέση. Προσέξτε να μη χτυπηθούν τα δάκτυλά σας ανάμεσα στο μοχλό και τη συσκευή.

## הודעות בטיחות

נספח זה מכיל את הודעות הסכנה ואזהרות הבטיחות המופיעות בספרים השונים המתייחסים אל Expandable Storage Plus, דגם DU3 ודגם TU3.

הודעות אלה מופיעות הן באנגלית והן בשפות אחרות.

**הודעות סכנה** הודעת סכנה מזהירה מפני מצב העלול לגרום מוות או להיות מסוכן ביותר לבני אדם.

**הודעת זהירות** הודעת זהירות מפנה את תשומת הלב למצב העלול להיות מסוכן לבני אדם בגלל תנאים קיימים מסוימים.

השתמשו תמיד בנוהלי עבודה בטוחים כאשר אתם מטפלים במכונות. השתמשו בשיקול דעת כדי לזהות מצבים מסוכנים שאינם מתוארים בהודעות אלה.

### הודעות סכנה

#### סכנה

בצעדים הבאים אתם עומדים לנתק את כבלי החשמל. בכבלים אלה עובר זרם חשמלי אם יחידת מפצל הכוח של מסד המכשירים או יחידת האל-פסק (UPS) עדיין דולקים.

#### סכנה

אל תנסו לפתוח את מכסי מכלול ספק הכוח והמאוורר.

#### סכנה

אל תחברו כבל חשמל למכלול ספק הכוח והמאוורר עד שהתקנת היחידה תושלם וכל ברגי החיזוק יהיו מהודקים.

#### סכנה

שקע חשמלי שאינו מחווט כהלכה יכול לגרום למתח חשמלי מסוכן בחלקי מתכת של המערכת או ההתקנים המחוברים למערכת. הלקוח אחראי להבטיח כי השקע מחווט ומוארק כראוי, כדי למנוע סכנת התחשמלות. בזמן סערת ברקים, אין לחבר כבלים של צגים, מדפסות, טלפונים או מגיני ברקים של קווי תקשורת.

## הודעות זהירות

**זהירות:**  
ליחידה זו יכולים להיות שני כבלי חשמל. לניתוק הזרם, יש לנתק את שני הכבלים.



**זהירות:**  
יחידה זו שוקלת 38.5 ק"ג.



**זהירות:**  
אל תסירו את המכסה, אל תבצעו טיפול שירות, אין חלקים שאפשר לטפל בהם

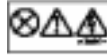

**זהירות:**  
הגנת נתיך כפולה (פאזה/אפס).



**זהירות:**  
חיווי מצב "כוננות" (standby) מופיע מימין לציון DC בדיוק מעל המתג SW1. כאשר המתג SW1 מוסט ימינה, בדיוק מתחת לחיווי הכוננות, מתח הרשת של היחידה אינו מנותק.



### זהירות:

המייצב חייב להיות מחובר כראוי בתחתית מסד המכשירים כדי למנוע מהמסד ליפול קדימה בזמן הוצאת היחידות מהמסד. אל תמשכו החוצה או תתקינו יחידות אם המייצב אינו מחובר אל מסד המכשירים.

### זהירות:

יחידת 2104 מדגם DU3 שוקלת 38.5 ק"ג כאשר המספר המרבי של כונני דיסקים מותקן בתוכה. אל תנסו להרים את היחידה לתוך המסד לפני שתנתקו את כל המודולים של כונני הדיסקים.

### זהירות:

יחידת 2104 מדגם DU3 שוקלת 38.5 ק"ג כאשר המספר המרבי של כונני דיסקים מותקן בתוכה. אל תנסו להוציא את היחידה מהמסד לפני שתנתקו את כל המודולים של כונני הדיסקים.

### זהירות:

אל תנסו להרים לבדכם את היחידה. בקשו עזרה מאדם נוסף.



**זהירות:**

אל תכניסו ידיים או מכשירים לחלל הריק שבו היה קודם מכלול המאוורר.

**זהירות:**

אל תכניסו ידיים או מכשירים לחלל הריק שבו היה קודם לכן מכלול ספק הכוח והמאוורר.

**זהירות:**

אל תכניסו ידיים או מכשירים לחלל הריק שבו היה קודם לכן מכלול כרטיסי המיתוג.

**זהירות:**

אל תכניסו ידיים או מכשירים לחלל הריק שבו היה קודם לכן מכלול כרטיסי SCSI.

**זהירות:**

מוצר זה מצויד בכבל חשמל ובתקע עם שלושה חוטים, לבטיחות המשתמש. חברו כבל חשמל זה לשקע חשמל מוארק כהלכה כדי למנוע סכנת התחשמלות.

**זהירות:**

אל תגעו בשקעים או במכסי השקעים אלא באמצעות מכשירי הבדיקה, לפני שבדיקת בטיחות זו תושלם.

**זהירות:**

אם הקריאה שונה מאינסוף, אל תמשיכו. בצעו את התיקונים הדרושים בחיווט לפני שתמשיכו. אל תפעילו את הנתח של קו ההזנה CB עד שכל הצעדים שלעיל יבוצעו.

**זהירות:**

משקלה של יחידת 2104 מדגם TU3 יכול להגיע עד 54.5 ק"ג כאשר המספר המרבי של כונני דיסקים מותקן בתוכה. אל תנסו להרים אותה ללא עזרה של אדם נוסף.

**זהירות:**

אל תשתמשו בידידות של המאוורר או של מכלולי המאוורר וספק הכוח כאמצעי לנשיאת היחידה. ידיות אלה אינן מיועדות לתמוך במשקל היחידה.

**זהירות:**

כשדוחפים את המכלול למקומו עד הסוף, ידית המנוף מוסטת למצב סגור באופן אוטומטי. היזהרו שאצבעותיכם לא ייתפסו בין המנוף למכלול.

---

## Biztonsági figyelmeztetések

Ez a függelék azokat a veszélyjelző és figyelmeztető megjegyzéseket tartalmazza, amelyek a Expandable Storage Plus: 2104 DU3-as és TU3-as modellekhez tartozó könyvekben szerepelnek.

Ezek a figyelmeztetések angolul és más nyelveken olvashatóak.

- Veszély!** A veszélyt jelző megjegyzés az emberekre halálos, vagy különösen veszélyes helyzetekre hívja fel a figyelmet.
- Figyelmeztetés!** A figyelmeztető megjegyzés olyan helyzetekre hívja fel a figyelmet, ahol a fennálló körülmények az emberekre veszélyes helyzetet teremtenek.

Mindig tartsa be az előírt biztonsági eljárásokat a gépek szerelésénél! Hagyatkozson a saját értékítéletére azon biztonsági feltételek esetén, amelyeket ezek a figyelmeztetések nem ismertetnek!

### Veszély!

#### Vigyázat, veszély!

A következő lépésben a tápkábelt távolítja el. Ezek a kábelek feszültség alatt állnak, ha a tápelosztó vagy a szünetmentes tápegység (UPS) be van kapcsolva.

#### Vigyázat, veszély!

Ne próbálja kinyitni a tápegység borítóját!

#### Vigyázat, veszély!

Ne csatlakoztasson hálózati kábelt a tápegységhez, amíg az nincs a helyén és a rögzítőcsavarjai nem tartják szorosan!

#### Vigyázat, veszély!

A nem megfelelően kábelezett elektromos foglalat veszélyes feszültséget vezethet a rendszer fém részeire és a csatlakoztatott eszközökbe.  
A vásárló felelőssége, hogy biztosítsa a foglalat helyes bekötését és földelését az áramütés megelőzése érdekében.  
Zivatar alatt ne húzza szét a monitorok, nyomtatók, telefonok és állomásvédő eszközök kommunikációs kábeleit!

## Figyelmeztetések

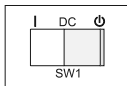
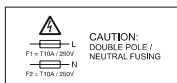
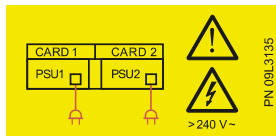

### Figyelem:

Előfordulhat, hogy az egységnek két tápkábele van. A teljes áramtalanítás érdekében húzza ki mindkét tápkábelt!

### Figyelem:

Az egység súlya 38.5 kg.

### Figyelem:

Ne távolítsa el a fedelet és ne próbálkozzon az egység szerelésével, nincs benne javítható elem!

### Figyelem:

Dupla pólusú/semleges biztosítékok

### Figyelem:

A "Készenléti" állapotot a DC-től jobbra, az SW1 kapcsoló feletti szimbólum jelzi. Ha az SW1 kapcsolót jobb oldali pozícióba állítja a "Készenléti" szimbólum alá, az egység tápellátása nem szűnik meg.

### Figyelem:

A stabilizátort megfelelően kell a tartókeret aljára szerelni úgy, hogy a tartókeret a 2104 DU3-as modell kiserelésékor ne dőljön előre.

Ne húzzon ki és ne szereljen be egységet, ha a tartókeretre nincs stabilizátor erősítve!

### Figyelem:

A stabilizátort megfelelően kell a tartókeret aljára szerelni úgy, hogy a tartókeret a 2104 DU3-as modell beszerelésékor ne dőljön előre.

Ne távolítson el és ne szereljen be egységet, ha a tartókeretre nincs stabilizátor erősítve!

### Figyelem:

Ha minden lemez meghajtó telepítve van, a 2104 DU3-as modell súlya 38.5 kg is lehet. Ne próbálja meg beemelni a 2104-as modellt a tartókeretbe, amíg nincs eltávolítva az összes lemez meghajtó modul!

### Figyelem:

Ha minden lemez meghajtó telepítve van, a 2104 DU3-as modell súlya 38.5 kg is lehet. Ne próbálja meg kiserelni a 2104-as modellt a tartókeretből, amíg nincs eltávolítva az összes lemez meghajtó modul!

**Figyelem:**

Ne próbálja egymaga felemelni a 2104-as modellt! Kérje más személy segítségét!

**Figyelem:**

Ne tegye a kezét vagy az eszközeit a ventilátor üres helyére!

**Figyelem:**

Ne tegye a kezét vagy az eszközeit a ventilátoros tápegység üres helyére!

**Figyelem:**

Ne tegye a kezét vagy az eszközeit a kapcsolókártya-egység üres helyére!

**Figyelem:**

Ne tegye a kezét vagy az eszközeit a SCSI illesztőkártya egységének üres helyére!

**Figyelem:**

E terméket a felhasználó biztonsága érdekében háromeres kábellel és dugasszal szerelték fel. Az áramütés elkerülése érdekében megfelelően földelt aljzatot használjon!

**Figyelem:**

Csak mérőműszerekkel érintse az aljzatot és az aljzat fedőlemezét, mielőtt ezt a biztonsági ellenőrzést befejezné!

**Figyelem:**

Abban az esetben, ha a kijelzőn nem végtelen látható, ne lépjen tovább! Folytatás előtt javítsa ki a vezetékek kapcsolásait! Ne kapcsoljon át a CB áramkörre, amíg a fenti műveleteket be nem fejezte!

**Figyelem:**

Ha minden lemezmeghajtó telepítve van, a 2104 TU3-as modell súlya 54.5 kg is lehet. Ne próbálja felemelni mások segítségével!

**Figyelem:**

A 2104-as egység szállításához ne használja a ventilátor vagy a szellőztető- és tápegység fogantyúját! Ezeket a fogantyúkat nem az egység súlyának megtartására tervezték.

**Figyelem:**

Ahogy az összeszerelt egységet a helyére tolja, úgy záródik fokozatosan a retesz. Vigyázzon, hogy az ujja ne csípődjön be a retesz és az egység közé!

---

## 安全上の注意

この付録は、Exp Plus: 2104 モデル DU3 および TU3 に関連する各種マニュアルで使用されている危険と注意の注記を収録しています。

### 危険の注記

危険の注記は、人が死亡または重傷を負う可能性がある状態について注意を喚起しています。

### 注意の注記

注意の注記は、ある条件によっては人が重傷を負う可能性があることについて注意を喚起しています。

機器を作動させるときは常に、安全についての作業手順に従ってください。そこに記述されていないケースであっても、ユーザー自身の判断で安全な状態で作業するようにしてください。

### 危険の注記

## 危険

次のステップで電源ケーブルを取り外します。ラックの配電盤や **UPS (無停電電源装置)** の電源がオンになっている場合、このケーブルには電流が通っています。

## 危険

ファン付き電源装置のカバーを開けないでください。

## 危険

装置が完全に設置され、装置の取り付けねじを締め付けるまで、電源コードをファン付き電源装置につながないでください。

## 危険

電源の配線が正しくないと、システムの金属部分やこのシステムに接続された他の装置に危険な電圧が発生することがあります。  
電源コンセントの配線や、接地工事を正しく行い、感電を防止するのはお客様の責任です。  
雷が発生している間は、モニター (表示装置)、プリンター、電話線、通信線の保護装置などの装置に接続されているケーブルを取り扱う作業は避けてください。

## 注意の注記

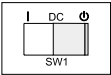
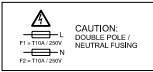
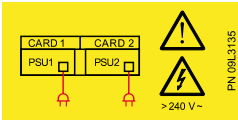

### ⚠ 注意

この装置には、電源コードが 2 本付いています。電源を完全に遮断するためには、2 本とも外してください。

### ⚠ 注意

この装置の重量は 38.5 kg です。

### ⚠ 注意

カバーを外さないでください。保守作業をしないでください。保守可能な部品はありません。

### ⚠ 注意

2 極 / 中性線ヒューズ使用

### ⚠ 注意

「スタンバイ」状態は、SW1 スイッチの上の DC の右にある記号で示されます。SW1 が「スタンバイ」記号の下で右側にセットされている場合、装置の AC 電源は完全に遮断されていません。

### ⚠ 注意

2104 モデル DU3 をラックから取り外す際、ラックが前に倒れることを防ぐために、安定板をラック底面前部に正しく取り付けてください。

安定板がラックに取り付けられていない場合は、装置の取り外しや取り付けをしないでください。

### ⚠ 注意

2104 モデル DU3 をラックに取り付ける際、ラックが前に倒れることを防ぐために、安定板をラック底面前部に正しく取り付けてください。

安定板がラックに取り付けられていない場合は、装置の取り外しや取り付けをしないでください。

### ⚠ 注意

2104 モデル DU3 の重量は、ディスク・ドライブ・モジュールを取り付けた最大構成で 38.5kg 以上です。すべてのディスク・ドライブ・モジュールが取り外されるまでは、ラックに 2104 を取り付けないでください。

## 注意

2104 モデル DU3 の重量は、ディスク・ドライブ・モジュールを取り付けた最大構成で 38.5kg 以上です。すべてのディスク・ドライブ・モジュールが取り外されるまでは、ラックから2104 を取り外さないでください。

## 注意

2104を一人で持ち上げないでください。他の人の助けを借りてください。

## 注意

ファンを取り出したあとの空間に手やツールを差し込まないでください。

## 注意

ファン付き電源装置を取り出したあとの空間に手やツールを差し込まないでください。

## 注意

スイッチ・カード・アセンブリーを取り出したあとの空間に手やツールを差し込まないでください。

## 注意

SCSI インターフェース・カード・アセンブリーを取り出したあとの空間に手やツールを差し込まないでください。

## 注意

この製品には、使用者保護のために 3 線式の電源ケーブルとプラグが付けられています。感電事故防止のために、この電源ケーブルと適切に接地された電源コンセントを使用してください。

## 注意

安全チェックが完了するまでは、テスト・プローブ以外のもので電源コンセントや電源コンセントの表面プレートにさわることがないようにしてください。

## 注意

電源ピンが絶縁されていることを確認するまでは作業を進めないでください。必要があれば、配線の修正を行ってください。上記のすべてのステップが正しく完了するまでは、サーキットブレーカーのスイッチを入れしないでください。

## 注意

2104 モデル TU3 の重量は、ディスク・ドライブ・モジュールを取り付けた最大構成で 54.5 kg 以上です。他の人の助けなしで装置を持ち上げないでください。

## 注意

2104 を運ぶ場合に、ファン付き電源装置やファンに取り付けてあるハンドルを使用しないでください。これらのハンドルは装置の重量を支えるようには作られていません。

## 注意

アセンブリーを一杯に押し込むと、レバーは閉じられた方に自動的に移動します。レバーとアセンブリーの間に指がはさまれることのないように 注意してください。



---

## 안전 경고

이 부록에는 Expandable Storage Plus: 2104 모델 DU3 및 TU3와 관련된 여러 책에서 사용되는 위험 및 경고 주의사항이 들어 있습니다.

주의사항은 영어와 그외 다양한 언어로 표시됩니다.

위험 주의사항

사용자에게 치명적일 수 있거나 매우 위험한 상황에 대해 주의를 환기시킵니다.

경고 주의사항

기존 조건때문에 사용자에게 위협할 수 있는 상황에 대해 주의를 환기시킵니다.

기계 작업을 할 때는 항상 안전 작업 절차를 따르십시오. 이 주의사항에 나와있지 않은 안전에 관한 상황은 스스로 판단해서 조치를 취하십시오.

### 위험 주의사항

#### 위험

다음 단계에서 전원 케이블을 제거하는 경우, 랙 분산 장치 또는 무정전 전원 장치(UPS)의 전원이 켜져 있으면 이 케이블에는 전류가 흐르고 있는 상태입니다.

#### 위험

송풍기 및 전원 공급 장치의 덮개를 열지 마십시오.

#### 위험

송풍기 및 전원 공급 장치가 완전히 장착되고 나사를 완전히 조이기 전에는 송풍기 및 전원 공급 장치에 전원 케이블 플러그를 꽂지 마십시오.

#### 위험

제대로 배선되지 않은 전기 콘센트는 시스템이나 해당 시스템에 부착된 장치의 금속 부분에 위험한 감전을 일으킬 수 있습니다. 감전을 방지하기 위해 콘센트가 제대로 배선되고 접지되었는지 확인하는 것은 고객의 책임입니다. 노우 중에는 표시장치, 프린터, 전화 또는 통신 회선용 장치 보호기의 케이블을 뽑지 마십시오.

## 경고 주의사항

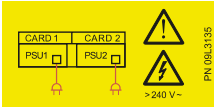

### 주의:

이 장치에 두 개의 라인 코드가 있습니다. 모든 전원을 차단하려면 두 개의 라인 코드를 모두 연결 해제하십시오.



### 주의:

이 장치의 무게는 **38.5 kg**입니다.



### 주의:

덮개를 제거하지 마십시오. 서비스 가능 부품이 아니오니 서비스하지 마십시오.



### 주의:

이중 중성극 퓨즈



### 주의:

"Standby" 상태는 SW1 스위치 바로 위쪽의 "DC" 오른쪽에 기호로 표시됩니다. SW1이 "Standby" 기호 아래의 오른쪽 위치로 설정되면 장치의 AC 전원은 차단되지 않습니다.

### 주의:

**2104** 모델 **DU3**가 랙에서 제거되는 동안 앞쪽으로 넘어지는 것을 방지하기 위해서는 스테블라이저가 랙의 앞쪽 아래 부분에 제대로 설치되어 있어야 합니다. 스테블라이저가 랙에 접속되어 있지 않다면 어떤 장치도 꺼내거나 설치하지 마십시오.

### 주의:

**2104** 모델 **DU3**가 랙에 설치되는 동안 앞쪽으로 넘어지는 것을 방지하기 위해서는 스테블라이저가 랙의 앞쪽 아래 부분에 제대로 설치되어 있어야 합니다. 스테블라이저가 랙에 접속되어 있지 않다면 어떤 장치도 제거하거나 설치하지 마십시오.

### 주의:

디스크 드라이브 모듈이 설치되어 있는 **2104** 모델 **DU3**는 **38.5kg(85lb)**까지 무게가 나갑니다. 모든 디스크 드라이브 모듈이 제거되지 않은 경우, **2104**를 랙으로 들어올리지 마십시오.

### 주의:

디스크 드라이브 모듈이 설치되어 있는 **2104** 모델 **DU3**는 **38.5kg(85lb)**까지 무게가 나갑니다. 모든 디스크 드라이브 모듈이 제거되지 않은 경우, **2104**를 랙에서 제거하지 마십시오.

### 주의:

**2104**를 혼자 들어올리려고 하지 마십시오. 다른 서비스 직원에게 도움을 요청하십시오.

### 주의:

송풍기 장치가 있는 빈 공간에 손이나 툴을 넣지 마십시오.

### 주의:

송풍기 및 전원 공급 장치가 있는 빈 공간에 손이나 툴을 넣지 마십시오.

### 주의:

스위치 카드 장치가 있는 빈 공간에 손이나 툴을 넣지 마십시오.

### 주의:

**SCSI** 인터페이스 카드 장치가 있는 빈 공간에 손이나 툴을 넣지 마십시오.

### 주의:

이 제품은 사용자 안전을 위해 3회선 전원 케이블 및 플러그가 장착되어 있습니다. 감전을 피하려면 제대로 접지된 전기 콘센트에 이 전원 케이블을 사용하십시오.

주의:

해당 안전 점검을 완료하기 전에 테스트 탐침 이외의 다른 도구로 전원 콘센트 나 전원 콘센트 보호용 덮개를 만지지 마십시오.

주의:

충분히 숙지하지 않은 경우 계속하지 마십시오. 계속하기 전에 배선에 필요한 보정을 하십시오. 위의 모든 단계를 완료할 때까지 분기 회로 **CB**의 전원을 꺼지 마십시오.

주의:

디스크 드라이브 모듈이 설치되어 있는 **2104** 모델 **TU3**는 **54.5kg(120lb)**까지 무게가 나갑니다. 다른 사람의 도움 없이 들어 올리려고 하지 마십시오.

주의:

**2104** 운반시에 송풍기 또는 송풍기 및 전원 공급 장치의 핸들을 사용하지 마십시오. 이 핸들은 장치의 무게를 지탱하지 못합니다.

주의:

장치를 완전히 제자리로 밀어넣으면, 레버가 자동으로 닫힘 위치로 이동합니다. 레버와 장치 간에 손가락이 끼이지 않도록 주의하십시오.

---

## Avisos de Segurança

Este apêndice contém avisos de perigo e cuidado utilizados nos diversos manuais relativos a Expandable Storage Plus: 2104 Modelos DU3 e TU3.

Os avisos encontram-se em língua inglesa e noutros idiomas.

### Aviso de perigo

Um aviso de perigo chama a atenção para uma situação que seja potencialmente letal ou extremamente perigosa para as pessoas.

### Aviso de cuidado

Um aviso de cuidado chama a atenção para uma situação que seja potencialmente perigosa para as pessoas devido a alguma condição existente.

Utilize sempre procedimentos seguros ao trabalhar com máquinas. Recorra ao senso comum para identificar condições de segurança que estes avisos não incluam.

### Avisos de Perigo

#### PERIGO

A etapa seguinte consiste em remover os cabos de alimentação. Estes cabos estão sob tensão se a unidade de distribuição de alimentação do bastidor ou se a unidade de fonte de alimentação ininterruptível (UPS) ainda estiver ligada.

#### PERIGO

N

## Avisos de Cuidado

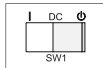
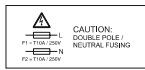
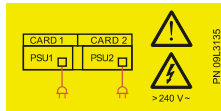

### CUIDADO:

Esta unidade pode ter dois cabos eléctricos. Para remover toda a alimentação, desligue ambos os cabos eléctricos.

### CUIDADO:

Esta unidade pesa 38.5 kg.

### CUIDADO:

Não remova a tampa, não tente efectuar a manutenção, as peças não precisam de assistência.

### CUIDADO:

Fusível de dupla polaridade/neutro

### CUIDADO:

O símbolo que se encontra à direita de "CC" logo acima do interruptor, SW1, indica uma condição "Standby". Ao comutar o SW1 para a posição da direita logo abaixo do símbolo "Standby", a alimentação de CA da unidade não é desligada.

### CUIDADO:

O estabilizador deve estar correctamente ligado à frente de baixo do bastidor por forma a evitar que este se incline para a frente enquanto o 2104 Modelo DU3 está a ser retirado do bastidor. Não retire nem instale unidade alguma se não tiver um estabilizador ligado ao bastidor.

### CUIDADO:

O estabilizador deve estar correctamente ligado à frente de baixo do bastidor por forma a evitar que este se incline para a frente enquanto o 2104 Modelo DU3 está a ser instalado no bastidor. Não remova nem instale unidade alguma se não tiver um estabilizador ligado ao bastidor.

### CUIDADO:

Um 2104 Modelo DU3 pesa cerca de 38.5kg com o número máximo de módulos de unidades de disco instalados. Não tente levantar o 2104 para o bastidor, a menos que tenham sido removidos todos os módulos de unidades de disco.

### CUIDADO:

Um 2104 Modelo DU3 pesa cerca de 38.5kg com o número máximo de módulos de unidades de disco instalados. Não tente remover o 2104 do bastidor, a menos que tenham sido removidos todos os módulos de unidades de disco.

### CUIDADO:

Não tente levantar o 2104 sozinho. Peça ajuda para o efeito.

### CUIDADO:

Não introduza as mãos ou ferramentas no espaço vazio que continha o conjunto do ventilador.

### CUIDADO:

Não introduza as mãos ou ferramentas no espaço vazio que continha o conjunto de fonte-de-alimentação-e-ventilador.

### CUIDADO:

Não introduza as mãos ou ferramentas no espaço vazio que continha o conjunto da placa de interruptor.

**CUIDADO:**

Não introduza as mãos ou ferramentas no espaço vazio que continha o conjunto da placa de interface SCSI.

**CUIDADO:**

Este produto está equipado com cabo de alimentação e ficha de 3 condutores para segurança do utilizador. Utilize este cabo em conjunto com uma tomada devidamente ligada à terra para evitar choques eléctricos.

**CUIDADO:**

Não toque na tomada de corrente, nem no respectivo painel frontal, com objectos que não sejam pontas de prova até ter concluído esta verificação de segurança.

**CUIDADO:**

Se a leitura não for infinito, não continue a verificação. Efectue as correcções necessárias ao sistema de ligações antes de prosseguir. Não ligue o CB do circuito de derivação enquanto não concluir satisfatoriamente os passos descritos acima.

**CUIDADO:**

Um 2104 Modelo TU3 pode pesar até 54.5 kg com o número máximo de módulos de unidades de disco instalados. Não tente levantar sem ajuda.

**CUIDADO:**

Não utilize os manípulos dos conjuntos de ventilador ou de fonte-de-alimentação-e-ventilador para transportar o 2104. Estes manípulos não foram concebidos para suportar o peso da unidade.

**CUIDADO:**

Ao empurrar o conjunto totalmente para dentro, a alavanca move-se automaticamente para a posição fechada. Tenha cuidado para não entalar os dedos.

---

## Avisos de seguridad

Este apéndice contiene los avisos de peligro y precaución que se utilizan en los diversos manuales que hacen referencia a Expandable Storage Plus: 2104 Modelos DU3 y TU3.

Los avisos se muestran en inglés y en otros idiomas diferentes.

### Aviso de peligro

Un aviso de peligro llama la atención sobre una situación que, potencialmente, podría causar la muerte o un daño muy grave a las personas.

### Aviso de precaución

Un aviso de precaución llama la atención sobre una situación que, potencialmente, puede resultar peligrosa para las personas a causa de una condición existente.

Siga procedimientos de trabajo seguros siempre que trabaje con máquinas. Utilice su propio juicio para identificar condiciones de seguridad que no se describen en estos avisos.

### Avisos de peligro

#### PELIGRO

En el siguiente paso va a extraer los cables de alimentación. Estos cables están cargados si la unidad de distribución de alimentación del bastidor o la unidad de suministro de alimentación ininterrumpido todavía están conectadas.

#### PELIGRO

No intente abrir las cubiertas del conjunto ventilador-y-suministro-de-alimentación.

#### PELIGRO

No enchufe un cable de alimentación en el conjunto ventilador-y-suministro-de-alimentación hasta que el conjunto esté bien colocado en su sitio y los tornillos de mariposa estén apretados completamente.

#### PELIGRO

Una toma eléctrica que no tenga un cableado correcto puede hacer que las partes metálicas del sistema o los dispositivos conectados al sistema tengan un voltaje peligroso. Es la responsabilidad del usuario asegurarse de que la toma esté cableada y conectada a tierra correctamente para prevenir una descarga eléctrica. Durante una tormenta eléctrica, no desconecte los cables de las estaciones de pantalla, impresoras, teléfonos o protectores de estaciones para líneas de comunicación.

## Avisos de precaución

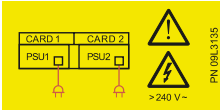

### PRECAUCIÓN:

Esta unidad tiene dos cables. Para eliminar toda la alimentación, desconecte los dos.



### PRECAUCIÓN:

Esta unidad pesa 38.5 kg.



### PRECAUCIÓN:

No extraiga la cubierta, no lo repare, no hay ningún componente que se pueda reparar.

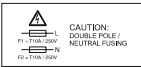

### PRECAUCIÓN:

Fusible de doble polo/neutro

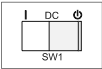

### PRECAUCIÓN:

Una condición de "espera" se indica con el símbolo que se encuentra a la derecha de "DC" directamente encima del conmutador, SW1. Cuando SW1 se coloca en la posición correcta directamente debajo del símbolo "En espera", la alimentación de CA de la unidad no está desconectada.

### PRECAUCIÓN:

El estabilizador debe estar conectado de manera correcta a la parte frontal inferior del bastidor para evitar que el bastidor se incline hacia adelante mientras se extrae el 2104 Modelo DU3 del bastidor.

No extraiga ni instale ninguna unidad si no está conectado un estabilizador al bastidor.

### PRECAUCIÓN:

El estabilizador debe estar conectado de manera correcta a la parte frontal inferior del bastidor para evitar que el bastidor se incline hacia adelante mientras se instala en el bastidor el 2104 Modelo DU3.

No extraiga ni instale ninguna unidad si no está conectado un estabilizador al bastidor.

### PRECAUCIÓN:

Un 2104 Modelo DU3 pesa hasta 38.5 kg (85 lb) con el número máximo de módulos de unidades de disco instalados. No intente alzar el 2104 hacia el bastidor a menos que se hayan extraído todos los módulos de unidades de disco.

### PRECAUCIÓN:

Un 2104 Modelo DU3 pesa hasta 38.5 kg (85 lb) con el número máximo de módulos de unidades de disco instalados. No intente extraer el 2104 del bastidor a menos que se hayan extraído todos los módulos de unidades de disco.

### PRECAUCIÓN:

No intente levantar el 2104 sólo. Pida ayuda a otra persona.

### PRECAUCIÓN:

No introduzca las manos ni herramientas en el espacio vacío que ocupaba el conjunto del ventilador.

### PRECAUCIÓN:

No introduzca las manos ni herramientas en el espacio vacío que ocupaba el conjunto ventilador-y-suministro-de-alimentación.



**PRECAUCIÓN:**

No introduzca las manos ni herramientas en el espacio vacío que ocupaba el conjunto de la tarjeta conmutadora.

**PRECAUCIÓN:**

No introduzca las manos ni herramientas en el espacio vacío que ocupaba el conjunto de la tarjeta de la interfaz SCSI.

**PRECAUCIÓN:**

Este producto está equipado con un cable de alimentación de tres alambres y enchufe para más seguridad para el usuario. Utilice este cable de alimentación junto con una toma eléctrica conectada a tierra correctamente para evitar una descarga eléctrica.

**PRECAUCIÓN:**

No toque la toma de alimentación o la placa frontal de la misma excepto con las sondas de comprobación antes de haber completado esta comprobación de seguridad.

**PRECAUCIÓN:**

Si la lectura no es infinita, no continúe. Realice las correcciones necesarias en la instalación alámbrica antes de continuar. Hasta que no se hayan completado de manera satisfactoria todos los pasos anteriores no se debe encender el CB del circuito de derivación.

**PRECAUCIÓN:**

Un 2104 Modelo TU3 puede pesar hasta 54.5 kg (120 lb) con el número máximo de módulos de unidades de disco instalados. No intente levantar uno sin la ayuda de una segunda persona.

**PRECAUCIÓN:**

No utilice las asas del conjunto del ventilador ni las del conjunto ventilador-y-suministro-de-alimentación para llevar el 2104. Estas asas no están hechas para soportar el peso de la unidad.

**PRECAUCIÓN:**

Mientras empuja el conjunto hacia su sitio, la palanca se mueve de manera automática hacia la posición de cerrado. Asegúrese de que los dedos no se queden comprimidos entre la palanca y el conjunto.

---

## 安全警告

本附錄包含危險及注意事項，適用在與 Expandable Storage Plus: 2104 DU3 及 TU3 機型相關的不同書籍中。

注意事項以英文及其他不同語言顯示。

危險注意事項

「危險注意事項」是要提醒人們注意潛在致命或極度危險的狀況。

警告注意事項

「警告注意事項」是要提醒人們注意因現存條件而產生潛在危險的狀況。

不論何時使用機器，務必採用安全的工作程序。注意事項未說明的安全狀況，請運用自我判斷力加以識別。

### 危險注意事項

#### 危險

下一步您需要拔掉電源線。如果框架式電源分送裝置或不斷電系統（UPS）仍舊開著，則這些電源線仍處於通電狀態。

#### 危險

請勿嘗試開啓風扇與電源供應組的蓋子。

#### 危險

除非供應組已確實歸位，且螺絲已完全鎖緊，否則請勿將電源線插頭插入風扇與電源供應組。

#### 危險

未正確接線的電源插座，可能會使系統或與系統相連之裝置的金屬部分，帶有危險的電壓。客戶有責任確定插座已正確接線及接地，以避免電擊。雷電交加時，請勿切斷顯示站、印表機、電話，或通訊線路工作站防護設備的電源線。

## 警告注意事項

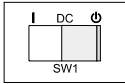
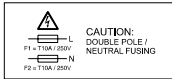
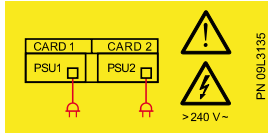

### 注意:

此裝置可能有兩條電線。要除去所有電力，請一併切斷這兩條電線。

### 注意:

此裝置重量為 **38.5 公斤**。

### 注意:

請勿將蓋子移除，沒有可用的零件時，請勿自行修理。

### 注意:

**雙極/無熔絲保險**

### 注意:

指示「待機」狀態的符號，位於 **SW1** 開關正上方的 **DC** 右側。當 **SW1** 切換到右側，即「待機」符號的正下方時，該裝置的交流電源尚未關閉。

### 注意:

穩壓器必須正確地連接在框架的下方前緣，以避免從框架移除 **2104 DU3** 機型的時候，框架的尖端遭到磨平。如果穩壓器尚未連接到框架，請勿拉出或安裝任何裝置。

### 注意:

穩壓器必須正確地連接在框架的下方前緣，以避免將 **2104 DU3** 機型安裝到框架上的時候，框架的尖端遭到磨平。如果穩壓器尚未連接到框架，請勿移除或安裝任何裝置。

### 注意:

**2104 DU3** 機型如安裝最大數量的硬碟模組時，重量可達 **38.5 公斤 (85 磅)**。除非已移除所有的硬碟模組，否則請勿嘗試將 **2104** 搬上框架。

### 注意:

**2104 DU3** 機型如安裝最大數量的硬碟模組時，重量可達 **38.5 公斤 (85 磅)**。除非已移除所有的硬碟模組，否則請勿嘗試將 **2104** 搬下框架。

### 注意:

請勿嘗試獨自搬動 **2104**。請尋求他人的協助。

### 注意:

請勿將手或工具插入裝有風扇組的空間。

### 注意:

請勿將手或工具插入裝有風扇與電源供應組的空間。

**注意:**

請勿將手或工具插入裝有切換卡組的空間。

**注意:**

請勿將手或工具插入裝有 **SCSI** 介面卡組的空間。

**注意:**

本產品配有三線電源線及插頭，以保護使用者的安全。使用電源線連接正確接地的電源插座，以避免電擊。

**注意:**

在完成安全檢查之前，請勿用探針以外的東西，碰觸電源插座或電源插座面板。

**注意:**

如果表上的讀數不是無窮大，請勿繼續。在繼續動作之前，請對線路進行必要的更正。請勿打開分支電路 **CB** 的電源，直到上述所有步驟均照要求完成為止。

**注意:**

**2104 TU3** 機型如安裝最大數量的硬碟模組時，重量可達 **54.5** 公斤 (**120** 磅)。沒有他人協助時，請勿嘗試獨自搬動。

**注意:**

請勿使用風扇或風扇與電源供應組的把手來搬運 **2104**。這些把手無法承受裝置的重量。

**注意:**

當您將供應組確實歸位時，開關桿會自動移至開關的位置。請確保您的手指沒有放在開關桿及供應組之間。



Part Number: 07K9278

Printed in the U.S.A.

GA33-3311-01



(1P) P/N: 07K9278

