

Advanced SerialRAID Adapters

User's Guide and Maintenance Information

Advanced SerialRAID Adapters

User's Guide and Maintenance Information

Third Edition (September 2000)

This softcopy of 14 January 2002 is a minor revision to SA33-3285-02. It contains new technical changes that are not shown in the printed book. Such changes are shown by a colon (;) to the left of each change. Changes that are also in the printed book are shown by a vertical line to the left of each change.

The following paragraph does not apply to any country where such provisions are inconsistent with local law: THIS PUBLICATION IS PRINTED "AS IS" WITHOUT WARRANTY OF ANY KIND, EITHER EXPRESS OR IMPLIED, INCLUDING, BUT NOT LIMITED TO, THE IMPLIED WARRANTIES OF MERCHANTABILITY OR FITNESS FOR A PARTICULAR PURPOSE. Some states do not allow disclaimer of express or implied warranties in certain transactions; therefore, this statement may not apply to you.

This publication could contain technical inaccuracies or typographical errors. Changes are periodically made to the information herein; these changes will be incorporated in new editions of the publication.

It is possible that this publication may contain reference to, or information about, products (machines and programs), programming, or services that are not announced in your country. Such references or information must not be construed to mean that such products, programming, or services will be offered in your country. Any reference to a licensed program in this publication is not intended to state or imply that you can use only the licensed program indicated. You can use any functionally equivalent program instead.

© Copyright International Business Machines Corporation 1996, 2000. All rights reserved.

Note to U.S. Government Users — Documentation related to restricted rights — Use, duplication, or disclosure is subject to restrictions set forth in the GSA ADP Schedule Contract.

Contents

Safety Notices.	xv
Definitions of Safety Notices	xv
Safety Notice for Installing, Relocating, or Servicing.	xv
About This Book	xvii
Who Should Use This Book	xvii
What This Book Contains	xvii
If You Need More Information.	xvii
Web Support Pages.	xviii
Numbering Convention.	xviii

Part 1. User Information 1

Chapter 1. Introducing SSA and the Advanced SerialRAID Adapters	3
Serial Storage Architecture (SSA)	3
The Advanced SerialRAID Adapters (type 4–P)	4
Fast-Write Cache Feature	5
128 MB Memory Module Feature	5
Lights of the Advanced SerialRAID Adapters	6
Port Addresses of the Advanced SerialRAID Adapters	6
SSA Adapter ID during Bring-Up	6
Chapter 2. Introducing SSA Loops	7
Loops, Links, and Data Paths	7
Simple Loop	8
Simple Loop — One Disk Drive Missing	9
Simple Loop — Two Disk Drives Missing	10
One Loop with Two Adapters in One Using System.	11
One Loop with Two Adapters in Each of Two Using Systems	12
Two Loops with One Adapter	14
Two Loops with Two Adapters.	15
Large Configurations	16
Switching Off Using Systems	17
Switching On Using Systems	17
Configuring Devices on an SSA Loop	18
SSA Link Speed	18
Identifying and Addressing SSA Devices	19
Location Code Format	19
Pdisks, Hdisks, and Disk Drive Identification	19
SSA Unique IDs	21
Rules for SSA Loops.	22
Checking the Level of the Adapter Microcode.	23
Rules for the Physical Relationship between Disk Drives and Adapters	24
One Pair of Adapter Connectors in the Loop	24
Pairs of Adapter Connectors in the Loop – Some Shared Data	25
Pairs Of Adapter Connectors in the Loop – Mainly Shared Data	26

Reserving Disk Drives	27
Fast-Write Cache	27
Chapter 3. RAID Functions and Array States	29
RAID Functions	29
Availability	29
Disk Drives That Are Not in Arrays	30
RAID-0 Array States	31
Good State	31
Offline State.	31
RAID-1 Array States	32
RAID-5 Array States	33
Good State	33
Exposed State	33
Degraded State	33
Rebuilding State	34
Offline State.	34
RAID-5 Array State Flowchart	35
RAID-10 Array States	36
Good State	36
Exposed State	36
Degraded State	37
Rebuilding State	37
Offline State.	37
Unknown State.	38
Multiple States	38
Chapter 4. Using the SSA SMIT Menus	39
Getting Access to the SSA Adapters SMIT Menu	40
Getting Access to the SSA Disks SMIT Menu.	41
Getting Access to the SSA RAID Arrays SMIT Menu	43
Chapter 5. Hot Spare Management	45
Deciding how to Configure Hot Spare Disk Drive Pools	45
Choosing How Many Hot Spare Disk Drives to Include in Each Pool	51
Choosing the Error Threshold (Alarm) Level for a Hot Spare Pool	51
Rules for Hot Spare Disk Drive Pools	52
Solving Hot Spare Pool Problems	53
Chapter 6. Using the RAID Array Configurator	57
Installing and Configuring SSA RAID Arrays	58
Getting Access to the SSA RAID Arrays SMIT Menu	59
Adding an SSA RAID Array.	60
Deleting an SSA RAID Array	70
Creating a Hot Spare Disk Drive	72
Changing or Showing the Status of a Hot Spare Pool	74
Showing the Disks That Are Protected by Hot Spares	77
Listing the Disks That Are in a Hot Spare Pool	80
Adding a New Hot Spare Pool.	83
Adding Disks to, or Removing Disks from, a Hot Spare Pool.	86

Dealing with RAID Array Problems	89
Getting Access to the SSA RAID Array SMIT Menu	90
Identifying and Correcting or Removing Failed Disk Drives	91
Installing a Replacement Disk Drive	95
Using Other Configuration Functions	97
Getting Access to the SSA RAID Array SMIT Menu	98
Listing All Defined SSA RAID Arrays	100
Listing All Supported SSA RAID Arrays	101
Listing All SSA RAID Arrays That Are Connected to a RAID Manager	102
Listing the Status of All Defined SSA RAID Arrays	104
Listing or Identifying SSA Physical Disk Drives	108
Listing or Deleting Old RAID Arrays Recorded in an SSA RAID Manager	130
Changing or Showing the Attributes of an SSA RAID Array	135
Changing Member Disks in an SSA RAID Array	137
Changing or Showing the Use of an SSA Disk Drive	144
Changing the Use of Multiple SSA Physical Disks	147
Copying RAID-1 or RAID-10 Arrays	148
Chapter 7. Copying Data from Arrays and from Volume Groups	149
Copying Data from an Array	151
Using the ssaraid Command to Create a RAID-Copy Array from a RAID-1 or RAID-10 Array	151
Using SMIT to Create a RAID-Copy Array from a RAID-1 or RAID-10 Array	155
Using the ssa_make_copy Command to Create a RAID Copy from a RAID-1 or RAID-10 Array	159
ssa_make_copy Command	161
Purpose	161
Syntax	161
Description	161
Flags	162
Example 1: Copying a Complete Volume Group	164
Example 2: Copying One Logical Volume	165
Example 3: Copying One Logical Volume by Logical Volume Name or by FS Name	166
Example 4: Copying One Logical Volume by Logical Volume Name or by FS Name (2)	168
Example 4: Copying a Complete Volume Group and Recreating the Copy on Another Using System	169
Example 5: Running an Automatic Copy of a Volume Group	170
ssa_delete_copy Command	171
Purpose	171
Syntax	171
Flags	171
SMIT Menus for 3-Way Copy Operations	172
Getting Access to the Array Copy Services Menu	172
Array Copy Services	173
Effects of Array Copy on Other SMIT Menus	186
Change/Show Attributes of an SSA RAID Array	186
List Status Of All Defined SSA RAID Arrays	188
Identify Disks in an SSA RAID Array	189

Remove a Disk From an SSA RAID Array	190
Swap Members of an SSA RAID Array	191
Chapter 8. Split-Site Management	193
Configuration of RAID-1 and RAID-10 Arrays	193
Operation after a Loss of Member Disks	194
One Half of the Array Is Not Present	195
Array is Offline because Adapter Is Not Known to the Remaining Half of the Array	203
Array is Offline because the Split and Join Procedure Was Not Performed Correctly	205
Chapter 9. Using the SSA Spare Tool	209
Chapter 10. Using the Fast-Write Cache Feature	211
Fast-Write Cache Card Battery	211
Configuring the Fast-Write Cache Feature	211
Getting Access to the Fast-Write Menus	213
Enabling or Disabling Fast-Write for One Disk Drive	214
Enabling or Disabling Fast-Write for Multiple Devices.	215
Bypassing the Cache in a One-Way Fast-Write Network.	217
Dealing with Fast-Write Problems	218
SRN 42521	218
SRN 42524	220
SRN 42525	220
Chapter 11. SSA Error Logs	221
Error Logging	221
Summary	221
Detailed Description.	222
Error Logging Management	228
Summary	228
Detailed Description.	228
Error Log Analysis	229
Summary	229
Detailed Description.	230
Good Housekeeping	233
Chapter 12. Using the SSA Command Line Interface for RAID Configurations	235
Command Syntax	237
Options	238
Object Types	238
Instruct Types.	238
Examples	239
Example 1: To Create a RAID-0 Array.	239
Example 2: To Create a RAID-1 Array.	239
Example 3: To Create a RAID-5 Array.	240
Example 4: To Create a RAID-10 Array	240
Example 5: To Create a Hot Spare Pool	241
Example 6: To List All Defined SSA Objects	241

Example 7: To Change an Attribute of an Object	242
Example 8: To Exchange a Member Disk Drive of an Existing Array	242
Example 9: To Make a New System Disk.	243
Example 10: To Delete an Array.	243
SSARAID Command Attributes	244
RAID Arrays Creation and Change Attributes	244
RAID Arrays Change Attributes	248
Hot Spare Pool Creation and Change Attribute	249
Physical Disk Drive Change Attributes.	249
Action Attributes (RAID-1, RAID-5, and RAID-10 Only)	251
Couple Action Attributes (RAID-1 and RAID-10 Only).	252
Uncouple Action Attributes (RAID-1 and RAID-10 Only)	252
Return Codes.	253
Chapter 13. Using the Programming Interface	255
SSA Subsystem Overview	255
Device Drivers	255
Interface between the SSA Adapter Device Driver and Head Device Driver	256
Trace Formatting.	256
SSA Adapter Device Driver	257
Purpose	257
Syntax	257
Description.	257
PCI SSA Adapter ODM Attributes	257
Device-Dependent Subroutines	258
Summary of SSA Error Conditions	259
Managing Dumps	259
Files	260
IOCINFO (Device Information) SSA Adapter Device Driver ioctl Operation	261
Purpose	261
Description.	261
Files	261
SSA_TRANSACTION SSA Adapter Device Driver ioctl Operation.	262
Purpose	262
Description.	262
Return Values.	263
Files	263
SSA_GET_ENTRY_POINT SSA Adapter Device Driver ioctl Operation	264
Purpose	264
Description.	264
Return Values.	264
Files	264
SSA Adapter Device Driver Direct Call Entry Point.	265
Purpose	265
Description.	265
Return Values.	265
ssadisk SSA Disk Device Driver.	266
Purpose	266
Syntax	266
Configuration Issues	266

Device Attributes	270
Device-Dependent Subroutines	272
Error Conditions	274
Special Files	276
IOCINFO (Device Information) SSA Disk Device Driver ioctl Operation	277
Purpose	277
Description.	277
Files	277
SSADISK_ISAL_CMD (ISAL Command) SSA Disk Device Driver ioctl Operation	278
Purpose	278
Description.	278
Return Values.	279
Files	280
SSADISK_ISALMgr_CMD (ISAL Manager Command) SSA Disk Device Driver ioctl Operation	281
Purpose	281
Description.	281
Return Values.	282
Files	282
SSADISK_SCSI_CMD (SCSI Command) SSA Disk Device Driver ioctl Operation	283
Purpose	283
Description.	283
Return Values.	284
Files	284
SSADISK_LIST_PDISKS SSA Disk Device Driver ioctl Operation.	285
Purpose	285
Description.	285
Return Values.	286
Files	286
SSA Disk Concurrent Mode of Operation Interface	287
Device Driver Entry Point	287
Top Kernel Extension Entry Point	288
SSA Disk Fencing	290
SSA Target Mode	291
Configuring the SSA Target Mode	292
Buffer Management	293
Understanding Target-Mode Data Pacing.	293
Using SSA Target Mode	294
Execution of Target Mode Requests	294
SSA tmssa Device Driver	295
Purpose	295
Syntax	295
Description.	295
Configuration Information	296
Device-Dependent Subroutines	296
Errors	302
tmssa Special File	304
Purpose	304
Description.	304
Implementation Specifics	304

Related Information	304
IOCINFO (Device Information) tmssa Device Driver ioctl Operation	305
Purpose	305
Description.	305
TMIOSTAT (Status) tmssa Device Driver ioctl Operation.	307
Purpose	307
Description.	307
TMCHGIMPARM (Change Parameters) tmssa Device Driver ioctl Operation	308
Purpose	308
Description.	308

Part 2. Maintenance Information 311

Chapter 14. SSA Adapter Information	313
Installing the SSA Adapter	313
Cron Table Entries	313
Microcode Maintenance	314
Checking the ID and Level of the Microcode Package	314
Maintaining the Adapter Microcode	315
Maintaining the Disk Drive Microcode	315
Vital Product Data (VPD) for the SSA Adapter	316
Adapter Power-On Self-Tests (POSTs)	317

Chapter 15. Removal and Replacement Procedures	319
Exchanging Disk Drives	319
Changing Pdisk and Hdisk Numbers	326
Removing and Replacing an Advanced SerialRAID Adapter	327
Removing an SDRAM Module of an Advanced SerialRAID Adapter	329
Installing an SDRAM Module of an Advanced SerialRAID Adapter	330
Removing the Fast-Write Cache Option Card of an Advanced SerialRAID Adapter	332
Installing the Fast-Write Cache Option Card of an Advanced SerialRAID Adapter	334
Removing the Battery Assembly from the Fast-Write Cache Option Card of an Advanced SerialRAID Adapter	336
Installing a Battery Assembly into the Fast-Write Cache Option Card of an Advanced SerialRAID Adapter	338
Part Numbers.	340

Chapter 16. Using the SSA Command Line Utilities	341
ssa_sesdd Command	341
Purpose	341
Syntax	341
Description.	341
Flags	341
Examples	342
ssaadap Command	343
Purpose	343
Syntax	343
Description.	343
Flags	343

ssacand Command	344
Purpose	344
Syntax	344
Description.	344
Flags	344
ssa_certify Command	345
Purpose	345
Syntax	345
Description.	345
Flags	345
ssaconn Command	347
Purpose	347
Syntax	347
Description.	347
Flags	347
ssa_diag Command.	348
Purpose	348
Syntax	348
Description.	348
Flags	348
Output	348
ssadisk Command	349
Purpose	349
Syntax	349
Description.	349
Flags	349
ssadload Command.	350
Purpose	350
Syntax	350
Description.	350
Flags	351
Examples	351
ssa_ela Command	353
Purpose	353
Syntax	353
Description.	353
Flags	353
Output	354
ssaencl Command	355
Purpose	355
Syntax	355
Description.	355
Flags	355
Examples	357
ssa_format Command	358
Purpose	358
Syntax	358
Description.	358
Flags	358
Output	359

ssa_fw_status Command	360
Purpose	360
Syntax	360
Description.	360
Flags	360
Output	360
Examples	360
ssa_getdump Command	361
Purpose	361
Syntax	361
Description.	361
Flags	362
Output	363
ssaidentify Command	364
Purpose	364
Syntax	364
Description.	364
Flags	364
ssa_progress Command	365
Purpose	365
Syntax	365
Description.	365
Flags	365
Output	365
Examples	365
ssa_rescheck Command	366
Purpose	366
Syntax	366
Description.	366
Flags	366
Output	366
Examples	367
Return Codes.	367
ssa_servicemode Command	368
Purpose	368
Syntax	368
Description.	368
Flags	368
Output	368
ssa_speed Command	369
Purpose	369
Syntax	369
Description.	369
Flags	369
Output	370
Examples	370
ssavfynn Command.	371
Purpose	371
Syntax	371
Description.	371

Flags	371
Output	371
ssaxlate Command	372
Purpose	372
Syntax	372
Description.	372
Flags	372
Chapter 17. SSA Service Aids	373
The Identify Function	375
Starting the SSA Service Aids	376
Set Service Mode Service Aid	378
Link Verification Service Aid	383
Configuration Verification Service Aid	387
Format Disk Service Aid	389
Certify Disk Service Aid	391
Display/Download Disk Drive Microcode Service Aid	393
Link Speed Service Aid	396
Service Aid Service Request Numbers (SRNs)	400
Using the Service Aids for SSA-Link Problem Determination	400
Example 1. Normal Loops.	401
Example 2. Broken Loop (Cable Removed)	403
Example 3. Broken Loop (Disk Drive Removed)	406
Finding the Physical Location of a Device	409
Finding the Device When Service Aids Are Available	409
Finding the Device When No Service Aids Are Available.	409
Chapter 18. SSA Problem Determination Procedures	411
Service Request Numbers (SRNs)	411
The SRN Table	411
Using the SRN Table	411
Software and Microcode Errors	441
SSA Loop Configurations that Are Not Valid	441
SSA Maintenance Analysis Procedures (MAPs)	443
How to Use the MAPs	443
MAP 2010: START	444
MAP 2320: SSA Link	445
MAP 2323: SSA Intermittent Link Error	450
MAP 2324: SSA RAID	454
MAP 2410: SSA Repair Verification	475
SSA Link Errors	478
SSA Link Error Problem Determination	478
Link Status (Ready) Lights	481
Service Aid	482
Repair Actions	482

Part 3. Appendixes 483

Appendix. Communications Statements 485

Federal Communications Commission (FCC) Statement	485
Japanese Voluntary Control Council for Interference (VCCI) Statement	485
Korean Government Ministry of Communication (MOC) Statement	485
New Zealand Compliance Statement	485
International Electrotechnical Commission (IEC) Statement	486
Avis de conformité à la réglementation d'Industrie Canada	486
Industry Canada Compliance Statement	486
United Kingdom Telecommunications Requirements	486
European Union (EU) Statement	486
Radio Protection for Germany	486
Taiwan Class A Compliance Statement	487
Glossary	489
Index	493

Safety Notices

For a translation of the *danger* and *caution* notices contained in this book, see the *Safety Information* manual, SA23-2652.

Definitions of Safety Notices

A *danger* notice indicates the presence of a hazard that has the potential of causing death or serious personal injury.

This book contains no *danger* notices.

A *caution* notice indicates the presence of a hazard that has the potential of causing moderate or minor personal injury.

This book contains two *caution* notices. Those caution notices are in this safety section.

An *attention* notice indicates an action that could cause damage to a program, device, system, or data.

Safety Notice for Installing, Relocating, or Servicing

Before connecting or removing any cables to or from connectors at the using system, be sure to follow the steps in the installation or relocation checklist specified in the *Installation and Service Guide* for your using system. For safety checks when servicing, refer to that manual and to the *Installation and Service Guide* for your subsystem.

CAUTION:

A lithium battery can cause fire, explosion, or a severe burn. Do not recharge, disassemble, heat above 100°C (212°F), solder directly to the cell, incinerate, or expose cell contents to water. Keep away from children. Replace only with the part number specified with your system. Use of another battery might present a risk of fire or explosion.

The battery connector is polarized; do not try to reverse the polarity.

Dispose of the battery according to local regulations.

Each Advanced SerialRAID Adapter card contains a lithium battery.

CAUTION:

The Fast-Write Cache Option Card contains a nickel-cadmium (NiCad) battery. To avoid possible explosion, do not incinerate the battery. Exchange it only with a manufacturer-approved part. Recycle or discard the battery as instructed by local regulations and where recycling facilities exist.

About This Book

Who Should Use This Book

This book is for people who operate or service a RISC system that contains one or more Advanced SerialRAID Adapters. To follow the instructions in this book, you should be familiar with the basic operational procedures for a RISC system.

What This Book Contains

Part 1 of this book is mainly for the user. It describes:

- The Advanced SerialRAID Adapters
- SSA loops
- The RAID facilities that are provided by the adapter
- How to use the SSA SMIT menus
- How to use the RAID configuration utility to configure arrays of SSA disk drives, and how to deal with problems such as the failure of a disk drive in a RAID array
- How to use the SSA Spare Tool
- How to configure the Fast-Write feature
- SSA error logs
- How to use the SSA Command Line Interface
- How to use the programming interface

Part 2 of this book is mainly for service representatives. It describes:

- General technical topics about the Advanced SerialRAID Adapters
- Removal and replacement procedures
- How to use the SSA Command Line Utilities
- The SSA service aids
- Problem determination procedures, including Service Request Numbers (SRNs) and Maintenance analysis procedures (MAPs)

The appendix contains the communications statements for the adapter.

A glossary and an index are provided.

If You Need More Information

The *Problem Solving Guide and Reference*, SC23-2204, is the first book you should use if you have a problem with your system.

Other books that you might need are:

- The operator guide for your system
- *Diagnostic Information for Multiple Bus Systems*, SA38-0509
- *Technical Reference* for your adapter

Web Support Pages

When you are installing an SSA device or subsystem, upgrading your SSA subsystem, or doing preventive maintenance on your SSA subsystem, refer to the web page shown here. This web page provides access to the latest SSA publications, microrocde, and support information for the using system, SSA adapters, and SSA subsystem.

<http://www.storage.ibm.com/hardsoft/products/ssa>

Numbering Convention

In this book:

KB means 1 000 bytes.

MB means 1 000 000 bytes.

GB means 1 000 000 000 bytes.

Part 1. User Information

Chapter 1. Introducing SSA and the Advanced SerialRAID Adapters

This chapter describes:

- Serial storage architecture (SSA).
- The Advanced SerialRAID Adapter and the Advanced SerialRAID Plus Adapter. Physically, the two types of adapter are the same. The Advanced SerialRAID Plus Adapter, however, provides additional functions.

In this book, the name “Advanced SerialRAID Adapter” is used both for the Advanced SerialRAID Adapter and for the Advanced SerialRAID Plus Adapter, unless otherwise stated.

Serial Storage Architecture (SSA)

Serial Storage Architecture (SSA) is an industry-standard interface that provides high-performance fault-tolerant attachment of I/O storage devices. In SSA subsystems, transmissions to several destinations are multiplexed; the effective bandwidth is further increased by spatial reuse of the individual links. Commands are forwarded automatically from device to device along a loop until the target device is reached. Multiple commands can be travelling around the loop simultaneously. SSA retains the SCSI-2 commands, queuing model, and status and sense bytes.

The Advanced SerialRAID Adapters (type 4-P)

The Advanced SerialRAID Adapters (see Figure 1) are 40-MB-per-second Serial Storage Architecture (SSA), Peripheral Component Interconnect (PCI) adapters that serve as the interface between systems that use PCI architecture and devices that use SSA. These adapters provide support for two SSA loops. Each loop can contain a maximum of eight pairs of adapter connectors and a maximum of 48 disk drives. See also “Rules for SSA Loops” on page 22.

- | | | | |
|----------|--------------|----------|-------------------|
| 1 | Connector B2 | 5 | Green light |
| 2 | Green light | 6 | Connector A1 |
| 3 | Connector B1 | 7 | Type-number label |
| 4 | Connector A2 | | |

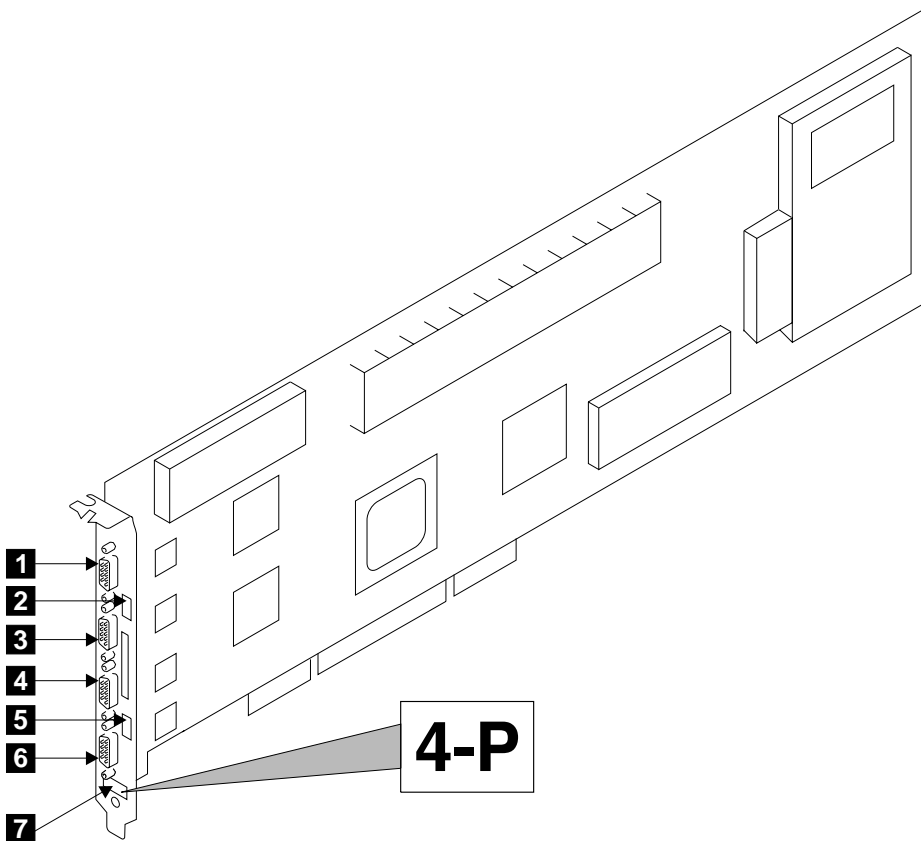

Figure 1. An Advanced SerialRAID Adapter Card (Type 4-P)

Note: In the SSA service aids, this adapter is called “IBM SSA 160 SerialRAID Adapter (14109100)”.

The adapter card has four SSA connectors that are arranged in two pairs. Connectors A1 and A2 are one pair; connectors B1 and B2 are the other pair.

The SSA links must be configured as loops. Each loop is connected to a pair of connectors at the SSA adapter card. These connectors *must* be a valid pair (that is, A1 and A2 or B1 and B2); otherwise, the disk drives on the loop are not fully configured, and the diagnostics fail. Operations to all the disk drives on a particular loop can continue if that loop breaks at any one point.

This adapter also contains *array management software* that provides RAID functions to control the *arrays* of the RAID subsystem (see also Chapter 3, “RAID Functions and Array States” on page 29). An array can contain several *member disk drives*. Each array is handled as one disk by the operating system. The array management software translates requests to this disk into requests to the member disk drives. Although this adapter is a RAID adapter, it can be configured so that all, some, or none of the disk drives that are attached to it are member disk drives of arrays.

The Advanced SerialRAID Adapter can be connected, by way of one or two SSA loops, to other SSA adapters. These adapters can be either in the same using system, or in separate using systems. (See “Rules for SSA Loops” on page 22 for details of valid configurations.)

Fast-Write Cache Feature

An optional 32 MB Fast-Write Cache feature is available for the Advanced SerialRAID Adapter. This feature improves performance for jobs that include many write operations.

128 MB Memory Module Feature

An optional 128 MB dual inline memory module (DIMM) feature is available. This feature is recommended for two-way fast-write operations.

Lights of the Advanced SerialRAID Adapters

Each pair of connectors has a green light that indicates the operational status of its related loop:

Status of Light	Meaning
-----------------	---------

Off	Both SSA connectors are inactive. If disk drives or other SSA adapters are connected to these connectors, either those disk drives or adapters are failing, or their SSA links are not active.
------------	--

Permanently on	Both SSA links are active (normal operating condition).
-----------------------	---

Slow Flash	Only one SSA link is active.
-------------------	------------------------------

Port Addresses of the Advanced SerialRAID Adapters

The port addresses used in some SRNs that relate to these adapters can be numbers 0 through 3. They correspond to the port connectors on the SSA adapter:

0 = Connector A1

1 = Connector A2

2 = Connector B1

3 = Connector B2

SSA Adapter ID during Bring-Up

All adapters that can be used on RISC using systems generate a three-digit configuration program indicator number. During system bring-up, this indicator number appears on the three-digit display of the using system. The numbers are:

80C	Advanced SerialRAID Adapter (type 4-P) is being identified or configured.
-----	---

Chapter 2. Introducing SSA Loops

This chapter describes the principles of SSA loops, how SSA devices are known to the system programs, and the rules that you must observe when you configure your SSA loops.

Loops, Links, and Data Paths

In the simplest SSA configuration, SSA devices are connected through two or more SSA links to an SSA adapter that is located in a using system. The devices, SSA links, and SSA adapter are configured in loops. Each loop provides a data path that starts at one connector of the SSA adapter and passes through a link (SSA cable) to the devices. The loop continues through the devices, then returns through another link to a second connector on the SSA adapter.

The maximum permitted length for an external copper cable that connects two SSA nodes (for example, disk drives) is 25 meters (82 feet).

The maximum permitted length for an external fiber optic cable that connects two SSA nodes (for example, disk drives) is 10 kilometers (32800 feet). Some devices, however, can operate only at shorter distances. See your subsystem documentation for details.

Details of the rules for configuring SSA loops are given for each SSA adapter in “Rules for SSA Loops” on page 22.

Simple Loop

Figure 2 shows a simple SSA loop. The devices that are attached to the SSA adapter card **1** are connected through SSA links **2**. These SSA links are configured as a loop. Data and commands to a particular device pass through all other devices on the link between the adapter and the target device.

Data can travel in either direction round the loop. The adapter can, therefore, get access to the devices **3** (disk drives in this example) through two data paths. The adapter always, however, uses the path that has the fewest interconnecting devices between the adapter and the destination device. The using system cannot detect which data path is being used.

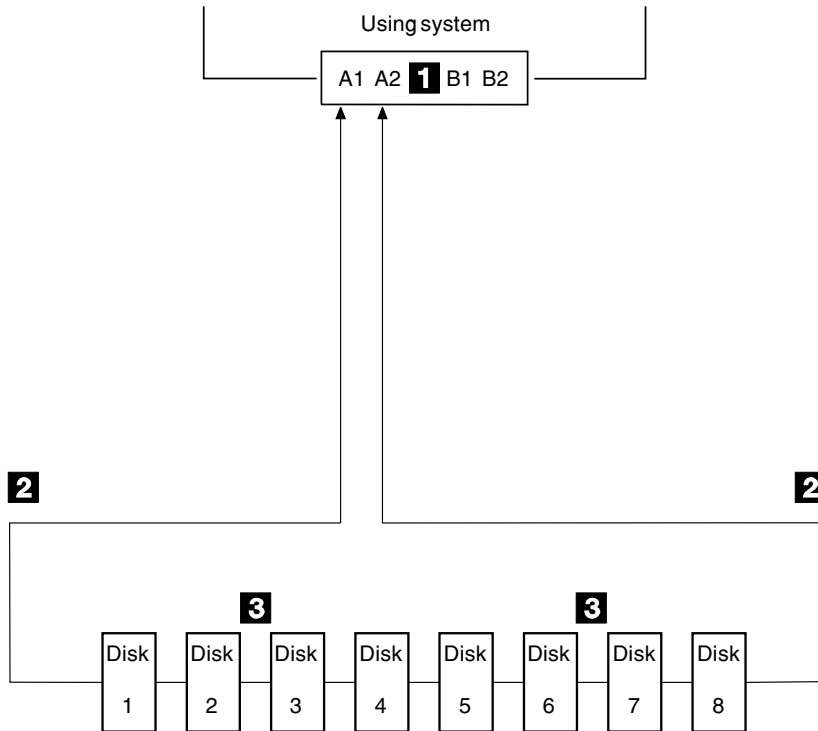

Figure 2. Simple Loop

Simple Loop — One Disk Drive Missing

If a disk drive fails, or is switched off, the loop is broken, and one of the data paths to a particular disk drive is no longer available. The disk drives on the remainder of the loop continue to work, but an error is reported to the system. The adapter now uses the alternative path to some of the devices.

In Figure 3, disk drive number 3 has failed. Disk drives 1 and 2 can communicate with the using system only through connector A1 of the SSA adapter. Disk drives 4 through 8 can communicate only through connector A2 of the SSA adapter.

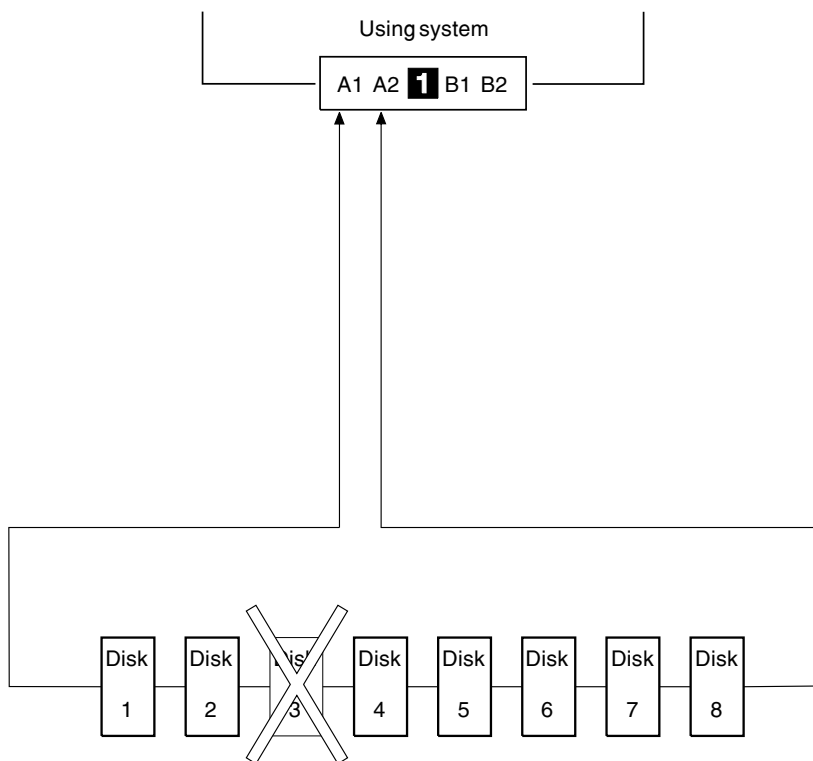

Figure 3. Simple Loop with One Disk Drive Missing

Simple Loop — Two Disk Drives Missing

If two or more disk drives are switched off, fail, or are removed from the loop, some disk drives might become isolated from the SSA adapter.

In Figure 4, disk drives 3 and 7 have been removed. Disk drives 1 and 2 can communicate with the using system only through connector A1 of the SSA adapter. Disk drive number 8 can communicate with the using system only through connector A2 of the SSA adapter. Disk drives 4, 5, and 6 are isolated from the SSA adapter.

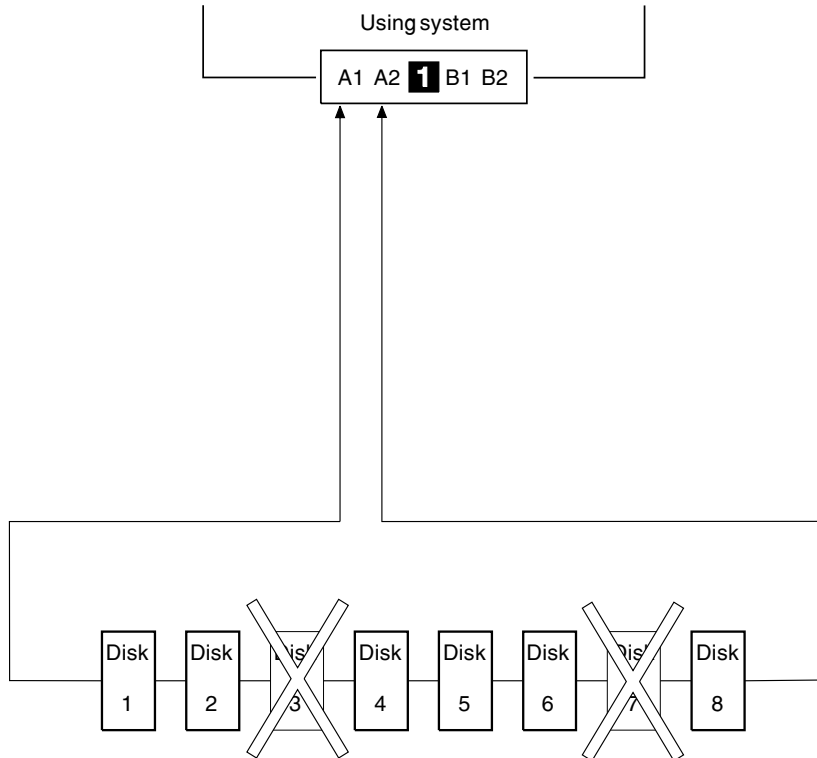

Figure 4. Simple Loop with Two Disk Drives Missing

One Loop with Two Adapters in One Using System

In Figure 5, the loop contains two SSA adapters **1** and **2** that are both in the same using system. In this configuration, all the disk drives can still communicate with the using system if one SSA adapter fails.

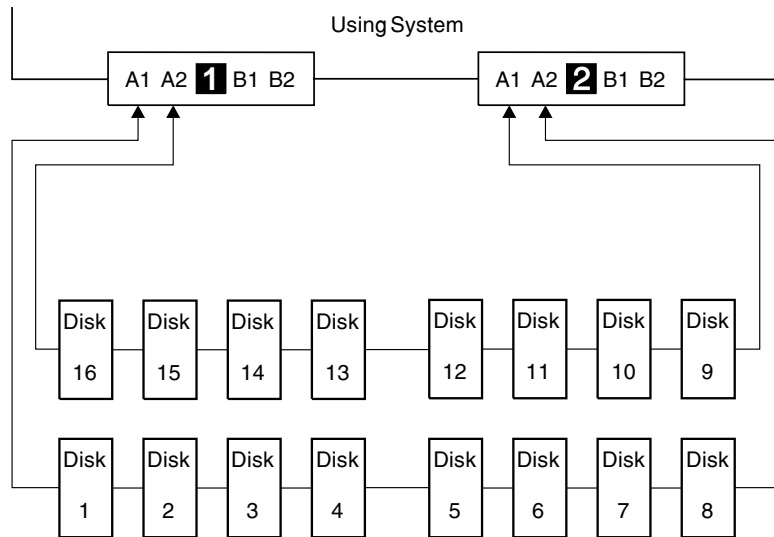

Figure 5. One Loop with Two Adapters in One Using System

One Loop with Two Adapters in Each of Two Using Systems

If the loop contains four SSA adapters, with two adapters in each of two using systems, disk drives become isolated if they are connected between the two adapters of one using system, and both those adapters fail, or are held reset, **but remain powered on**.

Bypass Note: Your SSA Disk Subsystem, or SSA Disk Enclosure, might contain bypass cards. Each bypass card can switch the internal strings of the subsystem, or enclosure, if it detects that neither of its connectors is connected to a powered-on SSA adapter or device. Therefore, if the two SSA adapters fail, or are held reset, but remain powered on, the bypass card does not operate, and the disk drives become isolated. (For more information about bypass cards, see the publications for your disk subsystem or enclosure.)

In Figure 6, SSA adapters **1** and **2** are in using system 1; SSA adapters **3** and **4** are in using system 2. In each using system, the two adapters are connected to each other.

If the two SSA adapters of either using system fail, or are held reset, but remain powered on, all the disk drives can still communicate with the other using system.

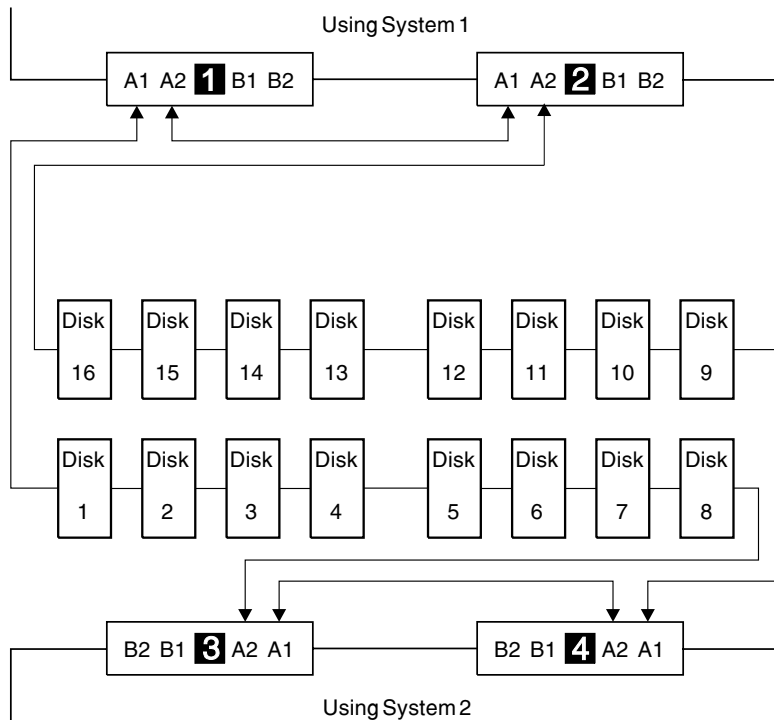

Figure 6. One Loop, Two Adapters in Each of Two Using Systems

If, however, disk drives are connected into the link between two SSA adapters that are in the same using system, those disk drives become isolated if both SSA adapters fail, or are held reset, but remain powered on (see also “Bypass Note” on page 12). In Figure 7, disk drives 13 through 16 have been connected between the SSA adapters in using system 1. If both adapters fail, or are held reset, but remain powered on, disk drives 1 through 12 can still communicate with using system 2. Disk drives 13 through 16, however, cannot communicate with using system 2, because their data paths are through the adapters in using system 1. When using system 1 is rebooted, disk drives 13 through 16 remain unavailable for a long time.

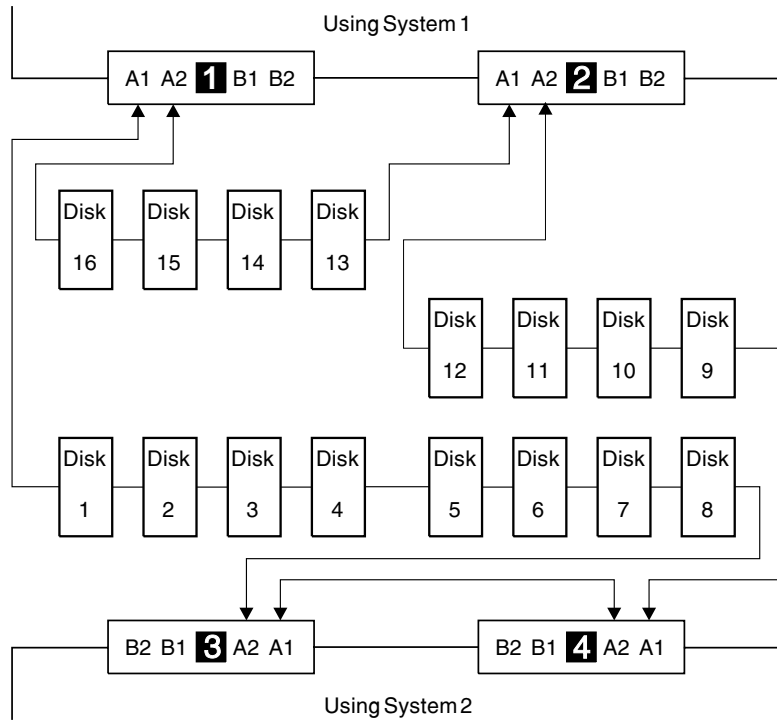

Figure 7. Disk Drives Isolated by Failing Using System

Two Loops with One Adapter

If only one SSA adapter is contained in the SSA loops, the adapter can provide support for up to 96 disk drives (a maximum of 48 per loop).

Figure 8 shows an example configuration that has two loops and one adapter:

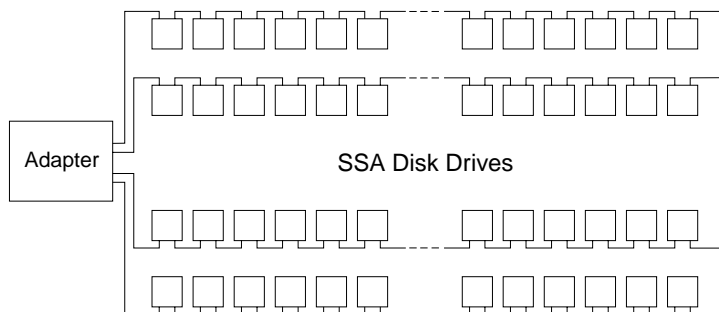

Figure 8. Two Loops with One Adapter

Two Loops with Two Adapters

The two adapters can provide support for up to 96 SSA disk drives (a maximum of 48 per loop).

Figure 9 shows an example configuration that has two loops and two adapters:

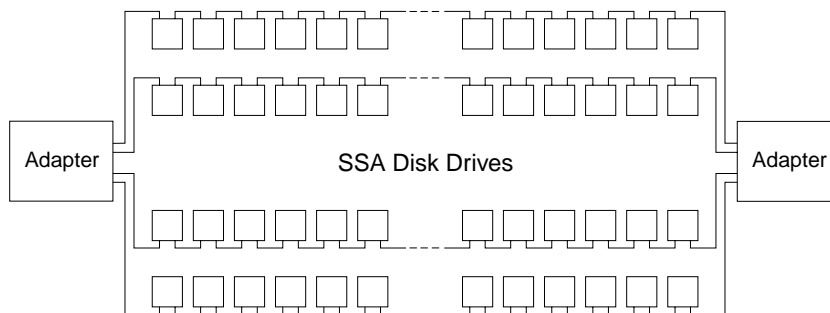

Figure 9. Two Loops with Two Adapters

Large Configurations

Up to eight SSA adapters can be connected in a particular SSA loop, and up to 48 disk drives can be included in that loop. Figure 10 shows an example of a large configuration that has eight adapters in eight using systems.

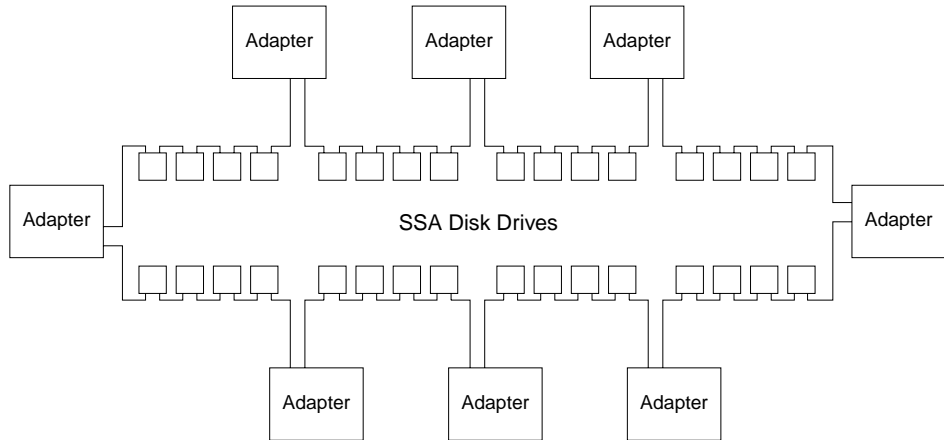

Figure 10. A Large Configuration of Thirty-Two Disk Drives Connected to Eight SSA Adapters in Eight Using Systems

Figure 11 shows an example of a large configuration that has eight adapters in four using systems.

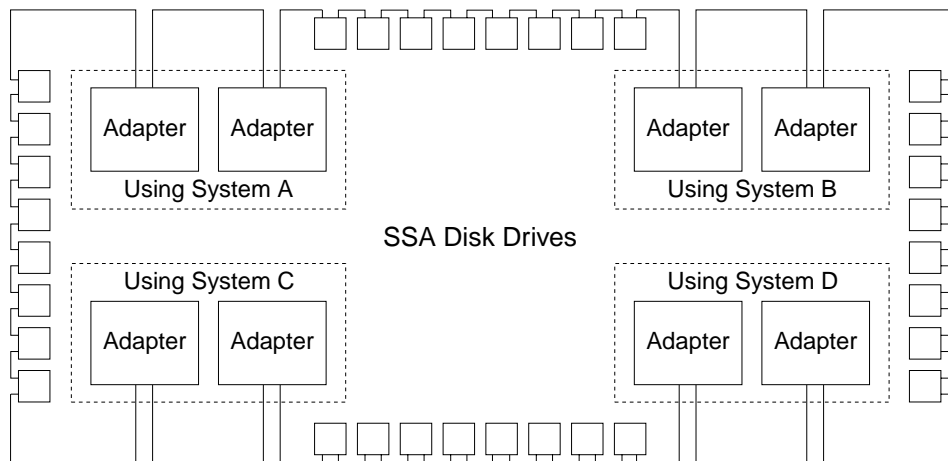

Figure 11. A Large Configuration of Thirty-Two Disk Drives Connected to Eight SSA Adapters in Four Using Systems,

Switching Off Using Systems

Be careful if you want to switch off one or more using systems in a large configuration. If any disk subsystem in the configuration does not use bypass cards, some using systems might lose access to disk drives if you:

- Switch off more than one using system at a time
- Switch off a using system when a disk drive has failed.

Note: For more information about bypass cards, see the publications for your disk subsystems or enclosures.

Switching On Using Systems

When you switch on using systems of a large configuration, ensure that each using system configures all the disk drives in the SSA loop. You can switch on each using system and give the **cfgmgr** command to ensure that all the disk drives are configured. If, however, you need your pdisk assignments to be constant between using systems, follow the procedures given in “Configuring Devices on an SSA Loop” on page 18.

Configuring Devices on an SSA Loop

If an SSA loop contains three or more SSA adapters that are installed in two or more using systems, you must ensure that all those using systems are switched on, and that all the disk drives in all those using systems are configured, as follows:

- If all the using systems are switched off (Micro Channel or PCI):
 1. For each Micro Channel system:
 - a. Set Secure mode on each using system.
 - b. Switch on all the using systems.
 - c. Wait for 200 to be displayed on the operator panel of each system.

 - For each PCI system:
 - a. Switch on one using system only.
 - b. Wait for the first display (logo) to appear on the screen. Press F1 **immediately**. The using system goes into System Management Services mode.
 2. When each using system is in the state described in the preceding steps:
 - For Micro Channel systems, set Normal mode to continue the boot process.
 - For PCI systems, press F10 (Exit) to continue the boot process.
- If one or more using systems are switched on (Micro Channel or PCI):
 1. Switch on the remaining using systems.
 2. On each using system:
 - a. Run the **cfgmgr** command to configure all the disk drives.
 - b. Manually **vary on** the volume groups and mount the file systems as required.

SSA Link Speed

Some SSA devices can run at 20 MB per second; others can run at 40 MB per second. Both types of devices can exist in a particular configuration, but for best performance all links should run at the same speed. Two types of SSA cable are available:

- 20 MB per second SSA cables (color coded black)
- 40 MB per second SSA cables (color coded blue).

The speed at which a link runs is automatically agreed between its two nodes. Under some fault conditions, a link that normally runs at 40 MB per second might run at 20 MB per second. The automatic **run_ssa_link_speed** diagnostic searches for pairs of 40-MB-per-second nodes that are running at only 20 MB per second. This diagnostic is started by an entry in the cron table. If you are using 20-MB-per-second cables to connect 40-MB-per-second SSA nodes, delete the **run_ssa_link_speed** entry from the cron table. This action prevents the logging of errors that can be solved only by the installation of 40-MB-per-second cables.

Identifying and Addressing SSA Devices

This section describes how SSA adapters and devices are known to the using system programs.

Location Code Format

Location codes identify the locations of adapters and devices in the using system and its attached subsystems and devices. These codes are displayed when the diagnostic programs isolate a problem. For information about the location codes that are used by the using system, see the *Operator Guide* for the using system.

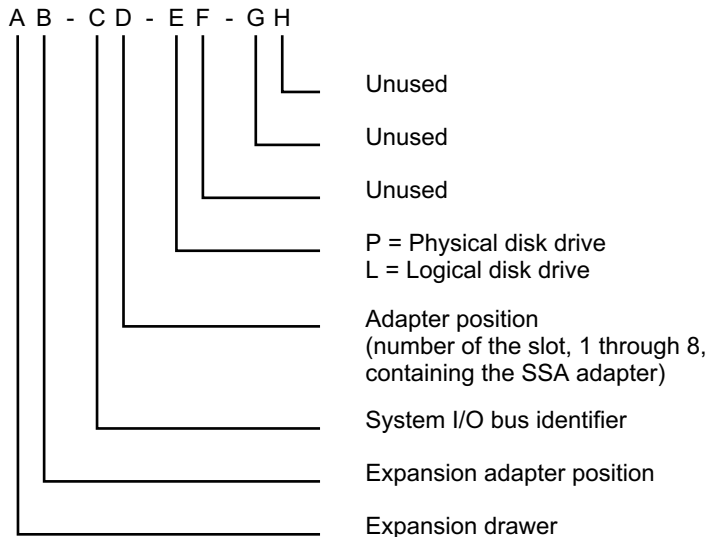

The location code shows only the position of the SSA adapter in the using system and the type of device that is attached. The location of the device within the SSA loop must be found by use of a service aid. The service aids use the IEEE-standard 16-digit unique ID of the device.

Pdisks, Hdisks, and Disk Drive Identification

The *physical* disk drives (**pdisks**) in an SSA subsystem can be configured as logical units (LUNs). A LUN is also known as an **hdisk**, and can consist of one or more physical disk drives. An hdisk in an SSA subsystem might, therefore, consist of one pdisk or several pdisks.

The configuration software allocates an identification (hdisk and pdisk number) to each disk drive during the configuration of the SSA link. The disk drives do not have fixed physical addresses.

The numeric identifiers of pdisks, hdisks, and the disk drive slots are not related to each other. For example, pdisk1 is not necessarily in slot 1 of the physical unit in which it is installed.

The configuration software first recognizes the disk drive by its machine-readable serial number. The serial number of the disk drive is also displayed by the service aids. The service aids show the number as the last eight digits of the IEEE SSA Unique ID.

Service actions are always related to physical disk drives. For this reason, errors that occur on SSA disk drives are always logged against the physical disk drive (pdisk).

|
|
|
|
|

If a disk drive that has been formatted on a machine of a particular type (for example, a personal computer) is later installed into a using system that is of a different type (for example, a large host system), that disk drive is configured only as a pdisk during the configuration of the using system.

SSA Unique IDs

Each SSA device has a specific identifier that is not used by any other SSA device in the whole world. This identifier is called the IEEE SSA Unique ID (UID) of the device. It is written into the device during manufacture.

The full UID consists of 16 characters. The label on the side of a disk drive shows the full UID. The label on the front of a disk drive shows the serial number of the disk drive. The serial number is actually part of the UID. Also part of the UID, the Connection Address consists of the LUN name and the device-type identifier. The software uses this information to access the device.

Full UID	0000XXXXXXXXNNNNNN
Disk drive serial number	XXXXXXXXXX
Connection Address	XXXXXXXXNNNNLLD

where:

XXXXXX	=	IEEE Organization Identifier (manufacturer)
NNNNNN	=	Product / ID (assigned unique number)
LL	=	LUN (always 00 for a LUN device)
D	=	Device type: (D for an SSA Physical disk drive) (E for a fast-write logical disk) (F for a RAID-0 array) (K for a RAID-5 array)

You might need to know the UID of a disk drive if you want to use the **mkdev** command to give that disk drive a specific hdisk number.

Rules for SSA Loops

For SSA loops that include an Advanced SerialRAID Adapter (type 4–P), the following rules apply:

- Each SSA loop must be connected to a valid pair of connectors on the SSA adapter (that is, either connectors A1 and A2, or connectors B1 and B2).
- A maximum of one pair of adapter connectors can be connected in a particular SSA loop.
- All member disk drives of an array must be on the same SSA loop.
- A maximum of 48 SSA disk drives can be connected in a particular SSA loop.
- If an SSA adapter that is in a two-way configuration is connected to two SSA loops, and a second adapter is connected to each loop, both loops must be connected to the same second adapter.
- Each SSA loop can be connected to no more than two adapters on any one using system.
- The number of adapters that are supported in an SSA loop is determined by whether any disk drives are configured for RAID or fast-write operations, and by the type of adapter (see Table 1).

Table 1. Number of Adapters that are Supported in an SSA Loop

Array Type	Number of Adapters in Loop	Type of Adapters Allowed
Non-RAID	8	Advanced SerialRAID Adapter
		PCI SSA Multi-Initiator/RAID EL Adapter
		Micro Channel SSA Multi-Initiator/RAID EL Adapter
RAID-0	1	Advanced SerialRAID Adapter
RAID-1	2	Advanced SerialRAID Adapter at microcode level above 5000
RAID-5	2	Advanced SerialRAID Adapter
		PCI SSA Multi-Initiator/RAID EL Adapter
		Micro Channel SSA Multi-Initiator/RAID EL Adapter
RAID-10	2	Advanced SerialRAID Adapter at microcode level above 5000
Fast-Write	1	Advanced SerialRAID Adapter at microcode level below 5000
	2	Advanced SerialRAID Adapter at microcode level above 5000

See the *SSA Adapters: User's Guide and Maintenance Information* manual, SA33-3272 (Version 01 or above) for more information about the level of code that is required in the Micro Channel SSA Multi-Initiator/RAID EL Adapter (type 4–M) or the PCI SSA Multi-Initiator/RAID EL Adapter (type 4–N).

Checking the Level of the Adapter Microcode

If you need to check the level of the adapter microcode:

1. Type, on the command line:

```
lscfg -vl ssan
```

where `ssan` is the name of the adapter whose microcode you are checking; for example, `ssa0`.

A list of vital product data (VPD) is displayed.

2. Find **ROS Level and ID**, for example, 5000.

Rules for the Physical Relationship between Disk Drives and Adapters

The physical relationship between the disk drives and the adapters in an SSA loop can affect the performance of the subsystem. The following rules help you to get best performance from your subsystem.

One Pair of Adapter Connectors in the Loop

The following sequence enables you to determine the best relationship between the disk drives and the adapter on an SSA loop that contains only one pair of adapter connectors.

1. Determine which data is accessed most frequently.
2. Assign that data to those disk drives that are farthest (round the loop) from the adapter connectors. By doing this action, you prevent the activity of the busiest disk drive from obstructing the data path to the other disk drives.

For example, the loop that is shown in Figure 12 contains 16 disk drives, and the adapter connectors are between disk drives 1 and 16. The most-frequently-accessed data, therefore, should be on disk drives 8 and 9.

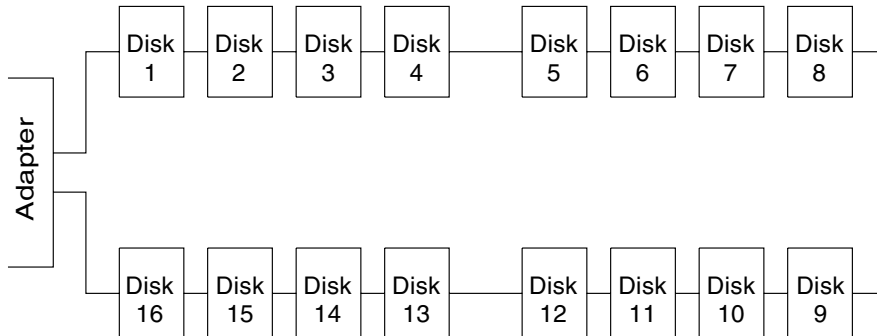

Figure 12. One Pair of Connectors in the Loop

Pairs of Adapter Connectors in the Loop – Some Shared Data

The following sequence enables you to determine the best relationship between the disk drives and the adapter on an SSA loop that contains two or more pairs of adapter connectors. Some of the disk drives share data access with other disk drives.

1. For each pair of connectors, identify all the data that the loop is to access.
2. For each pair of connectors, identify the data that the loop is to access most frequently.
3. Assign the data for each pair of adapter connectors to the disk drives that are connected immediately next to the pair of connectors in the loop. Assign the most-frequently-accessed data to those disk drives that are farthest from the adapter connectors. By doing this action, you prevent the activity of the busiest disk drive from obstructing the data path to the other disk drives.

For example, the loop that is shown in Figure 13 contains 16 disk drives. The connectors of adapter A are between disk drives 1 and 16, and the connectors of adapter B are between disks 8 and 9. Therefore:

- Adapter A should access disk drives 1 through 4 and disk drives 13 through 16. The most-frequently-accessed data should be on disk drives 4 and 13.
- Adapter B should access disk drives 5 through 8 and disk drives 9 through 12. The most-frequently-accessed data should be on disk drives 5 and 12.

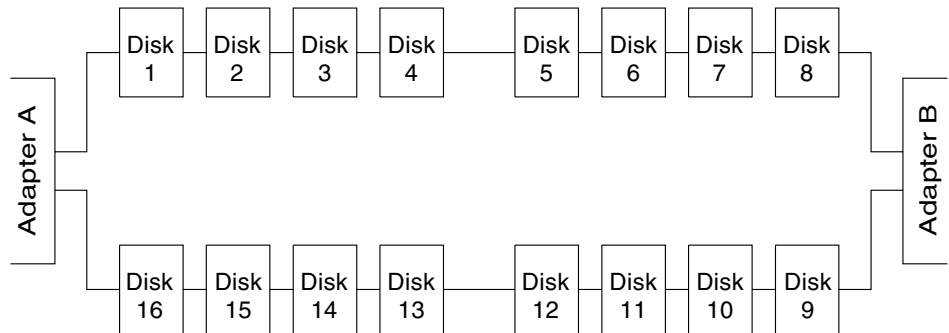

Figure 13. Pairs of Connectors in the Loop – Some Shared Data

Pairs Of Adapter Connectors in the Loop – Mainly Shared Data

The following sequence enables you to determine the best relationship between the disk drives and the adapter, or adapters, on an SSA loop that contains two or more pairs of adapter connectors. Most of the disk drives share data access with each other.

1. Determine which data is shared between the pairs of adapter connectors.
2. Assign this data to the disk drives that are equally spaced between the sharing pairs of adapter connectors.

For example, the loop that is shown in Figure 14 contains 16 disks and four adapters. In this loop:

- The pairs of adapter connectors should be spaced between the disk drives.
- Data that is shared by adapters A and B should be put onto disk drives 1 through 4.
- Data that is shared by adapters B and C should be put onto disk drives 5 through 8.

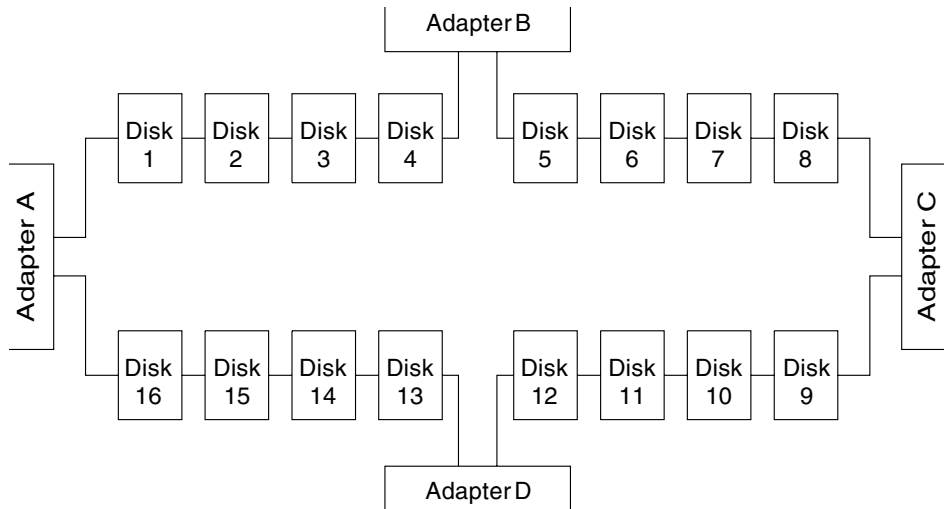

Figure 14. Pairs of Connectors in the Loop – Mainly Shared Data

Note: For configurations such as that shown here, we recommend that the adapters be installed in separate using systems. Otherwise, disk drives can become isolated should both adapters fail, or be held reset, in one of the using systems. See “One Loop with Two Adapters in One Using System” on page 11 and “One Loop with Two Adapters in Each of Two Using Systems” on page 12 for more information.

If two using systems are switched off, disk drives can become isolated if the SSA subsystem does not have bypass cards (see “Bypass Note” on page 12). If more than one using system is rebooted at the same time, disk drives can become isolated while the boot is running.

Reserving Disk Drives

The Advanced SerialRAID Adapter, the Micro Channel SSA Multi-Initiator/RAID EL Adapter, and the PCI SSA Multi-Initiator/RAID EL Adapter implement reservation by using commands that are sent directly from adapter to adapter. They do not use the SCSI reservation command. The advantages of this method are:

- System software can read the Physical Volume ID (PVID) from a reserved disk drive.
- It is possible to use the **ssa_rescheck** command to determine which adapter is holding a reservation to a disk drive.
- The diagnostics can detect particular failure conditions on reserved disk drives that they cannot detect with the other reservation method.
- Fencing can be used on a reserved disk drive.
- Node_number locking is supported. With node_number locking, the disk drive is not locked to an adapter, but rather to a using system. To enable a disk drive to be locked to a using system, each using system in an SSA network must have a unique node number. The node number is stored as the node_number attribute of ssar. It can be queried with the **lsattr** command and set by using the **chdev** command. The **ssavfynn** command (described in “ssavfynn Command” on page 371) can be used to verify that no duplicate node numbers exist.
- If a reservation is challenged (that is, a node that does not hold the reservation attempts to access a reserved SSA logical disk), the adapter verifies that a valid path still exists to the node that is holding the reservation. If no path exists, the reservation is removed, and the new node is allowed access to the disk drive. Therefore, if an adapter is used to reserve a disk drive, and is then disconnected or powered off, that disk drive becomes effectively unreserved.

Fast-Write Cache

SSA adapters that are on SSA loops of up to two SSA adapters can use the Fast-Write cache feature. For a two-way configuration, the two adapters can be in the same, or in different, using systems. Fast-write functions can be enabled for single disk drives or for RAID arrays. Performance improvements are related to the type of disk drive (single disk or RAID array type) and the workload. If two-way fast-write functions are used in a two-host system configuration, the performance improvements are greater when concurrent access is not permitted to disk drives. When concurrent access is permitted, performance improvements are less.

Chapter 3. RAID Functions and Array States

This chapter describes the RAID functions and the states of RAID arrays.

RAID Functions

Redundant Array of Independent Disks (RAID) technology provides:

- Larger disk size
- Immediate availability and recovery of data
- Redundancy of data at a level that you can choose.

RAID technology stores data across groups of disk drives that are known as *arrays*. These arrays are contained in array subsystems, which can be configured with one or more arrays. All arrays, except RAID-0 arrays, can provide data redundancy that ensures that no data is lost if one disk drive in the array fails.

An Advanced SerialRAID Adapter, which uses microcode below level 5000, provides RAID-0 and RAID-5 functions to control the arrays of the RAID subsystem. An Advanced SerialRAID Plus Adapter, which uses microcode at or above level 5000, provides RAID-0, RAID-1, RAID-5, and RAID-10 functions.

The main characteristics of the various RAID types are as follows:

- RAID-0 provides data striping across disk drives, but provides no added protection against loss of data.
- RAID-1 provides data mirroring across two member disk drives to protect against loss of data.
- RAID-5 provides data striping with parity data across disk drives to provide protection against loss of data.
- RAID-10 provides data striping and data mirroring across disk drives to provide protection against loss of data.

Availability

Availability is an important consideration that can affect the way you configure your arrays. It is the ability of a system to *continue operating*, although one or more of its components have failed.

- RAID-0 provides data *availability* equivalent to that of a standard disk drive, but with better performance for long data transfer operations.
- RAID-1 provides good data availability because data is mirrored on two member disk drives, as it is with RAID-10. RAID-1 arrays, however, have only two member disk drives. Member disk drives of a RAID-1 array can be configured to be in separate domains. Separate domains ensure that data remains available if, for example, a complete domain fails through loss of power.
- RAID-5 provides good data *availability* with good performance for workloads that include many read and write operations.
- RAID-10 provides good data *availability* and performance that is better than that provided by RAID-5, especially when a member disk drive has failed. For long data

transfer operations, performance is better than that provided by RAID-1 because data is striped across member disk drives. For short data transfer operations, performance is better because operations are distributed across the member disk drives, and the effect of skew is reduced. Member disk drives of a RAID-10 array can be configured to be in separate domains. Separate domains ensure that data remains available if, for example, a complete domain fails through loss of power.

Disk Drives That Are Not in Arrays

Disk drives that are connected to an SSA RAID adapter do not need to be members of an array. The SSA RAID adapter handles such disk drives in the same way as a non-RAID SSA adapter does. It transfers data directly between the disk drives and the system, and uses no RAID functions.

|
|
|

When first installed, all disk drives are, by default, defined as system disks; that is, they are not members of an array. Before they can be added to arrays, you must redefine them so that the system no longer has direct access to them.

RAID-0 Array States

A RAID-0 array can be in either of two states. A knowledge of those states is useful when you are configuring your arrays. The states are described here.

Good State

A RAID-0 array is in the Good state when all the member disk drives of that array are present.

Offline State

A RAID-0 array enters Offline state when one or more member disk drives become missing. Read and write operations are not allowed.

RAID-1 Array States

RAID-1 array states are the same as RAID-10 array states. For details, see “RAID-10 Array States” on page 36.

In RAID-1 arrays, the first member disk drive of the array is defined as the primary disk drive and the second member disk drive is defined as the secondary disk drive. These definitions prevent operation on separate member disk drives of the array when the array becomes split, but separate systems can still access one of the member disk drives. RAID-10 defines the first and third disk drives to be primary member disk drives. RAID-1 defines the first disk drive to be the equivalent of the first and third disk drives together. If the first disk drive is missing in RAID-1, it is equivalent to the first and third disk drives being missing in RAID-10.

RAID-5 Array States

A RAID-5 array can be in one of several states. A knowledge of those states is useful when you are configuring your arrays. The states are described here. A flowchart for the RAID-5 array states is shown in Figure 15 on page 35.

Good State

A RAID-5 array is in the Good state when all the member disk drives of that array are present.

Exposed State

A RAID-5 array enters the Exposed state when a member disk drive becomes missing (logically or physically) from that array. When an array is in the Exposed state, you can reintroduce the missing disk drive, or exchange it for a new one. If the missing disk drive is reintroduced, the array returns to the Good state. The array management software does not need to rebuild the data. If a new disk drive is exchanged for the missing disk drive, the array management software rebuilds the data that was on the original disk drive before it became missing, then writes that rebuilt data to the replacement disk drive. When the data is correct, the array management software returns the array to the Good state.

Read Operations while in the Exposed State

When a read operation is performed on an array that is in the Exposed state, the array management software recreates the data that was contained on the missing disk drive. On the Advanced SerialRAID Adapter, the array management software immediately exchanges a hot spare disk drive for the missing disk drive, if a hot spare disk drive is enabled and available when the read command is sent.

Write Operations while in the Exposed State

When a write command is sent to an array that is in the Exposed state, the array management software does the following:

- If a hot spare disk drive is enabled and available when the write command is sent, the array management software immediately exchanges the hot spare disk drive for the missing disk drive, and returns the array to the Rebuilding state.
- If no hot spare disk drive is enabled and available, the first write operation causes the array to enter the Degraded state. The written data is not protected. If the power fails during a write operation, data might be lost (64 KB) unless the array is configured to allow read-only operations while in the Exposed state. Most application programs, however, cannot be run when write operations are not allowed.

Degraded State

A RAID-5 array enters the Degraded state if, while in the Exposed state, it receives a write command. If a hot spare disk drive is available, the array management software immediately exchanges the hot spare disk drive for the missing disk drive, and returns the array to the Rebuilding state. If no hot spare disk drive is available, and a write operation is performed on the array, the array remains in the Degraded state until you take action to return that array to the Good state.

While in Degraded state, an array is not protected. If another disk drive in the array fails, or the power fails during a write operation, data might be lost.

You can return the disk drive to the array, or install another disk drive by using the procedure in step 37 on page 473 of MAP 2324: SSA RAID to logically add the device to the array. The array management software starts a rebuilding operation to synchronize the new disk drive with the data that is contained in the other disk drives of the array. This action returns the array to the Good state.

Rebuilding State

A RAID-5 array enters the Rebuilding state when:

- That array is first created
- A member disk drive is replaced
- An adapter is replaced, but a correct shutdown has not been performed

Initial Rebuilding Operation

When an array is first created, it enters the Rebuilding state while parity is rebuilt. If a disk drive fails during the initial rebuilding operation, no hot spare disk drive is exchanged for the failing disk drive.

Disk Drive Replacement

An array enters Rebuilding state after a missing disk drive has been returned to the array or exchanged for a replacement disk drive. When the array is in this state, all the member disk drives are present, but the data and parity are being rebuilt on the returned or replacement disk drive. The array management software allows read and write operations on a disk drive that is in Rebuilding state. If the power fails before the rebuilding is complete, the array management software restarts the complete rebuilding operation when the power returns.

Adapter Replacement

If, for any reason, an adapter is exchanged for a replacement adapter, and a correct shutdown has not been performed, the parity is rebuilt on **all** the associated arrays when the replacement adapter powers on.

Offline State

A RAID-5 array enters Offline state when two or more member disk drives become missing. Read and write operations are not allowed.

RAID-5 Array State Flowchart

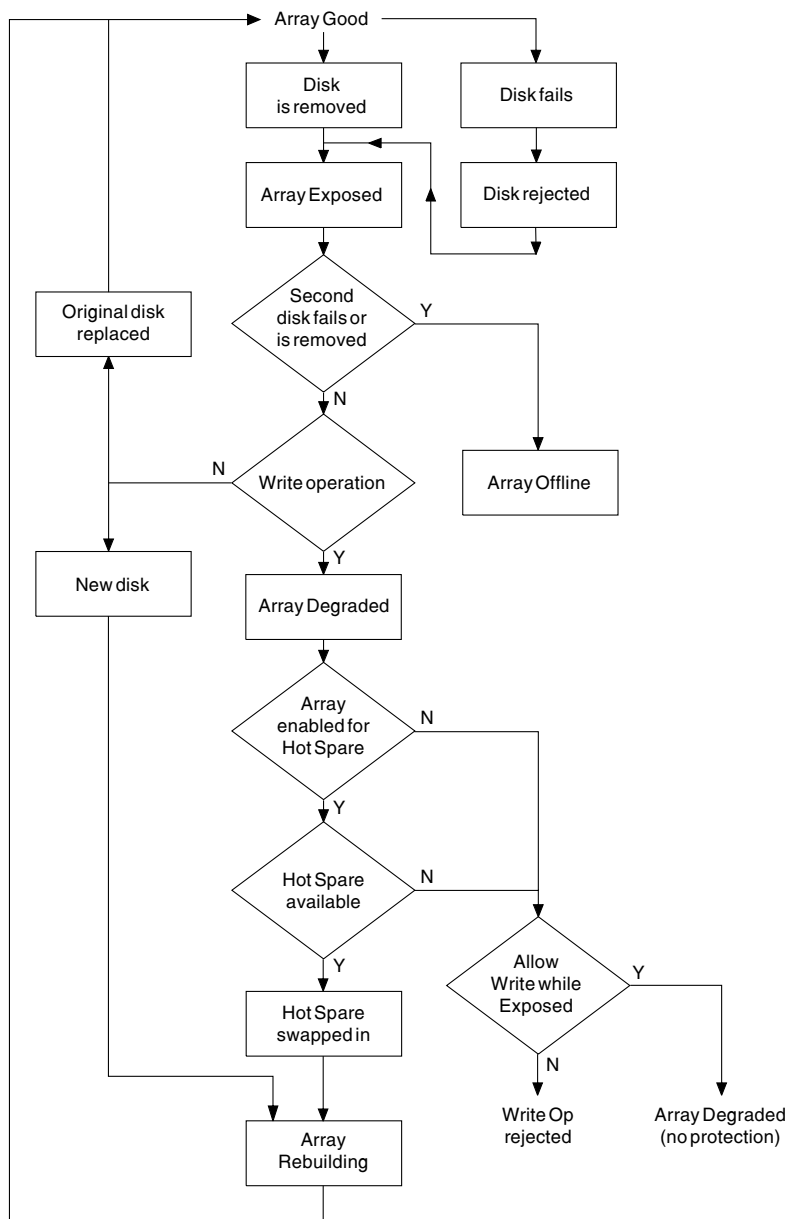

Figure 15. RAID-5 Array State Flowchart

RAID-10 Array States

Configuration information of the array is held in a reserved area sector on each of the first three member disk drives of the array. If fewer than two of these sectors can be read or written, the array normally goes into the Offline state.

An important characteristic of RAID-10 is that the mirrored pairs can be located in different sites in different power domains. The availability of a RAID-10 array is, therefore, better than that of RAID-5 array. However, if both domains of a two-site configuration are both operational, but communication is lost between the sites, it is important to ensure that each system does not continue to operate on its own copy of the array. Under this condition the data might not be consistent. To prevent this problem from occurring, the first, third, and fifth member disk drives of the array are the primary members; the second, fourth, and sixth member disk drives are the secondary members. Access to at least one of the primary disk drives that contain the configuration information is normally required for array operations to continue. Therefore:

- If a network partition exists, the using system that has access to the primary configuration disk drives continues to operate. The using system that has access to only the secondary configuration disk drives cannot normally access the array.
- If the using system fails at the site that contains the secondary member disk drive, the using system that has access to the primary configuration disk drives continues to operate.
- If the using system that has access to the primary configuration disk drives fails and the primary configuration disk drives also fail, only the site that contains the secondary configuration disk drives remains operational. Normally, the using system that is at the secondary site is not allowed access to the array. To allow this using system access to the array, the user must use the RAID array configurator to set a flag that allows the using system to operate on only the secondary disk drives.

A RAID-10 array can be in one of several states. A knowledge of those states is useful when you are configuring your arrays. The states are described here.

Good State

A RAID-10 array is in the Good state when:

- All the member disk drives of that array are present.
- No member disk drive is deconfigured.
- Read and write operations can be done on the array.
- No rebuilding operations need to be done.

The array is fully protected from the loss of multiple member disk drives if one copy of the mirrored data is still available. Some unsynchronized records might still be under repair.

Exposed State

A RAID-10 array is in the Exposed state when member disk drives are missing but still configured. Read and write operations can be performed on the array, although write

operations put the array into the Degraded state. When the missing member disk drives are reintroduced, the array returns to the Good state.

Degraded State

A RAID-10 array is in the Degraded state when one or more member disk drives are missing or deconfigured, and a write operation has occurred. Read and write operations can be performed on the array. The missing member disk drives are deconfigured so that they are permanently excluded from the array. If they become available again, they can be introduced only as new members.

A RAID-10 array is in the Degraded state also if the secondary half of the array operates while the primary half is deconfigured. Under this condition, the secondary half holds information about the members of the primary half to track recovery.

Rebuilding State

A RAID-10 array is in the Rebuilding state when a rebuilding operation is running on one or more member disk drives. Read and write operations can be performed on the array.

When an array is created, it enters the Rebuilding state to synchronize the member disk drives. When the rebuilding operation is complete, the array returns to the Good State.

If the medium-error table fills during a rebuilding operation, the array remains in the Rebuilding state until space becomes available in the table.

Offline State

A RAID-10 array can be in the Offline state for any of the following reasons:

- No NVRAM is available to operate the array.
- The array is split across SSA loops.
- **All** these three conditions exist:
 - In the secondary half of the array, the member disk drive that contains the configuration sector is present.
 - In the primary half of the array, no members that hold configuration sectors are present.
 - The Split Array Resolution flag is not set.
- **All** these three conditions exist:
 - In the primary half of the array, disk drive members that hold configuration sectors are present.
 - In the secondary half of the array, the member disk drive that contains the configuration sector is not present.
 - The Split Array Resolution flag is set.
- In the primary and secondary halves of the array, member disk drives that hold configuration sectors are present, and the Split Array Resolution flag is set on the secondary half. The array, however, was not initialized correctly.
- Two failures in a configuration update (configuration sectors, fence sector, label sector, medium-error table, or unsync table).

- Both member disk drives of a mirrored pair are missing, deconfigured, or rebuilding.

Unknown State

A RAID-10 array is in the Unknown state when not enough array members are present for the array configuration to be determined; that is, fewer than two of the first three members are present. Unless the Split Array Resolution flag is set, the array enters the Offline state to allow split arrays to operate if:

- The member disk drive that holds the configuration sector in the secondary half of the array is available
- and**
- Neither of the member disk drives that hold configuration sectors in the primary half of the array is available.

Multiple States

Different member disk drives of a RAID-10 array can be in different states. For example, one mirrored pair might be rebuilding while, in a different pair, one member disk drive is missing and the remaining member is in the Degraded state. A priority of array states of the different members is used when the state of an array is reported (highest priority first):

1. Unknown
2. Offline
3. Exposed
4. Degraded
5. Rebuilding

An error is logged whenever the state of an array changes, unless the state changes to Good or Rebuilding.

Chapter 4. Using the SSA SMIT Menus

This chapter describes how to use the system management interface tool (SMIT) to display and change characteristics of the SSA devices, and to access various service functions. Three SSA menus are available through the SMIT Devices menu.

- SSA Adapter
- SSA Disks
- SSA RAID Arrays

Notes:

1. Although this book always refers to the **smitty** commands, you can use either the **smitty** command, or the **smit** command. The procedures that you follow remain the same, whichever of the two commands you use. If you send the **smit** command from a graphics terminal, however, the menus are displayed slightly differently from those shown in this book. If you are not familiar with the selection of items from the graphics versions of the menus, use the **smitty** command. The menus will then appear as shown in this book.
2. Different microcode levels might cause slightly different versions of the menus to be displayed.
3. If you use fast-path commands, you might need to go through intermediate steps that are not shown in this book. Also, some menus might be displayed slightly differently from those shown in this book.

Getting Access to the SSA Adapters SMIT Menu

1. For fast-path access to the SSA RAID Array SMIT menus, type `smitty ssaa` and press Enter.
Otherwise:
 - a. Type `smitty` and press Enter. The System Management menu is displayed.
 - b. Select **Devices**. The Devices menu is displayed.
 - c. Select **SSA Adapters**.
2. The SSA Adapters menu is displayed:

```
SSA Adapters

Move cursor to desired item and press Enter.

List All SSA Adapters
Change/Show Characteristics of an SSA Adapter
Generate Error Report
Trace an SSA Adapter
Change/Show the SSA Node Number for this System
List All SSA Adapter Dumps
Copy an SSA Adapter Dump

F1=Help      F2=Refresh   F3=Cancel    F8=Image
F9=Shell     F10=Exit    Enter=Do
```

If you need help with an item, move the cursor to that item, and press F1 (Help).

Getting Access to the SSA Disks SMIT Menu

1. For fast-path access to the SSA RAID Array SMIT menus, type `smitty ssad` and press Enter.
Otherwise:
 - a. Type `smitty` and press Enter. The System Management menu is displayed.
 - b. Select **Devices**. The Devices menu is displayed.
 - c. Select **SSA Disks**.
2. The SSA Disks menu is displayed:

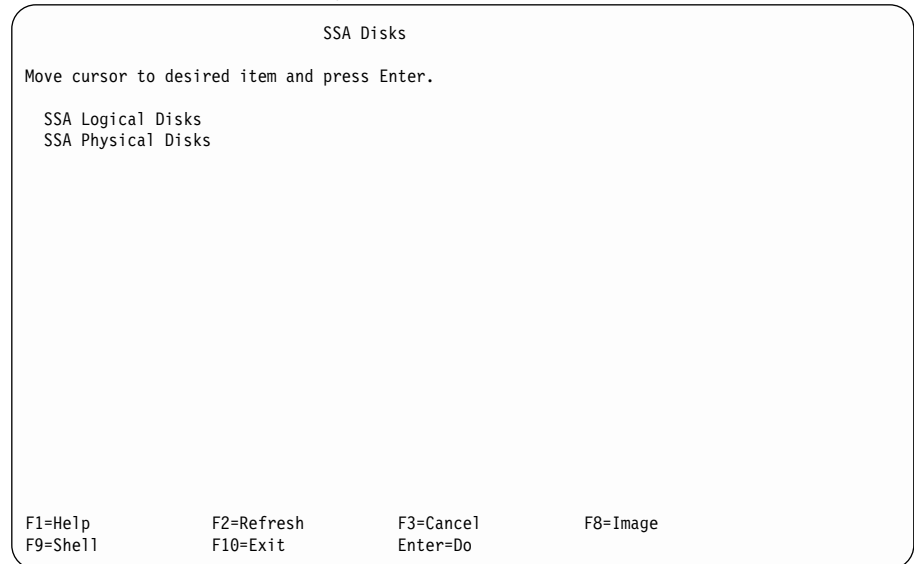

Select the type of SSA disk on which you want to work.

- SSA logical disks are configured into the using system as **hdisks**. SSA hdisks can be single disk drives or SSA RAID arrays.
 - SSA physical disks are configured into the using system as **pdisks**. SSA pdisks are used for service and configuration operations.
3. If you select **SSA Logical Disks**, go to step 4 on page 42.
If you select **SSA Physical Disks**, go to step 5 on page 42.

4. The SSA Logical Disks menu is displayed:

```
SSA Logical Disks

Move cursor to desired item and press Enter.

List All Defined SSA Logical Disks
List All Supported SSA Logical Disks
Add an SSA Logical Disk
Change/Show Characteristics of an SSA Logical Disk
Remove an SSA Logical Disk
Configure a Defined SSA Logical Disk
Generate Error Report
Trace an SSA Logical Disk
Show Logical to Physical SSA Disk Relationship
List Adapters Connected to an SSA Logical Disk
List SSA Logical Disks Connected to an SSA Adapter
Identify an SSA Logical Disk
Cancel all SSA Disk Identifications
Enable/Disable Fast-Write for Multiple Devices

F1=Help          F2=Refresh      F3=Cancel      F8=Image
F9=Shell         F10=Exit       Enter=Do
```

If you need help with an item, move the cursor to that item, and press F1 (Help).

5. The SSA Physical Disks menu is displayed:

```
SSA Physical Disks

Move cursor to desired item and press Enter.

List All Defined SSA Physical Disks
List All Supported SSA Physical Disks
Add an SSA Physical Disk
Change/Show Characteristics of an SSA Physical Disk
Remove an SSA Physical Disk
Configure a Defined SSA Physical Disk
Generate Error Report
Trace an SSA Physical Disk
Show Physical to Logical SSA Disk Relationship
List Adapters Connected to an SSA Physical Disk
List SSA Physical Disks Connected to an SSA Adapter
Identify an SSA Physical Disk
Cancel all SSA Disk Identifications
Show Connection Paths to an SSA Physical Disk

F1=Help          F2=Refresh      F3=Cancel      F8=Image
F9=Shell         F10=Exit       Enter=Do
```

If you need help with an item, move the cursor to that item, and press F1 (Help).

Getting Access to the SSA RAID Arrays SMIT Menu

1. For fast-path access to the SSA RAID Array SMIT menus, type `smitty ssaraid` and press Enter.
Otherwise:
 - a. Type `smitty` and press Enter. The System Management menu is displayed.
 - b. Select **Devices**. The Devices menu is displayed.
 - c. Select **SSA RAID Arrays**.
2. The SSA RAID Arrays menu is displayed:

```
SSA RAID Arrays

Move cursor to desired item and press Enter.

List All Defined SSA RAID Arrays
List All Supported SSA RAID Arrays
List All SSA RAID Arrays Connected to a RAID Manager
List Status Of All Defined SSA RAID Arrays
List/Identify SSA Physical Disks
List/Delete Old RAID Arrays Recorded in an SSA RAID Manager
List Status of Hot Spare Pools
List Status of Hot Spare Protection for an SSA RAID Array
List Components in a Hot Spare Pool
Add a Hot Spare Pool
Add an SSA RAID Array
Delete an SSA RAID Array
Change/Show Attributes of an SSA RAID Array
Change Member Disks in an SSA RAID Array
Change/Show Use of an SSA Physical Disk
Change Use of Multiple SSA Physical Disks
Change/Show/Delete a Hot Spare Pool

F1=Help      F2=Refresh  F3=Cancel   F8=Image
F9=Shell     F10=Exit   Enter=Do
```

For more information about how to use this menu, go to Chapter 6, “Using the RAID Array Configurator” on page 57.

Chapter 5. Hot Spare Management

With all levels of adapter code, disk drives can be configured to be hot spare disk drives. These hot spare disk drives can be used in any array that is on the same SSA loop. If the adapter microcode level is at, or higher than, level 50, each hot spare disk drive can be configured to a particular hot spare pool. The pdisks of arrays can also be configured to hot spare pools. You can, therefore, control which hot spare disk drive is to replace a particular failed member of an array. This chapter describes the ways in which you can use hot spare pools.

Deciding how to Configure Hot Spare Disk Drive Pools

RAID-1 and RAID-10 arrays provide data protection by writing the same data to two disk drives at the same time. You can provide more data protection if you put the two disk drives into separate physical domains. These physical domains can be separate SSA disk enclosures, separate power sources, or separate rooms or buildings. When you use separate physical domains, you provide some capability to recover from an unrecoverable loss of power.

For a RAID-1 or RAID-10 array to be able to recover after the failure of a physical domain, at least one copy of the data must remain available. It is important, therefore, that the action of replacing a failing disk drive with a hot spare disk drive does not cause an array member to move to another physical domain.

Figure 16 shows an array that has its primary disk drives (pdisk2, pdisk3, pdisk10 and pdisk11) in building 1, and its secondary disk drives (pdisk5, pdisk6, pdisk7 and pdisk8) in building 2. Pdisk1 and pdisk4 have been assigned as hot spare disk drives, but no hot spare pool has been defined.

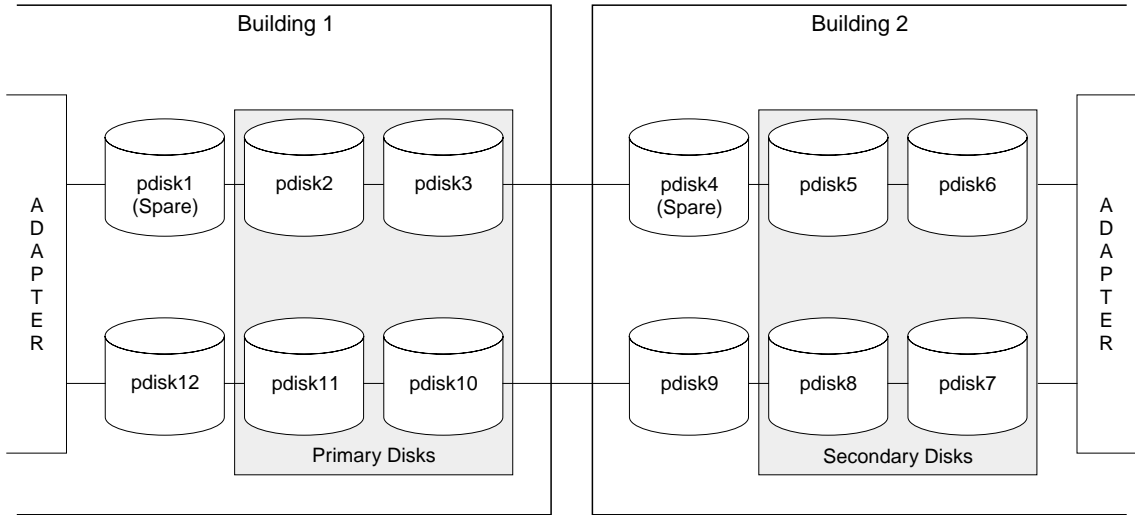

Figure 16. Primary Disks in Building 1; Secondary Disks in Building 2

If pdisk2 fails, the hot spare disk drive pdisk4 might replace pdisk 2 as one of the primary disk drives in the array, as shown in Figure 17.

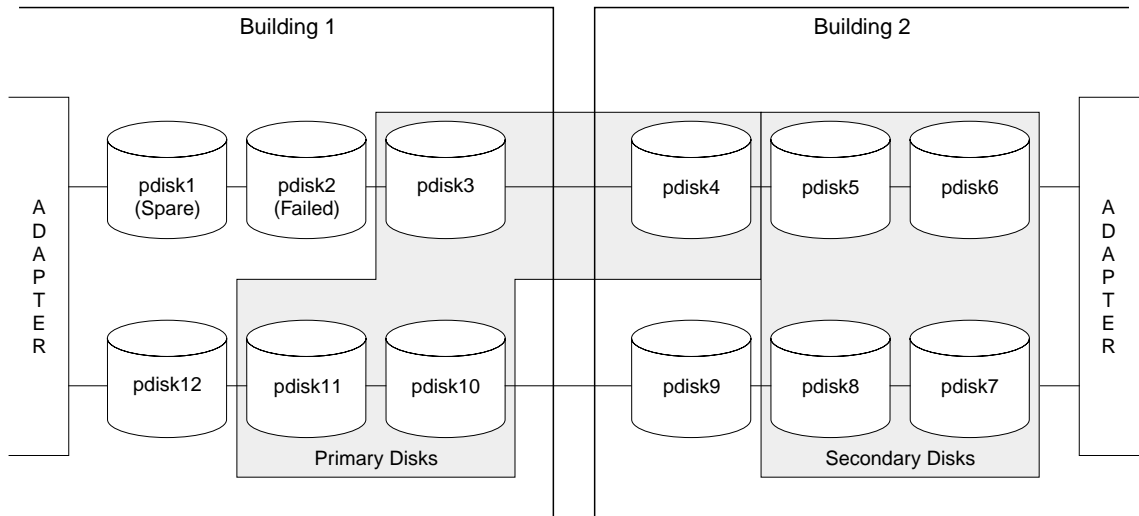

Figure 17. Primary Disk in Building 1; Secondary Disks in Building 2; Distributed Spares

Now, assume that for some reason, the disk drives in building 2 are no longer available. The example array is now in the Offline state because one of its four primary disk drives is in building 2. Only the three primary disk drives that are in building 1 are operational.

This problem can be solved if, in each building, a hot spare pool is created for the disk drives. In Figure 18, all the disk drives in building 1 have been made members of pool A1, and all the disk drives in building 2 have been made members of Pool A2. A failure of a member disk drive in Pool A1 now causes pdisk1 to be selected as the hot spare disk drive.

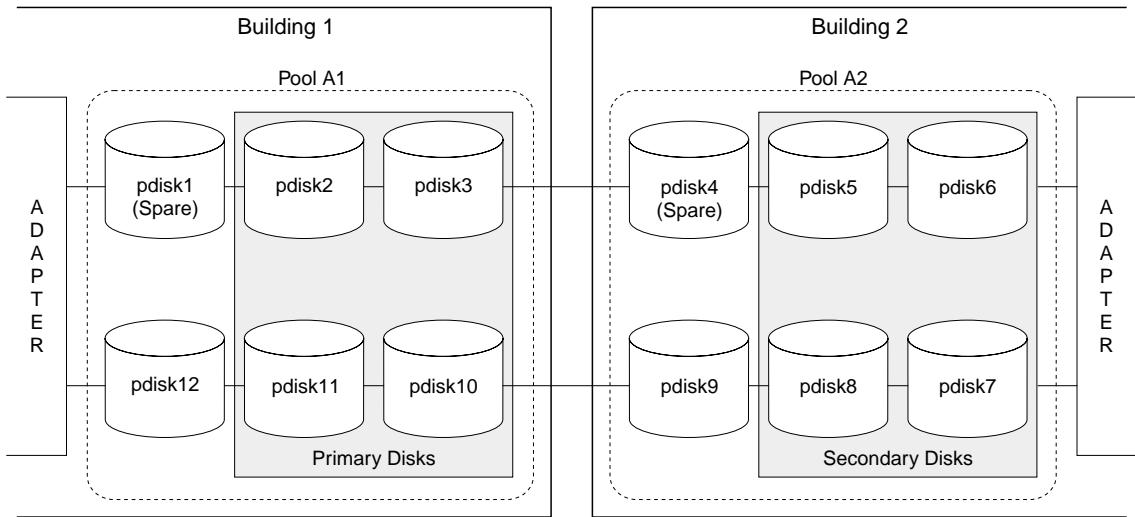

Figure 18. Primary Disk in Building 1; Secondary Disks in Building 2; Pools

Hot spare pools can be configured in other ways, as shown in figures 19 through 21.

Figure 19 shows how RAID-5 arrays can be protected against the complete failure of an SSA enclosure. Each pdisk of each array (hdisk) is in a different SSA enclosure. The hot spare disk drives are also in a different enclosure. Pools A1 and A2 each contain an hdisk and a hot spare disk drive. The pools ensure that, if any one SSA enclosure fails completely, three disk drives are always available for each hdisk.

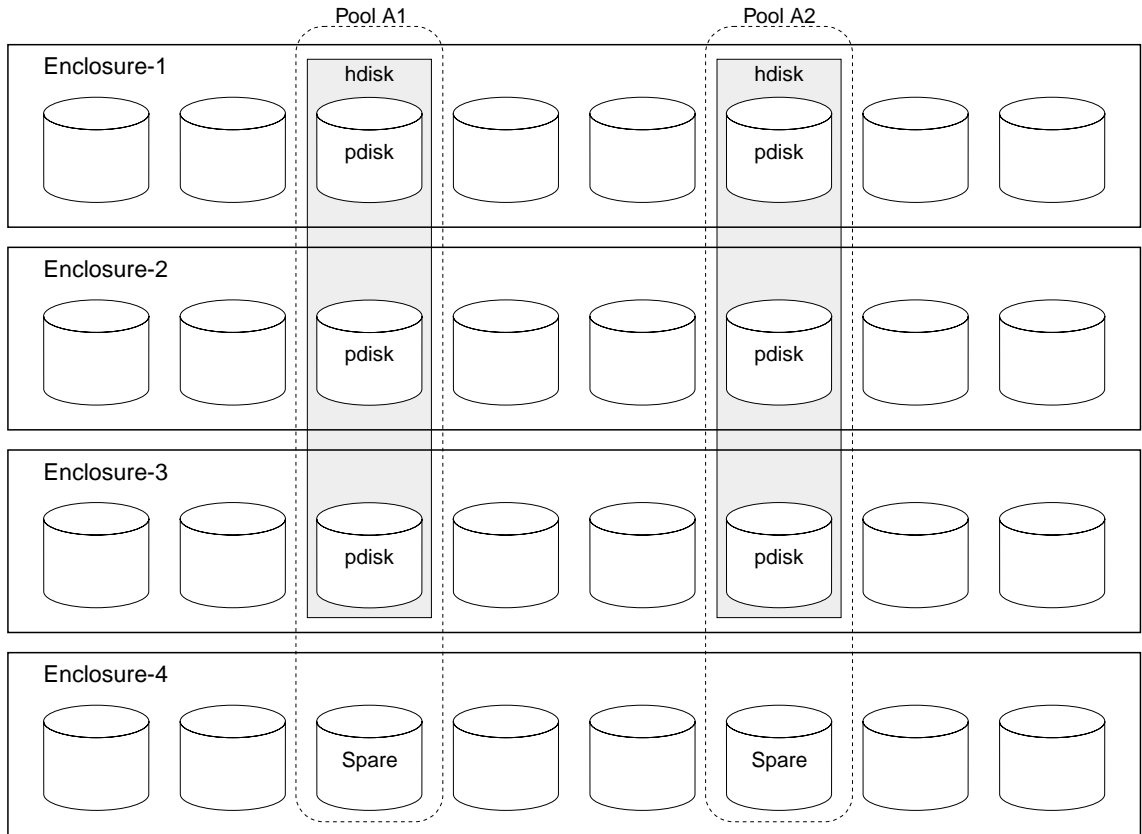

Figure 19. Pools and Hdisk across Enclosures

Figure 20 shows an alternative method of protecting RAID-5 arrays against the complete failure of an SSA Enclosure. This method uses a different hot spare disk drive to protect each member of the array.

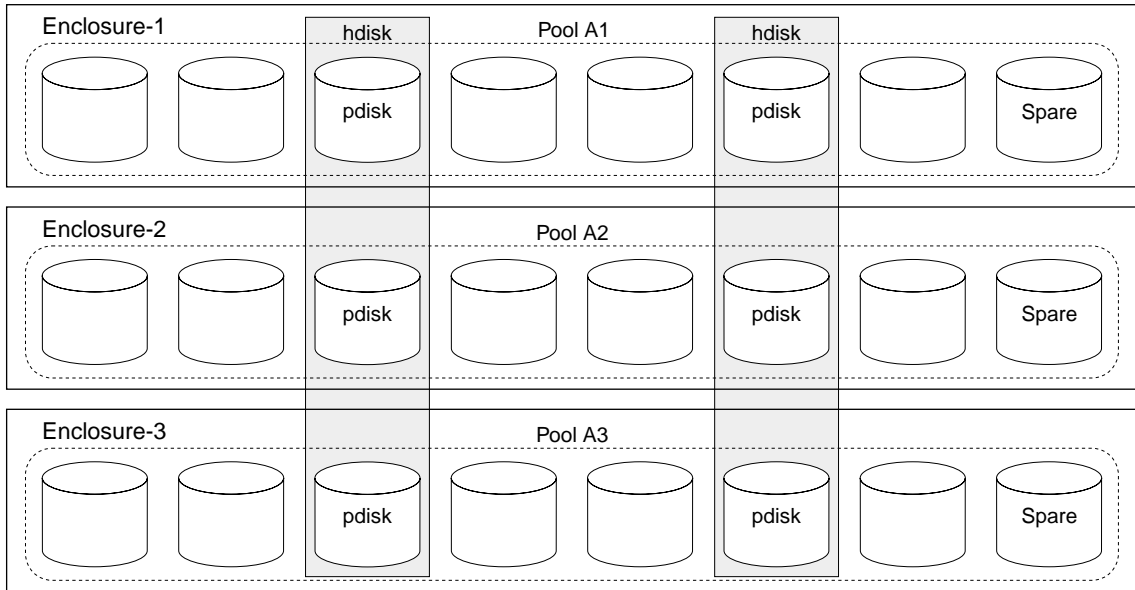

Figure 20. Pools along, and Hdisks across, Enclosures

Figure 21 shows how a RAID-10 array can be protected against the complete failure of an SSA enclosure.

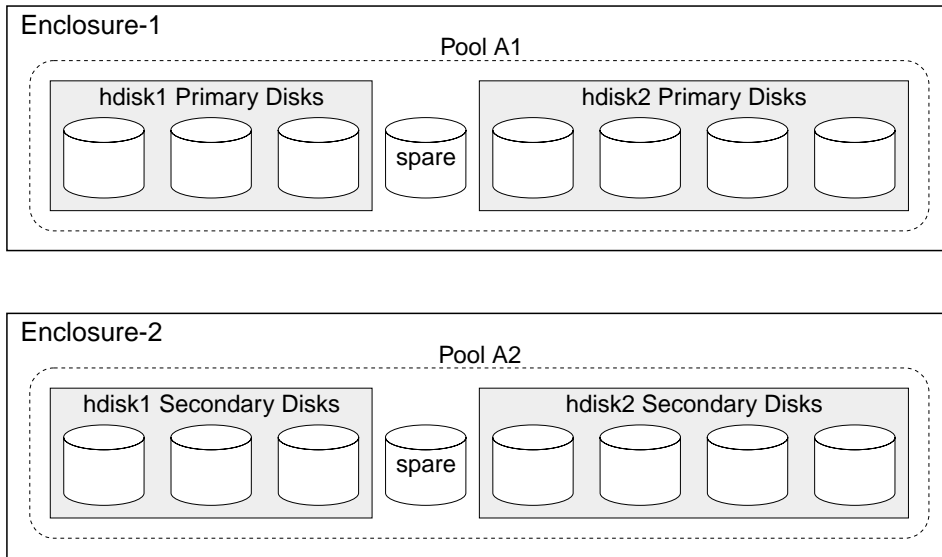

Figure 21. Pools and Hdisks along Enclosures

The primary disk drives of the array are in enclosure 1; the secondary disk drives are in enclosure 2. The secondary disk drives contain the same data as do the primary disk drives. Pool A1 contains all the primary disk drives of the arrays and a hot spare disk drive; pool A2 contains all the secondary disk drives and a hot spare disk drive. If one enclosure fails completely, the other enclosure can still recover from a disk drive failure because its disk drives and the hot spare disk drive are in the same pool.

Choosing How Many Hot Spare Disk Drives to Include in Each Pool

The number of hot spare disk drives that can be included in a hot spare pool is limited only by the number of disk drives that are permitted on a single SSA loop. When choosing how many disk drives to include in a hot spare pool, think about how many disk drives the hot spare is protecting and how much time might elapse before a failed disk drive can be replaced.

Choosing the Error Threshold (Alarm) Level for a Hot Spare Pool

Normally, a hot spare pool reports an error when any hot spare disk drive has been used. For some conditions, such as a disk drive failure at an unattended site, you might prefer to delay service activities until more than one disk drive in a hot spare pool has failed. You can specify this requirement when you create a hot spare pool. When you create the hot spare pool (see “Adding a New Hot Spare Pool” on page 83), set the Hot Spare Minimum parameter to be equal to the minimum number of hot spare disk drives

that is needed to protect the array in the selected pool. No error log entry is made until the number of hot spare disk drives that remains in the pool is less than the Hot Spare Minimum parameter.

Rules for Hot Spare Disk Drive Pools

- By default, all hot spare disk drives are in pool zero.
- Pool zero is called A0 for hot spare disk drives that are on SSA loop A, and B0 for hot spare disk drives that are on SSA loop B.
- Hot spare pool numbers are in the range A0 through A31 and B0 through B31. The pool number is automatically assigned when a hot spare pool is created.
- Arrays in pool zero can **never** use hot spare disk drives that are assigned to other hot spare pools.
- Each pdisk can be assigned to a hot spare pool.
- Each member disk drive of a RAID array can be assigned to a different hot spare pool.
- Disk drives can be added to a new pool only if they are in pool zero.
- If a disk drive is removed from a hot spare pool, that disk drive moves to pool zero.
- A hot spare pool can exist only on an SSA loop. For example, hot spare pool B1 on adapter ssa0 has no physical or logical connection to hot spare pool B1 on adapter ssa1.
- A hot spare pool can contain any number of hot spare disk drives. For instructions on how to configure hot spare pools, see Chapter 6, "Using the RAID Array Configurator" on page 57.
- If the **Choose Hot Spare Only from Preferred Pool** option is set to **yes**, hot spare disk drives are selected only from the hot spare pool that contains the failing member disk drive.
- If the **Choose Hot Spare Only from Preferred Pool** option is set to **no**, the selected hot spare disk drive can be:
 - A hot spare disk drive that is in the hot spare pool that contains the failing member disk drive
 - A hot spare disk drive that is in hot spare pool zero
 - A hot spare disk drive that is in any other hot spare pool
- If more than one hot spare disk drive is available in a pool, and the hot spare disk drives are of different sizes, the smallest appropriate disk drive is selected.

Solving Hot Spare Pool Problems

Hot spare pool problems are indicated by the state of the pool and by error codes in the system error log. When configuring or reconfiguring hot spare pools, it is recommended that you use the state of the hot spare pool to help guide your actions. If hot spare pool problems occur during normal operations, use the Service Request Number (SRN) that is generated by the diagnostics to guide your actions.

To display the operating state of a hot spare pool:

1. Type `smitty ssaraid` and press Enter.
2. Select **List Status of Hot Spare Pools**.
3. Select the SSA adapter that you want to inspect. The status of the hot spare pool is displayed:

```
COMMAND STATUS
Command: OK          stdout: yes          stderr: no
Before command completion, additional instructions may appear below.
ssal
Pool    Components  Spares  Configured  Minimum  Status
pool_A0    0           1       1           1        unused
pool_A1    3           2       2           1        full
pool_B1    6           1       1           1        full

F1=Help          F2=Refresh          F3=Cancel          F6=Command
F8=Image         F9=Shell           F10=Exit           /=Find
n=Find Next
```

The normal operating state for a hot spare pool is Full. Any other state indicates that a problem exists or some configuration actions are required. The possible states are:

Full The number of hot spare disk drives that are in the pool is equal to the number of hot spare disk drives that were in the pool when the pool was last configured.

Empty No hot spares are in the pool or hot spares in the pool are not of a suitable size for one or more of the arrays in the pool. Hot spare disk drives must have a capacity equal to or greater than that of the smallest disk drive in the array, or, if 'hot spare exact' has been selected for the array, the capacity of the hot spare disk drive must be exactly equal to that of the smallest disk drive in the array.

To add a hot spare disk drive to a pool:

1. Ensure that you have disk drives that:
 - Are assigned as hot spare disk drives, or as array candidate disk drives

- Have a size equal to, or greater than, the largest disk drive that they will be protecting
 - Are in pool 0 on the SSA loop on which the hot spare pool exists
2. If you are not sure whether your disk drives are assigned correctly:
 - a. Ensure that the required number of disk drives of the correct size are assigned as hot spare disk drives, or as array candidate disk drives (see “Changing the Use of Multiple SSA Physical Disks” on page 147).
 - b. Ensure that the disk drives that you are planning to use are in pool 0 (see “Listing the Disks That Are in a Hot Spare Pool” on page 80).
 3. Add the required number of disk drives to the pool (see “Adding Disks to, or Removing Disks from, a Hot Spare Pool” on page 86).

Reduced

The number of hot spare disk drives that are in the pool is less than the number of hot spare disk drives that were in the pool when the pool was last configured, but greater than the minimum number that is specified for this pool.

This condition does **not** cause an error to be logged.

If you removed a disk drive from the configuration on purpose:

1. Select **Change/Show/Delete a Hot Spare Pool** from the smit ssaraid menu (see “Adding Disks to, or Removing Disks from, a Hot Spare Pool” on page 86).
2. Select the reduced hot spare pool.
3. Verify that the contents of the pool are as required.
4. Press Enter.

If you have exchanged a failed disk drive, you might now want to add the exchanged disk drive to this pool (see “Adding Disks to, or Removing Disks from, a Hot Spare Pool” on page 86).

Critical The number of hot spare disk drives that are in the pool is less than the specified minimum number for that pool.

If you removed a disk drive from the configuration on purpose:

1. Select **Change/Show/Delete a Hot Spare Pool** from the smit ssaraid menu (see “Adding Disks to, or Removing Disks from, a Hot Spare Pool” on page 86).
2. Select the critical hot spare pool.
3. Verify that the contents of the pool are as required.
4. Press Enter.

If you have exchanged a failed disk drive, you must now add the exchanged disk drive to this pool (see “Adding Disks to, or Removing Disks from, a Hot Spare Pool” on page 86).

Inconsistent

The member disk drives in the pool do not agree about the size of the hot spare disk drives, or about the minimum number of hot spare disk drives that is required.

This state is probably caused by changes to the SSA loop; for example, the addition of disk drives or changes to the SSA cabling. If you did not intend to make such changes, and you correct them, the pool returns to its original state.

If you did intend to make the changes:

1. Select **Change/Show/Delete a Hot Spare Pool** from the smit ssaraid menu (see “Adding Disks to, or Removing Disks from, a Hot Spare Pool” on page 86).
2. Select the reduced hot spare pool.
3. Verify that the contents of the pool are as required.
4. Press Enter.

Mixed

An array in this pool has used a hot spare disk drive from another pool.

When replacement disk drives are installed in exchange for failed disk drives, the replacement disk drives are assigned as hot spare disk drives or as free disk drives. The hot spare pools, however, are no longer configured as intended. To correct the configuration:

1. Select **List Components in a Hot Spare Pool** (see “Listing the Disks That Are in a Hot Spare Pool” on page 80).
2. Select the mixed hot spare pool.
3. From the displayed list, note the number of the pdisk that has a status of wrong_pool.
4. Note the number of the hdisk to which the pdisk belongs.
5. Select **Swap Member Disks in an SSA RAID Array** (see “Changing Member Disks in an SSA RAID Array” on page 137).
6. Select the hdisk that you noted in step 4.

The **Disk to Remove** is the pdisk that you noted in step 3.

The **Disk to Add** is the replacement disk drive that was installed in exchange for the failed disk drive.

Unused

Hot spare disk drives exist in a pool, but they are not protecting any member disk drive.

This condition does **not** cause an error to be logged.

If required, you can move hot spare disk drives from this pool to a pool that contains RAID arrays. Alternatively, you can change the use of hot spare disk drives that are in this pool.

Chapter 6. Using the RAID Array Configurator

This chapter describes how to use the system management interface tool (SMIT) to manage your SSA RAID arrays. The SMIT provides a set of menus from which you can select the various functions of the **ssaraid** command. The **ssaraid** command allows you to create, delete, and manage your RAID arrays.

If you prefer to use the **ssaraid** command through the command line interface instead of through the menus, see Chapter 12, “Using the SSA Command Line Interface for RAID Configurations”. If you want to use the SMIT menus, remain in this chapter. Help information is available from each SMIT menu.

This chapter has three main parts:

- “Installing and Configuring SSA RAID Arrays” on page 58
- “Dealing with RAID Array Problems” on page 89
- “Using Other Configuration Functions” on page 97

Note: If you select a **List** function from a SMIT menu, and no resource of the required type exists, the following error pop-up window might be displayed:

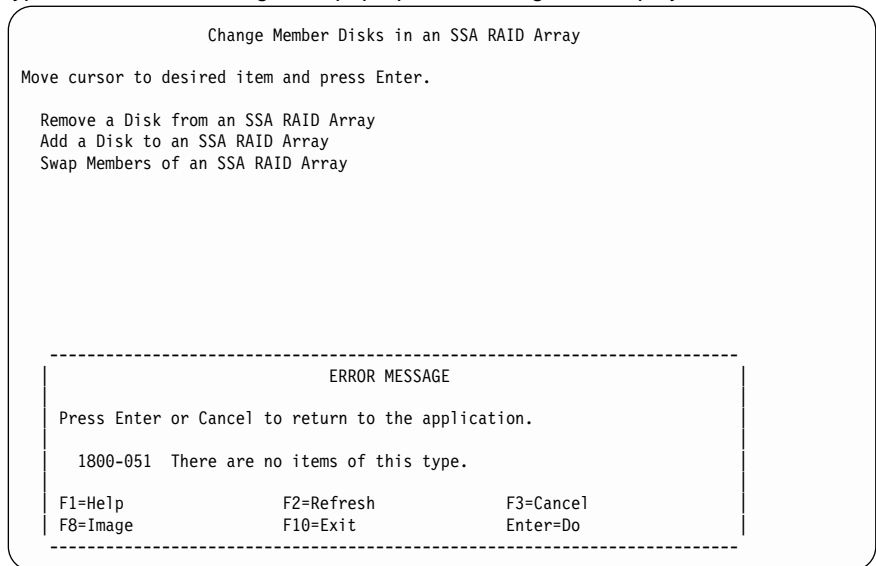

For example, if you select **Add a Disk to an SSA RAID Array**, and no exposed or degraded arrays exist, the error pop-up window is displayed.

Installing and Configuring SSA RAID Arrays

You can get to the required SMIT menu by using fast path commands, or by working through other menus. In this chapter, the fast path command for a particular option is given at the start of the description of that option.

Notes:

1. Although this book always refers to the **smitty** commands, you can use either the **smitty** command, or the **smit** command. The procedures that you follow remain the same, whichever of the two commands you use. If you send the **smit** command from a graphics terminal, however, the menus are displayed slightly differently from those shown in this book. If you are not familiar with the selection of items from the graphics versions of the menus, use the **smitty** command. The menus will then appear as shown in this book.
2. Different microcode levels might cause slightly different versions of the menus to be displayed.
3. If you use fast-path commands, you might need to go through intermediate steps that are not shown in this book. Also, some menus might be displayed slightly differently from those shown in this book.

Getting Access to the SSA RAID Arrays SMIT Menu

1. For fast-path access to the SSA RAID Array SMIT menus, type `smitty ssaraid` and press Enter.
Otherwise:
 - a. Type `smitty` and press Enter. The System Management menu is displayed.
 - b. Select **Devices**. The Devices menu is displayed.
 - c. Select **SSA RAID Arrays**.
2. The SSA RAID Arrays menu is displayed:

```
SSA RAID Arrays

Move cursor to desired item and press Enter.

List All Defined SSA RAID Arrays
List All Supported SSA RAID Arrays
List All SSA RAID Arrays Connected to a RAID Manager
List Status Of All Defined SSA RAID Arrays
List/Identify SSA Physical Disks
List/Delete Old RAID Arrays Recorded in an SSA RAID Manager
List Status of Hot Spare Pools
List Status of Hot Spare Protection for an SSA RAID Array
List Components in a Hot Spare Pool
Add a Hot Spare Pool
Add an SSA RAID Array
Delete an SSA RAID Array
Change/Show Attributes of an SSA RAID Array
Change Member Disks in an SSA RAID Array
Change/Show Use of an SSA Physical Disk
Change Use of Multiple SSA Physical Disks
Change/Show/Delete a Hot Spare Pool
Array Copy Services

F1=Help      F2=Refresh   F3=Cancel    F8=Image
F9=Shell     F10=Exit     Enter=Do
```

From the following list, find the option that you want, and go to the place that is indicated.

- “Adding an SSA RAID Array” on page 60
- “Deleting an SSA RAID Array” on page 70
- “Creating a Hot Spare Disk Drive” on page 72
- “Changing or Showing the Status of a Hot Spare Pool” on page 74
- “Showing the Disks That Are Protected by Hot Spares” on page 77
- “Listing the Disks That Are in a Hot Spare Pool” on page 80
- “Adding a New Hot Spare Pool” on page 83
- “Adding Disks to, or Removing Disks from, a Hot Spare Pool” on page 86

Adding an SSA RAID Array

This option lets you add an array to the configuration.

1. For fast path, type `smitty mkssaraid` and press Enter.

Otherwise, select **Add an SSA RAID Array** from the SSA RAID Arrays menu.

A list of adapters is displayed in a window:

```
SSA RAID Arrays

Move cursor to desired item and press Enter.

List All Defined SSA RAID Arrays
List All Supported SSA RAID Arrays
List All SSA RAID Arrays Connected to a RAID Manager
List Status Of All Defined SSA RAID Arrays
List/Identify SSA Physical Disks
List/Delete Old RAID Arrays Recorded in an SSA RAID Manager
List Status of Hot Spare Pools
List Status of Hot Spare Protection for an SSA RAID Array
List Components in a Hot Spare Pool
Add a Hot Spare Pool
-----
SSA RAID Manager

Move cursor to desired item and press Enter.

 ssa0 Available 00-04 IBM SSA 160 SerialRAID Adapter (14109100)

F1=Help           F2=Refresh       F3=Cancel
F8=Image          F10=Exit         Enter=Do
/=Find           n=Find Next
```

2. Select the adapter to which you want to add the array.
A list of array types is displayed in a window:

```
SSA RAID Arrays

Move cursor to desired item and press Enter.

List All Defined SSA RAID Arrays
List All Supported SSA RAID Arrays
List All SSA RAID Arrays Connected to a RAID Manager
List Status Of All Defined SSA RAID Arrays
List/Identify SSA Physical Disks
List/Delete Old RAID Arrays Recorded in an SSA RAID Manager
List Status of Hot Spare Pools

-----
RAID Array Type
-----
Move cursor to desired item and press Enter.

raid_0          RAID-0 array
raid_1          RAID-1 array
raid_5          RAID-5 array
raid_10         RAID-10 array

F1=Help          F2=Refresh      F3=Cancel
F8=Image         F10=Exit       Enter=Do
/=Find          n=Find Next
```

3. Select the type of array that you want to create.

If you select RAID-0, the following menu is displayed:

```

                                Add an SSA RAID Array

Type or select values in entry fields.
Press Enter AFTER making all desired changes.

                                [Entry Fields]
SSA RAID Manager                ssa0
RAID Array Type                 raid_0
* Member Disks                  +
Allow Page Splits               yes  +
Enable Fast-Write               no   +

F1=Help      F2=Refresh   F3=Cancel   F4=List
F5=Reset     F6=Command   F7=Edit     F8=Image
F9=Shell     F10=Exit     Enter=Do
```

For the meanings of the fields, see page 66.

If you select RAID-1, the following menu is displayed:

```

                                Add an SSA RAID Array

Type or select values in entry fields.
Press Enter AFTER making all desired changes.

                                [Entry Fields]
SSA RAID Manager                    ssa0
RAID Array Type                      raid_1
* Primary Disk                        +
* Secondary Disk                      +
Split Array Resolution                Primary      +
Enable Use of Hot Spares              yes        +
Choose Hot Spare only from Preferred Pool no        +
Allow Hot Spare Splits                no         +
Allow Page Splits                     yes        +
Initial Rebuild                       no         +
Enable Fast-Write                     no         +

F1=Help      F2=Refresh      F3=Cancel    F4=List
F5=Reset     F6=Command     F7=Edit      F8=Image
F9=Shell    F10=Exit       Enter=Do

```

For the meanings of the fields, see page 66.

If you select RAID-5, the following menu is displayed:

```

                                Add an SSA RAID Array

Type or select values in entry fields.
Press Enter AFTER making all desired changes.

                                [Entry Fields]
SSA RAID Manager                ssa0
RAID Array Type                 raid_5
* Member Disks
Strip Size (KB)                 64
Enable Use of Hot Spares        yes
Choose Hot Spare only from Preferred Pool  no
Allow Page Splits               yes
Enable-Fast Write               no

F1=Help      F2=Refresh      F3=Cancel      F4=List
F5=Reset     F6=Command     F7=Edit       F8=Image
F9=Shell     F10=Exit      Enter=Do

```

For the meanings of the fields, see page 66.

If you select RAID-10, the following menu is displayed:

```

                                Add an SSA RAID Array

Type or select values in entry fields.
Press Enter AFTER making all desired changes.

                                [Entry Fields]
SSA RAID Manager                    ssa0
RAID Array Type                      raid_10
* Primary Disks                       +
* Secondary Disks                     +
Strip Size (KB)                       16   +
Split Array Resolution                 Primary +
Enable Use of Hot Spares               yes  +
Choose Hot Spare only from Preferred Pool no  +
Allow Hot Spare Splits                 no   +
Allow Page Splits                      yes  +
Initial Rebuild                        no   +
Enable Fast-Write                      no   +

F1=Help      F2=Refresh      F3=Cancel      F4=List
F5=Reset     F6=Command     F7=Edit       F8=Image
F9=Shell    F10=Exit          Enter=Do
```

For the meanings of the fields, see page 66.

Meanings of the Fields

SSA RAID Manager

The name of an SSA RAID Manager. SSA RAID Managers are devices that control SSA RAID arrays.

RAID Array Type

The type of the SSA RAID array.

Member Disks

For a RAID-0 or a RAID-5 array, member disks are the disk drives that are to be added to the SSA RAID array. The array must consist of disk drives that are in the same loop.

Primary Disk

The primary disk drive of a RAID-1 array. A RAID-1 array must consist of two disk drives, one primary and one secondary, that are in the same loop. The data that is contained on the primary disk drive is a mirror copy of the data that is contained on the secondary disk drive.

Secondary Disk

The secondary disk drive of a RAID-1 array. A RAID-1 array must consist of two disk drives, one primary and one secondary, that are in the same loop. The data that is contained on the secondary disk drive is a mirror copy of the data that is contained on the primary disk drive.

Primary Disks

The primary disk drives of a RAID-10 array. A RAID-10 array consists of an even-numbered quantity (4 through 16) of disk drives that are in the same loop. The minimum RAID-10 array consists of two primary and two secondary disk drives. The data that is contained on the primary disk drives is a mirror copy of the data that is contained on the secondary disk drives. Ensure that you choose a quantity of primary disk drives that matches the quantity of secondary disk drives.

Secondary Disks

The secondary disk drives of a RAID-10 array. A RAID-10 array consists of an even-numbered quantity (4 through 16) of disk drives that are in the same loop. The data that is contained on the secondary disk drives is a mirror copy of the data that is contained on the primary disk drives. Ensure that you choose a quantity of secondary disk drives that matches the quantity of primary disk drives.

Strip Size

The maximum amount of contiguous data that is mapped to a single member disk drive.

Enable Use of Hot Spares

If you enable this option, the SSA RAID Manager can use any available hot spare disk drive to replace a failing member disk drive dynamically. The failing disk drive is rejected from the array, and the hot spare disk drive is put into the available place.

If you select **Exact**, the replacement disk drive is chosen only from hot spare disk drives whose size exactly matches the size of the failing disk drive.

Choose Hot Spare only from Preferred Pool

If you select **yes** for this option, a hot spare disk drive is selected only from the hot spare pool that contains the failed member disk drive.

If you select **no** for this option, a hot spare disk drive is selected, if available, from the hot spare pool that contains the failed member disk drive. If no hot spare disk drive is available in that pool, a hot spare disk drive is selected from the default hot spare pool for that SSA loop (Pool A0 or B0). If no hot spare disk drives are available in pool 0, a hot spare disk drive is selected from any other hot spare pool.

Allow Hot Spare Splits

If you select **no** for this option, the RAID manager does not attempt to use hot spare disk drives to replace missing members when a RAID-1 or RAID-10 array is split exactly in half, and all the primary or secondary member disk drives of that array are present.

It is recommended that this option be set to **no** if the RAID-1 or RAID-10 array is configured to protect against the loss of a physical domain.

Allow Page Splits

If you enable page splits, data that is being written to the array is split into 4096-byte pages. The pages are then written in parallel to the member disk drives of the array. These actions increase the general speed of write operations to the array, although the pages are written in a random sequence. If you disable this option, the data is written sequentially, but the general speed of write operations is decreased. The sequence in which data is written to the array might be critical to the program that is using the data, if an error occurs during the write operation.

Initial Rebuild

When a RAID-1 or a RAID-10 array is first created, the data that is contained in the primary member disk drive of the array is different from the data that is contained in the secondary disk drive of the array. When data is written to the array, it is written both to the primary disk drive and to the secondary disk drive. The data that is on the secondary disk drive is, therefore, a mirrored copy of the data that is on the primary disk drive.

If, however, you use a program that attempts to read data from the array before it has written any data to that array, the data that it reads might not be consistent. The data can be from either the primary disk drive or from the secondary disk drive, which at this time, are not mirrored copies of each other. If you use such a program, use the Initial Rebuild option.

If you select **no** for this option, any data that your program writes to the array is mirrored. Any data that your program reads from the array, however, might not be consistent because it might not have been written previously by this particular program.

If you select **yes** for this option, the array enters the Rebuilding state. The data that is on the primary disk drives is copied to the secondary disk drives. This operation might take several hours to complete, during which time, performance is affected.

Enable Fast-Write

Switches the fast-write cache on or off. This facility is not available on adapter cards that do not, or cannot, have a fast-write cache installed.

4. Move the cursor to the appropriate disk field (that is, **Member, Primary, or Secondary**), and press the List key to display a list of candidate disk drives.
5. If candidate disk drives are available, a list of those disk drives is displayed in a window:

Add an SSA RAID Array

Type or select values in entry fields.
Press Enter AFTER making all desired changes.

		[Entry Fields]	
SSA RAID Manager		ssa0	
RAID Array Type		raid_5	
* Member Disks			+
Enable Use of Hot Spares		yes	+

Member Disks

Move cursor to desired item and press F7.
ONE OR MORE items can be selected
Press Enter AFTER making all selections

Disks in Loop B are:

pdisk0	0004AC506C2900D	free	n/a	4.5GB	Physical	Disk
pdisk1	0004AC5119E000D	free	n/a	4.5GB	Physical	Disk
pdisk2	0004AC7C00E800D	free	n/a	4.5GB	Physical	Disk
pdisk3	0004AC9C00E700D	free	n/a	1.1GB	Physical	Disk

F1=Help	F2=Refresh	F3=Cancel
F7=Select	F8=Image	F10=Exit
Enter=Do	/=Find	n=Find Next

The disks selected must all be on the same loop.

If a list of disk drives is displayed, and the list contains enough disk drives for the array you are creating, go to step 6 on page 69.

If no list is displayed, or the list does not contain enough disk drives, go to "Changing or Showing the Use of an SSA Disk Drive" on page 144 for a description of how to assign disk drives as array candidates. When you have enough candidate disk drives, return to step 6 on page 69 in this section.

6. Select the disk drives that you want in the array. **You must select a minimum of:**
 - **Two disk drives if you are creating a RAID-0 array**
 - **One primary and one secondary disk drive if you are creating a RAID-1 array**
 - **Three disk drives if you are creating a RAID-5 array**
 - **Two primary and two secondary disk drives if you are creating a RAID-10 array**

Try to select disk drives of equal sizes. Although you can mix disk drives of various sizes, all the disk drives in a particular array are logically truncated to the size of the smallest disk drive in that array. For example, if you create an array from the four disk drives pdisk0, pdisk1, pdisk2, and pdisk3 that are shown on the screen in step 5 on page 68, all four disk drives are assigned as 1.1 GB disk drives, because pdisk3 is a 1.1 GB disk drive. If you use disk drives of various sizes, therefore, you waste some storage size.

Attention: When the array has been created, you can use it. You might, however, prefer to wait until the array state changes from Rebuilding to Good, because hot spare disk drives are not available until the array is in the Good state. If a disk drive fails before the array is in the Good state, you might no longer be able to write to the array.

7. Change other array attributes as required. For more information about each attribute, move the cursor to the attribute, and press the Help key.

Deleting an SSA RAID Array

This option allows you to delete arrays that you have created through the **Add an SSA RAID Array** option. The deleted array is broken into its member disk drives. You cannot delete arrays that do not have a corresponding hdisk.

1. For fast path, type smitty rmssaraid and press Enter.

Otherwise, select **Delete an SSA RAID Array** from the SSA RAID Arrays menu.

A list of arrays is displayed in a window:

```
SSA RAID Arrays
Move cursor to desired item and press Enter.

List All Defined SSA RAID Arrays
List All Supported SSA RAID Arrays
List All SSA RAID Arrays Connected to a RAID Manager
List Status Of All Defined SSA RAID Arrays
List/Identify SSA Physical Disks
List/Delete Old RAID Arrays Recorded in an SSA RAID Manager
List Status of Hot Spare Pools
List Status of Hot Spare Protection for an SSA RAID Array
List Components in a Hot Spare Pool
-----
SSA RAID Array
Move cursor to desired item and press Enter.

hdisk3      095231779F0737K good    3.4G RAID-5 array
hdisk4      09523173A02137K good    3.4G RAID-5 array

F1=Help      F2=Refresh      F3=Cancel
F8=Image     F10=Exit        Enter=Do
/=Find       n=Find Next
```

2. Select the array that you want to delete.

3. A prompt is displayed in a window:

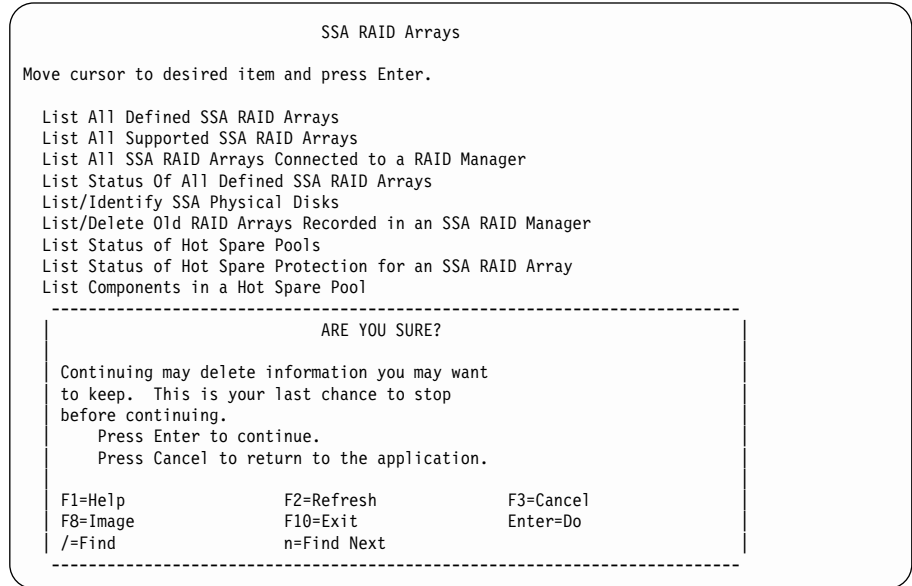

4. At the prompt, press Enter if you want to delete the array. Press Cancel if you do not want to delete the array.

Creating a Hot Spare Disk Drive

1. For fast path, type smitty chgssadisk and press Enter.

Otherwise, select **Change/Show Use of an SSA Physical Disk** from the SSA RAID Arrays menu.

A list of disk drives and their usage is displayed in a window:

```
SSA RAID Arrays
Move cursor to desired item and press Enter.

List All Defined SSA RAID Arrays
-----
SSA Physical Disk
Move cursor to desired item and press Enter. Use arrow keys to scroll.

# SSA physical disks which are members of arrays.
pdisk0      00022123DFHC00D member  n/a      4.5G  Physical d
pdisk1      0004AC5119E000D member  n/a      1.1G  Physical d
pdisk2      0004AC5119E000D member  n/a      1.1G  Physical d
pdisk3      08005AEA003500D member  n/a      4.5G  Physical d
pdisk4      08005AEA030D00D member  n/a      2.3G  Physical d
pdisk5      08005AEA080100D member  n/a      4.5G  Physical d
pdisk7      08005AEA087A00D member  n/a      4.5G  Physical d
# SSA physical disks which are hot spares.
pdisk6      08005AEA080800D spare    n/a      4.5G  Physical d

F1=Help      F2=Refresh   F3=Cancel
F8=Image     F10=Exit     Enter=Do
/=Find       n=Find Next
```

2. Using the arrow keys, scroll the information until you find the list of SSA physical disks that are not used.

3. Select the disk drive that you want to designate as a hot spare.

The following screen is displayed for the disk drive that you have chosen:

```
Change/Show Attributes of an SSA Physical Disk

Type or select values in entry fields.
Press Enter AFTER making all desired changes.

SSA RAID Manager          [Entry Fields]
SSA physical disk        ssa0
CONNECTION address       pdisk6
Current use              08005AEA080800D
                          Hot Spare Disk      +

F1=Help      F2=Refresh  F3=Cancel  F4=List
F5=Reset     F6=Command  F7=Edit    F8=Image
F9=Shell     F10=Exit   Enter=Do
```

Move the cursor to **Current Use**, and press the List key.

Note: If the **Current Use** field shows that the disk drive is owned by an array, you cannot change that use.

4. Select **Hot Spare Disk** in the **Current Use** field.
5. Press Enter.

Changing or Showing the Status of a Hot Spare Pool

This option shows you the existing configuration of the arrays and the status of each hot spare pool.

1. For fast path, type `smitty ls_hsm_status` and press Enter.

Otherwise, select **List Status of Hot Spare Pools** from the SSA RAID Arrays menu.

2. A list of adapters is displayed in a window:

```
SSA RAID Arrays
Move cursor to desired item and press Enter.

List All Defined SSA RAID Arrays
List All Supported SSA RAID Arrays
List All SSA RAID Arrays Connected to a RAID Manager
List Status Of All Defined SSA RAID Arrays
List/Identify SSA Physical Disks
List/Delete Old RAID Arrays Recorded in an SSA RAID Manager
List Status of Hot Spare Pools
-----
SSA RAID Manager
Move cursor to desired item and press F7.
ONE OR MORE items can be selected.
Press Enter AFTER making all selections.

  ssa0 Available 04-06 IBM SSA 160 SerialRAID Adapter (14109100)
  ssa1 Available 04-07 IBM SSA 160 SerialRAID Adapter (14109100)

F1=Help          F2=Refresh      F3=Cancel
F7=Select        F8=Image       F10=Exit
F Enter=Do       /=Find         n=Find Next
-----
```

Select the adapter whose hot spare pools you want to list.

3. A list of hot spare pools and their status is displayed:

```
COMMAND STATUS
Command: OK          stdout: yes          stderr: no
Before command completion, additional instructions may appear below.
ssal
Pool      Components  Spares  Configured  Minimum  Status
pool_A0   0             1       1           1        unused
pool_A1   7             0       1           1        empty
pool_B1   6             2       2           1        full

F1=Help      F2=Refresh   F3=Cancel   F6=Command
F8=Image     F9=Shell     F10=Exit    /=Find
n=Find Next
```

The columns of information displayed on the screen have the following meanings:

Pool The pool identifier.

Note: Until you have defined hot spare pools (see “Adding a New Hot Spare Pool” on page 83), all disk drives are in pool_A0 and pool_B0. Any RAID arrays that are in pool_A0 and pool_B0 cannot be restricted to make them select disk drives from only that pool.

Components

The number of array member disk drives that the hot spare disk drives in the pool are protecting.

Spares The number of hot spare disk drives that are now in the pool.

Configured

The number of hot spare disk drives that were in the pool when it was created or changed.

Minimum

The value that is selected to be the minimum number of hot spare disk drives that can exist in a pool before an error condition is logged. This number is normally set to be the same as the number of disk drives that were originally configured in the pool. You can, however, set the minimum to a lower number if you do not want to be alerted when a single hot spare disk drive has been used.

Status The status of the hot spare pool. Valid values for status are:

full The number of hot spare disk drives that are in the pool equals the number of hot spare disk drives that are configured for the pool.

empty The pool contains no hot spare disk drives, or the hot spare disk drives that are in the pool are not suitable as member disk drives of the pool.

reduced The number of hot spare disk drives that are in the pool is less than the number of hot spare disk drives that were originally configured, but greater than the configured minimum number.

critical The number of hot spare disk drives that are in the pool is less than the specified number of hot spare disk drives for that pool.

inconsistent Configuration data for the hot spare pool is saved on all hot spare disk drives. The hot spare disk drives that are in the pool, however, do not all contain the same configuration data.

mixed An array that is in this pool has used a hot spare disk drive that is from another pool.

unused Hot spare disk drives exist in a pool, but they are protecting no member disk drives.

Showing the Disks That Are Protected by Hot Spares

This option shows you which member disk drives of an array are protected by hot spare disk drives.

1. For fast path, type `smitty ls_hsm_array_status` and press Enter.

Otherwise, select **List Status of Hot Spare Protection for an SSA RAID Array** from the SSA RAID Arrays menu.

2. A list of adapters is displayed in a window:

```
SSA RAID Arrays

Move cursor to desired item and press Enter.

List All Defined SSA RAID Arrays
List All Supported SSA RAID Arrays
List All SSA RAID Arrays Connected to a RAID Manager
List Status Of All Defined SSA RAID Arrays
List/Identify SSA Physical Disks
List/Delete Old RAID Arrays Recorded in an SSA RAID Manager
List Status of Hot Spare Pools
-----
SSA RAID Manager

Move cursor to desired item and press F7.
ONE OR MORE items can be selected.
Press Enter AFTER making all selections.

 ssa0 Available 04-06 IBM SSA 160 SerialRAID Adapter (14109100)
 ssa1 Available 04-07 IBM SSA 160 SerialRAID Adapter (14109100)

F1=Help          F2=Refresh      F3=Cancel
F7=Select        F8=Image       F10=Exit
F Enter=Do       /=Find         n=Find Next
-----
```

Select the adapter whose protected member disk drives you want to list.

3. A list of protected member disk drives is displayed:

```
COMMAND STATUS
Command: OK          stdout: yes          stderr: no
Before command completion, additional instructions may appear below.
ssal
Component           Location           Size  Pool           Protected Status
-----
hdisk4              raid_10
pdisk13             04-02-REGY-06-P   18.2GB pool_B2       yes    good
pdisk11             04-02-REGY-08-P   9.2GB  pool_B1       yes    good
pdisk3              04-02-REGY-05-P   9.2GB  pool_B2       yes    good
pdisk6              04-02-REGY-03-P   9.2GB  pool_B1       yes    good
pdisk7              04-02-REGY-01-P   9.2GB  pool_B2       yes    good
pdisk15             04-02-REGY-07-P   18.2GB pool_B1       yes    good

F1=Help           F2=Refresh         F3=Cancel         F6=Command
F8=Image          F9=Shell           F10=Exit          /=Find
n=Find Next
```

The columns of information displayed on the screen have the following meanings:

Component

The array member disk drive of the hdisk that is listed on the screen.

Location

The physical location code of the array member disk drive.

Size

The size of the array member disk drive. This value is useful to know, if you have assigned a hot spare disk drive to a pool, but the array member disk drive is too large to be protected by the hot spare disk drive.

Pool

The pool to which the array member disk drive is assigned.

Protected

If set to **yes**, this field indicates that if the array member disk drive fails, a hot spare disk drive is available to replace it. That hot spare disk drive is selected from the listed hot spare pool or, if no hot spare disk drives are available in that pool, and **Choose Hot Spare Only from Preferred Pool** is set to **no** (see “Changing or Showing the Attributes of an SSA RAID Array” on page 135), the hot spare disk drive is selected from another pool.

If set to **no**, this field indicates that the array member disk drive is not protected. No suitable hot spare disk exists in the listed pool, and if **Choose Hot Spare Only from Preferred Pool** is set to **no** (see “Changing or Showing the Attributes of an SSA RAID Array” on page 135), no suitable hot spare disk exists in any other hot spare pool.

Status The status of the array member disk drive. Valid values for status are:

good The disk drive is working.

not_present

The disk drive cannot be detected. It has been removed or it has failed.

too_large

The member disk drive is too large to be protected by one of the hot spare disk drives that is in the pool.

Note: The size of the member disk drive is not the physical size of the disk drive, but the size that the array manager assigns to it. For example, if a RAID-10 array is created from three 9 GB disk drives and one 18 GB disk drive, the size that is assigned to each array member disk drive is 9 GB. The 18 GB disk drive can still be protected by a 9 GB hot spare disk drive.

wrong_pool

This member disk drive of the array has been replaced with a hot spare disk drive from another pool. This action has occurred because no hot spare disk drive was available in this pool when the array member disk drive failed. When all failed disk drives have been replaced, this array member disk drive should be exchanged with a disk drive that is in the same physical domain as are the other disk drives in the pool (see Chapter 5, “Hot Spare Management” on page 45).

Listing the Disks That Are in a Hot Spare Pool

This option shows you all the disk drives that are in a hot spare pool and shows the status of each disk drive.

1. For fast path, type `smitty ls_hsm_array_components` and press Enter.

Otherwise, select **List Components in a Hot Spare Pool** from the SSA RAID Arrays menu.

2. A list of adapters is displayed in a window:

```
SSA RAID Arrays
Move cursor to desired item and press Enter.

List All Defined SSA RAID Arrays
List All Supported SSA RAID Arrays
List All SSA RAID Arrays Connected to a RAID Manager
List Status Of All Defined SSA RAID Arrays
List/Identify SSA Physical Disks
List/Delete Old RAID Arrays Recorded in an SSA RAID Manager
List Status of Hot Spare Pools
List Status of Hot Spare Protection for an SSA RAID Array
List Components in a Hot Spare Pool
Add a Hot Spare Pool

-----
SSA RAID Manager
Move cursor to desired item and press Enter.

  ssa0 Available 00-04 IBM SSA 160 SerialRAID Adapter (14109100)

F1=Help      F2=Refresh      F3=Cancel
F8=Image     F10=Exit        Enter=Do
/=Find       n=Find Next
-----
```

Select the adapter whose hot spare pools you want to list.

3. A list of hot spare pools is displayed:

```

SSA RAID Arrays

Move cursor to desired item and press Enter.

List All Defined SSA RAID Arrays
List All Supported SSA RAID Arrays
List All SSA RAID Arrays Connected to a RAID Manager
-----
SSA Hot Spare Pools

Move cursor to desired item and press F7.
ONE OR MORE items can be selected.
Press Enter AFTER making all selections.

#####
# Hot Spare Pools in Loop A are:
pool_A1
#####
# Hot Spare Pools in Loop B are:
pool_B1

F1=Help          F2=Refresh       F3=Cancel
F7=Select        F8=Image         F10=Exit
F  Enter=Do      /=Find           n=Find Next
-----

```

Select the hot spare pool whose disk drives you want to list.

4. The pool status is displayed:

```

COMMAND STATUS

Command: OK          stdout: yes        stderr: no

Before command completion, additional instructions may appear below.

ssal : pool_B2

Component           Location           Size   Status
-----
hdisk4              raid_10
  pdisk13            04-02-REGY-06-P  18.2GB good
  pdisk3             04-02-REGY-05-P   9.2GB good
  pdisk7             04-02-REGY-01-P   9.2GB good

Hot Spare Disks
  pdisk9            04-02-REGY-02-P   9.2GB

F1=Help          F2=Refresh       F3=Cancel       F6=Command
F8=Image         F9=Shell         F10=Exit        /=Find
n=Find Next
-----

```

The columns of information displayed on the screen have the following meanings:

Component

The array member disk drive of the hdisk that is listed on the screen, or hot spare disk drives that are assigned to the pool.

Location

The physical location of the array member disk drive.

Size

The size of the array member disk drive. This value is useful to know, if you have assigned a hot spare disk drive to a pool, but the array member disk drive is too large to be protected by the hot spare disk drive.

Status The status of the array member disk drive. Valid values for status are:

good The disk drive is working.

not_present

The disk drive cannot be detected. It has been removed or it has failed.

too_large

The member disk drive is too large to be protected by any hot spare disk drive in the pool.

Note: The size of the member disk drive is not the physical size of the disk drive, but the size that the array manager assigns to it. For example, if a RAID-10 array is created from three 9 GB disk drives and one 18 GB disk drive, the size that is assigned to each array member disk drive is 9 GB. The 18 GB disk drive can still be protected by a 9 GB hot spare disk drive.

wrong_pool

This member disk drive of the array has been replaced with a hot spare disk drive from another pool. This action has occurred because no hot spare disk drive was available in this pool when the array member disk drive failed. When all failed disk drives have been replaced, this array member disk drive should be exchanged with a disk drive that is in the same physical domain as are the other disk drives in the pool (see Chapter 5, "Hot Spare Management" on page 45).

Adding a New Hot Spare Pool

This option allows you to add a new hot spare pool. If you are not sure how to configure hot spare pools, read Chapter 5, “Hot Spare Management” on page 45 before you proceed.

1. For fast path, type `smitty add_hsm_pool_adap` and press Enter.
Otherwise, select **Add a Hot Spare Pool** from the SSA RAID Arrays menu.
2. A list of adapters is displayed in a window:

```
SSA RAID Arrays
Move cursor to desired item and press Enter.

List All Defined SSA RAID Arrays
List All Supported SSA RAID Arrays
List All SSA RAID Arrays Connected to a RAID Manager
List Status Of All Defined SSA RAID Arrays
List/Identify SSA Physical Disks
List/Delete Old RAID Arrays Recorded in an SSA RAID Manager
List Status of Hot Spare Pools
List Status of Hot Spare Protection for an SSA RAID Array
List Components in a Hot Spare Pool
Add a Hot Spare Pool

-----
SSA RAID Manager
Move cursor to desired item and press Enter.

    ssa0 Available 00-04 IBM SSA 160 SerialRAID Adapter (14109100)

F1=Help          F2=Refresh      F3=Cancel
F8=Image         F10=Exit       Enter=Do
/=Find           n=Find Next
```

Select the adapter to which you want to add the hot spare pool.

3. A list that shows Loop A or Loop B is displayed:

```

SSA RAID Arrays

Move cursor to desired item and press Enter.

List All Defined SSA RAID Arrays
List All Supported SSA RAID Arrays
List All SSA RAID Arrays Connected to a RAID Manager
List Status Of All Defined SSA RAID Arrays
List/Identify SSA Physical Disks
List/Delete Old RAID Arrays Recorded in an SSA RAID Manager
List Status of Hot Spare Pools
List Status of Hot Spare Protection for an SSA RAID Array
List Components in a Hot Spare Pool
-----
SSA Loops

Move cursor to desired item and press Enter.

Loop A
Loop B

F1=Help           F2=Refresh        F3=Cancel
F7=Select         F8=Image          F10=Exit
F  Enter=Do       /=Find            n=Find Next
-----

```

Select the loop on which you want to create the hot spare pool.

4. The Hot Spare Pool Creation menu is displayed:

```

Add a Hot Spare Pool

Type or select values in entry fields.
Press Enter AFTER making all desired changes.

SSA RAID Manager                               [Entry Fields]
Spares Pool                                    ssal
* Components to Add                            pool_B3
Hot Spares Minimum                             []          +
                                                [1]         #

F1=Help           F2=Refresh        F3=Cancel        F4=List
F5=Reset          F6=Command        F7=Edit          F8=Image
F9=Shell          F10=Exit          Enter=Do

```

This menu automatically assigns the next available pool number to the new pool.

The Hot Spares Minimum field contains a default value of 1. This value defines the minimum number of spares that can exist in the pool before an error condition is logged. You should normally set this field to the number of hot spare disk drives that you intend to assign to this pool. You can, however, set it to a lower number if you do not want to be alerted when a single hot spare disk drive has been used (see “Choosing the Error Threshold (Alarm) Level for a Hot Spare Pool” on page 51).

5. Select **Components to Add** and press the List key.
6. A list of valid hot spare pool candidates is displayed. This list contains RAID disk drives, hot spare disk drives, and free disk drives that are now in pool zero on the selected SSA loop.

```

Add a Hot Spare Pool
-----
Ty -----
Pr -----
                                Components to Add
-----
Move cursor to desired item and press F7.
ONE OR MORE items can be selected.
Press Enter AFTER making all selections.
*
# SSA physical disks that are members of an array.
# hdisk4          raid_10
  pdisk13        AC7AAB76  04-02-REGY-06-P  18.2GB  good
  pdisk3         AC7AA0B2  04-02-REGY-05-P   9.2GB  good
  pdisk7         AC7AA0BD  04-02-REGY-01-P   9.2GB  good
#
# SSA physical disks that are hot spare disks.
  pdisk9         AC7AA2D6  04-02-REGY-02-P   9.2GB
#
# SSA physical disks that are free.
#
F1=Help          F2=Refresh      F3=Cancel
F1 F7=Select     F8=Image       F10=Exit
F5 Enter=Do      /=Find         n=Find Next
F9 -----
  
```

Select the disk drives that you want to add to the hot spare pool, and press Enter.

Notes:

- a. If all the member disk drives of an hdisk are now in pool zero, you can select the hdisk. This action adds all the member pdisks of the array to the hot spare pool that you are creating. If some of the member pdisks of an hdisk have already been assigned to another hot spare pool, the hdisk cannot be selected and is shown with a comment # flag in front of it, as shown in the example screen.
- b. If a free disk is selected from the list it is converted to a hot spare disk drive when it is added to the hot spare pool.

Adding Disks to, or Removing Disks from, a Hot Spare Pool

This option allows you to exchange the disk drives that are in the hot spare pool, or to resynchronize the state of the pool. If you are not sure how to configure hot spare pools, read Chapter 5, “Hot Spare Management” on page 45 before you proceed.

1. For fast path, type `smitty chg_hsm_pool_adap` and press Enter.

Otherwise, select **Change/Show/Delete a Hot Spare Pool** from the SSA RAID Arrays menu.

2. A list of adapters is displayed in a window:

```
SSA RAID Arrays

Move cursor to desired item and press Enter.

List All Defined SSA RAID Arrays
List All Supported SSA RAID Arrays
List All SSA RAID Arrays Connected to a RAID Manager
List Status Of All Defined SSA RAID Arrays
List/Identify SSA Physical Disks
List/Delete Old RAID Arrays Recorded in an SSA RAID Manager
List Status of Hot Spare Pools
List Status of Hot Spare Protection for an SSA RAID Array
List Components in a Hot Spare Pool
-----
SSA RAID Manager

Move cursor to desired item and press Enter.

  ssa0 Available 04-03 IBM SSA 160 SerialRAID Adapter (14109100)
  ssa1 Available 04-02 IBM SSA 160 SerialRAID Adapter (14109100)

F1=Help          F2=Refresh       F3=Cancel
F8=Image         F10=Exit         Enter=Do
F /|=Find        n=Find Next
```

Select the adapter on which you want to change the hot spare pool.

3. A list of hot spare pools is displayed:

```
SSA RAID Arrays
Move cursor to desired item and press Enter.
List All Defined SSA RAID Arrays
List All Supported SSA RAID Arrays
List All SSA RAID Arrays Connected to a RAID Manager
-----
SSA Hot Spare Pools
Move cursor to desired item and press Enter.

#####
# Hot Spare Pools in Loop A are:
pool_A1
pool_A2
#####
# Hot Spare Pools in Loop B are:
pool_B1
pool_B2

F1=Help          F2=Refresh      F3=Cancel
F7=Select        F8=Image       F10=Exit
Enter=Do         /=Find         n=Find Next
-----
```

Select the hot spare pool that you want to change.

4. The hot spare pool is displayed:

```

SSA Hot Spare Pools

Type or select values in entry fields.
Press Enter AFTER making all desired changes.

SSA RAID Manager          [Entry Fields]
Spares Pool               ssa1
Status                    pool_B2
Components in Pool        full
Hot Spares Previously Configured 3
Hot Spares in Pool       1
Components to Add         []      +
Components to Remove     []      +
Hot Spares Minimum       [1]     #

F1=Help      F2=Refresh  F3=Cancel  F4=List
F5=Reset     F6=Command  F7=Edit    F8=Image
F9=Shell     F10=Exit   Enter=Do

```

- To add disk drives to the pool:
 1. Select **Components to Add** and press the List key. A list of valid hot spare pool candidates is displayed. This list contains RAID disk drives, hot spare disk drives, and free disk drives that are in pool zero on the selected loop. The pop-up list is in the same format as the list that is used when a hot spare pool is created.
 2. Select the member disk drives to add to the pool and press Enter.
 3. If necessary, change the **Hot Spares Minimum** field.
 4. Press Enter.
- To remove disk drives from the pool:
 1. Select **Components to Remove** and press the List key. A list of disk drives that are now in the pool is displayed.
 2. Select the member disk drives that are to be removed from the pool and press Enter.
 3. If necessary, change the Hot Spares Minimum field.
 4. Press Enter. The member disk drives that have been removed from the pool are now moved to pool zero of the selected loop.

Notes:

1. If all member disk drives are removed from the pool, the pool is automatically deleted.
2. When all member adding and deleting tasks have been completed, if the pool status is anything other than **full**, go to “Solving Hot Spare Pool Problems” on page 53.

Dealing with RAID Array Problems

This part of the chapter describes how to solve problems that might occur on your SSA RAID arrays. You can get to the required SMIT menu by using fast path commands or by working through other menus. During problem determination, you can use any of the maintenance procedures described in Using Other Configuration Functions.

A hot spare disk drive automatically replaces a failed or missing disk drive in a RAID array if:

- The **Enable Use of Hot Spares** attribute is set to **yes**.
- A hot spare disk drive is available.

When a hot spare disk drive starts operating, its **Current Use** attribute is changed from **Hot Spare Disk** to **Member of an SSA RAID Array**. If a member disk drive of an array fails, but access to that disk drive is still possible, its **Current Use** attribute is changed from **Member of an SSA RAID Array** to **Rejected**. For all other changes to the use of a disk drive, you must use either the **ssaraid** commands or the SMIT menus.

Notes:

1. Although this book always refers to the **smitty** commands, you can use either the **smitty** command, or the **smit** command. The procedures that you follow remain the same, whichever of the two commands you use. If you send the **smit** command from a graphics terminal, however, the menus are displayed slightly differently from those shown in this book. If you are not familiar with the selection of items from the graphics versions of the menus, use the **smitty** command. The menus will then appear as shown in this book.
2. If you use fast-path commands, you might need to go through intermediate steps that are not shown in this book. Also, some menus might be displayed slightly differently from those shown in this book.

Getting Access to the SSA RAID Array SMIT Menu

1. For fast-path access to the SSA RAID Array SMIT menus, type `smitty ssaraid` and press Enter.
Otherwise:
 - a. Type `smitty` and press Enter. The System Management menu is displayed.
 - b. Select **Devices**. The Devices menu is displayed.
 - c. Select **SSA RAID Arrays**.
2. The SSA RAID Arrays menu is displayed:

```
SSA RAID Arrays

Move cursor to desired item and press Enter.

List All Defined SSA RAID Arrays
List All Supported SSA RAID Arrays
List All SSA RAID Arrays Connected to a RAID Manager
List Status Of All Defined SSA RAID Arrays
List/Identify SSA Physical Disks
List/Delete Old RAID Arrays Recorded in an SSA RAID Manager
List Status of Hot Spare Pools
List Status of Hot Spare Protection for an SSA RAID Array
List Components in a Hot Spare Pool
Add a Hot Spare Pool
Add an SSA RAID Array
Delete an SSA RAID Array
Change/Show Attributes of an SSA RAID Array
Change Member Disks in an SSA RAID Array
Change/Show Use of an SSA Physical Disk
Change Use of Multiple SSA Physical Disks
Change/Show/Delete a Hot Spare Pool

F1=Help      F2=Refresh   F3=Cancel   F8=Image
F9=Shell     F10=Exit    Enter=Do
```

From the following list, find the option that you want, and go to the place that is indicated.

- “Identifying and Correcting or Removing Failed Disk Drives” on page 91
- “Installing a Replacement Disk Drive” on page 95

Identifying and Correcting or Removing Failed Disk Drives

When a disk drive fails, the array rejects it. If access to the array is still possible, the **Current Use** attribute of the disk drive is changed from **Member of an SSA RAID Array** to **Rejected**. The disk drive is listed in the SMIT menus as a rejected disk drive. If the disk drive cannot be accessed, however, it cannot be listed as a rejected disk. (A disk drive cannot be accessed if its Check light is on, or its Power light is off.)

To find rejected disk drives that cannot be accessed, go to “MAP 2010: START” on page 444 to determine the cause of the failure.

To find rejected disk drives that can be accessed, do the following procedure:

1. For fast path, type `smitty lfssaraid` and press Enter.
Otherwise:
 - a. Select **List/Identify SSA Physical Disks** from the SSA RAID Arrays menu.
 - b. Select **List Rejected Array Disks**.
2. A list of adapters is displayed in a window:

```

                                List/Identify SSA Physical Disks
Move cursor to desired item and press Enter.

List Disks in an SSA RAID Array
List Hot Spares
List Rejected Array Disks
List Array Candidate Disks
List System Disks
Identify Disks in an SSA RAID Array
Identify Hot Spares
Identify Rejected Array Disks
Identify Array Candidate Disks
Identify System Disks

-----
                                SSA RAID Manager
Move cursor to desired item and press Enter.

    ssa0 Available 00-04 IBM SSA 160 SerialRAID Adapter (14109100)

F1=Help           F2=Refresh       F3=Cancel
F8=Image          F10=Exit         Enter=Do
/=Find           n=Find Next
-----
```

Select the adapter whose rejected disk drives you want to list.

3. A list of rejected disk drives is displayed:

```
COMMAND STATUS
Command: OK          stdout: yes          stderr: no
Before command completion, additional instructions may appear below.
pdisk4              08005AEA030D00D member  rejected  2.3G  Physical disk

F1=Help            F2=Refresh        F3=Cancel         F6=Command
F8=Image           F9=Shell          F10=Exit          /=Find
n=Find Next
```

4. Check the list of rejected disk drives against other error reports to find out why the disk drive was rejected from the array.
5. If you know the physical location of the rejected disk drive, go to step 12 on page 93. Otherwise, go to step 6 to identify the rejected disk drive.
6. For fast path, type `smitty ifssaraid` and press Enter.
Otherwise:
 - a. Return to the List/Identify SSA Physical Disks menu.
 - b. Select **Identify Rejected Array Disks**.
7. The list of adapters that was displayed in step 2 on page 91 is displayed again.

8. Select the adapter that contains the rejected disk drive.

The following menu is displayed:

Identify Rejected Array Disks

Type or select values in entry fields.
Press Enter AFTER making all desired changes.

SSA RAID Manager	[Entry Fields]	
* Rejected Array Disks	ssa0	+
Flash Disk Identification Lights	yes	+

F1=Help	F2=Refresh	F3=Cancel	F4=List
F5=Reset	F6=Command	F7=Edit	F8=Image
F9=Shell	F10=Exit	Enter=Do	

9. Select **yes** in the **Flash Disk Identification Lights** field.
10. Press the List key to list the disk drives.
11. From the displayed list, select the disk drives that you want to identify.
The Check light flashes on each disk drive that you have selected.
12. If the disk drive was rejected from the array because the disk drive itself has failed, go to step 13 on page 94.
If the disk drive was rejected from the array because some other part has failed (for example, a power supply unit, or an SSA cable):
 - a. Correct the problem, or call your service representative.
 - b. Add the disk drive to the array (see “Adding a Disk Drive to an SSA RAID Array” on page 140).
 - c. Run system diagnostics to verify that the repair is successful.Alternatively:
 - a. Change the use of the original disk drive so that it becomes a hot spare disk drive (see “Changing or Showing the Use of an SSA Disk Drive” on page 144).
 - b. Install a replacement disk drive (see “Installing a Replacement Disk Drive” on page 95).
 - c. Run system diagnostics to verify that the repair is successful.

13. Physically remove the failing disk drive for a new one (see the *Operator Guide* or *Service Guide* for the unit).
14. If you are going to install a replacement disk drive, go to “Installing a Replacement Disk Drive” on page 95.

Installing a Replacement Disk Drive

1. Physically install the replacement disk drive (see the *Operator Guide* or *Service Guide* for the unit).
2. If the failed disk drive has been exchanged for a hot spare disk drive, change the use of the new disk drive to **Hot Spare Disk** (see “Changing or Showing the Use of an SSA Disk Drive” on page 144). Run system diagnostics to verify that the disk drive is working correctly.

If no hot spare disk drive was available when the original disk drive failed, the array is now in the Exposed state or in the Degraded state. Change the use of the new disk drive to **Array Candidate Disk** (see “Changing or Showing the Use of an SSA Disk Drive” on page 144), and continue with this procedure to add the new disk drive to the array.

3. For fast path, type `smitty exssaraid` and press Enter.

Otherwise:

- a. Select **Change Member Disks of an SSA RAID Array** from the SSA RAID Arrays menu.
 - b. Select **Swap Members of an SSA RAID Array**.
4. A list of arrays is displayed:

```
Change Member Disks of an SSA RAID Array

Move cursor to desired item and press Enter.

Remove a Disk from an SSA RAID Array
Add a Disk to an SSA RAID Array
Swap Members of an SSA RAID Array

-----
SSA RAID Array
-----
Move cursor to desired item and press Enter.

hdisk3      00703795D3F7C0G system good      9.2GB  raid_1
hdisk4      00703784C540C00 system degraded 27.5GB  raid_10
hdisk5      007037943540C00 system good      27.5GB  raid_10

F1=Help      F2=Refresh      F3=Cancel
F8=Image     F10=Exit        Enter=Do
/=Find      n=Find Next
```

Select the array into which you are installing the replacement disk drive. This array is listed as exposed or degraded.

5. The following information is displayed:

```

                                Swap Members of an SSA RAID Array

Type or select values in entry fields.
Press Enter AFTER making all desired changes.

                                [Entry Fields]
SSA RAID Manager                    ssa1
SSA RAID Array                      hdisk4
RAID Array Type                    raid_10
Connection Address / Array Name     00703784C540C00
* Disk To Remove                    +
* Disk To Add                        +

F1=Help      F2=Refresh      F3=Cancel      F4=List
F5=Reset     F6=Command     F7=Edit       F8=Image
F9=Shell    F10=Exit       Enter=Do

```

6. Select **Disk to Remove**.
7. Press the List key to display the disk drive to remove. If the disk drive that you are replacing has been rejected by the array, that disk drive is listed as **BlankReservedZ**.
8. Select the required disk drive, and press Enter.
9. Select **Disk to Add**.
10. Press the List key to display the disk drive to add. Disk drives that are free or hot spare disk drives are listed.
11. Select the required disk drive, and press Enter.
12. Press Enter to perform the swap operation.

Using Other Configuration Functions

This part of the chapter describes the maintenance procedures that are available for your Advanced SerialRAID Adapter. You can use these procedures at any time. You can get to the required SMIT menu by using fast path commands or by working through other menus.

Notes:

1. Although this book always refers to the **smitty** commands, you can use either the **smitty** command, or the **smit** command. The procedures that you follow remain the same, whichever of the two commands you use. If you send the **smit** command from a graphics terminal, however, the menus are displayed slightly differently from those shown in this book. If you are not familiar with the selection of items from the graphics versions of the menus, use the **smitty** command. The menus will then appear as shown in this book.
2. If you use fast-path commands, you might need to go through intermediate steps that are not shown in this book. Also, some menus might be displayed slightly differently from those shown in this book.

Getting Access to the SSA RAID Array SMIT Menu

1. For fast-path access to the SSA RAID Array SMIT menus, type `smitty ssaraid` and press Enter.
Otherwise:
 - a. Type `smitty` and press Enter. The System Management menu is displayed.
 - b. Select **Devices**. The Devices menu is displayed.
 - c. Select **SSA RAID Arrays**.
2. The SSA RAID Arrays menu is displayed:

```
SSA RAID Arrays

Move cursor to desired item and press Enter.

List All Defined SSA RAID Arrays
List All Supported SSA RAID Arrays
List All SSA RAID Arrays Connected to a RAID Manager
List Status Of All Defined SSA RAID Arrays
List/Identify SSA Physical Disks
List/Delete Old RAID Arrays Recorded in an SSA RAID Manager
List Status of Hot Spare Pools
List Status of Hot Spare Protection for an SSA RAID Array
List Components in a Hot Spare Pool
Add a Hot Spare Pool
Add an SSA RAID Array
Delete an SSA RAID Array
Change/Show Attributes of an SSA RAID Array
Change Member Disks in an SSA RAID Array
Change/Show Use of an SSA Physical Disk
Change Use of Multiple SSA Physical Disks
Change/Show/Delete a Hot Spare Pool

F1=Help      F2=Refresh   F3=Cancel    F8=Image
F9=Shell     F10=Exit     Enter=Do
```

From the following list, find the option that you want, and go to the place that is indicated.

- “Listing All Defined SSA RAID Arrays” on page 100
- “Listing All Supported SSA RAID Arrays” on page 101
- “Listing All SSA RAID Arrays That Are Connected to a RAID Manager” on page 102
- “Listing the Status of All Defined SSA RAID Arrays” on page 104
- “Listing or Identifying SSA Physical Disk Drives” on page 108
 - “Listing the Disk Drives in an SSA RAID Array” on page 109
 - “Listing Hot Spare Disk Drives” on page 111
 - “Listing Rejected Array Disk Drives” on page 113
 - “Listing Array Candidate Disk Drives” on page 115
 - “Listing System Disk Drives” on page 117

- “Identifying the Disk Drives in an SSA RAID Array” on page 119
- “Identifying Hot Spare Disk Drives” on page 121
- “Identifying Rejected Array Disk Drives” on page 123
- “Identifying Array Candidate Disk Drives” on page 125
- “Identifying System Disk Drives” on page 127
- “Canceling all SSA Disk Drive Identifications” on page 129
- “Listing or Deleting Old RAID Arrays Recorded in an SSA RAID Manager” on page 130
 - “Listing Old RAID Arrays Recorded in an SSA RAID Manager” on page 131
 - “Deleting an Old RAID Array Recorded in an SSA RAID Manager” on page 133
- “Changing or Showing the Attributes of an SSA RAID Array” on page 135
- “Changing Member Disks in an SSA RAID Array” on page 137
 - “Removing a Disk Drive from an SSA RAID Array” on page 138
 - “Adding a Disk Drive to an SSA RAID Array” on page 140
 - “Swapping Members of an SSA RAID Array” on page 142
- “Changing or Showing the Use of an SSA Disk Drive” on page 144
- “Changing the Use of Multiple SSA Physical Disks” on page 147

Listing All Defined SSA RAID Arrays

This option lists all the arrays that are connected to the SSA adapter.

1. For fast path, type `smitty lsdssaraid` and press Enter.

Otherwise, select **List All Defined SSA RAID Arrays** from the SSA RAID Arrays menu.

2. A list of defined arrays is displayed:

```
COMMAND STATUS
Command: OK          stdout: yes          stderr: no
Before command completion, additional instructions may appear below.
hdisk3              095231779F0737K good      3.4G  RAID-5 array
hdisk4              09523173A02137K good      3.4G  RAID-5 array

F1=Help            F2=Refresh          F3=Cancel          F6=Command
F8=Image           F9=Shell            F10=Exit           /=Find
n=Find Next
```

Listing All Supported SSA RAID Arrays

This option lists all the types of array that are supported by the installed SSA RAID managers.

1. For fast path, type `smitty lsssaraid` and press Enter.
Otherwise, select **List All Supported SSA RAID Arrays** from the SSA RAID Arrays menu.
2. A list of supported arrays is displayed:

```
COMMAND STATUS
Command: OK          stdout: yes          stderr: no
Before command completion, additional instructions may appear below.
raid_0              RAID-0 array
raid_5              RAID-5 array

F1=Help            F2=Refresh          F3=Cancel           F6=Command
F8=Image           F9=Shell            F10=Exit            /=Find
n=Find Next
```

Listing All SSA RAID Arrays That Are Connected to a RAID Manager

This option lists all the SSA RAID disk drives that are connected to a particular RAID manager.

1. For fast path, type smitty lsmssaraid and press Enter.

Otherwise, select **List All SSA RAID Arrays Connected to a RAID Manager** from the SSA RAID Arrays menu.

2. A list of RAID managers is displayed in a window:

```
SSA RAID Arrays
Move cursor to desired item and press Enter.

List All Defined SSA RAID Arrays
List All Supported SSA RAID Arrays
List All SSA RAID Arrays Connected to a RAID Manager
List Status Of All Defined SSA RAID Arrays
List/Identify SSA Physical Disks
List/Delete Old RAID Arrays Recorded in an SSA RAID Manager
List Status of Hot Spare Pools
List Status of Hot Spare Protection for an SSA RAID Array
List Components in a Hot Spare Pool
Add a Hot Spare Pool

-----
SSA RAID Manager
Move cursor to desired item and press Enter.

ssa0 Available 00-04 IBM SSA 160 SerialRAID Adapter (14109100)

F1=Help          F2=Refresh      F3=Cancel
F8=Image         F10=Exit        Enter=Do
/=Find           n=Find Next
```

Select the RAID manager for which you want a list of connected arrays.

3. A list of arrays is displayed:

```
COMMAND STATUS
Command: OK          stdout: yes      stderr: no
Before command completion, additional instructions may appear below.
hdisk4      09523173A02137K good    3.4G RAID-5 array
hdisk3      095231779F0737K good    3.4G RAID-5 array

F1=Help      F2=Refresh  F3=Cancel   F6=Command
F8=Image     F9=Shell    F10=Exit    /=Find
n=Find Next
```

Listing the Status of All Defined SSA RAID Arrays

This option lists the status of each defined array.

1. For fast path, type `smitty lstssaraid` and press Enter.

Otherwise, select **List Status of All Defined SSA RAID Arrays** from the SSA RAID Arrays menu.

2. The following information is displayed:

```
SSA RAID Arrays
Move cursor to desired item and press Enter.

List All Defined SSA RAID Arrays
List All Supported SSA RAID Arrays
List All SSA RAID Arrays Connected to a RAID Manager
List Status Of All Defined SSA RAID Arrays
List/Identify SSA Physical Disks
List/Delete Old RAID Arrays Recorded in an SSA RAID Manager
List Status of Hot Spare Pools
List Status of Hot Spare Protection for an SSA RAID Array
-----
RAID Array Type
Move cursor to desired item and press Enter.

raid_1
raid_5
raid_10

F1=Help      F2=Refresh   F3=Cancel
F8=Image     F10=Exit    Enter=Do
/=Find      n=Find Next
-----
```

Select the type of RAID array for which you want to display the status.

Notes:

- a. No additional status information is available for RAID-0 arrays.
- b. The menu that is shown here does not show RAID-Copy arrays. See “Effects of Array Copy on Other SMIT Menus” on page 186 for more information.

3. The following information is displayed for RAID-5 arrays:

```
COMMAND STATUS
Command: OK          stdout: yes      stderr: no
Before command completion, additional instructions may appear below.

          Unsynced Parity Strips  Unbuilt Data Strips
hdisk3           0                0
hdisk4           0                0

F1=Help          F2=Refresh      F3=Cancel      F6=Command
F8=Image         F9=Shell        F10=Exit       /=Find
n=Find Next
```

The following information is displayed for RAID-1 and RAID-10 arrays:

```
COMMAND STATUS
Command: OK          stdout: yes      stderr: no
Before command completion, additional instructions may appear below.

Components
Primary      Secondary      Status
hdisk4       pdisk15        degraded
pdisk13      pdisk15        good
pdisk3       pdisk6         good
pdisk7       BlankReserved5Z degraded

F1=Help      F2=Refresh     F3=Cancel     F6=Command
F8=Image     F9=Shell      F10=Exit      /=Find
n=Find Next
```

Status data is given for the array and for each mirrored pair of disk drives in the array. The status values for the array are:

good The status of all mirrored pairs is **good**.

exposed

The status of one or more mirrored pairs is **exposed**. No mirrored pair is **degraded**.

degraded

The status of one or more mirrored pairs is **degraded**.

rebuilding

The status of one or more mirrored pairs is **rebuilding**. No mirrored pair is **exposed** or **degraded**.

offline One of the following conditions exists:

- The status of one or more mirrored pairs is **offline**.
- The first two member disk drives of the primary half are missing, and the Split Array Resolution flag is set to **Primary**.
- The first member disk drive of the secondary half is missing, and the Split Array Resolution flag is set to **Secondary**.

unknown

Not enough configuration data is available to determine the state of the array. Under these conditions, ignore the primary and secondary designations and the array-pair status.

The status values for mirrored pairs are:

good Both member disk drives of the mirrored pair are present and working.

exposed

One member disk drive of a mirrored pair is missing or has failed, but no write operation has been issued to the pair.

degraded

One member disk drive of a mirrored pair is missing or has failed, and a write operation has been issued to the working member disk drive.

rebuilding

A failed member disk drive in a mirrored pair has been exchanged and data is rebuilding.

offline Both member disk drives of a mirrored pair are missing or have failed.

Listing or Identifying SSA Physical Disk Drives

This option allows you to list the disk drives that are being used by a particular array, and to identify particular disk drives.

1. For fast path, type `smitty lsidssaraid` and press Enter.

Otherwise, select **List/Identify SSA Physical Disks** from the SSA RAID Arrays menu.

2. The following information is displayed:

```

                                List/Identify SSA Physical Disks

Move cursor to desired item and press Enter.

List Disks in an SSA RAID Array
List Hot Spares
List Rejected Array Disks
List Array Candidate Disks
List System Disks
Identify Disks in an SSA RAID Array
Identify Hot Spares
Identify Rejected Array Disks
Identify Array Candidate Disks
Identify System Disks
Cancel all SSA Disk Identifications

F1=Help          F2=Refresh      F3=Cancel      F8=Image
F9=Shell         F10=Exit       Enter=Do
```

Select the option that you want, and go to the instructions for that option:

- “Listing the Disk Drives in an SSA RAID Array” on page 109
- “Listing Hot Spare Disk Drives” on page 111
- “Listing Rejected Array Disk Drives” on page 113
- “Listing Array Candidate Disk Drives” on page 115
- “Listing System Disk Drives” on page 117
- “Identifying the Disk Drives in an SSA RAID Array” on page 119
- “Identifying Hot Spare Disk Drives” on page 121
- “Identifying Rejected Array Disk Drives” on page 123
- “Identifying Array Candidate Disk Drives” on page 125
- “Identifying System Disk Drives” on page 127
- “Canceling all SSA Disk Drive Identifications” on page 129

Listing the Disk Drives in an SSA RAID Array

This option allows you to list the disk drives that are contained in a particular array.

1. For fast path, type `smitty lssaraid` and press Enter.

Otherwise:

- a. Select **List/Identify SSA Physical Disks** from the SSA RAID Arrays menu.
 - b. Select **List Disks in an SSA RAID Array**.
2. A list of arrays is displayed in a window:

```

                                List/Identify SSA Physical Disks

Move cursor to desired item and press Enter.

List Disks in an SSA RAID Array
List Hot Spares
List Rejected Array Disks
List Array Candidate Disks
List System Disks
Identify Disks in an SSA RAID Array
Identify Hot Spares
Identify Rejected Array Disks
Identify Array Candidate Disks
-----
                                SSA RAID Array
Move cursor to desired item and press Enter.

hdisk3          095231779F0737K good      3.4G  RAID-5 array
hdisk4          09253173A02137K good      3.4G  RAID-5 array

F1=Help          F2=Refresh          F3=Cancel
F8=Image         F10=Exit            Enter=Do
/=Find           n=Find Next
-----
```

Select the array whose disk drives you want to list.

3. A list of disk drives is displayed:

```
COMMAND STATUS
Command: OK          stdout: yes      stderr: no
Before command completion, additional instructions may appear below.
pdisk1      0004AC5119E000D member present 1.1G Physical disk
pdisk4      08005AEA030D00D member present 2.3G Physical disk
pdisk7      08005AEA087A00D member present 4.5G Physical disk
pdisk8      08005AEA098100D member not_present n/a Physical disk

F1=Help      F2=Refresh   F3=Cancel   F6=Command
F8=Image     F9=Shell    F10=Exit    /=Find
n=Find Next
```

Listing Hot Spare Disk Drives

This option allows you to list the hot spare disk drives that are available to a particular array.

1. For fast path, type `smitty lhssaraid` and press Enter.

Otherwise:

- a. Select **List/Identify SSA Physical Disks** from the SSA RAID Arrays menu.
- b. Select **List Hot Spares**.

2. A list of adapters is displayed in a window:

```

List/Identify SSA Physical Disks

Move cursor to desired item and press Enter.

List Disks in an SSA RAID Array
List Hot Spares
List Rejected Array Disks
List Array Candidate Disks
List System Disks
Identify Disks in an SSA RAID Array
Identify Hot Spares
Identify Rejected Array Disks
Identify Array Candidate Disks
Identify System Disks
-----
SSA RAID Manager

Move cursor to desired item and press Enter.

 ssa0 Available 00-04 IBM SSA 160 SerialRAID Adapter (14109100)

F1=Help           F2=Refresh       F3=Cancel
F8=Image          F10=Exit         Enter=Do
/=Find           n=Find Next
-----
```

Select the adapter whose hot spare disk drives you want to list.

3. A list of hot spare disk drives is displayed:

```
COMMAND STATUS
Command: OK          stdout: yes          stderr: no
Before command completion, additional instructions may appear below.
pdisk3              0004AC5119E000D spare  n/a      1.1G    Physical disk
pdisk5              08005AEA030D00D spare  n/a      2.3G    Physical disk

F1=Help            F2=Refresh        F3=Cancel        F6=Command
F8=Image           F9=Shell          F10=Exit         /=Find
n=Find Next
```

Listing Rejected Array Disk Drives

This option allows you to list disk drives that have been rejected (probably because of failure) from arrays.

1. For fast path, type `smitty lfsaraid` and press Enter.

Otherwise:

- a. Select **List/Identify SSA Physical Disks** from the SSA RAID Arrays menu.
- b. Select **List Rejected Array Disks**.

2. A list of adapters is displayed in a window:

```

List/Identify SSA Physical Disks

Move cursor to desired item and press Enter.

List Disks in an SSA RAID Array
List Hot Spares
List Rejected Array Disks
List Array Candidate Disks
List System Disks
Identify Disks in an SSA RAID Array
Identify Hot Spares
Identify Rejected Array Disks
Identify Array Candidate Disks
Identify System Disks
-----
SSA RAID Manager

Move cursor to desired item and press Enter.

  ssa0 Available 00-04 IBM SSA 160 SerialRAID Adapter (14109100)

F1=Help           F2=Refresh       F3=Cancel
F8=Image          F10=Exit         Enter=Do
/=Find           n=Find Next
-----
```

Select the adapter whose rejected disk drives you want to list.

3. A list of rejected disk drives is displayed:

```
COMMAND STATUS
Command: OK          stdout: yes          stderr: no
Before command completion, additional instructions may appear below.
pdisk3              0004AC5119E000D rejected n/a          1.1G Physical disk
pdisk5              08005AEA030D00D rejected n/a          2.3G Physical disk

F1=Help            F2=Refresh        F3=Cancel         F6=Command
F8=Image           F9=Shell          F10=Exit          /=Find
n=Find Next
```

Listing Array Candidate Disk Drives

This option allows you to list disk drives that are available for adding to an array.

1. For fast path, type `smitty lcssaraid` and press Enter.
Otherwise:
 - a. Select **List/Identify SSA Physical Disks** from the SSA RAID Arrays menu.
 - b. Select **List Array Candidate Disks**.
2. A list of adapters is displayed in a window:

```

List/Identify SSA Physical Disks

Move cursor to desired item and press Enter.

List Disks in an SSA RAID Array
List Hot Spares
List Rejected Array Disks
List Array Candidate Disks
List System Disks
Identify Disks in an SSA RAID Array
Identify Hot Spares
Identify Rejected Array Disks
Identify Array Candidate Disks
Identify System Disks
-----
SSA RAID Manager
Move cursor to desired item and press Enter.

  ssa0 Available 00-04 IBM SSA 160 SerialRAID Adapter (14109100)

F1=Help           F2=Refresh       F3=Cancel
F8=Image          F10=Exit         Enter=Do
/=Find           n=Find Next
-----
```

Select the adapter whose candidate disk drives you want to list.

3. A list of candidate disk drives is displayed:

```
COMMAND STATUS
Command: OK          stdout: yes      stderr: no
Before command completion, additional instructions may appear below.
pdisk3              0004AC5119E000D free           1.1G  Physical disk
pdisk5              08005AEA030D00D free           2.3G  Physical disk

F1=Help             F2=Refresh          F3=Cancel          F6=Command
F8=Image            F9=Shell            F10=Exit           /=Find
n=Find Next
```

Listing System Disk Drives

This option allows you to list disk drives that are used by the using system. These disk drives are not member disk drives of an array.

1. For fast path, type `smitty lassaraid` and press Enter.

Otherwise:

- a. Select **List/Identify SSA Physical Disks** from the SSA RAID Arrays menu.
- b. Select **List System Disks**.

2. A list of adapters is displayed in a window:

```

List/Identify SSA Physical Disks

Move cursor to desired item and press Enter.

List Disks in an SSA RAID Array
List Hot Spares
List Rejected Array Disks
List Array Candidate Disks
List System Disks
Identify Disks in an SSA RAID Array
Identify Hot Spares
Identify Rejected Array Disks
Identify Array Candidate Disks
Identify System Disks
-----
SSA RAID Manager

Move cursor to desired item and press Enter.

  ssa0 Available 00-04 IBM SSA 160 SerialRAID Adapter (14109100)

F1=Help           F2=Refresh       F3=Cancel
F8=Image          F10=Exit         Enter=Do
/=Find           n=Find Next
-----
```

Select the adapter whose system disk drives you want to list.

3. A list of system disk drives is displayed:

```
COMMAND STATUS
Command: OK          stdout: yes      stderr: no
Before command completion, additional instructions may appear below.
pdisk3              0004AC5119E000D system          1.1G  Physical disk
pdisk5              08005AEA030D00D system          2.3G  Physical disk

F1=Help            F2=Refresh          F3=Cancel          F6=Command
F8=Image           F9=Shell            F10=Exit           /=Find
n=Find Next
```

Identifying the Disk Drives in an SSA RAID Array

This option allows you to identify the disk drives that are contained in a particular array.

1. For fast path, type `smitty issaraid` and press Enter.

Otherwise:

- a. Select **List/Identify SSA Physical Disks** from the SSA RAID Arrays menu.
- b. Select **Identify Disks in an SSA RAID Array**.

2. A list of arrays is displayed in a window:

```

List/Identify SSA Physical Disks

Move cursor to desired item and press Enter.

List Disks in an SSA RAID Array
List Hot Spares
List Rejected Array Disks
List Array Candidate Disks
List System Disks
Identify Disks in an SSA RAID Array
Identify Hot Spares
Identify Rejected Array Disks
Identify Array Candidate Disks
-----
SSA RAID Array
-----
Move cursor to desired item and press Enter.

hdisk3          095231779F0737K good      3.4G  RAID-5 array
hdisk4          09253173A02137K good      3.4G  RAID-5 array

F1=Help          F2=Refresh          F3=Cancel
F8=Image         F10=Exit            Enter=Do
/=Find          n=Find Next
-----
```

Select the array whose disk drives you want to identify.

Note: The menu shown here is displayed when you select a RAID-5 array. If you select a RAID-1 or a RAID-10 array, two lists of disk drives are available. One list is for primary disk drives; the other is for secondary disk drives.

3. The following information is displayed:

Identify Disks in an SSA RAID Array

Type or select values in entry fields.
Press Enter AFTER making all desired changes.

	Entry Fields	
SSA RAID Manager	ssa0	
SSA RAID Array	hdisk2	
* Member Disks		+
Flash Disk Identification Lights	yes	+

F1=Help	F2=Refresh	F3=Cancel	F4=List
F5=Reset	F6=Command	F7=Edit	F8=Image
F9=Shell	F10=Exit	Enter=Do	

4. Select **yes** in the **Flash Disk Identification Lights** field.
5. Press the List key to list the disk drives.
6. From the displayed list, select the disk drives that you want to identify.
The Check light flashes on each disk drive that you have selected.

Identifying Hot Spare Disk Drives

This option allows you to identify the hot spare disk drives that are available to a particular SSA RAID manager.

1. For fast path, type `smitty ihssaraid` and press Enter.
Otherwise:
 - a. Select **List/Identify SSA Physical Disks** from the SSA RAID Arrays menu.
 - b. Select **Identify Hot Spares**.
2. A list of arrays is displayed in a window:

```

List/Identify SSA Physical Disks

Move cursor to desired item and press Enter.

List Disks in an SSA RAID Array
List Hot Spares
List Rejected Array Disks
List Array Candidate Disks
List System Disks
Identify Disks in an SSA RAID Array
Identify Hot Spares
Identify Rejected Array Disks
Identify Array Candidate Disks
-----
                          SSA RAID Array
-----
Move cursor to desired item and press Enter.

  hdisk3          095231779F0737K good      3.4G  RAID-5 array
  hdisk4          09253173A02137K good      3.4G  RAID-5 array

F1=Help          F2=Refresh          F3=Cancel
F8=Image         F10=Exit            Enter=Do
/=Find           n=Find Next
-----
```

Select the RAID manager whose hot spare disk drives you want to identify.

3. The following information is displayed:

Identify Hot Spares

Type or select values in entry fields.
Press Enter AFTER making all desired changes.

SSA RAID Manager	[Entry Fields]	
* Hot Spare Disks	ssa0	+
Flash Disk Identification Lights	yes	+

F1=Help	F2=Refresh	F3=Cancel	F4=List
F5=Reset	F6=Command	F7=Edit	F8=Image
F9=Shell	F10=Exit	Enter=Do	

4. Select **yes** in the **Flash Disk Identification Lights** field.
5. Press the List key to list the disk drives.
6. From the displayed list, select the disk drives that you want to identify.
The Check light flashes on each disk drive that you have selected.

Identifying Rejected Array Disk Drives

This option allows you to identify disk drives that have been rejected (probably because of failure) from arrays.

1. For fast path, type `smitty ifssaraid` and press Enter.

Otherwise:

- a. Select **List/Identify SSA Physical Disks** from the SSA RAID Arrays menu.
- b. Select **Identify Rejected Array Disks**.

2. A list of arrays is displayed in a window:

```

List/Identify SSA Physical Disks

Move cursor to desired item and press Enter.

List Disks in an SSA RAID Array
List Hot Spares
List Rejected Array Disks
List Array Candidate Disks
List System Disks
Identify Disks in an SSA RAID Array
Identify Hot Spares
Identify Rejected Array Disks
Identify Array Candidate Disks
-----
                          SSA RAID Array
Move cursor to desired item and press Enter.

hdisk3          095231779F0737K good      3.4G  RAID-5 array
hdisk4          09253173A02137K good      3.4G  RAID-5 array

F1=Help          F2=Refresh          F3=Cancel
F8=Image         F10=Exit            Enter=Do
/=Find           n=Find Next
-----
```

Select the array whose rejected disk drives you want to identify.

3. The following information is displayed:

Identify Rejected Array Disks

Type or select values in entry fields.
Press Enter AFTER making all desired changes.

SSA RAID Manager	[Entry Fields]	
* Rejected Array Disks	ssa0	+
Flash Disk Identification Lights	yes	+

F1=Help	F2=Refresh	F3=Cancel	F4=List
F5=Reset	F6=Command	F7=Edit	F8=Image
F9=Shell	F10=Exit	Enter=Do	

4. Select **yes** in the **Flash Disk Identification Lights** field.
5. Press the List key to list the disk drives.
6. From the displayed list, select the disk drives that you want to identify.
The Check light flashes on each disk drive that you have selected.

Identifying Array Candidate Disk Drives

This option allows you to identify disk drives that are available for adding to an array.

1. For fast path, type `smitty icssaraid` and press Enter.

Otherwise:

- a. Select **List/Identify SSA Physical Disks** from the SSA RAID Arrays menu.
- b. Select **Identify Array Candidate Disks**.

2. A list of adapters is displayed in a window:

```

                                List/Identify SSA Physical Disks

Move cursor to desired item and press Enter.

List Disks in an SSA RAID Array
List Hot Spares
List Rejected Array Disks
List Array Candidate Disks
List System Disks
Identify Disks in an SSA RAID Array
Identify Hot Spares
Identify Rejected Array Disks
Identify Array Candidate Disks
Identify System Disks
-----
                                SSA RAID Manager

Move cursor to desired item and press Enter.

    ssa0 Available 00-04 IBM SSA 160 SerialRAID Adapter (14109100)

F1=Help           F2=Refresh       F3=Cancel
F8=Image          F10=Exit         Enter=Do
/=Find           n=Find Next
-----
```

Select the adapter whose candidate disk drives you want to identify.

3. The following information is displayed:

Identify Array Candidate Disks

Type or select values in entry fields.
Press Enter AFTER making all desired changes.

SSA RAID Manager	[Entry Fields]	
* Array Candidate Disks	ssa0	+
Flash Disk Identification Lights	yes	+

F1=Help F2=Refresh F3=Cancel F4=List
F5=Reset F6=Command F7=Edit F8=Image
F9=Shell F10=Exit Enter=Do

4. Select **yes** in the **Flash Disk Identification Lights** field.
5. Press the List key to list the disk drives.
6. From the displayed list, select the disk drives that you want to identify.
The Check light flashes on each disk drive that you have selected.

Identifying System Disk Drives

This option allows you to identify disk drives that are used by the using system. These disk drives are not member disk drives of any array.

1. For fast path, type `smitty iassaraid` and press Enter.

Otherwise:

- a. Select **List/Identify SSA Physical Disks** from the SSA RAID Arrays menu.
- b. Select **Identify System Disks**.

2. A list of adapters is displayed in a window:

```

List/Identify SSA Physical Disks

Move cursor to desired item and press Enter.

List Disks in an SSA RAID Array
List Hot Spares
List Rejected Array Disks
List Array Candidate Disks
List System Disks
Identify Disks in an SSA RAID Array
Identify Hot Spares
Identify Rejected Array Disks
Identify Array Candidate Disks
Identify System Disks
-----
SSA RAID Manager

Move cursor to desired item and press Enter.

  ssa0 Available 00-04 IBM SSA 160 SerialRAID Adapter (14109100)

F1=Help           F2=Refresh       F3=Cancel
F8=Image          F10=Exit         Enter=Do
/=Find           n=Find Next
-----
```

Select the adapter whose system disk drives you want to identify.

3. The following information is displayed:

Identify System Disks

Type or select values in entry fields.
Press Enter AFTER making all desired changes.

SSA RAID Manager	[Entry Fields]	
* System Disks	ssa0	+
Flash Disk Identification Lights	yes	+

F1=Help	F2=Refresh	F3=Cancel	F4=List
F5=Reset	F6=Command	F7=Edit	F8=Image
F9=Shell	F10=Exit	Enter=Do	

4. Select **yes** in the **Flash Disk Identification Lights** field.
5. Press the List key to list the disk drives.
6. From the displayed list, select the disk drives that you want to identify.
The Check light flashes on each disk drive that you have selected.

Canceling all SSA Disk Drive Identifications

This option allows you to cancel all disk drive identifications.

For fast path, type `smitty ssa_identify_cancel` and press Enter.

Otherwise:

1. Select **List/Identify SSA Physical Disks** from the SSA RAID Arrays menu.
2. Select **Cancel all SSA Disk Identifications**.

The Check lights of all identified disk drives stop flashing.

Listing or Deleting Old RAID Arrays Recorded in an SSA RAID Manager

If an array becomes disconnected from a RAID manager by some method other than the method described in “Deleting an SSA RAID Array” on page 70, a record of that array remains in the RAID manager. The record must be deleted manually. This option allows you to list the serial numbers of such arrays, and to delete the records of those arrays from the SSA RAID manager.

1. For fast path, type `smitty nvrssaraid` and press Enter.

Otherwise, select **List/Delete Old RAID Arrays in an SSA RAID Manager** from the SSA RAID Arrays menu.

2. The following menu is displayed:

```
List/Delete Old RAID Arrays in an SSA RAID Manager

Move cursor to desired item and press Enter.

List Old RAID Arrays Recorded in an SSA RAID Manager
Delete an Old RAID Array Recorded in an SSA RAID Manager

F1=Help      F2=Refresh   F3=Cancel    F8=Image
F9=Shell     F10=Exit     Enter=Do
```

If you want to list the arrays, select **List Old RAID Arrays Recorded in an SSA RAID Manager**, and go to step 3 on page 131 of Listing Old RAID Arrays Recorded in an SSA RAID Manager.

If you want to delete the arrays, select **Delete an Old RAID Array Recorded in an SSA RAID Manager**, and go to step 3 on page 133 of Deleting an Old RAID Array Recorded in an SSA RAID Manager.

Listing Old RAID Arrays Recorded in an SSA RAID Manager

This option allows you to list the serial numbers of disconnected arrays whose records remain in the RAID manager.

1. Select **List/Delete Old RAID Arrays in an SSA RAID Manager** from the SSA RAID Arrays menu.
2. Select **List Old RAID Arrays Recorded in an SSA RAID Manager**.
3. A list of RAID managers is displayed in a window:

```
List/Delete Old RAID Arrays in an SSA RAID Manager

Move cursor to desired item and press Enter.

List Old RAID Arrays Recorded in an SSA RAID Manager
Delete an Old RAID Array Recorded in an SSA RAID Manager

-----
SSA RAID Manager
-----
Move cursor to desired item and press Enter.

ssa0 Available 00-02 IBM SSA 160 SerialRAID Adapter (14109100)

F1=Help          F2=Refresh      F3=Cancel
F8=Image         F10=Exit        Enter=Do
/=Find           n=Find Next
```

4. Select the RAID manager for which you want a list of old arrays.

5. If any old arrays are in the RAID manager, a list of those arrays appears:

```
COMMAND STATUS
Command: OK          stdout: yes          stderr: no
Before command completion, additional instructions may appear below.
[TOP]
0952314698B637K
09523146994837K
0952314699A437K
0952314699CE37K
095231469A9337K
095231469B6D37K
095231469C4537K
095231469CEE37K
095231469D7A37K
095231469E2C37K
095231469F7C37K
09523146A42637K
09523146A4B737K
[MORE...15]
F1=Help           F2=Refresh       F3=Cancel        F6=Command
F8=Image          F9=Shell         F10=Exit         /=Find
n=Find Next
```

6. If you want to delete any records, note the names of those records, and go to “Deleting an Old RAID Array Recorded in an SSA RAID Manager” on page 133.

Deleting an Old RAID Array Recorded in an SSA RAID Manager

This option allows you to delete the records of RAID managers that have been disconnected, but whose records remain in the RAID manager.

1. Select **List/Delete Old RAID Arrays in an SSA RAID Manager** from the SSA RAID Arrays menu.
2. Select **Delete an Old RAID Array Recorded in an SSA RAID Manager**.
3. A list of RAID managers is displayed in a window:

```
List/Delete Old RAID Arrays in an SSA RAID Manager

Move cursor to desired item and press Enter.

List Old RAID Arrays Recorded in an SSA RAID Manager
Delete an Old RAID Array Recorded in an SSA RAID Manager

-----
SSA RAID Manager
-----
Move cursor to desired item and press Enter.

ssa0 Available 00-02 IBM SSA 160 SerialRAID Adapter (14109100)

F1=Help          F2=Refresh       F3=Cancel
F8=Image         F10=Exit         Enter=Do
/=Find           n=Find Next
```

Select the RAID manager from which you want to delete an old array.

4. The following information is displayed:

```

Delete an Old RAID Array Recorded in an SSA RAID Manager

Type or select values in entry fields.
Press Enter AFTER making all desired changes.

SSA RAID Manager                                [Entry Fields]
* Old SSA RAID Array Record to Delete           ssa0

F1=Help      F2=Refresh      F3=Cancel      F4=List
F5=Reset     F6=Command     F7=Edit       F8=Image
F9=Shell     F10=Exit       Enter=Do
```

Press the List key to list the records.

5. From the displayed list, select the record that you want to delete, and follow the instructions that are given on the screen.

Changing or Showing the Attributes of an SSA RAID Array

Each array type has several attributes associated with it. This option allows you to see, and possibly change, those attributes.

1. For fast path, type `smitty chssaraid` and press Enter.
Otherwise, select **Change/Show Attributes of an SSA RAID Array** from the SSA RAID Arrays menu.
2. A list of RAID managers is displayed in a window.
3. Select the required adapter from the list of RAID managers.

Note: If you are not sure which adapter to select, select **Change/Show Characteristics of an SSA Logical Disk** from the SSA Logical Disks menu (see “Getting Access to the SSA Adapters SMIT Menu” on page 40, and note the adapter that is listed as **adapter_a**).

A list of arrays is displayed in a window:

```
SSA RAID Arrays

Move cursor to desired item and press Enter.

List All Defined SSA RAID Arrays
List All Supported SSA RAID Arrays
List All SSA RAID Arrays Connected to a RAID Manager
List Status Of All Defined SSA RAID Arrays
List/Identify SSA Physical Disks
List/Delete Old RAID Arrays Recorded in an SSA RAID Manager
List Status of Hot Spare Pools
List Status of Hot Spare Protection for an SSA RAID Array
List Components in a Hot Spare Pool

-----
SSA RAID Array

Move cursor to desired item and press Enter.

   hdisk2          095231779F0737K good      3.4G  RAID-5 array
   hdisk3          09523173A02137K good      3.4G  RAID-5 array

F1=Help           F2=Refresh           F3=Cancel
F8=Image          F10=Exit             Enter=Do
/=Find            n=Find Next
```

Select the array whose attributes you want to see or change.

4. A list of attributes is displayed:

```
Change/Show Attributes of an SSA RAID Array

Type or select values in entry fields.
Press Enter AFTER making all desired changes.

SSA RAID Manager          [Entry Fields]
SSA RAID Array            ssa0
Connection Address / Array Name  hdisk3
RAID Array Type           00243199986267K
State                     raid_5
Member Disks              good
Size of Array             pdisk1 pdisk3 pdisk4 p>
Percentage Rebuilt        3.4G
Enable Use of Hot Spares   Not Rebuilding
Allow Page Splits         yes +
Current Use                yes +
                           System Disk +

F1=Help      F2=Refresh  F3=Cancel   F4=List
F5=Reset     F6=Command  F7=Edit     F8=Image
F9=Shell     F10=Exit   Enter=Do
```

Move the cursor to the attribute that you want to change, and press the List key.

5. A list of options for that attribute is displayed. Select the option that you want.
6. If you want to change another attribute, move the cursor to that attribute and press the List key.
7. Again, choose from the list of displayed options.
8. Repeat steps 6 and 7 for each attribute that you want to change.

Changing Member Disks in an SSA RAID Array

This option allows you to remove a disk drive from an array and install a replacement disk drive. All the data that is on the original disk drive is automatically written to the replacement disk drive.

1. For fast path, type `smitty swpssaraid` and press Enter.
Otherwise, select **Change Member Disks in an SSA RAID Array** from the SSA RAID Arrays menu.
2. The following menu is displayed:

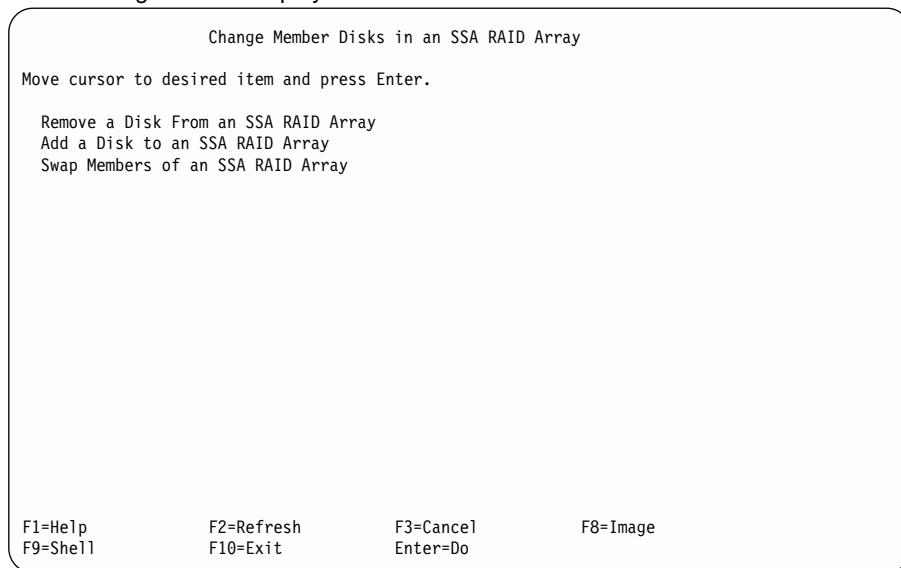

If you have an available disk drive, select **Swap Members of an SSA RAID Array**, and go to step 2 on page 142 of *Swapping Members of an SSA RAID Array*.

If you do not have an available disk drive, select **Remove a Disk from an SSA RAID Array**, and go to step 2 on page 138 of *Removing a Disk Drive from an SSA RAID Array*.

Removing a Disk Drive from an SSA RAID Array

This option allows you to remove a disk drive from an array so that you can install a replacement disk drive. Use this option when you do not have either an available online disk drive, or a spare slot for a replacement disk drive.

1. For fast path, type `smitty redssaraid` and press Enter.

Otherwise:

- a. Select **Change Member Disks in an SSA RAID Array** from the SSA RAID Arrays menu.
- b. Select **Remove a Disk from an SSA RAID Array**.

2. A list of arrays is displayed in a window:

```
Change Member Disks in an SSA RAID Array

Move cursor to desired item and press Enter.

Remove a Disk from an SSA RAID Array
Add a Disk to an SSA RAID Array
Swap Members of an SSA RAID Array

-----
SSA RAID Array
-----
Move cursor to desired item and press Enter.

hdisk3      095231779F0737K good    3.4G  RAID-5 array
hdisk4      09523173A02137K good    3.4G  RAID-5 array

F1=Help      F2=Refresh    F3=Cancel
F8=Image     F10=Exit      Enter=Do
/=Find       n=Find Next
```

Select the array from which you want to remove a disk drive.

3. The following information is displayed:

```
Remove a Disk from an SSA RAID Array

Type or select values in entry fields.
Press Enter AFTER making all desired changes.

SSA RAID Manager          [Entry Fields]
SSA RAID Array            ssa0
Connection Address / Array Name hdisk3
* Disk to Remove          095231779F0737K      +

F1=Help      F2=Refresh  F3=Cancel  F4=List
F5=Reset     F6=Command  F7=Edit    F8=Image
F9=Shell     F10=Exit   Enter=Do
```

Press the List key to list the disk drives.

4. From the displayed list, select the disk drive that you want to remove.
5. Physically remove the disk drive from the subsystem (see the *Operator Guide* or *Service Guide* for the unit).
6. Go to “Swapping Members of an SSA RAID Array” on page 142.

Adding a Disk Drive to an SSA RAID Array

This option allows you to install a replacement disk drive into a RAID-5 array that is running in the Exposed or Degraded state because a disk drive has been rejected or removed from the array. **You cannot use this procedure to add a disk drive to a RAID-1 or RAID-10 array.**

When you install the replacement disk drive, all the data that was contained on the original disk drive is automatically written to the replacement disk drive.

1. For fast path, type smitty addssaraid and press Enter.

Otherwise:

- a. Select **Change Member Disks of an SSA RAID Array** from the SSA RAID Arrays menu.
 - b. Select **Add a Disk to an SSA RAID Array**.
2. A list of arrays is displayed in a window:

```
Change Member Disks in an SSA RAID Array

Move cursor to desired item and press Enter.

Remove a Disk from an SSA RAID Array
Add a Disk to an SSA RAID Array
Swap Members of an SSA RAID Array

-----
SSA RAID Array
Move cursor to desired item and press Enter.
hdisk2          095231779F0737K degraded  3.4G  RAID-5 array
F1=Help          F2=Refresh          F3=Cancel
F8=Image         F10=Exit            Enter=Do
/=Find          n=Find Next
-----
```

Select the array to which you are adding the disk drive.

3. The following information is displayed:

```

                                Add a Disk to an SSA RAID Array

Type or select values in entry fields.
Press Enter AFTER making all desired changes.

                                [Entry Fields]
SSA RAID Manager                ssa0
SSA RAID Array                  hdisk3
Connection Address / Array Name 09523177F0737K
* Disk to Add                    +

F1=Help      F2=Refresh  F3=Cancel  F4=List
F5=Reset     F6=Command  F7=Edit   F8=Image
F9=Shell    F10=Exit   Enter=Do

```

Press the List key to list the disk drives.

4. From the displayed list, select the name of the disk drive that you are adding.

Swapping Members of an SSA RAID Array

This option allows you to swap a disk drive for a replacement disk drive.

1. For fast path, type `smitty exssaraid` and press Enter.

Otherwise:

- a. Select **Change Member Disks in an SSA RAID Array** from the SSA RAID Arrays menu.
- b. Select **Swap Members of an SSA RAID Array**.

2. A list of arrays is displayed in a window:

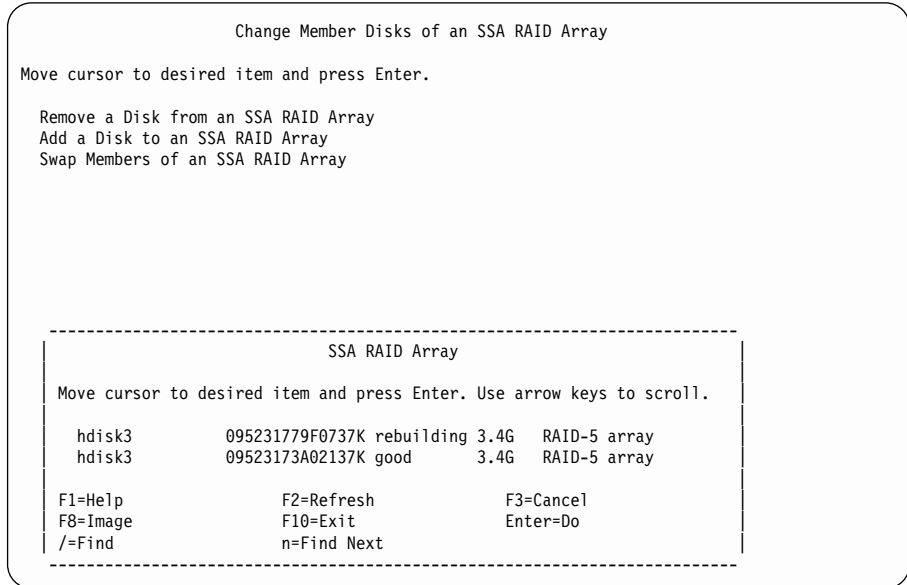

Select the array whose disk drives you want to swap.

3. The following information is displayed:

```
Swap Members of an SSA RAID Array

Type or select values in entry fields.
Press Enter AFTER making all desired changes.

SSA RAID Manager          [Entry Fields]
SSA RAID Array            ssa0
Connection Address / Array Name  hdisk3
* Disk To Remove          09523173A02137K      +
* Disk To Add              +

F1=Help      F2=Refresh  F3=Cancel  F4=List
F5=Reset     F6=Command  F7=Edit    F8=Image
F9=Shell     F10=Exit   Enter=Do
```

Select **Disk to Remove**, and press the List key.

4. From the displayed list, select the disk drive that you want to remove, and press Enter.

Note: If the disk drive that you are replacing has been removed, or the array has rejected it, it is listed as **BlankReservedZ**.

5. Select **Disk to Add**, and press the List key.
6. From the displayed list, select the name of the disk drive that you want to add, and press Enter.
7. Press Enter to perform the swap operation.

Changing or Showing the Use of an SSA Disk Drive

This option allows you to change, or see, how particular disk drives are used.

1. For fast path, type `smitty chgssadisk` and press Enter.

Otherwise, select **Change/Show Use of an SSA Physical Disk** from the SSA RAID Arrays menu.

2. A list of adapters is displayed in a window:

```

                                List/Identify SSA Physical Disks
Move cursor to desired item and press Enter.

List Disks in an SSA RAID Array
List Hot Spares
List Rejected Array Disks
List Array Candidate Disks
List System Disks
Identify Disks in an SSA RAID Array
Identify Hot Spares
Identify Rejected Array Disks
Identify Array Candidate Disks
Identify System Disks
-----
                                SSA RAID Manager
Move cursor to desired item and press Enter.

    ssa0 Available 00-04 IBM SSA 160 SerialRAID Adapter (14109100)
F1=Help           F2=Refresh       F3=Cancel
F8=Image          F10=Exit         Enter=Do
/=Find           n=Find Next
-----
```

Select the adapter whose disk drives you want to list.

3. A list of disk drives and their usage is displayed in a window:

```
SSA RAID Arrays
Move cursor to desired item and press Enter.

List All Defined SSA RAID Arrays
-----
SSA Physical Disk
Move cursor to desired item and press Enter. Use arrow keys to scroll.

# SSA physical disks which are members of arrays.
pdisk0      00022123DFHC00D member n/a      4.5G Physical d
pdisk1      0004AC5119E000D member n/a      1.1G Physical d
pdisk2      0004AC5119E000D member n/a      1.1G Physical d
pdisk3      08005AEA003500D member n/a      4.5G Physical d
pdisk4      08005AEA030D00D member n/a      2.3G Physical d
pdisk5      08005AEA080100D member n/a      4.5G Physical d
pdisk7      08005AEA087A00D member n/a      4.5G Physical d
# SSA physical disks which are hot spares.
pdisk6      08005AEA080800D spare  n/a      4.5G Physical d

F1=Help      F2=Refresh      F3=Cancel
F8=Image     F10=Exit       Enter=Do
/=Find      n=Find Next
-----
```

Using the arrow keys, scroll the information until you find the list of SSA physical disks that contains the disk drive that you want to change.

4. Select the disk drive that you want to change or show.

The following screen is displayed for the disk drive that you have chosen:

Change/Show Use of an SSA Physical Disk

Type or select values in entry fields.
Press Enter AFTER making all desired changes.

SSA RAID Manager	[Entry Fields]
SSA physical disk	ssa0
CONNECTION address	pdisk6
Current use	08005AEA080800D
	Hot Spare Disk +

F1=Help	F2=Refresh	F3=Cancel	F4=List
F5=Reset	F6=Command	F7=Edit	F8=Image
F9=Shell	F10=Exit	Enter=Do	

If you are only checking the use of the disk drive, and do not want to change it, go no further with these instructions. Otherwise, go to step 5.

5. **Note:** If the **Current Use** field shows that the disk drive is owned by an array, you cannot change that use.

Move the cursor to **Current Use**, and press the List key.

6. A list of uses is displayed. Make your selection, and press Enter.

Changing the Use of Multiple SSA Physical Disks

1. For fast path, type `smitty chgssadisks` and press Enter.
Otherwise, select **Change Use of Multiple SSA Physical Disks** from the SSA RAID Arrays menu.
2. A list of adapters is displayed in a window:

```

SSA RAID Arrays

Move cursor to desired item and press Enter.

List All Defined SSA RAID Arrays
List All Supported SSA RAID Arrays
List All SSA RAID Arrays Connected to a RAID Manager
List Status Of All Defined SSA RAID Arrays
List/Identify SSA Physical Disks
List/Delete Old RAID Arrays Recorded in an SSA RAID Manager
List Status of Hot Spare Pools
List Status of Hot Spare Protection for an SSA RAID Array
List Components in a Hot Spare Pool
Add a Hot Spare Pool
-----
SSA RAID Manager

Move cursor to desired item and press Enter.

    ssa0 Available 00-04 IBM SSA 160 SerialRAID Adapter (14109100)

F1=Help          F2=Refresh      F3=Cancel
F8=Image         F10=Exit       Enter=Do
/=Find           n=Find Next
-----

```

3. Select the adapter.
A list is displayed of the disk drives that are attached to the adapter:

```

SSA RAID Arrays

-----
SSA Physical Disks

Move cursor to desired item and press F7. Use arrow keys to scroll.
ONE OR MORE items can be selected.
Press Enter AFTER making all selections.

# SSA physical disks that are free.
pdisk7      0004AC51848900D free   n/a      2.3G   Physical d
pdisk8      0004AC51965300D free   n/a      2.3G   Physical d
pdisk10     0004AC51BD8F00D free   n/a      4.5G   Physical d
# SSA physical disks that are hot spares.
pdisk9      0004AC51BD8000D spare  n/a      4.5G   Physical d
# SSA physical disks that are system disks.
pdisk0      0004AC50A30300D system n/a      4.5G   Physical d

F1=Help          F2=Refresh      F3=Cancel
F7=Select        F8=Image        F10=Exit
Enter=Do         /=Find          n=Find Next
-----

```

4. Use the Select key to select the disk drives whose use you want to change. Select only those disk drives that are to have the same use. (For example, select only disk drives that are to become hot spare disk drives, or select only disk drives that are to become system disks.)

The following screen is displayed for the disk drives that you have chosen:

Change Use of Multiple SSA Physical Disks

Type or select values in entry fields.
Press Enter AFTER making all desired changes.

SSA RAID Manager	[Entry Fields]
SSA physical disk	ssa0
New use	pdisk6, pdisk7, pdisk8
	System Disks +

F1=Help	F2=Refresh	F3=Cancel	F4=List
F5=Reset	F6=Command	F7=Edit	F8=Image
F9=Shell	F10=Exit	Enter=Do	

5. If you want to select other uses for other disk drives, repeat this procedure for each different use.

Copying RAID-1 or RAID-10 Arrays

For details about this option, see Chapter 7, "Copying Data from Arrays and from Volume Groups" on page 149.

Chapter 7. Copying Data from Arrays and from Volume Groups

When disk drives are configured through the Logical Volume Manager for mirroring, you can use the Split Copy function to create a copy of a logical volume. You can then save that copy on a tape or other medium for backup purposes. When disk drives are configured as members of a RAID-1 or RAID-10 array, a similar function, called 3-Way Copy, is available. This chapter describes the 3-Way Copy function, and how it can be used. It does *not* describe the Split Copy function of the Logical Volume Manager.

Note: The 3-Way Copy function is available only with adapter microcode level A000 or above.

The 3-Way Copy procedure allows you to create a separate copy of an hdisk, of a complete volume group, or of part of a volume group. The copy is prepared on a separate disk drive for a RAID-1 array, or on several disk drives for a RAID-10 array. You cannot use the 3-Way Copy procedure for RAID-5 arrays, for RAID-0 arrays, or for non-RAID disk drives, whether or not they are configured for Logical Volume mirroring. When the copy has been prepared, and the copy operation is complete, the copy remains synchronized with the parent. It can be uncoupled later. The uncoupled copy is renamed from the original name so that it can be separately accessed after it is uncoupled.

If the RAID-1 arrays or RAID-10 arrays are used as raw hdisks, you control the 3-Way Copy function from SMIT menus or from `ssaraid` commands. Facilities are provided that allow you to identify suitable candidate disk drives for the copy and to couple those disk drives to the parent array. By using SMIT menus or an `ssaraid` command, you can uncouple the copy from the parent array; the uncoupled array becomes a new hdisk. Before the copy is uncoupled, all fast-write data is destaged to the array. Data held in a system cache that has not yet been sent to the adapter must be flushed before the uncouple operation.

If the RAID-1 or RAID-10 array is used to hold logical volumes, you can use the **`ssa_make_copy`** command to make and uncouple a copy of the complete logical volume group, or of part of a logical volume group. This command:

- Selects disk drives for the copy operation
- Synchronizes data from system cache memory to the array
- Copies the required logical volume group, logical volume, or file system to the copy disk drives
- Uncouples the copy disk drives from the parent array
- Renames the volume group and logical volumes

The complete procedure for synchronizing the data, copying to separate disk drives, and uncoupling the copy can therefore be done from a single command. You can use SMIT menus or `ssaraid` commands to copy and uncouple RAID-1 and RAID-10 arrays that hold logical volumes, as you do for raw hdisks. SMIT commands or `ssaraid` commands, however, operate only on whole hdisks. If you use these commands, you must ensure, in a separate operation, that all cached data in system memory has been

synchronized to the array before you run the copy operation. The recommended procedure for copying logical volumes is to use the **ssa_make_copy** command, rather than SMIT or ssaraid commands. The **ssa_delete_copy** command is provided to enable you to delete the copy after it has been backed up.

You can, for example, use the **ssa_make_copy** and **ssa_delete_copy** commands for nightly backups when an automated closed circle of operations is required to:

1. Prepare disk drives to copy the volume group that is held on a RAID-1 or RAID-10 array.
2. Uncouple the copy of the array.
3. Recreate the copy of the volume group.
4. Do either of the following:
 - Remove the copy volume group, delete the copy array, and repeat from step 1.
 - Remove the copy volume group, recouple the copy array to the parent volume group to allow the copy disk drives to be reused for another copy, and repeat from step 2. (Recoupling the copy disk drives to the parent starts a new copy process.)

The terms “couple” and “uncouple”, which are used in this section, have specific meanings:

couple To attach a copy disk drive to a RAID-1 array, or to attach an array of copy disk drives to a RAID-10 array so that data is copied from the RAID-1 or RAID-10 array to the copy array. The metadata of the copy array is updated to indicate that it is part of the parent RAID-1 or RAID-10 array. The metadata of the parent array is updated to show that the copy array is to be used as a copy. The copy array is taken offline and is no longer directly accessible.

uncouple To separate the copy array from the parent RAID-1 or RAID-10 array. The metadata of the copy array is updated to indicate that it is no longer part of the parent RAID-1 or RAID-10 array. The metadata of the parent array is updated to show that it is no longer associated with the copy array. The copy array is brought online and appears as a free resource.

Copying Data from an Array

Three methods are available by which you can create a RAID-Copy array from a RAID-1 or RAID-10 array. Those methods are:

- Using the **ssaraid** command from the command line
- Using SMIT
- Using the **ssa_make_copy** command (the recommended method)

Using the **ssaraid** Command to Create a RAID-Copy Array from a RAID-1 or RAID-10 Array

This section describes how to use the **ssaraid** command to create RAID-copy arrays. This method and the SMIT menu method (see “Using SMIT to Create a RAID-Copy Array from a RAID-1 or RAID-10 Array” on page 155) are particularly suitable if you are not using Logical Volume Manager (LVM).

Note: Data must be separately synchronized from system memory cache before the copy is uncoupled.

The procedure that is described here enables you to:

- Create a RAID-Copy array from available candidate disk drives
- Couple the RAID-Copy array to your selected parent RAID-1 or RAID-10 array
- Copy data from the parent array to the RAID-Copy array
- Uncouple the RAID-Copy array from the parent array
- Delete the RAID-Copy array when the copy data is no longer required

The following examples show how you might create a RAID-Copy of a RAID-1 array. For these examples, the RAID-1 array is called `hdisk5`, and the RAID manager for `hdisk5` is `ssa2`.

Note: If you are not sure which adapter is the RAID manager for the `hdisk` that you want to copy, give the command:

```
ssaadap -l hdiskx
```

where `hdiskx` is the name of the `hdisk` that you want to copy.

For more information on the **ssaraid** command, see Chapter 12, “Using the SSA Command Line Interface for RAID Configurations” on page 235.

1. List all the suitable disk drives that can be used to create a RAID-Copy array for the selected array. Type:

```
ssaraid -l ssa2 -t raid_copy -c -r hdisk5
```

A list of suitable candidate disk drives is displayed, for example:

```
000629CD8A3900D  
000629D03BD000D
```

All the free disk drives that are listed are large enough and have the correct format to become part of the RAID-Copy array for hdisk5.

2. With a disk drive from the list (for example, 000629CD8A3900D), create your RAID-Copy array. Type:

```
ssaraid -C -l ssa2 -t raid_copy -s 000629CD8A3900D -r hdisk5
```

A message is displayed; for example:

```
185439188B4F4CT created  
000629CD8A3900D changed
```

Your RAID-copy array is 185439188B4F4CT.

3. Couple the RAID-Copy array to the parent RAID array. Type:

```
ssaraid -A -l ssa2 -i couple -n hdisk5 -a raid_copy=185439188B4F4CT  
-a copy_verify_writes=true
```

A message is displayed; for example:

```
185439188B4F4CT changed  
185439188B4F4CT coupled
```

The copy operation starts immediately the array is coupled. If the RAID-Copy array already contains a copy of data from another array, you must use the force flag to reuse the array. Add:

```
-a force=yes
```

to the end of the command that is shown at the start of this step.

4. The time needed for the copy operation is related to the amount of data that you are copying. A large amount of data might take more than one hour to copy. To check whether the copy operation has completed, type:

```
ssaraid -I -l ssa2 -n hdisk5
```

While the copy operation is running, the following information is included in the displayed data:

```
array_coupled      true
copy_status        copying
copy_percentage    90
uncopied_strips    1234
copy_rate          50
copy_verify_writes true
```

When `copy_status` changes from copying to good, the copy operation has completed.

Alternatively, you can check the status of the copy operation by listing the coupled arrays that are being copied; for example:

```
ssaraid -I -l ssa2 -t raid_1 -a copy_status=copying
ssaraid -I -l ssa2 -t raid_1 -a copy_status=good
```

5. If the fast-write function was enabled on the parent array, it is recommended that, to increase the speed of the uncouple operation, you suspend fast-write caching and flush any cached data to the array. Type:

```
ssaraid -H -l ssa2 -n hdisk5 -a fw_suspended=true
```

6. If `copy_status=good`, you can now uncouple the copy array from the parent array. Type:

```
ssaraid -A -l ssa2 -i uncouple -n hdisk5
```

If the fast-write function is enabled for the parent array, the uncouple operation checks whether fast-write caching has been suspended. If you did not suspend fast-write caching in step 5, the uncouple operation now suspends the caching for the parent array, and flushes the fast-write cache data to disk. When the copy array has been uncoupled, the uncouple operation restarts caching for the parent array. A message is displayed; for example:

```
185439188B4F4CT created
185439188B4F4CT changed
8A8E39746BD3C4G uncoupled
```

185439188B4F4CT is the new RAID-Copy array serial number.

7. If you suspended caching in step 5, restart it. Type:

```
ssaraid -H -l ssa2 -n hdisk5 -a fw_suspended=false
```

8. The newly created RAID-Copy array is created as a free disk drive. You must now make it a system disk drive, and configured it on the using system:

- a. Using the RAID-Copy array serial number that was created in step 6 on page 153, type:

```
ssaraid -H -l ssa2 -n 185439188B4F4CT -a use=system
```

The RAID-Copy array is now a system disk drive.

- b. If you now give the **cfgmgr** command, the RAID-Copy array is configured, and is given the next available hdisk name; for example, hdisk6.

If you want to configure the RAID-Copy array, and use a specific hdisk name, type:

```
mkdev -t hdisk -p ssar -w 185439188B4F4CT -l hdiskname
```

where 185439188B4F4CT is the RAID-Copy serial number, and hdiskname is any hdisk name that you select; for example, hdisk5copy.

9. When you no longer need the data that is on the RAID-Copy array, you can recouple the RAID-Copy array to the parent array or delete it. To delete the RAID-Copy array type:

```
ssaraid -D -l ssa2 -n hdiskx -u
```

where hdiskx is the hdisk name that was assigned to the RAID-Copy array when that array was configured in step 8.

Using SMIT to Create a RAID-Copy Array from a RAID-1 or RAID-10 Array

This section describes how to use the SMIT menus to create RAID-copy arrays. This method and the **ssaraid** command method (see “Using the ssaraid Command to Create a RAID-Copy Array from a RAID-1 or RAID-10 Array” on page 151) are particularly suitable if you are not using Logical Volume Manager LVM). For more details about the SMIT menus, see “SMIT Menus for 3-Way Copy Operations” on page 172.

Note: Data must be separately synchronized from system memory cache before the copy is uncoupled.

The procedure that is described here enables you to :

- Create a RAID-Copy array from available candidate disk drives
 - Couple the RAID-Copy array to your selected parent RAID-1 or RAID-10 array
 - Copy data from the parent array to the RAID-Copy array
 - Uncouple the RAID-Copy array from the parent array
 - Delete the RAID-Copy array when the copy data is no longer required
1. Select **Array Copy Services** from the SSA RAID Arrays menu.
 2. Select **Prepare a RAID Array Copy**. A list of the RAID-1 and RAID-10 arrays that are not coupled to any copy arrays is displayed; for example:

```
Array Copy Services

Move cursor to desired item and press Enter.

Prepare a RAID Array Copy
Prepare Volume Group, Logical Volumes, or Filesystems Copy
Uncouple a RAID Array Copy
Uncouple a Volume Group, Logical Volumes, or Filesystems Copy
List All Copy Candidates
List All Uncoupled Copies
List All Uncoupled Volume Groups
Delete a RAID Array Copy
Delete a Volume Group, Logical Volumes, or Filesystems Copy
-----
                          Array to be Copied
-----
Move cursor to desired item and press Enter.

      hdisk4                      RAID-1 array
      hdisk5                      RAID-1 array

F1=Help          F2=Refresh          F3=Cancel
F8=Image        F10=Exit           Enter=Do
F11/=Find       n=Find Next

F1
F9
-----
```

3. Select the RAID-1 or RAID-10 array hdiskx that you want to copy, and press Enter. The Prepare a Copy menu is displayed:

Prepare a Copy

Type or select values in entry fields.
Press Enter AFTER making all desired changes.

	[Entry Fields]	
Array to be copied	hdisk3	
Number of disk drives required	1	
Minimum disk drive size required	9.1GB	
Verify copy during creation	no	+
Hot spare selection	Default	+
RAID copy to be coupled	<input type="checkbox"/>	+
OR		
Disk drives to be coupled	<input type="checkbox"/>	+

F1=Help	F2=Refresh	F3=Cancel	F4=List
F5=Reset	F6=Command	F7=Edit	F8=Image
F9=Shell	F10=Exit	Enter=Do	

4. If you want to verify that all the data written to the copy is readable, select **Verify copy during creation**, and change the entry to **yes**.

Note: When this option is set to **yes**, the time that is required to prepare the copy is increased.

If you are operating your RAID array in a split site configuration, you might want to select which hot spare pools are to be used for copy disks. If you do, select **Hot spare selection**, and select your hot spare preference. Press the Help key if you need more information about this entry.

If you want to couple an existing RAID-Copy array:

- a. Select **RAID Copy to be coupled**.
- b. Either type the name of the RAID-Copy array, or press the List key and select a RAID-Copy array from the list of available candidates.
- c. Press Enter. The RAID-Copy array is coupled to the parent array. The copy operation starts.

If you want use free disk drives to make a copy of a RAID array:

- a. Select **Disk drives to be coupled**.
- b. Either type the names of the disk drives to be coupled, or press the List key and select the disk drives from the displayed list of available candidate disk drives.

Note: The number of disks that you need to select is listed as **Number of disk drives required**.

- c. Press Enter. The new RAID-Copy array is created and coupled to the parent array. The copy operation starts.
5. The time needed for the copy operation is related to the amount of data that you are copying. A large amount of data can take more than one hour to copy. To check whether the copy operation has completed:
 - a. **Select Array Copy Services.**
 - b. Select **List all copy candidates**. The Copy State and percentage copied of all RAID-1 and RAID-10 arrays is displayed:

```

                                COMMAND STATUS
Command: OK                      stdout: yes                      stderr: no
Before command completion, additional instructions may appear below.
Array          Array Type      Coupled Disks      Copy State
hdisk3         raid_10          None               Not Copying      0%
hdisk4         raid_10          pdisk8             Copying          73%
                pdisk9
                pdisk10

F1=Help          F2=Refresh        F3=Cancel          F6=Command
F8=Image        F9=Shell          F10=Exit           /=Find
n=Find Next

```

- c. When the percentage copied for the particular array reaches 100%, the Copy State of that array changes to Good. You can now uncouple the RAID-Copy from the parent array.

6. To uncouple the RAID-Copy Array:
 - a. Select **Array Copy Services** from the SSA RAID Arrays menu.
 - b. Select **Uncouple a RAID Array Copy**. A list is displayed of all the RAID-1 and RAID-10 arrays that have been copied.
 - c. Select the array that you want to uncouple, for example, hdisk3, and press Enter.

When the array is uncoupled, a new hdisk is created. This hdisk contains a copy of the data that was on the parent array when the RAID-Copy array was uncoupled. The displayed output from the uncouple command includes the hdisk name that is assigned to the RAID-Copy array.

7. When you no longer need the data that is on the RAID-Copy array, you can recouple the RAID-Copy array to the parent array or delete it. To delete the RAID-Copy array:
 - a. Select **Array Copy Services** from the SSA RAID Arrays menu.
 - b. Select **Delete a RAID Array Copy**.
 - c. Select the RAID-Copy array to be deleted and press Enter. The hdisk is deleted from the system configuration. The RAID-Copy array is deleted, and its member disk drives are changed to free disk drives.

Using the `ssa_make_copy` Command to Create a RAID Copy from a RAID-1 or RAID-10 Array

Figure 22 shows a volume group that contains one physical volume: `hdisk1`. This `hdisk1` is a RAID-1 array.

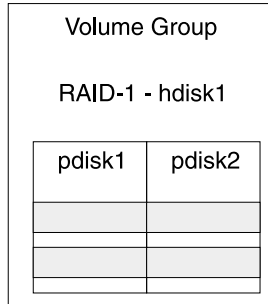

Figure 22. A Volume Group the Contains One Physical Volume

The `ssa_make_copy` command checks whether the `hdisk` is either a RAID-1 or a RAID-10 array. If the array is neither of these types, the command displays a warning, then stops.

If the `hdisk` is of the correct type, the `ssa_make_copy` command finds a suitable copy disk drive for RAID-1 or suitable copy disk drives for RAID-10. It then couples the copy disk drive, or drives, to the parent volume group, and runs the copy operation (see Figure 23).

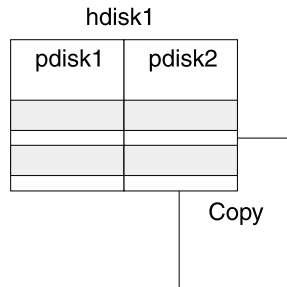

Figure 23. A Copy Disk Drive Coupled to the Parent `hdisk`

When the copy operation has completed and the copy array has been uncoupled, the fast-write cache (if present) is temporarily disabled, and data is flushed to the physical disk drives. The `ssa_make_copy` command then forces the parent volume group to synchronize. The synchronize operation flushes all data from memory to disk, and stops all I/O operations.

The command uncouples the copy disk drive from the parent `hdisk`, clears the PVID of the copy disk drive, restarts the I/O operations, and reenables the fast-write cache.

The **recreatevg** command is run on the RAID-Copy array. It creates the new volume group, renames the file systems, and mounts them to new mount points (see Figure 24).

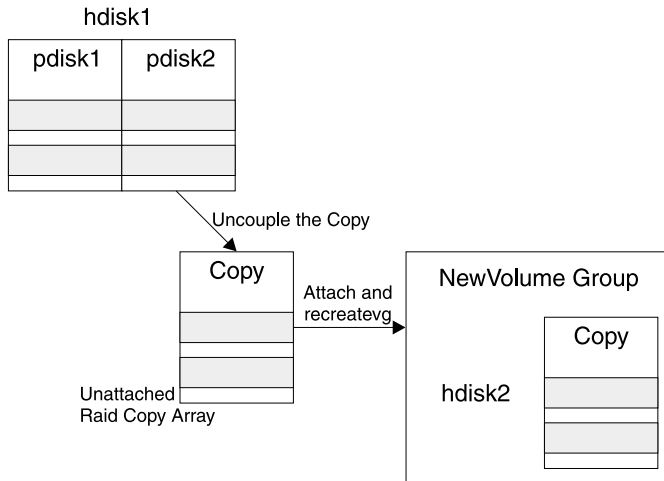

Figure 24. The RAID-Copy Array Uncoupled from the Parent hdisk

ssa_make_copy Command

Purpose

To create a RAID-Copy array from a RAID-1 or RAID-10 array.

Syntax

```
ssa_make_copy -v vgroupname -l lvname -f filename
                [-V newvgroupname]
                [-L newlvprename]
                [-F newfsprepoint]
                [-s]
                [-m|r]
                [-e]
                [-E filename]
```

```
ssa_make_copy -U -v vgroupname -l lvname -f filename
                [-s]
                [-e]
                [-E filename]
```

```
Usage: ssa_make_copy -P -v vgroupname -l lvname -f filename
                [-w]
```

```
ssa_make_copy -R -d pvname
                [-V newvgroupname]
                [-L newlvprename]
                [-F newfsprepoint]
                [-m|r]
```

Description

The **ssa_make_copy** command creates copy volume groups via the following process:

1. The command checks whether you can copy all or part of the volume group.
 - If you want to copy a whole volume group, the command checks whether all the hdisks in the volume group are RAID-1 or RAID-10 arrays. If any hdisk is of the wrong type, the command displays a warning, then stops.
 - If you want to copy logical volumes or file systems, the command checks whether all the logical volumes are in the same volume group, and whether all the hdisks that make up the volume group are RAID-1 or RAID-10 arrays. If any logical volume is not in the required volume group, or if any hdisk is of the wrong type, the command displays a warning, then stops.

Notes:

- a. If any hdisk in that is the volume group does not contain a logical volume, that hdisk is not copied.
- b. If active paging space exists on the volume group, you cannot copy any part of the volume group. For a copy of a volume group to be uncoupled, I/O operations must be temporarily stopped. I/O operations cannot be stopped for active paging space.

- c. If the dump logical volume and the boot logical volume are copied, a warning is displayed. You must delete the copies of these logical volumes after the copy volume group has been created.
 - d. If the logical volume that you want to copy has a file system **loglv** that is located in a different volume group, you cannot copy the logical volume.
2. The command searches for suitable RAID-Copy arrays that you have used SMIT or `ssaraid` commands to create previously, or it searches for appropriate free disk drives. It then either checks your RAID-Copy arrays, or automatically creates RAID-Copy arrays from the free disk drives.
 3. The command either automatically prepares suitable RAID-Copy disk drives or checks the RAID-Copy arrays that you have used SMIT or `ssaraid` commands to create.
 4. The copy disk drives are coupled to the arrays, and the adapter copies the data to the copy disk drives.
 5. When the copy operation is complete, the command waits for an external trigger.
 6. The command temporarily disables the fast-write cache (if enabled), and flushes the data to disk drive.
 7. The command then forces the parent volume group to synchronize. The synchronize operation flushes all data from memory to disk, and stops all I/O operations.
 8. Now the copy can be uncoupled from the parent volume group. The uncouple process makes a RAID-Copy array from the copy disk drives, and clears the PVID of the copy disk drive. The uncouple process occurs on **all** hdisks that have been copied; it can occur only when **all** I/O operations have stopped. The timing is very important here; I/O operations must be stopped for the minimum time possible. The copy disk drives are now unattached RAID-Copy arrays.
 9. I/O is restarted to the volume group.
 10. The fast-write cache is reenabled.
 11. RAID-Copy hdisks are configured from the RAID-Copy arrays.
 12. The **recreatevg** command is run against the new hdisks. This command:
 - Changes the physical volume ID (PVID) references of the VGDA to suit the PVIDs of the new hdisks
 - Renames the copy volume group and assigns a new VGID
 - Renames the copy logical volumes (default prefix **fs** can be used)
 - Changes the root mount point for the file systems in the new volume group (default prefix **/fs** can be used)
 - Mounts the file systems

Flags

- | | |
|-----------|--|
| -m | Mounts the file systems when the copy operation completes. The default is not to mount the file systems. |
| -r | Causes file systems that have been mounted to be read-only file systems. |
| -s | Synchronizes the file systems; that is, flushes the data from the using-system memory onto the disk drive. |

- F** Determines the name of the copy file system. If this flag is not provided, the default naming convention applies. For example, the copy of the original file system **/data** is named **/fs/data**.
- L** Determines the name of the copy logical volume. If this flag is not provided, the default naming convention applies. For example, the copy of the original logical volume **/lv001** is named **/fslv001**.
- I** Provides information.
- e | -E filename**
Calls the external trigger. You can use the external trigger when you want to automate the copy process. In the automated script, run the **ssa_make_copy -v vname -E external_file** command. This command causes the script **ssa_make_copy** script to wait until the file **external_file** has been created before it flushes the cache and stops I/O. You have already determined how long the copy operation takes to run. After that period, the file **external_file** is created. If the file exists before the copy operation has completed the script, an error is reported. The external trigger provides a good way to automatically stopping I/O at the correct moment. If the **-e** flag is used, the default filename applies: **/tmp/ssa_copy_svs_trigger**.
- U** Uncouples the copy. This command is run only when you want to recreate the copy volume group on another using system. When a copy array is uncoupled, a new hdisk is created. This hdisk contains a copy of the data that was on the parent when the copy was uncoupled.
- R** Recreates a copy of the volume group on the copy disk drives.
 - Changes PVID references of the VGDA to suit the PVIDs of the new hdisks.
 - Renames the volume group and assigns a new VGID. Renames the logical volumes.
 - Changes the root mount point for all the file systems in the new volume group.
 - Mounts the file systems.
- P** Prepares the volume group for a copy operation. This command does not complete until the copy operations have completed.
- w** Complete when copy ends. This flag can be used only with the **-P** flag. When this flag is specified, the script waits for the copy operation to end.

Example 1: Copying a Complete Volume Group

In this example, you are copying a complete volume group from the parent array to the RAID-Copy array.

To copy a complete volume group, give the commands:

```
ssa_make_copy -P -v vname  
ssa_make_copy -v vname
```

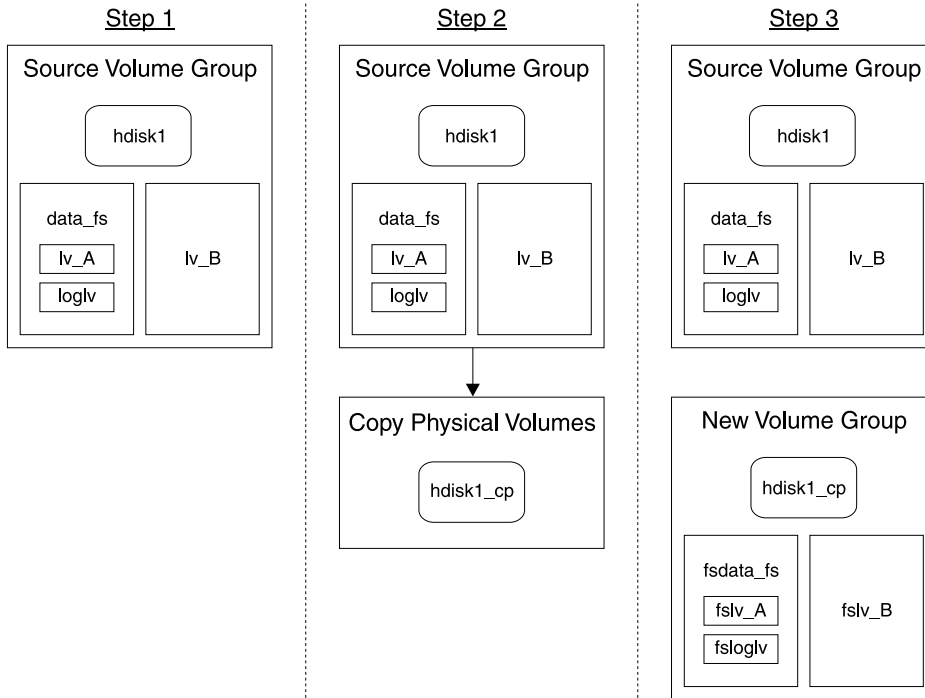

Figure 25. Copying a Complete Volume Group

Figure 25 shows, from left to right:

- The parent array that contains the source volume group.
- The empty RAID-Copy array coupled to the parent array.
- The uncoupled RAID-Copy array that now contains a copy of the complete new volume group. Note that in the copy, all names start with fs.

Example 2: Copying One Logical Volume

In this example, you are copying only one logical volume (-lv B) from the parent array to the RAID-Copy array.

To copy one logical volume, give the commands:

```
ssa_make_copy -P -l lv_B  
ssa_make_copy -l lv_B
```

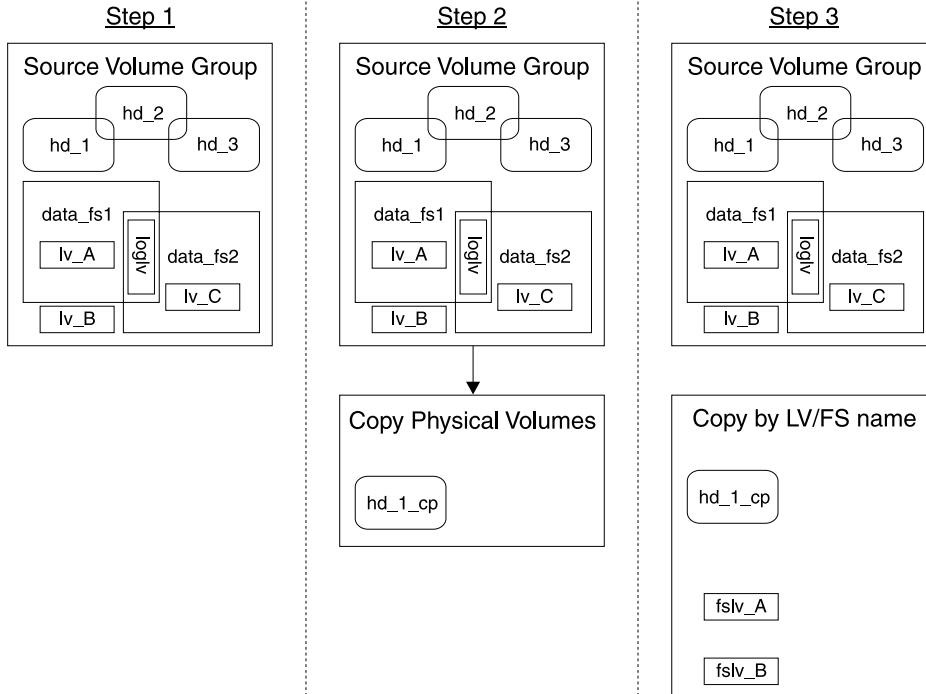

Figure 26. Copying One Logical Volume

Figure 26 shows, from left to right:

- The parent array that contains the source volume group.
- The empty RAID-Copy array coupled to the parent array.
- The uncoupled RAID-Copy array that now contains a copy of the logical volume. Note that in the copy, all names start with fs.

Although the purpose of this job is to copy the logical volume lv_B, by default the **ssa_make_copy** command has copied the complete contents of hdisk hd_1, which includes the logical volume lv_A. The logical volume fslv_A cannot be accessed, however, because its loglv is on hdisk hd_2 and has not been copied. If a logical volume has its loglv on a separate hdisk, the copy of that logical volume can be accessed only if the hdisk that contains the loglv is also copied.

Example 3: Copying One Logical Volume by Logical Volume Name or by FS Name

In this example, you are copying one logical volume (lv_A) from the parent array to the RAID-Copy array. You can use either the logical volume name (lv_A), or the FS name (data fs_1).

To copy one logical volume by logical volume name, give either of the following sets of commands:

```
ssa_make_copy -P -v vname -l lv_A
ssa_make_copy -v vname -l lv_A
```

or

```
ssa_make_copy -P -v vname -l lv_A -l lv_B
ssa_make_copy -v vname -l lv_A -l lv_B
```

To copy one logical volume by fs name, give the commands:

```
ssa_make_copy -P -v vname -f data_fs1
ssa_make_copy -v vname -f data_fs1
```

Although the logical volume lv_B is not shown in two of the commands, it is copied because it is stored on the same physical volume as lv_A is.

When you specify a logical volume or a file system that you want to copy, the vname is not required because it can be resolved.

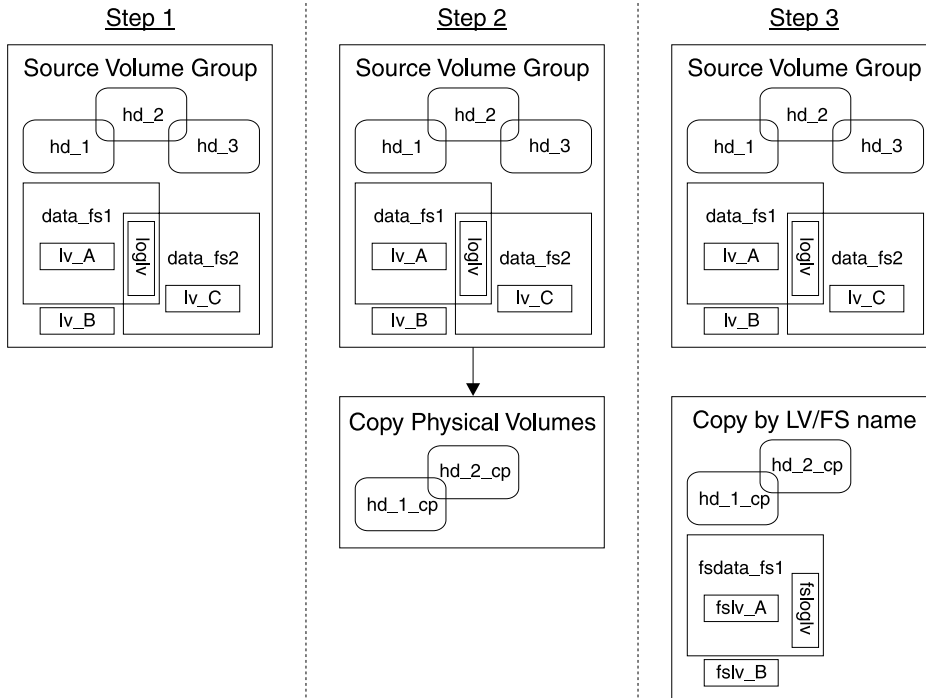

Figure 27. Copying One Logical Volume or Copying by FS Name (1)

Figure 27 shows, from left to right:

- The parent array that contains the source volume group.
- The empty RAID-Copy array coupled to the parent array.
- The uncoupled RAID-Copy array that now contains a copy of the logical volume. Note that in the copy, all names start with fs.

Example 4: Copying One Logical Volume by Logical Volume Name or by FS Name (2)

In this example, you are copying one logical volume (lv_C) from the parent array to the RAID-Copy array. You can use either the logical volume name (lv_C), or the FS name (data_fs2).

To copy one logical volume by logical volume name, give the commands:

```
ssa_make_copy -P -l lv_C  
ssa_make_copy -l lv_C
```

To copy one logical volume by fs name, type:

```
ssa_make_copy -P -f data_fs2  
ssa_make_copy -f data_fs2
```

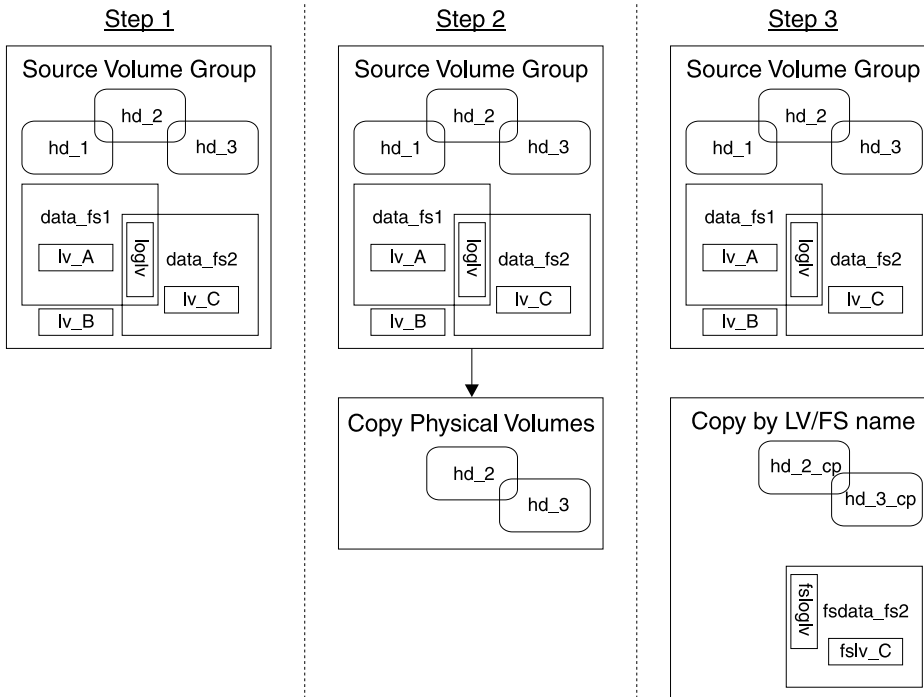

Figure 28. Copying One Logical Volume or Copying by FS Name (2)

Figure 28 shows, from left to right:

- The parent array that contains the source volume group.
- The empty RAID-Copy array coupled to the parent array.
- The uncoupled RAID-Copy array that now contains a copy of the logical volume. Note that in the copy, all names start with fs.

Example 4: Copying a Complete Volume Group and Recreating the Copy on Another Using System

In this example, you are copying a complete volume group, then recreating the copy on another using system.

1. On the original using system, give the commands:

```
ssa_make_copy -P -v vname  
ssa_make_copy -U -v vname
```

A message is displayed; for example:

```
Copy Array
```

```
hdiskx                014639AB30DC0T
```

```
Uncouple completed successfully
```

2. On the using system where you want to recreate the copy:

- a. Run the **cfgmgr** command to configure the new hdisks.

- b. Give the command:

```
ssaraid -Il ssan -n serial_number -z
```

where `serial_number` is the serial number of the RAID-Copy array hdisk: for example, 014639AB30DC0T.

A message is displayed; for example:

```
hdiskx                0146392AB30DC0T good          4.5GB    RAID Copy array
```

- c. To recreate the copy, give the command:

```
ssa_make_copy -R -d hdiskx
```

If you need multiple hdisks to recreate the copy, give the command:

```
ssa_make_copy -R -d hdiskx -d hdisky
```

Example 5: Running an Automatic Copy of a Volume Group

1. Prepare a volume group for copying:
 - a. Give the command:

```
ssa_make_copy -P -v vname
```
 - b. Wait for the copy to complete.
 - c. Wait for the external trigger to be created.
2. Uncouple the volume group:

Give the command:

```
ssa_make_copy -U -v vname
```
3. Recreate the volume group:

Give the command:

```
ssa_make_copy -v vname
```
4. **Either** delete the copy volume group and destroy the RAID-Copy array:
 - a. Give the command:

```
ssa_delete_copy -v newvgname -A
```
 - b. Repeat from step 1.

or delete the copy volume group and couple the children back to the parents:

 - a. Give the command:

```
ssa_delete_copy -v newvgname -C
```
 - b. Repeat from step 2.

or delete the volume group and detach the RAID-Copy array:

 - a. Repeat from step 1.
 - b. Give the command:

```
ssa_delete_copy -v newvgname
```

ssa_delete_copy Command

Purpose

To delete a RAID-Copy array after it has been backed up.

Syntax

```
ssa_delete_copy -v vgroupname | -p pvname -A/-C [-f]
```

Flags

- A** Deletes a copy and its RAID-Copy arrays.
- C** Deletes a copy and couples the RAID-Copy to its original parents.
- f** If the specified volume group is varied off, this flag forces the volume group to be exported.

If the specified volume group is varied on and file systems are mounted, this flag attempts to unmount the file systems.

SMIT Menus for 3-Way Copy Operations

This section describes the SMIT menus that are related to the 3-Way Copy function. These SMIT menus help you to develop your own shell scripts to manage the copy operations.

Getting Access to the Array Copy Services Menu

1. For fast path access to the SSA RAID Array SMIT menu, type `smitty ssaraid` and press Enter.

Otherwise:

- a. Type `smitty` and press Enter.
 - b. Select **Devices**. The Devices menu is displayed.
 - c. Select **SSA RAID Arrays**.
2. The SSA RAID Arrays menu is displayed:

```
SSA RAID Arrays

Move cursor to desired item and press Enter

List All Defined SSA RAID Arrays
List All Supported SSA RAID Arrays
List All SSA RAID Arrays Connected to a RAID Manager
List Status Of All Defined SSA RAID Arrays
List/Identify SSA Physical Disks
List/Delete Old RAID Arrays Recorded in an SSA RAID Manager
List Status of Hot Spare Pools
List Status of Hot Spare Protection for an SSA RAID Array
List Components in a Hot Spare Pool
Add a Hot Spare Pool
Add an SSA RAID Array
Delete an SSA RAID Array
Change/Show Attributes of an SSA RAID Array
Change Member Disks in an SSA RAID Array
Change/Show Use of an SSA Physical Disk
Change Use of Multiple SSA Physical Disks
Change/Show/Delete a Hot Spare Pool
Array Copy Services

F1=Help      F2=Refresh   F3=Cancel   F8=Image
F9=Shell     F10=Exit    Enter=Do
```

Select **Array Copy Services**.

Array Copy Services

For fast path access to the Array Copy Services menu, type `smitty ssa_copy` and press Enter. Otherwise, select **Array Copy Services** from the SSA RAID Arrays menu.

Note: Array Copy Services are designed to be run from shell scripts. These SMIT menus are intended as an aid to shell script development and as a problem determination tool.

```
Array Copy Services

Move cursor to desired item and press Enter.

Prepare a RAID Array Copy
Prepare Volume Group, Logical Volumes, or Filesystems Copy
Uncouple a RAID Array Copy
Uncouple a Volume Group, Logical Volumes, or Filesystems Copy
List All Copy Candidates
List All Uncoupled Copies
List All Uncoupled Volume Groups
Delete a RAID Array Copy
Delete a Volume Group, Logical Volumes, or Filesystems Copy

F1=Help      F2=Refresh   F3=Cancel    F8=Image
F9=Shell     F10=Exit    Enter=Do
```

The following Array Copy Services are available:

Prepare a RAID Array Copy

Select this option if you want to make a copy of a RAID array. If the RAID array is a member of an active volume group, select **Prepare a Volume Group, Logical Volumes, or Filesystems Copy**.

When this option is selected, an array selection menu is displayed, and is followed by the Prepare a Copy menu that is shown in “Prepare a Copy” on page 175.

Prepare Volume Group, Logical Volumes, or Filesystems Copy

Select this option if you want to copy a volume group or a part of a volume group. You must select this option if you want to copy any part of an active volume group. When this option is selected, a volume group selection menu is displayed. When the volume group is selected, the `ssa_make_copy` script selects disk drives to be used for the copy, and couples those disk drives to each array in the volume group. To get more control over this process, use the `ssa_make_copy` command directly from the command line or from in a shell script.

For fast path, type `smitty copy_pre_vg|vfs` and press Enter.

Uncouple a RAID Array Copy

Select this option if you want to uncouple a copy from an array. The copy must be in the Good state before it can be uncoupled. When the copy is uncoupled, a new hdisk is created. This hdisk contains the copied data.

When this option is selected, a RAID array selection menu is displayed. If you select a RAID array that has a copy status of good, the copy is uncoupled from its parent, and a new array is created. The new array uses the next available hdisk name.

For fast path, type `smitty copy_unarray` and press Enter.

Uncouple a Volume Group, Logical Volumes, or Filesystems Copy

Select this option if you want to uncouple a volume group. When this option is selected, a volume group selection menu is displayed. This menu is followed by the Uncouple a Volume Group, Logical Volumes, or Filesystems Copy menu (see page 177).

List all Copy Candidates

Select this option to list all SSA RAID arrays that can support disk copy. See “List All Copy Candidates” on page 179 for a description of the output data.

List all Uncoupled Copies

Select this option to find the parent array and the creation date of each array of type **raid_copy**. See “List All Uncoupled Copies” on page 181 for a description of the output data.

List all Uncoupled Volume Groups

Select this option to find the parent array and the creation date of each array in a volume group that contains arrays of type **raid_copy**. See “List All Uncoupled Volume Groups” on page 182 for a description of the output data.

Delete a RAID Array Copy

Select this option if you want to delete a RAID Array copy. The copy might be coupled to the array or uncoupled from the array. The copy can be in any state. The deletion of the copy causes all the data on the copy to be lost. See “Delete a RAID Array Copy” on page 183 for a description of what happens when a coupled copy or an uncoupled copy is deleted.

Delete a Volume Group, Logical Volumes, or Filesystems Copy

Select this option if you want to delete a volume group copy. The copy might be coupled to the array or uncoupled from the array. The copy can be in any state. The deletion of the copy causes all the data on the copy to be lost. See “Delete a Volume Group, Logical Volumes, or Filesystems Copy” on page 184 for a description of the delete options.

Prepare a Copy

For fast path, type `smitty copy_pre_array` and press Enter.

Otherwise, select **Prepare a Copy** from the Array Copy Services menu.

The Prepare a Copy menu is displayed:

```

                                Prepare a Copy

Type or select values in entry fields.
Press Enter AFTER making all desired changes.

                                [Entry Fields]
Array to be copied                hdisk3
Number of disk drives required    2
Minimum disk drive size required  9.1GB
Verify copy during creation       no
Hot spare selection               Default
RAID copy to be coupled          []
OR
Disk drives to be coupled         []

F1=Help      F2=Refresh    F3=Cancel    F4=List
F5=Reset     F6=Command   F7=Edit     F8=Image
F9=Shell     F10=Exit     Enter=Do

```

The meanings of the fields are:

Array to be copied

The array that you selected as the source data for the copy.

Number of disk drives required

The number of disk drives that must be coupled to the array to permit a copy to be performed.

Minimum disk drive size required

The effective size of each member disk drive of the array. Each disk drive that is coupled to the array must be at least this size. If larger disk drives are selected, the excess space remains unused.

Verify copy during creation

If you select **yes**, all data that is written to the copy is verified before the write operation completes. This action reduces the possibility that unrecoverable media errors are found when the copy is uncoupled and read, but increases the time required to perform the copy operation.

Hot spare selection

Default Assigns the coupled disk drives to the pool to which those disk drives were previously assigned:

Primary

Each coupled disk drive is assigned to the hot spare pool to which the Primary disk drive that it is copying is assigned.

Secondary

Each coupled disk drive is assigned to the hot spare pool to which the Secondary disk drive that it is copying is assigned.

To get more control over this process, use the **ssaraid** command directly from the command line or from inside a shell script (see “Using the ssaraid Command to Create a RAID-Copy Array from a RAID-1 or RAID-10 Array” on page 151).

RAID copy to be coupled

The name of the existing RAID copy to be used. Press the List key to list the uncoupled copies that you can use to create the new copy. Leave this field blank if you are going to select **Disk drives to be coupled**.

Disk drives to be coupled

A list of disk drives to be used for the copy. Press the List key to list the free disk drives that you can use to create the copy. The number of disk drives selected must equal **Number of disk drives required**. Leave this field blank if you are going to select **RAID copy to be coupled**.

Uncouple a Volume Group, Logical Volumes, or Filesystems Copy

For fast path, type `smitty copy_unvglvfs` and press Enter.

Otherwise, select **Uncouple a Volume Group, Logical Volumes, or Filesystems Copy** from the Array Copy Services menu.

The Uncouple a Volume Group, Logical Volumes or Filesystems Copy menu is displayed:

```
Uncouple a Volume Group, Logical Volumes or Filesystems Copy

Type or select values in entry fields.
Press Enter AFTER making all desired changes.

                                [Entry Fields]
Volume Group                    myvg01
New Volume Group name           []
Logical Volume prefix           []
Mount point                     []
Mount new file systems          no      +
Synchronize the file systems    no      +

F1=Help      F2=Refresh      F3=Cancel      F4=List
F5=Reset     F6=Command     F7=Edit       F8=Image
F9=Shell     F10=Exit       Enter=Do
```

The meanings of the fields are:

Volume Group

The name of the volume group from which this copy was taken.

New Volume Group name

The name of this copy of the volume group. In this field, enter the name of the new volume group. If this field remains blank a default volume group name is used.

Logical Volume prefix

The prefix that is added to the parent logical volume names when the new logical volumes are created during the uncouple operation. If no prefix is assigned, a default value is used.

Mount point

The mount point that is to be used for the new file systems. If no mount point is assigned, the default value is used.

Mount new file systems

If you select **no**, the file systems are not mounted when the copy is uncoupled.

|
| If you select **yes**, the file systems are mounted when the copy is uncoupled. If
| you select **read only**, the file systems are mounted for “read only” when the
| copy is uncoupled.

|
| **Synchronize the file systems**

| Select this option to schedule a synchronization operation before the copy is
| uncoupled.
|

List All Copy Candidates

For fast path, type `smitty copy_1stcopycand` and press Enter.

Otherwise, select **List All Copy Candidates** from the Array Copy Services menu.

The following information is displayed:

```
COMMAND STATUS
Command: OK          stdout: yes          stderr: no
Before command completion, additional instructions may appear below.
Array              Array Type      Coupled Disks      Copy State
hdisk3             raid_10         None                Not Copying      0%
hdisk4             raid_10         pdisk8              Copying           73%
                  pdisk9
                  pdisk10

F1=Help           F2=Refresh      F3=Cancel          F6=Command
F8=Image          F9=Shell        F10=Exit           /=Find
n=Find Next
```

The columns of information displayed on the screen have the following meanings:

Array The hdisk name of the RAID array. This field contains the array serial number if the array is not configured.

Array Type
The type of array listed. This is `raid_1` or `raid_10`

Coupled Disks
Disk drives to which the array data is being copied.

Copy State
The operational state of the array copy:

Not Copying
No copy is being created for this array.

Good The coupled disk drives contain an exact copy of the data that is on the array. The copy must be in the Good state before it can be uncoupled from the array.

|
|
|
|
|
|
|

Copying

Data is being copied to the coupled disk drives, but these coupled disk drives do not yet contain an exact copy of the data that is on the array.

Degraded

A copy has been created, but one or more coupled disk drives are missing or have failed. If missing disk drives are replaced or exchanged for new disk drives, the copy operation continues.

List All Uncoupled Copies

For fast path, type smitty copy_1stcopies and press Enter.

Otherwise, select **List All Uncoupled Copies** from the Array Copy Services menu.

The following information is displayed:

```
COMMAND STATUS
Command: OK          stdout: yes          stderr: no
Before command completion, additional instructions may appear below.
Copy                Status          Parent Array      Timestamp
hdisk9              good           hdisk2            Wed May 10 15:27:21 2000

F1=Help            F2=Refresh        F3=Cancel         F6=Command
F8=Image           F9=Shell          F10=Exit          /=Find
n=Find Next
```

The columns of information displayed on the screen have the following meanings:

Copy The name of the RAID-Copy array.

Status The status of the RAID-Copy array. Valid values for status are:

Good All the array components are present and operational.

Offline One or more array members are missing or have failed.

Unknown

A RAID-Copy array has been created, but has not been coupled to an array. An hdisk cannot be created from this RAID-Copy array. This RAID-Copy array can be only coupled to an array or deleted.

Parent Array

The name of the array from which the data was copied.

Timestamp

The date and time at which the copy was uncoupled from the parent array.

List All Uncoupled Volume Groups

For fast path, type `smitty copy_1stunvg` and press Enter.

Otherwise, select **List All Uncoupled Volume Groups** from the Array Copy Services menu.

The following information is displayed:

```
COMMAND STATUS
Command: OK          stdout: yes          stderr: no
Before command completion, additional instructions may appear below.
Copy                Status          Parent Array      Timestamp
fsmyvg01
  hdisk7            good           hdisk3           Fri May 12 13:23:49 2000
  hdisk8            good           hdisk4           Fri May 12 13:23:49 2000
fsmyvg02
  hdisk9            good           hdisk5           Fri May 12 14:11:18 2000
  hdisk10           good           hdisk6           Fri May 12 14:11:18 2000

F1=Help            F2=Refresh        F3=Cancel        F6=Command
F8=Image           F9=Shell          F10=Exit         /=Find
n=Find Next
```

The columns of information displayed on the screen have the following meanings:

Copy The new volume group name that was created when the copy of the parent volume group was uncoupled. Under the volume group name is listed the RAID arrays that were copied as part of that volume group.

Status The status of the RAID-Copy array. Valid values for status are:

Good All the array components are present and operational.

Offline One or more array members are missing or have failed.

Unknown

A RAID-Copy array has been created, but has not been coupled to an array. An hdisk cannot be created from this RAID-Copy array. This RAID-Copy array can be only coupled to an array or deleted.

Parent Array

The name of the array from which the data was copied.

Timestamp

The date and time at which the copy was uncoupled from the parent array.

Delete a RAID Array Copy

For fast path, type `smitty copy_delcopy` and press Enter.

Otherwise, select **Delete a RAID Array Copy** from the Array Copy Services menu.

The following information is displayed:

```
Array Copy Services
Move cursor to desired item and press Enter.
Prepare a RAID Array Copy
Prepare Volume Group, Logical Volumes, or Filesystems Copy
Uncouple a RAID Array Copy
Uncouple a Volume Group, Logical Volumes, or Filesystems Copy
List All Copy Candidates
List All Uncoupled Copies
List All Uncoupled Volume Groups
Delete a RAID Array Copy
Delete a Volume Group, Logical Volumes, or Filesystems Copy
-----
Delete a RAID Array Copy
Move cursor to desired item and press Enter.
      hdisk3          raid_1          Good          100%
      hdisk9          raid_copy       Good
F1=Help          F2=Refresh          F3=Cancel
F8=Image         F10=Exit            Enter=Do
F1 /=Find        n=Find Next
F9 -----
```

If you select a `raid_1` or a `raid_10` array from the pop-up menu and press Enter, the coupled pdisks change to free disk drives. The RAID array remains fully accessible.

If you select a RAID-Copy array, the array is deleted, and the pdisks change to free disk drives. Data on the RAID-Copy array is no longer accessible.

Delete a Volume Group, Logical Volumes, or Filesystems Copy

For fast path, type smitty copy_delvglvfs and press Enter.

Otherwise, select **Delete a Volume Group, Logical Volumes, or Filesystems Copy** from the Array Copy Services menu.

The following information is displayed:

```

                                Array Copy Services

Move cursor to desired item and press Enter.

Prepare a RAID Array Copy
Prepare Volume Group, Logical Volumes, or Filesystems Copy
Uncouple a RAID Array Copy
Uncouple a Volume Group, Logical Volumes, or Filesystems Copy
-----
                                Delete a Volume Group, Logical Volumes or Filesystems Copy

Move cursor to desired item and press Enter. Use arrow keys to scroll.

    fsmyvg01
      hdisk7          good          hdisk3          Fri May 12 13:2
      hdisk8          good          hdisk4          Fri May 12 13:2
    fsmyvg01
      hdisk9          good          hdisk5          Fri May 12 14:1
      hdisk10         good          hdisk6          Fri May 12 14:1

F1=Help           F2=Refresh       F3=Cancel
F8=Image         F10=Exit         Enter=Do
F1 /=Find        n=Find Next
F9
-----

```

If you select either the volume group name or any hdisk in that volume group, all the disk drives in the volume group are selected. The Action menu is displayed:

```

                                Delete a Volume Group, Logical Volumes, or Filesystems Copy

Type or select values in entry fields.
Press Enter AFTER making all desired changes.

Volume Group          [Entry Fields]
Action                vg00
Force                 Delete and Detach  +
                    no

F1=Help              F2=Refresh       F3=Cancel       F4=List
F5=Reset             F6=Command       F7=Edit         F8=Image
F9=Shell             F10=Exit         Enter=Do

```

The meanings of the fields are:

Volume Group

The volume group that you selected previously.

Action The possible actions are:

Delete and Detach

The volume group name is removed. Data on the volume group is no longer accessible. The RAID-Copy arrays change to free, and can be recoupled to parent arrays.

Delete The volume group name is removed, and pdisks that are in each array in the volume group change to free disk drives. Data on the volume group is no longer accessible.

Delete and Recouple

The volume group name is removed. Each array that is in the volume group is recoupled to its original parent.

Force (Yes/No)

If the specified volume group is varied off, **yes** forces the script to export the volume group.

If the specified volume group is varied on and file systems are mounted, **yes** attempts to unmount the file systems.

Effects of Array Copy on Other SMIT Menus

This section shows SMIT menus that are described elsewhere in this book. When Array Copy is used, however, additional fields or display panels are present.

Change/Show Attributes of an SSA RAID Array

The following information is displayed for RAID-1 or RAID-10 arrays:

```
Change/Show Attributes of an SSA RAID Array

Type or select values in entry fields.
Press Enter AFTER making all desired changes.

[TOP]                                     [Entry Fields]
SSA RAID Manager                          ssa1
SSA RAID Array                            hdisk2
Connection Address / Array Name          8A8E39195F60C40
RAID Array Type                          raid_10
State                                     good
Copy State                               copying
Size of Array                            18.2GB
Primary Disks                            pdisk0 pdisk6
Secondary Disks                          pdisk9 pdisk10
Copy Disks                                pdisk11 pdisk12
Percentage Rebuilt                       Not Rebuilding
Percentage Copied                         1
Split Array Resolution                   Primary          +
Enable Use of Hot Spares                 yes              +

[MORE...4]

F1=Help          F2=Refresh      F3=Cancel      F4=List
F5=Reset         F6=Command     F7=Edit        F8=Image
F9=Shell         F10=Exit       Enter=Do
```

The meanings of the additional fields are:

Copy State

The operational state of the array copy:

Not Copying

No copy is being created for this array.

Good The coupled disk drives contain an exact copy of the data that is on the array. The copy must be in the Good state before it can be uncoupled from the array.

Copying

Data is being copied to the coupled disk drives, but these coupled disk drives do not yet contain an exact copy of the data that is on the array.

Degraded

A copy has been created, but one or more coupled disk drives are missing or have failed. If missing disk drives are replaced or exchanged for new disk drives, the copy operation continues.

Coupled Disks

The disk drives that are coupled to the array and contain the copy of the array data. These disk drives are present only if an array copy has been created.

Percentage Copied

The percentage of the array data that has been copied onto the coupled disk drives. When this reaches 100%, the coupled disk drives contain an exact copy of the data that is on the array, and can be uncoupled at any time from the array.

For fields that are not defined here, see “Changing or Showing the Attributes of an SSA RAID Array” on page 135.

The following information is displayed for RAID-Copy arrays:

```
Change/Show Attributes of an SSA RAID Array

Type or select values in entry fields.
Press Enter AFTER making all desired changes.

[Entry Fields]
SSA RAID Manager          ssa1
SSA RAID Array           hdisk9
Connection Address / Array Name  8A8E39197D02C4T
RAID Array Type          raid_copy
State                    good
Size of Array            18.2GB
Member Disks             pdisk11 pdisk12
Parent Array             hdisk2
Copy Uncoupled           Thu May 11 09:31:11 20>
Allow Page Splits       yes +
Current Use              System Disk +

F1=Help      F2=Refresh  F3=Cancel   F4=List
F5=Reset     F6=Command  F7=Edit     F8=Image
F9=Shell    F10=Exit   Enter=Do
```

The meanings of the additional fields are:

State The status of the RAID-Copy array. Valid values for status are:

Good All the array components are present and operational.

Offline One or more array members are missing or have failed.

Unknown

A RAID-Copy array has been created, but has not been coupled to an array. An hdisk cannot be created from this RAID-Copy array. This RAID-Copy array can be only coupled to an array or deleted.

Parent Array

The name of the array from which the data was copied.

Copy Uncoupled

The date and time when the copy uncoupled from the parent array.

For fields that are not defined here, see “Changing or Showing the Attributes of an SSA RAID Array” on page 135.

List Status Of All Defined SSA RAID Arrays

For fast path, type smitty 1stssaraid and press Enter.

Otherwise, select **List Status Of All Defined SSA RAID Arrays** from the SSA RAID Arrays menu.

The following information is displayed for RAID-Copy arrays:

```
COMMAND STATUS
Command: OK          stdout: yes          stderr: no
Before command completion, additional instructions may appear below.

Components          Status
hdisk9              good
  pdisk11           good
  pdisk12           good
hdisk11             good
  pdisk18           good
  pdisk21           good
  pdisk17           good

F1=Help            F2=Refresh          F3=Cancel           F6=Command
F8=Image           F9=Shell            F10=Exit            /=Find
n=Find Next
```

Status data is given for the array and each disk drive in the array. The status values for the array are:

Good All the array components are present and operational.

Offline One or more array members are missing or have failed.

Unknown

A RAID-Copy array has been created, but has not been coupled to an array. An hdisk cannot be created from this RAID-Copy array. This RAID-Copy array can be only coupled to an array or deleted.

The status value for the disk drives is:

Good The disk drive is present and operational.

Identify Disks in an SSA RAID Array

For fast path, type `smitty issaraid` and press Enter.

Otherwise, select **Identify Disks in an SSA RAID Array** from the List/Identify SSA Physical Disks menu.

The following information is displayed for RAID arrays that have coupled disk drives:

```

                                Identify Disks in an SSA RAID Array

Type or select values in entry fields.
Press Enter AFTER making all desired changes.

                                [Entry Fields]
SSA RAID Manager                ssa1
SSA RAID Array                  hdisk2
Primary Disks                              +
Secondary Disks                            +
Coupled Disks                              +
Flash Disk Identification Lights  yes              +

F1=Help      F2=Refresh      F3=Cancel      F4=List
F5=Reset     F6=Command     F7>Edit       F8=Image
F9=Shell     F10=Exit        Enter=Do
```

1. For the primary, secondary, and coupled disk drives, press the List key to list the disk drives that you want to identify.
2. From the menu shown, select each disk drive that you want to identify, and press Enter.
3. Select **yes** in the **Flash Disk Identification Lights** field.

Remove a Disk From an SSA RAID Array

For fast path, type `smitty redssaraid` and press Enter.

Otherwise, select **Remove a Disk From an SSA RAID Array** from the Change Member Disks in an SSA RAID Array menu.

When the List key is pressed for the **Disk to Remove** option, the following pop-up menu is displayed:

```
Remove a Disk From an SSA RAID Array
Type or select values in entry fields.
Pr -----
          Disk to Remove
Move cursor to desired item and press Enter.
#####
# Primary Disks
* pdisk0      AC7AA078 04-07-P      present    9.1GB
  pdisk6      AC7AA8A4 04-07-P      present    9.1GB
#####
# Secondary Disks
  pdisk9      AC7AD176 04-07-P      present    9.1GB
  pdisk10     AC7AE3C9 04-07-P      rebuilding 9.1GB
#####
# Coupled Disks
  pdisk11     AC7AE417 04-07-P      present    9.1GB
  pdisk12     AC7AE41C 04-07-P      present    9.1GB
F1=Help      F2=Refresh      F3=Cancel
F1 F8=Image   F10=Exit        Enter=Do
F5 /=Find     n=Find Next
F9 -----
```

The status values for coupled disk drives are:

present

The disk drive is present and operational.

not_present

The disk drive is missing or has failed.

Swap Members of an SSA RAID Array

For fast path, type `smitty exssaraid` and press Enter.

Otherwise, select **Swap Members of an SSA RAID Array** from the Change Member Disks in an SSA RAID Array menu.

When the List key is pressed for the **Disk to Remove** option, the following pop-up menu is displayed:

```
Swap Members of an SSA RAID Array
Type or select values in entry fields.
Pr -----
          Disk to Remove
Move cursor to desired item and press Enter.

#####
# Primary Disks
* pdisk0      AC7AA078 04-07-P      present    9.1GB      +
* pdisk6      AC7AA8A4 04-07-P      present    9.1GB      +
#####
# Secondary Disks
pdisk9      AC7AD176 04-07-P      present    9.1GB
pdisk10     AC7AE3C9 04-07-P      present    9.1GB
#####
# Coupled Disks
pdisk11     AC7AE417 04-07-P      present    9.1GB
pdisk12     AC7AE41C 04-07-P      present    9.1GB

F1=Help      F2=Refresh    F3=Cancel
F1 F8=Image   F10=Exit      Enter=Do
F5 /=Find
F9 -----
```

The status values for coupled disks are:

present

The disk drive is present and operational.

not_present

The disk drive is missing or has failed.

Chapter 8. Split-Site Management

This chapter describes how to configure and manage a system in which the computing and disk drive resources are split between two or more sites, so that the system can continue to operate if one site is lost.

Configuration of RAID-1 and RAID-10 Arrays

RAID-1 and RAID-10 arrays hold data on mirrored pairs of disk drives; that is, the two disk drives of a particular pair contain the same data. If either disk drive fails, the data is still available. This characteristic of these array types allows the mirrored copies of the data to be held on disk drives that are in different domains. For example, the disk drives can be in different disk subsystems, or on different sites. If one domain loses power, the array continues to operate because one copy of the data is still available.

The RAID manager ensures that the two copies of the data are synchronized. It is possible for an array to become split in half, and for the adapters to become unable to communicate with each other. The design of the system must include precautions, therefore, that prevent both using systems from continuing to operate on the half of the array that each system can access. Such a condition causes the data on each mirrored pair to be inconsistent. The RAID manager allows only one half of the array to remain available. This action prevents two using systems writing different data to the separate halves of the array.

The Split Array Resolution flag determines whether the primary or secondary side of the array can operate when some of the configuration disks are not available. Normally, the Split Array Resolution flag is reset. When the Split Array Resolution flag is reset and the secondary configuration disk can be accessed, but no primary configuration disk drive can be accessed by an adapter, the array goes into the Offline state to that adapter.

Note: In the `ssaraid` command, the Split Array Resolution Flag is known as `split_resolution`.

When the Split Array Resolution flag is set and the secondary configuration disk drive can be detected, access to the array is permitted. If the Split Array Resolution flag is set, and the secondary configuration disk cannot be detected, the array goes into the Offline state.

The Split Array Resolution flag affects initialization of the array:

- If an array appears with the Split Array Resolution flag set, only member disk drives from the secondary half of the array are accepted. If member disk drives from the primary half of the array appear, they are exchanged into the array and a rebuilding process begins. These actions are logged for each primary disk drive. If all the member disk drives for the primary half of the array appear, and they are rebuilding, or they have completed rebuilding, the Split Array Resolution flag is reset.
- If, in a RAID-10 array, the first two primary disk drives and the first secondary disk drive are all in separate power domains, you can configure that array so that it can always continue to operate after a power failure of a single power domain. After the

loss of any power domain in this configuration, a using system continues to detect either all the primary configuration disk drives, or one primary and one secondary configuration disk drive, and continues to access the array without the need to set the Split Array Resolution flag.

Operation after a Loss of Member Disks

An array goes into the Offline state if, after any component failure or change in configuration, it becomes possible for the disk drives of mirrored pairs each to receive different data from different systems. Under such conditions, the disk drives of a mirrored pair might no longer contain matching data; that is, they are not synchronized.

An array can continue to operate although one of the following conditions might exist:

- The number of managing adapters is increased or decreased when all the primary and secondary configuration disk drives are working.
- A primary disk drive is missing, cannot be read, or cannot be written, but the other primary and secondary disk drives are working.
- The secondary configuration disk drive is missing, cannot be read, or cannot be written, but both primary configuration disk drives are working
- Both primary configuration disk drives are missing, but the secondary configuration disk drive is working, and all the adapters in the management list can be detected. The adapter microcode automatically sets the Split Array Resolution flag.
- Both primary disk drives can be detected, but they cannot be read or written and the secondary configuration disk drive is working. The adapter microcode automatically sets the Split Array Resolution flag.

The array goes into the Offline state for the following errors or reconfiguration:

- Both primary configuration disks are missing and less than all the managing adapters on the list are visible. Split Array Resolution needs to be set before operations to the array can continue.
- The secondary disk drives are missing and all the managing adapters are missing.
- The primary side of the array initializes, read or write operations are performed on the array, and the Split Array Resolution flag is not set on the primary configuration disk drives. Later, the secondary configuration disk drive appears. Its Split Array Resolution flag is set. Under these conditions, both the primary side and the secondary side might have been written independently, and the data might not be consistent on the mirrored pair members. You must determine whether the correct data is on the primary side or on the secondary side. Then you must reinitialize by changing the value of the Split Array Resolution flag on the side that does not have the correct data.

The HotSpareSplits parameter can be used to control whether hot spare disk drives are to be introduced when exactly half the member disk drives of an array are missing. In a split-site configuration when one site loses access to the other, it might be desirable that hot-spare disk drives are **not** introduced while half the disk drives are no longer visible. When the HotSpareSplits flag is set to **off** and all the secondary disk drives and the other adapter are not visible, hot spare disk drives are not introduced. Similarly, hot

spare disk drives are not introduced if the Split Array Resolution flag is set to **Secondary** (secondary disk drives only are being used), the HotSpareSplits flag is set to **off**, and all the primary disk drives and the other adapter are not visible.

Three types of array management problems can cause an array to be in the Offline state to the using system:

- One half of the array is not present.
- The adapter is not known to the remaining half of the array.
- The split and join procedure was not performed correctly.

This section describes those problems, gives examples of possible causes, and recommends recovery actions.

One Half of the Array Is Not Present

This condition produces SRN 48750.

This type of problem can be caused by:

- Disk drive failure
- Power failure in the using system
- Communication problems between two systems on the SSA network

Single-Host System with Primary Disk Drive Missing

Figure 29 shows a single-host system that has just been switched on. The system contains a RAID-1 array whose primary disk drive is missing. The array remains online, but in the Exposed state until one of the following occurs:

- The missing primary disk drive becomes available again before a write operation to the array occurs. Under this condition, the restored disk drive is returned as the array primary disk drive, and the array returns to the Good state.
- A write operation to the array occurs before the missing primary disk drive becomes available again. Under this condition:
 - If a hot spare disk drive is available, that hot spare disk drive automatically becomes the new primary disk drive, and the array goes into the Rebuilding state. If the missing primary disk drive then becomes available again, it is rejected.
 - If, after the write operation occurs, no hot spare disk drive is available, the array enters the Degraded state. If the missing primary disk drive then becomes available again, it is rejected.

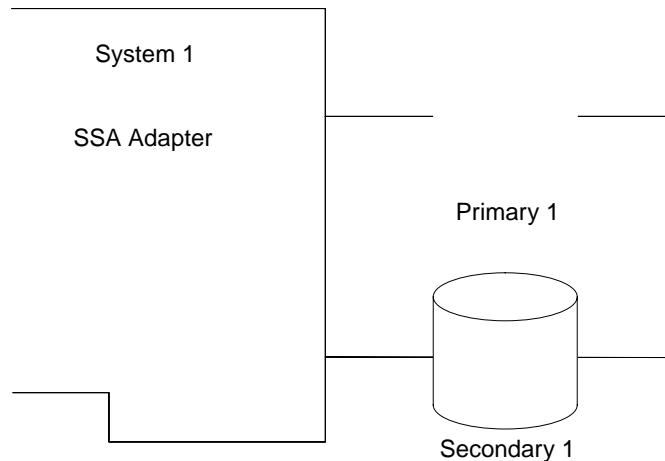

Figure 29. Single-Host System with Primary Disk Drive Missing

Dual-Host System with Primary Disk Drive Missing

Figure 30 shows a dual-host system that has just been switched on. The system contains a RAID-1 array whose primary disk drive is missing. The array remains online, but in the Exposed state until one of the following occurs:

- The missing primary disk drive becomes available again before a write operation to the array occurs. Under this condition, the restored disk drive is returned as the array primary disk drive, and the array returns to the Good state.
- A write operation to the array occurs before the missing primary disk drive becomes available again. Under this condition:
 - If a hot spare disk drive is available, that hot spare disk drive automatically becomes the new primary disk drive, and the array goes into the Rebuilding state. If the missing primary disk drive then becomes available again, it is rejected.
 - If, after the write operation occurs, no hot spare disk drive is available, the array enters the Degraded state. If the missing primary disk drive then becomes available again, it is rejected.

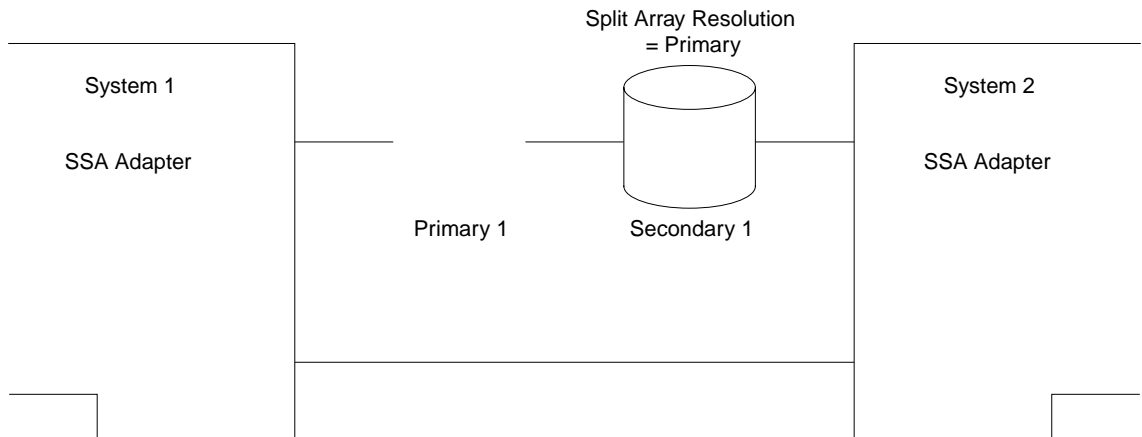

Figure 30. Dual-Host System with Primary Disk Drive Missing

Dual-Host System with Only One System Switched On

Figure 31 shows a dual-host system that has just been switched on. The system contains a RAID-1 array, but the primary disk drive is missing because system 1 is not switched on. The array remains in the Offline state on both systems until either of the following occurs:

- The primary disk drive becomes available.
- The Split Array Resolution flag is set to **Secondary**.

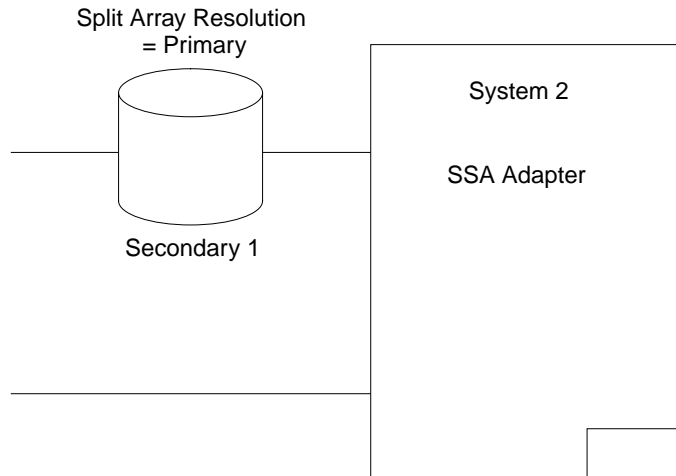

Figure 31. Dual-Host System with Only One System Switched On

Split Systems

The system can become split because communications have failed between the two systems.

System 1 Split from System 2: Figure 32 shows system 1 split from system 2.

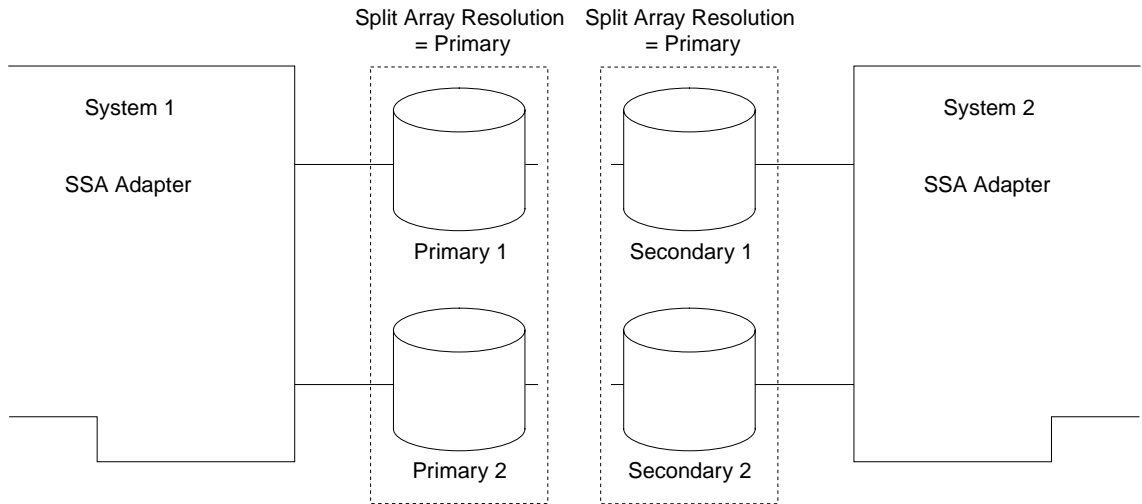

Figure 32. System 1 Split from System 2

On system 1, the array is in the Exposed or the Degraded state. On system 2, the array is in the Offline state, and SRN 48750 is generated. The array remains in the Offline state on system 2 until:

- The two systems are reconnected.
- The Split Array Resolution flag is set to **Secondary**.

Attention: You must set the Split Array Resolution flag to **Secondary** on **both** halves of the array if you need access from system 2. This action ensures that write operations can be performed only on the secondary half of the array. If data had been allowed to be written to both halves of the array, the data would become unsynchronized. If the two halves are later reconnected, and the Split Array Resolution flag is set differently on the primary and secondary side, the array enters the Offline state to both systems.

Normal Reconnection: When the systems are reconnected, the secondary disk drives are resynchronized with the primary disk drives, as shown in Figure 33.

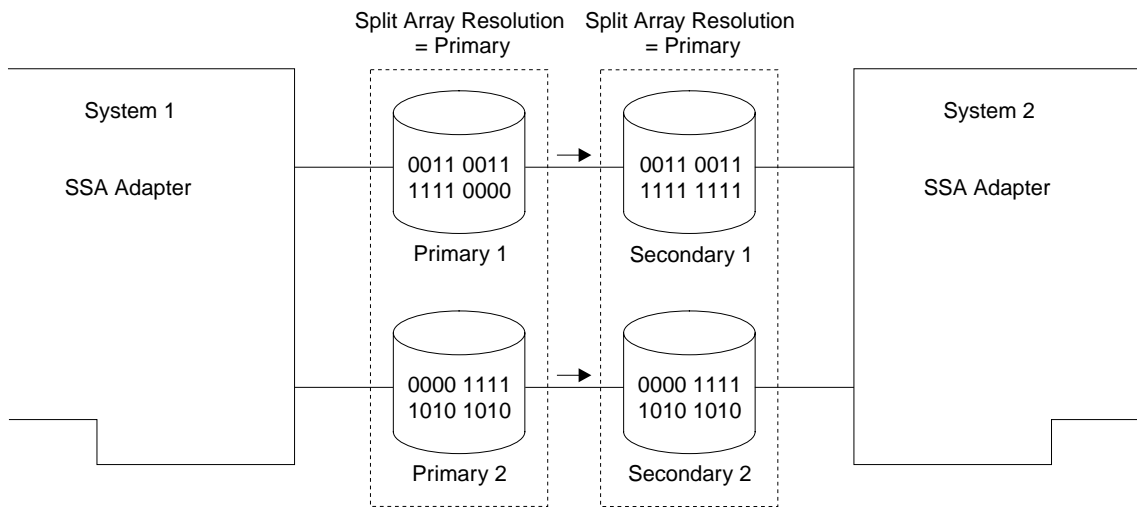

Figure 33. Reconnection of a Split Array

The array enters the Good state for both systems.

Failure of a Primary Disk Drive in a Dual-Host System: Figure 34 shows a dual-host system in which the primary disk drive of a RAID-1 array has failed.

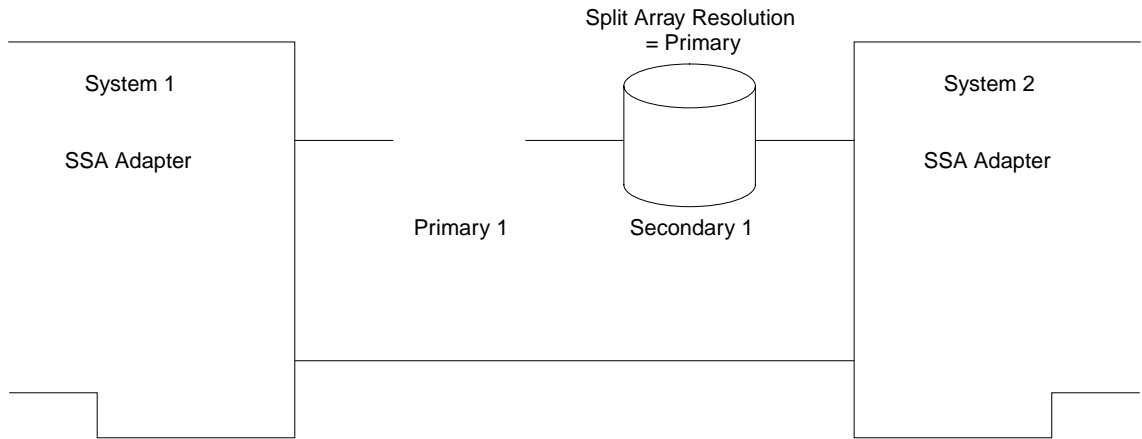

Figure 34. RAID-1 Disk Drive Failure

Because both adapters can still detect the secondary disk drive of the array, the Split Array Resolution flag is automatically set to **Secondary**, and I/O operations continue. The array is in the Exposed or Degraded state. When the primary disk drive is reconnected, it is resynchronized from the secondary disk drive, and the Split Array Resolution flag is automatically set to **Primary**.

RAID-1 Failure of a Host System and a Primary Disk Drive: Figure 35 shows system 2 disconnected from system 1. The array is in the Offline state. If you set Split Array Resolution to **Secondary**, the array goes into the Good state.

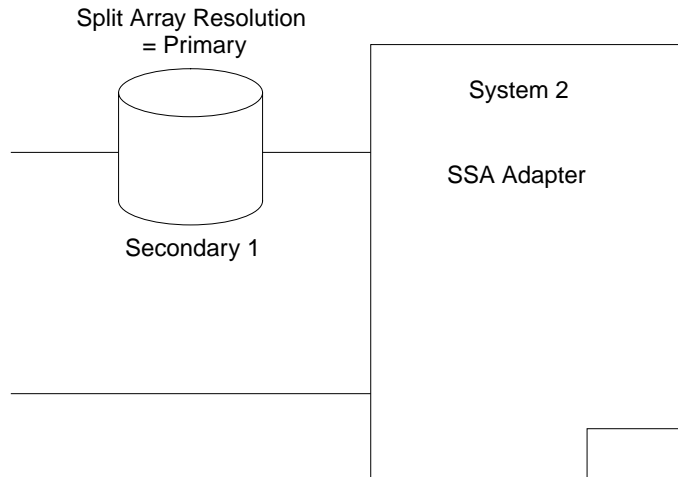

Figure 35. RAID-1 Failure of a Host System and a Primary Disk Drive

RAID-10 Failure of a Host System and a Primary Disk Drive: Figure 36 shows system 2 disconnected from system 1. The array is in the Offline state. If you set Split Array Resolution to **Secondary**, the array goes into the Good state.

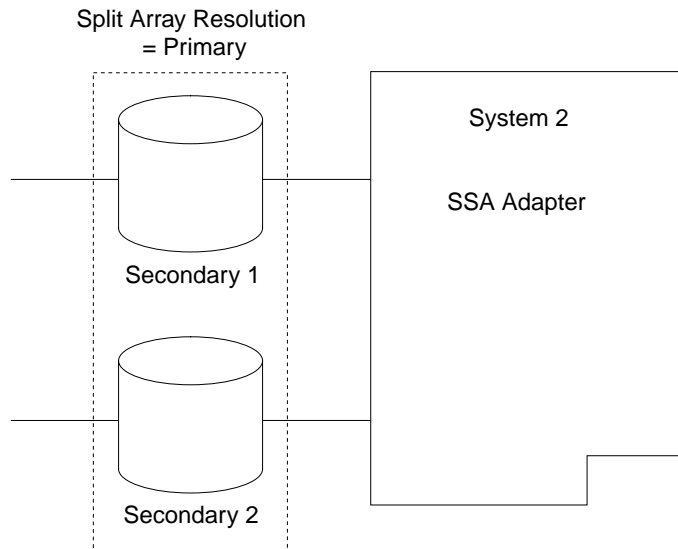

Figure 36. RAID-10 Failure of a Host System and a Primary Disk Drive

Array is Offline because Adapter Is Not Known to the Remaining Half of the Array

When this condition exists, the host system generates SRN 48755.

To maintain data consistency, SSA RAID-1 and RAID-10 arrays keep a record of the adapters to which they are connected. If exactly one half of the array is connected to a different adapter, the array remains in the Offline state unless you take specific action to make the array available.

This type of problem can be caused by:

- Incorrect reconfiguration of an array
- Simultaneous failure of an SSA adapter and a disk drive

Failure of an Adapter and a Disk Drive

In Figure 37, an SSA adapter and a disk drive have failed. When a new adapter is installed, the array remains in the Offline state until the state of the Split Array Resolution flag is changed back to **Primary**.

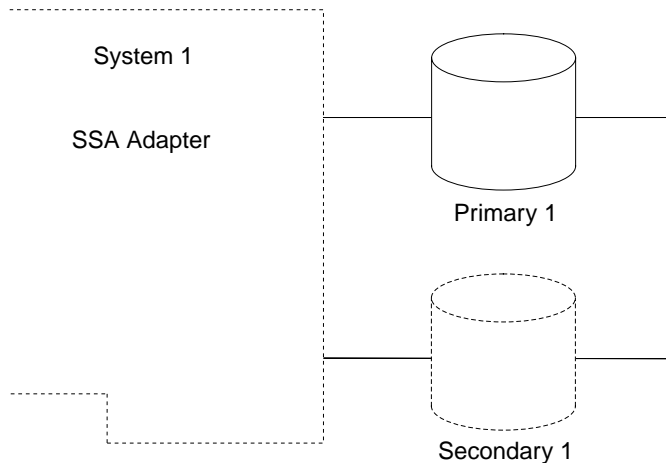

Figure 37. Failure of an Adapter and a Disk Drive

Moving an Array between Systems

In Figure 38, exactly half of a RAID-10 array is being moved from its original connections (adapter A and adapter B) to a new configuration where it is connected to adapter C and adapter D.

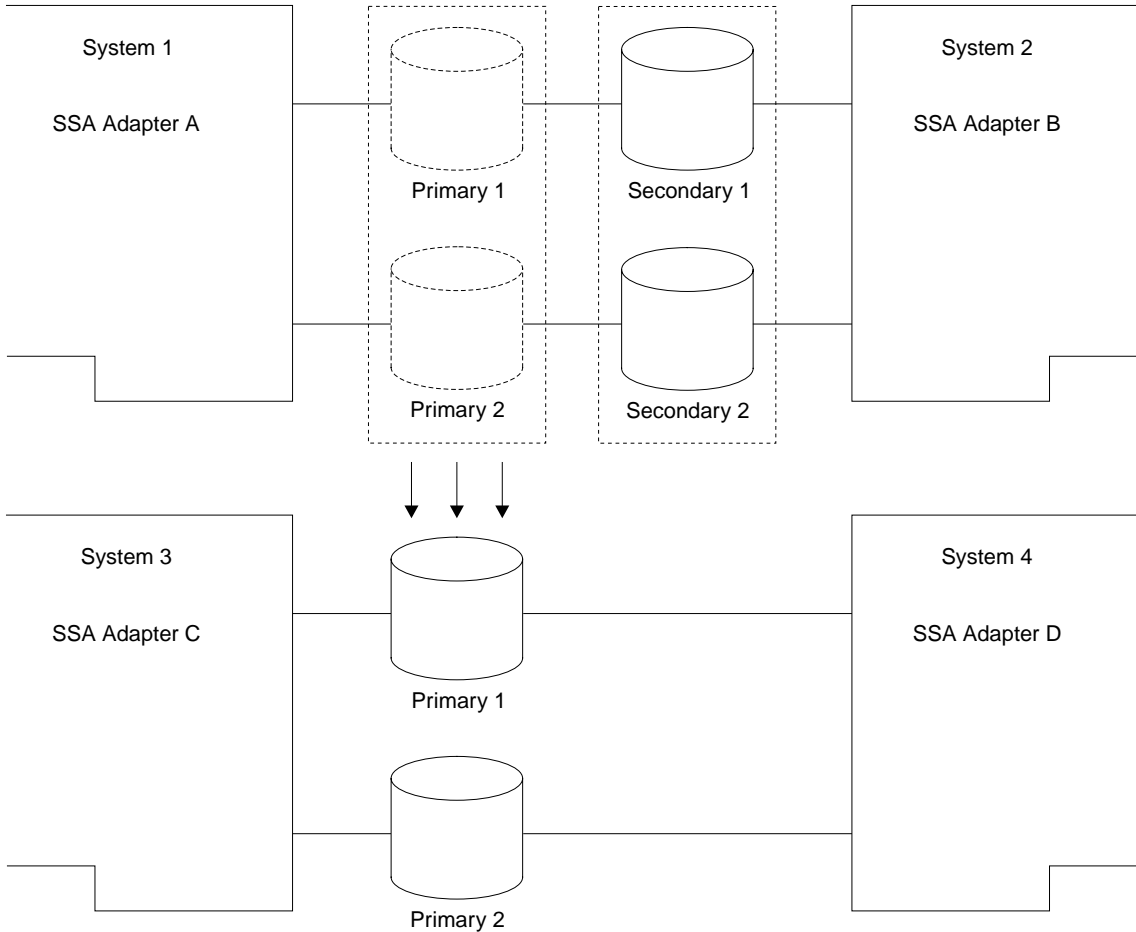

Figure 38. Moving a RAID-10 Array

Under these conditions:

- The half of the array that is still connected to adapter A and adapter B is in the Exposed state.
- The half of the array that is connected to adapter C and adapter D is in the Offline state. System 3 and system 4 generate SRN 48755.

You can solve this problem if you do one of the following:

- Return the primary half of the array to its original adapters.
- Move the secondary half of the array to the new adapters.

- Change the state of the Split Array Resolution flag on the new adapters.

Attention: This method helps you to recover the system from severe errors. Use this method only if the other half of the array has failed completely, and will never be used again.

Array is Offline because the Split and Join Procedure Was Not Performed Correctly

When this condition occurs, the host system generates SRN 48760.

The condition can be caused if a RAID-1 or a RAID-10 array has been split exactly in half, and a separate write operation has been performed to each half of the array.

This problem can occur in a dual-host configuration if:

- Only one adapter can be detected on the SSA loop, you change the state of the Split Array Resolution flag, and a separate write operation is performed to each half of the array.
- Both adapters can be detected on the SSA loop, but one half of the RAID array cannot be detected, and the following sequence of events occurs:
 1. A write operation is performed.
 2. The half of the array that could originally be detected can no longer be detected.
 3. The half of the array that could not originally be detected can now be detected, and data is written to it.
 4. The half of the array that could originally be detected can now be detected again.

The problem can also occur in a single-host system if only one half of the RAID array can be detected, and the following sequence of events occurs:

1. A write operation is performed.
2. The half of the array that could not originally be detected can now be detected.
3. The half of the array that could originally be detected can no longer be detected, and data is written to it.
4. The half of the array that could originally be detected can now be detected again.

RAID-10 Array Split

Figure 39 shows a RAID-10 array that has been split into halves.

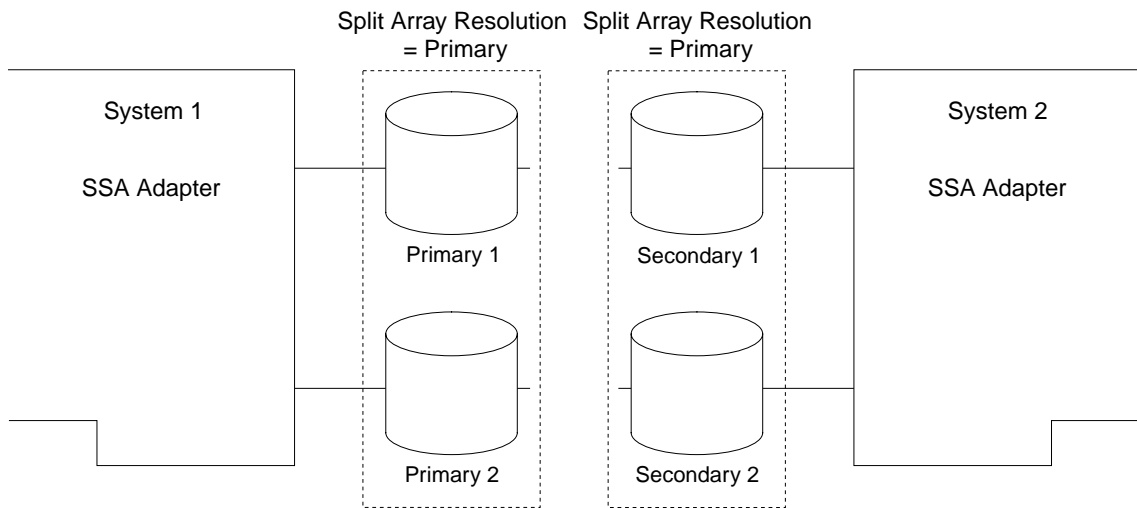

Figure 39. Forcing Access on a RAID-10 Array

The Split Array Resolution flag has been set to **Secondary** to permit I/O operations to be performed on the secondary half of the array. Only user actions can set this condition. Separate write operations can be performed to each half of the array. If these write operations are performed, however, the two halves of the array must not be reconnected.

RAID-10 Array with Unsynchronized Data

Figure 40 shows a RAID-10 array whose halves have been reconnected.

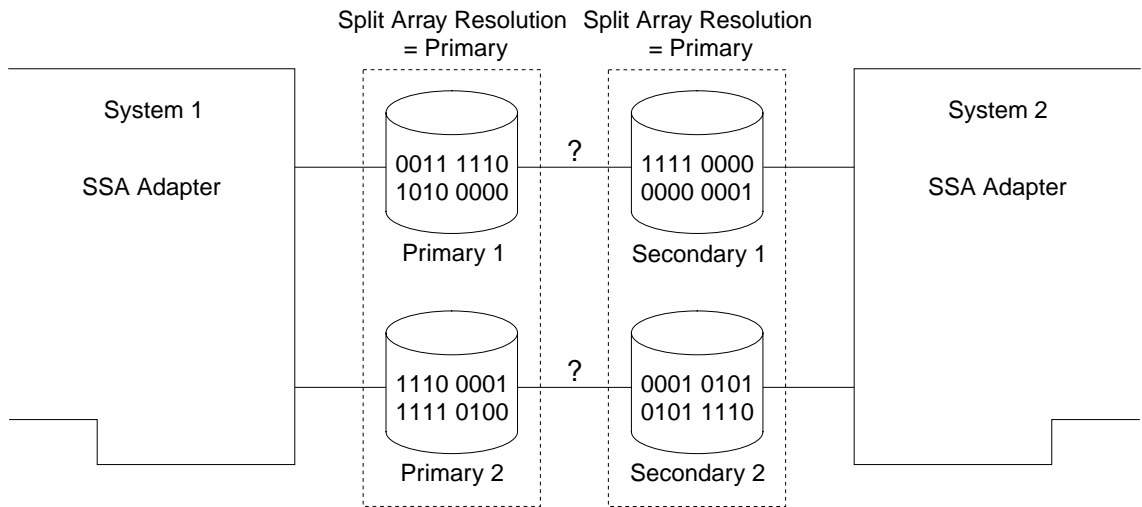

Figure 40. Reconnecting an Unsynchronized Array

Each half of the array contains different data, but no indication is given to which data is valid. Under these conditions, the array is in the Offline state, and both systems generate SRN 48760.

Chapter 9. Using the SSA Spare Tool

The SSA Spare Tool helps you to manage your SSA networks when Logical Volume Manager (LVM) mirrored volume groups are used. It works with the LVM to identify stale partitions or missing physical volumes in LVM mirrored volume groups. If the SSA Spare Tool finds any stale partitions or missing physical volumes:

- It automatically resynchronizes the stale partition if no replacement hardware is needed.
- It sends an email message that describes the actions taken, and indicates whether a disk drive must be exchanged for a new one.
- It logically exchanges the failed disk drive in the volume group with a preassigned spare disk drive. This process is called *hot sparing*.
- It synchronizes the new disk drive with the remaining disk drives in the volume group.
- It notifies you when it has logically exchanged a failed disk drive, and has synchronized the replacement disk drive with the other disk drives in the volume group.

When a failed disk drive has been physically exchanged and the data has been resynchronized, the SSA Spare tool can use various scripts to:

- Move the data from the temporary spare disk drive to the replacement disk drive.
- Prepare the spare disk drive so that it can again be used if another disk drive fails.

To obtain the SSA Spare Tool, go to the uniform resource locator (URL) address, and follow the instructions that are given there. The address is:

<http://www.storage.ibm.com/hardsoft/products/ssa>

Chapter 10. Using the Fast-Write Cache Feature

This chapter describes how to configure the Fast-Write Cache feature, and how to deal with any fast-write problems that might occur during fast-write operations.

Fast-Write Cache Card Battery

The Fast-Write Cache Option Card receives its power from a rechargeable battery. This battery can maintain data in the write cache for seven days after power has been removed from the adapter card. When an adapter is connected to the power, the Fast-Write Option Cache Card performs a fast-charge operation on the battery. This fast-charge operation lasts from 5 to 60 minutes, as determined by the charge state of the battery. During the fast-charge operation, you can enable, and get access to, fast-write disk drives. The fast-write function, however, remains inactive until the battery is fully charged.

Note: To determine whether the fast-write cache is active or inactive, give the command:

```
ssa_fw_status -a ssaX -c
```

The Fast-Write Cache Option Card keeps a record of the age of its battery. When the battery approaches the age at which it might not be able to maintain the data in the fast-write cache for seven days, an error is logged. This error recommends that the battery be exchanged for a new one. At this time, the fast-write cache continues to work normally. If the battery is not exchanged inside approximately three months from the time of the error, the fast-write cache is disabled and a new error is logged. This error indicates that the fast-write cache is no longer active.

Configuring the Fast-Write Cache Feature

This section describes how to use the system management tool (SMIT) to configure and install arrays and disks that have the fast-write attribute. It also gives guidance about the preferred setting for two-way fast-write operation. If you prefer to use the **ssaraid** command through the command line interface instead of through the menus, see Chapter 12, “Using the SSA Command Line Interface for RAID Configurations” on page 235.

You can get access to the SMIT panels by using fast path commands, or by working through the menus. In this chapter, the fast path command for a particular option is given at the start of the description of that option.

Notes:

1. Although this book always refers to the **smitty** commands, you can use either the **smitty** command, or the **smit** command. The procedures that you follow remain the same, whichever of the two commands you use. If you send the **smit** command from a graphics terminal, however, the menus are displayed slightly differently from

those shown in this book. If you are not familiar with the selection of items from the graphics versions of the menus, use the **smitty** command. The menus will then appear as shown in this book.

2. If you use fast-path commands, you might need to go through intermediate steps that are not shown in this book. Also, some menus might be displayed slightly differently from those shown in this book.

Getting Access to the Fast-Write Menus

1. For fast-path access to the Fast-Write SMIT menus, type `smitty ssadlog` and press Enter.
Otherwise:
 - a. Type `smitty` and press Enter. The System Management menu is displayed.
 - b. Select **Devices**. The Devices menu is displayed.
 - c. Select **SSA Disks**. The SSA Disks menu is displayed.
 - d. Select **SSA Logical Disks**.
2. The SSA Logical Disks menu is displayed:

```
SSA Logical Disks

Move cursor to desired item and press Enter.

List All Defined SSA Logical Disks
List All Supported SSA Logical Disks
Add an SSA Logical Disk
Change/Show Characteristics of an SSA Logical Disk
Remove an SSA Logical Disk
Configure a Defined SSA Logical Disk
Generate an Error Report
Trace an SSA Logical Disk
Show Logical to Physical SSA Disk Relationship
List Adapters Connected to an SSA Logical Disk
List SSA Logical Disks Connected to an SSA Adapter
Identify an SSA Logical Disk
Cancel all SSA Disk Identifications
Enable/Disable Fast-Write for Multiple Devices

F1=Help      F2=Refresh   F3=Cancel    F8=Image
F9=Shell     F10=Exit    Enter=Do
```

If you want to enable or disable a fast-write attribute for one logical disk drive, see “Enabling or Disabling Fast-Write for One Disk Drive” on page 214.

If you use the two-way fast-write function, and you want to disable the fast-write attribute for a disk drive if the partner adapter becomes not accessible, see “Bypassing the Cache in a One-Way Fast-Write Network” on page 217.

Enabling or Disabling Fast-Write for One Disk Drive

This option lets you enable or disable the fast-write function for one disk drive.

1. For fast-path access to the Change/Show Characteristics of an SSA Logical Disk menu:
 - a. Type `smitty chgssardsk` and press Enter.
 - b. From the menu displayed, select the logical disk that you want to change.

Otherwise:

- a. Select **Change/Show Characteristics of an SSA Logical Disk** from the SSA Logical Disks menu.
- b. From the menu displayed, select the logical disk that you want to change.

A list of options for the logical disk drives is displayed:

```
Change/Show Characteristics of an SSA Logical Disk

Type or select values in entry fields.
Press Enter AFTER making all desired changes.

[MORE...6]                                     [Entry Fields]
Location Label                                 [ ]
Parent                                         ssar
Size in Megabytes                             4512
adapter_a                                     ssa0
adapter_b                                     ssa1
primary_adapter                               adapter_a +
Connection address                           0004AC506C3600E
Physical volume IDENTIFIER                   00406fdac2fb8203000000>
ASSIGN physical volume identifier            no +
RESERVE disk on open                         yes +
Queue depth                                  [5] +
Maximum Coalesce                             [0x20000] +
Enable Fast-Write                            yes +
Bypass Cache In 1 Way Fast-Write Network    no +
[BOTTOM]
F1=Help          F2=Refresh          F3=Cancel          F4=List
F5=Reset         F6=Command          F7=Edit           F8=Image
F9=Shell         F10=Exit           Enter=Do
```

2. If you want to enable the fast-write function for a particular disk drive, set the **Enable Fast Write** option to **yes** for that disk drive.

If you want to disable the fast-write function for a particular disk drive, set the **Enable Fast Write** option to **no** for that disk drive.

Notes:

- a. If you are running a two-way fast-write operation, and you enable or disable the fast-write function, the hdisk on the second using system becomes unavailable. From the second using system, delete that hdisk, and reconfigure as follows:
 - 1) Type: `rmdev -l hdiskname -d`
 - 2) Run `cfgmgr` to reconfigure the new hdisk.
- b. You can disable the fast-write function from this menu only if no data for your selected device is present in the fast-write cache. If data for your selected

device is present in the fast-write cache, and you want to disable the fast-write function, go to “Enabling or Disabling Fast-Write for Multiple Devices”.

Enabling or Disabling Fast-Write for Multiple Devices

This option allows you to enable or disable the fast-write function on multiple devices. You can select multiple devices from the list that this option displays. The displayed list contains also offline and broken cache items, so that you can delete them.

1. For fast path access to the Enable/Disable Fast Write for Multiple Devices menu:
 - a. Type `smitty ssafastw` and press Enter.
 - b. From the menu displayed, select all the logical disk drives for which you are enabling or disabling the fast-write function.

Otherwise:

- a. Select **Enable/Disable Fast Write for Multiple Devices** from the SSA Logical Disks menu.
 - b. From the menu displayed, select all the logical disk drives for which you are enabling or disabling the fast-write function.
2. The Enable/Disable Fast Write for Multiple Devices menu appears:

```
Enable/Disable Fast Write for Multiple Devices

Type or select values in entry fields.
Press Enter AFTER making all desired changes.

List of Devices          [Entry Fields]
Enable Fast Write       hdisk1
Force Delete            no
                       no

[BOTTOM]
F1=Help                 F2=Refresh             F3=Cancel              F4=List
F5=Reset                F6=Command             F7=Edit                F8=Image
F9=Shell                 F10=Exit               Enter=Do
```

If you want to enable the fast-write function for the selected disk drives, set the **Enable Fast Write** option to **yes** for those disk drives. The state of the **Force Delete** option is ignored.

If you want to disable the fast-write function for the selected disk drives, set the **Enable Fast Write** option to **no** and the **Force Delete** option to **no** for those disk drives.

Notes:

- a. If you are running a two-way fast-write operation, and you enable or disable the fast-write function, the hdisk on the second using system becomes unavailable. From the second using system, delete that hdisk, and reconfigure as follows:
 - 1) Type: `rmdev -l hdiskname -d`
 - 2) Run `cfgmgr` to reconfigure the new hdisk.
 - b. The fast-write function is disabled only if no data for your selected devices is present in the fast-write cache. If data for your selected devices is present in the fast-write cache, and you want to disable the fast-write function, go to step 3.
3. If data for your selected devices is present in the fast-write cache, and you want to disable the fast-write function, set the **Enable Fast Write** option to **no**, and the **Force Delete** option to **yes**. The Force Delete screen is displayed:

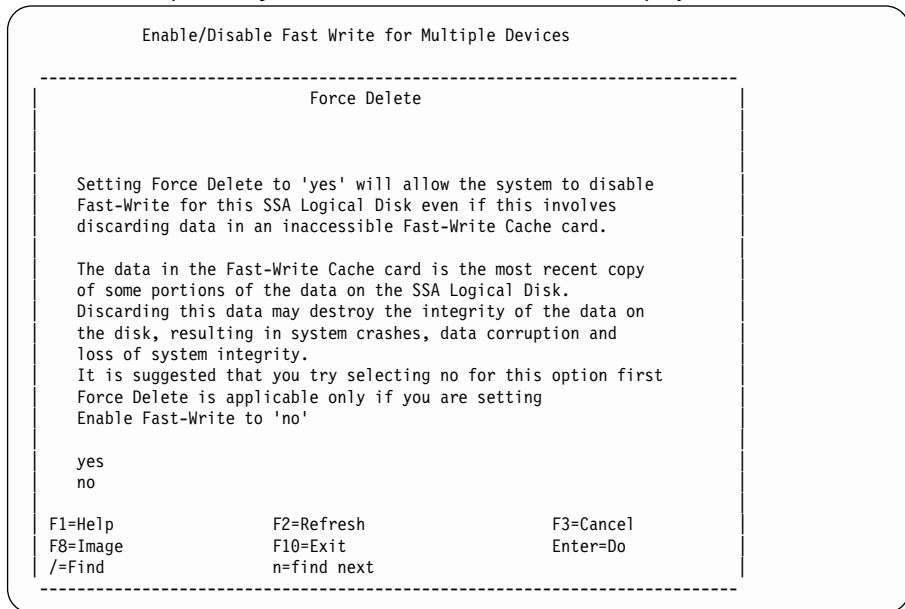

Bypassing the Cache in a One-Way Fast-Write Network

If you are using the two-way fast-write function (that is, two adapters have access to a fast-write disk drive), you can choose whether you want fast-write operations to continue if the partner adapter fails or becomes not accessible. By default, fast-write operations continue.

1. For fast-path access to the Change/Show Characteristics of an SSA Logical Disk menu:
 - a. Type smitty chgssardsk and press Enter.
 - b. From the menu displayed, select the logical disk that you want to change.

Otherwise:

- a. Select **Change/Show Characteristics of an SSA Logical Disk** from the SSA Logical Disks menu.
- b. From the menu displayed, select the logical disk that you want to change.

A list of options for the logical disk drives is displayed:

```

Change/Show Characteristics of an SSA Logical Disk

Type or select values in entry fields.
Press Enter AFTER making all desired changes.

[MORE...6]                                     [Entry Fields]
Location Label                                 [ ]
Parent                                         ssar
Size in Megabytes                             4512
adapter_a                                     ssa0
adapter_b                                     ssa1
primary_adapter                               adapter_a                                     +
Connection address                           0004AC506C3600E
Physical volume IDENTIFIER                   00406fdac2fb8203000000>
ASSIGN physical volume identifier             no                                             +
RESERVE disk on open                         yes                                             +
Queue depth                                  [5]                                           +
Maximum Coalesce                             [0x20000]                                     +
Enable Fast-Write                            yes                                             +
Bypass Cache In 1 Way Fast-Write Network     no                                             +
[BOTTOM]
F1=Help          F2=Refresh          F3=Cancel          F4=List
F5=Reset         F6=Command          F7=Edit           F8=Image
F9=Shell         F10=Exit             Enter=Do
  
```

2. If you do not want the fast-write function to continue on a particular disk drive if the partner adapter becomes not accessible, set the **Bypass Cache in 1 Way Fast-Write Network** flag to **yes** for that disk drive. With the flag set to **yes**, an error is logged when the cache is bypassed.

If you want the fast-write function to continue on a particular disk drive if the partner adapter becomes not accessible, set the **Bypass Cache in 1 Way Fast-Write Network** flag to **no** for that disk drive.

Dealing with Fast-Write Problems

This section describes how to recover from problems that might occur during fast-write operations. The type of problems are those in which data loss might have occurred or customer data recovery procedures need to be performed. These problems are indicated by any of the following Service Request Numbers (SRNs):

- 42521
- 42524
- 42525

If any of these SRNs occurs, do the following actions:

1. Go to “Service Request Numbers (SRNs)” on page 411, and find the SRN.
2. Do the actions that are given for the SRN, and come to this section when the actions tell you to do so.

Important: *Do not come to this section until the SRN actions tell you to do so.*

3. Find the SRN in this section, and do the actions given.

SRN 42521

You can use the **ssaraid** command to list the devices that are affected by this failure. The **ssaraid** command is in /usr/sbin.

- To list all devices that are affected by this cache failure, type:

```
ssaraid -l ssaX -Iz -a state=cache_data_error
```

where X is the number of the adapter that has reported the failure in the error log; for example, ssa3. The output from the command produces one line of information for each device, as follows:

```
2327340C228635K 2327340C228635K cache_data_error      9.1GB RAID-5 array
hdisk3          2327340C423235K cache_data_error      36.4GB RAID-5 array
pdisk5          08005AEA045E00D free                n/a 9.1GB Physical disk
```

For non-RAID disk drives, the pdisk is listed with the pdisk state. No array resource state exists.

For RAID arrays, the hdisk is listed with the array resource state.

The location of the corrupted data is not known, and no simple data recovery procedure is possible. To attempt data recovery, you must disable the fast-write cache, then make the devices available again.

- To disable the fast-write cache, type:

```
ssaraid -l ssaX -H -n Y -a fastwrite=off -a force=yes -u
```

where X is the number of the adapter that has reported the failure, and Y is the name of the device. (The name of the device can be either the logical disk name, or the SSA serial number.) A typical command line might be, therefore:

```
ssaraid -l ssa3 -H -n pdisk5 -a fastwrite=off -a force=yes -u
```

or:

```
ssaraid -l ssa3 -H -n 2327340C423235K -a fastwrite=off -a force=yes -u
```

The force attribute ensures that all data is lost from the fast-write cache. You cannot recover that data. The force attribute also prevents the reattachment of the disk to the using system; no logical disk can, therefore, be created. The actions of the force attribute are important, because the lost data might include file system metadata. If that data is damaged as a result of the fast-write cache failure, further data loss and system crashes might occur when you attempt to restart the file system.

When the fast-write cache has been disabled, you can attempt to recover the data on the device.

Attention: Ensure that the disk is not returned with its current use defined as **System Disk**, until you are sure that the file system is safe.

- To reattach the disk and create a logical disk, type:

```
ssaraid -l ssaX -H -n Y -a use=system -k Z -d
```

where X is the adapter number, Y is the 15-digit device serial number from the list function that you ran earlier, and Z is the name of a logical disk. For the logical disk, choose a name that is different from the names of existing logical disks. This action ensures that the logical disk that you have created is not automatically attached if the using system crashes and reboots.

When this operation has completed, a message is displayed. This message tells you that the logical disk (Z) has been attached, and that the device (/dev/Z) can be accessed. For example:

```
ssaraid -l ssa3 -H -n 2327340C228635K -a use=system -k ZZDataRecovery -d
```

```
2327340C228635K attached  
ZZDataRecovery Available
```

where /dev/ZZDataRecovery is the device.

You can now use standard commands (for example, **fsck** and **fsdb**) to attempt to repair any possible damage to the file system, before you attempt data recovery.

SRN 42524

If a Fast-Write Cache Option Card fails, or is removed from the adapter, the affected devices are all those that contain unsynchronized data when the cache card fails, or is removed. To list these devices, type:

```
ssaraid -l ssaX -Iz -a state=no_cache
```

where X is the adapter number. Use the recovery procedure that is described for SRN 42521. You must recover all the devices that are listed.

SRN 42525

If a Fast-Write Cache Option Card fails, or is removed from the adapter, the affected devices are all those that contain unsynchronized data when the cache card fails, or is removed. To list these devices, type:

```
ssaraid -l ssaX -Iz -a state=wrong_cache
```

where X is the adapter number. Use the recovery procedure that is described for SRN 42521. You must recover all the devices that are listed.

Chapter 11. SSA Error Logs

This chapter describes:

- Error logging
- Error logging management
- Error log analysis
- Good housekeeping

Each topic is discussed as a *summary*, then as a *detailed description*.

The summaries provide all the information that you need for routine service operations on SSA subsystems. For these operations, you have no need to inspect the system error log, or to attempt to analyze the contents of the log.

The detailed descriptions help you understand the meaning of the error log data so that you can further analyze the error log. For example, you might decide to fail-over an HACMP system when particular critical failures are logged.

Error Logging

Summary

Hardware errors can be detected by an SSA disk drive, an SSA Adapter, or the SSA device driver. The SSA adapter performs error recovery for disk drive errors; the SSA device driver performs error recovery for the SSA adapter. When a problem is detected that needs to be logged, all the relevant data is sent to the error logging service in the device driver. The error logging service then sends the data to the system error logger.

SSA errors are logged asynchronously; that is, independently of any system I/O activity. For example, if an SSA cable is unexpectedly disconnected, an Open Serial Link error is logged immediately. The SSA subsystem does not wait for a read or write command before it logs the error.

Sometimes, on the SSA network, the SSA adapter and SSA disk drives detect errors that were possibly caused by activities elsewhere on the network. (Such activities might be the rebooting of another using system, a system upgrade, or maintenance.) These errors do not need any service action, and should not cause any problem unless the automatic error log analysis determines that the error is critical.

Because SSA subsystems are designed for high availability, most subsystem errors do not cause I/O operations to fail. Some errors, therefore, might not be obvious to the user. To ensure that the user knows about such errors, a health-check is run to the adapter each hour. This health-check is started by a cron table entry that instructs the `run_ssa_healthcheck` shell script to run once each hour. When an SSA adapter receives a health-check, it logs any currently-active errors and conditions that it knows exist on the SSA subsystem.

Detailed Description

SSA error logs are grouped into types of errors. Each type of error is assigned to an Error Label and an Error ID. The Error Label specifies the text that appears when the error log is displayed. It also specifies the priority that is applied to each error type when the cause of a problem is determined. The Error ID is a numeric identifier for the Error Label. Table 2 shows the error labels that SSA subsystems use.

Table 2. Error Labels

Error Label	Error ID	Error Description
DISK_ERR1	21F54B38	An unrecovered media error has been detected. The problem will be solved automatically when data is next written to the failing block. If you are using RAID-5, no application has failed. If you are not using RAID-5, an application might have had a media error. Run error log analysis to determine whether the disk drive has become unreliable and should be exchanged for a new one.
DISK_ERR4	1581762B	A recovered media error has been detected. An occasional recovered media error is not serious. Multiple media errors per day on one disk drive, however, might indicate that the disk drive is failing. Run error log analysis to determine whether the disk drive should be exchanged for a new one.
SSA_ARRAY_ERROR	B4C00618	A RAID array failure has been detected, and the array is not fully operational. Usually, the data on the array is safe, but ensure that you follow the service procedures exactly so that you do not lose any data.
SSA_CACHE_ERROR	BC31DEA7	These errors indicate that the fast-write cache has detected a problem. Usually, the problem has been caused by user or service actions, such as moving a Fast-Write Cache Option card from one adapter to another, or moving a disk drive between adapters before the data in the cache card has been synchronized with the data on the disk drive. Take care when moving cache cards, or adapters that contain cache cards, because they might contain data that needs to be synchronized. Always follow the service procedures for the SRN carefully to ensure that you do not lose any data.
SSA_CACHE_BATTERY	26CA120B	This error recommends that the battery of the Fast-Write Cache Option card be exchanged for a new one.
SSA_DEGRADED_ERROR	3DB7729E	An error or condition has occurred that might cause some of the SSA functions to be unavailable or to be working with reduced performance.
SSA_DETECTED_ERROR	EC9903DF	Errors of this type are logged by the adapter when a device failure has been reported via SSA asynchronous messages. Because the system name of the device, or devices, that are sending these messages is not known, the error is logged against the adapter. The SRN indicates the service procedures that must be performed.

Table 2. Error Labels (continued)

Error Label	Error ID	Error Description
: SSA_DEVICE_ERROR	FE9E9357	<p>This error can be logged against the adapter or disk drive resource.</p> <p>When the error is logged against a disk drive, it indicates that the adapter has detected a failure on the disk drive. It is possible, however, that the failure was detected because the disk drive was unavailable for a short period. Run the error log analysis to determine whether the disk drive should be exchanged for a new one.</p> <p>When the error is logged against the adapter, it indicates that the adapter has received a report of a status that is not valid. The adapter cannot, however, determine which disk drive sent the bad data. Run diagnostics to all SSA disk drives. If no failure is found, the log might have been caused by a link error.</p>
: SSA_DISK_ERR1	1D2E2C3B	<p>An SSA disk drive has received a command or parameter that is not valid. This error might be caused by:</p> <ul style="list-style-type: none"> • A software error in the adapter • A software error in the disk drive • A hardware error
: SSA_DISK_ERR2	928F5165	The disk drive has performed an internal error recovery operation. No action is needed.
: SSA_DISK_ERR3	8BDD5B42	The disk drive has performed internal media maintenance. No action is needed.
: SSA_DISK_ERR4	F7863CFE	<p>One of the following has occurred:</p> <ul style="list-style-type: none"> • The disk drive has had an unrecovered hardware error. • The disk drive has had a hardware error that is now recovered, but the disk drive is reporting that it might be going to fail.
: SSA_ENCL_ERR1	BD797922	Errors of this type are logged when an enclosure (for example, a 7133 Model D40 or T40) reports a failure. The SRN indicates the service procedures that must be performed.
: SSA_ENCL_ERR2	A5BED0BC	Errors of this type are logged when an enclosure (for example, a 7133 Model D40 or T40) reports that the ambient temperature is outside the specified limits. The SRN indicates the service procedures that must be performed.
: SSA_HDW_ERROR	05F97A32	A hardware failure has occurred. Run diagnostics in Problem Determination mode to determine which FRUs to exchange for new FRUs.
: SSA_HDW_RECOVERED	B3FF2B19	A hardware error has occurred that has been recovered by the error recovery procedures. Run error log analysis to determine whether a FRU needs to be exchanged for a new FRU.

Table 2. Error Labels (continued)

Error Label	Error ID	Error Description
: SSA_LINK_ERROR	ABECECFD	Link errors might be detected by any node in the SSA loop. The adapter is notified of these errors. It performs any necessary error recovery, and logs the error. Link errors are normally associated with some other failure on the SSA loop. Link errors might be logged when other devices on the loop are switched on or off, or when cables or devices are disconnected during service activity. Intermittent link errors are not serious. If many link errors occur, however, one of the SSA links might be going to fail. Run error log analysis to determine whether any repair action is needed.
: SSA_LINK_OPEN	625E6B9A	SSA devices are normally configured in a closed loop. The loop consists of a series of links, each link connecting two SSA devices. A device can be an adapter card or a disk drive. If this loop becomes broken, the alternative signal path round the loop is automatically used. A link might be broken if: <ul style="list-style-type: none"> • A device is removed from the loop • A device on the loop is reset or switched off, or it fails • An SSA cable is removed, or it fails Each SSA device has a Ready light that indicates the operational status of the SSA loop to which that device is attached. The light is permanently on when the device can communicate with the two SSA devices that are logically next to it on the SSA loop. The light flashes if the device can communicate with only one of those two devices. The light is off if the device cannot communicate with either of the two SSA devices. Usually, an SSA device is present at each side of the point where the SSA loop is broken. Each of those devices has its Ready light flashing.
: SSA_LOGGING_ERROR	610BDA5E	The adapter has passed error log data for a disk drive to the device driver error logger, but the disk drive to which the data is related is not configured into the using system. This problem usually occurs because the disk drive was not available to the adapter when the cfgmgr command was previously run.
: SSA_SETUP_ERROR	48489B00	A user procedure has not been performed correctly. Use the SRN to determine the procedure that has caused the problem.
: SSA_SOFTWARE_ERROR	91FBD5DB	The software has detected an unexpected condition. If you have just installed the SSA subsystem, ensure that the latest versions of microcode and software have been installed. If the system is still operational and you have any hot spare disk drives attached to the adapter, an automatic dump might have been performed. Run ssa_getdump -l to see if any dump data is present. Software errors can result from hardware failures. Always solve hardware problems, therefore, before looking for software errors.

Disk drive errors on SSA subsystems are logged against the physical disk drive (pdisk) rather than the logical disk drive (hdisk). If you are looking for the cause of a problem where the failing hdisk is known, you can use either of the following methods to find that cause:

- Use the Configuration Verification service aid, or give the **ssaxlate -I hdisk** command, to determine which pdisks are associated with the hdisk.
- Give the **ssa_ela -I hdisk** command to run error log analysis. When ssa_ela is run to an hdisk, it performs an error log analysis for all the devices that support that hdisk. Those devices are one or more adapters and one or more pdisks.

The following example shows a part of an SSA error log. See the using-system documentation for a detailed description of all the fields that appear in the error log display.

```
LABEL:          SSA_LINK_OPEN
IDENTIFIER:     625E6B9A

Date/Time:      Tue 23 Sep 03:00:00
Sequence Number: 640
Machine Id:     00400076C400
Node Id:        identity
Class:          H
Type:           PERM
Resource Name:  ssa0
Resource Class: adapter
Resource Type:  ssa
Location:       04-07
```

The Type field can have the following flags: PEND, PERF, PERM, TEMP, UNKN, and INFO. These flags are described in the using-system documentation. The PERM flag, however, is also described here because the SSA definition of the flag is slightly different from the using-system software definition.

The PERM flag is used to log many SSA errors. The using-system software defines the PERM flag as an error from which recovery is not possible. For SSA devices, the error, although possibly permanent, is not necessarily obvious to the customer. The PERM flag is used here to ensure that when diagnostics are run in Problem Determination mode, the SSA error log analysis runs, and any problems that need service action are identified.

Detail Data Formats

The Detail Data fields of SSA error logs use two data formats:

- SCSI Sense Data format
- SSA Error Code format

SCSI Sense Data Format: Errors that are logged with the following labels have SCSI sense data in the detail data field in the error log:

DISK_ERR1	SSA_DISK_ERR2
DISK_ERR4	SSA_DISK_ERR3
SSA_DISK_ERR1	SSA_DISK_ERR4

SCSI sense data consists of 32 bytes of data. See “Error Log Analysis” on page 229 to find out how this data is used.

SSA Error Code Format: Errors that are logged with the following labels have SSA error code data in the detail data field in the error log:

SSA_ARRAY_ERROR	SSA_HDW_ERROR
SSA_CACHE_BATTERY	SSA_HDW_RECOVERED
SSA_CACHE_ERROR	SSA_LINK_ERROR
SSA_DEGRADED_ERROR	SSA_LINK_OPEN
SSA_DETECTED_ERROR	SSA_LOGGING_ERROR
SSA_DEVICE_ERROR	SSA_REMOTE_ERROR
SSA_ENCL_ERR1	SSA_SETUP_ERROR
SSA_ENCL_ERR2	SSA_SOFTWARE_ERROR

The SSA Error code data format consists of three bytes of error code followed by up to 153 bytes of debug data. See “Error Log Analysis” on page 229 to find out how this data is used.

run_ssa_healthcheck cron

The run_ssa_healthcheck program checks for SSA subsystem problems that do not cause I/O errors, but cause some loss or redundancy or functionality. It reports such errors each hour until the problem is solved. During SSA device driver installation, the following entry is added to the cron table:

```
0 * * * * /usr/lpp/diagnostics/bin/run_ssa_healthcheck 1>/dev/null 2>/dev/null
```

This run_ssa_healthcheck program sends a command to the adapter. The command causes the adapter to write a new error log entry for any problems that it can detect, although those problems might not be causing any failure in the user's applications. Such problems include:

- Adapter hardware faults
- Adapter configuration problems
- RAID array problems
- Fast-write cache problems
- Open serial link conditions
- Link configuration faults
- Disk drives that are returning Check status to an inquiry command

- Redundant power failures in SSA enclosures

The test runs hourly at a specific time in the hour.

run_ssa_link_speed cron

SSA links can run at 20 MB per second or at 40 MB per second. Normally, two SSA nodes that can communicate at 40 MB per second operate the link between them at 40 MB per second. Some faults, however, can cause a 40-MB-per-second link to run at only 20 MB per second. The `run_ssa_link_speed` program detects when a pair of high-speed nodes are running at low speed. The following entry is added to the cron table to invoke this program at 04:30 each day:

```
30 4 * * * /usr/lpp/diagnostics/bin/run_ssa_link_speed 1>/dev/null 2>/dev/null
```

If the program detects a problem, it sends an error code to the system error log.

You can also use the `ssa_speed -x` command to check whether any high-speed nodes are running at low speed (see “`ssa_speed` Command” on page 369.).

Duplicate Node Test

The `node_number` attribute of the `ssar` can be set to enable SSA disk fencing or SSA target mode operations. It is important, however, that duplicate node numbers do not exist on the subsystem. Each hour, therefore, the device driver performs a duplicate-node-number test. If this test finds a duplicate node number, it logs an error code under the `SSA_SETUP_ERROR` label. The device driver continues to log this error each hour until the problem is solved. This test runs separately from the `run_ssa_healthcheck`. The test is run hourly but not at any specific time in the hour.

Error Logging Management

Summary

If an error is permanent, it is reported each time that the health check is run. If an error is intermittent, it is logged each time that it occurs. Because a particular error need be logged only a defined number of times for the automatic error log analysis to determine that service activity is needed, the device driver stops the repeated logging of the same error. If error logging were not managed in this way, a repeated error could fill the error log and hide other errors that other components in the system might have logged. If error logging management is active for one type of error, a different type of error can still be sent to the error log. All types of error are, therefore, logged.

Detailed Description

Error logging management is performed for the following error types:

:	DISK_ERR4	SSA_ENCL_ERR2
	SSA_CACHE_BATTERY	SSA_HDW_ERROR
	SSA_CACHE_ERROR	SSA_HDW_RECOVERED
	SSA_DEGRADED_ERROR	SSA_LINK_ERROR
	SSA_DETECTED_ERROR	SSA_LINK_OPEN
	SSA_DEVICE_ERROR	SSA_LOGGING_ERROR
	SSA_DISK_ERR1	SSA_REMOTE_ERROR
	SSA_DISK_ERR4	SSA_SETUP_ERROR
:	SSA_ENCL_ERR1	SSA_SOFTWARE_ERROR

If one of these error types is permanent on a particular device, it is reported each time that the health check is run. The SSA adapter sends the resulting error-log entries to the device driver. The device driver error logger permits these error-log entries to be sent on to the error log until the number of entries for that error reaches a predetermined *threshold value*. After that value is reached, no more entries of that type are made for that device until the first error has been in the log for at least six hours.

The example in Figure 41 on page 229 shows an open-link error occurring. This type of error has a logging threshold value of three. The error is logged when the link is first broken (in this example, at about 04:30). The error is then logged each hour as a result of the health check.

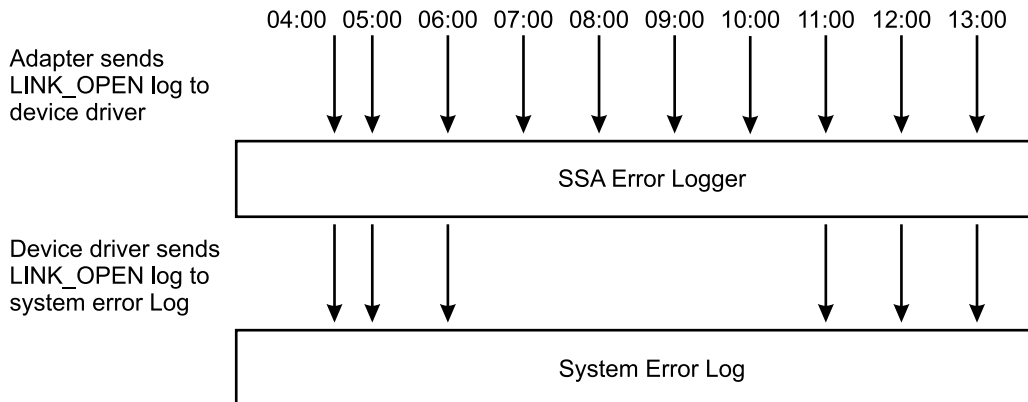

Figure 41. Example of an Open Link Error

The example also shows that, during any six hour period, no more than three errors of this type are sent to the error log. If other types of error occur for this device, or errors occur for another device, they are sent immediately to the error log. The actual threshold values that are used for any given error type are regularly reviewed, and might change with any new version of the device driver. They always permit, however, enough errors to be logged to ensure that the error log analysis produces an SRN when any service action is required.

Error Log Analysis

Summary

The error log is analyzed automatically every 24 hours. This automatic error log analysis is started by the `run_ssa_ela` cron job. If the results of the analysis show that any service activity is needed, the automatic error log analysis:

1. Sends an operator message (OPMSG) to the error log.
2. Displays an error message on `/dev/console`.
3. Sends a mail message to `ssa_adm`. The name `ssa_adm` is an alias (alternative) address that is set up in `/etc/aliases`. By default, `ssa_adm` is set to `root`. You can, however, change this alias to any valid mail address for your using system. See your using-system documentation for information about how to change alias addresses.

Error log analysis also runs automatically each time that diagnostics run in Problem Determination mode. In this mode, the error log analysis runs before any diagnostic test is run to the SSA devices. Diagnostics in Problem Determination mode, therefore, generate an SRN if any SSA error logs show that service activity is needed.

If you run the `ssa_ela` command from the command line, you can also run error log analysis to **all** SSA devices that are attached to a system.

If SD/6000 is installed on the system, it runs error log analysis whenever a hardware error is logged, and raises an incident if problems are found that need service activity.

Detailed Description

Error log analysis determines whether the data that is in the error log indicates that service activity is needed on the subsystem. The analysis uses the detailed data that is logged with each error. If service activity is needed, an SRN is produced. This SRN provides an entry point into the maintenance procedures that are given either in this book or in the *Service Guide* for the SSA subsystem. (See “Service Request Numbers (SRNs)” on page 411 for more information about SRNs.)

Error log analysis can be started in several ways:

- If you run diagnostics in Problem Determination mode to an SSA device, one of the following procedures occurs:
 - An error log analysis is performed for all SSA devices if any SSA device has a permanent (PERM) error in the error log.
 - An error log analysis is performed for that device before the physical device is tested. If errors are found, no test is performed on the hardware.
- Error log analysis is performed every 24 hours by the run_ssa_ela cron (see “run_ssa_ela cron” on page 232).

- You can use the **diag** command to run error log analysis. On the command line, enter:

```
diag -ecd [device]
```

Error log analysis runs for the selected device. If the analysis determines that service action is needed, a message is displayed. This message indicates that a problem was detected, and requests that diagnostics be run to that device.

- You can run error log analysis to all SSA devices. On the command line, enter:

```
ssa_ela
```

A list of SRNs for all SSA devices that need service action is displayed.

- You can run error log analysis for selected SSA devices. On the command line, enter:

```
ssa_ela [device]
```

The device that is selected can be an SSA adapter, a pdisk, or an hdisk. If an hdisk is selected, the error log analysis runs for the adapters that control the selected hdisk and the pdisk (or pdisks if it is a RAID array) that makes up the hdisk.

- If SD/6000 is installed on the using system, and a hardware error is logged, the SD/6000 runs error log analysis and reports an incident if problems are found that need service activity.

Error Log Analysis Routine

The purpose of the SSA error log analysis routine that is contained in the diagnostics is to generate an SRN for any logged errors that need service action. Normally, the error-log-analysis is related to the previous 24-hour period. If you want to perform an

error log analysis that is related to a period longer than 24 hours, use the **ssa_ela** command (see “Command Line Error Log Analysis” on page 232).

If the **detail data** field for the error record contains SCSI sense data:

- SSA_DISK_ERR2 or SSA_DISK_ERR3 type errors do not generate an SRN.
- DISK_ERR1 or DISK_ERR4 type errors (media errors) generate an SRN if more than a predetermined number of these errors exist in the log. The SRN is 1XXXX, where XXXX is the contents of bytes 20 and 21 of the detail data.
- SSA_DISK_ERR1 or SSA_DISK_ERR4 type errors generate the SRN 1XXXX, where XXXX is the contents of bytes 20 and 21 of the detail data.

If the **detail data** field contains SSA error code data, the first character of the data is used as an error-log-analysis threshold value. If the number of times that a particular error has been logged during the previous 24 hours is greater than the threshold value for that error, an SRN is generated. This SRN is generated from the next 5 characters of the detail data.

Examples:

- The following is logged for ssa0:

```
0400 0000 0000 00.. .... .... ....
```

Error log analysis produces SRN 40000.

- The following is logged for ssa0:

```
2450 1000 0000 00.. .... .... ....
```

Error log analysis produces SRN 45010 only if this error has occurred three times for ssa0 during the previous 24 hours.

If more than one type of error exists in the error log for a device, the error log analysis determines which error code has the highest priority, and returns that error code as the result of the analysis. Usually, the action of correcting the highest-priority error also corrects the lower-priority problems.

Command Line Error Log Analysis

A command line utility has been provided that allows you to run SSA error log analysis from a manually-entered command or from shell scripts. The utility is `ssa_ela`. It can perform SSA error log analysis on:

- All SSA devices
- A selected hdisk
- A selected pdisk
- A selected adapter
- Any of the above items for a history period of up to seven days

See “`ssa_ela` Command” on page 353 for details of how to use the utility.

run_ssa_ela cron

During installation of the SSA device drivers, the following entry is added to the cron table:

```
01 5 * * * /usr/lpp/diagnostics/bin/run_ssa_ela 1>/dev/null 2>/dev/null
```

This cron entry instructs the `run_ssa_ela` shell script to run at 05:01 each day for all SSA devices that are configured in the using system. The shell script analyzes the error log. If it finds any problems, the script warns the user in the following ways. It sends:

- A message to `/dev/console`. This message is displayed on the system console.
- An OPMSG to the error log. This message indicates the source of the error.
- A mail message to `ssa_adm`.

Note: `ssa_adm` is an alias address that is set up in `/etc/aliases`. By default this address is set to “root”, but you can change it to any valid mail address for the using system.

Good Housekeeping

The items described here can help you ensure that your SSA subsystem works correctly.

- When you are installing your SSA subsystem, ensure that `ssa_adm` is set to an address that is suitable for your installation.
- Regularly view the mail messages or OPMSGs that are in the error log, to determine whether the automatic error log analysis has detected any errors.
- If the automatic error log analysis has detected errors, but the diagnostics do not generate an SRN, run an error log analysis with the history option set. Type:
`ssa_ela -l Device [-h timeperiod]`

where `timeperiod` is the number of 24-hour periods.

Set `timeperiod` to include at least the 24 hours that preceded the error. For example, if at 09:00 on Monday you find that the error log analysis has reported an error on `pdisk3` at 05:01 on Sunday, type:

```
ssa_ela -l pdisk3 -h 3
```

where 3 is the number of 24-hour periods. An SRN for the error is generated.

Note: The error occurred on Sunday. When running the error log analysis, you need to include at least the 24 hours that preceded the error; that is, Saturday. In this example, therefore, `timeperiod` includes Saturday, Sunday, and Monday.

- If application programs fail, run diagnostics in Problem Determination mode to find the SRN.
- Have no concerns about events that occur in the error log, unless an application program fails, or error log analysis generates an SRN.

Chapter 12. Using the SSA Command Line Interface for RAID Configurations

You can use the **ssaraid** command from the command line instead of the from the SMIT panels (see Chapter 6, “Using the RAID Array Configurator” on page 57) to configure and manage your arrays. The Command Line Interface includes a README file that explains the syntax for the **ssaraid** command. The README file is located at: `/usr/lpp/devices.ssa.IBM_raid/ssaraid.README`

Using the **ssaraid** command from the Command Line Interface, you can do the following:

- List all the SSA adapters that provide support for RAID arrays in a system. Those adapters are called RAID Manager.
- List SSA objects that are connected to a particular RAID Manager:
 - List all objects of a given type (for example, RAID- 5 arrays).
 - List the preferred name (serial number) of an object.
 - List all member objects of another object (for example, a RAID array).
 - List the parent object of a member object.
 - List all candidate objects that can be used to exchange an existing member of a RAID array object.
 - List all candidate objects that can be used to create new RAID array objects.
- Give information about an object, such as size and current usage:
 - Give information in colon-separated format.
 - Give information in a summary format.
 - Give information for a specified device, its members, its parents, its exchange candidates, or its object candidates.
 - Give information for all objects of a particular type.
 - Limit the list to objects that have particular attribute values.
- Create an object:
 - Create a particular type of object that is built from the specified members.
 - Assign values for attributes of the created object.
 - Create customized device objects for the new object and, if required, use the option that allows you to specify the device name.
- Delete an object:
 - Delete the named RAID object.
 - Use the option that allows you to delete the device that is associated with the deleted RAID object.
- Change an object by specifying new values for attributes of that object.
- Perform an action on an object:
 - Swap, remove, or add disk drives in a RAID array.
 - Copy data from a RAID-1 or RAID-10 array onto a RAID-Copy array.

- List the objects that have support from a particular RAID manager:
 - List all the types of array objects.
 - List all the types of objects that can be created.
 - List all types of object.

Notes about the `ssaraid` Command:

1. You can specify RAID object names (arrays or member disk drives) as either the 15-character connection location, or as the device name.

The preferred name is the 15-character connection location. This name is the same as the SSA serial number for the device.

2. You can specify Boolean attribute values as any of the following:

0	1
f	t
false	true
n	y
no	yes
off	on

The attributes must be in lowercase.

Command Syntax

```
ssaraid -?  
ssaraid -M [-o] [-l RaidManager]  
ssaraid -l RaidManager [-n Name [-m|-p|-x|-e] | -t ObjectType [-r Name] [-c]]  
ssaraid -I -l RaidManager [-n Name [-m|-p|-x|-e] | -t ObjectType [-r Name] [-c]]  
        [-a Attribute=Value]...[-o|-z[-h] | -S[-o]]  
ssaraid -C -l RaidManager -t CreateType -s Member [Member]...  
        [-a Attribute=Value]... [-d [-k DeviceName]] [-n Name] [-r Name]  
ssaraid -D -l RaidManager -n Name [-u]  
ssaraid -H -l RaidManager -n Name [-u|-d [-k DeviceName]] [-a Attribute=Value]...  
ssaraid -A -l RaidManager -n Name -i InstructType [-a Attribute=Value]...  
ssaraid -Y[c|a|o] -l RaidManager
```

Legend:

RaidManager

The name of the SSA adapter that has RAID array support.

Name The name of the specific device upon which the operation is to be performed. See “Notes about the ssaraid Command” on page 236.

Object Type

The type of device upon which the operation is to be performed. See “Object Types” on page 238.

Attribute

The name of the attribute.

Value The value of the attribute.

DeviceName

The user-preferred name of the newly created device.

InstructType

The swap, remove, or add action that is to be performed on the object. See “Instruct Types” on page 238.

Options

You can use the following options with the **ssaraid** command:

Option	Description
-?	Print a short usage message.
-A	Perform an action on an object.
-C	Create an object.
-D	Delete an object.
-H	Change an object.
-I	Report information on an object.
-M	List all the available SSA RAID managers that are on the system.
-S	Show the hot spare pool information for an SSA RAID array.
-Ya	List all array types.
-Yc	List all create types.
-Yo	List all objects.
-a	An attribute and its desired value.
-c	List the candidates for an object type.
-d	Create the device for the specified RAID object.
-e	List copy disk drives that are coupled with the specified RAID object.
-h	Print column headers when showing object information in summary format.
-i	The instruct action to perform.
-k	The device name to use.
-l	The name of the SSA RAID manager to use.
-m	List the member objects for the named object.
-n	The name of an object, for example a RAID array, or member disk drive.
-o	Information is presented in colon-separated format.
-p	List the parent objects for the named object.
-r	The name of the reference object for RAID-Copy arrays.
-s	The disk drives that are to become members of the array.
-t	The type of the object to list or create.
-u	Remove the device for the specified RAID object.
-x	List exchange candidate disk drives for the named object.
-z	Information is presented in summary format.

Object Types

You can find the object types argument for the `-t` option if you type the following command:

```
> ssaraid -Yc -l ssa0
```

where `ssa0` is the name of the RAID manager.

Instruct Types

You can give the following instruct type as an argument to the `-i` option when that option is used with the `-A` option:

- * exchange
- * couple
- * uncouple

Examples

For the examples given here, assume that the following items of hardware are available in the system:

- A RAID Manager named ssa0
- Four SSA physical disks named pdisk0, pdisk1, pdisk2, and pdisk3

Example 1: To Create a RAID-0 Array

This example shows how to use three SSA physical disks to create a RAID-0 array. The attributes of the disks are all set to their default values.

Type the command:

```
> ssaraid -C -l ssa0 -t raid_0 -s pdisk0 pdisk1 pdisk2 -d
```

where:

- C specifies that this operation is a create operation.
- l ssa0 specifies that RAID Manager ssa0 is to be used.
- t raid_0 specifies that a RAID-0 array object is to be created.
- s pdisk... specifies the free pdisk that is to become the member disk of the new array.
- d specifies that a system disk is to be attached to the new array.

Example 2: To Create a RAID-1 Array

This example shows how to use two SSA physical disks to create a RAID-1 array. The attributes of the disks are all set to their default values.

Type the command:

```
> ssaraid -C -l ssa0 -t raid_1 -s pdisk0 pdisk1 -d
```

where:

- C specifies that this operation is a create operation.
- l ssa0 specifies that RAID Manager ssa0 is to be used.
- t raid_1 specifies that a RAID-1 array object is to be created.
- s pdisk... specifies the free pdisk that is to become the member disk of the new array. RAID-1 arrays provide support for only two member disk drives. The first disk drive that is specified becomes the primary member disk drive.
- d specifies that a system disk is to be attached to the new array.

Example 3: To Create a RAID-5 Array

This example shows how to use three SSA physical disks to create a RAID-5 array. The attributes of the disks are all set to their default values.

Type the command:

```
> ssaraid -C -l ssa0 -t raid_5 -s pdisk0 pdisk1 pdisk2 -d
```

where:

- C specifies that this operation is a create operation.
- l ssa0 specifies that RAID Manager ssa0 is to be used.
- t raid_5 specifies that a RAID-5 array object is to be created.
- s pdisk... specifies the free pdisk that is to become the member disk of the new array.
- d specifies that a system disk is to be attached to the new array.

This command causes a new SSA logical disk (hdiskX) to be created and attached to the new array. (X is the next available hdisk number; for example, hdisk5.)

Example 4: To Create a RAID-10 Array

This example shows how to use four SSA physical disks to create a RAID-10 array. The attributes of the disks are all set to their default values.

Type the command:

```
> ssaraid -C -l ssa0 -t raid_10 -s pdisk0 pdisk1 pdisk3 pdisk2 -d
```

where:

- C specifies that this operation is a create operation.
- l ssa0 specifies that RAID Manager ssa0 is to be used.
- t raid_10 specifies that a RAID-10 array object is to be created.
- s pdisk... specifies the free pdisk that is to become the member disk of the new array. RAID-10 arrays provide support for only even numbers of member disk drives. The sequence in which the disk drives are specified is important when you are determining which disk drives are primary and which are secondary members of the array. The first, third, fifth (and so on) disk drives are primary disk drives. The second, fourth, sixth (and so on) disk drives are secondary disk drives. In this example, pdisk0 and pdisk3 are the primary disk drives.
- d specifies that a system disk is to be attached to the new array.

Example 5: To Create a Hot Spare Pool

This example shows how to create a hot spare pool that contains an array member disk drive and a hot spare disk drive. The attributes of the disks are all set to their default values.

Type the command:

```
> ssaraid -C -l ssa0 -t spare_pool -n pool_B1 -s pdisk0 pdisk3
```

where:

- C specifies that this operation is a create operation.
- l ssa0 specifies that RAID Manager ssa0 is to be used.
- t spare_pool specifies that a spare pool is to be created.
- n pool_B1 specifies the name of the hot spare pool that is to be created. The format of the name must match the pool_XY format, where X defines the SSA loop and has a value A or B, and Y is a number 1 through 31.
- s pdisk... specifies the free pdisk that is to become the member disk of the hot spare pool. Valid members are RAID array member disk drives and hot spare disk drives.

Note: Not all RAID managers provide support for the hot spare pool function.

Example 6: To List All Defined SSA Objects

This example shows how to list all the defined SSA objects that are at present connected in summary format to a particular RAID manager.

Type the command:

```
> ssaraid -I -z -l ssa0
```

where:

- I specifies that this operation is a list operation.
- z specifies that the output is to be presented in summary format.
- t raid_5 specifies that a RAID-5 array object is to be created.
- l ssa0 specifies that all SSA objects that are connected to RAID Manager ssa0 are to be listed.

A result similar to that shown here is displayed:

pdisk0	0004AC506C4000D	member	n/a	4.5GB	Physical disk
pdisk1	0004AC506D6D00D	member	n/a	4.5GB	Physical disk
pdisk2	0004AC50A44200D	member	n/a	2.3GB	Physical disk
pdisk3	0004AC515EA400D	free	n/a	4.5GB	Physical disk
hdisk5	900335FE80C84CK	good		9.0GB	RAID-5 array

Example 7: To Change an Attribute of an Object

This example shows how to change an attribute of an object; for example, to change the new array so that it does not automatically call a hot spare disk drive if one of its member disk drives goes into the Offline state.

Type the command:

```
> ssaraid -H -l ssa0 -n hdisk5 -a spare=false
```

where:

-H specifies that this operation is a change operation.

-n hdisk5 specifies that the object hdisk5 is about to be changed.

-a spare= specifies the new value for the **spare** attribute.

A list of user-changeable attributes are available from “Hot Spare Pool Creation and Change Attribute” on page 249.

Example 8: To Exchange a Member Disk Drive of an Existing Array

This example shows how to exchange a member disk drive of an existing array with a free pdisk; for example, to exchange pdisk0 with pdisk3.

Type the command:

```
> ssaraid -A -l ssa0 -i exchange -n hdisk5 -a old_member=pdisk0 new_member=pdisk3
```

where:

-A specifies that this operation is an exchange operation.

-n hdisk5 specifies that the array about to be changed.

-a old_member= specifies the name of the existing member disk.

-new_member= specifies the name of the new member disk drive.

If you give a **List** command in summary format, a result similar to that shown here is displayed:

pdisk0	0004AC506C4000D	free	n/a	4.5GB	Physical disk
pdisk1	0004AC506D6D00D	member	n/a	4.5GB	Physical disk
pdisk2	0004AC50A44200D	member	n/a	2.3GB	Physical disk
pdisk3	0004AC515EA400D	member	n/a	4.5GB	Physical disk
hdisk5	900335FE80C84CK	rebuilding		9.0GB	RAID-5 array

Example 9: To Make a New System Disk

This example shows how use a single SSA disk to make a new system disk.

Type the command:

```
> ssaraid -H -l ssa0 -n pdisk0 -a use=system -d
```

where:

- H specifies that this operation is a change operation.
- l ssa0 specifies the RAID manager that is to be used.
- n pdisk specifies the pdisk that is to be changed to a system disk.
- a use specifies the new use of the pdisk.
- d specifies that a system disk is to be attached to the new array.

The result, in summary format, is similar to that shown here:

pdisk0	0004AC506C4000D	system	n/a	4.5GB	Physical disk
pdisk1	0004AC506D6D00D	member	n/a	4.5GB	Physical disk
pdisk2	0004AC50A44200D	member	n/a	2.3GB	Physical disk
pdisk3	0004AC515EA400D	member	n/a	4.5GB	Physical disk
hdisk5	900335FE80C84CK	rebuilding		9.0GB	RAID-5 array

Example 10: To Delete an Array

This example shows how to delete an array.

Type the command:

```
> ssaraid -D -l ssa0 -n hdisk5 -u
```

where:

- D specifies that this operation is a delete operation.
- l ssa0 specifies the RAID manager that is to be used.
- n hdisk specifies the hdisk that is to be deleted
- u specifies the system disk must be detached.

SSARaid Command Attributes

When using the **ssaraid** command, you can specify the following types of attribute:

- RAID array Creation and Change attributes
- RAID array Change attributes
- Physical Disk Drive Change attributes
- Action attributes

RAID Arrays Creation and Change Attributes

This section describes the creation and change attributes that you can use for:

- All RAID arrays
- RAID-1, RAID-5, and RAID-10 arrays only
- RAID-1 and RAID-10 arrays only
- RAID-5 arrays only
- RAID-10 arrays only

Creation and Change Attributes for All RAID Arrays

You can specify the following attributes with the **-a** option when you are using the **ssaraid** command with the **-C** or **-H** option to **create or change** a RAID array:

allow_page_splits=true/false (default=true)

*With the attribute set to **true**:*

When large blocks of data are sent to an array, those blocks can be internally split into smaller, 4096-byte blocks that can then be written in parallel to the member disk drives of the array. This action greatly improves the performance of write operations to the array, although the blocks are not written sequentially to the member disk drives.

*With the attribute set to **false**:*

The blocks of data are written sequentially to the member disk drives of the array. This action can have a negative effect on the performance of write operations to the array. The sequence in which the data is written to the array might be critical to the application program that is using the data, if an error occurs during the write operation.

fastwrite=on/off (default=off)

This attribute enables and disables the fast-write cache.

When using the fast-write cache, you can use the following attributes to control the operation of the cache:

fw_start_block (default=0)

See the definition for **fw_end_block** .

fw_end_block (default=array size)

This attribute and the **fw_start_block** attribute control the range of blocks for which the fast-write cache is enabled. Write operations that are outside the default range of 0 through array size write data directly to the array, and do not use the fast-write cache.

bypass_cache_if_oneway=true/false (default=false)

*With the attribute set to **true**:*

If the partner fast-write cache becomes not available, the fast-write cache operations to this disk drive are disabled, and an entry is made in the error log.

*With the attribute set to **false**:*

If the partner fast-write cache becomes not available, fast-write operations to this disk drive continue. If the SSA adapter fails during these operations, some data might not be flushed to the disk drive until the adapter has been repaired.

fw_suspended (default=false)

During a RAID-Copy uncouple operation, the fast-write function on the specified disk drive is suspended (stopped temporarily). If this uncouple operation fails to complete successfully (for example, because of a power failure), the fast-write function remains in suspended mode after the using system becomes online again. Use the **fw_suspended=false** attribute to reactivate the fast-write function on this disk drive.

Creation and Change Attributes for RAID-1, RAID-5, and RAID-10 Arrays Only

You can specify the following attributes with the **-a** option when you are using the **ssaraid** command with the **-C** or **-H** option to **create or change** a RAID-1, RAID-5, or RAID-10 array:

spare=true/false (default=true)

Normally, if the array is in the Exposed state, and a write operation to that array is attempted, the array enters the Degraded state. You can prevent the array from entering the Degraded state if you enable the **spare** attribute of the array, and provide a suitable hot spare disk drive to the RAID manager that is controlling the array. When the **spare** attribute is enabled, and a write operation is attempted to an array that is in the Exposed state, the RAID manager searches for an available hot spare disk drive to exchange for the failing disk drive. This action prevents the array from entering the Degraded state.

spare_exact=true/false (default=false)

When used with the **spare** attribute, the **spare_exact** attribute modifies the action of the RAID manager when the RAID manager attempts to exchange a hot spare disk drive for a failing disk drive. Normally, the RAID manager uses any hot spare disk drive that is large enough to replace the failing disk drive. The **spare_exact** attribute causes the RAID manager to use only a hot spare disk drive that has the exact size that the array requires. The size of the hot spare disk drive is determined by the size of the other member disk drives of the array. The sizes of all the member disks are logically truncated to the size of the smallest member disk drive. The hot spare disk drive must also have the size of the smallest member disk drive so that it can be exchanged for the failing disk drive.

read_only_when_exposed=true/false (default=false)

*With the attribute set to **false**:*

If the array enters the Exposed state, and write operations are made to the array:

- The first write operation causes the array to enter the Degraded state. The written data is not protected. If another disk drive in the array fails, or the power fails during a write operation, data might be lost. While the array is in the Degraded state, however, operations to the array continue.
- The rebuilding operation that runs on the replacement disk drive takes a long time to complete.

*With the attribute set to **true**:*

- If the array enters the Exposed state, and hot spare disk drives are not enabled, the array operates in read-only mode until the failing disk drive is exchanged for a replacement drive.
- If the array enters the Exposed state, and hot spare disk drives are enabled, a hot spare disk drive is added to the array when the first write operation to that array is attempted. If no suitable hot spare disk drive is available, the array operates in read-only mode.

spare_preferred (default=true)

This attribute is used with the **spare** attribute.

*With the attribute set to **true**,* a hot spare disk drive is selected only from the hot spare pool that contains the failed member disk drive.

*With the attribute set to **false**,* a hot spare disk drive (if available) is selected from the hot spare pool that contains the failed member disk drive. If no hot spare disk drive is available in that pool, a hot spare disk drive is selected from the default hot spare pool for that SSA loop (Pool A0 or B0). If no hot spare disk drive is available in the default pool, a hot spare disk drive is selected from any other hot spare pool that contains a hot spare disk drive.

Creation and Change Attributes for RAID-1 and RAID-10 Arrays Only

You can specify the following attributes with the `-a` option when you are using the `ssaraid` command with the `-C` or `-H` option to **create or change** a RAID-1 or RAID-10 array:

split_resolution=primary/secondary (default=primary)

This attribute selects the copy of the data that is to remain available if the primary disk drive is completely separated from the secondary disk drive.

hot_spare_splits=no/yes (default=no)

With the attribute set to **no**, the RAID manager does not attempt to use hot spare disk drives to replace missing member disk drives if a RAID-1 or RAID-10 array is split exactly in half, or all the secondary member disk drives are present. It is recommended that this attribute be set to **no** if the RAID-1 or RAID-10 array is configured to provide protection against the loss of a physical domain.

copy_rate (default=50)

This attribute controls the speed of the copy operation when an I/O operation is in progress. It can be set to any integer value 1 through 100. Higher values increase the speed of the copy operation, but decrease the speed of the I/O operation.

copy_verify_writes (default=no)

With the attribute set to **yes**, all data that is written to the RAID-Copy array is verified before the write operation completes. The results of this action are:

- Unrecoverable media errors are less likely to be found when the RAID-Copy array is uncoupled and read.
- More time is needed to perform the copy operation

fw_max_length (default=128)

This attribute sets the maximum size, in blocks, of write operations to the cache. Write operations that are larger than the specified value write data directly to the array, and do not use the fast-write cache.

Creation and Change Attribute for RAID-5 Arrays Only

You can specify the following attribute with the `-a` option when you are using the `ssaraid` command with the `-C` option to **create** a RAID-5 array:

fw_max_length (default=128 x (n-1), where n is the number of member disk drives in the array)

This attribute sets the maximum size, in blocks, of write operations to the cache. Write operations that are larger than the specified value write data directly to the array, and do not use the fast-write cache.

Note: You can set the maximum length to be less than, but not greater than, the default length. Any length that is greater than the default length is ignored, and the default is used.

strip_size (default=64)

This attribute is used only when the array is created. The strip size is the maximum amount of contiguous data that is mapped to one member disk drive. Valid values are: 64 (32 KB or 64 x 512 byte blocks) and 128 (64 KB or 128 x 512 byte blocks).

Creation and Change Attribute for RAID-10 Arrays Only

You can specify the following attribute with the `-a` option when you are using the `ssaraid` command with the `-C` option to **create** a RAID-10 array:

strip_size (default=32)

This attribute is used only when the array is created. The strip size is the maximum amount of contiguous data that is mapped to one member disk drive. Valid values are: 32 (16 KB or 32 x 512 byte blocks), 64 (32 KB or 64 x 512 byte blocks), and 128 (64 KB or 128 x 512 byte blocks).

RAID Arrays Change Attributes

This section describes the creation and change attributes that you can use for:

- All RAID arrays
- Hot spare disk drives only
- Array member disk drives only

Change Attributes for All RAID Arrays

You can specify the following attributes with the `-a` option only when you are using the `ssaraid` command with the `-H` option to **change** a RAID array:

use=system/free

*With the attribute set to **system**:*

The array is made usable by the operating system. If you specify also the `-d` option, a corresponding hdisk device is created for the array.

*With the attribute set to **free**:*

The array has no use assigned to it, and the operating system cannot use it as an hdisk. If you specify the `-u` option, you ensure that no corresponding device exists for the array.

force=yes/no

If an array is using a fast-write cache that is failing, you must specify this attribute as **yes** to allow the fast-write cache to be disabled.

Hot Spare Pool Creation and Change Attribute

You can specify the following attribute with the **-a** option when you are using the **ssaraid** command with the **-C** or **-H** option to **create or change** a hot spare pool:

minimum_spare(default=0)

This attribute determines the minimum number of hot spare disk drives that must be in this hot spare pool to prevent a hot spare pool error from being logged.

Physical Disk Drive Change Attributes

This section describes:

- Change attribute for hot spare disk drives only
- Change attribute for array member disk drives only
- Other change attributes for physical disk drives

Change Attribute for Hot Spare Disk Drives Only

You can specify the following attribute with the **-a** option only when you are using the **ssaraid** command with the **-H** option to **change** a hot spare disk drive:

spare_pool (default=pool_A0 or pool_B0, as determined by the network ID)

If you set this attribute, the hot spare disk drive is assigned to the specific hot spare pool.

Change Attribute for Array Member Disk Drives Only

You can specify the following attribute with the **-a** option only when you are using the **ssaraid** command with the **-H** option to **change** an array member disk drive:

spare_pool (default=pool_A0 or pool_B0, as determined by the network ID)

If you set this attribute, the array member disk drive is assigned to the specific hot spare pool. If the **spare_preferred** array attribute is set to **true** for the array to which this disk drive belongs, and this disk drive fails, a hot spare disk drive (if available) is selected only from the hot spare pool to which this disk drive is assigned.

If the **spare_preferred** array attribute is set to **false** for the array to which this disk drive belongs, and this disk drive fails, a hot spare disk drive (if available) is selected from the hot spare pool to which this disk drive is assigned. If no hot spare disk drive is available in that pool, a hot spare disk drive is selected from the default hot spare pool for that SSA loop (Pool A0 or B0). If no hot spare disk drive is available in the default hot spare pool, a hot spare disk drive is selected from any other hot spare pool that contains a hot spare disk drive.

Other Change Attributes for Physical Disk Drives

You can specify the following attributes with the `-a` option when you are using the `ssaraid` command with the `-H` option to change a physical disk drive.

use=system/spare/free

*With the attribute set to **system**:*

The physical disk drive can be used directly by the operating system. If you specify also the `-d` option, a corresponding `hdisk` device is created for the physical disk drive.

*With the attribute set to **spare**:*

The physical disk drive becomes a hot spare disk drive. It is, therefore, available for addition to any arrays on the RAID manager that are in the Exposed state. Specify also the `-u` option to ensure that no corresponding `hdisk` device exists for the physical disk drive.

*With the attribute set to **free**:*

The physical disk drive has no use assigned to it. It is, therefore, available for any new arrays that are to be created. Specify also the `-u` option.

If you use the `ssaraid` command with the `-I` option to display information about a physical disk drive, the following values for the **use** attribute can also be displayed:

member

The disk drive is a member of an array.

rejected

The disk drive was a member of an array. It was rejected from the array because it reported a problem.

You cannot change the use of member disk drives. You must first remove the disk drives from their array, either by deleting the array, or by exchanging them out of the array with the `-A` and `-i` exchange options of the `ssaraid` command.

You can assign new uses to disk drives that have been rejected. You must, however, first check the disk drives to find the cause of the problem.

fastwrite=on/off (default=off)

This attribute enables and disables the fast-write cache.

When using the fast-write cache, you can use the following attributes to control the operation of the cache:

fw_start_block (default=0)

See the definition for **fw_end_block**.

fw_end_block (default=array size)

This attribute and the **fw_start_block** attribute control the range of blocks for which the fast-write cache is enabled. Write operations that are outside the default range of 0 through array size write data directly to the disk, and do not use the fast-write cache.

fw_max_length (default=128)

This attribute sets the maximum size, in blocks, of write operations to the fast-write cache. Write operations that are larger than the specified value write data directly to the disk, and do not use the fast-write cache.

force=yes/no

If a disk is using a fast-write cache that is failing, you must specify this attribute as **yes** to allow the fast-write cache to be disabled.

Action Attributes (RAID-1, RAID-5, and RAID-10 Only)

You can specify the following attributes with the **-a** option when you are using the **ssaraid** command with the **-A** and **-i** exchange options to do maintenance on an array.

new_member=disk

This attribute specifies the disk drive that is to be added to the array, either in exchange for a failing disk drive that has caused the array to enter the Exposed state, or in exchange for a disk drive that the **old_member** attribute has specified.

old_member=disk

This attribute specifies the member disk drive that is to be removed from the array. You can use the attribute on its own, or with the **new_member** attribute.

Use the **old_member** attribute on its own if you want only to remove the disk drive from the array.

Use the **old_member** attribute and the **new_member** attribute together if you want to exchange the disk drives in one action, **and the subsystem has a spare slot available for the new disk drive**.

If no spare slot is available, use the following method to exchange the disk drives:

1. Logically remove the failing disk drive. For this action, use the **ssaraid** command with only the **old_member** attribute specified.
2. Physically remove the disk drive from the slot.
3. Install the new disk drive into the slot that contained the old disk drive.
4. Logically add the new disk drive to the array. For this action, use the **ssaraid** command with only the **new_member** attribute specified.

Notes:

1. If you specify the **new_member** attribute and the **old_member** attribute together, an in-place exchange is attempted; the **old_member** disk drive is replaced by the **new_member** disk drive in one operation.
2. You can remove disk drives only from arrays that are not in the Exposed state. When you remove a disk drive, the array enters the Exposed state, and remains in that state until you add the new disk drive.
3. RAID-5 arrays cannot operate if they lose more than one disk drive at a time.
4. To generate a list of suitable exchange candidates, use the **-x** flag with the **list** command.

Couple Action Attributes (RAID-1 and RAID-10 Only)

You can specify the following attributes with the `-a` option when you are using the `ssaraid` command with the `-A` and `-i couple` options to do actions on a RAID-1 or RAID-10 array.

raid_copy=copy

This attribute specifies the name that you have given to the existing RAID copy that you are going to use. The RAID copy must not be attached to any logical disk.

pool_selection=own/primary/secondary (default=own)

* **own** Assigns the coupled disk drives to the pool to which those disk drives were previously assigned.

* **primary**

Each coupled disk drive is assigned to the hot spare pool to which the primary disk drive that it is copying is assigned.

* **secondary**

Each coupled disk drive is assigned to the hot spare pool to which the secondary disk drive that it is copying is assigned.

force=yes/no

If the specified RAID-Copy array contains data that has been copied from another RAID array, use the **force=yes** flag to force this RAID-Copy to be coupled with the array. Note that the data that is stored on the RAID-Copy array is lost.

Uncouple Action Attributes (RAID-1 and RAID-10 Only)

You can specify the following attribute with the `-a` option when you are using the `ssaraid` command with the `-A` and `-i uncouple` options to do actions on a RAID-1 or RAID-10 array.

force=yes/no

If you use **force=yes** when you uncouple a coupled RAID array, the RAID-Copy array is destroyed. The RAID-Copy disk drives become free disk drives, and the copied data is lost.

Return Codes

Code	Description
0	Successful.
1	Some changes made, but finally not successful.
2	General problem accessing the object data manager (ODM).
3	Specified object (file, record, ODM object) not found.
4	Heap allocation failed.
5	Open/ioctl failure for RAID manager.
6	Bad Transaction result.
7	Array already known to cfgmgr.
8	System call failed.
9	Internal logic error.
10	Method not found, not executable, or not correct.
11	Problem communicating with back-end method.
12	Problem with environment variable, message catalog, and so on.
100	Problem with self-defining structure for RDVs.
101	The argument in the command line is not valid and given to back end.
102	Problem with FC_CandidateList transaction.
103	Problem with FC_ResrcList transaction.
104	Problem with FC_ResrcView transaction.

Chapter 13. Using the Programming Interface

SSA Subsystem Overview

Device Drivers

Two types of device driver provide support for all SSA subsystems:

- The SSA adapter device driver, which deals with the SSA adapter.
- The SSA head device drivers, which deal with devices that are attached to the SSA adapter. The SSA disk device driver is an example of an SSA head device driver.

For subsystems that use the Micro Channel SSA Multi-Initiator/RAID EL Adapter, the PCI SSA Multi-Initiator/RAID EL Adapter, or the Advanced SerialRAID Adapter, the Target-Mode SSA (TMSSA) device driver is also available. This device driver provides support for communications from using system to using system. For information about SSA Target Mode and the TMSSA device driver, see “SSA Target Mode” on page 291.

Responsibilities of the SSA Adapter Device Driver

The SSA adapter device driver provides a consistent interface to all SSA head device drivers, of which the SSA disk device driver is an example.

The SSA adapter device driver sends commands for SSA devices to the adapter that is related to those devices. When the SSA adapter device driver detects that the commands have completed, it informs the originator of the command.

Responsibilities of the SSA Disk Device Driver

The SSA disk device driver provides support for the SSA disk drives that are connected to an SSA adapter. That support consists of:

- Standard block I/O to SSA logical disks, which are represented as hdisks
- Character mode I/O to SSA logical disks, which are represented as rdisks
- Error reporting from SSA physical disks, which are represented as pdisks
- Diagnostics and service interface to SSA physical disks that are represented as pdisks
- Re-issue of commands in the event of an adapter reset

Interface between the SSA Adapter Device Driver and Head Device Driver

To communicate with the SSA adapter device driver, the SSA head device driver:

1. Uses the **fp_open** kernel service to open the required instance of the SSA adapter device driver.
2. Calls the **fp_ioctl** kernel service to issue the **SSA_GET_ENTRY_POINT** operation to the opened adapter.
3. Calls the function **SSA_Ipn_Directive** whose address was returned by the **ioctl** operation. These calls to **SSA_Ipn_Directive** are used for all communication with the SSA device.
4. Uses the **fp_close** kernel service to close the adapter.

Note: When **fp_close** is called, **SSA_Ipn_Directive** cannot be called.

Trace Formatting

The SSA adapter device driver and the SSA disk device driver can both make entries in the kernel trace buffer. The hook ID for the SSA adapter device driver is 45A. The hook ID for the SSA disk device driver is 45B. For information on how to use the kernel trace feature, refer to the **trace** command for the kernel debug program. With the PCI SSA Multi-Initiator/RAID EL Adapter, the Micro Channel SSA Multi-Initiator/RAID EL Adapter, or the Advanced SerialRAID Adapter, the Target-Mode SSA device driver can make entries in the kernel trace buffer; its hook ID is 3B4.

SSA Adapter Device Driver

Purpose

To provide support for the SSA adapter.

Syntax

```
#include /usr/include/sys/ssa.h
#include /usr/include/sys/devinfo.h
```

Description

The `/dev/ssa` special files provide an interface that allows client application programs to access SSA adapters and the SSA devices that are connected to those adapters. Multiple-head device drivers and application programs can all access a particular SSA adapter and its connected devices at the same time.

Configuring Devices

All the SSA adapters that are connected to the using system are normally configured automatically during the system boot sequence.

PCI SSA Adapter ODM Attributes

The PCI SSA adapter has a number of object data manager (ODM) attributes that you can display by using the `lsattr` command:

ucode Holds the file name of the microcode package file that supplies the adapter microcode that is present in an SSA adapter.

bus_io_addr

Holds the value of the bus I/O base address of the adapter registers that the SSA adapter device driver for this adapter will use.

bus_mem_start

Holds the value of the bus-memory start address that the SSA adapter device driver for this adapter will use.

bus_mem_start2

Holds the value of the bus-memory start address that the SSA adapter device driver for this adapter will use.

bus_mem_start3

Holds the value of the bus-memory start address that the SSA adapter device driver for this adapter will use.

bus_mem_start4

Holds the value of the bus-memory start address that the SSA adapter device driver for this adapter will use.

bus_intr_level

Holds the value of the bus interrupt level that the SSA adapter device driver for this adapter will use.

intr_priority

Holds the value of the interrupt priority that the SSA adapter device driver for this adapter will use.

daemon

Specifies whether to start the SSA adapter daemon. If the attribute is set to TRUE, the daemon is started when the adapter is configured.

The daemon holds the adapter device driver open although the operating system might not be using that adapter device driver at the time. This action allows the adapter device driver to reset the adapter card if the software that is running on it finds an unrecoverable problem. It also allows the adapter device driver to log errors against the adapter.

The ability of the device driver to log errors against the adapter is especially useful if the adapter is in an SSA loop that is used by another adapter, because failure of this adapter can affect the availability of the SSA loop to the other adapter.

You can use the **chdev** command to change the value of this attribute.

host_address

Holds the host address (using-system address) for this adapter.

scat_gat_pages

Specifies the number of 4-kilobyte pages that the device driver has kept for the management of scatter/gather lists. If many large transfer operations are to be performed, think about increasing the value of this attribute if the I/O does not reach the expected rate.

dma_mem

Specifies the size of the DMA memory. On systems that are using AIX version 4.3 or above, the memory should be big enough to hold the biggest expected I/O load. If you specify too small a size, the system cannot reach the best-possible I/O rate.

poll_threshold

Specifies how many command completions must occur in a 10 millisecond period to cause the adapter device driver to switch so that it is driven by polling-command completions rather than by interrupts. Polling might reduce the load on the system processor, but it can also cause longer I/O response times.

Device-Dependent Subroutines

The SSA adapter device driver provides support only for the **open**, **close**, and **ioctl** subroutines. It does not provide support for the **read** and **write** subroutines.

open and close Subroutines

The **open** and **openx** subroutines must be called by any application program that wants to send **ioctl** calls to the device driver.

You can use the **open** or the **openx** subroutine call to open the SSA adapter device driver. If you use the **openx** subroutine call, set the *ext* parameter to 0, because the call does not use it.

Summary of SSA Error Conditions

If an **open** or **ioctl** subroutine that has been issued to an SSA adapter fails, the subroutine returns -1, and the global variable **errno** is set to a value from the file **/usr/include/sys/errno.h**.

Possible **errno** values for the SSA adapter device driver are:

EINVAL

An unknown **ioctl** was attempted or the parameters supplied were not valid.

EIO An I/O error occurred.

ENOMEM

The command could not be completed because not enough real memory or paging space was available.

ENXIO The requested device does not exist.

Managing Dumps

The SSA adapter device driver is a target for the system dump facility.

The **DUMPQUERY** option returns a minimum transfer size of 0 bytes and a maximum transfer size that is appropriate for the SSA adapter.

To be processed, calls to the SSA adapter device driver **DUMPWRITE** option should use the *arg* parameter as a pointer to the **SSA_loreq_t** structure, which is defined in **/usr/include/sys/ssa.h**. Using this interface, commands for which the adapter provides support can be run on a previously started (opened) target device. The SSA adapter device driver ignores the *uiop* parameter.

Note: Only the **SsaMCB.MCB_Result** field of the **SSA_loreq_t** structure is set at completion of the **DUMPWRITE**. During the dump, no support is provided for error logging.

If the **dddump** entry point completes successfully, it returns a 0. If the entry point does not complete successfully, it returns one of the following:

EINVAL

A request that is not valid was sent to the adapter device driver; for example, a request for the **DUMPSTART** option was sent before a **DUMPINIT** option had been run successfully.

EIO The adapter device driver was unable to complete the command because the required resources were not available, or because an I/O error had occurred.

ETIMEDOUT

The adapter did not respond with status before the passed command time-out value expired.

Files

/dev/ssa0, /dev/ssa1, ..., /dev/ssan

Provide an interface to allow SSA head device drivers to access SSA devices or adapters.

IOCINFO (Device Information) SSA Adapter Device Driver ioctl Operation

Purpose

To return a structure that is defined in the `/usr/include/sys/devinfo.h` file.

Description

The **IOCINFO** **ioctl** operation returns a structure that is defined in the `/usr/include/sys/devinfo.h` header file. The caller supplies the address to an area that is of the type `struct devinfo`. This area is in the `arg` parameter to the **IOCINFO** operation. The device-type field for this component is **DD_BUS**; the subtype is **DS_SDA**.

The **IOCINFO** operation is defined for all device drivers that use the **ioctl** subroutine, as follows:

The operation returns a **devinfo** structure. The caller supplies the address of this structure in the argument to the **IOCINFO** operation. The device type in this structure is **DD_BUS**, and the subtype is **DS_SDA**. The `flags` field is set to **DF_FIXED**.

Files

`/dev/ssa0, /dev/ssa1, ..., /dev/ssan`

SSA_TRANSACTION SSA Adapter Device Driver ioctl Operation

Purpose

To send an SSA transaction to an SSA adapter.

Description

The **SSA_TRANSACTION** operation allows the caller to issue an IPN (Independent Packet Network) transaction to a selected SSA adapter. IPN is the language that is used to communicate with the SSA adapter. The caller must be root, or have an effective user ID of root, to issue this operation.

IPN is described in the *Technical Reference* for the adapter.

The *arg* parameter for the **SSA_TRANSACTION** operation specifies the address of a **SSA_TransactionParms_t** structure. This structure is defined in the **/usr/include/sys/ssa.h** file.

The **SSA_TRANSACTION** operation uses the following fields of the **SSA_TransactionParms_t** structure:

DestinationNode

Contains the target node for the transaction.

DestinationService

Contains the target service on that node.

MajorNumber

Major number of the transaction.

MinorNumber

Minor number of the transaction.

DirectiveStatusByte

Contains the directive status byte for the transaction. This contains a value that is defined in the **/usr/include/ipn/ipndef.h** file. A non-zero value indicates an error.

TransactionResult

Contains the IPN result word that is returned by IPN for the transaction. This contains values that are defined in the **/usr/include/ipn/ipntra.h** file. A non-zero value indicates an error.

ParameterDDR

Set by the caller to indicate the buffer for parameter data.

TransmitDDR

Set by the caller to indicate the buffer for transmit data.

ReceivedDDR

Set by the caller to indicate the buffer for received data.

StatusDDR

Set by the caller to indicate the buffer for status data.

TimeOutPeriod

Number of seconds after which the transaction is considered to have failed. A value of 0 indicates no time limit.

Note: If an operation takes longer to complete than the specified time-out, the adapter is reset to purge the command.

Attention: This is a very low-level interface. It is for use only by configuration methods and diagnostics software. Use of this interface might result in system hangs, system crashes, system corruption, or undetected data loss.

Return Values

When completed successfully, this operation returns a value of 0. Otherwise, a value of -1 is returned, and the **errno** global variable is set to one of the following values:

EIO Indicates an unrecoverable I/O error.

ENXIO Indicates an unknown device.

EINVAL Indicates an unknown command. Indicates a bad buffer type.

EACCESS Indicates user does not have root privilege.

ENOMEM Indicates not enough memory.

ENOSPC Indicates not enough file blocks.

EFAULT Indicates bad user address.

Files

/dev/ssa0, /dev/ssa1, ..., /dev/ssan

SSA_GET_ENTRY_POINT SSA Adapter Device Driver ioctl Operation

Purpose

To allow another kernel extension, typically a SSA head device driver, to determine the direct call entry point for the SSA adapter device driver. This operation is the entry point through which the head device driver communicates with the adapter device driver. The address that is supplied is valid only while the calling kernel extension holds an open file descriptor for the SSA adapter device driver. This operation is not valid for a user process.

Description

The *arg* parameter specifies the address of a **SSA_GetEntryPointParms_t** structure in kernel address space. The **SSA_GetEntryPointParms_t** structure is defined in the **/usr/include/sys/ssa.h** file.

On completion of the operation, the fields in the **SSA_GetEntryPointParms_t** structure are modified as follows:

EntryPoint

Address of the direct call entry point for the SSA adapter device driver, which is used to submit operations from a head device driver.

InterruptPriority

The off level interrupt priority at which the calling kernel extension is called back for completion of commands that are started by calling the direct call entry point.

Return Values

When completed successfully, this operation returns a value of 0. Otherwise, a value of -1 is returned and the **errno** global variable is set to the following value:

EINVAL

Indicates that the caller was not in kernel mode.

Files

/dev/ssa0, /dev/ssa1, ..., /dev/ssan

SSA Adapter Device Driver Direct Call Entry Point

Purpose

To allow another kernel extension to send transactions to the SSA adapter device driver. This function is not valid for a user process. When the function completes its run, an off-level interrupt notifies the caller. See **SSA_GET_ENTRY_POINT** SSA adapter ioctl operation.

Description

The entry point address is the address that is returned in *EntryPoint* by the **SSA_GET_ENTRY_POINT** ioctl operation. The function takes a single parameter of type **SSA_loreq_t**, which is defined in the `/usr/include/sys/ssa.h` file.

The fields of the **SSA_loreq_t** structure are used as follows:

SsaDPB An array of size `SSA_DPB_SIZE`, which is used by the SSA adapter device driver, and should be initialized to all NULLs.

SsaNotify

The address of the function in the SSA head device driver that the SSA adapter device driver calls when the directive has completed.

u0 The transaction to be executed. Valid transactions are described in the *Technical Reference* for the adapter.

Return Values

This function does not return errors. You can determine success or failure of the directive by examining the directive status byte and transaction result fields, which are set up in the SSA MCB. For details, see the *Technical Reference* for the adapter.

ssadisk SSA Disk Device Driver

Purpose

To provide support for Serial Storage Architecture (SSA) disk drives.

Syntax

```
#include <sys/devinfo.h>
#include <sys/ssa.h>
#include <sys/ssadisk.h>
```

Configuration Issues

SSA Logical Disks, SSA Physical Disks, and SSA RAID Arrays

Serial Storage Architecture (SSA) disk drives are represented in the operating system as SSA logical disks (**hdisk0**, **hdisk1**.....**hdiskN**) and SSA physical disks (**pdisk0**,**pdisk1**.....**pdiskM**). SSA RAID arrays are represented as SSA logical disks (**hdisk0**, **hdisk1**.....**hdiskM**). SSA logical disks represent the logical properties of the disk drive or array, and can have volume groups and file systems mounted on them. SSA physical disks represent the physical properties of the disk drive.

By default:

- One **pdisk** is always configured for each physical disk drive.
- One **hdisk** is configured either for each disk drive that is connected to the using system, or for each array.

By default, all disk drives are configured as system disk drives. The array management software deletes **hdisks** to create arrays.

SSA physical disks have the following properties. They:

- Are configured as **pdisk0**, **pdisk1**.....**pdiskn**
- Have errors logged against them in the system error log
- Provide support for a character special file (**/dev/pdisk0 /dev/pdisk1..../dev/pdiskn**)
- Provide support for the **ioctl** subroutine for servicing and diagnostics functions
- Do not accept **read** or **write** subroutine calls for the character special file

SSA logical disks have the following properties. They:

- Are configured as **hdisk0**, **hdisk1**.....**hdiskn**
- Provide support for a character special file (**/dev/rhdisk0, /dev/rhdisk1..../dev/rhdiskn**)
- Provide support for a block special file (**/dev/hdisk0, /dev/hdisk1..../dev/hdiskn**)
- Provide support for the **ioctl** subroutine call for nonservice and diagnostics functions only
- Accept the **read** and **write** subroutine call to the special files
- Can be members of volume groups, and have file systems mounted on them

Multiple Adapters

Some SSA subsystems (see “Rules for SSA Loops” on page 22) allow a disk drive to be controlled by up to two adapters in a particular using system. The disk drive has, therefore, two paths to each using system, and the SSA subsystem can continue to function if an adapter fails. If an adapter fails or the disk drive cannot be accessed from the original adapter, the SSA disk device driver switches to the alternative adapter without returning an error to any working application.

When a disk drive has been successfully opened, takeover by the alternative adapter does not occur simply because a drive becomes reserved or fenced out. However, during an open of an SSA logical disk, the device driver does attempt to access the disk drive through the alternative adapter if the path through the original adapter experiences reservation conflict or fenced-out status.

A medium error on the disk drive does not cause takeover to occur. Takeover occurs only after extensive error-recovery activity within the adapter and several retries by the device driver. Intermittent errors that last for only approximately one second usually do not cause adapter takeover.

When takeover has successfully occurred and the device driver has accessed the disk drive through the alternative adapter, the original adapter becomes the standby adapter. Takeover can, therefore, occur repeatedly from one adapter to another so long as one takeover event is completed before the next one starts. Completion of a takeover event is considered to have occurred when the device driver successfully accesses the disk drive through the alternative adapter.

When takeover has occurred, the device driver continues to use the alternative adapter to access the disk drive until either the system is rebooted, or takeover occurs back to the original adapter.

Each time the SSA disks are configured, the SSA disk device driver is informed which path or paths are available to each disk drive, and which adapter is to be used as the primary path. By default, primary paths to disk drives are shared equally among the adapters to balance the load. This static load balancing is performed once, when the devices are configured for the first time. You can use the **chdev** command to modify the primary path.

Because of the dynamic nature of the relationship between SSA adapters and disk drives, SSA pdisks and hdisks are not children of an adapter but of an SSA router. This router is called **ssar**. It does not represent any actual hardware, but exists only to be the parent device for the SSA logical disks and SSA physical disks.

Note: When the SSA disk device driver switches from using one adapter to using the other adapter to communicate with a disk, it issues a command that breaks any SSA-SCSI reserve condition that might exist on that disk. The reservation break is performed only if this using system has successfully reserved the disk drive through the original adapter. This check is to prevent adapter takeover from breaking reservations that are held by other using systems. If multiple using systems are connected to the SSA disks, SSA-SCSI reserve should not, therefore, be used as the only method for controlling access to the SSA disks.

Fencing is provided as an alternative method for controlling access to disks that are connected to multiple using systems.

The PCI SSA Multi-Initiator/RAID EL Adapter, the Micro Channel SSA Multi-Initiator/RAID EL Adapter, and the Advanced SerialRAID Adapter can reserve to a node number rather than to an adapter (see “Reserving Disk Drives” on page 27). It is highly recommended that you make use of this ability by setting the SSA router `node_number` attribute if multiple adapters are to be configured as described here.

Configuring SSA Disk Drive Devices

SSA disk drives are represented as SSA logical disks (**hdisk0, hdisk1.....hdiskn**) and SSA physical disks (**pdisk0, pdisk1.....pdiskn**). The properties of each are described in the SSA Subsystem Overview.

Normally, the system boot process automatically configures all the disk drives that are connected to the using system. You do not need to take any action to configure them.

Because SSA devices might be added to the SSA network while the using system is running and online, you might need to configure SSA disks after the boot process has completed. Under these conditions, use the **cfgmgr** command to configure the devices.

An exception is to configure a specific device with a specific name. You can do this with the **mkdev** command.

Using mkdev to Configure a Physical Disk

To use **mkdev** to configure an SSA **physical** disk, specify the following information:

Parent ssar

Class pdisk

Subclass
ssar

Type You can list the types by typing: `lsdev -P -c pdisk -s ssar`

ConnectionLocation

15-character unique identifier of the disk drive. You can determine the unique identifier in three ways:

- If the disk drive is already defined, you can use the **lsdev** command to determine the unique identity, as follows:
 1. Type `lsdev -Ccpdisk -r connwhere` and press Enter.
 2. Select the 15-character unique identifier (UID) for which characters 5 through 12 match the serial number that is on the front of the disk drive.
- Construct the 15-character unique identifier from the 12-character SSA UID that is shown on the label that is on the side of the disk drive. You can recognize the UID by its three-character suffix "00D".
- Run the **ssacand** command, and specify the adapter to which the physical disk is connected. For example:
`ssacand -a ssa0 -P`

Using mkdev to Configure a Logical Disk

To use **mkdev** to configure an SSA **logical** disk, specify the following information:

Parent ssar

Class disk

Subclass
ssar

Type hdisk

ConnectionLocation

15-character unique identifier of the logical disk.

If the logical disk is a system disk, you can determine the unique identifier in three ways:

- If the logical disk is already defined, you can use the **lsdev** command to determine the unique identity, as follows:
 1. Type `lsdev -Ccdisk -r connwhere` and press Enter.
 2. Select the 15-character unique identifier (UID) for which characters 5 through 12 match the serial number that is on the front of the disk drive.

- Construct the 15-character unique identifier from the 12-character SSA UID that is shown on the label that is on the side of the disk drive. You can recognize the UID by its three-character suffix “00D”.

- Run the **ssacand** command, and specify the adapter to which the logical disk is connected. For example:

```
ssacand -a ssa0 -L
```

If the logical disk is an array, you can determine the unique identifier in two ways:

- If the logical disk is already defined, you can use the **lsdev** command to determine the unique identity, as follows:
 1. Type `lsdev -Cdisk -r connwhere` and press Enter.
 2. Select the 15-character unique identifier (UID) that was given by the RAID configuration program when the array was created.
- Run the **ssacand** command, and specify the adapter to which the logical disk is connected. For example:

```
ssacand -a ssa0 -L
```

Device Attributes

SSA logical disks and SSA physical disks and the ssar router have several attributes. You can use the **lsattr** command to display these attributes.

Attributes of the SSA Router, **ssar**

node_number

This attribute must be set on systems that are using the SSA Fencing facility or the SSA Disk Concurrent Mode of Operation Interface facility. These facilities of the SSA disk device driver are used only in configurations where the SSA disk drives are connected to more than one using system. Therefore, in configurations where the SSA disk drives are connected to only one using system, the **node_number** attribute has no effect.

For configurations that use SSA Fencing or the SSA Disk Concurrent Mode of Operation Interface, set the **node_number** to a different value on each using system that is in the configuration.

Attributes Common to SSA Logical and SSA Physical Disks

adapter_a

Specifies either the name of one adapter that is connected to the device, or **none** if no adapter is connected as `adapter_a` now.

adapter_b

Specifies either the name of one adapter that is connected to the device, or **none** if no adapter is connected as `adapter_b` now.

primary_adapter

Specifies whether `adapter_a` or `adapter_b` is to be the primary adapter for this device.

You can use the **chdev** command to modify this attribute to one of the values: `adapter_a`, `adapter_b` or **assign**. If you set the value to **assign**, static load balancing is performed when this device is made available, and the system sets the value to either `adapter_a`, or `adapter_b`.

connwhere_shad

Holds a copy of the value of the *connwhere* parameter for this disk drive. SSA disks drives cannot be identified by the location field that the **lsdev** command gives, because they are connected in a loop, and do not have the hardware-selectable addresses of SCSI devices. The serial numbers of the disk drives are the only method of identification. The serial number of a particular disk drive is written in the *connwhere* field of the CuDv entry for that disk drive. This **connwhere_shad** attribute, which shadows the *connwhere* value, allows you to display the *connwhere* value for an SSA device for a `pdisk` or `hdisk`.

location

Describes, in text, the descriptions of the disk drives and their locations (for example, drawer number 1, slot number 1). The user enters the information for this attribute.

Attributes for SSA Logical Disks Only

pvid Holds the ODM copy of the PVID for this disk drive for an `hdisk`.

queue_depth

Specifies the maximum number of commands that the SSA disk device driver dispatches to a logical disk. The default value is correct for normal operating conditions. You can use the **chdev** command to modify this attribute. Valid entry values are 0 through 200. A value of 0 resets the `queue_depth` to its default value.

reserve_lock

Specifies whether the SSA disk device driver locks the device with a reservation when it is opened for an `hdisk`.

size_in_mb

Specifies the size of the logical disk in megabytes.

max_coalesce

The maximum number of bytes that the SSA disk device driver attempts to transfer to or from an SSA logical disk in one operation.

The default value is appropriate for most environments. For applications that perform very long sequential write operations, performance improves when data is written in blocks of 64 KB multiplied by (n-1), where n is the number of disks in the array. For example, if the array contains six member disks, the data would be written in blocks of 64 KB x 5. (These operations are known as *full-stride writes*.) To use full-stride writes, increase the value of this attribute to 64 KB x (n-1), or to some multiple of this number.

write_queue_mod

Alters the way in which write commands are queued to SSA logical disks. The default value is 0 for all SSA logical disks that do not use the fast-write cache; with this setting the SSA disk device driver maintains a single seek-ordered queue of `queue_depth` operations on the disk. Read operations and write operations are queued together in this mode.

If `write_queue_mod` is set to a non-zero value, the SSA disk device driver maintains two separate seek-ordered queues: one for read operations, and one for write operations. In this mode, the device driver issues up to `queue_depth` **read** commands and up to `write_queue_mod` **write** commands to the logical disk.

This facility is provided because, in some environments, it might be beneficial to hold back write commands in the device driver so that they can be coalesced into larger operations that can be handled as full-stride writes by the RAID software in the adapter.

This facility is not likely to be useful, unless a large percentage of the workload to a RAID-5 device consists of sequential write operations.

Device-Dependent Subroutines

The **open**, **read**, **write**, and **close** subroutines start typical physical volume operations.

open, read, write and close Subroutines

The **open** subroutine is mainly for use by the diagnostic commands and utilities. Correct authority is required for execution. If an attempt is made to run the **open** subroutine without the correct authority, the subroutine returns a value of -1, and sets the **errno** global variable to a value of **EPERM**.

The `ext` parameter that is passed to the **openx** subroutine selects the operation for the target device. The `/usr/include/sys/ssadisk.h` file defines possible values for the `ext` parameter.

The `ext` parameter can contain any combination of the following flag values logically ORed together:

SSADISK_PRIMARY

Opens the device by using the primary adapter as the path to the device. As a result of hardware errors, the device driver might automatically switch to the

secondary path, if one exists. You can prevent this switch by additionally specifying the **SSADISK_NOSWITCH** flag.

This flag has support both for SSA logical disk drives and for SSA physical disk drives. You cannot specify this flag and the **SSADISK_SECONDARY** flag together.

SSADISK_SECONDARY

Opens the device using the secondary adapter as the path to the device. As a result of hardware errors, the device driver might automatically switch to the primary path, if one exists. You can prevent this switch by additionally specifying the **SSADISK_NOSWITCH** flag.

This flag has support both for SSA logical disk drives and for SSA physical disk drives. You cannot specify this flag and the **SSADISK_PRIMARY** flag together.

SSADISK_NOSWITCH

If more than one adapter provides a path to the device, the device driver normally switches from one adapter to the other as part of its error recovery. This flag prevents the switch.

This flag has support both for SSA logical disk drives and for SSA physical disk drives.

SSADISK_FORCED_OPEN

Forces the **open** whether another initiator has the device reserved or not. If another initiator has the device reserved, the reservation is broken. Otherwise, the **open** operation runs normally.

This flag has support only for SSA logical disks. You cannot specify this flag and the **SSADISK_FENCEMODE** flag together.

SSADISK_RETAIN_RESERVATION

Retains the reservation of the device after a **close** operation by not issuing the release. This flag prevents other initiators from using the device unless they break the using system reservation.

Note: This flag does not cause the device to be explicitly reserved during the close if it was not reserved while it was open.

This flag has support only for SSA logical disk drives. You cannot specify this flag and the **SSADISK_FENCEMODE** together.

SSADISK_NO_RESERVE

Prevents the reservation of a device during an **openx** subroutine call to that device. This operation is provided so a device can be controlled by two processors that synchronize their activity by their own software procedures.

This flag overrides the setting of the attribute `reserve_lock` if the value of the attribute is "yes". This flag has support only for SSA logical disk drives. You cannot specify this flag and the **SSADISK_FENCEMODE** flag together.

SSADISK_SERVICEMODE

Opens an SSA physical disk in service mode. This flag wraps the SSA links on

each side of the indicated physical so that the disk can be removed from the loop for service, and no errors are caused on the loops.

This flag has support only for SSA physical disk drives. You cannot specify this flag and the **SSADISK_SCSIMODE** flag together.

SSADISK_SCSIMODE

Opens an SSA physical disk in SCSI passthrough mode. This action allows **SSADISK_IOCTL_SCSI** ioctls to be issued to the physical disk.

This flag has support only for SSA physical disk drives. You cannot specify this flag and the **SSADISK_SERVICEMODE** flag together.

SSADISK_NORETRY

Opens a device in no-retry mode.

When a device is opened in this mode, commands are not retried if an error occurs.

SSADISK_FENCEMODE

Opens an SSA logical disk drive in fence mode. The open subroutine succeeds although the using system might be fenced out from access to the disk drive. Only ioctls can be issued to the device while it is open in this mode. Any attempt to read from, or write to, a device that is opened in this mode is rejected with an error.

This flag has support only for SSA logical disk drives. You cannot specify this flag and the **SSADISK_NO_RESERVE** flag, **SSADISK_FORCED_OPEN** flag, or **SSADISK_RETAIN_RESERVATION** flag together.

You can find more specific information about the open operations in “SSA Options to the openx Subroutine” in the *Kernel Extensions and Device Support Programming Concepts* manuals for AIX versions 4.1 and upward.

readx and writex Subroutines

The **readx** and **writex** subroutines provide additional parameters that affect the transfer of raw data (that is, data that has not been processed or reduced). These subroutines pass the **ext** parameter, which specifies request options. The options are constructed by logically ORing zero or more of the following values:

HWRELOC

Request for hardware relocation that is safe.

UNSAFEREL

Request for hardware relocation that is not safe.

WRITEV

Request for write verification.

Error Conditions

Possible **errno** values that occur for **ioctl**, **open**, **read**, and **write** subroutines when the SSA disk device driver is used include:

EBUSY

One of the following conditions has occurred:

- An attempt was made to open an SSA physical device that has already been opened by another process.
- The target device is reserved by another initiator.

EFAULT

Illegal user address.

EINVAL

One of the following circumstances has occurred:

- The **read** or **write** subroutine supplied an *nbyte* parameter that is not an even multiple of the block size.
- The data buffer length exceeded the maximum length that is defined in the **devinfo** structure for an **ioctl** subroutine operation.
- The **openext** subroutine supplied a combination of extension flags that has no support.
- An **ioctl** subroutine operation that has no support was attempted.
- An attempt was made to configure a device that is still open.
- An illegal configuration command has been given.
- The data buffer length exceeded the maximum length that is defined for a **strategy** operation.

EIO

One of the following conditions has occurred:

- The target device cannot be located or is not responding.
- The target device has indicated an unrecovered hardware error.

ESOFT The target device has reported a recoverable media error.

EMEDIA

The target device has found an unrecovered media error.

ENODEV

One of the following conditions has occurred:

- An attempt was made to access a device that is not defined.
- An attempt was made to close a device that is not defined.

ENOTREADY

An attempt was made to open an SSA physical device in Service mode while an SSA logical device that uses it was in use.

ENXIO One of the following conditions has occurred:

- The **ioctl** subroutine supplied a parameter that is not valid.
- The **openext** subroutine supplied extension flags that selected a non-existent or nonfunctional adapter path.
- A **read** or **write** operation was attempted beyond the end of the fixed disk drive.

EPERM

The attempted subroutine requires appropriate authority.

ENOCCONNECT

The using system has been fenced out from access to this device.

ENOMEM

The system does not have enough real memory or enough paging space to complete the operation.

ENOLCK

An attempt was made to open a device in Service mode, and the device is in an SSA network that is not a loop.

Special Files

The **ssadisk** device driver uses raw and block special files to perform its functions.

Attention: Corruption of data, loss of data, or loss of system integrity (system crash) occurs if block special files are used to access devices that provide support for paging, logical volumes, or mounted file systems. Block special files are provided for logical volumes and for disk devices. They must be used only by the using system for managing file systems, for paging devices, and for logical volumes. These files should not be used for other purposes.

The special files that the **ssadisk** device driver uses include the following (listed by type of device):

- SSA logical disk drives:

/dev/hdisk0, /dev/hdisk1, ..., /dev/hdiskn

Provide an interface that allows SSA device drivers to have block I/O access to logical SSA disk drives.

/dev/rhdisk0, /dev/rhdisk1, ..., /dev/rhdiskn

Provide an interface that allows SSA device drivers to have character access (raw I/O access and control functions) to logical SSA disk drives.

- SSA physical disk drives:

/dev/pdisk0, /dev/pdisk1, ..., /dev/pdiskn

Provide an interface that allows SSA device drivers to have character access (control functions only) to physical SSA disk drives.

Note: The prefix **r** on a special file name indicates that the drive is accessed as a raw device rather than as a block device. To perform raw I/O with an SSA logical disk, all data transfers must be in multiples of the device block size. Also, all **lseek** subroutines that are made to the raw device driver must result in a file pointer value that is a multiple of the device block size.

IOCINFO (Device Information) SSA Disk Device Driver ioctl Operation

Purpose

To return a structure that is defined in the `/usr/include/sys/devinfo.h` file.

Description

The **IOCINFO** operation returns a structure that is defined in the `/usr/include/sys/devinfo.h` header file. The caller supplies the address to an area of type `struct devinfo` in the `arg` parameter to the **IOCINFO** operation. The device-type field for this component is **DD_SCDISK**; the subtype is **DS_PV**. The information that is returned includes the block size in bytes and the total number of blocks on the disk drive.

Files

`/dev/pdisk0, /dev/pdisk1, ..., /dev/pdiskn`

Provide an interface that allows SSA device drivers to have access to SSA physical disk drives.

`/dev/pdisk0, /dev/pdisk1, ..., /dev/pdiskn`

Provide an interface that allows SSA device drivers to have access to SSA logical disk drives.

SSADISK_ISAL_CMD (ISAL Command) SSA Disk Device Driver ioctl Operation

Purpose

To provide a method of sending Independent Network Storage Access Language (ISAL) commands to an SSA physical or logical disk drive. ISAL consists of a set of commands that allow a program to control and access a storage device.

The ISAL command set is described in the *Technical Reference* for the adapter.

Description

The **SSADISK_ISAL_CMD** operation allows the caller to issue an ISAL command to a selected logical or physical disk drive. The caller must be root, or have an effective user ID of root, to issue this ioctl.

The following ISAL commands (minor function codes) that are defined in the **/usr/include/ipn/ipnsal.h** file can be issued:

FN_ISAL_Read
FN_ISALWrite

FN_ISAL_Format
FN_ISAL_Progress

FN_ISAL_Lock
FN_ISAL_Unlock

FN_ISAL_Test
FN_ISAL_SCSI

FN_ISAL_Download
FN_ISAL_Fence

Notes:

1. Some of these commands are not valid for SSA hdisks, but are valid for SSA pdisks; others are valid for SSA hdisks, but are not valid for SSA pdisks. The adapter card (not the device driver) checks whether the commands are valid. If the caller attempts to send a command to a device for which that command is not valid, the adapter returns a non-zero result. The exception to this procedure occurs when any attempt is made to send a **FN_ISAL_Fence** command to a SSA physical disk. The device driver rejects any such attempt with **EINVAL**.
2. The adapter rejects the **FN_ISAL_SCSI** command with a non-zero result if that command is sent to a device that has not been opened with the **SSADISK_SCSIMODE** extension parameter.

The *arg* parameter for the **SSADISK_ISAL_CMD** ioctl is the address of an **ssadisk_ioctl_parms** structure. This structure is defined in the **/usr/include/sys/ssadisk.h** file.

The **SSADISK_ISAL_CMD** ioctl uses the following fields of the **ssadisk_ioctl_parms** structure:

- dsb** Contains the directive status byte that is returned for the command. The byte contains a value from the **/usr/include/ipn/ipndef.h** file. A non-zero value indicates an error.
- result** Contains the Independent Packet Network (IPN) result word that is returned by IPN for the command. The word contains values from the **/usr/include/ipn/ipntra.h** file. A non-zero value indicates an error.
- u0.isal.parameter_descriptor**
Set by the caller to indicate the buffer for parameter data.
- u0.isal.transmit_descriptor**
Set by the caller to indicate the buffer for transmit data.
- u0.isal.receive_descriptor**
Set by the caller to indicate the buffer for received data.
- u0.isal.status_descriptor**
Set by the caller to indicate the buffer for status data.
- u0.isal.minor_function**
Set by the caller to one of the ISAL commands that is defined in the **/usr/include/ipn/ipnsal.h** file and listed at the start of the description of this operation.

Note: Structures that are provided in the **/usr/include/ipn/ipnsal.h** file can be used to format the contents of the parameter buffer for the various commands. The device driver always overwrites, with the correct handle, the handle that is located in the first four bytes of the parameter buffer.

Return Values

If the command was successfully sent to the adapter card, this operation returns a value of 0. Otherwise, a value of -1 is returned, and the **errno** global variable set to one of the following values:

EIO An unrecoverable I/O error has occurred.

EINVAL

Either the caller has specified an ISAL command that is not in the list of supported ISAL commands, or the caller has attempted to send an **FN_ISAL_FENCE** command to an SSA physical disk.

EPERM

The caller did not have an effective user ID (EUID) of 0.

ENOMEM

The device driver was unable to allocate or pin enough memory to complete the operation.

If the return code is 0, the result field of the **ssadisk_ioctl_parms** structure is valid. This indicates whether the adapter was able to process the command successfully.

Files

/dev/pdisk0, /dev/pdisk1, ..., /dev/pdiskn

Provide an interface to allow SSA device drivers to access SSA physical disk drives.

/dev/hdisk0, /dev/hdisk1, ..., /dev/hdiskn

Provide an interface to allow SSA device drivers to access SSA logical disk drives.

SSADISK_ISALMgr_CMD (ISAL Manager Command) SSA Disk Device Driver ioctl Operation

Purpose

To provide a method of sending Independent Network Storage Access Language (ISAL) Manager commands to an SSA physical or logical disk drive. ISAL consists of a set of commands that allow a program to control and access a storage device.

The ISAL command set is described in the *Technical Reference* for the adapter.

Description

The **SSADISK_ISALMgr_CMD** operation allows the caller to issue an ISAL command to a selected logical or physical disk. The caller must be root, or have an effective user ID of root, to issue this ioctl.

The following ISAL commands (minor function codes) that are defined in the `/usr/include/ipn/ipnsal.h` file can be issued:

FN_ISALMgr_Inquiry
 FN_ISALMgr_HardwareInquiry

FN_ISALMgr_GetPhysicalResourceIDs
 FN_ISALMgrVPDInquiry

FN_ISALMgr_Characteristics
 FN_ISALMgr_Statistics

FN_ISALMgr_FlashIndicator

The *arg* parameter for the **SSADISK_ISALMgr_CMD** ioctl is the address of an **ssadisk_ioctl_parms** structure. This structure is defined in the `/usr/include/sys/ssadisk.h` file.

The **SSADISK_ISALMgr_CMD** ioctl uses the following fields of the **ssadisk_ioctl_parms** structure:

dsb Contains the directive status byte that is returned for the command. The byte contains a value from the `/usr/include/ipn/ipnndef.h` file. A non-zero value indicates an error.

result Contains the IPN result word that is returned by IPN for the command. The word contains values from the `/usr/include/ipn/ipntra.h` file. A non-zero value indicates an error.

u0.isal.parameter_descriptor
 Set by the caller to indicate the buffer for parameter data.

u0.isal.transmit_descriptor
 Set by the caller to indicate the buffer for transmit data.

u0.isal.receive_descriptor
 Set by the caller to indicate the buffer for received data.

u0.isal.status_descriptor

Set by the caller to indicate the buffer for status data.

u0.isal.minor_function

Set by the caller to one of the ISAL Manager Commands that is defined in the **/usr/include/ipn/ipnsal.h** file and listed at the start of the description of this operation.

Note: Structures are provided in the **/usr/include/ipn/ipnsal.h** file. This file can be used to format the contents of the parameter buffer for the various commands. The resource ID that is located in the first four bytes of the parameter buffer is always overwritten with the correct Resource ID for the device by the device driver.

Return Values

If the command was successfully sent to the adapter card, this operation returns a value of 0. Otherwise, a value of -1 is returned, and the **errno** global variable set to one of the following values:

EIO Indicates an unrecoverable I/O error.

EINVAL

Indicates that the caller has specified an ISAL manager command that is not in the list of supported ISAL manager commands. (The commands are listed at the start of the description of this operation.)

EPERM

Indicates that caller did not have an effective user ID (EUID) of 0.

ENOMEM

Indicates that the device driver was unable to allocate or pin enough memory to complete the operation.

If the return code is 0, the result field of the **ssadisk_ioctl_parms** structure is valid. The return code indicates whether the adapter was able to process the command successfully.

Files

/dev/pdisk0, /dev/pdisk1, ..., /dev/pdiskn

Provide an interface to allow SSA device drivers to access physical SSA disks.

/dev/hdisk0, /dev/hdisk1, ..., /dev/hdiskn

Provide an interface to allow SSA device drivers to access logical SSA disks.

SSADISK_SCSI_CMD (SCSI Command) SSA Disk Device Driver ioctl Operation

Purpose

To provide a method of sending Serial Storage Architecture - Small Computer Systems Interface (SSA-SCSI) commands to an SSA physical disk drive that has been opened with the **SSADISK_SCSIMODE** extension flag.

Description

The **SSADISK_SCSI_CMD** operation allows the caller to issue an SSA-SCSI command to a selected physical disk. The caller must be root, or have an effective user ID of root, to issue this ioctl.

The *arg* parameter for the **SSADISK_ISALMgr_CMD** operation is the address of an **ssadisk_ioctl_parms** structure. This structure is defined in the **/usr/include/sys/ssadisk.h** file.

The **SSADISK_SCSI_CMD** operation uses the following fields of the **ssadisk_ioctl_parms** structure:

- dsb** Contains the directive status byte that is returned for the command. The byte contains a value from the **/usr/include/ipn/ipndef.h** file. A non-zero value indicates an error.
- result** Contains the IPN result word that is returned by IPN for the command. The word contains values from the **/usr/include/ipn/ipntra.h** file. A non-zero value indicates an error.
- u0.scsi.data_descriptor**
Set by the caller to describe the buffer for any data that is transferred by the SCSI command. If no data is transferred, the length of the buffer should be set to 0.
- u0.scsi.direction**
Set by the caller to indicate the direction of the transfer. Valid values are:
- SSADISK_SCSI_DIRECTION_NONE**
No data transfer is involved for the command.
 - SSADISK_SCSI_DIRECTION_READ**
Data is transferred from the subsystem into the using system memory.
 - SSADISK_SCSI_DIRECTION_WRITE**
Data is transferred from the using system memory into the subsystem.
- u0.scsi.identifier**
Identifies the SSA-SCSI logical unit number to which the command should be sent. The format of this field is as defined for SSA_SCSI (bit 7=1 identifies the Target routine, bits 6-0 identify the Logical Unit routine).
- u0.scsi.cdb**
Set by the caller to define the SCSI Command Descriptor Block (CDB) for the command.

u0.scsi.cdb_length

Set by the caller to indicate the length of the CDB.

u0.scsi.scsi_status

Contains the SCSI status that is returned for the command.

The device driver does not know the contents of the CDB. The driver only passes on the CDB to the hardware. See the relevant hardware documentation to determine what CDBs are valid for a particular SSA physical disk.

Return Values

If the command was successfully sent to the adapter card, this operation returns a value of 0. Otherwise, it returns a value of -1, and sets the **errno** global variable set to one of the following values:

EIO Either an unrecoverable I/O error has occurred, or the hardware did not recognize the SCSI command as valid.

EINVAL

Either the `u0.scsi.cdb_length` field in the `ssadisk_ioctl_parms` structure was set to a length that is not valid, or the `u0.scsi.direction` field in the `ssadisk_ioctl_parms` structure was set to a value that is not valid.

EPERM

The caller did not have an effective user ID (EUID) of 0.

ENOMEM

The device driver was unable to allocate or pin enough memory to complete the operation.

If the return code is 0, the result field of the **ssadisk_ioctl_parms** structure is valid. The return code indicates whether the adapter was able to process the command successfully.

Files

/dev/pdisk0, /dev/pdisk1, ..., /dev/pdiskn

Provide an interface to allow SSA device drivers to access physical SSA disks.

/dev/hdisk0, /dev/hdisk1, ..., /dev/hdiskn

Provide an interface to allow SSA device drivers to access logical SSA disks.

SSADISK_LIST_PDISKS SSA Disk Device Driver ioctl Operation

Purpose

To provide a method of determining which SSA physical disk drives make up a SSA logical disk drive.

Description

The **SSADISK_LIST_PDISKS** operation can be issued by any user to an SSA logical disk (hdisk). The operation returns a list of the SSA physical disks (pdisks) that make up the specified logical disk drive.

The *arg* parameter for the **SSADISK_LIST_PDISKS** operation is the address of an **ssadisk_ioctl_parms** structure. This structure is defined in the **/usr/include/sys/ssadisk.h** file.

The **SSADISK_LIST_PDISKS** operation uses the following fields of the **ssadisk_ioctl_parms** structure:

u0.list_pdisks.name_array

Pointer to the array of **ssadisk_name_desc_t** structures that is in the caller memory. On return from the ioctl, this array is filled with the names of the hdisks.

u0.list_pdisks.name_array_elements

Set by the caller to indicate the number of elements that are in the array at which the **u0.list_pdisks.name_array** parameter is pointing.

u0.list_pdisks.name_count

On return from the ioctl, this field indicates the number of names that are in the name array at which the **u0.list_pdisks.name_array** parameter is pointing.

u0.list_pdisks.resource_count

On return from the ioctl, this field indicates the number of physical disk drives that make up the logical disk drive. This number might be less than **u0.list_pdisks.name_count** if, in the user memory, not enough elements were allocated in the named array to hold all the pdisk names, or if one or more physical disk drives that make up the logical disk have not been configured as physical disk drives.

Return Values

If the command was successfully sent to the adapter card, this operation returns a value of 0. Otherwise, a value of -1 is returned, and the **errno** global variable is set to one of the following values:

EIO An unrecoverable I/O error has occurred.

ENOMEM

The device driver was unable to allocate or pin enough memory to complete the operation.

Files

/dev/pdisk0, /dev/pdisk1, ..., /dev/pdiskn

Provide an interface to allow SSA device drivers to access SSA physical disks.

/dev/hdisk0, /dev/hdisk1, ..., /dev/hdiskn

Provide an interface to allow SSA device drivers to access SSA logical disks.

SSA Disk Concurrent Mode of Operation Interface

The SSA subsystem provides support for the broadcast of one-byte message codes from one using system to all other using systems that are connected to the same disk drive. This ability to pass messages can be used to synchronize access to the disk drive. The operating system has a concurrent mode interface to handle the sending and receiving of messages.

The concurrent mode of operation requires that a top kernel extension run on all the using systems that are sharing a disk drive. The top kernel extensions use the concurrent mode interface of the SSA disk device driver to communicate with each other through the SSA subsystem. The interface allows a top kernel extension to send and receive messages between using systems.

The concurrent mode interface consists of an entry point in the SSA disk device driver and an entry point in the top kernel extension. Two ioctls register and unregister the top kernel extension with the SSA disk device driver. The SSA Disk Device Driver entry point provides the method of sending messages, and of locking, unlocking, and testing the disk drive. The top kernel extension entry point processes interrupts, which might include the receiving of messages from other using systems.

Note: To ensure that the concurrent mode interface works, set the **node_number** attribute of the ssar router (see “Reserving Disk Drives” on page 27) to a different non-zero value for each using system that is sharing a disk drive.

Device Driver Entry Point

The SSA disk device driver concurrent mode entry point sends commands from the top kernel extension that is related to a specified SSA disk drive. The top kernel extension calls this entry point directly. The **DD_CONC_REGISTER** ioctl operation registers entry points.

This entry point function takes one argument that is defined in the **/usr/include/sys/ddconc.h** file. The argument is a pointer to a **conc_cmd** structure. The **conc_cmd** structures must be allocated by the top kernel extension. The concurrent mode command operation is specified by the **cmd_op** field in the **conc_cmd** structure. For each operation, the **devno** field of the **conc_cmd** structure specifies the appropriate SSA disk drive. The concurrent mode command operation can have the following values:

DD_CONC_SEND_REFRESH

Broadcasts the one-byte message code that is specified by the **message** field of the **conc_cmd** structure. The code is sent to all using systems that are connected to the SSA disk drive.

DD_CONC_LOCK

Locks the specified SSA disk drive for this using system only. No other using systems can modify data that is on the disk drive.

DD_CONC_UNLOCK

Unlocks the SSA disk drive. Other using systems can lock and modify data that is on the disk drive.

DD_CONC_TEST

Issues a test disk command to verify that the SSA disk drive is still accessible to this using system.

The concurrent mode entry point returns a value of **EINVAL** if any of the following is true:

- The top kernel extension did not perform a **DD_CONC_REGISTER** operation.
- The **conc_cmd** pointer is null.
- The devno field in the **conc_cmd** structure is not valid.
- The cmd_op field of the **conc_cmd** structure is not one of the four valid values that were previously listed.

If the concurrent mode entry point accepts the **conc_cmd** structure, the entry point returns a value of 0. If the SSA disk device driver does not have resources to issue the command, the driver queues the command until resources are available. The concurrent commands that are queued in the SSA disk device driver are issued before any read or write operations that are queued by the strategy entry point of the device driver.

The completion status of the concurrent mode commands are returned to the concurrent mode interrupt handler entry point of the top kernel extension.

Top Kernel Extension Entry Point

The top kernel extension must have a concurrent mode command interrupt handler entry point, which is called directly from the interrupt handler of the SSA disk device. This entry point function can take four arguments:

- **conc_cmd** pointer
- cmd_op field
- message_code field
- devno field

The **conc_cmd** pointer points at a **conc_cmd** structure. These arguments must be of the same type that is specified by the conc_intr_addr function pointer field of the **dd_conc_register** structure.

The following valid concurrent mode commands are defined in the **/usr/include/sys/ddcon.h** file. For each command, the devno field specifies the appropriate SSA disk drive.

DD_CONC_SEND_REFRESH

The **DD_CONC_SEND_REFRESH** device driver entry point has completed. The error field in the **conc_cmd** structure contains the return code that is necessary for the completion of this command. The possible values are defined in the **/usr/include/sys/errno.h** file. The **conc_cmd** pointer argument to the special interrupt handler entry point of the top kernel extension is non-null. The cmd_op, message_code, and devno fields are 0.

DD_CONC_LOCK

The **DD_CONC_SEND_LOCK** device driver entry point has completed. The

error field of the **conc_cmd** structure contains the return code that is necessary for the completion of this command. The possible values are defined in the **/usr/include/sys/errno.h** file. The **conc_cmd** pointer argument to the special interrupt handler entry point of the top kernel extension is non-null. The **cmd_op**, **message_code**, and **devno** fields are zero.

DD_CONC_UNLOCK

The **DD_CONC_UNLOCK** device driver entry point has completed. The error field in the **conc_cmd** structure contains the return code that is necessary for the completion of this command. The possible values are defined in the **/usr/include/sys/errno.h** file. The **conc_cmd** pointer argument to the special interrupt handler entry point of the top kernel extension is non-null. The **cmd_op**, **message_code**, and **devno** fields are zero.

DD_CONC_TEST

The **DD_CONC_TEST** device driver entry point has completed. The error field in the **conc_cmd** structure contains the return code that is necessary for the completion of this command. The possible values are defined in the **/usr/include/sys/errno.h** file. The **conc_cmd** pointer argument to the special interrupt handler entry point of the top kernel extension is non-null. The **cmd_op**, **message_code**, and **devno** fields are zero.

DD_CONC_RECV_REFRESH

A message with **message_code** was received for the SSA disk drive that is specified by the **devno** argument. The **conc_cmd** argument is null for this operation.

DD_CONC_RESET

The SSA disk drive that is specified by the **devno** argument was reset, and all pending messages or commands have been flushed. The argument **conc_cmd** is null for this operation.

- The concurrent command interrupt handler routine must have a short path length because it runs on the SSA disk device driver interrupt level. If much command processing is needed, this routine should schedule an off-level interrupt to its own off-level interrupt handler.
- The top kernel extension must have an interrupt priority that is no higher than the interrupt priority of the SSA disk device driver.
- The concurrent command interrupt handler routine might need to disable interrupts at INTCLASS0 if it is expected to use concurrent mode on SSA disk drives and on other types of disk drives. The other types of disk drives need their own device drivers to provide support for concurrent mode.
- A kernel extension that uses the **DD_CONC_REGISTER** ioctl must issue a **DD_CONC_UNREGISTER** ioctl before it closes the SSA disk drive.

SSA Disk Fencing

SSA disk fencing is a facility that is provided in the SSA subsystem. It allows multiple using systems to control access to a common set of disks.

Using the fencing commands that are provided by the hardware, you can prevent particular using systems from accessing a particular disk drive. Each disk drive has an access list that is independent of the access lists for the other disk drives.

Fencing is a function that is provided by the hardware and manipulated by hardware commands. The device driver also has some effect.

The SSA disk device driver provides support for fencing by allowing the **SSADISK_ISALCMD ioctl** operation to issue the **FN_ISAL_FENCE** command to SSA logical disk drives.

The **FN_ISAL_FENCE** command is defined in the *Technical Reference* for the adapter.

To use fencing, set the **node_number** attribute of the **ssar** router to a different value on each using system that is included in fencing. Use the **chdev** command to do this. For example, to set the **node_number** to a value of 3, type:

```
chdev -l ssar -a node_number=3
```

Note: The command fails if any target-mode SSA devices are active.

By default, the value of **node_number** is 0. This value has particular importance, because it is not possible to exclude a using system with node number 0 from access to the disk drive. Therefore, if a disk drive is moved from a machine that has been using fencing to a machine that has not been using fencing, the new machine can communicate with the disk drive.

If a using system attempts to use the **open** subroutine to open a disk drive to which it is not allowed access, the return code is -1 and the global variable **errno** is set to the value **ENOCONNECT**. Similarly, if an application already has a SSA logical disk open but that logical disk has been fenced out since the open, calls to the read or write subroutine fail, with **errno** set to **ENOCONNECT**.

The hardware fencing commands provide a method by which you can break through a fence. You can use the **SSADISK_ISALCMD ioctl** operation to give the command, but you must first open the disk drive. To open a disk drive from which the using system has been excluded, use the **openx** subroutine, and specify **SSADISK_FENCEMODE** extension flag as described in the section on SSA disk device driver device-dependent subroutines. While the disk drive is open in this mode, no read or write operations are permitted.

If fencing has excluded a using system from access to a disk drive, but that disk drive is also reserved to another using system, the reservation takes priority. The return code from the **open** subroutine is -1, and the global variable **errno** is set to **EBUSY**. If the using system attempts to break through the reservation by passing the **ext** parameter

SSADISK_FORCED_OPEN to the **openx** subroutine, the reservation is broken, but the open fails with **errno** set to **ENOCCONNECT**. To break through the fence, the SSA logical disk must be opened in **SSADISK_FENCEMODE** and the **SSADISK_ISALCMD** ioctl operation used to issue the appropriate hardware command to break the fence condition.

SSA Target Mode

The SSA Target-Mode interface (TMSSA) provides node-to-node communication through the SSA interface. The interface uses two special files that provide a logical connection to another node. One of the special files (the initiator-mode device) is used for write operations; the other (the target-mode device) is used for read operations. Data that is sent to a node is written to the initiator. Data that is read from a node is read from the target. The special files are:

/dev/tmssaXX.im

The initiator-mode device, which has an even, minor device number, and is write only.

/dev/tmssaXX.tm

The target-mode device, which has an odd, minor device number, and is read only.

The device is **tmssaXX**, where **XX** is the node number of the using system with which these files communicate. You are not aware of which path connects the two nodes. The path can change if, for example, SSA loops are changed, nodes are switched off, or any other physical change is made to the connected SSA loops. The TMSSA device driver can use any available path to the other node, but does not tell you which path is being used. Each node must have in its device configuration database a unique node number that is defined by the **node_number** attribute of the **ssar** device.

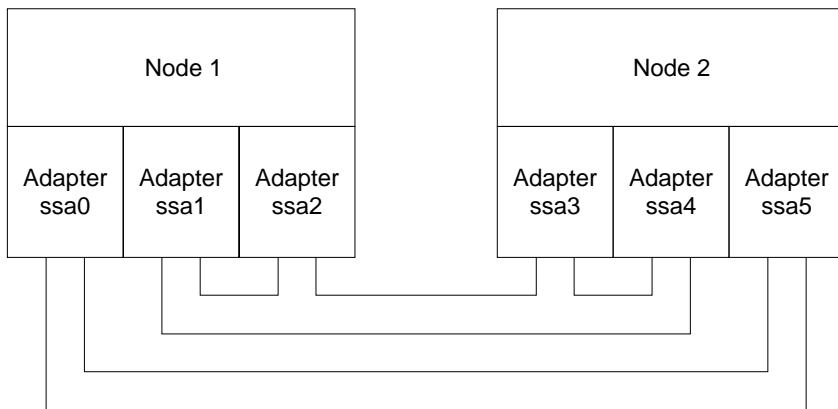

Figure 42. An Example of Node-to-Node Communications

Figure 42 shows an example configuration of two nodes. In this example, **tmssa** is, at first, using adapter **ssa0** on node 1 and adapter **ssa5** on node 2. Suddenly, the link

between the adapters fails. The tmssa device driver automatically switches to adapters ssa1 and ssa3 or adapters ssa1 and ssa4. The connections between nodes can be modified while they are in use, and the target-mode interface tries to recover.

The TMSSA uses either of two methods to read and write data:

- The blocking method, which waits until the I/O is complete or an error occurs before it returns control to you.
- The nonblocking method, which returns control to you immediately. With this method, the write operation occurs at a later time. The read operation returns the amount of data that is available at the time of the operation. The amount of returned data is not necessarily the same as the amount that you requested.

The tmssa device driver provides support for multiple concurrent read and write operations for different devices. It does not provide support for multiple read or write operations on the same device. The device driver blocks the operation until the device is free. Read and write operations can run concurrently on a particular device.

If a working path exists between two nodes, communication works. The path must be stable long enough for the driver to transmit the data. The maximum time taken to fail a write operation is $(A * R * T)$, where A is the number of adapters in the using system, R is the number of retries as defined by TM_MAXRETRY in the `/usr/include/sys/tmsscsi.h` file, and T is the retry time-out period. The minimum time taken to fail a write operation is the write time-out period. You can adjust the write time-out period and the retry time-out period; see “TMCHGIMPARM (Change Parameters) tmssa Device Driver ioctl Operation” on page 308.

You can use the select and poll routines to check for read and write capability, and can also be notified of the possibility of a read or write operation.

The amount of data that can be sent by one write operation in blocking mode has no limit, but the driver and adapter interface has been optimized for transfers of 512 bytes or less. In nonblocking mode, enough buffer space must be available for the write operation.

Each separate write operation is treated separately by the target, so, when reading, each separate write operation requires a separate read operation.

Configuring the SSA Target Mode

Each using system requires its own unique node number. The SSA adapter software specifies this node number, which is used by Target Mode SSA. The configuration database contains the ssar device. The **node_number** attribute sets the number for the node. Failure to have unique node numbers in the SSA loops causes unpredictable results with the target-mode interface. Node numbers that are not unique cause error logs. You can use the **ssavfynn** command to check for duplicate node numbers.

When the node is configured, it automatically inspects the existing SSA loops. It detects all nodes that are using the target mode SSA interface now. Each detected node is then added to the configuration database, if it is not already part of it. For each node that is added, **tmssaXX** is created, where **XX** is the node number of the detected node.

When configuration is complete, special files exist in the /dev directory. These files allow you to use the target mode interface with each node that is defined in the configuration database. Configuration does not need communication to be actually possible between the relevant using systems. Communication is needed only for the write operation.

Buffer Management

You can set the buffer sizes that are used by each device:

- To set the transmit buffer sizes, use the **chdev** command to adjust the **XmitBuffers** and **XmitBufferSize** attributes in the configuration database.
- To set the receive buffer size, use the **chdev** command to adjust the **RecvBuffers** and **RecvBufferSize** attributes in the configuration database.

The buffer sizes must be multiples of 128 bytes. The maximum buffer size is 512 bytes. A device can have as many buffers as it needs.

Data can be written into the buffers for the initiator-mode device at any time, whether or not nonblocking write operations are also transferring data from these buffers. The buffers for the target-mode device can be read at any time, even if a write operation to those buffers is occurring at the same time. It is not important if the sizes of the initiator-mode device buffers are different from the sizes of the target-mode device buffers to which the data is being sent. The total buffer space for the target-mode device, however, must be equal to, or greater than, the size of the initiator-mode device buffer size.

The SSA interface for target-mode transfers has been tuned for 512-byte transfers. Each write operation can send as much data as is required, unless that write operation is nonblocking. In a nonblocking write operation, the data that is being written must be completely transferred to the device buffers. Therefore, the maximum amount of data that can be written during a nonblocking write operation is determined by the size of the device buffers.

Understanding Target-Mode Data Pacing

An initiator-mode device can send data faster than the associated target-mode device application can read it. This condition occurs when:

- The previous write operation is complete, but all the device buffers are in use, and no space is available for the next write operation.
- The write operation is not yet completed, and the device has no available buffers.

In both these instances, the target-mode device driver stops the write operation temporarily, and uses the retry mechanism to try again later. These actions can cause the write operation to fail. As a result, the initiator-mode device is unable to send any data to the target-mode device for the whole of the retry period. Alternatively, the write operation might time out.

Think about these possibilities when you set the buffer sizes and the number of buffers for the devices. Determine carefully the retry period, total write time-out period, and the

amount of data that is being sent. For example, to write 64 KB of data with no retry operations, you need 64 KB read and write buffers. If you allow one retry operation, you need only 32 KB buffers.

Using SSA Target Mode

SSA Target Mode does not attempt to manage the data transfer between devices. It does, however, take action if buffers become full, and it ensures that read operations can read data from only one write operation. Any protocol that is needed to manage the communication of data must be implemented in user-supplied programs. The only delays that can occur when data is being received are delays that are characteristics of the SSA system and of the environment in which it operates, and delays that are caused by full buffers.

SSA Target Mode can concurrently send data to, and receive data from, all attached nodes. Blocking-read and blocking-write operations do nothing until data is available to be read, or until the write operation is complete.

Execution of Target Mode Requests

The write operation transfers the data into the device buffers. When a buffer is full, the SSA adapter starts to transfer the data to the remote using system. At the same time, the user's application program continues to fill the device buffer with the remaining data that is being transferred. If the amount of data that is being written is larger than the available buffer space, the application program waits until more space becomes available in the device buffers. As each buffer is sent, the tmssa device driver checks whether any more data is to be sent. If more data is to be sent, the device driver continues to send that data. If no more data is to be sent, and the write operation is in blocking mode, the device driver starts the waiting application program. If the write operation is in nonblocking mode, the write status is updated. If an unrecoverable error occurs, the write operation is ended, and the remaining buffers are discarded.

The read operation transfers received data from the device buffers to your application program. When the read operation ends, or the write operation stops sending data, the read operation returns the number of bytes read.

SSA tmssa Device Driver

Purpose

To provide support for using-system to using-system communications through the SSA target-mode device driver.

Syntax

```
#include /usr/include/sys/devinfo.h
#include /usr/include/sys/tmscsi.h
#include /usr/include/sys/scsi.h
#include /usr/include/sys/tmssa.h
```

Description

The Serial Storage Architecture (SSA) target-mode device driver provides an interface to allow using-system to using-system data transfer by using an SSA interface.

You can access the data transfer functions through character special files that are named **dev/tmssann.xx**, where **nn** is the node number of the node with which you are communicating. The **xx** can be either **im** (initiator-mode interface), or **tm** (target-mode interface). The caller uses the initiator-mode to transmit data, and the target-mode interface to receive data.

When the caller opens the initiator-mode special file, a logical path is set up. This path allows data to be transmitted. The user-mode caller issues a **write**, **writev**, **writex**, or **writevx** system call to start sending data. The kernel-mode user issues an **fp_write** or **fp_rwuio** service call to start sending data. The SSA target-mode device driver then builds a **send** command to describe the transfer, and the data is sent to the device. The data can be sent as a blocking write operation, or as a nonblocking write operation. When the write entry point returns, the calling program can access the transmit buffer.

When the caller opens the target-mode special file, a logical path is set up. This path allows data to be received. The user-mode caller issues a **read**, **readv**, **readx**, or **readvx** system call to start receiving data. The kernel-mode caller issues an **fp_read** or **fp_rwuio** service call to start receiving data. The SSA target-mode device driver then returns data that has been received for the application program.

The SSA target mode device driver allows an initiator-mode device to get access to the data transfer functions through the write entry point; it allows a target-mode device to get access through the read entry point.

The only rules that the SSA target mode device driver observes to manage the sending and receiving of data are:

- Separate write operations need separate read operations.
- Receive buffers that are full, delay the send operation when it tries to resend after a delay.

The calling program must observe any other rules that are needed to maintain, or otherwise manage, the communication of data. Delays that occur when data is received or sent through the target mode device driver are that are characteristics of the hardware and software driver environment.

Configuration Information

When **tmssan** is configured (where *n* is the remote node number), the **tmssan.im** and **tmssan.tm** special files are both created. An initiator-mode pair, or a target-mode pair, must exist for each device, whether either or both modes are being used. The target-mode node number for an attached device must be the same as the initiator-mode node number.

Each time that you use the **cfgmgr** command to configure the node, the target-mode device driver finds the remote nodes that are already connected, and automatically configures them. Each node is expected to be identified by a unique node number.

The target-mode device driver configuration entry point must be called only for the initiator-mode device number. The device driver configuration routine automatically creates the configuration data for the target-mode device minor number. This data is related to the initiator-mode data.

Device-Dependent Subroutines

The target-mode device driver provides support for the following subroutines:

- **open**
- **close**
- **read**
- **write**
- **ioctl**
- **select**

open Subroutine

The **open** subroutine allocates and initializes target, or initiator, device-dependent structures. No commands are sent to the device as a result of running the **open** subroutine.

The initiator-mode device or target-mode device must be configured but not already opened for that mode; otherwise, the **open** subroutine does not work. Before the initiator-mode device can be successfully opened, its special file must be opened for write operations only. Before the target-mode device can be successfully opened, its special file must be opened for read operations only.

Possible return values for the **errno** global variable include:

EBUSY

Attempted to run an **open** subroutine for a device instance that is already open.

EINVAL

Attempted to run an **open** subroutine for a device instance, but either a wrong open flag was used, or the device is not yet configured.

EIO An I/O error occurred.

ENOMEM

The SSA device does not have enough memory resources.

close Subroutine

The **close** subroutine deallocates resources that are local to the target device driver for the target or initiator device. No commands are sent to the device as a result of running the **close** subroutine.

Possible return values for the **errno** global variable include:

EINVAL

Attempted to run a **close** subroutine for a device instance that is not configured or not opened.

EIO An I/O error occurred.

EBUSY

The device is busy.

read Subroutine

Support for the **read** subroutine is provided only for the target-mode device. Support for data scattering is provided through the user-mode **readv** or **readvx** subroutine, or through the kernel-mode **fp_rwuio** service call. If the **read** subroutine is not successful, the return value is set to -1, and the **errno** global variable is set to the return value from the device driver. If the return value is something other than -1, the read operation was successful, and the return code indicates the number of bytes that were read. The caller should verify the number of bytes that were read. File offsets are not applicable and are ignored for target-mode read operations.

The adapter write operations provide the boundary that determines how read requests are controlled. If more data is received than is requested in the current read operation, the requested data is passed to the caller, and the remaining data is retained and returned for the next read operation for this target device. If less data is received in the **send** command than is requested, the received data is passed for the read request, and the return value indicates how many bytes were read.

If a write operation has not been completely received when a read request is made, the request blocks and waits for data. However, if the target device is opened with the **O_NDELAY** flag set, the read does not block; it returns immediately. If no data is available for the read request, the read is not successful, and the **errno** global variable is set to **EAGAIN**. If data is available, it is returned. The return value indicates the number of bytes that were received, whether the write operation for this data has ended or not.

Note: If the **O_NDELAY** flag is not set, the **read** subroutine can block for an undefined time while it waits for data. Because, in a read operation, the data can come at

any time, the device driver does not maintain an internal timer to interrupt the read. Therefore, if a time-out function is required, it must be started by the calling program.

If the calling program wants to break a blocked **read** subroutine, the program can generate a signal. The target-mode device driver receives the signal and ends the current **read** subroutine. If no bytes were read, the **errno** global variable is set to **EINTR**; otherwise, the return value indicates the amount of data that was read before the interrupt occurred. The read operation returns with whatever data has been received, whether the write operation has completed or not. If the remaining data for the write operation is received, it is put into a queue, where it waits for either another read request or a **close** command. When the target receives the signal and the current read is returned, another read operation can be started, or the target can be closed. If the read request that the calling program wants to break ends before the signal is generated, the read operation ends normally, and the signal is ignored.

The target-mode device driver attempts to queue received data in front of requests from the application program. A read-ahead buffer area is used to store the queued data. The length of this read-ahead buffer is determined by multiplying the value of the **RecvBufferSize** attribute by the value of the **RecvBuffers** attribute. These values are in the configuration database. While the application program runs **read** subroutines, the queued data is copied to the application data buffer, and the read-ahead buffer space is again made available for received data. If an error occurs while the data is being copied to the caller data buffer, the read operation fails, and the **errno** global variable is set to **EFAULT**. If the **read** subroutines are not run quickly enough to fill almost all the read-ahead buffers for the device, data reception is delayed until the application program runs a **read** subroutine again. When enough area is freed, data reception capability is restored from the device. Data might be delayed, but it is not lost or ignored.

The target-mode device driver controls only received data into its read entry point. The read entry point can optionally be used with the select entry point to provide a means of asynchronous notification of received data on one or more target devices.

Possible return values for the **errno** global variable include:

EAGAIN

Indicates that a nonblocking read request would have blocked, because data is available.

EFAULT

An error occurred while copying data to the caller buffer.

EINTR Interrupted by a signal.

EINVAL

Attempted to run a read operation for a device instance that is not configured, not open, or is not a target-mode minor device number.

EIO An I/O error occurred.

write subroutine

Support for the write entry point is provided only for the initiator-mode device driver. The write entry point generates one write operation in response to a calling program write request. If the device is opened with the `O_NDELAY` flag set, and the write request is for a length that is greater than the total buffer size of the device, the write request fails. The `errno` global variable is set to `EINVAL`. The total buffer size for the device is determined by multiplying the value of the `XmitBufferSize` attribute by the value of the `XmitBuffers` attribute. These values are in the configuration database.

Support for data gathering is through the user-mode `writev` or `writevx` subroutine, or through the kernel-mode `fp_rwuio` service call. The write buffers are gathered so that they are transferred, in sequence, as one write operation. The returned `errno` global variable is set to `EFAULT` if an error occurs while the caller data is being copied to the device buffers.

If the write operation is unsuccessful, the return value is set to -1 and the `errno` global variable is set to the value of the return value from the device driver. If the return value is other than -1, the write operation was successful and the return value indicates the number of bytes that were written. The caller should validate the number of bytes that are sent to check for any errors. Because the whole data transfer length is sent in a single write operation, you should suspect that a return code that is not equal to the expected total length is an error. File offsets are not applicable, and are ignored for target-mode write operations.

If the calling program needs to break a blocked write operation, a signal is generated. The target-mode device driver receives that signal, and ends the current write operation. The write operation that is in progress fails, and the `errno` global variable is set to `EINTR`. The write operation returns the number of bytes that were already sent, before the signal was generated. The calling program can then continue by issuing another write operation or an `ioctl` operation, or it can close the device. If the write operation that the caller attempts to break completes before the signal is generated, the write operation ends normally, and the signal is ignored.

If the buffers of remote using systems are full, or no device response status is received for the write operation, the target-mode device driver automatically retries the write operation. It retries the operation up to the number of times that is specified by the value `TM_MAXRETRY`. This value is defined in the `/usr/include/sys/tmcscli.h` file. By default, the target mode device driver delays each retry attempt by approximately two seconds to allow the target device to respond successfully. The caller can change the time delayed through the `TMCHGIMPARM` operation. If the write operation is still unsuccessful after the specified number of retries, it tries another SSA adapter. If this write operation has already tried all the SSA adapters, it fails. The calling program can retry the write operation, or perform other appropriate error recovery. No other error conditions are retried, but are returned with the appropriate `errno` global variable.

The target-mode device driver, by default, generates a time-out value, which is the amount of time allowed for the write operation to end. If the write operation does not end before the time-out value expires, the write operation fails. The time-out value is related to the length of the requested transfer, in bytes, and is calculated as follows:

```
timeout_value = ((transfer_length / 65536) + 1) * 20
```

In the calculation, 20 is the default scaling factor that generates the time-out value. The caller can customize the time-out value through the **TMCHGIMPARM** operation. The actual period that elapses before a time-out occurs can be up to 10 seconds longer than the calculated value, because it is related to the operation of the hardware at the time of the write operation. A time-out value of zero means that no time-out occurs. A value of zero is not allowed when the write operation is nonblocking, because a deadlock might occur. Under this condition, **EINVAL** is returned for the write operation.

If the caller opened the initiator-mode device with the **O_NDELAY** flag set, the write operation is nonblocking. In this mode, the device checks whether enough buffer space is available for the write operation. If enough buffer space is not available, the write operation fails, and the **errno** global variable is set to **EAGAIN**. If enough buffer space is available, the write operation immediately ends with all the data written successfully. The write operation now occurs asynchronously. If you want to track the progress of this write operation, use the **TMIOSTAT** operation. The driver keeps the status of the last write operation, which is then reported by the **TMIOSTAT** operation.

Possible return values for the **errno** global variable include:

EFAULT

The write operation was unsuccessful because of a kernel service error. This value is applicable only during data gathering.

EINTR Interrupted by signal.

EINVAL

Attempted to execute a write operation for a device instance that is not configured, not open, or is not an initiator-mode minor device number. If a nonblocking write operation, the transfer length is too long, or the time-out period is zero. If the transfer length is too long, try the operation again with a smaller transfer length. If the time-out period is zero, use **TMCHGIMPARM** to set the time-out value to another value.

EAGAIN

A nonblocking write operation could not proceed because not enough buffer space was available. Try the operation again later.

EIO One of the following I/O errors occurred:

- An error that cannot be produced again.
- The number of retried operations reached the limit that is specified in **TM_MAXRETRY** without success on an error that cannot be reproduced.
- The target-mode device of the remote node is not initialized or open.

Do the appropriate error recovery routine.

ETIMEDOUT

The command has timed out. Do the appropriate error recovery routine.

ioctl Subroutine

The following `ioctl` operations are provided by the target-mode device driver. Some are specific to either the target-mode device or the initiator-mode device. All require the respective device instance be open for the operation run.

IOCINFO

Returns a structure defined in the `/usr/include/sys/devinfo.h` file.

TMCHGIMPARM

Allows the caller to change some parameters that are used by the target mode device driver for a particular device instance.

TMIOSTAT

Allows the caller to get status information about the previously run write operation.

Possible return values for the `errno` global variable include:

EFAULT

The kernel service failed when it tried to access the caller buffers.

EINVAL

The device not open or not configured. The operation is not applicable to mode of this device. A parameter that is not valid was passed to the device driver.

select Entry Point

The `select` entry point allows the caller to know when a specified event has occurred on one or more target-mode devices. The event *input* parameter allows the caller to specify about which of one or more conditions it wants to be notified by a bitwise OR of one or more flags. The target-mode device driver provides support for the following `select` events:

POLLIN

Check whether received data is available.

POLLSYNC

Return only events that are currently pending. No asynchronous notification occurs.

The additional events, `POLLOUT` and `POLLPRI`, are not applicable. The target-mode device driver does not, therefore, provide support for them.

The *reventp* output parameter points to the result of the conditional checks. The device driver can return a bitwise OR of the following flags:

POLLIN

Received data is available.

The *chan* input parameter is used for specifying a channel number. This parameter is not applicable for nonmultiplexed device drivers. It should be set to 0 for the target-mode device driver.

The POLLIN event is indicated by the device driver when any data is received for this target instance. A nonblocking **read** subroutine, if subsequently issued by the caller, returns data. For a blocking read subroutine, the read does not return until either the requested length is received, or the write operation ends, whichever comes first.

Asynchronous notification of the POLLIN event occurs when received data is available. This notification occurs only if the select event POLLSYNC was not set.

The initiator-mode device driver provides support for the following select events:

POLLOUT

Check whether output is possible.

POLLPRI

Check whether an error occurred with the write operation.

POLLSYNC

Return only events that are currently pending. No asynchronous notification occurs.

An additional event POLLIN is not applicable and has no support from the initiator-mode device driver.

The *reventp* output parameter points to the result of the conditional checks. The device driver can return a bitwise OR of the following flags:

POLLOUT

If the initiator device is opened with the O_NDELAY flag, some buffer space is not being used now. Otherwise, this event is always set for the initiator-mode device.

POLLPRI

An error occurred with the latest write operation.

Asynchronous notification of the POLLOUT event occurs when buffer space is made available for further write operations.

Asynchronous notification of the POLLPRI event occurs if an error occurs with a write operation. Note that the error might be recovered successfully by the device driver.

Possible return values for the **errno** global variable include:

EINVAL

A specified event has no support, or the device instance is not configured or not open.

Errors

Errors that are detected by the target-mode device driver can be one of the following:

- A hardware error that occurred while receiving data, and cannot be reproduced
- A hardware error that occurred during an adapter command, and cannot be reproduced

- A hardware error that has not been recovered
- A software error that has been detected by the device driver

The target-mode device driver passes error-recovery responsibility for all detected errors to the caller. For these errors, the target-mode device driver does not know if this type of error is permanent or temporary. These types of errors are handled as temporary errors.

Only errors that the target-mode device driver can itself recover through retry operations can be determined to be either temporary or permanent. The error is ignored if it succeeds during retry (a recovered error). The return code to the caller indicates success if a recovered error occurs, or failure if an unrecovered error occurs. The caller can retry the command or operation, but success is probably low for unrecovered errors.

TMSSA does no error logging. If an error occurs, that error might be logged by the adapter device driver.

tmssa Special File

Purpose

To provide access to the SSA tmssa device driver.

Description

The Serial Storage Architecture (SSA) target-mode device driver provides an interface that allows the SSA interface to be used for data transfer from using system to using system.

You can access the data transfer functions through character special files that are named **dev/tmssann.xx**, where **nn** is the node number of the node with which you are communicating. The **xx** can be either **im** (initiator-mode interface), or **tm** (target-mode interface). The caller uses the initiator-mode to transmit data, and the target-mode interface to receive data.

The least significant bit of the minor device number indicates to the device driver which mode interface is selected by the caller. When the least significant bit of the minor device number is set to 1, the target-mode interface is selected. When the least significant bit is set to 0, the initiator-mode interface is selected. For example, **tmssa1.im** should be defined as an even-numbered minor device number to select the initiator-mode interface. **tmssa1.tm** should be defined as an odd-numbered minor device number to select the target-mode interface.

When the caller opens the initiator-mode special file, a logical path is set up. This path allows data to be transmitted. The user-mode caller issues a **write**, **writev**, **writex**, or **writevx** system call to start data transmission. The kernel-mode user issues an **fp_write** or **fp_rwuio** service call to start data transmission. The SSA target-mode device driver then builds a **send** command to describe the transfer, and the data is sent to the device. The transfer can be done as a blocking write operation or as a nonblocking write operation. When the write entry point returns, the calling program can access the transmit buffer.

When the caller opens the target-mode special file, a logical path is set up. This path allows data to be received. The user-mode caller issues a **read**, **readv**, **readx**, or **readvx** system call to start the receiving of data. The kernel-mode caller issues an **fp_read** or **fp_rwuio** service call to start the receiving of data. The SSA target-mode device driver then returns data that was received for the application program.

Implementation Specifics

The SSA tmssa device driver provides further information about implementation specifics. The **tmssa** special file is part of Base Operating System (BOS) Runtime. This file is in the **device.ssa.tm.rte** file set, which is in the **devices.ssa.tm** package.

Related Information

The **close** subroutine, **open** subroutine, **read** or **readx** subroutine, and **write** or **writex**.

IOCINFO (Device Information) tmssa Device Driver ioctl Operation

Purpose

To return information about the device in a structure that is defined in the `/usr/include/sys/devinfo.h` file.

Description

This operation allows you to supply a pointer to the address of an area of type **struct devinfo** in the *arg* parameter to the **IOCINFO** operation. This structure is defined in the `/usr/include/sys/devinfo.h` file. The SCSI target-mode union is used for this as follows:

Initiator-Device

buf_size

Size of transmit buffer.

num_bufs

Number of transmit buffers

max_transfer

Unused. Set to zero.

adap_devno

Major or Minor devno of SSA adapter to be used for the next transmit operation.

Use **TM_GetDevinfoNodeNum()** to read the node number to which the data is sent.

Target-Device

buf_size

Size of receive buffer.

num_bufs

Number of receive buffers

max_transfer

Unused. Set to zero.

adap_devno

Major or Minor devno of SSA adapter initially used by the paired initiator-mode device.

Use **TM_GetDevinfoNodeNum()** to read the node number from which the data is received.

The remainder of the structure is filled as follows:

devtype DD_TM SCSI.

flags Set to zero.

devsubtype DS_TM.

TMIOSTAT (Status) tmssa Device Driver ioctl Operation

Purpose

To allow the caller to put the status information for the current or previous write operation into a structure that is defined in the `/usr/include/sys/tmcscli.h` file.

Description

This operation returns information about the last write operation. Because a nonblocking write operation might still be running, you must ensure that the status information applies to a particular write operation. The `tm_get_stat` structure in the `/usr/include/sys/tmcscli.h` file is used to indicate the status, as follows:

status_validity

Bit 0 set, `scsi_status` valid

scsi_status

`SC_BUSY_STATUS` Write operation in progress

`SC_GOOD_STATUS` Write operation completed successfully

`SC_CHECK_CONDITION` Write operation failed

general_card_status

Unused. Set to zero.

b_error

`errno` for a failed write operation, or zero.

b_resid

Updated `uio_resid` for the write operation.

resvd1 Unused. Set to zero.

resvd2 Unused. Set to zero.

Note: The `tm_get_stat` structure works only for the initiator device.

TMCHGIMPARM (Change Parameters) tmssa Device Driver ioctl Operation

Purpose

To allow the caller to change the *retry* parameter and the *time out* parameter that are used by the target-mode device driver.

Description

This operation allows the caller to change the default set up of the device. It is allowed only for the initiator-mode device. The *arg* parameter to the **TMCHGIMPARM** operation contains the address of the **tm_chg_im_parm** structure that is defined in the **/usr/include/sys/tmcsesi.h** file.

Default values that are used by the device driver for the *retry* parameter and for the *time out* parameter usually do not require change. For some calling programs, however, default values can be changed to fine tune timing parameters that are related to error recovery.

When a parameter is changed, it remains changed until another **TMCHGIMPARM** operation occurs, or until the device is closed. When the device is opened, the parameters are set to the default values.

Parameters that can be changed with this operation are:

- The delay (in seconds) between device-driver-initiated retries of **send** commands (the *retry* parameter)
- The time allowed before the write operation times out (the *time out* parameter).

To indicate which of the possible two parameters the caller is changing, the caller sets the appropriate bit in the *chg_option* field. The caller can change either the *retry* parameter, or the *time out* parameter, or it can change both parameters.

To change the delay between **send** command retries, the caller sets the **TM_CHG_RETRY_DELAY** flag in the *chg_option* field and puts the required delay value (in seconds) into the *new_delay* field of the structure. With this command, the *retry* delay can be changed to any value 0 through 255, where 0 instructs the device driver to use as little delay as possible between retries. The default value is approximately two seconds.

To change the **send** command time-out value, the caller sets the **TM_CHG_SEND_TIMEOUT** flag in the *chg_option* field, sets the desired flag in the *timeout_type* field, and puts the desired time-out value into the *new_timeout* field of the structure. One flag must be set in the *timeout_type* field to indicate the required form of the time-out. If the **TM_FIXED_TIMEOUT** flag is set in the *timeout_type* field, the value that is put into the *new_timeout* field is a fixed time-out value for all **send** commands. If the **TM_SCALED_TIMEOUT** flag is set in the *timeout_type* field, the value that is put into the *new_timeout* field is a scaling-factor used in the calculation for time-outs as shown under the description of the write entry point. The default **send** command time-out value is a scaled time-out with a scaling factor of 20.

Regardless of the value of the `timeout_type` field, if the `new_timeout` field is set to a value of 0, the caller specifies “no time out” for the **send** command, allowing the command to take an indefinite amount of time. If the calling program wants to end a write operation, it generates a signal. This option is allowed only for blocking-type write operations.

Part 2. Maintenance Information

Chapter 14. SSA Adapter Information

For a description of the SSA adapter, port addresses, and the rules for SSA loops, see Chapter 1, “Introducing SSA and the Advanced SerialRAID Adapters”.

Installing the SSA Adapter

1. Install the adapter and disk drive microcode from the media that are supplied with the adapter. A README sheet of installation instructions is also supplied.
2. Install the adapter into a slot in the using system (see the *Installation and Service Guide* for the using system).
3. Switch on the using system. This action ensures that the latest version of the microcode that is available on the using system is downloaded into the adapter before the disk drives are connected.
4. Connect the SSA cables to the adapter and to the devices that are to be attached to the adapter. For information about how the cables are to be attached, see the configuration plan that was created when the subsystem was ordered.

If the configuration plan is not available, use the example configuration information that is given in the service information for the devices.

See also Chapter 2, “Introducing SSA Loops” on page 7 for general information about SSA loops and links.

Note: If, for any reason, an adapter is exchanged for a replacement adapter, all associated arrays that were not synchronized when the adapter failed are rebuilt.

Cron Table Entries

During the installation of the SSA software, the following four entries are made in the system cron table:

```
01 5 * * * /usr/lpp/diagnostics/bin/run_ssa_ela 1>/dev/null 2>/dev/null
0 * * * * /usr/lpp/diagnostics/bin/run_ssa_healthcheck 1>/dev/null 2>/dev/null
30 * * * * /usr/lpp/diagnostics/bin/run_ssa_enc1_healthcheck 1>/dev/null 2>/dev/null
30 4 * * * /usr/lpp/diagnostics/bin/run_ssa_link_speed 1>/dev/null 2>/dev/null
```

The first entry instructs the `run_ssa_ela` shell script to run at 05:01 each day. This shell script analyzes the error log. If it finds any problems, the script warns the user in the following ways. It sends:

- An error message to `/dev/console`. This message is displayed on the system console.
- An OPMSG to the error log. This message indicates the source of the error.
- A mail message to `ssa_adm`.

Note: `ssa_adm` is an alias mail address that is set up in `/etc/aliases`. By default, the address is set to “root”, but you can set it to any valid mail address for the using system.

The second entry instructs the `run_ssa_healthcheck` shell script to run once each hour. This shell script causes the SSA adapter to log any errors that might exist in the SSA subsystem, but that are not causing application programs to fail.

The third entry instructs the `run_ssa_encl_healthcheck` shell script to run at 30 minutes past each hour. This shell script searches for SSA enclosures that provide support for SCSI Enclosure Services (SES). If any of those enclosures detects errors, the shell script causes entries to be made in the error log .

The fourth entry instructs the `run_ssa_link_speed` shell script to run at 04:30 each day. This shell script searches for SSA links that are not running at the best speed. If one is found, an entry is made in the system error log.

Note: You can use 20-MB-per-second (black) SSA cables to connect 40-MB-per-second SSA nodes. If you do, however, the `run_ssa_link_speed` shell script might cause errors to be logged that can be solved only by exchanging the black cables for 40-MB-per-second cables (blue) SSA cables. If you are using 20-MB-per-second SSA cables to connect 40-MB-per-second SSA nodes, therefore, delete the `run_ssa_link_speed` cron entry.

Microcode Maintenance

This section describes how to:

- Check the ID and the level of the microcode package
- Maintain the adapter microcode
- Maintain the disk drive microcode

Checking the ID and Level of the Microcode Package

For some problems, the service request number (SRN) might ask you to check the microcode package ID or the microcode level before you exchange any field-replaceable units (FRUs).

To determine the microcode package ID, give the following command:

```
lsattr -E -l adapter -a ucode
```

where **adapter** is the ID of the adapter that you want to check; for example, `ssa0`.

An example of a response to this command is:

```
ucode 14109100.05.50 Name of adapter code download file False
```

The microcode package ID is 14109100.05.50

Note: The word “False” shows that this attribute cannot be changed.

To determine the adapter microcode level, use the Display or Change Configuration or Vital Product Data (VPD) service aid to display the VPD for the adapter (see the

Diagnostic Information for Multiple Bus Systems manual). The microcode level is shown in the ROS level field. Alternatively, give the following command:

```
lscfg -v1 adapter
```

where **adapter** is the ID of the adapter that you want to check.

You can determine the disk drive microcode level by using the Display/Download Disk Drive Microcode SSA service aid (see “Display/Download Disk Drive Microcode Service Aid” on page 393).

Maintaining the Adapter Microcode

Updates to microcode can be delivered on several types of media, or you can get them from web page <http://www.storage.ibm.com/hardsoft/products/ssa>

1. Install the microcode as described in the instructions that are provided with the installation media.
2. Run the **cfgmgr** command (if you have not already done so) to download the new microcode into the SSA adapter.
3. If the SSA loops that are connected to this adapter contain two or more SSA adapters, and those adapters are installed in two or more using systems, load the adapter microcode, then run the **cfgmgr** command on each using system.

If the level of the microcode that is stored in the using system is higher than the level of the microcode that is installed on the SSA adapter, the higher-level microcode is automatically downloaded to the adapter when the using system runs its configuration method.

Maintaining the Disk Drive Microcode

To download disk drive microcode, use the Display/Download Disk Drive Microcode SSA service aid (see “Display/Download Disk Drive Microcode Service Aid” on page 393).

Vital Product Data (VPD) for the SSA Adapter

The vital product data (VPD) for the SSA adapter can be displayed by using the using-system service aids. This section shows the types of information that are contained in the VPD.

Part number

The part number of the adapter card.

FRU number

The part number of the adapter card field-replaceable unit (FRU).

Serial number

The serial number of the adapter card.

Engineering change level

The engineering change level of the adapter card.

Manufacturing location

Manufacturer and plant code.

ROS level and ID

The version of read-only storage (ROS) code that is loaded on the adapter.

Loadable microcode level

The version of loadable code that is needed for the satisfactory operation of this card.

Device driver level

The minimum level of device driver that is needed for this level of card.

Description of function

A message that can be displayed.

Device specific (Z0)

The size, in megabytes, of the installed synchronous dynamic random-access memory (SDRAM) modules.

Device specific (Z1)

If the adapter contains a pluggable fast-write cache module, Z1 indicates the cache size in megabytes.

Device specific (Z2)

The SSA unique ID that is used to identify this adapter.

Adapter Power-On Self-Tests (POSTs)

Power-on self-tests (POSTs) are resident in the SSA adapter. These tests ensure that the adapter does not run the functional code until the hardware that uses the code has been tested. The hardware consists of only the adapter card, memory module, and, if installed, Fast-Write Cache Option Card and battery. Some POST failures cause the adapter to become unavailable to the using system. Other POST failures allow the adapter to be available, although some function might not be enabled. The particular tests that are run are related to the type of SSA adapter that is being used. If a POST fails and prevents the adapter from becoming available, exchange the adapter card for a new one. If a POST fails, but does not prevent the adapter from becoming available, an error is logged. That error indicates which FRUs must be exchanged for new FRUs.

Chapter 15. Removal and Replacement Procedures

Exchanging Disk Drives

1. If you are removing a disk drive under concurrent maintenance (see the service information for the device that contains the disk drive), you must first determine which hdisk is using the pdisk that you want to remove. To do this, you can either use the Configuration Verification service aid (see “Configuration Verification Service Aid” on page 387), or give the **ssaxlate** command from the command line (see “ssaxlate Command” on page 372).
 - If no hdisk is using the pdisk, go to step 13 on page 323.
 - If an hdisk is using the pdisk, you must now determine the *type* of the hdisk. The hdisk might be an SSA disk drive or a RAID disk. To determine whether the hdisk is a RAID disk, type:

```
smitty lsdssaraid
```

A list is displayed of all hdisks that are configured as RAID arrays.
 - If an hdisk that is a RAID-1, RAID-5, or RAID-10 array is using the pdisk, you can remove the disk drive from the array. Go to step 7 on page 322.
 - If an hdisk that is a RAID-0 array is using the pdisk:
 - a. Ask the customer to make a backup of the data (if possible) from the array, and to make the disk free.
 - b. Ensure that you delete the array before you exchange the pdisk.
 - c. Note the hdisk number.
 - d. Go to step 2.
 - If the hdisk is not a RAID pdisk:
 - a. Ask the customer to make a backup of the data (if possible) from the array, and to make the disk free.
 - b. Ensure that the fast-write function is disabled (see “Enabling or Disabling Fast-Write for One Disk Drive” on page 214).
 - c. Go to step 13 on page 323.
2. **Attention:** You should be here only if you are working with a RAID-0 array. For fast path, type `smitty mssaraid` and press Enter. Otherwise, select **Delete an SSA RAID Array** from the SSA RAID Array menu. A list of arrays is displayed in a window:

SSA RAID Arrays

Move cursor to desired item and press Enter.

List All Defined SSA RAID Arrays
List All Supported SSA RAID Arrays
List All SSA RAID Arrays Connected to a RAID Manager
List Status Of All Defined SSA RAID Arrays
List/Identify SSA Physical Disks
List/Delete Old RAID Arrays Recorded in an SSA RAID Manager
List Status of Hot Spare Pools
List Status of Hot Spare Protection for an SSA RAID Array
List Components in a Hot Spare Pool

SSA RAID Array

Move cursor to desired item and press Enter.

hdisk3	095231779F0737K	good	3.4G	RAID-0	array
hdisk4	09523173A02137K	good	3.4G	RAID-0	array

F1=Help	F2=Refresh	F3=Cancel
F8=Image	F10=Exit	Enter=Do
/=Find	n=Find Next	

3. Select the array that you want to delete.

4. A prompt is displayed in a window:

```
SSA RAID Arrays

Move cursor to desired item and press Enter.

List All Defined SSA RAID Arrays
List All Supported SSA RAID Arrays
List All SSA RAID Arrays Connected to a RAID Manager
List Status Of All Defined SSA RAID Arrays
List/Identify SSA Physical Disks
List/Delete Old RAID Arrays Recorded in an SSA RAID Manager
List Status of Hot Spare Pools
List Status of Hot Spare Protection for an SSA RAID Array
List Components in a Hot Spare Pool

-----
ARE YOU SURE?

Continuing may delete information you may want
to keep. This is your last chance to stop
before continuing.
Press Enter to continue.
Press Cancel to return to the application.

F1=Help           F2=Refresh       F3=Cancel
F8=Image          F10=Exit         Enter=Do
/=Find           n=Find Next
```

5. **Attention:** When an array is deleted, all the data that is contained in that array is lost.
At the prompt, press Enter if you want to delete the array. Press Cancel if you do not want to delete the array.
6. When you have deleted the array, go to step 13 on page 323.

7. **Attention:** You should be here only if you are working with a RAID-1, RAID-5, or RAID-10 array.

For fast path, type `smitty redssaraid` and press Enter.

Otherwise:

- a. Select **Change Member Disks in an SSA RAID Array** from the SSA RAID Array menu.
 - b. Select **Remove a Disk from an SSA RAID Array**.
8. A list of arrays is displayed in a window:

Change Member Disks in an SSA RAID Array

Move cursor to desired item and press Enter.

Remove a Disk from an SSA RAID Array
Add a Disk to an SSA RAID Array
Swap Members of an SSA RAID Array

SSA RAID Array

Move cursor to desired item and press Enter.

hdisk3	095231779F0737K good	3.4G	RAID-5 array
hdisk4	09523173A02137K good	3.4G	RAID-5 array

F1=Help F2=Refresh F3=Cancel
F8=Image F10=Exit Enter=Do
/=Find n=Find Next

Select the SSA RAID array from which you are removing the disk drive.

9. The following information is displayed:

```
Remove a Disk from an SSA RAID Array

Type or select values in entry fields.
Press Enter AFTER making all desired changes.

SSA RAID Manager          Entry Fields
SSA RAID Array           ssa0
Connection Address / Array Name  hdisk3
* Disk to Remove         095231779F0737K      +

F1=Help      F2=Refresh  F3=Cancel   F4=List
F5=Reset     F6=Command  F7=Edit     F8=Image
F9=Shell    F10=Exit   Enter=Do
```

Press F4 to list the disk drives.

10. A list of disk drives is displayed.
From the displayed list, select the disk drive that you want to remove.
11. If necessary, use the Identify function to find the disk drive that you want to remove (see "Finding the Physical Location of a Device" on page 409).
12. Press Enter to remove the disk drive from the array.
13. If the Check light of the disk drive that you are removing is off, use the Set Service Mode service aid to put that disk drive into Service Mode (see "Set Service Mode Service Aid" on page 378).
If the Check light of the disk drive that you are removing is on, you do not need to select Service Mode before you remove that disk drive.
14. Physically remove the disk drive. (See the service information for the device that contains the disk drive, then return to here.)
15. Physically install the replacement disk drive. (See the service information for the device that contains the disk drive, then return to here.)
16. If the disk drive is in Service Mode, reset Service Mode. (See "Set Service Mode Service Aid" on page 378, then return to here.)

17. On each using system to which this replacement disk drive is connected, you must now remove from the system configuration the reference to the pdisk that you have just removed.

Attention: If the disk drive is connected to more than one using system, the pdisk and hdisk numbers might be different on each system. If you are not sure what the pdisk and hdisk numbers are on either system, give the command:

```
odmget -q"connwhere like *NNNNNNNN*" CuDv
```

where NNNNNNNN is the serial number on the front of the removed disk drive. The hdisk and pdisk configuration data for the disk drive serial number is displayed.

To remove the reference to the pdisk that you have just removed, type:

```
rmdev -l [pdisknumber] -d
```

where [pdisknumber] is the pdisk number of the disk drive that you have just removed.

If the pdisk that you have just removed did not belong to a RAID array, you must also remove from the system configuration the reference to the hdisk. Type:

```
rmdev -l [hdisknumber] -d
```

where [hdisknumber] is the hdisk number of the disk drive that you have just removed.

18. If you installed the disk drive under concurrent maintenance, give the **cfgmgr** command on each using system to which that disk drive is connected. The command configures the disk drive.

If you installed the disk drive while the using system was switched off, switch on the using system when you are ready to do so. When you switch on the using system, the disk drive is automatically configured.

19. Use the Display/Download Microcode service aid to check whether the microcode is at the latest available level on the disk drive that you have just installed (see "Display/Download Disk Drive Microcode Service Aid" on page 393).
20. Select **Download Microcode to all SSA Physical Disk Drives**.
21. Select **Continue with Microcode Installation**.

Note: No microcode is downloaded if the latest available level of microcode is already on the disk drive.

22. The disk drive might have been configured with *new* hdisk and pdisk numbers. You can change these numbers. For example, if the disk drive is a replacement disk drive, you might want to make its pdisk and hdisk numbers match those of the original disk drive.

If you want to change the numbers, see "Changing Pdisk and Hdisk Numbers" on page 326. When you have changed the numbers, return to this section and go to step 23 on page 325.

If you do not want to change the numbers, go to step 23 on page 325.

23. If the disk drive that you are installing is a replacement for a disk drive that was a member of an SSA RAID array, go to step 24. Otherwise, go no further with these instructions.
24. Type `smitty ssaraid` and press Enter.
25. Select **Change/Show Use of an SSA Physical Disk**.
The pdisk that has been exchanged is listed under **SSA Physical Disks that are system disks**.
26. Select the pdisk from the list.
27. Change the Current Use parameter to **Hot Spare Disk** or to **Array Candidate Disk**.

Note: It is the user who should make the choice of Current Use parameter. That choice should be:

- **Hot Spare Disk** if the use of hot spares is enabled for the RAID arrays on the subsystem
- **Array Candidate Disk** if the use of hot spares is disabled for the RAID arrays on the subsystem.

Changing Pdisk and Hdisk Numbers

Pdisk and hdisk numbers are assigned automatically when the using system is configured. To help in system administration, it is sometimes useful to change these numbers. If you want to change the numbers, use the following procedure:

1. Find the pdisk or hdisk number that you want to change, and select a new (unused) name.
2. Give the command:

```
lsdev -Cl [disknumber] -Fconnwhere
```

where [disknumber] is the pdisk or hdisk number (for example, pdisk0) that you want to change.

The command returns a *ConnectionLocation* number (for example, 004AC5119E000D).

3. Make a note of this number; you will need it later in this procedure.
4. Give the command:

```
lsdev -Cl [disknumber] -Ftype
```

where [disknumber] is the pdisk or hdisk number (for example, pdisk0) that you want to change.

The command returns the device *Type* for the disk.

5. Make a note of this device type; you will need it later in this procedure.
6. Remove the existing pdisk or hdisk number from the configuration. Give the command:

```
rmdev -l [disknumber] -d
```

where [disknumber] is the pdisk or hdisk number (for example, pdisk0) that you want to remove.

7. Give the command:

```
mkdev -p ssar -t [Type] -c [Class] -s ssar -w [ConnectionLocation] -l [NewDiskName]
```

where:

[Type] is the disk type that you noted in step 5.

[Class] is *pdisk* for a pdisk, or *disk* for an hdisk.

[ConnectionLocation] is the number that you noted in step 3.

[NewDiskName] is the pdisk or hdisk number (for example, pdisk0) that you want for the disk.

For example:

```
mkdev -p ssar -t scsd -c pdisk -s ssar -w 004AC5119E000D -l pdisk50
```

Removing and Replacing an Advanced SerialRAID Adapter

Attention: The adapter assembly contains parts that are electrostatic-discharge (ESD) sensitive. Use the tools and procedures defined by your organization to protect such parts.

1. Remove the adapter from the using system (see the *Installation and Service Guide* for the using system).
2. If you are exchanging this adapter for another, remove from it the SDRAM module and, if present, the Fast-Write Cache Option Card. You must keep these items for the replacement adapter card.

Note: The Fast-Write Cache Option Card, if present, might contain customer data.

- See “Removing an SDRAM Module of an Advanced SerialRAID Adapter” on page 329 to remove the SDRAM module.
 - See also “Removing the Fast-Write Cache Option Card of an Advanced SerialRAID Adapter” on page 332 if you are removing the Fast-Write Cache Option Card.
3. Install the SDRAM module and, if present, the Fast-Write Cache Option Card, onto the replacement adapter card.
 - See “Installing an SDRAM Module of an Advanced SerialRAID Adapter” on page 330 to install the SDRAM module.
 - See also “Installing the Fast-Write Cache Option Card of an Advanced SerialRAID Adapter” on page 334 if you are installing a Fast-Write Cache Option Card.
 4. If the network into which you are installing this adapter is a two-way network **and** it contains RAID-1 or RAID-10 arrays with coupled disk drives (see Chapter 7, “Copying Data from Arrays and from Volume Groups” on page 149), go to step 5. If the network into which you are installing this adapter is not a two-way network **or** it does not contain RAID-1 or RAID-10 arrays with coupled disk drives, go to step 6 on page 328.
 5. **Attention:** If the network into which you are installing this adapter is a two-way network that contains RAID-1 or RAID-10 arrays with coupled disk drives, you must do the following procedure. If you do not, the coupled disks might return to 0% copied, or, if data sectors that are not valid exist in the array, the array might become unavailable to the using system.

Before you connect the adapter to the SSA loop, ensure that the latest version of adapter microcode is loaded onto the adapter, as follows:

- a. **Do not connect the external SSA cables to the adapter yet.**
- b. Switch on power to the using system, wait for the adapter to be configured. The adapter microcode is automatically downloaded.
- c. Connect the external SSA cables to the adapter.
- d. Run the **cfgmgr** command.

|
|
|
|
|
|

If you cannot do this procedure because, for example, the boot disks are on the SSA network, do the following:

- a. Run diagnostics to the SSA adapter that is on the partner system, to ensure that no array problems exist.
 - b. Wait until all coupled disk drives can be uncoupled, before you connect the new adapter to the network.
6. Install the adapter into the using system (see the *Installation and Service Guide* for the using system).

Removing an SDRAM Module of an Advanced SerialRAID Adapter

Attention: The adapter assembly contains parts that are electrostatic-discharge (ESD) sensitive. Use the tools and procedures defined by your organization to protect such parts.

1. Remove the adapter from the using system (see the *Installation and Service Guide* for the using system).
2. Refer to Figure 43.
3. Holding your thumbs against the connector **3**, open the clips **1** by pressing them in the directions shown by the arrows in the diagram. This action pulls the SDRAM module **2** out of the connector.
4. Remove the SDRAM module.

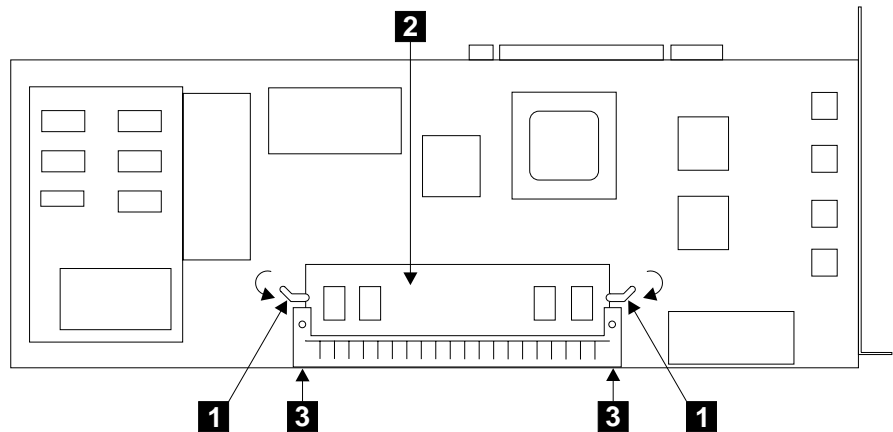

Figure 43. Removing the SDRAM Module

Installing an SDRAM Module of an Advanced SerialRAID Adapter

Attention:

- The adapter assembly contains parts that are electrostatic-discharge (ESD) sensitive. Use the tools and procedures defined by your organization to protect such parts.
 - If you are exchanging a new SDRAM for a failed SDRAM, ensure that new SDRAM is the same size as the old SDRAM. Refer to the label on each SDRAM.
1. Refer to Figure 44.

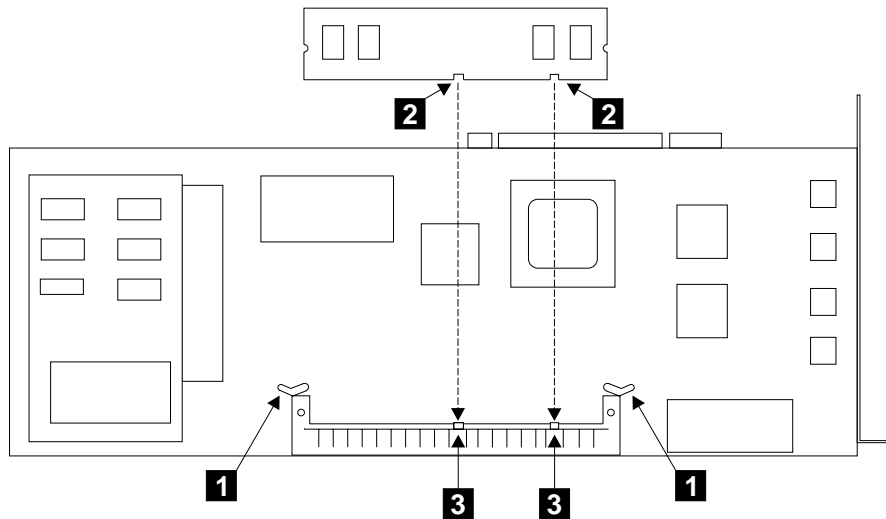

Figure 44. Checking the Clips, Slots and Guides

2. Ensure that the clips **1** are fully open.
3. Hold the SDRAM module so that its slots **2** align with the guides **3** of the connector.

4. Refer to Figure 45.

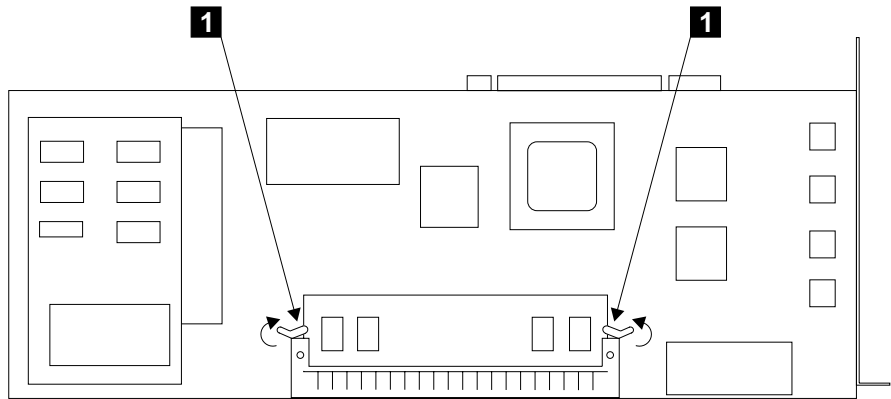

Figure 45. Installing the SDRAM Module

5. Carefully insert the SDRAM module into the connector.
6. Press strongly on the module until it is fully home.
7. Close the clips **1** by pivoting them in the directions shown by the arrows in the diagram. You hear a click when the clips are fully closed. If you cannot close the clips, the module is not fully home. Press the module fully home, then close the clips.
8. Reinstall the adapter into the using system (see the *Installation and Service Guide* for the using system).

Removing the Fast-Write Cache Option Card of an Advanced SerialRAID Adapter

Attention:

- The adapter assembly contains parts that are electrostatic-discharge (ESD) sensitive. Use the tools and procedures defined by your organization to protect such parts.
 - The Fast-Write Cache Option card might contain customer data.
1. Remove the adapter from the using system (see the *Installation and Service Guide* for the using system).
 2. Place the adapter card, with its components downward, onto a nonconducting surface.
 3. Refer to Figure 46.

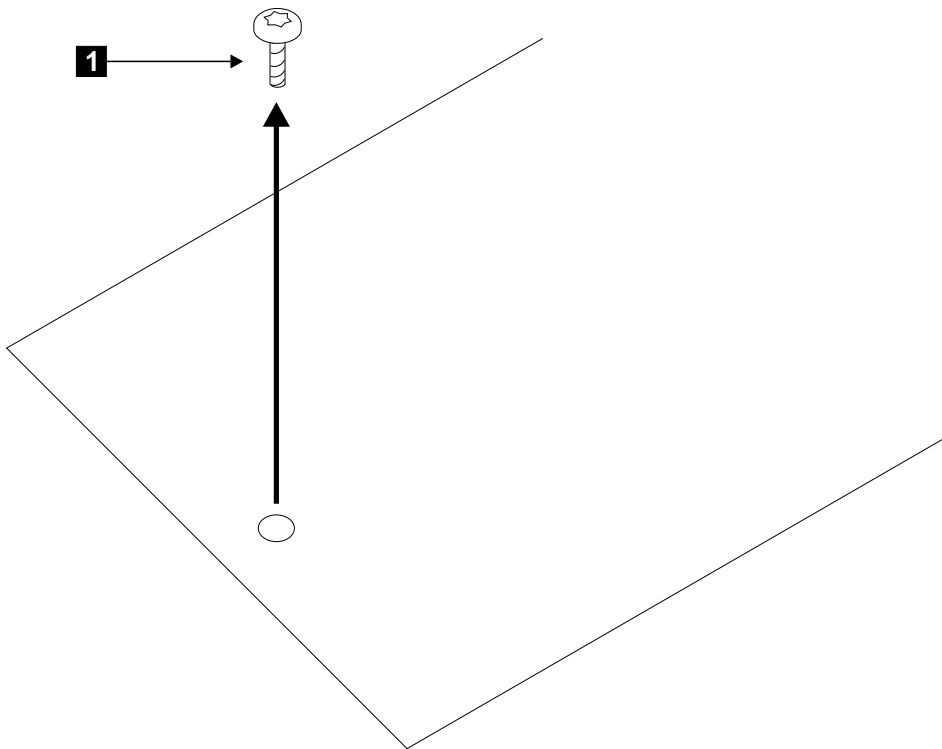

Figure 46. Removing the Mounting Screw from the Fast-Write Cache Option Card

4. Remove the mounting screw **1**. (The screw fastens the Fast-Write Cache Option card in position.)

5. Refer to Figure 47.

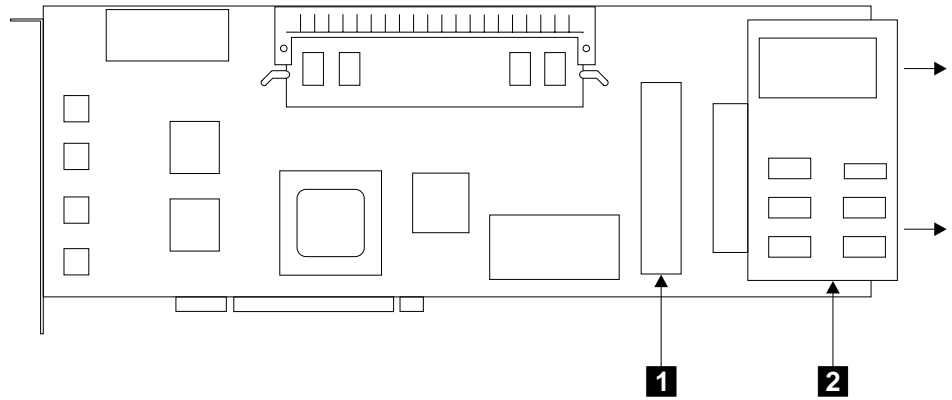

Figure 47. Removing the Fast-Write Cache Option Card

6. Invert the adapter card, so that its components are upward.
7. Carefully unplug the Fast-Write Cache Option card **2** from the connector **1**.

Installing the Fast-Write Cache Option Card of an Advanced SerialRAID Adapter

Attention: The adapter card contains parts that are electrostatic-discharge (ESD) sensitive. Use the tools and procedures defined by your organization to protect such parts.

1. Remove the adapter from the using system, if not already removed (see the *Installation and Service Guide* for the using system).
2. Place the adapter card, with its components upward, onto a nonconducting surface.
3. Refer to Figure 48.

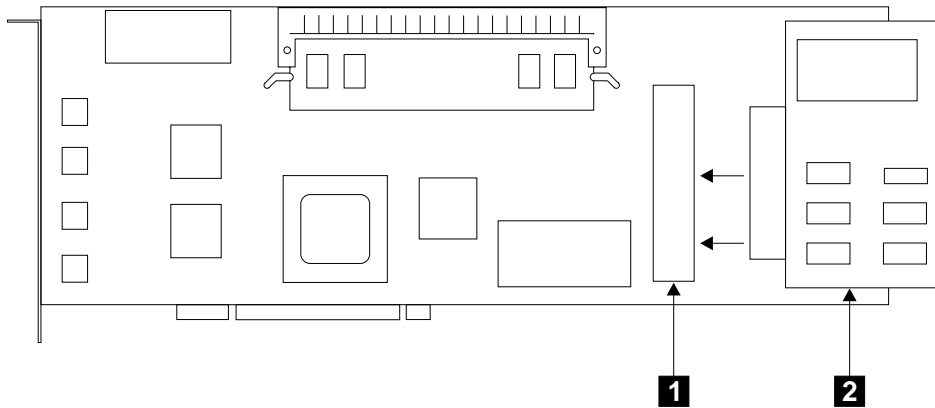

Figure 48. Installing the Fast-Write Cache Option Card

4. Carefully plug the Fast-Write Cache Option Card **2** into the connector **1**. Ensure that you push the cache card fully home.
5. Invert the adapter card, so that its components are downward.

6. Refer to Figure 49.

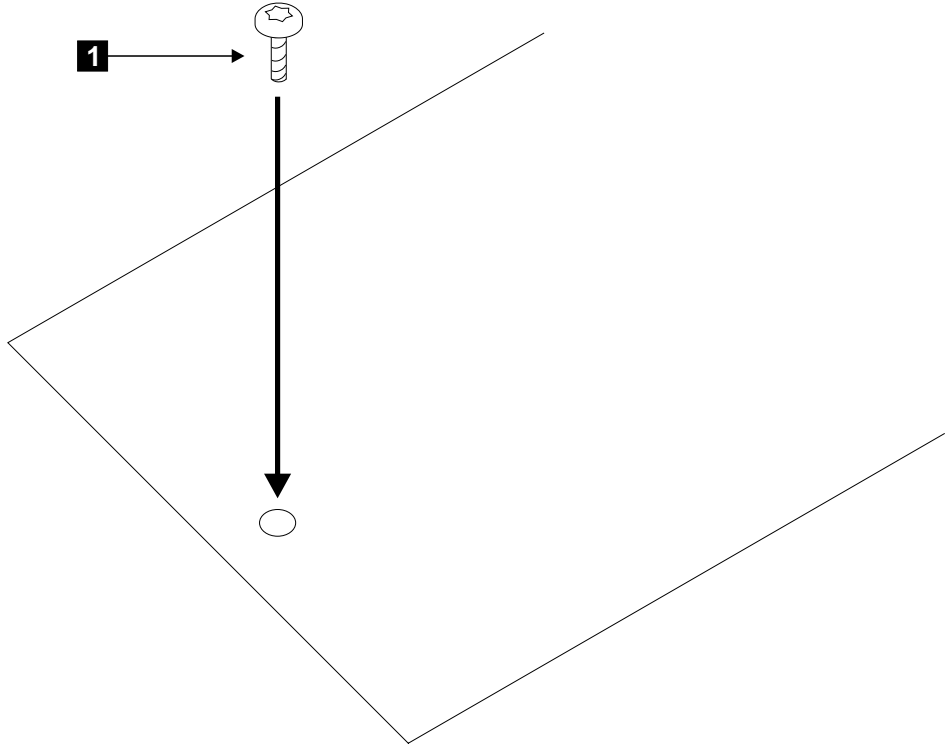

Figure 49. Installing the Mounting Screw of the Fast-Write Cache Option Card

7. Install the mounting screw **1**, and tighten it fully. (The screw is supplied with the Fast-Write Cache Option Card.)
8. Reinstall the adapter into the using system (see the *Installation and Service Guide* for the using system).

Note: The battery on the Fast-Write Option Card is not fully charged. After the adapter is connected to the power, initial battery charging completes in 5 to 60 minutes. During this time, the fast-write disks can be enabled and used, but the fast-write function remains inactive. To determine whether the fast-write cache is active or inactive, give the command:

```
ssa_fw_status -a ssaX -c
```

Removing the Battery Assembly from the Fast-Write Cache Option Card of an Advanced SerialRAID Adapter

Attention:

- The adapter assembly contains parts that are electrostatic-discharge (ESD) sensitive. Use the tools and procedures defined by your organization to protect such parts.
 - The Fast-Write Cache Option card might contain customer data.
1. Remove the adapter from the using system (see the *Installation and Service Guide* for the using system).
 2. Remove the Fast-Write Cache Option card (see “Removing the Fast-Write Cache Option Card of an Advanced SerialRAID Adapter” on page 332).
 3. Refer to Figure 50.

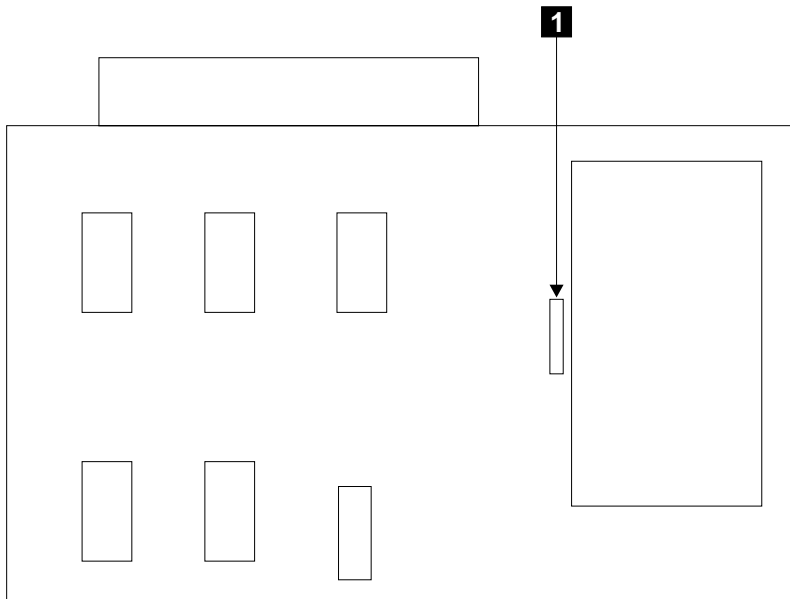

Figure 50. Releasing the Battery Assembly

4. **Attention:** The battery falls when it is released from the Fast-Write Cache Option card.
Hold the Fast-Write Cache Option card approximately 10 mm (0.5 in.) above a work surface.
5. Press the clip **1**. The battery assembly falls through the hole in the Fast-Write Cache Option card.

6. Refer to Figure 51.

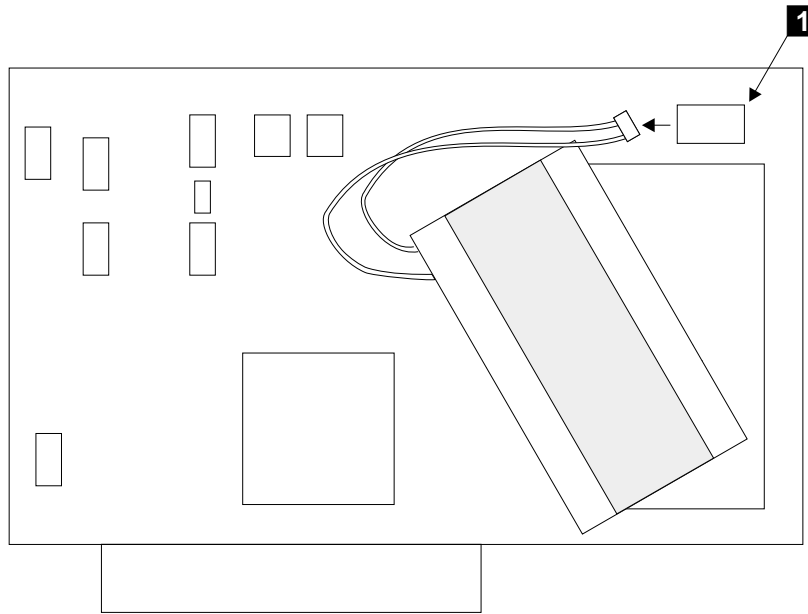

Figure 51. Disconnecting the Battery Assembly

7. Invert the Fast-Write Cache Option card.
8. Carefully unplug the battery assembly from the connector **1**.

Installing a Battery Assembly into the Fast-Write Cache Option Card of an Advanced SerialRAID Adapter

Attention:

- The adapter assembly contains parts that are electrostatic-discharge (ESD) sensitive. Use the tools and procedures defined by your organization to protect such parts.
 - The Fast-Write Cache Option card might contain customer data.
1. Refer to Figure 52.

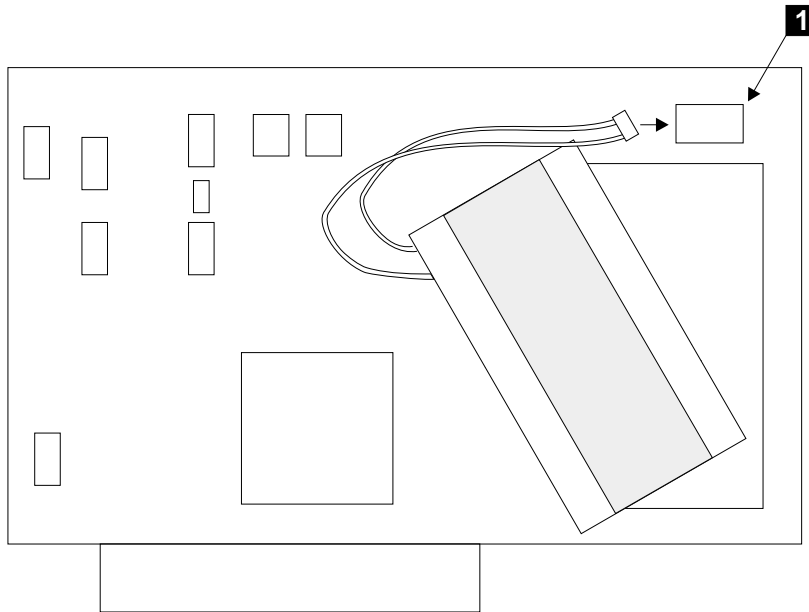

Figure 52. Connecting the Battery Assembly

2. Hold the Fast-Write Cache Option card so that the battery-assembly connector **1** is upward.
3. Connect the battery assembly to the connector **1**.

4. Refer to Figure 53.

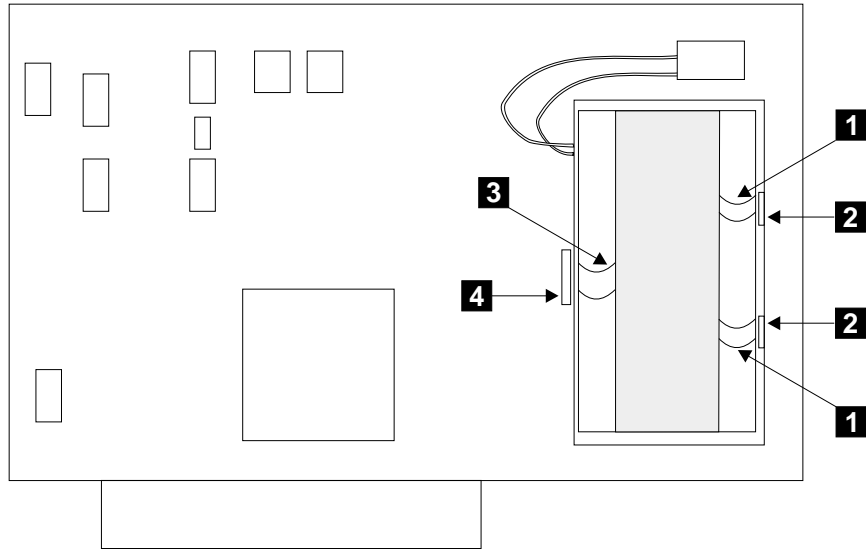

Figure 53. Installing the Battery Assembly

5. Locate the battery assembly so that the two lugs **1** are under the edges of the small slots **2**, and the clip **3** is over the larger slot **4**.
6. Carefully press the battery assembly downward until the clip latches under the edge of the slot.
7. Reinstall the Fast-Write Cache Option card (see “Installing the Fast-Write Cache Option Card of an Advanced SerialRAID Adapter” on page 334).
8. Reinstall the adapter into the using system (see the *Installation and Service Guide* for the using system).

Note: The battery on the Fast-Write Cache Option Card might be fully discharged. If it is, the diagnostics fail and generate SRN 42529 (see “Service Request Numbers (SRNs)” on page 411). While the battery is discharged, the adapter can be used; the Fast-Write Cache feature, however, remains disabled until the battery is charged. The battery becomes fully charged approximately one hour after the adapter is connected to the power.

9. You must now reset the battery-age counter. To do this action, go to the command line and type the command:

```
ssa_format -l SSA_Adapter -b
```

where `SSA_Adapter` is the name of the adapter onto which you have installed the Fast-Write Cache Option Card; for example, `ssa0`.

Part Numbers

- Advanced SerialRAID Adapter card without SDRAM module and without Fast-Write Cache Option card: 09L2090
- 64 MB module: 09L2104
- 128 MB module: 08J0663
- Fast-Write Cache Option Card: 09L2105
- Fast-write cache battery: 09L5609

Chapter 16. Using the SSA Command Line Utilities

The commands that are described here allow you to get access from the command line to some of the functions that are available in the SSA service aids. The commands are very simple and are intended for use mainly from within shell scripts. They do not provide many error checking routines or error messages. If you need such facilities, use the SSA service aids (see Chapter 17, “SSA Service Aids” on page 373).

Under most conditions, a command prints a usage string if the syntax is incorrect. No message is printed, however, if the command fails. If the command runs without error, the return code is 0. If an error occurs, the return code is a value other than 0.

ssa_sesdld Command

Purpose

To download new microcode to an SES enclosure.

Syntax

```
ssa_sesdld {-d device -f codefile | [-d device] [-f codefile] -u} [-t]
```

Description

This command can be used to download the latest level of microcode to all available SES enclosures, or to download a specified microcode file to a specified enclosure. To enable the latest level of microcode to be downloaded to all enclosures, either the microcode file must be located in the `/etc/microcode` directory, or the microcode filename and path name must be specified with the `-f` flag. To enable the microcode to be downloaded to a specified enclosure, the microcode file name and its full path name must be specified with the `-f` flag.

Flags

-d device

Specifies the SES enclosure to which the microcode will be sent. This flag is used with the `-f` flag or the `-u` flag.

-f codefile

Specifies the name of the microcode file to be downloaded. This flag can be used with the `-d` flag or the `-u` flag.

-u

When this flag is used with no other flags, the latest level of enclosure microcode that is available in the `/etc/microcode` directory is downloaded to all available SES enclosures if that latest level is higher than the version that exists in the enclosure. If this flag is used with the `-f` flag, the file that is specified by the `-f` flag is downloaded to all available SES enclosures if the level of that file is higher than the level that exists in the enclosure.

-t This optional flag allows new levels of microcode to be tested. The enclosure returns to the original level of microcode if the enclosure power is switched off, then switched on.

Examples

To install the latest level of microcode on all available SES enclosures, give the command:

```
ssa_sesdld -u
```

To install microcode file coral1014.hex on enclosure0, give the command:

```
ssa_sesdld -d enclosure0 -f /etc/microcode/coral1014.hex
```

To install microcode file coral1014.hex on all available SES enclosures whose existing level of microcode is lower than coral1014, give the command:

```
ssa_sesdld -f /etc/microcode/coral1014.hex -u
```

To install microcode file coral1014.hex on enclosure0 only if the existing level of microcode on enclosure0 is lower than coral1014, give the command:

```
ssa_sesdld -d enclosure0 -f /etc/microcode/coral1014.hex -u
```

ssaadap Command

Purpose

To list the adapters to which a logical disk or physical disk is connected.

Syntax

```
ssaadap -l LogicalDiskName  
ssaadap -l PhysicalDiskName
```

Description

The output is the list of SSA adapters to which the logical or physical disk is connected. If the list contains more than one adapter, the first adapter in the list is the primary adapter.

Flags

-l DiskName
Specifies the logical or physical disk.

ssacand Command

Purpose

To display the unused connection locations for an SSA adapter.

Syntax

```
ssacand -a AdapterName -P|-L
```

Description

The **ssacand** command lists the available connection locations of an SSA adapter. These connection locations are related to disk drives that, although connected to the adapter, are not yet configured as system disk drives.

Flags

-a AdapterName

Specifies the adapter whose connection locations are to be listed.

-P Produce a list of possible connection locations for physical disks.

-L Produce a list of possible connection locations for logical disks.

ssa_certify Command

Purpose

- To certify the physical disk drive so that data can be read from, or written to, the disk drive without problems.
- To certify a RAID-5 array to determine whether any array logical block addresses (LBAs) have been as unreadable.

Syntax

```
ssa_certify -l pdisk [-n MaxReadSize] [-a]  
ssa_certify -l hdisk [-b StartLBA] [-c]
```

Description

If the **ssa_certify** command is issued to a **pdisk**, it uses the **ISAL_Read**, **ISAL_Write**, or **ISAL_Characteristics** command to certify the disk drive. It returns 0 unless a nonmedia-related problem occurs. If such a problem occurs, the **ssa_certify** command prints a message to **stderr**.

If a media-related problem occurs, and the disk drive can perform automatic reassign operations, the command attempts to reassign soft-error blocks.

If the attempt to reassign the soft-error blocks fails, if the block has a hard media error, or if the disk drive cannot perform automatic reassign operations, the **ssa_certify** command returns 0, but prints, to **stdout**, the LBA of the failing block in decimal, followed by the word "Failed". For example:

```
>ssa_certify -l pdisk4  
436537676 Failed
```

If the disk drive cannot perform automatic reassign operations:

1. Stop all operations to the disk drive.
2. Use the **-a** flag, and rerun the Certify operation.

If the certify operation is successful, the **ssa_certify** command returns no output.

If the **ssa_certify** command is issued to a RAID-5 **hdisk** that contains LBAs that have been marked as unreadable, an LBA or an LBA count is printed to **stdout**. For example:

```
>ssa_certify -l hdisk2  
12288 failed
```

```
>ssa_certify -l hdisk2 -c  
4
```

Flags

-l pdisk

Specifies the physical disk drive (**pdisk**) that the user wants to certify.

-a

Enables the reassign action on devices that cannot already perform automatic

reassign operations. You must not use this flag when the **ssa_certify** command is running concurrently on an active using system.

-n MaxReadSize

Specifies the maximum size, in kilobytes, of each **read** command that is sent to the disk drive.

Default size for this flag = 3072 kilobytes

Minimum value that can be specified for this flag = 64 kilobytes

Maximum value that can be specified for this flag = 10240 kilobytes. Larger values for the MaxReadSize can cause other requests to be delayed if the **ssa_certify** command is run concurrently on an active using system

-b StartLBA

Specifies the RAID-5 array LBA from where the certify operation should start. If this flag is not set, the certify operation starts from LBA 0.

-c

Specifies that a count of unreadable blocks be printed.

ssaconn Command

Purpose

To display the SSA connection details for the physical disk.

Syntax

```
ssaconn -l PhysicalDiskName -a AdapterName
```

Description

The **ssaconn** command performs a function that is similar to the Link Verification service aid. The output from this command is:

```
PhysicalDiskName AdapterName hopcount1 hopcount2 hopcount3 hopcount4
```

The four hop counts represent the number of SSA devices that are between the physical disk and the A1, A2, B1, and B2 ports of the adapter, respectively. For example, if hop count 1 is 0, no devices are between the physical disk and the A1 port of the adapter. If hop count 4 is 5, five devices are between the physical disk and the B2 port of the adapter.

If the disk is not connected to a particular adapter port, the hop count is replaced by a – (dash) character.

Flags

-l PhysicalDiskName

Specifies the physical disk whose connection details are to be listed.

-a AdapterName

Specifies the adapter to whose ports the connection details are related.

ssa_diag Command

Purpose

To run diagnostic tests to a specified device.

Syntax

```
ssa_diag -l pdiskX  
ssa_diag -l ssaX
```

Description

The **ssa_diag** command is in `/usr/lpp/diagnostics/bin`.

Flags

- a** Causes the adapter to be reset if the device that is being tested is an adapter. This flag has no effect if the device is a disk drive.
- u** Forces a disk reservation to be broken if the device the device that is being tested is a disk drive. This flag has no effect if the device is an adapter, and is not valid for SSA Enhanced RAID Adapters or Advanced SerialRAID Adapters.
- s** Requests the output of the hardware status of a disk drive. This flag can be used only with a disk drive. It cannot be used with the **-a** flag or with the **-u** flag. Disk drive status output is:
 - 0** Good: the adapter has initialized the pdisk.
 - 1** Power: the pdisk has detected a loss of redundant power or cooling.
 - Note:** If the pdisk is in a 7133 Model D40 or Model T40, this status indicates that the enclosure has detected a degraded environment. Such an environment might be caused by a power, cooling, or temperature problem, or by an enclosure hardware failure.
 - 2** Failed: the adapter cannot initialize the pdisk.

Output

If an error occurs, the **ssa_diag** command generates an error message, for example: `ssa0 SRN 42500`, and sends it to stdout.

If no error occurs, the command sends no message to stdout.

A non-zero return code indicates an error. The command sends an error message to stderr.

ssadisk Command

Purpose

To display the names of disk drives that are connected to an SSA adapter.

Syntax

```
ssadisk -a AdapterName -P|-L
```

Description

The **ssadisk** command lists the names of disk drives that are connected to an SSA adapter. These names are related to devices that are in the customized device data base, and have the SSA adapter as their **adapter_a** or **adapter_b** attribute.

Flags

- a AdapterName**
Specifies the adapter to which the disk drives are connected.
- P** Produce a list of physical disks.
- L** Produce a list of logical disks.

ssadload Command

Purpose

To download microcode to SSA physical disk drives.

Syntax

```
ssadload -d PhysicalDiskName -f CodeFileName [-p]
ssadload -u [-d PhysicalDiskName | -a adapter ] [-p]
ssadload -s [-d PhysicalDiskName | -a adapter ]
```

Description

The **ssadload** command performs microcode downloads to SSA physical disk drives. The command has three modes of operation:

- **Load a specific level of microcode into a specific SSA physical disk drive.**

Using the command in this mode, you can force load any available level of microcode into any compatible SSA disk drive.

- **Ensure that either a specific SSA physical disk drive, or all the physical disk drives that are connected to the system, are using the latest levels of microcode that are available on the system.**

Using the command in this mode, you can ensure that the latest available level of microcode has been loaded onto all compatible SSA disk drives in the system.

- **Show the existing microcode level that is installed on either a specific SSA physical disk drive, or on all the SSA physical disk drives that are connected to the system.**

Using the command in this mode, you can check the level of microcode on the SSA disk drives that are connected to the system.

Notes:

1. The microcode files that this command can download have names of the pattern `ssadisk.ros.XXXX`, where `XXXX` identifies the microcode level (also known as the ROS id) that the file contains. Such microcode files are different from those with names of the pattern `ssadisk.XXXXXXX.YY`. These files contain a different type of disk microcode, and are automatically downloaded by the system configuration software as necessary. They cannot work with the **ssadload** command.
2. Microcode can be downloaded to SSA disk drives while the system is using those disk drives. You need not vary off any volume groups that contain the disk drives. If the microcode is downloaded to a disk drive that the system is using, the system might be delayed slightly while the microcode is downloading.
3. The microcode images are stored in the `/etc/microcode` directory.

Attention: Usually, you can download the microcode to disk drives that are in use. By doing so, however, you might cause a temporary delay in the operating system or in the user's application program. ***Do not download microcode to a disk drive that is in use, unless you have the user's permission. Always refer to the download instructions that are supplied with the microcode, and check for any special restrictions that might be applicable. If you are not sure, do not download to disk drives that are in use.***

Flags

-d PhysicalDiskName

Specifies the physical disk drive that is to receive the microcode.

-f CodeFileName

Specifies the microcode file to be downloaded.

-u

Ensures that all SSA physical disk drives are loaded with the latest level of microcode that is available on the system.

By default, this flag ensures that all SSA physical disk drives are loaded with the latest microcode. To update a specific disk drive, use this flag and the **-d** flag.

-s

Shows the existing levels of microcode that are installed on SSA physical disk drives.

By default, this flag shows the existing level of microcode that is installed on all SSA physical disk drives. To list a specific disk drive, use this flag and the **-d** flag.

-a adapter

Specifies the adapter on which the operation is to run so that you can update all disk drives that are connected to that adapter.

-p

Enables more than one copy of `ssadload` to run at the same time. Parallel download operations are therefore possible.

Attention: When this flag is used, a download operation to two disk drives that are in the same loop or array can occur if the using system contains two SSA adapters. The user must ensure that such operations do not occur.

Examples

- Using the **-f** flag:
`ssadload -d pdisk0 -f ssadisk.ros.7899`

With this flag, the command loads microcode file `ssadisk.ros.7899` onto `pdisk0`.

- Using the **-u** flag:
`ssadload -u`

With this flag, the command identifies the latest level of SSA disk drive microcode that is available in the `/etc/microcode` directory. It then ensures that all the disk drives are using microcode that is at that level or at a higher level. If it finds a disk drive that is using a lower level of microcode, the command downloads the latest level of microcode to that disk drive.

- Using the **-s** flag:
`ssadload -s`

With this flag, the command lists the existing levels of microcode of the available disk drives.

- Using the -s and -a adapter flags:

```
ssadload -s -a ssa0
```

With these flags, the command lists the existing levels of microcode of all the available disk drives that are connected to adapter ssa0.

- Using the -u, -a adapter, and -p flags:

```
ssadload -u -a ssa0 -p & ; ssadload -u -a ssa1 -p
```

With these flags, the command causes the update mechanism to run in parallel and update concurrently the microcode on all the available disk drives that are connected to adapters ssa0 and ssa1.

ssa_ela Command

Purpose

To look for the most significant error in the error log.

Syntax

```
ssa_ela  
ssa_ela -l Device [-h timeperiod]  
ssa_ela -l pdisk  
ssa_ela -l hdisk  
ssa_ela -l adapter
```

Description

The **ssa_ela** command (with no flags) scans the error log, and looks for all SSA errors. The command returns a list that contains one SRN for each SSA device that is on the system. Each SRN is for the most significant error of its related SSA device.

The **ssa_ela -l device [-h timeperiod]** command scans the error log, and looks for all SSA errors. The command returns the SRN for the most significant error.

The **ssa_ela -l pdisk** command scans the error log, and looks for errors that are logged against the specified pdisk. The command returns the SRN for the most significant error.

The **ssa_ela -l hdisk** command scans the error log, and looks for errors that are logged against any hardware that provides support for the specified hdisk (pdisks and adapters). The command returns the SRN for the most significant error.

The **ssa_ela -l adapter** command scans the error log, and looks for errors that are logged against the specified adapter. The command returns the SRN for the most significant error.

Flags

-l Device

Specifies the device whose error log you want to analyze for the most significant error.

-h timeperiod

Instructs the program to start searching the error log from a previous time that is a multiple of 24 hours. For example, -h 1 (the default setting) starts a search through the previous 24 hours. -h 2 starts a search through the previous 48 hours.

Output

If an error occurs, the **ssa_ela** command sends an error message to stdout, such as:
ssa0 SRN 42500

If no error occurs, the command sends no message to stdout.

A non-zero return code indicates an error. The command sends an error message to stderr.

ssaencl Command

Purpose

To allow the monitoring and changing of the status for SSA SES disk enclosures (subsystems).

Syntax

To display enclosure component settings:

```
ssaencl -l name [-s] [-v] [-i] [-r] [-b [card ...]] [-t [threshold ...]]
              [-a] [-f [fan ...]] [-d [drive_bay ...]] [-p [PSU ...]]
              [-o] [-c] [-e]
```

To modify enclosure component settings:

```
ssaencl -l name [-I ID [-U]] [-B mode | card=mode ...] [-S{d[drive_bay ...] |
              b[card...] | p[PSU ...] | r | c | o}] [-T threshold=value ...]
```

To display a usage message:

```
ssaencl -h
ssaencl -?
```

Description

The **ssaencl** command can be used to observe the existing settings of an SSA SES disk enclosure (subsystem), or to modify the settings of that enclosure. The command can be used only to observe **or** modify settings; it cannot be used to observe **and** modify settings at the same time.

When the command displays enclosure settings, it displays them in tables that the user can read easily. If the **-s** flag is specified, however, the command displays the settings in colon-separated format, as used by commands such as the SMIT commands.

Flags

-l name

Specifies the name of an SSA SES enclosure or pdisk. If a pdisk name is used, that pdisk must be in an SSA SES enclosure.

-s Displays output in colon-separated format.

-v Displays also VPD information.

-i Displays the enclosure identifier (as shown in the operator panel, if present).

-r Displays "RPO present TRUE/FALSE" (RPO is the remote power-on control)

-b [card]

Displays the status of the bypass cards. If no parameters are given, the status for all the bypass cards is displayed. Valid values for the **[card]** parameter are: 1, 4, 5, 8, 9, 12, 13, 16.

-t [threshold]

Displays all the temperature thresholds, or only the specified temperature thresholds. The valid values for the **[threshold]** parameter are:

lowarn The low-temperature warning threshold.

locrit The low-temperature critical threshold.

hiwarn The high-temperature warning threshold.

hicrit The high-temperature critical threshold.

-a Displays the ambient temperature of the enclosure.

-f [fan] Displays the status of all the fans, or of only the specified fans. Valid values for the **[fan]** parameter are: 1, 2, 3, and so on.

-d [drive_bay]

Displays the status of all the disk drive bays (slots), or of only the specified disk drive bays. Valid values for the **[drive_bay]** parameter are: 1, 2, 3, and so on.

-p [PSU]

Displays the status of all the power supply assemblies, or of only the specified power supply assemblies. Valid values for the **[PSU]** parameter are 1, 2, 3, and so on.

-o Displays the status of the operator panel.

-c Displays the status of the controller card.

-e Displays trace information (for service use only)

-I ID[-U]

Modifies the enclosure ID. The ID must be a four-character alphanumeric string. The optional -U flag causes the object data manager (ODM) to be updated to show the change.

-B mode

Modifies all bypass cards to the given mode.

-B card=mode

Modifies the specified bypass cards to be in the given modes. The valid values for the **mode** parameter are:

- Automatic
- Bypass
- Inline
- Open

Valid values for the **card** parameter are 1, 4, 5, 8, 9, 12, 13, 16.

-S Resets the “exchanged” flag of the selected FRU.

-S d[drive_bay ...]

Resets the flag for the selected disk drive bay (slot). Valid values for **drive_bay** are 1, 2, 3, and so on.

-S b[card ...]

Resets the flag for the bypass card. Valid values for card are 1, 4, 5, 8, 9, 12, 13, 16.

-S p[PSU ...]

Resets the flag for the selected PSU (power supply assembly). Valid values for PSU are 1, 2.

-S r Resets the flag for remote power on (RPO).

-S c Resets the flag for the controller card.

-S o Resets the flag for the operator panel.

-T threshold=value

Modifies the specified temperature thresholds to the given values. The valid values for the **[threshold]** parameter are:

lowarn The low-temperature warning threshold.

hiwarn The high-temperature warning threshold.

The **value** parameter is a temperature in degrees C.

Examples

- To display the status of all bypass cards on enclosure0, give the command:
ssaenc1 -l enclosure0 -b
- To display the status and VPD of the controller card in enclosure0, give the command:
ssaenc1 -l enclosure0 -c -v
- To modify the ID for enclosure0 to R2D2, give the command:
ssaenc1 -l enclosure0 -I R2D2
- To display the contents of disk bay (slot) 8 in enclosure0, give the command:
ssaenc1 -l enclosure0 -d 8

ssa_format Command

Purpose

To format the specified device.

Syntax

```
ssa_format -l pdisk
```

or

```
ssa_format -l SSA_Adapter [-b]
```

Description

The **ssa_format -l pdisk** command opens the pdisk special file, and uses the ISAL Format command to format the device. You can close the device while the format operation is running. If the command cannot format the device, it prints an error message.

The **ssa_format -l SSA_Adapter** command attempts to format the Fast-Write Cache Option Card (if present). If the data that is on the Fast-Write Cache Option Card has been moved onto a disk drive (destaged), the formatting operation sets all the data on the Fast-Write Cache Option Card to zero, for security reasons.

The **ssa_format -l SSA_Adapter -b** command resets the battery-age counter on the Fast-Write Cache Option Card. Use this option **only** when you have exchanged the Fast-Write Cache Option Card battery.

Possible failure conditions for the **ssa_format** command include:

- No Fast-Write Cache Option Card is present on the adapter card.
- The fast-write cache is not empty. Data is waiting to be written to another device. This message is displayed:
Cannot be formatted because it is not empty
- The adapter card does not provide support for the Fast-Write Cache feature. This message is displayed:
This adapter cannot be formatted

: The **ssa_progress -l pdisk** command allows you to check the progress of the format operation that the **ssa_format -l pdisk** command started.

Flags

-l pdisk

Specifies the pdisk that you want to format.

-l SSA_Adapter

Specifies the adapter whose Fast-Write Cache Option Card you want to format.

- b** Specifies that the battery-age counter be reset. When this flag is used, the data on the Fast-Write Cache Option Card is **not** set to zero.

Important: *Do not select the -b flag unless you have exchanged the battery. Otherwise, no error message will occur when the battery reaches the end of its life.*

Output

The **ssa_format** command sends all error messages to stderr.

ssa_fw_status Command

Purpose

To show the status of the fast-write cache.

Syntax

```
ssa_fw_status -a Adapter [-p|-l|-c]
```

Description

The **ssa_fw_status** command displays the status of the fast-write cache of an SSA adapter.

Flags

-a Adapter

Shows all fast-write status for the specific adapter.

-l

Displays the expected life of the battery.

-p

Displays the number of hours for which the battery has been powered-on.

-c

Shows the state of the fast-write cache.

Output

The **ssa_fw_status** command sends all error messages to stderr, and output to stdout.

Examples

- To show the status of the Fast Write cache on an SSA adapter, give the command:

```
ssa_fw_status -a ssa0
```
- To show the life of the battery, give the command:

```
ssa_fw_status -a ssa0 -l
```
- To show the number of hours for which the battery has been powered-on, give the command:

```
ssa_fw_status -a ssa0 -p
```
- To show whether the fast-write cache is active, give the command:

```
ssa_fw_status -a ssa0 -c
```

ssa_getdump Command

Purpose

To display SSA adapter dump locations, and to save the dump to a specified location.

Syntax

For the **List version** of the command:

```
ssa_getdump -l [-h] [-d pdiskxx] [-a AdapterName | -n AdapterUID | -s SlotNumber ]
```

For the **Copy version** of the command:

```
ssa_getdump -c [-h] -d pdiskxx  
                {-a AdapterName | -n AdapterUID | -s SlotNumber } [-x] -o OutputFile
```

Description

The **ssa_getdump** command has two modes of operation: List mode and Copy mode.

List Mode

In List mode, the command searches for adapter dumps on unused SSA disk drives. It searches the disk drives sequentially, and provides information about all the dumps that it finds. An example of the output from List mode is shown here:

ADAPTER DUMPS

DATE	TIME	ADAPTER UID	DISK	SLOT	SIZE	STATUS	SEQ	ADAP
961031	10:31:12.123	1234567890ABCDEF	pdisk22	12	1.5	4	12345	ssa0
??_xx	10:32:12.456	234567890ABCDEF1	pdisk22	3	13.5	3	12346	ssa1
961120	10:50:12.123	1234567890ABCDE7	pdisk22	7	1.5	4	12345	

You can switch off the headings by using the **-h** flag.

Where possible, the **ssa_getdump** command translates the adapter UID into the adapter name, for example, ssa0. If the command cannot translate the adapter UID, it leaves the ADAP field blank (see the third line of output in the example).

You can limit the search to specific disk drives or adapters by adding various optional arguments to the command.

Attention:

The command uses space in the tmp file when it copies a file. If the available space is not large enough, the command fails. Some dumps can be large.

Copy Mode

In Copy mode, the command copies data from a specified disk drive to a specified output location. You must specify the disk drive and the output location.

Flags

The **ssa_getdump** command uses several types of flag:

- Required flags for both modes
- Required flags for Copy mode
- Optional flags for List mode
- Optional flags for Copy mode

Required Flags for Both Modes

You **must** use one of these flags:

- l** Specifies that the program is to operate in List mode. The program searches for dumps.
- c** Specifies that the program is to operate in Copy mode. The program copies the dump (if one is found) from the specified location to the specified output point.

Required Flags for Copy Mode

You **must** use both of these flags:

- d pdiskxx**
Specifies the disk drive from which the data is to be copied (for example, pdisk2).
- o OutputFile**
Specifies where the **tar** command is to write its output.

You **must** use at least one of these flags:

- a AdapterName**
Specifies the adapter name for which the program must search (for example, ssa1). The adapter must be known to the searching machine.
- n AdapterUID**
Specifies the adapter UID for which the program must search. The adapter need not be known to the searching machine.
- s SlotNumber**
Specifies the slot that contains the disk drive, as shown in the List Output.

Optional Flags for List Mode

You can choose **either or both** of these flags:

- h** Prevents the heading lines from being displayed. This option is useful for scripts.
- d pdiskxx**
Allows the you to specify which disk drive is to be searched. By specifying the disk drive, you reduce the range of the search.

You can choose **either, but not both**, of these flags:

-a AdapterName

Specifies the adapter name for which the program must search (for example, ssa1). The adapter must be known to the searching machine.

-n AdapterUID

Specifies the adapter UID for which the program must search. The adapter need not be known to the searching machine.

-s SlotNumber

Specifies the slot that contains the disk drive, as shown in the List Output.

Optional Flags for Copy Mode

You can choose **either or both** of these flags:

-h Prevents the output of progress messages from the program.

-x Prevents the actions of the **compress** command and of the **tar** command. The program copies the dump directly to the specified output point (-o).

Note: You must ensure that the specified output point has enough free space to hold the dump.

Output

The **ssa_getdump** command sends all error messages to stderr, and the following to stdout.

- Header messages
- List mode output
- Copy progress messages

The command generates these return codes:

- | | |
|----------|--|
| 0 | The command has completed successfully. |
| 1 | Some parameters are not correct. |
| 2 | The disk name is not valid, or the pdisk is not present. |
| 3 | The name of the SSA adapter is not correct or not valid. |
| 4 | The UID or slot number of the SSA adapter is not correct. |
| 5 | Cannot open the file or directory in the temporary file /tmp. |
| 6 | Not enough disk space is available, or an error occurred during a write operation to the temporary file. |
| 7 | Not enough memory is available. |

Note: When in Copy mode, the command reads data from the disk in blocks of approximately 256 KB.

- | | |
|----------|--|
| 8 | An internal or object data manager (ODM) error has occurred. |
| 9 | An error occurred during a read operation in Copy mode. |

ssaidentify Command

Purpose

To set or clear Identify mode for a physical disk.

Syntax

```
ssaidentify -l PhysicalDiskName -y  
ssaidentify -l PhysicalDiskName -n
```

Description

If the -y parameter is specified, the disk is set into Identify mode. While the disk is in Identify mode, its amber Ready light flashes at approximately one-second intervals. The -n flag switches off Identify mode.

Flags

-l PhysicalDiskName

Specifies the device to place into Identify mode.

-y Switches on Identify mode.

-n Switches off Identify mode.

ssa_progress Command

Purpose

To show how much (by percentage) of a format operation has been completed, and to show the status of the format operation. The status can be “Complete”, “Formatting”, or “Failed”.

Syntax

```
ssa_progress -l pdisk
```

Description

The **ssa_progress** command opens the pdisk special file, and uses the ISAL Progress command to determine the percentage of the formatting operation that is complete.

: The **ssa_progress -l pdisk** command allows you to check the progress of the format
: operation that the **ssa_format -l pdisk** command started.

Flags

-l Pdisk

Specifies the pdisk of whose format operation you want to check progress and status.

Output

The **ssa_progress** command sends error messages to stderr, and progress messages to stdout.

Examples

- If the disk has been 30% formatted, the following messages are displayed:

```
> ssa_progress -l pdisk  
Formatting 30
```
- If the disk is not formatting, and is not format degraded, the following messages are displayed:

```
> ssa_progress -l pdisk  
Complete 100
```
- If the disk is format degraded, the following messages are displayed:

```
> ssa_progress -l pdisk  
Failed 0
```

ssa_rescheck Command

Purpose

To report the reservation status of an hdisk.

Syntax

```
ssa_rescheck -l hdisk [-h]
```

Description

The **ssa_rescheck** command tests the access paths to the specified hdisk. It checks whether the disk is reserved. If the disk is reserved, the command attempts to determine why the disk is reserved.

Flags

- l hdisk** Specifies the hdisk that you want to test.
- h** Switches off the header output.

Output

The **ssa_rescheck** command sends error messages to stderr. It sends header information and status output to stdout. The messages can be:

- OK** Access to the disk drive is possible.
- Open** Another program has opened the disk drive.
- Fail** Access to the disk drive is not possible.
- Busy** The disk drive is reserved to another adapter or using system.

Notes:

1. For an “SSA Enhanced Adapter”, Busy means that another adapter has reserved the disk drive. If both adapters are in the same using system, the other adapter shows OK or Open.
2. For an “SSA Enhanced RAID Adapter”, Busy means that the disk drive is reserved. The Reserved To field provides more information.

N/A The adapter cannot return reservation information. This occurs when the adapter is not an “SSA Enhanced RAID Adapter”.

None The disk drive is not reserved. If an adapter name or UID is shown, the disk drive is reserved to a specific adapter. If a node number or using-system name is shown, the disk drive is reserved to a specific node.

Examples

The following examples show typical output from the **rescheck** command. The Adapter In Use field shows which adapter path the using system is using.

`ssa_rescheck -l hdisk1` produces this type of output:

Disk	Primary Adapter	Secondary Adapter	Adapter In Use	Primary Access	Secondary Access	Reserved to
hdisk1	ssa0	-----	ssa0	OK	-----	none

`ssa_rescheck -l hdisk1 -h` produces this type of output:

hdisk1	ssa0	-----	ssa0	OK	-----	none
--------	------	-------	------	----	-------	------

The next example shows the disk drive Open by adapter ssa1. The disk drive is reserved to ssa1, and adapter ssa0 has a Busy status. Because the two adapters are in the same using system, the Busy status indicates that the node number is not set:

Disk	Primary Adapter	Secondary Adapter	Adapter In Use	Primary Access	Secondary Access	Reserved to
hdisk2	ssa1	ssa0	ssa1	Open	Busy	ssa1

The next example shows that the disk drive is reserved to a node, because the secondary access is OK (not Busy), and the Reserved To field shows the using system name:

Disk	Primary Adapter	Secondary Adapter	Adapter In Use	Primary Access	Secondary Access	Reserved to
hdisk2	ssa1	ssa0	ssa1	Open	OK	abcd.location.com

Return Codes

0 The command has completed successfully.

1 A system error has occurred.

Any other value

An error that is more serious than 0 or 1 has occurred.

ssa_servicemode Command

Purpose

To put the disk drive into Service Mode (set Service Mode), or to remove the disk drive from Service Mode (reset Service Mode).

Syntax

```
ssa_servicemode -l [-a AdapterName] -y|-n
```

Description

The **ssa_servicemode** command opens the adapter special file, and sends the appropriate IACL command to put the disk drive into, or remove it from, Service Mode. When the Service Mode has been successfully set or reset, the IACL command closes the adapter special file. If Service Mode cannot be set or reset for any reason, the **cop** command prints the appropriate error message.

Flags

- l pdisk**
Specifies the pdisk that you want to put into, or remove from, Service Mode.
- a AdapterName**
Specifies the adapter to which the pdisk is connected.
- y**
Puts the pdisk into Service Mode (set Service Mode).
- n**
Removes the pdisk from Service Mode (reset Service Mode).

Output

The **ssa_servicemode** command sends all error messages to stderr.

ssa_speed Command

Purpose

To determine the operating speed of SSA links.

Syntax

```
ssa_speed -l pdisk [-s]
ssa_speed -a AdapterName {-p Loop | -n Network} [-s]
ssa_speed -x [-e]
```

Description

The **ssa_speed** command either tests the existing link speeds of the selected pdisk or adapter, or searches for link speed exceptions on all SSA adapters in the using system.

Flags

-l pdisk

Specifies the pdisk that you want to test.

-a AdapterName

Specifies the adapter that you want to test. If you select the -a flag, you must also select the -p or the -n flag.

-s

Specifies the supported link speed.

-p Loop

Causes the **ssa_speed** command to show the operating speed of both ports. Valid Loop parameters are: A, a, B, b (for example, -p A, -p b).

-n Network

Causes the **ssa_speed** command to show the operating speed of all ports on the selected network. Valid Network parameters are: A, a, B, b (for example, -n A, -n b).

-x

Causes the **ssa_speed** command to test each adapter on the using system for link speed exceptions on all nodes. To do this, the command inspects the Supported Speed and the Current Speed for each pair of neighboring nodes in each network. If the Current Speed of a particular pair of nodes is less than the Supported Speed of the slowest device in that pair of nodes, the command returns the message: <adapter_name> <port_hop>, where <port_hop> is the lowest <port_hop> count of the tested pair.

-e

When used with the -x flag, the -e flag generates an error log entry if a link speed exception condition is detected.

Output

The **ssa_speed** command sends all error messages to stderr, and output to stdout.

Link speeds can be:

- 20 (20 MB)
- 40 (40 MB)
- 00 (not operational)
- ?? (not determined)

Examples

- To display the link speed of pdisk0, give the command:
`ssa_speed -l pdisk0`
- To display the adapter link speeds of ports A1 and A2 on ssa0, give the command:
`ssa_speed -a ssa0 -p A`
- To display the adapter link speeds of all the devices in network B on ssa0, give the command:
`ssa_speed -a ssa0 -n B`
- To find link speed exception conditions, give the command:
`ssa_speed -x`

ssavfynn Command

Purpose

To check for duplicated node numbers.

Note: It is recommended that this command be used only when all the adapters on the network are SSA RAID adapters.

Syntax

```
ssavfynn [-w]
```

Description

The **ssavfynn** command is in the `/usr/lpp/diagnostics/bin` file. It has no flags.

If the **ssavfynn** command runs and finds no duplicate node numbers on the SSA network, it returns no message.

If the command finds duplicate node numbers, it returns a message that is similar to that shown here:

```
SSA User Configuration Error:  
Node Number 1 is set on both  
Local Host 'abc.somewhere.ibm.com' and Remote Host 'xyz'
```

This message says that a problem exists between your machine (abc) and another machine (xyz) that is connected through the SSA network. The names shown are the DNS names of the machines.

Flags

-w Turns on the network-wide check. It checks local node numbers against remote node numbers, and remote node numbers against other remote node numbers. The normal check is local node numbers against remote node numbers.

Output

The **ssavfynn** command sends all error messages to stderr. It sends all configuration-problem messages to stdout.

ssaxlate Command

Purpose

To translate between logical disks (hdisks) and physical disks (pdisks).

Syntax

```
ssaxlate -l LogicalDiskName  
ssaxlate -l PhysicalDiskName
```

Description

If the parameter is a logical disk, the output is a list of names of the physical disks that provide support for that logical disk.

If the parameter is a physical disk, the output is a list of names of the logical disks that use that physical disk.

Flags

-l DiskName

Specifies the logical or physical disk.

Chapter 17. SSA Service Aids

Note: For some problems, you can use the SSA command line utilities instead of the SSA service aids. For information about the command line utilities, see Chapter 16, “Using the SSA Command Line Utilities” on page 341.

SSA service aids are resident in the using system. They help you to service SSA subsystems. This section describes those service aids, and tells how to use them.

Attention: Do not run the service aids from more than one using system at a time; otherwise, unexpected results might occur.

The SSA service aids are:

- **Set Service Mode:** This service aid enables you to determine the location of a particular disk drive on the SSA loop, and to remove that disk drive from the loop.
- **Link Verification:** This service aid tells you the operational status of the links that make an SSA loop.
- **Configuration Verification:** This service aid lets you determine the relationship between physical and logical disk drives.
- **Format Disk:** This service aid formats an SSA disk drive.
- **Certify Disk:** This service aid verifies that all the data on a disk drive can be read correctly.
- **Display/Download Disk Drive Microcode:** This service aid allows you to observe and modify the microcode level on all the SSA disk drives.
- **Link Speed:** This service aid allows you to observe the operating speed of each link on an SSA loop.
- **Physical Link Configuration:** This service aid provides support for SES-enabled SSA enclosures (subsystems). See your enclosure service information for a description of this service aid.
- **Enclosure Configuration:** This service aid provides support for SES-enabled SSA enclosures (subsystems). See your enclosure service information for a description of this service aid.
- **Enclosure Environment:** This service aid provides support for SES-enabled SSA enclosures (subsystems). See your enclosure service information for a description of this service aid.
- **Enclosure Settings:** This service aid provides support for SES-enabled SSA enclosures (subsystems). See your enclosure service information for a description of this service aid.

The selection menu for the SSA service aids allows you direct access to the SMIT menus for fast-write and RAID functions on SSA disks.

Before you use the service aids, ensure that you are familiar with the principles of SSA loops and physical disk drives (pdisks). If you are not familiar with these principles, first read Chapter 2, “Introducing SSA Loops” on page 7.

Note: The service aids refer to the Advanced SerialRAID Adapter as IBM SSA 160 SerialRAID Adapter (14109100). On some service screens, this name is shortened.

The Identify Function

The Identify function can be accessed from many of the service aid menus.

This function enables you to determine the location of a particular disk drive that you want to identify, but do not want to remove. When set, the Identify function causes the Check light of the disk drive to flash for identification (two seconds on, two seconds off), but has no effect on the normal operation of the disk drive. It also causes the Subsystem Check light (if present) of the unit containing the selected disk drive to flash. You can use the Identify function on any number of disk drives at the same time.

Instructions displayed by the service aids tell you when you can select the Identify function.

The service aids display the serial numbers of the devices. By checking the serial-number label on the device, you can verify that the correct device has its Check light flashing.

Note: Normally, you can reset the Identify function by selecting to switch it off from inside a service aid display, or by leaving that particular service aid display. If, however, you remove or switch off a disk drive that has the Identify function set, the function remains set on that disk drive. When you reinstall or switch on the disk drive, the disk drive Check light continues to flash. Under these conditions, you can reset the Identify function by either of the following methods:

- Type on the command line:
`ssaidentify -l pdiskName -n`
- Select the Link Verification service aid for that disk drive.

Starting the SSA Service Aids

To start the SSA service aids:

1. Start the using-system diagnostics (see the *Diagnostic Information for Multiple Bus Systems* manual), and go to the **Diagnostic Operating Instructions**.
2. Follow the instructions to select **Function Selection**.
3. Select **Task Selection** from the Function Selection menu.
4. Select **SSA Service Aids** from the Tasks Selection list.

The SSA Service Aids menu is displayed:

```
SSA SERVICE AIDS                                     802380
Move cursor onto selection, then press Enter.

      Set Service Mode
      Link Verification
      Configuration Verification
      Format Disk
      Certify Disk
      Display/Download Disk Drive Microcode
      Link Speed
      Physical Link Configuration
      Enclosure Configuration
      Enclosure Environment
      Enclosure Settings
      SMIT-SSA RAID Arrays
      SMIT-SSA Disks

F3=Cancel      F10=Exit
```

Notes:

- a. In some configurations of the using-system console:

Esc and **0** = Exit

Esc and **3** = Cancel

In such configurations, however, the displayed instructions for the function keys remain the same as those shown in the screen above.

- b. For some versions of AIX and for stand-alone diagnostics, the format of the service aid displays might be slightly different from that shown in this chapter. Functionally, however, the displays remain the same.

5. Select the service aid that you require, then go to the relevant instructions in this chapter:
 - “Set Service Mode Service Aid” on page 378
 - “Link Verification Service Aid” on page 383
 - “Configuration Verification Service Aid” on page 387
 - “Format Disk Service Aid” on page 389
 - “Certify Disk Service Aid” on page 391
 - “Display/Download Disk Drive Microcode Service Aid” on page 393
 - “Link Speed Service Aid” on page 396

Set Service Mode Service Aid

The Set Service Mode service aid enables you to determine the location of a particular disk drive, and to remove that disk drive from the unit in which it is installed. It causes the Check light of that disk drive to come on for identification, and stops all SSA loop activity through the disk drive. It also causes the Subsystem Check light (if present) of the unit containing the selected disk drive to come on. Only one disk drive at a time can be in Service Mode.

Before using this service aid, you must make the selected disk drive unavailable to the using system; otherwise, an error occurs.

SSA devices can be maintained concurrently; that is, they can be removed, installed, and tested on an SSA loop while the other devices on the loop continue to work normally. If a disk drive has its Check light on, the pdisk might not be configured. If the pdisk is not configured, you cannot select Service Mode. Under these conditions, you can remove the disk drive from the SSA loop without taking any special actions.

If a disk drive does *not* have its Check light on, the SSA loop that passes through it might still be active, although the disk drive itself might not be working. You must put that disk drive into Service Mode before you remove it from the SSA loop.

If you leave the Set Service Mode service aid, Service Mode is reset.

To use the Set Service Mode service aid:

1. Select **Set Service Mode** from the SSA Service Aids menu (see “Starting the SSA Service Aids” on page 376). A list of physical disk drives (pdisks) is displayed:

```
SET SERVICE MODE                                     802381

Move cursor onto selection, then press <Enter>.

systemname:pdisk0          AC50AE43  2GB SSA C Physical Disk Drive
systemname:pdisk1          AC706EA3 2GB SSA C Physical Disk Drive
systemname:pdisk2          AC1DBE11 2GB SSA C Physical Disk Drive
systemname:pdisk3          AC1DBEF4 2GB SSA C Physical Disk Drive
systemname:pdisk4          AC50AE58 2GB SSA C Physical Disk Drive
systemname:pdisk5          AC7C6E51 2GB SSA C Physical Disk Drive
systemname:pdisk6          AC706E9A 2GB SSA C Physical Disk Drive
systemname:pdisk7          AC1DEEE2 2GB SSA C Physical Disk Drive
systemname:pdisk8          AC1DBE32 2GB SSA C Physical Disk Drive

F3=Cancel      F10=Exit
```

The columns of information displayed on the screen have the following meanings:

systemname	Name of the using system to which the disk drives are connected.
pdisk0 through pdisk8	Physical disk drive resource identifiers.
AC50AE43 through AC1DBE32	Serial numbers of the physical disk drives. The actual serial number of a disk drive disk drive is shown on a label on the disk drive.
2 GB SSA C Physical Disk Drive	Descriptions of the disk drives.

2. Select the pdisk that you want to identify or put into Service Mode (for example, pdisk3). The following display appears with details of the disk drive that you have just selected:

```
SET SERVICE MODE 802382  
systemname:pdisk0 AC50AE43 4GB SSA C Physical Disk Drive
```

Move cursor onto selection, then press <Enter>.

- + Set or Reset Identify.
Select this option to set or reset the Identify indicator on the disk drive.
- > Set or Reset Service Mode.
Select this option to set or reset Service Mode on the disk drive.
ENSURE THAT NO OTHER HOST SYSTEM IS USING THIS DISK DRIVE BEFORE SELECTING THIS OPTION.

F3=Cancel

F10=Exit

3. Select Service Mode or the Identify function. (For this example, assume that you have selected Service Mode.) The list of pdisks is displayed again, and the disk drive that you selected is marked by a >, which shows that the disk drive is in Service Mode.

```
SET SERVICE MODE 802381

Move cursor onto selection, then press <Enter>.

systemname:pdisk0          AC50AE43  2GB SSA C Physical Disk Drive
systemname:pdisk1          AC706EA3  2GB SSA C Physical Disk Drive
systemname:pdisk2          AC1DBE11  2GB SSA C Physical Disk Drive
> systemname:pdisk3        AC1DBEF4  2GB SSA C Physical Disk Drive
systemname:pdisk4          AC50AE58  2GB SSA C Physical Disk Drive
systemname:pdisk5          AC7C6E51  2GB SSA C Physical Disk Drive
systemname:pdisk6          AC706E9A  2GB SSA C Physical Disk Drive
systemname:pdisk7          AC1DEEE2  2GB SSA C Physical Disk Drive
systemname:pdisk8          AC1DBE32  2GB SSA C Physical Disk Drive

F3=Cancel      F10=Exit
```

Notes:

- a. You can select only one disk drive at time.
- b. If you select Service Mode, and the selected disk drive is not in a closed loop or at the end of a string (see Chapter 2, “Introducing SSA Loops” on page 7), your selection fails and an error message is displayed. Use the Link Verification service aid to identify any open-link problems before trying to reselect Service Mode.
- c. If you select Service Mode, and a file system is mounted on the selected disk drive, your selection fails. Use the Configuration Verification service aid to determine which hdisk must be have its file system unmounted before you can select Service Mode.
- d. If the Check light of the disk drive that you have put into Service Mode does not come on, and you are not sure of the location of that disk drive, use the Identify function to help you find it (see “The Identify Function” on page 375).

4. Select a second disk drive if required (for example, pdisk5). The following display appears again:

```

SET SERVICE MODE                                     802382

  systemname:pdisk5                                AC7C6E51  4GB SSA C Physical Disk Drive

Move cursor onto selection, then press <Enter>.

+ Set or Reset Identify.
  Select this option to set or reset the Identify indicator
  on the disk drive.
> Set or Reset Service Mode.
  Select this option to set or reset Service Mode on the
  disk drive.
  ENSURE THAT NO OTHER HOST SYSTEM IS USING THIS DISK DRIVE
  BEFORE SELECTING THIS OPTION.

F3=Cancel      F10=Exit

```

5. Select Service Mode or the Identify function. If the original disk drive is to remain in Service Mode, you can select only the Identify function now. (Only one disk drive at a time can be in Service Mode.) The list of pdisks appears again. The pdisk that is in Identify Mode is identified by a +.

```

SET SERVICE MODE                                     802381

Move cursor onto selection, then press <Enter>.

  systemname:pdisk0                                AC50AE43  2GB SSA C Physical Disk Drive
  systemname:pdisk1                                AC706EA3  2GB SSA C Physical Disk Drive
  systemname:pdisk2                                AC1DBE11  2GB SSA C Physical Disk Drive
> systemname:pdisk3                                AC1DBEF4  2GB SSA C Physical Disk Drive
  systemname:pdisk4                                AC50AE58  2GB SSA C Physical Disk Drive
+ systemname:pdisk5                                AC7C6E51  2GB SSA C Physical Disk Drive
  systemname:pdisk6                                AC706E9A  2GB SSA C Physical Disk Drive
  systemname:pdisk7                                AC1DEEE2  2GB SSA C Physical Disk Drive
  systemname:pdisk8                                AC1DBE32  2GB SSA C Physical Disk Drive

F3=Cancel      F10=Exit

```

6. Identify other disk drives in the same way, if required.

Link Verification Service Aid

The Link Verification service aid helps you determine:

- Which devices are connected to the SSA loop
- Where an SSA loop has been broken
- The status of the disk drives on that SSA loop
- The location of enclosure faults that have been detected by the disk drives on that SSA loop

To use the Link Verification service aid:

1. Select **Link Verification** from the SSA Service Aids menu (see “Starting the SSA Service Aids” on page 376). The Link Verification adapter menu is displayed:

```
LINK VERIFICATION                                802385

Move cursor onto selection, then press <Enter>.

nunu:ssa0                04-02  IBM SSA 160 SerialRAID Adapter (
nunu:ssa1                04-04  IBM SSA 160 SerialRAID Adapter (
nunu:ssa2                04-07  IBM SSA 160 SerialRAID Adapter (

F3=Cancel      F10=Exit
```

2. Select the adapter that you want to test.

The columns of information displayed on the screen have the following meanings:

- The first column shows the adapter name. The format of the adapter name is:

systemname:adaptername (for example, nunu:ssa0)

where:

systemname is the name of the using system that contains the SSA adapter.

adaptername is the adapter resource identifier.

- The second column shows the adapter location code (for example, 04-02).
- The third column shows the description of the adapter (for example, IBM SSA 160 SerialRAID Adapter).

Note: If the adapter name is longer than the description field, the name is shortened, as shown in the screen above.

3. When you have selected an adapter, a list is displayed that shows all the devices that are connected to the adapter:

```
LINK VERIFICATION 802386

SSA Link Verification for:
  nunu:ssa0 04-02 IBM SSA 160 SerialRAID Adapter (

To Set or Reset Identify, move cursor onto selection, then press <Enter>.

Physical Serial# Adapter Port Status
A1 A2 B1 B2

[TOP]
nunu:pdisk2 AC7AA09A 0 12 Good
nunu:pdisk9 AC7AA2D6 1 11 Good
nunu:pdisk8 AC7AA0BD 2 10 Good
nunu:pdisk3 AC7AA0B1 3 9 Good
ssd32:ssa0:A  4 8 
nunu:pdisk6 AC7AA0B5 5 7 Good
nunu:pdisk1 AC7AA052 6 6 Good
nunu:pdisk7 AC7AA0B9 7 5 Good
nunu:pdisk5 AC7AA0B3 8 4 Good
[MORE...3]

F3=Cancel F10=Exit
```

The columns of information displayed on the screen have the following meanings:

- The **Physical** column lists the devices as they appear on the SSA loop. A device can be either a pdisk, or an adapter.

If the device is a pdisk, it is listed as:

systemname:pdiskname (for example, nunu:pdisk3)

where:

systemname is the name of the using system to which the pdisk is connected.

adaptername is the physical disk drive resource identifier.

If the device is an adapter, it is listed as:

systemname:adaptername:loop (for example, ssd32:ssa0:A)

where:

systemname is the name of the using system that contains the SSA adapter.

adaptername is the adapter resource identifier.

loop is the loop connection. **A** indicates that the adapter is connected through ports A1 and A2. **B** indicates that the adapter is connected through ports B1 and B2.

- The **Serial#** column lists the serial numbers of the pdisks. This column is blank if the device is an adapter.

- The **Adapter Port** column shows the address of each adapter port to which a particular device is connected. The device is connected to two ports except when the SSA loop is broken, under which condition the device is connected to only one port.
- The **Status** column shows the existing status of the physical disk drive, as known by the adapter. Status conditions are:
 - Good** The disk drive is working correctly.
 - Failed** The disk drive has failed.
 - Power** The disk drive has detected an enclosure fault.
 - Format** The disk drive is being formatted.

An SSA link must be configured in a loop around which data can travel in either direction. The loop is broken if a cable fails or is removed, or if a disk drive fails. Because each disk drive on the loop can be accessed from either direction, the broken loop does not prevent access to any data, unless that data is on the failed disk drive. If the loop is broken between two disk drives, the Ready lights on those disk drives flash to show that only one SSA path is active. Also, the Link Verification service aid shows that only one path is available to each disk drive on the broken loop.

You can find the physical location of any disk drive on the loop by using the Identify function (see “The Identify Function” on page 375).

Notes:

- a. In the lists of physical disk drives (pdisks) that are displayed by the service aids, you might see:

????? These question marks show where an SSA loop is broken. The service aid cannot display which, if any, devices are missing from this configuration.

***** These asterisks indicate an unconfigured device; that is, an SSA device that is in the SSA network, but whose type is not known. Such a condition can occur if the device has not been configured on the SSA network, or it has not been configured into the using system. If you have just switched on an SSA device or a disk drive enclosure (subsystem), you might need to wait for up to 30 seconds before the device is configured on the SSA network. If a new device has been added to the SSA network, you must give the **cfmgmr** command to configure that device into the using system.

For example:

```
LINK VERIFICATION 802386

SSA Link Verification for:
  nunu:ssa0 04-03 IBM SSA 160 SerialRAID Adapter (

To Set or Reset Identify, move cursor onto selection, then press <Enter>.

Physical Serial# Adapter Port Status
A1 A2 B1 B2

[TOP]
nunu:pdisk1 AC515E90 0 Good
nunu:pdisk2 AC515EAB 1 Good
?????
nunu:pdisk3 AC515EB1 1 Good
nunu:pdisk4 AC515EB9 0 Good
ganges:ssa0:A  0 7 Good
nunu:pdisk6 AC51606E 1 6 Good
*****  2 5 Good
nunu:pdisk0 AC506D6E 3 4 Good
[MORE...4]

F3=Cancel F10=Exit
```

This example shows that the SSA loop is broken between pdisk2 and pdisk3, and that an unconfigured device is present between pdisk6 and pdisk0.

- b. If you have just made changes to, or have just switched on, the unit in which the disk drive is installed, you might need to wait for up to 30 seconds before detailed information about the SSA network becomes available to the service aids.
4. When you have solved a problem, press the Cancel key to leave the display, then press Enter to reselect it. The display now shows the new status of the SSA links.

“Using the Service Aids for SSA-Link Problem Determination” on page 400 provides more examples of link problems and how to use this service aid to solve them.

Configuration Verification Service Aid

The Configuration Verification service aid enables you to determine the relationship between SSA logical units (hdisks) and SSA physical disk drives (pdisks). It also displays the connection information and operational status of the disk drive.

Notes:

1. User applications communicate with the hdisks; error data is logged against the pdisks.
2. If a disk drive that has been formatted on a machine of a particular type (for example, a personal computer) is later installed into a using system that is of a different type (for example, a large host system), that disk drive is configured only as a pdisk during the configuration of the using system.

In such an instance, use the Format service aid to reformat the disk drive, then give the **cfgmgr** command to correct the condition.

To use the Configuration Verification service aid:

1. Select **Configuration Verification** from the SSA Service Aids menu (see “Starting the SSA Service Aids” on page 376). A list of pdisks and hdisks is displayed:

```
CONFIGURATION VERIFICATION                                802390
Move cursor onto selection, then press <Enter>.

systemname:pdisk0                AC51DB47  4GB SSA C Physical Disk Drive
systemname:pdisk1                AC9EDE7F  9.1GB SSA C Physical Disk Drive
systemname:hdisk2                AC51DB47  SSA Logical Disk Drive
systemname:hdisk3                AC9EDE7F  SSA Logical Disk Drive

F3=Cancel      F10=Exit
```

2. Select the hdisk or pdisk that you want to verify.
3. If you select an hdisk, a list of pdisks is displayed:

```

CONFIGURATION VERIFICATION                                     802391

  systemname:hdisk2                AC51DB47  SSA Logical Disk Drive   Good

To set or reset Identify, move cursor onto selection, then press <Enter>.

Physical                               Serial# Adapter  Port  SSA_Addr  Status
systemname:pdisk0                    AC51DB47 00-02   A1    0         Good
                                       00-02   A2    1         Good

F3=Cancel      F10=Exit

```

If you select a pdisk, a list of hdisks is displayed:

```

CONFIGURATION VERIFICATION                                     802392

  systemname:pdisk0                AC51DB47  4GB SSA C Physical Disk Drive

Move cursor onto selection, then press <Enter>.

  systemname:hdisk2                AC51DB47  SSA Logical Disk Drive   Good

F3=Cancel      F10=Exit

```

Note: If you select the hdisk from this screen, the hdisk configuration is displayed.

Format Disk Service Aid

The Format Disk service aid formats SSA disk drives.

Attention: Formatting a disk drive destroys all the data on that disk drive. Use this procedure only when instructed to do so by the service procedures.

To use the Format Disk service aid:

1. Select **Format Disk** from the SSA Service Aids menu (see “Starting the SSA Service Aids” on page 376). A list of pdisks is displayed:

```
FORMAT DISK802395
Move cursor onto selection, then press <Enter>.

systemname:pdisk11          AC50AE43  9.1GB SSA C Physical Disk Drive
systemname:pdisk8           AC706EA3  9.1GB SSA C Physical Disk Drive
systemname:pdisk2           AC1DBE11  4GB SSA C Physical Disk Drive
systemname:pdisk3           AC1DBEF4  4GB SSA C Physical Disk Drive
systemname:pdisk7           AC50AE58  9.1GB SSA C Physical Disk Drive
systemname:pdisk12          AC7C6E51  9.1GB SSA C Physical Disk Drive
systemname:pdisk0           AC706E9A  4GB SSA C Physical Disk Drive
systemname:pdisk1           AC1DEEE2  4GB SSA C Physical Disk Drive
systemname:pdisk10          AC1DBE32  4GB SSA C Physical Disk Drive

F3=Cancel    F10=Exit
```

2. Select the pdisk that you want to format. The following instructions are displayed:

```
FORMAT DISK                                     802396
systemname:pdisk2                             AC1DBE11  4GB SSA C Physical Disk Drive
Move cursor onto selection, then press <Enter>.

+ Set or Reset Identify.
  Select this option to set or reset the Identify indicator
  on the disk drive.
Format.
  Select this option only if you are sure that you have selected
  the correct disk drive.
  FORMATTING DESTROYS ALL DATA ON THE DISK DRIVE.

F3=Cancel   F10=Exit
```

3. If you are not sure of the identification (pdisk number) of the disk drive that you want to format, use the Identify function to get a positive physical identification of the disk drive (see “The Identify Function” on page 375). You can further ensure that you have selected the correct disk drive by verifying that the serial number on the front of the disk drive is the same as the serial number that is displayed on the screen.
4. When you are sure that you have selected the correct disk drive, select **Format**.

Certify Disk Service Aid

The Certify service aid verifies that all the data on a disk drive can be read correctly. Other maintenance procedures tell you when you need to run this service aid.

To use the Certify Disk service aid:

1. Select **Certify Disk** from the SSA Service Aids menu (see “Starting the SSA Service Aids” on page 376). A list of pdisks is displayed:

```
CERTIFY DISK802404

Move cursor onto selection, then press <Enter>.

systemname:pdisk11          AC50AE43  9.1GB SSA C Physical Disk Drive
systemname:pdisk8           AC706EA3  9.1GB SSA C Physical Disk Drive
systemname:pdisk2           AC1DBE11  4GB SSA C Physical Disk Drive
systemname:pdisk3           AC1DBEF4  4GB SSA C Physical Disk Drive
systemname:pdisk7           AC50AE58  9.1GB SSA C Physical Disk Drive
systemname:pdisk12          AC7C6E51  9.1GB SSA C Physical Disk Drive
systemname:pdisk0           AC706E9A  4GB SSA C Physical Disk D Drive
systemname:pdisk1           AC1DEEE2  4GB SSA C Physical Disk D Drive
systemname:pdisk10          AC1DBE32  4GB SSA C Physical Disk Drive

F3=Cancel      F10=Exit
```

2. Select the pdisk that you want to certify. The following instructions are displayed:

```
CERTIFY DISK 802405
systemname:pdisk0          AC706E9A  4GB SSA C Physical Disk Drive
Move cursor onto selection, then press <Enter>.

+ Set or Reset Identify.
  Select this option to set or reset the Identify indicator
  on the disk drive.
  Certify.
  Select this option to start the Certify operation.

F3=Cancel    F10=Exit
```

3. If you are not sure of the identification (pdisk number) of the disk drive that you want to certify, use the Identify function to get a positive physical identification of the disk drive (see “The Identify Function” on page 375). You can further ensure that you have selected the correct disk drive by verifying that the serial number on the front of the disk drive is the same as the serial number that is displayed on the screen.
4. When you are sure that you have selected the correct disk drive, select **Certify**.

Display/Download Disk Drive Microcode Service Aid

The Display/Download Disk Drive Microcode service aid allows you to:

- Display the level of microcode that is installed on all available disk drives.
- Change the level of microcode, for a specific available disk drive, to any level that is available in the using-system microcode directory or on diskette.
- Change the level of microcode, for all available disk drives, to the latest level that is available in the using-system microcode directory or on diskette.

Attention: Usually, you can download the microcode to disk drives that are in use. By doing so, however, you might cause a temporary delay in the operating system or in the user's application program. ***Do not download microcode to a disk drive that is in use, unless you have the user's permission. Always refer to the download instructions that are supplied with the microcode, and check for any special restrictions that might be applicable. If you are not sure, do not download to disk drives that are in use.***

When you download new microcode to a disk drive, the new level of microcode is not shown by the **Display the Microcode Levels** option until the disk drives have been reconfigured. Run the **cfgmgr** command before you verify that the new level of microcode is correctly installed.

To use the Display/Download Disk Drive Microcode service aid:

1. Select **Display/Download Disk Drive Microcode** from the SSA Service Aids menu (see “Starting the SSA Service Aids” on page 376). The following menu is displayed:

```
MICROCODE DOWNLOAD                                     802420

Move cursor onto selection, then press Enter.

Display the Microcode levels of all SSA Physical Disk Drives
  Select this option to display the microcode levels installed
  on all 'Available' SSA disk drives.
Download Microcode to selected SSA Physical Disk Drives
  Select this option to change the level of microcode that is
  installed on selected 'Available' SSA disk drives.
Download Microcode to all SSA Physical Disk Drives
  Select this option to load the latest level of microcode
  on all 'Available' SSA disk drives.

F3=Cancel      F10=Exit
```

2. To display the levels of microcode that are installed on the SSA disk drives, select **Display the Microcode levels of all SSA Physical Disk Drives**. A list of pdisks is displayed:

```
MICROCODE DOWNLOAD                                     802421

To set or reset Identify, move cursor onto selection, then press <Enter>.

Physical          Serial#          ROSid

systemname:pdisk0    AC51DB47        8877
systemname:pdisk1    AC9EDE7F        9292

F3=Cancel      F10=Exit
```

3. **Attention:** For several seconds during microcode download, new data is written to the disk drive EEPROM. If the power fails while that data is being written, the disk drive microcode might become corrupted. **The microcode cannot be corrected.** Normally, exchange the disk drive for a new one. If you need to try to save data, you might be able to exchange the electronics card assembly of the disk drive. For more details, see the *Installation and Service Guide* for the unit that contains the disk drive.

To download microcode to one specific disk drive, select **Download Microcode to selected SSA Physical Disk Drives**, and follow the instructions that are displayed. You normally select this option when you do not want the microcode on the selected disk drive to be at the latest available level.

4. If you have a new level of microcode to install, or if you have replaced a disk drive and want to upgrade it to the present level, select **Download Microcode to all SSA Physical Disk Drives**. This option ensures that all disk drives have the latest level of microcode installed. It downloads microcode only to those disk drives whose level of microcode is lower than that in the microcode directory or on the microcode diskette.

Note: Different types of SSA disk drive might need different versions of the microcode. Microcode download files are provided for each type of disk drive. Where a system contains more than one type of SSA disk drive, this Service Aid selects the correct microcode file for each of those types.

Link Speed Service Aid

The Link Speed service aid allows you to display the operating speed of each link on an SSA adapter.

To use the Link Speed service aid:

1. Select **Link Speed** from the SSA Service Aids menu (see “Starting the SSA Service Aids” on page 376). A list of adapters is displayed:

```
LINK SPEED                                     802437

Move cursor onto selection, then press <Enter>.

systemname:ssa0           00-03           IBM SSA 160 SerialRAID Adapter (
systemname:ssa1           00-04           IBM SSA 160 SerialRAID Adapter (
systemname:ssa2           00-05           IBM SSA 160 SerialRAID Adapter (

F3=Cancel                 F10=Exit
```

2. Select the adapter that you want to inspect. A list of link speeds is displayed, as shown in this example screen:

```
LINK SPEED802438
SSA Link Speed for:
systemname:ssa0          00-03      IBM SSA 160 SerialRAID Adapter (

To set or reset Identify, move cursor onto selection, then press <Enter>.

Source                    Speed    Destination
systemname:ssa0:A1        40      systemname:pdisk3
systemname:pdisk3         40      systemname:pdisk2
systemname:pdisk2         20      systemname:pdisk1
systemname:pdisk1         40      systemname:pdisk0
systemname:pdisk0         40      systemname:ssa0:A2
systemname:ssa0:B1        40      systemname:pdisk5
systemname:pdisk5         40      systemname:pdisk4
systemname:pdisk4         40      systemname:ssa0:B2

F3=Cancel      F10=Exit
```

The screen shows an adapter that has four disk drives connected between ports A1 and A2, and two disk drives connected between ports B1 and B2. The link between pdisk1 and pdisk2 is working at 20 MB per second. Each row in the list represents one SSA link.

The **Source** field represents the link end that is closest to the A1 or B1 port.

The **Destination** field represents the link end that is closest to the A2 or B2 port.

Note: The **Source** and **Destination** fields have no other meaning. They do not indicate data flow.

The **Speed** field indicates the operating speed of the link as follows:

- 00** The link is not operational
- 20** 20 MB per second
- 40** 40 MB per second

Figure 54 gives a physical representation of the configuration that is shown on the screen.

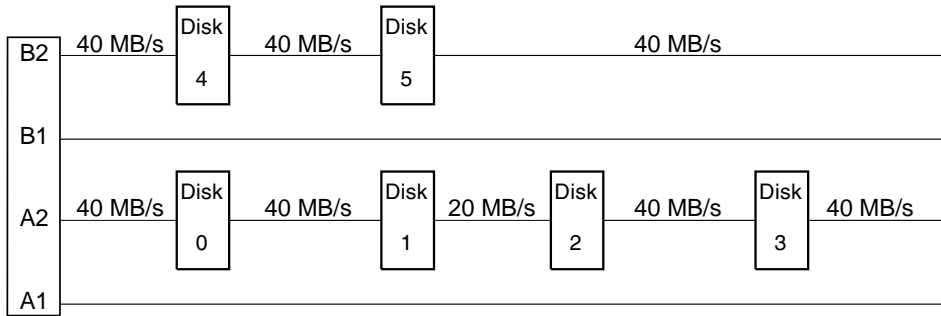

Figure 54. Configuration Shown by the Service Aid

This screen shows the same configuration, but here the link is broken between pdisk1 and pdisk2.

```

LINK SPEED                                     802438

SSA Link Speed for:
systemname:ssa0                               00-03      IBM SSA 160 SerialRAID Adapter (

To set or reset Identify, move cursor onto selection, then press <Enter>.

Source                                         Speed      Destination

systemname:ssa0:A1                           40        systemname:pdisk3
systemname:pdisk3                            40        systemname:pdisk2
systemname:pdisk2                            00        ?????
?????                                         00        systemname:pdisk1
systemname:pdisk1                            40        systemname:pdisk0
systemname:pdisk0                            40        systemname:ssa0:A2
systemname:ssa0:B1                           40        systemname:pdisk5
systemname:pdisk5                            40        systemname:pdisk4
systemname:pdisk4                            40        systemname:ssa0:B2

F3=Cancel      F10=Exit

```

Figure 55 gives a physical representation of the configuration that is shown on the screen.

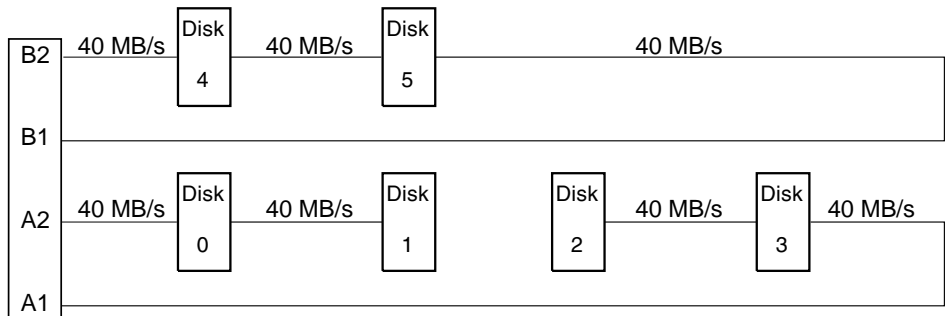

Figure 55. Configuration with Broken Link Shown by the Service Aid

Service Aid Service Request Numbers (SRNs)

If the SSA service aids detect an unrecoverable error, and are unable to continue, one of the following service request numbers (SRNs) might occur:

- SSA01
- SSA02
- SSA03

These SRNs are explained in the main SRN table (see “Service Request Numbers (SRNs)” on page 411).

Using the Service Aids for SSA-Link Problem Determination

If you have a problem with an SSA loop, use the Link Verification service aid (see “Link Verification Service Aid” on page 383). The following examples show various loops and the associated information that is displayed by the Link Verification service aid.

Example 1. Normal Loops

In Figure 56, disk drives 1 through 8 are connected to connectors A1 and A2 of the SSA adapter **1**. Disk drives 9 through 12 are connected to connectors B1 and B2 of the same SSA adapter. Disk drives 13 through 16 are connected to connectors A1 and A2 of a different SSA adapter **2**.

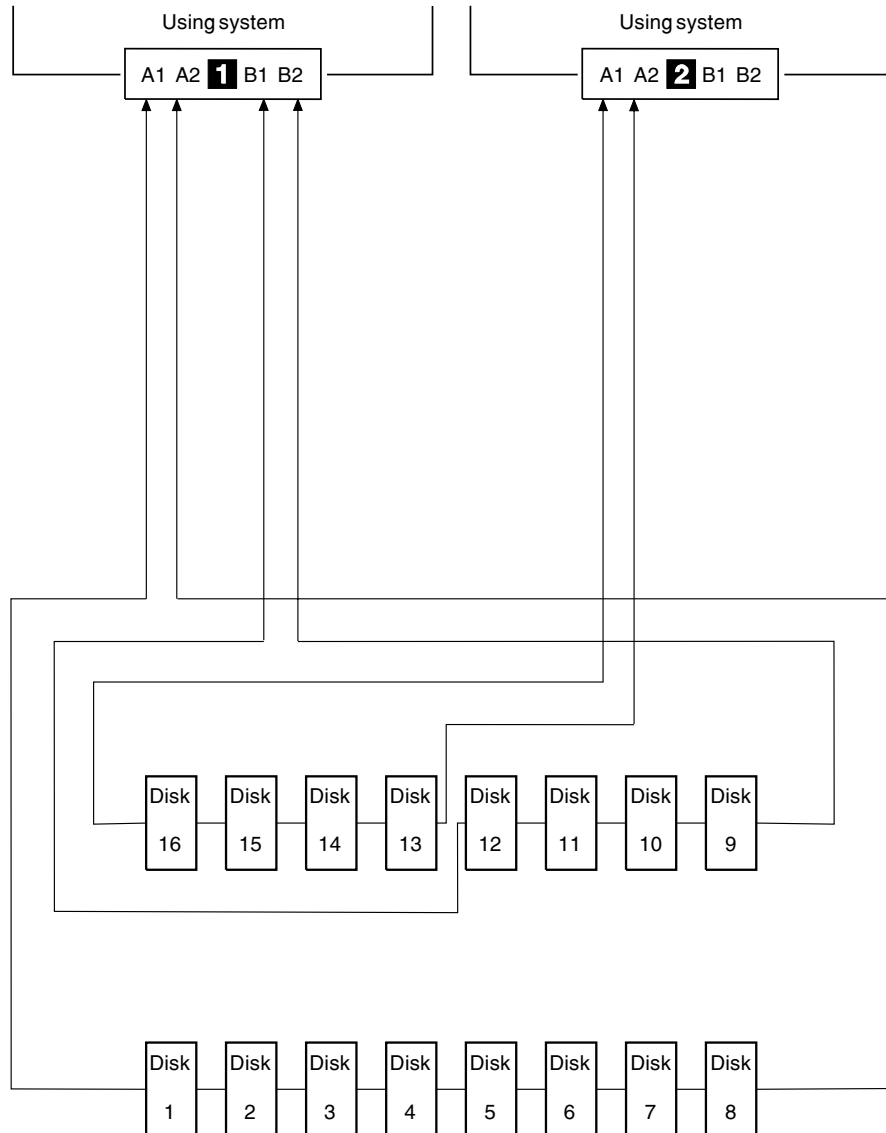

Figure 56. Normal Loop

For this example, the Link Verification service aid displays the following information:

```
LINK VERIFICATION802386
SSA Link Verification for:
  systemname:ssa0          00-04  IBM SSA 160 SerialRAID Adapter (
To Set or Reset Identify, move cursor onto selection, then press <Enter>.

  Physical                Serial#    Adapter Port      Status
                        A1  A2  B1  B2
[TOP]
systemname:pdisk11      AC50AE43    0  5                Good
systemname:pdisk8      AC706EA3    1  4                Good
systemname:pdisk2      AC1DBE11    2  3                Good
systemname:pdisk3      AC1DBEF4    3  2                Good
systemname:pdisk7      AC50AE58    4  1                Good
systemname:pdisk12     AC7C6E51    5  0                Good
systemname:pdisk0      AC706E9A           0  5                Good
systemname:pdisk1      AC1DEEE2           1  4                Good
systemname:pdisk10     AC1DBE32           2  3                Good
[MORE...4]

F3=Cancel      F10=Exit
```

Note: Scroll the display to see all the connected disk drives.

Example 2. Broken Loop (Cable Removed)

Each disk drive normally communicates with the adapter through one data path. Because data can pass round the loop in either direction, the adapter automatically reconfigures the loop to enable communication to continue to each disk drive if the loop becomes broken.

In Figure 57 on page 404, disk drives 1 through 8 should be connected to connectors A1 and A2 of the SSA adapter **1**, but the loop is broken because the SSA cable has been disconnected from connector A2. Disk drives 9 through 12 are connected to connectors B1 and B2 of the same SSA adapter. Disk drives 13 through 16 are connected to connectors A1 and A2 of a different SSA adapter **2**.

Although the broken loop is reported as an error, all the disk drives can still communicate with the using system. Disk drives 1 through 8 can communicate through connector A1 of the SSA adapter **1**. Disk drives 9 through 12 can communicate through connectors B1 and B2 of the same SSA adapter (normal loop); disk drives 13 through 16 can communicate through connectors A1 and A2 of the SSA adapter **2**.

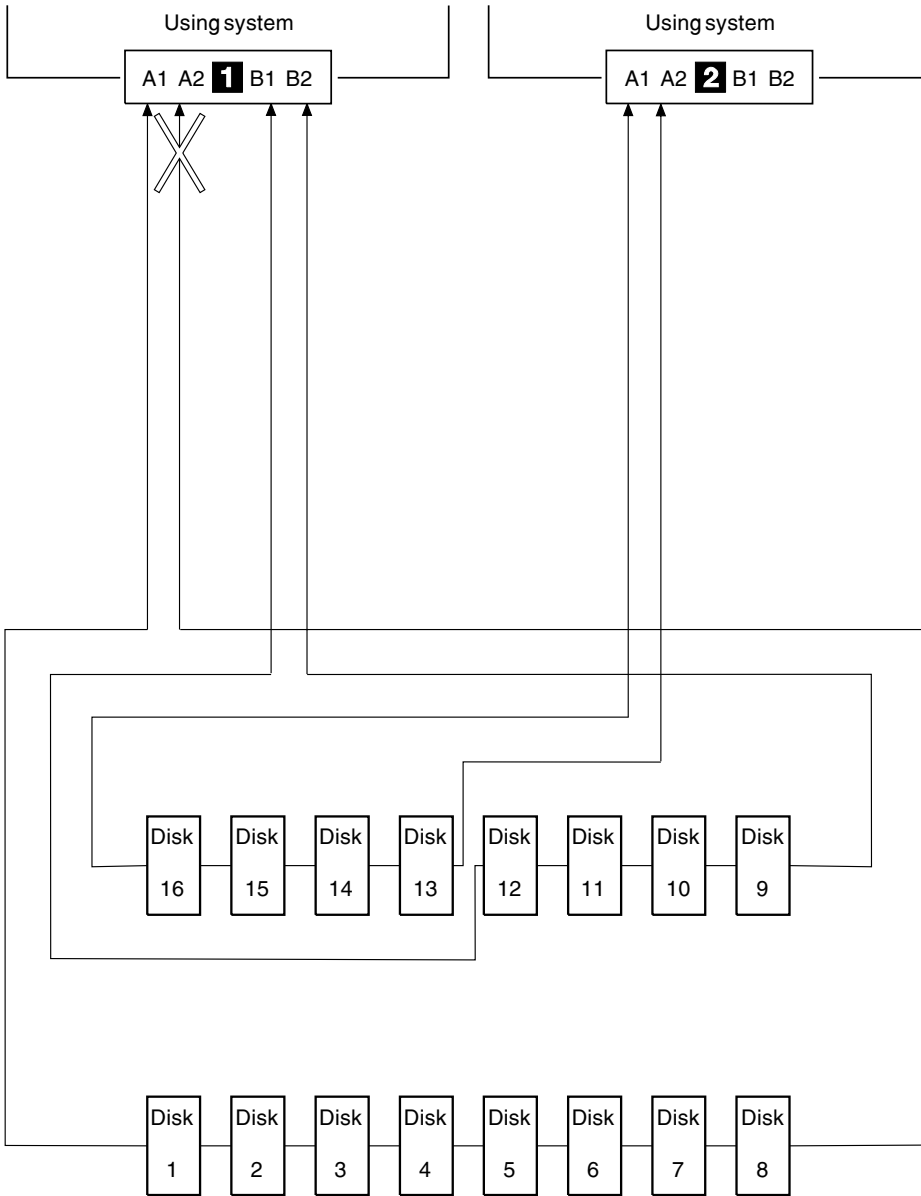

Figure 57. Broken Loop (Cable Removed)

For this example, the Link Verification service aid displays the following information:

```
LINK VERIFICATION                                     802386
SSA Link Verification for:
  systemname:ssa0                                00-04  IBM SSA 160 SerialRAID Adapter (
To Set or Reset Identify, move cursor onto selection, then press <Enter>.

  Physical                               Serial#      Adapter Port      Status
                                     A1  A2  B1  B2
[TOP]
systemname:pdisk11                      AC50AE43      0                    Good
systemname:pdisk8                       AC706EA3      1                    Good
systemname:pdisk2                       AC1DBE11      2                    Good
systemname:pdisk3                       AC1DBEF4      3                    Good
systemname:pdisk7                       AC50AE58      4                    Good
systemname:pdisk12                      AC7C6E51      5                    Good
systemname:pdisk0                       AC706E9A      6                    Good
systemname:pdisk1                       AC1DEEE2      7                    Good
?????
[MORE...8]

F3=Cancel      F10=Exit
```

Note that the column for adapter connector A2 shows no connections.

Example 3. Broken Loop (Disk Drive Removed)

In Figure 58 on page 407, disk drives 1 through 8 are connected to connectors A1 and A2 of the SSA adapter **1**, but the loop is broken because disk drive number 3 has been removed. Disk drives 9 through 12 are connected to connectors B1 and B2 of the same SSA adapter. Disk drives 13 through 16 are connected to connectors A1 and A2 of a different SSA adapter **2**.

Although the missing disk drive is reported as an error, all the remaining disk drives can still communicate with the using system. Disk drives 1 and 2 can communicate through connector A1 of the SSA adapter **1**. Disk drives 4 through 8 can communicate through connector A2 of the SSA adapter. Disk drives 9 through 12 can communicate through connectors B1 and B2 of the same SSA adapter (normal loop); disk drives 13 through 16 can communicate through connectors A1 and A2 of the SSA adapter **2**.

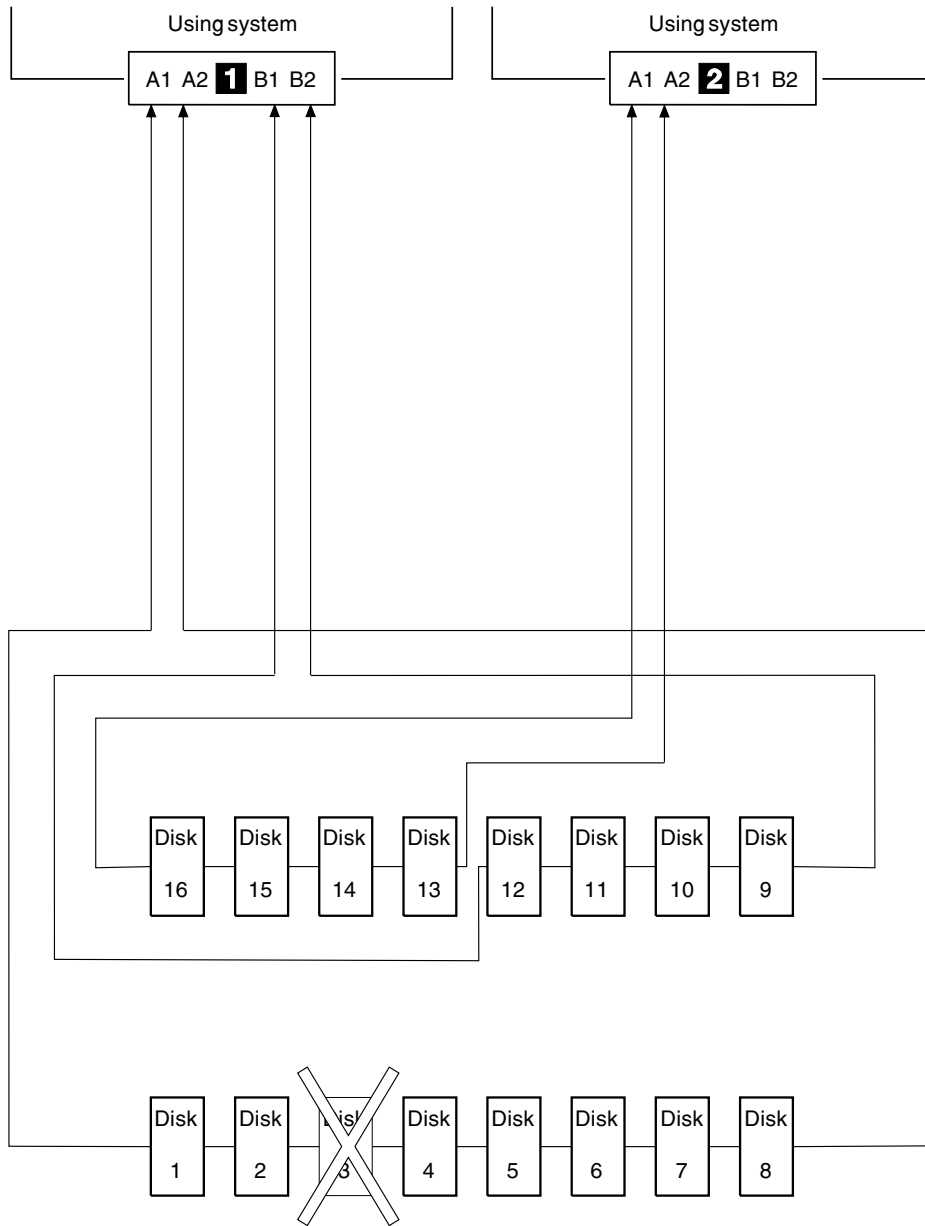

Figure 58. Broken Loop (Disk Drive Removed)

For this example, the Link Verification service aid displays the following information:

```
LINK VERIFICATION                                     802386
SSA Link Verification for:
  systemname:ssa0                                00-04  IBM SSA 160 SerialRAID Adapter (
To Set or Reset Identify, move cursor onto selection, then press <Enter>.

  Physical          Serial#      Adapter Port      Status
                    A1  A2  B1  B2
[TOP]
systemname:pdisk11  AC50AE43      0                      Good
systemname:pdisk8  AC706EA3      1                      Good
?????
systemname:pdisk3   AC1DBEF4      4                      Good
systemname:pdisk7   AC50AE58      3                      Good
systemname:pdisk12  AC7C6E51      2                      Good
systemname:pdisk0   AC706E9A      1                      Good
systemname:pdisk1   AC1DEEE2      0                      Good
systemname:pdisk10  AC1DBE32      0  7                    Good
[MORE...7]

F3=Cancel      F10=Exit
```

Note that the missing disk drive (pdisk8) is represented by a line of question marks.

Finding the Physical Location of a Device

The physical location of a device (for example, a disk drive or an SSA adapter) cannot be reported directly by the using system because of the way in which the SSA interface works. The address of an SSA device is related to the position of that device on the SSA loop. The address can, therefore, change if the configuration is changed.

Finding the Device When Service Aids Are Available

To help you to find the correct physical disk drive, the SSA service aids include an Identify function. This function, when selected, causes the Check light of the selected disk drive to flash. It also causes the Subsystem Check light (if present) of the unit containing the selected disk drive to flash.

Some devices, (for example, adapters) do not have Check lights. To find such a device, you can either use the Identify function to identify devices that are next to the SSA adapter on the SSA link, or use the procedure described in "Finding the Device When No Service Aids Are Available".

Finding the Device When No Service Aids Are Available

When no service aids are available, you must find the device by using the port (P) and SSA-address (AA) values that are provided by some service request numbers (SRNs). Examples of these SRNs are 43PAA, 44PAA, and 45PAA.

The port (P) values are related to the port connectors of the adapter:

- 0 = Connector A1
- 1 = Connector A2
- 2 = Connector B1
- 3 = Connector B2

The AA value is the decimal SSA-address value. It indicates the position of the device that you are trying to find (counted *along* the SSA loop).

Use the port value to locate the relevant connector on the SSA adapter, then follow the SSA cable to the first *real* device. Include other adapters as real devices if they are in the same SSA link. Do not include dummy devices or bypass cards.

The first device that you reach represents SSA-address count 0. Continue to follow the SSA links from device to device, increasing the SSA-address count by 1 for each device, until you reach the device that is indicated in the SRN.

: **Note:** If the SRN is 20xxx, 45xxx, or D6xxx, the failing link is between the device that
: is located at PAA, and the device that is located at PAA minus 1.

Chapter 18. SSA Problem Determination Procedures

SSA problem determination procedures are provided by power-on self-tests (POSTs), service request numbers, and maintenance analysis procedures (MAPs). Some of these procedures use the service aids that are described in Chapter 17, "SSA Service Aids" on page 373.

Service Request Numbers (SRNs)

Service request numbers (SRNs) are generated by the system error-log analysis, system configuration code, diagnostics, and customer problem-determination procedures. SRNs help you to identify the cause of a problem, the failing field-replaceable units (FRUs), and the service actions that might be needed to solve the problem.

The SRN Table

The table in this section lists the SRNs and describes the actions you should do. The table columns are:

SRN	The service request number.
Problem	A description of the problem and the action you must take.
Possible Causes	The condition or FRUs that might be causing the problem, and how likely it is (by percentage) that a particular FRU is causing the problem.

Abbreviations used in the table are:

DMA	Direct memory access.
FRU	Field-replaceable unit.
IOCC	Input/output channel controller.
PAA	P = Adapter port number
	AA = SSA address (see also "Finding the Device When No Service Aids Are Available" on page 409).
POS	Programmable option select (POS registers).
POST	Power-On Self-Test.
SDRAM	Synchronous dynamic random-access memory.

Using the SRN Table

Note: You should have been sent here from either diagnostics or a START MAP. Do not start problem determination from the SRN table; always go to the START MAP for the enclosure in which the device is installed.

1. Locate the SRN in the table. **If you cannot find the SRN**, refer to the documentation for the subsystem or device. If you still cannot find the SRN, you have a problem with the diagnostics, the microcode, or the documentation. Call your support center for assistance.

2. Read carefully the “Action” you must do for the problem. *Do not exchange FRUs unless you are instructed to do so.*
3. Normally exchange only one FRU at a time. After each FRU is exchanged, go to “MAP 2410: SSA Repair Verification” on page 475 to verify the repair.
4. When exchanging an adapter, always use the instructions that are supplied with the system unit.

SRN	Problem	Possible Causes
1xxxx	<p>Description: SRNs in this range are not adapter SRNs.</p> <p>Action: For SRNs in this range, see the documentation for your SSA enclosure or SSA subsystem.</p>	Not applicable.
20PAA	<p>Description: An open SSA link has been detected.</p> <p>Action: Run the Link Verification service aid to isolate the failure (see "Link Verification Service Aid" on page 383).</p> <p>If the SSA service aids are not available, go to the service information for the enclosure in which the device is installed</p>	<p>Possible FRUs:</p> <p>Device (45%) ("Exchanging Disk Drives" on page 319).</p> <p>SSA adapter card (45%) ("Removing and Replacing an Advanced SerialRAID Adapter" on page 327).</p> <p>External SSA cables (6%).</p> <p>Internal SSA connections (4%) (enclosure service information).</p>
21PAA to 29PAA	<p>Description: An SSA 'Threshold exceeded' link error has been detected.</p> <p>Action: Go to "MAP 2323: SSA Intermittent Link Error" on page 450.</p>	<p>Possible FRUs:</p> <p>Device (45%)("Exchanging Disk Drives" on page 319).</p> <p>SSA adapter card (45%) ("Removing and Replacing an Advanced SerialRAID Adapter" on page 327).</p> <p>External SSA cables (6%).</p> <p>Internal SSA connections (4%) (enclosure service information).</p>
2A002	<p>Description: Async code 02 has been received. Probably, a software error has occurred.</p> <p>Action: Go to "Software and Microcode Errors" on page 441 before exchanging any FRUs.</p>	<p>Possible FRUs:</p> <p>Device (50%) ("Exchanging Disk Drives" on page 319).</p> <p>SSA adapter card (50%) ("Removing and Replacing an Advanced SerialRAID Adapter" on page 327).</p>
2A003	<p>Description: Async code 03 has been received. Probably, a software error has occurred.</p> <p>Action: Go to "Software and Microcode Errors" on page 441 before exchanging any FRUs.</p>	<p>Software error.</p> <p>Possible FRUs:</p> <p>Device (50%) ("Exchanging Disk Drives" on page 319).</p> <p>SSA adapter card (50%) ("Removing and Replacing an Advanced SerialRAID Adapter" on page 327).</p>

SRN	Problem	Possible Causes
2A004	<p>Description: Async code 04 has been received. Probably, a software error has occurred.</p> <p>Action: Go to "Software and Microcode Errors" on page 441 before exchanging any FRUs.</p>	<p>Software error.</p> <p>Possible FRUs:</p> <p>Device (50%) ("Exchanging Disk Drives" on page 319).</p> <p>SSA adapter card (50%) ("Removing and Replacing an Advanced SerialRAID Adapter" on page 327).</p>
2A005 to 2A206	<p>Description: SRNs in this range are not adapter SRNs.</p> <p>Action: For SRNs in this range, see the documentation for your SSA enclosure or SSA subsystem.</p>	Not applicable.
2FFFF	<p>Description: An async code that is not valid has been received.</p> <p>Action: Go to "Software and Microcode Errors" on page 441.</p>	Software error.
300C0 301C0	<p>Description: SRNs in this range are not adapter SRNs.</p> <p>Action: For SRNs in this range, see the documentation for your SSA enclosure or SSA subsystem.</p>	Not applicable.
303FE	<p>Description: A disk drive microcode error has been detected.</p> <p>Action: Go to "Software and Microcode Errors" on page 441.</p>	<p>Software error.</p> <p>Possible FRUs:</p> <p>Device (100%) ("Exchanging Disk Drives" on page 319).</p>
303FF	<p>Description: An SCSI status that is not valid has been received.</p> <p>Action: Go to "Software and Microcode Errors" on page 441.</p>	<p>Possible FRUs:</p> <p>Device (100%) ("Exchanging Disk Drives" on page 319).</p>
31000	<p>Description: SRNs in this range are not adapter SRNs.</p> <p>Action: For SRNs in this range, see the documentation for your SSA enclosure or SSA subsystem.</p>	Not applicable.
33PAA	<p>Description: Excessive link reconfigurations have been detected.</p> <p>Action: Go to "MAP 2323: SSA Intermittent Link Error" on page 450.</p>	<p>Possible FRUs:</p> <p>External SSA cables (30%).</p> <p>Internal SSA connections (30%) (enclosure service information).</p> <p>Device (30%) ("Exchanging Disk Drives" on page 319).</p> <p>SSA adapter card (10%) ("Removing and Replacing an Advanced SerialRAID Adapter" on page 327).</p>

SRN	Problem	Possible Causes
34000	<p>Description: The adapter cannot initialize a device. This problem might be badly affecting the SSA loop. If the device was a member of a RAID array, you might not be able to list this disk drive by using the RAID facilities.</p> <p>Action: Exchange the FRUs for new FRUs.</p>	<p>Possible FRUs:</p> <p>Device (90%) (“Exchanging Disk Drives” on page 319).</p> <p>External SSA cables (5%)</p> <p>Internal SSA connections (5%) (enclosure service information)</p>
35000	<p>Description: Loop problems are causing the adapter to try to reset disk drives.</p> <p>Action: Check the log for other error information, including other 35000 errors, that might indicate which section of the loop is causing the problems.</p>	<p>Possible FRUs:</p> <p>External SSA cables (30%).</p> <p>Internal SSA connections (30%) (enclosure service information).</p> <p>Device (30%) (“Exchanging Disk Drives” on page 319).</p> <p>SSA adapter card (10%) (“Removing and Replacing an Advanced SerialRAID Adapter” on page 327).</p>
40000	<p>Description: The SSA adapter card has failed.</p> <p>Action: Exchange the FRU for a new FRU.</p>	<p>Possible FRUs:</p> <p>SSA adapter card (100%) (“Removing and Replacing an Advanced SerialRAID Adapter” on page 327).</p>
40016	<p>Description: A 16 MB SDRAM in the adapter card module has failed.</p> <p>Action: Exchange the FRUs for new FRUs.</p>	<p>Possible FRUs:</p> <p>16 MB SDRAM module (99%) (“Removing an SDRAM Module of an Advanced SerialRAID Adapter” on page 329).</p> <p>SSA adapter card (1%) (“Removing and Replacing an Advanced SerialRAID Adapter” on page 327).</p>
40064	<p>Description: A 64 MB SDRAM in the adapter card module has failed.</p> <p>Action: Exchange the FRUs for new FRUs.</p>	<p>Possible FRUs:</p> <p>64 MB SDRAM module (99%) (“Removing an SDRAM Module of an Advanced SerialRAID Adapter” on page 329).</p> <p>SSA adapter card (1%) (“Removing and Replacing an Advanced SerialRAID Adapter” on page 327).</p>

SRN	Problem	Possible Causes
40128	<p>Description: A 128 MB SDRAM in the adapter card module has failed.</p> <p>Action: Exchange the FRUs for new FRUs.</p>	<p>Possible FRUs:</p> <p>128 MB SDRAM module (99%) (“Removing an SDRAM Module of an Advanced SerialRAID Adapter” on page 329).</p> <p>SSA adapter card (1%) (“Removing and Replacing an Advanced SerialRAID Adapter” on page 327).</p>
42000	<p>Description: Either no SDRAM module is present on the adapter card, or the POST cannot determine the size of the existing SDRAM module.</p> <p>Action: Install an SDRAM module of the correct size, or exchange the existing SDRAM module for a new one of the correct size.</p>	<p>Possible FRUs:</p> <p>SDRAM module (99%) (“Removing an SDRAM Module of an Advanced SerialRAID Adapter” on page 329).</p> <p>SSA adapter card (1%) (“Removing and Replacing an Advanced SerialRAID Adapter” on page 327).</p>
42200	<p>Description: Other adapters on the SSA loop are using levels of microcode that are not compatible.</p> <p>Action: Install the latest level of adapter microcode onto all the other adapters on this SSA loop.</p>	User or service action.
42500	<p>Description: The Fast-Write Cache Option Card has failed.</p> <p>Action:</p> <ol style="list-style-type: none"> 1. Exchange the cache card for a new one. 2. Switch on power to the using system. 3. If the original cache card contained data that was not moved to a disk drive, new error codes are produced. Run diagnostics in System Verification mode to the adapter. If an SRN is produced, do the actions for that SRN. 	<p>Possible FRUs:</p> <p>Fast-Write Cache Option Card (98%) (“Removing the Fast-Write Cache Option Card of an Advanced SerialRAID Adapter” on page 332).</p> <p>SSA adapter card (2%) (“Removing and Replacing an Advanced SerialRAID Adapter” on page 327).</p>

SRN	Problem	Possible Causes
42510	<p>Description: Not enough SDRAM available to run the fast-write cache operation.</p> <p>Action:</p> <ol style="list-style-type: none"> 1. Start the using-system service aids. 2. Select Display or Change Configuration or Vital Product Data (VPD). 3. Select Display Vital Product Data. 4. Find the VPD for the SSA adapter that is logging the error. 5. Note the SDRAM and cache sizes (Device Specifics Z0 and Z1). 6. For fast-write operations, the size of the available SDRAM must be greater than the size of the fast-write cache. If you cannot determine the correct size of SDRAM to use, contact your support center. 	User or service action.
42515	<p>Description: A fast-write disk is installed, but no Fast-Write Cache Option Card has been detected.</p> <p>Action:</p> <ol style="list-style-type: none"> 1. If you have not already done so, run diagnostics in System Verification mode to the adapter . If a different SRN is generated, solve that problem first. 2. Do the following actions as appropriate: <ul style="list-style-type: none"> • If the cache card is not installed correctly, remove it from the adapter, then reinstall it correctly. • If the cache card is installed correctly, it might have failed. Exchange, for new FRUs, the FRUs that are shown in the list of possible FRUs for this SRN. • If the Fast-Write feature is not installed, and you want to delete the fast-write configuration for one or more disk drives that have been added to this subsystem: <ol style="list-style-type: none"> a. Verify with the customer that the fast-write configuration can be deleted for the disk drives. b. Type smitty devices and press Enter. c. Select SSA Disks. d. Select SSA Logical Disks. e. Select Enable/Disable Fast-Write for Multiple Devices. f. Select all the pdisks against which the message Fast-Write is enabled for these devices appears. g. Press Enter. h. Select no in the Enable Fast-Write field. i. Select yes in the Force Delete field. j. Press Enter. 	<ul style="list-style-type: none"> • The cache card is not installed correctly. • The Fast-Write feature is not installed on this machine, but a disk drive that is configured for fast-write operations has been added to the subsystem. <p>Possible FRUs:</p> <p>Fast-Write Cache Option Card (90%) (“Removing the Fast-Write Cache Option Card of an Advanced SerialRAID Adapter” on page 332).</p> <p>SSA adapter card (10%) (“Removing and Replacing an Advanced SerialRAID Adapter” on page 327).</p>

SRN	Problem	Possible Causes
42521	<p>Description: A Fast-Write Cache Option Card has failed. Data has been written to the cache card, and cannot now be recovered. The disk drives that have lost the data cannot be identified. All unsynchronized fast-write disk drives that are attached to this adapter are offline.</p> <p>Action:</p> <ol style="list-style-type: none"> 1. Ask the customer to refer to “Dealing with Fast-Write Problems” on page 218 to determine: <ul style="list-style-type: none"> • Which disk drives are affected by this error • How much data has been lost • Which data recovery procedures can be done 2. Ask the customer to disable the Fast-Write option for: <ul style="list-style-type: none"> • Each device for which the Fast-Write option is offline • All other devices that are connected to the failing adapter, and have the Fast-Write option enabled <p>For instructions on how to disable the Fast-Write option, see “Configuring the Fast-Write Cache Feature” on page 211.</p> 3. If this error has occurred because the Fast-Write Option Card has been switched off for more than seven days, or if the Fast-Write Option Card battery has been disconnected, clear the contents of the fast-write cache; type the command: <pre>ssa_format -l AdapterName</pre> <p>where AdapterName is the name of the adapter that contains the fast-write cache (for example, ssa0).</p> <p>If the Fast-Write Option Card has not been switched off, exchange it for a new one.</p> 4. Ask the customer to re-enable the Fast-Write option for the devices that are attached to the reformatted, or new, Fast-Write Option Card. 	<p>Possible FRUs:</p> <p>Fast-Write Cache Option Card (100%) (“Removing the Fast-Write Cache Option Card of an Advanced SerialRAID Adapter” on page 332).</p>
42523	<p>Description: The Fast-Write Cache Option Card has a bad version number.</p> <p>Action: Install the correct adapter microcode for this cache card.</p>	User or service action.

SRN	Problem	Possible Causes
42524	<p>Description: A fast-write disk drive (or drives) contains unsynchronized data, but the Fast-Write Cache Option Card cannot be detected. The disk drive (or drives) is offline.</p> <p>Action:</p> <ul style="list-style-type: none"> • If the Fast-Write Cache Option Card has been removed, reinstall it, and test the disk drive subsystem. • If the Fast-Write Cache Option card has failed: <ol style="list-style-type: none"> 1. Ask the customer to disable the Fast-Write option for: <ul style="list-style-type: none"> – Each device for which the Fast-Write option is offline – All other devices that are connected to the failing adapter, and have the Fast-Write option enabled <p>For instructions on how to disable the Fast-Write option, see “Dealing with Fast-Write Problems” on page 218.</p> <ol style="list-style-type: none"> 2. Exchange the Fast-Write Cache Option Card for a new one. 3. Ask the customer to re-enable the Fast-Write option for the devices that are attached to the new Fast-Write Cache Option Card. 	<p>System configuration problem.</p> <p>Possible FRUs:</p> <p>Fast-Write Cache Option Card (100%) (“Removing the Fast-Write Cache Option Card of an Advanced SerialRAID Adapter” on page 332).</p>

SRN	Problem	Possible Causes
42525	<p>Description: A fast-write logical disk contains unsynchronized data, but the Fast-Write Option Card does not contain that data. The failing disk drive is offline.</p> <p>Action:</p> <ul style="list-style-type: none"> • If the disk drive has just been moved from another adapter, do either of the following actions: <ul style="list-style-type: none"> – Return the disk drive to its original adapter. – Move the original Fast-Write Cache Option Card to this adapter so that the data can be synchronized. • If the wrong Fast-Write Cache Option Card has been installed (for example, if the adapter has been exchanged, but the original Fast-Write Cache Option Card is still on the old adapter card), install the original Fast-Write Cache Option Card onto this adapter. • If the adapter card has been switched off for more than seven days, the battery is discharged and data has been lost. If the adapter card has been switched off for fewer than seven days, exchange the Fast-Write Cache Option Card for a new one, then do the following: <ol style="list-style-type: none"> 1. Ask the customer to disable the Fast-Write option for: <ul style="list-style-type: none"> – Each device for which the Fast-Write option is offline – All other devices that are connected to the failing adapter and have the Fast-Write option enabled. <p>For instructions on how to disable the Fast-Write option, see “Dealing with Fast-Write Problems” on page 218.</p> <ol style="list-style-type: none"> 2. If the Fast-Write option has been disabled for a RAID-5 array, the hdisk for that array can no longer be configured. Delete the RAID-5 array, then recreate it. For instructions on how to delete the array, see “Deleting an SSA RAID Array” on page 70. 3. Ask the customer to re-enable the Fast-Write option for the devices that are attached to the Fast-Write Cache Option Card. 	<ul style="list-style-type: none"> • The data was not synchronized on the old adapter before the disk drive was moved to this adapter. • The wrong Fast-Write Option Card was installed onto this adapter. • The Fast-Write Option Card lost the data because the battery failed. <p>Possible FRUs:</p> <p>Fast-Write Cache Option Card (100%) (“Removing the Fast-Write Cache Option Card of an Advanced SerialRAID Adapter” on page 332).</p>
42527	<p>Description: A dormant fast-write cache entry exists. The fast-write cache contains unsynchronized data for a disk drive that is no longer available.</p> <p>Action: If possible, reconnect the disk drive to the adapter to enable the data to be synchronized. If you cannot reconnect the disk drive (for example, because the disk drive has failed), the user should delete the dormant fast-write cache entry (see “Enabling or Disabling Fast-Write for Multiple Devices” on page 215).</p>	User or service action.

SRN	Problem	Possible Causes
42528	<p>Description: A fast-write disk drive has been detected that was previously unsynchronized, but has since been configured on a different adapter.</p> <p>Action: If this disk drive contains data that should be kept, return the disk drive to the adapter to which it was previously connected.</p> <p>If the disk drive does not contain data that should be kept:</p> <ol style="list-style-type: none"> 1. Physically remove the disk drive from the system configuration. 2. Ask the user to delete all offline items (see "Enabling or Disabling Fast-Write for Multiple Devices" on page 215). 3. When the items have been deleted, reinstall the disk drive that you have just removed. 	User or service action.
42529	<p>Description: The fast-write cache is inactive. The battery is in a fast-charge operation. It remains in the fast-charge operation for up to one hour after the adapter has been connected to the power. During this time, the fast-write function remains inactive. (Inactive means that although fast-write disk drives can be enabled and accessed, they are not using the fast-write function.)</p> <p>Action: If the using system has been switched on for less than one hour, wait for the battery to complete charging.</p> <p>If the using system has been switched on for more than one hour, run diagnostics to the adapter in System Verification mode. If the same SRN is generated, exchange the FRU for a new FRU.</p>	<p>The using system has recently been switched on. The battery is still charging.</p> <p>Possible FRUs:</p> <p>Fast-Write Cache Option Card battery (100%) ("Removing the Fast-Write Cache Option Card of an Advanced SerialRAID Adapter" on page 332).</p>
4252A	<p>Description: The supply voltage to the Fast-Write Cache Option Card is low. The card has switched to Self-Refresh mode.</p> <p>Action: In the sequence shown, exchange the FRUs for new FRUs.</p>	<p>Possible FRUs:</p> <p>Fast-Write Cache Option Card (90%) ("Removing the Fast-Write Cache Option Card of an Advanced SerialRAID Adapter" on page 332).</p> <p>SSA adapter card (10%) ("Removing and Replacing an Advanced SerialRAID Adapter" on page 327).</p>
4252B	<p>Description: The Fast-Write Cache Option Card battery has reached the end of its life. The fast-write cache is disabled.</p> <p>Action: Exchange the FRU for a new FRU.</p>	<p>Possible FRUs:</p> <p>Fast-Write Cache Option Card battery (100%) ("Removing the Fast-Write Cache Option Card of an Advanced SerialRAID Adapter" on page 332).</p>

SRN	Problem	Possible Causes
4252C	<p>Description: The Fast-Write Cache Option Card battery needs to be exchanged for a new one.</p> <p>Action: Exchange the FRU for a new FRU.</p>	<p>Possible FRUs:</p> <p>Fast-Write Cache Option Card battery (100%) ("Removing the Fast-Write Cache Option Card of an Advanced SerialRAID Adapter" on page 332).</p>
4252D	<p>Description: Fast-write caching is suspended (stopped temporarily) for one or more devices.</p> <p>Action:</p> <ol style="list-style-type: none"> 1. Type smitty devices and press Enter. 2. Select SSA Disks. 3. Select SSA Logical Disks. 4. Select Enable/Disable Fast-Write for Multiple Devices. 5. Note the numbers of each hdisk that is listed under "Fast-Write is Suspended for these devices". 6. If you do not know which RAID Manager (SSA adapter) is managing the hdisk, give the following command from the command line: <pre>ssaadap -l hdiskn</pre> <p>Where hdiskn is the hdisk number that you noted in step 5.</p> 7. For each hdisk that you noted in step 5, give the following command from the command line: <pre>ssaraid -H -l RaidManager -n hdiskn -a fw_suspended=false</pre> <p>Where: RaidManager is the SSA adapter that is managing the fast-write device, and hdiskn is the hdisk number that you noted in step 5.</p> 	<ul style="list-style-type: none"> • An unexpected loss of power has occurred on the using system. • The user has stopped an uncouple operation.
42540	<p>Description: Two-way fast-write for a disk drive is configured to operate only when both caches are available. One cache, however, is now not available.</p> <p>Action:</p> <ol style="list-style-type: none"> 1. If the using system that contains the partner adapter is switched off, switch it on. 2. If the configuration has been changed, review the configuration rules, and restore a valid configuration. 3. Run diagnostics on the partner adapter, and correct all problems. (The partner adapter is the other adapter on the SSA loop that includes the adapter that reported the problem.) 4. If, while the other adapter is not available, the user wants to use the fast-write function on disk drives that are attached to this adapter, change the state of the Bypass Cache In 1-Way Fast-Write Network flag (see "Bypassing the Cache in a One-Way Fast-Write Network" on page 217). 	<ul style="list-style-type: none"> • Failure in another using system. • A user action has set Bypass Cache when 1-way. • Configuration change.

SRN	Problem	Possible Causes
43PAA	<p>Description: An SSA device on the link is preventing the completion of the loop configuration.</p> <p>Action: If the SSA service aids are available, run the Link Verification service aid (see “Link Verification Service Aid” on page 383) to determine which device is preventing configuration. (That device is the one beyond the last-configured device on an open SSA loop.)</p> <p>If the SSA service aids are not available, note the value of PAA in this SRN, and go to “Finding the Physical Location of a Device” on page 409.</p>	<p>Possible FRUs:</p> <p>Device (90%) (“Exchanging Disk Drives” on page 319).</p> <p>SSA adapter card (10%) (“Removing and Replacing an Advanced SerialRAID Adapter” on page 327).</p>
44PAA	<p>Description: An SSA device has a ‘Failed’ status.</p> <p>Action: If the SSA service aids are available, run the Link Verification service aid (see “Link Verification Service Aid” on page 383) to find the failing device. If no device is listed with a status of “Failed”, use the PAA part of the SRN to determine which device is failing. Before you exchange the failing device, run diagnostics in System Verification mode to that device to determine the cause of the problem.</p> <p>If the SSA service aids are not available, note the value of PAA in this SRN, and go to “Finding the Physical Location of a Device” on page 409. Exchange the failing FRU for a new FRU.</p>	<p>Possible FRUs:</p> <p>Device (100%) (“Exchanging Disk Drives” on page 319).</p>
45PAA	<p>Description: The SSA adapter has detected an open SSA loop.</p> <p>Action: If the SSA service aids are available, run the Link Verification service aid (see “Link Verification Service Aid” on page 383) to determine which part of the SSA loop is failing.</p> <p>If the SSA service aids are not available, note the value of PAA in this SRN, and go to “Finding the Physical Location of a Device” on page 409. Then go to “SSA Link Errors” on page 478 to solve the problem.</p>	<p>Possible FRUs:</p> <p>Device (40%) (“Exchanging Disk Drives” on page 319).</p> <p>SSA adapter card (40%) (“Removing and Replacing an Advanced SerialRAID Adapter” on page 327).</p> <p>External SSA cables, Fibre-Optic Extenders, fiber optic cables, or internal connections in the device enclosure (20%) (enclosure service information).</p>
46000	<p>Description: An array is in the Offline state because not enough disk drives are present in the array to maintain data availability.</p> <p>Action: If the SSA service aids are available, run the Link Verification service aid (see “Link Verification Service Aid” on page 383) to find power faults or broken SSA links that might be causing this problem.</p> <p>If the SSA service aids are not available, or the problem remains, go to “MAP 2324: SSA RAID” on page 454 to isolate the problem.</p>	<ul style="list-style-type: none"> • For a RAID-0 or a RAID-Copy array, at least one member disk drive of the array is missing. • For a RAID-5 array, at least two member disk drives cannot be accessed. • For a RAID-10 array, at least one mirrored pair of disk drives cannot be accessed. • Power problem. • System configuration problem.

SRN	Problem	Possible Causes
46500	<p>Description: A member disk drive is missing from an array, or the original SSA adapter is not available. The array is in the Offline state.</p> <p>Action:</p> <ul style="list-style-type: none"> • If the missing disk drive is still operational, reconnect it to the SSA loop. • If the original SSA adapter is operational, reconnect the offline array to that adapter. • If both the SSA adapter and the disk drive have failed, delete the array, then recreate it. 	<p>At least one disk drive missing from an array, and that array is not now connected to the SSA adapter that opened it. The array remains in the Offline state, because its data integrity cannot be verified. This problem might have occurred because:</p> <ul style="list-style-type: none"> • An SSA adapter card and a disk drive both failed. • The using-system configuration was changed while an array was still open.
47000	<p>Description: An attempt has been made to store in the SSA adapter the details of more than 128 arrays. Those arrays that cannot be stored become offline to the adapter.</p> <p>Action: The system user must delete from the SSA adapter the details of old arrays (see "Deleting an Old RAID Array Recorded in an SSA RAID Manager" on page 133).</p> <p>If no details of old arrays are present, or if existing old arrays cannot be removed, exchange the FRU for a new FRU.</p>	<p>User action.</p> <p>Possible FRUs:</p> <p>SSA adapter card (100%) ("Removing and Replacing an Advanced SerialRAID Adapter" on page 327).</p>
47500	<p>Description: Part of the array data might have been lost.</p> <p>Action: Go to "MAP 2324: SSA RAID" on page 454.</p>	<ul style="list-style-type: none"> • An unreadable data sector existed on a disk drive when an array was created. • An unreadable data sector was detected during a rebuilding operation on an array. • The SSA adapter was reset during an attempt to recover a failed disk drive.
48000	<p>Description: The SSA adapter has detected a link configuration that is not valid.</p> <p>Action: See "SSA Loop Configurations that Are Not Valid" on page 441.</p>	<p>SSA loop configuration problem.</p>
48500	<p>Description: The array filter has detected a link configuration that is not valid.</p> <p>Action: See "Rules for SSA Loops" on page 22, and correct the configuration.</p>	<p>SSA loop configuration problem.</p>

SRN	Problem	Possible Causes
48600	<p>Description: All the member disk drives of an array are not on the same SSA loop. The array is in the Exposed state, and write operations to the array are inhibited.</p> <p>Action: All the member disk drives of an array must be on the same SSA loop. Find all the members of the array:</p> <ol style="list-style-type: none"> 1. Type smitty devices and press Enter. 2. Select SSA RAID Arrays. 3. Select List/Identify SSA Physical Disks. 4. Select List Disks in an SSA RAID Array. 5. Select the hdisk that is in the Exposed state, and note all the pdisks. If necessary, use the Identify function to identify the disk drive. 6. Move all the member disk drives to the same SSA loop. 	SSA loop configuration problem.
48700	<p>Description: All the member disk drives of an array are not on the same SSA loop. The array is in the Offline state.</p> <p>Action: All the member disk drives of an array must be on the same SSA loop. Find all the members of the array:</p> <ol style="list-style-type: none"> 1. Type smitty devices and press Enter. 2. Select SSA RAID Arrays. 3. Select List/Identify SSA Physical Disks. 4. Select List Disks in an SSA RAID Array. 5. Select the hdisk that is in the Offline state, and note all the pdisks. If necessary, use the Identify function to identify the disk drives. 6. Move all the member disk drives to the same SSA loop. 	SSA loop configuration problem.

SRN	Problem	Possible Causes
48750	<p>Description: An array is in the Offline state because the primary or the secondary half of the array is not present.</p> <p>Action: Switch on the power to the other half of the array, or repair the broken loop that is preventing access to the other disk drives.</p> <p>If the other half of the array has become permanently unavailable because an unrecoverable error has occurred, you can force access to the available half of the array.</p> <p>Attention: Do not force access to the available half of the array unless you are sure that no updates to the other (unavailable) half of the array will be performed. See Chapter 8, "Split-Site Management" on page 193 before you perform this operation.</p> <p>To force access to the available half of the array, change the setting of the Split Array Resolution flag:</p> <ol style="list-style-type: none"> 1. Type <code>smitty ssaraid</code> and press Enter. 2. Select Change/Show Attributes of an SSA RAID Array. 3. Change the setting of the Split Array Resolution flag. 4. If possible, change the setting of the Split Array Resolution flag on the unavailable half of the array. <p>Attention: If the unavailable half of the array is reconnected to the available half before the setting of the Split Array Resolution flag has been changed, neither SSA adapter can get access to the array.</p>	<p>The adapter cannot get access the other adapter in the loop because one of the following conditions exists:</p> <ul style="list-style-type: none"> • The SSA adapter can detect the secondary half of the array, but the Split Array Resolution flag is set to Primary. • The SSA adapter can detect the primary half of the array, but the Split Array Resolution flag is set to Secondary. <p>This problem can be caused by a power failure on one half of the array, or by a broken SSA loop between the two halves of the array.</p>
48755	<p>Description: One of the following conditions exists:</p> <ul style="list-style-type: none"> • One member of a RAID-1 array has been detected, but the adapter is unknown to that array member. • All the primary, or all the secondary, disk drives of a RAID-10 array are present, but the adapter is unknown to the array. <p>Action: If the problem has resulted from an unplanned change to the using-system configuration, return the using system to its original configuration.</p> <p>If the problem has resulted from the failure of an SSA adapter and the failure of half the members of an array, do the following actions to attach the array to the adapter:</p> <ol style="list-style-type: none"> 1. Type <code>smitty ssaraid</code> and press Enter. 2. Select Change/Show Attributes of an SSA RAID Array. 3. Change the setting of the Split Array Resolution flag. The array becomes available, but remains in the Exposed state or the Degraded state until the missing array members are added. 4. Add the missing members of the array: <ol style="list-style-type: none"> a. Select Change Member Disks in an SSA RAID Array from the SSA RAID Arrays menu. b. Select Add a Disk to an SSA RAID Array once for each disk drive that you need to add to the array. 	<ul style="list-style-type: none"> • An SSA adapter and a pdisk have failed. • A RAID member disk drive is connected to another SSA adapter. • A split-site configuration has only one SSA adapter configured, and the adapter and all the primary, or secondary, disk drives fail.

SRN	Problem	Possible Causes
48760	<p>Description: An array is in the Offline state because the split/join procedure was not performed correctly. The data on the array is not constant.</p> <p>Action: See Chapter 8, "Split-Site Management" on page 193 before you attempt to recover the array.</p>	<p>This problem can occur if a RAID-1 array or a RAID-10 array has been split exactly in half, and a write operation has been performed independently to both halves of the array.</p>
48800	<p>Description: The Invalid-strip-table is full. Because of failures on multiple member disk drives of an array, at least 128 blocks of data are not accessible. Other data on the array might still be readable.</p> <p>Action:</p> <ol style="list-style-type: none"> 1. Type <code>smitty ssaraid</code> and press Enter. 2. Select List Status of All Defined SSA RAID Arrays. 3. The failed hdisk is listed with <code>Invalid data strips</code>. Make a note of the hdisk number. 4. Ask the customer to make a backup of all data that is still readable, and then to delete the failed array. 5. When the array has been deleted, run the following to each disk drive that was a member of the failed array: <ul style="list-style-type: none"> • <code>Diagnostics in System Verification mode</code> • <code>Certify service aid</code> 6. If, in the previous step, you found any disk drive failures, correct those failures. 7. Tell the customer that the array can now be recreated. 	<p>Possible FRUs:</p> <p>Device (100%) ("Exchanging Disk Drives" on page 319).</p>
48900	<p>Description: An array is not available; multiple devices have failed.</p> <p>Action: Run diagnostics and the <code>Certify service aid</code> to all the disk drives that were used to create the array. If problems occur, correct those problems before you attempt to recreate the array.</p>	<p>None.</p>

SRN	Problem	Possible Causes
48950	<p>Description: A disk drive has caused an array building operation to fail.</p> <p>Action:</p> <ol style="list-style-type: none"> 1. Type <code>smitty ssaraid</code> and press Enter. 2. Select List all Defined SSA RAID Arrays. The hdisk that is causing this problem is listed as exposed or degraded. 3. Ask the user to make a backup of the data that is on this array. Some data might not be accessible. 4. Return to the SSA RAID Arrays menu and select List/Identify SSA Physical Disks. 5. Select List Disks in an SSA RAID Array. 6. Select the failing hdisk. 7. Note the pdisk numbers of the member disk drives of the failed array. 8. Ask the user to delete the array. 9. Return to the SSA RAID Arrays menu and select Change/Show Use of an SSA Physical Disk. 10. Run diagnostics in System Verification mode to all disk drives that are listed as rejected (if any are listed). 11. If the diagnostics run successfully, run the Certify service aid (see "Certify Disk Service Aid" on page 391) to the disk drive that caused this SRN. 12. Run the Certify service aid (see "Certify Disk Service Aid" on page 391) to all the disk drives that were members of the failed array. 13. Run the Certify service aid to all the disk drives that were members of the failed array. 14. If problems occur on any disk drive, exchange that disk drive for a new one. 15. Ask the user to recreate the array. 	<p>A disk drive has failed during an array building operation. Because the failure occurred before an initial array building operation had completed, a hot spare disk drive has not replaced the failed disk drive.</p> <p>Possible FRUs:</p> <p>Device (100%) ("Exchanging Disk Drives" on page 319).</p>

SRN	Problem	Possible Causes
49000	<p>Description: An array is in the Degraded state. A disk drive might not be available for one of the following reasons:</p> <ul style="list-style-type: none"> • The disk drive has failed. • The disk drive has been removed from the subsystem. • An SSA link has failed. • A power failure has occurred. <p>Action: If the SSA service aids are available, run the Link Verification service aid (see “Link Verification Service Aid” on page 383) to find any failed disk drives, failed SSA links, or power failures that might have caused the problem.</p> <p>If you find any faults, go to the Start MAP (or equivalent) in the enclosure service information to isolate the problem, then go to 37 on page 473 of MAP 2324: SSA RAID to return the array to the Good state.</p> <p>If the SSA service aids are not available, or the Link Verification service aid does not find any faults, go to “MAP 2324: SSA RAID” on page 454 to isolate the problem.</p>	<ul style="list-style-type: none"> • A RAID-5 array causes this SRN if a disk drive is not available to the array, and a write command is sent to the array. • A RAID-1 or RAID-10 array causes this error if the array has one or more degraded mirrors. A RAID-1 or RAID-10 mirror becomes degraded when one disk drive in the mirror pair is not available, and a write command is sent to the array.
49100	<p>Description: An array is in the Exposed state. A disk drive can become not available for several reasons:</p> <ul style="list-style-type: none"> • The disk drive has failed. • The disk drive has been removed from the subsystem. • An SSA link has failed. • A power failure has occurred. <p>Action: If the SSA service aids are available, run the Link Verification service aid (see “Link Verification Service Aid” on page 383) to find any failed disk drives, failed SSA links, or power failures that might have caused the problem.</p> <p>If you find any faults, go to the Start MAP (or equivalent) in the enclosure service information to isolate the problem, then go to 37 on page 473 of MAP 2324: SSA RAID to return the array to the Good state.</p> <p>If the SSA service aids are not available, or the Link Verification service aid does not find any faults, go to “MAP 2324: SSA RAID” on page 454 to isolate the problem.</p>	<ul style="list-style-type: none"> • A RAID-5 array causes this error code if a disk drive is not available to the array. • A RAID-1 or RAID-10 array causes this error if the array has one or more exposed mirrors. A RAID-1 or RAID-10 mirror becomes exposed when one disk drive in the mirror pair is not available to the array.

SRN	Problem	Possible Causes
49500	<p>Description: No hot spare disk drives are available for an array that is configured for hot spare disk drives.</p> <p>Action: Determine whether any disk drives have failed or have been rejected. To do this action:</p> <ol style="list-style-type: none"> 1. Display the use of the disk drives that are attached to the SSA adapter that logged the error (see “Changing or Showing the Use of an SSA Disk Drive” on page 144). 2. Run diagnostics in Problem Determination mode to all pdisks that are attached to the adapter that logged this error. 3. If any disk drives have failed, first exchange those disk drives for new disk drives, and assign them to the use that has been specified by the user. If the problem remains, continue with the next step. 4. Type <code>smitty ssaraid</code> and press Enter. 5. Select List Status of Hot-Spare Protection for an SSA RAID Array. 6. Select the adapter that logged the error. 7. Observe the displayed list. Note which SSA loop contains any array member disk drives that are listed with a protected state of no. Devices that are in <code>pool_A0</code> are connected to loop A. Devices that are in <code>pool_B</code> are connected to loop B. 8. If the status field for the unprotected array member disk drive is too_large, the hot spare disk drive is not large enough to support that array component. Otherwise, no hot spare disk drive exists on the loop that you noted earlier. 9. Return to the SSA RAID Arrays menu and select Change/Show Use of an SSA Physical Disk. 10. Select the adapter that logged the error. 11. Find an appropriate disk drive, and change its use to hot spare (see “Changing or Showing the Use of an SSA Disk Drive” on page 144). 	<p>A RAID array is configured to use hot spare disk drives, but no disk drive can be found that is configured as a hot spare. This error code is used only when no hot spare pools have been assigned. All arrays and hot spare disk drives are in the default pool0.</p>

SRN	Problem	Possible Causes
49510	<p>Description: Hot-spare configuration is not synchronized. This problem has occurred because the cabling has changed or because new hot-spare disks have been added to the SSA loop.</p> <p>Action:</p> <ol style="list-style-type: none"> 1. If the changes were not planned, restore the system to its original configuration. If the changes were planned, go to step 2. 2. Type <code>smitty ssaraid</code> and press Enter. 3. Select List Status of Hot-Spare Pools. 4. Select the adapter that logged the error. If the adapter is not known, select all adapters. 5. Note the RAID Manager and pool number of spare-pools that have a status of "Inconsistent". 6. Select Change/Show/Delete a Hot-Spare Pool. 7. Select the RAID Manager and pool that you noted in step 5. 8. For each inconsistent spare-pool: <ol style="list-style-type: none"> a. Check whether the number of hot spare disk drives that are in the pool matches the user's requirements. b. If necessary, select Components to Add or Components to Remove to modify the hot spare disk drives that are in the pool. c. Set Hot-Spares Minimum to the alarm value that the user has specified. (This number is normally one less than the number of hot spare disk drives that are configured. It can, however, be a lower number.) d. Press Enter. 9. Reselect Change/Show/Delete a Hot Spare Pool. This action refreshes the display. 10. If the Status of the hot-spare pool has changed to "Full", the repair is complete. If any other status value is displayed, run diagnostics in System Verification mode to all SSA Adapters to determine the new SRN. 	SSA loop configuration problem.

SRN	Problem	Possible Causes
49520	<p>Description: Hot-spare tuning has been lost.</p> <p>Action:</p> <ol style="list-style-type: none"> 1. Type <code>smitty ssaraid</code> and press Enter. 2. Select List Status of Hot-Spare Pools. 3. Select the adapter that logged the error. If the adapter is not known, select all adapters. 4. Note the RAID Manager (adapter) and pool number of spare-pools that have a status of mixed. 5. Select List Components in a Hot-Spare Pool. 6. Select the RAID Manager and pool that you noted earlier. 7. Note the array name (<code>hdisk</code>) and member disk drive (<code>pdisk</code>) that have a status of wrong_pool. (This array member disk drive (<code>pdisk</code>) is exchanged later, after all rejected disk drives have been exchanged.) 8. Select Change/Show Use of an SSA Physical Disk, and select the RAID manager that you noted earlier. 9. Note all the disk drives that are listed as rejected. 10. Exchange all failed and rejected disk drives for new disk drives. 11. Select Change/Show Use of Multiple SSA Physical Disks. 12. Change the Current Use parameter of the exchanged disk drives to Hot Spare Disks. 13. If the user has a record of how disk drives are assigned to the hot-spare pools, use that information to assign the hot spare disk drives to the correct pools. If the user has no such record, see “Deciding how to Configure Hot Spare Disk Drive Pools” on page 45 to determine the best hot-spare configuration, then go to step 14. 14. Select Change/Show/Delete a Hot-Spare Pool. 15. Add the hot spare disk drives to the correct pool (see “Adding Disks to, or Removing Disks from, a Hot Spare Pool” on page 86). 16. Select Change Member Disks in an SSA RAID Array. 17. Swap the <code>pdisk</code>, whose name you noted in step 7, with a hot spare disk drive that is in the pool that you noted in step 4 (see “Changing Member Disks in an SSA RAID Array” on page 137). Note: If the customer chooses not to have the disk drive swapped, the only way to clear this error condition is to remove all the member disk drives from this hot spare pool, then recreate the pool. <i>If you do these actions, you change the configuration of the hot spare pool.</i> 18. Select Change/Show Use of an SSA Physical Disk. 19. Change to Hot Spare Disk the Current Use parameter of the disk drive (<code>pdisk</code>) whose name you noted in step 7. 20. Select Change/Show/Delete a Hot-Spare Pool. 21. Add to the correct pool the hot spare disk drive that you created in step 19. 	<p>An array member has used a hot spare disk drive from a pool other than its specified pool. If the hot-spare pools have been correctly configured, this error indicates that more than one disk drive might have failed.</p> <p>Possible FRUs:</p> <p>Device (100%) (“Exchanging Disk Drives” on page 319).</p>

SRN	Problem	Possible Causes
49530	<p>Description: The number of disk drives that remain in a hot-spare pool is less than the specified number.</p> <p>Action:</p> <ol style="list-style-type: none"> 1. Type smitty ssaraid and press Enter. 2. Select Change/Show Use of an SSA Physical Disk. 3. Note all the disk drives that are listed as rejected. 4. Exchange all the rejected disk drives for new disk drives. 5. Select Change/Show Use of Multiple SSA Physical Disks. 6. Change the Current Use parameter of the exchanged disk drives to Hot Spare Disks. 7. Select List Status of Hot-Spare Pools. 8. Select the adapter that logged the error. If the adapter is not known, select all adapters. The hot-spare pool that is listed as empty or critical is the pool to which the hot-spare disk drives must now be added. <p>Attention: If more than one hot-spare pool is listed as empty, critical, or reduced, refer to the user's pool assignment records to determine the correct pool to which the hot spare disk drives must now be assigned. If the user has no such record, see "Deciding how to Configure Hot Spare Disk Drive Pools" on page 45 to determine the best configuration. Then go to step 9.</p> <ol style="list-style-type: none"> 9. Select Change/Show/Delete a Hot-Spare Pool. 10. Add to the correct hot-spare pool the hot spare disk drives that you created in step 6. 	<p>The number of hot-spare disk drives that are now in the assigned pool is less than the specified minimum number.</p> <p>Possible FRUs: Device (100%) ("Exchanging Disk Drives" on page 319).</p>
49540	<p>Description: Adapters that do not provide support for hot-spare pools have been detected. This problem has occurred because the cabling has changed or because an SSA adapter that does not provide support for hot-spare pools has been added to the SSA loop.</p> <p>Action:</p> <ol style="list-style-type: none"> 1. If the changes were not planned, restore the system to its original configuration. <p>If the changes were planned, do either of the following actions:</p> <ul style="list-style-type: none"> • Update the microcode to the latest level if the SSA adapter is an Advanced SerialRAID Adapter. • For all hot-spare pools that are connected to this RAID Manger: <ol style="list-style-type: none"> a. Type smitty ssaraid and press Enter. b. Select Change/Show/Delete a Hot-Spare Pool. c. Remove all member disk drives from the pool. 	<p>Hot spare disk drives have been assigned to pools other than pool zero, but other SSA adapters on the SSA loop are using versions of microcode that do not provide support for spare pools.</p>
49800	<p>Description: A different adapter has been detected on each loop.</p> <p>Action: Go to "Rules for SSA Loops" on page 22 and observe the configuration rules for this adapter. Correct the configuration.</p>	<p>SSA loop configuration problem.</p>

SRN	Problem	Possible Causes
49950	<p>Description: An array copy disk drive is missing. The array copy is degraded. If the missing disk drive is restored to the network or exchanged for a new disk drive, the copy rebuilds. A disk drive might not be available for one of the following reasons:</p> <ul style="list-style-type: none"> • The disk drive has failed. • The disk drive has been removed from the subsystem. • An SSA link has failed. • A power failure has occurred. <p>Action: Go to "MAP 2324: SSA RAID" on page 454.</p>	<p>Possible FRUs:</p> <p>Device (100%) ("Exchanging Disk Drives" on page 319).</p>
4A100	<p>Description: The adapter cannot initialize a disk drive. The failing disk drive might, or might not, be configured on this system.</p> <p>Action: Run diagnostics in System Verification mode to all pdisks.</p> <p>If the diagnostics fail, exchange the pdisk for a new disk drive.</p> <p>If the diagnostics do not detect a failing pdisk, use the Link Verification service aid (see "Link Verification Service Aid" on page 383) to search for disk drives that are not configured. Such disk drives are listed as *****.</p> <p>Note: Other adapters in the SSA loop might also be listed as *****.</p> <p>Exchange, for new disk drives, all pdisks that are not configured.</p>	<p>Possible FRUs:</p> <p>Device (100%) ("Exchanging Disk Drives" on page 319).</p>
4BPAA	<p>Description: A disk drive at PAA cannot be configured, because its UID cannot be read.</p> <p>Action: If the SSA service aids are available:</p> <ol style="list-style-type: none"> 1. Run the Link Verification service aid (see "Link Verification Service Aid" on page 383) to find the failing device. The service aid lists the device as *****. 2. Exchange the FRU for a new FRU. <p>If the service aids are not available:</p> <ol style="list-style-type: none"> 1. Note the value of PAA in this SRN, then go to "Finding the Physical Location of a Device" on page 409. 2. Exchange the FRU for a new FRU. 	<p>Possible FRUs:</p> <p>Device (100%) ("Exchanging Disk Drives" on page 319).</p>
50000	<p>Description: The SSA adapter failed to respond to the device driver.</p> <p>Action: Exchange the FRU for a new FRU.</p>	<p>Possible FRUs:</p> <p>SSA adapter card (100%) ("Removing and Replacing an Advanced SerialRAID Adapter" on page 327).</p>
50001	<p>Description: A data parity error has occurred.</p> <p>Action: Exchange the FRU for a new FRU.</p>	<p>Possible FRUs:</p> <p>SSA adapter card (100%) ("Removing and Replacing an Advanced SerialRAID Adapter" on page 327).</p>

SRN	Problem	Possible Causes
50002	Description: An SSA adapter DMA error has occurred. Action: Exchange the FRU for a new FRU.	Possible FRUs: SSA adapter card (100%) ("Removing and Replacing an Advanced SerialRAID Adapter" on page 327).
50007	Description: The IOCC detected an internal error. Action: Exchange the FRU for a new FRU.	Possible FRUs: SSA adapter card (100%) ("Removing and Replacing an Advanced SerialRAID Adapter" on page 327).
50008	Description: Unable to read or write the POS registers or PCI configuration space. Action: Exchange the FRU for a new FRU.	Possible FRUs: SSA adapter card (100%) ("Removing and Replacing an Advanced SerialRAID Adapter" on page 327).
50010	Description: An SSA adapter or device drive protocol error has occurred. Action: Go to "Software and Microcode Errors" on page 441 before exchanging the FRU.	Possible FRUs: SSA adapter card (100%) ("Removing and Replacing an Advanced SerialRAID Adapter" on page 327).
50012	Description: The SSA adapter microcode has hung. Action: Run diagnostics in System Verification mode to the SSA adapter. If the diagnostics fail, exchange the FRU for a new FRU. If the diagnostics do not fail, go to "Software and Microcode Errors" on page 441 before exchanging the FRU.	Possible FRUs: SSA adapter card (100%) ("Removing and Replacing an Advanced SerialRAID Adapter" on page 327).
50013	Description: The SSA adapter card has failed. Action: Exchange the FRU for a new FRU.	Possible FRUs: SSA adapter card (100%) ("Removing and Replacing an Advanced SerialRAID Adapter" on page 327).
50100	Description: An attempt was made to log an error against a pdisk that is not available to the using system. Action: This problem has occurred for one of the following reasons: <ul style="list-style-type: none"> • A user has deleted a pdisk from the system configuration. In such an instance, the hdisk that is using the pdisk continues to operate normally. If the disk drive tries to log an error, however, this SRN (50100) is produced. Give the cfgmgr command to return the pdisk to the system configuration. • A device has tried to log an error during system configuration. To find the failing device, run diagnostics to the devices that are connected to this SSA adapter. 	Disk drive error during system configuration.

SRN	Problem	Possible Causes
50200	<p>Description: A duplicate node number has been detected. This problem is a user error.</p> <p>Action: See “SSA Disk Concurrent Mode of Operation Interface” on page 287. You can use the ssavfynn command line utility (see “ssavfynn Command” on page 371) to determine which node has the duplicate node number.</p>	SSA loop configuration problem.
50411	<p>Description: The SSA adapter has detected an SS_SIC_CLASS1 error. This error can be caused by an adapter hardware failure, or by excessive electrical interference on the SSA loop.</p> <p>Action: Exchange the FRUs for new FRUs in the given sequence.</p>	<p>Possible FRUs:</p> <p>SSA adapter card (40%) (“Removing and Replacing an Advanced SerialRAID Adapter” on page 327).</p> <p>External SSA cables (30%).</p> <p>Device (30%) (“Exchanging Disk Drives” on page 319).</p>
50422	<p>Description: The SSA adapter has detected an SS_TIMEOUT error. A transaction has exceeded its time out. This problem can be caused by disk drive errors.</p> <p>Action: Run diagnostics in Problem Determination mode to all the disk drives that are attached to the adapter.</p> <p>If you find any problems, solve those problems.</p> <p>If you do not find any problems, run diagnostics in System Verification mode to the adapter. If the diagnostics run successfully, go to “Software and Microcode Errors” on page 441 before you exchange the adapter.</p>	<p>Possible FRUs:</p> <p>SSA adapter card (70%) (“Removing and Replacing an Advanced SerialRAID Adapter” on page 327).</p> <p>Device (30%) (“Exchanging Disk Drives” on page 319).</p>
50425	<p>Description: The SSA adapter has detected an SS_LINK_CONFIG_FAILED error. SSA devices cannot be configured because one device in the SSA loop is causing link responses that are not valid.</p> <p>Action: Isolate the failing device:</p> <ol style="list-style-type: none"> 1. If only one SSA loop is connected to the adapter, go to step 2. If two SSA loops are connected to the adapter, disconnect one loop, and run diagnostics in System Verification mode to the adapter, to determine which loop contains the failing device. Then go to step 2. 2. Disconnect the first device on the SSA loop that contains the failing device, and run the diagnostics in System Verification mode to the adapter. 3. If the diagnostics show that the failing device is still in the SSA loop, reconnect the device, and disconnect the next device in sequence. 4. Run the diagnostics again. 5. Repeat steps 3 and 4 until you isolate the failing device. 	<p>Possible FRUs:</p> <p>Device (90%) (“Exchanging Disk Drives” on page 319).</p> <p>SSA adapter card (10%) (“Removing and Replacing an Advanced SerialRAID Adapter” on page 327).</p>

SRN	Problem	Possible Causes
504XX	<p>Description: The SSA adapter microcode has hung.</p> <p>Action: Run diagnostics in System Verification mode to the SSA adapter. If the diagnostics fail, exchange the FRU for a new FRU. If the diagnostics do not fail, go to "Software and Microcode Errors" on page 441.</p>	<p>Software error.</p> <p>Possible FRUs:</p> <p>SSA adapter card (100%) ("Removing and Replacing an Advanced SerialRAID Adapter" on page 327).</p>
54050	<p>Description: The adapter bus has been reset.</p> <p>Action: Exchange the FRUs for new FRUs.</p>	<p>Possible FRUs:</p> <p>SSA adapter card (60%) ("Removing and Replacing an Advanced SerialRAID Adapter" on page 327).</p> <p>Using-system board (40%) (using-system service information)</p>
60000	<p>Description: The SSA adapter is missing from the expected configuration.</p> <p>Action: Verify that the SSA adapter card is installed in the expected slot of the using system.</p> <p>If it is in the expected slot, exchange the FRU for a new FRU.</p> <p>If it is not in the expected slot, give the diag -a command, and answer the questions that are displayed.</p>	<p>Possible FRUs:</p> <p>SSA adapter card (100%) ("Removing and Replacing an Advanced SerialRAID Adapter" on page 327).</p>
60200 60210	<p>Description: SRNs in this range are not adapter SRNs.</p> <p>Action: For SRNs in this range, see the documentation for your SSA enclosure or SSA subsystem.</p>	Not applicable.
60240	<p>Description: A configuration problem has occurred. A device cannot be configured, for some unknown reason.</p> <p>Action: Go to the START MAP for the enclosure in which the device is installed. If no problem is found, go to "Software and Microcode Errors" on page 441.</p>	<p>Software error.</p> <p>SSA loop configuration problem.</p>
7XXXX	<p>Description: An SSA device is missing from the expected configuration of the SSA loop.</p> <p>Action: Go to the service information for the enclosure in which the missing device should be installed.</p> <p>Note: In this SRN, an X represents a digit 0 through F.</p>	An SSA enclosure diagnostic has detected a missing disk drive.
8XXXX	<p>Description: SRNs in this range are used by the SSA enclosure (subsystem).</p> <p>Action: Go to the service information for your SSA enclosure.</p> <p>Note: In this SRN, an X represents a digit 0 through F.</p>	Not applicable.
D0000 to D0FFF	<p>Description: SRNs in this range are not adapter SRNs.</p> <p>Action: For SRNs in this range, see the documentation for your SSA enclosure or SSA subsystem.</p>	Not applicable.

SRN	Problem	Possible Causes
D4000	<p>Description: The diagnostics cannot configure the SSA adapter.</p> <p>Action: Exchange the FRU for a new FRU.</p>	<p>Possible FRUs:</p> <p>SSA adapter card (100%) ("Removing and Replacing an Advanced SerialRAID Adapter" on page 327).</p>
D4050	<p>Description: The Enhanced Error Handling test has failed.</p> <p>Action: Exchange the FRUs for new FRUs.</p>	<p>Possible FRUs:</p> <p>SSA adapter card (60%) ("Removing and Replacing an Advanced SerialRAID Adapter" on page 327).</p> <p>Host System Board (40%) (using-system <i>Installation and Service Guide</i>).</p>
D4100	<p>Description: The diagnostics cannot open the SSA adapter.</p> <p>Action: Exchange the FRU for a new FRU.</p>	<p>Possible FRUs:</p> <p>SSA adapter card (100%) ("Removing and Replacing an Advanced SerialRAID Adapter" on page 327).</p>
D4300	<p>Description: The diagnostics have detected an SSA adapter POST failure.</p> <p>Action: Exchange the FRU for a new FRU.</p>	<p>Possible FRUs:</p> <p>SSA adapter card (100%) ("Removing and Replacing an Advanced SerialRAID Adapter" on page 327).</p>
D44XX	<p>Description: The diagnostics have detected that the SSA adapter has corrupted the microcode, but cannot download a new version of the microcode.</p> <p>Action: Exchange the FRU for a new FRU.</p> <p>Note: In this SRN, an X represents a digit 0 through F.</p>	<p>Possible FRUs:</p> <p>SSA adapter card (100%) ("Removing and Replacing an Advanced SerialRAID Adapter" on page 327).</p>
D6PAA	<p>Description: A high-speed SSA link is running at low speed. This error is logged when the run_ssa_link_speed cron runs the ssa_speed utility.</p> <p>Action:</p> <ol style="list-style-type: none"> 1. Read "Cron Table Entries" on page 313 before you exchange any FRUs. 2. If the SSA service aids are available, run the Link Speed service aid (see "Link Speed Service Aid" on page 396) to determine the cause of the problem. <p>If the SSA service aids are not available, note the value of PAA in this SRN, and go to "Finding the Physical Location of a Device" on page 409. Then go to "SSA Link Errors" on page 478 to solve the problem.</p>	<p>Possible FRUs:</p> <p>External SSA cables (30%).</p> <p>Internal connections in the device enclosure (30%) (enclosure service information).</p> <p>Device (30%) ("Exchanging Disk Drives" on page 319).</p> <p>SSA adapter card (10%) ("Removing and Replacing an Advanced SerialRAID Adapter" on page 327).</p>
D8XXX	<p>Description: SRNs in this range are used by the SSA enclosure (subsystem).</p> <p>Action: Go to the service information for your SSA enclosure.</p> <p>Note: In this SRN, an X represents a digit 0 through F.</p>	<p>Not applicable.</p>

SRN	Problem	Possible Causes
DFFFF	<p>Note: The description and action for this SRN are valid only if you have run diagnostics to the SSA attachment. If this SRN has occurred because you have run diagnostics to some other device, see the service information for that device.</p> <p>Description: A command or parameter that has been sent or received is not valid. This problem is caused either by the SSA adapter, or by an error in the microcode.</p> <p>Action: Go to "Software and Microcode Errors" on page 441 before exchanging the FRU.</p>	<p>Software error.</p> <p>Possible FRUs:</p> <p>SSA adapter card (100%) ("Removing and Replacing an Advanced SerialRAID Adapter" on page 327).</p>
SSA01	<p>Description: Not enough using-system memory is available for this service aid to continue.</p> <p>Action: Do one of the actions described here:</p> <ul style="list-style-type: none"> • This problem might be caused by a failed application program. Ask the user to end any failed application program, then try to run the service aid again. • Run diagnostics in Problem Determination mode to the system unit. If you find any problems, solve them, then try to run the service aid again. • Close down and reboot the using system, then try to run the service aid again. • Run diagnostics from diskette or CD-ROM to isolate the problem. If you do not find a problem, the operating system might have failed. 	None.
SSA02	<p>Description: An unknown error has occurred.</p> <p>Action: Do one of the actions described here:</p> <ul style="list-style-type: none"> • Run diagnostics in Problem Determination mode to the system unit. If you find any problems, solve them, then try to run the service aid again. • If diagnostics fail, or if the same problem occurs when you try the service aid again, run diagnostics from diskette or CD-ROM to isolate the problem. If you do not find a problem, the operating system might have failed. 	None.

SRN	Problem	Possible Causes
SSA03	<p>Description: The service aid was unable to open an hdisk. This problem might have occurred because a disk drive has failed or has been removed from the system.</p> <p>Action: Do the actions described here:</p> <ol style="list-style-type: none"> 1. Use the Configuration Verification service aid (see "Configuration Verification Service Aid" on page 387) to determine the location code of the SSA adapter to which the hdisk is attached. (For example, if the location code of the hdisk is 00-03-L, the location code of the SSA adapter is 00-03.) 2. Run the Link Verification service aid (see "Link Verification Service Aid" on page 383) to the SSA adapter. 3. If a link failure is indicated by the service aid, go to "MAP 2320: SSA Link" on page 445. 4. If no link failures are indicated, run diagnostics in System Verification mode to each pdisk that is attached to the SSA adapter. 	None.

Software and Microcode Errors

Some SRNs indicate that a problem might have been caused by a software error or by a microcode error. If you have one of these SRNs, do the following actions:

1. Make a note of the contents of the error log for the device that has the problem.
2. For AIX Versions 4.2 and above, run the **snab -b** command to collect system configuration data, and to dump data.

For AIX versions below 4.2, go to the using-system service aids and select Display Vital Product Data to display the VPD of the failing system. Make a note of the VPD for all the SSA adapters and disk drives.

3. Report the problem to your support center. The center can tell you whether you have a known problem, and can, if necessary, provide you with a correction for the software or microcode.

If the support center has no known correction for the SRN, exchange, for new FRUs, the FRUs that are listed in the SRN.

SSA Loop Configurations that Are Not Valid

Note: This section is related to SRN 48000.

SRN 48000 shows that the SSA loop contains more devices or adapters than are allowed. The maximum numbers allowed depend on the adapter; “Rules for SSA Loops” on page 22 describes these details for each adapter.

If the SRN occurred when you, or the customer, switched on the using system:

1. Switch off the using system.
2. Review the configuration that you are trying to make, and determine why that configuration is not valid.
3. Correct your configuration by reconfiguring the SSA cables or by removing the excess devices or adapters from the loop.
4. Switch on the using system.

Service Hint: Cables can easily become crossed. If you still have problems, disconnect all the cables from the SSA adapter, then reconnect them one at a time. For each cable that you reconnect, run the Link Verification service aid (see “Link Verification Service Aid” on page 383) to check whether the configuration is as you expect.

If the SRN occurred because additional devices or adapters were added to a working SSA loop:

1. Remove the additional devices or adapters that are causing the problem, and put the loop back into its original, working configuration.

Note: *It is important that you do these actions*, because they enable the configuration code to reset itself from the effects of the error.

2. Review the configuration that you are trying to make, and determine why that configuration is not valid.
3. Correct your configuration by reconfiguring the SSA cables or by removing the excess devices or adapters from the loop.

SSA Maintenance Analysis Procedures (MAPs)

The maintenance analysis procedures (MAPs) describe how to analyze a failure that has occurred in an SSA loop.

How to Use the MAPs

Attention: Unless the using system needs to be switched off for some other reason, *do not switch off the using system when servicing an SSA loop*. Enclosure power cables and external SSA cables that connect the devices to the using system can be disconnected while that system is running.

- To isolate the FRUs, do the actions and answer the questions given in the MAPs.
- When instructed to exchange two or more FRUs in sequence:
 1. Exchange the first FRU in the list for a new one.
 2. Verify that the problem is solved. For some problems, verification means running the diagnostic programs (see the using-system service procedures).
 3. If the problem remains:
 - a. Reinstall the original FRU.
 - b. Exchange the next FRU in the list for a new one.
 4. Repeat steps 2 and 3 until either the problem is solved, or all the related FRUs have been exchanged.
 5. Do the next action indicated by the MAP.

Attention: Disk drives are fragile. Handle them with care, and keep them well away from strong magnetic fields.

MAP 2010: START

This MAP is the entry point to the MAPs for the adapter. If you are not familiar with these MAPs, read “How to Use the MAPs” on page 443 first.

You might have been sent here because:

- The system problem determination procedures sent you here.
- A problem occurred during the installation of a disk subsystem or a disk drive.
- Another MAP sent you here.
- A customer observed a problem that was not detected by the system problem determination procedures.

Attention: Unless the using system needs to be switched off for some other reason, *do not switch off the using system when servicing the SSA loop*. Enclosure power cables and external SSA cables that connect the devices to the using system can be disconnected while that system is running.

1.

Do you have an SSA subsystem (5-character) SRN?

NO Go to step 2.

YES Go to “Service Request Numbers (SRNs)” on page 411.

2. (from step 1)

- If the system diagnostics are available, go to step 3.
- If the system diagnostics are not available, but the stand-alone diagnostics are available:
 - a. Load the stand-alone diagnostics.
 - b. Go to step 3.
- If neither the system diagnostics nor the stand-alone diagnostics are available, go to the problem determination procedures for the enclosure that contains the disk drives.

3. (from step 2)

Run the diagnostics in Problem Determination mode.

Did the diagnostics produce an SRN?

NO Go to step 5 in “MAP 2410: SSA Repair Verification” on page 475.

YES Go to step “Service Request Numbers (SRNs)” on page 411.

MAP 2320: SSA Link

This MAP helps you to isolate FRUs that are causing an SSA loop problem between a device and the SSA adapter, or between two devices. If you are not familiar with SSA loops, read the section Chapter 2, "Introducing SSA Loops" on page 7 before using this MAP. Chapter 2, "Introducing SSA Loops" explains SSA links, strings, and loops.

Attention: Unless the using system needs to be switched off for some other reason, *do not switch off the using system when servicing the SSA loop*. Enclosure power cables and external SSA cables that connect the devices to the using system can be disconnected while that system is running.

1.

Are the system service aids available?

NO Go to 2.

YES Go to step 3.

2. (from step 1)

Are any Ready (link status) lights flashing on this SSA loop?

NO Go to "Finding the Physical Location of a Device" on page 409.

YES Go to "SSA Link Errors" on page 478 to analyze the problem.

3. (from step 1)

Run the Link Verification service aid (see "Link Verification Service Aid" on page 383), and select the appropriate SSA adapter from the displayed Link Verification adapter menu.

If the service aid detects pdisks for the adapter you have selected, a list of pdisks is displayed. The diagram shows an example list:

```
LINK VERIFICATION 802386
SSA Link Verification for:
  nunu:ssa0          00-04  IBM SSA 160 SerialRAID Adapter (

To Set or Reset Identify, move cursor onto selection, then press <Enter>.

  Physical          Serial#      Adapter Port      Status
                   A1  A2  B1  B2
[TOP]
nunu:pdisk11       AC7AA09A      0  5              Good
nunu:pdisk8        AC7AA2D6      1  4              Good
nunu:pdisk2        AC7AA0BD      2  3              Good
nunu:pdisk3        AC7AA0B1      3  2              Good
nunu:pdisk7        AC7AA0B5      4  1              Good
nunu:pdisk12       AC7AA052      5  0              Good
nunu:pdisk0        AC7AA0B9              0  5              Good
nunu:pdisk1        AC7AA0B3              1  4              Good
nunu:pdisk10       AC7AA0B4              2  3              Good
[MORE...4]

F3=Cancel      F10=Exit
```

LINK VERIFICATION

802386

SSA Link Verification for:
nunu:ssa0

00-04 IBM SSA 160 SerialRAID Adapter (

To Set or Reset Identify, move cursor onto selection, then press <Enter>.

Physical	Serial#	Adapter Port				Status
		A1	A2	B1	B2	
[TOP]						
nunu:pdisk11	AC7AA09A	0	5		Good	
nunu:pdisk8	AC7AA2D6	1	4		Good	
nunu:pdisk2	AC7AA0BD	2	3		Power	
nunu:pdisk3	AC7AA0B1	3	2		Good	
nunu:pdisk7	AC7AA0B5	4	1		Good	
nunu:pdisk12	AC7AA052	5	0		Good	
nunu:pdisk0	AC7AA0B9		0	5	Good	
nunu:pdisk1	AC7AA0B3		1	4	Good	
nunu:pdisk10	AC7AA0B4		2	3	Good	
[MORE...4]						

F3=Cancel

F10=Exit

Does one of the pdisks have a 'Power' status?

NO Go to step 5 on page 448.

YES Go to the START MAP for the enclosure in which the SSA device is installed.

5. (from step 4)

Observe the Status column on the screen. If the status of any pdisk is 'Failed', that pdisk is failing. In the example shown here, pdisk2 is failing.

```
LINK VERIFICATION 802386
SSA Link Verification for:
  nunu:ssa0 00-04 IBM SSA 160 SerialRAID Adapter (

To Set or Reset Identify, move cursor onto selection, then press <Enter>.

Physical Serial# Adapter Port Status
A1 A2 B1 B2

[TOP]
nunu:pdisk11 AC7AA09A 0 5 Good
nunu:pdisk8 AC7AA2D6 1 4 Good
nunu:pdisk2 AC7AA0BD 2 3 Failed
nunu:pdisk3 AC7AA0B1 3 2 Good
nunu:pdisk7 AC7AA0B5 4 1 Good
nunu:pdisk12 AC7AA052 5 0 Good
nunu:pdisk0 AC7AA0B9 0 5 Good
nunu:pdisk1 AC7AA0B3 1 4 Good
nunu:pdisk10 AC7AA0B4 2 3 Good
[MORE...4]

F3=Cancel F10=Exit
```

Is one of the pdisks failing?

NO Go to step 6 on page 449.

YES

- a. Use the Identify function (as instructed on the screen) to find the failing disk. See "Finding the Physical Location of a Device" on page 409 if you need more information about finding the disk drive.
- b. Exchange the disk drive for a new one (see "Exchanging Disk Drives" on page 319).
- c. Go to "MAP 2410: SSA Repair Verification" on page 475 to verify the repair.

6. (from step 5)

Observe the list of pdisks the screen. A row of question marks (?????) shows that a link in one of the loops is broken. If two rows of question marks are displayed, two links are broken, one in each loop. In the example shown here, pdisk2 is missing.

```
LINK VERIFICATION802386
SSA Link Verification for:
  nunu:ssa000-04 IBM SSA 160 SerialRAID Adapter (

To Set or Reset Identify, move cursor onto selection, then press <Enter>.

PhysicalSerial#Adapter PortStatus
A1 A2 B1 B2

[TOP]
nunu:pdisk11AC7AA09A0 5Good
nunu:pdisk8AC7AA2D61 4Good
?????
nunu:pdisk3AC7AA0B13 2Good
nunu:pdisk7AC7AA0B54 1Good
nunu:pdisk12AC7AA0525 0Good
nunu:pdisk0AC7AA0B90 5Good
nunu:pdisk1AC7AA0B31 4Good
nunu:pdisk10AC7AA0B42 3Good
[MORE...4]

F3=CancelF10=Exit
```

Is a link broken between two pdisks?

NO No trouble found.

YES

- a. Find the devices that are on each side of the broken link. The Identify function, which is available on this display, helps you to find the locations of pdisks. See “Finding the Physical Location of a Device” on page 409 if you need more information about finding the disk drive.
- b. Go to “SSA Link Errors” on page 478. The information that is provided there can help you solve the problem. For information on how to identify and exchange the FRU, see the service information for the enclosure that contains the device.

MAP 2323: SSA Intermittent Link Error

This MAP helps you to isolate FRUs that are causing an intermittent SSA link problem. You are here because you have an SRN from the series 21xxx through 29xxx, or you have SRN 33xxx.

If you are not familiar with the SSA link, read the section Chapter 2, “Introducing SSA Loops” on page 7 before using this MAP. Chapter 2, “Introducing SSA Loops” explains SSA links, strings, and loops.

Attention: Unless the using system needs to be switched off for some other reason, *do not switch off the using system when servicing an SSA loop*. Power cables and external SSA cables can be disconnected while that system is running.

1.
 - a. Run the Link Verification service aid to the SSA adapter for which this error has been logged (see “Link Verification Service Aid” on page 383). A list of pdisks, similar to the example given here, is displayed:

```
LINK VERIFICATION                                     802386
SSA Link Verification for:
  nunu:ssa0                                           00-04  IBM SSA 160 SerialRAID Adapter (
To Set or Reset Identify, move cursor onto selection, then press <Enter>.
Physical#      Serial#      Adapter Port      Status
              A1  A2  B1  B2
[TOP]
nunu:pdisk1    AC7AA09A    0   3      Good
nunu:pdisk2    AC7AA2D6    1   2      Good
nunu:pdisk3    AC7AA0BD    2   1      Good
nunu:pdisk4    AC7AA0B1    3   0      Good
F3=Cancel      F10=Exit
```

Note: On the Link Verification screen, each adapter port is identified by the number of its related connector on the adapter card:

- Adapter port 0 is identified as A1
- Adapter port 1 is identified as A2
- Adapter port 2 is identified as B1
- Adapter port 3 is identified as B2

SRNs 21xx through 29xxx and SRN 33xxx include the adapter port number (0–3).

- b. Go to step 2.
2. (from step 1)

- a. Observe the SRN that sent you to this MAP. The last three characters are in the format PAA, where P is the number of the SSA adapter port, and AA is the SSA address of the device).

Note the value of PAA in the SRN. For example:

If the SRN is 24002, PAA = 002.

If the SRN is 24104, PAA = 104.

- b. Observe the Link Verification screen, and identify the physical device that is represented by PAA in the SRN. This device is the first of the two devices that are connected by the failing link.

If the SRN is in the series 21xxx through 29xxx, the second device of the two is located at PAA-1.

If the SRN is 33xxx, the second device of the two is located at PAA+1.

Note: If the SSA address (AA) in the SRN is higher than the highest SSA address that is displayed for the adapter port (P), that address is the address of the SSA adapter.

Read through the following examples if you need help in identifying the device, then go to 3 on page 453. Otherwise, go directly to 3 on page 453.

Example 1

If the SRN is 24002, the device is connected to adapter port 0 (shown as A1 on the screen), and has an SSA address of 02 (shown as 2 on the screen). In the example screen, that device is pdisk3, which is the first device of the two. The second device is pdisk2 (PAA-1).

If the SRN is 33002, the first device of the two is again pdisk3. The second device is pdisk4 (PAA+1).

```
LINK VERIFICATION 802386
SSA Link Verification for:
  nunu:ssa0 00-04 IBM SSA 160 SerialRAID Adapter (

To Set or Reset Identify, move cursor onto selection, then press <Enter>.

Physical Serial# Adapter Port Status
A1 A2 B1 B2
[TOP]
nunu:pdisk1 AC7AA09A 0 3 Good
nunu:pdisk2 AC7AA2D6 1 2 Good
nunu:pdisk3 AC7AA0BD 2 1 Good
nunu:pdisk4 AC7AA0B1 3 0 Good

F3=Cancel F10=Exit
```

Example 2

If the SRN is 24104, the device (in theory) is connected to adapter port 1 (shown as A2 on the screen). The device, however, has an SSA address of 04. That address is higher than the highest address that is displayed for adapter port 1. The devices are, therefore, the SSA adapter and pdisk1.

3. (from step 2)

The problem is in the SSA link between the two devices that you identified in step 2 on page 450.

Exchange, in the sequence shown, the following FRUs for new FRUs. Ensure that for *each* FRU exchange, you go to "MAP 2410: SSA Repair Verification" on page 475 to verify the repair.

- a. One of the two devices that are identified by the SRN (see "Exchanging Disk Drives" on page 319).
- b. The other of the two devices.
- c. The internal SSA connections of the enclosure or enclosures in which the devices are installed.
- d. The external SSA cable.

MAP 2324: SSA RAID

This MAP helps you to solve problems that have occurred in SSA RAID arrays.

Attention: Unless the using system needs to be switched off for some other reason, *do not switch off the using system when servicing an SSA link or an enclosure in which SSA devices are installed.* Enclosure power cables and external SSA cables that connect devices to the using system can be disconnected while that system is running.

Before starting this MAP, ensure that all the disk drives are working correctly:

1. Run diagnostics in Problem Determination mode to identify any disk drive problems that have occurred.
2. Run the Link Verification service aid (see “Link Verification Service Aid” on page 383) to find all power problems, SSA link problems, and SSA disk drives that have a Failed status.
3. Correct all those problems before you start this procedure.

Attention: Some of the steps in this MAP need you to change the configuration of the array, or to change the use of an SSA disk drive. Do not do those steps unless you have the user’s permission.

1. (from steps 3, 28, and 29)

You have been sent to this step either from another step in this MAP, or because you have one of the following Service Request Numbers (SRNs):

46000, 47000, 47500, 49000, 49100, 49500, 49950

Do you have SRN 49500?

NO

- a. Run diagnostics in System Verification mode to the SSA adapters.
- b. Go to step 2.

YES No hot spare disk drives are available.

Go to step 21 on page 466.

2. (from step 1)

Did the diagnostics produce SRN 46000, 47000, 47500, 49000, 49100, or 49950?

NO Go to step 3 on page 455.

YES Go to step 4 on page 455.

3. (from step 2)

Do you have any other SRN?

NO Go to step 22 on page 467.

YES

- a. Solve the problems that caused the SRN.
- b. Return to step 1 on page 454.

4. (from step 2)

Find your SRN in the following table, then do the appropriate actions.

Note: If you still do not have any of these SRNs, you are in the wrong MAP.

SRN	Cause	Action
46000	An array is in the Offline state.	Go to step 5.
47000	You have more than the maximum number of arrays allowed.	Go to step 8 on page 457.
47500	A partial loss of data has occurred.	Go to step 9 on page 458.
49000	An array is in the Degraded state.	Go to step 13 on page 460.
49100	An array is in the Exposed state.	Go to step 17 on page 463.
49950	An array-copy disk drive is missing.	Go to step 23 on page 467.

5. (from step 4)

An array is in the Offline state if it contains at least one member disk drive, but does not contain enough member disk drives to maintain data availability.

Are any disk drives missing or without power, or have any disk drives been recabled (not necessarily by you)?

NO Go to step 6 on page 456.

YES Restore the original configuration:

- a. Type `smitty ssaraid` and press Enter.
- b. Select **List All SSA RAID Arrays Connected to a RAID Manager**.
The status of the array changes to Good when the adapter can find all the member disk drives of the array.
- c. Go to "MAP 2410: SSA Repair Verification" on page 475 to verify the repair.

6. (from step 5)

Either one or more disk drives have failed, or an array that is not complete has been connected to the SSA adapter.

- If one or more disk drives have been added to this system, and those disk drives were previously members of an array on this system or on another system, do the following:
 - a. Type `smitty ssaraid` and press Enter.
 - b. Select **Delete an SSA RAID Array**.
 - c. Select the array that is in the Offline state, and delete it. ***All data that is on that RAID array is now lost.***
 - d. You must now locate and repair any failed disk drives, and make those disk drives available for the creation of a new array. Go to step 7 on page 457.
- If no disk drives have been added to this system, go to step 7 on page 457.

7. (from step 6)

The array data cannot be recovered. The following steps clear the error condition and change the disk drives to a usable state.

- a. Type `smitty ssaraid` and press Enter.
- b. Select **Change/Show Use of an SSA Physical Disk**.

Are any disk drives listed as “SSA physical disks that are rejected”?

NO Ask the user to delete and recreate the array that is in the Offline state.

YES

- a. Run diagnostics in System Verification mode to all the disk drives that are listed as rejected.
- b. Run the Certify service aid (see “Certify Disk Service Aid” on page 391) to all the disk drives that are listed as rejected.
- c. If any problems occur, exchange the failed disk drives for new disk drives (see “Exchanging Disk Drives” on page 319).
- d. Go to step 37 on page 473 to add the disk drive to the group of disk drives that are available for use by the RAID manager.

Note: A disk drive that is listed as rejected is not necessarily failing. For example, the array might have rejected the disk drive because a power problem, or an SSA link problem, caused that drive to become temporarily unavailable. Under such conditions, the disk drive can be reused.

If you think that a disk drive has been rejected because it is failing, check the error log history for that disk drive. For example, if you suspect `pdisk3`, type on the command line:

```
ssa_e1a -l pdisk3 -h 5
```

This command causes the error log for `pdisk3` to be analyzed for the previous five days. If a problem is detected, an SRN is generated.

- e. Go to “MAP 2410: SSA Repair Verification” on page 475 to verify the repair.

8. (from step 4)

An attempt has been made to create a new array, but the adapter already has the maximum number of arrays defined.

- a. Type `smitty ssaraid` and press Enter.
- b. Select **List/Delete Old RAID Arrays in an SSA RAID Manager**.
- c. Delete any array names that are no longer used.
- d. Go to “MAP 2410: SSA Repair Verification” on page 475 to verify the repair.

9. (from step 4)

Attention: Part of the data that is on the array has been damaged and cannot be recovered. **Before** any other action is taken, the user must recover all the data that is not damaged, and create a backup of that data.

- a. Type `smitty ssaraid` and press Enter.
- b. Select **List Status Of All Defined SSA RAID Arrays**.
- c. Select, in turn, each array type that is used in your subsystem, and press Enter.

Are any arrays listed as having an invalid data strip as shown in the following screen?

Note: This example screen shows the status of RAID-5 arrays. The screen shows similar information if you select a RAID-1 array or a RAID-0 array.

```
COMMAND STATUS
Command: OK          stdout: yes          stderr: no
Before command completion, additional instructions may appear below.

                Unsynced Parity Strips  Unbuilt Data Strips
hdisk3                0                0          Invalid data strip
hdisk4                0                0

F1=Help          F2=Refresh      F3=Cancel      F6=Command
F8=Image        F9=Shell       F10=Exit       /=Find
n=Find Next
```

NO Review the symptoms, then go to “MAP 2320: SSA Link” on page 445, and start the problem determination procedure again.

YES

- a. Note the `hdisk` number of the failing array.
- b. Go to step 10 on page 459.

10. (from step 9)
 - a. Type `smitty ssaraid` and press Enter.
 - b. Select **List/Identify SSA Physical Disks**.
 - c. Select **List Disks in an SSA RAID Array**.
 - d. Select the failing disk drive, and note the pdisk numbers of the disk drives that are members of the array.
 - e. Ask the user to create a backup of all the data from this array. Some data might not be accessible.
 - f. When the backup has been created, ask the user to delete the array.
 - g. Run diagnostics in System Verification mode to each of the pdisks that you noted previously.

Do the diagnostics fail when they are run to a particular disk drive?

NO Go to step 11.

YES

- a. Exchange the failing disk drive for a new one (see “Exchanging Disk Drives” on page 319).
- b. Go to step 37 on page 473 to add the disk drive to the group of disk drives that are available for use by the RAID manager.

11. (from step 10)

Run the Certify service aid (see “Certify Disk Service Aid” on page 391) to each of the pdisks that you noted previously.

Did the Certify service aid fail when it was run to a particular disk drive?

NO

- a. Ask the user to recreate the array.
- b. Go to step 22 on page 467.

YES

- a. Run the Format service aid (see “Format Disk Service Aid” on page 389) to the disk drive.
- b. Run the Certify service aid again to the disk drive.
- c. Go to step 12 on page 460.

12. (from step 11)

Did the Certify service aid fail again?

NO

- a. Ask the user to recreate the array.
- b. Go to step 22 on page 467.

YES

- a. Exchange the failing disk drive for a new one (see “Exchanging Disk Drives” on page 319).
- b. Go to step 37 on page 473 to add the disk drive to the group of disk drives that are available for use by the RAID manager.

13. (from step 4)

An array is in the Degraded state if one member disk drive of the array is missing, or has failed, and a write command has been sent to that array. When an array is in the Degraded state, its data is not protected.

- a. Type `smitty ssaraid` and press Enter.
- b. Select **Change/Show Use of an SSA Physical Disk**.
- c. Go to step 14 on page 461.

14. (from step 13)

Are any disk drives listed as “SSA physical disks that are rejected”?

NO A disk drive has not been detected by the adapter. Go to step 15 on page 462.

YES

- a. Run diagnostics in System Verification mode to all the disk drives that are listed as rejected.
- b. Run the Certify service aid (see “Certify Disk Service Aid” on page 391) to all the disk drives that are listed as rejected.
- c. If problems occur on any disk drive, exchange that disk drive for a new disk drive (see “Exchanging Disk Drives” on page 319), then continue from step 14e in this procedure.
- d. A disk drive that is listed as rejected is not necessarily failing. For example, the array might have rejected the disk drive because a power problem, or an SSA link problem, caused that drive to become temporarily unavailable. Under such conditions, the disk drive can be reused.

If you think that a disk drive has been rejected because it is failing, check the error log history for that disk drive. For example, if you suspect pdisk3, type on the command line:

```
ssa_e1a -l pdisk3 -h 5
```

This command causes the error log for pdisk3 to be analyzed for the previous five days. If a problem is detected, an SRN is generated.

- e. Type `smitty ssaraid` and press Enter.
- f. Select **Change/Show Use of an SSA Physical Disk** and, for all disks that you have tested or exchanged, change the **Current Use** to **Array Candidate Disk**.
- g. Select **Change Member Disks in an SSA RAID Array**.
- h. Select **Swap Members of an SSA RAID Array**.
- i. Select the degraded hdisk.
- j. Referring to the displayed instructions, exchange the failed member for a new disk drive. (The **Disk to Remove** is listed as BlankReserved; the **Disk to Add** is the disk drive that you tested or exchanged in step 14f.) When failed disk drives have been exchanged for new disk drives, the data is rebuilt, and the array changes its state to the Good state.

Note: The array can be used during the rebuilding operation. Inform the user, however, that while the rebuilding operation is running, the data is not protected against another disk drive failure. The rebuilding operation runs more slowly if the array is being used.

When the rebuilding operation is complete, ask the user to run diagnostics in System Verification mode to the SSA adapters, to ensure that the rebuilding operation has not found any more problems.

- k. Go to "MAP 2410: SSA Repair Verification" on page 475 to verify the repair.

15. (from step 14)

Does the Link Verification service aid indicate an open loop?

NO Go to step 16.

YES Go to "MAP 2320: SSA Link" on page 445.

16. (from step 15)

Does any SSA disk drive have its Check light on?

NO The disk drive might have been removed from the subsystem.

- a. Reinstall the removed drive, or select a new disk drive for addition to the array.
- b. Type `smitty ssaraid` and press Enter.
- c. Select **Change Member Disks in an SSA RAID Array**.
- d. Select **Swap Members of an SSA RAID Array**.
- e. Select the degraded hdisk.
- f. Referring to the displayed instructions, exchange the failed member for a new disk drive. (The **Disk to Remove** is listed as BlankReserved; the **Disk to Add** is the disk drive that you reinstalled or selected in step 16a.) When failed disk drives have been exchanged for new disk drives, the data is rebuilt, and the array changes its state to the Good state.

YES

- a. Exchange the failed disk drive for a new one (see "Exchanging Disk Drives" on page 319).
- b. Type `smitty ssaraid` and press Enter.
- c. Select **Change Member Disks in an SSA RAID Array**.
- d. Select **Swap Members of an SSA RAID Array**.
- e. Select the degraded hdisk.
- f. Referring to the displayed instructions, exchange the failed member for a new disk drive. (The **Disk to Remove** is listed as BlankReserved; the **Disk to Add** is the disk drive that you reinstalled or selected in step 16a.) When failed disk drives have been exchanged for new disk drives, the data is rebuilt, and the array changes its state to the Good state.

17. (from step 4)

A RAID-5 array is in the Exposed state when one member disk drive of the array is not available to the array. A RAID-1 or RAID-10 array is in the Exposed state when one or more mirrors are exposed. A mirror is exposed when one disk drive in the mirror pair is not available to the array.

If the missing disk drives are returned to the array, the array enters the Good state. No data rebuilding is necessary. If data is written to an array that is in the Exposed state, that data is not protected, and the array goes into the Degraded state (see Chapter 3, “RAID Functions and Array States” on page 29 for more information). Command line parameters are available that allow you to prevent such write operations.

a. Type `smitty ssaraid` and press Enter.

b. Select **Change/Show Use of an SSA Physical Disk**.

The status of the disk drives that are connected to the using system is displayed.

c. Go to step 18 on page 464.

18. (from step 17)

Are any disk drives listed as “SSA physical disks that are rejected”?

NO A disk drive has not been detected by the adapter. Go to step 19 on page 465.

YES

- a. Run diagnostics in System Verification mode to all the disk drives that are listed as rejected.
- b. Run the Certify service aid (see “Certify Disk Service Aid” on page 391) to all the disk drives that are listed as rejected.
- c. If problems occur on any disk drive, exchange that disk drive for a new disk drive (see “Exchanging Disk Drives” on page 319), then continue from step 18e in this procedure.
- d. A disk drive that is listed as rejected is not necessarily failing. For example, the array might have rejected the disk drive because a power problem, or an SSA link problem, caused that drive to become temporarily unavailable. Under such conditions, the disk drive can be reused.

If you think that a disk drive has been rejected because it is failing, check the error log history for that disk drive. For example, if you suspect pdisk3, type on the command line:

```
ssa_e1a -l pdisk3 -h 5
```

This command causes the error log for pdisk3 to be analyzed for the previous five days. If a problem is detected, an SRN is generated.

- e. Type `smitty ssaraid` and press Enter.
- f. Select **Change/Show Use of an SSA Physical Disk** and, for all disks that you have tested or exchanged, change the **Current Use** to **Array Candidate Disk**.
- g. Select **Change Member Disks in an SSA RAID Array**.
- h. Select **Swap Members of an SSA RAID Array**.
- i. Select the degraded hdisk.
- j. Referring to the displayed instructions, exchange the failed member for a new disk drive. (The **Disk to Remove** is listed as BlankReserved; the **Disk to Add** is the disk drive that you tested or exchanged in step 18f.) When failed disk drives have been exchanged for new disk drives, the data is rebuilt, and the array changes its state to the Good state.

Note: The array can be used during the rebuilding operation. Inform the user, however, that while the rebuilding operation is running, the data is not protected against another disk drive failure. The rebuilding operation runs more slowly if the array is being used.

When the rebuilding operation is complete, ask the user to run diagnostics in System Verification mode to the SSA adapters, to ensure that the rebuilding operation has not found any more problems.

- k. Go to “MAP 2410: SSA Repair Verification” on page 475 to verify the repair.

19. (from step 18)

Does the Link Verification service aid indicate an open loop?

NO Go to step 20.

YES Go to “MAP 2320: SSA Link” on page 445.

20. (from step 19)

Does any SSA disk drive have its Check light on?

NO The disk drive might have been removed from the subsystem.

- a. Reinstall the removed drive, or select a new disk drive for addition to the array.
- b. Type smitty ssaraid and press Enter.
- c. Select **Change Member Disks in an SSA RAID Array**.
- d. Select **Swap Members of an SSA RAID Array**.
- e. Select the degraded hdisk.
- f. Referring to the displayed instructions, exchange the failed member for a new disk drive. (The **Disk to Remove** is listed as BlankReserved; the **Disk to Add** is the disk drive that you reinstalled or selected in step 20a.) When failed disk drives have been exchanged for new disk drives, the data is rebuilt, and the array changes its state to the Good state.
- g. Go to “MAP 2410: SSA Repair Verification” on page 475 to verify the repair.

YES

- a. Exchange the failed disk drive for a new one (see “Exchanging Disk Drives” on page 319).
- b. Type smitty ssaraid and press Enter.
- c. Select **Change Member Disks in an SSA RAID Array**.
- d. Select **Swap Members of an SSA RAID Array**.
- e. Select the degraded hdisk.
- f. Referring to the displayed instructions, exchange the failed member for a new disk drive. (The **Disk to Remove** is listed as BlankReserved; the **Disk to Add** is the disk drive that you reinstalled or selected in step 20a.) When failed disk drives have been exchanged for new disk drives, the data is rebuilt, and the array changes its state to the Good state.
- g. Go to “MAP 2410: SSA Repair Verification” on page 475 to verify the repair.

21. (from step 1)

No spare disk drives are available for an array that is configured for hot spare disk drives.

- a. If the subsystem contains disk drives that have failed, repair those disk drives, or exchange them for new disk drives (see “Exchanging Disk Drives” on page 319).
- b. Type `smitty ssaraid` and press Enter.
- c. Select **Change/Show Use of an SSA Physical Disk**.

Are any disks listed as “SSA Physical disks that are hot spares”?

NO Review with the user the requirement for hot spare disk drives. If the customer wants hot spare disk drives, one or more disk drives must have their use changed to **Hot Spare Disk**.

If the customer does not want hot spare disk drives:

- a. Return to the SSA RAID Arrays menu.
- b. Select **Change/Show Attributes of an SSA RAID Array**.
- c. Change the **Enable Use of Hot Spares** attribute to **No**.

YES The following conditions must be met to make a hot spare disk drive available for use by an array:

- The hot spare disk drive and the array must be on the same SSA loop (see “Creating a Hot Spare Disk Drive” on page 72).
 - If the **spare_exact** parameter is set to **true**, the size of the hot spare disk drive must be the same as the size of the smallest member disk drive in the array. (See “Changing or Showing the Attributes of an SSA RAID Array” on page 135 to determine how the hot spare attribute is set; see “Listing the Disk Drives in an SSA RAID Array” on page 109 to determine the sizes of the disk drives that are in the array.)
 - If the **spare_exact** parameter is set to **false**, the size of the hot spare disk drive must be at least that of the smallest member disk in the array.
- a. Ensure that these conditions have been met.
 - b. Go to “MAP 2410: SSA Repair Verification” on page 475 to verify the repair.

22. (from step 7 in MAP 2410: SSA Repair Verification, and from steps 3, 11, and 12 in this MAP)

RAID Checkout

You are now starting the RAID checkout procedure

- a. Type `smitty ssaraid` and press Enter.
- b. Select **Change/Show Use of an SSA Physical Disk** from the SSA RAID Arrays menu.

Are any disks listed as “SSA physical disks that are rejected”?

NO Go to step 28 on page 470.

YES

- a. Run diagnostics in System Verification mode to all the disk drives that are listed as rejected.
- b. Run the Certify service aid (see “Certify Disk Service Aid” on page 391) to all the rejected disk drives.
- c. Go to step 27 on page 470.

23. (from steps 4 and 35)

An array is preparing a RAID array copy, but a coupled pdisk cannot be detected. All read and write operations to the array can complete normally. The array copy, however, cannot be uncoupled until the missing disk drive has been replaced and contains an exact copy of the data that is on the array.

- a. Type `smitty ssaraid` and press Enter.
- b. Select **Array Copy Services**.
- c. Select **List All Copy Candidates**.
- d. Note the hdisk that is in the Degraded copy state.
- e. Return to the SSA RAID Arrays menu.
- f. Select **Change/Show Use of an SSA Physical Disk**. The status of the disk drives that are connected to the using system is displayed.
- g. Go to step 24.

24. (from step 23)

Are any disk drives listed as “SSA physical disks that are rejected”?

NO A disk drive has not been detected by the adapter. Go to step 25 on page 468.

YES

- a. Run diagnostics in System Verification mode to all the disk drives that are listed as rejected.
- b. Run the Certify service aid (see “Certify Disk Service Aid” on page 391) to all the disk drives that are listed as rejected.

- c. If problems occur on any disk drive, exchange that disk drive for a new disk drive (see “Exchanging Disk Drives” on page 319), then continue from step 24e in this procedure.
- d. A disk drive that is listed as rejected is not necessarily failing. For example, the array might have rejected the disk drive because a power problem, or an SSA link problem, caused that drive to become temporarily unavailable. Under such conditions, the disk drive can be reused.

If you think that a disk drive has been rejected because it is failing, check the error log history for that disk drive. For example, if you suspect pdisk3, type on the command line:

```
ssa_e1a -l pdisk3 -h 5
```

This command causes the error log for pdisk3 to be analyzed for the previous five days. If a problem is detected, an SRN is generated.

- e. Type `smitty ssaraid` and press Enter.
 - f. Select **Change/Show Use of an SSA Physical Disk** and, for all disk drives that you have tested or exchanged, change the **Current Use** parameter to **Array Candidate Disk**.
 - g. Select **Change Member Disks in an SSA RAID Array**.
 - h. Select **Swap Members of an SSA RAID Array**.
 - i. Select the hdisk that is in the Degraded copy state (that is, the hdisk that you noted in step 23d on page 467).
 - j. Referring to the displayed instructions, select a disk drive to remove from the array, and the disk drive to add to the array. (The disk drive to remove is listed as *not_present*; the disk drive to add is the disk drive that you tested or exchanged in the previous steps.) When the exchange is complete, the array starts to copy its data to the coupled disk drive.
 - k. Go to “MAP 2410: SSA Repair Verification” on page 475 to verify the repair.
25. (from step 24)

Does the Link Verification service aid indicate an open loop?

- NO** Go to step 26.
- YES** Go to “MAP 2320: SSA Link” on page 445.

26. (from step 25)

Does any SSA disk drive have its Check light on?

- NO** The disk drive might have been removed from the subsystem.
 - a. Reinstall the removed drive, or select a new disk drive for addition to the array.
 - b. Type `smitty ssaraid` and press Enter.
 - c. Select **Change/Show Use of an SSA Physical Disk**. The pdisk that has been exchanged is listed under **SSA Physical Disks that are system disks**.

- d. Select the pdisk from the list, and change the **Current Use** parameter to **Array Candidate Disk**.
- e. Select **Change Member Disks in an SSA RAID Array**.
- f. Select **Swap Members of an SSA RAID Array**.
- g. Select the hdisk that is in the Degraded copy state (that is, the hdisk that you noted in step 23d on page 467).
- h. Referring to the displayed instructions, select a disk drive to remove from the array, and the disk drive to add to the array. (The disk drive to remove is listed as *not_present*; the disk drive to add is the disk drive that you reinstalled or selected in step 26a on page 468.) When the exchange is complete, the array starts to copy its data to the coupled disk drive.
- i. Go to “MAP 2410: SSA Repair Verification” on page 475 to verify the repair.

YES

- a. Exchange the failed disk drive for a new one (see “Exchanging Disk Drives” on page 319).
- b. Type `smitty ssaraid` and press Enter.
- c. Select **Change/Show Use of an SSA Physical Disk**. The pdisk that has been exchanged is listed under **SSA Physical Disks that are system disks**.
- d. Select the pdisk from the list, and change the **Current Use** parameter to **Array Candidate Disk**.
- e. Select **Change Member Disks in an SSA RAID Array**.
- f. Select **Swap Members of an SSA RAID Array**.
- g. Select the hdisk that is in the Degraded copy state (that is, the hdisk that you noted in step 23d on page 467).
- h. Referring to the displayed instructions, select a disk drive to remove from the array, and the disk drive to add to the array. (The disk drive to remove is listed as *not_present*; the disk drive to add is the disk drive that you exchanged in the previous steps.) When the exchange is complete, the array starts to copy its data to the coupled disk drive.
- i. Go to “MAP 2410: SSA Repair Verification” on page 475 to verify the repair.

27. (from step 22)

Is any disk drive failing?

NO A disk drive that is listed as rejected is not necessarily failing. For example, the array might have rejected the disk drive because a power problem, or an SSA link problem, caused that drive to become temporarily unavailable. Under such conditions, the disk drive can be reused.

If you think that a disk drive has been rejected because it is failing, check the error log history for that disk drive. For example, if you suspect pdisk3, type on the command line:

```
ssa_e1a -l pdisk3 -h 5
```

This command causes the error log for pdisk3 to be analyzed for the previous five days. If a problem is detected, an SRN is generated.

Go to step 28.

YES

- a. Exchange the failing disk drive for a new one (see “Exchanging Disk Drives” on page 319).
- b. Go to step 37 on page 473 to add the disk drive to the group of disk drives that are available for use by the RAID manager.

28. (from steps 22 and 27)

- a. Type `smitty ssaraid` and press Enter.
- b. Select **List All SSA RAID Arrays Connected to a RAID Manager**.
- c. List the arrays that are connected to each SSA Adapter.

Are any arrays listed with a status other than Good or Rebuilding?

NO Go to step 29.

YES Go to step 1 on page 454.

29. (from steps 28 and 35)

- a. Type `smitty ssaraid` and press Enter.
- b. Select **List Status Of All Defined SSA RAID Arrays**.
- c. Select, in turn, each type of array that is used on your subsystem, and press Enter.

Do any listed arrays have Invalid Data Strips?

NO Go to step 30 on page 471.

YES Go to step 1 on page 454.

30. (from step 29)

Do any RAID-5 arrays have Unsynced Parity Strips or Unbuilt Data Strips?

NO Go to step 31.

YES The rebuilding operation is running or has stopped before completion.

- a. Note the number of unsynced parity strips and unbuilt data strips.
- b. Press the Cancel key to leave the status display.
- c. Wait for a few moments, then reselect the status display.
- d. Again note the number of unsynced parity strips and unbuilt data strips. If the numbers are lower than those that you noted earlier, the rebuilding operation is running. Wait for the rebuilding operation to complete before you continue. If the numbers have not changed, the rebuilding operation has stopped.
- e. If this is the first time you have been through this step while solving this particular problem, return to step 1 on page 454. Otherwise:
 - 1) Delete the array (see “Deleting an SSA RAID Array” on page 70).
 - 2) Run the Certify service aid (see “Certify Disk Service Aid” on page 391) to each member disk drive.
 - 3) Recreate the array (see “Adding an SSA RAID Array” on page 60).
 - 4) Go to “MAP 2410: SSA Repair Verification” on page 475 to verify the repair.

31. (from step 30)

Have disk drives been going into the rejected state with no other failure indications?

NO Go to step 32.

YES This problem can occur if an array is accessed before all the member disk drives are available.

Verify that using-system procedures ensure that the power system switches on power to all the disk drives before, or when, it switches on the power to the using system.

32. (from step 31)

Was SRN 46000 logged, but no error found, when diagnostics were run in System Verification mode?

NO Go to step 33 on page 472.

YES An array was in the Offline state, but is now available.

Verify that using-system procedures ensure that the power system switches on power to all the disk drives before, or when, it switches on the power to the using system.

33. (from step 32)

Was SRN 49100 logged, but no error found, when diagnostics were run in System Verification mode?

NO Go to step 34.

YES An array was in the Exposed state, but is now in the Good state.

This problem might have occurred because a disk drive was temporarily removed from the system.

Verify that using-system procedures ensure that the power system switches on power to all the disk drives before, or when, it switches on the power to the using system.

34. (from step 33)

a. Type `smitty ssaraid` and press Enter.

b. Select **List Status of Hot Spare Pools**.

c. Display the pool status for each installed SSA adapter.

Are any pools listed with a status of “reduced”?

NO Go to step 35.

YES The number of hot spare disk drives that are in the pool is less than the number of hot spare disk drives that were originally assigned to that pool. If you have exchanged a failing disk drive, and changed its use to **Hot Spare Disk** or **Array Candidate Disk**, add that disk drive to the reduced hot spare pool. To do this action:

a. Type `smitty ssaraid` and press Enter.

b. Select **Change/Show/Delete a Hot Spare Pool**.

c. Select the adapter, and press Enter.

d. Select the hot spare pool, and press Enter.

e. Select **Components to Add**, and press the List key.

f. Select a free disk drive or a hot spare disk drive to add to the pool. If no free or hot spare disk drives exist in the list, review the configuration with the customer, or see Chapter 5, “Hot Spare Management” on page 45 for guidance.

g. Go to step 36 on page 473.

35. (from step 34)

a. Type `smitty ssaraid` and press Enter.

b. Select **Array Copy Services**.

c. Select **List all Copy Candidates**.

Are any hdisks listed that are in the Degraded copy state?

NO Go to step 36 on page 473.

YES Go to step 23 on page 467.

36. (from step 35)

You have solved all the problems.

- a. Run the repair verification or repair completion procedures that are defined by your using system.
- b. If you have previously created a backup, reload that data now.

37. (from steps 7, 10, 12, and 27)

Has a failed disk drive been exchanged for a new disk drive?

NO If you have repaired a power or cabling fault that caused the disk drive to be missing from the system, the drive might now be in a rejected state. You must change that disk drive into a usable disk drive:

- a. Type `smitty ssaraid` and press Enter.
- b. Select **Change/Show Use of an SSA Physical Disk**.
The disk drive that has been restored to the system is listed under **SSA Physical Disks that are rejected**.
- c. Select the disk drive that has been restored to the system.
- d. Change the Current Use parameter to **Hot Spare Disk** or to **Array Candidate Disk**.

Note: It is the user who should make the choice of Current Use parameter. That choice should be:

- **Hot Spare Disk** if the use of hot spares is enabled for the arrays on the subsystem
- **Array Candidate Disk** if the use of hot spares is disabled for the arrays on the subsystem

- e. Go to step 38 on page 474.

YES When a new disk drive has been added to the system, it is configured as a system disk drive. If the disk drive replacement procedure that you used has not already instructed you to do so, change the Current Use parameter of the disk drive to **Hot Spare Disk** or to **Array Candidate Disk**.

- a. Type `smitty ssaraid` and press Enter.
- b. Select **Change/Show Use of an SSA Physical Disk**.
The pdisk that has been exchanged is listed under **SSA Physical Disks that are system disks**.
- c. Select the pdisk from the list.
- d. Change the Current Use parameter to **Hot Spare Disk** or to **Array Candidate Disk**

Note: It is the user who should make the choice of Current Use parameter. That choice should be:

- **Hot Spare Disk** if the use of hot spares is enabled for the arrays on the subsystem

- **Array Candidate Disk** if the use of hot spares is disabled for the arrays on the subsystem

e. Go to step 38.

38. (from step 37)

You have changed the use of a disk drive. You must now ensure that the hot spare pools are correctly configured. To do this action:

- a. Type `smitty ssaraid` and press Enter.
- b. Select **List Status of Hot Spare Pools**.
- c. Select, in turn, each SSA adapter.
- d. If you are using pools other than A0 and B0, the hot spare pool to which the exchanged disk drive must now be added is listed with a status of reduced, critical, or empty.
- e. If multiple disk drives have been exchanged, and multiple hot spare pools exist, either ask the customer which disk drives are to be assigned to which hot spare pools, or see Chapter 5, "Hot Spare Management" on page 45 for guidance.
- f. Go to "MAP 2410: SSA Repair Verification" on page 475 to verify the repair.

MAP 2410: SSA Repair Verification

This MAP helps you to verify that FRUs that you have exchanged for new FRUs, or repair actions that you have done, have solved all the problems on the subsystem.

Attention: Unless the using system needs to be switched off for some other reason, *do not switch off the using system when servicing an SSA link or an enclosure in which SSA devices are installed.* Enclosure power cables and external SSA cables that connect devices to the using system can be disconnected while that system is running.

1. (from steps 3 and 5 in MAP 2320: SSA Link; step 3 in MAP 2323: SSA Intermittent Link Error; step 5 in MAP 2324: SSA RAID)

Have you exchanged a FRU?

NO

- a. Run diagnostics, in System Verification mode, to the device that reported the problem.

Note: Do not run Advanced Diagnostics; otherwise, errors might be logged on other using systems that share the same loop.

- b. Go to step 4 on page 476.

YES Go to step 2.

2. (from step 1)

Before you arrived at this MAP, you exchanged one or more FRUs for new FRUs. Some of those FRUs have Power lights (for example, disk drives and fan-and-power-supply assemblies).

If none of the FRUs that you exchanged has a Power light, go to step 3. If some, or all, of the FRUs that you exchanged have Power lights, check whether all those Power lights are on.

Do the FRUs that you have exchanged have their Power lights on?

NO

- a. Exchange, for a new one, the FRU whose Power light is off.
- b. Go to step 3.

YES Go to step 3.

3. (from step 2)

Are all Check lights off?

Note: For FRUs that do not have a Check light, answer **YES**.

NO Go to the START MAP for the enclosure in which the device that has its Check light on is installed.

YES

- a. Run diagnostics, in System Verification mode, to the device that reported the problem.

Notes:

- 1) Do not run Advanced Diagnostics; otherwise, errors might be logged on other using systems that share the same loop.
- 2) If you have just exchanged a disk drive or an SSA adapter, you might need to run `cfgmgr` to restore the device to the system configuration.

If the original problem was not reported by a device, run diagnostics to each SSA adapter in the using system.

b. Go to step 4.

4. (from step 3)

Do you still have the same SRN?

NO Go to step 5.

YES Go to step 6.

5. (from step 3 in MAP 2010: START and step 4 in this MAP)

Do you have any other SRN?

NO Go to step 7 on page 477.

YES Go to "Service Request Numbers (SRNs)" on page 411.

6. (from step 4)

Have you exchanged all the FRUs that were originally reported by the SRN?

NO Exchange the next FRU that is listed for the SRN.

YES

- a. Run diagnostics, in System Verification mode, to all the adapters that are in this SSA loop.
- b. Run diagnostics, in System Verification mode, to all the disk drives that are in this SSA loop.
- c. Run the Certify service aid (see "Certify Disk Service Aid" on page 391) to all the disk drives that are in this SSA loop.
- d. Correct all errors that are reported by the diagnostics.
- e. Go to step 7 on page 477.

7. (from steps 3 in MAP 2010: START and from steps 5 and 4 in this MAP)

Does your subsystem contain RAID arrays?

If you are not sure whether your subsystem contains RAID arrays:

- a. Type `smitty ssaraid` and press Enter.
- b. Select **List All Defined SSA RAID Arrays**.

NO Run the repair verification, or repair completion, procedures that are defined by your using system.

YES Go to the **RAID Checkout** at step 22 on page 467 of MAP 2324: SSA RAID.

SSA Link Errors

SSA link errors can be caused if:

- Power is removed from an SSA device.
- An SSA device is failing.
- An SSA device is removed.
- A cable is disconnected.

Such errors might be indicated by:

- SRN 45PAA
- A flashing link status (Ready) light on the SSA device at each end of the failing link
- The indication of an open link by the Link Verification service aid

SSA Link Error Problem Determination

Instead of using the normal MAPs to solve a link error problem, you can refer directly to the link status lights to isolate the failing FRU, as described here.

In an SSA loop, SSA devices are connected through two or more SSA links to an SSA adapter. Each SSA link is the connection between two SSA nodes (devices or adapters); for example, disk drive to disk drive, adapter to disk drive, or adapter to adapter.

An SSA link can contain several parts. When doing problem determination, think of the link and all its parts as one complete item.

Here are some examples of SSA links. Each link contains more than one part.

Example 1

In Figure 59, the link is between two disk drives that are in the same subsystem. It has three parts.

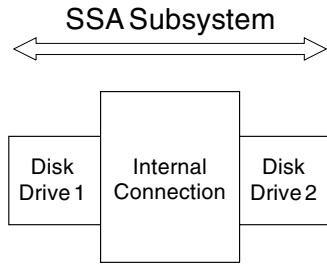

Figure 59. Three-Part Link in One Subsystem

Example 2

In Figure 60, the link is between two disk drives that are in the same subsystem. It has five parts.

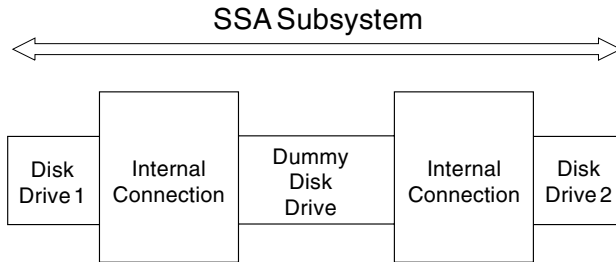

Figure 60. Five-Part Link in One Subsystem

Example 3

In Figure 61, the link is between two disk drives that are not in the same subsystem. It has seven parts.

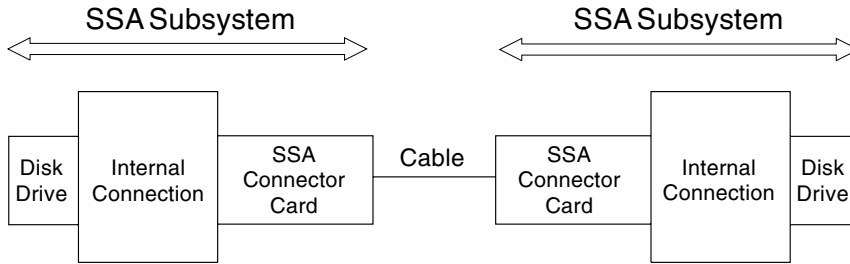

Figure 61. Seven-Part Link in Two Subsystems

Example 4

Figure 62, the link is between a disk drive and an SSA adapter. It has five parts.

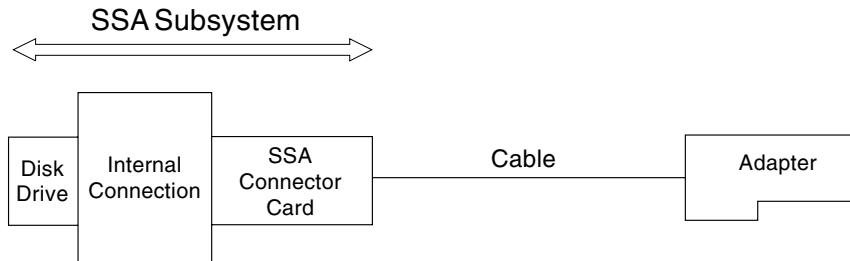

Figure 62. Five-Part Link between Disk Drive and Adapter

Example 5

In Figure 63, the link is between two SSA adapters. It has five parts. Note that it has fiber optic cables and optical connectors instead of normal SSA cables.

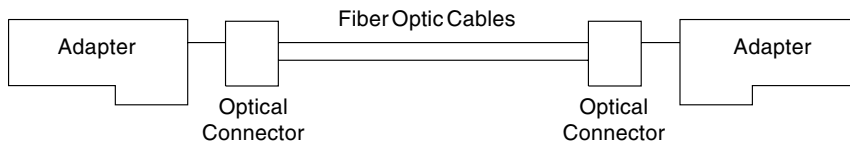

Figure 63. Five-Part Link between Two Adapters

Link Status (Ready) Lights

If a fault occurs that prevents the operation of a particular link, the link status lights of the various parts of the complete link show that the error has occurred.

You can find the failing link by looking for the flashing green status light at each end of the affected link. Some configurations might have other indicators along the link (for example, SSA connector cards) to help with FRU isolation.

The meanings of the disk drive and adapter lights are summarized here:

Status of Light	Meaning
Off	Both SSA links are inactive.
Permanently on	Both SSA links are active.
Slow flash (two seconds on, two seconds off)	Only one SSA link is active.

If your subsystem has other link status lights, see the subsystem service information for the subsystem for more details.

Service Aid

If service aids are available, you can use the Link Verification service aid to show that the SSA loop is broken.

```
LINK VERIFICATION                                     802386

SSA Link Verification for:
  systemname:ssa0                                00-04   SSA Enhanced RAID Adapter

To Set or Reset Identify, move cursor onto selection, then press <Enter>.

Physical          Serial#          Adapter Port          Status
                  A1  A2  B1  B2
[TOP]
systemname:pdisk11      AC50AE43      0  5          Good
systemname:pdisk8       AC706EA3      1  4          Good
systemname:pdisk2       AC1DBE11      2  3          Failed
systemname:pdisk3       AC1DBEF4      3  2          Good
systemname:pdisk7       AC50AE58      4  1          Good
systemname:pdisk12      AC7C6E51      5  0          Good
systemname:pdisk0       AC706E9A           0          Good
?????
systemname:pdisk10      AC1DBE32           3          Good
[MORE...4]

F3=Cancel          F10=Exit
```

This example screen shows a break in the SSA loop between the pdisk0 and pdisk10. In the condition shown by the display, the Ready lights on the pdisk0 and pdisk10 are both flashing.

To help locate these disk drives, select the pdisk, and press Enter. The Check light on the selected disk drive flashes. This action does not affect the customer's operations.

For more information about the service aids, see Chapter 17, "SSA Service Aids" on page 373.

Repair Actions

When you have determined the parts of the failing link, check whether the cause of the problem is obvious; for example, a loose cable connection, or a disk drive with its Check light on. If the cause is obvious, correct it. If the cause is not obvious, exchange the parts of the link, one at a time, until the problem is solved.

Part 3. Appendixes

Appendix. Communications Statements

The following statements apply to this product. The statements for other products intended for use with this product appear in their accompanying manuals.

Federal Communications Commission (FCC) Statement

This equipment has been tested and found to comply with the limits for a Class A digital device, pursuant to Part 15 of the FCC Rules. These limits are designed to provide reasonable protection against harmful interference when the equipment is operated in a commercial environment. This equipment generates, uses, and can radiate radio frequency energy and, if not installed and used in accordance with the instruction manual, may cause interference to radio communications. Operation of this equipment in a residential area is likely to cause harmful interference, in which case the user will be required to correct the interference at his own expense.

Properly shielded and grounded cables and connectors must be used in order to meet FCC emission limits. Neither the provider nor the manufacturer is responsible for any radio or television interference caused by using other than recommended cables and connectors or by unauthorized changes or modifications to this equipment. Unauthorized changes or modifications could void the user's authority to operate the equipment.

This device complies with Part 15 of FCC Rules. Operation is subject to the following two conditions: (1) this device may not cause harmful interference, and (2) this device must accept any interference received, including interference that may cause undesired operation.

Japanese Voluntary Control Council for Interference (VCCI) Statement

This product is a Class A Information Technology Equipment and conforms to the standards set by the Voluntary Control Council for Interference by Information Technology Equipment (VCCI). In a domestic environment, this product might cause radio interference, in which event the user might be required to take adequate measures.

Korean Government Ministry of Communication (MOC) Statement

Please note that this device has been approved for business purposes with regard to electromagnetic interference. If you find that this device is not suitable for your use, you can exchange it for one that is approved for non-business purposes.

New Zealand Compliance Statement

This is a Class A product. In a domestic environment this product might cause radio interference, in which event the user might be required to take adequate measures.

International Electrotechnical Commission (IEC) Statement

This product has been designed and built to comply with (IEC) Standard 950.

Avis de conformité à la réglementation d'Industrie Canada

Cet appareil numérique de la classe A est conforme à la norme NMB-003 du Canada.

Industry Canada Compliance Statement

This Class A digital apparatus complies with IECS-003.

United Kingdom Telecommunications Requirements

This apparatus is manufactured to the International Safety Standard EN60950 and as such is approved in the U.K. under approval number NS/G/1234/J/100003 for indirect connection to public telecommunications systems in the United Kingdom.

European Union (EU) Statement

This product is in conformity with the protection requirements of EU council directive 89/336/EEC on the approximation of the laws of the Member States relating to electromagnetic compatibility. Neither the provider nor the manufacturer can accept responsibility for any failure to satisfy the protection requirements resulting from a non-recommended modification of the product, including the fitting of option cards not supplied by the manufacturer.

Radio Protection for Germany

Zulassungsbescheinigung laut dem Deutschen Gesetz über die elektromagnetische Verträglichkeit von Geräten (EMVG) vom 30. August 1995 (bzw. der EMC EG Richtlinie 89/336):

Dieses Gerät ist berechtigt in Übereinstimmung mit dem Deutschen EMVG das EG-Konformitätszeichen - CE - zu führen. Verantwortlich für die Konformitätserklärung nach Paragraph 5 des EMVG ist die:

IBM Deutschland Informationssysteme GmbH, 70548 Stuttgart.

Informationen in Hinsicht EMVG Paragraph 3 Abs. (2) :

Das Gerät erfüllt die Schutzanforderungen nach EN 50082-1 und EN 55022 Klasse A.
--

EN 55022 Klasse A Geräte müssen mit folgendem Warnhinweis versehen werden:
"Warnung: dies ist eine Einrichtung der Klasse A. Diese Einrichtung kann im Wohnbereich Funkstörungen verursachen; in diesem Fall kann vom Betreiber verlangt werden, angemessene Massnahmen durchzuführen und dafür aufzukommen."

EN 50082-1 Hinweis:

"Wird dieses Gerät in einer industriellen Umgebung betrieben (wie in EN 50082-2

festgelegt), dann kann es dabei eventuell gestört werden. In solch einem Fall ist der Abstand bzw. die Abschirmung zu der industriellen Störquelle zu vergrößern.“

Anmerkung:

Um die Einhaltung des EMVG sicherzustellen sind die Geräte, wie in den Handbüchern angegeben, zu installieren und zu betreiben.

Taiwan Class A Compliance Statement

警告使用者:

這是甲類的資訊產品，在居住的環境中使用時，可能會造成射頻干擾，在這種情況下，使用者會被要求採取某些適當的對策。

Glossary

This glossary explains terms and abbreviations that are used in the manual. The glossary contains terms and definitions from the *IBM Dictionary of Computing*.

If you do not find the term or abbreviation for which you are looking, try the index or refer to the *IBM Dictionary of Computing* at URL:

<http://www.networking.ibm.com/nsg/nsgmain.htm>

A

array. Two or more disk drives that are interconnected to increase security, performance, or reliability.

attribute. A named property of an entity; for example, the attributes of a RAID array include state, current use, and size of array.

B

boot. To prepare a computer system for operation by loading an operating system.

buffer. A routine or storage that is used to compensate for a difference in rate of flow of data, or time of occurrence of events, when transferring data from one device to the other.

C

candidate disk. Disk drives that are available for use in an array.

component. The components of a RAID array are the member disk drives that are configured for that array. The component of a fast-write hdisk is the array or disk drive that is configured for fast-write operations.

contiguous. Touching or joining at a common edge or boundary; for example, an unbroken consecutive series of storage locations.

couple. To attach a copy array to a RAID-1 or RAID-10 array, and copy data from the RAID-1 or RAID-10 array to that copy array. The metadata of the copy array is updated to indicate that it is part of the parent RAID array. The metadata of the parent array is updated to show that the copy array is to be used as a third copy. The copy array is made offline, and is no longer accessible.

D

daemon. In the operating system, a program that runs unattended to perform a standard service. Some daemons are triggered automatically to perform their task; others operate periodically. Synonymous with demon.

deconfigure. To remove a disk drive from being a member of an array.

Degraded state. The state that a RAID array enters if, while in the Exposed state, it receives a write command. See also *Exposed state*.

descriptor. In the object data manager (ODM), a named and typed variable that defines one characteristic of an object.

device driver. (1) A file that contains the code needed to use an attached device. (2) A program that enables a computer to communicate with a specific peripheral device. (3) A collection of subroutines that control the interface between I/O device adapters and the processor.

domain. That part of a computer network in which the data processing resources are under common control.

DMA. Direct memory access.

E

EEPROM. Electrically erasable read-only memory.

enclosure. A device or unit that contains disk drives. A disk subsystem (for example, a 7133).

Exposed state. The state that a RAID array enters if a member disk drive becomes missing (logically or physically) from that array.

F

Failed status. The disk drive is not working.

fencing. SSA disk fencing is a facility that is provided in the SSA subsystem. It allows multiple using systems to control access to a common set of disk drives.

flag. A character that shows that a particular condition exists.

FRU. Field-replaceable unit.

G

GB. Gigabyte.

gigabyte (GB). 1000000000 bytes.

Good state. The state of a RAID array when all its member disk drives are present.

H

hdisk. A logical unit that can consist of one or more physical disk drives (pdisks). An hdisk in an SSA subsystem might, therefore, consist of one pdisk or several pdisks. An hdisk is also known as a LUN.

hot spare disk drive. A spare disk drive that is automatically added to a RAID array to logically replace a member disk drive that has failed.

hot spare pool. A configured group of disk drives that contains pdisks and a hot spare disk drive. The pool ensures that a hot spare disk drive is available if any pdisk in the group fails.

hot sparring. The process by which a spare disk drive is automatically added to a RAID array to logically replace a member disk drive that has failed.

I

interface. Hardware, software, or both, that links systems, programs, or devices.

IOCC. Input/output channel controller.

IPN. Independent Packet Network.

ISAL. Independent Network Storage Access Language.

K

KB. Kilobyte.

kernel. The part of the operating system that contains functions that are needed frequently.

kernel mode. In the operating system, the state in which a process runs in kernel mode. Contrast with *user mode*.

kilobyte (KB). 1000 bytes.

L

LBA. Logical block address.

logical disk. An hdisk. See *hdisk*.

LUN. Logical unit. See also *hdisk*.

M

maintenance analysis procedure (MAP). A service procedure for isolating a problem.

MAP. See *maintenance analysis procedure*.

MB. Megabyte.

megabyte (MB). 1000000 bytes.

member disk. A disk drive that is part of a RAID array.

metadata. Data that describes data objects.

microcode. One or more microinstructions used in a product as an alternative to hard-wired circuitry to implement functions of a processor or other system component.

mirrored pair. Two disk drives that contain the same data, and are referred to as one entity by the using system.

mirroring. The process of writing the same data to two disk drives at the same time. The two disk drives become a mirrored pair. The system can, therefore, continue to operate correctly when one of the mirrored disk drives fails.

N

node. In a network, a point at which one or more functional units connect channels or data circuits. For example, in an SSA subsystem, a disk drive or an adapter.

O

object data manager (ODM). In the operating system, a data manager intended for the storage of system data.

ODM. Object data manager (ODM)

Offline state. The state that a RAID array enters when two or more member disk drives become missing.

P

page split. The separation of amounts of data in preparation for data transfer. The operating system splits data on page boundaries, where a page is 4 KB.

parameter. A variable that is given a constant value for a specified application.

PCI. Peripheral Component Interconnect.

pdisk. Physical disk.

physical disk. The actual hardware disk drive.

POST. Power-on self-test.

power-on self-test (POST). A series of diagnostic tests that are run automatically by a device when the power is switched on.

primary half. The term that distinguishes one half of a split array. The term "secondary half" distinguishes the other half of the split array.

R

RAID. Redundant array of independent disks.

RAID array. In RAID systems, a group of disks that is handled as one large disk by the operating system.

RAID manager. The software that manages the logical units of an array system.

Rebuilding state. The state that a RAID array enters after a missing member disk drive has been returned to the array or exchanged for a replacement disk drive. While the array is in this state, the data and parity are rebuilt on the returned or replacement disk drive.

Rejected disk. A failing disk drive that the array management software has removed from a RAID array.

Reserved status. The disk drive is used by another using system also.

router. A computer that determines the path of network traffic flow.

S

SCSI. Small computer system interface.

SDRAM. Synchronous dynamic random-access memory.

secondary half. The term that distinguishes one half of a split array. The term "primary half" distinguishes the other half of the split array.

Serial Storage Architecture. An industry-standard interface that provides high-performance fault-tolerant attachment of I/O storage devices.

service request number. A number that helps you to identify the cause of a problem, the failing field-replaceable units (FRUs), and the service actions that might be needed to solve the problem. Service request numbers are generated by the system error-log analysis, system configuration code, and customer problem determination procedures.

SMIT. System management interface tool.

SRN. Service request number.

SSA. Serial Storage Architecture.

SSA unique ID. The specific identifier for a particular SSA device. Each SSA device has a specific identifier that is not used by any other SSA device in the whole world.

stretch. A set of stripes that is used to perform a particular level of array management.

strip. The maximum amount of contiguous user data that is mapped to one component.

stripe. A set of strips (with their mirrors) that have corresponding LBAs on each component.

system disk. A disk that is owned by the using system; that is, it does not belong to an array, and it is not a hot spare disk.

U

unconfigure. (a) To take a device from the available (configured) state to the defined state. (b) To take out of use by the existing computer system.

uncouple. To separate the copy array from the parent RAID-1 or RAID-10 array. The metadata of the copy array is updated to show that it is no longer part of the parent RAID array. The metadata of the parent array is updated to show that it is no longer associated with the copy array. The copy array is brought online and becomes available as a free resource.

unrecoverable error. An error for which recovery is impossible without the use of recovery methods that are outside the normal computer programs.

user mode. In the operating system, a mode in which a process is run in the user's program rather than in the kernel.

V

vary off. To make a device, control unit, or line not available for its normal intended use.

vary on. To make a device, control unit, or line available for its normal intended use.

vital product data (VPD). In the operating system, information that uniquely defines system, hardware, software, and microcode elements of a processing system.

VPD. Vital product data.

Index

Numerics

- 128 MB Memory Module feature 5
- 3-way copy
 - array copy services 173
 - Delete a RAID Array Copy option 183
 - Delete a Volume Group, Logical Volumes, or Filesystems Copy option 184
 - List All Copy Candidates option 179
 - List All Uncoupled Copies option 181
 - List All Uncoupled Volume Groups option 182
 - Prepare a Copy option 175
 - Uncouple a Volume Group, Logical Volumes, or File Systems Copy option 177
 - copying data from an array 151
 - description 149
 - effects of array copy on other SMIT menus 186
 - Change/Show Attributes of an SSA RAID Array option 186
 - Identify Disks in an SSA RAID Arrays option 189
 - List Status Of All Defined SSA RAID Arrays option 188
 - Remove a Disk From an SSA RAID Array option 190
 - Swap Members of an SSA RAID Array option 191
 - SMIT menus for 172
 - ssa_delete_copy command 171
 - ssa_make_copy command 161
 - using SMIT menus to create a copy array 155
 - using ssa_make_copy command to create a copy array 159
 - using ssaraid commands to create a copy array 151

A

- action attributes, RAID-1, RAID-5, and RAID-10 251
 - new_member=disk 251
 - old_member=disk 251
- adapter (PCI) ODM attributes 257
- adapter device driver
 - description 257
 - device-dependent subroutines 258
 - direct call entry point 265
 - description 265
 - purpose 265
 - return values 265
 - files 260
 - head device driver interface 256
 - IOCINFO ioctl operation 261
 - description 261
 - files 261
 - purpose 261

- adapter device driver (*continued*)
 - managing dumps 259
 - open and close subroutines 258
 - PCI ODM attributes 257
 - responsibilities 255
 - SSA_GET_ENTRY_POINT ioctl operation 264
 - description 264
 - files 264
 - purpose 264
 - return values 264
 - SSA_TRANSACTION ioctl operation 262
 - description 262
 - files 263
 - purpose 262
 - return value 263
 - summary of SSA error conditions 259
- adapter microcode maintenance 315
- adapter microcode, checking the level 23
- adapter POSTs (power-on self-tests) 317
- adapter takeover 267
- adapters
 - Advanced SerialRAID Adapter (type 4–P)
 - 128 MB Memory Module feature 5
 - description 4
 - Fast-Write feature 5
 - lights 6
 - port addresses 6
 - ID during bring-up 6
 - installing 313
- Add a Disk to an SSA RAID Array option 140
- Add a Hot Spare Pool option 83
- Add an SSA RAID Array option 60
- add_hsm_pool_adap command 83
- adding a new hot spare pool 83
- adding disks to a hot spare pool 86
- addresses, port
 - Advanced SerialRAID Adapter (type 4–P) 6
- addressing SSA Devices
 - location code format 19
 - unique IDs (UIDs) 21
- addssaraid command 140
- Advanced SerialRAID Adapter (type 4–P)
 - description 4
 - lights 6
 - port addresses 6
- array copy services 173
 - Delete a RAID Array Copy option 183
 - Delete a Volume Group, Logical Volumes, or Filesystems Copy option 184
 - List All Copy Candidates option 179
 - List All Uncoupled Copies option 181
 - List All Uncoupled Volume Groups option 182

- array copy services *(continued)*
 - Prepare a Copy option 175
 - Uncouple a Volume Group, Logical Volumes, or File Systems Copy option 177
- array states, RAID-0 31
 - Good 31
 - Offline 31
- array states, RAID-1 32
- array states, RAID-10 36
 - Degraded 37
 - Exposed 36
 - Good 36
 - multiple 38
 - Offline 37
 - Rebuilding 37
 - Unknown 38
- array states, RAID-5 33
 - Degraded 33
 - Exposed 33
 - read operations while in 33
 - write operations while in 33
- flowchart 35
- Good 33
- initial rebuilding operation 34
- Offline 34
- Rebuilding 34
 - adapter replacement 34
 - disk drive replacement 34
- arrays
 - adding a disk drive to an SSA RAID array 140
 - adding a new hot spare pool 83
 - adding disks to a hot spare pool 86
 - adding to the configuration 60
 - canceling all SSA disk drive identifications 129
 - changing member disks in an SSA RAID array 137
 - changing or showing the attributes of an SSA RAID array 135
 - changing or showing the status of a hot spare pool 74
 - changing or showing the use of an SSA disk drive 144
 - changing the use of multiple SSA physical disks 147
 - creating a hot spare disk drive 72
 - deleting an old RAID array recorded in an SSA RAID manager 133
 - deleting from the configuration 70
 - identifying and correcting or removing failed disk drives 91
 - identifying array candidate disk drives 125
 - identifying hot spare disk drives 121
 - identifying rejected array disk drives 123
 - identifying system disk drives 127
 - identifying the disk drives in an SSA RAID array 119
 - installing a replacement disk drive 95

- arrays *(continued)*
 - installing and configuring 58
 - listing all defined SSA RAID arrays 100
 - listing all SSA RAID arrays that are connected to a RAID manager 102
 - listing all supported SSA RAID arrays 101
 - listing hot spare disk drives 111
 - listing old RAID arrays recorded in an SSA RAID manager 131
 - listing rejected array disk drives 113, 115
 - listing system disk drives 117
 - listing the disk drives in an SSA RAID array 109
 - listing the disks that are in a hot spare pool 80
 - listing the status of all defined SSA RAID arrays 104
 - removing a disk drive from an SSA RAID array 138
 - removing disks from a hot spare pool 86
 - showing the disks that are protected by hot spares 77
 - swapping members of an SSA RAID array 142
- Attention notices
 - formatting disk drives 389
 - fragility of disk drives 443
 - service aids 373
- attributes
 - action
 - new_member=disk 251
 - old_member=disk 251
 - array member disk drives
 - spare_pool 249
 - couple action
 - force=yes/no 252
 - pool_selection=own/primary/secondary 252
 - raid_copy=copy 252
 - disk device driver 270
 - adapter_a 271
 - adapter_b 271
 - connwhere_shad 271
 - location 271
 - max_coalesce 271
 - node_number 270
 - primary_adapter 271
 - pvid 271
 - queue_depth 271
 - reserve_lock 271
 - size_in_mb 271
 - write_queue_mod 272
 - hot spare disk drives change
 - spare_pool 249
 - hot spare pool
 - minimum_spares 249
- ODM, PCI 257
 - bus_intr_level 257
 - bus_io_addr 257
 - bus_mem_start 257

- attributes (*continued*)
 - ODM, PCI (*continued*)
 - bus_mem_start2 257
 - bus_mem_start3 257
 - bus_mem_start4 257
 - daemon 258
 - dma_mem 258
 - host_address 258
 - intr_priority 257
 - poll_threshold 258
 - scat_gat_pages 258
 - ucode 257
 - physical disk change attributes 249
 - physical disk drive change
 - fastwrite=on/off 250
 - force=yes/no 251
 - fw_end_block 250
 - fw_max_length 250
 - fw_start_block 250
 - use=system/spare/free 250
 - RAID arrays change 248
 - force=yes/no 248
 - use=system/free 248
 - RAID arrays creation and change 244
 - allow_page_splits=true/false 244
 - bypass_cache-if_oneway 245
 - fastwrite=on/off 244
 - fw_end_block 244
 - fw_start_block 244
 - fw_suspended 245
 - RAID-1 and -10 creation and change
 - copy_rate 247
 - copy_verify_writes 247
 - fw_max_length 247
 - hot_spare_splits 247
 - split_resolution 247
 - RAID-1, -5, and -10 creation and change
 - read_only_when_exposed=true/false 245
 - spare_exact=true/false 245
 - spare_preferred 246
 - spare=true/false 245
 - RAID-10 creation and change
 - strip_size 248
 - RAID-5 creation and change 249
 - fw_max_length 248
 - strip_size 248
 - uncouple action
 - force=yes/no 252
- attributes common to logical and physical disks 271
- attributes for logical disks only 271
- attributes of the SSA router, ssar 270

B

- battery assembly, fast-write cache card
 - installing 338

- battery assembly, fast-write cache card (*continued*)
 - power 211
 - removing 336
- blue and black cables 314
- bring-up, SSA adapter ID 6
- broken loop (SSA link) 403, 406
- buffer management, SSA Target mode 293
- bypassing the cache in a one-way fast-write network 217

C

- cables
 - blue and black 314
- Cancel all SSA Disk Identifications option 129
- Certify Disk service aid 391
- change and creation attributes, hot spare pool 249
- change and creation attributes, RAID arrays 244
- change attributes
 - physical disk drives
 - fastwrite=on/off 250
 - force=yes/no 251
 - fw_end_block 250
 - fw_max_length 250
 - fw_start_block 250
 - use=system/spare/free 250
- change attributes, hot spare pool
 - minimum_spares 249
- change attributes, RAID arrays 248
 - array member disk drives
 - spare_pool 249
 - force=yes/no 248
 - hot spare disk drives
 - spare_pool 249
 - use=system/free 248
- Change Member Disks in an SSA RAID Array
 - option 137
- Change/Show Attributes of an SSA RAID Array 135
- Change/Show Attributes of an SSA RAID Array
 - option 135
- Change/Show Attributes of an SSA RAID Array option, effects of array copy 186
- Change/Show Characteristics of an SSA Logical Disk
 - option 214
- Change/Show Use of an SSA Disk option 144
- Change/Show/Delete a Hot Spare Pool option 86
- changing or showing the status of a hot spare pool 74
- changing pdisk and hdisk numbers 326
- checking the level of adapter microcode 23
- chg_hsm_pool_adap command 86
- chgssadisk command 72, 144
- chgssadisks command 147
- chgssardsk command 214
- choosing how many hot spare disk drives to include in each pool 51

- choosing the error threshold (alarm) level for a hot spare pool 51
- chssaraid command 135
- close subroutine
 - tmssa device driver 297
- command line error log analysis 232
- Command Line Interface for RAID 235
 - action attributes 251
 - command syntax 237
 - couple action attributes 252
 - hot spare pool creation and change attributes 249
 - instruct types 238
 - object types 238
 - options 238
 - physical disk change attributes 249
 - RAID arrays change attributes 248
 - RAID arrays creation and change attributes 244
 - return codes 253
 - SSARAIID command attributes 244
 - uncouple action attributes 252
- command line utilities
 - ssa_certify command 345
 - ssa_diag command 348
 - ssa_ela command 353
 - ssa_format command 358
 - ssa_fw_status command 360
 - ssa_getdump command 361
 - ssa_progress command 365
 - ssa_rescheck command 366
 - ssa_servicemode command 368
 - ssa_sesdld command 341
 - ssa_speed command 369
 - ssaadap command 343
 - ssacand command 344
 - ssaconn command 347
 - ssadisk command 349
 - ssadload command 350
 - ssaencl command 355
 - ssaidentify command 364
 - ssavfynn command 371
 - ssaxlate command 372
- command syntax of the RAID Command Line Interface 237
- commands
 - add_hsm_pool_adap 83
 - addssaraid 140
 - chg_hsm_pool_adap 86
 - chgssadisk 72, 144
 - chgssadisks 147
 - chgssardsk 214
 - chssaraid 135
 - exssaraid 95, 142
 - iassaraid 127
 - icssaraid 125
 - ifssaraid 92, 123
- commands (*continued*)
 - ihssaraid 121
 - issaraid 119
 - lassaraid 117
 - lcssaraid 115
 - lfssaraid 91, 113
 - lhssaraid 111
 - ls_hsm_array_components 80
 - ls_hsm_array_status 77
 - ls_hsm_status 74
 - lsdssaraid 100
 - lsidssaraid 108
 - lsmssaraid 102
 - lssaraid 109
 - lsssaraid 101
 - lstssaraid 104
 - mkssaraid 60
 - nvrssaraid 130
 - redssaraid 138
 - rmssaraid 70
 - smit (smitty) 59, 90, 98, 213
 - ssa_certify 345
 - ssa_delete_copy 171
 - ssa_diag 348
 - ssa_ela 353
 - ssa_format 358
 - ssa_fw_status 360
 - ssa_getdump 361
 - ssa_identify_cancel 129
 - ssa_make_copy 161
 - ssa_progress 365
 - ssa_rescheck 366
 - ssa_servicemode 368
 - ssa_sesdld 341
 - ssa_speed 369
 - ssaadap 343
 - ssacand 344
 - ssaconn 347
 - ssadisk 349
 - ssadload 350
 - ssadlog 213
 - ssaencl 355
 - ssafastw 215
 - ssaidentify 364
 - ssaraid 59, 90, 98
 - ssavfynn 371
 - ssaxlate 372
 - swpssaraid 137
- configuration information
 - tmssa device driver 296
- configuration of RAID-1 and RAID-10 arrays, split-site management 193
- Configuration Verification service aid 387
- configuring and installing SSA RAID arrays 58
 - adding a disk drive to an SSA RAID array 140

- configuring and installing SSA RAID arrays *(continued)*
 - adding a new hot spare pool 83
 - adding an SSA RAID array 60
 - adding disks to a hot spare pool 86
 - canceling all SSA disk drive identifications 129
 - changing member disks in an SSA RAID array 137
 - changing or showing the attributes of an SSA RAID array 135
 - changing or showing the status of a hot spare pool 74
 - changing or showing the use of an SSA disk drive 144
 - changing the use of multiple SSA physical disks 147
 - creating a hot spare disk drive 72
 - deleting an old RAID array recorded in an SSA RAID manager 133
 - deleting an SSA RAID array 70
 - getting access to the SMIT menu 59
 - identifying and correcting or removing failed disk drives 91
 - identifying array candidate disk drives 125
 - identifying hot spare disk drives 121
 - identifying rejected array disk drives 123
 - identifying system disk drives 127
 - identifying the disk drives in an SSA RAID array 119
 - installing a replacement disk drive 95
 - listing all defined SSA RAID arrays 100
 - listing all SSA RAID arrays that are connected to a RAID manager 102
 - listing all supported SSA RAID arrays 101
 - listing array candidate disk drives 115
 - listing hot spare disk drives 111
 - listing old RAID arrays recorded in an SSA RAID manager 131
 - listing rejected array disk drives 113
 - listing system disk drives 117
 - listing the disk drives in an SSA RAID array 109
 - listing the disks that are in a hot spare pool 80
 - listing the status of all defined SSA RAID arrays 104
 - removing a disk drive from an SSA RAID array 138
 - removing disks from a hot spare pool 86
 - showing the disks that are protected by hot spares 77
 - swapping members of an SSA RAID array 142
- configuring devices on an SSA loop 18
- configuring devices, adapter device driver 257
- configuring SSA disk drive devices 268, 269
 - using mkdev to configure a logical disk 269
 - using mkdev to configure a physical disk 269
- configuring the Fast-Write Cache feature 211
- configuring the SSA Target mode 292
- copying data from an array 151
- copying data from arrays and from volume groups 149
- correcting or removing failed disk drives 91
- couple action attributes, RAID-1 and RAID-10 252
 - force=yes/no 252
 - pool_selection=own/primary/secondary 252
- creating a hot spare 72
- creation and change attributes, all RAID arrays 244
 - allow_page_splits=true/false 244
 - bypass_cache-if_oneway 245
 - fastwrite=on/off 244
 - fw_end_block 244
 - fw_start_block 244
 - fw_suspended 245
- creation and change attributes, hot spare pool 249
- creation and change attributes, RAID arrays 244
- creation and change attributes, RAID-1 and -10 arrays 247
 - copy_rate 247
 - copy_verify_writes 247
 - fw_max_length 247
 - hot_spare_splits 247
 - split_resolution 247
- creation and change attributes, RAID-1, -5, and -10 arrays 245
 - read_only_when_exposed=true/false 245
 - spare_exact=true/false 245
 - spare_preferred 246
 - spare=true/false 245
- creation and change attributes, RAID-10 arrays 248
 - strip_size 248
- creation and change attributes, RAID-5 arrays 248
 - fw_max_length 248
 - strip_size 248
- cron table entries 313

D

- data paths and loops
 - examples
 - broken loop (cable removed) 403
 - broken loop (disk drive removed) 406
 - normal loops 401
- data paths, loops and links
 - configuring devices 18
- data paths, loops, and links 7
 - large configurations 16
 - one loop with two adapters in each of two using systems 12
 - one loop with two adapters in one using system 11
 - simple loop 8
 - simple loop, one disk drive missing 9
 - simple loop, two disk drives missing 10
 - two loops with one adapter 14
 - two loops with two adapters 15
- dealing with fast-write problems 218
- dealing with RAID array problems 89
- deciding how to configure hot spare disk drive pools 45

- Degraded state, RAID-10 37
- Degraded state, RAID-5 33
- Delete a RAID Array Copy option 183
- Delete a Volume Group, Logical Volumes, or Filesystems Copy option 184
- Delete an SSA RAID Array option 70
- detail data formats, error logging 225
- device attributes 270
- device driver entry point 287
- device drivers 255
 - adapter
 - configuring devices 257
 - description 257
 - device-dependent subroutines 258
 - direct call entry point 265
 - IOCINFO ioctl operation 261
 - managing dumps 259
 - open and close subroutines 258
 - purpose 257
 - SSA_GET_ENTRY_POINT ioctl operation 264
 - SSA_TRANSACTION ioctl operation 262
 - summary of SSA error conditions 259
 - syntax 257
 - disk
 - configuration issues 266
 - description 266
 - device attributes 270
 - device-dependent subroutines 272
 - error conditions 274
 - IOCINFO ioctl operation 277
 - open, read, write, and close subroutines 272
 - purpose 266
 - readx and writex subroutines 274
 - special files 276
 - SSA disk concurrent mode of operation
 - interface 287
 - SSADISK_ISAL_CMD ioctl operation 278
 - SSADISK_ISALMgr_CMD ioctl operation 281
 - SSADISK_LIST_PDISKS ioctl operation 285
 - SSADISK_SCSI_CMD ioctl operation 283
 - syntax 266
 - interface 256
 - PCI adapter
 - ODM attributes 257
 - responsibilities
 - adapter device driver 255
 - disk device driver 255
 - tmssa 295
 - configuration 296
 - description 295
 - device-dependent subroutines 296
 - IOCINFO ioctl operation 305
 - purpose 295
 - syntax 295
 - TMCHGIMPARM (change parameters) 308
- device drivers (*continued*)
 - tmssa (*continued*)
 - TMIOSTAT (status) 307
 - trace formatting 256
 - device-dependent routines
 - tmssa device driver 296
 - close subroutine 297
 - ioctl subroutine 301
 - open subroutine 296
 - read subroutine 297
 - select entry point 301
 - write subroutine 299
 - device-dependent subroutines
 - adapter device driver 258
 - disk device driver
 - open, read, write, and close subroutines 272
 - readx and writex subroutines 274
 - devices, finding the physical location 409
 - diagnostic aids
 - adapter POSTs (power-on self-tests) 317
 - SRNs (service request numbers) 411
 - direct call entry point 265
 - description 265
 - purpose 265
 - return values 265
 - disk device driver
 - configuration issues 266
 - configuring SSA disk drive devices 268
 - logical and physical disks and RAID arrays 266
 - multiple adapters 267
 - description 266
 - device attributes 270
 - device-dependent subroutines 272
 - error conditions 274
 - IOCINFO ioctl operation 277
 - description 277
 - files 277
 - purpose 277
 - open, read, write, and close subroutines 272
 - purpose 266
 - readx and writex subroutines 274
 - responsibilities 255
 - special files 276
 - SSA disk concurrent mode of operation
 - interface 287
 - device driver entry point 287
 - top kernel extension entry point 288
 - SSADISK_ISAL-CMD ioctl operation 278
 - description 278
 - files 280
 - purpose 278
 - return values 279
 - SSADISK_ISALMgr_CMD ioctl operation
 - description 281
 - SSADISK_ISALMgr-CMD ioctl operation 281

- disk device driver *(continued)*
 - files 282
 - purpose 281
 - return values 282
- SSADISK_LIST_PDISKS ioctl operation 285
 - description 285
 - files 286
 - purpose 285
 - return values 286
- SSADISK_SCSI_CMD ioctl operation 283
 - description 283
 - files 284
 - purpose 283
 - return values 284
- syntax 266

- disk drive microcode maintenance 315
- disk drives
 - failed, identifying, correcting, and removing 91
 - finding the physical location 409
 - formatted on different types of machine 387
 - identification 19
 - not in arrays 30
 - reservation of 27
 - unique IDs (UIDs) 21

- disk fencing 290
- Display/Download Disk Drive Microcode service aid 393
- dumps, managing 259
- duplicate node test, error logging 227

E

- effects of array copy on other SMIT menus 186
 - Change/Show Attributes of an SSA RAID Array option 186
 - Identify Disks in an SSA RAID Array option 189
 - List Status Of All Defined SSA RAID Arrays option 188
 - Remove a Disk From an SSA RAID Array option 190
 - Swap Members of an SSA RAID Array option 191
- enabling or disabling Fast-Write for multiple devices 215
- enabling or disabling Fast-Write for one disk drive 214
- error codes for service aids 400
- error conditions, disk device driver 274
- error log analysis
 - detailed description 230
 - command line error log analysis 232
 - error log analysis routine 230
 - run_ssa_ela cron 232
 - summary 229
- error log analysis routine 230
- error logging
 - detailed description 222
 - detail data formats 225

- error logging *(continued)*
 - detailed description *(continued)*
 - duplicate node test 227
 - run_ssa_healthcheck cron 226
 - run_ssa_link_speed cron 227
 - summary 221
 - tmssa device driver 302
- error logging management
 - detailed description 228
 - summary 228
- exchanging adapters and Rebuilding state, RAID-5 34
- exchanging disk drives 319
- execution of Target Mode requests 294
- Exposed state, RAID-10 36
- Exposed state, RAID-5 33
 - read operations while in 33
 - write operations while in 33
- exssaraid command 95, 142

F

- fast-write cache card
 - installing 334
 - removing 332
- fast-write cache card, battery assembly
 - installing 338
 - power 211
 - removing 336
- Fast-Write Cache feature
 - battery 211
 - bypassing the cache in a one-way fast-write network 217
 - configuring 211
 - dealing with problems 218
 - description 27
 - enabling or disabling Fast-Write for multiple devices 215
 - enabling or disabling Fast-Write for one disk drive 214
 - getting access to the Fast-Write menus 213
- Fast-Write feature 5
- Fast-Write menus, getting access 213
- fencing 290
- files
 - adapter device driver 260
 - IOCINFO ioctl operation 261, 277
 - SSA_GET_ENTRY_POINT ioctl operation 264
 - SSA_TRANSACTION ioctl operation 263
 - ssadisk SSA disk device driver 276
 - SSADISK_ISAL_CMD ioctl operation 280
 - SSADISK_ISALMgr_CMD ioctl operation 282
 - SSADISK_LIST_PDISKS ioctl operation 286
 - SSADISK_SCSI_CMD ioctl operation 284
- finding the physical location of a device 409
- flowchart for RAID-5 array states 35
- Format Disk service aid 389

FRU part numbers 340
full-stride writes, definition 272

G

getting access to the Fast-Write menus 213
getting access to the SSA Adapters SMIT menu 40
getting access to the SSA Disks SMIT menu 41
getting access to the SSA RAID Array SMIT menu 59
good housekeeping 233
Good state, RAID-0 31
Good state, RAID-10 36
Good state, RAID-5 33

H

hdisks and pdisks
 changing numbers 326
 explanation of 19
 reformatting a pdisk as an hdisk 387
head device driver/adaptor device driver interface 256
hot spare management 45
 choosing how many hot spare disk drives to include in each pool 51
 choosing the error threshold (alarm) level for a hot spare pool 51
 deciding how to configure hot spare disk drive pools 45
 rules for hot spare disk drive pools 52
 solving hot spare pool problems 53
hot spare pool creation and change attributes 249
hot spare pool, adding a new one 83
hot spare pool, adding disk to, or removing disks from 86
hot spare pool, changing or showing the status 74
hot spare pool, listing the disks 80
hot spare pool, showing the disks 77
housekeeping 233

I

iassaraid command 127
icssaraid command 125
identification of disk drives 19
Identify Array Candidate Disks option 125
Identify Disks in an SSA RAID Array option 119
Identify Disks in an SSA RAID Array option, effects of array copy 189
Identify function 375
Identify Hot Spares option 121
Identify Rejected Array Disks option 123
Identify System Disks option 127
identifying and correcting or removing failed disk drives 91
identifying SSA Devices
 location code format 19
 pdisks and hdisks 19
 unique IDs (UIDs) 21
IEEE SSA unique ID (UID) 21

ifssaraid command 92, 123
ihssaraid command 121
indicators
 Advanced SerialRAID Adapter (type 4–P) 6
installing a battery assembly into the fast-write cache card 338
installing an SDRAM module 330
installing and configuring SSA RAID arrays 58
 adding a disk drive to an SSA RAID array 140
 adding a new hot spare pool 83
 adding an SSA RAID array 60
 adding disks to a hot spare pool 86
 canceling all SSA disk drive identifications 129
 changing member disks in an SSA RAID array 137
 changing or showing the attributes of an SSA RAID array 135
 changing or showing the status of a hot spare pool 74
 changing or showing the use of an SSA disk drive 144
 changing the use of multiple SSA physical disks 147
 creating a hot spare disk drive 72
 deleting an old RAID array recorded in an SSA RAID manager 133
 deleting an SSA RAID array 70
 getting access to the SMIT menu 59
 identifying and correcting or removing failed disk drives 91
 identifying array candidate disk drives 125
 identifying hot spare disk drives 121
 identifying rejected array disk drives 123
 identifying system disk drives 127
 identifying the disk drives in an SSA RAID array 119
 installing a replacement disk drive 95
 listing all defined SSA RAID arrays 100
 listing all SSA RAID arrays that are connected to a RAID manager 102
 listing all supported SSA RAID arrays 101
 listing array candidate disk drives 115
 listing hot spare disk drives 111
 listing old RAID arrays recorded in an SSA RAID manager 131
 listing rejected array disk drives 113
 listing system disk drives 117
 listing the disk drives in an SSA RAID array 109
 listing the disks that are in a hot spare pool 80
 listing the status of all defined SSA RAID arrays 104
 removing a disk drive from an SSA RAID array 138
 removing disks from a hot spare pool 86
 showing the disks that are protected by hot spares 77
 swapping members of an SSA RAID array 142
installing the fast-write cache card 334

- installing the SSA adapter 313
- instruct types, Command Line Interface 238
- interface, adapter device driver/head device driver 256
- IOCINFO ioctl operation 261, 305
 - description 261, 305
 - disk device driver 277
 - description 277
 - files 277
 - purpose 277
 - files 261
 - purpose 261, 305
- ioctl subroutine
 - tmssa device driver 301
- issaraid command 119

L

- large configurations 16
 - switching off using systems 17
 - switching on using systems 17
- lassaraid command 117
- lcssaraid command 115
- lfssaraid command 91, 113
- lhssaraid command 111
- lights
 - Advanced SerialRAID Adapter (type 4–P) 6
- link error problem determination 478
- link errors 478
- link speed 18
- Link Speed service aid 396
- link status (ready) lights 481
- Link Verification service aid 383
- List All Copy Candidates option 179
- List All Defined SSA RAID Arrays option 100
- List All SSA RAID Arrays Connected to a RAID Manager option 102
- List All Supported SSA RAID Arrays option 101
- List all Uncoupled Copies option 181
- List All Uncoupled Volume Groups option 182
- List Array Candidate Disks option 115
- List Components in a Hot Spare Pool option 80
- List Disks in an SSA RAID Array option 109
- List Hot Spares option 111
- List Rejected Array Disks option 113
- List Status of All Defined SSA RAID Arrays option 104
- List Status Of All Defined SSA RAID Arrays option,
 - effects of array copy 188
- List Status of Hot Spare Pools option 74
- List Status of Hot Spare Protection for an SSA RAID Array option 77
- List System Disks option 117
- List/Identify SSA Physical Disks option 108
- listing the disks that are in a hot spare pool 80
- location code format 19

- loops and data paths
 - examples
 - broken loop (cable removed) 403
 - broken loop (disk drive removed) 406
 - normal loops 401
 - loops, links and data paths
 - large configurations 16
 - one loop with two adapters in each of two using systems 12
 - one loop with two adapters in one using system 11
 - simple loop 8
 - simple loop, one disk drive missing 9, 10
 - two loops with one adapter 14
 - two loops with one adapter in each of two using systems 15
 - loops, links, and data paths 7
 - configuring devices on a loop 18
 - ls_hsm_array_components command 80
 - ls_hsm_array_status command 77
 - ls_hsm_status command 74
 - lsdssaraid command 100
 - lsidssaraid command 108
 - lsmssaraid command 102
 - lssaraid command 109
 - lsssaraid command 101
 - lstssaraid command 104

M

- maintenance analysis procedures (MAPs) 443
- managing dumps 259
- MAP 2010 444
- MAP 2320 445
- MAP 2323 450
- MAP 2324 454
- MAP 2410 475
- microcode (adapter), checking the level 23
- microcode and software errors 441
- microcode maintenance 314
 - adapter 315
 - checking microcode package ID and level 314
 - disk drive 315
 - microcode package ID and level 314
- mkdev, configuring a logical disk 269
- mkdev, configuring a physical disk 269
- mkssaraid command 60
- multiple states, RAID-10 38

N

- node_number locking 27
- normal loops (SSA link) 401
- nvrssaraid command 130

O

- object types, Command Line Interface 238
- ODM attributes, PCI 257
- Offline state, RAID-10 37

- Offline state, RAID-5 34
- one loop with two adapters in each of two using systems 12
- one loop with two adapters in one using system 11
- open and close subroutines
 - adapter device driver 258
- open subroutine
 - tmssa device driver 296
- open, read, write, and close subroutines
 - disk device driver 272
- operation after a loss of member disks, split-site management 194
 - adapter not known to remaining half of the array 203
 - one half of the array is not present 195
 - split and join procedure not performed correctly 205
- options of the RAID Command Line Interface 238

P

- part numbers 340
- paths, data (SSA link) 7
 - examples
 - broken loop (cable removed) 403
 - broken loop (disk drive removed) 406
 - normal loops 401
- PCI adapter ODM attributes 257
- pdisks and hdisks
 - changing numbers 326
 - explanation of 19
 - identification 19
 - reformatting a pdisk as an hdisk 387
- physical disk change attributes, RAID-5 249
- physical relationship of disk drives and adapters 24
 - one pair of adapter connectors in the loop 24
 - pairs of adapter connectors in the loop, mainly shared data 26
 - pairs of adapter connectors in the loop, some shared data 25
- port addresses
 - Advanced SerialRAID Adapter (type 4–P) 6
- POSTs (power-on self-tests)
 - adapter 317
- powering off using systems in a large configuration 17
- powering on using systems in a large configuration 17
- Prepare a Copy option 175
- problem determination
 - for SSA links 400
 - POSTs, adapter (power-on self-tests) 317
 - procedures 411
 - SRNs (service request numbers) 411
 - SSA link error 478
- problems, RAID array 89

R

- RAID array configurator
 - adding a disk drive to an SSA RAID array 140
 - adding a new hot spare pool 83
 - adding an SSA RAID array 60
 - adding disks to a hot spare pool 86
 - canceling all SSA disk drive identifications 129
 - changing member disks in an SSA RAID array 137
 - changing or showing the attributes of an SSA RAID array 135
 - changing or showing the status of a hot spare pool 74
 - changing or showing the use of an SSA disk drive 144
 - changing the use of multiple SSA physical disks 147
 - creating a hot spare disk drive 72
 - deleting an old RAID array recorded in an SSA RAID manager 133
 - deleting an SSA RAID array 70
 - getting access to the SMIT menu 59
 - identifying and correcting or removing failed disk drives 91
 - identifying array candidate disk drives 125
 - identifying hot spare disk drives 121
 - identifying rejected array disk drives 123
 - identifying system disk drives 127
 - identifying the disk drives in an SSA RAID array 119
 - installing a replacement disk drive 95
 - installing and configuring SSA RAID arrays 58
 - listing all defined SSA RAID arrays 100
 - listing all SSA RAID arrays that are connected to a RAID manager 102
 - listing all supported SSA RAID arrays 101
 - listing array candidate disk drives 115
 - listing hot spare disk drives 111
 - listing old RAID arrays recorded in an SSA RAID manager 131
 - listing rejected array disk drives 113
 - listing system disk drives 117
 - listing the disk drives in an SSA RAID array 109
 - listing the disks that are in a hot spare pool 80
 - listing the status of all defined SSA RAID arrays 104
 - removing a disk drive from an SSA RAID array 138
 - removing disks from a hot spare pool 86
 - showing the disks that are protected by hot spares 77
 - swapping members of an SSA RAID array 142
- RAID array problems 89
- RAID Array SMIT menu, getting access 59
- RAID arrays
 - adding a disk drive to an SSA RAID array 140
 - adding a new hot spare pool 83
 - adding disks to a hot spare pool 86

RAID arrays (*continued*)

- adding to the configuration 60
- canceling all SSA disk drive identifications 129
- changing member disks in an SSA RAID array 137
- changing or showing the attributes of an SSA RAID array 135
- changing or showing the status of a hot spare pool 74
- changing or showing the use of an SSA disk drive 144
- changing the use of multiple SSA physical disks 147
- creating a hot spare disk drive 72
- deleting an old RAID array recorded in an SSA RAID manager 133
- deleting from the configuration 70
- identifying and correcting or removing failed disk drives 91
- identifying array candidate disk drives 125
- identifying hot spare disk drives 121
- identifying rejected array disk drives 123
- identifying system disk drives 127
- identifying the disk drives in an SSA RAID array 119
- installing a replacement disk drive 95
- installing and configuring 58
- listing all defined SSA RAID arrays 100
- listing all SSA RAID arrays that are connected to a RAID manager 102
- listing all supported SSA RAID arrays 101
- listing array candidate disk drives 115
- listing hot spare disk drives 111
- listing old RAID arrays recorded in an SSA RAID manager 131
- listing rejected array disk drives 113
- listing system disk drives 117
- listing the disk drives in an SSA RAID array 109
- listing the disks that are in a hot spare pool 80
- listing the status of all defined SSA RAID arrays 104
- removing a disk drive from an SSA RAID array 138
- removing disks from a hot spare pool 86
- showing the disks that are protected by hot spares 77
- swapping members of an SSA RAID array 142

RAID arrays change attributes 248

RAID arrays creation and change attributes 244

RAID Command Line Interface 235

- action attributes 251
- command syntax 237
- couple action attributes 252
- hot spare pool creation and change attributes 249
- instruct types 238
- object types 238
- options 238
- physical disk change attributes 249

RAID Command Line Interface (*continued*)

- RAID arrays change attributes 248
- RAID arrays creation and change attributes 244
- return codes 253
- SSARaid command attributes 244
- uncouple action attributes 252

RAID functions 29

RAID-0 array states 31

- Good 31
- Offline 31

RAID-1 and RAID-10 couple action attributes 252

RAID-1 and RAID-10 uncouple action attributes 252

RAID-1 array states 32

RAID-10 array states 36

- Degraded 37
- Exposed 36
- Good 36
- multiple 38
- Offline 37
- Rebuilding 37
- Unknown 38

RAID-5 action attributes 251

RAID-5 array states 33

- Degraded 33
- Exposed 33
- read operations while in 33
- write operations while in 33

flowchart 35

- Good 33
- initial rebuilding operation 34
- Offline 34
- Rebuilding 34
- adapter replacement 34
- disk drive replacement 34

RAID-5 physical disk change attributes 249

read subroutine

- tmssa device driver 297

readx and writex subroutines

- disk device driver 274

Rebuilding state, RAID-10 37

Rebuilding state, RAID-5 34

- adapter replacement 34
- disk drive replacement 34
- initial rebuilding operation 34

redssaraid command 138

reformatting a pdisk as an hdisk 387

relationship of disk drives and adapters 24

- one pair of adapter connectors in the loop 24
- pairs of adapter connectors in the loop, mainly shared data 26
- pairs of adapter connectors in the loop, some shared data 25

removal and replacement procedures

- changing pdisk and hdisk numbers 326
- exchanging disk drives 319

- removal and replacement procedures *(continued)*
 - installing a battery assembly into the fast-write cache card 338
 - installing an SDRAM module 330
 - installing the fast-write cache card 334
 - removing an SDRAM module 329
 - removing the battery assembly from the fast-write cache card 336
 - removing the fast-write cache card 332
- SSA adapter 327
- Remove a Disk from an SSA RAID Array option 138
- Remove a Disk From an SSA RAID Array option, effects of array copy 190
- removing an SDRAM module 329
- removing and replacing an SSA adapter 327
- removing disks from a hot spare pool 86
- removing the battery assembly from the fast-write cache card 336
- removing the fast-write cache card 332
- reserving disk drives 27
- responsibilities of the SSA adapter device driver 255
- responsibilities of the SSA disk device driver 255
- return codes, command line interface, RAID-5 253
- return values
 - direct call entry point 265
 - SSA_GET_ENTRY_POINT ioctl operation 264
 - SSA_TRANSACTION ioctl operation 263
 - SSADISK_ISAL_CMD ioctl operation 279
 - SSADISK_ISALMgr_CMD ioctl operation 282
 - SSADISK_LIST_PDISKS ioctl operation 286
 - SSADISK_SCSI_CMD ioctl operation 284
- rmssaraid command 70
- rules
 - for SSA loops 22
 - relationship between disk drives and adapters 24
 - one pair of adapter connectors in the loop 24
 - pairs of adapter connectors in the loop, mainly shared data 26
 - pairs of adapter connectors in the loop, some shared data 25
- rules for hot spare disk drive pools 52
- run_ssa_ela_cron 232
- run_ssa_healthcheck cron, error logging 226
- run_ssa_link_speed cron, error logging 227

S

- SDRAM module
 - installing 330
 - removing 329
- select entry point
 - tmssa device driver 301
- serial storage architecture (SSA) 3
- service aids 373
 - Certify Disk 391
 - Configuration Verification 387

- service aids *(continued)*
 - Display/Download Disk Drive Microcode 393
 - Format Disk 389
 - Identify function 375
 - Link Speed 396
 - Link Verification 383
 - Set Service Mode 378
 - SRNs 400
 - starting 376
- Set Service Mode service aid 378
- showing the disks that are protected by hot spares 77
- simple loop 8
- simple loop, one disk drive missing 9
- simple loop, two disk drives missing 10
- SMIT (or SMITTY) commands
 - add_hsm_pool_adap 83
 - addssaraid 140
 - chg_hsm_pool_adap 86
 - chgssadisk 72, 144
 - chgssadisks 147
 - chgssardsk 214
 - chssaraid 135
 - exssaraid 95, 142
 - iassaraid 127
 - icssaraid 125
 - ifssaraid 92, 123
 - ihssaraid 121
 - issaraid 119
 - lassaraid 117
 - lcssaraid 115
 - lfssaraid 91, 113
 - lhssaraid 111
 - ls_hsm_array_components 80
 - ls_hsm_array_status 77
 - ls_hsm_status 74
 - lsdssaraid 100
 - lsidssaraid 108
 - lsmssaraid 102
 - lssaraid 109
 - lsssaraid 101
 - lstssaraid 104
 - mkssaraid 60
 - nvrssaraid 130
 - redssaraid 138
 - rmssaraid 70
 - smit (smitty) 98
 - ssa_identify_cancel 129
 - ssafastw 215
 - swpssaraid 137
- SMIT (or SMITTY) options
 - Add a Disk to an SSA RAID Array 140
 - Add a Hot Spare Pool 83
 - Add an SSA RAID Array 60
 - Cancel all SSA Disk Identifications 129
 - Change Member Disks in an SSA RAID Array 137

SMIT (or SMITTY) options *(continued)*

- Change/Show Characteristics of an SSA Logical Disk 214
- Change/Show Use of an SSA Disk 144
- Change/Show/Delete a Hot Spare Pool 86
- Delete an SSA RAID Array 70
- Enable/Disable Fast-Write for Multiple Devices 215
- Identify Array Candidate Disks 125
- Identify Disks in an SSA RAID Array 119
- Identify Hot Spares 121
- Identify Rejected Array Disks 123
- Identify System Disks 127
- List All Defined SSA RAID Arrays 100
- List All SSA RAID Arrays Connected to a RAID Manager 102
- List All Supported SSA RAID Arrays 101
- List Array Candidate Disks 115
- List Components in a Hot Spare Pool 80
- List Disks in an SSA RAID Array 109
- List Hot Spares 111
- List Rejected Array Disks 113
- List Status of All Defined SSA RAID Arrays 104
- List Status of Hot Spare Pools 74
- List Status of Hot Spare Protection for an SSA RAID Array 77
- List System Disks 117
- List/Identify SSA Physical Disks 108
- Remove a Disk from an SSA RAID Array 138
- SSA Logical Disks 213
- Swap Members in an SSA RAID Array 142

SMIT menu for SSA adapters, getting access 40

SMIT menu for SSA disks, getting access 41

SMIT menu, getting access 59, 90, 98

SMIT menu, using 38

SMIT menus for 3-way copy operations 172

SMITTY (or SMIT) commands

- ssadlog 213
- ssaraid 59, 90, 98

software and microcode errors 441

solving hot spare pool problems 53

solving problems with SSA links 400

- examples
 - broken loop (cable removed) 403
 - broken loop (disk drive removed) 406
 - normal loops 401

Spare Tool, using 209

special files

- tmssa 304
 - description 304
 - implementation specifics 304
 - purpose 304

special files, disk device driver 276

split-site management 193

- configuration of RAID-1 and RAID-10 arrays 193
- operation after a loss of member disks 194

split-site management *(continued)*

- adapter not known to remaining half of the array 203
- one half of the array is not present 195
- split and join procedure not performed correctly 205

SRNs (service request numbers) 411

SSA adapter device driver/head device driver interface 256

SSA adapter ID during bring-up 6

SSA adapter, removal and replacement 327

SSA Adapters SMIT menu 40

SSA Adapters SMIT menu, getting access 40

SSA Command Line Interface for RAID 235

- action attributes 251
- command syntax 237
- couple action attributes 252
- hot spare pool creation and change attributes 249
- instruct types 238
- object types 238
- options 238
- physical disk change attributes 249
- RAID arrays change attributes 248
- RAID arrays creation and change attributes 244
- return codes 253
- SSARAID command attributes 244
- uncouple action attributes 252

SSA disk concurrent mode of operation interface 287

- device driver entry point 287
- top kernel extension entry point 288

SSA disk fencing 290

SSA Disks SMIT menu 41

SSA Disks SMIT menu, getting access 41

SSA error conditions, summary 259

SSA error logs 221

- error log analysis
 - detailed description 230
 - summary 229
- error logging
 - detailed description 222
 - summary 221
- error logging management
 - detailed description 228
 - summary 228

SSA link error problem determination 478

- link status (ready) lights 481
- service aid 482

ssa link errors 478

SSA link speed 18

SSA Logical Disks option 213

SSA loops

- configuring devices 18
- device unique IDs (UIDs) 21
- disk drive identification 19
- finding the physical location of a device 409

SSA loops *(continued)*

- large configurations 16
 - links and data paths 7
 - loops and data paths, examples
 - broken loop (cable removed) 403
 - broken loop (disk drive removed) 406
 - normal loops 401
 - one loop with two adapters in each of two using systems 12
 - one loop with two adapters in one using system 11
 - problem determination 400
 - rules 22
 - simple 8
 - simple, one disk drive missing 9
 - simple, two disk drives missing 10
 - two loops with one adapter 14
 - two loops with two adapters 15
- SSA RAID Array SMIT menu, getting access 59
- ## SSA RAID arrays
- adding a disk drive to an SSA RAID array 140
 - adding a new hot spare pool 83
 - adding disks to a hot spare pool 86
 - adding to the configuration 60
 - canceling all SSA disk drive identifications 129
 - changing member disks in an SSA RAID array 137
 - changing or showing the attributes of an SSA RAID array 135
 - changing or showing the status of a hot spare pool 74
 - changing or showing the use of an SSA disk drive 144
 - changing the use of multiple SSA physical disks 147
 - creating a hot spare disk drive 72
 - deleting an old RAID array recorded in an SSA RAID manager 133
 - deleting from the configuration 70
 - identifying and correcting or removing failed disk drives 91
 - identifying array candidate disk drives 125
 - identifying hot spare disk drives 121
 - identifying rejected array disk drives 123
 - identifying system disk drives 127
 - identifying the disk drives in an SSA RAID array 119
 - installing a replacement disk drive 95
 - installing and configuring 58
 - listing all defined SSA RAID arrays 100
 - listing all SSA RAID arrays that are connected to a RAID manager 102
 - listing all supported SSA RAID arrays 101
 - listing array candidate disk drives 115
 - listing hot spare disk drives 111
 - listing old RAID arrays recorded in an SSA RAID manager 131
 - listing rejected array disk drives 113

SSA RAID arrays *(continued)*

- listing system disk drives 117
 - listing the disk drives in an SSA RAID array 109
 - listing the disks that are in a hot spare pool 80
 - listing the status of all defined SSA RAID arrays 104
 - removing a disk drive from an SSA RAID array 138
 - removing disks from a hot spare pool 86
 - showing the disks that are protected by hot spares 77
 - swapping members of an SSA RAID array 142
- SSA SMIT menus, using 38
- ## SSA Target mode
- buffer management 293
 - configuring 292
 - execution of Target Mode requests 294
 - target-mode data pacing 293
 - using 294
- ## SSA Target Mode 291
- SSA unique IDs (UIDs) 21
- ssa_certify command 345
 - ssa_delete_copy command 171
 - ssa_diag command 348
 - ssa_ela command 353
 - ssa_format command 358
 - ssa_fw_status command 360
- ## SSA_GET_ENTRY_POINT ioctl operation 264
- description 264
 - files 264
 - purpose 264
 - return values 264
- ssa_getdump command 361
 - ssa_identify_cancel command 129
 - ssa_make_copy command 161
 - ssa_progress command 365
 - ssa_rescheck command 366
 - ssa_servicemode command 368
 - ssa_sesdld command 341
 - ssa_speed command 369
- ## SSA_TRANSACTION ioctl operation 262
- description 262
 - files 263
 - purpose 262
 - return values 263
- SSA, description 3
- ssaadap command 343
 - ssacand command 344
 - ssaconn command 347
 - ssadisk command 349
- ssadisk SSA disk device driver 266
- configuration issues 266
 - configuring SSA disk drive devices 268
 - logical and physical disks and RAID arrays 266
 - multiple adapters 267
 - device attributes 270

- ssadisk SSA disk device driver *(continued)*
 - attributes common to logical and physical disks 271
 - attributes for logical disks only 271
 - attributes of the SSA router, ssar 270
 - error conditions 274
 - special files 276
- SSADISK_ISAL_CMD ioctl operation
 - disk device driver 278
 - description 278
 - files 280
 - purpose 278
 - return values 279
- SSADISK_ISALMgr_CMD ioctl operation
 - disk device driver 281
 - description 281
 - files 282
 - purpose 281
 - return values 282
- SSADISK_LIST_PDISKS ioctl operation
 - disk device driver 285
 - description 285
 - files 286
 - purpose 285
 - return values 286
- SSADISK_SCSI_CMD ioctl operation
 - disk device driver 283
 - description 283
 - files 284
 - purpose 283
 - return values 284
- ssadload command 350
- ssadlog command 213
- ssaencl command 355
- ssafastw command 215
- ssaidentify command 364
- ssaraid command 59, 90, 98
- SSARAIID command attributes 244
 - action attributes 251
 - couple action attributes 252
 - hot spare pool creation and change attributes 249
 - physical disk change attributes 249
 - RAID arrays change attributes 248
 - RAID arrays creation and change attributes 244
 - uncouple action attributes 252
- ssavfynn command 371
- ssaxlate command 372
- starting the service aids 376
- states of arrays, RAID-0 31
 - Good 31
 - Offline 31
- states of arrays, RAID-1 32
- states of arrays, RAID-10 36
 - Degraded 37
 - Exposed 36

- states of arrays, RAID-10 *(continued)*
 - Good 36
 - multiple 38
 - Offline 37
 - Rebuilding 37
 - Unknown 38
- states of arrays, RAID-5 33
 - Degraded 33
 - Exposed 33
 - read operations while in 33
 - write operations while in 33
 - flowchart 35
 - Good 33
 - initial rebuilding operation 34
 - Offline 34
 - Rebuilding 34
 - adapter replacement 34
 - disk drive replacement 34
- summary of SSA error conditions 259
- Swap Members in an SSA RAID Array option 142
- Swap Members of an SSA RAID Array option, effects of array copy 191
- switching off using systems in a large configuration 17
- switching on using systems in a large configuration 17
- swpssaraid command 137

T

- takeover, adapter 267
- Target Mode 291
- target-mode data pacing 293
- the Fast-Write menus 213
- the SMIT menu 59
- three-way copy
 - array copy services 173
 - Delete a RAID Array Copy option 183
 - Delete a Volume Group, Logical Volumes, or Filesystems Copy option 184
 - List All Copy Candidates option 179
 - List All Uncoupled Copies option 181
 - List All Uncoupled Volume Groups option 182
 - Prepare a Copy option 175
 - Uncouple a Volume Group, Logical Volumes, or File Systems Copy option 177
 - copying data from an array 151
 - description 149
 - effects of array copy on other SMIT menus 186
 - Change/Show Attributes of an SSA RAID Array option 186
 - Identify Disks in an SSA RAID Arrays option 189
 - List Status Of All Defined SSA RAID Arrays option 188
 - Remove a Disk From an SSA RAID Array option 190
 - Swap Members of an SSA RAID Array option 191

- three-way copy (*continued*)
 - SMIT menus for 172
 - ssa_delete_copy command 171
 - ssa_make_copy command 161
 - using SMIT menus to create a copy array 155
 - using ssa_make_copy command to create a copy array 159
 - using ssaraid commands to create a copy array 151
- TMCHGIMPARM (change parameters) tmssa device driver ioctl operation 308
 - description 308
 - purpose 308
- TMIOSTAT (status) tmssa device driver ioctl operation 307
 - description 307
 - purpose 307
- tmssa device driver 295
 - description 295
 - IOCINFO ioctl operation 305
 - description 305
 - purpose 305
 - purpose 295
 - syntax 295
 - TMCHGIMPARM ioctl operation 308
 - description 308
 - purpose 308
 - TMIOSTAT ioctl operation 307
 - description 307
 - purpose 307
- tmssa special file 304
 - description 304
 - implementation specifics 304
 - purpose 304
- top kernel extension entry point 288
- trace formatting 256
- two loops with one adapter 14
- two loops with two adapters 15

U

- Uncouple a Volume Group, Logical Volumes, or File Systems Copy option 177
- uncouple action attributes, RAID-1 and RAID-10 252
 - force=yes/no 252
- unique IDs, SSA (UIDs) 21
- Unknown state, RAID-10 38
- using mkdev to configure a logical disk 269
- using mkdev to configure a physical disk 269
- using SMIT menus to create a copy array 155
- using SSA Target Mode 294
- using ssa_make_copy command to create a copy array 159
- using ssaraid commands to create a copy array 151
- using the SSA Command Line Interface for RAID 235
- using the SSA command line utilities 341
- using the SSA SMIT menus 38

- using the SSA Spare Tool 209
- using the ssaraid command instead of SMIT 235

V

- vital product data 316
- VPD (vital product data) 316

W

- write subroutine
 - tmssa device driver 299

Part Number: 27H0678

Printed in the U.S.A.

SA33-3285-02



(1P) P/N: 27H0678



Spine information:

Advanced SerialRAID Adapters **User's Guide and Maintenance Information**