

IBM

@server

pSeries 690
Service Guide

SA38-0589-01





@server[®]

pSeries 690
Service Guide

SA38-0589-01

Second Edition (April 2002)

Before using this information and the product it supports, read the information in "Safety Notices" on page xi, Appendix A, "Environmental Notices" on page 895, and Appendix B, "Notices" on page 897.

A reader's comment form is provided at the back of this publication. If the form has been removed, address comments to Information Development, Department H6DS-905-6C006, 11400 Burnet Road, Austin, Texas 78758-3493. To send comments electronically, use this commercial internet address: aix6kpub@austin.ibm.com. Any information that you supply may be used without incurring any obligation to you.

© **Copyright International Business Machines Corporation, 2001, 2002. All rights reserved.**

Note to U.S. Government Users -- Documentation related to restricted rights -- Use, duplication or disclosure is subject to restrictions set forth in GSA ADP Schedule Contract with IBM Corp.

Contents

Safety Notices	xi
Electrical Safety	xi
Laser Safety Information	xiii
Laser Compliance	xiii
Data Integrity and Verification	xv
About This Book	xvii
ISO 9000	xvii
Online Publications	xvii
Related Publications	xvii
Trademarks	xviii
Chapter 1. Reference Information	1
@server pSeries 690 Overview	1
Hardware Management Console (HMC)	3
Partition Standby and Full System Partition Power-On Options	4
Partition Requirements	5
Service Focal Point	5
Powering the System On and Off	15
Powering the System On	15
Powering the System Off	15
@server pSeries 690 Data Flow	16
Power-On Self-Test	17
POST Indicators	17
POST Keys	17
1 Key	17
5 Key	17
6 Key	18
8 Key	18
@server pSeries 690 System Locations	18
UEPO Switch	21
7040 Model 681 Processor Subsystem Processor Subsystem Locations	22
Media Subsystem Locations	25
7040 Model 61D I/O Subsystem Locations	27
7040 Model 61D I/O Subsystem Front View	27
7040 Model 61D I/O Subsystem Rear View	28
I/O Subsystem DASD Locations	28
I/O Subsystem PCI PHB and PCI Slot Locations	30
I/O and Media Subsystem Connections	31
I/O Subsystem Internal SCSI Distribution	32
I/O Subsystem Power Distribution	33
Power Subsystem Locations	34
Power Distribution Cabling	35
I/O Subsystem Power Distribution Cabling	38
Integrated Battery Feature Locations	40
Subsystem Positioning and Cabling	41

Operator Panel Cable and Diskette Drive Cable to the Media Subsystem (rear view)	41
I/O Subsystem Positions, Fully Populated Primary and Secondary Rack (rear view without IBF)	42
I/O Subsystem Positions, Fully Populated Primary and Secondary Rack (rear view with IBFs)	43
Placement of Subsystem 4 in a Two-Rack Configuration (rear view with IBF)	44
I/O Subsystems (1 Through 4 Without IBFs) RIO Cabling to I/O Books	45
I/O Subsystems (5 and 6) RIO Cabling to the Secondary I/O Book	46
I/O Subsystems (7 and 8) RIO Cabling to the Third I/O Book	47
I/O Subsystem (1 through 3 with IBFs) RIO Cabling to I/O Books	48
RIO Cable to I/O Subsystem (4 through 6) with IBFs Installed	49
I/O Subsystems (7 and 8) RIO Cabling to the Third I/O Book	50
Power and SCSI Cables to the Media Subsystem	51
IBM Hardware Management Console for pSeries (HMC) to the Primary I/O Book	52
System Memory	54
Memory to Processor Relationships	54
Memory Requirements	54
I/O Subsystem Features.	56
I/O to Processor Relationships	56
I/O Subsystem Power Supply (DCA) LED Status	56
Logical and Physical Locations	58
Physical Location Codes	58
Location Code Format	58
Multiple FRU Callout Instructions	59
AIX Location Codes	60
Non-SCSI Devices	60
SCSI Devices	61
AIX and Physical Location Code Reference Tables	62
Specifications.	138
@server pSeries 690 Physical Specifications and Loads	138
Weight Distribution	146
Total System Power Consumption	150
Service Inspection Guide	152
Chapter 2. Diagnostics Overview.	153
Maintenance Analysis Procedures (MAPs)	153
Checkpoints	154
FRU Isolation	155
Service Agent for the @server pSeries 690.	156
Using the Service Processor and Service Agent Features	156
Running Diagnostics on the Native Serial Port on a Full Machine Partition with an HMC attached.	156
Chapter 3. Maintenance Analysis Procedures (MAPs)	157
Entry MAP.	157
Quick Entry MAP.	159
Quick Entry MAP Table of Contents	159
MAP 1020: Problem Determination.	166

Purpose of This MAP	166
MAP 1320: Service Focal Point Procedures	172
MAP 1321: Quick Entry MAP for Systems with Service Focal Point	172
MAP 1322: End of Call MAP for Systems with Service Focal Point	175
MAP 1420: Recovery Procedures for Hot-Pluggable PCI Adapters	181
MAP 1421: Partition Will Not Boot Due to Faulty Adapter	181
MAP 1422: Slot is Empty Even When Populated	182
MAP 1520: Power	185
Map 1521: The System Will Not Power On And No Error Codes Are Available	189
Map 1522: UEPO Switch On The BPC Is In The Bypass Position	192
Map 1523: There Is a Bulk Power Regulator (BPR) Communications Fault	193
Map 1524: An Open Room EPO Switch Has Been Detected From One Side	193
Map 1525: There Is a 350 Volt Bulk Failure	195
Map 1526: There Is An Integrated Battery Feature (IBF) Failure	197
Map 1527: An Airflow Loss Has Been Detected	200
Map 1528: There Is A Processor (Critical/Warning) Overtemperature Fault	202
Map 1529: There Is A Bulk Power Assembly (BPA) Communication Failure	202
Map 152a: Loss of ac Power or Phase Missing.	204
Map 152b: 2.5 V Current/Voltage Problem in Processor Subsystem	206
Map 152c: 1.8 V Current/Voltage Problem in Processor Subsystem	212
Map 152d: 1.5 V Auxiliary Current/Voltage Problem in Processor Subsystem	223
Map 152e: 1.5 V CPU Current/Voltage Problem in Processor Subsystem	231
Map 152f: 3.3 V Current/Voltage Problem in Processor Subsystem	237
Map 152g: 5.0 V Current/Voltage Problem in Processor Subsystem	246
Map 152h: 3.3V Current/Voltage Problem in I/O Subsystem	253
Map 152i: 5.0 V Current/Voltage Problem in I/O Subsystem	261
Map 152j: 2.5 V Current/Voltage Problem in I/O Subsystem	270
Map 152k: 12.0 V Current/Voltage Problem in I/O Subsystem	278
Map 152l: -12.0V Current/Voltage Problem in I/O Subsystem	287
Map 152m: Cable Problem in Power Subsystem	295
Map 152n: DASD Subsystem Power Problem	299
MAP 1540: Problem Isolation Procedures	303
MAP 1541: JTAG Problem Isolation	304
MAP 1542: I/O Problem Isolation	312
MAP 1543: MCM Module Problem Isolation	332
MAP 1544: Inner L3 Module Problem Isolation	334
MAP 1545: Outer L3 Module Problem Isolation.	336
MAP 1546: Memory Book Problem Isolation.	338
MAP 1547: I/O Book Problem Isolation	341
MAP 1548: Memory and Processor Problem Isolation	343
MAP 1549: Attention Problem Isolation	345
MAP 154A: I2C Bus Problem Isolation	352
MAP 154B: Insufficient Hardware Resources Problem Isolation	355
Chapter 4. Checkpoints	359
IPL Flow	359
Service Processor Checkpoints	362
Firmware Checkpoints	370
Boot Problems	396

Chapter 5. Error Code to FRU Index	399
Performing Slow Boot	399
Confirming Initial Error Code	400
Four-Character Checkpoints	401
Replacing the Media Subsystem Operator Panel	401
Replacing the Network Adapter	401
Determining Location Code	401
Checkpoints and Error Codes Index	403
Operator Panel Error Codes	405
SPCN Error Codes	407
Firmware/POST Error Codes	470
Service Processor Error Codes	496
System Firmware Update Messages	680
Scan Dump Messages	680
Common Firmware Error Codes	681
Problem Determination-Generated Error Codes	691
Hypervisor Dump Retrieval Procedure	692
Hypervisor Dump Indications	692
Chapter 6. Using the Online and Standalone Diagnostics	695
Online and Standalone Diagnostics Operating Considerations	695
Identifying the Terminal Type to the Diagnostics	696
Undefined Terminal Types	696
Resetting the Terminal	696
Running Online Diagnostics	696
Online Diagnostics Modes of Operation	697
Service Mode	697
Running Online Diagnostics in Service Mode	697
Concurrent Mode	698
Running the Online Diagnostics in Concurrent Mode	698
Maintenance Mode	699
Running the Online Diagnostics in Maintenance Mode	699
Standalone Diagnostic Operation	700
Performing Slow Boot	700
Partitioned System Considerations for Standalone Diagnostics	700
Considerations for Running Standalone Diagnostics from CD-ROM	701
Loading the Standalone Diagnostics from CD-ROM	701
Running Standalone Diagnostics from a Network Installation Management (NIM)	
Server	701
NIM Server Configuration	702
Client Configuration and Booting Standalone Diagnostics from the NIM Server	703
Chapter 7. Using the Service Processor	705
Service Processor Menus	705
Accessing the Service Processor Menus Locally	706
Accessing the Service Processor Menus Remotely	706
Saving and Restoring Service Processor Settings	706
Menu Inactivity	706
General User Menu	707
Privileged User Menus	709

	Main Menu.	709
	Service Processor Setup Menu	711
	Passwords.	712
	System Power Control Menu.	717
	System Information Menu	722
	Language Selection Menu	727
	Call-In/Call-Out Setup Menu	728
	Modem Configuration Menu	729
	Serial Port Selection Menu	730
	Serial Port Speed Setup Menu	730
	Telephone Number Setup Menu.	732
	Call-Out Policy Setup Menu	733
	Customer Account Setup Menu	734
	Call-out Test	734
	Service Processor Parameters in Service Mode (Full System Partition)	734
	System Power-On Methods	734
	Service Processor Reboot/Restart Recovery	736
	Boot (IPL) Speed	736
	Failure During Boot Process	736
	Failure During Normal System Operation.	736
	Service Processor Reboot/Restart Policy Controls.	737
	System Firmware Updates	739
	Determining the Level of Firmware on the System.	739
	Update Diskette Images and Instructions.	739
	Configuring and Deconfiguring Processors or Memory	743
	Run-Time CPU Deconfiguration (CPU Gard)	743
	Service Processor System Monitoring - Surveillance	744
	System Firmware Surveillance	744
	Operating System Surveillance	745
	Call-Out (Call-Home)	746
	Console Mirroring	747
	System Configuration	747
	Service Processor Error Logs	748
	LCD Progress Indicator Log	749
(3)	Resetting the Service Processor	749
	Service Processor Operational Phases	751
	Pre-Standby Phase	751
	Standby Phase	752
	Bring-Up Phase	752
	Run-Time Phase.	753
	Chapter 8. Using System Management Services	755
	Password Utilities	756
	Display Error Log	757
	Remote Initial Program Load Setup	757
	IP Parameters	758
	Adapter Parameters.	759
	Ping	760
	SCSI Utilities	761
	Select Console	761

Multiboot	762
Select Software	762
Software Default	763
Select Install Device	763
Select Boot Devices	763
Multiboot Startup <OFF>	765
Select Language.	765
OK Prompt.	765
Exiting System Management Services.	765
Chapter 9. Removal and Replacement Procedures	767
Introduction	770
Handling Static-Sensitive Devices	771
Powering Off and Powering On the System	771
Hot-Pluggable FRUs	773
Power Subsystem	776
Bulk Power Assembly (BPA)	776
Bulk Power Regulator (BPR)	776
Bulk Power Controller (BPC)	777
Bulk Power Distributor (BPD)	778
Bulk Power Fan (BPF)	780
Bulk Power Enclosure (BPE)	780
Unit Emergency Power Off (UEPO) Card Assembly	782
Integrated Battery Feature (IBF)	783
Processor Subsystem	786
Installing the MCM/L3/Passthrough Plug Map	786
I/O Books and I/O Blanks	787
Battery	790
Processor Subsystem DCA (Distributed Converter Assembly) Books and DCA Blanks	792
Capacitor Books and Blanks	793
MCM Module (Processor) and Passthru Modules	794
L3 Cache Modules	805
VPD Card	820
System Clock Card	821
Processor Subsystem Chassis	822
Memory Books and Memory Blanks	825
Fan Controller.	827
Processor Fan Assemblies	828
Fan Chassis	828
Processor Subsystem Air Filters.	829
I/O Subsystem	830
I/O Subsystem PCI Slot LED Definitions	830
PCI Adapters	831
Non-Hot-Pluggable PCI Adapter.	831
Replacing a Double-Wide Blind Swap Adapter	834
Hot-Pluggable PCI Adapter	836
PCI Hot-Plug Manager Access	843
Blind Swap Cassette (BSC) Assembly Procedure	846
I/O Subsystem RIO Riser Card	856

I/O Subsystem Distributed Converter Assembly (DCA)	857
I/O Subsystem I/O Backplane Assembly	858
I/O Subsystem DASD Hard Disk Drive Assembly	860
I/O Subsystem DASD 4-Pack	862
I/O Subsystem DASD Fan	863
I/O Subsystem Chassis	864
Media Subsystem	865
CD-ROM, DVD-RAM, or Tape Drive	865
Diskette Drive	867
Operator Panel	868
Media Subsystem Chassis	870
Media Subsystem Internal Cables	871
Chapter 10. Parts Information	873
7040 Model 61R Rack Subsystem	874
7040 Model 681 Processor Subsystem Processor Subsystem (Front)	876
7040 Model 681 Processor Subsystem Processor Subsystem (Front)	878
7040 Model 681 Processor Subsystem Processor Subsystem (Rear)	880
7040 Model 681 Media Subsystem	882
Power and SCSI Cables to the Media Subsystem	884
7040 Model 61D I/O Subsystem	886
Front	886
Rear	887
Power Cabling	888
RIO Cables and I/O Power Cables	890
Keyboards and Mouse	892
System Power Cables	893
Tools	894
Appendix A. Environmental Notices	895
Product Recycling and Disposal	895
Environmental Design	895
Acoustical Noise Emissions	896
Declared Acoustical Noise Emissions	896
Appendix B. Notices	897
Appendix C. Service Processor Setup and Test	899
Service Processor Setup Checklist	899
Testing the Setup	900
Testing Call-In	900
Testing Call-Out	901
Serial Port Configuration	901
Appendix D. Modem Configurations	903
Sample Modem Configuration Files	903
Generic Modem Configuration Files	903
Specific Modem Configuration Files	903
Configuration File Selection	904
Examples for Using the Generic Sample Modem Configuration Files	905

Customizing the Modem Configuration Files	906
IBM 7852-400 DIP Switch Settings	906
Xon/Xoff Modems	907
Ring Detection	908
Terminal Emulators	908
Recovery Procedures	908
Transfer of a Modem Session	909
Recovery Strategy	910
Prevention Strategy	910
Modem Configuration Sample Files.	911
Sample File modem_m0.cfg	911
Sample File modem_m1.cfg	913
Sample File modem_z.cfg.	915
Sample File modem_z0.cfg	917
Sample File modem_f.cfg	919
Sample File modem_f0.cfg	922
Sample File modem_f1.cfg	925
Appendix E. Ground Path	929
Index	931

Safety Notices

A *danger* notice indicates the presence of a hazard that has the potential of causing death or serious personal injury. *Danger* notices appear on the following pages:

- xii
- 185
- 770
- 792
- 857

A *caution* notice indicates the presence of a hazard that has the potential of causing moderate or minor personal injury. *Caution* notices appear on the following pages:

- xii
- xiii
- 143
- 185
- 770
- 790
- 822
- 866

For a translation of the safety notices contained in this book, see the *System Unit Safety Information*, order number SA23-2652.

Electrical Safety

Observe the following safety instructions any time you are connecting or disconnecting devices attached to the system.

DANGER

An electrical outlet that is not correctly wired could place hazardous voltage on metal parts of the system or the devices that attach to the system. It is the responsibility of the customer to ensure that the outlet is correctly wired and grounded to prevent an electrical shock.

Use one hand, when possible, to connect or disconnect signal cables to prevent a possible shock from touching two surfaces with different electrical potentials.

During an electrical storm, do not connect cables for display stations, printers, telephones, or station protectors for communications lines.

CAUTION:

This product is equipped with a four-wire (three-phase and ground) power cable for the user's safety. Use this power cable with a properly grounded electrical outlet to avoid electrical shock.

DANGER

To prevent electrical shock hazard, disconnect all power cables from the electrical outlet before relocating the system.

CAUTION:

This unit has more than one power supply cord. Follow procedures for removal of power from the system when directed.

CAUTION:

Energy hazard, remove power before servicing.

CAUTION:

Energy hazard, remove all jewelry before servicing.

Laser Safety Information

CAUTION:

This product may contain a CD-ROM, DVD-ROM, or laser module on a PCI card, which are class 1 laser products.

Laser Compliance

All lasers are certified in the U.S. to conform to the requirements of DHHS 21 CFR Subchapter J for class 1 laser products. Outside the U.S., they are certified to be in compliance with the IEC 825 (first edition 1984) as a class 1 laser product. Consult the label on each part for laser certification numbers and approval information.

CAUTION:

All IBM laser modules are designed so that there is never any human access to laser radiation above a class 1 level during normal operation, user maintenance, or prescribed service conditions. Data processing environments can contain equipment transmitting on system links with laser modules that operate at greater than class 1 power levels. For this reason, never look into the end of an optical fiber cable or open receptacle. Only trained service personnel should perform the inspection or repair of optical fiber cable assemblies and receptacles.

Data Integrity and Verification

IBM computer systems contain mechanisms designed to reduce the possibility of undetected data corruption or loss. This risk, however, cannot be eliminated. Users who experience unplanned outages, system failures, power fluctuations or outages, or component failures must verify the accuracy of operations performed and data saved or transmitted by the system at or near the time of the outage or failure. In addition, users must establish procedures to ensure that there is independent data verification before relying on such data in sensitive or critical operations. Users should periodically check the IBM support websites for updated information and fixes applicable to the system and related software.

About This Book

This book provides maintenance information that is specific to the @server pSeries 690, adapters, and attached devices that do not have their own service information. It also contains Maintenance Analysis Procedures (MAPs) that are not common to other systems.

MAPs that are common to all systems are contained in the *RS/6000 and @server pSeries Diagnostic Information for Multiple Bus Systems*.

This book is used by the service representative to repair system failures. This book assumes that the service representative has had training on the system.

ISO 9000

ISO 9000 registered quality systems were used in the development and manufacturing of this product.

Online Publications

IBM @server pSeries publications are available online. To access the online books, visit our Web site at: http://www.ibm.com/servers/eserver/pseries/library/hardware_docs/

Related Publications

The following publications are available:

- The *System Unit Safety Information*, order number SA23-2652, contains translations of safety information used throughout this book.
- The *IBM Hardware Management Console for pSeries Operations Guide*, order number SA38-0590, contains information on how to set up and cable the hardware management console and verify system operation.
- The *IBM Hardware Management Console for pSeries Maintenance Guide*, order number SA38-0603, contains MAPS, removal and replacement procedures, error codes, and parts information that help trained service representatives diagnose and repair the hardware management console.
- The *@server pSeries 690 Installation Guide*, order number SA38-0587, contains information on how to set up and cable the system, install and remove options, and verify system operation.
- The *@server pSeries 690 User's Guide*, order number SA38-0588, contains information on how to use the system, use diagnostics, use service aids, and verify system operations.
- The *RS/6000 and @server pSeries Diagnostic Information for Multiple Bus Systems*, order number SA38-0509, contains common diagnostic procedures, error codes, service request numbers, and failing function codes. This manual is intended for trained service technicians.

- The *RS/6000 and @server pSeries Adapters, Devices, and Cable Information for Multiple Bus Systems*, order number SA38-0516, contains information about adapters, external devices, and cabling. This manual is intended to supplement information found in the *RS/6000 and @server pSeries Diagnostic Information for Multiple Bus Systems*.
- The *PCI Adapter Placement Reference*, order number SA38-0538, contains information regarding slot restrictions for adapters that can be used in this system.
- The *Site and Hardware Planning Information*, order number SA38-0508, contains information to help you plan your installation.
- The *Electronic Service Agent For pSeries and RS/6000 User's Guide*, order number LCD4-1060, contains information for use by the service representative to help set up and use the Service Director package.
- The *AIX Network Installation Management Guide and Reference*, order number SC23-4385, contains information to help you plan and install systems to use a network server to do functions such as installing the operating system or diagnostics on systems connected to the network.

Trademarks

The following terms are trademarks of International Business Machines Corporation in the United States, other countries, or both:

- AIX
- e (logo)
- pSeries
- RS/6000
- LANstreamer

Other company, product, and service names may be trademarks or service marks of others.

Chapter 1. Reference Information

This chapter provides an overview of the @server pSeries 690, including a logical description and a physical overview of the system. Additional details pertaining to the server are also provided. They include the following:

- Memory overview and ordering rules
- General description of the operator panel
- Cabling rules
- System location rules and descriptions
- Powering on and powering off the system
- Power flow
- Data flow

@server pSeries 690 Overview

The @server pSeries 690 server is a multiprocessor, multibus system composed of the following subsystems:

- 7040 Model 61R, a 24-inch wide and 42-EIA high rack unit that also contains the following:
 - An 8-EIA unit power subsystem, consisting of two redundant bulk power assemblies that distribute bulk power at 350 V to each of the subsystems.
 - An optional 2 EIA-unit internal battery feature (IBF), which is available in either a redundant or non-redundant configuration.
- 7040 Model 681 Processor Subsystem Processor Subsystem, a 17 EIA-unit processor subsystem, which contains the processors, L3 cache, memory, and service processor and a 1 EIA-unit media subsystem containing a diskette drive, a CD-ROM, and an operator panel, with space for up to three additional optional media devices.
- 7040 Model 61D I/O Subsystem, 4 EIA-units, which can have up to 20 PCI adapters and up to 16 DASD disk drives.
- A Hardware Management Console (HMC), which provides a standard user interface for configuring and operating partitioned systems. One HMC can support multiple partitions on multiple systems.

The basic system consists of the redundant bulk power subsystem, one processor subsystem, a media subsystem, and one I/O subsystem in the same rack, and one HMC, as shown in the following illustration:.

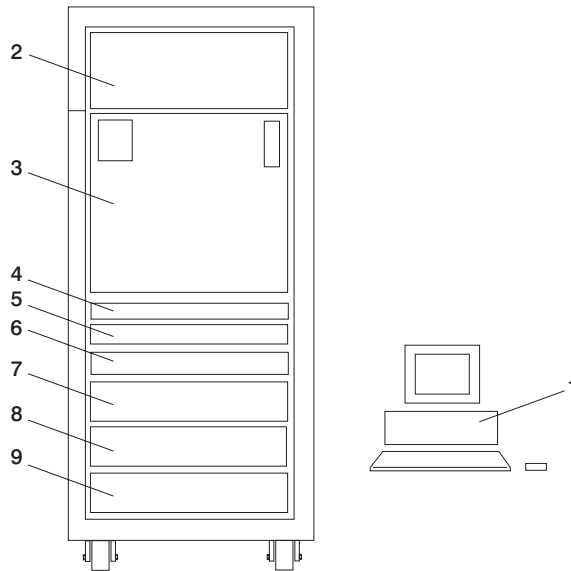

1	Hardware Management Console	5, 6*	7040 Model 61R primary Integrated Battery Feature (IBF), optional for the primary power subsystem. Redundant IBF, also optional, and installs from the rear.
2	7040 Model 61R Bulk Power Subsystem	7	7040 Model 61D I/O Subsystem
3	7040 Model 681 Processor Subsystem Processor Subsystem	8	7040 Model 61D I/O Subsystem (Optional)
4	7040 Model 681 Media Subsystem	9	7040 Model 61D I/O Subsystem (Optional)
		*	7040 Model 61D I/O Subsystem (Optional, If features 5 and 6 are not installed)

You can expand the system by adding I/O subsystems for a total of eight in a minimum of two racks. The preceding figure shows the single rack. Additional I/O drawers and integrated battery features are installed in a second rack.

A number of cables connect the power, processor, and I/O subsystems. These cables include the following:

- UPIC (Universal Power Interface Controller) cables
- RIO (Remote Input Output) cables

The ac power cords are connected to the bulk power subsystem, which distributes the power throughout the system.

Each I/O subsystem contains two I/O backplanes. Each backplane is capable of supporting the following:

- Up to 10 adapters each (20 per subsystem)
- Up to 8 disk drives (16 per subsystem) in two DASD 4-packs (4 per subsystem)
- One distributed converter assembly (DCA) (2 per subsystem)
- Two DASD fans (4 per subsystem)

On each I/O backplane, PCI bus slots 1 through 7 are 3.3 V dc connectors running at 66 MHz, supporting 64-bit PCI adapters. Slots 8 through 10 are 64-bit 5 V dc slots, running at 33 MHz.

The media subsystem provides space for up to three media devices (diskette drive, CD-ROM drive, and optional tape drive or DVD-RAM) in the front and two additional optional devices in the back.

Hardware Management Console (HMC)

The Hardware Management Console (HMC) supports your system with features that allow you to manage configuration and operation of partitions in a system, as well as add and remove hardware without interrupting system operation.

In this book, a system that is managed by the HMC is referred to as the managed system. The HMC uses its serial connection to the managed system to perform various functions. The HMC's main functions include the following:

- Creating and maintaining a multiple partition environment
- Detecting, reporting, and storing changes in hardware conditions
- Acting as a service focal point for service representatives to determine an appropriate service strategy

Partitioning the system is similar to partitioning a hard drive. When you partition a hard drive, you divide a single hard drive so that the operating system recognizes it as a number of separate hard drives. The same holds true for the HMC's partitioning capabilities, except the HMC allows you to divide the system's processors, memory, and I/O. On each of these divisions, you can install an operating system and use each partition as you would a separate physical machine. This division of system resources is called a *logical partition*.

The objective of partitioning is to provide users with the capability to split a single system into several independent systems, each capable of running applications in multiple, independent environments simultaneously. For example, partitioning makes it possible for a user to run a single application using different sets of data on separate partitions, as if it were running independently on separate physical systems.

Service representatives use Service Focal Point (SFP), an application that runs on the HMC, to start and end their service calls. SFP provides service representatives with event, vital product data (VPD), and diagnostic information.

The HMC is a closed system. Additional applications cannot be installed on the HMC. All the tasks needed to maintain the platform, the underlying operating system, and the HMC application code are available by using the HMC's management applications.

Partition Standby and Full System Partition Power-On Options

Booting your system in partition standby is markedly different from booting your system in a traditional single-machine full system partition. In partition standby, the system sets aside system memory for partition management.

Partition Standby Memory Issues

Unique issues are associated with assigning memory to each partition created in partition standby. In partition standby, the HMC allocates a portion of each assigned memory block to the system.

Each partition requires a minimum of 1 gigabyte (GB) of system memory. When you start creating partitions, the system sets aside 256 megabytes (MB) of contiguous memory for its own use, and allocates another 256 MB of contiguous memory for each 16 GB allocated.

Page Table Memory Usage: Partition page tables are additional memory required for a partition to operate, and is in addition to the total logical memory size of a partition. The partition table is outside of a partition's accessible memory. The partition page table must be constructed with contiguous real system memory segments. Use the following table to help you keep track of the system's page-table memory usage:

Partition Memory Size (256 MB increments)	Partition Page Table Size (4 16-byte entries per 4 K real page)	Partition Page Table Alignment	Assigned Memory Segments (256 MB)
1 GB	16 MB	16 MB	1
1 GB - 2 GB	32 MB	32 MB	1
2 GB - 3 GB	64 MB	64 MB	1
4 GB - 7 GB	128 MB	128 MB	1
8 GB - 15 GB	256 MB	256 MB	1
16 GB - 31 GB	512 MB	512 MB	2
32 GB - 63 GB	1 GB	1 GB	4
64 GB - 96 GB	2 GB	2 GB	8

In a full system partition, the operating system uses all of the installed memory; the system does not set aside contiguous memory for its own use.

Keep this in mind when you record the amount of memory used when you are completing the planning worksheets in the *IBM Hardware Management Console for pSeries Operations Guide*, order number SA38-0590.

Partition Requirements

To activate a partition, you need a *minimum* of the following:

- 1 GB of available system memory
- One available system processor
- One available network adapter (for error reporting)

If you attempt to activate a partition and the resources you specified aren't available at that time, activation fails. It is important to keep track of your system's resources and your activation times to avoid failures.

Service Focal Point

Service representatives use the HMC as the starting point for all service issues. The HMC groups various system management issues at one control point, allowing service representatives to use the Service Focal Point application to determine an appropriate service strategy.

Traditional service strategies become more complicated in a partitioned environment. Each partition runs on its own, unaware that other partitions exist on the same system. If one partition reports an error for a shared resource, such as a managed system power supply, other active partitions report the same error. The Service Focal Point application enables service representatives to avoid long lists of repetitive call-home information by recognizing that these errors repeat, and the filtering them into one error code..

Errors that require service are reported to the HMC as *serviceable events*. Because the HMC stores these serviceable events for 90 days and then discards them, it is important to have the partition and HMC date and time set correctly. For instance, if the date on a partition's software is set 90 days *behind* the HMC's set time, the serviceable events reported from this partition are immediately discarded. For more information about setting the HMC's date and time, see the *IBM Hardware Management Console Operations Guide for pSeries*, order number SA38-0590. To set the partition's date and time, see the documentation provided with the operating system that is running on that partition.

The following is an example of the Service Focal Point application's main screen in the Contents area:

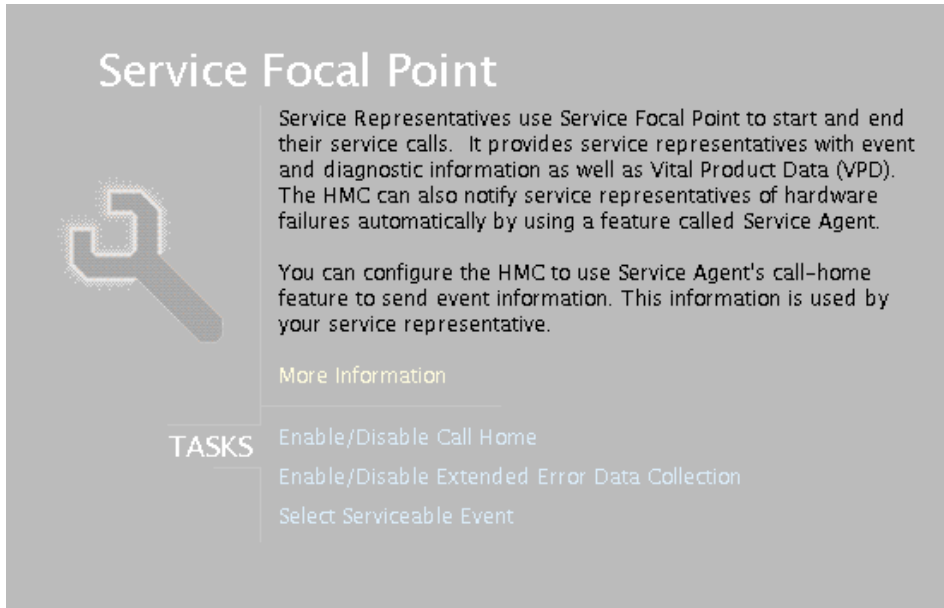

Getting Started

When you are setting up Service Focal Point, keep the following in mind:

- If the `/var` file system is full (either on the HMC or partitions), it can prevent Serviceable Events from being reported to the HMC.
- If the time configured on a partition is 90 days older than time configured on the HMC, serviceable events cannot be reported.
- Verify that the HMC hostnames are defined. For more information on using fully qualified and short hostnames, see the *IBM Hardware Management Console Operations Guide for pSeries*, order number SA38-0590.
- Verify that the HMC and managed system are on the network and that DNS is working correctly when being used. To do this, telnet to partitions from the HMC using the partition hostname. You can also verify that partitions are set up properly for service focal point by running the following command:

```
/opt/hsc/bin/lspartition -debug
```

and checking the **Active** flag. For example, the `lspartition -all` command shows a partition with host name `hmc1.yourdomain.yourcompany.com` and `LParID=001` as:

```
Hostname: hmc1.yourdomain.yourcompany.com
IPAddr: x.x.xxx.xxx
LParID:<001>
Active:<1>
OSType:<>
OSVers:<>
```

- If you need to add or change a partition name, see *IBM Hardware Management Console Operations Guide for pSeries*.

Automatic Call-Home Feature

You can configure the HMC to automatically call an appropriate service center when it identifies a serviceable event.

To enable or disable the call-home feature, you must be a member of one of the following roles:

- System Administrator
- Service Representative
- Advanced Operator
- Operator

To enable or disable the call-home feature for one or more systems, do the following:

Note: It is strongly recommended that you not disable the call-home feature. When you disable the call-home feature, serviceable events are not automatically reported to your service representative.

1. In the Navigation area, select the **Service Focal Point** icon.
2. In the Contents area, select **Enable / Disable Call Home**.
3. The **Enable / Disable call home** window displays a list of managed systems. Click on the managed system you want to enable or disable.
4. Click **Enable** to enable call-home for the selected system, or click **Disable** to disable call-home for the selected system.
5. Click **OK**.

Extended Error Data Collection

This feature allows you to enable or disable extended error data (EED) collection in one or more managed systems.

The following types of EED can be activated and deactivated independently:

- Central Service Processor (CSP) EED. CSP EED describes the current partition status on the managed system.
- Operating System (OS) EED. OS EED is the data collected from the partition that is experiencing problems.

EED is collected automatically for each serviceable event on a partition. The most recent serviceable event's EED is retained until a new serviceable event occurs. If EED collection is enabled on the HMC, the EED collected on a partition is transferred to and stored on the HMC's hard drive. You can store up to 20 sets of serviceable-event EED on the HMC's local file system at any given time.

To enable or disable extended error-data collection, you must be a member of one of the following roles:

- System Administrator

- Service Representative
- Advanced Operator
- Operator

To enable or disable extended error-data collection, do the following:

1. In the Navigation area, select the **Service Focal Point** icon.
2. In the Contents area, select **Enable / Disable Extended Error Data Collection**.
3. The Enable / Disable Extended Error Data Collection window displays a list of systems. The window also lists each system's error class, state, and type. Click the system for which you want to enable or disable extended error-data collection.
4. Click **Enable** to enable extended error-data collection for the selected managed system, or click **Disable** to disable extended error-data collection for the selected managed system.
5. Click **OK**.

Working With Serviceable Events

You can view, add, or update serviceable event information, including error details.

Viewing Serviceable Events: To view serviceable events, you must be a member of one of the following roles:

- System Administrator
- Service Representative
- Advanced Operator
- Operator

To view a serviceable event, do the following:

1. In the Navigation area, select the **Service Focal Point** icon.
2. In the Contents area, click **Select Serviceable Event**.
3. Designate the set of serviceable events you want to view by selecting the failing system's name, the error class, the serviceable event status, and the number of days to view. Click **OK** when you are finished.
4. The Serviceable Event Overview window opens, and the entries displayed are ordered by time stamp. Each line in the Serviceable Event Overview window corresponds to one error within a serviceable event. Information provided includes the following:
 - Event status
 - Original time stamp
 - Failing device name
 - Failing machine type/model/serial number
 - Error class
 - Descriptive error text

You can sort events by time stamp or status.

When you select a line in the Serviceable Event Overview window, all lines in the same serviceable event are selected. To open the Serviceable Event Details window for the selected event, select the event and then click **Event Details**.

Viewing Serviceable Event Details: To view serviceable event details, do the following:

1. Perform the steps in “Viewing Serviceable Events” on page 8.
2. The Serviceable Event Details window opens, showing extended serviceable event information. The Serviceable Event Detailed Attributes table includes the following information:
 - Status
 - Earliest original time stamp of any managed object
 - AIX error log
 - Should this error ever get called home?
 - Error was called home
 - Pointer to extended error data collection on the HMC

The lower table displays all of the errors associated with the selected serviceable event. The information is shown in the following sequence:

- Failing device system name
- Failing device machine type/model/serial
- Error class
- Descriptive error text

Viewing Serviceable Event Error Details: To view serviceable event error details, do the following:

1. Perform the steps in “Viewing Serviceable Event Details”.
2. Select an error in the lower table and click **Error Details**.

Viewing Service Processor Error Details: To view service processor error details, do the following:

1. Perform the steps in “Viewing Serviceable Event Error Details”.
2. If the serviceable event error details you are viewing are for a service processor-class error, the lower table on the resulting window contains service processor errors. Select a service processor error from the lower table and click **Service Processor Error Details** to see further details. A window similar to the

following displays:

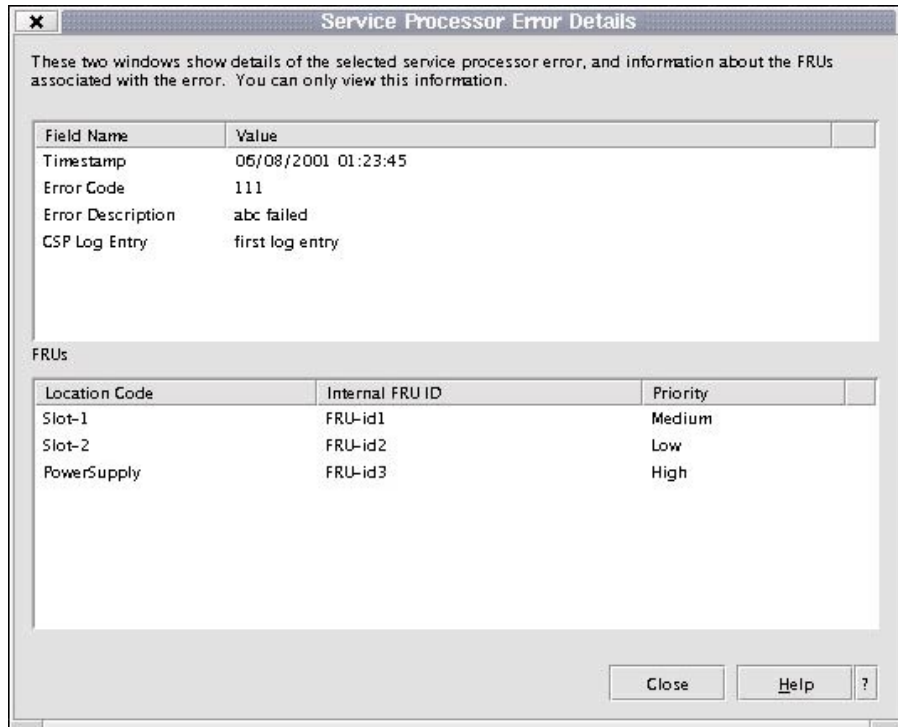

Saving and Managing Extended Error Data: To save extended error data, do the following:

1. In the Navigation area, select the **Service Focal Point** icon.
2. In the Contents area, click **Select Serviceable Event**.
3. Perform the steps in "Viewing Serviceable Event Details" on page 9.
4. Designate the set of serviceable events you want to view by selecting the failing system's name, the error class, the serviceable event status, and the number of days to view. Click **OK**.
5. Double-click the serviceable event, or select it and click **Event Details** from the menu.
6. Click **Save EE Data**.

Note: To save extended error data for only *one* error associated with the serviceable event (rather than for the entire serviceable event), select the error from the lower table and then click **Error Details**. In the next menu, click **Manage EE Data**.

Viewing and Adding Serviceable Event Comments: To add serviceable event comments, you must be a member of the Service Representative role.

To add comments to a serviceable event, do the following:

Note: You cannot edit or delete previous comments.

1. In the Navigation area, select the **Service Focal Point** icon.
2. In the Contents area, click **Select Serviceable Event**.
3. Perform the steps in “Viewing Serviceable Event Details” on page 9.
4. Designate the set of serviceable events you want to view by typing the failing system’s name, the error class, the serviceable event status, and the number of days to view. Click **OK**.
5. Double-click the serviceable event, or select it and click **Event Details** from the menu.
6. Select the error to which you want to add comments to and click **Comments....** If you want to close the event and add comments, click **Close Event** from this window. The Serviceable Event Comments window opens.
7. Type your name and add comments as appropriate. You can also review previous comments, but you cannot edit this information.
8. If you clicked **Comments** on the Serviceable Event Details window, clicking **OK** commits your entry and returns you to the Serviceable Event Details window.

If you clicked **Close Event** on the Serviceable Event Details window, clicking **OK** commits all changes and opens the Update FRU Information window. For more information about updating field replaceable units, see “Updating Field Replaceable Unit (FRU) Information” on page 12.

Closing a Serviceable Event: To close a serviceable event, do the following:

1. In the Navigation area, select the **Service Focal Point** icon.
2. In the Contents area, click **Select Serviceable Event**.
3. Perform the steps in “Viewing Serviceable Event Details” on page 9.
4. Designate the set of serviceable events you want to view by typing the failing system’s name, the error class, the serviceable event status, and the number of days to view. Click **OK**.
5. Double-click the serviceable event, or select it and click **Event Details** from the menu.
6. Select the error to which you want to add comments and click **Comments....**
7. Click **Close Event** from this window. The Serviceable Event Comments window opens.
8. Type your name and add comments as appropriate. You can also review previous comments, but you cannot edit this information.
9. If you clicked **Comments** on the Serviceable Event Details window, clicking **OK** commits your entry and returns you to the Serviceable Event Details window.

Note: You must close a serviceable event after it has been serviced to ensure that if a similar error is reported later, it is called home. If an old problem remains open, the new similar problem is reported as a duplicate. Duplicate errors are neither reported nor called home to a service center. Close a serviceable

event when the partition that reports the error is active. Closing the event causes the new status of the serviceable event to be properly sent to the partition.

Updating Field Replaceable Unit (FRU) Information: This task allows you to update the FRU information you changed or modified as a result of this serviceable event.

To update FRU information, do the following:

1. In the Navigation area, select the **Service Focal Point** icon.
2. In the Contents area, click **Select Serviceable Event**.
3. Perform the steps in “Viewing Serviceable Event Details” on page 9.
4. Specify the set of serviceable events you want to view by typing the failing system’s name, the error class, the serviceable event status, and the number of days to view. Click **OK**.
5. Double-click the serviceable event, or select it and click **Event Details** from the menu.
6. Click **FRU Information...** . A window similar to the following opens:

The upper list shows FRUs that are associated with the selected event. If a FRU was replaced, double-click the FRU to enter replacement information.

Location Code	Part Number	Original?	Replaced?	New Part Num	Timestamp
Slot-1	1234-XYZ	Yes	No		
Slot-2	5678-ABC	Yes	Yes	5555-DEF	07/11/2001 01:02:33
Power Supply	2468-QVC	No	Yes	2458-QVC	07/11/2001 01:02:33

Click the Add New FRU button to add information about replaced or added parts that are not listed above.

Location Code	Part Number	New Part Number

No FRUs to update for this event

OK Apply Cancel Help ?

In this example, three parts are involved in this serviceable event. The system recommended that the part in Slot-1 be changed (Original=Yes), but the representative decided not to change the part. The HMC also recommended that the part in Slot-2 be changed, and the part was replaced by a part, although one with a different part number. The part in PowerSupply was not in the initial recommendation for replacement, but was replaced with a part with the same part number.

The lower table shows any parts that you have replaced or added during your current update session but that have not been committed to the serviceable event. The changes from the lower table are committed by clicking the **OK** or **Apply**.

Replacing an Existing FRU: To replace a part already listed for this serviceable event, do the following:

1. Perform the steps in “Updating Field Replaceable Unit (FRU) Information” on page 12.
2. In the upper table, double-click the part you want to replace.
3. If the FRU has a new part number, type it in the **New FRU Part Number** field.
4. Click **Replace FRU**. The Update FRU Information window displays the FRU replacement information in the lower table. Click **OK** or **Apply** to commit the changes to the serviceable event.

Adding a New FRU: You can add a part to the serviceable event that was not listed in the upper table of the Update FRU Information window. To add a new FRU for this serviceable event, do the following:

1. Perform the steps in “Updating Field Replaceable Unit (FRU) Information” on page 12.
2. Click **Add New FRU to List**.
3. Type the FRU’s location code and its part number in the appropriate fields.
4. Click **Add to List**. The Update FRU Information window opens and displays the newly added FRU in the lower table, as shown in the following example.

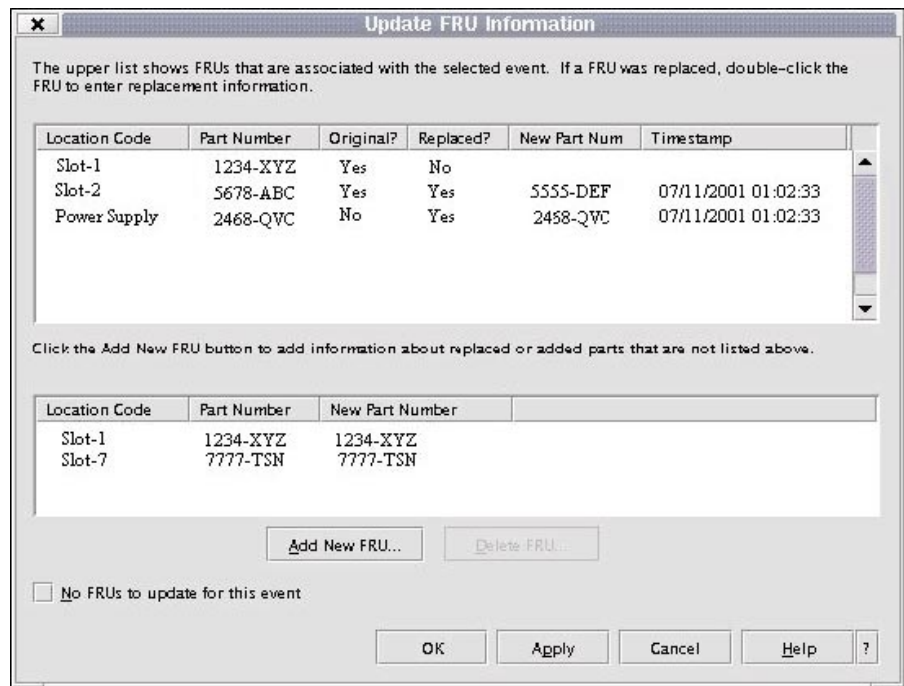

5. Click **OK** or **Apply** to commit these changes to the serviceable event.

Note: After you click **OK** or **Apply**, you cannot change this information. If you clicked the **Close Event** button in the Serviceable Event Details window, then clicking **OK** also completes the close dialog and changes the status of the serviceable event to *Closed*.

Viewing Serviceable Event Partition Information: You can view partition information associated with this serviceable event. This information includes each affected partition's state and resource use.

1. In the Navigation area, select the **Service Focal Point** icon.
2. In the Contents area, click **Select Serviceable Event**.
3. Perform the steps in "Viewing Serviceable Event Details" on page 9.
4. Specify the set of serviceable events you want to view by typing the failing system's name, the error class, the serviceable event status, and the number of days to view. Click **OK**.
5. Double-click the serviceable event, or select it and click **Event Details** from the menu.
6. Click **Partition Info...** A window similar to the following opens:



Powering the System On and Off

This section provides procedures for powering on and powering off the system.

Powering the System On

The system can be powered on after all of the following steps have been completed:

- All I/O drawer cables are connected
- UPIC cables are connected
- All PCI cables to supported subsystems are connected
- The hardware management console (HMC) is connected
- Power is connected to the system and the UEPO switch is set to On

After the required cables are installed, and the power cables are connected, the HMC graphical user interface provides a power-on function to turn on the power to the system. The power button on the media subsystem operator-panel can be pushed to initialize the system, but the preferred method is to use the HMC. Progress indicators, also referred to as *checkpoints*, are visible on the media subsystem operator panel display as the system power is turned on. The power LED on the media subsystem stops blinking and stays on, indicating the system power is on.

The processor subsystem and I/O subsystems are powered on through the system power control network (SPCN). When power is applied, the power LEDs on the media subsystem go from blinking to on continuously, and the power LEDs on the processor subsystem and I/O subsystem(s) come on and stay on. This indicates that power levels are satisfactory in the subsystems.

Powering the System Off

Note: This procedure turns the system off, but does not remove power from some parts of the system. For more information about how to power off and remove power from the system, go to “Powering Off and Powering On the System” on page 771 and “System Power-On Methods” on page 734.

The HMC user interface provides a power-off function to turn off the power to the system.

Also, if the system is operating in a Full System Partition under AIX, typing the **shutdown** command causes the system to shut down and power off. The **-F** option shuts down the system without notifying system users. Check with the system administrator before using this command. If you cannot use this method, you can power off the system by pressing the power button on the media subsystem operator panel.

Attention: Using the operator-panel power button to power off the system can cause unpredictable results in the data files, and the next IPL will take longer to complete.

@server pSeries 690 Data Flow

The following figure shows the data flow for the system.

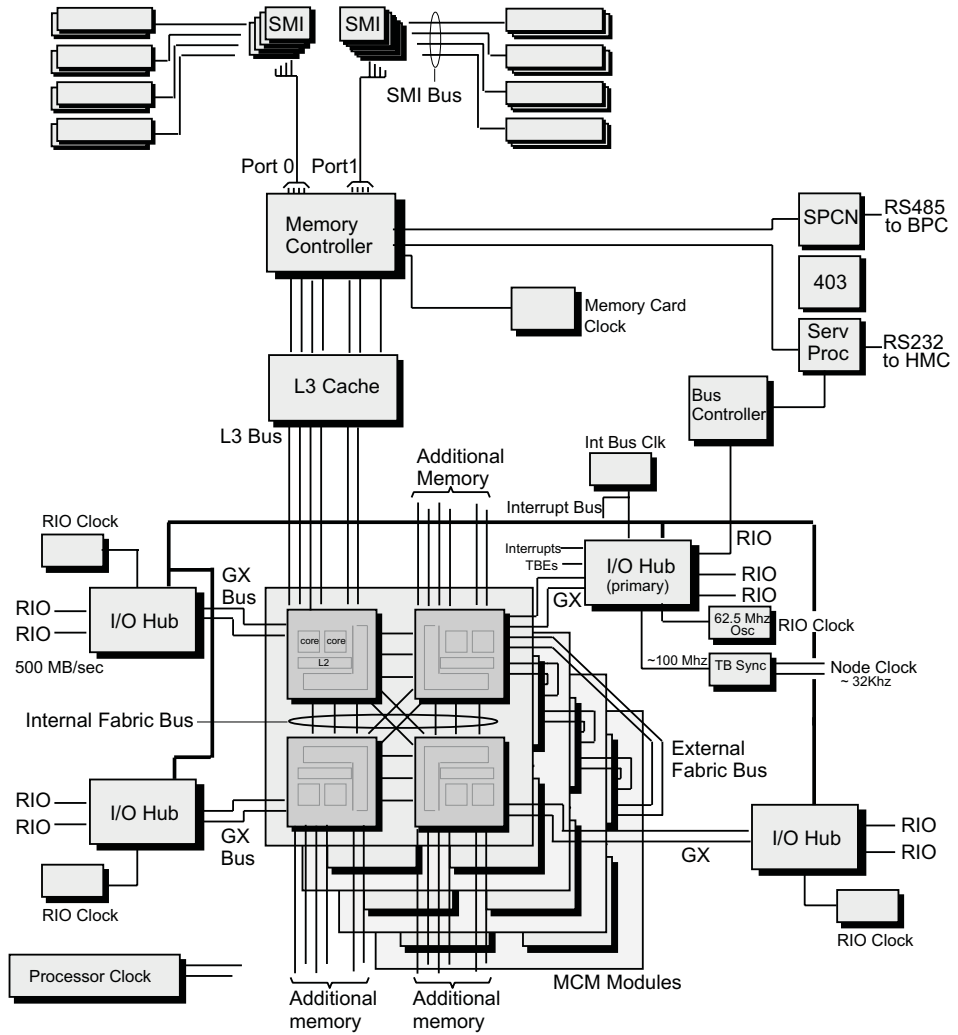

Power-On Self-Test

After power is turned on and before the operating system is loaded, the partition does a power-on self-test (POST). This test performs checks to ensure that the hardware is functioning correctly before the operating system is loaded. During the POST, a POST screen displays, and POST indicators display on the virtual terminal. The next section describes the POST indicators and functions that can be accessed during the POST.

POST Indicators

POST indicators indicate tests that are being performed as the partition is preparing to load the operating system. The POST indicators are words that display on the virtual terminal. Each time that the firmware starts another step in the POST, a POST indicator word displays on the console. The POST screen displays the following words:

Memory	Memory test
Keyboard	Initialize the keyboard and mouse. The time period for pressing a key to access the System Management Services, or to initiate a service mode boot is now open. See “POST Keys” for more information.
Network	Self-test on network adapters
SCSI	Adapters are being initialized
Speaker	Sounds an audible tone at the end of POST

POST Keys

The POST keys, if pressed *after* the **keyboard** POST indicator displays and *before* the last POST indicator (**speaker**) displays, cause the system to start services or boot modes used for configuring the system and diagnosing problems. The system will beep to remind you to press the POST key (if desired) at the appropriate time. The keys are described as follows:

1 Key

The numeric 1 key, when pressed during POST, starts the System Management Services (SMS) interface.

5 Key

The numeric 5 key, when pressed during POST, initiates a partition boot in service mode using the default service mode boot list.

This mode attempts to boot from the first device of each type found in the list. It does not search for other bootable devices of that type if the first device is not bootable. Instead, it continues to the next device type in the list. The firmware supports up to five entries in the boot list.

The default boot sequence is:

1. Diskette
2. CD-ROM

3. Hard file
4. Tape drive (if installed)
5. Network
 - a. Token ring
 - b. Ethernet

6 Key

The numeric 6 key works like the numeric 5 key, except that firmware uses the customized service mode boot list, which can be set in the AIX service aids.

8 Key

To enter the open firmware command line, press the numeric 8 key *after* the word **keyboard** displays and before the last word (**speaker**) displays during startup. After you press the 8 key, the remaining POST indicators display until initialization completes.

This option is used only by service personnel to collect additional debug information.

To exit from the open firmware command prompt, type **reset-all** or power off the system and reboot.

@server pSeries 690 System Locations

The @server pSeries 690 system consists of a minimum of four subsystems in one rack as follows:

- Processor subsystem
- Media subsystem
- One I/O subsystem
- Power subsystem

These components are connected by cables that transmit data and control signals. I/O subsystems can be added if further expansion of the system is required (up to seven additional I/O subsystems, using two racks).

The following figures show the minimum system configuration on the left. The minimum system configuration with the integrated battery feature (IBF) on the right.

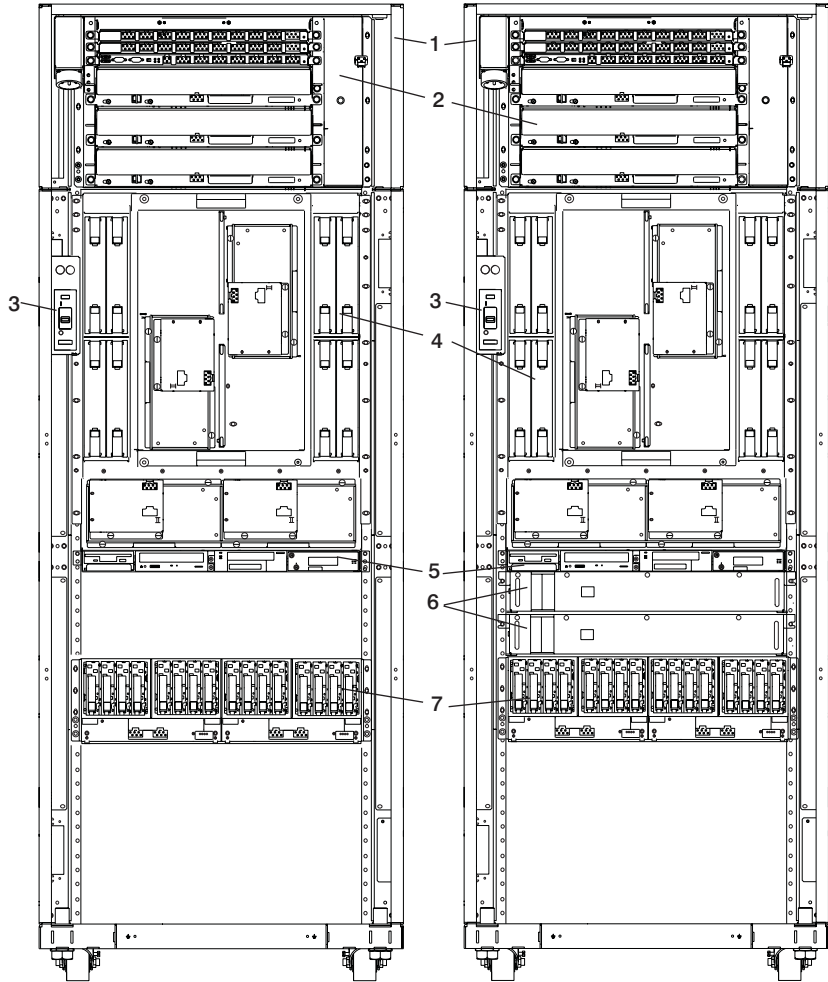

- | | | | |
|---|---------------------|---|-------------------------------------|
| 1 | Rack | 5 | Media Subsystem |
| 2 | Bulk Power Assembly | 6 | Optional Integrated Battery Feature |
| 3 | UEPO Switch | 7 | First I/O subsystem |
| 4 | Memory Books | | |

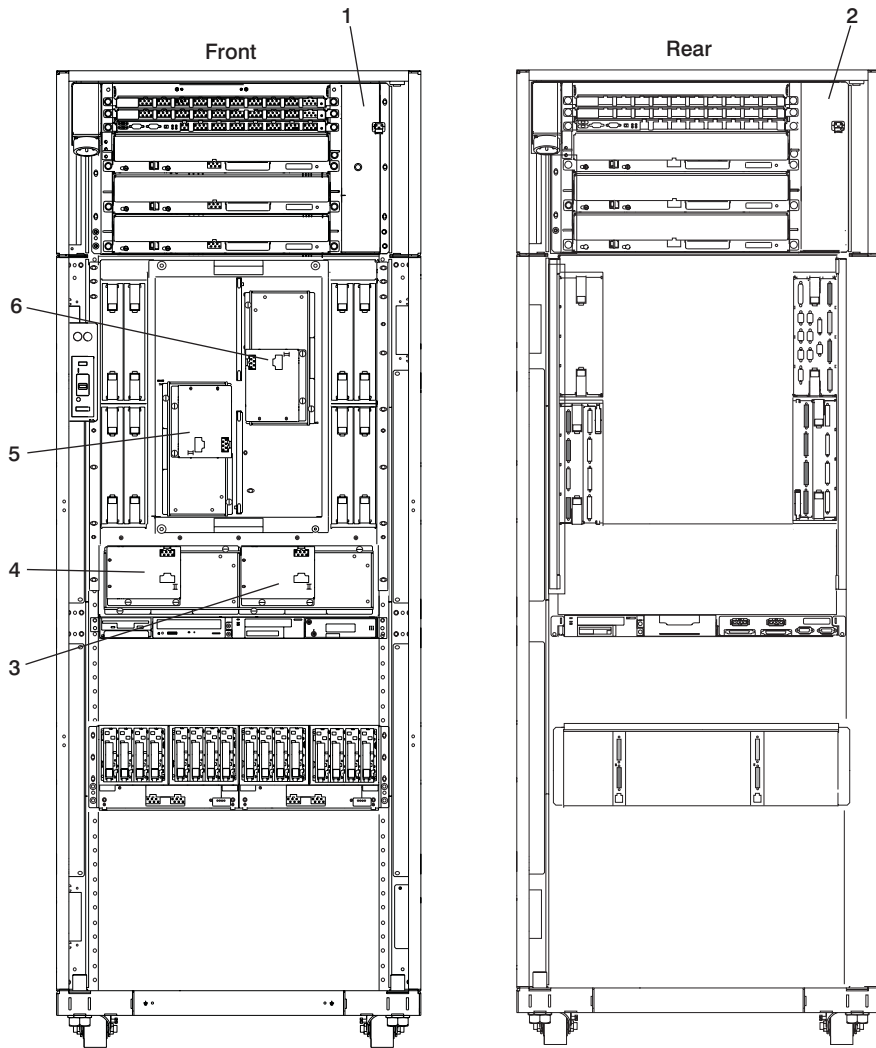

- | | | | |
|---|---------------------------------------|---|---------------------------------------|
| 1 | BPA Fan (U1.35-P1-F1) | 4 | Processor Subsystem Fan 1, (U1.18-F1) |
| 2 | BPA Fan (U1.35-P2-F1) | 5 | Processor Subsystem Fan 3, (U1.18-F3) |
| 3 | Processor Subsystem Fan 2, (U1.18-F2) | 6 | Processor Subsystem Fan 4, (U1.18-F4) |

Note: The I/O subsystem fan assemblies are inside the I/O subsystems, positioned from left to right behind the DASD 4-packs in order of fan assembly 1, fan assembly 2, fan assembly 3, and fan assembly 4.

UEPO Switch

The UEPO (Unit Emergency Power Off) switch is accessible through the external cover. The switch contains a room emergency power off (EPO) interlock connector and bypass switch, a dual element rack service amber LED (one element driven per bulk power controller), a service complete button (white) and start service button (green), an off button and four thermistors for BPC ambient temperature sensing. The UEPO switch is shown in the following figure.

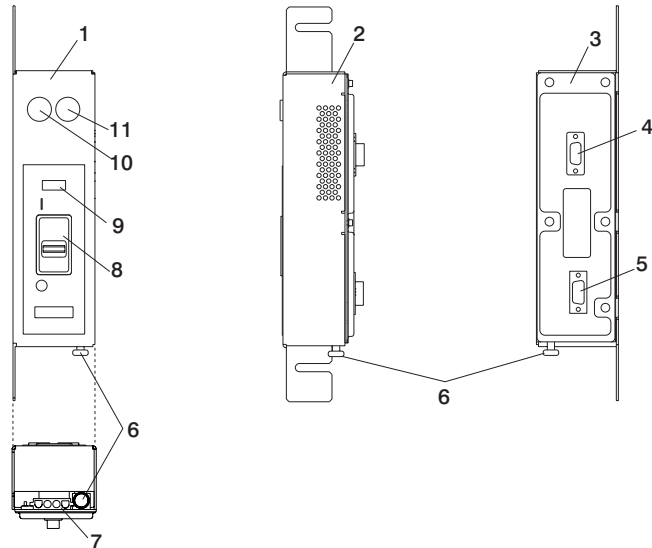

1	UEPO Front Panel	7	J02 Connector
2	UEPO Side Panel	8	Power Switch
3	UEPO Rear Panel	9	System Fault LED
4	J00 Connector Front BPA (Back)	10	Start Service Button (Green)
5	J01 Connector Rear BPA (Back)	11	Service Complete Button (White)
6	Room EPO Bypass Interlock		

The UEPO switch disables 350 V bulk power conversion and isolates all battery power to the battery compartments, without having to disconnect the heavy power cords under the customer's raised floor.

At the system level, the UEPO switch is connected to each of the two BPCs through two interface connectors. The switch can be concurrently replaced by forcing the BPCs into UEPO bypass mode, using the small slide switches on the face of the BPCs. The switch is mounted in the side pocket area of the rack and remains stationary when the front cover of the system is opened. The service buttons are used by service personnel to repair the power subsystem. If the system is off when the service complete button is pressed, the system will power on. A sliding plastic cover over the red switch prevents it from being accidentally activated in the customer environment.

7040 Model 681 Processor Subsystem Processor Subsystem Locations

This section provides a front view and a rear view of the processor subsystem with descriptions and locations for each part of the processor subsystem. Detailed location information for processor subsystem I/O books is also included.

7040 Model 681 Processor Subsystem Processor Subsystem Front View

Note: For slot assignments, see “Memory to Processor Relationships” on page 54.

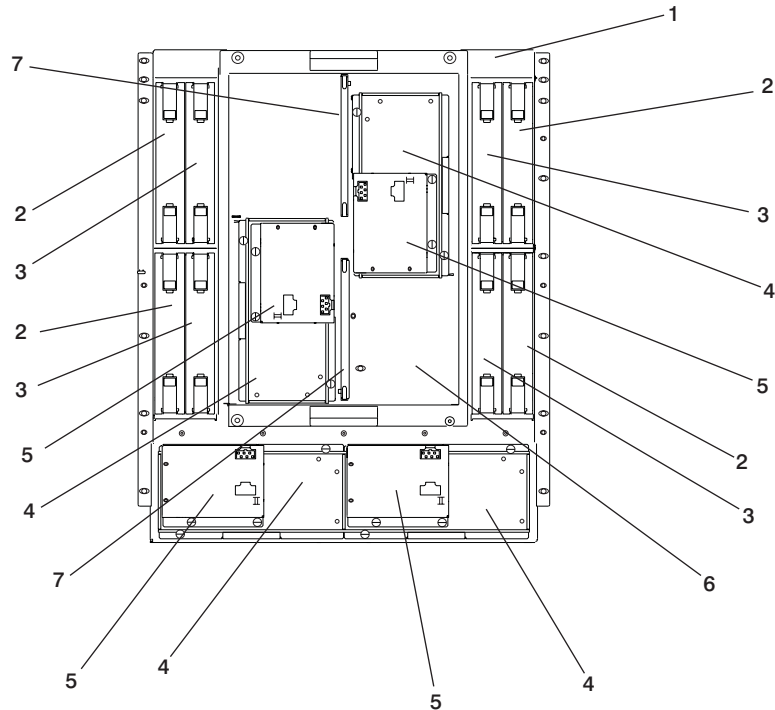

- | | | | |
|---|-----------------------------|---|----------------|
| 1 | Processor Subsystem Chassis | 5 | Fan Controller |
| 2 | Outer Memory Book | 6 | Fan Chassis |
| 3 | Inner Memory Book | 7 | Fan Filter |
| 4 | Fan | | |

7040 Model 681 Processor Subsystem Processor Subsystem Rear View

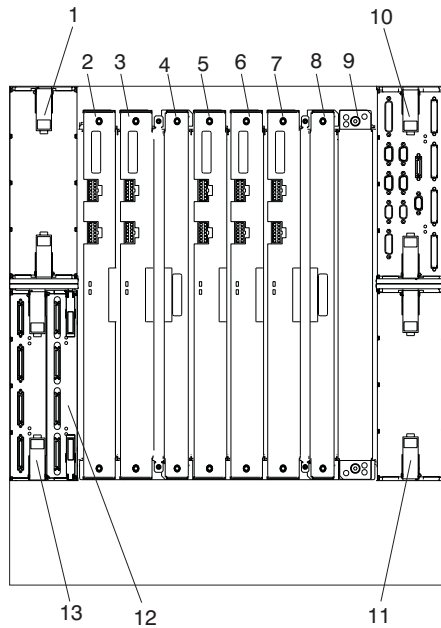

- | | | | |
|----------|-------------------|-----------|--|
| 1 | Slot 1 (Reserved) | 8 | Capacitor Book |
| 2 | DCA Book 1 | 9 | DCA Book 6 (reserved) |
| 3 | DCA Book 2 | 10 | Primary I/O book - Slot 0 |
| 4 | Capacitor Book | 11 | I/O Book 3 - Slot 3 |
| 5 | DCA Book 3 | 12 | I/O Book 2 - Slot 2 (Inner Connectors) |
| 6 | DCA Book 4 | 13 | I/O Book 2 - Slot 2 (Outer Connectors) |
| 7 | DCA Book 5 | | |

I/O Book Connector Locations

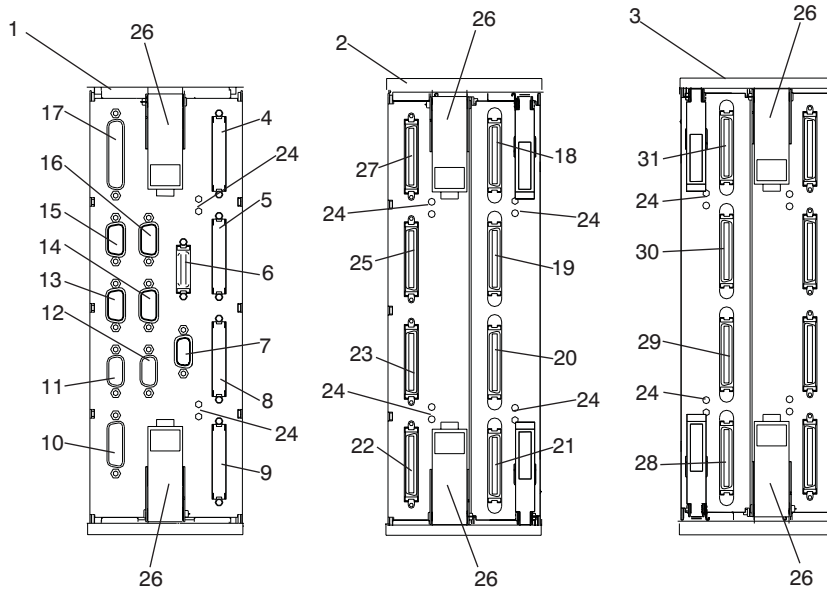

1	Primary I/O Book, Slot 0 (U1.18-P1-H2)	17	Debug (Manufacturing use only)
2	Secondary I/O Book, Slot 2 (U1.18-P1-H3)	18	I/O Port 3 (D1) (U1.18-P1-H3/Q5)
3	Third I/O Book, Slot 3 (U1.18-P1-H4)	19	I/O Port 3 (D0) (U1.18-P1-H3/Q6)
4	I/O Port 0 (A0) (U1.18-P1-H2/Q1)	20	I/O Port 2 (C1) (U1.18-P1-H3/Q7)
5	I/O Port 0 (A1) (U1.18-P1-H2/Q2)	21	I/O Port 2 (C0) (U1.18-P1-H3/Q8)
6	Operator Panel (U1.18-P1-H2/Q7)	22	I/O Port 4 (A0) (U1.18-P1-H3/Q4)
7	BPC Y-cable* connector U1.18-P1-H2/Q8 or U1.18-P1-H2/Q9	23	I/O Port 4 (A1) (U1.18-P1-H3/Q3)
8	I/O Port 1 (B0) (U1.18-P1-H2/Q3)	24	Indicator LEDs
9	I/O Port 1 (B1) (U1.18-P1-H2/Q4)	25	I/O Port 5 (B0) (U1.18-P1-H3/Q2)
10	Diskette Drive (U1.18-P1-H2/Q10)	26	Camming Latches
11	HMC 1 (U1.18-P1-H2/S3)	27	I/O Port 5 (B1) (U1.18-P1-H3/Q1)
12	HMC 2 (U1.18-P1-H2/S4)	28	I/O Port 6 (D1) (U1.18-P1-H4/Q5)
13	Serial Port 1 (U1.18-P1-H2/S1)	29	I/O Port 6 (D0) (U1.18-P1-H4/Q6)
14	Serial Port 2 (U1.18-P1-H2/S2)	30	I/O Port 7 (C1) (U1.18-P1-H4/Q7)
15	SPCN 0 (Manufacturing use only) (U1.18-P1-H2/Q5)	31	I/O Port 7 (C0) (U1.18-P1-H4/Q8)

- 16 SPCN 1 (Manufacturing use only) (U1.18-P1-H2/Q6)

* The Y-cable that attaches to this connector, terminates at BPC-A connector U1.35-P1-X4/Q10 and BPC-B connector U1.35-P2-X4/Q10.

Media Subsystem Locations

The following figures show locations for devices installed in the media subsystem, and the SCSI IDs for the media devices.

Note: The SCSI IDs shown for media indicate how installed devices are set when shipped from the factory.

Media Subsystem Front View

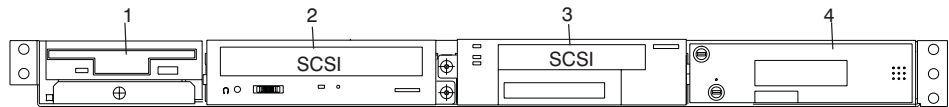

- | | | | |
|---|-------------------------------|---|---|
| 1 | Diskette Drive | 3 | Optional Media Drive (4 mm Tape, CD-ROM, or DVD-RAM), SCSI Address 06 |
| 2 | CD-ROM Drive, SCSI Address 05 | 4 | Operator Panel |

Media Subsystem Rear View

Note: DVD-RAM and 4 mm tape drives can be located in the rear of the media subsystem *only* if the room is maintained at a nominal room temperature of 24C (75.2F).

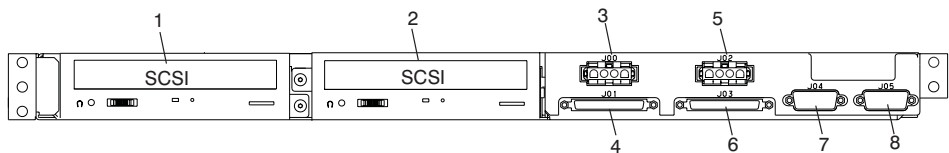

- | | | | |
|---|---|---|-----------------------------|
| 1 | Optional Media (4 mm Tape, CD-ROM, or DVD-RAM), SCSI Address 05 | 5 | Front SCSI Power Connection |
| 2 | Optional Media (4 mm Tape, CD-ROM, or DVD-RAM), SCSI Address 06 | 6 | Front SCSI Connection |
| 3 | Rear SCSI Power Connection | 7 | Diskette Drive Connection |
| 4 | Rear SCSI Connection | 8 | Operator Panel Connection |

Media Subsystem Operator Panel

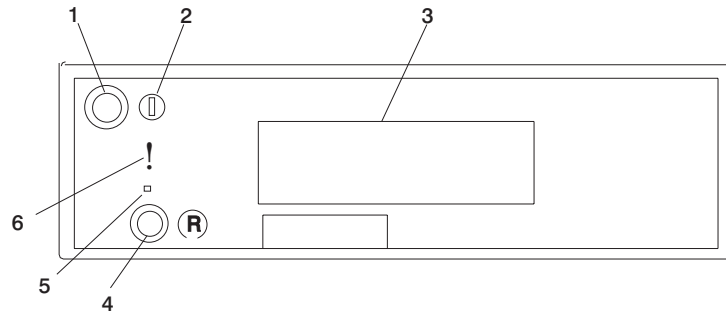

- | | | | |
|---|------------------------|---|---|
| 1 | Power on/off button | 4 | Reset button |
| 2 | Power on/off LED | 5 | Service processor reset button (Service use only) |
| 3 | Operator panel display | 6 | Disturbance or system attention LED |

Note: You must activate the service processor reset button very carefully. Using an insulated paper clip is recommended. Unbend the clip so that it has a straight section about two inches long. Insert the clip straight into the hole, keeping the clip perpendicular to the plastic bezel. When you engage the test reset switch, you should feel the detent of the switch. After you press the switch, the service processor resets and then shuts down the system.

7040 Model 61D I/O Subsystem Locations

This section shows the locations for the I/O subsystem. A front view and a rear view with descriptions and locations for each part of the I/O subsystem are shown.

7040 Model 61D I/O Subsystem Front View

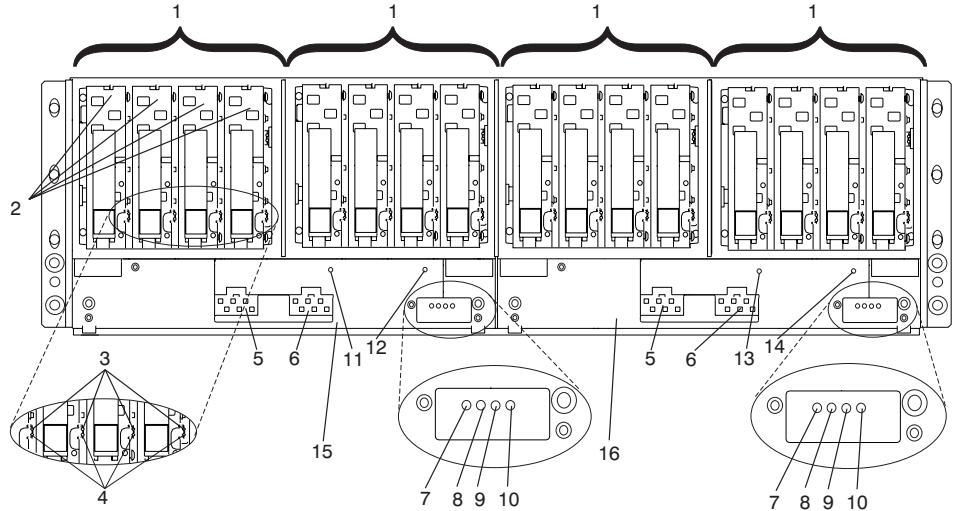

1	DASD 4-Pack	9	Drawer Fault/Identify LED (Amber)
2	DASD Disk Drive	10	Power Good Out LED (Green)
3	Disk Activity LED (Green)	11	Fan Fault LED (Amber) U1.x-F1
4	Disk Drive Fault/Identify LED (Amber)	12	Fan Fault LED (Amber) U1.x-F3
5	BPD 1 (Front) Cable In	13	Fan Fault LED (Amber) U1.x-F2
6	BPD 2 (Rear) Cable In	14	Fan Fault LED (Amber) U1.x-F4
7	Power Good In LED (Green)	15	I/O Subsystem Left DCA U1.x-V1
8	DCA Fault LED (Amber)	16	I/O Subsystem Right DCA U1.x-V2

Note: The fan fault LEDs shown in the preceding illustration indicate if an internal fan has a fault. The fan assemblies inside are positioned from left to right behind the DASD 4-packs in order of fan assembly 1, fan assembly 2, fan assembly 3, and fan assembly 4.

7040 Model 61D I/O Subsystem Rear View

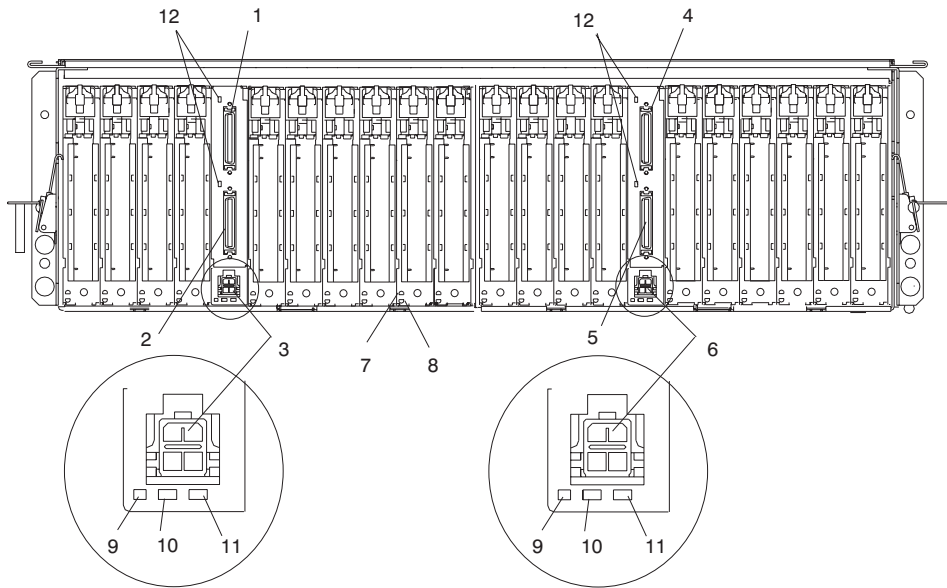

- | | | | |
|---|---|----|---|
| 1 | I/O port connector 1 (U1.x-P1/Q1) | 7 | I/O Card Power On LED (Green) |
| 2 | I/O port connector 0 (U1.x-P1/Q2) | 8 | I/O Adapter Fault/Identify LED (Amber/Bottom) |
| 3 | Media subsystem power connector (U1.x-P1-V1/Q3) | 9 | Auxiliary Power Good (Green) |
| 4 | I/O port connector 1 (U1.x-P2/Q1) | 10 | I/O Subsystem Backplane Fault (Amber) |
| 5 | I/O port connector 0 (U1.x-P2/Q2) | 11 | I/O Subsystem Backplane Power On (Green) |
| 6 | Media subsystem power connector (U1.x-P2-V1/Q3) | 12 | I/O LED (Currently Unused) |

I/O Subsystem DASH Locations

The following figures show the DASH drive positions in an I/O subsystem.

Note: The SCSI IDs are set when the drive is installed into the DASH 4-pack.

7040 Model 61D I/O Subsystem DASD Locations

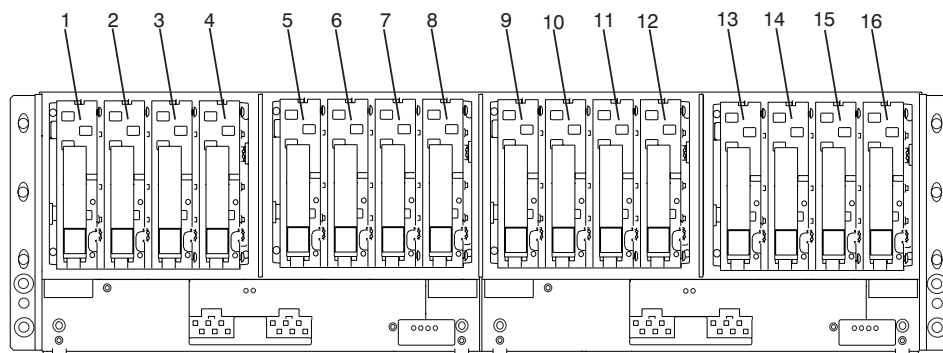

1	Ux.y-P2/Z2-A8	9	Ux.y-P1/Z2-A8
2	Ux.y-P2/Z2-A9	10	Ux.y-P1/Z2-A9
3	Ux.y-P2/Z2-Aa	11	Ux.y-P1/Z2-Aa
4	Ux.y-P2/Z2-Ab	12	Ux.y-P1/Z2-Ab
5	Ux.y-P2/Z1-A8	13	Ux.y-P1/Z1-A8
6	Ux.y-P2/Z1-A9	14	Ux.y-P1/Z1-A9
7	Ux.y-P2/Z1-Aa	15	Ux.y-P1/Z1-Aa
8	Ux.y-P2/Z1-Ab	16	Ux.y-P1/Z1-Ab

Note: In the preceding table, x is equal to the rack number and y is equal to the I/O subsystem position in the rack. The SCSI ID for each drive is set when the drive is installed. Each I/O subsystem can have up to four DASD four packs installed. The SCSI IDs for the drives in each four pack are 8, 9, a, and b, from left to right.

I/O Subsystem PCI PHB and PCI Slot Locations

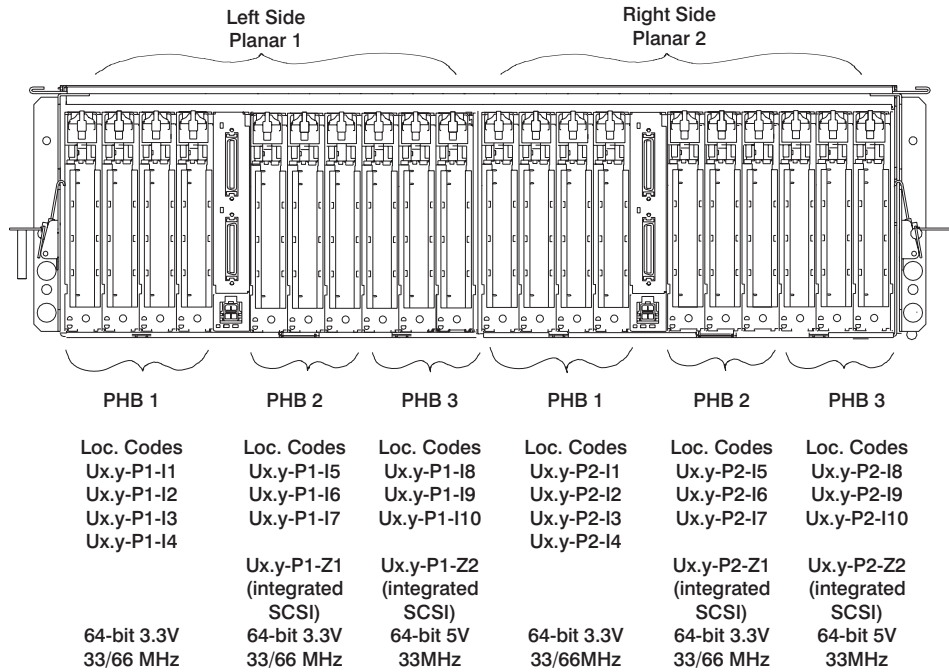

Ux.y - HMC location code
reference wherein x = rack
location and y = drawer position.

PHBs 2 and 3 on both planars contain integrated SCSI adapters
(slots P1-Z1, P1-Z2, P2-Z1, P2-Z2).

I/O Subsystem Rear View with Numbered Slots

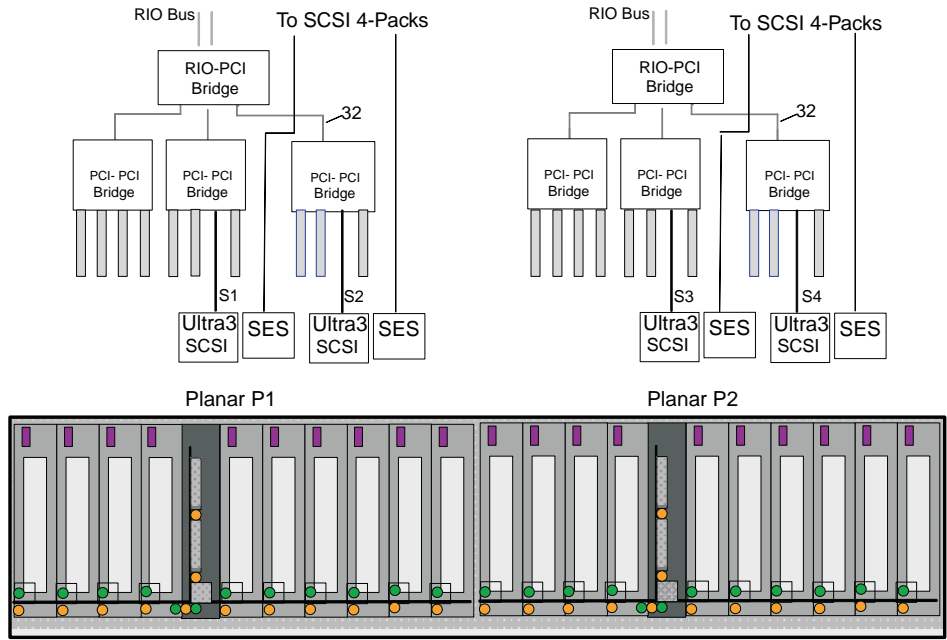

I/O and Media Subsystem Connections

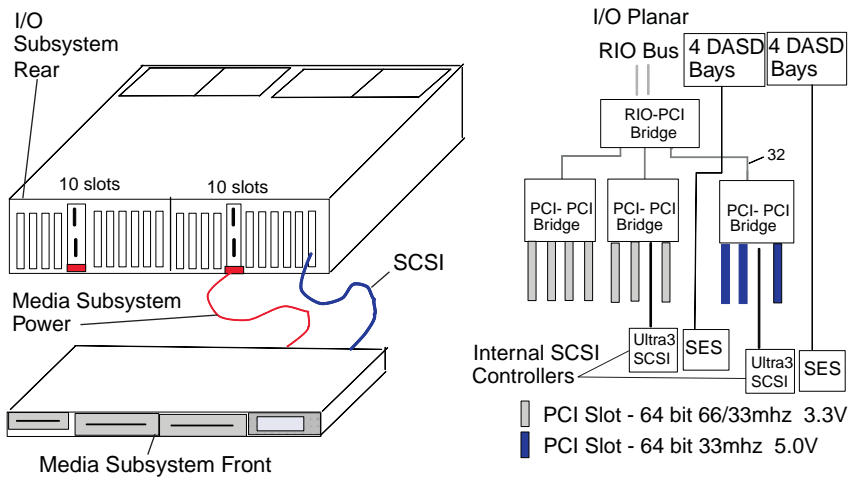

I/O Subsystem Internal SCSI Distribution

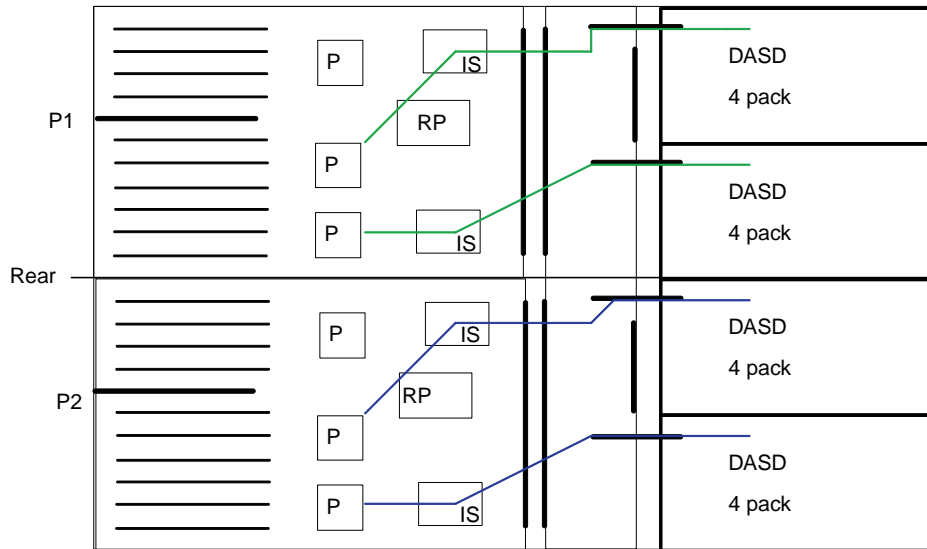

P=PCI-PCI bridge
 RP=RIO-PCI bridge
 IS=Internal SCSI Ultra 3

I/O Subsystem Power Distribution

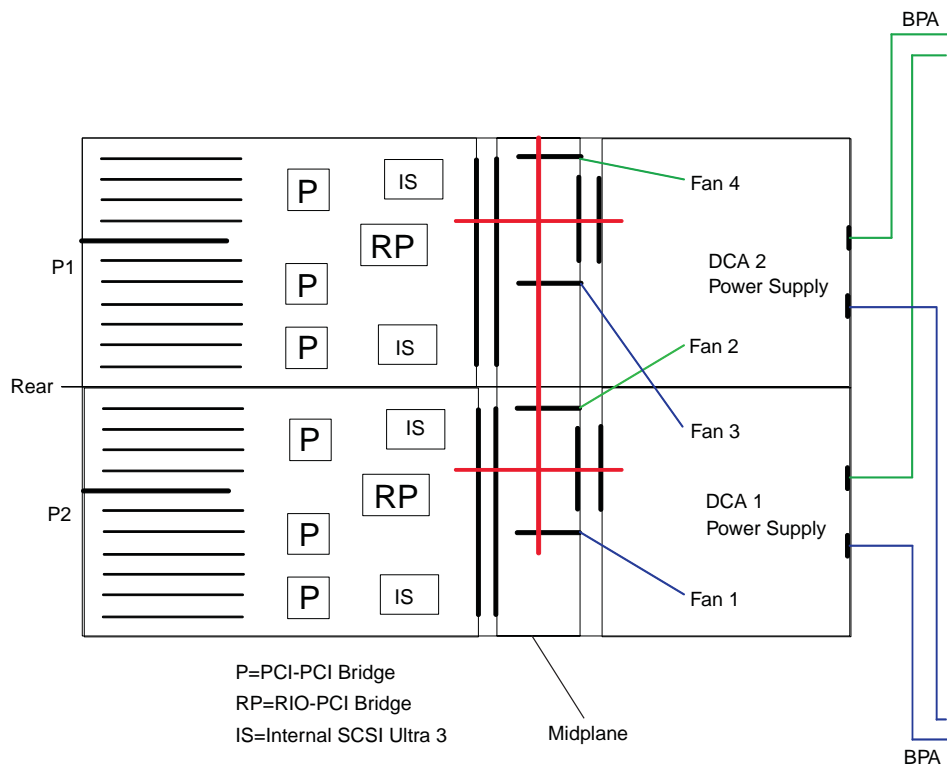

Power Subsystem Locations

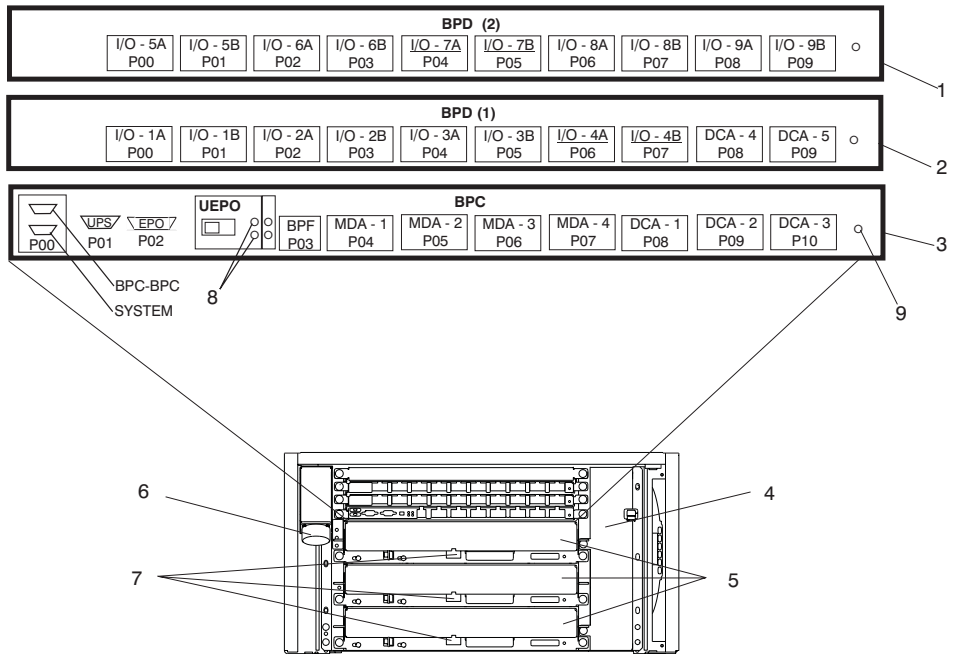

Note: BPD (2) connectors J04 and J05 (I/O-7A/P04 and I/O-7B/P05 in the preceding figure) are for I/O subsystem 4 when the IBF is installed.

- | | | | |
|---|------------------------------|---|---|
| 1 | Bulk Power Distributor (BPD) | 6 | ac Power In Connector |
| 2 | Bulk Power Distributor (BPD) | 7 | Connectors to IBF |
| 3 | Bulk Power Controller (BPC) | 8 | UEPO Power (PWR) LED
UEPO Power Complete (CMPLT) LED |
| 4 | Bulk Power Fan (BPF) | 9 | BPC Power Good LED |
| 5 | Bulk Power Regulators (BPR) | | |

Power Distribution Cabling

Power to the I/O subsystems, DCAs, Fans, and IBFs is connected from the bulk power distribution connectors to each subsystem through cables. The cable connectors are labeled on each end. The following describes the cables that connect from the BPC BPDs, and BPRs to the DCAs, fans, power supplies, I/O subsystems, and integrated battery features.

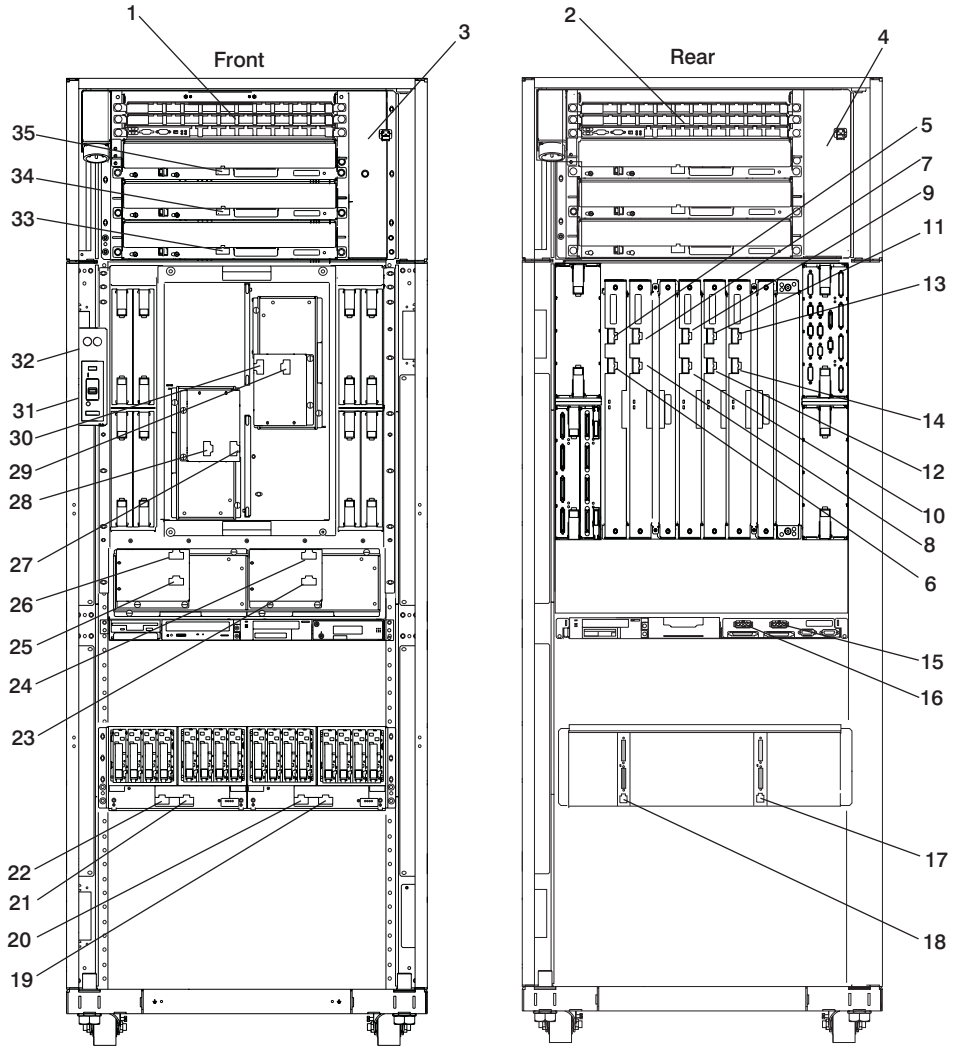

Key	From	To	Description	Label Color
1	Bulk Power BPE A Side		Bulk power enclosure on the A side of the system	
2	Bulk Power BPE B Side		Bulk power enclosure on the B side of the system	
3	A35-BPC-J03	A35-P1FAN (BPF-A)	A35-BPC-P03 to Bulk Power Fan P1-F1	Red with white stripe
4	B35-BPC-J03	B35-P2FAN (BPF-B)	B35-BPC-P03 to Bulk Power Fan P2-F1	Red
5	B35-BPC-J08	DCA-1 J01	B35-BPC-P08 to DCA-1-P01	Red
6	A35-BPC-J08	DCA-1 J00	A35-BPC-P08 to DCA-1-P00	Red with white stripe
7	B35-BPC-J09	DCA-2 J01	B35-BPC-P09 to DCA-2-P01	Red
8	A35-BPC-J09	DCA-2 J00	A35-BPC-P09 to DCA-2-P00	Red with white stripe
9	B35-BPC-J10	DCA-3 J01	B35-BPC-P10 to DCA-3-P01	Red
10	A35-BPC-J10	DCA-3 J00	A35-BPC-P10 to DCA-3-P00	Red with white stripe
11	B35-BPD-J08	DCA-4 J01	B35-BPD1-P08 to DCA-4-P01	Red
12	A35-BPD-J08	DCA-4 J00	A35-BPD1-P08 to DCA-4-P00	Red with white stripe
13	B35-BPD-J09	DCA-5 J01	B35-BPD1-P09 to DCA-5-P01	Red
14	A35-BPD-J09	DCA-5 J00	A35-BPD1-P09 to DCA-5-P00	Red with white stripe
15, 17	B17-Media-J02	I/O Subsystem 1B-J01	I/OB9-P01 to Media P02	
16, 18	B17-Media-J00	I/O Subsystem 1B-J00	I/OB9-P00 to Media P00	
19, 20, 21, 22	B35-BPDx-Jxx See "I/O Subsystem Power Distribution Cabling" on page 38 for I/O subsystem power cabling.	I/O Subsystem See "I/O Subsystem Power Distribution Cabling" on page 38 for I/O subsystem power cabling.	B35-BPDx-P0x to I/O Subsystem #x	
23	B35-BPC-J05	A09-MDA2-J02	A35-BPC-P05 to (AMD2-P01) J02	Red
24	A35-BPC-J05	A09-MDA2-J01	B35-BPC-P05 to (AMD2-P00) J01	Red with white stripe

Key	From	To	Description	Label Color
25	B35-BPC-J04	A09-MDA1-J02	A35-BPC-P04 to (AMD1-P01) J02	Red
26	A35-BPC-J04	A09-MDA1-J01	A35-BPC-P04 to (AMD1-P00) J01	Red with white stripe
27	A35-BPC-J06	A18-MDA3-J01	A35-BPC-P06 to (AMD3-P00) J01	Red with white stripe
28	B35-BPC-J06	A18-MDA3-J02	B35-BPC-P06 to (AMD3-P01) J02	Red
29	B35-BPC-J07	A18-MDA4-J02	B35-BPC-P07 to (AMD4-P00) J02	Red
30	A35-BPC-J07	A18-MDA4-J01	B35-BPC-P07 to (AMD4-P01) J01	Red with white stripe
31	B35-BPC-J02	UEPO Switch J01	B35-BPC-P02 to UEPO J01	Red
32	A35-BPC-J02	UEPO Switch J00	A35-BPC-P02 to UEPO J00	Red with white stripe
33	A35-BPR-J00	A13-IBF1-J01	A35-BPR-P00 to A13-IBF1-P00	
	B35-BPR-J00	B13-IBF1-J01	B35-BPR-P00 to B13-IBF1-P00	
34	A35-BPR-J00	A13-IBF2-J01	A35-BPR-P00 to A13-IBF2-P00	
	B35-BPR-J00	B13-IBF2-J01	B35-BPR-P00 to B13-IBF2-P00	
35	A35-BPR-J00	A17-IBF3-J01 (Secondary Frame)	A35-BPR-P00 to A-IBF3-P00 (Secondary Frame)	
	B35-BPR-J00	B17-IBF3-J01 (Secondary Frame)	B35-BPR-P00 to B-IBF3-P00 (Secondary Frame)	

I/O Subsystem Power Distribution Cabling

Power to the I/O subsystems is connected from the bulk power distribution connectors to each subsystem through cables. The cable connectors are labeled on each end. The following table describes the cables that connect from the BPDs to the I/O Subsystem DCAs (power supplies).

From	To (A=Primary) (Z=Secondary)	Description	Label Color
A35B-BPD1A-P00	A09B-DCA1-P01	BPD1A to I/O Subsystem #1	Purple W/Stripes
A35P-BPD1B-P00	A09B-DCA1-P00	BPD1B to I/O Subsystem #1	Purple
A35B-BPD1A-P01	A09B-DCA2-P01	BPD1A to I/O Subsystem #1	Purple W/Stripes
A35P-BPD1B-P01	A09B-DCA2-P00	BPD1B to I/O Subsystem #1	Purple
A35B-BPD1A-P02	A05B-DCA1-P01	BPD1A to I/O Subsystem #2	Yellow W/Stripes
A35P-BPD1B-P02	A05B-DCA1-P00	BPD1B to I/O Subsystem #2	Yellow
A35B-BPD1A-P03	A05B-DCA2-P01	BPD1A to I/O Subsystem #2	Yellow W/Stripes
A35P-BPD1B-P03	A05B-DCA2-P00	BPD1B to I/O Subsystem #2	Yellow
A35B-BPD1A-P04	A01B-DCA1-P01	BPD1A to I/O Subsystem #3	Green W/Stripes
A35P-BPD1B-P04	A01B-DCA1-P00	BPD1B to I/O Subsystem #3	Green
A35B-BPD1A-P05	A01B-DCA2-P01	BPD1A to I/O Subsystem #3	Green W/Stripes
A35P-BPD1B-P05	A01B-DCA2-P00	BPD1B to I/O Subsystem #3	Green
A35B-BPD1A-P06	A13B-DCA1-P01	BPD1A to I/O Subsystem #4 (no IBF)	Blue W/Stripes
A35P-BPD1B-P06	A13B-DCA1-P00	BPD1B to I/O Subsystem #4 (no IBF)	Blue
A35B-BPD1A-P07	A13B-DCA2-P01	BPD1A to I/O Subsystem #4 (no IBF)	Blue W/Stripes
A35P-BPD1B-P07	A13B-DCA2-P00	BPD1B to I/O Subsystem #4 (no IBF)	Blue
A35B-BPD2A-P04	Z09B-DCA1-P01	BPD1A to I/O Subsystem #4 (with IBF)	Yellow W/Stripes

From	To (A=Primary) (Z=Secondary)	Description	Label Color
A35P-BPD2B-P04	Z09B-DCA1-P00	BPD1B to I/O Subsystem #4 (with IBF)	Yellow
A35B-BPD2A-P05	Z09B-DCA2-P01	BPD1A to I/O Subsystem #4 (with IBF)	Yellow W/Stripes
A35P-BPD2B-P05	Z09B-DCA2-P00	BPD1B to I/O Subsystem #4 (with IBF)	Yellow
A35B-BPD2A-P00	Z01B-DCA1-P01	BPD2A to I/O Subsystem #5	Red W/Stripes
A35P-BPD2B-P00	Z01B-DCA1-P00	BPD2B to I/O Subsystem #5	Red
A35B-BPD2A-P01	Z01B-DCA2-P01	BPD2A to I/O Subsystem #5	Red W/Stripes
A35P-BPD2B-P01	Z01B-DCA2-P00	BPD2B to I/O Subsystem #5	Red
A35B-BPD2A-P02	Z05B-DCA1-P01	BPD2A to I/O Subsystem #6	Purple W/Stripes
A35P-BPD2B-P02	Z05B-DCA1-P00	BPD2B to I/O Subsystem #6	Purple
A35B-BPD2A-P03	Z05B-DCA2-P01	BPD2A to I/O Subsystem #6	Purple W/Stripes
A35P-BPD2B-P03	Z05B-DCA2-P00	BPD2B to I/O Subsystem #6	Purple
A35B-BPD2A-P06	Z13B-DCA1-P01	BPD2A to I/O Subsystem #7	Yellow W/Stripes
A35P-BPD2B-P06	Z13B-DCA1-P00	BPD2B to I/O Subsystem #7	Yellow
A35B-BPD2A-P07	Z13B-DCA2-P01	BPD2A to I/O Subsystem #7	Yellow W/Stripes
A35P-BPD2B-P07	Z13B-DCA2-P00	BPD2B to I/O Subsystem #7	Yellow
A35B-BPD2A-P08	Z19B-DCA1-P01	BPD2A to I/O Subsystem #8	Blue W/Stripes
A35P-BPD2B-P08	Z19B-DCA1-P00	BPD2B to I/O Subsystem #8	Blue
A35B-BPD2A-P09	Z19B-DCA2-P01	BPD2A to I/O Subsystem #8	Blue W/Stripes
A35P-BPD2B-P09	Z19B-DCA2-P00	BPD2B to I/O Subsystem #8	Blue

Integrated Battery Feature Locations

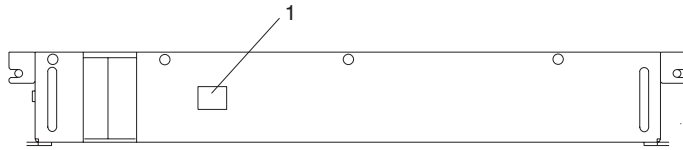

- 1 Connector to BPR

Subsystem Positioning and Cabling

This section shows subsystem positioning and cabling for the @server pSeries 690.

Operator Panel Cable and Diskette Drive Cable to the Media Subsystem (rear view)

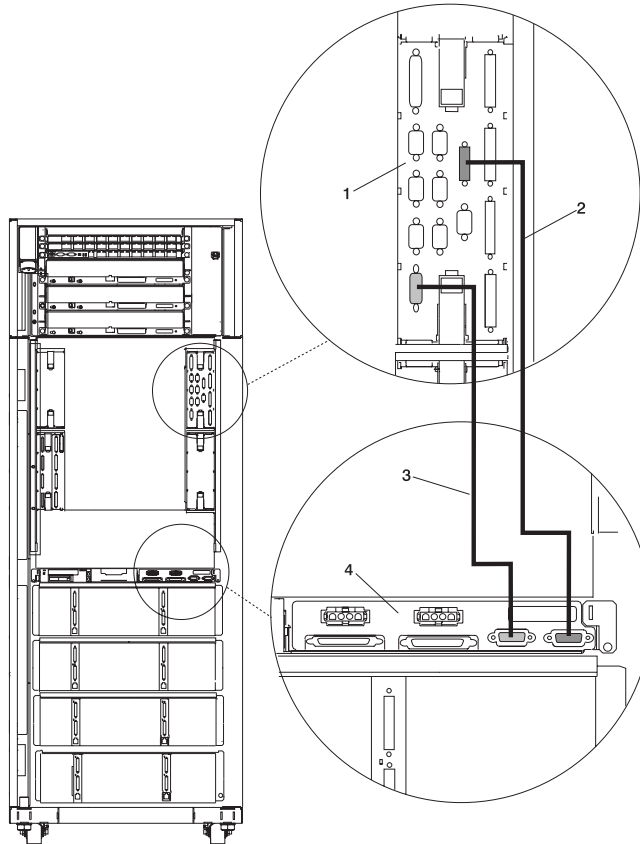

- | | | | |
|---|--|---|---------------------------|
| 1 | Primary I/O Book | 3 | Diskette Drive Data Cable |
| 2 | Cable Connecting the Operator Panel to the Media Subsystem | 4 | Media Subsystem |

I/O Subsystem Positions, Fully Populated Primary and Secondary Rack (rear view without IBF)

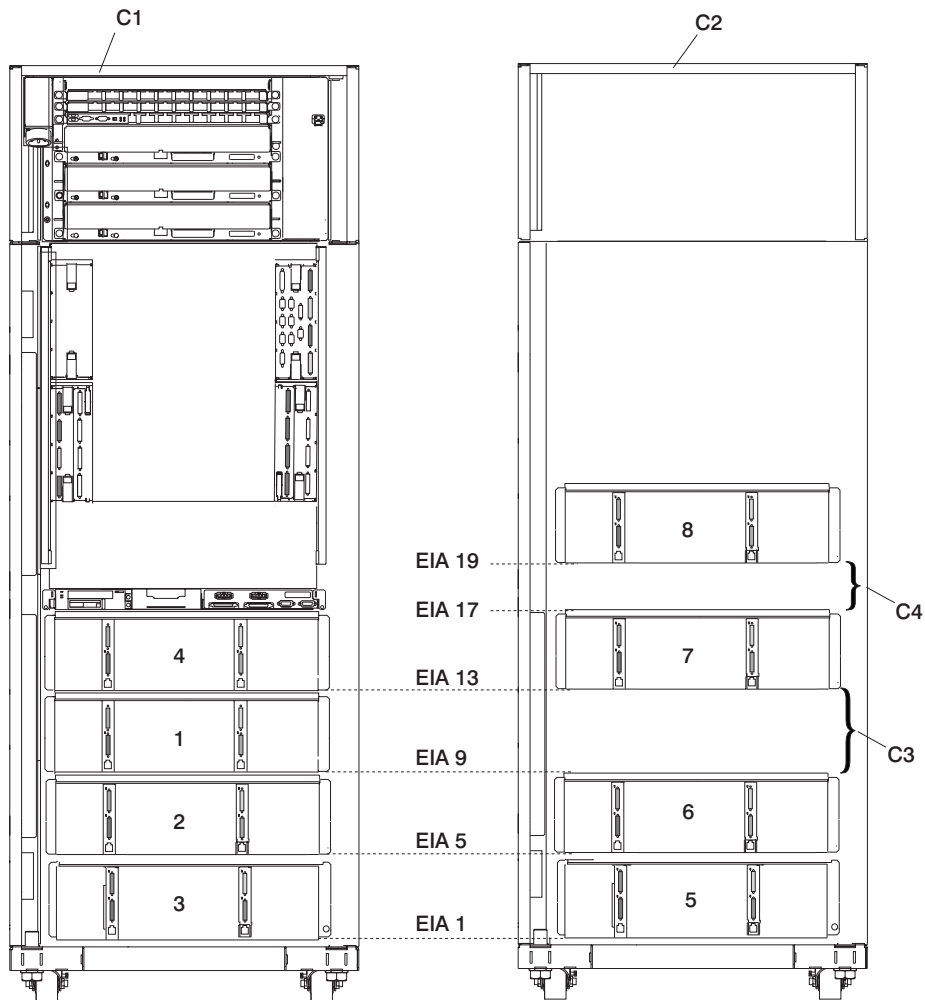

- C1** Primary Rack
- C2** Secondary Rack
- C3** Blank Space
- C4** Blank Space
- 1** First I/O Subsystem
- 2** Second I/O Subsystem

- 3** Third I/O Subsystem
- 4** Fourth I/O Subsystem
- 5** Fifth I/O Subsystem
- 6** Sixth I/O Subsystem
- 7** Seventh I/O Subsystem
- 8** Eighth I/O Subsystem

I/O Subsystem Positions, Fully Populated Primary and Secondary Rack (rear view with IBFs)

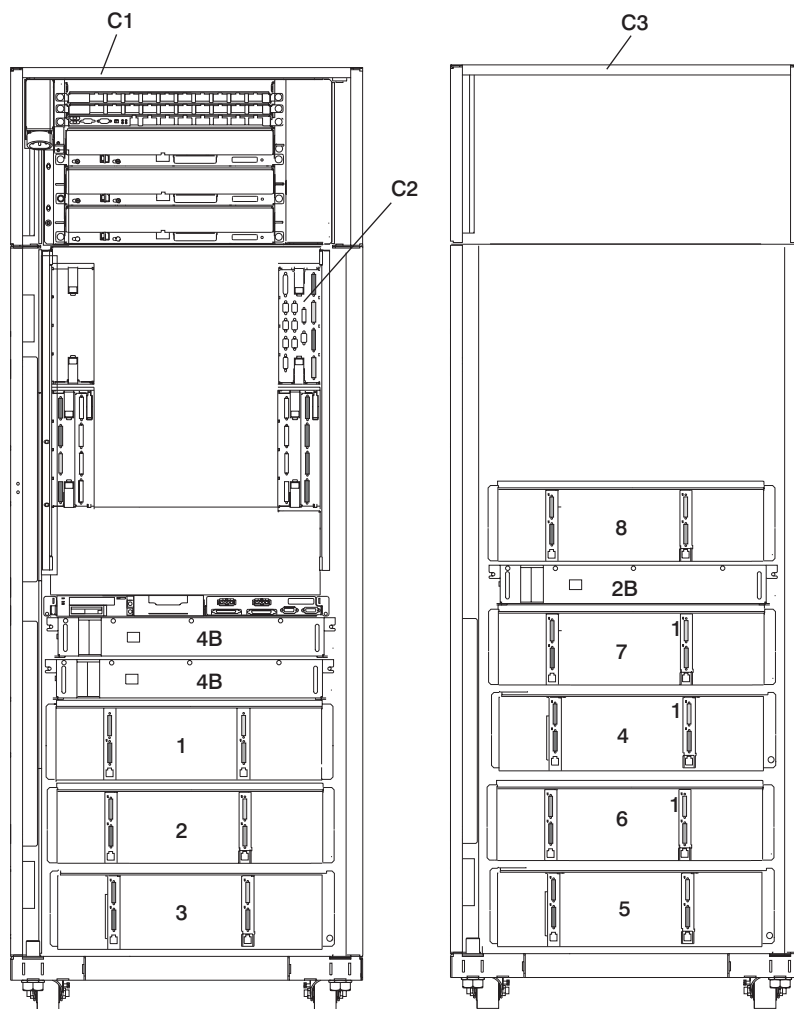

- | | | | |
|-----------|---------------------------|-----------|--------------------------------------|
| C1 | Primary Rack | 4B | Four IBFs (primary rack), Position 4 |
| C2 | Primary I/O Book (Book 0) | 5 | Fifth I/O Subsystem |
| C3 | Secondary Rack | 6 | Sixth I/O Subsystem |
| 1 | First I/O Subsystem | 7 | Seventh I/O Subsystem |
| 2 | Second I/O Subsystem | 2B | Two IBFs (secondary rack) |
| 3 | Third I/O Subsystem | 8 | Eighth I/O Subsystem |
| 4 | Fourth I/O Subsystem | | |

Placement of Subsystem 4 in a Two-Rack Configuration (rear view with IBF)

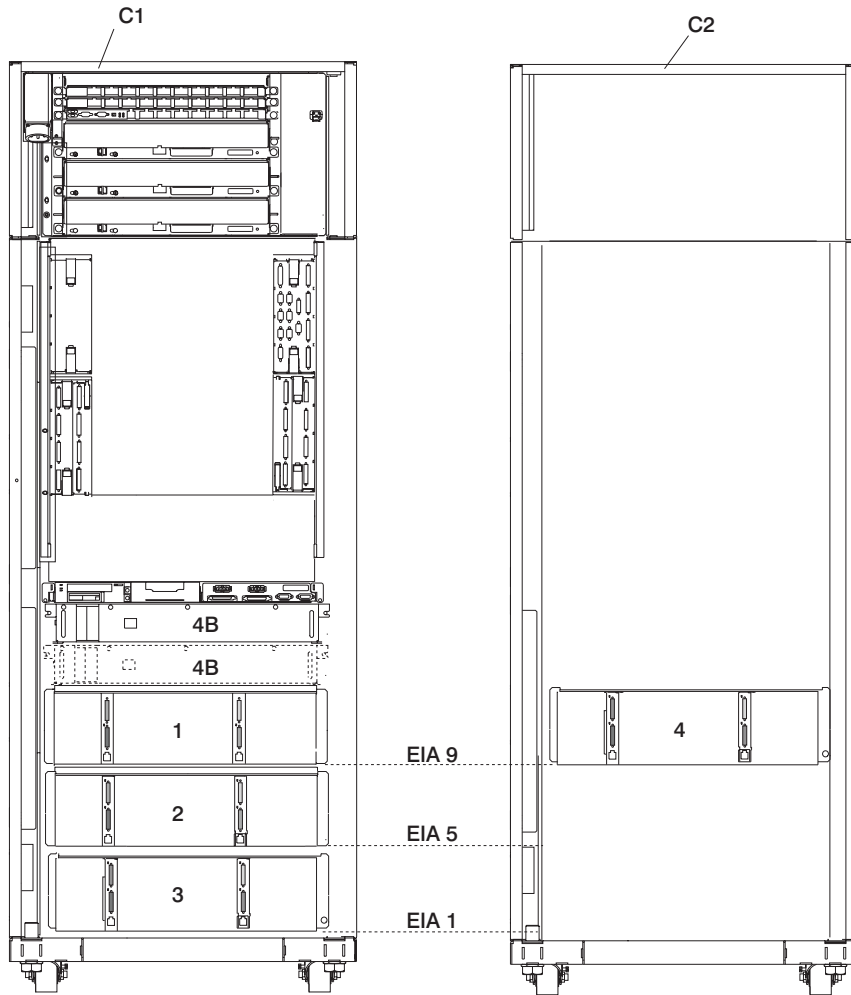

C1	Primary Rack	3	Third I/O Subsystem
C2	Secondary Rack	4	Fourth I/O Subsystem
1	First I/O Subsystem	4B	Four IBFs
2	Second I/O Subsystem		

Note: The physical location shown for I/O Subsystem 4 is populated only when IBFs are present and four or more I/O subsystems are installed.

I/O Subsystems (1 Through 4 Without IBFs) RIO Cabling to I/O Books

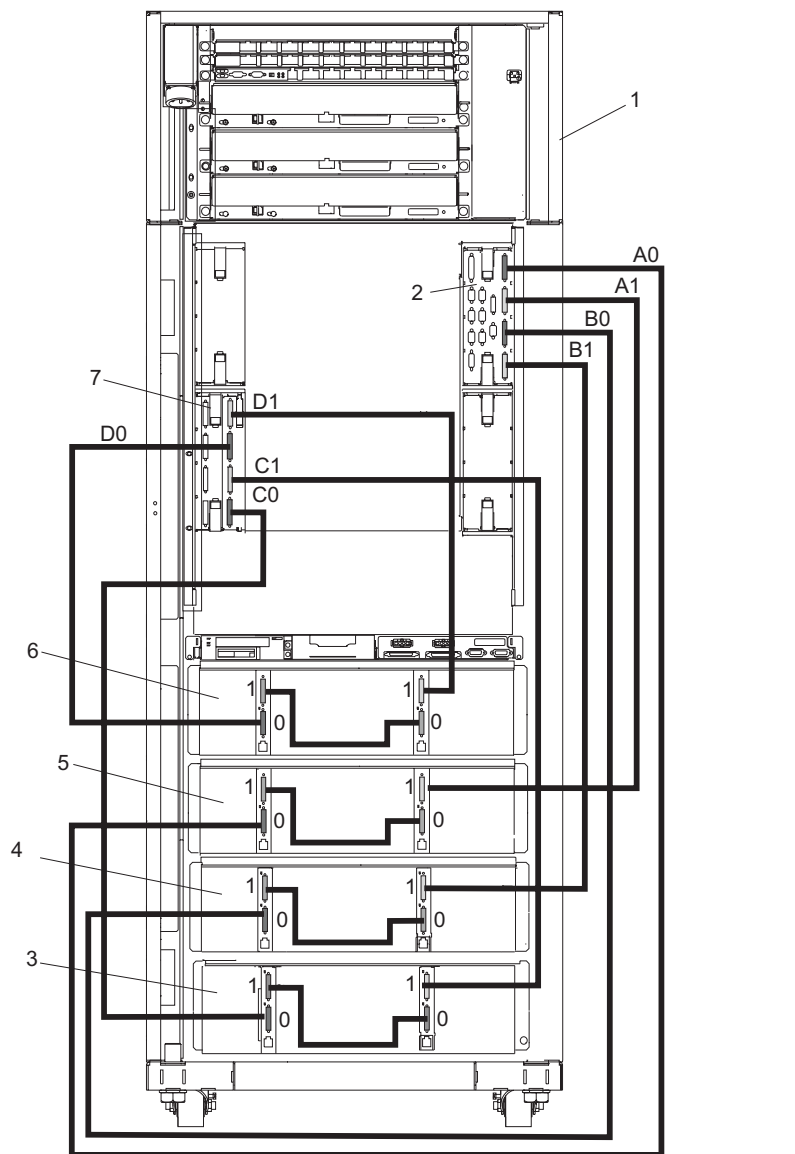

- | | | | |
|---|----------------------|---|----------------------|
| 1 | Primary Rack | 5 | First I/O Subsystem |
| 2 | Primary I/O Book | 6 | Fourth I/O Subsystem |
| 3 | Third I/O Subsystem | 7 | Secondary I/O Book |
| 4 | Second I/O Subsystem | | |

I/O Subsystems (5 and 6) RIO Cabling to the Secondary I/O Book

Shown Without IBFs

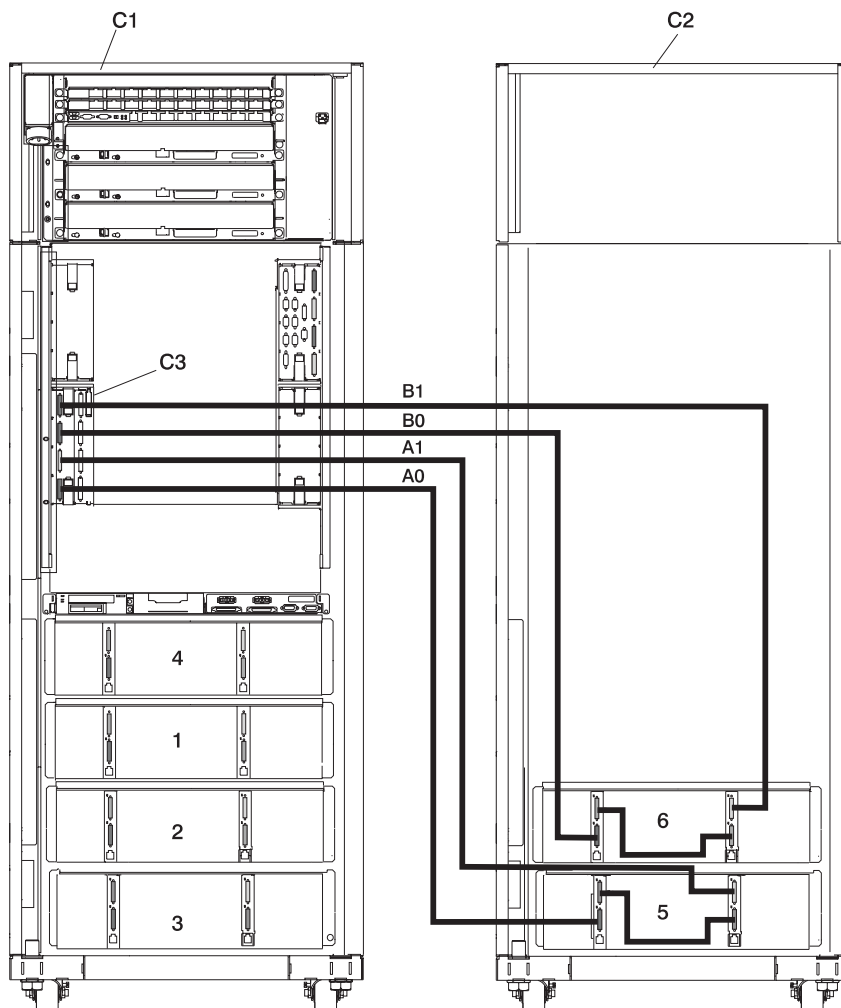

- C1** Primary Rack
- C2** Secondary Rack
- C3** Secondary I/O Book

- 5** Fifth I/O Subsystem
- 6** Sixth I/O Subsystem

Note: RIO cabling to I/O Subsystems 5 and 6 is the same for configurations with or without the IBFs.

I/O Subsystems (7 and 8) RIO Cabling to the Third I/O Book

Shown with IBFs

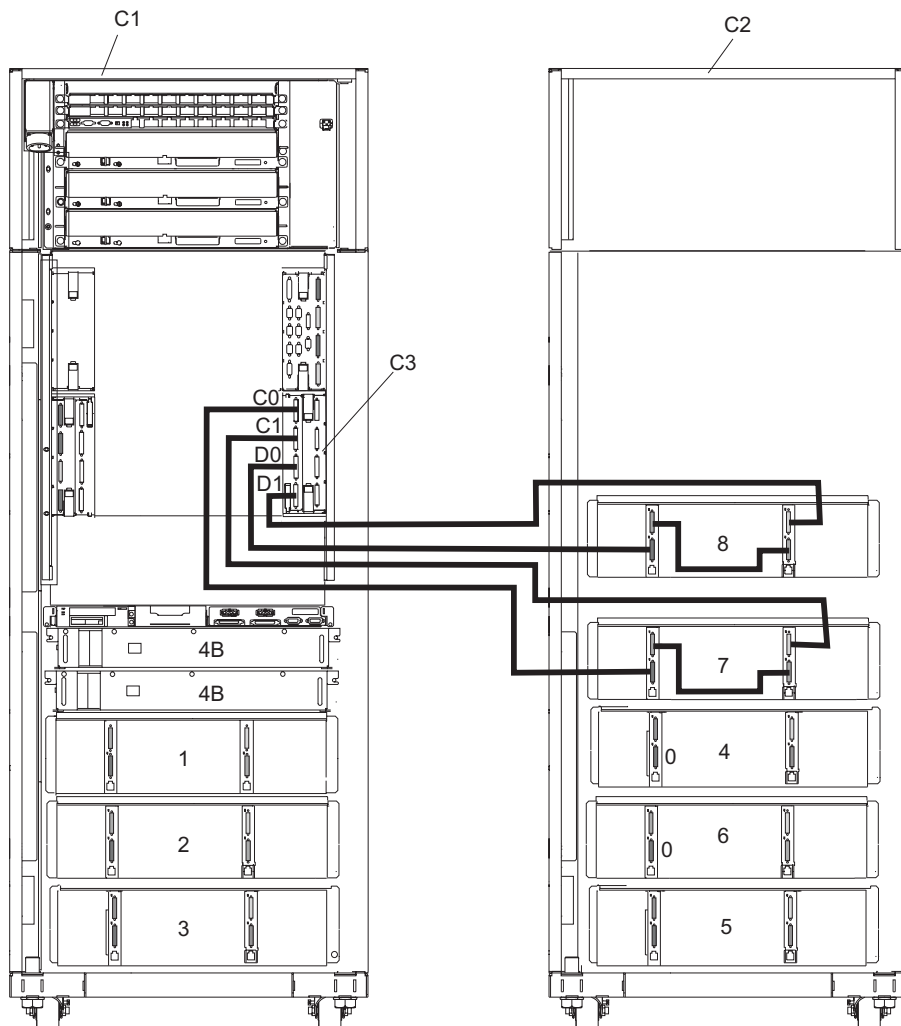

- | | | | |
|-----------|-------------------------|-----------|--------------------------------|
| C1 | Primary Rack | 4 | Fourth I/O Subsystem |
| C2 | Secondary Rack | 4B | Two IBFs (maximum), Position 4 |
| C3 | Third I/O Book (Book 3) | 5 | Fifth I/O Subsystem |
| 1 | First I/O Subsystem | 6 | Sixth I/O Subsystem |
| 2 | Second I/O Subsystem | 7 | Seventh I/O Subsystem |
| 3 | Third I/O Subsystem | 8 | Eighth I/O Subsystem |

Note: RIO cabling to I/O subsystems 7 and 8 is the same for configurations with or without the IBFs.

I/O Subsystem (1 through 3 with IBFs) RIO Cabling to I/O Books

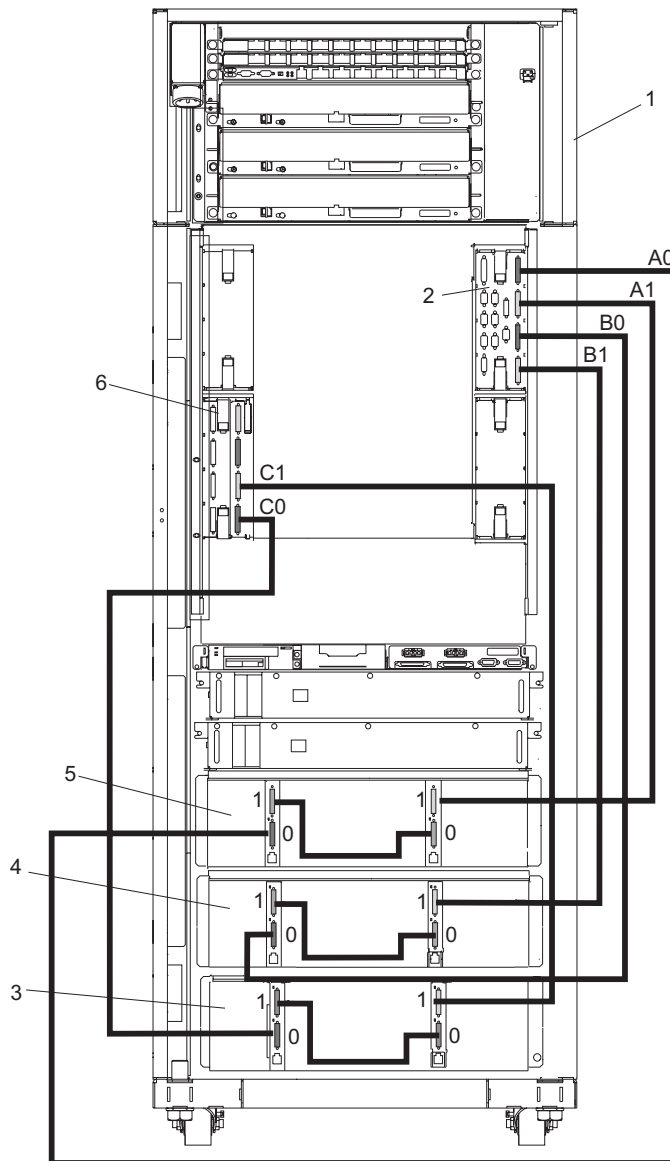

- | | | | |
|----------|----------------------|-----------|---------------------------------|
| 1 | Primary Rack | A0 | Connection to I/O Book (Book 0) |
| 2 | Primary I/O Book | A1 | Connection to I/O Book (Book 0) |
| 3 | Third I/O Subsystem | B0 | Connection to I/O Book (Book 0) |
| 4 | Second I/O Subsystem | B1 | Connection to I/O Book (Book 0) |
| 5 | First I/O Subsystem | C0 | Connection to I/O Book (Book 2) |
| 6 | Secondary I/O Book | C1 | Connection to I/O Book (Book 2) |

RIO Cable to I/O Subsystem (4 through 6) with IBFs Installed

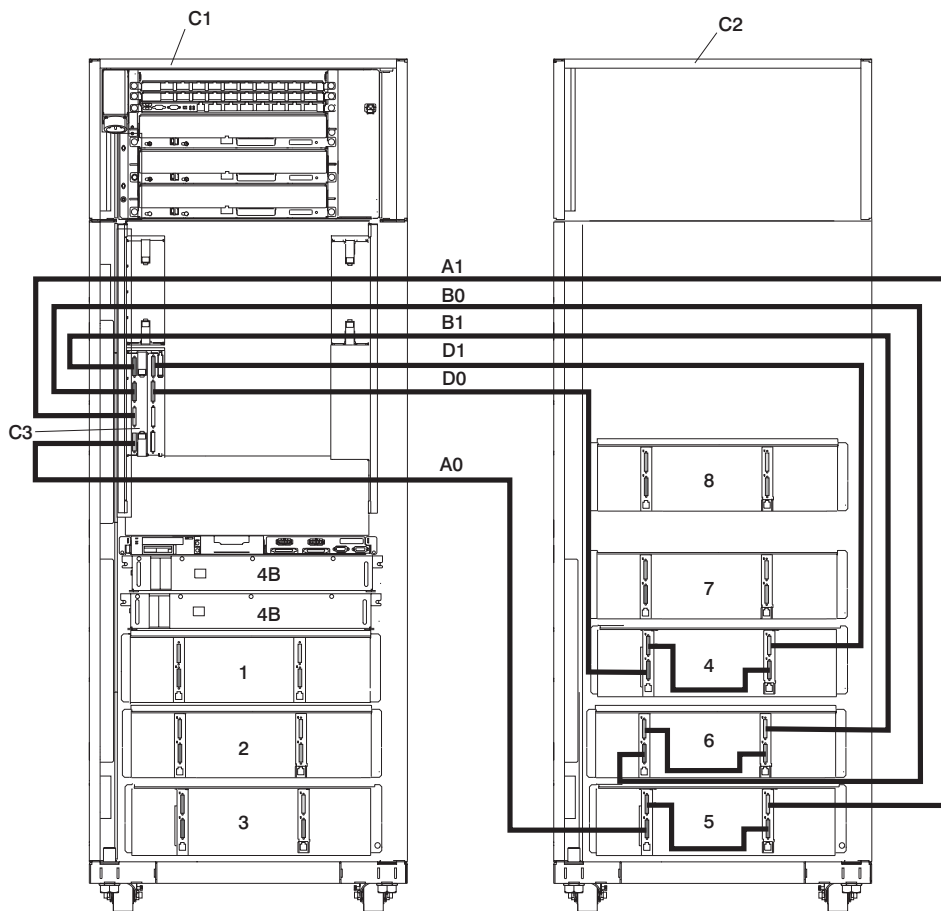

C1	Secondary Rack	6	Sixth I/O Subsystem
C2	Primary Rack	7	Seventh I/O Subsystem
C3	Secondary I/O Book in I/O Slot 3	8	Eighth I/O Subsystem
C4	Secondary I/O Book in Slot 2	A0	Connection to I/O Book (Book 2)
1	First I/O Subsystem	A1	Connection to I/O Book (Book 2)
2	Second I/O Subsystem	B0	Connection to I/O Book (Book 2)
3	Third I/O Subsystem	B1	Connection to I/O Book (Book 2)
4	Fourth I/O Subsystem	D0	Connection to I/O Book (Book 2)
4B	Integrated Battery Feature (IBF)	D1	Connection to I/O Book (Book 2)
5	Fifth I/O Subsystem		

I/O Subsystems (7 and 8) RIO Cabling to the Third I/O Book

Shown with IBFs

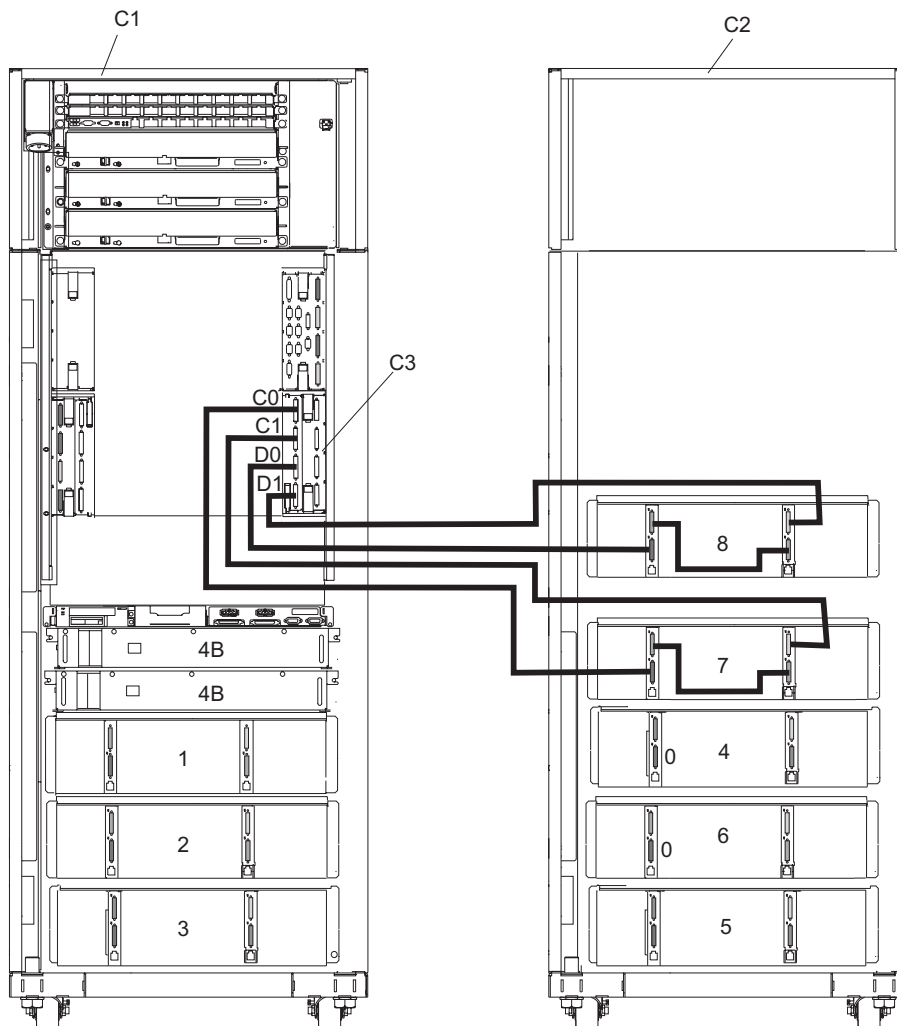

- C1** Primary Rack
- C2** Secondary Rack
- C3** Third I/O Book (Book 3)
- 1** First I/O Subsystem
- 2** Second Subsystem
- 3** Third I/O Subsystem
- 4** Fourth I/O Subsystem
- 4B** Two IBFs (maximum),
Position 4

- 5** Fifth I/O Subsystem
- 6** Sixth I/O Subsystem
- 7** Seventh I/O Subsystem
- 8** Eighth I/O Subsystem
- C0** Connection to I/O Book (Book 3)
- C1** Connection to I/O Book (Book 3)
- D0** Connection to I/O Book (Book 3)
- D1** Connection to I/O Book (Book 3)

Power and SCSI Cables to the Media Subsystem

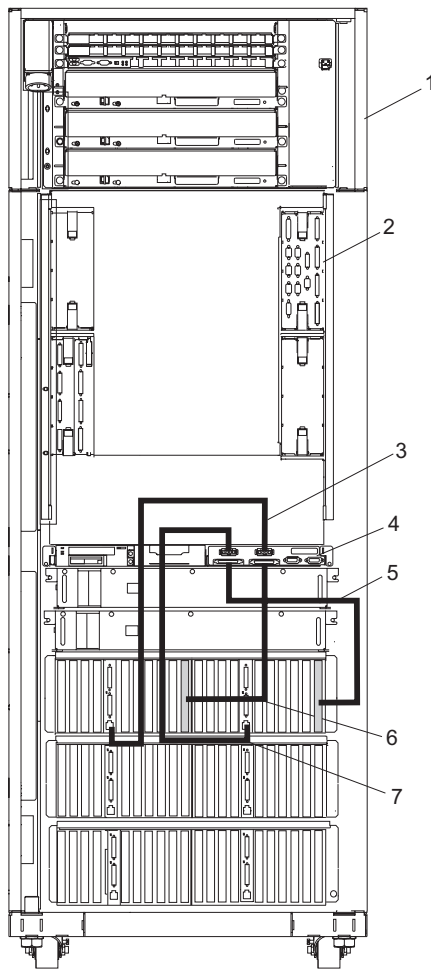

- | | | | |
|---|---|---|--|
| 1 | Primary Rack | 5 | SCSI Cable for Media Subsystem
Rear Drives |
| 2 | Primary I/O Book | 6 | SCSI Cable for Media Subsystem
Front Drives |
| 3 | Power Cable for Media Subsystem
Front Drives | 7 | Power Cable for Media Subsystem
Rear Drives |
| 4 | Rear of Media Subsystem | | |

IBM Hardware Management Console for pSeries (HMC) to the Primary I/O Book

To connect your HMC to the @server pSeries 690, connect the serial cable into serial port 1 located on the back of the HMC. Connect the other end of the serial cable into the HMC1 connector located on the primary I/O book on the managed system. The following illustration shows the location of the serial ports on the back of the HMC and the HMC connectors located on the processor subsystem.

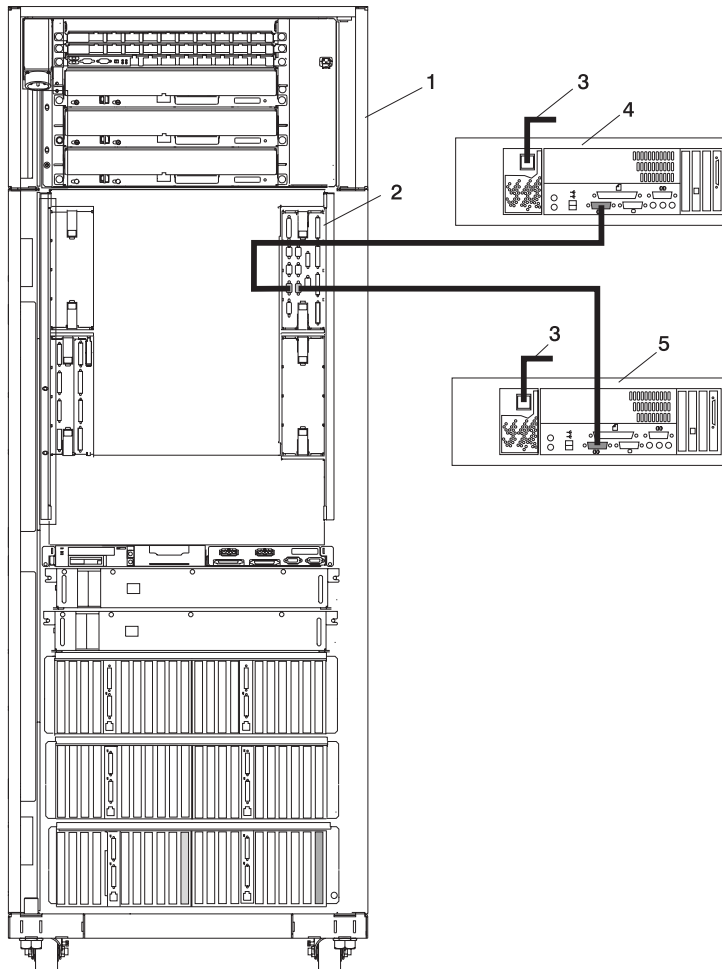

- | | | | |
|---|---|---|--|
| 1 | Primary Rack | 4 | Primary HMC Connected to HMC #1 in Primary I/O Book (HMC #1 may be labeled HSC #1) |
| 2 | Primary I/O Book | 5 | Optional Second HMC Connected to HMC #2 in Primary I/O Book (HMC #2 may be labeled HSC #2) |
| 3 | Power Plug to External Power Source (wall plug) | | |

Optional 8-port or 128 Port Async Adapters

Up to two optional async adapters can be installed in the HMC. The adapters have breakout boxes that allow connection to serial cables that connect to the managed system's HMC 1 serial ports. For information about installing these adapters in the HMC, see the *@server pSeries 690 Installation Guide*, form number SA38-0587.

System Memory

All of the main memory for the @server pSeries 690 consists of pluggable memory books in reserved slots with two memory controllers per book. The memory books are available in various sizes. Memory modules are not removable from the memory books. A minimum of 8 GB of memory must be installed for the system to operate.

Eight slots, located on the front of the processor subsystem, are available for system memory books. These slots are shown in “7040 Model 681 Processor Subsystem Processor Subsystem Front View” on page 22.

Memory to Processor Relationships

The following illustration shows the relationship between the memory riser cards, L3 cache, and the MCM modules:

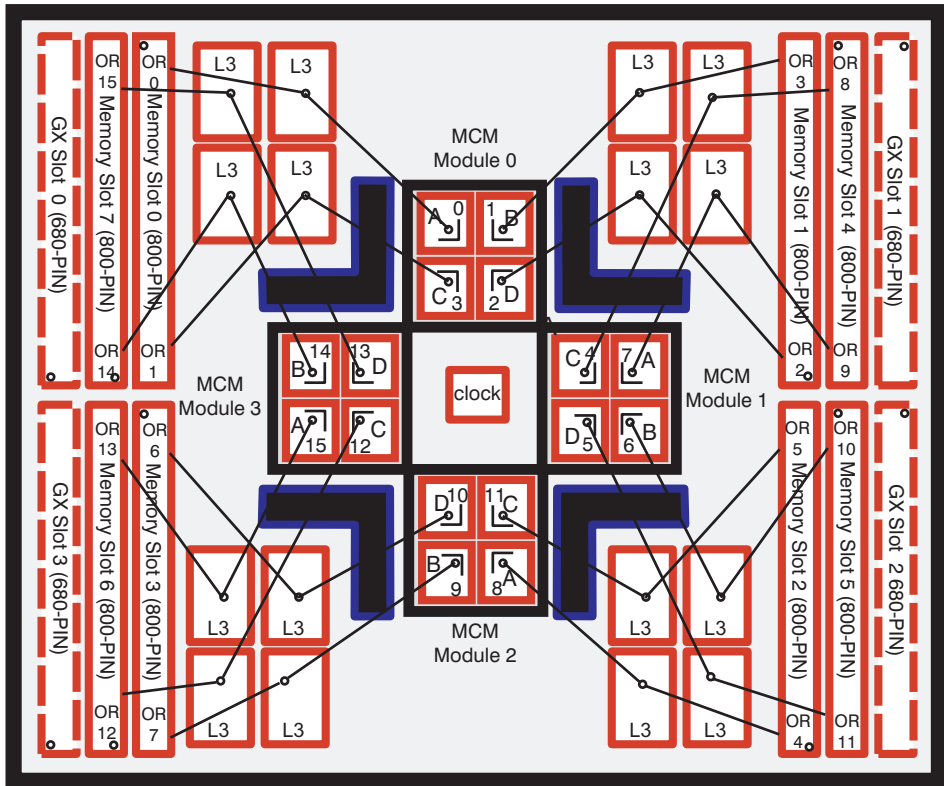

Memory Requirements

When the system is ordered, the installed memory will be positioned considering the following guidelines:

- The pSeries 690 has eight memory slots. Four memory slots utilize inward facing memory cards and four utilize outward facing memory cards. The inward facing

memory slots are utilized by the first and second processor module positions while the outward facing memory slots support the third and fourth 8-way processor module positions.

- A pSeries 690 system with only one processor MCM position populated has access to only two inward facing memory slots.
- Minimum system memory is 8 GB. Maximum system memory is 256 GB.
- Memory is available in 4 GB, 8 GB, 16 GB, and 32 GB inward facing and outward facing increments.
- The following memory configuration considerations are recommended to ensure the best performance is obtained for the system:
 - Memory should be installed in identical pairs.
 - All available memory locations should be populated with memory cards.
 - Memory sizes should be balanced as closely as possible across all populated MCM locations.
- The number of active memory positions on a system is related to the number of populated MCM locations. Two memory positions are activated for each MCM installed.
 - The first MCM installed activates the first and second inward facing memory positions.
 - The second MCM installed activates the third and fourth inward facing memory positions.
 - The third MCM installed activates the first and second outward facing memory positions.
 - The fourth MCM installed activates the third and fourth outward facing memory positions.
- It is recommended that all systems have access to a 4-mm or 8-mm tape drive for submission of system dump information, if required. This function may be accomplished via locally attached or network attached devices as appropriate.

I/O Subsystem Features

I/O subsystems have two redundant power supplies. One of these power supplies is capable of providing the necessary voltages and currents, independent of the other power supply. The left and right power-supply output voltages are connected and monitored by the power distribution board contained in the I/O subsystem.

The left and right power supplies are hot-pluggable and may be changed one at a time while the system is operational. Each power supply provides 5V dc, 3.3V dc, 12V dc, and 5V dc standby.

I/O to Processor Relationships

The following illustration shows the relationship between the I/O books, L3 cache, and the MCM modules:

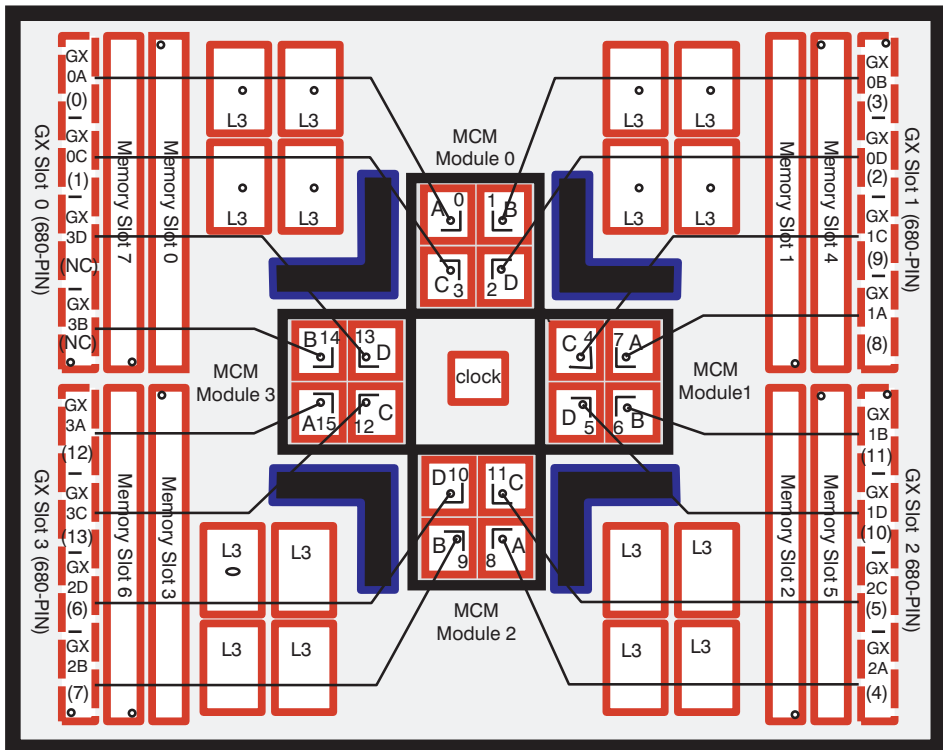

I/O Subsystem Power Supply (DCA) LED Status

Use the following table to determine the condition of the I/O subsystem power supply (DCA) based on the status of the power supply LEDs.

Status of LED	Operator Panel LED	Right Power Supply LED	Left Power Supply LED
Off	No power connected	No power connected or system power connected, not turned on, power supply detects NO faults	No power connected or system power connected, not turned on, power supply detects NO faults
On, fast blinking green, on for one second, off for one second	System power connected, power on initiated	System power connected, not turned on, power supply detected fault	System power connected, not turned on, power supply detected fault
On, slow blinking green, on for two seconds, off for two seconds	System power connected, not turned on	System power connected, not turned on, power supply detected system power control network fault	System power connected, not turned on, power supply detected system power control network fault
On, steady green	System power connected and turned on	System power connected and turned on	System power connected and turned on

Logical and Physical Locations

The @server pSeries 690 system uses physical location codes in conjunction with AIX location codes to provide mapping of the failing field replaceable units (FRUs). The location codes are produced by the system's firmware and the AIX operating system.

Physical Location Codes

Physical location codes provide a mapping of logical functions in a platform (or expansion sites for logical functions, such as connectors or ports) to their specific locations within the physical structure of the platform.

Location Code Format

The format for the location code is a string of alphanumeric characters separated by a dash (-), slash (/), pound sign (#) or period (.) character. The base location is all of the information preceding the slash (/) or pound sign (#). The base location identifies a device that is connected to or plugged into the parent. Extended location information follows the slash (/). Extended location information identifies a device that is part of the parent, a connector, or a cable. Cable information follows the pound sign (#). Cable information identifies a cable that is connected to parent. The following are examples:

- P1-C1 identifies a processor card C1 (MCM) plugged into planar (backplane) P1.
- P1-M1 identifies a memory card (book) M1 plugged into planar (backplane) P1.
- P1-H2/S1 identifies serial port 1 controller on planar (backplane) P1, the connector for serial port 1, the cable attached to serial port 1 would be represented by a # sign after the S1.
- P1-I2/E3 identifies a Ethernet controller 3 on the card in slot 2 (I2) on planar (backplane) P1, the connector for Ethernet controller 3, or the cable attached to Ethernet controller 3.
- P1-I2#E3 identifies the cable attached to Ethernet controller 3 on the card in slot 2 (I2) on planar (backplane) P1.

The period (.) identifies sublocations (SCSI addresses, cables). The following are examples:

- P1-C1.1 identifies processor 1 on processor card (MCM) plugged into planar (backplane) P1.
- P2-Z1-A3.1 identifies a SCSI device with SCSI address of LUN 1 at SCSI ID 3 attached to SCSI bus 1 from planar (backplane) 2.
- P1-I2#E3.2 identifies the second in a series of cables attached to Ethernet controller 3 on the card in slot 2 (I2) on planar (backplane) P1.

Depending on the AIX and firmware levels, AIX diagnostics may include the extended location information when identifying a planar (backplane) or card. The extended location information or cable information is always included when identifying a cable or connector. Location codes with extended location information that are displayed without a description identifying the devices always identify the cable attached to the port.

Multiple FRU Callout Instructions

If an eight-digit error code appears in the operator panel display or in Chapter 5, “Error Code to FRU Index” on page 399, a location code for a failing part may also be specified. If the location code includes a blank space followed by a lowercase x followed by a number, this is an error code with multiple FRU callouts. This error can typically happen with memory books or processors, and may involve mixed types of parts. In this case, check the system’s configuration for FRU part numbers to determine the appropriate set of FRUs.

You can determine the FRU part numbers of the electronic assemblies in the entire system by using the service processor menus. From the General User menu, select **Read VPD Image from Last System Boot**, then enter 90 to display detailed Vital Product Data (VPD).

You can determine the FRU part numbers of the electronic assemblies in a partition by using the **lscfg -vp | pg** command on the AIX command line to display the detailed VPD of all assemblies. Notice that the FRU part number information for processors and memory books may be at the bottom of the command output.

SCSI Devices

For SCSI devices, the location code is defined as follows:

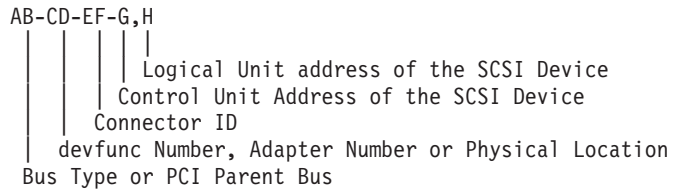

Where:

- AB-CD-EF are the same as non-SCSI devices.
- G defines the control unit address of the device. Values of 0 to 15 are valid.
- H defines the logical unit address of the device. Values of 0 to 255 are valid.

A bus location code is also generated as '00-XXXXXXXX', where XXXXXXXX is equivalent to the node's unit address.

Examples of physical location codes and AIX location codes are:

- PCI adapter in first I/O subsystem, slot 1 (primary rack):
 - Physical location code U1.9-P1-I1
 - AIX location code 2V-08
- PCI adapter in fifth I/O subsystem, slot 1 (secondary rack):
 - Location Code U2.1-P1-I1
 - AIX location Code 8V-08

AIX and Physical Location Code Reference Tables

The following illustrations show the location codes that are used to identify the major functional units in the @server pSeries 690 primary and secondary racks. The following figure shows the primary rack locations.

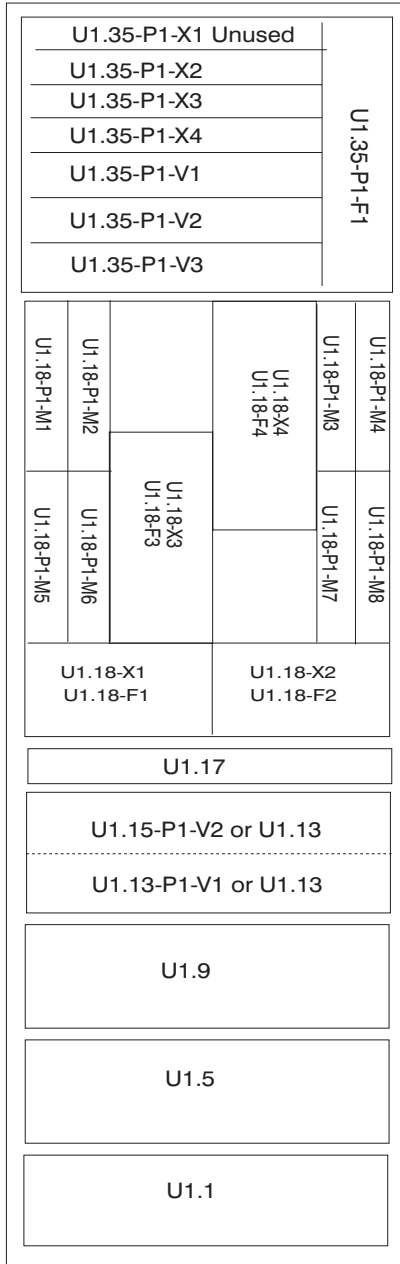

FRONT

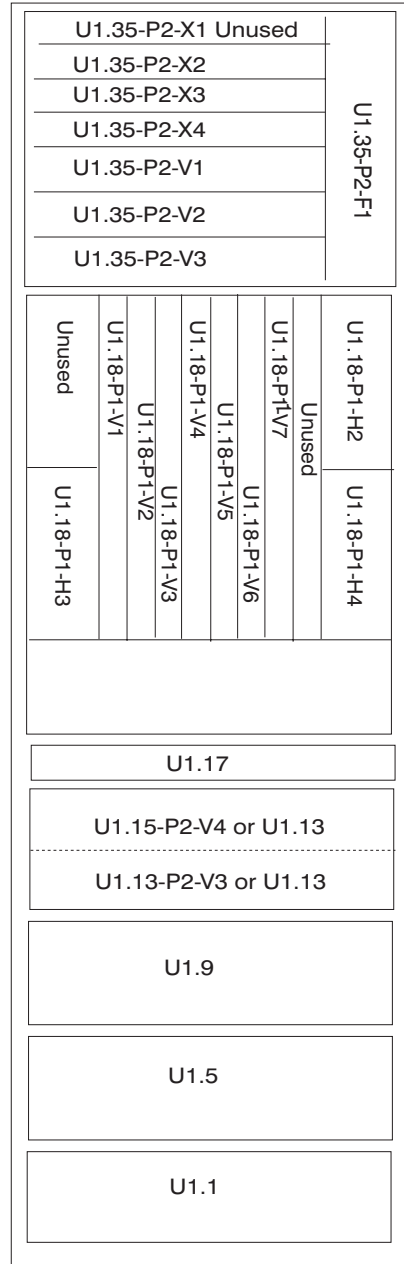

REAR

The following figure shows the secondary rack locations.

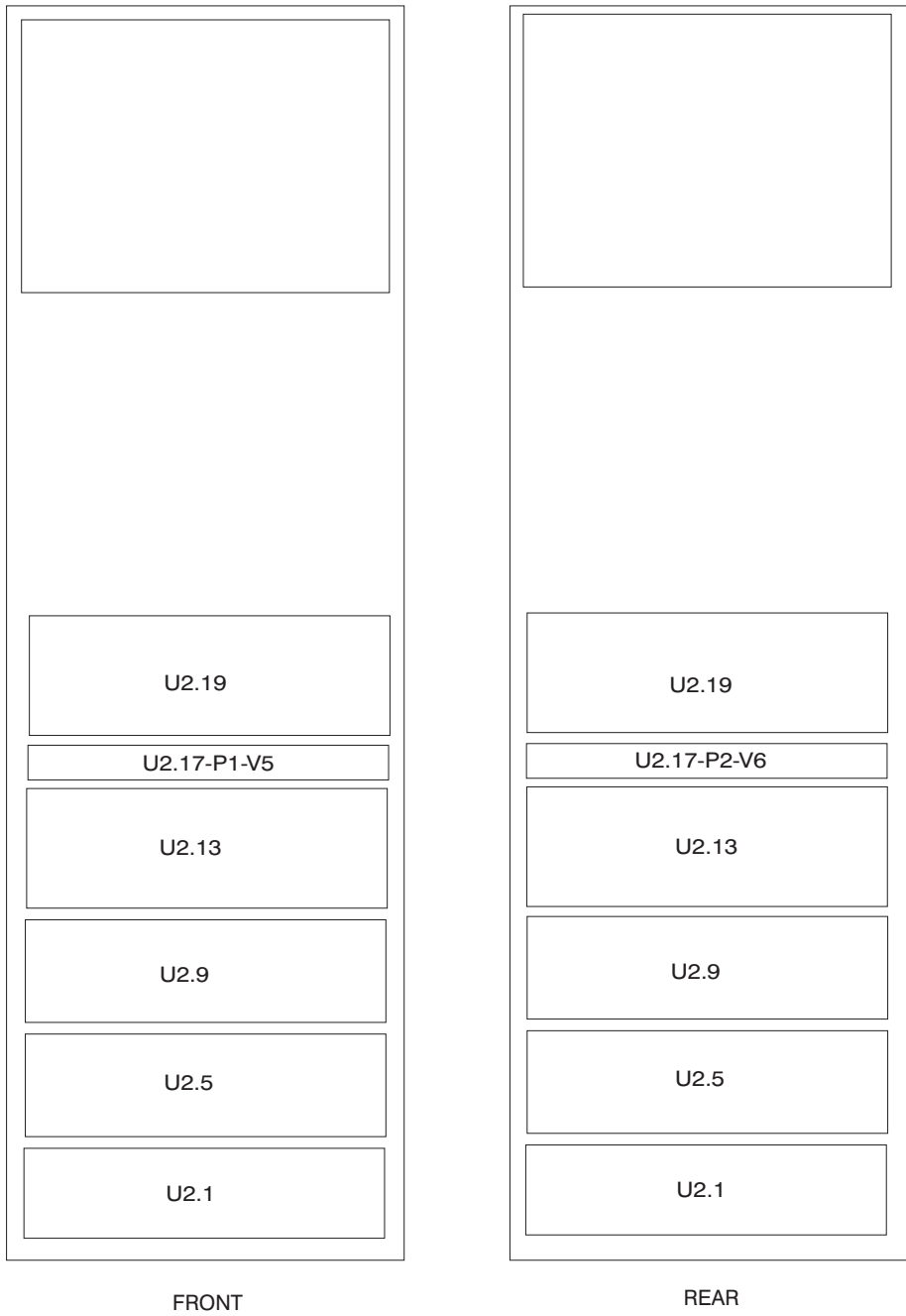

The following illustration shows the location codes that are used to identify the MCM modules and L3 modules (located behind fans 3--U1.18-P1-F3 and 4--U1.18-P1-F4).

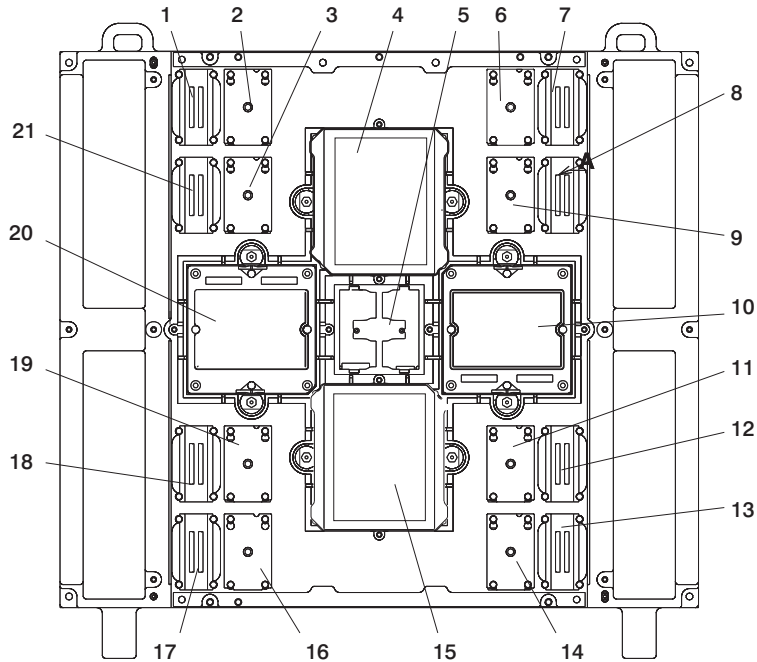

1	L3, Location: U1.18-P1-C5	12	L3, Location: U1.18-P1-C16
2	L3, Location: U1.18-P1-C6	13	L3, Location: U1.18-P1-C20
3	L3, Location: U1.18-P1-C10	14	L3, Location: U1.18-P1-C19
4	MCM 0, Location: U1.18-P1-C1	15	MCM 2, Location: U1.18-P1-C4
5	Clock Card, Location: U1.18-P1-X5	16	L3, Location: U1.18-P1-C18
6	L3, Location: U1.18-P1-C7	17	L3, Location: U1.18-P1-C17
7	L3, Location: U1.18-P1-C8	18	L3, Location: U1.18-P1-C13
8	L3, Location: U1.18-P1-C12	19	L3, Location: U1.18-P1-C14
9	L3, Location: U1.18-P1-C11	20	MCM 3, Location: U1.18-P1-C2
10	MCM 1, Location: U1.18-P1-C3	21	L3, Location: U1.18-P1-C9
11	L3, Location: U1.18-P1-C15		

The following tables contain location codes that are used to identify functional units in the @server pSeries 690 systems. Each table shows the locations for a physical part of the system.

FRU Name	Location Code	AIX Location Code	Physical Connection	Logical Connection
System Rack	(MT/M Serial#) U1			
Bulk Power Subsystem 1 Locations				
Bulk Power Enclosure A (front)	U1.35			
BPE Backplane A	U1.35-P1			
AC to BPE (A) Line Cord Connector	U1.35-P1/Q1			
AC to BPE (A) Line Cord	U1.35-P1/Q1#			
Bulk Power Reg 1	U1.35-P1-V1			
BPR 1 Connector	U1.35-P1-V1/Q1			
BPR 1 Cable to IBF 1A	U1.35-P1-V1/Q1#			
Bulk Power Distribution 3 (Unused)	U1.35-P1-X1			
SPARE	U1.35-P1-X1/Q1			
SPARE Cable	U1.35-P1-X1/Q1#			
SPARE	U1.35-P1-X1/Q2			
SPARE Cable	U1.35-P1-X1/Q2#			
SPARE	U1.35-P1-X1/Q3			
SPARE Cable	U1.35-P1-X1/Q3#			
SPARE	U1.35-P1-X1/Q4			
SPARE Cable	U1.35-P1-X1/Q4#			
SPARE	U1.35-P1-X1/Q5			
SPARE Cable	U1.35-P1-X1/Q5#			
SPARE	U1.35-P1-X1/Q6			
SPARE Cable	U1.35-P1-X1/Q6#			
SPARE	U1.35-P1-X1/Q7			
SPARE Cable	U1.35-P1-X1/Q7#			
SPARE	U1.35-P1-X1/Q8			
SPARE Cable	U1.35-P1-X1/Q8#			
SPARE	U1.35-P1-X1/Q9			
SPARE Cable	U1.35-P1-X1/Q9#			
SPARE	U1.35-P1-X1/Q10			

FRU Name	Location Code	AIX Location Code	Physical Connection	Logical Connection
SPARE Cable	U1.35-P1-X1/Q10#			
Bulk Power Reg 2 (BPR)	U1.35-P1-V2			
BPR 2 (BPR) Connector	U1.35-P1-V2/Q1			
BPR 2 Cable to IBF 2A	U1.35-P1-V2/Q1#			
Bulk Power Distribution 1	U1.35-P1-X3			
I/O Subsystem -1A Connector 0 I/O Subsystem 1 (DCA 1)	U1.35-P1-X3/Q1			
I/O Subsystem -1A Cable	U1.35-P1-X3/Q1#			
I/O Subsystem -1B Connector 1 I/O Subsystem 1 (DCA 2)	U1.35-P1-X3/Q2			
I/O Subsystem -1B Cable	U1.35-P1-X3/Q2#			
I/O Subsystem -2A Connector 2 I/O Subsystem 2 (DCA 1)	U1.35-P1-X3/Q3			
I/O Subsystem -2A Cable	U1.35-P1-X3/Q3#			
I/O Subsystem -2B Connector 3 I/O Subsystem 2 (DCA 2)	U1.35-P1-X3/Q4			
I/O Subsystem -2B Cable	U1.35-P1-X3/Q4#			
I/O Subsystem -3A Connector 4 I/O Subsystem 3 (DCA 1)	U1.35-P1-X3/Q5			
I/O Subsystem -3A Cable	U1.35-P1-X3/Q5#			
I/O Subsystem -3B Connector 5 I/O Subsystem 3 (DCA 2)	U1.35-P1-X3/Q6			

FRU Name	Location Code	AIX Location Code	Physical Connection	Logical Connection
I/O Subsystem -3B Cable	U1.35-P1-X3/Q6#			
I/O Subsystem -4A Connector 6 I/O Subsystem 4 (DCA 1)	U1.35-P1-X3/Q7#			
I/O Subsystem -4A Cable	U1.35-P1-X3/Q7#			
I/O Subsystem -4B Connector 7 I/O Subsystem 4 (DCA 2)	U1.35-P1-X3/Q8			
I/O Subsystem -4B Cable	U1.35-P1-X3/Q8#			
DCA-4 Connector	U1.35-P1-X3/Q9			
DCA-4 Cable	U1.35-P1-X3/Q9#			
DCA-5 Connector	U1.35-P1-X3/Q10			
DCA-5 Cable	U1.35-P1-X3/Q10#			
Bulk Power Distribution 2	U1.35-P1-X2			
I/O Subsystem -5A Connector 0 I/O Subsystem 5 (DCA 1)	U1.35-P1-X2/Q1			
I/O Subsystem -5A Cable	U1.35-P1-X2/Q1#			
I/O Subsystem -5B Connector 1 I/O Subsystem 5 (DCA 2)	U1.35-P1-X2/Q2			
I/O Subsystem -5B Cable	U1.35-P1-X2/Q2#			
I/O Subsystem -6A Connector 2 I/O Subsystem 6 (DCA 1)	U1.35-P1-X2/Q3			
I/O Subsystem -6A Cable	U1.35-P1-X2/Q3#			
I/O Subsystem -6B Connector 3 I/O Subsystem 6 (DCA 2)	U1.35-P1-X2/Q4			
I/O Subsystem -6B Cable	U1.35-P1-X2/Q4#			

FRU Name	Location Code	AIX Location Code	Physical Connection	Logical Connection
I/O Subsystem -7A Connector 4 I/O Subsystem 7 (DCA 1)	U1.35-P1-X2/Q5			
I/O Subsystem -7A Cable	U1.35-P1-X2/Q5#			
I/O Subsystem -7B Connector 5 I/O Subsystem 7 (DCA 2)	U1.35-P1-X2/Q6			
I/O Subsystem -7B Cable	U1.35-P1-X2/Q6#			
SPARE (Future Subsystem 8)	U1.35-P1-X2/Q7			
SPARE cable	U1.35-P1-X2/Q7#			
SPARE 5 (Future Subsystem 8)	U1.35-P1-X2/Q8			
SPARE cable	U1.35-P1-X2/Q8#			
SPARE connector	U1.35-P1-X2/Q9			
SPARE cable	U1.35-P1-X2/Q9#			
DCA-6 Connector	U1.35-P1-X2/Q10			
DCA-6 Cable	U1.35-P1-X2/Q10#			
Bulk Power Regulator 3	U1.35-P1-V3			
BPR 3 Connector	U1.35-P1-V3/Q1			
BPR 3 Cable to IBF 3A	U1.35-P1-V3/Q1#			
Bulk Power Fan (BPF)	U1.35-P1-F1			
BPF TO BPC Connector	U1.35-P1-F1/Q1			
BPF TO BPC Cable	U1.35-P1-F1/Q1#			
Bulk Power Controller A	U1.35-P1-X4			
BPC A - MDA-1 Connector	U1.35-P1-X4/Q1			
BPC A - MDA-1 Cable	U1.35-P1-X4/Q1#			
BPC A - MDA-2 Connector	U1.35-P1-X4/Q2			
BPC A - MDA-2 Cable	U1.35-P1-X4/Q2#			

FRU Name	Location Code	AIX Location Code	Physical Connection	Logical Connection
BPC A - MDA-3 Connector	U1.35-P1-X4/Q3			
BPC A - MDA-3 Cable	U1.35-P1-X4/Q3#			
BPC A - MDA-4 Connector	U1.35-P1-X4/Q4			
BPC A - MDA-4 Cable	U1.35-P1-X4/Q4#			
BPC A - DCA-1 Connector	U1.35-P1-X4/Q5			
BPC A - DCA-1 Cable	U1.35-P1-X4/Q5#			
BPC A - DCA-2 Connector	U1.35-P1-X4/Q6			
BPC A - DCA-2 Cable	U1.35-P1-X4/Q6#			
BPC A - DCA-3 Connector	U1.35-P1-X4/Q7			
BPC A - DCA-3 Cable	U1.35-P1-X4/Q7#			
BPC A TO BPC B Connector	U1.35-P1-X4/Q8			
BPC A TO BPC B Cable	U1.35-P1-X4/Q8#			
BPC A To Primary I/O Book Connector U1.18-P1-H2/Q8	U1.35-P1-X4/Q10			
BPC A "Y" Cable To Primary I/O Book Connector U1.18-P1-H2/Q8	U1.35-P1-X4/Q10#			
BPC A TO BPF A Connector	U1.35-P1-X4/Q11			
BPC A TO BPF A Cable	U1.35-P1-X4/Q11#			
UEPO Switch (attached to frame)	U1-V1			
UEPO Connector J00	U1-V1/Q1			
UEPO Cable to BPC A	U1-V1/Q1#			
UEPO Connector J01	U1-V1/Q2			

FRU Name	Location Code	AIX Location Code	Physical Connection	Logical Connection
UEPO Cable to BPC B	U1-V1/Q2#			
Bulk Power Enclosure B (back)	U1.35			
BPE Backplane B	U1.35-P2			
AC TO BPE (A) Line Cord Connector	U1.35-P2/Q1			
AC TO BPE (A) Line Cord	U1.35-P2/Q1#			
Bulk Power Regulator (BPR) 1	U1.35-P2-V1			
BPR 1 Connector	U1.35-P2-V1/Q1			
BPR 1 cable to IBF 1A	U1.35-P2-V1/Q1#			
Bulk Power Distribution 2	U1.35-P2-X2			
I/O Subsystem -5A Connector 0 I/O Subsystem 5 (DCA 1)	U1.35-P2-X2/Q1			
I/O Subsystem -5A Cable	U1.35-P2-X2/Q1#			
I/O Subsystem -5B Connector 1 I/O Subsystem 5 (DCA 2)	U1.35-P2-X2/Q2			
I/O Subsystem -5B Cable	U1.35-P2-X2/Q2#			
I/O Subsystem -6A Connector 2 I/O Subsystem 6 (DCA 1)	U1.35-P2-X2/Q3			
I/O Subsystem -6A Cable	U1.35-P2-X2/Q3#			
I/O Subsystem -6B Connector 3 I/O Subsystem 6 (DCA 2)	U1.35-P2-X2/Q4			
I/O Subsystem -6B Cable	U1.35-P2-X2/Q4#			
I/O Subsystem -7A Connector 4 I/O Subsystem 7 (DCA 1)	U1.35-P2-X2/Q5			

FRU Name	Location Code	AIX Location Code	Physical Connection	Logical Connection
I/O Subsystem -7A cable	U1.35-P2-X2/Q5#			
I/O Subsystem -7B Connector 5 I/O Subsystem 7 (DCA 2)	U1.35-P2-X2/Q6			
I/O Subsystem -7B cable	U1.35-P2-X2/Q6#			
SPARE (Future Drawer 8)	U1.35-P2-X2/Q7			
SPARE cable	U1.35-P2-X2/Q7#			
SPARE 5 (Future Drawer 8)	U1.35-P2-X2/Q8			
SPARE cable	U1.35-P2-X2/Q8#			
SPARE	U1.35-P2-X2/Q9			
SPARE cable	U1.35-P2-X2/Q9#			
DCA-6 Connector / FUTURE USE	U1.35-P2-X2/Q10			
DCA-6 Cable / FUTURE USE	U1.35-P2-X2/Q10#			
Bulk Power Regulator 2	U1.35-P2-V2			
BPR 2 Connector	U1.35-P2-V2/Q1			
BPR 2 Cable to IBF 2A	U1.35-P2-V2/Q1#			
Bulk Power Distribution 1	U1.35-P2-X3			
I/O Subsystem -1A Connector 0 I/O Subsystem 1 (DCA 1)	U1.35-P2-X3/Q1			
I/O Subsystem -1A Cable	U1.35-P2-X3/Q1#			
I/O Subsystem -1B Connector 1 I/O Subsystem 1 (DCA 2)	U1.35-P2-X3/Q2			
I/O Subsystem -1B Cable	U1.35-P2-X3/Q2#			
I/O Subsystem -2A Connector 2 I/O Subsystem 2 (DCA 1)	U1.35-P2-X3/Q3			

FRU Name	Location Code	AIX Location Code	Physical Connection	Logical Connection
I/O Subsystem -2A Cable	U1.35-P2-X3/Q3#			
I/O Subsystem -2B Connector 3 I/O Subsystem 2 (DCA 2)	U1.35-P2-X3/Q4			
I/O Subsystem -2B Cable	U1.35-P2-X3/Q4#			
I/O Subsystem -3A Connector 4 I/O Subsystem 3 (DCA 1)	U1.35-P2-X3/Q5			
I/O Subsystem -3A Cable	U1.35-P2-X3/Q5#			
I/O Subsystem -3B Connector 5 I/O Subsystem 3 (DCA 2)	U1.35-P2-X3/Q6			
I/O Subsystem -3B Cable	U1.35-P2-X3/Q6#			
I/O Subsystem -4A Connector 6 I/O Subsystem 4 (DCA 1)	U1.35-P2-X3/Q7			
I/O Subsystem -4A Cable	U1.35-P2-X3/Q7#			
I/O Subsystem -4B Connector 7 I/O Subsystem 4 (DCA 2)	U1.35-P2-X3/Q8			
I/O Subsystem -4B Cable	U1.35-P2-X3/Q8#			
DCA-4 Connector	U1.35-P2-X3/Q9			
DCA-4 Cable	U1.35-P2-X3/Q9#			
DCA-5 Connector	U1.35-P2-X3/Q10			
DCA-5 Cable	U1.35-P2-X3/Q10#			
Bulk Power Regulator 3	U1.35-P2-V3			
BPR 2 Connector	U1.35-P2-V3/Q1			
BPR 2 Cable to IBF 3A	U1.35-P2-V3/Q1#			

FRU Name	Location Code	AIX Location Code	Physical Connection	Logical Connection
Bulk Power Distribution (Unused)	U1.35-P2-X1			
SPARE	U1.35-P2-X1/Q1			
SPARE cable	U1.35-P2-X1/Q1#			
SPARE	U1.35-P2-X1/Q2			
SPARE cable	U1.35-P2-X1/Q2#			
SPARE	U1.35-P2-X1/Q3			
SPARE cable	U1.35-P2-X1/Q3#			
SPARE	U1.35-P2-X1/Q4			
SPARE cable	U1.35-P2-X1/Q4#			
SPARE	U1.35-P2-X1/Q5			
SPARE cable	U1.35-P2-X1/Q5#			
SPARE	U1.35-P2-X1/Q6			
SPARE cable	U1.35-P2-X1/Q6#			
SPARE	U1.35-P2-X1/Q7			
SPARE cable	U1.35-P2-X1/Q7#			
SPARE	U1.35-P2-X1/Q8			
SPARE cable	U1.35-P2-X1/Q8#			
SPARE	U1.35-P2-X1/Q9			
SPARE cable	U1.35-P2-X1/Q9#			
SPARE	U1.35-P2-X1/Q10			
SPARE cable	U1.35-P2-X1/Q10#			
Bulk Power Fan	U1.35-P2-F1			
BPF TO BPC Connector	U1.35-P2-F1/Q1			
BPF TO BPC Cable	U1.35-P2-F1/Q1#			
Bulk Power Controller B	U1.35-P2-X4			
BPC B - MDA-1 Connector	U1.35-P2-X4/Q1			
BPC B - MDA-1 Cable	U1.35-P2-X4/Q1#			
BPC B - MDA-2 Connector	U1.35-P2-X4/Q2			
BPC B - MDA-2 Cable	U1.35-P2-X4/Q2#			
BPC B - MDA-3 Connector	U1.35-P2-X4/Q3			

FRU Name	Location Code	AIX Location Code	Physical Connection	Logical Connection
BPC B - MDA-3 Cable	U1.35-P2-X4/Q3#			
BPC B - MDA-4 Connector	U1.35-P2-X4/Q4			
BPC B - MDA-4 Cable	U1.35-P2-X4/Q4#			
BPC B - DCA-1 Connector	U1.35-P2-X4/Q5			
BPC B - DCA-1 Cable	U1.35-P2-X4/Q5#			
BPC B - DCA-2 Connector	U1.35-P2-X4/Q6			
BPC B - DCA-2 Cable	U1.35-P2-X4/Q6#			
BPC B - DCA-3 Connector	U1.35-P2-X4/Q7			
BPC B - DCA-3 Cable	U1.35-P2-X4/Q7#			
BPC TO BPC Connector	U1.35-P2-X4/Q8			
BPC TO BPC Cable	U1.35-P2-X4/Q8#			
BPC TO EPOC Connector	U1.35-P2-X4/Q9			
BPC TO EPOC Cable	U1.35-P2-X4/Q9#			
BPC TO Primary I/O Book Connector U1.18-P1-H2/Q8	U1.35-P2-X4/Q10			
BPC B "Y" Cable To Primary I/O Book Connector U1.18-P1-H2/Q8	U1.35-P2-X4/Q10#			
BPC TO BPF Connector	U1.35-P2-X4/Q11			
BPC TO BPF Cable	U1.35-P2-X4/Q11#			
UEPO TO BPC A Connector	U1-V1/Q1			
UEPO TO BPC A Cable	U1-V1/Q1#			

FRU Name	Location Code	AIX Location Code	Physical Connection	Logical Connection
Processor Subsystem Locations				
Processor Subsystem	(MT/M Serial #) U1.18			
System Board (backplane)	U1.18-P1			
Memory Book - Slot 0	U1.18-P1-M2	00-00		
Memory Book - Slot 1	U1.18-P1-M3	00-00		
Memory Book - Slot 3	U1.18-P1-M6	00-00		
Memory Book - Slot 2	U1.18-P1-M7	00-00		
Memory Book - Slot 7	U1.18-P1-M1	00-00		
Memory Book - Slot 4	U1.18-P1-M4	00-00		
Memory Book - Slot 6	U1.18-P1-M5	00-00		
Memory Book - Slot 5	U1.18-P1-M8	00-00		
Primary I/O book - Slot 0	U1.18-P1-H2			
System VPD Module (Backup)	U1.18-P1-H2-N1			
Diskette Drive Controller	U1.18-P1-H2/D1	01-D1		
Serial Port 1 Connector	U1.18-P1-H2/S1	01-S1		
Serial Port 1 Cable	U1.18-P1-H2/S1#			
Serial Port 2 Connector	U1.18-P1-H2/S2	01-S2		
Serial Port 2 Cable	U1.18-P1-H2/S2#			
HMC Serial Port 1 Connector	U1.18-P1-H2/S3	01-S3		
HMC Serial Port 1 Cable	U1.18-P1-H2/S3#			
HMC Serial Port 2 Connector	U1.18-P1-H2/S4	01-S4		
HMC Serial Port 2 Cable	U1.18-P1-H2/S4#			
Debug Port Only	U1.18-P1-H2/R1	01-R1		

FRU Name	Location Code	AIX Location Code	Physical Connection	Logical Connection
Operator Panel Connector	U1.18-P1-H2/Q7			
Diskette Drive Connector	U1.18-P1-H2/Q10			
Diskette Drive Cable	U1.18-P1-H2/Q10#			
BPC A&B Connector	U1.18-P1-H2/Q8			
BPC A Connector	U1.18-P1-H2/Q8			
BPC A Cable	U1.18-P1-H2/Q8#			
BPC B Connector	U1.18-P1-H2/Q9			
BPC B Cable	U1.18-P1-H2/Q9#			
SPCN Port 0 Connector	U1.18-P1-H2/Q5			
SPCN Port 0 Cable	U1.18-P1-H2/Q5#			
SPCN Port 1 Connector	U1.18-P1-H2/Q6			
SPCN Port 1 Cable	U1.18-P1-H2/Q6#			
JTAG	U1.18-P1-H2			
NVRAM	U1.18-P1-H2			
System Firmware	U1.18-P1-H2/Y1			
Primary I/O book-0 Port 0 Connector 0 (1-2) (A0),	U1.18-P1-H2/Q1			
Primary I/O book-0 Port 0 (1-2) Cable 1, see "I/O Subsystems (1 Through 4 Without IBFs) RIO Cabling to I/O Books" on page 45 for cable connections.	U1.18-P1-H2/Q1#			
Primary I/O book-0 Port 0 Connector 1 (1-3) (A1)	U1.18-P1-H2/Q2			

FRU Name	Location Code	AIX Location Code	Physical Connection	Logical Connection
Primary I/O book-0 Port 0 Connector 1 (1-3) Cable 2, see "I/O Subsystems (1 Through 4 Without IBFs) RIO Cabling to I/O Books" on page 45 for cable connections.	U1.18-P1-H2/Q2#			
Primary I/O book-1 Port 1 Connector 2 (2-0) (B0)	U1.18-P1-H2/Q3			
Primary I/O book-1 Port 1 Connector 2 (2-0) Cable 3, see "I/O Subsystems (1 Through 4 Without IBFs) RIO Cabling to I/O Books" on page 45 for cable connections.	U1.18-P1-H2/Q3#			
Primary I/O book-1 Port 1 Connector 3 (2-1) (B1),	U1.18-P1-H2/Q4			
Primary I/O book-1 Port 1 Connector 3 (2-1) Cable 4 see "I/O Subsystems (1 Through 4 Without IBFs) RIO Cabling to I/O Books" on page 45 for cable connections.	U1.18-P1-H2/Q4#			
ISA Bridge	U1.18-P1-H2			
Real Time Clock (RTC)	U1.18-P1-H2			
Battery (TOD)	U1.18-P1-H2-V1			
Error logging VPD Card (MCM -0)	U1.18-P1-H2.3			
Error logging VPD Card (MCM -1)	U1.18-P1-H2.5			
Error logging VPD Card (MCM -2)	U1.18-P1-H2.4			
Error logging VPD Card (MCM -3)	U1.18-P1-H2.6			

FRU Name	Location Code	AIX Location Code	Physical Connection	Logical Connection
Error logging VPD Card (L3)	U1.18-P1-H2.1			
COD Security VPD Card	U1.18-P1-H2.2			
I/O Book 2, Slot 2	U1.18-P1-H3			
I/O Book 2, Port 11 Connector 3 (1-1) (B1)	U1.18-P1-H3/Q1			
I/O Book 2, Port 11 Connector 3 (1-1) Cable 1, see "I/O Subsystems (5 and 6) RIO Cabling to the Secondary I/O Book" on page 46 for cable connections.	U1.18-P1-H3/Q1#			
I/O Book 2, Port 11 Connector 2 (1-0) (B0)	U1.18-P1-H3/Q2			
I/O Book 2, Port 11 Connector 2 (1-0) Cable 2, see "I/O Subsystems (5 and 6) RIO Cabling to the Secondary I/O Book" on page 46 for cable connections.	U1.18-P1-H3/Q2#			
I/O Book 2, Port 10 Connector 1 (2-1) (A1)	U1.18-P1-H3/Q3			
I/O Book 2, Port 10 Connector 1 (2-1) Cable 3, see "I/O Subsystems (5 and 6) RIO Cabling to the Secondary I/O Book" on page 46 for cable connections.	U1.18-P1-H3/Q3#			
I/O Book 2, Port 10 Connector 0 (2-0) (A0)	U1.18-P1-H3/Q4			

FRU Name	Location Code	AIX Location Code	Physical Connection	Logical Connection
I/O Book 2, Port 10 Connector 0 (2-0) Cable 4, see "I/O Subsystems (5 and 6) RIO Cabling to the Secondary I/O Book" on page 46 for cable connections.	U1.18-P1-H3/Q4#			
I/O Book 2, Port 5 Connector 3 (1-1) (D1)	U1.18-P1-H3/Q5			
I/O Book 2, Port 5 Connector 3 (1-1) Cable 5, see "I/O Subsystems (1 Through 4 Without IBFs) RIO Cabling to I/O Books" on page 45 for cable connections.	U1.18-P1-H3/Q5#			
I/O Book 2, Port 5 Connector 2 (1-0) (D0)	U1.18-P1-H3/Q6			
I/O Book 2, Port 5 Connector 2 (1-0) Cable 6, see "I/O Subsystems (1 Through 4 Without IBFs) RIO Cabling to I/O Books" on page 45 for cable connections.	U1.18-P1-H3/Q6#			
I/O Book 2, Port 4 Connector 1 (2-1) (C1)	U1.18-P1-H3/Q7			
I/O Book 2, Port 4 Connector 1 (2-1) Cable 7, see "I/O Subsystems (1 Through 4 Without IBFs) RIO Cabling to I/O Books" on page 45 for cable connections.	U1.18-P1-H3/Q7#			
I/O Book 2, Port 4 Connector 0 (2-0) (C0)	U1.18-P1-H3/Q8			

FRU Name	Location Code	AIX Location Code	Physical Connection	Logical Connection
I/O Book 2, Port 4 Connector 1 (2-0) Cable 8 , see "I/O Subsystems (1 Through 4 Without IBFs) RIO Cabling to I/O Books" on page 45 for cable connections.	U1.18-P1-H3/Q8#			
I/O Book 3- Slot 3	U1.18-P1-H4			
I/O Book 3, Port 12 Connector 2 (1-0) (C0)	U1.18-P1-H4/Q1			
I/O Book 3, Port 12 Connector 2 (1-0) Cable 2 , see "I/O Subsystems (7 and 8) RIO Cabling to the Third I/O Book" on page 47 for cable connections.	U1.18-P1-H4/Q1#			
I/O Book 3, Port 12 Connector 3 (1-1) (C1)	U1.18-P1-H4/Q2			
I/O Book 3, Port 12 Connector 3 (1-1) Cable 1, see "I/O Subsystems (7 and 8) RIO Cabling to the Third I/O Book" on page 47 for cable connections.	U1.18-P1-H4/Q2#			
I/O Book 3, Port 13 Connector 0 (2-0) (D0)	U1.18-P1-H4/Q3			
I/O Book 3, Port 13 Connector 0 (2-0) Cable 4, see "I/O Subsystems (7 and 8) RIO Cabling to the Third I/O Book" on page 47 for cable connections.	U1.18-P1-H4/Q3#			
I/O Book 3, Port 13 Connector 1 (2-1) (D1)	U1.18-P1-H4/Q4			

FRU Name	Location Code	AIX Location Code	Physical Connection	Logical Connection
I/O Book 3, Port 13 Connector 1 (2-1) Cable 3, see "I/O Subsystems (7 and 8) RIO Cabling to the Third I/O Book" on page 47 for cable connections.	U1.18-P1-H4/Q4#			
I/O Book 3, Port 6 Connector 3 (1-1) (A0)	U1.18-P1-H4/Q5			
I/O Book 3, Port 6 Connector 3 (1-1) Cable 5	U1.18-P1-H4/Q5#			
I/O Book 3, Port 6 Connector 2 (1-0) (A1)	U1.18-P1-H4/Q6			
I/O Book 3, Port 6 Connector 2 (1-0) Cable 6	U1.18-P1-H4/Q6#			
I/O Book 3, Port 7 Connector 1 (2-1) (B0)	U1.18-P1-H4/Q7			
I/O Book 3, Port 7 Connector 1 (2-1) Cable 7	U1.18-P1-H4/Q7#			
I/O Book 3, Port 7 Connector 0 (2-0) (B1)	U1.18-P1-H4/Q8			
I/O Book 3, Port 7 Connector 1 (2-0) Cable 8	U1.18-P1-H4/Q8#			
DCA 1-RH	U1.18-P1-V1			
DCA 1- BPA A - BPC - 5 Connector	U1.18-P1-V1/Q1			
DCA 1- BPA A - BPC -5 Cable	U1.18-P1-V1/Q1#			
DCA 1- BPA B - BPC - 5 Connector	U1.18-P1-V1/Q2			
DCA 1- BPA B - BPC -5 Cable	U1.18-P1-V1/Q2#			
DCA 2-RH	U1.18-P1-V2			
DCA 2- BPA A - BPC - 6 Connector	U1.18-P1-V2/Q1			

FRU Name	Location Code	AIX Location Code	Physical Connection	Logical Connection
DCA 2- BPA A - BPC -6 Cable	U1.18-P1-V2/Q1#			
DCA 2- BPA B - BPC - 6 Connector	U1.18-P1-V2/Q2			
DCA 2- BPA B - BPC -6 Cable	U1.18-P1-V2/Q2#			
DCA 3-RH	U1.18-P1-V4			
DCA 3- BPA A - BPC - 7 Connector	U1.18-P1-V4/Q1			
DCA 3- BPA A - BPC - 7 Cable	U1.18-P1-V4/Q1#			
DCA 3- BPA B - BPC - 7 Connector	U1.18-P1-V4/Q2			
DCA 3- BPA B - BPC - 7 Cable	U1.18-P1-V4/Q2#			
DCA 4-RH	U1.18-P1-V5			
DCA 4- BPA A - BPD1 - 9 Connector	U1.18-P1-V5/Q1			
DCA 4- BPA A - BPD1 - 9 Cable	U1.18-P1-V5/Q1#			
DCA 4- BPA B - BPD1 - 9 Connector	U1.18-P1-V5/Q2			
DCA 4- BPA B - BPD1 - 9 Cable	U1.18-P1-V5/Q2#			
DCA 5-RH	U1.18-P1-V6			
DCA 5- BPA A - BPD1 - 10 Connector	U1.18-P1-V6/Q1			
DCA 5- BPA A - BPD1 - 10 Cable	U1.18-P1-V6/Q1#			
DCA 5- BPA B - BPD1 - 10 Connector	U1.18-P1-V6/Q2			
DCA 5- BPA B - BPD1 - 10 Cable	U1.18-P1-V6/Q2#			
DCA 6-RH	U1.18-P1-V8			
DCA 6- BPA A - BPD2 - 10 Connector	U1.18-P1-V8/Q1			
DCA 6- BPA A - BPD2 - 10 Cable	U1.18-P1-V8/Q1#			

FRU Name	Location Code	AIX Location Code	Physical Connection	Logical Connection
DCA 6- BPA B - BPD2 - 10 Connector	U1.18-P1-V8/Q2			
DCA 6- BPA B - BPD2 - 10 Cable	U1.18-P1-V8/Q2#			
RH CAP Card	U1.18-P1-V3			
RH CAP Card	U1.18-P1-V7			
Hourglass Card Assembly	U1.18-P1-X5			
MCM Module 0 4 & 8 way	U1.18-P1-C1			
Processor 0 (W/ L1 & L2 Cache)	U1.18-P1-C1	00-00		
Processor 1 (W/ L1 & L2 Cache)	U1.18-P1-C1	00-01		
Processor 2 (W/ L1 & L2 Cache)	U1.18-P1-C1	00-02		
Processor 3 (W/ L1 & L2 Cache)	U1.18-P1-C1	00-03		
Processor 4 (W/ L1 & L2 Cache)	U1.18-P1-C1	00-04		
Processor 5 (W/ L1 & L2 Cache)	U1.18-P1-C1	00-05		
Processor 6 (W/ L1 & L2 Cache)	U1.18-P1-C1	00-06		
Processor 7 (W/ L1 & L2 Cache)	U1.18-P1-C1	00-07		
MCM Module 3	U1.18-P1-C2			
Processor 24 (W/ L1 & L2 Cache)	U1.18-P1-C2	00-24		
Processor 25 (W/ L1 & L2 Cache)	U1.18-P1-C2	00-25		
Processor 26 (W/ L1 & L2 Cache)	U1.18-P1-C2	00-26		
Processor 27 (W/ L1 & L2 Cache)	U1.18-P1-C2	00-27		
Processor 28 (W/ L1 & L2 Cache)	U1.18-P1-C2	00-28		
Processor 29 (W/ L1 & L2 Cache)	U1.18-P1-C2	00-29		
Processor 30 (W/ L1 & L2 Cache)	U1.18-P1-C2	00-30		

FRU Name	Location Code	AIX Location Code	Physical Connection	Logical Connection
Processor 31 (W/ L1 & L2 Cache)	U1.18-P1-C2	00-31		
MCM Module 1	U1.18-P1-C3			
Processor 08 (W/ L1 & L2 Cache)	U1.18-P1-C3	00-08		
Processor 09 (W/ L1 & L2 Cache)	U1.18-P1-C3	00-09		
Processor 10 (W/ L1 & L2 Cache)	U1.18-P1-C3	00-10		
Processor 11 (W/ L1 & L2 Cache)	U1.18-P1-C3	00-11		
Processor 12 (W/ L1 & L2 Cache)	U1.18-P1-C3	00-12		
Processor 13 (W/ L1 & L2 Cache)	U1.18-P1-C3	00-13		
Processor 14 (W/ L1 & L2 Cache)	U1.18-P1-C3	00-14		
Processor 15 (W/ L1 & L2 Cache)	U1.18-P1-C3	00-15		
MCM Module 2	U1.18-P1-C4			
Processor 16 (W/ L1 & L2 Cache)	U1.18-P1-C4	00-16		
Processor 17 (W/ L1 & L2 Cache)	U1.18-P1-C4	00-17		
Processor 18 (W/ L1 & L2 Cache)	U1.18-P1-C4	00-18		
Processor 19 (W/ L1 & L2 Cache)	U1.18-P1-C4	00-19		
Processor 20 (W/ L1 & L2 Cache)	U1.18-P1-C4	00-20		
Processor 21 (W/ L1 & L2 Cache)	U1.18-P1-C4	00-21		
Processor 22 (W/ L1 & L2 Cache)	U1.18-P1-C4	00-22		
Processor 21 (W/ L1 & L2 Cache)	U1.18-P1-C4	00-23		
L3 Module (Proc 3D)	U1.18-P1-C5	00-00		
L3 Module (Proc 0A)	U1.18-P1-C6	00-00		
L3 Module (Proc 0B)	U1.18-P1-C7	00-00		
L3 Module (Proc 1C)	U1.18-P1-C8	00-00		
L3 Module (Proc 3B)	U1.18-P1-C9	00-00		

FRU Name	Location Code	AIX Location Code	Physical Connection	Logical Connection
L3 Module (Proc 0C)	U1.18-P1-C10	00-00		
L3 Module (Proc 0D)	U1.18-P1-C11	00-00		
L3 Module (Proc 1A)	U1.18-P1-C12	00-00		
L3 Module (Proc 3A)	U1.18-P1-C13	00-00		
L3 Module (Proc 2D)	U1.18-P1-C14	00-00		
L3 Module (Proc 2C)	U1.18-P1-C15	00-00		
L3 Module (Proc 1B)	U1.18-P1-C16	00-00		
L3 Module (Proc 3C)	U1.18-P1-C17	00-00		
L3 Module (Proc 2B)	U1.18-P1-C18	00-00		
L3 Module (Proc 2A)	U1.18-P1-C19	00-00		
L3 Module (Proc 1D)	U1.18-P1-C20	00-00		
Passthru Card Module 1	U1.18-P1-C3	00-00		
Passthru Card Module 3	U1.18-P1-C2	00-00		
Fan Controller Assembly 1	U1.18-X1			
Fan Controller 1 TO BPC A Connector	U1.18-X1/Q1			
Fan Controller 1 TO BPC A Cable	U1.18-X1/Q1#			
Fan Controller 1 TO BPC B Connector	U1.18-X1/Q2			
Fan Controller 1 TO BPC B Cable	U1.18-X1/Q2#			
Fan Controller Assembly 2	U1.18-X2			
Fan Controller 2 TO BPC A Connector	U1.18-X2/Q1			
Fan Controller 2 TO BPC A Connector	U1.18-X2/Q1#			
Fan Controller 2 TO BPC B Connector	U1.18-X2/Q2#			
Fan Controller 2 TO BPC B Connector	U1.18-X2/Q2#			
Fan Controller Assembly 3	U1.18-X3			
Fan Controller 3 TO BPC A Connector	U1.18-X3/Q1			

FRU Name	Location Code	AIX Location Code	Physical Connection	Logical Connection
Fan Controller 3 TO BPC A Cable	U1.18-X3/Q1#			
Fan Controller 3 TO BPC B Connector	U1.18-X3/Q2			
Fan Controller 3 TO BPC B Cable	U1.18-X3/Q2#			
Fan Controller Assembly 4	U1.18-X4			
Fan Controller 4 TO BPC A Connector	U1.18-X4/Q1			
Fan Controller 4 TO BPC A Cable	U1.18-X4/Q1#			
Fan Controller 4 TO BPC B Connector	U1.18-X4/Q2			
Fan Controller 4 TO BPC B Cable	U1.18-X4/Q2#			
Fan Assembly 1	U1.18-F1			
Fan Assembly 2	U1.18-F2			
Fan Assembly 3	U1.18-F3			
Fan Assembly 4	U1.18-F4			

FRU Name	Location Code	AIX Location Code	Physical Connection	Logical Connection
Media Subsystem Locations				
Media Drawer chassis	U1.17			
Media Drawer - Operator Panel,	U1.17-L1			
Operator Panel Connector	U1.17-L1/Q1			
Operator Panel Cable	U1.17-L1/Q1#			
System VPD Module	U1.17-L1-N1			
Media Drawer - Diskette	U1.17-D1			
Diskette Drive Connector	U1.17-D1/Q2			
Diskette Drive Cable	U1.17-D1/Q2#			
Media Drawer - DVD-RAM/CD-ROM	U1.x-Px-lx/Z1-A1			

FRU Name	Location Code	AIX Location Code	Physical Connection	Logical Connection
Media Drawer - Tape Drive	U1.x-Px-lx/Z1-A0			
Media Drawer connector	U1.17-A1/Q3			
Media Drawer cable	U1.17-A1/Q3#			
Media Drawer Power Connector	U1.17-A1/Q4			
Media Drawer Power Cable	U1.17-A1/Q4#			

FRU Name	Location Code	AIX Location Code	Physical Connection	Logical Connection
Internal Battery Feature Locations (If Installed)				
IBF (Battery) 1A to BPA A	U1.13-P1-V1	If Installed		
IBF 1A Connector	U1.13-P1-V1/Q1	If Installed		
IBF 1A Cable to BPA A - BPR 1	U1.13-P1-V1/Q1#	If Installed		
IBF (Battery) 2A to BPA A	U1.15-P1-V2	If Installed		
IBF 2A Connector	U1.15-P1-V2/Q1	If Installed		
IBF 2A Cable to BPA A - BPR 2	U1.15-P1-V2/Q1#	If Installed		
IBF (Battery) 1B to BPA B	U1.13-P2-V3	If Installed		
IBF 1B Connector	U1.13-P2-V3/Q1	If Installed		
IBF 1B Cable to BPA B -BPR 1	U1.13-P2-V3/Q1#	If Installed		
IBF (Battery) 2B to BPA B	U1.15-P2-V4	If Installed		
IBF 2B Connector	U1.15-P2-V4/Q1	If Installed		
IBF 2B Cable to BPA B -BPR 2	U1.15-P2-V4/Q1#	If Installed		
IBF (Battery) 3A to BPA A	U2.17-P1-V5	If Installed		
IBF 3A Connector	U2.17-P1-V5/Q1	If Installed		
IBF 3A Cable to BPA A - BPR 3	U2.17-P1-V5/Q1#	If Installed		
IBF (Battery) 3B to BPA B	U2.17-P2-V6	If Installed		

FRU Name	Location Code	AIX Location Code	Physical Connection	Logical Connection
IBF 3B Connector	U2.17-P2-V6/Q1	If Installed		
IBF 3B Cable to BPA B - BPR 3	U2.17-P2-V6/Q1#	If Installed		

FRU Name	Location Code	AIX Location Code	Physical Connection	Logical Connection
I/O Subsystem 1 Locations				
I/O Subsystem 1 Chassis & Midplane Card	(MT/M Serial #) U1.9			
I/O Subsystem Left IO backplane assembly	U1.9-P1			
I/O Subsystem Left IO backplane assembly VPD	U1.9-P1-N1			
EADS 1 - PCI Controller	U1.9-P1	2U-58, 2U-5A, 2U-5C, 2U-5E		
PCI Slot 1 Content	U1.9-P1-I1	2V-08 to 2V-0F or 2W-xx or 2X-xx		
PCI Slot 2 Content	U1.9-P1-I2	2Y-08 to 2Y-0F or 2Z-xx or 2a-xx		
PCI Slot 3 Content	U1.9-P1-I3	2b-08 to 2b-0F or 2c-xx or 2d-xx		
PCI Slot 4 Content	U1.9-P1-I4	2e-08 to 2e-0F or 2f-xx or 2g-xx		
EADS 2 - PCI Controller	U1.9-P1	2j-58, 2j-5A, 2j-5E		
PCI Slot 5 Content	U1.9-P1-I5	2k-08 to 2k-0F or 2m-xx or 2n-xx		
PCI Slot 6 Content	U1.9-P1-I6	2p-08 to 2p-0F or 2q-xx or 2r-xx		
PCI Slot 7 Content	U1.9-P1-I7	2v-08 to 2v-0F or 2w-xx or 2x-xx		
EADS 3 - PCI Controller	U1.9-P1	30-58, 30-5A, 30-5E		

FRU Name	Location Code	AIX Location Code	Physical Connection	Logical Connection
PCI Slot 8 Content	U1.9-P1-I8	31-08 to 31-0F or 32-xx or 32-xx		
PCI Slot 9 Content	U1.9-P1-I9	34-08 to 34-0F or 35-xx or 36-xx		
PCI Slot 10 Content	U1.9-P1-I10	3A-08 to 3A-0F or 3B-xx or 3C-xx		
I/O Riser Card	U1.9-P1			
I/O Port Connector	U1.9-P1/Q1			
I/O Port Cable From GX1A-port 1	U1.9-P1/Q1#			
I/O Port Connector	U1.9-P1/Q2			
I/O Port Cable to port 0 on next Riser card U1.9-P2.1/Q1	U1.9-P1/Q2#			
I/O Subsystem Right IO backplane assembly	U1.9-P2			
I/O Subsystem Right IO backplane assembly VPD	U1.9-P2-N1			
EADS 1 - PCI Controller	U1.9-P2	3E-58, 3E-5A, 3E-5C, 3E-5E		
PCI Slot 1 Content	U1.9-P2-I1	3F-08 to 3F-0F or 3G-xx or 3H-xx		
PCI Slot 2 Content	U1.9-P2-I2	3J-08 to 3J-0F or 3K-xx or 3L-xx		
PCI Slot 3 Content	U1.9-P2-I3	3M-08 to 3M-0F or 3N-xx or 3P-xx		
PCI Slot 4 Content	U1.9-P2-I4	3Q-08 to 3Q-0F or 3R-xx or 3S-xx		
EADS 2 - PCI Controller	U1.9-P2	3U-58, 3U-5A, 3U-5E		
PCI Slot 5 Content	U1.9-P2-I5	3V-08 to 3V-0F or 3W-xx or 3X-xx		

FRU Name	Location Code	AIX Location Code	Physical Connection	Logical Connection
PCI Slot 6 Content	U1.9-P2-I6	3Y-08 to 3Y-0F or 3Z-xx or 3a-xx		
PCI Slot 7 Content	U1.9-P2-I7	3e-08 to 3e-0F or 3f-xx or 3a-xx		
EADS 3 - PCI Controller	U1.9-P2	3j-58, 3j-5A, 3j-5E		
PCI Slot 8 Content	U1.9-P2-I8	3k-08 to 3k-0F or 3m-xx or 3n-xx		
PCI Slot 9 Content	U1.9-P2-I9	3p-08 to 3p-0F or 3q-xx or 3r-xx		
PCI Slot 10 Content	U1.9-P2-I10	3v-08 to 3v-0F or 3w-xx or 3x-xx		
I/O Riser Card	U1.9-P2			
I/O Port Connector	U1.9-P2/Q1			
I/O Port Cable From Riser port 1 P1.1/Q1	U1.9-P2/Q1#			
I/O Port Connector	U1.9-P2/Q2			
I/O Port Cable to GX1A-port 2	U1.9-P2/Q2#			
I/O Subsystem DCA 1	U1.9-V1			
DCA 1 to (BPA B) BPD1- 1A Connector P00	U1.9-V1/Q1			
DCA 1 to (BPA B) BPD1- 1A Cable	U1.9-V1/Q1#			
DCA 1 to (BPA A) BPD1- 1A Connector P00	U1.9-V1/Q2			
DCA 1 to (BPA A) BPD1- 1A Cable	U1.9-V1/Q2#			
Thermal Sensor	U1.9-V1			
I/O Subsystem DCA 2	U1.9-V2			
DCA 2 to (BPA B) BPD1- 1B Connector P01	U1.9-V2/Q1			
DCA 2 to (BPA B) BPD1- 1B Cable	U1.9-V2/Q1#			

FRU Name	Location Code	AIX Location Code	Physical Connection	Logical Connection
DCA 2 to (BPA A) BPD1- 1B Connector P01	U1.9-V2/Q2			
DCA 2 to (BPA A) BPD1- 1B Cable	U1.9-V2/Q2#			
Thermal Sensor	U1.9-V2			
I/O Subsystem SCSI controller 1 on P1	U1.9-P1/Z1	2s-08		
I/O Subsystem SCSI controller 2 on P1	U1.9-P1/Z2	37-08		
I/O Subsystem SCSI controller 1 on P2	U1.9-P2/Z1	3b-08		
I/O Subsystem SCSI controller 2 on P2	U1.9-P2/Z2	3s-08		
DASD 4 Pack Cage and card (1)	U1.9-P3			
DASD 4 Pack Cage and card (1) VPD	U1.9-P3-N1			
SCSI DASD 1 hdisk at ID 8 connected to controller 2 on P2	U1.9-P2/Z2-A8	3s-08-00-8,0		
SCSI DASD 2 hdisk at ID 9 connected to controller 2 on P2	U1.9-P2/Z2-A9	3s-08-00-9,0		
SCSI DASD 3 hdisk at ID A connected to controller 2 on P2	U1.9-P2/Z2-Aa	3s-08-00-10,0		
SCSI DASD 4 hdisk at ID A connected to controller 2 on P2	U1.9-P2/Z2-Ab	3s-08-00-11,0		
SCSI Enclosure Services SES connected to controller 2 on P2	U1.9-P2/Z2-Bf	3s-08-00-15,0		
DASD 4 Pack Cage and card (2)	U1.9-P4			
DASD 4 Pack Cage and card (2) VPD	U1.9-P4-N1			
SCSI DASD 1 hdisk at ID 8 connected to controller 1 on P2	U1.9-P2/Z1-A8	3b-08-00-8,0		
SCSI DASD 2 hdisk at ID 9 connected to controller 1 on P2	U1.9-P2/Z1-A9	3b-08-00-9,0		

FRU Name	Location Code	AIX Location Code	Physical Connection	Logical Connection
SCSI DASD 3 hdisk at ID A connected to controller 1 on P2	U1.9-P2/Z1-Aa	3b-08-00-10,0		
SCSI DASD 4 hdisk at ID B connected to controller 1 on P2	U1.9-P2/Z1-Ab	3b-08-00-11,0		
SCSI Enclosure Services SES connected to controller 1 on P2	U1.9-P2/Z1-Af	3b-08-00-15,0		
DASD 4 Pack Cage and card (3)	U1.9-P5			
DASD 4 Pack Cage and card (3) VPD	U1.9-P5-N1			
SCSI DASD 1 hdisk at ID 8 connected to controller 2 on P1	U1.9-P1/Z2-A8	37-08-00-8,0		
SCSI DASD 2 hdisk at ID 9 connected to controller 2 on P1	U1.9-P1/Z2-A9	37-08-00-9,0		
SCSI DASD 3 hdisk at ID A connected to controller 2 on P1	U1.9-P1/Z2-Aa	37-08-00-10,0		
SCSI DASD 4 hdisk at ID B connected to controller 2 on P1	U1.9-P1/Z2-Ab	37-08-00-11,0		
SCSI Enclosure Services SES connected to controller 2 on P1	U1.9-P1/Z2-Af	37-08-00-15,0		
DASD 4 Pack Cage and card (4)	U1.9-P6			
DASD 4 Pack Cage and card (4) VPD	U1.9-P6-N1			
SCSI DASD 1 hdisk at ID 8 connected to controller 1 on P1	U1.9-P1/Z1-A8	2s-08-00-8,0		
SCSI DASD 2 hdisk at ID 9 connected to controller 1 on P1	U1.9-P1/Z1-A9	2s-08-00-9,0		
SCSI DASD 3 hdisk at ID A connected to controller 1 on P1	U1.9-P1/Z1-Aa	2s-08-00-10,0		

FRU Name	Location Code	AIX Location Code	Physical Connection	Logical Connection
SCSI DASD 4 hdisk at ID B connected to controller 1 on P1	U1.9-P1/Z1-Ab	2s-08-00-11,0		
SCSI Enclosure Services SES connected to controller 1 on P1	U1.9-P1/Z1-Af	2s-08-00-15,0		
I/O Subsystem Fan (MSA)	U1.9-F1			
I/O Subsystem Fan (MSA)	U1.9-F2			
I/O Subsystem Fan (MSA)	U1.9-F3			
I/O Subsystem Fan (MSA)	U1.9-F4			
Media Drawer Power Connector	U1.9-P1-V1/Q3			
Media Drawer Power Cable	U1.9-P1-V1/Q3#			
Media Drawer Power Connector	U1.9-P2-V2/Q3			
Media Drawer Power Cable	U1.9-P2-V2/Q3#			

FRU Name	Location Code	AIX Location Code	Physical Connection	Logical Connection
I/O Subsystem 2 Locations				
I/O Subsystem 1 Chassis & Midplane Card	(MT/M Serial #) U1.5			
I/O Subsystem Left IO backplane assembly	U1.5-P1			
I/O Subsystem Left IO backplane assembly VPD	U1.5-P1-N1			
EADS 1 - PCI Controller	U1.5-P1	40-58, 40-5A, 40-5C, 40-5E		
PCI Slot 1 Content	U1.5-P1-I1	41-08 to 41-0F or 42-xx or 43-xx		

FRU Name	Location Code	AIX Location Code	Physical Connection	Logical Connection
PCI Slot 2 Content	U1.5-P1-I2	44-08 to 44-0F or 45-xx or 47-xx		
PCI Slot 3 Content	U1.5-P1-I3	47-08 to 47-0F or 48-xx or 49-xx		
PCI Slot 4 Content	U1.5-P1-I4	4A-08 to 4A-0F or 4B-xx or 4C-xx		
EADS 2 - PCI Controller	U1.5-P1	4E-58, 4E-5A, 4E-5E		
PCI Slot 5 Content	U1.5-P1-I5	4F-08 to 4F-0F or 4G-xx or 4H-xx		
PCI Slot 6 Content	U1.5-P1-I6	4J-08 to 4J-0F or 4K-xx or 4L-xx		
PCI Slot 7 Content	U1.5-P1-I7	4Q-08 to 4Q-0F or 4R-xx or 4S-xx		
EADS 3 - PCI Controller	U1.5-P1	4U-58, 4U-5A, 4U-5E		
PCI Slot 8 Content	U1.5-P1-I8	4V-08 to 4V-0F or 4W-xx or 4X-xx		
PCI Slot 9 Content	U1.5-P1-I9	4Y-08 to 4Y-0F or 4Z-xx or 4a-xx		
PCI Slot 10 Content	U1.5-P1-I10	4e-08 to 4e-0F or 4f-xx or 4g-xx		
I/O Riser Card	U1.5-P1			
I/O Port Connector	U1.5-P1/Q1			
I/O Port Cable From GX1A-port 1	U1.5-P1/Q1#			
I/O Port Connector	U1.5-P1/Q2			
I/O Port Cable to port 0 on next Riser card U1.5-P2.1/Q1	U1.5-P1/Q2#			
I/O Subsystem Right IO backplane assembly	U1.5-P2			
I/O Subsystem Right IO backplane assembly VPD	U1.5-P2-N1			

FRU Name	Location Code	AIX Location Code	Physical Connection	Logical Connection
EADS 1 - PCI Controller	U1.5-P2	4j-58, 4j-5A, 4j-5C, 4j-5E		
PCI Slot 1 Content	U1.5-P2-I1	4k-08 to 4k-0F or 4m-xx or 4n-xx		
PCI Slot 2 Content	U1.5-P2-I2	4p-08 to 4p-0F or 4q-xx or 4r-xx		
PCI Slot 3 Content	U1.5-P2-I3	4s-08 to 4s-0F or 4t-xx or 4t-xx		
PCI Slot 4 Content	U1.5-P2-I4	4v-08 to 4v-0F or 4t-xx or 4u-xx		
EADS 2 - PCI Controller	U1.5-P2	50-58, 50-5A, 50-5E		
PCI Slot 5 Content	U1.5-P2-I5	51-08 to 51-0F or 52-xx or 53-xx		
PCI Slot 6 Content	U1.5-P2-I6	54-08 to 54-0F or 55-xx or 56-xx		
PCI Slot 7 Content	U1.5-P2-I7	5A-08 to 5A-0F or 5B-xx or 5C-xx		
EADS 3 - PCI Controller	U1.5-P2	5E-58, 5E-5A, 5E-5E		
PCI Slot 8 Content	U1.5-P2-I8	5F-08 to 5F-0F or 5G-xx or 5H-xx		
PCI Slot 9 Content	U1.5-P2-I9	5J-08 to 5J-0F or 5K-xx or 5L-xx		
PCI Slot 10 Content	U1.5-P2-I10	5Q-08 to 5Q-0F or 5R-xx or 5S-xx		
I/O Riser Card	U1.5-P2.1			
I/O Port Connector	U1.5-P2.1/Q1			
I/O Port Cable From Riser port 1 P1.1/Q1	U1.5-P2.1/Q1#			
I/O Port Connector	U1.5-P2.1/Q2			
I/O Port Cable to GX1A-port 2	U1.5-P2.1/Q2#			
I/O Subsystem DCA 1	U1.5-V1			

FRU Name	Location Code	AIX Location Code	Physical Connection	Logical Connection
DCA 1 to (BPA B) BPD1- 1A Connector P02	U1.5-V1/Q1			
DCA 1 to (BPA B) BPD1- 1A Cable	U1.5-V1/Q1#			
DCA 1 to (BPA A) BPD1- 1A Connector P02	U1.5-V1/Q2			
DCA 1 to (BPA A) BPD1- 1A Cable	U1.5-V1/Q2#			
Thermal Sensor	U1.5-V1			
I/O Subsystem DCA 2	U1.5-V2			
DCA 2 to (BPA B) BPD1- 1B Connector P03	U1.5-V2/Q1			
DCA 2 to (BPA B) BPD1- 1B Cable	U1.5-V2/Q1#			
DCA 2 to (BPA A) BPD1- 1B Connector P03	U1.5-V2/Q2			
DCA 2 to (BPA A) BPD1- 1B Cable	U1.5-V2/Q2#			
Thermal Sensor	U1.5-V2			
I/O Subsystem SCSI controller 1 on P1	U1.5-P1/Z1	4M-08		
I/O Subsystem SCSI controller 2 on P1	U1.5-P1/Z2	4b-08		
I/O Subsystem SCSI controller 1 on P2	U1.5-P2/Z1	57-08		
I/O Subsystem SCSI controller 2 on P2	U1.5-P2/Z2	5M-08		
DASD 4 Pack Cage and card (1)	U1.5-P3			
DASD 4 Pack Cage and card (1) VPD	U1.5-P3-N1			
SCSI DASD 1 hdisk at ID 8 connected to controller 2 on P2	U1.5-P2/Z2-A8	5M-08-00-8,0		
SCSI DASD 2 hdisk at ID 9 connected to controller 2 on P2	U1.5-P2/Z2-A9	5M-08-00-9,0		

FRU Name	Location Code	AIX Location Code	Physical Connection	Logical Connection
SCSI DASD 3 hdisk at ID A connected to controller 2 on P2	U1.5-P2/Z2-Aa	5M-08-00-10,0		
SCSI DASD 4 hdisk at ID B connected to controller 2 on P2	U1.5-P2/Z2-Ab	5M-08-00-11,0		
SCSI Enclosure Services SES connected to controller 2 on P2	U1.5-P2/Z2-Af	5M-08-00-15,0		
DASD 4 Pack Cage and card (2)	U1.5-P4			
DASD 4 Pack Cage and card (2) VPD	U1.5-P4-N1			
SCSI DASD 1 hdisk at ID 8 connected to controller 1 on P2	U1.5-P2/Z1-A8	57-08-00-8,0		
SCSI DASD 2 hdisk at ID 9 connected to controller 1 on P2	U1.5-P2/Z1-A9	57-08-00-9,0		
SCSI DASD 3 hdisk at ID A connected to controller 1 on P2	U1.5-P2/Z1-Aa	57-08-00-10,0		
SCSI DASD 4 hdisk at ID B connected to controller 1 on P2	U1.5-P2/Z1-Ab	57-08-00-11,0		
SCSI Enclosure Services SES connected to controller 1 on P2	U1.5-P2/Z1-Af	57-08-00-15,0		
DASD 4 Pack Cage and card (3)	U1.5-P5			
DASD 4 Pack Cage and card (3) VPD	U1.5-P5/Z1-N1			
SCSI DASD 1 hdisk at ID 8 connected to controller 1 on P2	U1.5-P1/Z2-A8	4b-80-00-8,0		
SCSI DASD 2 hdisk at ID 9 connected to controller 1 on P2	U1.5-P1/Z2-A9	4b-80-00-9,0		
SCSI DASD 3 hdisk at ID A connected to controller 1 on P2	U1.5-P1/Z2-Aa	4b-80-00-10,0		

FRU Name	Location Code	AIX Location Code	Physical Connection	Logical Connection
SCSI DASD 4 hdisk at ID B connected to controller 1 on P2	U1.5-P1/Z2-Ab	4b-80-00-11,0		
SCSI Enclosure Services SES connected to controller 2 on P1	U1.5-P1/Z2-Af	4b-80-00-15,0		
DASD 4 Pack Cage and card (4)	U1.5-P6			
DASD 4 Pack Cage and card (4) VPD	U1.5-P6-N1			
SCSI DASD 1 hdisk at ID8 connected to controller 1 on P1	U1.5-P1/Z1-A8	4M-08-00-8,0		
SCSI DASD 2 hdisk at ID9 connected to controller 1 on P1	U1.5-P1/Z1-A9	4M-08-00-9,0		
SCSI DASD 3 hdisk at ID A connected to controller 1 on P1	U1.5-P1/Z1-Aa	4M-08-00-10,0		
SCSI DASD 4 hdisk at ID B connected to controller 1 on P1	U1.5-P1/Z1-Ab	4M-08-00-11,0		
SCSI Enclosure Services SES connected to controller 1 on P1	U1.5-P1/Z1-Af	4M-08-00-15,0		
I/O Subsystem Fan (MSA)	U1.5-F1			
I/O Subsystem Fan (MSA)	U1.5-F2			
I/O Subsystem Fan (MSA)	U1.5-F3			
I/O Subsystem Fan (MSA)	U1.5-F4			
Media Drawer Power Connector	U1.5-P1-X1/Q3			
Media Drawer Power Cable	U1.5-P1-X1/Q3#			
Media Drawer Power Connector	U1.5-P2-X2/Q3			
Media Drawer Power Cable	U1.5-P2-X2/Q3#			

FRU Name	Location Code	AIX Location Code	Physical Connection	Logical Connection
I/O Subsystem 3 Locations				
I/O Subsystem 1 Chassis & Midplane Card	(MT/M Serial #) U1.1			
I/O Subsystem Left IO backplane assembly	U1.1-P1			
I/O Subsystem Left IO backplane assembly VPD	U1.1-P1-N1			
EADS 1 - PCI Controller	U1.1-P1	5U-58, 5U-5A, 5U-5C, 5U-5E		
PCI Slot 1 Content	U1.1-P1-I1	5V-08 to 5V-0F or 5W-xx or 5X-xx		
PCI Slot 2 Content	U1.1-P1-I2	5Y-08 to 5Y-0F or 5Z-xx or 5a-xx		
PCI Slot 3 Content	U1.1-P1-I3	5b-08 to 5b-0F or 5c-xx or 5d-xx		
PCI Slot 4 Content	U1.1-P1-I4	5e-08 to 5e-0F or 5f-xx or 5g-xx		
EADS 2 - PCI Controller	U1.1-P1	5j-58, 5j-5A, 5j-5E		
PCI Slot 5 Content	U1.1-P1-I5	5k-08 to 5k-0F or 5m-xx or 5n-xx		
PCI Slot 6 Content	U1.1-P1-I6	5p-08 to 5p-0F or 5q-xx or 5r-xx		
PCI Slot 7 Content	U1.1-P1-I7	5v-08 to 5v-0F or 5w-xx or 5w-xx		
EADS 3 - PCI Controller	U1.1-P1	60-58, 60-5A, 60-5E		
PCI Slot 8 Content	U1.1-P1-I8	61-08 to 61-0F or 62-xx or 63-xx		
PCI Slot 9 Content	U1.1-P1-I9	64-08 to 64-0F or 65-xx or 66-xx		
PCI Slot 10 Content	U1.1-P1-I10	6A-08 to 6A-0F or 6B-xx or 6C-xx		

FRU Name	Location Code	AIX Location Code	Physical Connection	Logical Connection
I/O Riser Card	U1.1-P1			
I/O Port Connector	U1.1-P1/Q1			
I/O Port Cable From GX1A-port 1	U1.1-P1/Q1#			
I/O Port Connector	U1.1-P1/Q2			
I/O Port Cable to port 0 on next Riser card U1.1-P2.1/Q1	U1.1-P1/Q2#			
I/O Subsystem Right IO backplane assembly	U1.1-P2			
I/O Subsystem Right IO backplane assembly VPD	U1.1-P2-N1			
EADS 1 - PCI Controller	U1.1-P2	6E-58, 6E-5A, 6E-5C, 6E-5E		
PCI Slot 1 Content	U1.1-P2-I1	6F-08 to 6F-0F or 6G-xx or 6H-xx		
PCI Slot 2 Content	U1.1-P2-I2	6J-08 to 6J-0F or 6K-xx or 6L-xx		
PCI Slot 3 Content	U1.1-P2-I3	6M-08 to 6M-0F or 6N-xx or 6P-xx		
PCI Slot 4 Content	U1.1-P2-I4	6Q-08 to 6Q-0F or 6R-xx or 6S-xx		
EADS 2 - PCI Controller	U1.1-P2	6U-58, 6U-5A, 6U-5E		
PCI Slot 5 Content	U1.1-P2-I5	6V-08 to 6V1-0F or 6W-xx or 6F-xx		
PCI Slot 6 Content	U1.1-P2-I6	6Y-08 to 6Y-0F or 6Z-xx or 6a-xx		
PCI Slot 7 Content	U1.1-P2-I7	6e-08 to 6Y-0F or 6f-xx or 6g-xx		
EADS 3 - PCI Controller	U1.1-P2	6j-58, 6j-5A, 6j-5E		
PCI Slot 8 Content	U1.1-P2-I8	6k-08 to 6Y-0F or 6m-xx or 6n-xx		

FRU Name	Location Code	AIX Location Code	Physical Connection	Logical Connection
PCI Slot 9 Content	U1.1-P2-I9	6p-08 to 6p-0F or 6q-xx or 6r-xx		
PCI Slot 10 Content	U1.1-P2-I10	6v-08 to 6v-0F or 6w-xx or 6x-xx		
I/O Riser Card	U1.1-P2			
I/O Port Connector	U1.1-P2/Q1			
I/O Port Cable From Riser port 1 P1.1/Q1	U1.1-P2/Q1#			
I/O Port Connector	U1.1-P2/Q2			
I/O Port Cable to GX1A-port 2	U1.1-P2/Q2#			
I/O Subsystem DCA 1	U1.1-V1			
DCA 1 to (BPA B) BPD1- 1A Connector P04	U1.1-V1/Q1			
DCA 1 to (BPA B) BPD1- 1A Cable	U1.1-V1/Q1#			
DCA 1 to (BPA A) BPD1- 1A Connector P04	U1.1-V1/Q2			
DCA 1 to (BPA A) BPD1- 1A Cable	U1.1-V1/Q2#			
Thermal Sensor	U1.1-V1			
I/O Subsystem DCA 2	U1.1-V2			
DCA 2 to (BPA B) BPD1- 1B Connector P05	U1.1-V2/Q1			
DCA 2 to (BPA B) BPD1- 1B Cable	U1.1-V2/Q1#			
DCA 2 to (BPA A) BPD1- 1B Connector P05	U1.1-V2/Q2			
DCA 2 to (BPA A) BPD1- 1B Cable	U1.1-V2/Q2#			
Thermal Sensor	U1.1-V2			
I/O Subsystem SCSI controller 1 on P1	U1.1-P1/Z1	5s-08		
I/O Subsystem SCSI controller 2 on P1	U1.1-P1/Z2	67-08		

FRU Name	Location Code	AIX Location Code	Physical Connection	Logical Connection
I/O Subsystem SCSI controller 1 on P2	U1.1-P2/Z1	6b-08		
I/O Subsystem SCSI controller 2 on P2	U1.1-P2/Z2	6s-08		
DASD 4 Pack Cage and card (1)	U1.1-P3			
DASD 4 Pack Cage and card (1) VPD	U1.1-P3-N1			
SCSI DASD 1 hdisk at ID 8 connected to controller 2 on P2	U1.1-P2/Z2-A8	6s-08-00-8,0		
SCSI DASD 2 hdisk at ID 9 connected to controller 2 on P2	U1.1-P2/Z2-A9	6s-08-00-9,0		
SCSI DASD 3 hdisk at ID A connected to controller 2 on P2	U1.1-P2/Z2-Aa	6s-08-00-10,0		
SCSI DASD 4 hdisk at ID B connected to controller 2 on P2	U1.1-P2/Z2-Ab	6s-08-00-11,0		
SCSI Enclosure Services SES connected to controller 2 on P2	U1.1-P2/Z2-Bf	6s-08-00-15,0		
DASD 4 Pack Cage and card (2)	U1.1-P4			
DASD 4 Pack Cage and card (2) VPD	U1.1-P4-N1			
SCSI DASD 1 hdisk at ID 8 connected to controller 1 on P2	U1.1-P2/Z1-A8	6b-08-00-8,0		
SCSI DASD 2 hdisk at ID 9 connected to controller 1 on P2	U1.1-P2/Z1-A9	6b-08-00-9,0		
SCSI DASD 3 hdisk at ID A connected to controller 1 on P2	U1.1-P2/Z1-Aa	6b-08-00-10,0		
SCSI DASD 4 hdisk at ID B connected to controller 1 on P2	U1.1-P2/Z1-Ab	6b-08-00-11,0		
SCSI Enclosure Services SES connected to controller 1 on P2	U1.1-P2/Z1-Af	6b-08-00-15,0		

FRU Name	Location Code	AIX Location Code	Physical Connection	Logical Connection
DASD 4 Pack Cage and card (3)	U1.1-P5			
DASD 4 Pack Cage and card (3) VPD	U1.1-P5/Z1-N1			
SCSI DASD 1 hdisk at ID 8 connected to controller 2 on P1	U1.1-P1/Z2-A8	67-08-00-8,0		
SCSI DASD 2 hdisk at ID 9 connected to controller 2 on P1	U1.1-P1/Z2-A9	67-08-00-9,0		
SCSI DASD 3 hdisk at ID A connected to controller 2 on P1	U1.1-P1/Z2-Aa	67-08-00-10,0		
SCSI DASD 4 hdisk at ID B connected to controller 2 on P1	U1.1-P1/Z2-Ab	67-08-00-11,0		
SCSI Enclosure Services SES connected to controller 2 on P1	U1.1-P1/Z2-Af	67-08-00-15,0		
DASD 4 Pack Cage and card (4)	U1.1-P6			
DASD 4 Pack Cage and card (4) VPD	U1.1-P6/Z2-N1			
SCSI DASD 1 hdisk at ID 8 connected to controller 1 on P1	U1.1-P1/Z1-A8	5s-08-00-8,0		
SCSI DASD 2 hdisk at ID 9 connected to controller 1 on P1	U1.1-P1/Z1-A9	5s-08-00-9,0		
SCSI DASD 3 hdisk at ID A connected to controller 1 on P1	U1.1-P1/Z1-Aa	5s-08-00-10,0		
SCSI DASD 4 hdisk at ID B connected to controller 1 on P1	U1.1-P1/Z1-Ab	5s-08-00-11,0		
SCSI Enclosure Services SES connected to controller 1 on P1	U1.1-P1/Z1-Af	5s-08-00-15,0		
I/O Subsystem Fan (MSA)	U1.1-F1			
I/O Subsystem Fan (MSA)	U1.1-F2			

FRU Name	Location Code	AIX Location Code	Physical Connection	Logical Connection
I/O Subsystem Fan (MSA)	U1.1-F3			
I/O Subsystem Fan (MSA)	U1.1-F4			
Media Drawer Power Connector	U1.1-P1-X1/Q3			
Media Drawer Power Cable	U1.1-P1-X1/Q3#			
Media Drawer Power Connector	U1.1-P2-X2/Q3			
Media Drawer Power Cable	U1.1-P2-X2/Q3#			

FRU Name	Location Code	AIX Location Code	Physical Connection	Logical Connection
I/O Subsystem 4 Locations (If No IBF Installed)				
Note: If the Internal Battery Feature (IBF) is installed, I/O subsystem 4 is in I/O subsystem 7 position. See page 110.				
I/O Subsystem 1 Chassis & Midplane Card	(MT/M Serial #) U1.13			
I/O Subsystem Left IO backplane assembly	U1.13-P1			
I/O Subsystem Left IO backplane assembly VPD	U1.13-P1-N1			
EADS 1 - PCI Controller	U1.13-P1	70-58, 70-5A, 70-5C, 70-5E		
PCI Slot 1 Content	U1.13-P1-I1	71-08 to 71-0F or 72-xx or 73-xx		
PCI Slot 2 Content	U1.13-P1-I2	74-08 to 74-0F or 75-xx or 76-xx		
PCI Slot 3 Content	U1.13-P1-I3	77-08 to 77-0F or 78-xx or 79-xx		
PCI Slot 4 Content	U1.13-P1-I4	7A-08 to 7F-0F or 7B-xx or 7C-xx		

FRU Name	Location Code	AIX Location Code	Physical Connection	Logical Connection
EADS 2 - PCI Controller	U1.13-P1	7E-58, 7E-5A, 7E-5E		
PCI Slot 5 Content	U1.13-P1-I5	7F-08 to 7F-0F or 7G-xx or 7H-xx		
PCI Slot 6 Content	U1.13-P1-I6	7J-08 to 7J-0F or 7K-xx or 7L-xx		
PCI Slot 7 Content	U1.13-P1-I7	7Q-08 to 7Q-0F or 7R-xx or 7S-xx		
EADS 3 - PCI Controller	U1.13-P1	7U-58, 7U-5A, 7U-5E		
PCI Slot 8 Content	U1.13-P1-I8	7V-08 to 7V-0F or 7W-xx or 7X-xx		
PCI Slot 9 Content	U1.13-P1-I9	7Y-08 to 7Y-0F or 7Z-xx or 7a-xx		
PCI Slot 10 Content	U1.13-P1-I10	7e-08 to 7e-0F or 7f-xx or 7g-xx		
I/O Riser Card	U1.13-P1			
I/O Port Connector	U1.13-P1/Q1			
I/O Port Cable From GX1A-port 1	U1.13-P1/Q1#			
I/O Port Connector	U1.13-P1/Q2			
I/O Port Cable to port 0 on next Riser card U1.13-P2.1/Q1	U1.13-P1/Q2#			
I/O Subsystem Right IO backplane assembly	U1.13-P2			
I/O Subsystem Right IO backplane assembly VPD	U1.13-P2-N1			
EADS 1 - PCI Controller	U1.13-P2	7j-58, 7j-5A, 7j-5C, 7j-5E		
PCI Slot 1	U1.13-P2-I1	7k-08 to 7k-0F or 7m-xx or 7n-xx		
PCI Slot 2	U1.13-P2-I2	7p-08 to 7p-0F or 7q-xx or 7r-xx		

FRU Name	Location Code	AIX Location Code	Physical Connection	Logical Connection
PCI Slot 3	U1.13-P2-I3	7s-08 to 7s-0F or 7t-xx or 7u-xx		
PCI Slot 4	U1.13-P2-I4	7v-08 to 7v-0F or 7w-xx or 7x-xx		
EADS 2 - PCI Controller	U1.13-P2	80-58, 80-5A, 80-5E		
PCI Slot 5	U1.13-P2-I5	81-08 to 81-0F or 82-xx or 83-xx		
PCI Slot 6	U1.13-P2-I6	84-08 to 84-0F or 85-xx or 86-xx		
PCI Slot 7	U1.13-P2-I7	8A-08 to 8A-0F or 8B-xx or 8C-xx		
EADS 3 - PCI Controller	U1.13-P2	8E-58, 8E-5A, 8E-5E		
PCI Slot 8	U1.13-P2-I8	8F-08 to 8F-0F or 8G-xx or 8H-xx		
PCI Slot 9	U1.13-P2-I9	8J-08 to 8J-0F or 8K-xx or 8L-xx		
PCI Slot 10	U1.13-P2-I10	8Q-08 to 8Q-0F or 8R-xx or 8S-xx		
I/O Riser Card	U1.13-P2			
I/O Port Connector	U1.13-P2/Q1			
I/O Port Cable From Riser port 1 P1.1/Q1	U1.13-P2/Q1#			
I/O Port Connector	U1.13-P2/Q2			
I/O Port Cable to GX1A-port 2	U1.13-P2/Q2#			
I/O Subsystem DCA 1	U1.13-V1			
DCA 1 to (BPA B) BPD1- 1A Connector P06	U1.13-V1/Q1			
DCA 1 to (BPA B) BPD1- 1A Cable	U1.13-V1/Q1#			

FRU Name	Location Code	AIX Location Code	Physical Connection	Logical Connection
DCA 1 to (BPA A) BPD1- 1A Connector P06	U1.13-V1/Q2			
DCA 1 to (BPA A) BPD1- 1A Cable	U1.13-V1/Q2#			
Thermal Sensor	U1.13-V1			
I/O Subsystem DCA 2	U1.13-V2			
DCA 2 to (BPA B) BPD1- 1B Connector P07	U1.13-V2/Q1			
DCA 2 to (BPA B) BPD1- 1B Cable	U1.13-V2/Q1#			
DCA 2 to (BPA A) BPD1- 1B Connector P07	U1.13-V2/Q2			
DCA 2 to (BPA A) BPD1- 1B Cable	U1.13-V2/Q2#			
Thermal Sensor	U1.13-V2			
I/O Subsystem SCSI controller 1 on P1	U1.13-P1/Z1	7M-08		
I/O Subsystem SCSI controller 2 on P1	U1.13-P1/Z2	7b-08		
I/O Subsystem SCSI controller 1 on P2	U1.13-P2/Z1	87-08		
I/O Subsystem SCSI controller 2 on P2	U1.13-P2/Z2	8M-08		
DASD 4 Pack Cage and card (1)	U1.13-P3			
DASD 4 Pack Cage and card (1) VPD	U1.13-P3-N1			
SCSI DASD 1 hdisk at ID 8 connected to controller 2 on P2	U1.13-P2/Z2-A8	8M-08-00-8,0		
SCSI DASD 2 hdisk at ID 9 connected to controller 2 on P2	U1.13-P2/Z2-A9	8M-08-00-9,0		
SCSI DASD 3 hdisk at ID A connected to controller 2 on P2	U1.13-P2/Z2-Aa	8M-08-00-10,0		
SCSI DASD 4 hdisk at ID B connected to controller 2 on P2	U1.13-P2/Z2-Ab	8M-08-00-11,0		

FRU Name	Location Code	AIX Location Code	Physical Connection	Logical Connection
SCSI Enclosure Services SES connected to controller 2 on P2	U1.13-P2/Z2-Af	8M-08-00-15,0		
DASD 4 Pack Cage and card (2)	U1.13-P4			
DASD 4 Pack Cage and card (2) VPD	U1.13-P4-N1			
SCSI DASD 1 hdisk at ID 8 connected to controller 1 on P2	U1.13-P2/Z1-A8	87-08-00-8,0		
SCSI DASD 2 hdisk at ID 9 connected to controller 1 on P2	U1.13-P2/Z1-A9	87-08-00-9,0		
SCSI DASD 3 hdisk at ID A connected to controller 1 on P2	U1.13-P2/Z1-Aa	87-08-00-10,0		
SCSI DASD 4 hdisk at ID B connected to controller 1 on P2	U1.13-P2/Z1-Ab	87-08-00-11,0		
SCSI Enclosure Services SES connected to controller 1 on P2	U1.13-P2/Z1-Af	87-08-00-15,0		
DASD 4 Pack Cage and card (3)	U1.13-P5			
DASD 4 Pack Cage and card (3) VPD	U1.13-P5-N1			
SCSI DASD 1 hdisk at ID 8 connected to controller 2 on P1	U1.13-P1/Z2-A8	7b-08-00-8,0		
SCSI DASD 2 hdisk at ID 9 connected to controller 2 on P1	U1.13-P1/Z2-A9	7b-08-00-9,0		
SCSI DASD 3 hdisk at ID A connected to controller 2 on P1	U1.13-P1/Z2-Aa	7b-08-00-10,0		
SCSI DASD 4 hdisk at ID B connected to controller 2 on P1	U1.13-P1/Z2-Ab	7b-08-00-11,0		
SCSI Enclosure Services SES connected to controller 2 on P1	U1.13-P1/Z2-Af	7b-08-00-15,0		

FRU Name	Location Code	AIX Location Code	Physical Connection	Logical Connection
DASD 4 Pack Cage and card (4)	U1.13-P6			
DASD 4 Pack Cage and card (4) VPD	U1.13-P6-N1			
SCSI DASD 1 hdisk at ID 8 connected to controller 1 on P1	U1.13-P1/Z1-A8	7M-08-00-8,0		
SCSI DASD 2 hdisk at ID 9 connected to controller 1 on P1	U1.13-P1/Z1-A9	7M-08-00-9,0		
SCSI DASD 3 hdisk at ID A connected to controller 1 on P1	U1.13-P1/Z1-Aa	7M-08-00-10,0		
SCSI DASD 4 hdisk at ID B connected to controller 1 on P1	U1.13-P1/Z1-Ab	7M-08-00-11,0		
SCSI Enclosure Services SES connected to controller 1 on P1	U1.13-P1/Z1-Af	7M-08-00-15,0		
I/O Subsystem Fan (MSA)	U1.13-F1			
I/O Subsystem Fan (MSA)	U1.13-F2			
I/O Subsystem Fan (MSA)	U1.13-F3			
I/O Subsystem Blower (MSA)	U1.13-F4			
Media Drawer Power Connector	U1.13-P1-X1/Q3			
Media Drawer Power Cable	U1.13-P1-X1/Q3#			
Media Drawer Power Connector	U1.13-P2-X2/Q3			
Media Drawer Power Cable	U1.13-P2-X2/Q3#			

FRU Name	Location Code	AIX Location Code	Physical Connection	Logical Connection
I/O Subsystem 4 Locations (If IBF Installed)				
Note: If the Internal Battery Feature (IBF) is not installed, I/O Subsystem 4 is in I/O Subsystem 4 position. See page 104.				
I/O Subsystem 1 Chassis & Midplane Card	(MT/M Serial #) U2.9			
I/O Subsystem Left IO backplane assembly	U2.9-P1			
I/O Subsystem Left IO backplane assembly VPD	U2.9-P1-N1			
EADS 1 - PCI Controller	U2.9-P1	70-58, 70-5A, 70-5C, 70-5E		
PCI Slot 1 Content	U2.9-P1-I1	71-08 to 71-0F or 72-xx or 73-xx		
PCI Slot 2 Content	U2.9-P1-I2	74-08 to 74-0F or 75-xx or 76-xx		
PCI Slot 3 Content	U2.9-P1-I3	77-08 to 77-0F or 78-xx or 79-xx		
PCI Slot 4 Content	U2.9-P1-I4	7A-08 to 7A-0F or 7B-xx or 7C-xx		
EADS 2 - PCI Controller	U2.9-P1	7E-58, 7E-5A, 7E-5E		
PCI Slot 5 Content	U2.9-P1-I5	7F-08 to 7F-0F or 7G-xx or 7H-xx		
PCI Slot 6 Content	U2.9-P1-I6	7J-08 to 7J-0F or 7K-xx or 7L-xx		
PCI Slot 7 Content	U2.9-P1-I7	7Q-08 to 7Q-0F or 7R-xx or 7S-xx		
EADS 3 - PCI Controller	U2.9-P1	7U-58, 7U-5A, 7U-5E		
PCI Slot 8 Content	U2.9-P1-I8	7V-08 to 7V-0F or 7W-xx or 7X-xx		

FRU Name	Location Code	AIX Location Code	Physical Connection	Logical Connection
PCI Slot 9 Content	U2.9-P1-I9	7Y-08 to 7Y-0F or 7Z-xx or 7a-xx		
PCI Slot 10 Content	U2.9-P1-I10	7e-08 to 7e-0F or 7f-xx or 7g-xx		
I/O Riser Card	U2.9-P1			
I/O Port Connector	U2.9-P1/Q1			
I/O Port Cable From GX1A-port 3	U2.9-P1/Q1#			
I/O Port Connector	U2.9-P1/Q2			
I/O Port Cable to port 0 on next Riser card U2.9-P2/Q1	U2.9-P1/Q2#			
I/O Subsystem Right IO backplane assembly	U2.9-P2			
I/O Subsystem Right IO backplane assembly VPD	U2.9-P2-N1			
EADS 1 - PCI Controller	U2.9-P2	7j-58, 7j-5A, 7j-5C, 7j-5E		
PCI Slot 1 Content	U2.9-P2-I1	7k-08 to 7k-0F or 7m-xx or 7n-xx		
PCI Slot 2 Content	U2.9-P2-I2	7p-08 to 7p-0F or 7q-xx or 7r-xx		
PCI Slot 3 Content	U2.9-P2-I3	7s-08 to 7s-0F or 7t-xx or 7u-xx		
PCI Slot 4 Content	U2.9-P2-I4	7v-08 to 7v-0F or 7w-xx or 7x-xx		
EADS 2 - PCI Controller	U2.9-P2	80-58, 80-5A, 80-5E		
PCI Slot 5 Content	U2.9-P2-I5	81-08 to 81-0F or 82-xx or 83-xx		
PCI Slot 6 Content	U2.9-P2-I6	84-08 to 84-0F or 85-xx or 86-xx		
PCI Slot 7 Content	U2.9-P2-I7	8A-08 to 8A-0F or 8B-xx or 8C-xx		

FRU Name	Location Code	AIX Location Code	Physical Connection	Logical Connection
EADS 3 - PCI Controller	U2.9-P2	8E-58, 8E-5A, 8E-5E		
PCI Slot 8 Content	U2.9-P2-I8	8F-08 to 8F-0F or 8G-xx or 8H-xx		
PCI Slot 9 Content	U2.9-P2-I9	8J-08 to 8J-0F or 8K-xx or 8L-xx		
PCI Slot 10 Content	U2.9-P2-I10	8Q-08 to 8Q-0F or 8R-xx or 8S-xx		
I/O Riser Card	U2.9-P2			
I/O Port Connector	U2.9-P2/Q1			
I/O Port Cable From Riser port 1 P1.1/Q1	U2.9-P2/Q1#			
I/O Port Connector	U2.9-P2/Q2			
I/O Port Cable to GX1A-port 2	U2.9-P2/Q2#			
I/O Subsystem DCA 1	U2.9-V1			
DCA 1 to (BPA B) BPD2- 7A Connector P04	U2.9-V1/Q1			
DCA 1 to (BPA B) BPD2- 7A Cable	U2.9-V1/Q1#			
DCA 1 to (BPA A) BPD2- 7A Connector P04	U2.9-V1/Q2			
DCA 1 to (BPA A) BPD2- 7A Cable	U2.9-V1/Q2#			
Thermal Sensor	U2.9-V1			
I/O Subsystem DCA 2	U2.9-V2			
DCA 2 to (BPA B) BPD2- 7B Connector P05	U2.9-V2/Q1			
DCA 2 to (BPA B) BPD2- 7B Cable	U2.9-V2/Q1#			
DCA 2 to (BPA A) BPD2- 7B Connector P05	U2.9-V2/Q2			
DCA 2 to (BPA A) BPD2- 7B Cable	U2.9-V2/Q2#			

FRU Name	Location Code	AIX Location Code	Physical Connection	Logical Connection
Thermal Sensor	U2.9-V2			
I/O Subsystem SCSI controller 1 on P1	U2.9-P1/Z1	7M-08		
I/O Subsystem SCSI controller 2 on P1	U2.9-P1/Z2	7b-08		
I/O Subsystem SCSI controller 1 on P2	U2.9-P2/Z1	87-08		
I/O Subsystem SCSI controller 2 on P2	U2.9-P2/Z2	8M-08		
DASD 4 Pack Cage and card (1)	U2.9-P3			
DASD 4 Pack Cage and card (1) VPD	U2.9-P3-N1			
SCSI DASD 1 hdisk at ID 8 connected to controller 2 on P2	U2.9-P2/Z2-A8	8M-08-00-8,0		
SCSI DASD 2 hdisk at ID 9 connected to controller 2 on P2	U2.9-P2/Z2-A9	8M-08-00-9,0		
SCSI DASD 3 hdisk at ID A connected to controller 2 on P2	U2.9-P2/Z2-Aa	8M-08-00-10,0		
SCSI DASD 4 hdisk at ID B connected to controller 2 on P2	U2.9-P2/Z2-Ab	8M-08-00-11,0		
SCSI Enclosure Services SES connected to controller 2 on P2	U2.9-P2/Z2-Af	8M-08-00-15,0		
DASD 4 Pack Cage and card (2)	U2.9-P4			
DASD 4 Pack Cage and card (2) VPD	U2.9-P4-N1			
SCSI DASD 1 hdisk at ID 8 connected to controller 1 on P2	U2.9-P2/Z1-A8	87-08-00-8,0		
SCSI DASD 2 hdisk at ID 9 connected to controller 1 on P2	U2.9-P2/Z1-A9	87-08-00-9,0		
SCSI DASD 3 hdisk at ID A connected to controller 1 on P2	U2.9-P2/Z1-Aa	87-08-00-10,0		

FRU Name	Location Code	AIX Location Code	Physical Connection	Logical Connection
SCSI DASD 4 hdisk at ID B connected to controller 1 on P2	U2.9-P2/Z1-Ab	87-08-00-11,0		
SCSI Enclosure Services SES connected to controller 1 on P2	U2.9-P2/Z1-Af	87-08-00-15,0		
DASD 4 Pack Cage and card (3)	U2.9-P5			
DASD 4 Pack Cage and card (3) VPD	U2.9-P5-N1			
SCSI DASD 1 hdisk at ID 8 connected to controller 2 on P1	U2.9-P1/Z2-A8	7b-08-00-8,0		
SCSI DASD 2 hdisk at ID 9 connected to controller 2 on P1	U2.9-P1/Z2-A9	7b-08-00-9,0		
SCSI DASD 3 hdisk at ID A connected to controller 2 on P1	U2.9-P1/Z2-Aa	7b-08-00-10,0		
SCSI DASD 4 hdisk at ID B connected to controller 2 on P1	U2.9-P1/Z2-Ab	7b-08-00-11,0		
SCSI Enclosure Services SES connected to controller 2 on P1	U2.9-P1/Z2-Af	7b-08-00-15,0		
DASD 4 Pack Cage and card (4)	U2.9-P6			
DASD 4 Pack Cage and card (4) VPD	U2.9-P6-N1			
SCSI DASD 1 hdisk at ID 8 connected to controller 1 on P1	U2.9-P1/Z1-A8	7M-08-00-8,0		
SCSI DASD 2 hdisk at ID 9 connected to controller 1 on P1	U2.9-P1/Z1-A9	7M-08-00-9,0		
SCSI DASD 3 hdisk at ID A connected to controller 1 on P1	U2.9-P1/Z1-Aa	7M-08-0010,0		
SCSI DASD 4 hdisk at ID B connected to controller 1 on P1	U2.9-P1/Z1-Ab	7M-08-00-11,0		

FRU Name	Location Code	AIX Location Code	Physical Connection	Logical Connection
SCSI Enclosure Services SES connected to controller 1 on P1	U2.9-P1/Z1-Af	7M-08-00-15,0		
I/O Subsystem Fan (MSA)	U2.9-F1			
I/O Subsystem Fan (MSA)	U2.9-F2			
I/O Subsystem Fan (MSA)	U2.9-F3			
I/O Subsystem Fan (MSA)	U2.9-F4			
Media Drawer Power Connector	U2.9-P1-X1/Q3			
Media Drawer Power Cable	U2.9-P1-X1/Q3#			
Media Drawer Power Connector	U2.9-P2-X2/Q3			
Media Drawer Power Cable	U2.9-P2-X2/Q3#			

FRU Name	Location Code	AIX Location Code	Physical Connection	Logical Connection
I/O Subsystem 5 Locations				
I/O Subsystem 1 Chassis & Midplane Card	(MT/M Serial #) U2.1			
I/O Subsystem Left IO backplane assembly	U2.1-P1			
I/O Subsystem Left IO backplane assembly VPD	U2.1-P1-N1			
EADS 1 - PCI Controller	U2.1-P1	8U-58, 8U-5A, 8U-5C, 8U-5E		
PCI Slot 1 Content	U2.1-P1-I1	8V-08 to 8V-0F or 8W-xx or 8X-xx		
PCI Slot 2 Content	U2.1-P1-I2	8Y-08 to 8Y-0F or 8Z-xx or 8a-xx		

FRU Name	Location Code	AIX Location Code	Physical Connection	Logical Connection
PCI Slot 3 Content	U2.1-P1-I3	8b-08 to 8b-0F or 8c-xx or 8d-xx		
PCI Slot 4 Content	U2.1-P1-I4	8e-08 to 8e-0F or 8f-xx or 8g-xx		
EADS 2 - PCI Controller	U2.1-P1	8j-58, 8j-5A, 8j-5E		
PCI Slot 5 Content	U2.1-P1-I5	8k-08 to 8k-0F or 8m-xx or 8n-xx		
PCI Slot 6 Content	U2.1-P1-I6	8p-08 to 8p-0F or 8q-xx or 8r-xx		
PCI Slot 7 Content	U2.1-P1-I7	8v-08 to 8v-0F or 8w-xx or 8x-xx		
EADS 3 - PCI Controller	U2.1-P1	90-58, 90-5A, 90-5E		
PCI Slot 8 Content	U2.1-P1-I8	91-08 to 91-0F or 92-xx or 93-xx		
PCI Slot 9 Content	U2.1-P1-I9	94-08 to 94-0F or 95-xx or 96-xx		
PCI Slot 10 Content	U2.1-P1-I10	9A-08 to 9A-0F or 9B-xx or 9C-xx		
I/O Riser Card	U2.1-P1			
I/O Port Connector	U2.1-P1/Q1			
I/O Port Cable From GX1A-port 1	U2.1-P1/Q1#			
I/O Port Connector	U2.1-P1/Q2			
I/O Port Cable to port 0 on next Riser card U2.1-P2.1/Q1	U2.1-P1/Q2#			
I/O Subsystem Right IO backplane assembly	U2.1-P2			
I/O Subsystem Right IO backplane assembly VPD	U2.1-P2-N1			
EADS 1 - PCI Controller	U2.1-P2	9E-58, 9E-5A, 9E-5C, 9E-5E		

FRU Name	Location Code	AIX Location Code	Physical Connection	Logical Connection
PCI Slot 1 Content	U2.1-P2-I1	9F-08 to 9F-0F or 9G-xx or 9H-xx		
PCI Slot 2 Content	U2.1-P2-I2	9J-08 to 9J-0F or 9K-xx or 9L-xx		
PCI Slot 3 Content	U2.1-P2-I3	9M-08 to 9M-0F or 9N-xx or 9P-xx		
PCI Slot 4 Content	U2.1-P2-I4	9Q-08 to 9Q-0F or 9R-xx or 9S-xx		
EADS 2 - PCI Controller	U2.1-P2	9U-58, 9U-5A, 9U-5E		
PCI Slot 5 Content	U2.1-P2-I5	9V-08 to 9V-0F or 9W-xx or 9X-xx		
PCI Slot 6 Content	U2.1-P2-I6	9Y-08 to 9Y-0F or 9Z-xx or 9a-xx		
PCI Slot 7 Content	U2.1-P2-I7	9e-08 to 91-0F or 9Z-xx or 9a-xx		
EADS 3 - PCI Controller	U2.1-P2	9j-58, 9j-5A, 9j-5E		
PCI Slot 8 Content	U2.1-P2-I8	9k-08 to 9k-0F or 9m-xx or 9n-xx		
PCI Slot 9 Content	U2.1-P2-I9	9p-08 to 9p-0F or 9q-xx or 9r-xx		
PCI Slot 10 Content	U2.1-P2-I10	9v-08 to 9v-0F or 9w-xx or 9x-xx		
I/O Riser Card	U2.1-P2			
I/O Port Connector	U2.1-P2/Q1			
I/O Port Cable From Riser port 1 P1.1/Q1	U2.1-P2/Q1#			
I/O Port Connector	U2.1-P2/Q2			
I/O Port Cable to GX1A-port 2	U2.1-P2/Q2#			
I/O Subsystem DCA 1	U2.1-V1			

FRU Name	Location Code	AIX Location Code	Physical Connection	Logical Connection
DCA 1 to (BPA B) BPD1- 5A Connector P00	U2.1-V1/Q1			
DCA 1 to (BPA B) BPD1- 5A Cable	U2.1-V1/Q1#			
DCA 1 to (BPA A) BPD1- 5A Connector P00	U2.1-V1/Q2			
DCA 1 to (BPA A) BPD1- 5A Cable	U2.1-V1/Q2#			
Thermal Sensor	U2.1-V1			
I/O Subsystem DCA 2	U2.1-V2			
DCA 2 to (BPA B) BPD1- 5B Connector P01	U2.1-V2/Q1			
DCA 2 to (BPA B) BPD1- 5B Cable	U2.1-V2/Q1#			
DCA 2 to (BPA A) BPD1- 5B Connector P01	U2.1-V2/Q2			
DCA 2 to (BPA A) BPD1- 5B Cable	U2.1-V2/Q2#			
Thermal Sensor	U2.1-V2			
I/O Subsystem SCSI controller 1 on P1	U2.1-P1/Z1	8s-08		
I/O Subsystem SCSI controller 2 on P1	U2.1-P1/Z2	97-08		
I/O Subsystem SCSI controller 1 on P2	U2.1-P2/Z1	9b-08		
I/O Subsystem SCSI controller 2 on P2	U2.1-P2/Z2	9s-08		
DASD 4 Pack Cage and card (1)	U2.1-P3			
DASD 4 Pack Cage and card (1) VPD	U2.1-P3-N1			
SCSI DASD 1 hdisk at ID 8 connected to controller 2 on P2	U2.1-P2/Z2-A8	9s-08-00-8,0		
SCSI DASD 2 hdisk at ID 9 connected to controller 2 on P2	U2.1-P2/Z2-A9	9s-08-00-9,0		

FRU Name	Location Code	AIX Location Code	Physical Connection	Logical Connection
SCSI DASD 3 hdisk at ID A connected to controller 2 on P2	U2.1-P2/Z2-Aa	9s-08-00-10,0		
SCSI DASD 4 hdisk at ID B connected to controller 2 on P2	U2.1-P2/Z2-Ab	9s-08-00-11,0		
SCSI Enclosure Services SES connected to controller 2 on P2	U2.1-P2/Z2-Af	9s-08-00-15,0		
DASD 4 Pack Cage and card (2)	U2.1-P			
DASD 4 Pack Cage and card (2) VPD	U2.1-P4-N1			
SCSI DASD 1 hdisk at ID 8 connected to controller 1 on P2	U2.1-P2/Z1-A8	9b-08-00-8,0		
SCSI DASD 2 hdisk at ID 9 connected to controller 1 on P2	U2.1-P2/Z1-A9	9b-08-00-9,0		
SCSI DASD 3 hdisk at ID A connected to controller 1 on P2	U2.1-P2/Z1-Aa	9b-08-00-10,0		
SCSI DASD 4 hdisk at ID B connected to controller 1 on P2	U2.1-P2/Z1-Ab	9b-08-00-11,0		
SCSI Enclosure Services SES connected to controller 1 on P2	U2.1-P2/Z1-Af	9b-08-00-15,0		
DASD 4 Pack Cage and card (3)	U2.1-P5			
DASD 4 Pack Cage and card (3) VPD	U2.1-P5-N1			
SCSI DASD 1 hdisk at ID 8 connected to controller 2 on P1	U2.1-P1/Z2-A8	97-08-00-8,0		
SCSI DASD 2 hdisk at ID 9 connected to controller 2 on P1	U2.1-P1/Z2-A9	97-08-00-9,0		
SCSI DASD 3 hdisk at ID A connected to controller 2 on P1	U2.1-P1/Z2-Aa	97-08-00-10,0		

FRU Name	Location Code	AIX Location Code	Physical Connection	Logical Connection
SCSI DASD 4 hdisk at ID B connected to controller 2 on P1	U2.1-P1/Z2-Ab	97-08-00-11,0		
SCSI Enclosure Services SES connected to controller 2 on P1	U2.1-P1/Z2-Af	97-08-00-15,0		
DASD 4 Pack Cage and card (4)	U2.1-P6			
DASD 4 Pack Cage and card (4) VPD	U2.1-P6-N1			
SCSI DASD 1 hdisk at ID 8 connected to controller 1 on P1	U2.1-P1/Z1-A8	8s-08-00-8,0		
SCSI DASD 2 hdisk at ID 9 connected to controller 1 on P1	U2.1-P1/Z1-A9	8s-08-00-9,0		
SCSI DASD 3 hdisk at ID A connected to controller 1 on P1	U2.1-P1/Z1-Aa	8s-08-00-10,0		
SCSI DASD 4 hdisk at ID B connected to controller 1 on P1	U2.1-P1/Z1-Ab	8s-08-00-11,0		
SCSI Enclosure Services SES connected to controller 1 on P1	U2.1-P1/Z1-Af	8s-08-00-15,0		
I/O Subsystem Fan (MSA)	U2.1-F1			
I/O Subsystem Fan (MSA)	U2.1-F2			
I/O Subsystem Fan (MSA)	U2.1-F3			
I/O Subsystem Fan (MSA)	U2.1-F4			
Media Drawer Power Connector	U2.1-P1-X1/Q3			
Media Drawer Power Cable	U2.1-P1-X1/Q3#			
Media Drawer Power Connector	U2.1-P2-X2/Q3			
Media Drawer Power Cable	U2.1-P2-X2/Q3#			

FRU Name	Location Code	AIX Location Code	Physical Connection	Logical Connection
I/O Subsystem 6 Locations				
I/O Subsystem 1 Chassis & Midplane Card	(MT/M Serial #) U2.5			
I/O Subsystem Left IO backplane assembly	U2.5-P1			
I/O Subsystem Left IO backplane assembly VPD	U2.5-P1-N1			
EADS 1 - PCI Controller	U2.5-P1	A0-58, A0-5A, A0-5C, A0-5E		
PCI Slot 1 Content	U2.5-P1-I1	A1-08 to A1-0F or A2-xx or A3-xx		
PCI Slot 2 Content	U2.5-P1-I2	A4-08 to A4-0F or A5-xx or A6-xx		
PCI Slot 3 Content	U2.5-P1-I3	A7-08 to A7-0F or A8-xx or A9-xx		
PCI Slot 4 Content	U2.5-P1-I4	AA-08 to AA-0F or AB-xx or AC-xx		
EADS 2 - PCI Controller	U2.5-P1	AE-58, AE-5A, AE-5E		
PCI Slot 5 Content	U2.5-P1-I5	AF-08 to AF-0F or AG-xx or AH-xx		
PCI Slot 6 Content	U2.5-P1-I6	AJ-08 to AJ-0F or AK-xx or AL-xx		
PCI Slot 7 Content	U2.5-P1-I7	AQ-08 to AQ-0F or AR-xx or AS-xx		
EADS 3 - PCI Controller	U2.5-P1	AU-58, AU-5A, AU-5E		
PCI Slot 8 Content	U2.5-P1-I8	AV-08 to AV-0F or AW-xx or AX-xx		
PCI Slot 9 Content	U2.5-P1-I9	AY-08 to AY-0F or AZ-xx or Aa-xx		

FRU Name	Location Code	AIX Location Code	Physical Connection	Logical Connection
PCI Slot 10 Content	U2.5-P1-I10	Ae-08 to Ae-0F or Af-xx or Ag-xx		
I/O Riser Card	U2.5-P1			
I/O Port Connector	U2.5-P1/Q1			
I/O Port Cable From GX1A-port 1	U2.5-P1/Q1#			
I/O Port Connector	U2.5-P1/Q2			
I/O Port Cable to port 0 on next Riser card U2.5-P2.1/Q1	U2.5-P1/Q2#			
I/O Subsystem Right IO backplane assembly	U2.5-P2			
I/O Subsystem Right IO backplane assembly VPD	U2.5-P2-N1			
EADS 1 - PCI Controller	U2.5-P2	Aj-58, Aj-5A, Aj-5C, Aj-5E		
PCI Slot 1 Content	U2.5-P2-I1	Ak-08 to Ak-0F or Am-xx or An-xx		
PCI Slot 2 Content	U2.5-P2-I2	Ap-08 to Ap-0F or Aq-xx or Ar-xx		
PCI Slot 3 Content	U2.5-P2-I3	As-08 to As-0F or At-xx or Au-xx		
PCI Slot 4 Content	U2.5-P2-I4	Av-08 to Av-0F or Aw-xx or Ax-xx		
EADS 2 - PCI Controller	U2.5-P2	B0-58, B0-5A, B0-5E		
PCI Slot 5 Content	U2.5-P2-I5	B1-08 to B1-0F or B2-xx or B3-xx		
PCI Slot 6 Content	U2.5-P2-I6	B4-08 to B4-0F or B5-xx or B6-xx		
PCI Slot 7 Content	U2.5-P2-I7	BA-08 to BA-0F or BB-xx or BC-xx		
EADS 3 - PCI Controller	U2.5-P2	BE-58, BE-5A, BE-5E		

FRU Name	Location Code	AIX Location Code	Physical Connection	Logical Connection
PCI Slot 8 Content	U2.5-P2-I8	BF-08 to BF-0F or BG-xx or BH-xx		
PCI Slot 9 Content	U2.5-P2-I9	BJ-08 to BJ-0F or BK-xx or BL-xx		
PCI Slot 10 Content	U2.5-P2-I10	BQ-08 to BQ-0F or BR-xx or BS-xx		
I/O Riser Card	U2.5-P2			
I/O Port Connector	U2.5-P2/Q1			
I/O Port Cable From Riser port 1 P1.1/Q1	U2.5-P2/Q1#			
I/O Port Connector	U2.5-P2/Q2			
I/O Port Cable to GX1A-port 2	U2.5-P2/Q2#			
I/O Subsystem DCA 1	U2.5-V1			
DCA 1 to (BPA B) BPD2- 6A Connector P02	U2.5-V1/Q1			
DCA 1 to (BPA B) BPD2- 6A Cable	U2.5-V1/Q1#			
DCA 1 to (BPA A) BPD2- 6A Connector P02	U2.5-V1/Q2			
DCA 1 to (BPA A) BPD2- 6A Cable	U2.5-V1/Q2#			
Thermal Sensor	U2.5-V1			
I/O Subsystem DCA 2	U2.5-V2			
DCA 2 to (BPA B) BPD2- 6B Connector P03	U2.5-V2/Q1			
DCA 2 to (BPA B) BPD2- 6B Cable	U2.5-V2/Q1#			
DCA 2 to (BPA A) BPD2- 6B Connector P03	U2.5-V2/Q2			
DCA 2 to (BPA A) BPD2- 6B Cable	U2.5-V2/Q2#			
Thermal Sensor	U2.5-V2			

FRU Name	Location Code	AIX Location Code	Physical Connection	Logical Connection
I/O Subsystem SCSI controller 1 on P1	U2.5-P1/Z1	AM-08		
I/O Subsystem SCSI controller 2 on P1	U2.5-P1/Z2	Ab-08		
I/O Subsystem SCSI controller 1 on P2	U2.5-P2/Z1	B7-08		
I/O Subsystem SCSI controller 2 on P2	U2.5-P2/Z2	BM-08		
DASD 4 Pack Cage and card (1)	U2.5-P3			
DASD 4 Pack Cage and card (1) VPD	U2.5-P3-N1			
SCSI DASD 1 hdisk at ID 8 connected to controller 2 on P2	U2.5-P2/Z2-A8	BM-08-00-8,0		
SCSI DASD 2 hdisk at ID 9 connected to controller 2 on P2	U2.5-P2/Z2-A9	BM-08-00-9,0		
SCSI DASD 3 hdisk at ID A connected to controller 2 on P2	U2.5-P2/Z2-Aa	BM-08-00-A,0		
SCSI DASD 4 hdisk at ID B connected to controller 2 on P2	U2.5-P2/Z2-Ab	BM-08-00-B,0		
SCSI Enclosure Services SES connected to controller 2 on P2	U2.5-P2/Z2-Af	BM-08-00-F,0		
DASD 4 Pack Cage and card (2)	U2.5-P4			
DASD 4 Pack Cage and card (2) VPD	U2.5-P4-N1			
SCSI DASD 1 hdisk at ID 8 connected to controller 1 on P2	U2.5-P2/Z1-A8	B7-08-00-8,0		
SCSI DASD 2 hdisk at ID 9 connected to controller 1 on P2	U2.5-P2/Z1-A9	B7-08-00-9,0		
SCSI DASD 3 hdisk at ID A connected to controller 1 on P2	U2.5-P2/Z1-Aa	B7-08-00-10,0		
SCSI DASD 4 hdisk at ID B connected to controller 1 on P2	U2.5-P2/Z1-Ab	B7-08-00-11,0		

FRU Name	Location Code	AIX Location Code	Physical Connection	Logical Connection
SCSI Enclosure Services SES connected to controller 1 on P2	U2.5-P2/Z1-Af	B7-08-00-15,0		
DASD 4 Pack Cage and card (3)	U2.5-P5			
DASD 4 Pack Cage and card (3) VPD	U2.5-P5-N1			
SCSI DASD 1 hdisk at ID 8 connected to controller 2 on P1	U2.5-P1/Z2-A8	Ab-08-00-8,0		
SCSI DASD 2 hdisk at ID 9 connected to controller 2 on P1	U2.5-P1/Z2-A9	Ab-08-00-9,0		
SCSI DASD 3 hdisk at ID A connected to controller 2 on P1	U2.5-P1/Z2-Aa	Ab-08-00-10,0		
SCSI DASD 4 hdisk at ID B connected to controller 2 on P1	U2.5-P1/Z2-Ab	Ab-08-00-11,0		
SCSI Enclosure Services SES connected to controller 2 on P1	U2.5-P1/Z2-Af	Ab-08-00-15,0		
DASD 4 Pack Cage and card (4)	U2.5-P6			
DASD 4 Pack Cage and card (4) VPD	U2.5-P6-N1			
SCSI DASD 1 hdisk at ID 8 connected to controller 1 on P1	U2.5-P1/Z1-A8	AM-08-00-8,0		
SCSI DASD 2 hdisk at ID 9 connected to controller 1 on P1	U2.5-P1/Z1-A9	AM-08-00-9,0		
SCSI DASD 3 hdisk at ID A connected to controller 1 on P1	U2.5-P1/Z1-Aa	AM-08-00-10,0		
SCSI DASD 4 hdisk at ID B connected to controller 1 on P1	U2.5-P1/Z1-Ab	AM-08-00-11,0		
SCSI Enclosure Services SES connected to controller 1 on P1	U2.5-P1/Z1-Af	AM-08-00-15,0		

FRU Name	Location Code	AIX Location Code	Physical Connection	Logical Connection
I/O Subsystem Fan (MSA)	U2.5-F1			
I/O Subsystem Fan (MSA)	U2.5-F2			
I/O Subsystem Fan (MSA)	U2.5-F3			
I/O Subsystem Fan (MSA)	U2.5-F4			
Media Drawer Power Connector	U2.5-P1-X1/Q3			
Media Drawer Power Cable	U2.5-P1-X1/Q3#			
Media Drawer Power Connector	U2.5-P2-X2/Q3			
Media Drawer Power Cable	U2.5-P2-X2/Q3#			

FRU Name	Location Code	AIX Location Code	Physical Connection	Logical Connection
I/O Subsystem 7 Locations				
I/O Subsystem 1 Chassis & Midplane Card	(MT/M Serial #) U2.13			
I/O Subsystem Left IO backplane assembly	U2.13-P1			
I/O Subsystem Left IO backplane assembly VPD	U2.13-P1-N1			
EADS 1 - PCI Controller	U2.13-P1	BU-58, BU-5A, BU-5C, BU-5E		
PCI Slot 1 Content	U2.13-P1-I1	BV-08 to BV-0F or BW-xx or BX-xx		
PCI Slot 2 Content	U2.13-P1-I2	BY-08 to BY-0F or BZ-xx or Ba-xx		
PCI Slot 3 Content	U2.13-P1-I3	Bb-08 to Bb-0F or Bc-xx or Bd-xx		

FRU Name	Location Code	AIX Location Code	Physical Connection	Logical Connection
PCI Slot 4 Content	U2.13-P1-I4	Be-08 to Be-0F or Bf-xx or Bg-xx		
EADS 2 - PCI Controller	U2.13-P1	Bj-58, Bj-5A, Bj-5E		
PCI Slot 5 Content	U2.13-P1-I5	Bk-08 to Bk-0F or Bm-xx or Bn-xx		
PCI Slot 6 Content	U2.13-P1-I6	Bp-08 to Bp-0F or Bq-xx or Br-xx		
PCI Slot 7 Content	U2.13-P1-I7	Bv-08 to Bv-0F or Bw-xx or Bx-xx		
EADS 3 - PCI Controller	U2.13-P1	C0-58, C0-5A, C0-5E		
PCI Slot 8 Content	U2.13-P1-I8	C1-08 to C1-0F or C2-xx or C3-xx		
PCI Slot 9 Content	U2.13-P1-I9	C4-08 to C4-0F or C5-xx or C6-xx		
PCI Slot 10 Content	U2.13-P1-I10	CA-08 to CA-0F or CB-xx or CC-xx		
I/O Riser Card	U2.13-P1			
I/O Port Connector	U2.13-P1/Q1			
I/O Port Cable From GX1A-port 1	U2.13-P1/Q1#			
I/O Port Connector	U2.13-P1/Q2			
I/O Port Cable to port 0 on next Riser card U2.13-P2.1/Q1	U2.13-P1/Q2#			
I/O Subsystem Right IO backplane assembly	U2.13-P2			
I/O Subsystem Right IO backplane assembly VPD	U2.13-P2-N1			
EADS 1 - PCI Controller	U2.13-P2	CE-58, CE-5A, CE-5C, CE-5E		
PCI Slot 1 Content	U2.13-P2-I1	CF-08 to CF-0F or CG-xx or CH-xx		

FRU Name	Location Code	AIX Location Code	Physical Connection	Logical Connection
PCI Slot 2 Content	U2.13-P2-I2	CJ-08 to CJ-0F or CK-xx or CL-xx		
PCI Slot 3 Content	U2.13-P2-I3	CM-08 to CM-0F or CN-xx or CP-xx		
PCI Slot 4 Content	U2.13-P2-I4	CQ-08 to CQ-0F or CR-xx or CS-xx		
EADS 2 - PCI Controller	U2.13-P2	CU-58, CU-5A, CU-5E		
PCI Slot 5 Content	U2.13-P2-I5	CV-08 to CV-0F or CW-xx or CX-xx		
PCI Slot 6 Content	U2.13-P2-I6	CY-08 to CY-0F or CZ-xx or Ca-xx		
PCI Slot 7 Content	U2.13-P2-I7	Ce-08 to Ce-0F or Cf-xx or Cg-xx		
EADS 3 - PCI Controller	U2.13-P2	Cj-58, Cj-5A, Cj-5E		
PCI Slot 8 Content	U2.13-P2-I8	Ck-08 to Ck-0F or Cm-xx or Cn-xx		
PCI Slot 9 Content	U2.13-P2-I9	Cp-08 to Cp-0F or Cq-xx or Cr-xx		
PCI Slot 10 Content	U2.13-P2-I10	Cv-08 to Cv-0F or Cw-xx or Cx-xx		
I/O Riser Card	U2.13-P2			
I/O Port Connector	U2.13-P2/Q1			
I/O Port Cable From Riser port 1 P1.1/Q1	U2.13-P2/Q1#			
I/O Port Connector	U2.13-P2/Q2			
I/O Port Cable to GX1A-port 2	U2.13-P2/Q2#			
I/O Subsystem DCA 1	U2.13-V1			
DCA 1 to (BPA B) BPD2- 6A Connector P02	U2.13-V1/Q1			

FRU Name	Location Code	AIX Location Code	Physical Connection	Logical Connection
DCA 1 to (BPA B) BPD2- 6A Cable	U2.13-V1/Q1#			
DCA 1 to (BPA A) BPD2- 6A Connector P02	U2.13-V1/Q2			
DCA 1 to (BPA A) BPD2- 6A Cable	U2.13-V1/Q2#			
Thermal Sensor	U2.13-V1			
I/O Subsystem DCA 2	U2.13-V2			
DCA 2 to (BPA B) BPD2- 6B Connector P03	U2.13-V2/Q1			
DCA 2 to (BPA B) BPD2- 6B Cable	U2.13-V2/Q1#			
DCA 2 to (BPA A) BPD2- 6B Connector P03	U2.13-V2/Q2			
DCA 2 to (BPA A) BPD2- 6B Cable	U2.13-V2/Q2#			
Thermal Sensor	U2.13-V2			
I/O Subsystem SCSI controller 1 on P1	U2.13-P1/Z1	Bs-08		
I/O Subsystem SCSI controller 2 on P1	U2.13-P1/Z2	C7-08		
I/O Subsystem SCSI controller 1 on P2	U2.13-P2/Z1	Cb-08		
I/O Subsystem SCSI controller 2 on P2	U2.13-P2/Z2	Cs-08		
DASD 4 Pack Cage and card (1)	U2.13-P3			
DASD 4 Pack Cage and card (1) VPD	U2.13-P3-N1			
SCSI DASD 1 hdisk at ID 8 connected to controller 2 on P2	U2.13-P2/Z2-A8	Cs-08-00-8,0		
SCSI DASD 2 hdisk at ID 9 connected to controller 2 on P2	U2.13-P2/Z2-A9	Cs-08-00-9,0		
SCSI DASD 3 hdisk at ID A connected to controller 2 on P2	U2.13-P2/Z2-Aa	Cs-08-00-10,0		

FRU Name	Location Code	AIX Location Code	Physical Connection	Logical Connection
SCSI DASD 4 hdisk at ID B connected to controller 2 on P2	U2.13-P2/Z2-Ab	Cs-08-00-11,0		
SCSI Enclosure Services SES connected to controller 2 on P2	U2.13-P2/Z2-Af	Cs-08-00-15,0		
DASD 4 Pack Cage and card (2)	U2.13-P4			
DASD 4 Pack Cage and card (2) VPD	U2.13-P4-N1			
SCSI DASD 1 hdisk at ID 8 connected to controller 1 on P2	U2.13-P2/Z1-A8	Cb-08-00-8,0		
SCSI DASD 2 hdisk at ID 9 connected to controller 1 on P2	U2.13-P2/Z1-A9	Cb-08-00-9,0		
SCSI DASD 3 hdisk at ID A connected to controller 1 on P2	U2.13-P2/Z1-Aa	Cb-08-00-10,0		
SCSI DASD 4 hdisk at ID B connected to controller 1 on P2	U2.13-P2/Z1-Ab	Cb-08-00-11,0		
SCSI Enclosure Services SES connected to controller 1 on P2	U2.13-P2/Z1-Af	Cb-08-00-15,0		
DASD 4 Pack Cage and card (3)	U2.13-P5			
DASD 4 Pack Cage and card (3) VPD	U2.13-P5-N1			
SCSI DASD 1 hdisk at ID 8 connected to controller 2 on P1	U2.13-P1/Z2-A8	C7-08-00-8,0		
SCSI DASD 2 hdisk at ID 9 connected to controller 2 on P1	U2.13-P1/Z2-A9	C7-08-00-9,0		
SCSI DASD 3 hdisk at ID A connected to controller 2 on P1	U2.13-P1/Z2-Aa	C7-08-00-10,0		
SCSI DASD 4 hdisk at ID B connected to controller 2 on P1	U2.13-P1/Z2-Ab	C7-08-00-11,0		

FRU Name	Location Code	AIX Location Code	Physical Connection	Logical Connection
SCSI Enclosure Services SES connected to controller 2 on P1	U2.13-P1/Z2-Af	C7-08-00-15,0		
DASD 4 Pack Cage and card (4)	U2.13-P6			
DASD 4 Pack Cage and card (4) VPD	U2.13-P6-N1			
SCSI DASD 1 hdisk at ID 8 connected to controller 1 on P1	U2.13-P1/Z1-A8	Bs-08-00-8,0		
SCSI DASD 2 hdisk at ID 9 connected to controller 1 on P1	U2.13-P1/Z1-A9	Bs-08-00-9,0		
SCSI DASD 3 hdisk at ID A connected to controller 1 on P1	U2.13-P1/Z1-Aa	Bs-08-00-10,0		
SCSI DASD 4 hdisk at ID B connected to controller 1 on P1	U2.13-P1/Z1-Ab	Bs-08-00-11,0		
SCSI Enclosure Services SES connected to controller 1 on P1	U2.13-P1/Z1-Af	Bs-08-00-15,0		
I/O Subsystem Fan (MSA)	U2.13-F1			
I/O Subsystem Fan (MSA)	U2.13-F2			
I/O Subsystem Fan (MSA)	U2.13-F3			
I/O Subsystem Fan (MSA)	U2.13-F4			
Media Drawer Power Connector	U2.13-P1-X1/Q3			
Media Drawer Power Cable	U2.13-P1-X1/Q3#			
Media Drawer Power Connector	U2.13-P2-X2/Q3			
Media Drawer Power Cable	U2.13-P2-X2/Q3#			

FRU Name	Location Code	AIX Location Code	Physical Connection	Logical Connection
I/O Subsystem 8 Locations				
I/O Subsystem 1 Chassis & Midplane Card	(MT/M Serial #) U2.19			
I/O Subsystem Left IO backplane assembly	U2.19-P1			
I/O Subsystem Left IO backplane assembly VPD	U2.19-P1-N1			
EADS 1 - PCI Controller	U2.19-P1	D0-58, D0-5A, D0-5C, D0-5E		
PCI Slot 1 Content	U2.19-P1-I1	D1-08 to D1-0F or D2-xx or D3-xx		
PCI Slot 2 Content	U2.19-P1-I2	D4-08 to D4-0F or D5-xx or D6-xx		
PCI Slot 3 Content	U2.19-P1-I3	D7-08 to D7-0F or D8-xx or D9-xx		
PCI Slot 4 Content	U2.19-P1-I4	DA-08 to DA-0F or DB-xx or DC-xx		
EADS 2 - PCI Controller	U2.19-P1	DE-58, DE-5A, DE-5E		
PCI Slot 5 Content	U2.19-P1-I5	DF-08 to DF-0F or DG-xx or DH-xx		
PCI Slot 6 Content	U2.19-P1-I6	DJ-08 to DJ-0F or DK-xx or DL-xx		
PCI Slot 7 Content	U2.19-P1-I7	DQ-08 to DQ-0F or DR-xx or DS-xx		
EADS 3 - PCI Controller	U2.19-P1	DU-58, DU-5A, DU-5E		
PCI Slot 8 Content	U2.19-P1-I8	DV-08 to DV-0F or DW-xx or DX-xx		
PCI Slot 9 Content	U2.19-P1-I9	DY-08 to DY-0F or DZ-xx or Da-xx		

FRU Name	Location Code	AIX Location Code	Physical Connection	Logical Connection
PCI Slot 10 Content	U2.19-P1-I10	De-08 to De-0F or Df-xx or Dg-xx		
I/O Riser Card	U2.19-P1			
I/O Port Connector	U2.19-P1/Q1			
I/O Port Cable From GX1A-port 1	U2.19-P1/Q1#			
I/O Port Connector	U2.19-P1/Q2			
I/O Port Cable to port 0 on next Riser card U2.19-P2.1/Q1	U2.19-P1/Q2#			
I/O Subsystem Right IO backplane assembly	U2.19-P2			
I/O Subsystem Right IO backplane assembly VPD	U2.19-P2-N1			
EADS 1 - PCI Controller	U2.19-P2	Dj-58, Dj-5A, Dj-5C, Dj-5E		
PCI Slot 1 Content	U2.19-P2-I1	Dk-08 to Dk-0F or Dm-xx or Dn-xx		
PCI Slot 2 Content	U2.19-P2-I2	Dp-08 to Dp-0F or Dq-xx or Dr-xx		
PCI Slot 3 Content	U2.19-P2-I3	Ds-08 to Ds-0F or Dt-xx or Du-xx		
PCI Slot 4 Content	U2.19-P2-I4	Dv-08 to Dv-0F or Dw-xx or Dx-xx		
EADS 2 - PCI Controller	U2.19-P2	E0-58, E0-5A, E0-5E		
PCI Slot 5 Content	U2.19-P2-I5	E1-08 to E1-0F or E2-xx or E3-xx		
PCI Slot 6 Content	U2.19-P2-I6	E4-08 to E4-0F or E5-xx or E6-xx		
PCI Slot 7 Content	U2.19-P2-I7	EA-08 to EA-0F or EB-xx or EC-xx		
EADS 3 - PCI Controller	U2.19-P2	EE-58, EE-5A, EE-5E		

FRU Name	Location Code	AIX Location Code	Physical Connection	Logical Connection
PCI Slot 8 Content	U2.19-P2-I8	EF-08 to EF-0F or EG-xx or EH-xx		
PCI Slot 9 Content	U2.19-P2-I9	EJ-08 to EJ-0F or EK-xx or EL-xx		
PCI Slot 10 Content	U2.19-P2-I10	EQ-08 to EQ-0F or ER-xx or ES-xx		
I/O Riser Card	U2.19-P2			
I/O Port Connector	U2.19-P2/Q1			
I/O Port Cable From Riser port 1 P1.1/Q1	U2.19-P2/Q1#			
I/O Port Connector	U2.19-P2/Q2			
I/O Port Cable to GX1A-port 2	U2.19-P2/Q2#			
I/O Subsystem DCA 1	U2.19-V1			
DCA 1 to (BPA B) BPD2- 6A Connector P02	U2.19-V1/Q1			
DCA 1 to (BPA B) BPD2- 6A Cable	U2.19-V1/Q1#			
DCA 1 to (BPA C) BPD2- 6A Connector P02	U2.19-V1/Q2			
DCA 1 to (BPA C) BPD2- 6A Cable	U2.19-V1/Q2#			
Thermal Sensor	U2.19-V1			
I/O Subsystem DCA 2	U2.19-V2			
DCA 2 to (BPA B) BPD2- 6B Connector P03	U2.19-V2/Q1			
DCA 2 to (BPA B) BPD2- 6B Cable	U2.19-V2/Q1#			
DCA 2 to (BPA A) BPD2- 6B Connector P03	U2.19-V2/Q2			
DCA 2 to (BPA A) BPD2- 6B Cable	U2.19-V2/Q2#			
Thermal Sensor	U2.19-V2			

FRU Name	Location Code	AIX Location Code	Physical Connection	Logical Connection
I/O Subsystem SCSI controller 1 on P1	U2.19-P1/Z1	DM-08		
I/O Subsystem SCSI controller 2 on P1	U2.19-P1/Z2	Db-08		
I/O Subsystem SCSI controller 1 on P2	U2.19-P2/Z1	E7-08		
I/O Subsystem SCSI controller 2 on P2	U2.19-P2/Z2	EM-08		
DASD 4 Pack Cage and card (1)	U2.19-P3			
DASD 4 Pack Cage and card (1) VPD	U2.19-P3-N1			
SCSI DASD 1 hdisk at ID 8 connected to controller 2 on P2	U2.19-P2/Z2-A8	EM-08-00-8,0		
SCSI DASD 2 hdisk at ID 9 connected to controller 2 on P2	U2.19-P2/Z2-A9	EM-08-00-9,0		
SCSI DASD 3 hdisk at ID A connected to controller 2 on P2	U2.19-P2/Z2-Aa	EM-08-00-10,0		
SCSI DASD 4 hdisk at ID B connected to controller 2 on P2	U2.19-P2/Z2-Ab	EM-08-00-11,0		
SCSI Enclosure Services SES connected to controller 2 on P2	U2.19-P2/Z2-Af	EM-08-00-15,0		
DASD 4 Pack Cage and card (2)	U2.19-P4			
DASD 4 Pack Cage and card (2) VPD	U2.19-P4-N1			
SCSI DASD 1 hdisk at ID 8 connected to controller 1 on P2	U2.19-P2/Z1-A8	E7-08-00-8,0		
SCSI DASD 2 hdisk at ID 9 connected to controller 1 on P2	U2.19-P2/Z1-A9	E7-08-00-9,0		
SCSI DASD 3 hdisk at ID A connected to controller 1 on P2	U2.19-P2/Z1-Aa	E7-08-00-10,0		
SCSI DASD 4 hdisk at ID B connected to controller 1 on P2	U2.19-P2/Z1-Ab	E7-08-00-11,0		

FRU Name	Location Code	AIX Location Code	Physical Connection	Logical Connection
SCSI Enclosure Services SES connected to controller 1 on P2	U2.19-P2/Z1-Af	E7-08-00-15,0		
DASD 4 Pack Cage and card (3)	U2.19-P5			
DASD 4 Pack Cage and card (3) VPD	U2.19-P5-N1			
SCSI DASD 1 hdisk at ID 8 connected to controller 2 on P1	U2.19-P1/Z2-A8	Db-08-00-8,0		
SCSI DASD 2 hdisk at ID 9 connected to controller 2 on P1	U2.19-P1/Z2-A9	Db-08-00-9,0		
SCSI DASD 3 hdisk at ID A connected to controller 2 on P1	U2.19-P1/Z2-Aa	Db-08-00-10,0		
SCSI DASD 4 hdisk at ID B connected to controller 2 on P1	U2.19-P1/Z2-Ab	Db-08-00-11,0		
SCSI Enclosure Services SES connected to controller 2 on P1	U2.19-P1/Z2-Af	Db-08-00-15,0		
DASD 4 Pack Cage and card (4)	U2.19-P6			
DASD 4 Pack Cage and card (4) VPD	U2.19-P6-N1			
SCSI DASD 1 hdisk at ID 8 connected to controller 1 on P1	U2.19-P1/Z1-A8	DM-08-00-8,0		
SCSI DASD 2 hdisk at ID 9 connected to controller 1 on P1	U2.19-P1/Z1-A9	DM-08-00-9,0		
SCSI DASD 3 hdisk at ID A connected to controller 1 on P1	U2.19-P1/Z1-Aa	DM-08-00-10,0		
SCSI DASD 4 hdisk at ID B connected to controller 1 on P1	U2.19-P1/Z1-Ab	DM-08-00-11,0		
SCSI Enclosure Services SES connected to controller 1 on P1	U2.19-P1/Z1-Af	DM-08-00-15,0		

FRU Name	Location Code	AIX Location Code	Physical Connection	Logical Connection
I/O Subsystem Fan (MSA)	U2.19-F1			
I/O Subsystem Fan (MSA)	U2.19-F2			
I/O Subsystem Fan (MSA)	U2.19-F3			
I/O Subsystem Fan (MSA)	U2.19-F4			
Media Drawer Power Connector	U2.19-P1-X1/Q3			
Media Drawer Power Cable	U2.19-P1-X1/Q3#			
Media Drawer Power Connector	U2.19-P2-X2/Q3			
Media Drawer Power Cable	U2.19-P2-X2/Q3#			

Specifications

This section contains specifications for the @server pSeries 690 system.

@server pSeries 690 Physical Specifications and Loads

The following tables illustrate the physical, electrical and thermal, acoustical, and environmental characteristics of various @server pSeries 690 system configurations.

Power and Electrical Requirements

Redundant power line cords are standard on the pSeries 690. The system uses dual ac power cords. For maximum availability, each of the power cords should be fed from independent power grids.

The following table illustrates electrical and thermal characteristics for the pSeries 690.

Electrical/Thermal Characteristic			
Rated Voltage (V ac, 3 phase)	200 to 240	380 to 415	480
Rated Current (A, per phase)	45	25	20
Frequency (Hertz)	50 to 60	50 to 60	50 to 60
Power (Maximum in kVA)	15.7	15.7	15.7
Typical, full load power factor (pf)	0.99	0.97	0.93
Inrush current (Amps)	162 maximum (see note below)		
Thermal output (Maximum kBtu/hr)	53.3	53.3	53.3
Notes:			
1. Inrush currents occur only at initial application of power (very short duration for charging capacitors). No inrush currents occur during the normal power off-on cycle.			
2. System will function normally with a nominal input voltage in the range of 200-480 V, AC, three phase.			

The following table illustrates the line cord options for the pSeries 690 with their geographic, breaker rating, and cord information.

3-Phase Supply Voltage (50/60 Hz)	200-240 V	380-415 V	480 V
Geography	United States, Canada, Japan	Europe, Middle East, Africa, Asia Pacific	United States, Canada
Customer Circuit Breaker Rating (see Note 1 below)	60 A	30 A	30 A
Cord Information	6 and 14 foot, 6 AWG line cord	14 foot, 6 or 8 AWG line cord, (electrician installed)	6 and 14 foot, 10 AWG line cord

Recommended Receptacle	IEC309, 60 A, type 460R9W (not provided)	Not specified, electrician installed	IEC309, 30 A, type 430R7W (not provided)
-------------------------------	--	--------------------------------------	--

Notes:

1. The exact circuit breaker ratings may not be available in all countries. Where the specified circuit breaker ratings are not acceptable, use the nearest available rating. Use of a time delayed circuit breaker is recommended.
2. In two-frame systems, frame B receives its power from frame A. The power to frame B is 350 V dc fed from the BPD through UPIC cables.

Phase Imbalance and BPR Configuration: Depending on the number of Bulk Power Regulators (BPRs) in your system, phase imbalance can occur in line currents. All systems are provided with 2 bulk power assemblies (BPAs), with separate line cords. Phase currents will be divided between two line cords in normal operation. The following table illustrates phase imbalance as a function of BPR configuration.

Number of BPRs per BPA	Phase A Line Current	Phase B Line Current	Phase C Line Current
1	Power / Vline	Power / Vline	0
2	0.5 Power / Vline	0.866 Power / Vline	0.5 Power / Vline
3	0.577 Power / Vline	0.577 Power / Vline	0.577 Power / Vline

Note: Power is calculated from “Total System Power Consumption” on page 150. Vline is line-to-line nominal input voltage.

Balancing Power Panel Loads: The system requires three-phase power. Depending on the system configuration, the phase currents can be fully balanced or unbalanced. System configurations with three BPRs per BPA have balanced power panel loads, while configurations with only one or two BPRs per BPA have unbalanced loads:

- With two BPRs per BPA, two of the three phases will draw an equal amount of current, and will be, nominally, 57.8% of the current on the third phase.
- With one BPR per BPA, two of three phases will carry an equal amount of current, with no current drawn on the third phase. The following figure is an example of feeding several loads of this type from two power panels in a way that balances the load among the three phases.

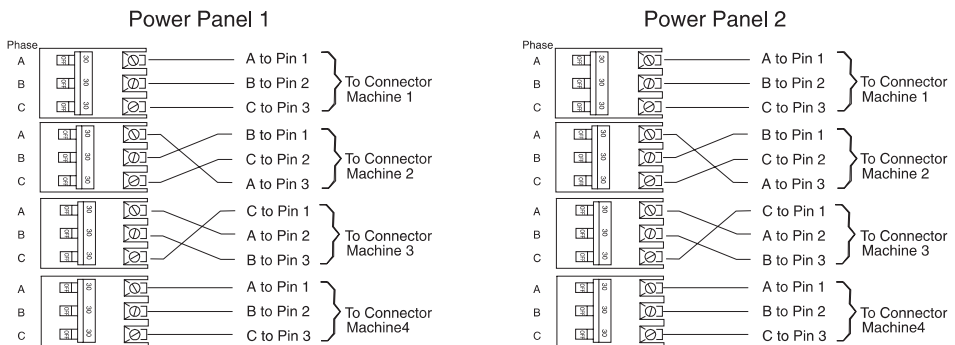

The method illustrated in the preceding figure requires that the connection from the three poles of each breaker to the three phase pins of a connector be varied. Some electricians may prefer to maintain a consistent wiring sequence from the breakers to the connectors. The following figure shows a way to balance the load without changing the wiring on the output of any breakers. The three-pole breakers are alternated with

single-pole breakers, so that the three-pole breakers do not all begin on Phase A.

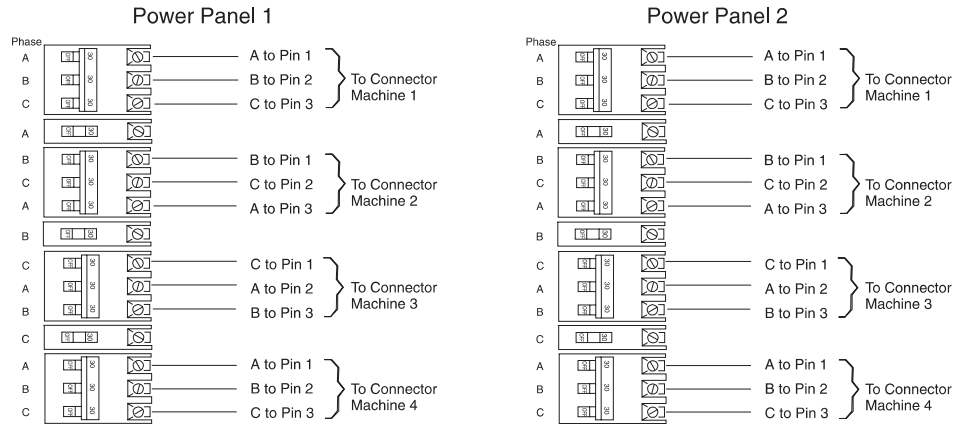

The following figure shows another way of distributing the unbalanced load evenly. Using this method, the three-pole breakers are alternated with two-pole breakers.

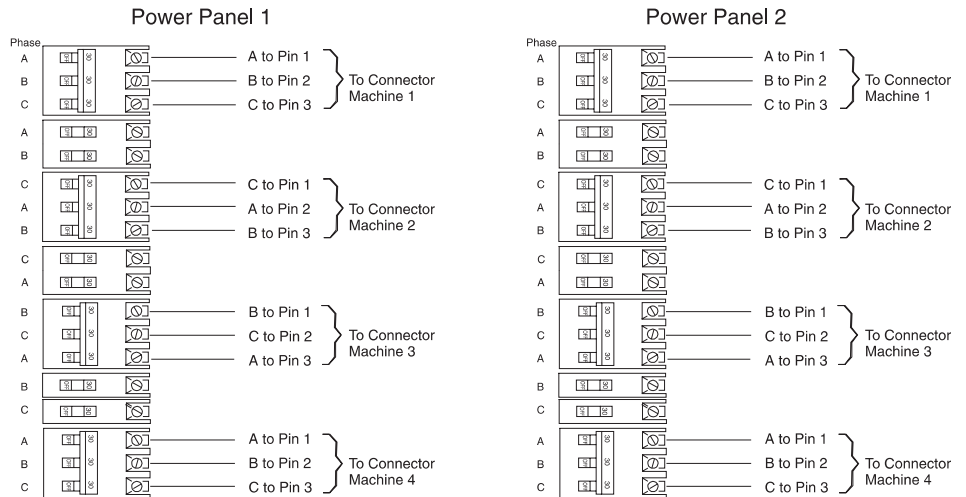

Power Cord Configuration: The power cords exit the system from different points of the frame as indicated in the following illustration.

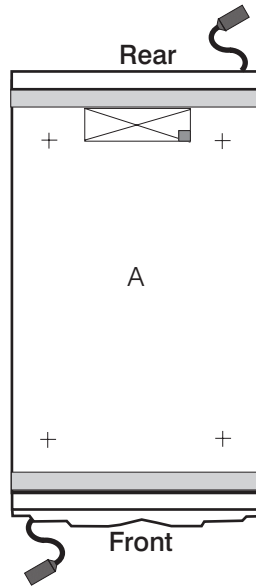

All Single-Frame Systems
(Top Down View)

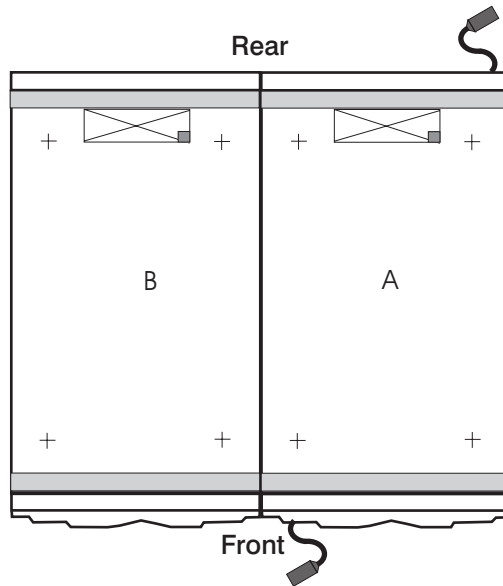

All Double-Frame Systems
(Top Down View)

Checking the Facility Outlets and Power Source:

CAUTION:

Do not touch the receptacle or the receptacle faceplate with anything other than your test probes before you have met the requirements in “Checking the Facility Outlets and Power Source” below.

Performing the following will ensure that appropriate power will be used by the pSeries 690. The following checklist is for reference purposes, and will likely be performed by a service engineer prior to installation.

- ___ 1. The pSeries 690 is equipped to use 200-240 V / 380-415 V / 480 V ac, three-phase. Check that the correct power source is available.
- ___ 2. Before system installation, locate and turn off the branch circuit CB (circuit breaker). Attach tag S229-0237, which reads “Do Not Operate.”

Note: All measurements are made with the receptacle faceplate in the normally installed position.

- ___ 3. Some receptacles are enclosed in metal housings. On receptacles of this type, perform the following steps:
 - a. Check for less than 1 volt from the receptacle case to any grounded metal structure in the building, such as a raised-floor metal structure, water pipe, building steel, or similar structure.
 - b. Check for less than 1 volt from receptacle ground pin to a grounded point in the building.

Note: If the receptacle case or faceplate is painted, be sure the probe tip penetrates the paint and makes good electrical contact with the metal.

- ___ 4. Check the resistance from the ground pin of the receptacle to the receptacle case. Check resistance from the ground pin to building ground. The reading should be less than 1.0 ohm, which indicates the presence of a continuous grounding conductor.
- ___ 5. If any of the checks made in substeps 2 and 3 are not correct, remove the power from the branch circuit and make the wiring corrections; then check the receptacle again.

Note: Do not use the digital multimeter to measure grounding resistance.

- ___ 6. Check for infinite resistance between the phase pins. This is a check for a wiring short.

CAUTION:

If the reading is other than infinity, do not proceed! You must make the necessary wiring corrections to satisfy the above criteria before continuing. Do not turn on the branch circuit CB until all the above steps are satisfactorily completed.

- ___ 7. Remove tag S229-0237, which reads “Do Not Operate.”
- ___ 8. Turn on the branch circuit CB. Measure for appropriate voltages between phases. If no voltage is present on the receptacle case or grounded pin, the receptacle is safe to touch.
- ___ 9. With an appropriate meter, verify that the voltage at the outlet is correct.

- ___ 10. Verify that the grounding impedance is correct by using the ECOS 1020, 1023, B7106, or an appropriately approved ground impedance tester.
- ___ 11. Turn off the branch circuit CB.
- ___ 12. Attach tag S229-0237, which reads “Do Not Operate.”
- ___ 13. You are now ready to install and connect the power cables to the pSeries 690.

Additional Installation Considerations: In the United States, installation must be made in accordance with Article 645 of the National Electric Code (NEC). In Canada, installation must be in accordance with Article 12-020 of the Canadian Electrical Code (CEC).

Dimensions and Weight

Physical Characteristic	Slimline Doors		Acoustical Doors	
	1 Frame	2 Frames	1 Frame	2 Frames
Height	2025 mm (79.72 in.)	2025 mm (79.72 in.)	2025 mm (79.72 in.)	2025 mm (79.72 in.)
Width	785 mm (30.91 in.)	1575 mm (62.00 in.)	785 mm (30.91 in.)	1575 mm (62.00 in.)
Depth	1342 mm (52.83 in.)	1342 mm (52.83 in.)	1494 mm (58.83 in.)	1494 mm (58.83 in.)
Weight (maximum configuration)	1170 kg (2580 lbs.)	1973 kg (4349 lbs.)	1184 kg (2610 lbs.)	2000 kg (4409 lbs.)
Notes:				
1. Doors are not installed during product shipment to the customer. A maximum configured system with batteries may exceed 1134 kg (2500 lbs.).				
2. When moving or relocating certain configurations of the system, the Bulk Power Regulators (BPRs) must be removed from the top of the rack (front and rear) to ensure product stability. Specifically, removal of BPRs from frame A and B in the front and rear is required in systems that have a single I/O drawer, with more than 2 BPRs installed per BPA in the primary rack.				

System Weights by Configuration

	Total System Weight (Pounds)							
	1	2	3	4	5	6	7	8
Number of I/O Subsystems								
Slimline Doors With IBF	2250	2415	2580	3633	3854	4019	4184	4349
Slimline Doors Without IBF	1865	2030	2195	2418	3266	3431	3596	3761
Acoustical Doors With IBF	2280	2445	2610	3693	3914	4079	4244	4409

Acoustical Doors Without IBF	<i>1923</i>	<i>2088</i>	<i>2253</i>	<i>2506</i>	3326	3491	3656	3821
No Doors With IBF	<i>2192</i>	<i>2357</i>	<i>2522</i>	<i>3517</i>	3738	3903	4068	4233
No Doors Without IBF	<i>1807</i>	<i>1972</i>	<i>2137</i>	<i>2302</i>	3150	3315	3480	3645
Note: Italicized numbers indicate single-frame systems.								

Number of I/O Subsystems	Total System Weight (Kilograms)							
	1	2	3	4	5	6	7	8
Slimline Doors With IBF	<i>1021</i>	<i>1095</i>	<i>1170</i>	1648	1748	1823	1898	1973
Slimline Doors Without IBF	<i>846</i>	<i>921</i>	<i>996</i>	<i>1097</i>	1481	1556	1631	1706
Acoustical Doors With IBF	<i>1034</i>	<i>1109</i>	<i>1184</i>	1675	1775	1850	1925	2000
Acoustical Doors Without IBF	<i>872</i>	<i>947</i>	<i>1022</i>	<i>1137</i>	1509	1583	1658	1733
No Doors With IBF	<i>994</i>	<i>1069</i>	<i>1144</i>	1595	1696	1770	1845	1920
No Doors Without IBF	<i>820</i>	<i>894</i>	<i>969</i>	<i>1044</i>	1429	1504	1579	1653
Note: Italicized numbers indicate single-frame systems.								

Acoustical Noise Emissions

Product Configuration	Acoustical Characteristic			
	Declared A-Weighted Sound Power Level, $L_{WA,d}$ (B)		Declared A-Weighted Sound Pressure Level, L_{pAm} (dB)	
	Operating	Idle	Operating	Idle
7040 Acoustical Doors	7.5	7.5	57	57
7040 Slimline Doors	7.9	7.9	62	62

Notes:

1. Noise levels cited are for a typical configuration (A-Frame: Bulk Power, CEC cage, battery option, media drawer, and two I/O drawers).
2. The 0.6-B (6-dB) reduction in noise emission levels with the acoustical rear door corresponds to a factor of 4 reduction. That is, the noise level of a single A-Frame with thin covers is about the same as the noise level of four A-Frames with acoustical covers.
3. L_{WA_d} is the upper-limit A-weighted sound power level; L_{pAm} is the mean A-weighted sound pressure level at the 1-meter bystander positions; 1 B = 10 dB.
4. All measurements made in conformance with ISO 7779 and declared in conformance with ISO 9296.

Environmental Specifications

Environmental Specification	Operating	Non-Operating	Storage	Shipping
Temperature	10 to 32°C (50 to 90°F)	10 to 43°C (50 to 109°F)	1 to 60°C (34 to 140°F)	-40 to 60°C (-40 to 140°F)
	Max. of 24 ° C (75.2 ° F) with 4mm tape or DVD RAM in rear positions of the Media Subsystem			
Relative Humidity (Noncondensing)	8 to 80 %	8 to 80 %	5 to 80 %	5 to 100 %
Maximum Wet Bulb	23°C (73°F)	27°C (73°F)	29°C (84°F)	29°C (84°F)

Notes:

1. Storage and shipping specifications are valid for a maximum duration of two weeks each.
2. The upper limit of the dry bulb temperature must be derated 1 degree C per 189 m (619 ft.) above 1295 m (4250 ft.). Maximum altitude for 1.1 GHz modules is 3048 m (10,000 ft.) and for 1.3 GHz modules is 2134 m (7000 ft)

Weight Distribution

The following table shows dimensions and weights used to calculate floor loading for the @server pSeries 690. All floor-loading calculations are intended for a raised-floor environment.

	1 Frame with Slimming Covers	2 Frames with Slimming Covers	1 Frame with Acoustical Covers	2 Frames with Acoustical Covers
Weight	1170 kg (2580 lbs.)	1973 kg (4349 lbs.)	1184 kg (2610 lbs.)	2000 kg (4409 lbs.)
Width	750 mm (29.5 in.)	1539 mm (60.6 in.)	750 mm (29.5 in.)	1539 mm (60.6 in.)

Depth	1173 mm (46.2 in.)	1173 mm (46.2 in.)	1173 mm (46.2 in.)	1173 mm (46.2 in.)
-------	--------------------	--------------------	--------------------	--------------------

Notes:

1. For 2 frame systems, widths of Frame A and Frame B. were added (the depth remains 1069 mm (42.1 in.), not including frame extenders).
2. For 2 frame systems, weights are based on maximum configuration (less than addition of maximum weights for each frame).
3. All floor-loading calculations are intended for a raised-floor environment.

The following table shows floor-loading specifications for systems with slimline covers. The values contained in the Condition column are described following the table.

Condition	a (sides) mm (in.)	b (front) mm (in.)	c (back) mm (in.)	1 Frame kg/m ² (lb./ft. ²)	2 Frames kg/m ² (lb./ft. ²)
1	25 (1.0)	135 (5.3)	135 (5.3)	1080.1 (221.2)	924.4 (189.3)
2	25 (1.0)	554 (21.8)	655 (25.8)	702.2 (143.8)	607.9 (124.5)
3	25 (1.0)	762 (30.0)	762 (30.0)	634.5 (129.9)	551.2 (112.9)
4	254 (10.0)	554 (21.8)	655 (25.8)	491.2 (100.6)	499.4 (102.3)
5	254 (10.0)	762 (30.0)	762 (30.0)	448.1 (91.8)	455.3 (93.3)
6	508 (20.0)	554 (21.8)	655 (25.8)	385.0 (78.9)	424.4 (86.9)
7	508 (20.0)	762 (30.0)	762 (30.0)	354.3 (72.6)	389.1 (79.7)
8	554 (21.8)	554 (21.8)	655 (25.8)	372.1 (76.2)	413.9 (84.8)
9	559 (22)	762 (30.0)	762 (30.0)	341.7 (70.0)	378.9 (77.6)
10	762 (30.0)	521 (20.5)	521 (20.5)	341.7 (70.0)	393.3 (80.6)
11	762 (30.0)	762 (30.0)	762 (30.0)	302.4 (61.9)	344.8 (70.6)

Definition of Conditions:

- Condition 1 indicates maximum floor loading when systems are stored cover-to-cover on all four sides with covers installed.
- Conditions 2 and 3 indicate floor loading when the system has no side clearance (beyond side covers) on both sides while front/back distances varied.
- Conditions 4 through 8 indicate floor loading at various points below the maximum weight-distribution distance of 762 mm (30.0 in.) from each edge of the frame.
- Conditions 9 through 10 indicate floor-loading options when the installation is limited to 342.0 kg/m² (70.0 lb/ft²).
- Condition 11 is the minimum floor loading required, based on the maximum weight-distribution area (30.0 in. from each side of the base frame).

Notes:

1. Service clearance is independent from weight distribution distance and must be at least 45 in. for the front of the frame and 36 in. for the rear of the frame (measured from the base frame).
2. Weight-distribution areas should not be overlapped.
3. Floor-loading weight distribution distances should not exceed 762 mm (30 in.) in any direction when measured from the base frame.

The following table shows floor-loading specifications for systems with acoustical covers. The values contained in the Condition column are described following the table.

Condition	a (sides) mm (in.)	b (front) mm (in.)	c (back) mm (in.)	1 Frame kg/m ² (lb./ft. ²)	2 Frames kg/m. ² (lb./ft ²)
1	25 (1.0)	135 (5.3)	135 (5.3)	1091.9 (223.6)	936.2 (191.7)
2	25 (1.0)	554 (21.8)	757 (29.8)	685.3 (140.4)	594.9 (121.8)
3	25 (1.0)	762 (30.0)	762 (30.0)	640.8 (131.2)	557.5 (114.2)
4	254 (10.0)	554 (21.8)	757 (29.8)	480.5 (98.4)	489.3 (100.2)
5	254 (10.0)	762 (30.0)	762 (30.0)	452.2 (92.6)	460.3 (94.3)
6	508 (20.0)	554 (21.8)	757 (29.8)	377.4 (77.3)	416.3 (85.3)
7	508 (20.0)	762 (30.0)	762 (30.0)	357.2 (73.2)	393.0 (80.5)
8	569 (22.4)	762 (30.0)	762 (30.0)	342.0 (70.0)	380.7 (78.0)
9	762 (30.0)	554 (21.8)	757 (29.8)	320.3 (65.6)	367.5 (75.3)
10	762 (30.0)	533 (21.0)	533 (21.0)	342.0 (70.0)	394.2 (80.7)
11	762 (30.0)	762 (30.0)	762 (30.0)	304.6 (62.4)	348.1 (71.3)

Definition of Conditions:

- Condition 1 indicates maximum floor loading when systems are stored cover-to-cover on all four sides with covers installed.
- Conditions 2 and 3 indicate floor loading when the system has no side clearance (beyond side covers) on both sides while front/back distances varied.
- Conditions 4 through 8 indicate floor loading at various points below the maximum weight-distribution distance of 762 mm (30.0 in.) from each edge of the frame.
- Conditions 9 through 10 indicate floor-loading options when the installation is limited to 342.0 kg/m² (70.0 lb/ft²).
- Condition 11 is the minimum floor loading required, based on the maximum weight-distribution area (30.0 in. from each side of the base frame).

Notes:

1. Service clearance is independent from weight-distribution distance and must be at least 45 in. at the front of the frame and 36 in. at the rear of the frame (measured from the base frame).
2. Weight-distribution areas should not be overlapped.
3. Floor-loading weight distribution distances should not exceed 762 mm (30 in.) in any direction when measured from the base frame.

Plan Views

The following illustration shows dimensional planning information for single-frame systems and double-frame systems.

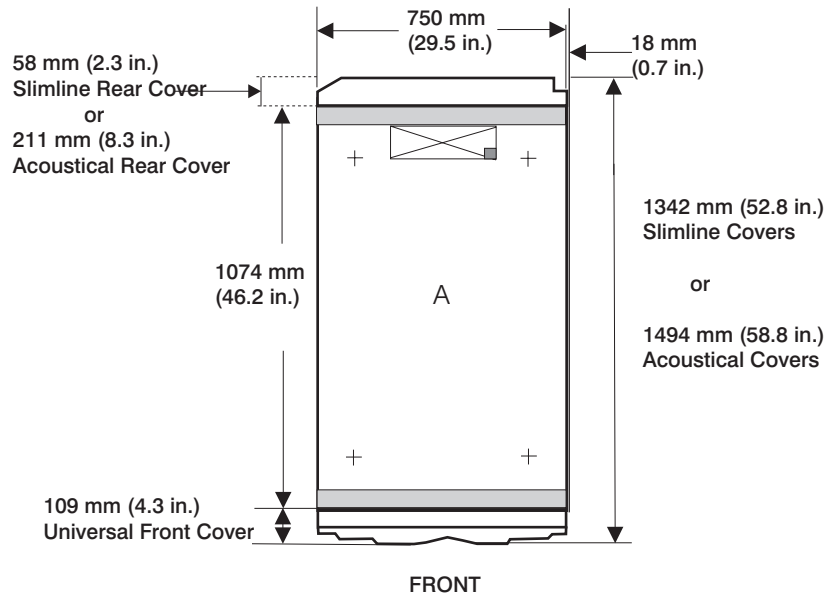

FRAME ENTRY/EXIT	DIMENSION	
	(mm)	(in.)
FRONT	117 by 403	4.6 by 15.9
REAR	117 by 403	4.6 by 15.9

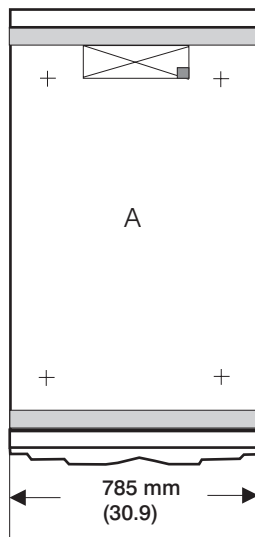

Single -Frame Systems

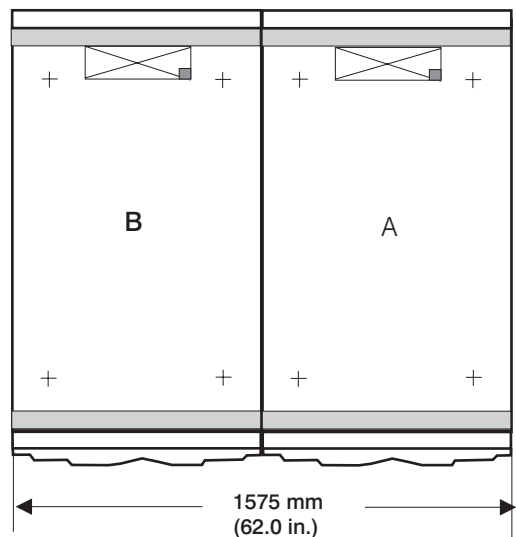

Double-Frame Systems

Total System Power Consumption

The following tables contain minimum and maximum power consumption for the 1.1 and 1.3 GHz @server pSeries 690. Minimum power consumption is based on a configuration consisting of a single 4 GB memory card, 1 PCI card per I/O subsystem, and 1 DASD device per I/O subsystem.

Maximum power consumption is based on a configuration consisting of two 32 GB memory cards per MCM module, maximum PCI cards (20 per I/O drawer), and maximum DASD (16 per I/O drawer).

Power consumption calculations are estimates. Actual values may vary.

Calculate heat load (Btu per hour) by multiplying the power (in watts) for the configuration by a factor of 3.4.

Note: Certain system configurations only support a maximum number of I/O drawers. If a system does not support a particular count of I/O drawers, it is indicated with "N/A".

Number of I/O Drawers (7040-61D)	1.1 GHz 8-way Modules (minimum power consumption, in watts)				1.1 GHz 8-way Modules (maximum power consumption, in watts)			
	8-way	16-way	24-way	32-way	8-way	16-way	24-way	32-way
1	1911	2867	3823	4779	3042	4586	6130	7674
2	2279	3235	4191	5147	4090	5634	7178	8722
3	N/A	3603	4559	5515	N/A	6682	8226	9770
4	N/A	3971	4927	5883	N/A	7730	9274	10818
5	N/A	N/A	5295	6251	N/A	N/A	10322	11866
6	N/A	N/A	5663	6619	N/A	N/A	11370	12914
7	N/A	N/A	N/A	6987	N/A	N/A	N/A	13962
8	N/A	N/A	N/A	7355	N/A	N/A	N/A	15010

Number of I/O Drawers (7040-61D)	1.3 GHz 4-way Modules (minimum power consumption, in watts)		1.3 GHz 4-way Modules (maximum power consumption, in watts)	
	8-way	16-way	8-way	16-way
1	3213	5471	4932	8366
2	3581	5839	5980	9414
3	3949	6207	7028	10462
4	4317	6575	8076	11510
5	N/A	6943	N/A	12558
6	N/A	7311	N/A	13606
7	N/A	7679	N/A	14654
8	N/A	8047	N/A	15702

Number of I/O Drawers (7040-61D)	1.3 GHz 8-way Modules (minimum power consumption, in watts)				1.3 GHz 8-way Modules (maximum power consumption, in watts)			
	8-way	16-way	24-way	32-way	8-way	16-way	24-way	32-way
1	2084	3213	4342	5471	3215	4932	6649	8366
2	2452	3581	4710	5839	4263	5980	7697	9414
3	N/A	3949	5078	6207	N/A	7028	8745	10462
4	N/A	4317	5446	6575	N/A	8076	9793	11510
5	N/A	N/A	5814	6943	N/A	N/A	10841	12558
6	N/A	N/A	6182	7311	N/A	N/A	11889	13606
7	N/A	N/A	N/A	7679	N/A	N/A	N/A	14654
8	N/A	N/A	N/A	8047	N/A	N/A	N/A	15702

Wattage Addition/Subtraction for Minimum and Maximum Configurations

Minimum configurations are based on a single 4 GB memory card and a single DASD/PCI card in each I/O subsystem. Maximum configurations are based on two 32 GB memory cards per MCM module, sixteen DASD per I/O subsystem and twenty PCI cards per I/O subsystem. To determine the typical power consumption for a specific configuration, use the following typical power values:

- 4 GB memory card - 137 Watts
- 8 GB memory card - 151 Watts
- 16 GB memory card - 235 Watts
- 32 GB memory card - 294 Watts
- Each PCI card - 20 Watts
- DASD - 20 Watts

Service Inspection Guide

Perform a service inspection on the system when:

- The system is inspected for a maintenance agreement.
- Service is requested and service has not recently been performed.
- An alterations and attachments review is performed.
- Changes have been made to the equipment that may affect its safe operation.
- External devices with their own power cables have those cables attached.

If the inspection indicates an unacceptable safety condition, the condition must be corrected before anyone can service the machine.

Note: The owner of the system is responsible to correct any unsafe conditions.

Perform the following checks:

1. Check the covers for sharp edges and for damage or alterations that expose the internal parts of the system.
2. Check the covers for proper fit to the rack. They should be in place and secure.
3. Gently rock the rack from side to side to verify the rack is stable.
4. Turn off the UEPO switch, turn off the circuit breakers on all optional IBF subsystems (if provided), then disconnect both power cords from the customer's receptacle.
5. Remove the covers.
6. Check for alterations or attachments. If there are any, check for obvious safety hazards, such as broken wires, sharp edges, or broken insulation.
7. Check the internal cables for damage.
8. Check for dirt, water, and any other contamination within the system.
9. Check the air filters in the processor subsystem to ensure they are clean. Replace if necessary.
10. Check the voltage label on the back of the system to ensure that it matches the voltage at the outlet.
11. Check the external power cable for damage.
12. With the external power cable connected to the system, check for 0.1 ohm or less resistance between the ground lug on the external power cable plug and the metal frame.
13. Perform the following checks on each device that has its own power cables:
 - a. Check for damage to the power cord.
 - b. Check for the correct grounded power cable.
 - c. With the external power cable connected to the device, check for 0.1 ohm or less resistance between the ground lug on the external power cable plug and the metal frame of the device.
14. Install the covers.

Chapter 2. Diagnostics Overview

@server pSeries 690 servers use an integrated set of software diagnostic procedures to facilitate system maintenance. This book and the *RS/6000 and @server pSeries Diagnostic Information for Multiple Bus Systems* are the basis of the diagnostic procedures for @server pSeries 690 systems. In particular, chapters 3, 4, 5, and 10 in this book are important for the trained service representative to understand and use when isolating a failure on the system.

The manufacturer recommends that systems configured with 4 GB of memory or greater have access to a 4-mm or 8-mm tape drive for submission of system dump information if it is required. This function can be accomplished through locally attached or network-attached devices, as appropriate.

Maintenance Analysis Procedures (MAPs)

Maintenance Analysis Procedures (MAPs) guide trained service representatives through the complex multirack @server pSeries 690 system. These MAPs are the entry point for all isolation and error-recovery procedures. @server pSeries 690 systems use a set of integrated procedures, to which the MAPs are the primary entry point.

The MAPs are as follows:

- Entry MAP
- Quick Entry MAP
- Service Focal Point Procedures
- Power MAP
- Problem Isolation MAP

The Entry Map is the starting point for problem determination. The purpose of this MAP is to quickly point to the appropriate MAP or service reference information either in this book, or in the common book set, which includes the *RS/6000 and @server pSeries Diagnostic Information for Multiple Bus Systems* and *PCI Adapter Placement Reference*.

The Quick Entry MAP is a subset of the Entry MAP and helps to save time for some types of problems.

The Power MAP deals with isolation of components and cables to diagnose a power problem. The nature of power problems can be related to powering the system on and off, or power failures that can occur after power is turned on.

The Problem Isolation MAP is used to locate defective components not found by normal diagnostics or error-isolation methods. This MAP provides a systematic method of isolation to the failing item or items.

Checkpoints

@server pSeries 690 systems use various types of checkpoints, error codes, and SRNs that are referred to throughout this book (primarily in Chapters 3, 4 and 5).

On an HMC-managed system, the checkpoints and error codes displayed on the physical operator panel are also displayed on the HMC virtual terminal associated with the managed system object.

On a system operating as a full system partition, checkpoints and error codes will appear on the physical operator panel from the beginning of the power-on process through the completion of booting AIX.

On a partitioned system, checkpoints and error codes for a partition are displayed on the HMC virtual operator panel associated with that logical partition. Checkpoints and error codes generated by logical partitions are not displayed on the managed system's physical operator panel.

During boot up of a partitioned system, there is a global initialization phase where one of the system processors is in control and initializing all of the system resources. During this phase, Exxx codes will be displayed on both the physical operator panel and the HMC managed-system object. After the global initialization phase completes, "LPAR..." is displayed on the physical operator panel and the HMC managed-system object.

Each logical partition also has a partition initialization phase where one of the system processors assigned to that partition is initializing all the resource of that partition. Exxx codes will be displayed on the virtual terminal of the HMC logical partition object during this partition initialization phase.

Codes that may appear in the service processor boot progress log, the AIX error log, the virtual terminal, and the operator panel display are as follows:

Checkpoints Checkpoints display in the operator panel from the time ac power is connected to the system until the AIX login prompt is displayed after a successful operating system boot. These checkpoints have the following forms:

8xxx 8xxx checkpoints are displayed from the time ac power is connected to the system until the OK prompt is displayed by the service processor on the operator panel display. (Several 9xxx checkpoints are displayed just before the OK prompt displays.)

9xxx 9xxx checkpoints are displayed by the service processor after the power-on sequence is initiated. A system processor takes control when 91FF displays on the operator panel display.

Note: Certain checkpoints may remain in the display for long periods of time. A spinning cursor is visible in the

upper-right corner of the display during these periods to indicate that system activity is continuing.

Exxx Exxx checkpoints indicate that a system processor is in control and is initializing the system resources. Control is being passed to AIX when E105 displays on the operator panel display. Location code information may also display on the operator panel during this time.

**0xxx
and**

2xxx 0xxx codes are AIX progress codes and configuration codes. Location codes may also display on the operator panel display during this time.

Error Codes If a fault is detected, an 8-digit error code is displayed in the operator panel display. A location code may be displayed at the same time on the second line.

SRNs Service request numbers, in the form xxx-xxx or xxx-xxxx, may also be displayed on the operator panel display and be noted in the AIX error log.

Checkpoints can become error codes if the system fails to advance past the point at which the code is presented. For a list of the checkpoints, see Chapter 4, "Checkpoints" on page 359. Each entry provides a description of the event and the recommended action if the system fails to advance.

SRNs are listed in the *RS/6000 and @server pSeries Diagnostic Information for Multiple Bus Systems*, order number SA38-0509.

FRU Isolation

For a list of error codes and recommended actions for each code, see Chapter 5, "Error Code to FRU Index" on page 399. These actions can refer to Chapter 10, "Parts Information" on page 873, Chapter 3, "Maintenance Analysis Procedures (MAPs)" on page 157, or provide informational message and directions. If a replacement part is indicated, direct reference is made to the part name. The respective AIX and physical location codes are listed for each occurrence as required. For a list of location codes, see "AIX and Physical Location Code Reference Tables" on page 62.

To look up part numbers and view component diagrams, see Chapter 10, "Parts Information" on page 873. The beginning of the chapter provides a parts index with the predominant field replaceable units (FRUs) listed by name. The remainder of the chapter provides illustrations of the various assemblies and components that compose @server pSeries 690 servers. The illustrations are ordered with processor subsystem components listed first, then I/O subsystem, and then accessories.

Service Agent for the @server pSeries 690

Service support for the @server pSeries 690 can be enhanced through the use of the application program, known as service agent for the @server pSeries 690. This application provides a number of advantages for the @server pSeries 690 customer, including automatic error reporting and analysis without customer intervention. Everything needed to use the service agent on the @server pSeries 690 is shipped with the system or with the Hardware Management Console for pSeries.

Using the Service Processor and Service Agent Features

The service processor and service agent features protect users against unnecessary system downtime by advising support personnel (both internal and external) of any unexpected changes in the system environment. In combination, the two features provide a flexible solution to automated system maintenance. For more information regarding the service processor, see Chapter 7, “Using the Service Processor” on page 705. For more information regarding the service agent application, see *IBM Hardware Management Console for pSeries Operations Guide*.

Running Diagnostics on the Native Serial Port on a Full Machine Partition with an HMC attached.

For a Full Machine Partition, the output of the S1 serial port is redirected, or wrapped to the virtual console window. When the S1 serial port is wrapped, the output of any command is directed from the S1 serial port to the virtual console terminal. If you close the virtual console window on the managed system, normal function is restored to the S1 serial port.

The implication of this is that the serial port wrap diagnostics may fail with a false SRN if the virtual console window on the managed system is not closed. Another method to prevent the false SRN is to unplug the HMC from it's port before running the wrap tests.”

After running diagnostics on the serial port, make sure that the S1 serial port is enabled for login (AIX command “chdev -l 'ttyx' -a login='enable'” where 'x' is the tty number corresponding to the S1 serial port).”

Chapter 3. Maintenance Analysis Procedures (MAPs)

This chapter contains Maintenance Analysis Procedures (MAPs) for the @server pSeries 690.

Entry MAP

When possible, run online diagnostics in service mode. Online diagnostics perform additional functions, compared to standalone diagnostics. This ensures that the error state of the system that was captured in NVRAM is available for your use in fixing the problem. The AIX error log and SMIT are only available when diagnostics are run from the hard drive. Always check Service Focal Point for any open service events in Service Action Event log.

If this system has a Hardware Management Console (HMC) with Service Focal Point (SFP), go to “MAP 1321: Quick Entry MAP for Systems with Service Focal Point” on page 172. Otherwise, use the following table to help determine your next step.

Notes:

1. Licensed programs frequently rely on system information stored in the VPD module on the media subsystem operator panel. If the MAPs indicate that the media subsystem operator panel should be replaced, swap the VPD module from the old media subsystem operator panel to the new one (see “Operator Panel” on page 868). If the old VPD module has to be replaced, call technical support for recovery instructions. If recovery is not possible, notify the system owner that new keys for licensed programs may be required.
2. If a network adapter is replaced, the network administrator must be notified so that the client IP addresses used by the system can be changed. In addition, the operating system configuration of the network controller may need to be changed in order to enable system startup. Also check to ensure that any client or system that addresses this system is updated.

Note: The various codes that might display on the HMC are all listed as error codes by Service Focal Point (SFP). To assist you in identifying the types of error data in this guide, use the following table.

SFP Name	Number of Digits in Error Code	Error code	Service Guide Name
Error Code	Any	Contains #	Menu Goal
Error Code	Any	Contains - (hyphen)	SRN
Error Code	5	Does not contain # or -	SRN
Error Code	6	Does not contain # or -	Error Code
Error Code	8	Does not contain # or -	Error Code, SRC, or Ref Code

Symptom	Starting Point
You have a problem that does not prevent the system from booting and the media subsystem operator panel is functional.	Go to the Fast Path MAP in the <i>RS/6000 and @server pSeries Diagnostic Information for Multiple Bus Systems</i> .
You do not have a symptom.	Go to MAP 0020 in the <i>RS/6000 and @server pSeries Diagnostic Information for Multiple Bus Systems</i>
You have an SRN.	Go to the Fast Path MAP in the <i>RS/6000 and @server pSeries Diagnostic Information for Multiple Bus Systems</i> .
The system stops and a 3-digit number is displayed in the operator panel display.	Record SRN 101-xxx, where xxx is the 3-digit number displayed in the operator panel display, then go to the Fast Path MAP in the <i>RS/6000 and @server pSeries Diagnostic Information for Multiple Bus Systems</i> .
The system stops and a 4-digit number beginning with 0 or 2 is displayed in the operator panel display.	Go to the Fast Path MAP in the <i>RS/6000 and @server pSeries Diagnostic Information for Multiple Bus Systems</i> .
All other symptoms.	Go to "Quick Entry MAP" on page 159.

Quick Entry MAP

Quick Entry MAP Table of Contents

Problem Description	Page No.
Service actions	160
OK does not appear in the media subsystem operator panel display before pressing the power on button. Other symptoms appear in the media subsystem operator panel display or LEDs before the power-on button is pressed.	160
8-Digit error codes	161
System stops with an 8-digit number displayed	161
System stops with a 4-digit number displayed that does not begin with 0 or 2.	161
System stops with a 3-digit number displayed (see below for 888 sequence).	161
Hardware Management Console (HMC) Problem	161
There appears to be a display problem (distortion, blurring, etc.)	162
Power and cooling problems	163
888 sequence in operator panel display	163
Other symptoms or problems	163

Attention: If you replace FRUs or perform an action on an I/O subsystem and the problem is still not corrected, go to “MAP 1542: I/O Problem Isolation” on page 312 unless you were already directed to any MAP 154x by the error code. Otherwise, call for support if the actions for an error code do not resolve the problem.

If you replace FRUs or perform an action, and the problem is corrected, go to “MAP 410: Repair Checkout” in the *RS/6000 and @server pSeries Diagnostic Information for Multiple Bus Systems*.

Note: Do not use MAP 410 to do the repair checkout if the only service actions that you perform are on the HMC.

Symptom	Action
Service Actions	
You have an open service event in the service action event log.	Go to "Service Focal Point" on page 5.
You have parts to exchange or a corrective action to perform.	<ol style="list-style-type: none"> 1. Go to Chapter 9, "Removal and Replacement Procedures" on page 767. 2. Go to "MAP 0410: Repair Checkout" in the <i>RS/6000 and @server pSeries Diagnostic Information for Multiple Bus Systems</i>.
You need to verify that a part exchange or corrective action corrected the problem.	Go to "MAP 0410: Repair Checkout" in the <i>RS/6000 and @server pSeries Diagnostic Information for Multiple Bus Systems</i> .
You need to verify correct system operation.	Go to "MAP 0410: Repair Checkout" in the <i>RS/6000 and @server pSeries Diagnostic Information for Multiple Bus Systems</i> .
OK does not appear in the media subsystem operator panel display before pressing the power-on button. Other symptoms appear in the media subsystem operator panel display or LEDs before the power on button is pressed.	
A bouncing or scrolling ball remains on the media subsystem operator panel display or the media subsystem operator panel display is filled with dashes	<ol style="list-style-type: none"> 1. Verify the operator panel cable from the primary I/O book to the media subsystem is connected and correctly seated at both ends. 2. If an ASCII terminal is available, connect it to the primary I/O book through serial port 1. <ol style="list-style-type: none"> a. If the service processor menu is displayed, then: <ol style="list-style-type: none"> 1) Replace the operator panel assembly, location: U1.17-L1. Refer to "Operator Panel" on page 868. 2) Replace the primary I/O book, location: U1.18-P1-H2. Refer to "I/O Books and I/O Blanks" on page 787. b. If the service processor menu is not displayed, then replace the primary I/O book, location: U1.18-P1-H2. Refer to "I/O Books and I/O Blanks" on page 787. 3. If an ASCII terminal is not available, replace the following, one at a time, in the sequence listed: <ol style="list-style-type: none"> a. Operator panel assembly, location: U1.17-L1. Refer to "Operator Panel" on page 868. b. Primary I/O book, location: U1.18-P1-H2. Refer to "I/O Books and I/O Blanks" on page 787.

Symptom	Action
You have a blank display on the operator panel. Other LEDs on the operator panel appear to behave normally.	<ol style="list-style-type: none"> 1. Check the processor subsystem to media subsystem cable. 2. Replace the operator panel assembly, Location: U1.17-L1. Refer to "Operator Panel" on page 868. 3. Replace the primary I/O book, Location: U1.18-P1-H2. Refer to "I/O Books and I/O Blanks" on page 787.
You have a blank display on the operator panel. Other LEDs on the operator panel are off.	Go to "MAP 1520: Power" on page 185.
8-Digit Error Codes	
You have an 8-digit error code displayed	<ol style="list-style-type: none"> 1. Look up the error code in the table in "Checkpoints and Error Codes Index" on page 403. 2. Look up the service action event (SAE) log. If the FRU has been changed other than the one in step 1, look at the most recent one.
System stops with an 8-digit number displayed	
The system stops with an 8-digit error code displayed when booting.	<ol style="list-style-type: none"> 1. Look up the error code in the table in "Checkpoints and Error Codes Index" on page 403. 2. Look up the SAE log. If the FRU has been changed other than the one in step 1, look at the most recent one.
System stops with a 4-digit number displayed that does not begin with 0 or 2.	
The system stops with a 4-digit checkpoint.	Go to "Checkpoints and Error Codes Index" on page 403. If you do not find the error code there, go to the Fast Path MAP in the <i>RS/6000 and @server pSeries Diagnostic Information for Multiple Bus Systems</i> .
System stops with a 3-digit number displayed (see below for 888 sequence)	
The system stops with a 3-digit error code.	<p>Add 101- to the left of the three digits to create an SRN. Go to <i>RS/6000 and @server pSeries Diagnostic Information for Multiple Bus Systems</i>.</p> <p>If there is a location code displayed under the 3-digit error code, then look at location to see if it matches failing component that the SRN pointed to. If they do not match, perform the action from <i>RS/6000 and @server pSeries Diagnostic Information for Multiple Bus Systems</i> first. If the problem still exists, then replace the failing component from that location code.</p>
Hardware Management Console (HMC) Problem	

Symptom	Action
<p>Hardware Management Console (HMC) cannot be used to manage a managed system, or the connection to the managed system is failing.</p>	<p>If the managed system is operating normally (no error codes or other symptoms), the HMC might have a problem, or the connection to the managed system might be damaged or incorrectly cabled. Do the following:</p> <ol style="list-style-type: none"> 1. Check the connections (serial cable) between the HMC and the managed system. Correct any cabling errors if found. If another serial cable is available, connect it in place of the existing cable and refresh the HMC graphical user interface. You may have to wait up to 30 seconds for the managed system to reconnect. 2. Verify that any connected HMC is connected to the managed system by checking the Management Environment of the HMC. Note: The managed system must have power connected and the system running, or waiting for a power-on instruction (the OK prompt is in the operator panel.) If the managed system does not appear in the Navigation area of the HMC Management Environment, then the HMC or the connection to the managed system might be failing. 3. Go to the Entry MAP in the <i>IBM Hardware Management Console for pSeries Maintenance Guide</i>, order number SA38-0603. 4. If you cannot fix the problem using the HMC tests in the <i>IBM Hardware Management Console for pSeries Maintenance Guide</i>, there might be a problem with the primary I/O book; replace the primary I/O book.
<p>Hardware management console (HMC) cannot callout using the attached modem and the customer's telephone line.</p>	<p>If the managed system is operating normally (no error codes or other symptoms), the HMC might have a problem, or the connection to the modem and telephone line may have a problem. Do the following:</p> <ol style="list-style-type: none"> 1. Check the connections between the HMC and the modem and telephone line. Correct any cabling errors if found. 2. Go to the Entry MAP in the <i>IBM Hardware Management Console for pSeries Maintenance Guide</i>, order number SA38-0603.
<p>There is a Display Problem (Distortion, Blurring, Etc.)</p>	

Symptom	Action
All display problems.	<ol style="list-style-type: none"> 1. If using the Hardware Management Console, go to the <i>IBM Hardware Management Console for pSeries Maintenance Guide</i>, order number SA38-0603. 2. If using a graphics display: <ol style="list-style-type: none"> a. Go to the problem determination procedures for the display. b. If you do not find a problem, replace the display adapter. 3. If using an ASCII terminal: <ol style="list-style-type: none"> a. Make sure that the ASCII terminal is connected to S1. b. If problems persist, go to the problem determination procedures for the terminal. c. If you do not find a problem, replace the primary I/O book.
Power and Cooling Problems	
The system will not power on and no error codes are available.	Go to "Map 1521: The System Will Not Power On And No Error Codes Are Available" on page 189.
The power light does not come on or stay on. (both the operator panel power-on LED and the I/O subsystem indicator panel power LEDs do not come on or stay on).	<ol style="list-style-type: none"> 1. Check service processor error log. 2. Go to "MAP 1520: Power" on page 185.
A rack or a rack-mounted unit will not power on.	<ol style="list-style-type: none"> 1. Check service processor error log. 2. Go to "MAP 1520: Power" on page 185.
You have a power problem.	<ol style="list-style-type: none"> 1. Check service processor error log. 2. Go to "MAP 1520: Power" on page 185.
The system attention LED on the media subsystem operator panel is on and there is no error code displayed.	<ol style="list-style-type: none"> 1. Check service processor error log. 2. Go to "MAP 1520: Power" on page 185.
888 Sequence in Operator Panel Display	
An 888 sequence is displayed in the media subsystem operator panel display.	Go to the Fast Path MAP in the <i>RS/6000 and @server pSeries Diagnostic Information for Multiple Bus Systems</i> .
Other Symptoms or Problems	
One or more partitions do not boot.	Go to "MAP 1020: Problem Determination" on page 166.
The operator panel displays OK and the fans and blowers are off.	The service processor is ready. The system is waiting for power-on.

Symptom	Action
All of the system POST indicators are displayed on the system console, the system pauses and then restarts. The term <i>POST indicators</i> refers to the device mnemonics (the words memory, keyboard, network, scsi, and speaker) that appear on the system console during the power-on self-test (POST).	Go to "Boot Problems" on page 396.
The system stops and all of the POST indicators are displayed on the system console. The term <i>POST indicators</i> refers to the device mnemonics (the words memory, keyboard, network, scsi, and speaker) that appear on the system console during the power-on self-test (POST).	Go to "Boot Problems" on page 396.
The system stops and the message STARTING SOFTWARE PLEASE WAIT... is displayed on the firmware console.	Go to Chapter 4, "Checkpoints" on page 359.
The system does not respond to the password being entered or the system login prompt is displayed when booting in service mode.	<ol style="list-style-type: none"> 1. If the password is being entered from the Hardware Management Console (HMC), go to the <i>IBM Hardware Management Console for pSeries Maintenance Guide</i>. 2. If the password is being entered from a keyboard attached to the system, then the keyboard or its controller may be faulty. In this case, replace these parts in the following order: <ol style="list-style-type: none"> a. Keyboard cable b. Keyboard c. USB card the keyboard is attached to. 3. If the password is being entered from an ASCII terminal, then use the Problem Determination Procedures for the ASCII terminal. Make sure the ASCII terminal is connected to S1. If the problem persists, replace the primary I/O book.
No codes are displayed on the operator panel within a few seconds of turning on the system. The operator panel is blank before the system is powered on.	Reseat the operator panel cable. If the problem is not resolved, replace in the following order: <ol style="list-style-type: none"> 1. Operator panel assembly. Swap the VPD module from the old operator panel to the new operator panel. 2. Primary I/O book. (See notes on 157.)

Symptom	Action
<p>The SMS configuration list or boot sequence selection menu shows more SCSI devices attached to a controller/adapter than are actually attached.</p>	<p>A device may be set to use the same SCSI bus ID as the control adapter. Note the ID being used by the controller/adapter (this can be checked and/or changed through an SMS utility), and verify that no device attached to the controller is set to use that ID.</p> <p>If settings do not appear to be in conflict:</p> <ol style="list-style-type: none"> 1. Go to "MAP 1542: I/O Problem Isolation" on page 312 2. Replace the SCSI cable. 3. Replace the device. 4. Replace the SCSI adapter <p>Note: In a "twin-tailed" configuration where there is more than one initiator device (normally another system) attached to the SCSI bus, it may be necessary to use SMS utilities to change the ID of the SCSI controller or adapter.</p>
<p>The System Management Services menu is displayed.</p>	<p>The device or media you are attempting to boot from may be faulty.</p> <ol style="list-style-type: none"> 1. Check the SMS error log for any errors. To check the error log: <ul style="list-style-type: none"> • Choose error log • If an error is logged, check the time stamp. • If the error was logged during the current boot attempt, record it. • Look up the error in Chapter 5, "Error Code to FRU Index" and do the listed action. • If no recent error is logged in the error log, continue to the next step below. 2. Try to boot from an alternate boot device connected to the same controller as the original boot device. If the boot succeeds, replace the original boot device (for removable media devices, try the media first). 3. Go to "Boot Problems" on page 396.
<p>You suspect a cable problem.</p>	<p>Go to <i>RS/6000 and @server pSeries Adapters, Devices, and Cable Information for Multiple Bus Systems</i>.</p>
<p>All other problems.</p>	<p>Go to "MAP 1020: Problem Determination" on page 166.</p>

MAP 1020: Problem Determination

Purpose of This MAP

Use this MAP to get an error code if you were not provided one by the customer or you are unable to load diagnostics. If you are able to load the diagnostics, go to MAP 0020 in the *RS/6000 and @server pSeries Diagnostic Information for Multiple Bus Systems*.

The service processor may have recorded one or more symptoms in its error log. Examine this error log before proceeding (see “System Information Menu” on page 722). The server may have been set up by using the HMC. Check the Service Action Event (SAE) log in the Service Focal Point. The SAE log may have recorded one or more symptoms in the Service Focal Point. To avoid unnecessary replacement of the same FRU for the same problem, it is necessary to check the SAE log for evidence of prior service activity on the same subsystem.

The service processor may have been set by the user to monitor system operations and to attempt recoveries. You can disable these actions while you diagnose and service the system. If the system was set up according to the recommendations of the *@server pSeries 690 User's Guide*, all the settings of the service processor (except language) were saved by using the SAVE/RESTORE HARDWARE MAINTENANCE POLICIES service aid. You can use the same service aid to restore the settings at the conclusion of your service action.

In case the service processor settings were not saved by the user, if you disable them, make notes of their current settings for restoration before you leave.

In addition to the parameters in the following table, you can disconnect the modem to prevent incoming signals that could cause the system to power on.

Following are the service processor settings. The service processor menus are described in Chapter 7, “Using the Service Processor” on page 705.

Surveillance	From the service processor Setup Menu, go to the Surveillance Setup Menu and disable surveillance. (Surveillance is automatically disabled in LPAR mode.)
Unattended Start	From the service processor System Power Control Menu, disable unattended start mode.
Reboot Policy	From the System Power Control Menu, go to the Reboot/Restart Policy Setup Menu and set: <ol style="list-style-type: none">1. Number of reboot attempts to 0 (zero)2. Use OS-Defined restart policy to No3. Enable supplemental restart policy to No.

Call Out	From the Call-In/Call-Out Setup Menu, go to the Serial Port Selection Menu and disable call-out on both serial ports. (Call-out is automatically disabled when the system is booted to operate with multiple partitions (also known as a <i>partitioned system</i>).
----------	---

Be prepared to record code numbers and use those numbers in the course of analyzing a problem. Go to “Step 1020-1”.

Step 1020-1

The following steps analyze a failure to load the diagnostic programs.

Note: Be prepared to answer questions regarding the operator panel display and to perform certain actions based on displayed POST indicators. Please be observant of these conditions.

1. Run diagnostics on any partition. Find your symptom in the following table; then follow the instructions given in the Action column.
If no fault is identified, continue to the next step.
2. Run diagnostics on the failing partition. Find your symptom in the following table; then follow the instructions given in the Action column.
If no fault is identified, continue to the next step.
3. Power off the system. Refer to “Powering Off the System and Removing Power” on page 771.
4. Load the standalone diagnostics in service mode to test the full system partition. Refer to Chapter 6, “Using the Online and Standalone Diagnostics” on page 695.
5. Wait until the diagnostics are loaded or the system appears to stop. If you receive an error code or if the system stops before diagnostics are loaded, find your symptom in the following table; then follow the instructions given in the Action column.
If no fault is identified, continue to the next step.
6. Run the standalone diagnostics on the entire system. Find your symptom in the following table; then follow the instructions given in the Action column.
If no fault is identified, call service support for assistance.

Symptom	Action
One or more partitions do not boot.	<ol style="list-style-type: none"> 1. Check service processor error log. If an error is indicated, go to the “Entry MAP” on page 157. 2. Check the Serviceable Action Event (SAE) log, refer to “Working With Serviceable Events” on page 8. If there is a Service Action Event, perform the recommended actions or go to the “Entry MAP” on page 157.

Symptom	Action
The system stopped and a code is displayed on the operator panel.	Go to the "Entry MAP" on page 157.
The system stops with a prompt to enter a password.	Enter the password. You cannot continue until a correct password has been entered. When you have entered a valid password, go to the beginning of this table and wait for one of the other conditions to occur.
The diagnostic operating instructions are displayed.	Go to MAP 0020 in the <i>RS/6000 and @server pSeries Diagnostic Information for Multiple Bus Systems</i> .
The power good LED does not come on or does not stay on, or you have a power problem.	Go to "MAP 1520: Power" on page 185.
The system login prompt is displayed.	<p>You may not have pressed the correct key or you may not have pressed the key soon enough when you were to trying to indicate a service mode IPL of the diagnostic programs. If this is the case, start again at the beginning of this step.</p> <p>Note: Perform the system shutdown procedure before turning off the system.</p> <p>If you are sure you pressed the correct key in a timely manner, go to "Step 1020-2" on page 170.</p>
The system does not respond when the password is entered.	Go to "Step 1020-2" on page 170.

Symptom	Action
<p>The system stopped. A POST indicator is displayed on the system console and an eight-digit error code is not displayed.</p>	<p>If the POST indicator represents:</p> <ol style="list-style-type: none"> 1. Memory, do a slow boot. If an error code points to memory, replace that memory book and run slow boot again. 2. Keyboard <ol style="list-style-type: none"> a. Replace the keyboard cable. b. Replace the keyboard. c. Replace the USB card that the keyboard is attached to. d. Go to "MAP 1542: I/O Problem Isolation" on page 312. 3. Network, go to "MAP 1542: I/O Problem Isolation" on page 312. 4. SCSI, go to "MAP 1542: I/O Problem Isolation" on page 312. 5. Speaker <ol style="list-style-type: none"> a. Replace the operator panel. b. Replace the primary I/O book, location: U1.18-P1-H2. c. Go to "MAP 1542: I/O Problem Isolation" on page 312.
<p>The System Management Services menu is displayed.</p>	<p>Go to "Step 1020-4" on page 171.</p>
<p>All other symptoms.</p>	<p>If you were directed here from the Entry MAP, go to "MAP 1542: I/O Problem Isolation" on page 312. Otherwise, find the symptom in the "Entry MAP" on page 157.</p>

Step 1020-2

There is a problem with the keyboard.

Find the type of keyboard you are using in the following table; then follow the instructions given in the Action column.

Keyboard Type	Action
Type 101 keyboard (U.S.). Identified by the size of the Enter key. The Enter key is in only one horizontal row of keys.	Record error code M0KB D001; then go to "Step 1020-3".
Type 102 keyboard (W.T.). Identified by the size of the Enter key. The Enter key extends into two horizontal rows.	Record error code M0KB D002; then go to "Step 1020-3".
Type 106 keyboard. (Identified by the Japanese characters.)	Record error code M0KB D003; then go to "Step 1020-3".
ASCII terminal keyboard	Go to the documentation for this type of ASCII terminal and continue with problem determination.

Step 1020-3

Take the following actions:

1. Find the eight-digit error code in Chapter 5, "Error Code to FRU Index" on page 399.

Note: If the eight-digit error code is not listed in Chapter 5, "Error Code to FRU Index", look for it in the following:

- Any supplemental service manuals for attached devices
- The diagnostic problem report screen for additional information
- The Service Hints service aid
- The CERADME file (by using the Service Hints service aid)

Note: Service aids can be found in *RS/6000 and @server pSeries Diagnostic Information for Multiple Bus Systems*.

2. Perform the action listed.

Step 1020-4

1. Turn off, then turn on the system unit.
2. When the keyboard indicator (the word **keyboard**) displays, press the 1 key on a directly attached keyboard or the 1 key on an ASCII terminal or 1 key on the HMC.
3. When the System Management Services menus appear, check the error log for any errors.
 - a. Choose Error Log
 - b. If an error is logged, check the time stamp.
 - c. If the error was logged during the current boot attempt, record it.
 - d. Look up the error in the Chapter 5, "Error Code to FRU Index" on page 399 and do the listed action.
 - e. If no recent error is logged in the error log, go to "MAP 1542: I/O Problem Isolation" on page 312.

MAP 1320: Service Focal Point Procedures

These procedures define the steps to be taken when servicing a machine equipped with Service Focal Point (SFP).

Note: The various codes that might display on the HMC are all listed as error codes by Service Focal Point (SFP). To assist you in identifying the types of error data in this guide, use the following table.

SFP Name	Number of Digits in Error Code	Error code	Service Guide Name
Error Code	Any	Contains #	Menu Goal
Error Code	Any	Contains - (hyphen)	SRN
Error Code	5	Does not contain # or -	SRN
Error Code	6	Does not contain # or -	Error Code
Error Code	8	Does not contain # or -	Error Code, SRC, or Ref Code

For steps to be taken when beginning service on a machine with SFP, see the “MAP 1321: Quick Entry MAP for Systems with Service Focal Point”.

For steps to be taken after service is complete on a machine with SFP, see the “MAP 1322: End of Call MAP for Systems with Service Focal Point” on page 175.

MAP 1321: Quick Entry MAP for Systems with Service Focal Point

Step 1321-1

For future reference, record the error code and the location code (that brought you to this MAP) of the FRU to be replaced . Record any other symptoms if an error code is not available.

Step 1321-2

At the HMC console, start Service Focal Point (SFP) and examine the service action event log for any open service action events. For SFP operating instructions, see “Service Focal Point” on page 5.

Does the HMC appear to operate correctly?

No Go to “Quick Entry MAP” on page 159, look up the HMC symptom, and follow the directions there.

Yes Go to “Step 1321-3”.

Step 1321-3

Are there any service action events that are open?

No Go to “Step 1321-14” on page 174.

Yes Go to “Step 1321-4” on page 173.

Step 1321-4

Record the list of open service action events.

Step 1321-5

From the list of serviceable events recorded in “Step 1321-4”, open the details of each service action event and examine the FRU list and error code(s) for each.

Step 1321-6

Are there any serviceable actions events with error codes of the form #xxxxxx in the list of error codes found in “Step 1321-5”?

No Go to “Step 1321-7”.

Yes Go to “Step 1321-18” on page 175.

Step 1321-7

Are there any serviceable events with FRU location codes reported in “Step 1321-5”?

No Go to “Step 1321-14” on page 174.

Yes Go to “Step 1321-8”.

Step 1321-8

From the list of open service action events with FRUs reported, examine the details of each service action event and record the error code.

Step 1321-9

Examine the list of error codes you obtained from “Step 1321-8” and look for any of the form 4xxB xxxx, A0D-34x, or A1D-34x.

Step 1321-10

Are there any error codes from step “Step 1321-8” of the form 4xxB xxxx, A0D-34x, or A1D-34x?

No Go to “Step 1321-13” on page 174.

Yes Go to “Step 1321-11”.

Step 1321-11

Do any of the error codes from “Step 1321-8” of the form 4xxB xxxx, A0D-34x, or A1D-34x have the same first two characters on the left as the first two characters on the left of the error code recorded in “Step 1321-1” on page 172 that sent you to this MAP?

No Go to “Step 1321-13” on page 174.

Yes Record the error codes from “Step 1321-8” of the form 4xxB xxxx, A0D-34x, or A1D-34x that have the same first two characters on the left as the first two characters on the left of the error code recorded in “Step 1321-1” on page 172 that sent you to this MAP. Also, record the service action event associated with each error code. Go to “Step 1321-12” on page 174.

Step 1321-12

From the list of open service action events with error codes of the form 4xxB xxxx, A0D-34x, or A1D-34x recorded in “Step 1321-11” on page 173, choose the service action event with the earliest time stamp (the one that occurred first), record its error code and FRU location(s), and proceed to “Step 1321-14” with this new code.

When future steps refer to the error code recorded in “Step 1321-1” on page 172, use this new error code and its location code(s) instead of the original error code that sent you to this MAP.

Step 1321-13

From the list of open service action events with FRUs reported, choose the service action event with the earliest time stamp (the one that occurred first), record its error code and FRU location(s), and proceed to “Step 1321-14” with this new error code. When future steps refer to the error code recorded in “Step 1321-1” on page 172, use this new error code and its location code(s) instead of the original error code that sent you to this MAP.

Step 1321-14

At the HMC console, open Service Focal Point (SFP) and examine the service action event log for any closed service action events. For SFP operating instructions, refer to “Service Focal Point” on page 5.

Step 1321-15

Are there any service action events that are closed?

No Go to the table in “Entry MAP” on page 157.

Yes Go to “Step 1321-16”.

Step 1321-16

Examine the details of the ten most-recently closed service action events.

Are there any error codes or symptoms in the ten latest closed service action events that are the same as the error code or symptom recorded in “Step 1321-1” on page 172?

No Go to the table in “Entry MAP” on page 157.

Yes Go to “Step 1321-17”.

Step 1321-17

Examine the FRUs of the same error codes or symptoms. **Are there any FRUs in the same error codes or symptoms of the closed service action events left to be replaced?**

No Go to the table in “Entry MAP” on page 157.

Yes Replace the next FRU of same error codes or symptoms of the closed service action events. Go to “MAP 0410: Repair Checkout” in *RS/6000 and @server pSeries Diagnostic Information for Multiple Bus Systems*.

Step 1321-18

From the list of serviceable events with error code(s) of the form #xxxxxx, examine the details of each serviceable event to display the description field of the error code(s) of the form #xxxxxx.

Step 1321-19

Double click on the description field to view the complete text.

Step 1321-20

Perform any actions that may be listed in the descriptions of all error codes of the form #xxxxxx before proceeding.

Step 1321-21**Did you find a problem?**

No Go to "Step 1321-7" on page 173.

Yes Go to "MAP 0410: Repair Checkout" in *RS/6000 and @server pSeries Diagnostic Information for Multiple Bus Systems*.

MAP 1322: End of Call MAP for Systems with Service Focal Point**Step 1322-1**

For future reference, record the SRC or symptom and the location code of the FRU you replaced.

Step 1322-2

For SFP operating instructions, refer to "Service Focal Point" on page 5. At the HMC console, open Service Focal Point (SFP) and examine the service action event log for any open service action events.

Step 1322-3**Are there any service action events that are open?**

No This completes the repair, return the system to the customer.

Yes Go to "Step 1322-4".

Step 1322-4

Record the list of open service action events.

Step 1322-5

From the list of serviceable events recorded in "Step 1322-4", perform "Step 1322-6" through "Step 1322-33" on page 179 for each open service action event.

Step 1322-6

Determine the error class of the serviceable event. Record for future use.

Step 1322-7

Examine the details of the open service action event.

Is the error code associated with this service action event the same as recorded in "Step 1322-1"?

No Go to "Step 1322-8".

Yes Go to "Step 1322-11".

Step 1322-8

Examine the FRU list of the service action event.

Are there any FRUs listed for the service action event?

No Go to "Step 1321-11" on page 173.

Yes Go to "Step 1321-9" on page 173.

Step 1322-9

Is the FRU list identical (same FRUs, same number of FRUs, and same order of FRUs) to the FRU list of the error code recorded in "Step 1322-1" on page 175?

No Go to "Step 1322-10".

Yes Go to "Step 1322-11".

Step 1322-10

The FRU list is different.

Is the FRU you replaced and recorded in "Step 1322-1" on page 175 in the list of FRUs for this service action event?

No Go to "Step 1322-33" on page 179.

Note: There are service action events that will remain open when you leave this MAP. Further service actions may be required to complete the repair.

Yes Go to "Step 1322-11".

Step 1322-11

Examine the details of this service action event and record the partition(s) involved in this service action event for use in a later step.

Step 1322-12

Is the error code associated with this service action event of the form A11-xxx or A01-xxx?

No Go to "Step 1322-17" on page 177.

Yes Go to "Step 1322-13" on page 177.

Step 1322-13

Have you begun a list of “Axx” partitions from prior service action events that you processed in this map?

No Go to “Step 1322-14”.

Yes Go to “Step 1322-15”.

Step 1322-14

Begin a new list of “Axx” partitions by copying the list of partitions obtained in “Step 1322-11” on page 176. Go to “Step 1322-16”.

Step 1322-15

Add the partition list obtained in “Step 1322-11” on page 176 to the existing list of “Axx” partitions obtained from processing previous service action events in this map.

Step 1322-16

Remove all entries in the list of all partition(s) you recorded in “Step 1322-11” on page 176. If you are referred to the list of partition(s) obtained in “Step 1322-11” on page 176 in future steps, the list is empty. Go to “Step 1322-17”.

Step 1322-17

Select and highlight the service action event from the “Error Associated With This Serviceable Event” window.

Step 1322-18

Select the **Close Event** button.

Step 1322-19

Add comments for the serviceable event. Include any unique additional information. Select the **OK** button.

Step 1322-20

The following steps will add or update FRU information.

Step 1322-21

Did you replace, add, or modify a FRU of the open service action event?

No Go to “Step 1322-23”.

Yes Go to “Step 1322-22”.

Step 1322-22

From the FRU list, select a FRU that you need to update. Double-click on the FRU and update the FRU information. Go to “Step 1322-24”.

Step 1322-23

Select the **No FRU Replaced for this Serviceable Event** option.

Step 1322-24

Select **OK** to close the service action event.

Step 1322-25

Is the list of all partition(s) you recorded in “Step 1322-11” on page 176 empty?

No Go to “Step 1322-26”.

Yes Go to “Step 1322-33” on page 179.

Step 1322-26

Does the list of all partition(s) you recorded in “Step 1322-11” on page 176 contain more than one entry?

No Go to “Step 1322-33” on page 179.

Yes Go to “Step 1322-27”.

Step 1322-27

Is the error class recorded in “Step 1322-6” on page 175 AIX?

No Go to “Step 1322-33” on page 179.

Yes Go to “Step 1322-28”.

Step 1322-28

Perform the following steps for each entry in the list of all partition(s) you recorded in “Step 1322-11” on page 176, except the partition you were using to debug the original problem.

Step 1322-29

From the HMC VTERM window of a partition in the list of all partitions, type `diag` at the AIX command prompt.

Step 1322-30

1. When the diagnostic operating instructions are displayed, press Enter.
2. Select the **Task Selection** option.

Note: If the terminal type is not defined, you are prompted to define it before you can proceed.

3. Select the **Log Repair** option.
4. Select the resource associated with the repair action. If the repair action was reseating a cable or adapter, select the resource associated with that repair action. If the resource associated with your repair action is not displayed on the Resource List, select `sysplanar0`.
5. Press **commit** after you have made your selection.

Step 1322-31

Exit from diagnostics in this partition and return to the AIX prompt.

Step 1322-32

Have all the partitions in the list of all partition(s) you recorded in “Step 1322-11” on page 176 been processed?

No Go to “Step 1322-28” on page 178 to process the next partition in the list you recorded in “Step 1322-11” on page 176.

Yes Go to “Step 1322-33”.

Step 1322-33

Have all the serviceable events recorded in “Step 1322-4” on page 175 been processed?

No Go “Step 1322-5” on page 175 and process the next service action event in the list of serviceable events recorded in list of serviceable events recorded in “Step 1322-4” on page 175.

Yes Go to “Step 1322-34”.

Step 1322-34

While processing all service action events, were you directed to “Step 1322-14” on page 177?

No This completes the repair, return the system to the customer.

Note: If during the processing of the list of open service action events, some service actions events were left open, further service actions may be required to complete the repair.

Yes Go to “Step 1322-35”.

Step 1322-35

Perform the following steps for each entry in the list of “Axx” partitions you began recording in “Step 1322-14” on page 177, except the partition you were using to debug the original problem.

Step 1322-36

From the HMC VTERM window of a partition in the list of “Axx” partitions, type diag at the AIX command prompt.

Step 1322-37

1. When the diagnostic operating instructions are displayed, press Enter.
2. Select the **Task Selection** option.

Note: If the terminal type is not defined, you are prompted to define it before you can proceed.

3. Select the **Log Repair** option.
4. Select the resource associated with the repair action. If the repair action was reseating a cable or adapter, select the resource associated with that repair action. If the resource associated with your repair action is not displayed on the Resource List, select sysplanar0.

5. Press **commit** after you have made your selection.

Step 1322-38

Exit from diagnostics in this partition and return to the AIX prompt.

Step 1322-39

Have all the partitions in the list of “Axx” partitions(s) you began recording in “Step 1322-14” on page 177 been processed?

No Go to “Step 1322-35” on page 179 to process the next partition in the list you recorded in “Step 1322-14” on page 177.

Yes This completes the repair, return the system to the customer.

Note: If during the processing of the list of open service action events, some service actions events were left open, further service actions may be required to complete the repair.

MAP 1420: Recovery Procedures for Hot-Pluggable PCI Adapters

This procedure is used to locate problems that might occur when performing a PCI adapter hot-plug operation.

Find the symptom in the following table; then follow the instructions given in the Action column.

Recovery Procedures for Hot-Pluggable PCI Adapters	
Symptom/Reference Code	Action
Partition will not boot rendering PCI hot-plug manager useless.	Go to "MAP 1421: Partition Will Not Boot Due to Faulty Adapter".
Partition boots, but PCI adapter is not recognized and slot status is empty.	Go to "MAP 1422: Slot is Empty Even When Populated" on page 182.

MAP 1421: Partition Will Not Boot Due to Faulty Adapter

Step 1421-1

The entire system must be shutdown and powered off to repair.

Does the customer wish to restore the partition by isolating the faulty adapter without powering off the entire system?

NO Go to "Step 1421-12" on page 182.

YES Go to "Step 1421-2".

Step 1421-2

At the HMC view the resources assigned to the partition that will not boot.

Step 1421-3

Remove the faulty resource from the partition that will not boot. Record the slot location and the adapter type.

Step 1421-4

Attempt to boot the partition.

Does the partition boot?

NO Go to "Step 1421-12" on page 182.

YES Go to "Step 1421-5".

Step 1421-5

Shutdown the partition.

Step 1421-6

Is the PCI slot power LED of the location recorded in “Step 1421-3” on page 181 on?

NO Go to “Step 1421-7”.

YES Go to “Step 1421-12”.

Step 1421-7

Are there any empty PCI slots attached to the system that are not assigned to any partitions?

NO Go to “Step 1421-12”.

YES Go to “Step 1421-8”.

Step 1421-8

Assign the available empty and unassigned slot to the partition that will not boot.

Step 1421-9

Insert a new adapter of the same type recorded in “Step 1421-3” on page 181 into the slot assigned in “Step 1421-8”.

Step 1421-10

Move any external cabling from the adapter in the slot recorded in “Step 1421-3” on page 181 to the adapter in the slot assigned in “Step 1421-8”.

Step 1421-11

Attempt to boot the partition.

Does the partition boot?

NO Go to “Step 1421-12”.

YES Partition and all resources are operational. Schedule repair for the slot recorded in “Step 1421-3” on page 181 with the customer. Go to “MAP 0410: Repair Checkout” in the *RS/6000 and @server pSeries Diagnostic Information for Multiple Bus Systems*. **This ends the procedure.**

Step 1421-12

Cannot isolate the adapter without powering off the entire system. Schedule repair for the slot recorded in “Step 1421-3” on page 181 with the customer. **This ends the procedure.**

MAP 1422: Slot is Empty Even When Populated

Step 1422-1

Record the I/O drawer and slot location of the slot that is populated with an adapter but shows empty in the PCI hot-plug manager. Also record the adapter type.

Step 1422-2

Is the PCI slot power LED of the location recorded in “Step 1422-1” on page 182 on?

NO Go to “Step 1422-3”.

YES Go to “Step 1422-7”.

Step 1422-3

Disconnect any external cables from the adapter identified in “Step 1422-1” on page 182.

Step 1422-4

Remove the adapter identified in “Step 1422-1” on page 182.

Step 1422-5

Follow the procedure “Installing a Hot-Pluggable PCI Adapter” on page 839 to add a new adapter at the location recorded in “Step 1422-1” on page 182. The new adapter should be the same type as that removed in “Step 1422-1” on page 182. Return to “Step 1422-6” after the new adapter is added.

Step 1422-6

Did the PCI hot-plug procedure successfully add a new adapter at the location recorded in “Step 1422-1” on page 182?

NO Go to “Step 1422-7”.

YES Go to “MAP 0410: Repair Checkout” in the *RS/6000 and @server pSeries Diagnostic Information for Multiple Bus Systems*. **This ends the procedure.**

Step 1422-7

Shutdown the partition that the faulty slot is assigned to.

Step 1422-8

Is the PCI slot power LED of the location recorded in “Step 1422-1” on page 182 on?

NO Go to “Step 1422-9”.

YES Go to “Step 1422-14” on page 184

Step 1422-9

Are there any empty PCI slots attached to the system that are not assigned to any partitions?

NO Go to “Step 1422-14” on page 184.

YES Go to “Step 1422-10”.

Step 1422-10

Assign the available empty and unassigned slot to the partition that the faulty slot is assigned to.

Step 1422-11

Insert a new adapter of the same type recorded in “Step 1422-1” on page 182 into the slot assigned in “Step 1422-10” on page 183.

Step 1422-12

Move any external cabling from the adapter in the slot recorded in “Step 1422-1” on page 182 to the adapter in the slot assigned in “Step 1422-10” on page 183.

Step 1422-13

Attempt to boot the partition.

Does the partition boot?.

NO Go to “Step 1422-14”.

YES Partition and all resources are operational. Schedule repair for the slot recorded in “Step 1422-1” on page 182 with the customer. Go to “MAP 0410: Repair Checkout” in the *RS/6000 and @server pSeries Diagnostic Information for Multiple Bus Systems*. **This ends the procedure.**

Step 1422-14

Cannot repair the adapter without powering off the entire system. Schedule repair for the slot recorded in “Step 1422-1” on page 182 with the customer. **This ends the procedure.**

MAP 1520: Power

This procedure is used to locate power problems in the processor subsystem, I/O subsystem(s) or rack. If a problem is detected, this procedure helps you isolate the problem to a failing unit.

Observe the following safety notices during service procedures.

DANGER

An electrical outlet that is not correctly wired could place hazardous voltage on metal parts of the system or the devices that attach to the system. It is the responsibility of the customer to ensure that the outlet is correctly wired and grounded to prevent an electrical shock.

Use one hand, when possible, to connect or disconnect signal cables to prevent a possible shock from touching two surfaces with different electrical potentials.

During an electrical storm, do not connect cables for display stations, printers, telephones, or station protectors for communications lines.

CAUTION:

This product is equipped with a three-wire power cable and plug for the user's safety. Use this power cable with a properly grounded electrical outlet to avoid electrical shock.

CAUTION:

Energy hazard, remove power before servicing.

Find the symptom in the following table; then follow the instructions given in the Action column.

Power Problems	
Symptom/Reference Code	Action
The system will not power on and no error codes are available	Go to "Map 152l: The System Will Not Power On And No Error Codes Are Available" on page 189.
1011 8700, 1011 8701	Go to "Map 152a: Loss of ac Power or Phase Missing" on page 204.
1014 6014, 1014 6814, 1014 B014, 1014 B914, 1015 6014, 1015 6814, 1015 B014, 1015 B914, 1016 6014, 1016 6814, 1016 B014, 1016 B914, 1017 6014, 1017 6814, 1017 B014, 1017 B914, 1021 6014, 1021 6814, 1021 B014, 1021 B914, 1022 6014, 1022 6814, 1022 B014, 1022 B914, 1023 6014, 1023 6814, 1023 B014, 1023 B914, 1024 6014, 1024 6814, 1024 B014, 1024 B914, 1025 6014, 1025 6814, 1025 B014, 1025 B914	Go to "Map 152h: 3.3V Current/Voltage Problem in I/O Subsystem" on page 253.
1014 6024, 1014 6824, 1014 B024, 1014 B924, 1015 6024, 1015 6824, 1015 B024, 1015 B924, 1016 6024, 1016 6824, 1016 B024, 1016 B924, 1017 6024, 1017 6824, 1017 B024, 1017 B924, 1021 6024, 1021 6824, 1021 B024, 1021 B924, 1022 6024, 1022 6824, 1022 B024, 1022 B924, 1023 6024, 1023 6824, 1023 B024, 1023 B924, 1024 6024, 1024 6824, 1024 B024, 1024 B924, 1025 6024, 1025 6824, 1025 B024, 1025 B924	Go to "Map 152i: 5.0 V Current/Voltage Problem in I/O Subsystem" on page 261.
1014 6034, 1014 6834, 1014 B034, 1014 B934, 1015 6034, 1015 6834, 1015 B034, 1015 B934, 1016 6034, 1016 6834, 1016 B034, 1016 B934, 1017 6034, 1017 6834, 1017 B034, 1017 B934, 1021 6034, 1021 6834, 1021 B034, 1021 B934, 1022 6034, 1022 6834, 1022 B034, 1022 B934, 1023 6034, 1023 6834, 1023 B034, 1023 B934, 1024 6034, 1024 6834, 1024 B034, 1024 B934, 1025 6034, 1025 6834, 1025 B034, 1025 B934	Go to "Map 152j: 2.5 V Current/Voltage Problem in I/O Subsystem" on page 270.
1014 6044, 1014 6844, 1014 B044, 1014 B944, 1015 6044, 1015 6844, 1015 B044, 1015 B944, 1016 6044, 1016 6844, 1016 B044, 1016 B944, 1017 6044, 1017 6844, 1017 B044, 1017 B944, 1021 6044, 1021 6844, 1021 B044, 1021 B944, 1022 6044, 1022 6844, 1022 B044, 1022 B944, 1023 6044, 1023 6844, 1023 B044, 1023 B944, 1024 6044, 1024 6844, 1024 B044, 1024 B944, 1025 6044, 1025 6844, 1025 B044, 1025 B944	Go to "Map 152k: 12.0 V Current/Voltage Problem in I/O Subsystem" on page 278.

Power Problems	
Symptom/Reference Code	Action
1014 6054, 1014 6854, 1014 B054, 1014 B954, 1015 6054, 1015 6854, 1015 B054, 1015 B954, 1016 6054, 1016 6854, 1016 B054, 1016 B954, 1017 6054, 1017 6854, 1017 B054, 1017 B954, 1021 6054, 1021 6854, 1021 B054, 1021 B954, 1022 6054, 1022 6854, 1022 B054, 1022 B954, 1023 6054, 1023 6854, 1023 B054, 1023 B954, 1024 6054, 1024 6854, 1024 B054, 1024 B954, 1025 6054, 1025 6854, 1025 B054, 1025 B954	Go to "Map 152l: -12.0V Current/Voltage Problem in I/O Subsystem" on page 287.
1014 CD96, 1014 CDA6, 1014 CDB6, 1014 CDC6, 1015 CD96, 1015 CDA6, 1015 CDB6, 1015 CDC6, 1016 CD96, 1016 CDA6, 1016 CDB6, 1016 CDC6, 1017 CD96, 1017 CDA6, 1017 CDB6, 1017 CDC6, 1021 CD96, 1021 CDA6, 1021 CDB6, 1021 CDC6, 1022 CD96, 1022 CDA6, 1022 CDB6, 1022 CDC6, 1023 CD96, 1023 CDA6, 1023 CDB6, 1023 CDC6, 1024 CD96, 1024 CDA6, 1024 CDB6, 1024 CDC6, 1025 CD96, 1025 CDA6, 1025 CDB6, 1025 CDC6	Go to "Map 152n: DASD Subsystem Power Problem" on page 299.
101A FE16 for BPC A or 101B FE16 for BPC B	Go to "Map 1522: UEPO Switch On The BPC Is In The Bypass Position" on page 192
101A 0856 or 101A FE56 for BPR 1A 101A 0866 or 101A FE66 for BPR 2A 101A 0876 or 101A FE76 for BPR 3A 101B 0856 or 101B FE56 for BPR 1B 101B 0866 or 101B FE66 for BPR 2B 101B 0876 or 101B FE76 for BPR 3B	Go to "Map 1523: There Is a Bulk Power Regulator (BPR) Communications Fault" on page 193.
101A FDB6 for BPI A or 101B FDB6 for BPI B	Go to "Map 1524: An Open Room EPO Switch Has Been Detected From One Side" on page 193.
101A 0D06 for BPA A or 101B 0D06 for BPA B	Go to "Map 1525: There Is a 350 Volt Bulk Failure" on page 195.
101A 7A86 or 101A 7B86 for IBF 1A 101A 7A96 or 101A 7B96 for IBF 2A 101A 7AA6 or 101A 7BA6 for IBF 3A 101B 7A86 or 101B 7B86 for IBF 1B 101B 7A96 or 101B 7B96 for IBF 2B 101B 7AA6 or 101B 7BA6 for IBF 3B	Go to "Map 1526: There Is An Integrated Battery Feature (IBF) Failure" on page 197.
101A 1C06, 101B 1C06, 101C 1C06, 1014 1C06, 1015 1C06, 1016 1C06, 1017 1C06, 1021 1C06, 1022 1C06, 1023 1C06	Go to "Map 1527: An Airflow Loss Has Been Detected" on page 200.
101C E006 or 101C E106	Go to "Map 1528: There Is A Processor (Critical/Warning) Overtemperature Fault" on page 202.
101A D216 for BPA A or 101B D216 for BPA B	Go to "Map 1529: There Is A Bulk Power Assembly (BPA) Communication Failure" on page 202.
101A F806 or 101A F906 for BPC A or 101B F806 or 101B F906 for BPC B	Go to "Map 152a: Loss of ac Power or Phase Missing" on page 204.

Power Problems

Symptom/Reference Code	Action
101A x115, 101A x125, 101A x135, 101A x215 101A x225, 101A x235, 101A x315, 101A x325, 101A x335, 101A x415, 101A x425, 101A x435, 101A x515, 101A x525, 101A x535, 101A x615, 101A x625, 101A x635, 101A x715, 101A x725, 101A x735, 101A x825, 101A x835, 101A x925, 101A x935, 101A xA25, 101A xA35 101B x115, 101B x125, 101B x135, 101B x215 101B x225, 101B x235, 101B x315, 101B x325, 101B x335, 101B x415, 101B x425, 101B x435, 101B x515, 101B x525, 101B x535, 101B x615, 101B x625, 101B x635, 101B x715, 101B x725, 101B x735, 101B x825, 101B x835, 101B x925, 101B x935, 101B xA25, 101B xA35	Go to "Map 152m: Cable Problem in Power Subsystem" on page 295.
101C 6014, 101C 6814, 101C B014, 101C B814	Go to "Map 152b: 2.5 V Current/Voltage Problem in Processor Subsystem" on page 206.
101C 6114, 101C 6914, 101C B114, 101C B914	Go to "Map 152c: 1.8 V Current/Voltage Problem in Processor Subsystem" on page 212.
101C 6124, 101C 6924, 101C B124, 101C B924	Go to "Map 152e: 1.5 V CPU Current/Voltage Problem in Processor Subsystem" on page 231.
101C 6134, 101C 6934, 101C B134, 101C B934	Go to "Map 152d: 1.5 V Auxiliary Current/Voltage Problem in Processor Subsystem" on page 223.
101C 6144, 101C 6944, 101C B144, 101C B944	Go to "Map 152f: 3.3 V Current/Voltage Problem in Processor Subsystem" on page 237.
101C 6514, 101C 6D14, 101C B514, 101C BD14	Go to "Map 152g: 5.0 V Current/Voltage Problem in Processor Subsystem" on page 246.

Map 1521: The System Will Not Power On And No Error Codes Are Available

Step 1521-1

Ensure that the following are true:

- Both power cords are properly connected
- The UEPO panel switch is in the ON position
- The UEPO BYPASS switches on both BPCs are in the Normal position
- The on/off switches located on all the BPRs are in the on (left) position

Note: A switch set to the off position cannot cause this problem, however, any switch found in the off position must be reset to the on position (wait 10 seconds) before proceeding.

- The cable from UEPO connector J00 to BPC-A connector J05 and the cable from UEPO connector J01 to BPC-B connector J05 are properly connected without visible sign of damage.
- The room temperature is *not* in excess of the maximum allowed (40 degrees Celsius or 104 degrees Fahrenheit)

Note: If the room temperature exceeds the specified maximum, the machine may continually cycle on and off.

Are all the above conditions true?

NO Correct any problems and go to "MAP 0410: Repair Checkout" in the *RS/6000 and @server pSeries Diagnostic Information for Multiple Bus Systems*.

YES Go to "Step 1521-2".

Step 1521-2

Check the LEDs on both sides of the bulk power assembly (BPA).

Are all LEDs off on *both* sides of BPA?

NO Go to "Step 1521-3".

YES Go to "Step 1521-9" on page 191

Step 1521-3

Check the following LED states on *both* Bulk Power Controllers (BPCs):

- UEPO PWR LED turned on
- BPC GOOD LED turned on
- All other LEDs are off

Are all of the above true?

NO Go to "Step 1521-4" on page 190.

YES Go to "Step 1521-5" on page 190.

Step 1521-4

Independent faults are indicated on both sides of the BPA. Each side must be isolated separately. Call for support. **This ends the procedure.**

Step 1521-5

Check the External (Room) EPO Connection if used.

If a room emergency power off (EPO) circuit is used, the external room EPO circuit is connected to the J02 connector on the lower edge of the UEPO Switch.

Is a cable connected into the connector J02 on the UEPO Switch?

NO Go to “Step 1521-6”.

YES Go to “Step 1521-7”.

Step 1521-6

Is the internal toggle switch on the EPO panel card set to the 'RM EPO BYPASS' position?

NO Set the internal toggle switch to the 'RM EPO BYPASS' position, and go to “MAP 0410: Repair Checkout” in the *RS/6000 and @server pSeries Diagnostic Information for Multiple Bus Systems*.

YES Exchange the UEPO card assembly. Follow all the steps in the removal and replacement procedure for the “Unit Emergency Power Off (UEPO) Card Assembly” on page 782. Go to “Step 1521-8” on page 191.

Step 1521-7

Note: Read the Danger and Caution notices under “Safety Notices” on page xi before continuing with this procedure.

Disconnect the cable from UEPO connector J02, and set the toggle switch to the 'RM EPO BYPASS' position.

Does the UEPO CMPLT LED on at least one BPC become lit?

NO Exchange the UEPO card assembly. Follow all the steps in the removal and replacement procedure for the “Unit Emergency Power Off (UEPO) Card Assembly” on page 782. Go to “Step 1521-8” on page 191.

YES Notify the customer that the room EPO circuit is defective at this connection and requires service. **This ends the procedure.**

Step 1521-8

Is the error code that sent you to this MAP still reported?

NO The problem has been corrected. Go to "MAP 0410: Repair Checkout" in the *RS/6000 and @server pSeries Diagnostic Information for Multiple Bus Systems*.

YES Call for support. **This ends the procedure.**

Step 1521-9

Note: Read the Danger and Caution notices under "Safety Notices" on page xi before continuing with this procedure.

1. Prepare a multimeter to measure up to 600 V ac.
2. Use the multimeter to measure the ac voltage at the test points on the frame labeled Phase A and Phase B.

Is the ac voltage greater than 180 V ac?

NO Inform the customer that the line voltage into the BPA is missing or too low. **This ends the procedure.**

YES Independent faults are indicated on both sides of the BPA. Each side must be isolated separately. Call for support. **This ends the procedure.**

Map 1522: UEPO Switch On The BPC Is In The Bypass Position

Step 1522-1

Check the UEPO Switch on the BPC on the BPA that is exhibiting the failure.

Is the switch in the NORMAL position?

NO Set UEPO switch on the BPC to the NORMAL position and go to "Step 1522-2".

YES Go to "Step 1522-2".

Step 1522-2

Press the **Service Complete** button.

Is error code 101A FE16 or 101B FE16 displayed?

NO The problem has already been corrected. Go to "MAP 0410: Repair Checkout" in the *RS/6000 and @server pSeries Diagnostic Information for Multiple Bus Systems*.

YES Replace the BPC on the side that is exhibiting the failure. Follow all the steps in the "Bulk Power Controller (BPC)" on page 777. Go to "Step 1522-3".

Step 1522-3

If not done already, press the **service complete** button.

Is error code 101A FE16 or 101B FE16 displayed?

NO The problem has been corrected. Go to "MAP 0410: Repair Checkout" in the *RS/6000 and @server pSeries Diagnostic Information for Multiple Bus Systems*. **This ends the procedure.**

YES Call for support. **This ends the procedure.**

Map 1523: There Is a Bulk Power Regulator (BPR) Communications Fault

Step 1523-1

Check the position of the on/off switch on the BPR referenced by the error code that sent you to this MAP.

Is the switch in the ON position (to the left)?

NO Set the switch to the ON position (to the left), and go to "MAP 0410: Repair Checkout" in the *RS/6000 and @server pSeries Diagnostic Information for Multiple Bus Systems*.

YES Go to "Step 1523-2".

Step 1523-2

Exchange the following FRUs one at a time:

- BPR referenced by the error code that sent you to this MAP. Follow all steps in the removal and replacement procedures for "Bulk Power Regulator (BPR)" on page 776.
- BPC on the side referenced by the error code that sent you to this MAP. Follow all steps in the removal and replacement procedures for "Bulk Power Controller (BPC)" on page 777.
- BPE on the side referenced by the error code that sent you to this MAP. Follow all steps in the removal and replacement procedures for "Bulk Power Enclosure (BPE)" on page 780.

After each FRU exchanged, is the error code that sent you to this MAP still reported?

NO Go to "MAP 0410: Repair Checkout" in the *RS/6000 and @server pSeries Diagnostic Information for Multiple Bus Systems*. **This ends the procedure.**

YES Replace the next FRU on the list.

Map 1524: An Open Room EPO Switch Has Been Detected From One Side

Step 1524-1

Check the unit emergency power off (UEPO) panel.

Is a customer room EPO cable plugged into the UEPO panel?

NO Go to "Step 1524-3" on page 194.

YES Go to "Step 1524-2" on page 194.

Step 1524-2

1. Set UEPO switch on both BPCs to the BYPASS position.
2. Unplug the customer room EPO cable.
3. Set switch (J4) on the UEPO panel to EPO BYPASS position.
4. Set UEPO switch on both BPCs back to the NORMAL position.
5. Press the **service complete** button.

Is 101A FDB6 or 101B FDB6 generated?

NO Go to "Step 1524-4".

YES Go to "Step 1524-3".

Step 1524-3

Exchange the following FRUs one at a time:

1. UEPO card assembly. Follow all steps in the removal and replacement procedures for "Unit Emergency Power Off (UEPO) Card Assembly" on page 782.
2. Cable from UEPO to BPC on the side referenced by the error code that sent you to this MAP.
3. BPC on the side referenced by the error code that sent you to this MAP. Follow all steps in the removal and replacement procedures for "Bulk Power Controller (BPC)" on page 777.

After each FRU exchanged, is the error code that sent you to this MAP still reported?

NO The problem has been corrected. Go to "MAP 0410: Repair Checkout" in the *RS/6000 and @server pSeries Diagnostic Information for Multiple Bus Systems*.

YES Replace the next FRU on the list. If all FRUs on the list have been replaced, call for support.

Step 1524-4

Perform the following actions one at a time:

1. Replace the UEPO card assembly. Follow all steps in the removal and replacement procedures for "Unit Emergency Power Off (UEPO) Card Assembly" on page 782.
2. Check with the customer's site services to have them test the room EPO switch for correct operation.

After each action is performed, is the error code that sent you to this MAP still reported?

NO The problem has been corrected. Go to "MAP 0410: Repair Checkout" in the *RS/6000 and @server pSeries Diagnostic Information for Multiple Bus Systems*.

YES Perform the next action on the list. If all actions on the list have been performed, call for support.

Map 1525: There Is a 350 Volt Bulk Failure

Step 1525-1

Notes:

1. This problem can be caused by any BPD plugged into the failing BPA.
2. The system can have one or two BPDs, depending on the system configuration.
3. Each BPD on the failing BPA must be checked independently.

The following steps check all the BPDs on the side of the BPA (A or B) referenced by the error code that sent you to this MAP.

Are there any remaining BPDs to be checked?

NO Go to "Step 1525-2".

YES Go to "Step 1525-4" on page 196.

Step 1525-2

Notes:

1. This problem can be caused by any BPR plugged into the failing BPA.
2. The system can have up to three BPRs, depending on the system configuration.
3. Each BPR on the failing BPA must be checked independently.

The following steps check all the BPRs on the side of the BPA (A or B) referenced by the error code that sent you to this MAP.

Are there any BPRs remaining to be checked?

NO

Exchange the following FRUs one at a time:

- BPC on the side referenced by the error code that sent you to this MAP. Follow all steps in the removal and replacement procedures for "Bulk Power Controller (BPC)" on page 777.
- Replace the BPE on the side referenced by the error code that sent you to this MAP. Follow all steps in the removal and replacement procedures for "Bulk Power Enclosure (BPE)" on page 780.

After each FRU is exchanged, is the error code that sent you to this MAP still reported?

NO The problem has been corrected. Go to "MAP 0410: Repair Checkout" in the *RS/6000 and @server pSeries Diagnostic Information for Multiple Bus Systems*.

YES Replace the next FRU on the list. If all FRUs on the list have been replaced, call for support.

YES Go to "Step 1525-3" on page 196.

Step 1525-3

Note: Be sure you are working on the side of the BPA (A or B) referenced by the error code that sent you to this MAP. FRUs on the operating side of the BPA (with BPC GOOD LED on) *must not* be disturbed during this procedure.

1. Turn the BPR on/off switch to the off position (to the right).
2. Unplug the BPR to be checked and carefully pull it approximately 25 mm (1 inch) away from the backplane without unplugging any cables.

If there is more than one BPR left to be checked, start with the uppermost unchecked BPR and make a note of which BPR you unplugged.

Does the BPC GOOD LED on the BPC come on and stay on?

- NO** Replug the BPR and set all the BPR on/off switches on this BPA to the on position (to the left), and continue with “Step 1525-2” on page 195.
- YES** Replace the BPR that is currently unplugged. Follow all steps in the removal and replacement procedures for “Bulk Power Regulator (BPR)” on page 776. Go to “Step 1525-5”.

Step 1525-4

Note: Be sure you are working on the side of the BPA (A or B) referenced by the error code that sent you to this MAP. FRUs on the operating side of the BPA (with BPC GOOD LED on) *must not* be disturbed during this procedure.

1. Turn all the BPR on/off switches on this BPA to the off position (to the right).
2. Unplug the BPD to be checked and carefully pull it approximately 25 mm (1 inch) away from the backplane without unplugging any cables.

If there is more than one BPD left to be checked, start with the uppermost unchecked BPD and make a note of which BPD you unplugged.

3. Set all the BPR on/off switches on this BPA to the on position (to the left).

Does the BPC GOOD LED on the BPC come on and stay on?

- NO** Replug the BPD and continue with “Step 1525-1” on page 195.
- YES** Replace the BPD that is currently unplugged. Follow all steps in the removal and replacement procedures for “Bulk Power Distributor (BPD)” on page 778. Go to “Step 1525-5”.

Step 1525-5

Is the error code that sent you to this MAP still reported?

- NO** The problem has been corrected. Go to “MAP 0410: Repair Checkout” in the *RS/6000 and @server pSeries Diagnostic Information for Multiple Bus Systems*.
- YES** Call for support.

Map 1526: There Is An Integrated Battery Feature (IBF) Failure

Step 1526-1

Is the IBF feature installed?

- NO** Replace the BPR that is connected to the IBF referenced in the error code that brought you to this MAP. Follow all steps in the removal and replacement procedures in “Bulk Power Regulator (BPR)” on page 776. Go to “Step 1526-7” on page 200.
- YES** Go to “Step 1526-2”.

Step 1526-2

Did any of the following error codes send you to this MAP?

- 101A 7A86
- 101A 7A96
- 101A 7AA6
- 101B 7A86
- 101B 7A96
- 101B 7AA6

- NO** Go to “Step 1526-3”.
- YES** Go to “Step 1526-5” on page 199.

Step 1526-3

Check the cable between the BPR and the IBF. The IBF LED on the IBF referenced in the error code that brought you to this MAP will be off.

Is the cable plugged on both sides?

- NO** Plug in the cable and go to “MAP 0410: Repair Checkout” in the *RS/6000 and @server pSeries Diagnostic Information for Multiple Bus Systems*.
- YES** Go to “Step 1526-4” on page 198.

Step 1526-4

Check the circuit breaker on the IBF referenced in the error code that brought you to this MAP. The IBF LED on the IBF referenced in the error code that brought you to this MAP will be off.

Is the circuit breaker set on?

NO Replace the IBF referenced in the error code that brought you to this MAP. Follow all steps in the removal and replacement procedures in “Integrated Battery Feature (IBF)” on page 783. Go to “Step 1526-7” on page 200.

YES

Exchange the following FRUs one at a time:

- The BPR that is connected to the IBF referenced in the error code that brought you to this MAP. Follow all steps in the removal and replacement procedures for “Bulk Power Regulator (BPR)” on page 776.
- The IBF that is referenced in the error code that brought you to this MAP. Follow all steps in the removal and replacement procedures for “Integrated Battery Feature (IBF)” on page 783.
- The cable between the BPR and the IBF referenced in the error code that brought you to this MAP.

After each FRU is exchanged, is the error code that sent you to this MAP still reported?

NO The problem has been corrected. Go to “MAP 0410: Repair Checkout” in the *RS/6000 and @server pSeries Diagnostic Information for Multiple Bus Systems*

YES Replace the next FRU on the list. If all FRUs in the list have been replaced, call for support.

Step 1526-5

Check the circuit breaker on the IBF referenced in the error code that brought you to this MAP. The IBF LED on the IBF referenced in the error code that brought you to this MAP will be off.

Is the circuit breaker set on?

NO Go to “Step 1526-6”

YES Replace the IBF referenced in the error code that brought you to this MAP. Follow all steps in the removal and replacement procedures in “Integrated Battery Feature (IBF)” on page 783. Go to “Step 1526-7” on page 200.

Step 1526-6

Set the breaker to the on (down) position. Wait 10 seconds after the LED on the IBF referenced in the error code that brought you to this MAP comes on.

Does the circuit breaker remain on?

NO

Exchange the following FRUs one at a time:

- The BPR that is connected to the IBF referenced in the error code that brought you to this MAP. Follow all steps in the removal and replacement procedures for “Bulk Power Regulator (BPR)” on page 776.
- The IBF that is referenced in the error code that brought you to this MAP. Follow all steps in the removal and replacement procedures for “Integrated Battery Feature (IBF)” on page 783.
- The cable between the BPR and the IBF referenced in the error code that brought you to this MAP.

After each FRU is exchanged, is the error code that sent you to this MAP still reported?

NO The problem has been corrected. Go to “MAP 0410: Repair Checkout” in the *RS/6000 and @server pSeries Diagnostic Information for Multiple Bus Systems*.

YES Replace the next FRU on the list. If all FRUs in the list have been replaced, call for support.

YES Go to “MAP 0410: Repair Checkout” in the *RS/6000 and @server pSeries Diagnostic Information for Multiple Bus Systems*.

Step 1526-7

Is the error code that sent you to this MAP still reported?

- NO** The problem has been corrected. Go to "MAP 0410: Repair Checkout" in the *RS/6000 and @server pSeries Diagnostic Information for Multiple Bus Systems*.
- YES** Call for support.

Map 1527: An Airflow Loss Has Been Detected

Step 1527-1

Check the following air inlets and outlets for blockage or obstruction:

- Front and rear frame door openings (except for acoustical foam)
- Bulk power assembly (BPA) cage
 - Inlet opening in left side of front BPA, BPA A
 - Outlet opening in right side of rear BPA, BPB B
 - Bulk power fan (BPF) cover is present on front BPA and absent on rear BPA
- Processor subsystem cage
 - Inlet opening at top front of processor subassembly
 - Outlet opening at top rear of processor subassembly
- I/O subsystem
 - Inlet opening at front of the I/O subassembly
 - Outlet opening at rear of I/O subassembly

Are all of these openings clear and unobstructed?

- NO** Remove any obstructions and go to "MAP 0410: Repair Checkout" in the *RS/6000 and @server pSeries Diagnostic Information for Multiple Bus Systems*.
- YES** Go to "Step 1527-2".

Step 1527-2

Do all book positions in the processor subsystem contain books or fillers?

- NO** Fill any open positions with books or fillers, and go to "MAP 0410: Repair Checkout" in the *RS/6000 and @server pSeries Diagnostic Information for Multiple Bus Systems*.
- YES** Go to "Step 1527-3" on page 201.

Step 1527-3

Are the air filters clean and free of any obstructions?

NO Clean and replace the air filters, then go to "MAP 0410: Repair Checkout" in the *RS/6000 and @server pSeries Diagnostic Information for Multiple Bus Systems*.

YES Go to "Step 1527-4".

Step 1527-4

Remove the blowers or fans from the affected subsystem.

Attention: Do not put your hand into the enclosure.

Push the spring-loaded door open and hold it open with one hand. Using a suitably long instrument (a 12-inch ruler or long-handled screwdriver), push gently against the recirculation flaps at the back of each blower or fan enclosure.

Are all the recirculation flaps in all enclosures free to swing up?

NO The enclosure is not a replaceable FRU. Call your next level of support.

YES Reinstall the blower or fans and go to "MAP 0410: Repair Checkout" in the *RS/6000 and @server pSeries Diagnostic Information for Multiple Bus Systems*.

Map 1528: There Is A Processor (Critical/Warning) Overtemperature Fault

Step 1528-1

Is the room ambient temperature in normal range (less than 35 deg C/ 95 deg F)?

- NO** Notify the customer. The customer must bring the room temperature within normal range. Go to "MAP 0410: Repair Checkout" in the *RS/6000 and @server pSeries Diagnostic Information for Multiple Bus Systems*.
- YES** Go to "Step 1528-2".

Step 1528-2

Are the system front and rear doors free of obstructions?

- NO** Notify the customer. The system must be free of obstructions for proper airflow. Go to "MAP 0410: Repair Checkout" in the *RS/6000 and @server pSeries Diagnostic Information for Multiple Bus Systems*.
- YES**

Exchange the following FRUs one at a time:

1. The processor MCM module 0, at location U1.18-P1-C1. Follow all steps in the removal and replacement procedures for "MCM Module (Processor) and Passthru Modules" on page 794.
2. The processor MCM module 3, at location U1.18-P1-C2, if present. Follow all steps in the removal and replacement procedures for "MCM Module (Processor) and Passthru Modules" on page 794.
3. The processor MCM module 1, at location U1.18-P1-C3. Follow all steps in the removal and replacement procedures for "MCM Module (Processor) and Passthru Modules" on page 794.
4. The processor MCM module 2, at location U1.18-P1-C4. Follow all steps in the removal and replacement procedures for "MCM Module (Processor) and Passthru Modules" on page 794.

After each FRU is exchanged, is the error code that sent you to this MAP still reported?

- NO** The problem has been corrected. Go to "MAP 0410: Repair Checkout" in the *RS/6000 and @server pSeries Diagnostic Information for Multiple Bus Systems*.
- YES** Replace the next FRU on the list. If all FRUs on the list have been replaced, call for support.

Map 1529: There Is A Bulk Power Assembly (BPA) Communication Failure

Step 1529-1

Check the position of the on/off switch on the BPRs.

Is the switch in the ON position (to the left)?

NO Set the switch to the ON position (to the left), and go to "MAP 0410: Repair Checkout" in the *RS/6000 and @server pSeries Diagnostic Information for Multiple Bus Systems*.

YES Go to "Step 1529-2".

Step 1529-2

Note: Read the Danger and Caution notices under "Safety Notices" on page xi before continuing with this procedure.

1. Prepare a multimeter to measure up to 600 V ac.
2. Use the multimeter to measure the ac voltage at the following test points on the face plate of the BPA that is not referenced by the error code that sent you to this MAP:
 - Phase A and phase B
 - Phase B and phase C
 - Phase C and phase A

Are all the readings greater than 180 V ac?

NO Go to "Step 1529-3" on page 204.

YES

Exchange the following FRUs one at a time:

1. BPR 1, that is connected to the IBF not referenced in the error code that brought you to this MAP. Follow all steps in the removal and replacement procedures for "Bulk Power Regulator (BPR)" on page 776.
2. BPR 2, that is connected to the IBF not referenced in the error code that brought you to this MAP. Follow all steps in the removal and replacement procedures for "Bulk Power Regulator (BPR)" on page 776.
3. BPR 3, that is connected to the IBF not referenced in the error code that brought you to this MAP. Follow all steps in the removal and replacement procedures for "Bulk Power Regulator (BPR)" on page 776.
4. BPC on the other side not referenced by the error code that sent you to this MAP. Follow all steps in the removal and replacement procedures for "Bulk Power Controller (BPC)" on page 777.
5. BPE on the other side not referenced by the error code that sent you to this MAP. Follow all steps in the removal and replacement procedures for "Bulk Power Enclosure (BPE)" on page 780.

After each FRU is exchanged, is the error code that sent you to this MAP still reported?

NO The problem has been corrected. Go to "MAP 0410: Repair Checkout" in the *RS/6000 and @server pSeries Diagnostic Information for Multiple Bus Systems*.

YES Replace the next FRU on the list. If all FRUs on the list have been replaced, call for support.

Step 1529-3

Inform the customer that the line voltage into the BPA is missing or too low, and needs to be checked.

Can the line voltage be checked now?

- NO** Defer this repair until the customer's utility can check the line voltage. **This ends the procedure.**
- YES** Go to "Step 1529-4".

Step 1529-4

Does the customer utility voltage checkout OK?

- NO** The customer must restore utility voltage. **This ends the procedure.**
- YES** Exchange the power cord, and go to "Step 1529-5".

Step 1529-5

Press the **service complete** button.

Is error code that sent you to this MAP still reported?

- NO** The problem has been corrected. Go to "MAP 0410: Repair Checkout" in the *RS/6000 and @server pSeries Diagnostic Information for Multiple Bus Systems*. **This ends the procedure.**
- YES**
- Call for support. **This ends the procedure.**

Map 152a: Loss of ac Power or Phase Missing

Step 152a-1

Press the Service complete button.

Is the error code that sent you to this MAP still reported?

- NO** This was a transient condition. The condition no longer exists. No service action is required.
- YES** Go to "Step 152a-2".

Step 152a-2

Check all LEDs on the BPA that is not referenced by the error code that sent you to this MAP.

Are they OK?

- NO** Defer this repair until the failure on the other BPA can be repaired. **This ends the procedure.**
- YES** Go to "Step 152a-3" on page 205.

Step 152a-3

Note: Read the Danger and Caution notices under “Safety Notices” on page xi before continuing with this procedure.

1. Prepare a multimeter to measure up to 600 V ac.
2. Use the multimeter to measure the ac voltage at the following test points on the faceplate of the BPA that is referenced by the error code that sent you to this MAP:
 - Phase A and phase B
 - Phase B and phase C
 - Phase C and phase A

Are all the readings greater than 180 V ac?

NO Go to “Step 152a-4” on page 206.

YES

Exchange the following FRUs one at a time:

1. BPR 1, that is connected to the BPA side referenced in the error code that brought you to this MAP. Follow all steps in the removal and replacement procedures for “Bulk Power Regulator (BPR)” on page 776.
2. BPR 2, that is connected to the BPA side referenced in the error code that brought you to this MAP. Follow all steps in the removal and replacement procedures for “Bulk Power Regulator (BPR)” on page 776.
3. BPR 3, that is connected to the BPA side referenced in the error code that brought you to this MAP. Follow all steps in the removal and replacement procedures for “Bulk Power Regulator (BPR)” on page 776.
4. BPC on the side referenced by the error code that sent you to this MAP. Follow all steps in the removal and replacement procedures for “Bulk Power Controller (BPC)” on page 777.
5. BPE on the side referenced by the error code that sent you to this MAP. Follow all steps in the removal and replacement procedures for “Bulk Power Enclosure (BPE)” on page 780.

After each FRU is exchanged, is the error code that sent you to this MAP still reported?

NO The problem has been corrected. Go to “MAP 0410: Repair Checkout” in the *RS/6000 and @server pSeries Diagnostic Information for Multiple Bus Systems*.

YES Replace the next FRU on the list. If all FRUs on the list have been replaced, call for support.

Step 152a-4

Inform the customer that the line voltage into the BPA is missing or too low, and must be checked.

Can the line voltage be checked now?

- NO** Defer this repair until the customer's utility can check the line voltage. **This ends the procedure.**
- YES** Go to "Step 152a-5".

Step 152a-5

Does the customer utility voltage checkout OK?

- NO** The customer must restore utility voltage. **This ends the procedure.**
- YES** Exchange the power cord, and go to "Step 152a-6".

Step 152a-6

Press the service complete button.

Is error code that sent you to this MAP still reported?

- NO** The problem has been corrected. Go to "MAP 0410: Repair Checkout" in the *RS/6000 and @server pSeries Diagnostic Information for Multiple Bus Systems*. **This ends the procedure.**
- YES**
- Call for support. **This ends the procedure.**

Map 152b: 2.5 V Current/Voltage Problem in Processor Subsystem

Step 152b-1

Record the error code and location code(s) that sent you to this MAP.

Step 152b-2

Turn off the power.

Examine the amber logic-power LEDs of all installed processor subsystem DCAs.

Step 152b-3

Are all amber logic-power LEDs of all installed processor subsystem DCAs off?

- Yes** Go to "Step 152b-4" on page 207.
- No** Call for support.

Step 152b-4

Pull out the following books about 25 mm (1 inch), if present:

- Memory book 0, at location U1.18-P1-M2
- Memory book 1, at location U1.18-P1-M3
- Memory book 2, at location U1.18-P1-M7
- Memory book 3, at location U1.18-P1-M6

Step 152b-5

Turn on the power.

Step 152b-6

Did the system stop with the same error code as recorded in “Step 152b-1” on page 206?

Yes Go to “Step 152b-12” on page 208.

No Go to “Step 152b-7”.

Step 152b-7

One of the books just removed is defective.

1. Turn off the power.
2. Make sure all amber logic-power LEDs of all installed processor subsystem DCAs are off.

Step 152b-8

Reinsert one of the books that is pulled out and listed in step 152b-4.

Step 152b-9

Turn on the power.

Step 152b-10

Did the system stop with the same error code as recorded in “Step 152b-1” on page 206?

Yes The book just reinserted is defective. Replace it. **This ends the procedure.**

Return the system to its original configuration.

Go to “MAP 0410: Repair Checkout” in the *RS/6000 and @server pSeries Diagnostic Information for Multiple Bus Systems*.

No Go to “Step 152b-11”.

Step 152b-11

Have all the books listed in step 152b-4 been reinserted?

Yes The symptom has changed. **This ends the procedure.**

Return the system to its original configuration.

Go to “MAP 0410: Repair Checkout” in the *RS/6000 and @server pSeries Diagnostic Information for Multiple Bus Systems*.

No Go to “Step 152b-8”.

Step 152b-12

Turn off the power.

Examine the amber logic-power LEDs of all installed processor subsystem DCAs.

Step 152b-13

Are all amber logic-power LEDs of all installed processor subsystem DCAs off?

Yes Go to “Step 152b-14”.

No Call for support.

Step 152b-14

Pull out the following books about 25 mm (1 inch), if present:

- Memory book 4, at location U1.18-P1-M4
- Memory book 5, at location U1.18-P1-M8
- Memory book 6, at location U1.18-P1-M5
- Memory book 7, at location U1.18-P1-M1

Step 152b-15

Turn on the power.

Step 152b-16

Did the system stop with the same error code as recorded in “Step 152b-1” on page 206?

Yes Go to “Step 152b-22” on page 209.

No Go to “Step 152b-17”.

Step 152b-17

One of the books just removed is defective.

1. Turn off the power.
2. Make sure all amber logic-power LEDs of all installed processor subsystem DCAs are off.

Step 152b-18

Reinsert one of the books that is pulled out and listed in step “Step 152b-14”.

Step 152b-19

Turn on the power.

Step 152b-20

Did the system stop with the same error code as recorded in “Step 152b-1” on page 206?

Yes The book just reinserted is defective. Replace it. **This ends the procedure.**

Return the system to its original configuration.

Go to “MAP 0410: Repair Checkout” in the *RS/6000 and @server pSeries Diagnostic Information for Multiple Bus Systems*.

No Go to “Step 152b-21”.

Step 152b-21

Have all the books listed in “Step 152b-14” on page 208 been reinserted?

Yes The symptom has changed. **This ends the procedure.**

Return the system to its original configuration.

Go to “MAP 0410: Repair Checkout” in the *RS/6000 and @server pSeries Diagnostic Information for Multiple Bus Systems*.

No Go to “Step 152b-18” on page 208.

Step 152b-22

Turn off the power.

Examine the amber logic-power LEDs of all installed processor subsystem DCAs.

Step 152b-23

Are all amber logic-power LEDs of all installed processor subsystem DCAs off?

Yes Go to “Step 152b-24”.

No Call for support.

Step 152b-24

Pull out the following books about 25 mm (1 inch), if present:

- Secondary I/O book, at location U1.18-P1-H3
- Third I/O book, at location U1.18-P1-H4
- Capacitor book, at location U1.18-P1-V3
- Capacitor book, at location U1.18-P1-V7

Step 152b-25

Turn on the power.

Step 152b-26

Did the system stop with the same error code as recorded in “Step 152b-1” on page 206?

Yes Go to “Step 152b-32” on page 210.

No Go to “Step 152b-27” on page 210.

Step 152b-27

One of the books just removed is defective.

1. Turn off the power.
2. Make sure all amber logic-power LEDs of all installed processor subsystem DCAs are off.

Step 152b-28

Reinsert one of the books that is pulled out and listed in “Step 152b-24” on page 209.

Step 152b-29

Turn on the power.

Step 152b-30

Did the system stop with the same error code as recorded in “Step 152b-1” on page 206?

Yes The book just reinserted is defective. Replace it. **This ends the procedure.**

Return the system to its original configuration.

Go to “MAP 0410: Repair Checkout” in the *RS/6000 and @server pSeries Diagnostic Information for Multiple Bus Systems*.

No Go to “Step 152b-31”.

Step 152b-31

Have all the books listed in “Step 152b-24” on page 209 been reinserted?

Yes The symptom has changed. **This ends the procedure.**

Return the system to its original configuration.

Go to “MAP 0410: Repair Checkout” in the *RS/6000 and @server pSeries Diagnostic Information for Multiple Bus Systems*.

No Go to “Step 152b-28”.

Step 152b-32

Turn off the power.

Examine the amber logic-power LEDs of all installed processor subsystem DCAs.

Step 152b-33

Are all amber logic-power LEDs of all installed processor subsystem DCAs off?

Yes Go to “Step 152b-34” on page 211.

No Call for support.

Step 152b-34

Replace the books in the following list, if present, one at a time and in the order listed:

- Primary I/O Book, at location U1.18-P1-H2
- DCA 1-RH, at location U1.18-P1-V1
- DCA 2-RH, at location U1.18-P1-V2
- DCA 3-RH, at location U1.18-P1-V4
- DCA 4-RH, at location U1.18-P1-V5
- DCA 5-RH, at location U1.18-P1-V6
- DCA 6-RH, at location U1.18-P1-V8

Step 152b-35

Turn on the power.

Step 152b-36

Did the system stop with the same error code as recorded in “Step 152b-1” on page 206?

Yes Go to “Step 152b-37”.

No The book just replaced is defective. **This ends the procedure.**

Return the system to its original configuration.

Go to “MAP 0410: Repair Checkout” in the *RS/6000 and @server pSeries Diagnostic Information for Multiple Bus Systems*.

Step 152b-37

Turn off the power.

Make sure all amber logic-power LEDs of all installed processor subsystem DCAs are off.

Step 152b-38

Remove the new book that was just installed in “Step 152b-34” and reinstall the original book.

Step 152b-39

Have all the books listed in “Step 152b-34” been replaced with new or original books?

Yes Go to “Step 152b-40”.

No Go to “Step 152b-34”.

Step 152b-40

Examine the amber logic-power LEDs of all installed processor subsystem DCAs.

Step 152b-41

Are all amber logic-power LEDs of all installed processor subsystem DCAs off?

Yes Go to “Step 152b-42” on page 212.

No Call for support.

Step 152b-42

Attention: Before replacing the system backplane, call for support.

Replace the system backplane at location U1.18-P1.

Step 152b-43

Turn on the power.

Step 152b-44

Did the system stop with the same error code as recorded in “Step 152b-1” on page 206?

Yes Go to “Step 152b-45”.

No The system backplane was defective. **This ends the procedure.**

Return the system to its original configuration.

Go to “MAP 0410: Repair Checkout” in the *RS/6000 and @server pSeries Diagnostic Information for Multiple Bus Systems*.

Step 152b-45

Turn off the power.

Make sure all amber logic-power LEDs of all installed processor subsystem DCAs are off.

Step 152b-46

Has the system backplane been replaced?

Yes Call for support.

No Go to “Step 152b-42”.

Map 152c: 1.8 V Current/Voltage Problem in Processor Subsystem

Step 152c-1

For future reference, record the error code in the operator panel display.

Step 152c-2

Turn off the power.

Examine the amber logic-power LEDs of all installed processor subsystem DCAs.

Step 152c-3

Are all amber logic-power LEDs of all installed processor subsystem DCAs off?

Yes Go to “Step 152c-4” on page 213.

No Call for support.

Step 152c-4

Pull out the following books about 25 mm (1 inch), if present:

- Memory book 0, at location U1.18-P1-M2
- Memory book 1, at location U1.18-P1-M3
- Memory book 2, at location U1.18-P1-M7
- Memory book 3, at location U1.18-P1-M6

Step 152c-5

Turn on the power.

Step 152c-6

Did the system stop with the same error code as recorded in “Step 152c-1” on page 212?

Yes Go to “Step 152c-12” on page 214.

No Go to “Step 152c-7”.

Step 152c-7

One of the books just removed is defective.

1. Turn off the power.
2. Make sure all amber logic-power LEDs of all installed processor subsystem DCAs are off.

Step 152c-8

Reinsert one of the books that is pulled out and listed in “Step 152c-4”.

Step 152c-9

Turn on the power.

Step 152c-10

Did the system stop with the same error code as recorded in “Step 152c-1” on page 212?

Yes The book just reinserted is defective. Replace it. **This ends the procedure.**

Return the system to its original configuration.

Go to “MAP 0410: Repair Checkout” in the *RS/6000 and @server pSeries Diagnostic Information for Multiple Bus Systems*.

No Go to “Step 152c-11”.

Step 152c-11

Have all the books listed in “Step 152c-4” been reinserted?

Yes The symptom has changed. **This ends the procedure.**

Return the system to its original configuration.

Go to “MAP 0410: Repair Checkout” in the *RS/6000 and @server pSeries Diagnostic Information for Multiple Bus Systems*.

No Go to “Step 152c-8”.

Step 152c-12

Turn off the power.

Examine the amber logic-power LEDs of all installed processor subsystem DCAs.

Step 152c-13

Are all amber logic-power LEDs of all installed processor subsystem DCAs off?

Yes Go to “Step 152c-14”.

No Call for support.

Step 152c-14

Pull out the following books about 25 mm (1 inch), if present:

- Memory book 4, at location U1.18-P1-M4
- Memory book 5, at location U1.18-P1-M8
- Memory book 6, at location U1.18-P1-M5
- Memory book 7, at location U1.18-P1-M1

Step 152c-15

Turn on the power.

Step 152c-16

Did the system stop with the same error code as recorded in “Step 152c-1” on page 212?

Yes Go to “Step 152c-22” on page 215.

No Go to “Step 152c-17”.

Step 152c-17

One of the books just removed is defective.

1. Turn off the power.
2. Make sure all amber logic-power LEDs of all installed processor subsystem DCAs are off.

Step 152c-18

Reinsert one of the books that is pulled out and listed in “Step 152c-14”.

Step 152c-19

Turn on the power.

Step 152c-20

Did the system stop with the same error code as recorded in “Step 152c-1” on page 212?

Yes The book just reinserted is defective. Replace it. **This ends the procedure.**

Return the system to its original configuration.

Go to “MAP 0410: Repair Checkout” in the *RS/6000 and @server pSeries Diagnostic Information for Multiple Bus Systems*.

No Go to “Step 152c-21”.

Step 152c-21

Have all the books listed in “Step 152c-14” on page 214 been reinserted?

Yes The symptom has changed. **This ends the procedure.**

Return the system to its original configuration.

Go to “MAP 0410: Repair Checkout” in the *RS/6000 and @server pSeries Diagnostic Information for Multiple Bus Systems*.

No Go to “Step 152c-18” on page 214.

Step 152c-22

Turn off the power.

Examine the amber logic-power LEDs of all installed processor subsystem DCAs.

Step 152c-23

Are all amber logic-power LEDs of all installed processor subsystem DCAs off?

Yes Go to “Step 152c-24”.

No Call for support.

Step 152c-24

Pull out the following books about 25 mm (1 inch), if present:

- Secondary I/O book, at location U1.18-P1-H3
- Third I/O book, at location U1.18-P1-H4
- Capacitor book, at location U1.18-P1-V3
- Capacitor book, at location U1.18-P1-V7

Step 152c-25

Turn on the power.

Step 152c-26

Did the system stop with the same error code as recorded in “Step 152c-1” on page 212?

Yes Go to “Step 152c-32” on page 216.

No Go to “Step 152c-27” on page 216.

Step 152c-27

One of the books just removed is defective.

Turn off the power.

Make sure all amber logic-power LEDs of all installed processor subsystem DCAs are off.

Step 152c-28

Reinsert one of the books that is pulled out and listed in “Step 152c-24” on page 215.

Step 152c-29

Turn on the power.

Step 152c-30

Did the system stop with the same error code as recorded in “Step 152c-1” on page 212?

Yes The book just reinserted is defective. Replace it. **This ends the procedure.**

Return the system to its original configuration.

Go to “MAP 0410: Repair Checkout” in the *RS/6000 and @server pSeries Diagnostic Information for Multiple Bus Systems*.

No Go to “Step 152c-31”.

Step 152c-31

Have all the books listed in “Step 152c-24” on page 215 been reinserted?

Yes The symptom has changed. **This ends the procedure.**

Return the system to its original configuration.

Go to “MAP 0410: Repair Checkout” in the *RS/6000 and @server pSeries Diagnostic Information for Multiple Bus Systems*.

No Go to “Step 152c-28”.

Step 152c-32

Turn off the power.

Examine the amber logic-power LEDs of all installed processor subsystem DCAs.

Step 152c-33

Are all amber logic-power LEDs of all installed processor subsystem DCAs off?

Yes Go to “Step 152c-34” on page 217.

No Call for support.

Step 152c-34

Replace the books in the following list, if present, one at a time and in the order listed:

- Primary I/O book, at location U1.18-P1-H2
- DCA 1-RH, at location U1.18-P1-V1
- DCA 2-RH, at location U1.18-P1-V2
- DCA 3-RH, at location U1.18-P1-V4
- DCA 4-RH, at location U1.18-P1-V5
- DCA 5-RH, at location U1.18-P1-V6
- DCA 6-RH, at location U1.18-P1-V8

Step 152c-35

Turn on the power.

Step 152c-36

Did the system stop with the same error code as recorded in “Step 152c-1” on page 212?

Yes Go to “Step 152c-37”.

No The book just replaced was defective. **This ends the procedure.**

Return the system to its original configuration.

Go to “MAP 0410: Repair Checkout” in the *RS/6000 and @server pSeries Diagnostic Information for Multiple Bus Systems*.

Step 152c-37

Turn off the power.

Make sure all amber logic-power LEDs of all installed processor subsystem DCAs are off.

Step 152c-38

Remove the new book that was just installed in “Step 152c-34” and reinstall the original book.

Step 152c-39

Have all the books listed in “Step 152c-34” been replaced with new or original books?

Yes Go to “Step 152c-40”.

No Go to “Step 152c-34”.

Step 152c-40

Turn off the power.

Examine the amber logic-power LEDs of all installed processor subsystem DCAs.

Step 152c-41

Are all amber logic-power LEDs of all installed processor subsystem DCAs off?

Yes Go to “Step 152c-42” on page 219.

No Call for support.

Step 152c-42

Record the location of each installed L3 module.

Attention: L3 modules have a limit of three plug cycles. Before removing any of the L3 modules in the following list, call for support.

Remove all of the following modules, if present:

- L3 module, at location U1.18-P1-C5
- L3 module, at location U1.18-P1-C6
- L3 module, at location U1.18-P1-C7
- L3 module, at location U1.18-P1-C8
- L3 module, at location U1.18-P1-C9
- L3 module, at location U1.18-P1-C10
- L3 module, at location U1.18-P1-C11
- L3 module, at location U1.18-P1-C12
- L3 module, at location U1.18-P1-C13
- L3 module, at location U1.18-P1-C14
- L3 module, at location U1.18-P1-C15
- L3 module, at location U1.18-P1-C16
- L3 module, at location U1.18-P1-C17
- L3 module, at location U1.18-P1-C18
- L3 module, at location U1.18-P1-C19
- L3 module, at location U1.18-P1-C20
- System clock, at location U1.18-P1-X5

Step 152c-43

Turn on the power.

Step 152c-44

Did the system stop with the same error code as recorded in “Step 152c-1” on page 212?

Yes Go to “Step 152c-50” on page 220.

No Go to “Step 152c-45”.

Step 152c-45

One of the modules just removed is defective.

Turn off the power.

Make sure all amber logic-power LEDs of all installed processor subsystem DCAs are off.

Step 152c-46

Reinstall one of the modules that is removed and listed in “Step 152c-42” on page 219.

Step 152c-47

Turn on the power.

Step 152c-48

Did the system stop with the same error code as recorded in “Step 152c-1” on page 212?

Yes The module just replaced was defective. **This ends the procedure.**

Return the system to its original configuration.

Go to “MAP 0410: Repair Checkout” in the *RS/6000 and @server pSeries Diagnostic Information for Multiple Bus Systems*.

No Go to “Step 152c-49”.

Step 152c-49

Have all the modules listed in “Step 152c-42” on page 219 been reinstalled?

Yes The symptom has changed. **This ends the procedure.**

Return the system to its original configuration.

Go to “MAP 0410: Repair Checkout” in the *RS/6000 and @server pSeries Diagnostic Information for Multiple Bus Systems*.

No Go to “Step 152c-45” on page 219.

Step 152c-50

Examine the amber logic-power LEDs of all installed processor subsystem DCAs.

Step 152c-51

Are all amber logic-power LEDs of all installed processor subsystem DCAs off?

Yes Go to “Step 152c-52”.

No Call for support.

Step 152c-52

Attention: Before replacing the system backplane, call for support.

Replace the system backplane, at location U1.18-P1.

Step 152c-53

Turn on the power.

Step 152c-54

Did the system stop with the same error code as recorded in “Step 152c-1” on page 212?

Yes Go to “Step 152c-55” on page 222.

No The system backplane was defective. **This ends the procedure.**

Return the system to its original configuration.

Go to “MAP 0410: Repair Checkout” in the *RS/6000 and @server pSeries Diagnostic Information for Multiple Bus Systems*.

Step 152c-55

Turn off the power.

Make sure all amber logic-power LEDs of all installed processor subsystem DCAs are off.

Step 152c-56

Has the system backplane been replaced?

Yes Call for support.

No Go to "Step 152c-52" on page 220.

Map 152d: 1.5 V Auxiliary Current/Voltage Problem in Processor Subsystem

Step 152d-1

Record the error code and the location code(s) that sent you to this MAP.

Step 152d-2

Turn off the power.

Examine the amber logic-power LEDs of all installed processor subsystem DCAs.

Step 152d-3

Are all amber logic-power LEDs of all installed processor subsystem DCAs off?

Yes Go to “Step 152d-4”.

No Call for support.

Step 152d-4

Pull out the following books about 25 mm (1 inch), if present:

- Memory book 0, at location U1.18-P1-M2
- Memory book 1, at location U1.18-P1-M3
- Memory book 2, at location U1.18-P1-M7
- Memory book 3, at location U1.18-P1-M6

Step 152d-5

Turn on the power.

Step 152d-6

Did the system stop with the same error code as recorded in “Step 152d-1”?

Yes Go to “Step 152d-12” on page 224.

No Go to “Step 152d-7”.

Step 152d-7

One of the books just removed is defective.

Turn off the power.

Make sure all amber logic-power LEDs of all installed processor subsystem DCAs are off.

Step 152d-8

Reinsert one of the books that is pulled out and listed in “Step 152d-4” on page 223.

Step 152d-9

Turn on the power.

Step 152d-10

Did the system stop with the same error code as recorded in “Step 152d-1” on page 223?

Yes The book just reinserted is defective. Replace it. **This ends the procedure.**

Return the system to its original configuration.

Go to “MAP 0410: Repair Checkout” in the *RS/6000 and @server pSeries Diagnostic Information for Multiple Bus Systems*.

No Go to “Step 152d-11”.

Step 152d-11

Have all the books listed in “Step 152d-4” on page 223 been reinserted?

Yes The symptom has changed. **This ends the procedure.**

Return the system to its original configuration.

Go to “MAP 0410: Repair Checkout” in the *RS/6000 and @server pSeries Diagnostic Information for Multiple Bus Systems*.

No Go to “Step 152d-8”.

Step 152d-12

Turn off the power.

Examine the amber logic-power LEDs of all installed processor subsystem DCAs.

Step 152d-13

Are all amber logic-power LEDs of all installed processor subsystem DCAs off?

Yes Go to “Step 152d-14”.

No Call for support.

Step 152d-14

Pull out the following books about 25 mm (1 inch), if present:

- Memory book 4, at location U1.18-P1-M4
- Memory book 5, at location U1.18-P1-M8
- Memory book 6, at location U1.18-P1-M5
- Memory book 7, at location U1.18-P1-M1

Step 152d-15

Turn on the power.

Step 152d-16

Did the system stop with the same error code as recorded in “Step 152d-1” on page 223?

Yes Go to “Step 152d-22” on page 226.

No Go to “Step 152d-17”.

Step 152d-17

One of the books just removed is defective.

Turn off the power.

Make sure all amber logic-power LEDs of all installed processor subsystem DCAs are off.

Step 152d-18

Reinsert one of the books that is pulled out and listed in “Step 152d-14” on page 224.

Step 152d-19

Turn on the power.

Step 152d-20

Did the system stop with the same error code as recorded in “Step 152d-1” on page 223?

Yes The book just reinserted is defective. Replace it. **This ends the procedure.**

Return the system to its original configuration.

Go to “MAP 0410: Repair Checkout” in the *RS/6000 and @server pSeries Diagnostic Information for Multiple Bus Systems*.

No Go to “Step 152d-21”.

Step 152d-21

Have all the books listed in “Step 152d-14” on page 224 been reinserted?

Yes The symptom has changed. **This ends the procedure.**

Return the system to its original configuration.

Go to “MAP 0410: Repair Checkout” in the *RS/6000 and @server pSeries Diagnostic Information for Multiple Bus Systems*.

No Go to “Step 152d-18”.

Step 152d-22

Turn off the power.

Examine the amber logic-power LEDs of all installed processor subsystem DCAs.

Step 152d-23

Are all amber logic-power LEDs of all installed processor subsystem DCAs off?

Yes Go to “Step 152d-24”.

No Call for support.

Step 152d-24

Pull out the following books about 25 mm (1 inch), if present:

- Secondary I/O book, at location U1.18-P1-H3
- Third I/O book, at location U1.18-P1-H4
- Capacitor book, at location U1.18-P1-V3
- Capacitor book, at location U1.18-P1-V7

Step 152d-25

Turn on the power.

Step 152d-26

Did the system stop with the same error code as recorded in “Step 152d-1” on page 223?

Yes Go to “Step 152d-32” on page 227.

No Go to “Step 152d-27”.

Step 152d-27

One of the books just removed is defective.

Turn off the power.

Make sure all amber logic-power LEDs of all installed processor subsystem DCAs are off.

Step 152d-28

Reinsert one of the books that is pulled out and listed in “Step 152d-24”.

Step 152d-29

Turn on the power.

Step 152d-30

Did the system stop with the same error code as recorded in “Step 152d-1” on page 223?

Yes The book just reinserted is defective. Replace it. **This ends the procedure.**

Return the system to its original configuration.

Go to “MAP 0410: Repair Checkout” in the *RS/6000 and @server pSeries Diagnostic Information for Multiple Bus Systems*.

No Go to “Step 152d-31”.

Step 152d-31

Have all the books listed in “Step 152d-24” on page 226 been reinserted?

Yes The symptom has changed. **This ends the procedure.**

Return the system to its original configuration.

Go to “MAP 0410: Repair Checkout” in the *RS/6000 and @server pSeries Diagnostic Information for Multiple Bus Systems*.

No Go to “Step 152d-28” on page 226.

Step 152d-32

Turn off the power.

Examine the amber logic-power LEDs of all installed processor subsystem DCAs.

Step 152d-33

Are all amber logic-power LEDs of all installed processor subsystem DCAs off?

Yes Go to “Step 152d-34”.

No Call for support.

Step 152d-34

Replace the books in the following list, if present, one at a time and in the order listed:

- DCA 1-RH, at location U1.18-P1-V1
- DCA 2-RH, at location U1.18-P1-V2
- DCA 3-RH, at location U1.18-P1-V4
- DCA 4-RH, at location U1.18-P1-V5
- DCA 5-RH, at location U1.18-P1-V6
- DCA 6-RH, at location U1.18-P1-V8

Step 152d-35

Turn on the power.

Step 152d-36

Did the system stop with the same error code as recorded in “Step 152d-1” on page 223?

Yes Go to “Step 152d-37”.

No The book just replaced was defective. **This ends the procedure.**

Return the system to its original configuration.

Go to “MAP 0410: Repair Checkout” in the *RS/6000 and @server pSeries Diagnostic Information for Multiple Bus Systems*.

Step 152d-37

Turn off the power.

Make sure all amber logic-power LEDs of all installed processor subsystem DCAs are off.

Step 152d-38

Remove the new book that was just installed in “Step 152d-34” on page 227 and reinstall the original book.

Step 152d-39

Have all the books listed in “Step 152d-34” on page 227 been replaced with new or original books?

Yes Go to “Step 152d-40”.

No Go to “Step 152d-34” on page 227.

Step 152d-40

Turn off the power.

Examine the amber logic-power LEDs of all installed processor subsystem DCAs.

Step 152d-41

Are all amber logic-power LEDs of all installed processor subsystem DCAs off?

Yes Go to “Step 152d-42”.

No Call for support.

Step 152d-42

Record the location of each installed L3 module.

Attention: L3 modules have a limit of three plug cycles. Before removing any of the L3s in the following list, call for support.

Remove all of the following modules if present:

- L3 module, at location U1.18-P1-C5
- L3 module, at location U1.18-P1-C6
- L3 module, at location U1.18-P1-C7

- L3 module, at location U1.18-P1-C8
- L3 module, at location U1.18-P1-C9
- L3 module, at location U1.18-P1-C10
- L3 module, at location U1.18-P1-C11
- L3 module, at location U1.18-P1-C12
- L3 module, at location U1.18-P1-C13
- L3 module, at location U1.18-P1-C14
- L3 module, at location U1.18-P1-C15
- L3 module, at location U1.18-P1-C16
- L3 module, at location U1.18-P1-C17
- L3 module, at location U1.18-P1-C18
- L3 module, at location U1.18-P1-C19
- L3 module, at location U1.18-P1-C20

Step 152d-43

Turn on the power.

Step 152d-44

Did the system stop with the same error code as recorded in “Step 152d-1” on page 223?

Yes Go to “Step 152d-50” on page 230.

No Go to “Step 152d-45”.

Step 152d-45

One of the modules just removed is defective.

Turn off the power.

Make sure all amber logic-power LEDs of all installed processor subsystem DCAs are off.

Step 152d-46

Reinstall one of the L3 modules that is removed and listed in “Step 152d-42” on page 228.

Step 152d-47

Turn on the power.

Step 152d-48

Did the system stop with the same error code as recorded in “Step 152d-1” on page 223?

Yes The module just replaced was defective. **This ends the procedure.**

Return the system to its original configuration.

Go to “MAP 0410: Repair Checkout” in the *RS/6000 and @server pSeries Diagnostic Information for Multiple Bus Systems*.

No Go to “Step 152d-49” on page 230.

Step 152d-49

Have all the modules listed in “Step 152d-42” on page 228 been reinstalled?

Yes The symptom has changed. **This ends the procedure.**

Return the system to its original configuration.

Go to “MAP 0410: Repair Checkout” in the *RS/6000 and @server pSeries Diagnostic Information for Multiple Bus Systems*.

No Go to “Step 152d-45” on page 229.

Step 152d-50

Examine the amber logic-power LEDs of all installed processor subsystem DCAs.

Step 152d-51

Are all amber logic-power LEDs of all installed processor subsystem DCAs off?

Yes Go to “Step 152d-52”.

No Call for support.

Step 152d-52

Attention: Before replacing the system backplane, call for support.

Replace the system backplane, at location U1.18-P1.

Step 152d-53

Turn on the power.

Step 152d-54

Did the system stop with the same error code as recorded in “Step 152d-1” on page 223?

Yes Go to “Step 152d-55”.

No The system backplane was defective. **This ends the procedure.**

Return the system to its original configuration.

Go to “MAP 0410: Repair Checkout” in the *RS/6000 and @server pSeries Diagnostic Information for Multiple Bus Systems*.

Step 152d-55

Turn off the power.

Make sure all amber logic-power LEDs of all installed processor subsystem DCAs are off.

Step 152d-56

Has the system backplane been replaced?

Yes Call for support.

No Go to “Step 152d-52”.

Map 152e: 1.5 V CPU Current/Voltage Problem in Processor Subsystem

Step 152e-1

Record the error code and the location code(s) that sent you to this MAP.

Step 152e-2

Turn off the power.

Examine the amber logic-power LEDs of all installed processor subsystem DCAs.

Step 152e-3

Are all amber logic-power LEDs of all installed processor subsystem DCAs off?

Yes Go to “Step 152e-4”.

No Call for support.

Step 152e-4

Pull out the following books about 25 mm (1 inch), if present:

- Capacitor book, at location U1.18-P1-V3
- Capacitor book, at location U1.18-P1-V7

Step 152e-5

Turn on the power.

Step 152e-6

Did the system stop with the same error code as recorded in “Step 152e-1”?

Yes Go to “Step 152e-12” on page 232.

No Go to “Step 152e-7”.

Step 152e-7

One of the books just removed is defective.

Turn off the power.

Make sure all amber logic-power LEDs of all installed processor subsystem DCAs are off.

Step 152e-8

Reinsert one of the books that is pulled out and listed in “Step 152e-4”.

Step 152e-9

Turn on the power.

Step 152e-10

Did the system stop with the same error code as recorded in “Step 152e-1” on page 231?

Yes The book just reinserted is defective. Replace it. **This ends the procedure.**

Return the system to its original configuration.

Go to “MAP 0410: Repair Checkout” in the *RS/6000 and @server pSeries Diagnostic Information for Multiple Bus Systems*.

No Go to “Step 152e-11”.

Step 152e-11

Have all the books listed in “Step 152e-4” on page 231 been reinserted?

Yes The symptom has changed. **This ends the procedure.**

Return the system to its original configuration.

Go to “MAP 0410: Repair Checkout” in the *RS/6000 and @server pSeries Diagnostic Information for Multiple Bus Systems*.

No Go to “Step 152e-8” on page 231.

Step 152e-12

Turn off the power.

Examine the amber logic-power LEDs of all installed processor subsystem DCAs.

Step 152e-13

Are all amber logic-power LEDs of all installed processor subsystem DCAs off?

Yes Go to “Step 152e-14”.

No Call for support.

Step 152e-14

Replace the books in the following list, if present, one at a time and in the order listed:

- DCA 1, at location U1.18-P1-V1
- DCA 2, at location U1.18-P1-V2
- DCA 3, at location U1.18-P1-V4
- DCA 4, at location U1.18-P1-V5
- DCA 5, at location U1.18-P1-V6
- DCA 6, at location U1.18-P1-V8

Step 152e-15

Turn on the power.

Step 152e-16

Did the system stop with the same error code as recorded in “Step 152e-1” on page 231?

Yes Go to “Step 152e-17”.

No The book just reinserted is defective. Replace it. **This ends the procedure.**
Return the system to its original configuration.

Go to “MAP 0410: Repair Checkout” in the *RS/6000 and @server pSeries Diagnostic Information for Multiple Bus Systems*.

Step 152e-17

Turn off the power.

Make sure all amber logic-power LEDs of all installed processor subsystem DCAs are off.

Step 152e-18

Remove the new book that was just installed in “Step 152e-14” on page 232 and reinstall the original book.

Step 152e-19

Have all the books listed in “Step 152e-14” on page 232 been replaced with new or original books?

Yes Go to “Step 152e-20”.

No Go to “Step 152e-14” on page 232.

Step 152e-20

Turn off the power.

Examine the amber logic-power LEDs of all installed processor subsystem DCAs.

Step 152e-21

Are all amber logic-power LEDs of all installed processor subsystem DCAs off?

Yes Go to “Step 152e-22”.

No Call for support.

Step 152e-22

Attention: Before you remove or replace any MCM or L3 module, *stop, read and understand* the following procedures: “MCM Module (Processor) and Passthru Modules” on page 794 and “L3 Cache Modules” on page 805.

Record the location of each installed MCM module.

Attention: MCM modules have a limit of three plug cycles. Before replacing any of the MCMs in the following list, call for support.

Record the original location on each MCM. Remove the following MCM modules, if present:

- MCM module 0, at location U1.18-P1-C1
- MCM module 3, at location U1.18-P1-C2
- MCM module 1, at location U1.18-P1-C3
- MCM module 2, at location U1.18-P1-C4

Step 152e-23

Turn on the power.

Step 152e-24

Did the system stop with the same error code as recorded in “Step 152e-1” on page 231?

Yes Go to “Step 152e-30” on page 236.

No Go to “Step 152e-25”.

Step 152e-25

One of the modules just removed is defective.

Turn off the power.

Make sure all amber logic-power LEDs of all installed processor subsystem DCAs are off.

Step 152e-26

Attention: Before you remove or replace any MCM or L3 module, *stop, read, and understand* the following procedures: “MCM Module (Processor) and Passthru Modules” on page 794 and “L3 Cache Modules” on page 805.

Reinstall one of the MCM modules that is removed and listed in “Step 152e-22” on page 234.

Step 152e-27

Turn on the power.

Step 152e-28

Did the system stop with the same error code as recorded in “Step 152e-1” on page 231?

Yes The module just reinserted was defective. **This ends the procedure.**

Return the system to its original configuration.

Go to “MAP 0410: Repair Checkout” in the *RS/6000 and @server pSeries Diagnostic Information for Multiple Bus Systems*.

No Go to “Step 152e-29”.

Step 152e-29

Have all the modules listed in “Step 152e-22” on page 234 been reinstalled?

Yes The symptom has changed. **This ends the procedure.**

Return the system to its original configuration.

Go to “MAP 0410: Repair Checkout” in the *RS/6000 and @server pSeries Diagnostic Information for Multiple Bus Systems*.

No Go to “Step 152e-25”.

Step 152e-30

Examine the amber logic-power LEDs of all installed processor subsystem DCAs.

Step 152e-31

Are all amber logic-power LEDs of all installed processor subsystem DCAs off?

Yes Go to "Step 152e-32".

No Call for support.

Step 152e-32

Attention: Before replacing the system backplane, call for support.

Replace the system backplane, at location U1.18-P1.

Step 152e-33

Turn on the power.

Step 152e-34

Did the system stop with the same error code as recorded in "Step 152e-1" on page 231?

Yes Go to "Step 152e-35".

No The system backplane was defective. **This ends the procedure.**

Return the system to its original configuration.

Go to "MAP 0410: Repair Checkout" in the *RS/6000 and @server pSeries Diagnostic Information for Multiple Bus Systems*.

Step 152e-35

Turn off the power.

Make sure all amber logic-power LEDs of all installed processor subsystem DCAs are off.

Step 152e-36

Has the system backplane been replaced?

Yes Call for support.

No Go to "Step 152e-32".

Map 152f: 3.3 V Current/Voltage Problem in Processor Subsystem

Step 152f-1

Record the error code and the location code(s) that sent you to this MAP.

Step 152f-2

Turn off the power.

Examine the amber logic-power LEDs of all installed processor subsystem DCAs.

Step 152f-3

Are all amber logic-power LEDs of all installed processor subsystem DCAs off?

Yes Go to “Step 152f-4”.

No Call for support.

Step 152f-4

Pull out the following books about 25 mm (1 inch), if present:

- Memory book 0, at location U1.18-P1-M2
- Memory book 1, at location U1.18-P1-M3
- Memory book 2, at location U1.18-P1-M7
- Memory book 3, at location U1.18-P1-M6

Step 152f-5

Turn on the power.

Step 152f-6

Did the system stop with the same error code as recorded in “Step 152f-1”?

Yes Go to “Step 152f-12” on page 238.

No Go to “Step 152f-7”.

Step 152f-7

One of the books just removed is defective.

Turn off the power.

Make sure all amber logic-power LEDs of all installed processor subsystem DCAs are off.

Step 152f-8

Reinsert one of the books that is pulled out and listed in “Step 152f-4”.

Step 152f-9

Turn on the power.

Step 152f-10

Did the system stop with the same error code as recorded in “Step 152f-1” on page 237?

Yes The book just reinserted is defective. Replace it. **This ends the procedure.**

Return the system to its original configuration.

Go to “MAP 0410: Repair Checkout” in the *RS/6000 and @server pSeries Diagnostic Information for Multiple Bus Systems*.

No Go to “Step 152f-11”.

Step 152f-11

Have all the books listed in “Step 152f-4” on page 237 been reinserted?

Yes The symptom has changed. **This ends the procedure.**

Return the system to its original configuration.

Go to “MAP 0410: Repair Checkout” in the *RS/6000 and @server pSeries Diagnostic Information for Multiple Bus Systems*.

No Go to “Step 152f-8” on page 237.

Step 152f-12

Turn off the power.

Examine the amber logic-power LEDs of all installed processor subsystem DCAs.

Step 152f-13

Are all amber logic-power LEDs of all installed processor subsystem DCAs off?

Yes Go to “Step 152f-14”.

No Call for support.

Step 152f-14

Pull out the following books about 25 mm (1 inch), if present:

- Memory book 4, at location U1.18-P1-M4
- Memory book 5, at location U1.18-P1-M8
- Memory book 6, at location U1.18-P1-M5
- Memory book 7, at location U1.18-P1-M1

Step 152f-15

Turn on the power.

Step 152f-16

Did the system stop with the same error code as recorded in “Step 152f-1” on page 237?

Yes Go to “Step 152f-22”.

No Go to “Step 152f-17”.

Step 152f-17

One of the books just removed is defective.

Turn off the power.

Make sure all amber logic-power LEDs of all installed processor subsystem DCAs are off.

Step 152f-18

Reinsert one of the books that is pulled out and listed in “Step 152f-14” on page 238.

Step 152f-19

Turn on the power.

Step 152f-20

Did the system stop with the same error code as recorded in “Step 152f-1” on page 237?

Yes The book just reinserted is defective. Replace it. **This ends the procedure.**

Return the system to its original configuration.

Go to “MAP 0410: Repair Checkout” in the *RS/6000 and @server pSeries Diagnostic Information for Multiple Bus Systems*.

No Go to “Step 152f-21”.

Step 152f-21

Have all the books listed in “Step 152f-14” on page 238 been reinserted?

Yes The symptom has changed. **This ends the procedure.**

Return the system to its original configuration.

Go to “MAP 0410: Repair Checkout” in the *RS/6000 and @server pSeries Diagnostic Information for Multiple Bus Systems*.

No Go to “Step 152f-18”.

Step 152f-22

Turn off the power.

Examine the amber logic-power LEDs of all installed processor subsystem DCAs.

Step 152f-23

Are all amber logic-power LEDs of all installed processor subsystem DCAs off?

Yes Go to “Step 152f-24”.

No Call for support.

Step 152f-24

Pull out the following books about 25 mm (1 inch), if present:

- Secondary I/O book, at location U1.18-P1-H3
- Third I/O book, at location U1.18-P1-H4

Step 152f-25

Turn on the power.

Step 152f-26

Did the system stop with the same error code as recorded in “Step 152f-1” on page 237?

Yes Go to “Step 152f-32” on page 241.

No Go to “Step 152f-27”.

Step 152f-27

The book just removed is defective.

Turn off the power.

Make sure all amber logic-power LEDs of all installed processor subsystem DCAs are off.

Step 152f-28

Reinsert the book that is pulled out and listed in “Step 152f-24”.

Step 152f-29

Turn on the power.

Step 152f-30

Did the system stop with the same error code as recorded in “Step 152f-1” on page 237?

Yes The book just reinserted is defective. Replace it. **This ends the procedure.**

Return the system to its original configuration.

Go to “MAP 0410: Repair Checkout” in the *RS/6000 and @server pSeries Diagnostic Information for Multiple Bus Systems*.

No Go to “Step 152f-31” on page 241.

Step 152f-31

Have all the books listed in “Step 152f-24” on page 240 been reinserted?

Yes The symptom has changed. **This ends the procedure.**

Return the system to its original configuration.

Go to “MAP 0410: Repair Checkout” in the *RS/6000 and @server pSeries Diagnostic Information for Multiple Bus Systems*.

No Go to “Step 152f-28” on page 240.

Step 152f-32

Turn off the power.

Examine the amber logic-power LEDs of all installed processor subsystem DCAs.

Step 152f-33

Are all amber logic-power LEDs of all installed processor subsystem DCAs off?

Yes Go to “Step 152f-34”.

No Call for support.

Step 152f-34

Replace the books in the following list, if present, one at a time and in the order listed:

- Primary I/O book, at location U1.18-P1-H2
- DCA 1-RH, at location U1.18-P1-V1
- DCA 2-RH, at location U1.18-P1-V2
- DCA 3-RH, at location U1.18-P1-V4
- DCA 4-RH, at location U1.18-P1-V5
- DCA 5-RH, at location U1.18-P1-V6
- DCA 6-RH, at location U1.18-P1-V8

Step 152f-35

Turn on the power.

Step 152f-36

Did the system stop with the same error code as recorded in “Step 152f-1” on page 237?

Yes Go to “Step 152f-37”.

No The book just replaced was defective. **This ends the procedure.**

Return the system to its original configuration.

Go to “MAP 0410: Repair Checkout” in the *RS/6000 and @server pSeries Diagnostic Information for Multiple Bus Systems*.

Step 152f-37

Turn off the power.

Make sure all amber logic-power LEDs of all installed processor subsystem DCAs are off.

Step 152f-38

Remove the new book that was just installed in “Step 152f-34” on page 241 and reinstall the original book.

Step 152f-39

Have all the books listed in “Step 152f-34” on page 241 been replaced with new or original books?

Yes Go to “Step 152f-40”.

No Go to “Step 152f-34” on page 241.

Step 152f-40

Turn off the power.

Examine the amber logic-power LEDs of all installed processor subsystem DCAs.

Step 152f-41

Are all amber logic-power LEDs of all installed processor subsystem DCAs off?

Yes Go to “Step 152f-42”.

No Call for support.

Step 152f-42

Remove the system clock card, at location U1.18-P1-X5.

Step 152f-43

Turn on the power.

Step 152f-44

Did the system stop with the same error code as recorded in “Step 152f-1” on page 237?

Yes Go to “Step 152f-50” on page 244.

No Go to “Step 152f-45”.

Step 152f-45

The system clock card is defective.

Turn off the power.

Make sure all amber logic-power LEDs of all installed processor subsystem DCAs are off.

Step 152f-46

Reinstall the system clock card that you removed in “Step 152f-42”.

Step 152f-47

Turn on the power.

Step 152f-48

Did the system stop with the same error code as recorded in “Step 152f-1” on page 237?

Yes The system clock card just reinserted is defective, replace it. **This ends the procedure.**

Return the system to its original configuration.

Go to “MAP 0410: Repair Checkout” in the *RS/6000 and @server pSeries Diagnostic Information for Multiple Bus Systems*.

No Go to “Step 152f-49”.

Step 152f-49

Have all the modules listed in “Step 152f-42” on page 243 been reinstalled?

Yes The symptom has changed. **This ends the procedure.**

Return the system to its original configuration.

Go to “MAP 0410: Repair Checkout” in the *RS/6000 and @server pSeries Diagnostic Information for Multiple Bus Systems*.

No Go to “Step 152f-45” on page 243.

Step 152f-50

Examine the amber logic-power LEDs of all installed processor subsystem DCAs.

Step 152f-51

Are all amber logic-power LEDs of all installed processor subsystem DCAs off?

Yes Go to “Step 152f-52”.

No Call for support.

Step 152f-52

Attention: Before replacing the system backplane, call for support.

Replace the system backplane, at location U1.18-P1.

Step 152f-53

Turn on the power.

Step 152f-54

Did the system stop with the same error code as recorded in “Step 152f-1” on page 237?

Yes Go to “Step 152f-55”.

No The system backplane was defective. **This ends the procedure.**

Return the system to its original configuration.

Go to “MAP 0410: Repair Checkout” in the *RS/6000 and @server pSeries Diagnostic Information for Multiple Bus Systems*.

Step 152f-55

Turn off the power.

Make sure all amber logic-power LEDs of all installed processor subsystem DCAs are off.

Step 152f-56

Has the system backplane been replaced?

Yes Call for support.

No Go to “Step 152f-52” on page 244.

Map 152g: 5.0 V Current/Voltage Problem in Processor Subsystem

Step 152g-1

For future reference, record the error code and the location code(s) that sent you to this MAP.

Step 152g-2

Turn off the power.

Examine the amber logic-power LEDs of all installed processor subsystem DCAs.

Step 152g-3

Are all amber logic-power LEDs of all installed processor subsystem DCAs off?

Yes Go to “Step 152g-4”.

No Call for support.

Step 152g-4

Pull out the following books about 25 mm (1 inch), if present:

- Memory book 0, at location U1.18-P1-M2
- Memory book 1, at location U1.18-P1-M3
- Memory book 2, at location U1.18-P1-M7
- Memory book 3, at location U1.18-P1-M6

Step 152g-5

Turn on the power.

Step 152g-6

Did the system stop with the same error code as recorded in “Step 152g-1”?

Yes Go to “Step 152g-12” on page 247.

No Go to “Step 152g-7”.

Step 152g-7

One of the books just removed is defective.

Turn off the power.

Make sure all amber logic-power LEDs of all installed processor subsystem DCAs are off.

Step 152g-8

Reinsert one of the books that is pulled out and listed in “Step 152g-4”.

Step 152g-9

Turn on the power.

Step 152g-10

Did the system stop with the same error code as recorded in “Step 152g-1” on page 246?

Yes The book just reinserted is defective. Replace it. **This ends the procedure.**

Return the system to its original configuration.

Go to “MAP 0410: Repair Checkout” in the *RS/6000 and @server pSeries Diagnostic Information for Multiple Bus Systems*.

No Go to “Step 152g-11”.

Step 152g-11

Have all the books listed in “Step 152g-4” on page 246 been reinserted?

Yes The symptom has changed. **This ends the procedure.**

Return the system to its original configuration.

Go to “MAP 0410: Repair Checkout” in the *RS/6000 and @server pSeries Diagnostic Information for Multiple Bus Systems*.

No Go to “Step 152g-8” on page 246.

Step 152g-12

Turn off the power.

Examine the amber logic-power LEDs of all installed processor subsystem DCAs.

Step 152g-13

Are all amber logic-power LEDs of all installed processor subsystem DCAs off?

Yes Go to “Step 152g-14”.

No Call for support.

Step 152g-14

Pull out the following books about 25 mm (1 inch), if present:

- Memory book 4, at location U1.18-P1-M4
- Memory book 5, at location U1.18-P1-M8
- Memory book 6, at location U1.18-P1-M5
- Memory book 7, at location U1.18-P1-M1

Step 152g-15

Turn on the power.

Step 152g-16

Did the system stop with the same error code as recorded in “Step 152g-1” on page 246?

Yes Go to “Step 152g-22”.

No Go to “Step 152g-17”.

Step 152g-17

One of the books just removed is defective.

Turn off the power.

Make sure all amber logic-power LEDs of all installed processor subsystem DCAs are off.

Step 152g-18

Reinsert one of the books that is pulled out and listed in “Step 152g-14” on page 247.

Step 152g-19

Turn on the power.

Step 152g-20

Did the system stop with the same error code as recorded in “Step 152g-1” on page 246?

Yes The book just reinserted is defective. Replace it. **This ends the procedure.**

Return the system to its original configuration.

Go to “MAP 0410: Repair Checkout” in the *RS/6000 and @server pSeries Diagnostic Information for Multiple Bus Systems*.

No Go to “Step 152g-21”.

Step 152g-21

Have all the books listed in “Step 152g-14” on page 247 been reinserted?

Yes The symptom has changed. **This ends the procedure.**

Return the system to its original configuration.

Go to “MAP 0410: Repair Checkout” in the *RS/6000 and @server pSeries Diagnostic Information for Multiple Bus Systems*.

No Go to “Step 152g-18”.

Step 152g-22

Turn off the power.

Examine the amber logic-power LEDs of all installed processor subsystem DCAs.

Step 152g-23

Are all amber logic-power LEDs of all installed processor subsystem DCAs off?

Yes Go to “Step 152g-24”.

No Call for support.

Step 152g-24

Pull out the following books about 25 mm (1 inch), if present:

- Secondary I/O book, at location U1.18-P1-H3
- Third I/O book, at location U1.18-P1-H4
- Cap card at U1.18-P1-V3
- Cap card at U1.18-P1-V7

Step 152g-25

Turn on the power.

Step 152g-26

Did the system stop with the same error code as recorded in “Step 152g-1” on page 246?

Yes Go to “Step 152g-32” on page 250.

No Go to “Step 152g-27”.

Step 152g-27

One of the books just removed is defective.

Turn off the power.

Make sure all amber logic-power LEDs of all installed processor subsystem DCAs are off.

Step 152g-28

Reinsert one of the books that is pulled out and listed in “Step 152g-24”.

Step 152g-29

Turn on the power.

Step 152g-30

Did the system stop with the same error code as recorded in “Step 152g-1” on page 246?

Yes The book just reinserted is defective. Replace it. **This ends the procedure.**

Return the system to its original configuration.

Go to “MAP 0410: Repair Checkout” in the *RS/6000 and @server pSeries Diagnostic Information for Multiple Bus Systems*.

No Go to “Step 152g-31” on page 250.

Step 152g-31

Have all the books listed in “Step 152g-24” on page 249 been reinserted?

Yes The symptom has changed. **This ends the procedure.**

Return the system to its original configuration.

Go to “MAP 0410: Repair Checkout” in the *RS/6000 and @server pSeries Diagnostic Information for Multiple Bus Systems*.

No Go to “Step 152g-28” on page 249.

Step 152g-32

Turn off the power.

Examine the amber logic-power LEDs of all installed processor subsystem DCAs.

Step 152g-33

Are all amber logic-power LEDs of all installed processor subsystem DCAs off?

Yes Go to “Step 152g-34”.

No Call for support.

Step 152g-34

Replace the book in the following list, if present, one at a time and in the order listed:

- Primary I/O book, at location U1.18-P1-H2
- DCA 1-RH at U1.18-P1-V1
- DCA 2-RH at U1.18-P1-V2

Step 152g-35

Turn on the power.

Step 152g-36

Did the system stop with the same error code as recorded in “Step 152g-1” on page 246?

Yes Go to “Step 152g-37”.

No The book just replaced was defective. **This ends the procedure.**

Return the system to its original configuration.

Go to “MAP 0410: Repair Checkout” in the *RS/6000 and @server pSeries Diagnostic Information for Multiple Bus Systems*.

Step 152g-37

Turn off the power.

Make sure all amber logic-power LEDs of all installed processor subsystem DCAs are off.

Step 152g-38

Remove the new book that was just installed in “Step 152g-34” on page 250 and reinstall the original book.

Step 152g-39

Have all the books listed in “Step 152g-34” on page 250 been replaced with new or original books?

Yes Go to “Step 152g-40”.

No Go to “Step 152g-34” on page 250.

Step 152g-40

Examine the amber logic-power LEDs of all installed processor subsystem DCAs.

Step 152g-41

Are all amber logic-power LEDs of all installed processor subsystem DCAs off?

Yes Go to “Step 152g-42”.

No Call for support.

Step 152g-42

Attention: Before replacing the system backplane, call for support.

Replace the system backplane, at location U1.18-P1.

Step 152g-43

Turn on the power.

Step 152g-44

Did the system stop with the same error code as recorded in “Step 152g-1” on page 246?

Yes Go to “Step 152g-45”.

No The system backplane was defective. **This ends the procedure.**

Return the system to its original configuration.

Go to “MAP 0410: Repair Checkout” in the *RS/6000 and @server pSeries Diagnostic Information for Multiple Bus Systems*.

Step 152g-45

Turn off the power.

Make sure all amber logic-power LEDs of all installed processor subsystem DCAs are off.

Step 152g-46

Has the system backplane been replaced?

Yes Call for support.

No Go to “Step 152g-42” on page 251.

Map 152h: 3.3V Current/Voltage Problem in I/O Subsystem

Step 152h-1

Record the error code and the location code(s) that sent you to this MAP.

Step 152h-2

Determine the I/O subsystem number from the error code (10yy xxxx) and the following list. The remaining steps of this map refer to this I/O subsystem:

- If yy=14, I/O subsystem number is 1, location is U1.9
- If yy=15, I/O subsystem number is 2, location is U1.5
- If yy=16, I/O subsystem number is 3, location is U1.1
- If yy=17, I/O subsystem number is 4, location is U1.13
- If yy=21, I/O subsystem number is 5, location is U2.1
- If yy=22, I/O subsystem number is 6, location is U2.5
- If yy=23, I/O subsystem number is 4, location is U2.9
- If yy=24, I/O subsystem number is 7, location is U2.13
- If yy=25, I/O subsystem number is 8, location is U2.19

Step 152h-3

Turn off the power.

Examine the green "power good out" LEDs of both I/O subsystem DCAs.

Step 152h-4

Are all green "power good out" LEDs of both I/O subsystem DCAs off?

Yes Go to "Step 152h-5".

No Call for support.

Step 152h-5

Remove the following adapter cards, if present, from the I/O subsystem. Record the adapter locations:

- Adapter card at P1-I1
- Adapter card at P1-I2
- Adapter card at P1-I3
- Adapter card at P1-I4
- Adapter card at P1-I5

Step 152h-6

Turn on the power.

Step 152h-7

Did the system stop with the same error code as recorded in "Step 152h-1"?

Yes Go to "Step 152h-13" on page 254.

No Go to "Step 152h-8" on page 254.

Step 152h-8

One of the cards just removed is defective.

Turn off the power.

Make sure all the green "power good out" LEDs of both I/O subsystem DCAs are off.

Step 152h-9

Reinsert one of the cards that is removed and listed in "Step 152h-5" on page 253.

Step 152h-10

Turn on the power.

Step 152h-11

Did the system stop with the same error code as recorded in "Step 152h-1" on page 253?

Yes The card just reinserted is defective. Replace it. **This ends the procedure.**

Return the system to its original configuration.

Go to "MAP 0410: Repair Checkout" in the *RS/6000 and @server pSeries Diagnostic Information for Multiple Bus Systems*.

No Go to "Step 152h-12".

Step 152h-12

Have all the cards listed in "Step 152h-5" on page 253 been reinserted?

Yes The symptom has changed. **This ends the procedure.**

Return the system to its original configuration.

Go to "MAP 0410: Repair Checkout" in the *RS/6000 and @server pSeries Diagnostic Information for Multiple Bus Systems*.

No Go to "Step 152h-9".

Step 152h-13

Turn off the power.

Examine the green "power good out" LEDs of both I/O subsystem DCAs.

Step 152h-14

Are all the green "power good out" LEDs of both I/O subsystem DCAs off?

Yes Go to "Step 152h-15" on page 255.

No Call for support.

Step 152h-15

Remove the following adapter cards, if present, from the I/O subsystem. record the adapter locations:

- Adapter card at P1-I6
- Adapter card at P1-I7
- Adapter card at P1-I8
- Adapter card at P1-I9
- Adapter card at P1-I10

Step 152h-16

Turn on the power.

Step 152h-17

Did the system stop with the same error code as recorded in “Step 152h-1” on page 253?

Yes Go to “Step 152h-23” on page 256.

No Go to “Step 152h-18”.

Step 152h-18

One of the cards just removed is defective.

Turn off the power.

Make sure all the green “power good out” LEDs of both I/O subsystem DCAs are off.

Step 152h-19

Reinsert one of the cards that is removed and listed in “Step 152h-15”.

Step 152h-20

Turn on the power.

Step 152h-21

Did the system stop with the same error code as recorded in “Step 152h-1” on page 253?

Yes The card just reinserted is defective. Replace it. **This ends the procedure.**

Return the system to its original configuration.

Go to “MAP 0410: Repair Checkout” in the *RS/6000 and @server pSeries Diagnostic Information for Multiple Bus Systems*.

No Go to “Step 152h-22” on page 256.

Step 152h-22

Have all the cards listed in “Step 152h-15” on page 255 been reinserted?

Yes The symptom has changed. **This ends the procedure.**

Return the system to its original configuration.

Go to “MAP 0410: Repair Checkout” in the *RS/6000 and @server pSeries Diagnostic Information for Multiple Bus Systems*.

No Go to “Step 152h-19” on page 255.

Step 152h-23

Turn off the power.

Examine the green “power good out” LEDs of both I/O subsystem DCAs.

Step 152h-24

Are all the green “power good out” LEDs of both I/O subsystem DCAs off?

Yes Go to “Step 152h-25”.

No Call for support.

Step 152h-25

Remove the following adapter cards, if present, from the I/O subsystem. record the adapter locations:

- Adapter card at P2-I1
- Adapter card at P2-I2
- Adapter card at P2-I3
- Adapter card at P2-I4
- Adapter card at P2-I5

Step 152h-26

Turn on the power.

Step 152h-27

Did the system stop with the same error code as recorded in “Step 152h-1” on page 253?

Yes Go to “Step 152h-33” on page 257.

No Go to “Step 152h-28”.

Step 152h-28

One of the cards just removed is defective.

Turn off the power.

Make sure all the green “power good out” LEDs of both I/O subsystem DCAs are off.

Step 152h-29

Reinsert one of the cards that is removed and listed in “Step 152h-25”.

Step 152h-30

Turn on the power.

Step 152h-31

Did the system stop with the same error code as recorded in “Step 152h-1” on page 253?

Yes The card just reinserted is defective. Replace it. **This ends the procedure.**

Return the system to its original configuration.

Go to “MAP 0410: Repair Checkout” in the *RS/6000 and @server pSeries Diagnostic Information for Multiple Bus Systems*.

No Go to “Step 152h-32”.

Step 152h-32

Have all the cards listed in “Step 152h-25” on page 256 been reinserted?

Yes The symptom has changed. **This ends the procedure.**

Return the system to its original configuration.

Go to “MAP 0410: Repair Checkout” in the *RS/6000 and @server pSeries Diagnostic Information for Multiple Bus Systems*.

No Go to “Step 152h-29” on page 256.

Step 152h-33

Turn off the power.

Examine the green “power good out” LEDs of both I/O subsystem DCAs.

Step 152h-34

Are all the green “power good out” LEDs of both I/O subsystem DCAs off?

Yes Go to “Step 152h-35”.

No Call for support.

Step 152h-35

Remove the following adapter cards, if present, from the I/O subsystem. Record the adapter locations:

- Adapter card at P2-I6
- Adapter card at P2-I7
- Adapter card at P2-I8
- Adapter card at P2-I9
- Adapter card at P2-I10

Step 152h-36

Turn on the power.

Step 152h-37

Did the system stop with the same error code as recorded in “Step 152h-1” on page 253?

Yes Go to “Step 152h-43”.

No Go to “Step 152h-38”.

Step 152h-38

One of the cards just removed is defective.

Turn off the power.

Make sure all the green “power good out” LEDs of both I/O subsystem DCAs are off.

Step 152h-39

Reinsert one of the cards that is removed and listed in “Step 152h-35” on page 257.

Step 152h-40

Turn on the power.

Step 152h-41

Did the system stop with the same error code as recorded in “Step 152h-1” on page 253?

Yes The card just reinserted is defective. Replace it. **This ends the procedure.**

Return the system to its original configuration.

Go to “MAP 0410: Repair Checkout” in the *RS/6000 and @server pSeries Diagnostic Information for Multiple Bus Systems*.

No Go to “Step 152h-42”.

Step 152h-42

Have all the cards listed in “Step 152h-35” on page 257 been reinserted?

Yes The symptom has changed. **This ends the procedure.**

Return the system to its original configuration.

Go to “MAP 0410: Repair Checkout” in the *RS/6000 and @server pSeries Diagnostic Information for Multiple Bus Systems*.

No Go to “Step 152h-39”.

Step 152h-43

Turn off the power.

Examine the green “power good out” LEDs of both I/O subsystem DCAs.

Step 152h-44

Are all the green "power good out" LEDs of both I/O subsystem DCAs off?

Yes Go to "Step 152h-45".

No Call for support.

Step 152h-45

Replace the DCAs in the following list, one at a time and in the order listed:

- DCA 1 at V1
- DCA 2 at V2

Step 152h-46

Turn on the power.

Step 152h-47

Did the system stop with the same error code as recorded in "Step 152h-1" on page 253?

Yes Go to "Step 152h-48".

No The DCA just replaced is defective. **This ends the procedure.**

Return the system to its original configuration.

Go to "MAP 0410: Repair Checkout" in the *RS/6000 and @server pSeries Diagnostic Information for Multiple Bus Systems*.

Step 152h-48

Turn off the power.

Make sure all the green "power good out" LEDs of both I/O subsystem DCAs are off.

Step 152h-49

Remove the new DCA that was just installed in "Step 152h-45" and reinstall the original DCA.

Step 152h-50

Have all the DCAs listed in "Step 152h-45" been replaced with new or original cards?

Yes Go to "Step 152h-51"

No Go to "Step 152h-45".

Step 152h-51

Examine the green "power good out" LEDs of both I/O subsystem DCAs.

Step 152h-52

Are all the green "power good out" LEDs of both I/O subsystem DCAs off?

Yes Go to "Step 152h-53".

No Call for support.

Step 152h-53

Replace the parts in the following list, one at a time and in the order listed::

- I/O subsystem backplane at P1
- I/O subsystem backplane at P2

Step 152h-54

Turn on the power.

Step 152h-55

Did the system stop with the same error code as recorded in "Step 152h-1" on page 253?

Yes Go to "Step 152h-56".

No The part just replaced is defective. Replace it. **This ends the procedure.**

Return the system to its original configuration.

Go to "MAP 0410: Repair Checkout" in the *RS/6000 and @server pSeries Diagnostic Information for Multiple Bus Systems*.

Step 152h-56

Turn off the power.

Make sure all the green "power good out" LEDs of both I/O subsystem DCAs are off.

Step 152h-57

Have all the cards listed in "Step 152h-53" been replaced with new or original cards?

Yes Call for support.

No Go to "Step 152h-53".

Map 152i: 5.0 V Current/Voltage Problem in I/O Subsystem

Step 152i-1

Record the error code and location code(s) that sent you to this MAP.

Step 152i-2

Determine the I/O subsystem number from the error code (10yy xxxx) and the following list. The remaining steps of this map refer to this I/O subsystem:

- If yy=14, I/O subsystem number is 1, location is U1.9
- If yy=15, I/O subsystem number is 2, location is U1.5
- If yy=16, I/O subsystem number is 3, location is U1.1
- If yy=17, I/O subsystem number is 4, location is U1.13
- If yy=21, I/O subsystem number is 5, location is U2.1
- If yy=22, I/O subsystem number is 6, location is U2.5
- If yy=23, I/O subsystem number is 4, location is U2.9
- If yy=24, I/O subsystem number is 7, location is U2.13
- If yy=25, I/O subsystem number is 8, location is U2.19

Step 152i-3

Turn off the power.

Examine the green "power good out" LEDs of both I/O subsystem DCAs.

Step 152i-4

Are all the green "power good out" LEDs of both I/O subsystem DCAs off?

Yes Go to "Step 152i-5".

No Call for support.

Step 152i-5

Remove the following adapter cards, if present, from the I/O subsystem. Record the adapter locations:

- Adapter card at P1-I1
- Adapter card at P1-I2
- Adapter card at P1-I3
- Adapter card at P1-I4
- Adapter card at P1-I5

Step 152i-6

Turn on the power.

Step 152i-7

Did the system stop with the same error code as recorded in "Step 152i-1"?

Yes Go to "Step 152i-13" on page 262.

No Go to "Step 152i-8" on page 262.

Step 152i-8

One of the cards just removed is defective.

Turn off the power.

Make sure all the green "power good out" LEDs of both I/O subsystem DCAs are off.

Step 152i-9

Reinsert one of the cards that is removed and listed in "Step 152i-5" on page 261.

Step 152i-10

Turn on the power.

Step 152i-11

Did the system stop with the same error code as recorded in "Step 152i-1" on page 261?

Yes The card just reinserted is defective. Replace it. **This ends the procedure.**
Return the system to its original configuration.
Go to "MAP 0410: Repair Checkout" in the *RS/6000 and @server pSeries Diagnostic Information for Multiple Bus Systems*.

No Go to "Step 152i-12".

Step 152i-12

Have all the cards listed in "Step 152i-5" on page 261 been reinserted?

Yes The symptom has changed. **This ends the procedure.**
Return the system to its original configuration.
Go to "MAP 0410: Repair Checkout" in the *RS/6000 and @server pSeries Diagnostic Information for Multiple Bus Systems*.

No Go to "Step 152i-9".

Step 152i-13

Turn off the power.

Examine the green "power good out" LEDs of both I/O subsystem DCAs.

Step 152i-14

Are all the green "power good out" LEDs of both I/O subsystem DCAs off?

Yes Go to "Step 152i-15".

No Call for support.

Step 152i-15

Remove the following adapter cards, if present, from the I/O subsystem. Record the adapter locations:

- Adapter card at P1-I6

- Adapter card at P1-I7
- Adapter card at P1-I8
- Adapter card at P1-I9
- Adapter card at P1-I10

Step 152i-16

Turn on the power.

Step 152i-17

Did the system stop with the same error code as recorded in “Step 152i-1” on page 261?

Yes Go to “Step 152i-23” on page 264.

No Go to “Step 152i-18”.

Step 152i-18

One of the cards just removed is defective.

Turn off the power.

Make sure all the green “power good out” LEDs of both I/O subsystem DCAs are off.

Step 152i-19

Reinsert one of the cards that is removed and listed in “Step 152i-15” on page 262.

Step 152i-20

Turn on the power.

Step 152i-21

Did the system stop with the same error code as recorded in “Step 152i-1” on page 261?

Yes The card just reinserted is defective. Replace it. **This ends the procedure.**

Return the system to its original configuration.

Go to “MAP 0410: Repair Checkout” in the *RS/6000 and @server pSeries Diagnostic Information for Multiple Bus Systems*.

No Go to “Step 152i-22”.

Step 152i-22

Have all the cards listed in “Step 152i-15” on page 262 been reinserted?

Yes The symptom has changed. **This ends the procedure.**

Return the system to its original configuration.

Go to “MAP 0410: Repair Checkout” in the *RS/6000 and @server pSeries Diagnostic Information for Multiple Bus Systems*.

No Go to “Step 152i-19”.

Step 152i-23

Turn off the power.

Examine all the green "power good out" LEDs of both I/O subsystem DCAs.

Step 152i-24

Are all the green "power good out" LEDs of both I/O subsystem DCAs off?

Yes Go to "Step 152i-25".

No Call for support.

Step 152i-25

Remove the following adapter cards, if present, from the I/O subsystem. record the adapter locations:

- Adapter card at P2-I1
- Adapter card at P2-I2
- Adapter card at P2-I3
- Adapter card at P2-I4
- Adapter card at P2-I5

Step 152i-26

Turn on the power.

Step 152i-27

Did the system stop with the same error code as recorded in "Step 152i-1" on page 261?

Yes Go to "Step 152i-33" on page 265.

No Go to "Step 152i-28".

Step 152i-28

One of the cards just removed is defective.

Turn off the power.

Make sure all the green "power good out" LEDs of both I/O subsystem DCAs are off.

Step 152i-29

Reinsert one of the cards that is removed and listed in "Step 152i-25".

Step 152i-30

Turn on the power.

Step 152i-31

Did the system stop with the same error code as recorded in “Step 152i-1” on page 261?

Yes The card just reinserted is defective. Replace it. **This ends the procedure.**

Return the system to its original configuration.

Go to “MAP 0410: Repair Checkout” in the *RS/6000 and @server pSeries Diagnostic Information for Multiple Bus Systems*.

No Go to “Step 152i-32”.

Step 152i-32

Have all the cards listed in “Step 152i-25” on page 264 been reinserted?

Yes The symptom has changed. **This ends the procedure.**

Return the system to its original configuration.

Go to “MAP 0410: Repair Checkout” in the *RS/6000 and @server pSeries Diagnostic Information for Multiple Bus Systems*.

No Go to “Step 152i-29” on page 264.

Step 152i-33

Turn off the power.

Examine all the green “power good out” LEDs of both I/O subsystem DCAs.

Step 152i-34

Are all the green “power good out” LEDs of both I/O subsystem DCAs off?

Yes Go to “Step 152i-35”.

No Call for support.

Step 152i-35

Remove the following adapter cards, if present, from the I/O subsystem. record the adapter locations:

- Adapter card at P2-I6
- Adapter card at P2-I7
- Adapter card at P2-I8
- Adapter card at P2-I9
- Adapter card at P2-I10

Step 152i-36

Turn on the power.

Step 152i-37

Did the system stop with the same error code as recorded in “Step 152i-1” on page 261?

Yes Go to “Step 152i-43”.

No Go to “Step 152i-38”.

Step 152i-38

One of the cards just removed is defective.

Turn off the power.

Make sure all the green “power good out” LEDs of both I/O subsystem DCAs are off.

Step 152i-39

Reinsert one of the cards that is removed and listed in “Step 152i-35” on page 265.

Step 152i-40

Turn on the power.

Step 152i-41

Did the system stop with the same error code as recorded in “Step 152i-1” on page 261?

Yes The card just reinserted is defective. Replace it. **This ends the procedure.**

Return the system to its original configuration.

Go to “MAP 0410: Repair Checkout” in the *RS/6000 and @server pSeries Diagnostic Information for Multiple Bus Systems*.

No Go to “Step 152i-42”.

Step 152i-42

Have all the cards listed in “Step 152i-35” on page 265 been reinserted?

Yes The symptom has changed. **This ends the procedure.**

Return the system to its original configuration.

Go to “MAP 0410: Repair Checkout” in the *RS/6000 and @server pSeries Diagnostic Information for Multiple Bus Systems*.

No Go to “Step 152i-39”.

Step 152i-43

Turn off the power.

Examine the green “power good out” LEDs of both I/O subsystem DCAs.

Step 152i-44

Are all the green "power good out" LEDs of both I/O subsystem DCAs off?

Yes Go to "Step 152i-45".

No Call for support.

Step 152i-45

Remove the following DASD 4-packs, if present, from the I/O subsystem. Record the DASD locations:

- DASD 4-pack at P3
- DASD 4-pack at P4
- DASD 4-pack at P5
- DASD 4-pack at P6

Step 152i-46

Turn on the power.

Step 152i-47

Did the system stop with the same error code as recorded in "Step 152i-1" on page 261?

Yes Go to "Step 152i-53" on page 268.

No Go to "Step 152i-48".

Step 152i-48

One of the DASDs just removed is defective.

Turn off the power.

Make sure all the green "power good out" LEDs of both I/O subsystem DCAs are off.

Step 152i-49

Reinsert one of the DASD 4-packs that is removed and listed in "Step 152i-45".

Step 152i-50

Turn on the power.

Step 152i-51

Did the system stop with the same error code as recorded in "Step 152i-1" on page 261?

Yes One of the DASD in the DASD 4-pack just reinserted is defective. Replace it.
This ends the procedure.

Return the system to its original configuration.

Go to "MAP 0410: Repair Checkout" in the *RS/6000 and @server pSeries Diagnostic Information for Multiple Bus Systems*.

No Go to "Step 152i-52" on page 268.

Step 152i-52

Have all the cards listed in “Step 152i-45” on page 267 been reinserted?

Yes The symptom has changed. **This ends the procedure.**

Return the system to its original configuration.

Go to “MAP 0410: Repair Checkout” in the *RS/6000 and @server pSeries Diagnostic Information for Multiple Bus Systems*.

No Go to “Step 152i-49” on page 267.

Step 152i-53

Turn off the power.

Examine the green “power good out” LEDs of both I/O subsystem DCAs.

Step 152i-54

Are all the green “power good out” LEDs of both I/O subsystem DCAs off?

Yes Go to “Step 152i-55”.

No Call for support.

Step 152i-55

Replace the books in the following list one at a time and in the order listed:

- DCA 1 at V1
- DCA 2 at V2

Step 152i-56

Turn on the power.

Step 152i-57

Did the system stop with the same error code as recorded in “Step 152i-1” on page 261?

Yes Go to “Step 152i-58”.

No The book just replaced was defective. **This ends the procedure.**

Return the system to its original configuration.

Go to “MAP 0410: Repair Checkout” in the *RS/6000 and @server pSeries Diagnostic Information for Multiple Bus Systems*.

Step 152i-58

Turn off the power.

Make sure all the green “power good out” LEDs of both I/O subsystem DCAs are off.

Step 152i-59

Remove the new card that was just installed in “Step 152i-55” and reinstall the original card.

Step 152i-60

Have all the cards listed in “Step 152i-55” on page 268 been replaced with new or original cards?

Yes Go to “Step 152i-61”.

No Go to “Step 152i-55” on page 268.

Step 152i-61

Examine the green “power good out” LEDs of both I/O subsystem DCAs.

Step 152i-62

Are all the green “power good out” LEDs of both I/O subsystem DCAs off?

Yes Go to “Step 152i-63”.

No Call for support.

Step 152i-63

Replace the parts in the following list one at a time and in the order listed:

- I/O subsystem backplane at P1
- I/O subsystem backplane at P2

Step 152i-64

Turn on the power.

Step 152i-65

Did the system stop with the same error code as recorded in “Step 152i-1” on page 261?

Yes Go to “Step 152i-66”.

No The card just replaced was defective. **This ends the procedure.**

Return the system to its original configuration.

Go to “MAP 0410: Repair Checkout” in the *RS/6000 and @server pSeries Diagnostic Information for Multiple Bus Systems*.

Step 152i-66

Turn off the power.

Make sure all the green “power good out” LEDs of both I/O subsystem DCAs are off.

Step 152i-67

Have all the cards listed in “Step 152i-63” been replaced?

Yes Call for support.

No Go to “Step 152i-63”.

Map 152j: 2.5 V Current/Voltage Problem in I/O Subsystem

Step 152j-1

Record the error code and location code(s) that sent you to this MAP.

Step 152j-2

Determine the I/O subsystem number from the error code (10yy xxxx) and the following list. The remaining steps of this map refer to this I/O subsystem:

- If yy=14, I/O subsystem number is 1, location is U1.9
- If yy=15, I/O subsystem number is 2, location is U1.5
- If yy=16, I/O subsystem number is 3, location is U1.1
- If yy=17, I/O subsystem number is 4, location is U1.13
- If yy=21, I/O subsystem number is 5, location is U2.1
- If yy=22, I/O subsystem number is 6, location is U2.5
- If yy=23, I/O subsystem number is 4, location is U2.9
- If yy=24, I/O subsystem number is 7, location is U2.13
- If yy=25, I/O subsystem number is 8, location is U2.19

Step 152j-3

Turn off the power.

Examine the green "power good out" LEDs of both I/O subsystem DCAs.

Step 152j-4

Are all the green "power good out" LEDs of both I/O subsystem DCAs off?

Yes Go to "Step 152j-5".

No Call for support.

Step 152j-5

Remove the following adapter cards, if present, from the I/O subsystem. record the adapter locations:

- Adapter card at P1-I1
- Adapter card at P1-I2
- Adapter card at P1-I3
- Adapter card at P1-I4
- Adapter card at P1-I5

Step 152j-6

Turn on the power.

Step 152j-7

Did the system stop with the same error code as recorded in "Step 152j-1"?

Yes Go to "Step 152j-13" on page 271.

No Go to "Step 152j-8" on page 271.

Step 152j-8

One of the cards just removed is defective.

Turn off the power.

Make sure all the green "power good out" LEDs of both I/O subsystem DCAs are off.

Step 152j-9

Reinsert one of the cards that is removed and listed in "Step 152j-5" on page 270.

Step 152j-10

Turn on the power.

Step 152j-11

Did the system stop with the same error code as recorded in "Step 152j-1" on page 270?

Yes The card just reinserted is defective. Replace it. **This ends the procedure.**

Return the system to its original configuration.

Go to "MAP 0410: Repair Checkout" in the *RS/6000 and @server pSeries Diagnostic Information for Multiple Bus Systems*.

No Go to "Step 152j-12".

Step 152j-12

Have all the cards listed in "Step 152j-5" on page 270 been reinserted?

Yes The symptom has changed. **This ends the procedure.**

Return the system to its original configuration.

Go to "MAP 0410: Repair Checkout" in the *RS/6000 and @server pSeries Diagnostic Information for Multiple Bus Systems*.

No Go to "Step 152j-9".

Step 152j-13

Turn off the power.

Examine the green "power good out" LEDs of both I/O subsystem DCAs.

Step 152j-14

Are all the green "power good out" LEDs of both I/O subsystem DCAs off?

Yes Go to "Step 152j-15" on page 272.

No Call for support.

Step 152j-15

Remove the following adapter cards, if present, from the I/O subsystem. record the adapter locations:

- Adapter card at P1-I6
- Adapter card at P1-I7
- Adapter card at P1-I8
- Adapter card at P1-I9
- Adapter card at P1-I10

Step 152j-16

Turn on the power.

Step 152j-17

Did the system stop with the same error code as recorded in “Step 152j-1” on page 270?

Yes Go to “Step 152j-23” on page 273.

No Go to “Step 152j-18”.

Step 152j-18

One of the cards just removed is defective.

Turn off the power.

Make sure all the green “power good out” LEDs of both I/O subsystem DCAs are off.

Step 152j-19

Reinsert one of the cards that is removed and listed in “Step 152j-15”.

Step 152j-20

Turn on the power.

Step 152j-21

Did the system stop with the same error code as recorded in “Step 152j-1” on page 270?

Yes The card just reinserted is defective. Replace it.

This ends the procedure.

Return the system to its original configuration.

Go to “MAP 0410: Repair Checkout” in the *RS/6000 and @server pSeries Diagnostic Information for Multiple Bus Systems*.

No Go to “Step 152j-22” on page 273.

Step 152j-22

Have all the cards listed in “Step 152j-15” on page 272 been reinserted?

Yes The symptom has changed. **This ends the procedure.**

Return the system to its original configuration.

Go to “MAP 0410: Repair Checkout” in the *RS/6000 and @server pSeries Diagnostic Information for Multiple Bus Systems*.

No Go to “Step 152j-19” on page 272.

Step 152j-23

Turn off the power.

Examine the green “power good out” LEDs of both I/O subsystem DCAs.

Step 152j-24

Are all the green “power good out” LEDs of both I/O subsystem DCAs off?

Yes Go to “Step 152j-25”.

No Call for support.

Step 152j-25

Remove the following adapter cards, if present, from the I/O subsystem. record the adapter locations:

- Adapter card at P2-I1
- Adapter card at P2-I2
- Adapter card at P2-I3
- Adapter card at P2-I4
- Adapter card at P2-I5

Step 152j-26

Turn on the power.

Step 152j-27

Did the system stop with the same error code as recorded in “Step 152j-1” on page 270?

Yes Go to “Step 152j-33” on page 274.

No Go to “Step 152j-28”.

Step 152j-28

One of the cards just removed is defective.

Turn off the power.

Make sure all the green “power good out” LEDs of both I/O subsystem DCAs are off.

Step 152j-29

Reinsert one of the cards that is removed and listed in “Step 152j-25”.

Step 152j-30

Turn on the power.

Step 152j-31

Did the system stop with the same error code as recorded in “Step 152j-1” on page 270?

Yes The card just reinserted is defective. Replace it. **This ends the procedure.**

Return the system to its original configuration.

Go to “MAP 0410: Repair Checkout” in the *RS/6000 and @server pSeries Diagnostic Information for Multiple Bus Systems*.

No Go to “Step 152j-32”.

Step 152j-32

Have all the cards listed in “Step 152j-25” on page 273 been reinserted?

Yes The symptom has changed. **This ends the procedure.**

Return the system to its original configuration.

Go to “MAP 0410: Repair Checkout” in the *RS/6000 and @server pSeries Diagnostic Information for Multiple Bus Systems*.

No Go to “Step 152j-29” on page 273.

Step 152j-33

Turn off the power.

Examine the green “power good out” LEDs of both I/O subsystem DCAs.

Step 152j-34

Are all the green “power good out” LEDs of both I/O subsystem DCAs off?

Yes Go to “Step 152j-35”.

No Call for support.

Step 152j-35

Remove the following adapter cards, if present, from the I/O subsystem. record the adapter locations:

- Adapter card at P2-I6
- Adapter card at P2-I7
- Adapter card at P2-I8
- Adapter card at P2-I9
- Adapter card at P2-I10

Step 152j-36

Turn on the power.

Step 152j-37

Did the system stop with the same error code as recorded in “Step 152j-1” on page 270?

Yes Go to “Step 152j-43”.

No Go to “Step 152j-38”.

Step 152j-38

One of the cards just removed is defective.

Turn off the power.

Make sure all the green “power good out” LEDs of both I/O subsystem DCAs are off.

Step 152j-39

Reinsert one of the cards that is removed and listed in “Step 152j-35” on page 274.

Step 152j-40

Turn on the power.

Step 152j-41

Did the system stop with the same error code as recorded in “Step 152j-1” on page 270?

Yes The card just reinserted is defective. Replace it. **This ends the procedure.**

Return the system to its original configuration.

Go to “MAP 0410: Repair Checkout” in the *RS/6000 and @server pSeries Diagnostic Information for Multiple Bus Systems*.

No Go to “Step 152j-42”.

Step 152j-42

Have all the cards listed in “Step 152j-35” on page 274 been reinserted?

Yes The symptom has changed. **This ends the procedure.**

Return the system to its original configuration.

Go to “MAP 0410: Repair Checkout” in the *RS/6000 and @server pSeries Diagnostic Information for Multiple Bus Systems*.

No Go to “Step 152j-39”.

Step 152j-43

Turn off the power.

Examine the green “power good out” LEDs of both I/O subsystem DCAs.

Step 152j-44

Are all the green "power good out" LEDs of both I/O subsystem DCAs off?

Yes Go to "Step 152j-45".

No Call for support.

Step 152j-45

Replace the cards in the following list one at a time and in the order listed:

- DCA 1 at V1
- DCA 2 at V2

Step 152j-46

Turn on the power.

Step 152j-47

Did the system stop with the same error code as recorded in "Step 152j-1" on page 270?

Yes Go to "Step 152j-48".

No The card just replaced is defective. **This ends the procedure.**

Return the system to its original configuration.

Go to "MAP 0410: Repair Checkout" in the *RS/6000 and @server pSeries Diagnostic Information for Multiple Bus Systems*.

Step 152j-48

Turn off the power.

Make sure all the green "power good out" LEDs of both I/O subsystem DCAs are off.

Step 152j-49

Remove the new card that was just installed in "Step 152j-45" and reinstall the original card.

Step 152j-50

Have all the cards listed in "Step 152j-45" been replaced with new or original cards?

Yes Go to "Step 152j-51"

No Go to "Step 152j-45".

Step 152j-51

Examine the green "power good out" LEDs of both I/O subsystem DCAs.

Step 152j-52

Are all the green "power good out" LEDs of both I/O subsystem DCAs off?

Yes Go to "Step 152j-53".

No Call for support.

Step 152j-53

Replace the parts in the following list one at a time and in the order listed:

- I/O subsystem backplane at P1
- I/O subsystem backplane at P2

Step 152j-54

Turn on the power.

Step 152j-55

Did the system stop with the same error code as recorded in "Step 152j-1" on page 270?

Yes Go to "Step 152j-56".

No The part just replaced is defective. Replace it. **This ends the procedure.**

Return the system to its original configuration.

Go to "MAP 0410: Repair Checkout" in the *RS/6000 and @server pSeries Diagnostic Information for Multiple Bus Systems*.

Step 152j-56

Turn off the power.

Make sure all the green "power good out" LEDs of both I/O subsystem DCAs are off.

Step 152j-57

Have all the cards listed in "Step 152j-53" been replaced with new or original cards?

Yes Call for support.

No Go to "Step 152j-53".

Map 152k: 12.0 V Current/Voltage Problem in I/O Subsystem

Step 152k-1

Record the error code and location code(s) that sent you to this MAP.

Step 152k-2

Determine the I/O subsystem number from the error code (10yy xxxx) and the following list. The remaining steps of this map refer to this I/O subsystem:

- If yy=14, I/O subsystem number is 1, location is U1.9
- If yy=15, I/O subsystem number is 2, location is U1.5
- If yy=16, I/O subsystem number is 3, location is U1.1
- If yy=17, I/O subsystem number is 4, location is U1.13
- If yy=21, I/O subsystem number is 5, location is U2.1
- If yy=22, I/O subsystem number is 6, location is U2.5
- If yy=23, I/O subsystem number is 4, location is U2.9
- If yy=24, I/O subsystem number is 7, location is U2.13
- If yy=25, I/O subsystem number is 8, location is U2.19

Step 152k-3

Turn off the power.

Examine the green "power good out" LEDs of both I/O subsystem DCAs.

Step 152k-4

Are all the green "power good out" LEDs of both I/O subsystem DCAs off?

Yes Go to "Step 152k-5".

No Call for support.

Step 152k-5

Remove the following adapter cards, if present, from the I/O subsystem. record the adapter locations:

- Adapter card at P1-I1
- Adapter card at P1-I2
- Adapter card at P1-I3
- Adapter card at P1-I4
- Adapter card at P1-I5

Step 152k-6

Turn on the power.

Step 152k-7

Did the system stop with the same error code as recorded in "Step 152k-1"?

Yes Go to "Step 152k-13" on page 279.

No Go to "Step 152k-8" on page 279.

Step 152k-8

One of the cards just removed is defective.

Turn off the power.

Make sure all the green "power good out" LEDs of both I/O subsystem DCAs are off.

Step 152k-9

Reinsert one of the cards that is removed and listed in "Step 152k-5" on page 278.

Step 152k-10

Turn on the power.

Step 152k-11

Did the system stop with the same error code as recorded in "Step 152k-1" on page 278?

Yes The card just reinserted is defective. Replace it. **This ends the procedure.**

Return the system to its original configuration.

Go to "MAP 0410: Repair Checkout" in the *RS/6000 and @server pSeries Diagnostic Information for Multiple Bus Systems*.

No Go to "Step 152k-12".

Step 152k-12

Have all the cards listed in "Step 152k-5" on page 278 been reinserted?

Yes The symptom has changed. **This ends the procedure.**

Return the system to its original configuration.

Go to "MAP 0410: Repair Checkout" in the *RS/6000 and @server pSeries Diagnostic Information for Multiple Bus Systems*.

No Go to "Step 152k-9".

Step 152k-13

Turn off the power.

Examine the green "power good out" LEDs of both I/O subsystem DCAs.

Step 152k-14

Are all the green "power good out" LEDs of both I/O subsystem DCAs off?

Yes Go to "Step 152k-15" on page 280.

No Call for support.

Step 152k-15

Remove the following adapter cards, if present, from the I/O subsystem. record the adapter locations:

- Adapter card at P1-I6
- Adapter card at P1-I7
- Adapter card at P1-I8
- Adapter card at P1-I9
- Adapter card at P1-I10

Step 152k-16

Turn on the power.

Step 152k-17

Did the system stop with the same error code as recorded in “Step 152k-1” on page 278?

Yes Go to “Step 152k-23” on page 281.

No Go to “Step 152k-18”.

Step 152k-18

One of the cards just removed is defective.

Turn off the power.

Make sure all the green “power good out” LEDs of both I/O subsystem DCAs are off.

Step 152k-19

Reinsert one of the cards that is removed and listed in “Step 152k-15”.

Step 152k-20

Turn on the power.

Step 152k-21

Did the system stop with the same error code as recorded in “Step 152k-1” on page 278?

Yes The card just reinserted is defective. Replace it. **This ends the procedure.**

Return the system to its original configuration.

Go to “MAP 0410: Repair Checkout” in the *RS/6000 and @server pSeries Diagnostic Information for Multiple Bus Systems*.

No Go to “Step 152k-22” on page 281.

Step 152k-22

Have all the cards listed in “Step 152k-15” on page 280 been reinserted?

Yes The symptom has changed. **This ends the procedure.**

Return the system to its original configuration.

Go to “MAP 0410: Repair Checkout” in the *RS/6000 and @server pSeries Diagnostic Information for Multiple Bus Systems*.

No Go to “Step 152k-19” on page 280.

Step 152k-23

Turn off the power.

Examine the green “power good out” LEDs of both I/O subsystem DCAs.

Step 152k-24

Are all the green “power good out” LEDs of both I/O subsystem DCAs off?

Yes Go to “Step 152k-25”.

No Call for support.

Step 152k-25

Remove the following adapter cards, if present, from the I/O subsystem. record the adapter locations:

- Adapter card at P2-I1
- Adapter card at P2-I2
- Adapter card at P2-I3
- Adapter card at P2-I4
- Adapter card at P2-I5

Step 152k-26

Turn on the power.

Step 152k-27

Did the system stop with the same error code as recorded in “Step 152k-1” on page 278?

Yes Go to “Step 152k-33” on page 282.

No Go to “Step 152k-28”.

Step 152k-28

One of the cards just removed is defective.

Turn off the power.

Make sure all the green “power good out” LEDs of both I/O subsystem DCAs are off.

Step 152k-29

Reinsert one of the cards that is removed and listed in “Step 152k-25”.

Step 152k-30

Turn on the power.

Step 152k-31

Did the system stop with the same error code as recorded in “Step 152k-1” on page 278?

Yes The card just reinserted is defective. Replace it. **This ends the procedure.**

Return the system to its original configuration.

Go to “MAP 0410: Repair Checkout” in the *RS/6000 and @server pSeries Diagnostic Information for Multiple Bus Systems*.

No Go to “Step 152k-32”.

Step 152k-32

Have all the cards listed in “Step 152k-25” on page 281 been reinserted?

Yes The symptom has changed. **This ends the procedure.**

Return the system to its original configuration.

Go to “MAP 0410: Repair Checkout” in the *RS/6000 and @server pSeries Diagnostic Information for Multiple Bus Systems*.

No Go to “Step 152k-29” on page 281.

Step 152k-33

Turn off the power.

Examine the green “power good out” LEDs of both I/O subsystem DCAs.

Step 152k-34

Are all the green “power good out” LEDs of both I/O subsystem DCAs off?

Yes Go to “Step 152k-35”.

No Call for support.

Step 152k-35

Remove the following adapter cards, if present, from the I/O subsystem. record the adapter locations:

- Adapter card at P2-I6
- Adapter card at P2-I7
- Adapter card at P2-I8
- Adapter card at P2-I9
- Adapter card at P2-I10

Step 152k-36

Turn on the power.

Step 152k-37

Did the system stop with the same error code as recorded in “Step 152k-1” on page 278?

Yes Go to “Step 152k-43”.

No Go to “Step 152k-38”.

Step 152k-38

One of the cards just removed is defective.

Turn off the power.

Make sure all the green “power good out” LEDs of both I/O subsystem DCAs are off.

Step 152k-39

Reinsert one of the cards that is removed and listed in “Step 152k-35” on page 282.

Step 152k-40

Turn on the power.

Step 152k-41

Did the system stop with the same error code as recorded in “Step 152k-1” on page 278?

Yes The card just reinserted is defective. Replace it. **This ends the procedure.**

Return the system to its original configuration.

Go to “MAP 0410: Repair Checkout” in the *RS/6000 and @server pSeries Diagnostic Information for Multiple Bus Systems*.

No Go to “Step 152k-42”.

Step 152k-42

Have all the cards listed in “Step 152k-35” on page 282 been reinserted?

Yes The symptom has changed. **This ends the procedure.**

Return the system to its original configuration.

Go to “MAP 0410: Repair Checkout” in the *RS/6000 and @server pSeries Diagnostic Information for Multiple Bus Systems*.

No Go to “Step 152k-39”.

Step 152k-43

Turn off the power.

Examine the green “power good out” LEDs of both I/O subsystem DCAs.

Step 152k-44

Are all the green "power good out" LEDs of both I/O subsystem DCAs off?

Yes Go to "Step 152k-45".

No Call for support.

Step 152k-45

Remove the following DASD 4-packs, if present, from the I/O subsystem. Record the DASD locations:

- DASD 4-pack at P3
- DASD 4-pack at P4
- DASD 4-pack at P5
- DASD 4-pack at P6

Step 152k-46

Turn on the power.

Step 152k-47

Did the system stop with the same error code as recorded in "Step 152k-1" on page 278?

Yes Go to "Step 152k-53" on page 285.

No Go to "Step 152k-48".

Step 152k-48

One of the DASDs just removed is defective.

Turn off the power.

Make sure all the green "power good out" LEDs of both I/O subsystem DCAs are off.

Step 152k-49

Reinsert one of the DASD 4-packs that is removed and listed in "Step 152k-45".

Step 152k-50

Turn on the power.

Step 152k-51

Did the system stop with the same error code as recorded in "Step 152k-1" on page 278?

Yes One of the DASD in the DASD 4-pack just reinserted is defective. Replace it.
This ends the procedure.

Return the system to its original configuration.

Go to "MAP 0410: Repair Checkout" in the *RS/6000 and @server pSeries Diagnostic Information for Multiple Bus Systems*.

No Go to "Step 152k-52" on page 285.

Step 152k-52

Have all the cards listed in “Step 152k-45” on page 284 been reinserted?

Yes The symptom has changed. **This ends the procedure.**

Return the system to its original configuration.

Go to “MAP 0410: Repair Checkout” in the *RS/6000 and @server pSeries Diagnostic Information for Multiple Bus Systems*.

No Go to “Step 152k-49” on page 284.

Step 152k-53

Turn off the power.

Examine the green “power good out” LEDs of both I/O subsystem DCAs.

Step 152k-54

Are all the green “power good out” LEDs of both I/O subsystem DCAs off?

Yes Go to “Step 152k-55”.

No Call for support.

Step 152k-55

Replace the books in the following list one at a time and in the order listed:

- DCA 1 at V1
- DCA 2 at V2

Step 152k-56

Turn on the power.

Step 152k-57

Did the system stop with the same error code as recorded in “Step 152k-1” on page 278?

Yes Go to “Step 152k-58”.

No The part just replaced was defective. **This ends the procedure.**

Return the system to its original configuration.

Go to “MAP 0410: Repair Checkout” in the *RS/6000 and @server pSeries Diagnostic Information for Multiple Bus Systems*.

Step 152k-58

Turn off the power.

Make sure all the green “power good out” LEDs of both I/O subsystem DCAs are off.

Step 152k-59

Remove the new card that was just installed in “Step 152k-55” and reinstall the original card.

Step 152k-60

Have all the cards listed in “Step 152k-55” on page 285 been replaced with new or original cards?

Yes Go to “Step 152k-61”.

No Go to “Step 152k-55” on page 285.

Step 152k-61

Examine the the green “power good out” LEDs of both I/O subsystem DCAs.

Step 152k-62

Are all the green “power good out” LEDs of both I/O subsystem DCAs off?

Yes Go to “Step 152k-63”.

No Call for support.

Step 152k-63

Replace the parts in the following list one at a time and in the order listed:

- I/O subsystem backplane at P1
- I/O subsystem backplane at P2

Step 152k-64

Turn on the power.

Step 152k-65

Did the system stop with the same error code as recorded in “Step 152k-1” on page 278?

Yes Go to “Step 152k-66”.

No The card just replaced was defective. **This ends the procedure.**

Return the system to its original configuration.

Go to “MAP 0410: Repair Checkout” in the *RS/6000 and @server pSeries Diagnostic Information for Multiple Bus Systems*.

Step 152k-66

Turn off the power.

Make sure all the green “power good out” LEDs of both I/O subsystem DCAs are off.

Step 152k-67

Have all the cards listed in “Step 152k-63” been replaced?

Yes Call for support.

No Go to “Step 152k-63”.

Map 152I: -12.0V Current/Voltage Problem in I/O Subsystem

Step 152I-1

Record the error code and location code(s) that sent you to this MAP.

Step 152I-2

Determine the I/O subsystem number from the error code (10yy xxxx) and the following list. The remaining steps of this map refer to this I/O subsystem:

- If yy=14, I/O subsystem number is 1, location is U1.9
- If yy=15, I/O subsystem number is 2, location is U1.5
- If yy=16, I/O subsystem number is 3, location is U1.1
- If yy=17, I/O subsystem number is 4, location is U1.13
- If yy=21, I/O subsystem number is 5, location is U2.1
- If yy=22, I/O subsystem number is 6, location is U2.5
- If yy=23, I/O subsystem number is 4, location is U2.9
- If yy=24, I/O subsystem number is 7, location is U2.13
- If yy=25, I/O subsystem number is 8, location is U2.19

Step 152I-3

Turn off the power.

Examine the green "power good out" LEDs of both I/O subsystem DCAs.

Step 152I-4

Are all the green "power good out" LEDs of both I/O subsystem DCAs off?

Yes Go to "Step 152I-5".

No Call for support.

Step 152I-5

Remove the following adapter cards, if present, from the I/O subsystem. record the adapter locations:

- Adapter card at P1-I1
- Adapter card at P1-I2
- Adapter card at P1-I3
- Adapter card at P1-I4
- Adapter card at P1-I5

Step 152I-6

Turn on the power.

Step 152I-7

Did the system stop with the same error code as recorded in "Step 152I-1"?

Yes Go to "Step 152I-13" on page 288.

No Go to "Step 152I-8" on page 288.

Step 152I-8

One of the cards just removed is defective.

Turn off the power.

Make sure all the green "power good out" LEDs of both I/O subsystem DCAs are off.

Step 152I-9

Reinsert one of the cards that is removed and listed in "Step 152I-5" on page 287.

Step 152I-10

Turn on the power.

Step 152I-11

Did the system stop with the same error code as recorded in "Step 152I-1" on page 287?

Yes The card just reinserted is defective. Replace it. **This ends the procedure.**
Return the system to its original configuration.
Go to "MAP 0410: Repair Checkout" in the *RS/6000 and @server pSeries Diagnostic Information for Multiple Bus Systems*.

No Go to "Step 152I-12".

Step 152I-12

Have all the cards listed in "Step 152I-5" on page 287 been reinserted?

Yes The symptom has changed. **This ends the procedure.**
Return the system to its original configuration.
Go to "MAP 0410: Repair Checkout" in the *RS/6000 and @server pSeries Diagnostic Information for Multiple Bus Systems*.

No Go to "Step 152I-9".

Step 152I-13

Turn off the power.

Examine the green "power good out" LEDs of both I/O subsystem DCAs.

Step 152I-14

Are all the green "power good out" LEDs of both I/O subsystem DCAs off?

Yes Go to "Step 152I-15".

No Call for support.

Step 152I-15

Remove the following adapter cards, if present, from the I/O subsystem. record the adapter locations:

- Adapter card at P1-I6

- Adapter card at P1-I7
- Adapter card at P1-I8
- Adapter card at P1-I9
- Adapter card at P1-I10

Step 152I-16

Turn on the power.

Step 152I-17

Did the system stop with the same error code as recorded in “Step 152I-1” on page 287?

Yes Go to “Step 152I-23” on page 290.

No Go to “Step 152I-18”.

Step 152I-18

One of the cards just removed is defective.

Turn off the power.

Make sure all the green “power good out” LEDs of both I/O subsystem DCAs are off.

Step 152I-19

Reinsert one of the cards that is removed and listed in “Step 152I-15” on page 288.

Step 152I-20

Turn on the power.

Step 152I-21

Did the system stop with the same error code as recorded in “Step 152I-1” on page 287?

Yes The card just reinserted is defective. Replace it. **This ends the procedure.**

Return the system to its original configuration.

Go to “MAP 0410: Repair Checkout” in the *RS/6000 and @server pSeries Diagnostic Information for Multiple Bus Systems*.

No Go to “Step 152I-22”.

Step 152I-22

Have all the cards listed in “Step 152I-15” on page 288 been reinserted?

Yes The symptom has changed. **This ends the procedure.**

Return the system to its original configuration.

Go to “MAP 0410: Repair Checkout” in the *RS/6000 and @server pSeries Diagnostic Information for Multiple Bus Systems*.

No Go to “Step 152I-19”.

Step 152I-23

Turn off the power.

Examine the green "power good out" LEDs of both I/O subsystem DCAs.

Step 152I-24

Are all the green "power good out" LEDs of both I/O subsystem DCAs off?

Yes Go to "Step 152I-25".

No Call for support.

Step 152I-25

Remove the following adapter cards, if present, from the I/O subsystem. record the adapter locations:

- Adapter card at P2-I1
- Adapter card at P2-I2
- Adapter card at P2-I3
- Adapter card at P2-I4
- Adapter card at P2-I5

Step 152I-26

Turn on the power.

Step 152I-27

Did the system stop with the same error code as recorded in "Step 152I-1" on page 287?

Yes Go to "Step 152I-33" on page 291.

No Go to "Step 152I-28".

Step 152I-28

One of the cards just removed is defective.

Turn off the power.

Make sure all the green "power good out" LEDs of both I/O subsystem DCAs are off.

Step 152I-29

Reinsert one of the cards that is removed and listed in "Step 152I-25".

Step 152I-30

Turn on the power.

Step 152I-31

Did the system stop with the same error code as recorded in “Step 152I-1” on page 287?

Yes The card just reinserted is defective. Replace it. **This ends the procedure.**

Return the system to its original configuration.

Go to “MAP 0410: Repair Checkout” in the *RS/6000 and @server pSeries Diagnostic Information for Multiple Bus Systems*.

No Go to “Step 152I-32”.

Step 152I-32

Have all the cards listed in “Step 152I-25” on page 290 been reinserted?

Yes The symptom has changed. **This ends the procedure.**

Return the system to its original configuration.

Go to “MAP 0410: Repair Checkout” in the *RS/6000 and @server pSeries Diagnostic Information for Multiple Bus Systems*.

No Go to “Step 152I-29” on page 290.

Step 152I-33

Turn off the power.

Examine the green “power good out” LEDs of both I/O subsystem DCAs.

Step 152I-34

Are all the green “power good out” LEDs of both I/O subsystem DCAs off?

Yes Go to “Step 152I-35”.

No Call for support.

Step 152I-35

Remove the following adapter cards, if present, from the I/O subsystem. record the adapter locations:

- Adapter card at P2-I6
- Adapter card at P2-I7
- Adapter card at P2-I8
- Adapter card at P2-I9
- Adapter card at P2-I10

Step 152I-36

Turn on the power.

Step 152I-37

Did the system stop with the same error code as recorded in “Step 152I-1” on page 287?

Yes Go to “Step 152I-43”.

No Go to “Step 152I-38”.

Step 152I-38

One of the cards just removed is defective.

Turn off the power.

Make sure all the green “power good out” LEDs of both I/O subsystem DCAs are off.

Step 152I-39

Reinsert one of the cards that is removed and listed in “Step 152I-35” on page 291.

Step 152I-40

Turn on the power.

Step 152I-41

Did the system stop with the same error code as recorded in “Step 152I-1” on page 287?

Yes The card just reinserted is defective. Replace it. **This ends the procedure.**

Return the system to its original configuration.

Go to “MAP 0410: Repair Checkout” in the *RS/6000 and @server pSeries Diagnostic Information for Multiple Bus Systems*.

No Go to “Step 152I-42”.

Step 152I-42

Have all the cards listed in “Step 152I-35” on page 291 been reinserted?

Yes The symptom has changed. **This ends the procedure.**

Return the system to its original configuration.

Go to “MAP 0410: Repair Checkout” in the *RS/6000 and @server pSeries Diagnostic Information for Multiple Bus Systems*.

No Go to “Step 152I-39”.

Step 152I-43

Turn off the power.

Examine the green “power good out” LEDs of both I/O subsystem DCAs.

Step 152I-44

Are all the green "power good out" LEDs of both I/O subsystem DCAs off?

Yes Go to "Step 152I-45".

No Call for support.

Step 152I-45

Replace the DCAs in the following list one at a time and in the order listed:

- DCA 1 at V1
- DCA 2 at V2

Step 152I-46

Turn on the power.

Step 152I-47

Did the system stop with the same error code as recorded in "Step 152I-1" on page 287?

Yes Go to "Step 152I-48".

No The DCA just replaced is defective. **This ends the procedure.**

Return the system to its original configuration.

Go to "MAP 0410: Repair Checkout" in the *RS/6000 and @server pSeries Diagnostic Information for Multiple Bus Systems*.

Step 152I-48

Turn off the power.

Make sure all the green "power good out" LEDs of both I/O subsystem DCAs are off.

Step 152I-49

Remove the new DCA that was just installed in "Step 152I-45" and reinstall the original DCA.

Step 152I-50

Have all the DCAs listed in "Step 152I-45" been replaced with new or original cards?

Yes Go to "Step 152I-51"

No Go to "Step 152I-45".

Step 152I-51

Examine the green "power good out" LEDs of both I/O subsystem DCAs.

Step 152I-52

Are all the green "power good out" LEDs of both I/O subsystem DCAs off?

Yes Go to "Step 152I-53" on page 294.

No Call for support.

Step 152I-53

Replace the parts in the following list one at a time and in the order listed:

- I/O subsystem backplane at P1
- I/O subsystem backplane at P2

Step 152I-54

Turn on the power.

Step 152I-55

Did the system stop with the same error code as recorded in “Step 152I-1” on page 287?

Yes Go to “Step 152I-56”.

No The part just replaced is defective. Replace it. **This ends the procedure.**

Return the system to its original configuration.

Go to “MAP 0410: Repair Checkout” in the *RS/6000 and @server pSeries Diagnostic Information for Multiple Bus Systems*.

Step 152I-56

Turn off the power.

Make sure all the green “power good out” LEDs of both I/O subsystem DCAs are off.

Step 152I-57

Have all the cards listed in “Step 152I-53” been replaced with new or original cards?

Yes Call for support.

No Go to “Step 152I-53”.

Map 152m: Cable Problem in Power Subsystem

Step 152m-1

Record the error code and location code(s) that sent you to this MAP. You should be supplied with two location codes from the action for the error code in the service guide. These location codes are the ends of the cable in question. The fourth nibble of the error code indicates the side of the power subsystem that detected the failure. For example, 101A indicates side A (front), and 101B indicates side B (rear). The following steps apply to the power subsystem side indicated by the error code recorded:

1. Generate the first FRU location code (from U1.35) to be replaced by taking the location code given for the action of the error code and truncating the connector ID (/Qx).
2. Generate the second FRU location code to be replaced by taking the location code (not from U1.35) given for the action of the error code and truncating the connector ID (/Qx).
3. Generate the third FRU location code to be replaced (the cable) by taking the location code (from U1.35) given for the action of the error code and appending a # (number sign). For example, the service guide for error code 101A x125 lists the location codes U1.35-P1-X3/Q1 and U1.9-V1/Q2. From the error code, you are working on the A (front) side. From the location codes, the FRUs, in order of replacement, (if required) are:
 - a. U1.35-P1-X3 - BPD1
 - b. U1.9-V1 - DCA1
 - c. U1.35-P1-X3# - cable

Refer to “AIX and Physical Location Code Reference Tables” on page 62 and “Power Distribution Cabling” on page 35.

Step 152m-2

Press the green **start service** button on the panel with the UEPO switch.

Step 152m-3

From the action column in the “Error Code to FRU” table entry for the error code recorded in “Step 152m-1”, find the location codes of both ends of the suspect power cable.

Step 152m-4

Examine both ends of the power cable, and make sure each end is properly connected and fully seated.

Step 152m-5

Is the power cable properly connected and seated fully at both ends?

Yes Go to “Step 152m-6” on page 296.

No Go to “Step 152m-12” on page 296.

Step 152m-6

Have you replaced the first FRU in the list of FRUs recorded in “Step 152m-1” on page 295 in a previous service action?

Yes Go to “Step 152m-18” on page 297.

No Go to “Step 152m-7”.

Step 152m-7

Is the power-on LED of the first FRU generated from the location codes recorded in “Step 152m-1” on page 295 off?

Yes Go to “Step 152m-8”.

No Call for support.

Step 152m-8

Replace the first FRU in the list of FRUs recorded in “Step 152m-1” on page 295 with power-on LED off. Press the white **service complete** button on the panel with the UEPO switch after replacement.

Step 152m-9

Does the error code recorded in “Step 152m-1” on page 295 reappear?

Yes Return the system to its original configuration. Go to “Step 152m-11”.

No Return the system to its original configuration. Go to “MAP 0410: Repair Checkout” in the *RS/6000 and @server pSeries Diagnostic Information for Multiple Bus Systems*.

Step 152m-10

Press the white **service complete** button on the panel with the UEPO switch.

Step 152m-11

Schedule non-concurrent service with the customer to replace the second FRU in the list of FRUs recorded in “Step 152m-1” on page 295. **This ends the procedure.**

Step 152m-12

Is the power-on LED of the first FRU generated from the location codes recorded in “Step 152m-1” on page 295 off?

Yes Go to “Step 152m-13”.

No Call for support.

Step 152m-13

Reseat and properly connect the power cable ends, with location codes recorded in “Step 152m-1” on page 295.

Step 152m-14

Set the power-on switches of all BPRs on the same side with the power cable that was not connected properly to the off (right) position.

Step 152m-15

Wait 30 seconds and then turn the power-on switches of the BPRs found in “Step 152m-14” on page 296 to the on (left) position.

Step 152m-16

Press the white **service complete** button on the panel with the UEPO switch after replacement.

Step 152m-17

Does the error code recorded in “Step 152m-1” on page 295 reappear?

Yes Go to “Step 152m-2” on page 295.

No Return the system to its original configuration. Go to “MAP 0410: Repair Checkout” in the *RS/6000 and @server pSeries Diagnostic Information for Multiple Bus Systems*.

Step 152m-18

Note: The following steps will require the system power to be removed. AIX must be shut down in all partitions before turning off the power.

Turn off the power. Turn off the UEPO switch. Examine the amber logic-power LEDs of all installed processor subsystem DCAs. Also examine the green “power good out” LEDs of all installed I/O subsystem DCAs.

Step 152m-19

Are all amber logic-power LEDs of all installed processor subsystem DCAs and all green “logic power out” LEDs of all installed I/O subsystem DCAs off?

Yes Go to “Step 152m-20”.

No Call for support.

Step 152m-20

Replace the second FRU in the list of FRUs recorded in step “Step 152m-1” on page 295.

Step 152m-21

Turn on the UEPO switch. Turn on the power.

Step 152m-22

Does the error code recorded in “Step 152m-1” on page 295 reappear?

Yes Go to “Step 152m-23”.

No Return the system to its original configuration. Go to “MAP 0410: Repair Checkout” in the *RS/6000 and @server pSeries Diagnostic Information for Multiple Bus Systems*.

Step 152m-23

Go to “Step 152m-24” on page 298.

Step 152m-24

Turn off the power. Turn off the UEPO switch. Examine the amber logic-power LEDs of all installed processor subsystem DCAs. Also examine the green "power good out" LEDs of all installed I/O subsystem DCAs.

Step 152m-25

Are all amber logic-power LEDs of all installed processor subsystem DCAs and all green "logic power out" LEDs of all installed I/O subsystem DCAs off?

Yes Go to "Step 152m-26".

No Call for support.

Step 152m-26

Replace the third FRU in the list of FRUs recorded in step 152m-1.

Step 152m-27

Turn on the UEPO switch. Turn on the power.

Step 152m-28

Does the error code recorded in "Step 152m-1" on page 295 reappear?

Yes Call for support.

No Return the system to its original configuration. Go to "MAP 0410: Repair Checkout" in the *RS/6000 and @server pSeries Diagnostic Information for Multiple Bus Systems*.

Map 152n: DASD Subsystem Power Problem

Step 152n-1

Record the error code and location code(s) that sent you to this MAP.

Step 152n-2

Press the green **start service** button on the panel with the UEPO switch.

Determine the I/O subsystem number from the error code (10yy xxxx) and the following list. The remaining steps of this map refer to this I/O subsystem:

- If yy=14, I/O subsystem number is 1, location is U1.9
- If yy=15, I/O subsystem number is 2, location is U1.5
- If yy=16, I/O subsystem number is 3, location is U1.1
- If yy=17, I/O subsystem number is 4, location is U1.13
- If yy=21, I/O subsystem number is 5, location is U2.1
- If yy=22, I/O subsystem number is 6, location is U2.5
- If yy=23, I/O subsystem number is 4, location is U2.9
- If yy=24, I/O subsystem number is 7, location is U2.13
- If yy=25, I/O subsystem number is 8, location is U2.19

Step 152n-3

Examine the last 2 characters of the error code recorded in “Step 152n-1”, and use the following list to determine which DASD backplane to service.

- If the last 2 characters of the error code is 96, then the following steps refer to DASD backplane D of I/O subsystem number found in “Step 152n-2”.
- If the last 2 characters of the error code is A6, then the following steps refer to DASD backplane C of I/O subsystem number found in “Step 152n-2”.
- If the last 2 characters of the error code is B6, then the following steps refer to DASD backplane B of I/O subsystem number found in “Step 152n-2”.
- If the last 2 characters of the error code is C6, then the following steps refer to DASD backplane A of I/O subsystem number found in “Step 152n-2”.

Step 152n-4

Turn off the power. Examine the green “power good out” LEDs of both I/O subsystem DCAs.

Step 152n-5

Are all the green “power good out” LEDs of both I/O subsystem DCAs off?

Yes Go to “Step 152n-6” on page 300.

No Call for support.

Step 152n-6

Are there any DASD in positions A8, A9, Aa, or Ab of the DASD backplane found in “Step 152n-2” on page 299 and “Step 152n-3” on page 299?

Yes Go to “Step 152n-7”.

No Go to “Step 152n-15” on page 301.

Step 152n-7

Turn on the power.

Step 152n-8

Did the error code recorded in “Step 152n-1” on page 299 reappear?

Yes Go to “Step 152n-14”.

No One of the DASD just removed is defective. Go to “Step 152n-9”.

Step 152n-9

Turn off the power. Make sure all green “power good out” LEDs of all installed I/O subsystem DCAs are off.

Step 152n-10

Reinstall one of the DASD removed in “Step 152n-6”.

Step 152n-11

Turn on the power.

Step 152n-12

Did the error code recorded in “Step 152n-1” on page 299 reappear?

Yes The DASD just reinstalled is defective. Replace it. **This ends the procedure.** Return the system to its original configuration.

Go to “MAP 0410: Repair Checkout” in the *RS/6000 and @server pSeries Diagnostic Information for Multiple Bus Systems*.

No Go to “Step 152n-13”.

Step 152n-13

Have all DASD that were removed in “Step 152n-6” been reinstalled?

Yes The problem has changed. **This ends the procedure.**

No Go to “Step 152n-9” to reinstall the next DASD.

Step 152n-14

Turn off the power. Make sure all green “power good out” LEDs of all installed I/O subsystem DCAs are off.

Step 152n-15

Replace the books in the following list, one at a time and in the listed order:

- DCA 1 at V1
- DCA 2 at V2

Step 152n-16

Turn on the power.

Step 152n-17

Did the system stop with the same error code as recorded in “Step 152n-1” on page 299?

Yes Go to “Step 152n-18”.

No The book just replaced was defective. **This ends the procedure.** Return the system to its original configuration. Go to “MAP 0410: Repair Checkout” in the *RS/6000 and @server pSeries Diagnostic Information for Multiple Bus Systems*.

Step 152n-18

Turn off the power then make sure all the green “power good out” LEDs of both I/O subsystem DCAs are off.

Step 152n-19

Remove the new card that was just installed in “Step 152n-15” and reinstall the original card.

Step 152n-20

Have all the cards listed in “Step 152n-15” been replaced with new or original cards??

Yes Go to “Step 152n-21”.

No Go to “Step 152n-15”.

Step 152n-21

Examine the green “power good out” LEDs of both I/O subsystem DCAs.

Step 152n-22

Are all the green “power good out” LEDs of both I/O subsystem DCAs off?

Yes Go to Step “Step 152n-23”.

No Call for support.

Step 152n-23

Replace the DASD backplane.

Step 152n-24

Turn on the power.

Step 152n-25

Did the system stop with the same error code as recorded in “Step 152m-1” on page 295?

Yes Call for support.

No The book just replaced was defective. **This ends the procedure.** Return the system to its original configuration. Go to “MAP 0410: Repair Checkout” in the *RS/6000 and @server pSeries Diagnostic Information for Multiple Bus Systems*.

MAP 1540: Problem Isolation Procedures

These procedures are used to locate problems in the processor subsystem, I/O subsystems, or rack. If a problem is detected, these procedures help you isolate the problem to a failing unit. Find the symptom in the following table; then follow the instructions given in the Action column.

Problem Isolation Procedures	
Symptom/Reference Code/Checkpoint	Action
You were sent here by the <i>RS/6000 and @server pSeries Diagnostic Information for Multiple Bus Systems</i> book.	Go to "MAP 1542: I/O Problem Isolation" on page 312.
406x 00B7	Go to "MAP 154B: Insufficient Hardware Resources Problem Isolation" on page 355. Attention: Before you remove or replace any MCM or L3 module, <i>stop, read and understand</i> the following procedures: "MCM Module (Processor) and Passthru Modules" on page 794 and "L3 Cache Modules" on page 805.
(3) 406x 0EB1, 406x 0EB2, 406x 0EB3, 406x 0EB4, (3) 406x 0EB5, 406x 0EB6, 406x 0EB7, 406x 0EB8, (3) 406x 0EB9, 406x 0EBA, 406x 0EBB, 406x 0EBC	Go to "MAP 1549: Attention Problem Isolation" on page 345. Attention: Before you remove or replace any MCM or L3 module, <i>stop, read and understand</i> the following procedures: "MCM Module (Processor) and Passthru Modules" on page 794 and "L3 Cache Modules" on page 805.
406x 0EB0	Go to "MAP 1541: JTAG Problem Isolation" on page 304.
(3) 406x 0C03, (3) 450x 25C7, 450x 25C8, 450x 25D3, 450x 25D5, (3) 450x 25D7, 450x 25D8, (3) 460x 25C7, 460x 25C8, 460x 25D3, 460x 25D5, (3) 460x 25D7, 460x 25D8, (3) 4B2x 25C7, 4B2x 25C8, 4B2x 25D3, 4B2x 25D5, (3) 4B2x 25D7, 4B2x 25D8	Go to "MAP 1543: MCM Module Problem Isolation" on page 332. Attention: Before you remove or replace any MCM or L3 module, <i>stop, read and understand</i> the following procedures: "MCM Module (Processor) and Passthru Modules" on page 794 and "L3 Cache Modules" on page 805.
(3) 450x 302A, 450x 302C, 450x305A, (3) 460x 302A, 460x 302C, 460x 305A, (3) 4B2x 302A, 4B2x 302C, 4B2x 305A	Go to "MAP 1544: Inner L3 Module Problem Isolation" on page 334. Attention: Before you remove or replace any MCM or L3 module, <i>stop, read and understand</i> the following procedures: "MCM Module (Processor) and Passthru Modules" on page 794 and "L3 Cache Modules" on page 805.

Problem Isolation Procedures	
Symptom/Reference Code/Checkpoint	Action
(3) 450x 302B, 450x 302D, 450x 305B (3) 460x 302B, 460x 302D, 460x 305B (3) 4B2x 302B, 4B2x 302D, 4B2x 305B	Go to "MAP 1545: Outer L3 Module Problem Isolation" on page 336. Attention: Before you remove or replace any MCM or L3 module, <i>stop, read and understand</i> the following procedures: "MCM Module (Processor) and Passthru Modules" on page 794 and "L3 Cache Modules" on page 805.
406x 0C09	Go to "MAP 1546: Memory Book Problem Isolation" on page 338.
406x 0C0A	Go to "MAP 1547: I/O Book Problem Isolation" on page 341.
(3) 406x 0001, 406x 0002, 406x 000A, 406x0 00B, (3) 406x 000C, 406x 000D, (3) B1xx 4645, B1xx 4648	Go to "MAP 154A: I2C Bus Problem Isolation" on page 352. Attention: Before you remove or replace any MCM or L3 module, <i>stop, read and understand</i> the following procedures: "MCM Module (Processor) and Passthru Modules" on page 794 and "L3 Cache Modules" on page 805.
E101, E102, E10A, E10B, E111, E120, E121, E122, E130, E134, E135, E138, E139, E13A, E149, E14C, E191, E19A, E19B, E19D, E1A0, E1A1, E1A2, E1A3, E1A4, E1A5, E1A6, E1A7, E1A8, E1A9, E1AA, E1AB, E1AC, E1AD, E1AE, E1AF, E1B1, E1C4, E1C5, E1C6, E1D0, E1D3, E1D4, E1DB, E1F0	Go to "MAP 1548: Memory and Processor Problem Isolation" on page 343. Attention: Before you remove or replace any MCM or L3 module, <i>stop, read and understand</i> the following procedures: "MCM Module (Processor) and Passthru Modules" on page 794 and "L3 Cache Modules" on page 805.

MAP 1541: JTAG Problem Isolation

Step 1541-1

Record the error code and location code(s) that sent you to this MAP.

Step 1541-2

Check the following list to find the location code(s) recorded in "Step 1541-1":

- L3 module at U1.18-P1-C5
- L3 module at U1.18-P1-C11
- L3 module at U1.18-P1-C14
- L3 module at U1.18-P1-C20
- L3 module at U1.18-P1-C9
- L3 module at U1.18-P1-C10
- L3 module at U1.18-P1-C6
- L3 module at U1.18-P1-C12
- L3 module at U1.18-P1-C13

- L3 module at U1.18-P1-C7
- L3 module at U1.18-P1-C15
- L3 module at U1.18-P1-C16
- L3 module at U1.18-P1-C17
- L3 module at U1.18-P1-C18
- L3 module at U1.18-P1-C19
- L3 module at U1.18-P1-C8
- MCM module 0 at U1.18-P1-C1
- MCM module 3 at U1.18-P1-C2
- MCM module 1 at U1.18-P1-C3
- MCM module 2 at U1.18-P1-C4

Step 1541-3

Is (are) the location code(s) recorded in “Step 1541-1” on page 304 listed in “Step 1541-2” on page 304?

Yes Go to “Step 1541-19” on page 307.

No Go to “Step 1541-4”.

Step 1541-4

Check the following list to find the location code(s) recorded in “Step 1541-1” on page 304:

- Primary I/O Book at U1.18-P1-H2
- Secondary I/O Book at U1.18-P1-H3
- Third I/O Book at U1.18-P1-H4
- Memory Book 6 at U1.18-P1-M5
- Memory Book 7 at U1.18-P1-M1

Step 1541-5

Is (are) the location code(s) recorded in “Step 1541-1” on page 304 listed in “Step 1541-4”?

Yes Go to “Step 1541-25” on page 308.

No Go to “Step 1541-6”.

Step 1541-6

Check the following list to find the location code(s) recorded in “Step 1541-1” on page 304:

- Memory Book 0 at U1.18-P1-M2
- Memory Book 1 at U1.18-P1-M3
- Memory Book 2 at U1.18-P1-M7
- Memory Book 3 at U1.18-P1-M6
- Memory Book 4 at U1.18-P1-M4
- Memory Book 5 at U1.18-P1-M8

Step 1541-7

Is (are) the location code(s) recorded in “Step 1541-1” on page 304 listed in “Step 1541-6” on page 305?

Yes Go to “Step 1541-31” on page 309.

No Go to “Step 1541-8”.

Step 1541-8

Turn off the power.

Examine the amber logic-power LEDs of all installed processor subsystem DCAs.

Step 1541-9

Are all the amber logic-power LEDs of all installed processor subsystem DCAs off?

Yes Go to “Step 1541-10”.

No Call for support.

Step 1541-10

Replace the item recorded in “Step 1541-1” on page 304.

Step 1541-11

Turn on the power.

Step 1541-12

Did the system stop with the same error code as recorded in “Step 1541-1” on page 304?

Yes Go to “Step 1541-13”.

No **This ends the procedure.**

Return the system to its original configuration.

Go to “MAP 0410: Repair Checkout” in the *RS/6000 and @server pSeries Diagnostic Information for Multiple Bus Systems*.

Step 1541-13

Turn off the power.

Step 1541-14

Examine the amber logic-power LEDs of all installed processor subsystem DCAs.

Step 1541-15

Are all the amber logic-power LEDs of all installed processor subsystem DCAs off?

Yes Go to “Step 1541-16” on page 307.

No Call for support.

Step 1541-16

Replace the primary I/O book at U1.18-P1-H2.

Step 1541-17

Turn on the power.

Step 1541-18

Did the system stop with the same error code as recorded in “Step 1541-1” on page 304?

Yes Go to “Step 1541-37” on page 310.

No The part just replaced was defective. **This ends the procedure.**

Return the system to its original configuration.

Go to “MAP 0410: Repair Checkout” in the *RS/6000 and @server pSeries Diagnostic Information for Multiple Bus Systems*.

Step 1541-19

Turn off the power.

Examine the amber logic-power LEDs of all installed processor subsystem DCAs.

Step 1541-20

Are all the amber logic-power LEDs of all installed processor subsystem DCAs off?

Yes Go to “Step 1541-21”.

No Call for support.

Step 1541-21

Attention: Before you remove or replace any MCM or L3 module, *stop, read and understand* the following procedures: “MCM Module (Processor) and Passthru Modules” on page 794 and “L3 Cache Modules” on page 805.

Attention: MCM and L3 modules have a limit of three plug cycles. Before removing any of the modules in the following list, call for support.

Replace the following modules or books, if present, one at a time and in the order listed:

- First location code item recorded, if any, “Step 1541-1” on page 304.
- Second location code item recorded, if any, in “Step 1541-1” on page 304.
- Third location code item recorded, if any, in “Step 1541-1” on page 304.
- Fourth location code item recorded, if any, in “Step 1541-1” on page 304.
- Primary I/O book at U1.18-P1-H2.
- L3 module, at location U1.18-P1-C5 if not recorded in “Step 1541-1” on page 304.
- L3 module, at location U1.18-P1-C11 if not recorded in “Step 1541-1” on page 304.
- L3 module, at location U1.18-P1-C14 if not recorded in “Step 1541-1” on page 304.
- L3 module, at location U1.18-P1-C20 if not recorded in “Step 1541-1” on page 304.
- L3 module, at location U1.18-P1-C9 if not recorded in “Step 1541-1” on page 304.

- L3 module, at location U1.18-P1-C10 if not recorded in “Step 1541-1” on page 304.
- L3 module, at location U1.18-P1-C6 if not recorded in “Step 1541-1” on page 304.
- L3 module, at location U1.18-P1-C12 if not recorded in “Step 1541-1” on page 304.
- L3 module, at location U1.18-P1-C13 if not recorded in “Step 1541-1” on page 304.
- L3 module, at location U1.18-P1-C7 if not recorded in “Step 1541-1” on page 304.
- L3 module, at location U1.18-P1-C15 if not recorded in “Step 1541-1” on page 304.
- L3 module, at location U1.18-P1-C16 if not recorded in “Step 1541-1” on page 304.
- L3 module, at location U1.18-P1-C17 if not recorded in “Step 1541-1” on page 304.
- L3 module, at location U1.18-P1-C18 if not recorded in “Step 1541-1” on page 304.
- L3 module, at location U1.18-P1-C19 if not recorded in “Step 1541-1” on page 304.
- L3 module, at location U1.18-P1-C8 if not recorded in “Step 1541-1” on page 304.
- MCM module 0 at U1.18-P1-C1 if not recorded in “Step 1541-1” on page 304.
- MCM module 3 at U1.18-P1-C2 if not recorded in “Step 1541-1” on page 304.
- MCM module 1 at U1.18-P1-C3 if not recorded in “Step 1541-1” on page 304.
- MCM module 2 at U1.18-P1-C4 if not recorded in “Step 1541-1” on page 304.

Step 1541-22

Turn on the power.

Step 1541-23

Did the system stop with the same error code as recorded in “Step 1541-1” on page 304?

Yes Go to “Step 1541-24”.

No The part just replaced was defective. **This ends the procedure.**

Return the system to its original configuration.

Go to “MAP 0410: Repair Checkout” in the *RS/6000 and @server pSeries Diagnostic Information for Multiple Bus Systems*.

Step 1541-24

Have all the MCMs and books listed in “Step 1541-21” on page 307 been replaced?

Yes Go to “Step 1541-25”.

No Go to “Step 1541-19” on page 307.

Step 1541-25

Turn off the power.

Examine the amber logic-power LEDs of all installed processor subsystem DCAs.

Step 1541-26

Are all the amber logic-power LEDs of all installed processor subsystem DCAs off?

Yes Go to “Step 1541-27” on page 309.

No Call for support.

Step 1541-27

Replace the following books, if present, one at a time:

- First location code item recorded, if any in “Step 1541-1” on page 304.
- Second location code item recorded, if any, in “Step 1541-1” on page 304.
- Third location code item recorded, if any, in “Step 1541-1” on page 304.
- Fourth location code item recorded, if any, in “Step 1541-1” on page 304.
- Primary I/O Book at U1.18-P1-H2 if not recorded in “Step 1541-1” on page 304.
- Secondary I/O Book at U1.18-P1-H3 if not recorded in “Step 1541-1” on page 304.
- Third I/O Book at U1.18-P1-H4 if not recorded in “Step 1541-1” on page 304.
- Memory Book 6 at U1.18-P1-M5 if not recorded in “Step 1541-1” on page 304.
- Memory Book 7 at U1.18-P1-M1 if not recorded in “Step 1541-1” on page 304.

Step 1541-28

Turn on the power.

Step 1541-29

Did the system stop with the same error code as recorded in “Step 1541-1” on page 304?

Yes Go to “Step 1541-30”.

No The book just replaced was defective. **This ends the procedure.**

Return the system to its original configuration.

Go to “MAP 0410: Repair Checkout” in the *RS/6000 and @server pSeries Diagnostic Information for Multiple Bus Systems*.

Step 1541-30

Have all the books listed in “Step 1541-27” been replaced?

Yes Go to “Step 1541-37” on page 310.

No Go to “Step 1541-25” on page 308.

Step 1541-31

Turn off the power.

Examine the amber logic-power LEDs of all installed processor subsystem DCAs.

Step 1541-32

Are all the amber logic-power LEDs of all installed processor subsystem DCAs off?

Yes Go to “Step 1541-33” on page 310.

No Call for support.

Step 1541-33

Replace the following books, if present, one at a time:

- First location code item recorded in “Step 1541-1” on page 304.
- Second location code item recorded, if any, in “Step 1541-1” on page 304.
- Third location code item recorded, if any, in “Step 1541-1” on page 304.
- Fourth location code item recorded, if any, in “Step 1541-1” on page 304.
- Primary I/O book at U1.18-P1-H2.
- Memory book 0 at U1.18-P1-M2 if not recorded in “Step 1541-1” on page 304.
- Memory book 1 at U1.18-P1-M3 if not recorded in “Step 1541-1” on page 304.
- Memory book 2 at U1.18-P1-M7 if not recorded in “Step 1541-1” on page 304.
- Memory book 3 at U1.18-P1-M6 if not recorded in “Step 1541-1” on page 304.
- Memory book 4 at U1.18-P1-M4 if not recorded in “Step 1541-1” on page 304.
- Memory book 5 at U1.18-P1-M8 if not recorded in “Step 1541-1” on page 304

Step 1541-34

Turn on the power.

Step 1541-35

Did the system stop with the same error code as recorded in “Step 1541-1” on page 304?

Yes Go to “Step 1541-36”.

No The book just replaced was defective. **This ends the procedure.**

Return the system to its original configuration.

Go to “MAP 0410: Repair Checkout” in the *RS/6000 and @server pSeries Diagnostic Information for Multiple Bus Systems*.

Step 1541-36

Have all the books listed in “Step 1541-33” been replaced?

Yes Go to “Step 1541-37”.

No Go to “Step 1541-31” on page 309.

Step 1541-37

Turn off the power.

Step 1541-38

Examine the amber logic-power LEDs of all installed processor subsystem DCAs.

Step 1541-39

Are all the amber logic-power LEDs of all installed processor subsystem DCAs off?

Yes Go to “Step 1541-40” on page 311.

No Call for support.

Step 1541-40

Attention: Before replacing the system backplane, call for support.

Replace the system backplane at U1.18-P1.

Step 1541-41

Turn on the power.

Step 1541-42

Did the system stop with the same error code as recorded in “Step 1541-1” on page 304?

Yes Go to “Step 1541-43”.

No The book just replaced was defective. **This ends the procedure.**

Return the system to its original configuration.

Go to “MAP 0410: Repair Checkout” in the *RS/6000 and @server pSeries Diagnostic Information for Multiple Bus Systems*.

Step 1541-43

Turn off the power.

Make sure the amber logic-power LEDs of all installed processor subsystem DCAs are off.

Step 1541-44

Call for support.

This ends the procedure.

MAP 1542: I/O Problem Isolation

This MAP is used to locate defective FRUs not found by normal diagnostics. For this procedure, diagnostics are run on a minimally configured system. If a failure is detected on the minimally configured system, the remaining FRUs are exchanged one at a time until the failing FRU is identified. If a failure is not detected, FRUs are added back until the failure occurs. The failure is then isolated to the failing FRU.

This I/O problem-determination MAP isolates I/O card and I/O subsystem failures. When I/O problem isolation is complete, all cables and cards exhibiting a failure will have been replaced or reseated.

Notes:

1. This MAP assumes that a CD-ROM drive is installed in the media subsystem and connected to a SCSI adapter in the first I/O subsystem, and that a Diagnostics CD-ROM is available.
2. If a general-access password or privileged-access password is installed, you are prompted to enter the password before the diagnostic CD-ROM can load.
3. The term *POST indicators* refers to the device mnemonics (words **Memory**, **Keyboard**, **Network**, **SCSI**, and **Speaker**) that appear on the system console during the power-on self-test (POST).
4. The service processor may have recorded one or more symptoms in its error log. It is a good idea to examine that error log before proceeding (see "System Information Menu" on page 722).
5. The service processor may have been set by the user to monitor system operations and to attempt recoveries. You can disable these actions while you diagnose and service the system. If you disable them, make notes of their current settings so that you can restore them easily. The following table lists the settings:

Surveillance	From the service processor Setup Menu, go to the Surveillance Setup Menu and disable surveillance. (Operating System Surveillance is disabled in partition mode.)
Unattended Start	From the service processor System Power Control Menu, disable unattended start mode.
Reboot Policy	From the System Power Control Menu, go to the Reboot/Restart Policy Setup Menu and set: a. Number of reboot attempts to 0 (zero) b. Use OS-Defined restart policy to No c. Enable supplemental restart policy to No .
Call Out	From the Call-In/Call-Out Setup Menu, go to the Serial Port Selection Menu and disable call-out on both serial ports.

The steps in this MAP will attempt to slow boot the system into service mode diagnostics. The following procedure describes booting a nonpartitioned system with an attached 3151 console. The procedure for booting a partitioned system with an attached HMC is slightly different and is described in "Performing Slow Boot" on page 399. "Performing Slow Boot" describes the procedure for booting online diagnostics (6 key

between the **Keyboard** and **Speaker** indicators) and the following procedure requires booting standalone diagnostics (5 key between the **Keyboard** and **Speaker** indicators). Therefore, on a partitioned system, make sure the partition you selected to boot in the following procedure has the CD-ROM allocated to it, as described in Chapter 6, "Using the Online and Standalone Diagnostics" on page 695.

Step 1542-1

1. Ensure that the diagnostics and the operating system are shut down.
2. Turn off the power.
3. Select slow boot mode (select **Disable Fast Boot**) on the System Power Control menu from the service processor main menu.
4. Turn on the power.
5. Insert the diagnostic CD-ROM into the CD-ROM drive.

Does the CD-ROM appear to operate correctly?

NO Go to "Boot Problems" on page 396, and perform steps 1-8 for an internally attached boot device.

YES Go to "Step 1542-2".

Step 1542-2

1. When the keyboard indicator is displayed (the word **Keyboard**), press the 5 key on the firmware console.
2. Enter the appropriate password when you are prompted to do so.

Is the Please define system console screen displayed?

NO Go to "Step 1542-3".

YES Go to "Step 1542-4".

Step 1542-3

The system is unable to boot standalone diagnostics.

Check the service processor error log and the media subsystem operator panel for additional error codes resulting from the slow boot in "Step 1542-1". Did the slow boot generate a different error code from the one that originally sent you to MAP 1542?

NO It appears you have a processor subsystem problem. Call for support. **This ends the procedure.**

YES Restore fast-boot mode (select **Enable Fast Boot**) on the System Power Control menu from the service processor main menu. Go to "Checkpoints and Error Codes Index" on page 403, and follow the actions for the new error code.

Step 1542-4

The system stopped with the Please define system console prompt appearing on the system console.

Standalone diagnostics can be booted. Perform the following:

1. Follow the instructions on the screen to select the system console.
2. When the DIAGNOSTIC OPERATING INSTRUCTIONS screen is displayed, press Enter.
3. If the terminal type has not been defined, you must use the Initialize Terminal option of the FUNCTION SELECTION menu to initialize the AIX operating system environment before you can continue with the diagnostics. This is a separate and different operation from selecting the firmware console display.
4. Select **Advanced Diagnostic Routines**.
5. When the DIAGNOSTIC MODE SELECTION menu displays, select **System Verification** to run diagnostics on all resources.

Did running diagnostics produce a different symptom?

NO Go to step number 6, below.

YES Go to “Entry MAP” on page 157. Use the new symptom.

6. Record any devices missing from the list of all adapters and devices. Continue with this MAP. When you have fixed the problem, use this record to verify that all devices appear when you run System Verification.

Are there any devices missing from the list of all adapters and devices?

NO Reinstall all remaining adapters, if any, and reconnect all devices. Return the system to its original configuration. Be sure to select fast-boot mode (select **Enable Fast Boot**) on the System Power Control menu from the service processor main menu. Go to “Map 0410: Repair Checkout” in the *RS/6000 and @server pSeries Diagnostic Information for Multiple Bus Systems*.

YES The boot attempts that follow will attempt to isolate any remaining I/O subsystem problems with missing devices. Ignore any codes that may display on the operator panel unless stated otherwise. Go to “Step 1542-5”.

Step 1542-5

There are missing devices associated with one or more I/O subsystems.

Note: Before continuing, check the cabling from the processor subsystem to I/O subsystem(s) to ensure that the system is cabled correctly. Refer to “Subsystem Positioning and Cabling” on page 41 for valid configurations. Record the current cabling configuration and then continue with the following steps:

1. Turn off the power.
2. At the primary I/O book, disconnect the cable connection at RIO port A0 (U1.18-P1-H2/Q1).
3. Disconnect the cable connection at I/O subsystem 1 left I/O port connector 0 (U1.9-P1/Q2). The RIO cable that was connected to RIO port A0 should now be loose and can be removed.
4. At the primary I/O book, disconnect the cable connection at RIO port A1 (U1.18-P1-H2/Q2) and reconnect it to RIO port A0 (U1.18-P1-H2/Q1).

5. Disconnect the cable connection at I/O subsystem 1 right I/O port connector 1 (U1.9-P2/Q1). The RIO cable that was connected to RIO port A0 on the primary I/O book should now be loose and can be removed.
6. Verify that processor subsystem RIO port A0 on primary I/O book (U1.18-P1-H2/Q1) is connected to I/O subsystem 1 left I/O port connector 0 (U1.9-P1/Q2).
7. Verify that I/O subsystem 1 left I/O port connector 1 (U1.9-P1/Q1) is connected to I/O subsystem 1 right I/O port connector 0 (U1.9-P2/Q2).
8. Turn on the power to boot standalone diagnostics from CD.
9. If the Please define the System Console screen is displayed, follow directions to select the system console.
10. Use the Display Configuration and Resource List to list all attached devices and adapters (refer to the *RS/6000 and @server pSeries Diagnostic Information for Multiple Bus Systems* if necessary).
11. Check that all attached devices and adapters are listed.

Did the Please define the System Console screen display and are all attached devices and adapters listed?

NO Go to “Step 1542-6” on page 316.

YES The RIO cable that was removed in step 5 above is defective. Replace the RIO cable. Connect the new RIO cable from I/O subsystem 1 right I/O port connector 1 (U1.9-P2/Q1) to processor subsystem RIO port A1 on primary I/O book (U1.18-P1-H2/Q2). Reconfigure the system to its original condition. Go to “Map 0410: Repair Checkout” in the *RS/6000 and @server pSeries Diagnostic Information for Multiple Bus Systems*.

Step 1542-6

The @server pSeries 690 server must have a minimum of one I/O subsystem and one media subsystem attached to the processor subsystem. The following steps reduce the system I/O to the required minimum of one I/O subsystem:

1. Turn off the system power.
2. Verify that processor subsystem RIO port A0 on primary I/O book (U1.18-P1-H2/Q1) is connected to I/O subsystem 1 left I/O port connector 0 (U1.9-P1/Q2).
3. Verify that I/O subsystem 1 right I/O port connector 1 (U1.9-P2/Q1) is connected to processor subsystem RIO port A1 on primary I/O book (U1.18-P1-H2/Q2).
4. Verify that I/O subsystem 1 left I/O port connector 1 (U1.9-P1/Q1) is connected to I/O subsystem 1 right I/O port connector 0 (U1.9-P2/Q2).
5. Disconnect cable at processor subsystem RIO port B0 on primary I/O book (U1.18-P1-H2/Q3), if cable attached.
6. Disconnect cable at processor subsystem RIO port B1 on primary I/O book (U1.18-P1-H2/Q4), if cable attached.
7. Unplug the secondary I/O book (U1.18-P1-H3), if present, and carefully pull it approximately 25 mm (1 inch) away from the backplane without disconnecting any cables
8. Unplug the third I/O book (U1.18-P1-H4), if present, and carefully pull it approximately 25 mm (1 inch) away from the backplane without disconnecting any cables.
9. Connect the previously removed RIO cable from I/O subsystem 1 right I/O port connector 1 (U1.9-P2/Q1) to processor subsystem RIO port A1 on primary I/O book (U1.18-P1-H2/Q2).
10. Verify that the power cable is connected between I/O subsystem 1 right media subsystem power connector (U1.9-P2-V1/Q3) and the media subsystem.
11. Disconnect power cables from remaining I/O subsystems.
All I/O subsystems except the primary subsystem should now be physically disconnected from the processor subsystem.

Go to "Step 1542-7" on page 317.

Step 1542-7

I/O subsystem 1 (U1.9) is the only I/O subsystem connected to the processor subsystem.

1. Turn on the power to boot standalone diagnostics from CD.
2. If the Please define the System Console screen is displayed, follow directions to select the system console.
3. Use the Display Configuration and Resource List to list all attached devices and adapters (refer to the *RS/6000 and @server pSeries Diagnostic Information for Multiple Bus Systems*, order number SA38-0509, if necessary).
4. Check that all attached devices and adapters are listed.

If the Please define the System Console prompt did not display or all attached devices and adapters are not listed, the problem is in the media subsystem or I/O subsystem 1 (U1.9).

Did the Please define the System Console screen display and are all attached devices and adapters listed?

NO Go to "Step 1542-8" on page 318.

YES Go to "Step 1542-21" on page 324.

Step 1542-8

Perform the following to deconfigure the media subsystem:

1. Turn off the power.
2. If you have not already done so, set the service processor settings with the instructions in step 5 on page 312. Then return here and continue.
3. Exit the service processor menus, and disconnect the power cable between the I/O subsystem 1 right media subsystem power connector (U1.9-P2-V1/Q3) and the media subsystem.
4. If a display adapter with keyboard and mouse connected to a Keyboard/Mouse Attachment (USB) card in I/O subsystem 1 (U1.9) is being used as the console, locate a standalone serial terminal (for example a 3151), and connect to the S1 serial port or use the HMC.
5. Remove the keyboard and mouse, if attached to the I/O subsystem 1 (U1.9).
6. Remove (unplug) the tape drive (if installed) from the media subsystem.
7. Disconnect the diskette drive cable from the diskette drive connector on the media subsystem.
8. Connect the power cable between the I/O subsystem 1 right media subsystem power connector (U1.9-P2-V1/Q3) and the media subsystem. The media subsystem operator panel momentarily displays an OK prompt.
9. Set the current drawer location to x.y=1.9. Use this value in future steps until changed in a later step.

Go to "Step 1542-9" on page 319.

Step 1542-9

Are there any adapters in slots 1, 2, 3, 4 or 5 (location codes Ux.y-P1-I1 through I5) on the left side of the I/O subsystem?

NO Go to "Step 1542-10".

YES Go to "Step 1542-13" on page 320.

Step 1542-10

Are there any adapters in slots 6, 7, 8, 9 or 10 (location codes Ux.y-P1-I6 through I10) on the left side of the I/O subsystem?

NO Go to "Step 1542-11".

YES Go to "Step 1542-14" on page 320.

Step 1542-11

Are there any adapters in slots 1, 2, 3, 4 or 5 (location codes Ux.y-P2-I1 through I5) on the right side of the I/O subsystem?

NO Go to "Step 1542-12".

YES Go to "Step 1542-15" on page 321.

Step 1542-12

Are there any adapters in slots 6, 7, 8, 9 or 10 (location codes Ux.y-P2-I7 through I10) on the right side of the I/O subsystem?

NO Go to "Step 1542-19" on page 323.

YES Go to "Step 1542-16" on page 321.

Step 1542-13

1. If it is not already off, turn off the power.
2. Remove all adapters from slots 1, 2, 3, 4 and 5 (location codes Ux.y-P1-I1 through I5) from the left side of the I/O subsystem that are not attached to the boot device.
3. Label and record the location of any cables attached to the adapters.
4. Record the slot number of the adapters.
5. Turn on the power to boot standalone diagnostics from CD.
6. If the TTY screen displays Enter 0 to select this console, press the 0 key on the TTY terminal's keyboard.
7. If the Please define the System Console screen is displayed, follow directions to select the system console.
8. Use the Display Configuration and Resource List to list all attached devices and adapters (refer to the *RS/6000 and @server pSeries Diagnostic Information for Multiple Bus Systems*, order number SA38-0509, if necessary).
9. Check that all attached devices and adapters are listed.

Did the Please define the System Console screen display and are all attached devices and adapters listed?

NO Go to "Step 1542-10" on page 319.

YES Go to "Step 1542-17" on page 322.

Step 1542-14

1. If it is not already off, turn off the power.
2. Remove all adapters from slots 6, 7, 8, 9 and 10 (location codes Ux.y-P1-I6 through I10) from the left side of the I/O subsystem that are not attached to the boot device.
3. Label and record the location of any cables attached to the adapters.
4. Record the slot number of the adapters.
5. Turn on the power to boot standalone diagnostics from CD.
6. If the TTY screen displays Enter 0 to select this console, press the 0 key on the TTY terminal's keyboard.
7. If the Please define the System Console screen is displayed, follow directions to select the system console.
8. Use the Display Configuration and Resource List to list all attached devices and adapters (refer to the *RS/6000 and @server pSeries Diagnostic Information for Multiple Bus Systems*, order number SA38-0509, if necessary).
9. Check that all attached devices and adapters are listed.

Did the Please define the System Console screen display and are all attached devices and adapters listed?

NO Go to "Step 1542-11" on page 319.

YES Go to "Step 1542-17" on page 322.

Step 1542-15

1. If it is not already off, turn off the power.
2. Remove all adapters from slots 1, 2, 3, 4 and 5 (location codes Ux.y-P2-I1 through I5) from the right side of the I/O subsystem that are not attached to the boot device.
3. Label and record the location of any cables attached to the adapters.
4. Record the slot number of the adapters.
5. Turn on the power to boot standalone diagnostics from CD.
6. If the TTY screen displays Enter 0 to select this console, press the 0 key on the TTY terminal's keyboard.
7. If the Please define the System Console screen is displayed, follow directions to select the system console.
8. Use the Display Configuration and Resource List to list all attached devices and adapters (refer to the *RS/6000 and @server pSeries Diagnostic Information for Multiple Bus Systems*, order number SA38-0509, if necessary).
9. Check that all attached devices and adapters are listed.

Did the Please define the System Console screen display and are all attached devices and adapters listed?

NO Go to "Step 1542-12" on page 319.

YES Go to "Step 1542-17" on page 322.

Step 1542-16

1. If it is not already off, turn off the power.
2. Remove all adapters from slots 6, 7, 8, 9 and 10 (location codes Ux.y-P2-I6 through I10) from the right side of the I/O subsystem that are not attached to the boot device.
3. Label and record the location of any cables attached to the adapters.
4. Record the slot number of the adapters.
5. Turn on the power to boot standalone diagnostics from CD.
6. If the TTY screen displays Enter 0 to select this console, press the 0 key on the TTY terminal's keyboard.
7. If the Please define the System Console screen is displayed, follow directions to select the system console.
8. Use the Display Configuration and Resource List to list all attached devices and adapters (refer to the *RS/6000 and @server pSeries Diagnostic Information for Multiple Bus Systems*, order number SA38-0509, if necessary).
9. Check that all attached devices and adapters are listed.

Did the Please define the System Console screen display and are all attached devices and adapters listed?

NO Go to "Step 1542-19" on page 323.

YES Go to "Step 1542-17" on page 322.

Step 1542-17

If the Please define the System Console screen displays and all attached devices and adapters are listed, the problem is with one of the adapter cards or devices that was removed or disconnected from the I/O subsystem.

1. Turn off the power.
2. Reinstall one adapter or device that was removed. Use the original adapter cards in their original slots when reinstalling adapters.
3. Turn on the power to boot standalone diagnostics from CD.
4. If the Please define the System Console screen is displayed, follow directions to select the system console.
5. Use the Display Configuration and Resource List to list all attached devices and adapters (refer to the *RS/6000 and @server pSeries Diagnostic Information for Multiple Bus Systems*, order number SA38-0509, if necessary).
6. Check that all attached devices and adapters are listed.

Did the Please define the System Console screen display and are all attached devices and adapters listed?

NO Go to "Step 1542-18".

YES Reinstall the next adapter or device and return to the beginning of this step. Continue repeating this process until an adapter or device causes the Please define the System Console screen to not display or all attached devices and adapters to not be listed.

After installing all of the adapters and the Please define the System Console screen does display and all attached devices and adapters are listed, return the system to its original configuration. Go to "Map 0410: Repair Checkout" in the *RS/6000 and @server pSeries Diagnostic Information for Multiple Bus Systems*.

Step 1542-18

Replace the adapter you just installed with a new adapter and try to boot standalone diagnostics from CD again.

1. If the Please define the System Console screen is displayed, follow directions to select the system console.
2. Use the Display Configuration and Resource List to list all attached devices and adapters (refer to the *RS/6000 and @server pSeries Diagnostic Information for Multiple Bus Systems*, order number SA38-0509, if necessary).
3. Check that all attached devices and adapters are listed.

Did the Please define the System Console screen display and are all attached devices and adapters listed?

NO The I/O subsystem backplane is defective. Replace the I/O subsystem backplane on the side of the problem adapter (Ux.y-P1 or Ux.y-P2). Go to "Step 1542-20" on page 324.

YES The adapter was defective. Go to "Step 1542-20" on page 324.

Step 1542-19

1. Turn off the power.
2. Disconnect the I/O subsystem power cables.
3. Replace the following parts, one at a time, in the sequence listed:
 - a. Boot device SCSI cable
 - b. Boot device SCSI adapter
 - c. Boot device SCSI backplane
 - d. Boot device
 - e. I/O subsystem backplane where boot device is located
 - f. Other I/O subsystem backplane
 - g. Both I/O subsystem DCAs
4. Reconnect the I/O subsystem power cables.
5. Turn on the power.
6. Boot standalone diagnostics from CD.
7. If the Please define the System Console screen is displayed, follow directions to select the system console.
8. Use the Display Configuration and Resource List to list all attached devices and adapters (refer to the *RS/6000 and @server pSeries Diagnostic Information for Multiple Bus Systems*, order number SA38-0509, if necessary).
9. Check that all attached devices and adapters are listed.

Did the Please define the System Console screen display and are all attached devices and adapters listed?

NO Replace the next part in the list and return to the beginning of this step. Continue repeating this process until a part causes the Please define the System Console screen to be displayed and all attached devices and adapters to be listed. If you have replaced all the items listed above and the Please define the System Console screen does not display or all attached devices and adapters are not listed, check any external devices and cabling. If you do not find a problem, contact your next level of support for assistance.

YES

Go to "Step 1542-20" on page 324.

Step 1542-20

1. Turn off the power.
2. The part just replaced fixed the problem.
3. If a display adapter with keyboard, and mouse were used, reinstall the display adapter card, keyboard and mouse.
4. Reconnect the diskette drive cable to the diskette drive connector on the media subsystem.
5. Reconnect the tape drive (if previously installed) to the internal SCSI bus cable.
6. Plug in all adapters that were previously removed but not reinstalled.
7. Reconnect the I/O subsystem power cables that were previously disconnected.

Reconfigure the system to its original condition. Go to "Map 0410: Repair Checkout" in the *RS/6000 and @server pSeries Diagnostic Information for Multiple Bus Systems*.

Step 1542-21

If the boot is successful, the problem is with a remaining I/O subsystem. Turn off the power.

Are there any I/O subsystems left to connect to the processor subsystem?

NO Reconfigure the system to its original condition. Go to "Map 0410: Repair Checkout" in the *RS/6000 and @server pSeries Diagnostic Information for Multiple Bus Systems*.

YES

Go to "Step 1542-22" on page 325.

Step 1542-22

Reconnect the next I/O subsystem in the configuration that you recorded earlier in this MAP. Use the following table to determine the next I/O subsystem to reconnect.

I/O Subsystem	Current x.y Value	New x.y Value	Go to:
1	1.9	1.5	"Step 1542-23" on page 326
2	1.5	1.1	"Step 1542-24" on page 326
3	1.1	1.13 (no IBF), 2.9 (with IBF)	"Step 1542-25" on page 327
4	1.13	2.1	"Step 1542-26" on page 328
4	2.9	2.1	"Step 1542-26" on page 328
5	2.1	2.5	"Step 1542-27" on page 329
6	2.5	2.13	"Step 1542-28" on page 330
7	2.13	2.19	"Step 1542-29" on page 331
8	2.19	2.19	"Step 1542-30" on page 332

Note: The I/O subsystems should be cabled as shown in "Subsystem Positioning and Cabling" on page 41.

Step 1542-23

1. Turn off the power.
2. At the primary I/O book, disconnect the cable connection at RIO port B0 (U1.18-P1-H2/Q3).
3. Disconnect the cable connection at I/O subsystem 2 left I/O port connector 0 (U1.5-P1/Q2). The RIO cable that was connected to RIO port B0 should now be loose and can be removed.
4. At the primary I/O book, disconnect the cable connection at RIO port B1 (U1.18-P1-H2/Q4) and reconnect it to RIO port B0 (U1.18-P1-H2/Q3).
5. Disconnect the cable connection at I/O subsystem 2 right I/O port connector 1 (U1.5-P2/Q1) and reconnect it to I/O subsystem 2 left I/O port connector 0 (U1.5-P1/Q2).
6. Verify that processor subsystem RIO port B0 on primary I/O book (U1.18-P1-H2/Q3) is connected to I/O subsystem 2 left I/O port connector 0 (U1.5-P1/Q2).
7. Verify that I/O subsystem 2 left I/O port connector 1 (U1.5-P1/Q1) is connected to I/O subsystem 2 right I/O port connector 0 (U1.5-P2/Q2).
8. Turn on the power to boot standalone diagnostics from CD.
9. If the Please define the System Console screen is displayed, follow directions to select the system console.
10. Use the Display Configuration and Resource List to list all attached devices and adapters (refer to the *RS/6000 and @server pSeries Diagnostic Information for Multiple Bus Systems*, order number SA38-0509, if necessary).
11. Check that all attached devices and adapters are listed.

Did the Please define the System Console screen display and are all attached devices and adapters listed?

- NO** Connect the previously removed RIO cable from I/O subsystem 2 right I/O port connector 1 (U1.5-P2/Q1) to processor subsystem RIO port B1 on primary I/O book (U1.18-P1-H2/Q4). Go to “Step 1542-9” on page 319.
- YES** The RIO cable that was removed in step number 3 above is defective. Replace the RIO cable. Connect the new RIO cable from I/O subsystem 2 right I/O port connector 1 (U1.5-P2/Q1) to processor subsystem RIO port B1 on primary I/O book (U1.18-P1-H2/Q4). Reconfigure the system to its original condition. Go to “Map 0410: Repair Checkout” in the *RS/6000 and @server pSeries Diagnostic Information for Multiple Bus Systems*.

Step 1542-24

1. Turn off the power.
2. Slide the secondary I/O book (U1.18-P1-H3) all the way into the processor backplane until it is firmly seated and latched.
3. At the secondary I/O book, disconnect the cable connection at RIO port A0 (U1.18-P1-H3/Q4).
4. At the secondary I/O book, disconnect the cable connection at RIO port A1 (U1.18-P1-H3/Q3).

5. At the secondary I/O book, disconnect the cable connection at RIO port B0 (U1.18-P1-H3/Q2).
6. At the secondary I/O book, disconnect the cable connection at RIO port B1 (U1.18-P1-H3/Q1).
7. At the secondary I/O book, disconnect the cable connection at RIO port D0 (U1.18-P1-H3/Q6).
8. At the secondary I/O book, disconnect the cable connection at RIO port D1 (U1.18-P1-H3/Q5).
9. At the secondary I/O book, disconnect the cable connection at RIO port C0 (U1.18-P1-H3/Q8).
10. Disconnect the cable connection at I/O subsystem 3 left I/O port connector 0 (U1.1-P1/Q2). The RIO cable that was connected to RIO port C0 should now be loose and can be removed.
11. At the secondary I/O book, disconnect the cable connection at RIO port C1 (U1.18-P1-H3/Q7) and reconnect it to RIO port C0 (U1.18-P1-H3/Q8).
12. Disconnect the cable connection at I/O subsystem 3 right I/O port connector 1 (U1.1-P2/Q1) and reconnect it to I/O subsystem 3 left I/O port connector 0 (U1.1-P1/Q2).
13. Verify that processor subsystem RIO port C0 on secondary I/O book (U1.18-P1-H3/Q8) is connected to I/O subsystem 3 left I/O port connector 0 (U1.1-P1/Q2).
14. Verify that I/O subsystem 3 left I/O port connector 1 (U1.1-P1/Q1) is connected to I/O subsystem 3 right I/O port connector 0 (U1.1-P2/Q2).
15. Turn on the power to boot standalone diagnostics from CD.
16. If the Please define the System Console screen is displayed, follow directions to select the system console.
17. Use the Display Configuration and Resource List to list all attached devices and adapters (refer to the *RS/6000 and @server pSeries Diagnostic Information for Multiple Bus Systems*, order number SA38-0509, if necessary).
18. Check that all attached devices and adapters are listed.

Did the Please define the System Console screen display and are all attached devices and adapters listed?

- NO** Connect the previously removed RIO cable from I/O subsystem 3 right I/O port connector 1 (U1.1-P2/Q1) to processor subsystem RIO port C1 on secondary I/O book (U1.18-P1-H3/Q7). Go to “Step 1542-9” on page 319.
- YES** The RIO cable that was removed in step 10 above is defective. Replace the RIO cable. Connect the new RIO cable from I/O subsystem 3 right I/O port connector 1 (U1.1-P2/Q1) to processor subsystem RIO port C1 on secondary I/O book (U1.18-P1-H3/Q7). Reconfigure the system to its original condition. Go to “Map 0410: Repair Checkout” in the *RS/6000 and @server pSeries Diagnostic Information for Multiple Bus Systems*.

Step 1542-25

1. Turn off the power.

2. At the secondary I/O book, disconnect the cable connection at RIO port D0 (U1.18-P1-H3/Q6).
3. Disconnect the cable connection at I/O subsystem 4 left I/O port connector 0 (Ux.y-P1/Q2). The RIO cable that was connected to RIO port D0 should now be loose and can be removed.
4. At the secondary I/O book, disconnect the cable connection at RIO port D1 (U1.18-P1-H3/Q5) and reconnect it to RIO port D0 (U1.18-P1-H3/Q6).
5. Disconnect the cable connection at I/O subsystem 4 right I/O port connector 1 (Ux.y-P2/Q1) and reconnect it to I/O subsystem 4 left I/O port connector 0 (Ux.y-P1/Q2).
6. Verify that processor subsystem RIO port D0 on secondary I/O book (U1.18-P1-H3/Q6) is connected to I/O subsystem 4 left I/O port connector 0 (Ux.y-P1/Q2).
7. Verify that I/O subsystem 4 left I/O port connector 1 (Ux.y-P1/Q1) is connected to I/O subsystem 4 right I/O port connector 0 (Ux.y-P2/Q2).
8. Turn on the power to boot standalone diagnostics from CD.
9. If the Please define the System Console screen is displayed, follow directions to select the system console.
10. Use the Display Configuration and Resource List to list all attached devices and adapters (refer to the *RS/6000 and @server pSeries Diagnostic Information for Multiple Bus Systems*, order number SA38-0509, if necessary).
11. Check that all attached devices and adapters are listed.

Did the Please define the System Console screen display and are all attached devices and adapters listed?

- NO** Connect the previously removed RIO cable from I/O subsystem 4 right I/O port connector 1 (Ux.y-P2/Q1) to processor subsystem RIO port D1 on secondary I/O book (U1.18-P1-H3/Q5). Go to “Step 1542-9” on page 319.
- YES** The RIO cable that was removed in step 3 above is defective. Replace the RIO cable. Connect the new RIO cable from I/O subsystem 4 right I/O port connector 1 (Ux.y-P2/Q1) to processor subsystem RIO port D1 on secondary I/O book (U1.18-P1-H3/Q5). Reconfigure the system to its original condition. Go to “Map 0410: Repair Checkout” in the *RS/6000 and @server pSeries Diagnostic Information for Multiple Bus Systems*.

Step 1542-26

1. Turn off the power.
2. At the secondary I/O book disconnect the cable connection at RIO port A0 (U1.18-P1-H3/Q4).
3. Disconnect the cable connection at I/O subsystem 5 left I/O port connector 0 (U2.1-P1/Q2).The RIO cable that was connected to RIO port A0 should now be loose and can be removed.
4. At the secondary I/O book, disconnect the cable connection at RIO port A1 (U1.18-P1-H3/Q3) and reconnect it to RIO port A0 (U1.18-P1-H3/Q4).

5. Disconnect the cable connection at I/O subsystem 5 right I/O port connector 1 (U2.1-P2/Q1) and reconnect it to I/O subsystem 5 left I/O port connector 0 (U2.1-P1/Q2).
6. Verify that processor subsystem RIO port A0 on secondary I/O book (U1.18-P1-H3/Q4) is connected to I/O subsystem 5 left I/O port connector 0 (U2.1-P1/Q2).
7. Verify that I/O subsystem 5 left I/O port connector 1 (U2.1-P1/Q1) is connected to I/O subsystem 5 right I/O port connector 0 (U2.1-P2/Q2).
8. Turn on the power to boot standalone diagnostics from CD.
9. If the Please define the System Console screen is displayed, follow directions to select the system console.
10. Use the Display Configuration and Resource List to list all attached devices and adapters (refer to the *RS/6000 and @server pSeries Diagnostic Information for Multiple Bus Systems*, order number SA38-0509, if necessary).
11. Check that all attached devices and adapters are listed.

Did the Please define the System Console screen display and are all attached devices and adapters listed?

- NO** Connect the previously removed RIO cable from I/O subsystem 5 right I/O port connector 1 (U2.1-P2/Q1) to processor subsystem RIO port A1 on secondary I/O book (U1.18-P1-H3/Q3). Go to “Step 1542-9” on page 319.
- YES** The RIO cable that was removed in step 3 on page 328 is defective. Replace the RIO cable. Connect the new RIO cable from I/O subsystem 5 right I/O port connector 1 (U2.1-P2/Q1) to processor subsystem RIO port A1 on secondary I/O book (U1.18-P1-H3/Q3). Reconfigure the system to its original condition. Go to “Map 0410: Repair Checkout” in the *RS/6000 and @server pSeries Diagnostic Information for Multiple Bus Systems*.

Step 1542-27

1. Turn off the power.
2. At the secondary I/O book, disconnect the cable connection at RIO port B0 (U1.18-P1-H3/Q2).
3. Disconnect the cable connection at I/O subsystem 6 left I/O port connector 0 (U2.5-P1/Q2). The RIO cable that was connected to RIO port B0 should now be loose and can be removed.
4. At the secondary I/O book, disconnect the cable connection at RIO port B1 (U1.18-P1-H3/Q1) and reconnect it to RIO port B0 (U1.18-P1-H3/Q2).
5. Disconnect the cable connection at I/O subsystem 6 right I/O port connector 1 (U2.5-P2/Q1) and reconnect it to I/O subsystem 6 left I/O port connector 0 (U2.5-P1/Q2).
6. Verify that processor subsystem RIO port B0 on secondary I/O book (U1.18-P1-H3/Q2) is connected to I/O subsystem 6 left I/O port connector 0 (U2.5-P1/Q2).
7. Verify that I/O subsystem 6 left I/O port connector 1 (U2.5-P1/Q1) is connected to I/O subsystem 6 right I/O port connector 0 (U2.5-P2/Q2).

8. Turn on the power to boot standalone diagnostics from CD.
9. If the Please define the System Console screen is displayed, follow directions to select the system console.
10. Use the Display Configuration and Resource List to list all attached devices and adapters (refer to the *RS/6000 and @server pSeries Diagnostic Information for Multiple Bus Systems*, order number SA38-0509, if necessary).
11. Check that all attached devices and adapters are listed.

Did the Please define the System Console screen display and are all attached devices and adapters listed?

- NO** Connect the previously removed RIO cable from I/O subsystem 6 right I/O port connector 1 (U2.5-P2/Q1) to processor subsystem RIO port B1 on secondary I/O book (U1.18-P1-H3/Q1). Go to “Step 1542-9” on page 319.
- YES** The RIO cable that was removed in step 3 on page 329 is defective. Replace the RIO cable. Connect the new RIO cable from I/O subsystem 6 right I/O port connector 1 (U2.5-P2/Q1) to processor subsystem RIO port B1 on secondary I/O book (U1.18-P1-H3/Q1). Reconfigure the system to its original condition. Go to “Map 0410: Repair Checkout” in the *RS/6000 and @server pSeries Diagnostic Information for Multiple Bus Systems*.

Step 1542-28

1. Turn off the power.
2. Slide the secondary I/O book (U1.18-P1-H4) all the way into the processor backplane until it is firmly seated and latched.
3. At the secondary I/O book, disconnect the cable connection at RIO port D0 (U1.18-P1-H4/Q6).
4. At the secondary I/O book, disconnect the cable connection at RIO port D1 (U1.18-P1-H4/Q5).
5. At the secondary I/O book, disconnect the cable connection at RIO port C0 (U1.18-P1-H4/Q8).
6. Disconnect the cable connection at I/O subsystem 7 left I/O port connector 0 (U2.13-P1/Q2). The RIO cable that was connected to RIO port C0 should now be loose and can be removed.
7. At the secondary I/O book, disconnect the cable connection at RIO port C1 (U1.18-P1-H4/Q7) and reconnect it to RIO port C0 (U1.18-P1-H4/Q8).
8. Disconnect the cable connection at I/O subsystem 7 right I/O port connector 1 (U2.13-P2/Q1) and reconnect it to I/O subsystem 7 left I/O port connector 0 (U2.13-P1/Q2).
9. Verify that processor subsystem RIO port C0 on secondary I/O book (U1.18-P1-H4/Q8) is connected to I/O subsystem 7 left I/O port connector 0 (U2.13-P1/Q2).
10. Verify that I/O subsystem 7 left I/O port connector 1 (U2.13-P1/Q1) is connected to I/O subsystem 7 right I/O port connector 0 (U2.13-P2/Q2).
11. Turn on the power to boot standalone diagnostics from CD.

12. If the Please define the System Console screen is displayed, follow directions to select the system console.
13. Use the Display Configuration and Resource List to list all attached devices and adapters (refer to the *RS/6000 and @server pSeries Diagnostic Information for Multiple Bus Systems*, order number SA38-0509, if necessary).
14. Check that all attached devices and adapters are listed.

Did the Please define the System Console screen display and are all attached devices and adapters listed?

- NO** Connect the previously removed RIO cable from I/O subsystem 7 right I/O port connector 1 (U2.13-P2/Q1) to processor subsystem RIO port C1 on secondary I/O book (U1.18-P1-H4/Q7). Go to “Step 1542-9” on page 319.
- YES** The RIO cable that was removed in step 6 on page 330 is defective. Replace the RIO cable. Connect the new RIO cable from I/O subsystem 7 right I/O port connector 1 (U2.13-P2/Q1) to processor subsystem RIO port C1 on secondary I/O book (U1.18-P1-H4/Q7). Reconfigure the system to its original condition. Go to “Map 0410: Repair Checkout” in the *RS/6000 and @server pSeries Diagnostic Information for Multiple Bus Systems*.

Step 1542-29

1. Turn off the power.
2. At the secondary I/O book, disconnect the cable connection at RIO port D0 (U1.18-P1-H4/Q6).
3. Disconnect the cable connection at I/O subsystem 8 left I/O port connector 0 (U2.19-P1/Q2). The RIO cable that was connected to RIO port D0 should now be loose and can be removed.
4. At the secondary I/O book, disconnect the cable connection at RIO port D1 (U1.18-P1-H4/Q5) and reconnect it to RIO port D0 (U1.18-P1-H4/Q6).
5. Disconnect the cable connection at I/O subsystem 8 right I/O port connector 1 (U2.19-P2/Q1) and reconnect it to I/O subsystem 8 left I/O port connector 0 (U2.19-P1/Q2).
6. Verify that processor subsystem RIO port D0 on secondary I/O book (U1.18-P1-H4/Q6) is connected to I/O subsystem 8 left I/O port connector 0 (U2.19-P1/Q2).
7. Verify that I/O subsystem 8 left I/O port connector 1 (U2.19-P1/Q1) is connected to I/O subsystem 8 right I/O port connector 0 (U2.19-P2/Q2).
8. Turn on the power to boot standalone diagnostics from CD.
9. If the Please define the System Console screen is displayed, follow directions to select the system console.
10. Use the Display Configuration and Resource List to list all attached devices and adapters (refer to the *RS/6000 and @server pSeries Diagnostic Information for Multiple Bus Systems*, order number SA38-0509, if necessary).
11. Check that all attached devices and adapters are listed.

Did the Please define the System Console screen display and are all attached devices and adapters listed?

NO Connect the previously removed RIO cable from I/O subsystem 8 right I/O port connector 1 (U2.19-P2/Q1) to processor subsystem RIO port D1 on secondary I/O book (U1.18-P1-H4/Q5). Go to “Step 1542-9” on page 319.

YES The RIO cable that was removed in step 3 on page 331 is defective. Replace the RIO cable. Connect the new RIO cable from I/O subsystem 8 right I/O port connector 1 (U2.19-P2/Q1) to processor subsystem RIO port D1 on secondary I/O book (U1.18-P1-H4/Q5). Reconfigure the system to its original condition. Go to “Map 0410: Repair Checkout” in the *RS/6000 and @server pSeries Diagnostic Information for Multiple Bus Systems*.

Step 1542-30

This ends the procedure.

Reconfigure the system to its original condition. Go to “Map 0410: Repair Checkout” in the *RS/6000 and @server pSeries Diagnostic Information for Multiple Bus Systems*.

MAP 1543: MCM Module Problem Isolation

Step 1543-1

Record the error code and the location code(s) that sent you to this MAP.

Step 1543-2

Turn off the power.

Examine the amber logic-power LEDs of all installed processor subsystem DCAs.

Step 1543-3

Are all amber logic-power LEDs of all installed processor subsystem DCAs off?

Yes Go to “Step 1543-4”.

No Call for support.

Step 1543-4

Attention: Some of the parts in the following list are modules that have a limit of three plug cycles. Before replacing any of the modules in the following list, call for support.

You may be asked to replace one or more of the following cards and modules:

- Passthru module at U1.18-P1-C2
- Passthru module at U1.18-P1-C3
- MCM module 0 at U1.18-P1-C1
- MCM module 2 at U1.18-P1-C4
- MCM module 1 at U1.18-P1-C3
- MCM module 3 at U1.18-P1-C2
- System clock card, at location U1.18-P1-X5

Replace the following books and modules, if present, one at a time:

1. Passthru module at U1.18-P1-C2 if not recorded in “Step 1543-1” on page 332.
2. Passthru module at U1.18-P1-C3 if not recorded in “Step 1543-1” on page 332.
3. System clock card, at location U1.18-P1-X5 if not recorded in “Step 1543-1” on page 332.
4. First location code item recorded, if any, in “Step 1543-1” on page 332.
5. Second location code item recorded, if any, in “Step 1543-1” on page 332.
6. Third location code item recorded, if any, in “Step 1543-1” on page 332.
7. Fourth location code item recorded, if any, in “Step 1543-1” on page 332.
8. MCM module 0 at U1.18-P1-C1 if not recorded in “Step 1543-1” on page 332.
9. MCM module 2 at U1.18-P1-C4 if not recorded in “Step 1543-1” on page 332.
10. MCM module 1 at U1.18-P1-C3 if not recorded in “Step 1543-1” on page 332.
11. MCM module 3 at U1.18-P1-C2 if not recorded in “Step 1543-1” on page 332.

Step 1543-5

Turn on the power.

Step 1543-6

Did the system stop with the same error code as recorded in “Step 1543-1” on page 332?

Yes Go to “Step 1543-7”.

No The module just replaced was defective. **This ends the procedure.**

Return the system to its original configuration.

Go to “MAP 0410: Repair Checkout” in the *RS/6000 and @server pSeries Diagnostic Information for Multiple Bus Systems*.

Step 1543-7

Have all the modules listed in “Step 1543-4” on page 332 been replaced?

Yes Go to “Step 1543-8”.

No Go to “Step 1543-2” on page 332.

Step 1543-8

Turn off the power.

Step 1543-9

Examine the amber logic-power LEDs of all installed processor subsystem DCAs.

Step 1543-10

Are all amber logic-power LEDs of all installed processor subsystem DCAs off?

Yes Go to “Step 1543-11” on page 334.

No Call for support.

Step 1543-11

Attention: Before replacing the system backplane, call for support.

Replace the system backplane at U1.18-P1.

Step 1543-12

Turn on the power.

Step 1543-13

Did the system stop with the same error code as recorded in “Step 1541-1” on page 304?

Yes Go to “Step 1543-14”.

No The part just replaced was defective. **This ends the procedure.**

Return the system to its original configuration.

Go to “MAP 0410: Repair Checkout” in the *RS/6000 and @server pSeries Diagnostic Information for Multiple Bus Systems*.

Step 1543-14

Turn off the power.

Make sure all amber logic-power LEDs of all installed processor subsystem DCAs are off.

Step 1543-15

Call for support.

This ends the procedure.

MAP 1544: Inner L3 Module Problem Isolation

Step 1544-1

Record the error code and the location code(s) that sent you to this MAP.

Step 1544-2

Turn off the power.

Examine the amber logic-power LEDs of all installed processor subsystem DCAs.

Step 1544-3

Are all amber logic-power LEDs of all installed processor subsystem DCAs off?

Yes Go to “Step 1544-4” on page 335.

No Call for support.

Step 1544-4

Attention: Some of the parts in the following list are modules that have a limit of three plug cycles. Before replacing any of the modules in the following list, call for support.

You may be asked to replace one or more of the following books and modules:

- Memory book 0 at U1.18-P1-M2
- Memory book 1 at U1.18-P1-M3
- Memory book 2 at U1.18-P1-M7
- Memory book 3 at U1.18-P1-M6
- L3 module at U1.18-P1-C6
- L3 module at U1.18-P1-C7
- L3 module at U1.18-P1-C10
- L3 module at U1.18-P1-C11
- L3 module at U1.18-P1-C14
- L3 module at U1.18-P1-C15
- L3 module at U1.18-P1-C18
- L3 module at U1.18-P1-C19

Replace the following books and modules, if present, one at a time:

1. First location code item recorded, if any, in “Step 1544-1” on page 334.
2. Second location code item recorded, if any, in “Step 1544-1” on page 334.
3. Third location code item recorded, if any, in “Step 1544-1” on page 334.

Step 1544-5

Turn on the power.

Step 1544-6

Did the system stop with the same error code as recorded in “Step 1544-1” on page 334?

Yes Go to “Step 1544-7”.

No The book or module just replaced was defective. **This ends the procedure.**

Return the system to its original configuration.

Go to “MAP 0410: Repair Checkout” in the *RS/6000 and @server pSeries Diagnostic Information for Multiple Bus Systems*.

Step 1544-7

Have all the books or modules listed in “Step 1544-4” been replaced?

Yes Go to “Step 1544-8”.

No Go to “Step 1544-2” on page 334.

Step 1544-8

Turn off the power.

Step 1544-9

Examine the amber logic-power LEDs of all installed processor subsystem DCAs.

Step 1544-10

Are all amber logic-power LEDs of all installed processor subsystem DCAs off?

Yes Go to "Step 1544-11".

No Call for support.

Step 1544-11

Attention: Before replacing the system backplane, call for support.

Replace the system backplane at U1.18-P1.

Step 1544-12

Turn on the power.

Step 1544-13

Did the system stop with the same error code as recorded in "Step 1544-1" on page 334?

Yes Go to "Step 1544-14".

No The part just replaced was defective. **This ends the procedure.**

Return the system to its original configuration.

Go to "MAP 0410: Repair Checkout" in the *RS/6000 and @server pSeries Diagnostic Information for Multiple Bus Systems*.

Step 1544-14

Turn off the power.

Make sure all amber logic-power LEDs of all installed processor subsystem DCAs are off.

Step 1544-15

Call for support.

This ends the procedure.

MAP 1545: Outer L3 Module Problem Isolation

Step 1545-1

Record the error code and the location code(s) that sent you to this MAP.

Step 1545-2

Turn off the power.

Examine the amber logic-power LEDs of all installed processor subsystem DCAs.

Step 1545-3

Are all amber logic-power LEDs of all installed processor subsystem DCAs off?

Yes Go to "Step 1545-4".

No Call for support.

Step 1545-4

Attention: Some of the parts in the following list are modules that have a limit of three plug cycles. Before replacing any of the modules in the following list, call for support.

You may be asked to replace one or more of the following books and modules:

- Memory book 4 at U1.18-P1-M4
- Memory book 5 at U1.18-P1-M8
- Memory book 6 at U1.18-P1-M5
- Memory book 7 at U1.18-P1-M1
- L3 module at U1.18-P1-C5
- L3 module at U1.18-P1-C8
- L3 module at U1.18-P1-C9
- L3 module at U1.18-P1-C12
- L3 module at U1.18-P1-C13
- L3 module at U1.18-P1-C16
- L3 module at U1.18-P1-C17
- L3 module at U1.18-P1-C20

Replace the following books and modules, if present, one at a time:

1. First location code item recorded, if any, in "Step 1545-1" on page 336.
2. Second location code item recorded, if any, in "Step 1545-1" on page 336.
3. Third location code item recorded, if any, in "Step 1545-1" on page 336.

Step 1545-5

Turn on the power.

Step 1545-6

Did the system stop with the same error code as recorded in "Step 1545-1" on page 336?

Yes Go to "Step 1545-7".

No The book or module just replaced was defective. **This ends the procedure.**

Return the system to its original configuration.

Go to "MAP 0410: Repair Checkout" in the *RS/6000 and @server pSeries Diagnostic Information for Multiple Bus Systems*.

Step 1545-7

Have all the books or modules listed in "Step 1545-4" been replaced??

Yes Go to "Step 1545-8" on page 338.

No Go to “Step 1545-2” on page 336.

Step 1545-8

Turn off the power.

Step 1545-9

Examine the amber logic-power LEDs of all installed processor subsystem DCAs.

Step 1545-10

Are all amber logic-power LEDs of all installed processor subsystem DCAs off?

Yes Go to “Step 1545-11”.

No Call for support.

Step 1545-11

Attention: Before replacing the system backplane, call for support.

Replace the system backplane at U1.18-P1.

Step 1545-12

Turn on the power.

Step 1545-13

Did the system stop with the same error code as recorded in “Step 1545-1” on page 336?

Yes Go to “Step 1545-14”.

No The part just replaced was defective. **This ends the procedure.**

Return the system to its original configuration.

Go to “MAP 0410: Repair Checkout” in the *RS/6000 and @server pSeries Diagnostic Information for Multiple Bus Systems*.

Step 1545-14

Turn off the power.

Make sure all amber logic-power LEDs of all installed processor subsystem DCAs are off.

Step 1545-15

Call for support.

This ends the procedure.

MAP 1546: Memory Book Problem Isolation

Step 1546-1

Record the error code and the location code(s) that sent you to this MAP.

Step 1546-2

Turn off the power.

Examine the amber logic-power LEDs of all installed processor subsystem DCAs.

Step 1546-3

Are all amber logic-power LEDs of all installed processor subsystem DCAs off?

Yes Go to “Step 1546-4”.

No Call for support.

Step 1546-4

Attention: Some of the parts in the following list are modules that have a limit of three plug cycles. Before replacing any of the modules in the following list, call for support.

Replace the following books and modules, if present, one at a time:

- First location code item recorded, if any, in “Step 1546-1” on page 338.
- Second location code item recorded, if any, in “Step 1546-1” on page 338.
- Third location code item recorded, if any, in “Step 1546-1” on page 338.
- Memory book 0 at U1.18-P1-M2 if not recorded in “Step 1546-1” on page 338.
- Memory book 1 at U1.18-P1-M3 if not recorded in “Step 1546-1” on page 338.
- Memory book 2 at U1.18-P1-M7 if not recorded in “Step 1546-1” on page 338.
- Memory book 3 at U1.18-P1-M6 if not recorded in “Step 1546-1” on page 338.
- Memory book 4 at U1.18-P1-M4 if not recorded in “Step 1546-1” on page 338.
- Memory book 5 at U1.18-P1-M8 if not recorded in “Step 1546-1” on page 338.
- Memory book 6 at U1.18-P1-M5 if not recorded in “Step 1546-1” on page 338.
- Memory book 7 at U1.18-P1-M1 if not recorded in “Step 1546-1” on page 338.
- L3 module at U1.18-P1-C5 if not recorded in “Step 1546-1” on page 338.
- L3 module at U1.18-P1-C6 if not recorded in “Step 1546-1” on page 338.
- L3 module at U1.18-P1-C7 if not recorded in “Step 1546-1” on page 338.
- L3 module at U1.18-P1-C8 if not recorded in “Step 1546-1” on page 338.
- L3 module at U1.18-P1-C9 if not recorded in “Step 1546-1” on page 338.
- L3 module at U1.18-P1-C10 if not recorded in “Step 1546-1” on page 338.
- L3 module at U1.18-P1-C11 if not recorded in “Step 1546-1” on page 338.
- L3 module at U1.18-P1-C12 if not recorded in “Step 1546-1” on page 338.
- L3 module at U1.18-P1-C13 if not recorded in “Step 1546-1” on page 338.
- L3 module at U1.18-P1-C14 if not recorded in “Step 1546-1” on page 338.
- L3 module at U1.18-P1-C15 if not recorded in “Step 1546-1” on page 338.
- L3 module at U1.18-P1-C16 if not recorded in “Step 1546-1” on page 338.
- L3 module at U1.18-P1-C17 if not recorded in “Step 1546-1” on page 338.
- L3 module at U1.18-P1-C18 if not recorded in “Step 1546-1” on page 338.
- L3 module at U1.18-P1-C19 if not recorded in “Step 1546-1” on page 338.
- L3 module at U1.18-P1-C20 if not recorded in “Step 1546-1” on page 338.

Step 1546-5

Turn on the power.

Step 1546-6

Did the system stop with the same error code as recorded in “Step 1546-1” on page 338?

Yes Go to “Step 1546-7”.

No The book or module just replaced was defective. **This ends the procedure.**
Return the system to its original configuration.

Go to “MAP 0410: Repair Checkout” in the *RS/6000 and @server pSeries Diagnostic Information for Multiple Bus Systems*.

Step 1546-7

Have all the books or modules listed in “Step 1546-4” on page 339 been replaced??

Yes Go to “Step 1546-8”.

No Go to “Step 1546-2” on page 339.

Step 1546-8

Turn off the power.

Step 1546-9

Examine the amber logic-power LEDs of all installed processor subsystem DCAs.

Step 1546-10

Are all amber logic-power LEDs of all installed processor subsystem DCAs off?

Yes Go to “Step 1546-11”.

No Call for support.

Step 1546-11

Attention: Before replacing the system backplane, call for support.

Replace the system backplane at U1.18-P1.

Step 1546-12

Turn on the power.

Step 1546-13

Did the system stop with the same error code as recorded in “Step 1546-1” on page 338?

Yes Go to “Step 1546-14” on page 341.

No The part just replaced was defective. **This ends the procedure.**

Return the system to its original configuration.

Go to “MAP 0410: Repair Checkout” in the *RS/6000 and @server pSeries Diagnostic Information for Multiple Bus Systems*.

Step 1546-14

Turn off the power.

Make sure all amber logic-power LEDs of all installed processor subsystem DCAs are off.

Step 1546-15

Call for support.

This ends the procedure.

MAP 1547: I/O Book Problem Isolation

Step 1547-1

Record the error code and the location code(s) that sent you to this MAP.

Step 1547-2

Turn off the power.

Examine the amber logic-power LEDs of all installed processor subsystem DCAs.

Step 1547-3

Are all amber logic-power LEDs of all installed processor subsystem DCAs off?

Yes Go to "Step 1547-4".

No Call for support.

Step 1547-4

Replace the following books, if present, one at a time:

- Primary I/O Book at U1.18-P1-H2
- Secondary I/O Book at U1.18-P1-H3
- Third I/O Book at U1.18-P1-H4

Step 1547-5

Turn on the power.

Step 1547-6

Did the system stop with the same error code as recorded in "Step 1547-1"?

Yes Go to "Step 1547-7".

No The book just replaced was defective. **This ends the procedure.**

Return the system to its original configuration.

Go to "MAP 0410: Repair Checkout" in the *RS/6000 and @server pSeries Diagnostic Information for Multiple Bus Systems*.

Step 1547-7

Have all the books or modules listed in "Step 1547-4" been replaced?

Yes Go to "Step 1547-8".

No Go to "Step 1547-2" on page 341.

Step 1547-8

Turn off the power.

Step 1547-9

Examine the amber logic-power LEDs of all installed processor subsystem DCAs.

Step 1547-10

Are all amber logic-power LEDs of all installed processor subsystem DCAs off?

Yes Go to "Step 1547-11".

No Call for support.

Step 1547-11

Attention: Before replacing the system backplane, call for support.

Replace the system backplane at U1.18-P1.

Step 1547-12

Turn on the power.

Step 1547-13

Did the system stop with the same error code as recorded in "Step 1547-1" on page 341?

Yes Go to "Step 1547-14".

No The part just replaced was defective. **This ends the procedure.**

Return the system to its original configuration.

Go to "MAP 0410: Repair Checkout" in the *RS/6000 and @server pSeries Diagnostic Information for Multiple Bus Systems*.

Step 1547-14

Turn off the power.

Make sure all amber logic-power LEDs of all installed processor subsystem DCAs are off.

Step 1547-15

Call for support.

This ends the procedure.

MAP 1548: Memory and Processor Problem Isolation

Step 1548-1

Record the error code and the location code(s) that sent you to this MAP.

Step 1548-2

Turn off the power.

Examine the amber logic-power LEDs of all installed processor subsystem DCAs.

Step 1548-3

Are all amber logic-power LEDs of all installed processor subsystem DCAs off?

Yes Go to “Step 1548-4”.

No Call for support.

Step 1548-4

Attention: Some of the parts in the following list are modules that have a limit of three plug cycles. Before replacing any of the modules in the following list, call for support.

Replace the following books and modules, if present, one at a time:

- First location code item recorded, if any, in “Step 1548-1”.
- Second location code item recorded, if any, in “Step 1548-1”.
- Third location code item recorded, if any, in “Step 1548-1”.
- Memory book 0 at U1.18-P1-M2 if not recorded in “Step 1548-1”.
- Memory book 1 at U1.18-P1-M3 if not recorded in “Step 1548-1”.
- L3 module at U1.18-P1-C6 if not recorded in “Step 1548-1”.
- L3 module at U1.18-P1-C7 if not recorded in “Step 1548-1”.
- L3 module at U1.18-P1-C10 if not recorded in “Step 1548-1”.
- L3 module at U1.18-P1-C11 if not recorded in “Step 1548-1”.
- Passthru module at U1.18-P1-C2 if not recorded in “Step 1548-1”.
- Passthru module at U1.18-P1-C3 if not recorded in “Step 1548-1”.
- MCM module 0 at U1.18-P1-C1 if not recorded in “Step 1548-1”.
- Memory book 2 at U1.18-P1-M7 if not recorded in “Step 1548-1”.
- Memory book 3 at U1.18-P1-M6 if not recorded in “Step 1548-1”.
- Memory book 4 at U1.18-P1-M4 if not recorded in “Step 1548-1”.
- Memory book 5 at U1.18-P1-M8 if not recorded in “Step 1548-1”.
- Memory book 6 at U1.18-P1-M5 if not recorded in “Step 1548-1”.
- Memory book 7 at U1.18-P1-M1 if not recorded in “Step 1548-1”.
- L3 module at U1.18-P1-C5 if not recorded in “Step 1548-1”.
- L3 module at U1.18-P1-C8 if not recorded in “Step 1548-1”.
- L3 module at U1.18-P1-C9 if not recorded in “Step 1548-1”.
- L3 module at U1.18-P1-C12 if not recorded in “Step 1548-1”.
- L3 module at U1.18-P1-C13 if not recorded in “Step 1548-1”.
- L3 module at U1.18-P1-C14 if not recorded in “Step 1548-1”.
- L3 module at U1.18-P1-C15 if not recorded in “Step 1548-1”.
- L3 module at U1.18-P1-C16 if not recorded in “Step 1548-1”.
- L3 module at U1.18-P1-C17 if not recorded in “Step 1548-1”.
- L3 module at U1.18-P1-C18 if not recorded in “Step 1548-1”.

- L3 module at U1.18-P1-C19 if not recorded in “Step 1548-1” on page 343.
- L3 module at U1.18-P1-C20 if not recorded in “Step 1548-1” on page 343.
- MCM module 2 at U1.18-P1-C4 if not recorded in “Step 1548-1” on page 343.
- MCM module 1 at U1.18-P1-C3 if not recorded in “Step 1548-1” on page 343.
- MCM module 3 at U1.18-P1-C2 if not recorded in “Step 1548-1” on page 343.

Step 1548-5

Turn on the power.

Step 1548-6

Did the system stop with the same error code as recorded in “Step 1548-1” on page 343?

Yes Go to “Step 1548-7”.

No The book or module just replaced was defective. **This ends the procedure.**
Return the system to its original configuration.

Go to “MAP 0410: Repair Checkout” in the *RS/6000 and @server pSeries Diagnostic Information for Multiple Bus Systems*.

Step 1548-7

Have all the books or modules listed in “Step 1548-4” on page 343 been replaced?

Yes Go to “Step 1548-8”.

No Go to “Step 1548-2” on page 343.

Step 1548-8

Turn off the power.

Step 1548-9

Examine the amber logic-power LEDs of all installed processor subsystem DCAs.

Step 1548-10

Are all amber logic-power LEDs of all installed processor subsystem DCAs off?

Yes Go to “Step 1548-11”.

No Call for support.

Step 1548-11

Attention: Before replacing the system backplane, call for support.

Replace the system backplane at U1.18-P1.

Step 1548-12

Turn on the power.

Step 1548-13

Did the system stop with the same error code as recorded in “Step 1548-1” on page 343?

Yes Go to “Step 1548-14”.

No The part just replaced was defective. **This ends the procedure.**

Return the system to its original configuration.

Go to “MAP 0410: Repair Checkout” in the *RS/6000 and @server pSeries Diagnostic Information for Multiple Bus Systems*.

Step 1548-14

Turn off the power.

Make sure all amber logic-power LEDs of all installed processor subsystem DCAs are off.

Step 1548-15

Call for support.

This ends the procedure.

MAP 1549: Attention Problem Isolation

Step 1549-1

Record the error code and the location code(s) that sent you to this MAP.

Step 1549-2

Turn off the power.

Examine the amber logic-power LEDs of all installed processor subsystem DCAs.

Step 1549-3

Are all amber logic-power LEDs of all installed processor subsystem DCAs off?

No Call for support.

Yes Go to “Step 1549-4”.

Step 1549-4

Examine the following table and locate the error code that sent you to this MAP to determine your next step.

Error Code	Action
406x 0EB1	Go to “Step 1549-5” on page 346.
406x 0EB2	Go to “Step 1549-9” on page 347.
406x 0EB3	Go to “Step 1549-13” on page 348.
406x 0EB4	Go to “Step 1549-33” on page 351.

Error Code	Action
406x 0EB5	Go to "Step 1549-29" on page 350.
406x 0EB6	Go to "Step 1549-33" on page 351.
406x 0EB7	Go to "Step 1549-33" on page 351.
406x 0EB8	Go to "Step 1549-33" on page 351.
406x 0EB9	Go to "Step 1549-33" on page 351.
406x 0EBA	Go to "Step 1549-17" on page 348.
406x 0EBB	Go to "Step 1549-21" on page 349.
406x 0EBC	Go to "Step 1549-25" on page 350.

Step 1549-5

Attention: Some of the parts in the following list are modules which have a limit of three plug cycles. Before replacing any of the modules in the following list, call for support. Replace the following books and modules, if present, one at a time:

- First location code item recorded, if any, in "Step 1549-1" on page 345.
- Second location code item recorded, if any, in "Step 1549-1" on page 345.
- Third location code item recorded, if any, in "Step 1549-1" on page 345.
- Primary I/O Book at U1.18-P1-H2 if not recorded in "Step 1549-1" on page 345.
- MCM module 0 at U1.18-P1-C1 if not recorded in "Step 1549-1" on page 345.
- MCM module 2 at U1.18-P1-C4 if not recorded in "Step 1549-1" on page 345.
- MCM module 1 at U1.18-P1-C3 if not recorded in "Step 1549-1" on page 345.
- MCM module 3 at U1.18-P1-C2 if not recorded in "Step 1549-1" on page 345.

Step 1549-6

Turn on the power.

Step 1549-7

Did the system stop with the same error code as recorded in "Step 1549-1" on page 345?

No The book or module just replaced was defective. **This ends the procedure.**

Return the system to its original configuration.

Go to "MAP 0410: Repair Checkout" in the *RS/6000 and @server pSeries Diagnostic Information for Multiple Bus Systems*.

Yes Go to "Step 1549-8".

Step 1549-8

Have all the books or modules listed in "Step 1549-5" been replaced?

No Go to "Step 1549-37" on page 352.

Yes Go to "Step 1549-2" on page 345.

Step 1549-9

Attention: Some of the parts in the following list are modules that have a limit of three plug cycles. Before replacing any of the modules in the following list, call for support.

Replace the following books and modules, if present, one at a time:

- First location code item recorded, if any, in “Step 1549-1” on page 345.
- Second location code item recorded, if any, in “Step 1549-1” on page 345.
- Third location code item recorded, if any, in “Step 1549-1” on page 345.
- Primary I/O Book at U1.18-P1-H2 if not recorded in “Step 1549-1” on page 345.
- L3 module at U1.18-P1-C6 if not recorded in “Step 1549-1” on page 345.
- L3 module at U1.18-P1-C7 if not recorded in “Step 1549-1” on page 345.
- L3 module at U1.18-P1-C10 if not recorded in “Step 1549-1” on page 345.
- L3 module at U1.18-P1-C11 if not recorded in “Step 1549-1” on page 345.
- L3 module at U1.18-P1-C5 if not recorded in “Step 1549-1” on page 345.
- L3 module at U1.18-P1-C8 if not recorded in “Step 1549-1” on page 345.
- L3 module at U1.18-P1-C9 if not recorded in “Step 1549-1” on page 345.
- L3 module at U1.18-P1-C12 if not recorded in “Step 1549-1” on page 345.
- L3 module at U1.18-P1-C13 if not recorded in “Step 1549-1” on page 345.
- L3 module at U1.18-P1-C14 if not recorded in “Step 1549-1” on page 345.
- L3 module at U1.18-P1-C15 if not recorded in “Step 1549-1” on page 345.
- L3 module at U1.18-P1-C16 if not recorded in “Step 1549-1” on page 345.
- L3 module at U1.18-P1-C17 if not recorded in “Step 1549-1” on page 345.
- L3 module at U1.18-P1-C18 if not recorded in “Step 1549-1” on page 345.
- L3 module at U1.18-P1-C19 if not recorded in “Step 1549-1” on page 345.
- L3 module at U1.18-P1-C20 if not recorded in “Step 1549-1” on page 345.

Step 1549-10

Turn on the power.

Step 1549-11

Did the system stop with the same error code as recorded in “Step 1549-1” on page 345?

No The book or module just replaced was defective. **This ends the procedure.**

Return the system to its original configuration.

Go to “MAP 0410: Repair Checkout” in the *RS/6000 and @server pSeries Diagnostic Information for Multiple Bus Systems*.

Yes Go to “Step 1549-12”.

Step 1549-12

Have all the books listed in “Step 1549-9” been replaced?

No “Step 1549-2” on page 345.

Yes Go to "Step 1549-13".

Step 1549-13

Replace the following books and modules, if present, one at a time:

- First location code item recorded, if any, in "Step 1549-1" on page 345.
- Second location code item recorded, if any, in "Step 1549-1" on page 345.
- Third location code item recorded, if any, in "Step 1549-1" on page 345.
- Memory book 0 at U1.18-P1-M2 if not recorded in "Step 1549-1" on page 345.
- Memory book 1 at U1.18-P1-M3 if not recorded in "Step 1549-1" on page 345.
- Primary I/O Book at U1.18-P1-H2 if not recorded in "Step 1549-1" on page 345.
-

Step 1549-14

Turn on the power.

Step 1549-15

Did the system stop with the same error code as recorded in "Step 1549-1" on page 345?

No The book or module just replaced was defective. **This ends the procedure.**

Return the system to its original configuration.

Go to "MAP 0410: Repair Checkout" in the *RS/6000 and @server pSeries Diagnostic Information for Multiple Bus Systems*.

Yes Go to "Step 1549-16".

Step 1549-16

Have all the books or modules listed in "Step 1549-13" been replaced?

No "Step 1549-2" on page 345.

Yes Go to "Step 1549-37" on page 352.

Step 1549-17

Replace the following books and modules, if present, one at a time:

- First location code item recorded, if any, in "Step 1549-1" on page 345.
- Second location code item recorded, if any, in "Step 1549-1" on page 345.
- Third location code item recorded, if any, in "Step 1549-1" on page 345.
- Memory book 2 at U1.18-P1-M7 if not recorded in "Step 1549-1" on page 345.
- Memory book 3 at U1.18-P1-M6 if not recorded in "Step 1549-1" on page 345.
- Primary I/O Book at U1.18-P1-H2 if not recorded in "Step 1549-1" on page 345.

Step 1549-18

Turn on the power.

Step 1549-19

Did the system stop with the same error code as recorded in “Step 1549-1” on page 345?

No

The book or module just replaced was defective. **This ends the procedure.**

Return the system to its original configuration.

Go to “MAP 0410: Repair Checkout” in the *RS/6000 and @server pSeries Diagnostic Information for Multiple Bus Systems*.

Yes Go to “Step 1549-20”.

Step 1549-20

Have all the books or modules listed in “Step 1549-17” on page 348 been replaced?

No “Step 1549-2” on page 345.

Yes Go to “Step 1549-37” on page 352.

Step 1549-21

Replace the following books and modules, if present, one at a time:

- First location code item recorded, if any, in “Step 1549-1” on page 345.
- Second location code item recorded, if any, in “Step 1549-1” on page 345.
- Third location code item recorded, if any, in “Step 1549-1” on page 345.
- Memory book 4 at U1.18-P1-M4 if not recorded in “Step 1549-1” on page 345.
- Memory book 5 at U1.18-P1-M8 if not recorded in “Step 1549-1” on page 345.
- Primary I/O Book at U1.18-P1-H2 if not recorded in “Step 1549-1” on page 345.

Step 1549-22

Turn on the power.

Step 1549-23

Did the system stop with the same error code as recorded in “Step 1549-1” on page 345?

No The book or module just replaced was defective. **This ends the procedure.**

Return the system to its original configuration.

Go to “MAP 0410: Repair Checkout” in the *RS/6000 and @server pSeries Diagnostic Information for Multiple Bus Systems*.

Yes Go to “Step 1549-24”.

Step 1549-24

Have all the books or modules listed in “Step 1549-21” been replaced?

No “Step 1549-2” on page 345.

Yes Go to “Step 1549-37” on page 352.

Step 1549-25

Replace the following books and modules, if present, one at a time:

- First location code item recorded, if any, in “Step 1549-1” on page 345.
- Second location code item recorded, if any, in “Step 1549-1” on page 345.
- Third location code item recorded, if any, in “Step 1549-1” on page 345.
- Memory book 6 at U1.18-P1-M5 if not recorded in “Step 1549-1” on page 345.
- Memory book 7 at U1.18-P1-M1 if not recorded in “Step 1549-1” on page 345.
- Primary I/O Book at U1.18-P1-H2 if not recorded in “Step 1549-1” on page 345.

Step 1549-26

Turn on the power.

Step 1549-27

Did the system stop with the same error code as recorded in “Step 1549-1” on page 345?

No The book or module just replaced was defective. **This ends the procedure.**

Return the system to its original configuration.

Go to “MAP 0410: Repair Checkout” in the *RS/6000 and @server pSeries Diagnostic Information for Multiple Bus Systems*.

Yes Go to “Step 1549-28”.

Step 1549-28

Have all the books or modules listed in “Step 1549-25” been replaced?

No “Step 1549-2” on page 345.

Yes Go to “Step 1549-37” on page 352.

Step 1549-29

Replace the following books and modules, if present, one at a time:

- First location code item recorded, if any, in “Step 1549-1” on page 345.
- Second location code item recorded, if any, in “Step 1549-1” on page 345.
- Third location code item recorded, if any, in “Step 1549-1” on page 345.
- Secondary I/O Book at U1.18-P1-H3 if not recorded in “Step 1549-1” on page 345.
- Third I/O Book at U1.18-P1-H4 if not recorded in “Step 1549-1” on page 345.
- Primary I/O Book at U1.18-P1-H2 if not recorded in “Step 1549-1” on page 345.

Step 1549-30

Turn on the power.

Step 1549-31

Did the system stop with the same error code as recorded in “Step 1549-1” on page 345?

No The book or module just replaced was defective. **This ends the procedure.**

Return the system to its original configuration.

Go to “MAP 0410: Repair Checkout” in the *RS/6000 and @server pSeries Diagnostic Information for Multiple Bus Systems*.

Yes Go to “Step 1549-32”.

Step 1549-32

Have all the books or modules listed in “Step 1549-29” on page 350 been replaced?

No “Step 1549-2” on page 345.

Yes Go to “Step 1549-37” on page 352.

Step 1549-33

Replace the following books and modules, if present, one at a time:

- Replace the Primary I/O Book at U1.18-P1-H2 if not recorded in “Step 1549-1” on page 345.
- First location code item recorded, if any, in “Step 1549-1” on page 345.
- Second location code item recorded, if any, in “Step 1549-1” on page 345.
- Third location code item recorded, if any, in “Step 1549-1” on page 345.

Step 1549-34

Turn on the power.

Step 1549-35

Did the system stop with the same error code as recorded in “Step 1549-1” on page 345?

No The book or module just replaced was defective. **This ends the procedure.**

Return the system to its original configuration.

Go to “MAP 0410: Repair Checkout” in the *RS/6000 and @server pSeries Diagnostic Information for Multiple Bus Systems*.

Yes Go to “Step 1549-36”.

Step 1549-36

Have all the books or modules listed in “Step 1549-33” been replaced?

No “Step 1549-2” on page 345.

Yes Call for support. **This ends the procedure.**

Step 1549-37

Turn off the power.

Step 1549-38

Examine the amber logic-power LEDs of all installed processor subsystem DCAs.

Step 1549-39

Are all amber logic-power LEDs of all installed processor subsystem DCAs off?

No Call for support.

Yes Go to "Step 1549-40".

Step 1549-40

Attention: Before replacing the system backplane, call for support.

Replace the system backplane at U1.18-P1.

Step 1549-41

Turn on the power.

Step 1549-42

Did the system stop with the same error code as recorded in "Step 1549-1" on page 345?

No The part just replaced was defective. **This ends the procedure.**

Return the system to its original configuration.

Go to "MAP 0410: Repair Checkout" in the *RS/6000 and @server pSeries Diagnostic Information for Multiple Bus Systems*.

Yes Go to "Step 1549-43".

Step 1549-43

Turn off the power. Make sure all amber logic-power LEDs of all installed processor subsystem DCAs are off.

Step 1549-44

Call for support. **This ends the procedure.**

MAP 154A: I2C Bus Problem Isolation**Step 154A-1**

Record the error code, location code(s) and word 16 that sent you to this MAP.

Step 154A-2

Turn off the power.

Examine the amber logic-power LEDs of all installed processor subsystem DCAs.

Step 154A-3

Are all amber logic-power LEDs of all installed processor subsystem DCAs off?

No Call for support.

Yes Go to "Step 154A-4".

Step 154A-4

Examine the following table and locate the error code that sent you to this MAP to determine your next step.

Error Code	Action
B1xx 4645	Go to "Step 154A-9" on page 354.
B1xx 4648	Go to "Step 154A-5".

Step 154A-5

Replace the following books and modules, if present, one at a time:

- First location code item recorded, if any, in "Step 154A-1" on page 352.
- Second location code item recorded, if any, in "Step 154A-1" on page 352.
- Primary I/O Book at U1.18-P1-H2 if not recorded in "Step 154A-1" on page 352.
- Secondary I/O Book at U1.18-P1-H3 if not recorded in "Step 154A-1" on page 352.
- Third I/O Book at U1.18-P1-H4 if not recorded in "Step 154A-1" on page 352.
- System clock card, at U1.18-P1-X5 if not recorded in "Step 154A-1" on page 352.

Step 154A-6

Turn on the power.

Step 154A-7

Did the system stop with the same error code as recorded in "Step 154A-1" on page 352?

No The book or module just replaced was defective. **This ends the procedure.**

Return the system to its original configuration.

Go to "MAP 0410: Repair Checkout" in the *RS/6000 and @server pSeries Diagnostic Information for Multiple Bus Systems*.

Yes Go to "Step 154A-8".

Step 154A-8

Have all the books listed in "Step 154A-5" been replaced?

No Go to "Step 154A-2" on page 352.

Yes Go to "Step 154A-14" on page 354.

Step 154A-9

Is the value recorded in “Step 154A-1” on page 352 for word 16 of this error code equal to 00000008 or 00000009?

No Go to “Step 154A-5” on page 353.

Yes Go to “Step 154A-10”.

Step 154A-10

Replace the following books and modules, if present, one at a time:

- First location code item recorded, if any, in “Step 154A-1” on page 352.
- Second location code item recorded, if any, in “Step 154A-1” on page 352.
- Primary I/O Book at U1.18-P1-H2 if not recorded in any, in “Step 154A-1” on page 352.
- Capacitor book, at location U1.18-P1-V3 if not recorded in “Step 154A-1” on page 352.
- Capacitor book, at location U1.18-P1-V7 if not recorded in “Step 154A-1” on page 352.

Step 154A-11

Turn on the power.

Step 154A-12

Did the system stop with the same error code as recorded in “Step 154A-1” on page 352?

No The book or module just replaced was defective. **This ends the procedure.**

Return the system to its original configuration.

Go to “MAP 0410: Repair Checkout” in the *RS/6000 and @server pSeries Diagnostic Information for Multiple Bus Systems*.

Yes Go to “Step 154A-12” on page 347.

Step 154A-13

Have all the books or modules listed in “Step 154A-10” been replaced?

No “Step 154A-2” on page 352.

Yes Go to “Step 154A-14”.

Step 154A-14

Turn on the power.

Step 154A-15

Examine the amber logic-power LEDs of all installed processor subsystem DCAs.

Step 154A-16

Are all amber logic-power LEDs of all installed processor subsystem DCAs off?

No Call for support.

Yes Go to “Step 154A-17”.

Step 154A-17

Attention: Before replacing the system backplane, call for support.

Replace the system backplane at U1.18-P1.

Step 154A-18

Turn on the power.

Step 154A-19

Did the system stop with the same error code as recorded in “Step 154A-1” on page 352?

No The book or module just replaced was defective. **This ends the procedure.**
Return the system to its original configuration.

Go to “MAP 0410: Repair Checkout” in the *RS/6000 and @server pSeries Diagnostic Information for Multiple Bus Systems*.

Yes Go to “Step 154A-20”.

Step 154A-20

Turn off the power.

Make sure all amber logic-power LEDs of all installed processor subsystem DCAs are off.

Step 154A-21

Call for support. **This ends the procedure.**

MAP 154B: Insufficient Hardware Resources Problem Isolation

Step 154B-1

Record the error code and the location code(s) that sent you to this MAP.

Step 154B-2

Turn off the power.

Examine the amber logic-power LEDs of all installed processor subsystem DCAs.

Step 154B-3

Are all amber logic-power LEDs of all installed processor subsystem DCAs off?

No Call for support.

Yes Go to “Step 154B-4” on page 356.

Step 154B-4

Attention: Some of the parts in the following list are modules that have a limit of three plug cycles. Before replacing any of the modules in the following list, call for support.

Replace the following books and modules, if present, one at a time:

- First location code item recorded, if any, in “Step 154B-1” on page 355.
- Second location code item recorded, if any, in “Step 154B-1” on page 355.
- Third location code item recorded, if any, in “Step 154B-1” on page 355.
- Primary I/O book at U1.18-P1-H2 if not recorded in “Step 154B-1” on page 355.
- Memory book 0 at U1.18-P1-M2 if not recorded in “Step 154B-1” on page 355.
- Memory book 1 at U1.18-P1-M3 if not recorded in “Step 154B-1” on page 355.
- Memory book 2 at U1.18-P1-M7 if not recorded in “Step 154B-1” on page 355.
- Memory book 3 at U1.18-P1-M6 if not recorded in “Step 154B-1” on page 355.
- MCM module 0 at U1.18-P1-C1 if not recorded in “Step 154B-1” on page 355.
- MCM module 2 at U1.18-P1-C4 if not recorded in “Step 154B-1” on page 355.
- MCM module 1 at U1.18-P1-C3 if not recorded in “Step 154B-1” on page 355.
- MCM module 3 at U1.18-P1-C2 if not recorded in “Step 154B-1” on page 355.

Step 154B-5

Turn on the power.

Step 154B-6

Did the system stop with the same error code as recorded in “Step 154B-1” on page 355?

No The book or module just replaced was defective. **This ends the procedure.**
Return the system to its original configuration.
Go to “MAP 0410: Repair Checkout” in the *RS/6000 and @server pSeries Diagnostic Information for Multiple Bus Systems*.

Yes Go to “Step 154B-7”.

Step 154B-7

Have all the books or modules listed in “Step 154B-4” been replaced?

No Go to “Step 154B-2” on page 355.

Yes Go to “Step 154B-8”.

Step 154B-8

Turn off the power.

Step 154B-9

Examine the amber logic-power LEDs of all installed processor subsystem DCAs.

Step 154B-10

Are all amber logic-power LEDs of all installed processor subsystem DCAs off?

No Call for support.

Yes Go to “Step 154A-11” on page 354.

Step 154B-11

Attention: Before replacing the system backplane, call for support.

Replace the system backplane at U1.18–P1.

Step 154B-12

Turn on the power.

Step 154B-13

Did the system stop with the same error code as recorded in “Step 154B-1” on page 355?

No The book or module just replaced was defective. **This ends the procedure.**

Return the system to its original configuration.

Go to “MAP 0410: Repair Checkout” in the *RS/6000 and @server pSeries Diagnostic Information for Multiple Bus Systems*.

Yes Go to “Step 154B-14”.

Step 154B-14

Turn off the power.

Make sure all amber logic-power LEDs of all installed processor subsystem DCAs are off.

Step 154B-15

Call for support. **This ends the procedure.**

Chapter 4. Checkpoints

Checkpoints display on the media subsystem operator panel and the virtual terminal while the system is powering on and going through the initial program load (IPL). This chapter explains the IPL flow of the system and provides a table that lists checkpoints that you might see in the media subsystem operator panel and in a virtual terminal window on the HMC.

IPL Flow

The IPL process starts when ac power is connected to the system. The IPL process has the following phases:

- **Phase 1: Service Processor Initialization**

Phase 1 starts when ac power is connected to the system and ends when OK is displayed in the media subsystem operator panel. 8xxx checkpoints are displayed during this phase. Several 9xxx codes may also be displayed. Service processor menus are available at the end of this phase by striking any key on the console keyboard.

- **Phase 2: Hardware Initialization by the Service Processor**

Phase 2 starts when system power-on is initiated by pressing the power on button on the media subsystem operator panel. 9xxx checkpoints are displayed during this time. 91FF, the last checkpoint in this phase, indicates the transition to phase 3 is taking place.

- **Phase 3: System Firmware initialization**

On a full system partition, at phase 3, a system processor takes over control and continues initializing partition resources. During this phase, checkpoints in the form Exxx are displayed. E105, the last checkpoint in this phase, indicates that control is being passed to the AIX boot program.

On a partitioned system, there is a global systemwide initialization phase 3, during which a system processor continues the initialization process. Checkpoints in this phase are of the form Exxx. This global phase 3 ends with a "LPAR. . ." on the operator panel. As a logical partition begins a partition-initialization phase 3, one of the system processors assigned to that partition continues initialization of resource assigned to that partition. Checkpoints in this phase are also of the form Exxx. This partition phase 3 ends with an E105 displayed on the partition's virtual operator panel on the HMC, indicating control has been passed to that logical partition's AIX boot program. For both the global and partition phase 3, location codes may also be displayed on the physical operator panel and the partition's virtual terminal, respectively.

- **Phase 4: AIX Boot**

When AIX starts to boot, checkpoints in the form 0xxx and 2xxx are displayed. This phase ends when the AIX login prompt displays on the AIX console.

The following table outlines the IPL phases from power-on to the AIX login prompt, matching the phases to corresponding operator-panel checkpoints for a typical partition boot. Also listed are the approximate boot times for each phase, along with their dependencies for each phase.

Note: The following table lists the major checkpoints only.

Phase #	Checkpoints on Operator Panel or HMC	Time in Phase (minutes)	Major Contributors to Time in Phase
Phase 1	8xxx => OK	Approx. 1	
Phase 2	9xxx => 91FF	3 to 6	Number of I/O drawers
Phase 3	Exxx => E105	1 to 3	Number of bootable adapters
Phase 4	0xxx or 2xxx => blank	2 to 30+	Number of SSA drives Number of SCSI drives Number of async sessions Number of processors Number of adapters Amount of memory

Checkpoints enable users and service personnel to know what the server is doing, with some detail, as it initializes. These checkpoints are not intended to be error indicators, but in some cases a server could hang at one of the checkpoints without displaying an 8-character error code. It is for these hang conditions, only, that any action should be taken with respect to checkpoints. The most appropriate action is included with each checkpoint.

Before taking actions listed with a checkpoint, check for additional symptoms in the service processor error log. See the “System Information Menu” on page 722 for information on how to access the service processor error log.

Note: Go to “MAP 1540: Problem Isolation Procedures” on page 303 for any of the following checkpoint hang conditions:

- A four-digit code in the range of 8xxx through EFFF not listed in the checkpoint tables.
- A four-digit code is in the checkpoint tables, but does not contain a repair action or FRU listing.
- All of the FRUs listed in the repair action have been replaced and the problem has not been corrected.

Checkpoints listed in the following tables are in the format 8xxx, 9xxx, Axxx, Bxxx, or Exxx, where x is any hexadecimal digit from 1-9 or A-F. If your system hangs with a checkpoint displayed that begins with anything other than 8, 9, A, B, or E, go to the *RS/6000 and @server pSeries Diagnostic Information for Multiple Bus Systems*.

Use the following table to determine where to find the checkpoint.

Symptom	Action
You have a code that is of the form 8xxx, 9xxx, Axxx, or Bxxx.	Go to “Service Processor Checkpoints” on page 362.
You have a code of the form Exxx.	Go to “Firmware Checkpoints” on page 370.
You have a four-character code that is <i>not</i> of the form 8xxx, 9xxx, Axxx, Bxxx, or Exxx.	See the <i>RS/6000 and @server pSeries Diagnostic Information for Multiple Bus Systems</i> .

Service Processor Checkpoints

Service processor checkpoints are in the range 8xxx to Bxxx. The message **OK** indicates successful service processor testing and initialization. Firmware checkpoints are listed in “Firmware Checkpoints” on page 370.

Note: A spinning (or twirling) slash displays in the upper-right corner of the operator panel display while some checkpoints are being displayed. If the slash stops spinning, a hang condition is indicated.

Checkpoint	Description	Action/ Possible Failing FRU
8000	Test of the service processor DRAM	See note 1 on page 368.
8004	Verify base code checksum	See note 1 on page 368.
8008	Verify base code mirror checksum	See note 1 on page 368.
8009	Set NVRAM configuration in TITAN	See note 1 on page 368.
800F	Start base code	See note 1 on page 368.
8010	Start supervisor in base code	See note 1 on page 368.
8012	Initialize hardware interrupts	See note 1 on page 368.
8014	Allocate and initialize area in DRAM	See note 1 on page 368.
8016	Initialize debugger and build VPD	See note 1 on page 368.
8018	Initialize service processor interfaces	See note 1 on page 368.
801A	Initialize external FLASH load	See note 1 on page 368.
801B	Initialize and test ISA hub chip	See note 1 on page 368.
801C	Initialize and test SUPER I/O chip	See note 1 on page 368.
801F	Initialize diskette, verify VDASD and start operational loader	See note 1 on page 368.
809x	Related to recovery mode system firmware update from diskette	See note 3 on page 369.
8092	Diskette initialization during recovery mode system firmware update	See note 3 on page 369.
8098	Firmware image being read during recovery mode system firmware update	See note 3 on page 369.
809C	Firmware image being written during recovery mode system firmware update	See note 3 on page 369.
809F	Diskette error during recovery mode system firmware update	See note 3 on page 369.
8100	Start operational loader	See note 1 on page 368.
81xx	Load code into DRAM from VDASD (where xx = number of loads)	See note 1 on page 368.

Checkpoint	Description	Action/ Possible Failing FRU
81FE	Load service processor operating system	See note 1 on page 368.
81FF	Start service processor operating system	See note 1 on page 368.
9000	Primary service processor task initializing	See note 1 on page 368.
9009	System processor IPL has started	See note 1 on page 368.
9010	Primary service processor thread waiting for response	See note 1 on page 368.
9020	Service processor state set to pre-standby	See note 1 on page 368.
9021	Service processor state set to standby	See note 1 on page 368.
9022	Service processor state set to IPL	See note 1 on page 368.
9023	Service processor state set to runtime	See note 1 on page 368.
9024	Service processor state set to terminate	See note 1 on page 368.
9025	Service processor state set to DPO	See note 1 on page 368.
9030	Waiting for secondary thread acknowledgement	See note 1 on page 368.
9033	I/O base initialization	See note 1 on page 368.
9034	I2C initialization	See note 1 on page 368.
9035	ISA initialization	See note 1 on page 368.
9036	Mailbox initialization	See note 1 on page 368.
9037	SLLA initialization (VPD)	See note 1 on page 368.
9038	NVRAM initialization	See note 1 on page 368.
9039	Serial port initialization	See note 1 on page 368.
903A	Serial I/O initialization	See note 1 on page 368.
903B	SPCN initialization	See note 1 on page 368.
9051	End of reset/reload operation: service processor dump has completed	See note 1 on page 368.
9055	Start menus thread	See note 1 on page 368.
9060	Checking/configuring modem on serial port 0	See note 4 on page 369.
9061	Checking/configuring modem on serial port 1	See note 4 on page 369.
906A	Create mailbox processing thread	See note 1 on page 368.
906B	Create menu interface thread	See note 1 on page 368.

Checkpoint	Description	Action/ Possible Failing FRU
906C	Create general thread	See note 1 on page 368.
906D	Create SPCN thread	See note 1 on page 368.
9070	Create thread to control LEDs on I/O subsystems	See note 1 on page 368.
9071	Initialize thread to control LEDs on I/O subsystems	See note 1 on page 368.
9080	Start VPD collection program	See note 1 on page 368.
9081	Start SC VPD data collection	See note 1 on page 368.
9082	I2C/SPCN VPD data collection	See note 1 on page 368.
9083	End SC VPD data collection	See note 1 on page 368.
9084	End I2C/SPCN VPD data collection	See note 1 on page 368.
90FD	Waiting for IBIST to complete	See note 1 on page 368.
9101	Setup load source	See note 1 on page 368.
9102	Open load source	See note 1 on page 368.
9103	Verify open status of load source	See note 1 on page 368.
9104	Waiting for SPCN VPD collection to be completed	See note 1 on page 368.
9105	Load IPL LIDs	See note 1 on page 368.
9106	Initialize MOPs	See note 1 on page 368.
9107	System flush	See note 1 on page 368.
9108	Processor scan interface BATs and LBIST	See note 1 on page 368.
9109	ABIST	See note 1 on page 368.
910A	Non-processor scan interface BATs and LBIST	See note 1 on page 368.
910B	Wire test	See note 1 on page 368.
910C	Initialize main storage (system memory)	See note 1 on page 368.
910D	Configure processors	See note 1 on page 368.
910E	Configure and initialize I/O	See note 1 on page 368.
910F	Test and initialize main storage (system memory)	See note 1 on page 368.
9110	Free IPL LIDs	See note 1 on page 368.
9111	Load run-time LIDS	See note 1 on page 368.
9112	Load dump LIDs	See note 1 on page 368.
9113	Enable attention	See note 1 on page 368.
9114	Enable function 22	See note 1 on page 368.
9115	Load system IPL program	See note 1 on page 368.

Checkpoint	Description	Action/ Possible Failing FRU
9116	Load system data areas (NACA/PACA)	See note 1 on page 368.
9117	Start system IPL program	See note 1 on page 368.
9119	Waiting for VPD collection to complete	See note 1 on page 368.
9184	Firmware image being loaded into service processor's control storage during firmware update.	<ol style="list-style-type: none"> 1. Remove, then reapply power to the system. If the service processor enters recovery mode (indicated by A1FD 0000 in the display), attempt to update the firmware again in recovery mode. If the service processor comes up to the OK prompt, try again to update the firmware using the service processor menus. 2. Call service support.
91C4	Flash update pending, either a firmware update or hypervisor dump.	<p>This checkpoint may be displayed during the firmware update process. The checkpoint may be displayed for a long period of time during the process. If process does not complete, the system may be hung.</p> <p>See note 1 on page 368.</p>
91FF	Control being handed to system processor from service processor	See note 1 on page 368.
9200	Scan interface BATs	See note 1 on page 368.
9300	Logic BIST	See note 1 on page 368.
9301	Scanned ABIST	See note 1 on page 368.
9302	Dedicated ABIST	See note 1 on page 368.
9303	Dedicated ABIST array fuse repair calculation	See note 1 on page 368.
9380	Built-in-self-test (BIST)	See note 2 on page 369.
9400	Service processor is requesting system flush	See note 1 on page 368.
9410	Service processor is issuing request to start instruction execution	See note 1 on page 368.
9411	Service processor is issuing request to stop instruction execution	See note 1 on page 368.
9420	Service processor is issuing request to start system clocks	See note 1 on page 368.
9421	Service processor is issuing request to stop system clocks	See note 1 on page 368.
94B0	Wire test faulty driver status refcode	See note 2 on page 369.

Checkpoint	Description	Action/ Possible Failing FRU
94B1	Wire test shorted net status refcode	See note 2 on page 369.
94B2	Wire test elastic interface test	See note 2 on page 369.
94BB	Wire test starting	See note 2 on page 369.
9501	IPL diagnostic initialization	See note 2 on page 369.
9502	IPL diagnostic L3 cache march test	See note 2 on page 369.
9503	IPL diagnostic L3 connections test	See note 2 on page 369.
9504	IPL diagnostic L2 cache march test	See note 2 on page 369.
9505	IPL diagnostic RIO wrap test	See note 2 on page 369.
9506	IPL diagnostic cleanup	See note 2 on page 369.
9507	IPL diagnostic test	See note 2 on page 369.
9508	IPL diagnostic main storage march test	See note 2 on page 369.
9509	IPL diagnostic main storage connections test	See note 2 on page 369.
950A	IPL diagnostic elastic interface slack test	See note 2 on page 369.
950B	IPL diagnostic fast initialization to zeros	See note 2 on page 369.
96C2	IPL MOPs processor configuration	See note 2 on page 369.
96C3	IPL MOPs main storage size	See note 2 on page 369.
96C4	IPL MOPs main storage configuration	See note 2 on page 369.
96C6	IPL MOPs I/O configuration	See note 2 on page 369.
96C7	IPL MOPs: enable chip machine checks	See note 2 on page 369.
96E1	Initialize run-time PRD objects and memory	See note 2 on page 369.
96E2	Run-time initialization: enable attention handling	See note 2 on page 369.
96EE	Firmware update module corrupted	See note 3 on page 369.

Checkpoint	Description	Action/ Possible Failing FRU
99FD	Service processor receiving firmware update module	See note 3 on page 369. Attention: This checkpoint may stay in the operator panel for some period of time during a firmware update or hypervisor dump with no indication of activity. Do not assume that the service processor is hung unless this checkpoint has been in the operator panel for at least 15 minutes. with no indication of activity. Attention: Do not remove power from the system, or reset the service processor, during a firmware update or hypervisor dump.
99FF	Service processor writing firmware update module	See note 3 on page 369. Attention: This checkpoint may stay in the operator panel for some period of time during a firmware update or hypervisor dump with no indication of activity. Do not assume that the service processor is hung unless this checkpoint has been in the operator panel for at least 15 minutes. with no indication of activity. Attention: Do not remove power from the system, or reset the service processor, during a firmware update or hypervisor dump.
A800	Start Service Processor dump process	See note 1 on page 368.
A801	Start dump to NVRAM	See note 1 on page 368.
A802	Start dump to debug port	See note 1 on page 368.
A803	NVRAM not usable	See note 1 on page 368.
A804	NVRAM dump done	See note 1 on page 368.
A805	Start dump to flash	See note 1 on page 368.
A806	Flash dump area done	See note 1 on page 368.
A807	Flash area not usable	See note 1 on page 368.
A808	Flash error log to debug port	See note 1 on page 368.

Checkpoint	Description	Action/ Possible Failing FRU
A809	Flash erase start	See note 1.
A80A	Flash erase end	See note 1.
A80B	Reserved; not used	See note 1.
A80C	Reserved; not used	See note 1.
A80D	Reserved; not used	See note 1.
A80E	Reserved; not used	See note 1.
A80F	Service processor dump done	See note 1.
A810-A8FF	Scan log dump in progress	<p>Informational message. (See “Scan Log Dump Policy” on page 715.)</p> <p>The last two characters of the checkpoints will change as the scan log dump progresses. If the last two characters do not change after five minutes, the service processor is hung and must be reset. Follow the procedure outlined in Note 1 following this table.</p> <p>When the scan log dump is complete, depending on how the reboot policy is set, the system will either:</p> <ul style="list-style-type: none"> • Go to the standby state (and the service processor menus will be available), indicated by OK or STBY in the operator panel, <p>OR</p> <ul style="list-style-type: none"> • Attempt to reboot.
B0F5	Delayed power-off sequence has begun	See note 1.
B0FA	Delayed power-off acknowledged	See note 1.
B0FF	Power-off requested program executing	See note 1.

Notes:

1. If the system fails to progress after this checkpoint is put in the display, do the following:
 - a. Activate the service processor pinhole reset switch on the system’s operator panel.
 - b. If the hang repeats, check with service support to see if there is a firmware update that fixes the problem.
 - c. If not, or the update does not fix the problem, replace the primary I/O book, location: U1.18-P1-H2.
 - d. If this procedure does not fix the problem, call service support.

2. If the system fails to progress after this checkpoint is put in the operator display, do the following:
 - a. Activate the service processor pinhole reset switch on the system's operator panel.
 - b. Reboot the system in slow mode. (Slow/fast IPL is set using a service processor menu.) If the hang repeats, check with service support to see if there is a system firmware update that fixes this problem.
 - c. If not, or the update does not fix the problem, call service support.
3. Recovery mode flash update has failed. Do the following:
 - a. Activate the service processor pinhole reset switch on the system's operator panel and try the recovery mode flash update again.
 - b. If the system hangs again, make a new set of firmware update diskettes, using new, blank diskettes. Retry the flash update with the new diskettes.
 - c. If the same hang occurs with the new diskettes, replace the following FRUs one at a time in this order:
 - 1) Diskette drive
 - 2) Primary I/O book, location: U1.18-P1-H2.
 - d. If this procedure does not fix the problem, call service support.
4. The service processor was unable to configure the modem(s) attached to the serial port(s) on the primary I/O book (a problem with the modem attached to the HMC is not indicated). Do the following:
 - a. Check the modem, modem cable, and serial port for loose or unconnected cables. Reset the service processor using the pinhole reset switch on the system's operator panel.
 - b. If the hang repeats, check with service support to see if there is a firmware update that fixes the problem.
 - c. If there is not, or the update does not fix the problem, replace the following FRUs, one at a time, in the following order:
 - 1) Modem cable
 - 2) Modem
 - d. If this procedure does not fix the problem, call service support.

Firmware Checkpoints

Firmware uses checkpoints (progress codes) in the range of Exxx to EFFF. These checkpoints occur during system startup and can be useful in diagnosing certain problems. Service processor checkpoints are listed in “Service Processor Checkpoints” on page 362.

If you have a checkpoint with no location code associated with it, see “Determining Location Code” on page 401. If a checkpoint has a location code associated with a FRU replacement, see “AIX and Physical Location Code Reference Tables” on page 62 for physical location information.

If you replace FRUs and the problem is still not corrected, go to “MAP 1542: I/O Problem Isolation” on page 312 unless otherwise indicated in the tables.

Note: If you receive a four-digit code in the range of E1xx to EFFF that is not listed in the table above, go to “MAP 1542: I/O Problem Isolation” on page 312.

Table 1. Firmware Checkpoints

Checkpoint	Description	Action/ Possible Failing FRU
E101	Create RTAS node	Go to “MAP 1540: Problem Isolation Procedures” on page 303.
E102	Load/Init RTAS	Go to “MAP 1540: Problem Isolation Procedures” on page 303.
E105	Transfer control to Operating System (normal boot).	See “Boot Problems” on page 396.
E10A	Load RTAS device tree	Go to “MAP 1540: Problem Isolation Procedures” on page 303.
E10B	Set RTAS device properties	Go to “MAP 1540: Problem Isolation Procedures” on page 303.
E111	GOOD CRC - jump to composite image	Go to “MAP 1540: Problem Isolation Procedures” on page 303.
E120	Initialize I/O and early memory block	Go to “MAP 1540: Problem Isolation Procedures” on page 303.
E121	Initialize service processor	Go to “MAP 1540: Problem Isolation Procedures” on page 303.
E122	RTAS sensor setup complete	Go to “MAP 1540: Problem Isolation Procedures” on page 303.
E130	Build device tree	Go to “MAP 1540: Problem Isolation Procedures” on page 303.
E131	Build device tree	Go to “MAP 1540: Problem Isolation Procedures” on page 303.
E132	Build device tree, just before setting up root node	Go to “MAP 1540: Problem Isolation Procedures” on page 303.
E133	Build device tree, just before setting up CPUs	Go to “MAP 1540: Problem Isolation Procedures” on page 303.

Table 1. Firmware Checkpoints (continued)

Checkpoint	Description	Action/ Possible Failing FRU
E134	Create memory node	Go to "MAP 1540: Problem Isolation Procedures" on page 303.
E135	Configuring memory nodes	Go to "MAP 1540: Problem Isolation Procedures" on page 303.
E138	Create options node	Go to "MAP 1540: Problem Isolation Procedures" on page 303.
E139	Create node aliases and system aliases	Go to "MAP 1540: Problem Isolation Procedures" on page 303.
E13A	Create packages node	Go to "MAP 1540: Problem Isolation Procedures" on page 303.
E140	Operating system load	See "Boot Problems" on page 396.
E149	Create boot mgr node	Go to "MAP 1540: Problem Isolation Procedures" on page 303.
E14C	Create terminal-emulator node	Go to "MAP 1540: Problem Isolation Procedures" on page 303.
E14D	Loading boot image	See "Boot Problems" on page 396.
E150	Create host (primary) PCI controller node	If a location code is specified, replace the adapter at that location code. If no location code is specified, go to "MAP 1542: I/O Problem Isolation" on page 312.
E151	Probing primary PCI bus	If a location code is specified, replace the adapter at that location code. If no location code is specified, go to "MAP 1542: I/O Problem Isolation" on page 312.
E152	Probing for adapter FCODE, evaluate if present	Follow the repair action listed for checkpoint E151.
E153	End adapter FCODE, probe/evaluate	Follow the repair action listed for checkpoint E151.
E154	Create PCI bridge node	Follow the repair action listed for checkpoint E151.
E155	Probing PCI bridge secondary bus	Follow the repair action listed for checkpoint E151.
E156	Create PCI ethernet node	If a location code is specified, replace the adapter at that location code. If no location code is specified, go to "MAP 1542: I/O Problem Isolation" on page 312.

Table 1. Firmware Checkpoints (continued)

Checkpoint	Description	Action/ Possible Failing FRU
E15B	Transferring control to operating system (service mode boot)	See "Boot Problems" on page 396.
E15F	Adapter VPD probe	Follow the repair action listed for checkpoint E151.
E170	Start of PCI Bus Probe	Follow the repair action listed for checkpoint E151.
E172	First pass of PCI device probe	Follow the repair action listed for checkpoint E151.
E174	Establishing host connection	<p>If the system is not connected to an active network, or if the target server is inaccessible (which can result from incorrect IP parameters being specified), the system still attempts to boot and because time-out durations are necessarily long to accommodate retries, the system may appear to hang.</p> <p>Restart the system and get to the SMS utilities menu. In the multi-boot menu, verify:</p> <ul style="list-style-type: none"> • Is the intended boot device correctly specified in the boot list? • Are the IP parameters correct? • Look at the server configuration for this client. • Attempt to ping the target server using the ping utility in SMS.
E175	BootP request	Follow the repair actions for checkpoint E174.
E176	TFTP file transfer	Follow the repair actions for checkpoint E174.
E177	Transfer failure due to TFTP error condition	See "Boot Problems" on page 396.
E17B	Processor clock speed measurement	Call service support.
E183	Service Processor POST	<ol style="list-style-type: none"> 1. Replace the service processor, location: U1.18-P1-H2. 2. Go to "MAP 1541: JTAG Problem Isolation" on page 304.
E191	Create ISA reserved node	Go to "MAP 1540: Problem Isolation Procedures" on page 303.

Table 1. Firmware Checkpoints (continued)

Checkpoint	Description	Action/ Possible Failing FRU
E19A	NVRAM auto-boot? variable not found - assume FALSE	Go to "MAP 1540: Problem Isolation Procedures" on page 303.
E19B	NVRAM menu? variable not found - assume FALSE	Go to "MAP 1540: Problem Isolation Procedures" on page 303.
E19D	Create NVRAM node	Go to "MAP 1540: Problem Isolation Procedures" on page 303.
E19E	Real-time clock (RTC) initialization	Refer to error code 28030xxx in "Firmware/POST Error Codes" on page 470.
E1A0	User requested boot to SMS menus via keyboard entry	Go to "MAP 1540: Problem Isolation Procedures" on page 303.
E1A1	User requested boot to open firmware prompt via keyboard entry	Go to "MAP 1540: Problem Isolation Procedures" on page 303.
E1A2	User requested boot using default service mode boot list via keyboard entry	Go to "MAP 1540: Problem Isolation Procedures" on page 303.
E1A3	User requested boot using customized service mode boot list via keyboard entry	Go to "MAP 1540: Problem Isolation Procedures" on page 303.
E1A4	User requested boot to SMS menus via HMC or CSP command	Go to "MAP 1540: Problem Isolation Procedures" on page 303.
E1A5	User requested boot to open firmware prompt via HMC or CSP command	Go to "MAP 1540: Problem Isolation Procedures" on page 303.
E1A6	User requested boot using default service mode boot list via HMC or CSP command	Go to "MAP 1540: Problem Isolation Procedures" on page 303.
E1A7	User requested boot using customized service mode boot list via HMC or CSP command	Go to "MAP 1540: Problem Isolation Procedures" on page 303.
E1A8	System booting to open firmware prompt	Go to "MAP 1540: Problem Isolation Procedures" on page 303.
E1A9	System booting to SMS menus	Go to "MAP 1540: Problem Isolation Procedures" on page 303.
E1AA	System NVRAM settings during boot	Go to "MAP 1540: Problem Isolation Procedures" on page 303.
E1AB	System booting using default service mode boot list	Go to "MAP 1540: Problem Isolation Procedures" on page 303.
E1AC	System booting using customized service mode boot list	Go to "MAP 1540: Problem Isolation Procedures" on page 303.
E1AD	System booting to operating system	Go to "MAP 1540: Problem Isolation Procedures" on page 303.

Table 1. Firmware Checkpoints (continued)

Checkpoint	Description	Action/ Possible Failing FRU
E1AE	System booted to multiboot menu via NVRAM settings	Go to "MAP 1540: Problem Isolation Procedures" on page 303.
E1AF	System booted to utilities menu via NVRAM settings	Go to "MAP 1540: Problem Isolation Procedures" on page 303.
E1B1	Create serial node	Go to "MAP 1540: Problem Isolation Procedures" on page 303.
E1B6	Probe for (ISA) keyboard	Replace the primary I/O book, Location: U1.18-P1-H2.
E1BD	Probe for (ISA) mouse	Replace the primary I/O book, Location: U1.18-P1-H2.
E1C4	Build ISA timer chip node	Go to "MAP 1540: Problem Isolation Procedures" on page 303.
E1C5	Create ISA interrupt controller (pic) node	Go to "MAP 1540: Problem Isolation Procedures" on page 303.
E1C6	Create DMA node	Go to "MAP 1540: Problem Isolation Procedures" on page 303.
E1D0	Create PCI SCSI node	Go to "MAP 1540: Problem Isolation Procedures" on page 303.
E1D3	Create SCSI block device node (SD)	Go to "MAP 1540: Problem Isolation Procedures" on page 303.
E1D4	Create SCSI byte device node (ST)	Go to "MAP 1540: Problem Isolation Procedures" on page 303.
E1DB	Create floppy controller (FDC) node	Go to "MAP 1540: Problem Isolation Procedures" on page 303.

Table 1. Firmware Checkpoints (continued)

Checkpoint	Description	Action/ Possible Failing FRU
E1DC	Dynamic console selection.	<ol style="list-style-type: none"> 1. If a console is attached, but nothing is displayed on it, go to "All display problems" in the Entry MAP. 2. If selection screens can be seen on the terminals and the appropriate key on the input device is pressed within 60 seconds but there is no response to the keystroke: <ol style="list-style-type: none"> a. If selecting the console with a keyboard attached to a USB card, replace the keyboard, then replace the USB card. b. If selecting the console with an ASCII terminal, suspect the terminal. Use the problem determination procedures for the terminal. <p>Note: Terminal setting should be:</p> <ul style="list-style-type: none"> • 9600 baud • no parity • 8 data bits • 1 stop bit
E1F0	Start O.B.E.	Go to "MAP 1540: Problem Isolation Procedures" on page 303.
E1F1	Begin selftest sequence on boot devices.	Go to "MAP 1542: I/O Problem Isolation" on page 312.
E1F2	Power-on password prompt	<p>The prompt should be visible on the firmware console (usually a VTERM on the HMC).</p> <p>If a console is attached but nothing is displayed on it, go to the "Entry MAP" on page 157 with the symptom "All display problems."</p>
E1F3	Privileged-access password prompt	<p>The prompt should be visible on the firmware console (usually a VTERM on the HMC).</p> <p>If a console is attached but nothing is displayed on it, go to the "Entry MAP" on page 157 with the symptom "All display problems."</p>

Table 1. Firmware Checkpoints (continued)

Checkpoint	Description	Action/ Possible Failing FRU
E1F4	End self-test sequence on boot devices; begin SMS.	Go to "MAP 1542: I/O Problem Isolation" on page 312.
E1F5	Build boot device list	Go to "MAP 1542: I/O Problem Isolation" on page 312.
E1F6	Determine boot device sequence	Go to "MAP 1542: I/O Problem Isolation" on page 312.
E1F7	No boot image located	Go to "Boot Problems" on page 396.
E1F8	Partition (system firmware) is waiting for a virtual terminal to be opened on HMC.	Open a virtual terminal for the partition on the HMC. If the partition hangs at this checkpoint after a virtual terminal is opened on the HMC: 1. Replace the service processor/RIO book, location: U1.18-P1-H2 2. Call service support.
E1FB	Scan SCSI bus for attached devices	1. If a location code is available, follow the Repair actions listed for error code 21A0 00XX. 2. If no location code is available, go to "MAP 1542: I/O Problem Isolation" on page 312.
E1FD	The operator panel alternates between the code E1FD and another Exxx code, where Exxx is the point at which the error occurred.	1. If a location code is available, follow the actions listed for error code 21A0 00xx. 2. If no location code is available, go to "MAP 1542: I/O Problem Isolation" on page 312.
E20F	System firmware has exited to open firmware prompt.	1. Replace the primary I/O book, Location: U1.18-P1-H2. 2. Call service support.
E440	Validate NVRAM, initialize partitions as needed	1. Check for system firmware updates. 2. Replace the primary I/O book, Location: U1.18-P1-H2. 3. Call service support.
E441	Generate /options node NVRAM configuration variable properties	1. Check for system firmware updates. 2. Replace the primary I/O book, Location: U1.18-P1-H2. 3. Call service support.

Table 1. Firmware Checkpoints (continued)

Checkpoint	Description	Action/ Possible Failing FRU
E442	Validate NVRAM partitions	<ol style="list-style-type: none"> 1. Check for system firmware updates. 2. Replace the primary I/O book, Location: U1.18-P1-H2. 3. Call service support.
E443	Generate NVRAM configuration variable dictionary words	Suspect a system firmware problem if problem persists. If a system firmware update is available, install it.
E500	Begin I/O drawer configuration	<ol style="list-style-type: none"> 1. Check for system firmware updates. 2. Go to "MAP 1542: I/O Problem Isolation" on page 312.
E501	Initialize I/O data structures	<ol style="list-style-type: none"> 1. Check for system firmware updates. 2. Go to "MAP 1542: I/O Problem Isolation" on page 312.
E502	Set up I/O data structure pointers	<ol style="list-style-type: none"> 1. Check for system firmware updates. 2. Go to "MAP 1542: I/O Problem Isolation" on page 312.
E503	Initialize location code data structures	<ol style="list-style-type: none"> 1. Check for system firmware updates. 2. Go to "MAP 1542: I/O Problem Isolation" on page 312.
E504	Initialize memory map data structures	<ol style="list-style-type: none"> 1. Check for system firmware updates. 2. Go to "MAP 1542: I/O Problem Isolation" on page 312.
E505	Enable the time base for all RIO hubs	<ol style="list-style-type: none"> 1. Check for system firmware updates. 2. Replace the I/O book specified by the location code. 3. Go to "MAP 1542: I/O Problem Isolation" on page 312.
E506	Reset time base of processors	<ol style="list-style-type: none"> 1. Check for system firmware updates. 2. Go to "MAP 1542: I/O Problem Isolation" on page 312.

Table 1. Firmware Checkpoints (continued)

Checkpoint	Description	Action/ Possible Failing FRU
E507	I/O hub assignment	<ol style="list-style-type: none"> 1. Check for system firmware updates. 2. Replace the I/O book specified by the location code. 3. Go to "MAP 1542: I/O Problem Isolation" on page 312.
E508	Begin initializing I/O hubs	<ol style="list-style-type: none"> 1. Check for system firmware updates. 2. Go to "MAP 1542: I/O Problem Isolation" on page 312.
E509	Begin configuring EADS chips in I/O subsystems	<ol style="list-style-type: none"> 1. Check for system firmware updates. 2. Go to "MAP 1542: I/O Problem Isolation" on page 312.
E50A	Check for missing I/O interface chips	<ol style="list-style-type: none"> 1. Check for system firmware updates. 2. Go to "MAP 1542: I/O Problem Isolation" on page 312.
E50B	Save I/O hub information	<ol style="list-style-type: none"> 1. Check for system firmware updates. 2. Go to "MAP 1542: I/O Problem Isolation" on page 312.
E50C	Copy all of the memory ranges	<ol style="list-style-type: none"> 1. Check for system firmware updates. 2. Go to "MAP 1542: I/O Problem Isolation" on page 312.
E50D	Copy all of the I/O data	<ol style="list-style-type: none"> 1. Check for system firmware updates. 2. Go to "MAP 1542: I/O Problem Isolation" on page 312.
E50E	Copy all of the I/O hub information	<ol style="list-style-type: none"> 1. Check for system firmware updates. 2. Go to "MAP 1542: I/O Problem Isolation" on page 312.
E50F	Clean up the error registers	<ol style="list-style-type: none"> 1. Check for system firmware updates. 2. Replace the I/O book specified by the location code. 3. Go to "MAP 1542: I/O Problem Isolation" on page 312.

Table 1. Firmware Checkpoints (continued)

Checkpoint	Description	Action/ Possible Failing FRU
E51F	End of I/O configuration	<ol style="list-style-type: none"> 1. Check for system firmware updates. 2. Go to "MAP 1542: I/O Problem Isolation" on page 312.
E520	Set up the I/O architecture registers	<ol style="list-style-type: none"> 1. Check for system firmware updates. 2. Replace the I/O book specified by the location code. 3. Go to "MAP 1542: I/O Problem Isolation" on page 312.
E521	Set up interrupts for the current I/O hub	<ol style="list-style-type: none"> 1. Check for system firmware updates. 2. Replace the I/O book specified by the location code. 3. Go to "MAP 1542: I/O Problem Isolation" on page 312.
E522	Set up miscellaneous registers for the current I/O hub	<ol style="list-style-type: none"> 1. Check for system firmware updates. 2. Replace the I/O book specified by the location code. 3. Go to "MAP 1542: I/O Problem Isolation" on page 312.
E523	Initialize data structures and enable all I/O hub ports	<ol style="list-style-type: none"> 1. Check for system firmware updates. 2. Replace the I/O book specified by the location code. 3. Go to "MAP 1542: I/O Problem Isolation" on page 312.
E524	Determine I/O configuration of current I/O hub	<ol style="list-style-type: none"> 1. Check for system firmware updates. 2. Replace the I/O book specified by the location code. 3. Go to "MAP 1542: I/O Problem Isolation" on page 312.
E525	Set up the ETE of the current I/O hub	<ol style="list-style-type: none"> 1. Check for system firmware updates. 2. Replace the I/O book specified by the location code. 3. Go to "MAP 1542: I/O Problem Isolation" on page 312.

Table 1. Firmware Checkpoints (continued)

Checkpoint	Description	Action/ Possible Failing FRU
E526	Reassign the I/O subsystems to the nearest I/O hub	<ol style="list-style-type: none"> 1. Replace the I/O cable specified by the location code. 2. Replace the I/O book that the failing I/O subsystem is attached to, U1.18-P1-Hx. 3. Replace the I/O subsystem backplane that the I/O cable in step 1 is attached to. 4. Go to "MAP 1542: I/O Problem Isolation" on page 312.
E527	Enable the memory map and I/O map for the current I/O hub port	<ol style="list-style-type: none"> 1. Check for system firmware updates. 2. Replace the I/O book specified by the location code. 3. Go to "MAP 1542: I/O Problem Isolation" on page 312.
E52F	End of configuration of the RIO hub	<ol style="list-style-type: none"> 1. Check for system firmware updates. 2. Go to "MAP 1542: I/O Problem Isolation" on page 312.
E530	Checking I/O hub ports on current I/O hub	<ol style="list-style-type: none"> 1. Check for system firmware updates. 2. Go to "MAP 1542: I/O Problem Isolation" on page 312.
E531	Get I/O hub node ID	<ol style="list-style-type: none"> 1. Replace the I/O cable specified by the location code. 2. Replace the I/O book that the failing I/O subsystem is attached to, U1.18-P1-Hx. 3. Replace the I/O subsystem backplane that the I/O cable in step 1 is attached to. 4. Go to "MAP 1542: I/O Problem Isolation" on page 312.

Table 1. Firmware Checkpoints (continued)

Checkpoint	Description	Action/ Possible Failing FRU
E532	I/O cable detected; enable the I/O hub port	<ol style="list-style-type: none"> 1. Replace the I/O cable specified by the location code. 2. Replace the I/O book that the failing I/O subsystem is attached to, U1.18-P1-Hx. 3. Replace the I/O subsystem backplane that the I/O cable in step 1 is attached to. 4. Go to "MAP 1542: I/O Problem Isolation" on page 312.
E533	Set up the I/O hub routing table	<ol style="list-style-type: none"> 1. Replace the I/O cable specified by the location code. 2. Replace the I/O book that the failing I/O subsystem is attached to, U1.18-P1-Hx. 3. Replace the I/O subsystem backplane that the I/O cable in step 1 is attached to. 4. Go to "MAP 1542: I/O Problem Isolation" on page 312.
E534	Get the node ID of the node on the other end of the I/O cable	<ol style="list-style-type: none"> 1. This error code may indicate that the I/O (RIO) cables are not properly connected to the I/O subsystems. Check the RIO cabling; refer to "I/O Book Connector Locations" on page 24 and "Subsystem Positioning and Cabling" on page 41. 2. Replace the RIO cable specified by the location code. 3. Replace the I/O book that the failing I/O subsystem is attached to, U1.18-P1-Hx. 4. Replace the I/O subsystem backplane that the I/O cable in step 1 is attached to. 5. Go to "MAP 1542: I/O Problem Isolation" on page 312.

Table 1. Firmware Checkpoints (continued)

Checkpoint	Description	Action/ Possible Failing FRU
E535	Valid node ID detected at other end of the I/O cable	<ol style="list-style-type: none"> 1. Replace the I/O cable specified by the location code. 2. Replace the I/O book that the failing I/O subsystem is attached to, U1.18-P1-Hx. 3. Replace the I/O subsystem backplane that the I/O cable in step 1 is attached to. 4. Go to "MAP 1542: I/O Problem Isolation" on page 312.
E536	I/O subsystem detected at other end of the I/O cable	<ol style="list-style-type: none"> 1. Check for system firmware updates. 2. Go to "MAP 1542: I/O Problem Isolation" on page 312.
E537	Configuring the I/O subsystem	<ol style="list-style-type: none"> 1. Replace the I/O cable specified by the location code. 2. Replace the I/O book that the failing I/O subsystem is attached to, U1.18-P1-Hx. 3. Replace the I/O subsystem backplane that the I/O cable in step 1 is attached to. 4. Go to "MAP 1542: I/O Problem Isolation" on page 312.
E538	Detected the I/O hub at other end of the I/O cable	<ol style="list-style-type: none"> 1. Check for system firmware updates. 2. Go to "MAP 1542: I/O Problem Isolation" on page 312.
E539	Enabling the I/O hub ports	<ol style="list-style-type: none"> 1. Check for system firmware updates. 2. Replace the I/O book specified by the location code. 3. Go to "MAP 1542: I/O Problem Isolation" on page 312.

Table 1. Firmware Checkpoints (continued)

Checkpoint	Description	Action/ Possible Failing FRU
E53A	Set up the RIO port speed of the exit port of the I/O subsystem connected to the RIO hub port	<ol style="list-style-type: none"> 1. Replace the RIO cable specified by the location code. 2. Replace the I/O book that the failing drawer is attached to, U1.18-P1-Hx. 3. Replace the I/O subsystem backplane that the RIO cable in step 1 is attached to. 4. Go to "MAP 1542: I/O Problem Isolation" on page 312.
E53B	End of looking for next node port	<ol style="list-style-type: none"> 1. Check for system firmware updates. 2. Go to "MAP 1542: I/O Problem Isolation" on page 312.
E53C	End of looking for next RIO hub port	<ol style="list-style-type: none"> 1. Check for system firmware updates. 2. Go to "MAP 1542: I/O Problem Isolation" on page 312.
E540	Begin initialization of I/O subsystem	<ol style="list-style-type: none"> 1. Check for system firmware updates. 2. Go to "MAP 1542: I/O Problem Isolation" on page 312.
E541	Initialize the routing table	<ol style="list-style-type: none"> 1. Replace the I/O cable specified by the location code. 2. Replace the I/O subsystem backplane that the I/O cable in step 1 is attached to. 3. Go to "MAP 1542: I/O Problem Isolation" on page 312.
E544	Enable the I/O ports	<ol style="list-style-type: none"> 1. Replace the I/O cable specified by the location code. 2. Replace the I/O subsystem backplane that the I/O cable in step 1 is attached to.
E545	Set up the device routing address for this new node ID	<ol style="list-style-type: none"> 1. Replace the I/O cable specified by the location code. 2. Replace the I/O subsystem backplane that the I/O cable in step 1 is attached to.

Table 1. Firmware Checkpoints (continued)

Checkpoint	Description	Action/ Possible Failing FRU
E546	Set up the I/O interface chip new node ID	<ol style="list-style-type: none"> 1. Replace the I/O cable specified by the location code. 2. Replace the I/O subsystem backplane that the I/O cable in step 1 is attached to.
E547	Set up the I/O interface chip routing table	<ol style="list-style-type: none"> 1. Replace the I/O cable specified by the location code. 2. Replace the I/O subsystem backplane that the I/O cable in step 1 is attached to.
E548	Disable any node mode	<ol style="list-style-type: none"> 1. Replace the I/O cable specified by the location code. 2. Replace the I/O subsystem backplane that the I/O cable in step 1 is attached to.
E549	Adjust I/O hub table	<ol style="list-style-type: none"> 1. Replace the I/O cable specified by the location code. 2. Replace the I/O book that the failing I/O subsystem is attached to, U1.18-P1-Hx. 3. Replace the I/O subsystem backplane that the I/O cable in step 1 is attached to.
E550	Begin to initialize I/O interface chip	<ol style="list-style-type: none"> 1. Replace the I/O cable specified by the location code. 2. Replace the I/O subsystem backplane that the I/O cable in step 1 is attached to.
E551	Set up the I/O speed	<ol style="list-style-type: none"> 1. Replace the I/O cable specified by the location code. 2. Replace the I/O subsystem backplane that the I/O cable in step 1 is attached to.
E552	Set up I/O interface chip registers	<ol style="list-style-type: none"> 1. Replace the I/O cable specified by the location code. 2. Replace the I/O subsystem backplane that the I/O cable in step 1 is attached to.
E553	Set up the I/O interface chip base address	<ol style="list-style-type: none"> 1. Replace the I/O cable specified by the location code. 2. Replace the I/O subsystem backplane that the I/O cable in step 1 is attached to.

Table 1. Firmware Checkpoints (continued)

Checkpoint	Description	Action/ Possible Failing FRU
E554	Set up more I/O interface chip registers	<ol style="list-style-type: none"> 1. Replace the I/O cable specified by the location code. 2. Replace the I/O subsystem backplane that the I/O cable in step 1 is attached to.
E555	Set up the I/O interface chip I/O link	<ol style="list-style-type: none"> 1. Replace the I/O cable specified by the location code. 2. Replace the I/O subsystem backplane that the I/O cable in step 1 is attached to.
E556	Set up and initialize I/O interface chips under current I/O interface chip	<ol style="list-style-type: none"> 1. Replace the I/O cable specified by the location code. 2. Replace the I/O subsystem backplane that the I/O cable in step 1 is attached to.
E55F	End of I/O drawer initialization	<ol style="list-style-type: none"> 1. Replace the I/O cable specified by the location code. 2. Replace the I/O book that the failing I/O subsystem is attached to, U1.18-P1-Hx. 3. Replace the I/O subsystem backplane that the I/O cable in step 1 is attached to.
E560	Begin initializing the I/O subsystem	<ol style="list-style-type: none"> 1. Check for system firmware updates. 2. Go to "MAP 1542: I/O Problem Isolation" on page 312.
E561	Set up I/O interface chip registers	<ol style="list-style-type: none"> 1. Replace the I/O cable specified by the location code. 2. Replace the I/O subsystem backplane that the I/O cable in step 1 is attached to.
E562	Set up I/O interface chip registers	<ol style="list-style-type: none"> 1. Replace the I/O cable specified by the location code. 2. Replace the I/O subsystem backplane that the I/O cable in step 1 is attached to.
E563	Set up I/O interface chip registers	<ol style="list-style-type: none"> 1. Replace the I/O cable specified by the location code. 2. Replace the I/O subsystem backplane that the I/O cable in step 1 is attached to.

Table 1. Firmware Checkpoints (continued)

Checkpoint	Description	Action/ Possible Failing FRU
E564	Set up I/O interface chip registers	<ol style="list-style-type: none"> 1. Replace the I/O cable specified by the location code. 2. Replace the I/O subsystem backplane that the I/O cable in step 1 is attached to.
E565	Set up I/O interface chip registers	<ol style="list-style-type: none"> 1. Replace the I/O cable specified by the location code. 2. Replace the I/O subsystem backplane that the I/O cable in step 1 is attached to.
E566	Enable device arbitration on the I/O interface chip	<ol style="list-style-type: none"> 1. Replace the I/O cable specified by the location code. 2. Replace the I/O subsystem backplane that the I/O cable in step 1 is attached to.
E567	Set up I/O interface chip registers	<ol style="list-style-type: none"> 1. Replace the I/O cable specified by the location code. 2. Replace the I/O subsystem backplane that the I/O cable in step 1 is attached to.
E568	Set up the external interrupt vector register	<ol style="list-style-type: none"> 1. Replace the I/O cable specified by the location code. 2. Replace the I/O subsystem backplane that the I/O cable in step 1 is attached to.
E569	Set up I/O interface chip registers	<ol style="list-style-type: none"> 1. Replace the I/O cable specified by the location code. 2. Replace the I/O subsystem backplane that the I/O cable in step 1 is attached to.
E56A	Set up I/O interface chip registers	<ol style="list-style-type: none"> 1. Replace the I/O cable specified by the location code. 2. Replace the I/O subsystem backplane that the I/O cable in step 1 is attached to.
E56B	Set up I/O interface chip registers	<ol style="list-style-type: none"> 1. Replace the I/O cable specified by the location code. 2. Replace the I/O subsystem backplane that the I/O cable in step 1 is attached to.

Table 1. Firmware Checkpoints (continued)

Checkpoint	Description	Action/ Possible Failing FRU
E56C	Set up I/O interface chip PCI bus	<ol style="list-style-type: none"> 1. Replace the I/O cable specified by the location code. 2. Replace the I/O subsystem backplane that the I/O cable in step 1 is attached to.
E56D	Identify devices on current bus	<ol style="list-style-type: none"> 1. Replace the I/O cable specified by the location code. 2. Replace the I/O subsystem backplane that the I/O cable in step 1 is attached to.
E56E	Begin initializing the service processor control chip	<ol style="list-style-type: none"> 1. Replace the I/O cable specified by the location code. 2. Replace the I/O subsystem backplane that the I/O cable in step 1 is attached to.
E56F	End initializing the service processor control chip	<ol style="list-style-type: none"> 1. Check for system firmware updates. 2. Go to "MAP 1542: I/O Problem Isolation" on page 312.
E570	Initialize the PCI-ISA bridge chip	<ol style="list-style-type: none"> 1. Replace the I/O cable specified by the location code. 2. Replace the I/O subsystem backplane that the I/O cable in step 1 is attached to.
E571	Initialize the integrated Ethernet (if present)	<ol style="list-style-type: none"> 1. Replace the I/O cable specified by the location code. 2. Replace the I/O subsystem backplane that the I/O cable in step 1 is attached to.
E572	Initialize the integrated SCSI	<ol style="list-style-type: none"> 1. Replace the I/O cable specified by the location code. 2. Replace the I/O subsystem backplane that the I/O cable in step 1 is attached to.
E57F	End of I/O interface chip initialization	<ol style="list-style-type: none"> 1. Check for system firmware updates. 2. Go to "MAP 1542: I/O Problem Isolation" on page 312.
E580	Begin initializing the EADS module	<ol style="list-style-type: none"> 1. Check for system firmware updates. 2. Go to "MAP 1542: I/O Problem Isolation" on page 312.

Table 1. Firmware Checkpoints (continued)

Checkpoint	Description	Action/ Possible Failing FRU
E581	Read the PCI bus configuration header	<ol style="list-style-type: none"> 1. This error code may indicate that the I/O (RIO) cables are not properly connected to the I/O subsystems. Check the RIO cabling; refer to "I/O Book Connector Locations" on page 24 and "Subsystem Positioning and Cabling" on page 41. 2. Replace the RIO cable specified by the location code. 3. Replace the I/O subsystem backplane that the I/O cable in step 1 is attached to.
E582	EADS has been detected	<ol style="list-style-type: none"> 1. Replace the I/O cable specified by the location code. 2. Replace the I/O subsystem backplane that the I/O cable in step 1 is attached to.
E583	Running BIST on the current EADS	<ol style="list-style-type: none"> 1. Replace the I/O cable specified by the location code. 2. Replace the I/O subsystem backplane that the I/O cable in step 1 is attached to.
E584	Checking function of current EADS	<ol style="list-style-type: none"> 1. Replace the I/O cable specified by the location code. 2. Replace the I/O subsystem backplane that the I/O cable in step 1 is attached to.
E585	Valid function of current EADS detected	<ol style="list-style-type: none"> 1. Replace the I/O cable specified by the location code. 2. Replace the I/O subsystem backplane that the I/O cable in step 1 is attached to.
E586	Set up EADS function	<ol style="list-style-type: none"> 1. Replace the I/O cable specified by the location code. 2. Replace the I/O subsystem backplane that the I/O cable in step 1 is attached to.
E587	Set up EADS BIST	<ol style="list-style-type: none"> 1. Replace the I/O cable specified by the location code. 2. Replace the I/O subsystem backplane that the I/O cable in step 1 is attached to.

Table 1. Firmware Checkpoints (continued)

Checkpoint	Description	Action/ Possible Failing FRU
E588	Set up EADS function registers	<ol style="list-style-type: none"> 1. Replace the I/O cable specified by the location code. 2. Replace the I/O subsystem backplane that the I/O cable in step 1 is attached to.
E589	Set up EADS function	<ol style="list-style-type: none"> 1. Replace the I/O cable specified by the location code. 2. Replace the I/O subsystem backplane that the I/O cable in step 1 is attached to.
E58A	Set up EADS function registers	<ol style="list-style-type: none"> 1. Replace the I/O cable specified by the location code. 2. Replace the I/O subsystem backplane that the I/O cable in step 1 is attached to.
E58B	Set up EADS function registers	<ol style="list-style-type: none"> 1. Replace the I/O cable specified by the location code. 2. Replace the I/O subsystem backplane that the I/O cable in step 1 is attached to.
E58C	Set up EADS function registers	<ol style="list-style-type: none"> 1. Replace the I/O cable specified by the location code. 2. Replace the I/O subsystem backplane that the I/O cable in step 1 is attached to.
E58D	Set up EADS function registers	<ol style="list-style-type: none"> 1. Replace the I/O cable specified by the location code. 2. Replace the I/O subsystem backplane that the I/O cable in step 1 is attached to.
E58E	Set up EADS function registers	<ol style="list-style-type: none"> 1. Replace the I/O cable specified by the location code. 2. Replace the I/O subsystem backplane that the I/O cable in step 1 is attached to.
E58F	Set up EADS function registers	<ol style="list-style-type: none"> 1. Replace the I/O cable specified by the location code. 2. Replace the I/O subsystem backplane that the I/O cable in step 1 is attached to.

Table 1. Firmware Checkpoints (continued)

Checkpoint	Description	Action/ Possible Failing FRU
E590	Set up EADS function registers	<ol style="list-style-type: none"> 1. Replace the I/O cable specified by the location code. 2. Replace the I/O subsystem backplane that the I/O cable in step 1 is attached to.
E591	Set up EADS function registers	<ol style="list-style-type: none"> 1. Replace the I/O cable specified by the location code. 2. Replace the I/O subsystem backplane that the I/O cable in step 1 is attached to.
E592	Set up EADS function registers	<ol style="list-style-type: none"> 1. Replace the I/O cable specified by the location code. 2. Replace the I/O subsystem backplane that the I/O cable in step 1 is attached to.
E593	Set up EADS function registers	<ol style="list-style-type: none"> 1. Replace the I/O cable specified by the location code. 2. Replace the I/O subsystem backplane that the I/O cable in step 1 is attached to.
E594	Begin probing slots	<ol style="list-style-type: none"> 1. Replace the I/O cable specified by the location code. 2. Replace the I/O subsystem backplane that the I/O cable in step 1 is attached to.
E595	Detected valid adapter in slot	<ol style="list-style-type: none"> 1. Check for system firmware updates. 2. Go to "MAP 1542: I/O Problem Isolation" on page 312.
E59E	End of walking bus of current EADS	<ol style="list-style-type: none"> 1. Check for system firmware updates. 2. Go to "MAP 1542: I/O Problem Isolation" on page 312.
E59F	End of EADS initialization	<ol style="list-style-type: none"> 1. Check for system firmware updates. 2. Go to "MAP 1542: I/O Problem Isolation" on page 312.
E5E0	Initialize system processor array	<ol style="list-style-type: none"> 1. Check for system firmware updates. 2. Go to "MAP 1542: I/O Problem Isolation" on page 312.

Table 1. Firmware Checkpoints (continued)

Checkpoint	Description	Action/ Possible Failing FRU
E5E1	Reserved	
E5E2	Initialization of the hypervisor, phase 1	<ol style="list-style-type: none"> 1. Check for system firmware updates. 2. Go to "MAP 1542: I/O Problem Isolation" on page 312.
E5E3	Not in quick-restart: load and set up open firmware code in memory	<ol style="list-style-type: none"> 1. Check for system firmware updates. 2. Go to "MAP 1542: I/O Problem Isolation" on page 312.
E5E4	Activate slave processors	<ol style="list-style-type: none"> 1. Check for system firmware updates. 2. Go to "MAP 1542: I/O Problem Isolation" on page 312.
E5E5	Initialize the hypervisor, phase 2	<ol style="list-style-type: none"> 1. Check for system firmware updates. 2. Go to "MAP 1542: I/O Problem Isolation" on page 312.
E5E6	Set L2 and processor status	<ol style="list-style-type: none"> 1. Check for system firmware updates. 2. Go to "MAP 1542: I/O Problem Isolation" on page 312.
E5E7	Save I/O hub information for RTAS and open firmware	<ol style="list-style-type: none"> 1. Check for system firmware updates. 2. Go to "MAP 1542: I/O Problem Isolation" on page 312.
E5E8	Set up registers	<ol style="list-style-type: none"> 1. Check for system firmware updates. 2. Go to "MAP 1542: I/O Problem Isolation" on page 312.
E5E9	Reset the quick restart path	<ol style="list-style-type: none"> 1. Check for system firmware updates. 2. Go to "MAP 1542: I/O Problem Isolation" on page 312.
E5EE	Hang state in main control code	<ol style="list-style-type: none"> 1. Check for system firmware updates. 2. Go to "MAP 1542: I/O Problem Isolation" on page 312.

Table 1. Firmware Checkpoints (continued)

Checkpoint	Description	Action/ Possible Failing FRU
E5EF	End of low-level firmware	<ol style="list-style-type: none"> 1. Check for system firmware updates. 2. Go to "MAP 1542: I/O Problem Isolation" on page 312.
E600	SSA PCI adapter open firmware has run successfully.	Replace the adapter.
E601	SSA PCI adapter BIST has started but failed to complete after 4 seconds.	Replace the adapter.
E602	SSA PCI open firmware has started.	Replace the adapter.
E603	SSA PCI adapter BIST has completed with an error.	Replace the adapter.
E604	SSA PCI adapter BIST and subsequent POSTs have completed successfully.	Replace the adapter.
E605	SSA PCI adapter BIST has completed successfully but subsequent POSTs have failed.	Replace the adapter.
E60E	SSA PCI open firmware about to exit (no stack corruption).	Replace the adapter.
E60F	SSA PCI open firmware has run unsuccessfully.	Replace the adapter.
E6FF	SSA PCI open firmware about to exit (with stack corruption).	Replace the adapter.
E700	Create system firmware VPD	System firmware may be corrupted. Reinstall system firmware.
E701	Create memory VPD.	<ol style="list-style-type: none"> 1. Check for system firmware updates. 2. Call for support.
E702	Create processor card VPD.	<ol style="list-style-type: none"> 1. Check for system firmware updates. 2. Call for support.
E703	Create operator panel VPD.	<ol style="list-style-type: none"> 1. Check for system firmware updates. 2. Call for support.
E704	Create processor subsystem VPD.	<ol style="list-style-type: none"> 1. Check for system firmware updates. 2. Call for support.

Table 1. Firmware Checkpoints (continued)

Checkpoint	Description	Action/ Possible Failing FRU
E705	Create clock card VPD.	<ol style="list-style-type: none"> 1. Check for system firmware updates. 2. Call for support.
E706	Create RIO extender card VPD.	<ol style="list-style-type: none"> 1. Check for system firmware updates. 2. Call for support.
E707	Create system VPD.	<ol style="list-style-type: none"> 1. Check for system firmware updates. 2. Call for support.
E708	Create RIO to PCI adapter VPD.	Go to "MAP 1542: I/O Problem Isolation" on page 312.
E709	Create VPD via SPCN.	<ol style="list-style-type: none"> 1. Check for system firmware updates. 2. Call service support.
E70A	Create service processor VPD.	<ol style="list-style-type: none"> 1. Check for system firmware updates. 2. Call for support.
E70B	Create L3 module VPD	<ol style="list-style-type: none"> 1. Check for system firmware updates. 2. Call service support.
E70C	Create I/O backplane VPD (I2C problem)	Go to "MAP 1542: I/O Problem Isolation" on page 312.
E70D	Create capacitor book VPD	<ol style="list-style-type: none"> 1. Check for system firmware updates. 2. Call service support.
E70F	Create CEC VPD	<ol style="list-style-type: none"> 1. Check for system firmware updates. 2. Call service support.
E7EE	Delaying while waiting for power subsystem VPD collection to be completed; informational only	<ol style="list-style-type: none"> 1. Check for system firmware updates. 2. Call service support.
E7FF	Successful end of VPD creation	Informational message. If the system hangs here, go to "MAP 1541: JTAG Problem Isolation" on page 304.
E800	RTAS initialization problem	<ol style="list-style-type: none"> 1. Check for system firmware updates. 2. Call service support.

Table 1. Firmware Checkpoints (continued)

Checkpoint	Description	Action/ Possible Failing FRU
E841	Initializing RTAS/open firmware device tree interface	<ol style="list-style-type: none"> 1. Check for system firmware updates. 2. Call service support.
E842	Initializing RTAS/service processor interface	<ol style="list-style-type: none"> 1. Check for system firmware updates. 2. Replace the primary I/O book Location: U1.18-P1-H2. 3. Call service support.
E843	Initializing RTAS/sensor interface	<ol style="list-style-type: none"> 1. Check for system firmware updates. 2. Call service support.
E844	Initializing RTAS/time-of-day clock interface	<ol style="list-style-type: none"> 1. Check for system firmware updates. 2. Replace the primary I/O book Location: U1.18-P1-H2. 3. Call service support.
E845	Initializing interface/sensor access	<ol style="list-style-type: none"> 1. Check for system firmware updates. 2. Call service support.
E84F	Initializing RTAS/operator panel interface	<ol style="list-style-type: none"> 1. Check for system firmware updates. 2. Call service support.
E850	Initializing RTAS/cache interface	<ol style="list-style-type: none"> 1. Check for system firmware updates. 2. Call service support.
E851	Initializing RTAS/hardware access	<ol style="list-style-type: none"> 1. Check for system firmware updates. 2. Call service support.
E852	Initializing RTAS/PCI bus interface	<ol style="list-style-type: none"> 1. Check for system firmware updates. 2. Go to "MAP 1542: I/O Problem Isolation" on page 312. 3. Call service support.
E860	Initializing RTAS/power subsystem interface	<ol style="list-style-type: none"> 1. Check for system firmware updates. 2. Call service support.

Table 1. Firmware Checkpoints (continued)

Checkpoint	Description	Action/ Possible Failing FRU
E861	Initializing RTAS/PCI bus interface	<ol style="list-style-type: none"> 1. Check for system firmware updates. 2. Go to "MAP 1542: I/O Problem Isolation" on page 312 3. Call service support.
E870	Initializing RTAS/logs interface	<ol style="list-style-type: none"> 1. Check for system firmware updates. 2. Call service support.
E871	Initializing RTAS/EEH handling interface	<ol style="list-style-type: none"> 1. Check for system firmware updates. 2. Go to "MAP 1542: I/O Problem Isolation" on page 312. 3. Call service support.
E872	Initializing RTAS/error inject interface	<ol style="list-style-type: none"> 1. Check for system firmware updates. 2. Call service support.
E873	Initializing RTAS/error handling interface	<ol style="list-style-type: none"> 1. Check for system firmware updates. 2. Call service support.
E880	Initializing RTAS/debug interface	<ol style="list-style-type: none"> 1. Check for system firmware updates. 2. Call service support.
E881	Initializing RTAS/utility interface	<ol style="list-style-type: none"> 1. Check for system firmware updates. 2. Call service support.
E882	Initializing RTAS/softpatch register interface	<ol style="list-style-type: none"> 1. Check for system firmware updates. 2. Call service support.
E890	Initializing RTAS/hot-plug interface	<ol style="list-style-type: none"> 1. Check for system firmware updates. 2. Call service support.
E8C1	Initializing interface/client memory access	<ol style="list-style-type: none"> 1. Check for system firmware updates. 2. Call service support.
E8D1	Initializing interface/special memory access	<ol style="list-style-type: none"> 1. Check for system firmware updates. 2. Call service support.
EAA1	Probe PCI-PCI bridge bus	Follow the repair actions for checkpoint E151.

Boot Problems

Attention: If the system is running partitions from partition standby (LPAR), the following procedure addresses the problem in which one partition will not boot while other partitions boot successfully and run the operating system successfully.

This procedure also addresses the problem in which a system does not boot to a full system partition. All of the system's resources are available to the diagnostics; the same general procedure applies, with the exception of moving resources between partitions.

Attention: It is the customer's responsibility to move devices between partitions. If a device must be moved to another partition to run standalone diagnostics, contact the customer or system administrator. (If the CD-ROM must be moved to another partition, all SCSI devices connected to that SCSI adapter must be moved because moves are done at the slot level, not at the device level.) Both partitions must be rebooted if a device is moved between partitions.

Depending on the boot device, a checkpoint may be displayed on the operator panel for an extended period of time while the boot image is retrieved from the device. This is particularly true for tape and network boot attempts. If the checkpoint/code is displayed for an extended time, there may be a problem loading the boot image from the device. If booting from CD-ROM or tape, watch for activity on the drive's LED indicator. A blinking LED indicates that the loading of either the boot image, or additional information required by the operating system being booted, is still being loaded.

For network boot attempts, refer to checkpoint E174.

If the checkpoint is displayed for an extended time, there may be a problem with the integrity of the boot image.

This procedure assumes that a CD-ROM drive is connected to the system, or that the diagnostics can be run from a NIM (Network Installation Management) server.

1. Look at the service action event-error log in the Service Focal Point on the HMC (see "Service Focal Point" on page 5 for instructions on accessing the service action event log). If there are open entries that affect devices in the boot path of the partition, perform the actions to correct those errors. If there are open entries that indicate problems with I/O cabling, perform the actions to correct those problems. Try to reboot the partition.

If the partition hangs with a 4-character checkpoint in the display, the partition must be deactivated, then reactivated before attempting to reboot.

If a 20EE xxxx error code is reported, the partition is already deactivated and in the error state. Reboot by activating the partition. If the system is running in full system partition, the power must be cycled before the system can be rebooted. If the reboot is still not successful, continue to step 2.

2. Boot to the SMS main menu as follows:
 - If you are rebooting a partition from partition standby (LPAR), go to the properties of the partition and select **Boot to SMS**, then activate the partition.

- If you are rebooting the system in full system partition, start the service processor menus, select option 2, **System Power Control Menu**, then select option 7, **Boot Mode Menu**, then select option 1, **Boot to SMS menu**. Enter 98 to return to the system power control menu, then select option 4, **Power-on System**. Enter y to confirm.

At the SMS main menu, select **Multiboot**.

- a. Check to see if the intended boot device is correctly specified in the boot list. If it is in the boot list:
 - 1) Remove all removable media from devices in the boot list from which you do not want to boot.
 - 2) If attempting to boot from a network, go to step 3.
If attempting to boot from a disk drive or CD-ROM, go to step 4.
 - b. If the intended boot device is not correctly listed in the boot sequence, add it to the boot sequence using the SMS menus. If the device can be added to the boot sequence, reboot the partition. If the intended boot device cannot be added to the boot list, ask the customer or system administrator to verify that the device you are trying to boot from is assigned to the correct partition. If it is, go to step 4.
3. If attempting to boot from the network:
 - a. Verify that the IP parameters are correct.
 - b. Attempt to "ping" the target server using the SMS ping utility. If the ping is not successful, have the network administrator verify the server configuration for this client.
 - c. Check with the network administrator to ensure that the network is up. Also ask the network administrator to verify the settings on the server from which you are trying to boot.
 - d. Check the network cabling to the adapter.
 - e. Restart the partition and retry the boot operation.
 4. Try to boot and run standalone diagnostics against the devices in the partition, particularly against the intended boot device. Standalone diagnostics can be run from CD-ROM or a NIM server. To boot standalone diagnostics, follow the detailed procedures in "Loading the Standalone Diagnostics from CD-ROM" on page 701 or "Running Standalone Diagnostics from a Network Installation Management (NIM) Server" on page 701.

Attention: Standalone diagnostics may be run on systems configured for either full system partition or partition standby. When attempting to boot diagnostics on a partition from partition standby, the device from which you are booting standalone diagnostics must be made available to the partition that is not able to boot, if it is not already in that partition. Contact the customer or system administrator if a device must be moved between partitions in order to boot standalone diagnostics. If devices are moved between partitions, both partitions must be rebooted. For more information, see "Standalone Diagnostic Operation" on page 700.

If standalone diagnostics boot successfully:

- a. Go to the Task Selection menu, and select **Display Configuration and Resource List**. If the intended boot device is not listed, ask the customer or system administrator to verify that it is assigned to the correct partition. If it is,

and does not appear in the NEW RESOURCE list, go to "MAP 0290: Missing Resource Problem Resolution" in the *RS/6000 and @server pSeries Diagnostic Information for Multiple Bus Systems*.

- b. Run diagnostics on the device you want to boot from. If an SRN, not an 8-digit error code, is reported, go to the *RS/6000 and @server pSeries Diagnostic Information for Multiple Bus Systems* manual.
- c. If the diagnostics are successful, it may be necessary to perform an operating system-specific recovery process, or reinstall the operating system.

If standalone diagnostics do not boot successfully from CD-ROM:

- a. Verify that the CD-ROM drive is assigned to the correct partition.
- b. Check the SCSI cabling to the CD-ROM drive. Check the power connector on the CD-ROM.
- c. It is possible that another SCSI device on the same bus is causing the problem. Do the following:
 - 1) Disconnect the power and signal cables from all other SCSI devices that are attached to the SCSI adapter to which the CD-ROM is attached.
 - 2) Try to boot standalone diagnostics again.
 - 3) If you are still unable to load standalone diagnostics, go to step 5.
 - 4) If standalone diagnostics load, one of the disconnected devices is causing the problem. Reconnect the devices one at a time and retry the boot operation until the problem recurs, and replace the device that caused the problem. Go to "MAP 410: Repair Checkout" in the *RS/6000 and @server pSeries Diagnostic Information for Multiple Bus Systems*.

If standalone diagnostics do not boot successfully from a NIM server:

- a. Verify that the network adapter is assigned to the correct partition.
 - b. Check the network settings and flag settings, as detailed in "Running Standalone Diagnostics from a Network Installation Management (NIM) Server" on page 701.
 - c. Follow the procedure outlined in step 3 on page 397.
5. Go to "MAP 1542: I/O Problem Isolation" on page 312.

Chapter 5. Error Code to FRU Index

The Error Code to FRU Index lists fault symptoms and possible causes. The most likely cause is listed first. Use this index to help you decide which FRUs to replace when servicing the system.

Attention: If you replace FRUs or perform an action on an I/O subsystem and the problem is still not corrected, go to “MAP 1542: I/O Problem Isolation” on page 312 unless you were already directed to any MAP 154x by the error code. Otherwise, call service support if the action(s) for an error code do not resolve the problem.

Attention: If the error code that brought you to this chapter originated in the AIX error log, remember that an error may require an additional 15 minutes to be propagated to the AIX error log.

If you replace FRUs and the problem is corrected, go to “MAP 0410: Repair Checkout” in the *RS/6000 and @server pSeries Diagnostic Information for Multiple Bus Systems*.

Performing Slow Boot

On this system, the error code displayed in the operator panel or in the service action event (SAE) log may not indicate the root cause of the problem. To fully analyze all of the available information, perform the following steps before doing a hardware repair or replacement:

1. Record the 8-character error code (and location code if present) in operator panel.
2. Do a slow-mode boot in service mode. (A fast-mode boot skips much of the built-in diagnostic testing.) A slow-mode boot may yield a new 8-character error code on the operator panel or new errors in the service processor error log. If a new error code is reported, record it for use in subsequent steps. Slow boot is selected through the service processor menus. The procedure for selecting service mode diagnostics is different for nonpartitioned systems and partitioned systems, as follows:
 - Nonpartitioned system:
Use the System Power Control Menu on the service processor main menu.
 - Partitioned system:
 - a. From the HMC, select **Partition Manager**.
 - b. Highlight the CEC name.
 - c. Right-click the mouse and select **Open Terminal Window**.
 - d. From the Service Processor Menu on the VTERM, select Option 2 **System Power Control Menu**.
 - e. Select option 6. Verify that the state changes to *currently disabled*. Disabling fast system boot automatically enables slow boot.
 - f. Select Option 98 to exit the system power control menu.
 - g. From the partition manager, highlight any available partition that has access to an AIX diagnostics boot image.
 - h. Right-click the mouse and select **Open Terminal Window** for this partition.

- i. Right-click the mouse again and select **activate** to make the partition active.
 - j. When the **keyboard** indicator appears in the open terminal window, enter 6 on the HMC keyboard before the speaker indicator is displayed.
3. A slow boot in service mode results in the Diagnostic Operating Instructions panel being displayed on the serial console or the HMC partition VTERM window.
4. Press Enter to continue to the Function Selection menu.
5. Enter option 5, **Single User Mode**.
6. When prompted, enter the root password.
7. At the prompt, run the **shutdown** command.

At this point, the service processor menus should be available to examine the service processor error log.

Confirming Initial Error Code

The service processor may have recorded one or more symptoms in its error log. If the system has attempted to boot since an error terminated normal operation, there may be specific fault information in the service processor error log. Examine this error log before proceeding (see “System Information Menu” on page 722).

In the service processor error log, the most recent error is at the top of the list and the oldest error is at the bottom. It is also important to look at the time stamp associated with each error. (The time stamps in the service processor error log reflect coordinated universal time (UTC), which is also referred to as Greenwich mean time.)

On this system, the error code displayed in the operator panel may not be indicative of the root cause of the problem. This is also true of the most recent error in the service processor error log.

Attempt to find the error code that originally sent you to the “Checkpoints and Error Codes Index” on page 403 table.

1. If you cannot find the error code in the service processor error log, start with the error code at the bottom of the list. Proceed to step 3.
2. If you can find the error code in the service processor error log, observe the time stamps and look for a group of failures that happened within minutes prior to this error code. In this group, start at the error code with the earliest time stamp. Proceed to step 3.
3. Examine the list of error codes you obtained from steps 1 or 2, and look for any of the form 4xxB xxxx.

Can you find any error codes of the form 4xxB xxxx?

No Proceed to step 6 on page 401.

Yes Proceed to step 4.

4. Do any of the error codes of the form 4xxB xxxx have the same first two characters on the left as the first two characters on the left of the error code that sent you to the MAP?

No Proceed to step 6.

Yes Proceed to step 5.

5. Adjust the order of the list of error codes you obtained from steps 1 or 2 by placing the error codes of the form 4xxB xxxx with the same first two characters as the error code that sent you to this MAP on the bottom of the list. Proceed to step 6. starting with the codes at the bottom of the adjusted list of error codes.
6. To get a list of possible FRUs, select the detail screen for each error code. Record the listed location codes and their order. Return to the step in the “Checkpoints and Error Codes Index” on page 403 table immediately after the step that sent you to this “Confirming Initial Error Code” procedure to perform the listed repair actions. If the repair actions for an error code are ineffective, continue to work upward through this group of error codes (which is forward in time from the earliest time stamp to the latest) until either the problem is fixed, you reach the error code that was first reported, or you are at the top of the list.

Four-Character Checkpoints

Four-character checkpoints in the form 8xxx, 9xxx, Axxx, Bxxx, and Exxx are listed in “Firmware Checkpoints” on page 370. If you have a four-character code that begins with any character other than 8, 9, A, B, or E, refer to the *RS/6000 and @server pSeries Diagnostic Information for Multiple Bus Systems*.

Replacing the Media Subsystem Operator Panel

Licensed programs frequently rely on system information that is stored in the VPD module on the media subsystem’s operator panel. If the MAPs indicate that the operator panel should be replaced, the pluggable VPD module must be swapped. If the old module is defective, or cannot be recovered, contact service support.

Replacing the Network Adapter

If a network adapter is replaced, the network administrator must be notified so that the client IP addresses used by the server can be updated. In addition, the operating system configuration of the network controller may need to be changed in order to enable system startup. Also check to ensure that any client or server that accesses this system is updated.

Determining Location Code

If you have an error code in the form 2xxx xxxx or Exxx, and no location code associated with it, the location code may possibly be found in the following places, depending on the state of the system:

- If the system will boot into AIX, the location code will be reported when error log analysis is run under AIX diagnostics.
- If the system will boot into the system management services (SMS) menus, the SMS error log will contain the location code associated with the error code. See “Display Error Log” on page 757.

- If the system halted when the error occurred, the error code and location can be found in the LCD progress indicator log, which can be accessed using the service processor menus. See “System Information Menu” on page 722, then select **Read Progress Indicator From Last System Boot**. Find the error code that directed you to this note in the list, and the location code is part of the entry in the log.

Checkpoints and Error Codes Index

The table below is an index to the checkpoints or error codes that you may receive to help diagnose a failure. Locate the code you received, and follow the instructions to determine your next step.

Table 2. Checkpoints and Error Codes Index

8-Digit Error Code or 4-Digit Checkpoint	What You Should Do
0000 xxxx	Operator Panel Error Codes Go to “Operator Panel Error Codes” on page 405, and follow the instructions in the operator panel error code table.
1xxx xxxx	System Power Control Network (SPCN) Error Codes 1. There may be additional error codes and information in the service processor error log. The system must be powered off to examine the contents of the service processor error log. Is the system already powered off or may the system be powered off at this time? NO Go to 3 below. YES Power off the system, if necessary, and go to 2 below. 2. Confirm this is the first error code that caused the failure, as described in “Confirming Initial Error Code” on page 400. 3. Go to “SPCN Error Codes” on page 407, and follow the instructions in the SPCN error code table.
2xxx xxxx	Firmware Error Codes Go to “Firmware/POST Error Codes” on page 470, and follow the instructions in the firmware error code table.
4xxx xxxx	Service Processor Error Codes 1. Is the error code of the form 4B2x xxxx, 450x xxxx, or 460x xxxx? NO Go to 4 below. YES Go to 2 below. 2. Find the error code in the service processor error log and check the value of word 13. 3. Is the value of word 13 C0xx xxxx? NO Go to 4 below. YES Go to “MAP 1541: JTAG Problem Isolation” on page 304. 4. Perform slow boot as described in “Performing Slow Boot” on page 399. 5. Confirm this is the first error code that caused the failure, as described in “Confirming Initial Error Code” on page 400. 6. Go to “Service Processor Error Codes” on page 496, and follow the instructions in the service processor error codes table.
8xxx 9xxx Axxx Bxxx	Service Processor Checkpoints Go to “Service Processor Checkpoints” on page 362 for more information on these checkpoints.

Table 2. Checkpoints and Error Codes Index (continued)

8-Digit Error Code or 4-Digit Checkpoint	What You Should Do
B006 xxxx B1xx xxxx	<p>Common Firmware Error Codes</p> <ol style="list-style-type: none"> 1. Perform slow boot, as described in “Performing Slow Boot” on page 399. 2. Confirm this is the first error code that caused the failure, as described in “Confirming Initial Error Code” on page 400. 3. Go to “Common Firmware Error Codes” on page 681, and follow the instructions in the Common Firmware Error Codes table.
Exxx	<p>Firmware Checkpoints</p> <p>Go to “Firmware Checkpoints” on page 370 for more information on these checkpoints.</p>
Mxxx xxxx	<p>Problem Determination-Generated Error Codes</p> <p>Go to “Problem Determination-Generated Error Codes” on page 691, and follow the instructions in the error code table.</p>

Operator Panel Error Codes

Attention: If you replace FRUs or perform an action on an I/O subsystem and the problem is still not corrected, go to “MAP 1542: I/O Problem Isolation” on page 312 unless you were already directed to any MAP 154x by the error code. Otherwise call support if the action(s) for an error code do not resolve the problem.

Attention: If the error code that brought you to this chapter originated in the AIX error log, remember that an error may require an additional 15 minutes to be propagated to the AIX error log.

If you replace FRUs and the problem is corrected, go to “MAP 0410: Repair Checkout” in the *RS/6000 and @server pSeries Diagnostic Information for Multiple Bus Systems*.

Error Code	Description	Action/ Possible Failing FRU
0000 1111	At power on, failure of power-good signal from power supply	<ol style="list-style-type: none"> 1. Primary I/O backplane Location: U1.18-P1-H2 2. DCAs providing power to the primary I/O book Locations: U1.18-P1-V1, U1.18-P1-V2
0000 1112	At power off, failure of power-good signal from power supply	<ol style="list-style-type: none"> 1. Primary I/O backplane Location: U1.18-P1-H2 2. DCAs providing power to the primary I/O book Locations: U1.18-P1-V1, U1.18-P1-V2
0000 1113	While powered on, failure of power-good signal from power supply	<ol style="list-style-type: none"> 1. Primary I/O backplane Location: U1.18-P1-H2 2. DCAs providing power to the primary I/O book Locations: U1.18-P1-V1, U1.18-P1-V2
0000 1114	Operator panel and service processor have been reset after main power disturbance	Informational message
0000 2222	Operator panel not communicating with service processor	<ol style="list-style-type: none"> 1. If system cannot be powered off, reset the service processor (via the pinhole reset or by disconnecting then reconnecting power). 2. Primary I/O book, Location: U1.18-P1-H2
0000 3333	SPCN communications error	Primary I/O book, Location: U1.18-P1-H2
0000 3334	I2C repeater error	Primary I/O book, Location: U1.18-P1-H2

Error Code	Description	Action/ Possible Failing FRU
0000 BBBB	Time-of-day battery malfunction	Time-of-day battery Location: U1.18-P1-H2-V1

SPCN Error Codes

Attention: If you replace FRUs or perform an action on an I/O subsystem and the problem is still not corrected, go to “MAP 1542: I/O Problem Isolation” on page 312 unless you were already directed to any MAP 154x by the error code. Otherwise call support if the action(s) for an error code do not resolve the problem.

Attention: If the error code that brought you to this chapter originated in the AIX error log, please be aware that an error may require an additional 15 minutes to be propagated to the AIX error log.

If you replace FRUs and the problem is corrected, go to “MAP 0410: Repair Checkout” in the *RS/6000 and @server pSeries Diagnostic Information for Multiple Bus Systems*.

Error Code	Description	Action/ Possible Failing FRU
1011 00AC	Last power-down was the result of loss of AC.	Informational message
1011 00CA	Thermal calibration in progress	Has this code been displayed longer than 15 minutes? YES Reboot the system. The code will be cleared when the system successfully reboots. NO Wait until this code has been displayed for 15 minutes to allow thermal calibration to complete. The system will not IPL while thermal calibration is in progress.
1011 3100	I2C Controller	Primary I/O book Location: U1.18-P1-H2
1011 3101	1. I2C bus 1 fault 2. Operator panel 3. Operator panel cable	1. Primary I/O book Location: U1.18-P1-H2 2. Operator panel Location: U1.17-L1 3. Operator panel cable Location: U1.17-L1/Q1#
1011 3102	I2C bus 2 fault	Primary I/O book Location: U1.18-P1-H2
1011 3104	I2C bus 4 fault	Primary I/O book Location: U1.18-P1-H2
1011 3106	I2C bus 6 fault	Primary I/O book Location: U1.18-P1-H2
1011 3113	RIO Bus Adapter	Primary I/O book Location: U1.18-P1-H2

Error Code	Description	Action/ Possible Failing FRU
1011 3114	PCI Backplane	<p>Was the primary I/O book at location U1.18-P1-H2 changed prior to the most recent reboot of the system?</p> <p>YES This error code may be due to down-level system power control network firmware on the new primary I/O book. The system will automatically update the system power control network firmware to the correct level. This error code should be cleared after the next reboot.</p> <p>NO Replace the primary I/O book, Location: U1.18-P1-H2</p>
1011 3115	Operator Panel	<ol style="list-style-type: none"> 1. Operator panel, location: U1.17-L1 2. Primary I/O book, Location: U1.18-P1-H2
1011 3118	SPCN	Primary I/O book Location: U1.18-P1-H2
1011 34A2	SPCN	Primary I/O book Location: U1.18-P1-H2
1011 8400	VPD Configuration	Primary I/O book Location: U1.18-P1-H2
1011 8401	VPD access problem	<ol style="list-style-type: none"> 1. System VPD module Location: U1.17-L1-N1 2. Primary I/O book Location: U1.18-P1-H2
1011 8402	VPD access problem	Primary I/O book Location: U1.18-P1-H2
1011 8403	VPD level mismatch	<ol style="list-style-type: none"> 1. System VPD module Location: U1.17-L1-N1 2. Primary I/O book Location: U1.18-P1-H2
1011 8404	MCM 2 VPD mismatch	<ol style="list-style-type: none"> 1. MCM 2 and VPD card, Locations: U1.18-P1-C4 and U1.18-P1-H2.4 2. Primary I/O book Location: U1.18-P1-H2

Error Code	Description	Action/ Possible Failing FRU
1011 8405	MCM 1 VPD mismatch	<ol style="list-style-type: none"> 1. MCM 1 and VPD card, Locations: U1.18-P1-C3 and U1.18-P1-H2.5 2. Primary I/O book Location: U1.18-P1-H2
1011 8406	MCM 3 VPD mismatch	<ol style="list-style-type: none"> 1. MCM 3 and VPD card, Locations: U1.18-P1-C2 and U1.18-P1-H2.6 2. Primary I/O book Location: U1.18-P1-H2
1011 8408	MCM 0 VPD mismatch	<ol style="list-style-type: none"> 1. MCM 0 and VPD card, locations: U1.18-P1-C1 and U1.18-P1-H2.3 2. Primary I/O book, location: U1.18-P1-H2
1011 8409	No valid processor VPD cards found on primary I/O book	<ol style="list-style-type: none"> 1. Verify that the processor VPD cards are properly installed and in the correct slots on the primary I/O book for the MCMs that are installed. 2. Go to "MAP 1543: MCM Module Problem Isolation" on page 332.
1011 840A	VPD +5 stuck high	Primary I/O book Location: U1.18-P1-H2
1011 840B	VPD 5 V power-on failure	Primary I/O book Location: U1.18-P1-H2
1011 840D	SPCN Configuration mismatch	<ol style="list-style-type: none"> 1. Set I/O type to correct value. See "Change I/O Type" on page 726. 2. Primary I/O book Location: U1.18-P1-H2
1011 840E	SPCN default configuration loaded	<ol style="list-style-type: none"> 1. Set I/O type to correct value. See "Change I/O Type" on page 726. 2. Primary I/O book Location: U1.18-P1-H2
1011 840F	SPCN Configuration mismatch	<ol style="list-style-type: none"> 1. Set I/O type to correct value. See "Change I/O Type" on page 726. 2. Primary I/O book Location: U1.18-P1-H2
1011 8413	Invalid MCM 0 VPD card or MCM	<ol style="list-style-type: none"> 1. Location: U1.18-P1-H2.3 and U1.18-P1-C1 See note on page 496. 2. Primary I/O book Location: U1.18-P1-H2

Error Code	Description	Action/ Possible Failing FRU
1011 8414	Invalid MCM 2 VPD card or MCM	<ol style="list-style-type: none"> 1. Location: U1.18-P1-H2.4 and U1.18-P1-C4 See note on page 496. 2. Primary I/O book Location: U1.18-P1-H2
1011 8415	Invalid MCM 1 VPD card or MCM	<ol style="list-style-type: none"> 1. Location: U1.18-P1-H2.5 and U1.18-P1-C3 See note on page 496. 2. Primary I/O book Location: U1.18-P1-H2
1011 8416	Invalid MCM 3 VPD card or MCM	<ol style="list-style-type: none"> 1. Location: U1.18-P1-H2.6 and U1.18-P1-C2 See note on page 496. 2. Primary I/O book Location: U1.18-P1-H2
1011 8423	No MCM 0 VPD card or MCM	<ol style="list-style-type: none"> 1. Location: U1.18-P1-H2.3 and U1.18-P1-C1 See note on page 496. 2. Primary I/O book Location: U1.18-P1-H2
1011 8424	No MCM 2 VPD card or MCM	<ol style="list-style-type: none"> 1. Location: U1.18-P1-H2.4 and U1.18-P1-C4 See note on page 496. 2. Primary I/O book Location: U1.18-P1-H2
1011 8425	No MCM 1 VPD card or MCM	<ol style="list-style-type: none"> 1. Location: U1.18-P1-H2.5 and U1.18-P1-C3 See note on page 496. 2. Primary I/O book Location: U1.18-P1-H2
1011 8426	No MCM 3 VPD card or MCM	<ol style="list-style-type: none"> 1. Location: U1.18-P1-H2.6 and U1.18-P1-C2 See note on page 496. 2. Primary I/O book Location: U1.18-P1-H2
1011 8430	SPCN configuration mismatch	<ol style="list-style-type: none"> 1. Set I/O type to correct value. See "Change I/O Type" on page 726. 2. Primary I/O book Location: U1.18-P1-H2
1011 8431	SPCN configuration mismatch	<ol style="list-style-type: none"> 1. Set I/O type to correct value. See "Change I/O Type" on page 726. 2. Primary I/O book Location: U1.18-P1-H2

Error Code	Description	Action/ Possible Failing FRU
1011 8440	SPCN configuration mismatch	<ol style="list-style-type: none"> 1. Set I/O type to correct value. See “Change I/O Type” on page 726. 2. Primary I/O book Location: U1.18-P1-H2
1011 8441	SPCN configuration mismatch	<ol style="list-style-type: none"> 1. Set I/O type to correct value. See “Change I/O Type” on page 726. 2. Primary I/O book Location: U1.18-P1-H2
1011 8468	Capacitor card fault	<ol style="list-style-type: none"> 1. If fewer than 3 DCAs are installed: <ol style="list-style-type: none"> a. If no capacitor card is installed in U1.18-P1-V3 or U1.18-P1-V7, install a card in U1.18-P1-V3. b. If a capacitor card is present in either U1.18-P1-V3 or U1.18-P1-V7, reseal it. If the problem is not fixed, replace it. 2. If 3 or more DCAs are installed: <ol style="list-style-type: none"> a. If no capacitor card is installed in U1.18-P1-V3, one is required. b. If a capacitor card is installed in U1.18-P1-V3, reseal it. If the problem is not fixed, replace it. 3. If the same error code reoccurs, replace the primary I/O book, location: U1.18-P1-H2.
1011 8469	Capacitor card fault	<ol style="list-style-type: none"> 1. If no capacitor card is installed in U1.18-P1-V7, install one. It is required. 2. If a capacitor card is present in U1.18-P1-V7, reseal it. If the problem is not fixed, replace it. 3. If the same error code reoccurs, replace the primary I/O book, location: U1.18-P1-H2.
1011 8700	BPA A ac loss	Go to “MAP 1520: Power” on page 185.
1011 8701	BPA B ac loss	Go to “MAP 1520: Power” on page 185.

(3)
(3)
(3)
(3)

Error Code	Description	Action/ Possible Failing FRU
1011 8710	BPC A communication failure	<ol style="list-style-type: none">1. BPC A cable to primary I/O book Location: U1.18-P1-H2/Q8#2. BPC A controller Location: U1.35-P1-X43. Primary I/O book Location: U1.18-P1-H2
1011 8711	BPC B communication failure	<ol style="list-style-type: none">1. BPC B cable to primary I/O book Location: U1.18-P1-H2/Q9#2. BPC B controller Location: U1.35-P2-X43. Primary I/O book Location: U1.18-P1-H2
1011 8722	BPC A and B are not at standby.	<ol style="list-style-type: none">1. BPC A controller Location: U1.35-P1-X42. BPC B controller Location: U1.35-P2-X43. Primary I/O book Location: U1.18-P1-H24. The system has lost AC phase(s) to the UEPO, go to "Map 152a: Loss of ac Power or Phase Missing" on page 204
1011 8731	BPC failure	<ol style="list-style-type: none">1. Insure that the red switch on the front of the EPO panel is in the ON position. If there is no external EPO cable, also insure that the internal toggle switch to the ROOM EPO BYPASS on the bottom of the EPO panel is set to the left before proceeding.2. BPC A controller Location: U1.35-P1-X4 and BPC-B controller, Location: U1.35-P2-X43. Primary I/O book Location: U1.18-P1-H2
1011 8750	BPC download failure on BPA A	<ol style="list-style-type: none">1. BPC A controller, Location: U1.35-P1-X42. Primary I/O book, Location: U1.18-P1-H2
1011 8751	BPC download failure on BPA B	<ol style="list-style-type: none">1. BPC-B controller, Location: U1.35-P2-X42. Primary I/O book, Location: U1.18-P1-H2

Error Code	Description	Action/ Possible Failing FRU
1011 8800	BPC A cable missing	<ol style="list-style-type: none"> 1. BPC A cable to primary I/O book Location: U1.18-P1-H2/Q8# 2. BPC A controller Location: U1.35-P1-X4 3. Primary I/O book Location: U1.18-P1-H2
1011 8801	BPC B cable missing	<ol style="list-style-type: none"> 1. BPC B cable to primary I/O book Location: U1.18-P1-H2/Q9# 2. BPC B controller Location: U1.35-P2-X4 3. Primary I/O book Location: U1.18-P1-H2
1011 xxxx	SPCN configuration error	<ol style="list-style-type: none"> 1. Set I/O type to correct value. See "Change I/O Type" on page 726. 2. Primary I/O book Location: U1.18-P1-H2
1014 1B17	Problem with fan 1 in first I/O subsystem in primary rack	<ol style="list-style-type: none"> 1. DCA-1 Location: U1.9-V1 2. Fan 1 Location:U1.9-F1
1014 1B27	Problem with fan 2 in first I/O subsystem in primary rack	<ol style="list-style-type: none"> 1. DCA-2 Location: U1.9-V2 2. Fan 2 Location:U1.9-F2
1014 1C06	Loss of airflow in first I/O subsystem location: U1.9	Go to "Map 1527: An Airflow Loss Has Been Detected" on page 200.
1014 6014	Overcurrent or overvoltage problem with 3.3V in first I/O subsystem	Go to "MAP 1520: Power" on page 185.
1014 6024	Overcurrent or overvoltage problem with 5.0V in first I/O subsystem	Go to "MAP 1520: Power" on page 185.
1014 6034	Overcurrent or overvoltage problem with 2.5V in first I/O subsystem	Go to "MAP 1520: Power" on page 185.
1014 6044	Overcurrent or overvoltage problem with 12.0V in first I/O subsystem	Go to "MAP 1520: Power" on page 185.
1014 6054	Overcurrent or overvoltage problem with -12.0V in first I/O subsystem	Go to "MAP 1520: Power" on page 185.
1014 6814	Overcurrent or overvoltage problem with 3.3V in first I/O subsystem	Go to "MAP 1520: Power" on page 185.
1014 6824	Overcurrent or overvoltage problem with 5.0V in first I/O subsystem	Go to "MAP 1520: Power" on page 185.
1014 6834	Overcurrent or overvoltage problem with 2.5V in first I/O subsystem	Go to "MAP 1520: Power" on page 185.

Error Code	Description	Action/ Possible Failing FRU
1014 6844	Overcurrent or overvoltage problem with 12.0V in first I/O subsystem	Go to "MAP 1520: Power" on page 185.
1014 6854	Overcurrent or overvoltage problem with -12.0V in first I/O subsystem	Go to "MAP 1520: Power" on page 185.
1014 7017	Problem with fan 3 in first I/O subsystem in primary rack	1. DCA-1 Location: U1.9-V1 2. Fan 3 Location:U1.9-F3
1014 7027	Problem with fan 4 in first I/O subsystem in primary rack	1. DCA-2 Location: U1.9-V2 2. Fan 4 Location:U1.9-F4
1014 7117	Problem with fan 1 and fan 3 in first I/O subsystem in primary rack	1. DCA-1 Location: U1.9-V1 2. Fans 1 and 3 Location:U1.9-F1 and U1.9-F3
1014 7127	Problem with fan 2 and fan 4 in first I/O subsystem in primary rack	1. DCA-2 Location: U1.9-V2 2. Fans 2 and 4 Location:U1.9-F2 and U1.9-F4
1014 B014	Overcurrent or overvoltage problem with 3.3V in first I/O subsystem	Go to "MAP 1520: Power" on page 185.
1014 B024	Overcurrent or overvoltage problem with 5.0V in first I/O subsystem	Go to "MAP 1520: Power" on page 185.
1014 B034	Overcurrent or overvoltage problem with 2.5V in first I/O subsystem	Go to "MAP 1520: Power" on page 185.
1014 B044	Overcurrent or overvoltage problem with 12.0V in first I/O subsystem	Go to "MAP 1520: Power" on page 185.
1014 B054	Overcurrent or overvoltage problem with -12.0V in first I/O subsystem	Go to "MAP 1520: Power" on page 185.
1014 B814	Overcurrent or overvoltage problem with 3.3V in first I/O subsystem	Go to "MAP 1520: Power" on page 185.
1014 B824	Overcurrent or overvoltage problem with 5.0V in first I/O subsystem	Go to "MAP 1520: Power" on page 185.
1014 B834	Overcurrent or overvoltage problem with 2.5V in first I/O subsystem	Go to "MAP 1520: Power" on page 185.
1014 B844	Overcurrent or overvoltage problem with 12.0V in first I/O subsystem	Go to "MAP 1520: Power" on page 185.
1014 B854	Overcurrent or overvoltage problem with -12.0V in first I/O subsystem	Go to "MAP 1520: Power" on page 185.
1014 CD96	A power short has been detected in the DASD subsystem in an I/O drawer.	Go to "MAP 1520: Power" on page 185.

Error Code	Description	Action/ Possible Failing FRU
1014 CDA6	A power short has been detected in the DASD subsystem in an I/O drawer.	Go to "MAP 1520: Power" on page 185.
1014 CDB6	A power short has been detected in the DASD subsystem in an I/O drawer.	Go to "MAP 1520: Power" on page 185.
1014 CDC6	A power short has been detected in the DASD subsystem in an I/O drawer.	Go to "MAP 1520: Power" on page 185.
1014 F4x6	Hardware configuration does not support N-mode power.	Call Service Support
1014 F516	An N+1 boundary (DCA or fan) has dropped to N-mode status in the first I/O subsystem, location: U1.9.	This is normally an informational message. It should be accompanied by other error codes that more precisely indicate where the failure is. Examine the service processor error log. If there are no other power-related error codes (in the time frame in which this code was generated) in the service processor error log, the FRU indicated with this error code, if any, should be replaced.
1014 F526	An N+1 boundary (DCA or fan) has dropped to N-mode status in the first I/O subsystem, location: U1.9.	This is normally an informational message. It should be accompanied by other error codes that more precisely indicate where the failure is. Examine the service processor error log. If there are no other power-related error codes (in the time frame in which this code was generated) in the service processor error log, the FRU indicated with this error code, if any, should be replaced.
1014 xx11	First I/O subsystem in primary rack, DCA-1	U1.9-V1
1014 xx13	Seeprom fault on DCA-1 in first I/O subsystem in primary rack	U1.9-V1
1014 xx15	First I/O subsystem in primary rack, DCA-1, cable fault	Go to "MAP 1520: Power" on page 185 with these location codes: U1.9-V1-Q1# U1.9-V1-Q2#
1014 xx21	First I/O subsystem in primary rack, DCA-2	U1.9-V2
1014 xx23	Seeprom fault on DCA-2 in first I/O subsystem in primary rack	U1.9-V2
1014 xx25	First I/O subsystem in primary rack, DCA-2, cable fault	Go to "MAP 1520: Power" on page 185 with these location codes: U1.9-V2-Q1# U1.9-V2-Q2#

Error Code	Description	Action/ Possible Failing FRU
1014 xx31	First I/O subsystem in primary rack, I/O subsystem backplane 1 fault	U1.9-P1
1014 xx33	Seeprom fault on I/O subsystem backplane 1 in first I/O subsystem in primary rack	U1.9-P1
1014 xx41	First I/O subsystem in primary rack, I/O subsystem backplane 2 fault	U1.9-P2
1014 xx43	Seeprom fault on I/O subsystem backplane 2 in first I/O subsystem in primary rack	U1.9-P2
1014 xx51	First I/O subsystem in primary rack, DASD backplane 1 fault	U1.9-P3
1014 xx53	Seeprom fault on DASD backplane 1 in first I/O subsystem in primary rack	U1.9-P3
1014 xx61	First I/O subsystem in primary rack, DASD backplane 2 fault	U1.9-P4
1014 xx63	Seeprom fault on DASD backplane 2 in first I/O subsystem in primary rack	U1.9-P4
1014 xx71	First I/O subsystem in primary rack, DASD backplane 3 fault	U1.9-P5
1014 xx73	Seeprom fault on DASD backplane 3 in first I/O subsystem in primary rack	U1.9-P5
1014 xx81	First I/O subsystem in primary rack, DASD backplane 4 fault	U1.9-P6
1014 xx83	Seeprom fault on DASD backplane 4 in first I/O subsystem in primary rack	U1.9-P6
1015 1B17	Problem with fan 1 in second I/O subsystem in primary rack.	1. DCA-1 Location: U1.5-V1 2. Fan 1 Location:U1.5-F1
1015 1B27	Problem with fan 2 in second I/O subsystem in primary rack.	1. DCA-1 Location: U1.5-V2 2. Fan 1 Location:U1.5-F2
1015 1C06	Loss of airflow in second I/O subsystem, location: U1.5	Go to "Map 1527: An Airflow Loss Has Been Detected" on page 200.
1015 6014	Overcurrent or overvoltage problem with 3.3V in second I/O subsystem	Go to "MAP 1520: Power" on page 185.
1015 6024	Overcurrent or overvoltage problem with 5.0V in second I/O subsystem	Go to "MAP 1520: Power" on page 185.
1015 6034	Overcurrent or overvoltage problem with 2.5V in second I/O subsystem	Go to "MAP 1520: Power" on page 185.

Error Code	Description	Action/ Possible Failing FRU
1015 6044	Overcurrent or overvoltage problem with 12.0V in second I/O subsystem	Go to "MAP 1520: Power" on page 185.
1015 6054	Overcurrent or overvoltage problem with -12.0V in second I/O subsystem	Go to "MAP 1520: Power" on page 185.
1015 6814	Overcurrent or overvoltage problem with 3.3V in second I/O subsystem	Go to "MAP 1520: Power" on page 185.
1015 6824	Overcurrent or overvoltage problem with 5.0V in second I/O subsystem	Go to "MAP 1520: Power" on page 185.
1015 6834	Overcurrent or overvoltage problem with 2.5V in second I/O subsystem	Go to "MAP 1520: Power" on page 185.
1015 6844	Overcurrent or overvoltage problem with 12.0V in second I/O subsystem	Go to "MAP 1520: Power" on page 185.
1015 6854	Overcurrent or overvoltage problem with -12.0V in second I/O subsystem	Go to "MAP 1520: Power" on page 185.
1015 7017	Problem with fan 3 in second I/O subsystem in primary rack	1. DCA-1 Location: U1.5-V1 2. Fan 3 Location: U1.5-F3
1015 7027	Problem with fan 4 in second I/O subsystem in primary rack	1. DCA-2 Location: U1.5-V2 2. Fan 4 Location: U1.5-F4
1015 7117	Problem with fan 1 and fan 3 in second I/O subsystem in primary rack	1. DCA-1 Location: U1.5-V1 2. Fans 1 and 3 Location: U1.5-F1 and U1.5-F3
1015 7127	Problem with fan 2 and fan 4 in second I/O subsystem in primary rack	1. DCA-2 Location: U1.5-V2 2. Fans 2 and 4 Location: U1.5-F2 and U1.5-F4
1015 B014	Overcurrent or overvoltage problem with 3.3V in second I/O subsystem	Go to "MAP 1520: Power" on page 185.
1015 B024	Overcurrent or overvoltage problem with 5.0V in second I/O subsystem	Go to "MAP 1520: Power" on page 185.
1015 B034	Overcurrent or overvoltage problem with 2.5V in second I/O subsystem	Go to "MAP 1520: Power" on page 185.
1015 B044	Overcurrent or overvoltage problem with 12.0V in second I/O subsystem	Go to "MAP 1520: Power" on page 185.
1015 B054	Overcurrent or overvoltage problem with -12.0V in second I/O subsystem	Go to "MAP 1520: Power" on page 185.
1015 B814	Overcurrent or overvoltage problem with 3.3V in second I/O subsystem	Go to "MAP 1520: Power" on page 185.

Error Code	Description	Action/ Possible Failing FRU
1015 B824	Overcurrent or overvoltage problem with 5.0V in second I/O subsystem	Go to "MAP 1520: Power" on page 185.
1015 B834	Overcurrent or overvoltage problem with 2.5V in second I/O subsystem	Go to "MAP 1520: Power" on page 185.
1015 B844	Overcurrent or overvoltage problem with 12.0V in second I/O subsystem	Go to "MAP 1520: Power" on page 185.
1015 B854	Overcurrent or overvoltage problem with -12.0V in second I/O subsystem	Go to "MAP 1520: Power" on page 185.
1015 CD96	A power short has been detected in the DASD subsystem in an I/O drawer.	Go to "MAP 1520: Power" on page 185.
1015 CDA6	A power short has been detected in the DASD subsystem in an I/O drawer.	Go to "MAP 1520: Power" on page 185.
1015 CDB6	A power short has been detected in the DASD subsystem in an I/O drawer.	Go to "MAP 1520: Power" on page 185.
1015 CDC6	A power short has been detected in the DASD subsystem in an I/O drawer.	Go to "MAP 1520: Power" on page 185.
1015 F4x6	Hardware configuration does not support N-mode power.	Call Service Support
1015 F516	An N+1 boundary (DCA or fan) has dropped to N-mode status in the second I/O subsystem, location: U1.5.	This is normally an informational message. It should be accompanied by other error codes that more precisely indicate where the failure is. Examine the service processor error log. If there are no other power-related error codes (in the time frame in which this code was generated) in the service processor error log, the FRU indicated with this error code, if any, should be replaced.
1015 F526	An N+1 boundary (DCA or fan) has dropped to N-mode status in the second I/O subsystem, location: U1.5.	This is normally an informational message. It should be accompanied by other error codes that more precisely indicate where the failure is. Examine the service processor error log. If there are no other power-related error codes (in the time frame in which this code was generated) in the service processor error log, the FRU indicated with this error code, if any, should be replaced.
1015 xx11	Second I/O subsystem in primary rack, DCA-1	U1.5-V1
1015 xx13	Seeprom fault on DCA-1 in second I/O subsystem in primary rack	U1.5-V1

Error Code	Description	Action/ Possible Failing FRU
1015 xx15	Second I/O subsystem in primary rack, DCA-1, cable fault	Go to "MAP 1520: Power" on page 185 with these location codes: U1.5-V1-Q1# U1.5-V1-Q2#
1015 xx21	Second I/O subsystem in primary rack, DCA-2	U1.5-V2
1015 xx23	Seeprom fault on DCA-2 in second I/O subsystem in primary rack	U1.5-V2
1015 xx25	Second I/O subsystem in primary rack, DCA-2, cable fault	Go to "MAP 1520: Power" on page 185 with these location codes: U1.5-V2-Q1# U1.5-V2-Q2#
1015 xx31	Second I/O subsystem in primary rack, I/O subsystem backplane 1 fault	U1.5-P1
1015 xx33	Seeprom fault on I/O subsystem backplane 1 in second I/O subsystem in primary rack	U1.5-P1
1015 xx41	Second I/O subsystem in primary rack, I/O subsystem backplane 2 fault	U1.5-P2
1015 xx43	Seeprom fault on I/O subsystem backplane 2 in second I/O subsystem in primary rack	U1.5-P2
1015 xx51	Second I/O subsystem in primary rack, DASD backplane 1 fault	U1.5-P3
1015 xx53	Seeprom fault on DASD backplane 1 in second I/O subsystem in primary rack	U1.5-P3
1015 xx61	Second I/O subsystem in primary rack, DASD backplane 2 fault	U1.5-P4
1015 xx63	Seeprom fault on DASD backplane 2 in second I/O subsystem in primary rack	U1.5-P4
1015 xx71	Second I/O subsystem in primary rack, DASD backplane 3 fault	U1.5-P5
1015 xx73	Seeprom fault on DASD backplane 3 in second I/O subsystem in primary rack	U1.5-P5
1015 xx81	Second I/O subsystem in primary rack, DASD backplane 4 fault	U1.5-P6
1015 xx83	Seeprom fault on DASD backplane 4 in second I/O subsystem in primary rack	U1.5-P6
1016 1B17	Problem with fan 1 in third I/O subsystem in primary rack	1. DCA-1 Location: U1.1-V1 2. Fan 1 Location:U1.1-F1

Error Code	Description	Action/ Possible Failing FRU
1016 1B27	Problem with fan 2 in third I/O subsystem in primary rack	<ol style="list-style-type: none"> DCA-2 Location: U1.1-V2 Fan 2 Location:U1.1-F2
1016 1C06	Loss of airflow in third I/O subsystem, location: U1.1	Go to "Map 1527: An Airflow Loss Has Been Detected" on page 200.
1016 6014	Overcurrent or overvoltage problem with 3.3V in third I/O subsystem	Go to "MAP 1520: Power" on page 185.
1016 6024	Overcurrent or overvoltage problem with 5.0V in third I/O subsystem	Go to "MAP 1520: Power" on page 185.
1016 6034	Overcurrent or overvoltage problem with 2.5V in third I/O subsystem	Go to "MAP 1520: Power" on page 185.
1016 6044	Overcurrent or overvoltage problem with 12.0V in third I/O subsystem	Go to "MAP 1520: Power" on page 185.
1016 6054	Overcurrent or overvoltage problem with -12.0V in third I/O subsystem	Go to "MAP 1520: Power" on page 185.
1016 6814	Overcurrent or overvoltage problem with 3.3V in third I/O subsystem	Go to "MAP 1520: Power" on page 185.
1016 6824	Overcurrent or overvoltage problem with 5.0V in third I/O subsystem	Go to "MAP 1520: Power" on page 185.
1016 6834	Overcurrent or overvoltage problem with 2.5V in third I/O subsystem	Go to "MAP 1520: Power" on page 185.
1016 6844	Overcurrent or overvoltage problem with 12.0V in third I/O subsystem	Go to "MAP 1520: Power" on page 185.
1016 6854	Overcurrent or overvoltage problem with -12.0V in third I/O subsystem	Go to "MAP 1520: Power" on page 185.
1016 7017	Problem with fan 3 in third I/O subsystem in primary rack	<ol style="list-style-type: none"> DCA-1 Location: U1.1-V1 Fan 3 Location: U1.1-F3
1016 7027	Problem with fan 4 in third I/O subsystem in primary rack	<ol style="list-style-type: none"> DCA-2 Location: U1.1-V2 Fan 4 Location: U1.1-F4
1016 7117	Problem with fan 1 and fan 3 in third I/O subsystem in primary rack	<ol style="list-style-type: none"> DCA-1 Location: U1.1-V1 Fans 1 and 3 Location: U1.1-F1 and U1.1-F3
1016 7127	Problem with fan 2 and fan 4 in third I/O subsystem in primary rack	<ol style="list-style-type: none"> DCA-2 Location: U1.1-V2 Fans 2 and 4 Location: U1.1-F2 and U1.1-F4

Error Code	Description	Action/ Possible Failing FRU
1016 B014	Overcurrent or overvoltage problem with 3.3V in third I/O subsystem	Go to "MAP 1520: Power" on page 185.
1016 B024	Overcurrent or overvoltage problem with 5.0V in third I/O subsystem	Go to "MAP 1520: Power" on page 185.
1016 B034	Overcurrent or overvoltage problem with 2.5V in third I/O subsystem	Go to "MAP 1520: Power" on page 185.
1016 B044	Overcurrent or overvoltage problem with 12.0V in third I/O subsystem	Go to "MAP 1520: Power" on page 185.
1016 B054	Overcurrent or overvoltage problem with -12.0V in third I/O subsystem	Go to "MAP 1520: Power" on page 185.
1016 B814	Overcurrent or overvoltage problem with 3.3V in third I/O subsystem	Go to "MAP 1520: Power" on page 185.
1016 B824	Overcurrent or overvoltage problem with 5.0V in third I/O subsystem	Go to "MAP 1520: Power" on page 185.
1016 B834	Overcurrent or overvoltage problem with 2.5V in third I/O subsystem	Go to "MAP 1520: Power" on page 185.
1016 B844	Overcurrent or overvoltage problem with 12.0V in third I/O subsystem	Go to "MAP 1520: Power" on page 185.
1016 B854	Overcurrent or overvoltage problem with -12.0V in third I/O subsystem	Go to "MAP 1520: Power" on page 185.
1016 CD96	A power short has been detected in the DASD subsystem in an I/O drawer.	Go to "MAP 1520: Power" on page 185.
1016 CDA6	A power short has been detected in the DASD subsystem in an I/O drawer.	Go to "MAP 1520: Power" on page 185.
1016 CDB6	A power short has been detected in the DASD subsystem in an I/O drawer.	Go to "MAP 1520: Power" on page 185.
1016 CDC6	A power short has been detected in the DASD subsystem in an I/O drawer.	Go to "MAP 1520: Power" on page 185.
1016 F4x6	Hardware configuration does not support N-mode power.	Call Service Support
1016 F516	An N+1 boundary (DCA or fan) has dropped to N-mode status in the third I/O subsystem, location: U1.1.	This is normally an informational message. It should be accompanied by other error codes that more precisely indicate where the failure is. Examine the service processor error log. If there are no other power-related error codes (in the time frame in which this code was generated) in the service processor error log, the FRU indicated with this error code, if any, should be replaced.

Error Code	Description	Action/ Possible Failing FRU
1016 F526	An N+1 boundary (DCA or fan) has dropped to N-mode status in the third I/O subsystem, location: U1.1.	This is normally an informational message. It should be accompanied by other error codes that more precisely indicate where the failure is. Examine the service processor error log. If there are no other power-related error codes (in the time frame in which this code was generated) in the service processor error log, the FRU indicated with this error code, if any, should be replaced.
1016 xx11	third I/O subsystem in primary rack, DCA-1	U1.1-V1
1016 xx13	Seeprom fault on DCA-1 in third I/O subsystem in primary rack	U1.1-V1
1016 xx15	Third I/O subsystem in primary rack, DCA-1, cable fault	Go to "MAP 1520: Power" on page 185 with these location codes: U1.1-V1-Q1# U1.1-V1-Q2#
1016 xx21	Third I/O subsystem in primary rack, DCA-2	U1.1-V2
1016 xx23	Seeprom fault on DCA-2 in third I/O subsystem in primary rack	U1.1-V2
1016 xx25	Third I/O subsystem in primary rack, DCA-2, cable fault	Go to "MAP 1520: Power" on page 185 with these location codes: U1.1-V2-Q1# U1.1-V2-Q2#
1016 xx31	Third I/O subsystem in primary rack, I/O subsystem backplane 1 fault	U1.5-P1
1016 xx33	Seeprom fault on I/O subsystem backplane 1 in third I/O subsystem in primary rack	U1.1-P1
1016 xx41	Third I/O subsystem in primary rack, I/O subsystem backplane 2 fault	U1.5-P2
1016 xx43	Seeprom fault on I/O subsystem backplane 2 in third I/O subsystem in primary rack	U1.1-P2
1016 xx51	Third I/O subsystem in primary rack, DASD backplane 1 fault	U1.5-P3
1016 xx53	Seeprom fault on DASD backplane 1 in third I/O subsystem in primary rack	U1.1-P3
1016 xx61	Third I/O subsystem in primary rack, DASD backplane 2 fault	U1.5-P4
1016 xx63	Seeprom fault on DASD backplane 2 in third I/O subsystem in primary rack	U1.1-P4
1016 xx71	Third I/O subsystem in primary rack, DASD backplane 3 fault	U1.5-P5

Error Code	Description	Action/ Possible Failing FRU
1016 xx73	Seeprom fault on DASD backplane 3 in third I/O subsystem in primary rack	U1.1-P5
1016 xx81	Third I/O subsystem in primary rack, DASD backplane 4 fault	U1.5-P6
1016 xx83	Seeprom fault on DASD backplane 4 in third I/O subsystem in primary rack	U1.1-P6
1017 1B17	Problem with fan 1 in fourth I/O subsystem (no IBF installed) in primary rack	1. DCA-1 Location: U1.13-V1 2. Fan 1 Location:U1.13-F1
1017 1B27	Problem with fan 2 in fourth I/O subsystem (no IBF installed) in primary rack	1. DCA-2 Location: U1.13-V2 2. Fan 2 Location:U1.13-F2
1017 1C06	Loss of airflow in fourth I/O subsystem, no IBF location: U1.13	Go to "Map 1527: An Airflow Loss Has Been Detected" on page 200.
1017 6014	Overcurrent or overvoltage problem with 3.3V in fourth I/O subsystem, no IBF	Go to "MAP 1520: Power" on page 185.
1017 6024	Overcurrent or overvoltage problem with 5.0V in fourth I/O subsystem, no IBF	Go to "MAP 1520: Power" on page 185.
1017 6034	Overcurrent or overvoltage problem with 2.5V in fourth I/O subsystem, no IBF	Go to "MAP 1520: Power" on page 185.
1017 6044	Overcurrent or overvoltage problem with 12.0V in fourth I/O subsystem, no IBF	Go to "MAP 1520: Power" on page 185.
1017 6054	Overcurrent or overvoltage problem with -12.0V in fourth I/O subsystem, no IBF	Go to "MAP 1520: Power" on page 185.
1017 6814	Overcurrent or overvoltage problem with 3.3V in fourth I/O subsystem, no IBF	Go to "MAP 1520: Power" on page 185.
1017 6824	Overcurrent or overvoltage problem with 5.0V in fourth I/O subsystem, no IBF	Go to "MAP 1520: Power" on page 185.
1017 6834	Overcurrent or overvoltage problem with 2.5V in fourth I/O subsystem, no IBF	Go to "MAP 1520: Power" on page 185.
1017 6844	Overcurrent or overvoltage problem with 12.0V in fourth I/O subsystem, no IBF	Go to "MAP 1520: Power" on page 185.

Error Code	Description	Action/ Possible Failing FRU
1017 6854	Overcurrent or overvoltage problem with -12.0V in fourth I/O subsystem, no IBF	Go to "MAP 1520: Power" on page 185.
1017 7017	Problem with fan 3 in fourth I/O subsystem (no IBF installed) in primary rack	<ol style="list-style-type: none"> 1. DCA-1 Location: U1.13-V1 2. Fan 3 Location: U1.13-F3
1017 7027	Problem with fan 4 in fourth I/O subsystem (no IBF installed) in primary rack	<ol style="list-style-type: none"> 1. DCA-2 Location: U1.13-V2 2. Fan 4 Location: U1.13-F4
1017 7117	Problem with fan 1 and fan 3 in fourth I/O subsystem (no IBF installed) in primary rack	<ol style="list-style-type: none"> 1. DCA-1 Location: U1.13-V1 2. Fans 1 and 3 Location: U1.13-F1 and U1.13-F3
1017 7127	Problem with fan 2 and fan 4 in fourth I/O subsystem (no IBF installed) in primary rack	<ol style="list-style-type: none"> 1. DCA-2 Location: U1.13-V2 2. Fans 2 and 4 Location: U1.13-F2 and U1.13-F4
1017 B014	Overcurrent or overvoltage problem with 3.3V in fourth I/O subsystem, no IBF	Go to "MAP 1520: Power" on page 185.
1017 B024	Overcurrent or overvoltage problem with 5.0V in fourth I/O subsystem, no IBF	Go to "MAP 1520: Power" on page 185.
1017 B034	Overcurrent or overvoltage problem with 2.5V in fourth I/O subsystem, no IBF	Go to "MAP 1520: Power" on page 185.
1017 B044	Overcurrent or overvoltage problem with 12.0V in fourth I/O subsystem, no IBF	Go to "MAP 1520: Power" on page 185.
1017 B054	Overcurrent or overvoltage problem with -12.0V in fourth I/O subsystem, no IBF	Go to "MAP 1520: Power" on page 185.
1017 B814	Overcurrent or overvoltage problem with 3.3V in fourth I/O subsystem, no IBF	Go to "MAP 1520: Power" on page 185.
1017 B824	Overcurrent or overvoltage problem with 5.0V in fourth I/O subsystem, no IBF	Go to "MAP 1520: Power" on page 185.
1017 B834	Overcurrent or overvoltage problem with 2.5V in fourth I/O subsystem, no IBF	Go to "MAP 1520: Power" on page 185.

Error Code	Description	Action/ Possible Failing FRU
1017 B844	Overcurrent or overvoltage problem with 12.0V in fourth I/O subsystem, no IBF	Go to "MAP 1520: Power" on page 185.
1017 B854	Overcurrent or overvoltage problem with -12.0V in fourth I/O subsystem, no IBF	Go to "MAP 1520: Power" on page 185.
1017 CD96	A power short has been detected in the DASD subsystem in an I/O drawer.	Go to "MAP 1520: Power" on page 185.
1017 CDA6	A power short has been detected in the DASD subsystem in an I/O drawer.	Go to "MAP 1520: Power" on page 185.
1017 CDB6	A power short has been detected in the DASD subsystem in an I/O drawer.	Go to "MAP 1520: Power" on page 185.
1017 CDC6	A power short has been detected in the DASD subsystem in an I/O drawer.	Go to "MAP 1520: Power" on page 185.
1017 F4x6	Hardware configuration does not support N-mode power.	Call Service Support
1017 F516	An N+1 boundary (DCA or fan) has dropped to N-mode status in the fourth I/O subsystem, location: U1.13.	This is normally an informational message. It should be accompanied by other error codes that more precisely indicate where the failure is. Examine the service processor error log. If there are no other power-related error codes (in the time frame in which this code was generated) in the service processor error log, the FRU indicated with this error code, if any, should be replaced.
1017 F526	An N+1 boundary (DCA or fan) has dropped to N-mode status in the fourth I/O subsystem, location: U1.13.	This is normally an informational message. It should be accompanied by other error codes that more precisely indicate where the failure is. Examine the service processor error log. If there are no other power-related error codes (in the time frame in which this code was generated) in the service processor error log, the FRU indicated with this error code, if any, should be replaced.
1017 xx11	Fourth I/O subsystem in primary rack (no IBF), DCA-1	U1.13-V1
1017 xx13	Seeprom fault on DCA-1 in fourth I/O subsystem (no IBF) in primary rack	U1.13-V1
1017 xx15	Fourth I/O subsystem in primary rack (no IBF), DCA-1, cable fault	Go to "MAP 1520: Power" on page 185 with these location codes: U1.13-V1-Q1# U1.13-V1-Q2#
1017 xx21	Fourth I/O subsystem in primary rack (no IBF), DCA-2	U1.13-V2

Error Code	Description	Action/ Possible Failing FRU
1017 xx23	Seeprom fault on DCA-2 in fourth I/O subsystem (no IBF) in primary rack	U1.13-V2
1017 xx25	Fourth I/O subsystem in primary rack (no IBF), DCA-2, cable fault	Go to "MAP 1520: Power" on page 185 with these location codes: U1.13-V2-Q1# U1.13-V2-Q2#
1017 xx31	Fourth I/O subsystem in primary rack, I/O subsystem backplane 1 fault	U1.13-P1
1017 xx33	Seeprom fault on I/O subsystem backplane 1 in fourth I/O subsystem (no IBF) in primary rack	U1.13-P1
1017 xx41	Fourth I/O subsystem in primary rack, I/O subsystem backplane 2 fault	U1.13-P2
1017 xx43	Seeprom fault on I/O subsystem backplane 2 in fourth I/O subsystem (no IBF) in primary rack	U1.13-P2
1017 xx51	Fourth I/O subsystem in primary rack, DASD backplane 1 fault	U1.13-P3
1017 xx53	Seeprom fault on DASD backplane 1 in fourth I/O subsystem (no IBF) in primary rack	U1.13-P3
1017 xx61	Fourth I/O subsystem in primary rack, DASD backplane 2 fault	U1.13-P4
1017 xx63	Seeprom fault on DASD backplane 2 in fourth I/O subsystem (no IBF) in primary rack	U1.13-P4
1017 xx71	Fourth I/O subsystem in primary rack, DASD backplane 3 fault	U1.13-P5
1017 xx73	Seeprom fault on DASD backplane 3 in fourth I/O subsystem (no IBF) in primary rack	U1.13-P5
1017 xx81	Fourth I/O subsystem in primary rack, DASD backplane 4 fault	U1.13-P6
1017 xx83	Seeprom fault on DASD backplane 4 in fourth I/O subsystem (no IBF) in primary rack	U1.13-P6
101A 0856	BPR 1A communications fault	Go to "Map 1523: There Is a Bulk Power Regulator (BPR) Communications Fault" on page 193.
101A 0866	BPR 2A communications fault	Go to "Map 1523: There Is a Bulk Power Regulator (BPR) Communications Fault" on page 193.
101A 0876	BPR 3A communications fault	Go to "Map 1523: There Is a Bulk Power Regulator (BPR) Communications Fault" on page 193.

(3)
(3)
(3)
(3)
(3)
(3)
(3)

Error Code	Description	Action/ Possible Failing FRU
101A 0D06	350 volt bulk failure, BPA-A	Go to “Map 1525: There Is a 350 Volt Bulk Failure” on page 195.
101A 1C06	Cage airflow missing (temperature problem)	Go to “Map 1527: An Airflow Loss Has Been Detected” on page 200.
101A 3F06	Invalid I/O subsystem configurations	<ol style="list-style-type: none"> Verify that the I/O subsystems are properly cabled. Note: This error code causes the service processor to hang. Refer to “Resetting the Service Processor” on page 749 if the service processor is hung. Call service support.
101A 7A86	IBF 1A failure	Go to “Map 1526: There Is An Integrated Battery Feature (IBF) Failure” on page 197.
101A 7A96	IBF 2A failure	Go to “Map 1526: There Is An Integrated Battery Feature (IBF) Failure” on page 197.
101A 7AA6	IBF 3A failure	Go to “Map 1526: There Is An Integrated Battery Feature (IBF) Failure” on page 197.
101A 7B86	IBF 1A failure	Go to “Map 1526: There Is An Integrated Battery Feature (IBF) Failure” on page 197.
101A 7B96	IBF 2A failure	Go to “Map 1526: There Is An Integrated Battery Feature (IBF) Failure” on page 197.
101A 7BA6	IBF 3A failure	Go to “Map 1526: There Is An Integrated Battery Feature (IBF) Failure” on page 197.
101A CE16	BPC-BPC communication failure	<ol style="list-style-type: none"> Check the cable between the two BPCs; reseal and look for bent pins. Replace BPC-A, location: U1.35-P1-X4 Replace BPC-B, location: U1.35-P2-X4.
101A D216	BPA-BPA communication failure	Go to “MAP 1520: Power” on page 185 for isolation.
101A D616	Problem with external UPS: utility failure	<ol style="list-style-type: none"> Verify the cabling between the UPS and the BPCs. Refer to the manufacturer’s documentation for the UPS. Call service support.

Error Code	Description	Action/ Possible Failing FRU
101A D716	Problem with external UPS: battery low	<ol style="list-style-type: none"> 1. Verify the cabling between the UPS and the BPCs. 2. Refer to the manufacturer's documentation for the UPS. 3. Call service support.
101A D756	Informational message about the IBF.	Informational message.
101A D766	Informational message about the IBF.	Informational message.
101A D776	Informational message about the IBF.	Informational message.
101A D816	External UPS: bypass active (informational message)	<p>Informational message. If a problem is suspected:</p> <ol style="list-style-type: none"> 1. Verify the cabling between the UPS and the BPCs. 2. Refer to the manufacturer's documentation for the UPS. 3. Call service support.
101A D916	External UPS: power restored (informational message)	<p>Informational message. If a problem is suspected:</p> <ol style="list-style-type: none"> 1. Verify the cabling between the UPS and the BPCs. 2. Refer to the manufacturer's documentation for the UPS. 3. Call service support.
101A DA16	External UPS: installed (informational message)	<p>Informational message. If a problem is suspected:</p> <ol style="list-style-type: none"> 1. Verify the cabling between the UPS and the BPCs. 2. Refer to the manufacturer's documentation for the UPS. 3. Call service support.
101A DB16	Problem with external UPS: UPS not available	<ol style="list-style-type: none"> 1. Verify the cabling between the UPS and the BPCs. 2. Refer to the manufacturer's documentation for the UPS. 3. Call service support.
101A DC16	External UPS: battery not low (informational message)	<p>Informational message. If a problem is suspected:</p> <ol style="list-style-type: none"> 1. Verify the cabling between the UPS and the BPCs. 2. Refer to the manufacturer's documentation for the UPS. 3. Call service support.
101A DC56	Informational message about the IBF.	Informational message.

Error Code	Description	Action/ Possible Failing FRU
101A DC66	Informational message about the IBF.	Informational message.
101A DC76	Informational message about the IBF.	Informational message.
101A DD16	External UPS: bypass ended (informational message)	Informational message. If a problem is suspected: 1. Verify the cabling between the UPS and the BPCs. 2. Refer to the manufacturer's documentation for the UPS. 3. Call service support.
101A DF16	Problem with external UPS: UPS failure	1. Verify the cabling between the UPS and the BPCs. 2. Refer to the manufacturer's documentation for the UPS. 3. Call service support.
101A E106	Critical logic over temperature	Go to "Map 1528: There Is A Processor (Critical/Warning) Overtemperature Fault" on page 202.
101A E206	Ambient room temperature too high	1. The ambient room temperature has reached a warning level (30 C) or a critical level (36 C). Ask the customer to correct the room temperature problem. 2. Call service support.
101A F4x6	Hardware configuration does not support N-mode power	Call service support.
101A F806	BPC A: loss of ac power or phase missing	Go to "Map 152a: Loss of ac Power or Phase Missing" on page 204.
101A F906	BPC A: loss of ac power or phase missing	Go to "Map 152a: Loss of ac Power or Phase Missing" on page 204.
101A F806	BPC A: loss of ac power or phase missing	Go to "Map 152a: Loss of ac Power or Phase Missing" on page 204.
101A F906	BPC A: loss of ac power or phase missing	Go to "Map 152a: Loss of ac Power or Phase Missing" on page 204.
101A FA06	Problem with EPO switch detected by BPC-A	Go to "Map 152a: Loss of ac Power or Phase Missing" on page 204.
101A FDB6	BPC A: open room EPO switch has been detected	Go to "Map 1524: An Open Room EPO Switch Has Been Detected From One Side" on page 193.
101A FE06	UEPO switch on BPC A is in the bypass position	Go to "Map 1522: UEPO Switch On The BPC Is In The Bypass Position" on page 192.
101A FE16	UEPO switch on BPC A is in the bypass position	Go to "Map 1522: UEPO Switch On The BPC Is In The Bypass Position" on page 192.

Error Code	Description	Action/ Possible Failing FRU
101A FE56	BPR 1A communications fault	Go to "Map 1523: There Is a Bulk Power Regulator (BPR) Communications Fault" on page 193.
101A FE66	BPR 2A communications fault	Go to "Map 1523: There Is a Bulk Power Regulator (BPR) Communications Fault" on page 193.
101A FE76	BPR 3A communications fault	Go to "Map 1523: There Is a Bulk Power Regulator (BPR) Communications Fault" on page 193.
101A x115	Power cable fault	Go to "MAP 1520: Power" on page 185 with these location codes: U1.35-P1-X4/Q1# to U1.18-X1/Q1#
101A x125	Power cable fault	Go to "MAP 1520: Power" on page 185 with these location codes: U1.35-P1-X3/Q1# to U1.9-V1/Q2#
101A x135	Power cable fault	Go to "MAP 1520: Power" on page 185 with these location codes: U1.35-P1-X2/Q1# to U2.1-V1/Q1#
101A x215	Power cable fault	Go to "MAP 1520: Power" on page 185 with these location codes: U1.35-P1-X4/Q2# to U1.18-X2/Q1#
101A x225	Power cable fault	Go to "MAP 1520: Power" on page 185 with these location codes: U1.35-P1-X3/Q2# to U1.9-V2/Q2#
101A x235	Power cable fault	Go to "MAP 1520: Power" on page 185 with these location codes: U1.35-P1-X2/Q2# to U2.1-V2/Q1#
101A x315	Power cable fault	Go to "MAP 1520: Power" on page 185 with these location codes: U1.35-P1-X4/Q3# to U1.18-X3/Q1#
101A x325	Power cable fault	Go to "MAP 1520: Power" on page 185 with these location codes: U1.35-P1-X3/Q3# to U1.5-V1/Q2#
101A x335	Power cable fault	Go to "MAP 1520: Power" on page 185 with these location codes: U1.35-P1-X2/Q3# to U2.5-V1/Q1#
101A x415	Power cable fault	Go to "MAP 1520: Power" on page 185 with these location codes: U1.35-P1-X4/Q4# to U1.18-X4/Q1#
101A x425	Power cable fault	Go to "MAP 1520: Power" on page 185 with these location codes: U1.35-P1-X3/Q4# to U1.5-V2/Q2#
101A x435	Power cable fault	Go to "MAP 1520: Power" on page 185 with these location codes: U1.35-P1-X2/Q4# to U2.5-V2/Q1#

Error Code	Description	Action/ Possible Failing FRU
101A x515	Power cable fault	Go to "MAP 1520: Power" on page 185 with these location codes: U1.35-P1-X4/Q5# to U1.18-P1-V1/Q1#
101A x525	Power cable fault	Go to "MAP 1520: Power" on page 185 with these location codes: U1.35-P1-X3/Q5# to U1.1-V1/Q2#
101A x535	Power cable fault	Go to "MAP 1520: Power" on page 185 with these location codes: U1.35-P1-X2/Q5# to U2.9-V1/Q1#
101A x615	Power cable fault	Go to "MAP 1520: Power" on page 185 with these location codes: U1.35-P1-X4/Q6# to U1.18-P1-V2/Q1#
101A x625	Power cable fault	Go to "MAP 1520: Power" on page 185 with these location codes: U1.35-P1-X3/Q6# to U1.1-V2/Q2#
101A x635	Power cable fault	Go to "MAP 1520: Power" on page 185 with these location codes: U1.35-P1-X2/Q6# to U2.9-V2/Q1#
101A x715	Power cable fault	Go to "MAP 1520: Power" on page 185 with these location codes: U1.35-P1-X4/Q7# to U1.18-P1-V4/Q1#
101A x725	Power cable fault	Go to "MAP 1520: Power" on page 185 with these location codes: U1.35-P1-X3/Q7# to U1.13-V1/Q2#
101A x735	Power cable fault	Go to "MAP 1520: Power" on page 185 with these location codes: U1.35-P1-X2/Q7# to U2.13-V1/Q1#
101A x825	Power cable fault	Go to "MAP 1520: Power" on page 185 with these location codes: U1.35-P1-X3/Q8# to U1.13-V2/Q2#
101A x835	Power cable fault	Go to "MAP 1520: Power" on page 185 with these location codes: U1.35-P1-X2/Q8# to U2.13-V2/Q1#
101A x925	Power cable fault	Go to "MAP 1520: Power" on page 185 with these location codes: U1.35-P1-X3/Q9# to U1.18-P1-V5/Q1#
101A x935	Power cable fault	Go to "MAP 1520: Power" on page 185 with these location codes: U1.35-P1-X2/Q9# to U2.19-V1/Q1#
101A xA25	Power cable fault	Go to "MAP 1520: Power" on page 185 with these location codes: U1.35-P1-X3/Q10# to U1.18-P1-V6/Q1#
101A xA35	Power cable fault	Go to "MAP 1520: Power" on page 185 with these location codes: U1.35-P1-X2/Q10# to U2.19-V2/Q1#

Error Code	Description	Action/ Possible Failing FRU
101A xx0x	BPA A-FRU not isolated	U1.35
101A xx11	BPA-A / BPC	U1.35-P1-X4
101A xx13	Seeprom (VPD) fault on BPC-A	U1.35-P1-X4
101A xx17	Fan fault on BPC-A (BPA-A fan)	1. BPE-A side fan Location: U1.35-P1-F1 2. BPC-A Location: U1.35-P1-X4
101A xx21	BPA-A / BPD-1	U1.35-P1-X3
101A xx22	BPC-A to BPD-1 communications fault	1. BPD-1 Location: U1.35-P1-X3 2. BPC-A Location: U1.35-P1-X4 3. BPE backplane A Location: U1.35-P1
101A xx23	Seeprom (VPD) fault on BPD-1A	U1.35-P1-X3
101A xx31	BPA-A / BPD-2	U1.35-P1-X2
101A xx32	BPC-A to BPD-2 communications fault	1. BPD-2 Location: U1.35-P1-X2 2. BPC-A Location: U1.35-P1-X4 3. BPE backplane A Location: U1.35-P1
101A xx33	Seeprom (VPD) fault on BPD-2A	U1.35-P1-X2
101A xx41	BPA-A / BPD-3	U1.35-P1-X1
101A xx42	BPC-A to BPD-3 communications fault	1. BPD-3 Location: U1.35-P1-X1 2. BPC-A Location: U1.35-P1-X4 3. BPE backplane A Location: U1.35-P1
101A xx43	Seeprom (VPD) fault on BPD-3A	U1.35-P1-X1
101A xx51	BPA-A / BPR-1	U1.35-P1-V1
101A xx52	BPC-A to BPR-1 communications fault	1. BPR-1 Location: U1.35-P1-V1 2. BPC-A Location: U1.35-P1-X4 3. BPE backplane A Location: U1.35-P1
101A xx53	Seeprom (VPD) fault on BPR-1A	U1.35-P1-V1
101A xx61	BPA-A / BPR-2	U1.35-P1-V2

Error Code	Description	Action/ Possible Failing FRU
101A xx62	BPC-A to BPR-2 communications fault	<ol style="list-style-type: none"> 1. BPR-2 Location: U1.35-P1-V2 2. BPC-A Location: U1.35-P1-X4 3. BPE backplane A Location: U1.35-P1
101A xx63	Seeprom (VPD) fault on BPR-2A	U1.35-P1-V2
101A xx71	BPA-A / BPR-3	U1.35-P1-V3
101A xx72	BPC-A to BPR-3 communications fault	<ol style="list-style-type: none"> 1. BPR-3 Location: U1.35-P1-V3 2. BPC-A Location: U1.35-P1-X4 3. BPE backplane A Location: U1.35-P1
101A xx73	Seeprom (VPD) fault on BPR-3A	U1.35-P1-V3
101A xx81	BPA-A / IBF 1	U1.13-P1-V1
101A xx83	Seeprom (VPD) fault on IBF-1A	U1.13-P1-V1
101A xx91	BPA-A / IBF 2	U1.15-P1-V2
101A xx93	Seeprom (VPD) fault on IBF-2A	U1.15-P1-V2
101A xxA1	BPA-A / IBF 3	U2.17-P1-V5
101A xxA3	Seeprom (VPD) fault on IBF-3A	U2.17-P1-V5
101A xxB1	BPA-A / EPO_SW	<ol style="list-style-type: none"> 1. Replace the UEPO switch, Location: U1-V1 2. Check the cable from BPC-A to the UEPO switch, Location U1-V1/Q1#
101B 0856	BPR 1B communications fault	Go to "Map 1523: There Is a Bulk Power Regulator (BPR) Communications Fault" on page 193.
101B 0866	BPR 2B communications fault	Go to "Map 1523: There Is a Bulk Power Regulator (BPR) Communications Fault" on page 193.
101B 0876	BPR 3B communications fault	Go to "Map 1523: There Is a Bulk Power Regulator (BPR) Communications Fault" on page 193.
101B 0D06	350 volt bulk failure, BPA-B	Go to "Map 1525: There Is a 350 Volt Bulk Failure" on page 195.
101B 1C06	Cage airflow missing (temperature problem)	Go to "Map 1527: An Airflow Loss Has Been Detected" on page 200.

(3)
(3)
(3)
(3)
(3)
(3)
(3)

Error Code	Description	Action/ Possible Failing FRU
101B 3F06	Invalid I/O subsystem configuration	<ol style="list-style-type: none">1. Verify that the I/O subsystems are properly cabled. Note: This error code causes the service processor to hang. Refer to "Resetting the Service Processor" on page 749 if the service processor is hung.2. Call service support.
101B 7A86	IBF 1B failure	Go to "Map 1526: There Is An Integrated Battery Feature (IBF) Failure" on page 197.
101B 7A96	IBF 2B failure	Go to "Map 1526: There Is An Integrated Battery Feature (IBF) Failure" on page 197.
101B 7AA6	IBF 3B failure	Go to "Map 1526: There Is An Integrated Battery Feature (IBF) Failure" on page 197.
101B 7B86	IBF 1B failure	Go to "Map 1526: There Is An Integrated Battery Feature (IBF) Failure" on page 197.
101B 7B96	IBF 2B failure	Go to "Map 1526: There Is An Integrated Battery Feature (IBF) Failure" on page 197.
101B 7BA6	IBF 3B failure	Go to "Map 1526: There Is An Integrated Battery Feature (IBF) Failure" on page 197.
101B CE16	BPC-BPC communication failure	<ol style="list-style-type: none">1. Check the cable between the two BPCs; reseal and look for bent pins.2. Replace BPC-A, location: U1.35-P1-X43. Replace BPC-B, location: U1.35-P2-X4.
101B D216	BPA-BPA communication failure	Go to "MAP 1520: Power" on page 185 for isolation.
101B D616	Problem with external UPS: utility failure	<ol style="list-style-type: none">1. Verify the cabling between the UPS and the BPCs.2. Refer to the manufacturer's documentation for the UPS.3. Call service support.

Error Code	Description	Action/ Possible Failing FRU
101B D716	Problem with external UPS: battery low	<ol style="list-style-type: none"> 1. Verify the cabling between the UPS and the BPCs. 2. Refer to the manufacturer's documentation for the UPS. 3. Call service support.
101B D716	Informational message about the IBF.	Informational message.
101B D766	Informational message about the IBF.	Informational message.
101B D776	Informational message about the IBF.	Informational message.
101B D816	External UPS: bypass active (informational message)	<p>Informational message. If a problem is suspected:</p> <ol style="list-style-type: none"> 1. Verify the cabling between the UPS and the BPCs. 2. Refer to the manufacturer's documentation for the UPS. 3. Call service support.
101B D916	External UPS: power restored (informational message)	<p>Informational message. If a problem is suspected:</p> <ol style="list-style-type: none"> 1. Verify the cabling between the UPS and the BPCs. 2. Refer to the manufacturer's documentation for the UPS. 3. Call service support.
101B DA16	External UPS: installed (informational message)	<p>Informational message. If a problem is suspected:</p> <ol style="list-style-type: none"> 1. Verify the cabling between the UPS and the BPCs. 2. Refer to the manufacturer's documentation for the UPS. 3. Call service support.
101B DB16	Problem with external UPS: UPS not available	<ol style="list-style-type: none"> 1. Verify the cabling between the UPS and the BPCs. 2. Refer to the manufacturer's documentation for the UPS. 3. Call service support.
101B DC16	External UPS: battery not low (informational message)	<p>Informational message. If a problem is suspected:</p> <ol style="list-style-type: none"> 1. Verify the cabling between the UPS and the BPCs. 2. Refer to the manufacturer's documentation for the UPS. 3. Call service support.
101B DC56	Informational message about the IBF.	Informational message.

Error Code	Description	Action/ Possible Failing FRU
101B DC66	Informational message about the IBF.	Informational message.
101B DC76	Informational message about the IBF.	Informational message.
101B DD16	External UPS: bypass ended (informational message)	Informational message. If a problem is suspected: <ol style="list-style-type: none"> 1. Verify the cabling between the UPS and the BPCs. 2. Refer to the manufacturer's documentation for the UPS. 3. Call service support.
101B DF16	Problem with external UPS: UPS failure	<ol style="list-style-type: none"> 1. Verify the cabling between the UPS and the BPCs. 2. Refer to the manufacturer's documentation for the UPS. 3. Call service support.
101B E106	Critical logic over temperature	Go to "Map 1528: There Is A Processor (Critical/Warning) Overtemperature Fault" on page 202.
101B E206	Ambient room temperature too high	<ol style="list-style-type: none"> 1. The ambient room temperature has reached a warning level (30 C) or a critical level (36 C). Ask the customer to correct the room temperature problem. 2. Call service support.
101B F4x6	Hardware configuration does not support N-mode power	Call service support.
101B F806	BPC B: loss of ac power or phase missing	Go to "Map 152a: Loss of ac Power or Phase Missing" on page 204.
101B F906	BPC B: loss of ac power or phase missing	Go to "Map 152a: Loss of ac Power or Phase Missing" on page 204.
101B FA06	BPC B: loss of ac power or phase missing	Go to "Map 152a: Loss of ac Power or Phase Missing" on page 204.
101B FDB6	BPC B: open room EPO switch has been detected	Go to "Map 1524: An Open Room EPO Switch Has Been Detected From One Side" on page 193.
101B FE06	UEPO switch on BPC B is in the bypass position	Go to "Map 1522: UEPO Switch On The BPC Is In The Bypass Position" on page 192.
101B FE16	UEPO switch on BPC B is in the bypass position	Go to "Map 1522: UEPO Switch On The BPC Is In The Bypass Position" on page 192.
101B FE56	BPR 1B communications fault	Go to "Map 1523: There Is a Bulk Power Regulator (BPR) Communications Fault" on page 193.

Error Code	Description	Action/ Possible Failing FRU
101B FE66	BPR 2B communications fault	Go to "Map 1523: There Is a Bulk Power Regulator (BPR) Communications Fault" on page 193.
101B FE76	BPR 3B communications fault	Go to "Map 1523: There Is a Bulk Power Regulator (BPR) Communications Fault" on page 193.
101B x115	Power cable fault	Go to "MAP 1520: Power" on page 185 with these location codes: U1.35-P2-X4/Q1# to U1.18-X1/Q2#
101B x125	Power cable fault	Go to "MAP 1520: Power" on page 185 with these location codes: U1.35-P2-X3/Q1# to U1.9-V1/Q1#
101B x135	Power cable fault	Go to "MAP 1520: Power" on page 185 with these location codes: U1.35-P2-X2/Q1# to U2.1-V1/Q2#
101B x215	Power cable fault	Go to "MAP 1520: Power" on page 185 with these location codes: U1.35-P2-X4/Q2# to U1.18-X2/Q2#
101B x225	Power cable fault	Go to "MAP 1520: Power" on page 185 with these location codes: U1.35-P2-X3/Q2# to U1.9-V2/Q1#
101B x235	Power cable fault	Go to "MAP 1520: Power" on page 185 with these location codes: U1.35-P2-X2/Q2# to U2.1-V2/Q2#
101B x315	Power cable fault	Go to "MAP 1520: Power" on page 185 with these location codes: U1.35-P2-X4/Q3# to U1.18-X3/Q2#
101B x325	Power cable fault	Go to "MAP 1520: Power" on page 185 with these location codes: U1.35-P2-X3/Q3# to U1.5-V1/Q1#
101B x335	Power cable fault	Go to "MAP 1520: Power" on page 185 with these location codes: U1.35-P2-X2/Q3# to U2.5-V1/Q2#
101B x415	Power cable fault	Go to "MAP 1520: Power" on page 185 with these location codes: U1.35-P2-X4/Q4# to U1.18-X4/Q2#
101B x425	Power cable fault	Go to "MAP 1520: Power" on page 185 with these location codes: U1.35-P2-X3/Q4# to U1.5-V2/Q1#
101B x435	Power cable fault	Go to "MAP 1520: Power" on page 185 with these location codes: U1.35-P2-X2/Q4# to U2.5-V2/Q2#
101B x515	Power cable fault	Go to "MAP 1520: Power" on page 185 with these location codes: U1.35-P2-X4/Q5# to U1.18-P1-V1/Q2#

Error Code	Description	Action/ Possible Failing FRU
101B x525	Power cable fault	Go to "MAP 1520: Power" on page 185 with these location codes: U1.35-P2-X3/Q5# to U1.1-V1/Q1#
101B x535	Power cable fault	Go to "MAP 1520: Power" on page 185 with these location codes: U1.35-P2-X2/Q5# to U2.9-V1/Q2#
101B x615	Power cable fault	Go to "MAP 1520: Power" on page 185 with these location codes: U1.35-P2-X4/Q6# to U1.18-P1-V2/Q2#
101B x625	Power cable fault	Go to "MAP 1520: Power" on page 185 with these location codes: U1.35-P2-X3/Q6# to U1.1-V2/Q1#
101B x635	Power cable fault	Go to "MAP 1520: Power" on page 185 with these location codes: U1.35-P2-X2/Q6# to U2.9-V2/Q2#
101B x715	Power cable fault	Go to "MAP 1520: Power" on page 185 with these location codes: U1.35-P2-X4/Q7# to U1.18-P1-V4/Q2#
101B x725	Power cable fault	Go to "MAP 1520: Power" on page 185 with these location codes: U1.35-P2-X3/Q7# to U1.13-V1/Q1#
101B x735	Power cable fault	Go to "MAP 1520: Power" on page 185 with these location codes: U1.35-P2-X2/Q7# to U2.13-V1/Q2#
101B x825	Power cable fault	Go to "MAP 1520: Power" on page 185 with these location codes: U1.35-P2-X3/Q8# to U1.13-V2/Q1#
101B x835	Power cable fault	Go to "MAP 1520: Power" on page 185 with these location codes: U1.35-P2-X2/Q8# to U2.13-V2/Q2#
101B x925	Power cable fault	Go to "MAP 1520: Power" on page 185 with these location codes: U1.35-P2-X3/Q9# to U1.18-P1-V5/Q2#
101B x935	Power cable fault	Go to "MAP 1520: Power" on page 185 with these location codes: U1.35-P2-X2/Q9# to U2.19-V1/Q2#
101B xA25	Power cable fault	Go to "MAP 1520: Power" on page 185 with these location codes: U1.35-P2-X3/Q10# to U1.18-P1-V6/Q2#
101B xA35	Power cable fault	Go to "MAP 1520: Power" on page 185 with these location codes: U1.35-P2-X2/Q10# to U2.19-V2/Q2#
101B xx0x	BPA B-FRU not isolated	U1.35
101B xx11	BPA-B / BPC	U1.35-P2-X4

Error Code	Description	Action/ Possible Failing FRU
101B xx13	Seeprom (VPD) fault on BPC-B	U1.35-P2-X4
101B xx17	Fan fault on BPC-B (BPA-B fan)	1. BPE-B side fan Location: U1.35-P2-F1 2. BPC-B Location: U1.35-P2-X4
101B xx21	BPA-B / BPD-1	U1.35-P2-X3
101B xx22	BPC-B to BPD-1 communications fault	1. BPD-1 Location: U1.35-P2-X3 2. BPC-B Location: U1.35-P2-X4 3. BPE backplane B Location: U1.35-P2
101B xx23	Seeprom (VPD) fault on BPD-1B	U1.35-P2-X3
101B xx31	BPA-B / BPD-2	U1.35-P2-X2
101B xx32	BPC-B to BPD-2 communications fault	1. BPD-2 Location: U1.35-P2-X2 2. BPC-B Location: U1.35-P2-X4 3. BPE backplane B Location: U1.35-P2
101B xx33	Seeprom (VPD) fault on BPD-2B	U1.35-P2-X2
101B xx41	BPA-B / BPD-3	U1.35-P2-X1
101B xx42	BPC-B to BPD-3 communications fault	1. BPD-3 Location: U1.35-P2-X1 2. BPC-B Location: U1.35-P2-X4 3. BPE backplane B Location: U1.35-P2
101B xx43	Seeprom (VPD) fault on BPD-3B	U1.35-P2-X1
101B xx51	BPA-B / BPR-1	U1.35-P2-V1
101B xx52	BPC-B to BPR-1 communications fault	1. BPR-1 Location: U1.35-P2-V1 2. BPC-B Location: U1.35-P2-X4 3. BPE backplane B Location: U1.35-P2
101B xx53	Seeprom (VPD) fault on BPR-1B	U1.35-P2-V1
101B xx61	BPA-B / BPR-2	U1.35-P2-V2

Error Code	Description	Action/ Possible Failing FRU
101B xx62	BPC-B to BPR-2 communications fault	<ol style="list-style-type: none"> 1. BPR-2 Location: U1.35-P2-V2 2. BPC-B Location: U1.35-P2-X4 3. BPE backplane B Location: U1.35-P2
101B xx63	Seeprom (VPD) fault on BPR-2B	U1.35-P2-V2
101B xx71	BPA-B / BPR-3	U1.35-P2-V3
101B xx72	BPC-B to BPR-3 communications fault	<ol style="list-style-type: none"> 1. BPR-3 Location: U1.35-P2-V3 2. BPC-B Location: U1.35-P2-X4 3. BPE backplane B Location: U1.35-P2
101B xx73	Seeprom (VPD) fault on BPR-3B	U1.35-P2-V3
101B xx81	BPA-B / IBF 1	U1.13-P2-V3
101B xx83	Seeprom (VPD) fault on IBF-1B	U1.13-P2-V3
101B xx91	BPA-B / IBF 2	U1.15-P2-V4
101B xx93	Seeprom (VPD) fault on IBF-2B	U1.15-P2-V4
101B xxA1	BPA-B / IBF 3	U2.17-P2-V6
101B xxA3	Seeprom (VPD) fault on IBF-3B	U2.17-P2-V6
101B xxB1	BPA-B / EPO_SW	<ol style="list-style-type: none"> 1. Replace the UEPO switch, Location: U1-V1 2. Check the cable from BPC-B to the UEPO switch, Location U1-V1/Q2#
101C 0FB6	MCM 0 running over temperature	<ol style="list-style-type: none"> 1. Verify that the MCM at U1.18-P1-C1 is installed. 2. Verify that there are no airflow problems with the MCM at U1.18-P1-C1 or its heatsink. 3. Verify that the MCM at U1.18-P1-C1 is installed correctly onto the processor backplane. 4. Call service support.

Error Code	Description	Action/ Possible Failing FRU
101C 0FC6	MCM 1 running over temperature	<ol style="list-style-type: none"> 1. Verify that the MCM at U1.18-P1-C3 is installed. 2. Verify that there are no airflow problems with the MCM at U1.18-P1-C3 or its heatsink. 3. Verify that the MCM at U1.18-P1-C3 is installed correctly onto the processor backplane. 4. Call service support.
101C 0FD6	MCM 2 running over temperature	<ol style="list-style-type: none"> 1. Verify that the MCM at U1.18-P1-C4 is installed. 2. Verify that there are no airflow problems with the MCM at U1.18-P1-C4 or its heatsink. 3. Verify that the MCM at U1.18-P1-C4 is installed correctly onto the processor backplane. 4. Call service support.
101C 0FE6	MCM 3 running over temperature	<ol style="list-style-type: none"> 1. Verify that the MCM at U1.18-P1-C2 is installed. 2. Verify that there are no airflow problems with the MCM at U1.18-P1-C2 or its heatsink. 3. Verify that the MCM at U1.18-P1-C2 is installed correctly onto the processor backplane. 4. Call service support.
101C 1C06	Loss of airflow in processor subsystem resulting in over-temperature	Go to "Map 1527: An Airflow Loss Has Been Detected" on page 200 with location U1.18.
101C 6114	Overcurrent or overvoltage problem with 1.8V in processor subsystem	Go to "MAP 1520: Power" on page 185.
101C 6124	Overcurrent or overvoltage problem with 1.5V in processor subsystem	Go to "MAP 1520: Power" on page 185.
101C 6134	Overcurrent or overvoltage problem with 1.5V in processor subsystem	Go to "MAP 1520: Power" on page 185.
101C 6144	Overcurrent or overvoltage problem with 3.3V in processor subsystem (oscillator)	Go to "MAP 1520: Power" on page 185.
101C 6514	Overcurrent or overvoltage problem with 5.0V in processor subsystem (autostart, standby)	Go to "MAP 1520: Power" on page 185.
101C 6814	Overcurrent or overvoltage problem with 2.5V in processor subsystem	Go to "MAP 1520: Power" on page 185.

Error Code	Description	Action/ Possible Failing FRU
101C 6914	Overcurrent or overvoltage problem with 1.8V in processor subsystem	Go to "MAP 1520: Power" on page 185.
101C 6924	Overcurrent or overvoltage problem with 1.5V in processor subsystem	Go to "MAP 1520: Power" on page 185.
101C 6934	Overcurrent or overvoltage problem with 1.5V in processor subsystem	Go to "MAP 1520: Power" on page 185.
101C 6944	Overcurrent or overvoltage problem with 3.3V in processor subsystem (oscillator)	Go to "MAP 1520: Power" on page 185.
101C 6D14	Overcurrent or overvoltage problem with 5.0V in processor subsystem (autostart, standby)	Go to "MAP 1520: Power" on page 185.
101C 7E06	No MCMs detected OR the actual number of MCMs does not match the expected number of MCMs	<ol style="list-style-type: none"> 1. Verify that the processor MCMs are plugged in a valid configuration. 2. Verify that the processor MCMs are seated properly. 3. Verify the processor VPD cards in the primary I/O book are of the proper number and are positioned and seated correctly. 4. Call service support.
101C 7EB6	MCM 0 running over temperature	<ol style="list-style-type: none"> 1. Verify that the MCM at U1.18-P1-C1 is installed. 2. Verify that there are no airflow problems with the MCM at U1.18-P1-C1 or its heatsink. 3. Verify that the MCM at U1.18-P1-C1 is installed correctly onto the processor backplane. 4. Call service support.
101C 7EC6	MCM 1 running over temperature	<ol style="list-style-type: none"> 1. Verify that the MCM at U1.18-P1-C3 is installed. 2. Verify that there are no airflow problems with the MCM at U1.18-P1-C3 or its heatsink. 3. Verify that the MCM at U1.18-P1-C3 is installed correctly onto the processor backplane. 4. Call service support.

(3)
(3)
(3)
(3)
(3)

Error Code	Description	Action/ Possible Failing FRU
101C 7ED6	MCM 2 running over temperature	<ol style="list-style-type: none"> 1. Verify that the MCM at U1.18-P1-C4 is installed. 2. Verify that there are no airflow problems with the MCM at U1.18-P1-C4 or its heatsink. 3. Verify that the MCM at U1.18-P1-C4 is installed correctly onto the processor backplane. 4. Call service support.
101C 7EE6	MCM 3 running over temperature	<ol style="list-style-type: none"> 1. Verify that the MCM at U1.18-P1-C2 is installed. 2. Verify that there are no airflow problems with the MCM at U1.18-P1-C2 or its heatsink. 3. Verify that the MCM at U1.18-P1-C2 is installed correctly onto the processor backplane. 4. Call service support.
101C 7F06	No MCMs detected OR the actual number of MCMs does not match the expected number of MCMs	<p>Note: This error code causes the service processor to hang. Refer to “Resetting the Service Processor” on page 749 if the service processor is hung.</p> <ol style="list-style-type: none"> 1. Verify that the processor MCMs are plugged in a valid configuration. 2. Verify that the processor MCMs are seated properly. 3. Verify the processor VPD cards in the primary I/O book are of the proper number and are positioned and seated correctly. 4. Call service support.
101C B014	Overcurrent or overvoltage problem with 2.5V in processor subsystem	Go to “MAP 1520: Power” on page 185.
101C B114	Overcurrent or overvoltage problem with 1.8V in processor subsystem	Go to “MAP 1520: Power” on page 185.
101C B124	Overcurrent or overvoltage problem with 1.5V in processor subsystem	Go to “MAP 1520: Power” on page 185.
101C B134	Overcurrent or overvoltage problem with 1.5V in processor subsystem	Go to “MAP 1520: Power” on page 185.
101C B144	Overcurrent or overvoltage problem with 3.3V in processor subsystem (oscillator)	Go to “MAP 1520: Power” on page 185.

Error Code	Description	Action/ Possible Failing FRU
101C B544	Overcurrent or overvoltage problem with 5.0V in processor subsystem (autostart, standby)	Go to "MAP 1520: Power" on page 185.
101C B814	Overcurrent or overvoltage problem with 2.5V in processor subsystem	Go to "MAP 1520: Power" on page 185.
101C B914	Overcurrent or overvoltage problem with 1.8V in processor subsystem	Go to "MAP 1520: Power" on page 185.
101C B924	Overcurrent or overvoltage problem with 1.5V in processor subsystem	Go to "MAP 1520: Power" on page 185.
101C B934	Overcurrent or overvoltage problem with 1.5V in processor subsystem	Go to "MAP 1520: Power" on page 185.
101C B944	Overcurrent or overvoltage problem with 3.3V in processor subsystem (oscillator)	Go to "MAP 1520: Power" on page 185.
101C BD44	Overcurrent or overvoltage problem with 5.0V in processor subsystem (autostart, standby)	Go to "MAP 1520: Power" on page 185.
101C E006	Processor over-temperature detected	Go to "Map 1528: There Is A Processor (Critical/Warning) Overtemperature Fault" on page 202.
101C E106	Processor over-temperature detected	Go to "Map 1528: There Is A Processor (Critical/Warning) Overtemperature Fault" on page 202.
101C E1B6	MCM 0 running over temperature	<ol style="list-style-type: none"> 1. Verify that the MCM at U1.18-P1-C1 is installed. 2. Verify that there are no airflow problems with the MCM at U1.18-P1-C1 or its heatsink. 3. Verify that the MCM at U1.18-P1-C1 is installed correctly onto the processor backplane. 4. Call service support.
101C E1C6	MCM 1 running over temperature	<ol style="list-style-type: none"> 1. Verify that the MCM at U1.18-P1-C3 is installed. 2. Verify that there are no airflow problems with the MCM at U1.18-P1-C3 or its heatsink. 3. Verify that the MCM at U1.18-P1-C3 is installed correctly onto the processor backplane. 4. Call service support.

Error Code	Description	Action/ Possible Failing FRU
101C E1D6	MCM 2 running over temperature	<ol style="list-style-type: none"> 1. Verify that the MCM at U1.18-P1-C4 is installed. 2. Verify that there are no airflow problems with the MCM at U1.18-P1-C4 or its heatsink. 3. Verify that the MCM at U1.18-P1-C4 is installed correctly onto the processor backplane. 4. Call service support.
101C E1E6	MCM 3 running over temperature	<ol style="list-style-type: none"> 1. Verify that the MCM at U1.18-P1-C2 is installed. 2. Verify that there are no airflow problems with the MCM at U1.18-P1-C2 or its heatsink. 3. Verify that the MCM at U1.18-P1-C2 is installed correctly onto the processor backplane. 4. Call service support.
101C F206	Error not isolated; VPD on BPR may be corrupted	Call service support.
101C F306	The power subsystem does not recognize the processor subsystem type or processor subsystem configuration	Call service support.
101C F406	Hardware configuration cannot support N-mode power	Call service support.
101C F606	The power subsystem does not recognize the processor subsystem type or processor subsystem configuration	Call service support.
101C F516	An N+1 boundary (DCA or fan) has dropped to N-mode status in the processor subsystem, location: U1.18	<p>This is normally an informational message. It should be accompanied by other error codes that more precisely indicate where the failure is. Examine the service processor error log. If there are no other power-related error codes (in the time frame in which this code was generated) in the service processor error log, the FRU indicated with this error code, if any, should be replaced.</p>

Error Code	Description	Action/ Possible Failing FRU
101C F526	An N+1 boundary (DCA or fan) has dropped to N-mode status in the processor subsystem, location: U1.18	This is normally an informational message. It should be accompanied by other error codes that more precisely indicate where the failure is. Examine the service processor error log. If there are no other power-related error codes (in the time frame in which this code was generated) in the service processor error log, the FRU indicated with this error code, if any, should be replaced.
101C F536	An N+1 boundary (DCA or fan) has dropped to N-mode status in the processor subsystem, location: U1.18	This is normally an informational message. It should be accompanied by other error codes that more precisely indicate where the failure is. Examine the service processor error log. If there are no other power-related error codes (in the time frame in which this code was generated) in the service processor error log, the FRU indicated with this error code, if any, should be replaced.
101C F546	An N+1 boundary (DCA or fan) has dropped to N-mode status in the processor subsystem, location: U1.18	This is normally an informational message. It should be accompanied by other error codes that more precisely indicate where the failure is. Examine the service processor error log. If there are no other power-related error codes (in the time frame in which this code was generated) in the service processor error log, the FRU indicated with this error code, if any, should be replaced.
101C F556	An N+1 boundary (DCA or fan) has dropped to N-mode status in the processor subsystem, location: U1.18	This is normally an informational message. It should be accompanied by other error codes that more precisely indicate where the failure is. Examine the service processor error log. If there are no other power-related error codes (in the time frame in which this code was generated) in the service processor error log, the FRU indicated with this error code, if any, should be replaced.

Error Code	Description	Action/ Possible Failing FRU
101C F566	An N+1 boundary (DCA or fan) has dropped to N-mode status in the processor subsystem, location: U1.18	This is normally an informational message. It should be accompanied by other error codes that more precisely indicate where the failure is. Examine the service processor error log. If there are no other power-related error codes (in the time frame in which this code was generated) in the service processor error log, the FRU indicated with this error code, if any, should be replaced.
101C F576	An N+1 boundary (DCA or fan) has dropped to N-mode status in the processor subsystem, location: U1.18	This is normally an informational message. It should be accompanied by other error codes that more precisely indicate where the failure is. Examine the service processor error log. If there are no other power-related error codes (in the time frame in which this code was generated) in the service processor error log, the FRU indicated with this error code, if any, should be replaced.
101C F586	An N+1 boundary (DCA or fan) has dropped to N-mode status in the processor subsystem, location: U1.18	This is normally an informational message. It should be accompanied by other error codes that more precisely indicate where the failure is. Examine the service processor error log. If there are no other power-related error codes (in the time frame in which this code was generated) in the service processor error log, the FRU indicated with this error code, if any, should be replaced.
101C F596	An N+1 boundary (DCA or fan) has dropped to N-mode status in the processor subsystem, location: U1.18	This is normally an informational message. It should be accompanied by other error codes that more precisely indicate where the failure is. Examine the service processor error log. If there are no other power-related error codes (in the time frame in which this code was generated) in the service processor error log, the FRU indicated with this error code, if any, should be replaced.

Error Code	Description	Action/ Possible Failing FRU
101C F5A6	An N+1 boundary (DCA or fan) has dropped to N-mode status in the processor subsystem, location: U1.18	This is normally an informational message. It should be accompanied by other error codes that more precisely indicate where the failure is. Examine the service processor error log. If there are no other power-related error codes (in the time frame in which this code was generated) in the service processor error log, the FRU indicated with this error code, if any, should be replaced.
101C xx11	Processor subsystem / DCA-1	U1.18-P1-V1
101C xx13	Seeprom (VPD) fault on processor subsystem DCA-1	U1.18-P1-V1
101C xx15	Processor subsystem / DCA-1 cable fault	Go to "MAP 1520: Power" on page 185 with these location codes: U1.18-P1-V1/Q1# U1.18-P1-V1/Q2#
101C xx21	Processor subsystem / DCA-2	U1.18-P1-V2
101C xx23	Seeprom (VPD) fault on processor subsystem DCA-2	U1.18-P1-V2
101C xx25	Processor subsystem / DCA-2 cable fault	Go to "MAP 1520: Power" on page 185 with these location codes: U1.18-P1-V2/Q1# U1.18-P1-V2/Q2#
101C xx31	Processor subsystem / DCA-3	U1.18-P1-V4
101C xx33	Seeprom (VPD) fault on processor subsystem DCA -3	U1.18-P1-V4
101C xx35	Processor subsystem / DCA-3 cable fault	Go to "MAP 1520: Power" on page 185 with these location codes: U1.18-P1-V4/Q1# U1.18-P1-V4/Q2#
101C xx41	Processor subsystem / DCA-4	U1.18-P1-V5
101C xx43	Seeprom (VPD) fault on processor subsystem DCA-4	U1.18-P1-V5
101C xx45	Processor subsystem / DCA-4 cable fault	Go to "MAP 1520: Power" on page 185 with these location codes: U1.18-P1-V5/Q1# U1.18-P1-V5/Q2#
101C xx51	Processor subsystem / DCA-5	U1.18-P1-V6
101C xx53	Seeprom (VPD) fault on processor subsystem DCA-5	U1.18-P1-V6
101C xx55	Processor subsystem / DCA-5 cable fault	Go to "MAP 1520: Power" on page 185 with these location codes: U1.18-P1-V6/Q1# U1.18-P1-V6/Q2#
101C xx61	Processor subsystem / DCA-6 (if installed)	U1.18-P1-V8
101C xx63	Seeprom (VPD) fault on processor subsystem DCA-6	U1.18-P1-V8

Error Code	Description	Action/ Possible Failing FRU
101C xx65	Processor subsystem / DCA-6 cable fault	Go to "MAP 1520: Power" on page 185 with these location codes: U1.18-P1-V8/Q1# U1.18-P1-V8/Q2#
101C xx71	Processor subsystem / MDA-1	U1.18-X1
101C xx73	Seeprom (VPD) fault on processor subsystem MDA -1	U1.18-X1
101C xx75	Processor subsystem / MDA-1 cable fault	Go to "MAP 1520: Power" on page 185 with these location codes: U1.18-X1/Q1# U1.18-X1/Q2#
101C xx77	Fan fault on processor subsystem fan 1	1. Fan 1 controller Location: U1.18-X1 2. Fan 1 Location: U1.18-F1
101C xx81	Processor subsystem / MDA-2	U1.18-X2
101C xx83	Seeprom (VPD) fault on processor subsystem MDA-2	U1.18-X2
101C xx85	Processor subsystem / MDA-2 cable fault	Go to "MAP 1520: Power" on page 185 with these location codes: U1.18-X2/Q1# U1.18-X2/Q2#
101C xx87	Fan fault on processor subsystem fan 2	1. Fan 2 controller Location: U1.18-X2 2. Fan 2 Location: U1.18-F2
101C xx91	Processor subsystem / MDA-3	U1.18-X3
101C xx93	Seeprom (VPD) fault on processor subsystem MDA-3	U1.18-X3
101C xx95	Processor subsystem / MDA-3 cable fault	Go to "MAP 1520: Power" on page 185 with these location codes: U1.18-X3/Q1# U1.18-X3/Q2#
101C xx97	Fan fault on processor subsystem fan 3	1. Fan 3 controller Location: U1.18-X3 2. Fan 3 Location: U1.18-F3
101C xxA1	Processor subsystem / MDA-4	U1.18-X4
101C xxA3	Seeprom (VPD) fault on processor subsystem MDA-4	U1.18-X4
101C xxA5	Processor subsystem / MDA-4 cable fault	Go to "MAP 1520: Power" on page 185 with these location codes: U1.18-X4/Q1# U1.18-X4/Q2#
101C xxA7	Fan fault on processor subsystem fan 4	1. Fan 4 controller Location: U1.18-X4 2. Fan 4 Location: U1.18-F4

Error Code	Description	Action/ Possible Failing FRU
10211B17	Problem with fan 1 in first I/O subsystem in second rack (I/O subsystem 5)	<ol style="list-style-type: none"> 1. DCA-1 Location: U2.1-V1 2. Fan 1 Location:U2.1-F1
1021 1B27	Problem with fan 2 in first I/O subsystem in second rack (I/O subsystem 5)	<ol style="list-style-type: none"> 1. DCA-2 Location: U2.1-V2 2. Fan 2 Location:U2.1-F2
1021 1C06	Loss of airflow in first I/O subsystem in second rack, location: U2.1	Go to "Map 1527: An Airflow Loss Has Been Detected" on page 200.
1021 6014	Overcurrent or overvoltage problem with 3.3V in 5th I/O subsystem	Go to "MAP 1520: Power" on page 185.
1021 6024	Overcurrent or overvoltage problem with 5.0V in 5th I/O subsystem	Go to "MAP 1520: Power" on page 185.
1021 6034	Overcurrent or overvoltage problem with 2.5V in 5th I/O subsystem	Go to "MAP 1520: Power" on page 185.
1021 6044	Overcurrent or overvoltage problem with 12.0V in 5th I/O subsystem	Go to "MAP 1520: Power" on page 185.
1021 6054	Overcurrent or overvoltage problem with -12.0V in 5th I/O subsystem	Go to "MAP 1520: Power" on page 185.
1021 6814	Overcurrent or overvoltage problem with 3.3V in 5th I/O subsystem	Go to "MAP 1520: Power" on page 185.
1021 6824	Overcurrent or overvoltage problem with 5.0V in 5th I/O subsystem	Go to "MAP 1520: Power" on page 185.
10216834	Overcurrent or overvoltage problem with 2.5V in 5th I/O subsystem	Go to "MAP 1520: Power" on page 185.
1021 6844	Overcurrent or overvoltage problem with 12.0V in 5th I/O subsystem	Go to "MAP 1520: Power" on page 185.
1021 6854	Overcurrent or overvoltage problem with -12.0V in 5th I/O subsystem	Go to "MAP 1520: Power" on page 185.
1021 7017	Problem with fan 3 in first I/O subsystem in second rack (I/O subsystem 5)	<ol style="list-style-type: none"> 1. DCA-1 Location: U2.1-V1 2. Fan 3 Location: U2.1-F3
1021 7027	Problem with fan 4 in first I/O subsystem in second rack (I/O subsystem 5)	<ol style="list-style-type: none"> 1. DCA-2 Location: U2.1-V2 2. Fan 4 Location: U2.1-F4

Error Code	Description	Action/ Possible Failing FRU
1021 7117	Problem with fan 1 and fan 3 in first I/O subsystem in second rack (I/O subsystem 5)	<ol style="list-style-type: none"> DCA-1 Location: U2.1-V1 Fans 1 and 3 Location: U2.1-F1 and U2.1-F3
1021 7127	Problem with fan 2 and fan 4 in first I/O subsystem in second rack (I/O subsystem 5)	<ol style="list-style-type: none"> DCA-2 Location: U2.1-V2 Fans 2 and 4 Location: U2.1-F2 and U2.1-F4
1021 B014	Overcurrent or overvoltage problem with 3.3V in 5th I/O subsystem	Go to "MAP 1520: Power" on page 185.
1021 B024	Overcurrent or overvoltage problem with 5.0V in 5th I/O subsystem	Go to "MAP 1520: Power" on page 185.
1021 B034	Overcurrent or overvoltage problem with 2.5V in 5th I/O subsystem	Go to "MAP 1520: Power" on page 185.
1021 B044	Overcurrent or overvoltage problem with 12.0V in 5th I/O subsystem	Go to "MAP 1520: Power" on page 185.
1021 B054	Overcurrent or overvoltage problem with -12.0V in 5th I/O subsystem	Go to "MAP 1520: Power" on page 185.
1021 B814	Overcurrent or overvoltage problem with 3.3V in 5th I/O subsystem	Go to "MAP 1520: Power" on page 185.
1021 B824	Overcurrent or overvoltage problem with 5.0V in 5th I/O subsystem	Go to "MAP 1520: Power" on page 185.
1021 B834	Overcurrent or overvoltage problem with 2.5V in 5th I/O subsystem	Go to "MAP 1520: Power" on page 185.
1021 B844	Overcurrent or overvoltage problem with 12.0V in 5th I/O subsystem	Go to "MAP 1520: Power" on page 185.
1021 B854	Overcurrent or overvoltage problem with -12.0V in 5th I/O subsystem	Go to "MAP 1520: Power" on page 185.
1021 CD96	A power short has been detected in the DASD subsystem in an I/O drawer.	Go to "MAP 1520: Power" on page 185.
1021 CDA6	A power short has been detected in the DASD subsystem in an I/O drawer.	Go to "MAP 1520: Power" on page 185.
1021 CDB6	A power short has been detected in the DASD subsystem in an I/O drawer.	Go to "MAP 1520: Power" on page 185.
1021 CDC6	A power short has been detected in the DASD subsystem in an I/O drawer.	Go to "MAP 1520: Power" on page 185.
1021 F4x6	Hardware configuration does not support N-mode power.	Call Service Support

Error Code	Description	Action/ Possible Failing FRU
1021 F516	An N+1 boundary (DCA or fan) has dropped to N-mode status in the first I/O subsystem in the secondary rack, location: U2.1.	This is normally an informational message. It should be accompanied by other error codes that more precisely indicate where the failure is. Examine the service processor error log. If there are no other power-related error codes (in the time frame in which this code was generated) in the service processor error log, the FRU indicated with this error code, if any, should be replaced.
1021 F526	An N+1 boundary (DCA or fan) has dropped to N-mode status in the first I/O subsystem in the secondary rack, location: U2.1.	This is normally an informational message. It should be accompanied by other error codes that more precisely indicate where the failure is. Examine the service processor error log. If there are no other power-related error codes (in the time frame in which this code was generated) in the service processor error log, the FRU indicated with this error code, if any, should be replaced.
1021 xx11	First I/O subsystem in second rack, DCA-1	U2.1-V1
1021 xx13	Seeprom fault on DCA-1 in first I/O subsystem secondary rack	U2.1-V1
1021 xx15	First I/O subsystem in second rack, DCA-1, cable fault	Go to "MAP 1520: Power" on page 185 with these location codes: U2.1-V1-Q1# U2.1-V1-Q2#
1021 xx21	First I/O subsystem in second rack, DCA-2	U2.1-V2
1021 xx23	Seeprom fault on DCA-2 in first I/O subsystem secondary rack	U2.1-V2
1021 xx25	First I/O subsystem in second rack, DCA-2, cable fault	Go to "MAP 1520: Power" on page 185 with these location codes: U2.1-V2-Q1# U2.1-V2-Q2#
1021 xx31	First I/O subsystem in secondary rack I/O subsystem backplane 1 fault	U2.1-P1
1021 xx33	Seeprom fault on I/O subsystem backplane 1 in first I/O subsystem in secondary rack	U2.1-P1
1021 xx41	First I/O subsystem in secondary rack I/O subsystem backplane 2 fault	U2.1-P2
1021 xx43	Seeprom fault on I/O subsystem backplane 2 in first I/O subsystem in secondary rack	U2.1-P2

Error Code	Description	Action/ Possible Failing FRU
1021 xx51	First I/O subsystem in secondary rack DASD backplane 1 fault	U2.1-P3
1021 xx53	Seeprom fault on DASD backplane 1 in first I/O subsystem in secondary rack	U2.1-P3
1021 xx61	First I/O subsystem in secondary rack DASD backplane 2 fault	U2.1-P4
1021 xx63	Seeprom fault on DASD backplane 2 in first I/O subsystem in secondary rack	U2.1-P4
1021 xx71	First I/O subsystem in secondary rack DASD backplane 3 fault	U2.1-P5
1021 xx73	Seeprom fault on DASD backplane 3 in first I/O subsystem in secondary rack	U2.1-P5
1021 xx81	First I/O subsystem in secondary rack DASD backplane 4 fault	U2.1-P6
1021 xx83	Seeprom fault on DASD backplane 4 in first I/O subsystem in secondary rack	U2.1-P6
1022 1B17	Problem with fan 1 in second I/O subsystem in second rack (I/O subsystem 6)	1. DCA-1 Location: U2.5-V1 2. Fan 1 Location:U2.5-F1
1022 1B27	Problem with fan 2 in second I/O subsystem in second rack (I/O subsystem 6)	1. DCA-2 Location: U2.5-V2 2. Fan 2 Location:U2.5-F2
1022 1C06	Loss of airflow in second I/O subsystem in second rack (I/O subsystem 6), location: U2.5	Go to "Map 1527: An Airflow Loss Has Been Detected" on page 200.
1022 6014	Overcurrent or overvoltage problem with 3.3V in second I/O subsystem in second rack (I/O subsystem 6)	Go to "MAP 1520: Power" on page 185.
1022 6024	Overcurrent or overvoltage problem with 5.0V in second I/O subsystem in second rack (I/O subsystem 6)	Go to "MAP 1520: Power" on page 185.
1022 6034	Overcurrent or overvoltage problem with 2.5V in second I/O subsystem in second rack (I/O subsystem 6)	Go to "MAP 1520: Power" on page 185.
1022 6044	Overcurrent or overvoltage problem with 12.0V in second I/O subsystem in second rack (I/O subsystem 6)	Go to "MAP 1520: Power" on page 185.

Error Code	Description	Action/ Possible Failing FRU
1022 6054	Overcurrent or overvoltage problem with -12.0V in second I/O subsystem in second rack (I/O subsystem 6)	Go to "MAP 1520: Power" on page 185.
1022 6814	Overcurrent or overvoltage problem with 3.3V in second I/O subsystem in second rack (I/O subsystem 6)	Go to "MAP 1520: Power" on page 185.
1022 6824	Overcurrent or overvoltage problem with 5.0V in second I/O subsystem in second rack (I/O subsystem 6)	Go to "MAP 1520: Power" on page 185.
1022 6834	Overcurrent or overvoltage problem with 2.5V in second I/O subsystem in second rack (I/O subsystem 6)	Go to "MAP 1520: Power" on page 185.
1022 6844	Overcurrent or overvoltage problem with 12.0V in second I/O subsystem in second rack (I/O subsystem 6)	Go to "MAP 1520: Power" on page 185.
1022 6854	Overcurrent or overvoltage problem with -12.0V in second I/O subsystem in second rack (I/O subsystem 6)	Go to "MAP 1520: Power" on page 185.
1022 7017	Problem with fan 3 in second I/O subsystem in second rack (I/O subsystem 6)	<ol style="list-style-type: none"> 1. DCA-1 Location: U2.5-V1 2. Fan 3 Location: U2.5-F3
1022 7027	Problem with fan 4 in second I/O subsystem in second rack (I/O subsystem 6)	<ol style="list-style-type: none"> 1. DCA-2 Location: U2.5-V2 2. Fan 4 Location: U2.5-F4
1022 7117	Problem with fan 1 and fan 3 in second I/O subsystem in second rack (I/O subsystem 6)	<ol style="list-style-type: none"> 1. DCA-1 Location: U2.5-V1 2. Fans 1 and 3 Location: U2.5-F1 and U2.5-F3
1022 7127	Problem with fan 2 and fan 4 in second I/O subsystem in second rack (I/O subsystem 6)	<ol style="list-style-type: none"> 1. DCA-2 Location: U2.5-V2 2. Fans 2 and 4 Location: U2.5-F2 and U2.5-F4
1022 B014	Overcurrent or overvoltage problem with 3.3V in second I/O subsystem in second rack (I/O subsystem 6)	Go to "MAP 1520: Power" on page 185.
1022 B024	Overcurrent or overvoltage problem with 5.0V in second I/O subsystem in second rack (I/O subsystem 6)	Go to "MAP 1520: Power" on page 185.
1022 B034	Overcurrent or overvoltage problem with 2.5V in 6th I/O subsystem	Go to "MAP 1520: Power" on page 185.
1022 B044	Overcurrent or overvoltage problem with 12.0V in 6th I/O subsystem	Go to "MAP 1520: Power" on page 185.

Error Code	Description	Action/ Possible Failing FRU
1022 B054	Overcurrent or overvoltage problem with -12.0V in 6th I/O subsystem	Go to "MAP 1520: Power" on page 185.
1022 B814	Overcurrent or overvoltage problem with 3.3V in 6th I/O subsystem	Go to "MAP 1520: Power" on page 185.
1022 B824	Overcurrent or overvoltage problem with 5.0V in second I/O subsystem in second rack (I/O subsystem 6)	Go to "MAP 1520: Power" on page 185.
1022 B834	Overcurrent or overvoltage problem with 2.5V in second I/O subsystem in second rack (I/O subsystem 6)	Go to "MAP 1520: Power" on page 185.
1022 B844	Overcurrent or overvoltage problem with 12.0V in second I/O subsystem in second rack (I/O subsystem 6)	Go to "MAP 1520: Power" on page 185.
1022 B854	Overcurrent or overvoltage problem with -12.0V in second I/O subsystem in second rack (I/O subsystem 6)	Go to "MAP 1520: Power" on page 185.
1022 CD96	A power short has been detected in the DASD subsystem in an I/O drawer.	Go to "MAP 1520: Power" on page 185.
1022 CDA6	A power short has been detected in the DASD subsystem in an I/O drawer.	Go to "MAP 1520: Power" on page 185.
1022 CDB6	A power short has been detected in the DASD subsystem in an I/O drawer.	Go to "MAP 1520: Power" on page 185.
1022 CDC6	A power short has been detected in the DASD subsystem in an I/O drawer.	Go to "MAP 1520: Power" on page 185.
1022 F4x6	Hardware configuration does not support N-mode power.	Call Service Support
1022 F516	An N+1 boundary (DCA or fan) has dropped to N-mode status in second I/O subsystem in second rack (I/O subsystem 6), location: U2.5.	This is normally an informational message. It should be accompanied by other error codes that more precisely indicate where the failure is. Examine the service processor error log. If there are no other power-related error codes (in the time frame in which this code was generated) in the service processor error log, the FRU indicated with this error code, if any, should be replaced.

Error Code	Description	Action/ Possible Failing FRU
1022 F526	An N+1 boundary (DCA or fan) has dropped to N-mode status in the second I/O subsystem in the secondary rack, location: U2.5.	This is normally an informational message. It should be accompanied by other error codes that more precisely indicate where the failure is. Examine the service processor error log. If there are no other power-related error codes (in the time frame in which this code was generated) in the service processor error log, the FRU indicated with this error code, if any, should be replaced.
1022 xx11	Second I/O subsystem in second I/O subsystem in second rack (I/O subsystem 6), DCA-1	U2.5-V1
1022 xx13	Seeprom fault on DCA-1 in second I/O subsystem in second rack (I/O subsystem 6)	U2.5-V1
1022 xx15	Second I/O subsystem in second rack (I/O subsystem 6), DCA-1, cable fault	Go to "MAP 1520: Power" on page 185 with these location codes: U2.5-V1-Q1# U2.5-V1-Q2#
1022 xx21	Second I/O subsystem in second rack (I/O subsystem 6), DCA-2	U2.5-V2
1022 xx23	Seeprom fault on DCA-2 in second I/O subsystem in secondary rack (I/O subsystem 6)	U2.5-V2
1022 xx25	Second I/O subsystem in second rack (I/O subsystem 6), DCA-2, cable fault	Go to "MAP 1520: Power" on page 185 with these location codes: U2.5-V2-Q1# U2.5-V2-Q2#
1022 xx31	Second I/O subsystem in secondary rack (I/O subsystem 6) I/O subsystem backplane 1 fault	U2.5-P1
1022 xx33	Seeprom fault on I/O subsystem backplane 1 in second I/O subsystem in secondary rack (I/O subsystem 6)	U2.5-P1
1022 xx41	Second I/O subsystem in secondary rack (I/O subsystem 6) I/O subsystem backplane 2 fault	U2.5-P2
1022 xx43	Seeprom fault on I/O subsystem backplane 2 in second I/O subsystem in secondary rack (I/O subsystem 6)	U2.5-P2
1022 xx51	Second I/O subsystem in secondary rack (I/O subsystem 6) DASD backplane 1 fault	U2.5-P3
1022 xx53	Seeprom fault on DASD backplane 1 in second I/O subsystem in secondary rack (I/O subsystem 6)	U2.5-P3

Error Code	Description	Action/ Possible Failing FRU
1022 xx61	Second I/O subsystem in secondary rack (I/O subsystem 6), DASD backplane 2 fault	U2.5-P4
1022 xx63	Seeprom fault on DASD backplane 2 in second I/O subsystem in secondary rack (I/O subsystem 6)	U2.5-P4
1022 xx71	Second I/O subsystem in secondary rack (I/O subsystem 6), DASD backplane 3 fault	U2.5-P5
1022 xx73	Seeprom fault on DASD backplane 3 in second I/O subsystem in secondary rack (I/O subsystem 6)	U2.5-P5
1022 xx81	Second I/O subsystem in secondary rack (I/O subsystem 6) DASD backplane 4 fault	U2.5-P6
1022 xx83	Seeprom fault on DASD backplane 4 in second I/O subsystem in secondary rack (I/O subsystem 6)	U2.5-P6
1023 1B17	Problem with fan 1 in fourth I/O subsystem (with IBF, moves to second rack)	1. DCA-1 Location: U2.9-V1 2. Fan 1 Location:U2.9-F1
1023 1B27	Problem with fan 2 in fourth I/O subsystem (with IBF, moves to second rack)	1. DCA-2 Location: U2.9-V2 2. Fan 2 Location:U2.9-F2
1023 1C06	Loss of airflow in fourth I/O subsystem, with IBF location: U2.9	Go to "Map 1527: An Airflow Loss Has Been Detected" on page 200.
1023 6014	Overcurrent or overvoltage problem with 3.3V in fourth I/O subsystem (with IBF, moves to second rack)	Go to "MAP 1520: Power" on page 185.
1023 6024	Overcurrent or overvoltage problem with 5.0V in fourth I/O subsystem (with IBF, moves to second rack)	Go to "MAP 1520: Power" on page 185.
1023 6034	Overcurrent or overvoltage problem with 2.5V in fourth I/O subsystem (with IBF, moves to second rack)	Go to "MAP 1520: Power" on page 185.
1023 6044	Overcurrent or overvoltage problem with 12.0V in fourth I/O subsystem (with IBF, moves to second rack)	Go to "MAP 1520: Power" on page 185.
1023 6054	Overcurrent or overvoltage problem with -12.0V in fourth I/O subsystem (with IBF, moves to second rack)	Go to "MAP 1520: Power" on page 185.

Error Code	Description	Action/ Possible Failing FRU
1023 6814	Overcurrent or overvoltage problem with 3.3V in fourth I/O subsystem (with IBF, moves to second rack)	Go to "MAP 1520: Power" on page 185.
1023 6824	Overcurrent or overvoltage problem with 5.0V in fourth I/O subsystem (with IBF, moves to second rack)	Go to "MAP 1520: Power" on page 185.
1023 6834	Overcurrent or overvoltage problem with 2.5V in fourth I/O subsystem (with IBF, moves to second rack)	Go to "MAP 1520: Power" on page 185.
1023 6844	Overcurrent or overvoltage problem with 12.0V in fourth I/O subsystem (with IBF, moves to second rack)	Go to "MAP 1520: Power" on page 185.
1023 6854	Overcurrent or overvoltage problem with -12.0V in fourth I/O subsystem (with IBF, moves to second rack)	Go to "MAP 1520: Power" on page 185.
1023 7017	Problem with fan 3 in fourth I/O subsystem (with IBF, moves to second rack)	<ol style="list-style-type: none"> DCA-1 Location: U2.9-V1 Fan 3 Location: U2.9-F3
1023 7027	Problem with fan 4 in fourth I/O subsystem (with IBF, moves to second rack)	<ol style="list-style-type: none"> DCA-2 Location: U2.9-V2 Fan 4 Location: U2.9-F4
1023 7117	Problem with fan 1 and fan 3 in fourth I/O subsystem (with IBF, moves to second rack)	<ol style="list-style-type: none"> DCA-1 Location: U2.9-V1 Fans 1 and 3 Location: U2.9-F1 and U2.9-F3
1023 7127	Problem with fan 2 and fan 4 in fourth I/O subsystem (with IBF, moves to second rack)	<ol style="list-style-type: none"> DCA-2 Location: U2.9-V2 Fans 2 and 4 Location: U2.9-F2 and U2.9-F4
1023 B014	Overcurrent or overvoltage problem with 3.3V in fourth I/O subsystem (with IBF, moves to second rack)	Go to "MAP 1520: Power" on page 185.
1023 B024	Overcurrent or overvoltage problem with 5.0V in fourth I/O subsystem (with IBF, moves to second rack)	Go to "MAP 1520: Power" on page 185.
1023 B034	Overcurrent or overvoltage problem with 2.5V in fourth I/O subsystem (with IBF, moves to second rack)	Go to "MAP 1520: Power" on page 185.
1023 B044	Overcurrent or overvoltage problem with 12.0V in fourth I/O subsystem (with IBF, moves to second rack)	Go to "MAP 1520: Power" on page 185.

Error Code	Description	Action/ Possible Failing FRU
1023 B054	Overcurrent or overvoltage problem with -12.0V in fourth I/O subsystem (with IBF, moves to second rack)	Go to "MAP 1520: Power" on page 185.
1023 B814	Overcurrent or overvoltage problem with 3.3V in fourth I/O subsystem (with IBF, moves to second rack)	Go to "MAP 1520: Power" on page 185.
1023 B824	Overcurrent or overvoltage problem with 5.0V in fourth I/O subsystem (with IBF, moves to second rack)	Go to "MAP 1520: Power" on page 185.
1023 B834	Overcurrent or overvoltage problem with 2.5V in fourth I/O subsystem (with IBF, moves to second rack)	Go to "MAP 1520: Power" on page 185.
1023 B844	Overcurrent or overvoltage problem with 12.0V in fourth I/O subsystem (with IBF, moves to second rack)	Go to "MAP 1520: Power" on page 185.
1023 B854	Overcurrent or overvoltage problem with -12.0V in fourth I/O subsystem (with IBF, moves to second rack)	Go to "MAP 1520: Power" on page 185.
1023 CD96	A power short has been detected in the DASD subsystem in an I/O drawer.	Go to "MAP 1520: Power" on page 185.
1023 CDA6	A power short has been detected in the DASD subsystem in an I/O drawer.	Go to "MAP 1520: Power" on page 185.
1023 CDB6	A power short has been detected in the DASD subsystem in an I/O drawer.	Go to "MAP 1520: Power" on page 185.
1023 CDC6	A power short has been detected in the DASD subsystem in an I/O drawer.	Go to "MAP 1520: Power" on page 185.
1023 F4x6	Hardware configuration does not support N-mode power.	Call Service Support
1023 F516	An N+1 boundary (DCA or fan) has dropped to N-mode status in the fourth subsystem (with IBF, location: U2.9).	This is normally an informational message. It should be accompanied by other error codes that more precisely indicate where the failure is. Examine the service processor error log. If there are no other power-related error codes (in the time frame in which this code was generated) in the service processor error log, the FRU indicated with this error code, if any, should be replaced.

Error Code	Description	Action/ Possible Failing FRU
1023 F526	An N+1 boundary (DCA or fan) has dropped to N-mode status in the fourth I/O subsystem (with IBF), location: U2.9.	This is normally an informational message. It should be accompanied by other error codes that more precisely indicate where the failure is. Examine the service processor error log. If there are no other power-related error codes (in the time frame in which this code was generated) in the service processor error log, the FRU indicated with this error code, if any, should be replaced.
1023 xx11	Fourth I/O subsystem moves to second rack (with IBF), DCA-1	U2.9-V1
1023 xx13	Seeprom fault on DCA-1 in fourth I/O subsystem (with IBF) in secondary rack	U2.9-V1
1023 xx15	Fourth I/O subsystem moves to second rack (with IBF), DCA-1, cable fault	Go to "MAP 1520: Power" on page 185 with these location codes: U2.9-V1-Q1# U2.9-V1-Q2#
1023 xx21	Fourth I/O subsystem moves to second rack (with IBF), DCA-2	U2.9-V2
1023 xx23	Seeprom fault on DCA-2 in fourth I/O subsystem (with IBF) in secondary rack	U2.9-V2
1023 xx25	Fourth I/O subsystem moves to second rack (with IBF), DCA-2, cable fault	Go to "MAP 1520: Power" on page 185 with these location codes: U2.9-V2-Q1# U2.9-V2-Q2#
1023 xx31	Fourth I/O subsystem (with IBF) in secondary rack I/O subsystem backplane 1 fault	U2.9-P1
1023 xx33	Seeprom fault on I/O subsystem backplane 1 in fourth I/O subsystem (with IBF) in secondary rack	U2.9-P1
1023 xx41	Fourth I/O subsystem (with IBF) in secondary rack I/O subsystem backplane 2 fault	U2.9-P2
1023 xx43	Seeprom fault on I/O subsystem backplane 2 in fourth I/O subsystem (with IBF) in secondary rack	U2.9-P2
1023 xx51	Fourth I/O subsystem (with IBF) in secondary rack DASD backplane 1 fault	U2.9-P3
1023 xx53	Seeprom fault on DASD backplane 1 in fourth I/O subsystem (with IBF) in secondary rack	U2.9-P3

Error Code	Description	Action/ Possible Failing FRU
1023 xx61	Fourth I/O subsystem (with IBF) in secondary rack DASD backplane 2 fault	U2.9-P4
1023 xx63	Seeprom fault on DASD backplane 2 in fourth I/O subsystem (with IBF) in secondary rack	U2.9-P4
1023 xx71	Fourth I/O subsystem (with IBF) in secondary rack DASD backplane 3 fault	U2.9-P5
1023 xx73	Seeprom fault on DASD backplane 3 in fourth I/O subsystem (with IBF) in secondary rack	U2.9-P5
1023 xx81	Fourth I/O subsystem (with IBF) in secondary rack DASD backplane 4 fault	U2.9-P6
1023 xx83	Seeprom fault on DASD backplane 4 in fourth I/O subsystem (with IBF) in secondary rack	U2.9-P6
1024 1B17	Problem with fan 1 in third I/O subsystem in second rack (I/O subsystem 7)	1. DCA-1 Location: U2.13-V1 2. Fan 1 Location:U2.13-F1
1024 1B27	Problem with fan 2 in third I/O subsystem in second rack (I/O subsystem 7)	1. DCA-2 Location: U2.13-V2 2. Fan 2 Location:U2.13-F2
1024 1C06	Loss of airflow in third I/O subsystem in second rack (I/O subsystem 7), location: U2.13	Go to "Map 1527: An Airflow Loss Has Been Detected" on page 200.
1024 6014	Overcurrent or overvoltage problem with 3.3V in third I/O subsystem in second rack (I/O subsystem 7)	Go to "MAP 1520: Power" on page 185.
1024 6024	Overcurrent or overvoltage problem with 5.0V in third I/O subsystem in second rack (I/O subsystem 7)	Go to "MAP 1520: Power" on page 185.
1024 6034	Overcurrent or overvoltage problem with 2.5V in third I/O subsystem in second rack (I/O subsystem 7)	Go to "MAP 1520: Power" on page 185.
1024 6044	Overcurrent or overvoltage problem with 12.0V in third I/O subsystem in second rack (I/O subsystem 7)	Go to "MAP 1520: Power" on page 185.
1024 6054	Overcurrent or overvoltage problem with -12.0V in third I/O subsystem in second rack (I/O subsystem 7)	Go to "MAP 1520: Power" on page 185.

Error Code	Description	Action/ Possible Failing FRU
1024 6814	Overcurrent or overvoltage problem with 3.3V in third I/O subsystem in second rack (I/O subsystem 7)	Go to "MAP 1520: Power" on page 185.
1024 6824	Overcurrent or overvoltage problem with 5.0V in third I/O subsystem in second rack (I/O subsystem 7)	Go to "MAP 1520: Power" on page 185.
1024 6834	Overcurrent or overvoltage problem with 2.5V in third I/O subsystem in second rack (I/O subsystem 7)	Go to "MAP 1520: Power" on page 185.
1024 6844	Overcurrent or overvoltage problem with 12.0V in third I/O subsystem in second rack (I/O subsystem 7)	Go to "MAP 1520: Power" on page 185.
1024 6854	Overcurrent or overvoltage problem with -12.0V in third I/O subsystem in second rack (I/O subsystem 7)	Go to "MAP 1520: Power" on page 185.
1024 7017	Problem with fan 3 in third I/O subsystem in second I/O subsystem in second rack (I/O subsystem 7)	<ol style="list-style-type: none"> DCA-1 Location: U2.13-V1 Fan 3 Location: U2.13-F3
1024 7027	Problem with fan 4 in third I/O subsystem in second rack (I/O subsystem 7)	<ol style="list-style-type: none"> DCA-2 Location: U2.13-V2 Fan 4 Location: U2.13-F4
1024 7117	Problem with fan 1 and fan 3 in third I/O subsystem in second rack (I/O subsystem 7)	<ol style="list-style-type: none"> DCA-1 Location: U2.13-V1 Fans 1 and 3 Location: U2.13-F1 and U2.13-F3
1024 7127	Problem with fan 2 and fan 4 in third I/O subsystem in second rack (I/O subsystem 7)	<ol style="list-style-type: none"> DCA-2 Location: U2.13-V2 Fans 2 and 4 Location: U2.13-F2 and U2.13-F4
1024 B014	Overcurrent or overvoltage problem with 3.3V in third I/O subsystem in second rack (I/O subsystem 7)	Go to "MAP 1520: Power" on page 185.
1024 B024	Overcurrent or overvoltage problem with 5.0V in third I/O subsystem in second rack (I/O subsystem 7)	Go to "MAP 1520: Power" on page 185.
1024 B034	Overcurrent or overvoltage problem with 2.5V in third I/O subsystem in second rack (I/O subsystem 7)	Go to "MAP 1520: Power" on page 185.
1024 B044	Overcurrent or overvoltage problem with 12.0V in third I/O subsystem in second rack (I/O subsystem 7)	Go to "MAP 1520: Power" on page 185.

Error Code	Description	Action/ Possible Failing FRU
1024 B054	Overcurrent or overvoltage problem with -12.0V in third I/O subsystem in second rack (I/O subsystem 7)	Go to "MAP 1520: Power" on page 185.
1024 B814	Overcurrent or overvoltage problem with 3.3V in third I/O subsystem in second rack (I/O subsystem 7)	Go to "MAP 1520: Power" on page 185.
1024 B824	Overcurrent or overvoltage problem with 5.0V in third I/O subsystem in second rack (I/O subsystem 7)	Go to "MAP 1520: Power" on page 185.
1024 B834	Overcurrent or overvoltage problem with 2.5V in third I/O subsystem in second rack (I/O subsystem 7)	Go to "MAP 1520: Power" on page 185.
1024 B844	Overcurrent or overvoltage problem with 12.0V in third I/O subsystem in second rack (I/O subsystem 7)	Go to "MAP 1520: Power" on page 185.
1024 B854	Overcurrent or overvoltage problem with -12.0V in third I/O subsystem in second rack (I/O subsystem 7)	Go to "MAP 1520: Power" on page 185.
1024 CD96	A power short has been detected in the DASD subsystem in an I/O drawer.	Go to "MAP 1520: Power" on page 185.
1024 CDA6	A power short has been detected in the DASD subsystem in an I/O drawer.	Go to "MAP 1520: Power" on page 185.
1024 CDB6	A power short has been detected in the DASD subsystem in an I/O drawer.	Go to "MAP 1520: Power" on page 185.
1024 CDC6	A power short has been detected in the DASD subsystem in an I/O drawer.	Go to "MAP 1520: Power" on page 185.
1024 F4x6	Hardware configuration does not support N-mode power.	Call Service Support
1024 F516	An N+1 boundary (DCA or fan) has dropped to N-mode status in third I/O subsystem in second rack (I/O subsystem 7), location: U2.13.	This is normally an informational message. It should be accompanied by other error codes that more precisely indicate where the failure is. Examine the service processor error log. If there are no other power-related error codes (in the time frame in which this code was generated) in the service processor error log, the FRU indicated with this error code, if any, should be replaced.

Error Code	Description	Action/ Possible Failing FRU
1024 F526	An N+1 boundary (DCA or fan) has dropped to N-mode status in third I/O subsystem in second rack (I/O subsystem 7), location: U2.13.	This is normally an informational message. It should be accompanied by other error codes that more precisely indicate where the failure is. Examine the service processor error log. If there are no other power-related error codes (in the time frame in which this code was generated) in the service processor error log, the FRU indicated with this error code, if any, should be replaced.
1024 xx11	Second I/O subsystem in third I/O subsystem in second rack (I/O subsystem 7), DCA-1	U2.13-V1
1024 xx13	Seeprom fault on DCA-1 in third I/O subsystem in second rack (I/O subsystem 7)	U2.13-V1
1024 xx15	Third I/O subsystem in second rack (I/O subsystem 7), DCA-1, cable fault	Go to "MAP 1520: Power" on page 185 with these location codes: U2.13-V1-Q1# U2.13-V1-Q2#
1024 xx21	Third I/O subsystem in second rack (I/O subsystem 7), DCA-2	U2.13-V2
1024 xx23	Seeprom fault on DCA-2 in third I/O subsystem in second rack (I/O subsystem 7)	U2.13-V2
1024 xx25	Third I/O subsystem in second rack (I/O subsystem 7), DCA-2, cable fault	Go to "MAP 1520: Power" on page 185 with these location codes: U2.13-V2-Q1# U2.13-V2-Q2#
1024 xx31	Third I/O subsystem in second rack (I/O subsystem 7) I/O subsystem backplane 1 fault	U2.13-P1
1024 xx33	Seeprom fault on I/O subsystem backplane 1 in third I/O subsystem in second rack (I/O subsystem 7)	U2.13-P1
1024 xx41	Third I/O subsystem in second rack (I/O subsystem 7) I/O subsystem backplane 2 fault	U2.13-P2
1024 xx43	Seeprom fault on I/O subsystem backplane 2 in third I/O subsystem in second rack (I/O subsystem 7)	U2.13-P2
1024 xx51	Third I/O subsystem in second rack (I/O subsystem 7) DASD backplane 1 fault	U2.13-P3
1024 xx53	Seeprom fault on DASD backplane 1 in third I/O subsystem in second rack (I/O subsystem 7)	U2.13-P3

Error Code	Description	Action/ Possible Failing FRU
1024 xx61	Third I/O subsystem in second rack (I/O subsystem 7), DASD backplane 2 fault	U2.13-P4
1024 xx63	Seeprom fault on DASD backplane 2 in third I/O subsystem in second rack (I/O subsystem 7)	U2.13-P4
1024 xx71	Third I/O subsystem in second rack (I/O subsystem 7), DASD backplane 3 fault	U2.13-P5
1024 xx73	Seeprom fault on DASD backplane 3 in third I/O subsystem in second rack (I/O subsystem 7)	U2.13-P5
1024 xx81	Third I/O subsystem in second rack (I/O subsystem 7) DASD backplane 4 fault	U2.13-P6
1024 xx83	Seeprom fault on DASD backplane 4 in third I/O subsystem in second rack (I/O subsystem 7)	U2.13-P6
1025 1B17	Problem with fan 1 in fourth I/O subsystem in second rack (I/O subsystem 8)	1. DCA-1 Location: U2.19-V1 2. Fan 1 Location:U2.19-F1
1025 1B27	Problem with fan 2 in fourth I/O subsystem in second rack (I/O subsystem 8)	1. DCA-2 Location: U2.19-V2 2. Fan 2 Location:U2.19-F2
1025 1C06	Loss of airflow in fourth I/O subsystem in second rack (I/O subsystem 8), location: U2.19	Go to "Map 1527: An Airflow Loss Has Been Detected" on page 200.
1025 6014	Overcurrent or overvoltage problem with 3.3V in fourth I/O subsystem in second rack (I/O subsystem 8)	Go to "MAP 1520: Power" on page 185.
1025 6024	Overcurrent or overvoltage problem with 5.0V in fourth I/O subsystem in second rack (I/O subsystem 8)	Go to "MAP 1520: Power" on page 185.
1025 6034	Overcurrent or overvoltage problem with 2.5V in fourth I/O subsystem in second rack (I/O subsystem 8)	Go to "MAP 1520: Power" on page 185.
1025 6044	Overcurrent or overvoltage problem with 12.0V in fourth I/O subsystem in second rack (I/O subsystem 8)	Go to "MAP 1520: Power" on page 185.
1025 6054	Overcurrent or overvoltage problem with -12.0V in fourth I/O subsystem in second rack (I/O subsystem 8)	Go to "MAP 1520: Power" on page 185.

Error Code	Description	Action/ Possible Failing FRU
1025 6814	Overcurrent or overvoltage problem with 3.3V in fourth I/O subsystem in second rack (I/O subsystem 8)	Go to "MAP 1520: Power" on page 185.
1025 6824	Overcurrent or overvoltage problem with 5.0V in fourth I/O subsystem in second rack (I/O subsystem 8)	Go to "MAP 1520: Power" on page 185.
1025 6834	Overcurrent or overvoltage problem with 2.5V in fourth I/O subsystem in second rack (I/O subsystem 8)	Go to "MAP 1520: Power" on page 185.
1025 6844	Overcurrent or overvoltage problem with 12.0V in fourth I/O subsystem in second rack (I/O subsystem 8)	Go to "MAP 1520: Power" on page 185.
1025 6854	Overcurrent or overvoltage problem with -12.0V in fourth I/O subsystem in second rack (I/O subsystem 8)	Go to "MAP 1520: Power" on page 185.
1025 7017	Problem with fan 3 in fourth I/O subsystem in second I/O subsystem in second rack (I/O subsystem 8)	<ol style="list-style-type: none"> DCA-1 Location: U2.19-V1 Fan 3 Location: U2.19-F3
1025 7027	Problem with fan 4 in fourth I/O subsystem in second rack (I/O subsystem 8)	<ol style="list-style-type: none"> DCA-2 Location: U2.19-V2 Fan 4 Location: U2.19-F4
1025 7117	Problem with fan 1 and fan 3 in fourth I/O subsystem in second rack (I/O subsystem 8)	<ol style="list-style-type: none"> DCA-1 Location: U2.19-V1 Fans 1 and 3 Location: U2.19-F1 and U2.19-F3
1025 7127	Problem with fan 2 and fan 4 in fourth I/O subsystem in second rack (I/O subsystem 8)	<ol style="list-style-type: none"> DCA-2 Location: U2.19-V2 Fans 2 and 4 Location: U2.19-F2 and U2.19-F4
1025 B014	Overcurrent or overvoltage problem with 3.3V in fourth I/O subsystem in second rack (I/O subsystem 8)	Go to "MAP 1520: Power" on page 185.
1025 B024	Overcurrent or overvoltage problem with 5.0V in fourth I/O subsystem in second rack (I/O subsystem 8)	Go to "MAP 1520: Power" on page 185.
1025 B034	Overcurrent or overvoltage problem with 2.5V in fourth I/O subsystem in second rack (I/O subsystem 8)	Go to "MAP 1520: Power" on page 185.
1025 B044	Overcurrent or overvoltage problem with 12.0V in fourth I/O subsystem in second rack (I/O subsystem 8)	Go to "MAP 1520: Power" on page 185.

Error Code	Description	Action/ Possible Failing FRU
1025 B054	Overcurrent or overvoltage problem with -12.0V in fourth I/O subsystem in second rack (I/O subsystem 8)	Go to "MAP 1520: Power" on page 185.
1025 B814	Overcurrent or overvoltage problem with 3.3V in fourth I/O subsystem in second rack (I/O subsystem 8)	Go to "MAP 1520: Power" on page 185.
1025 B824	Overcurrent or overvoltage problem with 5.0V in second I/O subsystem in fourth I/O subsystem in second rack (I/O subsystem 8)	Go to "MAP 1520: Power" on page 185.
1025 B834	Overcurrent or overvoltage problem with 2.5V in second I/O subsystem in fourth I/O subsystem in second rack (I/O subsystem 8)	Go to "MAP 1520: Power" on page 185.
1025 B844	Overcurrent or overvoltage problem with 12.0V in second I/O subsystem in fourth I/O subsystem in second rack (I/O subsystem 8)	Go to "MAP 1520: Power" on page 185.
1025 B854	Overcurrent or overvoltage problem with -12.0V in fourth I/O subsystem in second rack (I/O subsystem 8)	Go to "MAP 1520: Power" on page 185.
1025 CD96	A power short has been detected in the DASD subsystem in an I/O drawer.	Go to "MAP 1520: Power" on page 185.
1025 CDA6	A power short has been detected in the DASD subsystem in an I/O drawer.	Go to "MAP 1520: Power" on page 185.
1025 CDB6	A power short has been detected in the DASD subsystem in an I/O drawer.	Go to "MAP 1520: Power" on page 185.
1025 CDC6	A power short has been detected in the DASD subsystem in an I/O drawer.	Go to "MAP 1520: Power" on page 185.
1025 F4x6	Hardware configuration does not support N-mode power.	Call Service Support
1025 F516	An N+1 boundary (DCA or fan) has dropped to N-mode status in fourth I/O subsystem in second rack (I/O subsystem 8), location: U2.19.	This is normally an informational message. It should be accompanied by other error codes that more precisely indicate where the failure is. Examine the service processor error log. If there are no other power-related error codes (in the time frame in which this code was generated) in the service processor error log, the FRU indicated with this error code, if any, should be replaced.

Error Code	Description	Action/ Possible Failing FRU
1025 F526	An N+1 boundary (DCA or fan) has dropped to N-mode status in fourth I/O subsystem in second rack (I/O subsystem 8), location: U2.19.	This is normally an informational message. It should be accompanied by other error codes that more precisely indicate where the failure is. Examine the service processor error log. If there are no other power-related error codes (in the time frame in which this code was generated) in the service processor error log, the FRU indicated with this error code, if any, should be replaced.
1025 xx11	Second I/O subsystem in second I/O subsystem in fourth I/O subsystem in second rack (I/O subsystem 8), DCA-1	U2.19-V1
1025 xx13	Seeprom fault on DCA-1 in fourth I/O subsystem in second rack (I/O subsystem 8)	U2.19-V1
1025 xx15	Second I/O subsystem in fourth I/O subsystem in second rack (I/O subsystem 8), DCA-1, cable fault	Go to "MAP 1520: Power" on page 185 with these location codes: U2.19-V1-Q1# U2.19-V1-Q2#
1025 xx21	Second I/O subsystem in fourth I/O subsystem in second rack (I/O subsystem 8), DCA-2	U2.19-V2
1025 xx23	Seeprom fault on DCA-2 in fourth I/O subsystem in second rack (I/O subsystem 8)	U2.19-V2
1025 xx25	Second I/O subsystem in fourth I/O subsystem in second rack (I/O subsystem 8), DCA-2, cable fault	Go to "MAP 1520: Power" on page 185 with these location codes: U2.19-V2-Q1# U2.19-V2-Q2#
1025 xx31	Fourth I/O subsystem in second rack (I/O subsystem 8) I/O subsystem backplane 1 fault	U2.19-P1
1025 xx33	Seeprom fault on I/O subsystem backplane 1 in fourth I/O subsystem in second rack (I/O subsystem 8)	U2.19-P1
1025 xx41	Second I/O subsystem in fourth I/O subsystem in second rack (I/O subsystem 8) I/O subsystem backplane 2 fault	U2.19-P2
1025 xx43	Seeprom fault on I/O subsystem backplane 2 in fourth I/O subsystem in second rack (I/O subsystem 8)	U2.19-P2
1025 xx51	Fourth I/O subsystem in second rack (I/O subsystem 8) DASD backplane 1 fault	U2.19-P3

Error Code	Description	Action/ Possible Failing FRU
1025 xx53	Seeprom fault on DASD backplane 1 in fourth I/O subsystem in second rack (I/O subsystem 8)	U2.19-P3
1025 xx61	Fourth I/O subsystem in second rack (I/O subsystem 8), DASD backplane 2 fault	U2.19-P4
1025 xx63	Seeprom fault on DASD backplane 2 in fourth I/O subsystem in second rack (I/O subsystem 8)	U2.19-P4
1025 xx71	Fourth I/O subsystem in second rack (I/O subsystem 8), DASD backplane 3 fault	U2.19-P5
1025 xx73	Seeprom fault on DASD backplane 3 in fourth I/O subsystem in second rack (I/O subsystem 8)	U2.19-P5
1025 xx81	Fourth I/O subsystem in second rack (I/O subsystem 8) DASD backplane 4 fault	U2.19-P6
1025 xx83	Seeprom fault on DASD backplane 4 in fourth I/O subsystem in second rack (I/O subsystem 8)	U2.19-P6
1RRU 1C06		Go to "Map 1527: An Airflow Loss Has Been Detected" on page 200.
SPCNtoA		Go to "Map 1529: There Is A Bulk Power Assembly (BPA) Communication Failure" on page 202.
SPCNtoB		Go to "Map 1529: There Is A Bulk Power Assembly (BPA) Communication Failure" on page 202.

Firmware/POST Error Codes

Attention: If you replace FRUs or perform an action on an I/O subsystem and the problem is still not corrected, go to “MAP 1542: I/O Problem Isolation” on page 312 unless you were already directed to any MAP 154x by the error code. Otherwise call service support if the action(s) for an error code do not resolve the problem.

Attention: If the error code that brought you to this chapter originated in the AIX error log, remember that an error may require an additional 15 minutes to be propagated to the AIX error log.

If you replace FRUs and the problem is corrected, go to “MAP 0410: Repair Checkout” in the *RS/6000 and @server pSeries Diagnostic Information for Multiple Bus Systems*.

Error Code	Description	Action/ Possible Failing FRU
2011 00xy	I/O subsystem power supply failure	1. Replace power supply “y” in I/O subsystem “x”. If y=_, then the power supply is: y = power supply 3 = Both power supplies (I/O subsystem) 2 = Reserved 1 = Reserved See “AIX and Physical Location Code Tables” in Chapter 1, for location codes. 2. Check ac power source to I/O subsystem “x”. See “AIX and Physical Location Code Tables” in Chapter 1, for location codes.
2022 0000	The I/O bus is running slowly	1. Check cabling. 2. Call second level of support.

Error Code	Description	Action/ Possible Failing FRU
203w 0xyz	<p>Remote I/O (RIO) configuration warning.</p> <p>This code indicates that a RIO configuration was detected that does not result in complete loops. The system continues to boot, however performance or recovery capability may be reduced. In some cases, the problem may result in missing I/O. Remote I/O subsystems are connected in loops. Use the letters w, y, and z in the error code to isolate the location of the open loop. Check RIO cables for loose connections, and verify power on the I/O subsystems by the presence of fan motion.</p> <p>The following numbers may be used to help isolate the failing component.</p> <ul style="list-style-type: none"> • w = loop number, this is either 0 or 1 in a system with 2 RIO loops. • x = Always 0. • y is either 1 or 2 on a system with 2 loops. y indicates the nearest associated RIO port number on the processor subsystem according to the following table: y = Nearest RIO Port 1 = 0 2 = 1 3 = 2 4 = 3 • z = B, indicates a missing return line from the I/O subsystem to the processor subsystem. • z = C, indicates a missing link between two I/O subsystems. • z = E, indicates an I/O subsystem was found connected to RIO port 3 with no return to the processor subsystem, and no I/O subsystem was found connected to RIO port 2. In this case, the I/O connected to RIO port 3 is removed from the configuration since the cause of the error and the proper location of the I/O cannot be determined. 	Go to “MAP 1542: I/O Problem Isolation” on page 312.
20A8 0000	Insufficient information to boot.	Verify the IP address in the SMS menu.

Error Code	Description	Action/ Possible Failing FRU
20A8 0001	Client IP address is already in use by other network device	Verify the IP address in the SMS menu.
20A8 0002	Cannot get gateway IP address	Refer to Table 1 on page 370 using code E174 .
20A8 0003	Cannot get server hardware address	Refer to Table 1 on page 370 using code E174 .
20A8 0004	BootP failed	Refer to Table 1 on page 370 using code E175 .
20A8 0005	File transmission (TFTP) failed.	Check network connection, try again.
20A8 0006	Boot image too large	Contact your next level of support for assistance.
20D0 000F	Selftest failed on device, no error and/or location code information available	Refer to "Determining Location Code" on page 401 to see if a location code is available for the device the error was reported against. 1. Replace device indicated by the location code (if available). 2. Go to "MAP 1542: I/O Problem Isolation" on page 312.
20D0 0010	Selftest failed on device, cannot locate package	Contact your next level of support for assistance.
20D0 0011	Firmware RTAS attempt to allocate memory failed.	Contact your next level of support for assistance.
20D0 0800	Firmware update failure: partition does not have service authority	Using the HMC, grant service authority to that partition. Reboot the partition. Retry the flash update.
20D0 0801	System firmware update failure: more than one partition running	Shut down all other partitions, then retry the firmware update.
20D0 0997	Operating system terminated with error string	Call service support. A hypervisor dump may be available; see "Hypervisor Dump Retrieval Procedure" on page 692.
20D0 0998	Operating system terminated with error string	Call service support. A hypervisor dump may be available; see "Hypervisor Dump Retrieval Procedure" on page 692.
20D0 0999	Operating system terminated with error string	Call service support. A hypervisor dump may be available; see "Hypervisor Dump Retrieval Procedure" on page 692.

Error Code	Description	Action/ Possible Failing FRU
20D0 9001	Subsystem information not found in VPD	<ol style="list-style-type: none"> 1. If the location code starts with U1.17 or U1.18, the problem is in the system VPD module on the media subsystem operator panel. Replace the operator panel; do not swap the old VPD module onto the new operator panel. Call service support for instructions on programming the VPD information into the new VPD module. 2. If the location code indicates an I/O subsystem, call service support.
20D0 9002	Subsystem machine type and model information not found in VPD	<ol style="list-style-type: none"> 1. If the location code starts with U1.17 or U1.18, the problem is in the system VPD module on the media subsystem operator panel. Replace the operator panel; do not swap the old VPD module onto the new operator panel. Call service support for instructions on programming the VPD information into the new VPD module. 2. If the location code indicates an I/O subsystem, call service support.
20D0 9003	Subsystem serial number information not found in VPD	<ol style="list-style-type: none"> 1. If the location code starts with U1.17 or U1.18, the problem is in the system VPD module on the media subsystem operator panel. Replace the operator panel; do not swap the old VPD module onto the new operator panel. Call service support for instructions on programming the VPD information into the new VPD module. 2. If the location code indicates an I/O subsystem, call service support.
20D0 9004	Subsystem machine type and model field is empty in VPD	<ol style="list-style-type: none"> 1. If the location code starts with U1.17 or U1.18, the problem is in the system VPD module on the media subsystem operator panel. Replace the operator panel; do not swap the old VPD module onto the new operator panel. Call service support for instructions on programming the VPD information into the new VPD module. 2. If the location code indicates an I/O subsystem, call service support.

Error Code	Description	Action/ Possible Failing FRU
20D0 9005	Subsystem serial number field is empty in VPD	<ol style="list-style-type: none"> 1. If the location code starts with U1.17 or U1.18, the problem is in the system VPD module on the media subsystem operator panel. Replace the operator panel; do not swap the old VPD module onto the new operator panel. Call service support for instructions on programming the VPD information into the new VPD module. 2. If the location code indicates an I/O subsystem, call service support.
20D0 9006	Duplicate subsystem serial number found in VPD	<ol style="list-style-type: none"> 1. If the location code starts with U1.17 or U1.18, the problem is in the system VPD module on the media subsystem operator panel. Replace the operator panel; do not swap the old VPD module onto the new operator panel. Call service support for instructions on programming the VPD information into the new VPD module. 2. If the location code indicates an I/O subsystem, call service support.
20D0 9007	Invalid subsystem machine type and model information in VPD	<ol style="list-style-type: none"> 1. If the location code starts with U1.17 or U1.18, the problem is in the system VPD module on the media subsystem operator panel. Replace the operator panel; do not swap the old VPD module onto the new operator panel. Call service support for instructions on programming the VPD information into the new VPD module. 2. If the location code indicates an I/O subsystem, call service support.
20D0 9008	Invalid subsystem serial number found in VPD	<ol style="list-style-type: none"> 1. If the location code starts with U1.17 or U1.18, the problem is in the system VPD module on the media subsystem operator panel. Replace the operator panel; do not swap the old VPD module onto the new operator panel. Call service support for instructions on programming the VPD information into the new VPD module. 2. If the location code indicates an I/O subsystem, call service support.

Error Code	Description	Action/ Possible Failing FRU
20D1 0001	Failed to send state-change message to service processor	<ol style="list-style-type: none"> 1. Check for system firmware updates. Apply update if available. 2. Contact your next level of support for assistance.
20D1 0002	Failed to disable heartbeat alarm	<ol style="list-style-type: none"> 1. Check for system firmware updates. Apply update if available. 2. Contact your next level of support for assistance.
20D1 0003	Failed to send boot status in LPAR partition	<ol style="list-style-type: none"> 1. Check for system firmware updates. Apply update if available. 2. Contact your next level of support for assistance.
20D1 0004	Failed to locate service processor device tree node	<ol style="list-style-type: none"> 1. Check for system firmware updates. Apply update if available. 2. Contact your next level of support for assistance.
20D1 0005	Failed to reboot system in LPAR mode	<ol style="list-style-type: none"> 1. Check for system firmware updates. Apply update if available. 2. Contact your next level of support for assistance.
20D1 0006	Failed to reboot a partition in LPAR mode	<ol style="list-style-type: none"> 1. Check for system firmware updates. Apply update if available. 2. Contact your next level of support for assistance.
20D1 0007	Failed to set PCI read/write permissions array	<ol style="list-style-type: none"> 1. Check for system firmware updates. Apply update if available. 2. Contact your next level of support for assistance.
20D1 0008	Failed to set PCI read/write permissions array for slot	<ol style="list-style-type: none"> 1. Check for system firmware updates. Apply update if available. 2. Contact your next level of support for assistance.
20D1 0009	Missing or invalid subsystem serial number	<ol style="list-style-type: none"> 1. Check for system firmware updates. Apply update if available. 2. If a location code is shown with this error code, replace the part at that location. 3. Contact your next level of support for assistance. <p>Note: The location code identifies the failing subsystem.</p>

Error Code	Description	Action/ Possible Failing FRU
20D1 000A	Failed to send boot failed message to service processor	<ol style="list-style-type: none"> 1. Check for system firmware updates. Apply update if available. 2. Contact your next level of support for assistance.
20D1 000B	Failed to reset PCI read/write permissions array	<ol style="list-style-type: none"> 1. Check for system firmware updates. Apply update if available. 2. Contact your next level of support for assistance.
20D1 000C	Failed to send LMB-TABLE-INFO mailbox repair	<ol style="list-style-type: none"> 1. Check for system firmware updates. Apply update if available. 2. Contact your next level of support for assistance.
20D1 000D	Hypervisor function to get time-of-day failed	<ol style="list-style-type: none"> 1. Check for system firmware updates. Apply update if available. 2. Contact your next level of support for assistance.
20E0 0001	Privileged-access password entry error.	The password has been entered incorrectly. Try installing the password again.
20E0 0004	Battery drained or needs replacement	<ol style="list-style-type: none"> 1. Replace the battery, Location: U1.18-P1-H2-V1 2. If problem persists, replace the primary I/O book, Location: U1.18-P1-H2
20E0 0009	Invalid password entered - system locked	<p>The password has been entered incorrectly 3 times.</p> <p>Turn off, then turn on the system unit, then enter the password correctly.</p>
20EE 0003	IP parameter requires 3 dots "."	<p>Enter valid IP parameter.</p> <p>Example: 000.000.000.000</p>
20EE 0004	Invalid IP parameter	<p>Enter valid IP parameter.</p> <p>Example: 000.000.000.000</p>
20EE 0005	Invalid IP parameter (>255)	<p>Enter valid IP parameter.</p> <p>Example: 255.192.002.000</p>
20EE 0007	Keyboard not found	<ol style="list-style-type: none"> 1. Plug in keyboard. 2. Replace the USB card the keyboard is plugged into.

Error Code	Description	Action/ Possible Failing FRU
20EE 0008	No configurable adapters found in the system by the remote IPL menu in the SMS utilities	This warning occurs when the remote IPL menu in the SMS utilities cannot locate any LAN adapters that are supported by the remote IPL function. If a supported device is installed: 1. Replace the adapter. (See notes on page399.) 2. Replace the I/O subsystem backplane in the subsystem(s) containing the device/adapter.
20EE 0009	Unable to communicate with the service processor	Replace the primary I/O book, Location: U1.18-P1-H2
20EE 000B	The system was not able to find an operating system on the devices in the boot list.	Go to "Boot Problems" on page 396.

Error Code	Description	Action/ Possible Failing FRU
20EE 000C	Pointer to the operating system found in non-volatile storage.	<p>Values normally found in non-volatile storage that point to the location of an operating system were not found. This can happen for two reasons:</p> <ul style="list-style-type: none"> • Either your operating system doesn't support storing the values or • An event occurred that caused the system to lose non-volatile storage information (drainage or replacement of the battery). <p>If you are running AIX, reconstruct this information by running the bootlist command and specifying the device that the operating system is installed on. See the AIX documentation for the syntax and usage of the bootlist command. To boot the operating system so that the above-mentioned values can be reconstructed, power the system down and power it back on again to cause the system to look for the operating system in the devices contained in the custom boot list or in the default boot list, depending on the condition of the system. If this is not successful, use the SMS menus to modify the boot sequence (also known as the boot list) to include devices that are known to contain a copy of the operating system. For example, select a hard disk known to have a copy of the operating system as the first and only device in the boot sequence and attempt to boot again. If the problem persists, replace the primary I/O book, Location: U1.18-P1-H2</p>
20EE 000E	Unable to execute the lpar-mgr open firmware method	<ol style="list-style-type: none"> 1. Verify that the system is in LPAR mode, and reboot the system. 2. Reflash the system with the latest level of system firmware. 3. Call service support.
20EE 000F	Unable to find the lpar-mgr package node	<ol style="list-style-type: none"> 1. Verify that the system is in LPAR mode, and reboot the system. 2. Reflash the system with the latest level of system firmware. 3. Call service support.

Error Code	Description	Action/ Possible Failing FRU
20EE 0010	Unable to execute the root vpd method	<ol style="list-style-type: none"> 1. Verify that the system is in LPAR mode, and reboot the system. 2. Reflash the system with the latest level of system firmware. 3. Call service support.
20EE 0011	Unable to execute the root-lpar-vpd vpd method	<ol style="list-style-type: none"> 1. Verify that the system is in LPAR mode, and reboot the system. 2. Reflash the system with the latest level of system firmware. 3. Call service support.
20EE 0012	Unable to execute the mem-dimm-vpd method	<ol style="list-style-type: none"> 1. Verify that the system is in LPAR mode, and reboot the system. 2. Reflash the system with the latest level of system firmware. 3. Call service support.
20EE 0013	Unable to allocate memory for root-lpar-vpd vpd	<ol style="list-style-type: none"> 1. Verify that the system is in LPAR mode, and reboot the system. 2. Reflash the system with the latest level of system firmware. 3. Call service support.
20EE 0014	Unable to allocate memory for root-lpar-vpd location codes	Verify that the system is in LPAR mode, and try again. Otherwise, the system firmware may be corrupted.
20EE 0100	Fcode resident on an I/O adapter is not supported on this system	<p>Informational message. The adapter's Fcode driver is not supported on this system. IBM may produce a compatible driver in the future, but does not guarantee one. Additional information may be available from service support.</p> <p>This error code only affects boot-time operation, not the adapter's functionality under the operating system.</p>
20FB 0010	Failed to find keyword offset of SPCN configuration table in NVRAM.	Call service support.
20FB 0020	Invalid SPCN configuration table flag before SPCN table update.	Call service support.

Error Code	Description	Action/ Possible Failing FRU
20FC 0020	Failed to retrieve power, package, and/or cooling VPD via SPCN for the corresponding subsystem. Service processor mailbox failed to get VPD	<ol style="list-style-type: none"> 1. Check RIO cable connection. 2. Check for system firmware updates. 3. Replace corresponding I/O backplane (location code indicates which subsystem). 4. Replace the primary I/O book, Location: U1.18-P1-H2.
20FC 0021	Failed to retrieve power, package, and/or cooling VPD via SPCN for the subsystem. Service processor mailbox failed to get power, packaging, and cooling device VPD	<ol style="list-style-type: none"> 1. Check RIO cable connection. 2. Check for system firmware updates. 3. Replace corresponding I/O backplane (location code indicates which subsystem). 4. Replace the primary I/O book, Location: U1.18-P1-H2.
20FC 0030	Corrupted power, packaging, and/or cooling device VPD format in SPCN configuration table	<ol style="list-style-type: none"> 1. Check for system firmware updates. 2. Replace corresponding I/O backplane (location code indicates which subsystem).
20FF 0001	Problem with VPD	<ol style="list-style-type: none"> 1. Replace the part indicated by the location code. 2. If no location code is shown with the error code, call service support.
2100 0xxx	SCSI controller fault	<p>Before replacing any system components, refer to the notes in error code 21A0 0001.</p> <ol style="list-style-type: none"> 1. Replace the SCSI device.

Error Code	Description	Action/ Possible Failing FRU
21A0 0001	SCSI DASD: test unit ready failed; hardware error	<p>Before replacing any system components:</p> <ol style="list-style-type: none"> 1. Ensure that the controller and each device on the SCSI bus is assigned a unique SCSI ID. 2. Ensure that the SCSI bus is properly terminated. 3. Ensure that the SCSI signal and power cables are securely connected and not damaged. <p>The location code information is required to identify the ID of SCSI device failures as well as to indicate the location of the controller to which the device is attached. Check the system error logs to determine the location code information associated with the error code.</p> <ol style="list-style-type: none"> 1. Replace the SCSI device. 2. Replace the SCSI cable. 3. Replace the SCSI controller.
21A0 0002	SCSI DASD: test unit ready failed; sense data available	<p>Before replacing any system components, refer to the Action under error code 21A0 0001.</p> <ol style="list-style-type: none"> 1. Replace the media (if a removable media device). 2. Replace the SCSI device.
21A0 0003	SCSI DASD: send diagnostic failed; sense data available	<p>Before replacing any system components, refer to the Action under error code 21A0 0001.</p> <p>Replace the SCSI device.</p>
21A0 0004	SCSI DASD: send diagnostic failed - devofl command	<p>Before replacing any system components, refer to the Action under error code 21A0 0001.</p> <p>Replace the SCSI device.</p>
21E0 0001	SCSI tape: test unit ready failed; hardware error	<p>Before replacing any system components, refer to the Action under error code 21A0 0001.</p> <ol style="list-style-type: none"> 1. Replace the SCSI device. 2. Replace the SCSI cable. 3. Replace the SCSI controller.

Error Code	Description	Action/ Possible Failing FRU
21E0 0002	SCSI tape: test unit ready failed; sense data available	Before replacing any system components, refer to the Action under error code 21A0 0001. 1. Replace the media (if a removable media device). 2. Replace the SCSI device.
21E0 0003	SCSI tape: send diagnostic failed; sense data available	Before replacing any system components, refer to the Action under error code 21A0 0001. Replace the SCSI device.
21E0 0004	SCSI tape: send diagnostic failed - devofl command	Before replacing any system components, refer to the Action under error code 21A0 0001. Replace the SCSI device.
21ED 0001	SCSI C: test unit ready failed; hardware error	Before replacing any system components, refer to the Action under error code 21A0 0001. 1. Replace the SCSI device. 2. Replace the SCSI cable. 3. Replace the SCSI controller.
21ED 0002	SCSI changer: test unit ready failed; sense data available	Before replacing any system components, refer to the Action under error code 21A0 0001. 1. Replace the SCSI device. 2. Replace the media.
21ED 0003	SCSI changer: send diagnostic failed; sense data available	Before replacing any system components, refer to the Action under error code 21A0 0001. Replace the SCSI device.
21ED 0004	SCSI changer: send diagnostic failed - devofl command	Before replacing any system components, refer to the Action under error code 21A0 0001. Replace the SCSI device.
21EE 0001	Undetermined SCSI device: test unit ready failed; hardware error	Before replacing any system components, refer to the Action under error code 21A0 0001. 1. Replace the SCSI device. 2. Replace the SCSI cable. 3. If the missing SCSI devices are connected to the same backplane, replace the SCSI backplane. 4. Replace the SCSI controller.

Error Code	Description	Action/ Possible Failing FRU
21EE 0002	Undetermined SCSI device: test unit ready failed; sense data available	Before replacing any system components, refer to the Action under error code 21A0 0001. 1. Replace the SCSI device. 2. Replace the media.
21EE 0003	Undetermined SCSI device: send diagnostic failed; sense data available	Before replacing any system components, refer to the Action under error code 21A0 0001. Replace the SCSI device.
21EE 0004	Undetermined SCSI device: send diagnostic failed - devofl command	Before replacing any system components, refer to the Action under error code 21A0 0001. Replace the SCSI device.
21F0 0001	SCSI CD-ROM: test unit ready failed; hardware error	Before replacing any system components, refer to the Action under error code 21A0 0001. 1. Replace the SCSI device. 2. Replace the SCSI cable. 3. Replace the SCSI controller.
21F0 0002	SCSI CD-ROM: test unit ready failed; sense data available	Before replacing any system components, refer to the Action under error code 21A0 0001. 1. Replace the SCSI device. 2. Replace the media.
21F0 0003	SCSI CD-ROM: send diagnostic failed; sense data available	Before replacing any system components, refer to the Action under error code 21A0 0001. Replace the SCSI device.
21F0 0004	SCSI CD-ROM: send diagnostic failed - devofl command	Before replacing any system components, refer to the Action under error code 21A0 0001. Replace the SCSI device.
21F2 0001	SCSI read/write optical device: test unit ready failed; hardware error	Before replacing any system components, refer to the Action under error code 21A0 0001. 1. Replace the SCSI device. 2. Replace the SCSI cable. 3. Replace the SCSI controller.

Error Code	Description	Action/ Possible Failing FRU
21F2 0002	SCSI read/write optical device: test unit ready failed; sense data available	Before replacing any system components, refer to the Action under error code 21A0 0001. 1. Replace the SCSI device. 2. Replace the media.
21F2 0003	SCSI read/write optical drive: send diagnostic failed; sense data available	Before replacing any system components, refer to the Action under error code 21A0 0001. Replace the SCSI drive.
21F2 0004	SCSI read/write optical drive: send diagnostic failed - devofl command	Before replacing any system components, refer to the Action under error code 21A0 0001. Replace the SCSI drive.
2200 0001	PCI Ethernet BNC/RJ-45 or PCI Ethernet AUI/RJ-45 Adapter Internal Wrap Test failure	Replace the Adapter. See "Determining Location Code" on page 401 for location code information related to this error.
2200 1001	10/100 Mbps Ethernet PCI Adapter Internal Wrap Test failure	Replace the adapter. See "Determining Location Code" on page 401 for location code information related to this error.
2200 1002	10/100 Mbps Ethernet PCI Adapter failure	Replace the adapter. See "Determining Location Code" on page 401 for location code information related to this error.
2201 0001	PCI Auto LANstreamer Token Ring Adapter Adapter failed to complete hardware initialization.	Replace the adapter. See "Determining Location Code" on page 401 for location code information related to this error.
2201 1001	PCI Token Ring Adapter Adapter failed to complete hardware initialization.	Replace the adapter. See "Determining Location Code" on page 401 for location code information related to this error.
20EE 0013	Unable to allocate memory for root-lpar-vpd vpd	1. Verify that the system is in LPAR mode, and reboot the system. 2. Reflash the system with the latest level of system firmware. 3. Call service support.
25A0 0001	L2 Cache controller failure	Replace the MCM module specified by the location code.
25A1 0001	L2 Cache SRAM failure	Replace the MCM module specified by the location code.

Error Code	Description	Action/ Possible Failing FRU
25A8 0xxx	NVRAM problems	<p>Errors reported against NVRAM can be caused by low battery voltage and (more rarely) power outages that occur during normal system usage. With the exception of the 25A8 0000 error, these errors are warnings that the NVRAM data content had to be re-established and do not require any FRU replacement unless the error is persistent. When one of these errors occurs, any system customization (for example, boot device list) information has been lost, the system may need to be reconfigured.</p> <p>If the error is persistent, replace the primary I/O book, Location: U1.18-P1-H2</p>
25A8 0000	Initialization failed, device test failed	Refer to Action under error code 25A8 0xxx
25A8 0100	NVRAM data validation check failed.	<p>Turn off, turn on system unit and retry the operation before replacing any system component.</p> <p>Refer to Action under error code 25A8 0xxx</p>
25A8 0201	Unable to expand target partition - Saving configuration variable.	Refer to Action under error code 25A8 0xxx
25A8 0202	Unable to expand target partition - Writing error log entry.	Refer to Action under error code 25A8 0xxx
25A8 0203	Unable to expand target partition - Writing VPD data.	Refer to Action under error code 25A8 0xxx
25A8 0210	Setenv/\$Setenv parameter error - name contains a null character.	Refer to Action under error code 25A8 0xxx
25A8 0211	Setenv/\$Setenv parameter error - value contains a null character.	Refer to Action under error code 25A8 0xxx

Error Code	Description	Action/ Possible Failing FRU
25A8 0998	NVRAMRC script evaluation error - command line execution error	<p>Execution of a command line within the nvram configuration variable "nvramrc" (script) resulted in a "throw" being executed. This script can be modified by the system firmware SMS utilities, the operating system, PCI adapter rom code or utility, or an operator (via the open firmware script editing command nvedit). It may not be possible to resolve the problem without a detailed analysis of the nvram script, the current system configuration, and device tree contents.</p> <ol style="list-style-type: none"> 1. The problem can be caused by a SCSI adapter, whose SCSI bus ID has been changed from the default setting, no longer appearing in the system. This can be caused either by removing a SCSI adapter, or by a problem with a SCSI adapter. <ol style="list-style-type: none"> a. Select the SCSI ID utility from the SMS menu(s). <ol style="list-style-type: none"> 1) Verify the list of SCSI controllers/adapters. If the list is not correct, suspect a problem with the adapter(s) installed but not listed. 2) Select the option to Save the configuration information. 3) Restart the system. b. If the problem persists, boot the operating system and verify the SCSI bus IDs of any installed/available SCSI controllers (change as necessary), and restart the system. 2. Contact your support representative for further assistance.
25A8 0999	NVRAMRC script evaluation error - stack unbalanced on completion	This is a firmware debug environment error. There is no user action or FRU replacement for this error. If this error persists, call service support.
25A8 0A00	Unable to retrieve NVRAM LPAR table information	Refer to the actions for error code 25A8 0xxx.
25B0 0001	Memory book failure	Replace the memory book specified by the location code.
25B0 0004	Memory book is not supported	Replace the unsupported memory book(s) specified by the location code.

Error Code	Description	Action/ Possible Failing FRU
25Cy y001	Memory book is not supported	Replace unsupported memory book(s) specified by the location code.
25Cy y002	Memory book failure	Replace the memory book(s) specified by the location code.
2601 0000	Boot failed because the RIO cables, or the power subsystem cables, are not routed correctly to the I/O subsystems	<ol style="list-style-type: none"> 1. Check both ends of the RIO cable specified in the location code that appears with this error code. 2. Determine which I/O subsystem is at the end of the RIO cable specified by the location code shown with this error code. Check both ends of the power cables going to both DCAs in that I/O subsystem. <p>For information about I/O cabling and connector locations, see "I/O Book Connector Locations" on page 24 and "Subsystem Positioning and Cabling" on page 41.</p> <p>Note: The port location code identifies the I/O book number.</p>
2601 0001	Boot failed because the I/O subsystem has not been programmed correctly.	<p>For information about I/O book cabling and connector locations, see "I/O Book Connector Locations" on page 24 and "Subsystem Positioning and Cabling" on page 41.</p> <ol style="list-style-type: none"> 1. Ensure that power cables are correctly connected to drawers. 2. Firmware, including power code, may have to be flashed on both sides of the I/O subsystem. <p>Note: The location code identifies the I/O subsystem that has the problem</p> <ol style="list-style-type: none"> 3. Contact the next level of support.

Error Code	Description	Action/ Possible Failing FRU
2601 0002	RIO cable error or DCA power cable error detected on an I/O subsystem	<ol style="list-style-type: none"> 1. Check both ends of the RIO cable specified in the location code that appears with this error code. 2. Determine which I/O subsystem is at the end of the RIO cable specified by the location code shown with this error code. Check the power cables going to both DCAs in that I/O subsystem. <p>For information about I/O cabling and connector locations, see "I/O Book Connector Locations" on page 24 and "Subsystem Positioning and Cabling" on page 41.</p> <p>Note: The port location code identifies the I/O book number.</p>
2602 0001	Invalid PCI adapter vendor ID	<ol style="list-style-type: none"> 1. Move adapter to another slot (behind a different PCI bus). 2. Check for available firmware updates for adapter. Apply update if available. 3. Run AIX diagnostics on adapter. Replace if indicated. 4. Replace adapter. 5. Check for system firmware updates. Apply if update available. 6. Replace I/O subsystem backplane (See notes on Chapter 5, "Error Code to FRU Index" on page 399.)
2602 0002	Invalid PCI adapter device ID	<ol style="list-style-type: none"> 1. Move adapter to another slot (behind a different PCI bus). 2. Check for available firmware updates for adapter. Apply update if available. 3. Run AIX diagnostics on adapter. Replace if indicated. 4. Replace adapter. 5. Check for system firmware updates. Apply if update available. 6. Replace I/O subsystem backplane. (See notes on Chapter 5, "Error Code to FRU Index" on page 399.)

(3)
(3)
(3)
(3)
(3)
(3)
(3)
(3)
(3)
(3)
(3)
(3)
(3)
(3)
(3)
(3)
(3)
(3)
(3)
(3)
(3)
(3)
(3)
(3)
(3)
(3)

Error Code	Description	Action/ Possible Failing FRU
2602 0010	<p>PCI probe error, bridge in freeze state</p> <p>If the location code identifies a slot or PCI adapter:</p> <ol style="list-style-type: none">1. Check for system firmware updates. Apply if update available.2. Check the cabling to the adapter (in particular, the adapters that have serial ports). Serial ports may require null modems or special cabling configurations to avoid connecting driver outputs together. This may create a PCI slot power problem and force the adapter to be deconfigured.3. Use the hot plug service aid to reseal the adapter specified by the location code. See "Removing a Hot-Pluggable PCI Adapter" on page 841. If resealing the adapter fixes the problem, go to "MAP 0410: Repair Checkout" in the <i>RS/6000 and @server pSeries Diagnostic Information for Multiple Bus Systems</i> manual. If the problem is not resolved, continue with 4.4. Use the hot plug task to move the adapter to another slot (behind a different PCI bridge). The "I/O Subsystem PCI PHB and PCI Slot Locations" on page 30 identifies the PCI bridges and the associated slots. See "Removing a Hot-Pluggable PCI Adapter" on page 841 when removing the adapter, and "Installing a Hot-Pluggable PCI Adapter" on page 839 when installing the adapter in the new slot. <p>If the adapter is successfully reconfigured in the new slot (behind a different PCI bridge), the slot in which the adapter was originally plugged is bad. Replace the I/O backplane assembly that contains the slot in which the adapter was originally installed, location: Ux.y-Pz.</p> <p>If the adapter does not reconfigure successfully in the new slot, replace the adapter.</p> <ol style="list-style-type: none">5. Go to "MAP 1542: I/O Problem Isolation" on page 312. <p>If the location code does not identify, a slot or PCI adapter, or no location code is specified, go to "MAP 1542: I/O Problem Isolation" on page 312.</p>	

Error Code	Description	Action/ Possible Failing FRU
2602 0011	PCI probe error, bridge is not usable	<p>If the location code identifies a slot:</p> <ol style="list-style-type: none"> 1. Check the cabling to the adapter (in particular, the adapters that have serial ports). Serial ports may require null modems or special cabling configurations to avoid connecting driver outputs together. This may create a PCI slot power problem and force the adapter to be deconfigured. 2. Move adapter to another slot (behind a different PCI bus). 3. Check for available firmware updates for adapter. Apply update if available. 4. Replace adapter. 5. Check for system firmware updates. Apply if update available. 6. Replace I/O subsystem backplane (See notes on Chapter 5, "Error Code to FRU Index" on page 399.) <p>If the location code identifies an I/O subsystem backplane:</p> <ol style="list-style-type: none"> 1. Check for system firmware updates. Apply if update is available. 2. Replace I/O subsystem backplane.

Error Code	Description	Action/ Possible Failing FRU
2602 0012	PCI device run-time error, bridge in freeze state	<p>If the location code identifies a slot:</p> <ol style="list-style-type: none"> 1. Check the cabling to the adapter (in particular, the adapters that have serial ports). Serial ports may require null modems or special cabling configurations to avoid connecting driver outputs together. This may create a PCI slot power problem and force the adapter to be deconfigured. 2. Move adapter to another slot (behind a different PCI bus). 3. Check for available firmware updates for adapter. Apply update if available. 4. Replace adapter. 5. Check for system firmware updates. Apply if update available. 6. Replace I/O subsystem backplane (See notes on Chapter 5, "Error Code to FRU Index" on page 399). <p>If the location code identifies an I/O subsystem backplane:</p> <ol style="list-style-type: none"> 1. Check for system firmware updates. Apply if update is available. 2. Replace I/O subsystem backplane.
2680 0Axy	MX-PCI Bridge Bist Failure	<p>The problem is associated with bridge "y" in I/O subsystem "x". Replace the I/O board associated with x</p> <p>x = I/O subsystem</p> <p>1=0 2=1 3=2 4=3 5=4 6=5</p> <p>See "Determining Location Code" on page 401 or location code information related to this error.</p>

Error Code	Description	Action/ Possible Failing FRU
2680 0Cxx	Machine Check occurred	<ol style="list-style-type: none"> 1. Replace the part identified by the location code associated with this error code. 2. If the location code associated with this error code identifies an adapter, and replacing the adapter does not correct the problem, replace the I/O subsystem backplane. <p>See "Determining Location Code" on page 401 for location code information related to this error.</p>
2680 0Dxx	Machine check occurred; unable to isolate to a single device	Go to "MAP 1542: I/O Problem Isolation" on page 312.
2803 0xxx	Real-time-clock (RTC) errors	
2803 0001	RTC not updating - RTC initialization required	<p>Errors reported against the real-time clock can be caused by low battery voltage and (more rarely) power outages that occur during normal system usage. These errors are warnings that the RTC data content must be re-established and do not require any FRU replacement unless the error is persistent. When one of these errors occurs, the time and date information has been lost.</p> <p>To set/restore the time and date, use the operating system facility.</p> <p>If the error is persistent, replace the primary I/O book, Location: U1.18-P1-H2</p>
2803 0002	Bad time/date values	<ol style="list-style-type: none"> 1. Set time and date. 2. Refer to Action under error code 2803 0001.
2803 0003	RTC not updating - not correctable	Replace the primary I/O book, Location: U1.18-P1-H2
2803 0004	RTC operating mode parameters (for example, data mode) changed	<ol style="list-style-type: none"> 1. Set time and date. 2. Refer to Action under error code 2803 0001.
2803 0005	RTC battery error	Replace the primary I/O book, Location: U1.18-P1-H2 Note: Passwords, time, and date must be reset.
2803 F003	Real-time-clock not updating - not correctable (detected by hypervisor)	Replace the primary I/O book, location: U1.18-P1-H2.

Error Code	Description	Action/ Possible Failing FRU
2900 0002	ISA keyboard/mouse controller failed self-test	Replace the primary I/O book, Location: U1.18-P1-H2
29A0 0003	ISA keyboard not present/detected	Replace the primary I/O book, Location: U1.18-P1-H2
29A0 0004	ISA keyboard stuck key detected	Replace the primary I/O book, Location: U1.18-P1-H2
29B0 0004	ISA mouse not present/detected	Replace the primary I/O book, Location: U1.18-P1-H2
2B20 0011	Processor is manually disabled.	Use the service processor menus to re-enable the processor and reboot the system.
2B20 0022	Processor is deconfigured by the system.	The processor has previously failed BIST or POST. Replace the processor MCM indicated by the location code associated with the error code in the error log.
2B20 0031	Processor is failing POST	Replace the processor MCM indicated by the location code associated with the error code in the error log.
2B20 0042	Unknown processor card	Remove the unknown/unsupported processor MCM.
2B20 8880	Unrecoverable processor subsystem error	Replace the FRU indicated in the service processor error log entry. If the system has been rebooted, run diagnostics and look for an AIX error log entry in which the description says cache or cache controller error. Replace the FRUs listed in this entry.
2B20 8881	Software error	Call service support.
2B20 8882	Software error	Call service support.
2B20 8883	Software error	Call service support.
2B20 8884	Unrecoverable processor subsystem error	Replace the FRU indicated in the service processor error log entry. If the system has been rebooted, run diagnostics and look for an AIX error log entry in which the description says cache or cache controller error. Replace the FRUs listed in this entry.
2B20 8885	Unrecoverable internal hardware error	Run diagnostics. Look for an AIX error log entry in which the description says I/O bus time out, access, or other error or I/O bridge/device internal error. Replace the FRUs listed in this entry.
2B20 8888	Operating system termination request received	Informational message.

Error Code	Description	Action/ Possible Failing FRU
2B2x 00EE	An exception error has been reported on a global processor	<p>The type of interrupt that caused the exception is specified by the x as follows:</p> <ul style="list-style-type: none"> 0: Unknown interrupt 1: System reset interrupt (SRI) 2. Machine check interrupt (MCI) 3. Data storage interrupt (DSI) 4. Instruction storage interrupt (ISI) 5. External interrupt (EXI) 6. Alignment interrupt (ALI) 7. Program interrupt (SRI) 8. Floating unavailable interrupt (FUI) <ul style="list-style-type: none"> 1. Check for system firmware updates. Apply if available. 2. Call service support.
2BA0 0000	Service processor POST failure	Replace the primary I/O book, Location: U1.18-P1-H2
2BA0 0012	Service processor reports self test failure	Replace the primary I/O book, Location: U1.18-P1-H2
2BA0 0013	Service processor reports bad NVRAM CRC	Refer to the actions for 25A8 0xxx.
2BA0 0017	Service processor reports bad or low battery.	Refer to the actions for 25A8 0xxx.
2BA0 0041	Service processor VPD is corrupted.	Replace the primary I/O book, Location: U1.18-P1-H2
2BA0 0071	VPD data is corrupted for MCM 0	Replace the MCM and VPD card
2BA0 0073	VPD data is corrupted for MCM 2	Replace the MCM and VPD card
2Cmm mhhh	A processor's timebase enable signal is stuck enabled	<ul style="list-style-type: none"> 1. Replace the primary I/O book, location: U1.18-P1-H2. 2. hhh indicates the failing processor. Replace the MCM that contains the failing processor according to the following table: <ul style="list-style-type: none"> • hhh = 0 - 7: U1.18-P1-C1 • hhh = 8-15: U1.18-P1-C3 • hhh = 16-23: U1.18-P1-C4 • hhh = 24-31: U1.18-P1-C2

Error Code	Description	Action/ Possible Failing FRU
2Dmm mhhh	A processor's timebase enable signal is stuck disabled	<ol style="list-style-type: none"> 1. Replace the primary I/O book, location: U1.18-P1-H2. 2. hhh indicates the failing processor. Replace the MCM that contains the failing processor according to the following table: <ul style="list-style-type: none"> • hhh = 0 - 7: U1.18-P1-C1 • hhh = 8-15: U1.18-P1-C3 • hhh = 16-23: U1.18-P1-C4 • hhh = 24-31: U1.18-P1-C2

Service Processor Error Codes

Attention: Follow the procedure defined in “Checkpoints and Error Codes Index” on page 403. If you replace FRUs or perform an action on an I/O subsystem and the problem is still not corrected, go to “MAP 1542: I/O Problem Isolation” on page 312 unless you were already directed to any MAP 154x by the error code. Otherwise call support if the action(s) for an error code do not resolve the problem.

Attention: If the error code that brought you to this chapter originated in the AIX error log, remember that an error may require an additional 15 minutes to be propagated to the AIX error log.

If you replace FRUs and the problem is corrected, go to “MAP 0410: Repair Checkout” in the *RS/6000 and @server pSeries Diagnostic Information for Multiple Bus Systems*.

Note: The MCM and its associated VPD card are a single FRU, and must be replaced as a set.

Error Code	Description	Action/ Possible Failing FRU
4064 0001	Processor subsystem tests detected clock card assembly failure	Go to “MAP 1540: Problem Isolation Procedures” on page 303.
4064 0002	Processor subsystem tests detected backplane assembly failure	Go to “MAP 1540: Problem Isolation Procedures” on page 303.
4064 0003	Processor subsystem tests detected fault in MCM module 0	MCM module 0 and VPD card Location: U1.18-P1-C1 and U1.18-P1-H2.3
4064 0004	Processor subsystem tests detected fault in MCM module 2	MCM module 2 and VPD card Location: U1.18-P1-C4 and U1.18-P1-H2.4
4064 0005	Processor subsystem tests detected fault in MCM module 1	MCM module 1 and VPD card Location: U1.18-P1-C3 and U1.18-P1-H2.5
4064 0006	Processor subsystem tests detected fault in MCM module 3	MCM module 3 and VPD card Location: U1.18-P1-C2 and U1.18-P1-H2.6
4064 0007	Processor subsystem tests detected fault in L3 VPD card	<ol style="list-style-type: none"> L3 VPD card Location: U1.18-P1-H2.1 (Order the L3 cache module FRU to obtain a new L3 VPD card. Return the L3 cache module that was included in the FRU kit, and the failing L3 VPD card as “new defective”.) Primary I/O book Location: U1.18-P1-H2
4064 000A	Processor subsystem tests detected fault in primary I/O book 1 (slot 0)	Go to “MAP 1540: Problem Isolation Procedures” on page 303.

Error Code	Description	Action/ Possible Failing FRU
4064 000B	Processor subsystem tests detected fault in secondary I/O book (slot 1)	Go to "MAP 1540: Problem Isolation Procedures" on page 303.
4064 000C	Processor subsystem tests detected fault in I/O book 3 (slot 2)	Go to "MAP 1540: Problem Isolation Procedures" on page 303.
4064 000D	Processor subsystem tests detected fault in I/O book 4 (slot 3)	Go to "MAP 1540: Problem Isolation Procedures" on page 303.
4064 0010	Processor subsystem tests detected fault in Memory book (slot 0)	Memory book (slot 0) Location: U1.18-P1-M2
4064 0011	Processor subsystem tests detected fault in Memory book (slot 1)	Memory book (slot 1) Location: U1.18-P1-M3
4064 0012	Processor subsystem tests detected fault in Memory book (slot 2)	Memory book (slot 2) Location: U1.18-P1-M7
4064 0013	Processor subsystem tests detected fault in Memory book (slot 3)	Memory book (slot 3) Location: U1.18-P1-M6
4064 0014	Processor subsystem tests detected fault in Memory book (slot 4)	Memory book (slot 4) Location: U1.18-P1-M4
4064 0015	Processor subsystem tests detected fault in Memory book (slot 5)	Memory book (slot 5) Location: U1.18-P1-M8
4064 0016	Processor subsystem tests detected fault in Memory book (slot 6)	Memory book (slot 6) Location: U1.18-P1-M5
4064 0017	Processor subsystem tests detected fault in Memory book (slot 7)	Memory book (slot 7) Location: U1.18-P1-M1
4064 00B0	Processor subsystem tests detected possible problem with bus controller or CSP code	<ol style="list-style-type: none"> 1. Check for system firmware updates. 2. Primary I/O book, Location: U1.18-P1-H2 3. Call service support.
4064 00B1	Processor subsystem tests detected possible problem with bus controller	<ol style="list-style-type: none"> 1. Check for system firmware updates. 2. Primary I/O book, Location: U1.18-P1-H2 3. Call service support.
4064 00B3	Processor subsystem tests detected MCM 0/VPD problem	<ol style="list-style-type: none"> 1. Check for system firmware updates. 2. MCM module 0 and VPD card Location: U1.18-P1-C1 and U1.18-P1-H2.3
4064 00B4	Processor subsystem tests detected MCM 2/VPD problem	<ol style="list-style-type: none"> 1. Check for system firmware updates. 2. MCM module 2 and VPD card Location: U1.18-P1-C4 and U1.18-P1-H2.4

Error Code	Description	Action/ Possible Failing FRU
4064 00B5	Processor subsystem tests detected MCM 1/VPD problem	<ol style="list-style-type: none"> 1. Check for system firmware updates. 2. MCM module 1 and VPD card Location: U1.18-P1-C3 and U1.18-P1-H2.5
4064 00B6	Processor subsystem tests detected MCM 3/VPD problem	<ol style="list-style-type: none"> 1. Check for system firmware updates. 2. MCM module 3 and VPD card Location: U1.18-P1-C2 and U1.18-P1-H2.6
4064 00B7	Processor subsystem tests detected Insufficient hardware resources to continue IPL after processor subsystem testing and initialization completed	Go to "MAP 1540: Problem Isolation Procedures" on page 303.
4064 0A03	Reboot message (run-time array gard failure) for processor 0	Reboot the system in slow mode. Run diagnostics, then go to MAP 0235 in the <i>RS/6000 and @server pSeries Diagnostic Information for Multiple Bus Systems</i> , order number SA38-0509.
4064 0A04	Reboot message (run-time array gard failure) for processor 2	Reboot the system in slow mode. Run diagnostics, then go to MAP 0235 in the <i>RS/6000 and @server pSeries Diagnostic Information for Multiple Bus Systems</i> , order number SA38-0509.
4064 0A05	Reboot message (run-time array gard failure) for processor 1	Reboot the system in slow mode. Run diagnostics, then go to MAP 0235 in the <i>RS/6000 and @server pSeries Diagnostic Information for Multiple Bus Systems</i> , order number SA38-0509.
4064 0A06	Reboot message (run-time array gard failure) for processor 3	Reboot the system in slow mode. Run diagnostics, then go to MAP 0235 in the <i>RS/6000 and @server pSeries Diagnostic Information for Multiple Bus Systems</i> , order number SA38-0509.
4064 0B00	Processor subsystem tests detected fault in I/O book (slot 0 RIO port 0)	<ol style="list-style-type: none"> 1. Check for system firmware updates. 2. Check the I/O cabling between the primary I/O book and the I/O subsystems. 3. Primary I/O book Location: U1.18-P1-H2 4. Call service support.

Error Code	Description	Action/ Possible Failing FRU
4064 0B01	Processor subsystem tests detected fault in I/O book (slot 0 RIO port 1)	<ol style="list-style-type: none"> 1. Check for system firmware updates. 2. Check the I/O cabling between the primary I/O book and the I/O subsystems. 3. Primary I/O book Location: U1.18-P1-H2 4. Call service support.
4064 0B02	Processor subsystem tests detected fault in I/O book (slot 0 RIO port 2)	<ol style="list-style-type: none"> 1. Check for system firmware updates. 2. Check the I/O cabling between the primary I/O book and the I/O subsystems. 3. Primary I/O book Location: U1.18-P1-H2 4. Call service support.
4064 0B03	Processor subsystem tests detected fault in I/O book (slot 0 RIO port 3)	<ol style="list-style-type: none"> 1. Check for system firmware updates. 2. Check the I/O cabling between the primary I/O book and the I/O subsystems. 3. Primary I/O book Location: U1.18-P1-H2 4. Call service support.
4064 0B10	Processor subsystem tests detected fault in I/O book	<ol style="list-style-type: none"> 1. Check for system firmware updates. 2. Check the I/O cabling between the secondary I/O book and the I/O subsystems. 3. Secondary I/O book Location: U1.18-P1-H1 4. Call service support.
4064 0B11	Processor subsystem tests detected fault in I/O book	<ol style="list-style-type: none"> 1. Check for system firmware updates. 2. Check the I/O cabling between the secondary I/O book and the I/O subsystems. 3. Secondary I/O book Location: U1.18-P1-H1 4. Call service support.

Error Code	Description	Action/ Possible Failing FRU
4064 0B12	Processor subsystem tests detected fault in I/O book	<ol style="list-style-type: none"> 1. Check for system firmware updates. 2. Check the I/O cabling between the secondary I/O book and the I/O subsystems. 3. Secondary I/O book Location: U1.18-P1-H1 4. Call service support.
4064 0B13	Processor subsystem tests detected fault in I/O book	<ol style="list-style-type: none"> 1. Check for system firmware updates. 2. Check the I/O cabling between the secondary I/O book and the I/O subsystems. 3. Secondary I/O book Location: U1.18-P1-H1 4. Call service support.
4064 0B14	Processor subsystem tests detected fault in I/O book	<ol style="list-style-type: none"> 1. Check for system firmware updates. 2. Check the I/O cabling between the secondary I/O book and the I/O subsystems. 3. Secondary I/O book Location: U1.18-P1-H1 4. Call service support.
4064 0B15	Processor subsystem tests detected fault in I/O book	<ol style="list-style-type: none"> 1. Check for system firmware updates. 2. Check the I/O cabling between the secondary I/O book and the I/O subsystems. 3. Secondary I/O book Location: U1.18-P1-H1 4. Call service support.
4064 0B16	Processor subsystem tests detected fault in I/O book	<ol style="list-style-type: none"> 1. Check for system firmware updates. 2. Check the I/O cabling between the secondary I/O book and the I/O subsystems. 3. Secondary I/O book Location: U1.18-P1-H1 4. Call service support.

Error Code	Description	Action/ Possible Failing FRU
4064 0B17	Processor subsystem tests detected fault in I/O book	<ol style="list-style-type: none"> 1. Check for system firmware updates. 2. Check the I/O cabling between the secondary I/O book and the I/O subsystems. 3. Secondary I/O book Location: U1.18-P1-H1 4. Call service support.
4064 0B20	Processor subsystem tests detected fault in I/O book	<ol style="list-style-type: none"> 1. Check for system firmware updates. 2. Check the I/O cabling between the secondary I/O book and the I/O subsystems. 3. Secondary I/O book Location: U1.18-P1-H3 4. Call service support.
4064 0B21	Processor subsystem tests detected fault in I/O book	<ol style="list-style-type: none"> 1. Check for system firmware updates. 2. Check the I/O cabling between the secondary I/O book and the I/O subsystems. 3. Secondary I/O book Location: U1.18-P1-H3 4. Call service support.
4064 0B22	Processor subsystem tests detected fault in I/O book	<ol style="list-style-type: none"> 1. Check for system firmware updates. 2. Check the I/O cabling between the secondary I/O book and the I/O subsystems. 3. Secondary I/O book Location: U1.18-P1-H3 4. Call service support.
4064 0B23	Processor subsystem tests detected fault in I/O book	<ol style="list-style-type: none"> 1. Check for system firmware updates. 2. Check the I/O cabling between the secondary I/O book and the I/O subsystems. 3. Secondary I/O book Location: U1.18-P1-H3 4. Call service support.

Error Code	Description	Action/ Possible Failing FRU
4064 0B24	Processor subsystem tests detected fault in I/O book	<ol style="list-style-type: none"> 1. Check for system firmware updates. 2. Check the I/O cabling between the secondary I/O book and the I/O subsystems. 3. Secondary I/O book Location: U1.18-P1-H3 4. Call service support.
4064 0B25	Processor subsystem tests detected fault in I/O book	<ol style="list-style-type: none"> 1. Check for system firmware updates. 2. Check the I/O cabling between the secondary I/O book and the I/O subsystems. 3. Secondary I/O book Location: U1.18-P1-H3 4. Call service support.
4064 0B26	Processor subsystem tests detected fault in I/O book	<ol style="list-style-type: none"> 1. Check for system firmware updates. 2. Check the I/O cabling between the secondary I/O book and the I/O subsystems. 3. Secondary I/O book Location: U1.18-P1-H3 4. Call service support.
4064 0B27	Processor subsystem tests detected fault in I/O book	<ol style="list-style-type: none"> 1. Check for system firmware updates. 2. Check the I/O cabling between the secondary I/O book and the I/O subsystems. 3. Secondary I/O book Location: U1.18-P1-H3 4. Call service support.
4064 0B30	Processor subsystem tests detected fault in I/O book	<ol style="list-style-type: none"> 1. Check for system firmware updates. 2. Check the I/O cabling between the third I/O book and the I/O subsystems. 3. Third I/O book Location: U1.18-P1-H4 4. Call service support.

Error Code	Description	Action/ Possible Failing FRU
4064 0B31	Processor subsystem tests detected fault in I/O book	<ol style="list-style-type: none"> 1. Check for system firmware updates. 2. Check the I/O cabling between the third I/O book and the I/O subsystems. 3. Third I/O book Location: U1.18-P1-H4 4. Call service support.
4064 0B32	Processor subsystem tests detected fault in I/O book	<ol style="list-style-type: none"> 1. Check for system firmware updates. 2. Check the I/O cabling between the third I/O book and the I/O subsystems. 3. Third I/O book Location: U1.18-P1-H4 4. Call service support.
4064 0B33	Processor subsystem tests detected fault in I/O book	<ol style="list-style-type: none"> 1. Check for system firmware updates. 2. Check the I/O cabling between the third I/O book and the I/O subsystems. 3. Third I/O book Location: U1.18-P1-H4 4. Call service support.
4064 0B34	Processor subsystem tests detected fault in I/O book	<ol style="list-style-type: none"> 1. Check for system firmware updates. 2. Check the I/O cabling between the third I/O book and the I/O subsystems. 3. Third I/O book Location: U1.18-P1-H4 4. Call service support.
4064 0B35	Processor subsystem tests detected fault in I/O book	<ol style="list-style-type: none"> 1. Check for system firmware updates. 2. Check the I/O cabling between the third I/O book and the I/O subsystems. 3. Third I/O book Location: U1.18-P1-H4 4. Call service support.

Error Code	Description	Action/ Possible Failing FRU
4064 0B36	Processor subsystem tests detected fault in I/O book	<ol style="list-style-type: none"> 1. Check for system firmware updates. 2. Check the I/O cabling between the third I/O book and the I/O subsystems. 3. Third I/O book Location: U1.18-P1-H4 4. Call service support.
4064 0B37	Processor subsystem tests detected fault in I/O book	<ol style="list-style-type: none"> 1. Check for system firmware updates. 2. Check the I/O cabling between the third I/O book and the I/O subsystems. 3. Third I/O book Location: U1.18-P1-H4 4. Call service support.
4064 0BF0	Processor subsystem tests detected fault in I/O hub chip 0 (port x)	<ol style="list-style-type: none"> 1. Check the cabling on the following RIO ports: <ol style="list-style-type: none"> a. U1.18-P1-H2/Q1 b. U1.18-P1-H2/Q2 2. Replace the primary I/O book, Location: U1.18-P1-H2
4064 0BF1	Processor subsystem tests detected fault in I/O hub chip 1 (port x)	<ol style="list-style-type: none"> 1. Check the cabling on the following RIO ports: <ol style="list-style-type: none"> a. U1.18-P1-H2/Q3 b. U1.18-P1-H2/Q4 2. Replace the primary I/O book, Location: U1.18-P1-H2
4064 0BF2	Processor subsystem tests detected fault in I/O hub chip 2 (port x)	<ol style="list-style-type: none"> 1. Check the cabling on the following RIO ports: <ol style="list-style-type: none"> a. U1.18-P1-H1/Q3 b. U1.18-P1-H1/Q4 2. Replace the RIO book, Location: U1.18-P1-H1
4064 0BF3	Processor subsystem tests detected fault in I/O hub chip 3 (port x)	<ol style="list-style-type: none"> 1. Check the cabling on the following RIO ports: <ol style="list-style-type: none"> a. U1.18-P1-H1/Q1 b. U1.18-P1-H1/Q2 2. Replace the RIO book, Location: U1.18-P1-H1

Error Code	Description	Action/ Possible Failing FRU
4064 0BF4	Processor subsystem tests detected fault in I/O hub chip 4 (port x)	<ol style="list-style-type: none"> 1. Check the cabling on the following RIO ports: <ol style="list-style-type: none"> a. U1.18-P1-H3/Q7 b. U1.18-P1-H3/Q8 2. Replace the RIO book, Location: U1.18-P1-H3
4064 0BF5	Processor subsystem tests detected fault in I/O hub chip 5 (port x)	<ol style="list-style-type: none"> 1. Check the cabling on the following RIO ports: <ol style="list-style-type: none"> a. U1.18-P1-H3/Q5 b. U1.18-P1-H3/Q6 2. Replace the RIO book, Location: U1.18-P1-H3
4064 0BF6	Processor subsystem tests detected fault in I/O hub chip 6 (port x)	<ol style="list-style-type: none"> 1. Check the cabling on the following RIO ports: <ol style="list-style-type: none"> a. U1.18-P1-H4/Q5 b. U1.18-P1-H4/Q6 2. Replace the RIO book, Location: U1.18-P1-H4
4064 0BF7	Processor subsystem tests detected fault in I/O hub chip 7 (port x)	<ol style="list-style-type: none"> 1. Check the cabling on the following RIO ports: <ol style="list-style-type: none"> a. U1.18-P1-H4/Q7 b. U1.18-P1-H4/Q8 2. Replace the RIO book, Location: U1.18-P1-H4
4064 0BF8	Processor subsystem tests detected fault in I/O hub chip 8 (port x)	<ol style="list-style-type: none"> 1. Check the cabling on the following RIO ports: <ol style="list-style-type: none"> a. U1.18-P1-H1/Q7 b. U1.18-P1-H1/Q8 2. Replace the RIO book, Location: U1.18-P1-H1
4064 0BF9	Processor subsystem tests detected fault in I/O hub chip 9 (port x)	<ol style="list-style-type: none"> 1. Check the cabling on the following RIO ports: <ol style="list-style-type: none"> a. U1.18-P1-H1/Q5 b. U1.18-P1-H1/Q6 2. Replace the RIO book, Location: U1.18-P1-H1

Error Code	Description	Action/ Possible Failing FRU
4064 0BFA	Processor subsystem tests detected fault in I/O hub chip 10 (port x)	<ol style="list-style-type: none"> Check the cabling on the following RIO ports: <ol style="list-style-type: none"> U1.18-P1-H3/Q3 U1.18-P1-H3/Q4 Replace the RIO book, Location: U1.18-P1-H3
4064 0BFB	Processor subsystem tests detected fault in I/O hub chip 11 (port x)	<ol style="list-style-type: none"> Check the cabling on the following RIO ports: <ol style="list-style-type: none"> U1.18-P1-H3/Q1 U1.18-P1-H3/Q2 Replace the RIO book, Location: U1.18-P1-H3
4064 0BFC	Processor subsystem tests detected fault in I/O hub chip 12 (port x)	<ol style="list-style-type: none"> Check the cabling on the following RIO ports: <ol style="list-style-type: none"> U1.18-P1-H4/Q1 U1.18-P1-H4/Q2 Replace the RIO book, Location: U1.18-P1-H4.
4064 0BFD	Processor subsystem tests detected fault in I/O hub chip 13 (port x)	<ol style="list-style-type: none"> Check the cabling on the following RIO ports: <ol style="list-style-type: none"> U1.18-P1-H4/Q3 U1.18-P1-H4/Q4 Replace the RIO book, Location: U1.18-P1-H4
4064 0C03	Processor subsystem tests detected fault in all MCMs	Go to "MAP 1543: MCM Module Problem Isolation" on page 332.
4064 0C09	Processor subsystem tests detected fault in all memory books	Go to "MAP 1546: Memory Book Problem Isolation" on page 338.
4064 0C0A	Processor subsystem tests detected fault in all I/O books	Go to "MAP 1547: I/O Book Problem Isolation" on page 341.
4064 0C10	Processor subsystem tests detected mismatch between MCM 0 and VPD card	Plugging error with FRU kit Location: U1.18-P1-C1 and U1.18-P1-H2.3
4064 0C11	Processor subsystem tests detected mismatch between MCM 2 and VPD card	Plugging error with FRU kit Location: U1.18-P1-C4 and U1.18-P1-H2.4
4064 0C12	Processor subsystem tests detected mismatch between MCM 1 and VPD card	Plugging error with FRU kit Location: U1.18-P1-C3 and U1.18-P1-H2.5
4064 0C13	Processor subsystem tests detected mismatch between MCM 3 and VPD card	Plugging error with FRU kit Location: U1.18-P1-C2 and U1.18-P1-H2.6

Error Code	Description	Action/ Possible Failing FRU
4064 0CA5	Processor subsystem tests detected invalid processor subsystem configuration	Verify that MCMs, memory books, and L3 modules are correctly configured.
4064 0CA6	Processor subsystem tests detected no usable main storage	Reboot the system in slow mode to isolate the failure.
4064 0CA9	Processor subsystem tests detected configuration error with processor memory	Reboot the system in slow mode to isolate the failure.
4064 0D00	Processor subsystem tests detected fault in L3 cache module 0	L3 cache module 0 and L3 VPD card Location: U1.18-P1-C6 and U1.18-P1-H2.1
4064 0D01	Processor subsystem tests detected fault in L3 cache module 1	L3 cache module 1 and L3 VPD card Location: U1.18-P1-C7 and U1.18-P1-H2.1
4064 0D02	Processor subsystem tests detected fault in L3 cache module 2	L3 cache module 2 and L3 VPD card Location: U1.18-P1-C11 and U1.18-P1-H2.1
4064 0D03	Processor subsystem tests detected fault in L3 cache module 3	L3 cache module 3 and L3 VPD card Location: U1.18-P1-C10 and U1.18-P1-H2.1
4064 0D04	Processor subsystem tests detected fault in L3 cache module 4	L3 cache module 4 and L3 VPD card Location: U1.18-P1-C8 and U1.18-P1-H2.1
4064 0D05	Processor subsystem tests detected fault in L3 cache module 5	L3 cache module 5 and L3 VPD card Location: U1.18-P1-C20 and U1.18-P1-H2.1
4064 0D06	Processor subsystem tests detected fault in L3 cache module 6	L3 cache module 6 and L3 VPD card Location: U1.18-P1-C16 and U1.18-P1-H2.1
4064 0D07	Processor subsystem tests detected fault in L3 cache module 7	L3 cache module 7 and L3 VPD card Location: U1.18-P1-C12 and U1.18-P1-H2.1
4064 0D08	Processor subsystem tests detected fault in L3 cache module 8	L3 cache module 8 and L3 VPD card Location: U1.18-P1-C19 and U1.18-P1-H2.1
4064 0D09	Processor subsystem tests detected fault in L3 cache module 9	L3 cache module 9 and L3 VPD card Location: U1.18-P1-C18 and U1.18-P1-H2.1
4064 0D0A	Processor subsystem tests detected fault in L3 cache module 10	L3 cache module 10 and L3 VPD card Location: U1.18-P1-C14 and U1.18-P1-H2.1
4064 0D0B	Processor subsystem tests detected fault in L3 cache module 11	L3 cache module 11 and L3 VPD card Location: U1.18-P1-C15 and U1.18-P1-H2.1

Error Code	Description	Action/ Possible Failing FRU
4064 0D0C	Processor subsystem tests detected fault in L3 cache module 12	L3 cache module 12 and L3 VPD card Location: U1.18-P1-C17 and U1.18-P1-H2.1
4064 0D0D	Processor subsystem tests detected fault in L3 cache module 13	L3 cache module 13 and L3 VPD card Location: U1.18-P1-C5 and U1.18-P1-H2.1
4064 0D0E	Processor subsystem tests detected fault in L3 cache module 14	L3 cache module 14 and L3 VPD card Location: U1.18-P1-C9 and U1.18-P1-H2.1
4064 0D0F	Processor subsystem tests detected fault in L3 cache module 15	L3 cache module 15 and L3 VPD card Location: U1.18-P1-C13 and U1.18-P1-H2.1
4064 0EA0	Processor subsystem tests detected fault in MOPS service processor code	1. Check for system firmware updates. 2. Call service support.
4064 0EA1	Processor subsystem tests detected fault in processor subsystem code on main processor	1. Check for operating system updates. 2. Call service support.
4064 0EA2	Processor subsystem tests detected fault in PRD code on service processor	1. Check for system firmware updates. 2. Call service support.
4064 0EA4	Processor subsystem tests detected fault in service processor code	1. Check for system firmware updates. 2. Call service support.
4064 0EAF	Processor subsystem tests detected unknown service processor code and system type	1. Check for system firmware updates. 2. Call service support.
4064 0EB0	Processor subsystem tests detected JTAG problem	Go to "MAP 1540: Problem Isolation Procedures" on page 303.
4064 0EB1	Attention line 0 stuck fault	Go to "MAP 1540: Problem Isolation Procedures" on page 303.
4064 0EB2	Attention line 1 stuck fault	Go to "MAP 1540: Problem Isolation Procedures" on page 303.
4064 0EB3	Attention line 2 stuck fault	Go to "MAP 1540: Problem Isolation Procedures" on page 303.
4064 0EB4	Attention line 3 stuck fault	Go to "MAP 1540: Problem Isolation Procedures" on page 303.
4064 0EB5	Attention line 4 stuck fault	Go to "MAP 1540: Problem Isolation Procedures" on page 303.
4064 0EB6	Attention line 5 stuck fault	Go to "MAP 1540: Problem Isolation Procedures" on page 303.

Error Code	Description	Action/ Possible Failing FRU
4064 0EB7	Attention line 6 stuck fault	Go to "MAP 1540: Problem Isolation Procedures" on page 303.
4064 0EB8	Attention line 7 stuck fault	Go to "MAP 1540: Problem Isolation Procedures" on page 303.
4064 0EB9	Attention line 8 stuck fault	Go to "MAP 1540: Problem Isolation Procedures" on page 303.
4064 0EBA	Attention line 9 stuck fault	Go to "MAP 1540: Problem Isolation Procedures" on page 303.
4064 0EBB	Attention line 10 stuck fault	Go to "MAP 1540: Problem Isolation Procedures" on page 303.
4064 0EBC	Attention line 11 stuck fault	Go to "MAP 1540: Problem Isolation Procedures" on page 303.
4064 0EE1	Processor subsystem tests detected fault in service processor code (invalid MRU to mapping)	<ol style="list-style-type: none"> 1. Check for system firmware updates. 2. Call service support.
4064 0EE2	Processor subsystem tests detected fault in service processor firmware fault	<ol style="list-style-type: none"> 1. Check for system firmware updates. 2. Call service support.
4064 0EE5	Processor subsystem tests detected firmware error; no callout available	<ol style="list-style-type: none"> 1. Check for system firmware updates. 2. Call service support.
4065 0001	Display alter tests detected clock card assembly failure	Go to "MAP 1540: Problem Isolation Procedures" on page 303.
4065 0002	Display alter tests detected backplane assembly failure	Go to "MAP 1540: Problem Isolation Procedures" on page 303.
4065 0003	Display alter tests detected fault in MCM module 0	MCM module 0 and VPD card Location: U1.18-P1-C1 and U1.18-P1-H2.3
4065 0004	Display alter tests detected fault in MCM module 2	MCM module 2 and VPD card Location: U1.18-P1-C4 and U1.18-P1-H2.4
4065 0005	Display alter tests detected fault in MCM module 1	MCM module 1 and VPD card Location: U1.18-P1-C3 and U1.18-P1-H2.5
4065 0006	Display alter tests detected fault in MCM module 3	MCM module 3 and VPD card Location: U1.18-P1-C2 and U1.18-P1-H2.6

Error Code	Description	Action/ Possible Failing FRU
4065 0007	Display alter tests detected fault in L3 VPD card	<ol style="list-style-type: none"> L3 VPD card Location: U1.18-P1-H2.1 (Order the L3 cache module FRU to obtain a new L3 VPD card. Return the L3 cache module that was included in the FRU kit, and the failing L3 VPD card as "new defective.") Primary I/O book Location: U1.18-P1-H2
4065 000A	Display alter tests detected fault in primary I/O book 1 (slot 0)	Go to "MAP 1540: Problem Isolation Procedures" on page 303.
4065 000B	Display alter tests detected fault in secondary I/O book (slot 1)	Go to "MAP 1540: Problem Isolation Procedures" on page 303.
4065 000C	Display alter tests detected fault in I/O book 3 (slot 2)	Go to "MAP 1540: Problem Isolation Procedures" on page 303.
4065 000D	Display alter tests detected fault in I/O book 4 (slot 3)	Go to "MAP 1540: Problem Isolation Procedures" on page 303.
4065 0010	Display alter tests detected fault in Memory book (slot 0)	Memory book (slot 0) Location: U1.18-P1-M2
4065 0011	Display alter tests detected fault in Memory book (slot 1)	Memory book (slot 1) Location: U1.18-P1-M3
4065 0012	Display alter tests detected fault in Memory book (slot 2)	Memory book (slot 2) Location: U1.18-P1-M7
4065 0013	Display alter tests detected fault in Memory book (slot 3)	Memory book (slot 3) Location: U1.18-P1-M6
4065 0014	Display alter tests detected fault in Memory book (slot 4)	Memory book (slot 4) Location: U1.18-P1-M4
4065 0015	Display alter tests detected fault in Memory book (slot 5)	Memory book (slot 5) Location: U1.18-P1-M8
4065 0016	Display alter tests detected fault in Memory book (slot 6)	Memory book (slot 6) Location: U1.18-P1-M5
4065 0017	Display alter tests detected fault in Memory book (slot 7)	Memory book (slot 7) Location: U1.18-P1-M1
4065 00B0	Display alter tests detected possible problem with bus controller or CSP code	<ol style="list-style-type: none"> Check for system firmware updates. Primary I/O book, Location: U1.18-P1-H2 Call service support.

Error Code	Description	Action/ Possible Failing FRU
4065 00B1	Display alter tests detected possible problem with bus controller	<ol style="list-style-type: none"> 1. Check for system firmware updates. 2. Primary I/O book, Location: U1.18-P1-H2 3. Call service support. <p>1</p>
4065 00B3	Display alter tests detected MCM 0/VPD problem	<ol style="list-style-type: none"> 1. Check for system firmware updates. 2. MCM module 0 and VPD card Location: 2U1.18-P1-C1 and U1.18-P1-H2.3
4065 00B4	Display alter tests detected MCM 2/VPD problem	<ol style="list-style-type: none"> 1. Check for system firmware updates. 2. MCM module 2 and VPD card Location: U1.18-P1-C4 and U1.18-P1-H2.4
4065 00B5	Display alter tests detected MCM 1/VPD problem	<ol style="list-style-type: none"> 1. Check for system firmware updates. 2. MCM module 1 and VPD card Location: U1.18-P1-C3 and U1.18-P1-H2.5
4065 00B6	Display alter tests detected MCM 3/VPD problem	<ol style="list-style-type: none"> 1. Check for system firmware updates. 2. MCM module 3 and VPD card Location: U1.18-P1-C2 and U1.18-P1-H2.6
4065 00B7	Display alter tests detected hardware problem in the processor subsystem	Go to "MAP 1540: Problem Isolation Procedures" on page 303.
4065 0A03	Reboot message (run-time array gard failure) for processor 0	Reboot the system in slow mode. Run diagnostics, then go to MAP 0235 in the <i>RS/6000 and @server pSeries Diagnostic Information for Multiple Bus Systems</i> , order number SA38-0509.
4065 0A04	Reboot message (run-time array gard failure) for processor 2	Reboot the system in slow mode. Run diagnostics, then go to MAP 0235 in the <i>RS/6000 and @server pSeries Diagnostic Information for Multiple Bus Systems</i> , order number SA38-0509.
4065 0A05	Reboot message (run-time array gard failure) for processor 1	Reboot the system in slow mode. Run diagnostics, then go to MAP 0235 in the <i>RS/6000 and @server pSeries Diagnostic Information for Multiple Bus Systems</i> , order number SA38-0509.

Error Code	Description	Action/ Possible Failing FRU
4065 0A06	Reboot message (run-time array card failure) for processor 3	Reboot the system in slow mode. Run diagnostics, then go to MAP 0235 in the <i>RS/6000 and @server pSeries Diagnostic Information for Multiple Bus Systems</i> , order number SA38-0509.
4065 0B00	Display alter tests detected fault in I/O book (slot 0 RIO port 0)	<ol style="list-style-type: none"> 1. Check for system firmware updates. 2. Check the I/O cabling between the primary I/O book and the I/O subsystems. 3. Primary I/O book Location: U1.18-P1-H2 4. Call service support.
4065 0B01	Display alter tests detected fault in I/O book (slot 0 RIO port 1)	<ol style="list-style-type: none"> 1. Check for system firmware updates. 2. Check the I/O cabling between the primary I/O book and the I/O subsystems. 3. Primary I/O book Location: U1.18-P1-H2 4. Call service support.
4065 0B02	Display alter tests detected fault in I/O book (slot 0 RIO port 2)	<ol style="list-style-type: none"> 1. Check for system firmware updates. 2. Check the I/O cabling between the primary I/O book and the I/O subsystems. 3. Primary I/O book Location: U1.18-P1-H2 4. Call service support.
4065 0B03	Display alter tests detected fault in I/O book (slot 0 RIO port 3)	<ol style="list-style-type: none"> 1. Check for system firmware updates. 2. Check the I/O cabling between the primary I/O book and the I/O subsystems. 3. Primary I/O book Location: U1.18-P1-H2 4. Call service support.

Error Code	Description	Action/ Possible Failing FRU
4065 0B10	Display alter tests detected fault in I/O book	<ol style="list-style-type: none"> 1. Check for system firmware updates. 2. Check the I/O cabling between the secondary I/O book and the I/O subsystems. 3. Secondary I/O book Location: U1.18-P1-H1 4. Call service support.
4065 0B11	Display alter tests detected fault in I/O book	<ol style="list-style-type: none"> 1. Check for system firmware updates. 2. Check the I/O cabling between the secondary I/O book and the I/O subsystems. 3. Secondary I/O book Location: U1.18-P1-H1 4. Call service support.
4065 0B12	Display alter tests detected fault in I/O book	<ol style="list-style-type: none"> 1. Check for system firmware updates. 2. Check the I/O cabling between the secondary I/O book and the I/O subsystems. 3. Secondary I/O book Location: U1.18-P1-H1 4. Call service support.
4065 0B13	Display alter tests detected fault in I/O book	<ol style="list-style-type: none"> 1. Check for system firmware updates. 2. Check the I/O cabling between the secondary I/O book and the I/O subsystems. 3. Secondary I/O book Location: U1.18-P1-H1 4. Call service support.
4065 0B14	Display alter tests detected fault in I/O book	<ol style="list-style-type: none"> 1. Check for system firmware updates. 2. Check the I/O cabling between the secondary I/O book and the I/O subsystems. 3. Secondary I/O book Location: U1.18-P1-H1 4. Call service support.

Error Code	Description	Action/ Possible Failing FRU
4065 0B15	Display alter tests detected fault in I/O book	<ol style="list-style-type: none"> 1. Check for system firmware updates. 2. Check the I/O cabling between the secondary I/O book and the I/O subsystems. 3. Secondary I/O book Location: U1.18-P1-H1 4. Call service support.
4065 0B16	Display alter tests detected fault in I/O book	<ol style="list-style-type: none"> 1. Check for system firmware updates. 2. Check the I/O cabling between the secondary I/O book and the I/O subsystems. 3. Secondary I/O book Location: U1.18-P1-H1 4. Call service support.
4065 0B17	Display alter tests detected fault in I/O book	<ol style="list-style-type: none"> 1. Check for system firmware updates. 2. Check the I/O cabling between the secondary I/O book and the I/O subsystems. 3. Secondary I/O book Location: U1.18-P1-H1 4. Call service support.
4065 0B20	Display alter tests detected fault in I/O book	<ol style="list-style-type: none"> 1. Check for system firmware updates. 2. Check the I/O cabling between the secondary I/O book and the I/O subsystems. 3. Secondary I/O book Location: U1.18-P1-H3 4. Call service support.
4065 0B21	Display alter tests detected fault in I/O book	<ol style="list-style-type: none"> 1. Check for system firmware updates. 2. Check the I/O cabling between the secondary I/O book and the I/O subsystems. 3. Secondary I/O book Location: U1.18-P1-H3 4. Call service support.

Error Code	Description	Action/ Possible Failing FRU
4065 0B22	Display alter tests detected fault in I/O book	<ol style="list-style-type: none"> 1. Check for system firmware updates. 2. Check the I/O cabling between the secondary I/O book and the I/O subsystems. 3. Secondary I/O book Location: U1.18-P1-H3 4. Call service support.
4065 0B23	Display alter tests detected fault in I/O book	<ol style="list-style-type: none"> 1. Check for system firmware updates. 2. Check the I/O cabling between the secondary I/O book and the I/O subsystems. 3. Secondary I/O book Location: U1.18-P1-H3 4. Call service support.
4065 0B24	Display alter tests detected fault in I/O book	<ol style="list-style-type: none"> 1. Check for system firmware updates. 2. Check the I/O cabling between the secondary I/O book and the I/O subsystems. 3. Secondary I/O book Location: U1.18-P1-H3 4. Call service support.
4065 0B25	Display alter tests detected fault in I/O book	<ol style="list-style-type: none"> 1. Check for system firmware updates. 2. Check the I/O cabling between the secondary I/O book and the I/O subsystems. 3. Secondary I/O book Location: U1.18-P1-H3 4. Call service support.
4065 0B26	Display alter tests detected fault in I/O book	<ol style="list-style-type: none"> 1. Check for system firmware updates. 2. Check the I/O cabling between the secondary I/O book and the I/O subsystems. 3. Secondary I/O book Location: U1.18-P1-H3 4. Call service support.

Error Code	Description	Action/ Possible Failing FRU
4065 0B27	Display alter tests detected fault in I/O book	<ol style="list-style-type: none"> 1. Check for system firmware updates. 2. Check the I/O cabling between the secondary I/O book and the I/O subsystems. 3. Secondary I/O book Location: U1.18-P1-H3 4. Call service support.
4065 0B30	Display alter tests detected fault in I/O book	<ol style="list-style-type: none"> 1. Check for system firmware updates. 2. Check the I/O cabling between the third I/O book and the I/O subsystems. 3. Third I/O book Location: U1.18-P1-H4 4. Call service support.
4065 0B31	Display alter tests detected fault in I/O book	<ol style="list-style-type: none"> 1. Check for system firmware updates. 2. Check the I/O cabling between the third I/O book and the I/O subsystems. 3. Third I/O book Location: U1.18-P1-H4 4. Call service support.
4065 0B32	Display alter tests detected fault in I/O book	<ol style="list-style-type: none"> 1. Check for system firmware updates. 2. Check the I/O cabling between the third I/O book and the I/O subsystems. 3. Third I/O book Location: U1.18-P1-H4 4. Call service support.
4065 0B33	Display alter tests detected fault in I/O book	<ol style="list-style-type: none"> 1. Check for system firmware updates. 2. Check the I/O cabling between the third I/O book and the I/O subsystems. 3. Third I/O book Location: U1.18-P1-H4 4. Call service support.

Error Code	Description	Action/ Possible Failing FRU
4065 0B34	Display alter tests detected fault in I/O book	<ol style="list-style-type: none"> 1. Check for system firmware updates. 2. Check the I/O cabling between the third I/O book and the I/O subsystems. 3. Third I/O book Location: U1.18-P1-H4 4. Call service support.
4065 0B35	Display alter tests detected fault in I/O book	<ol style="list-style-type: none"> 1. Check for system firmware updates. 2. Check the I/O cabling between the third I/O book and the I/O subsystems. 3. Third I/O book Location: U1.18-P1-H4 4. Call service support.
4065 0B36	Display alter tests detected fault in I/O book	<ol style="list-style-type: none"> 1. Check for system firmware updates. 2. Check the I/O cabling between the third I/O book and the I/O subsystems. 3. Third I/O book Location: U1.18-P1-H4 4. Call service support.
4065 0B37	Display alter tests detected fault in I/O book	<ol style="list-style-type: none"> 1. Check for system firmware updates. 2. Check the I/O cabling between the third I/O book and the I/O subsystems. 3. Third I/O book Location: U1.18-P1-H4 4. Call service support.
4065 0BF0	Display alter tests detected fault in I/O hub chip 0 (port x)	<ol style="list-style-type: none"> 1. Check the cabling on the following RIO ports: <ol style="list-style-type: none"> a. U1.18-P1-H2/Q1 b. U1.18-P1-H2/Q2 2. Replace the primary I/O book, Location: U1.18-P1-H2

Error Code	Description	Action/ Possible Failing FRU
4065 0BF1	Display alter tests detected fault in I/O hub chip 1 (port x)	<ol style="list-style-type: none"> 1. Check the cabling on the following RIO ports: <ol style="list-style-type: none"> a. U1.18-P1-H2/Q3 b. U1.18-P1-H2/Q4 2. Replace the primary I/O book, Location: U1.18-P1-H2
4065 0BF2	Display alter tests detected fault in I/O hub chip 2 (port x)	<ol style="list-style-type: none"> 1. Check the cabling on the following RIO ports: <ol style="list-style-type: none"> a. U1.18-P1-H1/Q3 b. U1.18-P1-H1/Q4 2. Replace the RIO book, Location: U1.18-P1-H1
4065 0BF3	Display alter tests detected fault in I/O hub chip 3 (port x)	<ol style="list-style-type: none"> 1. Check the cabling on the following RIO ports: <ol style="list-style-type: none"> a. U1.18-P1-H1/Q1 b. U1.18-P1-H1/Q2 2. Replace the RIO book, Location: U1.18-P1-H1
4065 0BF4	Display alter tests detected fault in I/O hub chip 4 (port x)	<ol style="list-style-type: none"> 1. Check the cabling on the following RIO ports: <ol style="list-style-type: none"> a. U1.18-P1-H3/Q7 b. U1.18-P1-H3/Q8 2. Replace the RIO book, Location: U1.18-P1-H3
4065 0BF5	Display alter tests detected fault in I/O hub chip 5 (port x)	<ol style="list-style-type: none"> 1. Check the cabling on the following RIO ports: <ol style="list-style-type: none"> a. U1.18-P1-H3/Q5 b. U1.18-P1-H3/Q6 2. Replace the RIO book, Location: U1.18-P1-H3
4065 0BF6	Display alter tests detected fault in I/O hub chip 6 (port x)	<ol style="list-style-type: none"> 1. Check the cabling on the following RIO ports: <ol style="list-style-type: none"> a. U1.18-P1-H4/Q5 b. U1.18-P1-H4/Q6 2. Replace the RIO book, Location: U1.18-P1-H4

Error Code	Description	Action/ Possible Failing FRU
4065 0BF7	Display alter tests detected fault in I/O hub chip 7 (port x)	<ol style="list-style-type: none"> 1. Check the cabling on the following RIO ports: <ol style="list-style-type: none"> a. U1.18-P1-H4/Q7 b. U1.18-P1-H4/Q8 2. Replace the RIO book, Location: U1.18-P1-H4
4065 0BF8	Display alter tests detected fault in I/O hub chip 8 (port x)	<ol style="list-style-type: none"> 1. Check the cabling on the following RIO ports: <ol style="list-style-type: none"> a. U1.18-P1-H1/Q7 b. U1.18-P1-H1/Q8 2. Replace the RIO book, Location: U1.18-P1-H1
4065 0BF9	Display alter tests detected fault in I/O hub chip 9 (port x)	<ol style="list-style-type: none"> 1. Check the cabling on the following RIO ports: <ol style="list-style-type: none"> a. U1.18-P1-H1/Q5 b. U1.18-P1-H1/Q6 2. Replace the RIO book, Location: U1.18-P1-H1
4065 0BFA	Display alter tests detected fault in I/O hub chip 10 (port x)	<ol style="list-style-type: none"> 1. Check the cabling on the following RIO ports: <ol style="list-style-type: none"> a. U1.18-P1-H3/Q3 b. U1.18-P1-H3/Q4 2. Replace the RIO book, Location: U1.18-P1-H3
4065 0BFB	Display alter tests detected fault in I/O hub chip 11 (port x)	<ol style="list-style-type: none"> 1. Check the cabling on the following RIO ports: <ol style="list-style-type: none"> a. U1.18-P1-H3/Q1 b. U1.18-P1-H3/Q2 2. Replace the RIO book, Location: U1.18-P1-H3
4065 0BFC	Display alter tests detected fault in I/O hub chip 12 (port x)	<ol style="list-style-type: none"> 1. Check the cabling on the following RIO ports: <ol style="list-style-type: none"> a. U1.18-P1-H4/Q1 b. U1.18-P1-H4/Q2 2. Replace the RIO book, Location: U1.18-P1-H4.

Error Code	Description	Action/ Possible Failing FRU
4065 0BFD	Display alter tests detected fault in I/O hub chip 13 (port x)	<ol style="list-style-type: none"> 1. Check the cabling on the following RIO ports: <ol style="list-style-type: none"> a. U1.18-P1-H4/Q3 b. U1.18-P1-H4/Q4 2. Replace the RIO book, Location: U1.18-P1-H4
4065 0C03	Display alter tests detected fault in all MCMs	Go to "MAP 1543: MCM Module Problem Isolation" on page 332.
4065 0C09	Display alter tests detected fault in all memory books	Go to "MAP 1546: Memory Book Problem Isolation" on page 338.
4065 0C0A	Display alter tests detected fault in all I/O books	Go to "MAP 1547: I/O Book Problem Isolation" on page 341.
4065 0C10	Display alter tests detected mismatch between MCM 0 and VPD card	Plugging error with FRU kit Location: U1.18-P1-C1 and U1.18-P1-H2.3
4065 0C11	Display alter tests detected mismatch between MCM 2 and VPD card	Plugging error with FRU kit Location: U1.18-P1-C4 and U1.18-P1-H2.4
4065 0C12	Display alter tests detected mismatch between MCM 1 and VPD card	Plugging error with FRU kit Location: U1.18-P1-C3 and U1.18-P1-H2.5
4065 0C13	Display alter tests detected mismatch between MCM 3 and VPD card	Plugging error with FRU kit Location: U1.18-P1-C2 and U1.18-P1-H2.6
4065 0CA5	Display alter tests detected invalid processor subsystem configuration	Verify that MCMs, memory books, and L3 modules are correctly configured.
4065 0CA6	Display alter tests detected no usable main storage	Reboot the system in slow mode to isolate the failure.
4065 0CA9	Display alter tests detected configuration error with processor memory	Reboot the system in slow mode to isolate the failure.
4065 0D00	Display alter tests detected fault in L3 cache module 0	L3 cache module 0 and L3 VPD card Location: U1.18-P1-C6 and U1.18-P1-H2.1
4065 0D01	Display alter tests detected fault in L3 cache module 1	L3 cache module 1 and L3 VPD card Location: U1.18-P1-C7 and U1.18-P1-H2.1
4065 0D02	Display alter tests detected fault in L3 cache module 2	L3 cache module 2 and L3 VPD card Location: U1.18-P1-C11 and U1.18-P1-H2.1
4065 0D03	Display alter tests detected fault in L3 cache module 3	L3 cache module 3 and L3 VPD card Location: U1.18-P1-C10 and U1.18-P1-H2.1

Error Code	Description	Action/ Possible Failing FRU
4065 0D04	Display alter tests detected fault in L3 cache module 4	L3 cache module 4 and L3 VPD card Location: U1.18-P1-C8 and U1.18-P1-H2.1
4065 0D05	Display alter tests detected fault in L3 cache module 5	L3 cache module 5 and L3 VPD card Location: U1.18-P1-C20 and U1.18-P1-H2.1
4065 0D06	Display alter tests detected fault in L3 cache module 6	L3 cache module 6 and L3 VPD card Location: U1.18-P1-C16 and U1.18-P1-H2.1
4065 0D07	Display alter tests detected fault in L3 cache module 7	L3 cache module 7 and L3 VPD card Location: U1.18-P1-C12 and U1.18-P1-H2.1
4065 0D08	Display alter tests detected fault in L3 cache module 8	L3 cache module 8 and L3 VPD card Location: U1.18-P1-C19 and U1.18-P1-H2.1
4065 0D09	Display alter tests detected fault in L3 cache module 9	L3 cache module 9 and L3 VPD card Location: U1.18-P1-C18 and U1.18-P1-H2.1
4065 0D0A	Display alter tests detected fault in L3 cache module 10	L3 cache module 10 and L3 VPD card Location: U1.18-P1-C14 and U1.18-P1-H2.1
4065 0D0B	Display alter tests detected fault in L3 cache module 11	L3 cache module 11 and L3 VPD card Location: U1.18-P1-C15 and U1.18-P1-H2.1
4065 0D0C	Display alter tests detected fault in L3 cache module 12	L3 cache module 12 and L3 VPD card Location: U1.18-P1-C17 and U1.18-P1-H2.1
4065 0D0D	Display alter tests detected fault in L3 cache module 13	L3 cache module 13 and L3 VPD card Location: U1.18-P1-C5 and U1.18-P1-H2.1
4065 0D0E	Display alter tests detected fault in L3 cache module 14	L3 cache module 14 and L3 VPD card Location: U1.18-P1-C9 and U1.18-P1-H2.1
4065 0D0F	Display alter tests detected fault in L3 cache module 15	L3 cache module 15 and L3 VPD card Location: U1.18-P1-C13 and U1.18-P1-H2.1
4065 0EA0	Display alter tests detected fault in MOPS service processor code	<ol style="list-style-type: none"> 1. Check for system firmware updates. 2. Call service support.
4065 0EA1	Display alter tests detected fault in processor subsystem code on main processor	<ol style="list-style-type: none"> 1. Check for operating system updates. 2. Call service support.

Error Code	Description	Action/ Possible Failing FRU
4065 0EA2	Display alter tests detected fault in PRD code on service processor	<ol style="list-style-type: none"> 1. Check for system firmware updates. 2. Call service support.
4065 0EA4	Display alter tests detected fault in service processor code	<ol style="list-style-type: none"> 1. Check for system firmware updates. 2. Call service support.
4065 0EAF	Display alter tests detected unknown service processor code and system type	<ol style="list-style-type: none"> 1. Check for system firmware updates. 2. Call service support.
4065 0EB0	Display alter tests detected JTAG problem	Go to "MAP 1540: Problem Isolation Procedures" on page 303.
4065 0EB1	Attention line 0 stuck fault	Go to "MAP 1540: Problem Isolation Procedures" on page 303.
4065 0EB2	Attention line 1 stuck fault	Go to "MAP 1540: Problem Isolation Procedures" on page 303.
4065 0EB3	Attention line 2 stuck fault	Go to "MAP 1540: Problem Isolation Procedures" on page 303.
4065 0EB4	Attention line 3 stuck fault	Go to "MAP 1540: Problem Isolation Procedures" on page 303.
4065 0EB5	Attention line 4 stuck fault	Go to "MAP 1540: Problem Isolation Procedures" on page 303.
4065 0EB6	Attention line 5 stuck fault	Go to "MAP 1540: Problem Isolation Procedures" on page 303.
4065 0EB7	Attention line 6 stuck fault	Go to "MAP 1540: Problem Isolation Procedures" on page 303.
4065 0EB8	Attention line 7 stuck fault	Go to "MAP 1540: Problem Isolation Procedures" on page 303.
4065 0EB9	Attention line 8 stuck fault	Go to "MAP 1540: Problem Isolation Procedures" on page 303.
4065 0EBA	Attention line 9 stuck fault	Go to "MAP 1540: Problem Isolation Procedures" on page 303.
4065 0EBB	Attention line 10 stuck fault	Go to "MAP 1540: Problem Isolation Procedures" on page 303.
4065 0EBC	Attention line 11 stuck fault	Go to "MAP 1540: Problem Isolation Procedures" on page 303.
4065 0EE1	Display alter tests detected fault in service processor code (invalid MRU to mapping)	<ol style="list-style-type: none"> 1. Check for system firmware updates. 2. Call service support.
4065 0EE2	Display alter tests detected fault in service processor firmware fault	<ol style="list-style-type: none"> 1. Check for system firmware updates. 2. Call service support.

Error Code	Description	Action/ Possible Failing FRU
4065 0EE5	Display alter tests detected firmware error; no callout available	<ol style="list-style-type: none"> 1. Check for system firmware updates. 2. Call service support.
4066 0001	Scan interface basic assurance tests detected clock card assembly failure	Go to "MAP 1540: Problem Isolation Procedures" on page 303.
4066 0002	Scan interface basic assurance tests detected backplane assembly failure	Go to "MAP 1540: Problem Isolation Procedures" on page 303.
4066 0003	Scan interface basic assurance tests detected fault in MCM module 0	MCM module 0 and VPD card Location: U1.18-P1-C1 and U1.18-P1-H2.3
4066 0004	Scan interface basic assurance tests detected fault in MCM module 2	MCM module 2 and VPD card Location: U1.18-P1-C4 and U1.18-P1-H2.4
4066 0005	Scan interface basic assurance tests detected fault in MCM module 1	MCM module 1 and VPD card Location: U1.18-P1-C3 and U1.18-P1-H2.5
4066 0006	Scan interface basic assurance tests detected fault in MCM module 3	MCM module 3 and VPD card Location: U1.18-P1-C2 and U1.18-P1-H2.6
4066 0007	Scan interface basic assurance tests detected fault in L3 VPD card	<ol style="list-style-type: none"> 1. L3 VPD card Location: U1.18-P1-H2.1 (Order the L3 cache module FRU to obtain a new L3 VPD card. Return the L3 cache module that was included in the FRU kit, and the failing L3 VPD card as "new defective".) 2. Primary I/O book Location: U1.18-P1-H2
4066 000A	Scan interface basic assurance tests detected fault in primary I/O book 1 (slot 0)	Go to "MAP 1540: Problem Isolation Procedures" on page 303.
4066 000B	Scan interface basic assurance tests detected fault in secondary I/O book (slot 1)	Go to "MAP 1540: Problem Isolation Procedures" on page 303.
4066 000C	Scan interface basic assurance tests detected fault in I/O book 3 (slot 2)	Go to "MAP 1540: Problem Isolation Procedures" on page 303.
4066 000D	Scan interface basic assurance tests detected fault in I/O book 4 (slot 3)	Go to "MAP 1540: Problem Isolation Procedures" on page 303.
4066 0010	Scan interface basic assurance tests detected fault in Memory book (slot 0)	Memory book (slot 0) Location: U1.18-P1-M2
4066 0011	Scan interface basic assurance tests detected fault in Memory book (slot 1)	Memory book (slot 1) Location: U1.18-P1-M3
4066 0012	Scan interface basic assurance tests detected fault in Memory book (slot 2)	Memory book (slot 2) Location: U1.18-P1-M7

Error Code	Description	Action/ Possible Failing FRU
4066 0013	Scan interface basic assurance tests detected fault in Memory book (slot 3)	Memory book (slot 3) Location: U1.18-P1-M6
4066 0014	Scan interface basic assurance tests detected fault in Memory book (slot 4)	Memory book (slot 4) Location: U1.18-P1-M4
4066 0015	Scan interface basic assurance tests detected fault in Memory book (slot 5)	Memory book (slot 5) Location: U1.18-P1-M8
4066 0016	Scan interface basic assurance tests detected fault in Memory book (slot 6)	Memory book (slot 6) Location: U1.18-P1-M5
4066 0017	Scan interface basic assurance tests detected fault in Memory book (slot 7)	Memory book (slot 7) Location: U1.18-P1-M1
4066 00B0	Possible problem with bus controller or CSP code	<ol style="list-style-type: none"> 1. Check for system firmware updates. 2. Primary I/O book, Location: U1.18-P1-H2 3. Call service support.
4066 00B1	Possible problem with bus controller	<ol style="list-style-type: none"> 1. Check for system firmware updates. 2. Primary I/O book, Location: U1.18-P1-H2 3. Call service support.
4066 00B3	MCM 0/VPD problem	<ol style="list-style-type: none"> 1. Check for system firmware updates. 2. MCM module 0 and VPD card Location: U1.18-P1-C1 and U1.18-P1-H2.3
4066 00B4	MCM 2/VPD problem	<ol style="list-style-type: none"> 1. Check for system firmware updates. 2. MCM module 2 and VPD card Location: U1.18-P1-C4 and U1.18-P1-H2.4
4066 00B5	MCM 1/VPD problem	<ol style="list-style-type: none"> 1. Check for system firmware updates. 2. MCM module 1 and VPD card Location: U1.18-P1-C3 and U1.18-P1-H2.5
4066 00B6	MCM 3/VPD problem	<ol style="list-style-type: none"> 1. Check for system firmware updates. 2. MCM module 3 and VPD card Location: U1.18-P1-C2 and U1.18-P1-H2.6
4066 00B7	Hardware problem in the processor subsystem	Go to "MAP 1540: Problem Isolation Procedures" on page 303.

Error Code	Description	Action/ Possible Failing FRU
4066 0A03	Reboot message (run-time array gard failure) for processor 0	Reboot the system in slow mode. Run diagnostics, then go to MAP 0235 in the <i>RS/6000 and @server pSeries Diagnostic Information for Multiple Bus Systems</i> , order number SA38-0509.
4066 0A04	Reboot message (run-time array gard failure) for processor 2	Reboot the system in slow mode. Run diagnostics, then go to MAP 0235 in the <i>RS/6000 and @server pSeries Diagnostic Information for Multiple Bus Systems</i> , order number SA38-0509.
4066 0A05	Reboot message (run-time array gard failure) for processor 1	Reboot the system in slow mode. Run diagnostics, then go to MAP 0235 in the <i>RS/6000 and @server pSeries Diagnostic Information for Multiple Bus Systems</i> , order number SA38-0509.
4066 0A06	Reboot message (run-time array gard failure) for processor 3	Reboot the system in slow mode. Run diagnostics, then go to MAP 0235 in the <i>RS/6000 and @server pSeries Diagnostic Information for Multiple Bus Systems</i> , order number SA38-0509.
4066 0B00	Scan interface basic assurance tests detected fault in I/O book (slot 0 RIO port 0)	<ol style="list-style-type: none"> 1. Check for system firmware updates. 2. Check the I/O cabling between the primary I/O book and the I/O subsystems. 3. Primary I/O book Location: U1.18-P1-H2 4. Call service support.
4066 0B01	Scan interface basic assurance tests detected fault in I/O book (slot 0 RIO port 1)	<ol style="list-style-type: none"> 1. Check for system firmware updates. 2. Check the I/O cabling between the primary I/O book and the I/O subsystems. 3. Primary I/O book Location: U1.18-P1-H2 4. Call service support.
4066 0B02	Scan interface basic assurance tests detected fault in I/O book (slot 0 RIO port 2)	<ol style="list-style-type: none"> 1. Check for system firmware updates. 2. Check the I/O cabling between the primary I/O book and the I/O subsystems. 3. Primary I/O book Location: U1.18-P1-H2 4. Call service support.

Error Code	Description	Action/ Possible Failing FRU
4066 0B03	Scan interface basic assurance tests detected fault in I/O book (slot 0 RIO port 3)	<ol style="list-style-type: none"> 1. Check for system firmware updates. 2. Check the I/O cabling between the primary I/O book and the I/O subsystems. 3. Primary I/O book Location: U1.18-P1-H2 4. Call service support.
4066 0B10	Scan interface basic assurance tests detected fault in I/O book	<ol style="list-style-type: none"> 1. Check for system firmware updates. 2. Check the I/O cabling between the secondary I/O book and the I/O subsystems. 3. Secondary I/O book Location: U1.18-P1-H1 4. Call service support.
4066 0B11	Scan interface basic assurance tests detected fault in I/O book	<ol style="list-style-type: none"> 1. Check for system firmware updates. 2. Check the I/O cabling between the secondary I/O book and the I/O subsystems. 3. Secondary I/O book Location: U1.18-P1-H1 4. Call service support.
4066 0B12	Scan interface basic assurance tests detected fault in I/O book	<ol style="list-style-type: none"> 1. Check for system firmware updates. 2. Check the I/O cabling between the secondary I/O book and the I/O subsystems. 3. Secondary I/O book Location: U1.18-P1-H1 4. Call service support.
4066 0B13	Scan interface basic assurance tests detected fault in I/O book	<ol style="list-style-type: none"> 1. Check for system firmware updates. 2. Check the I/O cabling between the secondary I/O book and the I/O subsystems. 3. Secondary I/O book Location: U1.18-P1-H1 4. Call service support.

Error Code	Description	Action/ Possible Failing FRU
4066 0B14	Scan interface basic assurance tests detected fault in I/O book	<ol style="list-style-type: none"> 1. Check for system firmware updates. 2. Check the I/O cabling between the secondary I/O book and the I/O subsystems. 3. Secondary I/O book Location: U1.18-P1-H1 4. Call service support.
4066 0B15	Scan interface basic assurance tests detected fault in I/O book	<ol style="list-style-type: none"> 1. Check for system firmware updates. 2. Check the I/O cabling between the secondary I/O book and the I/O subsystems. 3. Secondary I/O book Location: U1.18-P1-H1 4. Call service support.
4066 0B16	Scan interface basic assurance tests detected fault in I/O book	<ol style="list-style-type: none"> 1. Check for system firmware updates. 2. Check the I/O cabling between the secondary I/O book and the I/O subsystems. 3. Secondary I/O book Location: U1.18-P1-H1 4. Call service support.
4066 0B17	Scan interface basic assurance tests detected fault in I/O book	<ol style="list-style-type: none"> 1. Check for system firmware updates. 2. Check the I/O cabling between the secondary I/O book and the I/O subsystems. 3. Secondary I/O book Location: U1.18-P1-H1 4. Call service support.
4066 0B20	Scan interface basic assurance tests detected fault in I/O book	<ol style="list-style-type: none"> 1. Check for system firmware updates. 2. Check the I/O cabling between the secondary I/O book and the I/O subsystems. 3. Secondary I/O book Location: U1.18-P1-H3 4. Call service support.

Error Code	Description	Action/ Possible Failing FRU
4066 0B21	Scan interface basic assurance tests detected fault in I/O book	<ol style="list-style-type: none"> 1. Check for system firmware updates. 2. Check the I/O cabling between the secondary I/O book and the I/O subsystems. 3. Secondary I/O book Location: U1.18-P1-H3 4. Call service support.
4066 0B22	Scan interface basic assurance tests detected fault in I/O book	<ol style="list-style-type: none"> 1. Check for system firmware updates. 2. Check the I/O cabling between the secondary I/O book and the I/O subsystems. 3. Secondary I/O book Location: U1.18-P1-H3 4. Call service support.
4066 0B23	Scan interface basic assurance tests detected fault in I/O book	<ol style="list-style-type: none"> 1. Check for system firmware updates. 2. Check the I/O cabling between the secondary I/O book and the I/O subsystems. 3. Secondary I/O book Location: U1.18-P1-H3 4. Call service support.
4066 0B24	Scan interface basic assurance tests detected fault in I/O book	<ol style="list-style-type: none"> 1. Check for system firmware updates. 2. Check the I/O cabling between the secondary I/O book and the I/O subsystems. 3. Secondary I/O book Location: U1.18-P1-H3 4. Call service support.
4066 0B25	Scan interface basic assurance tests detected fault in I/O book	<ol style="list-style-type: none"> 1. Check for system firmware updates. 2. Check the I/O cabling between the secondary I/O book and the I/O subsystems. 3. Secondary I/O book Location: U1.18-P1-H3 4. Call service support.

Error Code	Description	Action/ Possible Failing FRU
4066 0B26	Scan interface basic assurance tests detected fault in I/O book	<ol style="list-style-type: none"> 1. Check for system firmware updates. 2. Check the I/O cabling between the secondary I/O book and the I/O subsystems. 3. Secondary I/O book Location: U1.18-P1-H3 4. Call service support.
4066 0B27	Scan interface basic assurance tests detected fault in I/O book	<ol style="list-style-type: none"> 1. Check for system firmware updates. 2. Check the I/O cabling between the secondary I/O book and the I/O subsystems. 3. Secondary I/O book Location: U1.18-P1-H3 4. Call service support.
4066 0B30	Scan interface basic assurance tests detected fault in I/O book	<ol style="list-style-type: none"> 1. Check for system firmware updates. 2. Check the I/O cabling between the third I/O book and the I/O subsystems. 3. Third I/O book Location: U1.18-P1-H4 4. Call service support.
4066 0B31	Scan interface basic assurance tests detected fault in I/O book	<ol style="list-style-type: none"> 1. Check for system firmware updates. 2. Check the I/O cabling between the third I/O book and the I/O subsystems. 3. Third I/O book Location: U1.18-P1-H4 4. Call service support.
4066 0B32	Scan interface basic assurance tests detected fault in I/O book	<ol style="list-style-type: none"> 1. Check for system firmware updates. 2. Check the I/O cabling between the third I/O book and the I/O subsystems. 3. Third I/O book Location: U1.18-P1-H4 4. Call service support.

Error Code	Description	Action/ Possible Failing FRU
4066 0B33	Scan interface basic assurance tests detected fault in I/O book	<ol style="list-style-type: none"> 1. Check for system firmware updates. 2. Check the I/O cabling between the third I/O book and the I/O subsystems. 3. Third I/O book Location: U1.18-P1-H4 4. Call service support.
4066 0B34	Scan interface basic assurance tests detected fault in I/O book	<ol style="list-style-type: none"> 1. Check for system firmware updates. 2. Check the I/O cabling between the third I/O book and the I/O subsystems. 3. Third I/O book Location: U1.18-P1-H4 4. Call service support.
4066 0B35	Scan interface basic assurance tests detected fault in I/O book	<ol style="list-style-type: none"> 1. Check for system firmware updates. 2. Check the I/O cabling between the third I/O book and the I/O subsystems. 3. Third I/O book Location: U1.18-P1-H4 4. Call service support.
4066 0B36	Scan interface basic assurance tests detected fault in I/O book	<ol style="list-style-type: none"> 1. Check for system firmware updates. 2. Check the I/O cabling between the third I/O book and the I/O subsystems. 3. Third I/O book Location: U1.18-P1-H4 4. Call service support.
4066 0B37	Scan interface basic assurance tests detected fault in I/O book	<ol style="list-style-type: none"> 1. Check for system firmware updates. 2. Check the I/O cabling between the third I/O book and the I/O subsystems. 3. Third I/O book Location: U1.18-P1-H4 4. Call service support.

Error Code	Description	Action/ Possible Failing FRU
4066 0BF0	Scan interface basic assurance tests detected fault in I/O hub chip 0 (port x)	<ol style="list-style-type: none"> 1. Check the cabling on the following RIO ports: <ol style="list-style-type: none"> a. U1.18-P1-H2/Q1 b. U1.18-P1-H2/Q2 2. Replace the primary I/O book, Location: U1.18-P1-H2
4066 0BF1	Scan interface basic assurance tests detected fault in I/O hub chip 1 (port x)	<ol style="list-style-type: none"> 1. Check the cabling on the following RIO ports: <ol style="list-style-type: none"> a. U1.18-P1-H2/Q3 b. U1.18-P1-H2/Q4 2. Replace the primary I/O book, Location: U1.18-P1-H2
4066 0BF2	Scan interface basic assurance tests detected fault in I/O hub chip 2 (port x)	<ol style="list-style-type: none"> 1. Check the cabling on the following RIO ports: <ol style="list-style-type: none"> a. U1.18-P1-H1/Q3 b. U1.18-P1-H1/Q4 2. Replace the RIO book, Location: U1.18-P1-H1
4066 0BF3	Scan interface basic assurance tests detected fault in I/O hub chip 3 (port x)	<ol style="list-style-type: none"> 1. Check the cabling on the following RIO ports: <ol style="list-style-type: none"> a. U1.18-P1-H1/Q1 b. U1.18-P1-H1/Q2 2. Replace the RIO book, Location: U1.18-P1-H1
4066 0BF4	Scan interface basic assurance tests detected fault in I/O hub chip 4 (port x)	<ol style="list-style-type: none"> 1. Check the cabling on the following RIO ports: <ol style="list-style-type: none"> a. U1.18-P1-H3/Q7 b. U1.18-P1-H3/Q8 2. Replace the RIO book, Location: U1.18-P1-H3
4066 0BF5	Scan interface basic assurance tests detected fault in I/O hub chip 5 (port x)	<ol style="list-style-type: none"> 1. Check the cabling on the following RIO ports: <ol style="list-style-type: none"> a. U1.18-P1-H3/Q5 b. U1.18-P1-H3/Q6 2. Replace the RIO book, Location: U1.18-P1-H3

Error Code	Description	Action/ Possible Failing FRU
4066 0BF6	Scan interface basic assurance tests detected fault in I/O hub chip 6 (port x)	<ol style="list-style-type: none"> 1. Check the cabling on the following RIO ports: <ol style="list-style-type: none"> a. U1.18-P1-H4/Q5 b. U1.18-P1-H4/Q6 2. Replace the RIO book, Location: U1.18-P1-H4
4066 0BF7	Scan interface basic assurance tests detected fault in I/O hub chip 7 (port x)	<ol style="list-style-type: none"> 1. Check the cabling on the following RIO ports: <ol style="list-style-type: none"> a. U1.18-P1-H4/Q7 b. U1.18-P1-H4/Q8 2. Replace the RIO book, Location: U1.18-P1-H4
4066 0BF8	Scan interface basic assurance tests detected fault in I/O hub chip 8 (port x)	<ol style="list-style-type: none"> 1. Check the cabling on the following RIO ports: <ol style="list-style-type: none"> a. U1.18-P1-H1/Q7 b. U1.18-P1-H1/Q8 2. Replace the RIO book, Location: U1.18-P1-H1
4066 0BF9	Scan interface basic assurance tests detected fault in I/O hub chip 9 (port x)	<ol style="list-style-type: none"> 1. Check the cabling on the following RIO ports: <ol style="list-style-type: none"> a. U1.18-P1-H1/Q5 b. U1.18-P1-H1/Q6 2. Replace the RIO book, Location: U1.18-P1-H1
4066 0BFA	Scan interface basic assurance tests detected fault in I/O hub chip 10 (port x)	<ol style="list-style-type: none"> 1. Check the cabling on the following RIO ports: <ol style="list-style-type: none"> a. U1.18-P1-H3/Q3 b. U1.18-P1-H3/Q4 2. Replace the RIO book, Location: U1.18-P1-H3
4066 0BFB	Scan interface basic assurance tests detected fault in I/O hub chip 11 (port x)	<ol style="list-style-type: none"> 1. Check the cabling on the following RIO ports: <ol style="list-style-type: none"> a. U1.18-P1-H3/Q1 b. U1.18-P1-H3/Q2 2. Replace the RIO book, Location: U1.18-P1-H3

Error Code	Description	Action/ Possible Failing FRU
4066 0BFC	Scan interface basic assurance tests detected fault in I/O hub chip 12 (port x)	<ol style="list-style-type: none"> 1. Check the cabling on the following RIO ports: <ol style="list-style-type: none"> a. U1.18-P1-H4/Q1 b. U1.18-P1-H4/Q2 2. Replace the RIO book, Location: U1.18-P1-H4.
4066 0BFD	Scan interface basic assurance tests detected fault in I/O hub chip 13 (port x)	<ol style="list-style-type: none"> 1. Check the cabling on the following RIO ports: <ol style="list-style-type: none"> a. U1.18-P1-H4/Q3 b. U1.18-P1-H4/Q4 2. Replace the RIO book, Location: U1.18-P1-H4
4066 0C03	Scan interface basic assurance tests detected fault in all MCMs	Go to "MAP 1543: MCM Module Problem Isolation" on page 332.
4066 0C09	Scan interface basic assurance tests detected fault in all memory books	Go to "MAP 1546: Memory Book Problem Isolation" on page 338.
4066 0C0A	Scan interface basic assurance tests detected fault in all I/O books	Go to "MAP 1547: I/O Book Problem Isolation" on page 341.
4066 0C10	Mismatch between MCM 0 and VPD card	Plugging error with FRU kit Location: U1.18-P1-C1 and U1.18-P1-H2.3
4066 0C11	Mismatch between MCM 2 and VPD card	Plugging error with FRU kit Location: U1.18-P1-C4 and U1.18-P1-H2.4
4066 0C12	Mismatch between MCM 1 and VPD card	Plugging error with FRU kit Location: U1.18-P1-C3 and U1.18-P1-H2.5
4066 0C13	Mismatch between MCM 3 and VPD card	Plugging error with FRU kit Location: U1.18-P1-C2 and U1.18-P1-H2.6
4066 0CA5	Scan interface basic assurance tests detected invalid processor subsystem configuration	Verify that MCMs, memory books, and L3 modules are correctly configured.
4066 0CA6	Scan interface basic assurance tests detected no usable main storage	Reboot the system in slow mode to isolate the failure.
4066 0CA9	Scan interface basic assurance tests detected configuration error with processor memory	Reboot the system in slow mode to isolate the failure.
4066 0D00	Scan interface basic assurance tests detected fault in L3 cache module 0	L3 cache module 0 and L3 VPD card Location: U1.18-P1-C6 and U1.18-P1-H2.1
4066 0D01	Scan interface basic assurance tests detected fault in L3 cache module 1	L3 cache module 1 and L3 VPD card Location: U1.18-P1-C7 and U1.18-P1-H2.1

Error Code	Description	Action/ Possible Failing FRU
4066 0D02	Scan interface basic assurance tests detected fault in L3 cache module 2	L3 cache module 2 and L3 VPD card Location: U1.18-P1-C11 and U1.18-P1-H2.1
4066 0D03	Scan interface basic assurance tests detected fault in L3 cache module 3	L3 cache module 3 and L3 VPD card Location: U1.18-P1-C10 and U1.18-P1-H2.1
4066 0D04	Scan interface basic assurance tests detected fault in L3 cache module 4	L3 cache module 4 and L3 VPD card Location: U1.18-P1-C8 and U1.18-P1-H2.1
4066 0D05	Scan interface basic assurance tests detected fault in L3 cache module 5	L3 cache module 5 and L3 VPD card Location: U1.18-P1-C20 and U1.18-P1-H2.1
4066 0D06	Scan interface basic assurance tests detected fault in L3 cache module 6	L3 cache module 6 and L3 VPD card Location: U1.18-P1-C16 and U1.18-P1-H2.1
4066 0D07	Scan interface basic assurance tests detected fault in L3 cache module 7	L3 cache module 7 and L3 VPD card Location: U1.18-P1-C12 and U1.18-P1-H2.1
4066 0D08	Scan interface basic assurance tests detected fault in L3 cache module 8	L3 cache module 8 and L3 VPD card Location: U1.18-P1-C19 and U1.18-P1-H2.1
4066 0D09	Scan interface basic assurance tests detected fault in L3 cache module 9	L3 cache module 9 and L3 VPD card Location: U1.18-P1-C18 and U1.18-P1-H2.1
4066 0D0A	Scan interface basic assurance tests detected fault in L3 cache module 10	L3 cache module 10 and L3 VPD card Location: U1.18-P1-C14 and U1.18-P1-H2.1
4066 0D0B	Scan interface basic assurance tests detected fault in L3 cache module 11	L3 cache module 11 and L3 VPD card Location: U1.18-P1-C15 and U1.18-P1-H2.1
4066 0D0C	Scan interface basic assurance tests detected fault in L3 cache module 12	L3 cache module 12 and L3 VPD card Location: U1.18-P1-C17 and U1.18-P1-H2.1
4066 0D0D	Scan interface basic assurance tests detected fault in L3 cache module 13	L3 cache module 13 and L3 VPD card Location: U1.18-P1-C5 and U1.18-P1-H2.1
4066 0D0E	Scan interface basic assurance tests detected fault in L3 cache module 14	L3 cache module 14 and L3 VPD card Location: U1.18-P1-C9 and U1.18-P1-H2.1
4066 0D0F	Scan interface basic assurance tests detected fault in L3 cache module 15	L3 cache module 15 and L3 VPD card Location: U1.18-P1-C13 and U1.18-P1-H2.1
4066 0EA0	Scan interface basic assurance tests detected fault in MOPS service processor code	<ol style="list-style-type: none"> 1. Check for system firmware updates. 2. Call service support.

Error Code	Description	Action/ Possible Failing FRU
4066 0EA1	Scan interface basic assurance tests detected fault in processor subsystem code on main processor	<ol style="list-style-type: none"> 1. Check for operating system updates. 2. Call service support.
4066 0EA2	Scan interface basic assurance tests detected fault in PRD code on service processor	<ol style="list-style-type: none"> 1. Check for system firmware updates. 2. Call service support.
4066 0EA4	Scan interface basic assurance tests detected fault in service processor code	<ol style="list-style-type: none"> 1. Check for system firmware updates. 2. Call service support.
4066 0EAF	Scan interface basic assurance tests detected unknown service processor code and system type	<ol style="list-style-type: none"> 1. Check for system firmware updates. 2. Call service support.
4066 0EB0	Scan interface basic assurance tests detected JTAG problem	Go to "MAP 1540: Problem Isolation Procedures" on page 303.
4066 0EB1	Attention line 0 stuck fault	Go to "MAP 1540: Problem Isolation Procedures" on page 303.
4066 0EB2	Attention line 1 stuck fault	Go to "MAP 1540: Problem Isolation Procedures" on page 303.
4066 0EB3	Attention line 2 stuck fault	Go to "MAP 1540: Problem Isolation Procedures" on page 303.
4066 0EB4	Attention line 3 stuck fault	Go to "MAP 1540: Problem Isolation Procedures" on page 303.
4066 0EB5	Attention line 4 stuck fault	Go to "MAP 1540: Problem Isolation Procedures" on page 303.
4066 0EB6	Attention line 5 stuck fault	Go to "MAP 1540: Problem Isolation Procedures" on page 303.
4066 0EB7	Attention line 6 stuck fault	Go to "MAP 1540: Problem Isolation Procedures" on page 303.
4066 0EB8	Attention line 7 stuck fault	Go to "MAP 1540: Problem Isolation Procedures" on page 303.
4066 0EB9	Attention line 8 stuck fault	Go to "MAP 1540: Problem Isolation Procedures" on page 303.
4066 0EBA	Attention line 9 stuck fault	Go to "MAP 1540: Problem Isolation Procedures" on page 303.
4066 0EBB	Attention line 10 stuck fault	Go to "MAP 1540: Problem Isolation Procedures" on page 303.
4066 0EBC	Attention line 11 stuck fault	Go to "MAP 1540: Problem Isolation Procedures" on page 303.
4066 0EE1	Scan interface basic assurance tests detected fault in service processor code (invalid MRU to mapping)	<ol style="list-style-type: none"> 1. Check for system firmware updates. 2. Call service support.

Error Code	Description	Action/ Possible Failing FRU
4066 0EE2	Scan interface basic assurance tests detected fault in service processor firmware fault	<ol style="list-style-type: none"> 1. Check for system firmware updates. 2. Call service support.
4066 0EE5	Scan interface basic assurance tests detected firmware error; no callout available	<ol style="list-style-type: none"> 1. Check for system firmware updates. 2. Call service support.
4067 0001	Bus tests detected clock card assembly failure	Go to "MAP 1540: Problem Isolation Procedures" on page 303.
4067 0002	Bus tests detected backplane assembly failure	Go to "MAP 1540: Problem Isolation Procedures" on page 303.
4067 0003	Bus tests detected fault in MCM module 0	MCM module 0 and VPD card Location: U1.18-P1-C1 and U1.18-P1-H2.3
4067 0004	Bus tests detected fault in MCM module 2	MCM module 2 and VPD card Location: U1.18-P1-C4 and U1.18-P1-H2.4
4067 0005	Bus tests detected fault in MCM module 1	MCM module 1 and VPD card Location: U1.18-P1-C3 and U1.18-P1-H2.5
4067 0006	Bus tests detected fault in MCM module 3	MCM module 3 and VPD card Location: U1.18-P1-C2 and U1.18-P1-H2.6
4067 0007	Bus tests detected fault in L3 VPD card	<ol style="list-style-type: none"> 1. L3 VPD card Location: U1.18-P1-H2.1 (Order the L3 cache module FRU to obtain a new L3 VPD card. Return the L3 cache module that was included in the FRU kit, and the failing L3 VPD card as "new defective".) 2. Primary I/O book Location: U1.18-P1-H2
4067 000A	Bus tests detected fault in primary I/O book 1 (slot 0)	Go to "MAP 1540: Problem Isolation Procedures" on page 303.
4067 000B	Bus tests detected fault in secondary I/O book (slot 1)	Go to "MAP 1540: Problem Isolation Procedures" on page 303.
4067 000C	Bus tests detected fault in I/O book 3 (slot 2)	Go to "MAP 1540: Problem Isolation Procedures" on page 303.
4067 000D	Bus tests detected fault in I/O book 4 (slot 3)	Go to "MAP 1540: Problem Isolation Procedures" on page 303.
4067 0010	Bus tests detected fault in Memory book (slot 0)	Memory book (slot 0) Location: U1.18-P1-M2
4067 0011	Bus tests detected fault in Memory book (slot 1)	Memory book (slot 1) Location: U1.18-P1-M3

Error Code	Description	Action/ Possible Failing FRU
4067 0012	Bus tests detected fault in Memory book (slot 2)	Memory book (slot 2) Location: U1.18-P1-M7
4067 0013	Bus tests detected fault in Memory book (slot 3)	Memory book (slot 3) Location: U1.18-P1-M6
4067 0014	Bus tests detected fault in Memory book (slot 4)	Memory book (slot 4) Location: U1.18-P1-M4
4067 0015	Bus tests detected fault in Memory book (slot 5)	Memory book (slot 5) Location: U1.18-P1-M8
4067 0016	Bus tests detected fault in Memory book (slot 6)	Memory book (slot 6) Location: U1.18-P1-M5
4067 0017	Bus tests detected fault in Memory book (slot 7)	Memory book (slot 7) Location: U1.18-P1-M1
4067 00B0	Bus tests detected possible problem with bus controller or CSP code	<ol style="list-style-type: none"> 1. Check for system firmware updates. 2. Primary I/O book, Location: U1.18-P1-H2 3. Call service support.
4067 00B1	Bus tests detected possible problem with bus controller	<ol style="list-style-type: none"> 1. Check for system firmware updates. 2. Primary I/O book, Location: U1.18-P1-H2 3. Call service support.
4067 00B3	Bus tests detected MCM 0/VPD problem	<ol style="list-style-type: none"> 1. Check for system firmware updates. 2. MCM module 0 and VPD card Location: U1.18-P1-C1 and U1.18-P1-H2.3
4067 00B4	Bus tests detected MCM 2/VPD problem	<ol style="list-style-type: none"> 1. Check for system firmware updates. 2. MCM module 2 and VPD card Location: U1.18-P1-C4 and U1.18-P1-H2.4
4067 00B5	Bus tests detected MCM 1/VPD problem	<ol style="list-style-type: none"> 1. Check for system firmware updates. 2. MCM module 1 and VPD card Location: U1.18-P1-C3 and U1.18-P1-H2.5
4067 00B6	Bus tests detected MCM 3/VPD problem	<ol style="list-style-type: none"> 1. Check for system firmware updates. 2. MCM module 3 and VPD card Location: U1.18-P1-C2 and U1.18-P1-H2.6

Error Code	Description	Action/ Possible Failing FRU
4067 00B7	Bus tests detected hardware problem in the processor subsystem	Go to "MAP 1540: Problem Isolation Procedures" on page 303.
4067 0A03	Reboot message (run-time array gard failure) for processor 0	Reboot the system in slow mode. Run diagnostics, then go to MAP 0235 in the <i>RS/6000 and @server pSeries Diagnostic Information for Multiple Bus Systems</i> , order number SA38-0509.
4067 0A04	Reboot message (run-time array gard failure) for processor 2	Reboot the system in slow mode. Run diagnostics, then go to MAP 0235 in the <i>RS/6000 and @server pSeries Diagnostic Information for Multiple Bus Systems</i> , order number SA38-0509.
4067 0A05	Reboot message (run-time array gard failure) for processor 1	Reboot the system in slow mode. Run diagnostics, then go to MAP 0235 in the <i>RS/6000 and @server pSeries Diagnostic Information for Multiple Bus Systems</i> , order number SA38-0509.
4067 0A06	Reboot message (run-time array gard failure) for processor 3	Reboot the system in slow mode. Run diagnostics, then go to MAP 0235 in the <i>RS/6000 and @server pSeries Diagnostic Information for Multiple Bus Systems</i> , order number SA38-0509.
4067 0B00	Bus tests detected fault in I/O book (slot 0 RIO port 0)	<ol style="list-style-type: none"> 1. Check for system firmware updates. 2. Check the I/O cabling between the primary I/O book and the I/O subsystems. 3. Primary I/O book Location: U1.18-P1-H2 4. Call service support.
4067 0B01	Bus tests detected fault in I/O book (slot 0 RIO port 1)	<ol style="list-style-type: none"> 1. Check for system firmware updates. 2. Check the I/O cabling between the primary I/O book and the I/O subsystems. 3. Primary I/O book Location: U1.18-P1-H2 4. Call service support.

Error Code	Description	Action/ Possible Failing FRU
4067 0B02	Bus tests detected fault in I/O book (slot 0 RIO port 2)	<ol style="list-style-type: none"> 1. Check for system firmware updates. 2. Check the I/O cabling between the primary I/O book and the I/O subsystems. 3. Primary I/O book Location: U1.18-P1-H2 4. Call service support.
4067 0B03	Bus tests detected fault in I/O book (slot 0 RIO port 3)	<ol style="list-style-type: none"> 1. Check for system firmware updates. 2. Check the I/O cabling between the primary I/O book and the I/O subsystems. 3. Primary I/O book Location: U1.18-P1-H2 4. Call service support.
4067 0B10	Bus tests detected fault in I/O book	<ol style="list-style-type: none"> 1. Check for system firmware updates. 2. Check the I/O cabling between the secondary I/O book and the I/O subsystems. 3. Secondary I/O book Location: U1.18-P1-H1 4. Call service support.
4067 0B11	Bus tests detected fault in I/O book	<ol style="list-style-type: none"> 1. Check for system firmware updates. 2. Check the I/O cabling between the secondary I/O book and the I/O subsystems. 3. Secondary I/O book Location: U1.18-P1-H1 4. Call service support.
4067 0B12	Bus tests detected fault in I/O book	<ol style="list-style-type: none"> 1. Check for system firmware updates. 2. Check the I/O cabling between the secondary I/O book and the I/O subsystems. 3. Secondary I/O book Location: U1.18-P1-H1 4. Call service support.

Error Code	Description	Action/ Possible Failing FRU
4067 0B13	Bus tests detected fault in I/O	<ol style="list-style-type: none"> 1. Check for system firmware updates. 2. Check the I/O cabling between the secondary I/O book and the I/O subsystems. 3. Secondary I/O book Location: U1.18-P1-H1 4. Call service support.
4067 0B14	Bus tests detected fault in I/O book	<ol style="list-style-type: none"> 1. Check for system firmware updates. 2. Check the I/O cabling between the secondary I/O book and the I/O subsystems. 3. Secondary I/O book Location: U1.18-P1-H1 4. Call service support.
4067 0B15	Bus tests detected fault in I/O book	<ol style="list-style-type: none"> 1. Check for system firmware updates. 2. Check the I/O cabling between the secondary I/O book and the I/O subsystems. 3. Secondary I/O book Location: U1.18-P1-H1 4. Call service support.
4067 0B16	Bus tests detected fault in I/O book	<ol style="list-style-type: none"> 1. Check for system firmware updates. 2. Check the I/O cabling between the secondary I/O book and the I/O subsystems. 3. Secondary I/O book Location: U1.18-P1-H1 4. Call service support.
4067 0B17	Bus tests detected fault in I/O book	<ol style="list-style-type: none"> 1. Check for system firmware updates. 2. Check the I/O cabling between the secondary I/O book and the I/O subsystems. 3. Secondary I/O book Location: U1.18-P1-H1 4. Call service support.

Error Code	Description	Action/ Possible Failing FRU
4067 0B20	Bus tests detected fault in I/O book	<ol style="list-style-type: none"> 1. Check for system firmware updates. 2. Check the I/O cabling between the secondary I/O book and the I/O subsystems. 3. Secondary I/O book Location: U1.18-P1-H3 4. Call service support.
4067 0B21	Bus tests detected fault in I/O book	<ol style="list-style-type: none"> 1. Check for system firmware updates. 2. Check the I/O cabling between the secondary I/O book and the I/O subsystems. 3. Secondary I/O book Location: U1.18-P1-H3 4. Call service support.
4067 0B22	Bus tests detected fault in I/O book	<ol style="list-style-type: none"> 1. Check for system firmware updates. 2. Check the I/O cabling between the secondary I/O book and the I/O subsystems. 3. Secondary I/O book Location: U1.18-P1-H3 4. Call service support.
4067 0B23	Bus tests detected fault in I/O book	<ol style="list-style-type: none"> 1. Check for system firmware updates. 2. Check the I/O cabling between the secondary I/O book and the I/O subsystems. 3. Secondary I/O book Location: U1.18-P1-H3 4. Call service support.
4067 0B24	Bus tests detected fault in I/O book	<ol style="list-style-type: none"> 1. Check for system firmware updates. 2. Check the I/O cabling between the secondary I/O book and the I/O subsystems. 3. Secondary I/O book Location: U1.18-P1-H3 4. Call service support.

Error Code	Description	Action/ Possible Failing FRU
4067 0B25	Bus tests detected fault in I/O book	<ol style="list-style-type: none"> 1. Check for system firmware updates. 2. Check the I/O cabling between the secondary I/O book and the I/O subsystems. 3. Secondary I/O book Location: U1.18-P1-H3 4. Call service support.
4067 0B26	Bus tests detected fault in I/O book	<ol style="list-style-type: none"> 1. Check for system firmware updates. 2. Check the I/O cabling between the secondary I/O book and the I/O subsystems. 3. Secondary I/O book Location: U1.18-P1-H3 4. Call service support.
4067 0B27	Bus tests detected fault in I/O book	<ol style="list-style-type: none"> 1. Check for system firmware updates. 2. Check the I/O cabling between the secondary I/O book and the I/O subsystems. 3. Secondary I/O book Location: U1.18-P1-H3 4. Call service support.
4067 0B30	Bus tests detected fault in I/O book	<ol style="list-style-type: none"> 1. Check for system firmware updates. 2. Check the I/O cabling between the third I/O book and the I/O subsystems. 3. Third I/O book Location: U1.18-P1-H4 4. Call service support.
4067 0B31	Bus tests detected fault in I/O book	<ol style="list-style-type: none"> 1. Check for system firmware updates. 2. Check the I/O cabling between the third I/O book and the I/O subsystems. 3. Third I/O book Location: U1.18-P1-H4 4. Call service support.

Error Code	Description	Action/ Possible Failing FRU
4067 0B32	Bus tests detected fault in I/O book	<ol style="list-style-type: none"> 1. Check for system firmware updates. 2. Check the I/O cabling between the third I/O book and the I/O subsystems. 3. Third I/O book Location: U1.18-P1-H4 4. Call service support.
4067 0B33	Bus tests detected fault in I/O book	<ol style="list-style-type: none"> 1. Check for system firmware updates. 2. Check the I/O cabling between the third I/O book and the I/O subsystems. 3. Third I/O book Location: U1.18-P1-H4 4. Call service support.
4067 0B34	Bus tests detected fault in I/O book	<ol style="list-style-type: none"> 1. Check for system firmware updates. 2. Check the I/O cabling between the third I/O book and the I/O subsystems. 3. Third I/O book Location: U1.18-P1-H4 4. Call service support.
4067 0B35	Bus tests detected fault in I/O book	<ol style="list-style-type: none"> 1. Check for system firmware updates. 2. Check the I/O cabling between the third I/O book and the I/O subsystems. 3. Third I/O book Location: U1.18-P1-H4 4. Call service support.
4067 0B36	Bus tests detected fault in I/O book	<ol style="list-style-type: none"> 1. Check for system firmware updates. 2. Check the I/O cabling between the third I/O book and the I/O subsystems. 3. Third I/O book Location: U1.18-P1-H4 4. Call service support.

Error Code	Description	Action/ Possible Failing FRU
4067 0B37	Bus tests detected fault in I/O book	<ol style="list-style-type: none"> 1. Check for system firmware updates. 2. Check the I/O cabling between the third I/O book and the I/O subsystems. 3. Third I/O book Location: U1.18-P1-H4 4. Call service support.
4067 0BF0	Bus tests detected fault in I/O hub chip 0 (port x)	<ol style="list-style-type: none"> 1. Check the cabling on the following RIO ports: <ol style="list-style-type: none"> a. U1.18-P1-H2/Q1 b. U1.18-P1-H2/Q2 2. Replace the primary I/O book, Location: U1.18-P1-H2
4067 0BF1	Bus tests detected fault in I/O hub chip 1 (port x)	<ol style="list-style-type: none"> 1. Check the cabling on the following RIO ports: <ol style="list-style-type: none"> a. U1.18-P1-H2/Q3 b. U1.18-P1-H2/Q4 2. Replace the primary I/O book, Location: U1.18-P1-H2
4067 0BF2	Bus tests detected fault in I/O hub chip 2 (port x)	<ol style="list-style-type: none"> 1. Check the cabling on the following RIO ports: <ol style="list-style-type: none"> a. U1.18-P1-H1/Q3 b. U1.18-P1-H1/Q4 2. Replace the RIO book, Location: U1.18-P1-H1
4067 0BF3	Bus tests detected fault in I/O hub chip 3 (port x)	<ol style="list-style-type: none"> 1. Check the cabling on the following RIO ports: <ol style="list-style-type: none"> a. U1.18-P1-H1/Q1 b. U1.18-P1-H1/Q2 2. Replace the RIO book, Location: U1.18-P1-H1
4067 0BF4	Bus tests detected fault in I/O hub chip 4 (port x)	<ol style="list-style-type: none"> 1. Check the cabling on the following RIO ports: <ol style="list-style-type: none"> a. U1.18-P1-H3/Q7 b. U1.18-P1-H3/Q8 2. Replace the RIO book, Location: U1.18-P1-H3

Error Code	Description	Action/ Possible Failing FRU
4067 0BF5	Bus tests detected fault in I/O hub chip 5 (port x)	<ol style="list-style-type: none"> 1. Check the cabling on the following RIO ports: <ol style="list-style-type: none"> a. U1.18-P1-H3/Q5 b. U1.18-P1-H3/Q6 2. Replace the RIO book, Location: U1.18-P1-H3
4067 0BF6	Bus tests detected fault in I/O hub chip 6 (port x)	<ol style="list-style-type: none"> 1. Check the cabling on the following RIO ports: <ol style="list-style-type: none"> a. U1.18-P1-H4/Q5 b. U1.18-P1-H4/Q6 2. Replace the RIO book, Location: U1.18-P1-H4
4067 0BF7	Bus tests detected fault in I/O hub chip 7 (port x)	<ol style="list-style-type: none"> 1. Check the cabling on the following RIO ports: <ol style="list-style-type: none"> a. U1.18-P1-H4/Q7 b. U1.18-P1-H4/Q8 2. Replace the RIO book, Location: U1.18-P1-H4
4067 0BF8	Bus tests detected fault in I/O hub chip 8 (port x)	<ol style="list-style-type: none"> 1. Check the cabling on the following RIO ports: <ol style="list-style-type: none"> a. U1.18-P1-H1/Q7 b. U1.18-P1-H1/Q8 2. Replace the RIO book, Location: U1.18-P1-H1
4067 0BF9	Bus tests detected fault in I/O hub chip 9 (port x)	<ol style="list-style-type: none"> 1. Check the cabling on the following RIO ports: <ol style="list-style-type: none"> a. U1.18-P1-H1/Q5 b. U1.18-P1-H1/Q6 2. Replace the RIO book, Location: U1.18-P1-H1
4067 0BFA	Bus tests detected fault in I/O hub chip 10 (port x)	<ol style="list-style-type: none"> 1. Check the cabling on the following RIO ports: <ol style="list-style-type: none"> a. U1.18-P1-H3/Q3 b. U1.18-P1-H3/Q4 2. Replace the RIO book, Location: U1.18-P1-H3

Error Code	Description	Action/ Possible Failing FRU
4067 0BFB	Bus tests detected fault in I/O hub chip 11 (port x)	<ol style="list-style-type: none"> 1. Check the cabling on the following RIO ports: <ol style="list-style-type: none"> a. U1.18-P1-H3/Q1 b. U1.18-P1-H3/Q2 2. Replace the RIO book, Location: U1.18-P1-H3
4067 0BFC	Bus tests detected fault in I/O hub chip 12 (port x)	<ol style="list-style-type: none"> 1. Check the cabling on the following RIO ports: <ol style="list-style-type: none"> a. U1.18-P1-H4/Q1 b. U1.18-P1-H4/Q2 2. Replace the RIO book, Location: U1.18-P1-H4.
4067 0BFD	Bus tests detected fault in I/O hub chip 13 (port x)	<ol style="list-style-type: none"> 1. Check the cabling on the following RIO ports: <ol style="list-style-type: none"> a. U1.18-P1-H4/Q3 b. U1.18-P1-H4/Q4 2. Replace the RIO book, Location: U1.18-P1-H4
4067 0C03	Bus tests detected fault in all MCMs	Go to "MAP 1543: MCM Module Problem Isolation" on page 332.
4067 0C09	Bus tests detected fault in all memory books	Go to "MAP 1546: Memory Book Problem Isolation" on page 338.
4067 0C0A	Bus tests detected fault in all I/O books	Go to "MAP 1547: I/O Book Problem Isolation" on page 341.
4067 0C10	Bus tests detected mismatch between MCM 0 and VPD card	Plugging error with FRU kit Location: U1.18-P1-C1 and U1.18-P1-H2.3
4067 0C11	Bus tests detected mismatch between MCM 2 and VPD card	Plugging error with FRU kit Location: U1.18-P1-C4 and U1.18-P1-H2.4
4067 0C12	Bus tests detected mismatch between MCM 1 and VPD card	Plugging error with FRU kit Location: U1.18-P1-C3 and U1.18-P1-H2.5
4067 0C13	Bus tests detected mismatch between MCM 3 and VPD card	Plugging error with FRU kit Location: U1.18-P1-C2 and U1.18-P1-H2.6
4067 0CA5	Bus tests detected invalid processor subsystem configuration	Verify that MCMs, memory books, and L3 modules are correctly configured.
4067 0CA6	Bus tests detected no usable main storage	Reboot the system in slow mode to isolate the failure.
4067 0CA9	Bus tests detected configuration error with processor memory	Reboot the system in slow mode to isolate the failure.

Error Code	Description	Action/ Possible Failing FRU
4067 0D00	Bus tests detected fault in L3 cache module 0	L3 cache module 0 and L3 VPD card Location: U1.18-P1-C6 and U1.18-P1-H2.1
4067 0D01	Bus tests detected fault in L3 cache module 1	L3 cache module 1 and L3 VPD card Location: U1.18-P1-C7 and U1.18-P1-H2.1
4067 0D02	Bus tests detected fault in L3 cache module 2	L3 cache module 2 and L3 VPD card Location: U1.18-P1-C11 and U1.18-P1-H2.1
4067 0D03	Bus tests detected fault in L3 cache module 3	L3 cache module 3 and L3 VPD card Location: U1.18-P1-C10 and U1.18-P1-H2.1
4067 0D04	Bus tests detected fault in L3 cache module 4	L3 cache module 4 and L3 VPD card Location: U1.18-P1-C8 and U1.18-P1-H2.1
4067 0D05	Bus tests detected fault in L3 cache module 5	L3 cache module 5 and L3 VPD card Location: U1.18-P1-C20 and U1.18-P1-H2.1
4067 0D06	Bus tests detected fault in L3 cache module 6	L3 cache module 6 and L3 VPD card Location: U1.18-P1-C16 and U1.18-P1-H2.1
4067 0D07	Bus tests detected fault in L3 cache module 7	L3 cache module 7 and L3 VPD card Location: U1.18-P1-C12 and U1.18-P1-H2.1
4067 0D08	Bus tests detected fault in L3 cache module 8	L3 cache module 8 and L3 VPD card Location: U1.18-P1-C19 and U1.18-P1-H2.1
4067 0D09	Bus tests detected fault in L3 cache module 9	L3 cache module 9 and L3 VPD card Location: U1.18-P1-C18 and U1.18-P1-H2.1
4067 0D0A	Bus tests detected fault in L3 cache module 10	L3 cache module 10 and L3 VPD card Location: U1.18-P1-C14 and U1.18-P1-H2.1
4067 0D0B	Bus tests detected fault in L3 cache module 11	L3 cache module 11 and L3 VPD card Location: U1.18-P1-C15 and U1.18-P1-H2.1
4067 0D0C	Bus tests detected fault in L3 cache module 12	L3 cache module 12 and L3 VPD card Location: U1.18-P1-C17 and U1.18-P1-H2.1
4067 0D0D	Bus tests detected fault in L3 cache module 13	L3 cache module 13 and L3 VPD card Location: U1.18-P1-C5 and U1.18-P1-H2.1
4067 0D0E	Bus tests detected fault in L3 cache module 14	L3 cache module 14 and L3 VPD card Location: U1.18-P1-C9 and U1.18-P1-H2.1

Error Code	Description	Action/ Possible Failing FRU
4067 0D0F	Bus tests detected fault in L3 cache module 15	L3 cache module 15 and L3 VPD card Location: U1.18-P1-C13 and U1.18-P1-H2.1
4067 0EA0	Bus tests detected fault in MOPS service processor code	1. Check for system firmware updates. 2. Call service support.
4067 0EA1	Bus tests detected fault in processor subsystem code on main processor	1. Check for operating system update. 2. Call service support.
4067 0EA2	Bus tests detected fault in PRD code on service processor	1. Check for system firmware updates. 2. Call service support.
4067 0EA4	Bus tests detected fault in service processor code	1. Check for system firmware updates. 2. Call service support.
4067 0EAF	Bus tests detected unknown service processor code and system type	1. Check for system firmware updates. 2. Call service support.
4067 0EB0	Bus tests detected JTAG problem	Go to "MAP 1540: Problem Isolation Procedures" on page 303.
4067 0EB1	Attention line 0 stuck fault	Go to "MAP 1540: Problem Isolation Procedures" on page 303.
4067 0EB2	Attention line 1 stuck fault	Go to "MAP 1540: Problem Isolation Procedures" on page 303.
4067 0EB3	Attention line 2 stuck fault	Go to "MAP 1540: Problem Isolation Procedures" on page 303.
4067 0EB4	Attention line 3 stuck fault	Go to "MAP 1540: Problem Isolation Procedures" on page 303.
4067 0EB5	Attention line 4 stuck fault	Go to "MAP 1540: Problem Isolation Procedures" on page 303.
4067 0EB6	Attention line 5 stuck fault	Go to "MAP 1540: Problem Isolation Procedures" on page 303.
4067 0EB7	Attention line 6 stuck fault	Go to "MAP 1540: Problem Isolation Procedures" on page 303.
4067 0EB8	Attention line 7 stuck fault	Go to "MAP 1540: Problem Isolation Procedures" on page 303.
4067 0EB9	Attention line 8 stuck fault	Go to "MAP 1540: Problem Isolation Procedures" on page 303.
4067 0EBA	Attention line 9 stuck fault	Go to "MAP 1540: Problem Isolation Procedures" on page 303.
4067 0EBB	Attention line 10 stuck fault	Go to "MAP 1540: Problem Isolation Procedures" on page 303.

Error Code	Description	Action/ Possible Failing FRU
4067 0EBC	Attention line 11 stuck fault	Go to "MAP 1540: Problem Isolation Procedures" on page 303.
4067 0EE1	Bus tests detected fault in service processor code (invalid MRU to mapping)	<ol style="list-style-type: none"> 1. Check for system firmware updates. 2. Call service support.
4067 0EE2	Bus tests detected fault in service processor firmware fault	<ol style="list-style-type: none"> 1. Check for system firmware updates. 2. Call service support.
4067 0EE5	Bus tests detected firmware error; no callout available	<ol style="list-style-type: none"> 1. Check for system firmware updates. 2. Call service support.
4068 0001	Other bus tests detected clock card assembly failure	Go to "MAP 1540: Problem Isolation Procedures" on page 303.
4068 0002	Other bus tests detected backplane assembly failure	Go to "MAP 1540: Problem Isolation Procedures" on page 303.
4068 0003	Other bus tests detected fault in MCM module 0	MCM module 0 and VPD card Location: U1.18-P1-C1 and U1.18-P1-H2.3
4068 0004	Other bus tests detected fault in MCM module 2	MCM module 2 and VPD card Location: U1.18-P1-C4 and U1.18-P1-H2.4
4068 0005	Other bus tests detected fault in MCM module 1	MCM module 1 and VPD card Location: U1.18-P1-C3 and U1.18-P1-H2.5
4068 0006	Other bus tests detected fault in MCM module 3	MCM module 3 and VPD card Location: U1.18-P1-C2 and U1.18-P1-H2.6
4068 0007	Other bus tests detected fault in L3 VPD card	<ol style="list-style-type: none"> 1. L3 VPD card Location: U1.18-P1-H2.1 (Order the L3 cache module FRU to obtain a new L3 VPD card. Return the L3 cache module that was included in the FRU kit, and the failing L3 VPD card as "new defective".) 2. Primary I/O book Location: U1.18-P1-H2
4068 000A	Other bus tests detected fault in primary I/O book 1 (slot 0)	Go to "MAP 1540: Problem Isolation Procedures" on page 303.
4068 000B	Other bus tests detected fault in secondary I/O book (slot 1)	Go to "MAP 1540: Problem Isolation Procedures" on page 303.
4068 000C	Other bus tests detected fault in I/O book 3 (slot 2)	Go to "MAP 1540: Problem Isolation Procedures" on page 303.

Error Code	Description	Action/ Possible Failing FRU
4068 000D	Other bus tests detected fault in I/O book 4 (slot 3)	Go to "MAP 1540: Problem Isolation Procedures" on page 303.
4068 0010	Other bus tests detected fault in Memory book (slot 0)	Memory book (slot 0) Location: U1.18-P1-M2
4068 0011	Other bus tests detected fault in Memory book (slot 1)	Memory book (slot 1) Location: U1.18-P1-M3
4068 0012	Other bus tests detected fault in Memory book (slot 2)	Memory book (slot 2) Location: U1.18-P1-M7
4068 0013	Other bus tests detected fault in Memory book (slot 3)	Memory book (slot 3) Location: U1.18-P1-M6
4068 0014	Other bus tests detected fault in Memory book (slot 4)	Memory book (slot 4) Location: U1.18-P1-M4
4068 0015	Other bus tests detected fault in Memory book (slot 5)	Memory book (slot 5) Location: U1.18-P1-M8
4068 0016	Other bus tests detected fault in Memory book (slot 6)	Memory book (slot 6) Location: U1.18-P1-M5
4068 0017	Other bus tests detected fault in Memory book (slot 7)	Memory book (slot 7) Location: U1.18-P1-M1
4068 00B0	Other bus tests detected possible problem with bus controller or CSP code	<ol style="list-style-type: none"> 1. Check for system firmware updates. 2. Primary I/O book, Location: U1.18-P1-H2 3. Call service support.
4068 00B1	Other bus tests detected possible problem with bus controller	<ol style="list-style-type: none"> 1. Check for system firmware updates. 2. Primary I/O book, Location: U1.18-P1-H2 3. Call service support.
4068 00B3	Other bus tests detected MCM 0/VPD problem	<ol style="list-style-type: none"> 1. Check for system firmware updates. 2. MCM module 0 and VPD card Location: U1.18-P1-C1 and U1.18-P1-H2.3
4068 00B4	Other bus tests detected MCM 2/VPD problem	<ol style="list-style-type: none"> 1. Check for system firmware updates. 2. MCM module 2 and VPD card Location: U1.18-P1-C4 and U1.18-P1-H2.4
4068 00B5	Other bus tests detected MCM 1/VPD problem	<ol style="list-style-type: none"> 1. Check for system firmware updates. 2. MCM module 1 and VPD card Location: U1.18-P1-C3 and U1.18-P1-H2.5

Error Code	Description	Action/ Possible Failing FRU
4068 00B6	Other bus tests detected MCM 3/VPD problem	<ol style="list-style-type: none"> 1. Check for system firmware updates. 2. MCM module 3 and VPD card Location: U1.18-P1-C2 and U1.18-P1-H2.6
4068 00B7	Other bus tests detected hardware problem in the processor subsystem	Go to "MAP 1540: Problem Isolation Procedures" on page 303.
4068 0A03	Reboot message (run-time array gard failure) for processor 0	Reboot the system in slow mode. Run diagnostics, then go to MAP 0235 in the <i>RS/6000 and @server pSeries Diagnostic Information for Multiple Bus Systems</i> , order number SA38-0509.
4068 0A04	Reboot message (run-time array gard failure) for processor 2	Reboot the system in slow mode. Run diagnostics, then go to MAP 0235 in the <i>RS/6000 and @server pSeries Diagnostic Information for Multiple Bus Systems</i> , order number SA38-0509.
4068 0A05	Reboot message (run-time array gard failure) for Processor 1	Reboot the system in slow mode. Run diagnostics, then go to MAP 0235 in the <i>RS/6000 and @server pSeries Diagnostic Information for Multiple Bus Systems</i> , order number SA38-0509.
4068 0A06	Reboot message (run-time array gard failure) for Processor 3	Reboot the system in slow mode. Run diagnostics, then go to MAP 0235 in the <i>RS/6000 and @server pSeries Diagnostic Information for Multiple Bus Systems</i> , order number SA38-0509.
4068 0B00	Other bus tests detected fault in I/O book (slot 0 RIO port 0)	<ol style="list-style-type: none"> 1. Check for system firmware updates. 2. Check the I/O cabling between the primary I/O book and the I/O subsystems. 3. Primary I/O book Location: U1.18-P1-H2 4. Call service support.
4068 0B01	Other bus tests detected fault in I/O book (slot 0 RIO port 1)	<ol style="list-style-type: none"> 1. Check for system firmware updates. 2. Check the I/O cabling between the primary I/O book and the I/O subsystems. 3. Primary I/O book Location: U1.18-P1-H2 4. Call service support.

Error Code	Description	Action/ Possible Failing FRU
4068 0B02	Other bus tests detected fault in I/O book (slot 0 RIO port 2)	<ol style="list-style-type: none"> 1. Check for system firmware updates. 2. Check the I/O cabling between the primary I/O book and the I/O subsystems. 3. Primary I/O book Location: U1.18-P1-H2 4. Call service support.
4068 0B03	Other bus tests detected fault in I/O book (slot 0 RIO port 3)	<ol style="list-style-type: none"> 1. Check for system firmware updates. 2. Check the I/O cabling between the primary I/O book and the I/O subsystems. 3. Primary I/O book Location: U1.18-P1-H2 4. Call service support.
4068 0B10	Other bus tests detected fault in I/O book	<ol style="list-style-type: none"> 1. Check for system firmware updates. 2. Check the I/O cabling between the secondary I/O book and the I/O subsystems. 3. Secondary I/O book Location: U1.18-P1-H1 4. Call service support.
4068 0B11	Other bus tests detected fault in I/O book	<ol style="list-style-type: none"> 1. Check for system firmware updates. 2. Check the I/O cabling between the secondary I/O book and the I/O subsystems. 3. Secondary I/O book Location: U1.18-P1-H1 4. Call service support.
4068 0B12	Other bus tests detected fault in I/O book	<ol style="list-style-type: none"> 1. Check for system firmware updates. 2. Check the I/O cabling between the secondary I/O book and the I/O subsystems. 3. Secondary I/O book Location: U1.18-P1-H1 4. Call service support.

Error Code	Description	Action/ Possible Failing FRU
4068 0B13	Other bus tests detected fault in I/O book	<ol style="list-style-type: none"> 1. Check for system firmware updates. 2. Check the I/O cabling between the secondary I/O book and the I/O subsystems. 3. Secondary I/O book Location: U1.18-P1-H1 4. Call service support.
4068 0B14	Other bus tests detected fault in I/O book	<ol style="list-style-type: none"> 1. Check for system firmware updates. 2. Check the I/O cabling between the secondary I/O book and the I/O subsystems. 3. Secondary I/O book Location: U1.18-P1-H1 4. Call service support.
4068 0B15	Other bus tests detected fault in I/O book	<ol style="list-style-type: none"> 1. Check for system firmware updates. 2. Check the I/O cabling between the secondary I/O book and the I/O subsystems. 3. Secondary I/O book Location: U1.18-P1-H1 4. Call service support.
4068 0B16	Other bus tests detected fault in I/O book	<ol style="list-style-type: none"> 1. Check for system firmware updates. 2. Check the I/O cabling between the secondary I/O book and the I/O subsystems. 3. Secondary I/O book Location: U1.18-P1-H1 4. Call service support.
4068 0B17	Other bus tests detected fault in I/O book	<ol style="list-style-type: none"> 1. Check for system firmware updates. 2. Check the I/O cabling between the secondary I/O book and the I/O subsystems. 3. Secondary I/O book Location: U1.18-P1-H1 4. Call service support.

Error Code	Description	Action/ Possible Failing FRU
4068 0B20	Other bus tests detected fault in I/O book	<ol style="list-style-type: none"> 1. Check for system firmware updates. 2. Check the I/O cabling between the secondary I/O book and the I/O subsystems. 3. Secondary I/O book Location: U1.18-P1-H3 4. Call service support.
4068 0B21	Other bus tests detected fault in I/O book	<ol style="list-style-type: none"> 1. Check for system firmware updates. 2. Check the I/O cabling between the secondary I/O book and the I/O subsystems. 3. Secondary I/O book Location: U1.18-P1-H3 4. Call service support.
4068 0B22	Other bus tests detected fault in I/O book	<ol style="list-style-type: none"> 1. Check for system firmware updates. 2. Check the I/O cabling between the secondary I/O book and the I/O subsystems. 3. Secondary I/O book Location: U1.18-P1-H3 4. Call service support.
4068 0B23	Other bus tests detected fault in I/O book	<ol style="list-style-type: none"> 1. Check for system firmware updates. 2. Check the I/O cabling between the secondary I/O book and the I/O subsystems. 3. Secondary I/O book Location: U1.18-P1-H3 4. Call service support.
4068 0B24	Other bus tests detected fault in I/O book	<ol style="list-style-type: none"> 1. Check for system firmware updates. 2. Check the I/O cabling between the secondary I/O book and the I/O subsystems. 3. Secondary I/O book Location: U1.18-P1-H3 4. Call service support.

Error Code	Description	Action/ Possible Failing FRU
4068 0B25	Other bus tests detected fault in I/O book	<ol style="list-style-type: none"> 1. Check for system firmware updates. 2. Check the I/O cabling between the secondary I/O book and the I/O subsystems. 3. Secondary I/O book Location: U1.18-P1-H3 4. Call service support.
4068 0B26	Other bus tests detected fault in I/O book	<ol style="list-style-type: none"> 1. Check for system firmware updates. 2. Check the I/O cabling between the secondary I/O book and the I/O subsystems. 3. Secondary I/O book Location: U1.18-P1-H3 4. Call service support.
4068 0B27	Other bus tests detected fault in I/O book	<ol style="list-style-type: none"> 1. Check for system firmware updates. 2. Check the I/O cabling between the secondary I/O book and the I/O subsystems. 3. Secondary I/O book Location: U1.18-P1-H3 4. Call service support.
4068 0B30	Other bus tests detected fault in I/O book	<ol style="list-style-type: none"> 1. Check for system firmware updates. 2. Check the I/O cabling between the third I/O book and the I/O subsystems. 3. Third I/O book Location: U1.18-P1-H4 4. Call service support.
4068 0B31	Other bus tests detected fault in I/O book	<ol style="list-style-type: none"> 1. Check for system firmware updates. 2. Check the I/O cabling between the third I/O book and the I/O subsystems. 3. Third I/O book Location: U1.18-P1-H4 4. Call service support.

Error Code	Description	Action/ Possible Failing FRU
4068 0B32	Other bus tests detected fault in I/O book	<ol style="list-style-type: none"> 1. Check for system firmware updates. 2. Check the I/O cabling between the third I/O book and the I/O subsystems. 3. Third I/O book Location: U1.18-P1-H4 4. Call service support.
4068 0B33	Other bus tests detected fault in I/O book	<ol style="list-style-type: none"> 1. Check for system firmware updates. 2. Check the I/O cabling between the third I/O book and the I/O subsystems. 3. Third I/O book Location: U1.18-P1-H4 4. Call service support.
4068 0B34	Other bus tests detected fault in I/O book	<ol style="list-style-type: none"> 1. Check for system firmware updates. 2. Check the I/O cabling between the third I/O book and the I/O subsystems. 3. Third I/O book Location: U1.18-P1-H4 4. Call service support.
4068 0B35	Other bus tests detected fault in I/O book	<ol style="list-style-type: none"> 1. Check for system firmware updates. 2. Check the I/O cabling between the third I/O book and the I/O subsystems. 3. Third I/O book Location: U1.18-P1-H4 4. Call service support.
4068 0B36	Other bus tests detected fault in I/O book	<ol style="list-style-type: none"> 1. Check for system firmware updates. 2. Check the I/O cabling between the third I/O book and the I/O subsystems. 3. Third I/O book Location: U1.18-P1-H4 4. Call service support.

Error Code	Description	Action/ Possible Failing FRU
4068 0B37	Other bus tests detected fault in I/O book	<ol style="list-style-type: none"> 1. Check for system firmware updates. 2. Check the I/O cabling between the third I/O book and the I/O subsystems. 3. Third I/O book Location: U1.18-P1-H4 4. Call service support.
4068 0BF0	Other bus tests detected fault in I/O hub chip 0 (port x)	<ol style="list-style-type: none"> 1. Check the cabling on the following RIO ports: <ol style="list-style-type: none"> a. U1.18-P1-H2/Q1 b. U1.18-P1-H2/Q2 2. Replace the primary I/O book, Location: U1.18-P1-H2
4068 0BF1	Other bus tests detected fault in I/O hub chip 1 (port x)	<ol style="list-style-type: none"> 1. Check the cabling on the following RIO ports: <ol style="list-style-type: none"> a. U1.18-P1-H2/Q3 b. U1.18-P1-H2/Q4 2. Replace the primary I/O book, Location: U1.18-P1-H2
4068 0BF2	Other bus tests detected fault in I/O hub chip 2 (port x)	<ol style="list-style-type: none"> 1. Check the cabling on the following RIO ports: <ol style="list-style-type: none"> a. U1.18-P1-H1/Q3 b. U1.18-P1-H1/Q4 2. Replace the RIO book, Location: U1.18-P1-H1
4068 0BF3	Other bus tests detected fault in I/O hub chip 3 (port x)	<ol style="list-style-type: none"> 1. Check the cabling on the following RIO ports: <ol style="list-style-type: none"> a. U1.18-P1-H1/Q1 b. U1.18-P1-H1/Q2 2. Replace the RIO book, Location: U1.18-P1-H1
4068 0BF4	Other bus tests detected fault in I/O hub chip 4 (port x)	<ol style="list-style-type: none"> 1. Check the cabling on the following RIO ports: <ol style="list-style-type: none"> a. U1.18-P1-H3/Q7 b. U1.18-P1-H3/Q8 2. Replace the RIO book, Location: U1.18-P1-H3

Error Code	Description	Action/ Possible Failing FRU
4068 0BF5	Other bus tests detected fault in I/O hub chip 5 (port x)	<ol style="list-style-type: none"> 1. Check the cabling on the following RIO ports: <ol style="list-style-type: none"> a. U1.18-P1-H3/Q5 b. U1.18-P1-H3/Q6 2. Replace the RIO book, Location: U1.18-P1-H3
4068 0BF6	Other bus tests detected fault in I/O hub chip 6 (port x)	<ol style="list-style-type: none"> 1. Check the cabling on the following RIO ports: <ol style="list-style-type: none"> a. U1.18-P1-H4/Q5 b. U1.18-P1-H4/Q6 2. Replace the RIO book, Location: U1.18-P1-H4
4068 0BF7	Other bus tests detected fault in I/O hub chip 7 (port x)	<ol style="list-style-type: none"> 1. Check the cabling on the following RIO ports: <ol style="list-style-type: none"> a. U1.18-P1-H4/Q7 b. U1.18-P1-H4/Q8 2. Replace the RIO book, Location: U1.18-P1-H4
4068 0BF8	Other bus tests detected fault in I/O hub chip 8 (port x)	<ol style="list-style-type: none"> 1. Check the cabling on the following RIO ports: <ol style="list-style-type: none"> a. U1.18-P1-H1/Q7 b. U1.18-P1-H1/Q8 2. Replace the RIO book, Location: U1.18-P1-H1
4068 0BF9	Other bus tests detected fault in I/O hub chip 9 (port x)	<ol style="list-style-type: none"> 1. Check the cabling on the following RIO ports: <ol style="list-style-type: none"> a. U1.18-P1-H1/Q5 b. U1.18-P1-H1/Q6 2. Replace the RIO book, Location: U1.18-P1-H1
4068 0BFA	Other bus tests detected fault in I/O hub chip 10 (port x)	<ol style="list-style-type: none"> 1. Check the cabling on the following RIO ports: <ol style="list-style-type: none"> a. U1.18-P1-H3/Q3 b. U1.18-P1-H3/Q4 2. Replace the RIO book, Location: U1.18-P1-H3

Error Code	Description	Action/ Possible Failing FRU
4068 0BFB	Other bus tests detected fault in I/O hub chip 11 (port x)	<ol style="list-style-type: none"> 1. Check the cabling on the following RIO ports: <ol style="list-style-type: none"> a. U1.18-P1-H3/Q1 b. U1.18-P1-H3/Q2 2. Replace the RIO book, Location: U1.18-P1-H3
4068 0BFC	Other bus tests detected fault in I/O hub chip 12 (port x)	<ol style="list-style-type: none"> 1. Check the cabling on the following RIO ports: <ol style="list-style-type: none"> a. U1.18-P1-H4/Q1 b. U1.18-P1-H4/Q2 2. Replace the RIO book, Location: U1.18-P1-H4.
4068 0BFD	Other bus tests detected fault in I/O hub chip 13 (port x)	<ol style="list-style-type: none"> 1. Check the cabling on the following RIO ports: <ol style="list-style-type: none"> a. U1.18-P1-H4/Q3 b. U1.18-P1-H4/Q4 2. Replace the RIO book, Location: U1.18-P1-H4
4068 0C03	Other bus tests detected fault in all MCMs	Go to "MAP 1543: MCM Module Problem Isolation" on page 332.
4068 0C09	Other bus tests detected fault in all memory books	Go to "MAP 1546: Memory Book Problem Isolation" on page 338.
4068 0C0A	Other bus tests detected fault in all I/O books	Go to "MAP 1547: I/O Book Problem Isolation" on page 341.
4068 0C10	Other bus tests detected mismatch between MCM 0 and VPD card	Plugging error with FRU kit Location: U1.18-P1-C1 and U1.18-P1-H2.3
4068 0C11	Other bus tests detected mismatch between MCM 2 and VPD card	Plugging error with FRU kit Location: U1.18-P1-C4 and U1.18-P1-H2.4
4068 0C12	Other bus tests detected mismatch between MCM 1 and VPD card	Plugging error with FRU kit Location: U1.18-P1-C3 and U1.18-P1-H2.5
4068 0C13	Other bus tests detected mismatch between MCM 3 and VPD card	Plugging error with FRU kit Location: U1.18-P1-C2 and U1.18-P1-H2.6
4068 0CA5	Other bus tests detected invalid processor subsystem configuration	Verify that MCMs, memory books, and L3 modules are correctly configured.
4068 0CA6	Other bus tests detected no usable main storage	Reboot the system in slow mode to isolate the failure.
4068 0CA9	Other bus tests detected configuration error with processor memory	Reboot the system in slow mode to isolate the failure.

Error Code	Description	Action/ Possible Failing FRU
4068 0D00	Other bus tests detected fault in L3 cache module 0	L3 cache module 0 and L3 VPD card Location: U1.18-P1-C6 and U1.18-P1-H2.1
4068 0D01	Other bus tests detected fault in L3 cache module 1	L3 cache module 1 and L3 VPD card Location: U1.18-P1-C7 and U1.18-P1-H2.1
4068 0D02	Other bus tests detected fault in L3 cache module 2	L3 cache module 2 and L3 VPD card Location: U1.18-P1-C11 and U1.18-P1-H2.1
4068 0D03	Other bus tests detected fault in L3 cache module 3	L3 cache module 3 and L3 VPD card Location: U1.18-P1-C10 and U1.18-P1-H2.1
4068 0D04	Other bus tests detected fault in L3 cache module 4	L3 cache module 4 and L3 VPD card Location: U1.18-P1-C8 and U1.18-P1-H2.1
4068 0D05	Other bus tests detected fault in L3 cache module 5	L3 cache module 5 and L3 VPD card Location: U1.18-P1-C20 and U1.18-P1-H2.1
4068 0D06	Other bus tests detected fault in L3 cache module 6	L3 cache module 6 and L3 VPD card Location: U1.18-P1-C16 and U1.18-P1-H2.1
4068 0D07	Other bus tests detected fault in L3 cache module 7	L3 cache module 7 and L3 VPD card Location: U1.18-P1-C12 and U1.18-P1-H2.1
4068 0D08	Other bus tests detected fault in L3 cache module 8	L3 cache module 8 and L3 VPD card Location: U1.18-P1-C19 and U1.18-P1-H2.1
4068 0D09	Other bus tests detected fault in L3 cache module 9	L3 cache module 9 and L3 VPD card Location: U1.18-P1-C18 and U1.18-P1-H2.1
4068 0D0A	Other bus tests detected fault in L3 cache module 10	L3 cache module 10 and L3 VPD card Location: U1.18-P1-C14 and U1.18-P1-H2.1
4068 0D0B	Other bus tests detected fault in L3 cache module 11	L3 cache module 11 and L3 VPD card Location: U1.18-P1-C15 and U1.18-P1-H2.1
4068 0D0C	Other bus tests detected fault in L3 cache module 12	L3 cache module 12 and L3 VPD card Location: U1.18-P1-C17 and U1.18-P1-H2.1
4068 0D0D	Other bus tests detected fault in L3 cache module 13	L3 cache module 13 and L3 VPD card Location: U1.18-P1-C5 and U1.18-P1-H2.1
4068 0D0E	Other bus tests detected fault in L3 cache module 14	L3 cache module 14 and L3 VPD card Location: U1.18-P1-C9 and U1.18-P1-H2.1

Error Code	Description	Action/ Possible Failing FRU
4068 0D0F	Other bus tests detected fault in L3 cache module 15	L3 cache module 15 and L3 VPD card Location: U1.18-P1-C13 and U1.18-P1-H2.1
4068 0EA0	Other bus tests detected fault in MOPS service processor code	1. Check for system firmware updates. 2. Call service support.
4068 0EA1	Other bus tests detected fault in processor subsystem code on main processor	1. Check for operating system updates. 2. Call service support.
4068 0EA2	Other bus tests detected fault in PRD code on service processor	1. Check for system firmware updates. 2. Call service support.
4068 0EA4	Other bus tests detected fault in service processor code	1. Check for system firmware updates. 2. Call service support.
4068 0EAF	Other bus tests detected unknown service processor code and system type	1. Check for system firmware updates. 2. Call service support.
4068 0EB0	Other bus tests detected JTAG problem	Go to "MAP 1540: Problem Isolation Procedures" on page 303.
4068 0EB1	Attention line 0 stuck fault	Go to "MAP 1540: Problem Isolation Procedures" on page 303.
4068 0EB2	Attention line 1 stuck fault	Go to "MAP 1540: Problem Isolation Procedures" on page 303.
4068 0EB3	Attention line 2 stuck fault	Go to "MAP 1540: Problem Isolation Procedures" on page 303.
4068 0EB4	Attention line 3 stuck fault	Go to "MAP 1540: Problem Isolation Procedures" on page 303.
4068 0EB5	Attention line 4 stuck fault	Go to "MAP 1540: Problem Isolation Procedures" on page 303.
4068 0EB6	Attention line 5 stuck fault	Go to "MAP 1540: Problem Isolation Procedures" on page 303.
4068 0EB7	Attention line 6 stuck fault	Go to "MAP 1540: Problem Isolation Procedures" on page 303.
4068 0EB8	Attention line 7 stuck fault	Go to "MAP 1540: Problem Isolation Procedures" on page 303.
4068 0EB9	Attention line 8 stuck fault	Go to "MAP 1540: Problem Isolation Procedures" on page 303.
4068 0EBA	Attention line 9 stuck fault	Go to "MAP 1540: Problem Isolation Procedures" on page 303.
4068 0EBB	Attention line 10 stuck fault	Go to "MAP 1540: Problem Isolation Procedures" on page 303.

Error Code	Description	Action/ Possible Failing FRU
4068 0EBC	Attention line 11 stuck fault	Go to "MAP 1540: Problem Isolation Procedures" on page 303.
4068 0EE1	Other bus tests detected fault in service processor code (invalid MRU to mapping)	<ol style="list-style-type: none"> 1. Check for system firmware updates. 2. Call service support.
4068 0EE2	Other bus tests detected fault in service processor firmware fault	<ol style="list-style-type: none"> 1. Check for system firmware updates. 2. Call service support.
4068 0EE5	Other bus tests detected firmware error; no callout available	<ol style="list-style-type: none"> 1. Check for system firmware updates. 2. Call service support.
4069 0001	Memory tests detected clock card assembly failure	Go to "MAP 1540: Problem Isolation Procedures" on page 303.
4069 0002	Memory tests detected backplane assembly failure	Go to "MAP 1540: Problem Isolation Procedures" on page 303.
4069 0003	Memory tests detected fault in MCM module 0	MCM module 0 and VPD card Location: U1.18-P1-C1 and U1.18-P1-H2.3
4069 0004	Memory tests detected fault in MCM module 2	MCM module 2 and VPD card Location: U1.18-P1-C4 and U1.18-P1-H2.4
4069 0005	Memory tests detected fault in MCM module 1	MCM module 1 and VPD card Location: U1.18-P1-C3 and U1.18-P1-H2.5
4069 0006	Memory tests detected fault in MCM module 3	MCM module 3 and VPD card Location: U1.18-P1-C2 and U1.18-P1-H2.6
4069 0007	Memory tests detected fault in L3 VPD card	<ol style="list-style-type: none"> 1. L3 VPD card Location: U1.18-P1-H2.1 (Order the L3 cache module FRU to obtain a new L3 VPD card. Return the L3 cache module that was included in the FRU kit, and the failing L3 VPD card as "new defective".) 2. Primary I/O book Location: U1.18-P1-H2
4069 000A	Memory tests detected fault in primary I/O book 1 (slot 0)	Go to "MAP 1540: Problem Isolation Procedures" on page 303.
4069 000B	Memory tests detected fault in secondary I/O book (slot 1)	Go to "MAP 1540: Problem Isolation Procedures" on page 303.
4069 000C	Memory tests detected fault in I/O book 3 (slot 2)	Go to "MAP 1540: Problem Isolation Procedures" on page 303.

Error Code	Description	Action/ Possible Failing FRU
4069 000D	Memory tests detected fault in I/O book 4 (slot 3)	Go to "MAP 1540: Problem Isolation Procedures" on page 303.
4069 0010	Memory tests detected fault in Memory book (slot 0)	Memory book (slot 0) Location: U1.18-P1-M2
4069 0011	Memory tests detected fault in Memory book (slot 1)	Memory book (slot 1) Location: U1.18-P1-M3
4069 0012	Memory tests detected fault in Memory book (slot 2)	Memory book (slot 2) Location: U1.18-P1-M7
4069 0013	Memory tests detected fault in Memory book (slot 3)	Memory book (slot 3) Location: U1.18-P1-M6
4069 0014	Memory tests detected fault in Memory book (slot 4)	Memory book (slot 4) Location: U1.18-P1-M4
4069 0015	Memory tests detected fault in Memory book (slot 5)	Memory book (slot 5) Location: U1.18-P1-M8
4069 0016	Memory tests detected fault in Memory book (slot 6)	Memory book (slot 6) Location: U1.18-P1-M5
4069 0017	Memory tests detected fault in Memory book (slot 7)	Memory book (slot 7) Location: U1.18-P1-M1
4069 00B0	Memory tests detected possible problem with bus controller or CSP code	<ol style="list-style-type: none"> 1. Check for system firmware updates. 2. Primary I/O book, Location: U1.18-P1-H2 3. Call service support.
4069 00B1	Memory tests detected possible problem with bus controller	<ol style="list-style-type: none"> 1. Check for system firmware updates. 2. Primary I/O book, Location: U1.18-P1-H2 3. Call service support.
4069 00B3	Memory tests detected MCM 0/VPD problem	<ol style="list-style-type: none"> 1. Check for system firmware updates. 2. MCM module 0 and VPD card Location: U1.18-P1-C1 and U1.18-P1-H2.3
4069 00B4	Memory tests detected MCM 2/VPD problem	<ol style="list-style-type: none"> 1. Check for system firmware updates. 2. MCM module 2 and VPD card Location: U1.18-P1-C4 and U1.18-P1-H2.4
4069 00B5	Memory tests detected MCM 1/VPD problem	<ol style="list-style-type: none"> 1. Check for system firmware updates. 2. MCM module 1 and VPD card Location: U1.18-P1-C3 and U1.18-P1-H2.5

Error Code	Description	Action/ Possible Failing FRU
4069 00B6	Memory tests detected MCM 3/VPD problem	<ol style="list-style-type: none"> 1. Check for system firmware updates. 2. MCM module 3 and VPD card Location: U1.18-P1-C2 and U1.18-P1-H2.6
4069 00B7	Memory tests detected hardware problem in the processor subsystem	Go to "MAP 1540: Problem Isolation Procedures" on page 303.
4069 0A03	Reboot message (run-time array gard failure) for processor 0	Reboot the system in slow mode. Run diagnostics, then go to MAP 0235 in the <i>RS/6000 and @server pSeries Diagnostic Information for Multiple Bus Systems</i> , order number SA38-0509.
4069 0A04	Reboot message (run-time array gard failure) for processor 2	Reboot the system in slow mode. Run diagnostics, then go to MAP 0235 in the <i>RS/6000 and @server pSeries Diagnostic Information for Multiple Bus Systems</i> , order number SA38-0509.
4069 0A05	Reboot message (run-time array gard failure) for processor 1	Reboot the system in slow mode. Run diagnostics, then go to MAP 0235 in the <i>RS/6000 and @server pSeries Diagnostic Information for Multiple Bus Systems</i> , order number SA38-0509.
4069 0A06	Reboot message (run-time array gard failure) for processor 3	Reboot the system in slow mode. Run diagnostics, then go to MAP 0235 in the <i>RS/6000 and @server pSeries Diagnostic Information for Multiple Bus Systems</i> , order number SA38-0509.
4069 0B00	Memory tests detected fault in I/O book (slot 0 RIO port 0)	<ol style="list-style-type: none"> 1. Check for system firmware updates. 2. Check the I/O cabling between the primary I/O book and the I/O subsystems. 3. Primary I/O book Location: U1.18-P1-H2 4. Call service support.
4069 0B01	Memory tests detected fault in I/O book (slot 0 RIO port 1)	<ol style="list-style-type: none"> 1. Check for system firmware updates. 2. Check the I/O cabling between the primary I/O book and the I/O subsystems. 3. Primary I/O book Location: U1.18-P1-H2 4. Call service support.

Error Code	Description	Action/ Possible Failing FRU
4069 0B02	Memory tests detected fault in I/O book (slot 0 RIO port 2)	<ol style="list-style-type: none"> 1. Check for system firmware updates. 2. Check the I/O cabling between the primary I/O book and the I/O subsystems. 3. Primary I/O book Location: U1.18-P1-H2 4. Call service support.
4069 0B03	Memory tests detected fault in I/O book (slot 0 RIO port 3)	<ol style="list-style-type: none"> 1. Check for system firmware updates. 2. Check the I/O cabling between the primary I/O book and the I/O subsystems. 3. Primary I/O book Location: U1.18-P1-H2 4. Call service support.
4069 0B10	Memory tests detected fault in I/O book	<ol style="list-style-type: none"> 1. Check for system firmware updates. 2. Check the I/O cabling between the secondary I/O book and the I/O subsystems. 3. Secondary I/O book Location: U1.18-P1-H1 4. Call service support.
4069 0B11	Memory tests detected fault in I/O book	<ol style="list-style-type: none"> 1. Check for system firmware updates. 2. Check the I/O cabling between the secondary I/O book and the I/O subsystems. 3. Secondary I/O book Location: U1.18-P1-H1 4. Call service support.
4069 0B12	Memory tests detected fault in I/O book	<ol style="list-style-type: none"> 1. Check for system firmware updates. 2. Check the I/O cabling between the secondary I/O book and the I/O subsystems. 3. Secondary I/O book Location: U1.18-P1-H1 4. Call service support.

Error Code	Description	Action/ Possible Failing FRU
4069 0B13	Memory tests detected fault in I/O book	<ol style="list-style-type: none"> 1. Check for system firmware updates. 2. Check the I/O cabling between the secondary I/O book and the I/O subsystems. 3. Secondary I/O book Location: U1.18-P1-H1 4. Call service support.
4069 0B14	Memory tests detected fault in I/O book	<ol style="list-style-type: none"> 1. Check for system firmware updates. 2. Check the I/O cabling between the secondary I/O book and the I/O subsystems. 3. Secondary I/O book Location: U1.18-P1-H1 4. Call service support.
4069 0B15	Memory tests detected fault in I/O book	<ol style="list-style-type: none"> 1. Check for system firmware updates. 2. Check the I/O cabling between the secondary I/O book and the I/O subsystems. 3. Secondary I/O book Location: U1.18-P1-H1 4. Call service support.
4069 0B16	Memory tests detected fault in I/O book	<ol style="list-style-type: none"> 1. Check for system firmware updates. 2. Check the I/O cabling between the secondary I/O book and the I/O subsystems. 3. Secondary I/O book Location: U1.18-P1-H1 4. Call service support.
4069 0B17	Memory tests detected fault in I/O book	<ol style="list-style-type: none"> 1. Check for system firmware updates. 2. Check the I/O cabling between the secondary I/O book and the I/O subsystems. 3. Secondary I/O book Location: U1.18-P1-H1 4. Call service support.

Error Code	Description	Action/ Possible Failing FRU
4069 0B20	Memory tests detected fault in I/O book	<ol style="list-style-type: none"> 1. Check for system firmware updates. 2. Check the I/O cabling between the secondary I/O book and the I/O subsystems. 3. Secondary I/O book Location: U1.18-P1-H3 4. Call service support.
4069 0B21	Memory tests detected fault in I/O book	<ol style="list-style-type: none"> 1. Check for system firmware updates. 2. Check the I/O cabling between the secondary I/O book and the I/O subsystems. 3. Secondary I/O book Location: U1.18-P1-H3 4. Call service support.
4069 0B22	Memory tests detected fault in I/O book	<ol style="list-style-type: none"> 1. Check for system firmware updates. 2. Check the I/O cabling between the secondary I/O book and the I/O subsystems. 3. Secondary I/O book Location: U1.18-P1-H3 4. Call service support.
4069 0B23	Memory tests detected fault in I/O book	<ol style="list-style-type: none"> 1. Check for system firmware updates. 2. Check the I/O cabling between the secondary I/O book and the I/O subsystems. 3. Secondary I/O book Location: U1.18-P1-H3 4. Call service support.
4069 0B24	Memory tests detected fault in I/O book	<ol style="list-style-type: none"> 1. Check for system firmware updates. 2. Check the I/O cabling between the secondary I/O book and the I/O subsystems. 3. Secondary I/O book Location: U1.18-P1-H3 4. Call service support.

Error Code	Description	Action/ Possible Failing FRU
4069 0B25	Memory tests detected fault in I/O book	<ol style="list-style-type: none"> 1. Check for system firmware updates. 2. Check the I/O cabling between the secondary I/O book and the I/O subsystems. 3. Secondary I/O book Location: U1.18-P1-H3 4. Call service support.
4069 0B26	Memory tests detected fault in I/O book	<ol style="list-style-type: none"> 1. Check for system firmware updates. 2. Check the I/O cabling between the secondary I/O book and the I/O subsystems. 3. Secondary I/O book Location: U1.18-P1-H3 4. Call service support.
4069 0B27	Memory tests detected fault in I/O book	<ol style="list-style-type: none"> 1. Check for system firmware updates. 2. Check the I/O cabling between the secondary I/O book and the I/O subsystems. 3. Secondary I/O book Location: U1.18-P1-H3 4. Call service support.
4069 0B30	Memory tests detected fault in I/O book	<ol style="list-style-type: none"> 1. Check for system firmware updates. 2. Check the I/O cabling between the third I/O book and the I/O subsystems. 3. Third I/O book Location: U1.18-P1-H4 4. Call service support.
4069 0B31	Memory tests detected fault in I/O book	<ol style="list-style-type: none"> 1. Check for system firmware updates. 2. Check the I/O cabling between the third I/O book and the I/O subsystems. 3. Third I/O book Location: U1.18-P1-H4 4. Call service support.

Error Code	Description	Action/ Possible Failing FRU
4069 0B32	Memory tests detected fault in I/O book	<ol style="list-style-type: none"> 1. Check for system firmware updates. 2. Check the I/O cabling between the third I/O book and the I/O subsystems. 3. Third I/O book Location: U1.18-P1-H4 4. Call service support.
4069 0B33	Memory tests detected fault in I/O book	<ol style="list-style-type: none"> 1. Check for system firmware updates. 2. Check the I/O cabling between the third I/O book and the I/O subsystems. 3. Third I/O book Location: U1.18-P1-H4 4. Call service support.
4069 0B34	Memory tests detected fault in I/O book	<ol style="list-style-type: none"> 1. Check for system firmware updates. 2. Check the I/O cabling between the third I/O book and the I/O subsystems. 3. Third I/O book Location: U1.18-P1-H4 4. Call service support.
4069 0B35	Memory tests detected fault in I/O book	<ol style="list-style-type: none"> 1. Check for system firmware updates. 2. Check the I/O cabling between the third I/O book and the I/O subsystems. 3. Third I/O book Location: U1.18-P1-H4 4. Call service support.
4069 0B36	Memory tests detected fault in I/O book	<ol style="list-style-type: none"> 1. Check for system firmware updates. 2. Check the I/O cabling between the third I/O book and the I/O subsystems. 3. Third I/O book Location: U1.18-P1-H4 4. Call service support.

Error Code	Description	Action/ Possible Failing FRU
4069 0B37	Memory tests detected fault in I/O book	<ol style="list-style-type: none"> 1. Check for system firmware updates. 2. Check the I/O cabling between the third I/O book and the I/O subsystems. 3. Third I/O book Location: U1.18-P1-H4 4. Call service support.
4069 0BF0	Memory tests detected fault in I/O hub chip 0 (port x)	<ol style="list-style-type: none"> 1. Check the cabling on the following RIO ports: <ol style="list-style-type: none"> a. U1.18-P1-H2/Q1 b. U1.18-P1-H2/Q2 2. Replace the primary I/O book, Location: U1.18-P1-H2
4069 0BF1	Memory tests detected fault in I/O hub chip 1 (port x)	<ol style="list-style-type: none"> 1. Check the cabling on the following RIO ports: <ol style="list-style-type: none"> a. U1.18-P1-H2/Q3 b. U1.18-P1-H2/Q4 2. Replace the primary I/O book, Location: U1.18-P1-H2
4069 0BF2	Memory tests detected fault in I/O hub chip 2 (port x)	<ol style="list-style-type: none"> 1. Check the cabling on the following RIO ports: <ol style="list-style-type: none"> a. U1.18-P1-H1/Q3 b. U1.18-P1-H1/Q4 2. Replace the RIO book, Location: U1.18-P1-H1
4069 0BF3	Memory tests detected fault in I/O hub chip 3 (port x)	<ol style="list-style-type: none"> 1. Check the cabling on the following RIO ports: <ol style="list-style-type: none"> a. U1.18-P1-H1/Q1 b. U1.18-P1-H1/Q2 2. Replace the RIO book, Location: U1.18-P1-H1
4069 0BF4	Memory tests detected fault in I/O hub chip 4 (port x)	<ol style="list-style-type: none"> 1. Check the cabling on the following RIO ports: <ol style="list-style-type: none"> a. U1.18-P1-H3/Q7 b. U1.18-P1-H3/Q8 2. Replace the RIO book, Location: U1.18-P1-H3

Error Code	Description	Action/ Possible Failing FRU
4069 0BF5	Memory tests detected fault in I/O hub chip 5 (port x)	<ol style="list-style-type: none"> 1. Check the cabling on the following RIO ports: <ol style="list-style-type: none"> a. U1.18-P1-H3/Q5 b. U1.18-P1-H3/Q6 2. Replace the RIO book, Location: U1.18-P1-H3
4069 0BF6	Memory tests detected fault in I/O hub chip 6 (port x)	<ol style="list-style-type: none"> 1. Check the cabling on the following RIO ports: <ol style="list-style-type: none"> a. U1.18-P1-H4/Q5 b. U1.18-P1-H4/Q6 2. Replace the RIO book, Location: U1.18-P1-H4
4069 0BF7	Memory tests detected fault in I/O hub chip 7 (port x)	<ol style="list-style-type: none"> 1. Check the cabling on the following RIO ports: <ol style="list-style-type: none"> a. U1.18-P1-H4/Q7 b. U1.18-P1-H4/Q8 2. Replace the RIO book, Location: U1.18-P1-H4
4069 0BF8	Memory tests detected fault in I/O hub chip 8 (port x)	<ol style="list-style-type: none"> 1. Check the cabling on the following RIO ports: <ol style="list-style-type: none"> a. U1.18-P1-H1/Q7 b. U1.18-P1-H1/Q8 2. Replace the RIO book, Location: U1.18-P1-H1
4069 0BF9	Memory tests detected fault in I/O hub chip 9 (port x)	<ol style="list-style-type: none"> 1. Check the cabling on the following RIO ports: <ol style="list-style-type: none"> a. U1.18-P1-H1/Q5 b. U1.18-P1-H1/Q6 2. Replace the RIO book, Location: U1.18-P1-H1
4069 0BFA	Memory tests detected fault in I/O hub chip 10 (port x)	<ol style="list-style-type: none"> 1. Check the cabling on the following RIO ports: <ol style="list-style-type: none"> a. U1.18-P1-H3/Q3 b. U1.18-P1-H3/Q4 2. Replace the RIO book, Location: U1.18-P1-H3

Error Code	Description	Action/ Possible Failing FRU
4069 0BFB	Memory tests detected fault in I/O hub chip 11 (port x)	<ol style="list-style-type: none"> 1. Check the cabling on the following RIO ports: <ol style="list-style-type: none"> a. U1.18-P1-H3/Q1 b. U1.18-P1-H3/Q2 2. Replace the RIO book, Location: U1.18-P1-H3
4069 0BFC	Memory tests detected fault in I/O hub chip 12 (port x)	<ol style="list-style-type: none"> 1. Check the cabling on the following RIO ports: <ol style="list-style-type: none"> a. U1.18-P1-H4/Q1 b. U1.18-P1-H4/Q2 2. Replace the RIO book, Location: U1.18-P1-H4.
4069 0BFD	Memory tests detected fault in I/O hub chip 13 (port x)	<ol style="list-style-type: none"> 1. Check the cabling on the following RIO ports: <ol style="list-style-type: none"> a. U1.18-P1-H4/Q3 b. U1.18-P1-H4/Q4 2. Replace the RIO book, Location: U1.18-P1-H4
4069 0C03	Memory tests detected fault in all MCMs	Go to "MAP 1543: MCM Module Problem Isolation" on page 332.
4069 0C09	Memory tests detected fault in all memory books	Go to "MAP 1546: Memory Book Problem Isolation" on page 338.
4069 0C0A	Memory tests detected fault in all I/O books	Go to "MAP 1547: I/O Book Problem Isolation" on page 341.
4069 0C10	Memory tests detected mismatch between MCM 0 and VPD card	Plugging error with FRU kit Location: U1.18-P1-C1 and U1.18-P1-H2.3
4069 0C11	Memory tests detected mismatch between MCM 2 and VPD card	Plugging error with FRU kit Location: U1.18-P1-C4 and U1.18-P1-H2.4
4069 0C12	Memory tests detected mismatch between MCM 1 and VPD card	Plugging error with FRU kit Location: U1.18-P1-C3 and U1.18-P1-H2.5
4069 0C13	Memory tests detected mismatch between MCM 3 and VPD card	Plugging error with FRU kit Location: U1.18-P1-C2 and U1.18-P1-H2.6
4069 0CA5	Memory tests detected invalid processor subsystem configuration	Verify that MCMs, memory books, and L3 modules are correctly configured.
4069 0CA6	Memory tests detected no usable main storage	Reboot the system in slow mode to isolate the failure.
4069 0CA9	Memory tests detected configuration error with processor memory	Reboot the system in slow mode to isolate the failure.

Error Code	Description	Action/ Possible Failing FRU
4069 0D00	Memory tests detected fault in L3 cache module 0	L3 cache module 0 and L3 VPD card Location: U1.18-P1-C6 and U1.18-P1-H2.1
4069 0D01	Memory tests detected fault in L3 cache module 1	L3 cache module 1 and L3 VPD card Location: U1.18-P1-C7 and U1.18-P1-H2.1
4069 0D02	Memory tests detected fault in L3 cache module 2	L3 cache module 2 and L3 VPD card Location: U1.18-P1-C11 and U1.18-P1-H2.1
4069 0D03	Memory tests detected fault in L3 cache module 3	L3 cache module 3 and L3 VPD card Location: U1.18-P1-C10 and U1.18-P1-H2.1
4069 0D04	Memory tests detected fault in L3 cache module 4	L3 cache module 4 and L3 VPD card Location: U1.18-P1-C8 and U1.18-P1-H2.1
4069 0D05	Memory tests detected fault in L3 cache module 5	L3 cache module 5 and L3 VPD card Location: U1.18-P1-C20 and U1.18-P1-H2.1
4069 0D06	Memory tests detected fault in L3 cache module 6	L3 cache module 6 and L3 VPD card Location: U1.18-P1-C16 and U1.18-P1-H2.1
4069 0D07	Memory tests detected fault in L3 cache module 7	L3 cache module 7 and L3 VPD card Location: U1.18-P1-C12 and U1.18-P1-H2.1
4069 0D08	Memory tests detected fault in L3 cache module 8	L3 cache module 8 and L3 VPD card Location: U1.18-P1-C19 and U1.18-P1-H2.1
4069 0D09	Memory tests detected fault in L3 cache module 9	L3 cache module 9 and L3 VPD card Location: U1.18-P1-C18 and U1.18-P1-H2.1
4069 0D0A	Memory tests detected fault in L3 cache module 10	L3 cache module 10 and L3 VPD card Location: U1.18-P1-C14 and U1.18-P1-H2.1
4069 0D0B	Memory tests detected fault in L3 cache module 11	L3 cache module 11 and L3 VPD card Location: U1.18-P1-C15 and U1.18-P1-H2.1
4069 0D0C	Memory tests detected fault in L3 cache module 12	L3 cache module 12 and L3 VPD card Location: U1.18-P1-C17 and U1.18-P1-H2.1
4069 0D0D	Memory tests detected fault in L3 cache module 13	L3 cache module 13 and L3 VPD card Location: U1.18-P1-C5 and U1.18-P1-H2.1
4069 0D0E	Memory tests detected fault in L3 cache module 14	L3 cache module 14 and L3 VPD card Location: U1.18-P1-C9 and U1.18-P1-H2.1

Error Code	Description	Action/ Possible Failing FRU
4069 0D0F	Memory tests detected fault in L3 cache module 15	L3 cache module 15 and L3 VPD card Location: U1.18-P1-C13 and U1.18-P1-H2.1
4069 0EA0	Memory tests detected fault in MOPS service processor code	1. Check for system firmware updates. 2. Call service support.
4069 0EA1	Memory tests detected fault in processor subsystem code on main processor	1. Check for operating system updates. 2. Call service support.
4069 0EA2	Memory tests detected fault in PRD code on service processor	1. Check for system firmware updates. 2. Call service support.
4069 0EA4	Memory tests detected fault in service processor code	1. Check for system firmware updates. 2. Call service support.
4069 0EAF	Memory tests detected unknown service processor code and system type	1. Check for system firmware updates. 2. Call service support.
4069 0EB0	Memory tests detected JTAG problem	Go to "MAP 1540: Problem Isolation Procedures" on page 303.
4069 0EB1	Attention line 0 stuck fault	Go to "MAP 1540: Problem Isolation Procedures" on page 303.
4069 0EB2	Attention line 1 stuck fault	Go to "MAP 1540: Problem Isolation Procedures" on page 303.
4069 0EB3	Attention line 2 stuck fault	Go to "MAP 1540: Problem Isolation Procedures" on page 303.
4069 0EB4	Attention line 3 stuck fault	Go to "MAP 1540: Problem Isolation Procedures" on page 303.
4069 0EB5	Attention line 4 stuck fault	Go to "MAP 1540: Problem Isolation Procedures" on page 303.
4069 0EB6	Attention line 5 stuck fault	Go to "MAP 1540: Problem Isolation Procedures" on page 303.
4069 0EB7	Attention line 6 stuck fault	Go to "MAP 1540: Problem Isolation Procedures" on page 303.
4069 0EB8	Attention line 7 stuck fault	Go to "MAP 1540: Problem Isolation Procedures" on page 303.
4069 0EB9	Attention line 8 stuck fault	Go to "MAP 1540: Problem Isolation Procedures" on page 303.
4069 0EBA	Attention line 9 stuck fault	Go to "MAP 1540: Problem Isolation Procedures" on page 303.
4069 0EBB	Attention line 10 stuck fault	Go to "MAP 1540: Problem Isolation Procedures" on page 303.

Error Code	Description	Action/ Possible Failing FRU
4069 0EBC	Attention line 11 stuck fault	Go to "MAP 1540: Problem Isolation Procedures" on page 303.
4069 0EE1	Memory tests detected fault in service processor code (invalid MRU to mapping)	<ol style="list-style-type: none"> 1. Check for system firmware updates. 2. Call service support.
4069 0EE2	Memory tests detected fault in service processor firmware fault	<ol style="list-style-type: none"> 1. Check for system firmware updates. 2. Call service support.
4069 0EE5	Memory tests detected firmware error; no callout available	<ol style="list-style-type: none"> 1. Check for system firmware updates. 2. Call service support.
406A 0001	Self tests detected clock card assembly failure	Go to "MAP 1540: Problem Isolation Procedures" on page 303.
406A 0002	Self tests detected backplane assembly failure	Go to "MAP 1540: Problem Isolation Procedures" on page 303.
406A 0003	Self tests detected fault in MCM module 0	MCM module 0 and VPD card Location: U1.18-P1-C1 and U1.18-P1-H2.3
406A 0004	Self tests detected fault in MCM module 2	MCM module 2 and VPD card Location: U1.18-P1-C4 and U1.18-P1-H2.4
406A 0005	Self tests detected fault in MCM module 1	MCM module 1 and VPD card Location: U1.18-P1-C3 and U1.18-P1-H2.5
406A 0006	Self tests detected fault in MCM module 3	MCM module 3 and VPD card Location: U1.18-P1-C2 and U1.18-P1-H2.6
406A 0007	Self tests detected fault in L3 VPD card	<ol style="list-style-type: none"> 1. L3 VPD card Location: U1.18-P1-H2.1 (Order the L3 cache module FRU to obtain a new L3 VPD card. Return the L3 cache module that was included in the FRU kit, and the failing L3 VPD card as "new defective".) 2. Primary I/O book Location: U1.18-P1-H2
406A 000A	Self tests detected fault in primary I/O book 1 (slot 0)	Go to "MAP 1540: Problem Isolation Procedures" on page 303.
406A 000B	Self tests detected fault in secondary I/O book (slot 1)	Go to "MAP 1540: Problem Isolation Procedures" on page 303.
406A 000C	Self tests detected fault in I/O book 3 (slot 2)	Go to "MAP 1540: Problem Isolation Procedures" on page 303.

Error Code	Description	Action/ Possible Failing FRU
406A 000D	Self tests detected fault in I/O book 4 (slot 3)	Go to "MAP 1540: Problem Isolation Procedures" on page 303.
406A 0010	Self tests detected fault in Memory book (slot 0)	Memory book (slot 0) Location: U1.18-P1-M2
406A 0011	Self tests detected fault in Memory book (slot 1)	Memory book (slot 1) Location: U1.18-P1-M3
406A 0012	Self tests detected fault in Memory book (slot 2)	Memory book (slot 2) Location: U1.18-P1-M7
406A 0013	Self tests detected fault in Memory book (slot 3)	Memory book (slot 3) Location: U1.18-P1-M6
406A 0014	Self tests detected fault in Memory book (slot 4)	Memory book (slot 4) Location: U1.18-P1-M4
406A 0015	Self tests detected fault in Memory book (slot 5)	Memory book (slot 5) Location: U1.18-P1-M8
406A 0016	Self tests detected fault in Memory book (slot 6)	Memory book (slot 6) Location: U1.18-P1-M5
406A 0017	Self tests detected fault in Memory book (slot 7)	Memory book (slot 7) Location: U1.18-P1-M1
406A 00B0	Self tests detected possible problem with bus controller or CSP code	<ol style="list-style-type: none"> 1. Check for system firmware updates. 2. Primary I/O book, Location: U1.18-P1-H2 3. Call service support.
406A 00B1	Self tests detected possible problem with bus controller	<ol style="list-style-type: none"> 1. Check for system firmware updates. 2. Primary I/O book, Location: U1.18-P1-H2 3. Call service support.
406A 00B3	Self tests detected MCM 0/VPD problem	<ol style="list-style-type: none"> 1. Check for system firmware updates. 2. MCM module 0 and VPD card Location: U1.18-P1-C1 and U1.18-P1-H2.3
406A 00B4	Self tests detected MCM 2/VPD problem	<ol style="list-style-type: none"> 1. Check for system firmware updates. 2. MCM module 2 and VPD card Location: U1.18-P1-C4 and U1.18-P1-H2.4
406A 00B5	Self tests detected MCM 1/VPD problem	<ol style="list-style-type: none"> 1. Check for system firmware updates. 2. MCM module 1 and VPD card Location: U1.18-P1-C3 and U1.18-P1-H2.5

Error Code	Description	Action/ Possible Failing FRU
406A 00B6	Self tests detected MCM 3/VPD problem	<ol style="list-style-type: none"> 1. Check for system firmware updates. 2. MCM module 3 and VPD card Location: U1.18-P1-C2 and U1.18-P1-H2.6
406A 00B7	Self tests detected hardware problem in the processor subsystem	Go to "MAP 1540: Problem Isolation Procedures" on page 303.
406A 0A03	Reboot message (run-time array gard failure) for processor 0	Reboot the system in slow mode. Run diagnostics, then go to MAP 0235 in the <i>RS/6000 and @server pSeries Diagnostic Information for Multiple Bus Systems</i> , order number SA38-0509.
406A 0A04	Reboot message (run-time array gard failure) for processor 2	Reboot the system in slow mode. Run diagnostics, then go to MAP 0235 in the <i>RS/6000 and @server pSeries Diagnostic Information for Multiple Bus Systems</i> , order number SA38-0509.
406A 0A05	Reboot message (run-time array gard failure) for processor 1	Reboot the system in slow mode. Run diagnostics, then go to MAP 0235 in the <i>RS/6000 and @server pSeries Diagnostic Information for Multiple Bus Systems</i> , order number SA38-0509.
406A 0A06	Reboot message (run-time array gard failure) for processor 3	Reboot the system in slow mode. Run diagnostics, then go to MAP 0235 in the <i>RS/6000 and @server pSeries Diagnostic Information for Multiple Bus Systems</i> , order number SA38-0509.
406A 0B00	Self-tests detected fault in I/O book (slot 0 RIO port 0)	<ol style="list-style-type: none"> 1. Check for system firmware updates. 2. Check the I/O cabling between the primary I/O book and the I/O subsystems. 3. Primary I/O book Location: U1.18-P1-H2 4. Call service support.
406A 0B01	Self-tests detected fault in I/O book (slot 0 RIO port 1)	<ol style="list-style-type: none"> 1. Check for system firmware updates. 2. Check the I/O cabling between the primary I/O book and the I/O subsystems. 3. Primary I/O book Location: U1.18-P1-H2 4. Call service support.

Error Code	Description	Action/ Possible Failing FRU
406A 0B02	Self-tests detected fault in I/O book (slot 0 RIO port 2)	<ol style="list-style-type: none"> 1. Check for system firmware updates. 2. Check the I/O cabling between the primary I/O book and the I/O subsystems. 3. Primary I/O book Location: U1.18-P1-H2 4. Call service support.
406A 0B03	Self-tests detected fault in I/O book (slot 0 RIO port 3)	<ol style="list-style-type: none"> 1. Check for system firmware updates. 2. Check the I/O cabling between the primary I/O book and the I/O subsystems. 3. Primary I/O book Location: U1.18-P1-H2 4. Call service support.
406A 0B10	Self-tests detected fault in I/O book	<ol style="list-style-type: none"> 1. Check for system firmware updates. 2. Check the I/O cabling between the secondary I/O book and the I/O subsystems. 3. Secondary I/O book Location: U1.18-P1-H1 4. Call service support.
406A 0B11	Self-tests detected fault in I/O book	<ol style="list-style-type: none"> 1. Check for system firmware updates. 2. Check the I/O cabling between the secondary I/O book and the I/O subsystems. 3. Secondary I/O book Location: U1.18-P1-H1 4. Call service support.
406A 0B12	Self-tests detected fault in I/O book	<ol style="list-style-type: none"> 1. Check for system firmware updates. 2. Check the I/O cabling between the secondary I/O book and the I/O subsystems. 3. Secondary I/O book Location: U1.18-P1-H1 4. Call service support.

Error Code	Description	Action/ Possible Failing FRU
406A 0B13	Self-tests detected fault in I/O book	<ol style="list-style-type: none"> 1. Check for system firmware updates. 2. Check the I/O cabling between the secondary I/O book and the I/O subsystems. 3. Secondary I/O book Location: U1.18-P1-H1 4. Call service support.
406A 0B14	Self-tests detected fault in I/O book	<ol style="list-style-type: none"> 1. Check for system firmware updates. 2. Check the I/O cabling between the secondary I/O book and the I/O subsystems. 3. Secondary I/O book Location: U1.18-P1-H1 4. Call service support.
406A 0B15	Self-tests detected fault in I/O book	<ol style="list-style-type: none"> 1. Check for system firmware updates. 2. Check the I/O cabling between the secondary I/O book and the I/O subsystems. 3. Secondary I/O book Location: U1.18-P1-H1 4. Call service support.
406A 0B16	Self-tests detected fault in I/O book	<ol style="list-style-type: none"> 1. Check for system firmware updates. 2. Check the I/O cabling between the secondary I/O book and the I/O subsystems. 3. Secondary I/O book Location: U1.18-P1-H1 4. Call service support.
406A 0B17	Self-tests detected fault in I/O book	<ol style="list-style-type: none"> 1. Check for system firmware updates. 2. Check the I/O cabling between the secondary I/O book and the I/O subsystems. 3. Secondary I/O book Location: U1.18-P1-H1 4. Call service support.

Error Code	Description	Action/ Possible Failing FRU
406A 0B20	Self-tests detected fault in I/O book	<ol style="list-style-type: none"> 1. Check for system firmware updates. 2. Check the I/O cabling between the secondary I/O book and the I/O subsystems. 3. Secondary I/O book Location: U1.18-P1-H3 4. Call service support.
406A 0B21	Self-tests detected fault in I/O book	<ol style="list-style-type: none"> 1. Check for system firmware updates. 2. Check the I/O cabling between the secondary I/O book and the I/O subsystems. 3. Secondary I/O book Location: U1.18-P1-H3 4. Call service support.
406A 0B22	Self-tests detected fault in I/O book	<ol style="list-style-type: none"> 1. Check for system firmware updates. 2. Check the I/O cabling between the secondary I/O book and the I/O subsystems. 3. Secondary I/O book Location: U1.18-P1-H3 4. Call service support.
406A 0B23	Self-tests detected fault in I/O book	<ol style="list-style-type: none"> 1. Check for system firmware updates. 2. Check the I/O cabling between the secondary I/O book and the I/O subsystems. 3. Secondary I/O book Location: U1.18-P1-H3 4. Call service support.
406A 0B24	Self-tests detected fault in I/O book	<ol style="list-style-type: none"> 1. Check for system firmware updates. 2. Check the I/O cabling between the secondary I/O book and the I/O subsystems. 3. Secondary I/O book Location: U1.18-P1-H3 4. Call service support.

Error Code	Description	Action/ Possible Failing FRU
406A 0B25	Self-tests detected fault in I/O book	<ol style="list-style-type: none"> 1. Check for system firmware updates. 2. Check the I/O cabling between the secondary I/O book and the I/O subsystems. 3. Secondary I/O book Location: U1.18-P1-H3 4. Call service support.
406A 0B26	Self-tests detected fault in I/O book	<ol style="list-style-type: none"> 1. Check for system firmware updates. 2. Check the I/O cabling between the secondary I/O book and the I/O subsystems. 3. Secondary I/O book Location: U1.18-P1-H3 4. Call service support.
406A 0B27	Self-tests detected fault in I/O book	<ol style="list-style-type: none"> 1. Check for system firmware updates. 2. Check the I/O cabling between the secondary I/O book and the I/O subsystems. 3. Secondary I/O book Location: U1.18-P1-H3 4. Call service support.
406A 0B30	Self-tests detected fault in I/O book	<ol style="list-style-type: none"> 1. Check for system firmware updates. 2. Check the I/O cabling between the third I/O book and the I/O subsystems. 3. Third I/O book Location: U1.18-P1-H4 4. Call service support.
406A 0B31	Self-tests detected fault in I/O book	<ol style="list-style-type: none"> 1. Check for system firmware updates. 2. Check the I/O cabling between the third I/O book and the I/O subsystems. 3. Third I/O book Location: U1.18-P1-H4 4. Call service support.

Error Code	Description	Action/ Possible Failing FRU
406A 0B32	Self-tests detected fault in I/O book	<ol style="list-style-type: none"> 1. Check for system firmware updates. 2. Check the I/O cabling between the third I/O book and the I/O subsystems. 3. Third I/O book Location: U1.18-P1-H4 4. Call service support.
406A 0B33	Self-tests detected fault in I/O book	<ol style="list-style-type: none"> 1. Check for system firmware updates. 2. Check the I/O cabling between the third I/O book and the I/O subsystems. 3. Third I/O book Location: U1.18-P1-H4 4. Call service support.
406A 0B34	Self-tests detected fault in I/O book	<ol style="list-style-type: none"> 1. Check for system firmware updates. 2. Check the I/O cabling between the third I/O book and the I/O subsystems. 3. Third I/O book Location: U1.18-P1-H4 4. Call service support.
406A 0B35	Self-tests detected fault in I/O book	<ol style="list-style-type: none"> 1. Check for system firmware updates. 2. Check the I/O cabling between the third I/O book and the I/O subsystems. 3. Third I/O book Location: U1.18-P1-H4 4. Call service support.
406A 0B36	Self-tests detected fault in I/O book	<ol style="list-style-type: none"> 1. Check for system firmware updates. 2. Check the I/O cabling between the third I/O book and the I/O subsystems. 3. Third I/O book Location: U1.18-P1-H4 4. Call service support.

Error Code	Description	Action/ Possible Failing FRU
406A 0B37	Self-tests detected fault in I/O book	<ol style="list-style-type: none"> 1. Check for system firmware updates. 2. Check the I/O cabling between the third I/O book and the I/O subsystems. 3. Third I/O book Location: U1.18-P1-H4 4. Call service support.
406A 0BF0	Self-tests detected fault in I/O hub chip 0 (port x)	<ol style="list-style-type: none"> 1. Check the cabling on the following RIO ports: <ol style="list-style-type: none"> a. U1.18-P1-H2/Q1 b. U1.18-P1-H2/Q2 2. Replace the primary I/O book, Location: U1.18-P1-H2
406A 0BF1	Self-tests detected fault in I/O hub chip 1 (port x)	<ol style="list-style-type: none"> 1. Check the cabling on the following RIO ports: <ol style="list-style-type: none"> a. U1.18-P1-H2/Q3 b. U1.18-P1-H2/Q4 2. Replace the primary I/O book, Location: U1.18-P1-H2
406A 0BF2	Self-tests detected fault in I/O hub chip 2 (port x)	<ol style="list-style-type: none"> 1. Check the cabling on the following RIO ports: <ol style="list-style-type: none"> a. U1.18-P1-H1/Q3 b. U1.18-P1-H1/Q4 2. Replace the RIO book, Location: U1.18-P1-H1
406A 0BF3	Self-tests detected fault in I/O hub chip 3 (port x)	<ol style="list-style-type: none"> 1. Check the cabling on the following RIO ports: <ol style="list-style-type: none"> a. U1.18-P1-H1/Q1 b. U1.18-P1-H1/Q2 2. Replace the RIO book, Location: U1.18-P1-H1
406A 0BF4	Self-tests detected fault in I/O hub chip 4 (port x)	<ol style="list-style-type: none"> 1. Check the cabling on the following RIO ports: <ol style="list-style-type: none"> a. U1.18-P1-H3/Q7 b. U1.18-P1-H3/Q8 2. Replace the RIO book, Location: U1.18-P1-H3

Error Code	Description	Action/ Possible Failing FRU
406A 0BF5	Self-tests detected fault in I/O hub chip 5 (port x)	<ol style="list-style-type: none"> 1. Check the cabling on the following RIO ports: <ol style="list-style-type: none"> a. U1.18-P1-H3/Q5 b. U1.18-P1-H3/Q6 2. Replace the RIO book, Location: U1.18-P1-H3
406A 0BF6	Self-tests detected fault in I/O hub chip 6 (port x)	<ol style="list-style-type: none"> 1. Check the cabling on the following RIO ports: <ol style="list-style-type: none"> a. U1.18-P1-H4/Q5 b. U1.18-P1-H4/Q6 2. Replace the RIO book, Location: U1.18-P1-H4
406A 0BF7	Self-tests detected fault in I/O hub chip 7 (port x)	<ol style="list-style-type: none"> 1. Check the cabling on the following RIO ports: <ol style="list-style-type: none"> a. U1.18-P1-H4/Q7 b. U1.18-P1-H4/Q8 2. Replace the RIO book, Location: U1.18-P1-H4
406A 0BF8	Self-tests detected fault in I/O hub chip 8 (port x)	<ol style="list-style-type: none"> 1. Check the cabling on the following RIO ports: <ol style="list-style-type: none"> a. U1.18-P1-H1/Q7 b. U1.18-P1-H1/Q8 2. Replace the RIO book, Location: U1.18-P1-H1
406A 0BF9	Self-tests detected fault in I/O hub chip 9 (port x)	<ol style="list-style-type: none"> 1. Check the cabling on the following RIO ports: <ol style="list-style-type: none"> a. U1.18-P1-H1/Q5 b. U1.18-P1-H1/Q6 2. Replace the RIO book, Location: U1.18-P1-H1
406A 0BFA	Self-tests detected fault in I/O hub chip 10 (port x)	<ol style="list-style-type: none"> 1. Check the cabling on the following RIO ports: <ol style="list-style-type: none"> a. U1.18-P1-H3/Q3 b. U1.18-P1-H3/Q4 2. Replace the RIO book, Location: U1.18-P1-H3

Error Code	Description	Action/ Possible Failing FRU
406A 0BFB	Self-tests detected fault in I/O hub chip 11 (port x)	<ol style="list-style-type: none"> 1. Check the cabling on the following RIO ports: <ol style="list-style-type: none"> a. U1.18-P1-H3/Q1 b. U1.18-P1-H3/Q2 2. Replace the RIO book, Location: U1.18-P1-H3
406A 0BFC	Self-tests detected fault in I/O hub chip 12 (port x)	<ol style="list-style-type: none"> 1. Check the cabling on the following RIO ports: <ol style="list-style-type: none"> a. U1.18-P1-H4/Q1 b. U1.18-P1-H4/Q2 2. Replace the RIO book, Location: U1.18-P1-H4.
406A 0BFD	Self-tests detected fault in I/O hub chip 13 (port x)	<ol style="list-style-type: none"> 1. Check the cabling on the following RIO ports: <ol style="list-style-type: none"> a. U1.18-P1-H4/Q3 b. U1.18-P1-H4/Q4 2. Replace the RIO book, Location: U1.18-P1-H4
406A 0C03	Self-tests detected fault in all MCMs	Go to “MAP 1543: MCM Module Problem Isolation” on page 332.
406A 0C09	Self-tests detected fault in all memory books	Go to “MAP 1546: Memory Book Problem Isolation” on page 338.
406A 0C0A	Self-tests detected fault in all I/O books	Go to “MAP 1547: I/O Book Problem Isolation” on page 341.
406A 0C10	Self-tests detected mismatch between MCM 0 and VPD card	Plugging error with FRU kit Location: U1.18-P1-C1 and U1.18-P1-H2.3
406A 0C11	Self-tests detected mismatch between MCM 2 and VPD card	Plugging error with FRU kit Location: U1.18-P1-C4 and U1.18-P1-H2.4
406A 0C12	Self-tests detected mismatch between MCM 1 and VPD card	Plugging error with FRU kit Location: U1.18-P1-C3 and U1.18-P1-H2.5
406A 0C13	Self-tests detected mismatch between MCM 3 and VPD card	Plugging error with FRU kit Location: U1.18-P1-C2 and U1.18-P1-H2.6
406A 0CA5	Self-tests detected invalid processor subsystem configuration	Verify that MCMs, memory books, and L3 modules are correctly configured.
406A 0CA6	Self-tests detected no usable main storage	Reboot the system in slow mode to isolate the failure.
406A 0CA9	Self-tests detected configuration error with processor memory	Reboot the system in slow mode to isolate the failure.

Error Code	Description	Action/ Possible Failing FRU
406A 0D00	Self-tests detected fault in L3 cache module 0	L3 cache module 0 and L3 VPD card Location: U1.18-P1-C6 and U1.18-P1-H2.1
406A 0D01	Self-tests detected fault in L3 cache module 1	L3 cache module 1 and L3 VPD card Location: U1.18-P1-C7 and U1.18-P1-H2.1
406A 0D02	Self-tests detected fault in L3 cache module 2	L3 cache module 2 and L3 VPD card Location: U1.18-P1-C11 and U1.18-P1-H2.1
406A 0D03	Self-tests detected fault in L3 cache module 3	L3 cache module 3 and L3 VPD card Location: U1.18-P1-C10 and U1.18-P1-H2.1
406A 0D04	Self-tests detected fault in L3 cache module 4	L3 cache module 4 and L3 VPD card Location: U1.18-P1-C8 and U1.18-P1-H2.1
406A 0D05	Self-tests detected fault in L3 cache module 5	L3 cache module 5 and L3 VPD card Location: U1.18-P1-C20 and U1.18-P1-H2.1
406A 0D06	Self-tests detected fault in L3 cache module 6	L3 cache module 6 and L3 VPD card Location: U1.18-P1-C16 and U1.18-P1-H2.1
406A 0D07	Self-tests detected fault in L3 cache module 7	L3 cache module 7 and L3 VPD card Location: U1.18-P1-C12 and U1.18-P1-H2.1
406A 0D08	Self-tests detected fault in L3 cache module 8	L3 cache module 8 and L3 VPD card Location: U1.18-P1-C19 and U1.18-P1-H2.1
406A 0D09	Self-tests detected fault in L3 cache module 9	L3 cache module 9 and L3 VPD card Location: U1.18-P1-C18 and U1.18-P1-H2.1
406A 0D0A	Self-tests detected fault in L3 cache module 10	L3 cache module 10 and L3 VPD card Location: U1.18-P1-C14 and U1.18-P1-H2.1
406A 0D0B	Self-tests detected fault in L3 cache module 11	L3 cache module 11 and L3 VPD card Location: U1.18-P1-C15 and U1.18-P1-H2.1
406A 0D0C	Self-tests detected fault in L3 cache module 12	L3 cache module 12 and L3 VPD card Location: U1.18-P1-C17 and U1.18-P1-H2.1
406A 0D0D	Self-tests detected fault in L3 cache module 13	L3 cache module 13 and L3 VPD card Location: U1.18-P1-C5 and U1.18-P1-H2.1
406A 0D0E	Self-tests detected fault in L3 cache module 14	L3 cache module 14 and L3 VPD card Location: U1.18-P1-C9 and U1.18-P1-H2.1

Error Code	Description	Action/ Possible Failing FRU
406A 0D0F	Self-tests detected fault in L3 cache module 15	L3 cache module 15 and L3 VPD card Location: U1.18-P1-C13 and U1.18-P1-H2.1
406A 0EA0	Self-tests detected fault in MOPS service processor code	1. Check for system firmware updates. 2. Call service support.
406A 0EA1	Self-tests detected fault in processor subsystem code on main processor	1. Check for operating system updates. 2. Call service support.
406A 0EA2	Self-tests detected fault in PRD code on service processor	1. Check for system firmware updates. 2. Call service support.
406A 0EA4	Self-tests detected fault in service processor code	1. Check for system firmware updates. 2. Call service support.
406A 0EAF	Self-tests detected unknown service processor code and system type	1. Check for system firmware updates. 2. Call service support.
406A 0EB0	Self-tests detected JTAG problem	Go to "MAP 1540: Problem Isolation Procedures" on page 303.
406A 0EB1	Attention line 0 stuck fault	Go to "MAP 1540: Problem Isolation Procedures" on page 303.
406A 0EB2	Attention line 1 stuck fault	Go to "MAP 1540: Problem Isolation Procedures" on page 303.
406A 0EB3	Attention line 2 stuck fault	Go to "MAP 1540: Problem Isolation Procedures" on page 303.
406A 0EB4	Attention line 3 stuck fault	Go to "MAP 1540: Problem Isolation Procedures" on page 303.
406A 0EB5	Attention line 4 stuck fault	Go to "MAP 1540: Problem Isolation Procedures" on page 303.
406A 0EB6	Attention line 5 stuck fault	Go to "MAP 1540: Problem Isolation Procedures" on page 303.
406A 0EB7	Attention line 6 stuck fault	Go to "MAP 1540: Problem Isolation Procedures" on page 303.
406A 0EB8	Attention line 7 stuck fault	Go to "MAP 1540: Problem Isolation Procedures" on page 303.
406A 0EB9	Attention line 8 stuck fault	Go to "MAP 1540: Problem Isolation Procedures" on page 303.
406A 0EBA	Attention line 9 stuck fault	Go to "MAP 1540: Problem Isolation Procedures" on page 303.
406A 0EBB	Attention line 10 stuck fault	Go to "MAP 1540: Problem Isolation Procedures" on page 303.

Error Code	Description	Action/ Possible Failing FRU
406A 0EBC	Attention line 11 stuck fault	Go to "MAP 1540: Problem Isolation Procedures" on page 303.
406A 0EE1	Self-tests detected fault in service processor code (invalid MRU to mapping)	<ol style="list-style-type: none"> 1. Check for system firmware updates. 2. Call service support.
406A 0EE2	Self-tests detected fault in service processor firmware fault	<ol style="list-style-type: none"> 1. Check for system firmware updates. 2. Call service support.
406A 0EE5	Self-tests detected firmware error; no callout available	<ol style="list-style-type: none"> 1. Check for system firmware updates. 2. Call service support.
406B 0001	Wire tests detected clock card assembly failure	Go to "MAP 1540: Problem Isolation Procedures" on page 303.
406B 0002	Wire tests detected backplane assembly failure	Go to "MAP 1540: Problem Isolation Procedures" on page 303.
406B 0003	Wire tests detected fault in MCM module 0	MCM module 0 and VPD card Location: U1.18-P1-C1 and U1.18-P1-H2.3
406B 0004	Wire tests detected fault in MCM module 2	MCM module 2 and VPD card Location: U1.18-P1-C4 and U1.18-P1-H2.4
406B 0005	Wire tests detected fault in MCM module 1	MCM module 1 and VPD card Location: U1.18-P1-C3 and U1.18-P1-H2.5
406B 0006	Wire tests detected fault in MCM module 3	MCM module 3 and VPD card Location: U1.18-P1-C2 and U1.18-P1-H2.6
406B 0007	Wire tests detected fault in L3 VPD card	<ol style="list-style-type: none"> 1. L3 VPD card Location: U1.18-P1-H2.1 (Order the L3 cache module FRU to obtain a new L3 VPD card. Return the L3 cache module that was included in the FRU kit, and the failing L3 VPD card as "new defective".) 2. Primary I/O book Location: U1.18-P1-H2
406B 000A	Wire tests detected fault in primary I/O book 1 (slot 0)	Go to "MAP 1540: Problem Isolation Procedures" on page 303.
406B 000B	Wire tests detected fault in secondary I/O book (slot 1)	Go to "MAP 1540: Problem Isolation Procedures" on page 303.
406B 000C	Wire tests detected fault in I/O book 3 (slot 2)	Go to "MAP 1540: Problem Isolation Procedures" on page 303.

Error Code	Description	Action/ Possible Failing FRU
406B 000D	Wire tests detected fault in I/O book 4 (slot 3)	Go to "MAP 1540: Problem Isolation Procedures" on page 303.
406B 0010	Wire tests detected fault in Memory book (slot 0)	Memory book (slot 0) Location: U1.18-P1-M2
406B 0011	Wire tests detected fault in Memory book (slot 1)	Memory book (slot 1) Location: U1.18-P1-M3
406B 0012	Wire tests detected fault in Memory book (slot 2)	Memory book (slot 2) Location: U1.18-P1-M7
406B 0013	Wire tests detected fault in Memory book (slot 3)	Memory book (slot 3) Location: U1.18-P1-M6
406B 0014	Wire tests detected fault in Memory book (slot 4)	Memory book (slot 4) Location: U1.18-P1-M4
406B 0015	Wire tests detected fault in Memory book (slot 5)	Memory book (slot 5) Location: U1.18-P1-M8
406B 0016	Wire tests detected fault in Memory book (slot 6)	Memory book (slot 6) Location: U1.18-P1-M5
406B 0017	Wire tests detected fault in Memory book (slot 7)	Memory book (slot 7) Location: U1.18-P1-M1
406B 00B0	Wire tests detected possible problem with bus controller or CSP code	<ol style="list-style-type: none"> 1. Check for system firmware updates. 2. Primary I/O book, Location: U1.18-P1-H2 3. Call service support.
406B 00B1	Wire tests detected possible problem with bus controller	<ol style="list-style-type: none"> 1. Check for system firmware updates. 2. Primary I/O book, Location: U1.18-P1-H2 3. Call service support.
406B 00B3	Wire tests detected MCM 0/VPD problem	<ol style="list-style-type: none"> 1. Check for system firmware updates. 2. MCM module 0 and VPD card Location: U1.18-P1-C1 and U1.18-P1-H2.3
406B 00B4	Wire tests detected MCM 2/VPD problem	<ol style="list-style-type: none"> 1. Check for system firmware updates. 2. MCM module 2 and VPD card Location: U1.18-P1-C4 and U1.18-P1-H2.4
406B 00B5	Wire tests detected MCM 1/VPD problem	<ol style="list-style-type: none"> 1. Check for system firmware updates. 2. MCM module 1 and VPD card Location: U1.18-P1-C3 and U1.18-P1-H2.5

Error Code	Description	Action/ Possible Failing FRU
406B 00B6	Wire tests detected MCM 3/VPD problem	<ol style="list-style-type: none"> 1. Check for system firmware updates. 2. MCM module 3 and VPD card Location: U1.18-P1-C2 and U1.18-P1-H2.6
406B 00B7	Wire tests detected hardware problem in the processor subsystem	Go to "MAP 1540: Problem Isolation Procedures" on page 303.
406B 0A03	Reboot message (run-time array gard failure) for processor 0	Reboot the system in slow mode. Run diagnostics, then go to MAP 0235 in the <i>RS/6000 and @server pSeries Diagnostic Information for Multiple Bus Systems</i> , order number SA38-0509.
406B 0A04	Reboot message (run-time array gard failure) for processor 2	Reboot the system in slow mode. Run diagnostics, then go to MAP 0235 in the <i>RS/6000 and @server pSeries Diagnostic Information for Multiple Bus Systems</i> , order number SA38-0509.
406B 0A05	Reboot message (run-time array gard failure) for processor 1	Reboot the system in slow mode. Run diagnostics, then go to MAP 0235 in the <i>RS/6000 and @server pSeries Diagnostic Information for Multiple Bus Systems</i> , order number SA38-0509.
406B 0A06	Reboot message (run-time array gard failure) for processor 3	Reboot the system in slow mode. Run diagnostics, then go to MAP 0235 in the <i>RS/6000 and @server pSeries Diagnostic Information for Multiple Bus Systems</i> , order number SA38-0509.
406B 0B00	Wire tests detected fault in I/O book (slot 0 RIO port 0)	<ol style="list-style-type: none"> 1. Check for system firmware updates. 2. Check the I/O cabling between the primary I/O book and the I/O subsystems. 3. Primary I/O book Location: U1.18-P1-H2 4. Call service support.
406B 0B01	Wire tests detected fault in I/O book (slot 0 RIO port 1)	<ol style="list-style-type: none"> 1. Check for system firmware updates. 2. Check the I/O cabling between the primary I/O book and the I/O subsystems. 3. Primary I/O book Location: U1.18-P1-H2 4. Call service support.

Error Code	Description	Action/ Possible Failing FRU
406B 0B02	Wire tests detected fault in I/O book (slot 0 RIO port 2)	<ol style="list-style-type: none"> 1. Check for system firmware updates. 2. Check the I/O cabling between the primary I/O book and the I/O subsystems. 3. Primary I/O book Location: U1.18-P1-H2 4. Call service support.
406B 0B03	Wire tests detected fault in I/O book (slot 0 RIO port 3)	<ol style="list-style-type: none"> 1. Check for system firmware updates. 2. Check the I/O cabling between the primary I/O book and the I/O subsystems. 3. Primary I/O book Location: U1.18-P1-H2 4. Call service support.
406B 0B10	Wire tests detected fault in I/O book	<ol style="list-style-type: none"> 1. Check for system firmware updates. 2. Check the I/O cabling between the secondary I/O book and the I/O subsystems. 3. Secondary I/O book Location: U1.18-P1-H1 4. Call service support.
406B 0B11	Wire tests detected fault in I/O book	<ol style="list-style-type: none"> 1. Check for system firmware updates. 2. Check the I/O cabling between the secondary I/O book and the I/O subsystems. 3. Secondary I/O book Location: U1.18-P1-H1 4. Call service support.
406B 0B12	Wire tests detected fault in I/O book	<ol style="list-style-type: none"> 1. Check for system firmware updates. 2. Check the I/O cabling between the secondary I/O book and the I/O subsystems. 3. Secondary I/O book Location: U1.18-P1-H1 4. Call service support.

Error Code	Description	Action/ Possible Failing FRU
406B 0B13	Wire tests detected fault in I/O book	<ol style="list-style-type: none"> 1. Check for system firmware updates. 2. Check the I/O cabling between the secondary I/O book and the I/O subsystems. 3. Secondary I/O book Location: U1.18-P1-H1 4. Call service support.
406B 0B14	Wire tests detected fault in I/O book	<ol style="list-style-type: none"> 1. Check for system firmware updates. 2. Check the I/O cabling between the secondary I/O book and the I/O subsystems. 3. Secondary I/O book Location: U1.18-P1-H1 4. Call service support.
406B 0B15	Wire tests detected fault in I/O book	<ol style="list-style-type: none"> 1. Check for system firmware updates. 2. Check the I/O cabling between the secondary I/O book and the I/O subsystems. 3. Secondary I/O book Location: U1.18-P1-H1 4. Call service support.
406B 0B16	Wire tests detected fault in I/O book	<ol style="list-style-type: none"> 1. Check for system firmware updates. 2. Check the I/O cabling between the secondary I/O book and the I/O subsystems. 3. Secondary I/O book Location: U1.18-P1-H1 4. Call service support.
406B 0B17	Wire tests detected fault in I/O book	<ol style="list-style-type: none"> 1. Check for system firmware updates. 2. Check the I/O cabling between the secondary I/O book and the I/O subsystems. 3. Secondary I/O book Location: U1.18-P1-H1 4. Call service support.

Error Code	Description	Action/ Possible Failing FRU
406B 0B20	Wire tests detected fault in I/O book	<ol style="list-style-type: none"> 1. Check for system firmware updates. 2. Check the I/O cabling between the secondary I/O book and the I/O subsystems. 3. Secondary I/O book Location: U1.18-P1-H3 4. Call service support.
406B 0B21	Wire tests detected fault in I/O book	<ol style="list-style-type: none"> 1. Check for system firmware updates. 2. Check the I/O cabling between the secondary I/O book and the I/O subsystems. 3. Secondary I/O book Location: U1.18-P1-H3 4. Call service support.
406B 0B22	Wire tests detected fault in I/O book	<ol style="list-style-type: none"> 1. Check for system firmware updates. 2. Check the I/O cabling between the secondary I/O book and the I/O subsystems. 3. Secondary I/O book Location: U1.18-P1-H3 4. Call service support.
406B 0B23	Wire tests detected fault in I/O book	<ol style="list-style-type: none"> 1. Check for system firmware updates. 2. Check the I/O cabling between the secondary I/O book and the I/O subsystems. 3. Secondary I/O book Location: U1.18-P1-H3 4. Call service support.
406B 0B24	Wire tests detected fault in I/O book	<ol style="list-style-type: none"> 1. Check for system firmware updates. 2. Check the I/O cabling between the secondary I/O book and the I/O subsystems. 3. Secondary I/O book Location: U1.18-P1-H3 4. Call service support.

Error Code	Description	Action/ Possible Failing FRU
406B 0B25	Wire tests detected fault in I/O book	<ol style="list-style-type: none"> 1. Check for system firmware updates. 2. Check the I/O cabling between the secondary I/O book and the I/O subsystems. 3. Secondary I/O book Location: U1.18-P1-H3 4. Call service support.
406B 0B26	Wire tests detected fault in I/O book	<ol style="list-style-type: none"> 1. Check for system firmware updates. 2. Check the I/O cabling between the secondary I/O book and the I/O subsystems. 3. Secondary I/O book Location: U1.18-P1-H3 4. Call service support.
406B 0B27	Wire tests detected fault in I/O book	<ol style="list-style-type: none"> 1. Check for system firmware updates. 2. Check the I/O cabling between the secondary I/O book and the I/O subsystems. 3. Secondary I/O book Location: U1.18-P1-H3 4. Call service support.
406B 0B30	Wire tests detected fault in I/O book	<ol style="list-style-type: none"> 1. Check for system firmware updates. 2. Check the I/O cabling between the third I/O book and the I/O subsystems. 3. Third I/O book Location: U1.18-P1-H4 4. Call service support.
406B 0B31	Wire tests detected fault in I/O book	<ol style="list-style-type: none"> 1. Check for system firmware updates. 2. Check the I/O cabling between the third I/O book and the I/O subsystems. 3. Third I/O book Location: U1.18-P1-H4 4. Call service support.

Error Code	Description	Action/ Possible Failing FRU
406B 0B32	Wire tests detected fault in I/O book	<ol style="list-style-type: none"> 1. Check for system firmware updates. 2. Check the I/O cabling between the third I/O book and the I/O subsystems. 3. Third I/O book Location: U1.18-P1-H4 4. Call service support.
406B 0B33	Wire tests detected fault in I/O book	<ol style="list-style-type: none"> 1. Check for system firmware updates. 2. Check the I/O cabling between the third I/O book and the I/O subsystems. 3. Third I/O book Location: U1.18-P1-H4 4. Call service support.
406B 0B34	Wire tests detected fault in I/O book	<ol style="list-style-type: none"> 1. Check for system firmware updates. 2. Check the I/O cabling between the third I/O book and the I/O subsystems. 3. Third I/O book Location: U1.18-P1-H4 4. Call service support.
406B 0B35	Wire tests detected fault in I/O book	<ol style="list-style-type: none"> 1. Check for system firmware updates. 2. Check the I/O cabling between the third I/O book and the I/O subsystems. 3. Third I/O book Location: U1.18-P1-H4 4. Call service support.
406B 0B36	Wire tests detected fault in I/O book	<ol style="list-style-type: none"> 1. Check for system firmware updates. 2. Check the I/O cabling between the third I/O book and the I/O subsystems. 3. Third I/O book Location: U1.18-P1-H4 4. Call service support.

Error Code	Description	Action/ Possible Failing FRU
406B 0B37	Wire tests detected fault in I/O book	<ol style="list-style-type: none"> 1. Check for system firmware updates. 2. Check the I/O cabling between the third I/O book and the I/O subsystems. 3. Third I/O book Location: U1.18-P1-H4 4. Call service support.
406B 0BF0	Wire tests detected fault in I/O hub chip 0 (port x)	<ol style="list-style-type: none"> 1. Check the cabling on the following RIO ports: <ol style="list-style-type: none"> a. U1.18-P1-H2/Q1 b. U1.18-P1-H2/Q2 2. Replace the primary I/O book, Location: U1.18-P1-H2
406B 0BF1	Wire tests detected fault in I/O hub chip 1 (port x)	<ol style="list-style-type: none"> 1. Check the cabling on the following RIO ports: <ol style="list-style-type: none"> a. U1.18-P1-H2/Q3 b. U1.18-P1-H2/Q4 2. Replace the primary I/O book, Location: U1.18-P1-H2
406B 0BF2	Wire tests detected fault in I/O hub chip 2 (port x)	<ol style="list-style-type: none"> 1. Check the cabling on the following RIO ports: <ol style="list-style-type: none"> a. U1.18-P1-H1/Q3 b. U1.18-P1-H1/Q4 2. Replace the RIO book, Location: U1.18-P1-H1
406B 0BF3	Wire tests detected fault in I/O hub chip 3 (port x)	<ol style="list-style-type: none"> 1. Check the cabling on the following RIO ports: <ol style="list-style-type: none"> a. U1.18-P1-H1/Q1 b. U1.18-P1-H1/Q2 2. Replace the RIO book, Location: U1.18-P1-H1
406B 0BF4	Wire tests detected fault in I/O hub chip 4 (port x)	<ol style="list-style-type: none"> 1. Check the cabling on the following RIO ports: <ol style="list-style-type: none"> a. U1.18-P1-H3/Q7 b. U1.18-P1-H3/Q8 2. Replace the RIO book, Location: U1.18-P1-H3

Error Code	Description	Action/ Possible Failing FRU
406B 0BF5	Wire tests detected fault in I/O hub chip 5 (port x)	<ol style="list-style-type: none"> 1. Check the cabling on the following RIO ports: <ol style="list-style-type: none"> a. U1.18-P1-H3/Q5 b. U1.18-P1-H3/Q6 2. Replace the RIO book, Location: U1.18-P1-H3
406B 0BF6	Wire tests detected fault in I/O hub chip 6 (port x)	<ol style="list-style-type: none"> 1. Check the cabling on the following RIO ports: <ol style="list-style-type: none"> a. U1.18-P1-H4/Q5 b. U1.18-P1-H4/Q6 2. Replace the RIO book, Location: U1.18-P1-H4
406B 0BF7	Wire tests detected fault in I/O hub chip 7 (port x)	<ol style="list-style-type: none"> 1. Check the cabling on the following RIO ports: <ol style="list-style-type: none"> a. U1.18-P1-H4/Q7 b. U1.18-P1-H4/Q8 2. Replace the RIO book, Location: U1.18-P1-H4
406B 0BF8	Wire tests detected fault in I/O hub chip 8 (port x)	<ol style="list-style-type: none"> 1. Check the cabling on the following RIO ports: <ol style="list-style-type: none"> a. U1.18-P1-H1/Q7 b. U1.18-P1-H1/Q8 2. Replace the RIO book, Location: U1.18-P1-H1
406B 0BF9	Wire tests detected fault in I/O hub chip 9 (port x)	<ol style="list-style-type: none"> 1. Check the cabling on the following RIO ports: <ol style="list-style-type: none"> a. U1.18-P1-H1/Q5 b. U1.18-P1-H1/Q6 2. Replace the RIO book, Location: U1.18-P1-H1
406B 0BFA	Wire tests detected fault in I/O hub chip 10 (port x)	<ol style="list-style-type: none"> 1. Check the cabling on the following RIO ports: <ol style="list-style-type: none"> a. U1.18-P1-H3/Q3 b. U1.18-P1-H3/Q4 2. Replace the RIO book, Location: U1.18-P1-H3

Error Code	Description	Action/ Possible Failing FRU
406B 0BFB	Wire tests detected fault in I/O hub chip 11 (port x)	<ol style="list-style-type: none"> 1. Check the cabling on the following RIO ports: <ol style="list-style-type: none"> a. U1.18-P1-H3/Q1 b. U1.18-P1-H3/Q2 2. Replace the RIO book, Location: U1.18-P1-H3
406B 0BFC	Wire tests detected fault in I/O hub chip 12 (port x)	<ol style="list-style-type: none"> 1. Check the cabling on the following RIO ports: <ol style="list-style-type: none"> a. U1.18-P1-H4/Q1 b. U1.18-P1-H4/Q2 2. Replace the RIO book, Location: U1.18-P1-H4.
406B 0BFD	Wire tests detected fault in I/O hub chip 13 (port x)	<ol style="list-style-type: none"> 1. Check the cabling on the following RIO ports: <ol style="list-style-type: none"> a. U1.18-P1-H4/Q3 b. U1.18-P1-H4/Q4 2. Replace the RIO book, Location: U1.18-P1-H4
406B 0C03	Wire tests detected fault in all MCMs	Go to "MAP 1543: MCM Module Problem Isolation" on page 332.
406B 0C09	Wire tests detected fault in all memory books	Go to "MAP 1546: Memory Book Problem Isolation" on page 338.
406B 0C0A	Wire tests detected fault in all I/O books	Go to "MAP 1547: I/O Book Problem Isolation" on page 341.
406B 0C10	Wire tests detected mismatch between MCM 0 and VPD card	Plugging error with FRU kit Location: U1.18-P1-C1 and U1.18-P1-H2.3
406B 0C11	Wire tests detected mismatch between MCM 2 and VPD card	Plugging error with FRU kit Location: U1.18-P1-C4 and U1.18-P1-H2.4
406B 0C12	Wire tests detected mismatch between MCM 1 and VPD card	Plugging error with FRU kit Location: U1.18-P1-C3 and U1.18-P1-H2.5
406B 0C13	Wire tests detected mismatch between MCM 3 and VPD card	Plugging error with FRU kit Location: U1.18-P1-C2 and U1.18-P1-H2.6
406B 0CA5	Wire tests detected invalid processor subsystem configuration	Verify that MCMs, memory books, and L3 modules are correctly configured.
406B 0CA6	Wire tests detected no usable main storage	Reboot the system in slow mode to isolate the failure.
406B 0CA9	Wire tests detected configuration error with processor memory	Reboot the system in slow mode to isolate the failure.

Error Code	Description	Action/ Possible Failing FRU
406B 0D00	Wire tests detected fault in L3 cache module 0	L3 cache module 0 and L3 VPD card Location: U1.18-P1-C6 and U1.18-P1-H2.1
406B 0D01	Wire tests detected fault in L3 cache module 1	L3 cache module 1 and L3 VPD card Location: U1.18-P1-C7 and U1.18-P1-H2.1
406B 0D02	Wire tests detected fault in L3 cache module 2	L3 cache module 2 and L3 VPD card Location: U1.18-P1-C11 and U1.18-P1-H2.1
406B 0D03	Wire tests detected fault in L3 cache module 3	L3 cache module 3 and L3 VPD card Location: U1.18-P1-C10 and U1.18-P1-H2.1
406B 0D04	Wire tests detected fault in L3 cache module 4	L3 cache module 4 and L3 VPD card Location: U1.18-P1-C8 and U1.18-P1-H2.1
406B 0D05	Wire tests detected fault in L3 cache module 5	L3 cache module 5 and L3 VPD card Location: U1.18-P1-C20 and U1.18-P1-H2.1
406B 0D06	Wire tests detected fault in L3 cache module 6	L3 cache module 6 and L3 VPD card Location: U1.18-P1-C16 and U1.18-P1-H2.1
406B 0D07	Wire tests detected fault in L3 cache module 7	L3 cache module 7 and L3 VPD card Location: U1.18-P1-C12 and U1.18-P1-H2.1
406B 0D08	Wire tests detected fault in L3 cache module 8	L3 cache module 8 and L3 VPD card Location: U1.18-P1-C19 and U1.18-P1-H2.1
406B 0D09	Wire tests detected fault in L3 cache module 9	L3 cache module 9 and L3 VPD card Location: U1.18-P1-C18 and U1.18-P1-H2.1
406B 0D0A	Wire tests detected fault in L3 cache module 10	L3 cache module 10 and L3 VPD card Location: U1.18-P1-C14 and U1.18-P1-H2.1
406B 0D0B	Wire tests detected fault in L3 cache module 11	L3 cache module 11 and L3 VPD card Location: U1.18-P1-C15 and U1.18-P1-H2.1
406B 0D0C	Wire tests detected fault in L3 cache module 12	L3 cache module 12 and L3 VPD card Location: U1.18-P1-C17 and U1.18-P1-H2.1
406B 0D0D	Wire tests detected fault in L3 cache module 13	L3 cache module 13 and L3 VPD card Location: U1.18-P1-C5 and U1.18-P1-H2.1
406B 0D0E	Wire tests detected fault in L3 cache module 14	L3 cache module 14 and L3 VPD card Location: U1.18-P1-C9 and U1.18-P1-H2.1

Error Code	Description	Action/ Possible Failing FRU
406B 0D0F	Wire tests detected fault in L3 cache module 15	L3 cache module 15 and L3 VPD card Location: U1.18-P1-C13 and U1.18-P1-H2.1
406B 0EA0	Wire tests detected fault in MOPS service processor code	1. Check for system firmware updates. 2. Call service support.
406B 0EA1	Wire tests detected fault in processor subsystem code on main processor	1. Check for operating system updates. 2. Call service support.
406B 0EA2	Wire tests detected fault in PRD code on service processor	1. Check for system firmware updates. 2. Call service support.
406B 0EA4	Wire tests detected fault in service processor code	1. Check for system firmware updates. 2. Call service support.
406B 0EAF	Wire tests detected unknown service processor code and system type	1. Check for system firmware updates. 2. Call service support.
406B 0EB0	Wire tests detected JTAG problem	Go to "MAP 1540: Problem Isolation Procedures" on page 303.
406B 0EB1	Attention line 0 stuck fault	Go to "MAP 1540: Problem Isolation Procedures" on page 303.
406B 0EB2	Attention line 1 stuck fault	Go to "MAP 1540: Problem Isolation Procedures" on page 303.
406B 0EB3	Attention line 2 stuck fault	Go to "MAP 1540: Problem Isolation Procedures" on page 303.
406B 0EB4	Attention line 3 stuck fault	Go to "MAP 1540: Problem Isolation Procedures" on page 303.
406B 0EB5	Attention line 4 stuck fault	Go to "MAP 1540: Problem Isolation Procedures" on page 303.
406B 0EB6	Attention line 5 stuck fault	Go to "MAP 1540: Problem Isolation Procedures" on page 303.
406B 0EB7	Attention line 6 stuck fault	Go to "MAP 1540: Problem Isolation Procedures" on page 303.
406B 0EB8	Attention line 7 stuck fault	Go to "MAP 1540: Problem Isolation Procedures" on page 303.
406B 0EB9	Attention line 8 stuck fault	Go to "MAP 1540: Problem Isolation Procedures" on page 303.
406B 0EBA	Attention line 9 stuck fault	Go to "MAP 1540: Problem Isolation Procedures" on page 303.
406B 0EBB	Attention line 10 stuck fault	Go to "MAP 1540: Problem Isolation Procedures" on page 303.

Error Code	Description	Action/ Possible Failing FRU
406B 0EBC	Attention line 11 stuck fault	Go to "MAP 1540: Problem Isolation Procedures" on page 303.
406B 0EE1	Wire tests detected fault in service processor code (invalid MRU to mapping)	<ol style="list-style-type: none"> 1. Check for system firmware updates. 2. Call service support.
406B 0EE2	Wire tests detected fault in service processor firmware fault	<ol style="list-style-type: none"> 1. Check for system firmware updates. 2. Call service support.
406B 0EE5	Wire tests detected firmware error; no callout available	<ol style="list-style-type: none"> 1. Check for system firmware updates. 2. Call service support.
406C 0001	IPL detected clock card assembly failure	Go to "MAP 1540: Problem Isolation Procedures" on page 303.
406C 0002	IPL detected backplane assembly failure	Go to "MAP 1540: Problem Isolation Procedures" on page 303.
406C 0003	IPL detected fault in MCM module 0	MCM module 0 and VPD card Location: U1.18-P1-C1 and U1.18-P1-H2.3
406C 0004	IPL detected fault in MCM module 2	MCM module 2 and VPD card Location: U1.18-P1-C4 and U1.18-P1-H2.4
406C 0005	IPL detected fault in MCM module 1	MCM module 1 and VPD card Location: U1.18-P1-C3 and U1.18-P1-H2.5
406C 0006	IPL detected fault in MCM module 3	MCM module 3 and VPD card Location: U1.18-P1-C2 and U1.18-P1-H2.6
406C 0007	IPL detected fault in L3 VPD card	<ol style="list-style-type: none"> 1. L3 VPD card Location: U1.18-P1-H2.1 (Order the L3 cache module FRU to obtain a new L3 VPD card. Return the L3 cache module that was included in the FRU kit, and the failing L3 VPD card as "new defective".) 2. Primary I/O book Location: U1.18-P1-H2
406C 000A	IPL detected fault in primary I/O book 1 (slot 0)	Go to "MAP 1540: Problem Isolation Procedures" on page 303.
406C 000B	IPL detected fault in secondary I/O book (slot 1)	Go to "MAP 1540: Problem Isolation Procedures" on page 303.
406C 000C	IPL detected fault in I/O book 3 (slot 2)	Go to "MAP 1540: Problem Isolation Procedures" on page 303.

Error Code	Description	Action/ Possible Failing FRU
406C 000D	IPL detected fault in I/O book 4 (slot 3)	Go to "MAP 1540: Problem Isolation Procedures" on page 303.
406C 0010	IPL detected fault in Memory book (slot 0)	Memory book (slot 0) Location: U1.18-P1-M2
406C 0011	IPL detected fault in Memory book (slot 1)	Memory book (slot 1) Location: U1.18-P1-M3
406C 0012	IPL detected fault in Memory book (slot 2)	Memory book (slot 2) Location: U1.18-P1-M7
406C 0013	IPL detected fault in Memory book (slot 3)	Memory book (slot 3) Location: U1.18-P1-M6
406C 0014	IPL detected fault in Memory book (slot 4)	Memory book (slot 4) Location: U1.18-P1-M4
406C 0015	IPL detected fault in Memory book (slot 5)	Memory book (slot 5) Location: U1.18-P1-M8
406C 0016	IPL detected fault in Memory book (slot 6)	Memory book (slot 6) Location: U1.18-P1-M5
406C 0017	IPL detected fault in Memory book (slot 7)	Memory book (slot 7) Location: U1.18-P1-M1
406C 00B0	IPL detected possible problem with bus controller or CSP code	<ol style="list-style-type: none"> 1. Check for system firmware updates. 2. Primary I/O book, Location: U1.18-P1-H2 3. Call service support.
406C 00B1	IPL detected possible problem with bus controller	<ol style="list-style-type: none"> 1. Check for system firmware updates. 2. Primary I/O book, Location: U1.18-P1-H2 3. Call service support.
406C 00B3	IPL detected MCM 0/VPD problem	<ol style="list-style-type: none"> 1. Check for system firmware updates. 2. MCM module 0 and VPD card Location: U1.18-P1-C1 and U1.18-P1-H2.3
406C 00B4	IPL detected MCM 2/VPD problem	<ol style="list-style-type: none"> 1. Check for system firmware updates. 2. MCM module 2 and VPD card Location: U1.18-P1-C4 and U1.18-P1-H2.4
406C 00B5	IPL detected MCM 1/VPD problem	<ol style="list-style-type: none"> 1. Check for system firmware updates. 2. MCM module 1 and VPD card Location: U1.18-P1-C3 and U1.18-P1-H2.5

Error Code	Description	Action/ Possible Failing FRU
406C 00B6	IPL detected MCM 3/VPD problem	<ol style="list-style-type: none"> 1. Check for system firmware updates. 2. MCM module 3 and VPD card Location: U1.18-P1-C2 and U1.18-P1-H2.6
406C 00B7	IPL detected hardware problem in the processor subsystem	Go to "MAP 1540: Problem Isolation Procedures" on page 303.
406C 0A03	Reboot message (run-time array gard failure) for processor 0	Reboot the system in slow mode. Run diagnostics, then go to MAP 0235 in the <i>RS/6000 and @server pSeries Diagnostic Information for Multiple Bus Systems</i> , order number SA38-0509.
406C 0A04	Reboot message (run-time array gard failure) for processor 2	Reboot the system in slow mode. Run diagnostics, then go to MAP 0235 in the <i>RS/6000 and @server pSeries Diagnostic Information for Multiple Bus Systems</i> , order number SA38-0509.
406C 0A05	Reboot message (run-time array gard failure) for processor 1	Reboot the system in slow mode. Run diagnostics, then go to MAP 0235 in the <i>RS/6000 and @server pSeries Diagnostic Information for Multiple Bus Systems</i> , order number SA38-0509.
406C 0A06	Reboot message (run-time array gard failure) for processor 3	Reboot the system in slow mode. Run diagnostics, then go to MAP 0235 in the <i>RS/6000 and @server pSeries Diagnostic Information for Multiple Bus Systems</i> , order number SA38-0509.
406C 0B00	IPL detected fault in I/O book (slot 0 RIO port 0)	<ol style="list-style-type: none"> 1. Check for system firmware updates. 2. Check the I/O cabling between the primary I/O book and the I/O subsystems. 3. Primary I/O book Location: U1.18-P1-H2 4. Call service support.
406C 0B01	IPL detected fault in I/O book (slot 0 RIO port 1)	<ol style="list-style-type: none"> 1. Check for system firmware updates. 2. Check the I/O cabling between the primary I/O book and the I/O subsystems. 3. Primary I/O book Location: U1.18-P1-H2 4. Call service support.

Error Code	Description	Action/ Possible Failing FRU
406C 0B02	IPL detected fault in I/O book (slot 0 RIO port 2)	<ol style="list-style-type: none"> 1. Check for system firmware updates. 2. Check the I/O cabling between the primary I/O book and the I/O subsystems. 3. Primary I/O book Location: U1.18-P1-H2 4. Call service support.
406C 0B03	IPL detected fault in I/O book (slot 0 RIO port 3)	<ol style="list-style-type: none"> 1. Check for system firmware updates. 2. Check the I/O cabling between the primary I/O book and the I/O subsystems. 3. Primary I/O book Location: U1.18-P1-H2 4. Call service support.
406C 0B10	IPL detected fault in I/O book	<ol style="list-style-type: none"> 1. Check for system firmware updates. 2. Check the I/O cabling between the secondary I/O book and the I/O subsystems. 3. Secondary I/O book Location: U1.18-P1-H1 4. Call service support.
406C 0B11	IPL detected fault in I/O book	<ol style="list-style-type: none"> 1. Check for system firmware updates. 2. Check the I/O cabling between the secondary I/O book and the I/O subsystems. 3. Secondary I/O book Location: U1.18-P1-H1 4. Call service support.
406C 0B12	IPL detected fault in I/O book	<ol style="list-style-type: none"> 1. Check for system firmware updates. 2. Check the I/O cabling between the secondary I/O book and the I/O subsystems. 3. Secondary I/O book Location: U1.18-P1-H1 4. Call service support.

Error Code	Description	Action/ Possible Failing FRU
406C 0B13	IPL detected fault in I/O book	<ol style="list-style-type: none"> 1. Check for system firmware updates. 2. Check the I/O cabling between the secondary I/O book and the I/O subsystems. 3. Secondary I/O book Location: U1.18-P1-H1 4. Call service support.
406C 0B14	IPL detected fault in I/O book	<ol style="list-style-type: none"> 1. Check for system firmware updates. 2. Check the I/O cabling between the secondary I/O book and the I/O subsystems. 3. Secondary I/O book Location: U1.18-P1-H1 4. Call service support.
406C 0B15	IPL detected fault in I/O book	<ol style="list-style-type: none"> 1. Check for system firmware updates. 2. Check the I/O cabling between the secondary I/O book and the I/O subsystems. 3. Secondary I/O book Location: U1.18-P1-H1 4. Call service support.
406C 0B16	IPL detected fault in I/O book	<ol style="list-style-type: none"> 1. Check for system firmware updates. 2. Check the I/O cabling between the secondary I/O book and the I/O subsystems. 3. Secondary I/O book Location: U1.18-P1-H1 4. Call service support.
406C 0B17	IPL detected fault in I/O book	<ol style="list-style-type: none"> 1. Check for system firmware updates. 2. Check the I/O cabling between the secondary I/O book and the I/O subsystems. 3. Secondary I/O book Location: U1.18-P1-H1 4. Call service support.

Error Code	Description	Action/ Possible Failing FRU
406C 0B20	IPL detected fault in I/O book	<ol style="list-style-type: none"> 1. Check for system firmware updates. 2. Check the I/O cabling between the secondary I/O book and the I/O subsystems. 3. Secondary I/O book Location: U1.18-P1-H3 4. Call service support.
406C 0B21	IPL detected fault in I/O book	<ol style="list-style-type: none"> 1. Check for system firmware updates. 2. Check the I/O cabling between the secondary I/O book and the I/O subsystems. 3. Secondary I/O book Location: U1.18-P1-H3 4. Call service support.
406C 0B22	IPL detected fault in I/O book	<ol style="list-style-type: none"> 1. Check for system firmware updates. 2. Check the I/O cabling between the secondary I/O book and the I/O subsystems. 3. Secondary I/O book Location: U1.18-P1-H3 4. Call service support.
406C 0B23	IPL detected fault in I/O book	<ol style="list-style-type: none"> 1. Check for system firmware updates. 2. Check the I/O cabling between the secondary I/O book and the I/O subsystems. 3. Secondary I/O book Location: U1.18-P1-H3 4. Call service support.
406C 0B24	IPL detected fault in I/O book	<ol style="list-style-type: none"> 1. Check for system firmware updates. 2. Check the I/O cabling between the secondary I/O book and the I/O subsystems. 3. Secondary I/O book Location: U1.18-P1-H3 4. Call service support.

Error Code	Description	Action/ Possible Failing FRU
406C 0B25	IPL detected fault in I/O book	<ol style="list-style-type: none"> 1. Check for system firmware updates. 2. Check the I/O cabling between the secondary I/O book and the I/O subsystems. 3. Secondary I/O book Location: U1.18-P1-H3 4. Call service support.
406C 0B26	IPL detected fault in I/O book	<ol style="list-style-type: none"> 1. Check for system firmware updates. 2. Check the I/O cabling between the secondary I/O book and the I/O subsystems. 3. Secondary I/O book Location: U1.18-P1-H3 4. Call service support.
406C 0B27	IPL detected fault in I/O book	<ol style="list-style-type: none"> 1. Check for system firmware updates. 2. Check the I/O cabling between the secondary I/O book and the I/O subsystems. 3. Secondary I/O book Location: U1.18-P1-H3 4. Call service support.
406C 0B30	IPL detected fault in I/O book	<p>I/O book (slot 3 RIO port 0) Location: U1.18-P1-H4/Q1</p> <ol style="list-style-type: none"> 1. Check for system firmware updates. 2. Check the I/O cabling between the third I/O book and the I/O subsystems. 3. Third I/O book Location: U1.18-P1-H4 4. Call service support.
406C 0B31	IPL detected fault in I/O book	<ol style="list-style-type: none"> 1. Check for system firmware updates. 2. Check the I/O cabling between the third I/O book and the I/O subsystems. 3. Third I/O book Location: U1.18-P1-H4 4. Call service support.

Error Code	Description	Action/ Possible Failing FRU
406C 0B32	IPL detected fault in I/O book	<ol style="list-style-type: none"> 1. Check for system firmware updates. 2. Check the I/O cabling between the third I/O book and the I/O subsystems. 3. Third I/O book Location: U1.18-P1-H4 4. Call service support.
406C 0B33	IPL detected fault in I/O book	<ol style="list-style-type: none"> 1. Check for system firmware updates. 2. Check the I/O cabling between the third I/O book and the I/O subsystems. 3. Third I/O book Location: U1.18-P1-H4 4. Call service support.
406C 0B34	IPL detected fault in I/O book	<ol style="list-style-type: none"> 1. Check for system firmware updates. 2. Check the I/O cabling between the third I/O book and the I/O subsystems. 3. Third I/O book Location: U1.18-P1-H4 4. Call service support.
406C 0B35	IPL detected fault in I/O book	<ol style="list-style-type: none"> 1. Check for system firmware updates. 2. Check the I/O cabling between the third I/O book and the I/O subsystems. 3. Third I/O book Location: U1.18-P1-H4 4. Call service support.
406C 0B36	IPL detected fault in I/O book	<ol style="list-style-type: none"> 1. Check for system firmware updates. 2. Check the I/O cabling between the third I/O book and the I/O subsystems. 3. Third I/O book Location: U1.18-P1-H4 4. Call service support.

Error Code	Description	Action/ Possible Failing FRU
406C 0B37	IPL detected fault in I/O book	<ol style="list-style-type: none"> 1. Check for system firmware updates. 2. Check the I/O cabling between the third I/O book and the I/O subsystems. 3. Third I/O book Location: U1.18-P1-H4 4. Call service support.
406C 0BF0	IPL detected fault in I/O hub chip 0 (port x)	<ol style="list-style-type: none"> 1. Check the cabling on the following RIO ports: <ol style="list-style-type: none"> a. U1.18-P1-H2/Q1 b. U1.18-P1-H2/Q2 2. Replace the primary I/O book, Location: U1.18-P1-H2
406C 0BF1	IPL detected fault in I/O hub chip 1 (port x)	<ol style="list-style-type: none"> 1. Check the cabling on the following RIO ports: <ol style="list-style-type: none"> a. U1.18-P1-H2/Q3 b. U1.18-P1-H2/Q4 2. Replace the primary I/O book, Location: U1.18-P1-H2
406C 0BF2	IPL detected fault in I/O hub chip 2 (port x)	<ol style="list-style-type: none"> 1. Check the cabling on the following RIO ports: <ol style="list-style-type: none"> a. U1.18-P1-H1/Q3 b. U1.18-P1-H1/Q4 2. Replace the RIO book, Location: U1.18-P1-H1
406C 0BF3	IPL detected fault in I/O hub chip 3 (port x)	<ol style="list-style-type: none"> 1. Check the cabling on the following RIO ports: <ol style="list-style-type: none"> a. U1.18-P1-H1/Q1 b. U1.18-P1-H1/Q2 2. Replace the RIO book, Location: U1.18-P1-H1
406C 0BF4	IPL detected fault in I/O hub chip 4 (port x)	<ol style="list-style-type: none"> 1. Check the cabling on the following RIO ports: <ol style="list-style-type: none"> a. U1.18-P1-H3/Q7 b. U1.18-P1-H3/Q8 2. Replace the RIO book, Location: U1.18-P1-H3

Error Code	Description	Action/ Possible Failing FRU
406C 0BF5	IPL detected fault in I/O hub chip 5 (port x)	<ol style="list-style-type: none"> 1. Check the cabling on the following RIO ports: <ol style="list-style-type: none"> a. U1.18-P1-H3/Q5 b. U1.18-P1-H3/Q6 2. Replace the RIO book, Location: U1.18-P1-H3
406C 0BF6	IPL detected fault in I/O hub chip 6 (port x)	<ol style="list-style-type: none"> 1. Check the cabling on the following RIO ports: <ol style="list-style-type: none"> a. U1.18-P1-H4/Q5 b. U1.18-P1-H4/Q6 2. Replace the RIO book, Location: U1.18-P1-H4
406C 0BF7	IPL detected fault in I/O hub chip 7 (port x)	<ol style="list-style-type: none"> 1. Check the cabling on the following RIO ports: <ol style="list-style-type: none"> a. U1.18-P1-H4/Q7 b. U1.18-P1-H4/Q8 2. Replace the RIO book, Location: U1.18-P1-H4
406C 0BF8	IPL detected fault in I/O hub chip 8 (port x)	<ol style="list-style-type: none"> 1. Check the cabling on the following RIO ports: <ol style="list-style-type: none"> a. U1.18-P1-H1/Q7 b. U1.18-P1-H1/Q8 2. Replace the RIO book, Location: U1.18-P1-H1
406C 0BF9	IPL detected fault in I/O hub chip 9 (port x)	<ol style="list-style-type: none"> 1. Check the cabling on the following RIO ports: <ol style="list-style-type: none"> a. U1.18-P1-H1/Q5 b. U1.18-P1-H1/Q6 2. Replace the RIO book, Location: U1.18-P1-H1
406C 0BFA	IPL detected fault in I/O hub chip 10 (port x)	<ol style="list-style-type: none"> 1. Check the cabling on the following RIO ports: <ol style="list-style-type: none"> a. U1.18-P1-H3/Q3 b. U1.18-P1-H3/Q4 2. Replace the RIO book, Location: U1.18-P1-H3

Error Code	Description	Action/ Possible Failing FRU
406C 0BFB	IPL detected fault in I/O hub chip 11 (port x)	<ol style="list-style-type: none"> 1. Check the cabling on the following RIO ports: <ol style="list-style-type: none"> a. U1.18-P1-H3/Q1 b. U1.18-P1-H3/Q2 2. Replace the RIO book, Location: U1.18-P1-H3
406C 0BFC	IPL detected fault in I/O hub chip 12 (port x)	<ol style="list-style-type: none"> 1. Check the cabling on the following RIO ports: <ol style="list-style-type: none"> a. U1.18-P1-H4/Q1 b. U1.18-P1-H4/Q2 2. Replace the RIO book, Location: U1.18-P1-H4.
406C 0BFD	IPL detected fault in I/O hub chip 13 (port x)	<ol style="list-style-type: none"> 1. Check the cabling on the following RIO ports: <ol style="list-style-type: none"> a. U1.18-P1-H4/Q3 b. U1.18-P1-H4/Q4 2. Replace the RIO book, Location: U1.18-P1-H4
406C 0C03	IPL detected fault in all MCMs	Go to "MAP 1543: MCM Module Problem Isolation" on page 332.
406C 0C09	IPL detected fault in all memory books	Go to "MAP 1546: Memory Book Problem Isolation" on page 338.
406C 0C0A	IPL detected fault in all I/O books	Go to "MAP 1547: I/O Book Problem Isolation" on page 341.
406C 0C10	IPL detected mismatch between MCM 0 and VPD card	Plugging error with FRU kit Location: U1.18-P1-C1 and U1.18-P1-H2.3
406C 0C11	IPL detected mismatch between MCM 2 and VPD card	Plugging error with FRU kit Location: U1.18-P1-C4 and U1.18-P1-H2.4
406C 0C12	IPL detected mismatch between MCM 1 and VPD card	Plugging error with FRU kit Location: U1.18-P1-C3 and U1.18-P1-H2.5
406C 0C13	IPL detected mismatch between MCM 3 and VPD card	Plugging error with FRU kit Location: U1.18-P1-C2 and U1.18-P1-H2.6
406C 0CA5	IPL detected invalid processor subsystem configuration	Verify that MCMs, memory books, and L3 modules are correctly configured.
406C 0CA6	IPL detected no usable main storage	Reboot the system in slow mode to isolate the failure.
406C 0CA9	IPL detected configuration error with processor memory	Reboot the system in slow mode to isolate the failure.

Error Code	Description	Action/ Possible Failing FRU
406C 0D00	IPL detected fault in L3 cache module 0	L3 cache module 0 and L3 VPD card Location: U1.18-P1-C6 and U1.18-P1-H2.1
406C 0D01	IPL detected fault in L3 cache module 1	L3 cache module 1 and L3 VPD card Location: U1.18-P1-C7 and U1.18-P1-H2.1
406C 0D02	IPL detected fault in L3 cache module 2	L3 cache module 2 and L3 VPD card Location: U1.18-P1-C11 and U1.18-P1-H2.1
406C 0D03	IPL detected fault in L3 cache module 3	L3 cache module 3 and L3 VPD card Location: U1.18-P1-C10 and U1.18-P1-H2.1
406C 0D04	IPL detected fault in L3 cache module 4	L3 cache module 4 and L3 VPD card Location: U1.18-P1-C8 and U1.18-P1-H2.1
406C 0D05	IPL detected fault in L3 cache module 5	L3 cache module 5 and L3 VPD card Location: U1.18-P1-C20 and U1.18-P1-H2.1
406C 0D06	IPL detected fault in L3 cache module 6	L3 cache module 6 and L3 VPD card Location: U1.18-P1-C16 and U1.18-P1-H2.1
406C 0D07	IPL detected fault in L3 cache module 7	L3 cache module 7 and L3 VPD card Location: U1.18-P1-C12 and U1.18-P1-H2.1
406C 0D08	IPL detected fault in L3 cache module 8	L3 cache module 8 and L3 VPD card Location: U1.18-P1-C19 and U1.18-P1-H2.1
406C 0D09	IPL detected fault in L3 cache module 9	L3 cache module 9 and L3 VPD card Location: U1.18-P1-C18 and U1.18-P1-H2.1
406C 0D0A	IPL detected fault in L3 cache module 10	L3 cache module 10 and L3 VPD card Location: U1.18-P1-C14 and U1.18-P1-H2.1
406C 0D0B	IPL detected fault in L3 cache module 11	L3 cache module 11 and L3 VPD card Location: U1.18-P1-C15 and U1.18-P1-H2.1
406C 0D0C	IPL detected fault in L3 cache module 12	L3 cache module 12 and L3 VPD card Location: U1.18-P1-C17 and U1.18-P1-H2.1
406C 0D0D	IPL detected fault in L3 cache module 13	L3 cache module 13 and L3 VPD card Location: U1.18-P1-C5 and U1.18-P1-H2.1
406C 0D0E	IPL detected fault in L3 cache module 14	L3 cache module 14 and L3 VPD card Location: U1.18-P1-C9 and U1.18-P1-H2.1

Error Code	Description	Action/ Possible Failing FRU
406C 0D0F	IPL detected fault in L3 cache module 15	L3 cache module 15 and L3 VPD card Location: U1.18-P1-C13 and U1.18-P1-H2.1
406C 0EA0	IPL detected fault in MOPS service processor code	1. Check for system firmware updates. 2. Call service support.
406C 0EA1	IPL detected fault in processor subsystem code on main processor	1. Check for operating system updates. 2. Call service support.
406C 0EA2	IPL detected fault in PRD code on service processor	1. Check for system firmware updates. 2. Call service support.
406C 0EA4	IPL detected fault in service processor code	1. Check for system firmware updates. 2. Call service support.
406C 0EAF	IPL detected unknown service processor code and system type	1. Check for system firmware updates. 2. Call service support.
406C 0EB0	IPL tests detected JTAG problem	Go to "MAP 1540: Problem Isolation Procedures" on page 303.
406C 0EB1	Attention line 0 stuck fault	Go to "MAP 1540: Problem Isolation Procedures" on page 303.
406C 0EB2	Attention line 1 stuck fault	Go to "MAP 1540: Problem Isolation Procedures" on page 303.
406C 0EB3	Attention line 2 stuck fault	Go to "MAP 1540: Problem Isolation Procedures" on page 303.
406C 0EB4	Attention line 3 stuck fault	Go to "MAP 1540: Problem Isolation Procedures" on page 303.
406C 0EB5	Attention line 4 stuck fault	Go to "MAP 1540: Problem Isolation Procedures" on page 303.
406C 0EB6	Attention line 5 stuck fault	Go to "MAP 1540: Problem Isolation Procedures" on page 303.
406C 0EB7	Attention line 6 stuck fault	Go to "MAP 1540: Problem Isolation Procedures" on page 303.
406C 0EB8	Attention line 7 stuck fault	Go to "MAP 1540: Problem Isolation Procedures" on page 303.
406C 0EB9	Attention line 8 stuck fault	Go to "MAP 1540: Problem Isolation Procedures" on page 303.
406C 0EBA	Attention line 9 stuck fault	Go to "MAP 1540: Problem Isolation Procedures" on page 303.
406C 0EBB	Attention line 10 stuck fault	Go to "MAP 1540: Problem Isolation Procedures" on page 303.

Error Code	Description	Action/ Possible Failing FRU
406C 0EBC	Attention line 11 stuck fault	Go to "MAP 1540: Problem Isolation Procedures" on page 303.
406C 0EE1	IPL detected fault in service processor code (invalid MRU to mapping)	<ol style="list-style-type: none"> 1. Check for system firmware updates. 2. Call service support.
406C 0EE2	IPL detected fault in service processor firmware fault	<ol style="list-style-type: none"> 1. Check for system firmware updates. 2. Call service support.
406C 0EE5	IPL detected firmware error; no callout available	<ol style="list-style-type: none"> 1. Check for system firmware updates. 2. Call service support.
406D 0001	Attention handler detected clock card assembly failure	Go to "MAP 1540: Problem Isolation Procedures" on page 303.
406D 0002	Attention handler detected backplane assembly failure	Go to "MAP 1540: Problem Isolation Procedures" on page 303.
406D 0003	Attention handler detected fault in MCM module 0	MCM module 0 and VPD card Location: U1.18-P1-C1 and U1.18-P1-H2.3
406D 0004	Attention handler detected fault in MCM module 2	MCM module 2 and VPD card Location: U1.18-P1-C4 and U1.18-P1-H2.4
406D 0005	Attention handler detected fault in MCM module 1	MCM module 1 and VPD card Location: U1.18-P1-C3 and U1.18-P1-H2.5
406D 0006	Attention handler detected fault in MCM module 3	MCM module 3 and VPD card Location: U1.18-P1-C2 and U1.18-P1-H2.6
406D 0007	Attention handler detected fault in L3 VPD card	<ol style="list-style-type: none"> 1. L3 VPD card Location: U1.18-P1-H2.1 (Order the L3 cache module FRU to obtain a new L3 VPD card. Return the L3 cache module that was included in the FRU kit, and the failing L3 VPD card as "new defective".) 2. Primary I/O book Location: U1.18-P1-H2
406D 000A	Attention handler detected fault in primary I/O book 1 (slot 0)	Go to "MAP 1540: Problem Isolation Procedures" on page 303.
406D 000B	Attention handler detected fault in secondary I/O book (slot 1)	Go to "MAP 1540: Problem Isolation Procedures" on page 303.
406D 000C	Attention handler detected fault in I/O book 3 (slot 2)	Go to "MAP 1540: Problem Isolation Procedures" on page 303.

Error Code	Description	Action/ Possible Failing FRU
406D 000D	Attention handler detected fault in I/O book 4 (slot 3)	Go to "MAP 1540: Problem Isolation Procedures" on page 303.
406D 0010	Attention handler detected fault in Memory book (slot 0)	Memory book (slot 0) Location: U1.18-P1-M2
406D 0011	Attention handler detected fault in Memory book (slot 1)	Memory book (slot 1) Location: U1.18-P1-M3
406D 0012	Attention handler detected fault in Memory book (slot 2)	Memory book (slot 2) Location: U1.18-P1-M7
406D 0013	Attention handler detected fault in Memory book (slot 3)	Memory book (slot 3) Location: U1.18-P1-M6
406D 0014	Attention handler detected fault in Memory book (slot 4)	Memory book (slot 4) Location: U1.18-P1-M4
406D 0015	Attention handler detected fault in Memory book (slot 5)	Memory book (slot 5) Location: U1.18-P1-M8
406D 0016	Attention handler detected fault in Memory book (slot 6)	Memory book (slot 6) Location: U1.18-P1-M5
406D 0017	Attention handler detected fault in Memory book (slot 7)	Memory book (slot 7) Location: U1.18-P1-M1
406D 00B0	Attention handler detected possible problem with bus controller or CSP code	<ol style="list-style-type: none"> 1. Check for system firmware updates. 2. Primary I/O book, Location: U1.18-P1-H2 3. Call service support.
406D 00B1	Attention handler detected possible problem with bus controller	<ol style="list-style-type: none"> 1. Check for system firmware updates. 2. Primary I/O book, Location: U1.18-P1-H2 3. Call service support.
406D 00B3	Attention handler detected MCM 0/VPD problem	<ol style="list-style-type: none"> 1. Check for system firmware updates. 2. MCM module 0 and VPD card Location: U1.18-P1-C1 and U1.18-P1-H2.3
406D 00B4	Attention handler detected MCM 2/VPD problem	<ol style="list-style-type: none"> 1. Check for system firmware updates. 2. MCM module 2 and VPD card Location: U1.18-P1-C4 and U1.18-P1-H2.4
406D 00B5	Attention handler detected MCM 1/VPD problem	<ol style="list-style-type: none"> 1. Check for system firmware updates. 2. MCM module 1 and VPD card Location: U1.18-P1-C3 and U1.18-P1-H2.5

Error Code	Description	Action/ Possible Failing FRU
406D 00B6	Attention handler detected MCM 3/VPD problem	<ol style="list-style-type: none"> 1. Check for system firmware updates. 2. MCM module 3 and VPD card Location: U1.18-P1-C2 and U1.18-P1-H2.6
406D 00B7	Attention handler detected hardware problem in the processor subsystem	Go to "MAP 1540: Problem Isolation Procedures" on page 303.
406D 0A03	Reboot message (run-time array gard failure) for processor 0	Reboot the system in slow mode. Run diagnostics, then go to MAP 0235 in the <i>RS/6000 and @server pSeries Diagnostic Information for Multiple Bus Systems</i> , order number SA38-0509.
406D 0A04	Reboot message (run-time array gard failure) for processor 2	Reboot the system in slow mode. Run diagnostics, then go to MAP 0235 in the <i>RS/6000 and @server pSeries Diagnostic Information for Multiple Bus Systems</i> , order number SA38-0509.
406D 0A05	Reboot message (run-time array gard failure) for processor 1	Reboot the system in slow mode. Run diagnostics, then go to MAP 0235 in the <i>RS/6000 and @server pSeries Diagnostic Information for Multiple Bus Systems</i> , order number SA38-0509.
406D 0A06	Reboot message (run-time array gard failure) for processor 3	Reboot the system in slow mode. Run diagnostics, then go to MAP 0235 in the <i>RS/6000 and @server pSeries Diagnostic Information for Multiple Bus Systems</i> , order number SA38-0509.
406D 0B00	Attention handler detected fault in I/O book (slot 0 RIO port 0)	<ol style="list-style-type: none"> 1. Check for system firmware updates. 2. Check the I/O cabling between the primary I/O book and the I/O subsystems. 3. Primary I/O book Location: U1.18-P1-H2 4. Call service support.
406D 0B01	Attention handler detected fault in I/O book (slot 0 RIO port 1)	<ol style="list-style-type: none"> 1. Check for system firmware updates. 2. Check the I/O cabling between the primary I/O book and the I/O subsystems. 3. Primary I/O book Location: U1.18-P1-H2 4. Call service support.

Error Code	Description	Action/ Possible Failing FRU
406D 0B02	Attention handler detected fault in I/O book (slot 0 RIO port 2)	<ol style="list-style-type: none"> 1. Check for system firmware updates. 2. Check the I/O cabling between the primary I/O book and the I/O subsystems. 3. Primary I/O book Location: U1.18-P1-H2 4. Call service support.
406D 0B03	Attention handler detected fault in I/O book (slot 0 RIO port 3)	<ol style="list-style-type: none"> 1. Check for system firmware updates. 2. Check the I/O cabling between the primary I/O book and the I/O subsystems. 3. Primary I/O book Location: U1.18-P1-H2 4. Call service support.
406D 0B10	Attention handler detected fault in I/O book	<ol style="list-style-type: none"> 1. Check for system firmware updates. 2. Check the I/O cabling between the secondary I/O book and the I/O subsystems. 3. Secondary I/O book Location: U1.18-P1-H1 4. Call service support.
406D 0B11	Attention handler detected fault in I/O book	<ol style="list-style-type: none"> 1. Check for system firmware updates. 2. Check the I/O cabling between the secondary I/O book and the I/O subsystems. 3. Secondary I/O book Location: U1.18-P1-H1 4. Call service support.
406D 0B12	Attention handler detected fault in I/O book	<ol style="list-style-type: none"> 1. Check for system firmware updates. 2. Check the I/O cabling between the secondary I/O book and the I/O subsystems. 3. Secondary I/O book Location: U1.18-P1-H1 4. Call service support.

Error Code	Description	Action/ Possible Failing FRU
406D 0B13	Attention handler detected fault in I/O book	<ol style="list-style-type: none"> 1. Check for system firmware updates. 2. Check the I/O cabling between the secondary I/O book and the I/O subsystems. 3. Secondary I/O book Location: U1.18-P1-H1 4. Call service support.
406D 0B14	Attention handler detected fault in I/O book	<ol style="list-style-type: none"> 1. Check for system firmware updates. 2. Check the I/O cabling between the secondary I/O book and the I/O subsystems. 3. Secondary I/O book Location: U1.18-P1-H1 4. Call service support.
406D 0B15	Attention handler detected fault in I/O book	<ol style="list-style-type: none"> 1. Check for system firmware updates. 2. Check the I/O cabling between the secondary I/O book and the I/O subsystems. 3. Secondary I/O book Location: U1.18-P1-H1 4. Call service support.
406D 0B16	Attention handler detected fault in I/O book	<ol style="list-style-type: none"> 1. Check for system firmware updates. 2. Check the I/O cabling between the secondary I/O book and the I/O subsystems. 3. Secondary I/O book Location: U1.18-P1-H1 4. Call service support.
406D 0B17	Attention handler detected fault in I/O book	<ol style="list-style-type: none"> 1. Check for system firmware updates. 2. Check the I/O cabling between the secondary I/O book and the I/O subsystems. 3. Secondary I/O book Location: U1.18-P1-H1 4. Call service support.

Error Code	Description	Action/ Possible Failing FRU
406D 0B20	Attention handler detected fault in I/O book	<ol style="list-style-type: none"> 1. Check for system firmware updates. 2. Check the I/O cabling between the secondary I/O book and the I/O subsystems. 3. Secondary I/O book Location: U1.18-P1-H3 4. Call service support.
406D 0B21	Attention handler detected fault in I/O book	<ol style="list-style-type: none"> 1. Check for system firmware updates. 2. Check the I/O cabling between the secondary I/O book and the I/O subsystems. 3. Secondary I/O book Location: U1.18-P1-H3 4. Call service support.
406D 0B22	Attention handler detected fault in I/O book	<ol style="list-style-type: none"> 1. Check for system firmware updates. 2. Check the I/O cabling between the secondary I/O book and the I/O subsystems. 3. Secondary I/O book Location: U1.18-P1-H3 4. Call service support.
406D 0B23	Attention handler detected fault in I/O book	<ol style="list-style-type: none"> 1. Check for system firmware updates. 2. Check the I/O cabling between the secondary I/O book and the I/O subsystems. 3. Secondary I/O book Location: U1.18-P1-H3 4. Call service support.
406D 0B24	Attention handler detected fault in I/O book	<ol style="list-style-type: none"> 1. Check for system firmware updates. 2. Check the I/O cabling between the secondary I/O book and the I/O subsystems. 3. Secondary I/O book Location: U1.18-P1-H3 4. Call service support.

Error Code	Description	Action/ Possible Failing FRU
406D 0B25	Attention handler detected fault in I/O book	<ol style="list-style-type: none"> 1. Check for system firmware updates. 2. Check the I/O cabling between the secondary I/O book and the I/O subsystems. 3. Secondary I/O book Location: U1.18-P1-H3 4. Call service support.
406D 0B26	Attention handler detected fault in I/O book	<ol style="list-style-type: none"> 1. Check for system firmware updates. 2. Check the I/O cabling between the secondary I/O book and the I/O subsystems. 3. Secondary I/O book Location: U1.18-P1-H3 4. Call service support.
406D 0B27	Attention handler detected fault in I/O book	<ol style="list-style-type: none"> 1. Check for system firmware updates. 2. Check the I/O cabling between the secondary I/O book and the I/O subsystems. 3. Secondary I/O book Location: U1.18-P1-H3 4. Call service support.
406D 0B30	Attention handler detected fault in I/O book	<ol style="list-style-type: none"> 1. Check for system firmware updates. 2. Check the I/O cabling between the third I/O book and the I/O subsystems. 3. Third I/O book Location: U1.18-P1-H4 4. Call service support.
406D 0B31	Attention handler detected fault in I/O book	<ol style="list-style-type: none"> 1. Check for system firmware updates. 2. Check the I/O cabling between the third I/O book and the I/O subsystems. 3. Third I/O book Location: U1.18-P1-H4 4. Call service support.

Error Code	Description	Action/ Possible Failing FRU
406D 0B32	Attention handler detected fault in I/O book	<ol style="list-style-type: none"> 1. Check for system firmware updates. 2. Check the I/O cabling between the third I/O book and the I/O subsystems. 3. Third I/O book Location: U1.18-P1-H4 4. Call service support.
406D 0B33	Attention handler detected fault in I/O book	<ol style="list-style-type: none"> 1. Check for system firmware updates. 2. Check the I/O cabling between the third I/O book and the I/O subsystems. 3. Third I/O book Location: U1.18-P1-H4 4. Call service support.
406D 0B34	Attention handler detected fault in I/O book	<ol style="list-style-type: none"> 1. Check for system firmware updates. 2. Check the I/O cabling between the third I/O book and the I/O subsystems. 3. Third I/O book Location: U1.18-P1-H4 4. Call service support.
406D 0B35	Attention handler detected fault in I/O book	<ol style="list-style-type: none"> 1. Check for system firmware updates. 2. Check the I/O cabling between the third I/O book and the I/O subsystems. 3. Third I/O book Location: U1.18-P1-H4 4. Call service support.
406D 0B36	Attention handler detected fault in I/O book	<ol style="list-style-type: none"> 1. Check for system firmware updates. 2. Check the I/O cabling between the third I/O book and the I/O subsystems. 3. Third I/O book Location: U1.18-P1-H4 4. Call service support.

Error Code	Description	Action/ Possible Failing FRU
406D 0B37	Attention handler detected fault in I/O book	<ol style="list-style-type: none"> 1. Check for system firmware updates. 2. Check the I/O cabling between the third I/O book and the I/O subsystems. 3. Third I/O book Location: U1.18-P1-H4 4. Call service support.
406D 0BF0	Attention handler detected fault in I/O hub chip 0 (port x)	<ol style="list-style-type: none"> 1. Check the cabling on the following RIO ports: <ol style="list-style-type: none"> a. U1.18-P1-H2/Q1 b. U1.18-P1-H2/Q2 2. Replace the primary I/O book, Location: U1.18-P1-H2
406D 0BF1	Attention handler detected fault in I/O hub chip 1 (port x)	<ol style="list-style-type: none"> 1. Check the cabling on the following RIO ports: <ol style="list-style-type: none"> a. U1.18-P1-H2/Q3 b. U1.18-P1-H2/Q4 2. Replace the primary I/O book, Location: U1.18-P1-H2
406D 0BF2	Attention handler detected fault in I/O hub chip 2 (port x)	<ol style="list-style-type: none"> 1. Check the cabling on the following RIO ports: <ol style="list-style-type: none"> a. U1.18-P1-H1/Q3 b. U1.18-P1-H1/Q4 2. Replace the RIO book, Location: U1.18-P1-H1
406D 0BF3	Attention handler detected fault in I/O hub chip 3 (port x)	<ol style="list-style-type: none"> 1. Check the cabling on the following RIO ports: <ol style="list-style-type: none"> a. U1.18-P1-H1/Q1 b. U1.18-P1-H1/Q2 2. Replace the RIO book, Location: U1.18-P1-H1
406D 0BF4	Attention handler detected fault in I/O hub chip 4 (port x)	<ol style="list-style-type: none"> 1. Check the cabling on the following RIO ports: <ol style="list-style-type: none"> a. U1.18-P1-H3/Q7 b. U1.18-P1-H3/Q8 2. Replace the RIO book, Location: U1.18-P1-H3

Error Code	Description	Action/ Possible Failing FRU
406D 0BF5	Attention handler detected fault in I/O hub chip 5 (port x)	<ol style="list-style-type: none"> 1. Check the cabling on the following RIO ports: <ol style="list-style-type: none"> a. U1.18-P1-H3/Q5 b. U1.18-P1-H3/Q6 2. Replace the RIO book, Location: U1.18-P1-H3
406D 0BF6	Attention handler detected fault in I/O hub chip 6 (port x)	<ol style="list-style-type: none"> 1. Check the cabling on the following RIO ports: <ol style="list-style-type: none"> a. U1.18-P1-H4/Q5 b. U1.18-P1-H4/Q6 2. Replace the RIO book, Location: U1.18-P1-H4
406D 0BF7	Attention handler detected fault in I/O hub chip 7 (port x)	<ol style="list-style-type: none"> 1. Check the cabling on the following RIO ports: <ol style="list-style-type: none"> a. U1.18-P1-H4/Q7 b. U1.18-P1-H4/Q8 2. Replace the RIO book, Location: U1.18-P1-H4
406D 0BF8	Attention handler detected fault in I/O hub chip 8 (port x)	<ol style="list-style-type: none"> 1. Check the cabling on the following RIO ports: <ol style="list-style-type: none"> a. U1.18-P1-H1/Q7 b. U1.18-P1-H1/Q8 2. Replace the RIO book, Location: U1.18-P1-H1
406D 0BF9	Attention handler detected fault in I/O hub chip 9 (port x)	<ol style="list-style-type: none"> 1. Check the cabling on the following RIO ports: <ol style="list-style-type: none"> a. U1.18-P1-H1/Q5 b. U1.18-P1-H1/Q6 2. Replace the RIO book, Location: U1.18-P1-H1
406D 0BFA	Attention handler detected fault in I/O hub chip 10 (port x)	<ol style="list-style-type: none"> 1. Check the cabling on the following RIO ports: <ol style="list-style-type: none"> a. U1.18-P1-H3/Q3 b. U1.18-P1-H3/Q4 2. Replace the RIO book, Location: U1.18-P1-H3

Error Code	Description	Action/ Possible Failing FRU
406D 0BFB	Attention handler detected fault in I/O hub chip 11 (port x)	<ol style="list-style-type: none"> 1. Check the cabling on the following RIO ports: <ol style="list-style-type: none"> a. U1.18-P1-H3/Q1 b. U1.18-P1-H3/Q2 2. Replace the RIO book, Location: U1.18-P1-H3
406D 0BFC	Attention handler detected fault in I/O hub chip 12 (port x)	<ol style="list-style-type: none"> 1. Check the cabling on the following RIO ports: <ol style="list-style-type: none"> a. U1.18-P1-H4/Q1 b. U1.18-P1-H4/Q2 2. Replace the RIO book, Location: U1.18-P1-H4.
406D 0BFD	Attention handler detected fault in I/O hub chip 13 (port x)	<ol style="list-style-type: none"> 1. Check the cabling on the following RIO ports: <ol style="list-style-type: none"> a. U1.18-P1-H4/Q3 b. U1.18-P1-H4/Q4 2. Replace the RIO book, Location: U1.18-P1-H4
406D 0C03	Attention handler detected fault in all MCMs	Go to "MAP 1543: MCM Module Problem Isolation" on page 332.
406D 0C09	Attention handler detected fault in all memory books	Go to "MAP 1546: Memory Book Problem Isolation" on page 338.
406D 0C0A	Attention handler detected fault in all I/O books	Go to "MAP 1547: I/O Book Problem Isolation" on page 341.
406D 0C10	Attention handler detected mismatch between MCM 0 and VPD card	Plugging error with FRU kit Location: U1.18-P1-C1 and U1.18-P1-H2.3
406D 0C11	Attention handler detected mismatch between MCM 2 and VPD card	Plugging error with FRU kit Location: U1.18-P1-C4 and U1.18-P1-H2.4
406D 0C12	Attention handler detected mismatch between MCM 1 and VPD card	Plugging error with FRU kit Location: U1.18-P1-C3 and U1.18-P1-H2.5
406D 0C13	Attention handler detected mismatch between MCM 3 and VPD card	Plugging error with FRU kit Location: U1.18-P1-C2 and U1.18-P1-H2.6
406D 0CA5	Attention handler detected invalid processor subsystem configuration	Verify that MCMs, memory books, and L3 modules are correctly configured.
406D 0CA6	Attention handler detected no usable main storage	Reboot the system in slow mode to isolate the failure.
406D 0CA9	Attention handler detected configuration error with processor memory	Reboot the system in slow mode to isolate the failure.

Error Code	Description	Action/ Possible Failing FRU
406D 0D00	Attention handler detected fault in L3 cache module 0	L3 cache module 0 and L3 VPD card Location: U1.18-P1-C6 and U1.18-P1-H2.1
406D 0D01	Attention handler detected fault in L3 cache module 1	L3 cache module 1 and L3 VPD card Location: U1.18-P1-C7 and U1.18-P1-H2.1
406D 0D02	Attention handler detected fault in L3 cache module 2	L3 cache module 2 and L3 VPD card Location: U1.18-P1-C11 and U1.18-P1-H2.1
406D 0D03	Attention handler detected fault in L3 cache module 3	L3 cache module 3 and L3 VPD card Location: U1.18-P1-C10 and U1.18-P1-H2.1
406D 0D04	Attention handler detected fault in L3 cache module 4	L3 cache module 4 and L3 VPD card Location: U1.18-P1-C8 and U1.18-P1-H2.1
406D 0D05	Attention handler detected fault in L3 cache module 5	L3 cache module 5 and L3 VPD card Location: U1.18-P1-C20 and U1.18-P1-H2.1
406D 0D06	Attention handler detected fault in L3 cache module 6	L3 cache module 6 and L3 VPD card Location: U1.18-P1-C16 and U1.18-P1-H2.1
406D 0D07	Attention handler detected fault in L3 cache module 7	L3 cache module 7 and L3 VPD card Location: U1.18-P1-C12 and U1.18-P1-H2.1
406D 0D08	Attention handler detected fault in L3 cache module 8	L3 cache module 8 and L3 VPD card Location: U1.18-P1-C19 and U1.18-P1-H2.1
406D 0D09	Attention handler detected fault in L3 cache module 9	L3 cache module 9 and L3 VPD card Location: U1.18-P1-C18 and U1.18-P1-H2.1
406D 0D0A	Attention handler detected fault in L3 cache module 10	L3 cache module 10 and L3 VPD card Location: U1.18-P1-C14 and U1.18-P1-H2.1
406D 0D0B	Attention handler detected fault in L3 cache module 11	L3 cache module 11 and L3 VPD card Location: U1.18-P1-C15 and U1.18-P1-H2.1
406D 0D0C	Attention handler detected fault in L3 cache module 12	L3 cache module 12 and L3 VPD card Location: U1.18-P1-C17 and U1.18-P1-H2.1
406D 0D0D	Attention handler detected fault in L3 cache module 13	L3 cache module 13 and L3 VPD card Location: U1.18-P1-C5 and U1.18-P1-H2.1
406D 0D0E	Attention handler detected fault in L3 cache module 14	L3 cache module 14 and L3 VPD card Location: U1.18-P1-C9 and U1.18-P1-H2.1

Error Code	Description	Action/ Possible Failing FRU
406D 0D0F	Attention handler detected fault in L3 cache module 15	L3 cache module 15 and L3 VPD card Location: U1.18-P1-C13 and U1.18-P1-H2.1
406D 0EA0	Attention handler detected fault in MOPS service processor code	<ol style="list-style-type: none"> 1. Check for system firmware updates. 2. Call service support.
406D 0EA1	Attention handler detected fault in processor subsystem code on main processor	<ol style="list-style-type: none"> 1. Check for operating system updates. 2. Call service support.
406D 0EA2	Attention handler detected fault in PRD code on service processor	<ol style="list-style-type: none"> 1. Check for system firmware updates. 2. Call service support.
406D 0EA4	Attention handler detected fault in service processor code	<ol style="list-style-type: none"> 1. Check for system firmware updates. 2. Call service support.
406D 0EAF	Attention handler detected unknown service processor code and system type	<ol style="list-style-type: none"> 1. Check for system firmware updates. 2. Call service support.
406D 0EB0	Attention handler detected JTAG problem	Go to "MAP 1540: Problem Isolation Procedures" on page 303.
406D 0EB1	Attention line 0 stuck fault	Go to "MAP 1540: Problem Isolation Procedures" on page 303.
406D 0EB2	Attention line 1 stuck fault	Go to "MAP 1540: Problem Isolation Procedures" on page 303.
406D 0EB3	Attention line 2 stuck fault	Go to "MAP 1540: Problem Isolation Procedures" on page 303.
406D 0EB4	Attention line 3 stuck fault	Go to "MAP 1540: Problem Isolation Procedures" on page 303.
406D 0EB5	Attention line 4 stuck fault	Go to "MAP 1540: Problem Isolation Procedures" on page 303.
406D 0EB6	Attention line 5 stuck fault	Go to "MAP 1540: Problem Isolation Procedures" on page 303.
406D 0EB7	Attention line 6 stuck fault	Go to "MAP 1540: Problem Isolation Procedures" on page 303.
406D 0EB8	Attention line 7 stuck fault	Go to "MAP 1540: Problem Isolation Procedures" on page 303.
406D 0EB9	Attention line 8 stuck fault	Go to "MAP 1540: Problem Isolation Procedures" on page 303.
406D 0EBA	Attention line 9 stuck fault	Go to "MAP 1540: Problem Isolation Procedures" on page 303.
406D 0EBB	Attention line 10 stuck fault	Go to "MAP 1540: Problem Isolation Procedures" on page 303.

Error Code	Description	Action/ Possible Failing FRU
406D 0EBC	Attention line 11 stuck fault	Go to "MAP 1540: Problem Isolation Procedures" on page 303.
406D 0EE1	Attention handler detected fault in service processor code (invalid MRU to mapping)	<ol style="list-style-type: none"> 1. Check for system firmware updates. 2. Call service support.
406D 0EE2	Attention handler detected fault in service processor firmware fault	<ol style="list-style-type: none"> 1. Check for system firmware updates. 2. Call service support.
406D 0EE5	Attention handler detected firmware error; no callout available	<ol style="list-style-type: none"> 1. Check for system firmware updates. 2. Call service support.
406E 0001	Scan control routineIPL detected detected clock card assembly failure	Go to "MAP 1540: Problem Isolation Procedures" on page 303.
406E 0002	Scan control routines detected backplane assembly failure	Go to "MAP 1540: Problem Isolation Procedures" on page 303.
406E 0003	Scan control routines detected fault in MCM module 0	MCM module 0 and VPD card Location: U1.18-P1-C1 and U1.18-P1-H2.3
406E 0004	Scan control routines detected fault in MCM module 2	MCM module 2 and VPD card Location: U1.18-P1-C4 and U1.18-P1-H2.4
406E 0005	Scan control routines detected fault in MCM module 1	MCM module 1 and VPD card Location: U1.18-P1-C3 and U1.18-P1-H2.5
406E 0006	Scan control routines detected fault in MCM module 3	MCM module 3 and VPD card Location: U1.18-P1-C2 and U1.18-P1-H2.6
406E 0007	Scan control routines detected fault in L3 VPD card	<ol style="list-style-type: none"> 1. L3 VPD card Location: U1.18-P1-H2.1 (Order the L3 cache module FRU to obtain a new L3 VPD card. Return the L3 cache module that was included in the FRU kit, and the failing L3 VPD card as "new defective".) 2. Primary I/O book Location: U1.18-P1-H2
406E 000A	Scan control routines detected fault in primary I/O book 1 (slot 0)	Go to "MAP 1540: Problem Isolation Procedures" on page 303.
406E 000B	Scan control routines detected fault in secondary I/O book (slot 1)	Go to "MAP 1540: Problem Isolation Procedures" on page 303.
406E 000C	Scan control routines detected fault in I/O book 3 (slot 2)	Go to "MAP 1540: Problem Isolation Procedures" on page 303.

Error Code	Description	Action/ Possible Failing FRU
406E 000D	Scan control routines detected fault in I/O book 4 (slot 3)	Go to "MAP 1540: Problem Isolation Procedures" on page 303.
406E 0010	Scan control routines detected fault in Memory book (slot 0)	Memory book (slot 0) Location: U1.18-P1-M2
406E 0011	Scan control routines detected fault in Memory book (slot 1)	Memory book (slot 1) Location: U1.18-P1-M3
406E 0012	Scan control routines detected fault in Memory book (slot 2)	Memory book (slot 2) Location: U1.18-P1-M7
406E 0013	Scan control routines detected fault in Memory book (slot 3)	Memory book (slot 3) Location: U1.18-P1-M6
406E 0014	Scan control routines detected fault in Memory book (slot 4)	Memory book (slot 4) Location: U1.18-P1-M4
406E 0015	Scan control routines detected fault in Memory book (slot 5)	Memory book (slot 5) Location: U1.18-P1-M8
406E 0016	Scan control routines detected fault in Memory book (slot 6)	Memory book (slot 6) Location: U1.18-P1-M5
406E 0017	Scan control routines detected fault in Memory book (slot 7)	Memory book (slot 7) Location: U1.18-P1-M1
406E 00B0	Scan control routines detected possible problem with bus controller or CSP code	<ol style="list-style-type: none"> 1. Check for system firmware updates. 2. Primary I/O book, Location: U1.18-P1-H2 3. Call service support.
406E 00B1	Scan control routines detected possible problem with bus controller	<ol style="list-style-type: none"> 1. Check for system firmware updates. 2. Primary I/O book, Location: U1.18-P1-H2 3. Call service support.
406E 00B3	Scan control routines detected MCM 0/VPD problem	<ol style="list-style-type: none"> 1. Check for system firmware updates. 2. MCM module 0 and VPD card Location: U1.18-P1-C1 and U1.18-P1-H2.3
406E 00B4	Scan control routines detected MCM 2/VPD problem	<ol style="list-style-type: none"> 1. Check for system firmware updates. 2. MCM module 2 and VPD card Location: U1.18-P1-C4 and U1.18-P1-H2.4
406E 00B5	Scan control routines detected MCM 1/VPD problem	<ol style="list-style-type: none"> 1. Check for system firmware updates. 2. MCM module 1 and VPD card Location: U1.18-P1-C3 and U1.18-P1-H2.5

Error Code	Description	Action/ Possible Failing FRU
406E 00B6	Scan control routines detected MCM 3/VPD problem	<ol style="list-style-type: none"> 1. Check for system firmware updates. 2. MCM module 3 and VPD card Location: U1.18-P1-C2 and U1.18-P1-H2.6
406E 00B7	Scan control routines detected hardware problem in the processor subsystem	Go to "MAP 1540: Problem Isolation Procedures" on page 303.
406E 0A03	Reboot message (run-time array gard failure) for processor 0	Reboot the system in slow mode. Run diagnostics, then go to MAP 0235 in the <i>RS/6000 and @server pSeries Diagnostic Information for Multiple Bus Systems</i> , order number SA38-0509.
406E 0A04	Reboot message (run-time array gard failure) for processor 2	Reboot the system in slow mode. Run diagnostics, then go to MAP 0235 in the <i>RS/6000 and @server pSeries Diagnostic Information for Multiple Bus Systems</i> , order number SA38-0509.
406E 0A05	Reboot message (run-time array gard failure) for processor 1	Reboot the system in slow mode. Run diagnostics, then go to MAP 0235 in the <i>RS/6000 and @server pSeries Diagnostic Information for Multiple Bus Systems</i> , order number SA38-0509.
406E 0A06	Reboot message (run-time array gard failure) for processor 3	Reboot the system in slow mode. Run diagnostics, then go to MAP 0235 in the <i>RS/6000 and @server pSeries Diagnostic Information for Multiple Bus Systems</i> , order number SA38-0509.
406E 0B00	Scan control routines detected fault in I/O book (slot 0 RIO port 0)	<ol style="list-style-type: none"> 1. Check for system firmware updates. 2. Check the I/O cabling between the primary I/O book and the I/O subsystems. 3. Primary I/O book Location: U1.18-P1-H2 4. Call service support.
406E 0B01	Scan control routines detected fault in I/O book (slot 0 RIO port 1)	<ol style="list-style-type: none"> 1. Check for system firmware updates. 2. Check the I/O cabling between the primary I/O book and the I/O subsystems. 3. Primary I/O book Location: U1.18-P1-H2 4. Call service support.

Error Code	Description	Action/ Possible Failing FRU
406E 0B02	Scan control routines detected fault in I/O book (slot 0 RIO port 2)	<ol style="list-style-type: none"> 1. Check for system firmware updates. 2. Check the I/O cabling between the primary I/O book and the I/O subsystems. 3. Primary I/O book Location: U1.18-P1-H2 4. Call service support.
406E 0B03	Scan control routines detected fault in I/O book (slot 0 RIO port 3)	<ol style="list-style-type: none"> 1. Check for system firmware updates. 2. Check the I/O cabling between the primary I/O book and the I/O subsystems. 3. Primary I/O book Location: U1.18-P1-H2 4. Call service support.
406E 0B10	Scan control routines detected fault in I/O book	<ol style="list-style-type: none"> 1. Check for system firmware updates. 2. Check the I/O cabling between the secondary I/O book and the I/O subsystems. 3. Secondary I/O book Location: U1.18-P1-H1 4. Call service support.
406E 0B11	Scan control routines detected fault in I/O book	<ol style="list-style-type: none"> 1. Check for system firmware updates. 2. Check the I/O cabling between the secondary I/O book and the I/O subsystems. 3. Secondary I/O book Location: U1.18-P1-H1 4. Call service support.
406E 0B12	Scan control routines detected fault in I/O book	<ol style="list-style-type: none"> 1. Check for system firmware updates. 2. Check the I/O cabling between the secondary I/O book and the I/O subsystems. 3. Secondary I/O book Location: U1.18-P1-H1 4. Call service support.

Error Code	Description	Action/ Possible Failing FRU
406E 0B13	Scan control routines detected fault in I/O book	<ol style="list-style-type: none"> 1. Check for system firmware updates. 2. Check the I/O cabling between the secondary I/O book and the I/O subsystems. 3. Secondary I/O book Location: U1.18-P1-H1 4. Call service support.
406E 0B14	Scan control routines detected fault in I/O book	<ol style="list-style-type: none"> 1. Check for system firmware updates. 2. Check the I/O cabling between the secondary I/O book and the I/O subsystems. 3. Secondary I/O book Location: U1.18-P1-H1 4. Call service support.
406E 0B15	Scan control routines detected fault in I/O book	<ol style="list-style-type: none"> 1. Check for system firmware updates. 2. Check the I/O cabling between the secondary I/O book and the I/O subsystems. 3. Secondary I/O book Location: U1.18-P1-H1 4. Call service support.
406E 0B16	Scan control routines detected fault in I/O book	<ol style="list-style-type: none"> 1. Check for system firmware updates. 2. Check the I/O cabling between the secondary I/O book and the I/O subsystems. 3. Secondary I/O book Location: U1.18-P1-H1 4. Call service support.
406E 0B17	Scan control routines detected fault in I/O book	<ol style="list-style-type: none"> 1. Check for system firmware updates. 2. Check the I/O cabling between the secondary I/O book and the I/O subsystems. 3. Secondary I/O book Location: U1.18-P1-H1 4. Call service support.

Error Code	Description	Action/ Possible Failing FRU
406E 0B20	Scan control routines detected fault in I/O book	<ol style="list-style-type: none"> 1. Check for system firmware updates. 2. Check the I/O cabling between the secondary I/O book and the I/O subsystems. 3. Secondary I/O book Location: U1.18-P1-H3 4. Call service support.
406E 0B21	Scan control routines detected fault in I/O book	<ol style="list-style-type: none"> 1. Check for system firmware updates. 2. Check the I/O cabling between the secondary I/O book and the I/O subsystems. 3. Secondary I/O book Location: U1.18-P1-H3 4. Call service support.
406E 0B22	Scan control routines detected fault in I/O book	<ol style="list-style-type: none"> 1. Check for system firmware updates. 2. Check the I/O cabling between the secondary I/O book and the I/O subsystems. 3. Secondary I/O book Location: U1.18-P1-H3 4. Call service support.
406E 0B23	Scan control routines detected fault in I/O book	<ol style="list-style-type: none"> 1. Check for system firmware updates. 2. Check the I/O cabling between the secondary I/O book and the I/O subsystems. 3. Secondary I/O book Location: U1.18-P1-H3 4. Call service support.
406E 0B24	Scan control routines detected fault in I/O book	<ol style="list-style-type: none"> 1. Check for system firmware updates. 2. Check the I/O cabling between the secondary I/O book and the I/O subsystems. 3. Secondary I/O book Location: U1.18-P1-H3 4. Call service support.

Error Code	Description	Action/ Possible Failing FRU
406E 0B25	Scan control routines detected fault in I/O book	<ol style="list-style-type: none"> 1. Check for system firmware updates. 2. Check the I/O cabling between the secondary I/O book and the I/O subsystems. 3. Secondary I/O book Location: U1.18-P1-H3 4. Call service support.
406E 0B26	Scan control routines detected fault in I/O book	<ol style="list-style-type: none"> 1. Check for system firmware updates. 2. Check the I/O cabling between the secondary I/O book and the I/O subsystems. 3. Secondary I/O book Location: U1.18-P1-H3 4. Call service support.
406E 0B27	Scan control routines detected fault in I/O book	<ol style="list-style-type: none"> 1. Check for system firmware updates. 2. Check the I/O cabling between the secondary I/O book and the I/O subsystems. 3. Secondary I/O book Location: U1.18-P1-H3 4. Call service support.
406E 0B30	Scan control routines detected fault in I/O book	<ol style="list-style-type: none"> 1. Check for system firmware updates. 2. Check the I/O cabling between the third I/O book and the I/O subsystems. 3. Third I/O book Location: U1.18-P1-H4 4. Call service support.
406E 0B31	Scan control routines detected fault in I/O book	<ol style="list-style-type: none"> 1. Check for system firmware updates. 2. Check the I/O cabling between the third I/O book and the I/O subsystems. 3. Third I/O book Location: U1.18-P1-H4 4. Call service support.

Error Code	Description	Action/ Possible Failing FRU
406E 0B32	Scan control routines detected fault in I/O book	<ol style="list-style-type: none"> 1. Check for system firmware updates. 2. Check the I/O cabling between the third I/O book and the I/O subsystems. 3. Third I/O book Location: U1.18-P1-H4 4. Call service support.
406E 0B33	Scan control routines detected fault in I/O book	<ol style="list-style-type: none"> 1. Check for system firmware updates. 2. Check the I/O cabling between the third I/O book and the I/O subsystems. 3. Third I/O book Location: U1.18-P1-H4 4. Call service support.
406E 0B34	Scan control routines detected fault in I/O book	<ol style="list-style-type: none"> 1. Check for system firmware updates. 2. Check the I/O cabling between the third I/O book and the I/O subsystems. 3. Third I/O book Location: U1.18-P1-H4 4. Call service support.
406E 0B35	Scan control routines detected fault in I/O book	<ol style="list-style-type: none"> 1. Check for system firmware updates. 2. Check the I/O cabling between the third I/O book and the I/O subsystems. 3. Third I/O book Location: U1.18-P1-H4 4. Call service support.
406E 0B36	Scan control routines detected fault in I/O book	<ol style="list-style-type: none"> 1. Check for system firmware updates. 2. Check the I/O cabling between the third I/O book and the I/O subsystems. 3. Third I/O book Location: U1.18-P1-H4 4. Call service support.

Error Code	Description	Action/ Possible Failing FRU
406E 0B37	Scan control routines detected fault in I/O book	<ol style="list-style-type: none"> 1. Check for system firmware updates. 2. Check the I/O cabling between the third I/O book and the I/O subsystems. 3. Third I/O book Location: U1.18-P1-H4 4. Call service support.
406E 0BF0	Scan control routines detected fault in I/O hub chip 0 (port x)	<ol style="list-style-type: none"> 1. Check the cabling on the following RIO ports: <ol style="list-style-type: none"> a. U1.18-P1-H2/Q1 b. U1.18-P1-H2/Q2 2. Replace the primary I/O book, Location: U1.18-P1-H2
406E 0BF1	Scan control routines detected fault in I/O hub chip 1 (port x)	<ol style="list-style-type: none"> 1. Check the cabling on the following RIO ports: <ol style="list-style-type: none"> a. U1.18-P1-H2/Q3 b. U1.18-P1-H2/Q4 2. Replace the primary I/O book, Location: U1.18-P1-H2
406E 0BF2	Scan control routines detected fault in I/O hub chip 2 (port x)	<ol style="list-style-type: none"> 1. Check the cabling on the following RIO ports: <ol style="list-style-type: none"> a. U1.18-P1-H1/Q3 b. U1.18-P1-H1/Q4 2. Replace the RIO book, Location: U1.18-P1-H1
406E 0BF3	Scan control routines detected fault in I/O hub chip 3 (port x)	<ol style="list-style-type: none"> 1. Check the cabling on the following RIO ports: <ol style="list-style-type: none"> a. U1.18-P1-H1/Q1 b. U1.18-P1-H1/Q2 2. Replace the RIO book, Location: U1.18-P1-H1
406E 0BF4	Scan control routines detected fault in I/O hub chip 4 (port x)	<ol style="list-style-type: none"> 1. Check the cabling on the following RIO ports: <ol style="list-style-type: none"> a. U1.18-P1-H3/Q7 b. U1.18-P1-H3/Q8 2. Replace the RIO book, Location: U1.18-P1-H3

Error Code	Description	Action/ Possible Failing FRU
406E 0BF5	Scan control routines detected fault in I/O hub chip 5 (port x)	<ol style="list-style-type: none"> 1. Check the cabling on the following RIO ports: <ol style="list-style-type: none"> a. U1.18-P1-H3/Q5 b. U1.18-P1-H3/Q6 2. Replace the RIO book, Location: U1.18-P1-H3
406E 0BF6	Scan control routines detected fault in I/O hub chip 6 (port x)	<ol style="list-style-type: none"> 1. Check the cabling on the following RIO ports: <ol style="list-style-type: none"> a. U1.18-P1-H4/Q5 b. U1.18-P1-H4/Q6 2. Replace the RIO book, Location: U1.18-P1-H4
406E 0BF7	Scan control routines detected fault in I/O hub chip 7 (port x)	<ol style="list-style-type: none"> 1. Check the cabling on the following RIO ports: <ol style="list-style-type: none"> a. U1.18-P1-H4/Q7 b. U1.18-P1-H4/Q8 2. Replace the RIO book, Location: U1.18-P1-H4
406E 0BF8	Scan control routines detected fault in I/O hub chip 8 (port x)	<ol style="list-style-type: none"> 1. Check the cabling on the following RIO ports: <ol style="list-style-type: none"> a. U1.18-P1-H1/Q7 b. U1.18-P1-H1/Q8 2. Replace the RIO book, Location: U1.18-P1-H1
406E 0BF9	Scan control routines detected fault in I/O hub chip 9 (port x)	<ol style="list-style-type: none"> 1. Check the cabling on the following RIO ports: <ol style="list-style-type: none"> a. U1.18-P1-H1/Q5 b. U1.18-P1-H1/Q6 2. Replace the RIO book, Location: U1.18-P1-H1
406E 0BFA	Scan control routines detected fault in I/O hub chip 10 (port x)	<ol style="list-style-type: none"> 1. Check the cabling on the following RIO ports: <ol style="list-style-type: none"> a. U1.18-P1-H3/Q3 b. U1.18-P1-H3/Q4 2. Replace the RIO book, Location: U1.18-P1-H3

Error Code	Description	Action/ Possible Failing FRU
406E 0BFB	Scan control routines detected fault in I/O hub chip 11 (port x)	<ol style="list-style-type: none"> 1. Check the cabling on the following RIO ports: <ol style="list-style-type: none"> a. U1.18-P1-H3/Q1 b. U1.18-P1-H3/Q2 2. Replace the RIO book, Location: U1.18-P1-H3
406E 0BFC	Scan control routines detected fault in I/O hub chip 12 (port x)	<ol style="list-style-type: none"> 1. Check the cabling on the following RIO ports: <ol style="list-style-type: none"> a. U1.18-P1-H4/Q1 b. U1.18-P1-H4/Q2 2. Replace the RIO book, Location: U1.18-P1-H4.
406E 0BFD	Scan control routines detected fault in I/O hub chip 13 (port x)	<ol style="list-style-type: none"> 1. Check the cabling on the following RIO ports: <ol style="list-style-type: none"> a. U1.18-P1-H4/Q3 b. U1.18-P1-H4/Q4 2. Replace the RIO book, Location: U1.18-P1-H4
406E 0C03	Scan control routines detected fault in all MCMs	Go to "MAP 1543: MCM Module Problem Isolation" on page 332.
406E 0C09	Scan control routines detected fault in all memory books	Go to "MAP 1546: Memory Book Problem Isolation" on page 338.
406E 0C0A	Scan control routines detected fault in all I/O books	Go to "MAP 1547: I/O Book Problem Isolation" on page 341.
406E 0C10	Scan control routines detected mismatch between MCM 0 and VPD card	Plugging error with FRU kit Location: U1.18-P1-C1 and U1.18-P1-H2.3
406E 0C11	Scan control routines detected mismatch between MCM 2 and VPD card	Plugging error with FRU kit Location: U1.18-P1-C4 and U1.18-P1-H2.4
406E 0C12	Scan control routines detected mismatch between MCM 1 and VPD card	Plugging error with FRU kit Location: U1.18-P1-C3 and U1.18-P1-H2.5
406E 0C13	Scan control routines detected mismatch between MCM 3 and VPD card	Plugging error with FRU kit Location: U1.18-P1-C2 and U1.18-P1-H2.6
406E 0CA5	Scan control routines detected invalid processor subsystem configuration	Verify that MCMs, memory books, and L3 modules are correctly configured.
406E 0CA6	Scan control routines detected no usable main storage	Reboot the system in slow mode to isolate the failure.
406E 0CA9	Scan control routines detected configuration error with processor memory	Reboot the system in slow mode to isolate the failure.

Error Code	Description	Action/ Possible Failing FRU
406E 0D00	Scan control routines detected fault in L3 cache module 0	L3 cache module 0 and L3 VPD card Location: U1.18-P1-C6 and U1.18-P1-H2.1
406E 0D01	Scan control routines detected fault in L3 cache module 1	L3 cache module 1 and L3 VPD card Location: U1.18-P1-C7 and U1.18-P1-H2.1
406E 0D02	Scan control routines detected fault in L3 cache module 2	L3 cache module 2 and L3 VPD card Location: U1.18-P1-C11 and U1.18-P1-H2.1
406E 0D03	Scan control routines detected fault in L3 cache module 3	L3 cache module 3 and L3 VPD card Location: U1.18-P1-C10 and U1.18-P1-H2.1
406E 0D04	Scan control routines detected fault in L3 cache module 4	L3 cache module 4 and L3 VPD card Location: U1.18-P1-C8 and U1.18-P1-H2.1
406E 0D05	Scan control routines detected fault in L3 cache module 5	L3 cache module 5 and L3 VPD card Location: U1.18-P1-C20 and U1.18-P1-H2.1
406E 0D06	Scan control routines detected fault in L3 cache module 6	L3 cache module 6 and L3 VPD card Location: U1.18-P1-C16 and U1.18-P1-H2.1
406E 0D07	Scan control routines detected fault in L3 cache module 7	L3 cache module 7 and L3 VPD card Location: U1.18-P1-C12 and U1.18-P1-H2.1
406E 0D08	Scan control routines detected fault in L3 cache module 8	L3 cache module 8 and L3 VPD card Location: U1.18-P1-C19 and U1.18-P1-H2.1
406E 0D09	Scan control routines detected fault in L3 cache module 9	L3 cache module 9 and L3 VPD card Location: U1.18-P1-C18 and U1.18-P1-H2.1
406E 0D0A	Scan control routines detected fault in L3 cache module 10	L3 cache module 10 and L3 VPD card Location: U1.18-P1-C14 and U1.18-P1-H2.1
406E 0D0B	Scan control routines detected fault in L3 cache module 11	L3 cache module 11 and L3 VPD card Location: U1.18-P1-C15 and U1.18-P1-H2.1
406E 0D0C	Scan control routines detected fault in L3 cache module 12	L3 cache module 12 and L3 VPD card Location: U1.18-P1-C17 and U1.18-P1-H2.1
406E 0D0D	Scan control routines detected fault in L3 cache module 13	L3 cache module 13 and L3 VPD card Location: U1.18-P1-C5 and U1.18-P1-H2.1
406E 0D0E	Scan control routines detected fault in L3 cache module 14	L3 cache module 14 and L3 VPD card Location: U1.18-P1-C9 and U1.18-P1-H2.1

Error Code	Description	Action/ Possible Failing FRU
406E 0D0F	Scan control routines detected fault in L3 cache module 15	L3 cache module 15 and L3 VPD card Location: U1.18-P1-C13 and U1.18-P1-H2.1
406E 0EA0	Scan control routines detected fault in MOPS service processor code	1. Check for system firmware updates. 2. Call service support.
406E 0EA1	Scan control routines detected fault in processor subsystem code on main processor	1. Check for operating system updates. 2. Call service support.
406E 0EA2	Scan control routines detected fault in PRD code on service processor	1. Check for system firmware updates. 2. Call service support.
406E 0EA4	Scan control routines detected fault in service processor code	1. Check for system firmware updates. 2. Call service support.
406E 0EAF	Scan control routines detected unknown service processor code and system type	1. Check for system firmware updates. 2. Call service support.
406E 0EB0	Scan control routines detected JTAG problem	Go to "MAP 1540: Problem Isolation Procedures" on page 303.
406E 0EB1	Attention line 0 stuck fault	Go to "MAP 1540: Problem Isolation Procedures" on page 303.
406E 0EB2	Attention line 1 stuck fault	Go to "MAP 1540: Problem Isolation Procedures" on page 303.
406E 0EB3	Attention line 2 stuck fault	Go to "MAP 1540: Problem Isolation Procedures" on page 303.
406E 0EB4	Attention line 3 stuck fault	Go to "MAP 1540: Problem Isolation Procedures" on page 303.
406E 0EB5	Attention line 4 stuck fault	Go to "MAP 1540: Problem Isolation Procedures" on page 303.
406E 0EB6	Attention line 5 stuck fault	Go to "MAP 1540: Problem Isolation Procedures" on page 303.
406E 0EB7	Attention line 6 stuck fault	Go to "MAP 1540: Problem Isolation Procedures" on page 303.
406E 0EB8	Attention line 7 stuck fault	Go to "MAP 1540: Problem Isolation Procedures" on page 303.
406E 0EB9	Attention line 8 stuck fault	Go to "MAP 1540: Problem Isolation Procedures" on page 303.
406E 0EBA	Attention line 9 stuck fault	Go to "MAP 1540: Problem Isolation Procedures" on page 303.
406E 0EBB	Attention line 10 stuck fault	Go to "MAP 1540: Problem Isolation Procedures" on page 303.

Error Code	Description	Action/ Possible Failing FRU
406E 0EBC	Attention line 11 stuck fault	Go to "MAP 1540: Problem Isolation Procedures" on page 303.
406E 0EE1	Scan control routines detected fault in service processor code (invalid MRU to mapping)	<ol style="list-style-type: none"> 1. Check for system firmware updates. 2. Call service support.
406E 0EE2	Scan control routines detected fault in service processor firmware fault	<ol style="list-style-type: none"> 1. Check for system firmware updates. 2. Call service support.
406E 0EE5	Scan control routines detected firmware error; no callout available	<ol style="list-style-type: none"> 1. Check for system firmware updates. 2. Call service support.
406F 0001	Error code generation/logging detected clock card assembly failure	Go to "MAP 1540: Problem Isolation Procedures" on page 303.
406F 0002	Error code generation/logging detected backplane assembly failure	Go to "MAP 1540: Problem Isolation Procedures" on page 303.
406F 0003	Error code generation/logging detected fault in MCM module 0	MCM module 0 and VPD card Location: U1.18-P1-C1 and U1.18-P1-H2.3
406F 0004	Error code generation/logging detected fault in MCM module 2	MCM module 2 and VPD card Location: U1.18-P1-C4 and U1.18-P1-H2.4
406F 0005	Error code generation/logging detected fault in MCM module 1	MCM module 1 and VPD card Location: U1.18-P1-C3 and U1.18-P1-H2.5
406F 0006	Error code generation/logging detected fault in MCM module 3	MCM module 3 and VPD card Location: U1.18-P1-C2 and U1.18-P1-H2.6
406F 0007	Error code generation/logging detected fault in L3 VPD card	<ol style="list-style-type: none"> 1. L3 VPD card Location: U1.18-P1-H2.1 (Order the L3 cache module FRU to obtain a new L3 VPD card. Return the L3 cache module that was included in the FRU kit, and the failing L3 VPD card as "new defective".) 2. Primary I/O book Location: U1.18-P1-H2
406F 000A	Error code generation/logging detected fault in I/O book 1 (slot 0)	Go to "MAP 1540: Problem Isolation Procedures" on page 303.
406F 000B	Error code generation/logging detected fault in primary I/O book (slot 1)	Go to "MAP 1540: Problem Isolation Procedures" on page 303.
406F 000C	Error code generation/logging detected fault in I/O book 3 (slot 2)	Go to "MAP 1540: Problem Isolation Procedures" on page 303.

Error Code	Description	Action/ Possible Failing FRU
406F 000D	Error code generation/logging detected fault in I/O book 4 (slot 3)	Go to "MAP 1540: Problem Isolation Procedures" on page 303.
406F 0010	Error code generation/logging detected fault in Memory book (slot 0)	Memory book (slot 0) Location: U1.18-P1-M2
406F 0011	Error code generation/logging detected fault in Memory book (slot 1)	Memory book (slot 1) Location: U1.18-P1-M3
406F 0012	Error code generation/logging detected fault in Memory book (slot 2)	Memory book (slot 2) Location: U1.18-P1-M7
406F 0013	Error code generation/logging detected fault in Memory book (slot 3)	Memory book (slot 3) Location: U1.18-P1-M6
406F 0014	Error code generation/logging detected fault in Memory book (slot 4)	Memory book (slot 4) Location: U1.18-P1-M4
406F 0015	Error code generation/logging detected fault in Memory book (slot 5)	Memory book (slot 5) Location: U1.18-P1-M8
406F 0016	Error code generation/logging detected fault in Memory book (slot 6)	Memory book (slot 6) Location: U1.18-P1-M5
406F 0017	Error code generation/logging detected fault in Memory book (slot 7)	Memory book (slot 7) Location: U1.18-P1-M1
406F 00B0	Error code generation/logging detected possible problem with bus controller or CSP code	<ol style="list-style-type: none"> 1. Check for system firmware updates. 2. Primary I/O book, Location: U1.18-P1-H2 3. Call service support.
406F 00B1	Error code generation/logging detected possible problem with bus controller	<ol style="list-style-type: none"> 1. Check for system firmware updates. 2. Primary I/O book, Location: U1.18-P1-H2 3. Call service support.
406F 00B3	Error code generation/logging detected MCM 0/VPD problem	<ol style="list-style-type: none"> 1. Check for system firmware updates. 2. MCM module 0 and VPD card Location: U1.18-P1-C1 and U1.18-P1-H2.3
406F 00B4	Error code generation/logging detected MCM 2/VPD problem	<ol style="list-style-type: none"> 1. Check for system firmware updates. 2. MCM module 2 and VPD card Location: U1.18-P1-C4 and U1.18-P1-H2.4
406F 00B5	Error code generation/logging detected MCM 1/VPD problem	<ol style="list-style-type: none"> 1. Check for system firmware updates. 2. MCM module 1 and VPD card Location: U1.18-P1-C3 and U1.18-P1-H2.5

Error Code	Description	Action/ Possible Failing FRU
406F 00B6	Error code generation/logging detected MCM 3/VPD problem	<ol style="list-style-type: none"> 1. Check for system firmware updates. 2. MCM module 3 and VPD card Location: U1.18-P1-C2 and U1.18-P1-H2.6
406F 00B7	Error code generation/logging detected hardware problem in the processor subsystem	Go to "MAP 1540: Problem Isolation Procedures" on page 303.
406F 0A03	Reboot message (run-time array gard failure) for processor 0	Reboot the system in slow mode. Run diagnostics, then go to MAP 0235 in the <i>RS/6000 and @server pSeries Diagnostic Information for Multiple Bus Systems</i> , order number SA38-0509.
406F 0A04	Reboot message (run-time array gard failure) for processor 2	Reboot the system in slow mode. Run diagnostics, then go to MAP 0235 in the <i>RS/6000 and @server pSeries Diagnostic Information for Multiple Bus Systems</i> , order number SA38-0509.
406F 0A05	Reboot message (run-time array gard failure) for processor 1	Reboot the system in slow mode. Run diagnostics, then go to MAP 0235 in the <i>RS/6000 and @server pSeries Diagnostic Information for Multiple Bus Systems</i> , order number SA38-0509.
406F 0A06	Reboot message (run-time array gard failure) for processor 3	Reboot the system in slow mode. Run diagnostics, then go to MAP 0235 in the <i>RS/6000 and @server pSeries Diagnostic Information for Multiple Bus Systems</i> , order number SA38-0509.
406F 0B00	Error code generation/logging detected fault in I/O book (slot 0 RIO port 0)	<ol style="list-style-type: none"> 1. Check for system firmware updates. 2. Check the I/O cabling between the primary I/O book and the I/O subsystems. 3. Primary I/O book Location: U1.18-P1-H2 4. Call service support.
406F 0B01	Error code generation/logging detected fault in I/O book (slot 0 RIO port 1)	<ol style="list-style-type: none"> 1. Check for system firmware updates. 2. Check the I/O cabling between the primary I/O book and the I/O subsystems. 3. Primary I/O book Location: U1.18-P1-H2 4. Call service support.

Error Code	Description	Action/ Possible Failing FRU
406F 0B02	Error code generation/logging detected fault in I/O book (slot 0 RIO port 2)	<ol style="list-style-type: none"> 1. Check for system firmware updates. 2. Check the I/O cabling between the primary I/O book and the I/O subsystems. 3. Primary I/O book Location: U1.18-P1-H2 4. Call service support.
406F 0B03	Error code generation/logging detected fault in I/O book (slot 0 RIO port 3)	<ol style="list-style-type: none"> 1. Check for system firmware updates. 2. Check the I/O cabling between the primary I/O book and the I/O subsystems. 3. Primary I/O book Location: U1.18-P1-H2 4. Call service support.
406F 0B10	Error code generation/logging detected fault in I/O book	<ol style="list-style-type: none"> 1. Check for system firmware updates. 2. Check the I/O cabling between the secondary I/O book and the I/O subsystems. 3. Secondary I/O book Location: U1.18-P1-H1 4. Call service support.
406F 0B11	Error code generation/logging detected fault in I/O book	<ol style="list-style-type: none"> 1. Check for system firmware updates. 2. Check the I/O cabling between the secondary I/O book and the I/O subsystems. 3. Secondary I/O book Location: U1.18-P1-H1 4. Call service support.
406F 0B12	Error code generation/logging detected fault in I/O book	<ol style="list-style-type: none"> 1. Check for system firmware updates. 2. Check the I/O cabling between the secondary I/O book and the I/O subsystems. 3. Secondary I/O book Location: U1.18-P1-H1 4. Call service support.

Error Code	Description	Action/ Possible Failing FRU
406F 0B13	Error code generation/logging detected fault in I/O book	<ol style="list-style-type: none"> 1. Check for system firmware updates. 2. Check the I/O cabling between the secondary I/O book and the I/O subsystems. 3. Secondary I/O book Location: U1.18-P1-H1 4. Call service support.
406F 0B14	Error code generation/logging detected fault in I/O book	<ol style="list-style-type: none"> 1. Check for system firmware updates. 2. Check the I/O cabling between the secondary I/O book and the I/O subsystems. 3. Secondary I/O book Location: U1.18-P1-H1 4. Call service support.
406F 0B15	Error code generation/logging detected fault in I/O book	<ol style="list-style-type: none"> 1. Check for system firmware updates. 2. Check the I/O cabling between the secondary I/O book and the I/O subsystems. 3. Secondary I/O book Location: U1.18-P1-H1 4. Call service support.
406F 0B16	Error code generation/logging detected fault in I/O book	<ol style="list-style-type: none"> 1. Check for system firmware updates. 2. Check the I/O cabling between the secondary I/O book and the I/O subsystems. 3. Secondary I/O book Location: U1.18-P1-H1 4. Call service support.
406F 0B17	Error code generation/logging detected fault in I/O book	<ol style="list-style-type: none"> 1. Check for system firmware updates. 2. Check the I/O cabling between the secondary I/O book and the I/O subsystems. 3. Secondary I/O book Location: U1.18-P1-H1 4. Call service support.

Error Code	Description	Action/ Possible Failing FRU
406F 0B20	Error code generation/logging detected fault in I/O book	<ol style="list-style-type: none"> 1. Check for system firmware updates. 2. Check the I/O cabling between the secondary I/O book and the I/O subsystems. 3. Secondary I/O book Location: U1.18-P1-H3 4. Call service support.
406F 0B21	Error code generation/logging detected fault in I/O book	<ol style="list-style-type: none"> 1. Check for system firmware updates. 2. Check the I/O cabling between the secondary I/O book and the I/O subsystems. 3. Secondary I/O book Location: U1.18-P1-H3 4. Call service support.
406F 0B22	Error code generation/logging detected fault in I/O book	<ol style="list-style-type: none"> 1. Check for system firmware updates. 2. Check the I/O cabling between the secondary I/O book and the I/O subsystems. 3. Secondary I/O book Location: U1.18-P1-H3 4. Call service support.
406F 0B23	Error code generation/logging detected fault in I/O book	<ol style="list-style-type: none"> 1. Check for system firmware updates. 2. Check the I/O cabling between the secondary I/O book and the I/O subsystems. 3. Secondary I/O book Location: U1.18-P1-H3 4. Call service support.
406F 0B24	Error code generation/logging detected fault in I/O book	<ol style="list-style-type: none"> 1. Check for system firmware updates. 2. Check the I/O cabling between the secondary I/O book and the I/O subsystems. 3. Secondary I/O book Location: U1.18-P1-H3 4. Call service support.

Error Code	Description	Action/ Possible Failing FRU
406F 0B25	Error code generation/logging detected fault in I/O book	<ol style="list-style-type: none"> 1. Check for system firmware updates. 2. Check the I/O cabling between the secondary I/O book and the I/O subsystems. 3. Secondary I/O book Location: U1.18-P1-H3 4. Call service support.
406F 0B26	Error code generation/logging detected fault in I/O book	<ol style="list-style-type: none"> 1. Check for system firmware updates. 2. Check the I/O cabling between the secondary I/O book and the I/O subsystems. 3. Secondary I/O book Location: U1.18-P1-H3 4. Call service support.
406F 0B27	Error code generation/logging detected fault in I/O book	<ol style="list-style-type: none"> 1. Check for system firmware updates. 2. Check the I/O cabling between the secondary I/O book and the I/O subsystems. 3. Secondary I/O book Location: U1.18-P1-H3 4. Call service support.
406F 0B30	Error code generation/logging detected fault in I/O book	<ol style="list-style-type: none"> 1. Check for system firmware updates. 2. Check the I/O cabling between the third I/O book and the I/O subsystems. 3. Third I/O book Location: U1.18-P1-H4 4. Call service support.
406F 0B31	Error code generation/logging detected fault in I/O book	<ol style="list-style-type: none"> 1. Check for system firmware updates. 2. Check the I/O cabling between the third I/O book and the I/O subsystems. 3. Third I/O book Location: U1.18-P1-H4 4. Call service support.

Error Code	Description	Action/ Possible Failing FRU
406F 0B32	Error code generation/logging detected fault in I/O book	<ol style="list-style-type: none"> 1. Check for system firmware updates. 2. Check the I/O cabling between the third I/O book and the I/O subsystems. 3. Third I/O book Location: U1.18-P1-H4 4. Call service support.
406F 0B33	Error code generation/logging detected fault in I/O book	<ol style="list-style-type: none"> 1. Check for system firmware updates. 2. Check the I/O cabling between the third I/O book and the I/O subsystems. 3. Third I/O book Location: U1.18-P1-H4 4. Call service support.
406F 0B34	Error code generation/logging detected fault in I/O book	<ol style="list-style-type: none"> 1. Check for system firmware updates. 2. Check the I/O cabling between the third I/O book and the I/O subsystems. 3. Third I/O book Location: U1.18-P1-H4 4. Call service support.
406F 0B35	Error code generation/logging detected fault in I/O book	<ol style="list-style-type: none"> 1. Check for system firmware updates. 2. Check the I/O cabling between the third I/O book and the I/O subsystems. 3. Third I/O book Location: U1.18-P1-H4 4. Call service support.
406F 0B36	Error code generation/logging detected fault in I/O book	<ol style="list-style-type: none"> 1. Check for system firmware updates. 2. Check the I/O cabling between the third I/O book and the I/O subsystems. 3. Third I/O book Location: U1.18-P1-H4 4. Call service support.

Error Code	Description	Action/ Possible Failing FRU
406F 0B37	Error code generation/logging detected fault in I/O book	<ol style="list-style-type: none"> 1. Check for system firmware updates. 2. Check the I/O cabling between the third I/O book and the I/O subsystems. 3. Third I/O book Location: U1.18-P1-H4 4. Call service support.
406F 0BF0	Error code generation/logging detected fault in I/O hub chip 0 (port x)	<ol style="list-style-type: none"> 1. Check the cabling on the following RIO ports: <ol style="list-style-type: none"> a. U1.18-P1-H2/Q1 b. U1.18-P1-H2/Q2 2. Replace the primary I/O book, Location: U1.18-P1-H2
406F 0BF1	Error code generation/logging detected fault in I/O hub chip 1 (port x)	<ol style="list-style-type: none"> 1. Check the cabling on the following RIO ports: <ol style="list-style-type: none"> a. U1.18-P1-H2/Q3 b. U1.18-P1-H2/Q4 2. Replace the primary I/O book, Location: U1.18-P1-H2
406F 0BF2	Error code generation/logging detected fault in I/O hub chip 2 (port x)	<ol style="list-style-type: none"> 1. Check the cabling on the following RIO ports: <ol style="list-style-type: none"> a. U1.18-P1-H1/Q3 b. U1.18-P1-H1/Q4 2. Replace the RIO book, Location: U1.18-P1-H1
406F 0BF3	Error code generation/logging detected fault in I/O hub chip 3 (port x)	<ol style="list-style-type: none"> 1. Check the cabling on the following RIO ports: <ol style="list-style-type: none"> a. U1.18-P1-H1/Q1 b. U1.18-P1-H1/Q2 2. Replace the RIO book, Location: U1.18-P1-H1
406F 0BF4	Error code generation/logging detected fault in I/O hub chip 4 (port x)	<ol style="list-style-type: none"> 1. Check the cabling on the following RIO ports: <ol style="list-style-type: none"> a. U1.18-P1-H3/Q7 b. U1.18-P1-H3/Q8 2. Replace the RIO book, Location: U1.18-P1-H3

Error Code	Description	Action/ Possible Failing FRU
406F 0BF5	Error code generation/logging detected fault in I/O hub chip 5 (port x)	<ol style="list-style-type: none"> 1. Check the cabling on the following RIO ports: <ol style="list-style-type: none"> a. U1.18-P1-H3/Q5 b. U1.18-P1-H3/Q6 2. Replace the RIO book, Location: U1.18-P1-H3
406F 0BF6	Error code generation/logging detected fault in I/O hub chip 6 (port x)	<ol style="list-style-type: none"> 1. Check the cabling on the following RIO ports: <ol style="list-style-type: none"> a. U1.18-P1-H4/Q5 b. U1.18-P1-H4/Q6 2. Replace the RIO book, Location: U1.18-P1-H4
406F 0BF7	Error code generation/logging detected fault in I/O hub chip 7 (port x)	<ol style="list-style-type: none"> 1. Check the cabling on the following RIO ports: <ol style="list-style-type: none"> a. U1.18-P1-H4/Q7 b. U1.18-P1-H4/Q8 2. Replace the RIO book, Location: U1.18-P1-H4
406F 0BF8	Error code generation/logging detected fault in I/O hub chip 8 (port x)	<ol style="list-style-type: none"> 1. Check the cabling on the following RIO ports: <ol style="list-style-type: none"> a. U1.18-P1-H1/Q7 b. U1.18-P1-H1/Q8 2. Replace the RIO book, Location: U1.18-P1-H1
406F 0BF9	Error code generation/logging detected fault in I/O hub chip 9 (port x)	<ol style="list-style-type: none"> 1. Check the cabling on the following RIO ports: <ol style="list-style-type: none"> a. U1.18-P1-H1/Q5 b. U1.18-P1-H1/Q6 2. Replace the RIO book, Location: U1.18-P1-H1
406F 0BFA	Error code generation/logging detected fault in I/O hub chip 10 (port x)	<ol style="list-style-type: none"> 1. Check the cabling on the following RIO ports: <ol style="list-style-type: none"> a. U1.18-P1-H3/Q3 b. U1.18-P1-H3/Q4 2. Replace the RIO book, Location: U1.18-P1-H3

Error Code	Description	Action/ Possible Failing FRU
406F 0BFB	Error code generation/logging detected fault in I/O hub chip 11 (port x)	<ol style="list-style-type: none"> Check the cabling on the following RIO ports: <ol style="list-style-type: none"> U1.18-P1-H3/Q1 U1.18-P1-H3/Q2 Replace the RIO book, Location: U1.18-P1-H3
406F 0BFC	Error code generation/logging detected fault in I/O hub chip 12 (port x)	<ol style="list-style-type: none"> Check the cabling on the following RIO ports: <ol style="list-style-type: none"> U1.18-P1-H4/Q1 U1.18-P1-H4/Q2 Replace the RIO book, Location: U1.18-P1-H4.
406F 0BFD	Error code generation/logging detected fault in I/O hub chip 13 (port x)	<ol style="list-style-type: none"> Check the cabling on the following RIO ports: <ol style="list-style-type: none"> U1.18-P1-H4/Q3 U1.18-P1-H4/Q4 Replace the RIO book, Location: U1.18-P1-H4
406F 0C03	Error code generation/logging detected fault in all MCMs	Go to "MAP 1543: MCM Module Problem Isolation" on page 332.
406F 0C09	Error code generation/logging detected fault in all memory books	Go to "MAP 1546: Memory Book Problem Isolation" on page 338.
406F 0C0A	Error code generation/logging detected fault in all I/O books	Go to "MAP 1547: I/O Book Problem Isolation" on page 341.
406F 0C10	Error code generation/logging detected mismatch between MCM 0 and VPD card	Plugging error with FRU kit Location: U1.18-P1-C1 and U1.18-P1-H2.3
406F 0C11	Error code generation/logging detected mismatch between MCM 2 and VPD card	Plugging error with FRU kit Location: U1.18-P1-C4 and U1.18-P1-H2.4
406F 0C12	Error code generation/logging detected mismatch between MCM 1 and VPD card	Plugging error with FRU kit Location: U1.18-P1-C3 and U1.18-P1-H2.5
406F 0C13	Error code generation/logging detected mismatch between MCM 3 and VPD card	Plugging error with FRU kit Location: U1.18-P1-C2 and U1.18-P1-H2.6
406F 0CA5	Error code generation/logging detected invalid processor subsystem configuration	Verify that MCMs, memory books, and L3 modules are correctly configured.
406F 0CA6	Error code generation/logging detected no usable main storage	Reboot the system in slow mode to isolate the failure.

Error Code	Description	Action/ Possible Failing FRU
406F 0CA9	Error code generation/logging detected configuration error with processor memory	Reboot the system in slow mode to isolate the failure.
406F 0D00	Error code generation/logging detected fault in L3 cache module 0	L3 cache module 0 and L3 VPD card Location: U1.18-P1-C6 and U1.18-P1-H2.1
406F 0D01	Error code generation/logging detected fault in L3 cache module 1	L3 cache module 1 and L3 VPD card Location: U1.18-P1-C7 and U1.18-P1-H2.1
406F 0D02	Error code generation/logging detected fault in L3 cache module 2	L3 cache module 2 and L3 VPD card Location: U1.18-P1-C11 and U1.18-P1-H2.1
406F 0D03	Error code generation/logging detected fault in L3 cache module 3	L3 cache module 3 and L3 VPD card Location: U1.18-P1-C10 and U1.18-P1-H2.1
406F 0D04	Error code generation/logging detected fault in L3 cache module 4	L3 cache module 4 and L3 VPD card Location: U1.18-P1-C8 and U1.18-P1-H2.1
406F 0D05	Error code generation/logging detected fault in L3 cache module 5	L3 cache module 5 and L3 VPD card Location: U1.18-P1-C20 and U1.18-P1-H2.1
406F 0D06	Error code generation/logging detected fault in L3 cache module 6	L3 cache module 6 and L3 VPD card Location: U1.18-P1-C16 and U1.18-P1-H2.1
406F 0D07	Error code generation/logging detected fault in L3 cache module 7	L3 cache module 7 and L3 VPD card Location: U1.18-P1-C12 and U1.18-P1-H2.1
406F 0D08	Error code generation/logging detected fault in L3 cache module 8	L3 cache module 8 and L3 VPD card Location: U1.18-P1-C19 and U1.18-P1-H2.1
406F 0D09	Error code generation/logging detected fault in L3 cache module 9	L3 cache module 9 and L3 VPD card Location: U1.18-P1-C18 and U1.18-P1-H2.1
406F 0D0A	Error code generation/logging detected fault in L3 cache module 10	L3 cache module 10 and L3 VPD card Location: U1.18-P1-C14 and U1.18-P1-H2.1
406F 0D0B	Error code generation/logging detected fault in L3 cache module 11	L3 cache module 11 and L3 VPD card Location: U1.18-P1-C15 and U1.18-P1-H2.1
406F 0D0C	Error code generation/logging detected fault in L3 cache module 12	L3 cache module 12 and L3 VPD card Location: U1.18-P1-C17 and U1.18-P1-H2.1
406F 0D0D	Error code generation/logging detected fault in L3 cache module 13	L3 cache module 13 and L3 VPD card Location: U1.18-P1-C5 and U1.18-P1-H2.1

Error Code	Description	Action/ Possible Failing FRU
406F 0D0E	Error code generation/logging detected fault in L3 cache module 14	L3 cache module 14 and L3 VPD card Location: U1.18-P1-C9 and U1.18-P1-H2.1
406F 0D0F	Error code generation/logging detected fault in L3 cache module 15	L3 cache module 15 and L3 VPD card Location: U1.18-P1-C13 and U1.18-P1-H2.1
406F 0EA0	Error code generation/logging detected fault in MOPS service processor code	1. Check for system firmware updates. 2. Call service support.
406F 0EA1	Error code generation/logging detected fault in processor subsystem code on main processor	1. Check for operating system updates. 2. Call service support.
406F 0EA2	Error code generation/logging detected fault in PRD code on service processor	1. Check for system firmware updates. 2. Call service support.
406F 0EA4	Error code generation/logging detected fault in service processor code	1. Check for system firmware updates. 2. Call service support.
406F 0EAF	Error code generation/logging detected unknown service processor code and system type	1. Check for system firmware updates. 2. Call service support.
406F 0EB0	Error code generation/logging detected JTAG problem	Go to "MAP 1540: Problem Isolation Procedures" on page 303.
406F 0EB1	Attention line 0 stuck fault	Go to "MAP 1540: Problem Isolation Procedures" on page 303.
406F 0EB2	Attention line 1 stuck fault	Go to "MAP 1540: Problem Isolation Procedures" on page 303.
406F 0EB3	Attention line 2 stuck fault	Go to "MAP 1540: Problem Isolation Procedures" on page 303.
406F 0EB4	Attention line 3 stuck fault	Go to "MAP 1540: Problem Isolation Procedures" on page 303.
406F 0EB5	Attention line 4 stuck fault	Go to "MAP 1540: Problem Isolation Procedures" on page 303.
406F 0EB6	Attention line 5 stuck fault	Go to "MAP 1540: Problem Isolation Procedures" on page 303.
406F 0EB7	Attention line 6 stuck fault	Go to "MAP 1540: Problem Isolation Procedures" on page 303.
406F 0EB8	Attention line 7 stuck fault	Go to "MAP 1540: Problem Isolation Procedures" on page 303.
406F 0EB9	Attention line 8 stuck fault	Go to "MAP 1540: Problem Isolation Procedures" on page 303.

Error Code	Description	Action/ Possible Failing FRU
406F 0EBA	Attention line 9 stuck fault	Go to "MAP 1540: Problem Isolation Procedures" on page 303.
406F 0EBB	Attention line 10 stuck fault	Go to "MAP 1540: Problem Isolation Procedures" on page 303.
406F 0EBC	Attention line 11 stuck fault	Go to "MAP 1540: Problem Isolation Procedures" on page 303.
406F 0EE1	Error code generation/logging detected fault in service processor code (invalid MRU to mapping)	<ol style="list-style-type: none"> 1. Check for system firmware updates. 2. Call service support.
406F 0EE2	Error code generation/logging detected fault in service processor firmware fault	<ol style="list-style-type: none"> 1. Check for system firmware updates. 2. Call service support.
406F 0EE5	Error code generation/logging detected firmware error; no callout available	<ol style="list-style-type: none"> 1. Check for system firmware updates. 2. Call service support.
4504 248B	Memory subsystem and processor subsystem tests detected fault in operator panel	Operator panel Location: U1.17-L1
4504 25C0	Memory subsystem and processor subsystem tests detected fault in system backplane	System backplane Location: U1.18-P1
4504 25C1	Memory subsystem and processor subsystem tests detected fault in 1.0 GHz clock card	Clock card Location: U1.18-P1-X5
4504 25D9	Memory subsystem and processor subsystem tests detected fault in L3 VPD card used with 1.1 GHz MCM and 1.3 GHz MCM	Go to "MAP 1548: Memory and Processor Problem Isolation" on page 343.
4504 25F1	Memory subsystem and processor subsystem tests detected fault in L3 VPD card used with 1.3 GHz MCM	Go to "MAP 1548: Memory and Processor Problem Isolation" on page 343.
4504 28B0	Memory subsystem and processor subsystem tests detected fault in I/O subsystem PCI backplane	I/O subsystem PCI backplane at location specified in error code
4504 28B1	Memory subsystem and processor subsystem tests detected fault in I/O subsystem DASD backplane	I/O subsystem DASD backplane at location specified in error code
4504 302A	Memory subsystem and processor subsystem tests detected fault in 8 GB memory book (inner)	Go to "MAP 1544: Inner L3 Module Problem Isolation" on page 334 to isolate the failing component.
4504 302B	Memory subsystem and processor subsystem tests detected fault in 8 GB memory book (outer)	Go to "MAP 1545: Outer L3 Module Problem Isolation" on page 336 to isolate the failing component.

Error Code	Description	Action/ Possible Failing FRU
4504 302C	Memory subsystem and processor subsystem tests detected fault in 32 GB memory book (inner)	Go to "MAP 1544: Inner L3 Module Problem Isolation" on page 334 to isolate the failing component.
4504 302D	Memory subsystem and processor subsystem tests detected fault in 32 GB memory book (outer)	Go to "MAP 1545: Outer L3 Module Problem Isolation" on page 336 to isolate the failing component.
4504 305C	Memory subsystem and processor subsystem tests detected fault in 4 GB inner memory book	Go to "MAP 1544: Inner L3 Module Problem Isolation" on page 334.
4504 305D	Memory subsystem and processor subsystem tests detected fault in 4 GB outer memory book	Go to "MAP 1545: Outer L3 Module Problem Isolation" on page 336.
4504 305E	Memory subsystem and processor subsystem tests detected fault in 16 GB inner memory book	Go to "MAP 1544: Inner L3 Module Problem Isolation" on page 334.
4504 305F	Memory subsystem and processor subsystem tests detected fault in 16 GB outer memory book	Go to "MAP 1545: Outer L3 Module Problem Isolation" on page 336.
4505 248B	Memory subsystem and display alter tests detected fault in operator panel	Operator panel Location: U1.17-L1
4505 25C0	Memory subsystem and display alter tests detected fault in system backplane	System backplane Location: U1.18-P1
4505 25C1	Memory subsystem and display alter tests detected fault in 1.0 GHz clock card	Clock card Location: U1.18-P1-X5
4505 25D9	Memory subsystem and display alter tests detected fault in L3 VPD card used with 1.1 GHz MCM and 1.3 GHz MCM	Go to "MAP 1548: Memory and Processor Problem Isolation" on page 343.
4505 25F1	Memory subsystem and display alter tests detected fault in L3 VPD card used with 1.3 GHz MCM	Go to "MAP 1548: Memory and Processor Problem Isolation" on page 343.
4505 28B0	Memory subsystem and display alter tests detected fault in I/O subsystem PCI backplane	I/O subsystem PCI backplane at location specified in error code
4505 28B1	Memory subsystem and display alter tests detected fault in I/O subsystem DASD backplane	I/O subsystem DASD backplane at location specified in error code
4505 302A	Memory subsystem and display alter tests detected fault in 8 GB memory book (inner)	Go to "MAP 1540: Problem Isolation Procedures" on page 303 to isolate the failing component.
4505 302B	Memory subsystem and display alter tests detected fault in 8 GB memory book (outer)	Go to "MAP 1540: Problem Isolation Procedures" on page 303 to isolate the failing component.

Error Code	Description	Action/ Possible Failing FRU
4505 302C	Memory subsystem and display alter tests detected fault in 32 GB memory book (inner)	Go to "MAP 1540: Problem Isolation Procedures" on page 303 to isolate the failing component.
4505 302D	Memory subsystem and display alter tests detected fault in 32 GB memory book (outer)	Go to "MAP 1540: Problem Isolation Procedures" on page 303 to isolate the failing component.
4505 305C	Memory subsystem and display alter tests detected fault in 4 GB inner memory book	Go to "MAP 1544: Inner L3 Module Problem Isolation" on page 334.
4505 305D	Memory subsystem and display alter tests detected fault in 4 GB outer memory book	Go to "MAP 1545: Outer L3 Module Problem Isolation" on page 336.
4505 305E	Memory subsystem and display alter tests detected fault in 16 GB inner memory book	Go to "MAP 1544: Inner L3 Module Problem Isolation" on page 334.
4505 305F	Memory subsystem and display alter tests detected fault in 16 GB outer memory book	Go to "MAP 1545: Outer L3 Module Problem Isolation" on page 336.
4506 248B	Memory subsystem and scan interface basic assurance tests detected fault in operator panel	Operator panel Location: U1.17-L1
4506 25C0	Memory subsystem and scan interface basic assurance tests detected fault in system backplane	System backplane Location: U1.18-P1
4506 25C1	Memory subsystem and scan interface basic assurance tests detected fault in 1.0 GHz clock card	Clock card Location: U1.18-P1-X5
4506 25D9	Memory subsystem and scan interface basic assurance tests detected fault in L3 VPD card used with 1.1 GHz MCM and 1.3 GHz MCM	Go to "MAP 1548: Memory and Processor Problem Isolation" on page 343.
4506 25F1	Memory subsystem and scan interface basic assurance tests detected fault in L3 VPD card used with 1.3 GHz MCM	Go to "MAP 1548: Memory and Processor Problem Isolation" on page 343.
4506 28B0	Memory subsystem and scan interface basic assurance tests detected fault in I/O subsystem PCI backplane	I/O subsystem PCI backplane at location specified in error code
4506 28B1	Memory subsystem and scan interface basic assurance tests detected fault in I/O subsystem DASD backplane	I/O subsystem DASD backplane at location specified in error code
4506 302A	Memory subsystem and scan interface basic assurance tests detected fault in 8 GB memory book (inner)	Go to "MAP 1540: Problem Isolation Procedures" on page 303 to isolate the failing component.
4506 302B	Memory subsystem and scan interface basic assurance tests detected fault in 8 GB memory book (outer)	Go to "MAP 1540: Problem Isolation Procedures" on page 303 to isolate the failing component.

Error Code	Description	Action/ Possible Failing FRU
4506 302C	Memory subsystem and scan interface basic assurance tests detected fault in 32 GB memory book (inner)	Go to "MAP 1540: Problem Isolation Procedures" on page 303 to isolate the failing component.
4506 302D	Memory subsystem and scan interface basic assurance tests detected fault in 32 GB memory book (outer)	Go to "MAP 1540: Problem Isolation Procedures" on page 303 to isolate the failing component.
4506 305C	Memory subsystem and scan interface basic assurance tests detected fault in 4 GB inner memory book	Go to "MAP 1544: Inner L3 Module Problem Isolation" on page 334.
4506 305D	Memory subsystem and scan interface basic assurance tests detected fault in 4 GB outer memory book	Go to "MAP 1545: Outer L3 Module Problem Isolation" on page 336.
4506 305E	Memory subsystem and scan interface basic assurance tests detected fault in 16 GB inner memory book	Go to "MAP 1544: Inner L3 Module Problem Isolation" on page 334.
4506 305F	Memory subsystem and scan interface basic assurance tests detected fault in 16 GB outer memory book	Go to "MAP 1545: Outer L3 Module Problem Isolation" on page 336.
4507 248B	Memory subsystem and bus tests detected fault in operator panel	Operator panel Location: U1.17-L1
4507 25C0	Memory subsystem and bus tests detected fault in system backplane	System backplane Location: U1.18-P1
4507 25C1	Memory subsystem and bus tests detected fault in 1.0 GHz clock card	Clock card Location: U1.18-P1-X5
4507 25D9	Memory subsystem and bus tests detected fault in L3 VPD card used with 1.1 GHz MCM and 1.3 GHz MCM	Go to "MAP 1548: Memory and Processor Problem Isolation" on page 343.
4507 25F1	Memory subsystem and bus tests detected fault in L3 VPD card used with 1.3 GHz MCM	Go to "MAP 1548: Memory and Processor Problem Isolation" on page 343.
4507 28B0	Memory subsystem and bus tests detected fault in I/O subsystem PCI backplane	I/O subsystem PCI backplane at location specified in error code
4507 28B1	Memory subsystem and bus tests detected fault in I/O subsystem DASD backplane	I/O subsystem DASD backplane at location specified in error code
4507 302A	Memory subsystem and bus tests detected fault in 8 GB memory book (inner)	Go to "MAP 1540: Problem Isolation Procedures" on page 303 to isolate the failing component.
4507 302B	Memory subsystem and bus tests detected fault in 8 GB memory book (outer)	Go to "MAP 1540: Problem Isolation Procedures" on page 303 to isolate the failing component.
4507 302C	Memory subsystem and bus tests detected fault in 32 GB memory book (inner)	Go to "MAP 1540: Problem Isolation Procedures" on page 303 to isolate the failing component.

Error Code	Description	Action/ Possible Failing FRU
4507 302D	Memory subsystem and bus tests detected fault in 32 GB memory book (outer)	Go to "MAP 1540: Problem Isolation Procedures" on page 303 to isolate the failing component.
4507 305C	Memory subsystem and bus tests detected fault in 4 GB inner memory book	Go to "MAP 1544: Inner L3 Module Problem Isolation" on page 334.
4507 305D	Memory subsystem and bus tests detected fault in 4 GB outer memory book	Go to "MAP 1545: Outer L3 Module Problem Isolation" on page 336.
4507 305E	Memory subsystem and bus tests detected fault in 16 GB inner memory book	Go to "MAP 1544: Inner L3 Module Problem Isolation" on page 334.
4507 305F	Memory subsystem and bus tests detected fault in 16 GB outer memory book	Go to "MAP 1545: Outer L3 Module Problem Isolation" on page 336.
4508 248B	Memory subsystem and other bus tests detected fault in operator panel	Operator panel Location: U1.17-L1
4508 25C0	Memory subsystem and other bus tests detected fault in system backplane	System backplane Location: U1.18-P1
4508 25C1	Memory subsystem and other bus tests detected fault in 1.0 GHz clock card	Clock card Location: U1.18-P1-X5
4508 25D9	Memory subsystem and other bus tests detected fault in L3 VPD card used with 1.1 GHz MCM and 1.3 GHz MCM	Go to "MAP 1548: Memory and Processor Problem Isolation" on page 343.
4508 25F1	Memory subsystem and other bus tests detected fault in L3 VPD card used with 1.3 GHz MCM	Go to "MAP 1548: Memory and Processor Problem Isolation" on page 343.
4508 28B0	Memory subsystem and other bus tests detected fault in I/O subsystem PCI backplane	I/O subsystem PCI backplane at location specified in error code
4508 28B1	Memory subsystem and other bus tests detected fault in I/O subsystem DASD backplane	I/O subsystem DASD backplane at location specified in error code
4508 302A	Memory subsystem and other bus tests detected fault in 8 GB memory book (inner)	Go to "MAP 1540: Problem Isolation Procedures" on page 303 to isolate the failing component.
4508 302B	Memory subsystem and other bus tests detected fault in 8 GB memory book (outer)	Go to "MAP 1540: Problem Isolation Procedures" on page 303 to isolate the failing component.
4508 302C	Memory subsystem and other bus tests detected fault in 32 GB memory book (inner)	Go to "MAP 1540: Problem Isolation Procedures" on page 303 to isolate the failing component.
4508 302D	Memory subsystem and other bus tests detected fault in 32 GB memory book (outer)	Go to "MAP 1540: Problem Isolation Procedures" on page 303 to isolate the failing component.

Error Code	Description	Action/ Possible Failing FRU
4508 305C	Memory subsystem and other bus tests detected fault in 4 GB inner memory book	Go to "MAP 1544: Inner L3 Module Problem Isolation" on page 334.
4508 305D	Memory subsystem and other bus tests detected fault in 4 GB outer memory book	Go to "MAP 1545: Outer L3 Module Problem Isolation" on page 336.
4508 305E	Memory subsystem and other bus tests detected fault in 16 GB inner memory book	Go to "MAP 1544: Inner L3 Module Problem Isolation" on page 334.
4508 305F	Memory subsystem and other bus tests detected fault in 16 GB outer memory book	Go to "MAP 1545: Outer L3 Module Problem Isolation" on page 336.
4509 248B	Memory subsystem and memory tests detected fault in operator panel	Operator panel Location: U1.17-L1
4509 25C0	Memory subsystem and memory tests detected fault in system backplane	System backplane Location: U1.18-P1
4509 25C1	Memory subsystem and memory tests detected fault in 1.0 GHz clock card	Clock card Location: U1.18-P1-X5
4509 25D9	Memory subsystem and memory tests detected fault in L3 VPD card used with 1.1 GHz MCM and 1.3 GHz MCM	Go to "MAP 1548: Memory and Processor Problem Isolation" on page 343.
4509 25F1	Memory subsystem and memory tests detected fault in L3 VPD card used with 1.3 GHz MCM	Go to "MAP 1548: Memory and Processor Problem Isolation" on page 343.
4509 28B0	Memory subsystem and memory tests detected fault in I/O subsystem PCI backplane	I/O subsystem PCI backplane at location specified in error code
4509 28B1	Memory subsystem and memory tests detected fault in I/O subsystem DASD backplane	I/O subsystem DASD backplane at location specified in error code
4509 302A	Memory subsystem and memory tests detected fault in 8 GB memory book (inner)	Go to "MAP 1540: Problem Isolation Procedures" on page 303 to isolate the failing component.
4509 302B	Memory subsystem and memory tests detected fault in 8 GB memory book (outer)	Go to "MAP 1540: Problem Isolation Procedures" on page 303 to isolate the failing component.
4509 302C	Memory subsystem and memory tests detected fault in 32 GB memory book (inner)	Go to "MAP 1540: Problem Isolation Procedures" on page 303 to isolate the failing component.
4509 302D	Memory subsystem and memory tests detected fault in 32 GB memory book (outer)	Go to "MAP 1540: Problem Isolation Procedures" on page 303 to isolate the failing component.
4509 305C	Memory subsystem and memory tests detected fault in 4 GB inner memory book	Go to "MAP 1544: Inner L3 Module Problem Isolation" on page 334.

Error Code	Description	Action/ Possible Failing FRU
4509 305D	Memory subsystem and memory tests detected fault in 4 GB outer memory book	Go to "MAP 1545: Outer L3 Module Problem Isolation" on page 336.
4509 305E	Memory subsystem and memory tests detected fault in 16 GB inner memory book	Go to "MAP 1544: Inner L3 Module Problem Isolation" on page 334.
4509 305F	Memory subsystem and memory tests detected fault in 16 GB outer memory book	Go to "MAP 1545: Outer L3 Module Problem Isolation" on page 336.
450A 248B	Memory subsystem and self-tests detected fault in operator panel	Operator panel Location: U1.17-L1
450A 25C0	Memory subsystem and self-tests detected fault in system backplane	System backplane Location: U1.18-P1
450A 25C1	Memory subsystem and self-tests detected fault in 1.0 GHz clock card	Clock card Location: U1.18-P1-X5
450A 25D9	Memory subsystem and self-tests detected fault in L3 VPD card used with 1.1 GHz MCM and 1.3 GHz MCM	Go to "MAP 1548: Memory and Processor Problem Isolation" on page 343.
450A 25F1	Memory subsystem and self-tests detected fault in L3 VPD card used with 1.3 GHz MCM	Go to "MAP 1548: Memory and Processor Problem Isolation" on page 343.
450A 28B0	Memory subsystem and self-tests detected fault in I/O subsystem PCI backplane	I/O subsystem PCI backplane at location specified in error code
450A 28B1	Memory subsystem and self-tests detected fault in I/O subsystem DASD backplane	I/O subsystem DASD backplane at location specified in error code
450A 302A	Memory subsystem and self-tests detected fault in 8 GB memory book (inner)	Go to "MAP 1540: Problem Isolation Procedures" on page 303 to isolate the failing component.
450A 302B	Memory subsystem and self-tests detected fault in 8 GB memory book (outer)	Go to "MAP 1540: Problem Isolation Procedures" on page 303 to isolate the failing component.
450A 302C	Memory subsystem and self-tests detected fault in 32 GB memory book (inner)	Go to "MAP 1540: Problem Isolation Procedures" on page 303 to isolate the failing component.
450A 302D	Memory subsystem and self-tests detected fault in 32 GB memory book (outer)	Go to "MAP 1540: Problem Isolation Procedures" on page 303 to isolate the failing component.
450A 305C	Memory subsystem and self-tests detected fault in 4 GB inner memory book	Go to "MAP 1544: Inner L3 Module Problem Isolation" on page 334.
450A 305D	Memory subsystem and self-tests detected fault in 4 GB outer memory book	Go to "MAP 1545: Outer L3 Module Problem Isolation" on page 336.

Error Code	Description	Action/ Possible Failing FRU
450A 305E	Memory subsystem and self-tests detected fault in 16 GB inner memory book	Go to "MAP 1544: Inner L3 Module Problem Isolation" on page 334.
450A 305F	Memory subsystem and self-tests detected fault in 16 GB outer memory book	Go to "MAP 1545: Outer L3 Module Problem Isolation" on page 336.
450B 248B	Memory subsystem and wire tests detected fault in operator panel	Operator panel Location: U1.17-L1
450B 25C0	Memory subsystem and wire tests detected fault in system backplane	System backplane Location: U1.18-P1
450B 25C1	Memory subsystem and wire tests detected fault in 1.0 GHz clock card	Clock card Location: U1.18-P1-X5
450B 25D9	Memory subsystem and wire tests detected fault in L3 VPD card used with 1.1 GHz MCM and 1.3 GHz MCM	Go to "MAP 1548: Memory and Processor Problem Isolation" on page 343.
450B 25F1	Memory subsystem and wire tests detected fault in L3 VPD card used with 1.3 GHz MCM	Go to "MAP 1548: Memory and Processor Problem Isolation" on page 343.
450B 28B0	Memory subsystem and wire tests detected fault in I/O subsystem PCI backplane	I/O subsystem PCI backplane at location specified in error code
450B 28B1	Memory subsystem and wire tests detected fault in I/O subsystem DASD backplane	I/O subsystem DASD backplane at location specified in error code
450B 302A	Memory subsystem and wire tests detected fault in 8 GB memory book (inner)	Go to "MAP 1540: Problem Isolation Procedures" on page 303 to isolate the failing component.
450B 302B	Memory subsystem and wire tests detected fault in 8 GB memory book (outer)	Go to "MAP 1540: Problem Isolation Procedures" on page 303 to isolate the failing component.
450B 302C	Memory subsystem and wire tests detected fault in 32 GB memory book (inner)	Go to "MAP 1540: Problem Isolation Procedures" on page 303 to isolate the failing component.
450B 302D	Memory subsystem and wire tests detected fault in 32 GB memory book (outer)	Go to "MAP 1540: Problem Isolation Procedures" on page 303 to isolate the failing component.
450B 305C	Memory subsystem and wire tests detected fault in 4 GB inner memory book	Go to "MAP 1544: Inner L3 Module Problem Isolation" on page 334.
450B 305D	Memory subsystem and wire tests detected fault in 4 GB outer memory book	Go to "MAP 1545: Outer L3 Module Problem Isolation" on page 336.
450B 305E	Memory subsystem and wire tests detected fault in 16 GB inner memory book	Go to "MAP 1544: Inner L3 Module Problem Isolation" on page 334.

Error Code	Description	Action/ Possible Failing FRU
450B 305F	Memory subsystem and wire tests detected fault in 16 GB outer memory book	Go to "MAP 1545: Outer L3 Module Problem Isolation" on page 336.
450C 248B	Memory subsystem and IPL detected fault in operator panel	Operator panel Location: U1.17-L1
450C 25C0	Memory subsystem and IPL detected fault in system backplane	System backplane Location: U1.18-P1
450C 25C1	Memory subsystem and IPL detected fault in 1.0 GHz clock card	Clock card Location: U1.18-P1-X5
450C 25D9	Memory subsystem and IPL detected fault in L3 VPD card used with 1.1 GHz MCM and 1.3 GHz MCM	Go to "MAP 1548: Memory and Processor Problem Isolation" on page 343.
450C 25F1	Memory subsystem and IPL detected fault in L3 VPD card used with 1.3 GHz MCM	Go to "MAP 1548: Memory and Processor Problem Isolation" on page 343.
450C 28B0	Memory subsystem and IPL detected fault in I/O subsystem PCI backplane	I/O subsystem PCI backplane at location specified in error code
450C 28B1	Memory subsystem and IPL detected fault in I/O subsystem DASD backplane	I/O subsystem DASD backplane at location specified in error code
450C 302A	Memory subsystem and IPL detected fault in 8 GB memory book (inner)	Go to "MAP 1540: Problem Isolation Procedures" on page 303 to isolate the failing component.
450C 302B	Memory subsystem and IPL detected fault in 8 GB memory book (outer)	Go to "MAP 1540: Problem Isolation Procedures" on page 303 to isolate the failing component.
450C 302C	Memory subsystem and IPL detected fault in 32 GB memory book (inner)	Go to "MAP 1540: Problem Isolation Procedures" on page 303 to isolate the failing component.
450C 302D	Memory subsystem and IPL detected fault in 32 GB memory book (outer)	Go to "MAP 1540: Problem Isolation Procedures" on page 303 to isolate the failing component.
450C 305C	Memory subsystem and IPL detected fault in 4 GB inner memory book	Go to "MAP 1544: Inner L3 Module Problem Isolation" on page 334.
450C 305D	Memory subsystem and IPL detected fault in 4 GB outer memory book	Go to "MAP 1545: Outer L3 Module Problem Isolation" on page 336.
450C 305E	Memory subsystem and IPL detected fault in 16 GB inner memory book	Go to "MAP 1544: Inner L3 Module Problem Isolation" on page 334.
450C 305F	Memory subsystem and IPL detected fault in 16 GB outer memory book	Go to "MAP 1545: Outer L3 Module Problem Isolation" on page 336.
450D 248B	Memory subsystem and attention handler detected fault in operator panel	Operator panel Location: U1.17-L1
450D 25C0	Memory subsystem and attention handler detected fault in system backplane	System backplane Location: U1.18-P1

Error Code	Description	Action/ Possible Failing FRU
450D 25C1	Memory subsystem and attention handler detected fault in 1.0 GHz clock card	Clock card Location: U1.18-P1-X5
450D 25D9	Memory subsystem and attention handler detected fault in L3 VPD card used with 1.1 GHz MCM and 1.3 GHz MCM	Go to "MAP 1548: Memory and Processor Problem Isolation" on page 343.
450D 25F1	Memory subsystem and attention handler detected fault in L3 VPD card used with 1.3 GHz MCM	Go to "MAP 1548: Memory and Processor Problem Isolation" on page 343.
450D 28B0	Memory subsystem and attention handler detected fault in I/O subsystem PCI backplane	I/O subsystem PCI backplane at location specified in error code
450D 28B1	Memory subsystem and attention handler detected fault in I/O subsystem DASD backplane	I/O subsystem DASD backplane at location specified in error code
450D 302A	Memory subsystem and attention handler detected fault in 8 GB memory book (inner)	Go to "MAP 1540: Problem Isolation Procedures" on page 303 to isolate the failing component.
450D 302B	Memory subsystem and attention handler detected fault in 8 GB memory book (outer)	Go to "MAP 1540: Problem Isolation Procedures" on page 303 to isolate the failing component.
450D 302C	Memory subsystem and attention handler detected fault in 32 GB memory book (inner)	Go to "MAP 1540: Problem Isolation Procedures" on page 303 to isolate the failing component.
450D 302D	Memory subsystem and attention handler detected fault in 32 GB memory book (outer)	Go to "MAP 1540: Problem Isolation Procedures" on page 303 to isolate the failing component.
450D 305C	Memory subsystem and attention handler detected fault in 4 GB inner memory book	Go to "MAP 1544: Inner L3 Module Problem Isolation" on page 334.
450D 305D	Memory subsystem and attention handler detected fault in 4 GB outer memory book	Go to "MAP 1545: Outer L3 Module Problem Isolation" on page 336.
450D 305E	Memory subsystem and attention handler detected fault in 16 GB inner memory book	Go to "MAP 1544: Inner L3 Module Problem Isolation" on page 334.
450D 305F	Memory subsystem and attention handler detected fault in 16 GB outer memory book	Go to "MAP 1545: Outer L3 Module Problem Isolation" on page 336.
450E 248B	Memory subsystem and scan control routines detected fault in operator panel	Operator panel Location: U1.17-L1
450E 25C0	Memory subsystem and scan control routines detected fault in system backplane	System backplane Location: U1.18-P1

Error Code	Description	Action/ Possible Failing FRU
450E 25C1	Memory subsystem and scan control routines detected fault in 1.0 GHz clock card	Clock card Location: U1.18-P1-X5
450E 25D9	Memory subsystem and scan control routines detected fault in L3 VPD card used with 1.1 GHz MCM and 1.3 GHz MCM	Go to "MAP 1548: Memory and Processor Problem Isolation" on page 343.
450E 25F1	Memory subsystem and scan control routines detected fault in L3 VPD card used with 1.3 GHz MCM	Go to "MAP 1548: Memory and Processor Problem Isolation" on page 343.
450E 28B0	Memory subsystem and scan control routines detected fault in I/O subsystem PCI backplane	I/O subsystem PCI backplane at location specified in error code
450E 28B1	Memory subsystem and scan control routines detected fault in I/O subsystem DASD backplane	I/O subsystem DASD backplane at location specified in error code
450E 302A	Memory subsystem and scan control routines detected fault in 8 GB memory book (inner)	Go to "MAP 1540: Problem Isolation Procedures" on page 303 to isolate the failing component.
450E 302B	Memory subsystem and scan control routines detected fault in 8 GB memory book (outer)	Go to "MAP 1540: Problem Isolation Procedures" on page 303 to isolate the failing component.
450E 302C	Memory subsystem and scan control routines detected fault in 32 GB memory book (inner)	Go to "MAP 1540: Problem Isolation Procedures" on page 303 to isolate the failing component.
450E 302D	Memory subsystem and scan control routines detected fault in 32 GB memory book (outer)	Go to "MAP 1540: Problem Isolation Procedures" on page 303 to isolate the failing component.
450E 305C	Memory subsystem and scan control routines detected fault in 4 GB inner memory book	Go to "MAP 1544: Inner L3 Module Problem Isolation" on page 334.
450E 305D	Memory subsystem and scan control routines detected fault in 4 GB outer memory book	Go to "MAP 1545: Outer L3 Module Problem Isolation" on page 336.
450E 305E	Memory subsystem and scan control routines detected fault in 16 GB inner memory book	Go to "MAP 1544: Inner L3 Module Problem Isolation" on page 334.
450E 305F	Memory subsystem and scan control routines detected fault in 16 GB outer memory book	Go to "MAP 1545: Outer L3 Module Problem Isolation" on page 336.
450F 248B	Memory subsystem and error code generation/logging detected fault in operator panel	Operator panel Location: U1.17-L1
450F 25C0	Memory subsystem and error code generation/logging detected fault in system backplane	System backplane Location: U1.18-P1

Error Code	Description	Action/ Possible Failing FRU
450F 25C1	Memory subsystem and error code generation/logging detected fault in 1.0 GHz clock card	Clock card Location: U1.18-P1-X5
450F 25D9	Memory subsystem and error code generation/logging detected fault in L3 VPD card used with 1.1 GHz MCM and 1.3 GHz MCM	Go to "MAP 1548: Memory and Processor Problem Isolation" on page 343.
450F 25F1	Memory subsystem and error code generation/logging detected fault in L3 VPD card used with 1.3 GHz MCM	Go to "MAP 1548: Memory and Processor Problem Isolation" on page 343.
450F 28B0	Memory subsystem and error code generation/logging detected fault in I/O subsystem PCI backplane	I/O subsystem PCI backplane at location specified in error code
450F 28B1	Memory subsystem and error code generation/logging detected fault in I/O subsystem DASD backplane	I/O subsystem DASD backplane at location specified in error code
450F 302A	Memory subsystem and error code generation/logging detected fault in 8 GB memory book (inner)	Go to "MAP 1540: Problem Isolation Procedures" on page 303 to isolate the failing component.
450F 302B	Memory subsystem and error code generation/logging detected fault in 8 GB memory book (outer)	Go to "MAP 1540: Problem Isolation Procedures" on page 303 to isolate the failing component.
450F 302C	Memory subsystem and error code generation/logging detected fault in 32 GB memory book (inner)	Go to "MAP 1540: Problem Isolation Procedures" on page 303 to isolate the failing component.
450F 302D	Memory subsystem and error code generation/logging detected fault in 32 GB memory book (outer)	Go to "MAP 1540: Problem Isolation Procedures" on page 303 to isolate the failing component.
450F 305C	Memory subsystem and error code generation/logging detected fault in 4 GB inner memory book	Go to "MAP 1544: Inner L3 Module Problem Isolation" on page 334.
450F 305D	Memory subsystem and error code generation/logging detected fault in 4 GB outer memory book	Go to "MAP 1545: Outer L3 Module Problem Isolation" on page 336.
450F 305E	Memory subsystem and error code generation/logging detected fault in 16 GB inner memory book	Go to "MAP 1544: Inner L3 Module Problem Isolation" on page 334.
450F 305F	Memory subsystem and error code generation/logging detected fault in 16 GB outer memory book	Go to "MAP 1545: Outer L3 Module Problem Isolation" on page 336.
4604 248B	I/O subsystem and processor subsystem tests detected fault in operator panel	Operator panel Location: U1.17-L1
4604 25C0	I/O subsystem and processor subsystem tests detected fault in system backplane	System backplane Location: U1.18-P1

Error Code	Description	Action/ Possible Failing FRU
4604 25C1	I/O subsystem and processor subsystem tests detected fault in 1.0 GHz clock card	Clock card Location: U1.18-P1-X5
4604 2738	I/O subsystem and processor subsystem tests detected fault in I/O book 1, 3, or 4	<ol style="list-style-type: none"> 1. If word 13 is CFF1 xxxx, a configuration problem exists. Ensure that the number of MCMs is consistent with the number of I/O books. 2. Replace I/O book 1, 3, or 4 at location specified in error code.
4604 273C	I/O subsystem and processor subsystem tests detected fault in primary I/O book - Slot 0	Primary I/O book - Slot 0 Location: U1.18-P1-H2
4604 28B0	I/O subsystem and processor subsystem tests detected fault in I/O subsystem PCI backplane	I/O subsystem PCI backplane at location specified in error code
4604 28B1	I/O subsystem and processor subsystem tests detected fault in I/O subsystem DASD backplane	I/O subsystem DASD backplane at location specified in error code
4605 248B	I/O subsystem and display alter tests detected fault in operator panel	Operator panel Location: U1.17-L1
4605 25C0	I/O subsystem and display alter tests detected fault in system backplane	System backplane Location: U1.18-P1
4605 25C1	I/O subsystem and display alter tests detected fault in 1.0 GHz clock card	Clock card Location: U1.18-P1-X5
4605 2738	I/O subsystem and display alter tests detected fault in I/O book 1, 3, or 4	<ol style="list-style-type: none"> 1. If word 13 is CFF1 xxxx, a configuration problem exists. Ensure that the number of MCMs is consistent with the number of I/O books. 2. Replace I/O book 1, 3, or 4 at location specified in error code.
4605 273C	I/O subsystem and display alter tests detected fault in primary I/O book - Slot 0	Primary I/O book - Slot 0 Location: U1.18-P1-H2
4605 28B0	I/O subsystem and display alter tests detected fault in I/O subsystem PCI backplane	I/O subsystem PCI backplane at location specified in error code
4605 28B1	I/O subsystem and display alter tests detected fault in I/O subsystem DASD backplane	I/O subsystem DASD backplane at location specified in error code
4606 248B	I/O subsystem and scan interface basic assurance tests detected fault in operator panel	Operator panel Location: U1.17-L1

Error Code	Description	Action/ Possible Failing FRU
4606 25C0	I/O subsystem and scan interface basic assurance tests detected fault in system backplane	System backplane Location: U1.18-P1
4606 25C1	I/O subsystem and scan interface basic assurance tests detected fault in 1.0 GHz clock card	Clock card Location: U1.18-P1-X5
4606 2738	I/O subsystem and scan interface basic assurance tests detected fault in I/O book 1, 3, or 4	<ol style="list-style-type: none"> 1. If word 13 is CFF1 xxxx, a configuration problem exists. Ensure that the number of MCMs is consistent with the number of I/O books. 2. Replace I/O book 1, 3, or 4 at location specified in error code.
4606 273C	I/O subsystem and scan interface basic assurance tests detected fault in primary I/O book - Slot 0	Primary I/O book - Slot 0 Location: U1.18-P1-H2
4606 28B0	I/O subsystem and scan interface basic assurance tests detected fault in I/O subsystem PCI backplane	I/O subsystem PCI backplane at location specified in error code
4606 28B1	I/O subsystem and scan interface basic assurance tests detected fault in I/O subsystem DASD backplane	I/O subsystem DASD backplane at location specified in error code
4607 248B	I/O subsystem and bus tests detected fault in operator panel	Operator panel Location: U1.17-L1
4607 25C0	I/O subsystem and bus tests detected fault in system backplane	System backplane Location: U1.18-P1
4607 25C1	I/O subsystem and bus tests detected fault in 1.0 GHz clock card	Clock card Location: U1.18-P1-X5
4607 2738	I/O subsystem and bus tests detected fault in I/O book 1, 3, or 4	<ol style="list-style-type: none"> 1. If word 13 is CFF1 xxxx, a configuration problem exists. Ensure that the number of MCMs is consistent with the number of I/O books. 2. Replace I/O book 1, 3, or 4 at location specified in error code.
4607 273C	I/O subsystem and bus tests detected fault in primary I/O book - Slot 0	Primary I/O book - Slot 0 Location: U1.18-P1-H2
4607 28B0	I/O subsystem and bus tests detected fault in I/O subsystem PCI backplane	I/O subsystem PCI backplane at location specified in error code
4607 28B1	I/O subsystem and bus tests detected fault in I/O subsystem DASD backplane	I/O subsystem DASD backplane at location specified in error code
4608 248B	I/O subsystem and other bus tests detected fault in operator panel	Operator panel Location: U1.17-L1
4608 25C0	I/O subsystem and other bus tests detected fault in system backplane	System backplane Location: U1.18-P1

Error Code	Description	Action/ Possible Failing FRU
4608 25C1	I/O subsystem and other bus tests detected fault in 1.0 GHz clock card	Clock card Location: U1.18-P1-X5
4608 2738	I/O subsystem and other bus tests detected fault in I/O book 1, 3, or 4	<ol style="list-style-type: none"> 1. If word 13 is CFF1 xxxx, a configuration problem exists. Ensure that the number of MCMs is consistent with the number of I/O books. 2. Replace I/O book 1, 3, or 4 at location specified in error code.
4608 273C	I/O subsystem and other bus tests detected fault in primary I/O book - Slot 0	Primary I/O book - Slot 0 Location: U1.18-P1-H2
4608 28B0	I/O subsystem and other bus tests detected fault in I/O subsystem PCI backplane	I/O subsystem PCI backplane at location specified in error code
4608 28B1	I/O subsystem and other bus tests detected fault in I/O subsystem DASD backplane	I/O subsystem DASD backplane at location specified in error code
4609 248B	I/O subsystem and memory tests detected fault in operator panel	Operator panel Location: U1.17-L1
4609 25C0	I/O subsystem and memory tests detected fault in system backplane	System backplane Location: U1.18-P1
4609 25C1	I/O subsystem and memory tests detected fault in 1.0 GHz clock card	Clock card Location: U1.18-P1-X5
4609 2738	I/O subsystem and memory tests detected fault in I/O book 1, 3, or 4	<ol style="list-style-type: none"> 1. If word 13 is CFF1 xxxx, a configuration problem exists. Ensure that the number of MCMs is consistent with the number of I/O books. 2. Replace I/O book 1, 3, or 4 at location specified in error code.
4609 273C	I/O subsystem and memory tests detected fault in primary I/O book - Slot 0	Primary I/O book - Slot 0 Location: U1.18-P1-H2
4609 28B0	I/O subsystem and memory tests detected fault in I/O subsystem PCI backplane	I/O subsystem PCI backplane at location specified in error code
4609 28B1	I/O subsystem and memory tests detected fault in I/O subsystem DASD backplane	I/O subsystem DASD backplane at location specified in error code
460A 248B	I/O subsystem and self-tests detected fault in operator panel	Operator panel Location: U1.17-L1
460A 25C0	I/O subsystem and self-tests detected fault in system backplane	System backplane Location: U1.18-P1

Error Code	Description	Action/ Possible Failing FRU
460A 25C1	I/O subsystem and self-tests detected fault in 1.0 GHz clock card	Clock card Location: U1.18-P1-X5
460A 2738	I/O subsystem and self-tests detected fault in I/O book 1, 3, or 4	<ol style="list-style-type: none"> 1. If word 13 is CFF1 xxxx, a configuration problem exists. Ensure that the number of MCMs is consistent with the number of I/O books. 2. Replace I/O book 1, 3, or 4 at location specified in error code.
460A 273C	I/O subsystem and self-tests detected fault in primary I/O book - Slot 0	Primary I/O book - Slot 0 Location: U1.18-P1-H2
460A 28B0	I/O subsystem and self-tests detected fault in I/O subsystem PCI backplane	I/O subsystem PCI backplane at location specified in error code
460A 28B1	I/O subsystem and self-tests detected fault in I/O subsystem DASD backplane	I/O subsystem DASD backplane at location specified in error code
460B 248B	I/O subsystem and wire tests detected fault in operator panel	Operator panel Location: U1.17-L1
460B 25C0	I/O subsystem and wire tests detected fault in system backplane	System backplane Location: U1.18-P1
460B 25C1	I/O subsystem and wire tests detected fault in 1.0 GHz clock card	Clock card Location: U1.18-P1-X5
460B 2738	I/O subsystem and wire tests detected fault in I/O book 1, 3, or 4	<ol style="list-style-type: none"> 1. If word 13 is CFF1 xxxx, a configuration problem exists. Ensure that the number of MCMs is consistent with the number of I/O books. 2. Replace I/O book 1, 3, or 4 at location specified in error code.
460B 273C	I/O subsystem and wire tests detected fault in primary I/O book - Slot 0	Primary I/O book - Slot 0 Location: U1.18-P1-H2
460B 28B0	I/O subsystem and wire tests detected fault in I/O subsystem PCI backplane	I/O subsystem PCI backplane at location specified in error code
460B 28B1	I/O subsystem and wire tests detected fault in I/O subsystem DASD backplane	I/O subsystem DASD backplane at location specified in error code
460C 248B	I/O subsystem and IPL detected fault in operator panel	Operator panel Location: U1.17-L1
460C 25C0	I/O subsystem and IPL detected fault in system backplane	System backplane Location: U1.18-P1
460C 25C1	I/O subsystem and IPL detected fault in 1.0 GHz clock card	Clock card Location: U1.18-P1-X5

Error Code	Description	Action/ Possible Failing FRU
460C 2738	I/O subsystem and IPL detected fault in I/O book 1, 3, or 4	<ol style="list-style-type: none"> 1. If word 13 is CFF1 xxxx, a configuration problem exists. Ensure that the number of MCMs is consistent with the number of I/O books. 2. Replace I/O book 1, 3, or 4 at location specified in error code.
460C 273C	I/O subsystem and IPL detected fault in primary I/O book - Slot 0	Primary I/O book - Slot 0 Location: U1.18-P1-H2
460C 28B0	I/O subsystem and IPL detected fault in I/O subsystem PCI backplane	I/O subsystem PCI backplane at location specified in error code
460C 28B1	I/O subsystem and IPL detected fault in I/O subsystem DASD backplane	I/O subsystem DASD backplane at location specified in error code
460D 248B	I/O subsystem and attention handler detected fault in operator panel	Operator panel Location: U1.17-L1
460D 25C0	I/O subsystem and attention handler detected fault in system backplane	System backplane Location: U1.18-P1
460D 25C1	I/O subsystem and attention handler detected fault in 1.0 GHz clock card	Clock card Location: U1.18-P1-X5
460D 2738	I/O subsystem and attention handler detected fault in I/O book 1, 3, or 4	<ol style="list-style-type: none"> 1. If word 13 is CFF1 xxxx, a configuration problem exists. Ensure that the number of MCMs is consistent with the number of I/O books. 2. Replace I/O book 1, 3, or 4 at location specified in error code.
460D 273C	I/O subsystem and attention handler detected fault in primary I/O book - Slot 0	Primary I/O book - Slot 0 Location: U1.18-P1-H2
460D 28B0	I/O subsystem and attention handler detected fault in I/O subsystem PCI backplane	I/O subsystem PCI backplane at location specified in error code
460D 28B1	I/O subsystem and attention handler detected fault in I/O subsystem DASD backplane	I/O subsystem DASD backplane at location specified in error code
460E 248B	I/O subsystem and scan control routines detected fault in operator panel	Operator panel Location: U1.17-L1
460E 25C0	I/O subsystem and scan control routines detected fault in system backplane	System backplane Location: U1.18-P1
460E 25C1	I/O subsystem and scan control routines detected fault in 1.0 GHz clock card	Clock card Location: U1.18-P1-X5

Error Code	Description	Action/ Possible Failing FRU
460E 2738	I/O subsystem and scan control routines detected fault in I/O book 1, 3, or 4	<ol style="list-style-type: none"> 1. If word 13 is CFF1 xxxx, a configuration problem exists. Ensure that the number of MCMs is consistent with the number of I/O books. 2. Replace I/O book 1, 3, or 4 at location specified in error code.
460E 273C	I/O subsystem and scan control routines detected fault in primary I/O book - Slot 0	Primary I/O book - Slot 0 Location: U1.18-P1-H2
460E 28B0	I/O subsystem and scan control routines detected fault in I/O subsystem PCI backplane	I/O subsystem PCI backplane at location specified in error code
460E 28B1	I/O subsystem and scan control routines detected fault in I/O subsystem DASD backplane	I/O subsystem DASD backplane at location specified in error code
460F 248B	I/O subsystem and error code generation/logging detected fault in operator panel	Operator panel Location: U1.17-L1
460F 25C0	I/O subsystem and error code generation/logging detected fault in system backplane	System backplane Location: U1.18-P1
460F 25C1	I/O subsystem and error code generation/logging detected fault in 1.0 GHz clock card	Clock card Location: U1.18-P1-X5
460F 2738	I/O subsystem and error code generation/logging detected fault in I/O book 1, 3, or 4	<ol style="list-style-type: none"> 1. If word 13 is CFF1 xxxx, a configuration problem exists. Ensure that the number of MCMs is consistent with the number of I/O books. 2. Replace I/O book 1, 3, or 4 at location specified in error code.
460F 273C	I/O subsystem and error code generation/logging detected fault in primary I/O book - Slot 0	Primary I/O book - Slot 0 Location: U1.18-P1-H2
460F 28B0	I/O subsystem and error code generation/logging detected fault in I/O subsystem PCI backplane	I/O subsystem PCI backplane at location specified in error code
460F 28B1	I/O subsystem and error code generation/logging detected fault in I/O subsystem DASD backplane	I/O subsystem DASD backplane at location specified in error code
4B24 248B	Processor subsystem detected fault in operator panel	Operator panel Location: U1.17-L1
4B24 25C0	Processor subsystem detected fault in system backplane	System backplane Location: U1.18-P1

(3)

(3)

Error Code	Description	Action/ Possible Failing FRU
4B24 25C1	Processor subsystem detected fault in 1.0 GHz clock card	Clock card Location: U1.18-P1-X5
4B24 25C7	Processor subsystem detected fault in 4-way processor MCM	Go to "MAP 1540: Problem Isolation Procedures" on page 303 to isolate the failing component.
4B24 25C8	Processor subsystem detected fault in 4-way processor MCM	Go to "MAP 1540: Problem Isolation Procedures" on page 303 to isolate the failing component.
4B24 25D3	Processor subsystem detected fault in 8-way processor MCM with VPD card	Go to "MAP 1540: Problem Isolation Procedures" on page 303 to isolate the failing component.
4B24 25D5	Processor subsystem detected fault in 8-way processor MCM with VPD card (8-, 16-, or 24-way)	Go to "MAP 1540: Problem Isolation Procedures" on page 303 to isolate the failing component.
4B24 25D7	Fault in 4-way processor MCM detected	Go to "MAP 1540: Problem Isolation Procedures" on page 303 to isolate the failing component.
4B24 25D8	Fault in 4-way processor MCM detected	Go to "MAP 1540: Problem Isolation Procedures" on page 303 to isolate the failing component.
4B24 28B0	Processor subsystem detected fault in I/O subsystem PCI backplane	I/O subsystem PCI backplane at location specified in error code
4B24 28B1	Processor subsystem detected fault in I/O subsystem DASD backplane	I/O subsystem DASD backplane at location specified in error code
4B25 248B	Processor subsystem and display alter tests detected fault in operator panel	Operator panel Location: U1.17-L1
4B25 25C0	Processor subsystem and display alter tests detected fault in system backplane	System backplane Location: U1.18-P1
4B25 25C1	Processor subsystem and display alter tests detected fault in 1.0 GHz clock card	Clock card Location: U1.18-P1-X5
4B25 25C7	Processor subsystem and display alter tests detected fault in 4-way processor MCM	Go to "MAP 1540: Problem Isolation Procedures" on page 303 to isolate the failing component.
4B25 25C8	Processor subsystem and display alter tests detected fault in 4-way processor MCM	Go to "MAP 1540: Problem Isolation Procedures" on page 303 to isolate the failing component.
4B25 25D3	Processor subsystem and display alter tests detected fault in 8-way processor MCM with VPD card	Go to "MAP 1540: Problem Isolation Procedures" on page 303 to isolate the failing component.
4B25 25D5	Processor subsystem and display alter tests detected fault in 8-way processor MCM with VPD card (8-, 16-, or 24-way)	Go to "MAP 1540: Problem Isolation Procedures" on page 303 to isolate the failing component.

	Error Code	Description	Action/ Possible Failing FRU
(3)	4B25 25D7	Fault in 4-way processor MCM detected	Go to "MAP 1540: Problem Isolation Procedures" on page 303 to isolate the failing component.
(3)	4B25 25D8	Fault in 4-way processor MCM detected	Go to "MAP 1540: Problem Isolation Procedures" on page 303 to isolate the failing component.
	4B25 28B0	Processor subsystem and display alter tests detected fault in I/O subsystem PCI backplane	I/O subsystem PCI backplane at location specified in error code
	4B25 28B1	Processor subsystem and display alter tests detected fault in I/O subsystem DASD backplane	I/O subsystem DASD backplane at location specified in error code
	4B26 248B	Processor subsystem and scan interface basic assurance tests detected fault in operator panel	Operator panel Location: U1.17-L1
	4B26 25C0	Processor subsystem and scan interface basic assurance tests detected fault in system backplane	System backplane Location: U1.18-P1
	4B26 25C1	Processor subsystem and scan interface basic assurance tests detected fault in 1.0 GHz clock card	Clock card Location: U1.18-P1-X5
	4B26 25C7	Processor subsystem and scan interface basic assurance tests detected fault in 4-way processor MCM	Go to "MAP 1540: Problem Isolation Procedures" on page 303 to isolate the failing component.
	4B26 25C8	Processor subsystem and scan interface basic assurance tests detected fault in 4-way processor MCM	Go to "MAP 1540: Problem Isolation Procedures" on page 303 to isolate the failing component.
	4B26 25D3	Processor subsystem and scan interface basic assurance tests detected fault in 8-way processor MCM with VPD card	Go to "MAP 1540: Problem Isolation Procedures" on page 303 to isolate the failing component.
	4B26 25D5	Processor subsystem and scan interface basic assurance tests detected fault in 8-way processor MCM with VPD card (8-, 16-, or 24-way)	Go to "MAP 1540: Problem Isolation Procedures" on page 303 to isolate the failing component.
(3)	4B26 25D7	Fault in 4-way processor MCM detected	Go to "MAP 1540: Problem Isolation Procedures" on page 303 to isolate the failing component.
(3)	4B26 25D8	Fault in 4-way processor MCM detected	Go to "MAP 1540: Problem Isolation Procedures" on page 303 to isolate the failing component.
	4B26 28B0	Processor subsystem and scan interface basic assurance tests detected fault in I/O subsystem PCI backplane	I/O subsystem PCI backplane at location specified in error code

Error Code	Description	Action/ Possible Failing FRU
4B26 28B1	Processor subsystem and scan interface basic assurance tests detected fault in I/O subsystem DASD backplane	I/O subsystem DASD backplane at location specified in error code
4B27 248B	Processor subsystem and bus tests detected fault in operator panel	Operator panel Location: U1.17-L1
4B27 25C0	Processor subsystem and bus tests detected fault in system backplane	System backplane Location: U1.18-P1
4B27 25C1	Processor subsystem and bus tests detected fault in 1.0 GHz clock card	Clock card Location: U1.18-P1-X5
4B27 25C7	Processor subsystem and bus tests detected fault in 4-way processor MCM	Go to "MAP 1540: Problem Isolation Procedures" on page 303 to isolate the failing component.
4B27 25C8	Processor subsystem and bus tests detected fault in 4-way processor MCM	Go to "MAP 1540: Problem Isolation Procedures" on page 303 to isolate the failing component.
4B27 25D3	Processor subsystem and bus tests detected fault in 8-way processor MCM with VPD card	Go to "MAP 1540: Problem Isolation Procedures" on page 303 to isolate the failing component.
4B27 25D5	Processor subsystem and bus tests detected fault in 8-way processor MCM with VPD card (8-, 16-, or 24-way)	Go to "MAP 1540: Problem Isolation Procedures" on page 303 to isolate the failing component.
(3) 4B27 25D7	Fault in 4-way processor MCM detected	Go to "MAP 1540: Problem Isolation Procedures" on page 303 to isolate the failing component.
(3) 4B27 25D8	Fault in 4-way processor MCM detected	Go to "MAP 1540: Problem Isolation Procedures" on page 303 to isolate the failing component.
4B27 28B0	Processor subsystem and bus tests detected fault in I/O subsystem PCI backplane	I/O subsystem PCI backplane at location specified in error code
4B27 28B1	Processor subsystem and bus tests detected fault in I/O subsystem DASD backplane	I/O subsystem DASD backplane at location specified in error code
4B28 248B	Processor subsystem and other bus tests detected fault in operator panel	Operator panel Location: U1.17-L1
4B28 25C0	Processor subsystem and other bus tests detected fault in system backplane	System backplane Location: U1.18-P1
4B28 25C1	Processor subsystem and other bus tests detected fault in 1.0 GHz clock card	Clock card Location: U1.18-P1-X5
4B28 25C7	Processor subsystem and other bus tests detected fault in 4-way processor MCM	Go to "MAP 1540: Problem Isolation Procedures" on page 303 to isolate the failing component.

(3)

(3)

Error Code	Description	Action/ Possible Failing FRU
4B28 25C8	Processor subsystem and other bus tests detected fault in 4-way processor MCM	Go to "MAP 1540: Problem Isolation Procedures" on page 303 to isolate the failing component.
4B28 25D3	Processor subsystem and other bus tests detected fault in 8-way processor MCM with VPD card	Go to "MAP 1540: Problem Isolation Procedures" on page 303 to isolate the failing component.
4B28 25D5	Processor subsystem and other bus tests detected fault in 8-way processor MCM with VPD card (8-, 16-, or 24-way)	Go to "MAP 1540: Problem Isolation Procedures" on page 303 to isolate the failing component.
4B28 25D7	Fault in 4-way processor MCM detected	Go to "MAP 1540: Problem Isolation Procedures" on page 303 to isolate the failing component.
4B28 25D8	Fault in 4-way processor MCM detected	Go to "MAP 1540: Problem Isolation Procedures" on page 303 to isolate the failing component.
4B28 28B0	Processor subsystem and other bus tests detected fault in I/O subsystem PCI backplane	I/O subsystem PCI backplane at location specified in error code
4B28 28B1	Processor subsystem and other bus tests detected fault in I/O subsystem DASD backplane	I/O subsystem DASD backplane at location specified in error code
4B29 248B	Processor subsystem and memory test detected fault in operator panel	Operator panel Location: U1.17-L1
4B29 25C0	Processor subsystem and memory test detected fault in system backplane	System backplane Location: U1.18-P1
4B29 25C1	Processor subsystem and memory test detected fault in 1.0 GHz clock card	Clock card Location: U1.18-P1-X5
4B29 25C7	Processor subsystem and memory test detected fault in 4-way processor MCM	Go to "MAP 1540: Problem Isolation Procedures" on page 303 to isolate the failing component.
4B29 25C8	Processor subsystem and memory test detected fault in 4-way processor MCM	Go to "MAP 1540: Problem Isolation Procedures" on page 303 to isolate the failing component.
4B29 25D3	Processor subsystem and memory test detected fault in 8-way processor MCM with VPD card	Go to "MAP 1540: Problem Isolation Procedures" on page 303 to isolate the failing component.
4B29 25D5	Processor subsystem and memory test detected fault in 8-way processor MCM with VPD card (8-, 16-, or 24-way)	Go to "MAP 1540: Problem Isolation Procedures" on page 303 to isolate the failing component.
4B29 25D7	Fault in 4-way processor MCM detected	Go to "MAP 1540: Problem Isolation Procedures" on page 303 to isolate the failing component.

(3)

(3)

Error Code	Description	Action/ Possible Failing FRU
4B29 25D8	Fault in 4-way processor MCM detected	Go to "MAP 1540: Problem Isolation Procedures" on page 303 to isolate the failing component.
4B29 28B0	Processor subsystem and memory test detected fault in I/O subsystem PCI backplane	I/O subsystem PCI backplane at location specified in error code
4B29 28B1	Processor subsystem and memory test detected fault in I/O subsystem DASD backplane	I/O subsystem DASD backplane at location specified in error code
4B2A 248B	Processor subsystem and self test detected fault in operator panel	Operator panel Location: U1.17-L1
4B2A 25C0	Processor subsystem and self test detected fault in system backplane	System backplane Location: U1.18-P1
4B2A 25C1	Processor subsystem and self test detected fault in 1.0 GHz clock card	Clock card Location: U1.18-P1-X5
4B2A 25C7	Processor subsystem and self test detected fault in 4-way processor MCM	Go to "MAP 1540: Problem Isolation Procedures" on page 303 to isolate the failing component.
4B2A 25C8	Processor subsystem and self test detected fault in 4-way processor MCM	Go to "MAP 1540: Problem Isolation Procedures" on page 303 to isolate the failing component.
4B2A 25D3	Processor subsystem and self test detected fault in 8-way processor MCM with VPD card	Go to "MAP 1540: Problem Isolation Procedures" on page 303 to isolate the failing component.
4B2A 25D5	Processor subsystem and self test detected fault in 8-way processor MCM with VPD card (8-, 16-, or 24-way)	Go to "MAP 1540: Problem Isolation Procedures" on page 303 to isolate the failing component.
4B2A 25D7	Fault in 4-way processor MCM detected	Go to "MAP 1540: Problem Isolation Procedures" on page 303 to isolate the failing component.
4B2A 25D8	Fault in 4-way processor MCM detected	Go to "MAP 1540: Problem Isolation Procedures" on page 303 to isolate the failing component.
4B2A 28B0	Processor subsystem and self test detected fault in I/O subsystem PCI backplane	I/O subsystem PCI backplane at location specified in error code
4B2A 28B1	Processor subsystem and self test detected fault in I/O subsystem DASD backplane	I/O subsystem DASD backplane at location specified in error code
4B2B 248B	Processor subsystem and wire test detected fault in operator panel	Operator panel Location: U1.17-L1
4B2B 25C0	Processor subsystem and wire test detected fault in system backplane	System backplane Location: U1.18-P1
4B2B 25C1	Processor subsystem and wire test detected fault in 1.0 GHz clock card	Clock card Location: U1.18-P1-X5

(3)

(3)

(3)

(3)

Error Code	Description	Action/ Possible Failing FRU
4B2B 25C7	Processor subsystem and wire test detected fault in 4-way processor MCM	Go to "MAP 1540: Problem Isolation Procedures" on page 303 to isolate the failing component.
4B2B 25C8	Processor subsystem and wire test detected fault in 4-way processor MCM	Go to "MAP 1540: Problem Isolation Procedures" on page 303 to isolate the failing component.
4B2B 25D3	Processor subsystem and wire test detected fault in 8-way processor MCM with VPD card	Go to "MAP 1540: Problem Isolation Procedures" on page 303 to isolate the failing component.
4B2B 25D5	Processor subsystem and wire test detected fault in 8-way processor MCM with VPD card (8-, 16-, or 24-way)	Go to "MAP 1540: Problem Isolation Procedures" on page 303 to isolate the failing component.
4B2B 25D7	Fault in 4-way processor MCM detected	Go to "MAP 1540: Problem Isolation Procedures" on page 303 to isolate the failing component.
4B2B 25D8	Fault in 4-way processor MCM detected	Go to "MAP 1540: Problem Isolation Procedures" on page 303 to isolate the failing component.
4B2B 28B0	Processor subsystem and wire test detected fault in I/O subsystem PCI backplane	I/O subsystem PCI backplane at location specified in error code
4B2B 28B1	Processor subsystem and wire test detected fault in I/O subsystem DASD backplane	I/O subsystem DASD backplane at location specified in error code
4B2C 248B	Processor subsystem and IPL detected fault in operator panel	Operator panel Location: U1.17-L1
4B2C 25C0	Processor subsystem and IPL detected fault in system backplane	System backplane Location: U1.18-P1
4B2C 25C1	Processor subsystem and IPL detected fault in 1.0 GHz clock card	Clock card Location: U1.18-P1-X5
4B2C 25C7	Processor subsystem and IPL detected fault in 4-way processor MCM	Go to "MAP 1540: Problem Isolation Procedures" on page 303 to isolate the failing component.
4B2C 25C8	Processor subsystem and IPL detected fault in 4-way processor MCM	Go to "MAP 1540: Problem Isolation Procedures" on page 303 to isolate the failing component.
4B2C 25D3	Processor subsystem and IPL detected fault in 8-way processor MCM with VPD card	Go to "MAP 1540: Problem Isolation Procedures" on page 303 to isolate the failing component.
4B2C 25D5	Processor subsystem and IPL detected fault in 8-way processor MCM with VPD card (8-, 16-, or 24-way)	Go to "MAP 1540: Problem Isolation Procedures" on page 303 to isolate the failing component.
4B2C 25D7	Fault in 4-way processor MCM detected	Go to "MAP 1540: Problem Isolation Procedures" on page 303 to isolate the failing component.

(3)

(3)

Error Code	Description	Action/ Possible Failing FRU
4B2C 25D8	Fault in 4-way processor MCM detected	Go to "MAP 1540: Problem Isolation Procedures" on page 303 to isolate the failing component.
4B2C 28B0	Processor subsystem and IPL detected fault in I/O subsystem PCI backplane	I/O subsystem PCI backplane at location specified in error code
4B2C 28B1	Processor subsystem and IPL detected fault in I/O subsystem DASD backplane	I/O subsystem DASD backplane at location specified in error code
4B2D 248B	Processor subsystem and attention handler detected fault in operator panel	Operator panel Location: U1.17-L1
4B2D 25C0	Processor subsystem and attention handler detected fault in system backplane	System backplane Location: U1.18-P1
4B2D 25C1	Processor subsystem and attention handler detected fault in 1.0 GHz clock card	Clock card Location: U1.18-P1-X5
4B2D 25C7	Processor subsystem and attention handler detected fault in 4-way processor MCM	Go to "MAP 1540: Problem Isolation Procedures" on page 303 to isolate the failing component.
4B2D 25C8	Processor subsystem and attention handler detected fault in 4-way processor MCM	Go to "MAP 1540: Problem Isolation Procedures" on page 303 to isolate the failing component.
4B2D 25D3	Processor subsystem and attention handler detected fault in 8-way processor MCM with VPD card	Go to "MAP 1540: Problem Isolation Procedures" on page 303 to isolate the failing component.
4B2D 25D5	Processor subsystem and attention handler detected fault in 8-way processor MCM with VPD card (8-, 16-, or 24-way)	Go to "MAP 1540: Problem Isolation Procedures" on page 303 to isolate the failing component.
4B2D 25D7	Fault in 4-way processor MCM detected	Go to "MAP 1540: Problem Isolation Procedures" on page 303 to isolate the failing component.
4B2D 25D8	Fault in 4-way processor MCM detected	Go to "MAP 1540: Problem Isolation Procedures" on page 303 to isolate the failing component.
4B2D 28B0	Processor subsystem and attention handler detected fault in I/O subsystem PCI backplane	I/O subsystem PCI backplane at location specified in error code
4B2D 28B1	Processor subsystem and attention handler detected fault in I/O subsystem DASD backplane	I/O subsystem DASD backplane at location specified in error code
4B2E 248B	Processor subsystem and scan control routines detected fault in operator panel	Operator panel Location: U1.17-L1

(3)

(3)

Error Code	Description	Action/ Possible Failing FRU
4B2E 25C0	Processor subsystem and scan control routines detected fault in system backplane	System backplane Location: U1.18-P1
4B2E 25C1	Processor subsystem and scan control routines detected fault in 1.0 GHz clock card	Clock card Location: U1.18-P1-X5
4B2E 25C7	Processor subsystem and scan control routines detected fault in 4-way processor MCM	Go to "MAP 1540: Problem Isolation Procedures" on page 303 to isolate the failing component.
4B2E 25C8	Processor subsystem and scan control routines detected fault in 4-way processor MCM	Go to "MAP 1540: Problem Isolation Procedures" on page 303 to isolate the failing component.
4B2E 25D3	Processor subsystem and scan control routines detected fault in 8-way processor MCM with VPD card	Go to "MAP 1540: Problem Isolation Procedures" on page 303 to isolate the failing component.
4B2E 25D5	Processor subsystem and scan control routines detected fault in 8-way processor MCM with VPD card (8-, 16-, or 24-way)	Go to "MAP 1540: Problem Isolation Procedures" on page 303 to isolate the failing component.
(3) 4B2E 25D7	Fault in 4-way processor MCM detected	Go to "MAP 1540: Problem Isolation Procedures" on page 303 to isolate the failing component.
(3) 4B2E 25D8	Fault in 4-way processor MCM detected	Go to "MAP 1540: Problem Isolation Procedures" on page 303 to isolate the failing component.
4B2E 28B0	Processor subsystem and scan control routines detected fault in I/O subsystem PCI backplane	I/O subsystem PCI backplane at location specified in error code
4B2E 28B1	Processor subsystem and scan control routines detected fault in I/O subsystem DASD backplane	I/O subsystem DASD backplane at location specified in error code
4B2F 248B	Processor subsystem and error code generation/logging detected fault in operator panel	Operator panel Location: U1.17-L1
4B2F 25C0	Processor subsystem and error code generation/logging detected fault in system backplane	System backplane Location: U1.18-P1
4B2F 25C1	Processor subsystem and error code generation/logging detected fault in 1.0 GHz clock card	Clock card Location: U1.18-P1-X5
4B2F 25C7	Processor subsystem and error code generation/logging detected fault in 4-way processor MCM	Go to "MAP 1540: Problem Isolation Procedures" on page 303 to isolate the failing component.
4B2F 25C8	Processor subsystem and error code generation/logging detected fault in 4-way processor MCM	Go to "MAP 1540: Problem Isolation Procedures" on page 303 to isolate the failing component.

(3)

(3)

Error Code	Description	Action/ Possible Failing FRU
4B2F 25D3	Processor subsystem and error code generation/logging detected fault in 8-way processor MCM with VPD card	Go to "MAP 1540: Problem Isolation Procedures" on page 303 to isolate the failing component.
4B2F 25D5	Processor subsystem and error code generation/logging detected fault in 8-way processor MCM with VPD card (8-, 16-, or 24-way)	Go to "MAP 1540: Problem Isolation Procedures" on page 303 to isolate the failing component.
4B2F 25D7	Fault in 4-way processor MCM detected	Go to "MAP 1540: Problem Isolation Procedures" on page 303 to isolate the failing component.
4B2F 25D8	Fault in 4-way processor MCM detected	Go to "MAP 1540: Problem Isolation Procedures" on page 303 to isolate the failing component.
4B2F 28B0	Processor subsystem and error code generation/logging detected fault in I/O subsystem PCI backplane	I/O subsystem PCI backplane at location specified in error code
4B2F 28B1	Processor subsystem and error code generation/logging detected fault in I/O subsystem DASD backplane	I/O subsystem DASD backplane at location specified in error code

System Firmware Update Messages

Error Code	Description	Action/ Possible Failing FRU
A1FD 0000	Firmware update recovery mode entered	Informational message
A1FD 0001	Service processor flash recovery	Insert Diskette #1
A1FD 0002	Service processor flash recovery	Insert Diskette #2
A1FD 0003	Service processor flash recovery	Insert Diskette #3
A1FD 0004	Service processor flash recovery	Insert Diskette #4
A1FD 000n	Service processor flash recovery	Insert Diskette #n

Scan Dump Messages

Table 3. Scan Dump Messages

Error Code	Description	Action/ Possible Failing FRU
A100 3000	Successful completion of scan dump	Informational message; may or may not be seen during a scan log dump.
A1FF 3000	Scan dump has been disabled	Informational message; may or may not be seen during a scan log dump.

Common Firmware Error Codes

Attention: Follow the procedure defined in “Checkpoints and Error Codes Index” on page 403. If you replace FRUs or perform an action on an I/O subsystem and the problem is still not corrected, go to “MAP 1542: I/O Problem Isolation” on page 312 unless you were already directed to any MAP 154x by the error code. Otherwise call support if the action(s) for an error code do not resolve the problem.

Attention: If the error code that brought you to this chapter originated in the AIX error log, remember that an error may require an additional 15 minutes to be propagated to the AIX error log.

If you replace FRUs and the problem is corrected, go to “MAP 0410: Repair Checkout” in the *RS/6000 and @server pSeries Diagnostic Information for Multiple Bus Systems*.

Error Code	Description	Action/ Possible Failing FRU
B006 1403	Missing service processor resource	<ol style="list-style-type: none"> 1. Check for system firmware updates. 2. Primary I/O book Location: U1.18-P1-H2
B006 1404	Service processor firmware fault	<ol style="list-style-type: none"> 1. Check for system firmware updates. 2. Primary I/O book Location: U1.18-P1-H2
B006 1405	Service processor firmware fault	<ol style="list-style-type: none"> 1. Check for system firmware updates. 2. Primary I/O book Location: U1.18-P1-H2
B006 1406	Service processor program error	<ol style="list-style-type: none"> 1. Check for system firmware updates. 2. Check for operating system updates 3. Primary I/O book Location: U1.18-P1-H2
B006 1407	Service processor resource allocation problem	<ol style="list-style-type: none"> 1. Check for system firmware updates. 2. Check for operating system updates 3. Primary I/O book Location: U1.18-P1-H2
B006 1408	Service processor program error	<ol style="list-style-type: none"> 1. Check for system firmware updates. 2. Check for operating system updates 3. Primary I/O book Location: U1.18-P1-H2

Error Code	Description	Action/ Possible Failing FRU
B006 1409	Service processor program error	1. Check for system firmware updates. 2. Primary I/O book Location: U1.18-P1-H2
B10F 1000	Service processor failure	Primary I/O book Location: U1.18-P1-H2
B10F 1002	Service processor failure	Primary I/O book Location: U1.18-P1-H2
B10F 1005	Service processor failure	Primary I/O book Location: U1.18-P1-H2
B10F 1007	Service processor failure	Primary I/O book Location: U1.18-P1-H2
B10F 1008	Service processor failure	Primary I/O book Location: U1.18-P1-H2
B10F 100E	Service processor boot flash corrupted	Primary I/O book Location: U1.18-P1-H2
B10F 100F	Service processor base flash corrupted	Primary I/O book Location: U1.18-P1-H2
B10F 1300	Service processor failure	Primary I/O book Location: U1.18-P1-H2
B10F 1370	Service processor flash update failure	Primary I/O book Location: U1.18-P1-H2
B10F 1380	Service processor program failure	Primary I/O book Location: U1.18-P1-H2
B10F 1381	Service processor flash error	Primary I/O book Location: U1.18-P1-H2
B10F 1384	Service processor failure	Primary I/O book Location: U1.18-P1-H2
B10F 1387	Service processor failure	Primary I/O book Location: U1.18-P1-H2
B10F 1400	Service processor failure	Primary I/O book Location: U1.18-P1-H2
B10F 1401	Service processor failure	Primary I/O book Location: U1.18-P1-H2
B10F 1670	Service processor flash update failure	Primary I/O book Location: U1.18-P1-H2
B10F 1672	Service processor firmware update invalid	Call second level of support
B10F 1675	Service processor memory failure	Primary I/O book Location: U1.18-P1-H2
B10F 1681	Service processor firmware update invalid	Call second level of support

Error Code	Description	Action/ Possible Failing FRU
B10F 1682	Service processor firmware update invalid	Call second level of support
B10F 1683	Service processor firmware update invalid	Call second level of support
B1xx 4600	Service processor failure	<ol style="list-style-type: none"> 1. Check for system firmware updates. 2. Primary I/O book Location: U1.18-P1-H2
B1xx 4601	System processor failure	Reboot the system in slow mode to isolate the failure.
B1xx 4602	RIO failure	<ol style="list-style-type: none"> 1. Primary I/O book Location: U1.18-P1-H2. 2. Go to MAP "MAP 1543: MCM Module Problem Isolation" on page 332.
B1xx 4603	Service processor firmware corrupted	<ol style="list-style-type: none"> 1. Reflash system firmware. 2. Primary I/O book Location: U1.18-P1-H2
B1xx 4606	Firmware failure	<ol style="list-style-type: none"> 1. Check for system firmware updates. 2. Operator panel Location: U1.17-L1
B1xx 4608	Service processor early termination	<ol style="list-style-type: none"> 1. Reset the system by removing, then reapplying power to the processor subsystem. 2. Reflash system firmware. 3. Primary I/O book Location: U1.18-P1-H2
B1xx 460A	Time-of-day clock has been reset	<ol style="list-style-type: none"> 1. Set time-of-day clock 2. Replace Primary I/O book Location: U1.18-P1-H2
B1xx 460B	NVRAM/Time-of-day battery	Replace battery Location: U1.18-P1-H2-V1
B1xx 4611	Service processor failure	<ol style="list-style-type: none"> 1. Reboot the system in slow mode to isolate the problem in the processor subsystem. 2. Primary I/O book Location: U1.18-P1-H2
B1xx 4612	Service processor firmware failure	<ol style="list-style-type: none"> 1. Check for system firmware updates. 2. Primary I/O book Location: U1.18-P1-H2

Error Code	Description	Action/ Possible Failing FRU
B1xx 4613	Service processor failure	Primary I/O book Location: U1.18-P1-H2
B1xx 4614	Service processor failure related to processor subsystem	Reboot the system in slow mode to isolate the problem in the processor subsystem.
B1xx 4620	Modem configuration failure	<ol style="list-style-type: none"> 1. Check modem configuration files. 2. Check for system firmware updates. 3. Modem and modem cable. 4. Primary I/O book Location: U1.18-P1-H2
B1xx 4621	Modem disconnection failure	<ol style="list-style-type: none"> 1. Check modem configuration files. 2. Check for system firmware updates. 3. Modem and modem cable. 4. Primary I/O book Location: U1.18-P1-H2
B1xx 4622	Service processor failure	<ol style="list-style-type: none"> 1. Operator panel Location: U1.17-L1 2. Check for system firmware updates. 3. Primary I/O book Location: U1.18-P1-H2
B1xx 4633	System power control network (SPCN) failure	<ol style="list-style-type: none"> 1. Check for system firmware updates. 2. Primary I/O book Location: U1.18-P1-H2
B1xx 4634	SPCN Loop Fault	<ol style="list-style-type: none"> 1. Check SPCN cabling. 2. Go to "MAP 1542: I/O Problem Isolation" on page 312.
B1xx 4635	AC input was removed, then restored.	Informational message. Look at the service processor error log for additional error codes relating to loss of ac power to the system.
B1xx 4636	System is running on battery back-up power	Informational message.
B1xx 4644	I2C connection failure	<ol style="list-style-type: none"> 1. Check for system firmware updates. 2. Primary I/O book Location: U1.18-P1-H2
B1xx 4645	I2C (non-processor) VPD system fault	Go to "MAP 1540: Problem Isolation Procedures" on page 303.

Error Code	Description	Action/ Possible Failing FRU
B1xx 4646	Vital product data (VPD) acquisition failure	<ol style="list-style-type: none"> 1. Check for system firmware updates. 2. Primary I/O book Location: U1.18-P1-H2
B1xx 4647	Machine type and model fields missing or invalid in system VPD	The machine type and model fields must be rewritten. Call service support.
B1xx 4648	Processor subsystem backplane VPD or power source problem	Go to "MAP 1540: Problem Isolation Procedures" on page 303.
B1xx 4650	System processor failure (all processors reset).	Reboot the system in slow mode to isolate the problem.
B1xx 4651	CPU GARD VPD on MCM 0	U1.18-P1-C1 and U1.18-P1-H2.3
B1xx 4652	CPU GARD VPD on MCM 1	U1.18-P1-C3 and U1.18-P1-H2.5
B1xx 4653	CPU GARD VPD on MCM 2	U1.18-P1-C4 and U1.18-P1-H2.4
B1xx 4654	CPU GARD VPD on MCM 3	U1.18-P1-C2 and U1.18-P1-H2.6
B1xx 4660	Memory subsystem failure (cannot isolate)	Reboot the system in slow mode to isolate the failure, then check the service processor error log for failing FRUs associated with this error code.
B1xx 4661	Memory book VPD failure	Reboot the system in slow mode to isolate the failure, then check the service processor error log for failing FRUs associated with this error code.
B1xx 4662	Memory book VPD failure	Reboot the system in slow mode to isolate the failure, then check the service processor error log for failing FRUs associated with this error code.
B1xx 4682	Problem with VPD on operator panel	<ol style="list-style-type: none"> 1. Replace the operator panel, Location: U1.17-L1 Do not swap the old VPD module onto the new op panel. Call service support for instructions on programming the new VPD module. 2. Call service support.
B1xx 4670	Processor subsystem problem	Reboot the system in slow mode to isolate the failure

Error Code	Description	Action/ Possible Failing FRU
B1xx 4690	Operating system surveillance time out (AIX to service processor interface failure)	<ol style="list-style-type: none"> <li data-bbox="871 244 1250 557">1. This error code indicates that the operating system terminated early (which usually implies an operating system crash). This error code may appear in the service processor error log by itself. However, in the AIX error log, there should be another error which points to the cause of the operating system crash. Use the other error as the starting point for your service action. <li data-bbox="871 574 1250 1182">2. The other possibility is that the operating system was not found during a prior boot attempt. To determine if this occurred, do the following: Look at the AIX error log entry containing B1xx4690. This will be a "SCAN_ERROR_CHRP" error with an identifier of BFEC0425. In the detail data, find the string "B1xx4690" (If present, it will be at byte 60 of the detail data.) Then go forward 8 bytes after the "B1" to byte 68 and look at bytes 68 and 69. If the values of bytes 68 and 69 are A2B0, this indicates that the firmware was unable to find a bootable device in the boot list that is set in the SMS menus. If the system is up, the boot list problem has been corrected and the B1xx 4690 can be treated as an informational message with no actions required. <li data-bbox="871 1199 1250 1216">3. Call service support.

Error Code	Description	Action/ Possible Failing FRU
B1xx 4691	System firmware surveillance interval exceeded (system firmware to service processor interface failure)	<ol style="list-style-type: none"> 1. Check for system firmware updates. 2. Go to the service processor main menu and select System Information Menu, then select Read Progress Indicators From Last System Boot. Begin your repair action with the error code or checkpoint immediately preceding B1xx 4691. If a location code displays with the error code or checkpoint, replace the part at that location. If changing that part does not fix the problem, or no location code is specified, and you have an 8-character error code, go to the "Checkpoints and Error Codes Index" on page 403. If changing that part does not fix the problem, or no location code is specified, and you have a 4-character checkpoint, go to "Firmware Checkpoints" on page 370. 3. If the problem is not solved, call the second level of support.
B1xx 4692	Operator panel task interface failure	<ol style="list-style-type: none"> 1. Check for system firmware updates. 2. Call service support
B1xx 4693	Service processor firmware failure	<ol style="list-style-type: none"> 1. Check for system firmware updates. 2. Call service support
B1xx 4694	System processor firmware failure	<ol style="list-style-type: none"> 1. Check for system firmware updates. 2. Primary I/O book Location: U1.18-P1-H2
B1xx 4695	System power control network (SPCN) to service processor interface failure	<ol style="list-style-type: none"> 1. Check for system firmware updates. 2. Primary I/O book Location: U1.18-P1-H2
B1xx 4696	System firmware interface failure	<ol style="list-style-type: none"> 1. Check for system firmware updates. 2. Call service support.
B1xx 4698	Service processor firmware problem	<ol style="list-style-type: none"> 1. Check for system firmware updates. 2. Call service support.

Error Code	Description	Action/ Possible Failing FRU
B1xx 4699	<p>Service processor firmware:</p> <p>This is usually an indication of a problem in the communication path between the HMC and the service processor. It may only be an informational message.</p> <p>If the managed server is down, go to the service processor error log and find the error log entry containing B1xx 4699. Look at the first two bytes of word 13 of the detailed entry information.</p> <p>If the managed server is running, look at the AIX error log entry containing B1xx 4699. This is a "SCAN_ERROR_CHRP" error with an identifier of BFE4C025. In the detail data, find the string "B1xx 4699". (If present, it will be at byte 60 of the detail data.) Then go forward 8 bytes after the "B1" to byte 68 and look at bytes 68 and 69.</p> <p>Perform the following actions based on the values of bytes 68 and 69 listed below from the AIX error log entry, or on the first two bytes of word 13 from the service processor error log entry:</p> <p>A800: This indicates an HMC/service processor initialization failure. Actions:</p> <ol style="list-style-type: none"> 1. Check for system firmware updates. 2. Replace the primary I/O book, location: U1.18-P1-H2. <p>A801: This indicates an HMC wrap failure. Actions:</p> <ol style="list-style-type: none"> 1. Replace the primary I/O book, location: U1.18-P1-H2. <p>A806: This indicates a loss of the surveillance heartbeat between the HMC and the service processor. Actions:</p> <ol style="list-style-type: none"> 1. Make sure that the HMC is booted and operational. 2. Check the serial cables that go from the HMC to the primary I/O book, location: U1.18-P1-H2. <p>If there are no other error codes or indications of a problem, the A806 (loss of surveillance heartbeat) was a temporary condition and has been resolved; the B1xx4699 code is then an informational message only.</p> <p>If the problem persists:</p> <ol style="list-style-type: none"> 1. Check the serial cables connecting the HMC to the primary I/O book, location: U1.18-P1-H2. 2. Run diagnostics on the serial port on the HMC. 3. Run diagnostics on the serial ports on the service processor in the managed server. <p>For all other values of bytes 68 and 69, or the first two bytes of word 13, do the following:</p> <ol style="list-style-type: none"> 1. Check for system firmware updates. 2. Reset the service processor by activating the pinhole reset switch on the operator panel. 3. Call service support. 	

Error Code	Description	Action/ Possible Failing FRU
B1xx 469A	System firmware interface	<ol style="list-style-type: none"> 1. Check for system firmware updates. 2. Call service support.
B1xx 469B	Firmware to I/O interface	<ol style="list-style-type: none"> 1. Check for system firmware updates. 2. Primary I/O book Location: U1.18-P1-H2
B1xx 469C	Firmware to I/O interface	<ol style="list-style-type: none"> 1. Check for system firmware updates. 2. Primary I/O book Location: U1.18-P1-H2
B1xx 469D	Service processor firmware	<ol style="list-style-type: none"> 1. Check for system firmware updates. 2. Primary I/O book Location: U1.18-P1-H2
B1xx 469E	Service processor firmware failure	<ol style="list-style-type: none"> 1. Check for system firmware updates. 2. Reboot the system in slow mode to isolate a problem in the processor subsystem. 3. Primary I/O book Location: U1.18-P1-H2
B1xx 469F	Service processor failure	<ol style="list-style-type: none"> 1. Check for system firmware updates. 2. Reboot the system in slow mode to isolate a problem in the processor subsystem. 3. Primary I/O book Location: U1.18-P1-H2
B1xx 8FF0	Informational message	No action required.
B1FD 0013	A firmware update has failed because the update image is invalid. The update was stopped before any changes were made to the currently installed firmware	Reset the service processor by activating the pinhole reset switch on the operator panel. Flash a valid firmware update image for the system type and model.
B1FD 0015	Too many firmware update diskettes were inserted (or the update image was faulty, or not the right image for the system)	<ol style="list-style-type: none"> 1. Ensure that the firmware update image is correct for the system type and model. 2. Replace the update diskettes with a new set of firmware update diskettes.

Error Code	Description	Action/ Possible Failing FRU
B1FD 0016	Firmware update diskette read error	<ol style="list-style-type: none"> 1. The firmware diskette may be faulty. Try another diskette. 2. Diskette drive Location: U1.17- D1. 3. Primary I/O book Location: U1.18-P1-H2.
B1FD 001A	Service processor recovery mode update fault	Reset the service processor by activating the pinhole reset switch on the operator panel. Attempt to flash a valid firmware update image for the system type and model again.
B1FD 001E	Service processor recovery mode update fault	Wrong firmware update diskette. Insert the correct update diskette.
B1FD 001F	Firmware update diskette bad	Replace the update diskette.

Problem Determination-Generated Error Codes

Table 4. Problem Determination-Generated Error Codes

Error Code	Description	Action/ Possible Failing FRU
M0BT 0000	The system hung during speaker POST. This error code is generated by the customer performing "Problem Determination" as described in the <i>@server pSeries 690 User's Guide</i> .	Go to "MAP 1542: I/O Problem Isolation" on page 312.
M0BT 0001	The system hung during "Starting Software...". This error code is generated by the customer performing "Problem Determination" as described in the <i>@server pSeries 690 User's Guide</i> .	Go to "MAP 1542: I/O Problem Isolation" on page 312.
M0KB D000	The system hung during keyboard POST. This error code is generated by the customer performing "Problem Determination" as described in the <i>@server pSeries 690 User's Guide</i> .	<ol style="list-style-type: none"> 1. Primary I/O book Location: U1.18-P1-H2 2. Keyboard
M0KB D001	The system did not respond to a keyboard entry. This error code is generated by the customer performing "Problem Determination" as described in the <i>@server pSeries 690 User's Guide</i> .	Type 101 keyboard.
M0KB D002	The system did not respond to a keyboard entry. This error code is generated by the customer performing "Problem Determination" as described in the <i>@server pSeries 690 User's Guide</i> .	Type 102 keyboard.
M0KB D003	The system did not respond to a keyboard entry. This error code is generated by the customer performing "Problem Determination" as described in the <i>@server pSeries 690 User's Guide</i> .	Kanji-type keyboard.
M0ME M002	The system hung during memory POST. This error code is generated by the customer performing "Problem Determination" as described in the <i>@server pSeries 690 User's Guide</i> .	Go to "MAP 1542: I/O Problem Isolation" on page 312.
M0NE T000	The system hung during network POST. This error code is generated by the customer performing "Problem Determination" as described in the <i>@server pSeries 690 User's Guide</i> .	Go to "MAP 1542: I/O Problem Isolation" on page 312.

Table 4. Problem Determination-Generated Error Codes (continued)

Error Code	Description	Action/ Possible Failing FRU
M0PS 0000	Power failure. This error code is generated by the customer performing "Problem Determination" as described in the <i>@server pSeries 690 User's Guide</i> .	Go to "MAP 1520: Power" on page 185.
M0SC SI00	Unable to load diagnostics. This error code is generated by the customer performing "Problem Determination" as described in the <i>@server pSeries 690 User's Guide</i> .	Go to "MAP 1542: I/O Problem Isolation" on page 312.
M0SC SI01	Unable to load diagnostics. This error code is generated by the customer performing "Problem Determination" as described in the <i>@server pSeries 690 User's Guide</i> .	Go to "MAP 1542: I/O Problem Isolation" on page 312.

Hypervisor Dump Retrieval Procedure

This procedure defines the requirements and methods for retrieving a hypervisor (LPAR) dump file following a system crash. This procedure is only applicable if the managed system had been running as a partitioned system before it crashed.

This procedure requires the managed system to be rebooted as a partitioned system. Retrieval must then take place from an AIX partition.

Hypervisor Dump Indications

If the system operator panel displays error code 20D00997, 20D00998, or 20D00999, this indicates that a system crash within the run-time firmware has occurred.

If error code 20D00997, 20D00998, or 20D00999 is in the service processor error log, also indicates that a system crash within the run-time firmware has occurred. The following is an example of a detailed service processor error log entry with error code 20D00999:

```
05/29/2001 21:06:12 Operating System Terminated with Error String
Error code: 20D00999
Detail: A2C1
```

```
SRC
```

```
-----
word11: B1194690 word12: 04A0005D word13: A2C1C0FA
word14: 00000000 word15: 00007701 word16: 00000008
word17: 00000000 word18: 00000000 word19: 00000000
```

```
20D00999
```

After a system crash has occurred, verify if a hypervisor dump has been collected, as described in the following section.

Retrieving the Hypervisor Dump file

After it has been determined that the managed system has crashed and a hypervisor dump exists, or the user wants to test for an existing dump file, the managed system must be rebooted as a partitioned system. A partition or partitions running AIX must then be activated. After rebooting, any partition running AIX may be used to retrieve the dump file. Do the following:

1. Install the **devices.chrp_lpar.base.ras** fileset.

The **devices.chrp_lpar.base.ras** AIX fileset must be installed and committed. To determine if the package has been previously installed, enter the following command on the AIX command line:

```
lslpp -l | grep devices.chrp_lpar.base.ras
```

If the output on the AIX console is similar to the following:

```
devices.chrp_lpar.base.ras 5.X.X.X COMMITTED CHRP LPAR RAS Support
```

the **devices.chrp_lpar.base.ras** fileset is already installed and no further action for step 1 is necessary. If no output is returned, the **devices.chrp_lpar.base** LPP must be installed from the AIX installation media by the customer or system administrator.

After the fileset is installed, the dump file is ready to be retrieved.

2. Enter `fetchdbg -k` at the command prompt.

This produces the following output:

```
Retrieving Dump File .....Dump read successful
```

This action results in a file being written into the **/tmp** directory named **dumpMMDDYY** where MM is the current month, DD is the current day, and YY is the current year. Forward the **/tmp/dumpMMDDYY** file to service support.

If the following text appears on the AIX console, note the error and reported it to service support:

```
Retrieving Dump File  
Error performing dump read
```

Chapter 6. Using the Online and Standalone Diagnostics

The diagnostics consist of online diagnostics and standalone diagnostics.

Attention: The AIX operating system must be installed in a partition in order to run online diagnostics on that partition. If the AIX operating system is not installed, use the standalone diagnostic procedures.

Online diagnostics, when they are installed, reside with AIX in the file system. They can be booted:

- In single user mode (referred to as *service mode*)
- To run in maintenance mode (referred to as *maintenance mode*)
- To run concurrently with other applications (referred to as *concurrent mode*)

Standalone diagnostics must be booted before they can be run. If booted, the diagnostics have no access to the AIX error log or the AIX configuration data.

Online and Standalone Diagnostics Operating Considerations

Note: When possible, run online diagnostics in service mode. Online diagnostics perform additional functions compared to standalone diagnostics. Running online diagnostics in service mode ensures that the error state of the system that has been captured in NVRAM is available for your use in analyzing the problem. The AIX error log and certain SMIT functions are only available when diagnostics are run from the disk drive.

Consider the following items before using the diagnostics:

- Standalone diagnostics can run on systems configured for either a full (or single) system partition or a multiple partitioned system. When running in a partitioned system, the device from which you are booting standalone diagnostics must be made available to the partition dedicated to running standalone diagnostics. This may require moving the device from the partition that currently contains the boot device (for example, the CD-ROM or network adapter connected to the NIM server that has a standalone diagnostic image) to the partition used to run standalone diagnostics. If you move devices, reboot both partitions. For more information, see “Standalone Diagnostic Operation” on page 700.
- When diagnostics are installed, the device support for some devices might not get installed. If this is the case, that device does not display in the diagnostic test list when running disk-based diagnostics.
- When running diagnostics in a partitioned system, diagnostics will work only with the resources that were assigned to that partition. You must run diagnostics in the partition containing the resource that you want to test.

Identifying the Terminal Type to the Diagnostics

When you run diagnostics, you must identify which type of terminal you are using. If the terminal type is not known when the FUNCTION SELECTION menu is displayed, the diagnostics do not allow you to continue until a terminal is selected from the DEFINE TERMINAL option menu.

Undefined Terminal Types

If you specify an undefined terminal type from the DEFINE TERMINAL option menu, the menu prompts the user to enter a valid terminal type. The menu redisplay until either a valid type is entered or you exit the DEFINE TERMINAL option.

Resetting the Terminal

If you enter a terminal type that is valid (according to the DEFINE TERMINAL option menu) but is not the correct type for the IBM Hardware Management Console for pSeries (HMC) virtual terminal window being used, you may be unable to read the screen, use the function keys, or use the Enter key. Bypass these difficulties by pressing Ctrl-C to reset the terminal. The screen display that results from this reset depends on the mode in which the system is being run:

- Online Normal or Maintenance Mode - The command prompt displays.
- Standalone Mode or Online Service Mode - The terminal type is reset to dumb, the Diagnostic Operating Instruction panel displays, and you are required to go through the DEFINE TERMINAL process again.

Running Online Diagnostics

Consider the following when you run the online diagnostics from a server or a disk:

- The diagnostics cannot be loaded and run from a disk until the AIX operating system has been installed and configured.
- The diagnostics cannot be loaded on a system (client) from a server if that system is not set up to boot from a server over a network. When the system is set up to boot from a server, the diagnostics are run in the same manner as they are from disk.
- On full system partitions, if the diagnostics are loaded from disk or a server, you must shut down the AIX operating system before turning off the system unit to prevent possible damage to disk data. Do this in either of the following ways:
 - If the diagnostics were loaded in standalone mode, press the F3 key until DIAGNOSTIC OPERATING INSTRUCTIONS displays. Then press the F3 key once again to shut down the AIX operating system.
 - If the diagnostics were loaded in maintenance or concurrent mode, type the shutdown -F command.
- Under some conditions, the system might stop, with instructions displayed on attached displays and terminals. Follow the instructions to select a console display.

Online Diagnostics Modes of Operation

Note: When running online diagnostics on a partition in a partitioned system, diagnostics can be run only on resources that are allocated to that partition.

The online diagnostics can be run in the following modes:

- Service Mode
- Concurrent Mode
- Maintenance Mode

Service Mode

Service mode provides the most complete checkout of the system resources. This mode also requires that no other programs be running on the partition or system on a full system partition. All partition or system on a full system partition resources, except the SCSI adapter and the disk drives used for paging, can be tested. However, note that the memory and processor are only tested during POST, and the results of the POST tests are reported by diagnostics.

Error-log analysis is done in service mode when you select the Problem Determination option on the DIAGNOSTIC MODE SELECTION menu.

Running Online Diagnostics in Service Mode

To run the online diagnostics in service mode from the boot hard disk, do the following:

1. From the HMC, select the **Partition Manager**.
2. Right-click on the mouse and select **Open Terminal Window**.
3. From the Service Processor Menu on the VTERM, select Option 2 **System Power Control**.
4. Select option 6. Verify that the state changes to currently disabled. Disabling fast system boot automatically enables slow boot.
5. Select Option 98 to exit the system power control menu.
6. Use the HMC to power on the managed system in a full system partition by selecting the managed system in the Contents area.
7. Right-click or select the desired system in the Contents area. Next, on the menu, choose **Selected**.
8. Select **Power On**.
9. Select the **Power on Diagnostic Stored Boot list** option (refer to “Full System Management Tasks” in the Hardware Management Console , order number SA38-0590, for more information on full system partitions).
10. Make sure that there are no media in the devices in the media subsystem.
11. Enter any passwords, if requested.

Concurrent Mode

Use concurrent mode to run online diagnostics on some of the system resources while the system is running normal activity.

Because the system is running in normal operation, the following resources cannot be tested in concurrent mode:

- SCSI adapters connected to paging devices
- Disk drive used for paging
- Some display adapters and graphics related devices
- Memory (tested during POST)
- Processor (tested during POST)

The following levels of testing exist in concurrent mode:

- The **share-test level** tests a resource while the resource is being shared by programs running in the normal operation. This testing is mostly limited to normal commands that test for the presence of a device or adapter.
- The **sub-test level** tests a portion of a resource while the remaining part of the resource is being used in normal operation. For example, this test could test one port of a multiport device while the other ports are being used in normal operation.
- The **full-test level** requires the device not be assigned to or used by any other operation. This level of testing on a disk drive might require the use of the **varyoff** command. The diagnostics display menus to allow you to vary off the needed resource.

Error-log analysis is done in concurrent mode when you select the Problem Determination option on the DIAGNOSTIC MODE SELECTION menu.

To run the online diagnostics in concurrent mode, you must be logged in to the AIX operating system and have proper authority to issue the commands (if help is needed, see the system operator).

The **diag** command loads the diagnostic controller and displays the online diagnostic menus.

Running the Online Diagnostics in Concurrent Mode

To run online diagnostics in concurrent mode, do the following:

1. Log in to the AIX operating system as root user or use CE Login.
2. Enter the **diag** command.
3. When the DIAGNOSTIC OPERATING INSTRUCTIONS display, follow the instructions to check out the desired resources.
4. When testing is complete, use the F3 key to return to the DIAGNOSTIC OPERATING INSTRUCTIONS. Press the F3 key again to return to the AIX operating system prompt. Be sure to vary on any resource that you had varied to off.
5. Press Ctrl-D to log off from root user or CE Login.

Maintenance Mode

Maintenance mode runs the online diagnostics using the customer's version of the AIX operating system. This mode requires that all activity on the partition running the AIX operating system be stopped so that the online diagnostics have most of the resources available to check. All of the system resources, except the SCSI adapters, memory, processor, and the disk drive used for paging, can be checked.

Error log analysis is done in maintenance mode when you select the **Problem Determination** option on the DIAGNOSTIC MODE SELECTION menu.

Use the **shutdown -m** command to stop all activity on the AIX operating system and put the AIX operating system into maintenance mode. The **diag** command is then used to invoke the diagnostic controller so you can run the diagnostics. After the diagnostic controller is loaded, follow the normal diagnostic instructions.

The AIX Documentation library is available at the following Web address: <http://www.ibm.com/servers/aix/library/>. Select **Technical Publications**. AIX documentation is also contained on the AIX Documentation CD. This documentation is made accessible by loading the documentation CD onto the hard disk or by mounting the CD in the CD-ROM drive.

Running the Online Diagnostics in Maintenance Mode

To run the online diagnostics in maintenance mode, do the following:

1. Stop all programs running on the partition except the AIX operating system (if help is needed, see the system operator).
2. Log in to the AIX operating system as root user or use CE Login.
3. Type the **shutdown -m** command.
4. When a message indicates the system is in maintenance mode, enter the **diag** command.

Note: It might be necessary to set *TERM* type again.

5. When DIAGNOSTIC OPERATING INSTRUCTIONS screen displays, follow the displayed instructions to check out the desired resources.
6. When testing is complete, use the F3 key to return to DIAGNOSTIC OPERATING INSTRUCTIONS. Press the F3 key again to return to the AIX operating system prompt.
7. Press Ctrl-D to log off from root user or CE Login.

Standalone Diagnostic Operation

Use standalone diagnostics to test the system when the online diagnostics are not installed and as a method of testing the disk drives that cannot be tested by the online diagnostics.

Note: No error log analysis is done by the standalone diagnostics. The CD-ROM drive and the SCSI controller that controls it cannot be tested by the standalone diagnostics. Standalone diagnostics:

- Are resident on CD-ROM or a Network Installation Management (NIM) server
- Provide a method to test the system when the online diagnostics are not installed or cannot be loaded from the disk drive
- Allow testing of the disk drives and other resources that cannot be tested by the online diagnostics
- Do not have access to the AIX configuration data
- Do not have access to the AIX error log
- Do not allow for running of error log analysis

Performing Slow Boot

To fully analyze all of the available information, perform the following steps before doing a hardware repair or replacement:

1. Record the 8-character error code (and location code if present) in the operator panel or that was reported by the customer.
2. Do a slow-mode boot in service mode. This boot can be specified using the System Power Control Menu on the service processor main menu. (A fast-mode boot skips much of the built-in diagnostic testing.) A slow-mode boot may yield a new 8-character error code on the operator panel and new errors in the service processor error log. If a new error code is reported, use this code to continue problem analysis.

Partitioned System Considerations for Standalone Diagnostics

To run standalone diagnostics on a full system partition, you must reboot the entire system. However, for a partition in a partitioned system, you can boot standalone diagnostics either in a given partition or on the entire system (which is the same procedure as a full system partition). For a partitioned system, before running standalone diagnostics on a given partition, the user must move the device from the existing location where standalone diagnostics is booted (the CD-ROM drive or the network adapter connected to the NIM server, in the case of NIM boot of standalone diagnostics), to the partition that will run standalone diagnostics. Devices on a partitioned system are moved on an I/O-slot basis.

If the CD-ROM drive is moved from one partition to another, all SCSI devices on the same SCSI adapter card which the CD-ROM drive is attached must be moved to the same partition. It is recommended that you attach few SCSI devices to the same SCSI controller card to prevent moving them, along with the CD-ROM drive, between

partitions. A reboot is required on the partition containing this device and on the moved device, but the system itself is *not* powered off in order to boot standalone diagnostics in a logical partitioned system partition.

Considerations for Running Standalone Diagnostics from CD-ROM

Consider the following when you run standalone diagnostics:

- The diagnostic CD must remain in the CD-ROM drive for the entire time that diagnostics are running.
- The diagnostic CD cannot be ejected from the CD-ROM drive after the diagnostics have loaded. The CD can only be ejected after the system has been turned off and then turned on (standalone mode) or after the diagnostics program has terminated (online concurrent mode).
- The CD-ROM drive from which diagnostics were loaded cannot be tested.
- The SCSI adapter (or circuitry) controlling the CD-ROM drive from which diagnostics were loaded cannot be tested.

Loading the Standalone Diagnostics from CD-ROM

To run standalone diagnostics in service mode from CD-ROM, do the following:

1. Stop all programs including the AIX operating system (get help if needed).
2. Remove all tapes, diskettes, and CD-ROMs.
3. Power off the @server pSeries 690 (refer to Full System Management Tasks in the Hardware Management Console , order number SA38-0590, for more information on full system partitions).
4. Right-click the mouse and select **Open Terminal Window**.
5. From the service processor menu on the VTERM, select option 2, **System Power Control Menu**.
6. Select option 6. Verify that the state changes to currently disabled. Disabling fast system boot automatically enables slow boot.
7. Select option 98 to exit the system power control menu.
8. Use the HMC to power on the managed server in a full system partition. Select the **Power on Diagnostic Default Boot List** (refer to Full System Management Tasks in the Hardware Management Console , order number SA38-0590, for more information on full system partitions).
9. Insert the CD-ROM into the CD-ROM drive in the media subsystem in the @server pSeries 690 (*not* into the HMC's CD-ROM drive).

Running Standalone Diagnostics from a Network Installation Management (NIM) Server

A client system connected to a network with a Network Installation Management (NIM) server can boot standalone diagnostics from the NIM server if the client-specific settings on both the NIM server and client are correct.

Notes:

1. All operations to configure the NIM server require root user authority.

2. If you replace the network adapter in the client, the network adapter hardware address settings for the client must be updated on the NIM server.
3. The **Cstate** for each standalone diagnostics client on the NIM server should be kept in the *diagnostic boot has been enabled* state.
4. On the client system, the NIM server network adapter should be put in the bootlist after the boot disk drive. This allows the system to boot in standalone diagnostics from the NIM server if there is a problem booting from the disk drive. Refer to the **Multiboot** section under "SMS" in the client system's service guide for information on setting the bootlist.

NIM Server Configuration

Refer to the "Advanced NIM Configuration Tasks" chapter of the *Network Installation Management Guide and Reference*, order number SC23-4385, for information on doing the following:

- Registering a client on the NIM server
- Enabling a client to run diagnostics from the NIM server

To verify that the client system is registered on the NIM server and the diagnostic boot is enabled, run the command **lsnim -a Cstate -Z ClientName** from the command line on the NIM server. Refer to the following table for system responses.

Note: The *ClientName* is the name of the system on which you want to run standalone diagnostics.

System Response	Client Status
#name:Cstate: ClientName:diagnostic boot has been enabled:	The client system is registered on the NIM server and enabled to run diagnostics from the NIM server.
#name:Cstate: ClientName:ready for a NIM operation: or #name:Cstate: ClientName:BOs installation has been enabled:	The client is registered on the NIM server but not enabled to run diagnostics from the NIM server. Note: If the client system is registered on the NIM server but Cstate has not been set, no data will be returned.
0042-053 lsnim: there is no NIM object named "ClientName"	The client is not registered on the NIM server.

Client Configuration and Booting Standalone Diagnostics from the NIM Server

To run standalone diagnostics on a client from the NIM server, do the following:

1. Remove any removable media (tape or CD-ROM).
2. Stop all programs including the AIX operating system (get help if needed).
3. If you are running standalone diagnostics in a full system partition, verify with the system administrator and system users that the system unit can shut down. Stop all programs, including the AIX operating system. Refer to the AIX operating system documentation for **shutdown** command information.

In a partitioned system, make the CD-ROM drive available to the partition used to run standalone diagnostics (refer to the Hardware Management Console for more information). Verify with the system administrator and system users using that partition that all applications on that partition must be stopped, and that the partition will be rebooted. Stop all programs on that partition, including the operating system.

4. If you are in a full system partition, power on the system unit to run standalone diagnostics. In a partitioned system, reboot the partition to run standalone diagnostics.
5. When the keyboard indicator is displayed (the word **keyboard** on a HMC virtual terminal window or the keyboard icon on a graphical display), press the number 1 key on the keyboard to display the SMS menu.
6. Enter any requested passwords.
7. Select **Utilities**.
8. Depending on the console type, select **RIPL** or **Remote Initial Program Load Setup**.
9. Enter the client address, server address, gateway address (if applicable), and subnet mask. If you are using a graphical interface Click **Save**. Exit to the SMS Utilities screen.
10. If the NIM server is set up to allow pinging from the client system, use the **ping** utility in the RIPL utility to verify that the client system can ping the NIM server. Under the **ping** utility, choose the network adapter that provides the attachment to the NIM server to do the ping operation. If the ping returns with an OK prompt, the client is prepared to boot from the NIM server. If ping returns with a FAILED prompt, the client cannot proceed with the NIM boot.

Note: If the ping fails, refer to “Boot Problems” on page 396, and follow the steps for network boot problems.

To temporarily change the system bootlist so that the network adapter attached to the NIM server network is first in the bootlist, do the following:

1. Exit to the SMS Main screen.
2. Depending on the console type, select **Multiboot** or **Select Boot Devices**.
3. Depending on the console type, select **Boot Sequence** or **Select Boot Devices**.
4. Record the current bootlist settings. (You must set the bootlist back to the original settings after running diagnostics from the NIM server.)

5. Change the bootlist so the network adapter attached to the NIM server is first in the bootlist.
6. Exit completely from SMS.
The system starts loading packets while doing a **bootp** from the network.

Follow the instructions on the screen to select the system console.

- If Diagnostics Operating Instructions Version x.x.x displays, standalone diagnostics have loaded successfully.
- If the AIX login prompt displays, standalone diagnostics did not load. Check the following items:
 - The bootlist on the client may be incorrect.
 - Cstate on the NIM server may be incorrect.
 - Network problems might be preventing you from connecting to the NIM server.

Verify the settings and the status of the network. If you continue to have problems, refer to “Boot Problems” on page 396, and follow the steps for network boot problems.

After running diagnostics, reboot the system and use SMS to change the bootlist sequence back to the original settings.

Chapter 7. Using the Service Processor

Note: The information in this chapter regarding the configuring of serial ports, and modems attached to those serial ports, applies only to the serial ports (S1 and S2) on the primary I/O book (location U1.18-P1-H2). None of this information is applicable to the serial ports, or modems attached to those serial ports, on the IBM Hardware Management Console for pSeries (HMC).

Note: On some of the system management services (or service processor) screens, you will see the term *LPAR*, which is equivalent to the term *partitioned system*.

The service processor runs on its own power boundary and continually monitors hardware attributes and the environmental conditions within the system. The service processor is controlled by firmware and does not require the AIX operating system to be operational to perform its tasks.

The service processor menus allow you to configure service processor options, as well as enable and disable functions.

Service processor menus are available using an HMC virtual terminal window when OK is displayed on the operator panel or when the service processor has detected a server problem (such as a surveillance failure).

Service Processor Menus

The service processor menus are divided into the following groups:

- General user menu - the user must know the general-access password.
- Privileged user menus - the user must know the privileged-access password.

If the server is powered off, the service processor menus can be accessed locally or remotely on the following:

- Serial port 1 (S1)
- Serial port 2 (S2)
- The HMC

Accessing the Service Processor Menus Locally

Service processor menus can be accessed by opening a virtual terminal window on the HMC, or by attaching an ASCII terminal to serial port 1 (S1) or serial port 2 (S2). After OK displays in the operator panel, press any key on the keyboard to signal the service.

Note: The service processor menus cannot be accessed simultaneously on a virtual terminal window on the HMC and on an ASCII terminal. Accessing the menus on the HMC locks out access to the ASCII terminals and the other way around.

When you gain access, the service processor prompts you for a password (if one is set), and when verified, displays the service processor menus.

The service processor menu prompt, represented by 0> or 1>, indicates the serial port to which the terminal is connected.

- An ASCII terminal can have the following prompts:
 - 0> indicates serial port 1 (S1)
 - 1> indicates serial port 2 (S2)
- The HMC always indicates 0>

Accessing the Service Processor Menus Remotely

If your system has a modem connected to serial port 1 or serial port 2 and is configured for call-in (see “Modem Configuration Menu” on page 729), access the service processor menus remotely as follows:

1. With the system powered off, call in from a remote terminal.
2. The service processor detects ring-indicate and prompts you for a password (if one is set). When verified, the service processor menus display remotely.

Saving and Restoring Service Processor Settings

All the settings that you make (except language) from the service processor menu can be backed up either for recovering from a fault that may corrupt these settings, or for replicating these settings to other servers that include a service processor.

The service aid, Save or Restore Hardware Management Policies, can be used to save your settings after initial setup or whenever the settings must be changed for system operation purposes.

It is strongly recommended that you use this service aid for backing up service processor settings to protect the usefulness of the service processor and the availability of the server. Refer to “Save or Restore Hardware Management Policies,” in the “Introduction to Tasks and Service Aids” section of the *RS/6000 and @server pSeries Diagnostic Information for Multiple Bus Systems*, order number SA38-0509.

Menu Inactivity

The service processor exits menu mode after ten minutes of inactivity and displays a message indicating that it has done so. Pressing any key on the virtual terminal window causes the main menu to display.

General User Menu

The menu options presented to the general user are a subset of the options available to the privileged user. The user must know the general-access password, if one is set, to access this menu.

```
GENERAL USER MENU
1. Power-on System
2. Power-off System
3. Read VPD Image from Last System Boot
4. Read Progress Indicators from Last System Boot
5. Read Service Processor Error Logs
6. Read System POST Errors
99. Exit from Menu
0>
```

- **Power-on System**

Allows the user to start the system using the current virtual terminal window as the active console.

- **Power-off System**

This option is not available on this system.

- **Read VPD Image from Last System Boot**

Displays manufacturer vital product data, such as serial numbers, part numbers, and so on, that were stored from the system boot prior to the one in progress now, for the entire system.

- **Read Progress Indicators from Last System Boot**

Displays a number of the boot progress indicators, which may include service processor checkpoints, IPL checkpoints, or AIX configuration codes, from the previous system boot. This information can be useful in diagnosing system faults.

Note: If you are running one or more logical partitions, enter the partition ID (0-15) to display progress indicators for that partition since the last system boot. If your system is running in full system partition mode, this option automatically displays details from partition 0.

The progress indicator codes are listed from top (latest) to bottom (oldest).

This information is not stored in nonvolatile storage. If the system is powered off using the power-on button on the operator panel, this information is retained. If the ac power is disconnected from the system, this information will be lost. For an example, refer to “LCD Progress Indicator Log” on page 749.

- **Read Service Processor Error Logs**

Displays the service processor error logs. For an example, refer to “Service Processor Error Logs” on page 748.

- **Read System POST Errors**

Displays additional error log information (this option is only for service personnel).

- **Exit from Menus**

Selecting this option will exit the service processor menus. You can re-enter the menus by pressing any key on the console.

Privileged User Menus

The following menus are available to privileged users only. The user must know the privileged-access password, if one is set, to access these menus.

Main Menu

A listing at the top of the main menu contains the following:

- Your system's current firmware version
- The firmware copyright notice
- The system name given to your server during setup

You need the firmware version for reference when you either update or repair the functions of your service processor.

The system name, an optional field, is the name that your server reports in problem messages. This name helps your support team (for example, your system administrator, network administrator, or service representative) to more quickly identify the location, configuration, and history of your server. Set the system name, from the main menu, using option 6.

Note: The information under the Service Processor Firmware heading in the following Main Menu illustration is example information only.

```
Service Processor Firmware
VERSION: RH011007
Copyright 2001 IBM Corporation
SYSTEM NAME
```

MAIN MENU

1. Service Processor Setup Menu
 2. System Power Control Menu
 3. System Information Menu
 4. Language Selection Menu
 5. Call-In/Call-Out Setup Menu
 6. Set System Name
 99. Exit from Menus
- 0>

- **Service Processor Setup Menu**
See “Service Processor Setup Menu” on page 711 for more information.
- **System Power Control Menu**
See “System Power Control Menu” on page 717 for more information.
- **System Information Menu**
See “System Information Menu” on page 722 for more information.
- **Language Selection Menu**
See “Language Selection Menu” on page 727 for more information.
- **Call-In/Call-Out Setup Menu**
See “Call-In/Call-Out Setup Menu” on page 728 for more information.
- **Set System Name**
Allows setting of the system name.

Service Processor Setup Menu

The following Service Processor Setup Menu is accessed from the Main Menu:

```
SERVICE PROCESSOR SETUP MENU

1. Change Privileged Access Password
2. Change General Access Password
3. Enable/Disable Console Mirroring:
   Currently Enabled
4. Start Talk Mode
5. OS Surveillance Setup Menu
   Not supported. In LPAR mode
6. Reset Service Processor
7. Reprogram Flash EPROM Menu
8. Serial Port Snoop Setup Menu
   Not supported. In LPAR mode
9. Scan Log Dump Policy:
   Currently Never
98. Return to Previous Menu
99. Exit from Menus

0>
```

Note: Unless otherwise stated in menu responses, settings become effective when a menu is exited using option 98 or 99.

Passwords

Passwords can be any combination of up to eight alphanumeric characters. You can enter longer passwords, but the entries are truncated to include only the first eight characters. The privileged-access password can be set from service processor menus or from System Management Services (SMS) utilities (see Chapter 8, “Using System Management Services” on page 755). The general-access password can be set only from service processor menus.

For security purposes, the service processor counts the number of attempts to enter passwords. The results of not recognizing a password within this error threshold are different, depending on whether the attempts are being made locally (at the server) or remotely (through a modem). The error threshold is three attempts.

If the error threshold is reached by someone entering passwords at the server, the service processor commands the server to resume the initial program load (IPL). This action is taken based on the assumption that the server is in an adequately secure location with only authorized users having access. Such users must still successfully enter a login password to access AIX.

If the error threshold is reached by someone entering passwords remotely, the service processor commands the server to power off to prevent potential security attacks on the server by unauthorized remote users. The following table lists what you can access with the privileged-access password and the general-access password.

Privileged Access Password	General Access Password	Resulting Menu
None	None	Service processor MAIN MENU displays.
Set	None	Users with the password see the service processor MAIN MENU. Users without password cannot log in.
Set	Set	Users see menus associated with the entered password.

If you *forget* the password, you must remove the battery for at least 30 seconds to disable the password. See “Battery” on page 790 for more information.

- **Change Privileged-Access Password**

Set or change the privileged-access password. It provides the user with the capability to access all service processor functions. This password is usually used by the system administrator or root user.

- **Change General-Access Password**

Set or change the general-access password. It provides limited access to service processor menus, and is usually available to all users who are allowed to power on the server, especially remotely.

Note: The general-access password can only be set or changed after the privileged access password is set.

- **Enable/Disable Console Mirroring**

Note: Console mirroring is disabled in partitioned systems.

Console mirroring is supported on serial port 1 (S1) and serial port 2 (S2). When console mirroring is enabled, the service processor sends information to all serial ports. The serial port from which console mirroring is enabled is referred to as the *active port*. The *mirror port* is determined when keyboard input is detected from one of the other ports. From this point on, the service processor sends information only to the active port and the mirror port. This capability can be enabled by local or remote users, providing local users with the capability to monitor remote sessions. Console mirroring can be enabled for the current session only. For more information, see “Console Mirroring” on page 747.

- **Start Talk Mode**

In a console-mirroring session, it is useful for those who are monitoring the session to be able to communicate with each other. Selecting **Start Talk Mode** activates the keyboards and displays for such communications while console mirroring is established. This is a full duplex link, so message interference is possible. Alternating messages between users works best.

- **OS Surveillance Setup Menu**

Note: This option is disabled in partitioned systems.

This menu can be used to set up operating system (OS) surveillance.

```
OS Surveillance Setup Menu

1. Surveillance:
   Currently Enabled

2. Surveillance Time Interval:
   2 minutes

3. Surveillance Delay:
   2 minutes

98. Return to Previous Menu

0>
```

- **Surveillance**

Can be set to Enabled or Disabled.

- **Surveillance Time Interval**

Can be set to any number from 2 through 255.

- **Surveillance Delay**

Can be set to any number from 0 through 255.

Refer to “Service Processor System Monitoring - Surveillance” on page 744 for more information about surveillance.

- **Reset Service Processor**

If this option is selected, entering Y causes the service processor to reboot.

- **Reprogram Flash EPROM Menu**

This option updates the system EPROMs. After entering Y to indicate that you want to continue, you are prompted to enter the update diskettes. Follow the instructions on the screen. When the update is complete, the service processor reboots.

All system EPROMs that can be reprogrammed are updated at the same time and are as follows:

- System power control network programming
- Service processor programming
- System firmware programming
- Run-Time Abstraction Services

- **Serial Port Snoop Setup Menu**

Note: This option is disabled in partitioned systems.

This menu can be used to set up serial port snooping, in which the user can configure serial port 1 as a "catch-all" reset device.

From the service processor main menu, select option 1, service processor setup menu, then select option 8 (Serial Port Snoop Setup Menu).

```
SERIAL PORT SNOOP SETUP MENU

1. System reset string:
   Currently Unassigned

2. Snoop Serial Port:
   Currently Unassigned

98. Return to Previous Menu

1>
```

Use the **Snoop Serial Port** option to select the serial port to snoop.

Note: Only serial port 1 is supported.

Use the system reset string option to enter the system reset string, which resets the machine when it is detected on the main console on Serial Port 1.

After serial port snooping is correctly configured, at any point after the system is booted to AIX, whenever the reset string is typed on the main console, the system uses the service processor reboot policy to restart.

Because pressing Enter after the reset string is not required, make sure that the string is not common or trivial. A mixed-case string is recommended.

- **Scan Log Dump Policy**

A scan dump is the collection of chip data that the service processor gathers after a system malfunction, such as a checkstop or hang. The scan dump data may contain chip scan rings, chip trace arrays, and SCOM contents.

The scan dump data are stored in the system control store. The size of the scan dump area is approximately 4 MB.

During the scan log dump, A8xx (in the range A810 to A8FF) displays in the operator panel. The xx characters will change as the scan log dump progresses. If the xx characters do not change after several minutes, the service processor is hung and must be reset.

When the scan log dump is complete, depending on how the reboot policy is set, the system will either:

- Go to the standby state (and the service processor menus will be available), indicated by OK or STBY in the operator panel

OR

- Attempt to reboot.

```
Scan Log Dump Policy Menu

1. Scan Log Dump Policy:
   Currently Never

2. Scan Log Dump Content:
   Not Applicable

98. Return to Previous Menu

0>
```

Option 1 displays the following screen:

```
Select from the following options:
(As needed=1, Never=2, Always=3, Immediate=4)

Enter new option:

0>
```

The scan log dump policy can be set to the following:

1 = As needed

The processor run-time diagnostics record the dump data based on the error type. Selecting this option will set the scan log dump policy to "Not Applicable". This is the default value.

2 = Never

Selecting this option will set the scan log dump policy to "Not Applicable".

3 = Always

Selecting this option will set the scan log dump policy to "Currently Checkstop Hardware Abbreviated"; this is the default. However, if the dump policy is set to always, the scan log dump content can be changed, by selecting option 2, to either "abbreviated" or "complete". Selecting "complete" will result in more data being stored in a larger scan dump, but the scan dump operation will take longer.

4 = Immediately

This option can only be used when the system is in the standby state with power on. It is used to dump the system data after a checkstop or machine check occurs when the system firmware is running, or when the operating system is booting or running.

The scan log dump policy can also be set from the Tasks menu in the AIX service aids.

System Power Control Menu

This menu is used to set power control options. Other menus that control boot options are available from this menu.

```
SYSTEM POWER CONTROL MENU

1. Enable/Disable Unattended Start Mode:
   Currently Enabled

2. Ring Indicate Power-On Menu

3. Reboot/Restart Policy Setup Menu

4. Power-On System

5. Power-Off System

6. Enable/Disable Fast System Boot
   Currently Enabled

7. Boot Mode Menu

98. Return to Previous Menu

99. Exit from Menus

0>
```

- **Enable/Disable Unattended Start Mode**

Use this option to instruct the service processor to restore the power state of the server after a temporary power failure. Unattended start mode can also be set through the System Management Services (SMS) menus. This option is intended to be used on servers that require automatic power-on after a power failure. For more information, see “System Power-On Methods” on page 734.

- **Ring Indicate Power-On Menu**



Ring indicate power-on is enabled by default on both serial port 1 (S1) and serial port 2 (S2). When ring indicate power-on is enabled, call-in is disabled.

If ring indicate power-on is enabled and call-in is already enabled, you will be asked to confirm your choice. Refer to the message displayed on your screen.

If the ring indicate power-on setting is changed, you must select option 30, **Refresh Modem Settings** to update the modem settings. If **Refresh Modem Settings** is selected, and the modem(s) have not been configured, you will be asked to configure the modems first. See "Call-In/Call-Out Setup Menu" on page 728 for information on configuring modems.

Option 2 is used to set the number of rings.

- **Reboot/Restart Policy Setup Menu**

The following menu controls the Reboot/Restart Policy:

```
Reboot/Restart Policy Setup Menu

1. Number of reboot attempts:
   Currently 1

2. Use OS-Defined restart policy?
   Currently Yes

3. Enable supplemental restart policy?
   Currently No

4. Call-Out before restart:
   Currently Disabled

98. Return to Previous Menu

0>
```

Reboot is the process of bringing up the system hardware; for example, from a system reset or power on. *Restart* is activating the operating system after the system hardware is reinitialized. Restart must follow a successful reboot.

- **Number of reboot attempts** - If the server fails to successfully complete the boot process, it attempts to reboot the number of times specified. Entry values equal to or greater than 0 are valid. Only successive failed reboot/restart attempts are counted.
- **Use OS-Defined restart policy** - Allows the service processor to react in the same way that the operating system does to major system faults by reading the setting of the operating system parameter **Automatically Restart/Reboot After a System Crash**. This parameter might already be defined, depending on the operating system or its version/level. If the operating system automatic restart setting is defined, it can be set to respond to a major fault by restarting or by not restarting. See your operating system documentation for details on setting up operating system automatic restarts. The default value is YES.

Note: For partitioned systems, this policy applies to errors at the system (or *global*) level, not at the partition level.

- **Enable supplemental restart policy** - The default setting is NO. If set to YES, the service processor restarts the system when the system loses control as detected by service processor surveillance, and either:
 - The **Use OS-Defined restart policy** is set to NO.
 - OR
 - The **Use OS-Defined restart policy** is set to YES, and the operating system has no automatic restart policy.
- **Call-Out before restart (Enabled/Disabled)** - If a restart is necessary due to a system fault, and you are running a full system partition, you can enable the service processor to call out and report the event. This option can be valuable if the number of these events becomes excessive, which might signal a bigger problem.
- **Power-On System**
Allows immediate power-on of the system.
- **Power-Off System**
This option is not available on this system.
- **Enable/Disable Fast System Boot**
Allows the user to select the IPL type, mode, and speed of the system boot.
Attention: Selecting the fast IPL results in several diagnostic tests being skipped and a shorter memory test being run.

- **Boot Mode Menu**

Note: This option is disabled in partitioned systems.

The Boot Mode Menu allows you to select a boot mode.

```
Boot Mode Menu

1. Boot to SMS Menu:
   Currently Disabled

2. Service Mode Boot from Saved List:
   Currently Disabled

3. Service Mode Boot from Default List:
   Currently Disabled

4. Boot to Open Firmware Prompt:
   Currently Disabled

98. Return to Previous Menu

0>
```

To select a boot mode, select a number and press Enter. The item corresponding to the selected number toggles between Disabled to Enabled. If a boot mode is Enabled, the boot mode selected is performed, and the Disabled/Enabled selection is reset to Disabled. The following describes each boot mode:

- **Boot to SMS Menu**

When this selection is enabled, the system boots to the System Management Services (SMS) Menu.

- **Service Mode Boot from Saved List**

This selection causes the system to perform a service mode boot using the service mode boot list saved in NVRAM. If the system boots AIX from the disk drive and AIX diagnostics are loaded on the disk drive, AIX boots to the diagnostics menu.

Using this option to boot the system is the preferred way to run online diagnostics.

- **Service Mode Boot from Default List**

This selection is similar to *Service Mode Boot from Saved List*, except the system boots using the default boot list that is stored in the system firmware. This is normally used to try to boot customer diagnostics from the CD-ROM drive.

Using this option to boot the system is the preferred way to run standalone diagnostics.

- **Boot to Open Firmware**

This option should only be used by service personnel to obtain additional debug information. When this selection is enabled, the system boots to the open firmware prompt.

System Information Menu

This menu provides access to system configuration information, error logs, system resources, and processor configuration.

```
SYSTEM INFORMATION MENU

1. Read VPD Image from Last System Boot
2. Read Progress Indicators from Last System Boot
3. Read Service Processor Error Logs
4. Read System POST Errors
5. Read NVRAM
6. Read Service Processor Configuration
7. Processor Configuration/Deconfiguration Menu
8. Memory Configuration/Deconfiguration Menu
9. Power Control Network Utilities Menu
10. LED Control Menu
98. Return to Previous Menu
99. Exit from Menus
0>
```

- **Read VPD Image from Last System Boot**

Displays manufacturer's vital product data (VPD), such as serial numbers, part numbers, and so on, that was stored from the system boot prior to the one in progress now. VPD from all devices in the system is displayed.

- **Read Progress Indicators from Last System Boot**

Displays a number of the boot progress indicators, which may include service processor checkpoints, IPL checkpoints, or AIX configuration codes, from the previous system boot. This information can be useful in diagnosing system faults.

Note: If you are running from a partitioned system, enter the partition ID (0-15) to display progress indicators for that partition since the last system boot. In a full system partition, this option automatically displays details from partition 0.

The progress indicator codes are listed from top (latest) to bottom (oldest).

This information is not stored in nonvolatile storage. If the system is powered off using the power-on button on the operator panel, this information is retained. If the ac power is disconnected from the system, this information will be lost. For an example, refer to "LCD Progress Indicator Log" on page 749.

- **Read Service Processor Error Logs**

Displays error conditions detected by the service processor. Refer to "Service Processor Error Logs" on page 748 for an example of this error log.

- **Read System POST Errors**

This option should only be used by service personnel to obtain additional debug information.

- **Read NVRAM**

Displays Non Volatile Random Access Memory (NVRAM) content.

- **Read Service Processor Configuration**

Displays current service processor configuration.

- **Processor Configuration/Deconfiguration Menu**

This menu allows the user to change the system processor configuration. If it is necessary to take one of the processors offline, use this menu to deconfigure a processor, and then reconfigure the processor at a later time. An example of this menu follows:

```
PROCESSOR CONFIGURATION/DECONFIGURATION MENU

77. Enable/Disable CPU Repeat Gard: Currently Enabled

  1.  0  3.0  (00)  Configured by system    2.  1  3.1  (00)  Deconfigured by system
  3.  2  3.2  (00)  Configured by system    4.  3  3.3  (00)  Configured by system
  5.  4  3.4  (00)  Configured by system    6.  5  3.5  (00)  Deconfigured by system
  7.  6  3.6  (00)  Configured by system    8.  7  3.7  (00)  Configured by system

98. Return to Previous Menu

0>
```

Note: This table is built from vital product data collected during the last boot sequence. The first time the system is powered on, or after the system's nonvolatile RAM (NVRAM) has been erased, this table may be empty. The table is rebuilt during the next boot into AIX.

The fields of the previous table represent the following:

Column 1

(1.) Menu selection index.

Column 2

(0) Logical processor device number assigned by AIX. You can display these logical device numbers by issuing the following command on the AIX command line:

```
lsdev -C | grep proc
```

Column 3

(3.0) Processor address list used by the service processor.

Column 4

(00) Error status of the processors.

The error status of each processor is indicated by AB, where B indicates the number of errors and A indicates the type of error according to the following:

1. Bring-up failure

2. Run-time non-recoverable failure
3. Run-time recoverable failure
4. Group integrity failure
5. Non-repeat-gardable error. The resource may be reconfigured on the next boot.

A status of 00 indicates that the CPU has not had any errors logged against it by the service processor.

To enable or disable CPU repeat gard, use menu option 77. CPU repeat gard is enabled by default.

If CPU repeat gard is disabled, processors that are in the "deconfigured by system" state will be reconfigured. These reconfigured processors are then tested during the boot process, and if they pass, they remain online. If they fail the boot testing, they are deconfigured even though CPU repeat gard is disabled.

The failure history of each CPU is retained. If a processor with a history of failures is brought back online by disabling repeat gard, it remains online if it passes testing during the boot process. However, if repeat gard is enabled, the processor is taken offline again because of its history of failures.

Note: The processor numbering scheme used by the service processor is different from the numbering scheme used by AIX. To ensure that the correct processor is selected, consult the AIX documentation before configuring or deconfiguring a processor.

Note: To determine the number of processors available to AIX, run the following command on the AIX command line: `bindprocessor -q`

- **Memory Configuration/Deconfiguration Menu**

These menus allow the user to change the system memory configuration. If it is necessary to take one of the memory books offline, this menu allows you to deconfigure a book, and then reconfigure the book at a later time.

When this option is selected, a menu displays. The following is an example of this menu:

```
MEMORY CONFIGURATION/DECONFIGURATION MENU

77. Enable/Disable Memory Repeat Gard: Currently Enabled

    1. Memory card

    98. Return to Previous Menu
```

After you select the memory card option by entering 1, a menu displays, allowing the selection of a memory book. The following is an example of this menu.

MEMORY CONFIGURATION/DECONFIGURATION MENU

1: 16.16(00) Configured by system 2: 17.17(00) Configured by system
3: 18.18(00) Configured by system 4: 19.19(00) Configured by system

98. Return to Previous Menu

Note: This table is built from vital product data collected during the last boot sequence. The first time the system is powered on, or after the system's nonvolatile RAM (NVRAM) has been erased, this table may be empty. The table is rebuilt during the next boot into AIX.

The fields in the previous table represent the following:

Column 1

1. Menu selection index/book number

Column 2

- xx.xx : Book address used by service processor

Column 3

- (00) Error status

The error status of the each memory book is indicated by AB, where B indicates the number of errors and A indicates the type of error according to the following:

1. Bring-up failure
2. Run-time non-recoverable failure
3. Run-time recoverable failure
4. Group integrity failure
5. Non-repeat-gardable error. The resource may be reconfigured on the next boot.

An error status of 00 (for example, 11.16(00)) indicates that the memory book has not had any errors logged against it by the service processor.

To change the memory configuration, select the number of the memory book. The memory book state will change from configured to deconfigured or from deconfigured to configured.

In the previous example menu, each line shows two books and indicates whether they are configured.

To enable or disable Memory Repeat Gard, use menu option 77 of the Processor Configuration/Deconfiguration Menu.

The failure history of each book is retained. If a book with a history of failures is brought back online by disabling Repeat Gard, it remains online if it passes testing during the boot process. However, if Repeat Gard is enabled, the book is taken offline again because of its history of failures.

The four inner memory books, if present, are listed first, followed by the four outer books, if present. The memory books are shown in the following order of physical location code:

1	U1.18-P1-M2	5	U1.18-P1-M4
2	U1.18-P1-M3	6	U1.18-P1-M8
3	U1.18-P1-M7	7	U1.18-P1-M5
4	U1.18-P1-M6	8	U1.18-P1-M1

- **Power Control Network Utilities Menu**

```
POWER CONTROL NETWORK UTILITIES MENU

1. Lamp Test for all Operator Panels

2. Display I/O Type
   Not Supported
3. Change I/O Type

98. Return to Previous Menu

0>
```

- **Lamp Test for All Operator Panels**

Selecting this option tests the media drawer operator panel's indicators by causing them to blink on and off for approximately 30 seconds.

- **Change I/O Type**

Use this option to change the I/O type of the primary I/O book after a service action or configuration change if the I/O type is incorrect. If this option is chosen, you will be asked to make the following entries:

1. For the I/O drawer address, type 1.
2. For the I/O type, type 98.

If either value is not valid, a failure message displays on the console. Press Enter to return to the Power Control Network Utilities Menu.

- **LED Indicator Menu**

This menu displays the state of the processor subsystem disturbance/system attention LED and the fault/identify LED on the I/O subsystem(s). Use this menu to toggle the attention/fault LEDs between identify (blinking) and off. An example of this menu follows:

```
LED Indicator

1. CEC LED at location U1.18 Currently in IDENTIFY state
2. Drawer LED at location U1.9 Currently in OFF state
3. Drawer LED at location U1.5 Currently in IDENTIFY state
4. Drawer LED at location U1.1 Currently in OFF state
5. Drawer LED at location U1.13 Currently in OFF state
6. Drawer LED at location U2.1 Currently in IDENTIFY state
7. Drawer LED at location U2.5 Currently in OFF state
98. Return to Previous Menu

Enter LED index

0 >
```

The processor subsystem disturbance/system attention LED is on the operator panel in the media drawer. The I/O drawer fault/identify LED is located on the front of each I/O subsystem.

Language Selection Menu

The service processor menus and messages are available in various languages. This menu allows selecting languages in which the service processor and system firmware menus and messages are displayed.

```
LANGUAGE SELECTION MENU

1. English
2. Francais
3. Deutsch
4. Italiano
5. Espanol
6. Svenska
98. Return to Previous Menu
99. Exit from Menus

0>
```

Note: Your virtual terminal window must support the ISO-8859 character set to correctly display languages other than English.

Call-In/Call-Out Setup Menu

Note: The information in this section regarding the configuring of serial ports, and modems attached to those serial ports, applies only to the serial ports (S1 and S2) on the primary I/O book (location U1.18-P1-H2). These serial ports are normally used for call-in and call-out.

Call-out is disabled in partitioned systems. The call-out function is normally handled by the Service Focal Point running application on the HMC.

None of these menus are applicable to the serial ports, or modems attached to those serial ports, on the hardware management console (HMC).

```
CALL-IN/CALL-OUT SETUP MENU

1. Modem Configuration Menu
2. Serial Port Selection Menu
3. Serial Port Speed Setup Menu
4. Telephone Number Setup Menu
5. Call-Out Policy Setup Menu
6. Customer Account Setup Menu

7. Call-Out Test
   Not supported in LPAR mode
98. Return to Previous Menu

99. Exit from Menus

0>
```

- **Modem Configuration Menu**, see “Modem Configuration Menu” on page 729.
- **Serial Port Selection Menu**, see “Serial Port Selection Menu” on page 730.
- **Serial Port Speed Setup Menu**, see “Serial Port Speed Setup Menu” on page 730.
- **Telephone Number Setup Menu**, see “Telephone Number Setup Menu” on page 732.
- **Call-Out Policy Setup Menu**, see “Call-Out Policy Setup Menu” on page 733.
- **Customer Account Setup Menu**, see “Customer Account Setup Menu” on page 734.
- **Call-Out Test** tests the configuration after the modem is installed and configured correctly.

Note: If the system is running in partition mode, the call-out option is disabled.

Modem Configuration Menu

Note: This option applies only to a modem attached to serial port 1 (S1) or serial port 2 (S2) on the primary I/O book.

The first two lines of the Modem Configuration Menu contain status of the current selections. Selections are made in the sections labeled Modem Ports and Modem Configuration File Name. Select the serial port that you want to activate and then select the modem configuration file for the modem on the port. If you want to set up all of the serial ports with modems, make your selections one port at a time.

```
Modem Configuration Menu

Port 1 Modem Configuration File Name:
Port 2 Modem Configuration File Name:

To make changes, First select the port and then the configuration file
name

Modem Ports:
 1. Serial port 1
 2. Serial port 2

Modem Configuration File Name:
 5. none9. modem_z_sp
 6. modem_f_sp          10. modem_m1_sp
 7. modem_f0_sp         11. modem_m0_sp
 8. modem_f1_sp         12. modem_m1_sp

30. Save configuration to NVRAM and Configure modem
98. Return to Previous Menu

0>
```

For information on choosing a modem configuration file, see “Sample Modem Configuration Files” on page 903 and “Transfer of a Modem Session” on page 909.

Serial Port Selection Menu

This menu allows you to enable or disable the call-in and call-out functions of each serial port in any combination.

Note: If the system is running in partition mode, call-out is disabled.

```
Serial Port Selection Menu

1. Serial Port 1 Call-Out:
   Currently Disabled
   Not Supported. In LPAR mode.

2. Serial Port 2 Call-Out:
   Currently Disabled
   Not Supported. In LPAR mode.

3. Serial Port 1 Call-In:
   Currently Disabled

4. Serial Port 2 Call-In:
   Currently Disabled

98. Return to Previous Menu

0>
```

Call-in and ring indicate power-on cannot be enabled at the same time. If ring-indicate power-on is already enabled and you try to enable call-in, a message prompts you for confirmation. Refer to the message displayed on the screen.

Serial Port Speed Setup Menu

This menu allows you to set serial port speed to enhance terminal performance or to accommodate modem capabilities.

```
Serial Port Speed Setup Menu

1. Serial Port 1 Speed:
   Currently 9600

2. Serial Port 2 Speed:
   Currently 9600

98. Return to Previous Menu

0>
```

A serial port speed of 9600 baud or higher is recommended. The following are valid serial port speeds:

50	600	4800
75	1200	7200
110	1800	9600
134	2000	19200
150	2400	38000
300	3600	57600

115200

Telephone Number Setup Menu

Note: These menus are available, however, the function of calling out to report a system failure is normally handled by the Service Focal Point application running on the HMC.

Use this menu to set or change the telephone numbers for reporting a system failure.

```
Telephone Number Setup Menu

1. Service Center Telephone Number:
   Currently Unassigned

2. Customer Administration Center Telephone Number:
   Currently Unassigned

3. Digital Pager Telephone Number:
   Currently Unassigned

4. Customer Voice Telephone Number:
   Currently Unassigned

5. Customer System Telephone Number:
   Currently Unassigned

98. Return to Previous Menu

0>
```

- **Service Center Telephone Number** is the number of the service center computer. The service center usually includes a computer that takes calls from servers with call-out capability. This computer is referred to as the "catcher." The catcher expects messages in a specific format to which the service processor conforms.
For more information about the format and catcher computers, refer to the README file in the AIX /usr/samples/syscatch directory. Contact your service provider for the correct service center telephone number to enter. Until you have that number, leave this field unassigned.
- **Customer Administration Center Telephone Number** is the number of the System Administration Center computer (catcher) that receives problem calls from servers. Contact your system administrator for the correct telephone number to enter here. Until you have that number, leave this field unassigned.
- **Digital Pager Telephone Number** is the number for a numeric pager carried by someone who responds to problem calls from your server. Contact your administration center representative for the correct telephone number to enter. For test purposes, use a test number, which you can change later (see the note on page 746).

Note: If the system is running in partition mode, call-out is disabled. However, if the system is booted in full system partition mode, at least one of the preceding three telephone numbers must be assigned in order for the call-out test to complete successfully.

- **Customer Voice Telephone Number** is the telephone number of a phone near the server or answered by someone responsible for the server. This is the telephone number left on the pager for callback. For test purposes, use a test number, which you can change later.
- **Customer System Telephone Number** is the telephone number to which your server's modem is connected. The service or administrative center representatives need this number to make direct contact with your server for problem investigation. This is also referred to as the *call-in* phone number.

Call-Out Policy Setup Menu

Note: Call-out is disabled in partitioned systems.

Call out settings can be set using the following menu:

```

CALL-OUT POLICY SETUP MENU

1. Call-Out policy (First/All):
   Currently First

2. Remote timeout, (in seconds):
   Currently 120

3. Remote latency, (in seconds):
   Currently 2

4. Number of retries:
   Currently 2

98. Return to Previous Menu

0>

```

- **Call-Out policy** can be set to first or all. If call-out policy is set to first, the service processor stops at the first successful call-out to one of the following numbers in the order listed:
 1. Service Center
 2. Customer Administrative Center
 3. Pager

If call-out policy is set to all, the service processor attempts a call-out to all of the following numbers in the order listed:

 1. Service Center
 2. Customer Administrative Center
 3. Pager
- **Remote timeout** and **remote latency** are functions of your service provider's catcher computer. Either use the defaults or contact your service provider for recommended settings.
- **Number of retries** is the number of times you want the server to retry calls that failed to complete.

Customer Account Setup Menu

This menu allows users to enter information that is specific to their account.

```
Customer Account Setup Menu

1. Customer Account Number:
   Currently Unassigned

2. Customer RETAIN Login userid:
   Currently Unassigned

3. Customer RETAIN login password:
   Currently Unassigned

98. Return to Previous Menu

0>
```

- **Customer Account Number** is assigned by your service provider for record-keeping and billing. If you have an account number, enter it. Otherwise, leave this field unassigned.
- **Customer RETAIN Login User ID** and **Customer RETAIN Login Password** apply to a service function to which your service provider might have access. Leave these fields unassigned if your service provider does not use RETAIN.

Call-out Test

Call-out test is disabled in partitioned systems.

Service Processor Parameters in Service Mode (Full System Partition)

When the system is in service mode, the following service processor functions are suspended:

- Unattended Start Mode
- Reboot/Restart Policy
- Call-Out
- Surveillance

When service mode is exited, the service processor functions are re-activated.

System Power-On Methods

This section discusses the following system power-on methods:

- Power-on Switch
- Service Processor Menus

Privileged users can power on the system by selecting the **System Control Power Menu** option from the main menu and then selecting the **Power-on System** option from the System Power Control Menu. General users should select **Power-on System** on the General User Menu.

- Remote Power-on via Ring-Indicate Signal

The server automatically powers on when it detects a "ring indicate" signal from a modem attached to serial port 1 (S1) or serial port 2 (S2).

A remote user can call the server to activate ring detection by the modem. Listen for a few more rings than the threshold number for starting the system. The system powers on without answering the call.

- Unattended start mode - refer to **Enable/Disable Unattended Start Mode** on page 717.

The service processor can be enabled to recover from the loss of ac power (see Enable/Disable Unattended Power-On Mode in the SYSTEM POWER CONTROL MENU). When ac power is restored, the system returns to the power state at the time ac loss occurred. For example, if the system was powered on when ac loss occurred, it reboots/restarts when power is restored. If the system was powered off when ac loss occurred, it remains off when power is restored.

- Timed power-on - refer to the **shutdown -t** command on servers using AIX.

Working in conjunction with AIX, the Service Processor in your server can operate a timer, much like the wake-up timer on your clock radio. You can set the timer so that your server powers on at a certain time after shutting down. The timer is battery-operated, so power interruptions that occur while the server is off do not affect its accuracy. Refer to the AIX **shutdown -t** command for details on setting the timer.

Note: If an ac power loss (exceeding the hold-up time of any optional IBFs) is in progress when the timed power-on attempt occurs, the server cannot power on when ac power is restored.

- Follow-up to a Failed Boot Attempt

The service processor initiates a power-on sequence if a failed boot attempt is detected (due to a hardware or software failure).

- Fast or Slow Boot (IPL)

Using the service processor menus, you can select the IPL type, mode, and speed of your system.

Attention: Selecting fast IPL results in several diagnostic tests being skipped and a shorter memory test being run.

Service Processor Reboot/Restart Recovery

Reboot describes bringing the system hardware back up; for example, from a system reset or power-on. The boot process ends when control passes to the operating system process.

Restart describes activating the operating system after the system hardware is reinitialized. Restart must follow a successful reboot.

Boot (IPL) Speed

When the server enters reboot recovery, slow IPL is automatically started, which gives the POST an opportunity to locate and report any problems that might otherwise be unreported.

Failure During Boot Process

During the boot process, either initially after system power-on or upon reboot after a system failure, the service processor monitors the boot progress. If progress stops, the service processor can reinitiate the boot process (reboot) if enabled to do so. The service processor can re-attempt this process according to the number of retries selected in the Reboot/Restart Policy Setup Menu.

Failure During Normal System Operation

When the boot process completes and control transfers to the operating system (OS), the service processor can monitor operating system activity (see the Set Surveillance Parameters option in the SERVICE PROCESSOR SETUP MENU). If OS activity stops due to a hardware- or software-induced failure, the service processor can initiate a reboot/restart process based on the settings in the Service Processor Reboot/Restart Policy Setup Menu and the OS automatic restart settings (see the operating system documentation), if you are running in a full system partition. Operating system surveillance is disabled in partitioned systems.

If you are using the AIX operating system, the menu item under SMIT for setting the restart policy is **Automatically Reboot After Crash** (True/False). The default is false. When the setting is true, and if the service processor parameter "Use OS-Defined Restart Policy" is yes (the default), the service processor takes over for AIX to reboot/restart after a hardware or surveillance failure.

Service Processor Reboot/Restart Policy Controls

The operating system's automatic restart policy (see operating system documentation) indicates the operating system response to a system crash. The service processor can be instructed to refer to that policy by the Use OS-Defined Restart Policy setup menu.

If the operating system has no automatic restart policy, or if it is disabled, then the service processor-restart policy can be controlled from the service processor menus. Use the Enable Supplemental Restart Policy selection.

Use OS-Defined restart policy - The default setting is yes. This causes the service processor to refer to the OS Automatic Restart Policy setting and take action (the same action the operating system would take if it could have responded to the problem causing the restart).

When this setting is no, or if the operating system did not set a policy, the service processor refers to enable supplemental restart policy for its action.

Enable supplemental restart policy - The default setting is no. If set to yes, the service processor restarts the server when the operating system loses control and either:

The **Use OS-Defined restart policy** is set to No.

OR

The **Use OS-Defined restart policy** is set to Yes and the operating system has no automatic restart policy.

Refer to "Service Processor Reboot/Restart Recovery" on page 736.

The following table describes the relationship among the operating system and service processor restart controls:

OS Automatic reboot/restart after crash setting	Service processor to use OS-Defined restart policy?	Service Processor Enable supplemental restart policy?	System response
None	No	No ¹	
None	No	Yes	Restarts
None	Yes ¹	No ¹	
None	Yes ¹	Yes	Restarts
False ²	No	No ¹	
False ²	No	Yes	Restarts
False ²	Yes ¹	No ¹	
False ²	Yes ¹	Yes	
True	No	No ¹	
True	No	Yes	Restarts
True	Yes ¹	No ¹	Restarts
True	Yes ¹	Yes	Restarts

¹ Service processor default

² AIX default

System Firmware Updates

This section describes the methods of reprogramming the system firmware. All types of firmware that can be reprogrammed are updated at the same time. They are as follows:

- System Power Control Network programming
- Service Processor programming
- IPL programming
- Run-time Abstraction Services

The following user-initiated processes can be used to update the firmware in the system:

- Service Processor menu
- Service Aids (available in AIX)
- AIX command line

Another method, called *recovery mode*, is initiated automatically by the service processor if the service processor programming has been corrupted. See 742 for more information.

Determining the Level of Firmware on the System

Note: This information may be superseded by the information that is available on CORE. Always check CORE for the latest images and instructions for checking the firmware level.

The firmware level is denoted by `XXYYMMDD`, where `XX` = model designation, `YY` = year, `MM` = month, and `DD` = day of the release.

The firmware level is displayed in the following places on the system:

- On the AIX command line, enter `lscfg -vp|grep -p Platform`. The line that begins with "ROM level (alterable).." displays the firmware level that is currently installed.
- At the top of the service processor main menu.

Update Diskette Images and Instructions

Update diskette images and instructions are available from CORE.

It is strongly recommended that you create a set of firmware update diskettes from CORE as soon as possible after a system is installed. As noted below, the diskette images can be downloaded to any personal computer or `@server` pSeries machine with access to CORE. This method is the only way to acquire a set of firmware update diskettes; they cannot be created by using the service processor menus or by using AIX.

Retain and store the latest firmware diskettes each time the firmware gets updated in the event that the firmware gets corrupted and must be reloaded.

Download the detailed instructions, as well as the latest flash images, from CORE. Before doing a system firmware update, check CORE for the latest code and images. Do not attempt a firmware update if you are unsure of the image you have, or of the procedure required for the update.

The images are available on CORE in either DOS format or AIX (backup) format:

- If downloading to a PC, download the DOS image and follow the instructions. The diskettes that are created will be in AIX (backup) format.
- If downloading to an @server machine, follow the instructions to create an image on disk drives or on diskettes.

Updating System Firmware From the Service Processor Menus

This method is recommended for all managed systems. Updating the system firmware using the service processor menus avoids the resource allocation issues that can arise if the managed system is a partitioned system. Using this method takes no longer than updating firmware using the AIX Service Aids or the AIX command line.

The service processor menus are available while the system is powered off. As a privileged user, from the service processor main menu, select **Service Processor Setup**, then select **Reprogram Flash EPROM Menu**. The update process requests update diskettes as needed.

Refer to the detailed instructions that are provided with the latest image on CORE.

Updating System Firmware from the AIX Service Aids

Attention: This method is not recommended for partitioned systems, but if the device resources are allocated properly, the firmware update can be done using the AIX service aid.

Attention: This service aid is supported only in online diagnostics.

If the firmware on a partitioned system is being updated:

- One partition running AIX must have service authority.
- All other partitions except the one with service authority must be shut down.
- The partition with service authority must own the device from which the firmware update image will be read.
- It is also recommended that the partition with service authority have a hard disk.

If the required devices are not in the partition with service authority, the customer or system administrator must reassign the appropriate resources to it. This requires rebooting the partition with service authority. To avoid the resource allocation issues, it is recommended that the service processor menus be used to update the firmware.

If the firmware on a full system partition is being updated, no special steps are required to perform the firmware update using the service aid.

Refer to the detailed instructions that are provided with the latest image on CORE.

Note: Because the system always reboots itself during this type of firmware update process, the update process can take from twenty to sixty minutes.

Updating System Firmware from the AIX Command Line

Attention: This method is not recommended for partitioned systems, but if the device resources are allocated properly, the firmware update can be done from the AIX command line.

If the firmware on a partitioned system is being updated:

- One partition running AIX must have service authority.
- All other partitions except the one with service authority must be shut down.
- The partition with service authority must own the device from which the firmware update image will be read.
- It is also recommended that the partition with service authority have a hard disk.

If the required devices are not in the partition with service authority, the customer or system administrator must reassign the appropriate resources to it. This requires rebooting the partition with service authority. To avoid the resource allocation issues, it is recommended that the service processor menus be used to update the firmware.

If the firmware on a full system partition is being updated, no special steps are required to perform the firmware update using the command line.

Refer to the detailed instructions that are provided with the latest image on CORE.

Note: Because the system always reboots itself during this type of firmware update process, the update process can take from twenty to sixty minutes.

Recovery Mode

If the service processor detects that its programming has been corrupted when it is powering on to standby mode, it will enter recovery mode. In recovery mode, it will ask for the firmware update diskettes by putting eight-digit codes on the operator panel.

The eight-digit codes are as follows:

Code	Action
A1FD 0000	System firmware has been corrupted and must be reflashed.
A1FD 0001	Insert update diskette 1.
A1FD 0002	Insert update diskette 2.
A1FD 0003	Insert update diskette 3.
A1FD 000n	Insert update diskette n.

Notes:

1. If the wrong diskette is inserted at any time, or if the diskette is left in the drive after it has been read, B1FD 001F is displayed, indicating that the wrong diskette is in the drive.
2. If B1FD 001A is displayed at any time during the process, the service processor must be reset by activating the pinhole reset switch on the operator panel.

After the update process is complete, the service processor resets itself and goes through a complete reboot.

Configuring and Deconfiguring Processors or Memory

All failures that crash the system with a machine check or check stop, even if intermittent, are reported as a diagnostic callout for service repair. To prevent the recurrence of intermittent problems and improve the availability of the system until a scheduled maintenance window, processors and memory books with a failure history are marked "bad" to prevent their being configured on subsequent boots.

A processor or memory book is marked "bad" under the following circumstances:

- A processor or memory book fails built-in self-test (BIST) or power-on self-test (POST) testing during boot (as determined by the service processor).
- A processor or memory book causes a machine check or check stop during runtime, and the failure can be isolated specifically to that processor or memory book (as determined by the processor runtime diagnostics in the service processor).
- A processor or memory book reaches a threshold of recovered failures that results in a predictive callout (as determined by the processor run-time diagnostics in the service processor).

During boot time, the service processor does not configure processors or memory books that are marked "bad."

If a processor or memory book is deconfigured, the processor or memory book remains offline for subsequent reboots until it is replaced or repeat guard is disabled. The repeat guard function also provides the user with the option of manually deconfiguring a processor or memory book, or re-enabling a previously deconfigured processor or memory book. For information on configuring or deconfiguring a processor, see the Processor Configuration/Deconfiguration Menu on page 723.

For information on configuring or deconfiguring a memory book, see the Memory Configuration/Deconfiguration Menu on page 724. Both of these menus are submenus under the System Information Menu.

You can enable or disable CPU Repeat Gard or Memory Repeat Gard using the Processor Configuration/Deconfiguration Menu.

Run-Time CPU Deconfiguration (CPU Gard)

L1 instruction cache recoverable errors, L1 data cache correctable errors, and L2 cache correctable errors are monitored by the processor runtime diagnostics (PRD) code running in the service processor. When a predefined error threshold is met, an error log with warning severity and threshold exceeded status is returned to AIX. At the same time, PRD marks the CPU for deconfiguration at the next boot. AIX will attempt to migrate all resources associated with that processor to another processor and then stop the defective processor.

Service Processor System Monitoring - Surveillance

Surveillance is a function in which the service processor monitors the system, and the system monitors the service processor. This monitoring is accomplished by periodic samplings called *heartbeats*.

Surveillance is available during two phases:

- System firmware bringup (automatic)
- Operating system runtime (optional)

Note: Operating system surveillance is disabled on partitioned systems.

System Firmware Surveillance

System firmware surveillance is automatically enabled during system power-on. It cannot be disabled by the user, and the surveillance interval and surveillance delay cannot be changed by the user.

If the service processor detects no heartbeats during system IPL (for a set period of time), it cycles the system power to attempt a reboot. The maximum number of retries is set from the service processor menus. If the fail condition persists, the service processor leaves the machine powered on, logs an error, and displays menus to the user. If Call-out is enabled, the service processor calls to report the failure and displays the operating-system surveillance failure code on the operator panel.

Operating System Surveillance

Note: Operating system surveillance is disabled in partitioned systems.

Operating system surveillance provides the service processor with a means to detect hang conditions, as well as hardware or software failures, while the operating system is running. It also provides the operating system with a means to detect a service processor failure caused by the lack of a return heartbeat.

Operating system surveillance is not enabled by default, allowing you to run operating systems that do not support this service processor option.

You can also use service processor menus and AIX service aids to enable or disable operating system surveillance.

For operating system surveillance to work correctly, you must set these parameters:

- Surveillance enable/disable
- Surveillance interval

The maximum time the service processor should wait for a heartbeat from the operating system before timeout.

- Surveillance delay

The length of time to wait from the time the operating system is started to when the first heartbeat is expected.

Surveillance does not take effect until the next time the operating system is started after the parameters have been set.

If desired, you can initiate surveillance mode immediately from service aids. In addition to the three options above, a fourth option allows you to select immediate surveillance, and rebooting of the system is not necessarily required.

If operating system surveillance is enabled (and system firmware has passed control to the operating system), and the service processor does not detect any heartbeats from the operating system, the service processor assumes the system is hung and takes action according to the reboot/restart policy settings. See “Service Processor Reboot/Restart Recovery” on page 736.

If surveillance is selected from the service processor menus which are only available at bootup, then surveillance is enabled by default as soon as the system boots. From service aids, the selection is optional.

Call-Out (Call-Home)

Note: Call-out is disabled on partitioned systems. The call-out function is handled by the Service Focal Point application on the Hardware Management Console (HMC).

The service processor can call out (call-home) when it detects one of the following conditions:

- System firmware surveillance failure
- Operating system surveillance failure (if supported by operating system)
- Restarts
- Critical hardware failure
- Abnormal operating system termination

To enable the call-out feature, do the following:

1. Connect a modem to any serial port.
2. Set up the following using the service processor menus or diagnostic service aids:
 - Enable call-out for the serial port where the modem is connected.
 - Enter the modem configuration file name.
 - Set up site-specific parameters (phone numbers for call-out, call-out policy, number of call-out retries, and so on).
3. To call out before restart, set **Call-out before restart** to ENABLED from the Reboot/Restart Policy Setup menu.

Note: Some modems, such as IBM 7857-017, are not designed for the paging function. Although they can be used for paging, they will return an error message when they do not get the expected response from another modem. Therefore, even though the paging was successful, the error message will cause the service processor to retry, continuing to place pager calls for the number of retries specified in the call-out policy setup menu. These retries result in redundant pages.

Console Mirroring

Console mirroring allows a user on one serial port to monitor the service processor activities on another serial port. This can be done on the locally attached HMC virtual terminal window or windows remotely attached through modems. Console mirroring is supported on any combination of locally or remotely attached monitors.

The serial port from which console mirroring is enabled is called the *primary port*. The mirror port is determined when keyboard input is detected from one of the other two serial ports. From this point forward, the service processor sends information to the active port and the mirror port only. Console mirroring ends when the service processor releases control of the serial ports to the system firmware.

Console mirroring is supported on serial port 1 (S1), serial port 2 (S2), and serial port 3 (S3). Remote attachment through a modem is supported on serial port 1 (S1) and serial port 2 (S2).

System Configuration

The following describes the configuration for console mirroring:

- Service processor
- Modem connected to one serial port and enabled for incoming calls
- Local HMC virtual terminal window connected to the other serial port. This local terminal can be connected directly to your server or connected through another modem.

Console mirroring can be started by either of the following methods:

- Remote session first, then local session added:
 1. Remote session is already in progress.
 2. Remote user uses service processor menus to enable console mirroring, allowing both consoles to be active.
- Local session first, then remote session added:
 1. Local session is already in progress.
 2. The service processor receives a call from the remote user.
 3. The local user selects the option to enable console mirroring. The service processor immediately begins mirroring service processor menus.

Service Processor Error Logs

The service processor error logs, an example of which follows, contain error conditions detected by the service processor.

```

                                Error Log
1. 11/30/99   19:41:56 Service Processor Firmware Failure
   B1004999

Enter error number for more details.
Press Return to continue, or 'x' to return to menu.
Press "C" to clear error log, any other key to continue. >
```

Note: The time stamp in this error log is coordinated universal time (UTC), which is also referred to as Greenwich mean time (GMT). AIX error logs have additional information available and can time stamp with local time.

Entering an error number provides nine words of system reference code (SRC) data; an example screen is shown below.

```

Detail:   6005

SRC
-----
word11:B1004999   word12:0110005D   word13:00000000
word14:00000000   word15:00001111   word16:00000000
word17:B1004AAA   word18:0114005D   word19:A4F1E909

B1004999

Press Return to continue, or 'x' to return to menu.
```

If Return is pressed, the contents of NVRAM will be dumped 320 bytes at a time, starting at address 0000.

LCD Progress Indicator Log

The following is an example of the LCD progress indicator log. It shows the types of entries that may appear in the log, and is for example purposes only.

The progress indicator codes are listed from top (latest) to bottom (oldest).

```

LCD Progress Indicator Log
B0FF
0539..17
0538..17
0539..17
0538..17
0539..17
0581
0538..17
0539..12
0538..12
0539..
0821..01-K1-00
0539..
0728..01-R1-00-00
0539..
0664..40-60-00-1,0
0539..
0777..U1.5-P1-I14/E1
0539..
0742..U1.5-P1-I12/E1
0539..
0776..U1.5-P1-I10/T1
E139
E1FB
E139
E183
Press Return to continue, or 'x' to return to menu. >
AAA1..U1.9-P1-I14
E172..U1.9-P1
E172..U1.9-P1-I14
E172..U1.9-P1
94BB
9109
9380
9108
9107
9106
9105
9118
9104
9103
9102
90FD
```

(3) Resetting the Service Processor

- (3) Some error conditions might cause the service processor to hang. The service
- (3) processor must be reset to recover from a hang condition. If the system is powered up,
- (3) resetting the service processor will cause the system to shut down. When the service
- (3) processor is reset, it goes through its power-up sequence, including self-tests.
- (3) Successful completion of the reset sequence is indicated by OK in the operator panel in
- (3) the media drawer.

(3) Before resetting the service processor, if the managed system is powered up and
(3) running AIX, shut down all partitions, or the full system partition. This action causes the
(3) system to shutdown and the system power is turned off.

(3) To reset the service processor when the managed system is powered off, perform any
(3) one of the following:

- (3) • If the service processor is responding to input from the HMC (or ASCII terminal),
(3) select **Service Processor Setup Menu** from the main menu, then select **Reset**
(3) **Service Processor**. This can only be done by a privileged user.
- (3) • Put the UEPO switch in the off position, then back to the on position.
- (3) • Activate the pinhole reset switch on the operator panel. For instructions on using the
(3) pinhole reset switch, see the note on "Media Subsystem Operator Panel" on page 26.

Service Processor Operational Phases

This section provides a high-level flow of the phases of the service processor.

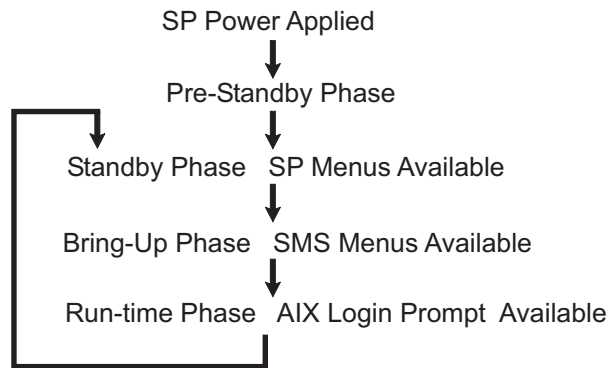

Pre-Standby Phase

This phase is entered when the server is connected to a power source. The server may or may not be fully powered on. This phase is exited when the power-on self-tests (POSTs) and configurations tasks are completed.

The pre-standby phase components are:

- Service Processor Initialization - service processor performs any necessary hardware and software initialization.
- Service Processor POST - service processor conducts power-on self-tests on its various work and code areas.
- Service Processor Unattended Start Mode Checks - To assist fault recovery. If unattended start mode is set, the service processor automatically reboots the server. The service processor does not wait for user input or power-on command, but moves through the phase and into the bring-up phase. Access the SMS menus or the service processor menus to reset the unattended start mode.

Standby Phase

The standby phase can be reached in either of two ways:

- With the server off and power connected (the normal path), recognized by 0K in the LCD display.
OR
- With the server on after an operating system fault, recognized by an 8-digit code in the LCD display.

In the standby phase, the service processor takes care of some automatic duties and is available for menu operation. The service processor remains in the standby phase until a power-on request is detected.

The standby phase components are as follows:

- Modem Configuration
The service processor configures the modem (if installed) so that incoming calls can be received, or outgoing calls can be placed.
- Dial In
Monitor incoming phone line to answer calls, prompt for a password, verify the password, and remotely display the standby menu. The remote session can be mirrored on the local HMC virtual terminal window if the server is so equipped and if the user enables this function.
- Menus
The service processor menus are password-protected. Before you can access them, you need either the general user-password or privileged-user password.
Service processor menus are available on ASCII terminals attached to the serial ports on the primary I/O book, and on terminal emulators. On HMC-managed systems, service processor menus are also available on the HMC graphical user interface.

Bring-Up Phase

On a system that is powered-on to full system partition, this phase is entered upon power-on, and exited upon loading of the operating system.

On a system that is powered-on to partition standby, this phase is entered upon power-on, and exited when the partition manager and hypervisor have been loaded and become fully operational in system memory. The end of this phase is indicated when LPAR displays on the operator panel. At this point, the server can start multiple logical partitions which would be activated through the HMC graphical user interface.

The bring-up phase components are as follows:

- Retry Request Check
The service processor checks to see if the previous boot attempt failed. If the specified number of failures are detected, the service processor displays an error code and places an outgoing call to notify an external party if the user has enabled this option.
- Dial Out

The service processor can dial a preprogrammed telephone number in the event of an IPL failure. The service processor issues an error report with the last reported IPL status indicated and any other available error information.

- Update Operator Panel

The service processor displays operator panel data on the HMC virtual terminal window if a remote connection is active.

- Environmental Monitoring

The service processor provides expanded error recording and reporting.

- System Firmware Surveillance (Heartbeat Monitoring)

The service processor monitors and times the interval between system firmware heartbeats.

- Responding to System Processor Commands

The service processor responds to any command issued by the system processor.

Run-Time Phase

This phase includes the tasks that the service processor performs during steady-state execution of the operating system.

- Environmental Monitoring

The service processor monitors voltages, temperatures, and fan speeds (on some servers).

- Responding to System Processor Commands

The service processor responds to any command issued by the system processor.

- Run-Time Surveillance (not supported on partitioned systems)

If the device driver is installed and surveillance enabled, the service processor monitors the system heartbeat. If the heartbeat times out, the service processor places an outgoing call. This is different from the bring-up phase scenario, where the specified number of reboot attempts are made before placing an outgoing call.

- HMC surveillance

On an HMC-managed system, the service processor monitors the communication link between the managed system and the HMC. If the service processor detects that this communication link has been broken, it will post an error to the operating system running on the managed system.

Chapter 8. Using System Management Services

Use the system management services menus to view information about your system or partition, and to perform tasks such as setting a password, changing the boot list, and setting the network parameters.

Note: On some of the system management services (or service processor) screens, you will see the term *LPAR*, which is equivalent to the term *logically partitioned system* or simply *partitioned system*.

Note: In a partitioned system, only those devices that are assigned to the partition that is being booted display in the SMS menus. In a full system partition, all devices in the system display in the SMS menus.

To start the system management services, do the following:

1. For a partitioned system, use the IBM Hardware Management Console for pSeries (HMC) to restart the partition.

For a full system partition, restart the system.

2. For a partitioned system, watch the virtual terminal window on the HMC.

For a full system partition, watch the firmware console.

3. Look for the POST indicators **memory**, **keyboard**, **network**, **scsi**, **speaker**, which appear across the bottom of the screen.

Press the numeric 1 key after the word **keyboard** appears, and before the word **speaker** appears.

For more information on the POST indicator words, refer to “POST Indicators” on page 17.

After the system management services starts, the following screen displays:

```
Utilities
1 Password Utilities...NOT available in LPAR mode.
2 Display Error Log
3 Remote Initial Program Load Setup
4 SCSI Utilities
5 Select Console...NOT available in LPAR mode.
6 MultiBoot
7 Select Language
8 OK Prompt

                                     [X=Exit]
===>
```

Each option on the system management services utilities menu is described in this section.

Password Utilities

Note: This utility is disabled in partitioned systems.

Entering this selection permits access to the options shown on the following screen:

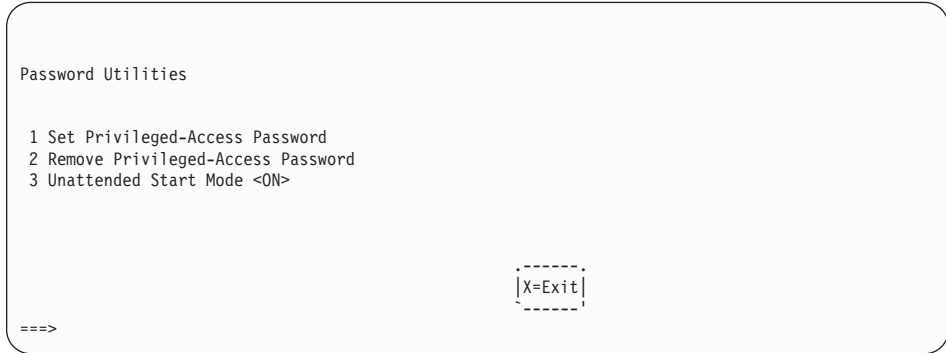

Set Privileged-Access Password: The privileged-access password protects against the unauthorized starting of the system programs. When this option is selected, another screen displays that allows the setting of a password.

You can set the password from either the service processor or system management services menus. After the password is set, both the service processor and system management services automatically use the same password. The password is limited to eight characters.

Remove Privileged-Access Password: If you previously had set a privileged-access password and want to remove it, select **Remove Privileged-Access Password**.

Note: If you *forget* your password, you must shut down the system and remove the battery for at least 30 seconds.

Unattended Start Mode <ON>: This selection is used to enable or disable unattended start mode. Use this option to instruct the service processor to restore the power-state of the server after a temporary power failure, which is necessary on servers that require automatic power-on after a power failure. The default setting is on.

Display Error Log

A screen similar to the following displays when you select this option. You can view or clear your system error log.

```

                                Error Log
-----
      Date      Time      ErrorCode  Location
Entry 1. 01/06/30 02:15:35 25a80011  U0.1-P1-H2
Entry 2. 01/07/01 03:18:36 20300026  U0.1-P1-H2
-----

[C=Clear Error Log]                [X=Exit Log]
```

Note: The time stamp in this error log is coordinated universal time (UTC), which is also referred to as Greenwich mean time (GMT). AIX error logs have more information available and can time stamp with your local time.

Remote Initial Program Load Setup

This option allows you to enable and set up the remote startup of your system or partition. You must first specify the network parameters as shown in the following screen:

```

Network Parameters
1. IP Parameters
2. Adapter Parameters
3. Ping

                                [X=Exit]

====>
```

Note: Some applications may require that IP addresses contain leading zeroes for numbers less than 100. For example, 129.132.4.20 may need to be entered as 129.132.004.020.

IP Parameters

Select the **IP Parameters** option from the Network Parameters menu to display a screen similar to the following:

```
IP Parameters
1. Client IP Address [9.3.146.162]
2. Server IP Address [9.3.146.171]
3. Gateway IP Address [0.0.0.0]
4. Subnet Mask [255.255.255.0]

                                     |X=Exit|

====>
```

To set an address using this menu, do the following:

1. Type the number of the selection (1, 2, 3, or 4).
2. Enter the address on the next screen.

Attention: If the client system and the server are on the same subnet, set the gateway IP address to [0.0.0.0].

Adapter Parameters

Note: In a partitioned system, only those network adapters that have been assigned to the partition being booted display in the IP Parameters menu. In a full system partition, all network adapters in the system are listed in the Adapter Parameters menu.

Select the **Adapter Parameters** option from the Network Parameters menu to view an adapter's hardware address, as well as configure network adapters that require setup. A screen similar to the following displays when you make this selection:

Adapter Parameters

Device	Slot	Hardware Address
1. Gigabit Ethernet	4: U0.1-P2-I4/E1	0004ac7c0135
2. token-ring	5: U0.1-P2-I5/T1	0020357a9105
3. ethernet	8: U0.2-P1-I5/E1	0060949d7ac5
4. token-ring	3: U0.3-P1-I3/T1	0004ac634e38

[X=Exit]

(PRESS ENTER AFTER MAKING A SELECTION) ==>

Select an adapter on this screen to display configuration menus for that adapter. If **Ethernet** is selected, you can set parameters that control how the Ethernet adapter communicates with the network. For example, the following screen shows the menu for the Ethernet adapter configuration:

1. Data Rate [Auto]
2. Full Duplex [No]

Ping

Select **Ping** from the Network Parameters menu to test a connection to a remote system unit. After selecting the **Ping** option, you must first choose an adapter to communicate with the remote system.

```
Adapter Parameters

      Device              Slot              Hardware Address
1. Gigabit Ethernet     4: U0.1-P2-I4/E1      0004ac7c0135
2. token-ring           5: U0.1-P2-I5/T1      0020357a9105
3. ethernet             8: U0.2-P1-I5/E1      0060949d7ac5
4. token-ring           3: U0.3-P1-I3/T1      0004ac634e38

                                     [X=Exit]

(PRESS ENTER AFTER MAKING A SELECTION) ==>
```

After determining which adapter to use to ping the remote system, you must provide the addresses needed to communicate with the remote system. Select the appropriate device from the Ping menu to display a screen similar to the following:

```
PING IP Address

1. Client IP Address     [9.3.146.162]
2. Server IP Address     [9.3.146.171]
3. Gateway IP Address    [0.0.0.0]
4. Subnet Mask           [0.0.0.0]

[E=Execute]              [X=Exit]

==>
```

SCSI Utilities

SCSI Utilities allow you to set delay times for the SCSI hard disk spin-up and to set SCSI IDs for SCSI controllers installed in the system.

```
SCSI Utilities
1. Harddrive Spin Up Delay
2. Change SCSI Id

X=Exit

====>
```

Using the **Harddrive Spin Up Delay** option allows you to change the spin up delay time for SCSI hard disk drives attached to your system. Spin up delay values can be entered manually, or you can use a default setting (two seconds). All values are measured in seconds.

Attention: Setting the value lower than the default can prevent successful booting because the system power-handling capabilities might be exceeded. If the system no longer boots after setting this value, access this utility again and increase the value. It is also possible that adding disk drives can cause similar symptoms. Changing this value changes the surge current requirements on the system. As you increase the value, the surge current requirements on the system are decreased.

Select Console

Note: This option is not available on partitioned systems. A virtual terminal window on the HMC is the default firmware console for a partitioned system. The following screen displays only if the system is running in a full system partition.

Select this option to define which display is used by the system for system management. If no console is selected, the console defaults to serial port 1 on the primary I/O book.

```
Press 0 to select this console
as the active console
```

Multiboot

Multiboot allows you to select a method for booting the system.

```
Multiboot
1  Select Software
2  Software Default
3  Select Install Device
4  Select Boot Devices
5  OK Prompt
6  Multiboot Startup <OFF>
```

```
[X=Exit]
```

```
===>
```

Select Software

If this option is supported by the operating system, the names of the operating system installed are shown. This option might not be supported by all operating systems.

If you are running AIX, and you receive the following message:

```
No Operating System Installed
```

this indicates that information in nonvolatile storage could have been lost, as would happen if the battery had been removed. To re-create this value, run the **bootlist** command under AIX with the appropriate parameters. See the **bootlist** command in your AIX documentation.

The AIX Documentation library is available at the following Web address: <http://www.ibm.com/servers/aix/library/>. Select **Technical Publications**. AIX documentation is also contained on the AIX Documentation CD. This documentation is made accessible by loading the documentation CD onto the hard disk or by mounting the CD in the CD-ROM drive.

Software Default

If this option is supported by the operating system, you can select the default operating system to start the system.

Select Install Device

Attention: In a partitioned system, only those devices from which an operating system can be installed that are assigned to the partition being booted display on the Select Install Device menu. In a full system partition, all devices from which an operating system can be installed display on the Select Install Device menu.

Select this option to produce a list of devices, such as the CD-ROM, from which the operating system may be installed. Select a device, and the system searches that device for an operating system to install. If the device supported by the operating system is that device, the name of the operating system displays.

Select Boot Devices

Attention: In a partitioned system, only those devices from which an operating system can be booted that are assigned to the partition being booted display on the Select Boot Devices menu. In a full system partition, devices from which an operating system can be booted display on the Select Boot Devices menu.

Select this option to view and change the customized boot list, which is the sequence of devices that the system searches when booting an operating system. The boot device list can contain up to five devices. The following is an example of this screen.

```
Select Boot Devices
```

```
1 Display Current Settings
2 Restore Default Settings
3 Configure 1st Boot Device
4 Configure 2nd Boot Device
5 Configure 3rd Boot Device
6 Configure 4th Boot Device
7 Configure 5th Boot Device
```

```
-----
|X=Exit|
-----
```

```
====>
```

Display Current Settings

Lists the current order of devices in the boot list. The following is an example of this screen.

```
Current Boot Sequence

1. Diskette
2. SCSI CD-ROM id=1 ( loc=U0.1-P2/Z1-A1 )
3. SCSI 9100 MB Harddisk id=8 ( loc=U0.1-P2/Z1-A8 )
4. Ethernet ( loc=U9.1-P2-I2/E1 )
5. None

                                     |X=Exit|

====>
```

Restore Default Settings

Restores the boot device list to the following default sequence:

- Primary diskette drive
- CD-ROM drive
- Tape (if installed)
- Hard disk drive
- Network device

Selecting any of the **Configure Boot Device** options displays a screen similar to the following.

```
Configure Nth Boot Device

Device   Current   Device
Number   Position  Name
-----
1         1         Diskette
2         4         Ethernet ( loc=U0.1-P2-I2/E1 )
3         -         Token-Ring ( loc=U0.2-P1-I4/T1 )
4         2         SCSI CD-ROM id=1 ( loc=U0.1-P2/Z1-A1 )
5         3         SCSI 18200 MB Harddisk id=8 ( loc=U0.1-P2/Z1-A8 )

                                     |X=Exit|

====>
```

Multiboot Startup <OFF>

Toggles between off and on to select whether Multiboot menu starts automatically on startup.

Select Language

Select this option to change the language used by the system management services screens and the service processor menus.

A screenshot of a terminal window titled "Select Language". It displays a numbered list of languages: 1. English, 2. Francais, 3. Deutsch, 4. Italiano, 5. Espanol, and 6. Svenska. Below the list is a prompt "===>" and a dashed box containing the text "X=Exit".

```
Select Language

1. English
2. Francais
3. Deutsch
4. Italiano
5. Espanol
6. Svenska

===>                                X=Exit
```

Note: To correctly display languages other than English, your system or your virtual terminal window must support the ISO-8859 character set.

OK Prompt

This option is for service personnel only to obtain additional debug information. It provides access to the open firmware command prompt. If it is necessary to exit from the open firmware command prompt, type:

```
reset-all
```

Exiting System Management Services

After you have finished using the system management services, type **x** (for exit) at the Utilities screen to boot your system or partition. On all other screens, typing **x** returns you to the previous screen.

Chapter 9. Removal and Replacement Procedures

Introduction	770
Handling Static-Sensitive Devices	771
Powering Off and Powering On the System	771
Powering Off the System and Removing Power	771
Powering On the System	772
Powering On the System Using the Service Processor	772
Hot-Pluggable FRUs	773
Power Subsystem	776
Bulk Power Assembly (BPA)	776
Bulk Power Regulator (BPR)	776
Removal	776
Replacement	776
Bulk Power Controller (BPC)	777
Removal	777
Replacement	777
Bulk Power Distributor (BPD)	778
Removal	778
Replacement	778
Bulk Power Fan (BPF)	780
Removal	780
Replacement	780
Bulk Power Enclosure (BPE)	780
Removal	780
Replacement	781
Unit Emergency Power Off (UEPO) Card Assembly	782
Removal	782
Replacement	783
Integrated Battery Feature (IBF)	783
Removal	783
Replacement	784
Processor Subsystem	786
Installing the MCM/L3/Passthrough Plug Map	786
Using this Label	786
I/O Books and I/O Blanks	787
Removal	787
Inspection	787
Replacement	789
Battery	790
Removal	790
Replacement	791
Processor Subsystem DCA (Distributed Converter Assembly) Books and DCA Blanks	792
Removal	792
Replacement	792
Capacitor Books and Blanks	793
Removal	793
Replacement	793

MCM Module (Processor) and Passthru Modules	794
Handling Static-Sensitive Modules	794
Removal	795
Replacement or New Installation	800
Testing MCMs and Passthru Modules for a Short Circuit.	802
L3 Cache Modules	805
Handling Static-Sensitive Modules	805
Removal	805
Replacement or New Installation	809
Testing L3 Cache Modules for a Short Circuit	812
Shorts Test Qualified Service Meters and Fail Criteria	818
VPD Card	820
Removal	820
Replacement	820
System Clock Card	821
Removal	821
Replacement	821
Processor Subsystem Chassis	822
Removal	822
Replacement	824
Memory Books and Memory Blanks	825
Removal	825
Inspection	825
Replacement	825
Fan Controller.	827
Removal	827
Replacement	827
Processor Fan Assemblies	828
Removal	828
Replacement	828
Fan Chassis	828
Removal	828
Replacement	828
Processor Subsystem Air Filters.	829
Removal	829
Replacement	829
I/O Subsystem	830
I/O Subsystem PCI Slot LED Definitions	830
PCI Adapters	831
Non-Hot-Pluggable PCI Adapter.	831
Removal	831
Replacement	832
Replacing a Double-Wide Blind Swap Adapter	834
Hot-Pluggable PCI Adapter	836
Replacing a Hot-Pluggable PCI Adapter	836
Installing a Hot-Pluggable PCI Adapter	839
Removing a Hot-Pluggable PCI Adapter	841
PCI Hot-Plug Manager Access	843
Accessing Hot-Plug Management Functions.	843
PCI Hot-Plug Manager Menu.	843

Blind Swap Cassette (BSC) Assembly Procedure	846
Removal	846
Replacement	847
I/O Subsystem RIO Riser Card	856
Removal	856
Replacement	856
I/O Subsystem Distributed Converter Assembly (DCA)	857
Removal	857
Replacement	857
I/O Subsystem I/O Backplane Assembly	858
Removal	858
Replacement	859
I/O Subsystem DASD Hard Disk Drive Assembly	860
Removal	860
Replacement	860
I/O Subsystem DASD 4-Pack	862
Removal	862
Replacement	862
I/O Subsystem DASD Fan	863
Removal	863
Replacement	863
I/O Subsystem Chassis	864
Removal	864
Replacement	865
Media Subsystem	865
CD-ROM, DVD-RAM, or Tape Drive	865
Removal	866
Replacement	866
Diskette Drive	867
Removal	867
Replacement	867
Operator Panel	868
Removal	868
Replacement	868
Media Subsystem Chassis	870
Removal	870
Replacement	870
Media Subsystem Internal Cables	871
Removal	871
Replacement	871

Introduction

Before performing any of the removal or replacement procedures in this chapter, read the following notices.

DANGER

An electrical outlet that is not correctly wired could place hazardous voltage on metal parts of the system or the devices that attach to the system. It is the responsibility of the customer to ensure that the outlet is correctly wired and grounded to prevent an electrical shock.

Use one hand, when possible, to connect or disconnect signal cables to prevent a possible shock from touching two surfaces with different electrical potentials.

During an electrical storm, do not connect cables for display stations, printers, telephones, or station protectors for communications lines.

CAUTION:

This product is equipped with a three-wire power cable and plug for the user's safety. Use this power cable with a properly grounded electrical outlet to avoid electrical shock.

CAUTION:

This unit has more than one power supply cord. To reduce the risk of electrical shock, disconnect two power supply cords before servicing.

Handling Static-Sensitive Devices

Attention: Disk drives, tape drives, and CD-ROM drives are sensitive to static electricity discharge. These devices are shipped in antistatic containers to prevent damage caused by electrostatic discharge.

Take the following precautions:

- If you have an antistatic wrist strap available, use it while handling the device.
- Do not remove the device from the antistatic container until you are ready to install the device in the system unit.
- With the device still in its antistatic container, touch it to a metal frame of the system.
- Grasp cards and boards by the edges. Hold drives by the frame. Avoid touching the solder joints or pins.
- If you need to lay the device down while it is out of the antistatic container, lay it on the antistatic container. Before picking it up again, touch the antistatic container and the metal frame of the system unit at the same time.
- Handle the devices carefully in order to prevent permanent damage.

Powering Off and Powering On the System

This section provides procedures for powering off and powering on the system. If you are instructed to remove the power from the system, the power cords must be disconnected from the power source.

Powering Off the System and Removing Power

The hardware management console user interface provides a Power Off function to shut down operating partitions and turn off the power in the system. Use the hardware management console to turn off the system when directed.

As the system goes off, the power LED on the operator panel starts blinking at a fast rate. B0FF appears in the primary operator panel display.

When the power-off sequence is complete, the system goes into Standby mode, as evidenced by the following:

- OK message displays in the operator panel display.
- The operator-panel LED will start blinking at a slow rate.
- The processor subsystem power LED will start blinking at a slow rate.

To completely remove power from the system, turn off the UEPO switch, turn off the circuit breakers on all optional IBF subsystems (if provided), then disconnect both power cords from the customer's receptacle.

Also, if the system is operating in Full System Partition mode under AIX, typing the **shutdown** command causes the system to shutdown and power off. The **-F** option shuts down the system without warning system users. Check with the system administrator before using the **-F** option. If you cannot use this method, you can power off the system by pressing the media subsystem operator-panel power button.

If you cannot use this method, use the following operator-panel power button procedure.

Attention: Using the media subsystem operator-panel power button to power off the system might cause unpredictable results in the data files, and the next IPL will take longer to complete.

1. Open the rack door.
2. Press the power button on the operator panel.

The power LED on the operator panel starts blinking at a fast rate. B0FF appears in the primary operator panel display.

When the power-off sequence is complete, the system goes into Standby mode, as evidenced by the following:

- 0K message displays in the operator panel display.
 - The operator-panel LED will start blinking at a slow rate.
 - The processor subsystem power LED will start blinking at a slow rate.
3. To completely remove power from the system, turn off the UEPO switch, turn off the circuit breakers on all optional IBF subsystems (if provided), then disconnect both power cords from the customer's receptacle.

Powering On the System

The hardware management console can be used to turn the system power on. Other methods of turning the power on are discussed below. Perform the following steps to power on the processor subsystem and attached I/O subsystems using the power button on the media subsystem operator panel.

1. Open the rack door. Look for 0K in the primary operator panel display, which indicates that the system is in standby mode.

Note: If the power has recently been connected to the system, you might need to allow approximately 5 minutes time after the OK prompt appears before pressing the power button on the media subsystem, or using the service processor to turn the system power on.

2. Press the power button on the media subsystem operator panel.

The power LED on the media subsystem operator panel starts blinking at a fast rate. 9xxx checkpoints appear in the operator panel display.

When the power-on sequence is complete; the following events occur:

- The power LED on the media subsystem operator panel stops blinking and stays on.
- The power LED on the processor subsystem stops blinking and stays on.
- If a secondary I/O subsystem is present, its power LED comes on and stays on.

Powering On the System Using the Service Processor

The system can be powered on using the System Power Control menu, which is a Service Processor menu that is available to the privileged user.

Hot-Pluggable FRUs

Note: You do not have to power off the system to remove a hot-pluggable FRU from the processor subsystem or from I/O subsystems.

FRUs can be considered as: not concurrently replaceable, concurrently replaceable with hot plug, and concurrently replaceable. The following table indicates which FRUs are hot-pluggable or non-hot-pluggable. Each FRU shown is identified as available for concurrent maintenance if applicable.

Processor Subsystem FRUs	Hot-Pluggable Concurrent Maintenance	Notes
Blowers	Yes	Processor subsystem and power blowers can be replaced with power on, follow the appropriate removal and replacement procedures.
DCA	Yes	DCAs can be replaced with power on, follow the appropriate removal and replacement procedures.
Bulk Power Enclosure	Yes	One Bulk Power Enclosure can be replaced with the system running, follow the appropriate removal and replacement procedures. Note: If you use the Start Service button and the ENBL LEDs on the enclosure components do not go off, do not proceed, contact the customer and schedule a time for replacement of the enclosure with power off.
Bulk Power Controller (BPC)	Yes	BPCs can be replaced with power on, follow the appropriate removal and replacement procedures.
Bulk Power Regulator (BPR)	Yes	BPRs can be replaced with power on, follow the appropriate removal and replacement procedures.
Bulk Power Distributor (BPD)	Yes	BPDs can be replaced with power on, follow the appropriate removal and replacement procedures.
UEPO Switch panel	Yes	UEPO Switch panel can be replaced with power on, follow the appropriate removal and replacement procedures.
BPF	Yes	BPF can be replaced with power on, follow the appropriate removal and replacement procedures.
IBF	Yes	IBF can be replaced with power on, follow the appropriate removal and replacement procedures.
Capacitor bank	No	
Processor subsystem chassis	No	

Processor Subsystem FRUs	Hot-Pluggable Concurrent Maintenance	Notes
MCM	No	
Memory cards	No	
L3 cache	No	
Clock card	No	
I/O books	No	

I/O Subsystem FRUs	Hot-Pluggable Concurrent Maintenance	Notes
- I/O backplane and riser card	No	
- DASD backplane	No	
- Disk drives	Yes	Note: The customer may require additional consideration or customer preparation for replacement.
- DCA (power supplies)	Yes	Only one DCA can be removed at a time.
- I/O fan assemblies	Yes	Can be replaced only if the DASD backplane is not installed.
- PCI adapters	Yes	Note: The customer may require additional consideration or customer preparation for replacement.

Media Subsystem FRUs	Hot-Pluggable Concurrent Maintenance	Notes
Operator Panel	No	
Diskette drive	Yes	<p>Must be removed from the configuration and the partition must be booted afterwards to ensure correct operation.</p> <p>Note: The customer may require additional consideration or customer preparation for replacement.</p>
CD ROM	Yes	<p>Must be removed from the configuration and the partition must be booted afterwards to ensure correct operation.</p> <p>Note: The customer may require additional consideration or customer preparation for replacement.</p>
Optional media SCSI devices	Yes	<p>Must be removed from the configuration and the partition must be booted afterwards to ensure correct operation.</p> <p>Note: The customer may require additional consideration or customer preparation for replacement.</p>

Power Subsystem

This section contains the removal and replacement procedures for the power subsystem.

Notes:

1. All pluggable BPA FRUs are replaced concurrent with system operation when the removal and replacement instructions are followed. Exceptions to this occur when multiple failures exist in the BPA.
2. Removal and replacement of the entire BPA enclosure (BPE) is also concurrent with system operation, unless there are multiple BPE failures.

Attention: Be sure to check for FRU redundancy to determine if the repair can be performed concurrently. If you cannot determine redundancy, delay the repair until the system can be shut down. See the “Hot-Pluggable FRUs” on page 773 for more specific details.

Bulk Power Assembly (BPA)

The bulk power assembly is on the top of the rack. This assembly provides power to the whole system. There are two sides to the BPA so that power is never completely removed from the system unless the system power is shut down, and the power cables are removed from the customer’s power source.

Bulk Power Regulator (BPR)

The BPRs are located in the bottom positions of the bulk power enclosure (BPE).

Removal

Attention: The BPR unit weighs approximately 12.47 kg (27.5 lbs).

1. Locate the BPR to be replaced.
2. Note the state of the BPR ENBL LED.
3. Press the green **Start Service** button on the UEPO switch.
4. Proceed only if the ENBL (Good) LED goes off or the repair has been scheduled (System outage - UEPO off),
5. Locate the BPR to be replaced and manually slide its Lock/Unlock switch to unlock (power switch to the right). At this point, the ENBL LEDs turn off.
6. If the integrated battery feature (IBF) is installed, manually turn off the IBF circuit breaker attached to the BPR being repaired. Unplug the battery cable from the front face of the BPR.
7. Loosen the left and right fasteners using the torque tool (part number 6422789). Push up on the BPR release levers, and slide the unit out of the slot.

Replacement

1. Make sure that the BPR release levers are in the UP position. Slide the unit into slot until one inch from BPE. Using both hands on the front of the BPR, firmly and quickly seat the BPR against the backplane.

2. Tighten the left fastener four turns with torque tool followed by four turns to the right fastener. Torque the left fastener to completion, followed by the right fastener. Return to the left fastener and ensure that it is properly torqued.
3. Move the BPR release levers to the DOWN position.
4. If the battery feature is installed, reconnect the battery cable to the connector on the front face of the BPR.
5. Manually turn on the IBF circuit breaker.
6. Move the BPR Lock/Unlock switch to lock (power switch to the left).
7. Press the white **Service Complete** button on the UEPO switch to indicate completion of this procedure, if this repair was completed during a system outage, bring the system back up.

Bulk Power Controller (BPC)

The BPC is located immediately above the top BPR.

Attention: This service procedure may produce other power error code(s) (101x xxxx) between the time the **Start Service** button is pressed and the **Service Complete** button is pressed, during concurrent repair. If the system behaves normally, as described by this procedure, ignore these error codes.

Removal

Attention: The BPC unit weighs approximately 3.18 kg (7 lbs).

- (3) 1. Locate the BPC to be replaced.
- (3) 2. Note the state of the BPC LEDs.
- (3) 3. Press the green **Start Service** button on the UEPO switch.
- (3) 4. Proceed only if the ENBL (Good) LED goes off or the repair has been scheduled (System outage - EPO off),
- (3) 5. Check the ENBL LED for all the BPRs (LED on right side of FRU) on same BPA side. For each BPR that has this LED in the ON state, manually slide the power switches to the right.
- (3) **Attention:** Do not switch off units where this LED is already off.
6. Verify that all cables are labeled for plug location and then unplug the cables from the BPC.
7. Loosen the left and right fasteners using torque tool (part number 6422789). Slide the unit out of the slot.

Replacement

- (3) **Attention:** Before proceeding, make sure that all the BPR ENBL LEDs are OFF. For each BPR that has this LED in the ON state, manually slide the power switches to the right. Do not switch off units where this LED is already off.

- (3) **Attention:** Make sure that the UEPO bypass switch on the BPC is in the BYPASS position.
- (3) 1. Slowly slide the BPC into slot and carefully seat the BPC against the backplane.
2. Tighten the left and right fasteners with the torque tool.

- 3. Plug all cables to the BPC, ensuring that the plug location and the cable label agree.
- (3) 4. Manually move any BPR power switches that are to the right (OFF) position, to the left (ON) position.
- (3) 5. Move the UEPO bypass switch to the NORMAL position.
- (3) 6. Press the white **Service Complete** button on the UEPO switch to indicate completion of this procedure. The BPA automatically configures as it powers on.

Bulk Power Distributor (BPD)

There can be two BPDs, located immediately above the BPC. If only one BPD is required, an air flow baffle must be installed in the top BPD position.

Attention: This service procedure may produce other power error code(s) (101x xxxx) between the time the **Start Service** button is pressed, and the **Service Complete** button is pressed, during concurrent repair. If the system behaves normally, as described by this procedure, ignore these error codes.

Removal

Attention: The BPD unit weighs approximately 2.27 kg (5 lbs).

- 1. Locate the BPD to be replaced.
- 2. Note the state of the BPD ENBL LED.
- 3. Press the green **Start Service** button on the UEPO switch.
- 4. Proceed only if the ENBL (Good) LED goes off or the repair has been scheduled (System outage - EPO off),
- (3) 5. Check the ENBL LED for all the BPRs (LED on right side of FRU) on same BPA side. For each BPR that has this LED in the ON state, manually slide the power switches to the right.
- (3) **Attention:** Do not switch off units where this LED is already off.
- (3) 6. Verify that all cables are labeled for plug location and then unplug the cables from the BPD.
- (3) 7. Loosen the left and right fasteners using the torque tool (part number 6422789). Slide the unit out of the slot.

Replacement

- (3) **Attention:** Before proceeding, make sure that all the BPR ENBL LEDs are OFF. For each BPR that has this LED in the ON state, manually slide the power switches to the right. Do not switch off units where this LED is already off.

- (3) **Attention:** Make sure that the UEPO bypass switch on the BPC is in the BYPASS position.
- (3) 1. Slowly slide the BPD into slot and carefully seat the BPD against the backplane.
- 2. Tighten the left and right fasteners with the torque tool.
- 3. Plug all cables to the BPD, ensuring that the plug location and the cable label agree.

- (3)
- (3)
- (3)
- 4. Manually move any BPR power switches that are to the right (OFF) position, to the left (ON) position.
- 5. Move the UEPO bypass switch to the NORMAL position.
- 6. Press the white **Service Complete** button on the UEPO switch to indicate completion of this procedure. The BPA automatically configures as it powers on.

Bulk Power Fan (BPF)

The BPF is located immediately to the right of the BPC and positioned vertically in the BPA.

Removal

Attention: The BPF unit weighs approximately 3.63 kg (8 lbs).

1. Locate the BPF to be replaced.
2. Note the state of the BPC ENBL LED on the same BPA side as the BPF to be replaced.
3. Press the green **Start Service** button on the UEPO switch.
4. Proceed only if the ENBL (Good) LED goes off or the repair has been scheduled (System outage - EPO off),
5. Verify that the BPF cable is labeled for plug location and then unplug the cable from the BPC.
6. Remove the fan cover plate and set aside for the replacement procedure.
7. Loosen the upper and lower fasteners using the torque tool (part number 6422789). Move the BPR release, levers if necessary, and slide the unit out of the slot.

Replacement

1. Ensure that the BPF fasteners are to the left side.
2. Slowly slide the BPF into the slot and carefully seat the BPF against the front of the BPE, moving the BPR release levers if necessary.
3. Tighten the upper and lower fasteners with the torque tool.
4. Return the BPR release levers to the down position, if necessary.
5. Plug the BPF cable to the BPC, ensuring that the plug location and the cable label agree.
6. Press the white **Service Complete** button on the UEPO switch to indicate completion of this procedure.

Bulk Power Enclosure (BPE)

Attention: This service procedure may produce other power error code(s) (101x xxxx) between the time the **Start Service** button is pressed and the **Service Complete** button is pressed, during concurrent repair. If the system behaves normally, as described by this procedure, ignore these error codes.

Removal

Attention: The BPE unit weighs approximately 18.14 kg (40 lbs).

1. Locate the BPE to be replaced.
2. Note the state of all ENBL LEDs in the BPE.
3. Press the green **Start Service** button on the UEPO switch.
4. Proceed only if *all* BPR ENBL LEDs go off or the repair has been scheduled (System outage - EPO off),

5. Manually slide all Lock/Unlock switches (power switches to the right, unlock) on all BPRs attached to the BPA side being repaired. At this point, the ENBL LEDs turn off.
6. Manually turn off all IBF circuit breakers attached to the BPA side being repaired.
7. Verify that all cables are labeled for plug location and then unplug the cables from the BPA in the following order:
 - a. BPC
 - b. BPD
 - c. BPR
 - d. IBF (if installed)
 - e. ac line power cord
8. Remove all pluggable FRUs from the BPE (BPRs, BPCs, BPDs, and BPF).
9. Remove the four mounting screws.

Note: Do not remove the two screws at the bottom left, as these fasten the cage rail to the frame.
10. Slide the unit out of the frame.

Replacement

Attention: Make sure that the all BPR Lock/Unlock switches (power switches) are in the unlock (right, OFF) position on this BPA before proceeding.

Attention: Make sure that the UEPO bypass switch on the BPC front panel is in the NORMAL position.

1. Slowly slide the BPE into the frame using the right side guide pins until the side flanges contact the frame.
2. Fasten the four mounting screws.
3. Replace all pluggable FRUs to the BPE (BPR, BPC, BPDs, BPF, and baffles).

Note: Be sure to check the board connector for each FRU for any visible signs of damage (such as broken sockets.) before plugging into the backplane. Replace any FRU that is damaged.

4. Plug all cables to the BPA FRUs, ensuring that the plug location and the cable label agree.
5. Plug in the ac line power cords.
6. Manually turn on all IBF circuit breakers (if installed) attached to the BPA side being repaired.
7. Manually move all Lock/Unlock switches (power switches) to the lock position (the left, ON position) on all BPRs attached to the BPA.
8. Press the white **Service Complete** button on the UEPO switch to indicate completion of this procedure. The BPA automatically configures as it powers on.

Unit Emergency Power Off (UEPO) Card Assembly

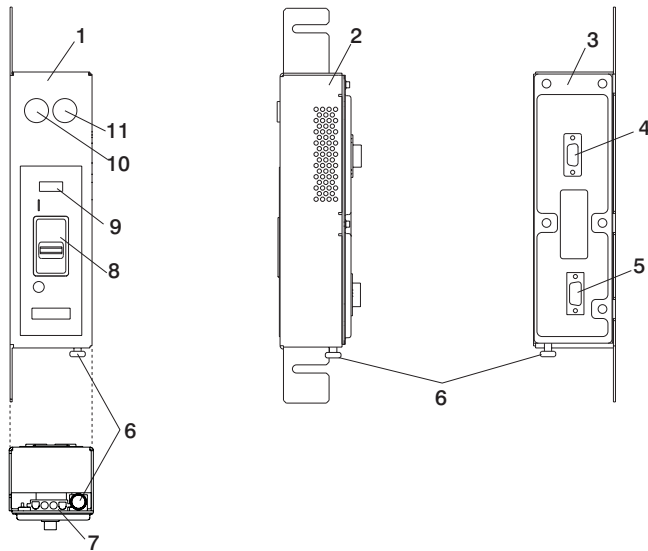

1	Simplified UEPO Front Panel	7	J02 Connector (White)
2	Simplified UEPO Side Panel	8	Power Switch
3	Simplified UEPO Rear Panel	9	System Fault LED
4	J00 Connector (Back)	10	Start Service Button (Green)
5	J01 Connector (Back)	11	Service Complete Button (White)
6	Room EPO Bypass Interlock		

Removal

Note: If you are replacing this assembly with a new assembly, the manufacturing label with the machine type, model number, and the serial number for the subsystem must be ordered to apply to the new part. For information on replacement labels, see Chapter 10, "Parts Information" on page 873.

1. Locate the system with the faulty UEPO switch.
2. Press the green **Start Service** button on the UEPO switch.
3. Switch the UEPO bypass switches on both BPCs to the "Bypass" position (to the right).
4. Ensure that the red switch on the EPO panel is in the ON position.
5. Verify that all cables are labeled for plug location and then unplug the cables from the UEPO card assembly.
6. Loosen, but do not remove, the two 8-mm M5 mounting screws. Slide the assembly forward and away from the frame.

Replacement

Note: If you are replacing this assembly with a new assembly, the manufacturing label with the machine type, model number, and the serial number for the subsystem must be ordered to apply to the new part. For information on replacement labels, see Chapter 10, “Parts Information” on page 873.

1. Place the assembly over the two 8-mm M5 screws, slide it downward, and tighten the screws.
2. Plug all cables to the UEPO card assembly, ensuring that the plug location and the cable label agree.
3. Install the external cable, if required, to connector J2.
 - a. If the external EPO connection is installed, the internal toggle switch is mechanically forced into the ROOM EPO ACTV position (to the right).
 - b. If there is no external EPO cable, manually set the internal toggle switch to the ROOM EPO BYPASS position. To set this switch, pull the knob down, to the ROOM EPO BYPASS position, and release the knob (to the left).
4. Ensure that the red UEPO switch is on (up position).
5. Switch the UEPO BYPASS switches on both BPCs back to NORMAL mode.
6. Press the white **Service Complete** button on the UEPO switch to indicate completion of this procedure.

Integrated Battery Feature (IBF)

Removal

Attention: This process requires:

- The use of a lift tool (PN 09P2481) and lift plate assembly tool (PN 11P4369).
- The lift tool wheels must be chocked to prevent it from moving during the operation. The frame must not be on its casters, the leveling pads must be engaged to prevent the frame from moving during the operation.

The IBFs (if installed) are mounted under the media subsystem.

1. Locate the IBF to be replaced.
2. Press the green **Start Service** button on the UEPO switch.
3. Turn off the IBF circuit breaker (to the right).
4. Unplug the battery cable from the front of the IBF and remove the 7-mm M5 screw (closest to the connector) that is holding the cable to the frame. This allows the cable to move so that the IBF can be removed.
5. Remove the two mounting bolts from the guide rails and retain for reuse during the replacement procedure.
6. Unpack the lift tool and follow assembly instructions included with the tool. Inspect the tool for damage (do not perform the remove procedure with a damaged lift tool). Read all safety instructions before performing this operation. Replace blue lift plate with orange lift plate (PN 11P4369). Orient two round holes in lift plate to the side of the lift tool that will be closest to the frame. Install the wheel chocks and engage the brake.

7. Raise plate to height such that the lift plate is just below the base of the IBF you are removing. Release pins on the lift plate and fully extend the center portion of the plate toward the IBF and lock it in place. Release pins on the extender arms and position them on both left and right side, arms must fit around the frame extenders and lock in place (do not adjust the lift tool once these arms are locked in place).
8. One person should gently pull and guide the IBF onto the lift plate. The IBF must be removed far enough to clear the front face of the frame. Retract extender arms and center portion of lift plate.

Note: Ensure the IBF is in the center of the lift plate.
9. Lower IBF to the bottom position of the lift tool.
10. Remove the wheel chocks and release the brake. Flip the crank handle 180 degrees. Carefully move the lift tool with the IBF to the staging area. The brake and wheel chocks must be in place when transferring the IBF to or from the packaging material.

Replacement

Note: Install rails in the frame if not already installed.

1. Position the lift tool such that the new IBF can be moved onto the lift plate.
2. Install the wheel chocks and engage the brake.
3. Move the new IBF onto the tool with the rear side toward the two holes of the lift plate. The side with the handles is considered the front side.

Note: Ensure the IBF is in the center of the lift plate.
Remove the wheel chocks and disengage the brake.

4. Position the lift tool as close as possible to the rack. Install the wheel chocks and engage the brake.
5. Raise plate to a height such that the lift plate is just above the rails of the slot you are installing it in. Release pins on the lift plate and fully extend the center portion of the plate toward the frame and lock it in place. Release pins on the extender arms and position them on both left and right side. Arms must fit around the frame extenders and lock in place (do not adjust the lift tool once these arms are locked in place).
6. One person should gently push the IBF into the frame. Adjust the height of the lift plate, as needed.
7. Lower the lift plate and remove it from the lift tool, repackage the lift tool.
8. Fasten the IBF to the mounting rails, using two mounting bolts.
9. Ensure the circuit breaker is in the off (right) position if it is not already off.
10. Plug the battery cable into the IBF. Fasten the cable retaining clamp (closest to the cable's connector) to the frame, using a 7-mm M5 screw
11. Reinstall all components removed during the removal process.
12. Set the circuit breaker to the on (left) position.

13. Press the white **Service Complete** button on the UEPO switch to indicate completion of this procedure.

Processor Subsystem

This section contains the removal and replacement procedures for the processor subsystem. Handle all processor subsystem FRUs with extreme care.

Installing the MCM/L3/Passthrough Plug Map

If the MCM/L3/Passthrough Plug Map is not installed in the system, install it before continuing with any repair action for MCMs or L3 cache module.

With the front cover open, locate the right frame extender (located on the opposite side of UEPO the switch). The 50 mm (~ 2 inch) wide label should be installed vertically, along this extender, approximately in line with EIA frame positions 22 - 28.

The trifold label has two velcro strips attached to the back. Remove the adhesive backing from the velcro and stick it on the frame extender as described above. A small piece of velcro is used to help keep it folded while attached to the frame. Refer to the following illustration for further information on the placement of this map.

P/N 11P4914

Using this Label

Whenever an MCM/Passthrough module is added or replaced/reseated during a repair action, a sticker with the module's serial number is provided for use with the map label according to its plugging location. If serial number label is not available, then record the serial number of the MCM/Passthrough module is added, re-seated, or replaced along with the number of times plugged. This module is then allowed three plugs with each plug recorded on label. If the module should need to be removed and re-installed a fourth time, it must be replaced.

The process is similar for the L3 module, except a separate serial number sticker is not provided, instead the serial number is located on a sticker attached to the L3 heatsink. Record the serial number of the L3 modules added, replaced, and re-seated along with the number of times plugged. If the module should need to be removed and re-installed a fourth time, it must be replaced.

I/O Books and I/O Blanks

The following procedure is for removing, inspecting, and replacing primary and secondary I/O books.

Note: If you are replacing a primary I/O book, check the system firmware level prior to replacing this part. For information on checking and updating firmware levels, see “System Firmware Updates” on page 739. If the new part is at an older firmware level than the system firmware level, update the system to the latest firmware code level after you replace the I/O book.

Removal

Note: If you are removing a primary I/O book, save the service processor settings so that you can reset the service processor after replacement. See “Saving and Restoring Service Processor Settings” on page 706 for information about saving the service processor settings.

1. Turn off power as described in “Powering Off the System and Removing Power” on page 771.
2. At the back of the system, remove the safety bars from the I/O books and blanks.
3. To ease replacement, record the connector locations of all cables attached to the I/O book. Disconnect all of the cables to the I/O book.
4. If the primary I/O book is being replaced, remove all VPD cards from the old primary I/O book and install them into the new primary I/O book. See “VPD Card” on page 820 for instructions on removing and replacing the VPD cards.
5. If the primary I/O book is being replaced, locate the backup copy of the service processor settings. If a backup copy is not available, use the “Save or Restore Hardware Management Policies,” in the “Introduction to Tasks and Service Aids” section of the *RS/6000 and @server pSeries Diagnostic Information for Multiple Bus Systems*, order number SA38-0509, to back up the service processor settings saved in NVRAM. If you cannot run the appropriate task, or the service processor settings were not previously backed up, the service processor settings must be entered manually after the primary I/O book is replaced.
6. Grasp the blue release latches located at the top and bottom of the memory book between your thumb and index finger, and press the tabs together. Actuate both blue handles simultaneously until the book fully unseats from the connector. Pivot the tabs and pull the book straight back.

Inspection

You must examine the connectors for any connector damage on the removed book using the 3X Magnification Glass (PN 11P4747) included in the system toolkit. If you identify a defect on the book, do not install the replacement book without contacting your next level support for instructions.

Note: For visual examples of damaged connectors please view the document on CORE, under 7040, entitled *7040-681 Memory and I/O Book Inspection Procedure*.

A damaged connector on a defective book may indicate a damaged system backplane. If an I/O book connector is damaged, then inspect the system backplane for damage.

If the removed I/O book is not damaged, carefully remove the new I/O book from the packaging. Be sure to protect the connector and the blue handles when you remove the I/O book from the cardboard box or ESD bag. Do not handle the I/O book by its connector or either of its blue handles. Remove the protective cover from the connector and install it on the defective I/O book.

Note: Do **not** stack books on top of each other. ESD bags do not provide sufficient stacking protection.

Note: Do **not** rest an I/O book on its connector or on its blue handles at any time.

Once the I/O book is out of the ESD bag, examine the Book VHDM connector using the 3X Magnification Glass (PN 11P4747) included in the system toolkit. **If any connector shows signs of damage, do not use it.**

Replacement

To replace an I/O book, do the following:

1. Inspect the new I/O book for damage. For more information, see “Inspection” on page 787.
2. Unlatch the two blue handles on the replacement book.
3. Taking care not to hit the connector against the CEC cage, use both hands to carefully place the book on the CEC guides.
4. Slide the book in until it reaches the alignment pins.
5. Using even pressure, actuate both blue handles simultaneously until the book is fully seated.
6. Repeat this process for all replacement I/O books.
7. If any cables were removed during the removal procedure, plug all cables into their correct locations.
8. Turn on the power as described in “Powering On the System” on page 772.

Note: If you are replacing a primary I/O book on a system with an HMC attached, you must set the system name through the Main Menu (for a privileged user) of the service processor menus. Reboot the HMC after setting the system name to allow the HMC to recognize the attached managed system by its new name. If the HMC does not recognize the attached managed system, the default assigned name is *unnamed*. After the system is selectable by its new name on the HMC console, the recover managed system task can be executed at the HMC console to restore partition information. The partition information is copied from the HMC console to the new service processor (part of the primary I/O book) NVRAM and may take 15 to 30 minutes to complete. Please wait for the operation to complete as indicated on the HMC console.

Note: If you are replacing a primary I/O book, make sure you enter the I/O type as described in “Change I/O Type” on page 726.

Note: If you are replacing a primary I/O book make sure you set the system time and date through the date operating system command.

Battery

CAUTION:

A lithium battery can cause fire, explosion, or a severe burn. Do not recharge, disassemble, heat above 100 degrees C (212 degrees F), solder directly to the cell, incinerate, or expose cell contents to water. Keep away from children. Replace only with the part number specified for your system. Use of another battery may represent a risk of fire or explosion.

The battery connector is polarized; do not attempt to reverse the polarity.

Dispose of the battery according to local regulations.

The battery is located in the primary I/O book.

Note: If you are removing a primary I/O book, save the service processor settings so that you can reset the service processor after replacement. See “Saving and Restoring Service Processor Settings” on page 706 for information about saving the service processor settings.

Removal

1. Remove the primary I/O book (see “I/O Books and I/O Blanks” on page 787).
2. Use a T10 torx driver to remove the screws for the short cover near the connectors.
3. Locate the battery near the spare VPD card connector as shown in the following illustration.

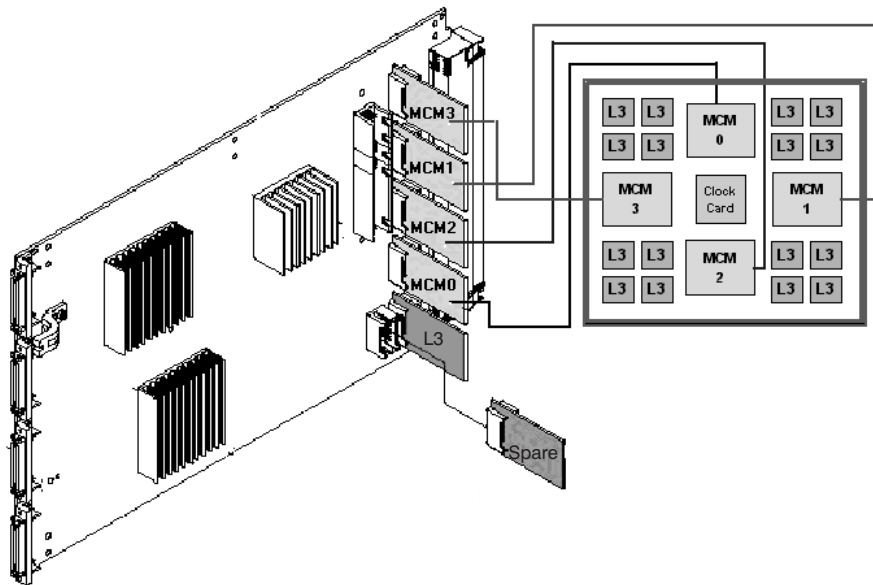

4. Use one finger to gently press the top edge of the battery in and down from the battery socket. Then use your thumb and index finger to pull the battery out of the

socket, as shown in the following illustration.

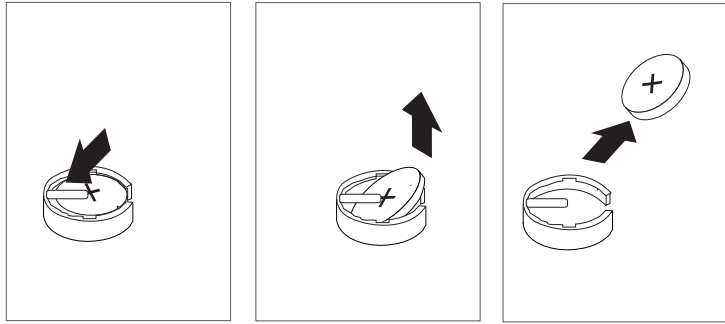

Replacement

Replace in reverse order.

Notes:

1. Ensure that the battery polarity is correct; place the battery in the socket with the positive side facing out.
2. Reset the service processor settings. See “Saving and Restoring Service Processor Settings” on page 706 for information about restoring the service processor settings.
3. Ensure that the customer resets the service processor information such as the date, time, and passwords.

Processor Subsystem DCA (Distributed Converter Assembly) Books and DCA Blanks

Removal

The following safety notice applies to power related field replaceable units.

DANGER

Do not attempt to open the covers of the power supply. Power supplies are not serviceable and are to be replaced as a unit.

1. Locate the DCA to be replaced.
2. Note the state of the DCA LED.
3. Press the green **Start Service** button on the UEPO switch.
4. Proceed only if *all* the DCA's LEDs go off or the repair has been scheduled (System outage - EPO off),
5. Loosen the upper and lower fasteners, using the torque tool (part number 6422789), alternating between the fasteners until the unit can slide out of the slot.
6. Grasp both sides of the DCA and pull it out of the drawer.

Replacement

1. Carefully slide the DCA into the slot as far as possible (the back edge of the top of the DCA is about 0.25 inch from the cage bracket).

Note: Do not force the DCA against the backplane, as this may damage the connector.

2. Hold the upper part of the DCA against the backplane, and use the torque tool to engage the upper fastener about two turns into the cage bracket.
3. Repeat the previous step for the lower fastener.
4. Alternate tightening the upper and lower fasteners until both are fully torqued in.
5. Check torque on both fasteners.
6. Plug all cables into their correct location in the DCA.
7. Press the white **Service Complete** button on the UEPO switch to indicate completion of this procedure.

Capacitor Books and Blanks

Removal

The following safety notice applies to power related field replaceable units.

DANGER

Do not attempt to open the covers of the power supply. Power supplies are not serviceable and are to be replaced as a unit.

1. Turn off power as described in “Powering Off the System and Removing Power” on page 771.
2. If you have not already done so, open the rear door of the rack unit.
3. Locate the capacitor book or blank to be removed.
4. Loosen the upper and lower fasteners, using the torque tool (part number 6422789), alternating between the fasteners until the unit can slide out of the slot.
5. Grasp both sides of the capacitor book or blank, and pull it out of the drawer.

Replacement

1. Carefully slide the capacitor book into the slot as far as possible (the back edge of the top of the capacitor book is about .25 inch from the cage bracket).

Note: Do not force the capacitor book against the backplane, as this may damage the connector.

2. Hold the upper part of the capacitor book against the backplane, and use the torque tool to engage the upper fastener about two turns into the cage bracket.
3. Repeat the previous step for the lower fastener.
4. Alternate tightening the upper and lower fasteners until both are fully torqued in.
5. Check torque on both fasteners.
6. If any cables were removed during the removal procedure, plug all cables into their correct locations.
7. Turn on the power as described in “Powering On the System” on page 772.

MCM Module (Processor) and Passthru Modules

Attention: All components must be replaced to the location from which they were removed. Before replacing MCMs, check with your support center to ensure you have been directed to replace the MCM(s) by a valid error code in Chapter 5, “Error Code to FRU Index” on page 399.

Handling Static-Sensitive Modules

Attention: MCM and L3 modules are sensitive to static electricity discharge. These devices are shipped in antistatic containers to prevent damage caused by electrostatic discharge.

Take the following precautions:

- Use an antistatic wrist strap while handling the device.
- Do not remove the device from the antistatic container until you are ready to install the device in the system unit.
- With the device still in its antistatic container, touch it to a metal frame of the system.
- Grasp modules by the heatsink. Avoid touching the interposer buttons.
- If you need to lay the device down while it is out of the antistatic container:
 - Lay the MCMs with the posts down on the antistatic mat.
 - Lay the L3s with the LGA connector down in the antistatic tray.

Before picking it up again, touch the antistatic container and the metal frame of the system unit at the same time.

- Handle the devices carefully in order to prevent permanent damage.

Attention: Before you remove or replace any MCM or L3 cache module, STOP, read and understand this entire procedure (MCM Module (Processor) and Passthru Modules) and the procedure for “L3 Cache Modules” on page 805. Also, check to ensure that the MCM/L3 Label Map is installed, refer to “Installing the MCM/L3/Passthrough Plug Map” on page 786

Attention: The MCM modules in this system can be attached to the backplane a maximum of three times. Check the *MCM/L3 Label Map* to confirm the number of times the target module has been unplugged. If it has been unplugged three times, order a new module. **If an MCM module is removed for a fourth time, it must be replaced with a new MCM module.** New MCMs are shipped with a new MCM/L3 plug count adhesive replacement label. When you install a new L3 cache module, place the new label in the correct position on the *MCM/L3 Label Map*. If a new *MCM/L3 Label Map* is needed, see “Tools” on page 894 for replacement label part number.

Note: The MCM module and its associated VPD card are a single FRU, and must be replaced as a set. See “VPD Card” on page 820 for VPD card removal and replacement procedure.

Attention: If the base configuration of the system has only one MCM, The passthru modules are replaced with a filler cover that is attached only by the cam locks.

Removal

Attention: If more than one module is to be replaced or reseated, begin with the uppermost module, replace it and then go to module(s) in the next lower position, until the lowermost module has been replaced or reseated. Before any MCM, passthru module, or cover is removed, perform a general cleaning operation, see step 3 of the following procedure.

1. Turn off the power as described in “Powering Off the System and Removing Power” on page 771.
2. Remove the fan chassis. See “Fan Chassis” on page 828.
3. Perform a general cleaning operation, using a sash brush, (*not* the one included with the FRU kit) and vacuum cleaner (see “Tools” on page 894 for the tool part numbers), to remove any accumulated dust and debris that has settled in the processor subsystem. Hold the vacuum hose near the brush to remove any debris that the brush generates.
4. Note the location of the module being removed on the *MCM/L3 Label Map* on the system to confirm the number of times the target module has been unplugged. If it has been unplugged three times, order a new module.

Attention: Each MCM *must* be returned to the location from which it was removed.

Note: If this is the first removal/reseat for the module, record the serial number of the module and the date of the action.

5. Ensure that the locking cams at the front of the MCM module are engaged with the module.
6. Remove DCA books and blanks 2 through 6, as well as both capacitor books. See “Processor Subsystem DCA (Distributed Converter Assembly) Books and DCA Blanks” on page 792 and “Capacitor Books and Blanks” on page 793.

7. Ensure that the actuation bolt behind the MCM module is in the down position.

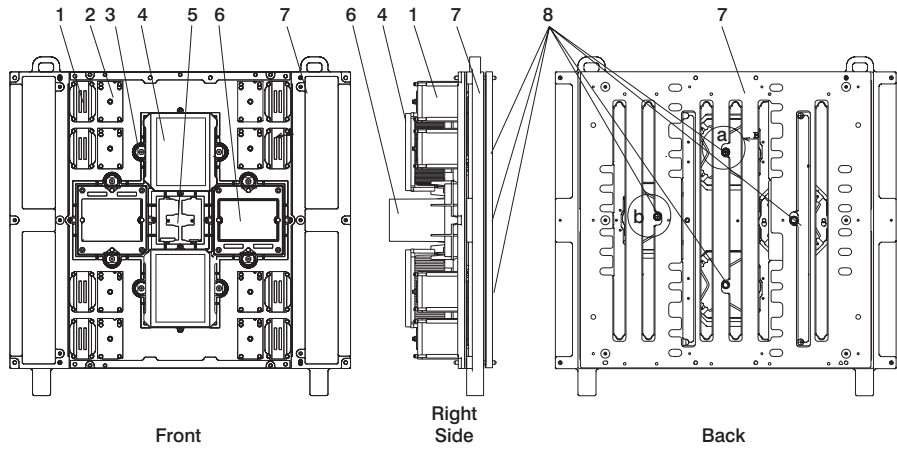

1	L3 Filler	5	System Clock Card
2	L3 Module Assembly	6	MCM Filler or Passthru Card
3	MCM Locking Cam	7	System Board
4	MCM Heatsink / Module Assembly	8	Actuation Bolt

8. Use the torque wrench (part number 11P4486, supplied with the system tool kit) to loosen the actuation bolt in the center of the MCM module. If installing a new MCM, remove the actuation bolt.
9. If installing a new MCM, insert the new actuation bolt supplied with the new MCM module.
10. Move the actuation bolt to the up position and hand tighten to hold the assembly in the up position.
11. At the front, hold the MCM module with one hand while using the 8-mm socket to unlatch the locking cams.

12. With both hands, grasp the module across the narrow span of the heatsink cap, and pull the MCM module from the system board and place it, posts-down, on the ESD mat.

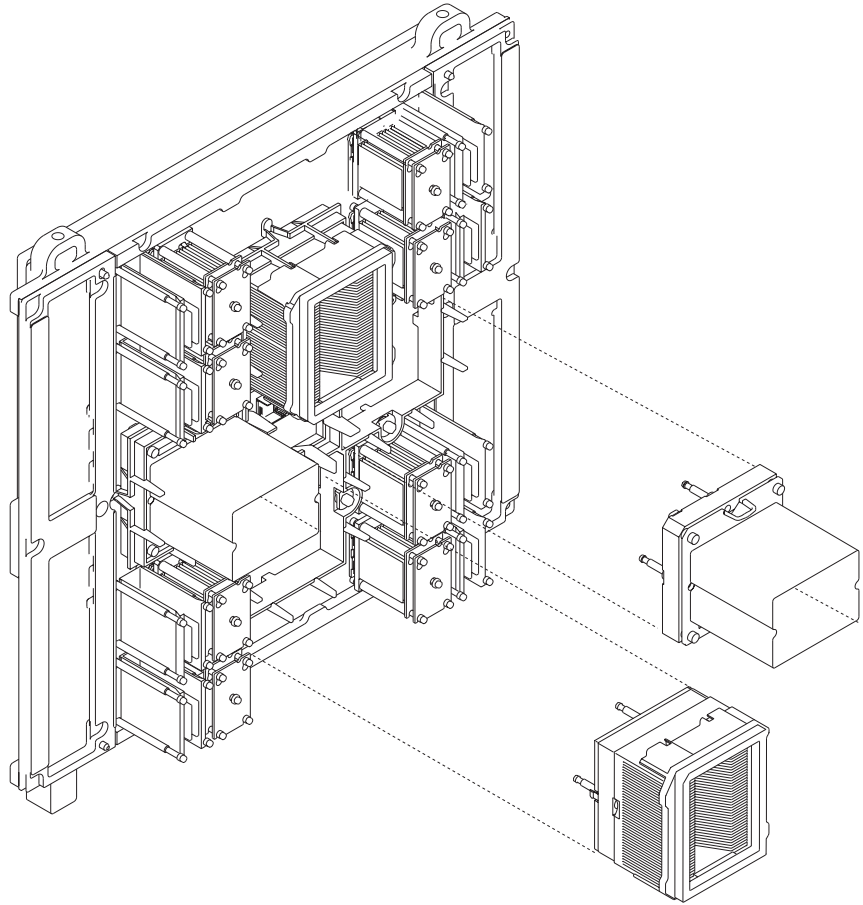

13. Using the new brush supplied with the new module, follow the procedures described in this step to clean the LGA site on the system backplane. The LGA site is the position from which you removed the MCM module.

Note: Before you remove the brush from its protective bag, loosen the bristles by pressing them on the ESD mat until they are 90° from the handle.

Attention: Each time an MCM module is removed from system backplane, the LGA site where the module connects *must* be cleaned. With the brush supplied with the replacement kit, use only downward strokes, starting in the upperleft location. Using firm pressure, brush left to right, top to bottom, using overlapping strokes as shown in the following illustration.

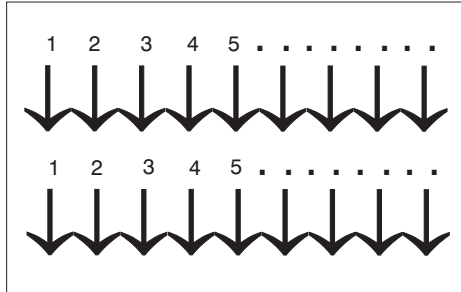

The brush must be discarded after cleaning only one LGA site.

14. Each time an MCM module (or passthru) is installed, the associated interposer *must* be inspected. Inspect the MCM (or passthru) interposer, using a magnifying glass (see "Tools" on page 894 for the tool part number). If either of the following conditions occur, the interposer is not acceptable and the module must be returned:

Shorts

If the button, a loop of the button wire, or an individual button wire lead extends more than three times the width of the wire outside of a connector hole chamfer (top side) or counter bore pin indent (bottom side).

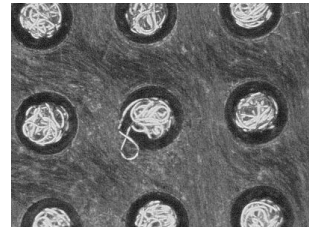
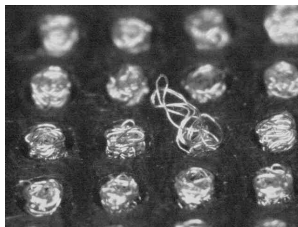

Missing buttons

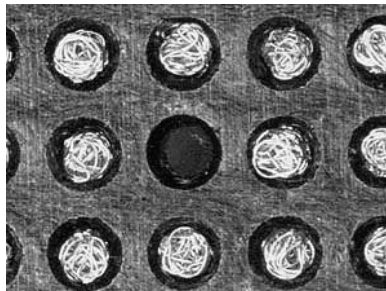

15. Record on the system log sheet on the system the date that this MCM has been removed.

Returning MCM Modules: The following procedure provides handling instructions for MCM modules to be packaged and returned to the plant of manufacture.

1. If you are replacing an MCM, use the packaging from the new module to return the old module. If the packaging is not available, order the following parts for MCM/Passthru protective packaging:
 - 1 Black Plastic Case (Top and Bottom) 02P3750
 - 1 MCM Heat Sink Cap - 7335949 or 7335963 (not required for Passthru)
 - 1 Corrugated Carton - 7335743 (carton + foam assembly including: 1 Bottom Foam Cushion, 1 Top Foam Cushion, 1 Desiccant (Optional for return packaging))
 - 1 ESD Bag - 7352456
 - 1 Foam Sheet - 7332979
2. Inspect the base of packaging PN 02P3750 and verify to see if an "AA" is labeled.
3. If the base has an "AA", place the MCM/Passthru module in the package base. If the base does not have an "AA", place one sheet of thin pink foam (PN 7332979) over the base and place the MCM module in the package base.
4. Place top adapter foam piece (PN 7335949) on the heat sink of the MCM module (not required for passthru module).
5. Complete the inner package by placing the top cover over the module and onto the base. Ensure the cover is secured to the base.
6. Reuse ESD bag PN 7352456 and place the packaged module inside the bag along with the desiccant. Seal with tape. (the desiccant is optional for returned parts)
7. Place this MCM/Passthru assembly in the foam cushion packaging carton (PN 7335743).
8. Seal carton and ship.

Replacement or New Installation

Note: This procedure is to be performed only by trained service personnel.

1. Go to “Testing MCMs and Passthru Modules for a Short Circuit” on page 802 and install the MCM/L3 module short-circuit test tool. Use the test tool during the MCM replacement procedure to ensure that the MCMs are installed without a short circuit. If you install an MCM and encounter a short circuit, the MCM you installed must be replaced.
2. If installing a new MCM, insert the new actuation bolt supplied with the new MCM module and move the actuation bolt and spring assembly to the up position and hand-tighten to hold the assembly in the up position. Perform a general cleaning operation, using a sash brush, (*not* the one included with the FRU kit) and vacuum cleaner (see “Tools” on page 894 for the part numbers), to remove any accumulated dust and debris that has settled in the processor subsystem. Hold the vacuum hose near the brush to remove any debris the brush generates.
3. Loosen the captive bolt in the center of the protective cover and remove the cover from the new MCM module, as shown in the following illustration.

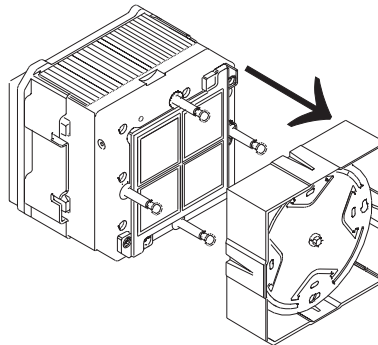

4. Grasp the module across the narrow span of the heatsink cap. Align the corner chamfer (flat corner) on the MCM module or the passthru to match the outline on the backplane.

Attention: Verify that the guide pins protrude above the connectors. Carefully push the MCM module into the socket, and maintain pressure while closing both locking cams.

5. Loosen the actuation bolt at the rear of the MCM module.
6. Push the actuation bolt in and slide the spring plate assembly to the down position.
7. Use the torque wrench (supplied with the system tool kit, see “Tools” on page 894 for the tool part number) to tighten the actuation bolt. When the wrench clicks, followed by about 15 degrees of free motion, the bolt is seated.

Attention: Do not over-torque the bolt.

Check the MCM/L3 short-circuit test tool to ensure that short circuit was not created when the MCM was installed.

If this is the last MCM you are installing, remove the MCM/L3 module short-circuit test tool and meter.

- Remove the primary I/O book (see “I/O Books and I/O Blanks” on page 787) and replace the VPD card that was provided with the MCM module.

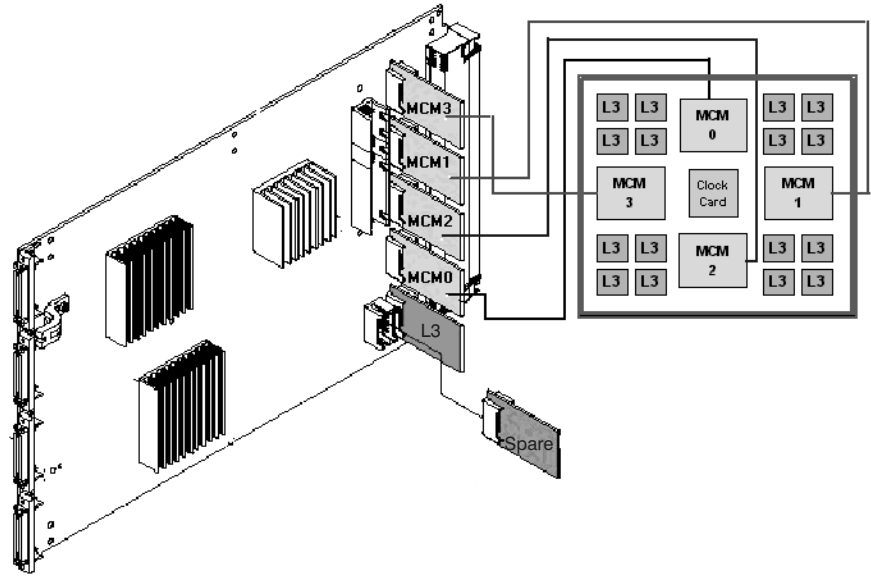

- Replace the primary I/O book.
- Replace the DCAs and DCA fillers that you removed earlier. See “Processor Subsystem DCA (Distributed Converter Assembly) Books and DCA Blanks” on page 792.
- Replace the fan chassis. See “Fan Chassis” on page 828.
- Turn on power as described in “Powering On the System” on page 772.

Testing MCMs and Passthru Modules for a Short Circuit

Performing this test ensures that a short circuit was not created when installing an MCM or a passthru module. Follow this procedure to install and use the MCM/L3 module short-circuit test tool (PN 44P0209) during MCM replacement.

Note: This procedure is to be carried out by trained personnel only. Ensure the UEPO switch is in the Off position before performing this procedure.

MCM Installation Shorts Test, Step 1: Attention: Be sure to record the resistance readings taken during these tests so that you can refer to them if needed.

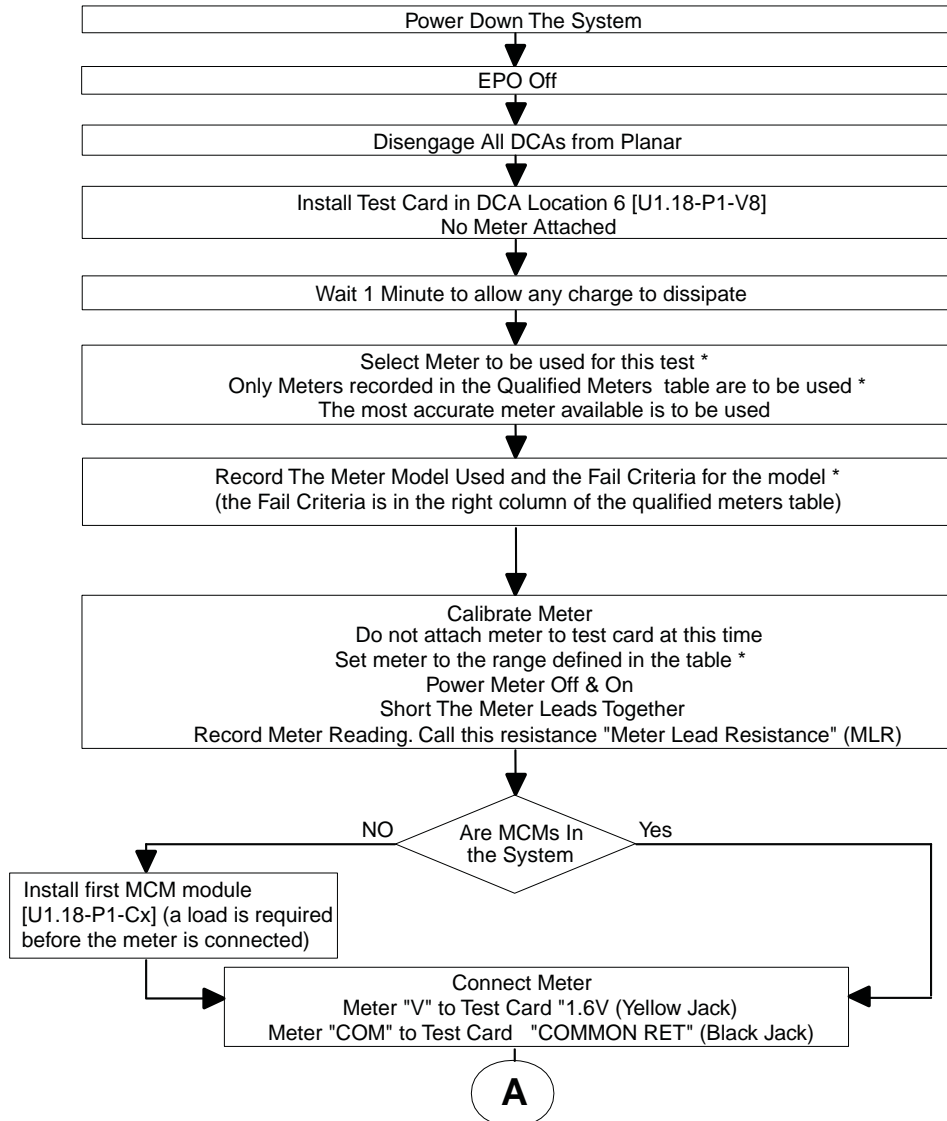

* See "Shorts Test Qualified Service Meters and Fail Criteria" on page 818.

MCM Installation Shorts Test, Step 2:

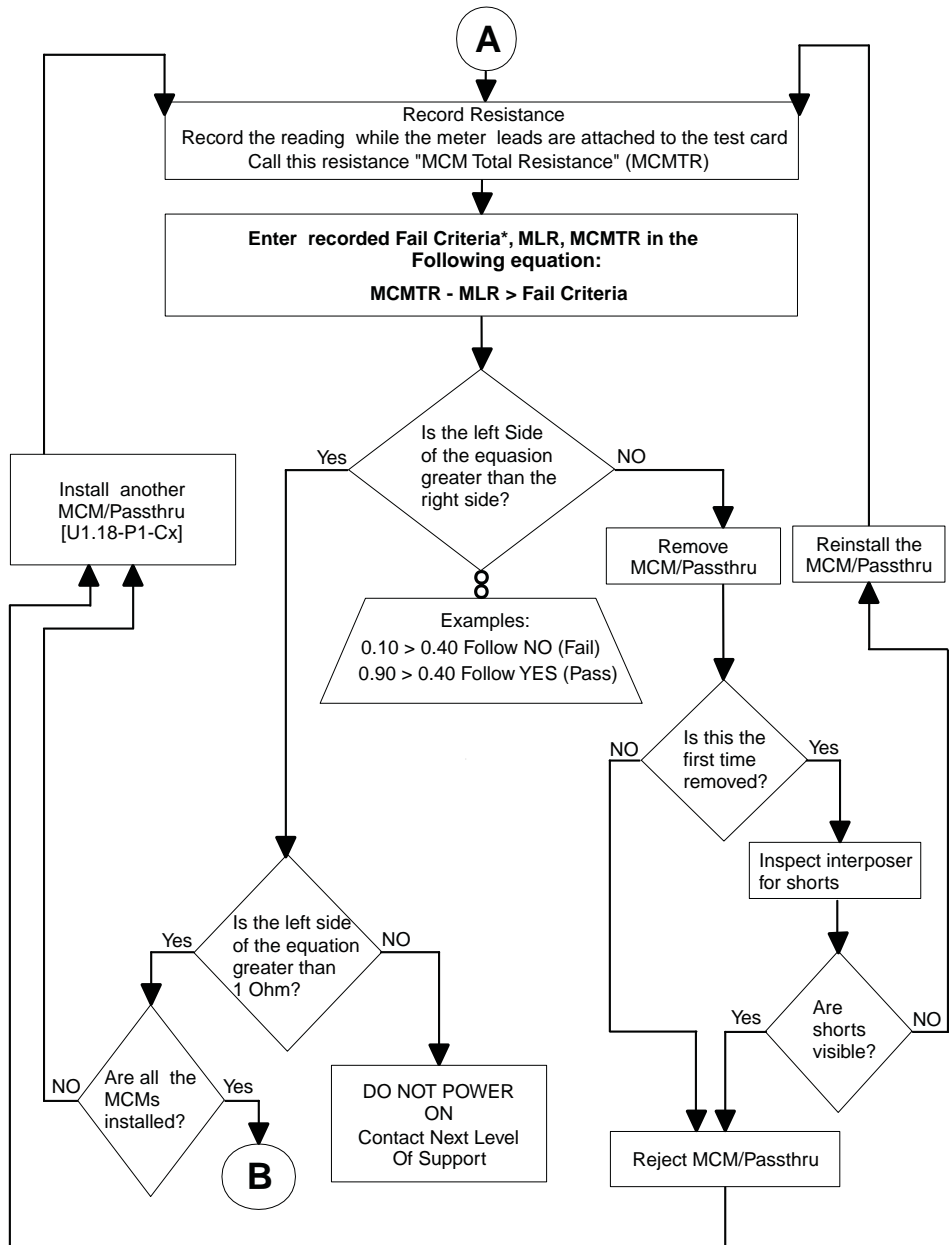

* See the Fail Criteria value in "Shorts Test Qualified Service Meters and Fail Criteria" on page 818.

MCM Installation Shorts Test, Step 3:

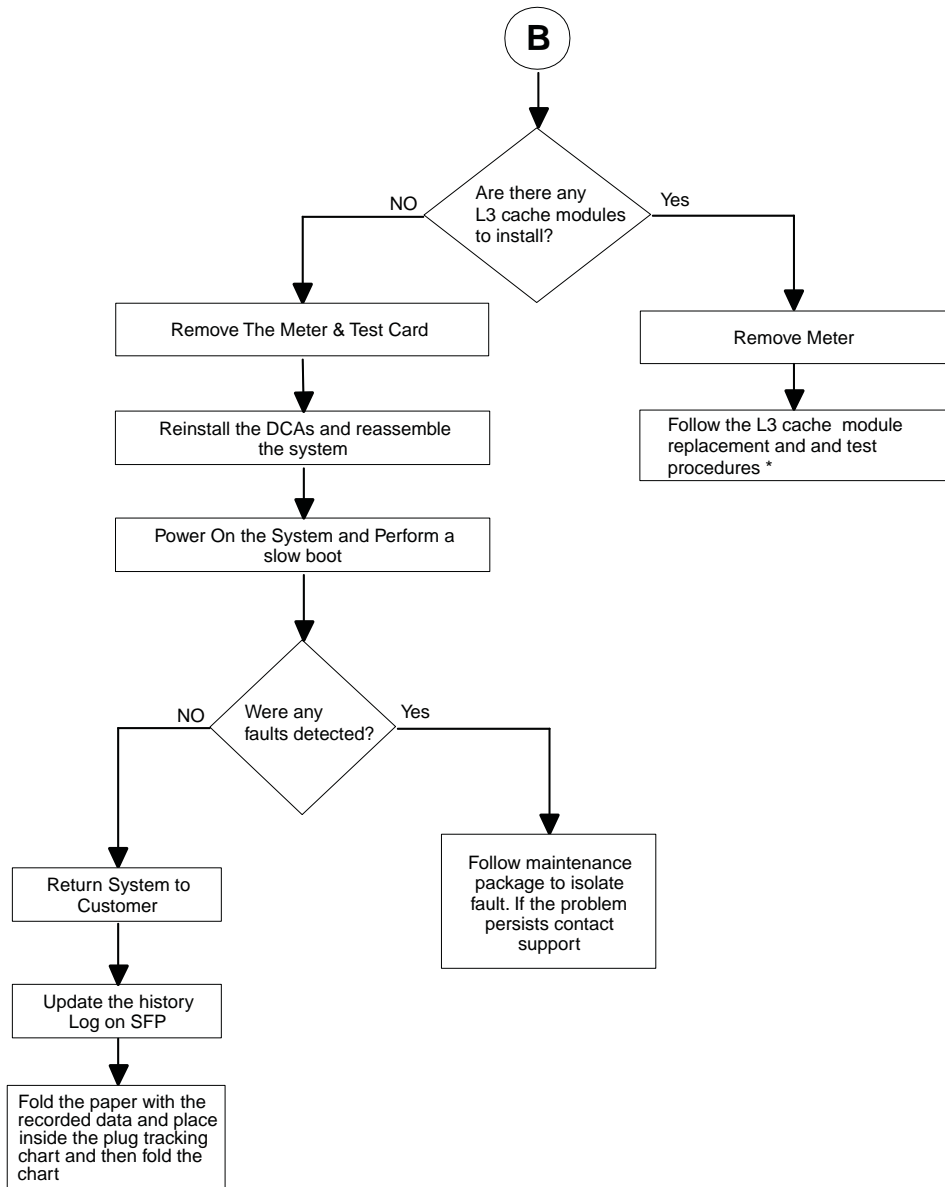

* See "L3 Cache Modules" on page 805.

L3 Cache Modules

Handling Static-Sensitive Modules

Attention: MCM and L3 modules are sensitive to static electricity discharge. These devices are shipped in antistatic containers to prevent damage caused by electrostatic discharge.

Take the following precautions:

- Use an antistatic wrist strap while handling the device.
- Do not remove the device from the antistatic container until you are ready to install the device in the system unit.
- With the device still in its antistatic container, touch it to a metal frame of the system.
- Grasp modules by the heatsink. Avoid touching the interposer buttons.
- If you need to lay the device down while it is out of the antistatic container:
 - Lay the MCMs with the posts down on the antistatic mat.
 - Lay the L3s with the LGA connector down in the antistatic tray.

Before picking it up again, touch the antistatic container and the metal frame of the system unit at the same time.

- Handle the devices carefully in order to prevent permanent damage.

Attention: Before you remove or replace any L3 cache module, STOP, read and understand this entire procedure. Also, check to ensure that the MCM/L3 Label Map is installed, refer to “Installing the MCM/L3/Passthrough Plug Map” on page 786.

Attention: The L3 cache modules in this system can be attached to the backplane a maximum of three times. **If an L3 cache module is removed for a fourth time, it must be replaced with a new L3 cache module.** Check the *MCM/L3 Label Map* to determine how many times the module has been removed before. New L3 cache modules are shipped with a new MCM/L3 plug count adhesive replacement label. When you install a new L3 cache module, place the new label in the correct position on the *MCM/L3 Label Map*. If a new *MCM/L3 Label Map* is needed, see “Tools” on page 894 for replacement label part number.

Removal

Attention: If more than one module is to be replaced or reseated, begin with the uppermost module, replace it and then go to the next highest position module, until the lowermost module has been replaced or reseated.

1. Turn off power as described in “Powering Off the System and Removing Power” on page 771.
2. Remove the fan chassis. See “Fan Chassis” on page 828.
3. Perform a general cleaning operation using a sash brush, (*not* the one included with the FRU kit) and vacuum cleaner (see “Tools” on page 894 for tool part numbers) to remove any accumulated dust and debris that has settled in the processor subsystem. Hold the vacuum hose near the brush to remove any debris the brush generates.

- Note the location of the module being removed.

Note: Arrange the four 4-position trays on the ESD mat in a pattern that corresponds to the locations of the L3 cache modules on the system backplane.

Attention: Each L3 cache module *must* be returned to the location from which it was removed.

Check the *MCM/L3 Label Map* on the system to confirm the number of times the target module has been unplugged. If it has been unplugged three times, order a new module. If this is the first removal/reseat for the module, record the serial number of the module and the date of the action.

- Use a 5-mm nut driver to loosen the set screw in the center of the L3 module spring plates as shown in the following illustration..

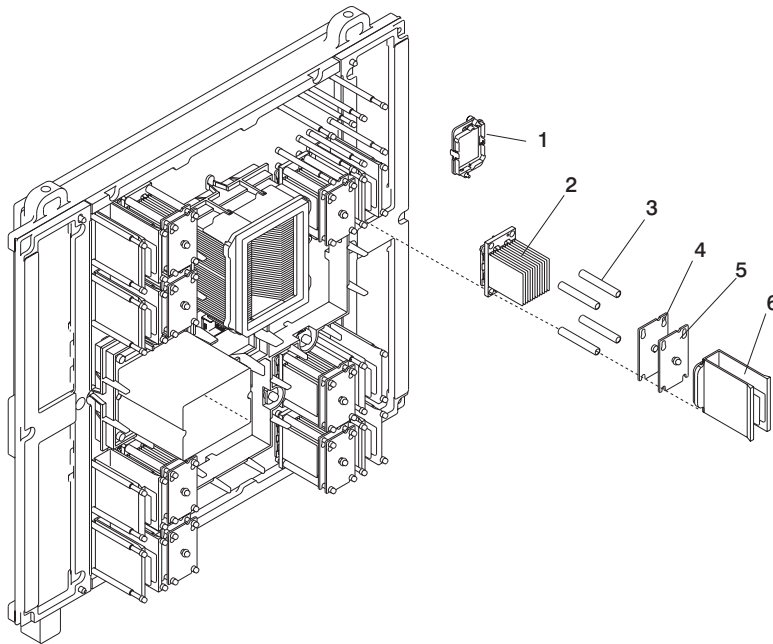

1	Protective Cover	4	Rear Spring Plate
2	L3 Cache Module and Heatsink	5	Front Spring Plate with Set Screw
3	Load Posts	6	L3 Filler (Used if no L3 cache module is installed)

- Slide both plates up and pull them away from the L3 cache module.
- Remove the sleeves from the posts.
- Use a disposable lint-free cloth to clean the sleeves.

- Pull the L3 cache module straight back, off the posts, and place it with the interposer facing down in the four-position tray from the tool kit.

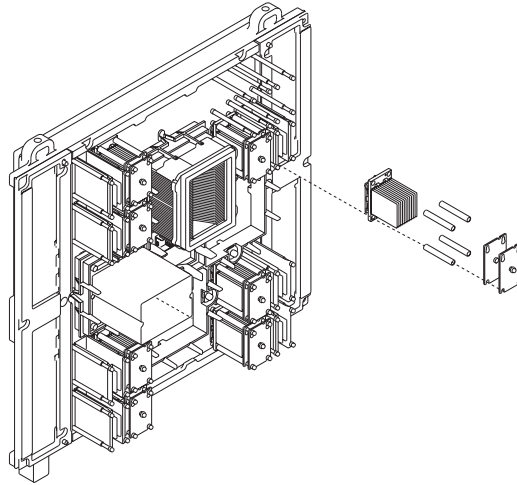

- Clean the LGA site using the brush supplied with the new module.

Note: Before you remove the brush from its protective bag, loosen the bristles by pressing them on the ESD mat until they are 90° from the handle.

Attention: Each time an L3 cache module is removed from the system backplane, the LGA site where the module connects *must* be cleaned. With the brush supplied with the replacement kit, use only downward strokes, starting in the upper left corner. Move left to right, top to bottom, using overlapping strokes as shown in the following illustration..

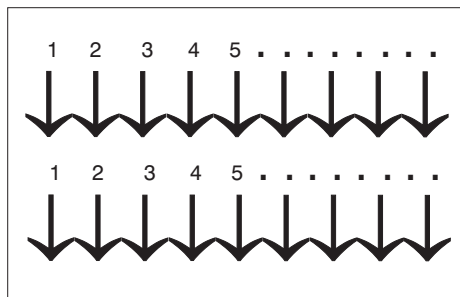

The brush must be discarded after cleaning four L3 sites.

- Each time an L3 cache module is installed, inspect the interposer before installation. The associated interposer *must* be inspected, using a magnifying glass. The interposer is not acceptable and the module must be returned if the either of the following conditions occur:

Shorts

If the button, a loop of the button wire, or an individual button wire lead extends more than three times the width of the wire outside of a connector hole chamfer (top side) or counter bore pin indent (bottom side).

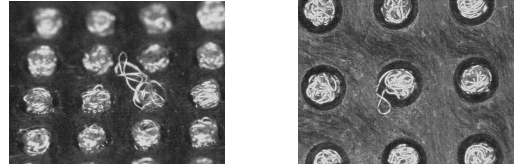

Missing buttons

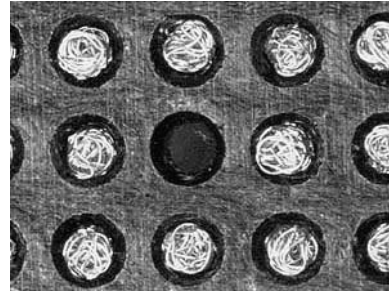

- Record on the system log sheet the date that this L3 cache module was removed.

Returning L3 Modules: The following procedure provides handling instructions for L3 modules to be packaged and returned to the plant of manufacture.

- If you are replacing an L3 module, use the packaging from the new module to return the old module. If the packaging is not available or does not include all the parts described below, order the following part for L3 module protective packaging:
 - 1 L3 protective package PN 7335692, which includes: 1 carton, 1 top foam cushion, 1 bottom foam cushion w/4 cavities, 1 ESD bag, 1 desiccant)
- Place bottom foam cushion, wrapped with ESD Bag, inside corrugated carton. Leaving the ESD bag open, place the L3 module with the cover into the bottom cushion, heat sink down. This will fit snugly into the cavity of the foam.
- Add the desiccant and seal the ESD bag with tape. (the desiccant is optional for returned parts)
- Place the top foam cushion over the assembly inside the carton.
- Seal the carton and ship.

Replacement or New Installation

1. Go to “Testing L3 Cache Modules for a Short Circuit” on page 812 and install the MCM/L3 module short-circuit test tool. Use the test tool during the L3 cache module replacement procedure to ensure that the L3 cache modules are installed without a short circuit. If you install an L3 cache module and encounter a short circuit, the L3 cache you installed must be replaced.
2. If installing a new L3 cache module, perform a general cleaning operation, using a sash brush, part number 450732 (*not* the one included with the FRU kit) and vacuum cleaner to remove any accumulated dust and debris that has settled in the processor subsystem. Hold the vacuum hose near the brush to remove any debris the brush generates then remove the L3 filler from the site where the new L3 cache module is to be located.
3. Loosen the captive thumbscrews on the protective cover and remove the cover from the new L3 cache module as shown in the following illustration.

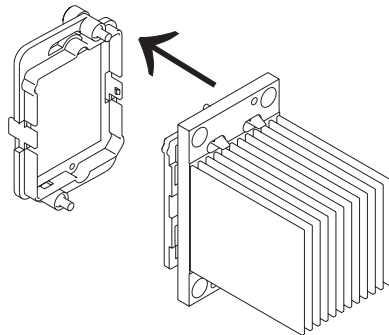

4. Align the flat corner on the L3 cache module to match the outline on the system backplane. Carefully slide the L3 cache module straight onto the posts until it meets the system backplane.
5. If you are installing a new L3 cache module, replace the sleeves that you removed earlier with the new sleeves provided with the L3 cache module kit. If you are reseating an existing module, use a lint free cloth to wipe any dust from the sleeves that you removed earlier

6. Be sure to align the notches at the upper right corner of each spring plate as shown in the following illustration. Replace the spring plates that you removed earlier with the new spring plates provided with the L3 cache module kit.

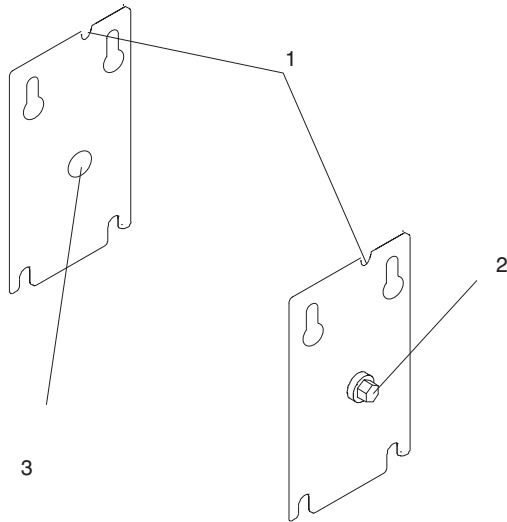

- 1 Notch on upper right corner
- 2 5-mm set screw
- 3 Reinforced center

7. Use your 5-mm nut driver to tighten the set screw in the center of the L3 cache module spring plates until the screw is seated.
 Check the MCM/L3 module short-circuit test tool to ensure that short circuit was not created when the L3 cache module was installed.
 If this is the last L3 cache module you are installing, remove the MCM/L3 module short-circuit test tool and meter.
8. Remove the primary I/O book (see “I/O Books and I/O Blanks” on page 787) and replace the VPD card that was provided with the L3 cache module.

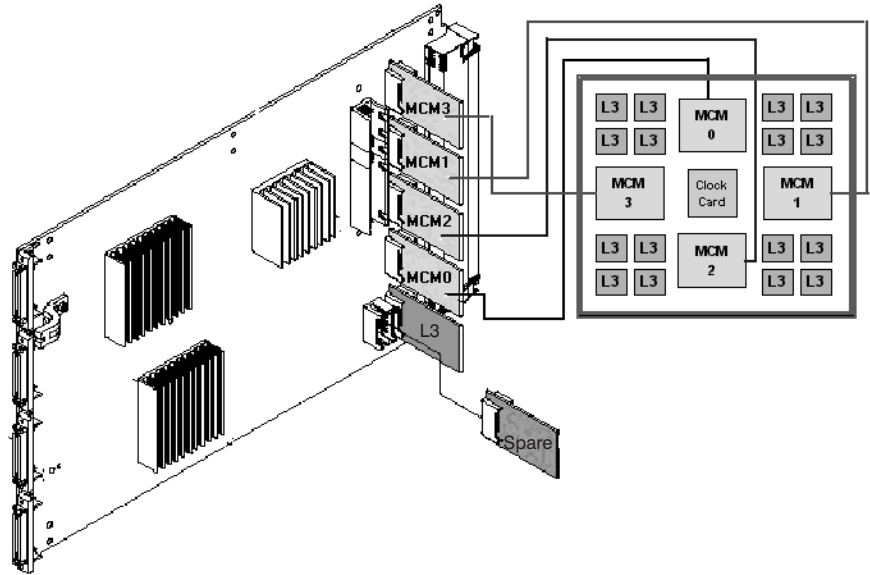

9. Replace the primary I/O book.
10. Replace the fan chassis. See “Fan Chassis” on page 828.
11. Turn on power as described in “Powering On the System” on page 772.

Testing L3 Cache Modules for a Short Circuit

Performing this test ensures that a short circuit was not created when an L3-cache module is installed. Follow this procedure to install and use the MCM/L3 module short-circuit test tool (PN 44P0209) during L3-cache module replacement.

Note: This procedure is to be carried out by trained personnel only. Ensure the UEPO switch is in the Off position before performing this procedure.

L3 Cache Shorts Test, Step 1: Attention: Be sure to record the resistance readings taken during these tests so that you can refer to them if needed.

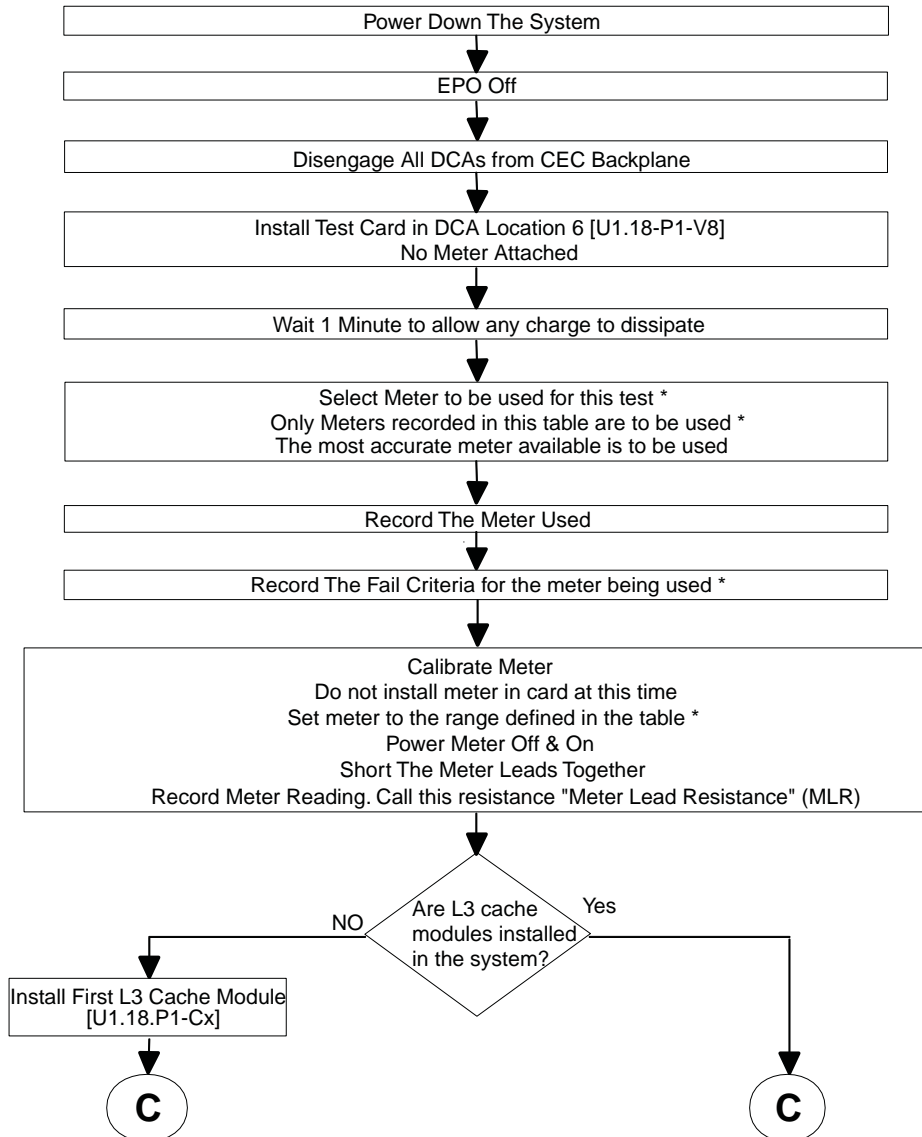

* See “Shorts Test Qualified Service Meters and Fail Criteria” on page 818.

L3 Cache Shorts Test, Step 2:

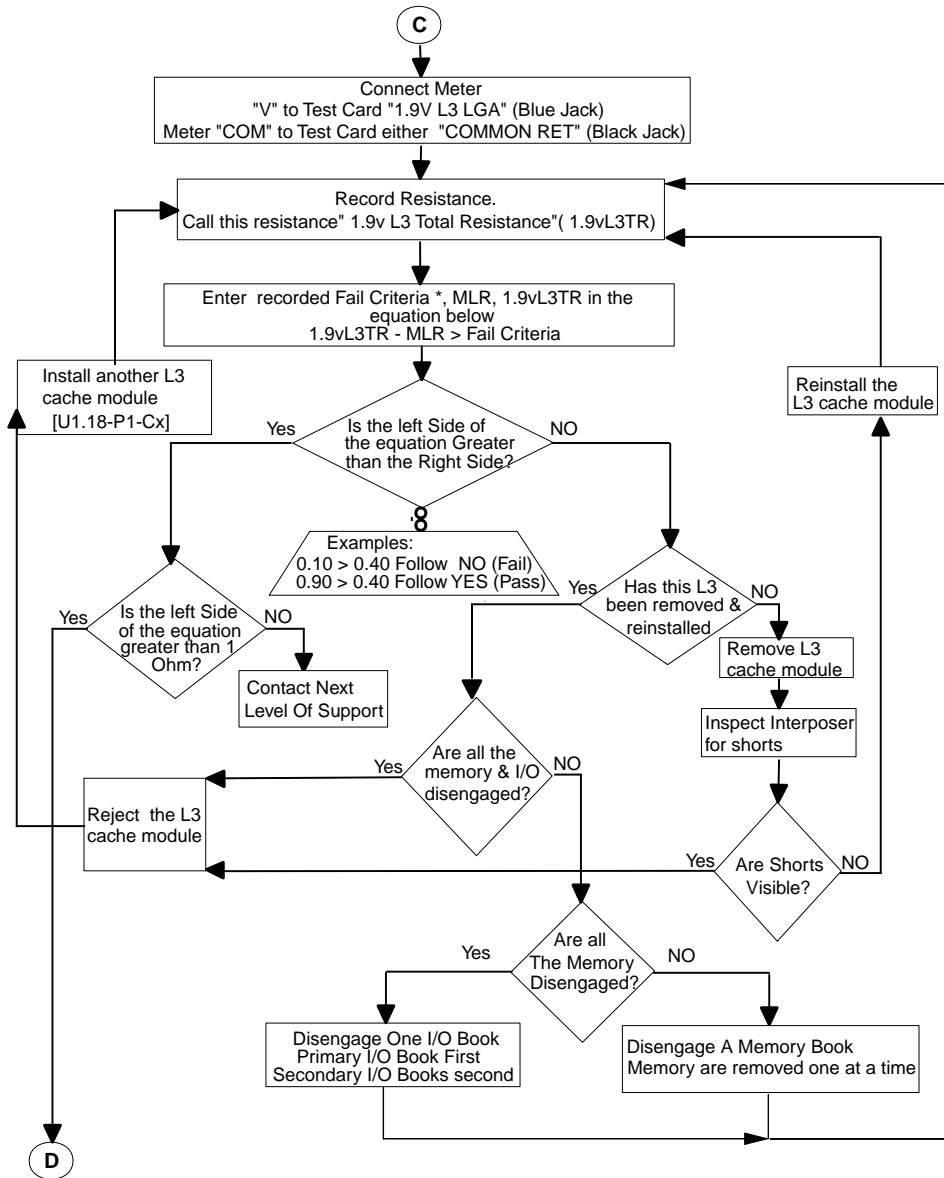

L3 Cache Shorts Test, Step 3:

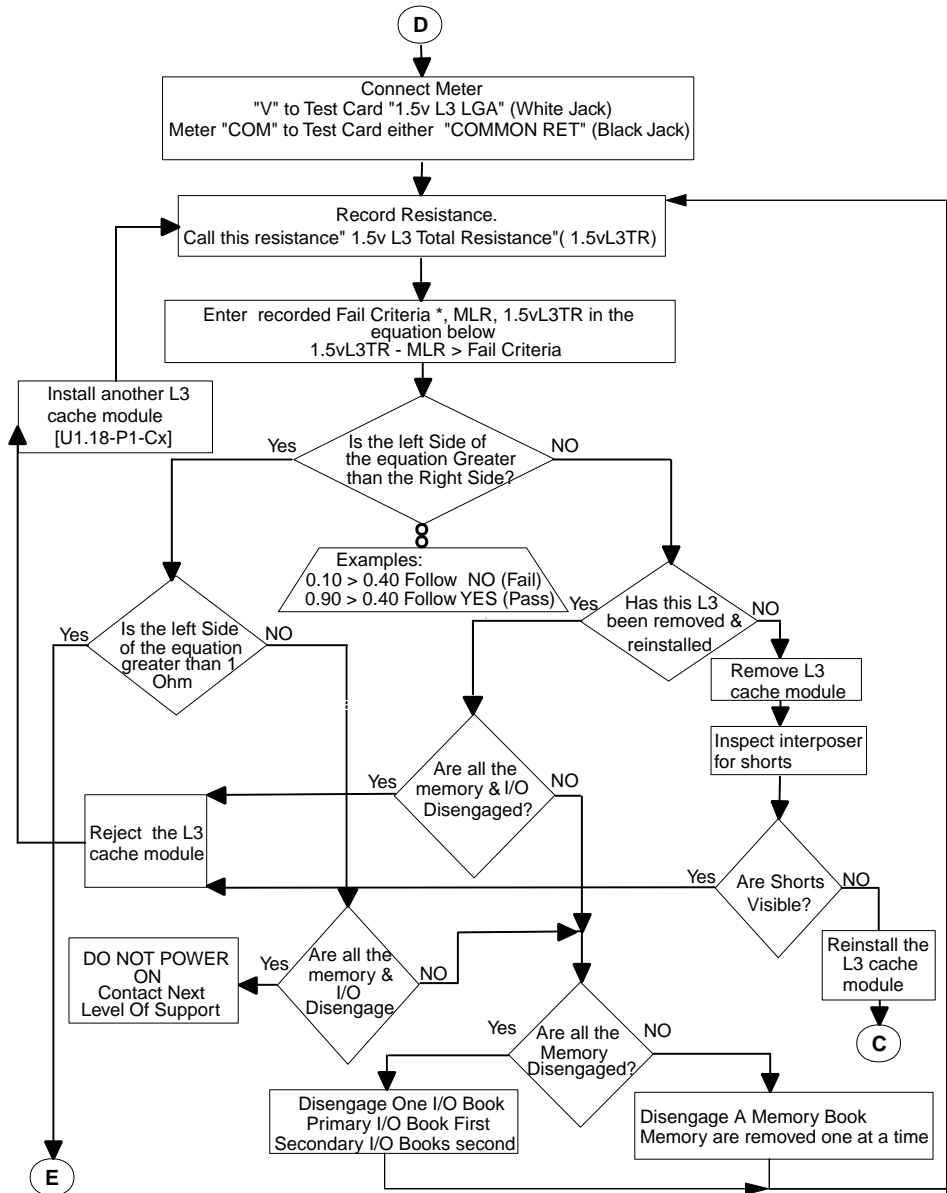

* See "Shorts Test Qualified Service Meters and Fail Criteria" on page 818.

L3: L3 Cache Shorts Test, Step 4:

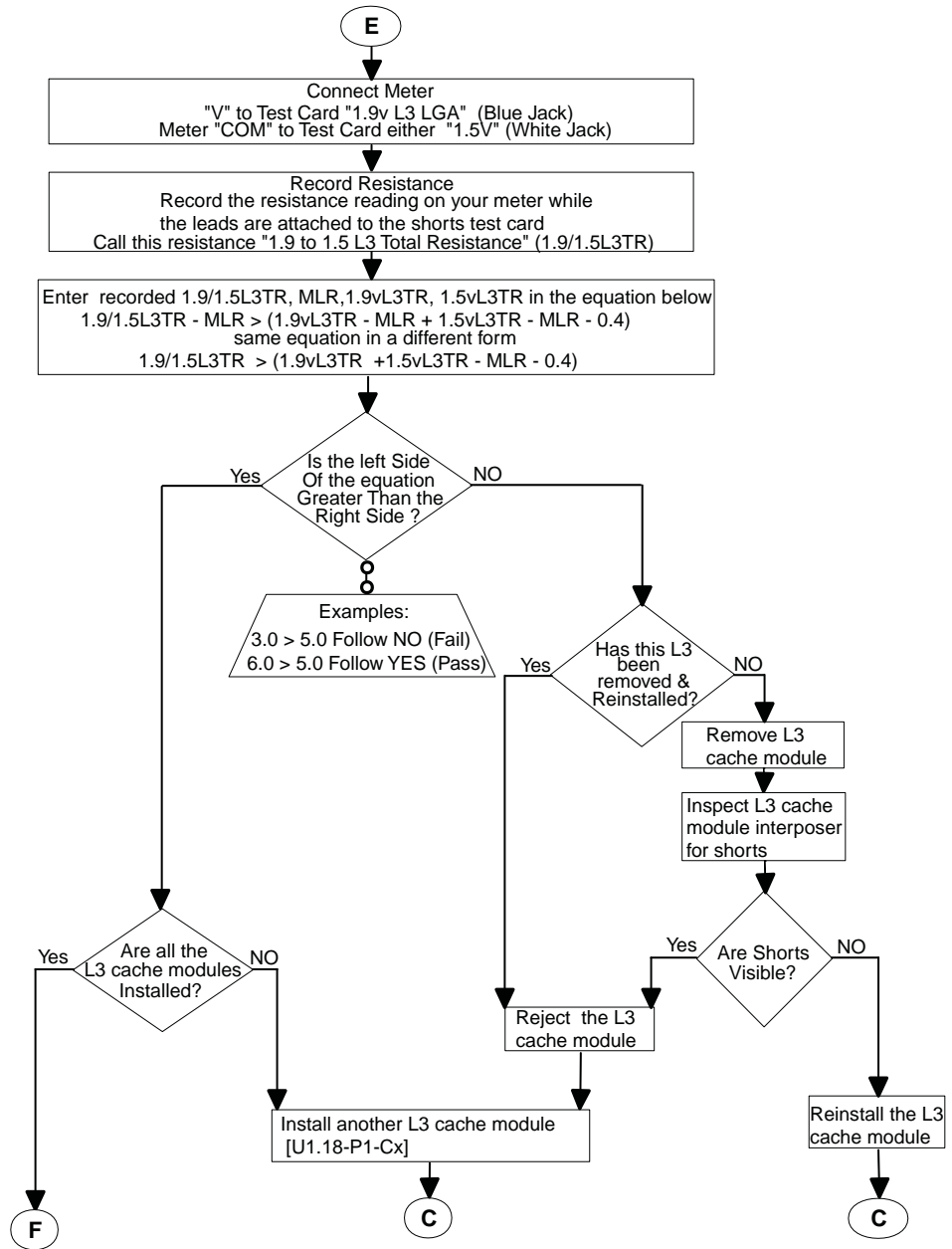

L3 Cache Shorts Test, Step 5:

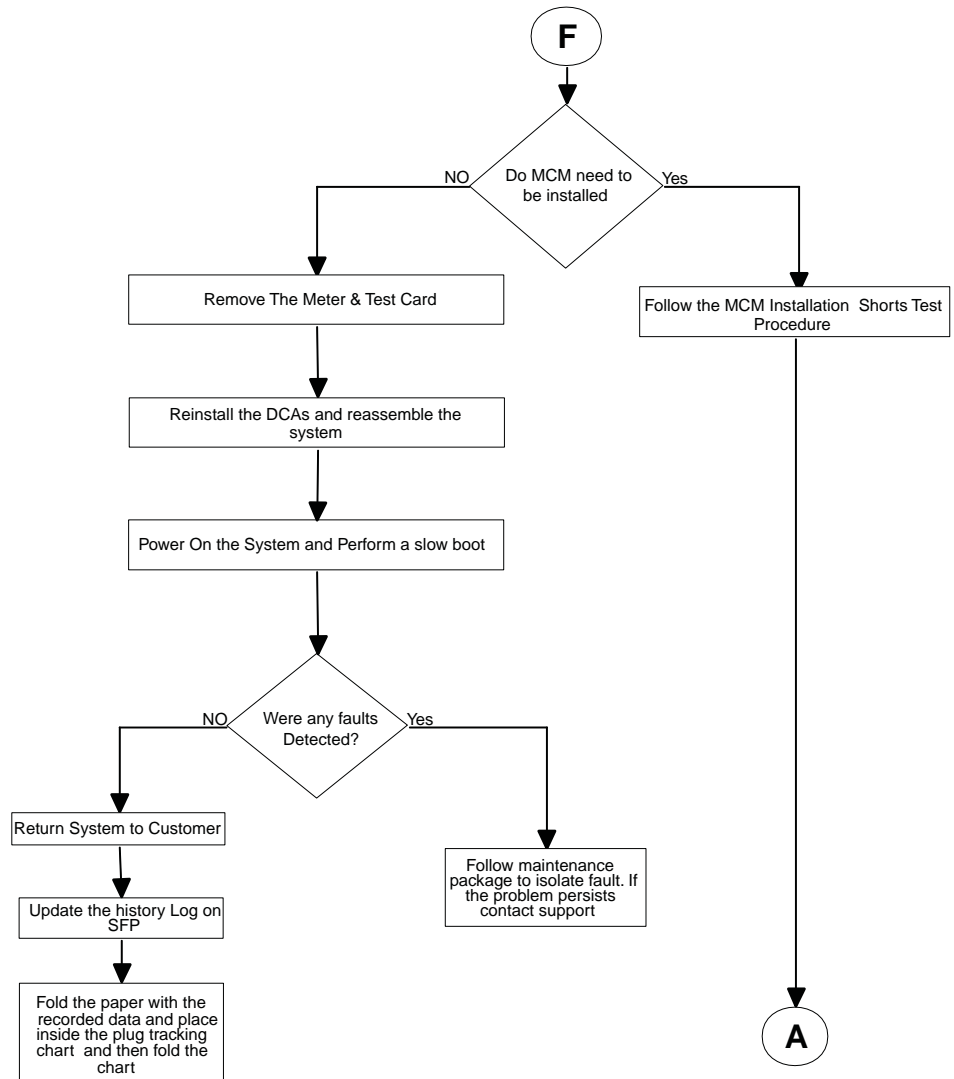

Shorts Test Qualified Service Meters and Fail Criteria

Table 5.

Manufacturer	Model	Range	Accuracy @ 1.0 ohms or less	Fail Criteria
Fluke	8060A	200 Ohms	+/-0.04Ω	+0.40Ω
Fluke	8060A/AA	200 Ohms	+/-0.04Ω	+0.40Ω
Fluke	8062A	200 Ohms	+/-0.04Ω	+0.40Ω
Fluke	187	500 Ohms	+/-0.10Ω	+0.40Ω
Fluke	189	500 Ohms	+/-0.10Ω	+0.40Ω
Fluke	83 (original models)	400 Ohms	+/-0.10Ω	+0.40Ω
Fluke	85 (original models)	400 Ohms	+/-0.10Ω	+0.40Ω
Fluke	87 (original models)	400 Ohms	+/-0.10Ω	+0.40Ω
Fluke	87-4	500 Ohms	+/-0.10Ω	+0.40Ω
Fluke	89-4	500 Ohms	+/-0.10Ω	+0.40Ω
+/-0.20 Accuracy				
Fluke	10	400 Ohms	+/-0.20Ω	+0.50Ω
Fluke	11	400 Ohms	+/-0.20Ω	+0.50Ω
Fluke	110	600 Ohms	+/-0.20Ω	+0.50Ω
Fluke	111	600 Ohms	+/-0.20Ω	+0.50Ω
Fluke	112	600 Ohms	+/-0.20Ω	+0.50Ω
Fluke	12	400 Ohms	+/-0.20Ω	+0.50Ω
Fluke	12B	400 Ohms	+/-0.20Ω	+0.50Ω
Fluke	16	400 Ohms	+/-0.20Ω	+0.50Ω
Fluke	175	600 Ohms	+/-0.20Ω	+0.50Ω
Fluke	177	600 Ohms	+/-0.20Ω	+0.50Ω
Fluke	179	600 Ohms	+/-0.20Ω	+0.50Ω
Fluke	18	400 Ohms	+/-0.20Ω	+0.50Ω
Fluke	21-2	320 Ohms	+/-0.20Ω	+0.50Ω
Fluke	21-3	320 Ohms	+/-0.20Ω	+0.50Ω
Fluke	23-2	320 Ohms	+/-0.20Ω	+0.50Ω
Fluke	26-3	400 Ohms	+/-0.20Ω	+0.50Ω
Fluke	29-2	400 Ohms	+/-0.20Ω	+0.50Ω
Fluke	70-2	320 Ohms	+/-0.20Ω	+0.50Ω
Fluke	70-3	320 Ohms	+/-0.20Ω	+0.50Ω
Fluke	73	320 Ohms	+/-0.20Ω	+0.50Ω
Fluke	73-2	320 Ohms	+/-0.20Ω	+0.50Ω

Table 5. (continued)

Manufacturer	Model	Range	Accuracy @ 1.0 ohms or less	Fail Criteria
Fluke	73-3	320 Ohms	+/-0.20Ω	+0.50Ω
Fluke	75	320 Ohms	+/-0.20Ω	+0.50Ω
Fluke	75-2	320 Ohms	+/-0.20Ω	+0.50Ω
Fluke	75-3	320 Ohms	+/-0.20Ω	+0.50Ω
Fluke	76	400 Ohms	+/-0.20Ω	+0.50Ω
Fluke	77	320 Ohms	+/-0.20Ω	+0.50Ω
Fluke	77-2	320 Ohms	+/-0.20Ω	+0.50Ω
Fluke	79-2	400 Ohms	+/-0.20Ω	+0.50Ω
Fluke	79-3	400 Ohms	+/-0.20Ω	+0.50Ω
Fluke	83 (with CAT III front panel marking)	400 Ohms	+/-0.20Ω	+0.50Ω
Fluke	83-3	400 Ohms	+/-0.20Ω	+0.50Ω
Fluke	85 (with CAT III front panel marking)	400 Ohms	+/-0.20Ω	+0.50Ω
Fluke	85-3	400 Ohms	+/-0.20Ω	+0.50Ω
Fluke	87 (with CAT III front panel marking)	400 Ohms	+/-0.20Ω	+0.50Ω
Fluke	87-3	200 Ohms	+/-0.20Ω	+0.50Ω

VPD Card

Note: The MCM module and its associated VPD card are a single FRU and must be replaced as a set.

Note: There is only one VPD card for all of the L3 modules. Replacing any L3 module requires replacing the associated VPD card.

The VPD cards are located in the primary I/O book.

Removal

1. Remove the primary I/O book (see “I/O Books and I/O Blanks” on page 787).
2. Use a T10 torx screw to remove the short cover near the connectors.
3. Locate the VPD card that must be replaced.

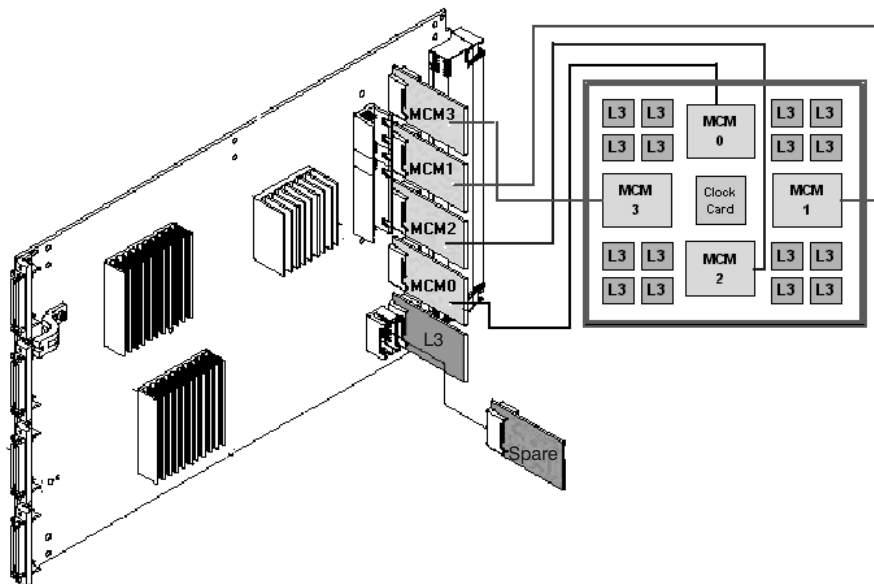

4. Remove the VPD card for the associated MCM or L3 modules.

Replacement

Replace in reverse order with the VPD card that was provided with the new MCM or L3 modules.

System Clock Card

Removal

1. Turn off power as described in “Powering Off the System and Removing Power” on page 771.
2. Remove the fan chassis. See “Fan Chassis” on page 828.
3. Squeeze the tabs on the clock card and pull the card straight out as shown in the following illustration.

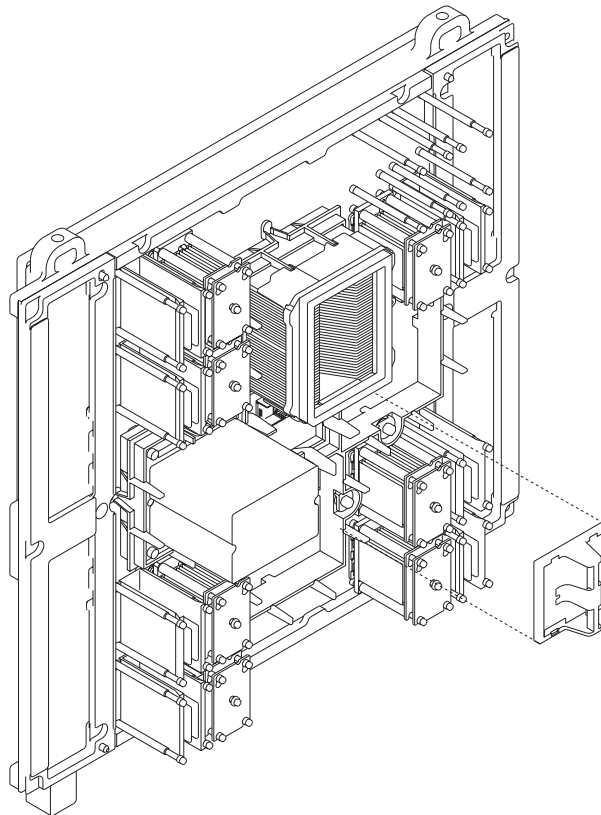

4. Clean the system board as described at the start of this procedure

Replacement

Note: Be sure to align the guide feature on the card with the guide feature on the system board.

1. Squeeze the tabs on the clock card and push the card straight in.
2. Replace the fan chassis. See “Fan Chassis” on page 828.
3. Turn on power as described in “Powering On the System” on page 772.

Processor Subsystem Chassis

CAUTION:

This unit weighs more than 55 kg (121.2 pounds). Material handling systems such as levers, slings, or lifts are required to safely move it. When this is not possible, specially trained persons or services (such as riggers or movers) must be used.

Three people are required to handle this operation, one to push, and two to pull the chassis.

Removal

Attention: All components must be replaced to the location from which they were removed. Before replacing processor subsystem chassis (backplane), check with your support center to ensure you have been directed to replace the processor subsystem chassis (backplane) by a valid error code in Chapter 5, “Error Code to FRU Index” on page 399.

Attention: This process requires:

- A safe area reserved to store parts that are removed from the system during this procedure.
- The use of a lift tool (part number 09P2481) and lift plate assembly tool (part number 11P4369).
- All components must be removed from the processor subsystem chassis to reduce its weight to the minimum.
 - DCA Books
 - Capacitor Books
 - I/O Books
 - Memory Books
 - Processor Fan Assemblies
 - MCM(s) (remove the MCMs only if the chassis is to be replaced)
 - L3 Cache (remove the L3 cache only if the chassis is to be replaced)
 - System Clock Card.
- The lift tool wheels must be chocked to prevent it from moving during the operation. The frame must not be on its casters, the leveling pads must be engaged to prevent the frame from moving during the operation.
 1. Unpack lift tool and follow assembly instructions included with the tool. Inspect the tool for damage (do not perform the remove procedure with a damaged lift tool). Read all safety instructions before performing this operation. Replace blue lift plate with orange lift plate (PN 11P4369). Orient two round holes in lift plate to the side of the lift tool that will be closest to the frame.
 2. Turn off power as described in “Powering Off the System and Removing Power” on page 771.
 3. Open the rack doors and remove them from the rack.
 4. Verify that all cables are labeled. If not, then label all cables and components along with their location at the front and rear of the system.
 5. Unplug all power cables from the line power source.

Attention: Because this procedure is performed with power removed from the system, references to using the white or green service buttons on the UEPO switch do not apply during the remainder of this procedure.

6. Unplug any cables attached to the I/O books and processor subsystem DCAs.
7. At the back of the system, remove the safety bars from the I/O books and blanks, using an allen wrench on the captive screws.
8. Remove the I/O books (and blanks if applicable). See “I/O Books and I/O Blanks” on page 787.
9. Remove the DCAs and capacitor books (and blanks if applicable). See “Processor Subsystem DCA (Distributed Converter Assembly) Books and DCA Blanks” on page 792.
10. At the front of the system, remove the safety bars from the memory books and blanks.
11. Remove the memory books (and blanks if applicable). See “Memory Books and Memory Blanks” on page 825.
12. Remove the four fan assemblies. See “Processor Fan Assemblies” on page 828.
13. Remove the fan chassis. See “Fan Chassis” on page 828.
14. Remove the MCM modules. See “MCM Module (Processor) and Passthru Modules” on page 794.
15. Remove the L3 modules. See “L3 Cache Modules” on page 805.
16. Remove the clock card. See “System Clock Card” on page 821.
17. Remove the media chassis. See “Media Subsystem Chassis” on page 870.
18. Remove two frame extender mounting bolts from EIA position 17 (10-mm bolt).
19. Remove the UEPO switch. See “Unit Emergency Power Off (UEPO) Card Assembly” on page 782.
20. Using an 8-mm extension socket, remove the screws attaching the hold down bracket to the vertical EIA rails at the rear of the system. Remove the bracket and store it in a safe place.

Note: The rear screws are used to mount the hold-down bracket.

21. Using an 8-mm extension socket remove the screws attaching the chassis to the vertical EIA rails at the front of the system.
22. Position the lift tool at the front of the rack, ensure that the extender arms on the lift plate are on the side facing the frame. Align the lift tool such that processor subsystem chassis will not be blocked (at the lip of the orange lift plate) from removal.
23. Raise plate to height such that the lift plate is just below the base of the processor subsystem chassis. Release pins on the lift plate and fully extend the center portion of the plate toward the processor subsystem chassis and lock it in place. Release pins on the extender arms and position them on both left and right side, arms must fit around the frame extenders and lock in place (do not adjust the lift tool once these arms are locked in place). Engage the lift tool brake. Install wheel chocks on lift tool casters.

Note: Ensure that any cables are clear of the extender arms when you attach the arms to the frame.

24. One person should gently push the processor subsystem chassis toward the tool from the rear of the system (do not bend vertical processor subsystem chassis support bars). Two people should gently pull and guide the processor subsystem chassis onto the lift plate. The processor subsystem chassis must be removed far enough to clear the front face of the frame. Use tie down strap to hold the processor subsystem chassis to the lift plate. Retract extender arms and center portion of lift plate.
25. Lower processor subsystem chassis to the bottom position of the lift tool.
26. Remove the wheel chocks and release the brake. Flip the crank handle 180 degrees. Carefully move the lift tool with the processor subsystem chassis to the staging area. The brake and wheel chocks must be in place when transferring the processor subsystem chassis to or from the packaging material.

Replacement

Note: If you are replacing this assembly with a new assembly, the manufacturing label with the machine type, model number, and the serial number for the subsystem must be ordered to apply to the new part. For information on replacement labels, see Chapter 10, “Parts Information” on page 873.

Attention: Look for small amounts of debris on the connecting surfaces between the backplane and processor modules. Mating the two surfaces is critical for the processor to function properly.

1. Position the lift tool such that the new processor subsystem chassis can be moved onto the lift plate.
2. Install the wheel chocks and engage the brake.
3. Position the plate at the correct level and move the new processor subsystem chassis onto the tool with the rear side flush with the lift plate. Strap the processor subsystem chassis to the lift plate using the tie-down strap.
4. Position the lift tool as close as possible to the front of the rack.
5. Raise the lift tool until it is level with the rails.
6. Release pins on the lift plate and fully extend the center portion of the plate toward the frame and lock it in place. Release pins on the extender arms and position them on both left and right side, arms must fit around the frame extenders and lock in place (do not adjust the lift tool once these arms are locked in place). Engage the lift tool brake. Install wheel chocks on lift tool casters.

Note: Ensure that any cables are clear of the extender arms when you attach the arms to the frame.

7. Remove the tie-down strap. One person should gently pull the processor subsystem chassis into the frame from the rear of the system (do not bend vertical processor subsystem chassis support bars). Two people should gently push and guide the processor subsystem chassis into the frame.

Note: Adjust the height of the lift plate, as needed.

8. After the processor subsystem chassis is installed in the frame, lower the lift plate and remove it from the lift tool, repackage the lift tool.
9. Reinstall all components removed during the removal process by reversing steps 22 on page 823 through 2 on page 822 of the removal procedure.

Memory Books and Memory Blanks

Removal

1. Turn off the system, and completely remove power as described in “Powering Off the System and Removing Power” on page 771.
2. Remove the safety bar from the memory slot.
3. Grasp the blue release latches located at the top and bottom of the memory book between your thumb and index finger, press the tabs together. Pivot the tabs and pull the book straight back.

Inspection

You must examine the connector for any connector damage on the removed book using the 3X Magnification Glass (PN 11P4747) included in the system toolkit. If you identify a defect on the book, do not install the replacement card without contacting your next level support for instructions.

Note: For visual examples of damaged connectors please view the document on CORE, under 7040, entitled *7040-681 Memory and I/O Book Inspection Procedure*.

A damaged connector on a defective book may indicate a damaged system backplane. If the memory book connector is damaged, then the adjacent memory book may need to be removed in order to inspect the system backplane for damage.

If the removed book is not damaged, carefully remove the new book from the packaging. Be sure to protect the connector and the blue handles when you remove the book from the cardboard box or ESD bag. Do not handle the book by its connector or either of its blue handles. Remove the protective cover from the connector and install it on the defective book.

Note: Do **not** stack books on top of each other. ESD bags do not provide sufficient stacking protection.

Note: Do **not** rest a book on its connector or on its blue handles at any time.

Once the memory book is out of the ESD bag, examine the book VHDM connector using the 3X Magnification Glass (PN 11P4747) included in the system toolkit. **If any connector shows signs of damage, do not use it.**

Replacement

Note: If there is no book installed in the position next to the one that you are replacing, install a filler (PN 21P8218) in that adjacent location.

To replace a book, do the following:

1. Inspect the new book for damage. For more information, see “Inspection” on page 825.
2. Unlatch the two blue handles on the replacement book.
3. Taking care not to hit the connector against the CEC cage, use both hands to carefully place the book on the CEC guides.
4. Slide the book in until it reaches the alignment pins.
5. Using even pressure, actuate both blue handles simultaneously until the book is fully seated.
6. Repeat this process for all replacement books.
7. Reinstall any safety bars removed to perform this procedure.
8. If any cables were removed during the removal procedure, plug all cables into their correct locations.
9. Turn on the power as described in “Powering On the System” on page 772.

Fan Controller

Removal

Attention: The fan controller weighs approximately 0.45 Kg (1 lb.)

1. Locate the fan controller to be replaced.
2. Note the state of the fan controller's LEDs.
3. Press the green **Start Service** button on the UEPO switch.
4. Proceed only if *all* the fan controller's LEDs go off or the repair has been scheduled (System outage - EPO off),
5. Label and remove the plugs from the fan controller.
6. Loosen the two knurled captive screws that attach the fan controller to the fan assembly.
7. Grasp the loosened screws, and pivot and pull the fan controller away from the fan assembly.

Replacement

1. Align the metal tabs opposite the captive screws into the corresponding slots in the fan assembly.
2. Pivot gently to seat the autodocking connector.
3. Tighten the knurled captive screws to the fan assembly.
4. Plug all cables into their correct location in the DCA.
5. Press the white **Service Complete** button on the UEPO switch to indicate completion of this procedure.

Processor Fan Assemblies

Removal

Attention: The fan controller weighs approximately 5 Kg (11 lb.)

1. Locate the fan assembly to be replaced.
2. Note the state of the fan controller's LEDs.
3. Press the green **Start Service** button on the UEPO switch.
4. Proceed only if *all* the fan controller's LEDs go off or the repair has been scheduled (System outage - EPO off),
5. Verify that all cables are labeled for plug location, and unplug the cables from the fan controller on the fan assembly.
6. Remove the fan controller (see "Fan Controller" on page 827).
7. Loosen the two knurled captive screws that attach the fan assembly to the enclosure.
8. Pull the fan assembly away from the enclosure opening.

Replacement

1. Position the fan assembly in front of the opening through the spring-loaded doors in the enclosure.
2. Slide the fan assembly into the enclosure opening and tighten the upper and lower fasteners.
3. Replace the fan controller onto the face of the fan assembly.
4. Plug all cables into their correct location in the DCA.
5. Press the white **Service Complete** button on the UEPO switch to indicate completion of this procedure.

Fan Chassis

Removal

1. Turn off power as described in "Powering Off the System and Removing Power" on page 771.
2. Remove the top two fans. See "Processor Fan Assemblies".
3. Loosen the four retained screws that attach the fan chassis to the processor subsystem chassis.
4. Pull the fan chassis out of the processor subsystem chassis.

Replacement

Replace in reverse order.

Processor Subsystem Air Filters

Attention: To maintain proper air flow, the air filters (part number 11P3781) must be inspected every 6 months and replaced as necessary. It is not necessary to remove power to the system or blower assemblies to replace the air filters.

Removal

1. Grasp finger tabs on the air filter and pull straight out.

Replacement

1. Slide the air filter into the slot. The filter is keyed to ensure correct orientation.

I/O Subsystem

I/O Subsystem PCI Slot LED Definitions

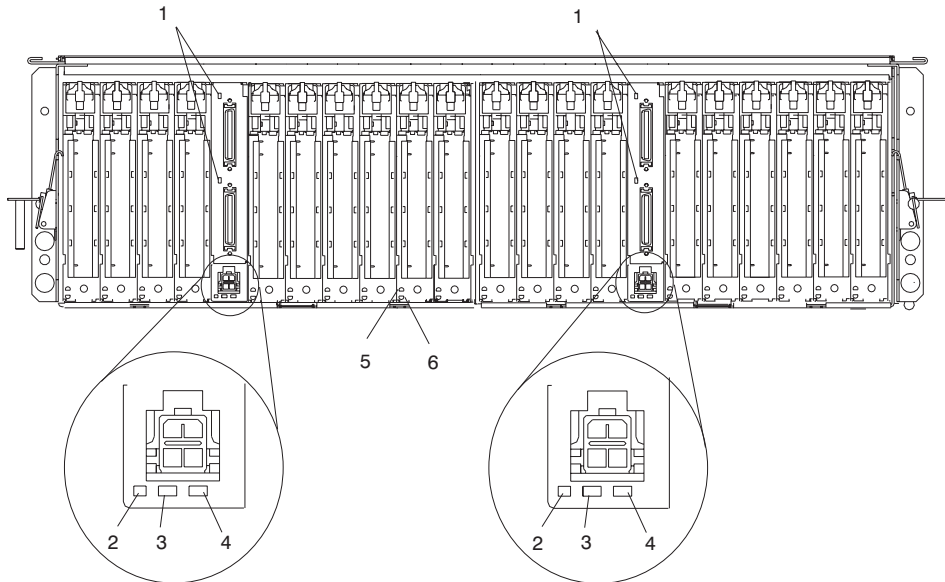

- | | |
|---|---|
| <p>1 I/O LED (Currently Unused)</p> <p>2 Auxiliary Power Good (Green)</p> <p>3 I/O Subsystem Backplane Fault (Amber)</p> | <p>4 I/O Subsystem Backplane Power On (Green)</p> <p>5 I/O Card Power On LED (Green)</p> <p>6 Failing I/O Card LED (Amber)</p> |
|---|---|

The following table describes the possible states of the LEDs associated with the I/O subsystem PCI slots. These LEDs are located at the rear of the I/O subsystem. One LED is associated with each PCI slot.

LED Indication	PCI Slot Status	Definition
Off	Off	Slot power is Off. It is safe to remove or replace adapters.
On (not flashing)	On	Slot power is On. Do not remove or replace adapters.
Flashing slowly (one flash per second)	Identify	Indicates slot has been identified by the software. Do not remove or replace adapters at this time.
Flashing rapidly (six to eight flashes per second)	Action	Indicates slot is ready for removing or replacing adapters.

PCI Adapters

Most PCI adapters can be removed and replaced, or installed in the system without turning off the power to the whole system. These adapters are referred to as *hot-pluggable PCI adapters*. Some adapters are not hot-pluggable and power must be removed from the system for adapter removal, replacement, or installation.

Before you remove or replace an adapter, determine if the PCI adapter you are working with is hot-pluggable. See the *PCI Adapter Placement Reference*, order number SA38-0538.

If you are removing a PCI adapter that is:

- Not hot-pluggable, go to “Non-Hot-Pluggable PCI Adapter”.
- Hot-pluggable, go to “Hot-Pluggable PCI Adapter” on page 836.

Non-Hot-Pluggable PCI Adapter

Note: The procedures for non-hot-pluggable PCI adapters listed below require the processes running on all partitions to be stopped and the entire machine to be powered off. To ensure power is removed, see “Powering Off the System and Removing Power” on page 771.

Removal

To remove a non-hot-pluggable adapter, perform the following steps:

1. Turn off power and remove the power from the system as described in “Powering Off the System and Removing Power” on page 771.
2. Determine the slot from which you are removing the adapter.
3. Disconnect any cables that are connected to the adapter being removed.
4. Press the center of the handle of the PCI card cassette to release the latch, then lower the handle completely.
5. When the handle is completely lowered, push the gray locking cross bar.
6. Carefully pull the PCI card cassette straight out from the I/O subsystem as shown in the following illustration. Take care not to pull EMC gaskets from neighboring

cassettes.

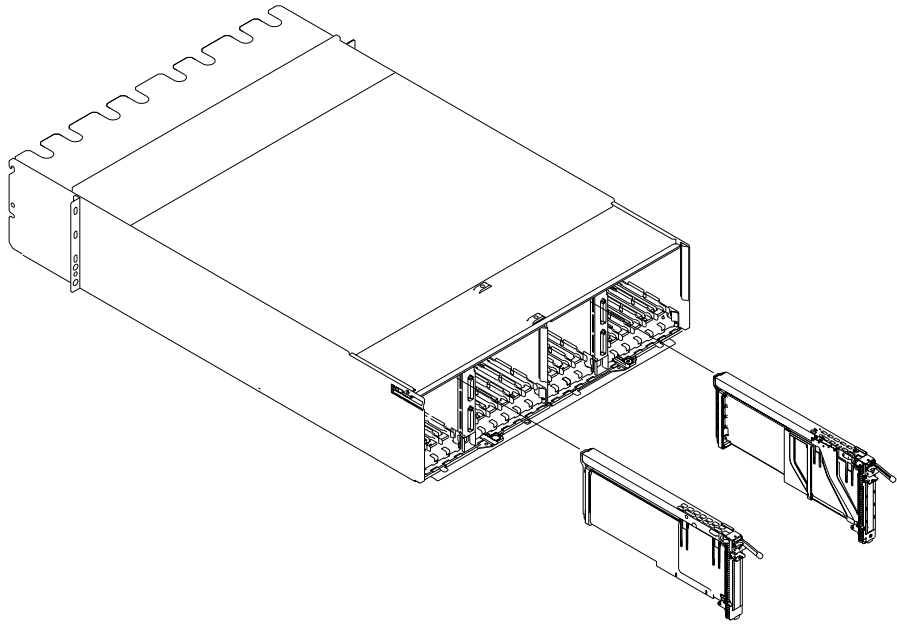

7. If you are installing another adapter in this slot, follow the instructions given in "Replacement".
8. If you are not installing another adapter in this slot, install a blank blindswap cassette into the slot.
9. Return the system to normal operations.
10. Connect power to the system and turn the power on as described in "Powering On the System" on page 772.

Replacement

Replace the adapter using the following procedure:

Note: If the adapter you are replacing is a double-wide adapter, see "Replacing a Double-Wide Blind Swap Adapter" on page 834 for the remaining steps to install the adapter.

1. Press the center of the handle of the PCI card cassette to release the latch, then lower the handle completely.
2. When the handle is completely lowered, push the gray locking cross bar.
3. Hold the assembly straight on and level with the slot.
4. Align the bottom edge of the PCI cassette cover with the PCI card guide rail on the I/O board.

Note: If there is a cassette to the left of the one you are installing, align the ridge on the cover with the "tick" in the notch of the neighboring cassette.

5. Slide the cassette partially into the guide.

6. Ensure the dovetail on the top track aligns with its mating component(s) on both sides.
7. When the cassette is fully inserted, prepare to activate the handle by lowering the gray locking bar. Lift the handle all the way up until you hear a click. The PCI Card should be completely seated.
8. Set the color slide to blue.
9. Connect power to the system and turn the power on as described in “Powering On the System” on page 772.
10. Ensure that the adapter is configured when the system completes the boot process.

Replacing a Double-Wide Blind Swap Adapter

Before installing a replacement adapter in a cassette that takes up two adapter positions, referred to as a *double-wide cassette*, perform the following checks:

- Check that the screws for the cassette are in place:
 - across the male dovetail side
 - holding the extension bracket
 - in the top center holding the cover
 - in the end of the top track
- Check to ensure the:
 - Rail and the metal bezel are aligned
 - The rail is not caught on the top of the bezel
 - The tailstock is aligned with the bezel
- Check the handle assembly, ensure that:
 - that pivot block is not broken
 - that the handle is set to the blue color
 - that the handle gray bar is not broken
- Check that all the EMC brackets are intact, and in place.
- Check that the light pipes are intact, and free from damage.
- Check the bezel hole to ensure that:
 - the handle is activated.
 - the hole in the tailstock aligns with the hole in the bezel.
- Check the cover assembly to assure that the cover end is held by the rear arm of the Bezel Assembly.

Replace the adapter using the following procedure:

1. Press the center of the handle of the PCI card cassette to release the latch, then lower the handle completely.
2. When the handle is completely lowered, push the gray locking cross bar.
3. Hold the assembly straight on with the PCI slots.
4. Place the double-wide blind swap cassette assembly with lower leading corner between installed single wide cassettes.
5. Slide the cassette partially into the guide.
6. Ensure the dove tail on the top track aligns with its mating component(s) on both sides. Once the dove tails are engaged, push the cassette fully into the drawer, you will feel some resistance when the cassette is fully inserted. When the cassette is fully inserted it should line up with the other installed cassettes.
7. If the cassette is fully inserted, press the button on the handle to unlock the gray crossbar.
8. Raise the handle with one hand and at the same time with your other hand, press down on the metal tab (adapter tailstock tab just below the handle mechanism) until the handle latches. You should hear a click as you lift the handle all the way up.

Note: You may have to release the handle and repeat this process while pressing on the tailstock tab to ensure that the PCI adapter is completely seated. When you are sure the adapter is completely seated, be sure that the handle is latched.

9. Connect power to the system and turn the power on as described in “Powering On the System” on page 772.
10. Ensure that the adapter is configured when the system completes the boot process.

Hot-Pluggable PCI Adapter

Note: The procedures for hot-pluggable PCI adapters listed below may result in unpredictable system behavior, depending on the adapter failure. The PCI hot-plug manager may become inoperable or indicate invalid or inconsistent slot status. In the event any of the hot-plug procedures below do not behave as described, proceed to “MAP 1420: Recovery Procedures for Hot-Pluggable PCI Adapters” on page 181.

Replacing a Hot-Pluggable PCI Adapter

Note: Use this procedure only when you are replacing one adapter with an identical adapter. If you are replacing an adapter with an adapter that is not identical to the adapter that was removed, go to “Removing a Hot-Pluggable PCI Adapter” on page 841 and “Installing a Hot-Pluggable PCI Adapter” on page 839.

To replace an adapter, perform the following steps:

1. Determine the slot from which you are removing the adapter.
2. Ensure that any processes or applications that might use the adapter are stopped.

Note: Removing a hot-pluggable PCI adapter requires the system administrator to take the PCI adapter offline before performing any PCI adapter hot-plug procedures. Before taking an adapter offline, the devices attached to the adapter must also be taken offline as well. This action prevents a service representative or user from causing an unexpected outage for system users.

For additional information about taking an adapter offline or removing it from the system configuration, see the *AIX System Management Guide: Operating System and Devices*. This publication is located on the *AIX Documentation* CD. The documentation information is made accessible by loading the documentation CD onto the hard disk or by mounting the CD in the CD-ROM drive.

3. Refer to “PCI Hot-Plug Manager Access” on page 843, and follow the steps in the access procedure to select **PCI Hot Plug Manager**. Then return here to continue.
4. Select **Unconfigure a Device** and press Enter.
5. Press F4 to display the Device Names menu.
6. From the menu, select the adapter you are removing.
7. Answer YES to **Keep Definition**. Press Enter.
8. The ARE YOU SURE screen displays. Press Enter to verify the information. Successful unconfigure is indicated by the OK message displayed next to the **Command** field at the top of the screen.
9. Press F3 to return to the PCI Hot-Plug Manager menu.
10. Select **Replace/Remove a PCI Hot-Plug Adapter** and press Enter. The Replace/Remove a PCI Hot-Plug Adapter menu displays.
11. Move the cursor to select the adapter that you are removing and press Enter.

12. Press the Tab key until the entry field displays the replace operation and then Press the Enter key. Follow the instructions that display on the screen until you are instructed to remove the adapter.
13. When you are instructed to remove the adapter from the adapter slot, disconnect any cables that are connected to the adapter being removed.
14. Press the center of the handle of the PCI adapter cassette to release the latch, then lower the handle completely.
15. When the handle is completely lowered, push the gray locking cross bar.
16. Carefully pull the PCI adapter cassette straight out from the I/O subsystem. Take care not to pull EMC gaskets from neighboring cassettes.

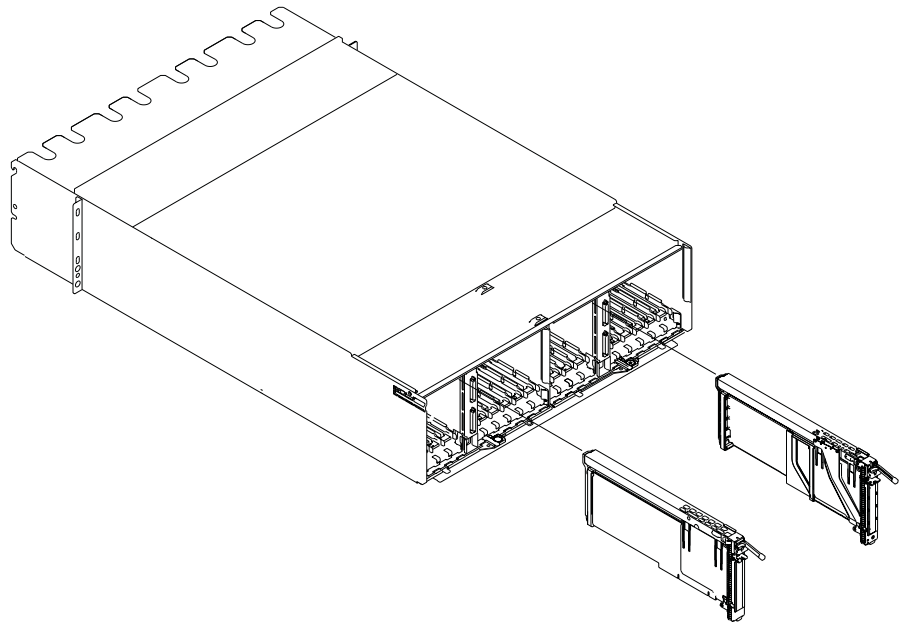

17. Install the replacement adapter in the blind-swap cassette, see “Blind Swap Cassette (BSC) Assembly Procedure” on page 846.
18. When the adapter is installed in the blind-swap cassette, install the adapter in the adapter slot:

Note: If the adapter you are replacing is a double-wide adapter, see for the remaining steps to install the adapter. Then go to step 19 on page 838 below.

- a. Lower the black handle completely.
- b. Push the gray locking cross bar until you hear a clicking sound.
- c. Hold the assembly straight on with the slot.
- d. Align the bottom edge of the PCI cassette cover with the PCI card guide rail on the I/O backplane.

Note: If there is a cassette to the left of the one you are installing, align the ridge on the cover with the "tick" in the notch of the neighboring cassette.

- e. Slide the cassette partially into the guide.
 - f. Ensure the dovetail on the top track aligns with its mating component(s) on both sides, then continue the installation.
 - g. When the cassette is fully inserted, prepare to activate the handle, lower the gray locking bar. Lift the handle all the way up until you hear a click. The PCI Card should be completely seated.
 - h. Set the color slide to blue.
19. Connect appropriate cables and devices to the adapter.
 20. Continue to follow the screen instructions until you receive a message that the replacement is successful. Successful replacement is indicated by the OK message displayed next to the **Command** field at the top of the screen.
 21. Press the F3 key to return to the PCI Hot-Plug Manager menu.
 22. Select **Install/Configure Devices Added After IPL** and press Enter. Then follow the instructions on the screen. Successful replacement is indicated by the OK message displayed next to the **Command** field at the top of the screen.
 23. Press F10 to exit the Hot-Plug Manager.
 24. Install any covers that you removed earlier, and return the system to the normal operations.

Installing a Hot-Pluggable PCI Adapter

Note: Before installing a new adapter, ensure the device driver for the adapter is loaded. Check with the system administrator if the device driver is not already loaded.

To install an adapter, perform the following steps:

1. Install the new adapter into a blind-swap cassette, see “Blind Swap Cassette (BSC) Assembly Procedure” on page 846.
2. Refer to “PCI Hot-Plug Manager Access” on page 843 and follow the steps in the access procedure to select **PCI Hot Plug Manager**. Then return here to continue.
3. From the PCI Hot-Plug Manager menu, select **Add a PCI Hot-Plug Adapter** and press Enter. The Add a Hot-Plug Adapter window displays.
4. See the *PCI Adapter Placement Reference*, order number SA38-0538, for adapter placement information. Select an empty PCI slot for the adapter.
5. Select the appropriate empty PCI slot from the ones listed on the screen, and press Enter.
- 6.
7. Follow the instructions on the screen to install the adapter until the visual indicator (LED) for the specified PCI slot is set to the Action state. See “I/O Subsystem PCI Slot LED Definitions” on page 830.
8. Install the new adapter in the adapter slot by performing the following:

Note: If the adapter you are replacing is a double-wide adapter, see for the remaining steps to install the adapter. Then go to step 9 below.

- a. Lower the black handle completely.
- b. Push the gray locking cross bar until you hear a clicking sound.
- c. Hold the assembly straight on and level with the slot.
- d. Align the bottom edge of the PCI cassette cover with the PCI card guide rail on the I/O backplane.

Note: If there is a cassette to the left of the one you are installing, align the ridge on the cover with the “tick” in the notch of the neighboring cassette.

- e. Slide the cassette partially into the guide.
- f. Ensure that the dovetail on the top track aligns with its mating component(s) on both sides, then continue the installation.
- g. When the cassette is fully inserted, prepare to activate the handle, lower the gray locking bar. Lift the handle all the way up until you hear a click. The PCI Card should be completely seated.
- h. Set the color slide to blue.
9. Connect appropriate cables and devices to the adapter.
10. Continue to follow the screen instructions until you receive a message that the installation is successful. Successful installation is indicated by the OK message displayed next to the **Command** field at the top of the screen.

11. Press the F3 key to return to the PCI Hot-Plug Manager menu.
12. Select **Install/Configure Devices Added After IPL** and press Enter. Then follow the instructions on the screen. Successful installation is indicated by the OK message displayed next to the **Command** field at the top of the screen.
13. If you do not have other adapters to install, continue with the next step.
OR
If you have other adapters to install, press the F3 key to return to the PCI Hot-Plug Manager menu and then return to step 3 on page 839.
14. Press F10 to exit the Hot-Plug Manager.
15. Install any covers that you removed earlier, and return the drawer to normal operations.

Removing a Hot-Pluggable PCI Adapter

Note: If you are removing an adapter and replacing it with an adapter that is identical to the adapter that was removed, use the “Replacing a Hot-Pluggable PCI Adapter” on page 836 procedure.

To remove an adapter, perform the following steps:

1. Open the door of the rack.
2. Determine the slot from which you are removing the adapter.
3. Ensure that any processes or applications that might use the adapter are stopped.

Note: Removing a hot-pluggable PCI adapter requires the system administrator to take the PCI adapter offline before performing any PCI adapter hot-plug procedures. Before taking an adapter offline, the devices attached to the adapter must also be taken offline as well. This action prevents a service representative or user from causing an unexpected outage for system users.

For additional information about taking an adapter offline or removing it from the system configuration, see the *AIX System Management Guide: Operating System and Devices*. This publication is located on the *AIX Documentation CD*. The documentation information is made accessible by loading the documentation CD onto the hard disk or by mounting the CD in the CD-ROM drive.

4. Refer to “PCI Hot-Plug Manager Access” on page 843, and follow the steps in the access procedure to select **PCI Hot Plug Manager**. Then return here to continue.
5. Select **Unconfigure a Device** and press Enter.
6. Press F4 to display the Device Names menu.
7. Select the adapter you are removing from the menu.
8. Use the Tab key to answer NO to **Keep Definition**. Press Enter.
9. The ARE YOU SURE screen displays. Press Enter to verify the information. Successful unconfigure is indicated by the OK message displayed next to the **Command** field at the top of the screen.
10. Press F3 to return to the PCI Hot-Plug Manager menu.
11. Select **Replace/Remove a PCI Hot-Plug Adapter** and press Enter. The Replace/Remove a PCI Hot-Plug Adapter menu displays.
12. Move the cursor to select the adapter that you are removing and press Enter. (The description entry displays as unknown).
13. Press the Tab key until the entry field displays the remove operation and then Press the Enter key. Follow the instructions that display on the screen until you are instructed to remove the adapter.
14. When you are instructed to remove the adapter from the adapter slot, disconnect any cables that are connected to the adapter being removed.
15. Press the center of the handle of the PCI card cassette to release the latch, then lower the handle completely.

16. When the handle is completely lowered, push the gray locking cross bar.
17. Carefully pull the PCI adapter cassette straight out from the I/O subsystem, as shown in the following illustration. Take care not to pull EMC gaskets from neighboring cassettes.

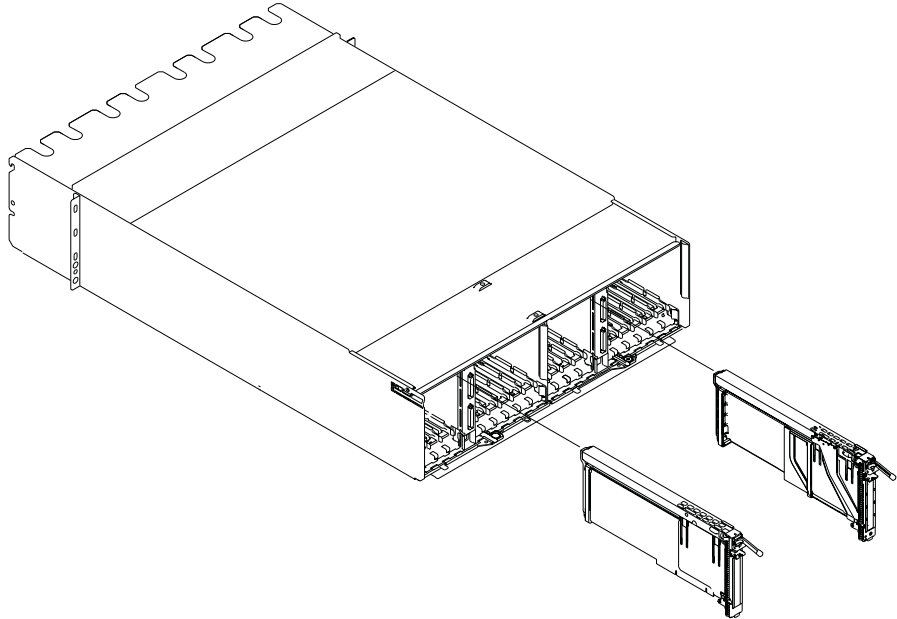

18. If you are not installing another adapter in this slot, install a blank blindswap cassette into the slot.
19. Continue to follow the screen instructions until you receive a message that the adapter removal is successful. Successful removal is indicated by the OK message displayed next to the **Command** field at the top of the screen.
20. If you do not have other adapters to remove, continue with the next step.
OR
If you have other adapters to remove, press the F3 key to return to the PCI Hot-Plug Manager menu and then return to step 11 on page 841.
21. Press F10 to exit the Hot-Plug Manager.
22. Install any covers that you removed earlier, and return the drawer to the normal operations.

PCI Hot-Plug Manager Access

The installation instructions for hot-pluggable PCI adapters refer you to these procedures when it is appropriate to perform them.

Note: A PCI adapter is only hot-pluggable if the PCI adapter is supported for hot-plug applications. See the *PCI Adapter Placement Reference*, order number SA38-0538.

Accessing Hot-Plug Management Functions

Note: Removing or installing a Hot-Pluggable PCI adapter requires the system administrator to take the PCI adapter offline prior to performing the operation. Before taking an adapter offline, the devices attached to the adapter must also be taken offline as well. This action prevents a service representative or user from causing an unexpected outage for system users.

For additional information about taking an adapter offline or removing it from the system configuration, see the *AIX Version 4.3 System Management Guide: Operating System and Devices*. This publication is located on the *AIX Documentation* CD. The documentation information is made accessible by loading the documentation CD onto the hard disk or by mounting the CD in the CD-ROM drive.

To access the hot-plug menus, do the following:

1. Log in as root user, if the system is a partitioned system, log in as root user on the partition that has the adapter assigned to it.
2. At the command line, type **smitty**.
3. Select **Devices**.
4. Select **PCI Hot Plug Manager** and press Enter.
5. The PCI Hot-Plug Manager menu displays. Return to the procedure that directed you here. The following describes the menu options.

PCI Hot-Plug Manager Menu

The following options are available from the PCI Hot Plug Manager menu:

Note: For information about the PCI slot LED states, see “I/O Subsystem PCI Slot LED Definitions” on page 830.

List PCI Hot-Plug Slots

Provides a descriptive list of all slots that support PCI hot-plug capability. If the listing for a slot indicates it holds an “Unknown” device, select the **Install/Configure Devices Added after IPL** to configure the adapter in that slot.

Add a PCI Hot-Plug Adapter

Allows the user to add a new PCI hot-plug-capable adapter to the slot with the system turned on. You will be asked to identify the PCI slot that you have selected prior to the actual operation. The selected PCI slot will go into the Action state and finally into the On state.

Note: The system will indicate the slot holds an “Unknown” device until you perform the **Install/Configure Devices Added After IPL** option to configure the adapter.

Replace/Remove a PCI Hot-Plug Adapter

Allows the user to remove an existing adapter, or replace an existing adapter with an identical one. For this option to work, the adapter must be in the Defined state (see “Unconfigure a Device” option below).

You will be asked to identify the PCI slot prior to the actual operation. The selected PCI slot will go into the Action state.

Identify a PCI Hot-Plug Slot

Allows the user to identify a PCI slot. The selected PCI slot will go into the Identify state. See “I/O Subsystem PCI Slot LED Definitions” on page 830.

Unconfigure a Device

Allows the user to put an existing PCI adapter into the Defined state if the device is no longer in use.

This step must be completed successfully before starting any removal or replacement operation. If this step fails, the customer must take action to release the device.

Configure a Defined Device

Allows a new PCI adapter to be configured into the system if software support is already available for the adapter. The selected PCI slot will go into the On state.

Install/Configure Devices Added After IPL

The system attempts to configure any new devices and tries to find and install any required software from a user-selected source.

The add, remove, and replace functions return information to the user indicating whether the operation was successful. If additional instructions are provided on the screen, complete the recommended actions. If the instructions do not resolve the problem, see the following:

- If the adapter is listed as Unknown, perform the **Install/Configure Devices Added After IPL** option to configure the adapter.
- If you receive a warning indicating that needed device packages are not installed, the system administrator must install the specified packages before you can configure or diagnose the adapter.
- If you receive a failure message indicating a hardware error, the problem might be either the adapter or the PCI slot. Isolate the problem by retrying the operation in a different PCI slot, or trying a different adapter in the slot. If you determine that you have failing hardware, call your service representative.

Blind Swap Cassette (BSC) Assembly Procedure

Removal

1. Remove the PCI card assembly from the I/O subsystem (for hot-pluggable adapters see "Removing a Hot-Pluggable PCI Adapter" on page 841, for non-hot-pluggable adapters see "Removal" on page 831).
2. Position the assembly on a flat surface, with the tailstock to the left and the card connector toward you.
3. Remove the three screws from the top cover groove, and the two screws at the heel corner.
4. Pop the rear end of the cover off the guide bump and remove the cover.
5. Position the assembly on a flat surface, with the tailstock to the right and the card connector toward you.
6. Remove the three screws from the top of the bezel assembly.
7. Position the assembly on a flat surface, with the tailstock to the left and the card connector toward you.
8. Flex the support arm downward until the top clip on the card arm is accessible.
9. Use a small screwdriver to lift the guide lock, and slide the card arm away from the PCI card until the card end is free.
10. Push the lower-front heel off the card, and remove the PCI card from the assembly.

Replacement

1. Ensure that you have the following parts:

- Bezel and linkage subassembly
- Cover
- Clip
- Insertion Clip (see the following note)
- Short card arm
- Long card arm
- Screws (10--2 are extra)

Note: If you are installing a Gigabit Ethernet (FC 2969 type 9U), Ultra3 SCSI (FC 6203 Type 4Y), or 10/100 BaseT Ethernet (FC 4962 Type AF), use the additional clips listed below to help when you are seating the adapter during installation.

There are different clips **(1)** for each adapter type **(2)**:

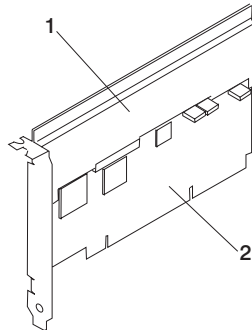

44P0323

Clip for Gigabit Ethernet FC 2969 type 9U

44P0324

Clip for Ultra3 SCSI FC 6203 Type 4Y

44P0321

Clip for 10/100 BaseT Ethernet FC 4962 Type AF

2. Position the bezel and linkage subassembly with the bezel to the left, on a flat ESD surface.
3. Pivot the bezel so that the lower end is away from the linkage sub-assembly.

Note: Ensure that the top front clip is in the uppermost position before continuing.

- a. If the adapter card is full-height (that is, taller than the tailstock of the card), do the following:
 - 1) Place the top corner of the PCI card so that it seats in the top front clip, as shown in the following diagram:

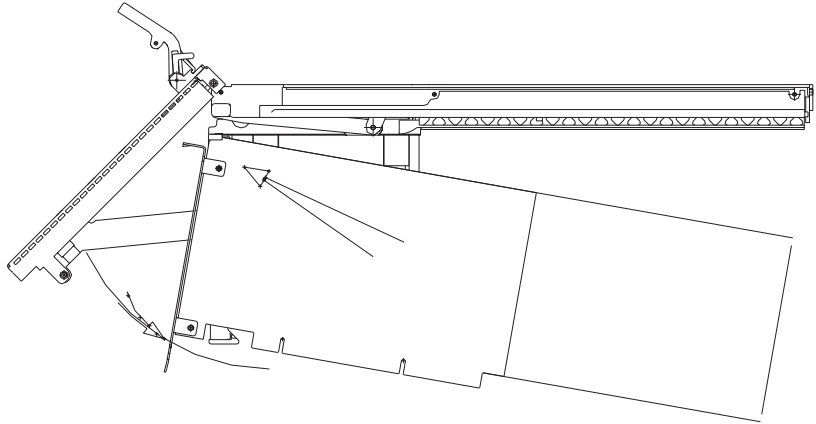

- 2) Rotate the bottom of the tailstock to fit in the front heel clip.
 - 3) To remove any slack in the fit, use pliers or screwdriver to adjust the top front clip downward.
- b. If the adapter card is not full-height (that is, shorter than the tailstock of the card), do the following:
 - 1) Place the bottom corner of the PCI card on the front heel clip.
 - 2) To remove any slack between the top and bottom clips, use pliers or screwdriver to adjust the top front clip downward. If the top clip is pushed too far down without engaging the card, remove the top front clip by popping it off the rail. Reattach the clip and start again.

4. Attach the appropriate short card (if the card does not extend beyond the mark at the top of the linkage subassembly) or long card arm to the support arm of the linkage subassembly as follows:

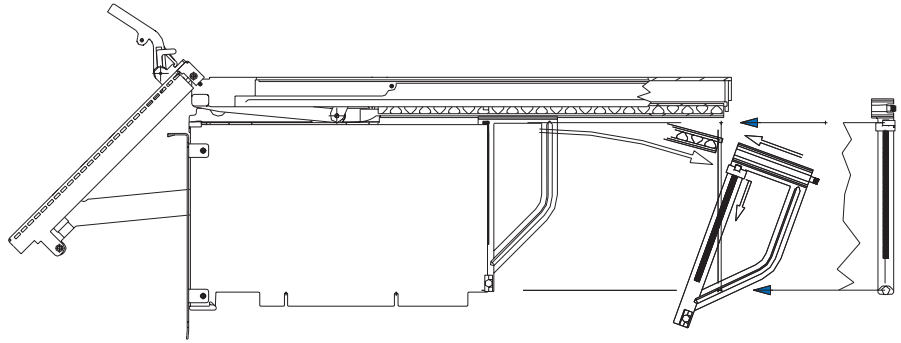

Note: Ensure the card arm is fully on the track and clears the end of the support arm of the linkage subassembly. A flat head screwdriver might be needed to push the card arm in the remaining distance.

- a. Bend the support arm downward, to allow the card arm to slide onto the end of the support arm.
- b. Slide the card arm until the top-rear and lower clips align with the edge of the card.
- c. Press the lower clip under the bottom edge of the card. The bottom of the clip should be even with the bottom of the card.
- d. Slide the top rear clip of the card arm downward to engage the top corner of the card. The card should now be securely stabilized in all the clips, as shown in the following illustration.
- e.

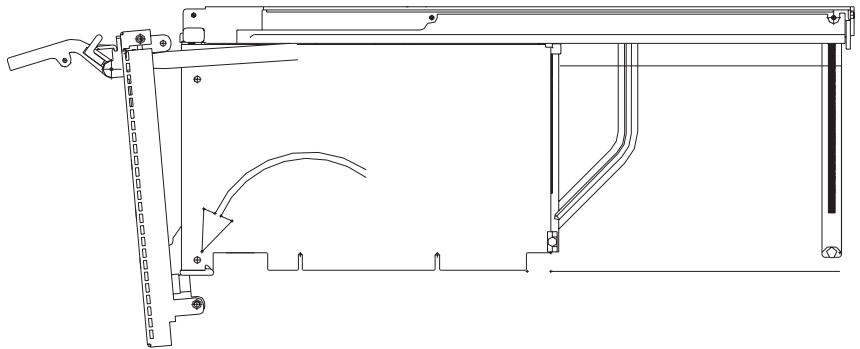

5. Tilt the top of the bezel away from the PCI card while lowering the bottom of the tailstock into bottom of the bezel, as shown in the following illustration.

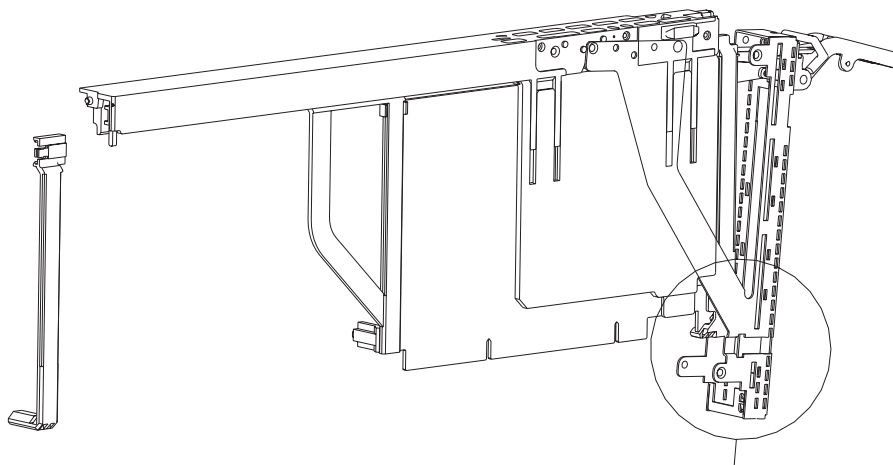

6. When the lower corner of the card is fully seated into the bezel, rotate the top of the bezel over the tailstock of the card.

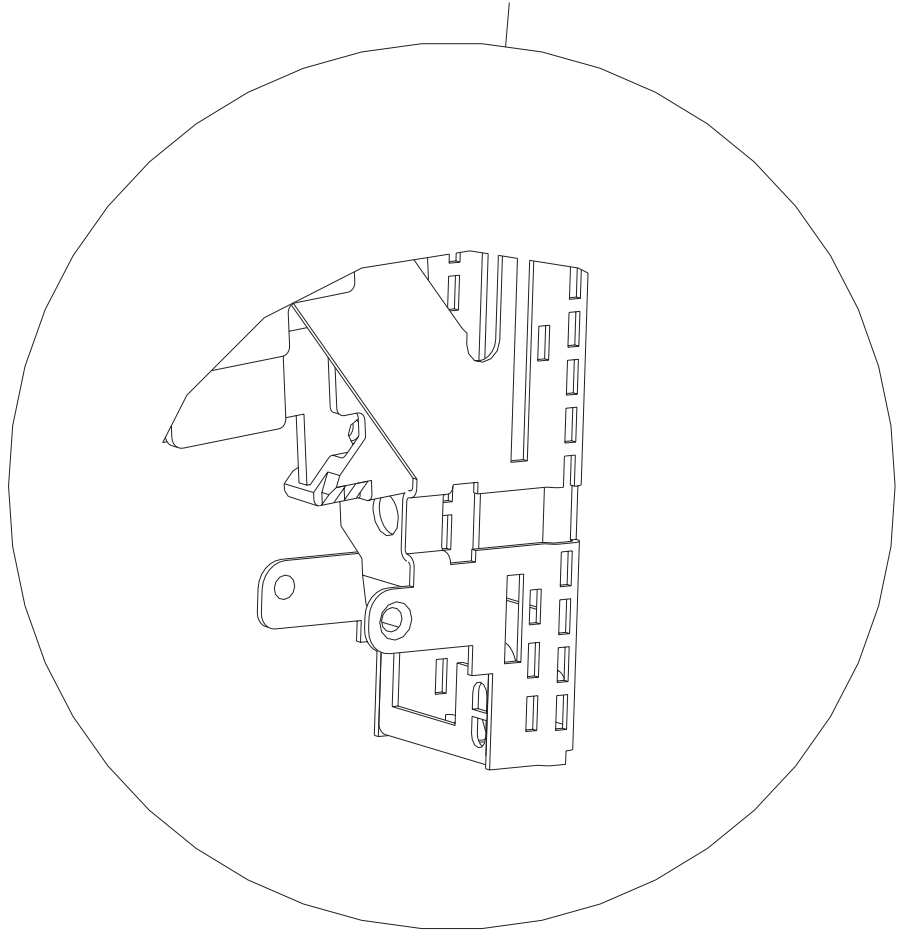

7. Position the bezel fully onto the assembly by snapping the three small holes on bezel arm over the three small embossments on the linkage assembly, as shown

in the following illustration.

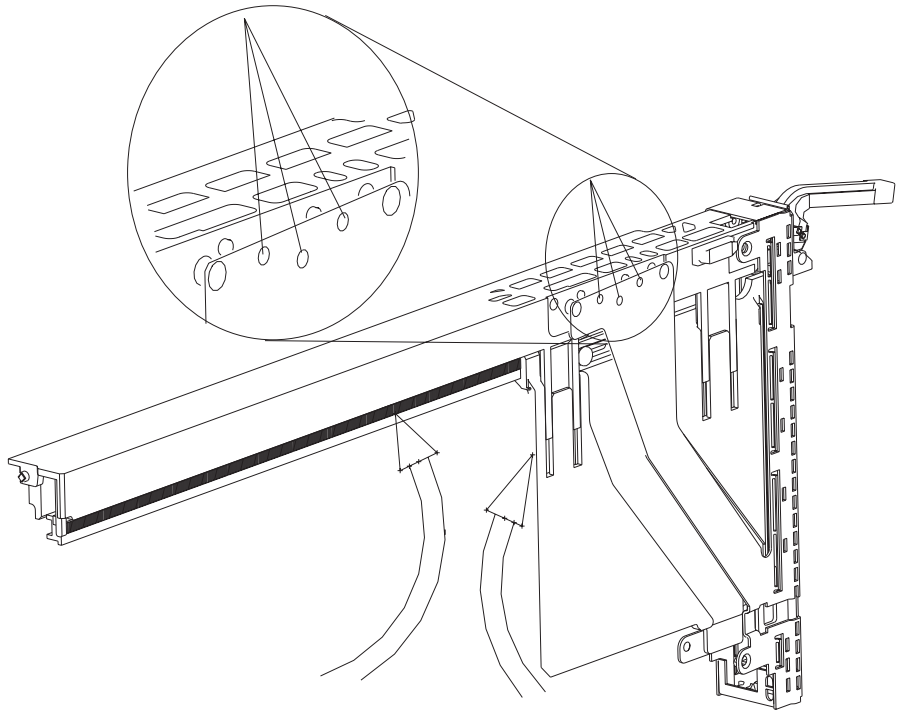

- Secure the bezel arm to the linkage assembly with three small screws in the sequence shown in the following illustration.

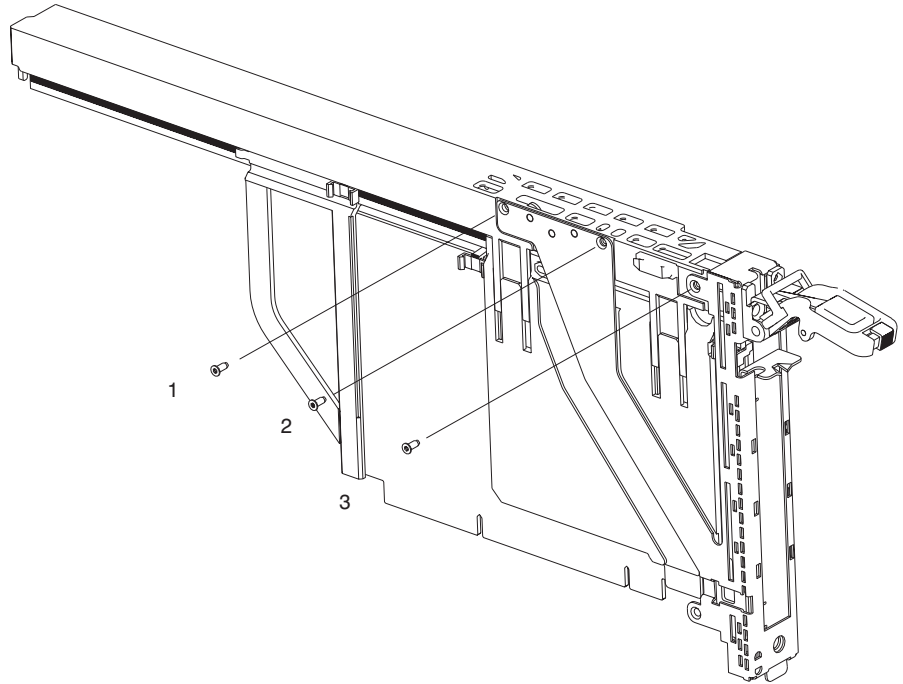

- With the tailstock to the left on a flat surface, position the cover over the linkage assembly.
- Tuck the top and bottom tabs at the left of the cover under the bezel.

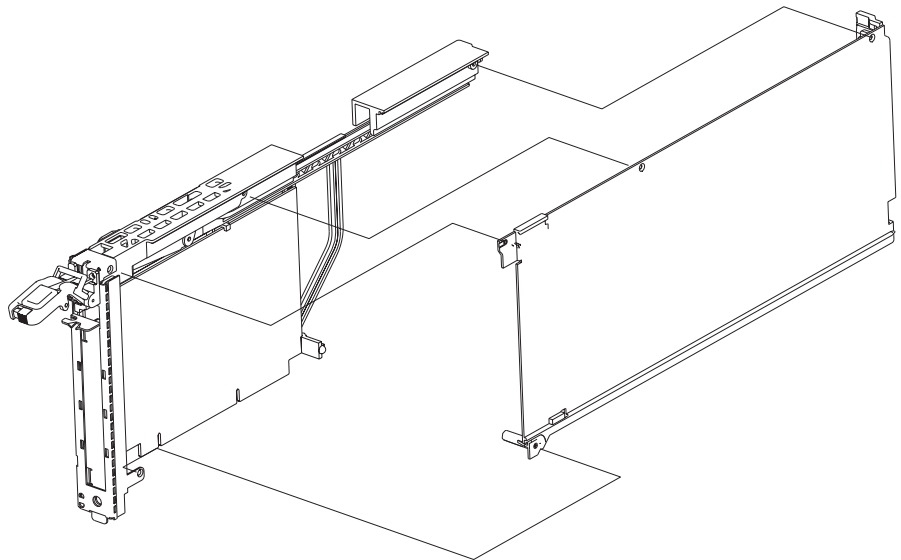

11. Snap the top-right corner of the cover over the guide bump on the linkage assembly.
12. Align the holes at the top of the cover with those in the linkage subassembly and screw the cover to the linkage subassembly in the sequence shown in the following illustration.

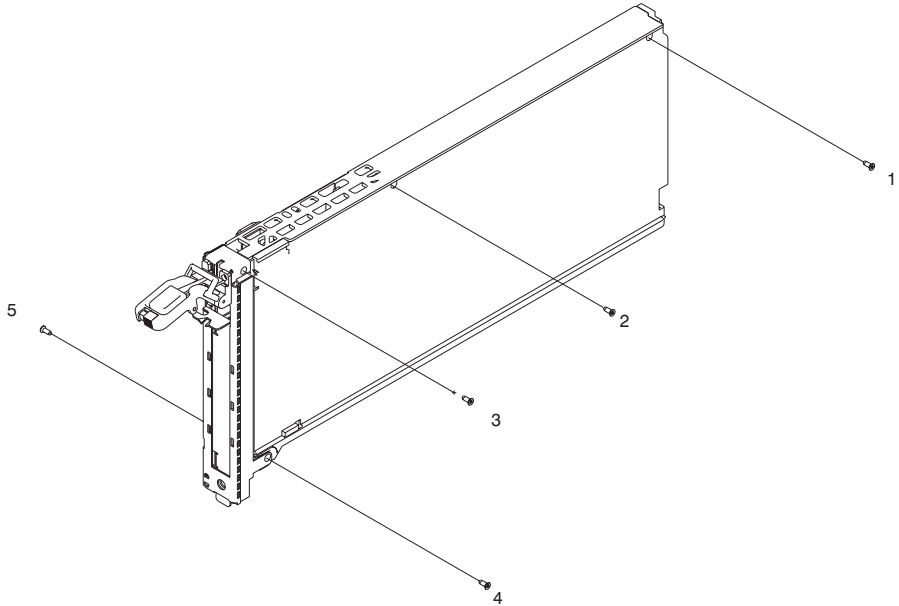

13. Snap the tailstock clip onto the tailstock by rotating it onto the bracket while inside the bezel opening.

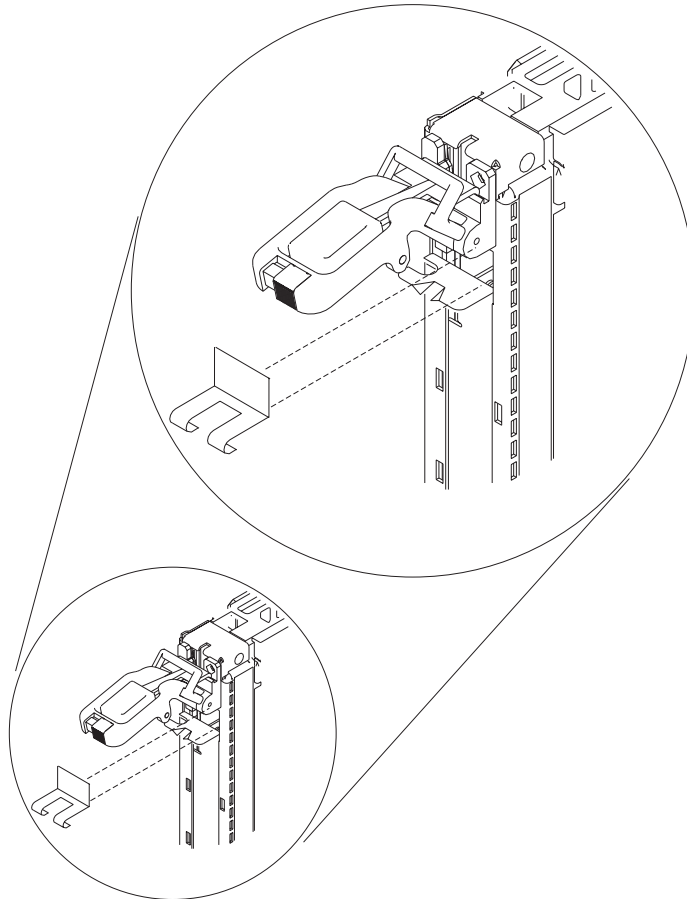

14. Raise the lever to the horizontal extended position and snap the tailstock clip onto the tailstock tab as follows.
15. Visually inspect the assembly and ensure that the following are correct:
 - The card moves up and down correctly when the handle is raised and lowered.
 - The tailstock clip rides within the bezel opening.

I/O Subsystem RIO Riser Card

Removal

Note: The RIO Riser Card is part of the I/O Subsystem Backplane FRU, it cannot be ordered separately

1. Turn off power as described in “Powering Off the System and Removing Power” on page 771.
2. Disconnect all cables from the RIO riser card.
3. Remove the I/O subsystem backplane, as described in “I/O Subsystem I/O Backplane Assembly” on page 858.
4. Remove the two screws that attach the RIO riser card to the I/O subsystem backplane.
5. Carefully pull the card out of the slot as shown in the following illustration.

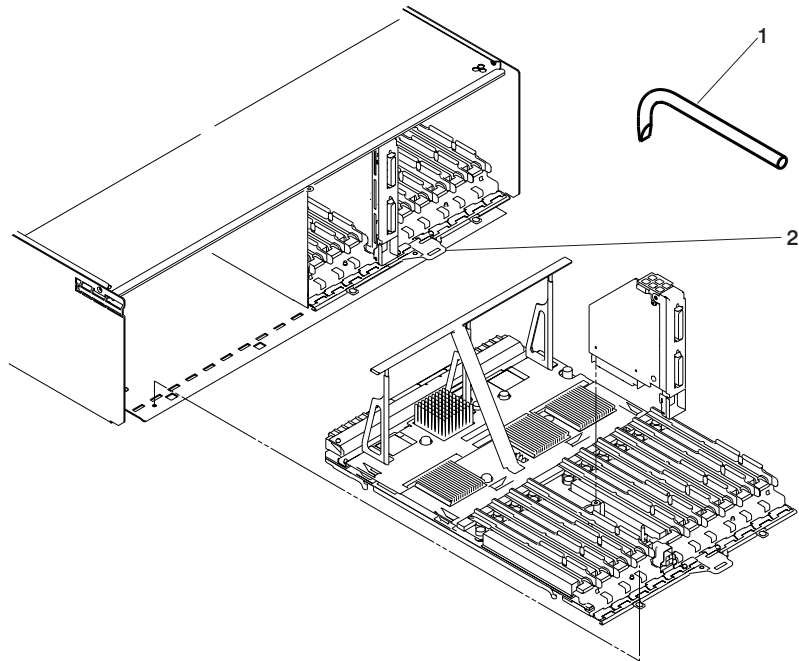

1 Backplane removal tool (PN 11P4789)

2 Backplane removal and insertion tab

Replacement

Replace in reverse order.

I/O Subsystem Distributed Converter Assembly (DCA)

Notes:

1. Each I/O subsystem can have up to two DCAs. You can replace each DCA separately. The removal and replacement procedures are identical for each DCA.
2. This procedure applies to the I/O subsystem DCAs.
3. If a subsystem has two DCAs, each is hot-pluggable. If only one needs to be removed, you do not have to power off the system. Do not attempt to replace two DCAs at once or to move DCAs from one I/O drawer to another to troubleshoot a problem. The machine type/serial number will be corrupted when these actions are attempted.

Removal

DANGER

Do not attempt to open the covers of the power supply. Power supplies are not serviceable and are to be replaced as a unit.

1. Locate the DCA to be replaced.
2. Note the state of the DCA's LEDs.
3. Press the green **Start Service** button on the UEPO switch.
4. Proceed only if *all* the DCA's LEDs go off or the repair has been scheduled (System outage - EPO off),
5. Verify the cable labeling and locations, then unplug the cables from the DCA.
6. Loosen the left and right fasteners, using the torque tool (P/N 6422789), alternating between the fasteners until the unit can slide out of the slot.
7. Grasp both sides of the front DCA and pull it out of the drawer.

Replacement

1. Carefully slide the DCA into the slot as far as possible (the back edge of the top of the DCA is about .25 inch from the cage bracket)

Note: Do not force the DCA against the backplane, as this may damage the connector.

2. Hold the upper part of the DCA against the backplane and use the torque tool to engage the left fastener about two turns into the cage bracket.
3. Repeat the previous step for the right fastener.
4. Alternate tightening the left and right fasteners until both are fully torqued in.
5. Check torque on both fasteners.
6. Plug all cables into their correct location in the DCA.
7. Press the white **Service Complete** button on the UEPO switch.

I/O Subsystem I/O Backplane Assembly

Removal

1. Turn off power as described in “Powering Off the System and Removing Power” on page 771.
2. Disconnect and label all cables from the adapters on the affected I/O backplane.
3. Remove and label adapters. (See “PCI Adapters” on page 831).
4. Remove the two screws securing the I/O backplane to the subsystem.
5. Insert the I/O subsystem backplane removal tool (part number 11P4789), and pry the tool backward to remove the board from the connector.

Note: If the I/O subsystem is in the bottom position of the rack, the I/O subsystem may need to be removed from the rack to allow correct usage of the I/O subsystem backplane removal tool to install a new I/O backplane.

6. Slide the I/O subsystem backplane assembly to the rear.

Note: Be sure to hold the board level to ensure that the board can clear the step in the cover and then again to clear the EMC gasket.

7. Remove the assembly.

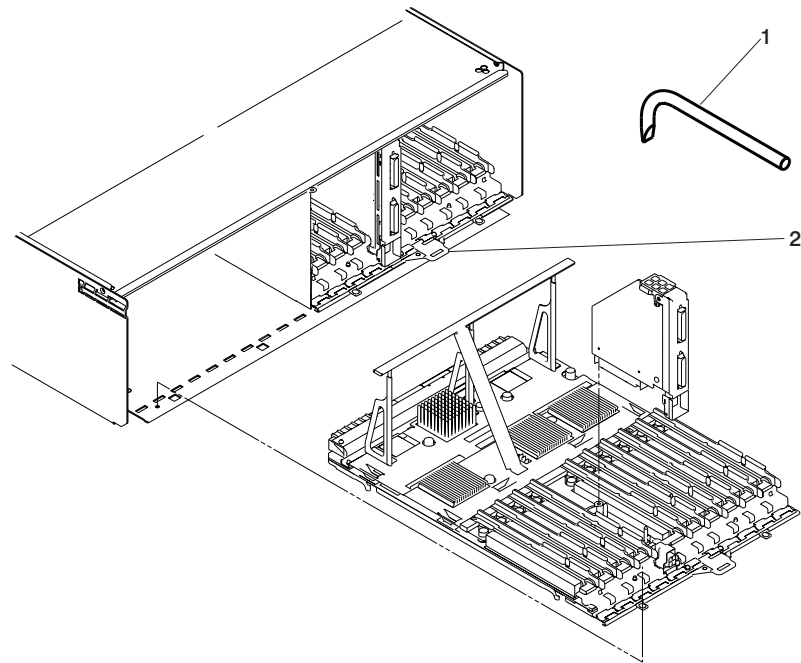

1 Backplane removal tool (PN 11P4789)

2 Backplane removal and insertion tab

Replacement

1. Align the I/O subsystem backplane assembly with the chassis opening and ensure that the Roll Bar clears the top-edge EMC gasket without damaging it.
2. Slide the I/O subsystem backplane assembly into the chassis. Ensure that the two pins in the chassis align with the bottom of the backplane. Align the backplane with the connector.
3. Continue to slide the backplane in slowly until it makes contact with the connector.
4. Upon contact, insert the insertion tool (part number 11P4789) to cam the backplane into the connector.
5. Pry with the tool until the screw holes on the chassis and the board align.
6. Secure with two screws.
7. Reinstall all adapters and reconnect all cables to the replaced I/O backplane.

I/O Subsystem DASD Hard Disk Drive Assembly

Removal

1. This procedure is a hot swap procedure. Refer to the ““SCSI Hot Swap Manager” in the “Introduction to Tasks and Service Aids” chapter in the *RS/6000 and @server pSeries Diagnostic Information for Multiple Bus Systems*, order number SA38-0509. Use the SCSI Hot Swap Manager Task to prepare to remove and replace a SCSI disk drive. Then continue with the following steps.
2. Press on the blue latch to release it from hooking the body.

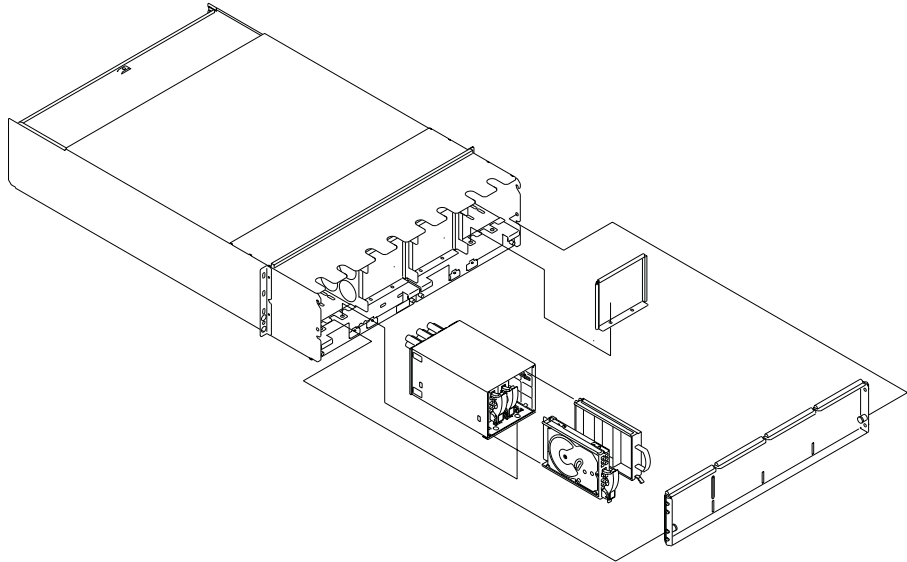

3. Move the black handle all the way down and pull out the assembly. A slight initial resistance is normal.
4. Ensure that the 4-pack has not been damaged. If the DASD assembly was installed incorrectly, the removal could force the metal tab in the 4-pack to bend over the camming slot.

Replacement

Note: All four bays in each DASD 4-pack must be occupied. If a bay does not have a DASD assembly, it must be occupied by a filler assembly.

1. Inspect the DASD 4-pack to ensure it is not damaged.
2. Ensure that the lower retaining screws are inserted and secured.
3. Ensure that the front retaining screws are inserted and secured without interfering with DCA.
4. Open fully the latch on the DASD assembly by pressing the blue handle and pulling the black handle. A thump signals that it is fully open.
5. With the handle to the bottom, insert the assembly into the appropriate slot.

6. Slide the assembly forward until the you feel some resistance. Verify that the spring on the top is contacting the edge of the 4-pack. This should be the only resistance.
7. Push the assembly forward with slightly more force until you meet more resistance. Verify that the tab on the black handle is located above the cam slot in the 4-pack.

Note: If the tab is not aligned with the slot, do not raise the handle. Remove the assembly and start again.

8. Lift the black handle to move the assembly in slightly.
9. Lift the handle and push forward until the blue latch hooks the assembly body.

I/O Subsystem DASD 4-Pack

Removal

1. Locate the DASD backplane to be replaced.
2. Turn off the power as described in “Powering Off and Powering On the System” on page 771.
3. Press the green **Start Service** button on the UEPO switch.
4. Remove the front cover from the I/O subsystem by grasping the pins at either side of the cover, pulling them towards the center of the drawer, and simultaneously lifting the cover up and to the front to release it from the I/O subsystem chassis.
5. Remove the DASD disk drive assemblies or DASD filler(s) from the affected 4-pack as shown in the following illustration.

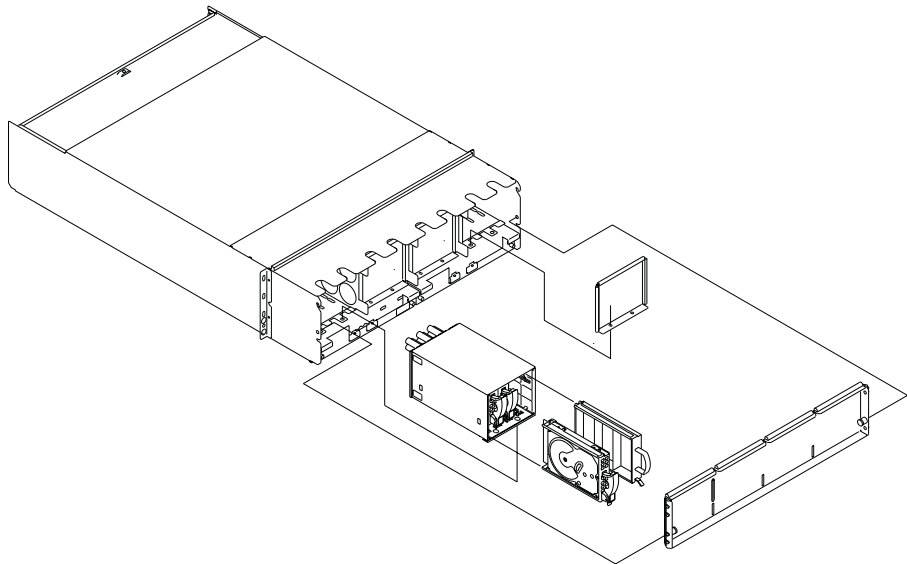

6. Remove two M4x0.7 screws at the lower inside front of the DASD 4-pack with a short-blade screwdriver.
7. Remove two M4x0.7 hex socket-head cap screws at the lower inside rear of the DASD 4-pack.
8. Grasp the DASD 4-pack through the cutouts in the top of the I/O subsystem, and pull the DASD 4-pack out of the front of the I/O subsystem.

Replacement

1. Perform steps 4 through 8 of the removal instructions in reverse order.
2. Press the white **Service Complete** button on the UEPO switch.

I/O Subsystem DASD Fan

Removal

1. Locate the fan to be replaced.
2. Turn off the power as described in “Powering Off and Powering On the System” on page 771.
3. Press the green **Start Service** button on the UEPO switch.
4. Remove the DASD cage from the front of the fan to be removed (see “I/O Subsystem DASD 4-Pack” on page 862).
5. Slide the black retention latch on the fan assembly upward and, with the handle located on the fan, pull the fan from the front of the I/O subsystem. A door automatically closes when the fan is removed, preventing loss of airflow while the fan is out of the enclosure.

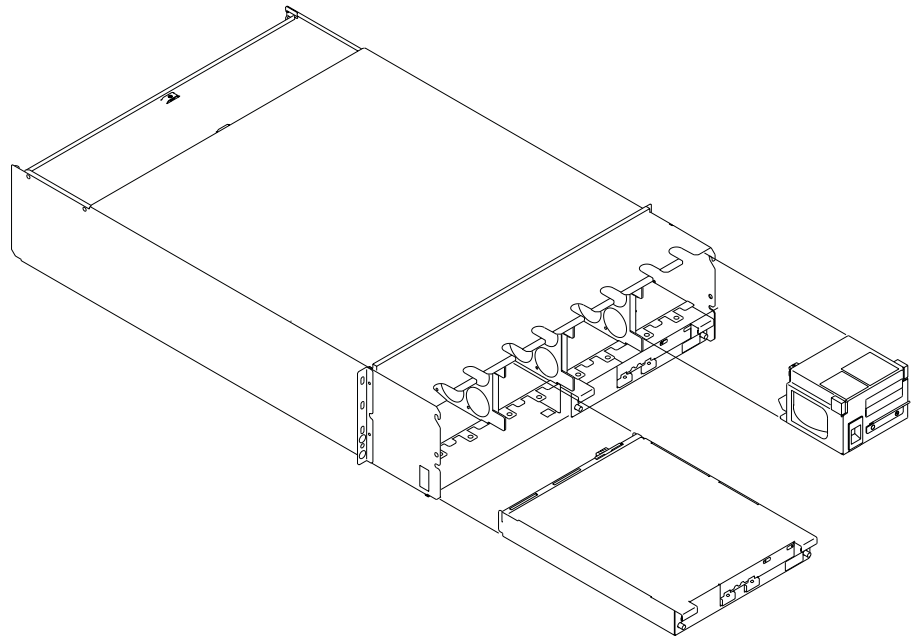

Replacement

Note: All four openings to the front of the fans must be covered either by a DASD 4-pack or by a DASD 4-pack filler.

Replace in reverse order. When you have completed the replacement of the DASD fan, press the white **Service Complete** button on the UEPO switch to complete the replacement.

I/O Subsystem Chassis

Removal

Attention: This process requires:

- The use of a lift tool (PN 09P2481) and lift plate assembly tool (PN 11P4369).
 - The lift tool wheels must be chocked to prevent it from moving during the operation. The frame must not be on its casters, the leveling pads must be engaged to prevent the frame from moving during the operation.
1. Unpack lift tool and follow assembly instructions included with the tool. Inspect the tool for damage (do not perform the remove procedure with a damaged lift tool). Read all safety instructions before performing this operation. Replace blue lift plate with orange lift plate (P/N 11P4369). Orient two round holes in lift plate to the side of the lift tool that will be closest to the frame.
 2. Turn off power as described in “Powering Off the System and Removing Power” on page 771.
 3. Unplug all power cables from the line power source.

Attention: Because this procedure is performed with power removed from the system, references to using the white or green service buttons on the UEPO switch do not apply during the remainder of this procedure.
 4. Open the rack doors and remove them from the rack.
 5. Verify that all cables are labeled. If not, then label all cables and components along with their location at the front and rear of the system.
 6. Remove all adapters as described in “PCI Adapters” on page 831.
 7. Remove all DASD hard disk drives as described in “I/O Subsystem DASD Hard Disk Drive Assembly” on page 860.
 8. Remove the screws that attach the I/O subsystem chassis to the rack.
 9. Position the lift tool at the front of the rack. Align the lift tool such that I/O subsystem chassis will not be blocked (at the lip of the orange lift plate) from removal. Install wheel chocks on lift tool casters. Engage the lift tool brake.
 10. Raise plate to height such that the lift plate is just below the base of the I/O subsystem chassis you are removing. Release pins on the extender arms and position them on both left and right side, arms must fit around the frame extenders and lock in place (do not adjust the lift tool once these arms are locked in place).
 11. One person should gently pull and guide the I/O subsystem chassis onto the lift plate. The I/O subsystem chassis must be removed far enough to clear the front face of the frame. Retract the extender arms.
 12. Lower I/O subsystem chassis to the bottom position of the lift tool.
 13. Remove the wheel chocks and release the brake. Flip the crank handle 180 degrees. Carefully move the lift tool with the I/O subsystem chassis to the staging area. The brake and wheel chocks must be in place when transferring the I/O subsystem chassis to or from the packaging material.

Replacement

Notes:

1. If you are replacing this assembly with a new assembly, the manufacturing label with the machine type, model number, and the serial number for the subsystem must be ordered to apply to the new part. For information on replacement labels, see Chapter 10, "Parts Information" on page 873.
2. Before beginning the replacement procedure, Install rails in the frame if not already installed.

Note:

1. Position the lift tool such that the new I/O subsystem chassis can be moved onto the lift plate.
2. Install the wheel chocks and engage the brake.
3. Move the new I/O subsystem chassis onto the tool with its rear (PCI adapter end) flush with the lift plate.
4. Position the lift tool as close as possible to the front of the rack. Install wheel chocks on lift tool casters. Engage the lift tool brake.
5. Raise plate to a height such that the lift plate is just above the rails onto which the I/O subsystem chassis will be installed. Release pins on the extender arms and position them on both left and right side. Arms must fit around the frame extenders and lock in place (do not adjust the lift tool once these arms are locked in place).
6. One person should gently push the I/O subsystem chassis toward the frame from the front of the system. Adjust the height of the lift plate, as needed. After the I/O subsystem is installed in the frame, retract extender arms.
7. Lower the lift plate and remove it from the lift tool, repackage the lift tool.
8. Reinstall all components removed during the removal process by reversing steps 8 on page 864 through 2 on page 864 of the removal procedure.

Media Subsystem

CD-ROM, DVD-RAM, or Tape Drive

Attention: DVD-RAM and 4-mm tape drives can be located in the rear of the media subsystem *only if the room is maintained at a nominal room temperature of 24°C (75.2°F)*.

Attention: Do not open the drive; no user adjustments or serviceable parts are inside.

CAUTION:

All IBM laser modules are designed so that there is never any human access to laser radiation above a class 1 level during normal operation, user maintenance, or prescribed service conditions. Data processing environments can contain equipment transmitting on system links with laser modules that operate at greater than class 1 power levels. For this reason, never look into the end of an optical fiber cable or open receptacle. Only trained service personnel should perform the inspection or repair of optical fiber cable assemblies and receptacles.

Removal

1. Ensure that the SCSI drive is in idle mode (the activity light remains off).
2. Loosen the thumbscrew that holds the SCSI drive assembly in the subsystem (the top screw is for the drive to the right, the bottom screw is for the left drive).

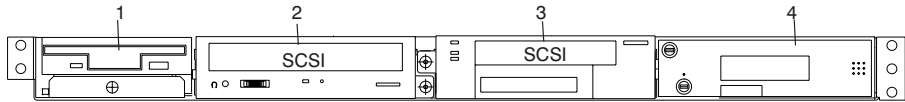

3. Carefully, grasping the thumbscrew and not the bezel, pull the drive assembly out until you can access the cables at the rear.
Attention: When performing the next two steps, always disconnect the power cable *before* disconnecting the SCSI cable.
4. Disconnect the power cable from the rear of the drive assembly.
5. Disconnect the SCSI cable from the rear of the drive assembly.
6. Remove the four mounting screws that hold the drive or blank to the carrier bracket and remove it from the carrier.

Replacement

Note: Ensure that the cables are routed through the grommet at the rear of the carrier.

Attention: When replacing a SCSI drive, always connect the SCSI cable *before* connecting the power cable.

Replace in reverse order.

Diskette Drive

Removal

1. Ensure that the diskette drive is in idle mode (the activity light remains off).
2. Loosen the thumbscrew that attaches the diskette carrier to the media subsystem.

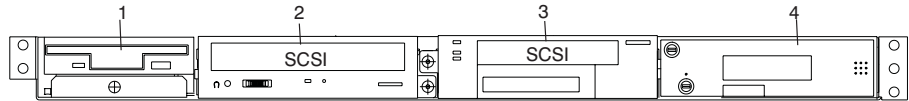

3. Carefully grasping the thumbscrew and not the bezel, pull the drive assembly out until you can access the cables at the rear.

Attention: When performing the next two steps, always disconnect the power cable *before* disconnecting the diskette signal cable.

4. Disconnect the power cable from the rear of the drive assembly.
5. Disconnect the diskette signal cable from the rear of the drive assembly.
6. Remove the four screws that connect the carrier to the diskette drive.

Replacement

Replace in reverse order.

Attention: When replacing a diskette drive, always connect the diskette signal cable *before* connecting the power cable.

Operator Panel

Removal

1. Turn off power as described in “Powering Off the System and Removing Power” on page 771.
2. Remove the upper-left and lower-right screws that hold the media subsystem in the rack, and pull the subsystem out no more than two inches.
3. Pry the spring clip on the left side just enough to release the panel while grasping the operator panel by the top and bottom front (do not pull on the bezel), and pull the operator panel out of the chassis.
4. Note the locations and disconnect the cables from the operator panel, then remove the operator panel as shown in the following illustration.

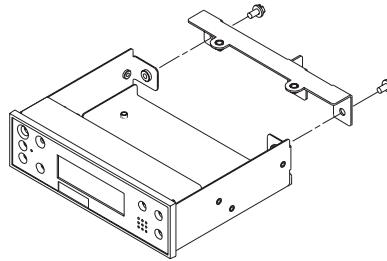

Replacement

1. Remove the VPD module from the old operator panel and insert it in the new operator panel. Make sure you insert the module in the same position as it was in the old panel.

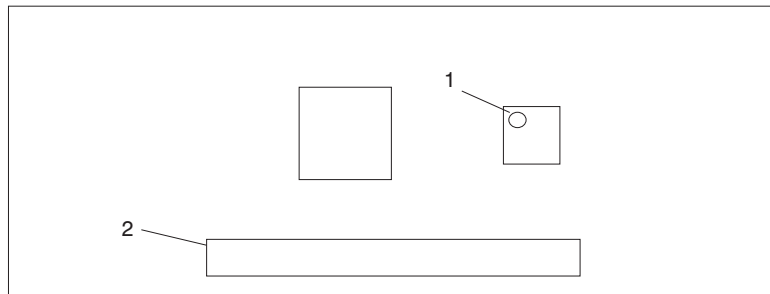

- 1 VPD Module
- 2 Cable Connector

2. Reconnect the cables to the operator panel.

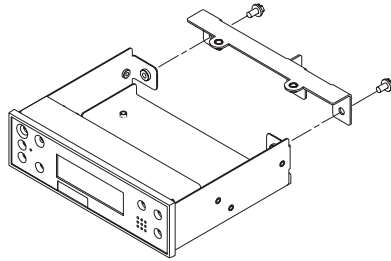

3. Push the operator panel into the chassis until the spring clip engages.
4. Push the chassis into the rack and replace the two mounting screws.
5. Turn on the power as described in “Powering On the System” on page 772.

Media Subsystem Chassis

Although there should be no need to ever remove the media chassis, this procedure provides instructions in case you need to remove it.

Removal

1. Turn off power as described in “Powering Off the System and Removing Power” on page 771.
2. Label and disconnect all cables from the rear of the media subsystem.

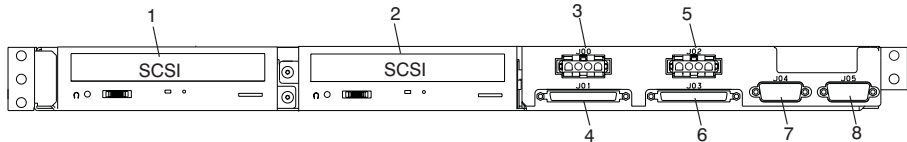

3. Remove the screw that holds the left side of the media subsystem chassis to the rack.
4. Remove the screw that holds the right side of the media subsystem chassis to the rack.

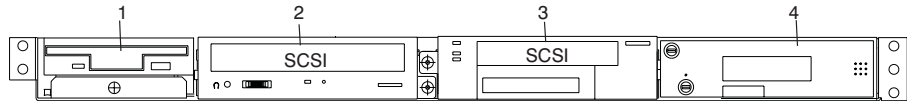

5. Carefully pull the chassis out of the front of the rack.

Replacement

Replace in reverse order.

If the new media drawer contains a new operator panel, remove the VPD module from the old operator panel and insert it in the new operator panel. Make sure you insert the module in the same position as it was in the old panel.

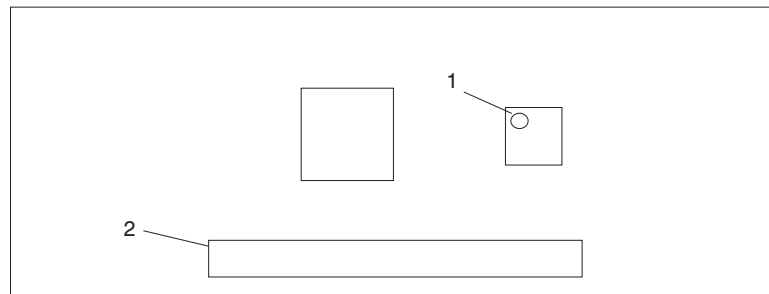

- 1 VPD Module
- 2 Cable Connector

Be sure to move any other parts or features from the old media drawer to the new media drawer if they are not included as part of the new media drawer.

Media Subsystem Internal Cables

Removal

1. Turn off power as described in “Powering Off the System and Removing Power” on page 771.
2. If you have not already done so, open the front door of the rack unit.
3. Remove the media subsystem from the rack as described in “Media Subsystem Chassis” on page 870, and place it on a work surface.
4. Remove the six screws and the eight 7-mm nuts that hold the cover to the subsystem, as shown in the following illustration.

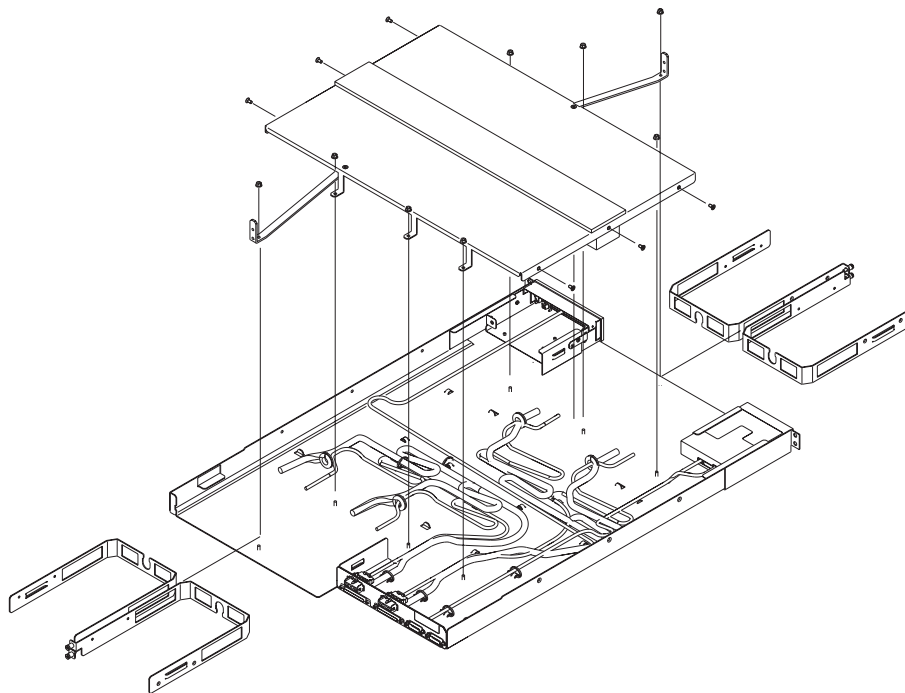

5. Loosen the four captive screws (one for each SCSI drive bay) to free the two truss brackets.
6. Remove the cover.
7. Release the ties that hold the affected cable. If ties must be cut, cut them from the underside of the chassis.
8. Disconnect the cable connector from the chassis.
9. Note the cable routing, and remove the cable from the subsystem chassis.

Replacement

Replace in reverse order.

Note: Be sure to secure the cables with the ties as they were originally installed. Allow enough length for a service loop in case the drives are removed in the future.

Chapter 10. Parts Information

This chapter contains parts information for the @server pSeries 690, which includes:

- 7040 Model 61R Rack Subsystem
- 7040 Model 681 Processor Subsystem Processor Subsystem
- 7040 Model 61D I/O Subsystem

The following 7040 FRUs each contain an IBM Manufacturing label with the machine type, model number, and the serial number for the subsystem of which they are a part:

- Unit Emergency Power Off (UEPO) Card Assembly 7040 Model 61R
- Processor Subsystem Chassis 7040 Model 681
- I/O Subsystem Chassis 7040 Model 61D

If any of the these FRUs are replaced as a result of a repair action, service representatives are required to order a duplicate replacement label from the Code A desk of their respective IBM manufacturing locations. Service representatives will need to provide the Code A desk with label information from the FRU scheduled to be replaced: Machine Type, Model Number, and Serial Number. The Code A desk will then create and ship a bill of material that contains a replacement label and labeling instructions to affix the duplicate labels on the replacement FRU.

7040 Model 61R Rack Subsystem

The rack subsystem consists of the rack, power subsystem, and the internal battery feature.

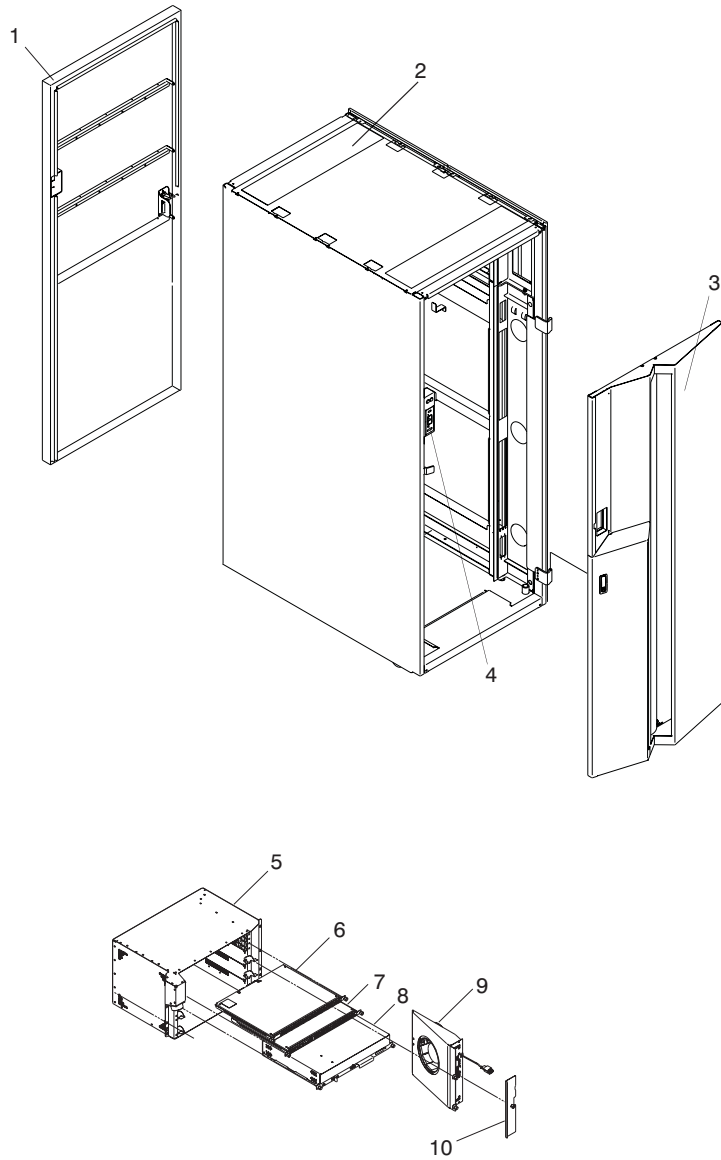

11 - Integrated Battery Feature (not pictured)

Index	Part Number	Units Per Assy	Description
1	44P0107	1	Rear Door
	44P0127		Rear Door (Accoustic)
2	11P3948	1	42U Frame
	44P0125	1	Cover, side left
	44P0126	1	Cover, side, right
	11P2890	1	Top hat
	11P2923	2	Shipping bar
3	44P0105	1	Front Door Primary Rack
	44P0106		Front Door Secondary Rack
	11P1097	1	Front Latch Primary Rack
	11P1096		Front Latch Secondary Rack
	11P1093	2	Latch Bracket
	11P4106	2	Door Hinge
	11P3990	1	Door key
	54G2882	12	Screw
	11P3535	2	Hinge
	2665525		Bolt
4	44P1124	1	Universal Emergency Power Off (UEPO) Switch
5	11P4205	2	Bulk Power Enclosure (BPE)
6	11P3646	4	Bulk Power Distribution (BPD)
7	11P3645	2	Bulk Power Controller (BPC)
	11P1597		Y-Cable (CSP)
8	44P1372	6	Bulk Power Regulator (BPR)
9	11P1787	2	Bulk Power Fan (BPF)
	11J5335		Bulk Power Assembly Rail
10	11P0287	1	Fan Cover Plate
11	11P3732	Up to 6	Integrated Battery Feature (IBF)

(3)

7040 Model 681 Processor Subsystem Processor Subsystem (Front)

This processor subsystem front view consists of the processor chassis, memory books, fans, and filters.

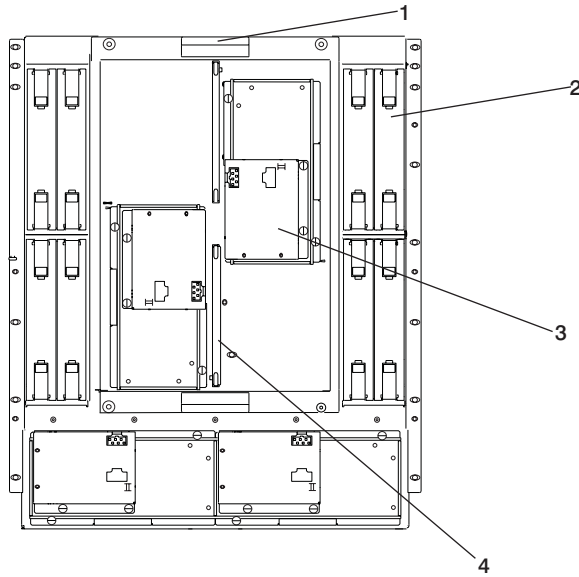

Index	Part Number	Units Per Assy	Description
1	11P4518	1	Processor subsystem chassis (with backplane)
2	11P2935	1 to 8	Memory book retainer See "7040 Model 681 Processor Subsystem Processor Subsystem (Front)" on page 878 for Memory books part numbers.
3	31L7627	4	Fan Controller (MDA)
	07H5349	4	Fans
4	11P3781	2	Air filter

7040 Model 681 Processor Subsystem Processor Subsystem (Front)

This processor subsystem front view consists of the memory books, MCM and L3 modules.

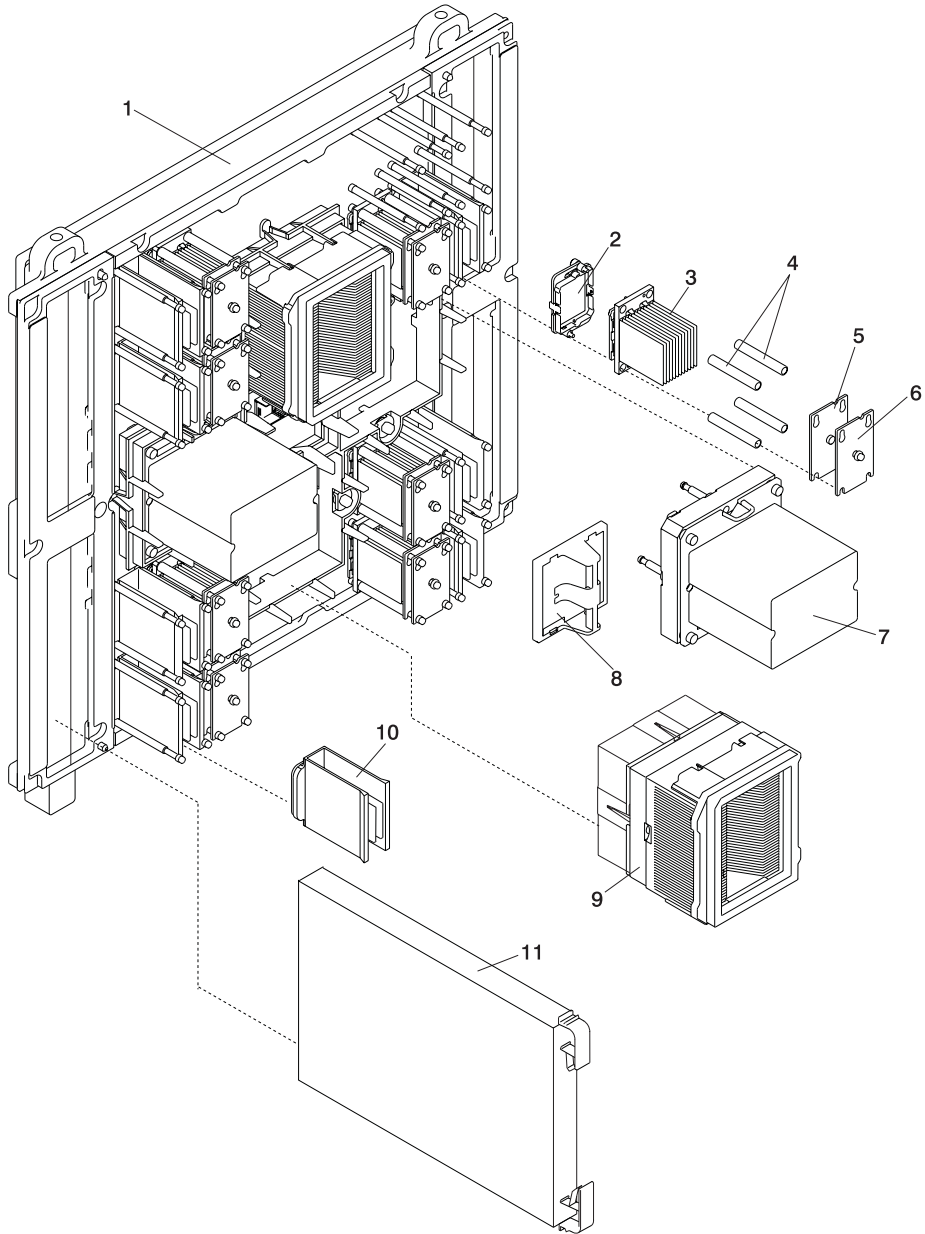

Index	Part Number	CCIN	Units Per Assy	Description
1	11P4518	25C0	1	System Backplane
2	NA			Protective Cover (Included as part of the L3 Cache Module FRU.) Note: Do not discard the protective cover. Use it when returning L3 FRUs.
3	09P3218	25D9	4 to 16	128 MB (4x32)/400 MHz L3 Cache kit Includes: <ul style="list-style-type: none"> • PN 21P7972 400 MHz VPD card (CCIN 25D9) • PN 11P3873 L3 Cache Module • PN 04N6923 Brush • PN 11P4055 Label • PN 44P0360 Mech Spring Kit
	09P3219	25F1	4 to 16	128 MB (4x32)/433 MHz L3 Cache kit Includes: <ul style="list-style-type: none"> • PN 21P788175 433 MHz VPD card • PN 11P3874 433 MHz L3 Cache Module • PN 04N6923 Brush • PN 11P4055 Label • PN 44P0360 Mech Spring Kit
4	21P4589			Load Post Sleeve
5	11P2788			Rear Spring Plate
6	11P2785			Front Spring Plate with Set Screw
7	21P7753	272D	Up to 3	MCM Passthru Module
8	21P7271	27C1	1	Clock Card
9	09P5629	25D5	1 to 4	1.1 GHz 8-way MCM with VPD card kit Includes: <ul style="list-style-type: none"> • PN 11P4952 3.2 STND MCM Module (and VPD Smart Card, CCIN 25D5) • PN 04N6923 Brush • PN 11P3876 Screw • PN 11P4055 Label
	09P5628	25C7	1 to 4	1.3 GHz 4-way MCM with VPD card kit Includes: <ul style="list-style-type: none"> • PN 11P4949 3.2 Fast MCM Module (and VPD Smart Card, CCIN 25C7) or • PN 11P4950 3.2 Fast MCM Module (and VPD Smart Card, CCIN 25C7) • PN 04N6923 Brush • PN 11P3876 Screw • PN 11P4055 Label

Index	Part Number	CCIN	Units Per Assy	Description
	09P5630	25D3	1 to 4	1.3 GHz 8-way MCM with VPD card kit Includes: <ul style="list-style-type: none"> • PN 11P4951 3.2 Fast MCM Module (and VPD Smart Card, CCIN 25D3) • PN 04N6923 Brush • PN 11P3876 Screw • PN 11P4055 Label
10	11P2793		Up to 12	L3 Filler
11	53P1013	305C	1 to 8	4 GB Memory Book I
	53P1018	305D		4 GB Memory Book O
	53P0374	302A		8 GB Memory Book I
	53P0386	302B		8 GB Memory Book O
	53P0378	305E		16 GB Memory Book I
	53P0390	305F		16 GB Memory Book O
	53P0382	302C		32 GB Memory Book I
	53P0394	302D		32 GB Memory Book O

7040 Model 681 Processor Subsystem Processor Subsystem (Rear)

This processor subsystem rear view consists of the RIO books, DCAs, and capacitor books, MCM and L3 modules, as well as the media subsystem.

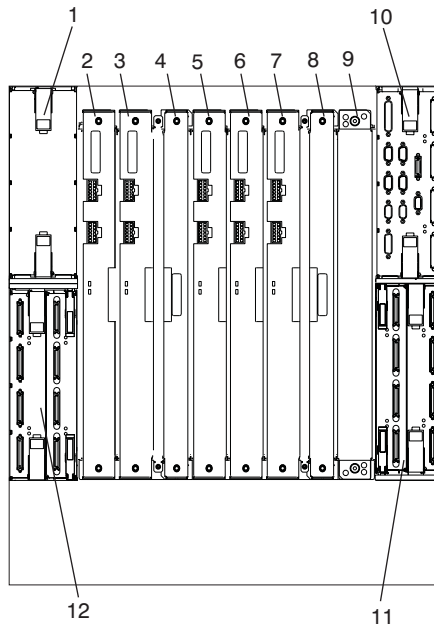

Index	Part Number	CCIN	Units Per Assy	Description
1				Reserved
2	11P3492		1	Distributed converter assembly DCA1
	11P1543		1	Cable assembly (DCA1) P00
	11P1544		1	Cable assembly (DCA1) P01
3	11P3492		1	Distributed Converter Assembly DCA2
	11P1545		1	Cable assembly (DCA2) P00
	11P1546		1	Cable assembly (DCA2) P01
4	11P1540		1	Capacitor card
5	11P3492		1 (if	Distributed converter assembly DCA3
	11P1547		installed)	Cable assembly (DCA3) P00
	11P1548		1	Cable assembly (DCA3) P01
			1	
6	11P3492		1 (if	Distributed converter assembly DCA4
	11P1549		installed)	Cable assembly (DCA4) P00
	11P1550		1	Cable assembly (DCA4) P01
			1	
7	11P3492		1 (if	Distributed converter assembly DCA5
	11P1551		installed)	Cable assembly (DCA5) P00
	11P1552		1	Cable cable assembly (DCA5) P01
			1	
8	11P1540		1	Capacitor card
9				Reserved
10	09P5687		1	Primary I/O book
	11P2936			I/O book retainer
	44P0206			9-9 pin serial cable connects the managed system primary I/O book to the HMC
	31L7196			9-25 pin serial cable connects the managed system primary I/O book to HMC async adapter
11	53P1573	2738	1	Third I/O book
	11P2936			I/O book retainer
12	53P1573	2738	1	Secondary I/O book
	11P2936			I/O book retainer

7040 Model 681 Media Subsystem

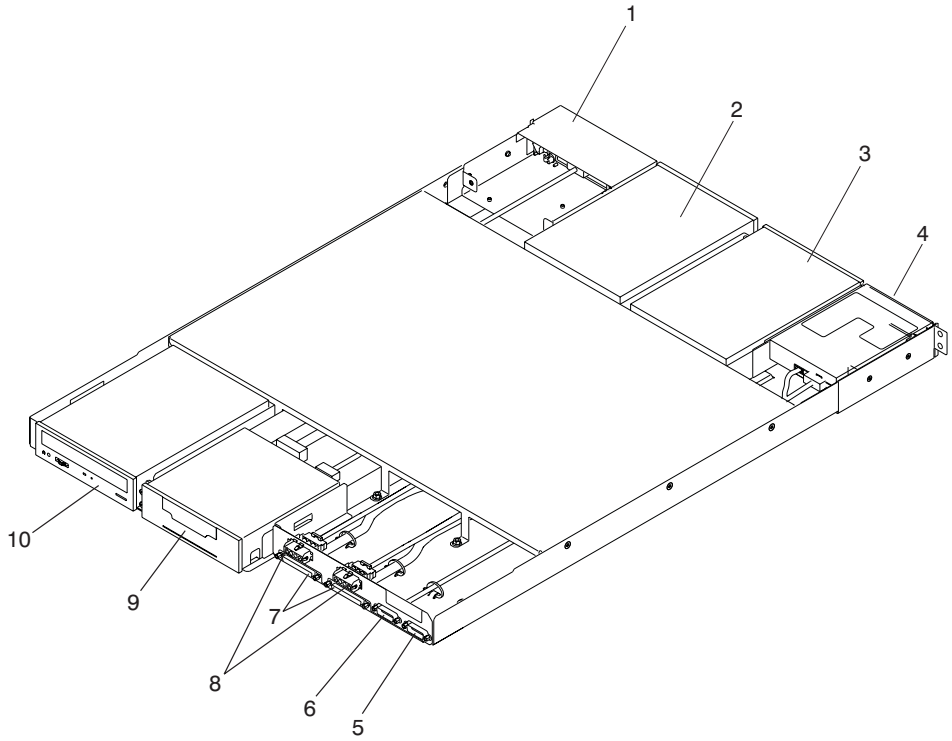

Index	Part Number	Units Per Assy	Description
1	24L1089 05G2882	1	Operator Panel Screw
2	See Note	1	Optional Media Device (SCSI Drive)
3	See Note	1 or 2	CD-ROM Drive (SCSI Drive)
4	76H4091	1	Diskette Drive
5	11P3549	1	Operator panel cable (J05)
6	11P4216 5420242	1	Diskette Drive Signal Cable (J04) Cable Tie
7	11P4215 5420242	2	Media Device SCSI Cables from J01 to rear drives, J03 to front drives Cable Tie
8	11P4214 5420242	2	Media Device Power Cables (J00 to rear drives, J02 to front drives) Cable Tie
9	See Note	1	Optional Media Device (SCSI Drive)
10	See Note	1	Optional Media Device (SCSI Drive)

Note: See *RS/6000 and @server pSeries Diagnostic Information for Multiple Bus Systems* for part numbers.

Note: See *RS/6000 and @server pSeries Diagnostic Information for Multiple Bus Systems* for part numbers.

Power and SCSI Cables to the Media Subsystem

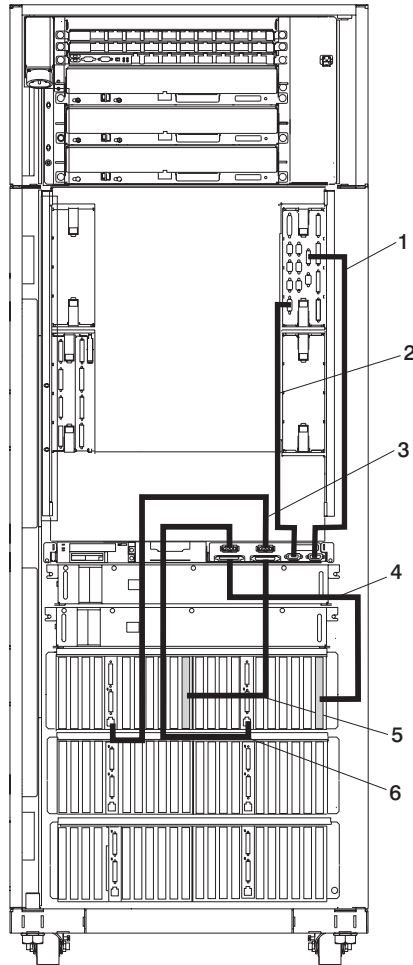

Index	Part Number	Units Per Assy	Description
1	11P4301	1	Cable Connecting the Operator Panel to the Media Subsystem
2	11P4300	1	Cable Connecting the Diskette Drive to the Media Subsystem
3	11P2352	1	Power Cable for Media Subsystem Front Components
4	11P4303	1	SCSI Cable for Media Subsystem Rear Components
5	11P4303	1	SCSI Cable for Media Subsystem Front Components
6	11P2351	1	Power Cable for Media Subsystem Rear Components

7040 Model 61D I/O Subsystem

The system can contain up to eight I/O subsystems. This section lists detail for one I/O subsystem. Depending on your configuration, the quantities of parts listed may increase by the actual number of I/O subsystems in your system.

Front

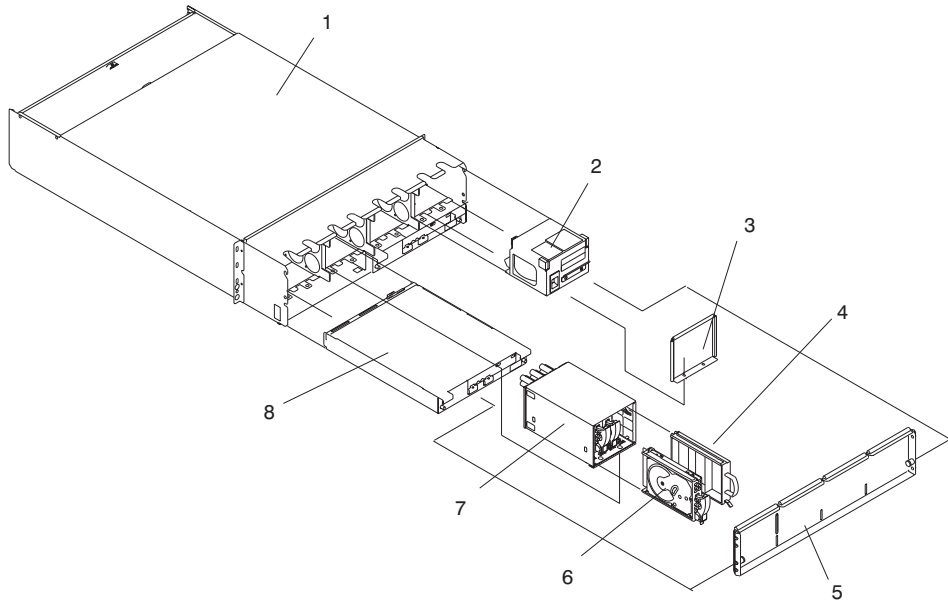

Index	Part Number	Units Per Assy	Description
1	44P0705	1	I/O Subsystem Chassis
	07H5247	2	Frame Rail
2	11P4624	1 to 4	Fan assembly
3	44P1277	1 to 4	DASD 4-Pack Filler
4	11P3662	Up to 15	DASD Filler
5	44P0189	1	Front Cover
6	See Note	1 to 16	SCSI DASD Disk Drives
7	11P4855	4	DASD-4 Pack Cage/Backplane Assembly
	11P3667		Screw - used on the DASD backplane assembly
8	11P3582	2	DCA

Note: See *RS/6000 and @server pSeries Diagnostic Information for Multiple Bus Systems* for part numbers.

Rear

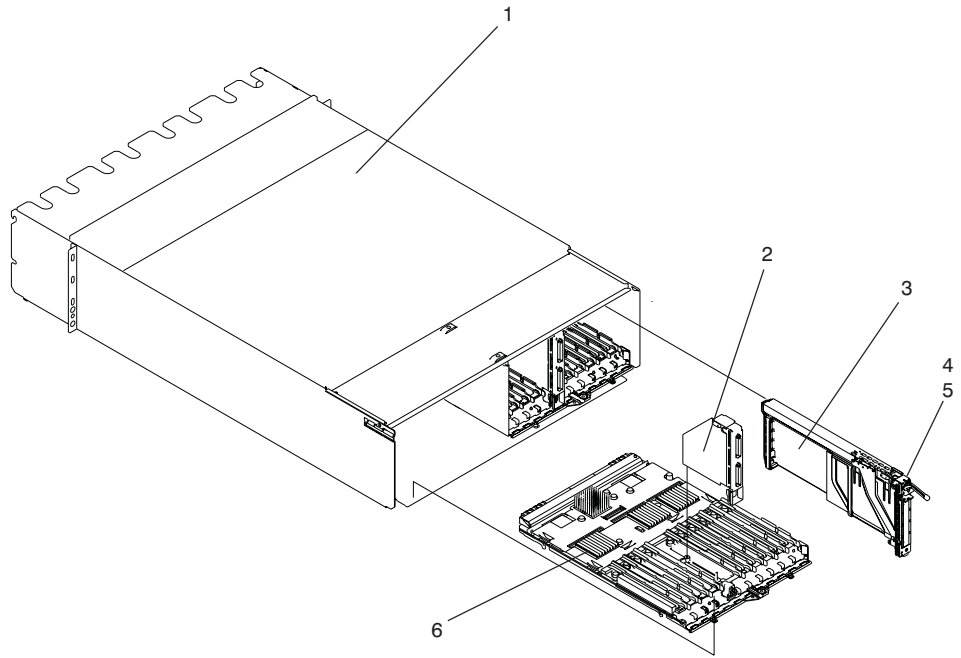

Index	Part Number	Units Per Assy	Description
1	44P0705	1	I/O Subsystem Chassis
2	NA	2	RIO Riser Card, part of the I/O subsystem backplane assembly
3	See note	1 to 20	PCI Adapter Card Assembly
	11P4089	1 to 20	PCI Filler Book
4	11P3793	1 to 20	Blind swap cassette, for standard PCI adapter
	11P4402	As needed	Blind swap cassette, for two adapter wide PCI adapter
	44P0323	As needed	Adapter clip, used with blind swap cassette: for Gigabit Ethernet FC 2969 type 9U
	44P0324	As needed	for Ultra3 SCSI FC 6203 Type 4Y
	44P0321	As needed	for 10/100 BaseT Ethernet FC 4962 Type AF
	44P0406	As needed	for Gigabit Fibre Channel PCI FC 6228 Type 4W
5	11P4861	1 to 20	PCI filler, for slots with no adapter
6	44P0199	1 to 2	I/O Backplane

Note: See *RS/6000 and @server pSeries Diagnostic Information for Multiple Bus Systems* for part numbers.

Power Cabling

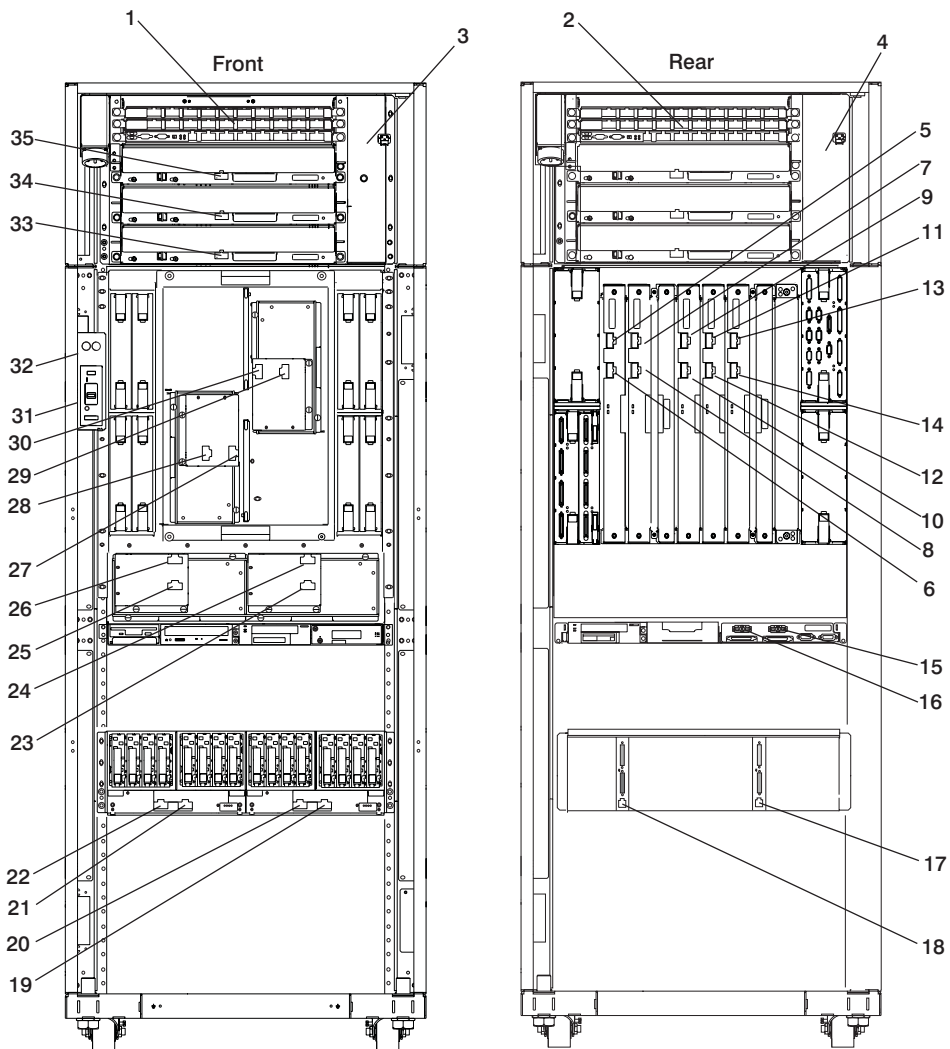

Index	Part Number	Units Per Assy	Description
1	NA 11P1598		Bulk Power Distribution on the A side of the system (BPD A Side) Cable A35-BPC-P00 to B35-BPC-P00
2	NA 11P1598		Bulk Power Distribution on the B side of the system (BPD B Side) Cable B35-BPC-P00 to A35-BPC-P00
3	NA	1	A35-BPC-P03 to Bulk Power Fan P1-F1, Cable attached to FAN (BPF-A)
4	NA	1	B35-BPC-P03 to Bulk Power Fan P2-F1, Cable attached to FAN (BPF-B)
5	11P4449	1	B35-BPC-P08 to DCA-1-P01, Red
6	11P4448	1	A35-BPC-P08 to DCA-1-P00, Red with white stripe
7	11P4451	1	B35-BPC-P09 to DCA-2-P01, Red
8	11P4450	1	A35-BPC-P09 to DCA-2-P00, Red with white stripe
9	11P4453	1	B35-BPC-P10 to DCA-3-P01, Red
10	11P4452	1	A35-BPC-P10 to DCA-3-P00, Red with white stripe
11	11P4455	1	B35-BPD1-P08 to DCA-4-P01, Red
12	11P4454	1	A35-BPD1-P08 to DCA-4-P00, Red with white stripe
13	11P4457	1	B35-BPD1-P09 to DCA-5-P01, Red
14	11P4456	1	A35-BPD1-P09 to DCA-5-P00, Red with white stripe
15 to 17	11P4734	1	I/OB9-P00 to Media P02
16 to 18	11P4735	1	I/OB9-P01 to Media P00
19, 20, 21, 22	NA		B35-BPDx-P0x to I/O Subsystem #x "RIO Cables and I/O Power Cables" on page 890
23	11P4462	1	B35-BPC-P05 to (AMD2-P01) MDA2-J02, Red
24	11P4461	1	A35-BPC-P05 to (AMD2-P00) MDA2-J01, Red with white stripe
25	11P4460	1	B35-BPC-P04 to (AMD1-P01) MDA1-J02, Red
26	11P4459	1	A35-BPC-P04 to (AMD1-P00) MDA1-J01, Red with white stripe
27	11P4463	1	A35-BPC-P06 to (AMD3-P00) MDA3-J01, Red with white stripe
28	11P4464	1	B35-BPC-P06 to (AMD3-P01) MDA3-J02, Red
29	11P4466	1	A35-BPC-P07 to (AMD4-P01) MDA4-J02, Red
30	11P4465	1	B35-BPC-P07 to (AMD4-P00) MDA4-J01, Red with white stripe
31	11P1596	1	B35-BPC-P02 to UEPO J01, Red
32	11P1595	1	A35-BPC-P02 to UEPO J00, Red with white stripe
33	05N6740	1	A35-BPR-P00 to A13-IBF1-P00 A35-BPR-P00 to A13-IBF2-P00
34	05N6740	1	B35-BPR-P00 to B13-IBF1-P00 B35-BPR-P00 to B13-IBF2-P00
35	11P2998	1	A35-BPR-P00 to A-IBF3-P00 (Secondary Frame)
35	11P4248	1	B35-BPR-P00 to B-IBF3-P00 (Secondary Frame)

RIO Cables and I/O Power Cables

Index Number	FRU Part Number	Units Per Assy	Description
	11P2355	Up to 6	RIO cable 0.5-meter
	11P0272	Up to 6	RIO cable 2-meter
	44H9137	Up to 6	RIO cable 15-meter
	11P4490	1	I/O Subsystem 1 power cable (DCA1-P01)
	11P4491	1	I/O Subsystem 1 power cable (DCA1-P00)
	11P4492	1	I/O Subsystem 1 power cable (DCA2-P01)
	11P4493	1	I/O Subsystem 1 power cable (DCA2-P00)
	11P4494	1	I/O Subsystem 2 power cable (DCA1-P01)
	11P4495	1	I/O Subsystem 2 power cable (DCA1-P00)
	11P4496	1	I/O Subsystem 2 power cable (DCA2-P01)
	11P4497	1	I/O Subsystem 2 power cable (DCA2-P00)
	11P4498	1	I/O Subsystem 3 power cable (DCA1-P01)
	11P4499	1	I/O Subsystem 3 power cable (DCA1-P00)
	11P4500	1	I/O Subsystem 3 power cable (DCA2-P01)
	11P4501	1	I/O Subsystem 3 power cable (DCA2-P00)
	11P4502	1	I/O Subsystem 4 power cable, primary rack (DCA1-P01)
	11P4503	1	I/O Subsystem 4 power cable, primary rack (DCA1-P00)
	11P4504	1	I/O Subsystem 4 power cable, primary rack (DCA2-P01)
	11P4505	1	I/O Subsystem 4 power cable, primary (DCA2-P00)
	11P4514	1	I/O Subsystem 4 power cable, secondary rack (DCA1-P01)
	11P4515	1	I/O Subsystem 4 power cable, secondary rack (DCA1-P00)
	11P4516	1	I/O Subsystem 4 power cable, secondary rack (DCA2-P01)
	11P4517	1	I/O Subsystem 4 power cable, secondary rack (DCA2-P00)
	11P4506	1	I/O Subsystem 5 power cable (DCA1-P01)
	11P4507	1	I/O Subsystem 5 power cable (DCA1-P00)
	11P4508	1	I/O Subsystem 5 power cable (DCA2-P01)
	11P4509	1	I/O Subsystem 5 power cable (DCA2-P00)
	11P4510	1	I/O Subsystem 6 power cable (DCA1-P01)
	11P4511	1	I/O Subsystem 6 power cable (DCA1-P00)
	11P4512	1	I/O Subsystem 6 power cable (DCA2-P01)
	11P4513	1	I/O Subsystem 6 power cable (DCA2-P00)
	44P0190	1	I/O Subsystem 7 power cable (DCA1-P01)
	44P0191	1	I/O Subsystem 7 power cable (DCA1-P00)
	44P0192	1	I/O Subsystem 7 power cable (DCA2-P01)
	44P0193	1	I/O Subsystem 7 power cable (DCA2-P00)
	44P0194	1	I/O Subsystem 8 power cable (DCA1-P01)

Index Number	FRU Part Number	Units Per Assy	Description
	44P0195	1	I/O Subsystem 8 power cable (DCA1-P00)
	44P0196	1	I/O Subsystem 8 power cable (DCA2-P01)
	44P0197	1	I/O Subsystem 8 power cable (DCA2-P00)

Keyboards and Mouse

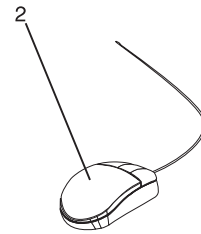
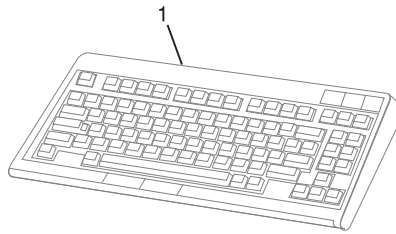

Index Number	FRU Part Number	Units Per Assy	Description
1	24P0440	1	Keyboard, 101 US English (ID 103P) USB
	24P0450	1	Keyboard, 101 French (ID 189) USB
	24P0458	1	Keyboard, 101 Italian (ID 142) USB
	24P0453	1	Keyboard, 101 German/Austrian (ID 129) USB
	24P0476	1	Keyboard, 101 UK English (ID 166) USB
	24P0470	1	Keyboard, 101 Spanish (ID 172) USB
	24P0459	1	Keyboard, 101 Japanese (ID 194) USB
	24P0444	1	Keyboard, 101 Brazilian Portuguese (ID 275) USB
	24P0431	1	Keyboard, 101 Swedish, Finnish (ID 153) USB
	24P0471	1	Keyboard, 101 LA Spanish (ID 171) USB
		1	Keyboard, 101 Korean (ID 413) USB
	24P0446	1	Keyboard, 101 Chinese (ID 467) USB
	24P0466	1	Keyboard, 101 Russian (ID 443) USB
	2	09N5532	1

System Power Cables

Index Number	FRU Part Number	Units Per Assy	Description
1	11P0916	2	Line Power Cord, US, Canada, Japan, 30 AMP 480 V ac
1	11P0367	2	Line Power Cord, US, Canada, Japan, 60 AMP 240 V ac
1	11P0914	2	Line Power Cord, US, Chicago, 30 AMP 480 V ac
1	11P0365	2	Line Power Cord, US, Chicago, 60 AMP 240 V ac
1	11P0917	2	World Trade Line Power Cord, 50 AMP 240 V ac

Tools

The following tools are needed to perform service actions on the @server pSeries 690. These tools can be ordered through your normal tools supplier.

Index	Part Number	Units Per Assy	Description
1	46H9635	1	Tool box
2	11P4486	1	Torque tool MCM
3	04N6923	1	Sash brush
4	11P4747	1	Magnifying glass
5	11P4654	1	L3 cache tray
6	11P4789	1	I/O backplane insertion tool
7	6422789	1	DCA removal tool
8	31L8313	1	Leveling tool (for rack)
9	47H0182	1	Torx, T10
10	11P4861	1	Blank cassette
11	11P3990	1	Door key
12	44P0182	1	DASD service tool
13	11P4914	1	MCM/L3/Pass-through plug-location map (tri-fold chart) should be installed in the primary rack
14	11P4055	NA	Plug count adhesive replacement label
15	44P0209	1	Test card asm, MCM/L3 Short-To-GND
16	00P7023	NA	Vacuum cleaner (110 Vac)
	36P2435	NA	Vacuum cleaner (220 Vac)
	36P2436		OMEGA FILTER 0.3 MICRON
	36P2437		CORD OMEGA UK PLUG
17	07H6824	12	Bracket, insert
18	07H6823	2	Bracket, 11 x 6 insert
19	11P1262	4	Bracket, asm w/ foam
20	07H6827	4	Blank filler plate - 3
21	07H6826	3	Blank filler plate - 1
22	54G2882	16	Screws
23	31L7174	1	Velcro (roll)
24	08J5557	1	Wheel chocks
25	44P0144		Tailgate assembly

Appendix A. Environmental Notices

Product Recycling and Disposal

This unit contains materials such as circuit boards, cables, electromagnetic compatibility gaskets and connectors which may contain lead and copper/beryllium alloys that require special handling and disposal at end of life. Before this unit is disposed of, these materials must be removed and recycled or discarded according to applicable regulations. IBM offers product return programs in several countries, for country specific instructions please refer to the following web site:
<http://www.ibm.com/ibm/environment/products/prp.phtml>

This product may contain a sealed lead acid battery(s) or nickel-cadmium battery(s). The battery(s) must be recycled or disposed of properly. Recycling facilities may not be available in your area. In the United States, IBM has established a collection process for reuse, recycling, or proper disposal of used sealed lead acid, nickel cadmium and nickel metal hydride batteries and battery packs from IBM equipment. For information on proper disposal of the batteries in this product, please contact IBM at 1-800-426-4333. For information on disposal of sealed lead acid or nickel cadmium batteries outside the United States, contact your local waste disposal or recycling facility.

Environmental Design

The environmental efforts that have gone into the design of this system signify IBM's commitment to improve the quality of its products and processes. Some of these accomplishments include the elimination of the use of Class 1 ozone-depleting chemicals in the manufacturing process and reductions in manufacturing wastes. For more information, contact an IBM account representative.

Acoustical Noise Emissions

The equivalent continuous A-weighted sound pressure level at workstations (emission sound pressure level at the 1-meter bystander positions) does not exceed 70 dB(A).

Der Geräuschpegel der Einheit ist kleiner oder gleich 70 db(A).

Declared Acoustical Noise Emissions

Product Configuration	Acoustical Characteristic			
	Declared A-Weighted Sound Power Level, $L_{WA(d)}$ (B)		Declared A-Weighted Sound Pressure Level, L_{pAm} (dB)	
	Operating	Idle	Operating	Idle
7040 Acoustical Doors	7.5	7.5	57	57
7040 Slimline Doors	7.9	7.9	62	62

Notes:

- Noise levels cited are for the typical configuration (A-Frame: Bulk Power, CEC cage, battery option, media drawer, and two I/O drawers).
- The 0.6-B (6-dB) reduction in noise emission levels with the acoustical rear door corresponds to a factor of 4 reduction. That is, the noise level of a single A-Frame with Slimline covers is about the same as the noise level of four A-Frames with acoustical covers.
- $L_{WA(d)}$ is the upper-limit A-weighted sound power level; L_{pAm} is the mean A-weighted sound pressure level at the 1-meter bystander positions; 1 B = 10 dB.
- All measurements made in conformance with ISO 7779 and declared in conformance with ISO 9296.

Appendix B. Notices

This information was developed for products and services offered in the U.S.A.

The manufacturer may not offer the products, services, or features discussed in this document in other countries. Consult the manufacturer's representative for information on the products and services currently available in your area. Any reference to the manufacturer's product, program, or service is not intended to state or imply that only that product, program, or service may be used. Any functionally equivalent product, program, or service that does not infringe any intellectual property right of the manufacturer may be used instead. However, it is the user's responsibility to evaluate and verify the operation of any product, program, or service.

The manufacturer may have patents or pending patent applications covering subject matter described in this document. The furnishing of this document does not give you any license to these patents. You can send license inquiries, in writing, to the manufacturer.

The following paragraph does not apply to the United Kingdom or any country where such provisions are inconsistent with local law: THIS MANUAL IS PROVIDED "AS IS" WITHOUT WARRANTY OF ANY KIND, EITHER EXPRESSED OR IMPLIED, INCLUDING, BUT NOT LIMITED TO, THE IMPLIED WARRANTIES OF NON-INFRINGEMENT, MERCHANTABILITY OR FITNESS FOR A PARTICULAR PURPOSE. Some states do not allow disclaimer of express or implied warranties in certain transactions; therefore, this statement may not apply to you.

This information could include technical inaccuracies or typographical errors. Changes are periodically made to the information herein; these changes will be incorporated in new editions of the publication. The manufacturer may make improvements and/or changes in the product(s) and/or the program(s) described in this publication at any time without notice.

Information concerning products made by other than the manufacturer was obtained from the suppliers of those products, their published announcements, or other publicly available sources. The manufacturer has not tested those products and cannot confirm the accuracy of performance, compatibility or any other claims related to products made by other than the manufacturer. Questions on the capabilities of products made by other than the manufacturer should be addressed to the suppliers of those products.

Appendix C. Service Processor Setup and Test

Attention: This procedure applies to modems attached to the serial ports (S1 and S2) on the primary I/O book (location U1.18-P1-H2). It does not affect the operation of the modem attached to the IBM Hardware Management Console for pSeries (HMC).

The call-out function is normally handled by the Service Focal Point running on the HMC.

For your convenience, an example of a basic service processor setup checklist is included here. Your setup may include more or fewer of the available features, so you can adjust this checklist for your own application.

Note: The call-out and surveillance options are disabled in partitioned systems.

Service Processor Setup Checklist

1. Shut down the managed system, and wait for the OK in the physical operator panel.
2. Open a virtual terminal on the HMC.
3. Bring up the service processor menus.
4. Set the system name.
5. Enable Surveillance.
6. Configure call-in/call-out.
See “Call-In/Call-Out Setup Menu” on page 728.
7. Attach modems if necessary. If modem attachment is not necessary, proceed to step 8. To attach a modem do the following:
 - Exit the service processor menus.
 - Disable 350V dc outputs from the BPA by placing the UEPO switch in the *off* position.
Attention: Power is still present within the BPA with the UEPO *off*.
 - Place the UEPO switch in the *on* position.
 - Proceed to step 8.
8. Test both of the following:
 - Call-In, page “Testing Call-In” on page 900
 - Call-Out, page “Testing Call-Out” on page 901
9. Use the “Save or Restore Hardware Management Policies,” in the “Introduction to Tasks and Service Aids” section of the *RS/6000 and @server pSeries Diagnostic Information for Multiple Bus Systems* to back up the service processor settings.

Note: This is strongly recommended to protect the usefulness of the service processor and the availability of the server.

Your service processor is now ready for use.

Testing the Setup

This section contains sample testing procedures to help ensure your setup is working.

These tests include communicating with the server operating system. Before you start, ensure that the necessary serial port(s) is configured. If you need assistance, refer to “Serial Port Configuration” on page 901.

The server should be powered off as a result of the “Service Processor Setup Checklist” on page 899.

Testing Call-In

1. At your remote terminal, call in to your server. Your server answers and offers you the service processor Main Menu after requesting your privileged-access password.
2. Select **System Power Control**.
3. Select **Power-On System**.
When you are asked if you wish to continue powering on the system, type **Y**.
4. After the system firmware and operating system have initialized the server, the login prompt displays at your remote terminal if you set up seamless modem transfer. This may take several minutes. When the login prompt displays, you have successfully called the service processor.
5. Type **logout** to disconnect from the operating system. The message No Carrier displays on your remote terminal.
6. Call your server again. The operating system answers and offers you the login prompt. If these tests are successful, call-in is working.
7. Log in and type **shutdown -F** to shut down your server.
8. The message No Carrier displays on your remote terminal.

Testing Call-Out

During the setup, you entered your phone numbers for the pager (on page 732) and customer voice (on page 733) These numbers are used for this test.

1. Your remote terminal is disconnected as a result of the Call-In test.
2. Call your server again.
3. At the service processor Main Menu, select **Call-In/Call-Out Setup** menu, then select **Call-Out** test. This action causes a simulated error condition for the purposes of this test.
4. After a few moments, a message displays, regarding an illegal entry. Press Enter to clear the message and return to the main menu.
5. When your telephone rings, answer the call. You should hear the sound of a telephone being dialed. This is your computer trying to page you.

If this test is successful, call-out is working correctly.

Serial Port Configuration

To configure the serial port on an AIX system, run the following from an AIX console:

1. Log in as root user.
2. To determine if you have any serial ports already configured, type:

```
lsdev -Cc tty
```

If no serial ports are configured, none are listed. If you want to configure serial ports that are not listed, continue with the remaining steps.

3. Identify the serial port(s) with the modem(s).
4. Type **smit tty**
5. Select **add tty**
6. Select **RS232**
7. Select **Baud rate 9600** or higher.
8. Select **login enable** and set the flow control to RTS.
9. Commit the selections and set up any other needed serial ports.
10. Exit SMIT.

Appendix D. Modem Configurations

Note: This appendix applies only to modems attached to the serial ports (S1 and S2) on the primary I/O book (location U1.18-P1-H2).

These configuration files do not apply to the modem attached to the IBM Hardware Management Console for pSeries (HMC).

Sample Modem Configuration Files

This appendix contains information about several sample modem configuration files that either work directly with your modem or provide a good starting point for a custom setup.

The sample modem configuration files are located in the firmware in **/usr/share/modems** subdirectory (if your server is using AIX) with the following names. A listing of each specific file is included in this appendix.

Generic Modem Configuration Files

AIX File Name	Service Processor Firmware File Name
modem_z.cfg	modem_z_sp
modem_z0.cfg	modem_z0_sp
modem_f.cfg	modem_f_sp
modem_f0.cfg	modem_f0_sp
modem_f1.cfg	modem_f1_sp

Specific Modem Configuration Files

AIX File Name	Service Processor Firmware File Name
modem_m0.cfg	modem_m0_sp
modem_m1.cfg	modem_m1_sp

Use the following selection procedures and your modem manual to determine which of the configuration files is suitable for your use.

Configuration File Selection

Use the following steps to select a configuration file:

1. Is your modem an IBM 7852-400?

If Yes, use modem configuration file **modem_m0.cfg** and go to step 7 on page 905.

Note: The IBM 7852-400 modem has DIP switches on the right side of the unit. See “IBM 7852-400 DIP Switch Settings” on page 906 for the correct switch settings.

If No, continue with step 2.

2. Is your modem an IBM 7857-017?

If Yes, use modem configuration file **modem_m1.cfg** and go to step 7 on page 905.

Note: The IBM 7857-017 modem has two telephone line connections on the back of the unit. One is marked **LL** (for Leased Line), and the other is marked **PTSN** (for Public Telephone Switched Network). The service processor expects to use the modem on the public network, so the telephone line should attach to the PTSN connector.

If No, continue with step 3.

3. Does your modem respond to the extended command set (prefixed with &)?

If Yes, go to step 5. If No, continue with step 4.

4. Does your modem respond to:

- ATZ reset command
- or
- ATZ n reset commands, where n can be 0, 1, and so on?

If ATZ, configuration file **modem_z.cfg** is recommended. If ATZ n , configuration file **modem_z0.cfg** is recommended.

Go to step 7 on page 905.

5. Does your modem command set include a test for V.42 error correction at the remote modem (often called “Auto-Reliable Mode”)?

If Yes, disable this test. You can use sample configuration files **/usr/share/modem_m0.cfg** or **/usr/share/modem_m1.cfg** as models to help you create a file for your particular modem. See “Customizing the Modem Configuration Files” on page 906 for more information. Go to step 7 on page 905.

If No, go to step 6.

6. Does your modem respond to:

- AT&F reset command
- or
- AT&F n reset commands, where n can be 0, 1, and so on?

If AT&F, configuration file **modem_f.cfg** is recommended. If AT&F n , configuration file **modem_f0.cfg** or **modem_f1.cfg** is recommended, depending on which provides the hardware flow control profile.

7. You have completed selection of the configuration file.

If your modem configuration selection is not available in the Service Processor Modem Configuration Menu, you must access it through the Configure Remote Maintenance Policy Service Aid.

If you find it necessary to adjust any of these configuration files, use the manual provided with your modem to accomplish that task. It is recommended you select settings that enable hardware flow control and respond to DTR.

Note: Some older modems do not respond to the **X0** or **&R1** commands. Edit out these commands from the modem configuration file if yours is such a modem. See your modem manual for more information.

Some modems, such as the IBM 7857-017, are not designed for the paging function. Although they can be used for paging, they return an error message when they do not get the expected response from another modem. Therefore, even though the paging was successful, the error message causes the service processor to retry, continuing to place pager calls for the number of retries specified in the Call-Out Policy Setup Menu. These retries result in redundant pages.

Examples for Using the Generic Sample Modem Configuration Files

The following table contains information to help you determine which modem configuration file to use with various modems.

Modem	Setup Z	Setup Z0 (Rare)	Setup F	Setup F0	Setup F1
AT&T DataPort 2001 (Ring interrupt only on first ring)				X	
Bocamodem 1440E			X		
Hayes Smart Modem 300	X				
IBM 5841	X				
IBM 5843	X				
IBM 7851				X	
IBM 7852-10				X	
IBM 7855					X
USRobotics 36.6K Sportster					X
Zoom V.32			X		

Customizing the Modem Configuration Files

You can create your own modem configuration files or modify the samples provided. After you customize your modem configuration files, you *must* access them through the Configure Remote Maintenance Policy Service Aid rather than from the service processor menus.

If you have already set up your serial ports, line speeds, authorizations, and telephone numbers from the service processor menus, use the service aid to specify your customized modem configuration files.

If you have not already set up your serial ports, line speeds, authorizations, and telephone numbers from the service processor menus, use the service aids to set them while you specify your customized modem configuration files.

To disable Auto-Reliable Mode testing of the remote modem, use the sample modem configuration file `/usr/share/modems/modem_f.cfg` as a model that you can modify, as follows:

1. Find the necessary command in your modem manual.
2. Copy the `/usr/share/modems/modem_f.cfg` file to a new file with a different name (for example, `modem_fx.cfg`).
3. In the new file (`modem_fx.cfg`), change the line `Send "ATE0T\r"` to `Send "ATcccE0T\r"` where `ccc` is the added command as specified in your modem manual, as follows.

Change the third line of each of the following stanzas:

- `condout`
- `condin`
- `ripo`

4. Save the changes.

IBM 7852-400 DIP Switch Settings

If you are using a 7852-400 modem to enable service processor communications, for proper operation, the dual inline package (DIP) switches must be set according to the following table:

Switch	Position	Function
1	Up	Force DTR
2	Up	Flow Control &E4
3	Down	Result Codes Enabled
4	Down	Modem Emulation Disabled
5	Up	Auto Answer Enabled
6	Up	Maximum Throughput Enabled
7	Up	RTS Normal Functions
8	Down	Enable Command Mode
9	Down	Remote Digital Loopback Test Enabled
10	Up	Dial-Up Line Enabled
11	*Up	AT Responses Enabled (Extended Responses Disabled)
12	*Down	Asynchronous Operation

Switch	Position	Function
13	UP	28.8KB Line Speed
14	Up	
15	Up	CD and DSR Normal Functions
16	Up	2-Wire Leased Line Enabled

* Only switches 11 and 12 are changed from the factory default settings.

Xon/Xoff Modems

Some early modems assume software flow control (Xon/Xoff) between the computer and the modem. Modems with this design send extra characters during and after the transmitted data. The service processor cannot accept these extra characters. If your configuration includes such a modem, your functional results may be unpredictable.

The sample modem configuration files included in this appendix do not support these modems, so custom configuration files are necessary. Anchor Automation 2400E is an example of such a modem.

If you experience unexplainable performance problems that may be due to Xon/Xoff characters, it is recommended that you upgrade your modem.

Ring Detection

Most modems produce an interrupt request each time they detect a ring signal. Some modems generate an interrupt only on the first ring signal that they receive. AT&T DataPort 2001 is an example of such a modem.

The service processor uses the ring interrupt request to count the number of rings when Ring Indicate Power-On (RIPO) is enabled. If your modem produces an interrupt on only the first ring, set Ring Indicate Power-On to start on the first ring. Otherwise, you can choose to start Ring Indicate Power-On on any ring count.

Terminal Emulators

The service processor is compatible with simple ASCII terminals, and therefore compatible with most emulators. When a remote session is handed off from the service processor to the operating system, agreement between terminal emulators becomes important.

The server's operating system will have some built-in terminal emulators. You may also have a commercially available terminal emulation. It is important that the local and host computers select the same or compatible terminal emulators so that the key assignments and responses match, ensuring successful communications and control.

For best formatting, choose line wrap in your terminal emulator setup.

Recovery Procedures

Situations such as line noises and power surges can sometimes cause your modem to enter an undefined state. When it is being used for dial-in, dial-out or ring indicate power-on, your modem is initialized each time one of these actions is expected. If one of these environmental conditions occur after your modem has been initialized, it might be necessary to recover your modem to a known state.

If your modem communicates correctly with remote users, it is probably in control. It may be wise to occasionally change some of the functional settings and then change them back, just for the sense of security that the modem is communicating, and to ensure it has been initialized recently.

If your system is particularly difficult to access physically, another strategy is to protect it with an Uninterruptible Power Source (UPS) and a phone-line surge protector.

In case recovery becomes necessary, shut down your system using established procedures. Disconnect the power cable and press the power button to drain capacitance while power is disconnected. Disconnect and reconnect modem power, and then reconnect system power to completely reinitialize your system.

Transfer of a Modem Session

Because many modem command variations exist, the sample modem configuration files located at the end of this appendix have been written to capture the largest number of workable modem settings.

The modem command **&Dn** (where *n* is a number) generally sets the modem response to the Data Terminal Ready (DTR) signal from the server's serial port. The desired response is that the modem will hold a connection while DTR is enabled, and drop the connection when DTR is released. Using this mechanism, the server hangs up on a connection under normal conditions.

Consult your modem manual for its specific response scheme for the **&Dn** command.

Two strategies are available for dealing with the modem's response to DTR:

- Recovery
- Prevention

Before you use one of these strategies, determine if your server's modem is set up correctly to respond to DTR.

With the remote terminal connected to serial port 1 and defined as the Primary Console Device, there are two tests you can perform:

1. Will the modem drop the connection after the System initialization complete message displays at the remote terminal?
If Yes, the modem is set up correctly.
If No, try another **&Dn** setting for your server's modem. See your modem manual for this information. The **&Dn** command appears in three places each in three of the sample modem configuration files, as follows:
2. Will the server's modem disconnect when the power drops? You can make this observation at the remote terminal by commanding your server to shut down and power off. (Use the AIX command **shutdown -F**.) Watch for the message NO CARRIER on your remote terminal.
If Yes, this is the correct response. The modem is set up correctly.
If No, try another **&Dn** setting for your server's modem. See your model manual for this information. The **&Dn** command appears in three places each in three of the sample modem configuration files. Only the following sample modem configuration files contain the **&Dn** command (in three places each):
 - modem_f.cfg
 - modem_f0.cfg
 - modem_f1.cfg

If you are using modem_z.cfg or modem_z0.cfg, you cannot control DTR response. If your remote terminal does not disconnect after logging off, you must command the remote terminal emulator to hang up. This then breaks the connection.

Recovery Strategy

The recovery strategy consists of making two calls to establish a remote session. This solution is the easiest to implement and allows more freedom for configuring your server's serial ports.

To set up a remote terminal session, dial into the service processor and start the system. After the operating system is loaded and initialized, the connection will be dropped. At this point, call the server back and the operating system will answer and offer you the login prompt.

Prevention Strategy

The disconnect is caused by the operating system when it initializes the Primary Console. The tests listed in "Transfer of a Modem Session" on page 909 are conducted with the remote terminal selected as the primary console to manifest the modem's response to DTR transitions.

- If a local ASCII terminal or a graphics console is to be a permanent part of your server, then make one of them the primary console. Your remote terminal will no longer experience the connection loss.
- If a local console is not a permanent part of your server, you can still assign either the unused graphics console or the unused serial port as the primary console. This gives you the desired seamless connection at your remote terminal. If you choose to use the unused serial port as the primary console, some initialization traffic will be sent to any serial device attached to that port. As a result, that serial device's connection and function could be affected. These impacts may make that port unattractive for devices other than a temporary local ASCII terminal.

Modem Configuration Sample Files

Sample File modem_m0.cfg

```
#
# COMPONENT_NAME: (ESPSETUP) ENTRY SERVICE PROCESSOR SETUP: modem_m0
#
# FUNCTIONS: Modem configuration file specifically for IBM 7852-400
# modem with Auto-Reliable feature. This feature must be turned off
# for Catcher calls. This example uses the AT&F reset command to
# choose the factory defaults.
#
# (C) COPYRIGHT International Business Machines Corp. 1996
# All Rights Reserved
# Licensed Materials - Property of IBM
#
# US Government Users Restricted Rights - Use, duplication or
# disclosure restricted by GSA ADP Schedule Contract with IBM Corp.
#
#
# The modem has configuration switches. They should be set to the
# factory default settings, except switches 11 and 12. These must be
# to UP ("AT" responses) and DOWN (Asynchronous operation), respectively.

ICDelay 1
DefaultTO 10
CallDelay 120
#
# %N Call-Out phone number %R Return phone number
#
#
# PROGRAMMING NOTE: No blanks between double quote marks (").

condout: send "AT&F&E2E0T\r" # Reset to factory defaults
# Reliable mode
# Echo off
ignore "0\r" or "OK\r\n" timeout 2 # Ignore modem response.
send "AT&E12&E14\r" # Disable pacing
# Disable data compression
expect "0\r" or "OK\r\n" timeout 2 # Confirm commands successful.
send "AT&SF1&S0S9=1\r" # DSR independent of CD
# Force DSR on.
# CD respond time=100ms
expect "0\r" or "OK\r\n" timeout 2 # Confirm commands successful.
send "ATV0S0=0\r" # Numeric response code
# Auto-Answer off
expect "0\r" or "OK\r\n" timeout 2 # Confirm commands successful.
done

connect: send "ATDT%N\r" # Tone dialing command.
# %N from Call Home setup.
# Expect a connection response.
expect "33\r" or "31\r" or "28\r" or "26\r" or "24\r" or "21\r" or
"19\r" or "13\r" or "12\r" or "1\r" busy "7\r"
timeout 60
done

retry: send "A/" # Repeat the previous command.
# Expect a connection response.
expect "33\r" or "31\r" or "28\r" or "26\r" or "24\r" or "21\r" or
"19\r" or "13\r" or "12\r" or "1\r" busy "7\r"
timeout 60
done

disconnect:
delay 2 # Separate from previous data.
```

```

send "+++" # Assure command mode.
delay 2 # Allow mode switching delay.
send "ATH0T\r" # Set modem switch-hook down
# (i.e., hang up).
ignore "0\r" or "OK\r" timeout 2 # Ignore modem response.
send "ATE0Q1\r" # Initialize modem: Echo OFF,
# Disable responses.

ignore "0\r" timeout 1
done

condin: send "AT&F&E2E0T\r" # Reset to factory defaults.
# Reliable mode
# Echo off
ignore "0\r" or "OK\r\n" timeout 2 # Ignore modem response.
send "AT&E12&E14\r" # Disable pacing
# Disable data compression
expect "0\r" or "OK\r\n" timeout 2 # Confirm commands successful
send "AT&SF1&S0S9=1\r" # DSR independent of CD.
# Force DSR on.
# CD respond time=100ms
expect "0\r" or "OK\r\n" timeout 2 # Confirm commands successful.
send "ATV0S0=2\r" # Numeric response code
# Answer on 2nd ring
expect "0\r" timeout 2 # Confirm commands successful.
done

waitcall: ignore "2\r" timeout 1 # Ignore first ring.
expect "2\r" timeout 10 # Pickup 2nd ring or timeout
# Expect a connection response.
expect "33\r" or "31\r" or "28\r" or "26\r" or "24\r" or "21\r" or
"19\r" or "13\r" or "12\r" or "1\r" busy "7\r"
timeout 60
done

page: send "ATDT%N,,,%R;\r" # %N = pager call center number
# Add enough commas to wait for
# time to enter paging number.
# %R = paging number
expect "0\r" timeout 60 # Confirm successful command.
delay 2 # Wait before hanging up.
send "ATH0\r" # Hang up.
expect "0\r" timeout 2 # Confirm successful command.
done

ripo: send "AT&F&E2E0T\r" # Reset to factory defaults.
# Reliable mode
# Echo off
ignore "0\r" or "OK\r\n" timeout 2 # Ignore modem response.
send "AT&E12&E14\r" # Disable pacing
# Disable data compression
expect "0\r" or "OK\r\n" timeout 2 # Confirm successful command.
send "AT&SF1&S0S9=1\r" # DSR independent of CD.
# Force DSR on.
# CD respond time=100ms
expect "0\r" or "OK\r\n" timeout 2 # Confirm commands successful.
send "ATV0S0=0\r" # Numeric response code
# Auto Answer OFF
expect "0\r" timeout 2 # Confirm commands successful.
done

error: # Handle unexpected modem
# responses.
expect "8\r" or "7\r" or "6\r" or "4\r" or "3\r"
delay 2
done

```

Sample File modem_m1.cfg

```
#
# COMPONENT_NAME: (ESPSETUP) ENTRY SERVICE PROCESSOR SETUP modem_m1
#
# FUNCTIONS: Modem configuration file specifically for IBM 7857-017 modem with
# Auto-Reliable feature. This feature must be turned off for Catcher calls.
# This example uses the AT&F reset command to choose the factory defaults.
#
# To allow dial commands for digital pagers, it is necessary to reduce
# the number of characters in the dial command. Each comma (delay) has
# been set to 6 seconds (S8=6) for that reason.
#
#
# (C) COPYRIGHT International Business Machines Corp. 1996
# All Rights Reserved
# Licensed Materials - Property of IBM
#
# US Government Users Restricted Rights - Use, duplication or
# disclosure restricted by GSA ADP Schedule Contract with IBM Corp.
#

ICDelay 1
DefaultTO 10
CallDelay 120
#
# %N Call-Out phone number %R Return phone number
#
#
# PROGRAMMING NOTE: No blanks between double quote marks (").

connect: send "AT&F*E0E0\r" # Reset to factory defaults.
# *E0=data compression disabled
# E0=echo disabled
ignore "0\r" or "OK\r\n" timeout 2 # Ignore modem response.
send "AT#F0*Q2S8=6\r" # Trellis modulation disabled
# Retrain with adaptive rate
# Set ,=6second
expect "0\r" or "OK\r\n" timeout 2 # Confirm commands successful
send "ATV0X0S0=0\r" # Numeric response code
# AT compatible messages
# Auto-Answer disabled
expect "0\r" or "OK\r\n" timeout 2 # Confirm commands successful.
done

connect: send "ATDT%N\r" # Tone dialing command.
# %N from Call Home setup.
expect "1\r" busy "7\r" timeout 60 # Expect a connection response.
done

retry: send "A/" # Repeat the previous command.
expect "1\r" busy "7\r" timeout 60 # Expect a connection response.
done

disconnect:
delay 2 # Separate from previous data.
send "+++" # Assure command mode.
delay 2 # Allow mode switching delay.
send "ATH0\r" # Set modem switch-hook down
# (i.e., hang up).
ignore "0\r" or "OK\r" timeout 2 # Ignore modem response.
send "ATEOQ1\r" # Initialize modem: Echo OFF,
# Disable responses.
ignore "0\r" timeout 1
done

condin: send "AT&F*E0E0\r" # Reset to factory defaults.
```

```

# *E0=data compression disabled
# E0=echo disabled
ignore "0\r" or "OK\r\n" timeout 2 # Ignore modem response.
send "AT#F0*Q2\r" # Trellis modulation disabled
# Retrain with adaptive rate
expect "0\r" or "OK\r\n" timeout 2 # Confirm commands successful
send "ATV0X0S0=2\r" # Numeric response code
# AT compatible messages
# Answer on 2nd ring
# Confirm commands successful.

expect "0\r" timeout 2
done

waitcall: ignore "2\r" timeout 1 # Ignore first ring.
expect "2\r" timeout 10 # Pick up second ring
# or timeout.
# Expect a connection response.

expect "1\r" timeout 60
done

page: send "ATD%N,%R\r" # %N = pager call center number
# commas=6sec wait time to
# enter paging number.
# %R = return number
expect "0\r" or "3\r" timeout 30 # Confirm successful command.
delay 2 # Wait before hanging up.
send "+++" # Assure command mode.
delay 2 # Allow mode switching delay.
send "ATH0\r" # Hang up.
expect "0\r" timeout 2 # Confirm successful command.
done

ribo: send "AT&F*E0E0\r" # Reset to factory defaults.
# *E0=data compression disabled
# E0=echo disabled
ignore "0\r" or "OK\r\n" timeout 2 # Ignore modem response.
send "AT#F0*Q2\r" # Trellis modulation disabled
# Retrain with adaptive rate
expect "0\r" or "OK\r\n" timeout 2 # Confirm successful command.
send "ATV0X0S0=0\r" # Numeric response code
# AT compatible messages
# Auto-Answer disabled
# Confirm commands successful.
#

error: # Handle unexpected modem
# responses.

expect "8\r" or "7\r" or "4\r" or "3\r"
delay 2
done

```

Sample File modem_z.cfg

```
#
# COMPONENT_NAME: (ESPSETUP) ENTRY SERVICE PROCESSOR SETUP Z
#
# FUNCTIONS: Modem configuration file for many early Hayes* compatible modems.
# This example uses the ATZ reset command to choose the factory defaults.
# This setup will work for many modems, but it is required for early vintage
# modems which respond to neither the ATZ0 reset command nor the extended (&)
# commands. Refer to your modem manual.
#
# * Trademark of Hayes Microcomputer Products, Inc.
#
# (C) COPYRIGHT International Business Machines Corp. 1996
# All Rights Reserved
# Licensed Materials - Property of IBM
#
# US Government Users Restricted Rights - Use, duplication or
# disclosure restricted by GSA ADP Schedule Contract with IBM Corp.
#
#
# If the modem has configuration switches, they should be set to the
# factory default settings.

ICDelay 1
DefaultT0 10
CallDelay 120
# AT Attention Code           , Inserts delay in dialing commands
# Z Reset to factory defaults Q0 Turn on responses
# E0 Turn echo off           Q1 Turn off responses
# V0 Use numeric responses   S0=0 Automatic answer inhibit
# +++ Escape to command mode S0=2 Answer on second ring
# H0 Hang-up                 T = Tone mode. When used as T\r, it is a
#                             no op to maintain program synchronization
#                             when modem may/will echo the commands.
#
# %N Call-Out phone number   %P Paging phone number
# %S Modem speed (available to users)
#
# Following are common responses from a wide range of modems:
# 16, 15, 12, 10, 5 and 1 are connection responses. Add others as required.
# 7=busy; 6=no dial tone; 4=error; 3=no carrier; 2=ring; 0=OK
#
# PROGRAMMING NOTE: No blanks between double quote marks (").

condout:  send "ATZQ0T\r"           # Reset to factory defaults.
          ignore "0\r" or "OK\r\n" timeout 2 # Ignore modem response.
          send "ATE0T\r"           # Initialize modem: Echo OFF,
          expect "0\r" or "OK\r\n" timeout 2 # Enable responses (Numeric),
          send "ATQ0V0T\r"         # Limit response codes.
          expect "0\r" timeout 2    # Confirm commands successful.
          send "ATS0=0\r"          # Set AutoAnswer OFF
          expect "0\r" timeout 2    # Confirm command successful.
          done

connect:  send "ATDT%N\r"          # Tone dialing command.
          # %N from Call Home setup.

          # Expect a connection response.
          expect "16\r" or "15\r" or "14\r" or "12\r" or "10\r" or "5\r" or "1\r" busy "7\r"
          timeout 60
          done

retry:    send "A/"               # Repeat the previous command.

          # Expect a connection response.
          expect "16\r" or "15\r" or "14\r" or "12\r" or "10\r" or "5\r" or "1\r" busy "7\r"
```

```

timeout 60
done

disconnect:
delay 2 # Separate from previous data.
send "+++ " # Assure command mode.
delay 2 # Allow mode switching delay.
send "ATH0T\r" # Set modem switch-hook down
# (i.e., hang up).

ignore "0\r" or "OK\r" timeout 2 # Ignore modem response.
send "ATE0Q1\r" # Initialize modem: Echo OFF,
# Disable responses.

ignore "0\r" timeout 1
done

condin: send "ATZ00T\r" # Reset to factory defaults.
ignore "0\r" or "OK\r\n" timeout 2 # Ignore modem response.
send "ATE0T\r" # Initialize modem: Echo OFF,
expect "0\r" or "OK\r\n" timeout 2 # Enable responses (Numeric),
send "ATQ0V0T\r" # Limit response codes.
expect "0\r" timeout 2 # Confirm commands successful.
send "ATS0=2\r" # Set AutoAnswer ON
expect "0\r" timeout 2 # Confirm command successful.
done

waitcall: ignore "2\r" timeout 1 # Ignore first ring.
expect "2\r" timeout 10 # Pick up second ring
# or timeout.
# Expect a connection response.

expect "16\r" or "15\r" or "14\r" or "12\r" or "10\r" or "5\r" or "1\r"
timeout 60
done

page: send "ATDT%N,,,%R;\r" # %N = pager call center number
# Add enough commas to wait for
# time to enter paging number.
# %R = paging number

# Confirm successful command.

expect "0\r" timeout 60
delay 2 # Wait before hanging up.
send "ATH0T\r" # Hang up.
expect "0\r" timeout 2 # Confirm successful command.
done

ripo: send "ATZ00T\r" # Reset to factory defaults.
ignore "0\r" or "OK\r\n" timeout 2 # Ignore modem response.
send "ATE0T\r" # Initialize modem: Echo OFF,
expect "0\r" or "OK\r\n" timeout 2 # Enable responses (Numeric),
send "ATQ0V0T\r" # Limit response codes.
expect "0\r" timeout 2 # Confirm commands successful.
send "ATS0=0\r" # Set AutoAnswer OFF
expect "0\r" timeout 2 # Confirm command successful.
done

error: # Handle unexpected modem
# responses.

expect "8\r" or "7\r" or "6\r" or "4\r" or "3\r"
delay 2
done

```

Sample File modem_z0.cfg

```
#
# COMPONENT_NAME: (ESPSETUP) ENTRY SERVICE PROCESSOR SETUP Z0
#
# FUNCTIONS: Modem configuration file for some early Hayes* compatible modems.
# This example uses the ATZ0 reset command to choose the factory defaults.
# This setup is recommended for modems that will respond to the ATZ0 command
# and which do not respond to the extended (&) commands. Refer to your modem
# manual.
#
# * Trademark of Hayes Microcomputer Products, Inc.
#
# (C) COPYRIGHT International Business Machines Corp. 1996
# All Rights Reserved
# Licensed Materials - Property of IBM
#
# US Government Users Restricted Rights - Use, duplication or
# disclosure restricted by GSA ADP Schedule Contract with IBM Corp.
#
#
# If the modem has configuration switches, they should be set to the
# factory default settings.

ICDelay 1
DefaultT0 10
CallDelay 120
# AT Attention Code           , Inserts delay in dialing commands
# Z0 Reset. Restore Profile 0 Q0 Turn on responses
# E0 Turn echo off           Q1 Turn off responses
# V0 Use numeric responses    S0=0 Automatic answer inhibit
# +++ Escape to command mode S0=2 Answer on second ring
# H0 Hang-up                 X0=0 Limit modem response codes
#                             T = Tone mode. When used as T\r, it is a
#                             no op to maintain program synchronization
#                             when modem may/will echo the commands.
#
#
# %N Call-Out phone number    %P Paging phone number
# %S Modem speed (available to users)
#
# Following are common responses from a wide range of modems:
# 16, 15, 12, 10, 5 and 1 are connection responses. Add others as required.
# 7=busy; 6=no dial tone; 4=error; 3=no carrier; 2=ring; 0=OK
#
# PROGRAMMING NOTE: No blanks between double quote marks (").

condout:  send "ATZ0Q0T\r"           # Reset modem. Select profile 0
          ignore "0\r" or "OK\r\n" timeout 2 # Ignore modem response.
          send "ATE0T\r"             # Initialize modem: Echo OFF,
          expect "0\r" or "OK\r\n" timeout 2 # Enable responses (Numeric),
          send "ATQ0V0X0T\r"         # Limit response codes.
          expect "0\r" timeout 2      # Confirm commands successful.
          send "ATS0=0\r"            # Set AutoAnswer OFF
          expect "0\r" timeout 2      # Confirm command successful.
          done

connect:  send "ATDT%N\r"            # Tone dialing command.
          # %N from Call Home setup.

          # Expect a connection response.
          expect "16\r" or "15\r" or "14\r" or "12\r" or "10\r" or "5\r" or "1\r" busy "7\r"
          timeout 60
          done

retry:    send "A/"                  # Repeat the previous command.
          # Expect a connection response.
```

```

expect "16\r" or "15\r" or "14\r" or "12\r" or "10\r" or "5\r" or "1\r" busy "7\r"
timeout 60
done

disconnect:
delay 2 # Separate from previous data.
send "+++" # Assure command mode.
delay 2 # Allow mode switching delay.
send "ATH0T\r" # Set modem switch-hook down
# (i.e., hang up).
ignore "0\r" or "OK\r" timeout 2 # Ignore modem response.
send "ATE0Q1\r" # Initialize modem: Echo OFF,
# Disable responses.

ignore "0\r" timeout 1
done

conadin:
send "ATZ0Q0T\r" # Reset modem. Select profile 0
ignore "0\r" or "OK\r\n" timeout 2 # Ignore modem response.
send "ATE0T\r" # Initialize modem: Echo OFF,
expect "0\r" or "OK\r\n" timeout 2 # Enable responses (Numeric),
send "ATQ0V0X0T\r" # Limit response codes.
expect "0\r" timeout 2 # Confirm commands successful.
send "ATS0=2\r" # Set AutoAnswer ON
expect "0\r" timeout 2 # Confirm command successful.
done

waitcall: ignore "2\r" timeout 1 # Ignore first ring.
expect "2\r" timeout 10 # Pick up second ring
# or timeout.
# Expect a connection response.

expect "16\r" or "15\r" or "14\r" or "12\r" or "10\r" or "5\r" or "1\r"
timeout 60
done

page: send "ATDT%N,,,%R;\r" # %N = pager call center number
# Add enough commas to wait for
# time to enter paging number.
# %R = paging number

# Confirm successful command.

expect "0\r" timeout 60
delay 2 # Wait before hanging up.
send "ATH0T\r" # Hang up.
expect "0\r" timeout 2 # Confirm successful command.
done

ripo: send "ATZ0Q0T\r" # Reset modem. Select profile 0
ignore "0\r" or "OK\r\n" timeout 2 # Ignore modem response.
send "ATE0T\r" # Initialize modem: Echo OFF,
expect "0\r" or "OK\r\n" timeout 2 # Enable responses (Numeric),
send "ATQ0V0X0T\r" # Limit response codes.
expect "0\r" timeout 2 # Confirm commands successful.
send "ATS0=0\r" # Set AutoAnswer OFF
expect "0\r" timeout 2 # Confirm command successful.
done # RI Power On enabled.

error: # Handle unexpected modem
# responses.
expect "8\r" or "7\r" or "6\r" or "4\r" or "3\r"
delay 2
done

```

Sample File modem_f.cfg

```
#
# COMPONENT_NAME: (ESPSETUP) ENTRY SERVICE PROCESSOR SETUP F
#
# FUNCTIONS: Modem configuration file for many recent Hayes* compatible modems.
# This example uses the AT&F reset command to choose the factory defaults.
# This set up is preferred for modems with extended (&) commands. For early
# vintage modems, setup Z or Z0 is recommended. If your modem responds to
# the extended (&) commands and to factory default choices (&Fn), setup file
# F0 or F1 is recommended.
#
# * Trademark of Hayes Microcomputer Products, Inc.
#
# (C) COPYRIGHT International Business Machines Corp. 1996
# All Rights Reserved
# Licensed Materials - Property of IBM
#
# US Government Users Restricted Rights - Use, duplication or
# disclosure restricted by GSA ADP Schedule Contract with IBM Corp.
#
#
# If the modem has configuration switches, they should be set to the
# factory default settings.

ICDelay 1
DefaultTO 10
CallDelay 120
# AT Attention Code , Inserts delay in dialing commands
# &F Reset to default profile Q0 Turn on responses
# E0 Turn echo off Q1 Turn off responses
# V0 Use numeric responses S0=0 Automatic answer inhibit
# +++ Escape to command mode S0=2 Answer on second ring
# H0 Hang-up X0=0 Limit modem response codes
# T = Tone mode. When used as T\r, it is a
# no op to maintain program synchronization
# when modem may/will echo the commands.
#
# &C1 Detect CD &D2 Respond to DTR (often the default)
#
# %N Call-Out phone number %P Paging phone number
# %S Modem speed (available to users)
#
# Following are common responses from a wide range of modems:
# 16, 15, 12, 10, 5 and 1 are connection responses. Add others as required.
# 7=busy; 6=no dial tone; 4=error; 3=no carrier; 2=ring; 0=OK
#
# PROGRAMMING NOTE: No blanks between double quote marks (").

conduit: send "AT&FQ0T\r" # Reset to factory defaults.
         ignore "0\r" or "OK\r\n" timeout 2 # Ignore modem response.
         send "ATE0T\r" # Initialize modem: Echo OFF,
         expect "0\r" or "OK\r\n" timeout 2 # Enable responses (Numeric),
         send "ATQ0V0X0T\r" # Limit response codes.
         expect "0\r" timeout 2 # Confirm commands successful.
         send "ATS0=0\r" # Set AutoAnswer OFF
         expect "0\r" timeout 2 # Confirm command successful.
         send "AT&C1&D2\r" # Detect carrier and DTR.
         expect "0\r" timeout 2 # Confirm command successful.
         done

connect: send "ATDT%N\r" # Tone dialing command.
         # %N from Call Home setup.

         # Expect a connection response.
         expect "16\r" or "15\r" or "14\r" or "12\r" or "10\r" or "5\r" or "1\r" busy "7\r"
         timeout 60
```

```

done

retry:    send "A/"                                # Repeat the previous command.

                                                # Expect a connection response.
expect "16\r" or "15\r" or "14\r" or "12\r" or "10\r" or "5\r" or "1\r" busy "7\r"
timeout 60
done

disconnect:
delay 2                                        # Separate from previous data.
send "+++"                                    # Assure command mode.
delay 2                                        # Allow mode switching delay.
send "ATH0T\r"                                # Set modem switch-hook down
                                                # (i.e., hang up).

ignore "0\r" or "OK\r" timeout 2             # Ignore modem response.
send "ATE0Q1\r"                               # Initialize modem: Echo OFF,
                                                # Disable responses.

ignore "0\r" timeout 1
done

condin:   send "AT&FQ0T\r"                      # Reset to factory defaults.
ignore "0\r" or "OK\r\n" timeout 2          # Ignore modem response.
send "ATE0T\r"                               # Initialize modem: Echo OFF,
expect "0\r" or "OK\r\n" timeout 2          # Enable responses (Numeric),
send "ATQ0V0X0T\r"                          # Limit response codes.
expect "0\r" timeout 2                      # Confirm commands successful.
send "ATS0=2\r"                              # Set AutoAnswer ON
expect "0\r" timeout 2                      # Confirm command successful.
send "AT&C1&D2\r"                           # Detect carrier and DTR.
expect "0\r" timeout 2                      # Confirm command successful.
done

waitcall: ignore "2\r" timeout 1              # Ignore first ring.
          expect "2\r" timeout 10            # Pick up second ring
                                                # or timeout.
                                                # Expect a connection response.
expect "16\r" or "15\r" or "14\r" or "12\r" or "10\r" or "5\r" or "1\r"
timeout 60
done

page:     send "ATDT%N,,,,%R;\r"              # %N = pager call center number
                                                # Add enough commas to wait for
                                                # time to enter paging number.
                                                # %R = paging number

                                                # Confirm successful command.
          expect "0\r" timeout 60
          delay 2                               # Wait before hanging up.
          send "ATH0T\r"                       # Hang up.
          expect "0\r" timeout 2               # Confirm successful command.
          done

ripo:     send "AT&FQ0T\r"                      # Reset to factory defaults.
ignore "0\r" or "OK\r\n" timeout 2          # Ignore modem response.
send "ATE0T\r"                               # Initialize modem: Echo OFF,
expect "0\r" or "OK\r\n" timeout 2          # Enable responses (Numeric),
send "ATQ0V0X0T\r"                          # Limit response codes.
expect "0\r" timeout 2                      # Confirm commands successful.
send "ATS0=0\r"                              # Set AutoAnswer OFF
expect "0\r" timeout 2                      # Confirm command successful.
send "AT&C1&D2\r"                           # Detect carrier and DTR.
expect "0\r" timeout 2                      # Confirm command successful.
done                                          # RI Power On enabled.

error:                                         # Handle unexpected modem

```

```
expect "8\r" or "7\r" or "6\r" or "4\r" or "3\r"  
delay 2  
done
```

Sample File modem_f0.cfg

```
#
# COMPONENT_NAME: (ESPSETUP) ENTRY SERVICE PROCESSOR SETUP F0
#
# FUNCTIONS: Modem configuration file for many recent Hayes* compatible modems.
# This example uses the AT&F0 reset command to choose the factory defaults.
# This set up is preferred for modems with extended (&) commands. For early
# vintage modems, setup Z or Z0 is recommended. If your modem responds to
# the extended (&) commands and to factory default choices (&Fn), but doesn't
# work properly with this setup file, setup F1 is recommended.
#
# * Trademark of Hayes Microcomputer Products, Inc.
#
# (C) COPYRIGHT International Business Machines Corp. 1996
# All Rights Reserved
# Licensed Materials - Property of IBM
#
# US Government Users Restricted Rights - Use, duplication or
# disclosure restricted by GSA ADP Schedule Contract with IBM Corp.
#
#
# If the modem has configuration switches, they should be set to the
# factory default settings.

ICDelay 1
DefaultT0 10
CallDelay 120
# AT Attention Code , Inserts delay in dialing commands
# &F0 Reset. Restore profile 0 Q0 Turn on responses
# E0 Turn echo off Q1 Turn off responses
# V0 Use numeric responses S0=0 Automatic answer inhibit
# +++ Escape to command mode S0=2 Answer on second ring
# H0 Hang-up X0=0 Limit modem response codes
# T = Tone mode. When used as T\r, it is a
# no op to maintain program synchronization
# when modem may/will echo the commands.
#
# &C1 Detect CD &D2 Respond to DTR (often the default)
# &R1 Ignore RTS (CTS)
#
# %N Call-Out phone number %P Paging phone number
# %S Modem speed (available to users)
#
# Following are common responses from a wide range of modems:
# 16, 15, 12, 10, 5 and 1 are connection responses. Add others as required.
# 7=busy; 6=no dial tone; 4=error; 3=no carrier; 2=ring; 0=OK
#
# PROGRAMMING NOTE: No blanks between double quote marks (").

connect: send "AT&F0Q0T\r" # Reset modem. Select profile 0
          ignore "0\r" or "OK\r\n" timeout 2 # Ignore modem response.
          send "ATE0T\r" # Initialize modem: Echo OFF,
          expect "0\r" or "OK\r\n" timeout 2 # Enable responses (Numeric),
          send "ATQ0V0X0T\r" # Limit response codes.
          expect "0\r" timeout 2 # Confirm commands successful.
          send "ATS0=0\r" # Set AutoAnswer OFF
          expect "0\r" timeout 2 # Confirm command successful.
          send "AT&C1&D2&R1\r" # Detect carrier and DTR,
          # Ignore RTS.
          expect "0\r" timeout 2 # Confirm command successful.
          done

connect: send "ATDT%N\r" # Tone dialing command.
          # %N from Call Home setup.
          # Expect a connection response.
```

```

expect "16\r" or "15\r" or "14\r" or "12\r" or "10\r" or "5\r" or "1\r" busy "7\r"
timeout 60
done

retry:      send "A/"                                # Repeat the previous command.

                                                    # Expect a connection response.
expect "16\r" or "15\r" or "14\r" or "12\r" or "10\r" or "5\r" or "1\r" busy "7\r"
timeout 60
done

disconnect:
delay 2      # Separate from previous data.
send "+++"  # Assure command mode.
delay 2      # Allow mode switching delay.
send "ATH0T\r" # Set modem switch-hook down
                                                    # (i.e., hang up).
ignore "0\r" or "OK\r" timeout 2 # Ignore modem response.
send "ATE0Q1\r" # Initialize modem: Echo OFF,
                                                    # Disable responses.

ignore "0\r" timeout 1
done

condin:     send "AT&F0Q0T\r" # Reset modem. Select profile 0
ignore "0\r" or "OK\r\n" timeout 2 # Ignore modem response.
send "ATE0T\r" # Initialize modem: Echo OFF,
expect "0\r" or "OK\r\n" timeout 2 # Enable responses (Numeric),
send "ATQ0V0X0T\r" # Limit response codes.
expect "0\r" timeout 2 # Confirm commands successful.
send "ATS0=2\r" # Set AutoAnswer ON
expect "0\r" timeout 2 # Confirm command successful.
send "AT&C1&D2&R1\r" # Detect carrier and DTR,
                                                    # Ignore RTS.
                                                    # Confirm command successful.

expect "0\r" timeout 2
done

waitcall:  ignore "2\r" timeout 1 # Ignore first ring.
            expect "2\r" timeout 10 # Pick up second ring
                                                    # or timeout.
                                                    # Expect a connection response.
expect "16\r" or "15\r" or "14\r" or "12\r" or "10\r" or "5\r" or "1\r"
timeout 60
done

page:      send "ATDT%N,,,%R;\r" # %N = pager call center number
                                                    # Add enough commas to wait for
                                                    # time to enter paging number.
                                                    # %R = paging number

                                                    # Confirm successful command.

            expect "0\r" timeout 60
            delay 2 # Wait before hanging up.
            send "ATH0T\r" # Hang up.
            expect "0\r" timeout 2 # Confirm successful command.
done

ripos:     send "AT&F0Q0T\r" # Reset modem. Select profile 0
ignore "0\r" or "OK\r\n" timeout 2 # Ignore modem response.
send "ATE0T\r" # Initialize modem: Echo OFF,
expect "0\r" or "OK\r\n" timeout 2 # Enable responses (Numeric),
send "ATQ0V0X0T\r" # Limit response codes.
expect "0\r" timeout 2 # Confirm commands successful.
send "ATS0=0\r" # Set AutoAnswer OFF
expect "0\r" timeout 2 # Confirm command successful.
send "AT&C1&D2&R1\r" # Detect carrier and DTR,
                                                    # Ignore RTS.
                                                    # Confirm command successful.

expect "0\r" timeout 2

```

```
done # RI Power On enabled.
error: # Handle unexpected modem
# responses.
expect "8\r" or "7\r" or "6\r" or "4\r" or "3\r"
delay 2
done
```

Sample File modem_f1.cfg

```
#
# COMPONENT_NAME: (ESPSETUP) ENTRY SERVICE PROCESSOR SETUP F1
#
# FUNCTIONS: Modem configuration file for many recent Hayes* compatible modems.
# This example uses the AT&F1 reset command to choose the factory defaults.
# This set up is for modems with extended (&) commands and which do not work
# properly with setup F0. For early vintage modems, setup Z or Z0 is
# recommended.
#
# * Trademark of Hayes Microcomputer Products, Inc.
#
# (C) COPYRIGHT International Business Machines Corp. 1996
# All Rights Reserved
# Licensed Materials - Property of IBM
#
# US Government Users Restricted Rights - Use, duplication or
# disclosure restricted by GSA ADP Schedule Contract with IBM Corp.
#
#
# If the modem has configuration switches, they should be set to the
# factory default settings.

ICDelay 1
DefaultT0 10
CallDelay 120
# AT Attention Code , Inserts delay in dialing commands
# &F1 Reset. Restore profile 1 Q0 Turn on responses
# E0 Turn echo off Q1 Turn off responses
# V0 Use numeric responses S0=0 Automatic answer inhibit
# +++ Escape to command mode S0=2 Answer on second ring
# H0 Hang-up X0=0 Limit modem response codes
# T = Tone mode. When used as T\r, it is a
# no op to maintain program synchronization
# when modem may/will echo the commands.
#
#
# &C1 Detect CD &D2 Respond to DTR (often the default)
# &R1 Ignore RTS (CTS)
#
# %N Call-Out phone number %P Paging phone number
# %S Modem speed (available to users)
#
# Following are common responses from a wide range of modems:
# 16, 15, 12, 10, 5 and 1 are connection responses. Add others as required.
# 7=busy; 6=no dial tone; 4=error; 3=no carrier; 2=ring; 0=OK
#
# PROGRAMMING NOTE: No blanks between double quote marks (").

conduit: send "AT&F1Q0T\r" # Reset modem. Select profile 1
ignore "\0\r" or "OK\r\n" timeout 2 # Ignore modem response.
send "ATE0T\r" # Initialize modem: Echo OFF,
expect "\0\r" or "OK\r\n" timeout 2 # Enable responses (Numeric),
send "ATQ0V0X0T\r" # Limit response codes.
expect "\0\r" timeout 2 # Confirm commands successful.
send "ATS0=0\r" # Set AutoAnswer OFF
expect "\0\r" timeout 2 # Confirm command successful.
send "AT&C1&D2&R1\r" # Detect carrier and DTR,
# Ignore RTS.
expect "\0\r" timeout 2 # Confirm command successful.
done

connect: send "ATDT%N\r" # Tone dialing command.
# %N from Call Home setup.

# Expect a connection response.
expect "16\r" or "15\r" or "14\r" or "12\r" or "10\r" or "5\r" or "1\r" busy "7\r"
```

```

timeout 60
done

retry:    send "A/"                                # Repeat the previous command.

                                                # Expect a connection response.
expect "16\r" or "15\r" or "14\r" or "12\r" or "10\r" or "5\r" or "1\r" busy "7\r"
timeout 60
done

disconnect:
delay 2                                         # Separate from previous data.
send "+++"                                     # Assure command mode.
delay 2                                         # Allow mode switching delay.
send "ATH0T\r"                                 # Set modem switch-hook down
                                                # (i.e., hang up).
ignore "0\r" or "OK\r" timeout 2              # Ignore modem response.
send "ATE0Q1\r"                                # Initialize modem: Echo OFF,
                                                # Disable responses.

ignore "0\r" timeout 1
done

conadin:   send "AT&F1Q0T\r"                    # Reset modem. Select profile 1
ignore "0\r" or "OK\r\n" timeout 2           # Ignore modem response.
send "ATE0T\r"                                # Initialize modem: Echo OFF,
expect "0\r" or "OK\r\n" timeout 2           # Enable responses (Numeric),
send "ATQ0V0X0T\r"                           # Limit response codes.
expect "0\r" timeout 2                       # Confirm commands successful.
send "ATS0=2\r"                               # Set AutoAnswer ON
expect "0\r" timeout 2                       # Confirm command successful.
send "AT&C1&D2&R1\r"                         # Detect carrier and DTR,
                                                # Ignore RTS.

expect "0\r" timeout 2                       # Confirm command successful.
done

waitcall: ignore "2\r" timeout 1              # Ignore first ring.
expect "2\r" timeout 10                      # Pick up second ring
                                                # or timeout.
                                                # Expect a connection response.
expect "16\r" or "15\r" or "14\r" or "12\r" or "10\r" or "5\r" or "1\r"
timeout 60
done

page:     send "ATDT%N,,,%R;\r"               # %N = pager call center number
                                                # Add enough commas to wait for
                                                # time to enter paging number.
                                                # %R = paging number

                                                # Confirm successful command.
expect "0\r" timeout 60
delay 2                                         # Wait before hanging up.
send "ATH0T\r"                                 # Hang up.
expect "0\r" timeout 2                       # Confirm successful command.
done

ripo:     send "AT&F1Q0T\r"                    # Reset modem. Select profile 1
ignore "0\r" or "OK\r\n" timeout 2           # Ignore modem response.
send "ATE0T\r"                                # Initialize modem: Echo OFF,
expect "0\r" or "OK\r\n" timeout 2           # Enable responses (Numeric),
send "ATQ0V0X0T\r"                           # Limit response codes.
expect "0\r" timeout 2                       # Confirm commands successful.
send "ATS0=0\r"                               # Set AutoAnswer OFF
expect "0\r" timeout 2                       # Confirm command successful.
send "AT&C1&D2&R1\r"                         # Detect carrier and DTR,
                                                # Ignore RTS.

expect "0\r" timeout 2                       # Confirm command successful.
done                                           # RI Power On enabled.

```

```
error:                                     # Handle unexpected modem
                                           # responses.
expect "8\r" or "7\r" or "6\r" or "4\r" or "3\r"
delay 2
done
```

Appendix E. Ground Path

The ground path for the pSeries 690 is shown in the following figure.

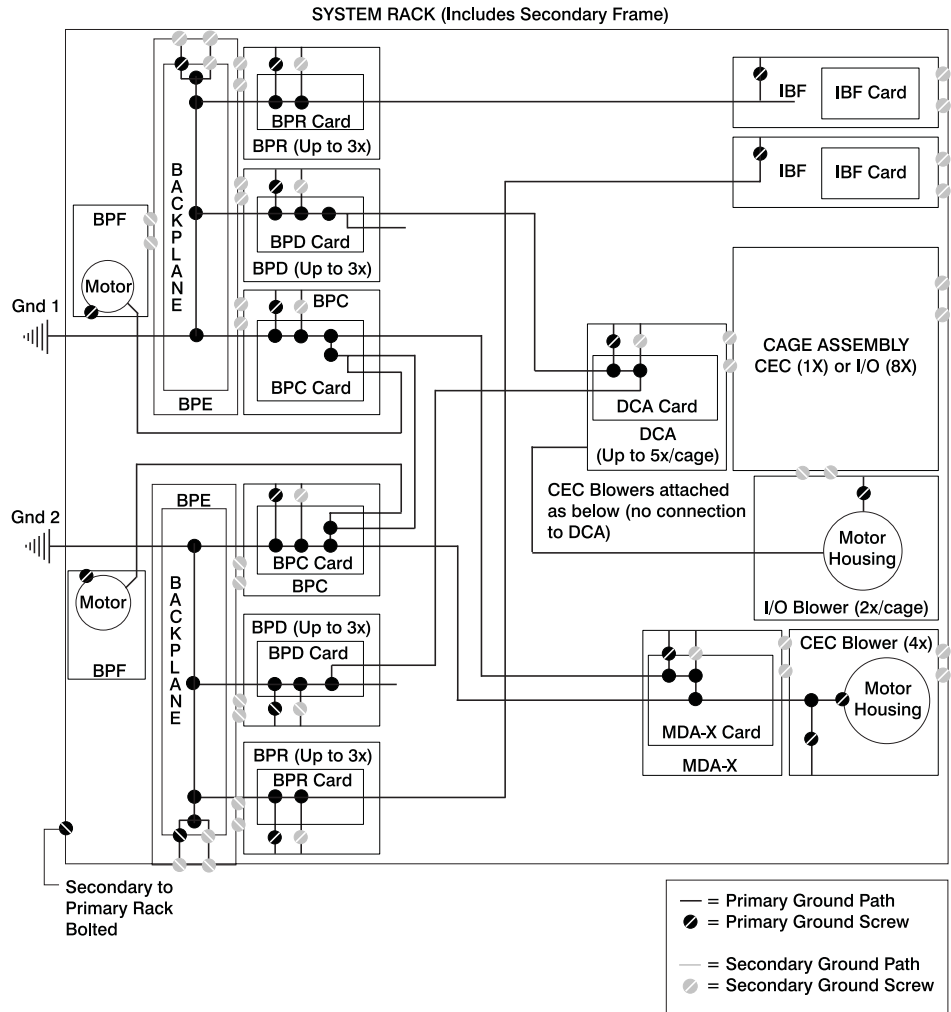

Index

Special characters

@server pSeries 690 overview 1

A

about this book xvii
acoustical
 noise
 emissions 896
adapter
 parameters 759
adding
 FRUs 13
 serviceable event comments 10
air filters 829
AIX documentation 699, 762
AIX location codes 60, 65
automatic call home
 overview 7

B

battery
 disposal, recycling 895
 removal 790
bay locations 25
bay locations, DASD 28
boot device
 select 763
boot mode menu 721
boot problems 396
boot sequence 764
bypass interlock, room EPO 21, 782

C

cabling
 I/O subsystem power 35, 38
call-in
 testing 900
call-in/call-out setup menu 728
call-out
 testing 901
call-out (call-home) 746
call-out policy setup menu 733
capacitor books and capacitor blanks 793
cd-rom removal 865
chassis
 fan 828
checkpoints 359
 description 154
 firmware 370
 service processor 362
code, error 399
common service processor error codes 681

configuration
 client 703
 modem
 customizing files 906
 file selection 904
 sample files 903
 specific files 903
 NIM server 702
 service processor
 serial port 901
configurations
 modem 903
configure
 memory 743
 processor 743
console
 select 761
console mirroring 747
 enable/disable 713
customer account setup menu 734
customizing files
 modem
 configuration 906

D

data flow 16
DCA books and DCA blanks 792
DCA power cables 35
deconfigure
 memory 743
 processor 743
description, ipl flow 359
device
 boot 763
 install 763
diagnostics
 considerations 695
 loading 701
 online 697
 concurrent mode 698
 maintenance mode 699
 overview 153
 running
 service mode 697
 running diagnostics on S1 port 156
 running online 696
 service mode 697
 standalone 700
 considerations 701
 NIM server 701
 partition considerations 700
 using 695

diskette drive removal 867
documentation
 AIX 699, 762
dvd-ram removal 865

E

entering open firmware 18
entry MAP 153, 157
environmental
 design 895
 notices 895
EPO bypass interlock 21, 782
error code to FRU index 399
error codes
 common firmware 681
 firmware/POST 470
 operator panel 405
 POST 399
 problem determination-generated 691
 scan dump 680
 service processor 496
 SPCN 407
 system firmware 680
error log
 display 757
error logs
 service processor 748
exit
 system management services 765
extended error data
 managing 10
external cables 890

F

fan assembly 828
fan chassis 828
fan controller 827
fan power cables 35
file selection
 modem
 configuration 904
firmware
 levels 739
 system
 updates 739
firmware checkpoints 370
firmware/POST error codes 470
flow, data 16
flow, IPL 359
focal point procedures, service 153
FRU
 hot-pluggable 773
 isolation 155
 updating information 12
FRU index 399

FRUs
 adding 13
 replacing 13

G

general user menu 707

H

handling static-sensitive devices 771
handling static-sensitive L3 modules 794, 805
handling static-sensitive MCM modules 794, 805
HMC 761
HMC cabling 52
hot-pluggable FRUs 773
hot-pluggable PCI adapter installation overview 843

I

I/O blanks 787
I/O books 787
I/O subsystem backplane assembly 858
I/O subsystem chassis 864
I/O subsystem DASD 4-pack 862
I/O subsystem disk drive assembly 860
I/O subsystem I/O bus adapter 863
I/O subsystem power cables 38
I/O subsystem RIO riser card 856
IBF power cables 35
index, error code to FRU 399
indicators, POST 17
information, reference 1
install device
 select 763
integratedl battery feature 40
introducing the system 1
IP parameters 758
IPL
 flow 359
 phases 359
isolation, FRU 155

K

keyboards 892, 893
keys
 numeric 1 key 17
 numeric 5 17
 numeric 6 18
 numeric 8 key 18

L

language
 select 765
language selection menu 727
laser compliance statement xiii, 866
laser safety information xiii
LCD progress indicator log 749

- LED
 - indicator
 - menu 726
- LED status 26
- location code
 - format 58
- location codes 58, 65
 - AIX 60
 - physical 58
- locations 18
 - AIX 62
 - DASD bays 28
 - DASD SCSI IDs 28
 - I/O subsystem front 27, 28, 29
 - location code reference tables 62
 - logical 58
 - media bays 25
 - media SCSI IDs 25
 - media subsystem operator panel 26
 - media, front 25
 - media, rear 25
 - physical 58, 62
 - processor subsystem front 18
 - processor subsystem rear 23, 24

M

- maintenance analysis procedures 153, 157
 - quick entry MAP 159
- maintenance analysis procedures (MAPs) 157, 158
 - hot-plug MAP 181
 - minimum configuration Map 312
 - power MAP 185
 - problem determination MAP 166
- managing
 - extended error data 10
- MAP hot-plug 181
- media subsystem cable removal 871
- media subsystem operator panel locations 26
- media subsystem, front 25
- media subsystem, rear 25
- memory
 - configure 743
 - deconfigure 743
- memory books and memory blanks 825
- memory configuration/deconfiguration menu 724
- menu
 - boot mode 721
 - call-in/call-out 728
 - call-out policy setup 733
 - customer account setup 734
 - general
 - user 707
 - language selection 727
 - LED indicator 726
 - main 709

- menu (*continued*)
 - memory configuration/deconfiguration 724
 - modem configuration 729
 - OS surveillance
 - setup 714
 - power control network utilities 726
 - privileged
 - user 709
 - processor configuration/deconfiguration 723
 - reboot/restart policy setup 719
 - ring indicate 718
 - serial port selection 730
 - serial port speed setup 730
 - setup 711
 - system information 722
 - system power control 717
 - telephone setup 732
- messages, service processor checkpoints 362
- minimum configuration Map 312
- modem
 - configuration
 - customizing files 906
 - file selection 904
 - sample files 903
 - specific files 903
 - configurations 903
- modem session
 - transfer 909
- modem_f.cfg, sample file 919
- modem_f0.cfg, sample file 922
- modem_f1.cfg, sample file 925
- modem_z.cfg, sample file 915
- modem_z0.cfg, sample file 917
- multiboot 762

N

- NIM server
 - configuration 702
 - client 703
 - standalone diagnostics 701
- noise emissions
 - acoustical 896
- notices
 - environmental 895

O

- OK prompt 765
- online diagnostics
 - concurrent mode 698
 - maintenance mode 699
 - modes of operation 697
 - running 696
 - service mode 697
- online publications xvii
- open firmware, entering 18

- operating considerations
 - online and standalone diagnostics 695
- operational phases
 - service processor 751
- operator panel error codes 405
- operator panel removal 868
- overview 1
 - diagnostics 153
 - hot-pluggable PCI adapter 843
 - service focal point 5
 - system 1

P

- parameters
 - adapter 759
 - IP 758
 - service processor
 - service mode 734
- partitions
 - considerations
 - standalone 700
- parts
 - keyboard 892, 893
- parts information 873
 - external cables 890
 - media subassembly 882
 - power subsystem 874
 - processor subsystem 876, 878, 880
 - rack subsystem 874
 - subassembly 886
- password
 - utilities 756
- passwords 712
 - general
 - change 713
 - privileged
 - change 713
- PCI
 - adapter removal 831
 - slot LED definitions 830
- phases, ipl 359
- physical location codes 58, 65
- ping 760
- POST 399
- POST indicators 17
- POST keys
 - numeric 1 17
 - numeric 5 key 17
 - numeric 6 key 18
 - numeric 8 key 18
- power cables
 - DCAs 35
 - fans 35
 - I/O subsystem 38
 - IBF 35

- power cables, I/O subsystem 38
- power control network utilities menu 726
- power MAP 153, 185
- power source 143
- power subsystem 34
- power supply fan removal 857
- power supply removal 857
- power-on
 - methods 734
- power-on self-test 17
- powering off 15, 771
- powering on 15, 771
- powering on and off 771
- powering on with service processor 772
- preface xvii
- primary console 910
- primary I/O book 787
- privileged user menus 709
- problem determination MAP 166
- problem determination-generated error codes 691
- problem isolation MAP 153
- problems, boot 396
- procedures, removal and replacement 765
- procedures, service focal point 153
- processor
 - configure 743
 - deconfigure 743
 - fans 828
- processor configuration/deconfiguration menu 723
- processor fan assembly 828
- processor fan controller 827
- processor fans 828
- processor subsystem chassis 822
- product disposal 895
- publications, online xvii

Q

- quick entry MAP 153, 159

R

- reboot/restart policy setup menu 719
- recovery
 - procedures 908
 - strategy 910
- recycling 895
- reference information 1
- reference tables
 - aix location code 62
 - physical location code 62
- related publications xvii
- remote initial program
 - load
 - setup 757
- removal and replacement introduction 770

- removal and replacement procedure
 - air filters 829
 - battery 790
 - capacitor books and capacitor blanks 793
 - cd-rom drive 865
 - DCA books and DCA blanks 792
 - diskette drive 867
 - dvd-ram drive 865
 - I/O blanks 787
 - I/O books 787
 - I/O subsystem backplane assembly 858
 - I/O subsystem chassis 864
 - I/O subsystem DASD 4-pack 862
 - I/O subsystem DASD assembly 860
 - I/O subsystem I/O bus adapter 863
 - I/O subsystem RIO riser card 856
 - media subsystem cables 871
 - memory books and memory blanks 825
 - operator panel 868
 - PCI adapters 831
 - power supply 857
 - power supply fan 857
 - primary I/O book 787
 - processor subsystem chassis 822
- removal and replacement procedures 765
- removal procedures 794
 - L3 cache modules 805
 - mcm filler covers 794
 - mcm modules 794
 - passthru modules 794
- replacement procedures 800
 - I/O book 789
 - L3 cache modules 809
 - mcm modules 800
 - memory modules 825
- replacing
 - FRUs 13
- restart recovery 736
- RETAIN 734
- retries 733
- ring indicate power-on menu 718
- room EPO bypass interlock 21, 782

S

- S1 port testing
 - native serial port 156
- safety
 - electrical xi
- safety notices xi
 - laser compliance statement xiii
- safety statement, laser 866
- sample files
 - modem
 - configurations 903
- saving service processor settings 899
- scan dump messages 680
- SCSI
 - utilities 761
- SCSI IDs 25, 28
- self-test, power-on 17
- serial port
 - selection menu 730
 - snoop setup menu 715
 - speed setup menu 730
- service agent feature 156
- service focal point
 - call home overview 7
 - extended error data collection 7
 - overview 5
 - serviceable events 8
- service focal point procedures 153
- service inspection guide 152
- service processor 705
 - access
 - local 706
 - remote 706
 - backup settings 899
 - boot mode menu 721
 - call-in
 - test 899
 - call-in/call-out setup menu 728
 - call-out
 - test 899
 - call-out call-home 746
 - call-out policy setup menu 733
 - checklist 899
 - checkpoints 362
 - console mirroring 747
 - customer account setup menu 734
 - error logs 748
 - feature 156
 - general user menu 707
 - language selection menu 727
 - main menu 709
 - memory configuration/deconfiguration menu 724
 - menus 705
 - modem configuration menu 729
 - monitoring - surveillance 744
 - operational phases 751
 - OS surveillance setup menu 714
 - parameters
 - service mode 734
 - passwords 712
 - power control network utilities menu 726
 - privileged user menus 709
 - procedures in service mode 734
 - processor configuration/deconfiguration menu 723
 - reboot/restart policy setup menu 719
 - reboot/restart recovery 736
 - ring indicate power-on menu 718

- service processor *(continued)*
 - serial port
 - configuration 901
 - serial port selection menu 730
 - serial port snoop setup menu 715
 - serial port speed setup menu 730
 - settings
 - saving and restoring 706
 - setup 899
 - setup checklist 899
 - setup menu 711
 - system information menu 722
 - system power control menu 717
 - telephone setup menu 732
 - test 899
 - using service processor 156
- service processor checkpoints 362
- service processor error codes 496
- serviceable event
 - viewing partition information 14
- serviceable events
 - adding comments 10
 - selecting and viewing 8
 - updating FRU information 12
 - viewing comments 10
 - viewing details 9
 - viewing error details 9
 - viewing service processor error details 9
 - working with 8
- setup and test
 - service processor 899
- setup menu 711
- slow boot 700
- software
 - default 763
 - select 762
- SPCN error codes 407
- specific files
 - modem
 - configuration 903
- specifications 138
 - distribution, weight 146
 - environmental 146
 - height 144
 - noise emissions 145
 - processor subsystem 138
 - weight 144
- standalone diagnostics 700
 - NIM server 701, 703
 - partition considerations 700
- surveillance
 - monitoring 744
- system firmware update messages 680
- system firmware updates 739
- system information menu 722

- system introduction 1
- system management services 755
 - display error log 757
 - exit 765
 - multiboot 762
 - OK prompt 765
 - password utilities 756
 - remote initial program load setup 757
 - SCSI utilities 761
 - select console 761
 - select language 765
- system power-on methods 734
- system specifications 138
- system, powering 15
- system, powering off 15, 771

T

- telephone setup menu 732
- terminal emulators 908
- terminal type
 - identifying 696
- testing the setup
 - call-in 900
 - call-out 901
- trademarks xviii
- transfer of a modem session 909

U

- UEPO card assembly 782
- UEPO locations 21
- UEPO removal and replacement 782
- unit emergency power off card assembly 782
- updating
 - FRU information 12
- using service agent 156
- utilities
 - SCSI 761

V

- viewing
 - serviceable event comments 10
 - serviceable event details 9
 - serviceable event error details 9
 - serviceable event partition information 14
- virtual terminal window 761

Readers' Comments — We'd Like to Hear from You

pSeries 690
Service Guide

Publication No. SA38-0589-01

Overall, how satisfied are you with the information in this book?

	Very Satisfied	Satisfied	Neutral	Dissatisfied	Very Dissatisfied
Overall satisfaction	<input type="checkbox"/>	<input type="checkbox"/>	<input type="checkbox"/>	<input type="checkbox"/>	<input type="checkbox"/>

How satisfied are you that the information in this book is:

	Very Satisfied	Satisfied	Neutral	Dissatisfied	Very Dissatisfied
Accurate	<input type="checkbox"/>	<input type="checkbox"/>	<input type="checkbox"/>	<input type="checkbox"/>	<input type="checkbox"/>
Complete	<input type="checkbox"/>	<input type="checkbox"/>	<input type="checkbox"/>	<input type="checkbox"/>	<input type="checkbox"/>
Easy to find	<input type="checkbox"/>	<input type="checkbox"/>	<input type="checkbox"/>	<input type="checkbox"/>	<input type="checkbox"/>
Easy to understand	<input type="checkbox"/>	<input type="checkbox"/>	<input type="checkbox"/>	<input type="checkbox"/>	<input type="checkbox"/>
Well organized	<input type="checkbox"/>	<input type="checkbox"/>	<input type="checkbox"/>	<input type="checkbox"/>	<input type="checkbox"/>
Applicable to your tasks	<input type="checkbox"/>	<input type="checkbox"/>	<input type="checkbox"/>	<input type="checkbox"/>	<input type="checkbox"/>

Please tell us how we can improve this book:

Thank you for your responses. May we contact you? Yes No

When you send comments to IBM, you grant IBM a nonexclusive right to use or distribute your comments in any way it believes appropriate without incurring any obligation to you.

Name

Address

Company or Organization

Phone No.

Readers' Comments — We'd Like to Hear from You
SA38-0589-01



Cut or Fold
Along Line

Fold and Tape

Please do not staple

Fold and Tape



NO POSTAGE
NECESSARY
IF MAILED IN THE
UNITED STATES

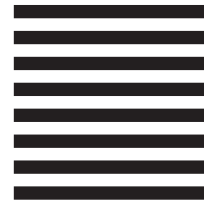

BUSINESS REPLY MAIL

FIRST-CLASS MAIL PERMIT NO. 40 ARMONK, NEW YORK

POSTAGE WILL BE PAID BY ADDRESSEE

Information Development
Department H6DS-905-6C006
11400 Burnet Road
Austin, TX 78758-3493



Fold and Tape

Please do not staple

Fold and Tape

SA38-0589-01

Cut or Fold
Along Line



April 2002

SA38-0589-01



Spine information:



pSeries 690

pSeries 690 Service Guide

SA38-0589-01