

pSeries 640 Model B80



Installation Guide

Note to Printer:

No Graphic to be printed on front cover.
Delete this note before printing.

Book trim size is 7 3/8 x 9 inches

Front Cover is 10pt. Carolina stock or equivalent C1S (coated one side)

pSeries 640 Model B80



Installation Guide

First Edition (October 2000)

Before using this information and the product it supports, read the information in "Safety Notices" on page vii, "Appendix B. Environmental Notices" on page 73, and "Appendix C. Notices" on page 75.

International Business Machines Corporation, 2000. All rights reserved. Note to U.S. Government Users Restricted Rights--Use, duplication or disclosure restricted by GSA ADP Schedule Contract with IBM Corp.

Contents

Safety Notices.	vii
Electrical Safety	vii
Unit Emissions	viii
Laser Safety Information	viii
Data Integrity and Verification	xi
About This Book	xiii
ISO 9000	xiii
Online Publications	xiii
Related Publications	xiii
Trademarks	xiv
Chapter 1. Installing the 7026 Model B80.	1
Step 1: Check Your Inventory	1
Step 2: Read the Safety Notices	4
Step 3: Need Help?	4
Step 4: Check the Power Source	4
Step 5: Review the Rack-Mounting Instructions	5
Step 6: Install the Rails and Rack-Mount Brackets	6
Step 7: Are All of the Internal Options Installed? .	12
Step 8: Install the Cable Management Arm	12
Step 9: Connect the Optional Keyboard and Mouse	13
Step 10: Connect the Serial and Parallel Devices	14
Step 11: Connect the First External SCSI Device	15
Step 12: Connect Any Additional External SCSI Devices	16
Step 13: Connect a Graphics Display	17
Step 14: Attach the Display Cable Toroid	17
Step 15: Connect the Adapter Cables	18
Step 16: Connect to the Internal Ethernet	18
Step 17: Plug in the Power Cables	19
Step 18: Attaching Cables to the Cable Management Arm	20
Step 19: Start Your System.	21
Step 20: Configure NIM Server	22
Step 21: Run System Verification.	23
Chapter 2. Verifying the Hardware Operation	25
Step 1. Considerations Before Running This Procedure	25
Step 2. Loading the Diagnostics	26
Step 3. Running the Verification Procedure	27
Step 4. Performing Additional System Verification	27
Step 5. Stopping the Diagnostics	27
Chapter 3. Installing Options for the 7026 Model B80	29
Safety Considerations	29
Handling Static-Sensitive Devices	30
Stopping the System Unit	30

Placing the Drawer in the Service Position	31
Returning the Drawer to the Operating Position	32
Removing and Replacing Covers	32
Main Chassis Cover Removal	32
Main Chassis Cover Replacement	33
Power Supply Chassis Cover Removal	34
Power Supply Chassis Cover Replacement	35
Front Bezel Removal	36
Front Bezel Replacement	37
Media Bay Tray Removal	37
Option List	38
PCI Adapter Options	39
Installing Adapters	39
Removing Adapters	41
Central Electronics Complex (CEC) Cover	42
CEC Box Cover Removal	42
CEC Box Cover Replacement	43
System Memory Options	44
Installing Memory Cards	44
Removing Memory Cards	46
Installing Memory Modules	48
Removing Memory Modules	49
Processor Card	50
Installing a Processor Card	50
Removing a Processor Card	52
Internal Drive Overview	54
Checklist for Handling Drives	54
Hot-Plug Units	54
Disk Drive Options	55
Installing a Hot-Plug Disk Drive	55
Removing a Hot-Plug Disk Drive	56
Configuring Disk Drives	59
Installing a Redundant Hot-Plug Power Supply	60
Installing Optional CD-ROM and Tape Drive	62
Replacing the Battery	63
Firmware Updates	66
Check the Current System Firmware and Service Processor Firmware Levels	66
System Firmware Updates	66
Appendix A. Communications Statements	69
Federal Communications Commission (FCC) Statement	69
European Union (EU) Statement	69
International Electrotechnical Commission (IEC) Statement	70
United Kingdom Telecommunications Safety Requirements	70
Avis de conformité aux normes du ministère des Communications du Canada	70
Canadian Department of Communications Compliance Statement	70
VCCI Statement	70
Electromagnetic Interference (EMI) Statement - Taiwan	71
Radio Protection for Germany	71

Appendix B. Environmental Notices	73
Product Recycling and Disposal	73
Environmental Design	73
Unit Emissions	73
 Appendix C. Notices	 75
 Appendix D. Running Standalone Diagnostics from a Network Installation Management (NIM) Server.	 77
 Appendix E. System Records	 79
Record the Identification Numbers	79
Device Records	80
SCSI ID and Bay Location Record	81
 Appendix F. System Relocation Procedure.	 83
 Index	 85
 Reader's Comments — We'd Like to Hear From You	 87

Safety Notices

A *danger* notice indicates the presence of a hazard that has the potential of causing death or serious personal injury. *Danger* notices appear on the following pages:

- vii
- viii
- 29

A *caution* notice indicates the presence of a hazard that has the potential of causing moderate or minor personal injury. *Caution* notices appear on the following pages:

- viii
- 9
- 19
- 29
- 63

For a translation of the safety notices contained in this book, see the *System Unit Safety Information*, order number SA23-2652.

Electrical Safety

Observe the following safety instructions any time you are connecting or disconnecting devices attached to the workstation.

DANGER

An electrical outlet that is not correctly wired could place hazardous voltage on metal parts of the system or the devices that attach to the system. It is the responsibility of the customer to ensure that the outlet is correctly wired and grounded to prevent an electrical shock.

Before installing or removing signal cables, ensure that the power cables for the system unit and all attached devices are unplugged.

When adding or removing any additional devices to or from the system, ensure that the power cables for those devices are unplugged before the signal cables are connected. If possible, disconnect all power cables from the existing system before you add a device.

Use one hand, when possible, to connect or disconnect signal cables to prevent a possible shock from touching two surfaces with different electrical potentials.

During an electrical storm, do not connect cables for display stations, printers, telephones, or station protectors for communication lines.

CAUTION:

This product is equipped with a three-wire power cable and plug for the user's safety. Use this power cable with a properly grounded electrical outlet to avoid electrical shock.

CAUTION:

This unit has more than one power cord. To reduce the risk of electrical shock, disconnect two power supply cords before servicing.

DANGER

To prevent electrical shock hazard, disconnect the power cable from the electrical outlet before relocating the system.

Unit Emissions

The unit-related emission value is equal to or lower than 70dB(A).

Der Geräuschpegel der Einheit ist kleiner oder gleich 70 db(A).

Laser Safety Information

The optical drive in this system unit is a laser product. The optical drive has a label that identifies its classification. The label, located on the drive, is shown below.

CLASS 1 LASER PRODUCT
LASER KLASSE 1
LUOKAN 1 LASERLAITE
APPAREIL À LASER DE CLASSE 1
IEC 825:1984 CENELEC EN 60 825:1991

The optical drive in this system unit is certified in the U.S. to conform to the requirements of the Department of Health and Human Services 21 Code of Federal Regulations (DHHS 21 CFR) Subchapter J for Class 1 laser products. Elsewhere, the drive is certified to conform to the requirements of the International Electrotechnical Commission (IEC) 825 (1st edition 1984) and CENELEC EN 60 825:1991 for Class 1 laser products.



CAUTION:

A class 3 laser is contained in the device. Do not attempt to operate the drive while it is disassembled. Do not attempt to open the covers of the drive as it is not serviceable and is to be replaced as a unit.

Class 1 laser products are not considered to be hazardous. The optical drive contains internally a Class 3B gallium—arsenide laser that is nominally 30 milliwatts at 830 nanometers. The design incorporates a combination of enclosures, electronics, and

redundant interlocks such that there is no exposure to laser radiation above a Class 1 level during normal operation, user maintenance, or servicing conditions.

Data Integrity and Verification

Notice

IBM computer systems contain mechanisms designed to reduce the possibility of undetected data corruption or loss. This risk, however, cannot be eliminated. Users who experience unplanned outages, system failures, power fluctuations or outages, or component failures must verify the accuracy of operations performed and data saved or transmitted by the system at or near the time of the outage or failure. In addition, users must establish procedures to ensure that there is independent data verification before relying on such data in sensitive or critical operations. Users should periodically check the IBM support websites for updated information and fixes applicable to the system and related software.

About This Book

This book provides information on how to set up the system unit, install and remove options, and verify system operation.

ISO 9000

ISO 9000 registered quality systems were used in the development and manufacturing of this product.

Online Publications

RS/6000 publications are available online. To access the online books, visit our Web site at: http://www.rs6000.ibm.com/resource/hardware_docs/

Related Publications

The following publications provide additional information about your system unit:

- The *System Unit Safety Information* book, order number SA23-2652, contains translations of safety information used throughout this book.
- The *pSeries 640 Model B80 User's Guide*, order number SA38-0580, contains information on how to use the system, use diagnostics, use service aids, and verify system operations.
- The *pSeries 640 Model B80 Service Guide*, order number SA38-0581, contains reference information, maintenance analysis procedures (MAPs), error codes, removal and replacement procedures, and a parts catalog.
- The *7014 Model T00 and T42 Rack Installation and Service Guide*, order number SA38-0577, contains information regarding the racks in which the 7026 Model B80 can be installed.
- The *Diagnostic Information for Multiple Bus Systems*, order number SA38-0509, contains diagnostic information, service request numbers (SRNs), and failing function codes (FFCs).
- The *Adapters, Devices, and Cables*, order number SA38-0516, contains information about adapters, devices, and cables for your system. This manual is intended to supplement the service information found in the *Diagnostic Information for Multiple Bus Systems*.
- The *Site and Hardware Planning Information*, order number SA38-0508, contains information to help you plan your installation.
- The *Network Installation Management Guide and Reference* contains information about installing the AIX Version 4.3 operating system and optional software on one or more diskless, dataless, and standalone machines from a central server.
- The *PCI Adapter Placement Reference*, order number SA38-0538, contains information regarding slot restrictions for adapters that can be used in this system.

Trademarks

The following terms are trademarks of International Business Machines Corporation in the United States, other countries, or both:

- AIX
- IBM
- RS/6000
- p Series 640

Other company, product, and service names may be trademarks or service marks of others.

Chapter 1. Installing the 7026 Model B80

Follow the procedures in this chapter to install the 7026 Model B80 (hereafter referred to as the Model B80 in this book).

Step 1: Check Your Inventory

The following items should have been packed with your server:

Note: The envelope labeled "Rack Mounting Kit" contains the "Slide Mounting Kit," "Latch Bracket Mounting Kit," and "cable management arm Mounting Kit." All kits contained in the "Rack Mounting Kit" are individually wrapped and labeled.

() Rack Mounting Template

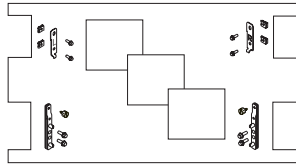

() Books



() "About Your Machine" document

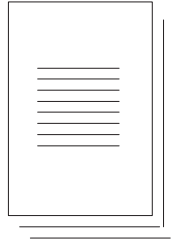

() Rack Mounting Kit Envelope contains: Slide Mounting Kit, Latch Bracket Mounting Kit, Cable Management Arm Mounting Kit document

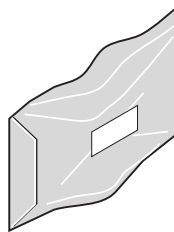

() Slide Mounting Kit contains: 8 screws, 2 mounting plates with preinstalled alignment pins, 16 assorted alignment pins (large and small)

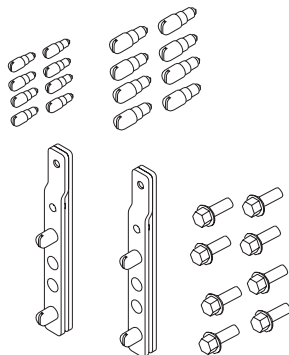

() Latch Bracket Mounting Kit contains: 2 latch brackets, 4 threaded screw clips, 4 screws, 2 plastic thumbscrews

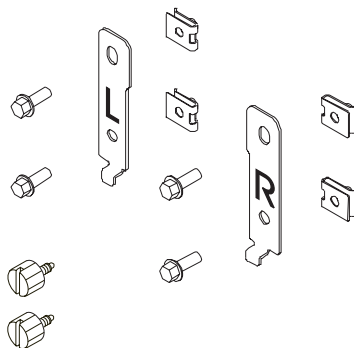

() Cable Management Arm Mounting Kit
contains: Two Screws

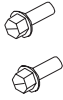

() 2 Rack Rails

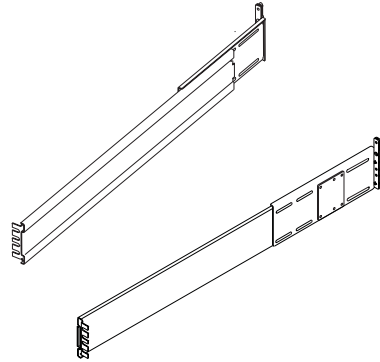

() Cable Management Arm

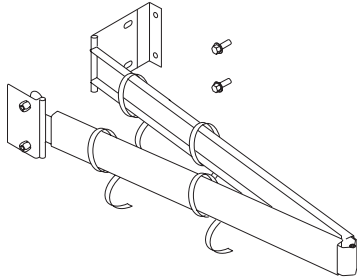

() RJ45 Connector to 9-pin Converter Cable (1)

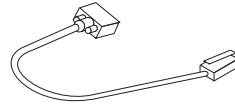

() Server Power Cable 1 Standard, 1 Optional
(configuration dependent)

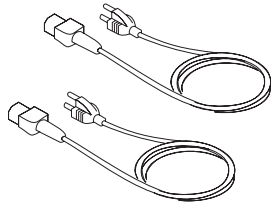

() Server

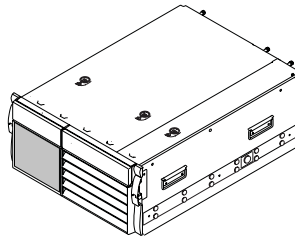

() Keyboard (optional) Wrist/Palm Rest
(optional)

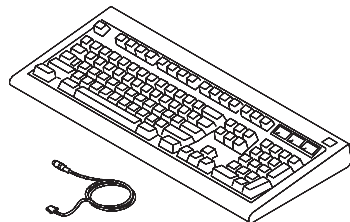

() Display and Cable (optional)

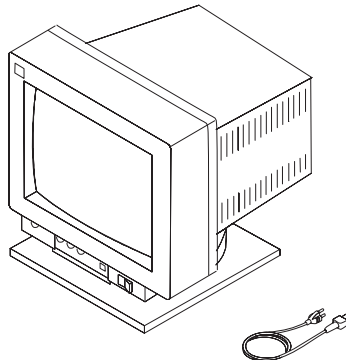

() Mouse (optional)

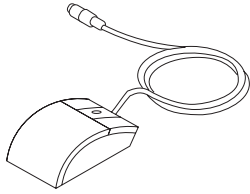

() Display Cable Toroid (with some units)



Step 2: Read the Safety Notices

Safety Notes:

1. Before continuing, refer to the *System Unit Safety Information*, SA23-2652, for Danger and Caution notices. Do not plug any cables into the server, adapters, or electrical outlets until you have reviewed this information.
2. This system drawer has the potential of having two power cables connected. Make sure none of the power cables are connected before continuing to the next step.

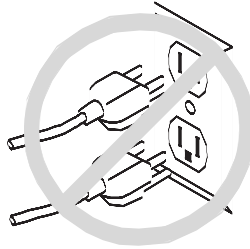

Step 3: Need Help?

If you encounter any difficulties while setting up your system and rack, contact your sales representative for assistance.

Step 4: Check the Power Source

This system can be equipped with the following power supplies:

- 115/230 V ac
- -48 V dc

Check that the correct power source is available. If your system is equipped to run a dc power supply, a dc power source is required. The dc power source can be ordered with the rack or supplied by the customer.

Step 5: Review the Rack-Mounting Instructions

Before continuing, make sure you review the following instructions for mounting the system drawer into the rack. If the system drawer was shipped already mounted in a rack, go to “Step 7: Are All of the Internal Options Installed?” on page 12.

- Do not install this system drawer in a rack where the internal rack ambient temperatures fall out of the following range: 10° C to 40° C (50° F to 104° F).
- Do not install this system drawer in a rack where the air flow is compromised.
- Care should be taken to ensure that a hazardous condition is not created due to uneven mechanical loading when installing this system drawer into a rack. If the rack the system drawer is being installed in has a stabilizer, it must be firmly attached before installing or removing this server. If the rack has no stabilizer bar installed, then the rack must be bolted to the floor.
- If your system drawer is set up to run ac electrical current and you are running between 100-127 volts it requires 6 amperes of current. If you are running between 200-240 volts your system needs 3 amperes of current. If your system is set up to run dc electrical current you need to be running at 12 amperes of current. Consideration should be given to the connection of the equipment to the supply circuit such that the overloading of circuits does not compromise the supply wiring or overcurrent protection.
- An electrical outlet that is not correctly wired could place hazardous voltage on the metal parts of the system or the devices that attach to the system. It is the responsibility of the customer to ensure that the outlet is correctly wired and grounded to prevent an electrical shock.

Step 6: Install the Rails and Rack-Mount Brackets

Note:

Before beginning:

- Before performing any of the steps, read through this procedure and study the illustrations.
- The rack rails come correctly adjusted to fit IBM-style racks. The rear portion of the rails can be adjusted to accommodate other racks.
- The rails are front-to-back and side-dependent. The left rail is labeled L and the right rail is labeled R. The attached mounting plates located on the rear of the rails contain two alignment pins and must be mounted to the rear of the rack.
- Use the rack-mounting template (supplied) to determine where in the rack the Model B80 is to be installed.

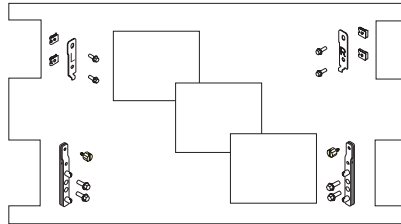

- If your rack has doors, remove the doors at this time. For *7014 Model T00 and T42 racks*, refer to *7014 Model T00 and T42 Rack Installation and Service Guide, SA38-0577*, for information about removing the rack doors.

To mount the rails into the system rack, do the following:

1. Locate and unpack the rack-mounting hardware kit. This kit contains all the screws, clips, and alignment plates necessary to securely mount the rails to your rack unit.
2. In the rack-mounting hardware kit, locate the latch-bracket mounting kit.
3. Locate the rack-mounting template.
4. Unpack both rails. Separate the left rail from the right rail, and place each on the floor in front of the rack.

To place the rails in the correct orientation, do the following:

- Rails are labeled L and R. The L denotes the left rail and R denotes the right rail.
- The portion of the rail that contains the adjustment plate and two alignment pins points to the rear of the rack.

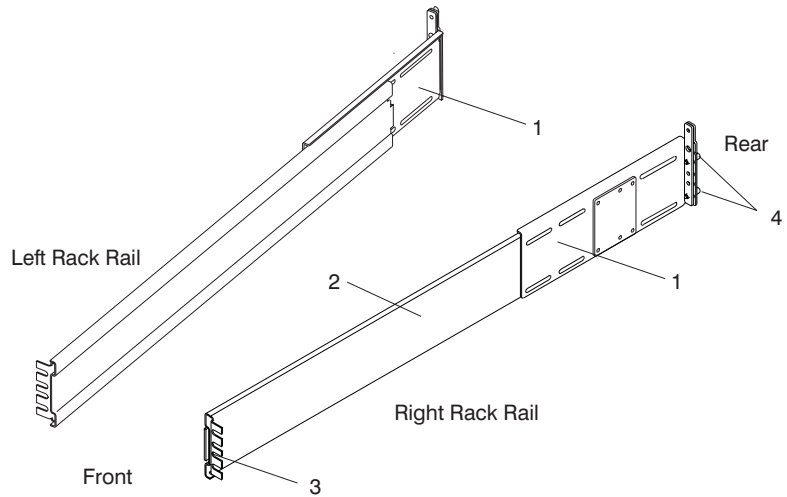

- 1 Rail Length Adjusting Plate
- 2 Outer Rail
- 3 Racking Mounting Slots
- 4 Alignment Pin

Note: The rail should now have the rail length adjusting plate facing the rear of the rack and the rack-mounting slots facing out toward the rack columns.

5. After determining the location on the rack you wish to place the system drawer, mount the rack-mounting template. The template has adhesive strips, located on the back. Remove the protective coating from each adhesive strip and lightly press the template into position on the rack.

Notes:

- a. The template contains numbered illustrations on how to mount your hardware. Follow the illustrations in numerical order. Do not move on to step 3 of the template until all four sections of step 2 have been completed.
 - b. Use the indicator lines located on the template edges to align with the holes located on the rack.
6. Locate and separate the following items from the rail-mounting hardware kit:
 - Two front rack-alignment plates with four installed alignment pins
 - Eight mounting screws
 - 8 large and 4 small alignment pins (may be needed for use in some racks)
 7. Locate and separate the following items from the latch-mounting hardware kit:
 - 2 Latch brackets (One labeled L and the other labeled R)
 - 4 Mounting screws
 - 4 Threaded nut clips

8. Using the rack-mounting template as a guide, install the two rail alignment plates and the two latch brackets. Ensure that all five holes in the alignment plate align with the holes in the rack rail. **Only finger-tighten all screws at this time.**

Attention: Tightening the screws at this time can cause considerable damage to the rails. At this point the rails **MUST** be free-floating in both the front and rear of the rack.

9. Install the rails into the rack, as follows:

Note: The installation procedure for the left and right rails is identical, but only the right rail installation is shown here.

- a. Stand in front of the rack and install the rails by inserting the alignment pins, located on the rear alignment plate, into the appropriate holes in the rear of the rack.

Note: The rails must be level from front to back, so when installing the rails ensure that the bottom alignment pins located on all of the alignment plates are installed in rack holes that align with each other.

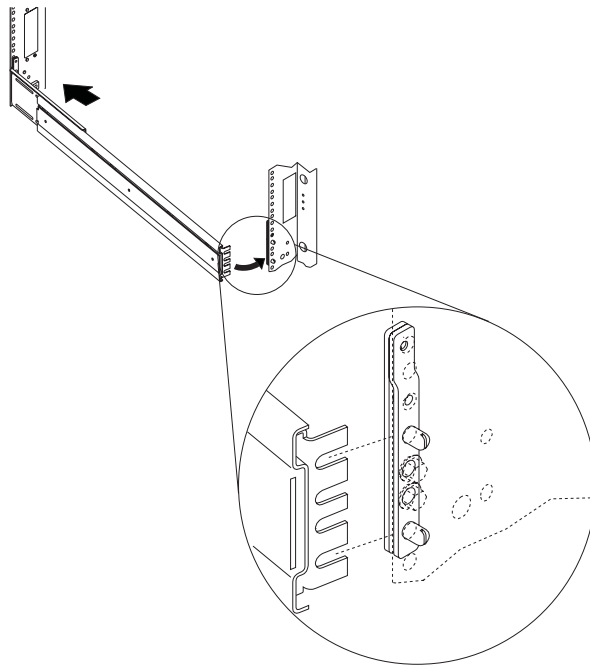

- b. Swing the front of the rail into the front alignment plate, making sure that the top and bottom rail fingers fit around the two alignment pins.
- c. Go to the rear of the rack and insert two screws in the two holes between the alignment pins. **Only finger-tighten the screws at this time.**

Attention: Tightening the screws at this time can cause considerable damage to the rails. At this point the rails **MUST** be free-floating in both the front and rear of the rack.

See the following illustration.

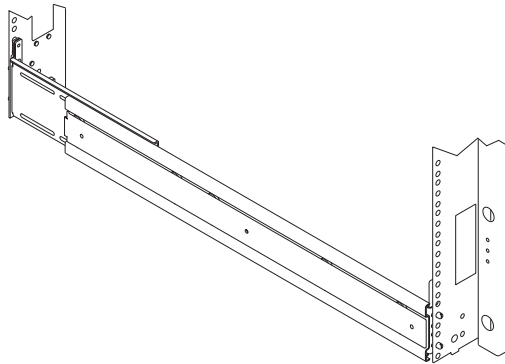

10. Pull out the telescoping section of each rail until it locks into position. The rail makes a clicking sound when it is put into the locked position.
You are now ready to mount the system drawer. If you have not already done so, remove the system from the box.
11. Install the system drawer on the rails, as follows:

CAUTION:

The stabilizer must be firmly attached to the bottom front of the rack to prevent the rack from turning over when the drawers are pulled out of the rack. Do not pull out or install any drawer or feature if the stabilizer is not attached to the rack.

CAUTION:

This unit weighs between 32 kg (70.5 pounds) and 55 kg (121.2 pounds). Three persons are required to safely move it. Using fewer than three persons to move it can result in injury.

12. Lift the system drawer by grasping the handles on each side.

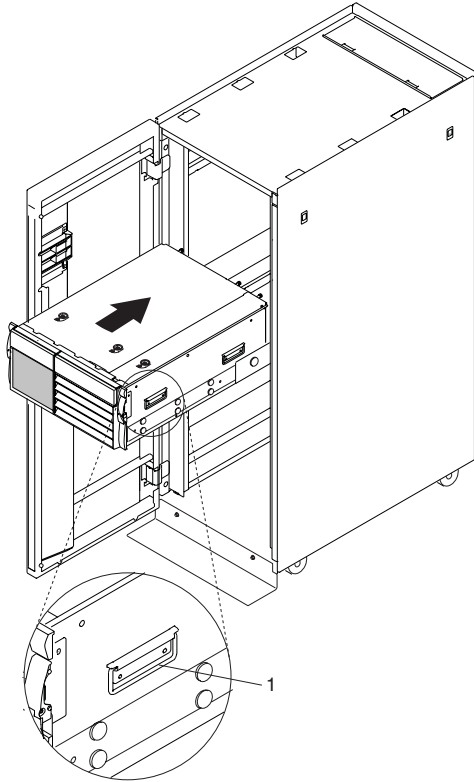

1 System Drawer Lifting Handle

13. Insert the system drawer wheels into the rail tracks and slide the system drawer slowly into the rails. Ensure that the system drawer wheels are correctly aligned in the rails before releasing the system drawer.

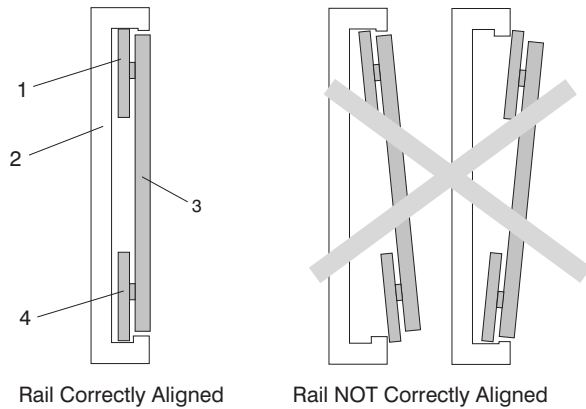

- 1 Top Rail Wheel
- 2 Outer Rail (Mounted in Rack)
- 3 Inner Rail (Mounted on System Drawer)
- 4 Bottom Rail Wheel

14. Continue sliding the system into the rack. Release buttons, located on each of the inner rails, will hit the front edge of the rails, stopping the system from going any further.
15. Holding the front handle of the system, use your other hand to depress the release button.
16. Continue sliding the system into the rack until the release buttons click in their locking holes.
17. Remove the front bezel from the system. Refer to "Front Bezel Removal" on page 36.
18. Depress both release buttons and continue sliding the drawer into the rack until the plastic release latches, located on both sides of the system drawer, have engaged the locking tabs located on the rack. The plastic latches make a clicking sound when they lock into position. This action secures the system drawer to the rack.
19. After the system drawer is installed on the rails and pushed back into the rack, use a screwdriver to tighten the screws in the alignment plates (front and rear). After the screws are tightened, the rails are secure and correctly aligned.
20. Replace the front bezel. Refer to "Front Bezel Replacement" on page 37. The rail installation is complete.

Step 7: Are All of the Internal Options Installed?

These instructions are for Model B80 systems that have internal options (such as adapters, disk drives, or memory upgrades) already installed. If you have internal options to install, go to “Chapter 3. Installing Options for the 7026 Model B80” on page 29.

Step 8: Install the Cable Management Arm

To install the Model B80 cable management arm, do the following:

1. Place the system drawer in the operating position (see “Returning the Drawer to the Operating Position” on page 32).
2. Place the two captive snap buttons, located on the cable management arm, into the unlocked (pulled out) position.
3. Align and insert the two captive snap buttons into the holes located on the back of the system drawer. Pushing in on the head of the snap buttons lock them into position.

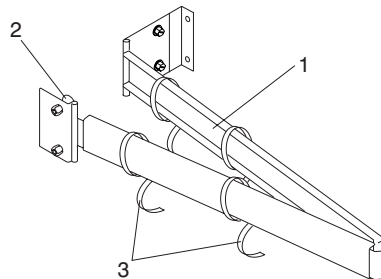

- 1 Cable Management Arm
- 2 Captive Snap Button (Quantity 2)
- 3 Velcro Cable Tie

4. Open the cable management arm so that the hinged mounting plate lies flat against the rack-mounting surface.
5. Align the threaded holes, located on the cable management arm mounting plate, with the holes in the rack-mounting surface.

Note: To avoid any binding of the cable management arm, ensure that the cable management arm is level.

6. Use two screws to secure the cable management arm mounting plate to the rack-mounting surface.

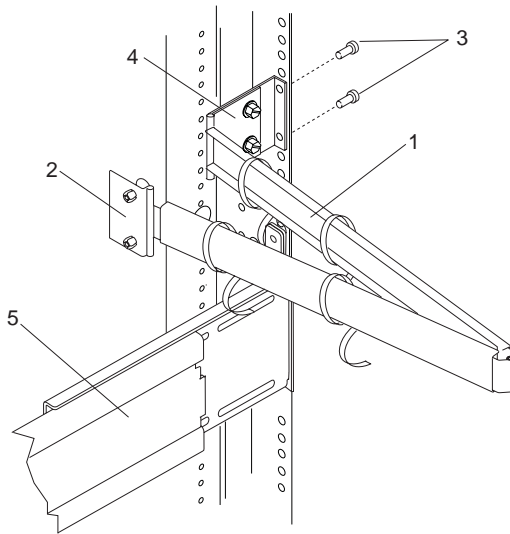

- 1 System Drawer Cable Management Arm
- 2 Cable Management Arm to System Mounting Plate
- 3 Cable Management Arm Mounting Screws (Quantity 2)
- 4 Cable Management Arm to Rack Mounting Plate
- 5 Installed Rack Rail

Step 9: Connect the Optional Keyboard and Mouse

For convenience, when you are cabling the rear of the system drawer, place the drawer in the operating position.

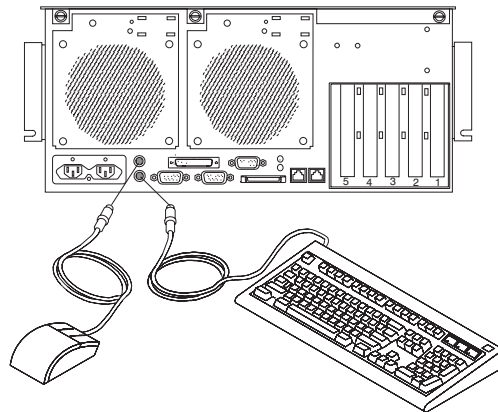

Step 10: Connect the Serial and Parallel Devices

If you have a parallel device (such as a printer), connect it to the parallel connector.

If you have an ASCII terminal, connect it to the serial port identified as serial port 1. If you only have one serial device, connect it to the serial connector S1.

Notes:

1. This system drawer is equipped with a serial port 1 located in the front and rear of the system.
2. To access the front serial port 1, use the RJ45 to 25-pin converter cable supplied with your system.
3. When using the front serial port 1, the rear serial port 1 is deactivated.
4. Use a 9-pin to 25-pin serial converter cable when activating the rear serial port 1. The 9-to-25-pin serial converters are a customer-purchased option.

You can connect additional serial devices to the other two serial ports located at the rear of the system drawer.

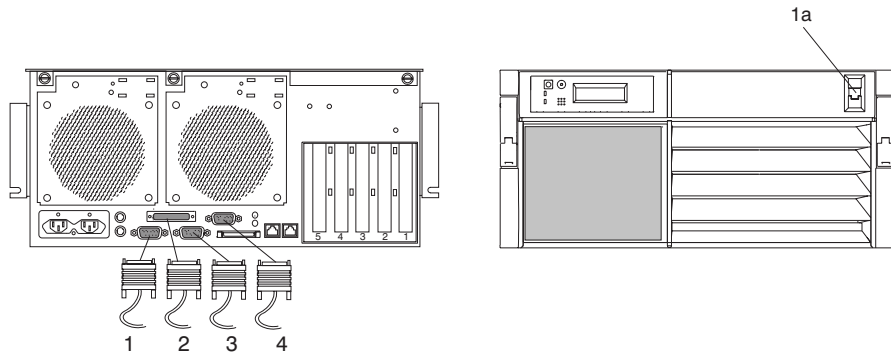

- 1 Serial Port 1 (Rear)
- 1a Serial Port 1 (Front)
- 2 Parallel Port
- 3 Serial Port 2
- 4 Serial Port 3

One RJ45 to 25-pin serial converter is provided with your system drawer. Use this converter when connecting to the front serial port 1. See the previous illustration for the front serial port 1 location.

Step 11: Connect the First External SCSI Device

If you do not have any SCSI devices to attach, skip to “Step 13: Connect a Graphics Display” on page 17.

1. Connect the SCSI cable to the SCSI connector.
2. Connect the other end of the SCSI cable to the SCSI device.
3. If this is the last device connected, connect the SCSI device terminator. If this is not the last device connected, go to the next step.

Note: The built-in SCSI interface is Ultra2 SCSI. When a cable is not attached to the SCSI connector on the server, the connector is automatically terminated.

4. Refer to the SCSI device documentation to set the SCSI device address. For future reference, you can record the address in “Appendix E. System Records” on page 79.

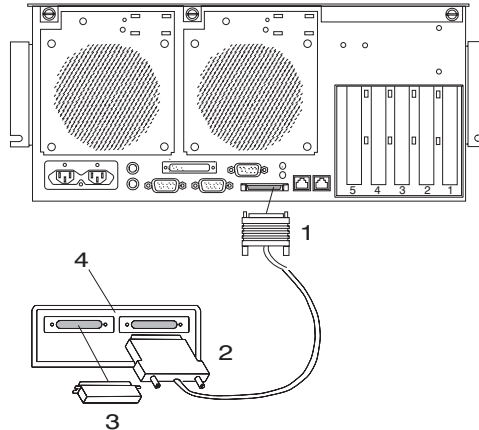

- 1 External SCSI Connector
- 2 SCSI Cable to SCSI Device
- 3 SCSI Terminator
- 4 SCSI Device

Step 12: Connect Any Additional External SCSI Devices

1. Locate the last SCSI device in the chain from the system.
2. Remove the SCSI terminator (1) from the last SCSI device in the chain.
3. Connect the new SCSI cable (2) to the SCSI connector on the last SCSI device.
4. Connect the other end of the SCSI cable (3) to the new SCSI device.
5. Repeat steps 1, 2, and 3 for each additional SCSI device that you attach.
6. Connect the SCSI device terminator (4) to the last SCSI device.
7. Refer to the SCSI device documentation to set the SCSI device address. For future reference, you can record the address in "Appendix E. System Records" on page 79.

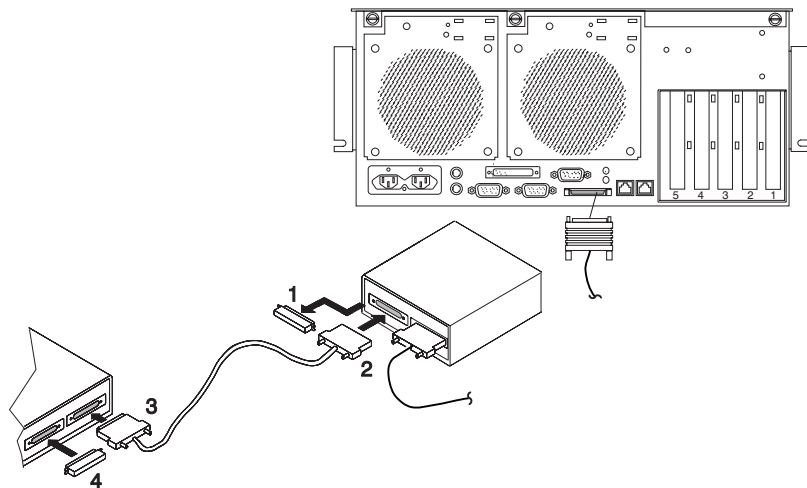

- 1 SCSI Terminator
- 2 SCSI Cable
- 3 SCSI Cable to Last SCSI Device
- 4 SCSI Terminator

Step 13: Connect a Graphics Display

Connect the display cable to the back of the display and to the graphics adapter connector. Consult the "About Your Machine" document for the locations of installed adapters.

For more display instructions, see your display documentation.

Note: Some displays require an additional cable.

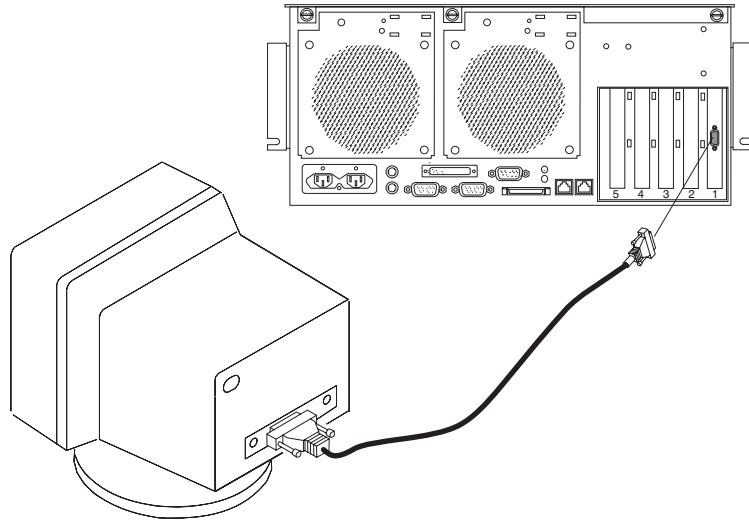

Step 14: Attach the Display Cable Toroid

If the cable for your display does not include a toroid, locate the toroid shipped with your server and follow the installation instructions included with the toroid.



Step 15: Connect the Adapter Cables

If you are using any optional adapters (such as token-ring or 8-port EIA-232), connect the cables to the appropriate connectors in slots 1 through 5. See the following illustration for adapter slot locations.

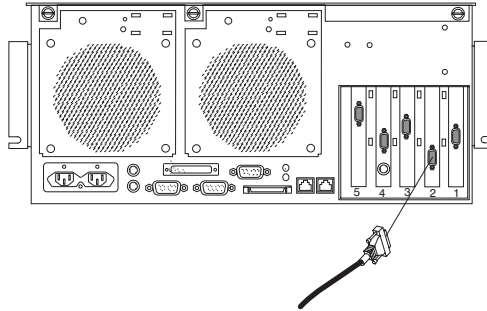

Step 16: Connect to the Internal Ethernet

If you are not using internal Ethernet, go to “Step 17: Plug in the Power Cables” on page 19.

This system is equipped to use Twisted-Pair (100/10 Base T) Ethernet. Internal Ethernet supports Network Installation Management (NIM).

Note: The twisted-pair connector is compatible with the IEEE 802.3 Ethernet network (100/10 Base T link enabled)

Connect the twisted-pair cable to one of two RJ45 connectors located on the rear of the system drawer. See the following illustration for RJ45 connector locations.

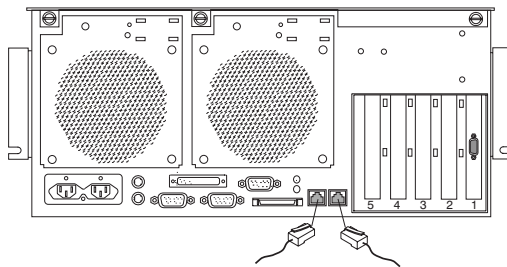

Step 17: Plug in the Power Cables

1. Plug the power cables into the server, display, and attached devices.

Notes:

- a. This system drawer could be equipped with two power supplies. Each power supply needs its own power cable.
- b. If your system is equipped with only one power supply, connect the power cable to the left power receptacle, labeled PS1. The second power receptacle labeled PS2 is used when a second (redundant) power supply has been added to the system drawer. See the following illustration.
- c. If you are using dc to power your system drawer, you need to have a dc power distribution source. The dc power distribution source can be ordered with the rack or supplied by the customer.

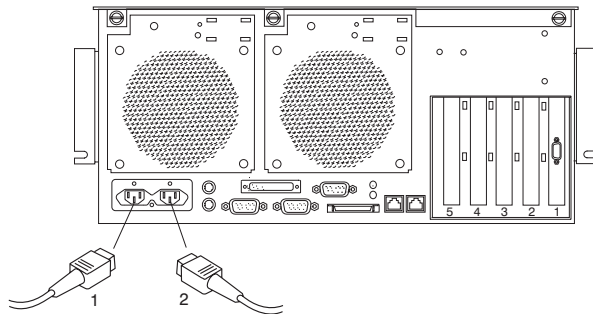

- 1 Default Power Supply Cable
- 2 Redundant Power Supply Cable

2. Plug the power cables into electrical outlets.

Note: If you are using dc voltage to power your system drawer plug the dc power cables into the dc power source.

CAUTION:

This product is equipped with a three-wire power cable and plug for your safety. Use this power cable with a properly grounded electrical outlet to avoid electrical shock.

3. If you removed the rack doors earlier, replace the doors.

Step 18: Attaching Cables to the Cable Management Arm

To attach the external cables to the cable management arm, do the following:

1. Pull the system out of the rack and place it in the service position. The rails should have locked in the fully extended position with a click.

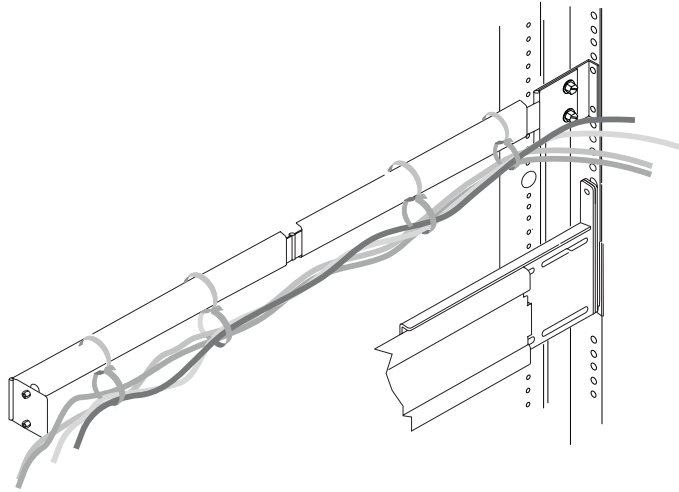

2. Loosely wrap the velcro strips around the external cables. The velcro strip came premounted on your cable management arm.

Note: To allow for cable movement, *do not* tightly wrap the velcro strip around the cables.

Step 19: Start Your System

1. If an operating system has been preinstalled in your Model B80 system, or if you plan to install one now, refer to the operating system installation documentation.

Note: Operating system installation is handled in one of the following ways:

- Preinstalled at the manufacturing site.
 - Installable from a CD-ROM if a CD-ROM drive is installed. The CD-ROM drive is a customer-installable option for the Model B80.
 - Installable from a NIM server. Refer to *Network Installation Management Guide and Reference* for information on installing your operating system from a NIM server.
2. Power on the system.
Perform the following steps to power on the system.
 - a. Look for 0K in the operator panel display, which indicates that the system is in standby mode. The green power LED should be blinking slowly.
 - b. Press the power button on the operator panel. The power LED on the operator panel stops blinking and stays on. Exxx checkpoints appear in the operator panel display.

Step 20: Configure NIM Server

Notes:

1. All operations to configure the NIM server require root access.
2. If you replace the network adapter in the client, the network adapter hardware address for the client needs to be updated on the NIM server.
3. The **Control State (Cstate)** for standalone clients on the NIM server should be kept in the *diagnostic boot has been enabled* state.
4. On the client system, the NIM server network adapter should be put in the bootlist after the boot disk drive. This allows the system to boot up in standalone diagnostics from the NIM server should there be a problem booting from the disk drive. Refer to the **Multiboot** section under SMS in the client system's service guide for information on setting the bootlist.

To verify that the client system is registered on the NIM server and diagnostic boot is enabled, run the following command on the NIM server:

```
lsnim -a Cstate -Z ClientName
```

and refer to the following table for system responses.

Note: The `ClientName` is the name of the system you want to run standalone diagnostics on.

Response System	Status Client
<code>#name:Cstate: ClientName: diagnostic boot has been enabled:</code>	The client system is registered on the NIM server and enabled to run diagnostics from the NIM server.
<code>#name:Cstate: ClientName: for a NIM operation:</code> or <code>#name:Cstate: ClientName:BOS installation has been enabled:</code>	The client system is registered on the NIM server but not enabled to run standalone diagnostics from the NIM server. Note: If the client system is registered on the NIM server but Cstate has not been set, no data will be returned.
<code>0042-053 lsnim: there is no NIM object named "ClientName"</code>	The client is not registered on the NIM server.

Refer to the *Network Installation Management Guide and Reference* for information on doing the following:

- Register a client on the NIM server.
- Enable a client to run diagnostics from the NIM server.

Refer to “Appendix D. Running Standalone Diagnostics from a Network Installation Management (NIM) Server” on page 77 for information on running standalone diagnostics.

Step 21: Run System Verification

- If your system displays the logon prompt and you want to test your hardware, go to “Chapter 2. Verifying the Hardware Operation” on page 25.
- If the logon prompt does not display, recheck your installation procedures and try starting your system again.
- If your system fails, call your service representative.

Chapter 2. Verifying the Hardware Operation

The system verification procedure checks the system for correct hardware operation. Use this procedure to verify that your system is set up correctly. If you have a problem with your system in the future, use this procedure to test the system hardware to help you determine if you have a hardware problem. Run the system verification procedure as described in the following steps.

Step 1. Considerations Before Running This Procedure

Read the following before using this procedure:

- The AIX operating system must be installed on your system before you attempt to perform this procedure.
- If this system unit is directly attached to another system unit or attached to a network, be sure communication with the other systems is stopped.
- This procedure requires use of all of the system resources. No other activity can be running on the system while you are performing this procedure.
- This procedure requires a display connected to a graphics adapter, or an ASCII terminal attached to the S1 port.
- This procedure runs the AIX Online Diagnostics in Service mode. If the system console is an ASCII terminal, see the documentation for your type of ASCII terminal to find the key sequences you need in order to respond to the diagnostics.
- If a console display is not selected, the diagnostics stop. The instructions for selecting a console display are displayed on all of the graphic displays and any terminal attached to the S1 port. Follow the displayed instructions to select a console display.

Step 2. Loading the Diagnostics

Note: If the system is in Standby mode (Power-On LED on the operator panel is slowly blinking and the operator panel displays 0K), skip the first three steps of this procedure. If the system is running, and you do not want to shut it down, begin with step 6.

1. Stop all application programs running on the operating system.
2. Stop the operating system by logging on as root user and typing shutdown.
3. Wait for the system to go into Standby mode.
 - The operator panel LED starts to blink at a slow rate.
 - 0K message appears in the operator panel.

The figure below shows the operator panel and the locations of operator panel components that are referred to in this procedure.

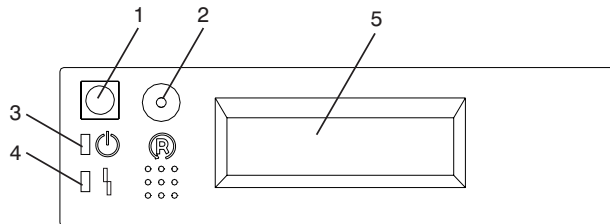

- 1 Power On/Off Button
- 2 Reset Button
- 3 Power On LED
- 4 System Attention LED
- 5 Operator Panel Display

4. If you are loading the diagnostics and running them from an ASCII terminal, do the following:
 - Set the attributes for the terminal to match the defaults of the diagnostics.
 - If you need to change any settings, record the normal settings, and be sure the terminal attributes are set to work with the diagnostics. If needed, see the documentation for your terminal hardware for terminal attributes.
5. Turn on the power by pressing the Power On/Off button once. Wait for the AIX operating system to load.
6. Log in as root user.
7. Type `diag` at the command prompt.
8. Follow the displayed instructions to select a console.
9. When the Diagnostic Operating Instructions display, see “Step 3. Running the Verification Procedure” on page 27.

If you are unable to load the diagnostics to the point when the Diagnostic Operating Instructions display, call your support center for assistance.

Step 3. Running the Verification Procedure

When the Diagnostic Operating Instructions display, do the following to run system verification:

1. Press Enter.
2. If the terminal type has not been defined, you must use the **Initialize Terminal** option on the Function Selection menu to initialize the operating system environment before you can continue with the diagnostics.
3. If you want to do a general checkout, with minimal operator action, select the **Diagnostic Routines** option on the Function Selection menu.

If you want to do a more complete checkout, including the use of wrap plugs, select the **Advanced Diagnostics** option on the Function Selection menu. The advanced diagnostics are primarily for the service representative; the diagnostics may instruct you to install wrap plugs to better isolate a problem.

4. Select the **System Verification** option on the Diagnostic Mode Selection menu.
5. If you want to run a general checkout of all installed resources, select the **All Resource** option on the Diagnostic Selection menu.

If you want to check one particular resource, select that resource on the Diagnostic Selection menu.

The checkout programs end with either of the following results:

- The Testing Complete menu displays with a message stating No trouble was found.
- The A Problem Was Detected On (Time Stamp) menu displays, with either a service request number (SRN) or an error code. Make a note of any codes displayed on the display or operator panel.

Step 4. Performing Additional System Verification

To perform additional system verification, do the following:

1. Press Enter to return to the Diagnostic Selection menu.
2. If you want to check other resources, select the resource. When you have checked all of the resources you need to check, go to "Step 5. Stopping the Diagnostics".

Step 5. Stopping the Diagnostics

To stop the diagnostics, do the following:

1. Press F10 to exit the diagnostics.
2. If you changed any attributes on your ASCII terminal to run the diagnostics, change the settings back to normal.
3. This completes the system verification. If the system failed any of the diagnostic tests, call your service representative. If you received an error code, record the code and report it to the service organization.

If the system passed all the diagnostic tests, the verification process is complete and your system is ready to use. If power is still on, turn off the power.

Chapter 3. Installing Options for the 7026 Model B80

This chapter provides instructions to help you add options to your system. Some option removal instructions are provided, in case you need to remove one option to install another. If you have several internal options to install, these instructions enable you to add them all at one time.

Before performing any of the installation and removal procedures in this chapter, read the following notice.

Safety Considerations

Observe the following safety precautions anytime you work with this system unit.

DANGER

An electrical outlet that is not correctly wired could place hazardous voltage on metal parts of the system unit or the devices that attach to the system unit. It is the responsibility of the customer to ensure that the outlet is correctly wired and grounded to prevent an electric shock.

Before installing or removing signal cables, ensure that the power cables for the system drawer and all non hot-plug attached devices are unplugged.

When adding or removing any additional devices to or from the system, ensure that the power cables for those devices are unplugged before the signal cables are connected. If possible, disconnect all power cables from the existing system unit before you add a device.

Use one hand, when possible, to connect or disconnect signal cables to prevent a possible shock from touching two surfaces with different electrical potentials.

During an electrical storm, do not connect cables for display stations, printers, telephones, or station protectors for communications lines.

CAUTION:

This system drawer uses 3-wire power cables and plugs for the user's safety. Use these power cables with properly grounded electrical outlets to avoid electrical shock.

CAUTION:

This unit has more than one power cord. To reduce the risk of electrical shock, disconnect two power supply cords before servicing.

Note: This unit will only have two power cords if the redundant power supply feature is installed.

Handling Static-Sensitive Devices

Attention: Adapters, planars boards, and disk drives are sensitive to static electricity discharge. These devices are wrapped in antistatic bags to prevent this damage.

Take the following precautions:

- If you have an antistatic wrist strap available, use it while handling the device.
- Do not remove the device from the antistatic bag until you are ready to install the device in the system unit.
- With the device still in its antistatic bag, touch it to a metal frame of the system drawer.
- Grasp cards and boards by the edges. Hold drives by the frame. Avoid touching the solder joints or pins.
- If you need to lay the device down while it is out of the antistatic bag, lay it on the antistatic bag. Before picking it up again, touch the antistatic bag and the metal frame of the system unit at the same time.
- Handle the devices carefully to prevent permanent damage.

Stopping the System Unit

Attention: When shutting down your system to install options, shut down all applications first and then shut down the operating system. The system power turns off and the system goes into Standby mode when the operating system is shut down. Before removing power from the system unit, ensure that the shutdown process is complete. Failure to do so can result in the loss of data. Some option-installation procedures do not require the system to be stopped for installation. If necessary, the option-installation procedures in this section will direct you here if stopping the system is required.

1. Log in to the system as root user.
2. Stop any applications that are running on the system.
3. At a command line, type shutdown to stop the operating system.
4. After you shut down the operating system, set the power switches of any attached devices to Off.
5. The shutdown procedure stops the operating system, removes power from parts of the system, and puts the system into Standby mode.
The OK prompt displays on the operator panel.

Placing the Drawer in the Service Position

Follow these steps to place a drawer in the service position.

Attention: Before placing the drawer in the service position, ensure that the rack is either bolted to the floor or that a stabilizer bar is correctly attached to the front base of the rack unit. Do not place a system drawer into an unstabilized rack.

1. Open the front door of the rack.
2. Lift the lower section of the release latches, which are located on each side of the system drawer. See the following illustration.

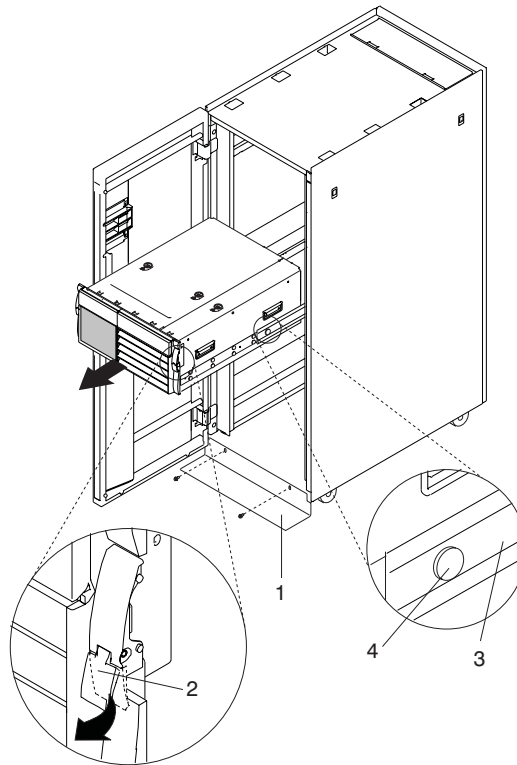

- 1 Stabilizing Bar
2 Release Latch in the Release Position

3. Grasp the top section of both latches and pull the drawer out until the rails are fully extended.

Note: The rails are fully extended and in the locked position when the two spring-loaded release buttons, located on each of the rails, click into the detents located on the fixed portion of the rail.

Returning the Drawer to the Operating Position

To place the drawer back into the operating position, do the following:

1. Press in both spring-loaded release buttons. The buttons are located on the slide rails that are mounted to each side of the drawer.
2. Push the drawer straight back into the rack until both front latches have locked into position.
3. Replace the door if it had been previously removed.
4. Close the rack door.

Removing and Replacing Covers

Before performing these procedures, read “Safety Considerations” on page 29.

Main Chassis Cover Removal

To remove the main chassis cover, do the following:

1. If you have not already done so, shut down the system as described in “Stopping the System Unit” on page 30
2. If you have not already done so, unplug the system unit power cable from the electrical outlet.
3. Open the rack door.
4. Place the drawer in the service position as described in “Placing the Drawer in the Service Position” on page 31.
5. Loosen the two captive thumbscrews located on the rear of the cover. See the illustration on page 33 for thumbscrew locations.
6. Use the two thumb rings on the cover to slide the cover toward the rear of the system unit. The movement releases both the front and rear edges of the main chassis cover.
7. Push the cover to the left about one-half inch to release the left edge of the cover from the chassis.
8. Lift the cover from the system drawer after the cover's front, rear, and left edges have cleared the chassis.

Note: The cover must be lifted straight up to clear the foam blades attached to the underside of the cover.

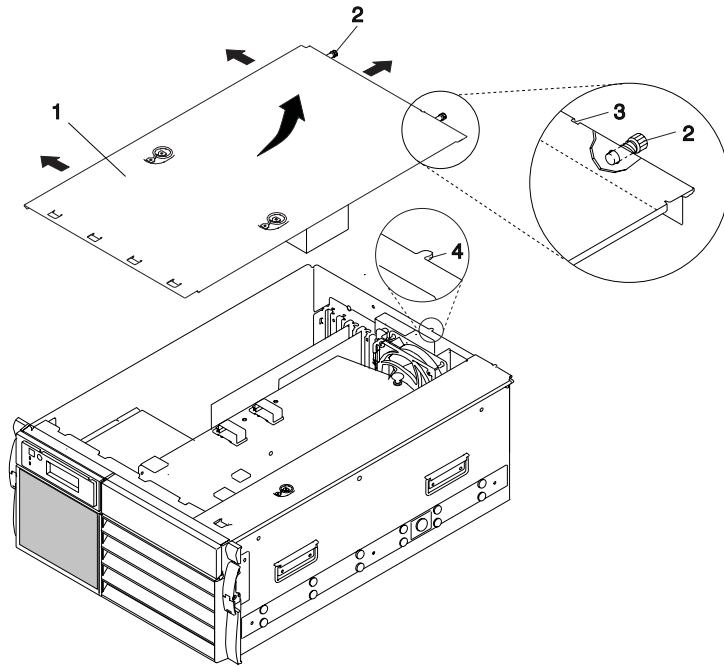

- 1 Main Chassis Cover
- 2 Captive Thumbscrew
- 3 Rear Alignment Tab Slot
- 4 Rear Alignment Tab

Main Chassis Cover Replacement

To replace the main chassis cover, do the following:

1. Carefully align the main chassis cover on top of the system drawer.
 - a. Push the left edge of the main chassis cover onto the left edge of the chassis.
 - b. Place the overhang on the right side, inside the chassis, while the back edge containing the thumbscrews remains outside and seats against the rear chassis wall.
2. Slide the cover toward the front of the chassis, ensuring that the cover lays flat against the chassis. The front tabs of the cover slide under the top front edge of the chassis and the rear alignment tab slides into the rear alignment tab slot.
3. Align the two captive thumbscrews with the screw holes on the back of the chassis and tighten the thumbscrews.
4. Place the system drawer back in the operating position as described in "Returning the Drawer to the Operating Position" on page 32.

Power Supply Chassis Cover Removal

To remove the power supply chassis cover, do the following:

1. Place the system drawer in the service position as described in “Placing the Drawer in the Service Position” on page 31.
2. Loosen the captive thumbscrew located on the rear of the cover. See the illustration on page 34 for the thumbscrew location.
3. Use the thumb ring on the cover to slide the cover toward the rear of the system. The movement releases both the front and rear edges of the power supply chassis cover.
4. Push the cover to the right about one-half inch to release the right edge of the cover from the chassis.
5. Lift the cover from the system drawer after the cover’s front, rear, and right edges have cleared the chassis.

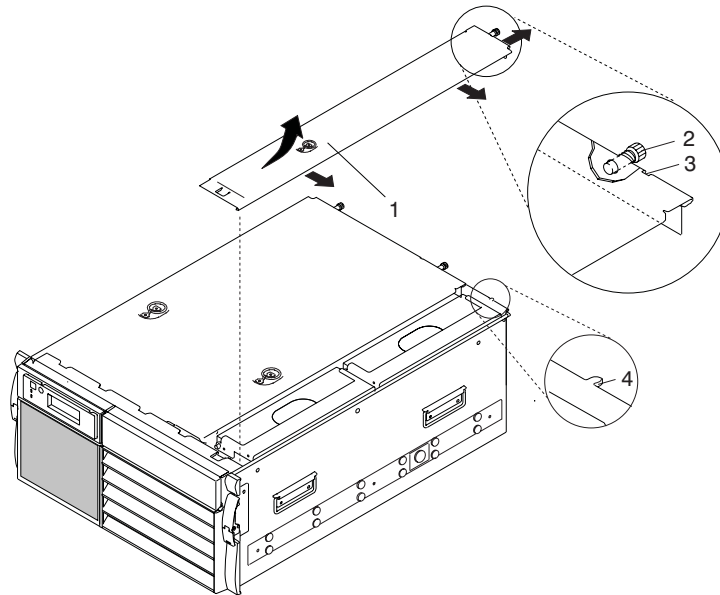

- 1 Power Supply Chassis Cover
- 2 Captive Thumbscrew
- 3 Rear Alignment Tab Slot
- 4 Rear Alignment Tab

Power Supply Chassis Cover Replacement

To replace the power supply chassis cover, do the following:

1. Carefully align the cover on top of the system drawer.
 - a. Push the right edge of the power supply chassis cover onto the right edge of the chassis.
 - b. Place the overhang on left side of the cover, inside the chassis, while the back edge containing the thumb screw remains outside, seating against the rear chassis wall.
2. Slide the cover toward the front of the chassis, ensuring that the cover lays flat against the chassis. The front tab of the cover slides under the top front edge of the chassis and the rear alignment tab slides into the rear alignment tab slot.
3. Align the captive thumbscrew with the screw hole on the back of the chassis and tighten the thumbscrew.
4. Place the system drawer back in the operating position as described in "Returning the Drawer to the Operating Position" on page 32.

Front Bezel Removal

Note: Removing the front bezel is necessary only when installing or removing any of the following:

- Disk drives
- Optional CD-ROM or tape drive
- Operator panel
- Front fans

To remove the front cover bezel, do the following:

1. Open the rack door.
2. Grasp the front bezel on each side and carefully pull it back toward you. Note the finger detents, located on each side of the bezel. Insert one of your fingers into each detent as you pull the bezel away from the chassis. The detents are designed to keep your hands from slipping away from the bezel as you remove it. See the following illustration.
3. Store the bezel in a safe place.

Note: The front bezel helps suppress EMC emissions and *must* be placed back onto the system drawer after servicing.

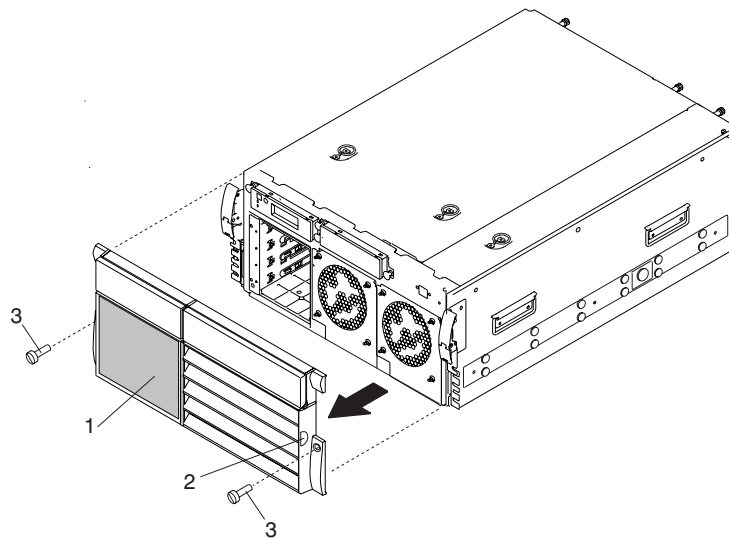

- 1 Front Bezel
- 2 Finger Detent

Front Bezel Replacement

To replace the front bezel, do the following:

1. Align the studs located on each end of the bezel cover with the holes located on each side of the front of the chassis.
2. Push the cover in until it is seated against the chassis.

Media Bay Tray Removal

To remove the media bay tray, do the following:

1. Remove the front bezel as described in “Front Bezel Removal” on page 36.
2. Locate the media bay tray, as shown in the following illustration.

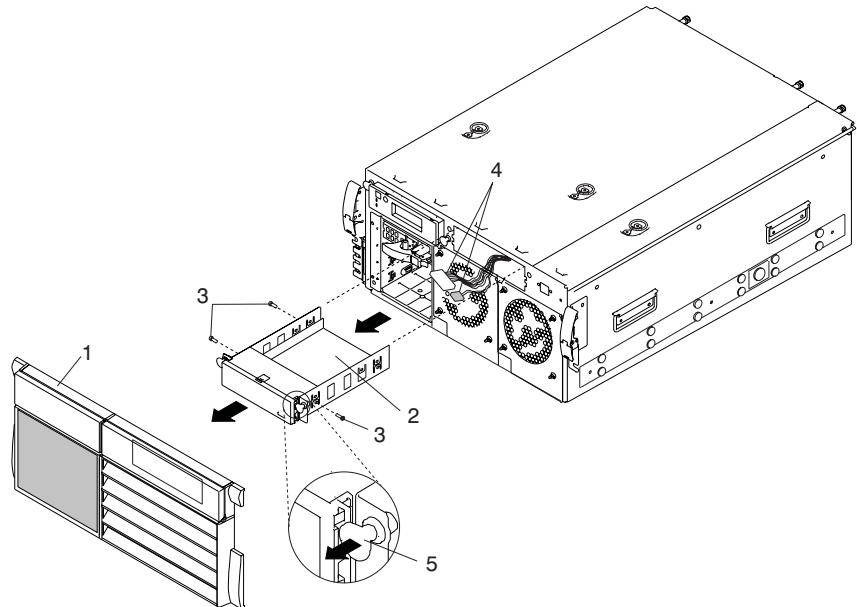

- 1 Front Bezel
- 2 Media Bay Tray Assembly
- 3 Media Bay Tray Screws (3 to 4)
- 4 Media SCSI and Power Cable
- 5 Media Bay Tray Snap Button

3. Pull out the media bay tray snap buttons and carefully pull out the media bay tray.

Note: The media cables are secured to the media bay tray.

Option List

Choose an option from the list below and go to the procedure for the option you are installing or removing.

- PCI Adapter Options, see page 39.
 - Installing Adapter Cards, see page 39.
 - Removing Adapter Cards, see page 41.
- System Memory Options, see page 44.
 - Installing Memory Cards, see page 44.
 - Removing Memory Cards, see page 46.
 - Installing Memory Modules, see page 48.
 - Removing Memory Modules, see page 49.
- Installing a Processor Card, see page 50.
- Removing a Processor Card, see page 52.
- Disk Drive Options, see page 55.
 - Installing a Hot-Plug Disk Drive, see page 55.
 - Removing a Hot-Plug Disk Drive, see page 56.
 - Configuring Disk Drives, see page 59.
- Installing the Redundant Power Supply, see page 60.
- Installing a CD-ROM Drive or Tape Drive, see page 62.
- Replacing the Battery, see page 63.

PCI Adapter Options

Before performing these procedures, read “Safety Considerations” on page 29.

Note: Before handling any card, board, or memory module, touch any metal surface of the chassis with one hand to minimize static electric discharge. Refer to “Handling Static-Sensitive Devices” on page 30.

Installing Adapters

To install an adapter, do the following:

1. If you have not already done so, shut down the system as described in “Stopping the System Unit” on page 30.
2. If you have not already done so, unplug the system unit power cable from the electrical outlet.
3. Open the front and rear rack doors.
4. Unplug all power cables from the rear of the system drawer.
5. Place the system drawer into the service position as described in “Placing the Drawer in the Service Position” on page 31.
6. Remove the main chassis cover as described in “Main Chassis Cover Removal” on page 32.
7. Refer to the *PCI Adapter Placement Reference* for information regarding slot restrictions for adapters that can be used in this system.
8. If you are installing a new adapter in an empty slot, remove the adapter bracket thumbscrew and slide out the expansion slot cover. See the illustration on page 40.

Note: Do not discard the expansion slot cover.

9. Carefully grasp the adapter by the edges and align the adapter with the expansion slot and connector.
10. Press the adapter firmly into the connector.
11. Use the thumbscrew you removed earlier from the expansion slot cover or previous adapter to secure the adapter card bracket to the system unit.
12. If you have other options to install, refer to “Option List” on page 38.
13. If you do not have other options to install, continue with the next step.
14. Replace the main chassis cover as described in “Main Chassis Cover Replacement” on page 33.
15. Push the system drawer back to its operating position as described in “Returning the Drawer to the Operating Position” on page 32.
16. Reconnect all cables.
17. Route cables through the cable management arm.
18. Turn on the power.
19. Close the rack doors.

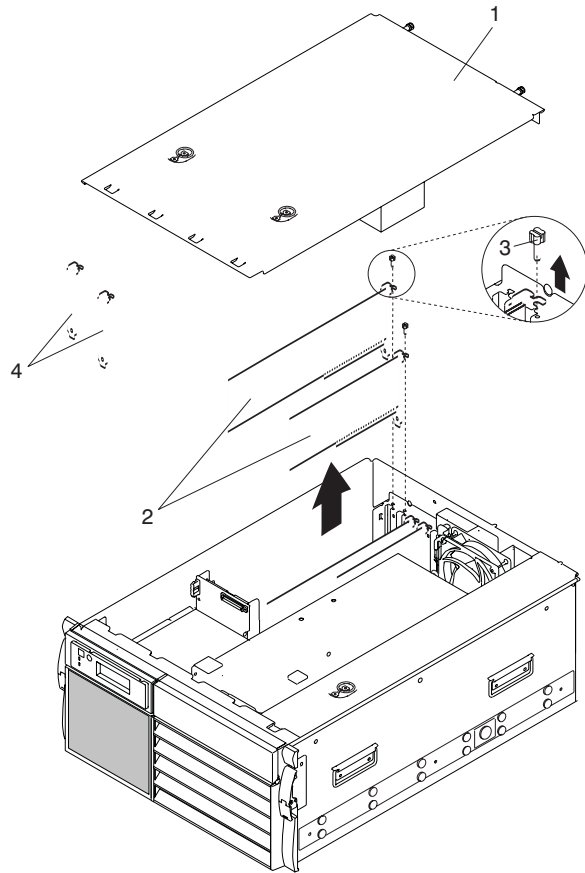

- 1 System Drawer Main Chassis Cover
- 2 Adapter Card (Up to 5)
- 3 Adapter Bracket Retaining Thumbscrew (1 per Adapter)

Removing Adapters

To remove an adapter, do the following:

1. If you have not already done so, shut down the system as described in “Stopping the System Unit” on page 30.
2. If you have not already done so, unplug the system unit power cable from the electrical outlet.
3. Open the front and rear rack doors.
4. Unplug all power cables from the rear of the system drawer.
5. Record the slot number and location of the adapter being removed.

Note: Adapter slots are numbered on the rear of the system drawer, from right to left, one through five.

6. Label and disconnect all cables attached to the adapter being removed.
7. Place the system drawer into the service position as described in “Placing the Drawer in the Service Position” on page 31.
8. Remove the main chassis cover as described in “Main Chassis Cover Removal” on page 32.
9. Locate the adapter.
10. Remove the adapter bracket retaining thumbscrew. See the illustration on page 40.
11. Carefully remove the adapter from the system drawer, and store it in a safe place.
12. If you are not installing another adapter into this slot location, replace the expansion slot cover and thumbscrew, if available. If you are installing another adapter, go to “Installing Adapters” on page 39.
13. If you have other options to install, refer to “Option List” on page 38.
14. If you do not have other options to install, continue with the next step.
15. Replace the main chassis cover as described in “Main Chassis Cover Replacement” on page 33.
16. Push the system drawer back to its operating position as described in “Returning the Drawer to the Operating Position” on page 32.
17. Reconnect all cables.
18. Turn on the power.
19. Close the rack doors.

Central Electronics Complex (CEC) Cover

Before performing these procedures, read “Safety Considerations” on page 29.

CEC Box Cover Removal

To remove the CEC box cover, do the following:

1. Remove the front bezel as described in “Front Bezel Removal” on page 36.
2. Remove the main chassis cover as described in “Main Chassis Cover Replacement” on page 33.
3. Remove the media bay tray as described in “Media Bay Tray Removal” on page 37.
4. Remove the cables from the cable clips on top of the CEC box cover.
5. Retract the captive snap button, located on the back of the CEC box cover. See the illustration on page 42 for location.
6. Slide the cover back to release the front tabs from the CEC box.
7. Lift the cover from the system drawer.
8. Return to the procedure that sent you here.

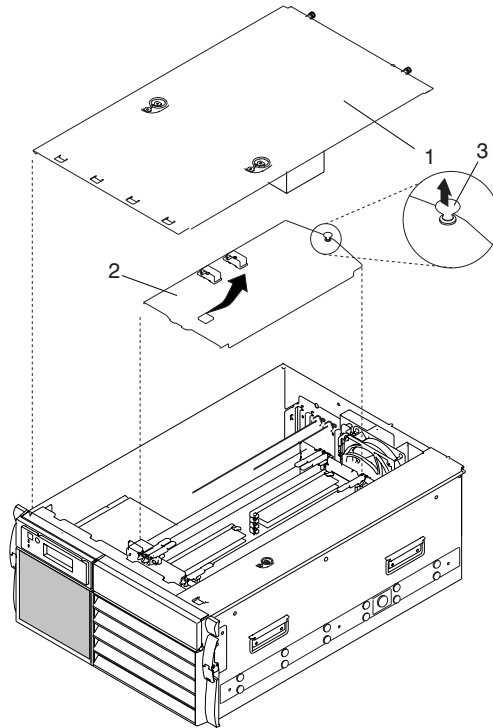

- 1 System Drawer Main Chassis Cover
- 2 CEC Box Cover
- 3 Snap Button

CEC Box Cover Replacement

To replace the CEC box cover, do the following:

1. Place the CEC box cover on top of the CEC box.
2. Ensure the snap button located on the back of the cover is in the retracted position.
3. Slide the cover forward, inserting the cover tabs into the slots located on the CEC box.
4. Push in the snap button, securing the cover.
5. Replace the media bay tray.
6. Place the cables in the cable clips on top of the CEC box cover.
7. Replace the main chassis cover as described in "Main Chassis Cover Replacement" on page 33.
8. Replace the front bezel.
9. Place the system drawer into the operating position as described in "Returning the Drawer to the Operating Position" on page 32.

System Memory Options

Note: Before handling any card, board, or memory module, touch any metal surface of the chassis with one hand to minimize static electric discharge. Refer to “Handling Static-Sensitive Devices” on page 30.

Before performing these procedures, read “Safety Considerations” on page 29.

Installing Memory Cards

To install a memory card, do the following:

1. If you have not already done so, shut down the system as described in “Stopping the System Unit” on page 30.
2. Open the rear rack door.
3. Unplug all power cables from the rear of the system drawer.
4. Place the system drawer into the service position as described in “Placing the Drawer in the Service Position” on page 31.
5. Remove the main chassis cover as described in “Main Chassis Cover Removal” on page 32.
6. Remove the front bezel as described in “Front Bezel Removal” on page 36.
7. Remove the media bay tray. Refer to “Media Bay Tray Removal” on page 37 for location.
8. Remove the CEC box cover as described in “CEC Box Cover Removal” on page 42.
9. Open the camming levers (and remove the air flow baffle if installed). Camming levers are in the correct position to receive a memory card when *both* levers are standing straight in an upright position. See the following illustration.

Attention: To prevent damage to the card and to the card connectors, open or close both camming levers at the same time.

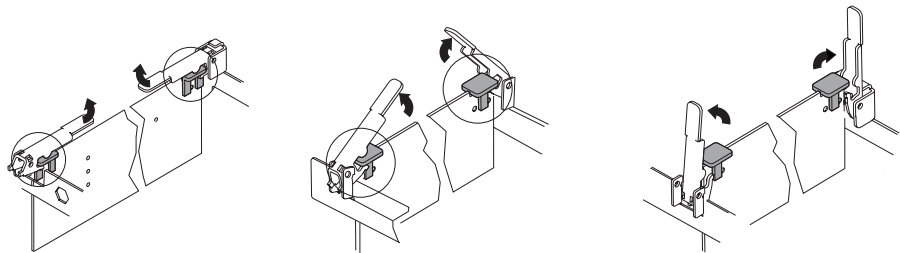

10. Remove the connector dust cover, if supplied. See the illustration on page 47.
11. Align the card with the connector.

12. Close the camming levers, securing the card into the connector.

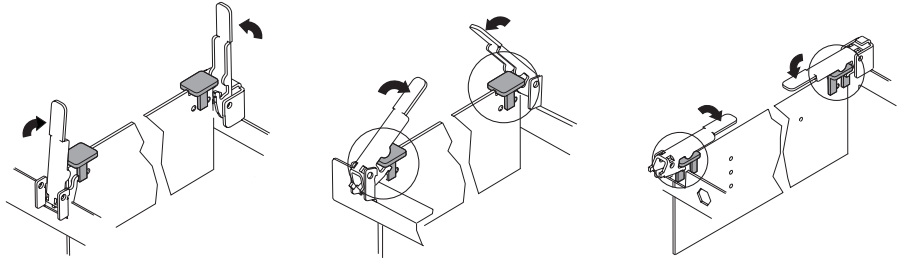

13. Make sure that the tabs on the new card are captured by the levers as shown in the following illustration.

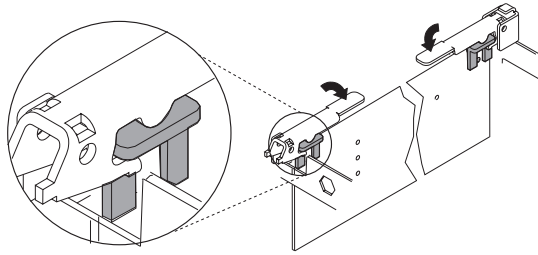

Note: After you have locked the camming levers, push the card in with your thumbs to ensure the card is properly seated.

14. If you have other options to install, refer to “Option List” on page 38.
15. If you do not have other options to install, continue with the next step.
16. Replace the CEC box cover as described in “CEC Box Cover Replacement” on page 43.
17. Replace the media bay tray.
18. Replace the front bezel as described in “Front Bezel Replacement” on page 37.
19. Replace the main chassis cover as described in “Main Chassis Cover Replacement” on page 33.
20. Reconnect the system drawer power cables.
21. Push the system drawer back into the operating position as described in “Returning the Drawer to the Operating Position” on page 32.
22. Turn on the power.
23. Close the rack door.

Removing Memory Cards

To remove a memory card, do the following:

1. If you have not already done so, shut down the system as described in “Stopping the System Unit” on page 30.
2. If you have not already done so, unplug the system unit power cable from the electrical outlet.
3. Open the rack door.
4. Unplug all power cables from the rear of the system drawer.
5. Place the system drawer into the service position as described in “Placing the Drawer in the Service Position” on page 31.
6. Remove the main chassis cover as described in “Main Chassis Cover Removal” on page 32.
7. Remove the front bezel as described in “Front Bezel Removal” on page 36.
8. Remove the media bay tray. Refer to “Media Bay Tray Removal” on page 37 for location.
9. Remove the CEC box cover as described in “CEC Box Cover Removal” on page 42.
10. The card is secured in place with camming levers at the corners of the memory card.
Attention: To prevent damage to the card and to the card connectors, open both camming levers at the same time.
11. Open the card camming levers and remove the card. When the camming levers are fully unlocked and placed in a position as shown in the illustration on page 47, the card automatically is unseated from its connector.
12. Carefully remove the memory card and place it in a safe location.
13. If you have other options to install, refer to “Option List” on page 38.
14. If you do not have other options to install, continue with the next step.
15. Replace the CEC box cover as described in “CEC Box Cover Replacement” on page 43.
16. Replace the media bay tray.
17. Replace the front bezel as described in “Front Bezel Replacement” on page 37.
18. Replace the main chassis drawer cover as described in “Main Chassis Cover Replacement” on page 33.
19. Reconnect the system drawer power cables.
20. Push system drawer back into the operating position as described in “Returning the Drawer to the Operating Position” on page 32.
21. Turn on the power.
22. Close the rack door.

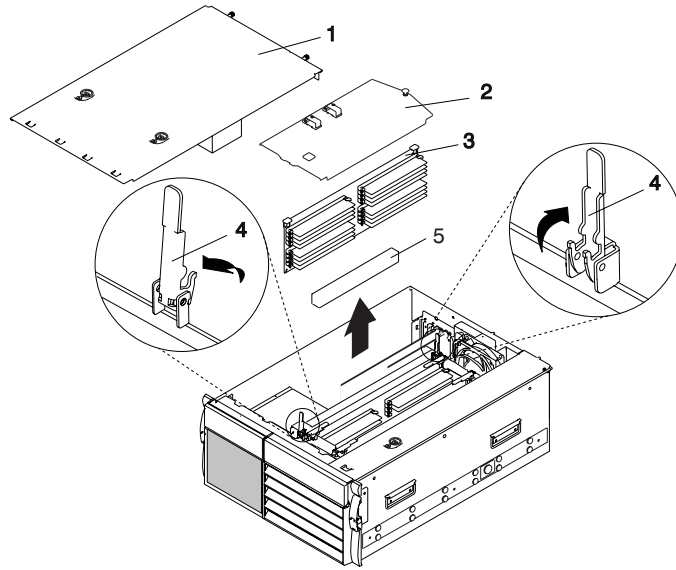

- 1 System Drawer Main Chassis Cover
- 2 CEC Box Cover
- 3 System Memory Card
- 4 Camming Lever
- 5 Connector Dust Cover

Installing Memory Modules

Note: Memory pairs must be the same size and type. Memory modules must be installed in pairs and in the correct slot configuration. For example slots, J1 and J2 are a pair, and slots J3 and J4 are a pair. This pairing goes through to and includes slots J15 and J16. See the illustration in step 4 on page 49.

To install a memory module, do the following:

1. If you have not already done so, shut down the system as described in “Stopping the System Unit” on page 30.
2. If you have not already done so, unplug the system unit power cable from the electrical outlet.
3. Remove the memory card as described in “Removing Memory Cards” on page 46.
4. With one hand, touch any metal surface of the chassis to minimize static electric discharge, and then pick up the memory module.
5. Locate the memory module connector on the memory card.
6. Ensure that the connector locking tabs are pushed out in the unlocked position before installing a new memory module, as shown in the following illustration.
7. Insert the memory module firmly into the connector. The locking tabs located on each end of the memory module connector should have moved back into the locked position.

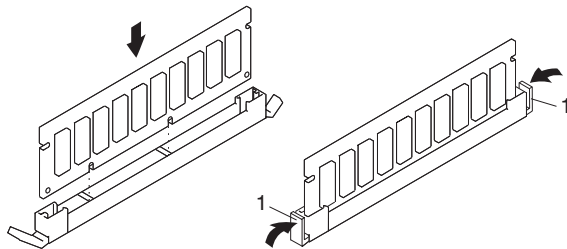

8. Ensure that the locking tabs are in the secure position. (Tabs are in the secure position when they are parallel to the side of the connector.)
9. Complete this procedure by following “Installing Memory Cards” on page 44.

Removing Memory Modules

Note: Memory modules are located on the memory boards. The memory modules must be removed in pairs as shown in step 4.

To remove a memory module, do the following:

1. If you have not already done so, shut down the system as described in “Stopping the System Unit” on page 30.
2. If you have not already done so, unplug the system unit power cable from the electrical outlet.
3. Remove the memory card as described in “Removing Memory Cards” on page 46.
4. Use the following illustration to locate and determine which memory modules you are removing.

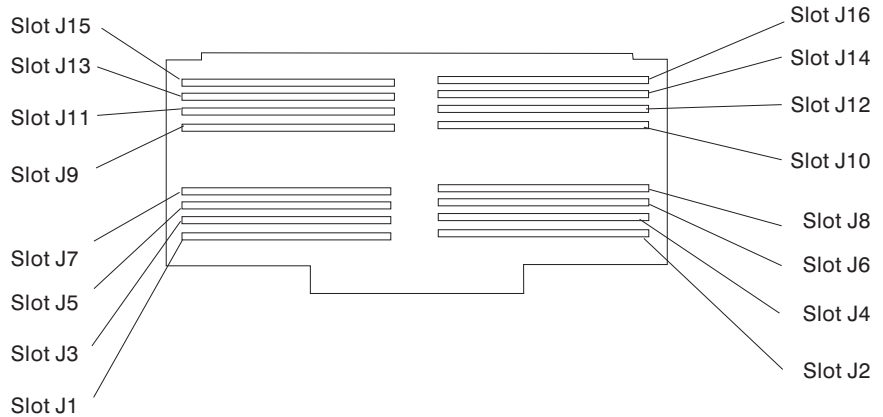

5. Remove the memory module by pushing the tabs out and then down. The camming action of the tabs begins forcing the memory module out of the connector.
6. Pull the memory module out of the connector.

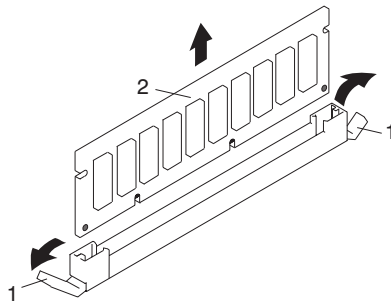

7. If you want to install memory modules, refer to “Installing Memory Modules” on page 48.
8. Complete this procedure by following “Installing Memory Cards” on page 44.

Processor Card

Before performing these procedures, read “Safety Considerations” on page 29.

Note: Before handling any card, board, or memory module, touch any metal surface of the chassis with one hand to minimize static electric discharge. Refer to “Handling Static-Sensitive Devices” on page 30.

Installing a Processor Card

Attention: Installing a new processor card into your system unit may require updating the firmware. Refer to “Firmware Updates” on page 66.

To install a processor card, do the following:

1. If you have not already done so, shut down the system as described in “Stopping the System Unit” on page 30.
2. If you have not already done so, unplug the system unit power cable from the electrical outlet.
3. Open the front and rear rack doors.
4. Unplug all power cables from the rear of the system drawer.
5. Place the system drawer into the service position as described in “Placing the Drawer in the Service Position” on page 31.
6. Remove the main chassis cover as described in “Main Chassis Cover Removal” on page 32.
7. Remove the front bezel as described in “Front Bezel Removal” on page 36.
8. Remove the media bay tray. Refer to “Media Bay Tray Removal” on page 37 for location.
9. Remove the CEC box cover as described in “CEC Box Cover Removal” on page 42.
10. Open the camming levers and remove the air flow baffle. Camming levers are in the correct position to receive a processor card when *both* levers are standing straight in an upright position. See the following illustration.

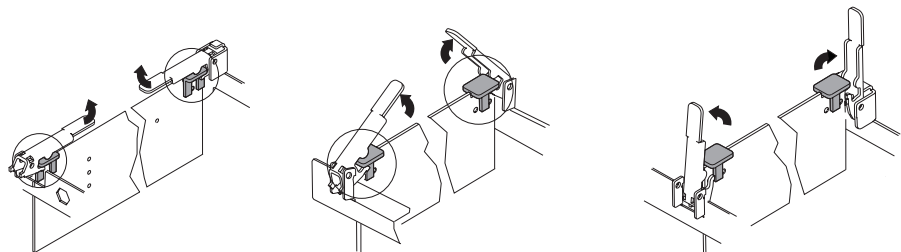

11. Align the card with the connector.

12. Close the camming levers securing the card into the connector.

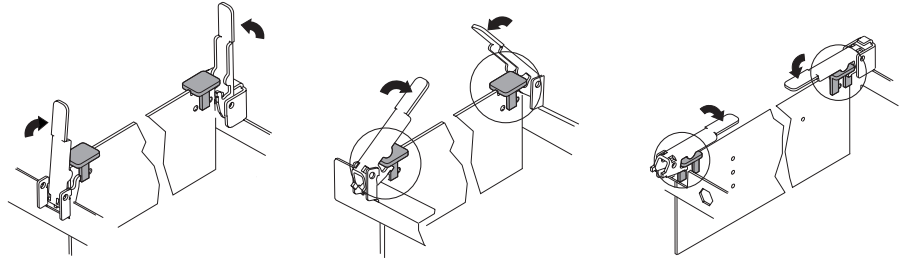

13. Ensure the tabs on the new card are captured by the levers as shown in the following illustration.

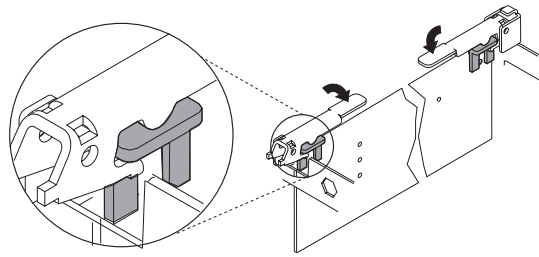

Note: After you have locked the camming levers, push the card in with your thumbs to ensure the card is properly seated.

14. If you have other options to install, refer to “Option List” on page 38.
15. If you do not have other options to install, continue with the next step.
16. Replace the CEC box cover as described in “CEC Box Cover Replacement” on page 43.
17. Replace the media bay tray.
18. Replace the front bezel as described in “Front Bezel Replacement” on page 37.
19. Replace the main chassis cover as described in “Main Chassis Cover Replacement” on page 33.
20. Reconnect the system drawer power cables.
21. Push the system drawer back into the operating position as described in “Returning the Drawer to the Operating Position” on page 32.
22. Close the rack doors.

Removing a Processor Card

To remove a processor card, do the following:

1. If you have not already done so, shut down the system as described in “Stopping the System Unit” on page 30.
2. If you have not already done so, unplug the system unit power cable from the electrical outlet.
3. Open the rack doors.
4. Unplug all power cables from the rear of the system drawer.
5. Place the system drawer into the service position as described in “Placing the Drawer in the Service Position” on page 31.
6. Remove the main chassis cover as described in “Main Chassis Cover Removal” on page 32.
7. Remove the front bezel as described in “Front Bezel Removal” on page 36.
8. Remove the media bay tray. Refer to “Media Bay Tray Removal” on page 37 for location.
9. Remove the CEC box cover as described in “CEC Box Cover Removal” on page 42.
10. Before handling any card, board, or memory module, touch any metal surface of the chassis with one hand to minimize static electric discharge. Refer to “Handling Static-Sensitive Devices” on page 30.
11. The processor card is secured in place with camming levers located at each top corner of the card.
12. Open the card camming levers and remove the card. When the camming levers are fully unlocked and placed in a position as shown in the illustration on page 53 the card automatically is unseated from its connector.

Attention: To prevent damage to the card and to the card connectors, open both camming levers at the same time.

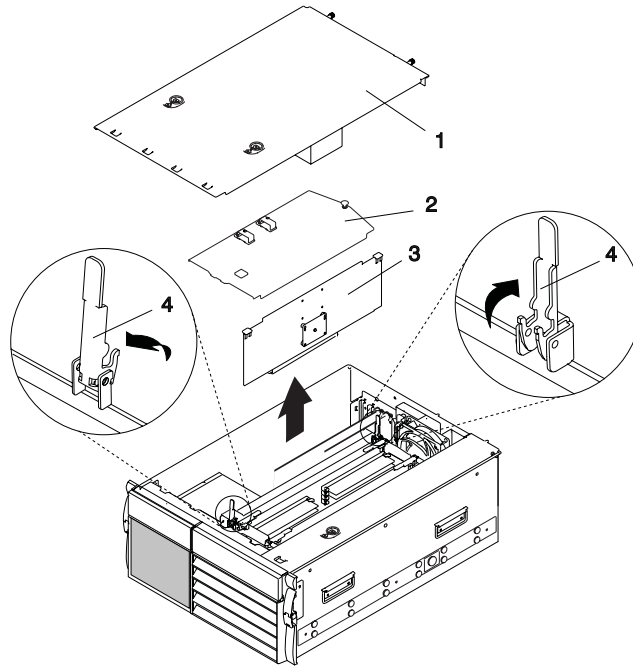

- 1 System Drawer Main Chassis Cover
- 2 CEC Box Cover
- 3 System Processor Card
- 4 Camming Lever

13. Carefully remove the processor card and place it in a safe location.
14. If you have other options to install, refer to “Option List” on page 38.
15. If you do not have other options to install, continue with the next step.
16. Replace the CEC box cover as described in “CEC Box Cover Replacement” on page 43.
17. Replace the media bay tray.
18. Replace the front bezel as described in “Front Bezel Replacement” on page 37.
19. Replace the main chassis cover as described in “Main Chassis Cover Replacement” on page 33.
20. Reconnect the system drawer cables.
21. Push the system drawer back into the operating position as described in “Returning the Drawer to the Operating Position” on page 32.
22. Close the rack doors.

Internal Drive Overview

The Model B80 has five drive bays, as shown in the illustration on page 54.

- One 5.25 inch media bay, used to mount an optional CD-ROM or tape drive.
- Four 1 inch disk drive bays.

Checklist for Handling Drives

Consider the following cautions when installing or removing media drives:

- Use caution when handling all disk drives. Disk drives are more likely to be damaged during installation and service than at any other time. A fall of as little as .25 inch, bumping, or rough handling can cause latent failures.
- Media drives are particularly sensitive to electrostatic discharge. Follow the electrostatic handling procedures found in "Handling Static-Sensitive Devices" on page 30 before handling the media drive.
- Refer to the documentation provided with your drive to determine if any drive-specific procedures must be followed, such as setting switches or jumpers, or attaching the drive to a carrier tray.
- SCSI devices in the optional media bay must have their SCSI address set to zero. Refer to the documentation provided with your drive for more information on setting the SCSI address.

The following illustration shows the locations and SCSI IDs of the internal drives.

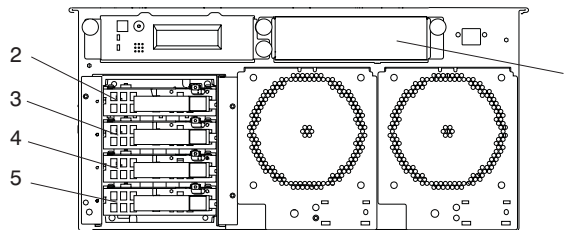

- 1 Media Bay - SCSI ID=0
- 2 Disk Drive - SCSI ID=8
- 3 Disk Drive - SCSI ID=9
- 4 Disk Drive - SCSI ID=10
- 5 Disk Drive - SCSI ID=11

Note: The disk drive SCSI IDs are preset at the manufacturer, and no further adjustment is required.

Hot-Plug Units

Note: You do not have to power down the system to remove hot-plug units.

The following units are hot-plug:

- Hot-plug power supplies (if the drawer has two power supplies and only one needs to be removed).
- Hot-plug disk drive units (DASD)

Disk Drive Options

Your system can have up to four disk drives installed. The disk drives are mounted in special carriers that allow the disk drives to plug into the slot bays while the system is in operation. To install or remove a disk drive, use the procedures in this section.

Note: To avoid complications, keep your default boot disk drive in the top disk drive slot.

Before performing the following procedures, read “Safety Notices” on page vii.

Installing a Hot-Plug Disk Drive

To install a hot-plug disk drive, do the following:

1. Open the rack door.
2. Remove the front bezel as described in “Front Bezel Removal” on page 36.
3. Locate the disk drive bay. See the illustration on page 54 for bay location.
4. With one hand, touch any metal surface of the chassis to minimize static electric discharge. Refer to “Handling Static-Sensitive Devices” on page 30.
5. Open the release handle on the disk drive carrier.
6. Install the disk drive in the drive slot. Align the disk drive with the drive slot rails, and slide the disk drive into the slot until it contacts the backplane at the rear of the disk drive cage. The drive should now be in far enough for the latch handle to engage the latch.
7. Ensure that the disk drive is fully seated by pushing the release handle into the secured position. This engages the disk drive’s locking latch.
8. Repeat this process for all the disk drives you are installing.
9. Replace the front bezel as described in “Front Bezel Replacement” on page 37.

Note: The front bezel *must* be installed on the system drawer before system operation continues.

10. Log in as root user.
11. At the command line, type `smitty`.
12. Select **Devices**.
13. Select **Install/Configure Devices Added After IPL** and press Enter. Follow the instructions on the screen. Successful configuration is indicated by the OK message displayed next to the **Command** field at the top of the screen.
14. Press F10 to exit `smitty` if you are not going to configure your disk drive. If you are going to configure your disk drive at this time press F3 until you have been returned to the **System Management Screen**, then go to step 3 on page 59.
15. Configure the new disk drive. See “Configuring Disk Drives” on page 59 for instructions on configuring the drive for use with your operating system.

16. If you have other options to install, refer to “Option List” on page 38.
17. If you do not have other options to install, continue with the next step.
18. Close the rack door.

Removing a Hot-Plug Disk Drive

Use this procedure only when temporarily removing a disk drive. To remove a hot-plug disk drive, do the following:

1. Log in as root user.
2. Enter the **smitty** command.
3. Select **Devices** and press Enter.
4. Select **Fixed Disk** and press Enter.
5. Select **List All Defined Disks** and press Enter.
From the listing determine which hard drives you will be removing and record their name and address.
6. Press F3 until you have been returned to the System Management Screen.
7. Select **System Storage Management (Physical and Logical Storage)** and press Enter.
8. Select **Logical Volume Manager** and press Enter.
9. Select **Physical Volumes** and press Enter.
10. Select **List Contents of a Physical Volume** and press Enter.
11. Press F4 and select the hard disk that you recorded in step 5 and press Enter.
12. Under **List Options**, select “status” and press Enter.
13. Confirm and record the volume group name, then press F3 until you are brought back to the Logical Volume Manager screen.
14. Select **Volume Groups** and press Enter.
15. Select **Deactivate a Volume Group** and press Enter.
16. Press F4 and select the volume group which you previously recorded in step 13 and press Enter.
17. Press Enter again. You should see an OK message at the top of your screen.
18. Press F3 until you are returned to the Volume Group screen.
19. Select **Export a Volume Group** and press Enter.
20. Press F4 and select the volume group which you previously recorded in step 13 and press Enter.
21. Press Enter again. You should see an OK message at the top of your screen.
22. Press F3 until you are returned to the System Storage Management (Physical and Logical Storage) screen.
23. Select **Removable Disk Management** and press Enter.
24. Select **Remove a Disk** and press Enter.
25. Select the identified disk drive you want to remove from the system, (recorded in step 5) and press Enter.
26. Select **No** and press Enter.
27. After the *Are You Sure* screen appears, press Enter.

28. You should see an OK message at the top of your screen.
29. Press F10 to exit **smitty**.
30. Open the rack door.
31. Remove the front bezel as described in “Front Bezel Removal” on page 36.
32. Grasp and pull the blue trigger located on the back of the disk drive release handle. Continue pulling on the handle until it is fully extended and the disk drive is removed from the system drawer.
33. If you are replacing a disk drive, go to “Installing a Hot-Plug Disk Drive” on page 55. If you are not replacing a disk drive go to the next step.
34. Replace the front bezel as described in “Front Bezel Replacement” on page 37.

Note: The front bezel helps suppress EMC emissions and *must* be placed back onto the system drawer after servicing.

35. Close the rack door.

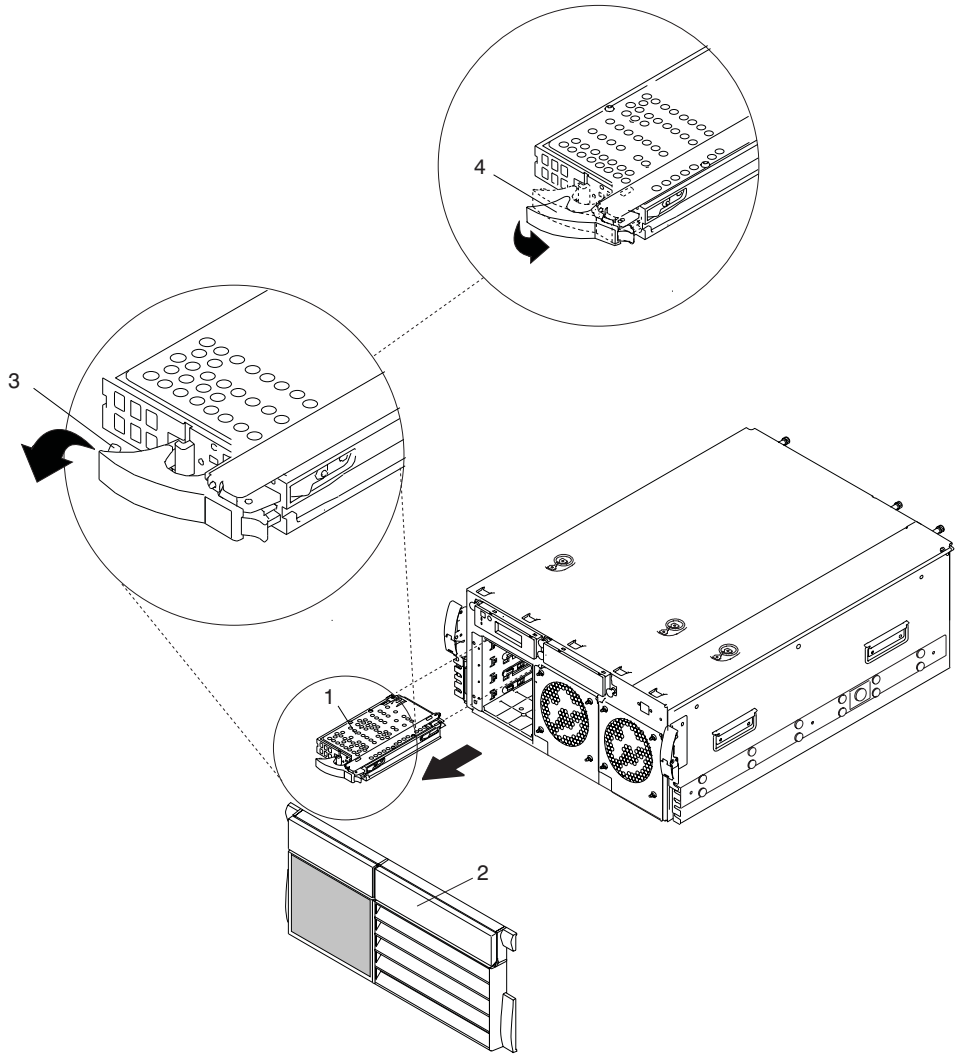

- 1 Disk Drive
- 2 Front Bezel
- 3 Disk Drive Locking Latch
- 4 Disk Drive Release Handle

Configuring Disk Drives

Note: If you are installing a disk drive with data on it, refer to your AIX documentation for instruction.

To configure a disk drive, do the following:

1. Log in as root user.
2. Enter the **smitty** command.
3. Select **System Storage Management (Physical and Logical Storage)** and press Enter.
4. Select **Logical Volume Manager** and press Enter.
5. Select **Volume Groups** and press Enter.
6. Select **Set Characteristics of a Volume Group** and press Enter.
7. Select **Add a Physical Volume to a Volume Group**.

Note: Do not select **Root Volume Group** if you plan on removing and inserting this hard disk drive.

8. Fill in the fields for the drive you are adding to the system. Press F4 for a list of selections.

See the *System Management Guide: Operating System and Devices* for further information on the drive configuration. This publication is located on the documentation CD. The documentation information is made accessible by loading the documentation CD onto the hard disk or by mounting the CD in the CD-ROM drive.

9. Press Enter. After the *Are You Sure* screen appears, press Enter.
10. Press F10 to exit **smitty**.

Installing a Redundant Hot-Plug Power Supply

Before performing this procedure, read the following:

- “Safety Notices” on page vii
- “Electrical Safety” on page vii

To add a redundant hot-plug power supply, do the following:

1. Open the rack doors.
2. Connect the power cable to the power receptacle on the rear of the drawer.
3. Place the system drawer in the service position as described in “Placing the Drawer in the Service Position” on page 31.
4. Remove the power supply chassis cover as described in “Power Supply Chassis Cover Removal” on page 34.
5. Remove the power supply dust cover. See the illustration on page 61.
6. Grasp the handle located on top of the new power supply. Pivot the handle upward to 90 degrees. See the illustration on page 61.
7. Carefully insert the power supply into the power supply bay, and align the guide pins into the slots on each end of the power supply bay.
8. Lightly press the power supply into the connector, then lower the power supply handle until it snaps into place. The power supply handle acts as a cam. When the handle is lowered, it seats and locks the power supply in the correct position.
9. Plug the power cable into a power outlet. The green LED on the top of the power supply should be on solid. If the LED is not on, contact your service representative.
10. If you have other options to install, refer to “Option List” on page 38.
11. If you do not have other options to install, continue with the next step.
12. Replace the power supply chassis cover as described in “Power Supply Chassis Cover Replacement” on page 35.
13. Close the rack doors.

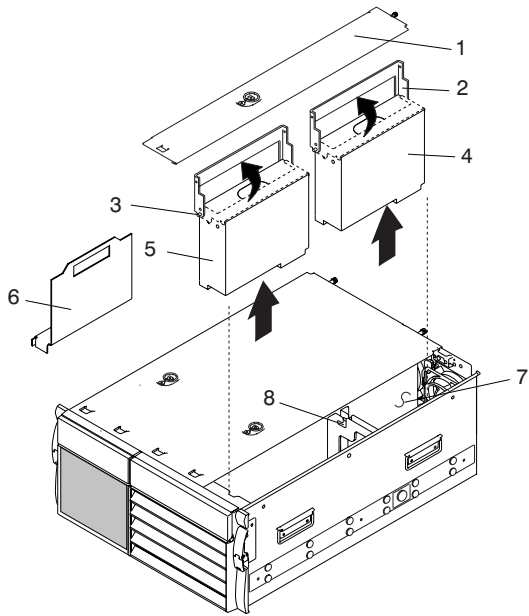

- 1 Power Supply Chassis Cover
- 2 Power Supply Handle (Service Position)
- 3 Power Supply Guide Pin
- 4 Primary Power Supply
- 5 Redundant Power Supply
- 6 Power Supply Dust Cover
- 7 Primary Power Supply Bay
- 8 Power Supply Guide Pin Slot

Installing Optional CD-ROM and Tape Drive

Note:

- The optional media bay and cables are serviced from the front of the system unit.
- The optional media bay tray can house a CD-ROM or tape drive. The following illustration shows the location of the optional media bay tray on the system drawer.

To install an optional CD-ROM or tape drive, do the following:

1. If you have not already done so, shut down the system as described in “Stopping the System Unit” on page 30.
2. If you have not already done so, unplug the system unit power cable from the electrical outlet.
3. Open the front rack door.
4. Remove the front bezel as described in “Front Bezel Removal” on page 36.
5. Locate the media bay tray, as shown in the following illustration.

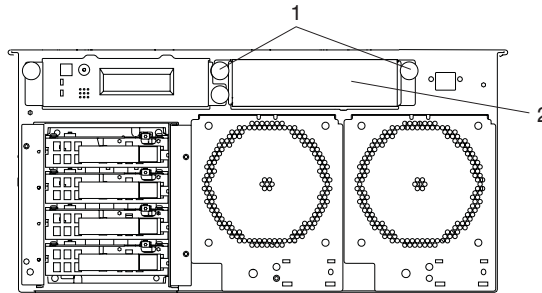

1 Media Bay Tray

6. Pull out the media bay tray snap buttons and locate the cables.
7. Connect the SCSI and power cables to their respective connectors on the device. The connectors are located on the back of the media drive.
8. Ensure the snap buttons are in the retracted (unlocked) position.
9. Carefully slide the drive into the system drawer until seated against the front of the chassis.

Note: Be careful not to damage or unplug the media device cables while performing this procedure.

10. Push in the captured snap buttons to lock the drive in place.
11. If you have other options to install, refer to “Option List” on page 38.
12. If you do not have other options to install, continue with the next step.
13. Replace the front cover bezel as described in “Front Bezel Replacement” on page 37.

14. If the system drawer is in the service position, return it to the operating position as described in “Returning the Drawer to the Operating Position” on page 32.
15. Reconnect the power cable.
16. Close the rack door.

Replacing the Battery

CAUTION:

A lithium battery can cause fire, explosion, or a severe burn. Do not recharge, disassemble, heat above 100°C (212°F), solder directly to the cell, incinerate, or expose cell contents to water. Keep away from children. Replace only with the part number specified for your system. Use of another battery may present a risk of fire or explosion.

The battery connector is polarized; do not attempt to reverse polarity.

Dispose of the battery according to local regulations.

Before performing these procedures, read “Safety Considerations” on page 29.

To replace the battery, do the following:

1. Open the rear rack door.
2. Shut down the system drawer as described in “Stopping the System Unit” on page 30.
3. Unplug all power cables from the rear of the system drawer.
4. Unsnap the cable management arm from the system and swing it out of the way.

Note: Do not remove the cables from the cable management arm.

5. With the system drawer in the operating position, remove fan #4 from the rear of the system drawer.

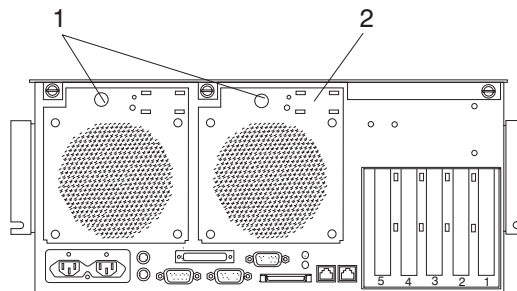

- 1 Snap Button (Located on top of rear fan mounting bracket)
- 2 Fan #4

- a. Pull out the snap button, located on the top of the rear fan plate.

- b. Gently pull the top of the fan out and then up, releasing the bottom edge of the rear fan.
- c. Remove the fan from the system drawer.

Note: All the fans used on the Model B80 have docking connectors that are automatically disconnected as the fan is being removed from the chassis.

6. Locate the battery on the I/O board, as shown in the following illustration.

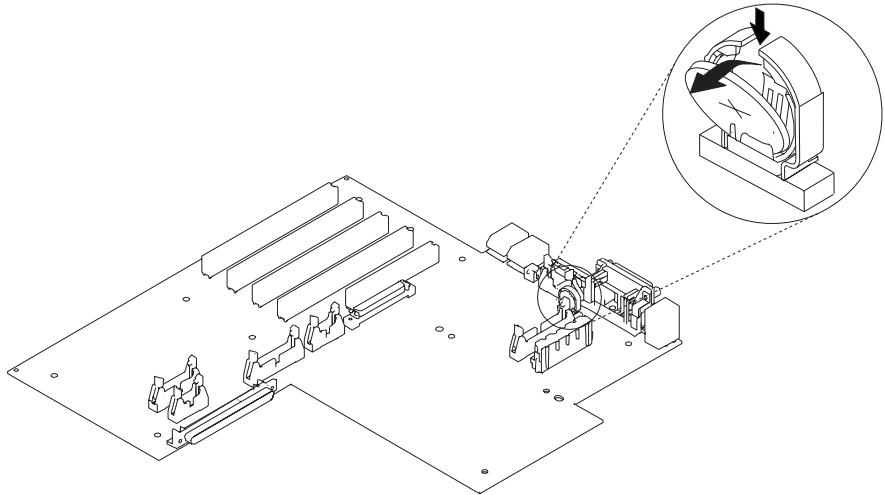

7. To remove the battery from its plastic mount, press down and toward the front of the system drawer.

Note: Do not wiggle the plastic mount from side to side or try to separate the plastic battery mount from the I/O board. The plastic mount connections are soldered to the I/O board. Permanent damage can result to the I/O board if the battery mount is damaged or removed.

8. Replace the battery with part number 15F8409 or equivalent.
9. When installing the new battery, ensure that the battery polarity is correct. For this system, the positive (+) side of the battery faces the front of the system drawer.
10. Gently insert the battery into the battery mount. Support the battery mount with your fingers while seating the battery.
11. Replace fan #4.
 - a. Insert the bottom edge of the fan plate into the chassis housing.
 - b. Pivot the fan up until the top edge rest against the chassis.
 - c. Push the snap button into the locked position.
 - d. Swing the cable management arm back to its original position. Use the two captive snap buttons, located on the cable management arm to system mounting plate, to secure it to the system.
12. Turn on the power.

13. Reset the time and date.
14. If you are running AIX, you might need to run the **bootlist** command while you are logged in as root user. This restores the custom bootlist and allows the option of *Select Software* under multiboot to start the operating system. IP (internet protocol) parameters may also need to be rebuilt. If your system cannot verify the boot to AIX, go to System Management Services to reset the boot list.

Firmware Updates

This section provides information and instruction for updating firmware. You may need to perform these steps if you are installing an option or if your support representative has instructed you to update your firmware.

Check the Current System Firmware and Service Processor Firmware Levels

To verify the current levels that are installed on the system, use the following steps:

1. Log in as root user.
2. Type the following at the command line:

```
lscfg -vp | grep -p alterable
```
3. Press Enter. This command produces a report similar to the following:
ROM Level . (alterable)sc000811 <===service processor F/W level
ROM Level . (alterable)NAN00210 <===system firmware level

Note:

In the example above, if the current version of service processor firmware is sc000811, the last six characters of the ROM Level represent a date in a *yyymmdd* format, where *yy* is the last two digits of the year, *mm* is the month and *dd* is the day of the firmware (Gregorian date).

Also in the example above, if the current version of system firmware is NAN00210, the last five characters of the ROM Level represent a date in a *yyddd* format, where *yy* is the last two digits of the year and *ddd* is the Julian date of the firmware.

Check the web site at <http://www.rs6000.ibm.com/support/micro> for the latest level of downloadable firmware. If the version of system firmware installed on your system is older than (has an earlier date) the system firmware shown on the web site, you should consider downloading and applying the update. If the version of service processor firmware installed on your system is older than (has an earlier date) the service processor firmware shown on the web site, you should consider downloading and applying the update.

System Firmware Updates

To update the system firmware, perform the following steps:

1. Log in as root user.
2. If the directory **/tmp/fwupdate** does not exist, create it by issuing the following command: `mkdir /tmp/fwupdate`
3. The firmware update file must be written into the **/tmp/fwupdate** directory on the Model B80. This can be done by using the **ftp** command to get the image from an ftp server, NFS-mounting the directory on the host server, or downloading it from the web site at <http://www.rs6000.ibm.com/support/micro>.

After the firmware update file has been written into the **/tmp/fwupdate** directory, verify its existence by entering the following command:

```
ls /tmp/fwupdate/cb*.img
```

The update file name will have the format *cbyydd.img*. The *cb* indicates that this is a combined image for a Model B80 server, *yy* is the last two digits of the year, and *ddd* is the Julian date of the update file.

4. After the update file has been written to the **/tmp/fwupdate** directory, enter the following commands:

```
cd /usr/lpp/diagnostics/bin
then
./update_flash -f /tmp/fwupdate/cbyydd.img
```

Notes:

- a. Make sure that you include the periods (.) in the commands shown above.
- b. AIX commands are case-sensitive. Type them exactly as shown.

You are asked by the system for confirmation to proceed with the firmware update and the required reboot. If you confirm, the system applies the new firmware, reboots, and returns to the AIX prompt. This may take up to ten minutes, depending on the configuration of the system.

Attention: On some systems, the message *Wait for rebooting before stopping* may appear on the system display. *Do not* turn off the system unit until the system has fully rebooted to the AIX login prompt. If a shutdown is necessary at that time, log in as root user and issue the **shutdown** command. While the update is in progress, you will see *Rebooting...* on the display for as long as three minutes.

The firmware update is complete.

Appendix A. Communications Statements

The following statement applies to this product. The statement for other products intended for use with this product appears in their accompanying documentation.

Federal Communications Commission (FCC) Statement

Note: This equipment has been tested and found to comply with the limits for a Class A digital device, pursuant to Part 15 of the FCC Rules. These limits are designed to provide reasonable protection against harmful interference when the equipment is operated in a commercial environment. This equipment generates, uses, and can radiate radio frequency energy and, if not installed and used in accordance with the instruction manual, may cause harmful interference to radio communications. Operation of this equipment in a residential area is likely to cause harmful interference in which case the user will be required to correct the interference at his own expense.

Properly shielded and grounded cables and connectors must be used in order to meet FCC emission limits. Neither the provider nor the manufacturer is responsible for any radio or television interference caused by using other than recommended cables and connectors or by unauthorized changes or modifications to this equipment. Unauthorized changes or modifications could void the user's authority to operate the equipment.

This device complies with Part 15 of the FCC Rules. Operation is subject to the following two conditions: (1) this device may not cause harmful interference, and (2) this device must accept any interference received, including interference that may cause undesired operation.

European Union (EU) Statement

This product is in conformity with the protection requirements of EU Council Directive 89/336/EEC on the approximation of the laws of the Member States relating to electromagnetic compatibility. The manufacturer cannot accept responsibility for any failure to satisfy the protection requirements resulting from a non-recommended modification of the product, including the fitting of option cards supplied by third parties. Consult with your dealer or sales representative for details on your specific hardware.

This product has been tested and found to comply with the limits for Class A Information Technology Equipment according to CISPR 22 / European Standard EN 55022. The limits for Class A equipment were derived for commercial and industrial environments to provide reasonable protection against interference with licensed communication equipment.

Attention: This is a Class A product. In a domestic environment this product may cause radio interference in which case the user may be required to take adequate measures.

International Electrotechnical Commission (IEC) Statement

This product has been designed and built to comply with IEC Standard 950.

United Kingdom Telecommunications Safety Requirements

This equipment is manufactured to the International Safety Standard EN60950 and as such is approved in the UK under the General Approval Number NS/G/1234/J/100003 for indirect connection to the public telecommunication network.

The network adapter interfaces housed within this equipment are approved separately, each one having its own independent approval number. These interface adapters, supplied by the manufacturer, do not use or contain excessive voltages. An excessive voltage is one which exceeds 70.7 V peak ac or 120 V dc. They interface with this equipment using Safe Extra Low Voltages only. In order to maintain the separate (independent) approval of the manufacturer's adapters, it is essential that other optional cards, not supplied by the manufacturer, do not use main voltages or any other excessive voltages. Seek advice from a competent engineer before installing other adapters not supplied by the manufacturer.

Avis de conformité aux normes du ministère des Communications du Canada

Cet appareil numérique de la classe A respecte toutes les exigences du Règlement sur le matériel brouilleur du Canada.

Canadian Department of Communications Compliance Statement

This Class A digital apparatus meets the requirements of the Canadian Interference—Causing Equipment Regulations.

VCCI Statement

この装置は、情報処理装置等電波障害自主規制協議会（VCCI）の基準に基づくクラスA情報技術装置です。この装置を家庭環境で使用すると電波妨害を引き起こすことがあります。この場合には使用者が適切な対策を講ずるよう要求されることがあります。

The following is a summary of the VCCI Japanese statement in the box above.

This is a Class A product based on the standard of the Voluntary Control Council for Interference by Information Technology Equipment (VCCI). If this equipment is used in a domestic environment, radio disturbance may arise. When such trouble occurs, the user may be required to take corrective actions.

Electromagnetic Interference (EMI) Statement - Taiwan

警告使用者:

這是甲類的資訊產品，在居住的環境中使用時，可能會造成射頻干擾，在這種情況下，使用者會被要求採取某些適當的對策。

The following is a summary of the EMI Taiwan statement above.

Warning: This is a Class A product. In a domestic environment this product may cause radio interference in which case the user will be required to take adequate measures.

Radio Protection for Germany

Dieses Gerät ist berechtigt in Übereinstimmung mit Dem deutschen EMVG vom 9.Nov.92 das EG-Konformitätszeichen zu führen.

Der Aussteller der Konformitätserklärung ist die IBM Germany.

Dieses Gerät erfüllt die Bedingungen der EN 55022 Klasse A. Für diese von Geräten gilt folgende Bestimmung nach dem EMVG:

Geräte dürfen an Orten, für die sie nicht ausreichend entstört sind, nur mit besonderer Genehmigung des Bundesministers für Post und Telekommunikation oder des Bundesamtes für Post und Telekommunikation betrieben werden. Die Genehmigung wird erteilt, wenn keine elektromagnetischen Störungen zu erwarten sind.

(Auszug aus dem EMVG vom 9.Nov.92, Para.3, Abs.4)

Hinweis

Dieses Genehmigungsverfahren ist von der Deutschen Bundespost noch nicht veröffentlicht worden.

Appendix B. Environmental Notices

Product Recycling and Disposal

This unit contains materials such as circuit boards and connectors with lead that require special handling and disposal at end of life. Before this unit is disposed of, these materials must be removed and recycled or discarded according to applicable regulations. This manual contains specific information on batteries where applicable. This product may contain nickel-cadmium and/or lithium batteries. The battery(s) must be recycled or disposed of properly. Recycling facilities may not be available in your area. In the United States, IBM has established a collection process for reuse, recycling, or proper disposal of used sealed lead acid, nickel cadmium and nickel metal hydride batteries and battery packs from IBM equipment. For information on proper disposal of the nickel cadmium batteries in this product, please contact IBM at 1-800-426-4333. For information on battery disposal outside the United States, contact your local waste disposal facility.

Environmental Design

The environmental efforts that have gone into the design of this system signify IBM's commitment to improve the quality of its products and processes. Some of these accomplishments include the elimination of the use of Class I ozone-depleting chemicals in the manufacturing process and reductions in manufacturing wastes. For more information, contact an IBM account representative.

Unit Emissions

The unit-related emission value is equal to or lower than 70dB(A).

Der Geräuschpegel der Einheit ist kleiner oder gleich 70 db(A).

Appendix C. Notices

This information was developed for products and services offered in the U.S.A.

The manufacturer may not offer the products, services, or features discussed in this document in other countries. Consult the manufacturer's representative for information on the products and services currently available in your area. Any reference to the manufacturer's product, program, or service is not intended to state or imply that only that product, program, or service may be used. Any functionally equivalent product, program, or service that does not infringe any intellectual property right of the manufacturer may be used instead. However, it is the user's responsibility to evaluate and verify the operation of any product, program, or service.

The manufacturer may have patents or pending patent applications covering subject matter described in this document. The furnishing of this document does not give you any license to these patents. You can send license inquiries, in writing, to the manufacturer.

The following paragraph does not apply to the United Kingdom or any country where such provisions are inconsistent with local law: THIS MANUAL IS PROVIDED "AS IS" WITHOUT WARRANTY OF ANY KIND, EITHER EXPRESSED OR IMPLIED, INCLUDING, BUT NOT LIMITED TO, THE IMPLIED WARRANTIES OF NON-INFRINGEMENT, MERCHANTABILITY OR FITNESS FOR A PARTICULAR PURPOSE. Some states do not allow disclaimer of express or implied warranties in certain transactions; therefore, this statement may not apply to you.

This information could include technical inaccuracies or typographical errors. Changes are periodically made to the information herein; these changes will be incorporated in new editions of the publication. The manufacturer may make improvements and/or changes in the product(s) and/or the program(s) described in this publication at any time without notice.

Information concerning products made by other than the manufacturer was obtained from the suppliers of those products, their published announcements or other publicly available sources. The manufacturer has not tested those products and cannot confirm the accuracy of performance, compatibility or any other claims related to products made by other than the manufacturer. Questions on the capabilities of products made by other than the manufacturer should be addressed to the suppliers of those products.

Appendix D. Running Standalone Diagnostics from a Network Installation Management (NIM) Server

A client system connected to a network with a Network Installation Management (NIM) server is capable of booting standalone diagnostics from the NIM server if the client system is registered on the NIM server and the NIM boot settings on both the server and client are correct.

To run standalone diagnostics on a client from the NIM server, do the following:

1. Remove any removable media (tape or CD-ROM).
2. Stop all programs including the AIX operating system (get help if needed).
3. Ensure that the system unit's power is turned off.
4. Turn the system unit's power on.
5. When the keyboard indicator is displayed (the word **keyboard** on an ASCII terminal or the keyboard icon on a graphical display), press the number 1 key on the keyboard to display the SMS menu.
6. Enter any requested passwords.
7. Select **Utilities**.
8. Depending on the console type, select **RIPL** or **Remote Initial Program Load Setup**.
9. Depending on the console type, select **Set Address** or **IP Parameters**.
10. Enter the client address, server address, gateway address (if applicable) and subnet mask into the Remote Initial Program Load (RIPL). If there is no gateway between the NIM server and NIM client, set the gateway address to 0.0.0.0. To determine if there is a gateway, either ask the system network administrator or compare the first 3 octets of the NIM server address and the client address. If they are the same, (for example, if the NIM server address is 9.3.126.16 and the NIM client address is 9.3.126.42, the first 3 octets (9.3.126) are the same), then set the gateway address in the RIPL field to 0.0.0.0.

Note: RIPL is located under the Utility menu in System Management Services (SMS) and should be referred to for information on setting these parameters.

11. If the NIM server is set up to allow pinging from the client system, use the **ping** utility in the RIPL utility to verify that the client system can ping the NIM server. Under the **ping** utility, choose the network adapter that provides the attachment to the NIM server to do the ping operation. If the ping comes back with an OK message, the client is prepared to boot from the NIM server. If ping returns with a FAILED message, the client does not proceed with the NIM boot.

Note: If the ping fails, check the NIM server setup and the RIPL setup. If the problem persists, contact your service representative and follow the steps for network boot problems.

Use the following procedure to temporarily change the system bootlist so that the network adapter attached to the NIM server network is first in the bootlist.

1. Exit to the SMS main screen.
2. Depending on the console type, select **Multiboot** or **Select Boot Devices**.
3. Depending on the console type, select **Boot Sequence** or **Select Boot Devices**.
4. Record the current bootlist settings. (You will have to set the bootlist back to the original settings after running diagnostics from the NIM server.)
5. Change the bootlist so the network adapter attached to the NIM server is first in the bootlist.
6. Exit completely from SMS.

The system should start loading packets while doing a **bootp** from the network.

7. Follow the instructions on the screen to select the system console.

If *Diagnostics Operating Instructions Version x.x.x* is displayed, standalone diagnostics has loaded successfully.

If the AIX login prompt is displayed, standalone diagnostics did not load. Check the following items:

- The bootlist on the client might be incorrect.
 - Cstate on the NIM server might be incorrect.
 - There might be network problems preventing you from connecting to the NIM server.
8. Verify the settings and the status of the network. If the ping fails, check the NIM server setup and the RIPL setup. If the problem persists, contact your service representative.
 9. After running diagnostics, reboot the system and use SMS to change the bootlist sequence back to the original settings.

Appendix E. System Records

Use this appendix to keep a record of your system configuration.

Record the Identification Numbers

Record and retain the following information:

Product Name	Model B80
CPU Type/Speed	_____
Serial Number	_____
Key Serial Number	_____

The system unit's serial number label is located on the front cover as shown in the following illustration.

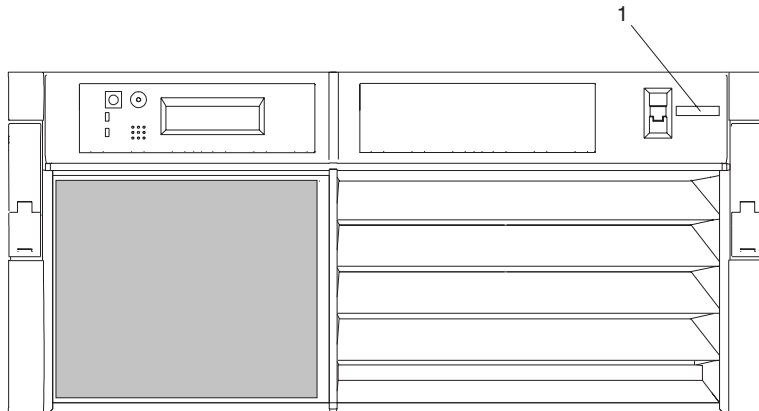

1 Serial Number Label

Device Records

Use the following tables to keep a record of the options installed in or attached to your system. This information can be helpful when you install additional options in your system or if your system needs service.

Table 1. Internal and External Options

Location	Option Description
Memory Card J2	
Memory (J1/J2)	128MB <input type="checkbox"/> 256MB <input type="checkbox"/> 512MB <input type="checkbox"/>
Memory (J3/J4)	128MB <input type="checkbox"/> 256MB <input type="checkbox"/> 512MB <input type="checkbox"/>
Memory (J5/J6)	128MB <input type="checkbox"/> 256MB <input type="checkbox"/> 512MB <input type="checkbox"/>
Memory (J7/J8)	128MB <input type="checkbox"/> 256MB <input type="checkbox"/> 512MB <input type="checkbox"/>
Memory (J9/J10)	128MB <input type="checkbox"/> 256MB <input type="checkbox"/> 512MB <input type="checkbox"/>
Memory (J11/J12)	128MB <input type="checkbox"/> 256MB <input type="checkbox"/> 512MB <input type="checkbox"/>
Memory (J13/J14)	128MB <input type="checkbox"/> 256MB <input type="checkbox"/> 512MB <input type="checkbox"/>
Memory (J15/J16)	128MB <input type="checkbox"/> 256MB <input type="checkbox"/> 512MB <input type="checkbox"/>
Memory Card J3	
Memory (J1/J2)	128MB <input type="checkbox"/> 256MB <input type="checkbox"/> 512MB <input type="checkbox"/>
Memory (J3/J4)	128MB <input type="checkbox"/> 256MB <input type="checkbox"/> 512MB <input type="checkbox"/>
Memory (J5/J6)	128MB <input type="checkbox"/> 256MB <input type="checkbox"/> 512MB <input type="checkbox"/>
Memory (J7/J8)	128MB <input type="checkbox"/> 256MB <input type="checkbox"/> 512MB <input type="checkbox"/>
Memory (J9/J10)	128MB <input type="checkbox"/> 256MB <input type="checkbox"/> 512MB <input type="checkbox"/>
Memory (J11/J12)	128MB <input type="checkbox"/> 256MB <input type="checkbox"/> 512MB <input type="checkbox"/>
Memory (J13/J14)	128MB <input type="checkbox"/> 256MB <input type="checkbox"/> 512MB <input type="checkbox"/>
Memory (J15/J16)	128MB <input type="checkbox"/> 256MB <input type="checkbox"/> 512MB <input type="checkbox"/>
IBM Mouse <input type="checkbox"/>	
Mouse Connector <input type="checkbox"/>	Other: _____
Keyboard Connector	Space Saving <input type="checkbox"/> Enhanced <input type="checkbox"/> Other: _____
Expansion Slot 5	_____
Expansion Slot 4	_____
Expansion Slot 3	_____
Expansion Slot 2	_____
Expansion Slot 1	_____
Parallel Port	_____
Serial Port 1	_____
Serial Port 2	_____
Serial Port 3	_____

SCSI ID and Bay Location Record

Refer to the following diagram of your server's bays when completing Table 2.

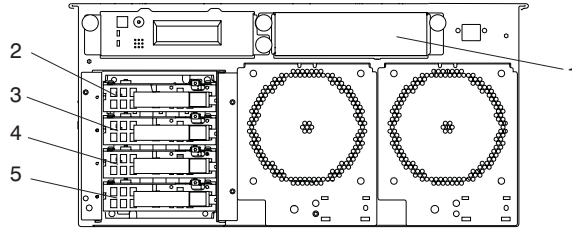

Note: If you attach a drive or other device to an adapter, record the expansion-slot number for that adapter in the adapter field of Table 2.

Table 2. Internal Files and Devices

Adapter	Location	SCSI ID	Drive Description
Integrated	Bay D01	0	<u>Media Drive</u>
Integrated	Bay D02	8	<u>Disk Drive</u>
Integrated	Bay D03	9	<u>Disk Drive</u>
Integrated	Bay D04	10	<u>Disk Drive</u>
Integrated	Bay D05	11	<u>Disk Drive</u>

Appendix F. System Relocation Procedure

Attention:

- *Do not* relocate a rack that has drawers installed in EIA positions 33 through 42. Remove these drawers before relocating to prevent the rack from overturning.
- *Do not* rely on the plastic latches to hold the system drawer in place when moving the rack. Use the two plastic thumbscrews found in the latch bracket mounting kit to secure the system to the rack.

To relocate the Model B80, do the following:

1. Locate the two screw holes just below the plastic release latches. See the following illustration for screw-hole location.
2. When the entire unit is being moved, use the two thumbscrews that were shipped with your system drawer to secure the system drawer to the rack.
3. The thumbscrews can be removed after the system has been relocated.

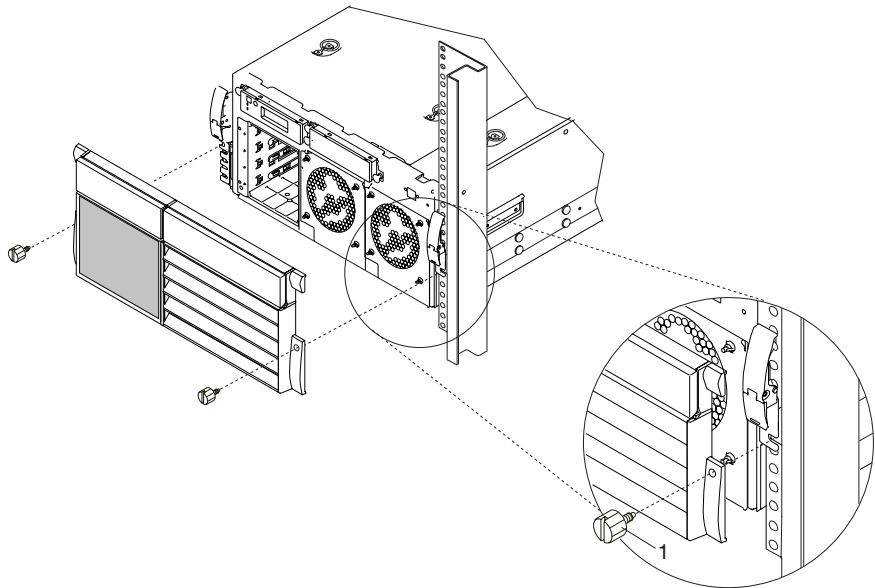

1 Thumbscrews (Quantity 2)

Index

A

about this book xiii
adapter cables, connection 18
adapter installation 39
adapter removal 41

B

battery
disposal, recycling 73
battery removal and replacement 63

C

cable management arm 12
CD-ROM installation 62
CEC box cover removal 42
CEC box cover replacement 43
configuring disk drives 59
connect adapter cables 18
connect external SCSI devices 15
connect graphics display 17
connect internal Ethernet 18
connect parallel devices 14
connect serial devices 14
connect the keyboard 13
connect the mouse 13
cover removals and replacements 32

D

device records 80
internal and external options 80
internal files and devices 81
diagnostics
loading 26
stopping 27
disk drives
configuring 59
display cable toroid 17
drawer, operating position 32
drawer, service position 31

E

external SCSI devices, connecting 15

F

firmware updates 66
front bezel removal 36
front bezel replacement 37

G

graphics display, connection 17

H

handling static-sensitive devices 30
hot-plug disk drive installation 55

hot-plug disk drive removal 56
hot-plug units 54

I

installation
adapters 39
cable management arm 12
CD-ROM 62
hot-plug disk drive 55
memory cards 44
memory modules 48
processor card 50
rail and rack-mount bracket 6
redundant hot-plug power supply 60
system 1
tape drive 62
installing options 29
internal drive overview 54
internal Ethernet, connection 18
Inventory 1

K

keyboard, connection 13

L

laser compliance statement viii
laser safety information viii
loading diagnostics 26

M

main chassis cover removal 32
main chassis cover replacement 33
media bay tray removal 37
media installation 62
memory card installation 44
memory card removal 46
memory module installation 48
memory module removal 49
mouse, connection 13

N

NIM server
NIM standalone diagnostics 22, 77

O

online publications xiii
operating position, drawer 32
option list 38
options 38
options, installation 29

P

parallel devices, connecting 14
placing drawer in service position 31

- power cables 19
- power source 4
- power supply chassis cover removal 34
- power supply chassis cover replacement 35
- preface xiii
- processor card installation 50
- processor card removal 52
- product disposal 73
- publications, online xiii

R

- rack-mounting instructions 5
- rail and rack-mount bracket, install 6
- records, device 80
- recycling 73
- redundant hot-plug power supply installation 60
- related publications xiii
- relocation
 - system 83
- removal
 - adapters 41
 - battery 63
 - CEC box cover 42
 - covers 32
 - front bezel 36
 - hot-plug disk drive 56
 - main chassis cover 32
 - media bay tray 37
 - memory cards 46
 - memory modules 49
 - power supply chassis cover 34
 - processor card 52
 - static-sensitive devices 30
- replacement
 - CEC box cover 43
 - covers 32
 - front bezel 37
 - main chassis cover 33
 - power supply chassis cover 35
- returning drawer to operating position 32

S

- safety, laser viii
- safety considerations 29
- safety notices vii
- serial devices, connecting 14
- service position, drawer 31
- start your system 21
- stopping diagnostics 27
- stopping the system unit 30
- system, starting 21
- system firmware updates 66
- system installation 1
- system records 79
 - key serial number 79
 - machine type/model 79

- system records 79 (*continued*)
 - serial number 79
- system relocation 83
- system unit
 - stopping 30
- system verification 25

T

- tape drive installation 62
- trademarks xiv

U

- units, hot-plug 54

V

- verifying system operation 25

Reader's Comments — We'd Like to Hear From You

pSeries 640 Model B80 Installation Guide

Form Number: SA38-0579-00

Overall how satisfied are you with the information in this book?

	Very Satisfied	Satisfied	Neutral	Dissatisfied	Very Dissatisfied
Overall Satisfaction	<input type="checkbox"/>	<input type="checkbox"/>	<input type="checkbox"/>	<input type="checkbox"/>	<input type="checkbox"/>

How satisfied are you that the information in this book is:

	Very Satisfied	Satisfied	Neutral	Dissatisfied	Very Dissatisfied
Accurate	<input type="checkbox"/>	<input type="checkbox"/>	<input type="checkbox"/>	<input type="checkbox"/>	<input type="checkbox"/>
Complete	<input type="checkbox"/>	<input type="checkbox"/>	<input type="checkbox"/>	<input type="checkbox"/>	<input type="checkbox"/>
Easy to find	<input type="checkbox"/>	<input type="checkbox"/>	<input type="checkbox"/>	<input type="checkbox"/>	<input type="checkbox"/>
Easy to understand	<input type="checkbox"/>	<input type="checkbox"/>	<input type="checkbox"/>	<input type="checkbox"/>	<input type="checkbox"/>
Well organized	<input type="checkbox"/>	<input type="checkbox"/>	<input type="checkbox"/>	<input type="checkbox"/>	<input type="checkbox"/>
Applicable to your tasks	<input type="checkbox"/>	<input type="checkbox"/>	<input type="checkbox"/>	<input type="checkbox"/>	<input type="checkbox"/>

Please tell us how we can improve this book:

Thank you for your response. May we contact you? Yes No

When you send comments to us, you grant us a nonexclusive right to use or distribute your comments in any way we believe appropriate without incurring any obligation to you.

Name

Address

Company or Organization

Phone Number

Cut or Fold
Along Line

Fold and Tape

Please do not Staple

Fold and Tape



NO POSTAGE
NECESSARY
IF MAILED IN THE
UNITED STATES

BUSINESS REPLY MAIL

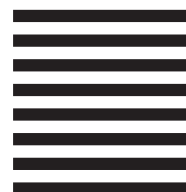

POSTAGE WILL BE PAID BY ADDRESSEE

Information Development
Department H6DS-9561
11400 Burnet Road
Austin, TX 78758-3493



Fold and Tape

Please do not Staple

Fold and Tape

Cut or Fold
Along Line



Part Number: 09P1414



Printed in the United States of America
on recycled paper containing 10%
recovered post-consumer fiber.

October 2000

SA38-0579-00



(1P) P/N: 09P1414

