

System to Rack Stabilizing Kit

# Installation Guide

## Note to Printer:

1. Cover to be self cover, no graphics.
2. Book trim size to be 7 3/8" x 9" (saddle stitched).
3. Discard this page and the following blank page.



System to Rack Stabilizing Kit

# Installation Guide

**First Edition (November 2000)**

Before using this information and the product it supports, read the information in "Safety Notices" on page v and "Appendix. Notices" on page 11.

**©International Business Machines Corporation 2000. All rights reserved.**

Note to U.S. Government Users -- Documentation related to restricted rights -- Use, duplication or disclosure is subject to restrictions set forth in GSA ADP Schedule Contract with IBM Corp.

---

# Contents

<b>Safety Notices</b> . . . . .	v
<b>About This Book</b> . . . . .	vii
ISO 9000 . . . . .	vii
Related Publications . . . . .	vii
<b>Chapter 1. Overview</b> . . . . .	1
<b>Chapter 2. System to Rack Stabilizing Kit Installation</b> . . . . .	3
Step 1. Install the Rear Stabilizing Pads . . . . .	3
Step 2: Mount the CEC Cover Card Supports . . . . .	5
Step 3. Install the Rear Stabilizing Bracket . . . . .	6
Step 4. Complete the Installation . . . . .	10
<b>Appendix. Notices</b> . . . . .	11
<b>Reader's Comments — We'd Like to Hear From You</b> . . . . .	13



---

## Safety Notices

Observe the following safety instructions any time you are connecting or disconnecting devices attached to the system unit.

### **DANGER**

**An electrical outlet that is not correctly wired could place hazardous voltage on metal parts of the system or the devices that attach to the system. It is the responsibility of the customer to ensure that the outlet is correctly wired and grounded to prevent an electrical shock.**

**Before installing or removing signal cables, ensure that the power cables for the system unit and all attached devices are unplugged.**

**When adding or removing any additional devices to or from the system, ensure that the power cables for those devices are unplugged before the signal cables are connected. If possible, disconnect all power cables from the existing system before you add a device.**

**Use one hand, when possible, to connect or disconnect signal cables to prevent a possible shock from touching two surfaces with different electrical potentials.**

**During an electrical storm, do not connect cables for display stations, printers, telephones, or station protectors for communication lines.**

### **CAUTION:**

**This unit has more than one power cord. To reduce the risk of electrical shock, disconnect two power supply cords before servicing.**





---

## About This Book

This book provides information on how to install the system to rack stabilizing kit into your system unit and rack.

---

### ISO 9000

ISO 9000 registered quality systems were used in the development and manufacturing of this product.

---

### Related Publications

The following publications provide additional information about your system unit:

- The *System Unit Safety Information* book, order number SA23-2652, contains translations of safety information used throughout this book.
- The system drawer's installation guide contains information on how to install the system drawer.
- The rack installation and service guide contains information regarding the racks in which this system drawer can be installed.



# Chapter 1. Overview

Before performing the following procedures, locate the system unit's installation guide that was shipped with your system drawer. Turn to Chapter 3. "Installing Options". When you are asked to remove a part from the system drawer, locate that part's removal and replacement procedure in the system unit's installation guide and familiarize yourself with each step.

The system to rack stabilizing kit is used in locations that are susceptible to severe shaking and vibration. In this type of environment, the rack should be bolted to the floor.

The following items should have been packed with your system to rack stabilizing kit:

( ) System to Rack Stabilizing Kit Installation Guide

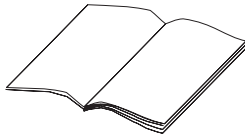

( ) CEC Card Supports (quantity 2)

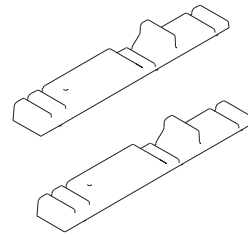

( ) Rear Stabilizing Bracket (quantity 1)

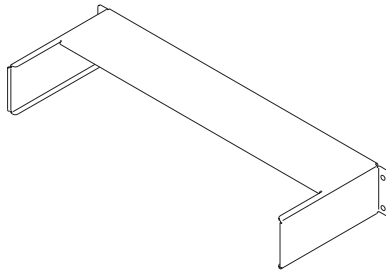

( ) System Drawer Grounding Plate (quantity 1)

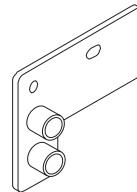

( ) Rear Stabilizing Bracket Support Pads (quantity 2)

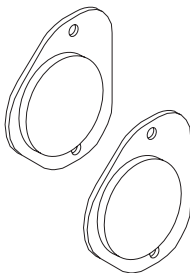

( ) Screws (quantity 12)

Screw Size	Screw Quantity
M5	
M4 Hex Head	
M4 Pan Head	
M3.5	



---

## Chapter 2. System to Rack Stabilizing Kit Installation

To install the system to rack stabilizing kit, perform the following four procedures. Note that each procedure is labeled as a step and that each step contains substeps. Complete each step (procedure) before going on to the next step.

---

### Step 1. Install the Rear Stabilizing Pads

Position yourself in front of your rack and do the following:

1. Open the front rack door.
2. If installed, remove the two thumbscrews located just below the release latches. See the following illustration.

**Note:** Your system drawer has two distinct front bezel designs. On one of the bezels, the thumbscrews are mounted through holes located on each side of the bezel. The bezel is then secured to the system drawer and rack. With the other bezel design, the thumbscrews are mounted directly through slots located just below the release latch and secure only the system drawer to the rack.

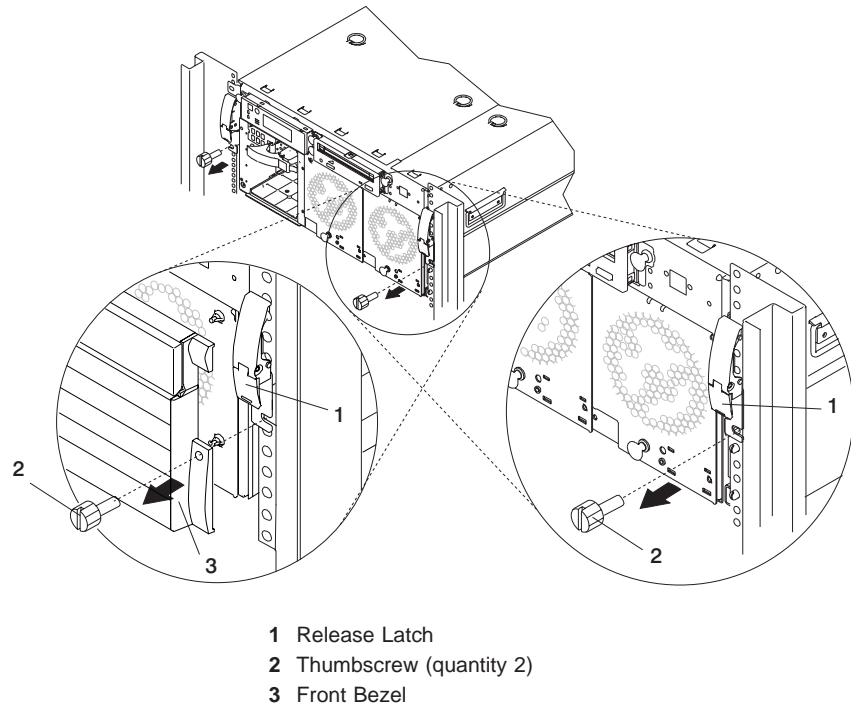

3. Remove the front bezel, as described in "Front Bezel Removal".
4. Place the system drawer into the service position, as described in "Placing the Drawer in the Service Position".

5. Mount the two large support pads to each side of the system drawer using two M4 hex head screws. The threaded mounting holes are located on each side and one inch in from the rear edge of the system drawer. See the following illustration for the mounting location.

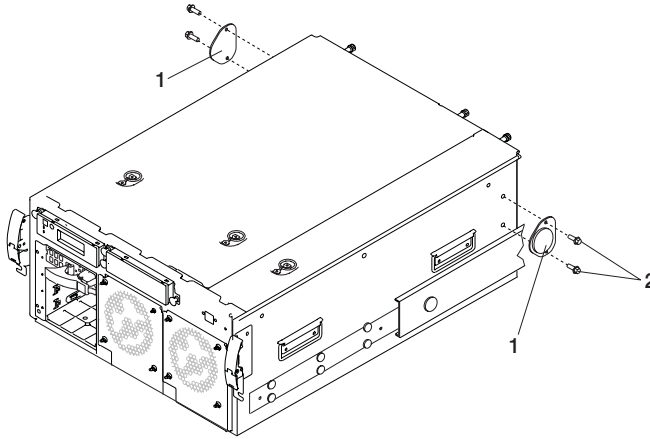

- 1 Rear Stabilizing Bracket Support Pad (quantity 2)
- 2 M4 Hex Head Screws (quantity 4)

---

## Step 2: Mount the CEC Cover Card Supports

To install the CEC cover card supports, do the following:

1. Continue with the system drawer in the service position.
2. Remove the main chassis cover, as described in "Main Chassis Cover Removal".
3. Remove the media bay tray, CD-ROM or tape drive, as described in "Media Bay Tray Removal".
4. If installed, remove the power and signal cables from the rear of the media device, and place your media device in a safe place.
5. Remove the CEC box cover, as described in "CEC Box Cover Removal".
6. Position the CEC cover, as shown in the following illustration.

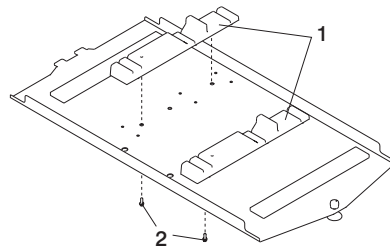

- 1 CEC Cover Card Supports (quantity 2)
- 2 M4 Pan Head Screws (quantity 4)

7. Position the supports as shown, securing each support into position with two M4 pan head screws.
8. Replace the CEC cover, as described in "CEC Box Cover Replacement".

---

### Step 3. Install the Rear Stabilizing Bracket

Position yourself at the rear of your rack and do the following:

1. Open the rear rack door.
2. Remove the two M5 hex head screws that secure the cable management arm to the adjustment plate.

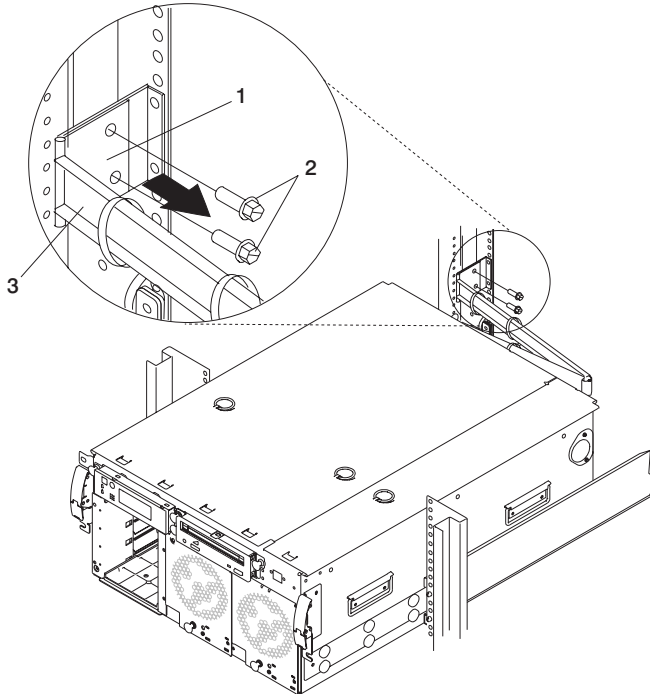

- 1 Cable Management Arm Hinged Mounting Plate
- 2 M5 Hex Head Screws (quantity 2 )
- 3 Cable Management Arm

3. Swing the cable management arm and connected cables out of the way.
4. Note the location of the adjustment plate and its two M5 hex head screws, and then remove them from the rack.



5. Remove the cable management arm adjustment plate.

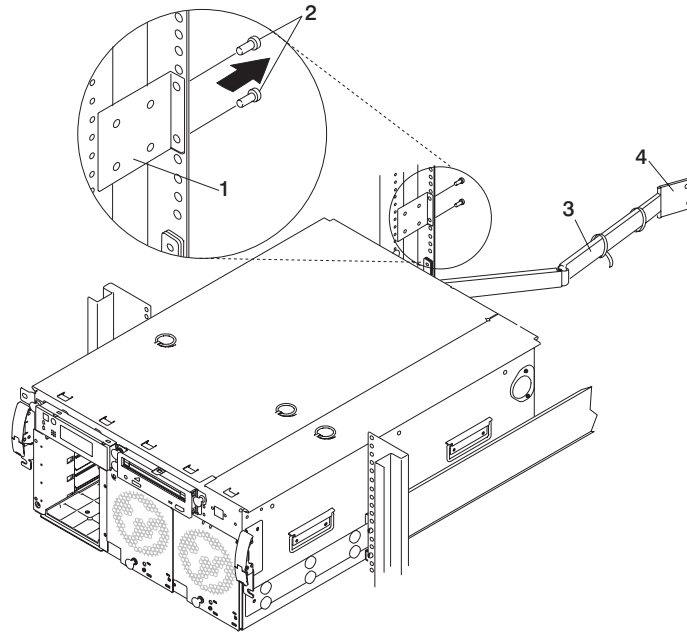

- 1 Cable Management Arm Adjusting Plate
- 2 M5 Hex Head Screws (quantity 2)
- 3 Cable Management Arm
- 4 Cable Management Arm Hinged Mounting Plate

6. Mount the grounding plate to the rear of the chassis using the two M3.5 hex head screws. See the following illustration for mounting location.

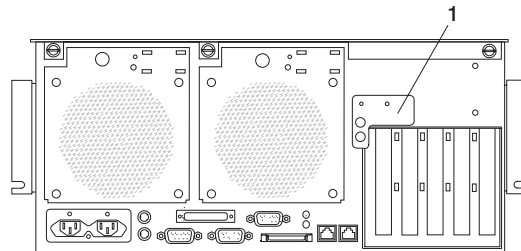

- 1 Mounted Grounding Plate

7. Align the right side of the rear stabilizing bracket with the rack location of the removed adjustment plate.

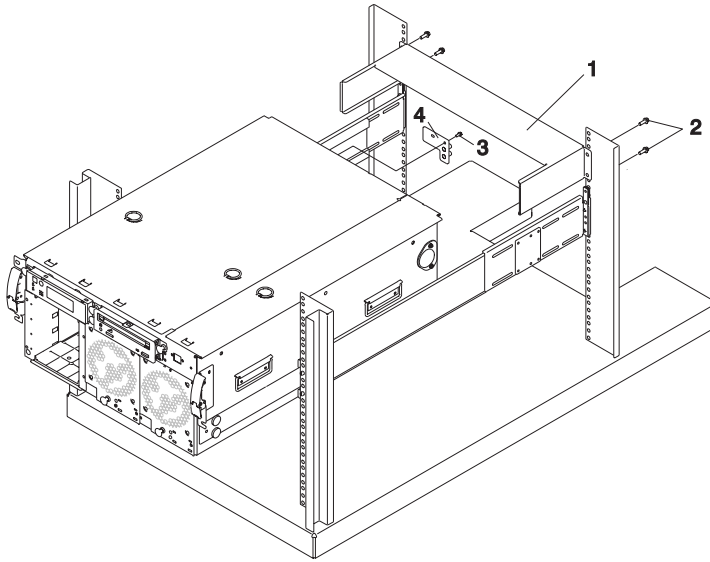

- 1 Cable Management Arm Adjusting Bracket
- 2 M5 Hex Head Screws (quantity 4)
- 3 M3.5 Hex Head Screws (quantity 2)
- 4 System Drawer Ground Plate

8. Secure the rear stabilizing bracket to the rack using four M5 hex head screws. Ensure that the bracket is level before tightening the screws.
9. Using the two M5 hex head screws removed from the cable management arm adjustment plate in substep 2, secure the cable management arm to the side of the installed rear stabilizing bracket. See the following illustration for screw hole

locations.

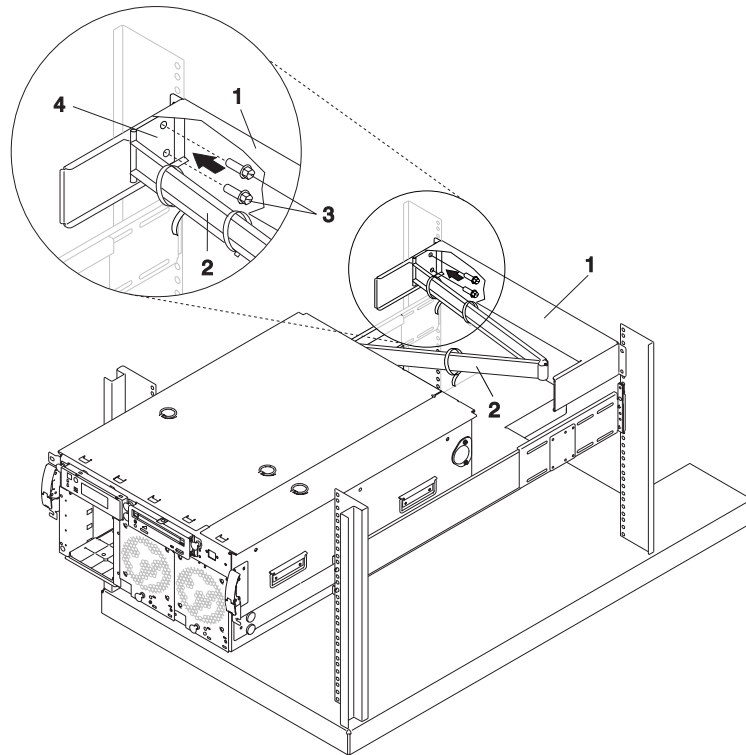

- 1 Rear Stabilizing Bracket
- 2 Cable Management Arm
- 3 M5 Hex Head Screws (quantity 2)
- 4 Cable Management Arm Hinged Mounting Plate

10. Close the rear rack door.

---

## Step 4. Complete the Installation

Go to the front of the system drawer and do the following:

1. Push system drawer into the rack
2. Align the slotted holes of the front support brackets to the mounting holes located on the rack. Mount a nut clip onto the aligned rack holes. See the following illustration.

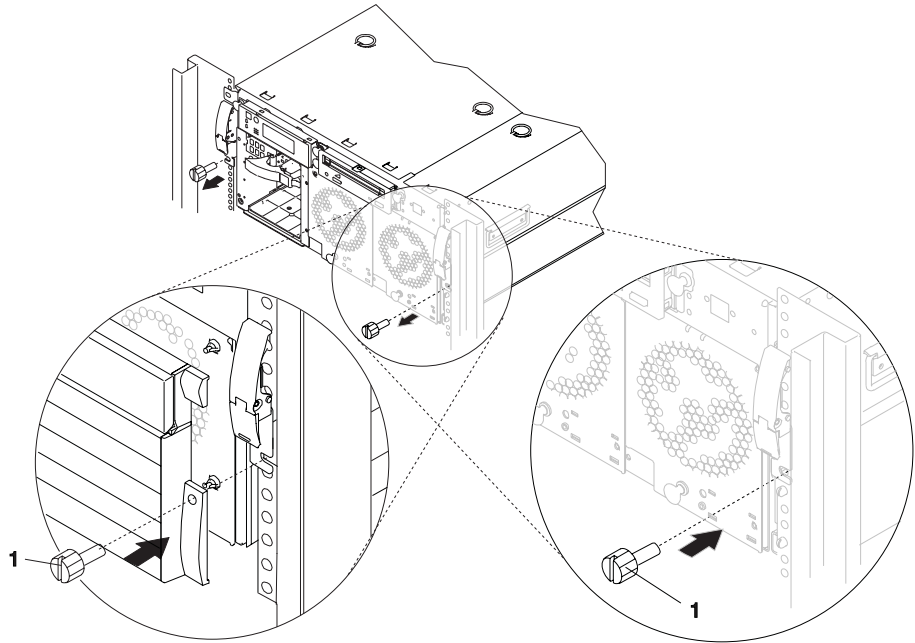

1 Thumbscrew (quantity 2)

3. Return the system drawer to the operating position, as described in "Returning the Drawer to the Operating Position".
4. Insert the two thumbscrews, removed earlier in Step 1. If your system did not have thumbscrews securing the system drawer to the rack, locate them in your "Latch Bracket Mounting Kit" and install them at this time. See "Chapter 1. Installing" in your system unit's installation guide for a description of the latch bracket mounting kit.
5. Close the front rack door.

---

## Appendix. Notices

This information was developed for products and services offered in the U.S.A.

The manufacturer may not offer the products, services, or features discussed in this document in other countries. Consult the manufacturer's representative for information on the products and services currently available in your area. Any reference to the manufacturer's product, program, or service is not intended to state or imply that only that product, program, or service may be used. Any functionally equivalent product, program, or service that does not infringe any intellectual property right of the manufacturer may be used instead. However, it is the user's responsibility to evaluate and verify the operation of any product, program, or service.

The manufacturer may have patents or pending patent applications covering subject matter described in this document. The furnishing of this document does not give you any license to these patents. You can send license inquiries, in writing, to the manufacturer.

**The following paragraph does not apply to the United Kingdom or any country where such provisions are inconsistent with local law: THIS MANUAL IS PROVIDED "AS IS" WITHOUT WARRANTY OF ANY KIND, EITHER EXPRESSED OR IMPLIED, INCLUDING, BUT NOT LIMITED TO, THE IMPLIED WARRANTIES OF NON-INFRINGEMENT, MERCHANTABILITY OR FITNESS FOR A PARTICULAR PURPOSE. Some states do not allow disclaimer of express or implied warranties in certain transactions; therefore, this statement may not apply to you.**

This information could include technical inaccuracies or typographical errors. Changes are periodically made to the information herein; these changes will be incorporated in new editions of the publication. The manufacturer may make improvements and/or changes in the product(s) and/or the program(s) described in this publication at any time without notice.

Information concerning products made by other than the manufacturer was obtained from the suppliers of those products, their published announcements, or other publicly available sources. The manufacturer has not tested those products and cannot confirm the accuracy of performance, compatibility or any other claims related to products made by other than the manufacturer. Questions on the capabilities of products made by other than the manufacturer should be addressed to the suppliers of those products.



---

## Reader's Comments — We'd Like to Hear From You

### System to Rack Stabilizing Kit Installation Guide

Form Number:SA23-1241-00

Overall how satisfied are you with the information in this book?

	Very Satisfied	Satisfied	Neutral	Dissatisfied	Very Dissatisfied
Overall Satisfaction	<input type="checkbox"/>	<input type="checkbox"/>	<input type="checkbox"/>	<input type="checkbox"/>	<input type="checkbox"/>

How satisfied are you that the information in this book is:

	Very Satisfied	Satisfied	Neutral	Dissatisfied	Very Dissatisfied
Accurate	<input type="checkbox"/>	<input type="checkbox"/>	<input type="checkbox"/>	<input type="checkbox"/>	<input type="checkbox"/>
Complete	<input type="checkbox"/>	<input type="checkbox"/>	<input type="checkbox"/>	<input type="checkbox"/>	<input type="checkbox"/>
Easy to find	<input type="checkbox"/>	<input type="checkbox"/>	<input type="checkbox"/>	<input type="checkbox"/>	<input type="checkbox"/>
Easy to understand	<input type="checkbox"/>	<input type="checkbox"/>	<input type="checkbox"/>	<input type="checkbox"/>	<input type="checkbox"/>
Well organized	<input type="checkbox"/>	<input type="checkbox"/>	<input type="checkbox"/>	<input type="checkbox"/>	<input type="checkbox"/>
Applicable to your tasks	<input type="checkbox"/>	<input type="checkbox"/>	<input type="checkbox"/>	<input type="checkbox"/>	<input type="checkbox"/>

Please tell us how we can improve this book:

Thank you for your response. May we contact you?  Yes  No

When you send comments to us, you grant us a nonexclusive right to use or distribute your comments in any way we believe appropriate without incurring any obligation to you.

---

**Name**

---

**Address**

---

**Company or Organization**

---

**Phone Number**

Cut or Fold  
Along Line

Fold and Tape

Please do not Staple

Fold and Tape



NO POSTAGE  
NECESSARY  
IF MAILED IN THE  
UNITED STATES

**BUSINESS REPLY MAIL**

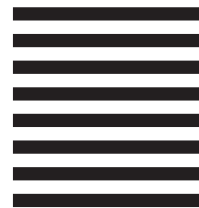

POSTAGE WILL BE PAID BY ADDRESSEE

Information Development  
Department H6DS-9561  
11400 Burnet Road  
Austin, TX 78758-3493



Fold and Tape

Please do not Staple

Fold and Tape

Cut or Fold  
Along Line





Part Number: 09P2368



Printed in the United States of America  
on recycled paper containing 10%  
recovered post-consumer fiber.

November 2000

SA23-1241-00



(1P) P/N: 09P2368

