

RS/6000 Enterprise Server Model M80  
@server pSeries 660 Model 6M1



# Service Guide

**Second Edition (September 2001)**

Before using this information and the product it supports, read the information in "Safety Notices" on page xi, Appendix A, "Environmental Notices" on page 547, and Appendix B, "Notices" on page 549.

A reader's comment form is provided at the back of this publication. If the form has been removed, address comments to Information Development, Department H6DS-905-6C006, 11400 Burnet Road, Austin, Texas 78758-3493. To send comments electronically, use this commercial internet address: [aix6kpub@austin.ibm.com](mailto:aix6kpub@austin.ibm.com). Any information that you supply may be used without incurring any obligation to you.

© **International Business Machines Corporation, 2000, 2001. All rights reserved.**

Note to U.S. Government Users -- Documentation related to restricted rights -- Use, duplication or disclosure is subject to restrictions set forth in GSA ADP Schedule Contract with IBM Corp.

---

# Contents

<b>Safety Notices</b> . . . . .	xi
Rack Safety Instructions . . . . .	xi
Electrical Safety . . . . .	xii
Laser Safety Information . . . . .	xiii
Laser Compliance . . . . .	xiii
<b>Data Integrity and Verification</b> . . . . .	xv
<b>About This Book</b> . . . . .	xvii
ISO 9000 . . . . .	xvii
Online Publications . . . . .	xvii
Related Publications . . . . .	xvii
Trademarks . . . . .	xviii
<b>Chapter 1. Reference Information</b> . . . . .	1
Overview . . . . .	1
Processors . . . . .	2
Memory . . . . .	2
Primary I/O Drawer . . . . .	3
Data Flow . . . . .	4
Powering the System On and Off . . . . .	5
Console Strategy . . . . .	6
Power-On Self-Test . . . . .	6
POST Indicators . . . . .	7
POST Keys . . . . .	7
1 Key . . . . .	7
5 Key . . . . .	7
6 Key . . . . .	8
8 Key . . . . .	8
System Locations . . . . .	9
CEC Drawer Front View With Bezel Removed . . . . .	10
CEC Drawer Rear View . . . . .	11
CEC Card Cage . . . . .	12
Primary I/O Drawer Front View With Cover On . . . . .	13
Secondary I/O Drawer Front View With Cover On . . . . .	14
Primary I/O Drawer Rear View . . . . .	15
Primary I/O Drawer Front View with Covers Removed . . . . .	16
Secondary I/O Drawer Rear View . . . . .	17
I/O Drawer Backplane PCI Slot Locations . . . . .	18
System Board Locations . . . . .	19
Memory Riser Card and Memory DIMM Locations . . . . .	20
Primary I/O Drawer Operator Panel . . . . .	22
Secondary I/O Drawer Operator Panel . . . . .	22
SCSI IDs and Bay Locations . . . . .	23
Primary I/O Drawer SCSI IDs . . . . .	23
System Memory . . . . .	24
Riser Card Memory Placement Rules . . . . .	24

I/O Drawer Features . . . . .	25
I/O Drawer Addressing . . . . .	25
I/O Drawer and Power Supply LED Status. . . . .	26
Secondary I/O Drawer Operator Panel Message Hierarchy . . . . .	27
Primary I/O Drawer Operator Panel Behavior During Power-On. . . . .	28
Secondary I/O Drawer Operator Panel Behavior During Power-On. . . . .	29
Logical and Physical Locations . . . . .	29
Physical Location Codes . . . . .	29
Location Code Format . . . . .	29
Multiple FRU Callout Instructions . . . . .	30
AIX Location Codes . . . . .	32
AIX and Physical Location Code Reference Tables . . . . .	33
Cabling the CEC Drawer, Primary I/O Drawer, and Secondary I/O Drawer(s) . . . . .	53
Connecting JTAG and V/S COMM Cables . . . . .	53
Connecting RIO and SPCN Cables . . . . .	53
System Cable Diagrams. . . . .	63
CEC Drawer Cable . . . . .	63
Primary I/O Drawer Cable . . . . .	64
Secondary I/O Drawer Cable . . . . .	65
DC Power Cable Routings . . . . .	66
Specifications . . . . .	67
CEC Drawer . . . . .	68
Noise Emission Notes . . . . .	71
Power Cables . . . . .	72
Service Inspection Guide . . . . .	73
<b>Chapter 2. Diagnostics Overview . . . . .</b>	<b>75</b>
Maintenance Analysis Procedures (MAPs). . . . .	75
Checkpoints. . . . .	76
FRU Isolation . . . . .	77
Electronic Service Agent for the @server pSeries and RS/6000 . . . . .	77
Using the Service Processor and Electronic Service Agent Features . . . . .	78
Service Processor. . . . .	78
Electronic Service Agent . . . . .	79
<b>Chapter 3. Maintenance Analysis Procedures (MAPs) . . . . .</b>	<b>81</b>
Entry MAP . . . . .	81
Quick Entry MAP . . . . .	82
Quick Entry MAP Table of Contents . . . . .	82
MAP 1020: Problem Determination . . . . .	89
MAP 1520: Power. . . . .	95
Map 1521: Cannot Power On the Primary I/O Drawer, Operator Panel Does Not Show OK Prompt . . . . .	96
Map 1522: Cannot Power On the CEC Drawer . . . . .	103
Map 1523: Cannot Power On the Secondary I/O Drawer, Operator Panel Power Present LED Does Not Come On . . . . .	110
Map 1524: The SPCN Error Codes Table Directed You Here and the Error Code is 1011 1C0x . . . . .	118
MAP 1540: Minimum Configuration. . . . .	122

<b>Chapter 4. Checkpoints</b>	147
IPL Flow	149
Service Processor Checkpoints	150
Firmware Checkpoints	156
Boot Problems and Concerns	167
Step 1	167
Step 2	167
Step 3	168
Step 4	168
Step 5	169
<b>Chapter 5. Error Code to FRU Index</b>	171
Four-Character Checkpoints	171
Replacing the Primary Drawer Operator Panel	171
Replacing the Network Adapter	171
Analyzing SPCN Errors on Secondary Drawers	172
Isolating the I/O Drawer Failure	172
Determining Location Code	172
Checkpoint and Error Code Index	173
Performing Slow Boot	174
Confirming Initial Error Code	174
Memory-Related Error Codes	175
Operator Panel Error Codes	176
SPCN Error Codes	177
Firmware/POST Error Codes	212
Service Processor Error Codes	233
System Firmware Update Messages	388
Common Firmware Error Codes	389
Scan Log Dump Progress Codes	398
Problem Determination-Generated Error Codes	398
<b>Chapter 6. Loading the System Diagnostics In Service Mode</b>	401
Default Boot List and Service Mode Bootlist	402
<b>Chapter 7. Using the Capacity Upgrade on Demand Feature</b>	403
System Processors	403
Process Flow for Capacity Upgrade on Demand	404
Installing a System with Capacity Upgrade on Demand	405
Verifying System Communication Capabilities	405
Configuring the Capacity Upgrade on Demand Feature	405
Enabling the Capacity Upgrade on Demand Feature	407
Enabling Additional Capacity Upgrade on Demand Processors	409
Determining Processor Configuration	409
Adding Processor Capacity	410
<b>Chapter 8. Using the Service Processor</b>	411
Service Processor Menus	412
Accessing the Service Processor Menus Locally	412
Accessing the Service Processor Menus Remotely	412
Saving and Restoring Service Processor Settings	412

Menu Inactivity . . . . .	413
General User Menu . . . . .	413
Privileged User Menus . . . . .	414
Main Menu. . . . .	414
Service Processor Setup Menu . . . . .	416
Passwords. . . . .	417
System Power Control Menu. . . . .	420
System Information Menu. . . . .	424
Memory Riser Card 1 Memory DIMM Locations for Service Processor Menus	428
Memory Riser Card 2 Memory DIMM Locations for Service Processor Menus	430
Language Selection Menu . . . . .	431
Call-In/Call-Out Setup Menu . . . . .	432
Modem Configuration Menu . . . . .	433
Serial Port Selection Menu . . . . .	434
Serial Port Speed Setup Menu . . . . .	434
Telephone Number Setup Menu. . . . .	435
Call-Out Policy Setup Menu . . . . .	436
Customer Account Setup Menu . . . . .	437
Service Processor Procedures in Service Mode . . . . .	437
Service Processor Functions . . . . .	438
System Power-On Methods . . . . .	439
Service Processor Reboot/Restart Recovery . . . . .	440
Boot (IPL) Speed . . . . .	440
Failure During Boot Process . . . . .	440
Failure During Normal System Operation. . . . .	440
Service Processor Reboot/Restart Policy Controls. . . . .	441
System Firmware Updates . . . . .	442
General Information on System Firmware Updates . . . . .	442
Determining the Level of Firmware on the System. . . . .	443
System Firmware Update Using a Locally Available Image . . . . .	443
Updating System Firmware From the Service Processor Menus . . . . .	444
Updating System Firmware from the AIX Service Aids . . . . .	444
Updating System Firmware from the AIX Command Line . . . . .	444
Recovery Mode . . . . .	445
Configuring and Deconfiguring Processors or Memory . . . . .	445
Run-Time CPU Deconfiguration (CPU Gard) . . . . .	446
Service Processor System Monitoring - Surveillance . . . . .	446
System Firmware Surveillance . . . . .	446
Operating System Surveillance . . . . .	446
Call-Out (Call-Home) . . . . .	447
Console Mirroring . . . . .	449
System Configuration . . . . .	449
Service Processor Error Log . . . . .	450
LCD Progress Indicator Log . . . . .	451
Service Processor Operational Phases . . . . .	452
Pre-Standby Phase . . . . .	452
Standby Phase . . . . .	452
Bring-Up Phase . . . . .	453
Run-Time Phase. . . . .	454

<b>Chapter 9. Using System Management Services</b>	456
Password Utilities	456
Display Error Log	457
Remote Initial Program Load Setup	457
SCSI Utilities	461
Select Console	461
MultiBoot	462
Select Language	465
OK Prompt	465
Exiting System Management Services	465
<b>Chapter 10. Removal and Replacement Procedures</b>	467
Handling Static-Sensitive Devices	468
Powering Off and Powering On the System	469
Powering Off the System	469
Powering On the System	469
Powering Off and Powering On the System Using the Service Processor	469
Hot-Pluggable FRUs	470
I/O Drawer PCI Slot LED Definitions	470
PCI Adapters	471
Non-Hot-Pluggable PCI Adapter	471
Removal	471
Replacement	472
Hot-Pluggable PCI Adapter	473
Removing a Hot-Pluggable PCI Adapter	473
Replacing a Hot-Pluggable PCI Adapter	474
Installing a Hot-Pluggable PCI Adapter	476
PCI Hot-Plug Manager Access	478
Accessing Hot-Plug Management Functions	478
PCI Hot-Plug Manager Menu	479
Memory Riser Cards and Memory Modules	481
Removal	481
Replacement	482
CEC Regulator Card	484
Removal	484
Replacement	484
Processor Card	485
Removal	485
Replacement	487
CEC Fans	490
Removal	490
Replacement	491
CEC Power Supplies	492
Removal	492
Replacement	492
CEC RIO Bus Adapter	493
Removal	493
Replacement	495
CEC Backplane	496
Removal	496

Replacement . . . . .	498
I/O Drawer Backplane Assembly . . . . .	498
Removal . . . . .	498
Replacement . . . . .	500
I/O Drawer RIO Bus Adapter . . . . .	501
Removal . . . . .	501
Replacement . . . . .	502
I/O Drawer Power Distribution Board . . . . .	503
Removal . . . . .	503
Replacement . . . . .	504
I/O Drawer Power Supplies and Power Supply Fan Assemblies . . . . .	505
Removal . . . . .	506
Replacement . . . . .	507
Power Supply Test Switch Procedure . . . . .	508
Internal Disk Drives . . . . .	509
Removal . . . . .	509
Replacement . . . . .	511
Fan Controller Card . . . . .	512
Removal . . . . .	512
Replacement . . . . .	512
CD-ROM Drive . . . . .	513
Removal . . . . .	513
Replacement . . . . .	514
Tape Drive . . . . .	515
Removal . . . . .	515
Replacement . . . . .	515
Diskette Drive . . . . .	516
Removal . . . . .	516
Replacement . . . . .	516
Operator Panel . . . . .	517
Removal . . . . .	517
Replacement . . . . .	518
Rear Service Position . . . . .	519
Front Service Position . . . . .	520
Battery . . . . .	521
Removal . . . . .	521
Replacement . . . . .	522
<b>Chapter 11. Parts Information . . . . .</b>	<b>523</b>
CEC Drawer Card Assembly . . . . .	525
CEC Drawer Backplane . . . . .	527
CEC Drawer Power Supplies . . . . .	529
CEC Drawer Fan Assemblies . . . . .	531
I/O Drawer . . . . .	535
CEC Drawer Internal Cables . . . . .	537
Primary I/O Drawer Cables . . . . .	539
Secondary I/O Drawer Cables . . . . .	541
External Cables . . . . .	542
Keyboards and Mouse . . . . .	543
Keyboards and Mouse (Black) . . . . .	545



<b>Appendix A. Environmental Notices.</b>	547
Product Recycling and Disposal.	547
Environmental Design	547
Acoustical Noise Emissions	547
Declared Acoustical Noise Emissions	548
Noise Emission Notes	548
 <b>Appendix B. Notices</b>	 549
 <b>Appendix C. Service Processor Setup and Test</b>	 551
Service Processor Setup Checklist.	551
Testing the Setup	552
Testing Call-In	552
Testing Call-Out	552
Serial Port Configuration	553
 <b>Appendix D. Using the chcod Command</b>	 555
Description.	555
Flags	555
 <b>Appendix E. Verifying Capacity Upgrade on Demand Processors</b>	 557
Determining Current Configuration	557
Recovery Procedures	557
Capacity Upgrade on Demand Diagnostics	557
Testing the System in the Capacity Upgrade on Demand Environment	558
 <b>Appendix F. Modem Configurations.</b>	 561
Sample Modem Configuration Files	561
Generic Modem Configuration Files	561
Specific Modem Configuration Files	561
Configuration File Selection	562
Examples for Using the Generic Sample Modem Configuration Files	564
Customizing the Modem Configuration Files.	564
IBM 7852-400 DIP Switch Settings.	565
Xon/Xoff Modems	565
Ring Detection	565
Terminal Emulators	566
Recovery Procedures	566
Transfer of a Modem Session	566
Recovery Strategy	567
Prevention Strategy.	568
Modem Configuration Sample Files	569
Sample File modem_m0.cfg	569
Sample File modem_m1.cfg	571
Sample File modem_z.cfg.	573
Sample File modem_z0.cfg	575
Sample File modem_f.cfg	577
Sample File modem_f0.cfg	580
Sample File modem_f1.cfg	583

<b>Appendix G. Rack Drawer Rail Instructions</b> . . . . .	587
Front Drawer-Stop Installation . . . . .	587
Drawer Rail Assembly and Installation. . . . .	588
Rails for an S00 Type Rack . . . . .	588
Rails for a T00 Type Rack . . . . .	588
Rail Installation . . . . .	588
Cable Routing . . . . .	589
<b>Index</b> . . . . .	593

---

## Safety Notices

A *danger* notice indicates the presence of a hazard that has the potential of causing death or serious personal injury. Danger notices appear on the following pages:

- xii
- 94
- 467
- 506

A *caution* notice indicates the presence of a hazard that has the potential of causing moderate or minor personal injury. Caution notices appear on the following pages:

- xii
- xiii
- 94
- 467
- 513
- 521

**Note:** For a translation of these notices, see the *System Unit Safety Information* manual, SA23-2652.

---

## Rack Safety Instructions

- Do not install this unit in a rack where the internal rack ambient temperatures will exceed 40 degrees C.
- Do not install this unit in a rack where the air flow is compromised. Any side, front or back of the unit used for air flow through the unit must not be in indirect contact with the rack.
- Ensure that a hazardous condition is not created due to uneven mechanical loading when installing this unit in a rack. If the rack has a stabilizer it must be firmly attached before installing or removed this unit.
- Consider the connection of the equipment to the supply circuit so that the overloaded circuits do not compromise the supply wiring or overcurrent protection.
- An electrical outlet that is not correctly wired could place hazardous voltage on the metal parts of the system or the devices that attach to the system. It is the responsibility of the customer to ensure that the outlet is correctly wired and grounded to prevent an electrical shock.

---

## Electrical Safety

Observe the following safety instructions any time you are connecting or disconnecting devices attached to the workstation.

### **DANGER**

**An electrical outlet that is not correctly wired could place hazardous voltage on metal parts of the system or the devices that attach to the system. It is the responsibility of the customer to ensure that the outlet is correctly wired and grounded to prevent an electrical shock.**

**Before installing or removing signal cables, ensure that the power cables for the system unit and all attached devices are unplugged.**

**When adding or removing any additional devices to or from the system, ensure that the power cables for those devices are unplugged before the signal cables are connected. If possible, disconnect all power cables from the existing system before you add a device.**

**Use one hand, when possible, to connect or disconnect signal cables to prevent a possible shock from touching two surfaces with different electrical potentials.**

**During an electrical storm, do not connect cables for display stations, printers, telephones, or station protectors for communications lines.**

### **CAUTION:**

**This product is equipped with a three-wire power cable and plug for the user's safety. Use this power cable with a properly grounded electrical outlet to avoid electrical shock.**

### **DANGER**

**To prevent electrical shock hazard, disconnect all power cables from the electrical outlet before relocating the system.**

### **CAUTION:**

**This unit has more than one power supply cord. To reduce the risk of electrical shock, disconnect two power supply cords before servicing.**

---

## Laser Safety Information

**CAUTION:**

**This product may contain a CD-ROM which is a class 1 laser product.**

## Laser Compliance

All lasers are certified in the U.S. to conform to the requirements of DHHS 21 CFR Subchapter J for class 1 laser products. Outside the U.S., they are certified to be in compliance with the IEC 825 (first edition 1984) as a class 1 laser product. Consult the label on each part for laser certification numbers and approval information.

**CAUTION:**

**All IBM laser modules are designed so that there is never any human access to laser radiation above a class 1 level during normal operation, user maintenance, or prescribed service conditions. Data processing environments can contain equipment transmitting on system links with laser modules that operate at greater than class 1 power levels. For this reason, never look into the end of an optical fiber cable or open receptacle. Only trained service personnel should perform the inspection or repair of optical fiber cable assemblies and receptacles.**



---

## Data Integrity and Verification

IBM computer systems contain mechanisms designed to reduce the possibility of undetected data corruption or loss. This risk, however, cannot be eliminated. Users who experience unplanned outages, system failures, power fluctuations or outages, or component failures must verify the accuracy of operations performed and data saved or transmitted by the system at or near the time of the outage or failure. In addition, users must establish procedures to ensure that there is independent data verification before relying on such data in sensitive or critical operations. Users should periodically check the IBM support websites for updated information and fixes applicable to the system and related software.





---

## About This Book

This book provides maintenance information that is specific to the RS/6000 Enterprise Server Model M80 and @server pSeries 660 Model 6M1, as well as to adapters and attached devices that do not have their own service information. In this book, the RS/6000 Enterprise Server Model M80 and @server pSeries 660 Model 6M1 are hereafter referred to as the "system" or the "server."

This book contains maintenance analysis procedures (MAPs) that are not common to other systems. MAPs that are common to all systems are contained in the *RS/6000 and @server pSeries Diagnostic Information for Multiple Bus Systems*.

This book is used by the service technician to repair system failures. This book assumes that the service technician has had training on the system unit.

---

## ISO 9000

ISO 9000 registered quality systems were used in the development and manufacturing of this product.

---

## Online Publications

RS/6000 and pSeries publications are available online. To access the online books, visit our Web site at: [http://www.rs6000.ibm.com/resource/hardware\\_docs/](http://www.rs6000.ibm.com/resource/hardware_docs/)

---

## Related Publications

The following publications provide additional information about your system unit:

- The *System Unit Safety Information*, order number SA23-2652, contains translations of safety information used throughout this book.
- The *RS/6000 Enterprise Server Model M80, @server pSeries 660 Model 6M1 User's Guide*, order number SA38-0565, contains information on how to use the system, use diagnostics, use service aids, and verify system operations.
- The *7014 Series Model T00 and T42 Rack Installation and Service Guide*, order number SA38-0577, contains information regarding the 7014 Series Model T00 Rack, in which the Enterprise Server Model M80 and @server pSeries 660 Model 6M1 may be installed.
- The *RS/6000 and @server pSeries Diagnostic Information for Multiple Bus Systems*, order number SA38-0509, contains common diagnostic procedures, error codes, service request numbers, and failing function codes. This manual is intended for trained service technicians.
- The *RS/6000 and @server pSeries Adapters, Devices, and Cable Information for Multiple Bus Systems*, order number SA38-0516 contains information about adapters, devices, and cables for your system. This manual is intended to supplement information found in the *RS/6000 and @server pSeries Diagnostic Information for Multiple Bus Systems*.

- The *PCI Adapter Placement Reference*, order number SA38-0538, contains information regarding slot restrictions for adapters that can be used in this system.
- The *Site and Hardware Planning Information*, order number SA38-0508, contains information to help you plan your installation.

---

## Trademarks

The following terms are trademarks of International Business Machines Corporation in the United States, other countries, or both:

- AIX
- e (logo)
- pSeries
- RS/6000

Other company, product, and service names may be trademarks or service marks of others.

---

## Chapter 1. Reference Information

This chapter provides an overview of the system, including a logical description and a physical overview. Additional details pertaining to the system are also provided, as follows:

- Memory overview and placement
- General description of the operator panel
- Cabling rules
- System location rules and descriptions
- Powering on and off the system
- Power flow
- Data flow

---

### Overview

The RS/6000 Enterprise Server Model M80 and @server pSeries 660 Model 6M1 systems are multiprocessor, multibus systems packaged in two to five drawers. The processors and memory are packaged in an 8 EIA-unit central electronics complex (CEC) drawer, and the optional DASD and I/O devices are in 5 EIA-unit I/O drawers. The basic system consists of one CEC drawer and one I/O drawer in the same rack. You can expand the system by adding up to three additional I/O drawers in a minimum of two racks.

A number of cables connect the CEC and I/O drawers. These cables include:

- SPCN (System Power Control Network) cables
- V/S COMM cables
- RIO (Remote Input Output) cables
- JTAG cable

An ac power cord (dc power cord in a dc-powered system) is connected to the CEC drawer (drawer 1), primary I/O drawer (drawer 0), and secondary I/O drawer (drawer 2). You can also connect two additional secondary drawers (drawers 3 and 4) in another rack with a separate power distribution unit and ac power cord (dc power cord in a dc-powered system). A dc-powered system has no power distribution unit.

## Processors

The CEC drawer is powered independently from the I/O drawer and supports two processor cards.

Model M80:

- Can have any combination of 2-way or 4-way processor cards running at 500 MHz
- All 500 MHz processors can have their own 4 MB L2 cache

Model 6M1:

- Can be ordered with 500 MHz processors or 750 MHz processors
- Systems with 500 MHz processors can have one or two 2-way processor cards
- Systems with 750 MHz processors can have any combination of 2-way and 4-way processor cards
- All 500 MHz processors can have their own 4 MB L2 cache
- All 750 MHz processors can have their own 8 MB L2 cache

The Capacity Upgrade on Demand feature is available for this system when a minimum of four processors running at 750 MHz are installed. The Capacity Upgrade on Demand feature is not available on systems in which 500 MHz processors are installed. For more information about Capacity Upgrade on Demand, see Chapter 7, "Using the Capacity Upgrade on Demand Feature" on page 403.

**Note:** In order for the system to boot, the first processor card slot must be populated.

## Memory

- Model M80: 1 GB (minimum) to 32 GB (maximum)
- Model 6M1: 1 GB (minimum) to 64 GB (maximum)
- One or two memory riser cards; each riser card has thirty-two sockets. 128 MB, 256 MB, 512 MB, and 1 GB dual inline memory modules (DIMMs) are available.
- Certain 32 MB DIMMs from older RS/6000 systems can also be used when upgrading the system memory.

## Primary I/O Drawer

The primary I/O drawer has the following:

- 14 PCI slots
- System operator panel
- SPCN controller
- System media
- Service processor
- Optional boot DASDs that occupy PCI slots 13 and 14
- Various connectors, including four serial port connectors, on the back of the drawer for the attachment of external devices

**Note:** Serial ports 1 and 2 can only be used to access the service processor menus. No "heartbeat"-type devices or cables can be used on these ports. "Heartbeat"-type devices or cables must be installed on serial port 3 or serial port 4.

The PCI bus speeds are as follows:

- Up to 33 MHz for the four 32-bit slots at 5 V
- Up to 66 MHz for the ten 64-bit slots at 3.3 V

Slots 1-5, 8-10, 13 and 14 support either 32- or 64-bit PCI adapters. The remaining slots are 32-bit only.

The CEC drawer includes the interrupt and system bus control logic.

The primary I/O drawer has space for up to three media devices. The diskette drive and CD-ROM drive are standard; the third media device is optional.

"Data Flow" on page 4 illustrates the system's data flow.

# Data Flow

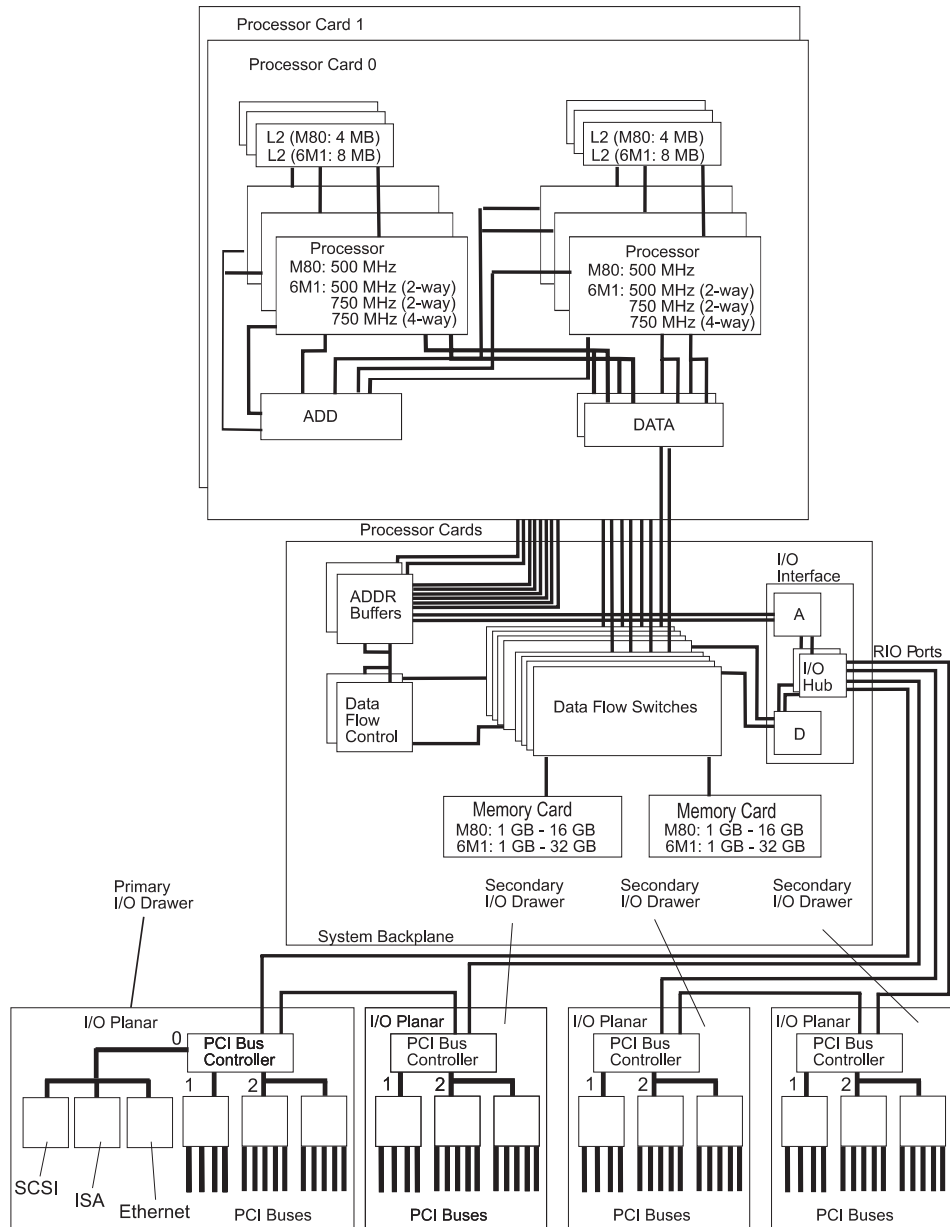

---

## Powering the System On and Off

The system can be powered on after the following cables are connected:

- V/S COMM Cable
- All RIO cables
- All SPCN cables
- JTAG Cable
- All PCI cables to supported drawers

After the required cables are installed, and the power cables are connected, the power button on the primary I/O drawer operator panel can be pushed to initialize the system. Progress indicators, also referred to as *checkpoints*, are visible on the primary I/O drawer operator panel display and the power LED on the primary I/O drawer stops blinking and stays on, indicating the system power is on.

The CEC drawer and secondary I/O drawers are powered on through the primary I/O drawer system power control network (SPCN). When power is applied, the power LEDs on the primary I/O drawer go from blinking to on continuously, and the power LED on the CEC drawer and secondary I/O drawer(s) comes on and stays on. This indicates that power levels are satisfactory in the drawers.

If the system is operating under AIX, type the `shutdown` command to power off the system. If you cannot use this method, you can power off the system by pressing the power button on the primary I/O drawer operator panel.

**Attention:** Using the power button on the operator panel to power off the system can cause unpredictable results in the data files, and the next IPL will take longer to complete.

For complete details on how to power on and off the system, go to “Powering Off and Powering On the System” on page 469 and “System Power-On Methods” on page 439.

---

## Console Strategy

The firmware starts a console-selection sequence at system boot time if any of the following is true:

- A console has not yet been selected.
- A previous console-selection sequence timed-out.
- A change in the system configuration has affected the console (keyboard installed/removed, mouse installed/removed, graphics adapter installed/removed or moved to another PCI slot).

The console-selection sequence allows you to select (from the appropriate input device) any one of the available console devices. If no console is selected within approximately 60 seconds, serial port 1 (S1) is selected as the console and the selection sequence times-out.

**Attention:** If an ASCII terminal is attached to serial port 1 (S1), and there is any interaction with this terminal, then:

- After OK displays in the operator panel,  
AND
- Before the power-on sequence is initiated,

the firmware will use this terminal as the console, regardless of the previous console selection.

After a console has been selected, the console-selection sequence is only started at boot time if there is a change in the system configuration (as previously described), or the contents of the system's nonvolatile memory (NVRAM) are lost.

**Note:** Moving an ASCII terminal from one serial port to another (from S1 to S2) cannot be detected by the firmware, so it does not constitute a configuration change.

You can also initiate a system console-selection sequence from the SMS menus.

---

## Power-On Self-Test

After power is turned on and before the operating system is loaded, the system does a power-on self-test (POST). This test performs checks to ensure that the hardware is functioning correctly before the operating system is loaded. During the POST, a POST screen displays, and POST indicators appear on the system console (if one is connected). The next section describes the POST indicators and functions that can be accessed during the POST.



---

## POST Indicators

POST indicators indicate tests that are being performed as the system is preparing to load the operating system. The POST indicators are words that display on the system console. Each time that the system starts a different step in the POST, a POST indicator word appears on the console. Each word is an indicator of the tests that are being performed.

The POST screen displays the following words:

<b>Memory</b>	Memory test
<b>Keyboard</b>	Initialize the keyboard and mouse. The window for pressing a key to access the System Management Services, or to initiate a service mode boot list, is now open. See “POST Keys” for more information.
<b>Network</b>	Self-test on network adapters
<b>SCSI</b>	Adapters are being initialized
<b>Speaker</b>	Sounds an audible tone at the end of POST

---

## POST Keys

The POST keys, if pressed *after* the **keyboard** POST indicator displays and *before* the last POST indicator (**speaker**) displays, cause the system to start services or to initiate service mode boots used for configuring the system and diagnosing problems. The keys are described below:

**Note:** The program function keys (F1-F12) on a keyboard attached to the system unit are no longer used and will be ignored during POST. After the keyboard POST indicator displays, you must use the numeric number keys to enter input.

### 1 Key

The numeric 1 key, when pressed during POST, starts the System Management Services (SMS) interface.

### 5 Key

The numeric 5 key, when pressed during POST, initiates a system boot in service mode using the default service mode boot list.

This mode attempts to boot from the first device of each type found in the list. It does not search for other bootable devices of that type if the first device is not bootable. Instead, it continues to the next device type in the list. The firmware supports up to five entries in the boot list.

The default boot sequence is:

1. Diskette
2. CD-ROM
3. Hard file
4. Tape drive (if installed)
5. Network
  - a. Token ring
  - b. Ethernet

## 6 Key

The numeric 6 key works like the numeric 5 key, except that firmware uses the customized service mode bootlist that was set up in System Management Services or in the AIX service aids.

## 8 Key

To enter the open firmware command line, press the numeric 8 key *after* the word **keyboard** displays and before the last word (**speaker**) displays during startup. After you press the 8 key, the remaining POST indicators display until initialization completes.

When initialization and POST are complete, the open firmware command line (an OK prompt) displays.

Use the open firmware command line to set up adapters that are not configurable with the System Management Services. Your adapter documentation directs you to use this option if it is needed.

To exit from the open firmware command prompt, type `reset-all` or power off the system and reboot.

## System Locations

The system consists of a minimum of two drawers in one rack: the CEC drawer and the primary I/O drawer. These two components are connected by cables that transmit data and control signals. Additional I/O drawers can be added if further expansion of the system is required. The following figure shows the system units.

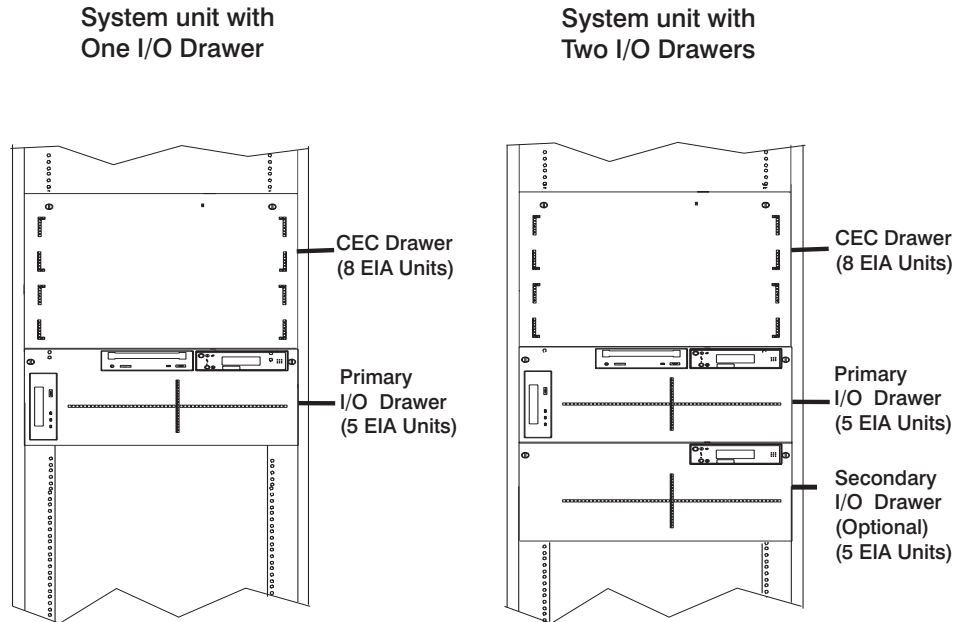

**Note:** For information about installing rack rails, see Appendix G, "Rack Drawer Rail Instructions" on page 587.

## CEC Drawer Front View With Bezel Removed

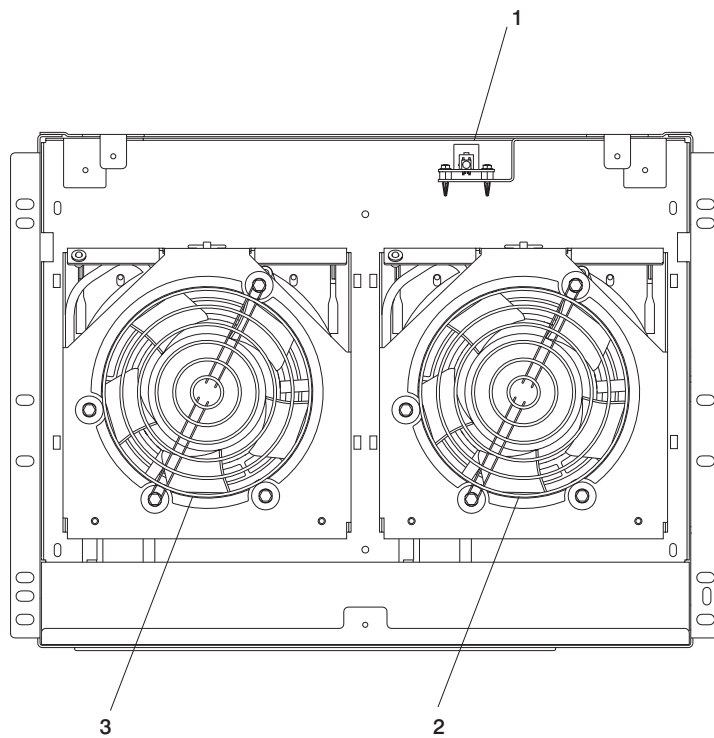

1 Power On/Off LED  
3 Fan 1

2 Fan 2

## CEC Drawer Rear View

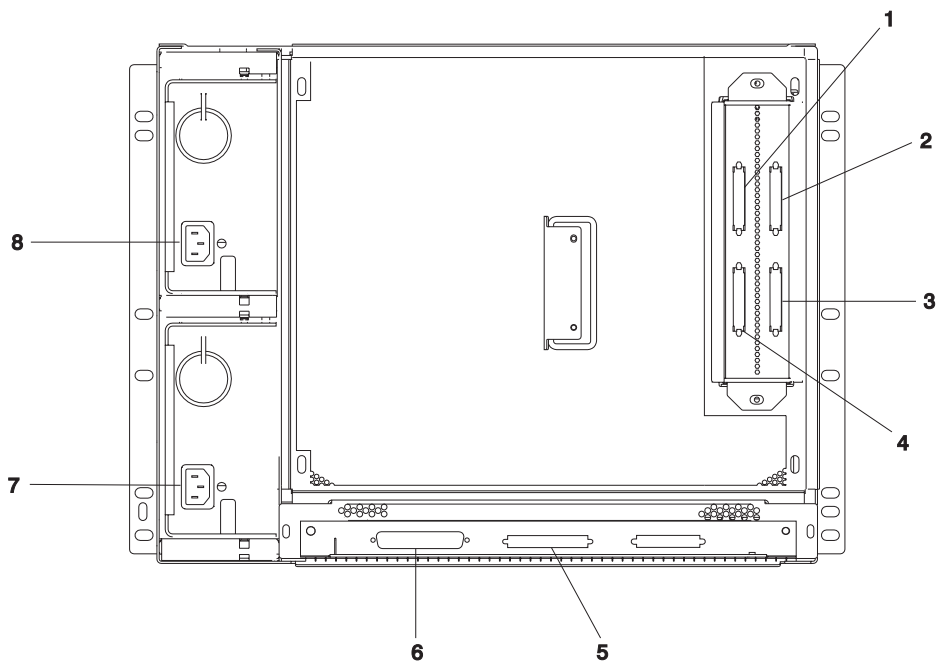

- |   |                  |   |                  |
|---|------------------|---|------------------|
| 1 | RIO connector A0 | 2 | RIO connector B0 |
| 3 | RIO connector B1 | 4 | RIO connector A1 |
| 5 | V/S COMM         | 6 | JTAG             |
| 7 | Power supply 1   | 8 | Power supply 2   |

## CEC Card Cage

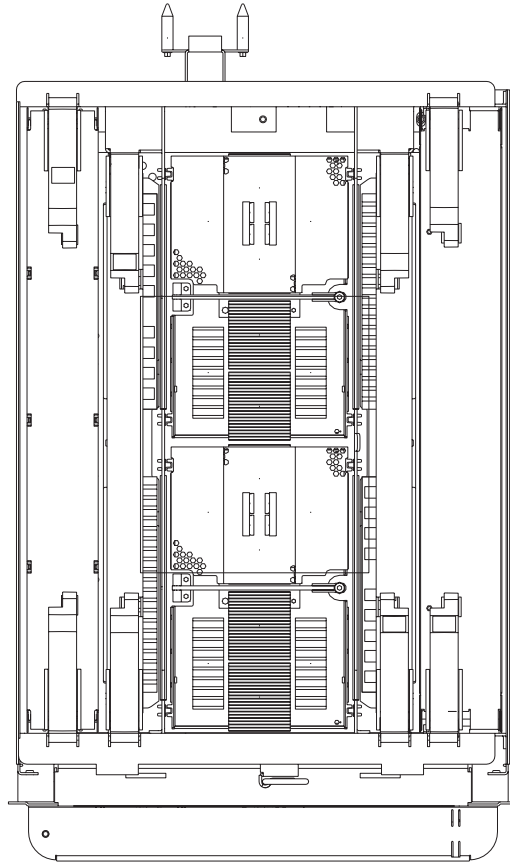

Rear of CEC drawer (viewed from top, cover removed)

## Primary I/O Drawer Front View With Cover On

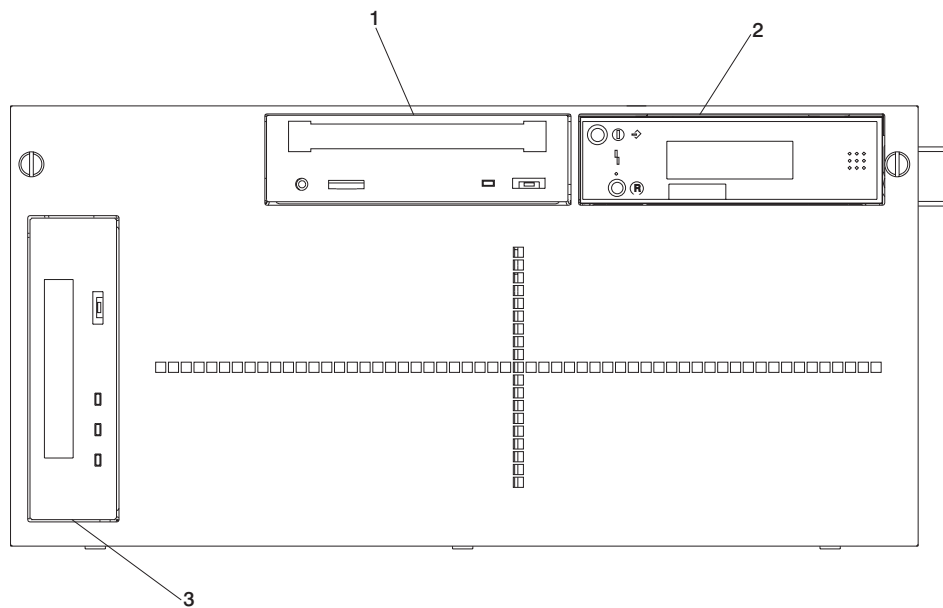

- 1 CD-ROM
- 3 Tape drive (optional)

- 2 Operator panel

## Secondary I/O Drawer Front View With Cover On

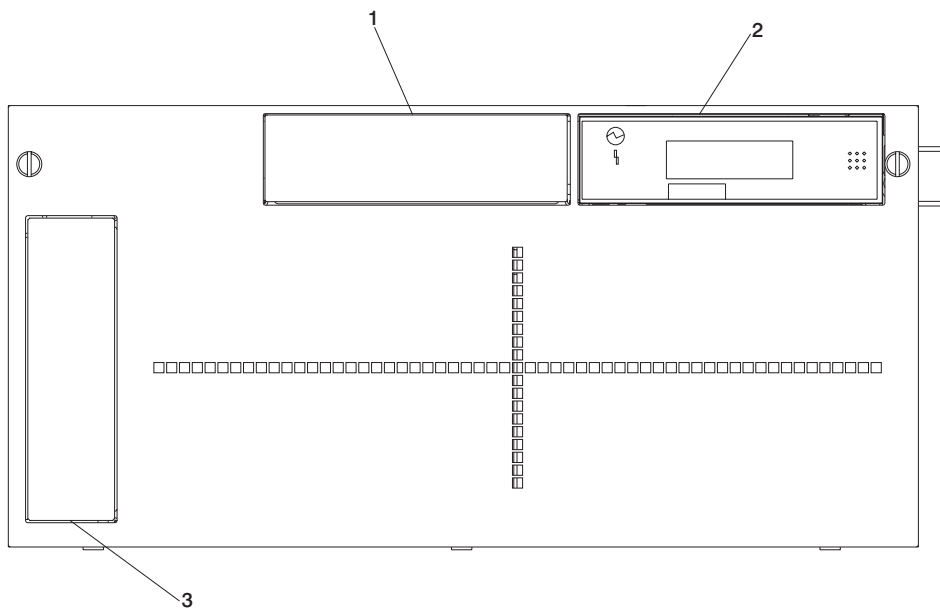

1 Optional media bay  
3 Optional media bay

2 Operator panel



## Primary I/O Drawer Rear View

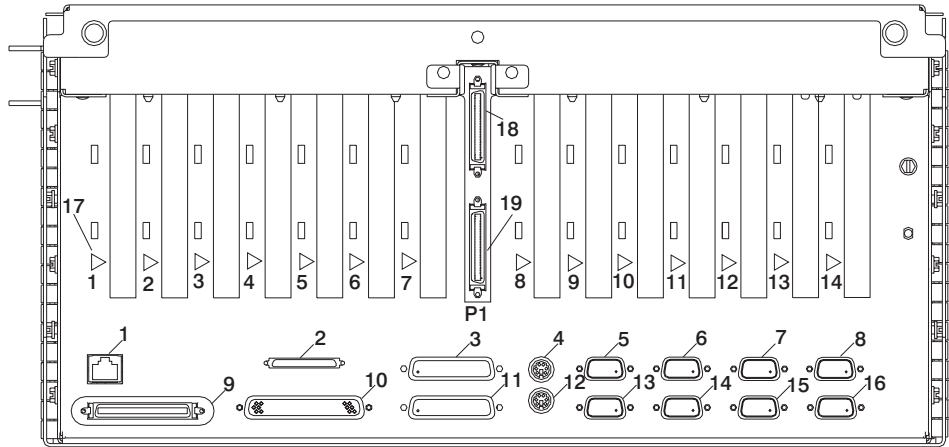

1	Ethernet connector	2	SCSI connector
3	Debug port	4	Mouse connector
5	Serial port 1	6	Serial port 2
7	J11 (SPCN 1 connector)	8	J14 (SPCN 3 connector, reserved)
9	V/S Comm	10	JTAG connector
11	Parallel port	12	Keyboard connector
13	Serial port 3	14	Serial port 4
15	J15 (SPCN 2 connector)	16	J16 (SPCN 4 connector)
17	Hot-plug LED (one for each adapter)	18	RIO 1 connector
19	RIO 0 connector		

## Primary I/O Drawer Front View with Covers Removed

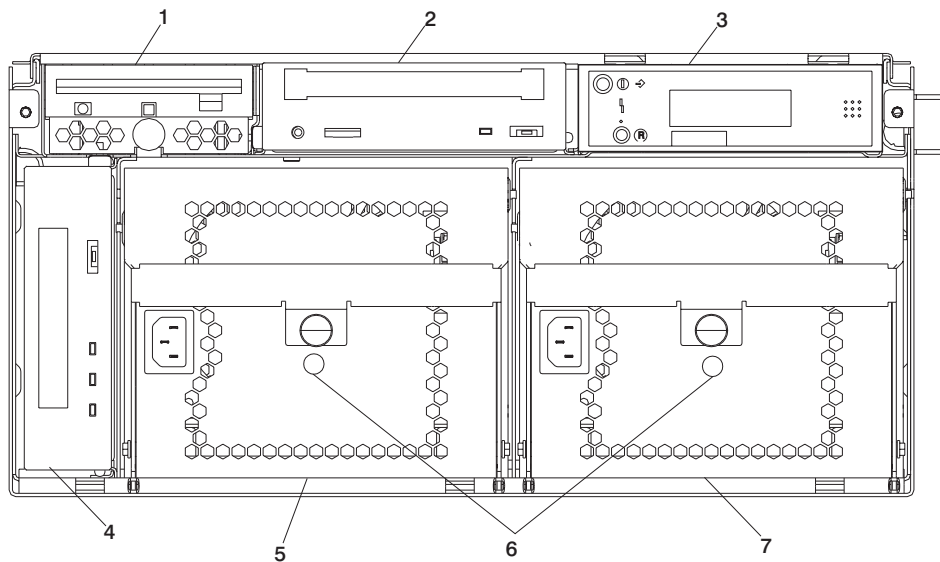

- |   |                        |   |                               |
|---|------------------------|---|-------------------------------|
| 1 | Bay A - Diskette       | 2 | Bay B - CD-ROM                |
| 3 | Bay C - Operator panel | 4 | Bay D - Tape drive (optional) |
| 5 | Power Supply 2         | 6 | Power Supply LEDs             |
| 7 | Power Supply 1         |   |                               |

## Secondary I/O Drawer Rear View

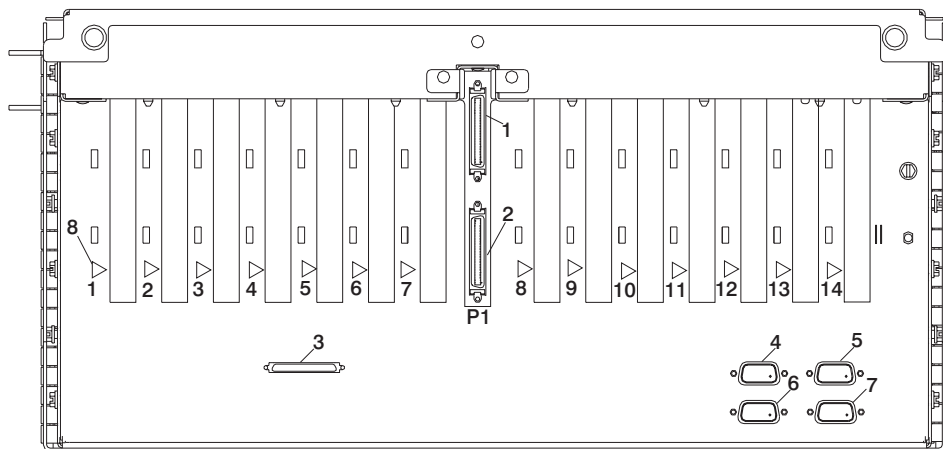

- |   |                        |      |                                     |
|---|------------------------|------|-------------------------------------|
| 1 | RIO 1 connector        | 2    | RIO 0 connector                     |
| 3 | SCSI connector         | 4    | J11 (SPCN 1 connector)              |
| 5 | J14 (SPCN 3 connector) | 6    | J16 (SPCN 2 connector)              |
| 7 | J15 (SPCN 4 connector) | 8-14 | Hot-plug LED (one for each adapter) |

## I/O Drawer Backplane PCI Slot Locations

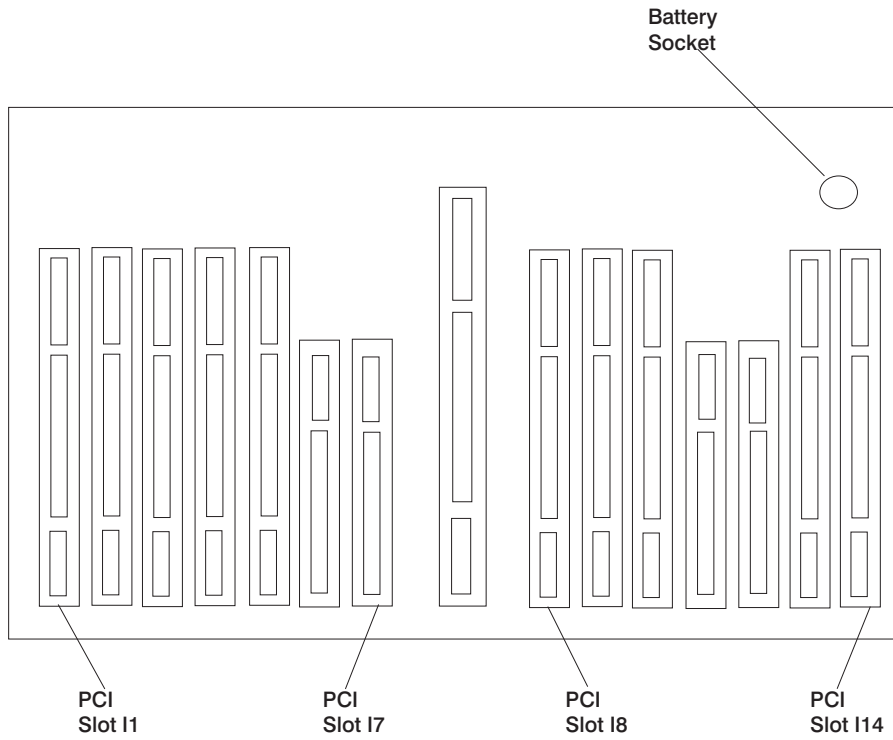

## System Board Locations

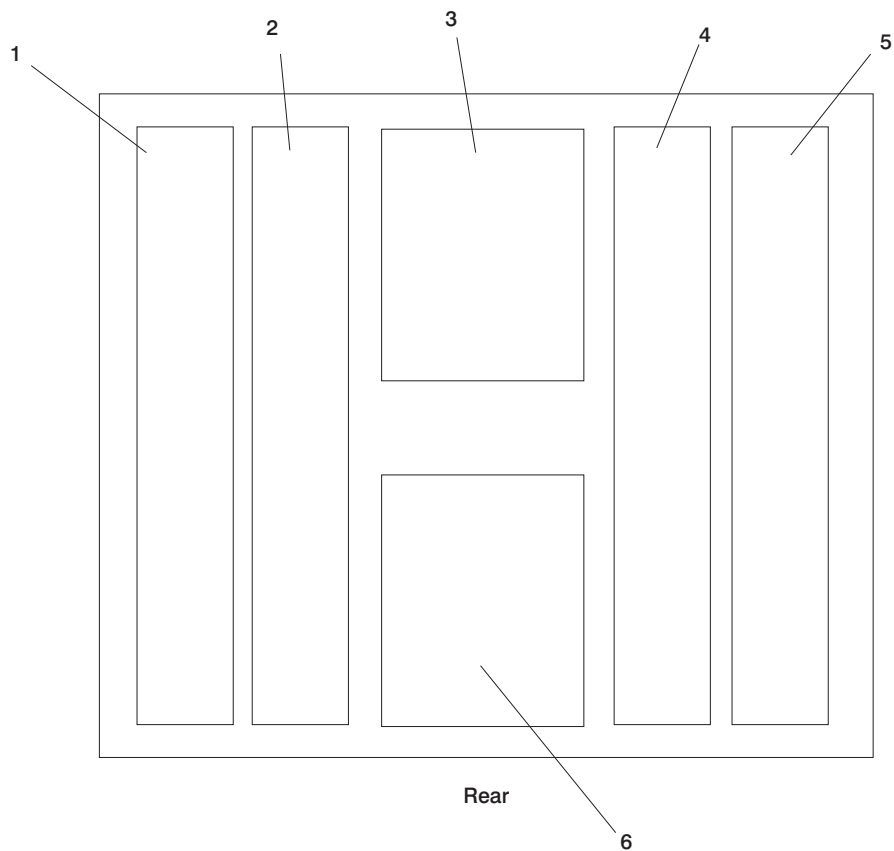

1	Regulator, M01	2	Memory Riser 1, M02
3	Processor 2, M04	4	Memory Riser 2, M05
5	RIO Adapter, M06	6	Processor 1, M03

**Note:** In order for the system to boot, the first processor card slot (M03) must be populated.

## Memory Riser Card and Memory DIMM Locations

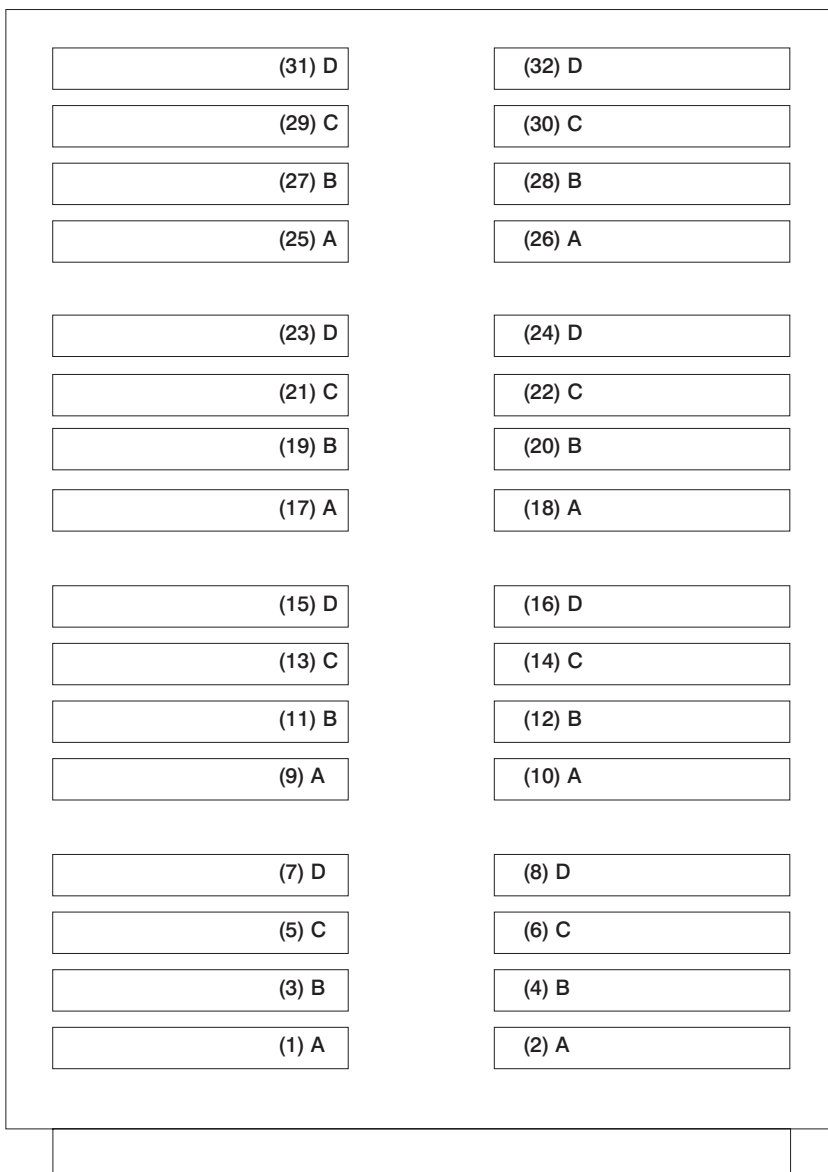

Location Code	Memory DIMMs
U1.1-P1-M1 x2	All Memory DIMMs on Riser Cards 1 and 2
U1.1-P1-M1.n	Individual Memory DIMMs on Riser Card 1 (n denotes DIMM number)
U1.1-P1-M1.1 x4	Memory Quad A Odd (DIMMs 1, 9, 17, 25)

<b>Location Code</b>	<b>Memory DIMMs</b>
U1.1-P1-M1.1 x8	Memory Octal A (DIMMs 1, 2, 9, 10, 17, 18, 25, 26)
U1.1-P1-M1.1 x32	All Memory DIMMs on Riser Card 1
U1.1-P1-M1.2 x4	Memory Quad A Even (DIMMs 2, 10, 18, 26)
U1.1-P1-M1.3 x4	Memory Quad B Odd (DIMMs 3, 11, 19, 27)
U1.1-P1-M1.3 x8	Memory Octal B (DIMMs 3, 4, 11, 12, 19, 20, 27, 28)
U1.1-P1-M1.4 x4	Memory Quad B Even (DIMMs 4, 12, 20, 28)
U1.1-P1-M1.5 x4	Memory Quad C Odd (DIMMs 5, 13, 21, 29)
U1.1-P1-M1.5 x8	Memory Octal C (DIMMs 5, 6, 13, 14, 21, 22, 29, 30)
U1.1-P1-M1.6 x4	Memory Quad C Even (DIMMs 6, 14, 22, 30)
U1.1-P1-M1.7 x4	Memory Quad D Odd (DIMMs 7, 15, 23, 31)
U1.1-P1-M1.7 x8	Memory Octal D (DIMMs 7, 8, 15, 16, 23, 24, 31, 32)
U1.1-P1-M1.8 x4	Memory Quad D Even (DIMMs 8, 16, 24, 32)
U1.1-P1-M2.n	Individual Memory DIMMs on Riser Card 2 (n denotes DIMM number)
U1.1-P1-M2.1 x4	Memory Quad A Odd (DIMMs 1, 9, 17, 25)
U1.1-P1-M2.1 x8	Memory Octal A (DIMMs 1, 2, 9, 10, 17, 18, 25, 26)
U1.1-P1-M2.1 x32	All Memory DIMMs on Riser Card 2
U1.1-P1-M2.2 x4	Memory Quad A Even (DIMMs 2, 10, 18, 26)
U1.1-P1-M2.3 x4	Memory Quad B Odd (DIMMs 3, 11, 19, 27)
U1.1-P1-M2.3 x8	Memory Octal B (DIMMs 3, 4, 11, 12, 19, 20, 27, 28)
U1.1-P1-M2.4 x4	Memory Quad B Even (DIMMs 4, 12, 20, 28)
U1.1-P1-M2.5 x4	Memory Quad C Odd (DIMMs 5, 13, 21, 29)
U1.1-P1-M2.5 x8	Memory Octal C (DIMMs 5, 6, 13, 14, 21, 22, 29, 30)
U1.1-P1-M2.6 x4	Memory Quad C Even (DIMMs 6, 14, 22, 30)
U1.1-P1-M2.7 x4	Memory Quad D Odd (DIMMs 7, 15, 23, 31)
U1.1-P1-M2.7 x8	Memory Octal D (DIMMs 7, 8, 15, 16, 23, 24, 31, 32)
U1.1-P1-M2.8 x4	Memory Quad D Even (DIMMs 8, 16, 24, 32)

For physical locations, see “Memory Riser Card and Memory DIMM Locations” on page 20.

## Primary I/O Drawer Operator Panel

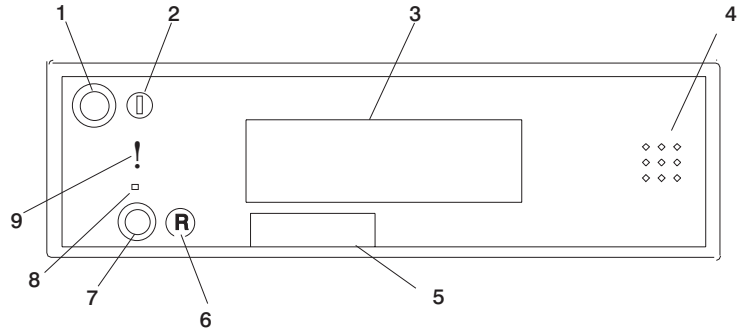

1	Power on/off button	2	Power on/off LED
3	Operator panel display	4	Speaker
5	Serial number plate	6	Reset icon
7	Reset button	8	Service use only
9	Disturbance or system attention LED		

**Note:** You must activate the service processor reset button very carefully. An insulated paper clip is recommended. Unbend the clip so that it has a straight section about two inches long. Insert the clip straight into the hole, keeping the clip perpendicular to the plastic bezel. When you engage the test reset switch, you should feel the detent of the switch. After you press the switch, the service processor resets and then shuts down the system.

## Secondary I/O Drawer Operator Panel

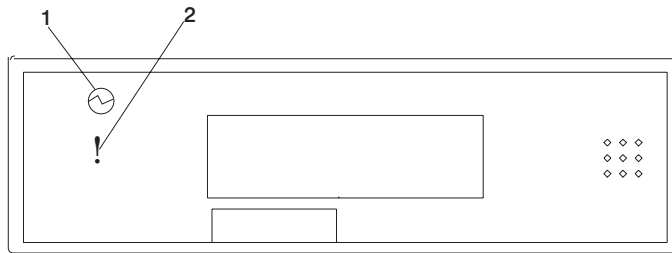

1	Power Present LED	2	Disturbance or System Attention LED
---	-------------------	---	-------------------------------------



## SCSI IDs and Bay Locations

The following figure shows the SCSI IDs for media devices. The SCSI IDs for the media devices installed at the factory are set using jumpers on the drives when the drives are installed.

### Primary I/O Drawer SCSI IDs

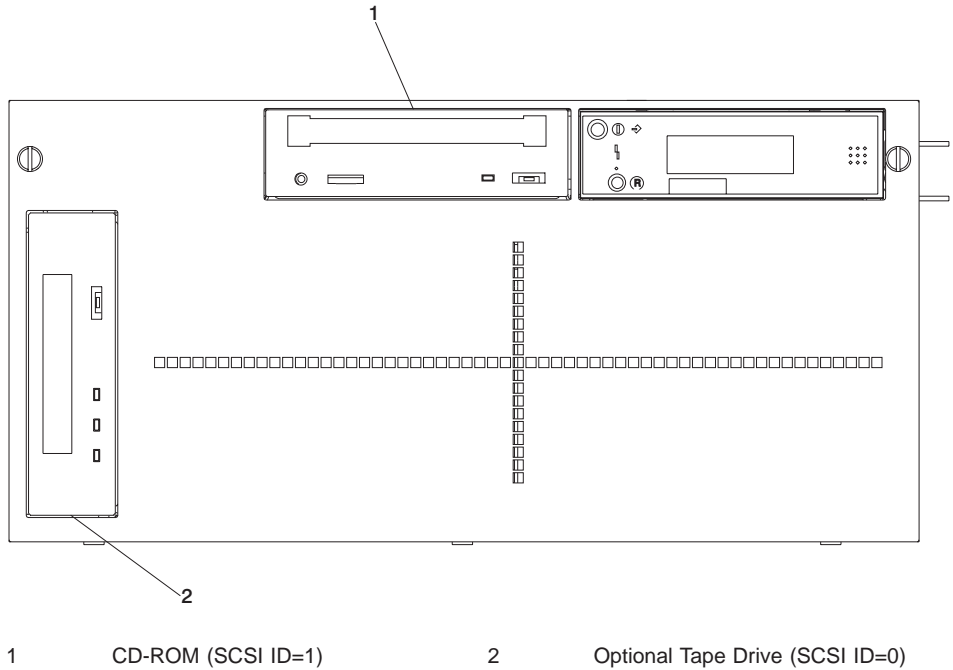

**Note:** The SCSI IDs shown for the media indicate how installed devices are set when shipped from the factory.

---

## System Memory

Two slots are available for system memory riser cards. The system memory riser cards are located for easy access in the CEC drawer. (These slots are shown in “System Board Locations” on page 19.) Each memory riser card has 32 DIMM slots.

Four sizes of DIMMs are available: 128 MB, 256 MB, 512 MB and 1 GB. In addition, certain 32 MB DIMMS from earlier RS/6000 systems can also be used.

## Riser Card Memory Placement Rules

The rules for one-way processor memory are as follows:

- Memory octals must contain DIMM modules of equal memory size.
- You must have at least one memory riser card populated with 8 DIMMs totaling 1 GB.
- Populate the memory card starting from the bottommost available slot of each eight-slot group. (see “Memory Riser Card and Memory DIMM Locations” on page 20.)
- If you have two memory riser cards installed, distribute the memory evenly (maintaining octals) between the two risers.

---

## I/O Drawer Features

I/O drawers may have two redundant power supplies. One of these power supplies is capable of providing the necessary voltages and currents independently of the other. The left and right power supply output voltages are connected and monitored by the power distribution board contained in the 5 EIA-unit I/O drawer. Both power supplies provide +12 V dc to the fans in the drawer to ensure sufficient cooling if one of the supplies fails. However, the short circuit prevention is on the I/O board to protect against shorts in one output, thus causing the +12 V dc to fail completely.

The left and right power supplies are hot-pluggable and may be changed one-at-a-time while the system is operational. Each power supply provides 5 V dc, 3.3 V dc, 12 V dc, and 5 V dc standby power.

The 5 V dc standby power is provided by both power supplies; this can be done because the power supplies contain overload protection against one supply shorting the other. Standby power (5 V dc) is provided to the part of the primary I/O drawer planar on which the SPCN and service processor logic reside.

## I/O Drawer Addressing

I/O drawer addressing refers to the drawer number that is displayed in the operator panel on secondary I/O drawers. This address is the drawer's location in the RIO (remote I/O) loop. The drawer number is displayed in the form of  $U0.n$ , where  $n$  is the drawer number. The drawer number is not displayed on the primary I/O drawer operator panel but it is assumed to be \*01 (or  $U0.1$ ). The first time you boot the system after a service action or configuration change that involves an I/O drawer or its backplane, the system may detect a duplicate or incorrect I/O drawer number. This situation can result in duplicate or incorrect drawer numbers being displayed when the system is booting up. The final drawer number will be assigned and displayed when the bootup is complete. The drawer numbers are not reassigned unless a service action or configuration change occurs.

When ac power (dc power in a dc-powered system) has been disconnected from an I/O drawer and then reconnected, the I/O drawer addresses on the secondary drawers will temporarily appear in the format \*0n, where  $n$  is the drawer number. After the system is powered on and the boot sequence has been initiated, the drawer numbers will be restored to the  $U0.n$  format.

## I/O Drawer and Power Supply LED Status

Status of LED	Operator Panel LED	Right Power Supply LED	Left Power Supply LED
Off	No power connected	No power connected or system power connected, not turned on, power supply detects NO faults	No power connected or system power connected, not turned on, power supply detects NO faults
On, fast blinking green, on for one second, off for one second	System power connected, power on initiated	System power connected, not turned on, power supply detected fault	System power connected, not turned on, power supply detected fault
On, slow blinking green, on for two seconds, off for two seconds	System power connected, not turned on	System power connected, not turned on, power supply detected system power control network fault	System power connected, not turned on, power supply detected system power control network fault
On, steady green	System power connected and turned on	System power connected and turned on	System power connected and turned on

## Secondary I/O Drawer Operator Panel Message Hierarchy

The messages that are displayed in the operator panel on secondary I/O drawers are arranged hierarchically, from highest priority to lowest priority. The message hierarchy is as follows:

1. 8-character error code

This indicates a critical error; the drawer power will be shut down. Standby power is still on, so the error message is still displayed in the operator panel. The I/O drawer Attention LED will be on. The error code displays on the top line of the display panel, left-justified. A FRU part number may also be displayed, right-justified, in the second line of the display.

2. 8-character informational message

This is a noncritical message, so the drawer power will not be shut down. The message should be investigated to see if service actions are indicated. A FRU part number may also be displayed, right-justified, in the second line of the display.

When 8-character codes are displayed, they are in the form 10n1xxxx, where n is the drawer number.

3. 8-character checkpoint

There is one 8-character checkpoint that displays, 10n100AA, where n is the drawer number. This checkpoint indicates that the system power control network firmware is being updated, and the checkpoint displays for approximately 15 seconds. This is the only checkpoint that displays on a secondary I/O drawer operator panel.

4. Drawer number

This will be in the form U0.n, where n is the drawer number. This message will normally display unless a higher-level message is required.

When ac power (dc power in a dc-powered system) has been disconnected from the system, then reconnected, the I/O drawer addresses on the secondary drawers will temporarily appear in the format \*0n, where n is the drawer number. After the system is powered on, and the boot sequence has been initiated, the drawer numbers are restored to the U0.n format.

## Primary I/O Drawer Operator Panel Behavior During Power-On

### After Connecting ac Power (dc Power in a dc-powered System)

Drawer State	Power LED	Drawer Operator Panel Display
Standby	Blinking slow	8xxx checkpoints followed by OK
System power ON	Blinking fast On solid	OK 9xxx checkpoints ending with E1FF
Receive firmware command	On solid	Exxx checkpoints ending with E105
Thereafter	On solid	0xxx checkpoints ending with a blank display

### After Power is Removed Because of a Shutdown

Drawer State	Power LED	Drawer Operator Panel Display
Standby	Blinking slowly	OK is displayed
System power ON	Blinking quickly On solid	OK 9xxx checkpoints ending with E1FF
Receive firmware command	On solid	Exxx checkpoints ending with E105
Thereafter	On solid	0xxx checkpoints ending with a blank display

Critical error codes are posted on the top line (left-justified) of the drawer display with the attention light on solid. Any location codes are posted on the bottom line (left-justified).

Noncritical error codes are not posted. The drawer display remains blank with the attention light on solid.

## Secondary I/O Drawer Operator Panel Behavior During Power-On

### After Connecting ac Power (dc Power in a dc-powered System)

Drawer State	Power LED	Drawer Operator Panel Display
Standby	Off	Display shows a temporary drawer number of the form *0n
Receive firmware command to power on	On solid	Message based on "Secondary I/O Drawer Operator Panel Message Hierarchy" on page 27.

### After Power is Removed Because of a Shutdown

Drawer State	Power LED	Drawer Operator Panel Display
Standby	Off	Message based on "Secondary I/O Drawer Operator Panel Message Hierarchy" on page 27
Receive firmware command to power on	On solid	Message based on "Secondary I/O Drawer Operator Panel Message Hierarchy" on page 27

---

## Logical and Physical Locations

The Model M80 and Model 6M1 systems use physical location codes in conjunction with AIX location codes to provide mapping of the failing field replaceable units (FRUs). The location codes are produced by the system unit's firmware and the AIX operating system.

---

## Physical Location Codes

Physical location codes provide a mapping of logical functions in a platform (or expansion sites for logical functions, such as connectors or ports) to their specific locations within the physical structure of the platform.

## Location Code Format

The format for the location code is a string of alphanumeric characters separated by a dash (-), slash (/), pound sign (#) or period (.) character. The base location is all of the information preceding the slash (/) or pound sign (#). The base location identifies a device that is connected to or plugged into the parent. Extended location information follows the slash (/). Extended location information identifies a device that is part of the parent, a connector, or a cable. Cable information follows the pound sign (#). Cable information identifies a cable that is connector to parent. The following are examples:

- P1-C1 identifies a processor card C1 plugged into planar P1.
- P1-M1 identifies a memory card M1 plugged into planar P1.
- P1-K1 identifies a keyboard attached to K1 on planar P1.
- P1/S1 identifies serial port 1 controller on planar P1, the connector for serial port 1, or the cable attached to serial port 1.
- P1-I2/E3 identifies a Ethernet controller 3 on the card in slot 2 (I2) on planar P1, the connector for Ethernet controller 3, or the cable attached to Ethernet controller 3.
- P1-I2#E3 identifies the cable attached to Ethernet controller 3 on the card in slot 2 (I2) on planar P1.

The period (.) identifies sublocations (DIMMs on a memory card, SCSI addresses, cables). The following are examples:

- P1-M1.4 identifies DIMM 4 on memory card 1 plugged into planar P1.
- P1-C1.1 identifies processor 1 plugged into processor card 1 which is plugged into planar P1.
- U0.1-P1/Z1-A3 identifies a SCSI device with SCSI ID 3 attached to SCSI bus 1 on planar 1 in the primary I/O drawer.
- P2-Z1-A3.1 identifies a SCSI device with SCSI address of LUN 1 at SCSI ID 3 attached to SCSI bus 1 from planar 2.
- P1-I2#E3.2 identifies the second in a series of cables attached to Ethernet controller 3 on the card in slot 2 (I2) on planar P1.

Depending on the AIX and firmware levels, AIX Diagnostics may include the extended location information when identifying a planar or card. The extended location information or cable information is always included when identifying a cable or connector. Location codes with extended location information that are displayed without a description identifying the devices always identify the cable attached to the port.

## Multiple FRU Callout Instructions

If an eight-digit error code appears in the operator panel display or in Chapter 5, “Error Code to FRU Index” on page 171, a location code for a failing part may also be specified. If the location code includes a blank space followed by a lowercase x followed by a number, this is an error code with multiple FRU callouts. This error can typically happen with memory DIMMs, memory riser cards, or processors and may involve mixed types of parts. In this case, check the system’s configuration for FRU part numbers to determine the appropriate set of FRUs.

For example, if the location code U1.1-P1-M1.1 x4 was displayed, this indicates memory quad A (four DIMMs) on the first memory riser card was suspected.

You can determine the FRU part numbers of the electronic assemblies in the system in one of the following ways:

- Using the service processor menus
  - From the general user menu, select Read VPD Image from Last System Boot, then enter 90 to display detailed vital product data (VPD).
- Using the **lscfg -vp | pg** command on the AIX command line



Enter the following command: `lscfg -vp | pg` to display the detailed VPD of all assemblies. Notice that the FRU part number information for processors and memory DIMMs may be at the bottom of the command output.

---

## AIX Location Codes

The basic formats of the AIX location codes are as follows:

- For non-SCSI devices/drives:  
AB-CD-EF-GH
- For SCSI devices/drives:  
AB-CD-EF-G,H

For planars, cards, and non-SCSI devices, the location code is defined as follows:

```
AB-CD-EF-GH
 |  |  |  |
 |  |  |  | Device/FRU/Port ID
 |  |  |  | Connector ID
 |  |  |  | devfunc Number, Adapter Number or Physical Location
 |  |  |  | Bus Type or PCI Parent Bus
```

- The AB value identifies a bus type or PCI parent bus as assigned by the firmware.
- The CD value identifies adapter number, adapter's devfunc number, or physical location. The *devfunc* number is defined as the PCI device number times 8, plus the function number.
- The EF value identifies a connector.
- The GH value identifies a port, address, device, or FRU.

Adapters and cards are identified only with AB-CD.

The possible values for CD depend on the adapter/card. For pluggable PCI adapters/cards, CD is the device's devfunc number (PCI device number times 8, plus the function number). The C and D are characters in the range of 0-9, and A-F (hex numbers). The location codes therefore uniquely identify multiple adapters on individual PCI cards.

EF is the connector ID, used to identify the adapter's connector to which a resource is attached.

GH is used to identify a port, device, or FRU. For example:

- For async devices, GH defines the port on the fanout box. The values are 00 to 15.
- For a diskette drive, H identifies either diskette drive 1 or 2. G is always 0.
- For all other devices, GH is equal to 00.

For integrated adapter, EF-GH is the same as the definition for a pluggable adapter. For example, the location code for a diskette drive is 01-D1-00-00. A second diskette drive is 01-D1-00-01.

For SCSI devices, the location code is defined as follows:

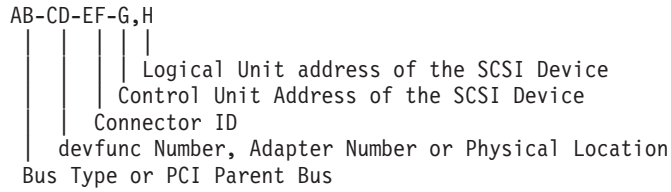

Where:

- AB-CD-EF are the same as non-SCSI devices.
- G defines the control unit address of the device. Values of 0 to 15 are valid.
- H defines the logical unit address of the device. Values of 0 to 255 are valid.

A bus location code is also generated as '00-XXXXXXXX', where XXXXXXXXX is equivalent to the node's unit address.

Examples of physical location codes and AIX location codes are:

PCI adapter in primary I/O drawer, Slot 1  
Location Code U0.1-P1-I1  
AIX location Code 20-58  
PCI adapter in secondary I/O drawer, Slot 1  
Location Code U0.2-P1-I1  
AIX location Code E0-58

## AIX and Physical Location Code Reference Tables

The following tables contain location codes that are used to identify functional units in the RS/6000 Enterprise Server Model M80 and @server pSeries 660 Model 6M1 systems. Each table below shows the locations for a physical part of the system.

FRU Name	Location Code	AIX Location Code	Physical Connection	Logical Connection
<b>CEC Drawer 1 Locations</b>				
CEC Drawer	U1.1			
CEC Backplane	U1.1-P1		MB1 in CEC	
RIO Port 0 Connector	U1.1-P1.1/Q1			
RIO Port 1 Connector	U1.1-P1.1/Q2			
RIO Port 2 Connector	U1.1-P1.1/Q3			
RIO Port 3 Connector	U1.1-P1.1/Q4			
All RIO Ports	U1.1-P1.1			
RIO Cable on port 0	U1.1-P1.1/Q1		A0	
RIO Cable on port 1	U1.1-P1.1/Q2		A1	
RIO Cable on port 2	U1.1-P1.1/Q3		B0	
RIO Cable on port 3	U1.1-P1.1/Q4		B1	

FRU Name	Location Code	AIX Location Code	Physical Connection	Logical Connection
V/S COMM Connector	U1.1-P1.1/Q1			
JTAG Connector	U1.1-P1/Q2			
All Memory (both riser cards)	U1.1-P1-M1 x2	00-00	CEC Connectors M02 and M05	
Memory Riser Card 1	U1.1-P1-M1	00-00	CEC Connector M02	
Memory DIMMs 1 - 32 on Riser Card 1	U1.1-P1-M1.1 to U1.1-P1-M1.32		Refer to "Memory Riser Card and Memory DIMM Locations" on page 20.	
Memory Quad A Odd on Riser Card 1	U1.1-P1-M1.1x4	00-00	Refer to "Memory Riser Card and Memory DIMM Locations" on page 20.	
Memory Octal A on Riser Card 1	U1.1-P1-M1.1 x8	00-00	Refer to "Memory Riser Card and Memory DIMM Locations" on page 20.	
All Memory DIMMs on Riser Card 1	U1.1-P1-M1.1 x32	00-00	Refer to "Memory Riser Card and Memory DIMM Locations" on page 20.	
Memory Quad A Even on Riser Card 1	U1.1-P1-M1.2 x4	00-00	Refer to "Memory Riser Card and Memory DIMM Locations" on page 20.	
Memory Quad B Odd on Riser Card 1	U1.1-P1-M1.3 x4	00-00	Refer to "Memory Riser Card and Memory DIMM Locations" on page 20.	

FRU Name	Location Code	AIX Location Code	Physical Connection	Logical Connection
Memory Octal B on Riser Card 1	U1.1-P1-M1.3 x8	00-00	Refer to "Memory Riser Card and Memory DIMM Locations" on page 20.	
Memory Quad B Even on Riser Card 1	U1.1-P1-M1.4 x4	00-00	Refer to "Memory Riser Card and Memory DIMM Locations" on page 20.	
Memory Quad C Odd on Riser Card 1	U1.1-P1-M1.5 x4	00-00	Refer to "Memory Riser Card and Memory DIMM Locations" on page 20.	
Memory Octal C on Riser Card 1	U1.1-P1-M1.5 x8	00-00	Refer to "Memory Riser Card and Memory DIMM Locations" on page 20.	
Memory Quad C Even on Riser Card 1	U1.1-P1-M1.6 x4	00-00	Refer to "Memory Riser Card and Memory DIMM Locations" on page 20.	
Memory Quad D Odd on Riser Card 1	U1.1-P1-M1.7 x4	00-00	Refer to "Memory Riser Card and Memory DIMM Locations" on page 20.	
Memory Octal D on Riser Card 1	U1.1-P1-M1.7 x8	00-00	Refer to "Memory Riser Card and Memory DIMM Locations" on page 20.	
Memory Quad D Even on Riser Card 1	U1.1-P1-M1.8 x4	00-00	Refer to "Memory Riser Card and Memory DIMM Locations" on page 20.	

<b>FRU Name</b>	<b>Location Code</b>	<b>AIX Location Code</b>	<b>Physical Connection</b>	<b>Logical Connection</b>
Memory Riser Card 2	U1.1-P1-M2	00-00	CEC Connector M5	
Memory DIMMs 1 - 32 on riser card 2	U1.1-P1-M2.1 to U1.1-P1-M2.32	00-00	Refer to "Memory Riser Card and Memory DIMM Locations" on page 20.	
Memory Quad A Odd on Riser Card 2	U1.1-P1-M2.1 x4	00-00	Refer to "Memory Riser Card and Memory DIMM Locations" on page 20.	
Memory Octal A on Riser Card 2	U1.1-P1-M2.1 x8	00-00	Refer to "Memory Riser Card and Memory DIMM Locations" on page 20.	
All Memory DIMMs on Riser Card 2	U1.1-P1-M2.1 x32	00-00	Refer to "Memory Riser Card and Memory DIMM Locations" on page 20.	
Memory Quad A Even on Riser Card 2	U1.1-P1-M2.2 x4	00-00	Refer to "Memory Riser Card and Memory DIMM Locations" on page 20.	
Memory Quad B Odd on Riser Card 2	U1.1-P1-M2.3 x4	00-00	Refer to "Memory Riser Card and Memory DIMM Locations" on page 20.	
Memory Octal B on Riser Card 2	U1.1-P1-M2.3 x8	00-00	Refer to "Memory Riser Card and Memory DIMM Locations" on page 20.	

FRU Name	Location Code	AIX Location Code	Physical Connection	Logical Connection
Memory Octal B Even on Riser Card 2	U1.1-P1-M2.4 x4	00-00	Refer to "Memory Riser Card and Memory DIMM Locations" on page 20.	
Memory Quad C Odd on Riser Card 2	U1.1-P1-M2.5 x4	00-00	Refer to "Memory Riser Card and Memory DIMM Locations" on page 20.	
Memory Octal C on Riser Card 2	U1.1-P1-M2.5 x8	00-00	Refer to "Memory Riser Card and Memory DIMM Locations" on page 20.	
Memory Quad C Even on Riser Card 2	U1.1-P1-M2.6 x4	00-00	Refer to "Memory Riser Card and Memory DIMM Locations" on page 20.	
Memory Quad D Odd on Riser Card 2	U1.1-P1-M2.7 x4	00-00	Refer to "Memory Riser Card and Memory DIMM Locations" on page 20.	
Memory Octal D on Riser Card 2	U1.1-P1-M2.7 x8	00-00	Refer to "Memory Riser Card and Memory DIMM Locations" on page 20.	
Memory Quad D Even on Riser Card 2	U1.1-P1-M2.8 x4	00-00	Refer to "Memory Riser Card and Memory DIMM Locations" on page 20.	
Processor Card 1	U1.1-P1-C1		Connector M03 in CEC Drawer	
2W Card 1, Processor 1	U1.1-P1-C1	00-00	Connector M03 in CEC Drawer	

<b>FRU Name</b>	<b>Location Code</b>	<b>AIX Location Code</b>	<b>Physical Connection</b>	<b>Logical Connection</b>
2W Card 1, Processor 2	U1.1-P1-C1	00-01	Connector M03 in CEC Drawer	
2W Card 1, Cache	U1.1-P1-C1		Connector M03 in CEC Drawer	
4W Card 1, Processor 1	U1.1-P1-C1	00-00	Connector M03 in CEC Drawer	
4W Card 1, Processor 2	U1.1-P1-C1	00-01	Connector M03 in CEC Drawer	
4W Card 1, Processor 3	U1.1-P1-C1	00-02	Connector M03 in CEC Drawer	
4W Card 1, Processor 4	U1.1-P1-C1	00-03	Connector M03 in CEC Drawer	
4W Card 1, Cache	U1.1-P1-C1		Connector M03 in CEC Drawer	
Processor Card 2	U1.1-P1-C2		Connector M04 in CEC Drawer	
2W Card 2, Processor 1	U1.1-P1-C2	00-02	Connector M04 in CEC Drawer	
2W Card 2, Processor 2	U1.1-P1-C2	00-03	Connector M04 in CEC Drawer	
2W Card 2, Cache	U1.1-P1-C2		Connector M04 in CEC Drawer	
4W Card 2, Processor 1	U1.1-P1-C2	00-04	Connector M04 in CEC Drawer	
4W Card 2, Processor 2	U1.1-P1-C2	00-05	Connector M04 in CEC Drawer	
4W Card 2, Processor 3	U1.1-P1-C2	00-06	Connector M04 in CEC Drawer	
4W Card 2, Processor 4	U1.1-P1-C2	00-07	Connector M04 in CEC Drawer	
4W Card 2 Cache	U1.1-P1-C2		Connector M04 in CEC Drawer	
All Processor Cards	U1.1-P1-C1 x2	00-00	Connector M03 and M04 in CEC Drawer	
Bus Extender Card	U1.1-P1.1		Connector M06 in CEC Drawer	
I/O Hub	U1.1-P1.1		Connector M06 in CEC Drawer	
I/O Clock (daughter card)	U1.1-P1.1.1		Connector M06 in CEC Drawer	



FRU Name	Location Code	AIX Location Code	Physical Connection	Logical Connection
Regulator 1	U1.1-P1-V1		Connector M01 in CEC Drawer	
Regulator 2	U1.1-P1-V1		Connector M01 in CEC Drawer	
Power Distribution Card	U1.1-X1			
LED Card	U1.1-L1			
Power Supply 1	U1.1-V1		PP1 in CEC drawer	
Power Supply 2	U1.1-V2		PP2 in CEC drawer	
Fan 1	U1.1-F1		BP1 in CEC drawer	
Fan 2	U1.1-F2		BP2 in CEC drawer	
<b>Primary I/O Drawer Locations</b>				
Primary I/O Drawer	U0.1			
RIO Bus Adapter	U0.1-P1.1			
RIO Port 0 Connector	U0.1-P1.1/Q1			
RIO Port 1 Connector	U0.1-P1.1/Q2			
All RIO Port Connectors	U0.1-P1.1			
Primary I/O drawer backplane	U0.1-P1			
PCI to PCI bridge 1	U0.1-P1	10-58, 10-5A, 10-5C, 10-5E		
PCI slot 1	U0.1-P1/I1	10-58		
PCI slot 1 content (card)	U0.1-P1-I1	11-08 through 11-0F or 12-xx or 13-xx		
PCI slot 2	U0.1-P1/I2	10-5A		
PCI slot 2 content (card)	U0.1-P1-I2	14-08 through 14-0F or 15-xx or 16-xx		
PCI slot 3	U0.1-P1/I3	10-5C		
PCI slot 3 content (card)	U0.1-P1-I3	17-08 through 17-0F or 18-xx or 19-xx		
PCI slot 4	U0.1-P1/I4	10-5E		

FRU Name	Location Code	AIX Location Code	Physical Connection	Logical Connection
PCI slot 4 content (card)	U0.1-P1-I4	1A-08 through 1A-0F or 1B-xx or 1C-xx		
PCI to PCI bridge 2	U0.1-P1	20-58, 20-5A, 20-5B, 20-5C, 20-5E		
PCI slot 5	U0.1-P1/I5	20-58		
PCI slot 5 content (card)	U0.1-P1-I5	21-08 through 21-0F or 22-xx or 23-xx		
PCI slot 6 (5V)	U0.1-P1/I6	20-5A		
PCI slot 6 content (card)	U0.1-P1-I6	24-08 through 24-0F or 25-xx or 26-xx		
PCI slot 7 (5V)	U0.1-P1/I7	20-5B		
PCI slot 7 content (card)	U0.1-P1-I7	27-08 through 27-0F or 28-xx or 29-xx		
PCI slot 8	U0.1-P1/I8	20-5C		
PCI slot 8 content (card)	U0.1-P1-I8	2A-08 through 2A-0F or 2B-xx or 2C-xx		
PCI slot 9	U0.1-P1/I9	20-5E		
PCI slot 9 content (card)	U0.1-P1-I9	2D-08 through 2D-0F or 2E-xx or 2F-xx		
PCI to PCI bridge 3	U0.1-P1	20-60, 20-62, 20-63, 20-64, 20-66		
PCI slot 10	U0.1-P1/I10	20-60		
PCI slot 10 content (card)	U0.1-P1-I10	31-08 through 31-0F or 32-xx or 33-xx		
PCI slot 11 (5V)	U0.1-P1/I11	20-62		
PCI slot 11 content (card)	U0.1-P1-I11	34-08 through 34-0F or 35-xx or 36-xx		
PCI slot 12 (5V)	U0.1-P1/I12	20-63		

FRU Name	Location Code	AIX Location Code	Physical Connection	Logical Connection
PCI slot 12 content (card)	U0.1-P1-I12	37-08 through 37-0F or 38-xx or 39-xx		
PCI slot 13	U0.1-P1/I13	20-64		
PCI slot 13 content (card)	U0.1-P1-I13	3A-08 through 3A-0F or 3B-xx or 3C-xx		
PCI slot 14	U0.1-P1/I14	20-66		
PCI slot 14 content (card)	U0.1-P1/I14	3D-08 through 3D-0F or 3E-xx or 3F-xx		
PCI bus controller 0	U0.1-P1	00-FFF7F08000		
PCI bus controller 1	U0.1-P1	00-FFF7F09000		
PCI bus controller 2	U0.1-P1	00-FFF7F0A000		
ISA Bus	U0.1-P1	10-80		
Service Processor	U0.1-P1			
JTAG Connector	U0.1-P1/Q4			
NVRAM	U0.1-P1			
Service Processor ISA Bridge	U0.1-P1			
Real Time Clock (RTC)	U0.1-P1			
Timer	U0.1-P1			
Interrupt Controller	U0.1-P1			
DMA Controller	U0.1-P1			
Diskette controller	U0.1-P1-D1	01-D1		
Diskette drive	U0.1-P1/D1	01-D1-00-00		
Keyboard controller / connector	U0.1-P1/K1	01-K1-00		
Keyboard	U0.1-P1/K1	01-K1-00-00		
Mouse controller	U0.1-P1/K1	01-K1-01		
Mouse connector	U0.1-P1-01	01-K1-01		
Mouse	U0.1-P1-01	01-K1-01-00		
Parallel port connector	U0.1-P1/R1	01-R1		
Serial port 1 connector	U0.1-P1/S1	01-S1		

FRU Name	Location Code	AIX Location Code	Physical Connection	Logical Connection
Serial port 2 connector	U0.1-P1/S2	01-S2		
Serial port 3 connector	U0.1-P1/S3	01-S3		
Serial port 4 connector	U0.1-P1/S4	01-S4		
Thermal sensor (ambient)	U0.1-L1			
Thermal sensor (left)	U0.1-P1			
Thermal sensor (right)	U0.1-P1			
Ethernet controller / connector	U0.1-P1/E1	40-58		
Internal SCSI controller	U0.1-P1/Z1	40-60		
External SCSI controller	U0.1-P1/Z2	40-61		
Tape drive	U0.1-P1-Z1-A0	40-60-00-0,0		
CD drive	U0.1-P1-Z1-A1	40-60-00-1,0		
Internal DASD 1	U0.1-P1-Z1-A4	40-60-00-4,0		
Internal DASD 2	U0.1-P1-Z1-A8	40-60-00-8,0		
SPCN controller	U0.1-P1			
VSCOM connector	U0.1-P1/Q1			
Primary I/O drawer operator panel	U0.1-L1			
System VPD Module	U0.1-L1-N1			
Battery	U0.1-P1-V3			
Power Distribution Board	U0.1-X1			
PDB Power Connector 1	U0.1-X1/V1			
PDB Power Connector 2	U0.1-X1/V2			
Fan Controller Card	U0.1-X2			
Power Supply 1 (w/Fan 5)	U0.1-V1		PDB connector J2	
Power Supply 2 (w/Fan 6)	U0.1-V2		PDB connector J1	
Fan 1	U0.1-F1		Fan connector P3 on power supply 1	

FRU Name	Location Code	AIX Location Code	Physical Connection	Logical Connection
Fan 2	U0.1-F2		Fan connector P3 on power supply 1	
Fan 3	U0.1-F3		Fan connector P3 on power supply 2	
Fan 4	U0.1-F4		Fan connector P3 on power supply 2	
Cooling unit (w/fan 9)	U0.1-F9		In cooling unit	
System firmware	U0.1-P1/Y1			
<b>Secondary I/O Drawer 2 Locations</b>				
Secondary I/O Drawer	U0.2			
RIO Bus Adapter	U0.2-P1.1			
RIO Port 0 Connector	U0.2-P1.1/Q1			
RIO Port 1 Connector	U0.2-P1.1/Q2			
All RIO Port Connectors	U0.2-P1.1			
Secondary I/O drawer backplane	U0.2-P1			
PCI to PCI bridge 1	U0.2-P1	50-58, 50-5A, 50-5C, 50-5E		
PCI slot 1	U0.2-P1/I1	50-58		
PCI slot 1 content (card)	U0.2-P1-I1	51-08 through 51-0F or 52-xx or 53-xx		
PCI slot 2	U0.2-P1/I2	50-5A		
PCI slot 2 content (card)	U0.2-P1-I2	54-08 through 54-0F or 55-xx or 56-xx		
PCI slot 3	U0.2-P1/I3	50-5C		
PCI slot 3 content (card)	U0.2-P1-I3	57-08 through 57-0F or 58-xx or 59-xx		
PCI slot 4	U0.2-P1/I4	50-5E		
PCI slot 4 content (card)	U0.2-P1-I4	5A-08 through 5A-0F or 5B-xx or 5C-xx		

FRU Name	Location Code	AIX Location Code	Physical Connection	Logical Connection
PCI to PCI bridge 2	U0.2-P1	60-58, 60-5A, 60-5B, 60-5C, 60-5E		
PCI slot 5	U0.2-P1/I5	60-58		
PCI slot 5 content (card)	U0.2-P1-I5	61-08 through 61-0F or 62-xx or 63-xx		
PCI slot 6 (5V)	U0.2-P1/I6	60-5A		
PCI slot 6 content (card)	U0.2-P1-I6	64-08 through 64-0F or 65-xx or 66-xx		
PCI slot 7 (5V)	U0.2-P1/I7	60-5B		
PCI slot 7 content (card)	U0.2-P1-I7	67-08 through 67-0F or 68-xx or 69-xx		
PCI slot 8	U0.2-P1/I8	60-5C		
PCI slot 8 content (card)	U0.2-P1-I8	6A-08 through 6A-0F or 6B-xx or 6C-xx		
PCI slot 9	U0.2-P1/I9	60-5E		
PCI slot 9 content (card)	U0.2-P1-I9	6D-08 through 6D-0F or 6E-xx or 6F-xx		
PCI to PCI bridge 3	U0.2-P1	60-60, 60-62, 60-63, 60-64, 60-66		
PCI slot 10	U0.2-P1/I10	60-60		
PCI slot 10 content (card)	U0.2-P1-I10	71-08 through 71-0F or 72-xx or 73-xx		
PCI slot 11 (5V)	U0.2-P1/I11	60-62		
PCI slot 11 content (card)	U0.2-P1-I11	74-08 through 74-0F or 75-xx or 76-xx		
PCI slot 12 (5V)	U0.2-P1/I12	60-63		
PCI slot 12 content (card)	U0.2-P1-I12	77-08 through 77-0F or 78-xx or 79-xx		
PCI slot 13	U0.2-P1/I13	60-64		

FRU Name	Location Code	AIX Location Code	Physical Connection	Logical Connection
PCI slot 13 content (card)	U0.2-P1-I13	7A-08 through 7A-0F or 7B-xx or 7C-xx		
PCI slot 14	U0.2-P1/I14	60-66		
PCI slot 14 content (card)	U0.2-P1/I14	7D-08 through 7D-0F or 7E-xx or 7F-xx		
PCI bus controller 1	U0.2-P1	00-FFF7E09000		
PCI bus controller 2	U0.2-P1	00-FFF7E0A000		
SPCN controller	U0.2-P1			
External SCSI connector	U0.2-P1/Z1			
Secondary I/O drawer VPD module	U0.2-L1-N1			
Thermal sensor (ambient)	U0.2-L1			
Thermal sensor (left)	U0.2-P1			
Thermal sensor (right)	U0.2-P1			
Power distribution board	U0.2-X1			
PDB power connector 1	U0.2-X1/V1			
PDB power connector 2	U0.2-X1/V2			
Fan Controller Card	U0.2-X2		I/O board connector J3	
Power Supply 1 (w/Fan 5)	U0.2-V1		PDB connector J2	
Power Supply 2 (w/Fan 6)	U0.2-V2		PDB connector J1	
Fan 1	U0.2-F1		Fan connector P3 on power supply 1	
Fan 2	U0.2-F2		Fan connector P3 on power supply 1	
Fan 3	U0.2-F3		Fan connector P3 on power supply 2	

FRU Name	Location Code	AIX Location Code	Physical Connection	Logical Connection
Fan 4	U0.2-F4		Fan connector P3 on power supply 2	
Cooling unit (w/fan 9)	U0.2-F9		In cooling unit	
SPCN firmware	U0.2-P1/Y3			
SPCN VPD	U0.2-P1/Y4			
<b>Secondary I/O Drawer 3 Locations</b>				
Secondary I/O Drawer	U0.3			
RIO Bus Adapter	U0.3-P1.1			
RIO Port 0 Connector	U0.3-P1.1/Q1			
RIO Port 1 Connector	U0.3-P1.1/Q2			
All RIO Port Connectors	U0.3-P1.1			
Secondary I/O drawer backplane	U0.3-P1			
PCI to PCI bridge 1	U0.3-P1	90-58, 90-5A, 90-5C, 90-5E		
PCI slot 1	U0.3-P1/I1	90-58		
PCI slot 1 content (card)	U0.3-P1-I1	91-08 through 91-0F or 92-xx or 93-xx		
PCI slot 2	U0.3-P1/I2	90-5A		
PCI slot 2 content (card)	U0.3-P1-I2	94-08 through 94-0F or 95-xx or 96-xx		
PCI slot 3	U0.3-P1/I3	90-5C		
PCI slot 3 content (card)	U0.3-P1-I3	97-08 through 97-0F or 98-xx or 99-xx		
PCI slot 4	U0.3-P1/I4	90-5E		
PCI slot 4 content (card)	U0.3-P1-I4	9A-08 through 9A-0F or 9B-xx or 9C-xx		
PCI to PCI bridge 2	U0.3-P1	A0-58, A0-5A, A0-5B, A0-5C, A0-5E		
PCI slot 5	U0.3-P1/I5	A0-58		



FRU Name	Location Code	AIX Location Code	Physical Connection	Logical Connection
PCI slot 5 content (card)	U0.3-P1-I5	A1-08 through A1-0F or A2-xx or A3-xx		
PCI slot 6 (5V)	U0.3-P1/I6	A0-5A		
PCI slot 6 content (card)	U0.3-P1-I6	A4-08 through A4-0F or A5-xx or A6-xx		
PCI slot 7 (5V)	U0.3-P1/I7	A0-5B		
PCI slot 7 content (card)	A0.3-P1-I7	A7-08 through A7-0F or A8-xx or A9-xx		
PCI slot 8	A0.3-P1/I8	A0-5C		
PCI slot 8 content (card)	U0.3-P1-I8	AA-08 through AA-0F or AB-xx or AC-xx		
PCI slot 9	U0.3-P1/I9	A0-5E		
PCI slot 9 content (card)	U0.3-P1-I9	AD-08 through AD-0F or AE-xx or AF-xx		
PCI to PCI bridge 3	U0.3-P1	A0-60, A0-62, A0-63, A0-64, A0-66		
PCI slot 10	U0.3-P1/I10	A0-60		
PCI slot 10 content (card)	U0.3-P1-I10	B1-08 through B1-0F or B2-xx or B3-xx		
PCI slot 11 (5V)	U0.3-P1/I11	A0-62		
PCI slot 11 content (card)	U0.3-P1-I11	B4-08 through B4-0F or B5-xx or B6-xx		
PCI slot 12 (5V)	U0.3-P1/I12	A0-63		
PCI slot 12 content (card)	U0.3-P1-I12	B7-08 through B7-0F or B8-xx or B9-xx		
PCI slot 13	U0.3-P1/I13	A0-64		

FRU Name	Location Code	AIX Location Code	Physical Connection	Logical Connection
PCI slot 13 content (card)	U0.3-P1-I13	BA-08 through BA-0F or BB-xx or BC-xx		
PCI slot 14	U0.3-P1/I14	A0-66		
PCI slot 14 content (card)	U0.3-P1/I14	BD-08 through BD-0F or BE-xx or BF-xx		
PCI bus controller 1	U0.3-P1	00-FFF7D09000		
PCI bus controller 2	U0.3-P1	00-FFF7D0A000		
SPCN controller	U0.3-P1			
External SCSI connector	U0.3-P1/Z1			
Secondary I/O drawer VPD module	U0.3-L1-N1			
Thermal sensor (ambient)	U0.3-L1			
Thermal sensor (left)	U0.3-P1			
Thermal sensor (right)	U0.3-P1			
Power distribution board	U0.3-X1			
PDB power connector 1	U0.3-X1/V1			
PDB power connector 2	U0.3-X1/V2			
Fan Controller Card	U0.3-X2			
Power Supply 1 (w/Fan 5)	U0.3-V1		PDB connector J2	
Power Supply 2 (w/Fan 6)	U0.3-V2		PDB connector J1	
Fan 1	U0.3-F1		Fan connector P3 on power supply 1	
Fan 2	U0.3-F2		Fan connector P3 on power supply 1	
Fan 3	U0.3-F3		Fan connector P3 on power supply 2	

FRU Name	Location Code	AIX Location Code	Physical Connection	Logical Connection
Fan 4	U0.3-F4		Fan connector P3 on power supply 2	
Cooling unit (w/fan 9)	U0.3-F9		In cooling unit	
SPCN firmware	U0.3-P1/Y3			
SPCN VPD	U0.3-P1/Y4			
<b>Secondary I/O Drawer 4 Locations</b>				
Secondary I/O Drawer	U0.4			
RIO Bus Adapter	U0.4-P1.1			
RIO Port 0 Connector	U0.4-P1.1/Q1			
RIO Port 1 Connector	U0.4-P1.1/Q2			
All RIO Port Connectors	U0.4-P1.1			
Secondary I/O drawer backplane	U0.4-P1			
PCI to PCI bridge 1	U0.4-P1	D0-58, D0-5A, D0-5C, D0-5E		
PCI slot 1	U0.4-P1/I1	D0-58		
PCI slot 1 content (card)	U0.4-P1-I1	D1-08 through D1-0F or D2-xx or D3-xx		
PCI slot 2	U0.4-P1/I2	D0-5A		
PCI slot 2 content (card)	U0.4-P1-I2	D4-08 through D4-0F or D5-xx or D6-xx		
PCI slot 3	U0.4-P1/I3	D0-5C		
PCI slot 3 content (card)	U0.4-P1-I3	D7-08 through D7-0F or D8-xx or D9-xx		
PCI slot 4	U0.4-P1/I4	D0-5E		
PCI slot 4 content (card)	U0.4-P1-I4	DA-08 through DA-0F or DB-xx or DC-xx		
PCI to PCI bridge 2	U0.4-P1	E0-58, E0-5A, E0-5B, E0-5C, E0-5E		
PCI slot 5	U0.4-P1/I5	E0-58		

FRU Name	Location Code	AIX Location Code	Physical Connection	Logical Connection
PCI slot 5 content (card)	U0.4-P1-I5	E1-08 through E1-0F or E2-xx or E3-xx		
PCI slot 6 (5V)	U0.4-P1/I6	E0-5A		
PCI slot 6 content (card)	U0.4-P1-I6	E4-08 through E4-0F or E5-xx or E6-xx		
PCI slot 7 (5V)	U0.4-P1/I7	E0-5B		
PCI slot 7 content (card)	A0.4-P1-I7	E7-08 through E7-0F or E8-xx or E9-xx		
PCI slot 8	A0.4-P1/I8	E0-5C		
PCI slot 8 content (card)	U0.4-P1-I8	EA-08 through EA-0F or EB-xx or EC-xx		
PCI slot 9	U0.4-P1/I9	E0-5E		
PCI slot 9 content (card)	U0.4-P1-I9	ED-08 through ED-0F or EE-xx or EF-xx		
PCI to PCI bridge 3	U0.4-P1	E0-60, E0-62, E0-63, E0-64, E0-66		
PCI slot 10	U0.4-P1/I10	E0-60		
PCI slot 10 content (card)	U0.4-P1-I10	F1-08 through F1-0F or F2-xx or F3-xx		
PCI slot 11 (5V)	U0.4-P1/I11	E0-62		
PCI slot 11 content (card)	U0.4-P1-I11	F4-08 through F4-0F or F5-xx or F6-xx		
PCI slot 12 (5V)	U0.4-P1/I12	E0-63		
PCI slot 12 content (card)	U0.4-P1-I12	F7-08 through F7-0F or F8-xx or F9-xx		
PCI slot 13	U0.4-P1/I13	E0-64		

FRU Name	Location Code	AIX Location Code	Physical Connection	Logical Connection
PCI slot 13 content (card)	U0.4-P1-I13	FA-08 through FA-0F or FB-xx or FC-xx		
PCI slot 14	U0.4-P1/I14	E0-66		
PCI slot 14 content (card)	U0.4-P1/I14	FD-08 through FD-0F or FE-xx or FF-xx		
PCI bus controller 1	U0.4-P1	00-FFF7C09000		
PCI bus controller 2	U0.4-P1	00-FFF7C0A000		
SPCN controller	U0.4-P1			
External SCSI connector	U0.4-P1/Z1			
Secondary I/O drawer VPD module	U0.4-L1-N1			
Thermal sensor (ambient)	U0.4-L1			
Thermal sensor (left)	U0.4-P1			
Thermal sensor (right)	U0.4-P1			
Power distribution board	U0.4-X1			
PDB power connector 1	U0.4-X1/V1			
PDB power connector 2	U0.4-X1/V2			
Fan controller card	U0.4-X2			
Power supply 1 (w/Fan 5)	U0.4-V1		PDB connector J2	
Power supply 2 (w/Fan 6)	U0.4-V2		PDB connector J1	
Fan 1	U0.4-F1		Fan connector P3 on power supply 1	
Fan 2	U0.4-F2		Fan connector P3 on power supply 1	
Fan 3	U0.4-F3		Fan connector P3 on power supply 2	

FRU Name	Location Code	AIX Location Code	Physical Connection	Logical Connection
Fan 4	U0.4-F4		Fan connector P3 on power supply 2	
Cooling unit (w/fan 9)	U0.4-F9		In cooling unit	
SPCN firmware	U0.4-P1/Y3			
SPCN VPD	U0.4-P1/Y4			
<b>SCSI Device Locations</b>				
SCSI Adapter x = drawer number y = PCI slot number z = connector		U0.x-P1-ly-Zz	AB-CD Where AB-CD identifies the adapter's slot	Bus ID 15
Media Device (Bay A1 or A2) When connected to PCI adapter in slot U0.x-P1-ly x = drawer number y = PCI slot number z = connector		U0.x-P1-ly-Zz-Ai	AB-CD-00-15, 0 Where AB-CD identifies the adapter's slot	Bus ID 15
SCSI Backplane, Bank C or D When connected to PCI adapter in slot U0.x-P1-ly x = drawer number y = PCI slot number z = connector		U0.x-P1-ly-Zz-Bb	AB-CD-00-15, 0 Where AB-CD identifies the adapter's slot	Bus ID 15

---

## Cabling the CEC Drawer, Primary I/O Drawer, and Secondary I/O Drawer(s)

The minimum system consists of two drawers. The CEC drawer contains the system processors, memory and supporting hardware. The primary I/O drawer contains PCI adapters, operator panel, disk drives, and media drives. The system must have one primary I/O drawer and it contains the service processor for the system. The system supports up to three additional I/O drawers in various rack configurations.

To connect the CEC drawer to the I/O drawers, use the following steps:

1. Connect the cables that only connect between the CEC drawer and the primary I/O drawer such as the JTAG and the V/S COMM cable.
2. Connecting the cables that connect between the CEC drawer and all the I/O drawers in loops, such as the RIO cables and the SPCN cables.

All power cables connect to the PDU. If a second PDU is specified along with secondary drawer power supplies for all drawers, the secondary power supplies connect to the secondary PDU.

### Connecting JTAG and V/S COMM Cables

Use the following figure to connect the JTAG and V/S COMM cables.

#### CEC Drawer Attached to One I/O Drawer

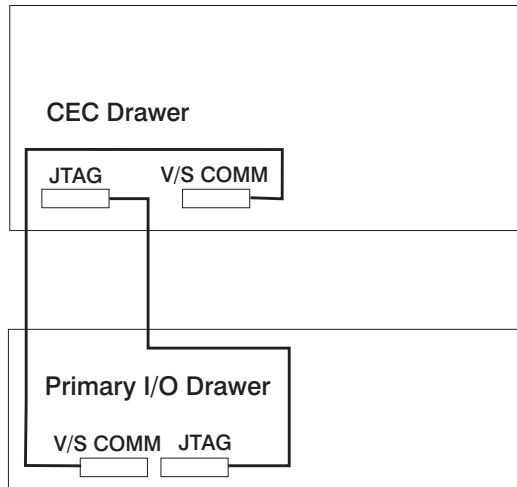

### Connecting RIO and SPCN Cables

The RIO and SPCN cables provide two functions in the system, remote data bus connection and power control. Follow these basic rules when connecting these two types of cables:

- The I/O drawers must be connected in a loop fashion for both the RIO cables and the SPCN cables. The loop connection provides redundant paths so that if a failure

occurs in part of a cable, the system will continue to operate. If a failure occurs, a warning message is displayed on the system console but the system continues to operate.

- One loop is required for the SPCN cabling. This loop begins and ends at the primary I/O drawer.
- Two loops are possible for the RIO cabling depending on the number and desired configuration of I/O drawers. These loops begin and end at the primary I/O drawer.

## RIO Cabling

The following rules apply to RIO cable connections:

- I/O drawers 0 and 1 are connected using the first RIO loop, which uses RIO ports 0 and 1 on the CEC drawer.
- The primary I/O drawer must be installed and connected to RIO port 0 of the CEC drawer. This connection is required to make the primary drawer the first drawer in the loop, which allows the firmware to initialize the system.

The following figures provide cabling examples for all valid cabling configurations. Match your configuration to the correct figure and connect your RIO cables as shown.

### CEC Drawer Attached to One I/O Drawer

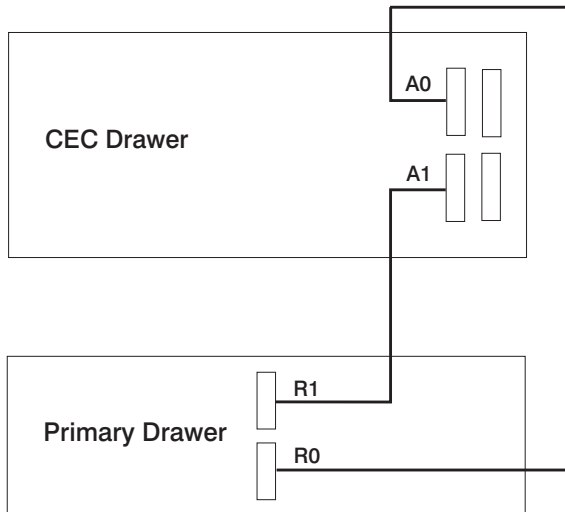



## CEC Drawer Attached to Two I/O Drawers Type A

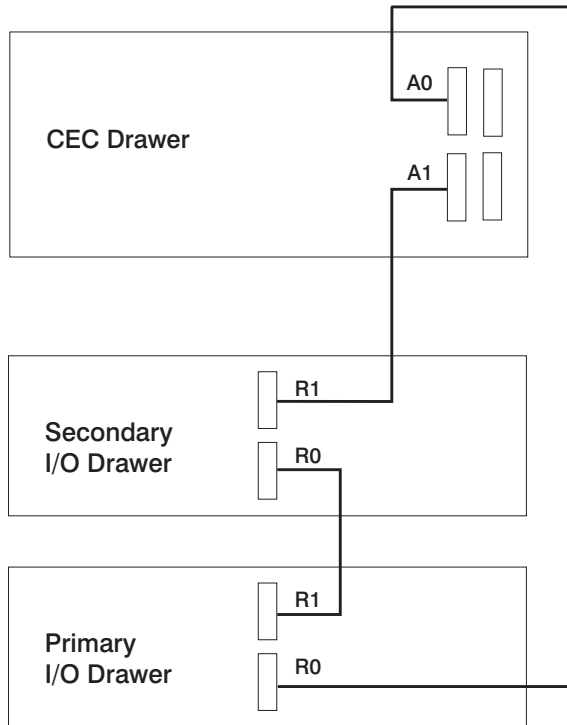

## CEC Drawer Attached to Two I/O Drawers Type B

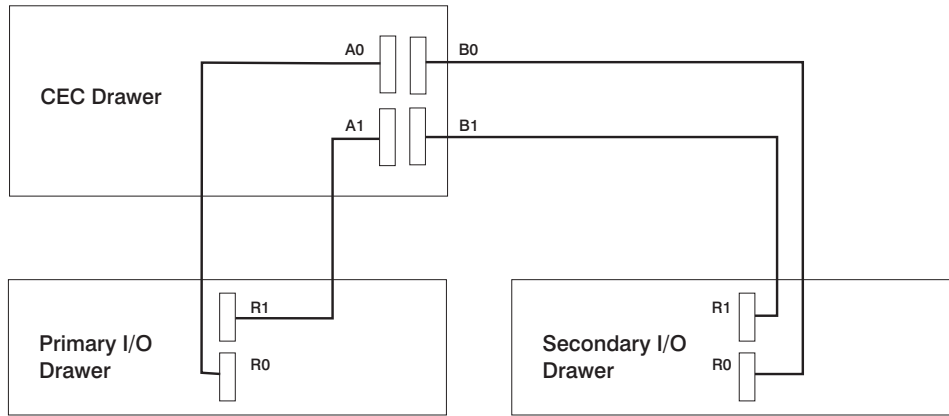

### CEC Drawer Attached to Three I/O Drawers

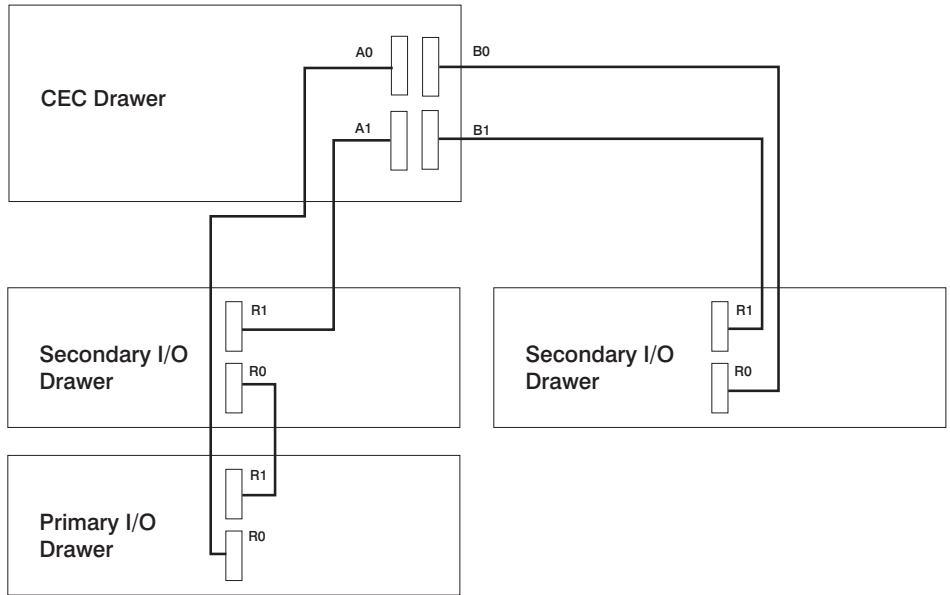

## CEC Drawer Attached to Four I/O Drawers

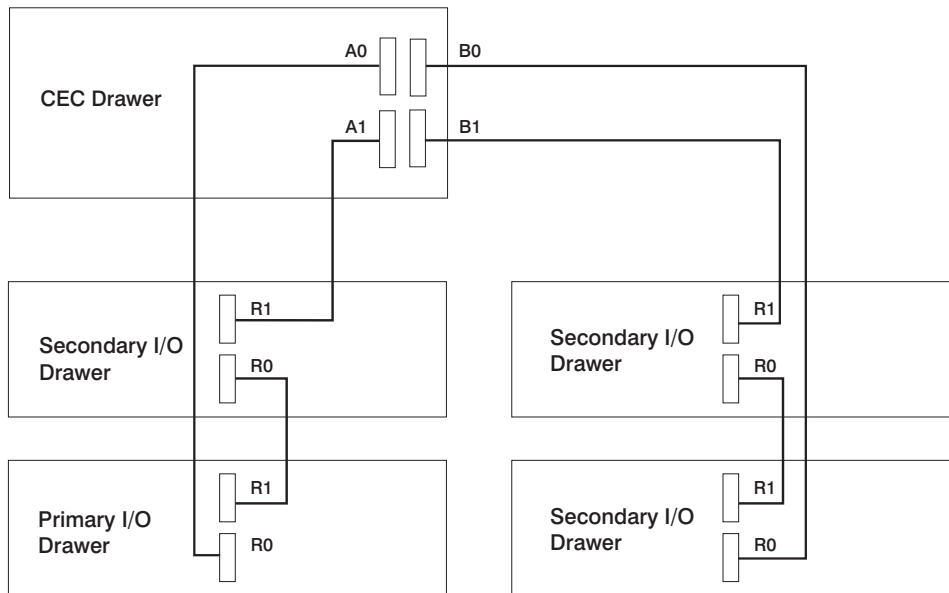

## SPCN Cabling

The following figures provide cabling examples for all valid cabling configurations. Match your configuration to the correct figure and connect your SPCN cables as shown.

### CEC Drawer Attached to One I/O Drawer

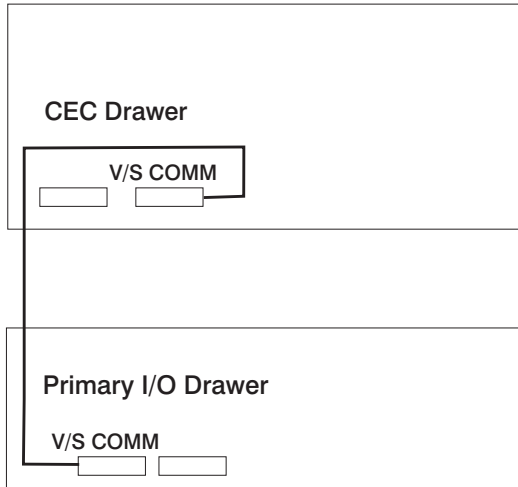

**Note:** The V/S COMM cable incorporates SPCN wiring.

## CEC Drawer Attached to Two I/O Drawers

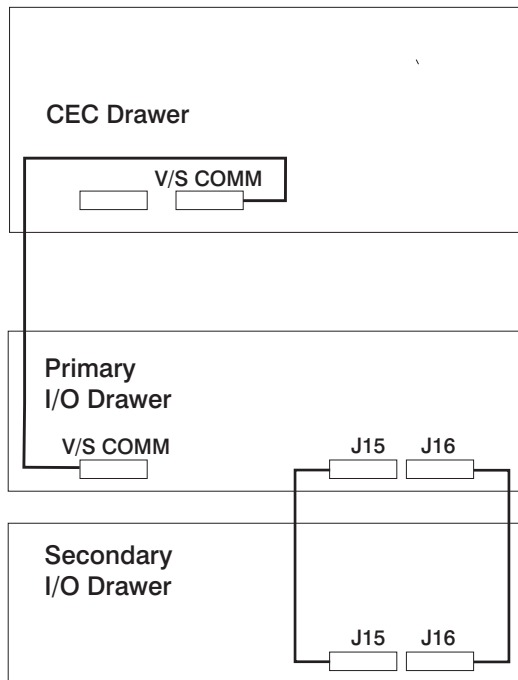

**Note:** The V/S COMM cable incorporates SPCN wiring.

## CEC Drawer Attached to Three I/O Drawers

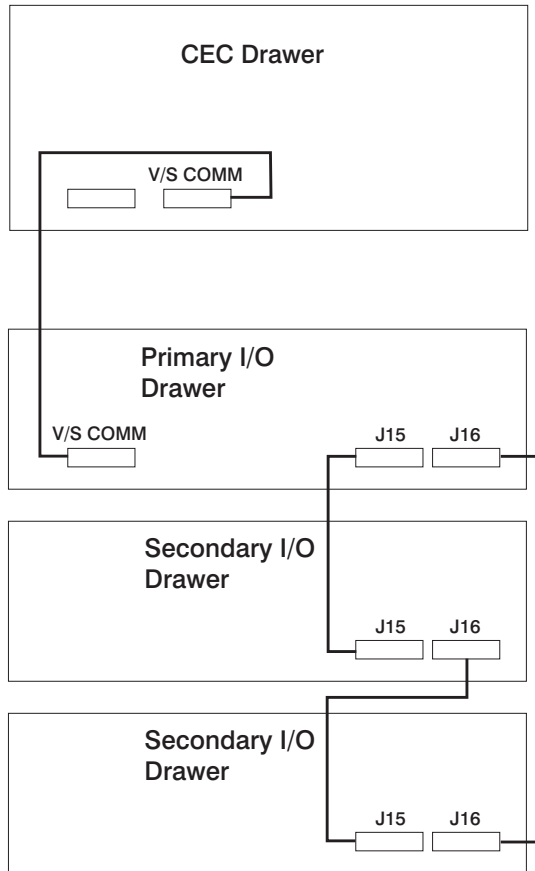

**Note:** The V/S COMM cable incorporates SPCN wiring.

## CEC Drawer Attached to Four I/O Drawers

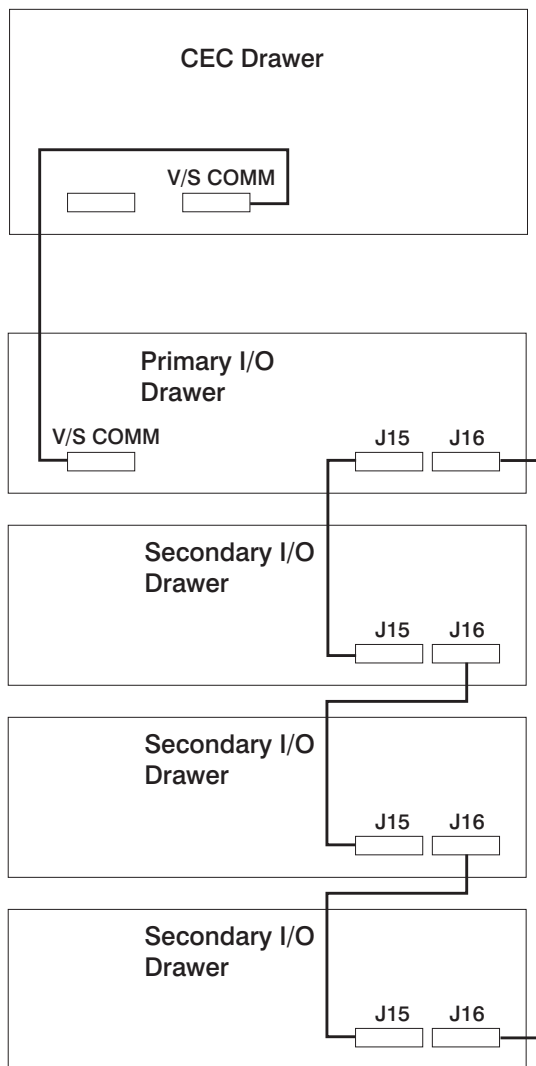

**Note:** The V/S COMM cable incorporates SPCN wiring.



## System Cable Diagrams

The following diagrams show system cable connections.

### CEC Drawer Cable

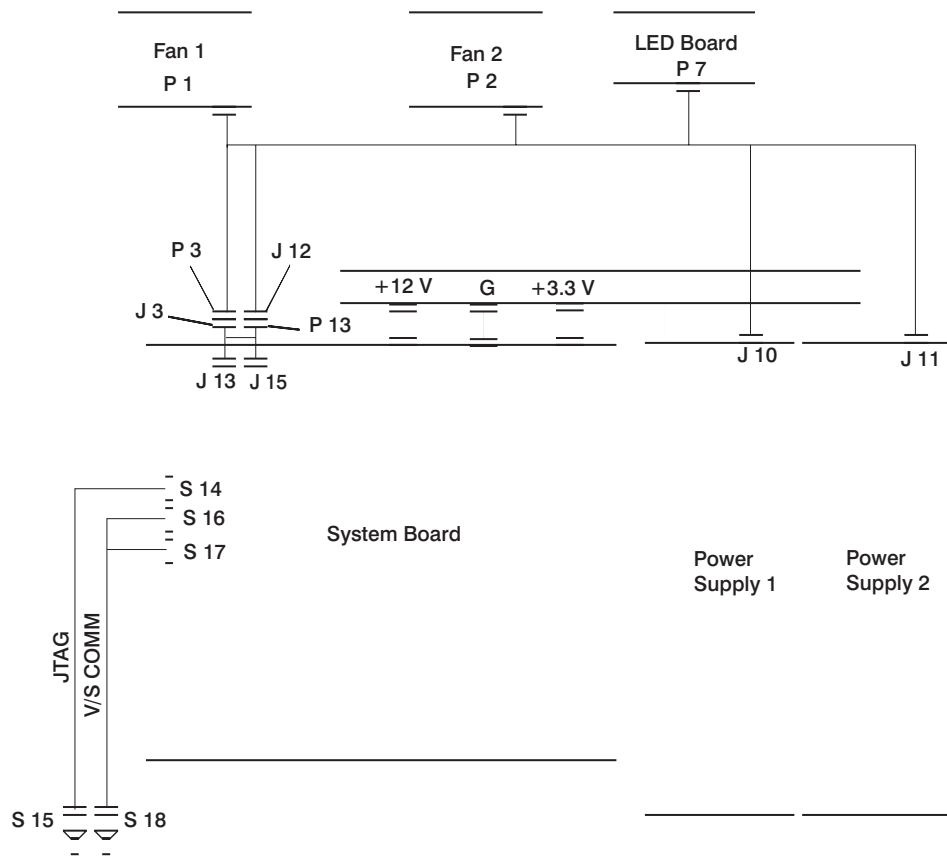

# Primary I/O Drawer Cable

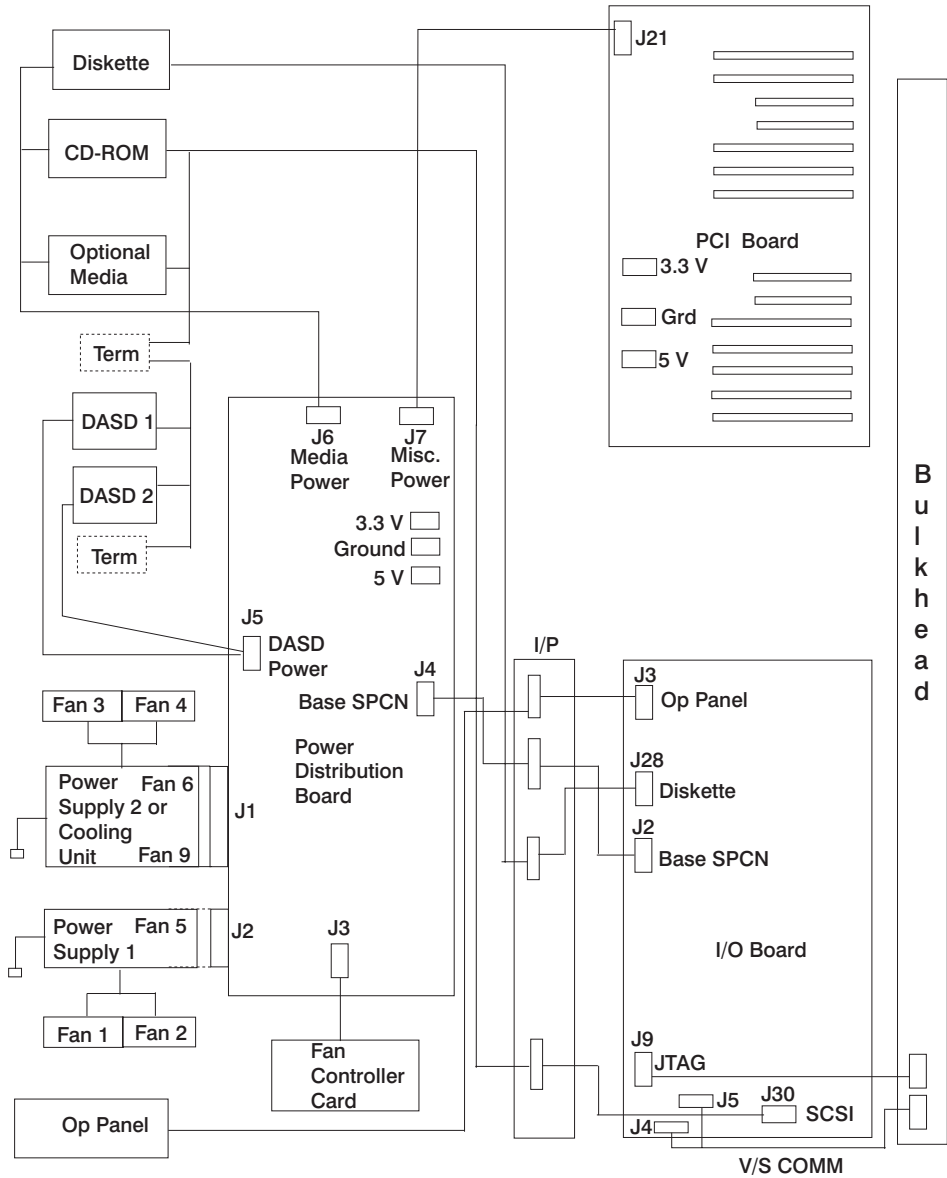

## Secondary I/O Drawer Cable

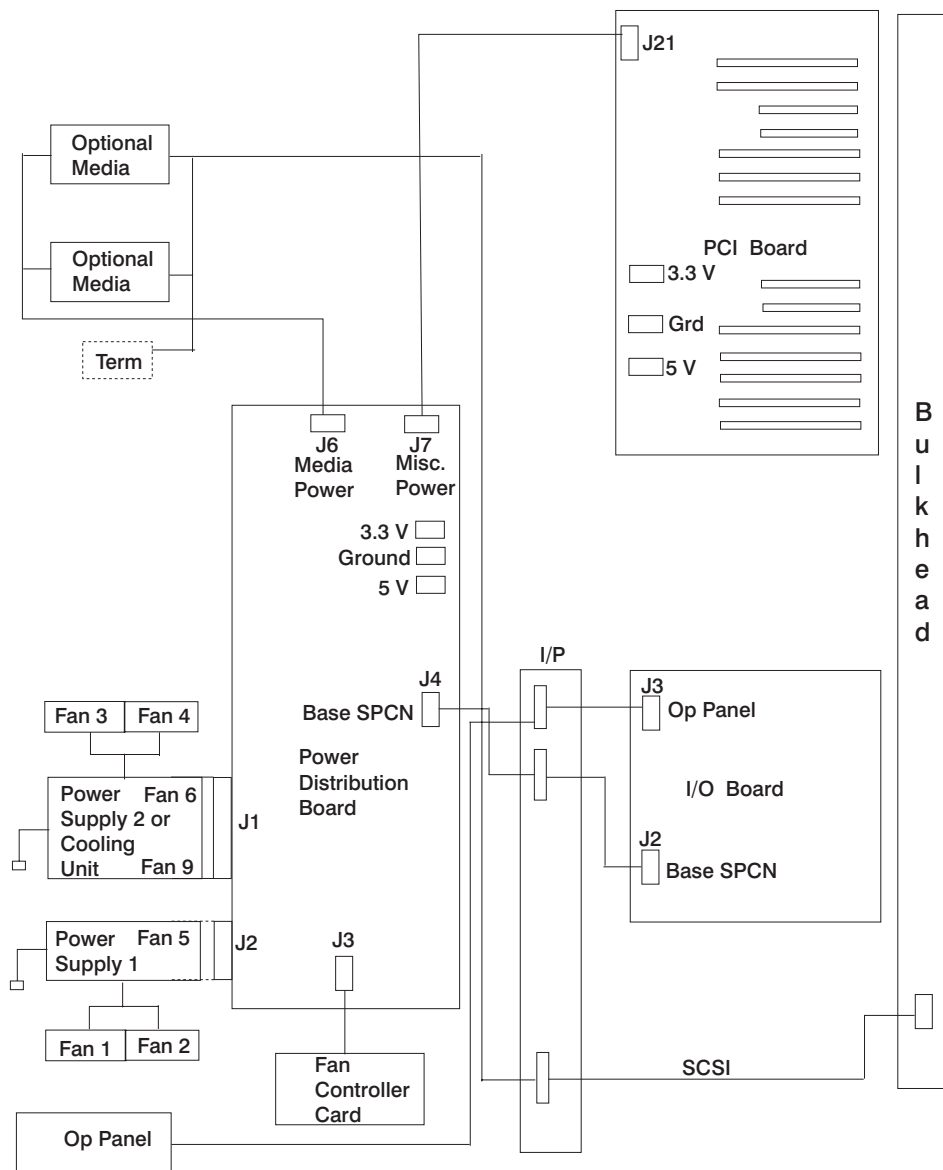

## DC Power Cable Routings

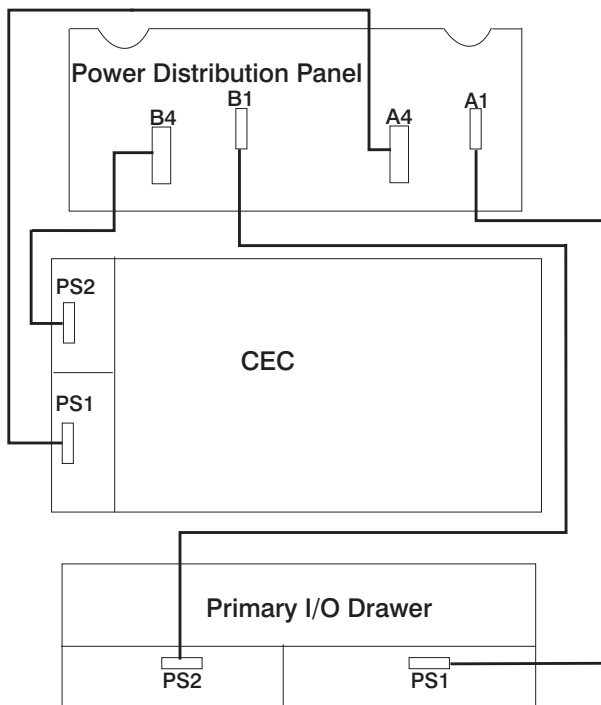

## Specifications

This section contains specifications for the system. Individual sections are provided for CEC drawer, rack, and I/O drawer specifications.

### CEC Drawer

The mechanical packaging, cooling, power supply, and environmental requirements for the CEC drawer are shown in the following table:

<b>Dimensions</b>		
Height	355.6 mm	14.0 in.
Width	445.5 mm	17.5 in.
Depth	825.5 mm	32.5 in.
<b>Weight</b>		
Minimum	69.7 kg	158 lbs.
Maximum	74.6 kg	169 lbs.

<b>Electrical</b>	
Power source loading typical in kVA	0.39
Power source loading maximum in kVA	0.6
Voltage range (V ac)	200 to 240
Frequency (hertz)	50 or 60
Thermal output (typical)	M80: 1265 Btu/hr 6M1: 772 Btu/hr
Thermal output (maximum)	M80: 1877 Btu/hr 6M1: 1378 Btu/hr
Power requirements (typical)	M80: 370 watts 6M1: 226 watts
Power requirements (maximum)	M80: 550 watts 6M1: 406 watts
Power factor	0.95
Inrush current	34 amps
Maximum altitude	2135 m (7000 ft.)

<b>Temperature Requirements</b>	<b>Operating</b>	<b>Non-Operating (Power Off)</b>
	10 to 40°C (50 to 104°F)	10 to 52°C (50 to 125°F)
<b>Humidity (Noncondensing)</b>	<b>Operating</b>	<b>Non-Operating (Power Off)</b>
Without tape drive	8 to 80%	8 to 80%
With tape drive	20 to 80%	8 to 80%
<b>Wet Bulb Requirements</b>		
Without tape drive	27°C (80°F)	27°C (80°F)
With tape drive	27°C (80°F)	27°C (80°F)
<b>Noise Emissions<sup>1,2</sup></b>	<b>Operating</b>	<b>Idle</b>
With M80 CEC drawer only		
$L_{wAd}$	6.4 bels	6.4 bels
$L_{pAm}$	N/A	N/A
$\langle L_{pA} \rangle_m$	48 dBA	48 dBA
Impulsive or prominent discrete tones	No	No

<b>Noise Emissions</b> <sup>1,2</sup>	<b>Operating</b>	<b>Idle</b>
With M80 and Primary I/O Drawer		
$L_{WAd}$	6.5 bels	6.5 bels
$L_{pAm}$	N/A	N/A
$\langle L_{pA} \rangle_m$	49 dBA	49 dBA
Impulsive or prominent discrete tones	No	No

<b>Clearances</b>	<b>Front</b>	<b>Back</b>	<b>Left</b>	<b>Right</b>
-------------------	--------------	-------------	-------------	--------------

<b>Install/Air Flow</b>	Maintenance of a proper service clearance should allow proper air flow.
<b>Service</b>	(See service clearances for the 7014 Series Model T00 Rack)
<ol style="list-style-type: none"> <li>1. See "Noise Emission Notes" on page 71 for definitions of noise emissions positions.</li> <li>2. Noise emissions data are based on the following configuration: the drawer is mounted in a 7014 Series Model T00 Rack, a power distribution unit is installed in the rack, and the system is operating in a normal environment of 25 °C (78 °F).</li> <li>3. Inrush currents occur only at initial application of power; no inrush occurs during normal power off-on cycle.</li> </ol>	

## 7014 Series Model T00 Rack

The mechanical packaging, cooling, power supply, and environmental requirements for the rack are shown in the following table:

<b>Dimensions</b>				
Height		1804 mm		71.0 in.
Width		644 mm		25.5 in.
Depth (including doors)		1098 mm		43.3 in.
<b>Weight</b> <sup>1</sup> (Base Rack)		244 kg		535 lbs.
<b>Electrical</b>	(see specifications for drawers or enclosures)			
<b>Temperature Range</b>	(see specifications for drawers or enclosures)			
<b>Humidity Requirements</b>	(see specifications for drawers or enclosures)			
<b>Noise Emissions</b>	(see specifications for drawers or enclosures)			
<b>Clearances</b>	<b>Front</b>	<b>Back</b>	<b>Left</b>	<b>Right</b>
<b>Install/Air Flow</b>	Maintenance of a proper service clearance should allow proper air flow.			
<b>Service</b>	See "System Service Clearances" on page 70.			
1. Configuration-dependent, base weight not including weight of drawers.				

## I/O Drawer Specifications

<b>Dimensions</b>		
Height	218.0 mm	8.6 in.
Width	445.0 mm	17.5 in.
Depth	820.0 mm	32.3 in.
<b>Weight</b>		
Minimum configuration	41 kg	90 lbs.
Maximum configuration	52 kg	115 lbs.
<b>Electrical</b>		
Power source loading (typical in kVA)	0.23	
Power source loading (maximum in kVA)	0.54	
Voltage range	200 to 240 V ac	
Frequency (hertz)	50 / 60	
Thermal output (typical)	750 Btu/hr	
Thermal output (maximum)	1750 Btu/hr	
Power requirements (typical)	220 watts	
Power requirements (maximum)	515 watts	
Power factor	0.95	
Inrush current	41 amps	
Maximum altitude	2135 m (7000 ft.)	

<b>Temperature Requirements</b>	<b>Operating</b> 10 to 40°C (50 to 104°F)	<b>Non-Operating</b> 10 to 52°C (50 to 125.6°F)
<b>Humidity (Noncondensing)</b>	<b>Operating</b>	<b>Non-Operating</b>
Without tape drive	8 to 80%	8 to 80%
With tape drive	20 to 80%	20 to 80%
<b>Wet Bulb Requirements</b>		
Without tape drive	27°C (80°F)	27°C (80°F)
With tape drive	23°C (73°F)	27°C (80°F)
<b>Noise Emissions<sup>1,2</sup></b>	<b>Operating</b>	<b>Idle</b>
$L_{wAd}$	5.8 bels	5.8 bels
$L_{pAm}$	N/A	N/A
$<L_{pA}>_m$	45 dBA	45 dBA
Impulsive or prominent discrete tones	No	No

<b>Clearances</b>	<b>Front</b>	<b>Back</b>	<b>Left</b>	<b>Right</b>
-------------------	--------------	-------------	-------------	--------------

<b>Install/Air Flow</b>	Maintenance of a proper service clearance should allow proper air flow.
<b>Service</b>	(See "System Service Clearances" on page 70)
<ol style="list-style-type: none"> <li>1. See "Noise Emission Notes" on page 71 for definitions of noise emissions positions.</li> <li>2. Noise emissions data are based on the following configuration: the drawer is mounted in a 7014 Series Model T00 Rack and a power distribution unit is installed in the rack.</li> <li>3. Inrush currents occur only at initial application of power; no inrush occurs during normal power off-on cycle.</li> </ol>	

## System Service Clearances

The amount of space required during service is indicated by the dotted line in the following figure.

For multiple racks placed side by side, the left and right clearances apply only to the leftmost and rightmost rack.

## Rack Configuration

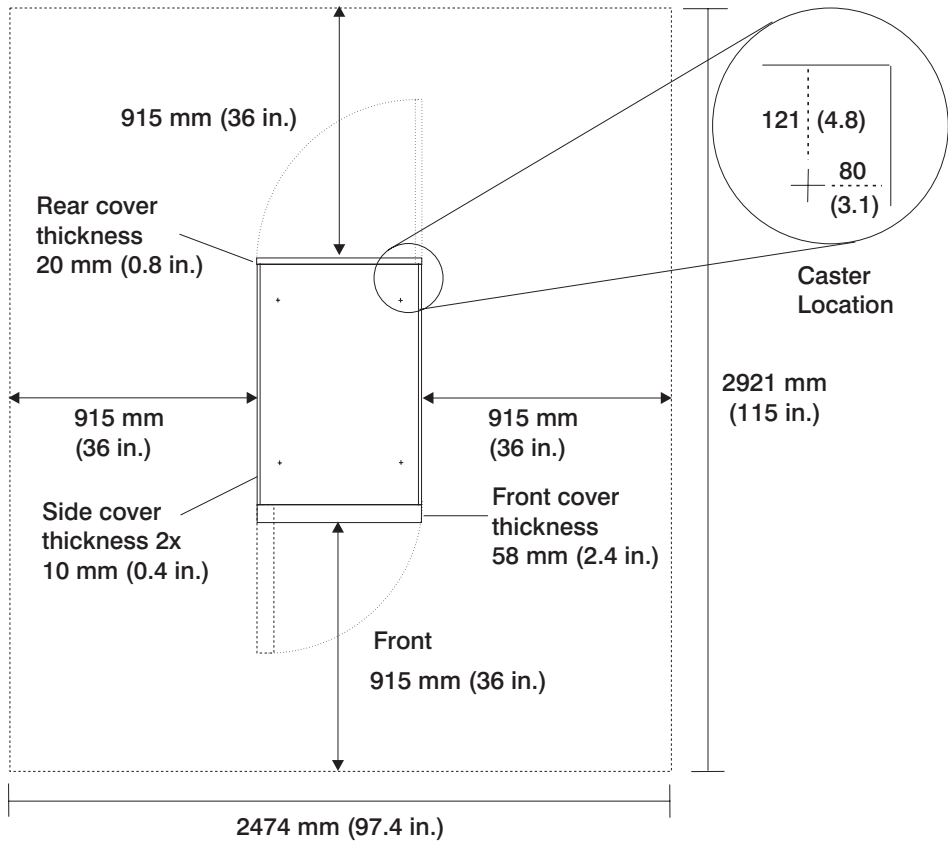

**Note:** Rack units are large and heavy and are not easily moved. Because maintenance activities require access at both the front and back, allow for extra room. The footprint shows the radius of the swinging doors on the I/O rack. The figure shows the minimum space required.



## Noise Emission Notes

1.  $L_{WA,d}$  is the declared (upper limit) sound power emission level for a production series of machines.
2.  $L_{pA,m}$  is the mean value of the A-weighted sound pressure emission levels at the operator position (if any) for a production series of machines.
3.  $\langle L_{pA} \rangle_m$  is the mean value of the space-averaged A-weighted sound pressure emission levels at the one-meter positions for a production series of machines.
4. N/A = Not Applicable (no operator position).
5. All measurements are made in accordance with ISO 7779 and reported in conformance with ISO 9296.

---

## Power Cables

To avoid electrical shock, a power cable with a grounded attachment plug is provided. Use only properly grounded outlets.

Power cables used in the United States and Canada are listed by Underwriter's Laboratories (UL) and certified by the Canadian Standards Association (CSA). These power cords consist of the following:

- Electrical cables, Type SVT or SJT
- Attachment plugs complying with National Electrical Manufacturers Association (NEMA) 5-15P

"For 230 V operation in the United States use a UL listed cable set consisting of a minimum 18 AWG, Type SVT or SJT three-conductor cable a maximum of 15 feet in length, and a tandem blade, grounding type attachment plug rated at 15 A, 250 V."

- Appliance couplers complying with International Electrotechnical Commission (IEC) Standard 320, Sheet C13

Power cables used in other countries consist of the following:

- Electrical cables, Type HD21
- Attachment plugs approved by the appropriate testing organization for the specific countries where they are used

"For units set at 230 V (outside of U.S.): use a cable set consisting of a minimum 18 AWG cable and grounding type attachment plug rated 15 A, 250 V. The cable set should have the appropriate safety approvals for the country in which the equipment will be installed and should be marked HAR.

Refer to Chapter 11, "Parts Information" on page 523 to find the power cables that are available.

---

## Service Inspection Guide

Perform a service inspection on the system when:

- The system is inspected for a maintenance agreement.
- Service is requested and service has not recently been performed.
- An alterations and attachments review is performed.
- Changes have been made to the equipment that may affect its safe operation.
- External devices with their own power cables have those cables attached.

If the inspection indicates an unacceptable safety condition, the condition must be corrected before anyone can service the machine.

**Note:** The owner of the system is responsible to correct any unsafe conditions.

Perform the following checks:

1. Check the covers for sharp edges and for damage or alterations that expose the internal parts of the system unit.
2. Check the covers for proper fit to the system unit. They should be in place and secure.
3. Gently rock the system unit from side to side to determine if it is steady.
4. Set the power switch of the system unit to Off.
5. Remove the covers.
6. Check for alterations or attachments. If there are any, check for obvious safety hazards, such as broken wires, sharp edges, or broken insulation.
7. Check the internal cables for damage.
8. Check for dirt, water, and any other contamination within the system unit.
9. Check the voltage label on the back of the system unit to ensure that it matches the voltage at the outlet.
10. Check the external power cable for damage.
11. With the external power cable connected to the system unit, check for 0.1 ohm or less resistance between the ground lug on the external power cable plug and the metal frame.
12. Perform the following checks on each device that has its own power cables:
  - a. Check for damage to the power cord.
  - b. Check for the correct grounded power cable.
  - c. With the external power cable connected to the device, check for 0.1 ohm or less resistance between the ground lug on the external power cable plug and the metal frame of the device.
13. Install the covers.



---

## Chapter 2. Diagnostics Overview

Model M80 and Model 6M1 systems use an integrated set of software diagnostic procedures to facilitate isolation of failing components and system maintenance. This book, along with the *RS/6000 and @server pSeries Diagnostic Information for Multiple Bus Systems*, are the basis of the diagnostic procedures for Model M80 and Model 6M1 systems. In particular, the following sections in this book are important for the trained service representative to understand and use when isolating a failure on the system:

- Chapter 4, “Checkpoints” on page 147
- Chapter 5, “Error Code to FRU Index” on page 171
- Chapter 6, “Loading the System Diagnostics In Service Mode” on page 401
- Chapter 11, “Parts Information” on page 523

The manufacturer recommends that systems configured with 4 GB of memory or greater have access to a 4 mm or 8 mm tape drive for submission of system dump information if required. This function can be accomplished through locally attached or network-attached devices, as appropriate.

---

### Maintenance Analysis Procedures (MAPs)

Maintenance analysis procedures (MAPs) guide the trained service person through the system. These MAPs are the entry point for all isolation and error-recovery procedures. The MAPs are consistent with existing procedures and methods. The system uses a set of integrated procedures, mentioned earlier, to which the MAPs are the primary entry point.

The MAPs are as follows:

- Entry MAP
- Quick Entry MAP
- Problem Determination MAP
- Power MAP
- Minimum Configuration MAP

The Entry Map is the starting point for problem determination. The purpose of this MAP is to quickly point to the appropriate MAP or service reference information either in this book, or in the common book set, which includes the *RS/6000 and @server pSeries Diagnostic Information for Multiple Bus Systems* and the *PCI Adapter Placement Reference*.

The Quick Entry MAP is a subset of the Entry MAP and helps to save time for some types of problems.

The Problem Determination MAP provides a structured analysis method to get an error code if one is not provided by the customer, or if diagnostics cannot be loaded.

The Power MAP deals with isolation of components to diagnose a power problem. The nature of power problems can be related to powering on and down the system, or power failures that can occur after power is turned on.

The Minimum Configuration MAP is used to locate defective components not found by normal diagnostics or error-isolation methods. This MAP provides a systematic method of isolation to the failing item or items.

---

## Checkpoints

These servers use various types of checkpoints, error codes, and SRNs, which are referred to throughout this book (primarily in Chapter 4, “Checkpoints” on page 147, Chapter 5, “Error Code to FRU Index” on page 171, Chapter 6, “Loading the System Diagnostics In Service Mode” on page 401, and Chapter 11, “Parts Information” on page 523). These codes may appear in the service processor boot progress log, the AIX error log, and the operator panel display. Understanding the definition and relationships of these codes is important to the service personnel who are installing or maintaining these servers.

Codes that can appear on the operator panel or in error logs are as follows:

### Checkpoints

Checkpoints display in the operator panel from the time ac power (dc power in a dc-powered system) is connected to the system until the AIX login prompt is displayed after a successful operating system boot. These checkpoints have the following forms:

**8xxx** 8xxx checkpoints display from the time ac power (dc power in a dc-powered system) is connected to the system until the OK prompt is displayed by the service processor on the operator panel display. (Several 9xxx checkpoints are displayed just before the OK prompt displays.)

**9xxx** 9xxx checkpoints are displayed by the service processor after the power-on sequence is initiated. A system processor takes over control when 91FF displays on the operator panel.

**Exxx** Exxx checkpoints indicate that a system processor is in control and is initializing the system resources. Control is being passed to AIX when E105 (normal mode boot) or E15B (service mode boot) displays on the operator panel.

**Note:** Location code information may also display on the operator panel during this time.

**0xxx** 0xxx codes are AIX checkpoints and configuration codes. Location codes may also be shown on the operator panel display during this time.

**2xxx** 2xxx codes are AIX checkpoints and configuration codes. Location codes may also be shown on the operator panel display during this time.

**Note:** Certain checkpoints may remain in the display for long periods of time. A spinning cursor is visible in the upper-right corner of the display during these periods to indicate that system activity is continuing.

### **Error Codes**

If a fault is detected, an 8-digit error code is displayed in the operator panel display. A location may be displayed at the same time on the second line of the display.

Checkpoints can become error codes if the system fails to advance past the point at which the code was presented.

For a list of checkpoints, see Chapter 4, “Checkpoints” on page 147. Each entry provides a description of the event and the recommended action if the system fails to advance.

**SRNs** Service request numbers, in the form xxx-xxx or xxx-xxxx, may also be displayed on the operator panel display and be noted in the AIX error log.

SRNs are listed in the *RS/6000 and @server pSeries Diagnostic Information for Multiple Bus Systems*, order number SA38-0509.

---

## **FRU Isolation**

For a list of error codes and recommended actions for each code, see Chapter 5, “Error Code to FRU Index” on page 171. These actions can refer to Chapter 11, “Parts Information” on page 523, Chapter 3, “Maintenance Analysis Procedures (MAPs)” on page 81, or provide informational message and directions. If a replacement part is indicated, direct reference is made to the part name. The respective AIX and physical location codes are listed for each occurrence as required. For a list of locations codes, see “AIX and Physical Location Code Reference Tables” on page 33.

To look up part numbers and view component diagrams, see Chapter 11, “Parts Information” on page 523. The beginning of the chapter provides a parts index with the predominant field replaceable units (FRUs) listed by name. The remainder of the chapter provides illustrations of the various assemblies and components which make up these servers.

---

## **Electronic Service Agent for the @server pSeries and RS/6000**

Service support for your system can be enhanced through the use of the application program, Electronic Service Agent. This application provides a number of advantages for the systems customer, including automatic error reporting and analysis without customer intervention. The Electronic Service Agent kit includes the *Electronic Service Agent for @server pSeries and RS/6000* CD, order number LCD4-1060, which contains documentation to help you set up and use Electronic Service Agent.

---

## Using the Service Processor and Electronic Service Agent Features

The service processor and Electronic Service Agent features protect users against unnecessary system downtime by advising support personnel (both internal and external) of any unexpected changes in the system environment. In combination, the two features provide a flexible solution to automated system maintenance.

### Service Processor

The service processor runs on its own power boundary and continually monitors hardware attributes, the AIX operating system, and the environmental conditions within the system. Any system failure which prevents the system from returning to an operational state (a fully functional AIX operating system) is reported by the service processor. The service processor is controlled by firmware and does not require the AIX operating system to be operational to perform its tasks. If any system failures are detected, the service processor has the ability to take predetermined corrective actions. The methods of corrective actions are:

- Surveillance
- Call home
- AIX operating system monitoring

Surveillance is a function in which the service processor monitors the system through *heartbeat* communication with the system firmware. The heartbeat is a periodic signal that the firmware can monitor. During system startup, the firmware surveillance monitor is automatically enabled to check for heartbeats from the firmware. If a heartbeat is not detected within a default period, the service processor cycles the system power and attempts to restart until the system either restarts successfully, or a predetermined retry threshold is reached. In the event the service processor is unsuccessful in bringing the system online (or in the event that the user asked to be alerted to any service processor-assisted restarts), the system can call home to report the error.

The call home function can be initialized to call either a service center telephone number, a customer administration center, or a digital pager telephone number. The service processor can be configured to stop at the first successful call to any of the numbers listed, or can be configured to call every number provided. If connected to the service center, the service processor transmits the relevant system information (the system's serial number and model type) and service request number (SRN). If connected to a digital pager service, the service processor inputs a customer voice telephone number defined by the customer. An established sequence of digits or the telephone number to a phone near the failed system could be used to signal a system administrator to a potential system failure.

During normal operations, the service processor can also be configured to monitor the AIX operating system. If AIX does not respond to the service processor heartbeat, the service processor assumes the operating system is hung. The service processor can automatically initiate a restart and, if enabled, initiate the call home function to alert the appropriate people to the system hang. Enabling operating system surveillance also enables AIX detect any service processor failures and report those failures to the Electronic Service Agent application.



Unlike the Electronic Service Agent, the service processor cannot be configured in a client/server environment where one system can be used to manage all dial-out functions for a set of systems.

Prior to installing the Electronic Service Agent feature, ensure that you have the latest level of system firmware. You also need a properly configured modem. For more information on configuring a modem, see “Modem Configuration Menu” on page 433.

## **Electronic Service Agent**

The Electronic Service Agent is a software extension to the AIX operating system that monitors the system while the AIX operating system is running. The Electronic Service Agent monitors and analyzes all recoverable system failures, and, if needed, can automatically place a service call to a service center (without user intervention).

The service center receives the machine type/serial number, host name, SRN, and a problem description. The service center analyzes the problem report and, if warranted, dispatches a service person to the customer site. The service center also determines if any hardware components need to be ordered prior to the service person's arrival.

The Electronic Service Agent code also gives the user the option to establish a single system as the problem reporting server. A single system, accessible over the user network, can be used as the central server for all the other systems on the local area network (LAN) that are running the Electronic Service Agent application. If the Electronic Service Agent application on a remote client decides a service request needs to be placed, the client forwards the information to the Electronic Service Agent server that dials the service center telephone number from its locally attached modem. In this scenario, the user only needs to maintain a single analog line for providing call-out capabilities for a large set of servers.

When used in a scalable parallel (SP) environment, a client/server type implementation is configured. The Electronic Service Agent client code runs on each of the SP nodes. The server component runs on the control workstation. In the event of any system failures, the relevant information is transmitted to the control workstation through the integrated Ethernet. After it has been alerted to the system failure, the control workstation initiates actions to prepare and send the service request.

A modem is required for enabling automated problem reporting to the service center. Configuration files for several types of modems are included as part of the Electronic Service Agent package. Refer to “Modem Configuration Menu” on page 433 for more information on configuring your modem.



---

## Chapter 3. Maintenance Analysis Procedures (MAPs)

This chapter contains maintenance analysis procedures (MAPs) for the system.

---

### Entry MAP

Use the following table to determine your starting point.

When possible, run online diagnostics in service mode. Online diagnostics perform additional functions, compared to standalone diagnostics. This ensures that the error state of the system is captured in NVRAM for your use in fixing the problem. The AIX error log and SMIT are only available when diagnostics are run from the hard drive.

#### Notes:

1. Licensed programs frequently rely on system information stored in the VPD module on the primary I/O drawer operator panel. If the MAPs indicate that the primary I/O drawer operator panel should be replaced, swap the VPD module from the old primary I/O drawer operator panel to the new one. If the old VPD module has to be replaced call technical support for recovery instructions. If recovery is not possible, notify the system owner that new keys for licensed programs may be required.
2. If a network adapter is replaced, the network administrator must be notified so that the client IP addresses used by the server can be changed. In addition, the operating system configuration of the network controller may need to be changed in order to enable system startup. Also check to ensure that any client or server that addresses this system is updated.

Symptom	Starting Point
You have a problem that does not prevent the system from booting and all I/O drawer operator panels are functional.	Go to the "Fast Path MAP" in the <i>RS/6000 and @server pSeries Diagnostic Information for Multiple Bus Systems</i> .
You have a problem that does not prevent the system from booting and an I/O drawer operator panel is not functioning.	Replace the following parts in the secondary I/O drawer with the non-functioning operator panel, one at a time, in the sequence listed: <ol style="list-style-type: none"><li>1. Secondary I/O drawer operator panel</li><li>2. Secondary I/O drawer backplane</li></ol>
You do not have a symptom.	Go to "MAP 0020: Problem Determination Procedure" in the <i>RS/6000 and @server pSeries Diagnostic Information for Multiple Bus Systems</i> .
You have an SRN.	Go to the "Fast Path MAP" in the <i>RS/6000 and @server pSeries Diagnostic Information for Multiple Bus Systems</i> .
The system stops and a 3-digit number is displayed in the operator panel display.	Record SRN 101-xxx, where xxx is the 3-digit number displayed in the operator panel display, then go to the "Fast Path MAP" in the <i>RS/6000 and @server pSeries Diagnostic Information for Multiple Bus Systems</i> .

Symptom	Starting Point
The system stops and a 4-digit number beginning with 0 or 2 is displayed in the operator panel display.	Go to the "Fast Path MAP" in the <i>RS/6000 and @server pSeries Diagnostic Information for Multiple Bus Systems</i> .
All other symptoms.	Go to "Quick Entry MAP".

---

## Quick Entry MAP

### Quick Entry MAP Table of Contents

Problem Description	Page No.
Service Actions	82
A Repeating Pattern of Error Code Data Appears on the Primary I/O Drawer Operator Panel Display	83
OK does not appear in the primary I/O drawer operator panel display before pressing the power on button	83
There is an 8-Digit Error Code	84
System stops with an 8-digit number displayed in the Primary I/O Drawer Operator Panel Display	84
Error Indication in Secondary I/O Drawer Operator Panel Display	85
System stops with a 4-Digit Number that does not begin with 0 or 2 Displayed	85
System Stops With a 3-Digit Number Displayed (888 sequence, see below)	85
There is a Display Problem (Distortion, Blurring, Etc.)	85
Power and Cooling Problems	86
888 sequence in Operator Panel Display	86
Other Symptoms or Problems	86

**Attention:** If you replace FRUs and the problem is still not corrected, go to "MAP 1540: Minimum Configuration" on page 122 unless otherwise indicated in the tables.

If you replace FRUs and the problem is corrected, go to "MAP 0410: Repair Checkout" in the *RS/6000 and @server pSeries Diagnostic Information for Multiple Bus Systems*.

Symptom	Action
<b>Service Actions</b>	
You have parts to exchange or a corrective action to perform.	<ol style="list-style-type: none"> <li>1. Go to Chapter 10, "Removal and Replacement Procedures" on page 467.</li> <li>2. Go to "MAP 0410: Repair Checkout" in the <i>RS/6000 and @server pSeries Diagnostic Information for Multiple Bus Systems</i>.</li> </ol>

Symptom	Action
You need to verify that a part exchange or corrective action corrected the problem.	Go to "MAP 0410: Repair Checkout" in the <i>RS/6000 and @server pSeries Diagnostic Information for Multiple Bus Systems</i> .
You need to verify correct system operation.	Go to "MAP 0410: Repair Checkout" in the <i>RS/6000 and @server pSeries Diagnostic Information for Multiple Bus Systems</i> .
<b>A Repeating Pattern of Error Code Data Appears on the Primary I/O Drawer Operator Panel Display</b>	
A sequence of displays, each appearing for five seconds, repeats continuously as follows: a blank display, followed by an eight-digit error code, followed by up to nine full panels of dump data.	<ol style="list-style-type: none"> <li>1. Record the 8-digit error code seen after the five second blank display.</li> <li>2. Reset the service processor via the pinhole reset.</li> <li>3. Go to "Checkpoint and Error Code Index" on page 173 with the error code you have recorded.</li> </ol>
<b>OK does not appear in the primary I/O drawer operator panel display before pressing the power on button</b>	
A bouncing or scrolling ball remains on the primary I/O drawer operator panel display or the primary I/O drawer operator panel display is filled with dashes	<p>If an ASCII terminal is available, connect it to the primary I/O drawer through serial port 1.</p> <ol style="list-style-type: none"> <li>1. If the service processor menu is displayed, then: <ol style="list-style-type: none"> <li>a. Replace the primary I/O drawer operator panel assembly, location: U0.1-L1. Refer to Chapter 10, "Removal and Replacement Procedures" on page 467.</li> <li>b. Replace the primary I/O drawer backplane, location: U0.1-P1. Refer to Chapter 10, "Removal and Replacement Procedures" on page 467.</li> </ol> </li> <li>2. If the service processor menu is not displayed, then replace the primary I/O drawer backplane, location: U0.1-P1. Refer to Chapter 10, "Removal and Replacement Procedures" on page 467.</li> </ol> <p>If an ASCII terminal is not available, replace the following, one at a time, in the sequence listed:</p> <ol style="list-style-type: none"> <li>1. Primary I/O drawer operator panel assembly, location: U0.1-L1. Refer to Chapter 10, "Removal and Replacement Procedures" on page 467.</li> <li>2. Primary I/O drawer backplane, location: U0.1-P1. Refer to Chapter 10, "Removal and Replacement Procedures" on page 467.</li> </ol>
You have a blank display on the primary I/O drawer operator panel	Go to "MAP 1520: Power" on page 94.

Symptom	Action
<b>There is an 8-Digit Error Code</b>	
You have an 8-digit error code in the form 10n1xxxx and <i>n</i> is greater than the number of I/O drawers in the system.	The failing drawer is drawer <i>n</i> . Look for the drawer with the same value of <i>n</i> in its operator panel, either in the form *0 <i>n</i> or U0. <i>n</i> . Substitute 2 for <i>n</i> when looking up the error code in "Checkpoint and Error Code Index" on page 173.
You have an 8-digit error code of the form 10n1xxxx and two or more drawers have the same drawer number.	<p>Shut down the system and remove all but one of the drawers with duplicate drawer numbers. Refer to the steps in "MAP 1540: Minimum Configuration" on page 122 for a procedure to connect/disconnect I/O drawers. Attempt to reboot the system.</p> <ol style="list-style-type: none"> <li>1. If the system still fails, you have found the failing drawer. Substitute 2 for <i>n</i> when looking up the error code in "Checkpoint and Error Code Index" on page 173.</li> <li>2. If the system boots, shut down and add another of the detached drawers back into the system. Repeat steps 1 and 2 until the failing drawer is isolated.</li> </ol> <p><b>Note:</b> As the system successfully boots, duplicate drawer numbers are resolved into unique drawer numbers.</p>
You have an 8-digit error code.	Look up the error code in the table in "Checkpoint and Error Code Index" on page 173.
<b>System stops with an 8-digit number displayed in the Primary I/O Drawer Operator Panel Display</b>	
You have an 8-digit error code of the form 10n1xxxx and <i>n</i> is greater than the number of I/O drawers in the system.	The failing drawer is drawer <i>n</i> . Look for the drawer with the same value of <i>n</i> in its operator panel, either in the form *0 <i>n</i> or U0. <i>n</i> . Substitute 2 for <i>n</i> when looking up the error code in "Checkpoint and Error Code Index" on page 173.

Symptom	Action
<p>You have an 8-digit error code of the form 10n1 xxxx and two or more drawers have the same drawer number.</p>	<p>Shut down the system and remove all but one of the drawers with duplicate drawer numbers. Refer to the steps in "MAP 1540: Minimum Configuration" on page 122 for a procedure to connect/reconnect I/O drawers. Attempt to reboot the system.</p> <ol style="list-style-type: none"> <li>1. If the system fails, you have found the failing drawer. Substitute 2 for n when looking up the error code in "Checkpoint and Error Code Index" on page 173.</li> <li>2. If the system boots, shut down and add another of the detached drawers back into the system. Repeat steps one and two until the failing drawer is isolated.</li> </ol> <p><b>Note:</b> As the system successfully boots, duplicate drawer numbers are resolved into unique drawer numbers.</p>
<p>The system stops with an 8-digit error code displayed when booting.</p>	<p>Record the error code. Go to "Checkpoint and Error Code Index" on page 173.</p>
<p><b>Error Indication in Secondary I/O Drawer Operator Panel Displays</b></p>	
<p>A bouncing or scrolling ball remains on a secondary I/O drawer operator panel display or a secondary I/O drawer operator panel display is filled with dashes.</p>	<p>Replace the following, one at a time, in the sequence listed:</p> <ol style="list-style-type: none"> <li>1. Secondary I/O drawer backplane</li> <li>2. Secondary I/O drawer operator panel assembly</li> </ol>
<p>You have an 8-digit error code in the form 10n1 xxxx.</p>	<p>This is the failing drawer. If <i>n</i> is greater than the number of I/O drawers in the system, substitute 2 for <i>n</i> when looking up the error code in "Checkpoint and Error Code Index" on page 173.</p>
<p><b>System stops with a 4-Digit Number that does not begin with 0 or 2 Displayed</b></p>	
<p>The system stops with a 4-digit checkpoint that does not begin with 0 or 2.</p>	<p>Go to Chapter 4, "Checkpoints" on page 147.</p>
<p><b>System Stops With a 3-Digit Number Displayed (888 sequence, see below)</b></p>	
<p>The system stops with a 3-digit error code.</p>	<p>Add 101- to the left of the three digits to create an SRN. Go to <i>RS/6000 and @server pSeries Diagnostic Information for Multiple Bus Systems</i>.</p>
<p><b>There is a Display Problem (Distortion, Blurring, Etc.)</b></p>	

Symptom	Action
All display problems.	<ol style="list-style-type: none"> <li>1. If using a graphics display:               <ol style="list-style-type: none"> <li>a. Go to the problem determination procedures for the display.</li> <li>b. If you do not find a problem, replace the display adapter.</li> <li>c. If you do not find a problem, suspect the I/O planar. Go to "MAP 1540: Minimum Configuration" on page 122.</li> </ol> </li> <li>2. If using an ASCII terminal:               <ol style="list-style-type: none"> <li>a. Make sure that the ASCII terminal is connected to S1.</li> <li>b. If problems persist, go to the problem determination procedures for the terminal.</li> <li>c. If you do not find a problem, suspect the I/O planar. Go to "MAP 1540: Minimum Configuration" on page 122.</li> </ol> </li> </ol>
<b>Power and Cooling Problems</b>	
You cannot power on the system.	Go to "MAP 1520: Power" on page 94.
The power on/off LED on an I/O drawer operator panel does not come on or stay on. (Both the I/O drawer operator panel power-on/off LED and the I/O drawer power supply LEDs do not come on or stay on.)	Go to "MAP 1520: Power" on page 94.
A rack or a rack mounted unit will not power on.	Go to "MAP 1520: Power" on page 94.
You have a power problem.	Go to "MAP 1520: Power" on page 94.
The system attention LED on the primary I/O drawer operator panel is on and there is no SRN displayed.	Go to "MAP 1520: Power" on page 94.
<b>888 sequence in Operator Panel Display</b>	
A flashing 888 is displayed in the primary I/O drawer operator panel display.	Go to the "Fast Path MAP" in the <i>RS/6000 and @server pSeries Diagnostic Information for Multiple Bus Systems</i> .
<b>Other Symptoms or Problems</b>	
The operator panel displays OK. Fans and blowers are off.	The service processor (SP) is ready. The system is waiting for power on.
All of the system POST indicators are displayed on the system console, the system pauses and then restarts. <i>POST indicators</i> refers to the device mnemonics (words memory, keyboard, network, scsi, and speaker) that appear on the system console during the power-on self-test (POST).	Go to "Boot Problems and Concerns" on page 167.



Symptom	Action
<p>The system stops and all of the POST indicators are displayed on the system console. <i>POST indicators</i> refers to the device mnemonics (words memory, keyboard, network, scsi, and speaker) that appear on the system console during the power-on self-test (POST).</p>	<p>Go to "MAP 1540: Minimum Configuration" on page 122 to isolate the problem.</p>
<p>The system stops and the message STARTING SOFTWARE PLEASE WAIT... is displayed on the system console.</p>	<p>Go to Chapter 4, "Checkpoints" on page 147.</p>
<p>The system does not respond to the password being entered or the system login prompt is displayed when booting in service mode.</p>	<ul style="list-style-type: none"> <li>• If the password is being entered, or the service mode boot is being initiated on a keyboard attached to the system, then the keyboard or its controller may be faulty. In this case, replace the following, one at a time, in the sequence listed: <ol style="list-style-type: none"> <li>1. Keyboard</li> <li>2. Primary I/O backplane, location: U0.1-P1</li> </ol> </li> <li>• If the password is being entered, or the service mode boot is being initiated, from an ASCII terminal, first insure that the terminal is connected to S1 or S2. Use the problem determination procedures for the ASCII terminal. <p>If the problem persists, replace the primary I/O backplane, location: U0.1-P1.</p> </li> </ul>
<p>No codes are displayed on the operator panel within a few seconds of turning on the system. The operator panel displays OK before the system is powered on.</p>	<p>Reseat the operator panel cable. If problem not resolved, replace these parts, one at a time, in the order listed:</p> <ol style="list-style-type: none"> <li>1. Operator panel assembly. Swap the VPD module.</li> <li>2. Primary I/O drawer backplane, location: U0.1-P1. (See notes on 81.)</li> </ol>
<p>The SMS configuration list or boot sequence selection menu shows more SCSI devices attached to a controller/adaptor than are actually attached.</p>	<p>A device may be set to use the same SCSI bus ID as the control adapter. Note the ID being used by the controller/adaptor (this can be checked and/or changed via an SMS utility), and verify that no device attached to the controller is set to use that ID.</p> <p>If settings do not appear to be in conflict:</p> <ol style="list-style-type: none"> <li>1. Replace the SCSI cable.</li> <li>2. Replace the device.</li> <li>3. Replace the SCSI adapter</li> </ol> <p><b>Note:</b> In a "twin-tailed" configuration where there is more than one initiator device (normally another system) attached to the SCSI bus, it may be necessary to use SMS to change the ID of the SCSI controller or adapter.</p>

Symptom	Action
The System Management Services menu is displayed.	<p>The device or media you are attempting to boot from may be faulty.</p> <ol style="list-style-type: none"> <li>1. Check the SMS error log for any errors. To check the error log: <ul style="list-style-type: none"> <li>• Choose error log</li> <li>• If an error is logged, check the time stamp.</li> <li>• If the error was logged during the current boot attempt, record it.</li> <li>• Look up the error in Chapter 5, “Error Code to FRU Index” on page 171 and do the listed action.</li> <li>• If no recent error is logged in the error log, continue to the next step below.</li> </ul> </li> <li>2. Try to boot from an alternate boot device connected to the same controller as the original boot device. If the boot succeeds, replace the original boot device (for removable media devices, try the media first).</li> <li>3. Go to “MAP 1540: Minimum Configuration” on page 122.</li> </ol>
You suspect a cable problem.	Go to the <i>RS/6000 and @server pSeries Adapters, Devices, and Cable Information for Multiple Bus Systems</i> .
All other problems.	Go to “MAP 1020: Problem Determination” on page 89.

---

## MAP 1020: Problem Determination

Use this MAP to get an error code if you were not provided one by the customer or you are unable to load diagnostics. If you are able to load the diagnostics, go to "MAP 0020: Problem Determination Procedure" in the *RS/6000 and @server pSeries Diagnostic Information for Multiple Bus Systems*.

The service processor may have recorded one or more symptoms in its error log. If the system has attempted to boot since an error terminated normal operation, there may be specific fault information in the service processor error log. Examine this error log before proceeding (see "System Information Menu" on page 424).

The service processor may have been set by the user to monitor server operations and to attempt recoveries. You can disable these actions while you diagnose and service the system. If the system was set up according to the recommendations of the *RS/6000 Enterprise Server Model M80, @server pSeries 660 Model 6M1 User's Guide*, all the settings of the service processor (except language) were saved by using the SAVE/RESTORE HARDWARE MAINTENANCE POLICIES service aid. You can use the same service aid to restore the settings at the end of your service action.

Just in case the service processor settings were not saved by the user, if you disable them, make notes of their current settings for restoration before you leave.

In addition to the parameters in the table below, you can disconnect the modem to prevent incoming signals that could cause the system to power on.

Following are the service processor settings. The service processor menus are described in Chapter 8, "Using the Service Processor" on page 411.

Surveillance	From the service processor Setup Menu, go to the Surveillance Setup Menu and disable surveillance.
Unattended Start	From the service processor System Power Control Menu, disable unattended start mode.
Reboot Policy	From the System Power Control Menu, go to the Reboot/Restart Policy Setup Menu and set: 1. Number of reboot attempts to <b>0</b> (zero) 2. Use OS-Defined restart policy to <b>No</b> 3. Enable supplemental restart policy to <b>No</b> .
Call Out	From the Call-In/Call-Out Setup Menu, go to the Serial Port Selection Menu and disable call-out on both serial ports.

Be prepared to record code numbers and use those numbers in the course of analyzing a problem. Go to "Step 1020-1" on page 90.

## Step 1020-1

The following steps analyze a failure to load the diagnostic programs.

**Note:** Be prepared to answer questions regarding the operator panel display and perform certain actions based on displayed POST indicators.

1. Power off the system. Refer to “Powering Off the System” on page 469.
2. Select slow boot mode (select disable fast boot) on the System Power Control menu from the service processor main menu.
3. Power on the system. Refer to “Powering On the System” on page 469
4. Insert the diagnostic CD-ROM into the CD-ROM drive.
5. When the keyboard indicator is displayed (the word Keyboard), press the 5 key on the system console.
6. Enter a password, if requested.
7. Wait until the diagnostics are loaded or the system appears to stop.
8. Find your symptom in the following table, then follow the instructions given in the Action column.

Symptom	Action
The system stopped and a code is displayed on the operator panel.	Go to the “Entry MAP” on page 81.
The system stops with a prompt to enter a password.	Enter the password. You are not allowed to continue until a correct password has been entered. When you have entered a valid password go to the beginning of this table and wait for one of the other conditions to occur.
The diagnostic operating instructions are displayed.	Go to “MAP 0020: Problem Determination Procedure” in the <i>RS/6000 and @server pSeries Diagnostic Information for Multiple Bus Systems</i> .
The primary I/O drawer power on/off LED does not come on or does not stay on or you have a power problem.	Go to “MAP 1520: Power” on page 94.
The system login prompt is displayed.	You may not have pressed the correct key or you may not have pressed the key soon enough when you were to trying to indicate a service mode IPL of the diagnostic programs. If this is the case, start over at the beginning of this step. <b>Note:</b> Perform the system shutdown procedure before turning off the system.  If you are sure you pressed the correct key in a timely manner, go to “Step 1020-2” on page 92.
The system does not respond when the password is entered.	Go to “Step 1020-2” on page 92.

<b>Symptom</b>	<b>Action</b>
The system stopped. A POST indicator is displayed on the system console and an eight-digit error code is not displayed.	<p>If the POST indicator represents:</p> <ol style="list-style-type: none"> <li>1. Memory, go to "MAP 1540: Minimum Configuration" on page 122.</li> <li>2. Keyboard               <ol style="list-style-type: none"> <li>a. Replace the keyboard.</li> <li>b. Go to "MAP 1540: Minimum Configuration" on page 122.</li> </ol> </li> <li>3. Network, go to "MAP 1540: Minimum Configuration" on page 122.</li> <li>4. SCSI, go to "MAP 1540: Minimum Configuration" on page 122.</li> <li>5. Speaker, "MAP 1540: Minimum Configuration" on page 122.</li> </ol>
The System Management Services menu is displayed	Go to "Step 1020-4" on page 93.
All other symptoms.	If you were directed here from the Entry MAP, go to "MAP 1540: Minimum Configuration" on page 122. Otherwise, find the symptom in the "Entry MAP" on page 81.

## Step 1020-2

There is a problem with the keyboard.

Find the type of keyboard you are using in the following table; then follow the instructions given in the Action column.

Keyboard Type	Action
Type 101 keyboard (U.S.). Identify by the size of the Enter key. The Enter key is in only one horizontal row of keys.	Record error code M0KBD001; then go to "Step 1020-3".
Type 102 keyboard (W.T.). Identify by the size of the Enter key. The Enter key extends into two horizontal rows.	Record error code M0KBD002; then go to "Step 1020-3".
Type 106 keyboard. (Identify by the Japanese characters.)	Record error code M0KBD003; then go to "Step 1020-3".
ASCII terminal keyboard	Go to the documentation for this type of ASCII terminal and continue problem determination.

## Step 1020-3

Perform the following:

1. Find the eight-digit error code in Chapter 5, "Error Code to FRU Index" on page 171.

**Note:** If the eight-digit error code is not listed in the Error Code to FRU Index, look for it in the following:

- Any supplemental service manuals for attached devices
- The diagnostic problem report screen for additional information
- The Service Hints service aid
- The CERADME file (by using the Service Hints service aid).

**Note:** Service aids can be found in *RS/6000 and @server pSeries Diagnostic Information for Multiple Bus Systems*.

2. Perform the action listed.

## Step 1020-4

1. Turn off, then turn on the system unit.
2. When the keyboard indicator (the word keyboard) is displayed, press the 1 key on the system console.
3. When the System Management Services menus appear, check the error log for any errors.
  - a. Choose Error Log
  - b. If an error is logged, check the time stamp.
  - c. If the error was logged during the current boot attempt, record it.
  - d. Look up the error in Chapter 5, "Error Code to FRU Index" on page 171 and do the listed action.
  - e. If no recent error is logged in the error log, go to "MAP 1540: Minimum Configuration" on page 122.

---

## MAP 1520: Power

This procedure is used to locate power problems in the CEC drawer, I/O drawer(s) or rack. If a problem is detected, this procedure helps you isolate the problem to a failing unit.

Observe the following safety notices during service procedures.

### **DANGER**

**An electrical outlet that is not correctly wired could place hazardous voltage on metal parts of the system or the devices that attach to the system. It is the responsibility of the customer to ensure that the outlet is correctly wired and grounded to prevent an electrical shock.**

**Before installing or removing signal cables, ensure that the power cables for the system unit and all attached devices are unplugged.**

**When adding or removing any additional devices to or from the system, ensure that the power cables for those devices are unplugged before the signal cables are connected. If possible, disconnect all power cables from the existing system before you add a device.**

**Use one hand, when possible, to connect or disconnect signal cables to prevent a possible shock from touching two surfaces with different electrical potentials.**

**During an electrical storm, do not connect cables for display stations, printers, telephones, or station protectors for communications lines.**

### **CAUTION:**

**This product is equipped with a three-wire power cable and plug for the user's safety. Use this power cable with a properly grounded electrical outlet to avoid electrical shock.**

### **CAUTION:**

**This unit has more than one power supply cord. To reduce the risk of electrical shock, disconnect two power supply cords before servicing.**

### **CAUTION:**

**Energy hazard, remove power before servicing. Disconnect two power supply cords.**



Find the symptom in the following table; then follow the instructions given in the Action column.

Symptom	Action
<b>Power Problems</b>	
The primary I/O drawer does not become powered on, no OK prompt.	Go to "Map 1521: Cannot Power On the Primary I/O Drawer, Operator Panel Does Not Show OK Prompt" on page 96.
The CEC drawer does not become powered on.	Go to "Map 1522: Cannot Power On the CEC Drawer" on page 103.
The secondary I/O drawer does not become powered on, no power present LED.	Go to "Map 1523: Cannot Power On the Secondary I/O Drawer, Operator Panel Power Present LED Does Not Come On" on page 110.
You have been directed here by the SPCN Error Codes table and the error code is 1011 1C0x.	Go to "Map 1524: The SPCN Error Codes Table Directed You Here and the Error Code is 1011 1C0x" on page 118.

---

## Map 1521: Cannot Power On the Primary I/O Drawer, Operator Panel Does Not Show OK Prompt

### Step 1521-1

Attempt to power on the primary I/O drawer (see “Powering Off and Powering On the System” on page 469)

**Does the primary I/O drawer power on?**

**NO** Go to “Step 1521-2”.

**YES** **This ends the procedure.** Go to “MAP 0410: Repair Checkout” in the *RS/6000 and @server pSeries Diagnostic Information for Multiple Bus Systems*.

### Step 1521-2

Look at the power supply LEDs at the front of the primary I/O drawer.

**Is the primary I/O drawer equipped with two power supplies?**

**NO** Go to “Step 1521-3”.

**YES** Go to “Step 1521-5” on page 97.

### Step 1521-3

**Is the power supply LED flashing?**

**NO** Go to “Step 1521-7” on page 97.

**YES** Go to “Step 1521-4”.

### Step 1521-4

Use the information in the “I/O Drawer and Power Supply LED Status” on page 26 to answer the following question.

**Is the power supply LED blinking quickly?**

**NO** Check the SPCN cabling.

Check internal drawer cabling from power distribution card to primary I/O backplane. See “Primary I/O Drawer Cables” on page 538.

Replace the I/O drawer power supply.

Replace the primary I/O drawer backplane.

Replace the I/O drawer power distribution card.

**This ends the procedure.** Go to “MAP 0410: Repair Checkout” in the *RS/6000 and @server pSeries Diagnostic Information for Multiple Bus Systems*.

**YES** Replace the power supply with the flashing LED.

**This ends the procedure.** Go to "MAP 0410: Repair Checkout" in the *RS/6000 and @server pSeries Diagnostic Information for Multiple Bus Systems*.

### Step 1521-5

**Is there a power supply with a flashing LED?**

**NO** Go to "Step 1521-7".

**YES** Go to "Step 1521-6".

### Step 1521-6

**Are both I/O drawer power supply LEDs flashing?**

**NO** Replace the power supply with the flashing LED.

**This ends the procedure.** Go to "MAP 0410: Repair Checkout" in the *RS/6000 and @server pSeries Diagnostic Information for Multiple Bus Systems*.

**YES** Check internal drawer cabling from power distribution card to primary I/O backplane. See "Primary I/O Drawer Cables" on page 538.

Replace the following, one at a time:

- Primary I/O drawer BACKPLANE
- Power distribution board

**This ends the procedure.** Go to "MAP 0410: Repair Checkout" in the *RS/6000 and @server pSeries Diagnostic Information for Multiple Bus Systems*.

### Step 1521-7

**Are all SPCN cables seated firmly and connected correctly between the primary I/O drawer, secondary I/O drawers, and CEC drawer?**

**NO** Fix the cable connections.

**This ends the procedure.** Go to "MAP 0410: Repair Checkout" in the *RS/6000 and @server pSeries Diagnostic Information for Multiple Bus Systems*.

**YES** Go to "Step 1521-8" on page 98.

## Step 1521-8

**Is this machine connected to dc power?**

**NO** Go to "Step 1521-12" on page 99.

**YES** Go to "Step 1521-9".

## Step 1521-9

**Are all circuit breakers reset at the rack power distribution panel?**

**NO** Reset the popped breaker by first turning off, then turning on.

**This ends the procedure.** Go to "MAP 0410: Repair Checkout" in the *RS/6000 and @server pSeries Diagnostic Information for Multiple Bus Systems*.

**YES** Go to "Step 1521-10".

## Step 1521-10

**Are all the dc power cables seated firmly and connected correctly from the rack power distribution panel to the rack drawers?**

**NO** Fix the connection.

**This ends the procedure.** Go to "MAP 0410: Repair Checkout" in the *RS/6000 and @server pSeries Diagnostic Information for Multiple Bus Systems*.

**YES** Go to "Step 1521-11".

## Step 1521-11

**Note:** Read the danger and caution notices under "Safety Notices" on page xi before continuing with this procedure.

Perform the following:

1. Disconnect the dc power cable from each power supply of the primary I/O drawer.
2. Use a multimeter to measure the dc voltage at the drawer end of each dc power cable.

**Is the dc voltage from -40 V dc to -60 V dc?**

**NO** There is no power to the drawer. Refer to the rack documentation to isolate the dc power problem. The *7014 Series Model T00 and T42 Rack Installation and Service Guide* is appropriate for most systems.

**This ends the procedure.**

**YES** Go to "Step 1521-17" on page 100.

## Step 1521-12

**Are all circuit breakers reset at the rack power distribution unit(s)?**

**NO** Reset the popped breaker.

**This ends the procedure.** Go to "MAP 0410: Repair Checkout" in the *RS/6000 and @server pSeries Diagnostic Information for Multiple Bus Systems*.

**YES** Go to "Step 1521-13".

## Step 1521-13

**Are all the ac power cables seated firmly and connected correctly from the rack power distribution unit(s) to the rack drawers?**

**NO** Fix the connection.

**This ends the procedure.** Go to "MAP 0410: Repair Checkout" in the *RS/6000 and @server pSeries Diagnostic Information for Multiple Bus Systems*.

**YES** Go to "Step 1521-14".

## Step 1521-14

Follow the ac power cable(s) from the primary I/O drawer to the appropriate power distribution unit.

**Is the power distribution unit power LED on?**

**NO** Go to "Step 1521-18" on page 101.

**YES** Go to "Step 1521-15".

## Step 1521-15

**Note:** Read the danger and caution notices under "Safety Notices" on page xi before continuing with this procedure.

Perform the following:

1. Disconnect the ac power cable(s) from the power distribution unit that supplies power to the primary I/O drawer.
2. Use a multimeter to measure the ac voltage at the power distribution unit socket(s) where the ac power cable(s), just removed, was (were) attached.

**Is the ac voltage from 200 V ac to 240 V ac?**

**NO** Replace the power distribution unit

**This ends the procedure.** Go to "MAP 0410: Repair Checkout" in the *RS/6000 and @server pSeries Diagnostic Information for Multiple Bus Systems*.

**YES** Go to "Step 1521-16" on page 100.

## Step 1521-16

Reconnect the ac power cable(s) to the power distribution unit.

**Note:** Read the danger and caution notices under “Safety Notices” on page xi before continuing with this procedure.

Perform the following:

1. Disconnect the ac power cable from each power supply of the primary I/O drawer.
2. Use a multimeter to measure the ac voltage at the drawer end of each ac power cable.

### Is the ac voltage from 200 V ac to 240 V ac?

**NO** Replace the ac power cable(s).

**This ends the procedure.** Go to “MAP 0410: Repair Checkout” in the *RS/6000 and @server pSeries Diagnostic Information for Multiple Bus Systems*.

**YES** Go to “Step 1521-17”.

## Step 1521-17

Check internal drawer cabling from power distribution card to primary I/O backplane. See “Primary I/O Drawer Cables” on page 538.

Replace the following in the primary I/O drawer, one at a time, disconnecting the ac power cable (dc power cable for a dc-powered system) to each power supply before replacement and reconnecting the ac power cable (dc power cable for a dc-powered system) to each supply after replacement:

- Primary I/O drawer operator panel
- Fan control card
- I/O drawer power supply (including redundant power supply, if present)
- Primary I/O drawer backplane

### Does the primary I/O drawer operator panel show the OK prompt?

**NO** Contact your next level of support for assistance.

**YES** **This ends the procedure.** Go to “MAP 0410: Repair Checkout” in the *RS/6000 and @server pSeries Diagnostic Information for Multiple Bus Systems*.

## Step 1521-18

**Is the ac power cable from the rack power distribution unit to the customer's ac power outlet connected and seated correctly at both ends?**

**NO** Connect the ac power cable correctly at both ends.

**This ends the procedure.** Go to "MAP 0410: Repair Checkout" in the *RS/6000 and @server pSeries Diagnostic Information for Multiple Bus Systems*.

**YES** Go to "Step 1521-19".

## Step 1521-19

**Note:** Read the danger and caution notices under "Safety Notices" on page xi before continuing with this procedure.

Perform the following:

1. Disconnect the mainline ac power cable from the power distribution unit that supplies power to the primary I/O drawer.
2. Use a multimeter to measure the ac voltage at the power distribution unit end of the mainline ac power cable.

**Is the ac voltage from 200 V ac to 240 V ac?**

**NO** Go to "Step 1521-20" on page 102.

**YES** Replace the power distribution unit.

**This ends the procedure.** Go to "MAP 0410: Repair Checkout" in the *RS/6000 and @server pSeries Diagnostic Information for Multiple Bus Systems*.

## Step 1521-20

**Note:** Read the danger and caution notices under “Safety Notices” on page xi before continuing with this procedure.

Perform the following:

1. Disconnect the mainline ac power cable from the customer’s ac power outlet.
2. Use a multimeter to measure the ac voltage at the customer’s ac power outlet.

### Is the ac voltage from 200 V ac to 240 V ac?

**NO** Inform the customer that the ac voltage at the power outlet is not correct.

**This ends the procedure.** Go to “MAP 0410: Repair Checkout” in the *RS/6000 and @server pSeries Diagnostic Information for Multiple Bus Systems*.

**YES** Replace the mainline ac power cable.

**This ends the procedure.** Go to “MAP 0410: Repair Checkout” in the *RS/6000 and @server pSeries Diagnostic Information for Multiple Bus Systems*.



---

## Map 1522: Cannot Power On the CEC Drawer

### Step 1522-1

Attempt to power on the CEC drawer (see “Powering Off and Powering On the System” on page 469).

**Does the CEC drawer power on?**

**NO** Go to “Step 1522-2”.

**YES** **This ends the procedure.** Go to “MAP 0410: Repair Checkout” in the *RS/6000 and @server pSeries Diagnostic Information for Multiple Bus Systems*.

### Step 1522-2

Look at the power supply LEDs at the back of the CEC drawer.

**Is there a power supply with a flashing LED?**

**NO** Go to “Step 1522-3”.

**YES** Replace the power supply with the flashing LED.

**This ends the procedure.** Go to “MAP 0410: Repair Checkout” in the *RS/6000 and @server pSeries Diagnostic Information for Multiple Bus Systems*.

### Step 1522-3

**Are all SPCN cables seated firmly and connected correctly between the primary I/O drawer, secondary I/O drawers and CEC drawer?**

**NO** Fix the SPCN cable connections

**This ends the procedure.** Go to “MAP 0410: Repair Checkout” in the *RS/6000 and @server pSeries Diagnostic Information for Multiple Bus Systems*.

**YES** Go to “Step 1522-4”.

### Step 1522-4

**Is this machine connected to dc power?**

**NO** Go to “Step 1522-8” on page 104.

**YES** Go to “Step 1522-5” on page 104.

## Step 1522-5

**Are all circuit breakers reset at the rack power distribution panel?**

**NO** Reset the popped breaker by first turning off, then turning on.

**This ends the procedure.** Go to "MAP 0410: Repair Checkout" in the *RS/6000 and @server pSeries Diagnostic Information for Multiple Bus Systems*.

**YES** Go to "Step 1522-6".

## Step 1522-6

**Are all the dc power cables seated firmly and connected correctly from the rack power distribution panel to the rack drawers?**

**NO** Fix the connection.

**This ends the procedure.** Go to "MAP 0410: Repair Checkout" in the *RS/6000 and @server pSeries Diagnostic Information for Multiple Bus Systems*.

**YES** Go to "Step 1522-7".

## Step 1522-7

**Note:** Read the danger and caution notices under "Safety Notices" on page xi before continuing with this procedure.

Perform the following:

1. Disconnect the dc power cable from each power supply of the CEC drawer.
2. Use a multimeter to measure the adc voltage at the drawer end of each dc power cable.

**Is the ac voltage from –40 V dc to –60 V dc?**

**NO** There is no power to the drawer. Refer to the rack documentation to isolate the dc power problem. The *7014 Series Model T00 and T42 Rack Installation and Service Guide* is appropriate for most systems.

**This ends the procedure.**

**YES** Go to "Step 1522-13" on page 106.

## Step 1522-8

**Are all circuit breakers reset at the rack power distribution unit(s)?**

**NO** Reset the popped breaker.

**This ends the procedure.** Go to "MAP 0410: Repair Checkout" in the *RS/6000 and @server pSeries Diagnostic Information for Multiple Bus Systems*.

**YES** Go to "Step 1522-9" on page 105.

## Step 1522-9

**Are all the ac power cables seated firmly and connected correctly from the rack power distribution unit(s) to the rack drawers?**

**NO** Fix the connection.

**This ends the procedure.** Go to "MAP 0410: Repair Checkout" in the *RS/6000 and @server pSeries Diagnostic Information for Multiple Bus Systems*.

**YES** Go to "Step 1522-10".

## Step 1522-10

Follow the ac power cable(s) from the CEC drawer to the appropriate power distribution unit.

**Is the power distribution unit power LED on?**

**NO** Go to "Step 1522-18" on page 108.

**YES** Go to "Step 1522-11".

## Step 1522-11

**Note:** Read the danger and caution notices under "Safety Notices" on page xi before continuing with this procedure.

Perform the following:

1. Disconnect the ac power cable(s) from the power distribution unit that supplies power to the CEC drawer.
2. Use a multimeter to measure the ac voltage at the power distribution unit socket(s) where the ac power cable(s), just removed, was (were) attached.

**Is the ac voltage from 200 V ac to 240 V ac?**

**NO** Replace the power distribution unit.

**This ends the procedure.** Go to "MAP 0410: Repair Checkout" in the *RS/6000 and @server pSeries Diagnostic Information for Multiple Bus Systems*.

**YES** Go to "Step 1522-12" on page 106.

## Step 1522-12

Reconnect the ac power cable(s) to the power distribution unit.

Perform the following:

1. Disconnect the ac power cable from each power supply of the CEC drawer.
2. Use a multimeter to measure the ac voltage at the drawer end of each ac power cable.

### Is the ac voltage from 200 V ac to 240 V ac?

**NO** Replace the ac power cable(s) unit.

**This ends the procedure.** Go to "MAP 0410: Repair Checkout" in the *RS/6000 and @server pSeries Diagnostic Information for Multiple Bus Systems*.

**YES** Go to "Step 1522-13".

## Step 1522-13

Disconnect the ac power cable (dc power cable for a dc-powered system) to each power supply of the CEC drawer and remove the following components from the CEC drawer, one at a time, in the sequence listed:

1. CEC processor card(s)
2. CEC RIO adapter card
3. CEC memory card(s)

Reconnect the ac power cables (dc power cable for a dc-powered system) to each power supply of the CEC drawer and attempt to power on the CEC.

### Does the CEC power on?

**NO** Go to "Step 1522-16" on page 107.

**YES** Go to "Step 1522-14" on page 107.

## Step 1522-14

Reinsert the following components in the CEC drawer, one at a time, disconnecting the ac power cable (dc power cable in a dc-powered system) to each power supply before reinsertion and reconnecting the ac power cable (dc power cable for a dc-powered system) to each power supply after reinsertion:

1. CEC processor card(s)
2. CEC RIO adapter card
3. CEC memory card(s)

### Does the CEC power on?

**NO** Replace the defective card just reinserted.

Reinsert any remaining cards in this step.

**This ends the procedure.** Go to "MAP 0410: Repair Checkout" in the *RS/6000 and @server pSeries Diagnostic Information for Multiple Bus Systems*.

**YES** Go to "Step 1522-15".

## Step 1522-15

### Have all cards in this step been reinserted?

**NO** Go to "Step 1522-14".

**YES** The symptom has changed. Call your next level of support for assistance.

**This ends the procedure.**

## Step 1522-16

Replace the following in the CEC drawer, one at a time, disconnecting the ac power cable (dc power cable in a dc-powered system) to each power supply before replacement and reconnecting the ac power cable (dc power cable for a dc-powered system) to each power supply after replacement:

1. CEC regulator card
2. CEC backplane

### Does the CEC power on?

**NO** Go to "Step 1522-17" on page 108.

**YES** Reinsert the cards removed in "Step 1522-13" on page 106.

**This ends the procedure.** Go to "MAP 0410: Repair Checkout" in the *RS/6000 and @server pSeries Diagnostic Information for Multiple Bus Systems*.

## Step 1522-17

**Have all cards in the previous step been replaced?**

**NO** Go to "Step 1522-16" on page 107.

**YES** Call your next level of support for assistance.

**This ends the procedure.**

## Step 1522-18

**Is the ac power cable from the rack power distribution unit to the customer's ac power outlet connected and seated correctly at both ends?**

**NO** Connect the ac power cable correctly at both ends.

**This ends the procedure.** Go to "MAP 0410: Repair Checkout" in the *RS/6000 and @server pSeries Diagnostic Information for Multiple Bus Systems*.

**YES** Go to "Step 1522-19".

## Step 1522-19

**Note:** Read the danger and caution notices under "Safety Notices" on page xi before continuing with this procedure.

Perform the following:

1. Disconnect the mainline ac power cable from the power distribution unit that supplies power to the CEC drawer.
2. Use a multimeter to measure the ac voltage at the power distribution unit end of the mainline ac power cable.

**Is the ac voltage from 200 V ac to 240 V ac?**

**NO** Go to "Step 1522-20".

**YES** Replace the power distribution unit.

**This ends the procedure.** Go to "MAP 0410: Repair Checkout" in the *RS/6000 and @server pSeries Diagnostic Information for Multiple Bus Systems*.

## Step 1522-20

**Note:** Read the danger and caution notices under "Safety Notices" on page xi before continuing with this procedure.

Perform the following:

1. Disconnect the mainline ac power cable from the customer's ac power outlet.
2. Use a multimeter to measure the ac voltage at the customer's ac power outlet.

**Is the ac voltage from 200 V ac to 240 V ac?**

- NO** Inform the customer that the ac voltage at the power outlet is not correct.  
**This ends the procedure.** Go to "MAP 0410: Repair Checkout" in the *RS/6000 and @server pSeries Diagnostic Information for Multiple Bus Systems*.
- YES** Replace the mainline ac power cable.  
**This ends the procedure.** Go to "MAP 0410: Repair Checkout" in the *RS/6000 and @server pSeries Diagnostic Information for Multiple Bus Systems*.

---

## Map 1523: Cannot Power On the Secondary I/O Drawer, Operator Panel Power Present LED Does Not Come On

### Step 1523-1

Attempt to power on the secondary I/O drawer (see "Powering Off and Powering On the System" on page 469)

**Does the secondary I/O drawer power on?**

**NO** Go to "Step 1523-2".

**YES** **This ends the procedure.** Go to "MAP 0410: Repair Checkout" in the *RS/6000 and @server pSeries Diagnostic Information for Multiple Bus Systems*.

### Step 1523-2

Look at the power supply LED(s) at the front of the secondary I/O drawer.

**Is the secondary I/O drawer equipped with two power supplies?**

**NO** Go to "Step 1523-3".

**YES** Go to "Step 1523-5" on page 111

### Step 1523-3

**Is the power supply LED flashing?**

**NO** Go to "Step 1523-7" on page 112.

**YES** Go to "Step 1523-4" on page 111.



## Step 1523-4

Use the information in the “I/O Drawer and Power Supply LED Status” on page 26 to answer the following question.

**NO** Check the SPCN cabling.

Check internal drawer cabling from power distribution card to secondary I/O backplane. See “Secondary I/O Drawer Cables” on page 540.

Replace the I/O drawer power supply.

Replace the secondary I/O drawer backplane.

Replace the I/O drawer power distribution card.

**This ends the procedure.** Go to “MAP 0410: Repair Checkout” in the *RS/6000 and @server pSeries Diagnostic Information for Multiple Bus Systems*.

**YES** Replace the power supply with the flashing LED.

**This ends the procedure.** Go to “MAP 0410: Repair Checkout” in the *RS/6000 and @server pSeries Diagnostic Information for Multiple Bus Systems*.

## Step 1523-5

**Is there a power supply with a flashing LED?**

**NO** Go to “Step 1523-7” on page 112.

**YES** Go to “Step 1523-6”.

## Step 1523-6

**Are both I/O drawer power supply LEDs flashing?**

**NO** Replace the power supply with the flashing LED.

**This ends the procedure.** Go to “MAP 0410: Repair Checkout” in the *RS/6000 and @server pSeries Diagnostic Information for Multiple Bus Systems*.

**YES** Check internal drawer cabling from power distribution card to secondary I/O backplane. See “Secondary I/O Drawer Cables” on page 540.

Replace the following, one at a time:

- Secondary I/O drawer backplane
- Power distribution board

**This ends the procedure.** Go to “MAP 0410: Repair Checkout” in the *RS/6000 and @server pSeries Diagnostic Information for Multiple Bus Systems*.

## Step 1523-7

**Are all SPCN cables seated firmly and connected correctly between the primary I/O drawer, secondary I/O drawers and CEC drawer?**

**NO** Fix the SPCN cable connections.

**This ends the procedure.** Go to "MAP 0410: Repair Checkout" in the *RS/6000 and @server pSeries Diagnostic Information for Multiple Bus Systems*.

**YES** Go to "Step 1523-8".

## Step 1523-8

**Is this machine connected to dc power?**

**NO** Go to "Step 1523-12" on page 113.

**YES** Go to "Step 1523-9".

## Step 1523-9

**Are all circuit breakers reset at the rack power distribution panel?**

**NO** Reset the popped breaker by first turning off, then turning on.

**This ends the procedure.** Go to "MAP 0410: Repair Checkout" in the *RS/6000 and @server pSeries Diagnostic Information for Multiple Bus Systems*.

**YES** Go to "Step 1523-10" on page 113.

## Step 1523-10

**Are all the dc power cables seated firmly and connected correctly from the rack power distribution panel to the rack drawers?**

**NO** Fix the connection.

**This ends the procedure.** Go to "MAP 0410: Repair Checkout" in the *RS/6000 and @server pSeries Diagnostic Information for Multiple Bus Systems*.

**YES** Go to "Step 1523-11".

## Step 1523-11

**Note:** Read the danger and caution notices under "Safety Notices" on page xi before continuing with this procedure.

Perform the following:

1. Disconnect the dc power cable from each power supply of the secondary I/O drawer.
2. Use a multimeter to measure the dc voltage at the drawer end of each dc power cable.

**Is the dc voltage from –40 V ac to –60 V ac?**

**NO** There is no power to the drawer. Refer to the rack documentation to isolate the dc power problem. The *7014 Series Model T00 and T42 Rack Installation and Service Guide* is appropriate for most systems.

**This ends the procedure.**

**YES** Go to "Step 1523-17" on page 115.

## Step 1523-12

**Are all circuit breakers reset at the rack power distribution unit(s)?**

**NO** Reset the popped breaker.

**This ends the procedure.** Go to "MAP 0410: Repair Checkout" in the *RS/6000 and @server pSeries Diagnostic Information for Multiple Bus Systems*.

**YES** Go to "Step 1523-13" on page 114.

## Step 1523-13

**Are all the ac power cables seated firmly and connected correctly from the rack power distribution unit(s) to the rack drawers?**

**NO** Fix the connection.

**This ends the procedure.** Go to "MAP 0410: Repair Checkout" in the *RS/6000 and @server pSeries Diagnostic Information for Multiple Bus Systems*.

**YES** Go to "Step 1523-14".

## Step 1523-14

Follow the ac power cable(s) from the secondary I/O drawer to the appropriate power distribution unit.

**Is the power distribution unit power LED on?**

**NO** Go to "Step 1523-18" on page 116.

**YES** Go to "Step 1523-15".

## Step 1523-15

**Note:** Read the danger and caution notices under "Safety Notices" on page xi before continuing with this procedure.

Perform the following:

1. Disconnect the ac power cable(s) from the power distribution unit that supplies power to the secondary I/O drawer.
2. Use a multimeter to measure the ac voltage at the power distribution unit socket(s) where the ac power cable(s), just removed, was (were) attached.

**Is the ac voltage from 200 V ac to 240 V ac?**

**NO** Replace the power distribution unit. Reconnect the ac power cable(s) to the power distribution unit.

**This ends the procedure.** Go to "MAP 0410: Repair Checkout" in the *RS/6000 and @server pSeries Diagnostic Information for Multiple Bus Systems*.

**YES** Go to "Step 1523-16" on page 115.

## Step 1523-16

Reconnect the ac power cable(s) to the power distribution unit.

**Note:** Read the danger and caution notices under “Safety Notices” on page xi before continuing with this procedure.

Perform the following:

1. Disconnect the ac power cable from each power supply of secondary I/O drawer.
2. Use a multimeter to measure the ac voltage at the drawer end of each ac power cable.

### Is the ac voltage from 200 V ac to 240 V ac?

**NO** Replace the ac power cable(s).

**This ends the procedure.** Go to “MAP 0410: Repair Checkout” in the *RS/6000 and @server pSeries Diagnostic Information for Multiple Bus Systems*.

**YES** Go to “Step 1523-17”.

## Step 1523-17

Check internal drawer cabling from power distribution card to secondary I/O backplane. See “Secondary I/O Drawer Cables” on page 540.

Replace the following in the secondary I/O drawer, one at a time, disconnecting the ac power cable (dc power cable for a dc-powered system) to each power supply before replacement and reconnecting the ac power cable (dc power cable for a dc-powered system) to each supply after replacement:

- Secondary I/O drawer operator panel
- Fan control card
- Power distribution card
- I/O drawer power supply (including redundant power supply, if present)
- Secondary I/O drawer backplane

### Does the secondary I/O drawer operator panel turn on the power present LED?

**NO** Contact your next level of support for assistance.

**YES** **This ends the procedure.** Go to “MAP 0410: Repair Checkout” in the *RS/6000 and @server pSeries Diagnostic Information for Multiple Bus Systems*.

## Step 1523-18

**Is the ac power cable from the rack power distribution unit to the customer's ac power outlet connected and seated correctly at both ends?**

**NO** Connect the ac power cable correctly at both ends.

**This ends the procedure.** Go to "MAP 0410: Repair Checkout" in the *RS/6000 and @server pSeries Diagnostic Information for Multiple Bus Systems*.

**YES** Go to "Step 1523-19".

## Step 1523-19

**Note:** Read the danger and caution notices under "Safety Notices" on page xi before continuing with this procedure.

Perform the following:

1. Disconnect the mainline ac power cable from the power distribution unit that supplies power to the secondary I/O drawer.
2. Use a multimeter to measure the ac voltage at the power distribution unit end of the mainline ac power cable.

**Is the ac voltage from 200 V ac to 240 V ac?**

**NO** Go to "Step 1523-20" on page 117.

**YES** Replace the power distribution unit.

**This ends the procedure.** Go to "MAP 0410: Repair Checkout" in the *RS/6000 and @server pSeries Diagnostic Information for Multiple Bus Systems*.

## Step 1523-20

**Note:** Read the danger and caution notices under “Safety Notices” on page xi before continuing with this procedure.

Perform the following:

1. Disconnect the mainline ac power cable from the customer's ac power outlet.
2. Use a multimeter to measure the ac voltage at the customer's ac power outlet.

### Is the ac voltage from 200 V ac to 240 V ac?

**NO** Inform the customer that the ac voltage at the power outlet is not correct.

**This ends the procedure.** Go to “MAP 0410: Repair Checkout” in the *RS/6000 and @server pSeries Diagnostic Information for Multiple Bus Systems*.

**YES** Replace the mainline ac power cable.

**This ends the procedure.** Go to “MAP 0410: Repair Checkout” in the *RS/6000 and @server pSeries Diagnostic Information for Multiple Bus Systems*.

---

## Map 1524: The SPCN Error Codes Table Directed You Here and the Error Code is 1011 1C0x

A CEC power supply is reporting a load fault.

**Note:** Read the danger and caution notices under “Safety Notices” on page xi before continuing with this procedure.

Perform the following steps to isolate the problem.

### Step 1524-1

1. Turn off the power.
2. Disconnect the ac power cables (dc power cables in a dc-powered system) from the CEC drawer.
3. At the top of the CEC drawer, remove the following cards, in the sequence listed:
  - a. CEC regulator at M01
  - b. CEC memory riser 1 at M02
  - c. CEC processor at M03
  - d. CEC processor at M04 (if present)
  - e. CEC memory riser 2 at M05 (if present)
  - f. CEC RIO adapter at M06
4. Reconnect the ac power cables (dc power cables in a dc-powered system) to the CEC drawer.
5. Turn on the power.

#### Is the error code 1011 1C0x displayed?

**NO** Go to “Step 1524-7” on page 121.

**YES** Go to “Step 1524-2”.

### Step 1524-2

1. Turn off the power.
2. Disconnect the ac power cables (dc power cables in a dc-powered system) from the CEC drawer.
3. Remove CEC power supply 2.
4. Reconnect the ac power cable (dc power cable in a dc-powered system) to the CEC power supply 1.
5. Turn on the power.

#### Is the error code 1011 1C0x displayed?

**NO** Go to “Step 1524-3” on page 119.

**YES** Go to “Step 1524-4” on page 119



### Step 1524-3

1. Turn off the power.
2. Reinstall CEC power supply 2 that was removed in “Step 1524-2” on page 118.
3. Reconnect the ac power cable (dc power cable in a dc-powered system) to the CEC power supply 2.
4. Turn on the power.

#### Is the error code 1011 1C0x displayed?

**NO** The symptom has changed.

**This ends the procedure.**

**YES** Replace CEC power supply 2, location: U1.1-V2.

**This ends the procedure.** Go to “MAP 0410: Repair Checkout” in the *RS/6000 and @server pSeries Diagnostic Information for Multiple Bus Systems*.

### Step 1524-4

1. Turn off the power.
2. Reinstall CEC power supply 2 that was removed in “Step 1524-2” on page 118.
3. Reconnect the ac power cable (dc power cable in a dc-powered system) to the CEC power supply 2.
4. Disconnect the ac cable (dc power cable in a dc-powered system) to CEC power supply 1.
5. Remove CEC power supply 1.
6. Turn on the power.

#### Is the error code 1011 1C0x displayed?

**NO** Replace CEC power supply 1, location: U1.1-V1.

**This ends the procedure.** Go to “MAP 0410: Repair Checkout” in the *RS/6000 and @server pSeries Diagnostic Information for Multiple Bus Systems*.

**YES** Go to “Step 1524-5” on page 120.

## Step 1524-5

1. Turn off the power.
2. Reinstall CEC power supply 2 that was removed in “Step 1524-4” on page 119.
3. Reconnect the ac power cable (dc power cable in a dc-powered system) to the CEC power supply 2.
4. Remove CEC fan 1. Disregard a CEC fan error code if it occurs during this step.
5. Turn on the power.

### Is the error code 1011 1C0x displayed?

**NO** Replace CEC fan 1, location: U1.1-F1. **This ends the procedure.** Go to “MAP 0410: Repair Checkout” in the *RS/6000 and @server pSeries Diagnostic Information for Multiple Bus Systems*.

**YES** Go to “Step 1524-6”.

## Step 1524-6

1. Turn off the power.
2. Reinstall CEC fan 1 that was removed in “Step 1524-5”.
3. Remove CEC fan 2. Disregard a CEC fan error code if it occurs during this step.
4. Turn on the power.

### Is the error code 1011 1C0x displayed?

**NO** Replace CEC fan 2, location: U1.1-F2. **This ends the procedure.** Go to “MAP 0410: Repair Checkout” in the *RS/6000 and @server pSeries Diagnostic Information for Multiple Bus Systems*.

**YES** Replace the CEC backplane, location: U1.1-P1. **This ends the procedure.** Go to “MAP 0410: Repair Checkout” in the *RS/6000 and @server pSeries Diagnostic Information for Multiple Bus Systems*.

## Step 1524-7

1. Turn off the power.
2. Disconnect the ac power cables (dc power cables in a dc-powered system) from the CEC drawer.
3. Reinstall one of the cards that was removed in “Step 1524-1” on page 118, in the sequence listed:
  - a. CEC regulator at M01
  - b. CEC RIO adapter at M06
  - c. CEC memory riser 1 at M02
  - d. CEC memory riser 2 at M05 (if present)
  - e. CEC processor at M03
  - f. CEC processor at M04 (if present)
4. Reconnect the ac power cables (dc power cables in a dc-powered system) to the CEC drawer.
5. Turn on the power.

### Is the error code 1011 1C0x displayed?

**NO** Go to “Step 1524-8”.

**YES** The last card you installed is defective. Replace the last card you installed. **This ends the procedure.** Go to “MAP 0410: Repair Checkout” in the *RS/6000 and @server pSeries Diagnostic Information for Multiple Bus Systems*.

## Step 1524-8

### Have all the cards that were removed in “Step 1524-7” been reinstalled?

**NO** Go to “Step 1524-7” and reinstall the next card in the list.

**YES** Replace the CEC backplane, location: U1.1-P1.

**This ends the procedure.** Go to “MAP 0410: Repair Checkout” in the *RS/6000 and @server pSeries Diagnostic Information for Multiple Bus Systems*.

---

## MAP 1540: Minimum Configuration

This MAP is used to locate defective FRUs not found by normal diagnostics. For this procedure, diagnostics are run on a minimally-configured system. If a failure is detected on the minimally-configured system, the remaining FRUs are exchanged one at a time until the failing FRU is identified. If a failure is not detected, FRUs are added back until the failure occurs. The failure is then isolated to the failing FRU.

### Notes:

1. Be sure to unplug the power cable from the rack that contains the CEC drawer, the primary I/O drawer, and any secondary I/O drawer before removing or installing CPU card(s), memory cards, CEC backplane, or I/O drawer backplane to avoid damage.
2. This MAP assumes that a CD-ROM drive is installed and connected to the internal SCSI adapter of the primary I/O drawer, and a diagnostic CD-ROM is available.
3. If a general-access password or privileged-access password is installed, you are prompted to enter the password before the diagnostic CD-ROM can load.
4. *POST indicators* refers to the device mnemonics (words memory, keyboard, network, scsi, and speaker) that appear on the system console during the power-on self-test (POST).
5. The service processor may have recorded one or more symptoms in its error log. It is a good idea to examine that error log before proceeding (see service processor System Information Menu).
6. The service processor may have been set by the user to monitor server operations and to attempt recoveries. You can disable these actions while you diagnose and service the system. If you disable them, make notes of their current settings so that you can restore them easily. The following table lists the settings:

Surveillance	From the service processor Setup Menu, go to the Surveillance Setup Menu and disable surveillance.
Unattended Start	From the service processor System Power Control Menu, disable unattended start mode.
Reboot Policy	From the System Power Control Menu, go to the Reboot/Restart Policy Setup Menu and set: a. Number of reboot attempts to <b>0</b> (zero) b. Use OS-Defined restart policy to <b>No</b> c. Enable supplemental restart policy to <b>No</b> .
Call Out	From the Call-In/Call-Out Setup Menu, go to the Serial Port Selection Menu and disable call-out on both serial ports.

## Step 1540-1

1. Ensure that the diagnostics and the operating system are shut down.
2. Turn off the power.
3. Select slow boot mode (select disable fast boot) on the System Power Control menu from the service processor main menu.
4. Turn on the power to boot standalone diagnostics from CD.
5. Insert the diagnostic CD-ROM into the CD-ROM drive.

### Does the CD-ROM appear to operate correctly?

**NO** Go to “Boot Problems and Concerns” on page 167.

**YES** Go to “Step 1540-2”.

## Step 1540-2

1. When the keyboard indicator is displayed (the word keyboard), press the 5 key on the system console.
2. Enter the appropriate password when you are prompted to do so.

### Is the Please define the System Console screen displayed?

**NO** Go to “Step 1540-3”.

**YES** Go to “Step 1540-12” on page 129.

## Step 1540-3

The system is unable to boot standalone diagnostics.

Check the service processor error log and the primary I/O drawer operator panel for additional error codes resulting from the slow boot in “Step 1540-1”.

### Did the slow boot generate a different error code from the one that originally sent you to MAP 1540?

**YES** Restore fast boot mode (select enable fast boot) on the System Power Control menu from the service processor main menu. Go to “Checkpoint and Error Code Index” on page 173 and follow the actions for the new error code.

**NO** Continue “Step 1540-3” below.

The boot attempts that follow will attempt to get the Please define the System Console prompt on the system console. Ignore any codes that may appear on the operator panel unless stated otherwise.

**Error Codes:**

Use the following table to locate, if possible, the error code that sent you to minimum configuration.

<b>First Four Characters of the Error Code</b>	<b>Last Four Characters of the Error Code</b>
406x	0009 00A1 00A3 00A6 00A7
450x 460x 4B2x	245B 245C 245D 24A5 24A6 25B3 25B4 267D 2733 27AA 27AB 288A
B006	1406 1407 1408
B1xx	4601 4602 4648 4660 4690 4691 469E 469F

### Four-Character Checkpoint:

Use the following table to locate, if possible, the checkpoint that sent you to minimum configuration.

91FF	94B1	9503
9380	94B2	9504
94BB	9501	9505
94B0	9502	9506

**Did you find the error code or checkpoint that sent you here in the previous tables or did the action that sent you to MAP 1540 explicitly tell you to run the CEC drawer minimum configuration?**

**NO** Go to "Step 1540-13" on page 130.

**YES** Go to "Step 1540-4".

### Step 1540-4

1. Turn off the power.
2. At the CEC drawer, disconnect the RIO cable at RIO port 0.
3. At the primary I/O drawer, disconnect the RIO cable at RIO port 0. The RIO cable should now be loose and can be removed.
4. At the CEC drawer, disconnect the RIO cable at RIO port 1 and reconnect it to RIO port 0.
5. Follow the RIO cable you have connected to RIO port 0 of the CEC drawer back to an I/O drawer, disconnect the I/O drawer end (RIO port 1, note location) of the RIO cable and reconnect it to the primary I/O drawer RIO port 0.
6. With only one RIO cable connected between the CEC drawer RIO port 0 and the primary I/O drawer RIO port 0, power the system on to boot standalone diagnostics from CD.

**Is the Please define the System Console screen displayed?**

**YES** The RIO cable you removed in substep 3 above is defective. Replace the RIO cable. Connect from CEC drawer RIO port 1 to the I/O drawer RIO port 1 noted in substep 5 above. The last item replaced was defective. Return the machine to the original configuration. Go to "MAP 0410: Repair Checkout" in the *RS/6000 and @server pSeries Diagnostic Information for Multiple Bus Systems*.

**NO** Reconnect the RIO cable that was removed in substep 3 above. Connect from CEC drawer RIO port 1 to the I/O drawer RIO port 1 noted in substep 5 above. Go to "Step 1540-5" on page 126.

## Step 1540-5

1. Turn off the power.
2. Disconnect the ac power cables (dc power cables in a dc-powered system) from the CEC drawer.
3. At the top of the CEC drawer, remove the following cards and DIMMs, in the sequence listed:
  - a. Memory DIMMs in octals B, C, and D on memory riser card 1 at M02, if present. This leaves only octal A and memory riser card 1 installed.
  - b. Memory riser card 2 at M05, if present.
4. With the CEC drawer now configured with only minimum required memory, connect the ac power cables (dc power cables in a dc-powered system) to the CEC drawer and turn on the power to boot standalone diagnostics from CD.
5. When the keyboard indicator is displayed (the word keyboard), press the 5 key on the system console.
6. Enter the appropriate password when you are prompted to do so.

### **Is the Please define the System Console screen displayed?**

**NO** Go to "Step 1540-8" on page 127.

**YES** Go to "Step 1540-6".

## Step 1540-6

1. Turn off the power.
2. Disconnect the ac power cables (dc power cables in a dc-powered system) from the CEC drawer.
3. Reinsert the following cards and DIMMs, in the sequence listed:
  - a. Memory DIMMs in octals B, C, and D on memory riser card 1 at M02, if previously present.
  - b. Memory riser card 2 at M05, if previously present.
4. Reconnect the ac power cables (dc power cables in a dc-powered system) to the CEC drawer.
5. Turn on the power to boot standalone diagnostics from CD.
6. When the keyboard indicator is displayed (the word Keyboard), press the 5 key on the system console.
7. Enter the appropriate password when you are prompted to do so.

### **Is the Please define the System Console screen displayed?**

**NO** The card you just reinserted is defective; replace with a new card. Return the machine to the original configuration. Go to "MAP 0410: Repair Checkout" in the *RS/6000 and @server pSeries Diagnostic Information for Multiple Bus Systems*.

**YES** Go to "Step 1540-7" on page 127.



## Step 1540-7

**Have all the cards in the list in “Step 1540-6” on page 126 been replaced with new or original cards?**

**NO** Go to “Step 1540-6” on page 126.

**YES** Go to “Step 1540-12” on page 129 to verify the I/O portion of the system.

## Step 1540-8

1. Turn off the power.
2. Disconnect the ac power cables (dc power cables in a dc-powered system) from the CEC drawer.
3. Replace the memory DIMMs in octal A on memory riser card 1 with memory DIMMs previously removed, if any, or replace with new memory DIMMs.
4. Connect the ac power cables (dc power cables in a dc-powered system) to the CEC drawer and turn on the power to boot standalone diagnostics from CD.

**Is the Please define the System Console screen displayed?**

**NO** Go to “Step 1540-9”.

**YES** The memory DIMMs you removed are failing; leave the new memory DIMMs installed. Return the machine to the original configuration. Go to “MAP 0410: Repair Checkout” in the *RS/6000 and @server pSeries Diagnostic Information for Multiple Bus Systems*.

## Step 1540-9

1. Turn off the power.
2. Disconnect the ac power cables (dc power cables in a dc-powered system) from the CEC drawer.
3. Replace the memory riser card at M02 with a new memory riser card.
4. Connect the ac power cables (dc power cables in a dc-powered system) to the CEC drawer and turn on the power to boot standalone diagnostics from CD.

**Is the Please define the System Console screen displayed?**

**NO** Go to “Step 1540-10” on page 128.

**YES** The memory riser card you removed is failing; leave the new memory riser card installed. Return the machine to the original configuration. Go to “MAP 0410: Repair Checkout” in the *RS/6000 and @server pSeries Diagnostic Information for Multiple Bus Systems*.

## Step 1540-10

1. Turn off the power.
2. Disconnect the ac power cables (dc power cables in a dc-powered system) from the CEC drawer.
3. Reinsert the original memory riser card at M02.
4. Replace the CEC RIO bus adapter at M06 with a new CEC RIO bus adapter.
5. Connect the ac power cables (dc power cables in a dc-powered system) to the CEC drawer and turn on the power to boot standalone diagnostics from CD.

### Is the Please define the System Console screen displayed?

**NO** Go to "Step 1540-11".

**YES** The clock I/O card you removed is failing; leave the new clock I/O card installed. Return the machine to the original configuration. Go to "MAP 0410: Repair Checkout" in the *RS/6000 and @server pSeries Diagnostic Information for Multiple Bus Systems*.

## Step 1540-11

**Attention:** Contact your second level of support before performing this action.

1. Turn off the power.
2. Disconnect the ac power cables (dc power cables in a dc-powered system) from the CEC drawer.
3. Replace the CEC backplane, processor at M03, and processor at M04 (if installed) with new components.
4. Reinsert the original CEC RIO bus adapter at M06.
5. Connect the ac power cables (dc power cables in a dc-powered system) to the CEC drawer and turn on the power to boot standalone diagnostics from CD.

### Is the Please define the System Console screen displayed?

**NO** Go to "Step 1540-13" on page 130.

**YES** The CEC components you removed are failing. Leave the new CEC components installed. Go to "MAP 0410: Repair Checkout" in the *RS/6000 and @server pSeries Diagnostic Information for Multiple Bus Systems*.

## Step 1540-12

The system stopped with the Please define the System Console prompt appearing on the system console.

Standalone diagnostics can be booted. Perform the following:

1. Follow the instructions on the screen to select the system console.
2. When the DIAGNOSTIC OPERATING INSTRUCTIONS screen is displayed, press Enter.
3. If the terminal type has not been defined, you must use the Initialize Terminal option of the FUNCTION SELECTION menu to initialize the AIX operating system environment before you can continue with the diagnostics. This is a separate operation from selecting the firmware console display.
4. Select **Advanced Diagnostic Routines**.
5. When the DIAGNOSTIC MODE SELECTION menu displays, select **System Verification** and run diagnostics on all resources.

### **Did running diagnostics produce a different symptom?**

**NO** Go to substep 6 of "Step 1540-9" on page 127.

**YES** Go to "Entry MAP" on page 81. Use the new symptom.

6. Record any devices missing from the list of all adapters and devices. Continue with this MAP. When you have fixed the problem, use this record to verify that all devices appear when you run System Verification.

### **Are there any devices missing from the list of all adapters and devices?**

**NO** Reinstall all remaining adapters, if any, and reconnect all devices. Return the system to its original configuration. Be sure to select fast boot mode (select enable fast boot) on the System Power Control menu from the service processor main menu. Go to "MAP 0410: Repair Checkout" in the *RS/6000 and @server pSeries Diagnostic Information for Multiple Bus Systems*.

**YES** The boot attempts that follow will attempt to isolate any remaining I/O drawer problems with missing devices. Ignore any codes that may appear on the operator panel unless stated otherwise.

Go to "Step 1540-13" on page 130.

## Step 1540-13

You were directed here because the defect seems to be related to the I/O system.

Select fast boot mode (select enable fast boot) on the System Power Control menu from the service processor main menu.

Look at the rear of the CEC drawer and locate the JTAG cable (connected to the rear of the CEC drawer connector position shown in Chapter 1).

Follow the JTAG cable back to the primary I/O drawer. Examine SPCN cable connections at J15 and J16. These cables, if any, go to secondary I/O drawers.

### Are any secondary I/O drawers attached to the system?

**NO** Did you perform "Step 1540-4" on page 125?

**NO** Go to "Step 1540-40" on page 145.

**YES** Go to "Step 1540-17" on page 133.

**YES** Did you perform "Step 1540-4" on page 125?

**NO** Go to "Step 1540-14" on page 131.

**YES** Go to "Step 1540-15" on page 132.

## Step 1540-14

There is at least one secondary I/O drawer attached to the CEC drawer. Perform the following steps to isolate a faulty RIO cable.

**Note:** Before continuing, check the cabling from the CEC drawer to I/O drawer(s) to ensure that the system is cabled correctly. Refer to “Cabling the CEC Drawer, Primary I/O Drawer, and Secondary I/O Drawer(s)” on page 53 for valid configurations. Record the current cabling configuration and then continue with the following steps.

1. Turn off the power.
2. At the CEC drawer, disconnect the cable connection at RIO port 0.
3. At the primary I/O drawer, disconnect the cable connection at RIO port 0. The RIO cable that was connected to RIO port 0 should now be loose and can be removed.
4. At the CEC drawer, disconnect the cable connection at RIO port 1 and reconnect it to RIO port 0.
5. Follow the RIO cable you have connected to RIO port 0 of the CEC drawer back to a secondary I/O drawer; disconnect the I/O drawer end (RIO port 1, note location) of the RIO cable and reconnect it to the primary I/O drawer RIO port 0.
6. Verify that primary I/O drawer RIO port 0 is connected to the CEC drawer RIO port 0.
7. Turn on the power to boot standalone diagnostics from CD.
8. If the Please define the System Console screen is displayed, follow directions to select the system console.
9. Use the Display Configuration and Resource List to list all attached devices and adapters (refer to the *RS/6000 and @server pSeries Diagnostic Information for Multiple Bus Systems* if necessary).
10. Check that all attached devices and adapters are listed.

**Did the Please define the System Console screen display and are all attached devices and adapters listed?**

**NO** Go to “Step 1540-15” on page 132.

**YES** The RIO cable that was removed in step 3 above is defective. Replace the RIO cable. Connect the new RIO cable from CEC drawer RIO port 1 to the secondary I/O drawer RIO port 1 noted in step 5 above. Reconfigure the system to its original condition. Go to “MAP 0410: Repair Checkout” in the *RS/6000 and @server pSeries Diagnostic Information for Multiple Bus Systems*.

## Step 1540-15

To isolate the primary I/O drawer perform the following steps.

1. Turn off the power.
2. Select fast boot mode (select enable fast boot) on the System Power Control menu from the service processor main menu.
3. Verify that primary I/O drawer RIO port 0 is connected to CEC drawer RIO port 0.
4. At the primary I/O drawer, remove the cable connected to RIO port 1.
5. Verify that the primary I/O drawer V/S COMM port is connected to CEC drawer V/S COMM port.
6. Verify that the primary I/O drawer JTAG port is connected to the CEC drawer JTAG port.

**Note:** The primary I/O drawer should be cabled as shown in “Cabling the CEC Drawer, Primary I/O Drawer, and Secondary I/O Drawer(s)” on page 53. Be sure to look at both RIO cables and SPCN cables.

7. Disconnect ac power cables (dc power cables in a dc-powered system) from remaining I/O drawer(s).

**Attention:** *For ac-powered systems*, the rack that you are working on may have I/O drawers that are connected to other CEC drawers or other third-party drawers attached to the power distribution unit. To avoid removing power from drawers that are used by other systems, when you are instructed to unplug power from an I/O drawer, remove only the power distribution unit (PDU) side of the single ac cables connected to the I/O drawer in question.

8. All I/O drawers except the primary I/O drawer should now be physically disconnected from the CEC drawer.

Go to “Step 1540-16”.

## Step 1540-16

The primary I/O drawer is the only remaining I/O drawer connected to the CEC drawer.

1. Turn on the power to boot standalone diagnostics from CD.
2. If the Please define the System Console screen is displayed, follow directions to select the system console.
3. Use the Display Configuration and Resource List to list all attached devices and adapters (refer to the *RS/6000 and @server pSeries Diagnostic Information for Multiple Bus Systems* if necessary).
4. Check that all attached devices and adapters are listed.

If the Please define the System Console prompt did not display or all attached devices and adapters are not listed, the problem is in the primary I/O drawer.

**Did the Please define the System Console screen display and are all attached devices and adapters listed?**

**NO** Go to “Step 1540-17” on page 133.

**YES** Go to “Step 1540-27” on page 139.

## Step 1540-17

To deconfigure the primary I/O drawer perform the following steps.

1. Turn off the power.
2. If you have not already done so, reset the service processor settings with the instructions in step 6 on page 122, then return here and continue.
3. Exit the service processor menus and remove the ac power cables (dc power cables in a dc-powered system) from the CEC drawer and the primary I/O drawer.  
**Attention:** *For ac-powered systems*, the rack that you are working on may have I/O drawers that are connected to other CEC drawers or other third-party drawers attached to the power distribution unit. To avoid removing power from drawers that are used by other systems, when you are instructed to unplug power from an I/O drawer, remove only the power distribution unit (PDU) side of the single ac cables connected to the I/O drawer in question.
4. If a display adapter with keyboard and mouse connected to the primary I/O drawer is being used as the console, locate a stand-alone serial terminal (possibly a 3151) and connect it to the S1 serial port.
5. Remove the keyboard and mouse if attached to the primary I/O drawer.
6. Remove (unplug) the tape drive (if installed) and the two internal hard drives (if installed) from the internal SCSI bus cable. Leave the CD-ROM attached.
7. Leave the remaining external cables (RIO-port 0, V/S COMM, RIO-port 1, and JTAG) connected.
8. Disconnect the diskette drive cable from the diskette drive connector on the primary I/O drawer backplane.
9. Plug in the ac power cables (dc power cables in a dc-powered system) for the CEC drawer and the primary I/O drawer. The primary I/O drawer operator panel should momentarily display an OK prompt.

### Are there any adapters in slots 1, 2, 3, or 4?

**NO** Go to "Step 1540-18" on page 134.

**YES** Go to "Step 1540-20" on page 134.

## Step 1540-18

**Are there any adapters in slots 5, 6, 7, 8, or 9?**

**NO** Go to "Step 1540-19".

**YES** Go to "Step 1540-21" on page 135.

## Step 1540-19

**Are there any adapters in slots 10, 11, 12, 13 or 14?**

**NO** Go to "Step 1540-25" on page 138.

**YES** Go to "Step 1540-22" on page 135.

## Step 1540-20

1. If it is not already off, turn off the power.
2. Remove all adapters from slots 1, 2, 3, and 4 that are not attached to the boot device.
3. Label and record the location of any cables attached to the adapters.
4. Record the slot number of the adapters.
5. Turn on the power to boot standalone diagnostics from CD.
6. If the TTY screen displays Enter 0 to select this console, press the 0 key on the TTY terminal's keyboard.
7. If the Please define the System Console screen is displayed, follow directions to select the system console.
8. Use the Display Configuration and Resource List to list all attached devices and adapters (refer to the *RS/6000 and @server pSeries Diagnostic Information for Multiple Bus Systems* if necessary).
9. Check that all attached devices and adapters are listed.

**Did the Please define the System Console screen display and are all attached devices and adapters listed?**

**NO** Go to "Step 1540-18".

**YES** Go to "Step 1540-23" on page 136.



## Step 1540-21

1. If it is not already off, turn off the power.
2. Remove all adapters from slots 5, 6, 7, 8 and 9 that are not attached to the boot device.
3. Label and record the location of any cables attached to the adapters.
4. Record the slot number of the adapters.
5. Turn on the power to boot standalone diagnostics from CD.
6. If the TTY screen displays Enter 0 to select this console, press the 0 key on the TTY terminal's keyboard.
7. If the Please define the System Console screen is displayed, follow directions to select the system console.
8. Use the Display Configuration and Resource List to list all attached devices and adapters (refer to the *RS/6000 and @server pSeries Diagnostic Information for Multiple Bus Systems* if necessary).
9. Check that all attached devices and adapters are listed.

### **Did the Please define the System Console screen display and are all attached devices and adapters listed?**

**NO** Go to "Step 1540-19" on page 134.

**YES** Go to "Step 1540-23" on page 136.

## Step 1540-22

1. If it is not already off, turn off the power.
2. Remove all adapters from slots 10, 11, 12, 13, and 14 that are not attached to the boot device.
3. Label and record the location of any cables attached to the adapters.
4. Record the slot number of the adapters.
5. Turn on the power to boot standalone diagnostics from CD.
6. If the TTY screen displays Enter 0 to select this console, press the 0 key on the TTY terminal's keyboard.
7. If the Please define the System Console screen is displayed, follow directions to select the system console.
8. Use the Display Configuration and Resource List to list all attached devices and adapters (refer to the *RS/6000 and @server pSeries Diagnostic Information for Multiple Bus Systems* if necessary).
9. Check that all attached devices and adapters are listed.

### **Did the Please define the System Console screen display and are all attached devices and adapters listed?**

**NO** Go to "Step 1540-25" on page 138.

**YES** Go to "Step 1540-23" on page 136.

## Step 1540-23

If the Please define the System Console screen does display and all attached devices and adapters are listed, the problem is with one of the adapter cards or devices that was removed or disconnected from the primary I/O drawer.

1. Turn off the power.
2. Reinstall one adapter or device that was removed. Use the original adapter cards in their original slots when reinstalling adapters.
3. Turn on the power to boot standalone diagnostics from CD.
4. If the Please define the System Console screen is displayed, follow directions to select the system console.
5. Use the Display Configuration and Resource List to list all attached devices and adapters (refer to the *RS/6000 and @server pSeries Diagnostic Information for Multiple Bus Systems* if necessary).
6. Check that all attached devices and adapters are listed.

### **Did the Please define the System Console screen display and are all attached devices and adapters listed?**

**NO** Go to "Step 1540-24" on page 137.

**YES** Reinstall the next adapter or device and return to the beginning of this step. Continue repeating this process until an adapter or device causes the Please define the System Console screen to not display or all attached devices and adapters to not be listed.

After installing all of the adapters and the Please define the System Console screen does display and all attached devices and adapters are listed, return the system to its original configuration. Go to "MAP 0410: Repair Checkout" in the *RS/6000 and @server pSeries Diagnostic Information for Multiple Bus Systems*.

## Step 1540-24

Replace the adapter you just installed with a new adapter and retry the boot to standalone diagnostics from CD.

1. If the Please define the System Console screen is displayed, follow directions to select the system console.
2. Use the Display Configuration and Resource List to list all attached devices and adapters (refer to the *RS/6000 and @server pSeries Diagnostic Information for Multiple Bus Systems* if necessary).
3. Check that all attached devices and adapters are listed.

### **Did the Please define the System Console screen display and are all attached devices and adapters listed?**

**NO** The I/O drawer backplane is defective. Replace the I/O drawer backplane; then continue below.

**YES** The adapter was defective. Continue below.

Go to "Step 1540-26" on page 139.

## Step 1540-25

1. Turn off the power.
2. Disconnect the I/O drawer ac power cables (dc power cables in a dc-powered system).
3. Replace the following parts, one at a time, in the sequence listed:
  - a. Boot device SCSI cable
  - b. Boot device
  - c. I/O drawer backplane
  - d. I/O drawer RIO adapter
  - e. I/O drawer operator panel
  - f. SPCN fan control card
  - g. Both power supplies
  - h. Power distribution card
4. Reconnect the I/O drawer ac power cables (dc power cables in a dc-powered system).
5. Turn on the power.
6. Boot standalone diagnostics from CD.
7. If the Please define the System Console screen is displayed, follow directions to select the system console.
8. Use the Display Configuration and Resource List to list all attached devices and adapters (refer to the *RS/6000 and @server pSeries Diagnostic Information for Multiple Bus Systems* if necessary).
9. Check that all attached devices and adapters are listed.

### **Did the Please define the System Console screen display and are all attached devices and adapters listed?**

**NO** Replace the next part in the list and return to the beginning of this step. Continue repeating this process until a part causes the Please define the System Console screen to be displayed and all attached devices and adapters to be listed.

If you have replaced all the items listed above and the Please define the System Console screen does not display or all attached devices and adapters are not listed, check any external devices and cabling. If you do not find a problem, contact your next level of support for assistance.

**YES** Go to "Step 1540-26" on page 139.

## Step 1540-26

1. Turn off the power.
2. The item just replaced fixed the problem.
3. If a display adapter with keyboard and mouse were used, reinstall the display adapter card, keyboard, and mouse.
4. Reconnect the diskette drive cable to the primary I/O drawer backplane.
5. Reconnect the tape drive (if previously installed) and the two internal hard drives (if previously installed) to the internal SCSI bus cable.
6. Plug in all adapters that were previously removed but not reinstalled.
7. Reconnect the primary I/O drawer ac power cables (dc power cables in a dc-powered system) that were previously disconnected.

Reconfigure the system to its original condition. Go to "MAP 0410: Repair Checkout" in the *RS/6000 and @server pSeries Diagnostic Information for Multiple Bus Systems*.

## Step 1540-27

If the Please define the System Console screen does display and all attached devices and adapters are listed, the problem is with a remaining secondary I/O drawer. Turn off the power.

### Is the primary I/O drawer the only drawer connected at this time?

**NO** Go to "Step 1540-28" on page 140.

**YES** Reconnect a secondary I/O drawer in the configuration that you recorded earlier in this MAP.

**Note:** The I/O drawers should be cabled as shown in "Cabling the CEC Drawer, Primary I/O Drawer, and Secondary I/O Drawer(s)" on page 53. Be sure to look at both RIO cables and SPCN cables.

1. Connect ac power (dc power in a dc-powered system) to this secondary I/O drawer.
2. All I/O drawers except the primary I/O drawer and one secondary I/O drawer should now be physically disconnected from the CEC drawer.

Go to "Step 1540-29" on page 140.

## Step 1540-28

The last I/O drawer connected was a secondary I/O drawer. If the power is on, turn off the power. Reconnect the next I/O drawer in the configuration you recorded earlier in this MAP.

**Note:** The I/O drawers should be cabled as shown in “Cabling the CEC Drawer, Primary I/O Drawer, and Secondary I/O Drawer(s)” on page 53. Be sure to look at both RIO cables and SPCN cables.

Go to “Step 1540-29”

## Step 1540-29

1. Turn on the power to boot standalone diagnostics from CD.
2. If the Please define the System Console screen is displayed, follow directions to select the system console.
3. Use the Display Configuration and Resource List to list all attached devices and adapters (refer to the *RS/6000 and @server pSeries Diagnostic Information for Multiple Bus Systems* if necessary).
4. Check that all attached devices and adapters are listed.

**Did the Please define the System Console screen display and are all attached devices and adapters listed?**

**NO** Is the SRC that sent you to MAP 1540 20FB99xy?

**NO** Go to “Step 1540-30”.

**YES** Go to “Step 1540-41” on page 146.

**YES** Is there another I/O drawer to connect?

**NO** The problem has changed. Call your next level of support.

**YES** Go to “Step 1540-28”.

## Step 1540-30

The problem is in the last secondary I/O drawer that was connected. To deconfigure this secondary I/O drawer, perform the following steps.

**Are there any adapters in slots 1, 2, 3, or 4?**

**NO** Go to “Step 1540-31” on page 141.

**YES** Go to “Step 1540-33” on page 141.

### Step 1540-31

**Are there any adapters in slots 5, 6, 7, 8 or 9?**

**NO** Go to "Step 1540-32".

**YES** Go to "Step 1540-34" on page 142.

### Step 1540-32

**Are there any adapters in slots 10, 11, 12, 13, or 14?**

**NO** Go to "Step 1540-38" on page 144.

**YES** Go to "Step 1540-35" on page 142.

### Step 1540-33

1. If it is not already off, turn off the power.
2. Remove all adapters from slots 1, 2, 3, and 4 that are not attached to the boot device.
3. Label and record the location of any cables attached to the adapters.
4. Record the slot number of the adapters.
5. Turn on the power to boot standalone diagnostics from CD.
6. If the TTY screen displays Enter 0 to select this console, press the 0 key on the TTY terminal's keyboard.
7. If the Please define the System Console screen is displayed, follow directions to select the system console.
8. Use the Display Configuration and Resource List to list all attached devices and adapters (refer to the *RS/6000 and @server pSeries Diagnostic Information for Multiple Bus Systems* if necessary).
9. Check that all attached devices and adapters are listed.

**Did the Please define the System Console screen display and are all attached devices and adapters listed?**

**NO** Go to "Step 1540-31".

**YES** Go to "Step 1540-36" on page 143.

## Step 1540-34

1. If it is not already off, turn off the power.
2. Remove all adapters from slots 5, 6, 7, 8 and 9 that are not attached to the boot device.
3. Label and record the location of any cables attached to the adapters.
4. Record the slot number of the adapters.
5. Turn on the power to boot standalone diagnostics from CD.
6. If the TTY screen displays Enter 0 to select this console, press the 0 key on the TTY terminal's keyboard.
7. If the Please define the System Console screen is displayed, follow directions to select the system console.
8. Use the Display Configuration and Resource List to list all attached devices and adapters (refer to the *RS/6000 and @server pSeries Diagnostic Information for Multiple Bus Systems* if necessary).
9. Check that all attached devices and adapters are listed.

### **Did the Please define the System Console screen display and are all attached devices and adapters listed?**

**NO** Go to "Step 1540-32" on page 141.

**YES** Go to "Step 1540-36" on page 143.

## Step 1540-35

1. If it is not already off, turn off the power.
2. Remove all adapters from slots 10, 11, 12, 13, and 14 that are not attached to the boot device.
3. Label and record the location of any cables attached to the adapters.
4. Record the slot number of the adapters.
5. Turn on the power to boot standalone diagnostics from CD.
6. If the TTY screen displays Enter 0 to select this console, press the 0 key on the TTY terminal's keyboard.
7. If the Please define the System Console screen is displayed, follow directions to select the system console.
8. Use the Display Configuration and Resource List to list all attached devices and adapters (refer to the *RS/6000 and @server pSeries Diagnostic Information for Multiple Bus Systems* if necessary).
9. Check that all attached devices and adapters are listed.

### **Did the Please define the System Console screen display and are all attached devices and adapters listed?**

**NO** Go to "Step 1540-38" on page 144.

**YES** Go to "Step 1540-36" on page 143.



## Step 1540-36

If the Please define the System Console screen does display and all attached devices and adapters are listed, the problem is with one of the adapter cards or devices that was removed or disconnected from the I/O drawer.

1. Turn off the power.
2. Replace one adapter or device that was removed. Use the original adapter cards in their original slots when reinstalling adapters.
3. Turn on the power to boot standalone diagnostics from CD.
4. If the Please define the System Console screen is displayed, follow directions to select the system console.
5. Use the Display Configuration and Resource List to list all attached devices and adapters (refer to the *RS/6000 and @server pSeries Diagnostic Information for Multiple Bus Systems* if necessary).
6. Check that all attached devices and adapters are listed.

### **Did the Please define the System Console screen display and are all attached devices and adapters listed?**

**NO** Go to "Step 1540-37".

**YES** Reinstall the next adapter or device and return to number 1 in this step. Continue repeating this process until an adapter or device causes the Please define the System Console screen to not be displayed or all attached devices and adapters to not be listed.

## Step 1540-37

Replace the adapter or device that is causing the Please define the System Console screen to not be displayed or all attached devices and adapters to not be listed with a new adapter.

Reinstall all remaining adapters and reconnect all devices. Return the system to its original configuration. Go to "MAP 0410: Repair Checkout" in the *RS/6000 and @server pSeries Diagnostic Information for Multiple Bus Systems*.

## Step 1540-38

1. Turn off the power.
2. Disconnect the I/O drawer ac power cables (dc power cables in a dc-powered system).
3. Replace the remaining parts (listed below) in this drawer, one at a time.
  - a. I/O drawer backplane
  - b. I/O drawer RIO adapter
  - c. Secondary drawer operator panel
  - d. SPCN fan control card
  - e. Both power supplies
  - f. Power distribution board
4. Reconnect the I/O drawer ac power cables (dc power cables in a dc-powered system).
5. Turn the power on.
6. Boot standalone diagnostics from CD.
7. If the Please define the System Console screen is displayed, follow directions to select the system console.
8. Use the Display Configuration and Resource List to list all attached devices and adapters (refer to the *RS/6000 and @server pSeries Diagnostic Information for Multiple Bus Systems* if necessary).
9. Check that all attached devices and adapters are listed.

### **Did the Please define the System Console screen display and are all attached devices and adapters listed?**

- NO** Replace the next part in the list and return to the beginning of this step. Continue repeating this process until a part causes the boot to be successful.
- If you have replaced all the items listed above and the boot is not successful, check any external devices and cabling. If you do not find a problem, contact your next level of support for assistance.
- YES** Go to "Step 1540-39".

## Step 1540-39

1. Turn off the power.
2. The item just replaced fixed the problem.
3. Plug in all adapters that were previously removed but not reinstalled.

Reconfigure the system to its original condition. Go to "MAP 0410: Repair Checkout" in the *RS/6000 and @server pSeries Diagnostic Information for Multiple Bus Systems*.

## Step 1540-40

The primary I/O drawer is the only I/O drawer that was connected to the CEC drawer. To isolate a faulty RIO cable perform the following steps.

**Note:** Before continuing, check the cabling from the CEC drawer to I/O drawer(s) to ensure that the system is cabled correctly. Refer to “Cabling the CEC Drawer, Primary I/O Drawer, and Secondary I/O Drawer(s)” on page 53 for valid configurations. Record the current cabling configuration and then continue with the following steps.

1. Turn off the power.
2. At the CEC drawer, disconnect the cable connection at RIO port 0.
3. At the primary I/O drawer, disconnect the cable connection at RIO port 0. The RIO cable that was connected to RIO port 0 should now be loose and can be removed.
4. At the CEC drawer, disconnect the cable connection at RIO port 1 and reconnect it to RIO port 0.
5. At the primary I/O drawer, disconnect the RIO connection at RIO port 1. Reconnect this RIO cable end to RIO port 0.
6. Verify that primary I/O drawer RIO port 0 is connected to the CEC drawer RIO port 0.
7. Turn the power on to boot standalone diagnostics from CD.
8. If the Please define the System Console screen is displayed, follow directions to select the system console.
9. Use the Display Configuration and Resource List to list all attached devices and adapters (refer to the *RS/6000 and @server pSeries Diagnostic Information for Multiple Bus Systems* if necessary).
10. Check that all attached devices and adapters are listed.

### **Did the Please define the System Console screen display and are all attached devices and adapters listed?**

**NO** Go to “Step 1540-17” on page 133

**YES** The RIO cable that was removed in step 3 above is defective. Replace the RIO cable. Connect the new RIO cable from CEC drawer RIO port 1 to the primary I/O drawer RIO port 1. Reconfigure the system to its original condition. Go to “MAP 0410: Repair Checkout” in the *RS/6000 and @server pSeries Diagnostic Information for Multiple Bus Systems*.

## Step 1540-41

1. Turn off the power.
2. Disconnect the I/O drawer ac power cables (dc power cables in a dc-powered system).
3. Replace the remaining parts (listed below) in this drawer, one at a time.
  - a. RIO bus adapter, location: U0.x-P1.1
  - b. Secondary I/O drawer backplane, location: U0.x-P1
4. Reconnect the I/O drawer ac power cables (dc power cables in a dc-powered system).
5. Turn the power on.
6. Boot standalone diagnostics from CD.
7. If the Please define the System Console screen is displayed, follow directions to select the system console.
8. Use the Display Configuration and Resource List to list all attached devices and adapters (refer to the *RS/6000 and @server pSeries Diagnostic Information for Multiple Bus Systems* if necessary).
9. Check that all attached devices and adapters are listed.

### **Did the Please define the System Console screen display and are all attached devices and adapters listed?**

**NO** Replace the next part in the list and return to the beginning of this step. Continue repeating this process until a part causes the Please define the System Console screen to be displayed and all attached devices and adapters to be listed

If you have replaced all the items listed above and the Please define the System Console screen does not display or all attached devices and adapters are not listed, check any external devices and cabling. If you do not find a problem, contact your next level of support for assistance.

**YES** The last item that was replaced in step 3 above was defective. Reconfigure the system to its original condition. Go to "MAP 0410: Repair Checkout" in the *RS/6000 and @server pSeries Diagnostic Information for Multiple Bus Systems*.

---

## Chapter 4. Checkpoints

Checkpoints display on the primary I/O drawer operator panel while the system is powering on and going through the initial program load (IPL). This chapter explains the IPL flow of the system and provides a table that lists checkpoints that you might see in the primary I/O drawer operator panel.

---

### IPL Flow

The IPL process starts when ac power (dc power in a dc-powered system) is connected to the system. The IPL process has four phases:

- **Phase 1: Service Processor Initialization**

Phase 1 starts when ac power (dc power in a dc-powered system) is connected to the system and ends when 0K is displayed in the primary I/O drawer operator panel. 8xxx checkpoints are displayed during this phase. Several 9xxx codes may also be displayed. Service processor menus are available at the end of this phase by pressing any key on the console keyboard.

- **Phase 2: Hardware Initialization by the Service Processor**

Phase 2 starts when system power up is initiated by pressing the power on button on the primary I/O drawer operator panel. 9xxx checkpoints are displayed during this time. 91FF, the last checkpoint in this phase, indicates the transition to Phase 3 is taking place.

- **Phase 3: System Firmware initialization**

At Phase 3, a system processor takes over control and continues initializing system resources. During this phase, checkpoints in the form Exxx are displayed. E105, the last checkpoint in this phase, indicates that control is being passed to the AIX boot program. Location codes may also be displayed in the second line of the primary I/O drawer operator panel.

- **Phase 4: AIX Boot**

When AIX starts to boot, checkpoints in the form 0xxx are displayed. Location codes may also be displayed in the second line of the primary I/O drawer operator panel. This phase ends when the AIX login prompt appears on the AIX console. The primary I/O drawer operator panel should be blank.

The following table outlines the IPL phases from power-on to the AIX login prompt, matching the phases to corresponding operator-panel checkpoints for a typical system boot. Also listed are the approximate boot times for each phase, along with their dependencies for each phase.

**Note:** The following table lists the major checkpoints only.

Phase #	Checkpoints on Operator Panel	Time in phase (minutes)	Major contributors to time in phase
Phase 1	8xxx => OK	Approx. 1	
Phase 2	9xxx => 91FF	3 to 6	Number of I/O drawers
Phase 3	Exxx => E105	1 to 3	Number of bootable adapters
Phase 4	0xxx => blank	2 to 30+	Number of SSA drives Number of SCSI drives Number of Async sessions Number of processors Number of adapters Amount of memory

Checkpoints enable users and service personnel to know what the server is doing, with some detail, as it initializes. These checkpoints are not intended to be error indicators, but in some cases a server could hang at one of the checkpoints without displaying an 8-character error code. It is for these hang conditions, only, that any action should be taken with respect to checkpoints. The most appropriate action is included with each checkpoint.

Before taking actions listed with a checkpoint, check for additional symptoms in the service processor error log. See the “System Information Menu” on page 424 for information on how to access the service processor error log.

**Note:** Go to “MAP 1540: Minimum Configuration” on page 122 for any of the following checkpoint conditions. If mentioned as an action, remember to run the System Rack Minimum Configuration:

- A four-digit code in the range of 8xxx through EFFF not listed in the checkpoint tables.
- A four-digit code is in the checkpoint tables, but does not contain a repair action or FRU listing.
- All of the FRUs listed in the repair action have been replaced and the problem has not been corrected.

Checkpoints listed in the following tables are in the format 8xxx, 9xxx, Axxx, Bxxx, or Exxx, where x is any hexadecimal digit from 1-9 or A-F. If your system hangs with a displayed checkpoint that begins with anything other than 8, 9, A, B, or E, go to the *RS/6000 and @server pSeries Diagnostic Information for Multiple Bus Systems*.

Use the following table to determine where to find the checkpoint.

Symptom	Action
You have a code that is of the form 8xxx, 9xxx, Axxx, or Bxxx.	Go to “Service Processor Checkpoints” on page 150.
You have a code of the form Exxx.	Go to “Firmware Checkpoints” on page 156.
You have a four-character code that is <i>not</i> of the form 8xxx, 9xxx, Axxx, Bxxx, or Exxx.	Refer to the <i>RS/6000 and @server pSeries Diagnostic Information for Multiple Bus Systems</i> manual.

## Service Processor Checkpoints

Service processor checkpoints are in the range 8xxx to Bxxx. **OK** in the primary I/O drawer's operator panel indicates successful service processor testing and initialization. Firmware checkpoints are listed in "Firmware Checkpoints" on page 156.

**Note:** A spinning (or twirling) slash will be shown in the upper-right corner of the operator panel display while some checkpoints are being displayed. If the slash stops spinning, a hang condition is indicated.

*Table 1. Service Processor Checkpoints*

Checkpoint	Description	Action/ Possible Failing FRU
8000	Test of the service processor DRAM	See note 1 on page 154
8004	Verify base code checksum	See note 1 on page 154
8008	Verify base code mirror checksum	See note 1 on page 154
8009	Set NVRAM configuration in TITAN	See note 1 on page 154
800F	Start base code	See note 1 on page 154
8010	Start supervisor in base code	See note 1 on page 154
8012	Initialize hardware interrupts	See note 1 on page 154
8014	Allocate and initialize area in DRAM	See note 1 on page 154
8016	Initialize debugger and build VPD	See note 1 on page 154
8018	Initialize service processor interfaces	See note 1 on page 154
801A	Initialize external FLASH load	See note 1 on page 154
801B	Initialize and test ISA hub chip	See note 1 on page 154
801C	Initialize and test SUPER I/O chip	See note 1 on page 154
801F	Initialize diskette, verify VDASD and start operational loader	See note 1 on page 154
809x	Related to recovery mode system firmware update from diskette	See note 3 on page 154
8092	Diskette initialization during recovery mode system firmware update	See note 3 on page 154
8098	Firmware image being read during recovery mode system firmware update	See note 3 on page 154
809C	Firmware image being written during recovery mode system firmware update	See note 3 on page 154
809F	Diskette error during recovery mode system firmware update	See note 3 on page 154
8100	Start operational loader	See note 1 on page 154
81xx	Load code into DRAM from VDASD (where xx = number of loads)	See note 1 on page 154



Table 1. Service Processor Checkpoints (continued)

Checkpoint	Description	Action/ Possible Failing FRU
81FE	Load service processor operating system	See note 1 on page 154
81FF	Start service processor operating system	See note 1 on page 154
9000	Primary service processor task initializing	See note 1 on page 154
9009	System processor IPL has started	See note 1 on page 154
9010	Primary service processor thread waiting for response	See note 1 on page 154
9020	Service processor state set to pre-standby	See note 1 on page 154
9021	Service processor state set to standby	See note 1 on page 154
9022	Service processor state set to IPL	See note 1 on page 154
9030	Waiting for secondary thread acknowledge	See note 1 on page 154
9033	I/O base initialization	See note 1 on page 154
9034	I2C initialization	See note 1 on page 154
9035	ISA initialization	See note 1 on page 154
9036	Mailbox initialization	See note 1 on page 154
9037	SLLA initialization (VPD)	See note 1 on page 154
9038	NVRAM initialization	See note 1 on page 154
9039	Serial port initialization	See note 1 on page 154
903A	Serial I/O initialization	See note 1 on page 154
903B	SPCN initialization	See note 1 on page 154
9051	End of reset/reload operation: service processor dump has completed	See note 1 on page 154
9060	Checking/configuring modem on serial port 1	See note 4 on page 154
9061	Checking/configuring modem on serial port 2	See note 4 on page 154
906A	Create mailbox processing thread	See note 1 on page 154
906B	Create menu interface thread	See note 1 on page 154
906C	Create general thread	See note 1 on page 154
906D	Create SPCN thread	See note 1 on page 154
9080	Start VPD collection program	See note 1 on page 154
9081	Start SC VPD data collection	See note 1 on page 154
9082	I2C/SPCN VPD data collection	See note 1 on page 154
9083	End SC VPD data collection	See note 1 on page 154

Table 1. Service Processor Checkpoints (continued)

Checkpoint	Description	Action/ Possible Failing FRU
9084	End I2C VPD data collection	See note 1 on page 154
90FD	Waiting for IBIST to complete	See note 1 on page 154
9101	Create CEC box	See note 1 on page 154
9102	Open load source	See note 1 on page 154
9103	Verify open status of load source	See note 1 on page 154
9104	Load IPL LIDs	See note 1 on page 154
9105	System flush	See note 1 on page 154
9106	Scan interface BATs	See note 1 on page 154
9107	ABIST	See note 1 on page 154
9108	LBIST	See note 1 on page 154
9109	LBIST	See note 1 on page 154
910A	Configure and initialize processors	See note 1 on page 154
910B	Configure main storage (system memory)	See note 1 on page 154
910C	Initialize main storage (system memory)	See note 1 on page 154
910D	Configure and initialize I/O	See note 1 on page 154
910E	Test main storage (system memory)	See note 1 on page 154
910F	Free IPL LIDS	See note 1 on page 154
9110	Load runtime LIDS	See note 1 on page 154
9111	Load dump LIDS	See note 1 on page 154
9112	Enable attention	See note 1 on page 154
9113	Enable function 22	See note 1 on page 154
9114	Load system IPL program	See note 1 on page 154
9115	Load system data areas (NACA/PACA)	See note 1 on page 154
9116	Start system IPL program	See note 1 on page 154
9118	Waiting for VPD collection to complete	See note 1 on page 154
9184	Firmware image being loaded into service processor's control storage during firmware update	<ol style="list-style-type: none"> <li>1. Remove, then reapply power to the system. If the service processor enters recovery mode, (indicated by A1FD 0000 in the display), attempt to update the firmware again in recovery mode. If the service processor comes up to the OK prompt, try again to update the firmware using the service processor menus.</li> <li>2. Call service support</li> </ol>

Table 1. Service Processor Checkpoints (continued)

Checkpoint	Description	Action/ Possible Failing FRU
91FF	Control being handed to system processor from service processor	See note 2 on page 154
9380	Built-in-self-test (BIST)	See note 2 on page 154
94B0	Wire test faulty driver status refcode	See note 2 on page 154
94B1	Wire test shorted net status refcode	See note 2 on page 154
94B2	Wire test L2 cache status refcode	See note 2 on page 154
94BB	Wire test status SRC refcode	See note 2 on page 154
9501	Main storage initialization	See note 2 on page 154
9502	Main storage L3 cache march test	See note 2 on page 154
9503	Main storage L3 connections test	See note 2 on page 154
9504	Main storage L3 cache march test	See note 2 on page 154
9505	MS extra testing (RIO, etc.)	See note 2 on page 154
9506	MS cleanup	See note 2 on page 154
99FD	Service processor receiving firmware update module	See note 1 on page 154
99FF	Service processor writing firmware update module	See note 1 on page 154
A800	Start service processor dump process	See note 1 on page 154
A801	Start dump to debug port	See note 1 on page 154
A802	Start dump to debug port	See note 1 on page 154
A803	NVRAM not usable	See note 1 on page 154
A804	NVRAM dump done	See note 1 on page 154
A805	Start dump to flash	See note 1 on page 154
A806	Flash dump area done	See note 1 on page 154
A807	Flash area not usable	See note 1 on page 154
A808	Flash error log to debug port	See note 1 on page 154
A809	Flash erase start	See note 1 on page 154
A80A	Flash erase end	See note 1 on page 154
A80B	Reserved; not used	See note 1 on page 154
A80C	Reserved; not used	See note 1 on page 154
A80D	Reserved; not used	See note 1 on page 154
A80E	Reserved; not used	See note 1 on page 154
A80F	Service processor dump done	See note 1 on page 154
B00B	Firmware delaying to determine if MOPs error is the result of power disturbance. After delay, SPCN is queried for CEC power status.	<ol style="list-style-type: none"> <li>1. Remove, then reapply power to the system.</li> <li>2. Call service support.</li> </ol>

Table 1. Service Processor Checkpoints (continued)

Checkpoint	Description	Action/ Possible Failing FRU
B0F5	Delayed power-off sequence has begun	See note 1
B0FA	Delayed power-off acknowledged	See note 1
B0FF	Power-off requested program executing	See note 1

**Notes:**

1. If the system fails to progress after this checkpoint is put in the display, do the following:
  - a. Activate the service processor pinhole reset switch on the system's operator panel.
  - b. If the hang repeats, check with service support to see if there is a firmware update that fixes the problem.
  - c. If not, or the update does not fix the problem, change the primary I/O backplane.
  - d. If this procedure does not fix the problem, call service support.
2. If the system fails to progress after this checkpoint is put in the display, do the following:
  - a. Activate the service processor pinhole reset switch on the system's operator panel.
  - b. If the hang repeats, check with service support to see if there is a firmware update that fixes the problem.
  - c. If not, or the update does not fix the problem, go to "MAP 1540: Minimum Configuration" on page 122.
  - d. If this procedure does not fix the problem, call service support.
3. Recovery mode flash update has failed. Do the following:
  - a. Activate the service processor pinhole reset switch on the system's operator panel and try the recovery mode flash update again.
  - b. If the system hangs again, make a new set of firmware update diskettes, using new, blank diskettes. Retry the flash update with the new diskettes.
  - c. If the same hang occurs with the new diskettes, replace the following FRUs one at a time in this order:
    - 1) Diskette drive
    - 2) I/O backplane in the primary I/O drawer
  - d. If this procedure does not fix the problem, call service support.
4. The service processor was unable to configure the modem(s) attached to the serial port(s). Do the following:
  - a. Check the modem, modem cable, and serial port for loose or unconnected cables. Reset the service processor using the pinhole reset switch on the primary I/O drawer operator panel.
  - b. If the hang repeats, check with service support to see if there is a firmware update that fixes the problem.
  - c. If there is not, or the update does not fix the problem, replace the following FRUs one at a time in this order:
    - 1) Modem cable

- 2) Modem
  - 3) I/O backplane in the primary I/O drawer
- d. If this procedure does not fix the problem, call service support.

---

## Firmware Checkpoints

System firmware uses checkpoints (progress codes) in the range of Exxx to EFFF. These checkpoints occur during system startup and can be useful in diagnosing certain problems. Service processor checkpoints are listed in “Service Processor Checkpoints” on page 150.

**Attention:** If you replace FRUs or perform an action and the problem is still not corrected, go to “MAP 1540: Minimum Configuration” on page 122 unless otherwise indicated in the tables.

If you replace FRUs or perform an action and the problem is corrected, go to “MAP 0410: Repair Checkout” in the *RS/6000 and @server pSeries Diagnostic Information for Multiple Bus Systems*.

### Note:

Firmware can hang due to multiple causes. In many cases, it can be caused by the primary processor or a memory problem in the first 64 MB of real memory. If a location code is not provided with the checkpoint, the following procedure will use the primary processor and low memory as the probable FRUs.

1. If firmware is hung (E100 through EFFF) and a location code is displayed on the second line of the operator panel, use that location code as the primary FRU.
2. If no location code is present or if replacing the primary FRU indicated in the location code did not fix the problem, then perform the following actions:
  - a. Power off the system and go to the service processor menus.
  - b. From the service processor main menu, select option 3, **System Information Menu**, then select option 5, **Read NVRAM**.
  - c. Enter 330 when prompted for an address.
  - d. Look at the byte of data at address 330. If the value is FF, go to note 3. If the value is 00-0F, replace the processor card, location: U1.1-P1-C1. Attempt to reboot the system. If the system hangs at the same checkpoint, go to 3. If the system hangs at a new checkpoint, perform the actions associated with the new checkpoint.
3. Power off the system. From the service processor main menu, select option 3, **System Information Menu**, then option 8, **Memory Configuration/Deconfiguration Menu**. Identify the first configured memory riser card and octal of DIMMs. Replace the first octal of DIMMs.
4. If replacing the first octal of configured DIMMs does not fix the problem, replace the memory riser card. If the problem is still not fixed, go to “MAP 1540: Minimum Configuration” on page 122

Table 2. Firmware Checkpoints

Checkpoint	Description	Action/ Possible Failing FRU
E100	Reserved	See the note on page "Note" on page 149.
E101	Create RTAS See the note on page node	See the note on page "Note" on page 149.
E102	Load/Init RTAS	See the note on page "Note" on page 149.
E105	Transfer control to operating system (normal boot).	See "Boot Problems and Concerns" on page 167.
E10A	Load RTAS device tree	See the note on page "Note" on page 149.
E10B	Set RTAS device properties	See the note on page "Note" on page 149.
E122	RTAS sensor on page setup complete	See the note on page "Note" on page 149.
E130	Build device tree	See the note on page "Note" on page 149.
E134	Create memory node	See the note on page "Note" on page 149.
E137	Create openprom node	See the note on page "Note" on page 149.
E138	Create options node	See the note on page "Note" on page 149.
E139	Create node aliases and system aliases	See the note on page "Note" on page 149.
E13A	Create packages node	See the note on page "Note" on page 149.
E140	Operating system load	See the note on page "Note" on page 149.
E149	Create boot mgr node	See the note on page "Note" on page 149.
E14C	Create terminal-emulator node	See the note on page "Note" on page 149.
E14D	Loading boot image	See "Boot Problems and Concerns" on page 167.
E14F	NVRAM initialization	See the note on page "Note" on page 149.

Table 2. Firmware Checkpoints (continued)

Checkpoint	Description	Action/ Possible Failing FRU
E150	Create host (primary) PCI controller node	<ol style="list-style-type: none"> <li>1. If a location code is associated with the checkpoint, replace the adapter identified by the location code. See "Determining Location Code" on page 172. If a network adapter is replaced, see "Replacing the Network Adapter" on page 171.</li> <li>2. Replace the drawer I/O backplane.</li> </ol>
E151	Probing primary PCI bus	<ol style="list-style-type: none"> <li>1. If a location code is associated with the checkpoint, replace the FRU identified by the location code. See "Determining Location Code" on page 172. If a network adapter is replaced, see "Replacing the Network Adapter" on page 171.</li> <li>2. Replace the drawer I/O backplane.</li> </ol>
E152	Probing for adapter FCODE, evaluate if present	Follow the repair action listed for checkpoint E151.
E153	End adapter FCODE, probe/evaluate	See "Note" on page 149.
E154	Create PCI bridge node	Follow the repair action listed for checkpoint E151.
E155	Probing PCI bridge secondary bus	Follow the repair action listed for checkpoint E151.
E156	Create PCI ethernet node	Follow the repair action listed for checkpoint E151.
E15A	Create 64-bit host (primary) PCI controller node	See "Note" on page 156.
E15B	Transferring control to operating system (service mode boot)	See "Boot Problems and Concerns" on page 167.
E15C	Probe primary 64-bit PCI bus	See "Note" on page 156.
E15D	Create host PCI controller node	See "Note" on page 156.
E15F	Adapter VPD probe	Follow the repair action listed for checkpoint E151.
E162	SP node VPD creation	See "Note" on page 156.
E163	Create CPU VPD	See "Note" on page 156.
E165	Create planar-clock VPD	See "Note" on page 156.
E166	Create CEC VPD	See "Note" on page 156.
E167	Collect power cards VPD.	See "Note" on page 156.
E170	Start of PCI bus probe	Follow the repair action listed for checkpoint E151.



Table 2. Firmware Checkpoints (continued)

Checkpoint	Description	Action/ Possible Failing FRU
E172	First pass PCI device probe	Follow the repair action listed for checkpoint E151.
E174	Establishing host connection	<p>If the system is not connected to an active network or if the target server is inaccessible (this can also result from incorrect IP parameters being supplied), the system will still attempt to boot. Because time-out durations are necessarily long to accommodate retries, the system may appear to be hung.</p> <p>Restart the system and access the Firmware SMS utilities. In the utilities check:</p> <ul style="list-style-type: none"> <li>• Is the intended boot device correctly specified in the boot list?</li> <li>• Are the IP parameters correct?</li> <li>• Verify the network connection (network could be down).</li> <li>• Have network administrator verify the server configuration for this client.</li> <li>• Attempt to “Ping” the target server using the SMS “Ping” utility.</li> </ul>
E175	BootP request	Refer to checkpoint E174.
E176	TFTP file transfer	See “Boot Problems and Concerns” on page 167.
E177	Transfer failure due to TFTP error condition	See “Boot Problems and Concerns” on page 167.
E17B	Processor clock speed check measurement	<p>Primary I/O backplane.</p> <p>See “Note” on page 149.</p>
E180	Service processor command setup	See “Note” on page 149.
E183	Service processor post	See “Note” on page 149.
E186	Request PS1 VPD	See “Note” on page 149.
E187	Add PS1 VPD to NVRAM and device tree	See “Note” on page 149.
E188	Request PS2 VPD	See “Note” on page 149.
E189	Add PS2 VPD to NVRAM and device tree	See “Note” on page 149.
E18C	VPD and data communications with I/O planar complete	See “Note” on page 149.
E190	Create ISA node	See “Note” on page 149.
E191	Create ISA reserved node	See “Note” on page 149.

Table 2. Firmware Checkpoints (continued)

Checkpoint	Description	Action/ Possible Failing FRU
E193	Initialize Super I/O	See "Note" on page 149.
E196	Probe ISA bus	See "Note" on page 149.
E199	Reboot after flash	Try to boot system a second time. If this does not work, replace the primary I/O backplane.  See "Note" on page 149.
E19B	Create service processor node	See "Note" on page 149.
E19C	Create tablet node	See "Note" on page 149.
E19D	Create NVRAM node	See "Note" on page 149.
E19E	Real-time clock (RTC) initialization	Refer to error code 28030xxx in "Firmware/POST Error Codes" on page 212.
E1AD	See description of checkpoint E1DE	See "Note" on page 149.
E1B0	Create lpt node	See "Note" on page 149.
E1B1	Create serial node	See "Note" on page 149.
E1B2	Create audio node	See "Note" on page 149.
E1B3	Create 8042 node	See "Note" on page 149.
E1B6	Probe for (ISA) keyboard	See "Note" on page 149.
E1BD	Probe for (ISA) mouse	See "Note" on page 149.
E1BF	Create pwr-mgmt node	See "Note" on page 149.
E1C4	Build ISA timer chip node	See "Note" on page 149.
E1C5	Create ISA interrupt controller (pic) node	See "Note" on page 149.
E1C6	Create DMA node	See "Note" on page 149.
E1D0	Create PCI SCSI node	Perform Repair actions from checkpoint E156.
E1D3	Create SCSI block device node (SD)	Perform Repair actions from checkpoint E156.
E1D4	Create SCSI byte device node (ST)	Perform Repair actions from checkpoint E156.
E1DB	Create floppy controller (FDC) node	Replace the primary I/O backplane. See "Note" on page 149.

Table 2. Firmware Checkpoints (continued)

Checkpoint	Description	Action/ Possible Failing FRU
E1DC	Dynamic console selection.	<p>If a console is attached but nothing is displayed on it, follow the steps associated with "All display problems" in the Entry MAP.</p> <p>If selection screen(s) can be seen on the terminals and the appropriate key on the input device associated with the desired display or terminal is pressed, within 60 seconds, but there is no response to the keystroke:</p> <ul style="list-style-type: none"> <li>• If selecting the console with a keyboard attached to the system, replace the keyboard. If replacing the keyboard does not fix the problem, replace the primary I/O backplane.</li> <li>• If selecting the console with an ASCII terminal, suspect the ASCII terminal. Use the problem determination procedures for the terminal. Replace the primary I/O backplane if these procedures do not reveal a problem.</li> </ul> <p><b>Note:</b> Terminal settings should be set to:</p> <ul style="list-style-type: none"> <li>– 9600 Baud</li> <li>– No Parity</li> <li>– 8 Data bits</li> <li>– 1 Stop bit</li> </ul>
E1DE	Alternating pattern of E1DE and E1AD is used to indicate a Default Catch condition before the firmware "checkpoint" word is available.	See "Note" on page 149.
E1DF	Create diskette drive (disk) node	See "Note" on page 149.
E1F0	Start O.B.E.	See "Note" on page 149.
E1F1	Begin selftest sequence on boot device(s). Begin SMS.	See "Note" on page 149.
E1F2	Power-on password prompt.	<p>Prompt should be visible on the system console.</p> <p>If a console is attached but nothing is displayed on it, go to the "Entry MAP" on page 81 with the symptom "All display problems."</p>

Table 2. Firmware Checkpoints (continued)

Checkpoint	Description	Action/ Possible Failing FRU
E1F3	Privileged-access password prompt	<p>Prompt should be visible on the system console.</p> <p>If a console is attached but nothing is displayed on it, go to the "Entry MAP" on page 81 with the symptom "All display problems."</p>
E1F5	Build boot device list	See "Note" on page 149.
E1F6	Determine boot device sequence	See "Note" on page 149.
E1F7	No boot image located	Follow the repair actions listed for error code 20EE00B.
E1FB	Scan SCSI bus for attached devices	If a location code is available, follow the repair actions listed for error code 21A000XX.

Table 2. Firmware Checkpoints (continued)

Checkpoint	Description	Action/ Possible Failing FRU
E1FD	The operator panel will alternate between the code E1FD and another Exxx code, where Exxx is the point at which the error occurred.	<p>Checkpoint E1FD indicates that an error has occurred during system startup. The display alternates between E1FD and another checkpoint, Exxx, where the error occurred. Check the list of checkpoints for Exxx. If the description for that checkpoint does not resolve the problem, return here for more instruction.</p> <p>Checkpoint E1FD may be displayed when an adapter or peripheral is malfunctioning. To find which device is most likely to have caused the error, follow these steps.</p> <ol style="list-style-type: none"> <li>1. Check the "progress codes from last boot" in the service processor's Information menu. Look for the last location code that was displayed before the E1FD error code.</li> <li>2. The device pointed to by this location is suspect.</li> <li>3. If the progress code listing only contains the E1FD and Exxx checkpoints, restart the system and power off when the E1FD and Exxx codes are displayed. Repeat step 1.</li> <li>4. Try removing the suspect device (if it is not integrated). Remove power from the system before changing the hardware configuration.</li> <li>5. Restart the system. If it now boots normally, without stopping at checkpoint E1FD, the device that was removed in the previous step should be replaced.</li> <li>6. If the above steps have not resolved the problem, go to "MAP 1540: Minimum Configuration" on page 122.</li> </ol>
E440	Validate NVRAM, initialize partitions as needed	<ol style="list-style-type: none"> <li>1. Verify that the system firmware levels are at the current release levels. Update as necessary.</li> <li>2. Replace primary I/O backplane if problem persists.</li> </ol> <p>See "Note" on page 149.</p>

Table 2. Firmware Checkpoints (continued)

Checkpoint	Description	Action/ Possible Failing FRU
E441	Generate/options node NVRAM configuration variable properties	<ol style="list-style-type: none"> <li>1. Verify that the system firmware levels are at the current release levels. Update as necessary.</li> <li>2. Replace primary I/O backplane if problem persists.</li> </ol> <p>See "Note" on page 149.</p>
E442	Validate NVRAM partitions	<ol style="list-style-type: none"> <li>1. Verify that the system firmware levels are at the current release levels. Update as necessary.</li> <li>2. Replace primary I/O backplane if problem persists.</li> </ol> <p>See "Note" on page 149.</p>
E443	Generate NVRAM configuration variable dictionary words	<p>Suspect a system firmware problem if problem persists. Verify that the system firmware is at current release level. Update downlevel system firmware.</p> <p>See "Note" on page 149.</p>
E500	Configure remote I/O subsystem	<ol style="list-style-type: none"> <li>1. Configure I/O subsystem.</li> <li>2. The appearance of this code indicates that the I/O subsystem configuration has started or progressed to the point where the code can be displayed.</li> </ol> <p>See "Note" on page 149.</p>

Table 2. Firmware Checkpoints (continued)

Checkpoint	Description	Action/ Possible Failing FRU
<p>E5xy (E511 - E5FF) Where x is not equal to 0, and y is not equal to 0.</p>	<p>Configure remote I/O subsystem components</p>	<p>The E5xy (E511 to E5FF) codes are reserved for activities relating to configuration or testing of the I/O subsystem, or remote I/O subsystem. A hang at one of these codes implies that a severe error occurred during the programming of I/O subsystem registers or when interacting with adapters plugged into the system. The last two digits in the checkpoint can be used to help isolate the location of the I/O activity that caused the problem.</p> <p>“x” indicates the I/O drawer number. “y” indicates the PCI bus occurrence.</p> <p>If y = _, then the PCI bus is:</p> <p>Y = PCI bus 1 = 0 2 = 1 3 = 2 4 = 3</p> <p>See “AIX and Physical Location Code Tables” in Chapter 1, for location codes.</p> <p>Using the information above, go to “MAP 1540: Minimum Configuration” on page 122.</p>
<p>E600</p>	<p>SSA PCI adapter open firmware has run successfully.</p>	<p>Replace the adapter. See “Determining Location Code” on page 172 for location code information related to this error.</p>
<p>E601</p>	<p>SSA PCI adapter BIST has started but failed to complete after four seconds.</p>	<p>Replace the adapter. See “Determining Location Code” on page 172 for location code information related to this error.</p>
<p>E602</p>	<p>SSA PCI adapter open firmware has started.</p>	<p>Replace the adapter. See “Determining Location Code” on page 172 for location code information related to this error.</p>
<p>E603</p>	<p>SSA PCI adapter BIST has completed with an error.</p>	<p>Replace the adapter. See “Determining Location Code” on page 172 for location code information related to this error.</p>

Table 2. Firmware Checkpoints (continued)

Checkpoint	Description	Action/ Possible Failing FRU
E604	SSA PCI adapter BIST and subsequent POSTs have completed successfully.	Replace the adapter. See “Determining Location Code” on page 172 for location code information related to this error.
E605	SSA PCI adapter BIST has completed successfully but the subsequent POSTs have failed.	Replace the adapter. See “Determining Location Code” on page 172 for location code information related to this error.
E60E	SSA PCI adapter open firmware about to exit (no stack corruption).	Replace the adapter. See “Determining Location Code” on page 172 for location code information related to this error.
E60F	SSA PCI adapter open firmware has run unsuccessfully.	Replace the adapter. See “Determining Location Code” on page 172 for location code information related to this error.
E6FF	SSA PCI adapter open firmware about to exit (with stack corruption).	Replace the adapter. See “Determining Location Code” on page 172 for location code information related to this error.
E700	Create system firmware VPD	Replace the primary I/O drawer backplane.
E701	Create memory VPD.	See “Note” on page 149.
E702	Create processor card VPD.	See “Note” on page 149.
E703	Create operator panel VPD.	See “Note” on page 149.
E704	Create CEC VPD.	See “Note” on page 149.
E705	Create clock card VPD.	See “Note” on page 149.
E706	Create RIO extender card VPD.	See “Note” on page 149.
E707	Create system VPD.	See “Note” on page 149.
E708	Create RIO to PCI adapter VPD.	See “Note” on page 149.
E709	Create VPD via SPCN.	See “Note” on page 149.
E70A	Create service processor VPD.	See “Note” on page 149.
E8xx	RTAS initialization problem.	Call for support.
EAA1	Probe PCI-PCI bridge.	Follow the repair actions for checkpoint E151.

**Note:** If you receive a four-digit code in the range of E1xx to EFFF that is not listed in the table above, go to “MAP 1540: Minimum Configuration” on page 122.



---

## Boot Problems and Concerns

Depending on the boot device, a checkpoint may be displayed on the operator panel for an extended period of time while the boot image is retrieved from the device. This is particularly true for tape and network boot attempts. If booting from CD-ROM or tape, watch for activity on the drive's LED indicator. A blinking LED indicates that the loading of either the boot image or additional information required by the operating system being booted is still in progress. If the checkpoint is displayed for an extended period of time and the drive LED is not indicating any activity, there might be a problem loading the boot image from the device.

**Note:** For network boot attempts, if the system is not connected to an active network or if the target server is inaccessible (this can also result from incorrect IP parameters being supplied), the system will still attempt to boot. Because time-out durations are necessarily long to accommodate retries, the system may appear to be hung.

This procedure assumes that a CD-ROM drive is connected to the internal SCSI connector and a diagnostics CD-ROM is available.

### Step 1

Restart the system and access the firmware SMS Main Menu. Select **Multiboot**.

1. If the intended boot device is correctly specified in the boot list:
  - a. Remove all removable media from devices in the boot list from which you do not want to boot.
  - b. If attempting to boot from the network, go to "Step 2".
  - c. If attempting to boot from a disk drive or CD-ROM, go to "Step 3" on page 168.
2. If the intended boot device is not correctly identified in the boot sequence, add it to the boot sequence using the SMS menus. If the intended boot device cannot be added to the boot sequence, go to "Step 3" on page 168.
3. Remove all removable media from devices in the boot list from which you do not want to boot.
4. If attempting to boot from the network, go to "Step 2".
5. If attempting to boot from a disk drive or CD-ROM, go to "Step 3" on page 168.

### Step 2

If attempting to boot from the network:

1. Verify that IP parameters are correct.
2. Attempt to "ping" the target server using the SMS Ping utility. If the ping is not successful, have the network administrator verify the server configuration for this client.
3. Check with the network administrator to ensure that the network is up.
4. Check the network cabling to the adapter.
5. Turn the power off, then on and retry the boot operation.

### Step 3

Try to boot and run standalone diagnostics against the system, particularly against the intended boot device.

If diagnostics boot successfully:

1. Go to the Task Selection Menu and select Display Configuration and Resource List. If the intended boot device is not listed, go to "MAP 0290: Missing Resource Problem Resolution" in the *RS/6000 and @server pSeries Diagnostic Information for Multiple Bus Systems*.
2. If an SRN, not an 8-digit error code, is reported, go to the *RS/6000 and @server pSeries Diagnostic Information for Multiple Bus Systems* manual.
3. If the diagnostics are successful, it may be necessary to perform an operating system-specific recovery process, or reinstall the operating system.

If diagnostics do not boot successfully:

1. Verify proper SCSI bus termination.
2. Check SCSI cabling.
3. It is possible that another attached SCSI device is causing the problem. Do the following:
  - a. Disconnect the signal and power cables from the disk drive cage backplane.
  - b. Disconnect the disk drive(s) in the disk drive cage from the backplane.
  - c. Disconnect the signal and power cables from any other SCSI devices attached to the SCSI adapter that the CD-ROM drive is attached to.
  - d. Try to boot the standalone diagnostics again.
  - e. If you are still unable to load standalone diagnostics, go to "Step 4".
  - f. If standalone diagnostics load, one of the disconnected devices is causing the problem. Reconnect the devices one at a time and retry the boot operation until the problem recurs and replace the device that caused the problem. (If the problem appears to be one of the disk drives in the disk drive cage, be aware it could be either the disk drive or the backplane.) Go to "MAP 0410: Repair Checkout" in *RS/6000 and @server pSeries Diagnostic Information for Multiple Bus Systems*.

### Step 4

It is possible that another installed adapter is causing the problem. Do the following:

1. Remove all installed adapters except the one the CD-ROM drive is attached to and the one used for the console.
2. Try to boot the standalone diagnostics again.
3. If unable to load standalone diagnostics, go to "Step 5" on page 169.
4. If standalone diagnostics load, reinstall adapters (and attached devices as applicable) one at a time and retry the boot operation until the problem recurs. Then replace the adapter or device that caused the problem. (The system board can also cause the device or adapter to fail.) Go to "MAP 0410: Repair Checkout" in *RS/6000 and @server pSeries Diagnostic Information for Multiple Bus Systems*.

## Step 5

The CD-ROM drive, SCSI cable, SCSI adapter, graphics adapter, or the primary I/O planar is most likely defective. A TTY terminal attached to the serial port also can be used to determine if the graphics adapter is causing the problem. This is done by removing the graphics adapter, attaching a TTY to the serial port, and retrying standalone diagnostics. If the standalone diagnostics load, replace the graphics adapter.

1. Replace the CD-ROM drive.
2. Replace the SCSI cable.
3. If the CD-ROM drive is attached to a SCSI adapter rather than the integrated SCSI on the system board, replace the SCSI adapter.
4. Replace the primary I/O planar.
5. If you replaced the indicated FRUs and the problem is still not corrected, or the above descriptions did not address your particular situation, go to "MAP 1540: Minimum Configuration" on page 122.
6. Go to "MAP 0410: Repair Checkout" in *RS/6000 and @server pSeries Diagnostic Information for Multiple Bus Systems*



---

## Chapter 5. Error Code to FRU Index

**Attention:** Start your activity in this chapter by going to “Checkpoint and Error Code Index” on page 173. In this table, you may be asked to perform additional procedures before looking up the actions for a 4-character checkpoint or 8-character error code.

The Error Code to FRU Index lists fault symptoms and possible causes. The most likely cause is listed first. Use this index to help you decide which FRUs to replace when servicing the system.

- If you replace FRUs or perform an action and the problem is still not corrected, go to “MAP 1540: Minimum Configuration” on page 122 unless otherwise indicated in the tables.
- If you replace FRUs or perform an action and the problem is corrected, go to “MAP 0410: Repair Checkout” in *RS/6000 and @server pSeries Diagnostic Information for Multiple Bus Systems*.

**Note:** Do not shut down the system if the FRU was replaced by hot swap.

---

### Four-Character Checkpoints

Four-character progress codes and checkpoints in the form 8xxx, 9xxx, Axxx, Bxxx, and Exxx are listed in “Firmware Checkpoints” on page 156. If you have a four-character code that begins with any character other than 8, 9, A, B, or E, refer to the *RS/6000 and @server pSeries Diagnostic Information for Multiple Bus Systems*.

---

### Replacing the Primary Drawer Operator Panel

Licensed programs frequently rely on system information that is stored in the VPD module on the primary drawer’s operator panel. If the MAPs indicate that the operator panel should be replaced, the pluggable VPD module must be swapped. If the old module is defective, or cannot be recovered, contact service support.

---

### Replacing the Network Adapter

If a network adapter is replaced, the network administrator must be notified so that the client IP addresses used by the server can be updated. In addition, the operating system configuration of the network controller may need to be changed in order to enable system startup. Also check to ensure that any client or server that accesses this system is updated.

---

## Analyzing SPCN Errors on Secondary Drawers

The drawer number of a secondary I/O drawer (which displays in the operator panel in the form *UO.n*, where *n* is the drawer number) does not change unless a repair action or a configuration change has occurred. However, after a secondary I/O drawer has been removed, added, or had its backplane replaced, there is a window of time during the IPL process in which the drawer number may appear to be out of range. For example, if there is one I/O drawer in the system and one is added, it may temporarily be assigned a drawer number of 5 or greater. The drawer numbers are reallocated and finalized during the latter stages of the boot process.

If a fatal SPCN error occurs while the drawer has a temporary number, the system halts with an 8-character error code displayed in the form 10n1xxxx, where *n* is the drawer number. To determine the error, if *n* is not equal to 1, substitute the number 2 for *n*, then look up the error code in Chapter 5, “Error Code to FRU Index” on page 171. Perform the indicated actions on the failing drawer.

If a nonfatal SPCN error occurs while the drawer has a temporary number, this temporary number may appear as part of a location code in the service processor error log or while running AIX diagnostics. If the nonfatal error became fatal or is the cause of a fatal error, the drawer address will have been resolved and the original error log entry can be ignored.

---

## Isolating the I/O Drawer Failure

The primary I/O drawer is drawer number 1, although it is not displayed on the operator panel.

To determine which I/O drawer is failing, you may find the attention LED on an I/O drawer indicates a fault. Check the LEDs on the front of each I/O drawer to isolate failures to a single drawer. See “Primary I/O Drawer Operator Panel” on page 22 and “Secondary I/O Drawer Operator Panel” on page 22 for the location and meaning of the LEDs on the I/O drawer operator panels.

---

## Determining Location Code

If you have an error code in the form 2xxx xxxx or Exxx, and no location code associated with it, the location code may possibly be found in three places, depending on the state of the system:

- If the system will boot into AIX, the location code will be reported when error log analysis is run under AIX diagnostics.
- If the system will boot into the system management services (SMS) menus, the SMS error log will contain the location code associated with the error code. See “Display Error Log” on page 457.
- If the system halted when the error occurred, the error code and location can be found in the LCD progress indicator log, which can be accessed using the service processor menus. See “System Information Menu” on page 424, then select “Read Progress Indicator From Last System Boot”. Find the error code that directed you to this note in the list, and the location code should be a part of the entry in the log.

## Checkpoint and Error Code Index

The table below is an index to the checkpoints or error codes that you may receive to help diagnose a failure. Locate the code you received and follow the instructions to determine your next step.

*Table 3. Checkpoint and Error Code Index*

<b>First 4 characters of code</b>	<b>What You Should Do</b>
0000 xxxx	Operator Panel Error Codes  Go to “Operator Panel Error Codes” on page 176 and follow the instructions in the operator panel error code table.
1xxx xxxx	System Power Control Network (SPCN) Error Codes  Go to “SPCN Error Codes” on page 177 and follow the instructions in the SPCN error code table.
2xxx xxxx	Firmware Error Codes  Go to “Firmware/POST Error Codes” on page 212 and follow the instructions in the firmware error code table.
4xxx xxxx	Service Processor Error Codes <ol style="list-style-type: none"> <li>1. Perform slow boot, see “Performing Slow Boot” on page 174.</li> <li>2. If the error codes are 406x xxxx or 450x xxxx, and if their actions call out memory DIMMs or cards containing memory DIMMs, go to “Memory-Related Error Codes” on page 175. For all other error codes, go to “Confirming Initial Error Code” on page 174.</li> <li>3. Go to “Service Processor Error Codes” on page 233 and follow the instructions in the Service Processor Error Codes table.</li> </ol>
8xxx 9xxx Axxx Bxxx	Service Processor Checkpoints  Go to “Service Processor Checkpoints” on page 150 for more information on these checkpoints.
B006 xxxx B1xx xxxx	Common Firmware Error Codes <ol style="list-style-type: none"> <li>1. Go to “Common Firmware Error Codes” on page 389 and follow the instructions in the Common Firmware Error Codes table.</li> <li>2. Perform slow boot, see “Performing Slow Boot” on page 174.</li> <li>3. Confirm this is the first error code that caused the failure as described in “Confirming Initial Error Code” on page 174.</li> </ol>
Exxx	Firmware Checkpoints  Go to “Firmware Checkpoints” on page 156 for more information on these checkpoints.
Mxxx xxxx	Problem Determination-Generated Error Codes  Go to “Problem Determination-Generated Error Codes” on page 398 and follow the instructions in the More General Error Code table.

---

## Performing Slow Boot

On this system, the error code displayed in the operator panel may not indicate the root cause of the problem. To fully analyze all of the available information, perform the following steps before doing a hardware repair or replacement:

1. Record the 8-character error code (and location code if present) in operator panel.
2. Do a slow-mode boot to the SMS menus. This can be specified using the System Power Control Menu on the service processor main menu. (A fast-mode boot skips much of the built-in diagnostic testing.) A slow-mode boot may yield a new 8-character error code on the operator panel and new errors in the service processor error log. If a new error code is reported, use it in subsequent steps to continue problem analysis. If the system hangs with the same error code, continue with the next step in the Checkpoint and Error Code Index. If no 8-character error code is displayed on the operator panel, use the original error code and continue with the next step in the Checkpoint and Error Code Index.
3. A slow boot in service mode should result in the Diagnostic Operating Instructions panel being displayed.
4. Press Enter to continue to the Function Selection menu.
5. Enter option 5, "Single User Mode."
6. When prompted, enter the root password.
7. At the prompt, issue the shutdown -F command.
8. At this point, the service processor menus should be available to examine the service processor error log.

---

## Confirming Initial Error Code

The service processor may have recorded one or more symptoms in its error log. If the system has attempted to boot since an error terminated normal operation, there may be specific fault information in the service processor error log. Examine this error log before proceeding (see "System Information Menu" on page 424).

In the service processor error log, the most recent error is at the top of the list and the oldest error is at the bottom. Examine the time stamp associated with each error. (The time stamps in the service processor error log reflect coordinated universal time (UTC), which is also referred to as Greenwich mean time.)

On this system, the error code displayed in the operator panel may not be indicative of the root cause of the problem. This is also true of the most recent error in the service processor error log.

Find the error code in the service processor error log that directed you to this note. (If the error code is not in the error log, perform the service actions for the error code that was first reported.) Examine the time stamps to look for a group of failures that happened within minutes prior to this error code. In this group, start at the error code with the earliest time stamp. To get a list of possible FRUs, select the detail screen for each error code and perform the listed repair actions. If the repair actions for an error code are ineffective, continue to work upward through this group of error codes (which is forward in time from the earliest time stamp to the latest) until the problem is fixed, or you reach the error code that was first reported. If the system is still not fixed, go to "MAP 1540: Minimum Configuration" on page 122.



---

## Memory-Related Error Codes

You have been directed here because you have an 8-character error code that indicates a problem with system memory. This section will help you isolate to the failing FRU.

- If the location code or the service action calls out one DIMM, do the following:
  1. Replace the memory DIMM.
  2. Replace the memory group (pair, quad, or octal).
  3. Replace the memory card.
- If more than one DIMM is called out, go to the service processor Memory Configuration/Deconfiguration Menu to verify memory DIMMs state (see "Memory Configuration/Deconfiguration Menu" on page 426 for more information) then do the following:
  1. From the Memory Configuration/Deconfiguration Menu, select the card(s) specified by the location code(s) of the failing DIMM(s). If the first character of the error status of any DIMM is 1, 2, or 3 (but not 0 or 4), this is a suspect DIMM. Record its location. See "System Information Menu" on page 424 for more information on the error status of the DIMMs.
  2. If only one DIMM was recorded in the previous step:
    - a. Replace the DIMM.
    - b. Replace the memory group (pair, quad, or octal).
    - c. Replace the memory card.
  3. If more than one DIMM was recorded, and the DIMMs reside in more than one group (pair, quad, or octal):
    - a. Replace the memory card.
    - b. Replace all of the failing DIMMs.
  4. If more than one DIMM was recorded, and the DIMMs reside in one group (pair, quad, or octal):
    - a. Replace all of the failing DIMMs.
    - b. Replace the memory card.

Boot the system to the SMS menus. Power off the system and go to the service processor Memory Configuration/Deconfiguration Menu to verify that all memory DIMMs are in the configured state after the repair action. Go to "MAP 0410: Repair Checkout" in *RS/6000 and @server pSeries Diagnostic Information for Multiple Bus Systems*.

## Operator Panel Error Codes

**Attention:** If you replace FRUs or perform an action and the problem is still not corrected, go to “MAP 1540: Minimum Configuration” on page 122 unless otherwise indicated in the tables.

If you replace FRUs and the problem is corrected, go to “MAP 0410: Repair Checkout” in *RS/6000 and @server pSeries Diagnostic Information for Multiple Bus Systems*.

**Note:** Do not shut down the system if the FRU was replaced by hot swap.

Table 4. Operator Panel Error Codes

Error Code	Description	Action/ Possible Failing FRU
0000 1111	At power on, failure of power-good signal from power supply	<ol style="list-style-type: none"> <li>1. Primary I/O backplane Location: U0.1-P1</li> <li>2. Primary I/O power supply Locations: U0.1-V1 U0.1-V2</li> </ol>
0000 1112	At power off, failure of power-good signal from power supply	<ol style="list-style-type: none"> <li>1. Primary I/O backplane Location: U0.1-P1</li> <li>2. Primary I/O power supply Locations: U0.1-V1 U0.1-V2</li> </ol>
0000 1113	While power on, failure of power-good signal from power supply	<ol style="list-style-type: none"> <li>1. Primary I/O backplane Location: U0.1-P1</li> <li>2. Primary I/O power supply Locations: U0.1-V1 U0.1-V2</li> </ol>
0000 1114	Primary I/O drawer operator panel and service processor have been reset after main power disturbance	Information message
0000 2222	Primary I/O drawer operator panel not communicating with service processor	<ol style="list-style-type: none"> <li>1. If system cannot be powered off, reset the service processor (by the pinhole reset or by disconnecting then reconnecting power).</li> <li>2. Primary I/O drawer backplane Location: U0.1-P1</li> </ol>
0000 3333	SPCN communications error	Primary I/O backplane Location: U0.1-P1
0000 3334	I2C repeater error	Primary I/O backplane Location: U0.1-P1
0000 BBBB	TOD battery malfunction	TOD battery Location: U0.1-P1-V3

## SPCN Error Codes

**Attention:** If a power supply or fan is hot-swapped, wait five minutes, then recheck the AIX error log. If the system has to be shut down to replace a power supply or fan, reboot the system, wait five minutes after the AIX login prompt appears, then recheck the AIX error log. If the detailed information for the most recent error with the same identifier indicates that the original problem has not been fixed by performing the first action in the action column, continue with the next action in the action column.

**Attention:** If you replace FRUs or perform an action and the problem is still not corrected, go to "MAP 1540: Minimum Configuration" on page 122 unless otherwise indicated in the tables.

If you replace FRUs and the problem is corrected, go to "MAP 0410: Repair Checkout" in *RS/6000 and @server pSeries Diagnostic Information for Multiple Bus Systems*.

**Note:** Do not shut down the system if the FRU was replaced by hot swap.

Table 5. SPCN Error Codes

Error Code	Description	Action/ Possible Failing FRU
1011 00AC	ac loss or brownout detected	Information message
1011 00EF	Room emergency power off detected	Information message
1011 1510	Power supply 1 power source failure	<ol style="list-style-type: none"> <li>1. Check input power to power supply 1 Location: U0.1-V1</li> <li>2. Primary I/O drawer power supply 1 Location: U0.1-V1</li> <li>3. Primary I/O backplane Location: U0.1-P1</li> </ol>
1011 1511	Power supply 1 fault	<ol style="list-style-type: none"> <li>1. Primary I/O drawer power supply 1 Location: U0.1-V1</li> <li>2. Primary I/O backplane Location: U0.1-P1</li> </ol>
1011 1512	Power supply 1 non-power fault	<ol style="list-style-type: none"> <li>1. Primary I/O drawer power supply 1 Location: U0.1-V1</li> <li>2. Primary I/O backplane Location: U0.1-P1</li> </ol>
1011 1513	Power supply 1 domain fault	<ol style="list-style-type: none"> <li>1. Primary I/O drawer power supply 1 Location: U0.1-V1</li> <li>2. Primary I/O backplane Location: U0.1-P1</li> </ol>

Table 5. SPCN Error Codes (continued)

Error Code	Description	Action/ Possible Failing FRU
1011 1514	Power supply 1 cooling fault	<ol style="list-style-type: none"> <li>1. Primary I/O drawer power supply 1 Location: U0.1-V1</li> <li>2. Primary I/O backplane Location: U0.1-P1</li> </ol>
1011 1516	Swapped power supply and cooling unit or power supply 1 missing	<ol style="list-style-type: none"> <li>1. Verify correct installation of power supply and cooling unit Location: U0.1-V1</li> <li>2. Primary I/O power supply 1 Location: U0.1-V1</li> </ol>
1011 1520	Power supply 2 power source failure	<ol style="list-style-type: none"> <li>1. Check input power to Power Supply 2 Location: U0.1-V2</li> <li>2. Primary I/O drawer power supply 2 Location: U0.1-V2</li> <li>3. Primary I/O backplane Location: U0.1-P1</li> </ol>
1011 1521	Power supply 2 fault	<ol style="list-style-type: none"> <li>1. Primary I/O drawer power supply 2 Location: U0.1-V2</li> <li>2. Primary I/O backplane Location: U0.1-P1</li> </ol>
1011 1522	Power supply 2 non-power fault	<ol style="list-style-type: none"> <li>1. Primary I/O drawer power supply 2 Location: U0.1-V2</li> <li>2. Primary I/O backplane Location: U0.1-P1</li> </ol>
1011 1523	Power supply 2 domain fault	<ol style="list-style-type: none"> <li>1. Primary I/O drawer power supply 2 Location: U0.1-V2</li> <li>2. Primary I/O backplane Location: U0.1-P1</li> </ol>
1011 1524	Power supply 2 cooling fault	<ol style="list-style-type: none"> <li>1. Primary I/O drawer power supply 2 Location: U0.1-V2</li> <li>2. Primary I/O backplane Location: U0.1-P1</li> </ol>
1011 1526	Power supply 2 missing	I/O drawer power supply 2 Location: U0.1-V2
1011 1611	CEC regulator 1 fault	Regulator card Location: U1.1-P1-V1
1011 1612	CEC regulator 1 non-power fault	Regulator card Location: U1.1-P1-V1
1011 1613	CEC regulator 1 domain fault	Regulator card Location: U1.1-P1-V1

Table 5. SPCN Error Codes (continued)

<b>Error Code</b>	<b>Description</b>	<b>Action/ Possible Failing FRU</b>
1011 1621	CEC regulator 2 fault	Regulator card Location: U1.1-P1-V1
1011 1622	CEC regulator 2 non-power fault	Regulator card Location: U1.1-P1-V1
1011 1623	CEC regulator 2 domain fault	Regulator card Location: U1.1-P1-V1
1011 1631	CEC regulator 3 fault	RIO expander card Location: U1.1-P1.1
1011 1632	CEC regulator 3 non-power fault	1. RIO expander card Location: U1.1-P1.1 2. Primary I/O backplane Location: U0.1-P1
1011 1633	CEC regulator 3 domain fault	RIO expander card Location: U1.1-P1.1
1011 1910	Power supply 1 power source failure	1. Check input to power supply 1 Location: U1.1-V1 2. CEC drawer power supply 1 Location: U1.1-V1 3. Primary I/O backplane Location: U0.1-P1
1011 1911	Power supply 1 fault	1. CEC drawer power supply 1 Location: U1.1-V1 2. Primary I/O backplane Location: U0.1-P1
1011 1912	Power supply 1 non-power fault	1. CEC drawer power supply 1 Location: U1.1-V1 2. Primary I/O backplane Location: U0.1-P1
1011 1913	Power supply 1 domain fault	1. CEC drawer power supply 1 Location: U1.1-V1 2. Primary I/O backplane Location: U0.1-P1
1011 1914	Power supply 1 cooling fault	1. CEC drawer power supply 1 Location: U1.1-V1 2. Primary I/O backplane Location: U0.1-P1
1011 1920	Power supply 2 power source failure	1. Check input power to Power Supply 2 Location: U1.1-V2 2. CEC drawer power supply 2 Location: U1.1-V2 3. Primary I/O backplane Location: U0.1-P1

Table 5. SPCN Error Codes (continued)

Error Code	Description	Action/ Possible Failing FRU
1011 1921	Power supply 2 fault	<ol style="list-style-type: none"> <li>1. CEC drawer power supply 2 Location: U1.1-V2</li> <li>2. Primary I/O backplane Location: U0.1-P1</li> </ol>
1011 1922	Power supply 2 non-power fault	<ol style="list-style-type: none"> <li>1. CEC drawer power supply 2 Location: U1.1-V2</li> <li>2. Primary I/O backplane Location: U0.1-P1</li> </ol>
1011 1923	Power supply 2 domain fault	<ol style="list-style-type: none"> <li>1. CEC drawer power supply 2 Location: U1.1-V2</li> <li>2. Primary I/O backplane Location: U0.1-P1</li> </ol>
1011 1924	Power supply 2 cooling fault	<ol style="list-style-type: none"> <li>1. CEC drawer power supply 2 Location: U1.1-V2</li> <li>2. Primary I/O backplane Location: U0.1-P1</li> </ol>
1011 1926	Power supply 2 missing	CEC drawer power supply 2 Location: U1.1-V2
1011 1B01	Load fault on +12V	<ol style="list-style-type: none"> <li>1. I/O drawer power supply Location: U0.1-V1</li> <li>2. If power supply U0.1-V2 present (no cooling unit), use the power supply you removed from U0.1-V1 to replace U0.1-V2</li> <li>3. Primary I/O backplane Location: U0.1-P1</li> </ol>
1011 1B02	Load fault on +5V	<ol style="list-style-type: none"> <li>1. I/O drawer power supply Location: U0.1-V1</li> <li>2. If power supply U0.1-V2 present (no cooling unit), use the power supply you removed from U0.1-V1 to replace U0.1-V2</li> <li>3. Primary I/O backplane Location: U0.1-P1</li> </ol>
1011 1B03	Load fault on +3.3V	<ol style="list-style-type: none"> <li>1. I/O drawer power supply Location: U0.1-V1</li> <li>2. If power supply U0.1-V2 present (no cooling unit), use the power supply you removed from U0.1-V1 to replace U0.1-V2</li> <li>3. Primary I/O backplane Location: U0.1-P1</li> </ol>

Table 5. SPCN Error Codes (continued)

Error Code	Description	Action/ Possible Failing FRU
1011 1B04	Load fault on -12V	<ol style="list-style-type: none"> <li>1. I/O drawer power supply Location: U0.1-V1</li> <li>2. If power supply U0.1-V2 present (no cooling unit), use the power supply you removed from U0.1-V1 to replace U0.1-V2</li> <li>3. Primary I/O backplane Location: U0.1-P1</li> </ol>
1011 1B05	Load fault on +1.8V	<ol style="list-style-type: none"> <li>1. I/O drawer power supply Location: U0.1-V1</li> <li>2. If power supply U0.1-V2 present (no cooling unit), use the power supply you removed from U0.1-V1 to replace U0.1-V2</li> <li>3. Primary I/O backplane Location: U0.1-P1</li> </ol>
1011 1B06	Load fault on +2.5V	<ol style="list-style-type: none"> <li>1. I/O drawer power supply Location: U0.1-V1</li> <li>2. If power supply U0.1-V2 present (no cooling unit), use the power supply you removed from U0.1-V1 to replace U0.1-V2</li> <li>3. Primary I/O backplane Location: U0.1-P1</li> </ol>
1011 1B07	Load fault on +2.5V	<ol style="list-style-type: none"> <li>1. I/O drawer power supply Location: U0.1-V1</li> <li>2. If power supply U0.1-V2 present (no cooling unit), use the power supply you removed from U0.1-V1 to replace U0.1-V2</li> <li>3. Primary I/O backplane Location: U0.1-P1</li> </ol>
1011 1C01	Load fault on the +12V bus	Go to "MAP 1520: Power" on page 94.
1011 1C03	Load fault on the +3.3V bus	Go to "MAP 1520: Power" on page 94.
1011 1C05	Load fault on the +1.8V bus	Go to "MAP 1520: Power" on page 94.
1011 1C06	Load fault on the +2.5V bus	Go to "MAP 1520: Power" on page 94.
1011 1C07	Load fault on the +2.5V bus	Go to "MAP 1520: Power" on page 94.
1011 1C08	Load fault on the +2.5V bus	Go to "MAP 1520: Power" on page 94.
1011 1F00	Power system communication fault	Primary I/O backplane Location: U0.1-P1

Table 5. SPCN Error Codes (continued)

Error Code	Description	Action/ Possible Failing FRU
1011 1F01	Secondary serial number write failed	<ol style="list-style-type: none"> <li>1. Check for system firmware update</li> <li>2. Call second level of support</li> </ol>
1011 2600	Pgood fault	Primary I/O backplane Location: U0.1-P1
1011 2601	Pgood fault	Primary I/O backplane Location: U0.1-P1
1011 2602	CEC power domain fault	<ol style="list-style-type: none"> <li>1. Check VS COMM and SPCN connections</li> <li>2. Reseat CEC drawer</li> <li>3. Check input power to power supplies Locations: U1.1-V1 U1.1-V2</li> <li>4. CEC power supplies Locations: U1.1-V1 U1.1-V2</li> <li>5. CEC backplane Location: U1.1-P1</li> <li>6. Primary I/O backplane Location: U0.1-P1</li> </ol>
1011 2603	Primary I/O drawer power domain fault	<ol style="list-style-type: none"> <li>1. Check input power to power supplies Locations: U0.1-V1 U0.1-V2</li> <li>2. Check VS COMM and SPCN connections</li> <li>3. Reseat CEC drawer</li> <li>4. Primary I/O drawer power supplies Locations: U0.1-V1 U0.1-V2</li> <li>5. I/O Drawer power distribution board Location: U0.1-X1</li> <li>6. Primary I/O backplane Location: U0.1-P1</li> </ol>
1011 2604	Power domain fault in CEC and primary I/O drawers	See error codes 1011 2602 and 1011 2603
1011 2610	Missing or unplugged memory	Inspect system memory in the CEC drawer for proper installation of DIMMs and memory riser cards. Location: U1.1
1011 2612	SPCN problem	Primary I/O drawer backplane Location: U0.1-P1
1011 2613	Power configuration fault	220V ac required



Table 5. SPCN Error Codes (continued)

<b>Error Code</b>	<b>Description</b>	<b>Action/ Possible Failing FRU</b>
1011 3100	I2C controller fault	Primary I/O backplane Location: U0.1-P1
1011 3101	I2C bus 1 fault	1. Primary I/O drawer operator panel Location: U0.1-L1 2. Primary I/O backplane Location: U0.1-P1
1011 3102	I2C bus 2 fault	Primary I/O backplane Location: U0.1-P1
1011 3104	I2C bus 4 fault	Primary I/O backplane Location: U0.1-P1
1011 3105	I2C bus 5 fault	1. Fan controller card Location: U0.1-X2 2. Primary I/O backplane Location: U0.1-P1 3. I/O drawer power distribution board Location: U0.1-X1
1011 3113	RIO bus adapter fault	Primary I/O drawer RIO bus adapter Location: U0.1-P1.1
1011 3114	PCI backplane fault	Primary I/O PCI backplane Location: U0.1-P1
1011 3115	Primary drawer operator panel fault	Primary I/O drawer operator panel Location: U0.1-L1
1011 3116	Fan controller fault	1. Fan controller card Location: U0.1-X2 2. Primary I/O backplane Location: U0.1-P1 3. I/O drawer power distribution board Location: U0.1-X1
1011 3117	System power/cooling control fault	I/O backplane Location: U0.1-P1
1011 3118	System power control network fault	I/O backplane Location: U0.1-P1
1011 311C	Thermal sensor fault	1. Primary I/O drawer operator panel Location: U0.1-L1 2. I/O backplane Location: U0.1-P1

Table 5. SPCN Error Codes (continued)

<b>Error Code</b>	<b>Description</b>	<b>Action/ Possible Failing FRU</b>
1011 7610	Slow I/O drawer fan 1	<ol style="list-style-type: none"> <li>1. Fan 1 Location: U0.1-F1</li> <li>2. Primary fan controller Location: U0.1-X2</li> <li>3. I/O drawer power distribution board Location: U0.1-X1</li> </ol>
1011 7611	Missing I/O drawer fan 1	Fan 1 Location: U0.1-F1
1011 7620	Slow I/O drawer fan 2	<ol style="list-style-type: none"> <li>1. Fan 2 Location: U0.1-F2</li> <li>2. Primary fan controller Location: U0.1-X2</li> <li>3. I/O drawer power distribution board Location: U0.1-X1</li> </ol>
1011 7621	Missing I/O drawer fan 2	Fan 2 Location: U0.1-F2
1011 7630	Slow I/O drawer fan 3	<ol style="list-style-type: none"> <li>1. Fan 3 Location: U0.1-F3</li> <li>2. Primary fan controller Location: U0.1-X2</li> <li>3. I/O drawer power distribution board Location: U0.1-X1</li> </ol>
1011 7631	Missing I/O drawer fan 3	Fan 3 Location: U0.1-F3
1011 7640	Slow I/O drawer fan 4	<ol style="list-style-type: none"> <li>1. Fan 4 Location: U0.1-F4</li> <li>2. Primary fan controller Location: U0.1-X2</li> <li>3. I/O drawer power distribution board Location: U0.1-X1</li> </ol>
1011 7641	Missing I/O drawer fan 4	Fan 4 Location: U0.1-F4
1011 7650	Slow I/O drawer fan 5 in I/O drawer power supply 1	<ol style="list-style-type: none"> <li>1. I/O drawer power supply 1 Location: U0.1-V1</li> <li>2. Primary fan controller Location: U0.1-X2</li> <li>3. I/O drawer power distribution board Location: U0.1-X1</li> </ol>
1011 7651	Missing I/O drawer fan 5 in I/O drawer power supply 1	I/O drawer power supply 1 Location: U0.1-V1

Table 5. SPCN Error Codes (continued)

Error Code	Description	Action/ Possible Failing FRU
1011 7660	Slow I/O drawer fan 6 in I/O drawer power supply 2	<ol style="list-style-type: none"> <li>I/O drawer power supply 2 Location: U0.1-V2</li> <li>Primary fan controller Location: U0.1-X2</li> <li>I/O drawer power distribution board Location: U0.1-X1</li> </ol>
1011 7661	Missing I/O drawer fan 6	I/O drawer power supply 2 Location: U0.1-V2
1011 7690	Slow I/O drawer fan 9 in cooling unit	<ol style="list-style-type: none"> <li>Fan 9 (Cooling unit) Location: U0.1-F9</li> <li>Primary fan controller Location: U0.1-X2</li> <li>I/O drawer power distribution board Location: U0.1-X1</li> </ol>
1011 7691	Missing I/O drawer fan 9 in cooling unit	Fan 9 (cooling unit) Location: U0.1-F9
1011 7710	Slow CEC fan 1	<ol style="list-style-type: none"> <li>Fan 1 Location: U1.1-F1</li> <li>Primary I/O backplane Location: U0.1-P1</li> </ol>
1011 7711	Missing CEC fan 1	<p>Fan 1 Location: U1.1-F1</p> <p><b>Note:</b> If the primary I/O drawer planar has been replaced recently, verify that the I/O type is set correctly before changing this fan. For more information on setting the I/O type, see "Power Control Network Utilities Menu" on page430.</p>
1011 7720	Slow CEC fan 2	<ol style="list-style-type: none"> <li>Fan 2 Location: U1.1-F2</li> <li>Primary I/O backplane Location: U0.1-P1</li> </ol>
1011 7721	Missing CEC fan 2	Fan 2 Location: U1.1-F2
1011 7731	Missing CEC fan 3 - invalid error on this system	If this error code occurs, it indicates that the I/O type of the primary I/O drawer planar is not correct. For more information on setting the I/O type, see "Power Control Network Utilities Menu" on page430.
1011 8400	VPD configuration problem	Ignore all location codes. Go to MAP 1540 and run CEC minimum configuration.

Table 5. SPCN Error Codes (continued)

Error Code	Description	Action/ Possible Failing FRU
1011 8401	VPD access problem	Ignore all location codes. Go to MAP 1540 and run CEC minimum configuration.
1011 8402	VPD access problem	Ignore all location codes. Go to MAP 1540 and run CEC minimum configuration.
1011 8403	VPD level mismatch	Ignore all location codes. Go to MAP 1540 and run CEC minimum configuration.
1011 8404	PU 2 mismatch	1. Processor card Location: U1.1-P1-C2 2. Primary I/O backplane Location: U0.1-P1
1011 8409	Processor card VPD problem	1. Ensure that the processor card(s) are the right type for the system and that they are properly installed. 2. CEC processor card Locations: U1.1-P1-C1 U1.1-P1-C2
1011 840A	VPD +5 stuck high	Ignore all location codes. Go to MAP 1540 and run CEC minimum configuration.
1011 840B	VPD +5 stuck low	Ignore all location codes. Go to MAP 1540 and run CEC minimum configuration.
1011 840C	Memory DIMM misplugged	Inspect system memory in the CEC drawer for proper installation of DIMMs and memory riser cards. Location: U1.1
1011 840D	I/O type mismatch	1. Check cabling 2. From the main service processor menu, select the <b>System Information Menu</b> , then select the <b>Power Control Network Utilities Menu</b> . Use option three to set the I/O type to 84. Reboot the system. 3. Primary I/O drawer backplane Location: U0.1-P1

Table 5. SPCN Error Codes (continued)

Error Code	Description	Action/ Possible Failing FRU
1011 840E	SPCN default configuration loaded	<ol style="list-style-type: none"> <li>1. Check cabling</li> <li>2. From the main service processor menu, select the <b>System Information Menu</b>, then select the <b>Power Control Network Utilities Menu</b>. Use option three to set the I/O type to 87. Reboot the system.</li> <li>3. Primary I/O drawer backplane Location: U0.1-P1</li> </ol>
1011 840F	I/O type not recognized	<ol style="list-style-type: none"> <li>1. Check cabling</li> <li>2. From the main service processor menu, select the <b>System Information Menu</b>, then select the <b>Power Control Network Utilities Menu</b>. Use option three to set the I/O type to 87. Reboot the system.</li> <li>3. Primary I/O drawer backplane Location: U0.1-P1</li> </ol>
1011 8413	Invalid processor 1 VPD	Processor card Location: U1.1-P1-C1
1011 8414	Invalid processor 2 VPD	Processor card Location: U1.1-P1-C2
1011 8423	No processor 1 VPD	Processor card Location: U1.1-P1-C1
1011 8424	No processor 2 VPD	Processor card Location: U1.1-P1-C2
1011 8430	V/S COMM cable not connected properly	Check cabling
1011 8431	Frame ID error	<ol style="list-style-type: none"> <li>1. Check cabling</li> <li>2. From the main service processor menu, select the <b>System Information Menu</b>, then select the <b>Power Control Network Utilities Menu</b>. Use option three to set the I/O type to 87. Reboot the system.</li> <li>3. Primary I/O drawer backplane Location: U0.1-P1</li> </ol>
1011 8441	Internal SPCN error in a drawer	<ol style="list-style-type: none"> <li>1. Check the internal SPCN cables in the CEC drawer Location: U1.1</li> <li>2. Check the internal SPCN cables in the I/O drawer Location: U0.x</li> </ol>

Table 5. SPCN Error Codes (continued)

Error Code	Description	Action/ Possible Failing FRU
1011 8450	The CEC processor(s) is (are) incompatible with the CEC regulator	If a CEC processor or CEC regulator was recently changed or if new firmware was recently loaded, check the part numbers or CCIN of the CEC processors and CEC regulator. CEC regulator Location: U1.1-P1-V1 Processor card Locations: U1.1-P1-C1 U1.1-P1-C2
1011 8A00	A different I/O drawer is connected to the CEC	Informational only
1011 9012	Invalid address	1. Check SPCN cabling 2. Primary I/O backplane Location: U0.1-P1
1011 9013	Invalid address	1. Check SPCN cabling 2. Primary I/O backplane Location: U0.1-P1
1011 9014	Invalid address mode	Update system firmware Location: U0.1-P1/Y1
1011 9038	Node fault	Primary I/O backplane Location: U0.1-P1
1011 9039	Node fault	Primary I/O backplane Location: U0.1-P1
1011 9042	EEPROM failure	Primary I/O backplane Location: U0.1-P1
1011 9043	Download failure	1. Check for system firmware update 2. Call second level of support
1011 9046	QDS packet sequence error	1. Check for system firmware update 2. Call second level of support
1011 9047	QDS block sequence error	1. Check for system firmware update 2. Call second level of support
1011 9080	Undefined status code received	Primary I/O backplane Location: U0.1-P1
1011 90F0	CEC drawer not present in configuration table	1. Check SPCN cabling 2. Reset system and reboot 3. Primary I/O backplane Location: U0.1-P1
1011 9101	SPCN failed to respond to service processor in time	Primary I/O backplane Location: U0.1-P1
1011 9102	Permanent address assignment failed	Primary I/O backplane Location: U0.1-P1

Table 5. SPCN Error Codes (continued)

<b>Error Code</b>	<b>Description</b>	<b>Action/ Possible Failing FRU</b>
1011 9103	Download initialize timeout	Primary I/O backplane Location: U0.1-P1
1011 9104	Download completion timeout	Primary I/O backplane Location: U0.1-P1
1011 9105	Load damaged timeout	Primary I/O backplane Location: U0.1-P1
1011 9109	Download failure	Primary I/O backplane Location: U0.1-P1
1011 9111	Network too large for service processor	1. Check for system firmware update 2. Call second level of support
1011 9114	Firmware image corrupted	1. Reinstall system firmware 2. Primary I/O backplane Location: U0.1-P1
1011 9116	SPCN communication with operator panel failure	1. Primary I/O drawer operator panel Location: U0.1-L1 2. Primary I/O backplane Location: U0.1-P1
1021 00AA	System power control network firmware update started (no error)	Informational message
1021 1510	Power supply 1 power source failure	1. Check input power to power supply 1 Location: U0.2-V1 2. I/O drawer power supply 1 Location: U0.2-V1 3. Secondary I/O backplane Location: U0.2-P1
1021 1511	Power supply 1 fault	1. I/O drawer power supply 1 Location: U0.2-V1 2. Secondary I/O backplane Location: U0.2-P1
1021 1512	Power supply 1 non-power fault	1. I/O drawer power supply 1 Location: U0.2-V1 2. Secondary I/O backplane Location: U0.2-P1
1021 1513	Power supply 1 domain fault	1. I/O drawer power supply 1 Location: U0.2-V1 2. Secondary I/O backplane Location: U0.2-P1
1021 1514	Power supply 1 cooling fault	1. I/O drawer power supply 1 Location: U0.2-V1 2. Secondary I/O backplane Location: U0.2-P1

Table 5. SPCN Error Codes (continued)

Error Code	Description	Action/ Possible Failing FRU
1021 1516	Swapped power supply and cooling unit or power supply 1 missing	<ol style="list-style-type: none"> <li>1. Verify correct installation of power supply and cooling unit Location: U0.2-V1</li> <li>2. Primary I/O power supply 1 Location: U0.2-V1</li> </ol>
1021 1520	Power supply 2 power source failure	<ol style="list-style-type: none"> <li>1. Check input power to power supply 2 Location: U0.2-V2</li> <li>2. I/O drawer power supply 2 Location: U0.2-V2</li> <li>3. Secondary I/O backplane Location: U0.2-P1</li> </ol>
1021 1521	Power supply 2 fault	<ol style="list-style-type: none"> <li>1. I/O drawer power supply 2 Location: U0.2-V2</li> <li>2. Secondary I/O backplane Location: U0.2-P1</li> </ol>
1021 1522	Power supply 2 fault	<ol style="list-style-type: none"> <li>1. I/O drawer power supply 2 Location: U0.2-V2</li> <li>2. Secondary I/O backplane Location: U0.2-P1</li> </ol>
1021 1523	Power supply 2 domain fault	<ol style="list-style-type: none"> <li>1. I/O drawer power supply 2 Location: U0.2-V2</li> <li>2. Secondary I/O backplane Location: U0.2-P1</li> </ol>
1021 1524	Power supply 2 cooling fault	<ol style="list-style-type: none"> <li>1. I/O drawer power supply 2 Location: U0.2-V2</li> <li>2. Secondary I/O backplane Location: U0.2-P1</li> </ol>
1021 1B01	Load fault on +12V	<ol style="list-style-type: none"> <li>1. I/O drawer power supply Location: U0.2-V1</li> <li>2. If power supply U0.2-V2 is present (no cooling unit), use the power supply you removed from U0.2-V1 to replace U0.2-V2</li> <li>3. Secondary I/O backplane Location: U0.2-P1</li> </ol>
1021 1B02	Load fault on +5V	<ol style="list-style-type: none"> <li>1. I/O drawer power supply Location: U0.2-V1</li> <li>2. If power supply U0.2-V2 is present (no cooling unit), use the power supply you removed from U0.2-V1 to replace U0.2-V2</li> <li>3. Secondary I/O backplane Location: U0.2-P1</li> </ol>



Table 5. SPCN Error Codes (continued)

Error Code	Description	Action/ Possible Failing FRU
1021 1B03	Load fault on +3.3V	<ol style="list-style-type: none"> <li>1. I/O drawer power supply Location: U0.2-V1</li> <li>2. If power supply U0.2-V2 is present (no cooling unit), use the power supply you removed from U0.2-V1 to replace U0.2-V2</li> <li>3. Secondary I/O backplane Location: U0.2-P1</li> </ol>
1021 1B04	Load fault on -12V	<ol style="list-style-type: none"> <li>1. I/O drawer power supply Location: U0.2-V1</li> <li>2. If power supply U0.2-V2 is present (no cooling unit), use the power supply you removed from U0.2-V1 to replace U0.2-V2</li> <li>3. Secondary I/O backplane Location: U0.2-P1</li> </ol>
1021 1B05	Load fault on +1.8V	<ol style="list-style-type: none"> <li>1. I/O drawer power supply Location: U0.2-V1</li> <li>2. If power supply U0.2-V2 is present (no cooling unit), use the power supply you removed from U0.2-V1 to replace U0.2-V2</li> <li>3. Secondary I/O backplane Location: U0.2-P1</li> </ol>
1021 1B06	Load fault on +2.5V	<ol style="list-style-type: none"> <li>1. I/O drawer power supply Location: U0.2-V1</li> <li>2. If power supply U0.2-V2 is present (no cooling unit), use the power supply you removed from U0.2-V1 to replace U0.2-V2</li> <li>3. Secondary I/O backplane Location: U0.2-P1</li> </ol>
1021 1B07	Load fault on +2.5V	<ol style="list-style-type: none"> <li>1. I/O drawer power supply Location: U0.2-V1</li> <li>2. If power supply U0.2-V2 is present (no cooling unit), use the power supply you removed from U0.2-V1 to replace U0.2-V2</li> <li>3. Secondary I/O backplane Location: U0.2-P1</li> </ol>
1021 2600	Pgood fault	Secondary I/O backplane Location: U0.2-P1
1021 2601	Pgood fault	Secondary I/O backplane Location: U0.2-P1

Table 5. SPCN Error Codes (continued)

Error Code	Description	Action/ Possible Failing FRU
1021 2603	Secondary I/O drawer power domain fault	<ol style="list-style-type: none"> <li>1. Check input power to power supplies Locations: U0.2-V1 U0.2-V2</li> <li>2. I/O drawer power supplies Locations: U0.2-V1 U0.2-V2</li> <li>3. I/O Drawer Power Distribution Board Location: U0.2-X1</li> <li>4. Secondary I/O backplane Location: U0.2-P1</li> </ol>
1021 2612	SPCN problem	Secondary I/O backplane Location: U0.2-P1
1021 3100	I2C controller fault	Secondary I/O backplane Location: U0.2-P1
1021 3101	I2C bus 1 fault	<ol style="list-style-type: none"> <li>1. Secondary I/O drawer operator panel Location: U0.2-L1</li> <li>2. Secondary I/O backplane Location: U0.2-P1</li> </ol>
1021 3102	I2C bus 2 fault	Secondary I/O backplane Location: U0.2-P1
1021 3104	I2C bus 4 fault	Secondary I/O backplane Location: U0.2-P1
1021 3105	I2C bus 5 fault	<ol style="list-style-type: none"> <li>1. Fan controller card Location: U0.2-X2</li> <li>2. Secondary I/O backplane Location: U0.2-P1</li> <li>3. I/O drawer power distribution board Location: U0.2-X1</li> </ol>
1021 3113	RIO bus adapter fault	RIO bus adapter Location: U0.2-P1.1
1021 3114	PCI backplane fault	Secondary I/O PCI backplane Location: U0.2-P1
1021 3115	Operator panel fault	Operator panel Location: U0.2-L1
1021 3116	Fan controller fault	<ol style="list-style-type: none"> <li>1. Fan controller card Location: U0.2-X2</li> <li>2. Secondary I/O backplane Location: U0.2-P1</li> <li>3. I/O drawer power distribution board Location: U0.2-X1</li> </ol>

Table 5. SPCN Error Codes (continued)

Error Code	Description	Action/ Possible Failing FRU
1021 3118	System power control network fault	Secondary I/O backplane Location: U0.2-P1
1021 311C	Thermal sensor fault	1. Secondary I/O drawer operator panel Location: U0.2-L1 2. Secondary I/O backplane Location: U0.2-P1
1021 7610	Slow I/O drawer fan 1	1. Fan 1 Location: U0.2-F1 2. Primary fan controller Location: U0.2-X2 3. I/O drawer power distribution board Location: U0.2-X1
1021 7611	Missing I/O drawer fan 1	Fan 1 Location: U0.2-F1
1021 7620	Slow I/O drawer fan 2	1. Fan 2 Location: U0.2-F2 2. Primary fan controller Location: U0.2-X2 3. I/O drawer power distribution board Location: U0.2-X1
1021 7621	Missing I/O drawer fan 2	Fan 2 Location: U0.2-F2
1021 7630	Slow I/O drawer fan 3	1. Fan 3 Location: U0.2-F3 2. Primary fan controller Location: U0.2-X2 3. I/O drawer power distribution board Location: U0.2-X1
1021 7631	Missing I/O drawer fan 3	Fan 3 Location: U0.2-F3
1021 7640	Slow I/O drawer fan 4	1. Fan 4 Location: U0.2-F4 2. Primary fan controller Location: U0.2-X2 3. I/O drawer power distribution board Location: U0.2-X1
1021 7641	Missing I/O drawer fan 4	Fan 4 Location: U0.2-F4

Table 5. SPCN Error Codes (continued)

Error Code	Description	Action/ Possible Failing FRU
1021 7650	Slow I/O drawer fan 5 in power supply 1	<ol style="list-style-type: none"> <li>I/O drawer power supply 1 Location: U0.2-V1</li> <li>Primary fan controller card Location: U0.2-X2</li> <li>I/O drawer power distribution board Location: U0.2-X1</li> </ol>
1021 7651	Missing I/O drawer fan 5 in power supply 1	I/O drawer power supply 1 Location: U0.2-V1
1021 7660	Slow I/O drawer fan 6 in I/O drawer power supply 2	<ol style="list-style-type: none"> <li>I/O drawer power supply 2 Location: U0.2-V2</li> <li>Primary fan controller Location: U0.2-X2</li> <li>I/O drawer power distribution board Location: U0.2-X1</li> </ol>
1021 7661	Missing I/O drawer fan 6 in I/O drawer power supply 2	I/O drawer power supply 2 Location: U0.2-V2
1021 7690	Slow secondary I/O drawer fan 9 in cooling unit	<ol style="list-style-type: none"> <li>Fan 9 (cooling unit) Location: U0.2-F9</li> <li>Primary fan controller Location: U0.2-X2</li> <li>I/O drawer power distribution board Location: U0.2-X1</li> </ol>
1021 7691	Missing secondary I/O drawer fan 9 in cooling unit	Fan 9 (cooling unit) Location: U0.2-F9
1021 8400	VPD configuration problem	<ol style="list-style-type: none"> <li>Check for system firmware update</li> <li>Call second level of support</li> </ol>
1021 8401	VPD access problem	<ol style="list-style-type: none"> <li>Check for system firmware update</li> <li>Call second level of support</li> </ol>
1021 840A	VPD +5 stuck high	Secondary I/O backplane Location: U0.2-P1
1021 840B	VPD +5 stuck low	Secondary I/O backplane Location: U0.2-P1

Table 5. SPCN Error Codes (continued)

Error Code	Description	Action/ Possible Failing FRU
1021 840D	I/O type mismatch	<ol style="list-style-type: none"> <li>1. Check cabling</li> <li>2. From the main service processor menu, select the <b>System Information Menu</b>, then select the <b>Power Control Network Utilities Menu</b>. Use option three to set the I/O type to 84. Reboot the system.</li> <li>3. Primary I/O drawer backplane Location: U0.1-P1</li> </ol>
1021 840E	SPCN default configuration loaded	<ol style="list-style-type: none"> <li>1. Check cabling</li> <li>2. From the main service processor menu, select the <b>System Information Menu</b>, then select the <b>Power Control Network Utilities Menu</b>. Use option three to set the I/O type to 84. Reboot the system.</li> <li>3. Primary I/O drawer backplane Location: U0.1-P1</li> </ol>
1021 840F	I/O type not recognized	<ol style="list-style-type: none"> <li>1. Check cabling</li> <li>2. From the main service processor menu, select the <b>System Information Menu</b>, then select the <b>Power Control Network Utilities Menu</b>. Use option three to set the I/O type to 84. Reboot the system.</li> <li>3. Primary I/O drawer backplane Location: U0.1-P1</li> </ol>
1021 8A00	A different I/O drawer is connected to the CEC	Informational only
1021 9012	Invalid address	<ol style="list-style-type: none"> <li>1. Check SPCN cabling</li> <li>2. Secondary I/O backplane Location: U0.2-P1</li> </ol>
1021 9013	Invalid address	<ol style="list-style-type: none"> <li>1. Check SPCN cabling</li> <li>2. Secondary I/O backplane Location: U0.2-P1</li> </ol>
1021 9014	Invalid address mode	<p>Update system firmware Location: U0.1-P1/Y1 Note: Allow up to 30 minutes for this update to take effect.</p>
1021 9021	SPCN temporary internal error	Information only
1021 9022	Secondary I/O drawer not present	Check cabling
1021 9023	Secondary I/O drawer is present but off	Information only

Table 5. SPCN Error Codes (continued)

<b>Error Code</b>	<b>Description</b>	<b>Action/ Possible Failing FRU</b>
1021 902D	Secondary I/O drawer not present	Information only
1021 9038	I/O drawer node fault	Secondary I/O backplane Location: U0.2-P1
1021 9039	I/O drawer node fault	Secondary I/O backplane Location: U0.2-P1
1021 9042	EEPROM failure	Secondary I/O backplane Location: U0.2-P1
1021 9043	Download failure	1. Check for system firmware update 2. Call second level of support
1021 9046	QDS packet sequence error	1. Check for system firmware update 2. Call second level of support
1021 9047	QDS block sequence error	1. Check for system firmware update 2. Call second level of support
1021 9080	Undefined status code received	Secondary I/O backplane Location: U0.2-P1
1021 90F0	Drawer not present in configuration table	1. Check SPCN cabling 2. Reset system and reboot 3. Secondary I/O backplane Location: U0.2-P1
1021 90F1	Drawer added to configuration table	Information only
1021 9102	Permanent address assignment failed	Secondary I/O backplane Location: U0.2-P1
1021 9109	Download failure	Secondary I/O backplane Location: U0.2-P1
1021 9113	Firmware image corrupted	Secondary I/O backplane Location: U0.2-P1
1021 9114	Firmware image corrupted	Secondary I/O backplane Location: U0.2-P1
1021 9116	SPCN communication with operator panel failure	1. Secondary I/O drawer operator panel Location: U0.2-L1 2. Secondary I/O backplane Location: U0.2-P1
1021 C62E	Polling error	1. Check cabling 2. Secondary I/O backplane Location: U0.2-P1 3. Primary I/O backplane Location: U0.1-P1
1031 00AA	System power control network firmware update started (no error)	Information message

Table 5. SPCN Error Codes (continued)

Error Code	Description	Action/ Possible Failing FRU
1031 1510	Power supply 1 power source failure	<ol style="list-style-type: none"> <li>1. Check input to power supply 1 Location: U0.3-V1</li> <li>2. I/O drawer power supply 1 Location: U0.3-V1</li> <li>3. Secondary I/O backplane Location: U0.3-P1</li> </ol>
1031 1511	Power supply 1 fault	<ol style="list-style-type: none"> <li>1. I/O drawer power supply 1 Location: U0.3-V1</li> <li>2. Secondary I/O backplane Location: U0.3-P1</li> </ol>
1031 1512	Power supply non-power fault	<ol style="list-style-type: none"> <li>1. I/O drawer power supply 1 Location: U0.3-V1</li> <li>2. Secondary I/O backplane Location: U0.3-P1</li> </ol>
1031 1513	Power supply domain fault	<ol style="list-style-type: none"> <li>1. I/O drawer power supply 1 Location: U0.3-V1</li> <li>2. Secondary I/O backplane Location: U0.3-P1</li> </ol>
1031 1514	Power supply 1 cooling fault	<ol style="list-style-type: none"> <li>1. I/O drawer power supply 1 Location: U0.3-V1</li> <li>2. Secondary I/O backplane Location: U0.3-P1</li> </ol>
1031 1516	Swapped power supply and cooling unit or power supply 1 missing	<ol style="list-style-type: none"> <li>1. Verify correct installation of power supply and cooling unit Location: U0.3-V1</li> <li>2. Primary I/O power supply 1 Location: U0.3-V1</li> </ol>
1031 1520	Power supply 2 power source failure	<ol style="list-style-type: none"> <li>1. Check input power to power supply 2 Location: U0.3-V2</li> <li>2. Secondary I/O drawer power supply 2 Location: U0.3-V2</li> <li>3. Secondary I/O backplane Location: U0.3-P1</li> </ol>
1031 1521	Power supply 2 fault	<ol style="list-style-type: none"> <li>1. I/O drawer power supply 2 Location: U0.3-V2</li> <li>2. Secondary I/O backplane Location: U0.3-P1</li> </ol>
1031 1522	Power supply 2 non-power fault	<ol style="list-style-type: none"> <li>1. I/O drawer power supply 2 Location: U0.3-V2</li> <li>2. Secondary I/O backplane Location: U0.3-P1</li> </ol>
1031 1523	Power supply 2 domain fault	<ol style="list-style-type: none"> <li>1. I/O drawer power supply 2 Location: U0.3-V2</li> <li>2. Secondary I/O backplane Location: U0.3-P1</li> </ol>

Table 5. SPCN Error Codes (continued)

Error Code	Description	Action/ Possible Failing FRU
1031 1524	Power supply 2 cooling fault	<ol style="list-style-type: none"> <li>1. I/O drawer power supply 2 Location: U0.3-V2</li> <li>2. Secondary I/O backplane Location: U0.3-P1</li> </ol>
1031 1526	Power supply 2 missing	I/O drawer power supply 2 Location: U0.3-V2
1031 1B01	Load fault on +12	<ol style="list-style-type: none"> <li>1. I/O drawer power supply Location: U0.3-V1</li> <li>2. If power supply U0.3-V2 is present (no cooling unit), use the power supply you removed from U0.3-V1 to replace U0.3-V2</li> <li>3. Secondary I/O backplane Location: U0.3-P1</li> </ol>
1031 1B02	Load fault on +5	<ol style="list-style-type: none"> <li>1. I/O drawer power supply Location: U0.3-V1</li> <li>2. If power supply U0.3-V2 is present (no cooling unit), use the power supply you removed from U0.3-V1 to replace U0.3-V2</li> <li>3. Secondary I/O backplane Location: U0.3-P1</li> </ol>
1031 1B03	Load fault on +3.3	<ol style="list-style-type: none"> <li>1. I/O drawer power supply Location: U0.3-V1</li> <li>2. If power supply U0.3-V2 is present (no cooling unit), use the power supply you removed from U0.3-V1 to replace U0.3-V2</li> <li>3. Secondary I/O backplane Location: U0.3-P1</li> </ol>
1031 1B04	Load fault on -12	<ol style="list-style-type: none"> <li>1. I/O drawer power supply Location: U0.3-V1</li> <li>2. If power supply U0.3-V2 is present (no cooling unit), use the power supply you removed from U0.3-V1 to replace U0.3-V2</li> <li>3. Secondary I/O backplane Location: U0.3-P1</li> </ol>
1031 1B05	Load fault on 1.8	<ol style="list-style-type: none"> <li>1. I/O drawer power supply Location: U0.3-V1</li> <li>2. If power supply U0.3-V2 is present (no cooling unit), use the power supply you removed from U0.3-V1 to replace U0.3-V2</li> <li>3. Secondary I/O backplane Location: U0.3-P1</li> </ol>



Table 5. SPCN Error Codes (continued)

Error Code	Description	Action/ Possible Failing FRU
1031 1B06	Load fault on 2.5	<ol style="list-style-type: none"> <li>I/O drawer power supply Location: U0.3-V1</li> <li>If power supply U0.3-V2 is present (no cooling unit), use the power supply you removed from U0.3-V1 to replace U0.3-V2</li> <li>Secondary I/O backplane Location: U0.3-P1</li> </ol>
1031 1B07	Load fault on 2.5	<ol style="list-style-type: none"> <li>I/O drawer power supply Location: U0.3-V1</li> <li>If power supply U0.3-V2 is present (no cooling unit), use the power supply you removed from U0.3-V1 to replace U0.3-V2</li> <li>Secondary I/O backplane Location: U0.3-P1</li> </ol>
1031 2600	Pgood fault	Secondary I/O backplane Location: U0.3-P1
1031 2601	Pgood fault	Secondary I/O backplane Location: U0.3-P1
1031 2603	Secondary I/O drawer power domain fault	<ol style="list-style-type: none"> <li>Check input power to power supplies Locations: U0.3-V1 U0.3-V2</li> <li>I/O drawer power supplies Locations: U0.3-V1 U0.3-V2</li> <li>I/O Drawer Power Distribution Board Location: U0.3-X1</li> <li>Secondary I/O backplane Location: U0.3-P1</li> </ol>
1031 2612	SPCN problem	Secondary I/O backplane Location: U0.3-P1
1031 3100	I2C controller fault	<ol style="list-style-type: none"> <li>Secondary I/O drawer operator panel Location: U0.3-L1</li> <li>Secondary I/O backplane Location: U0.3-P1</li> </ol>
1031 3101	I2C bus 1 fault	Secondary I/O backplane Location: U0.3-P1
1031 3102	I2C bus 2 fault	Secondary I/O backplane Location: U0.3-P1
1031 3104	I2C bus 4 fault	Secondary I/O backplane Location: U0.3-P1

Table 5. SPCN Error Codes (continued)

Error Code	Description	Action/ Possible Failing FRU
1031 3105	I2C bus 5 fault	<ol style="list-style-type: none"> <li>1. Fan controller card Location: U0.3-X2</li> <li>2. Secondary I/O backplane Location: U0.3-P1</li> <li>3. I/O drawer power distribution board Location: U0.3-X1</li> </ol>
1031 3113	RIO bus adapter fault	RIO bus adapter Location: U0.3-P1.1
1031 3114	PCI backplane fault	Secondary I/O backplane Location: U0.3-P1
1031 3115	Operator panel fault	Secondary I/O drawer operator panel Location: U0.3-L1
1031 3116	Fan controller fault	<ol style="list-style-type: none"> <li>1. Fan controller card Location: U0.3-X2</li> <li>2. Secondary I/O backplane Location: U0.3-P1</li> <li>3. I/O drawer power distribution board Location: U0.3-X1</li> </ol>
1031 3118	System power control network fault	Secondary I/O backplane Location: U0.3-P1
1031 311C	Thermal sensor fault	<ol style="list-style-type: none"> <li>1. Secondary I/O drawer operator panel Location: U0.3-L1</li> <li>2. Secondary I/O backplane Location: U0.3-P1</li> </ol>
1031 7610	Slow I/O drawer fan 1	<ol style="list-style-type: none"> <li>1. Fan 1 Location: U0.3-F1</li> <li>2. Fan controller card Location: U0.3-X2</li> <li>3. I/O drawer power distribution board Location: U0.3-X1</li> </ol>
1031 7611	Missing I/O drawer fan 1	Fan 1 Location: U0.3-F1
1031 7620	Slow I/O drawer fan 2	<ol style="list-style-type: none"> <li>1. Fan 2 Location: U0.3-F2</li> <li>2. Fan controller card Location: U0.3-X2</li> <li>3. I/O drawer power distribution board Location: U0.3-X1</li> </ol>
1031 7621	Missing I/O drawer fan 2	Fan 2 Location: U0.3-F2

Table 5. SPCN Error Codes (continued)

Error Code	Description	Action/ Possible Failing FRU
1031 7630	Slow I/O drawer fan 3	<ol style="list-style-type: none"> <li>1. Fan 3 Locaton: U0.3-F3</li> <li>2. Fan controller card Locaton: U0.3-X2</li> <li>3. I/O drawer power distribution board Location: U0.3-X1</li> </ol>
1031 7631	Missing I/O drawer fan 3	Fan 3 Location: U0.3-F3
1031 7640	Slow I/O drawer fan 4	<ol style="list-style-type: none"> <li>1. Fan 4 Locaton: U0.3-F4</li> <li>2. Fan controller card Locaton: U0.3-X2</li> <li>3. I/O drawer power distribution board Location: U0.3-X1</li> </ol>
1031 7641	Missing I/O drawer fan 4	Fan 4 Location: U0.3-F4
1031 7650	Slow I/O drawer fan 5 in power supply 1	<ol style="list-style-type: none"> <li>1. I/O drawer power supply 1 Locaton: U0.3-V1</li> <li>2. Fan controller card Locaton: U0.3-X2</li> <li>3. I/O drawer power distribution board Location: U0.3-X1</li> </ol>
1031 7651	Missing I/O drawer fan 5 in power supply 1	I/O drawer power supply 1 Location: U0.3-V1
1031 7660	Slow I/O drawer fan 6 in I/O drawer power supply 2	<ol style="list-style-type: none"> <li>1. I/O drawer power supply 2 Locaton: U0.3-V2</li> <li>2. Fan controller card Locaton: U0.3-X2</li> <li>3. I/O drawer power distribution board Location: U0.3-X1</li> </ol>
1031 7661	Missing I/O drawer fan 6 in I/O drawer power supply 2	I/O drawer power supply 2 Location: U0.3-V2
1031 7690	Slow I/O drawer fan 9 in cooling unit	<ol style="list-style-type: none"> <li>1. Fan 9 (cooling unit) Locaton: U0.3-F9</li> <li>2. Fan controller card Locaton: U0.3-X2</li> <li>3. I/O drawer power distribution board Location: U0.3-X1</li> </ol>
1031 7691	Missing I/O drawer fan 9 in cooling unit	Fan 9 (cooling unit) Location: U0.3-F9

Table 5. SPCN Error Codes (continued)

Error Code	Description	Action/ Possible Failing FRU
1031 8400	VPD configuration problem	<ol style="list-style-type: none"> <li>1. Check for system firmware update</li> <li>2. Call second level of support</li> </ol>
1031 8401	VPD access problem	<ol style="list-style-type: none"> <li>1. Check for system firmware update</li> <li>2. Call second level of support</li> </ol>
1031 840A	VPD +5 stuck high	Secondary I/O backplane Location: U0.3-P1
1031 840B	VPD +5 stuck low	Secondary I/O backplane Location: U0.3-P1
1031 840D	I/O type mismatch	<ol style="list-style-type: none"> <li>1. Check cabling</li> <li>2. From the main service processor menu, select the <b>System Information Menu</b>, then select the <b>Power Control Network Utilities Menu</b>. Use option three to set the I/O type to 84. Reboot the system.</li> <li>3. Primary I/O drawer backplane Location: U0.1-P1</li> </ol>
1031 840E	SPCN default configuration loaded	<ol style="list-style-type: none"> <li>1. Check cabling</li> <li>2. From the main service processor menu, select the <b>System Information Menu</b>, then select the <b>Power Control Network Utilities Menu</b>. Use option three to set the I/O type to 84. Reboot the system.</li> <li>3. Primary I/O drawer backplane Location: U0.1-P1</li> </ol>
1031 840F	I/O type not recognized	<ol style="list-style-type: none"> <li>1. Check cabling</li> <li>2. From the main service processor menu, select the <b>System Information Menu</b>, then select the <b>Power Control Network Utilities Menu</b>. Use option three to set the I/O type to 84. Reboot the system.</li> <li>3. Primary I/O drawer backplane Location: U0.1-P1</li> </ol>
1031 8A00	A different I/O drawer is connected to the CEC	Informational only
1031 9012	Invalid address	<ol style="list-style-type: none"> <li>1. Check SPCN cabling</li> <li>2. Secondary I/O backplane Location: U0.3-P1</li> </ol>

Table 5. SPCN Error Codes (continued)

Error Code	Description	Action/ Possible Failing FRU
1031 9013	Invalid address	1. Check SPCN cabling 2. Secondary I/O backplane Location: U0.3-P1
1031 9014	Invalid address mode	Update system firmware Location: U0.1-P1/Y1 Note: Allow up to 30 minutes for this update to take effect.
1031 9021	SPCN temporary internal error	Information only
1031 9022	Secondary I/O drawer not present	Check cabling
1031 9023	Secondary I/O drawer is present but off	Information only
1031 902D	Secondary I/O drawer not present	Information only
1031 9038	I/O drawer node fault	Secondary I/O backplane Location: U0.3-P1
1031 9039	I/O drawer node fault	Secondary I/O backplane Location: U0.3-P1
1031 9042	EEPROM failure	Secondary I/O backplane Location: U0.3-P1
1031 9043	Download failure	1. Check for system firmware update 2. Call second level of support
1031 9046	QDS packet sequence error	1. Check for system firmware update 2. Call second level of support
1031 9047	QDS block sequence error	1. Check for system firmware update 2. Call second level of support
1031 9080	Undefined status code received	Secondary I/O backplane Location: U0.3-P1
1031 90F0	Drawer not present in configuration table	1. Check SPCN cabling 2. Reset system and reboot 3. Secondary I/O backplane Location: U0.3-P1
1031 90F1	Drawer added to configuration table	Information only
1031 9102	Permanent address assignment failed	Secondary I/O backplane Location: U0.3-P1
1031 9109	Download failure	Secondary I/O backplane Location: U0.3-P1
1031 9113	Firmware image corrupted	Secondary I/O backplane Location: U0.3-P1
1031 9114	Firmware image corrupted	Secondary I/O backplane Location: U0.3-P1

Table 5. SPCN Error Codes (continued)

Error Code	Description	Action/ Possible Failing FRU
1031 9116	SPCN communication with operator panel failure	<ol style="list-style-type: none"> <li>1. Secondary I/O drawer operator panel Location: U0.3-L1</li> <li>2. Secondary I/O backplane Location: U0.3-P1</li> </ol>
1031 C62E	Polling error	<ol style="list-style-type: none"> <li>1. Check cabling</li> <li>2. Secondary I/O backplane Location: U0.3-P1</li> <li>3. Primary I/O backplane Location: U0.1-P1</li> </ol>
1041 00AA	System power control network firmware update started (no error)	Information message
1041 1510	Power supply 1 power source failure	<ol style="list-style-type: none"> <li>1. Check input to power supply 1 Location: U.4-V1</li> <li>2. I/O drawer power supply 1 Location: U0.4-V1</li> <li>3. Secondary I/O backplane Location: U0.4-P1</li> </ol>
1041 1511	Power supply 1 fault	<ol style="list-style-type: none"> <li>1. I/O drawer power supply 1 Location: U0.4-V1</li> <li>2. Secondary I/O backplane Location: U0.4-P1</li> </ol>
1041 1512	Power supply 1 non-power fault	<ol style="list-style-type: none"> <li>1. I/O drawer power supply 1 Location: U0.4-V1</li> <li>2. Secondary I/O backplane Location: U0.4-P1</li> </ol>
1041 1513	Power supply 1 domain fault	<ol style="list-style-type: none"> <li>1. I/O drawer power supply 1 Location: U0.4-V1</li> <li>2. Secondary I/O backplane Location: U0.4-P1</li> </ol>
1041 1514	Power supply 1 cooling fault	<ol style="list-style-type: none"> <li>1. I/O drawer power supply 1 Location: U0.4-V1</li> <li>2. Secondary I/O backplane Location: U0.4-P1</li> </ol>
1041 1516	Swapped power supply and cooling unit or power supply 1 missing	<ol style="list-style-type: none"> <li>1. Verify correct installation of power supply and cooling unit Location: U0.4-V1</li> <li>2. Primary I/O power supply 1 Location: U0.4-V1</li> </ol>
1041 1520	Power supply 2 power source failure	<ol style="list-style-type: none"> <li>1. Check input power to power supply 2 Location: U0.4-V2</li> <li>2. Secondary I/O drawer power supply 2 Location: U0.4-V2</li> <li>3. Secondary I/O backplane Location: U0.4-P1</li> </ol>

Table 5. SPCN Error Codes (continued)

Error Code	Description	Action/ Possible Failing FRU
1041 1521	Power supply 2 fault	<ol style="list-style-type: none"> <li>1. I/O drawer power supply 2 Locaton: U0.4-V2</li> <li>2. Secondary I/O backplane Locaton: U0.4-P1</li> </ol>
1041 1522	Power supply 2 non-power fault	<ol style="list-style-type: none"> <li>1. I/O drawer power supply 2 Locaton: U0.4-V2</li> <li>2. Secondary I/O backplane Locaton: U0.4-P1</li> </ol>
1041 1523	Power supply 2 domain fault	<ol style="list-style-type: none"> <li>1. I/O drawer power supply 2 Locaton: U0.4-V2</li> <li>2. Secondary I/O backplane Locaton: U0.4-P1</li> </ol>
1041 1524	Power supply 2 cooling fault	<ol style="list-style-type: none"> <li>1. I/O drawer power supply 2 Locaton: U0.4-V2</li> <li>2. Secondary I/O backplane Locaton: U0.4-P1</li> </ol>
1041 1526	Power supply 2 missing	I/O drawer power supply 2 Location: U0.4-V2
1041 1B01	Load fault on +12	<ol style="list-style-type: none"> <li>1. I/O drawer power supply Location: U0.4-V1</li> <li>2. If power supply U0.4-V2 is present (no cooling unit), use the power supply you removed from U0.4-V1 to replace U0.4-V2</li> <li>3. Secondary I/O backplane Location: U0.4-P1</li> </ol>
1041 1B02	Load fault on +5	<ol style="list-style-type: none"> <li>1. I/O drawer power supply Location: U0.4-V1</li> <li>2. If power supply U0.4-V2 is present (no cooling unit), use the power supply you removed from U0.4-V1 to replace U0.4-V2</li> <li>3. Secondary I/O backplane Location: U0.4-P1</li> </ol>
1041 1B03	Load fault on +3.3	<ol style="list-style-type: none"> <li>1. I/O drawer power supply Location: U0.4-V1</li> <li>2. If power supply U0.4-V2 is present (no cooling unit), use the power supply you removed from U0.4-V1 to replace U0.4-V2</li> <li>3. Secondary I/O backplane Location: U0.4-P1</li> </ol>

Table 5. SPCN Error Codes (continued)

Error Code	Description	Action/ Possible Failing FRU
1041 1B04	Load fault on -12	<ol style="list-style-type: none"> <li>I/O drawer power supply Location: U0.4-V1</li> <li>If power supply U0.4-V2 is present (no cooling unit), use the power supply you removed from U0.4-V1 to replace U0.4-V2</li> <li>Secondary I/O backplane Location: U0.4-P1</li> </ol>
1041 1B05	Load fault on 1.8	<ol style="list-style-type: none"> <li>I/O drawer power supply Location: U0.4-V1</li> <li>If power supply U0.4-V2 is present (no cooling unit), use the power supply you removed from U0.4-V1 to replace U0.4-V2</li> <li>Secondary I/O backplane Location: U0.4-P1</li> </ol>
1041 1B06	Load fault on 2.5	<ol style="list-style-type: none"> <li>I/O drawer power supply Location: U0.4-V1</li> <li>If power supply U0.4-V2 is present (no cooling unit), use the power supply you removed from U0.4-V1 to replace U0.4-V2</li> <li>Secondary I/O backplane Location: U0.4-P1</li> </ol>
1041 1B07	Load fault on 2.5	<ol style="list-style-type: none"> <li>I/O drawer power supply Location: U0.4-V1</li> <li>If power supply U0.4-V2 is present (no cooling unit), use the power supply you removed from U0.4-V1 to replace U0.4-V2</li> <li>Secondary I/O backplane Location: U0.4-P1</li> </ol>
1041 2600	Pgood fault	Secondary I/O backplane Location: U0.4-P1
1041 2601	Pgood fault	Secondary I/O backplane Location: U0.4-P1
1041 2603	Secondary I/O drawer power domain fault	<ol style="list-style-type: none"> <li>Check input power to power supplies Locations: U0.4-V1 U0.4-V2</li> <li>I/O drawer power supplies Locations: U0.4-V1 U0.4-V2</li> <li>I/O Drawer Power Distribution Board Location: U0.4-X1</li> <li>Secondary I/O backplane Location: U0.4-P1</li> </ol>



Table 5. SPCN Error Codes (continued)

Error Code	Description	Action/ Possible Failing FRU
1041 2612	SPCN problem	Secondary I/O backplane Location: U0.4-P1
1041 3100	I2C controller fault	Secondary I/O backplane Location: U0.4-P1
1041 3101	I2C bus 1 fault	1. Secondary I/O drawer operator panel Location: U0.4-L1 2. Secondary I/O backplane Location: U0.4-P1
1041 3102	I2C bus 2 fault	Secondary I/O backplane Location: U0.4-P1
1041 3104	I2C bus 4 fault	Secondary I/O backplane Location: U0.4-P1
1041 3105	I2C bus 5 fault	1. Fan controller card Location: U0.4-X2 2. Secondary I/O backplane Location: U0.4-P1 3. I/O drawer power distribution board Location: U0.4-X1
1041 3113	RIO bus adapter fault	RIO bus adapter Location: U0.4-P1.1
1041 3114	PCI backplane fault	Secondary I/O backplane Location: U0.4-P1
1041 3115	Operator panel fault	Secondary I/O drawer operator panel Location: U0.4-L1
1041 3116	Fan controller fault	1. Fan controller Location: U0.4-X2 2. Secondary I/O backplane Location: U0.4-P1 3. I/O drawer power distribution board Location: U0.4-X1
1041 3118	System power control network fault	Secondary I/O backplane Location: U0.4-P1
1041 311C	Thermal sensor fault	1. Secondary I/O operator panel Location: U0.4-L1 2. Secondary I/O backplane Location: U0.4-P1
1041 7610	Slow I/O drawer fan 1	1. Fan 1 Location: U0.4-F1 2. Fan controller card Location: U0.4-X2 3. I/O drawer power distribution board Location: U0.4-X1

Table 5. SPCN Error Codes (continued)

<b>Error Code</b>	<b>Description</b>	<b>Action/ Possible Failing FRU</b>
1041 7611	Missing I/O drawer fan 1	Fan 1 Location: U0.4-F1
1041 7620	Slow I/O drawer fan 2	1. Fan 2 Locaton: U0.4-F2 2. Fan controller card Locaton: U0.4-X2 3. I/O drawer power distribution board Location: U0.4-X1
1041 7621	Missing I/O drawer fan 2	Fan 2 Location: U0.4-F2
1041 7630	Slow I/O drawer fan 3	1. Fan 3 Locaton: U0.4-F3 2. Fan controller card Locaton: U0.4-X2 3. I/O drawer power distribution board Location: U0.4-X1
1041 7631	Missing I/O drawer fan 3	Fan 3 Location: U0.4-F3
1041 7640	Slow I/O drawer fan 4	1. Fan 4 Locaton: U0.4-F4 2. Fan controller card Locaton: U0.4-X2 3. I/O drawer power distribution board Location: U0.4-X1
1041 7641	Missing I/O drawer fan 4	Fan 4 Location: U0.4-F4
1041 7650	Slow I/O drawer fan 5 in power supply 1	1. Fan 5 I/O drawer power supply 1 Locaton: U0.4-V1 2. Fan controller card Locaton: U0.4-X2 3. I/O drawer power distribution board Location: U0.4-X1
1041 7651	Missing I/O drawer fan 5 in power supply 1	I/O drawer power supply 1 Location: U0.4-V1
1041 7660	Slow I/O drawer fan 6 in I/O drawer power supply 2	1. I/O drawer power supply 2 Locaton: U0.4-V2 2. Fan controller card Locaton: U0.4-X2 3. I/O drawer power distribution board Location: U0.4-X1

Table 5. SPCN Error Codes (continued)

Error Code	Description	Action/ Possible Failing FRU
1041 7661	Missing I/O drawer fan 6 in I/O drawer power supply 2	I/O drawer power supply 2 Location: U0.4-V2
1041 7690	Slow I/O drawer fan 9 in cooling unit	<ol style="list-style-type: none"> <li>1. Fan 9 (cooling unit) Location: U0.4-F9</li> <li>2. Fan controller card Location: U0.4-X2</li> <li>3. I/O drawer power distribution board Location: U0.4-X1</li> </ol>
1041 7691	Missing I/O drawer fan 9 in cooling unit	Fan 9 (cooling unit) Location: U0.4-F9
1041 8400	VPD configuration problem	<ol style="list-style-type: none"> <li>1. Check for system firmware update</li> <li>2. Call second level of support</li> </ol>
1041 8401	VPD access problem	<ol style="list-style-type: none"> <li>1. Check for system firmware update</li> <li>2. Call second level of support</li> </ol>
1041 840A	VPD +5 stuck high	Secondary I/O backplane Location: U0.4-P1
1041 840B	VPD +5 stuck low	Secondary I/O backplane Location: U0.4-P1
1041 840D	I/O type mismatch	<ol style="list-style-type: none"> <li>1. Check cabling</li> <li>2. From the main service processor menu, select the <b>System Information Menu</b>, then select the <b>Power Control Network Utilities Menu</b>. Use option three to set the I/O type to 84. Reboot the system.</li> <li>3. Primary I/O drawer backplane Location: U0.1-P1</li> </ol>
1041 840E	SPCN default configuration loaded	<ol style="list-style-type: none"> <li>1. Check cabling</li> <li>2. From the main service processor menu, select the <b>System Information Menu</b>, then select the <b>Power Control Network Utilities Menu</b>. Use option three to set the I/O type to 84. Reboot the system.</li> <li>3. Primary I/O drawer backplane Location: U0.1-P1</li> </ol>

Table 5. SPCN Error Codes (continued)

Error Code	Description	Action/ Possible Failing FRU
1041 840F	I/O type not recognized	<ol style="list-style-type: none"> <li>1. Check cabling</li> <li>2. From the main service processor menu, select the <b>System Information Menu</b>, then select the <b>Power Control Network Utilities Menu</b>. Use option three to set the I/O type to 84. Reboot the system.</li> <li>3. Primary I/O drawer backplane Location: U0.1-P1</li> </ol>
1041 8A00	A different I/O drawer is connected to the CEC	Informational only
1041 9012	Invalid address	<ol style="list-style-type: none"> <li>1. Check SPCN cabling</li> <li>2. Secondary I/O Backplane Location: U0.2-P1</li> </ol>
1041 9013	Invalid address	<ol style="list-style-type: none"> <li>1. Check SPCN cabling</li> <li>2. Secondary I/O Backplane Location: U0.2-P1</li> </ol>
1041 9014	Invalid address mode	<p>Update system firmware Location: U0.1-P1/Y1 Note: Allow up to 30 minutes for this update to take effect.</p>
1041 9021	SPCN temporary internal error	Information only
1041 9022	Secondary I/O drawer not present	Check cabling
1041 9023	Secondary I/O drawer is present but off	Information only
1041 902D	Secondary I/O drawer not present	Information only
1041 9038	I/O drawer node fault	Secondary I/O backplane Location: U0.4-P1
1041 9039	I/O drawer node fault	Secondary I/O backplane Location: U0.4-P1
1041 9042	EEPROM failure	Secondary I/O backplane Location: U0.4-P1
1041 9043	Download failure	<ol style="list-style-type: none"> <li>1. Check for system firmware update</li> <li>2. Call second level of support</li> </ol>
1041 9046	QDS packet sequence error	<ol style="list-style-type: none"> <li>1. Check for system firmware update</li> <li>2. Call second level of support</li> </ol>
1041 9047	QDS block sequence error	<ol style="list-style-type: none"> <li>1. Check for system firmware update</li> <li>2. Call second level of support</li> </ol>
1041 9080	Undefined status code received	Secondary I/O backplane Location: U0.4-P1

Table 5. SPCN Error Codes (continued)

Error Code	Description	Action/ Possible Failing FRU
1041 90F0	Drawer not present in configuration table	<ol style="list-style-type: none"> <li>1. Check SPCN cabling</li> <li>2. Reset system and reboot</li> <li>3. Secondary I/O backplane Location: U0.2-P1</li> </ol>
1041 90F1	Drawer added to configuration table	Information only
1041 9102	Permanent address assignment failed	Secondary I/O backplane Location: U0.4-P1
1041 9109	Download failure	Secondary I/O backplane Location: U0.4-P1
1041 9113	Firmware image corrupted	Secondary I/O backplane Location: U0.4-P1
1041 9114	Firmware image corrupted	Secondary I/O backplane Location: U0.4-P1
1041 9116	SPCN communication with operator panel failure	<ol style="list-style-type: none"> <li>1. Secondary I/O drawer operator panel Location: U0.4-P1</li> <li>2. Secondary I/O Backplane Location: U0.4-P1</li> </ol>
1041 C62E	Polling error	<ol style="list-style-type: none"> <li>1. Check cabling</li> <li>2. Secondary I/O backplane Location: U0.4-P1</li> <li>3. Primary I/O backplane Location: U0.1-P1</li> </ol>

## Firmware/POST Error Codes

**Attention:** If you replace FRUs or perform an action and the problem is still not corrected, go to “MAP 1540: Minimum Configuration” on page 122 unless otherwise indicated in the tables.

If you replace FRUs and the problem is corrected, go to “MAP 0410: Repair Checkout” in the *RS/6000 and @server pSeries Diagnostic Information for Multiple Bus Systems*.

**Note:** Do not shut down the system if the FRU was replaced by hot swap.

Table 6. Firmware Error Codes.

Error Code	Description	Action/ Possible Failing FRU
2011 00xy	I/O drawer Power Supply failure	<ol style="list-style-type: none"> <li>Replace power supply “y” in I/O drawer “x”.  If y=_, then the power supply is: y = power supply 3 = Both power supplies (I/O drawer) 2 = Reserved  1 = Reserved</li> </ol> <p>See “AIX and Physical Location Code Tables” in Chapter 1 for location codes.</p> <ol style="list-style-type: none"> <li>Check ac power source (dc power source in a dc powered system) to I/O drawer “x”.  See “AIX and Physical Location Code Tables” in Chapter 1 for location codes.</li> </ol>
2022 0000	The I/O bus is running slowly	<ol style="list-style-type: none"> <li>Check cabling</li> <li>Call second level of support</li> </ol>

Table 6. Firmware Error Codes. (continued)

Error Code	Description	Action/ Possible Failing FRU
203w 0xyz	Remote I/O (RIO) configuration warning.	<p>This code indicates that an RIO configuration was detected that does not result in complete loops. The system continues to boot, however performance or recovery capability may be reduced. In some cases, the problem may result in missing I/O. Remote I/O drawers are connected in loops. Use the letters w, y, and z in the error code to isolate the location of the open loop. Check RIO cables for loose connections, and verify power on the I/O drawers by the presence of fan motion. Go to “MAP 1540: Minimum Configuration” on page 122.</p> <p><b>Note:</b></p> <p>The following numbers may be used to help isolate the failing component.</p> <ul style="list-style-type: none"> <li>• w = loop number, this is either 0 or 1 in a system with 2 RIO loops.</li> <li>• x = Always 0.</li> <li>• y is either 1 or 2 on a system with 2 loops. y indicates the nearest associated RIO port number on the CEC drawer according to the following table: <ul style="list-style-type: none"> <li>y = Nearest RIO Port</li> <li>1 = 0</li> <li>2 = 1</li> <li>3 = 2</li> <li>4 = 3</li> </ul> </li> <li>• z = B, indicates a missing return line from the I/O drawer to the CEC drawer.</li> <li>• z = C, indicates a missing link between two I/O drawers.</li> <li>• z = E, indicates an I/O drawer was found connected to RIO port 3 with no return to the CEC drawer, and no I/O drawer was found connected to RIO port 2. In this case, the I/O connected to RIO port 3 is removed from the configuration since the cause of the error and the proper location of the I/O cannot be determined.</li> </ul>
20A8 0000	Insufficient information to boot.	Verify the IP address.

Table 6. Firmware Error Codes. (continued)

Error Code	Description	Action/ Possible Failing FRU
20A8 0001	Client IP address is already in use by other network device	Change IP address.
20A8 0002	Cannot get gateway IP address	Refer to Table 2 on page 157 using code <b>E174</b> .
20A8 0003	Cannot get server hardware address	Refer to Table 2 on page 157 using code <b>E174</b> .
20A8 0004	Bootup failed	Refer to Table 2 on page 157 using code <b>E175</b> .
20A8 0005	File transmission (TFTP) failed.	Check network connection, try again.
20A8 0006	Boot image too large	Contact your next level of support for assistance.
20D0 0xxx	Unknown/unrecognized device	
20D0 000F	Selftest failed on device, no error and/or location code information available	Refer to "Determining Location Code" on page 172 to see if a location code is available for the device the error was reported against. 1. Replace device indicated by the location code (if available). 2. Go to "MAP 1540: Minimum Configuration" on page 122
20D0 0010	Selftest failed on device, can't locate package	Contact your service support representative for assistance.
20D0 0011	Firmware RTAS attempt to allocate memory failed.	Contact your next level of support for assistance.
20E0 0xxx	Security	
20E0 0001	Privileged-access password entry error.	The password has been entered incorrectly. Retry installing the password.
20E0 0004	Battery drained or needs replacement	1. Replace battery Location: U0.1-P1-V3 2. Replace Primary I/O drawer backplane Location: U0.1-P1
20E0 0009	Invalid password entered - system locked	The password has been entered incorrectly 3 times.  Turn off, then turn on the system unit, then enter the password correctly.
20EE 0xxx	Informational	
20EE 0003	IP parameter requires 3 dots "."	Enter valid IP parameter.  Example: 000.000.000.000



Table 6. Firmware Error Codes. (continued)

Error Code	Description	Action/ Possible Failing FRU
20EE 0004	Invalid IP parameter	Enter valid IP parameter.  Example: 000.000.000.000
20EE 0005	Invalid IP parameter (>255)	Enter valid IP parameter.  Example: 255.192.002.000
20EE 0006	No recognized SCSI adapter present	This warning occurs when the selected SMS function cannot locate any SCSI adapter supported by the function. If a supported SCSI adapter is installed: 1. Replace SCSI adapter(s). 2. Replace the I/O drawer backplane in drawer(s) containing SCSI adapter(s).
20EE 0007	Keyboard not found	1. Plug in keyboard. 2. Replace primary I/O drawer backplane Location: U0.1-P1
20EE 0008	No configurable adapters were found in the system by the remote IPL menu in the SMS utilities	This warning occurs when the remote IPL menu in the SMS utilities cannot locate any LAN adapters that are supported by the remote IPL function. If a supported device is installed: 1. Replace the device or adapter. 2. Replace the I/O drawer planar in the drawer(s) containing the adapter.
20EE 0009	Unable to communicate with the service processor	Replace primary I/O drawer backplane Location: U0.1-P1
20EE 000B	The system was not able to find an operating system boot record on the devices listed in the boot list. This can be caused by the wrong devices being in the boot record, a problem that prevents the system from communicating with the device that contains the boot record, or the boot record being corrupted.	Go to "Boot Problems and Concerns" on page 167.

Table 6. Firmware Error Codes. (continued)

Error Code	Description	Action/ Possible Failing FRU
20EE 000C	Pointer to the operating system not found in non-volatile storage.	<p>Values normally found in non-volatile storage that point to the location of an operating system were not found. This can happen for two reasons; either your installed operating system does not support storing the values or some event occurred that caused the system to lose non-volatile storage information (drainage or replacement of the battery). If you are running AIX, this information can be reconstructed by running the <b>bootlist</b> command specifying the device that the operating system is installed on. Refer to your AIX documentation for the exact syntax and usage of the <b>bootlist</b> command.</p> <p>To boot the operating system so that the above mentioned values can be reconstructed, power the system down and power it back up again. This should cause the system to look for the operating system in the devices contained in the custom boot list or in the default boot list, depending on the condition of the system. If this is not successful, use the System Management Services menus to modify the boot sequence (also known as boot list) to include devices that are known to contain a copy of the operating system. For example, select a hard disk known to have a copy of the operating system as the first and only device in the boot sequence (boot list) and attempt to boot again.</p>
20FB 0xxx	Permanent addressing to map SPCN addresses to match RIO addresses. <b>Note:</b> 20FB 0xxx error codes will cause the system to hang.	
20FB 0010	Failed to find the keyword offset of SPCN configuration table in NVRAM	<ol style="list-style-type: none"> <li>1. Check RIO cable connections</li> <li>2. Clear NVRAM and retry</li> <li>3. Check for system firmware update</li> <li>4. Replace primary I/O drawer backplane Location: U0.1-P1</li> </ol>

Table 6. Firmware Error Codes. (continued)

Error Code	Description	Action/ Possible Failing FRU
20FB 0020	Invalid SPCN configuration table flag before SPCN table update	<ol style="list-style-type: none"> <li>1. Check RIO cable connections</li> <li>2. Clear NVRAM and retry</li> <li>3. Check for system firmware update</li> <li>4. Replace primary I/O drawer backplane Location: U0.1-P1</li> </ol>
20FB 0021	Invalid SPCN configuration table flag after SPCN table update	<ol style="list-style-type: none"> <li>1. Check RIO cable connections</li> <li>2. Clear NVRAM and retry</li> <li>3. Check for system firmware update</li> <li>4. Replace primary I/O drawer backplane Location: U0.1-P1</li> </ol>
20FB 0025	The number of I/O drawers reported by System Power Control Network (SPCN) is not equal to the number of I/O drawers reported by Remote I/O (RIO).	<ol style="list-style-type: none"> <li>1. If there is an error indication in any secondary I/O drawer operator panel, follow the repair action for that error indication.</li> <li>2. Go to "MAP 1540: Minimum Configuration" on page 122 to isolate the failing I/O drawer, then to isolate the failure within that drawer.</li> </ol>
20FB 0030	<p>Failure to read I/O drawer SPCN address</p> <p>Uninitialized--failed to read SPCN address</p>	<ol style="list-style-type: none"> <li>1. Check RIO cable connections</li> <li>2. Check for system firmware update</li> <li>3. Replace RIO card assembly</li> <li>4. Replace I/O backplane if not already replaced (location code indicates which drawer)</li> </ol>
20FB 0031	<p>Failure to read I/O drawer SPCN address</p> <p>Initialization in Process--SPCN initializing the VPD segments</p>	<ol style="list-style-type: none"> <li>1. Check RIO cable connections</li> <li>2. Check for system firmware update</li> <li>3. Replace RIO card assembly</li> <li>4. Replace I/O backplane if not already replaced (location code indicates which drawer)</li> </ol>
20FB 0032	<p>Failure to read I/O drawer SPCN address</p> <p>Initialization Unsuccessful</p>	<ol style="list-style-type: none"> <li>1. Check RIO cable connections</li> <li>2. Check for system firmware update</li> <li>3. Replace RIO card assembly</li> <li>4. Replace I/O backplane if not already replaced (location code indicates which drawer)</li> </ol>

Table 6. Firmware Error Codes. (continued)

Error Code	Description	Action/ Possible Failing FRU
20FB 003A	Failure to read I/O drawer SPCN address  Invalid RIO or I/O drawer number.	<ol style="list-style-type: none"> <li>1. Check RIO cable connections</li> <li>2. Check for system firmware update</li> <li>3. Replace RIO card assembly</li> <li>4. Replace I/O backplane if not already replaced (location code indicates which drawer)</li> </ol>
20FB 0040	Failed to match SPCN address to SPCN node entry address.	<ol style="list-style-type: none"> <li>1. Check RIO cable connections</li> <li>2. Check for system firmware update</li> <li>3. Replace RIO card assembly</li> <li>4. Replace I/O backplane if not already replaced (location code indicates which drawer)</li> </ol>
20FB 0050	CSP mailbox failed to update SPCN configuration table.	<ol style="list-style-type: none"> <li>1. Check RIO cable connections</li> <li>2. Check for CSP firmware update</li> <li>3. Replace primary I/O drawer backplane Location: U0.1-P1</li> </ol>
20FB 99xy	The number of I/O drawers reported by RIO does not match the number of I/O drawers reported by SPCN, where x is the number of drawers reported by RIO and y is the number of drawers reported by SPCN. This error code should cause the system to hang.	<ol style="list-style-type: none"> <li>1. Check RIO and SPCN cabling.</li> <li>2. If there is an error code displayed by any of the secondary I/O drawers, perform the actions for that error code.</li> <li>3. If there is no error code displayed by any of the secondary I/O drawers, examine the service processor error logs to obtain an error code.</li> </ol>
20FC 0xxx	Retrieving power, package, cooling VPD via SPCN for the CEC and I/O drawers	
20FC 0010	Failed to match RIO addressing with SPCN node entry address.	Replace I/O backplane if not already replaced (location code indicates which drawer)
20FC 0020	Failed to retrieve power, package, cooling VPD via SPCN for the corresponding drawer. Service processor mailbox failed to get VPD	<ol style="list-style-type: none"> <li>1. Check RIO cable connection</li> <li>2. Check for CSP firmware update</li> <li>3. Replace corresponding I/O backplane (location code indicates which drawer)</li> <li>4. Replace primary I/O drawer backplane if not already replaced Location: U0.1-P1</li> </ol>
20FC 0021	Failed to retrieve power, package, cooling VPD via SPCN. Service processor mailbox failed to get VPD	<ol style="list-style-type: none"> <li>1. Check for CSP firmware update</li> <li>2. Replace primary I/O drawer backplane Location: U0.1-P1</li> </ol>

Table 6. Firmware Error Codes. (continued)

Error Code	Description	Action/ Possible Failing FRU
20FC 0030	Corrupted VPD format in the SPCN configuration table.	<ol style="list-style-type: none"> <li>1. Check for system firmware update</li> <li>2. Replace the I/O drawer backplane (location code indicates which drawer)</li> </ol>
2100 0001	Unsupported SCSI bus mode	<p>Before replacing any system components, refer to the notes in error code 21A0 0xxx.</p> <ol style="list-style-type: none"> <li>1. Disconnect the SCSI cable from the SCSI controller the location code identifies and reboot the system.</li> <li>2. If the error code persists, replace the SCSI controller (or I/O planar if SCSI controller is integrated).</li> <li>3. Reconnect the SCSI cable disconnected in step 1, and remove all the SCSI devices attached to the cable and reboot the system.</li> <li>4. If the error code persists, replace the SCSI cable.</li> <li>5. One at a time, reconnect the SCSI devices disconnected in step 3. If the error code returns, replace the last SCSI device you reconnected.</li> </ol> <p>If all SCSI devices have been reattached and the error code has not been returned, there may have been a bad connection. Go to "MAP 0410: Repair Checkout" in the <i>RS/6000 and @server pSeries Diagnostic Information for Multiple Bus Systems</i>.</p>

Table 6. Firmware Error Codes. (continued)

Error Code	Description	Action/ Possible Failing FRU
2100 0002	Unsupported SCSI bus mode - high voltage differential	<p>Before replacing any system components, refer to the notes in error code 21A0 0xxx.</p> <ol style="list-style-type: none"> <li>1. Disconnect the SCSI cable from the SCSI controller the location code identifies and reboot the system.</li> <li>2. If the error code persists, replace the SCSI controller (or I/O planar if SCSI controller is integrated).</li> <li>3. Reconnect the SCSI cable disconnected in step 1, and remove all the SCSI devices attached to the cable and reboot the system.</li> <li>4. If the error code persists, replace the SCSI cable.</li> <li>5. One at a time, reconnect the SCSI devices disconnected in step 3. If the error code returns, replace the last SCSI device you reconnected.</li> </ol> <p>If all SCSI devices have been reattached and the error code has not been returned, there may have been a bad connection. Go to "MAP 0410: Repair Checkout" in the <i>RS/6000 and @server pSeries Diagnostic Information for Multiple Bus Systems</i>.</p>

Table 6. Firmware Error Codes. (continued)

Error Code	Description	Action/ Possible Failing FRU
2100 0004	Cannot determine SCSI bus mode	<p>Before replacing any system components, refer to the notes in error code 21A0 0xxx.</p> <ol style="list-style-type: none"> <li>1. Disconnect the SCSI cable from the SCSI controller the location code identifies and reboot the system.</li> <li>2. If the error code persists, replace the SCSI controller (or I/O planar if SCSI controller is integrated).</li> <li>3. Reconnect the SCSI cable disconnected in step 1, and remove all the SCSI devices attached to the cable and reboot the system.</li> <li>4. If the error code persists, replace the SCSI cable.</li> <li>5. One at a time, reconnect the SCSI devices disconnected in step 3. If the error code returns, replace the last SCSI device you reconnected.</li> </ol> <p>If all SCSI devices have been reattached and the error code has not been returned, there may have been a bad connection. Go to "MAP 0410: Repair Checkout" in the <i>RS/6000 and @server pSeries Diagnostic Information for Multiple Bus Systems</i>.</p>
21A0 0xxx	SCSI device errors	<p><b>Note:</b> Before replacing any system components:</p> <ol style="list-style-type: none"> <li>1. Ensure that the controller and each device on the SCSI bus is assigned a unique SCSI ID.</li> <li>2. Ensure SCSI bus is properly terminated:</li> <li>3. Ensure SCSI signal and power cables are securely connected and not damaged.</li> <li>4. The location code information is required to identify the ID of SCSI device failures as well as to indicate the location of the controller to which the device is attached. Check the system error logs to determine the location code information associated with the error code.</li> </ol>

Table 6. Firmware Error Codes. (continued)

Error Code	Description	Action/ Possible Failing FRU
21A0 0001	Test unit ready failed - hardware error	Refer to the notes in error code 21A000xxx. 1. Replace the SCSI device. 2. Replace the SCSI cable. 3. Replace the SCSI controller.
21A0 0002	Test unit ready failed - sense data available	Refer to the notes in error code 21A000xxx. 1. Replace the media (removable media devices). 2. Replace the SCSI device.
21A0 0003	Send diagnostic failed	Refer to the notes in error code 21A000xxx. Replace the SCSI device.
21A0 0004	Send diagnostic failed - devofl cmd	Refer to the notes in error code 21A000xxx. Replace the SCSI device.
21E0 0xxx	SCSI tape	Refer to 21A00xxx for a description and repair action for the xxx value.
21ED 0xxx	SCSI changer	Refer to 21A00xxx for a description and repair action for the xxx value.
21EE 0xxx	Other SCSI device type	Refer to 21A00xxx for a description and repair action for the xxx value.
21F0 0xxx	SCSI CD-ROM	Refer to 21A00xxx for a description and repair action for the xxx value.
21F2 0xxx	SCSI read/write optical	Refer to 21A00xxx for a description and repair action for the xxx value.
2200 0001	PCI Ethernet BNC/RJ-45 or PCI Ethernet AUI/RJ-45 adapter internal wrap test failure	Replace the Adapter See note "Determining Location Code" on page 172 for location code information related to this error.
2200 1001	10/100 Mbps Ethernet PCI adapter internal wrap test failure	Replace the Adapter See "Determining Location Code" on page 172 for location code information related to this error.
2201 0001	PCI auto LANstreamer token ring adapter Adapter failed to complete hardware initialization.	Replace the Adapter See "Determining Location Code" on page 172 for location code information related to this error.
2201 1001	PCI token ring adapter Adapter failed to complete hardware initialization.	Replace the Adapter See "Determining Location Code" on page 172 for location code information related to this error.



Table 6. Firmware Error Codes. (continued)

Error Code	Description	Action/ Possible Failing FRU
25A0 0001	Cache L2 controller failure	<ol style="list-style-type: none"> <li>1. Replace the processor card. See "Determining Location Code" on page 172 for processor card location information.</li> <li>2. Replace the CEC backplane. Location: U1.1-P1.</li> </ol>
25A1 0001	Cache L2 SRAM failure	<ol style="list-style-type: none"> <li>1. Replace the processor card. See "Determining Location Code" on page 172 for processor card location information.</li> </ol>
25A8 0xxx	NVRAM problems	<p>Errors reported against NVRAM can be caused by low battery voltage and (more rarely) power outages that occur during normal system usage. With the exception of the 25A80000 error, these errors are warnings that the NVRAM data content had to be reestablished and do not require any FRU replacement unless the error is persistent. When one of these errors occurs, any system customization (for example, boot device list) information has been lost, the system may need to be reconfigured.</p> <p>If the error is persistent, replace primary I/O drawer backplane Location: U0.1-P1</p>
25A8 0000	Initialization failed, device test failed	Refer to Action under error code 25A80xxx.
25A8 0001	Init-NVRAM invoked, all of NVRAM initialized	Refer to Action under error code 25A80xxx.
25A8 0002	Init-NVRAM invoked, some data partitions may have been preserved.	Refer to Action under error code 25A80xxx.
25A8 0011	Data corruption detected, all of NVRAM initialized	Refer to Action under error code 25A80xxx.
25A8 0012	Data corruption detected, some data partitions may have been preserved.	Refer to Action under error code 25A80xxx.
25A8 0100	NVRAM data validation check failed.	<p>Turn off, turn on system unit and retry the operation before replacing any system component.</p> <p>Refer to Action under error code 25A80xxx.</p>
25A8 0201	Unable to expand target partition - Saving configuration variable.	Refer to Action under error code 25A80xxx.

Table 6. Firmware Error Codes. (continued)

<b>Error Code</b>	<b>Description</b>	<b>Action/ Possible Failing FRU</b>
25A8 0202	Unable to expand target partition - Writing error log entry.	Refer to Action under error code 25A80xxx.
25A8 0203	Unable to expand target partition - Writing VPD data.	Refer to Action under error code 25A80xxx.
25A8 0210	Setenv/\$Setenv parameter error - name contains a null character.	Refer to Action under error code 25A80xxx.
25A8 0211	Setenv/\$Setenv parameter error - value contains a null character.	Refer to Action under error code 25A80xxx.

Table 6. Firmware Error Codes. (continued)

Error Code	Description	Action/ Possible Failing FRU
25A8 0998	NVRAMRC script evaluation error - command line execution error	<p>Execution of a command line within the nvram configuration variable "nvramrc" (script) resulted in a "throw" being executed. This script can be modified by the system firmware <b>SMS</b> utilities, the operating system, PCI adapter rom code or utility, or an operator (via the open firmware script editing command "nvedit"). It may not be possible to resolve the problem without a detailed analysis of the nvram script, the current system configuration, and device tree contents.</p> <ol style="list-style-type: none"> <li>1. The problem can be caused by a SCSI adapter, whose SCSI bus ID has been changed from the default setting, no longer appearing in the system. This can be caused either by removing a SCSI adapter, or a problem with a SCSI adapter.               <ol style="list-style-type: none"> <li>a. Select the SCSI ID utility from the <b>SMS</b> menu(s).                   <ol style="list-style-type: none"> <li>1) Verify the list of SCSI controllers/adapters. If the list is not correct, suspect a problem with the adapter(s) installed but not listed.</li> <li>2) Select the option to Save the configuration information.</li> <li>3) Restart the system.</li> </ol> </li> <li>b. If the problem persists, boot the operating system and verify the SCSI bus IDs of any installed/available SCSI controllers (change as necessary), and restart the system.</li> </ol> </li> <li>2. Contact your support representative for further assistance.</li> </ol>
25A8 0999	NVRAMRC script evaluation error - stack unbalanced on completion	This is a firmware debug environment error. There is no user action or FRU replacement for this error.

Table 6. Firmware Error Codes. (continued)

Error Code	Description	Action/ Possible Failing FRU												
25Cy y001	Memory DIMM is not supported	<p>Replace unsupported memory DIMM(s). Note that memory DIMM are in groups, but you may only receive an error for a single memory DIMM. Verify that all memory DIMMs in the group containing the specified memory DIMM are of the same type.</p> <p><b>yy</b> describes the memory DIMM as follows:</p> <table data-bbox="892 546 1253 812"> <tr> <td><b>00</b></td> <td>Unrecognized/Unsupported memory DIMM</td> </tr> <tr> <td><b>28</b></td> <td>512 MB memory DIMM</td> </tr> <tr> <td><b>38</b></td> <td>128 MB memory DIMM</td> </tr> <tr> <td><b>58</b></td> <td>32 MB memory DIMM</td> </tr> <tr> <td><b>68</b></td> <td>256 MB memory DIMM</td> </tr> <tr> <td><b>78</b></td> <td>1 GB memory DIMM</td> </tr> </table> <p><b>Notes:</b></p> <ol data-bbox="892 864 1262 1241" style="list-style-type: none"> <li>1. Refer to “System Memory” on page 24 for the memory DIMM configuration rules. Memory DIMMs must be replaced with a supported type of memory DIMM, and all memory DIMMs in a group must be of the same size.</li> <li>2. Check the system error logs to determine the location code associated with the error code. Refer to the “Logical and Physical Locations” on page 29 to locate the memory DIMM and the rest of its group.</li> </ol>	<b>00</b>	Unrecognized/Unsupported memory DIMM	<b>28</b>	512 MB memory DIMM	<b>38</b>	128 MB memory DIMM	<b>58</b>	32 MB memory DIMM	<b>68</b>	256 MB memory DIMM	<b>78</b>	1 GB memory DIMM
<b>00</b>	Unrecognized/Unsupported memory DIMM													
<b>28</b>	512 MB memory DIMM													
<b>38</b>	128 MB memory DIMM													
<b>58</b>	32 MB memory DIMM													
<b>68</b>	256 MB memory DIMM													
<b>78</b>	1 GB memory DIMM													

Table 6. Firmware Error Codes. (continued)

Error Code	Description	Action/ Possible Failing FRU
25Cy y002	<p>Memory DIMM failure</p> <p>Refer to “Memory Riser Card and Memory DIMM Locations” on page 20 to determine the octal DIMMs.</p> <p>See “System Information Menu” on page 424 for more information on the error status of memory DIMMs.</p>	<p>If one memory DIMM is called out:</p> <ol style="list-style-type: none"> <li>1. Replace the memory DIMM.</li> <li>2. Replace the entire octal that contains the memory DIMM.</li> <li>3. Replace the memory riser card.</li> </ol> <p>If more than one memory DIMM is called out, go to the “Memory Configuration/Deconfiguration menu”, which is under the “System Information Menu” on the main service processor menu:</p> <ol style="list-style-type: none"> <li>1. From the memory configuration/deconfiguration menu, select the card(s) specified by the location code(s) of the failing memory DIMM(s). If the first character of the error status of any memory DIMM is 1, 2, or 3 (but not 0 or 4), this is a suspect memory DIMM. Record its location.</li> <li>2. If only one DIMM was recorded in step one:             <ol style="list-style-type: none"> <li>a. Replace DIMM</li> <li>b. Replace the entire octal that contains the memory DIMM.</li> <li>c. Replace the memory riser card</li> </ol> </li> <li>3. If more than one DIMM was recorded in step one and the DIMMs reside in more than one octal:             <ol style="list-style-type: none"> <li>a. Replace the memory riser card</li> <li>b. Replace all failing DIMMs</li> </ol> </li> <li>4. If more than 1 DIMM was recorded in step one and they reside in one octal:             <ol style="list-style-type: none"> <li>a. Replace all failing DIMMs</li> <li>b. Replace the memory riser card</li> </ol> </li> </ol>

Table 6. Firmware Error Codes. (continued)

Error Code	Description	Action/ Possible Failing FRU
2602 0001	Invalid PCI adapter vendor ID	<ol style="list-style-type: none"> <li>1. Move adapter to another slot.</li> <li>2. Check for available firmware updates for adapter. Apply update if available.</li> <li>3. Run AIX diagnostics on adapter. Replace if indicated.</li> <li>4. Replace adapter.</li> <li>5. Check for system firmware updates. Apply if update available.</li> <li>6. Replace I/O drawer backplane (See notes on Chapter 5, "Error Code to FRU Index" on page 171.)</li> </ol>
2602 0002	Invalid PCI adapter device ID	<ol style="list-style-type: none"> <li>1. Move adapter to another slot.</li> <li>2. Check for available firmware updates for adapter. Apply update if available.</li> <li>3. Run AIX diagnostics on adapter. Replace if indicated.</li> <li>4. Replace adapter.</li> <li>5. Check for system firmware updates. Apply if update available.</li> <li>6. Replace I/O drawer backplane. (See notes on Chapter 5, "Error Code to FRU Index" on page 171.)</li> </ol>
2602 0003	Invalid PCI adapter class code	<ol style="list-style-type: none"> <li>1. Move adapter to another slot.</li> <li>2. Check for available firmware updates for adapter. Apply update if available.</li> <li>3. Run AIX diagnostics on adapter. Replace if indicated.</li> <li>4. Replace adapter.</li> <li>5. Check for system firmware updates. Apply if update available.</li> <li>6. Replace I/O drawer backplane (See notes on Chapter 5, "Error Code to FRU Index" on page 171.)</li> </ol>

Table 6. Firmware Error Codes. (continued)

Error Code	Description	Action/ Possible Failing FRU
2602 0007	Failed to allocate bus resources to PCI adapter	<ol style="list-style-type: none"> <li>1. Move adapter to another slot.</li> <li>2. Check for available firmware updates for adapter. Apply update if available.</li> <li>3. Run AIX diagnostics on adapter. Replace if indicated.</li> <li>4. Replace adapter.</li> <li>5. Check for system firmware updates. Apply if update available.</li> <li>6. Replace I/O drawer backplane (See notes on Chapter 5, "Error Code to FRU Index" on page 171.)</li> </ol>
2680 0Axy	MX-PCI bridge Bist failure	<p>The problem is associated with bridge "y" in I/O drawer "x."</p> <ol style="list-style-type: none"> <li>1. Replace I/O drawer backplane "x" indicates the I/O drawer number.</li> </ol> <p>See "AIX and Physical Location Code Tables" in Chapter 1 for location codes.</p>
2680 0Cxx	Machine check occurred	<ol style="list-style-type: none"> <li>1. Replace the part identified by the location code associated with this error code.</li> <li>2. If the location code associated with this error code identifies an adapter, and replacing the adapter does not correct the problem, replace the I/O drawer planar.</li> </ol> <p>See "Determining Location Code" on page 172 for location code information related to this error.</p>
2803 0xxx	RTC errors	

Table 6. Firmware Error Codes. (continued)

Error Code	Description	Action/ Possible Failing FRU
2803 0001	RTC not updating - RTC initialization required	<p>Errors reported against the Real time clock can be caused by low battery voltage and (more rarely) power outages that occur during normal system usage. These errors are warnings that the real time clock data content needs to be re-established and do not require any FRU replacement unless the error is persistent. When one of these errors occurs, the time and date information has been lost.</p> <p>To set/restore the time and date, use the operating system facility.</p> <p>If the error is persistent:</p> <ol style="list-style-type: none"> <li>1. Replace the battery Location: U0.1-P1-V3</li> <li>2. Replace primary I/O drawer backplane Location: U0.1-P1</li> </ol>
2803 0002	Bad time/date values	<ol style="list-style-type: none"> <li>1. Set time and date</li> <li>2. Refer to Action under error code 28030001.</li> </ol>
2803 0003	RTC not updating - not correctable	<ol style="list-style-type: none"> <li>1. Replace primary I/O drawer backplane Location: U0.1-P1</li> </ol>
2803 0004	RTC operating mode parameters (eg. data mode) changed	<ol style="list-style-type: none"> <li>1. Set time and date</li> <li>2. Refer to Action under error code 28030001.</li> </ol>
2803 0005	RTC battery error	<ol style="list-style-type: none"> <li>1. Replace the battery Location: U0.1-P1-V3. <b>Note:</b> Password, time, and date need to be set.</li> <li>2. Refer to Action under error code 28030001.</li> </ol>
2900 0002	Keyboard/mouse controller failed self-test	<p>Replace primary I/O drawer backplane Location: U0.1-P1</p>
29A0 0003	Keyboard not present/detected	<ol style="list-style-type: none"> <li>1. Keyboard</li> <li>2. Keyboard cable</li> <li>3. Replace primary I/O drawer backplane Location: U0.1-P1</li> </ol>



Table 6. Firmware Error Codes. (continued)

Error Code	Description	Action/ Possible Failing FRU
29A0 0004	Keyboard stuck key detected	<ol style="list-style-type: none"> <li>Keyboard</li> <li>Replace primary I/O drawer backplane Location: U0.1-P1</li> </ol>
29B0 0004	Mouse not present/detected	<ol style="list-style-type: none"> <li>Mouse</li> <li>Replace primary I/O drawer backplane Location: U0.1-P1</li> </ol>
2B2x xx11	Processor is manually disabled.	Use the service processor menus to re-enable the processor and reboot the system.
2B20 0022	Processor is deconfigured by the system.	<ol style="list-style-type: none"> <li>Replace the processor card at the location specified in the error log. See "Determining Location Code" on page 172 for location code information related to this error.</li> <li>CEC backplane Location: U1.1-P1</li> </ol>
2B2x xx31	Processor is failing POST	Replace the processor card at the location specified in the error log. See "Determining Location Code" on page 172 for location code information related to this error.
2B20 0031	Processor is failing POST or is manually disabled.	<ol style="list-style-type: none"> <li>If the processor is not enabled, then use the service processor menus to enable the processor. Then reboot the system.</li> <li>If the processor is failing POST, then replace the processor card at the location specified in the error log.</li> </ol> <p>See "Determining Location Code" on page 172 for location code information related to this error.</p>
2B20 0042	Unknown processor card	Remove the unknown processor card.
2BA0 0000	Service processor POST failure	Replace primay I/O drawer backplane Location: U0.1-P1
2BA0 0012	Service processor reports self test failure	Replace primary I/O drawer backplane Location: U0.1-P1
2BA0 0013	Service processor reports bad NVRAM CRC	If problem persists, replace primary I/O drawer backplane Location: U0.1-P1

Table 6. Firmware Error Codes. (continued)

Error Code	Description	Action/ Possible Failing FRU
2BA0 0017	Service processor reports bad or low battery.	<ol style="list-style-type: none"> <li>1. Replace the battery Location: U0.1-P1-V3</li> <li>2. Replace primary I/O drawer backplane Location: U0.1-P1</li> </ol>
2BA0 0041	Service processor VPD is corrupted.	Replace primary I/O drawer backplane Location: U0.1-P1

## Service Processor Error Codes

**Attention:** Follow the procedure defined in “Checkpoint and Error Code Index” on page 173. If you replace FRUs or perform an action and the problem is still not corrected, go to “MAP 1540: Minimum Configuration” on page 122 unless otherwise indicated in the tables.

If you replace FRUs or perform an action and the problem is corrected, go to “MAP 0410: Repair Checkout” in *RS/6000 and @server pSeries Diagnostic Information for Multiple Bus Systems*.

**Note:** Do not shut down the system if the FRU was replaced by hot swap.

Table 7. Service Processor Error Codes

Error Code	Description	Action/ Possible Failing FRU
4066 0001	Scan interface basic assurance tests detected CEC backplane failure	CEC backplane Location: U1.1-P1
4066 0003	Scan interface basic assurance tests detected processor fault	1. Verify loose or defective JTAG cable or connector. 2. All processors Locations: U1.1-P1-C1 U1.1-P1-C2
4066 0009	Scan interface basic assurance tests detected memory fault	All memory Location: U1.1-P1-M1 x2
4066 00A0	Scan interface basic assurance tests detected CSP service processor firmware fault	Update system firmware Location: U0.1-P1/Y1
4066 00A1	Scan interface basic assurance tests detected AIX or system firmware fault	1. Check for AIX updates 2. Check for system firmware updates Location: U0.1-P1/Y1
4066 00A2	Scan interface basic assurance tests detected service processor firmware (processor runtime diagnostics) fault	Check for system firmware updates Location: U0.1-P1/Y1
4066 00A3	Scan interface basic assurance tests detected memory plugging fault	All pluggable memory
4066 00A4	Scan interface basic assurance tests detected application-caused fault	Application software
4066 00A5	Scan interface basic assurance tests detected invalid system configuration	Verify system components are supported and properly installed.

Table 7. Service Processor Error Codes (continued)

Error Code	Description	Action/ Possible Failing FRU
4066 00A6	Scan interface basic assurance tests detected no usable memory	<ol style="list-style-type: none"> <li>1. Ensure that CEC memory is properly installed.</li> <li>2. If more than one DIMM is called out, go to the service processor Memory Configuration/Deconfiguration Menu to verify memory DIMMs state. See "Memory Configuration/Deconfiguration Menu" on page 426 for more information.</li> </ol>
4066 00A7	Scan interface basic assurance tests detected hardware problem	Go to "MAP 1540: Minimum Configuration" on page 122.
4066 00B0	Scan interface basic assurance tests detected bus controller lock-unlock failure	RIO bus adapter Location: U0.1-P1.1
4066 00B1	Scan interface basic assurance tests detected bus controller failure	RIO bus adapter Location: U0.1-P1.1
4066 00B3	Scan interface basic assurance tests detected clock fault	<ol style="list-style-type: none"> <li>1. Clock card Location: U1.1-P1.1.1</li> <li>2. CEC RIO bus adapter Location: U1.1-P1.1</li> </ol>
4066 00B7	Scan interface basic assurance tests detected insufficient hardware resources to continue IPL	This error code appears after the initial testing by the service processor firmware on the CEC was completed correctly, but a problem occurred when the firmware tried to communicate outside the CEC. Suspect a problem with the RIO interface, either cables or adapters.
4066 0200	Scan interface basic assurance tests detected memory riser card fault	Memory riser card 1 Location: U1.1-P1-M1
4066 0201	Scan interface basic assurance tests detected memory DIMM fault	Memory DIMM 1, riser 1 Location: U1.1-P1-M1.1
4066 0202	Scan interface basic assurance tests detected memory DIMM fault	Memory DIMM 2, riser 1 Location: U1.1-P1-M1.2
4066 0203	Scan interface basic assurance tests detected memory DIMM fault	Memory DIMM 9, riser 1 Location: U1.1-P1-M1.9
4066 0204	Scan interface basic assurance tests detected memory DIMM fault	Memory DIMM 10, riser 1 Location: U1.1-P1-M1.10
4066 0205	Scan interface basic assurance tests detected memory DIMM fault	Memory DIMM 17, riser 1 Location: U1.1-P1-M1.17
4066 0206	Scan interface basic assurance tests detected memory DIMM fault	Memory DIMM 18, riser 1 Location: U1.1-P1-M1.18

Table 7. Service Processor Error Codes (continued)

Error Code	Description	Action/ Possible Failing FRU
4066 0207	Scan interface basic assurance tests detected memory DIMM fault	Memory DIMM 25, riser 1 Location: U1.1-P1-M1.25
4066 0208	Scan interface basic assurance tests detected memory DIMM fault	Memory DIMM 26, riser 1 Location: U1.1-P1-M1.26
4066 020D	Scan interface basic assurance tests detected memory DIMM group fault	Memory octal A, riser 1 Location: U1.1-P1-M1.1 x8
4066 020E	Scan interface basic assurance tests detected memory DIMM group fault	Memory quad A odd, riser 1 Locations: U1.1-P1-M1.1 x4
4066 020F	Scan interface basic assurance tests detected memory DIMM group fault	Memory quad A even, riser 1 Locations: U1.1-P1-M1.2 x4
4066 0211	Scan interface basic assurance tests detected memory DIMM fault	Memory DIMM 3, riser 1 Location: U1.1-P1-M1.3
4066 0212	Scan interface basic assurance tests detected memory DIMM fault	Memory DIMM 4, riser 1 Location: U1.1-P1-M1.4
4066 0213	Scan interface basic assurance tests detected memory DIMM fault	Memory DIMM 11, riser 1 Location: U1.1-P1-M1.11
4066 0214	Scan interface basic assurance tests detected memory DIMM fault	Memory DIMM 12, riser 1 Location: U1.1-P1-M1.12
4066 0215	Scan interface basic assurance tests detected memory DIMM fault	Memory DIMM 19, riser 1 Location: U1.1-P1-M1.19
4066 0216	Scan interface basic assurance tests detected memory DIMM fault	Memory DIMM 20, riser 1 Location: U1.1-P1-M1.20
4066 0217	Scan interface basic assurance tests detected memory DIMM fault	Memory DIMM 27, riser 1 Location: U1.1-P1-M1.27
4066 0218	Scan interface basic assurance tests detected memory DIMM fault	Memory DIMM 28, riser 1 Location: U1.1-P1-M1.28
4066 021D	Scan interface basic assurance tests detected memory DIMM group fault	Memory octal B, riser 1 Location: U1.1-P1-M1.3 x8
4066 021E	Scan interface basic assurance tests detected memory DIMM group pair A fault	Memory quad B odd, riser 1 Location: U1.1-P1-M1.3 x4
4066 021F	Scan interface basic assurance tests detected memory DIMM group fault	Memory quad B even, riser 1 Location: U1.1-P1-M1.4 x4
4066 0221	Scan interface basic assurance tests detected memory DIMM fault	Memory DIMM 5, riser 1 Location: U1.1-P1-M1.5
4066 0222	Scan interface basic assurance tests detected memory DIMM fault	Memory DIMM 6, riser 1 Location: U1.1-P1-M1.6
4066 0223	Scan interface basic assurance tests detected memory DIMM fault	Memory DIMM 13, riser 1 Location: U1.1-P1-M1.13
4066 0224	Scan interface basic assurance tests detected memory DIMM fault	Memory DIMM 14, riser 1 Location: U1.1-P1-M1.14

Table 7. Service Processor Error Codes (continued)

Error Code	Description	Action/ Possible Failing FRU
4066 0225	Scan interface basic assurance tests detected memory DIMM fault	Memory DIMM 21, riser 1 Location: U1.1-P1-M1.21
4066 0226	Scan interface basic assurance tests detected memory DIMM fault	Memory DIMM 22, riser 1 Location: U1.1-P1-M1.22
4066 0227	Scan interface basic assurance tests detected memory DIMM fault	Memory DIMM 29, riser 1 Location: U1.1-P1-M1.29
4066 0228	Scan interface basic assurance tests detected memory DIMM fault	Memory DIMM 30, riser 1 Location: U1.1-P1-M1.30
4066 022D	Scan interface basic assurance tests detected memory DIMM group fault	Memory octal C, riser 1 Locations: U1.1-P1-M1.5 x8
4066 022E	Scan interface basic assurance tests detected memory DIMM group pair A fault	Memory quad C odd, riser 1 Locations: U1.1-P1-M1.5 x4
4066 022F	Scan interface basic assurance tests detected memory DIMM group fault	Memory quad C even, riser 1 Locations: U1.1-P1-M1.6 x4
4066 0231	Scan interface basic assurance tests detected memory DIMM fault	Memory DIMM 7, riser 1 Location: U1.1-P1-M1.7
4066 0232	Scan interface basic assurance tests detected memory DIMM fault	Memory DIMM 8, riser 1 Location: U1.1-P1-M1.8
4066 0233	Scan interface basic assurance tests detected memory DIMM fault	Memory DIMM 15, riser 1 Location: U1.1-P1-M1.15
4066 0234	Scan interface basic assurance tests detected memory DIMM fault	Memory DIMM 16, riser 1 Location: U1.1-P1-M1.16
4066 0235	Scan interface basic assurance tests detected memory DIMM fault	Memory DIMM 23, riser 1 Location: U1.1-P1-M1.23
4066 0236	Scan interface basic assurance tests detected memory DIMM fault	Memory DIMM 24, riser 1 Location: U1.1-P1-M1.24
4066 0237	Scan interface basic assurance tests detected memory DIMM fault	Memory DIMM 31, riser 1 Location: U1.1-P1-M1.31
4066 0238	Scan interface basic assurance tests detected memory DIMM fault	Memory DIMM 32, riser 1 Location: U1.1-P1-M1.32
4066 023D	Scan interface basic assurance tests detected memory DIMM group fault	Memory octal D, riser 1 Location: U1.1-P1-M1.7 x8
4066 023E	Scan interface basic assurance tests detected memory DIMM group fault	Memory quad D odd, riser 1 Location: U1.1-P1-M1.7 x4
4066 023F	Scan interface basic assurance tests detected memory DIMM group fault	Memory quad D even, riser 1 Location: U1.1-P1-M1.8 x4

Table 7. Service Processor Error Codes (continued)

Error Code	Description	Action/ Possible Failing FRU
4066 02FF	Scan interface basic assurance tests detected memory on riser fault	All memory on riser 1 Location: U1.1-P1-M1.1 x32 Memory failure on riser card 1 that cannot be automatically isolated. go to "MAP 1540: Minimum Configuration" on page 122 and run CEC drawer minimum configuration for further isolation.
4066 0300	Scan interface basic assurance tests detected processor card fault	Processor card Location: U1.1-P1-C1
4066 0400	Scan interface basic assurance tests detected processor card fault	Processor card Location: U1.1-P1-C2
4066 0500	Scan interface basic assurance tests detected memory riser card fault	Memory riser card 2 Location: U1.1-P1-M1
4066 0501	Scan interface basic assurance tests detected memory DIMM fault	Memory DIMM 1, riser 2 Location: U1.1-P1-M2.1
4066 0502	Scan interface basic assurance tests detected memory DIMM fault	Memory DIMM 2, riser 2 Location: U1.1-P1-M2.2
4066 0503	Scan interface basic assurance tests detected memory DIMM fault	Memory DIMM 9, riser 2 Location: U1.1-P1-M2.9
4066 0504	Scan interface basic assurance tests detected memory DIMM fault	Memory DIMM 10, riser 2 Location: U1.1-P1-M2.10
4066 0505	Scan interface basic assurance tests detected memory DIMM fault	Memory DIMM 17, riser 2 Location: U1.1-P1-M2.17
4066 0506	Scan interface basic assurance tests detected memory DIMM fault	Memory DIMM 18, riser 2 Location: U1.1-P1-M2.18
4066 0507	Scan interface basic assurance tests detected memory DIMM fault	Memory DIMM 25, riser 2 Location: U1.1-P1-M2.25
4066 0508	Scan interface basic assurance tests detected memory DIMM fault	Memory DIMM 26, riser 2 Location: U1.1-P1-M2.26
4066 050D	Scan interface basic assurance tests detected memory DIMM group fault	Memory octal A, riser 2 Location: U1.1-P1-M2.1 x8
4066 050E	Scan interface basic assurance tests detected memory DIMM group pair A fault	Memory quad A odd, riser 2 Location: U1.1-P1-M2.1 x4
4066 050F	Scan interface basic assurance tests detected memory DIMM group fault	Memory quad A even, riser 2 Location: U1.1-P1-M2.2 x4
4066 0511	Scan interface basic assurance tests detected memory DIMM fault	Memory DIMM 3, riser 2 Location: U1.1-P1-M2.3
4066 0512	Scan interface basic assurance tests detected memory DIMM fault	Memory DIMM 4, riser 2 Location: U1.1-P1-M2.4
4066 0513	Scan interface basic assurance tests detected memory DIMM fault	Memory DIMM 11, riser 2 Location: U1.1-P1-M2.11

Table 7. Service Processor Error Codes (continued)

Error Code	Description	Action/ Possible Failing FRU
4066 0514	Scan interface basic assurance tests detected memory DIMM fault	Memory DIMM 12, riser 2 Location: U1.1-P1-M2.12
4066 0515	Scan interface basic assurance tests detected memory DIMM fault	Memory DIMM 19, riser 2 Location: U1.1-P1-M2.19
4066 0516	Scan interface basic assurance tests detected memory DIMM fault	Memory DIMM 20, riser 2 Location: U1.1-P1-M2.20
4066 0517	Scan interface basic assurance tests detected memory DIMM fault	Memory DIMM 27, riser 2 Location: U1.1-P1-M2.27
4066 0518	Scan interface basic assurance tests detected memory DIMM fault	Memory DIMM 28, riser 2 Location: U1.1-P1-M2.28
4066 051D	Scan interface basic assurance tests detected memory DIMM group fault	Memory octal B, riser 2 Location: U1.1-P1-M2.3 x8
4066 051E	Scan interface basic assurance tests detected memory DIMM group fault	Memory quad B odd, riser 2 Location: U1.1-P1-M2.3 x4
4066 051F	Scan interface basic assurance tests detected memory DIMM group fault	Memory quad B even, riser 2 Location: U1.1-P1-M2.4 x4
4066 0521	Scan interface basic assurance tests detected memory DIMM fault	Memory DIMM 5, riser 2 Location: U1.1-P1-M2.5
4066 0522	Scan interface basic assurance tests detected memory DIMM fault	Memory DIMM 6, riser 2 Location: U1.1-P1-M2.6
4066 0523	Scan interface basic assurance tests detected memory DIMM fault	Memory DIMM 13, riser 2 Location: U1.1-P1-M2.13
4066 0524	Scan interface basic assurance tests detected memory DIMM fault	Memory DIMM 14, riser 2 Location: U1.1-P1-M2.14
4066 0525	Scan interface basic assurance tests detected memory DIMM fault	Memory DIMM 21, riser 2 Location: U1.1-P1-M2.21
4066 0526	Scan interface basic assurance tests detected memory DIMM fault	Memory DIMM 22, riser 2 Location: U1.1-P1-M2.22
4066 0527	Scan interface basic assurance tests detected memory DIMM fault	Memory DIMM 29, riser 2 Location: U1.1-P1-M2.29
4066 0528	Scan interface basic assurance tests detected memory DIMM fault	Memory DIMM 30, riser 2 Location: U1.1-P1-M2.30
4066 052D	Scan interface basic assurance tests detected memory DIMM group fault	Memory octal C, riser 2 Location: U1.1-P1-M2.5 x8
4066 052E	Scan interface basic assurance tests detected memory DIMM group pair A fault	Memory quad C odd, riser 2 Location: U1.1-P1-M2.5 x4
4066 052F	Scan interface basic assurance tests detected memory DIMM group fault	Memory quad C even, riser 2 Location: U1.1-P1-M2.6 x4
4066 0531	Scan interface basic assurance tests detected memory DIMM fault	Memory DIMM 7, riser 2 Location: U1.1-P1-M2.7



Table 7. Service Processor Error Codes (continued)

Error Code	Description	Action/ Possible Failing FRU
4066 0532	Scan interface basic assurance tests detected memory DIMM fault	Memory DIMM 8, riser 2 Location: U1.1-P1-M2.8
4066 0533	Scan interface basic assurance tests detected memory DIMM fault	Memory DIMM 15, riser 2 Location: U1.1-P1-M2.15
4066 0534	Scan interface basic assurance tests detected memory DIMM fault	Memory DIMM 16, riser 2 Location: U1.1-P1-M2.16
4066 0535	Scan interface basic assurance tests detected memory DIMM fault	Memory DIMM 23, riser 2 Location: U1.1-P1-M2.23
4066 0536	Scan interface basic assurance tests detected memory DIMM fault	Memory DIMM 24, riser 2 Location: U1.1-P1-M2.24
4066 0537	Scan interface basic assurance tests detected memory DIMM fault	Memory DIMM 31, riser 2 Location: U1.1-P1-M2.31
4066 0538	Scan interface basic assurance tests detected memory DIMM fault	Memory DIMM 32, riser 2 Location: U1.1-P1-M2.32
4066 053D	Scan interface basic assurance tests detected memory DIMM group fault	Memory octal D, riser 2 Location: U1.1-P1-M2.7 x8
4066 053E	Scan interface basic assurance tests detected memory DIMM group fault	Memory quad D odd, riser 2 Location: U1.1-P1-M2.7 x4
4066 053F	Scan interface basic assurance tests detected memory DIMM group fault	Memory quad D even, riser 2 Location: U1.1-P1-M2.8 x4
4066 05FF	Scan interface basic assurance tests detected memory on riser fault	Memory failure on riser card 2 that cannot be automatically isolated. go to "MAP 1540: Minimum Configuration" on page 122 and run CEC drawer minimum configuration for further isolation.
4066 0600	Scan interface basic assurance tests detected CEC RIO bus adapter	CEC RIO bus adapter Location: U1.1-P1.1
4066 0601	Scan interface basic assurance tests detected clock card fault	CEC clock card Location: U1.1-P1.1.1
4066 3101	Scan interface basic assurance tests detected RIO port 0 fault	CEC RIO bus adapter Location: U1.1-P1.1
4066 3102	Scan interface basic assurance tests detected RIO port 1 fault	CEC RIO bus adapter Location: U1.1-P1.1
4066 3103	Scan interface basic assurance tests detected RIO port 2 fault	CEC RIO bus adapter Location: U1.1-P1.1
4066 3104	Scan interface basic assurance tests detected RIO port 3 fault	CEC RIO bus adapter Location: U1.1-P1.1
4066 3121	Scan interface basic assurance tests detected RIO cable on port 0 fault	1. RIO cable on port 0 Location: U1.1-P1.1/Q1 2. CEC RIO bus adapter Location: U1.1-P1.1

Table 7. Service Processor Error Codes (continued)

Error Code	Description	Action/ Possible Failing FRU
4066 3122	Scan interface basic assurance tests detected RIO cable on port 1 fault	1. RIO cable on port 1 Location: U1.1-P1.1/Q2 2. CEC RIO bus adapter Location: U1.1-P1.1
4066 3123	Scan interface basic assurance tests detected RIO cable on port 2 fault	1. RIO cable on port 2 Location: U1.1-P1.1/Q3 2. CEC RIO bus adapter Location: U1.1-P1.1
4066 3124	Scan interface basic assurance tests detected RIO cable on port 3 fault	1. RIO cable on port 3 Location: U1.1-P1.1/Q4 2. CEC RIO bus adapter Location: U1.1-P1.1
4066 3140	Scan interface basic assurance tests detected RIO hub 0 fault	CEC RIO bus adapter Location: U1.1-P1.1
4066 3141	Scan interface basic assurance tests detected RIO hub 1 fault	CEC RIO bus adapter Location: U1.1-P1.1
4066 31FF	Scan interface basic assurance tests detected RIO port fault	CEC RIO bus adapter Location: U1.1-P1.1
4066 3200	Scan interface basic assurance tests detected primary I/O drawer fault	Go to "MAP 1540: Minimum Configuration" on page 122.
4066 3201	Scan interface basic assurance tests detected primary I/O drawer backplane fault	Primary I/O drawer backplane Location: U0.1-P1
4066 3280	Scan interface basic assurance tests detected primary RIO adapter fault	Primary RIO adapter Location: U0.1-P1.1
4066 3281	Scan interface basic assurance tests detected primary RIO port 0 fault	1. Check RIO cable Location: U0.1-P1.1/Q1 2. RIO bus adapter Location: U0.1-P1.1
4066 3282	Scan interface basic assurance tests detected primary RIO port 1 fault	1. Check RIO cable Location: U0.1-P1.1/Q2 2. RIO bus adapter Location: U0.1-P1.1
4066 3283	Scan interface basic assurance tests detected primary RIO ports fault	RIO bus adapter Location: U0.1-P1.1
4066 3284	Scan interface basic assurance tests detected PCI controller PHB0	1. RIO bus adapter Location: U0.1-P1.1 2. Primary I/O drawer backplane Location: U0.1-P1
4066 3285	Scan interface basic assurance tests detected PCI controller PHB1 fault	1. RIO bus adapter Location: U0.1-P1.1 2. Primary I/O drawer backplane Location: U0.1-P1

Table 7. Service Processor Error Codes (continued)

Error Code	Description	Action/ Possible Failing FRU
4066 3286	Scan interface basic assurance tests detected PCI controller PHB2	1. RIO bus adapter Location: U0.1-P1.1 2. Primary I/O drawer backplane Location: U0.1-P1
4067 0001	6xx bus processor runtime diagnostics detected CEC backplane failure	CEC backplane Location: U1.1-P1
4067 0003	6xx bus processor runtime diagnostics detected processor fault	All processors Location: U1.1-P1-C1
4067 0009	6xx bus processor runtime diagnostics detected memory fault	All memory Location: U1.1-P1-M1 x2
4067 00A0	6xx bus processor runtime diagnostics detected CSP service processor firmware fault	Update system firmware Location: U0.1-P1/Y1
4067 00A1	6xx bus processor runtime diagnostics detected AIX or system firmware fault	1. Check for AIX updates 2. Check for system firmware updates Location: U0.1-P1/Y1
4067 00A2	6xx bus processor runtime diagnostics detected service processor firmware (processor runtime diagnostics) fault	Check for system firmware updates Location: U0.1-P1/Y1
4067 00A3	6xx bus processor runtime diagnostics detected memory plugging fault	All pluggable memory
4067 00A4	6xx bus processor runtime diagnostics detected application caused fault	Application software
4067 00A5	6xx bus processor runtime diagnostics detected invalid system configuration	Verify system components are supported and properly installed.
4067 00A6	6xx bus processor runtime diagnostics detected no usable memory	1. Ensure that CEC memory is properly installed. 2. If more than one DIMM is called out, go to the service processor Memory Configuration/Deconfiguration Menu to verify memory DIMMs state. See "Memory Configuration/Deconfiguration Menu" on page 426 for more information.
4067 00A7	6xx bus processor runtime diagnostics detected hardware problem	Go to "MAP 1540: Minimum Configuration" on page 122 run CEC minimum configuration

Table 7. Service Processor Error Codes (continued)

<b>Error Code</b>	<b>Description</b>	<b>Action/ Possible Failing FRU</b>
4067 00B0	6xx bus processor runtime diagnostics detected bus controller lock-unlock failure	RIO bus adapter Location: U0.1-P1.1
4067 00B1	6xx bus processor runtime diagnostics detected bus controller failure	RIO bus adapter Location: U0.1-P1.1
4067 00B3	6xx bus processor runtime diagnostics detected clock fault	1. Clock card Location: U1.1-P1.1.1 2. CEC RIO bus adapter Location: U1.1-P1.1
4067 00B7	6xx bus processor runtime diagnostics detected insufficient hardware resources to continue IPL	This error code appears after the initial testing by the service processor firmware on the CEC was completed correctly, but a problem occurred when the firmware tried to communicate outside the CEC. Suspect a problem with the RIO interface, either cables or adapters.
4067 0200	6xx bus processor runtime diagnostics detected memory riser card fault	Memory riser card 1 Location: U1.1-P1-M1
4067 0201	6xx bus processor runtime diagnostics detected memory DIMM fault	Memory DIMM 1, riser 1 Location: U1.1-P1-M1.1
4067 0202	6xx bus processor runtime diagnostics detected memory DIMM fault	Memory DIMM 2, riser 1 Location: U1.1-P1-M1.2
4067 0203	6xx bus processor runtime diagnostics detected memory DIMM fault	Memory DIMM 9, riser 1 Location: U1.1-P1-M1.9
4067 0204	6xx bus processor runtime diagnostics detected memory DIMM fault	Memory DIMM 10, riser 1 Location: U1.1-P1-M1.10
4067 0205	6xx bus processor runtime diagnostics detected memory DIMM fault	Memory DIMM 17, riser 1 Location: U1.1-P1-M1.17
4067 0206	6xx bus processor runtime diagnostics detected memory DIMM fault	Memory DIMM 18, riser 1 Location: U1.1-P1-M1.18
4067 0207	6xx bus processor runtime diagnostics detected memory DIMM fault	Memory DIMM 25, riser 1 Location: U1.1-P1-M1.25
4067 0208	6xx bus processor runtime diagnostics detected memory DIMM fault	Memory DIMM 26, riser 1 Location: U1.1-P1-M1.26

Table 7. Service Processor Error Codes (continued)

<b>Error Code</b>	<b>Description</b>	<b>Action/ Possible Failing FRU</b>
4067 020D	6xx bus processor runtime diagnostics detected memory DIMM group fault	Memory octal A, riser 1 Location: U1.1-P1-M1.1 x8
4067 020E	6xx bus processor runtime diagnostics detected memory DIMM group fault	Memory quad A odd, riser 1 Locations: U1.1-P1-M1.1 x4
4067 020F	6xx bus processor runtime diagnostics detected memory DIMM group fault	Memory quad A even, riser 1 Locations: U1.1-P1-M1.2 x4
4067 0211	6xx bus processor runtime diagnostics detected memory DIMM fault	Memory DIMM 3, riser 1 Location: U1.1-P1-M1.3
4067 0212	6xx bus processor runtime diagnostics detected memory DIMM fault	Memory DIMM 4, riser 1 Location: U1.1-P1-M1.4
4067 0213	6xx bus processor runtime diagnostics detected memory DIMM fault	Memory DIMM 11, riser 1 Location: U1.1-P1-M1.11
4067 0214	6xx bus processor runtime diagnostics detected memory DIMM fault	Memory DIMM 12, riser 1 Location: U1.1-P1-M1.12
4067 0215	6xx bus processor runtime diagnostics detected memory DIMM fault	Memory DIMM 19, riser 1 Location: U1.1-P1-M1.19
4067 0216	6xx bus processor runtime diagnostics detected memory DIMM fault	Memory DIMM 20, riser 1 Location: U1.1-P1-M1.20
4067 0217	6xx bus processor runtime diagnostics detected memory DIMM fault	Memory DIMM 27, riser 1 Location: U1.1-P1-M1.27
4067 0218	6xx bus processor runtime diagnostics detected memory DIMM fault	Memory DIMM 28, riser 1 Location: U1.1-P1-M1.28
4067 021D	6xx bus processor runtime diagnostics detected memory DIMM group fault	Memory octal B, riser 1 Location: U1.1-P1-M1.3 x8
4067 021E	6xx bus processor runtime diagnostics detected memory DIMM group pair A fault	Memory quad B odd, riser 1 Location: U1.1-P1-M1.3 x4
4067 021F	6xx bus processor runtime diagnostics detected memory DIMM group fault	Memory quad B even, riser 1 Location: U1.1-P1-M1.4 x4
4067 0221	6xx bus processor runtime diagnostics detected memory DIMM fault	Memory DIMM 5, riser 1 Location: U1.1-P1-M1.5

Table 7. Service Processor Error Codes (continued)

<b>Error Code</b>	<b>Description</b>	<b>Action/ Possible Failing FRU</b>
4067 0222	6xx bus processor runtime diagnostics detected memory DIMM fault	Memory DIMM 6, riser 1 Location: U1.1-P1-M1.6
4067 0223	6xx bus processor runtime diagnostics detected memory DIMM fault	Memory DIMM 13, riser 1 Location: U1.1-P1-M1.13
4067 0224	6xx bus processor runtime diagnostics detected memory DIMM fault	Memory DIMM 14, riser 1 Location: U1.1-P1-M1.14
4067 0225	6xx bus processor runtime diagnostics detected memory DIMM fault	Memory DIMM 21, riser 1 Location: U1.1-P1-M1.21
4067 0226	6xx bus processor runtime diagnostics detected memory DIMM fault	Memory DIMM 22, riser 1 Location: U1.1-P1-M1.22
4067 0227	6xx bus processor runtime diagnostics detected memory DIMM fault	Memory DIMM 29, riser 1 Location: U1.1-P1-M1.29
4067 0228	6xx bus processor runtime diagnostics detected memory DIMM fault	Memory DIMM 30, riser 1 Location: U1.1-P1-M1.30
4067 022D	6xx bus processor runtime diagnostics detected memory DIMM group fault	Memory octal C, riser 1 Locations: U1.1-P1-M1.5 x8
4067 022E	6xx bus processor runtime diagnostics detected memory DIMM group pair A fault	Memory quad C odd, riser 1 Locations: U1.1-P1-M1.5 x4
4067 022F	6xx bus processor runtime diagnostics detected memory DIMM group fault	Memory quad C even, riser 1 Locations: U1.1-P1-M1.6 x4
4067 0231	6xx bus processor runtime diagnostics detected memory DIMM fault	Memory DIMM 7, riser 1 Location: U1.1-P1-M1.7
4067 0232	6xx bus processor runtime diagnostics detected memory DIMM fault	Memory DIMM 8, riser 1 Location: U1.1-P1-M1.8
4067 0233	6xx bus processor runtime diagnostics detected memory DIMM fault	Memory DIMM 15, riser 1 Location: U1.1-P1-M1.15
4067 0234	6xx bus processor runtime diagnostics detected memory DIMM fault	Memory DIMM 16, riser 1 Location: U1.1-P1-M1.16
4067 0235	6xx bus processor runtime diagnostics detected memory DIMM fault	Memory DIMM 23, riser 1 Location: U1.1-P1-M1.23

Table 7. Service Processor Error Codes (continued)

Error Code	Description	Action/ Possible Failing FRU
4067 0236	6xx bus processor runtime diagnostics detected memory DIMM fault	Memory DIMM 24, riser 1 Location: U1.1-P1-M1.24
4067 0237	6xx bus processor runtime diagnostics detected memory DIMM fault	Memory DIMM 31, riser 1 Location: U1.1-P1-M1.31
4067 0238	6xx bus processor runtime diagnostics detected memory DIMM fault	Memory DIMM 32, riser 1 Location: U1.1-P1-M1.32
4067 023D	6xx bus processor runtime diagnostics detected memory DIMM group fault	Memory octal D, riser 1 Location: U1.1-P1-M1.7 x8
4067 023E	6xx bus processor runtime diagnostics detected memory DIMM group fault	Memory quad D odd, riser 1 Location: U1.1-P1-M1.7 x4
4067 023F	6xx bus processor runtime diagnostics detected memory DIMM group fault	Memory quad D even, riser 1 Location: U1.1-P1-M1.8 x4
4067 02FF	6xx bus processor runtime diagnostics detected memory on riser fault	All memory on riser 1 Location: U1.1-P1-M1.1 x32 Memory failure on riser card 1 that cannot be automatically isolated. go to "MAP 1540: Minimum Configuration" on page 122 and run CEC drawer minimum configuration for further isolation.
4067 0300	6xx bus processor runtime diagnostics detected processor card fault	Processor card Location: U1.1-P1-C1
4067 0400	6xx bus processor runtime diagnostics detected processor card fault	Processor card Location: U1.1-P1-C2
4067 0500	6xx bus processor runtime diagnostics detected memory riser card fault	Memory riser card 2 Location: U1.1-P1-M1
4067 0501	6xx bus processor runtime diagnostics detected memory DIMM fault	Memory DIMM 1, riser 2 Location: U1.1-P1-M2.1
4067 0502	6xx bus processor runtime diagnostics detected memory DIMM fault	Memory DIMM 2, riser 2 Location: U1.1-P1-M2.2
4067 0503	6xx bus processor runtime diagnostics detected memory DIMM fault	Memory DIMM 9, riser 2 Location: U1.1-P1-M2.9

Table 7. Service Processor Error Codes (continued)

Error Code	Description	Action/ Possible Failing FRU
4067 0504	6xx bus processor runtime diagnostics detected memory DIMM fault	Memory DIMM 10, riser 2 Location: U1.1-P1-M2.10
4067 0505	6xx bus processor runtime diagnostics detected memory DIMM fault	Memory DIMM 17, riser 2 Location: U1.1-P1-M2.17
4067 0506	6xx bus processor runtime diagnostics detected memory DIMM fault	Memory DIMM 18, riser 2 Location: U1.1-P1-M2.18
4067 0507	6xx bus processor runtime diagnostics detected memory DIMM fault	Memory DIMM 25, riser 2 Location: U1.1-P1-M2.25
4067 0508	6xx bus processor runtime diagnostics detected memory DIMM fault	Memory DIMM 26, riser 2 Location: U1.1-P1-M2.26
4067 050D	6xx bus processor runtime diagnostics detected memory DIMM group fault	Memory octal A, riser 2 Location: U1.1-P1-M2.1 x8
4067 050E	6xx bus processor runtime diagnostics detected memory DIMM group pair A fault	Memory quad A odd, riser 2 Location: U1.1-P1-M2.1 x4
4067 050F	6xx bus processor runtime diagnostics detected memory DIMM group fault	Memory quad A even, riser 2 Location: U1.1-P1-M2.2 x4
4067 0511	6xx bus processor runtime diagnostics detected memory DIMM fault	Memory DIMM 3, riser 2 Location: U1.1-P1-M2.3
4067 0512	6xx bus processor runtime diagnostics detected memory DIMM fault	Memory DIMM 4, riser 2 Location: U1.1-P1-M2.4
4067 0513	6xx bus processor runtime diagnostics detected memory DIMM fault	Memory DIMM 11, riser 2 Location: U1.1-P1-M2.11
4067 0514	6xx bus processor runtime diagnostics detected memory DIMM fault	Memory DIMM 12, riser 2 Location: U1.1-P1-M2.12
4067 0515	6xx bus processor runtime diagnostics detected memory DIMM fault	Memory DIMM 19, riser 2 Location: U1.1-P1-M2.19
4067 0516	6xx bus processor runtime diagnostics detected memory DIMM fault	Memory DIMM 20, riser 2 Location: U1.1-P1-M2.20
4067 0517	6xx bus processor runtime diagnostics detected memory DIMM fault	Memory DIMM 27, riser 2 Location: U1.1-P1-M2.27



Table 7. Service Processor Error Codes (continued)

<b>Error Code</b>	<b>Description</b>	<b>Action/ Possible Failing FRU</b>
4067 0518	6xx bus processor runtime diagnostics detected memory DIMM fault	Memory DIMM 28, riser 2 Location: U1.1-P1-M2.28
4067 051D	6xx bus processor runtime diagnostics detected memory DIMM group fault	Memory octal B, riser 2 Location: U1.1-P1-M2.3 x8
4067 051E	6xx bus processor runtime diagnostics detected memory DIMM group fault	Memory quad B odd, riser 2 Location: U1.1-P1-M2.3 x4
4067 051F	6xx bus processor runtime diagnostics detected memory DIMM group fault	Memory quad B even, riser 2 Location: U1.1-P1-M2.4 x4
4067 0521	6xx bus processor runtime diagnostics detected memory DIMM fault	Memory DIMM 5, riser 2 Location: U1.1-P1-M2.5
4067 0522	6xx bus processor runtime diagnostics detected memory DIMM fault	Memory DIMM 6, riser 2 Location: U1.1-P1-M2.6
4067 0523	6xx bus processor runtime diagnostics detected memory DIMM fault	Memory DIMM 13, riser 2 Location: U1.1-P1-M2.13
4067 0524	6xx bus processor runtime diagnostics detected memory DIMM fault	Memory DIMM 14, riser 2 Location: U1.1-P1-M2.14
4067 0525	6xx bus processor runtime diagnostics detected memory DIMM fault	Memory DIMM 21, riser 2 Location: U1.1-P1-M2.21
4067 0526	6xx bus processor runtime diagnostics detected memory DIMM fault	Memory DIMM 22, riser 2 Location: U1.1-P1-M2.22
4067 0527	6xx bus processor runtime diagnostics detected memory DIMM fault	Memory DIMM 29, riser 2 Location: U1.1-P1-M2.29
4067 0528	6xx bus processor runtime diagnostics detected memory DIMM fault	Memory DIMM 30, riser 2 Location: U1.1-P1-M2.30
4067 052D	6xx bus processor runtime diagnostics detected memory DIMM group fault	Memory octal C, riser 2 Location: U1.1-P1-M2.5 x8
4067 052E	6xx bus processor runtime diagnostics detected memory DIMM group pair A fault	Memory quad C odd, riser 2 Location: U1.1-P1-M2.5 x4
4067 052F	6xx bus processor runtime diagnostics detected memory DIMM group fault	Memory quad C even, riser 2 Location: U1.1-P1-M2.6 x4

Table 7. Service Processor Error Codes (continued)

<b>Error Code</b>	<b>Description</b>	<b>Action/ Possible Failing FRU</b>
4067 0531	6xx bus processor runtime diagnostics detected memory DIMM fault	Memory DIMM 7, riser 2 Location: U1.1-P1-M2.7
4067 0532	6xx bus processor runtime diagnostics detected memory DIMM fault	Memory DIMM 8, riser 2 Location: U1.1-P1-M2.8
4067 0533	6xx bus processor runtime diagnostics detected memory DIMM fault	Memory DIMM 15, riser 2 Location: U1.1-P1-M2.15
4067 0534	6xx bus processor runtime diagnostics detected memory DIMM fault	Memory DIMM 16, riser 2 Location: U1.1-P1-M2.16
4067 0535	6xx bus processor runtime diagnostics detected memory DIMM fault	Memory DIMM 23, riser 2 Location: U1.1-P1-M2.23
4067 0536	6xx bus processor runtime diagnostics detected memory DIMM fault	Memory DIMM 24, riser 2 Location: U1.1-P1-M2.24
4067 0537	6xx bus processor runtime diagnostics detected memory DIMM fault	Memory DIMM 31, riser 2 Location: U1.1-P1-M2.31
4067 0538	6xx bus processor runtime diagnostics detected memory DIMM fault	Memory DIMM 32, riser 2 Location: U1.1-P1-M2.32
4067 053D	6xx bus processor runtime diagnostics detected memory DIMM group fault	Memory octal D, riser 2 Location: U1.1-P1-M2.7 x8
4067 053E	6xx bus processor runtime diagnostics detected memory DIMM group fault	Memory quad D odd, riser 2 Location: U1.1-P1-M2.7 x4
4067 053F	6xx bus processor runtime diagnostics detected memory DIMM group fault	Memory quad D even, riser 2 Location: U1.1-P1-M2.8 x4
4067 05FF	6xx bus processor runtime diagnostics detected memory on riser fault	Memory failure on riser card 2 that cannot be automatically isolated. go to "MAP 1540: Minimum Configuration" on page 122 and run CEC drawer minimum configuration for further isolation.
4067 0600	6xx bus processor runtime diagnostics detected CEC RIO bus adapter	CEC RIO bus adapter Location: U1.1-P1.1
4067 0601	6xx bus processor runtime diagnostics detected clock card fault	CEC clock card Location: U1.1-P1.1.1

Table 7. Service Processor Error Codes (continued)

Error Code	Description	Action/ Possible Failing FRU
4067 3101	6xx bus processor runtime diagnostics detected RIO port 0 fault	CEC RIO bus adapter Location: U1.1-P1.1
4067 3102	6xx bus processor runtime diagnostics detected RIO port 1 fault	CEC RIO bus adapter Location: U1.1-P1.1
4067 3103	6xx bus processor runtime diagnostics detected RIO port 2 fault	CEC RIO bus adapter Location: U1.1-P1.1
4067 3104	6xx bus processor runtime diagnostics detected RIO port 3 fault	CEC RIO bus adapter Location: U1.1-P1.1
4067 3121	6xx bus processor runtime diagnostics detected RIO cable on port 0 fault	1. RIO cable on port 0 Location: U1.1-P1.1/Q1 2. CEC RIO bus adapter Location: U1.1-P1.1
4067 3122	6xx bus processor runtime diagnostics detected RIO cable on port 1 fault	1. RIO cable on port 1 Location: U1.1-P1.1/Q2 2. CEC RIO bus adapter Location: U1.1-P1.1
4067 3123	6xx bus processor runtime diagnostics detected RIO cable on port 2 fault	1. RIO cable on port 2 Location: U1.1-P1.1/Q3 2. CEC RIO bus adapter Location: U1.1-P1.1
4067 3124	6xx bus processor runtime diagnostics detected RIO cable on port 3 fault	1. RIO cable on port 3 Location: U1.1-P1.1/Q4 2. CEC RIO bus adapter Location: U1.1-P1.1
4067 3140	6xx bus processor runtime diagnostics detected RIO hub 0 fault	CEC RIO bus adapter Location: U1.1-P1.1
4067 3141	6xx bus processor runtime diagnostics detected RIO hub 1 fault	CEC RIO bus adapter Location: U1.1-P1.1
4067 31FF	6xx bus processor runtime diagnostics detected RIO port fault	CEC RIO bus adapter Location: U1.1-P1.1
4067 3200	6xx bus processor runtime diagnostics detected primary I/O drawer fault	Go to "MAP 1540: Minimum Configuration" on page 122.
4067 3201	6xx bus processor runtime diagnostics detected primary I/O drawer backplane fault	Primary I/O drawer backplane Location: U0.1-P1
4067 3280	6xx bus processor runtime diagnostics detected primary RIO adapter fault	Primary RIO adapter Location: U0.1-P1.1
4067 3281	6xx bus processor runtime diagnostics detected primary RIO port 0 fault	1. Check RIO cable Location: U0.1-P1.1/Q1 2. RIO bus adapter Location: U0.1-P1.1

Table 7. Service Processor Error Codes (continued)

Error Code	Description	Action/ Possible Failing FRU
4067 3282	6xx bus processor runtime diagnostics detected primary RIO port 1 fault	1. Check RIO cable Location: U0.1-P1.1/Q2 2. RIO bus adapter Location: U0.1-P1.1
4067 3283	6xx bus processor runtime diagnostics detected primary RIO ports fault	RIO bus adapter Location: U0.1-P1.1
4067 3284	6xx bus processor runtime diagnostics detected PCI controller PHB0	1. RIO bus adapter Location: U0.1-P1.1 2. Primary I/O drawer backplane Location: U0.1-P1
4067 3285	6xx bus processor runtime diagnostics detected PCI controller PHB1	1. RIO bus adapter Location: U0.1-P1.1 2. Primary I/O drawer backplane Location: U0.1-P1
4067 3286	6xx bus processor runtime diagnostics detected PCI controller PHB2	1. RIO bus adapter Location: U0.1-P1.1 2. Primary I/O drawer backplane Location: U0.1-P1
4068 0001	Other bus processor runtime diagnostics detected CEC backplane failure	CEC backplane Location: U1.1-P1
4068 0003	Other bus processor runtime diagnostics detected processor fault	All processors Location: U1.1-P1-C1
4068 0009	Other bus processor runtime diagnostics detected memory fault	All memory Location: U1.1-P1-M1 x2
4068 00A0	Other bus processor runtime diagnostics detected CSP service processor firmware fault	Update system firmware Location: U0.1-P1/Y1
4068 00A1	Other bus processor runtime diagnostics detected AIX or system firmware fault	1. Check for AIX updates 2. Check for system firmware updates Location: U0.1-P1/Y1
4068 00A2	Other bus processor runtime diagnostics detected service processor firmware (processor runtime diagnostics) fault	Check for system firmware updates Location: U0.1-P1/Y1
4068 00A3	Other bus processor runtime diagnostics detected memory plugging fault	All pluggable memory
4068 00A4	Other bus processor runtime diagnostics detected application caused fault	Application software

Table 7. Service Processor Error Codes (continued)

Error Code	Description	Action/ Possible Failing FRU
4068 00A5	Other bus processor runtime diagnostics detected invalid system configuration	Verify system components are supported and properly installed.
4068 00A6	Other bus processor runtime diagnostics detected no usable memory	<ol style="list-style-type: none"> <li>1. Ensure that CEC memory is properly installed.</li> <li>2. If more than one DIMM is called out, go to the service processor Memory Configuration/Deconfiguration Menu to verify memory DIMMs state. See "Memory Configuration/Deconfiguration Menu" on page 426 for more information.</li> </ol>
4068 00A7	Other bus processor runtime diagnostics detected hardware problem	Go to minimum configuration and also run CEC minimum configuration
4068 00B0	Other bus processor runtime diagnostics detected bus controller lock-unlock failure	RIO bus adapter Location: U0.1-P1.1
4068 00B1	Other bus processor runtime diagnostics detected bus controller failure	RIO bus adapter Location: U0.1-P1.1
4068 00B3	Other bus processor runtime diagnostics detected clock fault	<ol style="list-style-type: none"> <li>1. Clock card Location: U1.1-P1.1.1</li> <li>2. CEC RIO bus adapter Location: U1.1-P1.1</li> </ol>
4068 00B7	Other bus processor runtime diagnostics detected insufficient hardware resources to continue IPL	This error code appears after the initial testing by the service processor firmware on the CEC was completed correctly, but a problem occurred when the firmware tried to communicate outside the CEC. Suspect a problem with the RIO interface, either cables or adapters.
4068 0200	Other bus processor runtime diagnostics detected memory riser card fault	Memory riser card 1 Location: U1.1-P1-M1
4068 0201	Other bus processor runtime diagnostics detected memory DIMM fault	Memory DIMM 1, riser 1 Location: U1.1-P1-M1.1
4068 0202	Other bus processor runtime diagnostics detected memory DIMM fault	Memory DIMM 2, riser 1 Location: U1.1-P1-M1.2

Table 7. Service Processor Error Codes (continued)

<b>Error Code</b>	<b>Description</b>	<b>Action/ Possible Failing FRU</b>
4068 0203	Other bus processor runtime diagnostics detected memory DIMM fault	Memory DIMM 9, riser 1 Location: U1.1-P1-M1.9
4068 0204	Other bus processor runtime diagnostics detected memory DIMM fault	Memory DIMM 10, riser 1 Location: U1.1-P1-M1.10
4068 0205	Other bus processor runtime diagnostics detected memory DIMM fault	Memory DIMM 17, riser 1 Location: U1.1-P1-M1.17
4068 0206	Other bus processor runtime diagnostics detected memory DIMM fault	Memory DIMM 18, riser 1 Location: U1.1-P1-M1.18
4068 0207	Other bus processor runtime diagnostics detected memory DIMM fault	Memory DIMM 25, riser 1 Location: U1.1-P1-M1.25
4068 0208	Other bus processor runtime diagnostics detected memory DIMM fault	Memory DIMM 26, riser 1 Location: U1.1-P1-M1.26
4068 020D	Other bus processor runtime diagnostics detected memory DIMM group fault	Memory octal A, riser 1 Location: U1.1-P1-M1.1 x8
4068 020E	Other bus processor runtime diagnostics detected memory DIMM group fault	Memory quad A odd, riser 1 Locations: U1.1-P1-M1.1 x4
4068 020F	Other bus processor runtime diagnostics detected memory DIMM group fault	Memory quad A even, riser 1 Locations: U1.1-P1-M1.2 x4
4068 0211	Other bus processor runtime diagnostics detected memory DIMM fault	Memory DIMM 3, riser 1 Location: U1.1-P1-M1.3
4068 0212	Other bus processor runtime diagnostics detected memory DIMM fault	Memory DIMM 4, riser 1 Location: U1.1-P1-M1.4
4068 0213	Other bus processor runtime diagnostics detected memory DIMM fault	Memory DIMM 11, riser 1 Location: U1.1-P1-M1.11
4068 0214	Other bus processor runtime diagnostics detected memory DIMM fault	Memory DIMM 12, riser 1 Location: U1.1-P1-M1.12
4068 0215	Other bus processor runtime diagnostics detected memory DIMM fault	Memory DIMM 19, riser 1 Location: U1.1-P1-M1.19
4068 0216	Other bus processor runtime diagnostics detected memory DIMM fault	Memory DIMM 20, riser 1 Location: U1.1-P1-M1.20

Table 7. Service Processor Error Codes (continued)

<b>Error Code</b>	<b>Description</b>	<b>Action/ Possible Failing FRU</b>
4068 0217	Other bus processor runtime diagnostics detected memory DIMM fault	Memory DIMM 27, riser 1 Location: U1.1-P1-M1.27
4068 0218	Other bus processor runtime diagnostics detected memory DIMM fault	Memory DIMM 28, riser 1 Location: U1.1-P1-M1.28
4068 021D	Other bus processor runtime diagnostics detected memory DIMM group fault	Memory octal B, riser 1 Location: U1.1-P1-M1.3 x8
4068 021E	Other bus processor runtime diagnostics detected memory DIMM group pair A fault	Memory quad B odd, riser 1 Location: U1.1-P1-M1.3 x4
4068 021F	Other bus processor runtime diagnostics detected memory DIMM group fault	Memory quad B even, riser 1 Location: U1.1-P1-M1.4 x4
4068 0221	Other bus processor runtime diagnostics detected memory DIMM fault	Memory DIMM 5, riser 1 Location: U1.1-P1-M1.5
4068 0222	Other bus processor runtime diagnostics detected memory DIMM fault	Memory DIMM 6, riser 1 Location: U1.1-P1-M1.6
4068 0223	Other bus processor runtime diagnostics detected memory DIMM fault	Memory DIMM 13, riser 1 Location: U1.1-P1-M1.13
4068 0224	Other bus processor runtime diagnostics detected memory DIMM fault	Memory DIMM 14, riser 1 Location: U1.1-P1-M1.14
4068 0225	Other bus processor runtime diagnostics detected memory DIMM fault	Memory DIMM 21, riser 1 Location: U1.1-P1-M1.21
4068 0226	Other bus processor runtime diagnostics detected memory DIMM fault	Memory DIMM 22, riser 1 Location: U1.1-P1-M1.22
4068 0227	Other bus processor runtime diagnostics detected memory DIMM fault	Memory DIMM 29, riser 1 Location: U1.1-P1-M1.29
4068 0228	Other bus processor runtime diagnostics detected memory DIMM fault	Memory DIMM 30, riser 1 Location: U1.1-P1-M1.30
4068 022D	Other bus processor runtime diagnostics detected memory DIMM group fault	Memory octal C, riser 1 Locations: U1.1-P1-M1.5 x8
4068 022E	Other bus processor runtime diagnostics detected memory DIMM group pair A fault	Memory quad C odd, riser 1 Locations: U1.1-P1-M1.5 x4

Table 7. Service Processor Error Codes (continued)

<b>Error Code</b>	<b>Description</b>	<b>Action/ Possible Failing FRU</b>
4068 022F	Other bus processor runtime diagnostics detected memory DIMM group fault	Memory quad C even, riser 1 Locations: U1.1-P1-M1.6 x4
4068 0231	Other bus processor runtime diagnostics detected memory DIMM fault	Memory DIMM 7, riser 1 Location: U1.1-P1-M1.7
4068 0232	Other bus processor runtime diagnostics detected memory DIMM fault	Memory DIMM 8, riser 1 Location: U1.1-P1-M1.8
4068 0233	Other bus processor runtime diagnostics detected memory DIMM fault	Memory DIMM 15, riser 1 Location: U1.1-P1-M1.15
4068 0234	Other bus processor runtime diagnostics detected memory DIMM fault	Memory DIMM 16, riser 1 Location: U1.1-P1-M1.16
4068 0235	Other bus processor runtime diagnostics detected memory DIMM fault	Memory DIMM 23, riser 1 Location: U1.1-P1-M1.23
4068 0236	Other bus processor runtime diagnostics detected memory DIMM fault	Memory DIMM 24, riser 1 Location: U1.1-P1-M1.24
4068 0237	Other bus processor runtime diagnostics detected memory DIMM fault	Memory DIMM 31, riser 1 Location: U1.1-P1-M1.31
4068 0238	Other bus processor runtime diagnostics detected memory DIMM fault	Memory DIMM 32, riser 1 Location: U1.1-P1-M1.32
4068 023D	Other bus processor runtime diagnostics detected memory DIMM group fault	Memory octal D, riser 1 Location: U1.1-P1-M1.7 x8
4068 023E	Other bus processor runtime diagnostics detected memory DIMM group fault	Memory quad D odd, riser 1 Location: U1.1-P1-M1.7 x4
4068 023F	Other bus processor runtime diagnostics detected memory DIMM group fault	Memory quad D even, riser 1 Location: U1.1-P1-M1.8 x4
4068 02FF	Other bus processor runtime diagnostics detected memory on riser fault	All memory on riser 1 Location: U1.1-P1-M1.1 x32 Memory failure on riser card 1 that cannot be automatically isolated. go to "MAP 1540: Minimum Configuration" on page 122 and run CEC drawer minimum configuration for further isolation.



Table 7. Service Processor Error Codes (continued)

<b>Error Code</b>	<b>Description</b>	<b>Action/ Possible Failing FRU</b>
4068 0300	Other bus processor runtime diagnostics detected processor card fault	Processor card Location: U1.1-P1-C1
4068 0400	Other bus processor runtime diagnostics detected processor card fault	Processor card Location: U1.1-P1-C2
4068 0500	Other bus processor runtime diagnostics detected memory riser card fault	Memory riser card 2 Location: U1.1-P1-M1
4068 0501	Other bus processor runtime diagnostics detected memory DIMM fault	Memory DIMM 1, riser 2 Location: U1.1-P1-M2.1
4068 0502	Other bus processor runtime diagnostics detected memory DIMM fault	Memory DIMM 2, riser 2 Location: U1.1-P1-M2.2
4068 0503	Other bus processor runtime diagnostics detected memory DIMM fault	Memory DIMM 9, riser 2 Location: U1.1-P1-M2.9
4068 0504	Other bus processor runtime diagnostics detected memory DIMM fault	Memory DIMM 10, riser 2 Location: U1.1-P1-M2.10
4068 0505	Other bus processor runtime diagnostics detected memory DIMM fault	Memory DIMM 17, riser 2 Location: U1.1-P1-M2.17
4068 0506	Other bus processor runtime diagnostics detected memory DIMM fault	Memory DIMM 18, riser 2 Location: U1.1-P1-M2.18
4068 0507	Other bus processor runtime diagnostics detected memory DIMM fault	Memory DIMM 25, riser 2 Location: U1.1-P1-M2.25
4068 0508	Other bus processor runtime diagnostics detected memory DIMM fault	Memory DIMM 26, riser 2 Location: U1.1-P1-M2.26
4068 050D	Other bus processor runtime diagnostics detected memory DIMM group fault	Memory octal A, riser 2 Location: U1.1-P1-M2.1 x8
4068 050E	Other bus processor runtime diagnostics detected memory DIMM group pair A fault	Memory quad A odd, riser 2 Location: U1.1-P1-M2.1 x4
4068 050F	Other bus processor runtime diagnostics detected memory DIMM group fault	Memory quad A even, riser 2 Location: U1.1-P1-M2.2 x4
4068 0511	Other bus processor runtime diagnostics detected memory DIMM fault	Memory DIMM 3, riser 2 Location: U1.1-P1-M2.3

Table 7. Service Processor Error Codes (continued)

<b>Error Code</b>	<b>Description</b>	<b>Action/ Possible Failing FRU</b>
4068 0512	Other bus processor runtime diagnostics detected memory DIMM fault	Memory DIMM 4, riser 2 Location: U1.1-P1-M2.4
4068 0513	Other bus processor runtime diagnostics detected memory DIMM fault	Memory DIMM 11, riser 2 Location: U1.1-P1-M2.11
4068 0514	Other bus processor runtime diagnostics detected memory DIMM fault	Memory DIMM 12, riser 2 Location: U1.1-P1-M2.12
4068 0515	Other bus processor runtime diagnostics detected memory DIMM fault	Memory DIMM 19, riser 2 Location: U1.1-P1-M2.19
4068 0516	Other bus processor runtime diagnostics detected memory DIMM fault	Memory DIMM 20, riser 2 Location: U1.1-P1-M2.20
4068 0517	Other bus processor runtime diagnostics detected memory DIMM fault	Memory DIMM 27, riser 2 Location: U1.1-P1-M2.27
4068 0518	Other bus processor runtime diagnostics detected memory DIMM fault	Memory DIMM 28, riser 2 Location: U1.1-P1-M2.28
4068 051D	Other bus processor runtime diagnostics detected memory DIMM group fault	Memory octal B, riser 2 Location: U1.1-P1-M2.3 x8
4068 051E	Other bus processor runtime diagnostics detected memory DIMM group fault	Memory quad B odd, riser 2 Location: U1.1-P1-M2.3 x4
4068 051F	Other bus processor runtime diagnostics detected memory DIMM group fault	Memory quad B even, riser 2 Location: U1.1-P1-M2.4 x4
4068 0521	Other bus processor runtime diagnostics detected memory DIMM fault	Memory DIMM 5, riser 2 Location: U1.1-P1-M2.5
4068 0522	Other bus processor runtime diagnostics detected memory DIMM fault	Memory DIMM 6, riser 2 Location: U1.1-P1-M2.6
4068 0523	Other bus processor runtime diagnostics detected memory DIMM fault	Memory DIMM 13, riser 2 Location: U1.1-P1-M2.13
4068 0524	Other bus processor runtime diagnostics detected memory DIMM fault	Memory DIMM 14, riser 2 Location: U1.1-P1-M2.14
4068 0525	Other bus processor runtime diagnostics detected memory DIMM fault	Memory DIMM 21, riser 2 Location: U1.1-P1-M2.21

Table 7. Service Processor Error Codes (continued)

<b>Error Code</b>	<b>Description</b>	<b>Action/ Possible Failing FRU</b>
4068 0526	Other bus processor runtime diagnostics detected memory DIMM fault	Memory DIMM 22, riser 2 Location: U1.1-P1-M2.22
4068 0527	Other bus processor runtime diagnostics detected memory DIMM fault	Memory DIMM 29, riser 2 Location: U1.1-P1-M2.29
4068 0528	Other bus processor runtime diagnostics detected memory DIMM fault	Memory DIMM 30, riser 2 Location: U1.1-P1-M2.30
4068 052D	Other bus processor runtime diagnostics detected memory DIMM group fault	Memory octal C, riser 2 Location: U1.1-P1-M2.5 x8
4068 052E	Other bus processor runtime diagnostics detected memory DIMM group pair A fault	Memory quad C odd, riser 2 Location: U1.1-P1-M2.5 x4
4068 052F	Other bus processor runtime diagnostics detected memory DIMM group fault	Memory quad C even, riser 2 Location: U1.1-P1-M2.6 x4
4068 0531	Other bus processor runtime diagnostics detected memory DIMM fault	Memory DIMM 7, riser 2 Location: U1.1-P1-M2.7
4068 0532	Other bus processor runtime diagnostics detected memory DIMM fault	Memory DIMM 8, riser 2 Location: U1.1-P1-M2.8
4068 0533	Other bus processor runtime diagnostics detected memory DIMM fault	Memory DIMM 15, riser 2 Location: U1.1-P1-M2.15
4068 0534	Other bus processor runtime diagnostics detected memory DIMM fault	Memory DIMM 16, riser 2 Location: U1.1-P1-M2.16
4068 0535	Other bus processor runtime diagnostics detected memory DIMM fault	Memory DIMM 23, riser 2 Location: U1.1-P1-M2.23
4068 0536	Other bus processor runtime diagnostics detected memory DIMM fault	Memory DIMM 24, riser 2 Location: U1.1-P1-M2.24
4068 0537	Other bus processor runtime diagnostics detected memory DIMM fault	Memory DIMM 31, riser 2 Location: U1.1-P1-M2.31
4068 0538	Other bus processor runtime diagnostics detected memory DIMM fault	Memory DIMM 32, riser 2 Location: U1.1-P1-M2.32
4068 053D	Other bus processor runtime diagnostics detected memory DIMM group fault	Memory octal D, riser 2 Location: U1.1-P1-M2.7 x8

Table 7. Service Processor Error Codes (continued)

Error Code	Description	Action/ Possible Failing FRU
4068 053E	Other bus processor runtime diagnostics detected memory DIMM group fault	Memory quad D odd, riser 2 Location: U1.1-P1-M2.7 x4
4068 053F	Other bus processor runtime diagnostics detected memory DIMM group fault	Memory quad D even, riser 2 Location: U1.1-P1-M2.8 x4
4068 05FF	Other bus processor runtime diagnostics detected memory on riser fault	Memory failure on riser card 2 that cannot be automatically isolated. go to "MAP 1540: Minimum Configuration" on page 122 and run CEC drawer minimum configuration for further isolation.
4068 0600	Other bus processor runtime diagnostics detected CEC RIO bus adapter	CEC RIO bus adapter Location: U1.1-P1.1
4068 0601	Other bus processor runtime diagnostics detected clock card fault	CEC clock card Location: U1.1-P1.1.1
4068 3101	Other bus processor runtime diagnostics detected RIO port 0 fault	CEC RIO bus adapter Location: U1.1-P1.1
4068 3102	Other bus processor runtime diagnostics detected RIO port 1 fault	CEC RIO bus adapter Location: U1.1-P1.1
4068 3103	Other bus processor runtime diagnostics detected RIO port 2 fault	CEC RIO bus adapter Location: U1.1-P1.1
4068 3104	Other bus processor runtime diagnostics detected RIO port 3 fault	CEC RIO bus adapter Location: U1.1-P1.1
4068 3121	Other bus processor runtime diagnostics detected RIO cable on port 0 fault	1. RIO cable on port 0 Location: U1.1-P1.1/Q1 2. CEC RIO bus adapter Location: U1.1-P1.1
4068 3122	Other bus processor runtime diagnostics detected RIO cable on port 1 fault	1. RIO cable on port 1 Location: U1.1-P1.1/Q2 2. CEC RIO bus adapter Location: U1.1-P1.1
4068 3123	Other bus processor runtime diagnostics detected RIO cable on port 2 fault	1. RIO cable on port 2 Location: U1.1-P1.1/Q3 2. CEC RIO bus adapter Location: U1.1-P1.1
4068 3124	Other bus processor runtime diagnostics detected RIO cable on port 3 fault	1. RIO cable on port 3 Location: U1.1-P1.1/Q4 2. CEC RIO bus adapter Location: U1.1-P1.1
4068 3140	Other bus processor runtime diagnostics detected RIO hub 0 fault	CEC RIO bus adapter Location: U1.1-P1.1
4068 3141	Other bus processor runtime diagnostics detected RIO hub 1 fault	CEC RIO bus adapter Location: U1.1-P1.1

Table 7. Service Processor Error Codes (continued)

<b>Error Code</b>	<b>Description</b>	<b>Action/ Possible Failing FRU</b>
4068 31FF	Other bus processor runtime diagnostics detected RIO port fault	CEC RIO bus adapter Location: U1.1-P1.1
4068 3200	Other bus processor runtime diagnostics detected primary I/O drawer fault	Go to "MAP 1540: Minimum Configuration" on page 122.
4068 3201	Other bus processor runtime diagnostics detected primary I/O drawer backplane fault	Primary I/O drawer backplane Location: U0.1-P1
4068 3280	Other bus processor runtime diagnostics detected primary RIO adapter fault	Primary RIO adapter Location: U0.1-P1.1
4068 3281	Other bus processor runtime diagnostics detected primary RIO port 0 fault	1. Check RIO cable Location: U0.1-P1.1/Q1 2. RIO bus adapter Location: U0.1-P1.1
4068 3282	Other bus processor runtime diagnostics detected primary RIO port 1 fault	1. Check RIO cable Location: U0.1-P1.1/Q2 2. RIO bus adapter Location: U0.1-P1.1
4068 3283	Other bus processor runtime diagnostics detected primary RIO ports fault	RIO bus adapter Location: U0.1-P1.1
4068 3284	Other bus processor runtime diagnostics detected PCI controller PHB0	1. RIO bus adapter Location: U0.1-P1.1 2. Primary I/O drawer backplane Location: U0.1-P1
4068 3285	Other bus processor runtime diagnostics detected PCI controller PHB1	1. RIO bus adapter Location: U0.1-P1.1 2. Primary I/O drawer backplane Location: U0.1-P1
4068 3286	Other bus processor runtime diagnostics detected PCI controller PHB2	1. RIO bus adapter Location: U0.1-P1.1 2. Primary I/O drawer backplane Location: U0.1-P1
4069 0001	Memory test detected CEC backplane failure	CEC backplane Location: U1.1-P1
4069 0003	Memory test detected processor fault	All processors Location: U1.1-P1-C1
4069 0009	Memory test detected memory fault	All memory Location: U1.1-P1-M1 x2
4069 00A0	Memory test detected CSP service processor firmware fault	Update system firmware Location: U0.1-P1/Y1

Table 7. Service Processor Error Codes (continued)

Error Code	Description	Action/ Possible Failing FRU
4069 00A1	Memory test detected AIX or system firmware fault	1. Check for AIX updates 2. Check for system firmware updates Location: U0.1-P1/Y1
4069 00A2	Memory test detected service processor firmware (processor runtime diagnostics) fault	Check for system firmware updates Location: U0.1-P1/Y1
4069 00A3	Memory test detected memory plugging fault	All pluggable memory
4069 00A4	Memory test detected application caused fault	Application software
4069 00A5	Memory test detected invalid system configuration	Verify system components are supported and properly installed.
4069 00A6	Memory test detected no usable memory	1. Ensure that CEC memory is properly installed. 2. If more than one DIMM is called out, go to the service processor Memory Configuration/Deconfiguration Menu to verify memory DIMMs state. See "Memory Configuration/Deconfiguration Menu" on page 426 for more information.
4069 00A7	Memory test detected hardware problem	Go to minimum configuration and also run CEC minimum configuration
4069 00B0	Memory test detected bus controller lock-unlock failure	RIO bus adapter Location: U0.1-P1.1
4069 00B1	Memory test detected bus controller failure	RIO bus adapter Location: U0.1-P1.1
4069 00B3	Memory test detected clock fault	1. Clock card Location: U1.1-P1.1.1 2. CEC RIO bus adapter Location: U1.1-P1.1
4069 00B7	Memory test detected insufficient hardware resources to continue IPL	This error code appears after the initial testing by the service processor firmware on the CEC was completed correctly, but a problem occurred when the firmware tried to communicate outside the CEC. Suspect a problem with the RIO interface, either cables or adapters.
4069 0200	Memory test detected memory riser card fault	Memory riser card 1 Location: U1.1-P1-M1
4069 0201	Memory test detected memory DIMM fault	Memory DIMM 1, riser 1 Location: U1.1-P1-M1.1

Table 7. Service Processor Error Codes (continued)

Error Code	Description	Action/ Possible Failing FRU
4069 0202	Memory test detected memory DIMM fault	Memory DIMM 2, riser 1 Location: U1.1-P1-M1.2
4069 0203	Memory test detected memory DIMM fault	Memory DIMM 9, riser 1 Location: U1.1-P1-M1.9
4069 0204	Memory test detected memory DIMM fault	Memory DIMM 10, riser 1 Location: U1.1-P1-M1.10
4069 0205	Memory test detected memory DIMM fault	Memory DIMM 17, riser 1 Location: U1.1-P1-M1.17
4069 0206	Memory test detected memory DIMM fault	Memory DIMM 18, riser 1 Location: U1.1-P1-M1.18
4069 0207	Memory test detected memory DIMM fault	Memory DIMM 25, riser 1 Location: U1.1-P1-M1.25
4069 0208	Memory test detected memory DIMM fault	Memory DIMM 26, riser 1 Location: U1.1-P1-M1.26
4069 020D	Memory test detected memory DIMM group fault	Memory octal A, riser 1 Location: U1.1-P1-M1.1 x8
4069 020E	Memory test detected memory DIMM group fault	Memory quad A odd, riser 1 Locations: U1.1-P1-M1.1 x4
4069 020F	Memory test detected memory DIMM group fault	Memory quad A even, riser 1 Locations: U1.1-P1-M1.2 x4
4069 0211	Memory test detected memory DIMM fault	Memory DIMM 3, riser 1 Location: U1.1-P1-M1.3
4069 0212	Memory test detected memory DIMM fault	Memory DIMM 4, riser 1 Location: U1.1-P1-M1.4
4069 0213	Memory test detected memory DIMM fault	Memory DIMM 11, riser 1 Location: U1.1-P1-M1.11
4069 0214	Memory test detected memory DIMM fault	Memory DIMM 12, riser 1 Location: U1.1-P1-M1.12
4069 0215	Memory test detected memory DIMM fault	Memory DIMM 19, riser 1 Location: U1.1-P1-M1.19
4069 0216	Memory test detected memory DIMM fault	Memory DIMM 20, riser 1 Location: U1.1-P1-M1.20
4069 0217	Memory test detected memory DIMM fault	Memory DIMM 27, riser 1 Location: U1.1-P1-M1.27
4069 0218	Memory test detected memory DIMM fault	Memory DIMM 28, riser 1 Location: U1.1-P1-M1.28
4069 021D	Memory test detected memory DIMM group fault	Memory octal B, riser 1 Location: U1.1-P1-M1.3 x8
4069 021E	Memory test detected memory DIMM group pair A fault	Memory quad B odd, riser 1 Location: U1.1-P1-M1.3 x4
4069 021F	Memory test detected memory DIMM group fault	Memory quad B even, riser 1 Location: U1.1-P1-M1.4 x4

Table 7. Service Processor Error Codes (continued)

Error Code	Description	Action/ Possible Failing FRU
4069 0221	Memory test detected memory DIMM fault	Memory DIMM 5, riser 1 Location: U1.1-P1-M1.5
4069 0222	Memory test detected memory DIMM fault	Memory DIMM 6, riser 1 Location: U1.1-P1-M1.6
4069 0223	Memory test detected memory DIMM fault	Memory DIMM 13, riser 1 Location: U1.1-P1-M1.13
4069 0224	Memory test detected memory DIMM fault	Memory DIMM 14, riser 1 Location: U1.1-P1-M1.14
4069 0225	Memory test detected memory DIMM fault	Memory DIMM 21, riser 1 Location: U1.1-P1-M1.21
4069 0226	Memory test detected memory DIMM fault	Memory DIMM 22, riser 1 Location: U1.1-P1-M1.22
4069 0227	Memory test detected memory DIMM fault	Memory DIMM 29, riser 1 Location: U1.1-P1-M1.29
4069 0228	Memory test detected memory DIMM fault	Memory DIMM 30, riser 1 Location: U1.1-P1-M1.30
4069 022D	Memory test detected memory DIMM group fault	Memory octal C, riser 1 Locations: U1.1-P1-M1.5 x8
4069 022E	Memory test detected memory DIMM group pair A fault	Memory quad C odd, riser 1 Locations: U1.1-P1-M1.5 x4
4069 022F	Memory test detected memory DIMM group fault	Memory quad C even, riser 1 Locations: U1.1-P1-M1.6 x4
4069 0231	Memory test detected memory DIMM fault	Memory DIMM 7, riser 1 Location: U1.1-P1-M1.7
4069 0232	Memory test detected memory DIMM fault	Memory DIMM 8, riser 1 Location: U1.1-P1-M1.8
4069 0233	Memory test detected memory DIMM fault	Memory DIMM 15, riser 1 Location: U1.1-P1-M1.15
4069 0234	Memory test detected memory DIMM fault	Memory DIMM 16, riser 1 Location: U1.1-P1-M1.16
4069 0235	Memory test detected memory DIMM fault	Memory DIMM 23, riser 1 Location: U1.1-P1-M1.23
4069 0236	Memory test detected memory DIMM fault	Memory DIMM 24, riser 1 Location: U1.1-P1-M1.24
4069 0237	Memory test detected memory DIMM fault	Memory DIMM 31, riser 1 Location: U1.1-P1-M1.31
4069 0238	Memory test detected memory DIMM fault	Memory DIMM 32, riser 1 Location: U1.1-P1-M1.32
4069 023D	Memory test detected memory DIMM group fault	Memory octal D, riser 1 Location: U1.1-P1-M1.7 x8
4069 023E	Memory test detected memory DIMM group fault	Memory quad D odd, riser 1 Location: U1.1-P1-M1.7 x4



Table 7. Service Processor Error Codes (continued)

Error Code	Description	Action/ Possible Failing FRU
4069 023F	Memory test detected memory DIMM group fault	Memory quad D even, riser 1 Location: U1.1-P1-M1.8 x4
4069 02FF	Memory test detected memory on riser fault	All memory on riser 1 Location: U1.1-P1-M1.1 x32 Memory failure on riser card 1 that cannot be automatically isolated. go to "MAP 1540: Minimum Configuration" on page 122 and run CEC drawer minimum configuration for further isolation.
4069 0300	Memory test detected processor card fault	Processor card Location: U1.1-P1-C1
4069 0400	Memory test detected processor card fault	Processor card Location: U1.1-P1-C2
4069 0500	Memory test detected memory riser card fault	Memory riser card 2 Location: U1.1-P1-M1
4069 0501	Memory test detected memory DIMM fault	Memory DIMM 1, riser 2 Location: U1.1-P1-M2.1
4069 0502	Memory test detected memory DIMM fault	Memory DIMM 2, riser 2 Location: U1.1-P1-M2.2
4069 0503	Memory test detected memory DIMM fault	Memory DIMM 9, riser 2 Location: U1.1-P1-M2.9
4069 0504	Memory test detected memory DIMM fault	Memory DIMM 10, riser 2 Location: U1.1-P1-M2.10
4069 0505	Memory test detected memory DIMM fault	Memory DIMM 17, riser 2 Location: U1.1-P1-M2.17
4069 0506	Memory test detected memory DIMM fault	Memory DIMM 18, riser 2 Location: U1.1-P1-M2.18
4069 0507	Memory test detected memory DIMM fault	Memory DIMM 25, riser 2 Location: U1.1-P1-M2.25
4069 0508	Memory test detected memory DIMM fault	Memory DIMM 26, riser 2 Location: U1.1-P1-M2.26
4069 050D	Memory test detected memory DIMM group fault	Memory octal A, riser 2 Location: U1.1-P1-M2.1 x8
4069 050E	Memory test detected memory DIMM group pair A fault	Memory quad A odd, riser 2 Location: U1.1-P1-M2.1 x4
4069 050F	Memory test detected memory DIMM group fault	Memory quad A even, riser 2 Location: U1.1-P1-M2.2 x4
4069 0511	Memory test detected memory DIMM fault	Memory DIMM 3, riser 2 Location: U1.1-P1-M2.3
4069 0512	Memory test detected memory DIMM fault	Memory DIMM 4, riser 2 Location: U1.1-P1-M2.4

Table 7. Service Processor Error Codes (continued)

Error Code	Description	Action/ Possible Failing FRU
4069 0513	Memory test detected memory DIMM fault	Memory DIMM 11, riser 2 Location: U1.1-P1-M2.11
4069 0514	Memory test detected memory DIMM fault	Memory DIMM 12, riser 2 Location: U1.1-P1-M2.12
4069 0515	Memory test detected memory DIMM fault	Memory DIMM 19, riser 2 Location: U1.1-P1-M2.19
4069 0516	Memory test detected memory DIMM fault	Memory DIMM 20, riser 2 Location: U1.1-P1-M2.20
4069 0517	Memory test detected memory DIMM fault	Memory DIMM 27, riser 2 Location: U1.1-P1-M2.27
4069 0518	Memory test detected memory DIMM fault	Memory DIMM 28, riser 2 Location: U1.1-P1-M2.28
4069 051D	Memory test detected memory DIMM group fault	Memory octal B, riser 2 Location: U1.1-P1-M2.3 x8
4069 051E	Memory test detected memory DIMM group fault	Memory quad B odd, riser 2 Location: U1.1-P1-M2.3 x4
4069 051F	Memory test detected memory DIMM group fault	Memory quad B even, riser 2 Location: U1.1-P1-M2.4 x4
4069 0521	Memory test detected memory DIMM fault	Memory DIMM 5, riser 2 Location: U1.1-P1-M2.5
4069 0522	Memory test detected memory DIMM fault	Memory DIMM 6, riser 2 Location: U1.1-P1-M2.6
4069 0523	Memory test detected memory DIMM fault	Memory DIMM 13, riser 2 Location: U1.1-P1-M2.13
4069 0524	Memory test detected memory DIMM fault	Memory DIMM 14, riser 2 Location: U1.1-P1-M2.14
4069 0525	Memory test detected memory DIMM fault	Memory DIMM 21, riser 2 Location: U1.1-P1-M2.21
4069 0526	Memory test detected memory DIMM fault	Memory DIMM 22, riser 2 Location: U1.1-P1-M2.22
4069 0527	Memory test detected memory DIMM fault	Memory DIMM 29, riser 2 Location: U1.1-P1-M2.29
4069 0528	Memory test detected memory DIMM fault	Memory DIMM 30, riser 2 Location: U1.1-P1-M2.30
4069 052D	Memory test detected memory DIMM group fault	Memory octal C, riser 2 Location: U1.1-P1-M2.5 x8
4069 052E	Memory test detected memory DIMM group pair A fault	Memory quad C odd, riser 2 Location: U1.1-P1-M2.5 x4
4069 052F	Memory test detected memory DIMM group fault	Memory quad C even, riser 2 Location: U1.1-P1-M2.6 x4
4069 0531	Memory test detected memory DIMM fault	Memory DIMM 7, riser 2 Location: U1.1-P1-M2.7

Table 7. Service Processor Error Codes (continued)

Error Code	Description	Action/ Possible Failing FRU
4069 0532	Memory test detected memory DIMM fault	Memory DIMM 8, riser 2 Location: U1.1-P1-M2.8
4069 0533	Memory test detected memory DIMM fault	Memory DIMM 15, riser 2 Location: U1.1-P1-M2.15
4069 0534	Memory test detected memory DIMM fault	Memory DIMM 16, riser 2 Location: U1.1-P1-M2.16
4069 0535	Memory test detected memory DIMM fault	Memory DIMM 23, riser 2 Location: U1.1-P1-M2.23
4069 0536	Memory test detected memory DIMM fault	Memory DIMM 24, riser 2 Location: U1.1-P1-M2.24
4069 0537	Memory test detected memory DIMM fault	Memory DIMM 31, riser 2 Location: U1.1-P1-M2.31
4069 0538	Memory test detected memory DIMM fault	Memory DIMM 32, riser 2 Location: U1.1-P1-M2.32
4069 053D	Memory test detected memory DIMM group fault	Memory octal D, riser 2 Location: U1.1-P1-M2.7 x8
4069 053E	Memory test detected memory DIMM group fault	Memory quad D odd, riser 2 Location: U1.1-P1-M2.7 x4
4069 053F	Memory test detected memory DIMM group fault	Memory quad D even, riser 2 Location: U1.1-P1-M2.8 x4
4069 05FF	Memory test detected memory on riser fault	Memory failure on riser card 2 that cannot be automatically isolated. go to "MAP 1540: Minimum Configuration" on page 122 and run CEC drawer minimum configuration for further isolation.
4069 0600	Memory test detected CEC RIO bus adapter	CEC RIO bus adapter Location: U1.1-P1.1
4069 0601	Memory test detected clock card fault	CEC clock card Location: U1.1-P1.1.1
4069 3101	Memory test detected RIO port 0 fault	CEC RIO bus adapter Location: U1.1-P1.1
4069 3102	Memory test detected RIO port 1 fault	CEC RIO bus adapter Location: U1.1-P1.1
4069 3103	Memory test detected RIO port 2 fault	CEC RIO bus adapter Location: U1.1-P1.1
4069 3104	Memory test detected RIO port 3 fault	CEC RIO bus adapter Location: U1.1-P1.1
4069 3121	Memory test detected RIO cable on port 0 fault	1. RIO cable on port 0 Location: U1.1-P1.1/Q1 2. CEC RIO bus adapter Location: U1.1-P1.1

Table 7. Service Processor Error Codes (continued)

<b>Error Code</b>	<b>Description</b>	<b>Action/ Possible Failing FRU</b>
4069 3122	Memory test detected RIO cable on port 1 fault	<ol style="list-style-type: none"> <li>1. RIO cable on port 1 Location: U1.1-P1.1/Q2</li> <li>2. CEC RIO bus adapter Location: U1.1-P1.1</li> </ol>
4069 3123	Memory test detected RIO cable on port 2 fault	<ol style="list-style-type: none"> <li>1. RIO cable on port 2 Location: U1.1-P1.1/Q3</li> <li>2. CEC RIO bus adapter Location: U1.1-P1.1</li> </ol>
4069 3124	Memory test detected RIO cable on port 3 fault	<ol style="list-style-type: none"> <li>1. RIO cable on port 3 Location: U1.1-P1.1/Q4</li> <li>2. CEC RIO bus adapter Location: U1.1-P1.1</li> </ol>
4069 3140	Memory test detected RIO hub 0 fault	CEC RIO bus adapter Location: U1.1-P1.1
4069 3141	Memory test detected RIO hub 1 fault	CEC RIO bus adapter Location: U1.1-P1.1
4069 31FF	Memory test detected RIO port fault	CEC RIO bus adapter Location: U1.1-P1.1
4069 3200	Memory test detected primary I/O drawer fault	Go to "MAP 1540: Minimum Configuration" on page 122.
4069 3201	Memory test detected primary I/O drawer backplane fault	Primary I/O drawer backplane Location: U0.1-P1
4069 3280	Memory test detected primary RIO adapter fault	Primary RIO adapter Location: U0.1-P1.1
4069 3281	Memory test detected primary RIO port 0 fault	<ol style="list-style-type: none"> <li>1. Check RIO cable Location: U0.1-P1.1/Q1</li> <li>2. RIO bus adapter Location: U0.1-P1.1</li> </ol>
4069 3282	Memory test detected primary RIO port 1 fault	<ol style="list-style-type: none"> <li>1. Check RIO cable Location: U0.1-P1.1/Q2</li> <li>2. RIO bus adapter Location: U0.1-P1.1</li> </ol>
4069 3283	Memory test detected primary RIO ports fault	RIO bus adapter Location: U0.1-P1.1
4069 3284	Memory test detected PCI controller PHB0	<ol style="list-style-type: none"> <li>1. RIO bus adapter Location: U0.1-P1.1</li> <li>2. Primary I/O drawer backplane Location: U0.1-P1</li> </ol>
4069 3285	Memory test detected PCI controller PHB1	<ol style="list-style-type: none"> <li>1. RIO bus adapter Location: U0.1-P1.1</li> <li>2. Primary I/O drawer backplane Location: U0.1-P1</li> </ol>

Table 7. Service Processor Error Codes (continued)

Error Code	Description	Action/ Possible Failing FRU
4069 3286	Memory test detected PCI controller PHB2	1. RIO bus adapter Location: U0.1-P1.1 2. Primary I/O drawer backplane Location: U0.1-P1
406A 0001	Self test detected CEC backplane failure	CEC backplane Location: U1.1-P1
406A 0003	Self test detected processor fault	All processors Location: U1.1-P1-C1
406A 0009	Self test detected memory fault	All memory Location: U1.1-P1-M1 x2
406A 00A0	Self test detected CSP service processor firmware fault	Update system firmware Location: U0.1-P1/Y1
406A 00A1	Self test detected AIX or system firmware fault	1. Check for AIX updates 2. Check for system firmware updates Location: U0.1-P1/Y1
406A 00A2	Self test detected service processor firmware (processor runtime diagnostics) fault	Check for system firmware updates Location: U0.1-P1/Y1
406A 00A3	Self test detected memory plugging fault	All pluggable memory
406A 00A4	Self test detected application caused fault	Application software
406A 00A5	Self test detected invalid system configuration	Verify system components are supported and properly installed.
406A 00A6	Self test detected no usable memory	1. Ensure that CEC memory is properly installed. 2. If more than one DIMM is called out, go to the service processor Memory Configuration/Deconfiguration Menu to verify memory DIMMs state. See "Memory Configuration/Deconfiguration Menu" on page 426 for more information.
406A 00A7	Self test detected hardware problem	Go to minimum configuration and also run CEC minimum configuration
406A 00B0	Self test detected bus controller lock-unlock failure	RIO bus adapter Location: U0.1-P1.1
406A 00B1	Self test detected bus controller failure	RIO bus adapter Location: U0.1-P1.1

Table 7. Service Processor Error Codes (continued)

Error Code	Description	Action/ Possible Failing FRU
406A 00B3	Self test detected clock fault	1. Clock card Location: U1.1-P1.1.1 2. CEC RIO bus adapter Location: U1.1-P1.1
406A 00B7	Self test detected insufficient hardware resources to continue IPL	This error code appears after the initial testing by the service processor firmware on the CEC was completed correctly, but a problem occurred when the firmware tried to communicate outside the CEC. Suspect a problem with the RIO interface, either cables or adapters.
406A 0200	Self test detected memory riser card fault	Memory riser card 1 Location: U1.1-P1-M1
406A 0201	Self test detected memory DIMM fault	Memory DIMM 1, riser 1 Location: U1.1-P1-M1.1
406A 0202	Self test detected memory DIMM fault	Memory DIMM 2, riser 1 Location: U1.1-P1-M1.2
406A 0203	Self test detected memory DIMM fault	Memory DIMM 9, riser 1 Location: U1.1-P1-M1.9
406A 0204	Self test detected memory DIMM fault	Memory DIMM 10, riser 1 Location: U1.1-P1-M1.10
406A 0205	Self test detected memory DIMM fault	Memory DIMM 17, riser 1 Location: U1.1-P1-M1.17
406A 0206	Self test detected memory DIMM fault	Memory DIMM 18, riser 1 Location: U1.1-P1-M1.18
406A 0207	Self test detected memory DIMM fault	Memory DIMM 25, riser 1 Location: U1.1-P1-M1.25
406A 0208	Self test detected memory DIMM fault	Memory DIMM 26, riser 1 Location: U1.1-P1-M1.26
406A 020D	Self test detected memory DIMM group fault	Memory octal A, riser 1 Location: U1.1-P1-M1.1 x8
406A 020E	Self test detected memory DIMM group fault	Memory quad A odd, riser 1 Locations: U1.1-P1-M1.1 x4
406A 020F	Self test detected memory DIMM group fault	Memory quad A even, riser 1 Locations: U1.1-P1-M1.2 x4
406A 0211	Self test detected memory DIMM fault	Memory DIMM 3, riser 1 Location: U1.1-P1-M1.3
406A 0212	Self test detected memory DIMM fault	Memory DIMM 4, riser 1 Location: U1.1-P1-M1.4
406A 0213	Self test detected memory DIMM fault	Memory DIMM 11, riser 1 Location: U1.1-P1-M1.11

Table 7. Service Processor Error Codes (continued)

Error Code	Description	Action/ Possible Failing FRU
406A 0214	Self test detected memory DIMM fault	Memory DIMM 12, riser 1 Location: U1.1-P1-M1.12
406A 0215	Self test detected memory DIMM fault	Memory DIMM 19, riser 1 Location: U1.1-P1-M1.19
406A 0216	Self test detected memory DIMM fault	Memory DIMM 20, riser 1 Location: U1.1-P1-M1.20
406A 0217	Self test detected memory DIMM fault	Memory DIMM 27, riser 1 Location: U1.1-P1-M1.27
406A 0218	Self test detected memory DIMM fault	Memory DIMM 28, riser 1 Location: U1.1-P1-M1.28
406A 021D	Self test detected memory DIMM group fault	Memory octal B, riser 1 Location: U1.1-P1-M1.3 x8
406A 021E	Self test detected memory DIMM group pair A fault	Memory quad B odd, riser 1 Location: U1.1-P1-M1.3 x4
406A 021F	Self test detected memory DIMM group fault	Memory quad B even, riser 1 Location: U1.1-P1-M1.4 x4
406A 0221	Self test detected memory DIMM fault	Memory DIMM 5, riser 1 Location: U1.1-P1-M1.5
406A 0222	Self test detected memory DIMM fault	Memory DIMM 6, riser 1 Location: U1.1-P1-M1.6
406A 0223	Self test detected memory DIMM fault	Memory DIMM 13, riser 1 Location: U1.1-P1-M1.13
406A 0224	Self test detected memory DIMM fault	Memory DIMM 14, riser 1 Location: U1.1-P1-M1.14
406A 0225	Self test detected memory DIMM fault	Memory DIMM 21, riser 1 Location: U1.1-P1-M1.21
406A 0226	Self test detected memory DIMM fault	Memory DIMM 22, riser 1 Location: U1.1-P1-M1.22
406A 0227	Self test detected memory DIMM fault	Memory DIMM 29, riser 1 Location: U1.1-P1-M1.29
406A 0228	Self test detected memory DIMM fault	Memory DIMM 30, riser 1 Location: U1.1-P1-M1.30
406A 022D	Self test detected memory DIMM group fault	Memory octal C, riser 1 Locations: U1.1-P1-M1.5 x8
406A 022E	Self test detected memory DIMM group pair A fault	Memory quad C odd, riser 1 Locations: U1.1-P1-M1.5 x4
406A 022F	Self test detected memory DIMM group fault	Memory quad C even, riser 1 Locations: U1.1-P1-M1.6 x4
406A 0231	Self test detected memory DIMM fault	Memory DIMM 7, riser 1 Location: U1.1-P1-M1.7
406A 0232	Self test detected memory DIMM fault	Memory DIMM 8, riser 1 Location: U1.1-P1-M1.8

Table 7. Service Processor Error Codes (continued)

<b>Error Code</b>	<b>Description</b>	<b>Action/ Possible Failing FRU</b>
406A 0233	Self test detected memory DIMM fault	Memory DIMM 15, riser 1 Location: U1.1-P1-M1.15
406A 0234	Self test detected memory DIMM fault	Memory DIMM 16, riser 1 Location: U1.1-P1-M1.16
406A 0235	Self test detected memory DIMM fault	Memory DIMM 23, riser 1 Location: U1.1-P1-M1.23
406A 0236	Self test detected memory DIMM fault	Memory DIMM 24, riser 1 Location: U1.1-P1-M1.24
406A 0237	Self test detected memory DIMM fault	Memory DIMM 31, riser 1 Location: U1.1-P1-M1.31
406A 0238	Self test detected memory DIMM fault	Memory DIMM 32, riser 1 Location: U1.1-P1-M1.32
406A 023D	Self test detected memory DIMM group fault	Memory octal D, riser 1 Location: U1.1-P1-M1.7 x8
406A 023E	Self test detected memory DIMM group fault	Memory quad D odd, riser 1 Location: U1.1-P1-M1.7 x4
406A 023F	Self test detected memory DIMM group fault	Memory quad D even, riser 1 Location: U1.1-P1-M1.8 x4
406A 02FF	Self test detected memory on riser fault	All memory on riser 1 Location: U1.1-P1-M1.1 x32 Memory failure on riser card 1 that cannot be automatically isolated. go to "MAP 1540: Minimum Configuration" on page 122 and run CEC drawer minimum configuration for further isolation.
406A 0300	Self test detected processor card fault	Processor card Location: U1.1-P1-C1
406A 0400	Self test detected processor card fault	Processor card Location: U1.1-P1-C2
406A 0500	Self test detected memory riser card fault	Memory riser card 2 Location: U1.1-P1-M1
406A 0501	Self test detected memory DIMM fault	Memory DIMM 1, riser 2 Location: U1.1-P1-M2.1
406A 0502	Self test detected memory DIMM fault	Memory DIMM 2, riser 2 Location: U1.1-P1-M2.2
406A 0503	Self test detected memory DIMM fault	Memory DIMM 9, riser 2 Location: U1.1-P1-M2.9
406A 0504	Self test detected memory DIMM fault	Memory DIMM 10, riser 2 Location: U1.1-P1-M2.10
406A 0505	Self test detected memory DIMM fault	Memory DIMM 17, riser 2 Location: U1.1-P1-M2.17



Table 7. Service Processor Error Codes (continued)

<b>Error Code</b>	<b>Description</b>	<b>Action/ Possible Failing FRU</b>
406A 0506	Self test detected memory DIMM fault	Memory DIMM 18, riser 2 Location: U1.1-P1-M2.18
406A 0507	Self test detected memory DIMM fault	Memory DIMM 25, riser 2 Location: U1.1-P1-M2.25
406A 0508	Self test detected memory DIMM fault	Memory DIMM 26, riser 2 Location: U1.1-P1-M2.26
406A 050D	Self test detected memory DIMM group fault	Memory octal A, riser 2 Location: U1.1-P1-M2.1 x8
406A 050E	Self test detected memory DIMM group pair A fault	Memory quad A odd, riser 2 Location: U1.1-P1-M2.1 x4
406A 050F	Self test detected memory DIMM group fault	Memory quad A even, riser 2 Location: U1.1-P1-M2.2 x4
406A 0511	Self test detected memory DIMM fault	Memory DIMM 3, riser 2 Location: U1.1-P1-M2.3
406A 0512	Self test detected memory DIMM fault	Memory DIMM 4, riser 2 Location: U1.1-P1-M2.4
406A 0513	Self test detected memory DIMM fault	Memory DIMM 11, riser 2 Location: U1.1-P1-M2.11
406A 0514	Self test detected memory DIMM fault	Memory DIMM 12, riser 2 Location: U1.1-P1-M2.12
406A 0515	Self test detected memory DIMM fault	Memory DIMM 19, riser 2 Location: U1.1-P1-M2.19
406A 0516	Self test detected memory DIMM fault	Memory DIMM 20, riser 2 Location: U1.1-P1-M2.20
406A 0517	Self test detected memory DIMM fault	Memory DIMM 27, riser 2 Location: U1.1-P1-M2.27
406A 0518	Self test detected memory DIMM fault	Memory DIMM 28, riser 2 Location: U1.1-P1-M2.28
406A 051D	Self test detected memory DIMM group fault	Memory octal B, riser 2 Location: U1.1-P1-M2.3 x8
406A 051E	Self test detected memory DIMM group fault	Memory quad B odd, riser 2 Location: U1.1-P1-M2.3 x4
406A 051F	Self test detected memory DIMM group fault	Memory quad B even, riser 2 Location: U1.1-P1-M2.4 x4
406A 0521	Self test detected memory DIMM fault	Memory DIMM 5, riser 2 Location: U1.1-P1-M2.5
406A 0522	Self test detected memory DIMM fault	Memory DIMM 6, riser 2 Location: U1.1-P1-M2.6
406A 0523	Self test detected memory DIMM fault	Memory DIMM 13, riser 2 Location: U1.1-P1-M2.13
406A 0524	Self test detected memory DIMM fault	Memory DIMM 14, riser 2 Location: U1.1-P1-M2.14

Table 7. Service Processor Error Codes (continued)

<b>Error Code</b>	<b>Description</b>	<b>Action/ Possible Failing FRU</b>
406A 0525	Self test detected memory DIMM fault	Memory DIMM 21, riser 2 Location: U1.1-P1-M2.21
406A 0526	Self test detected memory DIMM fault	Memory DIMM 22, riser 2 Location: U1.1-P1-M2.22
406A 0527	Self test detected memory DIMM fault	Memory DIMM 29, riser 2 Location: U1.1-P1-M2.29
406A 0528	Self test detected memory DIMM fault	Memory DIMM 30, riser 2 Location: U1.1-P1-M2.30
406A 052D	Self test detected memory DIMM group fault	Memory octal C, riser 2 Location: U1.1-P1-M2.5 x8
406A 052E	Self test detected memory DIMM group pair A fault	Memory quad C odd, riser 2 Location: U1.1-P1-M2.5 x4
406A 052F	Self test detected memory DIMM group fault	Memory quad C even, riser 2 Location: U1.1-P1-M2.6 x4
406A 0531	Self test detected memory DIMM fault	Memory DIMM 7, riser 2 Location: U1.1-P1-M2.7
406A 0532	Self test detected memory DIMM fault	Memory DIMM 8, riser 2 Location: U1.1-P1-M2.8
406A 0533	Self test detected memory DIMM fault	Memory DIMM 15, riser 2 Location: U1.1-P1-M2.15
406A 0534	Self test detected memory DIMM fault	Memory DIMM 16, riser 2 Location: U1.1-P1-M2.16
406A 0535	Self test detected memory DIMM fault	Memory DIMM 23, riser 2 Location: U1.1-P1-M2.23
406A 0536	Self test detected memory DIMM fault	Memory DIMM 24, riser 2 Location: U1.1-P1-M2.24
406A 0537	Self test detected memory DIMM fault	Memory DIMM 31, riser 2 Location: U1.1-P1-M2.31
406A 0538	Self test detected memory DIMM fault	Memory DIMM 32, riser 2 Location: U1.1-P1-M2.32
406A 053D	Self test detected memory DIMM group fault	Memory octal D, riser 2 Location: U1.1-P1-M2.7 x8
406A 053E	Self test detected memory DIMM group fault	Memory quad D odd, riser 2 Location: U1.1-P1-M2.7 x4
406A 053F	Self test detected memory DIMM group fault	Memory quad D even, riser 2 Location: U1.1-P1-M2.8 x4
406A 05FF	Self test detected memory on riser fault	Memory failure on riser card 2 that cannot be automatically isolated. go to "MAP 1540: Minimum Configuration" on page 122 and run CEC drawer minimum configuration for further isolation.

Table 7. Service Processor Error Codes (continued)

Error Code	Description	Action/ Possible Failing FRU
406A 0600	Self test detected CEC RIO bus adapter	CEC RIO bus adapter Location: U1.1-P1.1
406A 0601	Self test detected clock card fault	CEC clock card Location: U1.1-P1.1.1
406A 3101	Self test detected RIO port 0 fault	CEC RIO bus adapter Location: U1.1-P1.1
406A 3102	Self test detected RIO port 1 fault	CEC RIO bus adapter Location: U1.1-P1.1
406A 3103	Self test detected RIO port 2 fault	CEC RIO bus adapter Location: U1.1-P1.1
406A 3104	Self test detected RIO port 3 fault	CEC RIO bus adapter Location: U1.1-P1.1
406A 3121	Self test detected RIO cable on port 0 fault	1. RIO cable on port 0 Location: U1.1-P1.1/Q1 2. CEC RIO bus adapter Location: U1.1-P1.1
406A 3122	Self test detected RIO cable on port 1 fault	1. RIO cable on port 1 Location: U1.1-P1.1/Q2 2. CEC RIO bus adapter Location: U1.1-P1.1
406A 3123	Self test detected RIO cable on port 2 fault	1. RIO cable on port 2 Location: U1.1-P1.1/Q3 2. CEC RIO bus adapter Location: U1.1-P1.1
406A 3124	Self test detected RIO cable on port 3 fault	1. RIO cable on port 3 Location: U1.1-P1.1/Q4 2. CEC RIO bus adapter Location: U1.1-P1.1
406A 3140	Self test detected RIO hub 0 fault	CEC RIO bus adapter Location: U1.1-P1.1
406A 3141	Self test detected RIO hub 1 fault	CEC RIO bus adapter Location: U1.1-P1.1
406A 31FF	Self test detected RIO port fault	CEC RIO bus adapter Location: U1.1-P1.1
406A 3200	Self test detected primary I/O drawer fault	Go to "MAP 1540: Minimum Configuration" on page 122.
406A 3201	Self test detected primary I/O drawer backplane fault	Primary I/O drawer backplane Location: U0.1-P1
406A 3280	Self test detected primary RIO adapter fault	Primary RIO adapter Location: U0.1-P1.1
406A 3281	Self test detected primary RIO port 0 fault	1. Check RIO cable Location: U0.1-P1.1/Q1 2. RIO bus adapter Location: U0.1-P1.1

Table 7. Service Processor Error Codes (continued)

Error Code	Description	Action/ Possible Failing FRU
406A 3282	Self test detected primary RIO port 1 fault	1. Check RIO cable Location: U0.1-P1.1/Q2 2. RIO bus adapter Location: U0.1-P1.1
406A 3283	Self test detected primary RIO ports fault	RIO bus adapter Location: U0.1-P1.1
406A 3284	Self test detected PCI controller PHB0	1. RIO bus adapter Location: U0.1-P1.1 2. Primary I/O drawer backplane Location: U0.1-P1
406A 3285	Self test detected PCI controller PHB1	1. RIO bus adapter Location: U0.1-P1.1 2. Primary I/O drawer backplane Location: U0.1-P1
406A 3286	Self test detected PCI controller PHB2	1. RIO bus adapter Location: U0.1-P1.1 2. Primary I/O drawer backplane Location: U0.1-P1
406B 0001	Wire test detected CEC backplane failure	CEC backplane Location: U1.1-P1
406B 0003	Wire test detected processor fault	All processors Location: U1.1-P1-C1
406B 0009	Wire test detected memory fault	All memory Location: U1.1-P1-M1 x2
406B 00A0	Wire test detected CSP service processor firmware fault	Update system firmware Location: U0.1-P1/Y1
406B 00A1	Wire test detected AIX or system firmware fault	1. Check for AIX updates 2. Check for system firmware updates Location: U0.1-P1/Y1
406B 00A2	Wire test detected service processor firmware (processor runtime diagnostics) fault	Check for system firmware updates Location: U0.1-P1/Y1
406B 00A3	Wire test detected memory plugging fault	All pluggable memory
406B 00A4	Wire test detected application caused fault	Application software
406B 00A5	Wire test detected invalid system configuration	Verify system components are supported and properly installed.

Table 7. Service Processor Error Codes (continued)

Error Code	Description	Action/ Possible Failing FRU
406B 00A6	Wire test detected no usable memory	<ol style="list-style-type: none"> <li>1. Ensure that CEC memory is properly installed.</li> <li>2. If more than one DIMM is called out, go to the service processor Memory Configuration/Deconfiguration Menu to verify memory DIMMs state. See "Memory Configuration/Deconfiguration Menu" on page 426 for more information.</li> </ol>
406B 00A7	Wire test detected hardware problem	Go to minimum configuration and also run CEC minimum configuration
406B 00B0	Wire test detected bus controller lock-unlock failure	RIO bus adapter Location: U0.1-P1.1
406B 00B1	Wire test detected bus controller failure	RIO bus adapter Location: U0.1-P1.1
406B 00B3	Wire test detected clock fault	<ol style="list-style-type: none"> <li>1. Clock card Location: U1.1-P1.1.1</li> <li>2. CEC RIO bus adapter Location: U1.1-P1.1</li> </ol>
406B 00B7	Wire test detected insufficient hardware resources to continue IPL	This error code appears after the initial testing by the service processor firmware on the CEC was completed correctly, but a problem occurred when the firmware tried to communicate outside the CEC. Suspect a problem with the RIO interface, either cables or adapters.
406B 0200	Wire test detected memory riser card fault	Memory riser card 1 Location: U1.1-P1-M1
406B 0201	Wire test detected memory DIMM fault	Memory DIMM 1, riser 1 Location: U1.1-P1-M1.1
406B 0202	Wire test detected memory DIMM fault	Memory DIMM 2, riser 1 Location: U1.1-P1-M1.2
406B 0203	Wire test detected memory DIMM fault	Memory DIMM 9, riser 1 Location: U1.1-P1-M1.9
406B 0204	Wire test detected memory DIMM fault	Memory DIMM 10, riser 1 Location: U1.1-P1-M1.10
406B 0205	Wire test detected memory DIMM fault	Memory DIMM 17, riser 1 Location: U1.1-P1-M1.17
406B 0206	Wire test detected memory DIMM fault	Memory DIMM 18, riser 1 Location: U1.1-P1-M1.18
406B 0207	Wire test detected memory DIMM fault	Memory DIMM 25, riser 1 Location: U1.1-P1-M1.25

Table 7. Service Processor Error Codes (continued)

<b>Error Code</b>	<b>Description</b>	<b>Action/ Possible Failing FRU</b>
406B 0208	Wire test detected memory DIMM fault	Memory DIMM 26, riser 1 Location: U1.1-P1-M1.26
406B 020D	Wire test detected memory DIMM group fault	Memory octal A, riser 1 Location: U1.1-P1-M1.1 x8
406B 020E	Wire test detected memory DIMM group fault	Memory quad A odd, riser 1 Locations: U1.1-P1-M1.1 x4
406B 020F	Wire test detected memory DIMM group fault	Memory quad A even, riser 1 Locations: U1.1-P1-M1.2 x4
406B 0211	Wire test detected memory DIMM fault	Memory DIMM 3, riser 1 Location: U1.1-P1-M1.3
406B 0212	Wire test detected memory DIMM fault	Memory DIMM 4, riser 1 Location: U1.1-P1-M1.4
406B 0213	Wire test detected memory DIMM fault	Memory DIMM 11, riser 1 Location: U1.1-P1-M1.11
406B 0214	Wire test detected memory DIMM fault	Memory DIMM 12, riser 1 Location: U1.1-P1-M1.12
406B 0215	Wire test detected memory DIMM fault	Memory DIMM 19, riser 1 Location: U1.1-P1-M1.19
406B 0216	Wire test detected memory DIMM fault	Memory DIMM 20, riser 1 Location: U1.1-P1-M1.20
406B 0217	Wire test detected memory DIMM fault	Memory DIMM 27, riser 1 Location: U1.1-P1-M1.27
406B 0218	Wire test detected memory DIMM fault	Memory DIMM 28, riser 1 Location: U1.1-P1-M1.28
406B 021D	Wire test detected memory DIMM group fault	Memory octal B, riser 1 Location: U1.1-P1-M1.3 x8
406B 021E	Wire test detected memory DIMM group pair A fault	Memory quad B odd, riser 1 Location: U1.1-P1-M1.3 x4
406B 021F	Wire test detected memory DIMM group fault	Memory quad B even, riser 1 Location: U1.1-P1-M1.4 x4
406B 0221	Wire test detected memory DIMM fault	Memory DIMM 5, riser 1 Location: U1.1-P1-M1.5
406B 0222	Wire test detected memory DIMM fault	Memory DIMM 6, riser 1 Location: U1.1-P1-M1.6
406B 0223	Wire test detected memory DIMM fault	Memory DIMM 13, riser 1 Location: U1.1-P1-M1.13
406B 0224	Wire test detected memory DIMM fault	Memory DIMM 14, riser 1 Location: U1.1-P1-M1.14
406B 0225	Wire test detected memory DIMM fault	Memory DIMM 21, riser 1 Location: U1.1-P1-M1.21
406B 0226	Wire test detected memory DIMM fault	Memory DIMM 22, riser 1 Location: U1.1-P1-M1.22

Table 7. Service Processor Error Codes (continued)

Error Code	Description	Action/ Possible Failing FRU
406B 0227	Wire test detected memory DIMM fault	Memory DIMM 29, riser 1 Location: U1.1-P1-M1.29
406B 0228	Wire test detected memory DIMM fault	Memory DIMM 30, riser 1 Location: U1.1-P1-M1.30
406B 022D	Wire test detected memory DIMM group fault	Memory octal C, riser 1 Locations: U1.1-P1-M1.5 x8
406B 022E	Wire test detected memory DIMM group pair A fault	Memory quad C odd, riser 1 Locations: U1.1-P1-M1.5 x4
406B 022F	Wire test detected memory DIMM group fault	Memory quad C even, riser 1 Locations: U1.1-P1-M1.6 x4
406B 0231	Wire test detected memory DIMM fault	Memory DIMM 7, riser 1 Location: U1.1-P1-M1.7
406B 0232	Wire test detected memory DIMM fault	Memory DIMM 8, riser 1 Location: U1.1-P1-M1.8
406B 0233	Wire test detected memory DIMM fault	Memory DIMM 15, riser 1 Location: U1.1-P1-M1.15
406B 0234	Wire test detected memory DIMM fault	Memory DIMM 16, riser 1 Location: U1.1-P1-M1.16
406B 0235	Wire test detected memory DIMM fault	Memory DIMM 23, riser 1 Location: U1.1-P1-M1.23
406B 0236	Wire test detected memory DIMM fault	Memory DIMM 24, riser 1 Location: U1.1-P1-M1.24
406B 0237	Wire test detected memory DIMM fault	Memory DIMM 31, riser 1 Location: U1.1-P1-M1.31
406B 0238	Wire test detected memory DIMM fault	Memory DIMM 32, riser 1 Location: U1.1-P1-M1.32
406B 023D	Wire test detected memory DIMM group fault	Memory octal D, riser 1 Location: U1.1-P1-M1.7 x8
406B 023E	Wire test detected memory DIMM group fault	Memory quad D odd, riser 1 Location: U1.1-P1-M1.7 x4
406B 023F	Wire test detected memory DIMM group fault	Memory quad D even, riser 1 Location: U1.1-P1-M1.8 x4
406B 02FF	Wire test detected memory on riser fault	All memory on riser 1 Location: U1.1-P1-M1.1 x32 Memory failure on riser card 1 that cannot be automatically isolated. go to "MAP 1540: Minimum Configuration" on page 122 and run CEC drawer minimum configuration for further isolation.
406B 0300	Wire test detected processor card fault	Processor card Location: U1.1-P1-C1

Table 7. Service Processor Error Codes (continued)

<b>Error Code</b>	<b>Description</b>	<b>Action/ Possible Failing FRU</b>
406B 0400	Wire test detected processor card fault	Processor card Location: U1.1-P1-C2
406B 0500	Wire test detected memory riser card fault	Memory riser card 2 Location: U1.1-P1-M1
406B 0501	Wire test detected memory DIMM fault	Memory DIMM 1, riser 2 Location: U1.1-P1-M2.1
406B 0502	Wire test detected memory DIMM fault	Memory DIMM 2, riser 2 Location: U1.1-P1-M2.2
406B 0503	Wire test detected memory DIMM fault	Memory DIMM 9, riser 2 Location: U1.1-P1-M2.9
406B 0504	Wire test detected memory DIMM fault	Memory DIMM 10, riser 2 Location: U1.1-P1-M2.10
406B 0505	Wire test detected memory DIMM fault	Memory DIMM 17, riser 2 Location: U1.1-P1-M2.17
406B 0506	Wire test detected memory DIMM fault	Memory DIMM 18, riser 2 Location: U1.1-P1-M2.18
406B 0507	Wire test detected memory DIMM fault	Memory DIMM 25, riser 2 Location: U1.1-P1-M2.25
406B 0508	Wire test detected memory DIMM fault	Memory DIMM 26, riser 2 Location: U1.1-P1-M2.26
406B 050D	Wire test detected memory DIMM group fault	Memory octal A, riser 2 Location: U1.1-P1-M2.1 x8
406B 050E	Wire test detected memory DIMM group pair A fault	Memory quad A odd, riser 2 Location: U1.1-P1-M2.1 x4
406B 050F	Wire test detected memory DIMM group fault	Memory quad A even, riser 2 Location: U1.1-P1-M2.2 x4
406B 0511	Wire test detected memory DIMM fault	Memory DIMM 3, riser 2 Location: U1.1-P1-M2.3
406B 0512	Wire test detected memory DIMM fault	Memory DIMM 4, riser 2 Location: U1.1-P1-M2.4
406B 0513	Wire test detected memory DIMM fault	Memory DIMM 11, riser 2 Location: U1.1-P1-M2.11
406B 0514	Wire test detected memory DIMM fault	Memory DIMM 12, riser 2 Location: U1.1-P1-M2.12
406B 0515	Wire test detected memory DIMM fault	Memory DIMM 19, riser 2 Location: U1.1-P1-M2.19
406B 0516	Wire test detected memory DIMM fault	Memory DIMM 20, riser 2 Location: U1.1-P1-M2.20
406B 0517	Wire test detected memory DIMM fault	Memory DIMM 27, riser 2 Location: U1.1-P1-M2.27
406B 0518	Wire test detected memory DIMM fault	Memory DIMM 28, riser 2 Location: U1.1-P1-M2.28



Table 7. Service Processor Error Codes (continued)

<b>Error Code</b>	<b>Description</b>	<b>Action/ Possible Failing FRU</b>
406B 051D	Wire test detected memory DIMM group fault	Memory octal B, riser 2 Location: U1.1-P1-M2.3 x8
406B 051E	Wire test detected memory DIMM group fault	Memory quad B odd, riser 2 Location: U1.1-P1-M2.3 x4
406B 051F	Wire test detected memory DIMM group fault	Memory quad B even, riser 2 Location: U1.1-P1-M2.4 x4
406B 0521	Wire test detected memory DIMM fault	Memory DIMM 5, riser 2 Location: U1.1-P1-M2.5
406B 0522	Wire test detected memory DIMM fault	Memory DIMM 6, riser 2 Location: U1.1-P1-M2.6
406B 0523	Wire test detected memory DIMM fault	Memory DIMM 13, riser 2 Location: U1.1-P1-M2.13
406B 0524	Wire test detected memory DIMM fault	Memory DIMM 14, riser 2 Location: U1.1-P1-M2.14
406B 0525	Wire test detected memory DIMM fault	Memory DIMM 21, riser 2 Location: U1.1-P1-M2.21
406B 0526	Wire test detected memory DIMM fault	Memory DIMM 22, riser 2 Location: U1.1-P1-M2.22
406B 0527	Wire test detected memory DIMM fault	Memory DIMM 29, riser 2 Location: U1.1-P1-M2.29
406B 0528	Wire test detected memory DIMM fault	Memory DIMM 30, riser 2 Location: U1.1-P1-M2.30
406B 052D	Wire test detected memory DIMM group fault	Memory octal C, riser 2 Location: U1.1-P1-M2.5 x8
406B 052E	Wire test detected memory DIMM group pair A fault	Memory quad C odd, riser 2 Location: U1.1-P1-M2.5 x4
406B 052F	Wire test detected memory DIMM group fault	Memory quad C even, riser 2 Location: U1.1-P1-M2.6 x4
406B 0531	Wire test detected memory DIMM fault	Memory DIMM 7, riser 2 Location: U1.1-P1-M2.7
406B 0532	Wire test detected memory DIMM fault	Memory DIMM 8, riser 2 Location: U1.1-P1-M2.8
406B 0533	Wire test detected memory DIMM fault	Memory DIMM 15, riser 2 Location: U1.1-P1-M2.15
406B 0534	Wire test detected memory DIMM fault	Memory DIMM 16, riser 2 Location: U1.1-P1-M2.16
406B 0535	Wire test detected memory DIMM fault	Memory DIMM 23, riser 2 Location: U1.1-P1-M2.23
406B 0536	Wire test detected memory DIMM fault	Memory DIMM 24, riser 2 Location: U1.1-P1-M2.24
406B 0537	Wire test detected memory DIMM fault	Memory DIMM 31, riser 2 Location: U1.1-P1-M2.31

Table 7. Service Processor Error Codes (continued)

Error Code	Description	Action/ Possible Failing FRU
406B 0538	Wire test detected memory DIMM fault	Memory DIMM 32, riser 2 Location: U1.1-P1-M2.32
406B 053D	Wire test detected memory DIMM group fault	Memory octal D, riser 2 Location: U1.1-P1-M2.7 x8
406B 053E	Wire test detected memory DIMM group fault	Memory quad D odd, riser 2 Location: U1.1-P1-M2.7 x4
406B 053F	Wire test detected memory DIMM group fault	Memory quad D even, riser 2 Location: U1.1-P1-M2.8 x4
406B 05FF	Wire test detected memory on riser fault	Memory failure on riser card 2 that cannot be automatically isolated. go to "MAP 1540: Minimum Configuration" on page 122 and run CEC drawer minimum configuration for further isolation.
406B 0600	Wire test detected CEC RIO bus adapter	CEC RIO bus adapter Location: U1.1-P1.1
406B 0601	Wire test detected clock card fault	CEC clock card Location: U1.1-P1.1.1
406B 3101	Wire test detected RIO port 0 fault	CEC RIO bus adapter Location: U1.1-P1.1
406B 3102	Wire test detected RIO port 1 fault	CEC RIO bus adapter Location: U1.1-P1.1
406B 3103	Wire test detected RIO port 2 fault	CEC RIO bus adapter Location: U1.1-P1.1
406B 3104	Wire test detected RIO port 3 fault	CEC RIO bus adapter Location: U1.1-P1.1
406B 3121	Wire test detected RIO cable on port 0 fault	1. RIO cable on port 0 Location: U1.1-P1.1/Q1 2. CEC RIO bus adapter Location: U1.1-P1.1
406B 3122	Wire test detected RIO cable on port 1 fault	1. RIO cable on port 1 Location: U1.1-P1.1/Q2 2. CEC RIO bus adapter Location: U1.1-P1.1
406B 3123	Wire test detected RIO cable on port 2 fault	1. RIO cable on port 2 Location: U1.1-P1.1/Q3 2. CEC RIO bus adapter Location: U1.1-P1.1
406B 3124	Wire test detected RIO cable on port 3 fault	1. RIO cable on port 3 Location: U1.1-P1.1/Q4 2. CEC RIO bus adapter Location: U1.1-P1.1
406B 3140	Wire test detected RIO hub 0 fault	CEC RIO bus adapter Location: U1.1-P1.1

Table 7. Service Processor Error Codes (continued)

Error Code	Description	Action/ Possible Failing FRU
406B 3141	Wire test detected RIO hub 1 fault	CEC RIO bus adapter Location: U1.1-P1.1
406B 31FF	Wire test detected RIO port fault	CEC RIO bus adapter Location: U1.1-P1.1
406B 3200	Wire test detected primary I/O drawer fault	Go to "MAP 1540: Minimum Configuration" on page 122.
406B 3201	Wire test detected primary I/O drawer backplane fault	Primary I/O drawer backplane Location: U0.1-P1
406B 3280	Wire test detected primary RIO adapter fault	Primary RIO adapter Location: U0.1-P1.1
406B 3281	Wire test detected primary RIO port 0 fault	1. Check RIO cable Location: U0.1-P1.1/Q1 2. RIO bus adapter Location: U0.1-P1.1
406B 3282	Wire test detected primary RIO port 1 fault	1. Check RIO cable Location: U0.1-P1.1/Q2 2. RIO bus adapter Location: U0.1-P1.1
406B 3283	Wire test detected primary RIO ports fault	RIO bus adapter Location: U0.1-P1.1
406B 3284	Wire test detected PCI controller PHB0	1. RIO bus adapter Location: U0.1-P1.1 2. Primary I/O drawer backplane Location: U0.1-P1
406B 3285	Wire test detected PCI controller PHB1	1. RIO bus adapter Location: U0.1-P1.1 2. Primary I/O drawer backplane Location: U0.1-P1
406B 3286	Wire test detected PCI controller PHB2	1. RIO bus adapter Location: U0.1-P1.1 2. Primary I/O drawer backplane Location: U0.1-P1
406C 0001	IPL MOPS detected CEC backplane failure	CEC backplane Location: U1.1-P1
406C 0003	IPL MOPS detected processor fault	All processors Location: U1.1-P1-C1
406C 0009	IPL MOPS detected memory fault	All memory Location: U1.1-P1-M1 x2
406C 00A0	IPL MOPS detected CSP service processor firmware fault	Update system firmware Location: U0.1-P1/Y1
406C 00A1	IPL MOPS detected AIX or system firmware fault	1. Check for AIX updates 2. Check for system firmware updates Location: U0.1-P1/Y1

Table 7. Service Processor Error Codes (continued)

Error Code	Description	Action/ Possible Failing FRU
406C 00A2	IPL MOPS detected service processor firmware (processor runtime diagnostics) fault	Check for system firmware updates Location: U0.1-P1/Y1
406C 00A3	IPL MOPS detected memory plugging fault	All pluggable memory
406C 00A4	IPL MOPS detected application caused fault	Application software
406C 00A5	IPL MOPS detected invalid system configuration	Verify system components are supported and properly installed.
406C 00A6	IPL MOPS detected no usable memory	<ol style="list-style-type: none"> <li>1. Ensure that CEC memory is properly installed.</li> <li>2. If more than one DIMM is called out, go to the service processor Memory Configuration/Deconfiguration Menu to verify memory DIMMs state. See "Memory Configuration/Deconfiguration Menu" on page 426 for more information.</li> </ol>
406C 00A7	IPL MOPS detected hardware problem	Go to minimum configuration and also run CEC minimum configuration
406C 00B0	IPL MOPS detected bus controller lock-unlock failure	RIO bus adapter Location: U0.1-P1.1
406C 00B1	IPL MOPS detected bus controller failure	RIO bus adapter Location: U0.1-P1.1
406C 00B3	IPL MOPS detected clock fault	<ol style="list-style-type: none"> <li>1. Clock card Location: U1.1-P1.1.1</li> <li>2. CEC RIO bus adapter Location: U1.1-P1.1</li> </ol>
406C 00B7	IPL MOPS detected insufficient hardware resources to continue IPL	This error code appears after the initial testing by the service processor firmware on the CEC was completed correctly, but a problem occurred when the firmware tried to communicate outside the CEC. Suspect a problem with the RIO interface, either cables or adapters.
406C 0200	IPL MOPS detected memory riser card fault	Memory riser card 1 Location: U1.1-P1-M1
406C 0201	IPL MOPS detected memory DIMM fault	Memory DIMM 1, riser 1 Location: U1.1-P1-M1.1
406C 0202	IPL MOPS detected memory DIMM fault	Memory DIMM 2, riser 1 Location: U1.1-P1-M1.2

Table 7. Service Processor Error Codes (continued)

Error Code	Description	Action/ Possible Failing FRU
406C 0203	IPL MOPS detected memory DIMM fault	Memory DIMM 9, riser 1 Location: U1.1-P1-M1.9
406C 0204	IPL MOPS detected memory DIMM fault	Memory DIMM 10, riser 1 Location: U1.1-P1-M1.10
406C 0205	IPL MOPS detected memory DIMM fault	Memory DIMM 17, riser 1 Location: U1.1-P1-M1.17
406C 0206	IPL MOPS detected memory DIMM fault	Memory DIMM 18, riser 1 Location: U1.1-P1-M1.18
406C 0207	IPL MOPS detected memory DIMM fault	Memory DIMM 25, riser 1 Location: U1.1-P1-M1.25
406C 0208	IPL MOPS detected memory DIMM fault	Memory DIMM 26, riser 1 Location: U1.1-P1-M1.26
406C 020D	IPL MOPS detected memory DIMM group fault	Memory octal A, riser 1 Location: U1.1-P1-M1.1 x8
406C 020E	IPL MOPS detected memory DIMM group fault	Memory quad A odd, riser 1 Locations: U1.1-P1-M1.1 x4
406C 020F	IPL MOPS detected memory DIMM group fault	Memory quad A even, riser 1 Locations: U1.1-P1-M1.2 x4
406C 0211	IPL MOPS detected memory DIMM fault	Memory DIMM 3, riser 1 Location: U1.1-P1-M1.3
406C 0212	IPL MOPS detected memory DIMM fault	Memory DIMM 4, riser 1 Location: U1.1-P1-M1.4
406C 0213	IPL MOPS detected memory DIMM fault	Memory DIMM 11, riser 1 Location: U1.1-P1-M1.11
406C 0214	IPL MOPS detected memory DIMM fault	Memory DIMM 12, riser 1 Location: U1.1-P1-M1.12
406C 0215	IPL MOPS detected memory DIMM fault	Memory DIMM 19, riser 1 Location: U1.1-P1-M1.19
406C 0216	IPL MOPS detected memory DIMM fault	Memory DIMM 20, riser 1 Location: U1.1-P1-M1.20
406C 0217	IPL MOPS detected memory DIMM fault	Memory DIMM 27, riser 1 Location: U1.1-P1-M1.27
406C 0218	IPL MOPS detected memory DIMM fault	Memory DIMM 28, riser 1 Location: U1.1-P1-M1.28
406C 021D	IPL MOPS detected memory DIMM group fault	Memory octal B, riser 1 Location: U1.1-P1-M1.3 x8
406C 021E	IPL MOPS detected memory DIMM group pair A fault	Memory quad B odd, riser 1 Location: U1.1-P1-M1.3 x4
406C 021F	IPL MOPS detected memory DIMM group fault	Memory quad B even, riser 1 Location: U1.1-P1-M1.4 x4
406C 0221	IPL MOPS detected memory DIMM fault	Memory DIMM 5, riser 1 Location: U1.1-P1-M1.5

Table 7. Service Processor Error Codes (continued)

<b>Error Code</b>	<b>Description</b>	<b>Action/ Possible Failing FRU</b>
406C 0222	IPL MOPS detected memory DIMM fault	Memory DIMM 6, riser 1 Location: U1.1-P1-M1.6
406C 0223	IPL MOPS detected memory DIMM fault	Memory DIMM 13, riser 1 Location: U1.1-P1-M1.13
406C 0224	IPL MOPS detected memory DIMM fault	Memory DIMM 14, riser 1 Location: U1.1-P1-M1.14
406C 0225	IPL MOPS detected memory DIMM fault	Memory DIMM 21, riser 1 Location: U1.1-P1-M1.21
406C 0226	IPL MOPS detected memory DIMM fault	Memory DIMM 22, riser 1 Location: U1.1-P1-M1.22
406C 0227	IPL MOPS detected memory DIMM fault	Memory DIMM 29, riser 1 Location: U1.1-P1-M1.29
406C 0228	IPL MOPS detected memory DIMM fault	Memory DIMM 30, riser 1 Location: U1.1-P1-M1.30
406C 022D	IPL MOPS detected memory DIMM group fault	Memory octal C, riser 1 Locations: U1.1-P1-M1.5 x8
406C 022E	IPL MOPS detected memory DIMM group pair A fault	Memory quad C odd, riser 1 Locations: U1.1-P1-M1.5 x4
406C 022F	IPL MOPS detected memory DIMM group fault	Memory quad C even, riser 1 Locations: U1.1-P1-M1.6 x4
406C 0231	IPL MOPS detected memory DIMM fault	Memory DIMM 7, riser 1 Location: U1.1-P1-M1.7
406C 0232	IPL MOPS detected memory DIMM fault	Memory DIMM 8, riser 1 Location: U1.1-P1-M1.8
406C 0233	IPL MOPS detected memory DIMM fault	Memory DIMM 15, riser 1 Location: U1.1-P1-M1.15
406C 0234	IPL MOPS detected memory DIMM fault	Memory DIMM 16, riser 1 Location: U1.1-P1-M1.16
406C 0235	IPL MOPS detected memory DIMM fault	Memory DIMM 23, riser 1 Location: U1.1-P1-M1.23
406C 0236	IPL MOPS detected memory DIMM fault	Memory DIMM 24, riser 1 Location: U1.1-P1-M1.24
406C 0237	IPL MOPS detected memory DIMM fault	Memory DIMM 31, riser 1 Location: U1.1-P1-M1.31
406C 0238	IPL MOPS detected memory DIMM fault	Memory DIMM 32, riser 1 Location: U1.1-P1-M1.32
406C 023D	IPL MOPS detected memory DIMM group fault	Memory octal D, riser 1 Location: U1.1-P1-M1.7 x8
406C 023E	IPL MOPS detected memory DIMM group fault	Memory quad D odd, riser 1 Location: U1.1-P1-M1.7 x4
406C 023F	IPL MOPS detected memory DIMM group fault	Memory quad D even, riser 1 Location: U1.1-P1-M1.8 x4

Table 7. Service Processor Error Codes (continued)

Error Code	Description	Action/ Possible Failing FRU
406C 02FF	IPL MOPS detected memory on riser fault	All memory on riser 1 Location: U1.1-P1-M1.1 x32 Memory failure on riser card 1 that cannot be automatically isolated. go to "MAP 1540: Minimum Configuration" on page 122 and run CEC drawer minimum configuration for further isolation.
406C 0300	IPL MOPS detected processor card fault	Processor card Location: U1.1-P1-C1
406C 0400	IPL MOPS detected processor card fault	Processor card Location: U1.1-P1-C2
406C 0500	IPL MOPS detected memory riser card fault	Memory riser card 2 Location: U1.1-P1-M1
406C 0501	IPL MOPS detected memory DIMM fault	Memory DIMM 1, riser 2 Location: U1.1-P1-M2.1
406C 0502	IPL MOPS detected memory DIMM fault	Memory DIMM 2, riser 2 Location: U1.1-P1-M2.2
406C 0503	IPL MOPS detected memory DIMM fault	Memory DIMM 9, riser 2 Location: U1.1-P1-M2.9
406C 0504	IPL MOPS detected memory DIMM fault	Memory DIMM 10, riser 2 Location: U1.1-P1-M2.10
406C 0505	IPL MOPS detected memory DIMM fault	Memory DIMM 17, riser 2 Location: U1.1-P1-M2.17
406C 0506	IPL MOPS detected memory DIMM fault	Memory DIMM 18, riser 2 Location: U1.1-P1-M2.18
406C 0507	IPL MOPS detected memory DIMM fault	Memory DIMM 25, riser 2 Location: U1.1-P1-M2.25
406C 0508	IPL MOPS detected memory DIMM fault	Memory DIMM 26, riser 2 Location: U1.1-P1-M2.26
406C 050D	IPL MOPS detected memory DIMM group fault	Memory octal A, riser 2 Location: U1.1-P1-M2.1 x8
406C 050E	IPL MOPS detected memory DIMM group pair A fault	Memory quad A odd, riser 2 Location: U1.1-P1-M2.1 x4
406C 050F	IPL MOPS detected memory DIMM group fault	Memory quad A even, riser 2 Location: U1.1-P1-M2.2 x4
406C 0511	IPL MOPS detected memory DIMM fault	Memory DIMM 3, riser 2 Location: U1.1-P1-M2.3
406C 0512	IPL MOPS detected memory DIMM fault	Memory DIMM 4, riser 2 Location: U1.1-P1-M2.4
406C 0513	IPL MOPS detected memory DIMM fault	Memory DIMM 11, riser 2 Location: U1.1-P1-M2.11

Table 7. Service Processor Error Codes (continued)

Error Code	Description	Action/ Possible Failing FRU
406C 0514	IPL MOPS detected memory DIMM fault	Memory DIMM 12, riser 2 Location: U1.1-P1-M2.12
406C 0515	IPL MOPS detected memory DIMM fault	Memory DIMM 19, riser 2 Location: U1.1-P1-M2.19
406C 0516	IPL MOPS detected memory DIMM fault	Memory DIMM 20, riser 2 Location: U1.1-P1-M2.20
406C 0517	IPL MOPS detected memory DIMM fault	Memory DIMM 27, riser 2 Location: U1.1-P1-M2.27
406C 0518	IPL MOPS detected memory DIMM fault	Memory DIMM 28, riser 2 Location: U1.1-P1-M2.28
406C 051D	IPL MOPS detected memory DIMM group fault	Memory octal B, riser 2 Location: U1.1-P1-M2.3 x8
406C 051E	IPL MOPS detected memory DIMM group fault	Memory quad B odd, riser 2 Location: U1.1-P1-M2.3 x4
406C 051F	IPL MOPS detected memory DIMM group fault	Memory quad B even, riser 2 Location: U1.1-P1-M2.4 x4
406C 0521	IPL MOPS detected memory DIMM fault	Memory DIMM 5, riser 2 Location: U1.1-P1-M2.5
406C 0522	IPL MOPS detected memory DIMM fault	Memory DIMM 6, riser 2 Location: U1.1-P1-M2.6
406C 0523	IPL MOPS detected memory DIMM fault	Memory DIMM 13, riser 2 Location: U1.1-P1-M2.13
406C 0524	IPL MOPS detected memory DIMM fault	Memory DIMM 14, riser 2 Location: U1.1-P1-M2.14
406C 0525	IPL MOPS detected memory DIMM fault	Memory DIMM 21, riser 2 Location: U1.1-P1-M2.21
406C 0526	IPL MOPS detected memory DIMM fault	Memory DIMM 22, riser 2 Location: U1.1-P1-M2.22
406C 0527	IPL MOPS detected memory DIMM fault	Memory DIMM 29, riser 2 Location: U1.1-P1-M2.29
406C 0528	IPL MOPS detected memory DIMM fault	Memory DIMM 30, riser 2 Location: U1.1-P1-M2.30
406C 052D	IPL MOPS detected memory DIMM group fault	Memory octal C, riser 2 Location: U1.1-P1-M2.5 x8
406C 052E	IPL MOPS detected memory DIMM group pair A fault	Memory quad C odd, riser 2 Location: U1.1-P1-M2.5 x4
406C 052F	IPL MOPS detected memory DIMM group fault	Memory quad C even, riser 2 Location: U1.1-P1-M2.6 x4
406C 0531	IPL MOPS detected memory DIMM fault	Memory DIMM 7, riser 2 Location: U1.1-P1-M2.7
406C 0532	IPL MOPS detected memory DIMM fault	Memory DIMM 8, riser 2 Location: U1.1-P1-M2.8



Table 7. Service Processor Error Codes (continued)

Error Code	Description	Action/ Possible Failing FRU
406C 0533	IPL MOPS detected memory DIMM fault	Memory DIMM 15, riser 2 Location: U1.1-P1-M2.15
406C 0534	IPL MOPS detected memory DIMM fault	Memory DIMM 16, riser 2 Location: U1.1-P1-M2.16
406C 0535	IPL MOPS detected memory DIMM fault	Memory DIMM 23, riser 2 Location: U1.1-P1-M2.23
406C 0536	IPL MOPS detected memory DIMM fault	Memory DIMM 24, riser 2 Location: U1.1-P1-M2.24
406C 0537	IPL MOPS detected memory DIMM fault	Memory DIMM 31, riser 2 Location: U1.1-P1-M2.31
406C 0538	IPL MOPS detected memory DIMM fault	Memory DIMM 32, riser 2 Location: U1.1-P1-M2.32
406C 053D	IPL MOPS detected memory DIMM group fault	Memory octal D, riser 2 Location: U1.1-P1-M2.7 x8
406C 053E	IPL MOPS detected memory DIMM group fault	Memory quad D odd, riser 2 Location: U1.1-P1-M2.7 x4
406C 053F	IPL MOPS detected memory DIMM group fault	Memory quad D even, riser 2 Location: U1.1-P1-M2.8 x4
406C 05FF	IPL MOPS detected memory on riser fault	Memory failure on riser card 2 that cannot be automatically isolated. go to "MAP 1540: Minimum Configuration" on page 122 and run CEC drawer minimum configuration for further isolation.
406C 0600	IPL MOPS detected CEC RIO bus adapter	CEC RIO bus adapter Location: U1.1-P1.1
406C 0601	IPL MOPS detected clock card fault	CEC clock card Location: U1.1-P1.1.1
406C 3101	IPL MOPS detected RIO port 0 fault	CEC RIO bus adapter Location: U1.1-P1.1
406C 3102	IPL MOPS detected RIO port 1 fault	CEC RIO bus adapter Location: U1.1-P1.1
406C 3103	IPL MOPS detected RIO port 2 fault	CEC RIO bus adapter Location: U1.1-P1.1
406C 3104	IPL MOPS detected RIO port 3 fault	CEC RIO bus adapter Location: U1.1-P1.1
406C 3121	IPL MOPS detected RIO cable on port 0 fault	1. RIO cable on port 0 Location: U1.1-P1.1/Q1 2. CEC RIO bus adapter Location: U1.1-P1.1

Table 7. Service Processor Error Codes (continued)

<b>Error Code</b>	<b>Description</b>	<b>Action/ Possible Failing FRU</b>
406C 3122	IPL MOPS detected RIO cable on port 1 fault	<ol style="list-style-type: none"> <li>1. RIO cable on port 1 Location: U1.1-P1.1/Q2</li> <li>2. CEC RIO bus adapter Location: U1.1-P1.1</li> </ol>
406C 3123	IPL MOPS detected RIO cable on port 2 fault	<ol style="list-style-type: none"> <li>1. RIO cable on port 2 Location: U1.1-P1.1/Q3</li> <li>2. CEC RIO bus adapter Location: U1.1-P1.1</li> </ol>
406C 3124	IPL MOPS detected RIO cable on port 3 fault	<ol style="list-style-type: none"> <li>1. RIO cable on port 3 Location: U1.1-P1.1/Q4</li> <li>2. CEC RIO bus adapter Location: U1.1-P1.1</li> </ol>
406C 3140	IPL MOPS detected RIO hub 0 fault	CEC RIO bus adapter Location: U1.1-P1.1
406C 3141	IPL MOPS detected RIO hub 1 fault	CEC RIO bus adapter Location: U1.1-P1.1
406C 31FF	IPL MOPS detected RIO port fault	CEC RIO bus adapter Location: U1.1-P1.1
406C 3200	IPL MOPS detected primary I/O drawer fault	Go to "MAP 1540: Minimum Configuration" on page 122.
406C 3201	IPL MOPS detected primary I/O drawer backplane fault	Primary I/O drawer backplane Location: U0.1-P1
406C 3280	IPL MOPS detected primary RIO adapter fault	Primary RIO adapter Location: U0.1-P1.1
406C 3281	IPL MOPS detected primary RIO port 0 fault	<ol style="list-style-type: none"> <li>1. Check RIO cable Location: U0.1-P1.1/Q1</li> <li>2. RIO bus adapter Location: U0.1-P1.1</li> </ol>
406C 3282	IPL MOPS detected primary RIO port 1 fault	<ol style="list-style-type: none"> <li>1. Check RIO cable Location: U0.1-P1.1/Q2</li> <li>2. RIO bus adapter Location: U0.1-P1.1</li> </ol>
406C 3283	IPL MOPS detected primary RIO ports fault	RIO bus adapter Location: U0.1-P1.1
406C 3284	IPL MOPS detected PCI controller PHB0	<ol style="list-style-type: none"> <li>1. RIO bus adapter Location: U0.1-P1.1</li> <li>2. Primary I/O drawer backplane Location: U0.1-P1</li> </ol>
406C 3285	IPL MOPS detected PCI controller PHB1	<ol style="list-style-type: none"> <li>1. RIO bus adapter Location: U0.1-P1.1</li> <li>2. Primary I/O drawer backplane Location: U0.1-P1</li> </ol>

Table 7. Service Processor Error Codes (continued)

Error Code	Description	Action/ Possible Failing FRU
406C 3286	IPL MOPS detected PCI controller PHB2	1. RIO bus adapter Location: U0.1-P1.1 2. Primary I/O drawer backplane Location: U0.1-P1
406D 0001	Attention handler detected CEC backplane failure	CEC backplane Location: U1.1-P1
406D 0003	Attention handler detected processor fault	All processors Location: U1.1-P1-C1
406D 0009	Attention handler detected memory fault	All memory Location: U1.1-P1-M1 x2
406D 00A0	Attention handler detected CSP service processor firmware fault	Update system firmware Location: U0.1-P1/Y1
406D 00A1	Attention handler detected AIX or system firmware fault	1. Check for AIX updates 2. Check for system firmware updates Location: U0.1-P1/Y1
406D 00A2	Attention handler detected service processor firmware (processor runtime diagnostics) fault	Check for system firmware updates Location: U0.1-P1/Y1
406D 00A3	Attention handler detected memory plugging fault	All pluggable memory
406D 00A4	Attention handler detected application caused fault	Application software
406D 00A5	Attention handler detected invalid system configuration	Verify system components are supported and properly installed.
406D 00A6	Attention handler detected no usable memory	1. Ensure that CEC memory is properly installed. 2. If more than one DIMM is called out, go to the service processor Memory Configuration/Deconfiguration Menu to verify memory DIMMs state. See "Memory Configuration/Deconfiguration Menu" on page 426 for more information.
406D 00A7	Attention handler detected hardware problem	Go to minimum configuration and also run CEC minimum configuration
406D 00B0	Attention handler detected bus controller lock-unlock failure	RIO bus adapter Location: U0.1-P1.1
406D 00B1	Attention handler detected bus controller failure	RIO bus adapter Location: U0.1-P1.1

Table 7. Service Processor Error Codes (continued)

Error Code	Description	Action/ Possible Failing FRU
406D 00B3	Attention handler detected clock fault	1. Clock card Location: U1.1-P1.1.1 2. CEC RIO bus adapter Location: U1.1-P1.1
406D 00B7	Attention handler detected insufficient hardware resources to continue IPL	This error code appears after the initial testing by the service processor firmware on the CEC was completed correctly, but a problem occurred when the firmware tried to communicate outside the CEC. Suspect a problem with the RIO interface, either cables or adapters.
406D 0200	Attention handler detected memory riser card fault	Memory riser card 1 Location: U1.1-P1-M1
406D 0201	Attention handler detected memory DIMM fault	Memory DIMM 1, riser 1 Location: U1.1-P1-M1.1
406D 0202	Attention handler detected memory DIMM fault	Memory DIMM 2, riser 1 Location: U1.1-P1-M1.2
406D 0203	Attention handler detected memory DIMM fault	Memory DIMM 9, riser 1 Location: U1.1-P1-M1.9
406D 0204	Attention handler detected memory DIMM fault	Memory DIMM 10, riser 1 Location: U1.1-P1-M1.10
406D 0205	Attention handler detected memory DIMM fault	Memory DIMM 17, riser 1 Location: U1.1-P1-M1.17
406D 0206	Attention handler detected memory DIMM fault	Memory DIMM 18, riser 1 Location: U1.1-P1-M1.18
406D 0207	Attention handler detected memory DIMM fault	Memory DIMM 25, riser 1 Location: U1.1-P1-M1.25
406D 0208	Attention handler detected memory DIMM fault	Memory DIMM 26, riser 1 Location: U1.1-P1-M1.26
406D 020D	Attention handler detected memory DIMM group fault	Memory octal A, riser 1 Location: U1.1-P1-M1.1 x8
406D 020E	Attention handler detected memory DIMM group fault	Memory quad A odd, riser 1 Locations: U1.1-P1-M1.1 x4
406D 020F	Attention handler detected memory DIMM group fault	Memory quad A even, riser 1 Locations: U1.1-P1-M1.2 x4
406D 0211	Attention handler detected memory DIMM fault	Memory DIMM 3, riser 1 Location: U1.1-P1-M1.3
406D 0212	Attention handler detected memory DIMM fault	Memory DIMM 4, riser 1 Location: U1.1-P1-M1.4
406D 0213	Attention handler detected memory DIMM fault	Memory DIMM 11, riser 1 Location: U1.1-P1-M1.11

Table 7. Service Processor Error Codes (continued)

Error Code	Description	Action/ Possible Failing FRU
406D 0214	Attention handler detected memory DIMM fault	Memory DIMM 12, riser 1 Location: U1.1-P1-M1.12
406D 0215	Attention handler detected memory DIMM fault	Memory DIMM 19, riser 1 Location: U1.1-P1-M1.19
406D 0216	Attention handler detected memory DIMM fault	Memory DIMM 20, riser 1 Location: U1.1-P1-M1.20
406D 0217	Attention handler detected memory DIMM fault	Memory DIMM 27, riser 1 Location: U1.1-P1-M1.27
406D 0218	Attention handler detected memory DIMM fault	Memory DIMM 28, riser 1 Location: U1.1-P1-M1.28
406D 021D	Attention handler detected memory DIMM group fault	Memory octal B, riser 1 Location: U1.1-P1-M1.3 x8
406D 021E	Attention handler detected memory DIMM group pair A fault	Memory quad B odd, riser 1 Location: U1.1-P1-M1.3 x4
406D 021F	Attention handler detected memory DIMM group fault	Memory quad B even, riser 1 Location: U1.1-P1-M1.4 x4
406D 0221	Attention handler detected memory DIMM fault	Memory DIMM 5, riser 1 Location: U1.1-P1-M1.5
406D 0222	Attention handler detected memory DIMM fault	Memory DIMM 6, riser 1 Location: U1.1-P1-M1.6
406D 0223	Attention handler detected memory DIMM fault	Memory DIMM 13, riser 1 Location: U1.1-P1-M1.13
406D 0224	Attention handler detected memory DIMM fault	Memory DIMM 14, riser 1 Location: U1.1-P1-M1.14
406D 0225	Attention handler detected memory DIMM fault	Memory DIMM 21, riser 1 Location: U1.1-P1-M1.21
406D 0226	Attention handler detected memory DIMM fault	Memory DIMM 22, riser 1 Location: U1.1-P1-M1.22
406D 0227	Attention handler detected memory DIMM fault	Memory DIMM 29, riser 1 Location: U1.1-P1-M1.29
406D 0228	Attention handler detected memory DIMM fault	Memory DIMM 30, riser 1 Location: U1.1-P1-M1.30
406D 022D	Attention handler detected memory DIMM group fault	Memory octal C, riser 1 Locations: U1.1-P1-M1.5 x8
406D 022E	Attention handler detected memory DIMM group pair A fault	Memory quad C odd, riser 1 Locations: U1.1-P1-M1.5 x4
406D 022F	Attention handler detected memory DIMM group fault	Memory quad C even, riser 1 Locations: U1.1-P1-M1.6 x4
406D 0231	Attention handler detected memory DIMM fault	Memory DIMM 7, riser 1 Location: U1.1-P1-M1.7
406D 0232	Attention handler detected memory DIMM fault	Memory DIMM 8, riser 1 Location: U1.1-P1-M1.8

Table 7. Service Processor Error Codes (continued)

<b>Error Code</b>	<b>Description</b>	<b>Action/ Possible Failing FRU</b>
406D 0233	Attention handler detected memory DIMM fault	Memory DIMM 15, riser 1 Location: U1.1-P1-M1.15
406D 0234	Attention handler detected memory DIMM fault	Memory DIMM 16, riser 1 Location: U1.1-P1-M1.16
406D 0235	Attention handler detected memory DIMM fault	Memory DIMM 23, riser 1 Location: U1.1-P1-M1.23
406D 0236	Attention handler detected memory DIMM fault	Memory DIMM 24, riser 1 Location: U1.1-P1-M1.24
406D 0237	Attention handler detected memory DIMM fault	Memory DIMM 31, riser 1 Location: U1.1-P1-M1.31
406D 0238	Attention handler detected memory DIMM fault	Memory DIMM 32, riser 1 Location: U1.1-P1-M1.32
406D 023D	Attention handler detected memory DIMM group fault	Memory octal D, riser 1 Location: U1.1-P1-M1.7 x8
406D 023E	Attention handler detected memory DIMM group fault	Memory quad D odd, riser 1 Location: U1.1-P1-M1.7 x4
406D 023F	Attention handler detected memory DIMM group fault	Memory quad D even, riser 1 Location: U1.1-P1-M1.8 x4
406D 02FF	Attention handler detected memory on riser fault	All memory on riser 1 Location: U1.1-P1-M1.1 x32 Memory failure on riser card 1 that cannot be automatically isolated. go to "MAP 1540: Minimum Configuration" on page 122 and run CEC drawer minimum configuration for further isolation.
406D 0300	Attention handler detected processor card fault	Processor card Location: U1.1-P1-C1
406D 0400	Attention handler detected processor card fault	Processor card Location: U1.1-P1-C2
406D 0500	Attention handler detected memory riser card fault	Memory riser card 2 Location: U1.1-P1-M1
406D 0501	Attention handler detected memory DIMM fault	Memory DIMM 1, riser 2 Location: U1.1-P1-M2.1
406D 0502	Attention handler detected memory DIMM fault	Memory DIMM 2, riser 2 Location: U1.1-P1-M2.2
406D 0503	Attention handler detected memory DIMM fault	Memory DIMM 9, riser 2 Location: U1.1-P1-M2.9
406D 0504	Attention handler detected memory DIMM fault	Memory DIMM 10, riser 2 Location: U1.1-P1-M2.10
406D 0505	Attention handler detected memory DIMM fault	Memory DIMM 17, riser 2 Location: U1.1-P1-M2.17

Table 7. Service Processor Error Codes (continued)

Error Code	Description	Action/ Possible Failing FRU
406D 0506	Attention handler detected memory DIMM fault	Memory DIMM 18, riser 2 Location: U1.1-P1-M2.18
406D 0507	Attention handler detected memory DIMM fault	Memory DIMM 25, riser 2 Location: U1.1-P1-M2.25
406D 0508	Attention handler detected memory DIMM fault	Memory DIMM 26, riser 2 Location: U1.1-P1-M2.26
406D 050D	Attention handler detected memory DIMM group fault	Memory octal A, riser 2 Location: U1.1-P1-M2.1 x8
406D 050E	Attention handler detected memory DIMM group pair A fault	Memory quad A odd, riser 2 Location: U1.1-P1-M2.1 x4
406D 050F	Attention handler detected memory DIMM group fault	Memory quad A even, riser 2 Location: U1.1-P1-M2.2 x4
406D 0511	Attention handler detected memory DIMM fault	Memory DIMM 3, riser 2 Location: U1.1-P1-M2.3
406D 0512	Attention handler detected memory DIMM fault	Memory DIMM 4, riser 2 Location: U1.1-P1-M2.4
406D 0513	Attention handler detected memory DIMM fault	Memory DIMM 11, riser 2 Location: U1.1-P1-M2.11
406D 0514	Attention handler detected memory DIMM fault	Memory DIMM 12, riser 2 Location: U1.1-P1-M2.12
406D 0515	Attention handler detected memory DIMM fault	Memory DIMM 19, riser 2 Location: U1.1-P1-M2.19
406D 0516	Attention handler detected memory DIMM fault	Memory DIMM 20, riser 2 Location: U1.1-P1-M2.20
406D 0517	Attention handler detected memory DIMM fault	Memory DIMM 27, riser 2 Location: U1.1-P1-M2.27
406D 0518	Attention handler detected memory DIMM fault	Memory DIMM 28, riser 2 Location: U1.1-P1-M2.28
406D 051D	Attention handler detected memory DIMM group fault	Memory octal B, riser 2 Location: U1.1-P1-M2.3 x8
406D 051E	Attention handler detected memory DIMM group fault	Memory quad B odd, riser 2 Location: U1.1-P1-M2.3 x4
406D 051F	Attention handler detected memory DIMM group fault	Memory quad B even, riser 2 Location: U1.1-P1-M2.4 x4
406D 0521	Attention handler detected memory DIMM fault	Memory DIMM 5, riser 2 Location: U1.1-P1-M2.5
406D 0522	Attention handler detected memory DIMM fault	Memory DIMM 6, riser 2 Location: U1.1-P1-M2.6
406D 0523	Attention handler detected memory DIMM fault	Memory DIMM 13, riser 2 Location: U1.1-P1-M2.13
406D 0524	Attention handler detected memory DIMM fault	Memory DIMM 14, riser 2 Location: U1.1-P1-M2.14

Table 7. Service Processor Error Codes (continued)

Error Code	Description	Action/ Possible Failing FRU
406D 0525	Attention handler detected memory DIMM fault	Memory DIMM 21, riser 2 Location: U1.1-P1-M2.21
406D 0526	Attention handler detected memory DIMM fault	Memory DIMM 22, riser 2 Location: U1.1-P1-M2.22
406D 0527	Attention handler detected memory DIMM fault	Memory DIMM 29, riser 2 Location: U1.1-P1-M2.29
406D 0528	Attention handler detected memory DIMM fault	Memory DIMM 30, riser 2 Location: U1.1-P1-M2.30
406D 052D	Attention handler detected memory DIMM group fault	Memory octal C, riser 2 Location: U1.1-P1-M2.5 x8
406D 052E	Attention handler detected memory DIMM group pair A fault	Memory quad C odd, riser 2 Location: U1.1-P1-M2.5 x4
406D 052F	Attention handler detected memory DIMM group fault	Memory quad C even, riser 2 Location: U1.1-P1-M2.6 x4
406D 0531	Attention handler detected memory DIMM fault	Memory DIMM 7, riser 2 Location: U1.1-P1-M2.7
406D 0532	Attention handler detected memory DIMM fault	Memory DIMM 8, riser 2 Location: U1.1-P1-M2.8
406D 0533	Attention handler detected memory DIMM fault	Memory DIMM 15, riser 2 Location: U1.1-P1-M2.15
406D 0534	Attention handler detected memory DIMM fault	Memory DIMM 16, riser 2 Location: U1.1-P1-M2.16
406D 0535	Attention handler detected memory DIMM fault	Memory DIMM 23, riser 2 Location: U1.1-P1-M2.23
406D 0536	Attention handler detected memory DIMM fault	Memory DIMM 24, riser 2 Location: U1.1-P1-M2.24
406D 0537	Attention handler detected memory DIMM fault	Memory DIMM 31, riser 2 Location: U1.1-P1-M2.31
406D 0538	Attention handler detected memory DIMM fault	Memory DIMM 32, riser 2 Location: U1.1-P1-M2.32
406D 053D	Attention handler detected memory DIMM group fault	Memory octal D, riser 2 Location: U1.1-P1-M2.7 x8
406D 053E	Attention handler detected memory DIMM group fault	Memory quad D odd, riser 2 Location: U1.1-P1-M2.7 x4
406D 053F	Attention handler detected memory DIMM group fault	Memory quad D even, riser 2 Location: U1.1-P1-M2.8 x4
406D 05FF	Attention handler detected memory on riser fault	Memory failure on riser card 2 that cannot be automatically isolated. go to "MAP 1540: Minimum Configuration" on page 122 and run CEC drawer minimum configuration for further isolation.



Table 7. Service Processor Error Codes (continued)

Error Code	Description	Action/ Possible Failing FRU
406D 0600	Attention handler detected CEC RIO bus adapter	CEC RIO bus adapter Location: U1.1-P1.1
406D 0601	Attention handler detected clock card fault	CEC clock card Location: U1.1-P1.1.1
406D 3101	Attention handler detected RIO port 0 fault	CEC RIO bus adapter Location: U1.1-P1.1
406D 3102	Attention handler detected RIO port 1 fault	CEC RIO bus adapter Location: U1.1-P1.1
406D 3103	Attention handler detected RIO port 2 fault	CEC RIO bus adapter Location: U1.1-P1.1
406D 3104	Attention handler detected RIO port 3 fault	CEC RIO bus adapter Location: U1.1-P1.1
406D 3121	Attention handler detected RIO cable on port 0 fault	1. RIO cable on port 0 Location: U1.1-P1.1/Q1 2. CEC RIO bus adapter Location: U1.1-P1.1
406D 3122	Attention handler detected RIO cable on port 1 fault	1. RIO cable on port 1 Location: U1.1-P1.1/Q2 2. CEC RIO bus adapter Location: U1.1-P1.1
406D 3123	Attention handler detected RIO cable on port 2 fault	1. RIO cable on port 2 Location: U1.1-P1.1/Q3 2. CEC RIO bus adapter Location: U1.1-P1.1
406D 3124	Attention handler detected RIO cable on port 3 fault	1. RIO cable on port 3 Location: U1.1-P1.1/Q4 2. CEC RIO bus adapter Location: U1.1-P1.1
406D 3140	Attention handler detected RIO hub 0 fault	CEC RIO bus adapter Location: U1.1-P1.1
406D 3141	Attention handler detected RIO hub 1 fault	CEC RIO bus adapter Location: U1.1-P1.1
406D 31FF	Attention handler detected RIO port fault	CEC RIO bus adapter Location: U1.1-P1.1
406D 3200	Attention handler detected primary I/O drawer fault	Go to "MAP 1540: Minimum Configuration" on page 122.
406D 3201	Attention handler detected primary I/O drawer backplane fault	Primary I/O drawer backplane Location: U0.1-P1
406D 3280	Attention handler detected primary RIO adapter fault	Primary RIO adapter Location: U0.1-P1.1
406D 3281	Attention handler detected primary RIO port 0 fault	1. Check RIO cable Location: U0.1-P1.1/Q1 2. RIO bus adapter Location: U0.1-P1.1

Table 7. Service Processor Error Codes (continued)

Error Code	Description	Action/ Possible Failing FRU
406D 3282	Attention handler detected primary RIO port 1 fault	1. Check RIO cable Location: U0.1-P1.1/Q2 2. RIO bus adapter Location: U0.1-P1.1
406D 3283	Attention handler detected primary RIO ports fault	RIO bus adapter Location: U0.1-P1.1
406D 3284	Attention handler detected PCI controller PHB0	1. RIO bus adapter Location: U0.1-P1.1 2. Primary I/O drawer backplane Location: U0.1-P1
406D 3285	Attention handler detected PCI controller PHB1	1. RIO bus adapter Location: U0.1-P1.1 2. Primary I/O drawer backplane Location: U0.1-P1
406D 3286	Attention handler detected PCI controller PHB2	1. RIO bus adapter Location: U0.1-P1.1 2. Primary I/O drawer backplane Location: U0.1-P1
406E 0001	Scan control routines detected CEC backplane failure	CEC backplane Location: U1.1-P1
406E 0003	Scan control routines detected processor fault	All processors Location: U1.1-P1-C1
406E 0009	Scan control routines detected memory fault	All memory Location: U1.1-P1-M1 x2
406E 00A0	Scan control routines detected CSP service processor firmware fault	Update system firmware Location: U0.1-P1/Y1
406E 00A1	Scan control routines detected AIX or system firmware fault	1. Check for AIX updates 2. Check for system firmware updates Location: U0.1-P1/Y1
406E 00A2	Scan control routines detected service processor firmware (processor runtime diagnostics) fault	Check for system firmware updates Location: U0.1-P1/Y1
406E 00A3	Scan control routines detected memory plugging fault	All pluggable memory
406E 00A4	Scan control routines detected application caused fault	Application software
406E 00A5	Scan control routines detected invalid system configuration	Verify system components are supported and properly installed.

Table 7. Service Processor Error Codes (continued)

Error Code	Description	Action/ Possible Failing FRU
406E 00A6	Scan control routines detected no usable memory	<ol style="list-style-type: none"> <li>1. Ensure that CEC memory is properly installed.</li> <li>2. If more than one DIMM is called out, go to the service processor Memory Configuration/Deconfiguration Menu to verify memory DIMMs state. See "Memory Configuration/Deconfiguration Menu" on page 426 for more information.</li> </ol>
406E 00A7	Scan control routines detected hardware problem	Go to minimum configuration and also run CEC minimum configuration
406E 00B0	Scan control routines detected bus controller lock-unlock failure	RIO bus adapter Location: U0.1-P1.1
406E 00B1	Scan control routines detected bus controller failure	RIO bus adapter Location: U0.1-P1.1
406E 00B3	Scan control routines detected clock fault	<ol style="list-style-type: none"> <li>1. Clock card Location: U1.1-P1.1.1</li> <li>2. CEC RIO bus adapter Location: U1.1-P1.1</li> </ol>
406E 00B7	Scan control routines detected insufficient hardware resources to continue IPL	This error code appears after the initial testing by the service processor firmware on the CEC was completed correctly, but a problem occurred when the firmware tried to communicate outside the CEC. Suspect a problem with the RIO interface, either cables or adapters.
406E 0200	Scan control routines detected memory riser card fault	Memory riser card 1 Location: U1.1-P1-M1
406E 0201	Scan control routines detected memory DIMM fault	Memory DIMM 1, riser 1 Location: U1.1-P1-M1.1
406E 0202	Scan control routines detected memory DIMM fault	Memory DIMM 2, riser 1 Location: U1.1-P1-M1.2
406E 0203	Scan control routines detected memory DIMM fault	Memory DIMM 9, riser 1 Location: U1.1-P1-M1.9
406E 0204	Scan control routines detected memory DIMM fault	Memory DIMM 10, riser 1 Location: U1.1-P1-M1.10
406E 0205	Scan control routines detected memory DIMM fault	Memory DIMM 17, riser 1 Location: U1.1-P1-M1.17
406E 0206	Scan control routines detected memory DIMM fault	Memory DIMM 18, riser 1 Location: U1.1-P1-M1.18
406E 0207	Scan control routines detected memory DIMM fault	Memory DIMM 25, riser 1 Location: U1.1-P1-M1.25

Table 7. Service Processor Error Codes (continued)

<b>Error Code</b>	<b>Description</b>	<b>Action/ Possible Failing FRU</b>
406E 0208	Scan control routines detected memory DIMM fault	Memory DIMM 26, riser 1 Location: U1.1-P1-M1.26
406E 020D	Scan control routines detected memory DIMM group fault	Memory octal A, riser 1 Location: U1.1-P1-M1.1 x8
406E 020E	Scan control routines detected memory DIMM group fault	Memory quad A odd, riser 1 Locations: U1.1-P1-M1.1 x4
406E 020F	Scan control routines detected memory DIMM group fault	Memory quad A even, riser 1 Locations: U1.1-P1-M1.2 x4
406E 0211	Scan control routines detected memory DIMM fault	Memory DIMM 3, riser 1 Location: U1.1-P1-M1.3
406E 0212	Scan control routines detected memory DIMM fault	Memory DIMM 4, riser 1 Location: U1.1-P1-M1.4
406E 0213	Scan control routines detected memory DIMM fault	Memory DIMM 11, riser 1 Location: U1.1-P1-M1.11
406E 0214	Scan control routines detected memory DIMM fault	Memory DIMM 12, riser 1 Location: U1.1-P1-M1.12
406E 0215	Scan control routines detected memory DIMM fault	Memory DIMM 19, riser 1 Location: U1.1-P1-M1.19
406E 0216	Scan control routines detected memory DIMM fault	Memory DIMM 20, riser 1 Location: U1.1-P1-M1.20
406E 0217	Scan control routines detected memory DIMM fault	Memory DIMM 27, riser 1 Location: U1.1-P1-M1.27
406E 0218	Scan control routines detected memory DIMM fault	Memory DIMM 28, riser 1 Location: U1.1-P1-M1.28
406E 021D	Scan control routines detected memory DIMM group fault	Memory octal B, riser 1 Location: U1.1-P1-M1.3 x8
406E 021E	Scan control routines detected memory DIMM group pair A fault	Memory quad B odd, riser 1 Location: U1.1-P1-M1.3 x4
406E 021F	Scan control routines detected memory DIMM group fault	Memory quad B even, riser 1 Location: U1.1-P1-M1.4 x4
406E 0221	Scan control routines detected memory DIMM fault	Memory DIMM 5, riser 1 Location: U1.1-P1-M1.5
406E 0222	Scan control routines detected memory DIMM fault	Memory DIMM 6, riser 1 Location: U1.1-P1-M1.6
406E 0223	Scan control routines detected memory DIMM fault	Memory DIMM 13, riser 1 Location: U1.1-P1-M1.13
406E 0224	Scan control routines detected memory DIMM fault	Memory DIMM 14, riser 1 Location: U1.1-P1-M1.14
406E 0225	Scan control routines detected memory DIMM fault	Memory DIMM 21, riser 1 Location: U1.1-P1-M1.21
406E 0226	Scan control routines detected memory DIMM fault	Memory DIMM 22, riser 1 Location: U1.1-P1-M1.22

Table 7. Service Processor Error Codes (continued)

Error Code	Description	Action/ Possible Failing FRU
406E 0227	Scan control routines detected memory DIMM fault	Memory DIMM 29, riser 1 Location: U1.1-P1-M1.29
406E 0228	Scan control routines detected memory DIMM fault	Memory DIMM 30, riser 1 Location: U1.1-P1-M1.30
406E 022D	Scan control routines detected memory DIMM group fault	Memory octal C, riser 1 Locations: U1.1-P1-M1.5 x8
406E 022E	Scan control routines detected memory DIMM group pair A fault	Memory quad C odd, riser 1 Locations: U1.1-P1-M1.5 x4
406E 022F	Scan control routines detected memory DIMM group fault	Memory quad C even, riser 1 Locations: U1.1-P1-M1.6 x4
406E 0231	Scan control routines detected memory DIMM fault	Memory DIMM 7, riser 1 Location: U1.1-P1-M1.7
406E 0232	Scan control routines detected memory DIMM fault	Memory DIMM 8, riser 1 Location: U1.1-P1-M1.8
406E 0233	Scan control routines detected memory DIMM fault	Memory DIMM 15, riser 1 Location: U1.1-P1-M1.15
406E 0234	Scan control routines detected memory DIMM fault	Memory DIMM 16, riser 1 Location: U1.1-P1-M1.16
406E 0235	Scan control routines detected memory DIMM fault	Memory DIMM 23, riser 1 Location: U1.1-P1-M1.23
406E 0236	Scan control routines detected memory DIMM fault	Memory DIMM 24, riser 1 Location: U1.1-P1-M1.24
406E 0237	Scan control routines detected memory DIMM fault	Memory DIMM 31, riser 1 Location: U1.1-P1-M1.31
406E 0238	Scan control routines detected memory DIMM fault	Memory DIMM 32, riser 1 Location: U1.1-P1-M1.32
406E 023D	Scan control routines detected memory DIMM group fault	Memory octal D, riser 1 Location: U1.1-P1-M1.7 x8
406E 023E	Scan control routines detected memory DIMM group fault	Memory quad D odd, riser 1 Location: U1.1-P1-M1.7 x4
406E 023F	Scan control routines detected memory DIMM group fault	Memory quad D even, riser 1 Location: U1.1-P1-M1.8 x4
406E 02FF	Scan control routines detected memory on riser fault	All memory on riser 1 Location: U1.1-P1-M1.1 x32 Memory failure on riser card 1 that cannot be automatically isolated. go to "MAP 1540: Minimum Configuration" on page 122 and run CEC drawer minimum configuration for further isolation.
406E 0300	Scan control routines detected processor card fault	Processor card Location: U1.1-P1-C1

Table 7. Service Processor Error Codes (continued)

<b>Error Code</b>	<b>Description</b>	<b>Action/ Possible Failing FRU</b>
406E 0400	Scan control routines detected processor card fault	Processor card Location: U1.1-P1-C2
406E 0500	Scan control routines detected memory riser card fault	Memory riser card 2 Location: U1.1-P1-M1
406E 0501	Scan control routines detected memory DIMM fault	Memory DIMM 1, riser 2 Location: U1.1-P1-M2.1
406E 0502	Scan control routines detected memory DIMM fault	Memory DIMM 2, riser 2 Location: U1.1-P1-M2.2
406E 0503	Scan control routines detected memory DIMM fault	Memory DIMM 9, riser 2 Location: U1.1-P1-M2.9
406E 0504	Scan control routines detected memory DIMM fault	Memory DIMM 10, riser 2 Location: U1.1-P1-M2.10
406E 0505	Scan control routines detected memory DIMM fault	Memory DIMM 17, riser 2 Location: U1.1-P1-M2.17
406E 0506	Scan control routines detected memory DIMM fault	Memory DIMM 18, riser 2 Location: U1.1-P1-M2.18
406E 0507	Scan control routines detected memory DIMM fault	Memory DIMM 25, riser 2 Location: U1.1-P1-M2.25
406E 0508	Scan control routines detected memory DIMM fault	Memory DIMM 26, riser 2 Location: U1.1-P1-M2.26
406E 050D	Scan control routines detected memory DIMM group fault	Memory octal A, riser 2 Location: U1.1-P1-M2.1 x8
406E 050E	Scan control routines detected memory DIMM group pair A fault	Memory quad A odd, riser 2 Location: U1.1-P1-M2.1 x4
406E 050F	Scan control routines detected memory DIMM group fault	Memory quad A even, riser 2 Location: U1.1-P1-M2.2 x4
406E 0511	Scan control routines detected memory DIMM fault	Memory DIMM 3, riser 2 Location: U1.1-P1-M2.3
406E 0512	Scan control routines detected memory DIMM fault	Memory DIMM 4, riser 2 Location: U1.1-P1-M2.4
406E 0513	Scan control routines detected memory DIMM fault	Memory DIMM 11, riser 2 Location: U1.1-P1-M2.11
406E 0514	Scan control routines detected memory DIMM fault	Memory DIMM 12, riser 2 Location: U1.1-P1-M2.12
406E 0515	Scan control routines detected memory DIMM fault	Memory DIMM 19, riser 2 Location: U1.1-P1-M2.19
406E 0516	Scan control routines detected memory DIMM fault	Memory DIMM 20, riser 2 Location: U1.1-P1-M2.20
406E 0517	Scan control routines detected memory DIMM fault	Memory DIMM 27, riser 2 Location: U1.1-P1-M2.27
406E 0518	Scan control routines detected memory DIMM fault	Memory DIMM 28, riser 2 Location: U1.1-P1-M2.28

Table 7. Service Processor Error Codes (continued)

Error Code	Description	Action/ Possible Failing FRU
406E 051D	Scan control routines detected memory DIMM group fault	Memory octal B, riser 2 Location: U1.1-P1-M2.3 x8
406E 051E	Scan control routines detected memory DIMM group fault	Memory quad B odd, riser 2 Location: U1.1-P1-M2.3 x4
406E 051F	Scan control routines detected memory DIMM group fault	Memory quad B even, riser 2 Location: U1.1-P1-M2.4 x4
406E 0521	Scan control routines detected memory DIMM fault	Memory DIMM 5, riser 2 Location: U1.1-P1-M2.5
406E 0522	Scan control routines detected memory DIMM fault	Memory DIMM 6, riser 2 Location: U1.1-P1-M2.6
406E 0523	Scan control routines detected memory DIMM fault	Memory DIMM 13, riser 2 Location: U1.1-P1-M2.13
406E 0524	Scan control routines detected memory DIMM fault	Memory DIMM 14, riser 2 Location: U1.1-P1-M2.14
406E 0525	Scan control routines detected memory DIMM fault	Memory DIMM 21, riser 2 Location: U1.1-P1-M2.21
406E 0526	Scan control routines detected memory DIMM fault	Memory DIMM 22, riser 2 Location: U1.1-P1-M2.22
406E 0527	Scan control routines detected memory DIMM fault	Memory DIMM 29, riser 2 Location: U1.1-P1-M2.29
406E 0528	Scan control routines detected memory DIMM fault	Memory DIMM 30, riser 2 Location: U1.1-P1-M2.30
406E 052D	Scan control routines detected memory DIMM group fault	Memory octal C, riser 2 Location: U1.1-P1-M2.5 x8
406E 052E	Scan control routines detected memory DIMM group pair A fault	Memory quad C odd, riser 2 Location: U1.1-P1-M2.5 x4
406E 052F	Scan control routines detected memory DIMM group fault	Memory quad C even, riser 2 Location: U1.1-P1-M2.6 x4
406E 0531	Scan control routines detected memory DIMM fault	Memory DIMM 7, riser 2 Location: U1.1-P1-M2.7
406E 0532	Scan control routines detected memory DIMM fault	Memory DIMM 8, riser 2 Location: U1.1-P1-M2.8
406E 0533	Scan control routines detected memory DIMM fault	Memory DIMM 15, riser 2 Location: U1.1-P1-M2.15
406E 0534	Scan control routines detected memory DIMM fault	Memory DIMM 16, riser 2 Location: U1.1-P1-M2.16
406E 0535	Scan control routines detected memory DIMM fault	Memory DIMM 23, riser 2 Location: U1.1-P1-M2.23
406E 0536	Scan control routines detected memory DIMM fault	Memory DIMM 24, riser 2 Location: U1.1-P1-M2.24
406E 0537	Scan control routines detected memory DIMM fault	Memory DIMM 31, riser 2 Location: U1.1-P1-M2.31

Table 7. Service Processor Error Codes (continued)

Error Code	Description	Action/ Possible Failing FRU
406E 0538	Scan control routines detected memory DIMM fault	Memory DIMM 32, riser 2 Location: U1.1-P1-M2.32
406E 053D	Scan control routines detected memory DIMM group fault	Memory octal D, riser 2 Location: U1.1-P1-M2.7 x8
406E 053E	Scan control routines detected memory DIMM group fault	Memory quad D odd, riser 2 Location: U1.1-P1-M2.7 x4
406E 053F	Scan control routines detected memory DIMM group fault	Memory quad D even, riser 2 Location: U1.1-P1-M2.8 x4
406E 05FF	Scan control routines detected memory on riser fault	Memory failure on riser card 2 that cannot be automatically isolated. go to "MAP 1540: Minimum Configuration" on page 122 and run CEC drawer minimum configuration for further isolation.
406E 0600	Scan control routines detected CEC RIO bus adapter	CEC RIO bus adapter Location: U1.1-P1.1
406E 0601	Scan control routines detected clock card fault	CEC clock card Location: U1.1-P1.1.1
406E 3101	Scan control routines detected RIO port 0 fault	CEC RIO bus adapter Location: U1.1-P1.1
406E 3102	Scan control routines detected RIO port 1 fault	CEC RIO bus adapter Location: U1.1-P1.1
406E 3103	Scan control routines detected RIO port 2 fault	CEC RIO bus adapter Location: U1.1-P1.1
406E 3104	Scan control routines detected RIO port 3 fault	CEC RIO bus adapter Location: U1.1-P1.1
406E 3121	Scan control routines detected RIO cable on port 0 fault	1. RIO cable on port 0 Location: U1.1-P1.1/Q1 2. CEC RIO bus adapter Location: U1.1-P1.1
406E 3122	Scan control routines detected RIO cable on port 1 fault	1. RIO cable on port 1 Location: U1.1-P1.1/Q2 2. CEC RIO bus adapter Location: U1.1-P1.1
406E 3123	Scan control routines detected RIO cable on port 2 fault	1. RIO cable on port 2 Location: U1.1-P1.1/Q3 2. CEC RIO bus adapter Location: U1.1-P1.1
406E 3124	Scan control routines detected RIO cable on port 3 fault	1. RIO cable on port 3 Location: U1.1-P1.1/Q4 2. CEC RIO bus adapter Location: U1.1-P1.1
406E 3140	Scan control routines detected RIO hub 0 fault	CEC RIO bus adapter Location: U1.1-P1.1



Table 7. Service Processor Error Codes (continued)

<b>Error Code</b>	<b>Description</b>	<b>Action/ Possible Failing FRU</b>
406E 3141	Scan control routines detected RIO hub 1 fault	CEC RIO bus adapter Location: U1.1-P1.1
406E 31FF	Scan control routines detected RIO port fault	CEC RIO bus adapter Location: U1.1-P1.1
406E 3200	Scan control routines detected primary I/O drawer fault	Go to "MAP 1540: Minimum Configuration" on page 122.
406E 3201	Scan control routines detected primary I/O drawer backplane fault	Primary I/O drawer backplane Location: U0.1-P1
406E 3280	Scan control routines detected primary RIO adapter fault	Primary RIO adapter Location: U0.1-P1.1
406E 3281	Scan control routines detected primary RIO port 0 fault	1. Check RIO cable Location: U0.1-P1.1/Q1 2. RIO bus adapter Location: U0.1-P1.1
406E 3282	Scan control routines detected primary RIO port 1 fault	1. Check RIO cable Location: U0.1-P1.1/Q2 2. RIO bus adapter Location: U0.1-P1.1
406E 3283	Scan control routines detected primary RIO ports fault	RIO bus adapter Location: U0.1-P1.1
406E 3284	Scan control routines detected PCI controller PHB0	1. RIO bus adapter Location: U0.1-P1.1 2. Primary I/O drawer backplane Location: U0.1-P1
406E 3285	Scan control routines detected PCI controller PHB1	1. RIO bus adapter Location: U0.1-P1.1 2. Primary I/O drawer backplane Location: U0.1-P1
406E 3286	Scan control routines detected PCI controller PHB2	1. RIO bus adapter Location: U0.1-P1.1 2. Primary I/O drawer backplane Location: U0.1-P1
406F 0001	Error code generation/logging detected CEC backplane failure	CEC backplane Location: U1.1-P1
406F 0003	Error code generation/logging detected processor fault	All processors Location: U1.1-P1-C1
406F 0009	Error code generation/logging detected memory fault	All memory Location: U1.1-P1-M1 x2
406F 00A0	Error code generation/logging detected CSP service processor firmware fault	Update system firmware Location: U0.1-P1/Y1

Table 7. Service Processor Error Codes (continued)

Error Code	Description	Action/ Possible Failing FRU
406F 00A1	Error code generation/logging detected AIX or system firmware fault	1. Check for AIX updates 2. Check for system firmware updates Location: U0.1-P1/Y1
406F 00A2	Error code generation/logging detected service processor firmware (processor runtime diagnostics) fault	Check for system firmware updates Location: U0.1-P1/Y1
406F 00A3	Error code generation/logging detected memory plugging fault	All pluggable memory
406F 00A4	Error code generation/logging detected application caused fault	Application software
406F 00A5	Error code generation/logging detected invalid system configuration	Verify system components are supported and properly installed.
406F 00A6	Error code generation/logging detected no usable memory	1. Ensure that CEC memory is properly installed. 2. If more than one DIMM is called out, go to the service processor Memory Configuration/Deconfiguration Menu to verify memory DIMMs state. See "Memory Configuration/Deconfiguration Menu" on page 426 for more information.
406F 00A7	Error code generation/logging detected hardware problem	Go to minimum configuration and also run CEC minimum configuration
406F 00B0	Error code generation/logging detected bus controller lock-unlock failure	RIO bus adapter Location: U0.1-P1.1
406F 00B1	Error code generation/logging detected bus controller failure	RIO bus adapter Location: U0.1-P1.1
406F 00B3	Error code generation/logging detected clock fault	1. Clock card Location: U1.1-P1.1.1 2. CEC RIO bus adapter Location: U1.1-P1.1
406F 00B7	Error code generation/logging detected insufficient hardware resources to continue IPL	This error code appears after the initial testing by the service processor firmware on the CEC was completed correctly, but a problem occurred when the firmware tried to communicate outside the CEC. Suspect a problem with the RIO interface, either cables or adapters.
406F 0200	Error code generation/logging detected memory riser card fault	Memory riser card 1 Location: U1.1-P1-M1

Table 7. Service Processor Error Codes (continued)

<b>Error Code</b>	<b>Description</b>	<b>Action/ Possible Failing FRU</b>
406F 0201	Error code generation/logging detected memory DIMM fault	Memory DIMM 1, riser 1 Location: U1.1-P1-M1.1
406F 0202	Error code generation/logging detected memory DIMM fault	Memory DIMM 2, riser 1 Location: U1.1-P1-M1.2
406F 0203	Error code generation/logging detected memory DIMM fault	Memory DIMM 9, riser 1 Location: U1.1-P1-M1.9
406F 0204	Error code generation/logging detected memory DIMM fault	Memory DIMM 10, riser 1 Location: U1.1-P1-M1.10
406F 0205	Error code generation/logging detected memory DIMM fault	Memory DIMM 17, riser 1 Location: U1.1-P1-M1.17
406F 0206	Error code generation/logging detected memory DIMM fault	Memory DIMM 18, riser 1 Location: U1.1-P1-M1.18
406F 0207	Error code generation/logging detected memory DIMM fault	Memory DIMM 25, riser 1 Location: U1.1-P1-M1.25
406F 0208	Error code generation/logging detected memory DIMM fault	Memory DIMM 26, riser 1 Location: U1.1-P1-M1.26
406F 020D	Error code generation/logging detected memory DIMM group fault	Memory octal A, riser 1 Location: U1.1-P1-M1.1 x8
406F 020E	Error code generation/logging detected memory DIMM group fault	Memory quad A odd, riser 1 Locations: U1.1-P1-M1.1 x4
406F 020F	Error code generation/logging detected memory DIMM group fault	Memory quad A even, riser 1 Locations: U1.1-P1-M1.2 x4
406F 0211	Error code generation/logging detected memory DIMM fault	Memory DIMM 3, riser 1 Location: U1.1-P1-M1.3
406F 0212	Error code generation/logging detected memory DIMM fault	Memory DIMM 4, riser 1 Location: U1.1-P1-M1.4
406F 0213	Error code generation/logging detected memory DIMM fault	Memory DIMM 11, riser 1 Location: U1.1-P1-M1.11
406F 0214	Error code generation/logging detected memory DIMM fault	Memory DIMM 12, riser 1 Location: U1.1-P1-M1.12
406F 0215	Error code generation/logging detected memory DIMM fault	Memory DIMM 19, riser 1 Location: U1.1-P1-M1.19
406F 0216	Error code generation/logging detected memory DIMM fault	Memory DIMM 20, riser 1 Location: U1.1-P1-M1.20
406F 0217	Error code generation/logging detected memory DIMM fault	Memory DIMM 27, riser 1 Location: U1.1-P1-M1.27
406F 0218	Error code generation/logging detected memory DIMM fault	Memory DIMM 28, riser 1 Location: U1.1-P1-M1.28
406F 021D	Error code generation/logging detected memory DIMM group fault	Memory octal B, riser 1 Location: U1.1-P1-M1.3 x8

Table 7. Service Processor Error Codes (continued)

Error Code	Description	Action/ Possible Failing FRU
406F 021E	Error code generation/logging detected memory DIMM group pair A fault	Memory quad B odd, riser 1 Location: U1.1-P1-M1.3 x4
406F 021F	Error code generation/logging detected memory DIMM group fault	Memory quad B even, riser 1 Location: U1.1-P1-M1.4 x4
406F 0221	Error code generation/logging detected memory DIMM fault	Memory DIMM 5, riser 1 Location: U1.1-P1-M1.5
406F 0222	Error code generation/logging detected memory DIMM fault	Memory DIMM 6, riser 1 Location: U1.1-P1-M1.6
406F 0223	Error code generation/logging detected memory DIMM fault	Memory DIMM 13, riser 1 Location: U1.1-P1-M1.13
406F 0224	Error code generation/logging detected memory DIMM fault	Memory DIMM 14, riser 1 Location: U1.1-P1-M1.14
406F 0225	Error code generation/logging detected memory DIMM fault	Memory DIMM 21, riser 1 Location: U1.1-P1-M1.21
406F 0226	Error code generation/logging detected memory DIMM fault	Memory DIMM 22, riser 1 Location: U1.1-P1-M1.22
406F 0227	Error code generation/logging detected memory DIMM fault	Memory DIMM 29, riser 1 Location: U1.1-P1-M1.29
406F 0228	Error code generation/logging detected memory DIMM fault	Memory DIMM 30, riser 1 Location: U1.1-P1-M1.30
406F 022D	Error code generation/logging detected memory DIMM group fault	Memory octal C, riser 1 Locations: U1.1-P1-M1.5 x8
406F 022E	Error code generation/logging detected memory DIMM group pair A fault	Memory quad C odd, riser 1 Locations: U1.1-P1-M1.5 x4
406F 022F	Error code generation/logging detected memory DIMM group fault	Memory quad C even, riser 1 Locations: U1.1-P1-M1.6 x4
406F 0231	Error code generation/logging detected memory DIMM fault	Memory DIMM 7, riser 1 Location: U1.1-P1-M1.7
406F 0232	Error code generation/logging detected memory DIMM fault	Memory DIMM 8, riser 1 Location: U1.1-P1-M1.8
406F 0233	Error code generation/logging detected memory DIMM fault	Memory DIMM 15, riser 1 Location: U1.1-P1-M1.15
406F 0234	Error code generation/logging detected memory DIMM fault	Memory DIMM 16, riser 1 Location: U1.1-P1-M1.16
406F 0235	Error code generation/logging detected memory DIMM fault	Memory DIMM 23, riser 1 Location: U1.1-P1-M1.23
406F 0236	Error code generation/logging detected memory DIMM fault	Memory DIMM 24, riser 1 Location: U1.1-P1-M1.24
406F 0237	Error code generation/logging detected memory DIMM fault	Memory DIMM 31, riser 1 Location: U1.1-P1-M1.31

Table 7. Service Processor Error Codes (continued)

Error Code	Description	Action/ Possible Failing FRU
406F 0238	Error code generation/logging detected memory DIMM fault	Memory DIMM 32, riser 1 Location: U1.1-P1-M1.32
406F 023D	Error code generation/logging detected memory DIMM group fault	Memory octal D, riser 1 Location: U1.1-P1-M1.7 x8
406F 023E	Error code generation/logging detected memory DIMM group fault	Memory quad D odd, riser 1 Location: U1.1-P1-M1.7 x4
406F 023F	Error code generation/logging detected memory DIMM group fault	Memory quad D even, riser 1 Location: U1.1-P1-M1.8 x4
406F 02FF	Error code generation/logging detected memory on riser fault	All memory on riser 1 Location: U1.1-P1-M1.1 x32 Memory failure on riser card 1 that cannot be automatically isolated. go to "MAP 1540: Minimum Configuration" on page 122 and run CEC drawer minimum configuration for further isolation.
406F 0300	Error code generation/logging detected processor card fault	Processor card Location: U1.1-P1-C1
406F 0400	Error code generation/logging detected processor card fault	Processor card Location: U1.1-P1-C2
406F 0500	Error code generation/logging detected memory riser card fault	Memory riser card 2 Location: U1.1-P1-M2
406F 0501	Error code generation/logging detected memory DIMM fault	Memory DIMM 1, riser 2 Location: U1.1-P1-M2.1
406F 0502	Error code generation/logging detected memory DIMM fault	Memory DIMM 2, riser 2 Location: U1.1-P1-M2.2
406F 0503	Error code generation/logging detected memory DIMM fault	Memory DIMM 9, riser 2 Location: U1.1-P1-M2.9
406F 0504	Error code generation/logging detected memory DIMM fault	Memory DIMM 10, riser 2 Location: U1.1-P1-M2.10
406F 0505	Error code generation/logging detected memory DIMM fault	Memory DIMM 17, riser 2 Location: U1.1-P1-M2.17
406F 0506	Error code generation/logging detected memory DIMM fault	Memory DIMM 18, riser 2 Location: U1.1-P1-M2.18
406F 0507	Error code generation/logging detected memory DIMM fault	Memory DIMM 25, riser 2 Location: U1.1-P1-M2.25
406F 0508	Error code generation/logging detected memory DIMM fault	Memory DIMM 26, riser 2 Location: U1.1-P1-M2.26
406F 050D	Error code generation/logging detected memory DIMM group fault	Memory octal A, riser 2 Location: U1.1-P1-M2.1 x8
406F 050E	Error code generation/logging detected memory DIMM group pair A fault	Memory quad A odd, riser 2 Location: U1.1-P1-M2.1 x4

Table 7. Service Processor Error Codes (continued)

<b>Error Code</b>	<b>Description</b>	<b>Action/ Possible Failing FRU</b>
406F 050F	Error code generation/logging detected memory DIMM group fault	Memory quad A even, riser 2 Location: U1.1-P1-M2.2 x4
406F 0511	Error code generation/logging detected memory DIMM fault	Memory DIMM 3, riser 2 Location: U1.1-P1-M2.3
406F 0512	Error code generation/logging detected memory DIMM fault	Memory DIMM 4, riser 2 Location: U1.1-P1-M2.4
406F 0513	Error code generation/logging detected memory DIMM fault	Memory DIMM 11, riser 2 Location: U1.1-P1-M2.11
406F 0514	Error code generation/logging detected memory DIMM fault	Memory DIMM 12, riser 2 Location: U1.1-P1-M2.12
406F 0515	Error code generation/logging detected memory DIMM fault	Memory DIMM 19, riser 2 Location: U1.1-P1-M2.19
406F 0516	Error code generation/logging detected memory DIMM fault	Memory DIMM 20, riser 2 Location: U1.1-P1-M2.20
406F 0517	Error code generation/logging detected memory DIMM fault	Memory DIMM 27, riser 2 Location: U1.1-P1-M2.27
406F 0518	Error code generation/logging detected memory DIMM fault	Memory DIMM 28, riser 2 Location: U1.1-P1-M2.28
406F 051D	Error code generation/logging detected memory DIMM group fault	Memory octal B, riser 2 Location: U1.1-P1-M2.3 x8
406F 051E	Error code generation/logging detected memory DIMM group fault	Memory quad B odd, riser 2 Location: U1.1-P1-M2.3 x4
406F 051F	Error code generation/logging detected memory DIMM group fault	Memory quad B even, riser 2 Location: U1.1-P1-M2.4 x4
406F 0521	Error code generation/logging detected memory DIMM fault	Memory DIMM 5, riser 2 Location: U1.1-P1-M2.5
406F 0522	Error code generation/logging detected memory DIMM fault	Memory DIMM 6, riser 2 Location: U1.1-P1-M2.6
406F 0523	Error code generation/logging detected memory DIMM fault	Memory DIMM 13, riser 2 Location: U1.1-P1-M2.13
406F 0524	Error code generation/logging detected memory DIMM fault	Memory DIMM 14, riser 2 Location: U1.1-P1-M2.14
406F 0525	Error code generation/logging detected memory DIMM fault	Memory DIMM 21, riser 2 Location: U1.1-P1-M2.21
406F 0526	Error code generation/logging detected memory DIMM fault	Memory DIMM 22, riser 2 Location: U1.1-P1-M2.22
406F 0527	Error code generation/logging detected memory DIMM fault	Memory DIMM 29, riser 2 Location: U1.1-P1-M2.29
406F 0528	Error code generation/logging detected memory DIMM fault	Memory DIMM 30, riser 2 Location: U1.1-P1-M2.30
406F 052D	Error code generation/logging detected memory DIMM group fault	Memory octal C, riser 2 Location: U1.1-P1-M2.5 x8

Table 7. Service Processor Error Codes (continued)

Error Code	Description	Action/ Possible Failing FRU
406F 052E	Error code generation/logging detected memory DIMM group pair A fault	Memory quad C odd, riser 2 Location: U1.1-P1-M2.5 x4
406F 052F	Error code generation/logging detected memory DIMM group fault	Memory quad C even, riser 2 Location: U1.1-P1-M2.6 x4
406F 0531	Error code generation/logging detected memory DIMM fault	Memory DIMM 7, riser 2 Location: U1.1-P1-M2.7
406F 0532	Error code generation/logging detected memory DIMM fault	Memory DIMM 8, riser 2 Location: U1.1-P1-M2.8
406F 0533	Error code generation/logging detected memory DIMM fault	Memory DIMM 15, riser 2 Location: U1.1-P1-M2.15
406F 0534	Error code generation/logging detected memory DIMM fault	Memory DIMM 16, riser 2 Location: U1.1-P1-M2.16
406F 0535	Error code generation/logging detected memory DIMM fault	Memory DIMM 23, riser 2 Location: U1.1-P1-M2.23
406F 0536	Error code generation/logging detected memory DIMM fault	Memory DIMM 24, riser 2 Location: U1.1-P1-M2.24
406F 0537	Error code generation/logging detected memory DIMM fault	Memory DIMM 31, riser 2 Location: U1.1-P1-M2.31
406F 0538	Error code generation/logging detected memory DIMM fault	Memory DIMM 32, riser 2 Location: U1.1-P1-M2.32
406F 053D	Error code generation/logging detected memory DIMM group fault	Memory octal D, riser 2 Location: U1.1-P1-M2.7 x8
406F 053E	Error code generation/logging detected memory DIMM group fault	Memory quad D odd, riser 2 Location: U1.1-P1-M2.7 x4
406F 053F	Error code generation/logging detected memory DIMM group fault	Memory quad D even, riser 2 Location: U1.1-P1-M2.8 x4
406F 05FF	Error code generation/logging detected memory on riser fault	Memory failure on riser card 2 that cannot be automatically isolated. go to "MAP 1540: Minimum Configuration" on page 122 and run CEC drawer minimum configuration for further isolation.
406F 0600	Error code generation/logging detected CEC RIO bus adapter	CEC RIO bus adapter Location: U1.1-P1.1
406F 0601	Error code generation/logging detected clock card fault	CEC clock card Location: U1.1-P1.1.1
406F 3101	Error code generation/logging detected RIO port 0 fault	CEC RIO bus adapter Location: U1.1-P1.1
406F 3102	Error code generation/logging detected RIO port 1 fault	CEC RIO bus adapter Location: U1.1-P1.1
406F 3103	Error code generation/logging detected RIO port 2 fault	CEC RIO bus adapter Location: U1.1-P1.1

Table 7. Service Processor Error Codes (continued)

Error Code	Description	Action/ Possible Failing FRU
406F 3104	Error code generation/logging detected RIO port 3 fault	CEC RIO bus adapter Location: U1.1-P1.1
406F 3121	Error code generation/logging detected RIO cable on port 0 fault	1. RIO cable on port 0 Location: U1.1-P1.1/Q1 2. CEC RIO bus adapter Location: U1.1-P1.1
406F 3122	Error code generation/logging detected RIO cable on port 1 fault	1. RIO cable on port 1 Location: U1.1-P1.1/Q2 2. CEC RIO bus adapter Location: U1.1-P1.1
406F 3123	Error code generation/logging detected RIO cable on port 2 fault	1. RIO cable on port 2 Location: U1.1-P1.1/Q3 2. CEC RIO bus adapter Location: U1.1-P1.1
406F 3124	Error code generation/logging detected RIO cable on port 3 fault	1. RIO cable on port 3 Location: U1.1-P1.1/Q4 2. CEC RIO bus adapter Location: U1.1-P1.1
406F 3140	Error code generation/logging detected RIO hub 0 fault	CEC RIO bus adapter Location: U1.1-P1.1
406F 3141	Error code generation/logging detected RIO hub 1 fault	CEC RIO bus adapter Location: U1.1-P1.1
406F 31FF	Error code generation/logging detected RIO port fault	CEC RIO bus adapter Location: U1.1-P1.1
406F 3200	Error code generation/logging detected primary I/O drawer fault	Go to "MAP 1540: Minimum Configuration" on page 122.
406F 3201	Error code generation/logging detected primary I/O drawer backplane fault	Primary I/O drawer backplane Location: U0.1-P1
406F 3280	Error code generation/logging detected primary RIO adapter fault	Primary RIO adapter Location: U0.1-P1.1
406F 3281	Error code generation/logging detected primary RIO port 0 fault	1. Check RIO cable Location: U0.1-P1.1/Q1 2. RIO bus adapter Location: U0.1-P1.1
406F 3282	Error code generation/logging detected primary RIO port 1 fault	1. Check RIO cable Location: U0.1-P1.1/Q2 2. RIO bus adapter Location: U0.1-P1.1
406F 3283	Error code generation/logging detected primary RIO ports fault	RIO bus adapter Location: U0.1-P1.1
406F 3284	Error code generation/logging detected PCI controller PHB0	1. RIO bus adapter Location: U0.1-P1.1 2. Primary I/O drawer backplane Location: U0.1-P1



Table 7. Service Processor Error Codes (continued)

Error Code	Description	Action/ Possible Failing FRU
406F 3285	Error code generation/logging detected PCI controller PHB1	1. RIO bus adapter Location: U0.1-P1.1 2. Primary I/O drawer backplane Location: U0.1-P1
406F 3286	Error code generation/logging detected PCI controller PHB2	1. RIO bus adapter Location: U0.1-P1.1 2. Primary I/O drawer backplane Location: U0.1-P1
4506 245B	Memory system and scan interface basic assurance tests detected 2W 4M processor fault	Processor card Locations: U1.1-P1-C1 U1.1-P1-C2
4506 245C	Memory system and scan interface basic assurance tests detected 2W 2M processor fault	Processor card Locations: U1.1-P1-C1 U1.1-P1-C2
4506 245D	Memory system and scan interface basic assurance tests detected 4W 4M processor fault	Processor card Locations: U1.1-P1-C1 U1.1-P1-C2
4506 248B	Memory system and scan interface basic assurance tests detected primary I/O drawer operator panel fault	Operator Panel Location: U0.1-L1
4506 24A5	Memory system and scan interface basic assurance tests detected 2W 500 MHz processor fault	Processor card Locations: U1.1-P1-C1 U1.1-P1-C2
4506 24A6	Memory system and scan interface basic assurance tests detected 4W 500 MHz processor fault	Processor card Locations: U1.1-P1-C1 U1.1-P1-C2
4506 25AB	Memory system and scan interface basic assurance tests detected 400 MHz clock fault	400 MHz clock Location: U1.1-P1.1.1
4506 25AD	Memory system and scan interface basic assurance tests detected 540 MHz clock fault	540 MHz clock Location: U1.1-P1.1.1
4506 25B1	Memory system and scan interface basic assurance tests detected 750 MHz clock fault	750 MHz clock Location: U1.1-P1.1.1
4506 25B3	Memory system and scan interface basic assurance tests detected 4W 750 MHz processor fault	Processor card Locations: U1.1-P1-C1 U1.1-P1-C2
4506 25B4	Memory system and scan interface basic assurance tests detected 2W 750 MHz processor fault	Processor card Locations: U1.1-P1-C1 U1.1-P1-C2
4506 25DA	Memory system and scan interface basic assurance tests detected 500 MHz clock fault	500 MHz clock Location: U1.1-P1.1.1

Table 7. Service Processor Error Codes (continued)

<b>Error Code</b>	<b>Description</b>	<b>Action/ Possible Failing FRU</b>
4506 267D	Memory system and scan interface basic assurance tests detected an 8W, 750 MHz regulator fault	8W regulator card Location: U1.1-P1-V1
4506 2687	Memory system and scan interface basic assurance tests detected remote I/O bus adapter fault	Remote I/O bus adapter Location: U0.1-P1.1
4506 271A	Memory system and scan interface basic assurance tests detected primary I/O planar fault	Primary I/O planar Location: U0.1-P1
4506 271D	Memory system and scan interface basic assurance tests detected secondary I/O planar fault	Secondary I/O planar Locations: U0.2-P1 U0.3-P1 U0.4-P1
4506 2733	Memory system and scan interface basic assurance tests detected I/O clock fault	CEC RIO bus adapter Location: U1.1-P1.1
4506 27AA	Memory system and scan interface basic assurance tests detected a 2W/4W regulator fault	2W/4W regulator card Location: U1.1-P1-V1
4506 27AB	Memory system and scan interface basic assurance tests detected an 8W regulator fault	8W regulator card Location: U1.1-P1-V1
4506 281C	Memory system and scan interface basic assurance tests detected CEC backplane fault	CEC backplane Location: U1.1-P1
4506 281D	Memory system and scan interface basic assurance tests detected Model 6M1 CEC backplane fault	CEC backplane Location: U1.1-P1
4506 285D	Memory system and scan interface basic assurance tests detected SPCN fan controller fault	1. SPCN fan controller Location: U0.1-X2 2. I/O drawer power distribution board Location: U0.1-X1
4506 288A	Memory system and scan interface basic assurance tests detected memory riser card fault	1. Go to the service processor Memory Configuration/Deconfiguration Menu to verify memory DIMMs state. See "Memory Configuration/Deconfiguration Menu" on page 426 for more information. 2. Memory riser card Locations: U1.1-P1-M1 U1.1-P1-M2

Table 7. Service Processor Error Codes (continued)

Error Code	Description	Action/ Possible Failing FRU
4506 300A	Memory system and scan interface basic assurance tests detected 32 MB DIMM fault	Memory DIMM Locations: U1.1-P1-M1.n U1.1-P1-M2.n
4506 300B	Memory system and scan interface basic assurance tests detected 128 MB DIMM fault	Memory DIMM Locations: U1.1-P1-M1.n U1.1-P1-M2.n
4506 300C	Memory system and scan interface basic assurance tests detected 256 MB DIMM fault	Memory DIMM Locations: U1.1-P1-M1.n U1.1-P1-M2.n
4506 300D	Memory system and scan interface basic assurance tests detected 512 MB (stacked) DIMM fault	Memory DIMM Locations: U1.1-P1-M1.n U1.1-P1-M2.n
4506 300E	Memory system and scan interface basic assurance tests detected 512 MB (unstacked) DIMM fault	Memory DIMM Locations: U1.1-P1-M1.n U1.1-P1-M2.n
4506 301F	Memory system and scan interface basic assurance tests detected 128 MB DIMM fault	Memory DIMM Locations: U1.1-P1-M1.n U1.1-P1-M2.n
4506 303A	Memory system and scan interface basic assurance tests detected 1 GB DIMM fault	Memory DIMM Locations: U1.1-P1-M1.n U1.1-P1-M2.n
4506 515B	Memory system and scan interface basic assurance tests detected 1100W ac power supply fault	1100W ac power supply Locations: U1.1-V1 U1.1-V2
4506 51ac	Memory system and scan interface basic assurance tests detected 595W ac power supply fault	595W ac power supply Locations: U0.1-V1 U0.1-V2
4506 51AD	Memory system and scan interface basic assurance tests detected 595W dc power supply fault	595W dc power supply Locations: U0.1-V1 U0.1-V2
4506 51AE	Memory system and scan interface basic assurance tests detected 1100W dc power supply fault	1100W dc power supply Locations: U1.1-V1 U1.1-V2
4507 245B	Memory system and 6xx bus processor runtime diagnostics detected 2W/4M processor fault	Go to the service processor Processor Configuration/Deconfiguration Menu to check the states of the processors. See "Processor Configuration/Deconfiguration Menu" on page 425 for more information. Replace the card that has the bad processors. Locations: U1.1-P1-C1 U1.1-P1-C2

Table 7. Service Processor Error Codes (continued)

Error Code	Description	Action/ Possible Failing FRU
4507 245C	Memory system and 6xx bus processor runtime diagnostics detected 2W 2M processor fault	Go to the service processor Processor Configuration/Deconfiguration Menu to check the states of the processors. See "Processor Configuration/Deconfiguration Menu" on page 425 for more information. Replace the card that has the bad processors. Locations: U1.1-P1-C1 U1.1-P1-C2
4507 245D	Memory system and 6xx bus processor runtime diagnostics detected 4W 4M processor fault	1. Go to the service processor Processor Configuration/Deconfiguration Menu to check the states of the processors. See "Processor Configuration/Deconfiguration Menu" on page 425 for more information. Replace the card that has the bad processors. Locations: U1.1-P1-C1 U1.1-P1-C2
4507 248B	Memory system and 6xx bus processor runtime diagnostics detected primary I/O drawer operator panel fault	Operator panel Location: U0.1-L1
4507 24A5	Memory system and scan interface basic assurance tests detected 2W 500 MHz processor fault	1. Go to the service processor Processor Configuration/Deconfiguration Menu to check the states of the processors. See "Processor Configuration/Deconfiguration Menu" on page 425 for more information. Replace the card that has the bad processors. Locations: U1.1-P1-C1 U1.1-P1-C2
4507 24A6	Memory system and scan interface basic assurance tests detected 4W 500 MHz processor fault	1. Go to the service processor Processor Configuration/Deconfiguration Menu to check the states of the processors. See "Processor Configuration/Deconfiguration Menu" on page 425 for more information. Replace the card that has the bad processors. Locations: U1.1-P1-C1 U1.1-P1-C2

Table 7. Service Processor Error Codes (continued)

Error Code	Description	Action/ Possible Failing FRU
4507 25AB	Memory system and 6xx bus processor runtime diagnostics detected 400 MHz clock fault	400 MHz clock Location: U1.1-P1.1.1
4507 25AD	Memory system and 6xx bus processor runtime diagnostics detected 540 MHz clock fault	540 MHz clock Location: U1.1-P1.1.1
4507 25B1	Memory system and 6xx bus processor runtime diagnostics detected 750 MHz clock fault	750 MHz clock Location: U1.1-P1.1.1
4507 25B3	Memory system and scan interface basic assurance tests detected 4W 750 MHz processor fault	1. Go to the service processor Processor Configuration/Deconfiguration Menu to check the states of the processors. See "Processor Configuration/Deconfiguration Menu" on page 425 for more information. Replace the card that has the bad processors. Locations: U1.1-P1-C1 U1.1-P1-C2
4507 25B4	Memory system and scan interface basic assurance tests detected 2W 750 MHz processor fault	1. Go to the service processor Processor Configuration/Deconfiguration Menu to check the states of the processors. See "Processor Configuration/Deconfiguration Menu" on page 425 for more information. Replace the card that has the bad processors. Locations: U1.1-P1-C1 U1.1-P1-C2
4507 25DA	Memory system and 6xx bus processor runtime diagnostics detected 500 MHz clock fault	500 MHz clock Location: U1.1-P1.1.1
4507 267D	Memory system and 6xx bus processor runtime diagnostics detected an 8W, 750 MHz regulator fault	8W regulator card Location: U1.1-P1-V1
4507 2687	Memory system and 6xx bus processor runtime diagnostics detected remote I/O bus adapter fault	Remote I/O bus adapter Location: U0.1-P1.1
4507 271A	Memory system and 6xx bus processor runtime diagnostics detected primary I/O backplane fault	Primary I/O backplane Location: U0.1-P1

Table 7. Service Processor Error Codes (continued)

Error Code	Description	Action/ Possible Failing FRU
4507 271D	Memory system and 6xx bus processor runtime diagnostics detected secondary I/O backplane fault	Secondary I/O backplane Locations: U0.2-P1 U0.3-P1 U0.4-P1
4507 2733	Memory system and 6xx bus processor runtime diagnostics detected I/O clock fault	CEC RIO bus adapter Location: U1.1-P1.1
4507 27AA	Memory system and 6xx bus processor runtime diagnostics detected a 2W/4W regulator fault	2W/4W regulator card Location: U1.1-P1-V1
4507 27AB	Memory system and 6xx bus processor runtime diagnostics detected an 8W regulator fault	8W regulator card Location: U1.1-P1-V1
4507 281C	Memory system and 6xx bus processor runtime diagnostics detected CEC backplane fault	CEC backplane Location: U1.1-P1
4507 281D	Memory system and 6xx bus processor runtime diagnostics detected Model 6M1 CEC backplane fault	CEC backplane Location: U1.1-P1
4507 285D	Memory system and 6xx bus processor runtime diagnostics detected SPCN fan controller fault	1. SPCN fan controller Location: U0.1-X2 2. I/O Drawer Power Distribution Board Location: U0.1-X1
4507 288A	Memory system and 6xx bus PRD detected memory riser card fault	1. Go to the service processor Memory Configuration/Deconfiguration Menu to verify memory DIMMs state. See "Memory Configuration/Deconfiguration Menu" on page 426 for more information. 2. Memory riser card Locations: U1.1-P1-M1 U1.1-P1-M2
4507 300A	Memory system and 6xx bus processor runtime diagnostics detected 32 MB DIMM fault	Memory DIMM Locations: U1.1-P1-M1.n U1.1-P1-M2.n
4507 300B	Memory system and 6xx bus processor runtime diagnostics detected 128 MB DIMM fault	Memory DIMM Locations: U1.1-P1-M1.n U1.1-P1-M2.n
4507 300C	Memory system and 6xx bus processor runtime diagnostics detected 256 MB DIMM fault	Memory DIMM Locations: U1.1-P1-M1.n U1.1-P1-M2.n

Table 7. Service Processor Error Codes (continued)

<b>Error Code</b>	<b>Description</b>	<b>Action/ Possible Failing FRU</b>
4507 300D	Memory system and 6xx bus processor runtime diagnostics detected 512 MB (stacked) DIMM fault	Memory DIMM Locations: U1.1-P1-M1.n U1.1-P1-M2.n
4507 300E	Memory system and 6xx bus processor runtime diagnostics detected 512 MB (unstacked) DIMM fault	Memory DIMM Locations: U1.1-P1-M1.n U1.1-P1-M2.n
4507 301F	Memory system and 6xx bus processor runtime diagnostics detected 128 MB DIMM fault	Memory DIMM Locations: U1.1-P1-M1.n U1.1-P1-M2.n
4507 303A	Memory system and 6xx bus processor runtime diagnostics detected 1 GB DIMM fault	Memory DIMM Locations: U1.1-P1-M1.n U1.1-P1-M2.n
4507 515B	Memory system and 6xx bus processor runtime diagnostics detected 1100W ac power supply fault	1100W ac power supply Locations: U1.1-V1 U1.1-V2
4507 51AC	Memory system and 6xx bus processor runtime diagnostics detected 595W ac power supply fault	595W ac power supply Locations: U0.1-V1 U0.1-V2
4507 51AD	Memory system and 6xx bus processor runtime diagnostics detected 595W dc power supply fault	595W dc power supply Locations: U0.1-V1 U0.1-V2
4507 51AE	Memory system and 6xx bus processor runtime diagnostics detected 1100W dc power supply fault	1100W dc power supply Locations: U1.1-V1 U1.1-V2
4508 245B	Memory system and other bus processor runtime diagnostics detected 2W 4M processor fault	Processor card Locations: U1.1-P1-C1 U1.1-P1-C2
4508 245C	Memory system and other bus processor runtime diagnostics detected 2W 2M processor fault	Processor card Locations: U1.1-P1-C1 U1.1-P1-C2
4508 245D	Memory system and other bus processor runtime diagnostics detected 4W 4M processor fault	Processor card Locations: U1.1-P1-C1 U1.1-P1-C2d
4508 248B	Memory system and other bus processor runtime diagnostics detected primary I/O drawer operator panel fault	Operator Panel Location: U0.1-L1
4508 24A5	Memory system and other bus processor runtime diagnostics detected 2W 500 MHz processor fault	Processor card Locations: U1.1-P1-C1 U1.1-P1-C2d

Table 7. Service Processor Error Codes (continued)

<b>Error Code</b>	<b>Description</b>	<b>Action/ Possible Failing FRU</b>
4508 24A6	Memory system and other bus processor runtime diagnostics detected 4W 500 MHz processor fault	Processor card Locations: U1.1-P1-C1 U1.1-P1-C2d
4508 25AB	Memory system and other bus processor runtime diagnostics detected 400 MHz clock fault	400 MHz clock Location: U1.1-P1.1.1
4508 25AD	Memory system and other bus processor runtime diagnostics detected 540 MHz clock fault	540 MHz clock Location: U1.1-P1.1.1
4508 25B1	Memory system and other bus processor runtime diagnostics detected 750 MHz clock fault	540 MHz clock Location: U1.1-P1.1.1
4508 25B3	Memory system and other bus processor runtime diagnostics detected 4W 750 MHz processor fault	Processor card Locations: U1.1-P1-C1 U1.1-P1-C2
4508 25B4	Memory system and other bus processor runtime diagnostics detected 2W 750 MHz processor fault	Processor card Locations: U1.1-P1-C1 U1.1-P1-C2
4508 25DA	Memory system and other bus processor runtime diagnostics detected 500 MHz clock fault	750 MHz clock Location: U1.1-P1.1.1
4508 267D	Memory system and other bus processor runtime diagnostics detected an 8W, 750 MHz regulator fault	8W regulator card Location: U1.1-P1-V1
4508 2687	Memory system and other bus processor runtime diagnostics detected remote I/O bus adapter fault	Remote I/O bus adapter Location: U0.1-P1.1
4508 271A	Memory system and other bus processor runtime diagnostics detected primary I/O planar fault	Primary I/O planar Location: U0.1-P1
4508 271D	Memory system and other bus processor runtime diagnostics detected secondary I/O planar fault	Secondary I/O planar Locations: U0.2-P1 U0.3-P1 U0.4-P1
4508 2733	Memory system and other bus processor runtime diagnostics detected I/O clock fault	CEC RIO bus adapter Location: U1.1-P1.1
4508 27AA	Memory system and other bus processor runtime diagnostics detected a 2W/4W regulator fault	2W/4W regulator card Location: U1.1-P1-V1



Table 7. Service Processor Error Codes (continued)

Error Code	Description	Action/ Possible Failing FRU
4508 27AB	Memory system and other bus processor runtime diagnostics detected an 8W regulator fault	8W regulator card Location: U1.1-P1-V1
4508 281C	Memory system and other bus processor runtime diagnostics detected CEC backplane fault	CEC backplane Location: U1.1-P1
4508 281D	Memory system and other bus processor runtime diagnostics detected Model 6M1 CEC backplane fault	CEC backplane Location: U1.1-P1
4508 285D	Memory system and other bus processor runtime diagnostics detected SPCN fan controller fault	1. SPCN fan controller Location: U0.1-X2 2. I/O drawer power distribution board Location: U0.1-X1
4508 288A	Memory system and other bus processor runtime diagnostics detected memory riser card fault	1. Go to the service processor Memory Configuration/Deconfiguration Menu to verify memory DIMMs state. See "Memory Configuration/Deconfiguration Menu" on page 426 for more information. 2. Memory riser card Locations: U1.1-P1-M1 U1.1-P1-M2
4508 300A	Memory system and other bus processor runtime diagnostics detected 32 MB DIMM fault	Memory DIMM Locations: U1.1-P1-M1.n U1.1-P1-M2.n
4508 300B	Memory system and other bus processor runtime diagnostics detected 128 MB DIMM fault	Memory DIMM Locations: U1.1-P1-M1.n U1.1-P1-M2.n
4508 300C	Memory system and other bus processor runtime diagnostics detected 256 MB DIMM fault	Memory DIMM Locations: U1.1-P1-M1.n U1.1-P1-M2.n
4508 300D	Memory system and other bus processor runtime diagnostics detected 512 MB (stacked) DIMM fault	Memory DIMM Locations: U1.1-P1-M1.n U1.1-P1-M2.n
4508 300E	Memory system and other bus processor runtime diagnostics detected 512 MB (unstacked) DIMM fault	Memory DIMM Locations: U1.1-P1-M1.n U1.1-P1-M2.n
4508 301F	Memory system and other bus processor runtime diagnostics detected 128 MB DIMM fault	Memory DIMM Locations: U1.1-P1-M1.n U1.1-P1-M2.n

Table 7. Service Processor Error Codes (continued)

Error Code	Description	Action/ Possible Failing FRU
4508 303A	Memory system and other bus processor runtime diagnostics detected 1 GB DIMM fault	Memory DIMM Locations: U1.1-P1-M1.n U1.1-P1-M2.n
4508 515B	Memory system and other bus processor runtime diagnostics detected 1100W ac power supply fault	1100W ac power supply Locations: U1.1-V1 U1.1-V2
4508 51AC	Memory system and other bus processor runtime diagnostics detected 595W ac power supply fault	595W ac power supply Locations: U0.1-V1 U0.1-V2
4508 51AD	Memory system and other bus processor runtime diagnostics detected 595W dc power supply fault	595W dc power supply Locations: U0.1-V1 U0.1-V2
4508 51AE	Memory system and other bus processor runtime diagnostics detected 1100W dc power supply fault	1100W dc power supply Locations: U1.1-V1 U1.1-V2
4509 245B	Memory system and memory test detected 2W 4M processor fault	Processor card Locations: U1.1-P1-C1 U1.1-P1-C2
4509 245C	Memory system and memory test detected 2W 2M processor fault	Processor card Locations: U1.1-P1-C1 U1.1-P1-C2
4509 245D	Memory system and memory test detected 4W 4M processor fault	Processor card Locations: U1.1-P1-C1 U1.1-P1-C2
4509 248B	Memory system and memory test detected primary I/O drawer operator panel fault	Operator Panel Location: U0.1-L1
4509 24A5	Memory system and memory test detected 2W 500 MHz processor fault	Processor card Locations: U1.1-P1-C1 U1.1-P1-C2
4509 24A6	Memory system and memory test detected 4W 500 MHz processor fault	Processor card Locations: U1.1-P1-C1 U1.1-P1-C2
4509 25AB	Memory system and memory test detected 400 MHz clock fault	400 MHz clock Location: U1.1-P1.1.1
4509 25AD	Memory system and memory test detected 540 MHz clock fault	540 MHz clock Location: U1.1-P1.1.1
4509 25B1	Memory system and memory test detected 750 MHz clock fault	750 MHz clock Location: U1.1-P1.1.1
4509 25B3	Memory system and memory test detected 4W 750 MHz processor fault	Processor card Locations: U1.1-P1-C1 U1.1-P1-C2

Table 7. Service Processor Error Codes (continued)

Error Code	Description	Action/ Possible Failing FRU
4509 25B4	Memory system and memory test detected 2W 750 MHz processor fault	Processor card Locations: U1.1-P1-C1 U1.1-P1-C2
4509 25DA	Memory system and memory test detected 500 MHz clock fault	500 MHz clock Location: U1.1-P1.1.1
4509 267D	Memory system and memory test detected an 8W, 750 MHz regulator fault	8W regulator card Location: U1.1-P1-V1
4509 2687	Memory system and memory test detected remote I/O bus adapter fault	Remote I/O bus adapter Location: U0.1-P1.1
4509 271A	Memory system and memory test detected primary I/O planar fault	Primary I/O planar Location: U0.1-P1
4509 271D	Memory system and memory test detected secondary I/O planar fault	Secondary I/O planar Locations: U0.2-P1 U0.3-P1 U0.4-P1
4509 2733	Memory system and memory test detected I/O clock fault	CEC RIO bus adapter Location: U1.1-P1.1
4509 27AA	Memory system and memory test detected a 2W/4W regulator fault	2W/4W regulator card Location: U1.1-P1-V1
4509 27AB	Memory system and memory test detected an 8W regulator fault	8W regulator card Location: U1.1-P1-V1
4509 281C	Memory system and memory test detected CEC backplane fault	CEC backplane Location: U1.1-P1
4509 281D	Memory system and memory test detected Model 6M1 CEC backplane fault	CEC backplane Location: U1.1-P1
4509 285D	Memory system and memory test detected SPCN fan controller fault	1. SPCN fan controller Location: U0.1-X2 2. I/O drawer power distribution board Location: U0.1-X1
4509 288A	Memory system and memory test detected memory riser card fault	1. Go to the service processor Memory Configuration/Deconfiguration Menu to verify memory DIMMs state. See "Memory Configuration/Deconfiguration Menu" on page 426 for more information. 2. Memory riser card Locations: U1.1-P1-M1 U1.1-P1-M2

Table 7. Service Processor Error Codes (continued)

Error Code	Description	Action/ Possible Failing FRU
4509 300A	Memory system and memory test detected 32 MB DIMM fault	Memory DIMM Locations: U1.1-P1-M1.n U1.1-P1-M2.n
4509 300B	Memory system and memory test detected 128 MB DIMM fault	Memory DIMM Locations: U1.1-P1-M1.n U1.1-P1-M2.n
4509 300C	Memory system and memory test detected 256 MB DIMM fault	Memory DIMM Locations: U1.1-P1-M1.n U1.1-P1-M2.n
4509 300D	Memory system and memory test detected 512 MB (stacked) DIMM fault	Memory DIMM Locations: U1.1-P1-M1.n U1.1-P1-M2.n
4509 300E	Memory system and memory test detected 512 MB (unstacked) DIMM fault	Memory DIMM Locations: U1.1-P1-M1.n U1.1-P1-M2.n
4509 301F	Memory system and memory test detected 128 MB DIMM fault	Memory DIMM Locations: U1.1-P1-M1.n U1.1-P1-M2.n
4509 303A	Memory system and memory test detected 1 GB DIMM fault	Memory DIMM Locations: U1.1-P1-M1.n U1.1-P1-M2.n
4509 515B	Memory system and memory test detected 1100W ac power supply fault	1100W ac power supply Locations: U1.1-V1 U1.1-V2
4509 51AC	Memory system and memory test detected 595W ac power supply fault	595W ac power supply Locations: U0.1-V1 U0.1-V2
4509 51AD	Memory system and memory test detected 595W dc power supply fault	595W dc power supply Locations: U0.1-V1 U0.1-V2
4509 51AE	Memory system and memory test detected 1100W dc power supply fault	1100W dc power supply Locations: U1.1-V1 U1.1-V2
450A 245B	Memory system and self test detected 2W 4M processor fault	Processor card Locations: U1.1-P1-C1 U1.1-P1-C2
450A 245C	Memory system and self test detected 2W 2M processor fault	Processor card Locations: U1.1-P1-C1 U1.1-P1-C2
450A 245D	Memory system and self test detected 4W 4M processor fault	Processor card Locations: U1.1-P1-C1 U1.1-P1-C2
450A 248B	Memory system and self test detected primary I/O drawer operator panel fault	Operator Panel Location: U0.1-L1

Table 7. Service Processor Error Codes (continued)

<b>Error Code</b>	<b>Description</b>	<b>Action/ Possible Failing FRU</b>
450A 24A5	Memory system and self test detected 2W 500 MHz processor fault	Processor card Locations: U1.1-P1-C1 U1.1-P1-C2
450A 24A6	Memory system and self test detected 4W 500 MHz processor fault	Processor card Locations: U1.1-P1-C1 U1.1-P1-C2
450A 25AB	Memory system and self test detected 400 MHz clock fault	400 MHz clock Location: U1.1-P1.1.1
450A 25AD	Memory system and self test detected 540 MHz clock fault	540 MHz clock Location: U1.1-P1.1.1
450A 25B1	Memory system and self test detected 750 MHz clock fault	750 MHz clock Location: U1.1-P1.1.1
450A 25B3	Memory system and self test detected 4W 750 MHz processor fault	Processor card Locations: U1.1-P1-C1 U1.1-P1-C2
450A 25B4	Memory system and self test detected 2W 750 MHz processor fault	Processor card Locations: U1.1-P1-C1 U1.1-P1-C2
450A 25DA	Memory system and self test detected 500 MHz clock fault	500 MHz clock Location: U1.1-P1.1.1
450A 267D	Memory system and self test detected an 8W, 750 MHz regulator fault	8W regulator card Location: U1.1-P1-V1
450A 2687	Memory system and self test detected remote I/O bus adapter fault	Remote I/O bus adapter Location: U0.1-P1.1
450A 271A	Memory system and self test detected primary I/O planar fault	Primary I/O planar Location: U0.1-P1
450A 271D	Memory system and self test detected secondary I/O planar fault	Secondary I/O planar Locations: U0.2-P1 U0.3-P1 U0.4-P1
450A 2733	Memory system and self test detected I/O clock fault	CEC RIO bus adapter Location: U1.1-P1.1
450A 27AA	Memory system and self test detected a 2W/4W regulator fault	2W/4W regulator card Location: U1.1-P1-V1
450A 27AB	Memory system and self test detected an 8W regulator fault	8W regulator card Location: U1.1-P1-V1
450A 281C	Memory system and self test detected CEC backplane fault	CEC backplane Location: U1.1-P1
450A 281D	Memory system and self test detected Model 6M1 CEC backplane fault	CEC backplane Location: U1.1-P1

Table 7. Service Processor Error Codes (continued)

Error Code	Description	Action/ Possible Failing FRU
450A 285D	Memory system and self test detected SPCN fan controller fault	<ol style="list-style-type: none"> <li>SPCN fan controller Location: U0.1-X2</li> <li>I/O drawer power distribution board Location: U0.1-X1</li> </ol>
450A 288A	Memory system and self test detected memory riser card fault	<ol style="list-style-type: none"> <li>Go to the service processor Memory Configuration/Deconfiguration Menu to verify memory DIMMs state. See "Memory Configuration/Deconfiguration Menu" on page 426 for more information.</li> <li>Memory riser card Locations: U1.1-P1-M1 U1.1-P1-M2</li> </ol>
450A 300A	Memory system and self test detected 32 MB DIMM fault	Memory DIMM Locations: U1.1-P1-M1.n U1.1-P1-M2.n
450A 300B	Memory system and self test detected 128 MB DIMM fault	Memory DIMM Locations: U1.1-P1-M1.n U1.1-P1-M2.n
450A 300C	Memory system and self test detected 256 MB DIMM fault	Memory DIMM Locations: U1.1-P1-M1.n U1.1-P1-M2.n
450A 300D	Memory system and self test detected 512 MB (stacked) DIMM fault	Memory DIMM Locations: U1.1-P1-M1.n U1.1-P1-M2.n
450A 300E	Memory system and self test detected 512 MB (unstacked) DIMM fault	Memory DIMM Locations: U1.1-P1-M1.n U1.1-P1-M2.n
450A 301F	Memory system and self test detected 128 MB DIMM fault	Memory DIMM Locations: U1.1-P1-M1.n U1.1-P1-M2.n
450A 303A	Memory system and self test detected 1 GB DIMM fault	Memory DIMM Locations: U1.1-P1-M1.n U1.1-P1-M2.n
450A 515B	Memory system and self test detected 1100W ac power supply fault	1100W ac power supply Locations: U1.1-V1 U1.1-V2
450A 51AC	Memory system and self test detected 595W ac power supply fault	595W ac power supply Locations: U0.1-V1 U0.1-V2
450A 51AD	Memory system and self test detected 595W dc power supply fault	595W dc power supply Locations: U0.1-V1 U0.1-V2

Table 7. Service Processor Error Codes (continued)

<b>Error Code</b>	<b>Description</b>	<b>Action/ Possible Failing FRU</b>
450A 51AE	Memory system and self test detected 1100W dc power supply fault	1100W dc power supply Locations: U1.1-V1 U1.1-V2
450B 245B	Memory system and wire test detected 2W 4M processor fault	Processor card Locations: U1.1-P1-C1 U1.1-P1-C2
450B 245C	Memory system and wire test detected 2W 2M processor fault	Processor card Locations: U1.1-P1-C1 U1.1-P1-C2
450B 245D	Memory system and wire test detected 4W 4M processor fault	Processor card Locations: U1.1-P1-C1 U1.1-P1-C2
450B 248B	Memory system and wire test detected primary I/O drawer operator panel fault	Operator Panel Location: U0.1-L1
450B 24A5	Memory system and wire test detected 2W 500 MHz processor fault	Processor card Locations: U1.1-P1-C1 U1.1-P1-C2
450B 24A6	Memory system and wire test detected 4W 500 MHz processor fault	Processor card Locations: U1.1-P1-C1 U1.1-P1-C2
450B 25AB	Memory system and wire test detected 400 MHz clock fault	400 MHz clock Location: U1.1-P1.1.1
450B 25AD	Memory system and wire test detected 540 MHz clock fault	540 MHz clock Location: U1.1-P1.1.1
450B 25B1	Memory system and wire test detected 750 MHz clock fault	750 MHz clock Location: U1.1-P1.1.1
450B 25B3	Memory system and wire test detected 4W 750 MHz processor fault	Processor card Locations: U1.1-P1-C1 U1.1-P1-C2
450B 25B4	Memory system and wire test detected 2W 750 MHz processor fault	Processor card Locations: U1.1-P1-C1 U1.1-P1-C2
450B 25DA	Memory system and wire test detected 500 MHz clock fault	500 MHz clock Location: U1.1-P1.1.1
450B 267D	Memory system and wire test detected an 8W, 750 MHz regulator fault	8W regulator card Location: U1.1-P1-V1
450B 2687	Memory system and wire test detected remote I/O bus adapter fault	Remote I/O bus adapter Location: U0.1-P1.1
450B 271A	Memory system and wire test detected primary I/O backplane fault	Primary I/O backplane Location: U0.1-P1

Table 7. Service Processor Error Codes (continued)

Error Code	Description	Action/ Possible Failing FRU
450B 271D	Memory system and wire test detected secondary I/O backplane fault	Secondary I/O backplane Locations: U0.2-P1 U0.3-P1 U0.4-P1
450B 2733	Memory system and wire test detected I/O clock fault	CEC RIO bus adapter Location: U1.1-P1.1
450B 27AA	Memory system and wire test detected a 2W/4W regulator fault	2W/4W regulator card Location: U1.1-P1-V1
450B 27AB	Memory system and wire test detected an 8W regulator fault	8W regulator card Location: U1.1-P1-V1
450B 281C	Memory system and wire test detected CEC backplane fault	CEC backplane Location: U1.1-P1
450B 281D	Memory system and wire test detected Model 6M1 CEC backplane fault	CEC backplane Location: U1.1-P1
450B 285D	Memory system and wire test detected SPCN fan controller fault	1. SPCN fan controller Location: U0.1-X2 2. I/O drawer power distribution board Location: U0.1-X1
450B 288A	Memory system and wire test detected memory riser card fault	1. Go to the service processor Memory Configuration/Deconfiguration Menu to verify memory DIMMs state. See "Memory Configuration/Deconfiguration Menu" on page 426 for more information. 2. Memory riser card Locations: U1.1-P1-M1 U1.1-P1-M2
450B 300A	Memory system and wire test detected 32 MB DIMM fault	Memory DIMM Locations: U1.1-P1-M1.n U1.1-P1-M2.n
450B 300B	Memory system and wire test detected 128 MB DIMM fault	Memory DIMM Locations: U1.1-P1-M1.n U1.1-P1-M2.n
450B 300C	Memory system and wire test detected 256 MB DIMM fault	Memory DIMM Locations: U1.1-P1-M1.n U1.1-P1-M2.n
450B 300D	Memory system and wire test detected 512 MB (stacked) DIMM fault	Memory DIMM Locations: U1.1-P1-M1.n U1.1-P1-M2.n
450B 300E	Memory system and wire test detected 512 MB (unstacked) DIMM fault	Memory DIMM Locations: U1.1-P1-M1.n U1.1-P1-M2.n



Table 7. Service Processor Error Codes (continued)

Error Code	Description	Action/ Possible Failing FRU
450B 301F	Memory system and wire test detected 128 MB DIMM fault	Memory DIMM Locations: U1.1-P1-M1.n U1.1-P1-M2.n
450B 303A	Memory system and wire test detected 1 GB DIMM fault	Memory DIMM Locations: U1.1-P1-M1.n U1.1-P1-M2.n
450B 515B	Memory system and wire test detected 1100W ac power supply fault	1100W ac power supply Locations: U1.1-V1 U1.1-V2
450B 51AC	Memory system and wire test detected 595W ac power supply fault	595W ac power supply Locations: U0.1-V1 U0.1-V2
450B 51AD	Memory system and wire test detected 595W dc power supply fault	595W dc power supply Locations: U0.1-V1 U0.1-V2
450B 51AE	Memory system and wire test detected 1100W dc power supply fault	1100W dc power supply Locations: U1.1-V1 U1.1-V2
450C 245B	Memory system and IPL MOPS detected 2W 4M processor fault	Processor card Locations: U1.1-P1-C1 U1.1-P1-C2
450C 245C	Memory system and IPL MOPS detected 2W 2M processor fault	Processor card Locations: U1.1-P1-C1 U1.1-P1-C2
450C 245D	Memory system and IPL MOPS detected 4W 4M processor fault	Processor card Locations: U1.1-P1-C1 U1.1-P1-C2
450C 248B	Memory system and IPL MOPS detected primary I/O drawer operator panel fault	Operator Panel Location: U0.1-L1
450C 24A5	Memory system and IPL MOPS detected 2W 500 MHz processor fault	Processor card Locations: U1.1-P1-C1 U1.1-P1-C2
450C 24A6	Memory system and IPL MOPS detected 4W 500 MHz processor fault	Processor card Locations: U1.1-P1-C1 U1.1-P1-C2
450C 25AB	Memory system and IPL MOPS detected 400 MHz clock fault	400 MHz clock Location: U1.1-P1.1.1
450C 25AD	Memory system and IPL MOPS detected 540 MHz clock fault	540 MHz clock Location: U1.1-P1.1.1
450C 25B1	Memory system and IPL MOPS detected 750 MHz clock fault	750 MHz clock Location: U1.1-P1.1.1

Table 7. Service Processor Error Codes (continued)

<b>Error Code</b>	<b>Description</b>	<b>Action/ Possible Failing FRU</b>
450C 25B3	Memory system and IPL MOPS detected 4W 750 MHz processor fault	Processor card Locations: U1.1-P1-C1 U1.1-P1-C2
450C 25B4	Memory system and IPL MOPS detected 2W 750 MHz processor fault	Processor card Locations: U1.1-P1-C1 U1.1-P1-C2
450C 25DA	Memory system and IPL MOPS detected 500 MHz clock fault	500 MHz clock Location: U1.1-P1.1.1
450C 267D	Memory system and IPL MOPS detected an 8W, 750 MHz regulator fault	8W regulator card Location: U1.1-P1-V1
450C 2687	Memory system and IPL MOPS detected remote I/O bus adapter fault	Remote I/O bus adapter Location: U0.1-P1.1
450C 271A	Memory system and IPL MOPS detected primary I/O planar fault	Primary I/O planar Location: U0.1-P1
450C 271D	Memory system and IPL MOPS detected secondary I/O planar fault	Secondary I/O planar Locations: U0.2-P1 U0.3-P1 U0.4-P1
450C 2733	Memory system and IPL MOPS detected I/O clock fault	CEC RIO bus adapter Location: U1.1-P1.1
450C 27AA	Memory system and IPL MOPS detected a 2W/4W regulator fault	2W/4W regulator card Location: U1.1-P1-V1
450C 27AB	Memory system and IPL MOPS detected an 8W regulator fault	8W regulator card Location: U1.1-P1-V1
450C 281C	Memory system and IPL MOPS detected CEC backplane fault	CEC backplane Location: U1.1-P1
450C 281D	Memory system and IPL MOPS detected Model 6M1 CEC backplane fault	CEC backplane Location: U1.1-P1
450C 285D	Memory system and IPL MOPS detected SPCN fan controller fault	1. SPCN fan controller Location: U0.1-X2 2. I/O drawer power distribution board Location: U0.1-X1

Table 7. Service Processor Error Codes (continued)

Error Code	Description	Action/ Possible Failing FRU
450C 288A	Memory system and IPL MOPS detected memory riser card fault	<ol style="list-style-type: none"> <li>Go to the service processor Memory Configuration/Deconfiguration Menu to verify memory DIMMs state. See "Memory Configuration/Deconfiguration Menu" on page 426 for more information.</li> <li>Memory riser card Locations: U1.1-P1-M1 U1.1-P1-M2</li> </ol>
450C 300A	Memory system and IPL MOPS detected 32 MB DIMM fault	Memory DIMM Locations: U1.1-P1-M1.n U1.1-P1-M2.n
450C 300B	Memory system and IPL MOPS detected 128 MB DIMM fault	Memory DIMM Locations: U1.1-P1-M1.n U1.1-P1-M2.n
450C 300C	Memory system and IPL MOPS detected 256 MB DIMM fault	Memory DIMM Locations: U1.1-P1-M1.n U1.1-P1-M2.n
450C 300D	Memory system and IPL MOPS detected 512 MB (stacked) DIMM fault	Memory DIMM Locations: U1.1-P1-M1.n U1.1-P1-M2.n
450C 300E	Memory system and IPL MOPS detected 512 MB (unstacked) DIMM fault	Memory DIMM Locations: U1.1-P1-M1.n U1.1-P1-M2.n
450C 301F	Memory system and IPL MOPS detected 128 MB DIMM fault	Memory DIMM Locations: U1.1-P1-M1.n U1.1-P1-M2.n
450C 303A	Memory system and IPL MOPS detected 1 GB DIMM fault	Memory DIMM Locations: U1.1-P1-M1.n U1.1-P1-M2.n
450C 515B	Memory system and IPL MOPS detected 1100W ac power supply fault	1100W ac power supply Locations: U1.1-V1 U1.1-V2
450C 51AC	Memory system and IPL MOPS detected 595W ac power supply fault	595W ac power supply Locations: U0.1-V1 U0.1-V2
450C 51AD	Memory system and IPL MOPS detected 595W dc power supply fault	595W dc power supply Locations: U0.1-V1 U0.1-V2
450C 51AE	Memory system and IPL MOPS detected 1100W dc power supply fault	1100W dc power supply Locations: U1.1-V1 U1.1-V2

Table 7. Service Processor Error Codes (continued)

<b>Error Code</b>	<b>Description</b>	<b>Action/ Possible Failing FRU</b>
450D 245B	Memory system and attention handler detected 2W 4M processor fault	Processor card Locations: U1.1-P1-C1 U1.1-P1-C2
450D 245C	Memory system and attention handler detected 2W 2M processor fault	Processor card Locations: U1.1-P1-C1 U1.1-P1-C2
450D 245D	Memory system and attention handler detected 4W 4M processor fault	Processor card Locations: U1.1-P1-C1 U1.1-P1-C2
450D 248B	Memory system and attention handler detected primary I/O drawer operator panel fault	Operator Panel Location: U0.1-L1
450D 24A5	Memory system and attention handler detected 2W 500 MHz processor fault	Processor card Locations: U1.1-P1-C1 U1.1-P1-C2
450D 24A6	Memory system and attention handler detected 4W 500 MHz processor fault	Processor card Locations: U1.1-P1-C1 U1.1-P1-C2
450D 25AB	Memory system and attention handler detected 400 MHz clock fault	400 MHz clock Location: U1.1-P1.1.1
450D 25AD	Memory system and attention handler detected 540 MHz clock fault	540 MHz clock Location: U1.1-P1.1.1
450D 25B1	Memory system and attention handler detected 750 MHz clock fault	750 MHz clock Location: U1.1-P1.1.1
450D 25B3	Memory system and attention handler detected 4W 750 MHz processor fault	Processor card Locations: U1.1-P1-C1 U1.1-P1-C2
250D 25B4	Memory system and attention handler detected 2W 750 MHz processor fault	Processor card Locations: U1.1-P1-C1 U1.1-P1-C2
450D 25DA	Memory system and attention handler detected 500 MHz clock fault	500 MHz clock Location: U1.1-P1.1.1
450D 267D	Memory system and attention handler detected an 8W, 750 MHz regulator fault	8W regulator card Location: U1.1-P1-V1
450D 2687	Memory system and attention handler detected remote I/O bus adapter fault	Remote I/O bus adapter Location: U0.1-P1.1
450D 271A	Memory system and attention handler detected primary I/O planar fault	Primary I/O planar Location: U0.1-P1
450D 271D	Memory system and attention handler detected secondary I/O planar fault	Secondary I/O planar Locations: U0.2-P1 U0.3-P1 U0.4-P1

Table 7. Service Processor Error Codes (continued)

Error Code	Description	Action/ Possible Failing FRU
450D 2733	Memory system and attention handler detected I/O clock fault	CEC RIO bus adapter Location: U1.1-P1.1
450D 27AA	Memory system and attention handler detected a 2W/4W regulator fault	2W/4W regulator card Location: U1.1-P1-V1
450D 27AB	Memory system and attention handler detected an 8W regulator fault	8W regulator card Location: U1.1-P1-V1
450D 281C	Memory system and attention handler detected CEC backplane fault	CEC backplane Location: U1.1-P1
450D 281D	Memory system and attention handler detected Model 6M1 CEC backplane fault	CEC backplane Location: U1.1-P1
450D 285D	Memory system and attention handler detected SPCN fan controller fault	1. SPCN fan controller Location: U0.1-X2 2. I/O drawer power distribution board Location: U0.1-X1
450D 288A	Memory system and attention handler detected memory riser card fault	1. Go to the service processor Memory Configuration/Deconfiguration Menu to verify memory DIMMs state. See "Memory Configuration/Deconfiguration Menu" on page 426 for more information. 2. Memory riser card Locations: U1.1-P1-M1 U1.1-P1-M2
450D 300A	Memory system and attention handler detected 32 MB DIMM fault	Memory DIMM Locations: U1.1-P1-M1.n U1.1-P1-M2.n
450D 300B	Memory system and attention handler detected 128 MB DIMM fault	Memory DIMM Locations: U1.1-P1-M1.n U1.1-P1-M2.n
450D 300C	Memory system and attention handler detected 256 MB DIMM fault	Memory DIMM Locations: U1.1-P1-M1.n U1.1-P1-M2.n
450D 300D	Memory system and attention handler detected 512 MB (stacked) DIMM fault	Memory DIMM Locations: U1.1-P1-M1.n U1.1-P1-M2.n
450D 300E	Memory system and attention handler detected 512 MB (unstacked) DIMM fault	Memory DIMM Locations: U1.1-P1-M1.n U1.1-P1-M2.n
450D 301F	Memory system and attention handler detected 128 MB DIMM fault	Memory DIMM Locations: U1.1-P1-M1.n U1.1-P1-M2.n

Table 7. Service Processor Error Codes (continued)

Error Code	Description	Action/ Possible Failing FRU
450D 303A	Memory system and attention handler detected 1 GB DIMM fault	Memory DIMM Locations: U1.1-P1-M1.n U1.1-P1-M2.n
450D 515B	Memory system and attention handler detected 1100W ac power supply fault	1100W ac power supply Locations: U1.1-V1 U1.1-V2
450D 51AC	Memory system and attention handler detected 595W ac power supply fault	595W ac power supply Locations: U0.1-V1 U0.1-V2
450D 51AD	Memory system and attention handler detected 595W dc power supply fault	595W dc power supply Locations: U0.1-V1 U0.1-V2
450D 51AE	Memory system and attention handler detected 1100W dc power supply fault	1100W dc power supply Locations: U1.1-V1 U1.1-V2
450E 245B	Memory system and scan control routines detected 2W 4M processor fault	Processor card Locations: U1.1-P1-C1 U1.1-P1-C2
450E 245D	Memory system and scan control routines detected 4W 4M processor fault	Processor card Locations: U1.1-P1-C1 U1.1-P1-C2
450E 248B	Memory system and scan control routines detected primary I/O drawer operator panel fault	Operator Panel Location: U0.1-L1
450E 24A5	Memory system and scan control routines detected 2W 500 MHz processor fault	Processor card Locations: U1.1-P1-C1 U1.1-P1-C2
450E 24A6	Memory system and scan control routines detected 4W 500 MHz processor fault	Processor card Locations: U1.1-P1-C1 U1.1-P1-C2
450E 25AB	Memory system and scan control routines detected 400 MHz clock fault	400 MHz clock Location: U1.1-P1.1.1
450E 25AD	Memory system and scan control routines detected 540 MHz clock fault	540 MHz clock Location: U1.1-P1.1.1
450E 25B1	Memory system and scan control routines detected 750 MHz clock fault	750 MHz clock Location: U1.1-P1.1.1
450E 25B3	Memory system and scan control routines detected 4W 750 MHz processor fault	Processor card Locations: U1.1-P1-C1 U1.1-P1-C2
450E 25B4	Memory system and scan control routines detected 2W 750 MHz processor fault	Processor card Locations: U1.1-P1-C1 U1.1-P1-C2
450E 25DA	Memory system and scan control routines detected 500 MHz clock fault	500 MHz clock Location: U1.1-P1.1.1

Table 7. Service Processor Error Codes (continued)

<b>Error Code</b>	<b>Description</b>	<b>Action/ Possible Failing FRU</b>
450E 267D	Memory system and attention handler detected an 8W, 750 MHz regulator fault	8W regulator card Location: U1.1-P1-V1
450E 2687	Memory system and scan control routines detected remote I/O bus adapter fault	Remote I/O bus adapter Location: U0.1-P1.1
450E 271A	Memory system and scan control routines detected primary I/O planar fault	Primary I/O planar Location: U0.1-P1
450E 271D	Memory system and scan control routines detected secondary I/O planar fault	Secondary I/O planar Locations: U0.2-P1 U0.3-P1 U0.4-P1
450E 2733	Memory system and scan control routines detected I/O clock fault	CEC RIO bus adapter Location: U1.1-P1.1
450E 27AA	Memory system and scan control routines detected a 2W/4W regulator fault	2W/4W regulator card Location: U1.1-P1-V1
450E 27AB	Memory system and scan control routines detected an 8W regulator fault	8W regulator card Location: U1.1-P1-V1
450E 281C	Memory system and scan control routines detected CEC backplane fault	CEC backplane Location: U1.1-P1
450E 281D	Memory system and scan control routines detected Model 6M1 CEC backplane fault	CEC backplane Location: U1.1-P1
450E 285D	Memory system and scan control routines detected SPCN fan controller fault	1. SPCN fan controller Location: U0.1-X2 2. I/O drawer power distribution board Location: U0.1-X1
450E 288A	Memory system and scan control routines detected memory riser card fault	1. Go to the service processor Memory Configuration/Deconfiguration Menu to verify memory DIMMs state. See "Memory Configuration/Deconfiguration Menu" on page 426 for more information. 2. Memory riser card Locations: U1.1-P1-M1 U1.1-P1-M2
450E 300A	Memory system and scan control routines detected 32 MB DIMM fault	Memory DIMM Locations: U1.1-P1-M1.n U1.1-P1-M2.n

Table 7. Service Processor Error Codes (continued)

<b>Error Code</b>	<b>Description</b>	<b>Action/ Possible Failing FRU</b>
450E 300B	Memory system and scan control routines detected 128 MB DIMM fault	Memory DIMM Locations: U1.1-P1-M1.n U1.1-P1-M2.n
450E 300C	Memory system and scan control routines detected 256 MB DIMM fault	Memory DIMM Locations: U1.1-P1-M1.n U1.1-P1-M2.n
450E 300D	Memory system and scan control routines detected 512 MB (stacked) DIMM fault	Memory DIMM Locations: U1.1-P1-M1.n U1.1-P1-M2.n
450E 300E	Memory system and scan control routines detected 512 MB (unstacked) DIMM fault	Memory DIMM Locations: U1.1-P1-M1.n U1.1-P1-M2.n
450E 301F	Memory system and scan control routines detected 128 MB DIMM fault	Memory DIMM Locations: U1.1-P1-M1.n U1.1-P1-M2.n
450E 303A	Memory system and scan control routines detected 1 GB DIMM fault	Memory DIMM Locations: U1.1-P1-M1.n U1.1-P1-M2.n
450E 515B	Memory system and scan control routines detected 1100W ac power supply fault	1100W ac power supply Locations: U1.1-V1 U1.1-V2
450E 51AC	Memory system and scan control routines detected 595W ac power supply fault	595W ac power supply Locations: U0.1-V1 U0.1-V2
450E 51AD	Memory system and scan control routines detected 595W dc power supply fault	595W dc power supply Locations: U0.1-V1 U0.1-V2
450E 51AE	Memory system and scan control routines detected 1100W dc power supply fault	1100W dc power supply Locations: U1.1-V1 U1.1-V2
450F 245B	Memory system and error code detected 2W 4M processor fault	Processor card Locations: U1.1-P1-C1 U1.1-P1-C2
450F 245C	Memory system and error code detected 2W 2M processor fault	Processor card Locations: U1.1-P1-C1 U1.1-P1-C2
450F 245D	Memory system and error code detected 4W 4M processor fault	Processor card Locations: U1.1-P1-C1 U1.1-P1-C2
450F 248B	Memory system and error code detected primary I/O drawer operator panel fault	Operator Panel Location: U0.1-L1
450F 24A5	Memory system and error code detected 2W 500 MHz processor fault	Processor card Locations: U1.1-P1-C1 U1.1-P1-C2



Table 7. Service Processor Error Codes (continued)

Error Code	Description	Action/ Possible Failing FRU
450F 24A6	Memory system and error code detected 4W 500 MHz processor fault	Processor card Locations: U1.1-P1-C1 U1.1-P1-C2
450F 25AB	Memory system and error code detected 400 MHz clock fault	400 MHz clock Location: U1.1-P1.1.1
450F 25AD	Memory system and error code detected 540 MHz clock fault	540 MHz clock Location: U1.1-P1.1.1
450F 25B1	Memory system and error code detected 750 MHz clock fault	750 MHz clock Location: U1.1-P1.1.1
450F 25B3	Memory system and error code detected 4W 750 MHz processor fault	Processor card Locations: U1.1-P1-C1 U1.1-P1-C2
450F 25B4	Memory system and error code detected 2W 750 MHz processor fault	Processor card Locations: U1.1-P1-C1 U1.1-P1-C2
450F 25DA	Memory system and error code detected 500 MHz clock fault	500 MHz clock Location: U1.1-P1.1.1
450F 267D	Memory system and error code detected an 8W, 750 MHz regulator fault	8W regulator card Location: U1.1-P1-V1
450F 2687	Memory system and error code detected remote I/O bus adapter fault	Remote I/O bus adapter Location: U0.1-P1.1
450F 271A	Memory system and error code detected primary I/O planar fault	Primary I/O planar Location: U0.1-P1
450F 271D	Memory system and error code detected secondary I/O planar fault	Secondary I/O planar Locations: U0.2-P1 U0.3-P1 U0.4-P1
450F 2733	Memory system and error code detected I/O clock fault	CEC RIO bus adapter Location: U1.1-P1.1
450F 27AA	Memory system and error code detected a 2W/4W regulator fault	2W/4W regulator card Location: U1.1-P1-V1
450F 27AB	Memory system and error code detected an 8W regulator fault	8W regulator card Location: U1.1-P1-V1
450F 281C	Memory system and error code detected CEC backplane fault	CEC backplane Location: U1.1-P1
450F 281D	Memory system and error code detected Model 6M1 CEC backplane fault	CEC backplane Location: U1.1-P1
450F 285D	Memory system and error code detected SPCN fan controller fault	1. SPCN fan controller Location: U0.1-X2 2. I/O drawer power distribution board Location: U0.1-X1

Table 7. Service Processor Error Codes (continued)

Error Code	Description	Action/ Possible Failing FRU
450F 288A	Memory system and error code detected memory riser card fault	<ol style="list-style-type: none"> <li>Go to the service processor Memory Configuration/Deconfiguration Menu to verify memory DIMMs state. See "Memory Configuration/Deconfiguration Menu" on page 426 for more information.</li> <li>Memory riser card Locations: U1.1-P1-M1 U1.1-P1-M2</li> </ol>
450F 300A	Memory system and error code detected 32 MB DIMM fault	Memory DIMM Locations: U1.1-P1-M1.n U1.1-P1-M2.n
450F 300B	Memory system and error code detected 128 MB DIMM fault	Memory DIMM Locations: U1.1-P1-M1.n U1.1-P1-M2.n
450F 300C	Memory system and error code detected 256 MB DIMM fault	Memory DIMM Locations: U1.1-P1-M1.n U1.1-P1-M2.n
450F 300D	Memory system and error code detected 512 MB (stacked) DIMM fault	Memory DIMM Locations: U1.1-P1-M1.n U1.1-P1-M2.n
450F 300E	Memory system and error code detected 512 MB (unstacked) DIMM fault	Memory DIMM Locations: U1.1-P1-M1.n U1.1-P1-M2.n
450F 301F	Memory system and error code detected 128 MB DIMM fault	Memory DIMM Locations: U1.1-P1-M1.n U1.1-P1-M2.n
450F 303A	Memory system and error code detected 1 GB DIMM fault	Memory DIMM Locations: U1.1-P1-M1.n U1.1-P1-M2.n
450F 515B	Memory system and error code detected 1100W ac power supply fault	1100W ac power supply Locations: U1.1-V1 U1.1-V2
450F 51AC	Memory system and error code detected 595W ac power supply fault	595W ac power supply Locations: U0.1-V1 U0.1-V2
450F 51AD	Memory system and error code detected 595W dc power supply fault	595W dc power supply Locations: U0.1-V1 U0.1-V2
450F 51AE	Memory system and error code detected 1100W dc power supply fault	1100W dc power supply Locations: U1.1-V1 U1.1-V2

Table 7. Service Processor Error Codes (continued)

<b>Error Code</b>	<b>Description</b>	<b>Action/ Possible Failing FRU</b>
4606 245B	Other bus PRD detected 2W 4M processor fault	Processor card Locations: U1.1-P1-C1 U1.1-P1-C2
4606 245C	Other bus PRD detected 2W 2M processor fault	Processor card Locations: U1.1-P1-C1 U1.1-P1-C2
4606 245D	Other bus PRD detected 4W 4M processor fault	Processor card Locations: U1.1-P1-C1 U1.1-P1-C2
4606 248B	Other bus PRD detected primary I/O drawer operator panel fault	Operator Panel Location: U0.1-L1
4606 24A5	Other bus PRD detected 2W 500 MHz processor fault	Processor card Locations: U1.1-P1-C1 U1.1-P1-C2
4606 24A6	Other bus PRD detected 4W 500 MHz processor fault	Processor card Locations: U1.1-P1-C1 U1.1-P1-C2
4606 25AB	Other bus PRD detected 400 MHz clock fault	400 MHz clock Location: U1.1-P1.1.1
4606 25AD	Other bus PRD detected 540 MHz clock fault	540 MHz clock Location: U1.1-P1.1.1
4606 25B1	Other bus PRD detected 750 MHz clock fault	750 MHz clock Location: U1.1-P1.1.1
4606 25B3	Other bus PRD detected 4W 750 MHz processor fault	Processor card Locations: U1.1-P1-C1 U1.1-P1-C2
4606 25B4	Other bus PRD detected 2W 750 MHz processor fault	Processor card Locations: U1.1-P1-C1 U1.1-P1-C2
4606 25DA	Other bus PRD detected 500 MHz clock fault	500 MHz clock Location: U1.1-P1.1.1
4606 267D	Other bus PRD detected an 8W, 750 MHz regulator fault	8W regulator card Location: U1.1-P1-V1
4606 2687	Other bus PRD detected remote I/O bus adapter fault	Remote I/O bus adapter Location: U1.1-P1.1
4606 271A	Other bus PRD detected primary I/O planar fault	Primary I/O planar Location: U0.1-P1
4606 271D	Other bus PRD detected secondary I/O planar fault	Secondary I/O planar Locations: U0.2-P1 U0.3-P1 U0.4-P1
4606 2733	Other bus PRD detected I/O clock fault	CEC RIO bus adapter Location: U1.1-P1.1

Table 7. Service Processor Error Codes (continued)

Error Code	Description	Action/ Possible Failing FRU
4606 27AA	Other bus PRD detected a 2W/4W regulator fault	2W/4W regulator card Location: U1.1-P1-V1
4606 27AB	Other bus PRD detected an 8W regulator fault	8W regulator card Location: U1.1-P1-V1
4606 281C	Other bus PRD detected CEC backplane fault	CEC backplane Location: U1.1-P1
4606 281D	Other bus PRD detected Model 6M1 CEC backplane fault	CEC backplane Location: U1.1-P1
4606 285D	Other bus PRD detected SPCN fan controller fault	1. SPCN fan controller Location: U0.1-X2 2. I/O drawer power distribution board Location: U0.1-X1
4606 288A	Other bus PRD detected memory riser card fault	1. Go to the service processor Memory Configuration/Deconfiguration Menu to verify memory DIMMs state. See "Memory Configuration/Deconfiguration Menu" on page 426 for more information. 2. Memory riser card Locations: U1.1-P1-M1 U1.1-P1-M2
4606 300A	Other bus PRD detected 32 MB DIMM fault	Memory DIMM Locations: U1.1-P1-M1.n U1.1-P1-M2.n
4606 300B	Other bus PRD detected 128 MB DIMM fault	Memory DIMM Locations: U1.1-P1-M1.n U1.1-P1-M2.n
4606 300C	Other bus PRD detected 256 MB DIMM fault	Memory DIMM Locations: U1.1-P1-M1.n U1.1-P1-M2.n
4606 300D	Other bus PRD detected 512 MB (stacked) DIMM fault	Memory DIMM Locations: U1.1-P1-M1.n U1.1-P1-M2.n
4606 300E	Other bus PRD detected 512 MB (unstacked) DIMM fault	Memory DIMM Locations: U1.1-P1-M1.n U1.1-P1-M2.n
4606 301F	Other bus PRD detected 128 MB DIMM fault	Memory DIMM Locations: U1.1-P1-M1.n U1.1-P1-M2.n
4606 303A	Other bus PRD detected 1 GB DIMM fault	Memory DIMM Locations: U1.1-P1-M1.n U1.1-P1-M2.n

Table 7. Service Processor Error Codes (continued)

Error Code	Description	Action/ Possible Failing FRU
4606 515B	Other bus PRD detected 1100W ac power supply fault	1100W ac power supply Locations: U1.1-V1 U1.1-V2
4606 51AC	Other bus PRD detected 595W ac power supply fault	595W ac power supply Locations: U0.1-V1 U0.1-V2
4606 51AD	Other bus PRD detected 595W dc power supply fault	595W dc power supply Locations: U0.1-V1 U0.1-V2
4606 51AE	Other bus PRD detected 1100W dc power supply fault	1100W dc power supply Locations: U1.1-V1 U1.1-V2
4607 245B	I/O system and 6xx bus processor runtime diagnostics detected 2W 4M processor fault	Go to the service processor Processor Configuration/Deconfiguration Menu to check the states of the processors. See "Processor Configuration/Deconfiguration Menu" on page 425 for more information. Replace the card that has the bad processors. Locations: U1.1-P1-C1 U1.1-P1-C2
4607 245C	I/O system and 6xx bus processor runtime diagnostics detected 2W 2M processor fault	Go to the service processor Processor Configuration/Deconfiguration Menu to check the states of the processors. See "Processor Configuration/Deconfiguration Menu" on page 425 for more information. Replace the card that has the bad processors. Locations: U1.1-P1-C1 U1.1-P1-C2
4607 245D	I/O system and 6xx bus processor runtime diagnostics detected 4W 4M processor fault	Go to the service processor Processor Configuration/Deconfiguration Menu to check the states of the processors. See "Processor Configuration/Deconfiguration Menu" on page 425 for more information. Replace the card that has the bad processors. Locations: U1.1-P1-C1 U1.1-P1-C2
4607 248B	I/O system and 6xx bus processor runtime diagnostics detected primary I/O drawer operator panel fault	Operator panel Location: U0.1-L1

Table 7. Service Processor Error Codes (continued)

Error Code	Description	Action/ Possible Failing FRU
4607 24A5	I/O system and 6xx bus processor runtime diagnostics detected 2W 500 MHz processor fault	Go to the service processor Processor Configuration/Deconfiguration Menu to check the states of the processors. See "Processor Configuration/Deconfiguration Menu" on page 425 for more information. Replace the card that has the bad processors. Locations: U1.1-P1-C1 U1.1-P1-C2
4607 24A6	I/O system and 6xx bus processor runtime diagnostics detected 4W 500 MHz processor fault	Go to the service processor Processor Configuration/Deconfiguration Menu to check the states of the processors. See "Processor Configuration/Deconfiguration Menu" on page 425 for more information. Replace the card that has the bad processors. Locations: U1.1-P1-C1 U1.1-P1-C2
4607 25AB	I/O system and 6xx bus processor runtime diagnostics detected 400 MHz clock fault	400 MHz clock Location: U1.1-P1.1.1
4607 25AD	I/O system and 6xx bus processor runtime diagnostics detected 540 MHz clock fault	540 MHz clock Location: U1.1-P1.1.1
4607 25B1	I/O system and 6xx bus processor runtime diagnostics detected 750 MHz clock fault	750 MHz clock Location: U1.1-P1.1.1
4607 25B3	I/O system and 6xx bus processor runtime diagnostics detected 4W 750 MHz processor fault	Go to the service processor Processor Configuration/Deconfiguration Menu to check the states of the processors. See "Processor Configuration/Deconfiguration Menu" on page 425 for more information. Replace the card that has the bad processors. Locations: U1.1-P1-C1 U1.1-P1-C2

Table 7. Service Processor Error Codes (continued)

Error Code	Description	Action/ Possible Failing FRU
4607 25B4	I/O system and 6xx bus processor runtime diagnostics detected 2W 750 MHz processor fault	Go to the service processor Processor Configuration/Deconfiguration Menu to check the states of the processors. See "Processor Configuration/Deconfiguration Menu" on page 425 for more information. Replace the card that has the bad processors. Locations: U1.1-P1-C1 U1.1-P1-C2
4607 25DA	I/O system and 6xx bus processor runtime diagnostics detected 500 MHz clock fault	500 MHz clock Location: U1.1-P1.1.1
4607 267D	I/O system and 6xx bus processor runtime diagnostics detected an 8W, 750 MHz regulator fault	8W regulator card Location: U1.1-P1-V1
4607 2687	I/O system and 6xx bus processor runtime diagnostics detected remote I/O bus adapter fault	Remote I/O bus adapter Location: U0.1-P1.1
4607 271A	I/O system and 6xx bus processor runtime diagnostics detected primary I/O backplane fault	Primary I/O backplane Location: U0.1-P1
4607 271D	I/O system and 6xx bus processor runtime diagnostics detected secondary I/O backplane fault	Secondary I/O backplane Locations: U0.2-P1 U0.3-P1 U0.4-P1
4607 2733	I/O system and 6xx bus processor runtime diagnostics detected I/O clock fault	CEC RIO bus adapter Location: U1.1-P1.1
4607 27AA	I/O system and 6xx bus processor runtime diagnostics detected a 2W/4W regulator fault	2W/4W regulator card Location: U1.1-P1-V1
4607 27AB	I/O system and 6xx bus processor runtime diagnostics detected an 8W regulator fault	8W regulator card Location: U1.1-P1-V1
4607 281D	I/O system and 6xx bus processor runtime diagnostics detected Model 6M1 CEC backplane fault	CEC backplane Location: U1.1-P1
4607 281C	I/O system and 6xx bus processor runtime diagnostics detected CEC backplane fault	CEC backplane Location: U1.1-P1

Table 7. Service Processor Error Codes (continued)

Error Code	Description	Action/ Possible Failing FRU
4607 285D	I/O system and 6xx bus processor runtime diagnostics detected SPCN fan controller fault	<ol style="list-style-type: none"> <li>1. SPCN fan controller Location: U0.1-X2</li> <li>2. I/O Drawer Power Distribution Board Location: U0.1-X1</li> </ol>
4607 288A	I/O system and 6xx bus processor runtime diagnostics detected memory riser card fault	<ol style="list-style-type: none"> <li>1. Go to the service processor Memory Configuration/Deconfiguration Menu to verify memory DIMMs state. See "Memory Configuration/Deconfiguration Menu" on page 426 for more information.</li> <li>2. Memory riser card Locations: U1.1-P1-M1 U1.1-P1-M2</li> </ol>
4607 300A	I/O system and 6xx bus processor runtime diagnostics detected 32 MB DIMM fault	Memory DIMM Locations: U1.1-P1-M1.n U1.1-P1-M2.n
4607 300B	I/O system and 6xx bus processor runtime diagnostics detected 128 MB DIMM fault	Memory DIMM Locations: U1.1-P1-M1.n U1.1-P1-M2.n
4607 300C	I/O system and 6xx bus processor runtime diagnostics detected 256 MB DIMM fault	Memory DIMM Locations: U1.1-P1-M1.n U1.1-P1-M2.n
4607 300D	I/O system and 6xx bus processor runtime diagnostics detected 512 MB (stacked) DIMM fault	Memory DIMM Locations: U1.1-P1-M1.n U1.1-P1-M2.n
4607 300E	I/O system and 6xx bus processor runtime diagnostics detected 512 MB (unstacked) DIMM fault	Memory DIMM Locations: U1.1-P1-M1.n U1.1-P1-M2.n
4607 301F	I/O system and 6xx bus processor runtime diagnostics detected 128 MB DIMM fault	Memory DIMM Locations: U1.1-P1-M1.n U1.1-P1-M2.n
4607 303A	I/O system and 6xx bus processor runtime diagnostics detected 1 GB DIMM fault	Memory DIMM Locations: U1.1-P1-M1.n U1.1-P1-M2.n
4607 515B	I/O system and 6xx bus processor runtime diagnostics detected 1100W ac power supply fault	1100W ac power supply Locations: U1.1-V1 U1.1-V2
4607 51AC	I/O system and 6xx bus processor runtime diagnostics detected 595W ac power supply fault	595W ac power supply Locations: U0.1-V1 U0.1-V2
4607 51AD	I/O system and 6xx bus processor runtime diagnostics detected 595W dc power supply fault	595W dc power supply Locations: U0.1-V1 U0.1-V2



Table 7. Service Processor Error Codes (continued)

Error Code	Description	Action/ Possible Failing FRU
4607 51AE	I/O system and 6xx bus processor runtime diagnostics detected 1100W dc power supply fault	1100W dc power supply Locations: U1.1-V1 U1.1-V2
4608 245B	I/O system and other bus processor runtime diagnostics detected 2W 4M processor fault	Processor card Locations: U1.1-P1-C1 U1.1-P1-C2
4608 245C	I/O system and other bus processor runtime diagnostics detected 2W 2M processor fault	Processor card Locations: U1.1-P1-C1 U1.1-P1-C2
4608 245D	I/O system and other bus processor runtime diagnostics detected 4W 4M processor fault	Processor card Locations: U1.1-P1-C1 U1.1-P1-C2
4608 248B	I/O system and other bus processor runtime diagnostics detected primary I/O drawer operator panel fault	Operator Panel Location: U0.1-L1
4608 24A5	I/O system and other bus processor runtime diagnostics detected 2W 500 MHz processor fault	Processor card Locations: U1.1-P1-C1 U1.1-P1-C2
4608 24A6	I/O system and other bus processor runtime diagnostics detected 4W 500 MHz processor fault	Processor card Locations: U1.1-P1-C1 U1.1-P1-C2
4608 25AB	I/O system and other bus processor runtime diagnostics detected 400 MHz clock fault	400 MHz clock Location: U1.1-P1.1.1
4608 25AD	I/O system and other bus processor runtime diagnostics detected 540 MHz clock fault	540 MHz clock Location: U1.1-P1.1.1
4608 25B1	I/O system and other bus processor runtime diagnostics detected 750 MHz clock fault	750 MHz clock Location: U1.1-P1.1.1
4608 25B3	I/O system and other bus processor runtime diagnostics detected 4W 750 MHz processor fault	Processor card Locations: U1.1-P1-C1 U1.1-P1-C2
4608 25B4	I/O system and other bus processor runtime diagnostics detected 2W 750 MHz processor fault	Processor card Locations: U1.1-P1-C1 U1.1-P1-C2
4608 25DA	I/O system and other bus processor runtime diagnostics detected 500 MHz clock fault	500 MHz clock Location: U1.1-P1.1.1
4608 267D	I/O system and other bus processor runtime diagnostics detected an 8W, 750 MHz regulator fault	8W regulator card Location: U1.1-P1-V1
4608 2687	I/O system and other bus processor runtime diagnostics detected remote I/O bus adapter fault	Remote I/O bus adapter Location: U1.1-P1.1

Table 7. Service Processor Error Codes (continued)

<b>Error Code</b>	<b>Description</b>	<b>Action/ Possible Failing FRU</b>
4608 271A	I/O system and other bus processor runtime diagnostics detected primary I/O planar fault	Primary I/O planar Location: U0.1-P1
4608 271D	I/O system and other bus processor runtime diagnostics detected secondary I/O planar fault	Secondary I/O planar Locations: U0.2-P1 U0.3-P1 U0.4-P1
4608 2733	I/O system and other bus processor runtime diagnostics detected I/O clock fault	CEC RIO bus adapter Location: U1.1-P1.1
4608 27AA	I/O system and other bus processor runtime diagnostics detected a 2W/4W regulator fault	2W/4W regulator card Location: U1.1-P1-V1
4608 27AB	I/O system and other bus processor runtime diagnostics detected an 8W regulator fault	8W regulator card Location: U1.1-P1-V1
4608 281C	I/O system and other bus processor runtime diagnostics detected CEC backplane fault	CEC backplane Location: U1.1-P1
4608 281D	I/O system and other bus processor runtime diagnostics detected Model 6M1 CEC backplane fault	CEC backplane Location: U1.1-P1
4608 285D	I/O system and other bus processor runtime diagnostics detected SPCN fan controller fault	1. SPCN fan controller Location: U0.1-X2 2. I/O drawer power distribution board Location: U0.1-X1
4608 288A	I/O system and other bus processor runtime diagnostics detected memory riser card fault	1. Go to the service processor Memory Configuration/Deconfiguration Menu to verify memory DIMMs state. See "Memory Configuration/Deconfiguration Menu" on page 426 for more information. 2. Memory riser card Locations: U1.1-P1-M1 U1.1-P1-M2
4608 300A	I/O system and other bus processor runtime diagnostics detected 32 MB DIMM fault	Memory DIMM Locations: U1.1-P1-M1.n U1.1-P1-M2.n
4608 300B	I/O system and other bus processor runtime diagnostics detected 128 MB DIMM fault	Memory DIMM Locations: U1.1-P1-M1.n U1.1-P1-M2.n

Table 7. Service Processor Error Codes (continued)

Error Code	Description	Action/ Possible Failing FRU
4608 300C	I/O system and other bus processor runtime diagnostics detected 256 MB DIMM fault	Memory DIMM Locations: U1.1-P1-M1.n U1.1-P1-M2.n
4608 300D	I/O system and other bus processor runtime diagnostics detected 512 MB (stacked) DIMM fault	Memory DIMM Locations: U1.1-P1-M1.n U1.1-P1-M2.n
4608 300E	I/O system and other bus processor runtime diagnostics detected 512 MB (unstacked) DIMM fault	Memory DIMM Locations: U1.1-P1-M1.n U1.1-P1-M2.n
4608 301F	I/O system and other bus processor runtime diagnostics detected 128 MB DIMM fault	Memory DIMM Locations: U1.1-P1-M1.n U1.1-P1-M2.n
4608 303A	I/O system and other bus processor runtime diagnostics detected 1 GB DIMM fault	Memory DIMM Locations: U1.1-P1-M1.n U1.1-P1-M2.n
4608 515B	I/O system and other bus processor runtime diagnostics detected 1100W ac power supply fault	1100W ac power supply Locations: U1.1-V1 U1.1-V2
4608 51AC	I/O system and other bus processor runtime diagnostics detected 595W ac power supply fault	595W ac power supply Locations: U0.1-V1 U0.1-V2
4608 51AD	I/O system and other bus processor runtime diagnostics detected 595W dc power supply fault	595W dc power supply Locations: U0.1-V1 U0.1-V2
4608 51AE	I/O system and other bus processor runtime diagnostics detected 1100W dc power supply fault	1100W dc power supply Locations: U1.1-V1 U1.1-V2
4609 245B	I/O system and memory test detected 2W 4M processor fault	Processor card Locations: U1.1-P1-C1 U1.1-P1-C2
4609 245C	I/O system and memory test detected 2W 2M processor fault	Processor card Locations: U1.1-P1-C1 U1.1-P1-C2
4609 245D	I/O system and memory test detected 4W 4M processor fault	Processor card Locations: U1.1-P1-C1 U1.1-P1-C2
4609 248B	I/O system and memory test detected primary I/O drawer operator panel fault	Operator Panel Location: U0.1-L1
4609 24A5	I/O system and memory test detected 2W 500 MHz processor fault	Processor card Locations: U1.1-P1-C1 U1.1-P1-C2
4609 24A6	I/O system and memory test detected 4W 500 MHz processor fault	Processor card Locations: U1.1-P1-C1 U1.1-P1-C2

Table 7. Service Processor Error Codes (continued)

<b>Error Code</b>	<b>Description</b>	<b>Action/ Possible Failing FRU</b>
4609 25AB	I/O system and memory test detected 400 MHz clock fault	400 MHz clock Location: U1.1-P1.1.1
4609 25AD	I/O system and memory test detected 540 MHz clock fault	540 MHz clock Location: U1.1-P1.1.1
4609 25B1	I/O system and memory test detected 750 MHz clock fault	750 MHz clock Location: U1.1-P1.1.1
4609 25B3	I/O system and memory test detected 4W 750 MHz processor fault	Processor card Locations: U1.1-P1-C1 U1.1-P1-C2
4609 25B4	I/O system and memory test detected 2W 750 MHz processor fault	Processor card Locations: U1.1-P1-C1 U1.1-P1-C2
4609 25DA	I/O system and memory test detected 500 MHz clock fault	500 MHz clock Location: U1.1-P1.1.1
4609 267D	I/O system and memory test detected an 8W, 750 MHz regulator fault	8W regulator card Location: U1.1-P1-V1
4609 2687	I/O system and memory test detected remote I/O bus adapter fault	Remote I/O bus adapter Location: U1.1-P1.1
4609 271A	I/O system and memory test detected primary I/O planar fault	Primary I/O planar Location: U0.1-P1
4609 271D	I/O system and memory test detected secondary I/O planar fault	Secondary I/O planar Locations: U0.2-P1 U0.3-P1 U0.4-P1
4609 2733	I/O system and memory test detected I/O clock fault	CEC RIO bus adapter Location: U1.1-P1.1
4609 27AA	I/O system and memory test detected a 2W/4W regulator fault	2W/4W regulator card Location: U1.1-P1-V1
4609 27AB	I/O system and memory test detected an 8W regulator fault	8W regulator card Location: U1.1-P1-V1
4609 281C	I/O system and memory test detected CEC backplane fault	CEC backplane Location: U1.1-P1
4609 281D	I/O system and memory test detected Model 6M1 CEC backplane fault	CEC backplane Location: U1.1-P1
4609 285D	I/O system and memory test detected SPCN fan controller fault	1. SPCN fan controller Location: U0.1-X2 2. I/O drawer power distribution board Location: U0.1-X1

Table 7. Service Processor Error Codes (continued)

Error Code	Description	Action/ Possible Failing FRU
4609 288A	I/O system and memory test detected memory riser card fault	<ol style="list-style-type: none"> <li>1. Go to the service processor Memory Configuration/Deconfiguration Menu to verify memory DIMMs state. See "Memory Configuration/Deconfiguration Menu" on page 426 for more information.</li> <li>2. Memory riser card Locations: U1.1-P1-M1 U1.1-P1-M2</li> </ol>
4609 300A	I/O system and memory test detected 32 MB DIMM fault	Memory DIMM Locations: U1.1-P1-M1.n U1.1-P1-M2.n
4609 300B	I/O system and memory test detected 128 MB DIMM fault	Memory DIMM Locations: U1.1-P1-M1.n U1.1-P1-M2.n
4609 300C	I/O system and memory test detected 256 MB DIMM fault	Memory DIMM Locations: U1.1-P1-M1.n U1.1-P1-M2.n
4609 300D	I/O system and memory test detected 512 MB (stacked) DIMM fault	Memory DIMM Locations: U1.1-P1-M1.n U1.1-P1-M2.n
4609 300E	I/O system and memory test detected 512 MB (unstacked) DIMM fault	Memory DIMM Locations: U1.1-P1-M1.n U1.1-P1-M2.n
4609 301F	I/O system and memory test detected 128 MB DIMM fault	Memory DIMM Locations: U1.1-P1-M1.n U1.1-P1-M2.n
4609 303A	I/O system and memory test detected 1 GB DIMM fault	Memory DIMM Locations: U1.1-P1-M1.n U1.1-P1-M2.n
4609 515B	I/O system and memory test detected 1100W ac power supply fault	1100W ac power supply Locations: U1.1-V1 U1.1-V2
4609 51AC	I/O system and memory test detected 595W ac power supply fault	595W ac power supply Locations: U0.1-V1 U0.1-V2
4609 51AD	I/O system and memory test detected 595W dc power supply fault	595W dc power supply Locations: U0.1-V1 U0.1-V2
4609 51AE	I/O system and memory test detected 1100W dc power supply fault	1100W dc power supply Locations: U1.1-V1 U1.1-V2

Table 7. Service Processor Error Codes (continued)

<b>Error Code</b>	<b>Description</b>	<b>Action/ Possible Failing FRU</b>
460A 245B	I/O system and self test detected 2W 4M processor fault	Processor card Locations: U1.1-P1-C1 U1.1-P1-C2
460A 245C	I/O system and self test detected 2W 2M processor fault	Processor card Locations: U1.1-P1-C1 U1.1-P1-C2
460A 245D	I/O system and self test detected 4W 4M processor fault	Processor card Locations: U1.1-P1-C1 U1.1-P1-C2
460A 248B	I/O system and self test detected primary I/O drawer operator panel fault	Operator Panel Location: U0.1-L1
460A 24A5	I/O system and self test detected 2W 500 MHz processor fault	Processor card Locations: U1.1-P1-C1 U1.1-P1-C2
460A 24A6	I/O system and self test detected 4W 500 MHz processor fault	Processor card Locations: U1.1-P1-C1 U1.1-P1-C2
460A 25AB	I/O system and self test detected 400 MHz clock fault	400 MHz clock Location: U1.1-P1.1.1
460A 25AD	I/O system and self test detected 540 MHz clock fault	540 MHz clock Location: U1.1-P1.1.1
460A 25B1	I/O system and self test detected 750 MHz clock fault	750 MHz clock Location: U1.1-P1.1.1
460A 25B3	I/O system and self test detected 4W 750 MHz processor fault	Processor card Locations: U1.1-P1-C1 U1.1-P1-C2
460A 25B4	I/O system and self test detected 2W 750 MHz processor fault	Processor card Locations: U1.1-P1-C1 U1.1-P1-C2
460A 25DA	I/O system and self test detected 500 MHz clock fault	500 MHz clock Location: U1.1-P1.1.1
460A 267D	I/O system and self test detected an 8W, 750 MHz regulator fault	8W regulator card Location: U1.1-P1-V1
460A 2687	I/O system and self test detected remote I/O bus adapter fault	Remote I/O bus adapter Location: U1.1-P1.1
460A 271A	I/O system and self test detected primary I/O planar fault	Primary I/O planar Location: U0.1-P1
460A 271D	I/O system and self test detected secondary I/O planar fault	Secondary I/O planar Locations: U0.2-P1 U0.3-P1 U0.4-P1
460A 2733	I/O system and self test detected I/O clock fault	CEC RIO bus adapter Location: U1.1-P1.1

Table 7. Service Processor Error Codes (continued)

Error Code	Description	Action/ Possible Failing FRU
460A 27AA	I/O system and self test detected a 2W/4W regulator fault	2W/4W regulator card Location: U1.1-P1-V1
460A 27AB	I/O system and self test detected an 8W regulator fault	8W regulator card Location: U1.1-P1-V1
460A 281C	I/O system and self test detected CEC backplane fault	CEC backplane Location: U1.1-P1
460A 281D	I/O system and self test detected Model 6M1 CEC backplane fault	CEC backplane Location: U1.1-P1
460A 285D	I/O system and self test detected SPCN fan controller fault	1. SPCN fan controller Location: U0.1-X2 2. I/O drawer power distribution board Location: U0.1-X1
460A 288A	I/O system and self test detected memory riser card fault	1. Go to the service processor Memory Configuration/Deconfiguration Menu to verify memory DIMMs state. See "Memory Configuration/Deconfiguration Menu" on page 426 for more information. 2. Memory riser card Locations: U1.1-P1-M1 U1.1-P1-M2
460A 300A	I/O system and self test detected 32 MB DIMM fault	Memory DIMM Locations: U1.1-P1-M1.n U1.1-P1-M2.n
460A 300B	I/O system and self test detected 128 MB DIMM fault	Memory DIMM Locations: U1.1-P1-M1.n U1.1-P1-M2.n
460A 300C	I/O system and self test detected 256 MB DIMM fault	Memory DIMM Locations: U1.1-P1-M1.n U1.1-P1-M2.n
460A 300D	I/O system and self test detected 512 MB (stacked) DIMM fault	Memory DIMM Locations: U1.1-P1-M1.n U1.1-P1-M2.n
460A 300E	I/O system and self test detected 512 MB (unstacked) DIMM fault	Memory DIMM Locations: U1.1-P1-M1.n U1.1-P1-M2.n
460A 301F	I/O system and self test detected 128 MB DIMM fault	Memory DIMM Locations: U1.1-P1-M1.n U1.1-P1-M2.n
460A 303A	I/O system and self test detected 1 GB DIMM fault	Memory DIMM Locations: U1.1-P1-M1.n U1.1-P1-M2.n

Table 7. Service Processor Error Codes (continued)

<b>Error Code</b>	<b>Description</b>	<b>Action/ Possible Failing FRU</b>
460A 515B	I/O system and self test detected 1100W ac power supply fault	1100W ac power supply Locations: U1.1-V1 U1.1-V2
460A 51AC	I/O system and self test detected 595W ac power supply fault	595W ac power supply Locations: U0.1-V1 U0.1-V2
460A 51AD	I/O system and self test detected 595W dc power supply fault	595W dc power supply Locations: U0.1-V1 U0.1-V2
460A 51AE	I/O system and self test detected 1100W dc power supply fault	1100W dc power supply Locations: U1.1-V1 U1.1-V2
460B 245B	I/O system and wire test detected 2W 4M processor fault	Processor card Locations: U1.1-P1-C1 U1.1-P1-C2
460B 245C	I/O system and wire test detected 2W 2M processor fault	Processor card Locations: U1.1-P1-C1 U1.1-P1-C2
460B 245D	I/O system and wire test detected 4W 4M processor fault	Processor card Locations: U1.1-P1-C1 U1.1-P1-C2
460B 248B	I/O system and wire test detected primary I/O drawer operator panel fault	Operator Panel Location: U0.1-L1
460B 24A5	I/O system and wire test detected 2W 500 MHz processor fault	Processor card Locations: U1.1-P1-C1 U1.1-P1-C2
460B 24A6	I/O system and wire test detected 4W 500 MHz processor fault	Processor card Locations: U1.1-P1-C1 U1.1-P1-C2
460B 25AB	I/O system and wire test detected 400 MHz clock fault	400 MHz clock Location: U1.1-P1.1.1
460B 25AD	I/O system and wire test detected 540 MHz clock fault	540 MHz clock Location: U1.1-P1.1.1
460B 25B1	I/O system and wire test detected 750 MHz clock fault	750 MHz clock Location: U1.1-P1.1.1
460B 25B3	I/O system and wire test detected 4W 750 MHz processor fault	Processor card Locations: U1.1-P1-C1 U1.1-P1-C2
460B 25B4	I/O system and wire test detected 2W 750 MHz processor fault	Processor card Locations: U1.1-P1-C1 U1.1-P1-C2
460B 25DA	I/O system and wire test detected 500 MHz clock fault	500 MHz clock Location: U1.1-P1.1.1



Table 7. Service Processor Error Codes (continued)

Error Code	Description	Action/ Possible Failing FRU
460B 267D	I/O system and wire test detected an 8W, 750 MHz regulator fault	8W regulator card Location: U1.1-P1-V1
460B 2687	I/O system and wire test detected remote I/O bus adapter fault	Remote I/O bus adapter Location: U1.1-P1.1
460B 271A	I/O system and wire test detected primary I/O planar fault	Primary I/O planar Location: U0.1-P1
460B 271D	I/O system and wire test detected secondary I/O planar fault	Secondary I/O planar Locations: U0.2-P1 U0.3-P1 U0.4-P1
460B 2733	I/O system and wire test detected I/O clock fault	CEC RIO bus adapter Location: U1.1-P1.1
460B 27AA	I/O system and wire test detected a 2W/4W regulator fault	2W/4W regulator card Location: U1.1-P1-V1
460B 27AB	I/O system and wire test detected an 8W regulator fault	8W regulator card Location: U1.1-P1-V1
460B 281C	I/O system and wire test detected CEC backplane fault	CEC backplane Location: U1.1-P1
460B 281D	I/O system and wire test detected Model 6M1 CEC backplane fault	CEC backplane Location: U1.1-P1
460B 285D	I/O system and wire test detected SPCN fan controller fault	1. SPCN fan controller Location: U0.1-X2 2. I/O drawer power distribution board Location: U0.1-X1
460B 288A	I/O system and wire test detected memory riser card fault	1. Go to the service processor Memory Configuration/Deconfiguration Menu to verify memory DIMMs state. See "Memory Configuration/Deconfiguration Menu" on page 426 for more information. 2. Memory riser card Locations: U1.1-P1-M1 U1.1-P1-M2
460B 300A	I/O system and wire test detected 32 MB DIMM fault	Memory DIMM Locations: U1.1-P1-M1.n U1.1-P1-M2.n
460B 300B	I/O system and wire test detected 128 MB DIMM fault	Memory DIMM Locations: U1.1-P1-M1.n U1.1-P1-M2.n
460B 300C	I/O system and wire test detected 256 MB DIMM fault	Memory DIMM Locations: U1.1-P1-M1.n U1.1-P1-M2.n

Table 7. Service Processor Error Codes (continued)

<b>Error Code</b>	<b>Description</b>	<b>Action/ Possible Failing FRU</b>
460B 300D	I/O system and wire test detected 512 MB (stacked) DIMM fault	Memory DIMM Locations: U1.1-P1-M1.n U1.1-P1-M2.n
460B 300E	I/O system and wire test detected 512 MB (unstacked) DIMM fault	Memory DIMM Locations: U1.1-P1-M1.n U1.1-P1-M2.n
460B 301F	I/O system and wire test detected 128 MB DIMM fault	Memory DIMM Locations: U1.1-P1-M1.n U1.1-P1-M2.n
460B 303A	I/O system and wire test detected 1 GB DIMM fault	Memory DIMM Locations: U1.1-P1-M1.n U1.1-P1-M2.n
460B 515B	I/O system and wire test detected 1100W ac power supply fault	1100W ac power supply Locations: U1.1-V1 U1.1-V2
460B 51AC	I/O system and wire test detected 595W ac power supply fault	595W ac power supply Locations: U0.1-V1 U0.1-V2
460B 51AD	I/O system and wire test detected 595W dc power supply fault	595W dc power supply Locations: U0.1-V1 U0.1-V2
460B 51AE	I/O system and wire test detected 1100W dc power supply fault	1100W dc power supply Locations: U1.1-V1 U1.1-V2
460C 245B	I/O system and IPL MOPS detected 2W 4M processor fault	Processor card Locations: U1.1-P1-C1 U1.1-P1-C2
460C 245C	I/O system and IPL MOPS detected 2W 2M processor fault	Processor card Locations: U1.1-P1-C1 U1.1-P1-C2
460C 245D	I/O system and IPL MOPS detected 4W 4M processor fault	Processor card Locations: U1.1-P1-C1 U1.1-P1-C2
460C 248B	I/O system and IPL MOPS detected primary I/O drawer operator panel fault	Operator Panel Location: U0.1-L1
460C 24A5	I/O system and IPL MOPS detected 2W 500 MHz processor fault	Processor card Locations: U1.1-P1-C1 U1.1-P1-C2
460C 24A6	I/O system and IPL MOPS detected 4W 500 MHz processor fault	Processor card Locations: U1.1-P1-C1 U1.1-P1-C2
460C 25AB	I/O system and IPL MOPS detected 400 MHz clock fault	400 MHz clock Location: U1.1-P1.1.1

Table 7. Service Processor Error Codes (continued)

<b>Error Code</b>	<b>Description</b>	<b>Action/ Possible Failing FRU</b>
460C 25AD	I/O system and IPL MOPS detected 540 MHz clock fault	540 MHz clock Location: U1.1-P1.1.1
460C 25B1	I/O system and IPL MOPS detected 750 MHz clock fault	750 MHz clock Location: U1.1-P1.1.1
460C 25B3	I/O system and IPL MOPS detected 4W 750 MHz processor fault	Processor card Locations: U1.1-P1-C1 U1.1-P1-C2
460C 25B4	I/O system and IPL MOPS detected 2W 750 MHz processor fault	Processor card Locations: U1.1-P1-C1 U1.1-P1-C2
460C 25DA	I/O system and IPL MOPS detected 500 MHz clock fault	500 MHz clock Location: U1.1-P1.1.1
460C 267D	I/O system and wire test detected an 8W, 750 MHz regulator fault	8W regulator card Location: U1.1-P1-V1
460C 2687	I/O system and IPL MOPS detected remote I/O bus adapter fault	Remote I/O bus adapter Location: U1.1-P1.1
460C 271A	I/O system and IPL MOPS detected primary I/O planar fault	Primary I/O planar Location: U0.1-P1
460C 271D	I/O system and IPL MOPS detected secondary I/O planar fault	Secondary I/O planar Locations: U0.2-P1 U0.3-P1 U0.4-P1
460C 2733	I/O system and IPL MOPS detected I/O clock fault	CEC RIO bus adapter Location: U1.1-P1.1
460C 27AA	I/O system and IPL MOPS detected a 2W/4W regulator fault	2W/4W regulator card Location: U1.1-P1-V1
460C 27AB	I/O system and IPL MOPS detected an 8W regulator fault	8W regulator card Location: U1.1-P1-V1
460C 281C	I/O system and IPL MOPS detected CEC backplane fault	CEC backplane Location: U1.1-P1
460C 281D	I/O system and IPL MOPS detected Model 6M1 CEC backplane fault	CEC backplane Location: U1.1-P1
460C 285D	I/O system and IPL MOPS detected SPCN fan controller fault	1. SPCN fan controller Location: U0.1-X2 2. I/O drawer power distribution board Location: U0.1-X1

Table 7. Service Processor Error Codes (continued)

Error Code	Description	Action/ Possible Failing FRU
460C 288A	I/O system and IPL MOPS detected memory riser card fault	<ol style="list-style-type: none"> <li>Go to the service processor Memory Configuration/Deconfiguration Menu to verify memory DIMMs state. See "Memory Configuration/Deconfiguration Menu" on page 426 for more information.</li> <li>Memory riser card Locations: U1.1-P1-M1 U1.1-P1-M2</li> </ol>
460C 300A	I/O system and IPL MOPS detected 32 MB DIMM fault	Memory DIMM Locations: U1.1-P1-M1.n U1.1-P1-M2.n
460C 300B	I/O system and IPL MOPS detected 128 MB DIMM fault	Memory DIMM Locations: U1.1-P1-M1.n U1.1-P1-M2.n
460C 300C	I/O system and IPL MOPS detected 256 MB DIMM fault	Memory DIMM Locations: U1.1-P1-M1.n U1.1-P1-M2.n
460C 300D	I/O system and IPL MOPS detected 512 MB (stacked) DIMM fault	Memory DIMM Locations: U1.1-P1-M1.n U1.1-P1-M2.n
460C 300E	I/O system and IPL MOPS detected 512 MB (unstacked) DIMM fault	Memory DIMM Locations: U1.1-P1-M1.n U1.1-P1-M2.n
460C 301F	I/O system and IPL MOPS detected 128 MB DIMM fault	Memory DIMM Locations: U1.1-P1-M1.n U1.1-P1-M2.n
460C 303A	I/O system and IPL MOPS detected 1 GB DIMM fault	Memory DIMM Locations: U1.1-P1-M1.n U1.1-P1-M2.n
460C 515B	I/O system and IPL MOPS detected 1100W ac power supply fault	1100W ac power supply Locations: U1.1-V1 U1.1-V2
460C 51AC	I/O system and IPL MOPS detected 595W ac power supply fault	595W ac power supply Locations: U0.1-V1 U0.1-V2
460C 51AD	I/O system and IPL MOPS detected 595W dc power supply fault	595W dc power supply Locations: U0.1-V1 U0.1-V2
460C 51AE	I/O system and IPL MOPS detected 1100W dc power supply fault	1100W dc power supply Locations: U1.1-V1 U1.1-V2

Table 7. Service Processor Error Codes (continued)

<b>Error Code</b>	<b>Description</b>	<b>Action/ Possible Failing FRU</b>
460D 245B	I/O system and attention handler detected 2W 4M processor fault	Processor card Locations: U1.1-P1-C1 U1.1-P1-C2
460D 245C	I/O system and attention handler detected 2W 2M processor fault	Processor card Locations: U1.1-P1-C1 U1.1-P1-C2
460D 245D	I/O system and attention handler detected 4W 4M processor fault	Processor card Locations: U1.1-P1-C1 U1.1-P1-C2
460D 248B	I/O system and attention handler detected primary I/O drawer operator panel fault	Operator Panel Location: U0.1-L1
460D 24A5	I/O system and attention handler detected 2W 500 MHz processor fault	Processor card Locations: U1.1-P1-C1 U1.1-P1-C2
460D 24A6	I/O system and attention handler detected 4W 500 MHz processor fault	Processor card Locations: U1.1-P1-C1 U1.1-P1-C2
460D 25AB	I/O system and attention handler detected 400 MHz clock fault	400 MHz clock Location: U1.1-P1.1.1
460D 25AD	I/O system and attention handler detected 540 MHz clock fault	540 MHz clock Location: U1.1-P1.1.1
460D 25B1	I/O system and attention handler detected 750 MHz clock fault	750 MHz clock Location: U1.1-P1.1.1
460D 25B3	I/O system and attention handler detected 4W 750 MHz processor fault	Processor card Locations: U1.1-P1-C1 U1.1-P1-C2
460D 25B4	I/O system and attention handler detected 2W 750 MHz processor fault	Processor card Locations: U1.1-P1-C1 U1.1-P1-C2
460D 25DA	I/O system and attention handler detected 500 MHz clock fault	500 MHz clock Location: U1.1-P1.1.1
460D 267D	I/O system and wire test detected an 8W, 750 MHz regulator fault	8W regulator card Location: U1.1-P1-V1
460D 2687	I/O system and attention handler detected remote I/O bus adapter fault	Remote I/O bus adapter Location: U1.1-P1.1
460D 271A	I/O system and attention handler detected primary I/O planar fault	Primary I/O planar Location: U0.1-P1
460D 271D	I/O system and attention handler detected secondary I/O planar fault	Secondary I/O planar Locations: U0.2-P1 U0.3-P1 U0.4-P1
460D 2733	I/O system and attention handler detected I/O clock fault	CEC RIO bus adapter Location: U1.1-P1.1

Table 7. Service Processor Error Codes (continued)

Error Code	Description	Action/ Possible Failing FRU
460D 27AA	I/O system and attention handler detected a 2W/4W regulator fault	2W/4W regulator card Location: U1.1-P1-V1
460D 27AB	I/O system and attention handler detected an 8W regulator fault	8W regulator card Location: U1.1-P1-V1
460D 281C	I/O system and attention handler detected CEC backplane fault	CEC backplane Location: U1.1-P1
460D 281D	I/O system and attention handler detected Model 6M1 CEC backplane fault	CEC backplane Location: U1.1-P1
460D 285D	I/O system and attention handler detected SPCN fan controller fault	1. SPCN fan controller Location: U0.1-X2 2. I/O drawer power distribution board Location: U0.1-X1
460D 288A	I/O system and attention handler detected memory riser card fault	1. Go to the service processor Memory Configuration/Deconfiguration Menu to verify memory DIMMs state. See "Memory Configuration/Deconfiguration Menu" on page 426 for more information. 2. Memory riser card Locations: U1.1-P1-M1 U1.1-P1-M2
460D 300A	I/O system and attention handler detected 32 MB DIMM fault	Memory DIMM Locations: U1.1-P1-M1.n U1.1-P1-M2.n
460D 300B	I/O system and attention handler detected 128 MB DIMM fault	Memory DIMM Locations: U1.1-P1-M1.n U1.1-P1-M2.n
460D 300C	I/O system and attention handler detected 256 MB DIMM fault	Memory DIMM Locations: U1.1-P1-M1.n U1.1-P1-M2.n
460D 300D	I/O system and attention handler detected 512 MB (stacked) DIMM fault	Memory DIMM Locations: U1.1-P1-M1.n U1.1-P1-M2.n
460D 300E	I/O system and attention handler detected 512 MB (unstacked) DIMM fault	Memory DIMM Locations: U1.1-P1-M1.n U1.1-P1-M2.n
460D 301F	I/O system and attention handler detected 128 MB DIMM fault	Memory DIMM Locations: U1.1-P1-M1.n U1.1-P1-M2.n
460D 303A	I/O system and attention handler detected 1 GB DIMM fault	Memory DIMM Locations: U1.1-P1-M1.n U1.1-P1-M2.n

Table 7. Service Processor Error Codes (continued)

Error Code	Description	Action/ Possible Failing FRU
460D 515B	I/O system and attention handler detected 1100W ac power supply fault	1100W ac power supply Locations: U1.1-V1 U1.1-V2
460D 51AC	I/O system and attention handler detected 595W ac power supply fault	595W ac power supply Locations: U0.1-V1 U0.1-V2
460D 51AD	I/O system and attention handler detected 595W dc power supply fault	595W dc power supply Locations: U0.1-V1 U0.1-V2
460D 51AE	I/O system and attention handler detected 1100W dc power supply fault	1100W dc power supply Locations: U1.1-V1 U1.1-V2
460E 245B	I/O system and scan control routines detected 2W 4M processor fault	Processor card Locations: U1.1-P1-C1 U1.1-P1-C2
460E 245C	I/O system and scan control routines detected 2W 2M processor fault	Processor card Locations: U1.1-P1-C1 U1.1-P1-C2
460E 245D	I/O system and scan control routines detected 4W 4M processor fault	Processor card Locations: U1.1-P1-C1 U1.1-P1-C2
460E 248B	I/O system and scan control routines detected primary I/O drawer operator panel fault	Operator Panel Location: U0.1-L1
460E 24A5	I/O system and scan control routines detected 2W 500 MHz processor fault	Processor card Locations: U1.1-P1-C1 U1.1-P1-C2
460E 24A6	I/O system and scan control routines detected 4W 500 MHz processor fault	Processor card Locations: U1.1-P1-C1 U1.1-P1-C2
460E 25AB	I/O system and scan control routines detected 400 MHz clock fault	400 MHz clock Location: U1.1-P1.1.1
460E 25AD	I/O system and scan control routines detected 540 MHz clock fault	540 MHz clock Location: U1.1-P1.1.1
460E 25B1	I/O system and scan control routines detected 750 MHz clock fault	750 MHz clock Location: U1.1-P1.1.1
460E 25B3	I/O system and scan control routines detected 4W 750 MHz processor fault	Processor card Locations: U1.1-P1-C1 U1.1-P1-C2
460E 25B4	I/O system and scan control routines detected 2W 750 MHz processor fault	Processor card Locations: U1.1-P1-C1 U1.1-P1-C2
460E 25DA	I/O system and scan control routines detected 500 MHz clock fault	500 MHz clock Location: U1.1-P1.1.1

Table 7. Service Processor Error Codes (continued)

Error Code	Description	Action/ Possible Failing FRU
460E 267D	I/O system and scan control routines detected an 8W, 750 MHz regulator fault	8W regulator card Location: U1.1-P1-V1
460E 2687	I/O system and scan control routines detected remote I/O bus adapter fault	Remote I/O bus adapter Location: U1.1-P1.1
460E 271A	I/O system and scan control routines detected primary I/O planar fault	Primary I/O planar Location: U0.1-P1
460E 271D	I/O system and scan control routines detected secondary I/O planar fault	Secondary I/O planar Locations: U0.2-P1 U0.3-P1 U0.4-P1
460E 2733	I/O system and scan control routines detected I/O clock fault	CEC RIO bus adapter Location: U1.1-P1.1
460E 27AA	I/O system and scan control routines detected a 2W/4W regulator fault	2W/4W regulator card Location: U1.1-P1-V1
460E 27AB	I/O system and scan control routines detected an 8W regulator fault	8W regulator card Location: U1.1-P1-V1
460E 281C	I/O system and scan control routines detected CEC backplane fault	CEC backplane Location: U1.1-P1
460E 281D	I/O system and scan control routines detected Model 6M1 CEC backplane fault	CEC backplane Location: U1.1-P1
460E 285D	I/O system and scan control routines detected SPCN fan controller fault	1. SPCN fan controller Location: U0.1-X2 2. I/O drawer power distribution board Location: U0.1-X1
460E 288A	I/O system and scan control routines detected memory riser card fault	1. Go to the service processor Memory Configuration/Deconfiguration Menu to verify memory DIMMs state. See "Memory Configuration/Deconfiguration Menu" on page 426 for more information. 2. Memory riser card Locations: U1.1-P1-M1 U1.1-P1-M2
460E 300A	I/O system and scan control routines detected 32 MB DIMM fault	Memory DIMM Locations: U1.1-P1-M1.n U1.1-P1-M2.n
460E 300B	I/O system and scan control routines detected 128 MB DIMM fault	Memory DIMM Locations: U1.1-P1-M1.n U1.1-P1-M2.n



Table 7. Service Processor Error Codes (continued)

<b>Error Code</b>	<b>Description</b>	<b>Action/ Possible Failing FRU</b>
460E 300C	I/O system and scan control routines detected 256 MB DIMM fault	Memory DIMM Locations: U1.1-P1-M1.n U1.1-P1-M2.n
460E 300D	I/O system and scan control routines detected 512 MB (stacked) DIMM fault	Memory DIMM Locations: U1.1-P1-M1.n U1.1-P1-M2.n
460E 300E	I/O system and scan control routines detected 512 MB (unstacked) DIMM fault	Memory DIMM Locations: U1.1-P1-M1.n U1.1-P1-M2.n
460E 301F	I/O system and scan control routines detected 128 MB DIMM fault	Memory DIMM Locations: U1.1-P1-M1.n U1.1-P1-M2.n
460E 303A	I/O system and scan control routines detected 1 GB DIMM fault	Memory DIMM Locations: U1.1-P1-M1.n U1.1-P1-M2.n
460E 515B	I/O system and scan control routines detected 1100W ac power supply fault	1100W ac power supply Locations: U1.1-V1 U1.1-V2
460E 51AC	I/O system and scan control routines detected 595W ac power supply fault	595W ac power supply Locations: U0.1-V1 U0.1-V2
460E 51AD	I/O system and scan control routines detected 595W dc power supply fault	595W dc power supply Locations: U0.1-V1 U0.1-V2
460E 51AE	I/O system and scan control routines detected 1100W dc power supply fault	1100W dc power supply Locations: U1.1-V1 U1.1-V2
460F 245B	I/O system and error code generation/logging detected 2W 4M processor fault	Processor card Locations: U1.1-P1-C1 U1.1-P1-C2
460F 245C	I/O system and error code generation/logging detected 2W 2M processor fault	Processor card Locations: U1.1-P1-C1 U1.1-P1-C2
460F 245D	I/O system and error code generation/logging detected 4W 4M processor fault	Processor card Locations: U1.1-P1-C1 U1.1-P1-C2
460F 248B	I/O system and error code generation/logging detected primary I/O drawer operator panel fault	Operator Panel Location: U0.1-L1
460F 24A5	I/O system and error code generation/logging detected 2W 500 MHz processor fault	Processor card Locations: U1.1-P1-C1 U1.1-P1-C2
460F 24A6	I/O system and error code generation/logging detected 4W 500 MHz processor fault	Processor card Locations: U1.1-P1-C1 U1.1-P1-C2

Table 7. Service Processor Error Codes (continued)

<b>Error Code</b>	<b>Description</b>	<b>Action/ Possible Failing FRU</b>
460F 25AB	I/O system and error code generation/logging detected 400 MHz clock fault	400 MHz clock Location: U1.1-P1.1.1
460F 25AD	I/O system and error code generation/logging detected 540 MHz clock fault	540 MHz clock Location: U1.1-P1.1.1
460F 25B1	I/O system and error code generation/logging detected 750 MHz clock fault	750 MHz clock Location: U1.1-P1.1.1
460F 25B3	I/O system and error code generation/logging detected 4W 750 MHz processor fault	Processor card Locations: U1.1-P1-C1 U1.1-P1-C2
460F 25B4	I/O system and error code generation/logging detected 2W 750 MHz processor fault	Processor card Locations: U1.1-P1-C1 U1.1-P1-C2
460F 25DA	I/O system and error code generation/logging detected 500 MHz clock fault	500 MHz clock Location: U1.1-P1.1.1
460F 267D	I/O system and error code generation/logging detected an 8W, 750 MHz regulator fault	8W regulator card Location: U1.1-P1-V1
460F 2687	I/O system and error code generation/logging detected remote I/O bus adapter fault	Remote I/O bus adapter Location: U1.1-P1.1
460F 271A	I/O system and error code generation/logging detected primary I/O planar fault	Primary I/O planar Location: U0.1-P1
460F 271D	I/O system and error code generation/logging detected secondary I/O planar fault	Secondary I/O planar Locations: U0.2-P1 U0.3-P1 U0.4-P1
460F 2733	I/O system and error code generation/logging detected I/O clock fault	CEC RIO bus adapter Location: U1.1-P1.1
460F 27AA	I/O system and error code generation/logging detected a 2W/4W regulator fault	2W/4W regulator card Location: U1.1-P1-V1
460F 27AB	I/O system and error code generation/logging detected an 8W regulator fault	8W regulator card Location: U1.1-P1-V1
460F 281C	I/O system and error code generation/logging detected CEC backplane fault	CEC backplane Location: U1.1-P1

Table 7. Service Processor Error Codes (continued)

Error Code	Description	Action/ Possible Failing FRU
460F 281D	I/O system and error code generation/logging detected Model 6M1 CEC backplane fault	CEC backplane Location: U1.1-P1
460F 285D	I/O system and error code generation/logging detected SPCN fan controller fault	1. SPCN fan controller Location: U0.1-X2 2. I/O drawer power distribution board Location: U0.1-X1
460F 288A	I/O system and error code generation/logging detected memory riser card fault	1. Go to the service processor Memory Configuration/Deconfiguration Menu to verify memory DIMMs state. See "Memory Configuration/Deconfiguration Menu" on page 426 for more information. 2. Memory riser card Locations: U1.1-P1-M1 U1.1-P1-M2
460F 300A	I/O system and error code generation/logging detected 32 MB DIMM fault	Memory DIMM Locations: U1.1-P1-M1.n U1.1-P1-M2.n
460F 300B	I/O system and error code generation/logging detected 128 MB DIMM fault	Memory DIMM Locations: U1.1-P1-M1.n U1.1-P1-M2.n
460F 300C	I/O system and error code generation/logging detected 256 MB DIMM fault	Memory DIMM Locations: U1.1-P1-M1.n U1.1-P1-M2.n
460F 300D	I/O system and error code generation/logging detected 512 MB (stacked) DIMM fault	Memory DIMM Locations: U1.1-P1-M1.n U1.1-P1-M2.n
460F 300E	I/O system and error code generation/logging detected 512 MB (unstacked) DIMM fault	Memory DIMM Locations: U1.1-P1-M1.n U1.1-P1-M2.n
460F 301F	I/O system and error code generation/logging detected 128 MB DIMM fault	Memory DIMM Locations: U1.1-P1-M1.n U1.1-P1-M2.n
460F 303A	I/O system and error code generation/logging detected 1 GB DIMM fault	Memory DIMM Locations: U1.1-P1-M1.n U1.1-P1-M2.n
460F 515B	I/O system and error code generation/logging detected 1100W ac power supply fault	1100W ac power supply Locations: U1.1-V1 U1.1-V2
460F 51AC	I/O system and error code generation/logging detected 595W ac power supply fault	595W ac power supply Locations: U0.1-V1 U0.1-V2

Table 7. Service Processor Error Codes (continued)

<b>Error Code</b>	<b>Description</b>	<b>Action/ Possible Failing FRU</b>
460F 51AD	I/O system and error code generation/logging detected 595W dc power supply fault	595W dc power supply Locations: U0.1-V1 U0.1-V2
460F 51AE	I/O system and error code generation/logging detected 1100W dc power supply fault	1100W dc power supply Locations: U1.1-V1 U1.1-V2
4B26 245B	Processor system and scan interface basic assurance tests detected 2W 4M processor fault	Go to "MAP 1540: Minimum Configuration" on page 122.
4B26 245C	Processor system and scan interface basic assurance tests detected 2W 2M processor fault	Go to "MAP 1540: Minimum Configuration" on page 122.
4B26 245D	Processor system and scan interface basic assurance tests detected 4W 4M processor fault	Go to "MAP 1540: Minimum Configuration" on page 122.
4B26 248B	Processor system and scan interface basic assurance tests detected primary I/O drawer operator panel fault	Operator Panel Location: U0.1-L1
4B26 24A5	Processor system and scan interface basic assurance tests detected 2W 500 MHz processor fault	Go to "MAP 1540: Minimum Configuration" on page 122.
4B26 24A6	Processor system and scan interface basic assurance tests detected 4W 500 MHz processor fault	Go to "MAP 1540: Minimum Configuration" on page 122.
4B26 25AB	Processor system and scan interface basic assurance tests detected 400 MHz clock fault	400 MHz clock Location: U1.1-P1.1.1
4B26 25AD	Processor system and scan interface basic assurance tests detected 540 MHz clock fault	540 MHz clock Location: U1.1-P1.1.1
4B26 25B1	Processor system and scan interface basic assurance tests detected 750 MHz clock fault	750 MHz clock Location: U1.1-P1.1.1
4B26 25B3	Processor system and scan interface basic assurance tests detected 4W 750 MHz processor fault	Go to "MAP 1540: Minimum Configuration" on page 122.
4B26 25B4	Processor system and scan interface basic assurance tests detected 2W 750 MHz processor fault	Go to "MAP 1540: Minimum Configuration" on page 122.
4B26 25DA	Processor system and scan interface basic assurance tests detected 500 MHz clock fault	500 MHz clock Location: U1.1-P1.1.1

Table 7. Service Processor Error Codes (continued)

Error Code	Description	Action/ Possible Failing FRU
4B26 267D	Processor system and scan interface basic assurance tests detected an 8W, 750 MHz regulator fault	8W regulator card Location: U1.1-P1-V1
4B26 2687	Processor system and scan interface basic assurance tests detected remote I/O bus adapter fault	Remote I/O bus adapter Location: U1.1-P1.1
4B26 271A	Processor system and scan interface basic assurance tests detected primary I/O planar fault	Primary I/O planar Location: U0.1-P1
4B26 271D	Processor system and scan interface basic assurance tests detected secondary I/O planar fault	Secondary I/O planar Locations: U0.2-P1 U0.3-P1 U0.4-P1
4B26 2733	Processor system and scan interface basic assurance tests detected I/O clock fault	CEC RIO bus adapter Location: U1.1-P1.1
4B26 27AA	Processor system and scan interface basic assurance tests detected a 2W/4W regulator fault	2W/4W regulator card Location: U1.1-P1-V1
4B26 27AB	Processor system and scan interface basic assurance tests detected an 8W regulator fault	8W regulator card Location: U1.1-P1-V1
4B26 281C	Processor system and scan interface basic assurance tests detected CEC backplane fault	CEC backplane Location: U1.1-P1
4B26 281D	Processor system and scan interface basic assurance tests detected Model 6M1 CEC backplane fault	CEC backplane Location: U1.1-P1
4B26 285D	Processor system and scan interface basic assurance tests detected SPCN fan controller fault	1. SPCN fan controller Location: U0.1-X2 2. I/O drawer power distribution board Location: U0.1-X1
4B26 288A	Processor system and scan interface basic assurance tests detected memory riser card fault	1. Go to the service processor Memory Configuration/Deconfiguration Menu to verify memory DIMMs state. See "Memory Configuration/Deconfiguration Menu" on page 426 for more information. 2. Memory riser card Locations: U1.1-P1-M1 U1.1-P1-M2

Table 7. Service Processor Error Codes (continued)

<b>Error Code</b>	<b>Description</b>	<b>Action/ Possible Failing FRU</b>
4B26 300A	Processor system and scan interface basic assurance tests detected 32 MB DIMM fault	Memory DIMM Locations: U1.1-P1-M1.n U1.1-P1-M2.n
4B26 300B	Processor system and scan interface basic assurance tests detected 128 MB DIMM fault	Memory DIMM Locations: U1.1-P1-M1.n U1.1-P1-M2.n
4B26 300C	Processor system and scan interface basic assurance tests detected 256 MB DIMM fault	Memory DIMM Locations: U1.1-P1-M1.n U1.1-P1-M2.n
4B26 300D	Processor system and scan interface basic assurance tests detected 512 MB (stacked) DIMM fault	Memory DIMM Locations: U1.1-P1-M1.n U1.1-P1-M2.n
4B26 300E	Processor system and scan interface basic assurance tests detected 512 MB (unstacked) DIMM fault	Memory DIMM Locations: U1.1-P1-M1.n U1.1-P1-M2.n
4B26 301F	Processor system and scan interface basic assurance tests detected 128 MB DIMM fault	Memory DIMM Locations: U1.1-P1-M1.n U1.1-P1-M2.n
4B26 303A	Processor system and scan interface basic assurance tests detected 1 GB DIMM fault	Memory DIMM Locations: U1.1-P1-M1.n U1.1-P1-M2.n
4B26 515B	Processor system and scan interface basic assurance tests detected 1100W ac power supply fault	1100W ac power supply Locations: U1.1-V1 U1.1-V2
4B26 51AC	Processor system and scan interface basic assurance tests detected 595W ac power supply fault	595W ac power supply Locations: U0.1-V1 U0.1-V2
4B26 51AD	Processor system and scan interface basic assurance tests detected 595W dc power supply fault	595W dc power supply Locations: U0.1-V1 U0.1-V2
4B26 51AE	Processor system and scan interface basic assurance tests detected 1100W dc power supply fault	1100W dc power supply Locations: U1.1-V1 U1.1-V2
4B27 245B	Processor system and 6xx bus processor runtime diagnostics detected 2W 4M processor fault	Go to the service processor Processor Configuration/Deconfiguration Menu to check the states of the processors. See "Processor Configuration/Deconfiguration Menu" on page 425 for more information. Replace the card that has the bad processors. Locations: U1.1-P1-C1 U1.1-P1-C2

Table 7. Service Processor Error Codes (continued)

Error Code	Description	Action/ Possible Failing FRU
4B27 245C	Processor system and 6xx bus processor runtime diagnostics detected 2W 2M processor fault	Go to the service processor Processor Configuration/Deconfiguration Menu to check the states of the processors. See "Processor Configuration/Deconfiguration Menu" on page 425 for more information. Replace the card that has the bad processors. Locations: U1.1-P1-C1 U1.1-P1-C2
4B27 245D	Processor system and 6xx bus processor runtime diagnostics detected 4W 4M processor fault	Go to the service processor Processor Configuration/Deconfiguration Menu to check the states of the processors. See "Processor Configuration/Deconfiguration Menu" on page 425 for more information. Replace the card that has the bad processors. Locations: U1.1-P1-C1 U1.1-P1-C2
4B27 248B	Processor system and 6xx bus processor runtime diagnostics detected primary I/O drawer operator panel fault	Operator panel Location: U0.1-L1
4B27 24A5	Processor system and 6xx bus processor runtime diagnostics detected 2W 500 MHz processor fault	Go to the service processor Processor Configuration/Deconfiguration Menu to check the states of the processors. See "Processor Configuration/Deconfiguration Menu" on page 425 for more information. Replace the card that has the bad processors. Locations: U1.1-P1-C1 U1.1-P1-C2
4B27 24A6	Processor system and 6xx bus processor runtime diagnostics detected 4W 500 MHz processor fault	Go to the service processor Processor Configuration/Deconfiguration Menu to check the states of the processors. See "Processor Configuration/Deconfiguration Menu" on page 425 for more information. Replace the card that has the bad processors. Locations: U1.1-P1-C1 U1.1-P1-C2

Table 7. Service Processor Error Codes (continued)

<b>Error Code</b>	<b>Description</b>	<b>Action/ Possible Failing FRU</b>
4B27 25AB	Processor system and 6xx bus processor runtime diagnostics detected 400 MHz clock fault	400 MHz clock Location: U1.1-P1.1.1
4B27 25B1	Processor system and 6xx bus processor runtime diagnostics detected 750 MHz clock fault	750 MHz clock Location: U1.1-P1.1.1
4B27 25B3	Processor system and 6xx bus processor runtime diagnostics detected 4W 750 MHz processor fault	Go to the service processor Processor Configuration/Deconfiguration Menu to check the states of the processors. See "Processor Configuration/Deconfiguration Menu" on page 425 for more information. Replace the card that has the bad processors. Locations: U1.1-P1-C1 U1.1-P1-C2
4B27 25B4	Processor system and 6xx bus processor runtime diagnostics detected 2W 750 MHz processor fault	Go to the service processor Processor Configuration/Deconfiguration Menu to check the states of the processors. See "Processor Configuration/Deconfiguration Menu" on page 425 for more information. Replace the card that has the bad processors. Locations: U1.1-P1-C1 U1.1-P1-C2
4B27 25DA	Processor system and 6xx bus processor runtime diagnostics detected 500 MHz clock fault	500 MHz clock Location: U1.1-P1.1.1
4B27 267D	Processor system and 6xx bus processor runtime diagnostics detected an 8W, 750 MHz regulator fault	8W regulator card Location: U1.1-P1-V1
4B27 2687	Processor system and 6xx bus processor runtime diagnostics detected remote I/O bus adapter fault	Remote I/O bus adapter Location: U0.1-P1.1
4B27 271A	Processor system and 6xx bus processor runtime diagnostics detected primary I/O backplane fault	Primary I/O backplane Location: U0.1-P1
4B27 271D	Processor system and 6xx bus processor runtime diagnostics detected secondary I/O backplane fault	Secondary I/O backplane Locations: U0.2-P1 U0.3-P1 U0.4-P1



Table 7. Service Processor Error Codes (continued)

<b>Error Code</b>	<b>Description</b>	<b>Action/ Possible Failing FRU</b>
4B27 2733	Processor system and 6xx bus processor runtime diagnostics detected I/O clock fault	CEC RIO bus adapter Location: U1.1-P1.1
4B27 27AA	Processor system and 6xx bus processor runtime diagnostics detected a 2W/4W regulator fault	2W/4W regulator card Location: U1.1-P1-V1
4B27 27AB	Processor system and 6xx bus processor runtime diagnostics detected an 8W regulator fault	8W regulator card Location: U1.1-P1-V1
4B27 281C	Processor system and 6xx bus processor runtime diagnostics detected CEC backplane fault	CEC backplane Location: U1.1-P1
4B27 281D	Processor system and 6xx bus processor runtime diagnostics detected Model 6M1 CEC backplane fault	CEC backplane Location: U1.1-P1
4B27 285D	Processor system and 6xx bus processor runtime diagnostics detected SPCN fan controller fault	1. SPCN fan controller Location: U0.1-X2 2. Processor system and 6xx bus processor runtime diagnostics Location: U0.1-X1
4B27 288A	Processor system and 6xx bus processor runtime diagnostics detected memory riser card fault	1. Go to the service processor Memory Configuration/Deconfiguration Menu to verify memory DIMMs state. See "Memory Configuration/Deconfiguration Menu" on page 426 for more information. 2. Memory riser card Locations: U1.1-P1-M1 U1.1-P1-M2
4B27 300A	Processor system and 6xx bus processor runtime diagnostics detected 32 MB DIMM fault	Memory DIMM Locations: U1.1-P1-M1.n U1.1-P1-M2.n
4B27 300B	Processor system and 6xx bus processor runtime diagnostics detected 128 MB DIMM fault	Memory DIMM Locations: U1.1-P1-M1.n U1.1-P1-M2.n
4B27 300C	Processor system and 6xx bus processor runtime diagnostics detected 256 MB DIMM fault	Memory DIMM Locations: U1.1-P1-M1.n U1.1-P1-M2.n
4B27 300D	Processor system and 6xx bus processor runtime diagnostics detected 512 MB (stacked) DIMM fault	Memory DIMM Locations: U1.1-P1-M1.n U1.1-P1-M2.n

Table 7. Service Processor Error Codes (continued)

<b>Error Code</b>	<b>Description</b>	<b>Action/ Possible Failing FRU</b>
4B27 300E	Processor system and 6xx bus processor runtime diagnostics detected 512 MB (unstacked) DIMM fault	Memory DIMM Locations: U1.1-P1-M1.n U1.1-P1-M2.n
4B27 301F	Processor system and 6xx bus processor runtime diagnostics detected 128 MB DIMM fault	Memory DIMM Locations: U1.1-P1-M1.n U1.1-P1-M2.n
4B27 303A	Processor system and 6xx bus processor runtime diagnostics detected 1 GB DIMM fault	Memory DIMM Locations: U1.1-P1-M1.n U1.1-P1-M2.n
4B27 515B	Processor system and 6xx bus processor runtime diagnostics detected 1100W ac power supply fault	1100W ac power supply Locations: U1.1-V1 U1.1-V2
4B27 51AC	Processor system and 6xx bus processor runtime diagnostics detected 595W ac power supply fault	595W ac power supply Locations: U0.1-V1 U0.1-V2
4B27 51AD	Processor system and 6xx bus processor runtime diagnostics detected 595W dc power supply fault	595W dc power supply Locations: U0.1-V1 U0.1-V2
4B27 51AE	Processor system and 6xx bus processor runtime diagnostics detected 1100W dc power supply fault	1100W dc power supply Locations: U1.1-V1 U1.1-V2
4B28 245B	Processor system and other bus processor runtime diagnostics detected 2W 4M processor fault	Go to "MAP 1540: Minimum Configuration" on page 122.
4B28 245C	Processor system and other bus processor runtime diagnostics detected 2W 2M processor fault	Go to "MAP 1540: Minimum Configuration" on page 122.
4B28 245D	Processor system and other bus processor runtime diagnostics detected 4W 4M processor fault	Go to "MAP 1540: Minimum Configuration" on page 122.
4B28 248B	Processor system and other bus processor runtime diagnostics detected primary I/O drawer operator panel fault	Operator Panel Location: U0.1-L1
4B28 24A5	Processor system and other bus processor runtime diagnostics detected 2W 500 MHz processor fault	Go to "MAP 1540: Minimum Configuration" on page 122.
4B28 24A6	Processor system and other bus processor runtime diagnostics detected 4W 500 MHz processor fault	Go to "MAP 1540: Minimum Configuration" on page 122.

Table 7. Service Processor Error Codes (continued)

<b>Error Code</b>	<b>Description</b>	<b>Action/ Possible Failing FRU</b>
4B28 25AB	Processor system and other bus processor runtime diagnostics detected 400 MHz clock fault	400 MHz clock Location: U1.1-P1.1.1
4B28 25AD	Processor system and other bus processor runtime diagnostics detected 540 MHz clock fault	540 MHz clock Location: U1.1-P1.1.1
4B28 25B1	Processor system and other bus processor runtime diagnostics detected 750 MHz clock fault	750 MHz clock Location: U1.1-P1.1.1
4B28 25B3	Processor system and other bus processor runtime diagnostics detected 4W 750 MHz processor fault	Go to "MAP 1540: Minimum Configuration" on page 122.
4B28 25B4	Processor system and other bus processor runtime diagnostics detected 2W 750 MHz processor fault	Go to "MAP 1540: Minimum Configuration" on page 122.
4B28 25DA	Processor system and other bus processor runtime diagnostics detected 500 MHz clock fault	500 MHz clock Location: U1.1-P1.1.1
4B28 267D	Processor system and other bus processor runtime diagnostics detected an 8W, 750 MHz regulator fault	8W regulator card Location: U1.1-P1-V1
4B28 2687	Processor system and other bus processor runtime diagnostics detected remote I/O bus adapter fault	Remote I/O bus adapter Location: U1.1-P1.1
4B28 271A	Processor system and other bus processor runtime diagnostics detected primary I/O planar fault	Primary I/O planar Location: U0.1-P1
4B28 271D	Processor system and other bus processor runtime diagnostics detected secondary I/O planar fault	Secondary I/O planar Locations: U0.2-P1 U0.3-P1 U0.4-P1
4B28 2733	Processor system and other bus processor runtime diagnostics detected I/O clock fault	CEC RIO bus adapter Location: U1.1-P1.1
4B28 27AA	Processor system and other bus processor runtime diagnostics detected a 2W/4W regulator fault	2W/4W regulator card Location: U1.1-P1-V1
4B28 27AB	Processor system and other bus processor runtime diagnostics detected an 8W regulator fault	8W regulator card Location: U1.1-P1-V1

Table 7. Service Processor Error Codes (continued)

Error Code	Description	Action/ Possible Failing FRU
4B28 281C	Processor system and other bus processor runtime diagnostics detected CEC backplane fault	CEC backplane Location: U1.1-P1
4B28 281D	Processor system and other bus processor runtime diagnostics detected Model 6M1 CEC backplane fault	CEC backplane Location: U1.1-P1
4B28 285D	Processor system and other bus processor runtime diagnostics detected SPCN fan controller fault	1. SPCN fan controller Location: U0.1-X2 2. I/O drawer power distribution board Location: U0.1-X1
4B28 288A	Processor system and other bus processor runtime diagnostics detected memory riser card fault	1. Go to the service processor Memory Configuration/Deconfiguration Menu to verify memory DIMMs state. See "Memory Configuration/Deconfiguration Menu" on page 426 for more information. 2. Memory riser card Locations: U1.1-P1-M1 U1.1-P1-M2
4B28 300A	Processor system and other bus processor runtime diagnostics detected 32 MB DIMM fault	Memory DIMM Locations: U1.1-P1-M1.n U1.1-P1-M2.n
4B28 300B	Processor system and other bus processor runtime diagnostics detected 128 MB DIMM fault	Memory DIMM Locations: U1.1-P1-M1.n U1.1-P1-M2.n
4B28 300C	Processor system and other bus processor runtime diagnostics detected 256 MB DIMM fault	Memory DIMM Locations: U1.1-P1-M1.n U1.1-P1-M2.n
4B28 300D	Processor system and other bus processor runtime diagnostics detected 512 MB (stacked) DIMM fault	Memory DIMM Locations: U1.1-P1-M1.n U1.1-P1-M2.n
4B28 300E	Processor system and other bus processor runtime diagnostics detected 512 MB (unstacked) DIMM fault	Memory DIMM Locations: U1.1-P1-M1.n U1.1-P1-M2.n
4B28 301F	Processor system and other bus processor runtime diagnostics detected 128 MB DIMM fault	Memory DIMM Locations: U1.1-P1-M1.n U1.1-P1-M2.n
4B28 303A	Processor system and other bus processor runtime diagnostics detected 1 GB DIMM fault	Memory DIMM Locations: U1.1-P1-M1.n U1.1-P1-M2.n

Table 7. Service Processor Error Codes (continued)

<b>Error Code</b>	<b>Description</b>	<b>Action/ Possible Failing FRU</b>
4B28 515B	Processor system and other bus processor runtime diagnostics detected 1100W ac power supply fault	1100W ac power supply Locations: U1.1-V1 U1.1-V2
4B28 51AC	Processor system and other bus processor runtime diagnostics detected 595W ac power supply fault	595W ac power supply Locations: U0.1-V1 U0.1-V2
4B28 51AD	Processor system and other bus processor runtime diagnostics detected 595W dc power supply fault	595W dc power supply Locations: U0.1-V1 U0.1-V2
4B28 51AE	Processor system and other bus processor runtime diagnostics detected 1100W dc power supply fault	1100W dc power supply Locations: U1.1-V1 U1.1-V2
4B29 245B	Processor system and memory test detected 2W 4M processor fault	Go to "MAP 1540: Minimum Configuration" on page 122.
4B29 245C	Processor system and memory test detected 2W 2M processor fault	Go to "MAP 1540: Minimum Configuration" on page 122.
4B29 245D	Processor system and memory test detected 4W 4M processor fault	Go to "MAP 1540: Minimum Configuration" on page 122.
4B29 248B	Processor system and memory test detected primary I/O drawer operator panel fault	Operator Panel Location: U0.1-L1
4B29 24A5	Processor system and memory test detected 2W 500 MHz processor fault	Go to "MAP 1540: Minimum Configuration" on page 122.
4B29 24A6	Processor system and memory test detected 4W 500 MHz processor fault	Go to "MAP 1540: Minimum Configuration" on page 122.
4B29 25AB	Processor system and memory test detected 400 MHz clock fault	400 MHz clock Location: U1.1-P1.1.1
4B29 25AD	Processor system and memory test detected 540 MHz clock fault	540 MHz clock Location: U1.1-P1.1.1
4B29 25B1	Processor system and memory test detected 750 MHz clock fault	750 MHz clock Location: U1.1-P1.1.1
4B29 25B3	Processor system and memory test detected 4W 750 MHz processor fault	Go to "MAP 1540: Minimum Configuration" on page 122.
4B29 25B4	Processor system and memory test detected 2W 750 MHz processor fault	Go to "MAP 1540: Minimum Configuration" on page 122.
4B29 25DA	Processor system and memory test detected 500 MHz clock fault	500 MHz clock Location: U1.1-P1.1.1

Table 7. Service Processor Error Codes (continued)

Error Code	Description	Action/ Possible Failing FRU
4B29 267D	Processor system and memory test detected an 8W, 750 MHz regulator fault	8W regulator card Location: U1.1-P1-V1
4B29 2687	Processor system and memory test detected remote I/O bus adapter fault	Remote I/O bus adapter Location: U1.1-P1.1
4B29 271A	Processor system and memory test detected primary I/O planar fault	Primary I/O planar Location: U0.1-P1
4B29 271D	Processor system and memory test detected secondary I/O planar fault	Secondary I/O planar Locations: U0.2-P1 U0.3-P1 U0.4-P1
4B29 2733	Processor system and memory test detected I/O clock fault	CEC RIO bus adapter Location: U1.1-P1.1
4B29 27AA	Processor system and memory test detected a 2W/4W regulator fault	2W/4W regulator card Location: U1.1-P1-V1
4B29 27AB	Processor system and memory test detected an 8W regulator fault	8W regulator card Location: U1.1-P1-V1
4B29 281C	Processor system and memory test detected CEC backplane fault	CEC backplane Location: U1.1-P1
4B29 281D	Processor system and memory test detected Model 6M1 CEC backplane fault	CEC backplane Location: U1.1-P1
4B29 285D	Processor system and memory test detected SPCN fan controller fault	1. SPCN fan controller Location: U0.1-X2 2. I/O drawer power distribution board Location: U0.1-X1
4B29 288A	Processor system and memory test detected memory riser card fault	1. Go to the service processor Memory Configuration/Deconfiguration Menu to verify memory DIMMs state. See "Memory Configuration/Deconfiguration Menu" on page 426 for more information. 2. Memory riser card Locations: U1.1-P1-M1 U1.1-P1-M2
4B29 300A	Processor system and memory test detected 32 MB DIMM fault	Memory DIMM Locations: U1.1-P1-M1.n U1.1-P1-M2.n
4B29 300B	Processor system and memory test detected 128 MB DIMM fault	Memory DIMM Locations: U1.1-P1-M1.n U1.1-P1-M2.n

Table 7. Service Processor Error Codes (continued)

Error Code	Description	Action/ Possible Failing FRU
4B29 300C	Processor system and memory test detected 256 MB DIMM fault	Memory DIMM Locations: U1.1-P1-M1.n U1.1-P1-M2.n
4B29 300D	Processor system and memory test detected 512 MB (stacked) DIMM fault	Memory DIMM Locations: U1.1-P1-M1.n U1.1-P1-M2.n
4B29 300E	Processor system and memory test detected 512 MB (unstacked) DIMM fault	Memory DIMM Locations: U1.1-P1-M1.n U1.1-P1-M2.n
4B29 301F	Processor system and memory test detected 128 MB DIMM fault	Memory DIMM Locations: U1.1-P1-M1.n U1.1-P1-M2.n
4B29 303A	Processor system and memory test detected 1 GB DIMM fault	Memory DIMM Locations: U1.1-P1-M1.n U1.1-P1-M2.n
4B29 515B	Processor system and memory test detected 1100W ac power supply fault	1100W ac power supply Locations: U1.1-V1 U1.1-V2
4B29 51AC	Processor system and memory test detected 595W ac power supply fault	595W ac power supply Locations: U0.1-V1 U0.1-V2
4B29 51AD	Processor system and memory test detected 595W dc power supply fault	595W dc power supply Locations: U0.1-V1 U0.1-V2
4B29 51AE	Processor system and memory test detected 1100W dc power supply fault	1100W dc power supply Locations: U1.1-V1 U1.1-V2
4B2A 245B	Processor system and self test detected 2W 4M processor fault	Go to "MAP 1540: Minimum Configuration" on page 122.
4B2A 245C	Processor system and self test detected 2W 2M processor fault	Go to "MAP 1540: Minimum Configuration" on page 122.
4B2A 245D	Processor system and self test detected 4W 4M processor fault	Go to "MAP 1540: Minimum Configuration" on page 122.
4B2A 248B	Processor system and self test detected primary I/O drawer operator panel fault	Operator Panel Location: U0.1-L1
4B2A 24A5	Processor system and self test detected 2W 500 MHz processor fault	Go to "MAP 1540: Minimum Configuration" on page 122.
4B2A 24A6	Processor system and self test detected 4W 500 MHz processor fault	Go to "MAP 1540: Minimum Configuration" on page 122.
4B2A 25AB	Processor system and self test detected 400 MHz clock fault	400 MHz clock Location: U1.1-P1.1.1

Table 7. Service Processor Error Codes (continued)

<b>Error Code</b>	<b>Description</b>	<b>Action/ Possible Failing FRU</b>
4B2A 25AD	Processor system and self test detected 540 MHz clock fault	540 MHz clock Location: U1.1-P1.1.1
4B2A 25B1	Processor system and self test detected 750 MHz clock fault	750 MHz clock Location: U1.1-P1.1.1
4B2A 25B3	Processor system and self test detected 4W 750 MHz processor fault	Go to "MAP 1540: Minimum Configuration" on page 122.
4B2A 25B4	Processor system and self test detected 2W 750 MHz processor fault	Go to "MAP 1540: Minimum Configuration" on page 122.
4B2A 25DA	Processor system and self test detected 500 MHz clock fault	500 MHz clock Location: U1.1-P1.1.1
4B2A 267D	Processor system and self test detected an 8W, 750 MHz regulator fault	8W regulator card Location: U1.1-P1-V1
4B2A 2687	Processor system and self test detected remote I/O bus adapter fault	Remote I/O bus adapter Location: U1.1-P1.1
4B2A 271A	Processor system and self test detected primary I/O planar fault	Primary I/O planar Location: U0.1-P1
4B2A 271D	Processor system and self test detected secondary I/O planar fault	Secondary I/O planar Locations: U0.2-P1 U0.3-P1 U0.4-P1
4B2A 2733	Processor system and self test detected I/O clock fault	CEC RIO bus adapter Location: U1.1-P1.1
4B2A 27AA	Processor system and self test detected a 2W/4W regulator fault	2W/4W regulator card Location: U1.1-P1-V1
4B2A 27AB	Processor system and self test detected an 8W regulator fault	8W regulator card Location: U1.1-P1-V1
4B2A 281C	Processor system and self test detected CEC backplane fault	CEC backplane Location: U1.1-P1
4B2A 281D	Processor system and self test detected Model 6M1 CEC backplane fault	CEC backplane Location: U1.1-P1
4B2A 285D	Processor system and self test detected SPCN fan controller fault	1. SPCN fan controller Location: U0.1-X2 2. I/O drawer power distribution board Location: U0.1-X1



Table 7. Service Processor Error Codes (continued)

Error Code	Description	Action/ Possible Failing FRU
4B2A 288A	Processor system and self test detected memory riser card fault	<ol style="list-style-type: none"> <li>Go to the service processor Memory Configuration/Deconfiguration Menu to verify memory DIMMs state. See "Memory Configuration/Deconfiguration Menu" on page 426 for more information.</li> <li>Memory riser card Locations: U1.1-P1-M1 U1.1-P1-M2</li> </ol>
4B2A 300A	Processor system and self test detected 32 MB DIMM fault	Memory DIMM Locations: U1.1-P1-M1.n U1.1-P1-M2.n
4B2A 300B	Processor system and self test detected 128 MB DIMM fault	Memory DIMM Locations: U1.1-P1-M1.n U1.1-P1-M2.n
4B2A 300C	Processor system and self test detected 256 MB DIMM fault	Memory DIMM Locations: U1.1-P1-M1.n U1.1-P1-M2.n
4B2A 300D	Processor system and self test detected 512 MB (stacked) DIMM fault	Memory DIMM Locations: U1.1-P1-M1.n U1.1-P1-M2.n
4B2A 300E	Processor system and self test detected 512 MB (unstacked) DIMM fault	Memory DIMM Locations: U1.1-P1-M1.n U1.1-P1-M2.n
4B2A 301F	Processor system and self test detected 128 MB DIMM fault	Memory DIMM Locations: U1.1-P1-M1.n U1.1-P1-M2.n
4B2A 303A	Processor system and self test detected 1 GB DIMM fault	Memory DIMM Locations: U1.1-P1-M1.n U1.1-P1-M2.n
4B2A 515B	Processor system and self test detected 1100W ac power supply fault	1100W ac power supply Locations: U1.1-V1 U1.1-V2
4B2A 51AC	Processor system and self test detected 595W ac power supply fault	595W ac power supply Locations: U0.1-V1 U0.1-V2
4B2A 51AD	Processor system and self test detected 595W dc power supply fault	595W dc power supply Locations: U0.1-V1 U0.1-V2
4B2A 51AE	Processor system and self test detected 1100W dc power supply fault	1100W dc power supply Locations: U1.1-V1 U1.1-V2
4B2B 245B	Processor system and wire test detected 2W 4M processor fault	Go to "MAP 1540: Minimum Configuration" on page 122.

Table 7. Service Processor Error Codes (continued)

<b>Error Code</b>	<b>Description</b>	<b>Action/ Possible Failing FRU</b>
4B2B 245C	Processor system and wire test detected 2W 2M processor fault	Go to "MAP 1540: Minimum Configuration" on page 122.
4B2B 245D	Processor system and wire test detected 4W 4M processor fault	Go to "MAP 1540: Minimum Configuration" on page 122.
4B2B 248B	Processor system and wire test detected primary I/O drawer operator panel fault	Operator Panel Location: U0.1-L1
4B2B 24A5	Processor system and wire test detected 2W 500 MHz processor fault	Go to "MAP 1540: Minimum Configuration" on page 122.
4B2B 24A6	Processor system and wire test detected 4W 500 MHz processor fault	Go to "MAP 1540: Minimum Configuration" on page 122.
4B2B 25AB	Processor system and wire test detected 400 MHz clock fault	400 MHz clock Location: U1.1-P1.1.1
4B2B 25AD	Processor system and wire test detected 540 MHz clock fault	540 MHz clock Location: U1.1-P1.1.1
4B2B 25B1	Processor system and wire test detected 750 MHz clock fault	750 MHz clock Location: U1.1-P1.1.1
4B2B 25B3	Processor system and wire test detected 4W 750 MHz processor fault	Go to "MAP 1540: Minimum Configuration" on page 122.
4B2B 25B4	Processor system and wire test detected 2W 750 MHz processor fault	Go to "MAP 1540: Minimum Configuration" on page 122.
4B2B 25DA	Processor system and wire test detected 500 MHz clock fault	500 MHz clock Location: U1.1-P1.1.1
4B2B 267D	Processor system and wire test detected an 8W, 750 MHz regulator fault	8W regulator card Location: U1.1-P1-V1
4B2B 2687	Processor system and wire test detected remote I/O bus adapter fault	Remote I/O bus adapter Location: U1.1-P1.1
4B2B 271A	Processor system and wire test detected primary I/O planar fault	Primary I/O planar Location: U0.1-P1
4B2B 271D	Processor system and wire test detected secondary I/O planar fault	Secondary I/O planar Locations: U0.2-P1 U0.3-P1 U0.4-P1
4B2B 2733	Processor system and wire test detected I/O clock fault	CEC RIO bus adapter Location: U1.1-P1.1
4B2B 27AA	Processor system and wire test detected a 2W/4W regulator fault	2W/4W regulator card Location: U1.1-P1-V1

Table 7. Service Processor Error Codes (continued)

Error Code	Description	Action/ Possible Failing FRU
4B2B 27AB	Processor system and wire test detected an 8W regulator fault	8W regulator card Location: U1.1-P1-V1
4B2B 281C	Processor system and wire test detected CEC backplane fault	CEC backplane Location: U1.1-P1
4B2B 281D	Processor system and wire test detected Model 6M1 CEC backplane fault	CEC backplane Location: U1.1-P1
4B2B 285D	Processor system and wire test detected SPCN fan controller fault	1. SPCN fan controller Location: U0.1-X2 2. I/O drawer power distribution board Location: U0.1-X1
4B2B 288A	Processor system and wire test detected memory riser card fault	1. Go to the service processor Memory Configuration/Deconfiguration Menu to verify memory DIMMs state. See "Memory Configuration/Deconfiguration Menu" on page 426 for more information. 2. Memory riser card Locations: U1.1-P1-M1 U1.1-P1-M2
4B2B 300A	Processor system and wire test detected 32 MB DIMM fault	Memory DIMM Locations: U1.1-P1-M1.n U1.1-P1-M2.n
4B2B 300B	Processor system and wire test detected 128 MB DIMM fault	Memory DIMM Locations: U1.1-P1-M1.n U1.1-P1-M2.n
4B2B 300C	Processor system and wire test detected 256 MB DIMM fault	Memory DIMM Locations: U1.1-P1-M1.n U1.1-P1-M2.n
4B2B 300D	Processor system and wire test detected 512 MB (stacked) DIMM fault	Memory DIMM Locations: U1.1-P1-M1.n U1.1-P1-M2.n
4B2B 300E	Processor system and wire test detected 512 MB (unstacked) DIMM fault	Memory DIMM Locations: U1.1-P1-M1.n U1.1-P1-M2.n
4B2B 301F	Processor system and wire test detected 128 MB DIMM fault	Memory DIMM Locations: U1.1-P1-M1.n U1.1-P1-M2.n
4B2B 303A	Processor system and wire test detected 1 GB DIMM fault	Memory DIMM Locations: U1.1-P1-M1.n U1.1-P1-M2.n

Table 7. Service Processor Error Codes (continued)

<b>Error Code</b>	<b>Description</b>	<b>Action/ Possible Failing FRU</b>
4B2B 515B	Processor system and wire test detected 1100W ac power supply fault	1100W ac power supply Locations: U1.1-V1 U1.1-V2
4B2B 51AC	Processor system and wire test detected 595W ac power supply fault	595W ac power supply Locations: U0.1-V1 U0.1-V2
4B2B 51AD	Processor system and wire test detected 595W dc power supply fault	595W dc power supply Locations: U0.1-V1 U0.1-V2
4B2B 51AE	Processor system and wire test detected 1100W dc power supply fault	1100W dc power supply Locations: U1.1-V1 U1.1-V2
4B2C 245B	Processor system and IPL MOPS detected 2W 4M processor fault	Go to "MAP 1540: Minimum Configuration" on page 122.
4B2C 245D	Processor system and IPL MOPS detected 4W 4M processor fault	Go to "MAP 1540: Minimum Configuration" on page 122.
4B2C 248B	Processor system and IPL MOPS detected primary I/O drawer operator panel fault	Operator Panel Location: U0.1-L1
4B2C 24A5	Processor system and IPL MOPS detected 2W 500 MHz processor fault	Go to "MAP 1540: Minimum Configuration" on page 122.
4B2C 24A6	Processor system and IPL MOPS detected 4W 500 MHz processor fault	Go to "MAP 1540: Minimum Configuration" on page 122.
4B2C 25AB	Processor system and IPL MOPS detected 400 MHz clock fault	400 MHz clock Location: U1.1-P1.1.1
4B2C 25AD	Processor system and IPL MOPS detected 540 MHz clock fault	540 MHz clock Location: U1.1-P1.1.1
4B2C 25B1	Processor system and IPL MOPS detected 750 MHz clock fault	750 MHz clock Location: U1.1-P1.1.1
4B2C 25B3	Processor system and IPL MOPS detected 4W 750 MHz processor fault	Go to "MAP 1540: Minimum Configuration" on page 122.
4B2C 25B4	Processor system and IPL MOPS detected 2W 750 MHz processor fault	Go to "MAP 1540: Minimum Configuration" on page 122.
4B2C 25DA	Processor system and IPL MOPS detected 500 MHz clock fault	500 MHz clock Location: U1.1-P1.1.1
4B2C 267D	Processor system and IPL MOPS detected an 8W, 750 MHz regulator fault	8W regulator card Location: U1.1-P1-V1
4B2C 2687	Processor system and IPL MOPS detected remote I/O bus adapter fault	Remote I/O bus adapter Location: U1.1-P1.1

Table 7. Service Processor Error Codes (continued)

Error Code	Description	Action/ Possible Failing FRU
4B2C 271A	Processor system and IPL MOPS detected primary I/O planar fault	Primary I/O planar Location: U0.1-P1
4B2C 271D	Processor system and IPL MOPS detected secondary I/O planar fault	Secondary I/O planar Locations: U0.2-P1 U0.3-P1 U0.4-P1
4B2C 2733	Processor system and IPL MOPS detected I/O clock fault	CEC RIO bus adapter Location: U1.1-P1.1
4B2C 27AA	Processor system and IPL MOPS detected a 2W/4W regulator fault	2W/4W regulator card Location: U1.1-P1-V1
4B2C 27AB	Processor system and IPL MOPS detected an 8W regulator fault	8W regulator card Location: U1.1-P1-V1
4B2C 281C	Processor system and IPL MOPS detected CEC backplane fault	CEC backplane Location: U1.1-P1
4B2C 281D	Processor system and IPL MOPS detected Model 6M1 CEC backplane fault	CEC backplane Location: U1.1-P1
4B2C 285D	Processor system and IPL MOPS detected SPCN fan controller fault	1. SPCN fan controller Location: U0.1-X2 2. I/O drawer power distribution board Location: U0.1-X1
4B2C 288A	Processor system and IPL MOPS detected memory riser card fault	1. Go to the service processor Memory Configuration/Deconfiguration Menu to verify memory DIMMs state. See "Memory Configuration/Deconfiguration Menu" on page 426 for more information. 2. Memory riser card Locations: U1.1-P1-M1 U1.1-P1-M2
4B2C 300A	Processor system and IPL MOPS detected 32 MB DIMM fault	Memory DIMM Locations: U1.1-P1-M1.n U1.1-P1-M2.n
4B2C 300B	Processor system and IPL MOPS detected 128 MB DIMM fault	Memory DIMM Locations: U1.1-P1-M1.n U1.1-P1-M2.n
4B2C 300C	Processor system and IPL MOPS detected 256 MB DIMM fault	Memory DIMM Locations: U1.1-P1-M1.n U1.1-P1-M2.n
4B2C 300D	Processor system and IPL MOPS detected 512 MB (stacked) DIMM fault	Memory DIMM Locations: U1.1-P1-M1.n U1.1-P1-M2.n

Table 7. Service Processor Error Codes (continued)

<b>Error Code</b>	<b>Description</b>	<b>Action/ Possible Failing FRU</b>
4B2C 300E	Processor system and IPL MOPS detected 512 MB (unstacked) DIMM fault	Memory DIMM Locations: U1.1-P1-M1.n U1.1-P1-M2.n
4B2C 301F	Processor system and IPL MOPS detected 128 MB DIMM fault	Memory DIMM Locations: U1.1-P1-M1.n U1.1-P1-M2.n
4B2C 303A	Processor system and IPL MOPS detected 1 GB DIMM fault	Memory DIMM Locations: U1.1-P1-M1.n U1.1-P1-M2.n
4B2C 515B	Processor system and IPL MOPS detected 1100W ac power supply fault	1100W ac power supply Locations: U1.1-V1 U1.1-V2
4B2C 51AC	Processor system and IPL MOPS detected 595W ac power supply fault	595W ac power supply Locations: U0.1-V1 U0.1-V2
4B2C 51AD	Processor system and IPL MOPS detected 595W dc power supply fault	595W dc power supply Locations: U0.1-V1 U0.1-V2
4B2C 51AE	Processor system and IPL MOPS detected 1100W dc power supply fault	1100W dc power supply Locations: U1.1-V1 U1.1-V2
4B2D 245B	Processor system and IPL MOPS detected 2W 4M processor fault	Go to "MAP 1540: Minimum Configuration" on page 122.
4B2D 245D	Processor system and IPL MOPS detected 4W 4M processor fault	Go to "MAP 1540: Minimum Configuration" on page 122.
4B2D 248B	Processor system and IPL MOPS detected primary I/O drawer operator panel fault	Operator Panel Location: U0.1-L1
4B2D 24A5	Processor system and IPL MOPS detected 2W 500 MHz processor fault	Go to "MAP 1540: Minimum Configuration" on page 122.
4B2D 24A6	Processor system and IPL MOPS detected 4W 500 MHz processor fault	Go to "MAP 1540: Minimum Configuration" on page 122.
4B2D 25AB	Processor system and IPL MOPS detected 400 MHz clock fault	400 MHz clock Location: U1.1-P1.1.1
4B2D 25AD	Processor system and IPL MOPS detected 540 MHz clock fault	540 MHz clock Location: U1.1-P1.1.1
4B2D 25B1	Processor system and IPL MOPS detected 750 MHz clock fault	750 MHz clock Location: U1.1-P1.1.1
4B2D 25B3	Processor system and IPL MOPS detected 4W 750 MHz processor fault	Go to "MAP 1540: Minimum Configuration" on page 122.

Table 7. Service Processor Error Codes (continued)

Error Code	Description	Action/ Possible Failing FRU
4B2D 25B4	Processor system and IPL MOPS detected 2W 750 MHz processor fault	Go to "MAP 1540: Minimum Configuration" on page 122.
4B2D 25DA	Processor system and IPL MOPS detected 500 MHz clock fault	500 MHz clock Location: U1.1-P1.1.1
4B2D 267D	Processor system and IPL MOPS detected an 8W, 750 MHz regulator fault	8W regulator card Location: U1.1-P1-V1
4B2D 2687	Processor system and IPL MOPS detected remote I/O bus adapter fault	Remote I/O bus adapter Location: U1.1-P1.1
4B2D 271A	Processor system and IPL MOPS detected primary I/O planar fault	Primary I/O planar Location: U0.1-P1
4B2D 271D	Processor system and IPL MOPS detected secondary I/O planar fault	Secondary I/O planar Locations: U0.2-P1 U0.3-P1 U0.4-P1
4B2D 2733	Processor system and IPL MOPS detected I/O clock fault	CEC RIO bus adapter Location: U1.1-P1.1
4B2D 27AA	Processor system and IPL MOPS detected a 2W/4W regulator fault	2W/4W regulator card Location: U1.1-P1-V1
4B2D 27AB	Processor system and IPL MOPS detected an 8W regulator fault	8W regulator card Location: U1.1-P1-V1
4B2D 281C	Processor system and IPL MOPS detected CEC backplane fault	CEC backplane Location: U1.1-P1
4B2D 281D	Processor system and IPL MOPS detected Model 6M1 CEC backplane fault	CEC backplane Location: U1.1-P1
4B2D 285D	Processor system and IPL MOPS detected SPCN fan controller fault	1. SPCN fan controller Location: U0.1-X2 2. I/O drawer power distribution board Location: U0.1-X1
4B2D 288A	Processor system and IPL MOPS detected memory riser card fault	1. Go to the service processor Memory Configuration/Deconfiguration Menu to verify memory DIMMs state. See "Memory Configuration/Deconfiguration Menu" on page 426 for more information. 2. Memory riser card Locations: U1.1-P1-M1 U1.1-P1-M2

Table 7. Service Processor Error Codes (continued)

<b>Error Code</b>	<b>Description</b>	<b>Action/ Possible Failing FRU</b>
4B2D 300A	Processor system and IPL MOPS detected 32 MB DIMM fault	Memory DIMM Locations: U1.1-P1-M1.n U1.1-P1-M2.n
4B2D 300B	Processor system and IPL MOPS detected 128 MB DIMM fault	Memory DIMM Locations: U1.1-P1-M1.n U1.1-P1-M2.n
4B2D 300C	Processor system and IPL MOPS detected 256 MB DIMM fault	Memory DIMM Locations: U1.1-P1-M1.n U1.1-P1-M2.n
4B2D 300D	Processor system and IPL MOPS detected 512 MB (stacked) DIMM fault	Memory DIMM Locations: U1.1-P1-M1.n U1.1-P1-M2.n
4B2D 300E	Processor system and IPL MOPS detected 512 MB (unstacked) DIMM fault	Memory DIMM Locations: U1.1-P1-M1.n U1.1-P1-M2.n
4B2D 301F	Processor system and IPL MOPS detected 128 MB DIMM fault	Memory DIMM Locations: U1.1-P1-M1.n U1.1-P1-M2.n
4B2D 303A	Processor system and IPL MOPS detected 1 GB DIMM fault	Memory DIMM Locations: U1.1-P1-M1.n U1.1-P1-M2.n
4B2D 515B	Processor system and IPL MOPS detected 1100W ac power supply fault	1100W ac power supply Locations: U1.1-V1 U1.1-V2
4B2D 51AC	Processor system and IPL MOPS detected 595W ac power supply fault	595W ac power supply Locations: U0.1-V1 U0.1-V2
4B2D 51AD	Processor system and IPL MOPS detected 595W dc power supply fault	595W dc power supply Locations: U0.1-V1 U0.1-V2
4B2D 51AE	Processor system and IPL MOPS detected 1100W dc power supply fault	1100W dc power supply Locations: U1.1-V1 U1.1-V2
4B2E 245B	Processor system and scan control routines detected 2W 4M processor fault	Go to "MAP 1540: Minimum Configuration" on page 122.
4B2E 245C	Processor system and scan control routines detected 2W 2M processor fault	Go to "MAP 1540: Minimum Configuration" on page 122.
4B2E 245D	Processor system and scan control routines detected 4W 4M processor fault	Go to "MAP 1540: Minimum Configuration" on page 122.
4B2E 248B	Processor system and scan control routines detected primary I/O drawer operator panel fault	Operator Panel Location: U0.1-L1



Table 7. Service Processor Error Codes (continued)

Error Code	Description	Action/ Possible Failing FRU
4B2E 24A5	Processor system and scan control routines detected 2W 500 MHz processor fault	Go to "MAP 1540: Minimum Configuration" on page 122.
4B2E 24A6	Processor system and scan control routines detected 4W 500 MHz processor fault	Go to "MAP 1540: Minimum Configuration" on page 122.
4B2E 25AB	Processor system and scan control routines detected 400 MHz clock fault	400 MHz clock Location: U1.1-P1.1.1
4B2E 25AD	Processor system and scan control routines detected 540 MHz clock fault	540 MHz clock Location: U1.1-P1.1.1
4B2E 25B1	Processor system and scan control routines detected 750 MHz clock fault	750 MHz clock Location: U1.1-P1.1.1
4B2E 25B3	Processor system and scan control routines detected 4W 750 MHz processor fault	Go to "MAP 1540: Minimum Configuration" on page 122.
4B2E 25B4	Processor system and scan control routines detected 2W 750 MHz processor fault	Go to "MAP 1540: Minimum Configuration" on page 122.
4B2E 25DA	Processor system and scan control routines detected 500 MHz clock fault	500 MHz clock Location: U1.1-P1.1.1
4B2E 267D	Processor system and scan control routines detected an 8W, 750 MHz regulator fault	8W regulator card Location: U1.1-P1-V1
4B2E 2687	Processor system and scan control routines detected remote I/O bus adapter fault	Remote I/O bus adapter Location: U1.1-P1.1
4B2E 271A	Processor system and scan control routines detected primary I/O planar fault	Primary I/O planar Location: U0.1-P1
4B2E 271D	Processor system and scan control routines detected secondary I/O planar fault	Secondary I/O planar Locations: U0.2-P1 U0.3-P1 U0.4-P1
4B2E 2733	Processor system and scan control routines detected I/O clock fault	CEC RIO bus adapter Location: U1.1-P1.1
4B2E 27AA	Processor system and scan control routines detected a 2W/4W regulator fault	2W/4W regulator card Location: U1.1-P1-V1
4B2E 27AB	Processor system and scan control routines detected an 8W regulator fault	8W regulator card Location: U1.1-P1-V1
4B2E 281C	Processor system and scan control routines detected CEC backplane fault	CEC backplane Location: U1.1-P1

Table 7. Service Processor Error Codes (continued)

Error Code	Description	Action/ Possible Failing FRU
4B2E 281D	Processor system and scan control routines detected Model 6M1 CEC backplane fault	CEC backplane Location: U1.1-P1
4B2E 285D	Processor system and scan control routines detected SPCN fan controller fault	1. SPCN fan controller Location: U0.1-X2 2. I/O drawer power distribution board Location: U0.1-X1
4B2E 288A	Processor system and scan control routines detected memory riser card fault	1. Go to the service processor Memory Configuration/Deconfiguration Menu to verify memory DIMMs state. See "Memory Configuration/Deconfiguration Menu" on page 426 for more information. 2. Memory riser card Locations: U1.1-P1-M1 U1.1-P1-M2
4B2E 300A	Processor system and scan control routines detected 32 MB DIMM fault	Memory DIMM Locations: U1.1-P1-M1.n U1.1-P1-M2.n
4B2E 300B	Processor system and scan control routines detected 128 MB DIMM fault	Memory DIMM Locations: U1.1-P1-M1.n U1.1-P1-M2.n
4B2E 300C	Processor system and scan control routines detected 256 MB DIMM fault	Memory DIMM Locations: U1.1-P1-M1.n U1.1-P1-M2.n
4B2E 300D	Processor system and scan control routines detected 512 MB (stacked) DIMM fault	Memory DIMM Locations: U1.1-P1-M1.n U1.1-P1-M2.n
4B2E 300E	Processor system and scan control routines detected 512 MB (unstacked) DIMM fault	Memory DIMM Locations: U1.1-P1-M1.n U1.1-P1-M2.n
4B2E 301F	Processor system and scan control routines detected 128 MB DIMM fault	Memory DIMM Locations: U1.1-P1-M1.n U1.1-P1-M2.n
4B2E 303A	Processor system and scan control routines detected 1 GB DIMM fault	Memory DIMM Locations: U1.1-P1-M1.n U1.1-P1-M2.n
4B2E 515B	Processor system and scan control routines detected 1100W ac power supply fault	1100W ac power supply Locations: U1.1-V1 U1.1-V2
4B2E 51AC	Processor system and scan control routines detected 595W ac power supply fault	595W ac power supply Locations: U0.1-V1 U0.1-V2

Table 7. Service Processor Error Codes (continued)

<b>Error Code</b>	<b>Description</b>	<b>Action/ Possible Failing FRU</b>
4B2E 51AD	Processor system and scan control routines detected 595W dc power supply fault	595W dc power supply Locations: U0.1-V1 U0.1-V2
4B2E 51AE	Processor system and scan control routines detected 1100W dc power supply fault	1100W dc power supply Locations: U1.1-V1 U1.1-V2
4B2F 245B	Processor system and error code detected 2W 4M processor fault	Go to "MAP 1540: Minimum Configuration" on page 122.
4B2F 245C	Processor system and error code detected 2W 2M processor fault	Go to "MAP 1540: Minimum Configuration" on page 122.
4B2F 245D	Processor system and error code detected 4W 4M processor fault	Go to "MAP 1540: Minimum Configuration" on page 122.
4B2F 248B	Processor system and error code detected primary I/O drawer operator panel fault	Operator Panel Location: U0.1-L1
4B2F 24A5	Processor system and error code detected 2W 500 MHz processor fault	Go to "MAP 1540: Minimum Configuration" on page 122.
4B2F 24A6	Processor system and error code detected 4W 500 MHz processor fault	Go to "MAP 1540: Minimum Configuration" on page 122.
4B2F 25AB	Processor system and error code detected 400 MHz clock fault	400 MHz clock Location: U1.1-P1.1.1
4B2F 25AD	Processor system and error code detected 540 MHz clock fault	540 MHz clock Location: U1.1-P1.1.1
4B2F 25B1	Processor system and error code detected 750 MHz clock fault	750 MHz clock Location: U1.1-P1.1.1
4B2F 25B3	Processor system and error code detected 4W 750 MHz processor fault	Go to "MAP 1540: Minimum Configuration" on page 122.
4B2F 25B4	Processor system and error code detected 2W 750 MHz processor fault	Go to "MAP 1540: Minimum Configuration" on page 122.
4B2F 25DA	Processor system and error code detected 500 MHz clock fault	500 MHz clock Location: U1.1-P1.1.1
4B2F 267D	Processor system and error code detected an 8W, 750 MHz regulator fault	8W regulator card Location: U1.1-P1-V1
4B2F 2687	Processor system and error code detected remote I/O bus adapter fault	Remote I/O bus adapter Location: U1.1-P1.1
4B2F 271A	Processor system and error code detected primary I/O planar fault	Primary I/O planar Location: U0.1-P1

Table 7. Service Processor Error Codes (continued)

Error Code	Description	Action/ Possible Failing FRU
4B2F 271D	Processor system and error code detected secondary I/O planar fault	Secondary I/O planar Locations: U0.2-P1 U0.3-P1 U0.4-P1
4B2F 2733	Processor system and error code detected I/O clock fault	CEC RIO bus adapter Location: U1.1-P1.1
4B2F 27AA	Processor system and error code detected a 2W/4W regulator fault	2W/4W regulator card Location: U1.1-P1-V1
4B2F 27AB	Processor system and error code detected an 8W regulator fault	8W regulator card Location: U1.1-P1-V1
4B2F 281C	Processor system and error code detected CEC backplane fault	CEC backplane Location: U1.1-P1
4B2F 281D	Processor system and error code detected Model 6M1 CEC backplane fault	CEC backplane Location: U1.1-P1
4B2F 285D	Processor system and error code detected SPCN fan controller fault	1. SPCN fan controller Location: U0.1-X2 2. I/O drawer power distribution board Location: U0.1-X1
4B2F 288A	Processor system and error code detected memory riser card fault	1. Go to the service processor Memory Configuration/Deconfiguration Menu to verify memory DIMMs state. See "Memory Configuration/Deconfiguration Menu" on page 426 for more information. 2. Memory riser card Locations: U1.1-P1-M1 U1.1-P1-M2
4B2F 300A	Processor system and error code detected 32 MB DIMM fault	Memory DIMM Locations: U1.1-P1-M1.n U1.1-P1-M2.n
4B2F 300B	Processor system and error code detected 128 MB DIMM fault	Memory DIMM Locations: U1.1-P1-M1.n U1.1-P1-M2.n
4B2F 300C	Processor system and error code detected 256 MB DIMM fault	Memory DIMM Locations: U1.1-P1-M1.n U1.1-P1-M2.n
4B2F 300D	Processor system and error code detected 512 MB (stacked) DIMM fault	Memory DIMM Locations: U1.1-P1-M1.n U1.1-P1-M2.n
4B2F 300E	Processor system and error code detected 512 MB (unstacked) DIMM fault	Memory DIMM Locations: U1.1-P1-M1.n U1.1-P1-M2.n

Table 7. Service Processor Error Codes (continued)

<b>Error Code</b>	<b>Description</b>	<b>Action/ Possible Failing FRU</b>
4B2F 301F	Processor system and error code detected 128 MB DIMM fault	Memory DIMM Locations: U1.1-P1-M1.n U1.1-P1-M2.n
4B2F 303A	Processor system and error code detected 1 GB DIMM fault	Memory DIMM Locations: U1.1-P1-M1.n U1.1-P1-M2.n
4B2F 515B	Processor system and error code detected 1100W ac power supply fault	1100W ac power supply Locations: U1.1-V1 U1.1-V2
4B2F 51AC	Processor system and error code detected 595W ac power supply fault	595W ac power supply Locations: U0.1-V1 U0.1-V2
4B2F 51AD	Processor system and error code detected 595W dc power supply fault	595W dc power supply Locations: U0.1-V1 U0.1-V2
4B2F 51AE	Processor system and error code detected 1100W dc power supply fault	1100W dc power supply Locations: U1.1-V1 U1.1-V2

---

## System Firmware Update Messages

*Table 8. System Firmware Update Messages*

<b>Error Code</b>	<b>Description</b>	<b>Action/ Possible Failing FRU</b>
A1FD 0000	Firmware update recovery mode entered	Information message
A1FD 0001	Service processor flash recovery	Insert Diskette #1
A1FD 0002	Service processor flash recovery	Insert Diskette #2
A1FD 0003	Service processor flash recovery	Insert Diskette #3
A1FD 0004	Service processor flash recovery	Insert Diskette #4

## Common Firmware Error Codes

**Attention:** Follow the procedure defined in “Checkpoint and Error Code Index” on page 173. If you replace FRUs or perform an action and the problem is still not corrected, go to “MAP 1540: Minimum Configuration” on page 122 unless otherwise indicated in the tables.

If you replace FRUs and the problem is corrected, go to “MAP 0410: Repair Checkout” in *RS/6000 and @server pSeries Diagnostic Information for Multiple Bus Systems*.

**Note:** Do not shut down the system if the FRU was replaced by hot swap.

Table 9. Common Firmware Error Codes

Error Code	Description	Action/ Possible Failing FRU
B006 1403	Missing service processor resource	<ol style="list-style-type: none"> <li>1. Update system firmware Location: U0.1-P1/Y1</li> <li>2. Primary drawer I/O backplane Location: U0.1-P1</li> </ol>
B006 1404	Service processor firmware fault	<ol style="list-style-type: none"> <li>1. Update system firmware Location: U0.1-P1/Y1</li> <li>2. Primary drawer I/O backplane Location: U0.1-P1</li> </ol>
B006 1405	Service processor firmware fault	<ol style="list-style-type: none"> <li>1. Update system firmware Location: U0.1-P1/Y1</li> <li>2. Primary drawer I/O backplane Location: U0.1-P1</li> </ol>
B006 1406	Service processor program error	<ol style="list-style-type: none"> <li>1. Update system firmware Location: U0.1-P1/Y1</li> <li>2. Check for AIX updates</li> <li>3. Primary drawer I/O backplane Location: U0.1-P1</li> </ol>
B006 1407	Service processor resource allocation problem	<ol style="list-style-type: none"> <li>1. Update system firmware Location: U0.1-P1/Y1</li> <li>2. Check for AIX updates</li> <li>3. Primary drawer I/O backplane Location: U0.1-P1</li> </ol>
B006 1408	Service processor program error	<ol style="list-style-type: none"> <li>1. Update system firmware Location: U0.1-P1/Y1</li> <li>2. Check for AIX updates</li> <li>3. Primary drawer I/O backplane Location: U0.1-P1</li> </ol>
B006 1409	Service processor program error	<ol style="list-style-type: none"> <li>1. Update system firmware Location: U0.1-P1/Y1</li> <li>2. Primary drawer I/O backplane Location: U0.1-P1</li> </ol>
B10F 1000	Service processor failure	Primary I/O drawer backplane Location: U0.1-P1

Table 9. Common Firmware Error Codes (continued)

<b>Error Code</b>	<b>Description</b>	<b>Action/ Possible Failing FRU</b>
B10F 1002	Service processor failure	Primary I/O drawer backplane Location: U0.1-P1
B10F 1005	Service processor failure	Primary I/O drawer backplane Location: U0.1-P1
B10F 1007	Service processor failure	Primary I/O drawer backplane Location: U0.1-P1
B10F 1008	Service processor failure	Primary I/O drawer backplane Location: U0.1-P1
B10F 100E	Service processor boot flash corrupted	Primary I/O drawer backplane Location: U0.1-P1
B10F 100F	Service processor base flash corrupted	Primary I/O drawer backplane Location: U0.1-P1
B10F 1300	Service processor failure	Primary I/O drawer backplane Location: U0.1-P1
B10F 1370	Service processor flash update failure	1. Retry flash update 2. Primary I/O drawer backplane Location: U0.1-P1
B10F 1380	Service processor program failure	1. Update system firmware 2. Primary I/O drawer backplane Location: U0.1-P1
B10F 1381	Service processor flash error	1. Update system firmware 2. Primary I/O drawer backplane Location: U0.1-P1
B10F 1384	Service processor failure	Primary I/O drawer backplane Location: U0.1-P1
B10F 1387	Service processor failure	Primary I/O drawer backplane Location: U0.1-P1
B10F 1400	Service processor failure	Primary I/O drawer backplane Location: U0.1-P1
B10F 1401	Service processor failure	Primary I/O drawer backplane Location: U0.1-P1
B10F 1670	Service processor flash update failure	1. Retry flash update 2. Primary I/O drawer backplane Location: U0.1-P1
B10F 1672	Service processor firmware update invalid	Call second level of support
B10F 1675	Service processor memory failure	Primary I/O drawer backplane Location: U0.1-P1
B10F 1681	Service processor firmware update invalid	Call second level of support
B10F 1682	Service processor firmware update invalid	Call second level of support



Table 9. Common Firmware Error Codes (continued)

Error Code	Description	Action/ Possible Failing FRU
B10F 1683	Service processor firmware update invalid	Call second level of support
B1FD 0013	A firmware update has failed because the update image is invalid. The update was aborted before any changes were made to the currently installed firmware.	Reset the service processor (by activating the pinhole reset switch or by disconnecting, then reconnecting power).  Then install a valid firmware update image for the specific system type and model.
B1FD 0015	Too many firmware update diskettes inserted (or wrong faulty update image).	<ol style="list-style-type: none"> <li>1. Assure the firmware update image is correct for the specific system type and model.</li> <li>2. Replace the update diskettes with a new set of firmware diskettes.</li> </ol>
B1FD 0016	Diskette read error	<ol style="list-style-type: none"> <li>1. The firmware diskette may be faulty. Try another diskette.</li> <li>2. Replace the diskette drive.</li> <li>3. Replace the primary I/O backplane.</li> </ol>
B1FD 001A	Service processor firmware update fault	Reset the service processor with the pinhole reset or by disconnecting then reconnecting power.
B1FD 001E	System firmware update Fault	Wrong system firmware update diskette. Insert correct diskette.
B1FD 001F	Bad diskette	Replace diskette
B1xx 0013	A firmware update has failed because the update image is invalid. The update was aborted before any changes were made to the currently installed firmware.	Install a valid firmware update image for the specific system type and model.
B1xx 4600	Service processor error	Primary I/O drawer backplane Location: U0.1-P1
B1xx 4601	CPU subsystem problem	No isolation possible, contact next level of support.
B1xx 4602	RIO bus fault	<ol style="list-style-type: none"> <li>1. Check/reseat RIO cables</li> <li>2. RIO bus adapter Location: U0.1-P1.1</li> <li>3. CEC RIO adapter Location: U1.1-P1.1</li> </ol>
B1xx 4603	CSP firmware corrupted	<ol style="list-style-type: none"> <li>1. Reload system firmware</li> <li>2. Primary I/O backplane Location: U0.1-P1</li> </ol>

Table 9. Common Firmware Error Codes (continued)

Error Code	Description	Action/ Possible Failing FRU
B1xx 4606	Firmware failure	<ol style="list-style-type: none"> <li>1. Check for system firmware updates Location: U0.1-P1/Y1</li> <li>2. Primary I/O drawer operator panel Location: U0.1-L1</li> <li>3. Primary I/O drawer backplane Location: U0.1-P1</li> </ol>
B1xx 4608	CSP early termination	<ol style="list-style-type: none"> <li>1. Reset the system by disconnecting and reconnecting system power</li> <li>2. Reload system firmware</li> <li>3. Primary I/O backplane Location: U0.1-P1</li> </ol>
B1xx 460A	TOD clock has been reset	<ol style="list-style-type: none"> <li>1. Set TOD Clock</li> <li>2. Primary I/O Drawer Backplane Location: U0.1-P1</li> </ol>
B1xx 460B	TOD battery failure	Replace TOD battery Location: U0.1-P1-V3
B1xx 4611	Service processor fault	<ol style="list-style-type: none"> <li>1. Primary I/O drawer backplane Location: U0.1-P1</li> <li>2. Processor card Locations: U1.1-P1-C1 U1.1-P1-C2</li> </ol>
B1xx 4620	Modem configuration failure (/S1 or /S2)	<ol style="list-style-type: none"> <li>1. Check modem configuration files</li> <li>2. Check for system firmware updates Location: U0.1-P1/Y1</li> <li>3. Modem</li> </ol>
B1xx 4621	Modem disconnect failure (/S1 or /S2)	<ol style="list-style-type: none"> <li>1. Check modem configuration files</li> <li>2. Check for system firmware updates Location: U0.1-P1/Y1</li> <li>3. Modem</li> </ol>
B1xx 4622	Primary I/O drawer operator panel fault	<ol style="list-style-type: none"> <li>1. Primary I/O drawer operator panel Location: U0.1-P1-L1</li> <li>2. Check for system firmware updates Location: U0.1-P1/Y1</li> <li>3. Primary I/O drawer backplane Location: U0.1-P1</li> </ol>
B1xx 4633	Service processor/system power control network firmware fault	<ol style="list-style-type: none"> <li>1. Check for system firmware updates Location: U0.1-P1/Y1</li> <li>2. Primary I/O drawer backplane Location: U0.1-P1</li> </ol>

Table 9. Common Firmware Error Codes (continued)

Error Code	Description	Action/ Possible Failing FRU
B1xx 4634	System power control network loop fault	1. Check SPCN cabling 2. Go to "MAP 1540: Minimum Configuration" on page 122.
B1xx 4644	Processor VPD fault	Ignore all location codes. Go to MAP 1540 and run CEC minimum configuration.
B1xx 4645	Non-processor VPD fault	Ignore all location codes. Go to MAP 1540 and run CEC minimum configuration.
B1xx 4646	General VPD fault	Ignore all location codes. Go to MAP 1540 and run CEC minimum configuration.
B1xx 4647	The machine type and model reported by the CEC hardware do not match the machine type and model stored in the VPD module on the operator panel.	Replace the operator panel, Location: U0.1-L1. Do not swap the VPD module from the old operator panel onto the new operator panel; leave the new, unprogrammed VPD module on the new operator panel. Call service support to get instructions on reprogramming the machine type and model and the system serial number in the VPD module.
B1xx 4648	CEC backplane VPD or power source failure	Ignore all location codes. Go to MAP 1540 and run CEC minimum configuration.
B1xx 4649	Power supply VPD fault	CEC power supply Location: U1.1-V1
B1xx 4650	A system processor failure has been detected by the service processor. All system processors have been reset in an attempt to recover operations.	Information only. If the problem persists, check the error logs for other fault indicators.  If no other fault indications are found, go to "MAP 1540: Minimum Configuration" on page 122 and run the CEC minimum configuration.
B1xx 4651	CPU 1 VPD fault	Processor card Location: U1.1-P1-C1
B1xx 4652	CPU 2 VPD fault	Processor card Location: U1.1-P1-C2
B1xx 4660	Memory subsystem failure	Go to "MAP 1540: Minimum Configuration" on page 122.
B1xx 4661	Memory riser VPD failure	Go to "MAP 1540: Minimum Configuration" on page 122.
B1xx 4662	Memory DIMM VPD failure	Go to "MAP 1540: Minimum Configuration" on page 122.

Table 9. Common Firmware Error Codes (continued)

Error Code	Description	Action/ Possible Failing FRU
B1xx 4671	Critical temperature fault in primary I/O drawer	<ol style="list-style-type: none"> <li>1. Check ambient temperature</li> <li>2. Check air supply to fans</li> <li>3. Check fans for proper installation and operation</li> <li>4. Check for any unsupported cards that may be too hot</li> <li>5. I/O drawer operator panel Location: U0.1-L1</li> <li>6. Primary I/O drawer backplane Location: U0.1-P1</li> </ol>
B1xx 4672	Critical temperature fault in secondary I/O drawer	<ol style="list-style-type: none"> <li>1. Check ambient temperature</li> <li>2. Check air supply to fans</li> <li>3. Check fans for proper installation and operation</li> <li>4. Check for any unsupported cards that may be too hot</li> <li>5. I/O drawer operator panel Location: U0.1-L1</li> <li>6. Primary I/O drawer backplane Location: U0.1-P1</li> </ol>
B1xx 4673	Critical temperature fault in secondary I/O drawer 3	<ol style="list-style-type: none"> <li>1. Check ambient temperature</li> <li>2. Check air supply to fans</li> <li>3. Check fans for proper installation and operation</li> <li>4. Check for any unsupported cards that may be too hot</li> <li>5. I/O drawer operator panel Location: U0.1-L1</li> <li>6. Primary I/O drawer backplane Location: U0.1-P1</li> </ol>
B1xx 4674	Critical temperature fault in secondary I/O drawer 4 in secondary I/O drawer 3	<ol style="list-style-type: none"> <li>1. Check ambient temperature</li> <li>2. Check air supply to fans</li> <li>3. Check fans for proper installation and operation</li> <li>4. Check for any unsupported cards that may be too hot</li> <li>5. I/O drawer operator panel Location: U0.1-L1</li> <li>6. Primary I/O drawer backplane Location: U0.1-P1</li> </ol>

Table 9. Common Firmware Error Codes (continued)

Error Code	Description	Action/ Possible Failing FRU
B1xx 4681	JTAG scan interface problem	<ol style="list-style-type: none"> <li>1. JTAG cabling</li> <li>2. Clock card Location: U1.1-P1.1.1</li> <li>3. Processor cards and CEC backplane Locations: U1.1-P1-C1 U1.1-P1-C2 U1.1-P1</li> <li>4. Primary I/O drawer backplane Location: U0.1-P1</li> </ol>
B1xx 4690	Operating system surveillance time out (AIX to service processor interface failure)	<ol style="list-style-type: none"> <li>1. This error code indicates that the operating system terminated early (which usually implies an operating system crash). This error code may appear in the service processor error log by itself. However, in the AIX error log, there should be another error which points to the cause of the operating system crash. Use the other error as the starting point for your service action.</li> <li>2. The other possibility is that the operating system was not found during a prior boot attempt. To determine if this occurred, do the following: Look at the AIX error log entry containing B1xx4690. This will be a "SCAN_ERROR_CHRP" error with an identifier of BFEC0425. In the detail data, find the string "B1xx4690" (If present, it will be at byte 60 of the detail data.) Then go forward 8 bytes after the "B1" to byte 68 and look at bytes 68 and 69. If the values of bytes 68 and 69 are A2B0, this indicates that the firmware was unable to find a bootable device in the boot list that is set in the SMS menus. If the system is up, the boot list problem has been corrected and the B1xx 4690 can be treated as an informational message with no actions required.</li> <li>3. Call service support.</li> </ol>

Table 9. Common Firmware Error Codes (continued)

Error Code	Description	Action/ Possible Failing FRU
B1xx 4691	System firmware surveillance time out (System firmware to service processor interface failure)	<ol style="list-style-type: none"> <li>1. Check for system firmware updates Location: U0.1-P1/Y1</li> <li>2. If accessible, go to the service processor main menu and select <b>System Information Menu</b>. Then, select <b>Read Progress Indicators From Last System Boot</b>. Begin your repair action with the error code (use Chapter 5) or checkpoint (use Chapter 4) immediately preceding B1xx 4691. If a location code appears with the error code or checkpoint, replace the part at that location. If no location code is specified, follow the repair actions for the error code or checkpoint. If a location code appears with the error code or checkpoint, replace the part at that location. If no location code is specified, follow the repair actions for the error code or checkpoint</li> <li>3. If the service processor menus are not accessible, reboot the system and watch the primary drawer operator panel display. Record the last 4-digit checkpoint before any 8-digit error code. Use this checkpoint and go to "Checkpoint and Error Code Index" on page 173 and follow the instructions.</li> <li>4. If the problem is not solved, call the second level of support.</li> </ol>
B1xx 4692	Service processor firmware/operator panel task interface problem detected	<ol style="list-style-type: none"> <li>1. Check for system firmware updates Location: U0.1-P1/Y1</li> <li>2. Call second level of support</li> </ol>

Table 9. Common Firmware Error Codes (continued)

Error Code	Description	Action/ Possible Failing FRU
B1xx 4693	Service processor firmware error	<ol style="list-style-type: none"> <li>1. Check for system firmware updates.</li> <li>2. The type and model field in the VPD module may be set incorrectly. The type and model field can be viewed using the service processor function "Read VPD Image from Last System Boot", which is option 1 in the "System Information Menu" on page 424. If the type and model field is not set correctly, call service support.</li> <li>3. Call service support.</li> </ol>
B1xx 4694	Service processor firmware failure	<ol style="list-style-type: none"> <li>1. Check for system firmware update Location: U0.1-P1/Y2</li> <li>2. Primary I/O Drawer Backplane Location: U0.1-P1</li> </ol>
B1xx 4695	Service processor/system power control network firmware interface problem detected	<ol style="list-style-type: none"> <li>1. Check for system firmware update Location: U0.1-P1/Y2</li> <li>2. Primary I/O drawer backplane Location: U0.1-P1</li> </ol>
B1xx 4696	Firmware problem / AIX interface problem detected	Call second level of support
B1xx 4698	Firmware problem	<ol style="list-style-type: none"> <li>1. Check for system firmware updates</li> <li>2. Call second level of support</li> </ol>
B1xx 4699	Service processor firmware error	<ol style="list-style-type: none"> <li>1. Check for system firmware updates Location: U0.1-P1/Y1</li> <li>2. Call second level of support</li> </ol>
B1xx 469A	System firmware interface problem	<ol style="list-style-type: none"> <li>1. Check for system firmware update</li> <li>2. Call second level of support</li> </ol>
B1xx 469B	Firmware to I/O interface problem	<ol style="list-style-type: none"> <li>1. Check for system firmware update</li> <li>2. Primary I/O drawer backplane Location: U0.1-P1</li> </ol>
B1xx 469C	Firmware to I/O interface problem	<ol style="list-style-type: none"> <li>1. Check for system firmware update</li> <li>2. Primary I/O drawer backplane Location: U0.1-P1</li> </ol>

Table 9. Common Firmware Error Codes (continued)

Error Code	Description	Action/ Possible Failing FRU
B1xx 469E	Possible service processor firmware problem	<ol style="list-style-type: none"> <li>1. Check for system firmware updates Location: U0.1-P1/Y1</li> <li>2. Go to "MAP 1540: Minimum Configuration" on page 122, run CEC minimum configuration.</li> <li>3. Primary I/O drawer backplane Location: U0.1-P1</li> </ol>
B1xx 469F	Possible service processor firmware problem	<ol style="list-style-type: none"> <li>1. Check for system firmware updates Location: U0.1-P1/Y1</li> <li>2. Go to "MAP 1540: Minimum Configuration" on page 122, run CEC minimum configuration</li> <li>3. Primary I/O drawer backplane Location: U0.1-P1</li> </ol>
B1xx 8FF0	Informational message	No action required

---

## Scan Log Dump Progress Codes

Table 10. Scan Log Dump Progress Codes

Error Code	Description	Action/ Possible Failing FRU
D130 xxxx	Scan log dump in progress	Informational message only. As the dump progresses, the xxxx characters in the display will change. When the scan log dump is complete, the system may reboot, depending on the reboot policy settings.

---

## Problem Determination-Generated Error Codes

Table 11. Problem Determination-Generated Error Codes

Error Code	Description	Action/ Possible Failing FRU
M0BT 0000	The system hung during speaker POST. This error code is generated by the customer performing "Problem Determination" in the <i>RS/6000 Enterprise Server Model M80, @server pSeries 660 Model 6M1 User's Guide</i> .	Go to "MAP 1540: Minimum Configuration" on page 122.



Table 11. Problem Determination-Generated Error Codes (continued)

Error Code	Description	Action/ Possible Failing FRU
M0BT 0001	The system hung during "Starting Software...". This error code is generated by the customer performing "Problem Determination" in the <i>RS/6000 Enterprise Server Model M80, @server pSeries 660 Model 6M1 User's Guide</i> .	Go to "MAP 1540: Minimum Configuration" on page 122.
M0KB D000	The system hung during keyboard POST. This error code is generated by the customer performing "Problem Determination" in the <i>RS/6000 Enterprise Server Model M80, @server pSeries 660 Model 6M1 User's Guide</i> .	<ol style="list-style-type: none"> <li>1. Service processor Location: U0.1-P1-X1</li> <li>2. Keyboard</li> </ol>
M0KB D001	The system did not respond to a keyboard entry. This error code is generated by the customer performing "Problem Determination" in the <i>RS/6000 Enterprise Server Model M80, @server pSeries 660 Model 6M1 User's Guide</i> .	Type 101 keyboard.
M0KB D002	The system did not respond to a keyboard entry. This error code is generated by the customer performing "Problem Determination" in the <i>RS/6000 Enterprise Server Model M80, @server pSeries 660 Model 6M1 User's Guide</i> .	Type 102 keyboard.
M0KB D003	The system did not respond to a keyboard entry. This error code is generated by the customer performing "Problem Determination" in the <i>RS/6000 Enterprise Server Model M80, @server pSeries 660 Model 6M1 User's Guide</i> .	Kanji-type keyboard.
M0ME M002	The system hung during memory POST. This error code is generated by the customer performing "Problem Determination" in the <i>RS/6000 Enterprise Server Model M80, @server pSeries 660 Model 6M1 User's Guide</i> .	Go to "MAP 1540: Minimum Configuration" on page 122.

Table 11. Problem Determination-Generated Error Codes (continued)

Error Code	Description	Action/ Possible Failing FRU
M0NE T000	The system hung during network POST. This error code is generated by the customer performing "Problem Determination" in the <i>RS/6000 Enterprise Server Model M80, @server pSeries 660 Model 6M1 User's Guide</i> .	Go to "MAP 1540: Minimum Configuration" on page 122.
M0PS 0000	Power failure. This error code is generated by the customer performing "Problem Determination" in the <i>RS/6000 Enterprise Server Model M80, @server pSeries 660 Model 6M1 User's Guide</i> .	Go to "MAP 1520: Power" on page 94.
M0SC SI00	Unable to load diagnostics. This error code is generated by the customer performing "Problem Determination" in the <i>RS/6000 Enterprise Server Model M80, @server pSeries 660 Model 6M1 User's Guide</i> .	Go to "MAP 1540: Minimum Configuration" on page 122.
M0SC SI01	Unable to load diagnostics. This error code is generated by the customer performing "Problem Determination" in the <i>RS/6000 Enterprise Server Model M80, @server pSeries 660 Model 6M1 User's Guide</i> .	Go to "MAP 1540: Minimum Configuration" on page 122.

---

## Chapter 6. Loading the System Diagnostics In Service Mode

The system diagnostics can be booted from the default boot list or from the service mode boot list. (The service mode boot list can be modified using the system diagnostics “Display or Change Bootlist” service aid. The service mode boot list cannot be modified under the System Management Services).

For more information about using standalone or online diagnostics, see “Using the Standalone and Online Diagnostics” in *RS/6000 and @server pSeries Diagnostic Information for Multiple Bus Systems*, order number SA38-0509.

**Attention:** If this system unit is attached to another system, be sure you isolate this system unit before stopping the operating system or running diagnostic programs. Some system-cabling changes (such as installing wrap plugs or removing a device from the configuration) may require action by the operator of the attached system before making the cabling changes on this system.

To load **standalone diagnostics** from the default boot list, perform the following procedure:

1. Verify with the system administrator and users that all programs may be stopped, then do so.
2. Turn off the system.

**Note:** If AIX is running, enter the **shutdown** command.

3. Wait until the Power LED stops flashing and remains off, then press the power button to turn on the system.
4. Immediately insert the diagnostic CD-ROM into the CD-ROM drive.
5. When or after the **keyboard** indicator appears during startup, press the numeric 5 key on the keyboard.
6. Enter any requested passwords.

**Online diagnostics** can be loaded by booting from a hard file in the custom boot list by pressing the numeric 6 key on the keyboard.

To boot from the devices listed in the service mode boot list, perform the following procedure:

1. Verify with the system administrator and users that all programs may be stopped, then do so.
2. Turn off the system.

**Note:** If AIX is running, enter the **shutdown** command.

3. Wait until the Power LED stops flashing and remains off, then press the power button to turn the system on.
4. When or after the keyboard indicator appears during startup, press the numeric 6 key on the keyboard.

5. Enter any requested passwords.

After any requested passwords have been entered, the system attempts to boot from the first device of each type found on the list. If no bootable image is found on the first device of each type on the list, the system does not search through the other devices of that type for a bootable image; instead, it polls the first device of the next type.

If all types of devices in the boot list have been polled without finding a bootable image, the system restarts. This action gives the user the opportunity to start the System Management Services (by pressing the number 1 key on a directly attached keyboard or the number 1 on an ASCII terminal) before the system attempts to boot again.

---

## Default Boot List and Service Mode Bootlist

The default boot list is:

1. Diskette
2. CD-ROM
3. Tape
4. Hard file
5. Network
  - Token-ring
  - Ethernet

Pressing the numeric 5 key on the keyboard causes the system to load **standalone diagnostics** if a diagnostic CD is present in the CD-ROM drive.

Pressing the numeric 6 key on the keyboard loads **online diagnostics** from the hard file in the customized service mode boot list. No diagnostic CD should be in the CD-ROM drive because **online diagnostics** are typically run from a hard disk. Like the default boot list, the service mode boot list can contain five entries. The numeric 6 key works like the numeric 5 key with the following exceptions:

- The system searches for a boot record according to the service mode boot list.
- If the service mode boot list is discovered by a cyclical redundancy check to be corrupted, the system rebuilds the service mode boot list according to the default boot list. (The default boot list contains five entries, and for each matching device type found in the system unit, the system makes an entry in the custom boot list.)
- If no service mode boot list is present, the system uses the default boot list.

---

## Chapter 7. Using the Capacity Upgrade on Demand Feature

The Capacity Upgrade on Demand feature allows a new system to be ordered with extra processor capacity that can be enabled by the system administrator. Also, if a system that is already in use requires additional processor capacity, the system can be upgraded with additional capacity that can be enabled by the system administrator anytime additional capacity is required. The service representative can also enable processors during hardware upgrade installation.

**Note:** The Capacity Upgrade on Demand feature is available for this system when a minimum of four processors running at 750 MHz processor are installed. The Capacity Upgrade on Demand feature is not available on systems in which 500 MHz processors are installed.

---

### System Processors

The processors are ordered by feature code (FC) for the system on which you are installing the additional capacity. The following feature codes can be ordered with the system, or added as upgrades to allow additional processors to be installed in the system and then enabled later.

#### **FC 8306**

This Capacity Upgrade on Demand feature code causes a processor board with four processors to be installed, but none of the processors are enabled. Only one of these feature codes can be installed.

#### **FC 8307**

This Capacity Upgrade on Demand feature code causes a processor board with four processors to be installed, and two of the processors are enabled.

After the system is running with any of the above features installed, if the system administrator enables additional processors on a processor board, the records for the system are changed to show that the appropriate feature code is in use.

As processors are enabled by the system administrator, the feature records for the system are automatically updated in the AIX error logs to reflect the number of processors in use. For system records purposes, the error logs record changes to the processor configuration and the changes are sent, using the Electronic Service Agent, to the CUoD (Capacity Upgrade on Demand) project office.

## Process Flow for Capacity Upgrade on Demand

The following flowchart provides an overview of the process that is required to enable Capacity Upgrade on Demand on systems that need reserve capacity.

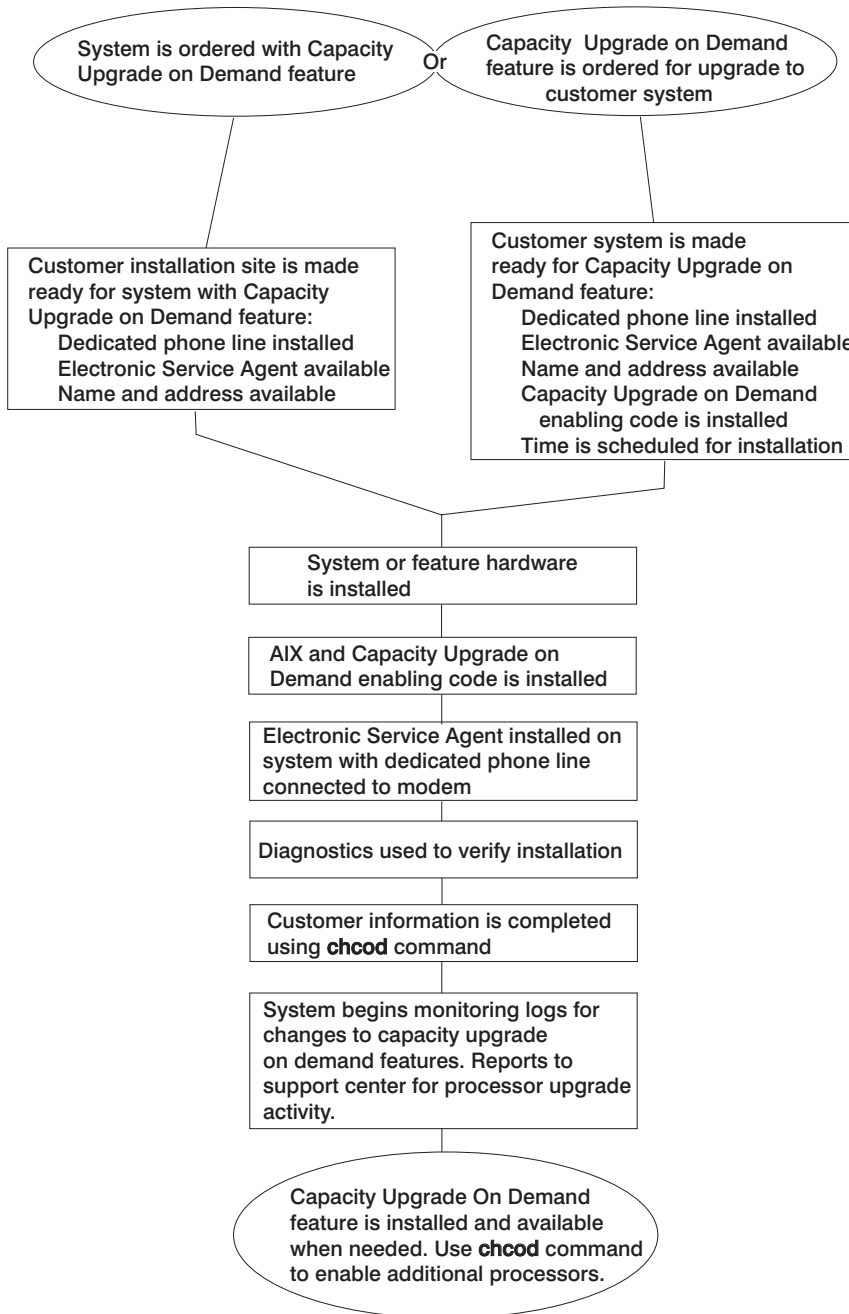

---

## Installing a System with Capacity Upgrade on Demand

If you are installing a system that was ordered with a processor Capacity Upgrade on Demand feature, continue with this section to install the Capacity Upgrade on Demand feature.

If the Capacity Upgrade on Demand feature is already installed in your system and you want to upgrade to use additional processors, go to “Enabling Additional Capacity Upgrade on Demand Processors” on page 409.

## Verifying System Communication Capabilities

The system *must* have Electronic Service Agent installed and configured to call out on a dedicated phone line. The service representative is responsible for ensuring that Electronic Service Agent is operational.

To verify the system communication capabilities, do the following:

1. As part of the Capacity Upgrade on Demand system installation, the service representative must configure and test the Electronic Service Agent. Locate the CD that contains the Electronic Service Agent application and user’s guide PDF document provided with the system.
2. Use the Electronic Service Agent user’s guide to complete the tasks in the following sections:
  - Prerequisites
  - Obtaining and installing Electronic Service Agent
  - Basic Electronic Service Agent configuration
  - Advanced configuration tasks that *must* be completed to support Capacity Upgrade on Demand:
    - If the system having Capacity Upgrade on Demand installed is not the Electronic Service Agent gateway, the Electronic Service Agent client code must be installed on this system and this system must be added to the list of Electronic Service Agent-monitored systems.
    - A test PMR must be sent to the Electronic Service Agent server and completed successfully.
3. Return here and continue with these instructions after completing steps 1 and 2 above.

## Configuring the Capacity Upgrade on Demand Feature

This section provides instructions to use the **chcod** command to configure the Capacity Upgrade on Demand feature and allow the system to update the system records. For full details about the **chcod** command syntax, go to Appendix D, “Using the chcod Command” on page 555.

**Note:** Ensure that the system and all new hardware have been installed before beginning this procedure.

**Note:** If the Capacity Upgrade on Demand processor feature is not installed, the service representative should install the processor feature at this time. Do *not* continue with the steps below. Refer to the installation instructions that were provided with the feature.

To install a system with the Capacity Upgrade on Demand feature hardware, do the following:

1. Log in to the system as root user or as a user with system group privileges.
2. Type the following command:

```
chcod
```

Record the displayed information below:

```
Current MailAddress _____Reserved_____
```

```
Current CustInfo _____
```

```
Current Model and System ID = IBM, xxxx-_____IBM, _____
```

```
Current number of authorized proc(s) out of (xx_____) installed on system = (yy_____)
```

where (xx) is the number of processors installed in the system, (yy) is the number of Capacity Upgrade on Demand-enabled processors.

If (yy) is equal to 0, then Capacity Upgrade on Demand is not enabled.

If (yy) is greater than 0, then Capacity Upgrade on Demand is enabled.

3. To enable testing of all the installed processors, disable Capacity Upgrade on Demand by setting the number `_of_` processors (yy) equal to 0:

```
chcod -r proc -n 0
```

4. Shut down and reboot the system, as follows:

```
shutdown -Fr
```

5. To verify the installed processors, type the following at the command line:

```
bindprocessor -q
```

Information about installed processor boards displays. The available processors should be listed as 0 to 7.

If the number of installed processors is not correct, use the normal maintenance package procedures to correct any problems.

6. To test the system, type the following at the command line:

```
diag
```

7. Select **Advanced Diagnostics**.

8. Select System Verification mode on `sysplanar0` and all processors. Use the normal maintenance package procedures to correct any problems.



## Enabling the Capacity Upgrade on Demand Feature

When the system is ready to return to normal operations, enable the Capacity Upgrade on Demand feature, as follows:

1. Log in to the system as root user or as a user with system group privileges.
2. Type the following at the command line:

```
chcod -c "CustomerNname-CustomerNumber_nnnnnnn-CustomerPhoneNumber_(333)_444-5555"
```

**Note:** You can obtain the customer number and the customer phone number from the customer or the marketing representative. Use that information when you use the **chcod** command. For example:

```
chcod -c Jane_Doe-CustomerNumber_9999999-Phone_(333)_444-5555
```

**Note:** The customer information cannot contain any blank spaces.

To verify that the information was entered correctly, type the following at the command line:

```
chcod
```

The following information is displayed:

```
Current MailAddress _____Reserved_____
```

```
Current CustInfo      Jane_Doe-CustomerNumber_9999999-Phone_(333)_444-5555
```

```
Current Model and System ID = IBM, xxxx-xxx_IBM,xxxxxxx
```

```
Current number of authorized proc(s) out of (xx____) installed on system = (0)
```

3. Type the following at the command line:

```
chcod -r proc -n total_number_of_processors
```

where the *total\_number\_of\_processors* is equal to the value of (yy) recorded in step 2 on page 406.

4. To verify the error log, type the following at the command line:

```
errpt -a | pg
```

The following information displays:

```
LABEL :          COD_CHANGED
IDENTIFIER :     nnnnnAnnB
Date/Time :     DDD MM YY  TIME
Machine ID :    nnnnnnnnnnnnnn
Note ID :      abcdefxxx
Class :        x
Type :         INFO
Resource Name : Cod Notify
Description
CHANGING CAPACITY UPGRADE ON DEMAND
Probable Causes
User Causes
USER RAN Chcod COMMAND
```

```
Recommended Action
NONE
Detail Data
SYSTEM MODEL
IBM, xxxx-xxx_IBM, xxxxxxxxx
RESOURCE CHANGE
proc
RESOURCE INSTALLED
.....
```

The RESOURCE INSTALLED is equal to the total number of installed processors (xx).

```
OLD VALUE
0
NEW VALUE
.....
```

The NEW VALUE must equal (yy), recorded in step 2 on page 406.

5. Shutdown and reboot the system, as follows:

```
shutdown -Fr
```

6. Log in to the system as root user or as a user with system group privileges.

7. Type the following at the command line:

```
chcod
```

The following information displays:

```
Current MailAddress _____Reserved_____
```

```
Current CustInfo Jane_Doe-CustomerNumber_9999999-Phone_(333)_444-5555
```

```
Current Model and System ID = IBM, xxxx-xxx_IBM,xxxxxxx
```

```
Current number of authorized proc(s) out of (xx____) installed on system = (yy____)
```

The values of (xx) and (yy) should match the values recorded in step 2 on page 406.

The processor Capacity Upgrade on Demand feature is enabled and ready to be used. If you want to enable additional processors, go to “Enabling Additional Capacity Upgrade on Demand Processors” on page 409.

---

## Enabling Additional Capacity Upgrade on Demand Processors

This section provides instructions to use the **chcod** command to enable the appropriate processors as they are needed. For details about the **chcod** command syntax, go to Appendix D, “Using the chcod Command” on page 555.

If the Capacity Upgrade on Demand feature is already installed in your system and you want to upgrade to use additional processors, continue with this section.

### Determining Processor Configuration

If your system has a Capacity Upgrade on Demand processor board feature, to determine the current configuration of installed processors and processors authorized for use, do the following:

1. Log in to the system as root user or as a user with system group privileges.
2. Type the following command:

```
chcod
```

Record the displayed information below:

```
Current MailAddress _____Reserved_____
```

```
Current CustInfo      Jane_Doe-CustomerNumber_9999999-Phone_(333)_444-5555
```

```
Current Model and System ID = IBM, xxxx-xxx_IBM,xxxxxxx
```

```
Current number of authorized proc(s) out of (xx____) installed on system = (yy____)
```

The values of (xx) and (yy) are the current values for the number of processors installed (xx) and the number of authorized processors (yy). Use this information about the current configuration to determine the number of processors to enable.

3. Continue with “Adding Processor Capacity” on page 410 to enable any additional processors that you need.

## Adding Processor Capacity

To enable additional processors in the configuration of a system that has the Capacity Upgrade on Demand feature installed and running, do the following.

1. To increase the number of authorized processors, type the following at the command line:

```
chcod -r proc -n total_number_of_processors
```

The following is an example of the above command:

```
chcod -r proc -n 6
```

In the example above, the value of **-n 6** is equal to the total number of processors that you want to have authorized (*yy*) by entering this command. To upgrade your system to use more of the installed processors, increase the value of (*yy*) in increments of 2. In this case, 6 would represent 4 base processors plus 2 additional Capacity Upgrade on Demand processors.

When the system performs the command to enable additional processors, information about the new system configuration is added to the error log and sent through the Electronic Service Agent to the service support center.

2. Shut down and reboot the system to enable the additional processors, as follows:

```
shutdown -Fr
```

3. Log in to the system as root user or as a user with system group privileges.
4. Type the following at the command line:

```
chcod
```

The following information displays:

```
Current MailAddress _____Reserved_____
```

```
Current CustInfo      Jane_Doe-CustomerNumber_9999999-Phone_(333)_444-5555
```

```
Current Model and System ID = IBM, xxxx-xxx_IBM,xxxxxxx
```

```
Current number of authorized proc(s) out of (xx____) installed on system = (yy____)
```

The values of (*yy*) should match the value you entered for the *total\_number\_of\_processors* in step 1.

For details about the flag variables entered in the **chcod** command, see Appendix D, "Using the chcod Command" on page 555.

## Chapter 8. Using the Service Processor

The service processor menus make it possible for you to configure service processor options, as well as enable and disable functions.

Service processor menus are available using an ASCII terminal when 0K is displayed on the primary I/O drawer operator panel or when the service processor has detected a server problem (such as a surveillance failure).

For a summary of the service processor functions and the methods used to invoke them, see the following table.

Service Processor Functions	Service Processor Menus (ASCII terminals)	AIX Service Aids (ASCII or graphics terminals)	SMS (ASCII or graphics terminals)
Read VPD image from last system boot	Y <sup>3</sup>		
Read System POST Errors	Y <sup>3</sup>		
Read Service Processor Error Logs	Y <sup>3</sup>		
View Progress Indicators from last boot	Y <sup>3</sup>		
Power-off System	Y <sup>2</sup>		
Read NVRAM	Y <sup>2</sup>		
Start Talk Mode	Y <sup>2</sup>		
Enable/Disable Console Mirroring	Y <sup>2</sup>		
Setup Reboot/Restart Policy	Y <sup>2</sup>	Y <sup>1</sup>	
Enable/Disable Modem	Y <sup>2</sup>	Y <sup>1</sup>	
Setup Modem Configuration	Y <sup>2</sup>	Y <sup>1</sup>	
Setup Dial-out Phone Numbers	Y <sup>2</sup>	Y <sup>1</sup>	
Setup Surveillance	Y <sup>2</sup>	Y <sup>1</sup>	
Select Modem Line Speed	Y <sup>2</sup>	Y <sup>1</sup>	
Update System EPROMs	Y <sup>2</sup>	Y <sup>1</sup>	
Save/Restore Hardware Maintenance Policies		Y <sup>1</sup>	
Change General-Access Password	Y <sup>2</sup>		
Change Privileged-Access Password	Y <sup>2</sup>		Y <sup>2</sup>
Select Language	Y <sup>2</sup>		Y <sup>2</sup>
Enable/Disable Unattended Start Mode	Y <sup>2</sup>	Y <sup>1</sup>	Y <sup>2</sup>
Passwords required (if set): <sup>1</sup> Operating system root password <sup>2</sup> Privileged-access password <sup>3</sup> General-access (power-on) password			

---

## Service Processor Menus

The service processor menus are divided into two groups:

- General user menus - the user must know the general-access password.
- Privileged user menus - the user must know the privileged-access password.

If the server is powered off, the service processor menus can be accessed locally or remotely.

### Accessing the Service Processor Menus Locally

Service processor menus can be accessed locally by connecting an ASCII terminal to serial port 1 (S1) or serial port 2 (S2). Access to the service processor menus is not available on serial port 3 (S3) or serial port 4 (S4). Because the presence of the ASCII terminal cannot be confirmed by the service processor, you must press a key (any key) on the ASCII keyboard to confirm its presence after 0K appears in the primary drawer operator panel display.

When you gain access, the service processor prompts you for a password (if set), and when verified, displays the service processor menus.

The service processor menu prompt, represented by 0> or 1>, indicates the serial port to which the terminal is connected.

- 0> indicates serial port 1 (S1)
- 1> indicates serial port 2 (S2)

### Accessing the Service Processor Menus Remotely

If your system has a modem connected and is configured for call-in (see “Modem Configuration Menu” on page 433), the service processor menus can be accessed remotely as follows:

1. With the system powered off, call in from a remote terminal.
2. The service processor detects ring-indicate and prompts you for a password (if set).  
When verified, the service processor menus display remotely.

### Saving and Restoring Service Processor Settings

All the settings you make (except language) from the service processor menus can be backed up either for recovering from a fault that may corrupt these settings, or for replicating these settings to other servers that include a service processor.

The AIX service aid, Save or Restore Hardware Management Policies, can be used to save your settings after initial setup or whenever the settings must be changed for system operation purposes.

It is strongly recommended that you use this AIX service aid for backing up service processor settings to protect the usefulness of the service processor and the availability of the server. Refer to “Save or Restore Hardware Management Policies,” in the “Introducing Tasks and Service Aids” section of the *RS/6000 and @server pSeries Diagnostic Information for Multiple Bus Systems*, SA38-0509.

## Menu Inactivity

The service processor exits menu mode after ten minutes of inactivity, and displays a message indicating that it has done so. Pressing any key on the ASCII terminal causes the main menu to be displayed.

---

## General User Menu

The menu options presented to the general user are a subset of the options available to the privileged user. The user must know the general-access password, if set, to access this menu.

```
GENERAL USER MENU

1. Power-on System
2. Power-off System
3. Read VPD Image from Last System Boot
4. Read Progress Indicators from Last System Boot
5. Read Service Processor Error Logs
6. Read System POST Errors
99. Exit from Menus

1>
```

- **Power-on System**

Allows the user to start the system using the current ASCII terminal as the active console.

- **Power-off System**

Allows the user to power off the system using the current ASCII terminal as the active console.

- **Read VPD Image from Last System Boot**

Displays manufacturer vital product data, such as serial numbers, part numbers, and so on, that were stored during the system boot prior to the one in progress now.

- **Read Progress Indicators from Last System Boot**

Displays a number of the boot progress indicators, which may include service processor checkpoints, IPL checkpoints, and/or AIX configuration codes, from the previous system boot. This information can be useful in diagnosing system faults.

The progress indicator codes are listed from top (latest) to bottom (oldest).

This information is not stored in non-volatile storage. If the system is powered off using the power-on button on the operator panel, this information is retained. If the ac power (dc power in a dc-powered system) is disconnected from the system, this information will be lost. For an example, refer to “LCD Progress Indicator Log” on page 451.

- **Read Service Processor Error Logs**

Displays the service processor error logs. For an example, refer to “Service Processor Error Log” on page 450.

- **Read System POST Errors**

This option should only be used by service personnel to display additional error log information.

- **Exit from Menus**

Selecting this option will exit the service processor menus. You can re-enter the menus by pressing any key on the console.

---

## Privileged User Menus

The following menus are available to privileged users only. The user must know the privileged-access password, if set, to access these menus.

## Main Menu

At the top of the Main Menu is a listing containing:

- Your system’s current firmware version
- The firmware copyright notice
- The system name given to your server during setup

You need the firmware version for reference when you either update or repair the functions of your service processor.

The system name, an optional field, is the name that your server reports in problem messages. This name helps your support team (for example, your system administrator, network administrator, or service representative) to more quickly identify the location, configuration, and history of your server. The system name is set from the Main Menu using option 6.

**Note:** The information under the Service Processor Firmware heading in the following Main Menu illustration is example information only.



```
Service Processor Firmware
VERSION: MM000313
Copyright 2000 IBM Corporation
SYSTEM NAME
```

MAIN MENU

1. Service Processor Setup Menu
2. System Power Control Menu
3. System Information Menu
4. Language Selection Menu
5. Call-In/Call-Out Setup Menu
6. Set System Name
99. Exit from Menus

1>

- **Service Processor Setup Menu**  
See “Service Processor Setup Menu” on page 416 for more information.
- **System Power Control Menu**  
See “System Power Control Menu” on page 420 for more information.
- **System Information Menu**  
See “System Information Menu” on page 424 for more information.
- **Language Selection Menu**  
See “Language Selection Menu” on page 431 for more information.
- **Call-In/Call-Out Setup Menu**  
See “Call-In/Call-Out Setup Menu” on page 432 for more information.
- **Set System Name**  
Allows setting of the system name.

## Service Processor Setup Menu

The Service Processor Setup menu shown below is accessed from the Main Menu.

```
SERVICE PROCESSOR SETUP MENU
1. Change Privileged Access Password
2. Change General Access Password
3. Enable/Disable Console Mirroring:
   Currently Enabled
4. Start Talk Mode
5. OS Surveillance Setup Menu
6. Reset Service Processor
7. Reprogram Flash EPROM Menu
8. Serial Port Snoop Setup Menu
98. Return to Previous Menu
99. Exit from Menus
1>
```

**Note:** Unless otherwise stated in menu responses, settings become effective when a menu is exited using option 98 or 99.

## Passwords

Passwords can be any combination of up to eight alphanumeric characters. You can enter longer passwords, but the entries are truncated to include only the first eight characters. The privileged-access password can be set from service processor menus or from System Management Services (SMS) utilities (see Chapter 9, “Using System Management Services” on page 455). The general-access password can be set only from service processor menus.

For security purposes, the service processor counts the number of attempts to enter correct passwords. The results of not recognizing a correct password within this error threshold are different, depending on whether the attempts are being made locally (at the server) or remotely (through a modem). The error threshold is three attempts.

If the error threshold is reached by someone entering passwords at the server, the service processor commands the server to resume the initial program load (IPL). This action is taken based on the assumption that the server is in an adequately secure location with only authorized users having access. Such users must still successfully enter a login password to access AIX.

If the error threshold is reached by someone entering passwords remotely, the service processor commands the server to power down to prevent potential security attacks on the server by unauthorized remote users. The following table lists what you can access with the privileged-access password and the general-access password.

Privileged Access Password	General Access Password	Resulting Menu
None	None	Service processor MAIN MENU displays
Set	None	Users with the password see the service processor MAIN MENU. Users without password cannot log in.
Set	Set	Users see menus associated with the entered password

**Note:** If you *forget* the password, you must remove the battery for at least 30 seconds to disable the password.

- **Change Privileged-Access Password**

Set or change the privileged-access password. It provides the user with access to all service processor functions. This password is usually used by the system administrator or root user.

- **Change General-Access Password**

Set or change the general-access password. It provides limited access to service processor menus, and is usually available to all users who are allowed to power on the server, especially remotely.

**Note:** The general-access password can only be set or changed after the privileged-access password is set.

- **Enable/Disable Console Mirroring**

Console mirroring is supported on serial port 1 (S1) and serial port 2 (S2). When console mirroring is enabled, the service processor sends information to both serial ports. The serial port from which console mirroring is enabled is referred to as the *active port*. The *mirror port* is determined when keyboard input is detected from the other port. From this point on, the service processor only sends information to the active port and the mirror port. This capability can be enabled by local or remote users, providing local users the capability to monitor remote sessions. Console mirroring can be enabled for the current session only. For more information, see “Console Mirroring” on page 449.

- **Start Talk Mode**

In a console mirroring session, it is useful for those who are monitoring the session to be able to communicate with each other. Selecting this menu item activates the keyboards and displays for such communications while console mirroring is established. This is a full duplex link, so message interference is possible. Alternating messages between users works best.

- **OS Surveillance Setup Menu**

This menu can be used to set up operating system (OS) surveillance.

```
OS Surveillance Setup Menu

1. Surveillance:
   Currently Enabled

2. Surveillance Time Interval:
   5 minutes

3. Surveillance Delay:
   10 minutes

98. Return to Previous Menu

1>
```

- **Surveillance**

Can be set to Enabled or Disabled.

- **Surveillance Time Interval**

Can be set to any number from 2 through 255.

- **Surveillance Delay**

Can be set to any number from 0 through 255.

Refer to “Service Processor System Monitoring - Surveillance” on page 446 for more information about surveillance.

- **Reset Service Processor**

If this option is selected, entering Y causes the service processor to reboot.

- **Reprogram Flash EPROM Menu**

This option updates the system EPROMs. After entering Y to indicate that you want to continue, you are prompted to enter the update diskettes. Follow the instructions on the screen. When the update is complete, the service processor reboots.

All system EPROMs that can be reprogrammed are updated at the same time. They are as follows:

- System power control network programming
- Service processor programming
- System firmware
- Run-time abstraction services

- **Serial Port Snoop Setup Menu**

This menu can be used to set up serial port snooping, in which the user can configure serial port 1 as a "catch-all" reset device.

From the service processor main menu, select option 1, Service Processor Setup Menu, then select option 8 (Serial Port Snoop Setup Menu).

```
SERIAL PORT SNOOP SETUP MENU

1. System reset string:
   Currently Unassigned

2. Snoop Serial Port:
   Currently Unassigned

98. Return to Previous Menu

1>
```

Use the system reset string option to enter the system reset string, which resets the machine when it is detected on the main console on serial port 1.

Use the snoop serial port option to select the serial port to snoop.

**Note:** Only serial port 1 is supported.

After serial port snooping is correctly configured, at any point after the system unit is booted to AIX, whenever the reset string is typed on the main console, the system unit reboots.

Pressing Enter after the reset string is not required, so make sure that the string is not common or trivial. A mixed-case string is recommended.

## System Power Control Menu

This menu is used to set power control options. Other menus that control boot options are available here:

```
SYSTEM POWER CONTROL MENU

1. Enable/Disable Unattended Start Mode:
   Currently Enabled

2. Ring-Indicate Power-On Menu

3. Reboot/Restart Policy Setup Menu

4. Power-On System

5. Power-Off System

6. Enable/Disable Fast System Boot
   Currently Enabled

7. Boot Mode Menu

98. Return to Previous Menu

99. Exit from Menus

1>
```

- **Enable/Disable Unattended Start Mode**

Use this option to instruct the service processor to restore the power state of the server after a temporary power failure. Unattended start mode can also be set through the System Management Services (SMS) menus. It is intended to be used on servers that require automatic power-on after a power failure. For more information, see “System Power-On Methods” on page 439.

- **Ring-Indicate Power-On Menu**

```
RING-INDICATE POWER-ON MENU

1. Ring-indicate power-on :
   Currently Enabled

2. Number of rings:
   Currently 3

30. Refresh Modem Settings

98. Return to Previous Menu
```

Ring-indicate is enabled by default on both serial port 1 (S1) and serial port 2 (S2). When ring-indicate power-on is enabled, call-in is disabled.

If ring-indicate power-on is enabled and call-in is already enabled, you will be asked to confirm your choice. Refer to the message displayed on your screen.

If the ring-indicate power-on setting is changed, you must select option 30 (Refresh Modem Settings) to update the modem settings. If option 30 (Refresh Modem Setting) is selected, and the modem(s) have not been configured, you will be asked to configure the modems first. See “Call-In/Call-Out Setup Menu” on page 432 for information on configuring modems.

Option 2 is used to set the number of rings.

**Note:** In order for the ring-indicate power-on settings to take effect and ring-indicate power-on to be enabled, the service processor menus must be exited completely. Enter 99 at the Main Menu screen to completely exit the service processor menus.

- **Reboot/Restart Policy Setup Menu**

The following menu controls reboot/restart policy:

```
Reboot/Restart Policy Setup Menu

1. Number of reboot attempts:
   Currently 1

2. Use OS-Defined restart policy?
   Currently Yes

3. Enable supplemental restart policy?
   Currently No

4. Call-Out before restart:
   Currently Disabled

98. Return to Previous Menu

1>
```

*Reboot* is the process of bringing up the system hardware; for example, from a system reset or power on. *Restart* is activating the operating system after the system hardware is re-initialized. Restart must follow a successful reboot.

- **Number of reboot attempts** - If the server fails to successfully complete the boot process, it attempts to reboot the number of times specified. Values equal to or greater than 0 are valid. Only successive failed reboot/restart attempts are counted.
- **Use OS-Defined restart policy** - Allows the service processor to react or not react in the same way as the operating system to major system faults by reading the setting of the operating system parameter **Automatically Restart/Reboot After a System Crash**. This parameter may or may not be defined, depending on the operating system or its version/level. If the operating system automatic restart setting is defined, then it can be set to respond to a major fault by restarting or by not restarting. See your operating system documentation for details on setting up operating system automatic restarts. The default value is Yes.

- **Enable supplemental restart policy** - The default setting is No. If set to Yes, the service processor restarts the system when the system loses control as detected by service processor surveillance, and either:

The **Use OS-Defined restart policy** is set to No.

OR

The **Use OS-Defined restart policy** is set to Yes, and the operating system has no automatic restart policy.

Refer to “Service Processor Reboot/Restart Recovery” on page 440.

- **Call-Out before restart (enabled/disabled)** - If a restart is necessary due to a system fault, you can enable the service processor to call out and report the event. This option can be valuable if the number of these events becomes excessive, signalling a bigger problem.

- **Power-On System**

Allows immediate power-on of the system. For other power-on methods, see “Powering On the System” on page 469.

- **Power-Off System**

Allows the user to power-off the system.

- **Enable/Disable Fast System Boot**

Allows the user to select the speed of the system boot.

**Attention:** Selecting the fast IPL results in several diagnostic tests being skipped and a shorter memory test being run.



- **Boot Mode Menu**

The Boot Mode Menu allows you to select a boot mode.

```
Boot Mode Menu

1. Boot to SMS Menu:
   Currently Disabled

2. Service Mode Boot from Saved List:
   Currently Disabled

3. Service Mode Boot from Default List:
   Currently Disabled

4. Boot to Open Firmware Prompt:
   Currently Disabled

98. Return to Previous Menu

1>
```

To select a boot mode, select a number and press Enter. The item corresponding to the selected number toggles from disabled to enabled. If the same number is selected again, the item toggles from enabled to disabled. If a boot mode is enabled, the boot mode selected is performed, and the disabled/enabled selection is reset to disabled. Following is a description for each boot mode:

- **Boot to SMS Menu**

When this selection is enabled, the system boots to the System Management Services (SMS) menu.

- **Service Mode Boot from Saved List**

This selection causes the system to perform a service mode boot using the service mode boot list saved in NVRAM. If the system boots AIX from the disk drive and AIX diagnostics are loaded on the disk drive, AIX boots in service mode to the diagnostics menu.

Using this option to boot the system is the preferred way to run online diagnostics.

- **Service Mode Boot from Default List**

This selection is similar to “Service Mode Boot from Saved List”, except the system boots using the default boot list that is stored in the system firmware. This is normally used to try to boot customer diagnostics from the CD-ROM drive.

Using this option to boot the system is the preferred way to run standalone diagnostics.

- **Boot to Open Firmware**

When this selection is enabled, the system boots to the open firmware prompt.

This option should only be used by service personnel to obtain additional debug information.

## System Information Menu

This menu provides access to system configuration information, error logs, system resources, and processor configuration.

```
SYSTEM INFORMATION MENU

1. Read VPD Image from Last System Boot
2. Read Progress Indicators from Last System Boot
3. Read Service Processor Error Logs
4. Read System POST Errors
5. Read NVRAM
6. Read Service Processor Configuration
7. Processor Configuration/Deconfiguration Menu
8. Memory Configuration/Deconfiguration Menu
9. Power Control Network Utilities Menu
98. Return to Previous Menu
99. Exit from Menus

1>
```

- **Read VPD Image from Last System Boot**

Displays manufacturer's vital product data (VPD), such as serial numbers, part numbers, and so on, that were stored during the system boot prior to the one in progress now.

- **Read Progress Indicators from Last System Boot**

Displays a number of the boot progress indicators, which may include service processor checkpoints, IPL checkpoints, and/or AIX configuration codes, from the previous system boot. This information can be useful in diagnosing system faults.

The progress indicator codes are listed from top (latest) to bottom (oldest).

This information is not stored in non-volatile storage. If the system is powered off using the power-on button on the operator panel, this information is retained. If the ac power (dc power in a dc-powered system) is disconnected from the system, this information will be lost. For an example, refer to "LCD Progress Indicator Log" on page 451.

- **Read Service Processor Error Logs**

Displays the service processor error log. Refer to "Service Processor Error Log" on page 450 for an example of this error log.

- **Read System POST Errors**

This option should only be used by service personnel to display additional error log information.

- **Read NVRAM**

Displays non-volatile random access memory (NVRAM) content.

- **Read Service Processor Configuration**

Displays current service processor configuration.

- **Processor Configuration/Deconfiguration Menu**

This menu allows the user to change the system processor configuration. If it is necessary to take one of the processors offline, this menu allows you to deconfigure a processor, and then reconfigure the processor at a later time. An example of this menu is shown below:

```
PROCESSOR CONFIGURATION/DECONFIGURATION MENU

77. Enable/Disable CPU Repeat Gard: Currently Enabled

  1. 0 3.0 (00) Configured by system
  2. 1 3.1 (31) Deconfigured by system
  3. 2 3.2 (00) Configured by system
  4. 3 3.3 (00) Configured by system
  5. 4 4.0 (00) Configured by system
  6. 5 4.1 (00) Configured by system
  7. 6 4.2 (00) Configured by system
  8. 7 4.3 (00) Configured by system
98. Return to Previous Menu

1>
```

**Note:** This table is built from vital product data collected during the last boot sequence. The first time the system is powered up, or after the system's non-volatile RAM (NVRAM) has been erased, this table may be empty. The table is rebuilt during the next boot into AIX.

The fields of the previous table represent the following:

- Column 1** (1.) Menu selection index.
- Column 2** (0) Logical processor device number assigned by AIX. You can display these logical device numbers by issuing the following command on the AIX command line:  
`lsdev -C | grep proc`
- Column 3** (3.0) Processor address list used by the service processor and should be ignored.
- Column 4** (00) Error status of the processors.

The error status of each processor is indicated by AB, where B indicates the number of errors and A indicates the type of error according to the following table:

1. Bring-up failure
2. Run-time non-recoverable failure
3. Run-time recoverable failure

A status of 00 indicates that the CPU has not had any errors logged against it by the service processor.

To enable or disable CPU Repeat Gard, use menu option 77. CPU Repeat Gard is enabled by default.

If CPU Repeat Gard is disabled, processors that are in the deconfigured by system state will be reconfigured. These reconfigured processors are then tested during the boot process, and if they pass, they remain online. If they fail the boot testing, they are deconfigured, even though CPU Repeat Gard is disabled.

The failure history of each CPU is retained. If a processor with a history of failures is brought back online by disabling Repeat Gard, it remains online if it passes testing during the boot process. However, if Repeat Gard is enabled, the processor is taken offline again because of its history of failures.

**Note:** The processor numbering scheme used by the service processor is different from the numbering scheme used by AIX. Consult the AIX documentation before configuring or deconfiguring a processor to ensure that the correct processor is selected.

The AIX Documentation library is available at the following Web address: <http://www-1.ibm.com/servers/aix/library/>. Select **Technical Publications**. AIX documentation is also contained on the AIX Documentation CD. The documentation is made accessible by loading the documentation CD onto the hard disk or by mounting the CD in the CD-ROM drive.

- **Memory Configuration/Deconfiguration Menu**

These menus allow the user to change the system memory configuration. If it is necessary to take one of the memory DIMMs offline, this menu allows you to deconfigure a DIMM, and then reconfigure the DIMM at a later time.

When this option is selected, a menu displays, showing the memory riser cards in the system. Type the number of the memory riser card on which the DIMM is plugged that you want to configure or deconfigure. An example of this menu is shown below:

```
MEMORY CONFIGURATION/DECONFIGURATION MENU

77. Enable/Disable Memory Repeat Gard: Currently Enabled

    1. Memory riser card 1
    2. Memory riser card 2
    98. Return to Previous Menu
```

After you select a memory riser card, a menu allowing the selection of a memory DIMM is displayed. The following is an example of this menu.

```
MEMORY CONFIGURATION/DECONFIGURATION MENU

 1: 11.16(00) Configured by system   2: 11.17(00) Configured by system
 9: 11.18(00) Configured by system  10: 11.19(00) Configured by system
17: 11.20(00) Configured by system  18: 11.21(00) Configured by system
25: 11.22(00) Configured by system  26: 11.23(00) Configured by system

 3: 11.24(00) Configured by system   4: 11.25(00) Configured by system
11: 11.26(00) Configured by system  12: 11.27(00) Configured by system
19: 11.28(00) Configured by system  20: 11.29(00) Configured by system
27: 11.30(00) Configured by system  28: 11.31(00) Configured by system

98. Return to Previous Menu

Memory DIMMs are managed as a group.
Deconfiguring a DIMM will make the whole group unavailable.

0>
```

**Note:** This table is built from vital product data collected during the last boot sequence. The first time the system is powered up, or after the system's non-volatile RAM (NVRAM) has been erased, this table may be empty. The table is rebuilt during the next boot into AIX.

The DIMMs in the system are presented by group. Octal A is shown first, followed by octals B, C, and D, if present. The menu selection index/DIMM number and the DIMM address correspond to the numbers shown in "Memory Riser Card 1 Memory DIMM Locations for Service Processor Menus" on page 428 and "Memory Riser Card 2 Memory DIMM Locations for Service Processor Menus" on page 429.

The fields in the previous table represent the following:

- Column 1**        1. Menu selection index/DIMM number
- Column 2**        11.xx (riser card 1) or 10.xx (riser card 2) DIMM address used by service processor
- Column 3**        (00) Error status

## Memory Riser Card 1 Memory DIMM Locations for Service Processor Menus

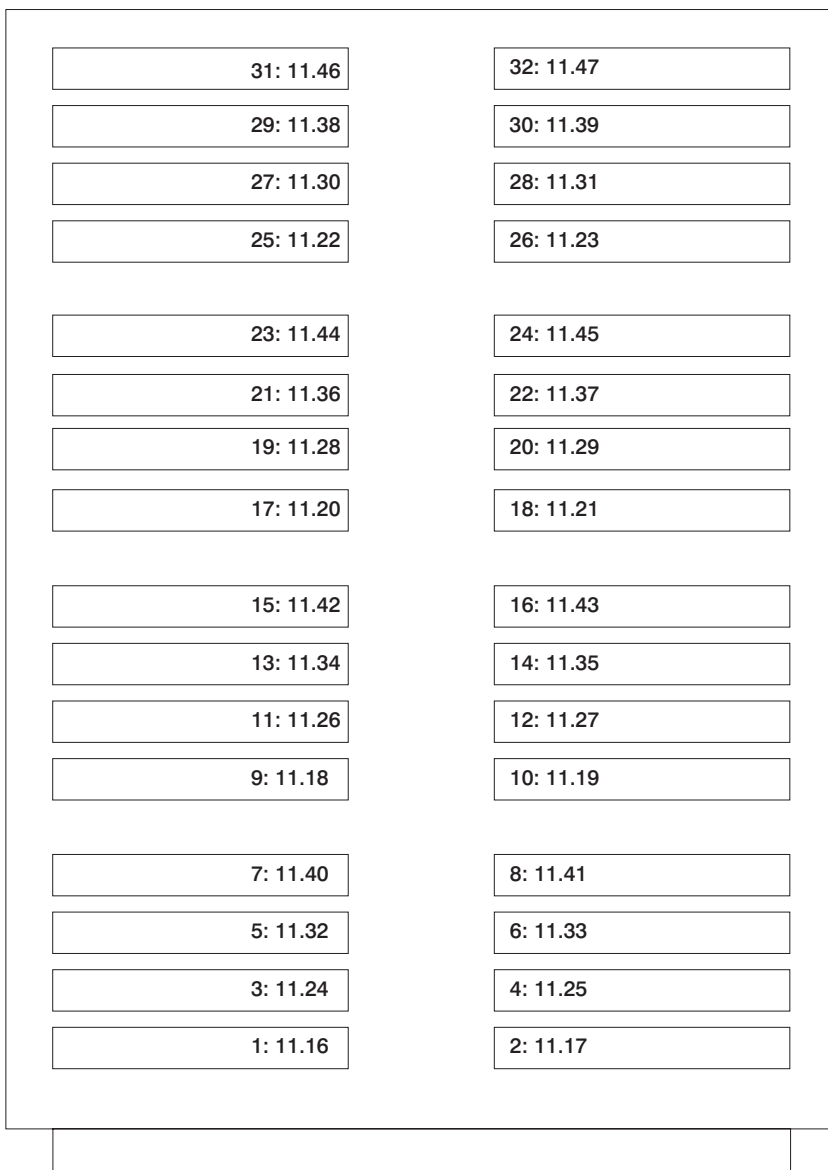

## Memory Riser Card 2 Memory DIMM Locations for Service Processor Menus

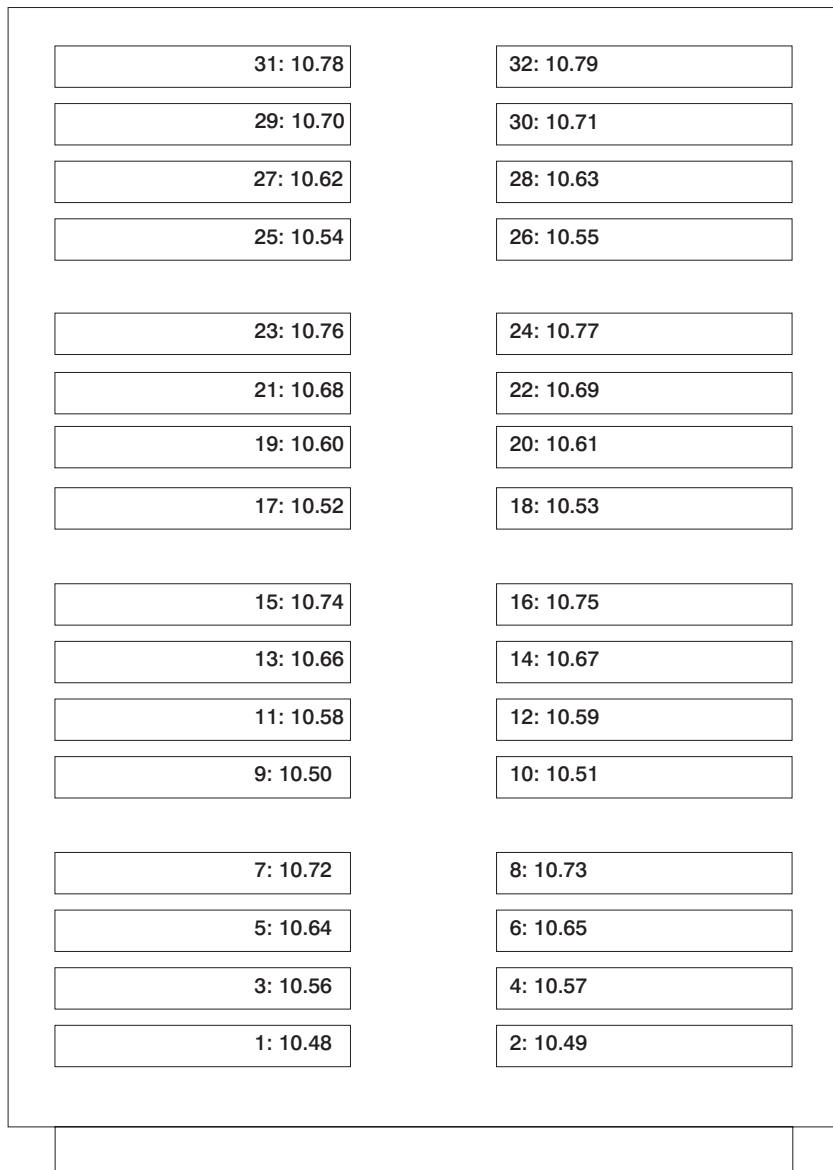

- **Power Control Network Utilities Menu**

This menu allows the user to do a lamp test on the operator panels and display, or change the I/O type.

```

POWER CONTROL NETWORK UTILITIES MENU

1. Lamp Test for all Operator Panels
2. Display I/O Type
3. Change I/O Type
98. Return to Previous Menu

1>

```

- **Lamp Test for all Operator Panels**

Selecting this option tests the operator panel indicators as follows:

Operator Panel Location	Lamp Test Results
Primary I/O drawer	Indicators blink on and off for approximately 30 seconds.
Secondary I/O drawers	Indicators come on and stay on for approximately 30 seconds.

- **Display I/O Type**

I/O type and other data displays (blinks in one-second intervals) on all secondary I/O drawer operator panels. All secondary I/O types are 84. Nothing displays on the primary I/O drawer operator panel. After 20-30 seconds, the Power Control Network Utilities Menu redisplay on the console.

- **Change I/O Type**

Use this option to change the I/O type of the primary I/O drawer after a service action or configuration change if the I/O type is incorrect. If this option is chosen, you are asked to make the following entries.

1. For the I/O drawer address (drawer number), type:
  - 1 for primary I/O drawer.
  - n for secondary I/O drawers (n = 2, 3, 4).
2. For the I/O type, type:
  - 87 for primary I/O drawer.
  - 84 for all secondary I/O drawers.

If you enter an invalid value, a failure message displays on the console. The Power Control Network Utilities Menu is then redisplayed on the console.



## Language Selection Menu

The service processor menus and messages are available in various languages. This menu allows a language to be selected in which the service processor and system firmware menus and messages are displayed.

```
LANGUAGE SELECTION MENU

1. English
2. Francais
3. Deutsch
4. Italiano
5. Espanol
6. Svenska
98. Return to Previous Menu
99. Exit from Menus
1>
```

**Note:** Your ASCII terminal must support the ISO-8859 character set to correctly display languages other than English.

## Call-In/Call-Out Setup Menu

This menu is used to configure a modem for the service processor to use to support the system:

```
CALL-IN/CALL-OUT SETUP MENU

1. Modem Configuration Menu
2. Serial Port Selection Menu
3. Serial Port Speed Setup Menu
4. Telephone Number Setup Menu
5. Call-Out Policy Setup Menu
6. Customer Account Setup Menu
7. Call-Out Test
98. Return to Previous Menu
99. Exit from Menus

1>
```

- **Modem Configuration Menu**, see “Modem Configuration Menu” on page 433.
- **Serial Port Selection Menu**, see “Serial Port Selection Menu” on page 434.
- **Serial Port Speed Setup Menu**, see “Serial Port Speed Setup Menu” on page 434.
- **Telephone Number Setup Menu**, see “Telephone Number Setup Menu” on page 435.
- **Call-Out Policy Setup Menu**, see “Call-Out Policy Setup Menu” on page 436.
- **Customer Account Setup Menu**, see “Customer Account Setup Menu” on page 437.
- **Call-Out Test Menu** tests the configuration after the modem is installed and configured. In order for this test to execute successfully, at least one of the following numbers must be assigned:
  - Service center telephone number
  - Customer administration center telephone number
  - Digital pager telephone number

## Modem Configuration Menu

The first two lines of the Modem Configuration Menu are status lines showing the current selections. Selections are made in the two sections labeled Modem Ports and Modem Configuration File Name. Select the serial port that you want to activate and then select the modem configuration file for the modem on the port. If you want to set up both of the serial ports with modems, make your selections one port at a time.

**Note:** Modem configuration is only supported on serial port 1 (S1) and serial port 2 (S2).

```
Modem Configuration Menu

Port 1 Modem Configuration File Name:
Port 2 Modem Configuration File Name:

To make changes, First select the port and then the configuration file
name

Modem Ports:
 1. Serial port 1
 2. Serial port 2

Modem Configuration File Name:
 5. none                9. modem_z_sp
 6. modem_f_sp         10. modem_m1_sp
 7. modem_f0_sp        11. modem_m0_sp
 8. modem_f1_sp        12. modem_m1_sp

30. Save configuration to NVRAM and Configure modem
98. Return to Previous Menu

0>
```

For information on choosing a modem configuration file, see “Sample Modem Configuration Files” on page 561, and “Transfer of a Modem Session” on page 566.

## Serial Port Selection Menu

This menu allows you to enable or disable the call-in and call-out functions of each serial port in any combination.

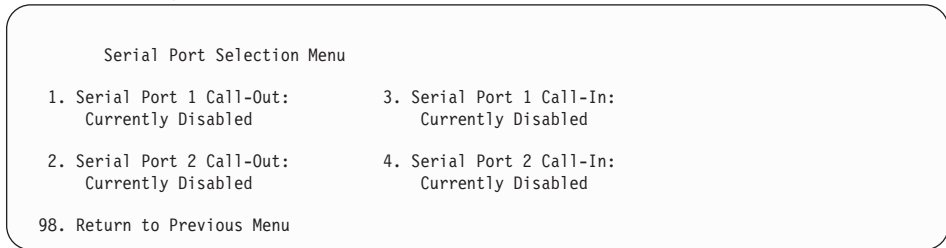

Call-in and ring-indicate power-on cannot be enabled at the same time. If ring-indicate power-on is already enabled and you try to enable call-in, a message prompts you for confirmation. Refer to the message displayed on the screen.

## Serial Port Speed Setup Menu

This menu allows you to set serial port speed to enhance terminal performance or to accommodate modem capabilities.

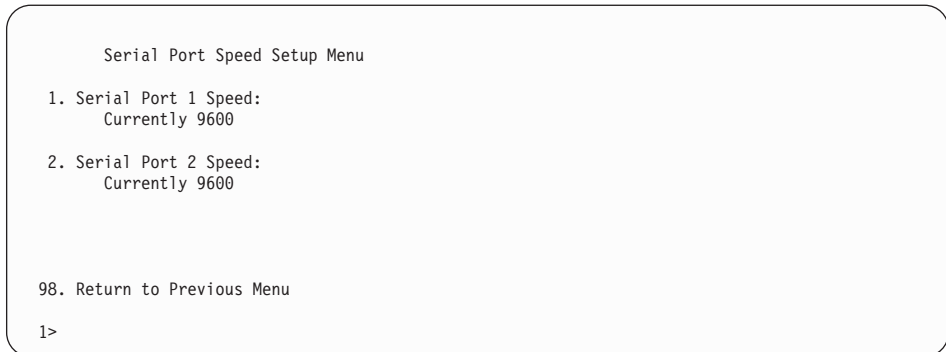

A serial port speed of 9600 baud or higher is recommended. Valid serial port speeds are as follows:

50	600	4800
75	1200	7200
110	1800	9600
134	2000	19200
150	2400	38000
300	3600	57600
		115200

## Telephone Number Setup Menu

Use this menu to set or change the telephone numbers for reporting a system failure.

```
Telephone Number Setup Menu

1. Service Center Telephone Number:
   Currently Unassigned

2. Customer Administration Center Telephone Number:
   Currently Unassigned

3. Digital Pager Telephone Number:
   Currently Unassigned

4. Customer Voice Telephone Number:
   Currently Unassigned

5. Customer System Telephone Number:
   Currently Unassigned

98. Return to Previous Menu

1>
```

- **Service Center Telephone Number** is the number of the service center computer. The service center usually includes a computer that takes calls from servers with call-out capability. This computer is referred to as the "catcher." The catcher expects messages in a specific format to which the service processor conforms.  
For more information about the format and catcher computers, refer to the README file in the AIX /usr/samples/syscatch directory. Contact your service provider for the correct service center telephone number to enter. Until you have that number, leave this field unassigned.
- **Customer Administration Center Telephone Number** is the number of the system administration center computer (catcher) that receives problem calls from servers. Contact your system administrator for the correct telephone number to enter here. Until you have that number, leave this field unassigned.
- **Digital Pager Telephone Number** is the number for a numeric pager carried by someone who responds to problem calls from your server. Contact your administration center representative for the correct telephone number to enter. For test purposes, use a test number, which you can change later. See the note on page 447 for information about using certain modems for paging.  
  
**Note:** At least one of the preceding three telephone numbers must be assigned in order for the call-out test to execute successfully.
- **Customer Voice Telephone Number** is the telephone number of a phone near the server or answered by someone responsible for the server. This is the telephone number left on the pager for callback. For test purposes, use a test number, which you can change later.
- **Customer System Telephone Number** is the telephone number to which your server's modem is connected. The service or administration center representatives need this number to make direct contact with your server for problem investigation. This is also referred to as the *call-in* phone number.

## Call-Out Policy Setup Menu

Callout settings can be set using the following menu:

```
CALL-OUT POLICY SETUP MENU

1. Call-Out policy (First/All):
   Currently First

2. Remote timeout, (in seconds):
   Currently 120

3. Remote latency, (in seconds):
   Currently 2

4. Number of retries:
   Currently 2

98. Return to Previous Menu

1>
```

- **Call-Out policy** can be set to first or all. If call-out policy is set to first, the service processor stops at the first successful call-out to one of the following numbers in the order listed:

1. Service center
2. Customer administrative center
3. Pager

If call-out policy is set to all, the service processor attempts a call-out to all of the following numbers in the order listed:

1. Service center
2. Customer administrative center
3. Pager

- **Remote timeout** and **remote latency** are functions of your service provider's catcher computer. Either use the defaults or contact your service provider for recommended settings.
- **Number of retries** is the number of times you want the server to retry calls that fail to complete.

## Customer Account Setup Menu

This menu allows users to enter information that is specific to their account.

```
Customer Account Setup Menu

1. Customer Account Number:
   Currently Unassigned

2. Customer RETAIN Login userid:
   Currently Unassigned

3. Customer RETAIN login password:
   Currently Unassigned

98. Return to Previous Menu

1>
```

- **Customer Account Number** is assigned by your service provider for record-keeping and billing. If you have an account number, enter it. Otherwise, leave this field unassigned.
- **Customer RETAIN Login User ID** and **Customer RETAIN Login Password** apply to a service function to which your service provider may or may not have access. Leave these fields unassigned if your service provider does not use RETAIN.

---

## Service Processor Procedures in Service Mode

When the system is in service mode, the following service-processor parameters are suspended:

- Unattended start mode
- Reboot/restart policy
- Call-out
- Surveillance

When service mode is exited, the service processor parameters revert to the customer settings.

## Service Processor Functions

This section discusses some of the service processor functions in greater detail. The service processor supports the functions listed in the following table.

Built-in Functions	Initialization and Test	Service Processor BIST	
		System Chip Initialization	
	Error Data Collection	BIST/POST errors and status	
		Isolation to Field Replaceable Unit (FRU) on failure	
	Configuration	CPU Complex validation	
		VPD Collection	
	System Management	Reset and Reboot on System Firmware failure	
		Reboot on system failure	
	Local User Function	User Interface	Local async console
			Text-based menus with NLS
Operator Panel messages			
Power and Miscellaneous		Power On/Off	
		Configurable Reboot Policy	
Status and Data Access		VPD	
		Error data (SP)	
		Error data (system)	
Service Processor Setup Utilities		Passwords	
		Phone numbers	
		Language (NLS) selection	
		Call-In/Call-Out enable/disable	
		System Name	
Modem Configuration			
Remote User Functions	Call-Out (Call Home) Reporting	OS termination	
		Boot failure	
		Surveillance failure	
		Checkstop	
		Machine check	
		Identify system by name	
	Call-In	Power-on through ring-indicate	
		Password/security check	
		Console mirroring	



---

## System Power-On Methods

This section discusses the following system power-on methods:

- Power-on switch

- Service processor menus

Privileged users can power on the system by selecting the **System Control Power Menu** option from the main menu and then selecting the **Power-on System** option from the system power control menu. General users should select **Power-on System** on the general user menu.

- Remote power-on via ring-indicate signal

The server automatically powers on when it detects a "ring-indicate" signal from a modem attached to serial port 1 (S1) or serial port 2 (S2).

A remote user can call the server to activate ring detection by the modem. Listen for a few more rings than the threshold number for starting the system. The system powers on without answering the call.

- Unattended start mode - refer to **Enable/Disable Unattended Start Mode** on page 420.

The service processor can be enabled to recover from the loss of ac power (dc power in a dc-powered system) (see **Enable/Disable Unattended Power-On Mode** in the **System Control Power Menu**). When ac power (dc power in a dc-powered system) is restored, the system returns to the power state at the time ac loss (dc loss in a dc-powered system) occurred. For example, if the system was powered on when ac loss (dc loss in a dc-powered system) occurred, it reboots/restarts when power is restored. If the system was powered-off when ac loss (dc loss in a dc-powered system) occurred, it remains off when power is restored.

It is recommended that the CEC and I/O drawers both receive their ac power (dc power in a dc-powered system) from the same building circuit on the same circuit breaker, if not the same electrical outlet box, in such a way that primary power cannot be lost to one unit separately from the other. If such a condition occurs, unattended start mode may not be able to restart system operation when a primary power interruption is restored.

- Timed power-on - refer to the **shutdown -t** command on servers using AIX.

Working in conjunction with AIX, the service processor in your server can operate a timer, much like the wake-up timer on your clock radio. You can set the timer so that your server powers on at a certain time after shutting down. The timer is battery-operated, so power interruptions that occur while the server is off do not affect its accuracy. Refer to the AIX **shutdown -t** command for details on setting the timer.

**Note:** If an ac power (dc power in a dc-powered system) loss is in progress when the timed power-on attempt occurs, the server is not able to power on when ac power (dc power in a dc-powered system) is restored.

- Follow-up to a failed boot attempt

The service processor initiates a power-on sequence if a failed boot attempt is detected (due to a hardware or software failure).

- Fast/slow boot (IPL) settings

Using the service processor menus, you can select the IPL type, mode, and speed of your system boot.

**Attention:** Selecting fast IPL results in several diagnostic tests being skipped and a shorter memory test being run.

---

## Service Processor Reboot/Restart Recovery

*Reboot* describes bringing the system hardware back up; for example, from a system reset or power-on. The boot process ends when control passes to the operating system process.

*Restart* describes activating the operating system after the system hardware is re-initialized. Restart must follow a successful reboot.

### Boot (IPL) Speed

When the server enters reboot recovery, slow IPL is automatically started, which gives the POST an opportunity to locate and report any problems that may otherwise be undetected.

### Failure During Boot Process

During the boot process, either initially after system power-on or upon reboot after a system failure, the service processor monitors the boot progress. If progress stops, the service processor can re-initiate the boot process (reboot) if enabled to do so. The service processor can re-attempt this process according to the number of retries that has been set in the Reboot/Restart Policy Setup Menu.

### Failure During Normal System Operation

When the boot process completes and control transfers to the operating system (OS), the service processor can monitor operating system activity (see the **Set Surveillance Parameters** option in the Service Processor Setup Menu). If OS activity stops due to a hardware- or software-induced failure, the service processor can initiate a reboot/restart process based on the settings in the Service Processor Reboot/Restart Policy Setup Menu and the OS automatic restart settings (see the operating system documentation).

If you are using the AIX operating system, the menu item under SMIT for setting the restart policy is Automatically Reboot After Crash (True/False). The default is false. When the setting is true, and if the service processor parameter "Use OS-Defined Restart Policy" is yes (the default), the service processor takes over for AIX to reboot/restart after a hardware or surveillance failure.

### Service Processor Reboot/Restart Policy Controls

The operating system's automatic restart policy (see operating system documentation) indicates the operating system response to a system crash. The service processor can be instructed to refer to that policy by the Use OS-Defined Restart Policy setup menu.

If the operating system has no automatic restart policy, or if it is disabled, then the service processor restart policy can be controlled from the service processor menus. Use the Enable Supplemental Restart Policy selection.

**Use OS-Defined restart policy** - The default setting is yes. This causes the service processor to refer to the OS automatic restart policy setting and take action (the same action the operating system would take if it could have responded to the problem causing the restart).

When this setting is no, or if the operating system did not set a policy, the service processor refers to enable supplemental restart policy for its action.

**Enable supplemental restart policy** - The default setting is no. If set to yes, the service processor restarts the server when the operating system loses control and either:

The **Use OS-Defined restart policy** is set to no.

OR

The **Use OS-Defined restart policy** is set to yes and the operating system has no automatic restart policy.

The following table describes the relationship among the operating system and service processor restart controls:

OS Automatic reboot/restart after crash setting	Service processor to use OS-Defined restart policy?	Service Processor Enable supplemental restart policy?	System response
None	No	No <sup>1</sup>	
None	No	Yes	Restarts
None	Yes <sup>1</sup>	No <sup>1</sup>	
None	Yes <sup>1</sup>	Yes	Restarts
False <sup>2</sup>	No	No <sup>1</sup>	
False <sup>2</sup>	No	Yes	Restarts
False <sup>2</sup>	Yes <sup>1</sup>	No <sup>1</sup>	
False <sup>2</sup>	Yes <sup>1</sup>	Yes	
True	No	No <sup>1</sup>	
True	No	Yes	Restarts
True	Yes <sup>1</sup>	No <sup>1</sup>	Restarts
True	Yes <sup>1</sup>	Yes	Restarts

<sup>1</sup> Service processor default

<sup>2</sup> AIX default

---

## System Firmware Updates

This section provides information and instructions for updating the system firmware. You may need to perform these steps if you are installing an option or if your support representative has instructed you to update your firmware.

Always check the pSeries & RS/6000 Support Web site for the latest firmware images and update instructions. The Web address is: <http://www.rs6000.ibm.com/support/micro>

Downloading the firmware update image and update instructions from the Web is preferred.

If the system is running, but access to the Web is not available, see “System Firmware Update Using a Locally Available Image” on page 443.

If the system cannot be powered on, but the service processor menus are available, see “Updating System Firmware From the Service Processor Menu” on page 444.

If the service processor programming has been corrupted, the service processor will automatically enter recovery mode when power is applied to the system. Recovery mode is described later in this section.

To check the level of firmware that is currently on the system, see “Determining the Level of Firmware on the System” on page 443.

## General Information on System Firmware Updates

All the types of system firmware that can be reprogrammed are updated at the same time. They are:

- System power control network programming
- Service processor programming
- IPL programming
- Run-time abstraction services

It is strongly recommended that you create a set of firmware update diskettes from the Web site as soon as possible after a system is installed. As noted below, the diskette images can be downloaded to any personal computer, pSeries, or RS/6000 system with Internet access. This method is the only way to acquire a set of firmware update diskettes; they cannot be created by using the service processor menus or by using AIX.

Retain and store the latest firmware diskettes each time the firmware gets updated in the event that the firmware becomes corrupted and must be reloaded.

Download the detailed instructions, as well as the latest flash images, from this Web site. Before doing a system firmware update, check the Web site for the latest code and images. Do not attempt a firmware update if you are unsure of the image you have, or of the procedure required for the update.

The images are available on the Web site in either DOS format or AIX (backup) format:

- If downloading to a PC, download the DOS image and follow the instructions. The diskettes that are created will be in AIX (backup) format.
- If downloading to a pSeries or RS/6000 system, follow the instructions to create an image on a disk drive or on diskettes.

## Determining the Level of Firmware on the System

**Note:** This information may be superseded by the information that is available on the Web site listed below. Always check the Web site for the latest images and instructions for checking the firmware level. The Web address is:  
<http://www.rs6000.ibm.com/support/micro>

The firmware level is denoted by XXYYMMDD, where XX = model designation, YY = year, MM = month, and DD = day of the release.

The firmware level can be determined by either of the following methods:

- On the AIX command line, by typing:

```
lscfg -vp|grep -F .MM
```

A line that begins with ROM level (alterable).. displays the firmware level that is currently on the system.

- Looking at the top of the service processor main menu.

## System Firmware Update Using a Locally Available Image

To update the system firmware using a locally available image, perform the following steps:

1. Log in as root user.
2. If the directory **/tmp/fwupdate** does not exist, create it by issuing the following command:

```
mkdir /tmp/fwupdate
```

3. The firmware update file must be written into the **/tmp/fwupdate** directory on the system. This can be done by using the **ftp** command to get the image from an ftp server or NFS-mounting the directory on the host server, for example.

The firmware update file can also be transferred to the target system by backing up the image onto diskette from another server and restoring it into the **/tmp/fwupdate** directory.

After the firmware update file has been written into the **/tmp/fwupdate** directory, verify its existence by entering the following command:

```
ls /tmp/fwupdate/MM*.img
```

The update file will have the format MMyyymmdd.img. The MM indicates that this is an update image for a Model M80 or Model 6M1 system: yy is the year, mm is the month, and dd is the day of the update file.

4. After the update file has been written to the **/tmp/fwupdate** directory, enter the following commands:

```
cd /usr/lpp/diagnostics/bin  
  
./update_flash -f /tmp/fwupdate/MMyymmdd.img
```

**Attention:** Do not overlook the periods (.) in the commands shown above. AIX commands are case-sensitive. Type them exactly as shown.

You will be asked for confirmation to proceed with the firmware update and the required reboot. If you confirm, the system will apply the new firmware, reboot, and return to the AIX prompt. This may take up to ten minutes depending on the configuration of the system.

**Attention:** On some systems, the message `Wait for rebooting before stopping` may display on the system console. Do not turn off the system until the system has fully rebooted to the AIX login prompt. If a shutdown is necessary at that time, log in as root user and issue the **shutdown** command.

While the update is in progress, you will see `Rebooting...` on the display for several minutes.

The firmware update is complete.

## Updating System Firmware From the Service Processor Menus

This procedure requires a set of firmware update diskettes in backup format.

The service processor menus are available while the system is powered off. As a privileged user, from the service processor main menu, select **Service Processor Setup**, then select **Reprogram Flash EPROM Menu**. The update process requests update diskettes as needed.

## Updating System Firmware from the AIX Service Aids

**Note:** This service aid is supported only in online diagnostics.

Refer to the detailed instructions that are provided on the Web site with the latest image.

## Updating System Firmware from the AIX Command Line

Refer to the detailed instructions that are provided on the Web site with the latest image.

**Note:** The update process can take up to sixty minutes, and the system reboots itself during the update process.

## Recovery Mode

If the service processor detects that its programming has been corrupted when it is powering up to standby mode, it will enter recovery mode. In recovery mode, it will ask for the firmware update diskettes by putting eight-digit codes on the operator panel.

The eight-digit codes are as follows:

Code	Action
A1FD 0000	System firmware has been corrupted and must be reflashed.
A1FD 0001	Insert update diskette 1.
A1FD 0002	Insert update diskette 2.
A1FD 0003	Insert update diskette 3.
A1FD 000n	Insert update diskette n.

**Notes:**

1. If the wrong diskette is inserted at any time, or if the diskette is left in the drive after it has been read, B1FD 001F is displayed, indicating that the wrong diskette is in the drive.
2. If B1FD 001A is displayed at any time during the process, the service processor must be reset by activating the pinhole reset switch on the primary drawer operator panel.

After the update process is complete, the service processor resets itself and goes through a complete reboot.

---

## Configuring and Deconfiguring Processors or Memory

All failures that crash the system with a machine check or check stop, even if intermittent, are reported as a diagnostic callout for service repair. To prevent the recurrence of intermittent problems and improve the availability of the system until a scheduled maintenance window, processors and memory DIMMs with a failure history are marked "bad" to prevent their being configured on subsequent boots.

A processor or memory DIMM is marked "bad" under the following circumstances:

- A processor or memory DIMM fails built-in self-test (BIST) or power-on self-test (POST) during boot (as determined by the service processor).
- A processor or memory DIMM causes a machine check or check stop during run time, and the failure can be isolated specifically to that processor or memory DIMM (as determined by the processor run-time diagnostics in the service processor).
- A processor or memory DIMM reaches a threshold of recovered failures that results in a predictive callout (as determined by the processor run-time diagnostics in the service processor).

During boot time, the service processor does not configure processors or memory DIMMs that are marked "bad."

If a processor or memory DIMM is deconfigured, the processor or memory DIMM remains offline for subsequent reboots until it is replaced or Repeat Gard is disabled. The Repeat Gard function also allows users to manually deconfigure a processor or memory DIMM, or re-enable a previously deconfigured processor or memory DIMM. For information on configuring or deconfiguring a processor, see the Processor Configuration/Deconfiguration Menu on page 425. For information on configuring or

deconfiguring a memory DIMM, see the Memory Configuration/Deconfiguration Menu on page 426. Both of these are submenus under the System Information Menu.

You can enable or disable CPU Repeat Gard or Memory Repeat Gard using the Processor Configuration/Deconfiguration Menu, which is a submenu under the System Information Menu.

## Run-Time CPU Deconfiguration (CPU Gard)

L1 instruction cache recoverable errors, L1 data cache correctable errors, and L2 cache correctable errors are monitored by the processor run time diagnostics (PRD) code running in the service processor. When a predefined error threshold is met, an error log entry with warning severity and threshold exceeded status is returned to AIX. At the same time, PRD marks the CPU for deconfiguration at the next boot. AIX will attempt to migrate all resources associated with that processor to another processor and then stop the defective processor.

---

## Service Processor System Monitoring - Surveillance

Surveillance is a function in which the service processor monitors the system, and the system monitors the service processor. This monitoring is accomplished by periodic samplings called *heartbeats*.

Surveillance is available during two phases:

- System firmware bring-up (automatic)
- Operating system run time (optional)

## System Firmware Surveillance

System firmware surveillance is automatically enabled during system power-on. It cannot be disabled by the user, and the surveillance interval and surveillance delay cannot be changed by the user.

If the service processor detects no heartbeats during system IPL (for a set time period), it cycles the system power to attempt a reboot. The maximum number of retries is set from the service processor menus. If the fail condition persists, the service processor leaves the machine powered on, logs an error, and displays menus to the user. If call-out is enabled, the service processor calls to report the failure and displays the operating system surveillance failure code on the operator panel.

## Operating System Surveillance

Operating system surveillance provides the service processor with a means to detect hang conditions, as well as hardware or software failures, while the operating system is running. It also provides the operating system with a means to detect a service processor failure caused by the lack of a return heartbeat.

Operating system surveillance is not enabled by default, allowing you to run operating systems that do not support this service processor option.



You can also use the service processor menus and the AIX diagnostic service aids to enable or disable operating system surveillance.

For operating system surveillance to work correctly, you must set the following parameters:

- Surveillance enable/disable
- Surveillance interval

The maximum time the service processor waits between heartbeats from the operating system before reporting a surveillance failure.

- Surveillance delay

The maximum time the service processor waits for the first heartbeat from the operating system, after the operating system has been started, before reporting a surveillance failure.

Surveillance does not take effect until the next time the operating system is started after the parameters have been set.

You can initiate surveillance mode immediately from service aids. In addition to the three options above, a fourth option allows you to select immediate surveillance, and rebooting of the system is not necessarily required.

If operating system surveillance is enabled (and system firmware has passed control to the operating system), and the service processor does not detect any heartbeats from the operating system within the surveillance delay period, the service processor assumes the system is hung and takes action according to the reboot/restart policy settings. See “Service Processor Reboot/Restart Recovery” on page 440.

If surveillance is selected from the service processor menus that are only available at bootup, then surveillance is enabled by default as soon as the system boots. From service aids, the selection is optional.

---

## Call-Out (Call-Home)

The service processor can call out (call-home) when it detects one of the following conditions:

- System firmware surveillance failure
- Operating system surveillance failure (if supported by operating system)
- Restarts
- Critical hardware failure
- Abnormal operating system termination

To enable the call-out feature, do the following:

1. Connect a modem to serial port 1 (S1) or serial port 2 (S2).
2. Set up the following using the service processor menus or the diagnostic service aids:
  - Enable call-out for the serial port where the modem is connected.

- Enter the modem configuration file name.
  - Set up site-specific parameters (phone numbers for call-out, call-out policy, number of call-out retries, and so on).
3. To call out before restart, set **Call-out before restart** to enabled from the Reboot/Restart Policy Setup menu.

**Note:** Some modems, such as IBM 7857-017, are not designed for the paging function. Although they can be used for paging, they will return an error message when they do not get the expected response from another modem. Therefore, even though the paging was successful, the error message will cause the service processor to retry, continuing to place pager calls for the number of retries specified in the Call-Out Policy Setup Menu. These retries result in redundant pages.

---

## Console Mirroring

Console mirroring is supported on serial port 1 (S1) and serial port 2 (S2). When console mirroring is enabled, the service processor sends information to both serial ports. The serial port from which console mirroring is enabled is referred to as the *active port*. The *mirror port* is determined when keyboard input is detected from the other port. From this point on, the service processor only sends information to the active port and the mirror port. This capability can be enabled by local or remote users, providing local users the capability to monitor remote sessions. Console mirroring can be enabled for the current session only.

## System Configuration

The following describes the configuration for console mirroring:

- Service processor
- Modem connected to one serial port and enabled for incoming calls
- Local ASCII terminal connected to the other serial port. This local terminal can be connected directly to your server or connected through another modem.

Console mirroring can be started in the following scenarios:

- Remote session first, then local session added:
  1. Remote session is already in progress.
  2. Remote user uses service processor menus to enable console mirroring, allowing both consoles to be active.
- Local session first, then remote session added:
  1. Local session is already in progress.
  2. The service processor receives a call from the remote user.
  3. The local user selects the option to enable console mirroring. The service processor immediately begins mirroring service processor menus.

---

## Service Processor Error Log

The service processor error log, an example of which follows, contains information about error conditions detected by the service processor.

```
                                Error Log

1. 11/30/99   19:41:56 Service Processor Firmware Failure
   B1004999

Enter error number for more details.
Press Return to continue, or 'x' to return to menu.
Press "C" to clear error log, any other key to continue. >
```

**Note:** The time stamp in this error log is coordinated universal time (UTC), which is also referred to as Greenwich mean time (GMT). The AIX error log has additional information and time stamps with local time.

Entering an error number provides nine words of system reference code (SRC) data; an example screen follows:

```
Detail:   6005

SRC
-----
word11:B1004999   word12:0110005D   word13:00000000
word14:00000000   word15:00001111   word16:00000 000
word17:B1004AAA   word18:0114005D   word19:A4F1E909

B1004999

Press Return to continue, or 'x' to return to menu.
```

If Return is pressed, the contents of NVRAM will be dumped 320 bytes at a time, starting at address 0000.

---

## LCD Progress Indicator Log

The following is an example of the LCD progress indicator log. It shows the types of entries that the log might contain, and is for example purposes only.

The progress indicator codes are listed from top (latest) to bottom (oldest).

```

LCD Progress Indicator Log
B0FF
0539..17
0538..17
0539..17
0538..17
0539..17
0581
0538..17
0539..12
0538..12
0539..
0821..01-K1-00
0539..
0728..01-R1-00-00
0539..
0664..40-60-00-1,0
0539..
0777..U0.2-P1-I14/E1
0539..
0742..U0.2-P1-I12/E1
0539..
0776..U0.2-P1-I10/T1
E139
E1FB
E139
E183
Press Return to continue, or 'x' to return to menu. >
EAA1..U0.1-P1-I14
E172..U0.1-P1
E172..U0.1-P1-I14
E172..U0.1-P1
94BB
9109
9380
9108
9107
9106
9105
9118
9104
9103
9102
90FD
```

---

## Service Processor Operational Phases

This section provides a high-level flow of the phases of the service processor.

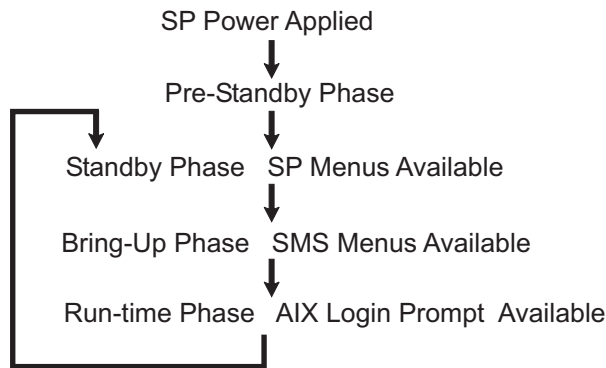

### Pre-Standby Phase

This phase is entered when the server is first connected to a power source. This phase is exited when the power-on self-test (POST) and configuration tasks are completed.

The pre-standby phase components are:

- Service processor initialization - the service processor performs any necessary hardware and firmware initializations.
- Service processor POST - the service processor conducts power-on self-tests on its work and code areas.
- Service processor unattended start mode checks - To assist fault recovery. If unattended start mode is set, the service processor automatically reboots the server. The service processor does not wait for user input or a power-on command, but moves through the phase and into the bring-up phase. Access the system management services (SMS) menus or the service processor menus to reset the unattended start mode.

### Standby Phase

The standby phase can be reached in either of the following ways:

- With the server off and power connected (the normal path), recognized by 0K in the LCD display.
- OR
- With the server on after an operating system fault, recognized by an 8-digit code in the LCD display.

In the standby phase, the service processor takes care of some automatic duties and its menus are available. The service processor remains in the standby phase until a power-on request is detected.

The standby phase components are as follows:

- **Modem Configuration**  
The service processor configures the modem (if installed) so that incoming calls can be received, or outgoing calls can be placed.
- **Dial In**  
Monitor incoming phone line to answer calls, prompt for a password, verify the password, and remotely display the standby menu. The remote session can be mirrored on the local ASCII console if the server is so equipped and the user enables this function.
- **Menus**  
The service processor menus are password-protected. Before you can access them, you need either the general user password or the privileged user password.

## **Bring-Up Phase**

This phase is entered upon power-on, and exited upon loading of the operating system.

The bring-up phase components are as follows:

- **Retry request check**  
The service processor checks to see if the previous boot attempt failed. If the specified number of failures is detected, the service processor displays an error code and places an outgoing call to notify an external party if the user has enabled this option.
- **Dial out**  
The service processor can dial a preprogrammed telephone number in the event of a boot failure. The service processor issues an error report with the last-reported boot status and any other available error information.
- **Update operator panel**  
The service processor displays operator panel data on the ASCII terminal if a remote connection is active.
- **Environmental monitoring**  
The service processor provides expanded error recording and reporting.
- **System firmware surveillance (heartbeat monitoring)**  
The service processor monitors and times the interval between system firmware heartbeats.
- **Responding to system processor commands**  
The service processor responds to any command issued by the system processor.

## Run-Time Phase

This phase includes the tasks that the service processor performs during steady-state execution of the operating system.

- Environmental monitoring

The service processor monitors voltages, temperatures, and fan speeds.

- Responding to system processor commands

The service processor responds to any command issued by the system processor.

- Run-time surveillance (heartbeat monitoring)

If the device driver is installed and surveillance enabled, the service processor monitors the system heartbeat. If the heartbeat times out, the service processor places an outgoing call. This is different from the bring-up phase scenario, where the specified number of reboot attempts is made before placing an outgoing call.



---

## Chapter 9. Using System Management Services

Use the System Management Services menus to view information about your system and to perform tasks such as setting a password, changing the boot list, and setting the network parameters.

The text-based open firmware command line (the OK prompt), which is available from the System Management Services Utilities menu, allows you to configure certain adapters.

To start the System Management Services, do the following:

1. Turn on or restart the system.
2. Watch for the banner screen to appear on the console display. The banner screen will be lines of text in the form of repeated logos.
3. After the banner screen is displayed, the POST indicator words memory, keyboard, network, scsi and speaker appear across the bottom of the screen.  
Press the numeric 1 key after the word keyboard appears, and before the last word speaker appears.

For more information on the POST indicator words, refer to "POST Indicators" on page 7.

**Note:** The System Management Services can also be started using the Service Processor Boot Mode Menu. See "Boot Mode Menu" on page 423.

After the System Management Services starts, the following Utilities screen displays:

```
Utilities

1 Password Utilities
2 Display Error Log
3 Remote Initial Program Load Setup
4 SCSI Utilities
5 Select Console
6 MultiBoot
7 Select Language
8 OK Prompt

                                     [X=Exit]
                                     -----

====>
```

Each option on the System Management Services Utilities menu is described in this section.

---

## Password Utilities

Entering this selection permits access to the options shown on the following screen:

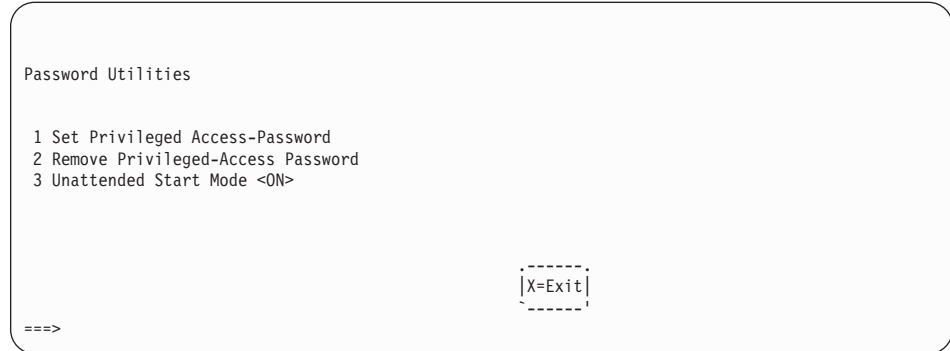

**Set Privileged-Access Password:** The privileged-access password protects against the unauthorized starting of the system programs. When this option is selected, another screen displays that allows the setting of a password.

You can set the password from either the service processor or System Management Services menus. After the password is set, both the service processor and System Management Services automatically use the same password. The password is limited to eight characters.

**Remove Privileged-Access Password:** If you previously had set a privileged-access password and want to remove it, select **Remove Privileged-Access Password**.

**Note:** If you *forget* your password, you must shut down the system and remove the battery for at least 30 seconds.

**Unattended Start Mode <ON>:** This selection is used to enable or disable unattended start mode. Use this option to instruct the service processor to restore the power state of the server after a temporary power failure, which is necessary on servers that require automatic power-on after a power failure. The default setting is ON.

## Display Error Log

A screen similar to the following displays when you select this option. You can view or clear your system error log.

```

                                Error Log
-----
      Date      Time      ErrorCode  Location
Entry 1. 99/06/30 02:15:35 25a80011  U1.1-P1.1/Q1
Entry 2. 99/07/01 03:18:36 20300026  U1.1-P1.1/Q1
-----

[C=Clear Error Log]                [X=Exit Log ]

```

**Note:** The time stamp in this error log is Coordinated Universal Time (UCT), which is also referred to as Greenwich Mean Time (GMT). The AIX error log has more information available and time stamps with your local time.

## Remote Initial Program Load Setup

This option allows you to enable and set up the remote startup of your system. You must first specify the network parameters as shown in the following screen:

```

Network Parameters
1. IP Parameters
2. Adapter Parameters
3. Ping

                                [X=Exit ]
=====

```

**Note:** Some applications may require that IP addresses contain leading zeroes for numbers less than 100. For example, 129.132.4.20 may need to be entered as 129.132.004.020.

## IP Parameters

Select the **IP Parameters** option from the Network Parameters menu to display a screen similar to the following:

```
IP Parameters

1. Client IP Address [9.3.146.162]
2. Server IP Address [9.3.146.171]
3. Gateway IP Address [0.0.0.0]
4. Subnet Mask [255.255.255.0]

[X=Exit]

==>
```

To set an address using this menu, do the following:

1. Type the number of the selection (1, 2, 3, or 4).
2. Enter the address on the next screen.

**Attention:** If the client system and the server are on the same subnet, set the gateway IP address to [0.0.0.0].

## Adapter Parameters

Select the **Adapter Parameters** option from the Network Parameters menu to view an adapter's hardware address, as well as configure network adapters that require setup. A screen similar to the following displays when you make this selection:

Adapter Parameters		
Device	Slot	Hardware Address
1. Gigabit Ethernet	4: P1-I4/E1	0004ac7c0135
2. token-ring	5: P1-I5/T1	0020357a9105
3. ethernet	Integrated:P1/E1	0060949d7ac5
4. ethernet	2: P1-I2/E1	0004ac5e692b
5. token-ring	3: P1-I3/T1	0004ac634e38

[X=Exit]

(PRESS ENTER AFTER MAKING A SELECTION) ==>

Select an adapter on this screen to display configuration menus for that adapter. If ethernet is selected, you can set parameters that control how the ethernet adapter communicates with the network. For example, the following screen shows the menu for the ethernet adapter configuration:

1. Data Rate [Auto]
2. Full Duplex [No]

## Ping

Select **Ping** from the Network Parameters menu to test a connection to a remote system unit. After selecting the ping option, you must first choose an adapter to communicate with the remote system.

Adapter Parameters

Device	Slot	Hardware Address
1. Gigabit Ethernet	4: P1-I4/E1	0004ac7c0135
2. token-ring	5: P1-I5/T1	0020357a9105
3. ethernet	Integrated:P1/E1	0060949d7ac5
4. ethernet	2: P1-I2/E1	0004ac5e692b
5. token-ring	3: P1-I3/T1	0004ac634e38

[X=Exit]

(PRESS ENTER AFTER MAKING A SELECTION) ==>

After determining which adapter to use to ping the remote system, you must provide the addresses needed to communicate with the remote system. Select the appropriate device from the Ping menu to display a screen similar to the following:

PING IP Address

1. Client IP Address	[9.3.146.162]
2. Server IP Address	[9.3.146.171]
3. Gateway IP Address	[0.0.0.0]
4. Subnet Mask	[0.0.0.0]

[E=Execute]                      [X=Exit]

==>

## SCSI Utilities

SCSI Utilities allow you to set delay times for the SCSI hard disk spin-up and to set SCSI IDs for SCSI controllers installed in the system.



Using the Harddrive Spin Up Delay option allows you to change the spin up delay time for SCSI hard disk drives attached to your system. Spin up delay values can be entered manually, or you can use a default setting (two seconds). All values are measured in seconds.

**Attention:** Setting the value lower than the default can prevent successful booting because the system power handling capabilities might be exceeded. If the system no longer boots after setting this value, access this utility again and increase the value. It is also possible that adding disk drives can cause similar symptoms. Changing this value changes the surge current requirements on the system. As you increase the value, the surge current requirements on the system are decreased.

## Select Console

Select this option to define which display is used by the system for system management. If no console is selected, the console defaults to serial port 1.

Selecting this option causes a screen similar to the one that follows to display on each console that can be used as a firmware console. Follow the instructions on the screen to select a particular console.

**Note:** The firmware console is independent from the AIX console.

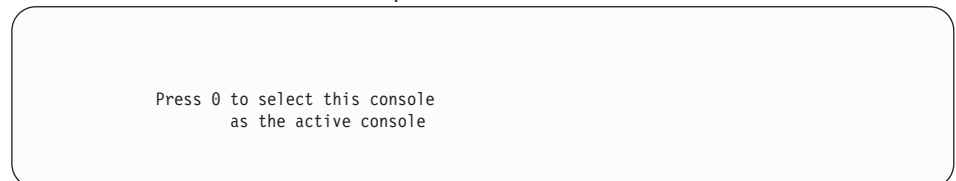

## MultiBoot

Multiboot allows you to select a method for booting the system.

```
Multiboot
1  Select Software
2  Software Default
3  Select Install Device
4  Select Boot Devices
5  OK Prompt
6  Multiboot Startup <OFF>
```

```
|X=Exit|
```

```
===>
```

### Select Software

If this option is supported by the operating system, the names of the operating system installed are shown. This option might not be supported by all operating systems.

If you are running AIX, and you receive the following message:

```
No Operating System Installed
```

This indicates that information in nonvolatile storage could have been lost, as would happen if the battery had been removed. To re-create this value, run the **bootlist** command under AIX with the appropriate parameters. See the **bootlist** command in your AIX documentation. The AIX Documentation library is available at the following Web address: <http://www-1.ibm.com/servers/aix/library/>. Select **Technical Publications**. AIX documentation is also contained on the AIX Documentation CD. The documentation is made accessible by loading the documentation CD onto the hard disk or by mounting the CD in the CD-ROM drive.

### Software Default

If this option is supported by the operating system, you can select the default operating system to start the system. This option might not be supported by all operating systems.

### Select Install Device

Produces a list of devices, such as the CD-ROM, from which the operating system may be installed. Select a device, and the system searches that device for an operating system to install.



## Select Boot Devices

Select this option to view and change the custom boot list, which is the sequence of devices read at startup time. The boot list can contain up to five devices. The following is an example of this screen.

```
Select Boot Devices

1 Display Current Settings
2 Restore Default Settings
3 Configure 1st Boot Device
4 Configure 2nd Boot Device
5 Configure 3rd Boot Device
6 Configure 4th Boot Device
7 Configure 5th Boot Device

                                     |X=Exit|

====>
```

## Display Current Settings

Lists the current order of devices in the boot list. The following is an example of this screen.

```
Current Boot Sequence

1. Diskette
2. SCSI CD-ROM ( loc=P1/Z1-A1 )
3. SCSI 9100 MB Harddisk ( loc=P1/Z1-A5 )
4. Ethernet ( loc=P1-I4/E1 )
5. None

                                     |X=Exit|

===>
```

## Restore Default Settings

Restores the boot list to the following default sequence:

- Primary diskette drive
- CD-ROM drive
- Tape (if installed)
- Hard disk drive
- Network device

Selecting any of the **Configure Boot Device** options displays a screen similar to the following.

```
Configure Nth Boot Device

Device   Current   Device
Number   Position  Name
-----
1         1         Diskette
2         4         Ethernet ( loc=P1-I4/E1 )
3         -         Token-Ring ( loc=P1-I5/T1 )
4         2         SCSI CD-ROM ( loc=P1/Z1-A1 )
5         3         SCSI 9100 MB Harddisk ( loc=P1/Z1-A5 )

                                     [X=Exit]

===>
```

### OK Prompt

Provides access to the open firmware command prompt.

This option should only be used by service personnel to obtain additional debug information.

### Multiboot Startup <OFF>

Toggles between off and on to select whether Multiboot menu starts automatically on startup.

## Select Language

Select this option to change the language used by the System Management Services screens and the service processor menus.



**Note:** To correctly display languages other than English, your ASCII terminal must support the ISO-8859 character set.

## OK Prompt

This option provides access to the open firmware command prompt.

This option should only be used by service personnel to obtain additional debug information.

## Exiting System Management Services

After you have finished using the System Management Services, type **x** at the utilities menu to exit the System Management Services and boot your system.



---

## Chapter 10. Removal and Replacement Procedures

Before performing any of the removal or replacement procedures in this chapter, read the following notices.

### **DANGER**

An electrical outlet that is not correctly wired could place hazardous voltage on metal parts of the system or the devices that attach to the system. It is the responsibility of the customer to ensure that the outlet is correctly wired and grounded to prevent an electrical shock.

Before installing or removing signal cables, ensure that the power cables for the system unit and all attached devices are unplugged.

When adding or removing any additional devices to or from the system, ensure that the power cables for those devices are unplugged before the signal cables are connected. If possible, disconnect all power cables from the existing system before you add a device.

Use one hand, when possible, to connect or disconnect signal cables to prevent a possible shock from touching two surfaces with different electrical potentials.

During an electrical storm, do not connect cables for display stations, printers, telephones, or station protectors for communications lines.

### **CAUTION:**

This product is equipped with a three-wire power cable and plug for the user's safety. Use this power cable with a properly grounded electrical outlet to avoid electrical shock.

### **CAUTION:**

This unit has more than one power supply cord. To reduce the risk of electrical shock, disconnect two power supply cords before servicing.

---

## Handling Static-Sensitive Devices

**Attention:** Disk drives, tape drives, and CD-ROM drives are sensitive to static electricity discharge. These devices are wrapped in antistatic bags to prevent this damage.

Take the following precautions:

- If you have an antistatic wrist strap available, use it while handling the device.
- Do not remove the device from the antistatic bag until you are ready to install the device in the system unit.
- With the device still in its antistatic bag, touch it to a metal frame of the system.
- Grasp cards and boards by the edges. Hold drives by the frame. Avoid touching the solder joints or pins.
- If you need to lay the device down while it is out of the antistatic bag, lay it on the antistatic bag. Before picking it up again, touch the antistatic bag and the metal frame of the system unit at the same time.
- Handle the devices carefully in order to prevent permanent damage.

---

## Powering Off and Powering On the System

This section provides procedures for powering off and powering on the system.

### Powering Off the System

If the system is operating under AIX, type shutdown to power off the system.

If you cannot use this method, you can power off the system by using the following operator panel power button procedure.

**Attention:** Using the primary I/O drawer operator panel power button to power off the system might cause unpredictable results in the data files, and the next IPL will take longer to complete.

1. Open the rack door.
2. Press the power button on the primary I/O drawer operator panel.  
The power LED on the primary I/O drawer operator panel starts blinking at a fast rate. B0FF displays in the primary operator panel display.  
When the power-off sequence is complete, the system goes into Standby mode, as evidenced by the following:
  - 0K displays in the primary operator panel display.
  - The primary I/O drawer operator panel LED will start blinking at a slow rate.
  - The CEC drawer power LED will start blinking at a slow rate.
  - If a secondary I/O drawer is present, its power LED will go off.
3. Disconnect the ac power cords (dc power cords in a dc-powered system) from the drawers.

### Powering On the System

To power on the CEC drawer and attached I/O drawers, do the following:

1. Open the rack door. Look for 0K in the primary operator panel display, which indicates that the system is in Standby mode.
2. Press the power button on the primary I/O drawer operator panel.

The power LED on the primary I/O drawer operator panel starts blinking at a fast rate. 9xxx checkpoints appear in the operator panel display.

When the power-on sequence is complete:

- The power LED on the primary I/O drawer operator panel stops blinking and stays on.
- The power LED on the CEC drawer stops blinking and stays on.
- If a secondary I/O drawer is present, its power LED comes on and stays on.

### Powering Off and Powering On the System Using the Service Processor

The system can be powered off and on using the System Power Control menu, which is a service processor menu that is available to the privileged user. See "System Power Control Menu" on page 420.

## Hot-Pluggable FRUs

**Note:** You do not have to power off the system to remove a hot-pluggable FRU from the CEC drawer or from I/O drawers.

The following FRUs are hot-pluggable:

- Some PCI adapters of an I/O drawer
- Power supplies in an I/O drawer or CEC drawer (if the drawer has two power supplies and only one needs to be removed)
- Rear fans on the CEC drawers

## I/O Drawer PCI Slot LED Definitions

The following table describes the possible states of the LEDs associated with the I/O drawer PCI slots. These LEDs are located at the rear of the I/O drawer. One LED is associated with each PCI slot.

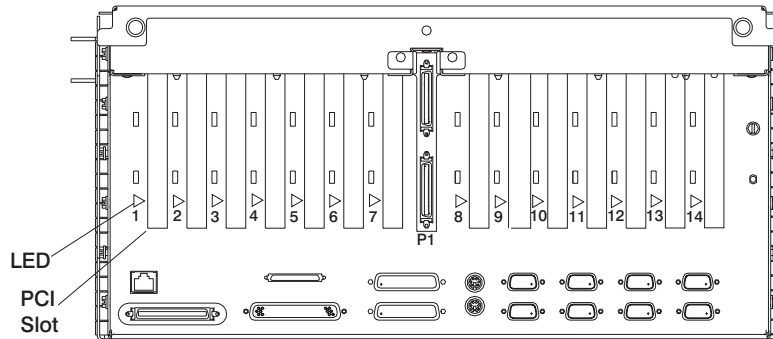

LED Indication	PCI Slot Status	Definition
Off	Off	Slot power is off. It is safe to remove or replace an adapter.
On (not flashing)	On	Slot power is on. Do not remove or replace an adapter.
Flashing slowly (one flash per second)	Identify	Slot has been identified by the software. Do not remove or replace an adapter at this time.
Flashing rapidly (six to eight flashes per second)	Action	Slot is ready for removal or replacement of an adapter.



---

## PCI Adapters

With this system, you can install PCI adapters with the power on. These adapters are referred to as *hot-pluggable* PCI adapters. Some adapters are not hot-pluggable and power must be removed from the system for adapter installation.

Before you install the adapter, determine if the PCI adapter you are installing is hot-pluggable. See the *PCI Adapter Placement Reference*, order number SA38-0538.

If you are removing a PCI adapter that is:

- Not hot-pluggable, go to “Non-Hot-Pluggable PCI Adapter”.
- Hot-pluggable, go to “Hot-Pluggable PCI Adapter” on page 473.

---

## Non-Hot-Pluggable PCI Adapter

### Removal

To remove a non-hotpluggable adapter, do the following:

1. Turn off power and unplug the system unit power cable from the electrical outlet.  
If the system is operating under AIX, type `shutdown` to power off the system.  
If you cannot use this method, you can power off the system by using the following operator panel power button procedure.  
**Attention:** Using the primary I/O drawer operator panel power button to power off the system may cause unpredictable results in the data files, and the next IPL will take longer to complete.
  - a. Open the rack door.
  - b. Press the power button on the primary I/O drawer operator panel.

The primary I/O drawer operator panel Power LED starts blinking at a fast rate. B0FF displays in the primary operator panel display.

When the power-off sequence is complete, the system will go into Standby mode, as evidenced by:

- 0K displays in the primary operator panel display.
  - The primary I/O drawer operator panel LED will start blinking at a slow rate.
  - The CEC drawer power LED will start blinking at a slow rate.
2. Place the I/O drawer in the rear service position, as follows:
    - a. If you have not already done so, open the front door of the rack unit.
    - b. Loosen the two thumbscrews that attach the front bezel to the drawer.
    - c. Grasp both sides of the front bezel and pull the bezel off the drawer.
    - d. If you have not already done so, open the rear door of the rack unit.
    - e. If present, remove the two retaining screws that secure the drawer to the rails.
    - f. Ensure that the cables do not restrain drawer movement.

- g. Grasp the bar at the rear of the drawer, and pull the drawer to the rear until it is stopped by the two detents on the top of the drawer.
3. Remove the two thumbscrews, and remove the top cover from the drawer.
4. Determine the slot from which you are removing the adapter.
5. Disconnect any cables that are connected to the adapter being removed.
6. Turn the locking latch and lift the plastic stop for the adapter.
7. Carefully grasp the adapter by the edges and pull it straight out from the I/O board.
8. If you are installing another adapter in this slot, follow the instructions given under "Replacement" below.
9. If you are not installing another adapter in this slot, place a blank slot cover in the adapter slot and then lower the plastic stop over the adapter bracket. Rotate the locking latch clockwise until it clicks into the locked position.
10. Replace the system unit covers and return the drawer to the normal operating position.

## Replacement

To replace an adapter, perform the removal steps in the reverse order.

---

## Hot-Pluggable PCI Adapter

### Removing a Hot-Pluggable PCI Adapter

**Note:** If you are removing an adapter and replacing it with an adapter that is identical to the adapter removed, use the “Replacing a Hot-Pluggable PCI Adapter” on page 474 procedure.

To remove an adapter, do the following:

1. Place the I/O drawer in the rear service position:
  - a. If you have not already done so, open the front door of the rack unit.
  - b. Loosen the two thumbscrews that attach the front bezel to the drawer.
  - c. Grasp both sides of the front bezel and pull the bezel off the drawer.
  - d. If you have not already done so, open the rear door of the rack unit.
  - e. If present, remove the two retaining screws that secure the drawer to the rails. Refer to “Rear Service Position” on page 519.
  - f. Ensure that the cables do not restrain drawer movement.
  - g. Grasp the bar at the rear of the drawer, and pull the drawer to the rear until it is stopped by the detents.
2. Remove the two thumbscrews and remove the top cover from the drawer.
3. Determine the slot from which you are removing the adapter.
4. Ensure that any processes or applications that might use the adapter are stopped.

**Note:** Removing a hot-pluggable PCI adapter requires the system administrator to take the PCI adapter offline before performing any PCI adapter hot-plug procedures. Before taking an adapter offline, the devices attached to the adapter must be taken offline as well. This action prevents a service representative or user from causing an unexpected outage for system users.

For additional information about taking an adapter offline or removing it from the system configuration, see the *AIX System Management Guide: Operating System and Devices*. This publication is located on the *AIX Documentation CD*. The documentation information is made accessible by loading the documentation CD onto the hard disk or by mounting the CD in the CD-ROM drive.

5. Refer to “PCI Hot-Plug Manager Access” on page 478, and follow the steps in the access procedure to select **PCI Hot Plug Manager**. Then return here to continue.
6. Select **Unconfigure a Device** and press Enter.
7. Press F4 to display the Device Names menu.
8. Select the adapter you are removing from the menu.
9. Use the Tab key to answer NO to **Keep Definition**. Press Enter.

10. The ARE YOU SURE screen displays. Press Enter to verify the information. Successful unconfigure is indicated by the OK message displayed next to the **Command** field at the top of the screen.
11. Press F3 to return to the PCI Hot-Plug Manager menu.
12. Select **Replace/Remove a PCI Hot-Plug Adapter** and press Enter. The Replace/Remove a PCI Hot-Plug Adapter menu displays.
13. Move the cursor to select the adapter that you are removing and press Enter. (The description entry displays as unknown).
14. Press the Tab key until the entry field displays the remove operation and then Press the Enter key. Follow the instructions that display on the screen until you are instructed to remove the adapter.
15. When you are instructed to remove the adapter from the adapter slot, disconnect any cables that are connected to the adapter being removed.
16. Turn the locking latch and lift the plastic stop for the adapter.
17. Carefully grasp the adapter by the edges and pull it straight out from the I/O board.
18. If you are not installing another adapter in this slot, place a blank slot cover in the adapter slot and then lower the plastic stop over the adapter bracket. Rotate the locking latch clockwise until it clicks into the locked position.
19. Continue to follow the screen instructions until you receive a message that the adapter removal is successful. Successful removal is indicated by the OK message displayed next to the **Command** field at the top of the screen.
20. If you do not have other adapters to remove, continue with the next step.  
OR  
If you have other adapters to remove, press the F3 key to return to the PCI Hot-Plug Manager menu and then return to step 12.
21. Press F10 to exit the Hot-Plug Manager.
22. If you have added, removed, or replaced any adapters, run the **diag -a** command. If the system responds with a menu or prompt, follow the instructions to complete the device configuration.
23. Replace the system unit covers and return the drawer to the normal operating position.

## Replacing a Hot-Pluggable PCI Adapter

**Note:** Use this procedure only when you are replacing an adapter with an identical adapter. If you are replacing an adapter with an adapter that is not identical to the adapter removed, go to “Removing a Hot-Pluggable PCI Adapter” on page 473 and “Installing a Hot-Pluggable PCI Adapter” on page 476.

To replace an adapter, do the following:

1. Place the I/O drawer in the rear service position:
  - a. If you have not already done so, open the front door of the rack unit.
  - b. Loosen the two thumbscrews that attach the front bezel to the drawer.
  - c. Grasp both sides of the front bezel and pull the bezel off the drawer.

- d. If you have not already done so, open the rear door of the rack unit.
  - e. If present, remove the two retaining screws that secure the drawer to the rails. Refer to “Rear Service Position” on page 519.
  - f. Ensure that the cables do not restrain drawer movement.
  - g. Grasp the bar at the rear of the drawer, and pull the drawer to the rear until it is stopped by the detents.
2. Remove the two thumbscrews and remove the top cover from the drawer.
  3. Determine the slot from which you are removing the adapter.
  4. Ensure that any processes or applications that might use the adapter are stopped.

**Note:** Removing a hot-pluggable PCI adapter requires the system administrator to take the PCI adapter offline before performing any PCI adapter hot-plug procedures. Before taking an adapter offline, the devices attached to the adapter must be taken offline as well. This action prevents a service representative or user from causing an unexpected outage for system users.

For additional information about taking an adapter offline or removing it from the system configuration, see the *AIX System Management Guide: Operating System and Devices*. This publication is located on the *AIX Documentation CD*. Access the documentation information loading the documentation CD onto the hard disk or by mounting the CD in the CD-ROM drive.

5. Refer to “PCI Hot-Plug Manager Access” on page 478, and follow the steps in the access procedure to select **PCI Hot Plug Manager**. Then return here to continue.
6. Select **Unconfigure a Device** and press Enter.

**Note:** If the adapter or device has a problem that prevents it from replacement by hot swap, it must be replaced by shutting down the system. Go to the *RS/6000 and @server pSeries Diagnostic Information for Multiple Bus Systems Map 210 - 3*.

7. Press F4 to display the Device Names menu.
8. Select the adapter you are removing from the menu.
9. Answer YES to **Keep Definition**. Press Enter.
10. The ARE YOU SURE screen displays. Press Enter to verify the information. Successful unconfigure is indicated by the OK message displayed next to the **Command** field at the top of the screen.
11. Press F3 to return to the PCI Hot-Plug Manager menu.
12. Select **Replace/Remove a PCI Hot-Plug Adapter** and press Enter. The Replace/Remove a PCI Hot-Plug Adapter menu displays.
13. Move the cursor to select the adapter that you are removing and press Enter.
14. Press the Tab key until the entry field displays the replace operation and then Press the Enter key. Follow the instructions that display on the screen until you are instructed to remove the adapter.

15. When you are instructed to remove the adapter from the adapter slot, disconnect any cables that are connected to the adapter being removed.
16. Turn the locking latch and lift the plastic stop for the adapter.
17. Carefully grasp the adapter by the edges and pull it straight out from the I/O board.
18. Replace the adapter in the adapter slot. Carefully grasp the adapter by the edges and align the adapter in the slot guides. Insert the adapter fully into the adapter slot connector. If you are installing a full-length adapter, ensure that both ends of the adapter engage the card guides.
19. Lower the plastic stop over the adapter bracket and rotate the locking latch clockwise until it clicks into the locked position. Some full-length cards can be supported by rotating the blue adapter latch on the right end of the adapter counterclockwise.
20. Connect appropriate cables and devices to the adapter.
21. Continue to follow the screen instructions until you receive a message that the replacement is successful. Successful replacement is indicated by the OK message displayed next to the **Command** field at the top of the screen.
22. Press the F3 key to return to the PCI Hot-Plug Manager menu.
23. Select **Install/Configure Devices Added After IPL** and press Enter. Then follow the instructions on the screen. Successful replacement is indicated by the OK message displayed next to the **Command** field at the top of the screen.
24. If you do not have other adapters to replace, continue with the next step.  
OR  
If you have other adapters to replace, press the F3 key to return to the PCI Hot-Plug Manager menu and then return to step 12 on page 475.
25. Press F10 to exit the Hot-Plug Manager.  
If you have added, removed, or replaced any adapters, run the **diag -a** command. If the system responds with a menu or prompt, follow the instructions to complete the device configuration.
26. Replace the system unit covers and return the drawer to the normal operating position.

## Installing a Hot-Pluggable PCI Adapter

To install an adapter, do the following:

1. Place the I/O drawer in the rear service position:
  - a. If you have not already done so, open the front door of the rack unit.
  - b. Loosen the two thumbscrews that attach the front bezel to the drawer.
  - c. Grasp both sides of the front bezel and pull the bezel off the drawer.
  - d. If you have not already done so, open the rear door of the rack unit.
  - e. If present, remove the two retaining screws at the rear of the drawer. Refer to "Rear Service Position" on page 519.
  - f. Ensure that the cables do not restrain drawer movement.
  - g. Grasp the bar at the rear of the drawer, and pull the drawer to the rear until it is stopped by the detents.
2. Remove the two thumbscrews and remove the top cover from the drawer.

3. Refer to “PCI Hot-Plug Manager Access” on page 478 and follow the steps in the access procedure to select **PCI Hot Plug Manager**. Then return here to continue.
4. From the PCI Hot-Plug Manager menu, select **Add a PCI Hot-Plug Adapter** and press Enter. The Add a Hot-Plug Adapter window displays.
5. For adapter placement information, see the *PCI Adapter Placement Reference*, order number SA38-0538. Then select an empty PCI slot for the adapter.
6. Select the appropriate empty PCI slot from the ones listed on the screen, and press Enter.
7. Turn the locking latch, lift the plastic stop, and remove the blank cover.
8. Follow the instructions on the screen to install the adapter until the visual indicator (LED) for the specified PCI slot is set to the Action state. See “I/O Drawer PCI Slot LED Definitions” on page 470.
9. When you are instructed to install the adapter in the adapter slot, carefully grasp the adapter by the edges and align the adapter in the slot guides. Insert the adapter fully into the adapter slot connector. If you are installing a full-length adapter, ensure that both ends of the adapter engage the card guides.
10. Lower the plastic stop over the adapter bracket and rotate the locking latch clockwise until it clicks into the locked position. Some full-length cards can be supported by rotating the blue adapter latch on the right end of the adapter counterclockwise.
11. Connect appropriate cables and devices to the adapter.
12. Continue to follow the screen instructions until you receive a message that the installation is successful. Successful installation is indicated by the OK message displayed next to the **Command** field at the top of the screen.
13. Press the F3 key to return to the PCI Hot-Plug Manager menu.
14. Select **Install/Configure Devices Added After IPL** and press Enter. Then follow the instructions on the screen. Successful installation is indicated by the OK message displayed next to the **Command** field at the top of the screen.
15. If you do not have other adapters to install, continue with the next step.  
OR  
If you have other adapters to install, press the F3 key to return to the PCI Hot-Plug Manager menu and then return to step 4.
16. Press F10 to exit the Hot-Plug Manager.  
If you have added, removed, or replaced any adapters, run the **diag -a** command. If the system responds with a menu or prompt, follow the instructions to complete the device configuration.
17. Replace the system unit covers and return the drawer to the normal operating position.

---

## PCI Hot-Plug Manager Access

The installation instructions for hot-pluggable PCI adapters refer you to these procedures when it is appropriate to perform them.

**Note:** A PCI adapter is only hot-pluggable if the PCI adapter is supported for hot-plug applications. See the *PCI Adapter Placement Reference*, order number SA38-0538.

## Accessing Hot-Plug Management Functions

**Note:** Removing or installing a Hot-Pluggable PCI adapter requires the system administrator to take the PCI adapter offline prior to performing the operation. Before taking an adapter offline, the devices attached to the adapter must be taken offline as well. This action prevents a service representative or user from causing an unexpected outage for system users.

For additional information about taking an adapter offline or removing it from the system configuration, see the *AIX System Management Guide: Operating System and Devices*. This publication is located on the *AIX Documentation CD*. The documentation information is made accessible by loading the documentation CD onto the hard disk or by mounting the CD in the CD-ROM drive.

To access the hot-plug menus, do the following:

1. Log in as root user.
2. At the command line, type `smitty`.
3. Select **Devices**.
4. Select **PCI Hot Plug Manager** and press Enter.
5. The PCI Hot-Plug Manager menu displays. Return to the procedure that directed you here. The following section contains a description of the menu options.



## PCI Hot-Plug Manager Menu

The following options are available from the PCI Hot Plug Manager menu:

**Note:** For information about the PCI slot LED states, see “I/O Drawer PCI Slot LED Definitions” on page 470.

### List PCI Hot-Plug Slots

Provides a descriptive list of all slots that support PCI hot-plug capability. If the listing for a slot indicates it holds an “Unknown” device, select the **Install/Configure Devices Added after IPL** to configure the adapter in that slot.

### Add a PCI Hot-Plug Adapter

Allows the user to add a new PCI hot-plug-capable adapter to the slot with the system turned on. You will be asked to identify the PCI slot that you have selected prior to the actual operation. The selected PCI slot will go into the Action state and finally into the On state.

**Note:** The system will indicate the slot holds an “Unknown” device until you perform the **Install/Configure Devices Added After IPL** option to configure the adapter.

### Replace/Remove a PCI Hot-Plug Adapter

Allows the user to remove an existing adapter, or replace an existing adapter with an identical one. For this option to work, the adapter must be in the Defined state. See **Unconfigure a Device** option below.

You will be asked to identify the PCI slot prior to the actual operation. The selected PCI slot will go into the Action state.

### Identify a PCI Hot-Plug Slot

Allows the user to identify a PCI slot. The selected PCI slot will go into the Identify state. See “I/O Drawer PCI Slot LED Definitions” on page 470.

### **Unconfigure a Device**

Allows the user to put an existing PCI adapter into the Defined state if the device is no longer in use.

This step must be completed successfully before starting any removal or replacement operation. If this step fails, the customer must take action to release the device.

### **Configure a Defined Device**

Allows a new PCI adapter to be configured into the system if software support is already available for the adapter. The selected PCI slot will go into the On state.

### **Install/Configure Devices Added After IPL**

The system attempts to configure any new devices and tries to find and install any required software from a user-selected source.

The add, remove, and replace functions return information to the user indicating whether the operation was successful. If additional instructions are provided on the screen, complete the recommended actions. If the instructions do not resolve the problem, see the following:

- If the adapter is listed as Unknown, perform the **Install/Configure Devices Added After IPL** option to configure the adapter.
- If you receive a warning indicating that needed device packages are not installed, the system administrator must install the specified packages before you can configure or diagnose the adapter.
- If you receive a failure message indicating a hardware error, the problem might be either the adapter or the PCI slot. Isolate the problem by retrying the operation in a different PCI slot, or trying a different adapter in the slot.

---

## Memory Riser Cards and Memory Modules

### Removal

**Note:** For -48 vdc systems, you must first remove a long jackscrew. See steps 1 through 4 in “CEC Backplane” on page 496.

1. Turn off power as described in “Powering Off the System” on page 469.
2. Remove the card-cage retaining screws in the back of the CEC drawer.
3. Grasp the handle located in the rear center of the CEC card-cage and pull it straight back.
4. Pull up on the release latches of the memory card, and carefully pull the card out of the slot.

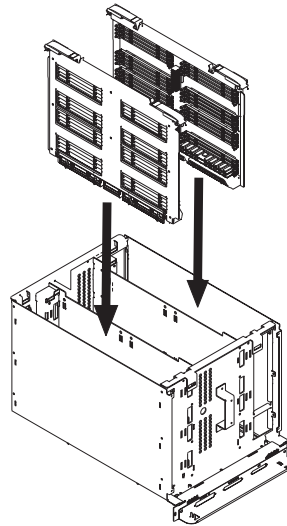

5. Locate the memory module connectors and determine which memory modules you want to remove. Refer to “Memory Riser Card and Memory DIMM Locations” on page 20 for memory module locations.

6. Remove the memory module by pushing the tabs out on the memory connectors.

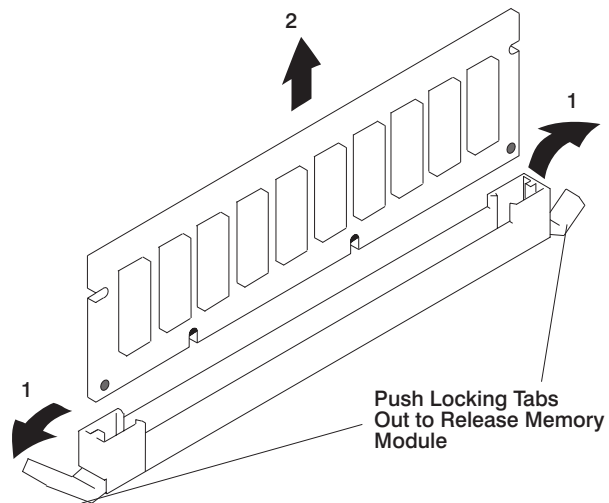

## Replacement

1. With one hand, touch any metal surface of the chassis to minimize static electrical charges, and then pick up the memory module.
2. Locate the memory module connector on the memory card.
3. Insert the memory module firmly into the connector.

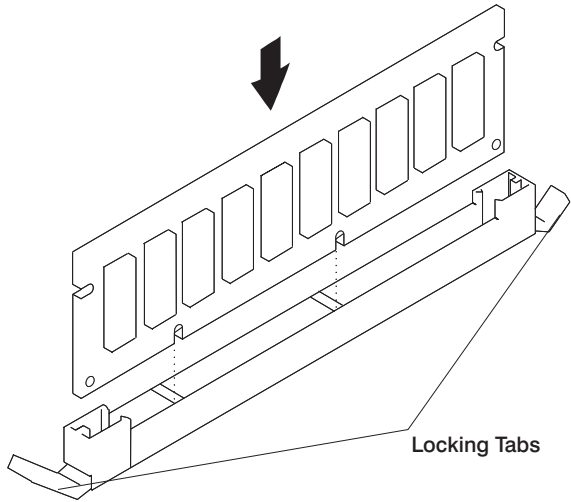

4. Secure the memory module with the locking tabs located at each end of the connector.
5. Replace the memory card into the system unit.
6. Push the CEC drawer back into the rack, and replace the CEC card-cage retaining screws.

---

## CEC Regulator Card

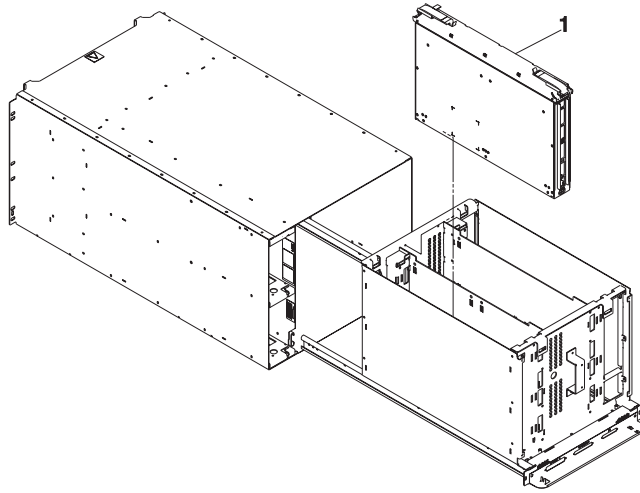

### Removal

**Note:** For -48 vdc systems, you must first remove a long jackscrew. See steps 1 through 4 in “CEC Backplane” on page 496.

1. Turn off power as described in “Powering Off the System” on page 469.
2. Remove the card-cage retaining screws in the back of the CEC drawer.
3. Grasp the handle located in the center rear of the CEC card-cage, and pull the CEC card-cage out from the drawer.
4. Pull up on the release latches on the CEC regulator card **(1)** and carefully remove the card from its slot.

### Replacement

Replace in reverse order.

---

## Processor Card

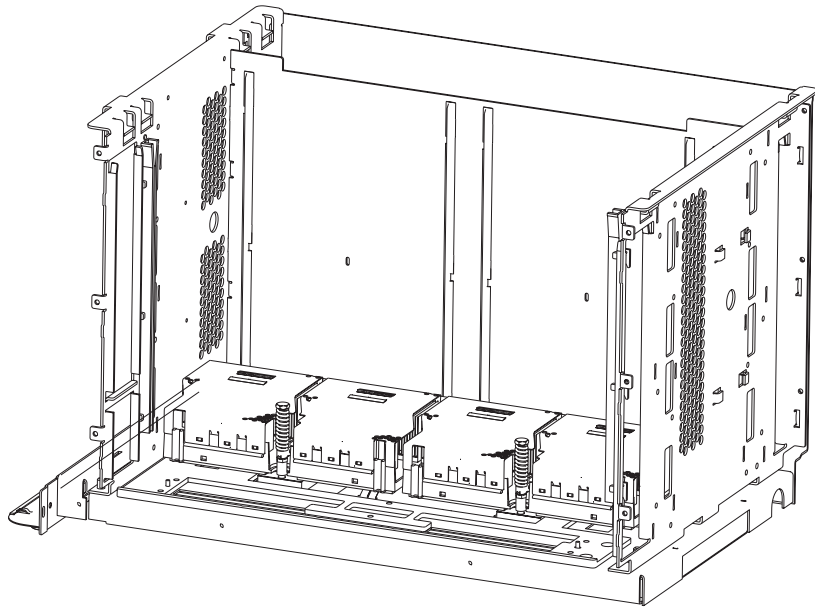

## Removal

**Note:** For -48 vdc systems, you must first remove a long jackscrew. See steps 1 through 4 in “CEC Backplane” on page 496.

**Attention:** The processor cards in this system can only be attached to the backplane once. *If a processor card is removed, it must be replaced with a new processor card.*

Before proceeding, make sure you have been directed to replace the processor card(s) by the action for a valid error code in Chapter 5, “Error Code to FRU Index” on page 171 or by a second level of support.

1. Turn off power as described in “Powering Off the System” on page 469.
2. Remove the card-cage retaining screws in the back of the CEC drawer.
3. Grasp the handle located in the center rear of the CEC card-cage, and pull the CEC card-cage out from the drawer.
4. Inspect the area around the outside of the CEC card-cage for excessive dirt or dust. You may need to vacuum the external surfaces of the CEC card-cage, especially when excessive dirt or dust is present. Vacuum *before* opening the cage.
5. Remove the screws from the processor air cover.

6. Remove the processor air cover from the CEC card-cage.

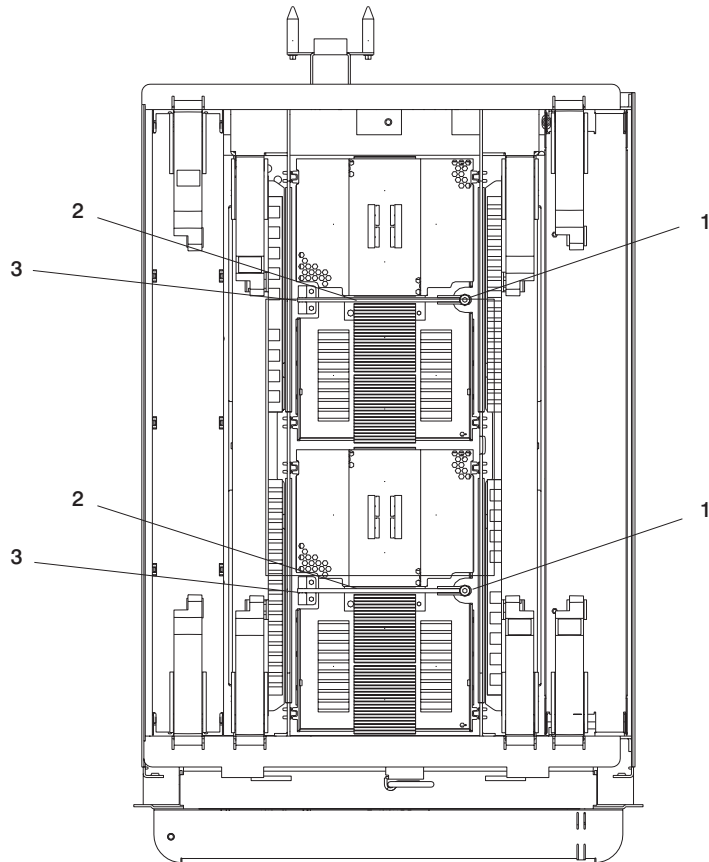

7. Locate the spring screws **(1)** attached to the processor card you want to remove. Using a 3/8" hex driver, turn the spring screw counterclockwise to loosen and remove the screw. Do not drop the screw into the CEC card-cage.
8. The processor latches **(2)**, which pivots at the opposite end of the spring screw, raises slightly after the screw is removed. Grasp the end of the processor latch bar where the spring screw was located and pull it straight up out of the card-cage. Rest the latch bar against the sheet metal of the CEC card-cage.
9. Grasp the center of the processor card and remove the card by pulling it straight up and out of the CEC card-cage. After you have removed the processor card, place the card top-side down on a work surface.



## Replacement

**Attention:** Look for small amounts of debris on the connecting surfaces between the backplane and the processor card. Mating the two surfaces is critical for the processor to function properly.

1. Gently lift one end of the processor card and then the other until it slides up and off of the contact surface. Place the top of the new processor card on your work surface. Carefully remove the array cover (1) from the bottom of the processor card. Orient the array cover on the original processor card so that the side containing the part number is facing the original processor card. Gently slide the array cover over the contact surface until it snaps onto the original processor card. Put the original processor in a protected area.

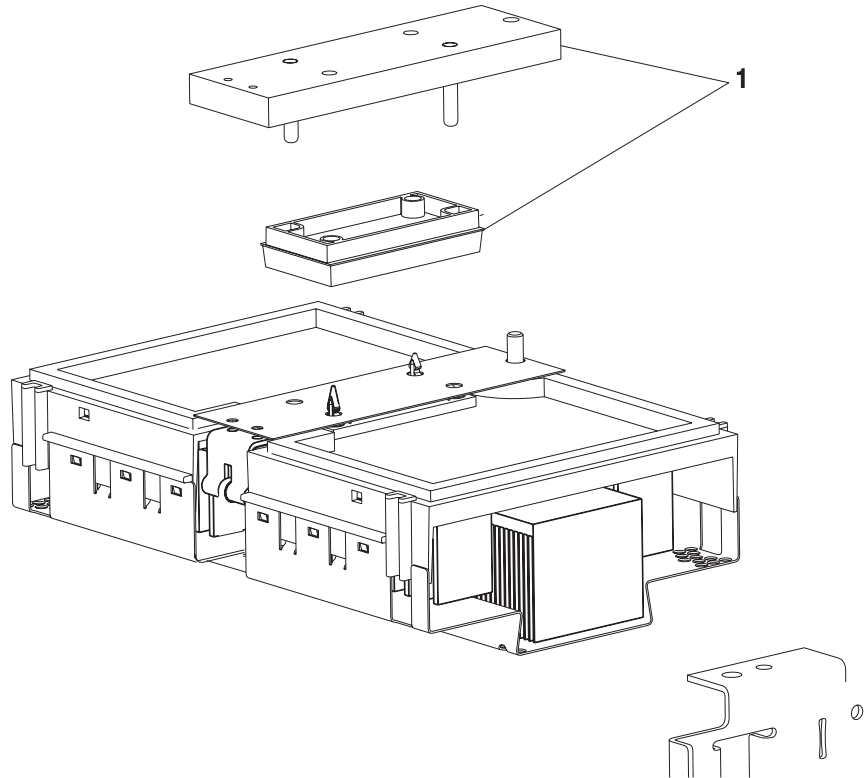

2. This step instructs you how to use the special brush provided with the new processor. It is important that you follow these instructions very carefully:
  - a. Remove the brush from the packaging.
  - b. Refer to the following figure:

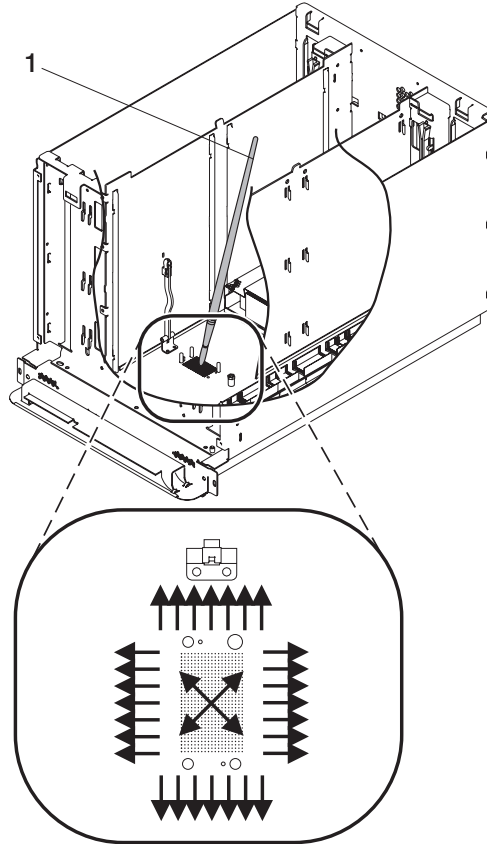

- c. Starting with the brush **(1)** in the center of the processor contact surface that is on the CEC backplane, use an outward brushing motion to clear the debris away from the area where the surfaces of the processor card and the CEC backplane meet. (Do not brush the processor card or the contact surface on the bottom of the processor card).
3. Grasp the center of the new processor card and align the square notch with the processor latch pivot. The processor latch pivot is on your left as you face the rear of the CEC card-cage. Align the holes in the processor card with the guide pins on the CEC backplane, and press down until the processor card is fully seated.
4. Pivot the processor card latch down over the processor card.
5. Insert the spring screw into the end of the processor latch opposite the pivot end (right side, viewed from the rear of the CEC card-cage). Turn the spring screw clockwise into the threaded hole of the CEC backplane, then tighten the screw until

it stops turning. It is recommended that you use a nut driver and not a ratchet to tighten the spring screw. This is a compression fitting, so be careful *not* to overtighten the spring screw.

**Attention:** Examine the processor card to see that it is fully seated and make sure that the processor latch is back to its original position. If it is not fully seated, the processor will fail to function properly.

6. Complete the replacement by reversing the removal procedures.

---

## CEC Fans

The CEC drawer has two fans. You can replace each fan separately. The removal and replacement procedures are the same for each fan. Each CEC fan is hot-pluggable. If only one needs to be removed, you do not have to power off the system.

### Removal

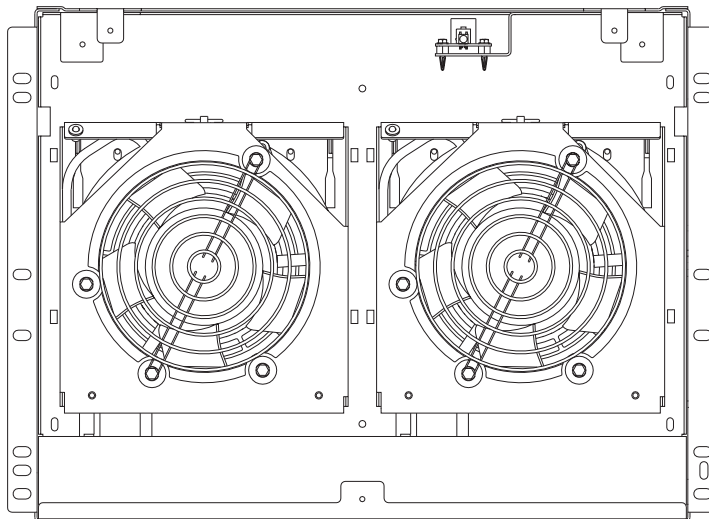

1. Loosen the two thumbscrews that attach the front bezel to the drawer.
2. Grasp both sides of the front bezel and pull it off the CEC drawer.

3. Remove the screws **(1)** connecting the front EMC shield to the CEC, as shown in the following diagram.

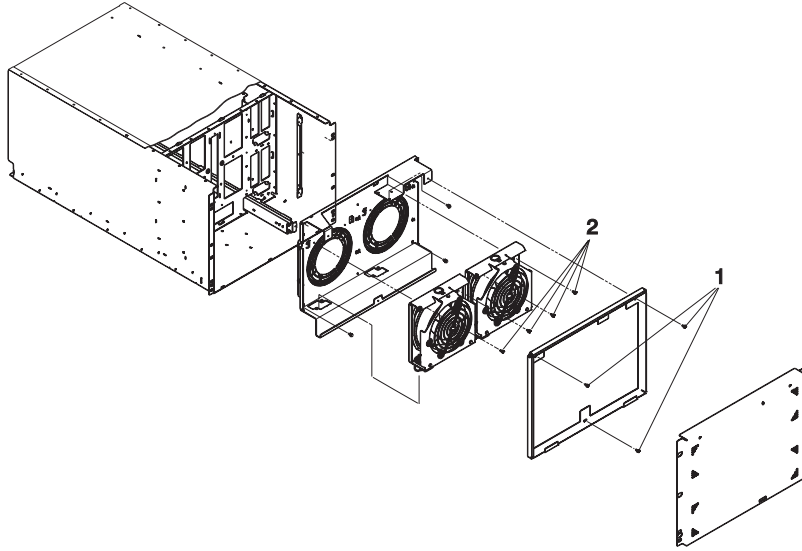

4. Remove the EMC shield.  
**Attention:** Do not allow the screws removed in the following step to fall into the fan assembly.
5. Carefully remove the screws **(2)** connecting the digital fan assemblies to the fan-mounting assembly.
6. To remove the digital fan assemblies, pull up and away from the CEC.

## Replacement

Replace in reverse order.

**Attention:** After hot-plugging a CEC fan, wait at least 5 minutes and then examine the system error logs to make sure CEC fan errors are not being logged.

---

## CEC Power Supplies

The CEC drawer has two power supplies. You can replace each power supply separately. The removal and replacement procedures are the same for each power supply.

Each CEC power supply is hot-pluggable. If only one needs to be removed, you do not have to power off the system.

## Removal

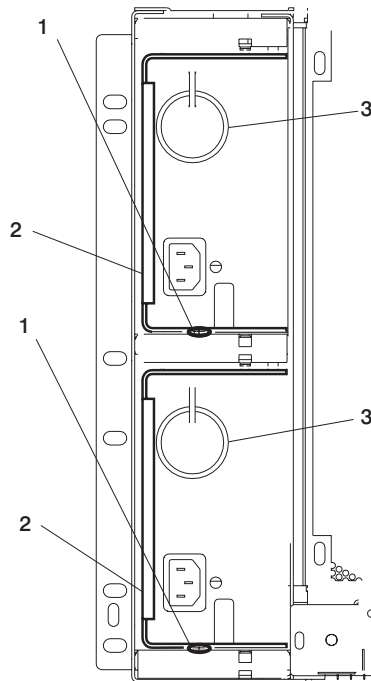

1. Carefully remove the end of the ac cord on the CEC power supply you want to replace. *Do not* remove both ac cords, as power will be lost to the CEC, forcing the system to power off.
2. Remove the screw keeping the latch handle in place, as shown in **(1)** above.
3. After the latch handle swings freely, position the latch handle **(2)** so that it is perpendicular to the rear of the CEC drawer.
4. Pull on the ring attached to the power supply **(3)** and the latch handle (maintaining its perpendicular position) to move the power supply away from the CEC drawer.
5. Remove the power supply.

## Replacement

Replace in reverse order.

---

## CEC RIO Bus Adapter

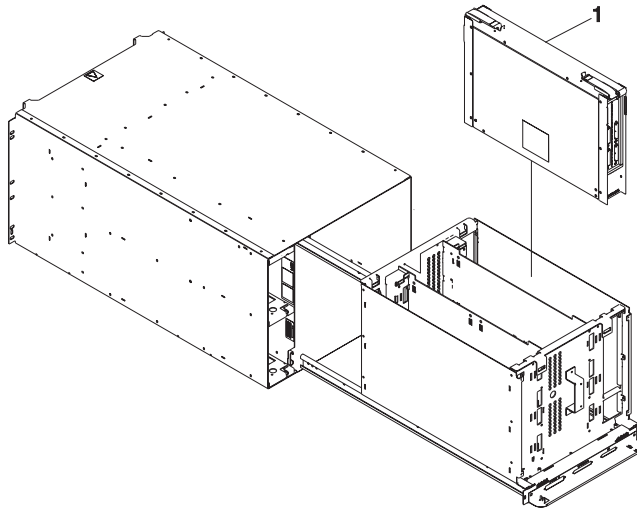

### Removal

**Note:** For -48 vdc systems, you must first remove a long jackscrew. See steps 1 through 4 in “CEC Backplane” on page 496.

1. Turn off power as described in “Powering Off the System” on page 469.
2. For easy replacement, record the locations of the RIO cables attached to the rear of the CEC drawer.
3. Disconnect all of the RIO cables attached to the rear of the CEC drawer.
4. Remove the card-cage retaining screws in the back of the CEC drawer.
5. Grasp the handle located in the center rear of the CEC card-cage and pull it straight back.
6. Unscrew the two screws attaching the EMC tunnel to the CEC.
7. Pull up on the release latches of the CEC RIO adapter card and carefully pull the card out of the slot.

8. If you are removing the clock card, remove the clock card cover (1).
9. Grasp the clock card by its handle (2) and pull it straight out of the RIO bus adapter card (3).

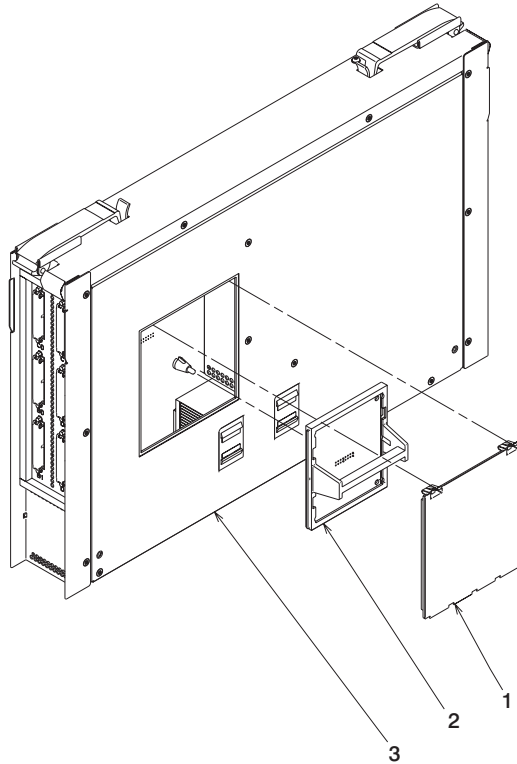



## Replacement

Remove the clock card from the old CEC RIO bus adapter using the previous procedure, and put it into the new CEC RIO bus adapter. Do this by aligning the three pins on the CEC RIO bus adapter with the holes on the clock card.

---

## CEC Backplane

**Attention:** The processor cards in this system can only be attached to the backplane once. *If the CEC backplane is replaced with a new backplane, the processor(s) must also be replaced with a new processor card(s).*

**Attention:** Before proceeding, make sure you have been directed to replace the backplane and processor card(s) by the action for a valid error code in Chapter 5, "Error Code to FRU Index" on page 171 or by instruction from your second level of support.

### Removal

1. Turn off power as described in "Powering Off the System" on page 469.
2. Remove the card-cage handle retaining screws **(1)** and the card-cage handle **(2)** located in the rear center of the CEC.
3. Remove the four rear CEC EMC shield retaining screws **(3)** located in each corner of the EMC shield.
4. Remove the rear CEC EMC shield **(4)** by grasping the flanges on each side of the shield, as shown in the following figure.

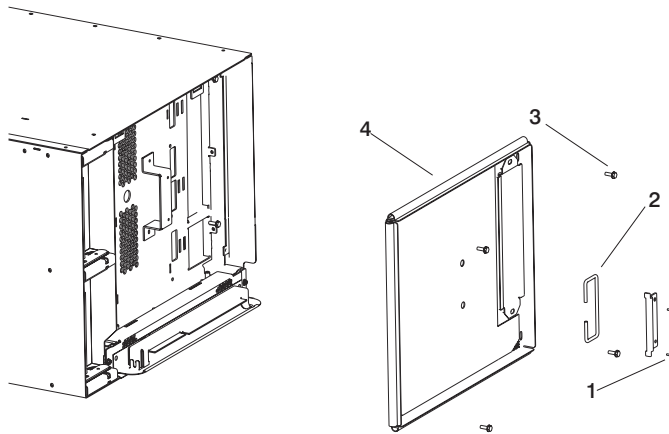

**Note:** For -48 vdc systems, you must first remove a long jackscrew (5) that protrudes from the rear center of the CEC card-cage. Refer to the following figure.

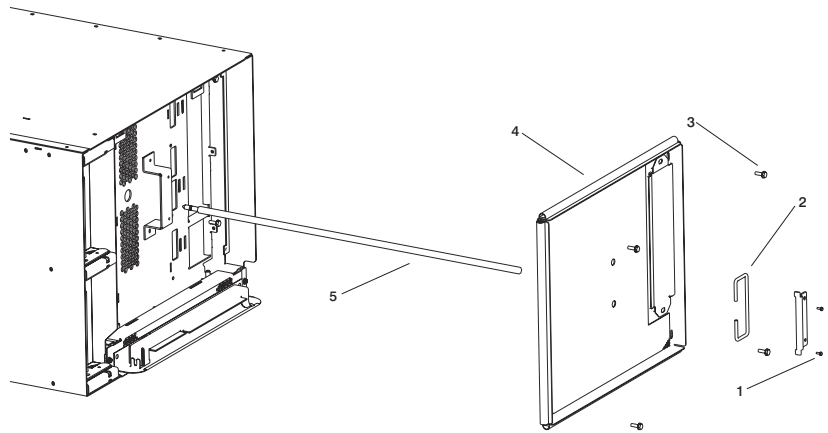

5. Remove the two card-cage retaining screws in the back of the CEC drawer.
6. Grasp the handle located in the center rear of the CEC card-cage and pull it straight back.
7. Disconnect all of the RIO cables attached to the rear of the CEC drawer. For easy replacement, record their locations.
8. Disconnect the JTAG cable.
9. Disconnect the V/S COMM cable.
10. Pull up on the release latches of the CEC RIO adapter card and carefully pull the card out of the slot.
11. Pull up on the release latches of the memory riser card(s) and carefully pull the card(s) out of the slot(s).
12. Pull up on the release latches of the CEC regulator card and carefully pull the card out of the slot.
13. Remove the processor card(s) as shown in "Processor Card" on page 485.
14. Support the bottom of the CEC card-cage with a telescoping table or other suitable means. Leave the drawer open.

15. Remove the six cage-to-slide screws (1) to separate the CEC card-cage from the drawer enclosure, as shown in following figure.

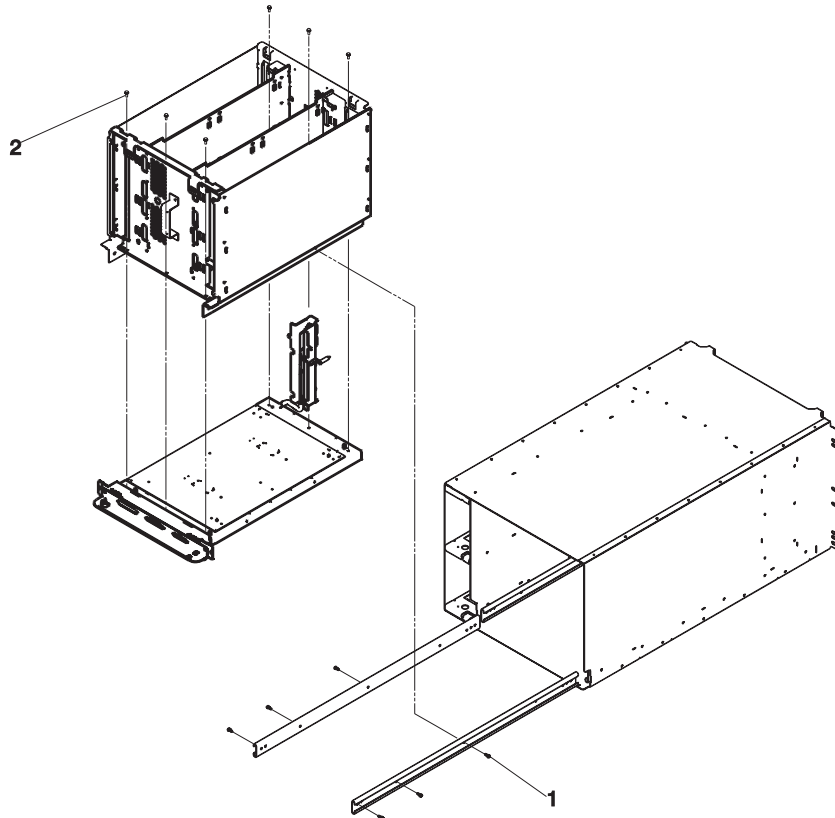

16. Place the CEC card-cage on a suitable work surface.  
**Attention:** Make sure adequate support is given to the *edges* of the CEC backplane so that clearance is allowed for components attached to it. *Under no circumstances must any of the components (such as modules or heat sinks) come in contact with the work surface.* These attached components will not support the weight of the CEC card-cage without sustaining some damage.
17. Reach in through the top of the card-cage/backplane assembly to remove the 6 cage-to-backplane screws (2) and carefully lift the CEC card-cage off the CEC backplane. Refer to the previous figure.

## Replacement

Replace in reverse order.

---

## I/O Drawer Backplane Assembly

### Removal

1. Turn off power as described in “Powering Off the System” on page 469.

2. Place the I/O drawer in the rear service position, as described in “Rear Service Position” on page 519.
3. Remove the two thumbscrews and remove the back cover.

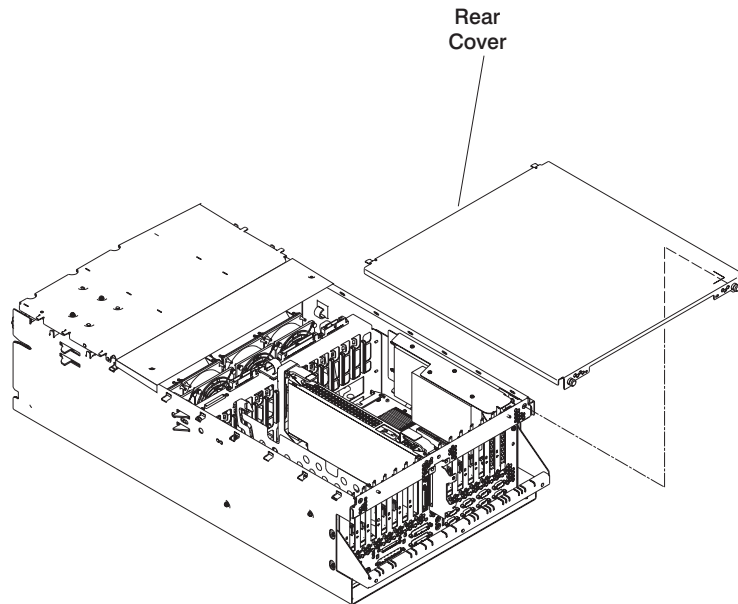

4. Disconnect and label all cables from the rear of the assembly.
5. Remove boot disk drives if installed. See “Internal Disk Drives” on page 509.
6. Remove and label adapters. See “PCI Adapters” on page 471.
7. Remove two screws from each side of the assembly.
8. Disconnect and label all cables from the front of the assembly.

- Slide the I/O drawer backplane assembly to the rear and remove the assembly.

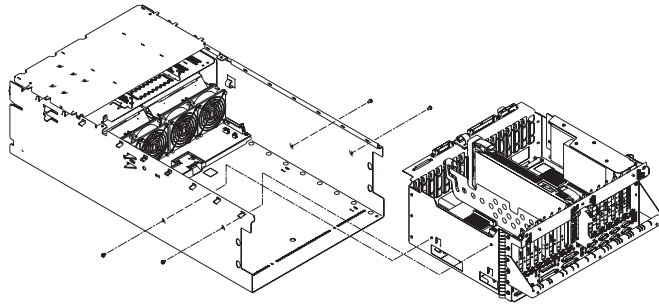

- Remove the RIO card assembly, as described in “I/O Drawer RIO Bus Adapter” on page 501.
- Remove the bar from the old assembly and install on the new assembly. See “I/O Drawer” on page 532.

## Replacement

- Replace in reverse order.
- Set the drawer type using the service processor menus.
  - From the SP Main Menu, select **System Information Menu** (option 3).
  - Select **Power Control Network Utilities Menu** (option 9).
  - Select **Change I/O Type** (option 3).
  - For the I/O drawer address (drawer number), type:
    - 1 for primary drawer.
    - n for secondary drawers (n=2, 3, or 4).
  - For the I/O type, type:
    - 87 for the primary I/O drawer.
    - 84 for all secondary drawers.
- Check firmware level by checking the Version on the title of the Service Processor Main Menu. If the firmware level is not at the correct level, proceed as follows:
  - Reprogram all system EPROMs using the Service Processor Setup Menu.
  - Select **Reprogram Flash EPROM Menu** (option 7).
- The service processor settings have been set to default values. These settings must be restored if not previously set to default values.
  - Manually reset all settings.
  - If the service processor settings had previously been saved, the settings may be restored using the procedure in “Saving and Restoring Service Processor Settings” on page 412.

---

## I/O Drawer RIO Bus Adapter

### Removal

1. Turn off power as described in “Powering Off the System” on page 469.
2. Place the I/O drawer in the rear service position, as described in “Rear Service Position” on page 519.
3. Remove the two thumbscrews and remove the rear cover.

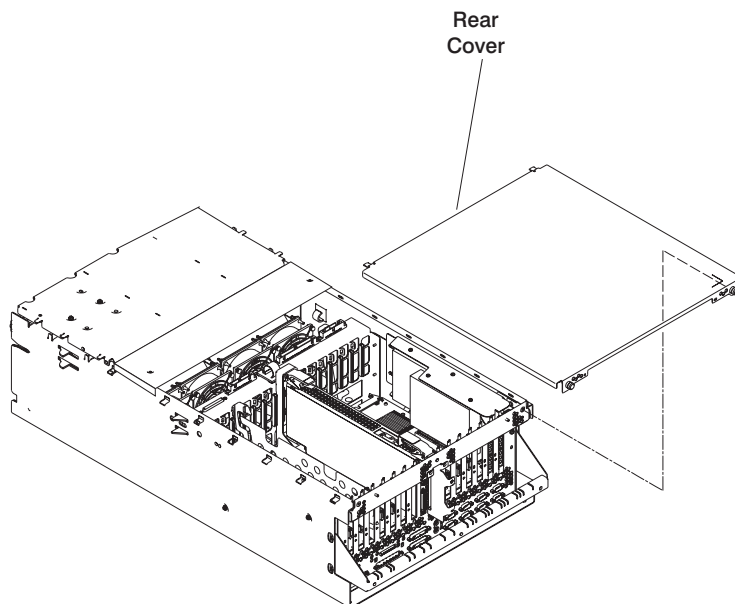

4. Disconnect all cables from the card assembly.

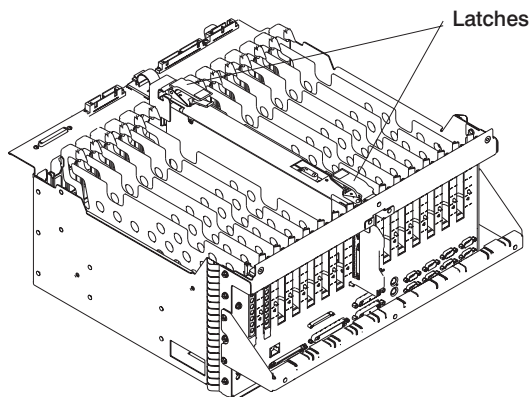

5. Remove the screw and remove the retainer bracket from the rear release latch.
6. Pull up on the release latches, and carefully pull the card out of the slot.

## **Replacement**

Replace in reverse order.



---

## I/O Drawer Power Distribution Board

### Removal

1. Turn off power as described in “Powering Off the System” on page 469.
2. Place the I/O drawer in the rear service position, as described in “Rear Service Position” on page 519.
3. Remove the two thumbscrews and remove the rear cover.

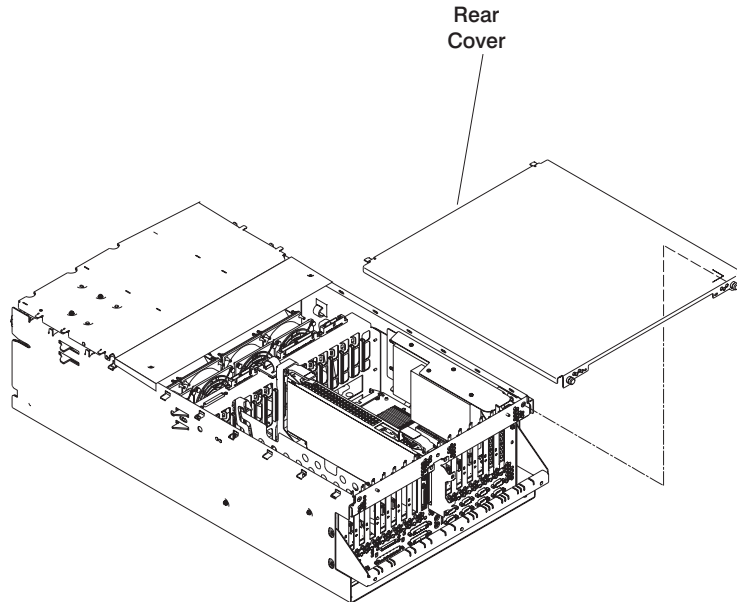

4. Remove any adapters or files installed in slots 12, 13, or 14.
5. Disconnect the four I/P cables from the I/O tray.
6. Remove two screws from each side of the I/O drawer board assembly.
7. Disconnect the miscellaneous power cable from PCI board connector J21.
8. Slide the I/O drawer board assembly to the rear to disconnect the assembly from the power distribution board bus bar.
9. Place the I/O drawer in the front service position as described in “Front Service Position” on page 520.
10. Remove the power supplies as described in “I/O Drawer Power Supplies and Power Supply Fan Assemblies” on page 505.

11. Loosen the two screws from the center cover and remove the cover.

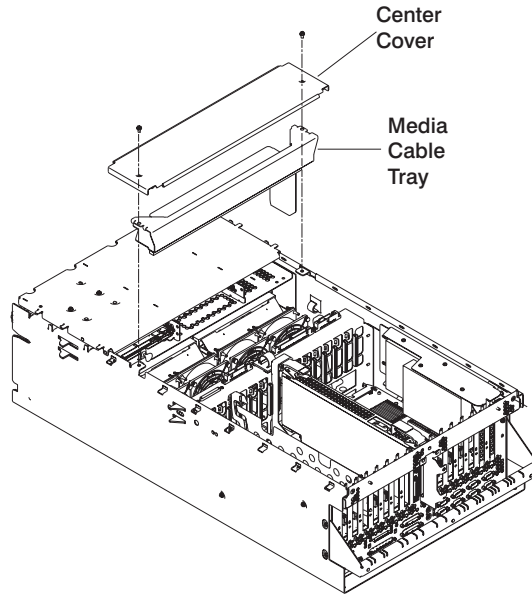

12. Remove the media cable tray.
13. Remove the screws from the power distribution board.

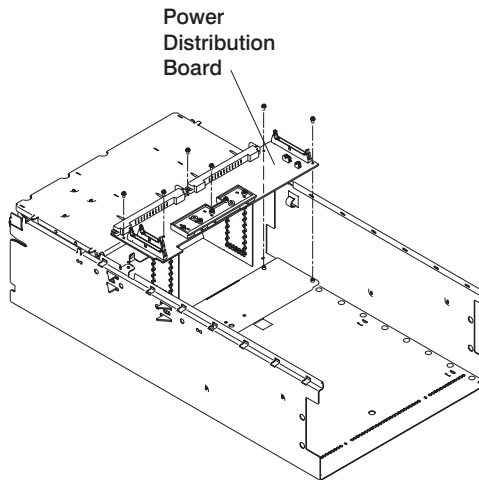

14. Remove the power distribution board.

## Replacement

Replace in reverse order.

---

## I/O Drawer Power Supplies and Power Supply Fan Assemblies

### Notes:

1. Each drawer can have up to two power supplies. You can replace each power supply separately. The removal and replacement procedures are the same for each power supply.
2. The procedure described in this section applies to the I/O drawer power supplies.
3. Power supplies for the CEC and I/O drawers cannot be interchanged.
4. If a drawer has two power supplies, each is hot-pluggable. If only one needs to be removed, you do not have to power off the system.
5. Each power supply has a test switch. See "Power Supply Test Switch Procedure" on page 508.
6. If your drawer has only one power supply, the unused power supply position must be filled with a cooling unit, which must have a power supply fan assembly attached to it.
7. Do not hot-plug a power supply if the ambient room temperature is greater than 32°C (90°F), as it can cause loss of data or data corruption.
8. Be sure that the replacement power supply is ready to install. If the power supply is removed for longer than four minutes, a shutdown command is issued to the operating system.
9. Power supply 1 fan assembly (fans 1 and 2) is located on the rear of the primary power supply. Power supply 2 fan assembly (fans 3 and 4) is located on the rear of the secondary power supply. If only one fan in a fan assembly is bad, the fan assembly must be replaced. Power supply fan 5 is located in the primary power supply and if that fan fails, the power supply must be replaced. Power supply fan 6 is located in the secondary power supply and if that fan fails, the power supply must be replaced. Fan 9 is located in the cooling unit.

**Attention:** After hot-plugging a power supply, wait at least 5 minutes and then examine the system error logs to make sure power supply errors or power supply fan errors are not being logged.

## Removal

### DANGER

**Do not attempt to open the covers of the power supply. Power supplies are not serviceable and are to be replaced as a unit.**

1. If you have not already done so, open the front door of the rack unit.
2. Loosen the two thumbscrews that attach the front bezel to the drawer.
3. Grasp both sides of the front bezel and pull it off the drawer.
4. Unplug the power cord from the power supply you are removing.
5. Pull the snap button out on the power supply handle.
6. Grasp the handle of the power supply and pivot it downward.

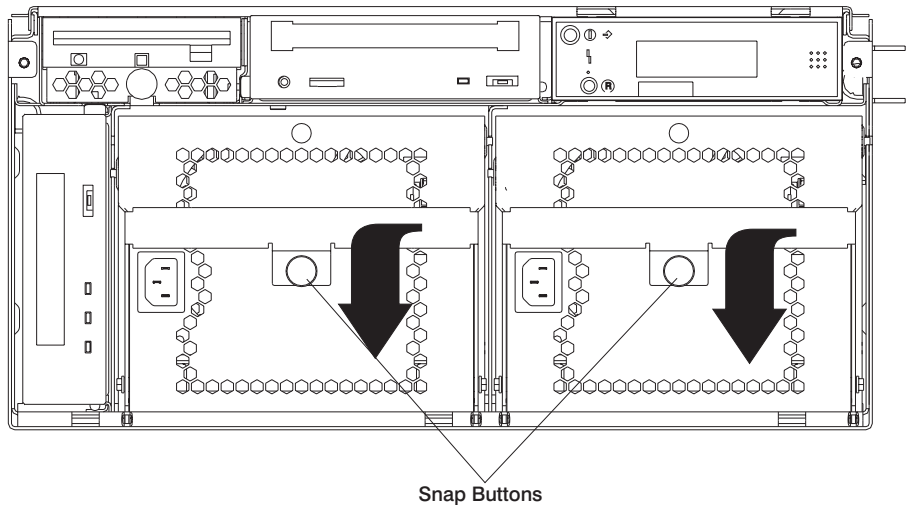

7. Pull the power supply out of the drawer.
8. Remove the external fan assembly from the power supply and save it for replacement.

9. Pull out on the snap button and remove the fan assembly from the power supply.

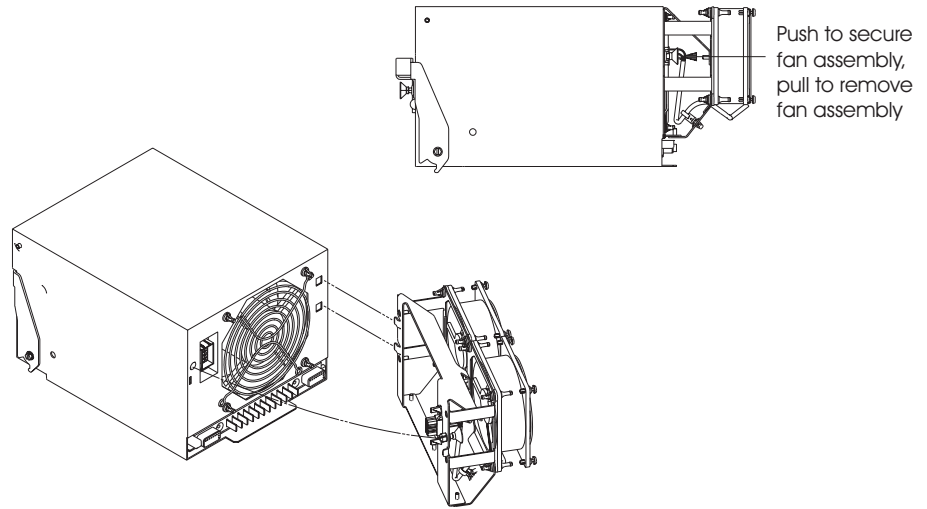

## Replacement

**Note:** The power supply handle must be in the down position for replacement.

Replace in the reverse order.

---

## Power Supply Test Switch Procedure

Before you replace a power supply, use this procedure to determine if the power supply needs replacing.

1. Perform steps 1 through 7 in “I/O Drawer Power Supplies and Power Supply Fan Assemblies” on page 505.
2. Connect the line cord to the power supply and look at the front of the power supply.
  - If the LED on the front of the power supply is not blinking, the power supply is defective. Continue with step 8 in “I/O Drawer Power Supplies and Power Supply Fan Assemblies” on page 505.
  - If the LED on the front of the power supply is blinking, go to the next step.

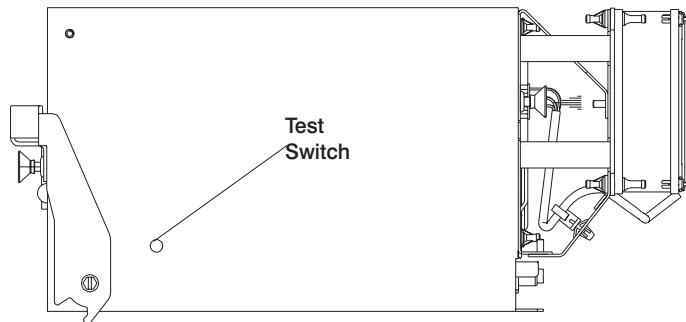

3. Use a pencil to press the test switch on the side of the power supply.
  - If the LED on the front of the power supply is on steady and the fans spin, the power supply is good and can be returned to the system.
  - If the LED on the front of the power supply is not on steady and the fans do not spin, the power supply is defective. Continue with step 8 in “I/O Drawer Power Supplies and Power Supply Fan Assemblies” on page 505.

---

## Internal Disk Drives

### Removal

1. Turn off power as described in “Powering Off the System” on page 469
2. Place the drawer in the rear service position as described in “Rear Service Position” on page 519.
3. Remove the two thumbscrews and remove the back top cover.
4. Remove the screw from the back of the disk drive carrier.
5. Slide the carrier forward and remove. The carrier has keyed slots **(1)** that engage mounting posts **(2)** on the chassis.
6. Disconnect the internal cables from the drives.
7. If you are replacing a defective boot drive, remove the mounting screws **(3)** from the carrier.

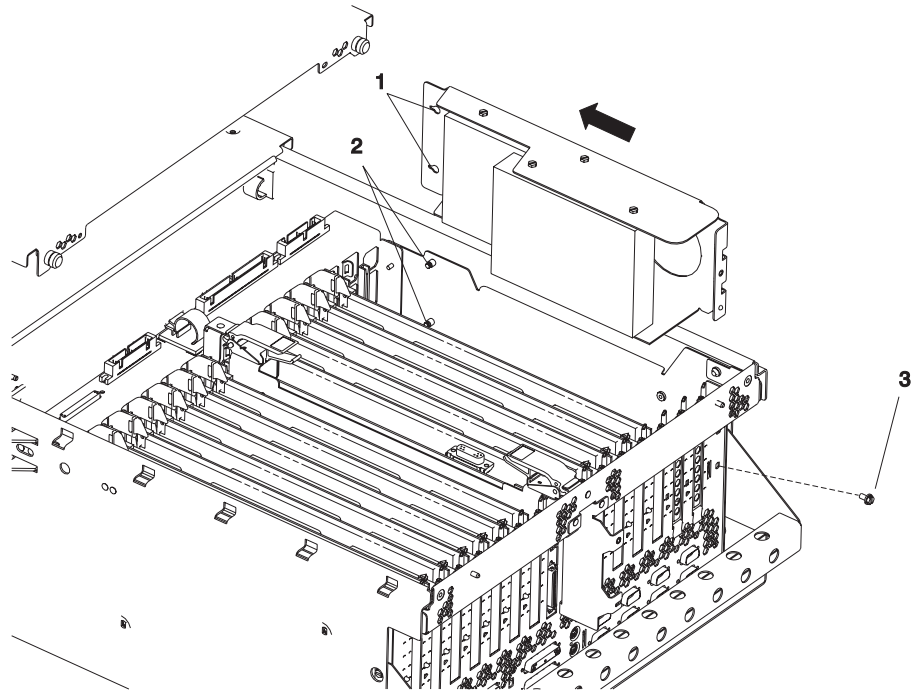

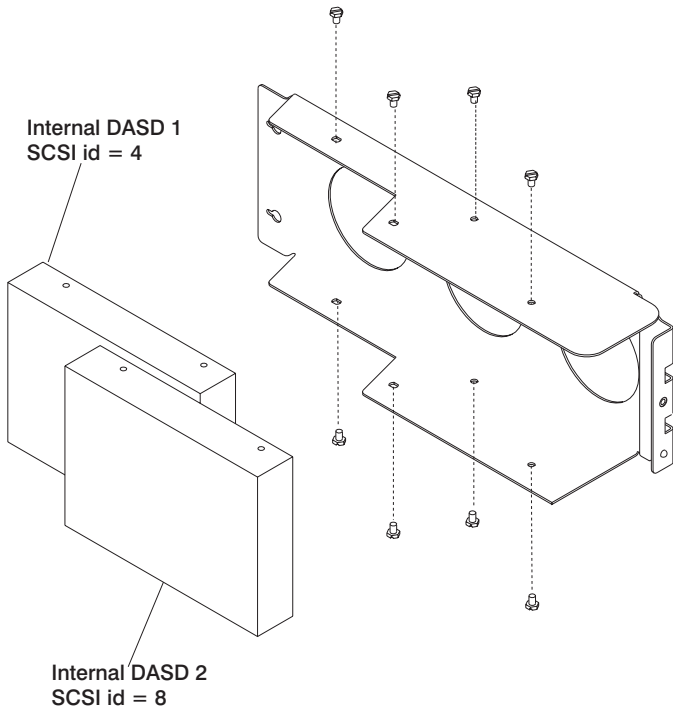



## Replacement

Replace in reverse order. Refer to the following diagram for help with connecting the cables to the internal disk drives.

Alternate Internal Disk Drive Connections

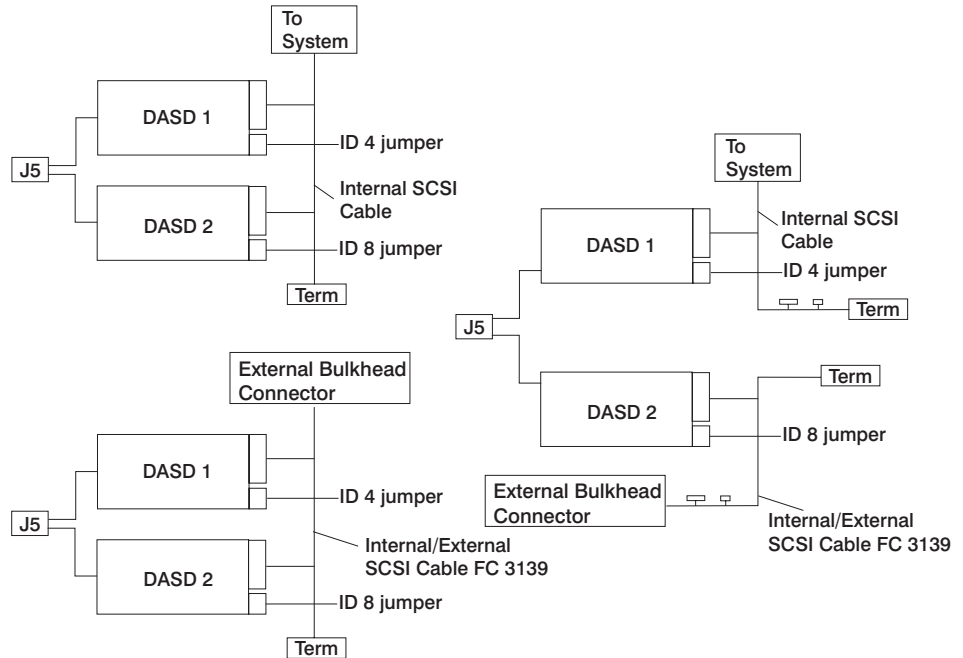

### Notes:

1. The SCSI ID jumpers are integrated in the SCSI cable.
2. Unused SCSI connectors on the SCSI cables are shown for each configuration. Carefully select the correct SCSI connectors and ID jumpers.
3. When using the FC 3139 internal/external cable, one or more of the following external cables will also be required:
  - FC 2118
  - FC 2424
  - FC 2425

For descriptions and part numbers of the feature codes, see “External Cables” on page 542.

---

## Fan Controller Card

### Removal

1. Turn off power as described in "Powering Off the System" on page 469.
2. Place the drawer in the front service position as described in "Front Service Position" on page 520.
3. Remove the two screws from the center top cover and remove the cover.
4. Disconnect the cable from the fan controller card.
5. Pull the snap button out.
6. Remove the fan controller card.

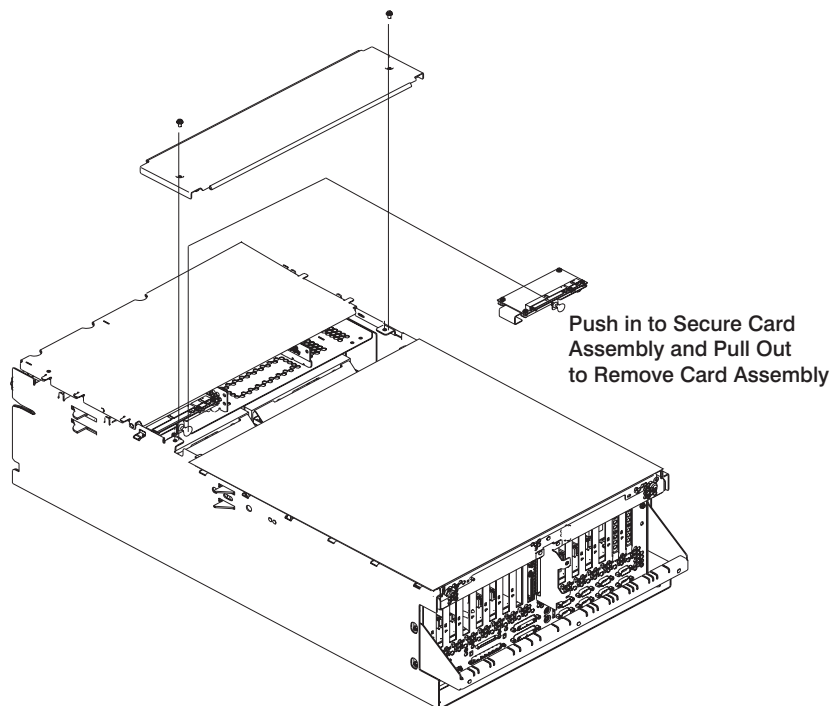

### Replacement

Replace in reverse order.

---

## CD-ROM Drive

**Attention:** Do not open the drive; no user adjustments or serviceable parts are inside.

**CAUTION:**

A class 1 laser is contained in the device. Do not attempt to operate the drive while it is disassembled. Do not attempt to open the covers of the drive as it is not serviceable and is replaced as a unit.

### Removal

1. Turn off power as described in “Powering Off the System” on page 469.
2. If you have not already done so, open the front door of the rack unit.
3. Loosen the two thumbscrews that attach the front bezel to the I/O drawer.
4. Grasp both sides of the front bezel and pull it off the drawer.
5. Push the release latch to the left and pull out the CD-ROM.

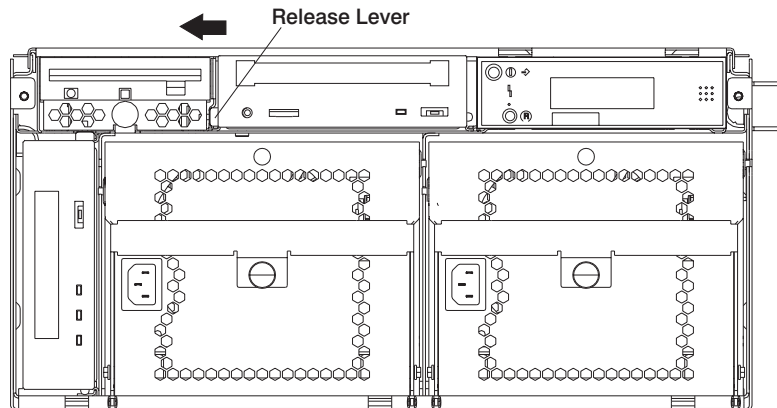

6. Disconnect the cables from the CD-ROM.

7. Remove the screws that connect the carrier to the CD-ROM.

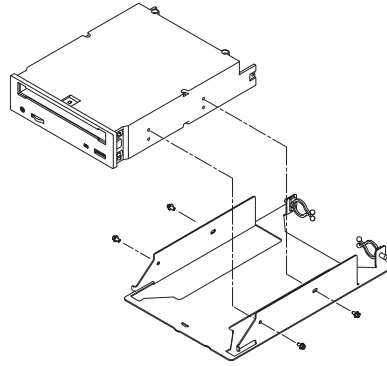

## Replacement

Replace in reverse order.

---

## Tape Drive

### Removal

1. Turn off power as described in “Powering Off the System” on page 469.
2. If you have not already done so, open the front door of the rack unit.
3. Loosen the two thumbscrews that attach the front bezel to the I/O drawer.
4. Grasp both sides of the front bezel and pull it off the drawer.
5. Push up on the release latch and pull the tape drive out.

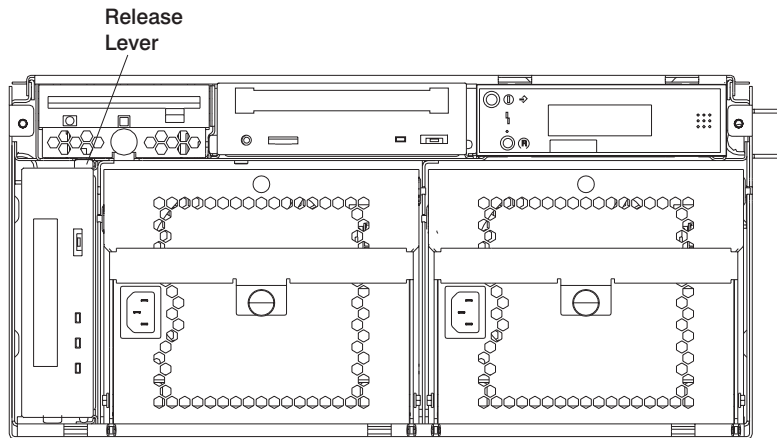

6. Disconnect the cables from the tape drive.
7. Remove the screws that connect the carrier to the tape drive.

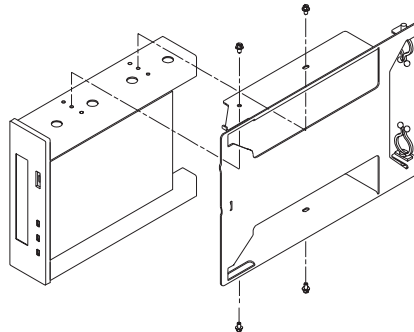

### Replacement

Replace in reverse order.

---

## Diskette Drive

### Removal

1. Turn off power as described in "Powering Off the System" on page 469.
2. If you have not already done so, open the front door of the rack unit.
3. Loosen the two thumbscrews that attach the front bezel to the I/O drawer.
4. Grasp both sides of the front bezel and pull it off the drawer.
5. Pull out on the snap button and pull the diskette drive out.

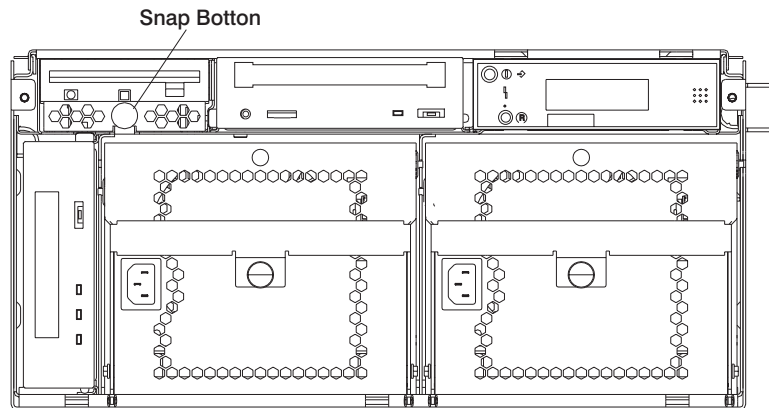

6. Disconnect the cables from the diskette drive.
7. Remove the screws that connect the carrier to the diskette drive.

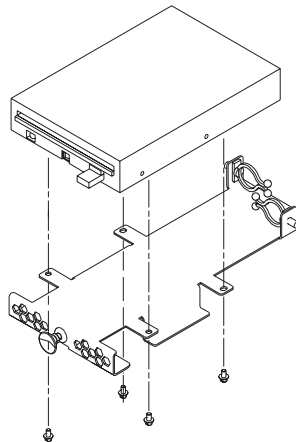

### Replacement

Replace in reverse order.

---

## Operator Panel

### Removal

1. Turn off power as described in “Powering Off the System” on page 469.
2. Place the I/O drawer in the front service position as described in “Front Service Position” on page 520.
3. Loosen the two retaining screws that attach the front bezel to the drawer.
4. Grasp both sides of the front bezel and pull it off the drawer.
5. Place the drawer in the front service position as described in “Front Service Position” on page 520.
6. Remove the two screws **(1)** from the top of the operator panel.

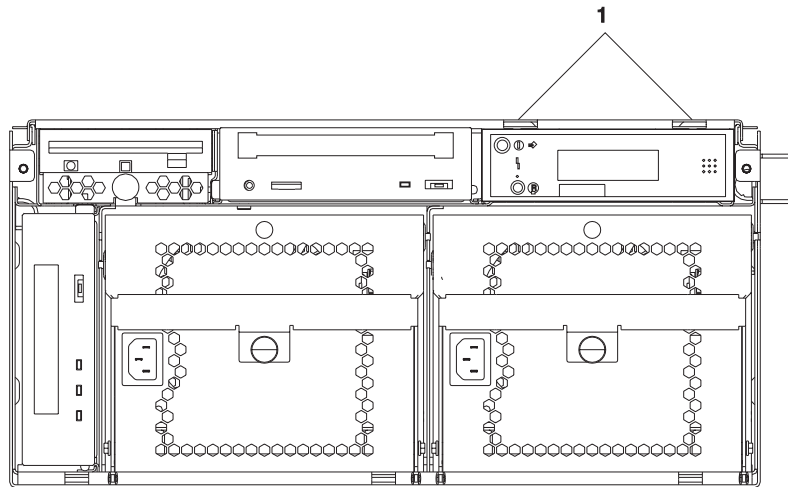

7. Pull out the operator panel.
8. Disconnect the cables from the operator panel.

9. Remove the operator panel from the mounting bracket.

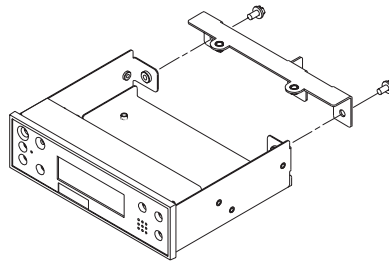

## Replacement

1. Remove the VPD module from the old operator panel and insert it in the new operator panel. Make sure you insert the module in the same position as it was in the old panel.

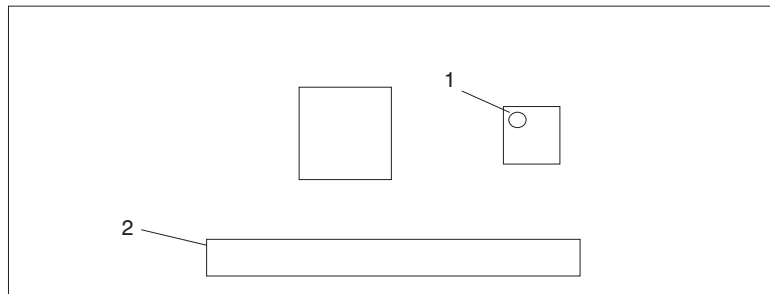

- 1 VPD Module
- 2 Cable Connector

2. To replace, perform removal steps in reverse order.



---

## Rear Service Position

To place a drawer in the rear service position, do the following:

1. If you have not already done so, open the front door of the rack unit.
2. Loosen the two thumbscrews that attach the front bezel to the drawer.
3. Grasp both sides of the front bezel and pull it off the drawer.
4. If you have not already done so, open the rear door of the rack unit.
5. If present, remove two screws securing the drawer to the rack.

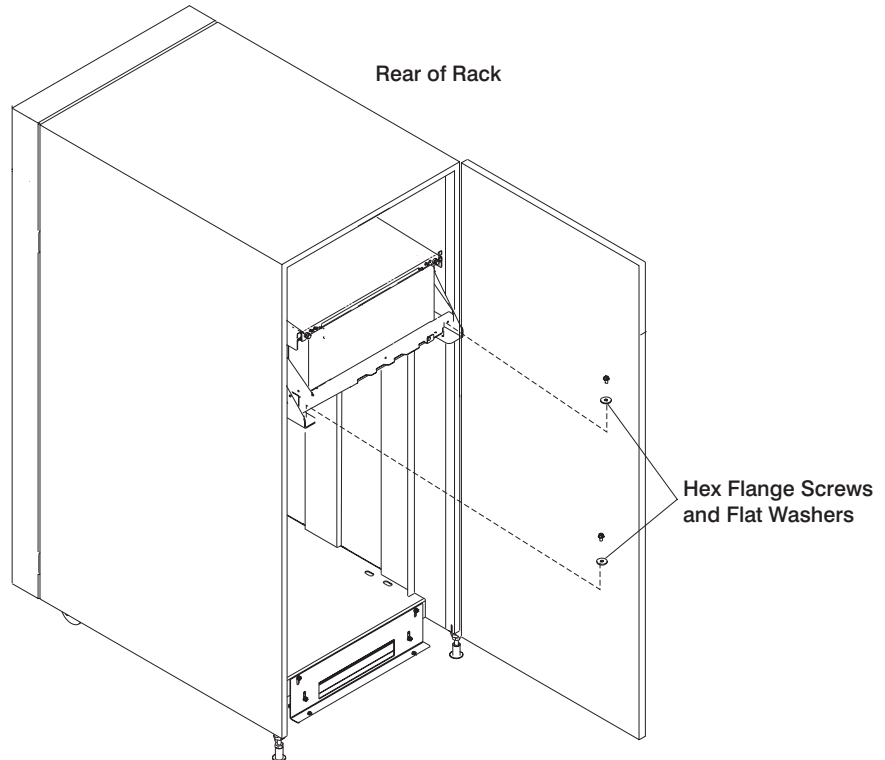

6. Grasp the bar at the rear of the drawer, and pull the drawer to the rear until it is stopped by the two detents.

---

## Front Service Position

To place a drawer in the front service position, do the following:

**Attention:** Do not pull the drawer out from the front. The drawer must be pushed to the front service position from the rear of the system.

1. If you have not already done so, open the front door of the rack unit.
2. Loosen the two thumbscrews that attach the front bezel to the drawer.
3. Grasp both sides of the front bezel and pull it off the drawer.
4. Remove the screws that attach the left and right retaining brackets and remove the brackets.
5. If you have not already done so, open the rear door of the rack unit.
6. If present, remove two screws securing the drawer to the rack. Refer to "Rear Service Position" on page 519.
7. Push the drawer forward until it is stopped by the two detents.

---

## Battery

### Removal

#### CAUTION:

A lithium battery can cause fire, explosion, or severe burn. Do not recharge, disassemble, heat above 100°C (212°F), solder directly to the cell, incinerate, or expose cell contents to water. Keep away from children. Replace only with the part number specified for your system. Use of another battery may present a risk of fire or explosion.

The battery connector is polarized; do not attempt to reverse polarity.

Dispose of the battery according to local regulations.

1. Place the I/O drawer in the rear service position, as described in “Rear Service Position” on page 519.
2. Remove the two thumbscrews and remove the back top cover.
3. Locate the battery on the PCI board.

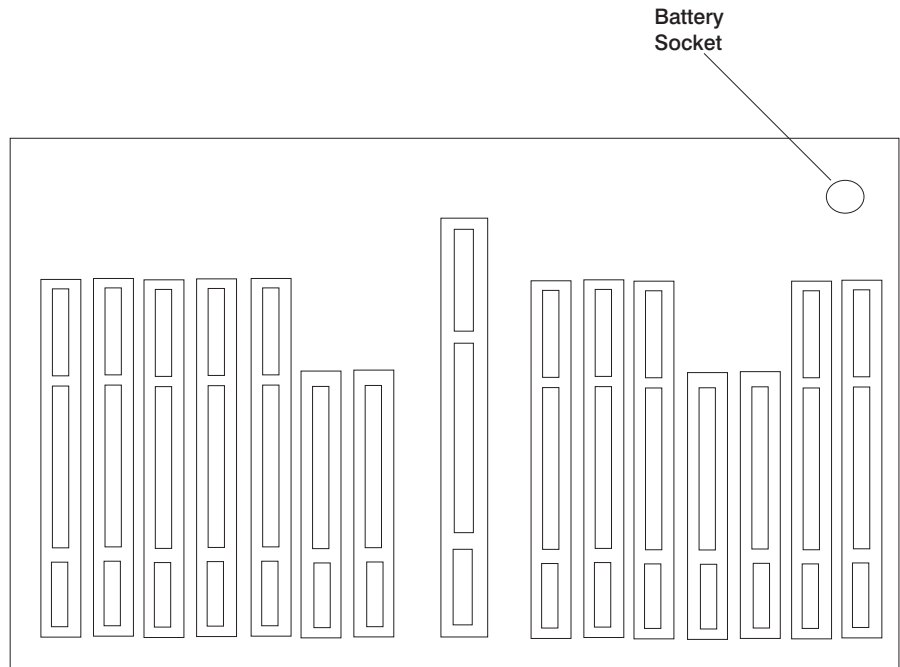

4. Remove any adapters or DASD in slots 13 and 14 to gain access to the battery.
5. Use one finger to gently slide the battery away from the notch in the battery socket. Then use your thumb and index finger to hold the battery as it pushes out of the socket. (The spring mechanism behind the battery pushes it out.)

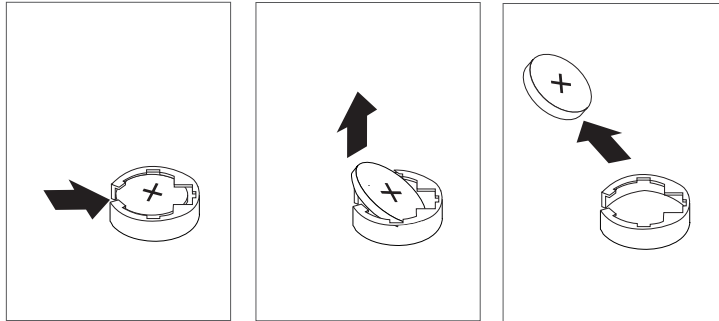

## Replacement

Tilt the battery so that you can insert it into the battery socket. Slide the battery into the battery socket, then push it down into the socket.

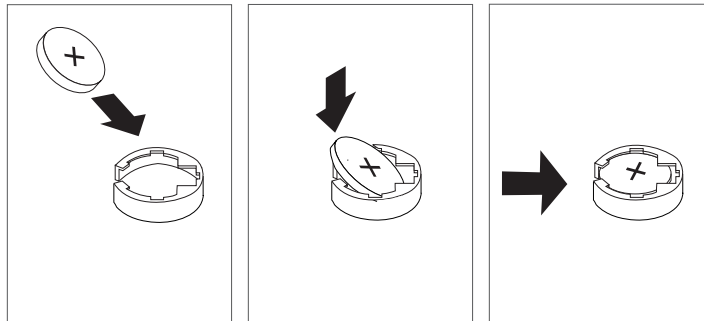

### Notes:

1. Be sure to tell the customer to reset the time and date.
2. Ensure that the battery polarity is correct; place the battery in the socket with the positive side facing upward.

---

## **Chapter 11. Parts Information**

This chapter contains parts information for the system.

# CEC Drawer Card Assembly

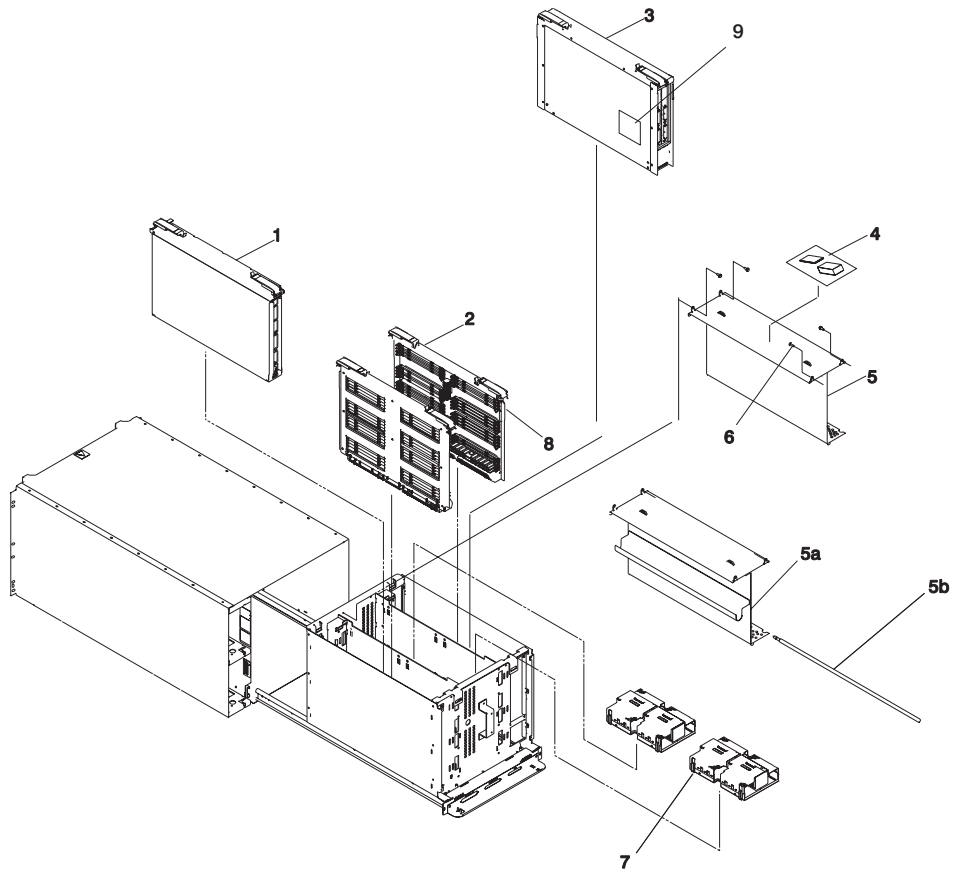

Index	Part Number	CCIN Number	Units Per Assy	Description
1	24L0965 OR 24L0964 OR 21P6270	27AB 267D	1	2-way / 4-way regulator assembly OR 6-way / 8-way regulator assembly OR 8-way 750 MHz regulator assembly
2	04N3033	288A	Up to 2	Memory riser card
3	04N3867	2733	1	RIO card assembly
4	04N3959		1	Orientation label
5	24L0971		1	Cover processor air flange
5a	21P6357		1	Cover processor air flange (-48 vdc systems only)
5b	21P6356		1	Jackscrew (-48 vdc systems only)
6	1621811		4	Screw cover
7	04N6930	24A5	Up to 2	2-way 500 MHz processor
	04N6931	24A6	Up to 2	4-way 500 MHz processor
	53P1089	25B4	Up to 2	2-way 750 MHz processor
	53P1090	25B3	Up to 2	4-way 750 MHz processor
8	07L7729		Up to 32	32 MB DIMM
	93H4702		Up to 32	128 MB DIMM
	09L5585		Up to 32	128 MB DIMM
	07L9030		Up to 32	256 MB DIMM
	10L5417		Up to 32	512 MB DIMM F/C 4131 (Cannot be mixed with F/C 4100 in an octal)
	07L9758		Up to 32	512 MB DIMM F/C 4100 (Cannot be mixed with F/C 4131 in an octal)
	09P0466		Up to 32	1 GB DIMM
	44H8167		Up to 32	Memory DIMM filler
9	04N4831  21P6148	25DA  25B1	1	500 MHz clock card  750 MHz clock card  (See "CEC RIO Bus Adapter" on page 493 for replacement procedure.)

## CEC Drawer Backplane

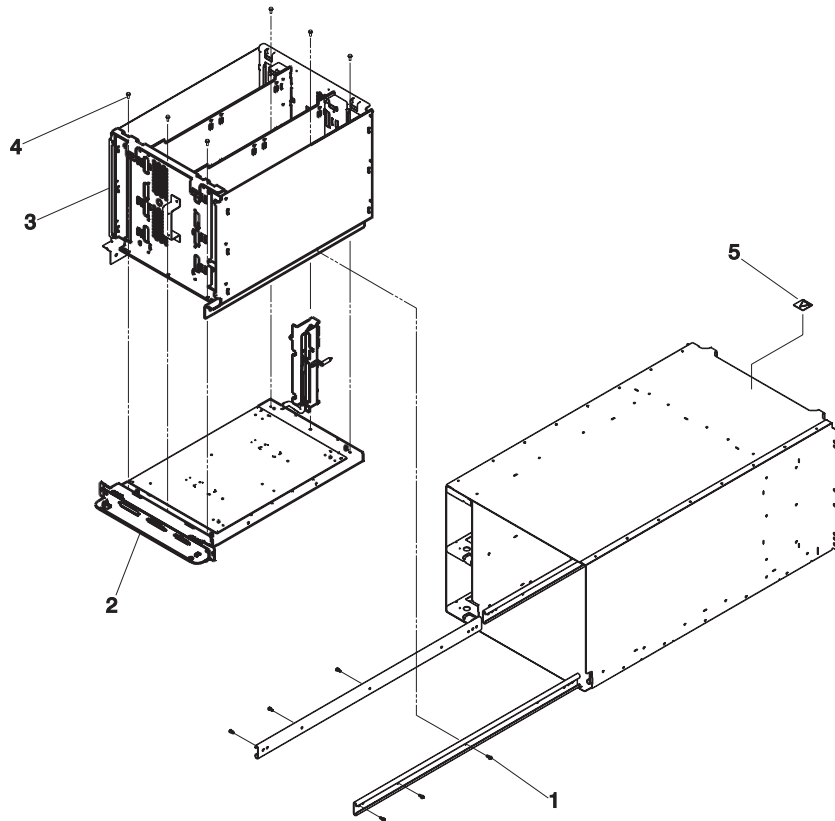



<b>Index</b>	<b>Part Number</b>	<b>CCIN Number</b>	<b>Units Per Assy</b>	<b>Description</b>
1	42L0972		6	CEC MTG screw
2	04N6572	281C	1	500MHz backplane/stiffener assembly
2	04N3524	281D	1	750MHz backplane/stiffener assembly
3	24L0972		1	CEC cage assembly
4	1621813		6	Cage/stiffener screw
5	05L0066		1	Weight warning label

## CEC Drawer Power Supplies

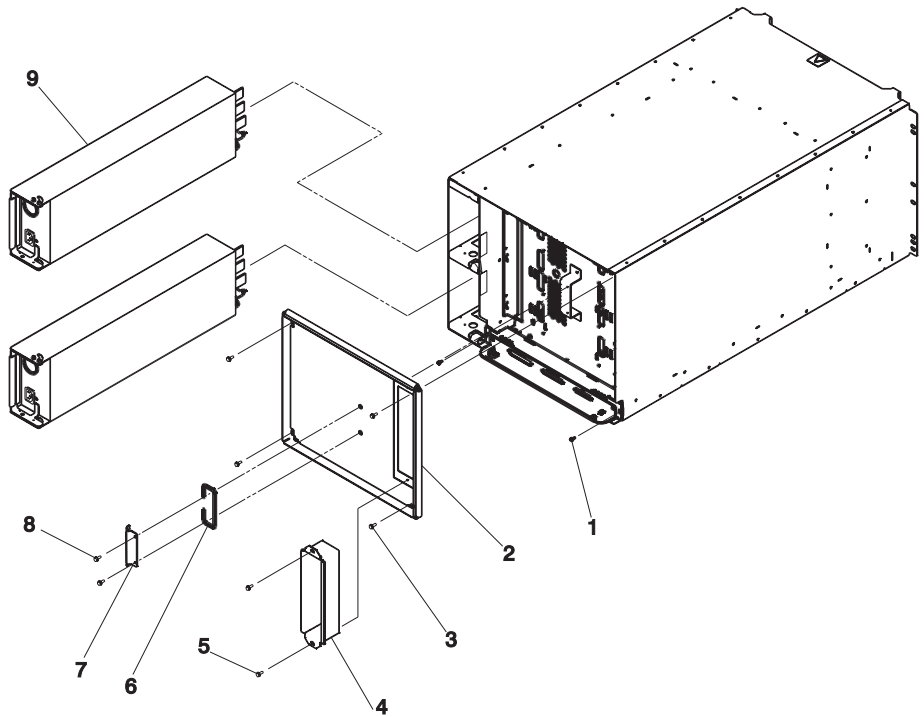

<b>Index</b>	<b>Part Number</b>	<b>Units Per Assy</b>	<b>Description</b>
1	75G2878	2	CEC cage MTG screw
2	24L0774	1	Rear EMC shield
3	1621811	4	EMC shield screw
4	90H9196	1	EMC tunnel
5	24L2643	2	EMC tunnel screw
6	90H9196	1	CEC handle rod
7	24L2643	1	CEC handle bracket
8	1621807	2	CEC handle screw
9	24L0728 44L0045	Up to 2 Up to 2	ac power supply (1100W) dc power supply (1100W)

## CEC Drawer Fan Assemblies

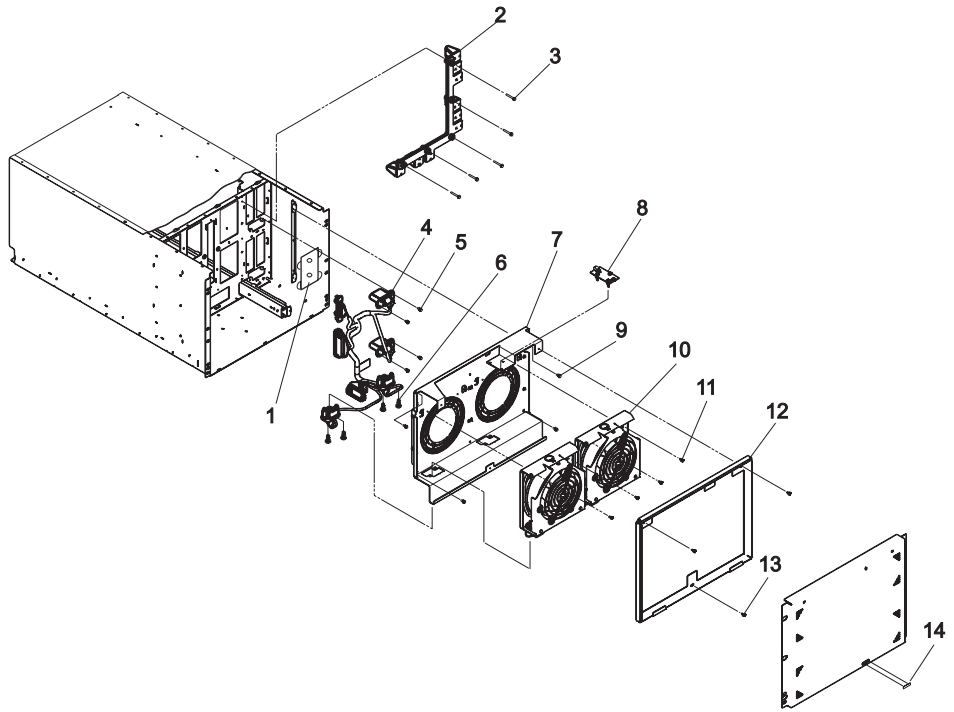

<b>Index</b>	<b>Part Number</b>	<b>Units Per Assy</b>	<b>Description</b>
1	90H6641	1	SPCN bracket
2	24L0888	1	Busbar, power distribution unit
3	1621817	5	Busbar screws
4	97H7471	1	Power harness
5	1621811	4	Fan-mounting screw
6	90H6284	1	Shoulder screw power harness
7	24L0883	1	Fan-mounting assembly
8	44L0026	1	LED board assembly
9	1621811	4	Fan-mounting screw
10	04N3345	2	Digital fan assembly
11	44H8681	4	Fan-mounting screw
12	24L0775	1	Front EMC shield
13	44H8681	3	Front EMC screw
14	21H7141	1	Security label

# I/O Drawer

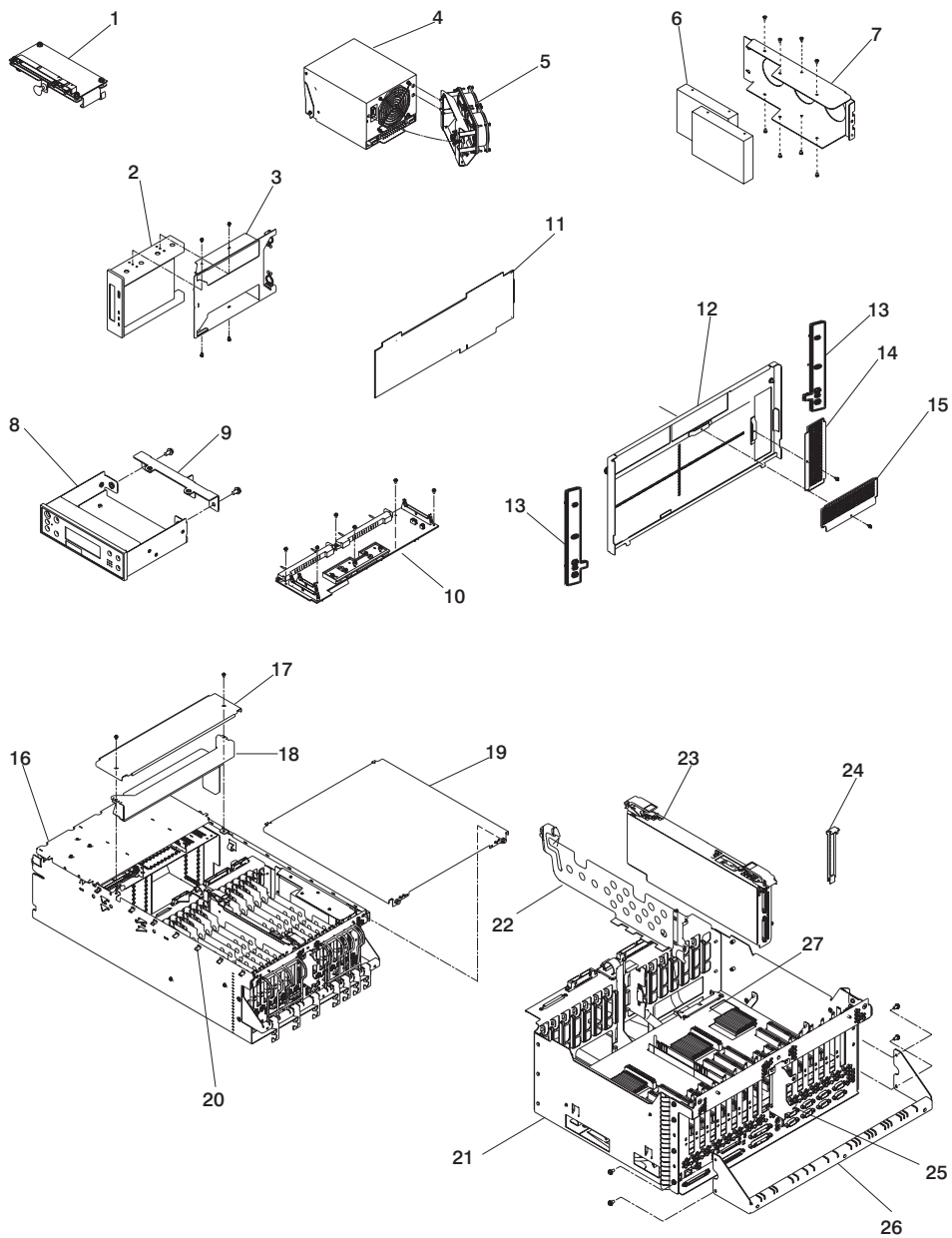

Index	Part Number	CCIN Number	Units Per Assy	Description
1	11K1107		1	Fan controller card
2	See note		1	Tape drive
3	41L5691		1	Tape drive carrier
4	11K0812		Up to 2	AC power supply (595 watt)
	41L5413		Up to 2	DC power supply
	03N2829		1	Cooling unit (Power supply filler)
5	41L5448		1	Fan assembly
6	See note		Up to 2	Disk drive
7	03N2897		1	Disk drive mounting bracket
8	24L1089		1	Primary operator panel
	24L0955		1	Secondary operator panel
9	03N2965		1	Operator panel bracket
10	00P2382		1	Power distribution board
11	See note		Up to 14	Adapter card
12	03N3176		1	Bezel (ac systems)
	00P1746		1	Bezel OEM (ac systems)
	03N3610		1	Bezel (dc systems)
	09P0751		1	Bezel OEM (dc systems)
13	11K0358		2	Trim/ship bracket
14	03N3253		1	Bezel blank (tape drive)
	59H4118		1	Bezel black (tape drive)
	94H0136		1	Bezel (tape drive)
15	03N3253		1	Bezel blank (CD-ROM)
	97H7611		1	Bezel black (CD-ROM)
16	11K0207		1	Chassis
17	41L5206		1	Center cover
18	11K0243		1	Cable tray
19	41L5208		2	Back cover
20	11K0868		14	Clip (AC cord)
21	41L5560		1	Primary I/O tray assembly
	41L5561		1	Secondary I/O tray assembly
22	44L0041		13	I/O divider
23	04N6907	2691	1	RIO card assembly
24	03K8992		As required	I/O blanks
25	11K0584		1	RIO cable bracket
26	09P4061		1	Tie bar
27	16G8095		1	Battery
	21P5041		1	SP Control W/S Adapter
	21P6323		1	SAMI CABLE, internal
<b>Note:</b>				
See RS/6000 and @server pSeries Diagnostic Information for Multiple Bus Systems for part numbers.				

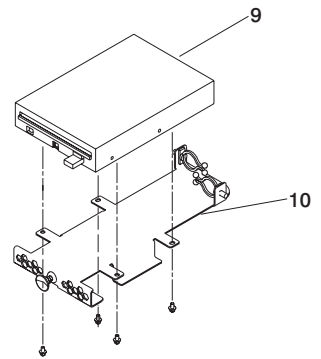
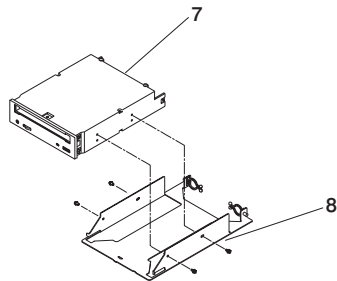
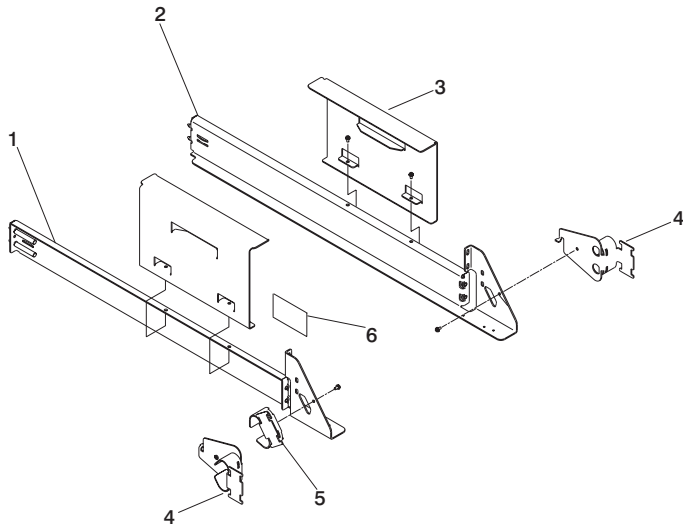



Index	Part Number	Units Per Assy	Description
1	03N3845	1	Left rail assembly
2	03N3847	1	Right rail assembly
3	09P0327	2	Anti-tip bracket
4	00P2402	2	Channel cable bracket (T00 Rack)
5	11K0826	2	Channel cable bracket (S00 Rack)
6	11K0851	1	Reset bracket
7	See note	2	CD-ROM drive
8	41L5691	1	CD-ROM carrier
9	76H4091	1	Diskette drive
10	41L5688	1	Diskette drive carrier
	00G1268	As required	Screw - M4
	33G3907	As required	Screw - M3
<b>Note:</b>			
See <i>RS/6000 and @server pSeries Diagnostic Information for Multiple Bus Systems</i> for part numbers.			

# CEC Drawer Internal Cables

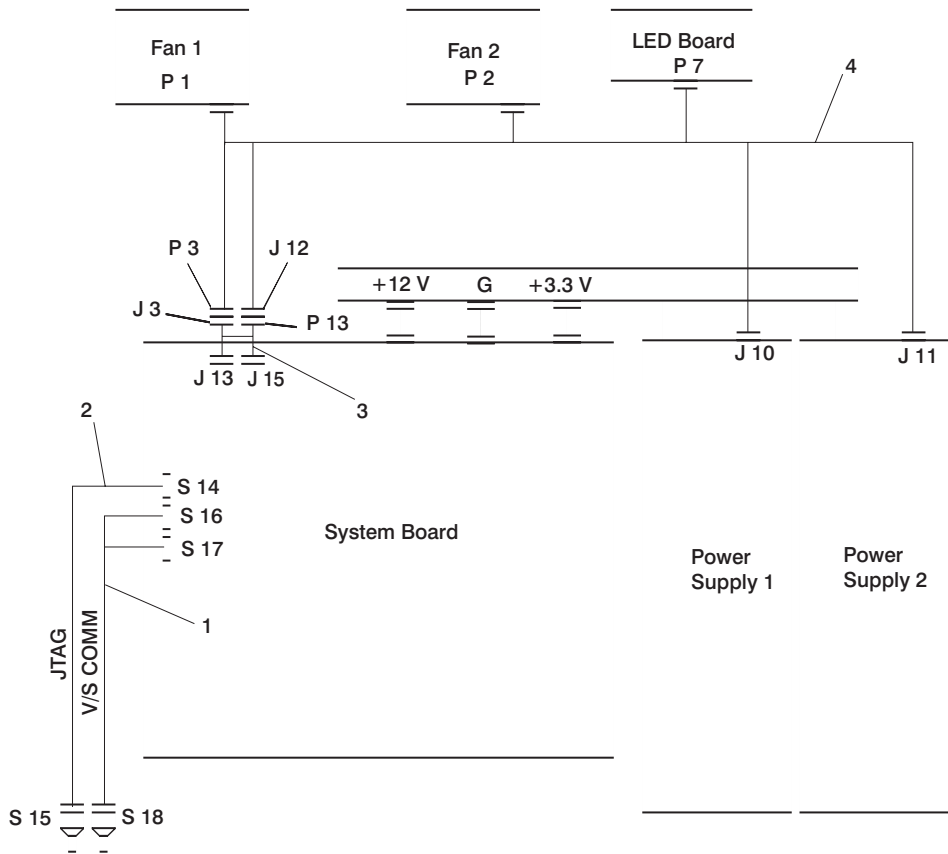

<b>Index</b>	<b>Part Number</b>	<b>Units Per Assy</b>	<b>Description</b>
1	97H7603	1	V/S COMM power cable
2	97H7600	1	JTAG power cable
3	97H7472	1	Miscellaneous power cable
4	97H7471	1	Miscellaneous power cable

# Primary I/O Drawer Cables

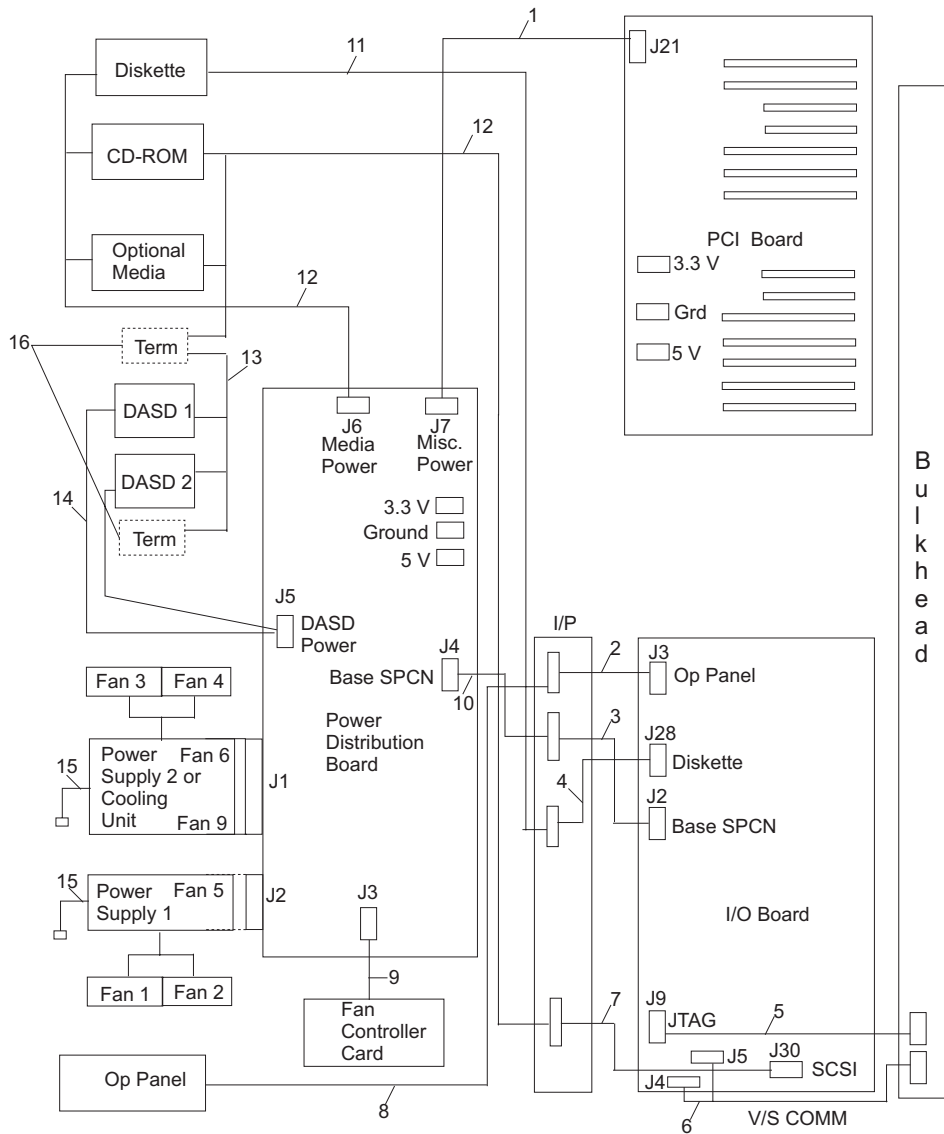

Index	Part Number	Units Per Assy	Description
1	03N3040	1	Misc. power cable (PDB to PCI board)
2	41L5517	1	Operator Panel Cable (I/O board to I/P)
3	41L5518	1	Base SPCN Cable (I/O board to I/P)
4	41L5516	1	Diskette Cable (I/O board to I/P)
5	41L5946	1	JTAG Cable (I/O board to bulkhead)
6	41L5521	1	V/S COMM Cable (I/O board to bulkhead)
7	41L5519	1	Internal SCSI (I/O board to I/P)
8	41L5649	1	Operator Panel Cable (I/P to Op panel)
9	42L5652	1	Fan Cont. Card Cable (PDB to FCC)
10	41L5650	1	Base SPCN Cable (I/P to PDB)
11	41L5522	1	Diskette Cable (I/P to diskette)
12	11K0233	1	Internal SCSI Cable (signal and power)
13	00P1676	1	Internal SCSI Cable (Int. to IPL DASD)
	09P1709	1	Internal/external SCSI Cable (Ext. SCSI adapter to IPL DASD)
14	09P1449	1	DASD power cable (PDB to IPL DASD)
15	34G0240	Up to 2	ac power cable
	00P1799	Up to 2	dc power cable
16	88G3977	1	SCSI Terminator

## Secondary I/O Drawer Cables

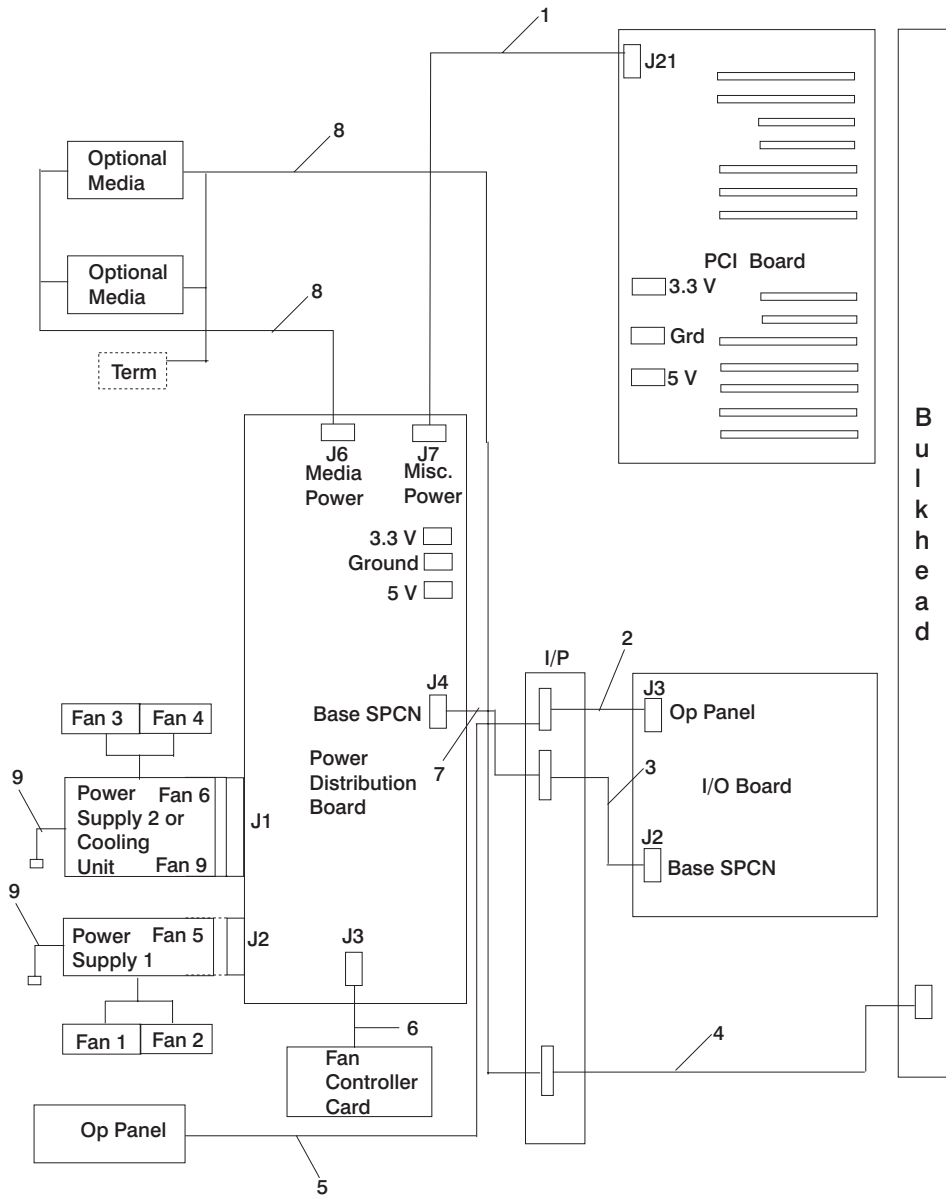

<b>Index</b>	<b>Part Number</b>	<b>Units Per Assy</b>	<b>Description</b>
1	03N3040	1	Misc. power cable (PDB to PCI board)
2	41L5517	1	Operator panel cable (I/O board to I/P)
3	41L5518	1	Base SPCN cable (I/O board to I/P)
4	03N3448	1	SCSI cable (bulkhead to I/P)
5	41L5649	1	Operator panel cable (I/P to Op panel)
6	41L5652	1	Fan cont. card cable (PDB to FCC)
7	41L5650	1	Base SPCN cable (I/P to PDB)
8	11K0233	1	Internal SCSI cable (signal and power)
9	34G0240	Up to 2	ac power cable
	00P1799	Up to 2	dc power cable

## External Cables

FRU Part Number	Units Per Assy	Description
21H7375	1	JTAG cable 3-meter
44L0033	1	V/S COMM cable 3-meter
97H7328	1	V/S COMM cable 6-meter
44L0005	Up to 6	RIO cable 3-meter
97H7490	Up to 6	RIO cable 6-meter
04N7014	Up to 6	RIO cable 15-meter
09P1251	Up to 3	SPCN cable 3-meter
21F9469	Up to 3	SPCN cable 6-meter
21F9358	Up to 3	SPCN cable 15-meter
1614920	4	JTAG cable standoff (CEC and primary I/O drawer)
46G3537	4 to 16	RIO cable standoff (I/O drawer)
44H7478	4	V/S COMM cable standoff (CEC and primary I/O drawer)
44H7478	8	RIO cable standoff (CEC drawer)
62X0388	20	Primary I/O drawer: parallel cable standoff debug cable standoff serial cable standoff SPCN cable standoff
62X0388	8 to 24	Secondary I/O drawer: SPCN cable standoff
07L7411	2 to 8	External SCSI cable standoff (I/O drawer)
09P1716	0 to 1	Internal disk to external SCSI connector cable (FC 3139)
76H0518	0 to 1	Converter cable, VHDCI to P, Mini 68-pin to 68-pin, 0.3M (FC 2118)
52G4291	0 to 1	Cable SCSI, 0.6M, 68-pin (P-type) to 68-pin (P-type), SE or DIFF (FC 2424)
52G4233	0 to 1	Cable SCSI, 2.5M, 68-pin (P-type) to 68-pin (P-type), SE or DIFF (FC 2425)



## Keyboards and Mouse



Index	FRU Part Number	Units Per Assy	Description
1	93H8120	1	Keyboard, 101 United States English (ID 103P)
	93H8121	1	Keyboard, 102 Canada French (ID 058)
	93H8122	1	Keyboard, 102 Canada French (ID 445)
	93H8123	1	Keyboard, 102 Spanish (ID 171)
	93H8124	1	Keyboard, 104 Brazil Portuguese (ID 275)
	93H8125	1	Keyboard, 102 Arabic (ID 238)
	93H8126	1	Keyboard, 102 Belgium French (ID 120)
	93H8127	1	Keyboard, 102 Belgium (ID 120)
	93H8128	1	Keyboard, 102 Bulgarian (ID 442)
	93H8129	1	Keyboard, 102 Czech (ID 243)
	93H8130	1	Keyboard, 102 Danish (ID 159)
	93H8131	1	Keyboard, 102 Dutch (ID 143)
	93H8132	1	Keyboard, 102 French (ID 189)
	93H8133	1	Keyboard, 102 German (ID 129)
	93H8134	1	Keyboard, 102 Greek (ID 319)
	93H8135	1	Keyboard, 101 Hebrew (ID 212)
	93H8136	1	Keyboard, 102 Hungarian (ID 208)
	93H8137	1	Keyboard, 102 Iceland (ID 197)

<b>Index</b>	<b>FRU Part Number</b>	<b>Units Per Assy</b>	<b>Description</b>
	93H8138	1	Keyboard, 102 Italy (ID 142)
	93H8139	1	Keyboard, 102 Norwegian (ID 155)
	93H8140	1	Keyboard, 102 Polish (ID 214)
	93H8141	1	Keyboard, 102 Portuguese (ID 163)
	93H8142	1	Keyboard, 102 Romanian (ID 446)
	93H8143	1	Keyboard, 101 Russian (ID 443)
	93H8144	1	Keyboard, 102 Serbian (ID 118)
	93H8145	1	Keyboard, 102 Slovak (ID 245)
	93H8146	1	Keyboard, 102 Spanish (ID 172)
	93H8147	1	Keyboard, 102 Sweden/Finland (ID 153)
	93H8148	1	Keyboard, 105 Swiss F/G (ID 150)
	93H8149	1	Keyboard, 102 Turkish (ID 179)
	93H8150	1	Keyboard, 102 Turkish (ID 440)
	93H8151	1	Keyboard, 102 UK English (ID 166)
	93H8152	1	Keyboard, 102 Latvia (ID 234)
	93H8153	1	Keyboard, US English ISO9995 (ID 103P)
	93H8154	1	Keyboard, 106 Japan (ID 194)
	93H8155	1	Keyboard, 101 Chinese/US (ID 467)
	93H8156	1	Keyboard, 103 Korea (ID 413)
	93H8157	1	Keyboard, 101 Thailand (ID 191)
2	76H5084	1	Three Button Mouse

## Keyboards and Mouse (Black)



Index Number	FRU Part Number	Units Per Assy	Description
1	07L9446	1	Keyboard, 101 United States English (ID 103P)
	07L9447	1	Keyboard, 102 Canada French (ID 058)
	07L9448	1	Keyboard, 102 Canada French (ID 445)
	07L9449	1	Keyboard, 102 Spanish (ID 171)
	07L9450	1	Keyboard, 104 Brazil Portuguese (ID 275)
	07L9451	1	Keyboard, 102 Arabic (ID 238)
	07L9452	1	Keyboard, 102 Belgium French (ID 120)
	07L9453	1	Keyboard, 102 Belgium (ID 120)
	07L9454	1	Keyboard, 102 Bulgarian (ID 442)
	07L9455	1	Keyboard, 102 Czech (ID 243)
	07L9456	1	Keyboard, 102 Danish (ID 159)
	07L9457	1	Keyboard, 102 Dutch (ID 143)
	07L9458	1	Keyboard, 102 French (ID 189)
	07L9459	1	Keyboard, 102 German (ID 129)
	07L9460	1	Keyboard, 102 Greek (ID 319)
	07L9461	1	Keyboard, 101 Hebrew (ID 212)
	07L9462	1	Keyboard, 102 Hungarian (ID 208)
	07L9463	1	Keyboard, 102 Iceland (ID 197)
	07L9464	1	Keyboard, 102 Italy (ID 142)
	07L9465	1	Keyboard, 102 Norwegian (ID 155)
	07L9466	1	Keyboard, 102 Polish (ID 214)
	07L9467	1	Keyboard, 102 Portuguese (ID 163)
	07L9468	1	Keyboard, 102 Romanian (ID 446)
	07L9469	1	Keyboard, 101 Russian (ID 443)
	07L9470	1	Keyboard, 102 Serbian (ID 118)
	07L9471	1	Keyboard, 102 Slovak (ID 245)
	07L9472	1	Keyboard, 102 Spanish (ID 172)

<b>Index Number</b>	<b>FRU Part Number</b>	<b>Units Per Assy</b>	<b>Description</b>
	07L9473	1	Keyboard, 102 Sweden/Finland (ID 153)
	07L9474	1	Keyboard, 105 Swiss F/G (ID 150)
	07L9475	1	Keyboard, 102 Turkish (ID 179)
	07L9476	1	Keyboard, 102 Turkish (ID 440)
	07L9477	1	Keyboard, 102 UK English (ID 166)
	07L9478	1	Keyboard, 102 Latvia (ID 234)
	07L9479	1	Keyboard, US English ISO9995 (ID 103P)
	07L9480	1	Keyboard, 106 Japan (ID 194)
	07L9481	1	Keyboard, 101 Chinese/US (ID 467)
	07L9482	1	Keyboard, 103 Korea (ID 413)
	07L9483	1	Keyboard, 101 Thailand (ID 191)
2	08L0362	1	Three Button Mouse (Black)

---

## Appendix A. Environmental Notices

---

### Product Recycling and Disposal

This unit contains materials such as circuit boards, cables, electromagnetic compatibility gaskets and connectors which may contain lead and copper/beryllium alloys that require special handling and disposal at end of life. Before this unit is disposed of, these materials must be removed and recycled or discarded according to applicable regulations. IBM offers product-return programs in several countries. For country specific instructions refer to the following web site:  
<http://www.ibm.com/ibm/environment/products/prp.phtml>

**This product may contain a sealed lead acid, nickel cadmium, nickel metal hydride, lithium, or lithium ion battery. Consult your user manual or service manual for specific battery information. The battery must be recycled or disposed of properly. Recycling facilities may not be available in your area. For information on disposal of batteries, contact your local waste disposal facility.**

In the United States, IBM has established a collection process for reuse, recycling, or proper disposal of used IBM sealed lead acid, nickel cadmium, nickel metal hydride, and other battery packs from IBM Equipment. For information on proper disposal of these batteries, please contact IBM at 1-800-426-4333. Have the IBM part number listed on the battery available prior to your call.

---

### Environmental Design

The environmental efforts that have gone into the design of this system signify IBM's commitment to improve the quality of its products and processes. Some of these accomplishments include the elimination of the use of Class 1 ozone-depleting chemicals in the manufacturing process and reductions in manufacturing wastes. For more information, contact an IBM account representative.

---

### Acoustical Noise Emissions

The equivalent continuous A-weighted sound pressure level at workstations (emission sound pressure level at the 1-meter bystander positions) does not exceed 70 dB(A).

Der Geräuschpegel der Einheit ist kleiner oder gleich 70 db(A).

## Declared Acoustical Noise Emissions

<b>Noise Emissions<sup>1</sup></b> With M80 CEC drawer only	<b>Operating</b>	<b>Idle</b>
$L_{WA_d}$	6.4 bels	6.4 bels
$L_{pA_m}$	N/A	N/A
$\langle L_{pA} \rangle_m$	48 dBA	48 dBA
Impulsive or prominent discrete tones	No	No
<b>Noise Emissions<sup>1</sup></b> With M80 and Primary I/O Drawer	<b>Operating</b>	<b>Idle</b>
$L_{WA_d}$	6.5 bels	6.5 bels
$L_{pA_m}$	N/A	N/A
$\langle L_{pA} \rangle_m$	49 dBA	49 dBA
Impulsive or prominent discrete tones	No	No
<b>Noise Emissions<sup>2</sup></b>	<b>Operating</b>	<b>Idle</b>
$L_{WA_d}$	5.8 bels	5.8 bels
$L_{pA_m}$	N/A	N/A
$\langle L_{pA} \rangle_m$	45 dBA	45 dBA
Impulsive or prominent discrete tones	No	No

1. Noise emissions data are based on the following configuration: the drawer is mounted in a 7014 Series Model T00 Rack, a power distribution unit is installed in the rack, and the system is operating in a normal environment of 25 °C (78 °F).
2. Noise emissions data are based on the following configuration: the drawer is mounted in a 7014 Series Model T00 Rack and a power distribution unit is installed in the rack.

### Noise Emission Notes

1.  $L_{WA_d}$  is the declared (upper limit) sound power emission level for a production series of machines.
2.  $L_{pA_m}$  is the mean value of the A-weighted sound pressure emission levels at the operator position (if any) for a production series of machines.
3.  $\langle L_{pA} \rangle_m$  is the mean value of the space-averaged A-weighted sound pressure emission levels at the one-meter positions for a production series of machines.
4. N/A = Not Applicable (no operator position).
5. All measurements are made in accordance with ISO 7779 and reported in conformance with ISO 9296.

---

## Appendix B. Notices

This information was developed for products and services offered in the U.S.A.

The manufacturer may not offer the products, services, or features discussed in this document in other countries. Consult the manufacturer's representative for information on the products and services currently available in your area. Any reference to the manufacturer's product, program, or service is not intended to state or imply that only that product, program, or service may be used. Any functionally equivalent product, program, or service that does not infringe any intellectual property right of the manufacturer may be used instead. However, it is the user's responsibility to evaluate and verify the operation of any product, program, or service.

The manufacturer may have patents or pending patent applications covering subject matter described in this document. The furnishing of this document does not give you any license to these patents. You can send license inquiries, in writing, to the manufacturer.

**The following paragraph does not apply to the United Kingdom or any country where such provisions are inconsistent with local law: THIS MANUAL IS PROVIDED "AS IS" WITHOUT WARRANTY OF ANY KIND, EITHER EXPRESSED OR IMPLIED, INCLUDING, BUT NOT LIMITED TO, THE IMPLIED WARRANTIES OF NON-INFRINGEMENT, MERCHANTABILITY OR FITNESS FOR A PARTICULAR PURPOSE. Some states do not allow disclaimer of express or implied warranties in certain transactions; therefore, this statement may not apply to you.**

This information could include technical inaccuracies or typographical errors. Changes are periodically made to the information herein; these changes will be incorporated in new editions of the publication. The manufacturer may make improvements and/or changes in the product(s) and/or the program(s) described in this publication at any time without notice.

Information concerning products made by other than the manufacturer was obtained from the suppliers of those products, their published announcements, or other publicly available sources. The manufacturer has not tested those products and cannot confirm the accuracy of performance, compatibility or any other claims related to products made by other than the manufacturer. Questions on the capabilities of products made by other than the manufacturer should be addressed to the suppliers of those products.





---

## Appendix C. Service Processor Setup and Test

For your convenience, an example of a basic service processor setup checklist is included here. Your setup may include more or fewer of the available features, so you can adjust this checklist for your own application so that it is helpful to you.

---

### Service Processor Setup Checklist

1. Unplug the power cord from the server.
2. Attach a local terminal for this setup procedure.
3. Plug in the system and power on the local terminal.  
**Attention:** Make sure that system power remains off.
4. Start the service processor menus. See Chapter 8, “Using the Service Processor” on page 411.
5. Set the system name. See “Privileged User Menus” on page 414.
6. Enable surveillance. See “Service Processor Functions” on page 438.
7. Configure Call-In/Call-Out. See “Call-In/Call-Out Setup Menu” on page 432.
8. Exit the service processor menus.
9. Unplug the power cord from the system.
10. Attach modems (if needed). See “Accessing the Service Processor Menus Remotely” on page 412.
11. Plug in the system.  
**Attention:** Make sure that the system power remains off.
12. Test both of the following:
  - Call-In, see “Testing Call-In” on page 552
  - Call-Out, see “Testing Call-Out” on page 552
13. Use the “Save or Restore Hardware Management Policies,” in the “Introduction to Tasks and Service Aids” section of the *RS/6000 and @server pSeries Diagnostic Information for Multiple Bus Systems* to back up the service processor settings.  
  
**Note:** This step is strongly recommended to protect the usefulness of the service processor and the availability of the server.

Your service processor is now ready for use.

---

## Testing the Setup

This section contains sample testing procedures to help ensure that your setup is working.

These tests include communicating with the server operating system. Before you start, ensure that the necessary serial port(s) is configured. If you need assistance, refer to “Serial Port Configuration” on page 553.

The server should be powered off as a result of the “Service Processor Setup Checklist” on page 551.

## Testing Call-In

1. At your remote terminal, call in to your server. Your server answers and offers you the Service Processor Main Menu after requesting your privileged access password.
2. Select **System Power Control**.
3. Select **Power-On System**.  
When you are asked if you wish to continue powering on the system, type **Y**.
4. After the system firmware and operating system have initialized the server, the login prompt displays at your remote terminal if you set up Seamless Modem Transfer (refer to “Transfer of a Modem Session” on page 566 for more information). This may take several minutes. When the login prompt displays, you have successfully called the service processor.
5. Type `logout` to disconnect from the operating system. The message `No Carrier` displays on your remote terminal.
6. Call your server again. The operating system answers and offers you the login prompt. If these tests are successful, call-in is working.
7. Log in and type `shutdown` to shut down your server.
8. The message `No Carrier` displays on your remote terminal.

## Testing Call-Out

During the setup, you entered your phone numbers for the pager (on page 435) and customer voice (on page 435). These numbers are used for this test.

1. Your remote terminal is disconnected as a result of the Call-In test.
2. Call your server again.
3. At the service processor main menu, select **Call-In/Call-Out Setup** menu, then select **Call-Out** test. This action causes a simulated error condition for the purposes of this test.
4. After a few moments, a message displays, regarding an illegal entry. Press `Enter` to clear the message and return to the main menu.
5. When your telephone rings, answer the call. You should hear the sound of a telephone being dialed. Your computer is trying to page you.

If this test is successful, call-out is working correctly.

Return to the “Telephone Number Setup Menu” on page 435 to enter the actual telephone numbers your server will use for reporting problems.

## Serial Port Configuration

To configure the serial port on an AIX system, run the following from an AIX console:

1. Log in as root user.
2. To determine if you have any serial ports already configured, type:

```
lsdev -Cc tty
```

If no serial ports are configured, none are listed. If you want to configure serial ports that are not listed, continue with the remaining steps.

3. Identify the serial port(s) with the modem(s).
4. Type `smit tty`
5. Select **add tty**
6. Select **RS232**
7. Select **Baud rate 9600** or higher.
8. Select **login enable** and set the flow control to RTS.
9. Commit the selections and set up any other needed serial ports.
10. Exit SMIT.



---

## Appendix D. Using the `chcod` Command

---

### Description

The `chcod` command manages the Capacity Upgrade on Demand feature, which allows configuration of more *ResourceType*, in this instance processors, on the system than were initially configured. The additional resources may be enabled if they are available, and if the system supports Capacity Upgrade on Demand for the specified *ResourceType*. Only one *ResourceType* can be managed at a time. The change in the number of *ResourceType* takes effect after the next system boot.

Capacity Upgrade on Demand management also includes displaying the current number of *ResourceType* that have Capacity Upgrade on Demand support, monitoring the number of *ResourceType* on the system, and notifying appropriately. Notification occurs when *NbrResources* changes and also on a periodic basis. Notification (in the form of error logging) is sent through Electronic Service Agent to the service support center. The *CustomerInfo* text is included in the error log.

The `chcod` command syntax is as follows:

```
chcod [-r ResourceType -n NbrResource] [-c CustomerInfo] [-h]
```

---

### Flags

**-c** *CustomerInfo*

Specifies the text string to include in the error log. *CustomerInfo* cannot be more than 255 characters in length. Blank spaces cannot be included in the string. After *CustomerInfo* has been specified, subsequent uses of the `chcod` command do not have to specify the `-c` flag, but you do have the option of changing it. *CustomerInfo* can consist of alphanumeric characters and any of "." (decimal point), "," (comma), "-" (hyphen), "(" (open parenthesis), or ")" (closed parenthesis). This flag is optional.

**-h** Displays the usage message. This flag is optional.

**-n** *NbrResources*

Specifies the number of *ResourceType* to be authorized on the system. The value for *NbrResources* should be entered in increments of 2. The number that is entered represents the total number of processors for the system. If you are adding the first additional processor board, the number should be 6, 8, 10, or 12. Each time a processor board is added, the total number of desired processors is entered. If the number is 0, Capacity on Demand will be disabled for the specified *ResourceType*. This flag is optional. If `-n` is specified, then `-r` must also be specified.

**-r** *ResourceType*

Specifies the *ResourceType* (proc for processors) to be enabled and monitored on the system. The system must support Capacity Upgrade on Demand for *ResourceType*. If `-r` is specified, then `-n` must also be specified.

The default for the **chcod** command (with no flags) displays the current value of *CustomerInfo*, a reserved field named *MailAddr*, the system's model name and serial number, and the current values for any *ResourceType*.

---

## Appendix E. Verifying Capacity Upgrade on Demand Processors

Capacity Upgrade on Demand data is stored in system hardware. If a system failure occurs where certain hardware must be replaced, the Capacity Upgrade on Demand data may be lost. Use the following procedures to ensure that the Capacity Upgrade on Demand data is restored (if necessary) after a service action.

---

### Determining Current Configuration

Before performing any other actions, use this procedure to determine the system configuration:

1. Log in to the system as root user or as a user with system group privileges.
2. Type the following at the command line:  
`chcod`
3. The configured Capacity Upgrade on Demand features are displayed. Make a note of the current configuration.

---

### Recovery Procedures

Perform any required service actions to repair the system. After the service action is complete, use the following procedure to check the Capacity Upgrade on Demand information and if necessary, return the system to its original configuration.

1. Log in to the system as root user or as a user with system group privileges.
2. Type the following at the command line:  
`chcod`
3. The configured Capacity Upgrade on Demand features are displayed. Compare the current configuration with the configuration you recorded earlier.

If the system configurations do not match, use the procedures beginning with “Installing a System with Capacity Upgrade on Demand” on page 405 to reinstall the Capacity Upgrade on Demand feature and reconfigure the hardware, as appropriate.

---

### Capacity Upgrade on Demand Diagnostics

Capacity Upgrade on Demand monitors its resources. Notification of the number of enabled devices is sent to the CUoD project office monthly and whenever the number of resources change.

Unauthorized devices cannot be tested by AIX diagnostics, nor do they appear when running the **lscfg** command on the NEW RESOURCE menu, or any AIX diagnostic task. For example, a system may have eight processors originally installed, but only six of the eight have been authorized for use. Diagnostics will only show the six authorized processors in the diagnostic test list or NEW RESOURCE list. The two unused processors cannot be tested by standalone and online diagnostics, and will not display in the diagnostic test list. However, they are tested by the power-on self-test (POST), and if a processor has failed, the failure is:

- Logged in the POST error log
- Logged in the AIX error log
- Reported at boot time by automatic error log analysis
- Reported if the sysplanar0 diagnostics are run

System Management Services and service processor menus are not affected by Capacity Upgrade on Demand and all processors are tested at boot time. If one processor failed at IPL, Capacity Upgrade on Demand still enables the number of authorized processors, having the remaining good processors marked as available for future capacity and the failed processors marked as failed. The customer can continue to run the system without degradation. However, in such a case, the failing processor card should be replaced at the customer's convenience to allow the customer to add capacity as needed.

Use the **chcod** command to manage Capacity Upgrade on Demand resources. It is also used to determine the number of resources that are authorized and the total number of resources installed.

## Testing the System in the Capacity Upgrade on Demand Environment

To test all the processors installed in a machine that has a Capacity Upgrade on Demand feature installed, do the following:

1. Log in to the system as root user or as a user with system group privileges.
2. To determine if Capacity Upgrade on Demand is currently enabled, type the following command:

```
chcod
```

Record the displayed information below:

Current MailAddress \_\_\_\_\_Reserved\_\_\_\_\_

Current CustInfo \_\_\_\_\_

Current Model and System ID = IBM, xxxx-\_\_\_\_\_IBM, \_\_\_\_\_

Current number of authorized proc(s) out of (xx\_\_\_\_) installed on system = (yy\_\_\_\_)

where (xx) is the number processors installed in the system, (yy) is the number of Capacity Upgrade on Demand-enabled processors.

If (yy) is equal to 0, then Capacity Upgrade on Demand is not enabled.

If (yy) is greater than 0, then Capacity Upgrade on Demand is enabled.

3. To enable testing of all the installed processors, disable Capacity Upgrade on Demand by setting the number \_of \_ processors (yy) equal to 0:

```
chcod -r proc -n 0
```

4. Shut down and reboot the system, as follows:

```
shutdown -Fr
```

5. To verify the installed processors, type the following at the command line:



```
bindprocessor -q
```

Information about installed processor boards displays.

- If two processor boards are installed, the available processors should be listed as 0 to 7.
  - If the number of installed processors is not correct, use the normal maintenance package procedures to correct any problems.
6. To test the system, type the following at the command line:  
diag
  7. Select **Advanced Diagnostics**.
  8. Select System Verification mode on sysplanar0 and all processors. Use the normal maintenance package procedures to correct any problems.
  9. When the system is ready to return to normal operations, reset the Capacity Upgrade on Demand feature, as follows:
    - a. Log in to the system as root user or as a user with system group privileges.
    - b. Type the following at the command line:  
chcod -r proc -n NbrResources  
  
where *NbrResources* is equal to the value of (yy) recorded in step 2 on page 558.
  10. Shut down and reboot the system, as follows:  
shutdown -Fr
  11. Allow the system to do a normal boot.



---

## Appendix F. Modem Configurations

The service processor is designed to place little demand on an attached modem, thereby increasing the setup and connection success rates.

---

### Sample Modem Configuration Files

This appendix contains information about several sample modem configuration files that either work directly with your modem or provide a good starting point for a custom setup.

The sample modem configuration files are located in your service processor firmware in the **/usr/share/modems** subdirectory (if your server is using AIX) with the following names. A listing of each specific file is included in this appendix.

### Generic Modem Configuration Files

AIX File Name	Service Processor Firmware File Name
modem_z.cfg	modem_z_sp
modem_z0.cfg	modem_z0_sp
modem_f.cfg	modem_f_sp
modem_f0.cfg	modem_f0_sp
modem_f1.cfg	modem_f1_sp

### Specific Modem Configuration Files

AIX File Name	Service Processor Firmware File Name
modem_m0.cfg	modem_m0_sp
modem_m1.cfg	modem_m1_sp

Use the following selection procedures and your modem manual to determine which of the configuration files is suitable for your use.

---

## Configuration File Selection

Use the following steps to select a configuration file:

1. Is your modem an IBM 7852-400?

If Yes, use modem configuration file **modem\_m0.cfg** and go to step 7 on page 563.

**Note:** The IBM 7852-400 modem has DIP switches on the right side of the unit. See “IBM 7852-400 DIP Switch Settings” on page 565 for the correct switch settings.

If No, continue with step 2.

2. Is your modem an IBM 7857-017?

If Yes, use modem configuration file **modem\_m1.cfg** and go to step 7 on page 563.

**Note:** The IBM 7857-017 modem has two telephone line connections on the back of the unit. One is marked **LL** (for Leased Line), and the other is marked **PTSN** (for Public Telephone Switched Network). The service processor expects to use the modem on the public network, so the telephone line should attach to the PTSN connector.

If No, continue with step 3.

3. Does your modem respond to the extended command set (prefixed with &)?

If Yes, go to step 5.

If No, continue with step 4.

4. Does your modem respond to:

- ATZ reset command

or

- ATZ $n$  reset commands, where  $n$  can be 0, 1, and so on?

If ATZ, configuration file **modem\_z.cfg** is recommended.

If ATZ $n$ , configuration file **modem\_z0.cfg** is recommended.

Go to step 7 on page 563.

5. Does your modem command set include a test for V.42 error correction at the remote modem (often called “Auto-Reliable Mode”)?

If Yes, disable this test. You can use sample configuration files

**/usr/share/modem\_m0.cfg** or **/usr/share/modem\_m1.cfg** as models to help you create a file for your particular modem. See “Customizing the Modem Configuration Files” on page 564 for more information. Go to step 7 on page 563.

If No, go to step 6.

6. Does your modem respond to:

- AT&F reset command

or

- AT&F $n$  reset commands, where  $n$  can be 0, 1, and so on?

If AT&F, configuration file **modem\_f.cfg** is recommended.

If AT&Fn, configuration file **modem\_f0.cfg** or **modem\_f1.cfg** is recommended, depending on which provides the hardware flow control profile.

7. You have completed selection of the configuration file.

If your modem configuration selection is not available in the Service Processor Modem Configuration Menu, you must access it through the Configure Remote Maintenance Policy Service Aid.

If you find it necessary to adjust any of these configuration files, use the manual provided with your modem to accomplish that task. It is recommended you select settings that enable hardware flow control and respond to DTR.

**Note:** Some older modems do not respond to the **X0** or **&R1** commands. Edit out these commands from the modem configuration file if yours is such a modem. See your modem manual for more information.

Some modems, such as the IBM 7857-017, are not designed for the paging function. Although they can be used for paging, they return an error message when they do not get the expected response from another modem. Therefore, even though the paging was successful, the error message causes the service processor to retry, continuing to place pager calls for the number of retries specified in the Call-Out Policy Setup Menu. These retries result in redundant pages.

## Examples for Using the Generic Sample Modem Configuration Files

The following table contains information to help you determine which modem configuration file to use with various modems.

Modem	Setup Z	Setup Z0 (Rare)	Setup F	Setup F0	Setup F1
AT&T DataPort 2001 (Ring interrupt only on first ring)				X	
Bocamodem 1440E			X		
Hayes Smart Modem 300	X				
IBM 5841	X				
IBM 5843	X				
IBM 7851				X	
IBM 7852-10				X	
IBM 7855					X
USRobotics 36.6K Sportster					X
Zoom V.32			X		

## Customizing the Modem Configuration Files

You can create your own modem configuration files or modify the samples provided. After you customize your modem configuration files, you *must* access them through the Configure Remote Maintenance Policy Service Aid rather than from the service processor menus.

**Note:** If you have already set up your serial ports, line speeds, authorizations, and telephone numbers from the service processor menus, use the service aid to specify your customized modem configuration files.

If you have not already set up your serial ports, line speeds, authorizations, and telephone numbers from the service processor menus, use the service aids to set them while you specify your customized modem configuration files.

To disable Auto-Reliable Mode testing of the remote modem, use the sample modem configuration file `/usr/share/modems/modem_f.cfg` as a model that you can modify, as follows:

1. Find the necessary command in your modem manual.
2. Copy the `/usr/share/modems/modem_f.cfg` file to a new file with a different name (for example, `modem_fx.cfg`).
3. In the new file (`modem_fx.cfg`), change the line `Send "ATE0T\r"` to `Send "ATcccE0T\r"` where `ccc` is the added command as specified in your modem manual, as follows:

Change the third line of each of the following stanzas:

- `condout`

- condin
  - ripo
4. Save the changes.

## IBM 7852-400 DIP Switch Settings

If you are using a 7852-400 modem to enable service processor communications, for proper operation, the dual inline package (DIP) switches must be set according to the following table:

Switch	Position	Function
1	Up	Force DTR
2	Up	Flow Control &E4
3	Down	Result Codes Enabled
4	Down	Modem Emulation Disabled
5	Up	Auto Answer Enabled
6	Up	Maximum Throughput Enabled
7	Up	RTS Normal Functions
8	Down	Enable Command Mode
9	Down	Remote Digital Loopback Test Enabled
10	Up	Dial-Up Line Enabled
11	*Up	AT Responses Enabled (Extended Responses Disabled)
12	*Down	Asynchronous Operation
13	Up	28.8KB Line Speed
14	Up	
15	Up	CD and DSR Normal Functions
16	Up	2-Wire Leased Line Enabled

\* Only switches 11 and 12 are changed from the factory default settings.

## Xon/Xoff Modems

Some early modems assume software flow control (Xon/Xoff) between the computer and the modem. Modems with this design send extra characters during and after the transmitted data. The service processor cannot accept these extra characters. If your configuration includes such a modem, your functional results may be unpredictable.

The sample modem configuration files included in this appendix do not support these modems, so custom configuration files are necessary. Anchor Automation 2400E is an example of such a modem.

If you experience unexplainable performance problems that may be due to Xon/Xoff characters, it is recommended that you upgrade your modem.

## Ring Detection

Most modems produce an interrupt request each time they detect a ring signal. Some modems generate an interrupt only on the first ring signal that they receive. AT&T DataPort 2001 is an example of such a modem.

The service processor uses the ring interrupt request to count the number of rings when Ring Indicate Power-On (RIPO) is enabled. If your modem produces an interrupt on only the first ring, set Ring Indicate Power-On to start on the first ring. Otherwise, you can choose to start Ring Indicate Power-On on any ring count.

## Terminal Emulators

The service processor is compatible with simple ASCII terminals, and therefore compatible with most emulators. When a remote session is handed off from the service processor to the operating system, agreement between terminal emulators becomes important.

The server's operating system will have some built-in terminal emulators. You may also have a commercially available terminal emulation. It is important that the local and host computers select the same or compatible terminal emulators so that the key assignments and responses match, ensuring successful communications and control.

For best formatting, choose line wrap in your terminal emulator setup.

## Recovery Procedures

Situations such as line noises and power surges can sometimes cause your modem to enter an undefined state. When it is being used for dial-in, dial-out or ring indicate power-on, your modem is initialized each time one of these actions is expected. If one of these environmental conditions occur after your modem has been initialized, it might be necessary to recover your modem to a known state.

If your modem communicates correctly with remote users, it is probably in control. It may be wise to occasionally change some of the functional settings and then change them back, just for the sense of security that the modem is communicating, and to ensure it has been initialized recently.

If your system is particularly difficult to access physically, another strategy is to protect it with an Uninterruptible Power Source (UPS) and a phone-line surge protector.

In case recovery becomes necessary, shut down your system using established procedures. Disconnect the power cable and press the power button to drain capacitance while power is disconnected. Disconnect and reconnect modem power, and then reconnect system power to completely reinitialize your system.

---

## Transfer of a Modem Session

Because many modem command variations exist, the sample modem configuration files located at the end of this appendix have been written to capture the largest number of workable modem settings.

The modem command **&Dn** (where *n* is a number) generally sets the modem response to the Data Terminal Ready (DTR) signal from the server's serial port. The desired response is that the modem will hold a connection while DTR is enabled, and drop the connection when DTR is released. Using this mechanism, the server hangs up on a connection under normal conditions.



Consult your modem manual for its specific response scheme for the **&Dn** command.

Two strategies are available for dealing with the modem's response to DTR:

- Recovery
- Prevention

Before you use one of these strategies, determine if your server's modem is set up correctly to respond to DTR.

With the remote terminal connected to serial port 1 and defined as the Primary Console Device, there are two tests you can perform:

1. Will the modem drop the connection after the System initialization complete message displays at the remote terminal?

If Yes, the modem is set up correctly.

If No, try another **&Dn** setting for your server's modem. See your modem manual for this information. The **&Dn** command appears in three places each in three of the sample modem configuration files, as follows:

2. Will the server's modem disconnect when the power drops? You can make this observation at the remote terminal by commanding your server to shut down and power off. (Use the AIX command **shutdown -F**.) Watch for the message NO CARRIER on your remote terminal.

If Yes, this is the correct response. The modem is set up correctly.

If No, try another **&Dn** setting for your server's modem. See your model manual for this information. The **&Dn** command appears in three places each in three of the sample modem configuration files. Only the following sample modem configuration files contain the **&Dn** command (in three places each):

- modem\_f.cfg
- modem\_f0.cfg
- modem\_f1.cfg

If you are using modem\_z.cfg or modem\_z0.cfg, you cannot control DTR response. If your remote terminal does not disconnect after logging off, you must command the remote terminal emulator to hang up. This then breaks the connection.

## Recovery Strategy

The recovery strategy consists of making two calls to establish a remote session. This solution is the easiest to implement and allows more freedom for configuring your server's serial ports.

To set up a remote terminal session, dial into the service processor and start the system. After the operating system is loaded and initialized, the connection will be dropped. At this point, call the server back and the operating system will answer and offer you the login prompt.

## Prevention Strategy

The disconnect is caused by the operating system when it initializes the Primary Console. The tests listed in “Transfer of a Modem Session” on page 566 are conducted with the remote terminal selected as the primary console to manifest the modem’s response to DTR transitions.

- If a local ASCII terminal or a graphics console is to be a permanent part of your server, then make one of them the primary console. Your remote terminal will no longer experience the connection loss.
- If a local console is not a permanent part of your server, you can still assign either the unused graphics console or the unused serial port as the primary console. This gives you the desired seamless connection at your remote terminal.
- If you choose to use the unused serial port as the primary console, some initialization traffic will be sent to any serial device attached to that port. As a result, that serial device’s connection and function could be affected. These impacts may make that port unattractive for devices other than a temporary local ASCII terminal.

---

## Modem Configuration Sample Files

### Sample File modem\_m0.cfg

```
#
# COMPONENT_NAME: (ESPSETUP) ENTRY SERVICE PROCESSOR SETUP: modem_m0
#
# FUNCTIONS: Modem configuration file specifically for IBM 7852-400
# modem with Auto-Reliable feature. This feature must be turned off
# for Catcher calls. This example uses the AT&F reset command to
# choose the factory defaults.
#
# (C) COPYRIGHT International Business Machines Corp. 1996
# All Rights Reserved
# Licensed Materials - Property of IBM
#
# US Government Users Restricted Rights - Use, duplication or
# disclosure restricted by GSA ADP Schedule Contract with IBM Corp.
#
#
# The modem has configuration switches. They should be set to the
# factory default settings, except switches 11 and 12. These must be
# to UP ("AT" responses) and DOWN (Asynchronous operation), respectively.

ICDelay 1
DefaultTO 10
CallDelay 120
#
# %N Call-Out phone number %R Return phone number
#
#
# PROGRAMMING NOTE: No blanks between double quote marks (").

condout: send "AT&F&E2E0T\r" # Reset to factory defaults
# Reliable mode
# Echo off
ignore "0\r" or "OK\r\n" timeout 2 # Ignore modem response.
send "AT&E12&E14\r" # Disable pacing
# Disable data compression
expect "0\r" or "OK\r\n" timeout 2 # Confirm commands successful.
send "AT&SF1&S0S9=1\r" # DSR independent of CD
# Force DSR on.
# CD respond time=100ms
expect "0\r" or "OK\r\n" timeout 2 # Confirm commands successful.
send "ATV0S0=0\r" # Numeric response code
# Auto-Answer off
expect "0\r" or "OK\r\n" timeout 2 # Confirm commands successful.
done

connect: send "ATDT%N\r" # Tone dialing command.
# %N from Call Home setup.
# Expect a connection response.
expect "33\r" or "31\r" or "28\r" or "26\r" or "24\r" or "21\r" or
"19\r" or "13\r" or "12\r" or "1\r" busy "7\r"
timeout 60
done

retry: send "A/" # Repeat the previous command.
# Expect a connection response.
expect "33\r" or "31\r" or "28\r" or "26\r" or "24\r" or "21\r" or
"19\r" or "13\r" or "12\r" or "1\r" busy "7\r"
timeout 60
done

disconnect:
delay 2 # Separate from previous data.
```

```

send "+++" # Assure command mode.
delay 2 # Allow mode switching delay.
send "ATH0T\r" # Set modem switch-hook down
# (i.e., hang up).
ignore "0\r" or "OK\r" timeout 2 # Ignore modem response.
send "ATE0Q1\r" # Initialize modem: Echo OFF,
# Disable responses.

ignore "0\r" timeout 1
done

condin: send "AT&F&E2E0T\r" # Reset to factory defaults.
# Reliable mode
# Echo off
ignore "0\r" or "OK\r\n" timeout 2 # Ignore modem response.
send "AT&E12&E14\r" # Disable pacing
# Disable data compression
expect "0\r" or "OK\r\n" timeout 2 # Confirm commands successful
send "AT&SF1&S0S9=1\r" # DSR independent of CD.
# Force DSR on.
# CD respond time=100ms
expect "0\r" or "OK\r\n" timeout 2 # Confirm commands successful.
send "ATV0S0=2\r" # Numeric response code
# Answer on 2nd ring
expect "0\r" timeout 2 # Confirm commands successful.
done

waitcall: ignore "2\r" timeout 1 # Ignore first ring.
expect "2\r" timeout 10 # Pickup 2nd ring or timeout
# Expect a connection response.
expect "33\r" or "31\r" or "28\r" or "26\r" or "24\r" or "21\r" or
"19\r" or "13\r" or "12\r" or "1\r" busy "7\r"
timeout 60
done

page: send "ATDT%N,,,%R;\r" # %N = pager call center number
# Add enough commas to wait for
# time to enter paging number.
# %R = paging number
expect "0\r" timeout 60 # Confirm successful command.
delay 2 # Wait before hanging up.
send "ATH0\r" # Hang up.
expect "0\r" timeout 2 # Confirm successful command.
done

ripo: send "AT&F&E2E0T\r" # Reset to factory defaults.
# Reliable mode
# Echo off
ignore "0\r" or "OK\r\n" timeout 2 # Ignore modem response.
send "AT&E12&E14\r" # Disable pacing
# Disable data compression
expect "0\r" or "OK\r\n" timeout 2 # Confirm successful command.
send "AT&SF1&S0S9=1\r" # DSR independent of CD.
# Force DSR on.
# CD respond time=100ms
expect "0\r" or "OK\r\n" timeout 2 # Confirm commands successful.
send "ATV0S0=0\r" # Numeric response code
# Auto Answer OFF
expect "0\r" timeout 2 # Confirm commands successful.
done

error: # Handle unexpected modem
# responses.
expect "8\r" or "7\r" or "6\r" or "4\r" or "3\r"
delay 2
done

```

## Sample File modem\_m1.cfg

```
#
# COMPONENT_NAME: (ESPSETUP) ENTRY SERVICE PROCESSOR SETUP modem_m1
#
# FUNCTIONS: Modem configuration file specifically for IBM 7857-017 modem with
# Auto-Reliable feature. This feature must be turned off for Catcher calls.
# This example uses the AT&F reset command to choose the factory defaults.
#
# To allow dial commands for digital pagers, it is necessary to reduce
# the number of characters in the dial command. Each comma (delay) has
# been set to 6 seconds (S8=6) for that reason.
#
#
# (C) COPYRIGHT International Business Machines Corp. 1996
# All Rights Reserved
# Licensed Materials - Property of IBM
#
# US Government Users Restricted Rights - Use, duplication or
# disclosure restricted by GSA ADP Schedule Contract with IBM Corp.
#

ICDelay 1
DefaultTO 10
CallDelay 120
#
# %N Call-Out phone number %R Return phone number
#
#
# PROGRAMMING NOTE: No blanks between double quote marks (").

connect: send "AT&F*E0E0\r" # Reset to factory defaults.
# *E0=data compression disabled
# E0=echo disabled
ignore "0\r" or "OK\r\n" timeout 2 # Ignore modem response.
send "AT#F0*Q2S8=6\r" # Trellis modulation disabled
# Retrain with adaptive rate
# Set ,=6second
expect "0\r" or "OK\r\n" timeout 2 # Confirm commands successful
send "ATV0X0S0=0\r" # Numeric response code
# AT compatible messages
# Auto-Answer disabled
expect "0\r" or "OK\r\n" timeout 2 # Confirm commands successful.
done

connect: send "ATDT%N\r" # Tone dialing command.
# %N from Call Home setup.
expect "1\r" busy "7\r" timeout 60 # Expect a connection response.
done

retry: send "A/" # Repeat the previous command.
expect "1\r" busy "7\r" timeout 60 # Expect a connection response.
done

disconnect:
delay 2 # Separate from previous data.
send "+++" # Assure command mode.
delay 2 # Allow mode switching delay.
send "ATH0\r" # Set modem switch-hook down
# (i.e., hang up).
ignore "0\r" or "OK\r" timeout 2 # Ignore modem response.
send "ATEOQ1\r" # Initialize modem: Echo OFF,
# Disable responses.
ignore "0\r" timeout 1
done

condin: send "AT&F*E0E0\r" # Reset to factory defaults.
```

```

# *E0=data compression disabled
# E0=echo disabled
ignore "0\r" or "OK\r\n" timeout 2 # Ignore modem response.
send "AT#F0*Q2\r" # Trellis modulation disabled
# Retrain with adaptive rate
expect "0\r" or "OK\r\n" timeout 2 # Confirm commands successful
send "ATV0X0S0=2\r" # Numeric response code
# AT compatible messages
# Answer on 2nd ring
# Confirm commands successful.

expect "0\r" timeout 2
done

waitcall: ignore "2\r" timeout 1 # Ignore first ring.
expect "2\r" timeout 10 # Pick up second ring
# or timeout.
# Expect a connection response.

expect "1\r" timeout 60
done

page: send "ATD%N,%R\r" # %N = pager call center number
# commas=6sec wait time to
# enter paging number.
# %R = return number
expect "0\r" or "3\r" timeout 30 # Confirm successful command.
delay 2 # Wait before hanging up.
send "+++" # Assure command mode.
delay 2 # Allow mode switching delay.
send "ATH0\r" # Hang up.
expect "0\r" timeout 2 # Confirm successful command.
done

ribo: send "AT&F*E0E0\r" # Reset to factory defaults.
# *E0=data compression disabled
# E0=echo disabled
ignore "0\r" or "OK\r\n" timeout 2 # Ignore modem response.
send "AT#F0*Q2\r" # Trellis modulation disabled
# Retrain with adaptive rate
expect "0\r" or "OK\r\n" timeout 2 # Confirm successful command.
send "ATV0X0S0=0\r" # Numeric response code
# AT compatible messages
# Auto-Answer disabled
# Confirm commands successful.
#

error: # Handle unexpected modem
# responses.

expect "8\r" or "7\r" or "4\r" or "3\r"
delay 2
done

```

## Sample File modem\_z.cfg

```
#
# COMPONENT_NAME: (ESPSETUP) ENTRY SERVICE PROCESSOR SETUP Z
#
# FUNCTIONS: Modem configuration file for many early Hayes* compatible modems.
# This example uses the ATZ reset command to choose the factory defaults.
# This setup will work for many modems, but it is required for early vintage
# modems which respond to neither the ATZ0 reset command nor the extended (&)
# commands. Refer to your modem manual.
#
# * Trademark of Hayes Microcomputer Products, Inc.
#
# (C) COPYRIGHT International Business Machines Corp. 1996
# All Rights Reserved
# Licensed Materials - Property of IBM
#
# US Government Users Restricted Rights - Use, duplication or
# disclosure restricted by GSA ADP Schedule Contract with IBM Corp.
#
#
# If the modem has configuration switches, they should be set to the
# factory default settings.

ICDelay 1
DefaultT0 10
CallDelay 120
# AT Attention Code           , Inserts delay in dialing commands
# Z Reset to factory defaults Q0 Turn on responses
# E0 Turn echo off           Q1 Turn off responses
# V0 Use numeric responses   S0=0 Automatic answer inhibit
# +++ Escape to command mode S0=2 Answer on second ring
# H0 Hang-up                 T = Tone mode. When used as T\r, it is a
#                             no op to maintain program synchronization
#                             when modem may/will echo the commands.
#
# %N Call-Out phone number   %P Paging phone number
# %S Modem speed (available to users)
#
# Following are common responses from a wide range of modems:
# 16, 15, 12, 10, 5 and 1 are connection responses. Add others as required.
# 7=busy; 6=no dial tone; 4=error; 3=no carrier; 2=ring; 0=OK
#
# PROGRAMMING NOTE: No blanks between double quote marks (").

condout:  send "ATZQ0T\r"           # Reset to factory defaults.
          ignore "0\r" or "OK\r\n" timeout 2 # Ignore modem response.
          send "ATE0T\r"           # Initialize modem: Echo OFF,
          expect "0\r" or "OK\r\n" timeout 2 # Enable responses (Numeric),
          send "ATQ0V0T\r"         # Limit response codes.
          expect "0\r" timeout 2    # Confirm commands successful.
          send "ATS0=0\r"          # Set AutoAnswer OFF
          expect "0\r" timeout 2    # Confirm command successful.
          done

connect:  send "ATDT%N\r"          # Tone dialing command.
          # %N from Call Home setup.

          # Expect a connection response.
          expect "16\r" or "15\r" or "14\r" or "12\r" or "10\r" or "5\r" or "1\r" busy "7\r"
          timeout 60
          done

retry:    send "A/"               # Repeat the previous command.

          # Expect a connection response.
          expect "16\r" or "15\r" or "14\r" or "12\r" or "10\r" or "5\r" or "1\r" busy "7\r"
```

```

timeout 60
done

disconnect:
delay 2 # Separate from previous data.
send "+++ " # Assure command mode.
delay 2 # Allow mode switching delay.
send "ATH0T\r" # Set modem switch-hook down
# (i.e., hang up).

ignore "0\r" or "OK\r" timeout 2 # Ignore modem response.
send "ATE0Q1\r" # Initialize modem: Echo OFF,
# Disable responses.

ignore "0\r" timeout 1
done

condin: send "ATZ00T\r" # Reset to factory defaults.
ignore "0\r" or "OK\r\n" timeout 2 # Ignore modem response.
send "ATE0T\r" # Initialize modem: Echo OFF,
expect "0\r" or "OK\r\n" timeout 2 # Enable responses (Numeric),
send "ATQ0V0T\r" # Limit response codes.
expect "0\r" timeout 2 # Confirm commands successful.
send "ATS0=2\r" # Set AutoAnswer ON
expect "0\r" timeout 2 # Confirm command successful.
done

waitcall: ignore "2\r" timeout 1 # Ignore first ring.
expect "2\r" timeout 10 # Pick up second ring
# or timeout.
# Expect a connection response.

expect "16\r" or "15\r" or "14\r" or "12\r" or "10\r" or "5\r" or "1\r"
timeout 60
done

page: send "ATDT%N,,,%R;\r" # %N = pager call center number
# Add enough commas to wait for
# time to enter paging number.
# %R = paging number

# Confirm successful command.

expect "0\r" timeout 60
delay 2 # Wait before hanging up.
send "ATH0T\r" # Hang up.
expect "0\r" timeout 2 # Confirm successful command.
done

ripo: send "ATZ00T\r" # Reset to factory defaults.
ignore "0\r" or "OK\r\n" timeout 2 # Ignore modem response.
send "ATE0T\r" # Initialize modem: Echo OFF,
expect "0\r" or "OK\r\n" timeout 2 # Enable responses (Numeric),
send "ATQ0V0T\r" # Limit response codes.
expect "0\r" timeout 2 # Confirm commands successful.
send "ATS0=0\r" # Set AutoAnswer OFF
expect "0\r" timeout 2 # Confirm command successful.
done

error: # Handle unexpected modem
# responses.

expect "8\r" or "7\r" or "6\r" or "4\r" or "3\r"
delay 2
done

```



## Sample File modem\_z0.cfg

```
#
# COMPONENT_NAME: (ESPSETUP) ENTRY SERVICE PROCESSOR SETUP Z0
#
# FUNCTIONS: Modem configuration file for some early Hayes* compatible modems.
# This example uses the ATZ0 reset command to choose the factory defaults.
# This setup is recommended for modems that will respond to the ATZ0 command
# and which do not respond to the extended (&) commands. Refer to your modem
# manual.
#
# * Trademark of Hayes Microcomputer Products, Inc.
#
# (C) COPYRIGHT International Business Machines Corp. 1996
# All Rights Reserved
# Licensed Materials - Property of IBM
#
# US Government Users Restricted Rights - Use, duplication or
# disclosure restricted by GSA ADP Schedule Contract with IBM Corp.
#
#
# If the modem has configuration switches, they should be set to the
# factory default settings.

ICDelay 1
DefaultT0 10
CallDelay 120
# AT Attention Code           , Inserts delay in dialing commands
# Z0 Reset. Restore Profile 0 Q0 Turn on responses
# E0 Turn echo off           Q1 Turn off responses
# V0 Use numeric responses    S0=0 Automatic answer inhibit
# +++ Escape to command mode S0=2 Answer on second ring
# H0 Hang-up                 X0=0 Limit modem response codes
#                               T = Tone mode. When used as T\r, it is a
#                               no op to maintain program synchronization
#                               when modem may/will echo the commands.
#
#
# %N Call-Out phone number    %P Paging phone number
# %S Modem speed (available to users)
#
# Following are common responses from a wide range of modems:
# 16, 15, 12, 10, 5 and 1 are connection responses. Add others as required.
# 7=busy; 6=no dial tone; 4=error; 3=no carrier; 2=ring; 0=OK
#
# PROGRAMMING NOTE: No blanks between double quote marks (").

conduit:  send "ATZ0Q0T\r"           # Reset modem. Select profile 0
          ignore "0\r" or "OK\r\n" timeout 2 # Ignore modem response.
          send "ATE0T\r"           # Initialize modem: Echo OFF,
          expect "0\r" or "OK\r\n" timeout 2 # Enable responses (Numeric),
          send "ATQ0V0X0T\r"       # Limit response codes.
          expect "0\r" timeout 2    # Confirm commands successful.
          send "ATS0=0\r"          # Set AutoAnswer OFF
          expect "0\r" timeout 2    # Confirm command successful.
          done

connect:  send "ATDT%N\r"           # Tone dialing command.
          # %N from Call Home setup.

          # Expect a connection response.
          expect "16\r" or "15\r" or "14\r" or "12\r" or "10\r" or "5\r" or "1\r" busy "7\r"
          timeout 60
          done

retry:    send "A/"                # Repeat the previous command.
          # Expect a connection response.
```

```

expect "16\r" or "15\r" or "14\r" or "12\r" or "10\r" or "5\r" or "1\r" busy "7\r"
timeout 60
done

disconnect:
delay 2 # Separate from previous data.
send "+++" # Assure command mode.
delay 2 # Allow mode switching delay.
send "ATH0T\r" # Set modem switch-hook down
# (i.e., hang up).
ignore "0\r" or "OK\r" timeout 2 # Ignore modem response.
send "ATE0Q1\r" # Initialize modem: Echo OFF,
# Disable responses.

ignore "0\r" timeout 1
done

condin:
send "ATZ0Q0T\r" # Reset modem. Select profile 0
ignore "0\r" or "OK\r\n" timeout 2 # Ignore modem response.
send "ATE0T\r" # Initialize modem: Echo OFF,
expect "0\r" or "OK\r\n" timeout 2 # Enable responses (Numeric),
send "ATQ0V0X0T\r" # Limit response codes.
expect "0\r" timeout 2 # Confirm commands successful.
send "ATS0=2\r" # Set AutoAnswer ON
expect "0\r" timeout 2 # Confirm command successful.
done

waitcall: ignore "2\r" timeout 1 # Ignore first ring.
expect "2\r" timeout 10 # Pick up second ring
# or timeout.
# Expect a connection response.

expect "16\r" or "15\r" or "14\r" or "12\r" or "10\r" or "5\r" or "1\r"
timeout 60
done

page:
send "ATDT%N,,,%R;\r" # %N = pager call center number
# Add enough commas to wait for
# time to enter paging number.
# %R = paging number

# Confirm successful command.

expect "0\r" timeout 60
delay 2 # Wait before hanging up.
send "ATH0T\r" # Hang up.
expect "0\r" timeout 2 # Confirm successful command.
done

ripo:
send "ATZ0Q0T\r" # Reset modem. Select profile 0
ignore "0\r" or "OK\r\n" timeout 2 # Ignore modem response.
send "ATE0T\r" # Initialize modem: Echo OFF,
expect "0\r" or "OK\r\n" timeout 2 # Enable responses (Numeric),
send "ATQ0V0X0T\r" # Limit response codes.
expect "0\r" timeout 2 # Confirm commands successful.
send "ATS0=0\r" # Set AutoAnswer OFF
expect "0\r" timeout 2 # Confirm command successful.
done # RI Power On enabled.

error: # Handle unexpected modem
# responses.
expect "8\r" or "7\r" or "6\r" or "4\r" or "3\r"
delay 2
done

```

## Sample File modem\_f.cfg

```
#
# COMPONENT_NAME: (ESPSETUP) ENTRY SERVICE PROCESSOR SETUP F
#
# FUNCTIONS: Modem configuration file for many recent Hayes* compatible modems.
# This example uses the AT&F reset command to choose the factory defaults.
# This set up is preferred for modems with extended (&) commands. For early
# vintage modems, setup Z or Z0 is recommended. If your modem responds to
# the extended (&) commands and to factory default choices (&Fn), setup file
# F0 or F1 is recommended.
#
# * Trademark of Hayes Microcomputer Products, Inc.
#
# (C) COPYRIGHT International Business Machines Corp. 1996
# All Rights Reserved
# Licensed Materials - Property of IBM
#
# US Government Users Restricted Rights - Use, duplication or
# disclosure restricted by GSA ADP Schedule Contract with IBM Corp.
#
#
# If the modem has configuration switches, they should be set to the
# factory default settings.

ICDelay 1
DefaultTO 10
CallDelay 120
# AT Attention Code , Inserts delay in dialing commands
# &F Reset to default profile Q0 Turn on responses
# E0 Turn echo off Q1 Turn off responses
# V0 Use numeric responses S0=0 Automatic answer inhibit
# +++ Escape to command mode S0=2 Answer on second ring
# H0 Hang-up X0=0 Limit modem response codes
# T = Tone mode. When used as T\r, it is a
# no op to maintain program synchronization
# when modem may/will echo the commands.
#
# &C1 Detect CD &D2 Respond to DTR (often the default)
#
# %N Call-Out phone number %P Paging phone number
# %S Modem speed (available to users)
#
# Following are common responses from a wide range of modems:
# 16, 15, 12, 10, 5 and 1 are connection responses. Add others as required.
# 7=busy; 6=no dial tone; 4=error; 3=no carrier; 2=ring; 0=OK
#
# PROGRAMMING NOTE: No blanks between double quote marks (").

conduit: send "AT&FQ0T\r" # Reset to factory defaults.
         ignore "0\r" or "OK\r\n" timeout 2 # Ignore modem response.
         send "ATE0T\r" # Initialize modem: Echo OFF,
         expect "0\r" or "OK\r\n" timeout 2 # Enable responses (Numeric),
         send "ATQ0V0X0T\r" # Limit response codes.
         expect "0\r" timeout 2 # Confirm commands successful.
         send "ATS0=0\r" # Set AutoAnswer OFF
         expect "0\r" timeout 2 # Confirm command successful.
         send "AT&C1&D2\r" # Detect carrier and DTR.
         expect "0\r" timeout 2 # Confirm command successful.
         done

connect: send "ATDT%N\r" # Tone dialing command.
         # %N from Call Home setup.

         # Expect a connection response.
         expect "16\r" or "15\r" or "14\r" or "12\r" or "10\r" or "5\r" or "1\r" busy "7\r"
         timeout 60
```

```

done

retry:    send "A/"                                # Repeat the previous command.

                                                # Expect a connection response.
expect "16\r" or "15\r" or "14\r" or "12\r" or "10\r" or "5\r" or "1\r" busy "7\r"
timeout 60
done

disconnect:
delay 2                                        # Separate from previous data.
send "+++"                                    # Assure command mode.
delay 2                                        # Allow mode switching delay.
send "ATH0T\r"                                # Set modem switch-hook down
                                                # (i.e., hang up).

ignore "0\r" or "OK\r" timeout 2             # Ignore modem response.
send "ATE0Q1\r"                               # Initialize modem: Echo OFF,
                                                # Disable responses.

ignore "0\r" timeout 1
done

condin:   send "AT&FQ0T\r"                      # Reset to factory defaults.
ignore "0\r" or "OK\r\n" timeout 2          # Ignore modem response.
send "ATE0T\r"                               # Initialize modem: Echo OFF,
expect "0\r" or "OK\r\n" timeout 2          # Enable responses (Numeric),
send "ATQ0V0X0T\r"                          # Limit response codes.
expect "0\r" timeout 2                      # Confirm commands successful.
send "ATS0=2\r"                              # Set AutoAnswer ON
expect "0\r" timeout 2                      # Confirm command successful.
send "AT&C1&D2\r"                           # Detect carrier and DTR.
expect "0\r" timeout 2                      # Confirm command successful.
done

waitcall: ignore "2\r" timeout 1              # Ignore first ring.
          expect "2\r" timeout 10            # Pick up second ring
                                                # or timeout.
                                                # Expect a connection response.
expect "16\r" or "15\r" or "14\r" or "12\r" or "10\r" or "5\r" or "1\r"
timeout 60
done

page:     send "ATDT%N,,,,,%R;\r"            # %N = pager call center number
                                                # Add enough commas to wait for
                                                # time to enter paging number.
                                                # %R = paging number

                                                # Confirm successful command.
          expect "0\r" timeout 60
          delay 2                              # Wait before hanging up.
          send "ATH0T\r"                      # Hang up.
          expect "0\r" timeout 2              # Confirm successful command.
          done

ripo:     send "AT&FQ0T\r"                      # Reset to factory defaults.
ignore "0\r" or "OK\r\n" timeout 2          # Ignore modem response.
send "ATE0T\r"                               # Initialize modem: Echo OFF,
expect "0\r" or "OK\r\n" timeout 2          # Enable responses (Numeric),
send "ATQ0V0X0T\r"                          # Limit response codes.
expect "0\r" timeout 2                      # Confirm commands successful.
send "ATS0=0\r"                              # Set AutoAnswer OFF
expect "0\r" timeout 2                      # Confirm command successful.
send "AT&C1&D2\r"                           # Detect carrier and DTR.
expect "0\r" timeout 2                      # Confirm command successful.
done                                           # RI Power On enabled.

error:    # Handle unexpected modem

```

```
expect "8\r" or "7\r" or "6\r" or "4\r" or "3\r" # responses.  
delay 2  
done
```

## Sample File modem\_f0.cfg

```
#
# COMPONENT_NAME: (ESPSETUP) ENTRY SERVICE PROCESSOR SETUP F0
#
# FUNCTIONS: Modem configuration file for many recent Hayes* compatible modems.
# This example uses the AT&F0 reset command to choose the factory defaults.
# This set up is preferred for modems with extended (&) commands. For early
# vintage modems, setup Z or Z0 is recommended. If your modem responds to
# the extended (&) commands and to factory default choices (&Fn), but doesn't
# work properly with this setup file, setup F1 is recommended.
#
# * Trademark of Hayes Microcomputer Products, Inc.
#
# (C) COPYRIGHT International Business Machines Corp. 1996
# All Rights Reserved
# Licensed Materials - Property of IBM
#
# US Government Users Restricted Rights - Use, duplication or
# disclosure restricted by GSA ADP Schedule Contract with IBM Corp.
#
#
# If the modem has configuration switches, they should be set to the
# factory default settings.

ICDelay 1
DefaultT0 10
CallDelay 120
# AT Attention Code , Inserts delay in dialing commands
# &F0 Reset. Restore profile 0 Q0 Turn on responses
# E0 Turn echo off Q1 Turn off responses
# V0 Use numeric responses S0=0 Automatic answer inhibit
# +++ Escape to command mode S0=2 Answer on second ring
# H0 Hang-up X0=0 Limit modem response codes
#
# T = Tone mode. When used as T\r, it is a
# no op to maintain program synchronization
# when modem may/will echo the commands.
#
# &C1 Detect CD &D2 Respond to DTR (often the default)
# &R1 Ignore RTS (CTS)
#
# %N Call-Out phone number %P Paging phone number
# %S Modem speed (available to users)
#
# Following are common responses from a wide range of modems:
# 16, 15, 12, 10, 5 and 1 are connection responses. Add others as required.
# 7=busy; 6=no dial tone; 4=error; 3=no carrier; 2=ring; 0=OK
#
# PROGRAMMING NOTE: No blanks between double quote marks (").

connect: send "AT&F0Q0T\r" # Reset modem. Select profile 0
          ignore "0\r" or "OK\r\n" timeout 2 # Ignore modem response.
          send "ATE0T\r" # Initialize modem: Echo OFF,
          expect "0\r" or "OK\r\n" timeout 2 # Enable responses (Numeric),
          send "ATQ0V0X0T\r" # Limit response codes.
          expect "0\r" timeout 2 # Confirm commands successful.
          send "ATS0=0\r" # Set AutoAnswer OFF
          expect "0\r" timeout 2 # Confirm command successful.
          send "AT&C1&D2&R1\r" # Detect carrier and DTR,
          # Ignore RTS.
          expect "0\r" timeout 2 # Confirm command successful.
          done

connect: send "ATDT%N\r" # Tone dialing command.
          # %N from Call Home setup.

          # Expect a connection response.
```

```

expect "16\r" or "15\r" or "14\r" or "12\r" or "10\r" or "5\r" or "1\r" busy "7\r"
timeout 60
done

retry:      send "A/"                                # Repeat the previous command.

                                                    # Expect a connection response.
expect "16\r" or "15\r" or "14\r" or "12\r" or "10\r" or "5\r" or "1\r" busy "7\r"
timeout 60
done

disconnect:
delay 2      # Separate from previous data.
send "+++"  # Assure command mode.
delay 2      # Allow mode switching delay.
send "ATH0T\r" # Set modem switch-hook down
                                                    # (i.e., hang up).
ignore "0\r" or "OK\r" timeout 2 # Ignore modem response.
send "ATE0Q1\r" # Initialize modem: Echo OFF,
                                                    # Disable responses.

ignore "0\r" timeout 1
done

condin:     send "AT&F0Q0T\r" # Reset modem. Select profile 0
ignore "0\r" or "OK\r\n" timeout 2 # Ignore modem response.
send "ATE0T\r" # Initialize modem: Echo OFF,
expect "0\r" or "OK\r\n" timeout 2 # Enable responses (Numeric),
send "ATQ0V0X0T\r" # Limit response codes.
expect "0\r" timeout 2 # Confirm commands successful.
send "ATS0=2\r" # Set AutoAnswer ON
expect "0\r" timeout 2 # Confirm command successful.
send "AT&C1&D2&R1\r" # Detect carrier and DTR,
                                                    # Ignore RTS.
                                                    # Confirm command successful.

expect "0\r" timeout 2
done

waitcall:  ignore "2\r" timeout 1 # Ignore first ring.
expect "2\r" timeout 10 # Pick up second ring
                                                    # or timeout.
                                                    # Expect a connection response.
expect "16\r" or "15\r" or "14\r" or "12\r" or "10\r" or "5\r" or "1\r"
timeout 60
done

page:      send "ATDT%N,,,%R;\r" # %N = pager call center number
                                                    # Add enough commas to wait for
                                                    # time to enter paging number.
                                                    # %R = paging number

                                                    # Confirm successful command.

expect "0\r" timeout 60
delay 2 # Wait before hanging up.
send "ATH0T\r" # Hang up.
expect "0\r" timeout 2 # Confirm successful command.
done

ripos:     send "AT&F0Q0T\r" # Reset modem. Select profile 0
ignore "0\r" or "OK\r\n" timeout 2 # Ignore modem response.
send "ATE0T\r" # Initialize modem: Echo OFF,
expect "0\r" or "OK\r\n" timeout 2 # Enable responses (Numeric),
send "ATQ0V0X0T\r" # Limit response codes.
expect "0\r" timeout 2 # Confirm commands successful.
send "ATS0=0\r" # Set AutoAnswer OFF
expect "0\r" timeout 2 # Confirm command successful.
send "AT&C1&D2&R1\r" # Detect carrier and DTR,
                                                    # Ignore RTS.
                                                    # Confirm command successful.

expect "0\r" timeout 2

```

```
done                                # RI Power On enabled.
error:                               # Handle unexpected modem
                                     # responses.
expect "8\r" or "7\r" or "6\r" or "4\r" or "3\r"
delay 2
done
```



## Sample File modem\_f1.cfg

```
#
# COMPONENT_NAME: (ESPSETUP) ENTRY SERVICE PROCESSOR SETUP F1
#
# FUNCTIONS: Modem configuration file for many recent Hayes* compatible modems.
# This example uses the AT&F1 reset command to choose the factory defaults.
# This set up is for modems with extended (&) commands and which do not work
# properly with setup F0. For early vintage modems, setup Z or Z0 is
# recommended.
#
# * Trademark of Hayes Microcomputer Products, Inc.
#
# (C) COPYRIGHT International Business Machines Corp. 1996
# All Rights Reserved
# Licensed Materials - Property of IBM
#
# US Government Users Restricted Rights - Use, duplication or
# disclosure restricted by GSA ADP Schedule Contract with IBM Corp.
#
#
# If the modem has configuration switches, they should be set to the
# factory default settings.

ICDelay 1
DefaultT0 10
CallDelay 120
# AT Attention Code           , Inserts delay in dialing commands
# &F1 Reset. Restore profile 1 Q0 Turn on responses
# E0 Turn echo off           Q1 Turn off responses
# V0 Use numeric responses    S0=0 Automatic answer inhibit
# +++ Escape to command mode S0=2 Answer on second ring
# H0 Hang-up                 X0=0 Limit modem response codes
#                             T = Tone mode. When used as T\r, it is a
#                             no op to maintain program synchronization
#                             when modem may/will echo the commands.
#
#
# &C1 Detect CD               &D2 Respond to DTR (often the default)
# &R1 Ignore RTS (CTS)
#
# %N Call-Out phone number   %P Paging phone number
# %S Modem speed (available to users)
#
# Following are common responses from a wide range of modems:
# 16, 15, 12, 10, 5 and 1 are connection responses. Add others as required.
# 7=busy; 6=no dial tone; 4=error; 3=no carrier; 2=ring; 0=OK
#
# PROGRAMMING NOTE: No blanks between double quote marks (").

conduit:  send "AT&F1Q0T\r"           # Reset modem. Select profile 1
          ignore "0\r" or "OK\r\n" timeout 2 # Ignore modem response.
          send "ATE0T\r"             # Initialize modem: Echo OFF,
          expect "0\r" or "OK\r\n" timeout 2 # Enable responses (Numeric),
          send "ATQ0V0X0T\r"         # Limit response codes.
          expect "0\r" timeout 2      # Confirm commands successful.
          send "ATS0=0\r"             # Set AutoAnswer OFF
          expect "0\r" timeout 2      # Confirm command successful.
          send "AT&C1&D2&R1\r"       # Detect carrier and DTR,
          # Ignore RTS.
          expect "0\r" timeout 2      # Confirm command successful.
          done

connect:  send "ATDT%N\r"            # Tone dialing command.
          # %N from Call Home setup.

          # Expect a connection response.
          expect "16\r" or "15\r" or "14\r" or "12\r" or "10\r" or "5\r" or "1\r" busy "7\r"
```

```

timeout 60
done

retry:    send "A/"                                # Repeat the previous command.

                                                # Expect a connection response.
expect "16\r" or "15\r" or "14\r" or "12\r" or "10\r" or "5\r" or "1\r" busy "7\r"
timeout 60
done

disconnect:
delay 2                                        # Separate from previous data.
send "+++"                                    # Assure command mode.
delay 2                                        # Allow mode switching delay.
send "ATH0T\r"                                # Set modem switch-hook down
                                                # (i.e., hang up).
ignore "0\r" or "OK\r" timeout 2             # Ignore modem response.
send "ATE0Q1\r"                              # Initialize modem: Echo OFF,
                                                # Disable responses.

ignore "0\r" timeout 1
done

condin:   send "AT&F1Q0T\r"                    # Reset modem. Select profile 1
ignore "0\r" or "OK\r\n" timeout 2          # Ignore modem response.
send "ATE0T\r"                              # Initialize modem: Echo OFF,
expect "0\r" or "OK\r\n" timeout 2          # Enable responses (Numeric),
send "ATQ0V0X0T\r"                          # Limit response codes.
expect "0\r" timeout 2                      # Confirm commands successful.
send "ATS0=2\r"                              # Set AutoAnswer ON
expect "0\r" timeout 2                      # Confirm command successful.
send "AT&C1&D2&R1\r"                        # Detect carrier and DTR,
                                                # Ignore RTS.

expect "0\r" timeout 2                      # Confirm command successful.
done

waitcall: ignore "2\r" timeout 1              # Ignore first ring.
          expect "2\r" timeout 10            # Pick up second ring
                                                # or timeout.
                                                # Expect a connection response.
expect "16\r" or "15\r" or "14\r" or "12\r" or "10\r" or "5\r" or "1\r"
timeout 60
done

page:     send "ATDT%N,,,%R;\r"              # %N = pager call center number
                                                # Add enough commas to wait for
                                                # time to enter paging number.
                                                # %R = paging number

                                                # Confirm successful command.
expect "0\r" timeout 60
delay 2                                        # Wait before hanging up.
send "ATH0T\r"                                # Hang up.
expect "0\r" timeout 2                      # Confirm successful command.
done

ripo:     send "AT&F1Q0T\r"                    # Reset modem. Select profile 1
ignore "0\r" or "OK\r\n" timeout 2          # Ignore modem response.
send "ATE0T\r"                              # Initialize modem: Echo OFF,
expect "0\r" or "OK\r\n" timeout 2          # Enable responses (Numeric),
send "ATQ0V0X0T\r"                          # Limit response codes.
expect "0\r" timeout 2                      # Confirm commands successful.
send "ATS0=0\r"                              # Set AutoAnswer OFF
expect "0\r" timeout 2                      # Confirm command successful.
send "AT&C1&D2&R1\r"                        # Detect carrier and DTR,
                                                # Ignore RTS.

expect "0\r" timeout 2                      # Confirm command successful.
done                                          # RI Power On enabled.

```

```
error:                                     # Handle unexpected modem
                                           # responses.
expect "8\r" or "7\r" or "6\r" or "4\r" or "3\r"
delay 2
done
```



---

## Appendix G. Rack Drawer Rail Instructions

This appendix provides information for installing rails into your rack or system.

Read the safety information in “Safety Notices” on page xi before using these procedures.

---

### Front Drawer-Stop Installation

Install a drawer stop **(2)**, part number 11K0358, on each side at the front of the rack to prevent the drawer from sliding out the front. Use six screws **(1)**, part number 73H2932, and four nut clips **(3)**, part number 74F1823, to attach the drawer stops.

**Note:** To put the drawer in the front-service position, the drawer stops have to be removed temporarily.

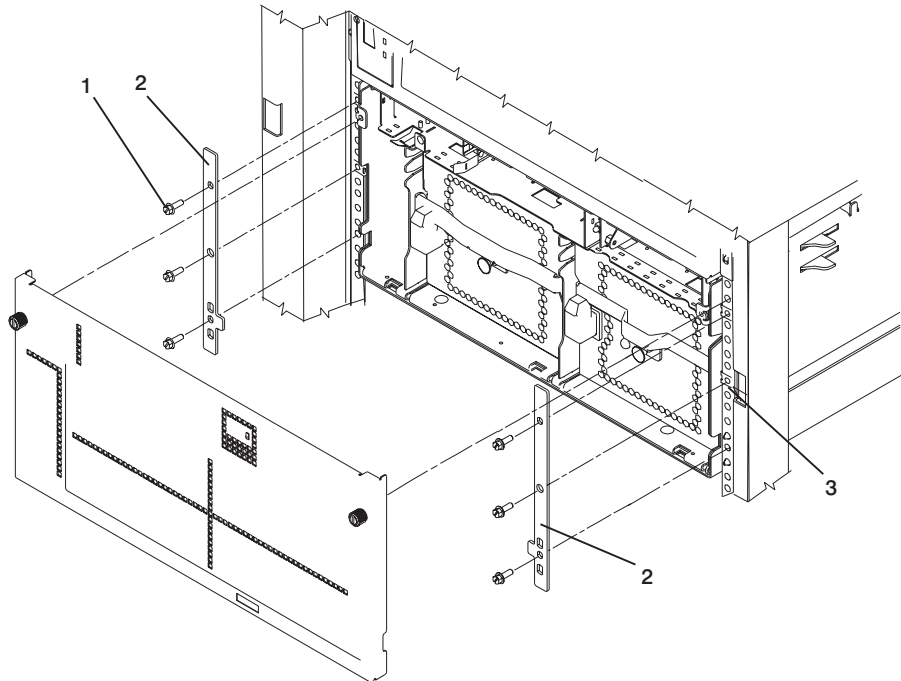

---

## Drawer Rail Assembly and Installation

The drawer rails require assembly before you put them in your rack.

Use two screws, part number 00G1268, to attach an anti-tip guide **(2)**, part number 09P0327, to each rail. The left rail **(1)** is part number 03N3845 and the right rail **(5)** is part number 03N3847.

---

## Rails for an S00 Type Rack

Use one screw, part number 00G1268, to attach a Model S00 type cable guide **(4)**, part number 11K0826, to the right rail. The model S00 type rack does not have enough room on the left side of the rack for a cable guide. Install a guide only on the right rails.

---

## Rails for a T00 Type Rack

Use one screw, part number 00G1268, to attach a Model T00 type cable guide **(3)**, part number 00P2402, to each rail. The model T00 type rack has room for guides on both the left and the right rails.

---

## Rail Installation

As you install the right rail into the rack, install the drawer latch reset bracket, part number 11K0851, above the right rail. Refer to the *Installation Guide* for your system drawers to install the rails in your rack.

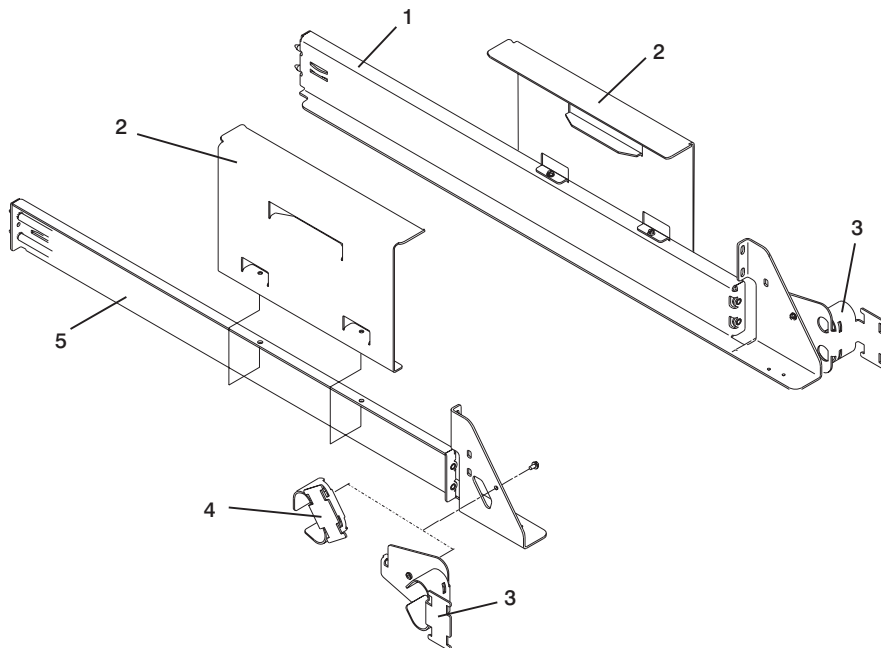

---

## Cable Routing

Use the following descriptions to route and secure the cables in the rack drawer.

**I/O Drawer Cables:** If present, connect the RIO drawer cables to the I/O drawer and secure them with the RIO cable retainer **(3)**, part number 11K0584. Use two screws **(2)**, part number 00G1268.

To hold the cables, use the cable hanging brackets **(1)**, part number 11K1013, as needed.

Route the cables over the cable guides, and secure the cables with Velcro strips, part number 07H6855 or 51H9502.

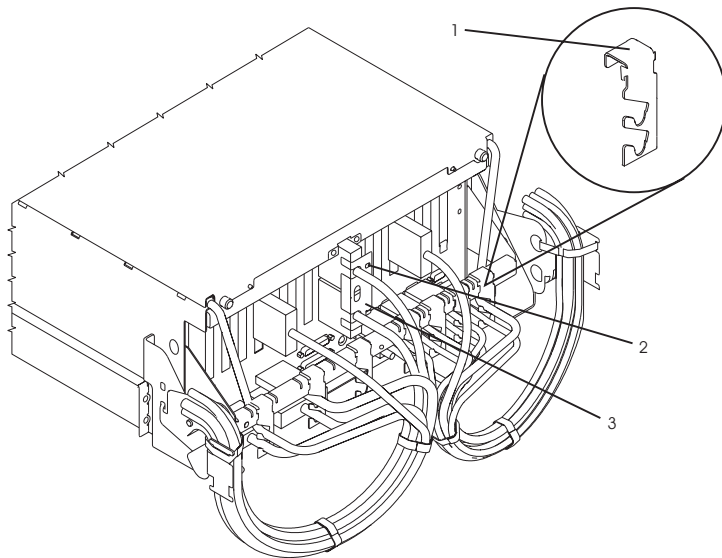

**CEC Drawer Cables:** Arrange the CEC drawer cables in the CEC drawer cable bracket **(3)**, part number 11K0249, and fasten the bracket to the back of the CEC drawer. (Fasteners **(1)** push in to lock and pull out to unlock.)

Route the cables over the cable guides, and secure the cables with Velcro strips **(2)**, part number 07H6855 or 51H9502.

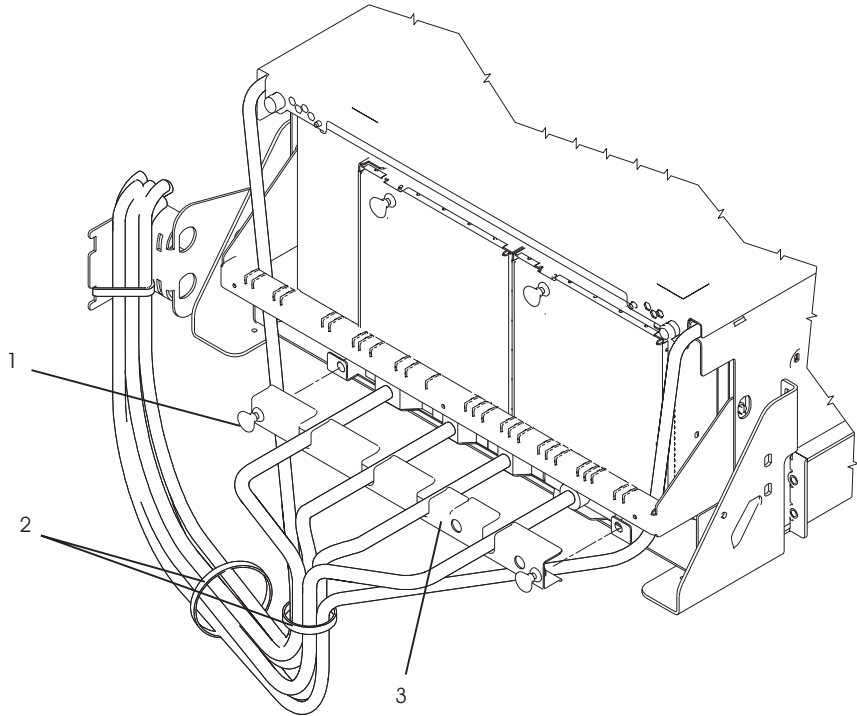



**Securing Drawer Cables:** Route the cables over the cable guides **(2)** and secure the cables with Velcro strips **(1)**, part number 07H6855 or 51H9502. Leave a loop large enough so that the drawer can be pulled out the back.

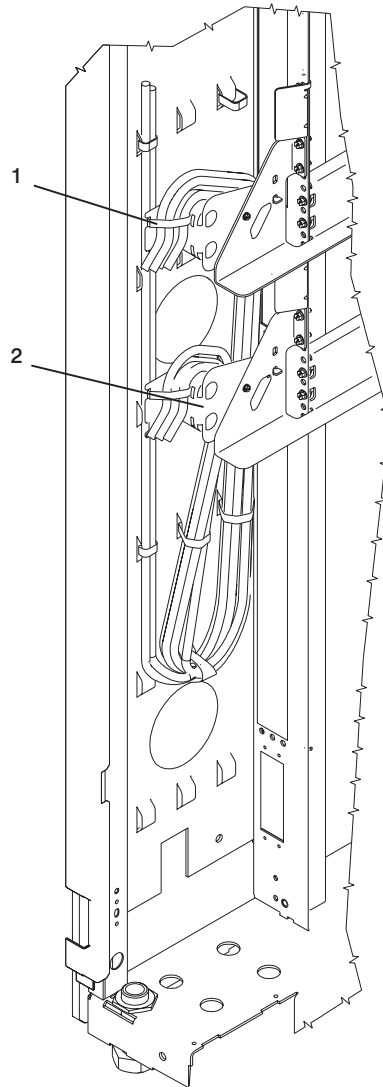



---

# Index

## A

- about this book xvii
- acoustical
  - noise
    - emissions 547
- AIX location codes 32, 33
- AIX operating system documentation 426, 462

## B

- battery
  - disposal, recycling 547
  - removal 521
- bay locations 23
- boot list 402
- boot mode menu 423
- boot problems 167

## C

- cables
  - JTAG 53
  - RIO 53
  - SPCN 53, 59
  - V/S COMM 53
- cabling 53
- call-in
  - testing 552
- call-in/call-out setup menu 432
- call-out
  - testing 552
- call-out (call-home) 447
- call-out policy setup menu 436
- capacity upgrade on demand 403
  - adding processor capacity 410
  - chcod command 555
  - determining current configuration 557
  - determining processor configuration 409
  - diagnostics 557
  - enabling additional processors 409
  - process flow 404
  - recovery 557
  - recovery procedures 557
  - system processors 403
  - testing the system 558
  - verifying and installing 405
- CD-ROM removal 513
- CEC 484
  - backplane 496
  - fans 490
  - power supplies 492
  - processor card 485
  - regulator card 484
  - RIO Bus Adapter 493

- CEC backplane 496
- CEC fans 490
- CEC power supplies 492
- CEC regulator card 484
- CEC RIO Bus adapter 493
- chcod command 555
- checkpoints 147
  - boot problems 167
  - description 76
  - firmware 156
  - service processor 150
- clearances, service 70
- code, error 171
- common service processor error codes 389
- configuration, rack 70
- configure, processor/memory 445
- connecting cables 53
- connecting the CEC drawer and I/O drawers 53
- console mirroring 449
- console strategy 6
- customer account setup menu 437

## D

- data flow 4
- dc power cable routings 66
- dc power cables 66
- deconfigure, processor/memory 445
- description, IPL flow 147
- diagnostics
  - online 401
  - overview 75
  - standalone 401
- diskette drive removal 516

## E

- electronic service agent 78
- emissions
  - noise 547
- entering open firmware 8
- entry MAP 75
- error code to FRU index 171
- error codes
  - common firmware 389
  - firmware/POST 212
  - operator panel 176
  - problem determination generated 398
  - service processor 233
  - SPCN 177
  - system firmware 388
- error logs 450

## F

- fan controller card removal 512
- firmware 443
  - level 443
  - update 443
- firmware checkpoints 156
- firmware updates
  - system 442
- firmware/POST error codes 212
- flow, data 4
- flow, IPL 147
- front service position 520
- FRU
  - hot-pluggable 470
  - index 171
  - isolation 77

## G

- general user menu 413

## H

- handling static-sensitive devices 468
- hot-pluggable FRUs 470

## I

- I/O drawer
  - backplane assembly 498
  - features 25
  - PCI slot LED definitions 470
  - power distribution board 503
  - RIO bus adapter 501
- indicators, POST 7
- information, reference 1
- installing cables 53
- internal disk drives removal 509
- IPL
  - flow 147
  - phases 147
- isolation, FRU 77

## J

- JTAG, cable connection 53

## K

- keys
  - numeric 1 key 7
  - numeric 5 key 7
  - numeric 6 key 8
  - numeric 8 key 8

## L

- language selection menu 431
- language, select 465
- laser compliance statement xiii
- laser safety information xiii

- LCD progress indicator log 451
- LED status 22
- loading the system diagnostics 401
- location codes 29, 33
  - AIX 32
  - format 29
  - physical 29
- locations 9
  - AIX 33
  - bays 23
  - cable diagram 64, 65
  - CEC card cage 12
  - CEC drawer front 9
  - CEC drawer front, bezel removed 10
  - CEC drawer rear 11
  - location code reference tables 33
  - logical 29
  - memory DIMM 20
  - memory riser card 20
  - PCI board 18
  - physical 29, 33
  - primary I/O drawer bay 16
  - primary I/O drawer front 13
  - primary I/O drawer operator panel 22
  - primary I/O drawer rear 15
  - SCSI IDs 23
  - secondary I/O drawer bay 17
  - secondary I/O drawer front 14
  - secondary I/O drawer operator panel 22
  - system board 19

## M

- maintenance analysis procedures 75
- maintenance analysis procedures (MAPs) 81, 82
  - entry MAP 81
  - minimum configuration MAP 122
  - power MAP 94
  - problem determination MAP 89
  - quick entry MAP 82
- memory configuration/deconfiguration menu 426, 427
- memory riser cards and memory modules 481
- memory, description 24
- messages, service processor checkpoints 150
- minimum configuration MAP 75, 122
- minus 48 vdc power
  - CEC backplane 497
  - CEC fans 490
  - CEC power supplies 492
  - CEC regulator card 484
  - CEC RIO Bus Adapter 493
  - memory riser cards and memory modules 481
  - processor card 485
- modem
  - configuration file selection 562
  - configurations 561

- modem (*continued*)
  - transfer 566
- modem\_f.cfg, sample file 577
- modem\_f0.cfg, sample file 580
- modem\_f1.cfg, sample file 583
- modem\_m0.cfg, sample file 569
- modem\_m1.cfg, sample file 571
- modem\_z.cfg, sample file 573
- modem\_z0.cfg, sample file 575

**N**

- noise
  - emissions 547
- noise emission 71, 548

**O**

- online diagnostics 401
- online publications xvii
- open firmware, entering 8
- operating system documentation, AIX 426, 462
- operator panel error codes 176
- operator panel removal 517
- ordering publications xvii
- overview
  - diagnostics 75
  - system 1

**P**

- parts information 523
  - CEC drawer backplane 526
  - CEC drawer card assembly 524
  - CEC drawer fan assemblies 530
  - CEC drawer internal cables 536
  - CEC drawer power supplies 528
  - external cables 542
  - I/O drawer 532
  - keyboard 543, 545
  - primary I/O drawer cables 538
  - secondary I/O drawer cables 540
- PCI
  - adapter removal 471
  - hot-plug manager access 478
  - hot-pluggable adapter removal 473
  - non-hot-pluggable adapter removal 471
  - slot LED definitions 470
- phases, IPL 147
- physical location codes 29, 33
- POST indicators 7
- POST keys
  - numeric 1 key 7
  - numeric 5 key 7
  - numeric 6 key 8
  - numeric 8 key 8
- power cables 72
- power control network utilities menu 430
- power MAP 75, 94
- power supply fan removal 505
- power supply removal 505
- power supply test switch 508
- power-on self-test 6
- powering on and off 5, 469
- preface xvii
- primary console 568
- primary I/O drawer cable diagram 64
- primary I/O drawer operator panel locations 22
- privileged user menus 414
- problem determination generated error codes 398
- problem determination MAP 75, 89
- processor card 485
- processor configuration/deconfiguration menu 425
- processor/memory
  - configure 445
  - deconfigure 445
- product disposal 547
- publications, online xvii
- publications, ordering xvii

**Q**

- quick entry MAP 75, 82

**R**

- rack configuration 70
- rear service position 519
- reboot/restart policy setup menu 421
- recycling 547
- reference information 1
- reference tables
  - aix location code 33
  - physical location code 33
- related publications xvii
- removal and replacement procedures 467
  - battery 521
  - CD-ROM drive 513
  - CEC backplane 496
  - CEC fans 490
  - CEC RIO Bus Adapter 493
  - diskette drive 516
  - fan controller card 512
  - I/O drawer backplane assembly 498
  - I/O drawer power distribution board 503
  - I/O drawer RIO bus adapter 501
  - internal disk drives 509
  - memory riser cards and memory modules 481
  - operator panel 517
  - PCI adapters 471
  - power supply 505
  - power supply fan 505
  - processor card 485
  - tape drive 515
- removal procedure 467
- replacement procedure 467

replacement procedure *(continued)*  
    memory modules 482  
restart recovery 440  
RETAIN 437  
retries 436  
ring-indicate power-on menu 420  
RIO cabling 54  
riser card memory placement rules 24

## S

safety xi  
    electrical xii  
    laser compliance statement xiii  
    notices xi  
    rack xi  
saving service processor settings 551  
SCSI IDs 23  
secondary I/O drawer cable diagram 65  
secondary I/O drawer operator panel locations 22  
self-test, power-on 6  
serial port  
    selection menu 434  
    snoop setup menu 419  
    speed setup menu 434  
service clearance 70  
service inspection guide 73  
service mode 401  
service processor  
    backup settings 551  
    boot mode menu 423  
    call-in/call-out setup menu 432  
    call-out call-home 447  
    call-out policy setup menu 436  
    checklist 551  
    checkpoints 150  
    console mirroring 449  
    customer account setup menu 437  
    error log 450  
    functions 438  
    general user menu 413  
    language selection menu 431  
    main menu 414  
    memory configuration/deconfiguration menu 426,  
        427  
    menus 412  
    menus list 411  
    modem configuration menu 433  
    monitoring - surveillance 446  
    operational phases 452  
    OS surveillance setup menu 418  
    passwords 417  
    power control network utilities menu 430  
    power-on methods 439  
    privileged user menus 414  
    procedures in service mode 437

service processor *(continued)*  
    processor configuration/deconfiguration menu 425  
    reboot/restart policy setup menu 421  
    ring-indicate power-on menu 420  
    serial port selection menu 434  
    serial port snoop setup menu 419  
    serial port speed setup menu 434  
    service processor reboot/restart recovery 440  
    setup 551  
    setup checklist 551  
    setup menu 416  
    system information menu 424  
    system power control menu 420  
    telephone setup menu 435  
    test 551  
service processor checkpoints 150  
service processor error codes 233  
service processor feature 78  
setup menu 416  
SPCN cabling 59  
SPCN error codes 177  
specifications 67  
    7014 Series Model T00 Rackrack 68  
    cec drawer 67  
    I/O drawer 69  
    noise emission notes 71, 548  
standalone diagnostics 401  
strategy, console 6  
system diagnostics, loading 401  
system firmware update messages 388  
system firmware updates 442  
system information menu 424  
system management services 455  
    display error log 457  
    multiboot 462  
    OK prompt 465  
    password utilities 456  
    remote initial program load setup 457  
    SCSI utilities 461  
    select console 461  
    select language 465  
system memory 24  
system power-on methods 439  
system specifications 67  
system, powering on and off 5

## T

tape drive removal 515  
telephone setup menu 435  
testing the setup  
    call-in 552  
    call-out 552  
trademarks xviii  
transfer of a modem session 566

## **U**

using

- electronic service agent 78
- service processor 78

## **V**

V/S COMM, cable connection 53

## **W**

Web sites

- AIX library 426, 462
- firmware updates 442, 443
- microcode updates 442, 443
- RS/6000 and pSeries publications xvii





---

## Readers' Comments — We'd Like to Hear from You

RS/6000 Enterprise Server Model M80  
@server pSeries 660 Model 6M1  
Service Guide

Publication No. SA38-0571-01

Overall, how satisfied are you with the information in this book?

	Very Satisfied	Satisfied	Neutral	Dissatisfied	Very Dissatisfied
Overall satisfaction	<input type="checkbox"/>	<input type="checkbox"/>	<input type="checkbox"/>	<input type="checkbox"/>	<input type="checkbox"/>

How satisfied are you that the information in this book is:

	Very Satisfied	Satisfied	Neutral	Dissatisfied	Very Dissatisfied
Accurate	<input type="checkbox"/>	<input type="checkbox"/>	<input type="checkbox"/>	<input type="checkbox"/>	<input type="checkbox"/>
Complete	<input type="checkbox"/>	<input type="checkbox"/>	<input type="checkbox"/>	<input type="checkbox"/>	<input type="checkbox"/>
Easy to find	<input type="checkbox"/>	<input type="checkbox"/>	<input type="checkbox"/>	<input type="checkbox"/>	<input type="checkbox"/>
Easy to understand	<input type="checkbox"/>	<input type="checkbox"/>	<input type="checkbox"/>	<input type="checkbox"/>	<input type="checkbox"/>
Well organized	<input type="checkbox"/>	<input type="checkbox"/>	<input type="checkbox"/>	<input type="checkbox"/>	<input type="checkbox"/>
Applicable to your tasks	<input type="checkbox"/>	<input type="checkbox"/>	<input type="checkbox"/>	<input type="checkbox"/>	<input type="checkbox"/>

Please tell us how we can improve this book:

Thank you for your responses. May we contact you?  Yes  No

When you send comments to IBM, you grant IBM a nonexclusive right to use or distribute your comments in any way it believes appropriate without incurring any obligation to you.

---

Name

---

Address

---

Company or Organization

---

Phone No.

Readers' Comments — We'd Like to Hear from You  
SA38-0571-01



Cut or Fold  
Along Line

Fold and Tape

Please do not staple

Fold and Tape



NO POSTAGE  
NECESSARY  
IF MAILED IN THE  
UNITED STATES

# BUSINESS REPLY MAIL

FIRST-CLASS MAIL PERMIT NO. 40 ARMONK, NEW YORK

POSTAGE WILL BE PAID BY ADDRESSEE

Information Development  
Department H6DS-905-6C006  
11400 Burnet Road  
Austin, TX 78758-3493

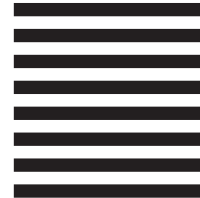

Fold and Tape

Please do not staple

Fold and Tape

SA38-0571-01

Cut or Fold  
Along Line





Printed in U.S.A.

September 2001

SA38-0571-01



Spine information:

RS/6000 Enterprise Server  
Model M80  
@server pSeries 660 Model  
6MI



**Service Guide**

SA38-0571-01