

RS/6000 Enterprise Server Model H80
@server pSeries 660 Models 6H0 and 6H1



Service Guide

Fourth Edition (April 2002)

Before using this information and the product it supports, read the information in "Safety Notices" on page xi, Appendix A, "Environmental Notices" on page 493, and Appendix B, "Notices" on page 495.

A reader's comment form is provided at the back of this publication. If the form has been removed, address comments to Information Development, Department H6DS-905-6C006, 11501 Burnet Road, Austin, Texas 78758-3493. To send comments electronically, use this commercial internet address: aix6kpub@austin.ibm.com. Any information that you supply may be used without incurring any obligation to you.

© **International Business Machines Corporation 2000, 2002. All rights reserved.**

Note to U.S. Government Users -- Documentation related to restricted rights -- Use, duplication or disclosure is subject to restrictions set forth in GSA ADP Schedule Contract with IBM Corp.

Contents

Safety Notices	xi
Rack Safety Instructions	xi
Electrical Safety	xii
Laser Safety Information	xiii
Laser Compliance	xiii
Data Integrity and Verification	xv
About This Book	xvii
ISO 9000	xvii
Online Publications	xvii
Related Publications	xvii
Trademarks	xviii
Chapter 1. Reference Information	1
Overview	1
Data Flow with One-Way Processor	3
Data Flow with Two- to Six-Way Processor	4
Powering the System On and Off	4
Console Strategy	5
Power-On Self-Test	6
POST Indicators	6
POST Keys	6
1 Key	7
5 Key	7
6 Key	7
8 Key	7
System Unit Locations	8
CEC Drawer Front View	9
CEC Drawer Top View	10
CEC Drawer Rear View	11
Primary I/O Drawer Front View	12
Primary I/O Drawer Top View	12
Primary I/O Drawer Rear View	14
Primary I/O Drawer Front View with Covers Removed	15
Secondary I/O Drawer Front View	16
Secondary I/O Drawer Top View	16
Secondary I/O Drawer Rear View	18
PCI Board Locations	19
System Board Locations	20
Memory Riser Card and Memory DIMM Locations	21
One-Way Processor Card Memory DIMM Locations	22
Primary I/O Drawer Operator Panel	23
Secondary I/O Drawer Operator Panel	24
SCSI IDs and Bay Locations	25
System Memory	26
One-Way Processor Memory Placement Rules	26

Riser Card Memory Placement Rules	26
I/O Drawer Features	27
I/O Drawer Addressing	27
I/O Drawer and Power Supply LED Status.	28
Message Hierarchy for Secondary I/O Drawer Operator Panel	29
Primary I/O Drawer Operator Panel Behavior During Power-On.	30
Secondary I/O Drawer Operator Panel Behavior During Power-On.	31
Logical and Physical Locations	32
Physical Location Codes	32
Location Code Format	32
Multiple FRU Callout Instructions	33
AIX Location Codes	34
AIX and Physical Location Code Reference Tables	36
Cabling the CEC Drawer, Primary I/O Drawer, and Secondary I/O Drawer	48
Connecting JTAG and VS COM Cables	48
Connecting RIO and SPCN Cables	49
System Cable Diagrams.	54
CEC Drawer Cable Diagram	54
Primary I/O Drawer Cable Diagram	55
Secondary I/O Drawer Cable Diagram	56
DC Power Cable Routings	57
Specifications	58
CEC Drawer	58
7014 Model T00 and T42 Rack	60
I/O Drawer	62
Noise Emission Notes	64
System Service Clearances	65
Power Cables	66
Service Inspection Guide	67
Chapter 2. Diagnostics Overview	69
Maintenance Analysis Procedures (MAPs).	69
Checkpoints.	70
FRU Isolation	71
Electronic Service Agent for the @server pSeries and RS/6000	71
Using the Service Processor and Electronic Service Agent Features	72
Service Processor.	72
Electronic Service Agent	73
Chapter 3. Maintenance Analysis Procedures (MAPs)	75
Entry MAP	75
Quick Entry MAP	76
Quick Entry MAP Table of Contents	76
MAP 1020: Problem Determination	84
MAP 1520: Power.	89
Map 1521: Cannot Power On The Primary I/O Drawer, Operator Panel Does Not Show OK Prompt	91
Map 1522: Cannot Power On The CEC Drawer	97
Map 1523: Cannot Power On The Secondary I/O Drawer, Operator Panel Power Present LED Does Not Come On	104

Map 1524: The SPCN Error Codes Table Directed You Here and the Error Code is 1011 1C0x	109
MAP 1540: Minimum Configuration	113
Chapter 4. Checkpoints	137
IPL Flow	137
Service Processor Checkpoints	140
Firmware Checkpoints	147
Boot Problems and Concerns	159
Chapter 5. Error Code to FRU Index	163
Four-Character Checkpoints	163
Replacing the Primary Drawer Operator Panel	163
Replacing the Network Adapter	163
Analyzing SPCN Errors on Secondary Drawers	163
Isolating the I/O Drawer Failure	164
Determining Location Code	164
Checkpoint and Error Code Index	165
Performing Slow Boot	166
Confirming Initial Error Code	166
Memory-Related Error Codes	167
Operator Panel Error Codes	168
SPCN Error Codes	169
Firmware Error Codes	190
Service Processor Error Codes	213
System Firmware Update Messages	354
Common Firmware Error Codes	354
Scan Log Dump Progress Codes	363
Problem Determination Generated Error Codes	364
Chapter 6. Loading the System Diagnostics In Service Mode	367
Default Boot List and Service Mode Bootlist	368
Chapter 7. Using the Service Processor	369
Service Processor Menus	370
Accessing the Service Processor Menus Locally	370
Accessing the Service Processor Menus Remotely	370
Saving and Restoring Service Processor Settings	370
Menu Inactivity	371
General User Menu	371
Privileged User Menus	372
Main Menu	372
Service Processor Setup Menu	374
Passwords	375
System Power Control Menu	378
System Information Menu	382
Memory Riser Card 1 Memory DIMM Locations for Service Processor Menus	387
Memory Riser Card 2 Memory DIMM Locations for Service Processor Menus	387
Processor Card Memory DIMM Locations for Service Processor Menus	388
Language Selection Menu	390

Call-In/Call-Out Setup Menu	391
Modem Configuration Menu	392
Serial Port Selection Menu	393
Serial Port Speed Setup Menu	393
Telephone Number Setup Menu	394
Call-Out Policy Setup Menu	395
Customer Account Setup Menu	396
Service Processor Procedures in Service Mode	396
Service Processor Functions	397
System Power-On Methods	398
Service Processor Reboot/Restart Recovery	399
Boot (IPL) Speed	399
Failure During Boot Process	399
Failure During Normal System Operation	399
Service Processor Reboot/Restart Policy Controls	399
System Firmware Updates	401
General Information on System Firmware Updates	401
Determining the Level of Firmware on the System	402
System Firmware Update Using a Locally Available Image	402
Updating System Firmware From the Service Processor Menus	403
Updating System Firmware from the AIX Service Aids	403
Updating System Firmware from the AIX Command Line	403
Recovery Mode	403
Configuring and Deconfiguring Processors or Memory	404
Run-Time CPU Deconfiguration (CPU Gard)	405
Service Processor System Monitoring - Surveillance	405
System Firmware Surveillance	405
Operating System Surveillance	405
Call-Out (Call-Home)	406
Console Mirroring	408
System Configuration	408
Service Processor Error Log	409
LCD Progress Indicator Log	410
Service Processor Operational Phases	411
Pre-Standby Phase	411
Standby Phase	411
Bring-Up Phase	412
Run-Time Phase	413
Chapter 8. Using System Management Services	416
Password Utilities	416
Display Error Log	417
Remote Initial Program Load Setup	417
SCSI Utilities	421
Select Console	421
MultiBoot	422
Select Language	425
OK Prompt	425
Exiting System Management Services	425

Chapter 9. Removal and Replacement Procedures	427
Handling Static-Sensitive Devices	428
Powering Off and Powering On the System	429
Powering Off the System	429
Powering On the System	429
Powering Off and Powering On the System Using the Service Processor	429
Hot-Pluggable FRUs	430
I/O Drawer PCI Slot LED Definitions	430
PCI Adapters	431
Non-Hot-Pluggable PCI Adapter	431
Removal	431
Replacement	432
Hot-Pluggable PCI Adapter	433
Replacing a Hot-Pluggable PCI Adapter	433
Installing a Hot-Pluggable PCI Adapter	435
Removing a Hot-Pluggable PCI Adapter	436
PCI Hot-Plug Manager Access	438
Accessing Hot-Plug Management Functions	438
PCI Hot-Plug Manager Menu	438
Memory Riser Cards and Memory DIMMs	441
Removal	441
Replacement	442
Processor Card	443
Removal	443
Replacement	443
CEC Fans	444
Removal	444
Replacement	444
CEC Backplane	445
Removal	445
Replacement	446
I/O Drawer Backplane Assembly	447
Removal	447
Replacement	448
RIO Card Assembly	449
Removal	449
Replacement	450
CEC Drawer Power Distribution Board	451
Removal	451
Replacement	451
I/O Drawer Power Distribution Board	452
Removal	452
Replacement	453
Power Supplies and Power Supply Fan Assemblies	454
Removal	455
Replacement	456
Power Supply Test Switch Procedure	457
Internal Disk Drives	458
Removal	458
Replacement	460

Fan Controller Card	461
Removal	461
Replacement	461
CD-ROM Drive	462
Removal	462
Replacement	462
Tape Drive	463
Removal	463
Replacement	463
Diskette Drive.	464
Removal	464
Replacement	464
Operator Panel	465
Removal	465
Replacement	466
Rear Service Position	467
Front Service Position	468
Battery	469
Removal	469
Replacement	470
Chapter 10. Parts Information	471
CEC Drawer	472
I/O Drawer.	477
CEC Drawer Internal Cables	481
Primary I/O Drawer Internal Cables	483
Secondary I/O Drawer Internal Cables	485
External Cables	487
Keyboards and Mouse	488
Keyboards and Mouse (Black)	490
Appendix A. Environmental Notices.	493
Product Recycling and Disposal.	493
Environmental Design	493
Acoustical Noise Emissions	493
Declared Acoustical Noise Emissions	494
Noise Emission Notes	494
Appendix B. Notices	495
Appendix C. Service Processor Setup and Test	497
Service Processor Setup Checklist	497
Testing the Setup	498
Testing Call-In	498
Testing Call-Out	498
Serial Port Configuration	499
Appendix D. Modem Configurations	501
Sample Modem Configuration Files	501
Generic Modem Configuration Files	501

Specific Modem Configuration Files	501
Configuration File Selection	502
Examples for Using the Generic Sample Modem Configuration Files	503
Customizing the Modem Configuration Files.	504
IBM 7852-400 DIP Switch Settings.	505
Xon/Xoff Modems	505
Ring Detection	506
Terminal Emulators	506
Recovery Procedures	506
Transfer of a Modem Session	507
Recovery Strategy	508
Prevention Strategy.	508
Modem Configuration Sample Files	509
Sample File modem_m0.cfg	509
Sample File modem_m1.cfg	511
Sample File modem_z.cfg.	513
Sample File modem_z0.cfg	515
Sample File modem_f.cfg	517
Sample File modem_f0.cfg	519
Sample File modem_f1.cfg	521
Appendix E. Rack Drawer Rail Instructions	525
Front Drawer-Stop Installation	525
Drawer Rail Assembly and Installation.	526
Rails for an S00 Type Rack	526
Rails for a T00 Type Rack	526
Rail Installation	526
Cable Routing	527
Index	531

Safety Notices

A *danger* notice indicates the presence of a hazard that has the potential of causing death or serious personal injury. *Danger* notices appear on the following pages:

- xii
- 89
- 427
- 455

A *caution* notice indicates the presence of a hazard that has the potential of causing moderate or minor personal injury. *Caution* notices appear on the following pages:

- xii
- xiii
- 89
- 427
- 462
- 469

For a translation of the safety notices contained in this book, see the *System Unit Safety Information*, order number SA23-2652.

Rack Safety Instructions

- Do not install this unit in a rack where the internal rack ambient temperatures will exceed 40 degrees C.
- Do not install this unit in a rack where the air flow is compromised. Any side, front or back of the unit used for air flow through the unit must not be in direct contact with the rack.
- Care should be taken to ensure that a hazardous condition is not created due to uneven mechanical loading when installing this unit in a rack. If the rack has a stabilizer it must be firmly attached before installing or removing this unit.
- Consideration should be given to the connection of the equipment to the supply circuit so that overloading of circuits does not compromise the supply wiring or overcurrent protection. To provide the correct power connection to the rack, refer to the rating labels located on the equipment in the rack to determine the total power requirement for the supply circuit.
- An electrical outlet that is not correctly wired could place hazardous voltage on the metal parts of the system or the devices that attach to the system. It is the responsibility of the customer to ensure that the outlet is correctly wired and grounded to prevent an electrical shock.

Electrical Safety

Observe the following safety instructions any time you are connecting or disconnecting devices attached to the workstation.

DANGER

An electrical outlet that is not correctly wired could place hazardous voltage on metal parts of the system or the devices that attach to the system. It is the responsibility of the customer to ensure that the outlet is correctly wired and grounded to prevent an electrical shock.

Before installing or removing signal cables, ensure that the power cables for the system unit and all attached devices are unplugged.

When adding or removing any additional devices to or from the system, ensure that the power cables for those devices are unplugged before the signal cables are connected. If possible, disconnect all power cables from the existing system before you add a device.

Use one hand, when possible, to connect or disconnect signal cables to prevent a possible shock from touching two surfaces with different electrical potentials.

During an electrical storm, do not connect cables for display stations, printers, telephones, or station protectors for communications lines.

CAUTION:

This product is equipped with a three-wire power cable and plug for the user's safety. Use this power cable with a properly grounded electrical outlet to avoid electrical shock.

DANGER

Do not attempt to open the covers of the power supply. Power supplies are not serviceable and are to be replaced as a unit.

CAUTION:

This unit has more than one power supply cord. To reduce the risk of electrical shock, disconnect two power supply cords before servicing.

Laser Safety Information

CAUTION:

This product may contain a CD-ROM which is a class 1 laser product.

Laser Compliance

All lasers are certified in the U.S. to conform to the requirements of DHHS 21 CFR Subchapter J for class 1 laser products. Outside the U.S., they are certified to be in compliance with the IEC 825 (first edition 1984) as a class 1 laser product. Consult the label on each part for laser certification numbers and approval information.

CAUTION:

All IBM laser modules are designed so that there is never any human access to laser radiation above a class 1 level during normal operation, user maintenance, or prescribed service conditions. Data processing environments can contain equipment transmitting on system links with laser modules that operate at greater than class 1 power levels. For this reason, never look into the end of an optical fiber cable or open receptacle. Only trained service personnel should perform the inspection or repair of optical fiber cable assemblies and receptacles.

Data Integrity and Verification

IBM computer systems contain mechanisms designed to reduce the possibility of undetected data corruption or loss. This risk, however, cannot be eliminated. Users who experience unplanned outages, system failures, power fluctuations or outages, or component failures must verify the accuracy of operations performed and data saved or transmitted by the system at or near the time of the outage or failure. In addition, users must establish procedures to ensure that there is independent data verification before relying on such data in sensitive or critical operations. Users should periodically check the IBM support websites for updated information and fixes applicable to the system and related software.

About This Book

This book provides maintenance information that is specific to the RS/6000 Enterprise Server Model H80, @server pSeries 660 Models 6H0 and 6H1, as well as adapters and attached devices that do not have their own service information. It also contains maintenance analysis procedures (MAPs) that are not common to other systems. In this book, the RS/6000 Enterprise Server Model H80, @server pSeries 660 Models 6H0 and 6H1 is hereafter referred to as the "system."

This book also contains Maintenance Analysis Procedures (MAPs) that are not common to other systems. MAPs that are common to all systems are contained in the *RS/6000 and @server pSeries Diagnostics Information for Multiple Bus Systems*.

This book is used by the service technician to repair system failures. This book assumes that the service technician has had training on the system unit.

ISO 9000

ISO 9000 registered quality systems were used in the development and manufacturing of this product.

Online Publications

RS/6000 and pSeries publications are available online. To access the online books, visit our Web site at: http://www.rs6000.ibm.com/resource/hardware_docs/

Related Publications

The following publications are available:

- The *System Unit Safety Information*, order number SA23-2652, contains translations of safety information used throughout this book.
- The *RS/6000 Enterprise Server Model H80 @server pSeries 660 Models 6H0 and 6H1 Installation Guide*, order number SA38-0575, contains information on how to set up and cable the system, install and remove options, and verify system operation.
- The *RS/6000 Enterprise Server Model H80 @server pSeries 660 Models 6H0 and 6H1 User's Guide*, order number SA38-0565, contains information on how to use the system, use diagnostics, use service aids, and verify system operations.
- The *7014 Model T00 and T42 Rack Installation and Service Guide*, order number SA38-0577, contains information regarding the 7014 Model T00 and T42 Rack, in which the RS/6000 Enterprise Server Model H80, @server pSeries 660 Models 6H0 and 6H1 may be installed.
- The *RS/6000 and @server pSeries Diagnostics Information for Multiple Bus Systems*, order number SA38-0509, contains common diagnostic procedures, error codes, service request numbers, and failing function codes. This manual is intended for trained service technicians.

- The *RS/6000 and @server pSeries Adapters, Devices, and Cable Information for Multiple Bus Systems*, order number SA38-0516, contains information about adapters, external devices, and cabling. This manual is intended to supplement information found in the *RS/6000 and @server pSeries Diagnostics Information for Multiple Bus Systems*.
- The *PCI Adapter Placement Reference*, order number SA38-0538, contains information regarding slot restrictions for adapters that can be used in this system.
- The *Site and Hardware Planning Information*, order number SA38-0508, contains information to help you plan your installation.
- The *SP Systems Service Guide*, order number GA22-7442, which contains servicing information for SP systems.
- The *Clustered @server Installation and Service Guide.*, order number GA22-7863, which contains service and installation information for clustered @serversystems.

Trademarks

The following terms are trademarks of International Business Machines Corporation in the United States, other countries, or both:

- AIX
- RS/6000
- pSeries
- e(logo)

Other company, product, and service names may be trademarks or service marks of others.

Chapter 1. Reference Information

This chapter provides an overview of the system, including a logical description and a physical overview. Additional details pertaining to the system are also provided. These include:

- Memory overview and placement
- General description of the operator panel
- Cabling rules
- System location rules and descriptions
- Powering on and off the system
- Power flow
- Data flow

Overview

The RS/6000 Enterprise Server Model H80, @server pSeries 660 Models 6H0 and 6H1 are multiprocessor, multibus systems packaged in drawers. The processors and memory are packaged in a 5 EIA-unit central electronics complex (CEC drawer), and the I/O devices are in a 5 EIA-unit I/O drawer. The basic system consists of one CEC drawer and one I/O drawer in the same rack. Connections between the CEC drawer and I/O drawers are made through a number of cables, which include the V/S COMM cable, RIO (remote input/output) cables, and JTAG cable.

Processors

The Model H80 and Model 6H1 can have one to six processors, of either of two processor types, in various configurations:

- Minimum configuration is one 450 MHz processor, which has 2 MB of L2 cache.
- Two or four 450 MHz processors, each with 4 MB of L2 cache.
- Six 500 MHz processors, each with 4 MB of L2 cache.

OR

- Minimum configuration is either one 600 MHz processor, which has 2 MB of L2 cache, or one 750 MHz processor, which has 8 MB of L2 cache.
- Two or four 600 MHz processors, each with 4 MB of L2 cache.
- Two or four 750 MHz processors, each with 8 MB of L2 cache.
- Six 668 MHz processors, each with 8 MB of L2 cache.
- Six 750 MHz processors, each with 8 MB of L2 cache.

The Model 6H0 can have one to four processors, of either of two processor types, in various configurations:

- Minimum configuration is one 450 MHz processor, which has 2 MB of L2 cache.
- Two or four 450 MHz processors, each with 4 MB of L2 cache.

OR

- Minimum configuration is either one 600 MHz processor, which has 2 MB of L2 cache, or one 750 MHz processor, which has 8 MB of L2 cache.
- Two or four 600 MHz processors, each with 4 MB of L2 cache.
- Two or four 750 MHz processors, each with 8 MB of L2 cache.

Memory

- 256 MB (minimum) to 32 GB (maximum)
- One or two memory riser cards; each riser card has sixteen sockets. 128 MB, 256 MB, 512 MB, and 1 GB dual inline memory modules (DIMMs) are available.
- Certain 32 MB DIMMs from older RS/6000 systems can also be used when upgrading the system memory.

Power is provided to the system rack through an ac power cord that is connected to a distribution bus. Power is connected from the distribution bus to each drawer independently. All drawers use 200 - 240 V ac power or -48 V dc power.

The primary I/O drawer has the following:

- 14 PCI slots
- System operator panel
- SPCN controller
- Interrupt and system bus control logic
- Service processor
- Optional boot DASDs
- Various connectors, including four serial port connectors, on the back of the drawer for the attachment of external devices.

Note: Serial ports 1 and 2 can only be used to access the service processor menus. No "heartbeat"-type devices or cables can be used on these ports. "Heartbeat"-type devices or cables must be installed on serial port 3 or serial port 4.

The PCI bus speeds are as follows:

- Up to 33 Mhz for the four 32-bit slots at 5 V
- Up to 66 Mhz for the ten 64-bit slots at 3.3 V

Slots 1-5, 8-10, 13 and 14 support either 32- or 64-bit PCI adapters. The remaining slots are 32-bit only.

The primary I/O drawer has space for up to three media devices (tape, CD-ROM, and diskette drive). Two optional disk drives can occupy PCI slots 13 and 14.

The system data flow diagrams are shown in "Data Flow with One-Way Processor" on page 3 and "Data Flow with Two- to Six-Way Processor" on page 4.

Data Flow with One-Way Processor

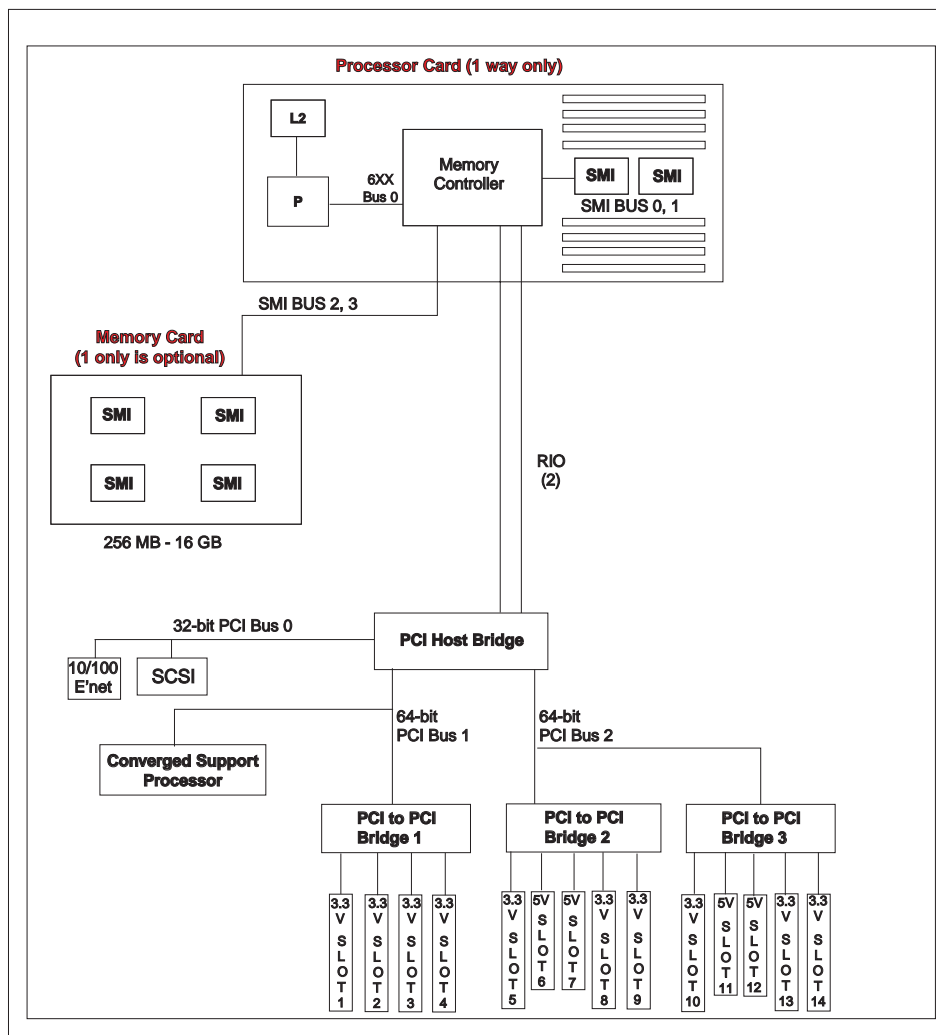

Data Flow with Two- to Six-Way Processor

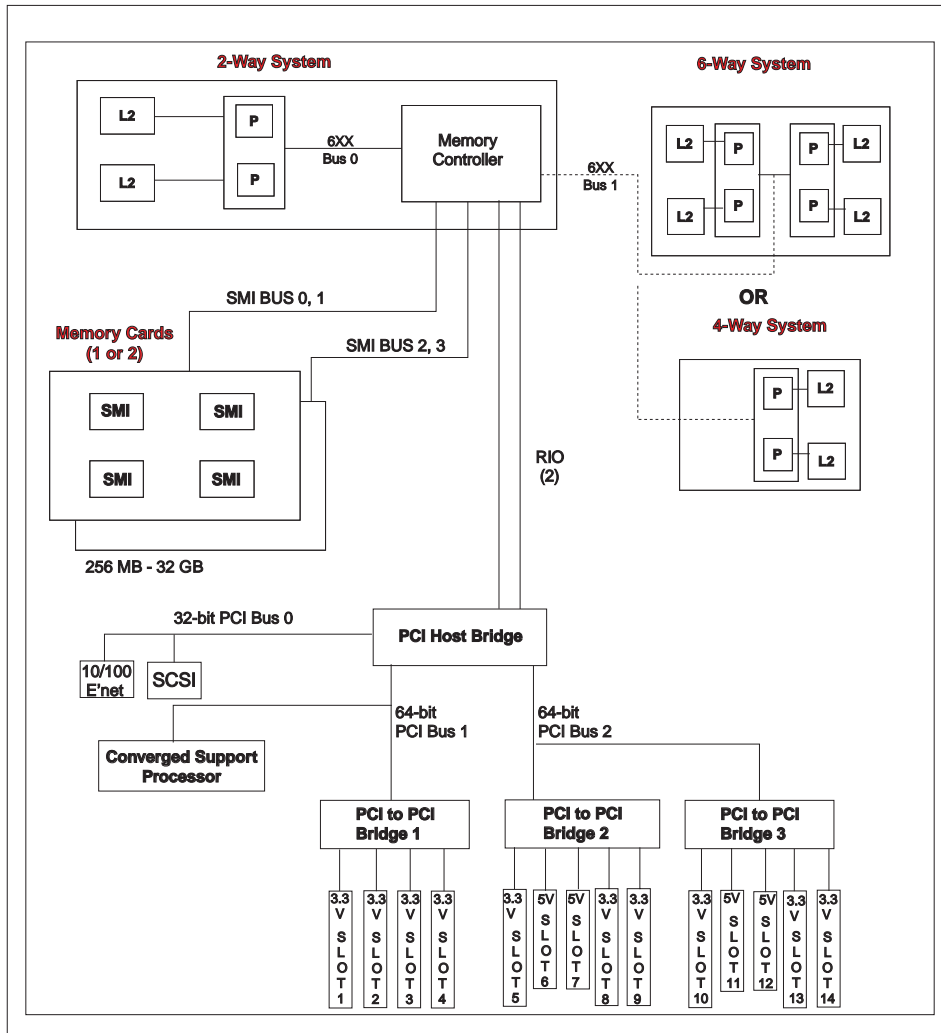

Powering the System On and Off

The system can be powered on after the following cables are connected:

- V/S COMM Cable
- All RIO cables
- All SPCN cables
- JTAG Cable
- All PCI cables to supported drawers

After the required cables are installed, and the power cables are connected, the power button on the primary I/O drawer operator panel can be pushed to initialize the system. Progress indicators, also referred to as *checkpoints*, are visible on the primary I/O drawer operator panel display and the power LED on the primary I/O drawer stops blinking and stays on, indicating the system power is on.

The CEC drawer and secondary I/O drawers are powered on through the primary I/O drawer system power control network (SPCN). When power is applied, the power LEDs on the CEC drawer and primary I/O drawer go from blinking to on continuously, and the power LED on the secondary I/O drawer comes on and stays on. This indicates that power levels are satisfactory in the drawers.

If the system is operating under AIX, type the shutdown command to power off the system. If you cannot use this method, you can power off the system by pressing the primary I/O drawer operator-panel power button.

Attention: Using the operator-panel power pushbutton to power off the system can cause unpredictable results in the data files, and the next IPL will take longer to complete.

For complete details on how to power on and off the system, go to “Powering Off and Powering On the System” on page 429 and “System Power-On Methods” on page 398.

Console Strategy

The firmware starts a console-selection sequence at system boot time if any of the following is true:

- A console has not yet been selected.
- A previous console-selection sequence timed-out.
- A change in the system configuration affects the console (keyboard installed/removed, mouse installed/removed, graphics adapter installed/removed or moved to another PCI slot).

The console-selection sequence allows you to select (from the appropriate input device) any one of the available console devices. If no console is selected within approximately 60 seconds, serial port 1 (S1) is selected as the console and the selection sequence times-out.

Attention: If an ASCII terminal is attached to serial port 1 (S1), and there is any interaction with this terminal, then:

- After OK displays in the operator panel
AND
- Before the power-on sequence is initiated

the firmware will use this terminal as the console, regardless of the previous console selection.

After a console has been selected, the console-selection sequence is only started at boot time if there is a change in the system configuration (as described above), or the contents of the system's nonvolatile memory (NVRAM) are lost.

Note: Moving an ASCII terminal from one serial port to another (from S1 to S2) cannot be detected by the firmware, so it does not constitute a configuration change.

You can also initiate a system console-selection sequence from the SMS menus.

Power-On Self-Test

After power is turned on and before the operating system is loaded, the system does a power-on self-test (POST). This test performs checks to ensure that the hardware is functioning correctly before the operating system is loaded. During the POST, a POST screen displays, and POST indicators appear on the firmware console (if one is connected). The next section describes the POST indicators and functions that can be accessed during the POST.

POST Indicators

POST indicators indicate tests that are being performed as the system is preparing to load the operating system. The POST indicators are words that display on the system console. Each time that the system starts a different step in the POST, a POST indicator word appears on the console. Each word is an indicator of the tests that are being performed.

The POST screen displays the following words:

Memory	Memory test
Keyboard	Initialize the keyboard and mouse. The time period for pressing a key to access the System Management Services, or to initiate a service mode boot is now open. See "POST Keys" for more information.
Network	Self-test on network adapters
SCSI	Adapters are being initialized
Speaker	Sounds an audible tone at the end of POST

POST Keys

The POST keys, if pressed *after* the keyboard POST indicator displays and *before* the last POST indicator speaker displays, cause the system to start services or to initiate service mode boots used for configuring the system and diagnosing problems. The keys are described below:

Note: The program function keys (F1-F12) on a keyboard attached to the I/O drawer are not used and will be ignored. After the keyboard POST indicator displays, you must use the numeric number keys to enter input.

1 Key

The numeric 1 key, when pressed during POST, starts the System Management Services (SMS) interface.

5 Key

The numeric 5 key, when pressed during POST, initiates a system boot in service mode using the default service mode boot list.

This mode attempts to boot from the first device of each type found in the list. It does not search for other bootable devices of that type if the first device is not bootable. Instead, it continues to the next device type in the list. The firmware supports up to five entries in the boot list.

The default boot sequence is:

1. Diskette
2. CD-ROM
3. Hard file
4. Tape drive (if installed)
5. Network
 - a. Token ring
 - b. Ethernet

6 Key

The numeric 6 key works like the numeric 5 key, except that firmware uses the customized service mode bootlist that was set up using the AIX service aids.

8 Key

To enter the open firmware command line, press the numeric 8 key *after* the word keyboard displays and before the last word speaker displays during startup. After you press the 8 key, the remaining POST indicators display until initialization completes.

When initialization and POST are complete, the open firmware command line (an OK prompt) displays.

The open firmware command line should only be used by service personnel to obtain additional debug information.

To exit from the open firmware command prompt, type `reset-all` or power off the system and reboot.

System Unit Locations

The system consists of a minimum of two drawers in one rack: the CEC drawer and the primary I/O drawer. These two components are connected by cables that transmit data and control signals. An additional I/O drawer can be added if further expansion of the system is required. The following figure shows the units.

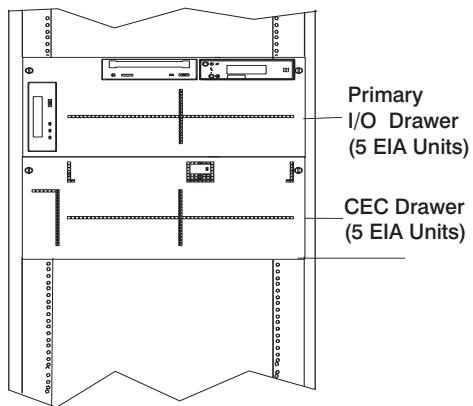

CEC Drawer Front View

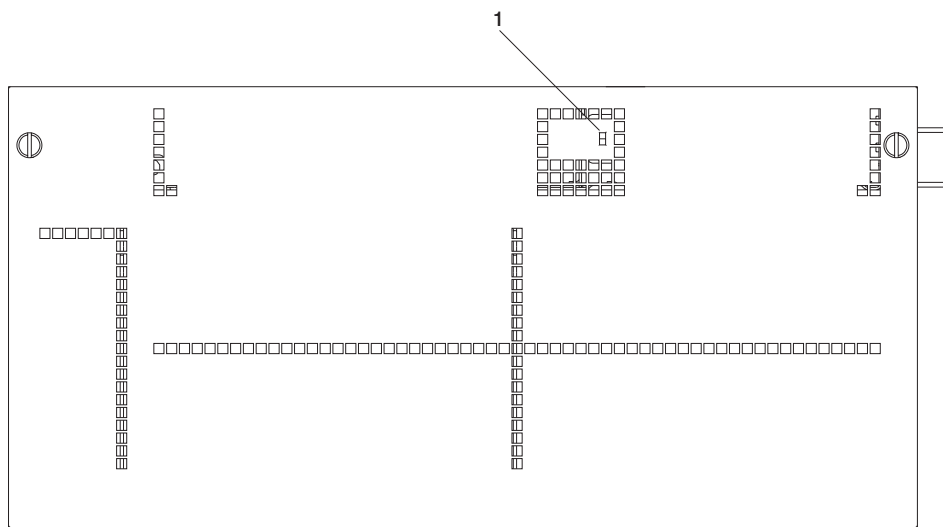

1 Power-On LED

CEC Drawer Top View

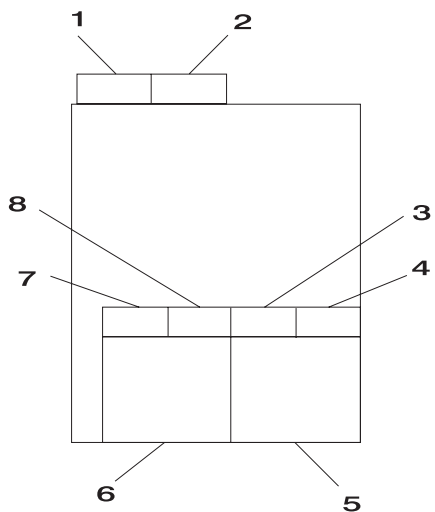

1	Fan 8 U1.1-F8	2	Fan 7 U1.1-F7
3	Fan 2 U1.1-F2	4	Fan 1 U1.1-F1
5	Power Supply 1 with Fan 5 U1.1-V1	6	Power Supply 2 with Fan 6 U1.1-V2 or Cooling Unit Fan 9 U1.1-F9
7	Fan 4 U1.1-F4	8	Fan 3 U1.1-F3

CEC Drawer Rear View

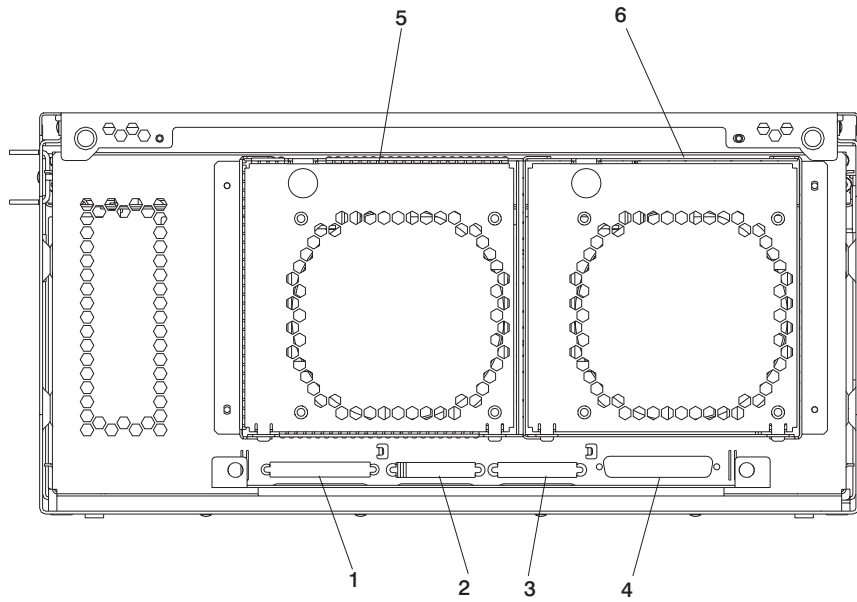

1	V/S COMM	2	RIO 0
3	RIO 1	4	JTAG
5	Fan 7	6	Fan 8

Primary I/O Drawer Front View

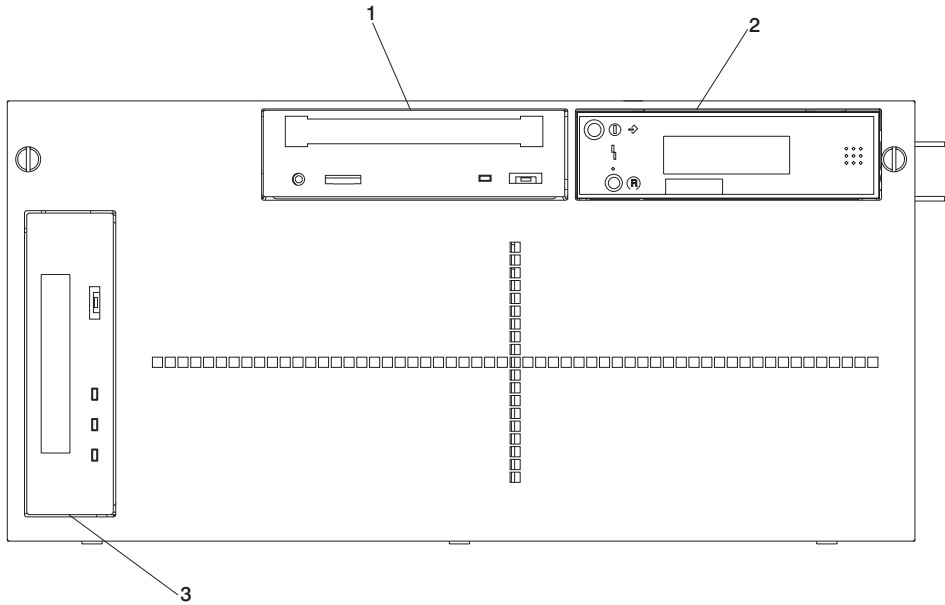

- | | | | |
|---|-----------------------|---|----------------|
| 1 | CD-ROM drive | 2 | Operator panel |
| 3 | Tape drive (optional) | | |

Primary I/O Drawer Top View

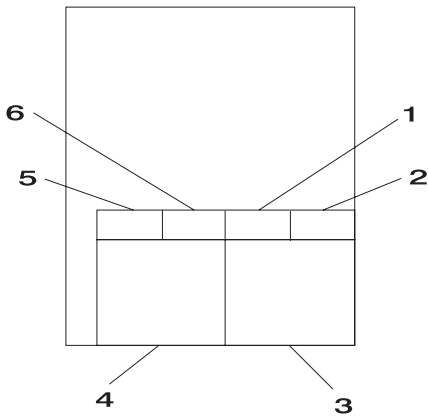

- | | | | |
|---|-----------------------------------|---|--------------------------------------------------------------------|
| 1 | Fan 2 U0.1-F2 | 2 | Fan 1 U0.1-F1 |
| 3 | Power Supply 1 with Fan 5 U0.1-V1 | 4 | Power Supply 2 with Fan 6 U0.1-V2
or Cooling Unit Fan 9 U0.1-F9 |

5

Fan 4 U0.1-F4

6

Fan 3 U0.1-F3

Primary I/O Drawer Rear View

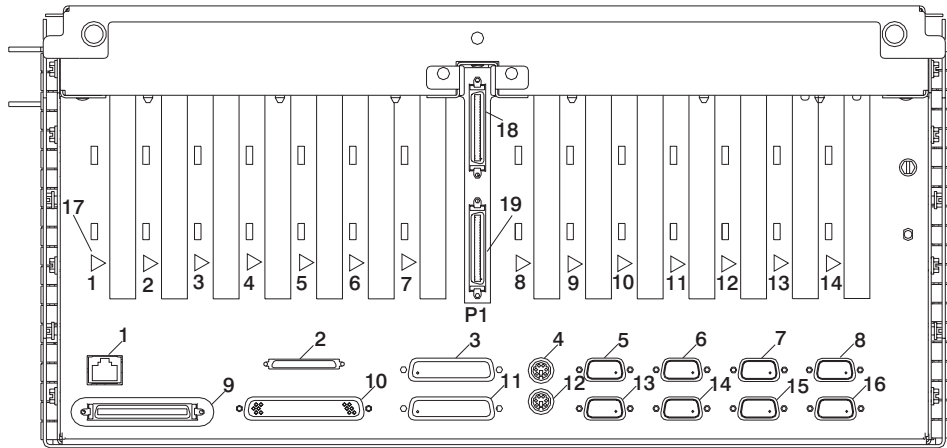

1	Ethernet connector	2	SCSI connector
3	Debug	4	Mouse connector
5	Serial port 1	6	Serial port 2
7	J11 (SPCN 1 connector)	8	J14 (SPCN 3 connector, reserved)
9	V/S COMM	10	JTAG connector
11	Parallel port	12	Keyboard connector
13	Serial port 3	14	Serial port 4
15	J15 (SPCN 2 connector)	16	J16 (SPCN 4 connector)
17	Hot-Plug LED (one for each adapter)	18	RIO 1 connector
19	RIO 0 connector		

Primary I/O Drawer Front View with Covers Removed

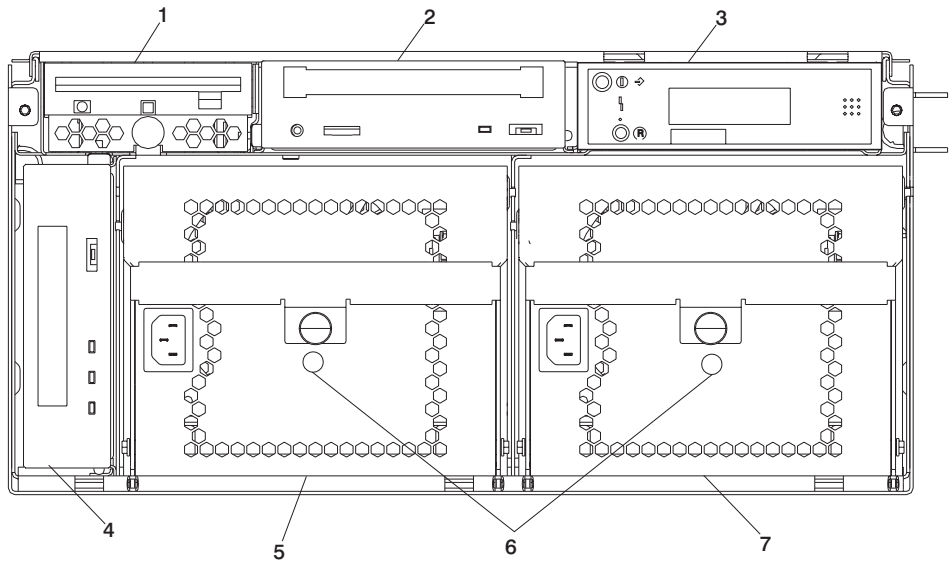

1	Bay A - Diskette drive	2	Bay B - CD-ROM drive
3	Bay C - Operator panel	4	Bay D - Tape drive (optional)
5	Power supply 2	6	Power supply LEDs
7	Power supply 1		

Secondary I/O Drawer Front View

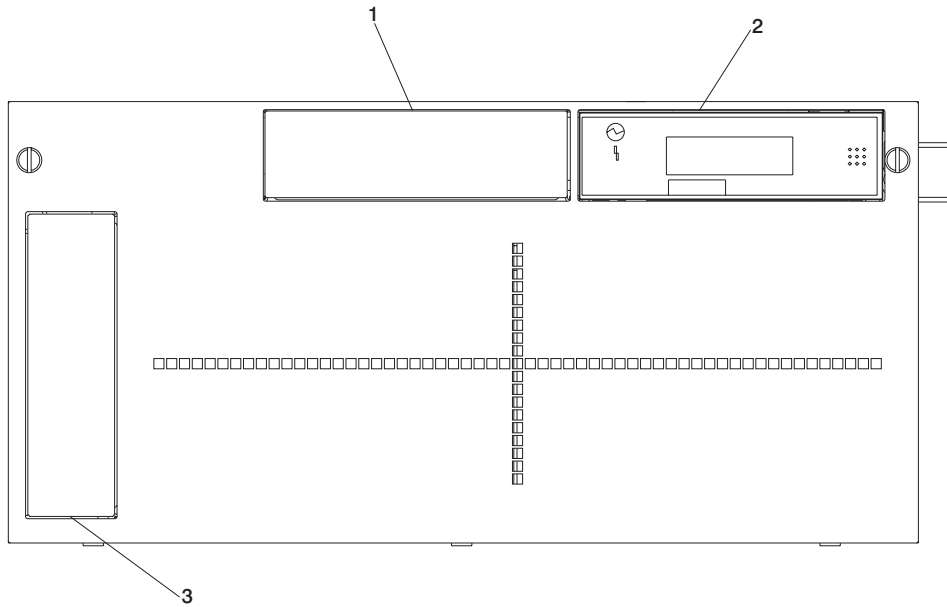

- | | | | |
|---|--------------------|---|----------------|
| 1 | Optional media bay | 2 | Operator panel |
| 3 | Optional media bay | | |

Secondary I/O Drawer Top View

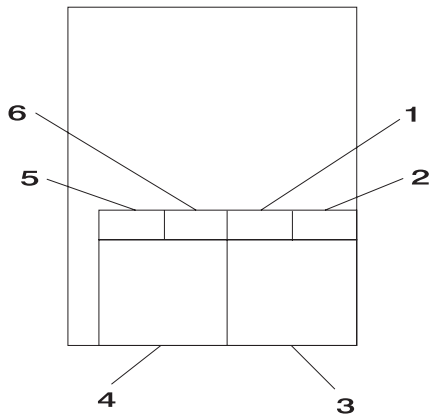

- | | | | |
|---|---------------------|---|-----------------------|
| 1 | Fan 2 U0.2-F2 | 2 | Fan 1 U0.2-F1 |
| 3 | Power Supply 1 with | 4 | Power Supply 2 with |
| | Fan 5 U0.2-V1 | | Fan 6 U0.2-V2 |
| | | | or Cooling Unit Fan 9 |
| | | | U0.2-F9 |

5

Fan 4 U0.2-F4

6

Fan 3 U0.2-F3

Secondary I/O Drawer Rear View

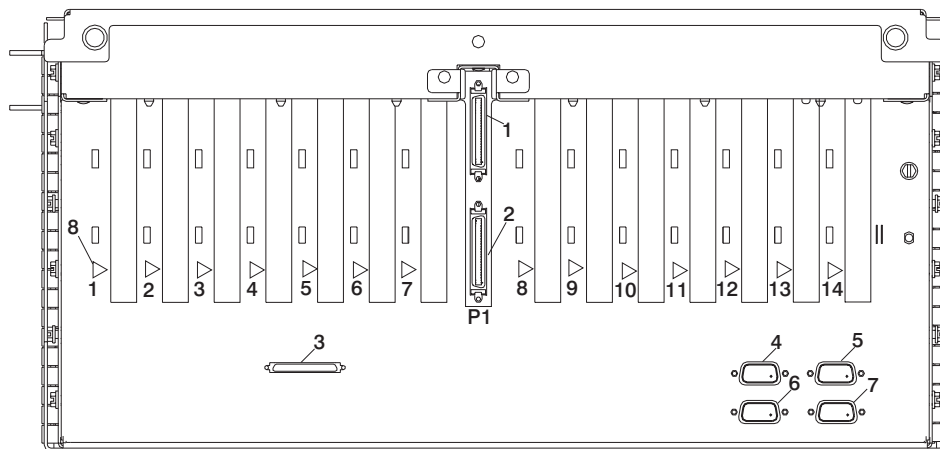

1	RIO 1 connector	2	RIO 0 connector
3	SCSI connector	4	J11 (SPCN 1 connector)
5	J14 (SPCN 3 connector)	6	J16 (SPCN 2 connector)
7	J15 (SPCN 4 connector)	8	Hot-plug LED (one for each adapter)

PCI Board Locations

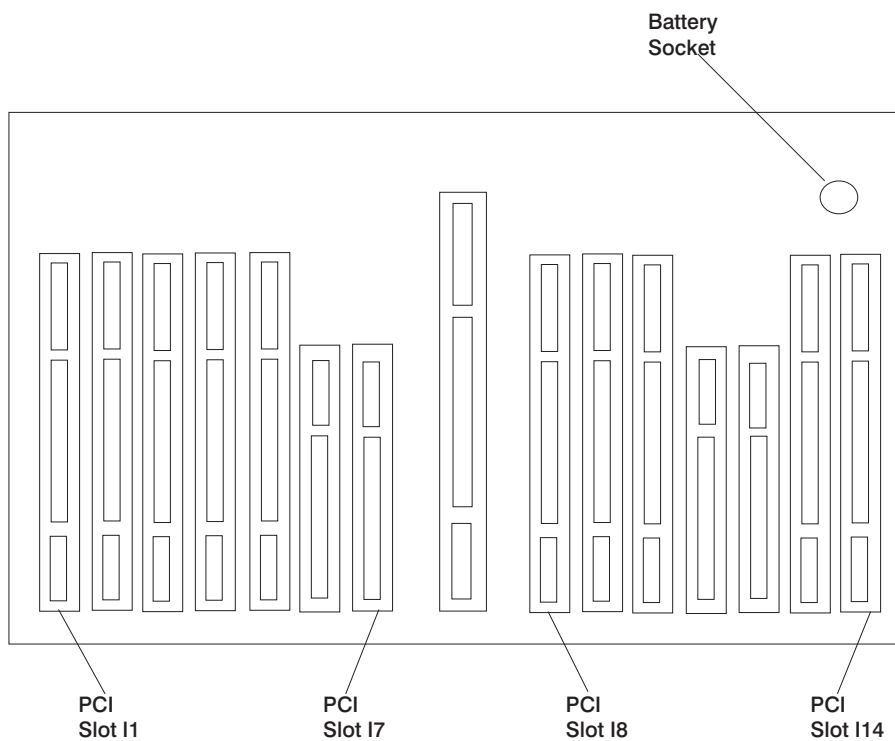

System Board Locations

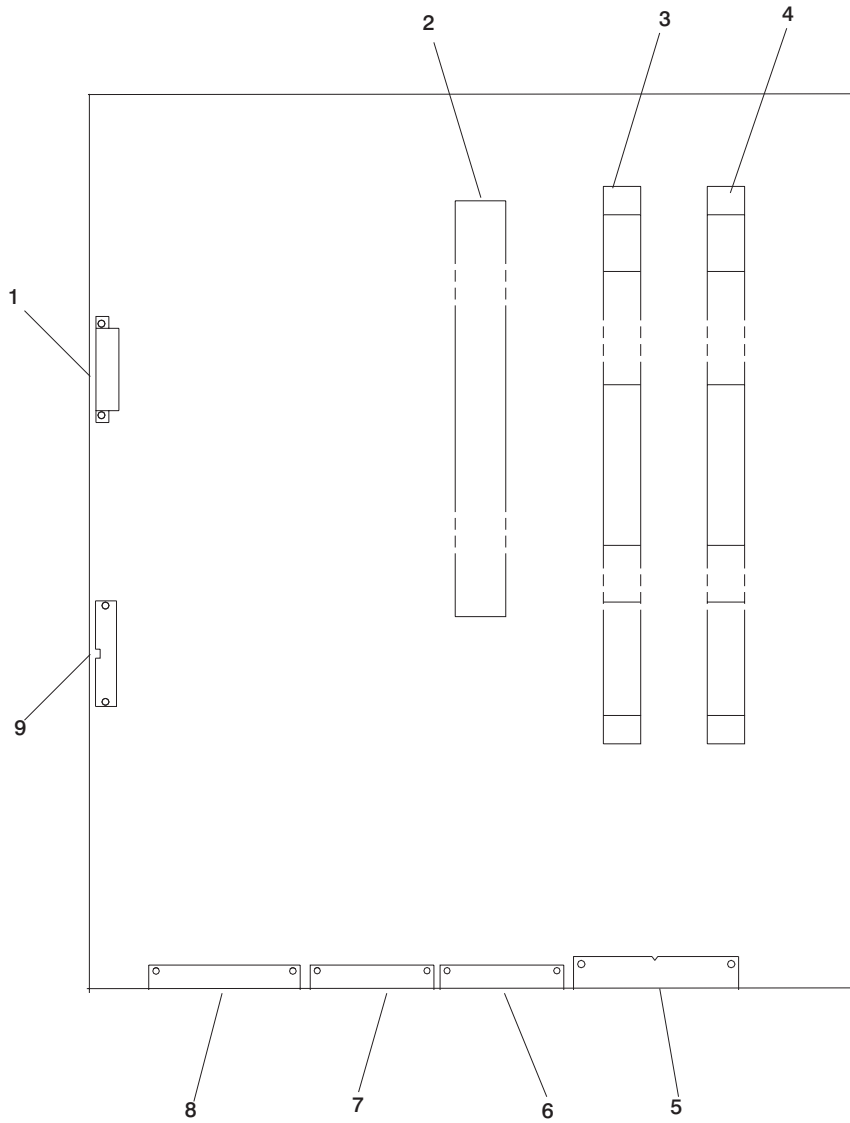

- | | | | |
|---|------------------------------------|---|-------------------------------|
| 1 | Power distribution board connector | 2 | Processor card connector |
| 3 | Memory riser card 1 connector | 4 | Memory riser card 2 connector |
| 5 | JTAG connector | 6 | RIO 1 connector |
| 7 | RIO 0 connector | 8 | V/S COMM connector |
| 9 | SPCN connector | | |

Memory Riser Card and Memory DIMM Locations

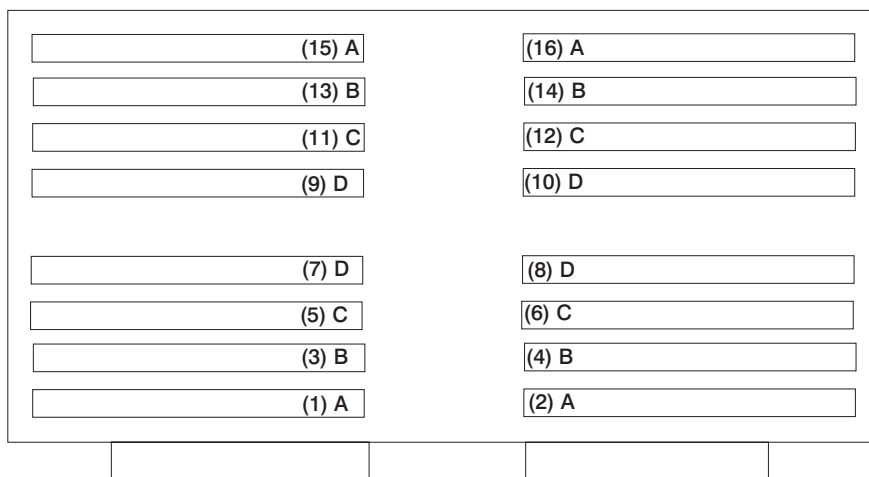

Location Code	Memory DIMMs
U1.1-P1-M1.n	Memory DIMMs on riser card 1 (n denotes DIMM number)
U1.1-P1-M2.n	Memory DIMMs on riser card 2 (n denotes DIMM number)
U1.1-P1-M1.1 x2	Memory pair A (DIMMs 1 and 15)
U1.1-P1-M1.1 x4	Memory quad A (DIMMs 1, 2, 15, 16)
U1.1-P1-M1.3 x4	Memory quad B (DIMMs 3, 4, 13, 14)
U1.1-P1-M1.5 x4	Memory quad C (DIMMs 5, 6, 11, 12)
U1.1-P1-M1.7 x4	Memory quad D (DIMMs 7, 8, 9, 10)
U1.1-P1-M2.1 x2	Memory pair A (DIMMs 1 and 15)
U1.1-P1-M2.1 x4	Memory quad A (DIMMs 1, 2, 15, 16)
U1.1-P1-M2.3 x4	Memory quad B (DIMMs 3, 4, 13, 14)
U1.1-P1-M2.5 x4	Memory quad C (DIMMs 5, 6, 11, 12)
U1.1-P1-M2.7 x4	Memory quad D (DIMMs 7, 8, 9, 10)
U1.1-P1-M1.1 x16	All memory DIMMs on riser card 1
U1.1-P1-M2.1 x16	All memory DIMMs on riser card 2
U1.1-P1-M1 x2	All memory DIMMs on riser cards 1 and 2

One-Way Processor Card Memory DIMM Locations

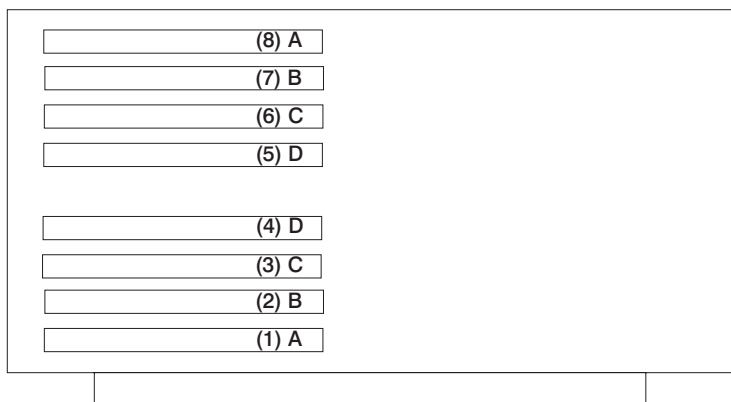

Location Code	Memory DIMMs
U1.1-P1-C1-Mn	Memory DIMMs on processor card (n denotes DIMM number)
U1.1-P1-C1-M1 x2	Memory pair A (DIMMs 1 and 8)
U1.1-P1-C1-M2 x2	Memory pair B (DIMMs 2 and 7)
U1.1-P1-C1-M3 x2	Memory pair C (DIMMs 3 and 6)
U1.1-P1-C1-M4 x2	Memory pair D (DIMMs 4 and 5)
U1.1-P1-C1-M1 x8	All memory DIMMs on processor card

Primary I/O Drawer Operator Panel

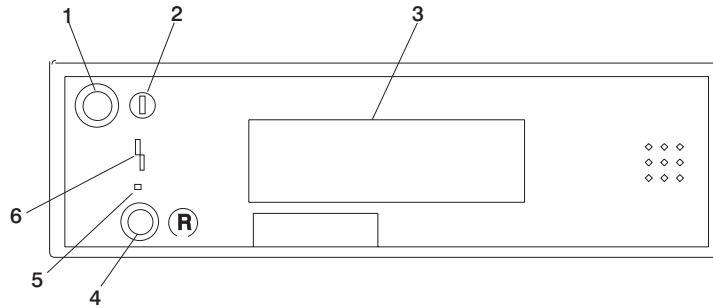

1	Power on/off button	2	Power on/off LED
3	Operator panel display	4	Reset button
5	Service processor reset button opening	6	Disturbance or system attention LED

Note: The service processor reset button should only be activated as part of a service action and must therefore be activated very carefully. An insulated paper clip is recommended. Unbend the clip so that it has a straight section about two inches long. Insert the clip straight into the hole, keeping the clip perpendicular to the plastic bezel. When you engage the reset switch, you should feel the detent of the switch. After you press the switch, the service processor resets and then shuts down the system.

Secondary I/O Drawer Operator Panel

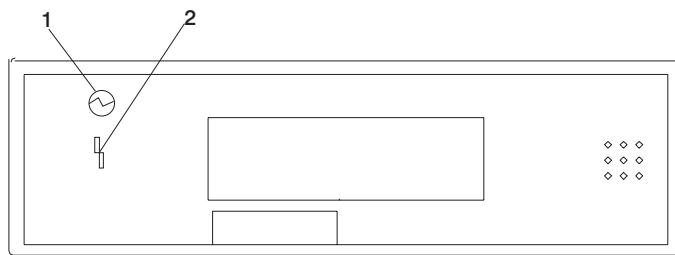

1

Power present LED

2

Disturbance or system
attention LED

SCSI IDs and Bay Locations

The following figure shows the SCSI IDs for media devices. The SCSI IDs for media devices installed at the factory are set using jumpers on the drives when they are installed. The SCSI IDs are set as shown in the following figure.

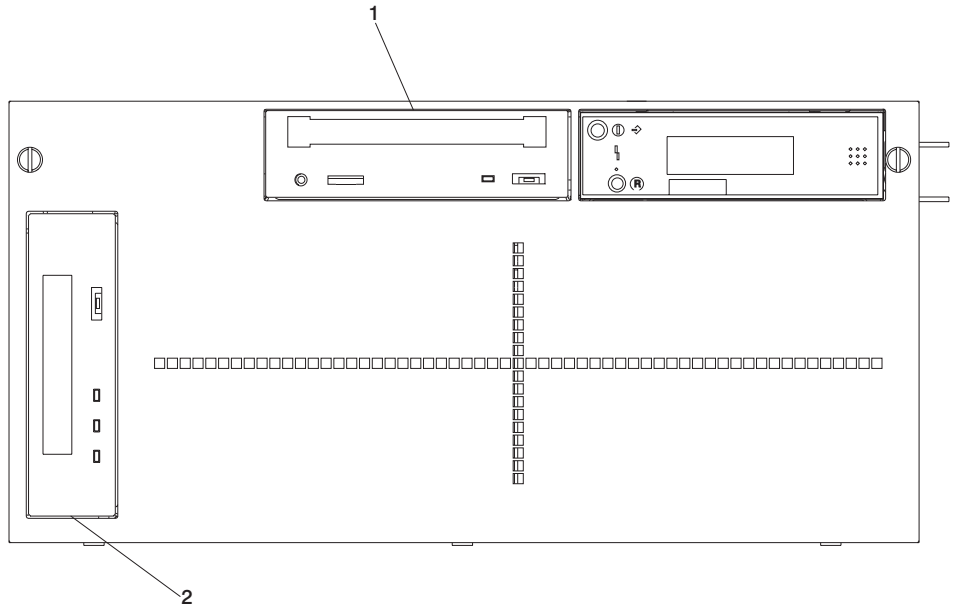

Note: The SCSI IDs shown for media devices indicate how the IDs are set when the system is shipped from the factory.

- | | | | |
|---|---------------------------|---|-------------------------|
| 1 | CD-ROM drive (SCSI ID= 1) | 2 | Tape drive (SCSI ID= 0) |
|---|---------------------------|---|-------------------------|

System Memory

Two slots are available for system memory riser cards. The system memory riser cards are located for easy access in the CEC drawer. (These slots are shown in “System Board Locations” on page 20.) Each memory riser card has 16 DIMM slots.

Four sizes of DIMMs are available: 128 MB, 256 MB, 512 MB and 1 GB. In addition, certain 32 MB DIMMS from earlier RS/6000 systems can also be used.

One-Way Processor Memory Placement Rules

The rules for one-way processor memory are as follows:

- Minimum memory is 1 pair of DIMMs in slots 1 and 8 (see “One-Way Processor Card Memory DIMM Locations” on page 22).
- Maximum memory is 4 DIMM pairs in slots 1 through 8 (see “One-Way Processor Card Memory DIMM Locations” on page 22).
- Each memory riser slot must have a memory filler card installed.
- When you are installing a memory riser card:
 - Memory DIMMs must be moved from the one-way processor card to the memory riser card.
 - The memory riser card must then have a minimum of four DIMMS (1 quad).

Riser Card Memory Placement Rules

The rules for riser card memory are as follows:

- Memory quads must contain DIMMs of equal memory size.
- Quad memory size may be mixed on a riser card.
- The minimum memory is four DIMMs. This memory must occupy quad A, which is slots 1, 2, 15, and 16 (see “Memory Riser Card and Memory DIMM Locations” on page 21).
- Populate the riser card starting with quad A and continuing with quads B, C, and D (see “Memory Riser Card and Memory DIMM Locations” on page 21).

I/O Drawer Features

I/O drawers may have two redundant power supplies. One of these power supplies is capable of providing the necessary voltages and currents independently of the other. The left and right power supply output voltages are connected and monitored by the power distribution board contained in the 5 EIA-unit I/O drawer. Both power supplies provide +12 V dc to the fans in the drawer to ensure sufficient cooling if one of the supplies fails. However, the short circuit prevention is on the I/O board to protect against shorts in one output, thus causing the +12 V dc to fail completely.

The left and right power supplies are hot-pluggable and may be changed one-at-a-time while the system is operational. Each power supply provides 5 V dc, 3.3 V dc, 12 V dc, and 5 V dc standby power.

The 5 V dc standby power is provided by both power supplies; this can be done because the power supplies contain overload protection against one supply shorting the other. Standby power (5 V dc) is provided to the part of the primary I/O drawer planar on which the SPCN and service processor logic reside.

I/O Drawer Addressing

I/O drawer addressing refers to the drawer number that is displayed in the operator panel on secondary I/O drawers. This address is the drawer's location in the RIO (remote I/O) loop. The drawer number is displayed in the form U0.n, where n is the drawer number. The primary I/O drawer number is 1 by default, but it is not displayed on the operator panel. The first time that the system is booted after a service action or configuration change that involves an I/O drawer or its backplane, the system may detect a duplicate or incorrect I/O drawer number. This situation can result in duplicate or incorrect drawer numbers being displayed when the system is booting up. The final drawer number will be assigned and displayed, when the bootup is complete. The drawer numbers are not reassigned unless a service action or configuration change occurs.

When ac power has been disconnected from the system or from a drawer, then reconnected, the I/O drawer address temporarily displays in the format *0n, where n is the drawer number. After the system is powered on, and the boot sequence has been initiated, the drawer numbers are restored to the U0.n format.

I/O Drawer and Power Supply LED Status

The following table summarizes the possible conditions of I/O drawer and power supply LEDs:

Status of LED	Operator Panel LED	Right Power Supply LED	Left Power Supply LED
Off	No power connected	No power connected or system power connected, not turned on, power supply detects NO faults	No power connected or system power connected, not turned on, power supply detects NO faults
On, blinking green	System power connected, not turned on	System power connected, not turned on, power supply detected fault	System power connected, not turned on, power supply detected fault
On, steady green	System power connected and turned on	System power connected and turned on	System power connected and turned on

Message Hierarchy for Secondary I/O Drawer Operator Panel

The messages that are displayed in the operator panel on secondary I/O drawers are arranged hierarchically, from highest priority to lowest priority. The message hierarchy is as follows:

1. 8-character error code

This indicates a critical error; the drawer power will be shut down. Standby power is still on, so the error message is still displayed in the operator panel. The I/O drawer Attention LED will be on. The error code displays on the top line of the display panel, left-justified. A FRU part number may also be displayed, right-justified, in the second line of the display.

2. 8-character informational message

This is a noncritical message, so the drawer power will not be shut down. The message should be investigated to see if service actions are indicated. A FRU part number may also be displayed, right-justified, in the second line of the display.

When 8-character codes are displayed, they are in the form 10n1xxxx, where n is the drawer number.

3. 8-character checkpoint

There is one 8-character checkpoint that will be displayed, 10n100AA, where n is the drawer number. This checkpoint indicates that the system power control network firmware is being updated, and the checkpoint will be displayed for approximately 15 seconds. This is the only checkpoint that displays on a secondary I/O drawer operator panel.

4. Drawer number

This will be in the form U0.n, where n is the drawer number. This message will normally be displayed unless a higher-level message is required.

When ac power has been disconnected from the system, then reconnected, the I/O drawer addresses on the secondary drawers will temporarily display in the format *0n, where n is the drawer number. After the system is powered on, and the boot sequence has been initiated, the drawer numbers are restored to the U0.n format.

Primary I/O Drawer Operator Panel Behavior During Power-On

After Connecting AC Power

Drawer State	Power LED	Drawer Operator Panel Display
Standby	Blinking slowly	8xxx checkpoints followed by OK
System power On	Blinking fast	9xxx checkpoints ending with E1FF
Receive firmware command	On solid	Exxx checkpoints ending with E105
Thereafter	On solid	0xxx checkpoints ending with a blank display

After Power is Removed Because of a Breakdown

Drawer State	Power LED	Drawer Operator Panel Display
Standby	Blinking slowly	OK is displayed
System power On	Blinking fast	9xxx checkpoints ending with E1FF
Receive firmware command	On solid	Exxx checkpoints ending with E105
Thereafter	On solid	0xxx checkpoints ending with a blank display

Critical error codes are posted on the top line (left-justified) of the drawer display with the attention light on solid. Any location codes are posted on the bottom line (left-justified).

Noncritical error codes are not posted. The drawer display remains blank with the attention light on solid.

Secondary I/O Drawer Operator Panel Behavior During Power-On

After Connecting AC Power

Drawer State	Power LED	Drawer Operator Panel Display
Standby	Off	Display shows a temporary drawer ID
Receive firmware command to power on	On solid	Message based on "Message Hierarchy for Secondary I/O Drawer Operator Panel" on page 29.

After Power is Removed Because of a Shutdown

Drawer State	Power LED	Drawer Operator Panel Display
Standby	Off	Message based on "Message Hierarchy for Secondary I/O Drawer Operator Panel" on page 29
Receive firmware command to power on	On solid	Message based on "Message Hierarchy for Secondary I/O Drawer Operator Panel" on page 29

Logical and Physical Locations

The system uses physical location codes in conjunction with AIX location codes to provide mapping of the failing field replaceable units (FRUs). The location codes are produced by the system unit's firmware and the AIX operating system.

Physical Location Codes

Physical location codes provide a mapping of logical functions in a platform (or expansion sites for logical functions, such as connectors or ports) to their specific locations within the physical structure of the platform.

Location Code Format

The format for the location code is a string of alphanumeric characters separated by a dash (-), slash (/), pound sign (#) or period (.) character. The base location is all of the information preceding the slash (/) or pound sign (#). The base location identifies a device that is connected to or plugged into the parent. Extended location information follows the slash (/). Extended location information identifies a device that is part of the parent, a connector, or a cable. Cable information follows the pound sign (#). Cable information identifies a cable that is connector to parent. The following are examples:

- P1-C1 identifies a processor card C1 plugged into planar P1.
- P1-M1 identifies a memory card M1 plugged into planar P1.
- P1-K1 identifies a keyboard attached to K1 on planar P1.
- P1/S1 identifies serial port 1 controller on planar P1, the connector for serial port 1, or the cable attached to serial port 1.
- P1-I2/E3 identifies an Ethernet controller 3 on the card in slot 2 (I2) on planar P1, the connector for Ethernet controller 3, or the cable attached to Ethernet controller 3.
- P1-I2#E3 identifies the cable attached to Ethernet controller 3 on the card in slot 2 (I2) on planar P1.

The period (.) identifies sublocations (DIMMs on a memory card, SCSI addresses, cables). The following are examples:

- P1-M1.4 identifies DIMM 4 on memory card 1 plugged into planar P1.
- P1-C1.1 identifies processor 1 plugged into processor card 1 which is plugged into planar P1.
- U0.1-P1/Z1-A3 identifies a SCSI device with SCSI ID 3 attached to SCSI bus 1 on planar 1 in the primary I/O drawer.
- P2-Z1-A3.1 identifies a SCSI device with SCSI address of LUN 1 at SCSI ID 3 attached to SCSI bus 1 from planar 2.
- P1-I2#E3.2 identifies the second in a series of cables attached to Ethernet controller 3 on the card in slot 2 (I2) on planar P1.

Depending on the AIX and firmware levels, AIX diagnostics may include the extended location information when identifying a planar or card. The extended location information or cable information is always included when identifying a cable or connector. Location codes with extended location information that are displayed without a description identifying the devices always identify the cable attached to the port.

Multiple FRU Callout Instructions

If an eight-digit error code appears in the operator panel display or in Chapter 5, “Error Code to FRU Index” on page 163, a location code for a failing part may also be specified. If the location code includes a blank space followed by a lowercase x followed by a number, this is an error code with multiple FRU callouts. This error can typically happen with memory DIMMs, memory riser cards, or processors and may involve mixed types of parts. In this case, check the system’s configuration FRU part numbers to determine the appropriate set of FRUs.

For example, if the location code U1.1-P1-M1.1 x2 was displayed, this indicates memory pair A (two DIMMs) on the first memory riser card was suspected.

You can determine the FRU part numbers of the electronic assemblies in the system in two ways:

- Using the service processor menus
From the general user menu, select **Read VPD Image from Last System Boot**, then enter 90 to display detailed vital product data (VPD).
- Using the **lscfg -vp | pg** command on the AIX command line
Type the following command: `lscfg -vp | pg` to display the detailed VPD of all assemblies. Notice that the FRU part number information for processors and memory DIMMs may be at the bottom of the command output.

For SCSI devices, the location code is defined as follows:

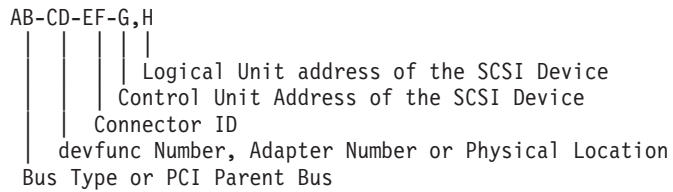

Where:

- AB-CD-EF are the same as non-SCSI devices.
- G defines the control unit address of the device. Values of 0 to 15 are valid.
- H defines the logical unit address of the device. Values of 0 to 255 are valid.

A bus location code is also generated as '00-XXXXXXXX', where XXXXXXXXX is equivalent to the node's unit address.

Examples of physical location codes and AIX location codes are:

1. PCI adapter in primary I/O drawer, slot 1
 - Location Code U0.1-P1-I1
 - AIX Location Code 11-08
2. PCI adapter in secondary I/O drawer, slot 1
 - Location Code U0.2-P1-I1
 - AIX Location Code 51-08

AIX and Physical Location Code Reference Tables

The following tables contain location codes that are used to identify functional units in the system. Each of the following tables shows the locations for a physical part of the system.

FRU Name	Location Code	AIX Location Code	Physical Connection	Logical Connection
CEC Drawer				
CEC Drawer	U1.1	00-00		
CEC Backplane	U1.1-P1	00-00		
Processor Card	U1.1-P1-C1	00-00 to 00-0A	Connector M03	
Processor Card Cache	U1.1-P1-C1	00-00		
I/O Hub and Interrupt Controller	U1.1-P1-C1	00-00		
Regulator	U1.1-P1-C1	00-00		
Memory Controller	U1.1-P1-C1	00-00		
Memory DIMMs on Processor Card	U1.1-P1-C1-M1 to U1.1-P1-C1-M8	00-00	Refer to "One-Way Processor Card Memory DIMM Locations" on page 22.	
Memory Pair A on Processor Card	U1.1-P1-C1-M1 x2	00-00	Refer to "One-Way Processor Card Memory DIMM Locations" on page 22.	
Memory Pair B on Processor Card	U1.1-P1-C1-M2 x2	00-00	Refer to "One-Way Processor Card Memory DIMM Locations" on page 22.	
Memory Pair C on Processor Card	U1.1-P1-C1-M3 x2	00-00	Refer to "One-Way Processor Card Memory DIMM Locations" on page 22.	
Memory Pair D on Processor Card	U1.1-P1-C1-M4 x2	00-00	Refer to "One-Way Processor Card Memory DIMM Locations" on page 22.	

FRU Name	Location Code	AIX Location Code	Physical Connection	Logical Connection
All memory DIMMs on Processor Card	U1.1-P1-C1-M1 x8	00-00	Refer to "One-Way Processor Card Memory DIMM Locations" on page 22.	
Riser Card 1 Memory DIMMs 1 - 16	U1.1-P1-M1.1 to U1.1-P1-M1.16	00-00	Refer to "Memory Riser Card and Memory DIMM Locations" on page 21.	
Memory pair A on riser card 1	U1.1-P1-M1.1 x2	00-00	Refer to "Memory Riser Card and Memory DIMM Locations" on page 21.	
Memory quad A on riser card 1	U1.1-P1-M1.1 x4	00-00	Refer to "Memory Riser Card and Memory DIMM Locations" on page 21.	
Memory quad B on riser card 1	U1.1-P1-M1.3 x4	00-00	Refer to "Memory Riser Card and Memory DIMM Locations" on page 21.	
Memory quad C on riser card 1	U1.1-P1-M1.5 x4	00-00	Refer to "Memory Riser Card and Memory DIMM Locations" on page 21.	
Memory quad D on riser card 1	U1.1-P1-M1.7 x4	00-00	Refer to "Memory Riser Card and Memory DIMM Locations" on page 21.	
All memory on riser card 1	U1.1-P1-M1.1 x16	00-00	Refer to "Memory Riser Card and Memory DIMM Locations" on page 21.	
Riser Card 2 Memory DIMMs 1 - 16	U1.1-P1-M2.1 to U1.1-P1-M2.16	00-00	Refer to "Memory Riser Card and Memory DIMM Locations" on page 21..	

FRU Name	Location Code	AIX Location Code	Physical Connection	Logical Connection
Memory quad A on riser card 2	U1.1-P1-M2.1 x4	00-00	Refer to "Memory Riser Card and Memory DIMM Locations" on page 21.	
Memory quad B on riser card 2	U1.1-P1-M2.3 x4	00-00	Refer to "Memory Riser Card and Memory DIMM Locations" on page 21.	
Memory quad C on riser card 2	U1.1-P1-M2.5 x4	00-00	Refer to "Memory Riser Card and Memory DIMM Locations" on page 21.	
Memory quad D on riser card 2	U1.1-P1-M2.7 x4	00-00	Refer to "Memory Riser Card and Memory DIMM Locations" on page 21.	
All memory on riser card 2	U1.1-P1-M2.1 x16	00-00	Refer to "Memory Riser Card and Memory DIMM Locations" on page 21.	
All memory (both riser cards)	U1.1-P1-M1 x2	00-00	Connectors M01 and M02	
RIO Port 0 Connector	U1.1-P1-C1/Q3			
RIO Port 1 Connector	U1.1-P1-C1/Q2			
RIO Port 0 Cable/Connector	U1.1-P1/Q3			
RIO Port 1 Cable/Connector	U1.1-P1/Q2			
V/S COMM Connector	U1.1-P1/Q1			
JTAG Connector	U1.1-P1/Q4			
Thermal Sensor	U1.1-P1			
Power Distribution Card	U1.1-X1			
Power Distribution Card Connector 1	U1.1-X1/V1			

FRU Name	Location Code	AIX Location Code	Physical Connection	Logical Connection
Power Distribution Card Connector 2	U1.1-X1/V2			
Fan Controller Card	U1.1-X2		PDB connector J3	
LED Card	U1.1-L1		PDB connector J6	
Power Supply 1 (w/Fan 5)	U1.1-V1		PDB connector J2	
Power Supply 2 (w/Fan 6)	U1.1-V2		PDB connector J1	
Fan 1	U1.1-F1		Fan connector P3 on power supply 1	
Fan 2	U1.1-F2		Fan connector P3 on power supply 1	
Fan 3	U1.1-F3		Fan connector P3 on power supply 2	
Fan 4	U1.1-F4		Fan connector P3 on power supply 2	
Fan 7	U1.1-F7		PDB connector J7	
Fan 8	U1.1-F8		PDB connector J7	
Fan 9	U1.1-F9		In cooling unit	
Primary I/O Drawer Locations				
Primary I/O Drawer	U0.1			
Primary I/O Backplane	U0.1-P1			
Service Processor	U0.1-P1			
NVRAM	U0.1-P1	Not used by AIX		
Service Processor ISA Bridge	U0.1-P1	Not used by AIX		
Real Time Clock (RTC)	U0.1-P1	Not used by AIX		
Timer	U0.1-P1	Not used by AIX		
Interrupt Controller	U0.1-P1	Not used by AIX		
DMA Controller	U0.1-P1	Not used by AIX		
SPCN Controller	U0.1-P1		I/O board connector J2	

FRU Name	Location Code	AIX Location Code	Physical Connection	Logical Connection
Battery	U0.1-P1-V3			
Diskette Controller	U0.1-P1/D1	01-D1		
Diskette Drive Connector	U0.1-P1-D1	01-D1-00-00	I/O board connector J28	
Keyboard Controller	U0.1-P1/K1	01-K1-00		
Keyboard Connector	U0.1-P1-K1	01-K1-00-00		
Mouse Controller	U0.1-P1-K11	01-K1-01		
Mouse	U0.1-P1-O1	01-K1-01-00		
V/S COMM Connector	U0.1-P1/Q1			
JTAG Connector	U0.1-P1/Q4	Not used by AIX	I/O board connector J9	
Parallel Port	U0.1-P1/R1	01-R1		
Serial Port 1	U0.1-P1/S1	01-S1		
Serial Port 2	U0.1-P1/S2	01-S2		
Serial Port 3	U0.1-P1/S3	01-S3		
Serial Port 4	U0.1-P1/S4	01-S4		
RIO Bus Adapter	U0.1-P1.1			
RIO Port 0 Connector	U0.1-P1.1/Q1			
RIO Port 1 Connector	U0.1-P1.1/Q2			
PCI Bus Controller 1	U0.1-P1	00-fff7f09000		
ISA Bus	U0.1-P1	10-80		
PCI to PCI Bridge 1	U0.1-P1	10-58 10-5A 10-5C 10-5E		
PCI Slot 1	U0.1-P1/I1	10-58		
PCI Slot 1 Content	U0.1-P1-I1	11-08 thru 11-0F or 12-xx or 13-xx		
PCI Slot 2	U0.1-P1/I2	10-5A		
PCI Slot 2 Content	U0.1-P1-I2	14-08 thru 14-0F or 15-xx or 16-xx		
PCI Slot 3	U0.1-P1/I3	10-5C		

FRU Name	Location Code	AIX Location Code	Physical Connection	Logical Connection
PCI Slot 3 Content	U0.1-P1-I3	17-08 thru 17-0F or 18-xx or 19-xx		
PCI Slot 4	U0.1-P1/I4	10-5E		
PCI Slot 4 Content	U0.1-P1-I4	1A-08 thru 1A-0F or 1B-xx or 1C-xx		
PCI Bus Controller 2	U0.1-P1	00-fff7f0a000		
PCI to PCI Bridge 2	U0.1-P1	20-58 20-5A 20-5B 20-5C 20-5E		
PCI Slot 5	U0.1-P1/I5	20-58		
PCI Slot 5 Content	U0.1-P1-I5	21-08 thru 21-0F or 22-xx or 23-xx		
PCI Slot 6 (5V)	U0.1-P1/I6	20-5A		
PCI Slot 6 Content	U0.1-P1-I6	24-08 thru 24-0F or 25-xx or 26-xx		
PCI Slot 7 (5V)	U0.1-P1/I7	20-5B		
PCI Slot 7 Content	U0.1-P1-I7	27-08 thru 27-0F or 28-xx or 29-xx		
PCI Slot 8	U0.1-P1/I8	20-5C		
PCI Slot 8 Content	U0.1-P1-I8	2A-08 thru 2A-0F or 2B-xx or 2C-xx		
PCI Slot 9	U0.1-P1/I9	20-5E		
PCI Slot 9 Content	U0.1-P1-I9	2D-08 thru 2D-0F or 2E-xx or 2F-xx		
PCI to PCI Bridge 3	U0.1-P1	20-60 20-62 20-63 20-64 20-66		
PCI Slot 10	U0.1-P1/10	20-60		

FRU Name	Location Code	AIX Location Code	Physical Connection	Logical Connection
PCI Slot 10 Content	U0.1-P1-I10	31-08 thru 31-0F or 32-xx or 33-xx		
PCI Slot 11 (5V)	U0.1-P1/I11	20-62		
PCI Slot 11 Content	U0.1-P1-I11	34-08 thru 34-0F or 35-xx or 36-xx		
PCI Slot 12 (5V)	U0.1-P1/I12	20-63		
PCI Slot 12 Content	U0.1-P1-I12	37-08 thru 37-0F or 38-xx or 39-xx		
PCI Slot 13	U0.1-P1/I13	20-64		
PCI Slot 13 Content	U0.1-P1-I13	3A-08 thru 3A-0F or 3B-xx or 3C-xx		
PCI Slot 14	U0.1-P1/I14	20-66		
PCI Slot 14 Content	U0.1-P1-I14	3D-08 thru 3D-0F or 3E-xx or 3F-xx		
PCI Bus Controller 0	U0.1-P1	00-fff7f08000		
Integrated Ethernet	U0.1-P1/E1	40-58		
Internal SCSI Controller	U0.1-P1/Z1	40-60		
CD-ROM drive	U0.1-P1/Z1-A1	40-60-00-1		
Tape drive	U0.1-P1/Z1-A0	40-60-00-0		
Internal DASD 1	U0.1-P1/Z1-A4	40-60-00-4		
Internal DASD 2	U0.1-P1/Z1-A8	40-60-00-8		
External SCSI Controller	U0.1-P1/Z2	40-61		
Thermal Sensor (Right)	U0.1-P1			
Thermal Sensor (Left)	U0.1-P1			
Power Distribution Card	U0.1-X1			
Power Distribution Card Connector 1	U0.1-X1/V1			

FRU Name	Location Code	AIX Location Code	Physical Connection	Logical Connection
Power Distribution Card Connector 2	U0.1-X1/V2			
Fan Controller Card	U0.1-X2		PDB connector J3	
Operator Panel	U0.1-L1	N/A	I/O board connector J3	
System VPD Module	U0.1-L1-N1			
Thermal Sensor (Ambient)	U0.1-L1			
Power Supply 1 (w/Fan 5)	U0.1-V1		PDB connector J2	
Power Supply 2 (w/Fan 6)	U0.1-V2		PDB connector J1	
Fan 1	U0.1-F1		Fan connector P3 on power supply 1	
Fan 2	U0.1-F2		Fan connector P3 on power supply 1	
Fan 3	U0.1-F3		Fan connector P3 on power supply 2	
Fan 4	U0.1-F4		Fan connector P3 on power supply 2	
Fan 9	U0.1-F9		In cooling unit	
Service Processor Firmware	U0.1-P1/Y2			
System Firmware	U0.1-P1/Y1			
SPCN Firmware	U0.1-P1/Y3			
SPCN VPD	U0.1-P1/Y4			
Secondary I/O Drawer Locations				
Secondary I/O Drawer	U0.2			
Secondary I/O Backplane	U0.2-P1			
SPCN Controller	U0.2-P1		I/O board connector J2	
Ext. SCSI Connector	U0.2-P1/Z1			
RIO Bus Adapter	U0.2-P1.1			
RIO Port 0 Connector	U0.2-P1.1/Q1			

FRU Name	Location Code	AIX Location Code	Physical Connection	Logical Connection
RIO Port 1 Connector	U0.2-P1.1/Q2			
PCI Bus Controller 1	U0.2-P1	00-fff7e09000		
PCI to PCI Bridge 1	U0.2-P1	50-58 50-5A 50-5C 50-5E		
PCI Slot 1	U0.2-P1/I1	50-58		
PCI Slot 1 Content	U0.2-P1-I1	51-08 thru 51-0F or 52-xx or 53-xx		
PCI Slot 2	U0.2-P1/I2	50-5A		
PCI Slot 2 Content	U0.2-P1-I2	54-08 thru 54-0F or 55-xx or 55-xx		
PCI Slot 3	U0.2-P1/I3	50-5C		
PCI Slot 3 Content	U0.2-P1-I3	57-08 thru 57-0F or 58-xx or 59-xx		
PCI Slot 4	U0.2-P1/I4	50-5E		
PCI Slot 4 Content	U0.2-P1-I4	5A-08 thru 5A-0F or 5B-xx or 5C-xx		
PCI Bus Controller 2	U0.2-P1	000fff7e0a000		
PCI to PCI Bridge 2	U0.2-P1	60-58 60-5A 60-5B 60-5C 60-5E		
PCI Slot 5	U0.2-P1/I5	60-58		
PCI Slot 5 Content	U0.2-P1-I5	61-08 thru 61-0F or 62-xx or 63-xx		
PCI Slot 6 (5V)	U0.2-P1/I6	60-5A		
PCI Slot 6 Content	U0.2-P1-I6	64-08 thru 64-0F or 65-xx or 66-xx		
PCI Slot 7 (5V)	U0.2-P1/I7	60-5B		

FRU Name	Location Code	AIX Location Code	Physical Connection	Logical Connection
PCI Slot 7 Content	U0.2-P1-I7	67-08 thru 67-0F or 68-xx or 69-xx		
PCI Slot 8	U0.2-P1/I8	60-5C		
PCI Slot 8 Content	U0.2-P1-I8	6A-08 thru 6A-0F or 6B-xx or 6C-xx		
PCI Slot 9	U0.2-P1/I9	60-5E		
PCI Slot 9 Content	U0.2-P1-I9	6D-08 thru 6D-0F or 6E-xx or 6F-xx		
PCI to PCI Bridge 3	U0.2-P1	60-60 60-62 60-63 60-64 60-66		
PCI Slot 10	U0.2-P1/I10	60-60		
PCI Slot 10 Content	U0.2-P1-I10	71-08 thru 71-0F or 72-xx or 73-xx		
PCI Slot 11 (5V)	U0.2-P1/I11	60-62		
PCI Slot 11 Content	U0.2-P1-I11	74-08 thru 74-0F or 75-xx or 76-xx		
PCI Slot 12 (5V)	U0.2-P1-I12	60-63		
PCI Slot 12 Content	U0.2-P1-I12	77-08 thru 77-0F or 78-xx or 79-xx		
PCI Slot 13	U0.2-P1-/13	60-64		
PCI Slot 13 Content	U0.2-P1-I13	7A-08 thru 7A-0F or 7B-xx or 7C-xx		
PCI Slot 14	U0.2-P1-/14	60-66		
PCI Slot 14 Content	U0.2-P1-I14	7D-08 thru 7D-0F or 7E-xx or 7F-xx		
Thermal Sensor (Right)	U0.2-P1			

FRU Name	Location Code	AIX Location Code	Physical Connection	Logical Connection
Thermal Sensor (Left)	U0.2-P1			
Power Distribution Board	U0.2-X1			
Power Distribution Board Connector 1	U0.2-X1/V1			
Power Distribution Board Connector 2	U0.2-X1/V2			
Fan Controller Card	U0.2-X2		PDB connector J3	
Operator Panel	U0.2-L1		I/O board connector J3	
I/O Drawer VPD Module	U0.2-L1-N1			
Thermal Sensor (Ambient)	U0.2-L1			
Power Supply 1 (w/Fan 5)	U0.2-V1		PDB connector J2	
Power Supply 2 (w/Fan6)	U0.2-V2		PDB connector J1	
Fan 1	U0.2-F1		Fan connector P3 on power supply 1	
Fan 2	U0.2-F2		Fan connector P3 on power supply 1	
Fan 3	U0.2-F3		Fan connector P3 on power supply 2	
Fan 4	U0.2-F4		Fan connector P3 on power supply 2	
Fan 9	U0.2-F9		In cooling unit	
SPCN Firmware	U0.2-P1/Y3			
SPCN VPD	U0.2-P1/Y4			
SCSI Device Locations				
SCSI Adapter x=drawer number y=PCI Slot number z=connector		U0.x-P1-l/y/Zz	AB-CD Where AB-CD identifies the adapter's slot	Bus ID 15

FRU Name	Location Code	AIX Location Code	Physical Connection	Logical Connection
Media Device (Bay A1 or A2) When connected to PCI adapter in slot U0.x-P1-l-y x=drawer number y=PCI Slot number z=connector		U0.x-P1-l-y-Zz -Ai	AB-CD-00-15,0 Where AB-CD identifies the adapter's slot	Bus ID 15
SCSI Backplane, Bank C or D When connected to PCI adapter in slot U0.x-P1-l-y x=drawer number y=PCI Slot number z=connector		U0.x-P1-l-y-Zz -Bb	AB-CD-00-15,0 Where AB-CD identifies the adapter's slot	Bus ID 15

Cabling the CEC Drawer, Primary I/O Drawer, and Secondary I/O Drawer

The minimum system consists of two drawers. The CEC drawer contains the system processors, memory and supporting hardware. The primary I/O drawer contains PCI adapters, operator panel, disk drives, and media drives. The Model H80 and Models 6H0 and 6H1 must have one primary I/O drawer, which contains the service processor for the system. The system supports up to two I/O drawers in various rack configurations.

There are two steps to connecting the CEC drawer to the I/O drawers.

1. Connect the cables that only connect the CEC drawer and the primary I/O drawer, such as the JTAG and the V/S COMM cable.
2. Connecting the cables that connect the CEC drawer and all the I/O drawers in loops, such as the RIO cables and the SPCN cables.

All power cables connect to the PDU. If a second PDU is specified along with secondary drawer power supplies for all drawers, the secondary power supplies connect to the secondary PDU.

Connecting JTAG and VS COM Cables

Use the following figure to connect the JTAG and V/S COMM cables.

CEC Drawer Attached to I/O Drawer

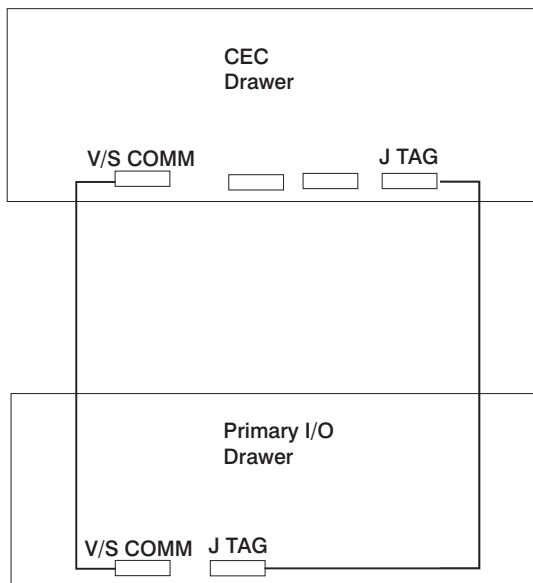

Connecting RIO and SPCN Cables

The RIO and SPCN cables provide two functions in the system: remote data bus connection and power control. The following basic rules must be followed when connecting these two types of cables:

- The I/O drawers must be connected in a loop fashion for both the RIO cables and the SPCN cables. The loop connection provides redundant paths so that if a failure occurs in part of a cable, the system will continue to operate. If a failure occurs, a warning message is displayed on the system console but the system continues to operate.
- One loop is required for the SPCN cabling. This loop begins and ends at the primary I/O drawer.
- Two loops are possible for the RIO cabling, depending on the number and desired configuration of I/O drawers. These loops begin and end at the primary I/O drawer.

RIO Cabling

The following rules apply to RIO cable connections:

- I/O drawers 0 and 1 are connected using the first RIO loop, which uses RIO ports 0 and 1 on the CEC drawer.
- The primary I/O drawer must be installed and connected to RIO port 0 of the CEC drawer. The connection must be made from RIO port 0 of the CEC drawer to RIO port 0 of the primary I/O drawer. This connection is required to make the primary drawer the first drawer in the loop, which allows the firmware to initialize the system.

The following figures provide cabling examples for all valid cabling configurations. Match your configuration to the correct figure and connect your RIO cables as shown.

CEC Drawer Attached to One I/O Drawer

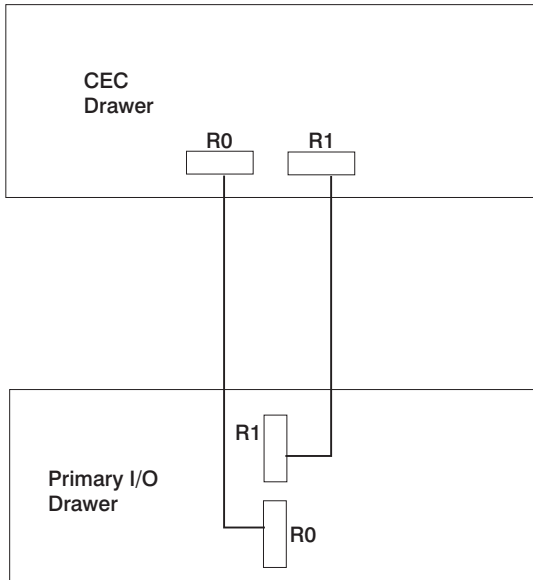

CEC Drawer Attached to Two I/O Drawers

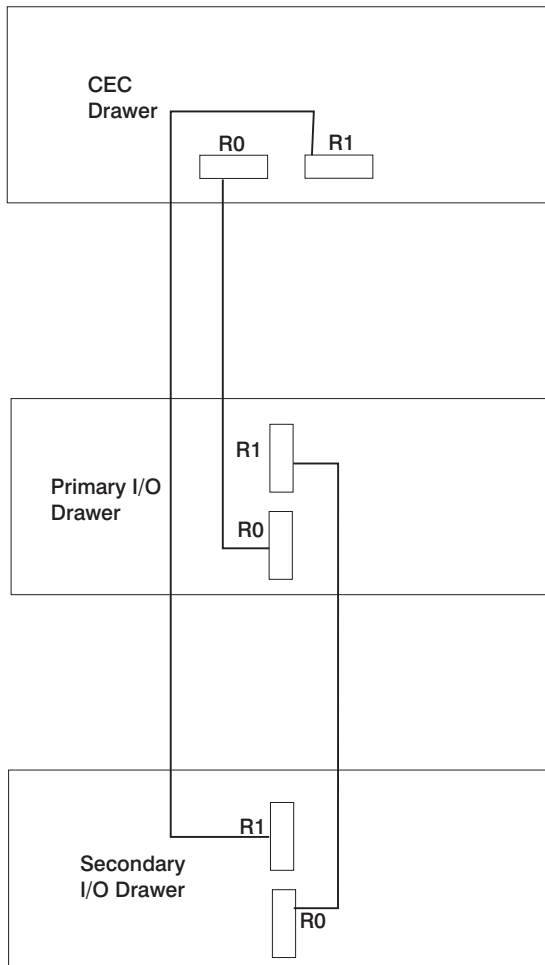

SPCN Cabling

The following figures provide cabling examples for all valid cabling configurations. Match your configuration to the correct figure and connect your SPCN cables as shown.

CEC Drawer Attached to One I/O Drawer

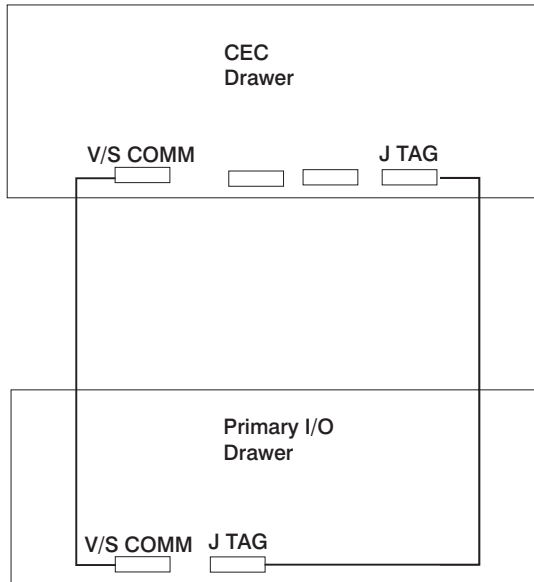

Note: The V/S COMM cable includes SPCN signals in addition to other signals.

CEC Drawer Attached to Two I/O Drawers

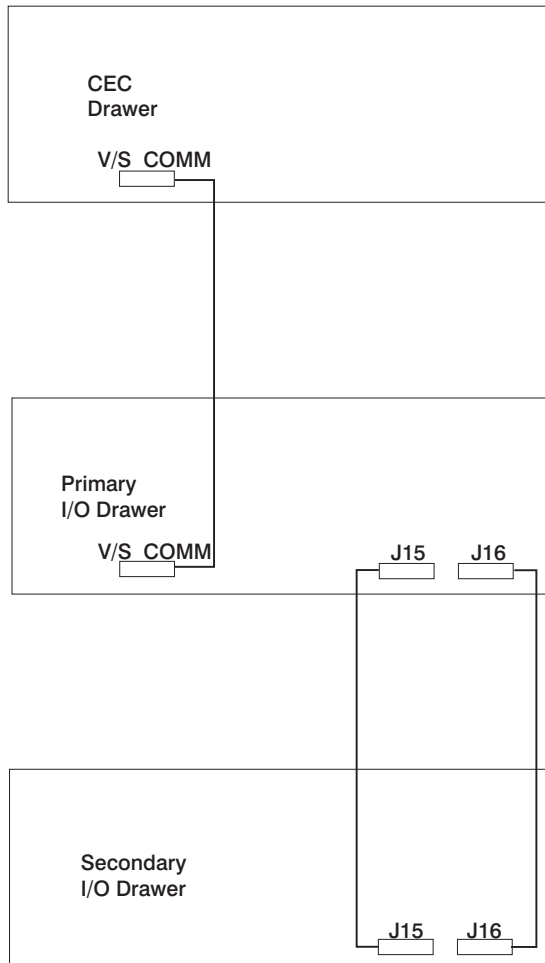

System Cable Diagrams

The following diagrams show the system cable connections.

CEC Drawer Cable Diagram

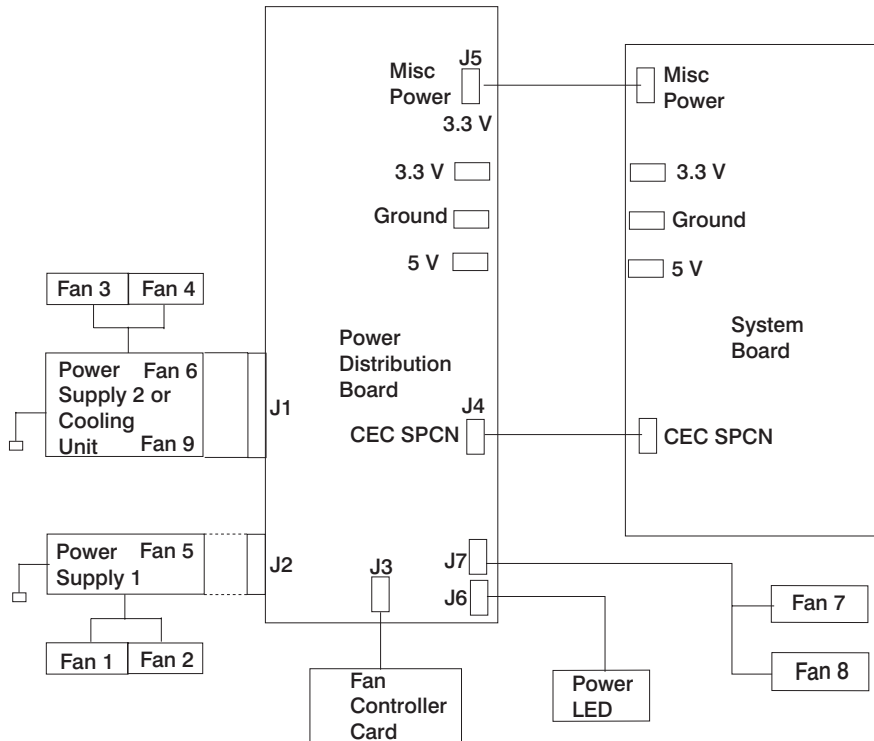

Primary I/O Drawer Cable Diagram

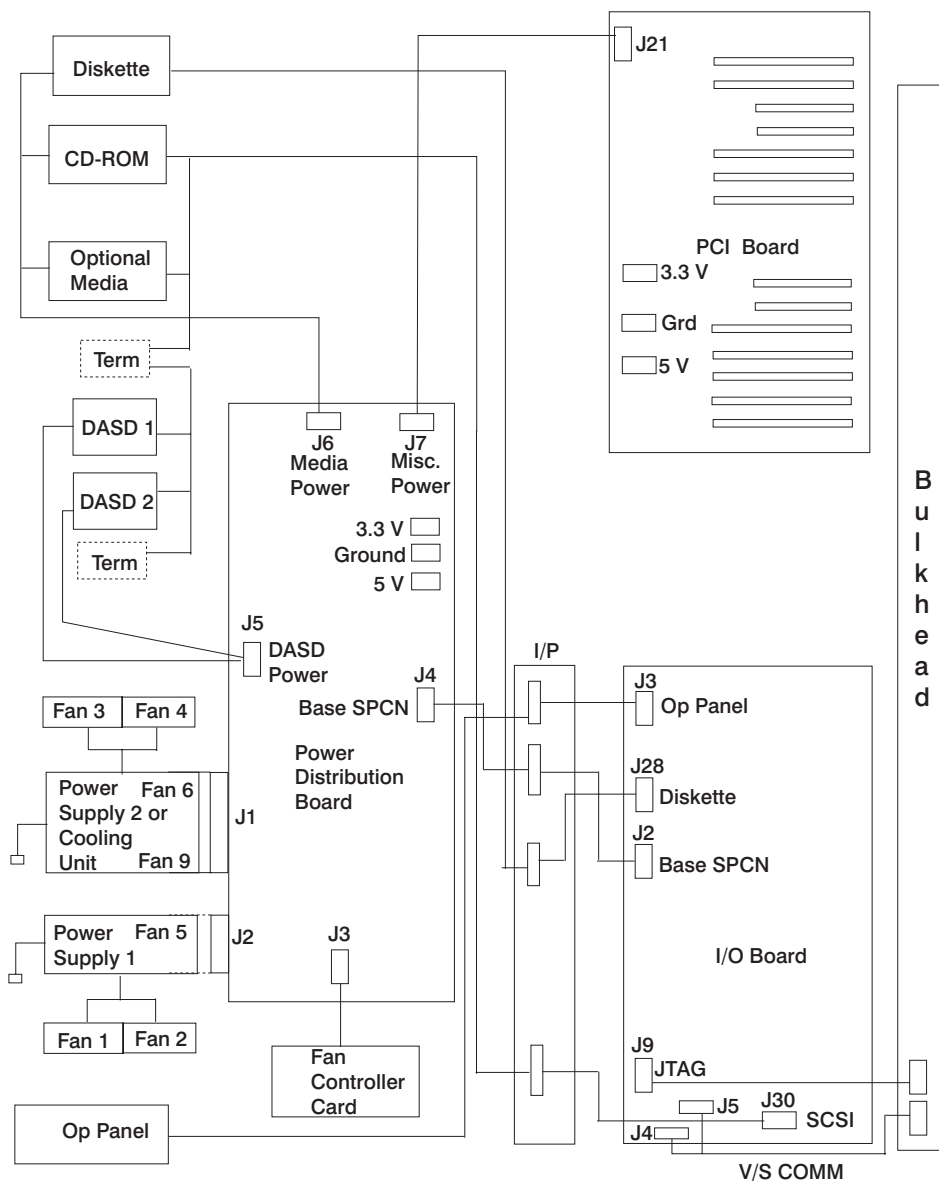

Secondary I/O Drawer Cable Diagram

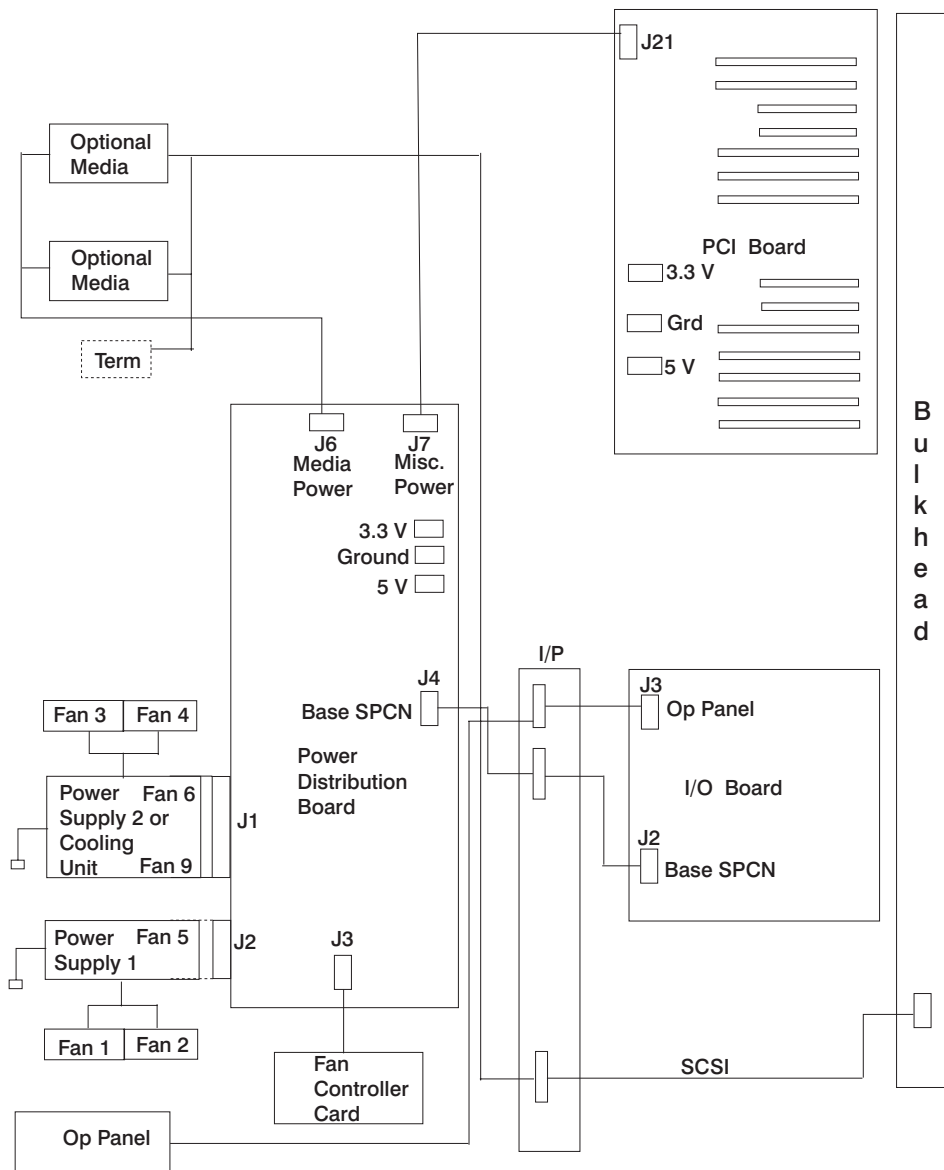

DC Power Cable Routings

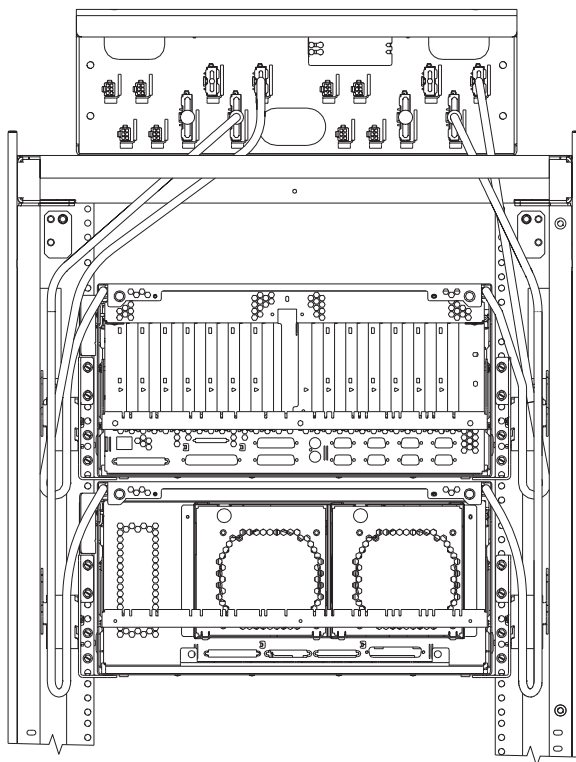

Specifications

This section contains specifications for the system. Individual sections are provided for CEC drawer, rack, and the I/O drawer specifications.

CEC Drawer

The mechanical packaging, cooling, power supply, and environmental requirements for the CEC drawer are shown in the following table:

Dimensions		
Height	218 mm 8.58 in. (5 EIA Units)	
Width	445 mm 17.5 in.	
Depth	820 mm 32.3 in.	
Weight		
Minimum configuration	41 kg 90 lbs.	
Maximum configuration	52 kg 115 lbs.	
Electrical		
Power source loading typical in kVA	0.32	
Power source loading maximum in kVA	0.48	
Voltage range (V ac)	200 to 240	
Frequency (hertz)	50 or 60	
Thermal output (typical)	1025 Btu/hr	
Thermal output (maximum)	1536 Btu/hr	
Power requirements (typical)	300 watts	
Power requirements (maximum)	450 watts	
Power factor	0.95	
Inrush current ¹	40 amps	
Maximum altitude ²	2135 m (7000 ft.)	
Temperature Requirements²	Operating	Non-Operating
	10 to 40°C (50 to 104°F)	10 to 52°C (50 to 125.6°F)
Humidity Noncondensing	Operating	Non-Operating
Without tape drive	8 to 80%	8 to 80%
With tape drive	20 to 80%	8 to 80%
Wet Bulb Requirements		
Without tape drive	27°C (80.6°F)	27°C (80.6°F)
With tape drive	23°C (73°F)	27°C (80.6°F)
Noise Emissions³	Operating	Idle
With H80 CEC Drawer only		
L _{WAd}	5.8 bels	5.8 bels
L _{pAm}	N/A	N/A
<L _{pA} > _m	45 dBA	45 dBA
Impulsive or prominent discrete tones	No	No

Noise Emissions³	Operating	Idle
With H80 and Primary I/O Drawer		
$L_{WA,d}$	6.2 bels	6.2 bels
$L_{pA,m}$	N/A	N/A
$\langle L_{pA} \rangle_m$	48 dBA	48 dBA
Impulsive or prominent discrete tones	No	No
Install/Air Flow Clearance	Maintenance of proper service clearances should allow proper air flow.	
Service Clearance	(See service clearances for the 7014 T00 Rack)	
<ol style="list-style-type: none"> 1. Inrush currents occur only at initial application of power, no inrush occurs during normal power off-on cycle. 2. For altitudes above 915 meters, the maximum temperature limit is derated by 1 degree C for every 137 meters of elevation above 915 meters. 3. See "Noise Emission Notes" on page 64 for definitions of noise emissions positions. 		

7014 Model T00 and T42 Rack

The mechanical packaging, cooling, power supply, and environmental requirements for the rack are shown in the following table:

Dimensions				
Height	1804 mm 71.0 in.			
Capacity	36 EIA Units			
With PDP - DC only	1926 mm 75.8 in.			
Width without side panels	623 mm 24.5 in.			
With side panels	644 mm 25.4 in.			
Depth with rear door	1042 mm 41.0 in.			
RS/6000 T00 with both doors	1098 mm 43.3 in.			
pSeries T00 with both doors	1147 mm 45.2 in.			
Weight				
Base Rack	244 kg 535 lbs			
Full Rack ¹	816 kg 1795 lbs			
Electrical² (sum specified values for drawers or enclosures in rack)				
DC Rack				
Power source loading maximum in kVA ³	8.4			
AC Rack				
Power source loading maximum in kVA (per PDB) ⁴	4.8			
Voltage range (V ac)	200 to 240			
Frequency (hertz)	50 or 60			
Temperature Requirements	(see specifications for drawers or enclosures)			
Humidity Requirements	(see specifications for drawers or enclosures)			
Noise Emissions	(see specifications for drawers or enclosures)			
Clearances	Front	Back	Left	Right
Install/Air Flow	Maintenance of a proper service clearance should allow proper air flow.			
Service	915mm(36 in)	915mm(36 in)	915mm(36 in)	915mm(36 in)

1. Configuration dependent, base rack weight plus the weight of the drawers mounted in the rack. The rack can support up to a maximum weight of 35 lbs/EIA (Unit).
2. The total rack power should be derived from the sum of the power used by the drawers in the rack.
3. The Power Distribution Panel (PDP) on the DC powered rack can hold up to eighteen (nine per power source) 48 volt 20 to 50 amp circuit breakers (configuration dependent). Each power source supports up to 8.4 kVA.
4. Each AC Power Distribution Bus (PDB) can supply 4.8 kVA. A rack can have up to four PDB's as required by the drawers mounted in the rack.

I/O Drawer

The mechanical packaging, cooling, power supply, and environmental requirements for the I/O drawer are shown in the following table:

Dimensions				
Height	218.0 mm 8.6 in.			
Width	445.0 mm 17.5 in.			
Depth	820.0 mm 32.3 in.			
Weight				
Minimum configuration	41 kg 90 lbs.			
Maximum configuration	52 kg 115 lbs.			
Electrical				
Power source loading (typical in kVA)	0.23			
Power source loading (maximum in kVA)	0.54			
Voltage range	200 to 240 V ac			
Frequency (hertz)	50 / 60			
Thermal output (typical)	750 Btu/hr			
Thermal output (maximum)	1750 Btu/hr			
Power requirements (typical)	220 watts			
Power requirements (maximum)	515 watts			
Power factor	0.95			
Inrush current ³	41 amps			
Maximum altitude	2135 m (7000 ft.)			
Temperature Requirements	Operating			Non-Operating
	10 to 40°C			10 to 52°C
	(50 to 104°F)			(50 to 125.6°F)
Humidity (Noncondensing)	Operating			Non-Operating
Without tape drive	8 to 80%			8 to 80%
With tape drive	20 to 80%			20 to 80%
Wet Bulb Requirements				
Without tape drive	27°C (80°F)			27°C (80°F)
With tape drive	23°C (73°F)			27°C (80°F)
Noise Emissions ^{1,2}	Operating			Idle
L_{wAd}	5.8 bels			5.8 bels
L_{pAm}	N/A			N/A
$<L_{pA}>_m$	45 dBA			45 dBA
Impulsive or prominent discrete tones	No			No
Clearances	Front	Back	Left	Right
Install/Air Flow	Maintenance of a proper service clearance should allow proper air flow.			
Service	(See "System Service Clearances" on page 65)			

1. See "Noise Emission Notes" on page 64 for definitions of noise emissions positions.
2. Noise emissions data are based on the following configuration: the drawer is mounted in a T00 Rack and a power distribution unit.
3. Inrush currents occur only at initial application of power, no inrush occurs during normal power off-on cycle.

Noise Emission Notes

1. $L_{WA,d}$ is the declared (upper limit) sound power emission level for a production series of machines.
2. $L_{pA,m}$ is the mean value of the A-weighted sound pressure emission levels at the operator position (if any) for a production series of machines.
3. $\langle L_{pA} \rangle_m$ is the mean value of the space-averaged A-weighted sound pressure emission levels at the one-meter positions for a production series of machines.
4. N/A = Not Applicable (no operator position).
5. All measurements are made in accordance with ISO DIS 779 and reported in conformance with ISO DIS 7574/4.

System Service Clearances

The amount of space needed by the units during service is indicated by the dotted line in the following figure.

For multiple racks placed side by side, the left and right clearances apply only to the leftmost and rightmost rack.

Rack Configuration

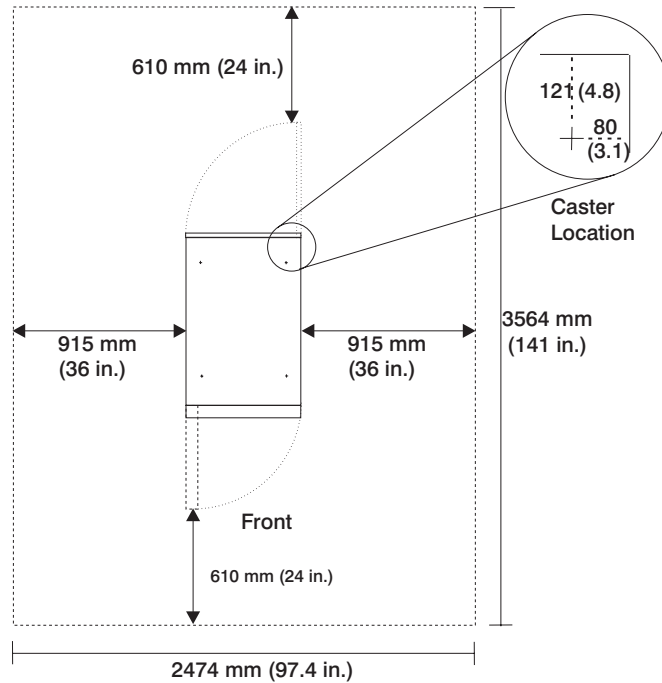

Note: Rack units are large and heavy and are not easily moved. Because maintenance activities require access at both the front and back, allow for extra room. The footprint shows the radius of the swinging doors on the rack. The figure shows the minimum space required.

Power Cables

To avoid electrical shock, a power cable with a grounded attachment plug is provided. Use only properly grounded outlets.

Power cables used in the United States and Canada are listed by Underwriter's Laboratories (UL) and certified by the Canadian Standards Association (CSA). These power cords consist of the following:

- Electrical cables, Type SVT or SJT
- Attachment plugs complying with National Electrical Manufacturers Association (NEMA) 5-15P

"For 230 V operation in the United States use a UL listed cable set consisting of a minimum 18 AWG, Type SVT or SJT three-conductor cable a maximum of 15 feet in length, and a tandem blade, grounding type attachment plug rated at 15 A, 250 V."

- Appliance couplers complying with International Electrotechnical Commission (IEC) Standard 320, Sheet C13

Power cables used in other countries consist of the following:

- Electrical cables, Type HD21
- Attachment plugs approved by the appropriate testing organization for the specific countries where they are used

"For units set at 230 V (outside of U.S.): use a cable set consisting of a minimum 18 AWG cable and grounding type attachment plug rated 15 A, 250 V. The cable set should have the appropriate safety approvals for the country in which the equipment will be installed and should be marked 'HAR'."

Refer to Chapter 10, "Parts Information" on page 471 to find the power cables that are available.

Service Inspection Guide

Perform a service inspection on the system when:

- The system is inspected for a maintenance agreement.
- Service is requested and service has not recently been performed.
- An alterations and attachments review is performed.
- Changes have been made to the equipment that may affect its safe operation.
- External devices with their own power cables have those cables attached.

If the inspection indicates an unacceptable safety condition, the condition must be corrected before anyone can service the machine.

Note: The owner of the system is responsible to correct any unsafe conditions.

Perform the following checks:

1. Check the covers for sharp edges and for damage or alterations that expose the internal parts of the system unit.
2. Check the covers for proper fit to the system unit. They should be in place and secure.
3. Gently rock the system unit from side to side to determine if it is steady.
4. Set the power switch of the system unit to Off.
5. Remove the covers.
6. Check for alterations or attachments. If there are any, check for obvious safety hazards, such as broken wires, sharp edges, or broken insulation.
7. Check the internal cables for damage.
8. Check for dirt, water, and any other contamination within the system unit.
9. Check the voltage label on the back of the system unit to ensure that it matches the voltage at the outlet.
10. Check the external power cable for damage.
11. With the external power cable connected to the system unit, check for 0.1 ohm or less resistance between the ground lug on the external power cable plug and the metal frame.
12. Perform the following checks on each device that has its own power cables:
 - a. Check for damage to the power cord.
 - b. Check for the correct grounded power cable.
 - c. With the external power cable connected to the device, check for 0.1 ohm or less resistance between the ground lug on the external power cable plug and the metal frame of the device.
13. Install the covers.

Chapter 2. Diagnostics Overview

Model H80 and Models 6H0 and 6H1 systems use an integrated set of software diagnostic procedures to facilitate isolation of failing components and system maintenance. This book, along with the *RS/6000 and @server pSeries Diagnostics Information for Multiple Bus Systems*, are the basis of the diagnostic procedures for Model H80 and Models 6H0 and 6H1 systems. In particular, the following sections in this book are important for the trained service representative to understand and use when isolating a failure on the system:

- Chapter 4, “Checkpoints” on page 137
- Chapter 5, “Error Code to FRU Index” on page 163
- Chapter 6, “Loading the System Diagnostics In Service Mode” on page 367
- Chapter 10, “Parts Information” on page 471

The manufacturer recommends that systems configured with 4 GB of memory or greater have access to a 4 mm or 8 mm tape drive for submission of system dump information if required. This function can be accomplished through locally attached or network-attached devices, as appropriate.

Maintenance Analysis Procedures (MAPs)

Maintenance analysis procedures (MAPs) guide the trained service person through the system. These MAPs are the entry point for all isolation and error-recovery procedures. The MAPs are consistent with existing procedures and methods. The system uses a set of integrated procedures, mentioned earlier, to which the MAPs are the primary entry point.

The MAPs are as follows:

- Entry MAP
- Quick Entry MAP
- Problem Determination MAP
- Power MAP
- Minimum Configuration MAP

The Entry Map is the starting point for problem determination. The purpose of this MAP is to quickly point to the appropriate MAP or service reference information either in this book, or in the common book set, which includes the *RS/6000 and @server pSeries Diagnostics Information for Multiple Bus Systems* and the *PCI Adapter Placement Reference*.

The Quick Entry MAP is a subset of the Entry MAP and helps to save time for some types of problems.

The Problem Determination MAP provides a structured analysis method to get an error code if one is not provided by the customer, or if diagnostics cannot be loaded.

The Power MAP deals with isolation of components to diagnose a power problem. The nature of power problems can be related to powering on and down the system, or power failures that can occur after power is turned on.

The Minimum Configuration MAP is used to locate defective components not found by normal diagnostics or error-isolation methods. This MAP provides a systematic method of isolation to the failing item or items.

Checkpoints

These servers use various types of checkpoints, error codes, and SRNs, which are referred to throughout this book (primarily in Chapter 4, “Checkpoints” on page 137, Chapter 5, “Error Code to FRU Index” on page 163, Chapter 6, “Loading the System Diagnostics In Service Mode” on page 367, and Chapter 10, “Parts Information” on page 471). These codes may appear in the service processor boot progress log, the AIX error log, and the operator panel display. Understanding the definition and relationships of these codes is important to the service personnel who are installing or maintaining these servers.

Codes that can appear on the operator panel or in error logs are as follows:

Checkpoints

Checkpoints display in the operator panel from the time ac power (dc power in a dc-powered system) is connected to the system until the AIX login prompt is displayed after a successful operating system boot. These checkpoints have the following forms:

8xxx 8xxx checkpoints display from the time ac power (dc power in a dc-powered system) is connected to the system until the OK prompt is displayed by the service processor on the operator panel display. (Several 9xxx checkpoints are displayed just before the OK prompt displays.)

9xxx 9xxx checkpoints are displayed by the service processor after the power-on sequence is initiated. A system processor takes over control when 91FF displays on the operator panel.

Exxx Exxx checkpoints indicate that a system processor is in control and is initializing the system resources. Control is being passed to AIX when E105 (normal mode boot) or E15B (service mode boot) displays on the operator panel.

Note: Location code information may also display on the operator panel during this time.

0xxx 0xxx codes are AIX checkpoints and configuration codes. Location codes may also be shown on the operator panel display during this time.

2xxx 2xxx codes are AIX checkpoints and configuration codes. Location codes may also be shown on the operator panel display during this time.

Note: Certain checkpoints may remain in the display for long periods of time. A spinning cursor is visible in the upper-right corner of the display during these periods to indicate that system activity is continuing.

Error Codes

If a fault is detected, an 8-digit error code is displayed in the operator panel display. A location may be displayed at the same time on the second line of the display.

Checkpoints can become error codes if the system fails to advance past the point at which the code was presented.

For a list of checkpoints, see Chapter 4, “Checkpoints” on page 137. Each entry provides a description of the event and the recommended action if the system fails to advance.

SRNs Service request numbers, in the form xxx-xxx or xxx-xxxx, may also be displayed on the operator panel display and be noted in the AIX error log.

SRNs are listed in the *RS/6000 and @server pSeries Diagnostics Information for Multiple Bus Systems*, order number SA38-0509.

FRU Isolation

For a list of error codes and recommended actions for each code, see Chapter 5, “Error Code to FRU Index” on page 163. These actions can refer to Chapter 10, “Parts Information” on page 471, Chapter 3, “Maintenance Analysis Procedures (MAPs)” on page 75, or provide informational message and directions. If a replacement part is indicated, direct reference is made to the part name. The respective AIX and physical location codes are listed for each occurrence as required. For a list of locations codes, see “AIX and Physical Location Code Reference Tables” on page 36.

To look up part numbers and view component diagrams, see Chapter 10, “Parts Information” on page 471. The beginning of the chapter provides a parts index with the predominant field replaceable units (FRUs) listed by name. The remainder of the chapter provides illustrations of the various assemblies and components which make up these servers.

Electronic Service Agent for the @server pSeries and RS/6000

Service support for your system can be enhanced through the use of the application program, Electronic Service Agent. This application provides a number of advantages for the systems customer, including automatic error reporting and analysis without customer intervention. The Electronic Service Agent kit includes the *Electronic Service Agent for @server pSeries and RS/6000* CD, order number LCD4-1060, which contains documentation to help you set up and use Electronic Service Agent.

Using the Service Processor and Electronic Service Agent Features

The service processor and Electronic Service Agent features protect users against unnecessary system downtime by advising support personnel (both internal and external) of any unexpected changes in the system environment. In combination, the two features provide a flexible solution to automated system maintenance.

Service Processor

The service processor runs on its own power boundary and continually monitors hardware attributes, the AIX operating system, and the environmental conditions within the system. Any system failure which prevents the system from returning to an operational state (a fully functional AIX operating system) is reported by the service processor. The service processor is controlled by firmware and does not require the AIX operating system to be operational to perform its tasks. If any system failures are detected, the service processor has the ability to take predetermined corrective actions. The methods of corrective actions are:

- Surveillance
- Call home
- AIX operating system monitoring

Surveillance is a function in which the service processor monitors the system through *heartbeat* communication with the system firmware. The heartbeat is a periodic signal that the firmware can monitor. During system startup, the firmware surveillance monitor is automatically enabled to check for heartbeats from the firmware. If a heartbeat is not detected within a default period, the service processor cycles the system power and attempts to restart until the system either restarts successfully, or a predetermined retry threshold is reached. In the event the service processor is unsuccessful in bringing the system online (or in the event that the user asked to be alerted to any service processor-assisted restarts), the system can call home to report the error.

The call home function can be initialized to call either a service center telephone number, a customer administration center, or a digital pager telephone number. The service processor can be configured to stop at the first successful call to any of the numbers listed, or can be configured to call every number provided. If connected to the service center, the service processor transmits the relevant system information (the system's serial number and model type) and service request number (SRN). If connected to a digital pager service, the service processor inputs a customer voice telephone number defined by the customer. An established sequence of digits or the telephone number to a phone near the failed system could be used to signal a system administrator to a potential system failure.

During normal operations, the service processor can also be configured to monitor the AIX operating system. If AIX does not respond to the service processor heartbeat, the service processor assumes the operating system is hung. The service processor can automatically initiate a restart and, if enabled, initiate the call home function to alert the appropriate people to the system hang. Enabling operating system surveillance also enables AIX detect any service processor failures and report those failures to the Electronic Service Agent application.

Unlike the Electronic Service Agent, the service processor cannot be configured in a client/server environment where one system can be used to manage all dial-out functions for a set of systems.

Prior to installing the Electronic Service Agent feature, ensure that you have the latest level of system firmware. You also need a properly configured modem. For more information on configuring a modem, see “Modem Configuration Menu” on page 392.

Electronic Service Agent

The Electronic Service Agent is a software extension to the AIX operating system that monitors the system while the AIX operating system is running. The Electronic Service Agent monitors and analyzes all recoverable system failures, and, if needed, can automatically place a service call to a service center (without user intervention).

The service center receives the machine type/serial number, host name, SRN, and a problem description. The service center analyzes the problem report and, if warranted, dispatches a service person to the customer site. The service center also determines if any hardware components need to be ordered prior to the service person's arrival.

The Electronic Service Agent code also gives the user the option to establish a single system as the problem reporting server. A single system, accessible over the user network, can be used as the central server for all the other systems on the local area network (LAN) that are running the Electronic Service Agent application. If the Electronic Service Agent application on a remote client decides a service request needs to be placed, the client forwards the information to the Electronic Service Agent server that dials the service center telephone number from its locally attached modem. In this scenario, the user only needs to maintain a single analog line for providing call-out capabilities for a large set of servers.

When used in a scalable parallel (SP) environment, a client/server type implementation is configured. The Electronic Service Agent client code runs on each of the SP nodes. The server component runs on the control workstation. In the event of any system failures, the relevant information is transmitted to the control workstation through the integrated Ethernet. After it has been alerted to the system failure, the control workstation initiates actions to prepare and send the service request.

A modem is required for enabling automated problem reporting to the service center. Configuration files for several types of modems are included as part of the Electronic Service Agent package. Refer to “Modem Configuration Menu” on page 392 for more information on configuring your modem.

Chapter 3. Maintenance Analysis Procedures (MAPs)

This chapter contains maintenance analysis procedures (MAPs) for the system.

Entry MAP

Use the following table to determine your starting point. When possible, run online diagnostics in service mode. Online diagnostics perform additional functions, compared to standalone diagnostics. This ensures that the error state of the system is captured in NVRAM for your use in fixing the problem. The AIX error log and SMIT are only available when diagnostics are run from the hard drive.

Notes:

1. Licensed programs frequently rely on system information stored on the VPD module on the operator panel assembly. If the MAPs indicate that the operator panel assembly should be replaced, swap the VPD module from the old operator panel to the new one. If recovery is not possible, notify the system owner that new keys for licensed programs may be required.
2. If a network adapter is replaced, the network administrator must be notified so that the client IP addresses used by the server can be changed. In addition, the operating system configuration of the network controller may need to be changed in order to enable system startup. Also check to ensure that any client or server that addresses this system is updated.
3. If you are servicing an SP system, go to the Start-of-Call MAP 100 in the *SP Systems Service Guide*.
4. If you are servicing a clustered @server system, go to the start of call MAP 100 in the *Clustered @server Installation and Service Guide*.

Symptom	Starting Point
You have a problem that does not prevent the system from booting and all the I/O drawer operator panels are functional.	Go to the Fast Path MAP in the <i>Diagnostics Information for Multiple Bus Systems</i> .
You have a problem that does not prevent the system from booting and the secondary I/O drawer operator panel is not functioning.	Replace the following parts one at a time in the secondary I/O drawer with the non-functioning operator panel. <ol style="list-style-type: none">1. Secondary I/O drawer operator panel.2. Secondary I/O drawer operator panel cable.
You do not have a symptom.	Go to MAP 0020 in the <i>Diagnostics Information for Multiple Bus Systems</i> .
You have an SRN.	Go to the Fast Path MAP in the <i>Diagnostics Information for Multiple Bus Systems</i> .
The system stops and a 3-digit number is displayed in the operator panel display.	Record SRN 101-xxx, where xxx is the 3-digit number displayed in the operator panel display, then go to the Fast Path MAP in the <i>Diagnostics Information for Multiple Bus Systems</i> .

Symptom	Starting Point
The system stops and a 4-digit number beginning with 0 or 2 is displayed in the operator panel display.	Go to the Fast Path MAP in the <i>Diagnostics Information for Multiple Bus Systems</i> .
All other symptoms.	Go to "Quick Entry MAP".

Quick Entry MAP

Quick Entry MAP Table of Contents

Problem Description	Page No.
Service Actions	77
A Repeating Pattern of Error Code Data Appears on the Primary I/O Drawer Operator Panel Display	77
OK Does Not Appear in the Primary I/O Drawer Operator Panel Display Before Pressing the Power On Button	77
There is an 8-Digit Error Code	77
System Stops With an 8-Digit Number Displayed in the Primary I/O Drawer Operator Panel Display	78
An Error Indication in the Secondary I/O Drawer Operator Panel Display	79
System Stops With a 4-Digit Number That Does Not Begin With a 0 or 2 Displayed	79
System Stops With a 3-Digit Number Displayed (888 sequence, see below)	80
There is a Display Problem (Distortion, Blurring, Etc.)	80
Power and Cooling Problems	80
An 888 sequence appears in Operator Panel Display	81
Other Symptoms or Problems	81

Attention: If you replace FRUs or perform an action and the problem is still not corrected, go to "MAP 1540: Minimum Configuration" on page 113 unless otherwise indicated in the tables.

If you replace FRUs and the problem is corrected, go to "MAP 410: Repair Checkout" in the *Diagnostics Information for Multiple Bus Systems*.

Symptom	Action
Service Actions	
You have parts to exchange or a corrective action to perform.	<ol style="list-style-type: none"> 1. Go to the <i>Removal and Replacement Procedures</i>. 2. Go to the <i>Repair Checkout Procedure</i> in the <i>Diagnostics Information for Multiple Bus Systems</i>.
You need to verify that a part exchange or corrective action corrected the problem.	Go to the <i>Repair Checkout Procedure</i> in the <i>Diagnostics Information for Multiple Bus Systems</i> .
You need to verify correct system operation.	Go to the <i>System Checkout Procedure</i> in the <i>Diagnostics Information for Multiple Bus Systems</i> .
A Repeating Pattern of Error Code Data Appears on the Primary I/O Drawer Operator Panel Display	
A sequence of displays, each appearing for five seconds, repeats continuously as follows: A blank display, followed by an eight-digit error code, followed by up to nine full panels of dump data.	<ol style="list-style-type: none"> 1. Record the 8-digit error code seen after the five second blank display. 2. Reset the service processor, using the pinhole reset. 3. Go to "Checkpoint and Error Code Index" on page 165 with the error code you have recorded.
OK Does Not Appear in the Primary I/O Drawer Operator Panel Display Before Pressing the Power On Button	
A bouncing or scrolling ball remains on the primary I/O drawer operator panel display or the primary I/O drawer operator panel display is filled with dashes.	<p>If an ASCII terminal is available, connect it to the primary I/O drawer through serial port 1.</p> <ol style="list-style-type: none"> 1. If the service processor menu is displayed: <ol style="list-style-type: none"> a. Replace the primary I/O drawer operator panel assembly. Refer to "Operator Panel" on page 465. b. Replace the primary I/O drawer backplane. Refer to "I/O Drawer Backplane Assembly" on page 447. 2. If the service processor menu is not displayed, replace the primary I/O drawer backplane. Refer to "I/O Drawer Backplane Assembly" on page 447. <p>If an ASCII terminal is <i>not</i> available, replace the following, one at a time.</p> <ol style="list-style-type: none"> 1. Primary I/O drawer operator panel assembly. Refer to "Operator Panel" on page 465. 2. Primary I/O drawer backplane. Refer to "I/O Drawer Backplane Assembly" on page 447.
You have a blank display on the primary I/O drawer operator panel.	Go to "MAP 1520: Power" on page 89.
There is an 8-Digit Error Code	

Symptom	Action
You have an 8-digit error code in the form 10n1xxxx and <i>n</i> is greater than the number of I/O drawers in the system.	The failing drawer is drawer <i>n</i> . Look for the drawer with the same value of <i>n</i> in its operator panel, either in the form *0 <i>n</i> or U0 <i>n</i> . Substitute 2 for <i>n</i> when looking up the error code in "Checkpoint and Error Code Index" on page 165.
You have an 8-digit error code of the form 10n1xxxx and two or more drawers have the same drawer number.	<p>Shut down the system and remove all but one of the drawers with duplicate drawer numbers. Refer to the steps in "MAP 1540: Minimum Configuration" on page 113 for a procedure to connect/disconnect I/O drawers. Attempt to reboot the system.</p> <ol style="list-style-type: none"> 1. If the system still fails, you have found the failing drawer. Substitute 2 for <i>n</i> when looking up the error code in Go to "Checkpoint and Error Code Index" on page 165. 2. If the system boots, shut down and add another of the detached drawers back into the system. Repeat steps 1 and 2 until the failing drawer is isolated. <p>Note: As the system successfully boots, duplicate drawer numbers are resolved into unique drawer numbers.</p>
You have an 8-digit error code.	Go to "Checkpoint and Error Code Index" on page 165.
System Stops With an 8-Digit Number Displayed in the Primary I/O Drawer Operator Panel Display	
You have an 8-digit error code of the form 10n1xxxx and <i>n</i> is greater than the number of I/O drawers in the system.	The failing drawer is drawer <i>n</i> . Look for the drawer with the same value of <i>n</i> in its operator panel, either in the form *0 <i>N</i> or U0. <i>n</i> . Substitute 2 for <i>n</i> when looking up the error code in the "Checkpoint and Error Code Index" on page 165.

Symptom	Action
<p>You have an 8-digit error code of the form 10n1 xxxx and two or more drawers have the same drawer number.</p>	<p>Shut down the system and remove all but one of the drawers with duplicate drawer numbers. Refer to the steps in "MAP 1540: Minimum Configuration" on page 113 for a procedure to connect/reconnect I/O drawers. Attempt to reboot the system.</p> <ol style="list-style-type: none"> 1. If the system fails, you have found the failing drawer. Substitute 2 for n when looking up the error code in "Checkpoint and Error Code Index" on page 165. 2. If the system boots, shut down and add another of the detached drawers back into the system. Repeat steps one and two until the failing drawer is isolated. <p>Note: As the system successfully boots, duplicate drawer numbers are resolved into unique drawer numbers.</p>
<p>The system stops with an 8-digit error code displayed when booting.</p>	<p>Go to "Checkpoint and Error Code Index" on page 165.</p>
<p>An Error Indication in the Secondary I/O Drawer Operator Panel Display</p>	
<p>A bouncing or scrolling ball remains on the secondary I/O drawer operator panel display or the secondary I/O drawer operator panel display is filled with dashes.</p>	<p>Replace the following, one at a time:</p> <ol style="list-style-type: none"> 1. Secondary I/O drawer backplane Location: U0.2-P1 2. Secondary I/O drawer operator panel assembly Location: U0.2-L1
<p>You have an 8-digit error code in the form 10n1 xxxx.</p>	<p>This is the failing drawer. If n is greater than the number of I/O drawers in the system, substitute 2 for n when looking up the error code in "Checkpoint and Error Code Index" on page 165.</p>
<p>System Stops With a 4-Digit Number That Does Not Begin With 0 or 2 Displayed</p>	

Symptom	Action
<p>The system stops and a 4-digit checkpoint that does not begin with 0 or 2 displayed in the operator panel display or on the console.</p>	<p>If the number displayed begins with the characters "8", "9", "A", or "B", then go to "Service Processor Checkpoints" on page 140.</p> <p>If the number displayed is in the range E1xx-EFFF, make note of any location code that is displayed on the second line of the operator panel. If the location code indicates a card slot (for example, P1-I3), replace the card in the indicated slot. If this does not correct the problem, then go to "Firmware Checkpoints" on page 147.</p> <p>For all other numbers record SRN 101-xxxx, where xxxx is the four-digit number displayed in the operator panel, then go to the <i>Fast Path MAP in RS/6000 and @server pSeries Diagnostics Information for Multiple Bus Systems</i>.</p> <p>Note: If the operator panel displays two sets of numbers, use the bottom set of numbers as the error code.</p>
<p>System Stops With a 3-Digit Number Displayed (888 sequence, see below)</p>	
<p>The system stops with a 3-digit error code.</p>	<p>Add 101- to the left of the 3 digits to make an SRN. Go to <i>Diagnostics Information for Multiple Bus Systems</i>.</p>
<p>There is a Display Problem (Distortion, Blurring, Etc.)</p>	
<p>All display problems.</p>	<ol style="list-style-type: none"> 1. If using a graphics display: <ol style="list-style-type: none"> a. Go to the problem determination procedures for the display. b. If you do not find a problem, replace the display adapter. c. If you do not find a problem, suspect the I/O planar. Go to "MAP 1540: Minimum Configuration" on page 113. 2. If using an ASCII terminal: <ol style="list-style-type: none"> a. Make sure that the ASCII terminal is connected to S1. b. If problems persist, go to the problem determination procedures for the terminal. c. If you do not find a problem, suspect the I/O planar. Go to "MAP 1540: Minimum Configuration" on page 113.
<p>Power and Cooling Problems</p>	
<p>You cannot power on the system.</p>	<p>Go to "MAP 1520: Power" on page 89.</p>

Symptom	Action
The power on/off LED on an I/O drawer operator panel does not come on or stay on. (both the I/O drawer operator panel power-on/off LED and the I/O drawer power supply LEDs do not come on or stay on).	Go to "MAP 1520: Power" on page 89.
A rack or a rack mounted unit will not power on.	Go to "MAP 1520: Power" on page 89.
You have a power problem.	Go to "MAP 1520: Power" on page 89.
The system attention LED on the primary I/O drawer operator panel is on and there is no SRN displayed.	Go to "MAP 1520: Power" on page 89.
888 sequence in Operator Panel Display	
An 888 sequence is displayed in the primary I/O drawer operator panel display.	Go to the Fast Path MAP in the <i>Diagnostics Information for Multiple Bus Systems</i> .
Other Symptoms or Problems	
The operator panel displays OK. Fans and blowers are off.	The service processor (SP) is ready. The system is waiting for power-on.
All of the system POST indicators are displayed on the system console, the system pauses and then restarts. The term "POST indicators" refers to the device mnemonics (words memory, keyboard, network, scsi, and speaker) that appear on the system console during the power-on self-test (POST).	Go to "Boot Problems and Concerns" on page 159.
The system stops and all of the POST indicators are displayed on the system console. The term "POST indicators" refers to the device mnemonics (words memory, keyboard, network, scsi, and speaker) that appear on the system console during the power-on self-test (POST).	Go to "MAP 1540: Minimum Configuration" on page 113 to isolate the problem.
The system stops and the message STARTING SOFTWARE PLEASE WAIT... is displayed on the system console.	Go to Chapter 4, "Checkpoints" on page 137.

Symptom	Action
<p>The system does not respond to the password being entered or the system login prompt is displayed when booting in service mode.</p>	<ol style="list-style-type: none"> 1. If the password is being entered, or the service mode boot is being initiated, on a keyboard attached to the system, then the keyboard or its controller may be faulty. In this case, replace these parts in the following order: <ol style="list-style-type: none"> a. Keyboard b. Primary I/O backplane, location: U0.1-P1 2. If the password is being entered, or the service mode boot is being initiated, from an ASCII terminal, first insure that the terminal is connected to S1 or S2. Use the problem determination procedures for the ASCII terminal. <p>If the problem persists, replace the primary I/O backplane, location: U0.1-P1.</p>
<p>No codes are displayed on the operator panel within a few seconds of turning on the system. The operator panel displays OK before the system is powered on.</p>	<p>Reseat the operator panel cable. If problem not resolved, replace in order:</p> <ol style="list-style-type: none"> 1. Operator panel assembly. Swap the VPD module. 2. Primary I/O backplane. (See notes on 75.)
<p>The SMS configuration list or boot sequence selection menu shows more SCSI devices attached to a controller/adaptor than are actually attached.</p>	<p>A device may be set to use the same SCSI bus ID as the control adapter. Note the ID being used by the controller/adaptor (this can be checked and/or changed via an SMS utility), and verify that no device attached to the controller is set to use that ID.</p> <p>If settings do not appear to be in conflict:</p> <ol style="list-style-type: none"> 1. Replace the SCSI cable. 2. Replace the device. 3. Replace the SCSI adapter <p>Note: In a "twin-tailed" configuration where there is more than one initiator device (normally another system) attached to the SCSI bus, it may be necessary to use System Management Services to change the ID of the SCSI controller or adapter.</p>

Symptom	Action
The System Management Services menu is displayed.	<p>The device or media you are attempting to boot from may be faulty.</p> <ol style="list-style-type: none"> 1. Check the SMS error log for any errors. To check the error log: <ul style="list-style-type: none"> • Choose error log • If an error is logged, check the time stamp. • If the error was logged during the current boot attempt, record it. • Look up the error in "Chapter 5, "Error Code to FRU Index"" and do the listed action. • If no recent error is logged in the error log, continue to the next step below. 2. Try to boot from an alternate boot device connected to the same controller as the original boot device. If the boot succeeds, replace the original boot device (for removable media devices, try the media first). 3. Go to "MAP 1540: Minimum Configuration" on page 113.
You suspect a cable problem.	Go to the <i>RS/6000 and @server pSeries Adapters, Devices, and Cable Information for Multiple Bus Systems</i> .
All other problems.	Go to "MAP 1020: Problem Determination" on page 84.

MAP 1020: Problem Determination

Use this MAP to get an error code if you were not provided one by the customer or you are unable to load diagnostics. If you are able to load the diagnostics, go to MAP 0020 in the *Diagnostics Information for Multiple Bus Systems*.

The service processor may have recorded one or more symptoms in its error log. It is a good idea to examine that error log before proceeding (see “System Information Menu” on page 382).

The service processor may have been set by the user to monitor server operations and to attempt recoveries. You can disable these actions while you diagnose and service the system. If the system was set up according to the recommendations of the *RS/6000 Enterprise Server Model H80 @server pSeries 660 Models 6H0 and 6H1 User's Guide*, all the settings of the service processor (except language) were saved by using the SAVE/RESTORE HARDWARE MAINTENANCE POLICIES service aid. You can use that service aid to restore the settings at the end of your service action.

Just in case the service processor settings were not saved by the user, if you disable them, you should make notes of their current settings for restoration before you leave.

In addition to the parameters in the table below, you can disconnect the modem to prevent incoming signals that could cause the system to power on.

Following are the service processor settings of your interest. The service processor menus are described in Chapter 7, “Using the Service Processor” on page 369.

Surveillance	From the service processor setup menu, go to the surveillance setup menu and disable surveillance.
Unattended start	From the service processor system power control menu, disable unattended start mode.
Reboot policy	From the system power control menu, go to the reboot/restart policy setup menu and set: 1. Number of reboot attempts to 0 (zero) 2. Use OS-Defined restart policy to No 3. Enable supplemental restart policy to No .
Call out	From the call-in/call-out setup menu, go to the serial port selection menu and disable call-out on both serial ports.

Be prepared to record code numbers and use those numbers in the course of analyzing a problem. Go to “Step 1020-1” on page 85.

Step 1020-1

The following steps analyze a failure to load the diagnostic programs.

Note: Be prepared to answer questions regarding the operator panel display and to perform certain actions based on displayed POST indicators. Please be observant of these conditions.

1. Power off the system. Refer to “Powering Off the System” on page 429.
2. Select slow boot mode (select disable fast boot) on the system power control menu from the service processor main menu.
3. Power on the system. Refer to “Powering On the System” on page 429
4. Insert the diagnostic CD-ROM into the CD-ROM drive.
5. When the keyboard indicator is displayed (the word keyboard), press the 5 key on the system console.
6. Enter a password, if requested.
7. Wait until the diagnostics are loaded or the system appears to stop.
8. Find your symptom in the following table; then follow the instructions given in the Action column.

Symptom	Action
The system stopped and a code is displayed on the operator panel.	Go to the "Entry MAP" on page 75.
The system stops with a prompt to enter a password.	Enter the password. You are not allowed to continue until a correct password has been entered. When you have entered a valid password, go to the beginning of this table and wait for one of the other conditions to occur.
The diagnostic operating instructions are displayed.	Go to MAP 0020 in the <i>Diagnostics Information for Multiple Bus Systems</i> .
The primary I/O drawer power on/off LED does not come on or does not stay on or you have a power problem.	Go to "MAP 1520: Power" on page 89.
The system login prompt is displayed.	<p>You may not have pressed the correct key or you may not have pressed the key soon enough when you were to indicate a service mode IPL of the diagnostic programs. If this is the case, start over at the beginning of this step.</p> <p>Note: Perform the system shutdown procedure before turning off the system.</p> <p>If you are sure you pressed the correct key in a timely manner, go to "Step 1020-2" on page 87.</p>
The system does not respond when the password is entered.	Go to "Step 1020-2" on page 87.
The system stopped. A POST indicator is displayed on the system console and an eight-digit error code is not displayed.	<p>If the POST indicator represents:</p> <ol style="list-style-type: none"> 1. Memory, go to "MAP 1540: Minimum Configuration" on page 113. 2. Keyboard <ol style="list-style-type: none"> a. Replace the keyboard. b. Go to "MAP 1540: Minimum Configuration" on page 113. 3. Network, go to "MAP 1540: Minimum Configuration" on page 113. 4. SCSI, go to "MAP 1540: Minimum Configuration" on page 113. 5. Speaker, go to "MAP 1540: Minimum Configuration" on page 113.
The System Management Services menu is displayed	Go to "Step 1020-4" on page 88.
All other symptoms.	If you were directed here from the Entry MAP, go to "MAP 1540: Minimum Configuration" on page 113. Otherwise, find the symptom in the "Entry MAP" on page 75.

Step 1020-2

There is a problem with the keyboard.

Find the type of keyboard you are using in the following table; then follow the instructions given in the Action column.

Keyboard Type	Action
Type 101 keyboard (U.S.). Identify by the size of the Enter key. The Enter key is in only one horizontal row of keys.	Record error code M0KB D001; then go to "Step 1020-3".
Type 102 keyboard (W.T.). Identify by the size of the Enter key. The Enter key extends into two horizontal rows.	Record error code M0KB D002; then go to "Step 1020-3".
Type 106 keyboard. (Identify by the Japanese characters.)	Record error code M0KB D003; then go to "Step 1020-3".
ASCII terminal keyboard	Go to the documentation for this type of ASCII terminal and continue problem determination.

Step 1020-3

Take the following actions:

1. Find the eight-digit error code in Chapter 5, "Error Code to FRU Index" on page 163.

Note: If the eight-digit error code is not listed in Chapter 5, "Error Code to FRU Index", look for it in the following:

- Any supplemental service manuals for attached devices
- The diagnostic problem report screen for additional information
- The Service Hints service aid
- The CERADME file (by using the Service Hints service aid).

Note: Service aids can be found in *Diagnostics Information for Multiple Bus Systems*.

2. Perform the action listed.

Step 1020-4

1. Turn off, then turn on the system unit.
2. When the keyboard indicator (the word keyboard) is displayed, press the 1 key on the system console.
3. When the System Management Services menus appear, check the error log for any errors.
 - a. Choose Error Log
 - b. If an error is logged, check the time stamp.
 - c. If the error was logged during the current boot attempt, record it.
 - d. Look up the error in the Chapter 5, "Error Code to FRU Index" on page 163 and do the listed action.
 - e. If no recent error is logged in the error log, go to "MAP 1540: Minimum Configuration" on page 113.

MAP 1520: Power

This procedure is used to locate power problems in the CEC drawer, I/O drawers, or rack(s). If a problem is detected, this procedure helps you isolate the problem to a failing unit.

Observe the following safety notices during service procedures.

DANGER

An electrical outlet that is not correctly wired could place hazardous voltage on metal parts of the system or the devices that attach to the system. It is the responsibility of the customer to ensure that the outlet is correctly wired and grounded to prevent an electrical shock.

Before installing or removing signal cables, ensure that the power cables for the system unit and all attached devices are unplugged.

When adding or removing any additional devices to or from the system, ensure that the power cables for those devices are unplugged before the signal cables are connected. If possible, disconnect all power cables from the existing system before you add a device.

Use one hand, when possible, to connect or disconnect signal cables to prevent a possible shock from touching two surfaces with different electrical potentials.

During an electrical storm, do not connect cables for display stations, printers, telephones, or station protectors for communications lines.

CAUTION:

This product is equipped with a three-wire power cable and plug for the user's safety. Use this power cable with a properly grounded electrical outlet to avoid electrical shock.

CAUTION:

This unit has more than one power supply cord. To reduce the risk of electrical shock, disconnect two power supply cords before servicing.

CAUTION:

Energy hazard, remove power before servicing.

Find the symptom in the following table; then follow the instructions given in the Action column.

Symptom	Action
Power Problems	
The primary I/O drawer does not become powered on, no OK prompt.	Go to "Map 1521: Cannot Power On The Primary I/O Drawer, Operator Panel Does Not Show OK Prompt" on page 91.
The CEC drawer does not become powered on.	Go to "Map 1522: Cannot Power On The CEC Drawer" on page 97.
The secondary I/O drawer does not become powered on, no power present LED.	Go to "Map 1523: Cannot Power On The Secondary I/O Drawer, Operator Panel Power Present LED Does Not Come On" on page 104.
You have been directed here by the SPCN Error Codes table and the error code is 1011 1C0x	Go to "Map 1524: The SPCN Error Codes Table Directed You Here and the Error Code is 1011 1C0x" on page 109.

Map 1521: Cannot Power On The Primary I/O Drawer, Operator Panel Does Not Show OK Prompt

Step 1521-1

Attempt to power on the primary I/O drawer (see “Powering Off and Powering On the System” on page 429)

Does the primary I/O drawer power on?

NO Go to “Step 1521-2”.

YES **This ends the procedure.** Go to “Map 0410: Repair Checkout” in the *Diagnostics Information for Multiple Bus Systems*.

Step 1521-2

Look at the power supply LED(s) at the front of the primary I/O drawer.

Is the primary I/O drawer equipped with two power supplies?

NO Go to “Step 1521-3”.

YES Go to “Step 1521-5” on page 92.

Step 1521-3

Is the power supply LED flashing?

NO Go to “Step 1521-7” on page 92.

YES Go to “Step 1521-4”.

Step 1521-4

Use the information in the “I/O Drawer and Power Supply LED Status” on page 28 to answer the following question.

Is the power supply LED blinking quickly?

NO Check the SPCN cabling.
Check internal drawer cabling from power distribution card to primary I/O backplane. See “Primary I/O Drawer Internal Cables” on page 483 in Chapter 10.

Replace the I/O drawer power supply.

Replace the primary I/O drawer backplane.

Replace the I/O drawer power distribution card.

This ends the procedure. Go to “Map 0410: Repair Checkout” in the *Diagnostics Information for Multiple Bus Systems*

YES Replace the power supply with the flashing LED.

This ends the procedure. Go to “Map 0410: Repair Checkout” in the *Diagnostics Information for Multiple Bus Systems*

Step 1521-5

Is there a power supply with a flashing LED?

NO Go to "Step 1521-7".

YES Go to "Step 1521-6".

Step 1521-6

Are both I/O drawer power supply LEDs flashing?

NO Replace the power supply with the flashing LED.

This ends the procedure. Go to "Map 0410: Repair Checkout" in the *Diagnostics Information for Multiple Bus Systems*

YES Check internal drawer cabling from power distribution card to primary I/O backplane. See "Primary I/O Drawer Internal Cables" on page 483 in Chapter 10.

Replace the following one at a time:

1. primary I/O drawer backplane
2. power distribution board

This ends the procedure. Go to "Map 0410: Repair Checkout" in the *Diagnostics Information for Multiple Bus Systems*

Step 1521-7

Are all circuit breakers reset at the rack power distribution unit(s)?

NO Reset the circuit breaker.

This ends the procedure. Go to "Map 0410: Repair Checkout" in the *Diagnostics Information for Multiple Bus Systems*.

YES Go to "Step 1521-8".

Step 1521-8

Are all the cables seated firmly and correctly connected between primary I/O drawer, secondary I/O drawers and CEC drawer?

NO Fix the cable connections.

This ends the procedure. Go to "Map 0410: Repair Checkout" in the *Diagnostics Information for Multiple Bus Systems*.

YES Go to "Step 1521-9" on page 93.

Step 1521-9

Are all the ac power cables seated firmly and connected correctly from the rack power distribution unit(s) to the rack drawers?

NO Fix the connection.

This ends the procedure. Go to "Map 0410: Repair Checkout" in the *Diagnostics Information for Multiple Bus Systems*.

YES Go to "Step 1521-10".

Step 1521-10

Follow the ac power cable(s) from the primary I/O drawer to the appropriate power distribution unit.

Is the power distribution unit power LED on?

NO Go to "Step 1521-14" on page 95.

YES Go to "Step 1521-11".

Step 1521-11

Note: Read the Danger and Caution notices under "Safety Notices" on page xi before continuing with this procedure.

Perform the following:

1. Disconnect the ac power cable(s) from the power distribution unit that supplies power to the primary I/O drawer.
2. Use a multimeter to measure the ac voltage at the power distribution unit socket(s) where the ac power cable(s), just removed, was (were) attached.

Is the ac voltage from 200 V ac to 240 V ac?

NO Replace the power distribution unit.

This ends the procedure. Go to "Map 0410: Repair Checkout" in the *Diagnostics Information for Multiple Bus Systems*.

YES Go to "Step 1521-12" on page 94.

Step 1521-12

Reconnect the ac power cable(s) to the power distribution unit.

Note: Read the Danger and Caution notices under “Safety Notices” on page xi before continuing with this procedure.

Perform the following:

1. Disconnect the ac power cable from each power supply of the primary I/O drawer.
2. Use a multimeter to measure the ac voltage at the drawer end of each ac power cable.

Is the ac voltage from 200 V ac to 240 V ac?

NO Replace the ac power cable(s).

This ends the procedure. Go to “Map 0410: Repair Checkout” in the *Diagnostics Information for Multiple Bus Systems*.

YES Go to “Step 1521-13” on page 95.

Step 1521-13

Check internal drawer cabling from power distribution card to primary I/O backplane. See “Primary I/O Drawer Internal Cables” on page 483 in Chapter 10.

Replace the following in the primary I/O drawer, one at a time, disconnecting the ac power cable to each power supply before replacement and reconnecting the ac power cable to each supply after replacement:

- Primary I/O drawer operator panel
- Power supply (including redundant power supply, if present)
- Primary I/O drawer backplane

Does the Primary I/O Drawer Operator Panel Show the OK Prompt?

NO Contact your next level of support for assistance.

YES **This ends the procedure.** Go to “Map 0410: Repair Checkout” in the *Diagnostics Information for Multiple Bus Systems*.

Step 1521-14

Is the ac power cable from the rack power distribution unit to the customer’s ac power outlet connected and seated correctly at both ends?

NO Connect the ac power cable correctly at both ends.

This ends the procedure. Go to “Map 0410: Repair Checkout” in the *Diagnostics Information for Multiple Bus Systems*.

YES Go to “Step 1521-15”.

Step 1521-15

Note: Read the Danger and Caution notices under “Safety Notices” on page xi before continuing with this procedure.

Perform the following:

1. Disconnect the mainline ac power cable from the power distribution unit that supplies power to the primary I/O drawer.
2. Use a multimeter to measure the ac voltage at the power distribution unit end of the mainline ac power cable.

Is the ac voltage from 200 V ac to 240 V ac?

NO Go to “Step 1521-16” on page 96.

YES Replace the power distribution unit.

This ends the procedure. Go to “Map 0410: Repair Checkout” in the *Diagnostics Information for Multiple Bus Systems*.

Step 1521-16

Note: Read the Danger and Caution notices under "Safety Notices" on page xi before continuing with this procedure.

Perform the following:

1. Disconnect the mainline ac power cable from the customer's ac power outlet.
2. Use a multimeter to measure the ac voltage at the customer's ac power outlet.

Is the ac voltage from 200 V ac to 240 V ac?

NO Inform the customer that the ac voltage at the power outlet is not correct.

This ends the procedure. Go to "Map 0410: Repair Checkout" in the *Diagnostics Information for Multiple Bus Systems*.

YES Replace the mainline ac power cable.

This ends the procedure. Go to "Map 0410: Repair Checkout" in the *Diagnostics Information for Multiple Bus Systems*.

Map 1522: Cannot Power On The CEC Drawer

Step 1522-1

Attempt to power on the CEC drawer (see “Powering Off and Powering On the System” on page 429)

Does the CEC drawer power on?

NO Go to “Step 1522-2”.

YES **This ends the procedure.** Go to “Map 0410: Repair Checkout” in the *Diagnostics Information for Multiple Bus Systems*.

Step 1522-2

Look at the power supply LED(s) at the front of the CEC drawer.

Is the CEC drawer equipped with two power supplies?

NO Go to “Step 1522-3”.

YES Go to “Step 1522-5” on page 98

This ends the procedure. Go to “Map 0410: Repair Checkout” in the *Diagnostics Information for Multiple Bus Systems*.

Step 1522-3

Is the power supply LED flashing?

NO Go to “Step 1522-7” on page 99.

YES Go to “Step 1522-4” on page 98.

Step 1522-4

Use the information in the “I/O Drawer and Power Supply LED Status” on page 28 to answer the following question.

Note: This table also applies to the CEC drawer LEDs.

Is the power supply LED blinking quickly?

NO Check the SPCN cabling.

Replace the CEC drawer power supply.

Replace the CEC drawer backplane.

This ends the procedure. Go to “Map 0410: Repair Checkout” in the *Diagnostics Information for Multiple Bus Systems*

YES Replace the power supply with the flashing LED.

This ends the procedure. Go to “Map 0410: Repair Checkout” in the *Diagnostics Information for Multiple Bus Systems*

Step 1522-5

Is there a power supply with a flashing LED?

NO Go to “Step 1522-7” on page 99.

YES Go to “Step 1522-6”.

Step 1522-6

Are both I/O drawer power supply LEDs flashing?

NO Replace the power supply with the flashing LED.

This ends the procedure. Go to “Map 0410: Repair Checkout” in the *Diagnostics Information for Multiple Bus Systems*

YES Replace the CEC backplane.

This ends the procedure. Go to “Map 0410: Repair Checkout” in the *Diagnostics Information for Multiple Bus Systems*

Step 1522-7

Are all circuit breakers reset at the rack power distribution unit(s)?

NO Reset the circuit breaker..

This ends the procedure. Go to "Map 0410: Repair Checkout" in the *Diagnostics Information for Multiple Bus Systems*.

YES Go to "Step 1522-8".

Step 1522-8

Are all the cables seated firmly and correctly connected between the primary I/O drawer, secondary I/O drawers and CEC drawer?

NO Fix the cable connections

This ends the procedure. Go to "Map 0410: Repair Checkout" in the *Diagnostics Information for Multiple Bus Systems*.

YES Go to "Step 1522-9".

Step 1522-9

Are all the ac power cables seated firmly and connected correctly from the rack power distribution unit(s) to the rack drawers?

NO Fix the connection.

This ends the procedure. Go to "Map 0410: Repair Checkout" in the *Diagnostics Information for Multiple Bus Systems*.

YES Go to "Step 1522-10".

Step 1522-10

Follow the ac power cable(s) from the CEC drawer to the appropriate power distribution unit.

Is the power distribution unit power LED on?

NO Go to "Step 1522-18" on page 102.

YES Go to "Step 1522-11" on page 100.

Step 1522-11

Note: Read the Danger and Caution notices under "Safety Notices" on page xi before continuing with this procedure.

Perform the following:

1. Disconnect the ac power cable(s) from the power distribution unit that supplies power to the CEC drawer.
2. Use a multimeter to measure the ac voltage at the power distribution unit socket(s) where the ac power cable(s), just removed, was (were) attached.

Is the ac voltage from 200 V ac to 240 V ac?

NO Replace the power distribution unit.

This ends the procedure. Go to "Map 0410: Repair Checkout" in the *Diagnostics Information for Multiple Bus Systems*.

YES Go to "Step 1522-12".

Step 1522-12

Reconnect the ac power cable(s) to the power distribution unit.

Note: Read the Danger and Caution notices under "Safety Notices" on page xi before continuing with this procedure.

Perform the following:

1. Disconnect the ac power cable from each power supply of the CEC drawer.
2. Use a multimeter to measure the ac voltage at the drawer end of each ac power cable.

Is the ac voltage from 200 V ac to 240 V ac?

NO Replace the ac power cable(s).

This ends the procedure. Go to "Map 0410: Repair Checkout" in the *Diagnostics Information for Multiple Bus Systems*.

YES Go to "Step 1522-13" on page 101.

Step 1522-13

Disconnect the ac power cable to each power supply of the CEC drawer and remove the following from the CEC drawer:

1. CEC processor card
2. CEC memory card(s)

Reconnect the ac power cables to each power supply of the CEC drawer and attempt to power on the CEC.

Does the CEC power on?

NO Go to "Step 1522-16" on page 102.

YES Go to "Step 1522-14".

Step 1522-14

Disconnect the ac power cable from each power supply. Then reinsert the following components in the CEC drawer, one at a time, in the sequence listed. After reinserting, reconnect the ac power cable to each power supply.

1. CEC processor card
2. CEC memory card(s)

Does the CEC power on?

NO Replace the defective card just reinserted.

Reinsert any remaining cards in this step.

This ends the procedure. Go to "Map 0410: Repair Checkout" in the *Diagnostics Information for Multiple Bus Systems*.

YES Go to "Step 1522-15".

Step 1522-15

Have all cards in this step been reinserted?

NO Go to "Step 1522-14".

This ends the procedure. Go to "Map 0410: Repair Checkout" in the *Diagnostics Information for Multiple Bus Systems*.

YES The symptom has changed. Call your next level of support for assistance.

Step 1522-16

Disconnect the ac power cable from the power supply. Then replace the CEC backplane. After replacing, reconnect the ac power cable to the power supply.

Does the CEC power on?

NO Go to "Step 1522-17".

YES Reinsert the cards removed in "Step 1522-13" on page 101.

This ends the procedure. Go to "Map 0410: Repair Checkout" in the *Diagnostics Information for Multiple Bus Systems*.

Step 1522-17

Have all cards in this step been replaced?

NO Go to "Step 1522-16".

This ends the procedure. Go to "Map 0410: Repair Checkout" in the *Diagnostics Information for Multiple Bus Systems*.

YES Call your next level of support for assistance.

This ends the procedure. Go to "Map 0410: Repair Checkout" in the *Diagnostics Information for Multiple Bus Systems*.

Step 1522-18

Is the ac power cable from the rack power distribution unit to the customer's ac power outlet connected and seated correctly at both ends?

NO Connect the ac power cable correctly at both ends.

This ends the procedure. Go to "Map 0410: Repair Checkout" in the *Diagnostics Information for Multiple Bus Systems*.

YES Go to "Step 1522-19" on page 103.

Step 1522-19

Note: Read the Danger and Caution notices under “Safety Notices” on page xi before continuing with this procedure.

Perform the following:

1. Disconnect the mainline ac power cable from the power distribution unit that supplies power to the CEC drawer.
2. Use a multimeter to measure the ac voltage at the power distribution unit end of the mainline ac power cable.

Is the ac voltage from 200 V ac to 240 V ac?

NO Go to “Step 1522-20”.

YES Replace the power distribution unit.

This ends the procedure. Go to “Map 0410: Repair Checkout” in the *Diagnostics Information for Multiple Bus Systems*.

Step 1522-20

Note: Read the Danger and Caution notices under “Safety Notices” on page xi before continuing with this procedure.

Perform the following:

1. Disconnect the mainline ac power cable from customer’s ac power outlet.
2. Use a multimeter to measure the ac voltage at the customer’s ac power outlet.

Is the ac voltage from 200 V ac to 240 V ac?

NO Inform the customer that the ac voltage at the power outlet is not correct.

This ends the procedure. Go to “Map 0410: Repair Checkout” in the *Diagnostics Information for Multiple Bus Systems*.

YES Replace the mainline ac power cable.

This ends the procedure. Go to “Map 0410: Repair Checkout” in the *Diagnostics Information for Multiple Bus Systems*.

Map 1523: Cannot Power On The Secondary I/O Drawer, Operator Panel Power Present LED Does Not Come On

Step 1523-1

Attempt to power on the secondary I/O drawer (see “Powering Off and Powering On the System” on page 429.)

Does the secondary I/O drawer power on?

NO Go to “Step 1523-2”.

YES **This ends the procedure.** Go to “Map 0410: Repair Checkout” in the *Diagnostics Information for Multiple Bus Systems*.

Step 1523-2

Look at the power supply LED(s) at the front of the secondary I/O drawer.

Is the secondary I/O drawer equipped with two power supplies?

NO Go to “Step 1523-3”.

YES Go to “Step 1523-5” on page 105

This ends the procedure. Go to “Map 0410: Repair Checkout” in the *Diagnostics Information for Multiple Bus Systems*.

Step 1523-3

Is the power supply LED flashing?

NO Go to “Step 1523-7” on page 106.

YES Go to “Step 1523-4” on page 105.

Step 1523-4

Use the information in the “I/O Drawer and Power Supply LED Status” on page 28 to answer the following question.

Is the power supply LED blinking quickly?

- NO** Check the SPCN cabling.
Check internal drawer cabling from power distribution card to primary I/O backplane. See “Primary I/O Drawer Internal Cables” on page 483 in Chapter 10.

Replace the I/O drawer power supply.

Replace the secondary I/O drawer backplane.

Replace the I/O drawer power distribution card.

This ends the procedure. Go to “Map 0410: Repair Checkout” in the *Diagnostics Information for Multiple Bus Systems*
- YES** Replace the power supply with the flashing LED.

This ends the procedure. Go to “Map 0410: Repair Checkout” in the *Diagnostics Information for Multiple Bus Systems*

Step 1523-5

Is there a power supply with a flashing LED?

- NO** Go to “Step 1523-7” on page 106.
- YES** Go to “Step 1523-6”.

Step 1523-6

Are both I/O drawer power supply LEDs flashing?

- NO** Replace the power supply with the flashing LED.

This ends the procedure. Go to “Map 0410: Repair Checkout” in the *Diagnostics Information for Multiple Bus Systems*
- YES** Check internal drawer cabling from power distribution card to primary I/O backplane. See “Primary I/O Drawer Internal Cables” on page 483 in Chapter 10.

Replace the following one at a time:
1. secondary I/O drawer backplane
 2. power distribution board
- This ends the procedure.** Go to “Map 0410: Repair Checkout” in the *Diagnostics Information for Multiple Bus Systems*

Step 1523-7

Are all circuit breakers reset at the rack power distribution unit(s)?

NO Reset the tripped circuit breaker.

This ends the procedure. Go to "Map 0410: Repair Checkout" in the *Diagnostics Information for Multiple Bus Systems*.

YES Go to "Step 1523-8".

Step 1523-8

Are all the cables seated firmly and correctly connected between the primary I/O drawer, secondary I/O drawers and CEC drawer?

NO Fix the cable connections.

This ends the procedure. Go to "Map 0410: Repair Checkout" in the *Diagnostics Information for Multiple Bus Systems*.

YES Go to "Step 1523-9".

Step 1523-9

Are all the ac power cables seated firmly and connected correctly from the rack power distribution unit(s) to the rack drawers?

NO Fix the connection.

This ends the procedure. Go to "Map 0410: Repair Checkout" in the *Diagnostics Information for Multiple Bus Systems*.

YES Go to "Step 1523-10".

Step 1523-10

Follow the ac power cable(s) from the secondary I/O drawer to the appropriate power distribution unit.

Is the power distribution unit power LED on?

NO Go to "Step 1523-14" on page 108.

YES Go to "Step 1523-11" on page 107.

Step 1523-11

Note: Read the Danger and Caution notices under “Safety Notices” on page xi before continuing with this procedure.

Perform the following:

1. Disconnect the ac power cable(s) from the power distribution unit that supplies power to the secondary I/O drawer.
2. Use a multimeter to measure the ac voltage at the power distribution unit socket(s) where the ac power cable(s), just removed, was (were) attached.

Is the ac voltage from 200 V ac to 240 V ac?

NO Replace the power distribution unit. Reconnect the ac power cable(s) to the power distribution unit.

This ends the procedure. Go to “Map 0410: Repair Checkout” in the *Diagnostics Information for Multiple Bus Systems*.

YES Go to “Step 1523-12”.

Step 1523-12

Reconnect the ac power cables(s) to the power distribution unit.

Note: Read the Danger and Caution notices under “Safety Notices” on page xi before continuing with this procedure.

Perform the following:

1. Disconnect the ac power cable from each power supply of secondary I/O drawer.
2. Use a multimeter to measure the ac voltage at the drawer end of each ac power cable.

Is the ac voltage from 200 V ac to 240 V ac?

NO Replace the ac power cable(s).

This ends the procedure. Go to “Map 0410: Repair Checkout” in the *Diagnostics Information for Multiple Bus Systems*.

YES Go to “Step 1523-13” on page 108.

Step 1523-13

Check internal drawer cabling from power distribution card to primary I/O backplane. See "Primary I/O Drawer Internal Cables" on page 483 in Chapter 10.

Disconnect the ac power cable from each power supply. Then replace the following components in the secondary I/O drawer, one at a time, in the sequence listed. After replacing, reconnect the ac power cable to each power supply.

- Secondary I/O drawer operator panel
- Secondary I/O drawer backplane
- Power supply (including redundant power supply, if present)

Does the secondary I/O drawer operator panel turn on the power present LED?

NO Contact your next level of support for assistance.

YES **This ends the procedure.** Go to "Map 0410: Repair Checkout" in the *Diagnostics Information for Multiple Bus Systems*.

Step 1523-14

Is the ac power cable from the secondary rack power distribution unit to the customer's ac power outlet connected and seated correctly at both ends?

NO Connect the ac power cable correctly at both ends.

This ends the procedure. Go to "Map 0410: Repair Checkout" in the *Diagnostics Information for Multiple Bus Systems*.

YES Go to "Step 1523-15".

Step 1523-15

Note: Read the Danger and Caution notices under "Safety Notices" on page xi before continuing with this procedure.

Perform the following:

1. Disconnect the mainline ac power cable from the power distribution unit that supplies power to the secondary I/O drawer.
2. Use a multimeter to measure the ac voltage at the power distribution unit end of the mainline ac power cable.

Is the ac voltage from 200 V ac to 240 V ac?

NO Go to "Step 1523-16" on page 109.

YES Replace the power distribution unit.

This ends the procedure. Go to "Map 0410: Repair Checkout" in the *Diagnostics Information for Multiple Bus Systems*.

Step 1523-16

Note: Read the Danger and Caution notices under “Safety Notices” on page xi before continuing with this procedure.

Perform the following:

1. Disconnect the mainline ac power cable from the customer’s ac power outlet.
2. Use a multimeter to measure the ac voltage at the customer’s ac power outlet.

Is the ac voltage from 200 V ac to 240 V ac?

NO Inform the customer that the ac voltage at the power outlet is not correct.

This ends the procedure. Go to “Map 0410: Repair Checkout” in the *Diagnostics Information for Multiple Bus Systems*.

YES Replace the mainline ac power cable.

This ends the procedure. Go to “Map 0410: Repair Checkout” in the *Diagnostics Information for Multiple Bus Systems*.

Map 1524: The SPCN Error Codes Table Directed You Here and the Error Code is 1011 1C0x

A CEC power supply is reporting a load fault.

Note: Read the danger and caution notices under “Safety Notices” on page xi before continuing with this procedure.

Perform the following steps to isolate the problem.

Step 1524-1

1. Turn off the power.
2. Disconnect the ac power cables (dc power cables in a dc-powered system) from the CEC drawer.
3. At the top of the CEC drawer, remove the following cards, in the sequence listed:
 - a. CEC memory riser 1 (if present)
 - b. CEC processor
 - c. CEC memory riser 2 (if present)
4. Reconnect the ac power cables (dc power cables in a dc-powered system) to the CEC drawer.
5. Turn on the power.

Is the error code 1011 1C0x displayed?

NO Go to “Step 1524-7” on page 111.

YES Go to “Step 1524-2” on page 110.

Step 1524-2

1. Turn off the power.
2. Disconnect the ac power cables (dc power cables in a dc-powered system) from the CEC drawer.
3. Remove CEC power supply 2 (if present) or cooling unit.
4. Reconnect the ac power cable (dc power cable in a dc-powered system) to the CEC power supply 1.
5. Turn on the power.

Is the error code 1011 1C0x displayed?

NO Go to "Step 1524-3".

YES Go to "Step 1524-4"

Step 1524-3

1. Turn off the power.
2. Reinstall CEC power supply 2 or cooling unit that was removed in "Step 1524-2".
3. Reconnect the ac power cable (dc power cable in a dc-powered system) to the CEC power supply 2 (if present).
4. Turn on the power.

Is the error code 1011 1C0x displayed?

NO The symptom has changed.

This ends the procedure.

YES Replace CEC power supply 2 or cooling unit, location: U1.1-V2.

This ends the procedure. Go to "MAP 410: Repair Checkout" in the *RS/6000 and @server pSeries Diagnostics Information for Multiple Bus Systems*.

Step 1524-4

1. Turn off the power.
2. Reinstall CEC power supply 2 or cooling unit that was removed in "Step 1524-2".
3. Reconnect the ac power cable (dc power cable in a dc-powered system) to the CEC power supply 2 (if present).
4. Disconnect the ac cable (dc power cable in a dc-powered system) to CEC power supply 1.
5. Remove CEC power supply 1 if CEC power supply 2 is present. If location U1.1-V2 has a cooling unit, then replace CEC power supply 1.
6. Turn on the power.

Is the error code 1011 1C0x displayed?

NO If CEC power supply 2 is present, replace CEC power supply 1, location: U1.1-V1.

This ends the procedure. Go to "MAP 410: Repair Checkout" in the *RS/6000 and @server pSeries Diagnostics Information for Multiple Bus Systems*.

YES Go to "Step 1524-5".

Step 1524-5

1. Turn off the power.
2. Reinstall CEC power supply 1 if it was removed in "Step 1524-4" on page 110 or replace the original CEC power supply 1, if it was replaced with a new one in "Step 1524-4" on page 110.
3. Reconnect the ac power cable (dc power cable in a dc-powered system) to the CEC power supply 1.
4. Remove CEC fan 7. Disregard a CEC fan error code if it occurs during this step.
5. Turn on the power.

Is the error code 1011 1C0x displayed?

NO Replace CEC fan 7, location: U1.1-F7. **This ends the procedure.** Go to "MAP 410: Repair Checkout" in the *RS/6000 and @server pSeries Diagnostics Information for Multiple Bus Systems*.

YES Go to "Step 1524-6".

Step 1524-6

1. Turn off the power.
2. Reinstall CEC fan 7 that was removed in "Step 1524-5".
3. Remove CEC fan 8. Disregard a CEC fan error code if it occurs during this step.
4. Turn on the power.

Is the error code 1011 1C0x displayed?

NO Replace CEC fan 8, location: U1.1-F8. **This ends the procedure.** Go to "MAP 410: Repair Checkout" in the *RS/6000 and @server pSeries Diagnostics Information for Multiple Bus Systems*.

YES Replace the CEC backplane, location: U1.1-P1. **This ends the procedure.** Go to "MAP 410: Repair Checkout" in the *RS/6000 and @server pSeries Diagnostics Information for Multiple Bus Systems*.

Step 1524-7

1. Turn off the power.
2. Disconnect the ac power cables (dc power cables in a dc-powered system) from the CEC drawer.
3. Reinstall one of the cards that was removed in "Step 1524-1" on page 109, in the sequence listed:
 - a. CEC memory riser 1 (if present)
 - b. CEC memory riser 2 (if present)
 - c. CEC processor

4. Reconnect the ac power cables (dc power cables in a dc-powered system) to the CEC drawer.
5. Turn on the power.

Is the error code 1011 1C0x displayed?

NO Go to "Step 1524-8".

YES The last card you installed is defective. Replace the last card you installed. **This ends the procedure.** Go to "MAP 410: Repair Checkout" in the *RS/6000 and @server pSeries Diagnostics Information for Multiple Bus Systems*.

Step 1524-8

Have all the cards that were removed in "Step 1524-7" on page 111 been reinstalled?

NO Go to "Step 1524-7" on page 111 and reinstall the next card in the list.

YES Replace the CEC backplane, location: U1.1-P1.

This ends the procedure. Go to "MAP 410: Repair Checkout" in the *RS/6000 and @server pSeries Diagnostics Information for Multiple Bus Systems*.

MAP 1540: Minimum Configuration

This MAP is used to locate defective FRUs not found by normal diagnostics. For this procedure, diagnostics are run on a minimally configured system. If a failure is detected on the minimally configured system, the remaining FRUs are exchanged one at a time until the failing FRU is identified. If a failure is not detected, FRUs are added back until the failure occurs. The failure is then isolated to the failing FRU.

Notes:

1. Be sure to unplug the power cable from the rack that contains the CEC drawer, the primary drawer, and any secondary drawer before removing or installing the processor cards, memory cards, CEC backplane or I/O backplane to avoid damage.
2. This MAP assumes that a CD-ROM drive is installed and connected to a the internal SCSI adapter of the primary drawer, and a diagnostics CD-ROM is available.
3. If a general access password or privileged-access password is installed, you are prompted to enter the password before the diagnostic CD-ROM can load.
4. The term *POST indicators* refers to the device mnemonics (words memory, keyboard, network, scsi, and speaker) that appear on the system console during the power-on self-test (POST).
5. The service processor may have recorded one or more symptoms in its error log. It is a good idea to examine that error log before proceeding (see service processor system information menu).
6. The service processor may have been set by the user to monitor server operations and to attempt recoveries. You can disable these actions while you diagnose and service the system. If you disable them, make notes of their current settings so that you can restore them easily. The following table lists the settings:

Surveillance	From the service processor setup menu, go to the surveillance setup menu and disable surveillance.
Unattended start	From the service processor system power control menu, disable unattended start mode.
Reboot policy	From the system power control menu, go to the reboot/restart policy setup menu and set: a. Number of reboot attempts to 0 (zero) b. Use OS-Defined restart policy to No c. Enable supplemental restart policy to No .
Call out	From the call-in/call-out setup menu, go to the serial port selection menu and disable call-out on both serial ports.

Step 1540-1

1. Ensure that the diagnostics and the operating system are shut down.
2. Turn off the power.
3. Select slow boot mode (select disable fast boot) on the system power control menu from the service processor main menu.
4. Turn on the power to boot standalone diagnostics from CD.

Does the primary I/O drawer power come on and stay on?

NO Go to “Step 1540-4” on page 116.

YES Go to step 5.

5. Insert the diagnostic CD-ROM into the CD-ROM drive.

Does the CD-ROM appear to operate correctly?

NO Go to “Boot Problems and Concerns” on page 159.

YES Go to “Step 1540-2”.

Step 1540-2

1. When the keyboard indicator is displayed (the word keyboard), press the 5 key on the system console.
2. Enter the appropriate password when you are prompted to do so.

Is the Please define the System Console screen displayed?

NO Go to “Step 1540-3”.

YES Go to “Step 1540-10” on page 120.

Step 1540-3

The system is unable to boot standalone diagnostics.

Check the Service Processor error log and the primary I/O drawer operator panel for additional error codes resulting from the slow boot in step 1540-1.

Did the slow boot generate a different error code than the one that originally sent you to MAP 1540?

YES Restore fast boot mode (select enable fast boot) on the system power control menu from the service processor main menu, go to “Checkpoint and Error Code Index” on page 165 and follow the actions for the new error code.

NO Continue “Step 1540-3” below.

The boot attempts that follow will attempt to get the Please define system console prompt on the system console. Ignore any codes that may appear on the operator panel unless stated otherwise.

Use the following table to locate, if possible, the error code that sent you to minimum configuration:

Note: x = indicates any character (6 to F) associated with this code.

First Four Characters	Second Four Characters
406x	0009 00A1 00A3 00A6 00A7
<hr/> 450x or 460x or 4B2x	<hr/> 244C 244D 244E 244F 24A1 24A2 24A3 24A4 25BB 25BD 25BE 25BF 25CB 25EA 25EB 25F2 263D 271A 271D 288D 2A00
<hr/> B006	<hr/> 1406 1407 1408
<hr/> B1xx	<hr/> 4601 4648 4660 4690 4691 469E 469F

Use the following table to locate, if possible, the checkpoint that sent you to minimum configuration:

Checkpoint	Checkpoint	Checkpoint
91FF	94B2	9503
9380	94BB	9504
94B0	9501	9505
94B1	9502	9506

Did you find the error code or checkpoint that sent you here in the above tables or did the action that sent you to MAP 1540 explicitly tell you to run the CEC Drawer Minimum Configuration?

NO Go to “Step 1540-13” on page 122.

YES Go to “Step 1540-4”.

Step 1540-4

1. Turn off the power.
2. At the CEC drawer, disconnect the RIO cable at RIO port 0.
3. At the primary I/O drawer, disconnect the RIO cable at RIO port 0. The RIO cable should be loose and can be removed from the system.
4. At the CEC drawer, disconnect the RIO cable at RIO port 1 and reconnect it to RIO port 0.
5. Follow the RIO cable you have connected to RIO port 0 of the CEC drawer back to an I/O drawer, disconnect the I/O drawer end (RIO port 1, note location) of the RIO cable and reconnect it to the primary I/O drawer RIO port 0.
6. With only one RIO cable connected between the CEC drawer RIO port 0 and the primary I/O drawer RIO port 0, power the system on to boot standalone diagnostics from CD.

Is the Please Define the System Console **screen displayed?**

NO Reconnect the RIO cable that was removed in substep 3 above. Connect from CEC drawer RIO port 1 to the I/O drawer RIO port 1 noted in substep 5 above. Go to “Step 1540-5” on page 117.

YES The RIO cable you removed in substep 3 above is defective. Replace the RIO cable. Connect from CEC drawer RIO port 1 to the I/O drawer RIO port 1 noted in substep 5 above. The last item replaced was defective. Return the machine to the original configuration. Go to “MAP 410: Repair Checkout” in the *Diagnostics Information for Multiple Bus Systems*.

Step 1540-5

1. Turn off the power.
2. Disconnect the ac power cable(s) from the front of the CEC drawer.
3. If the system has a one-way processor card with memory DIMMs installed, record the DIMM locations and remove all the memory DIMMs except the ones in slots 1 and 8–pair A. If a memory riser card with memory DIMMs is installed in slot U1.1-P1-M1, record the DIMM locations and remove all the memory DIMMs except the ones in slots 1, 2, 15, and 16–quad A.

Make sure the minimum memory DIMMs configuration of 256 MB is installed in the memory riser card in the first slot of the system, or the one-way processor card if there is no memory riser card. Use either a pair or a quad, depending on the memory DIMMs available.

4. Replace the second memory riser card from slot U1.1-P1-M2, (if present), with a memory filler card if one is available. Otherwise, record the DIMM locations, remove all the memory DIMMs from the second memory riser card and install it back in slot U1.1-P1-M2.
5. With the CEC drawer now configured with only minimum required memory, connect the ac power cable to the CEC drawer and turn on the power to boot standalone diagnostics from CD.

Is the Please define the System Console screen displayed?

- NO** Go to “Step 1540-6” on page 118.
- YES** Go to “Step 1540-8” on page 119.

Step 1540-6

1. Turn off the power.
2. Disconnect the ac power cable from the CEC drawer.
3. Replace the items in the following list, ONE at a time.
 - a. Memory DIMMs quad A on memory riser card 1, if present, with new or previously removed DIMMs
 - b. Memory riser card (Location: U1.1-P1-M1), if present, with a new or previously removed memory riser card
 - c. Memory riser card (Location: U1.1-P1-M2), if present, with a new or previously removed memory riser card
 - d. Memory DIMMs pair A on one-way processor card, if present, with new or previously removed DIMMs
 - e. Processor card (Location: U1.1-P1-C1)
 - f. CEC drawer backplane (Location: U1.1-P1)
4. Reconnect the ac power to the CEC drawer.
5. Turn on the power to boot standalone diagnostics from CD.

Is the Please define the System Console screen displayed?

- NO** Go to "Step 1540-7".
- YES** The last item replaced was defective. Return the machine to the original configuration. Go to "MAP 410: Repair Checkout" in the *Diagnostics Information for Multiple Bus Systems*.

Step 1540-7

Have all the parts, if present, listed in "Step 1540-6" been replaced?

- NO** Go to "Step 1540-6".
- YES** Go to "Step 1540-11" on page 121.

Step 1540-8

1. Turn off the power.
2. Disconnect the ac power cable from the CEC drawer.
3. Reinsert the cards in the following list one at a time. Continue to reinsert cards in the list until you have reinserted all the cards in the list.
 - a. Memory DIMMs in quads B in memory riser card 1 if previously present or memory DIMMs in pairs B in one-way processor card if previously present.
 - b. Memory DIMMs in quads C in memory riser card 1 if previously present or memory DIMMs in pairs C in one-way processor card if previously present.
 - c. Memory DIMMs in quads D in memory riser card 1 if previously present or memory DIMMs in pairs D in one-way processor card if previously present.
 - d. If a memory riser card filler was installed in the place of the memory riser card 2, replace the memory riser card filler with memory riser card 2.
 - e. Memory DIMMs in quad A in memory riser card 2 if previously present.
 - f. Memory DIMMs in quad B in memory riser card 2 if previously present.
 - g. Memory DIMMs in quad C in memory riser card 2 if previously present.
 - h. Memory DIMMs in quad D in memory riser card 2 if previously present.
4. Reconnect the ac power cable to the CEC drawer.
5. Turn on the power to boot standalone diagnostics from CD.

Is the Please define the System Console screen displayed?

- NO** The DIMMs or memory riser card you just reinserted or the one-way processor card is defective. Isolate to the failing memory DIMM pairs or quads by temporarily replacing with new or previously removed or populated memory DIMM pairs or quads. Otherwise, the memory riser card or one-way processor card is bad. Return to the original configuration and replace the failing memory DIMM or memory riser card or one-way processor card with new memory DIMMs, memory riser card, or one-way processor card. Return the machine to the original configuration. Go to "MAP 410: Repair Checkout" in the *Diagnostics Information for Multiple Bus Systems*.
- YES** Go to "Step 1540-9" on page 120.

Step 1540-9

Have all the cards in the list in “Step 1540-8” on page 119 been replaced with new or original cards?

NO Go to “Step 1540-8” on page 119.

YES Go to “Step 1540-10”.

Step 1540-10

The system stopped with the Please define system console prompt appearing on the system console.

Standalone diagnostics can be booted. Perform the following:

1. Follow the instructions on the screen to select the system console.
2. When the DIAGNOSTIC OPERATING INSTRUCTIONS screen is displayed, press Enter.
3. If the terminal type has not been defined, you must use the **Initial Terminal** option of the FUNCTION SELECTION menu to initialize the AIX operating system environment before you can continue with the diagnostics. This is a separate and different operation from selecting the console display.
4. Select **Advanced Diagnostic Routines**.
5. When the DIAGNOSTIC MODE SELECTION menu displays, select **System Verification**.
6. Record any devices missing from the list of all adapters and devices. Continue with this MAP. When you have fixed the problem, use this record to verify that all devices appear when you run System Verification.

Are there any devices missing from the list of all adapters and devices?

NO Reinstall all remaining adapters, if any, and reconnect all devices. Return the system to its original configuration. Be sure to select fast boot mode (select enable fast boot) on the system power control menu from the service processor main menu. Go to “Map 0410: Repair Checkout” in the *Diagnostics Information for Multiple Bus Systems*

YES The boot attempts that follow will attempt to isolate any remaining I/O drawer problems with missing devices. Ignore any codes that may appear on the operator panel unless stated otherwise. Go to “Step 1540-11” on page 121.

Step 1540-11

You were directed here because the defect seems to be related to the I/O system.

Select fast boot mode (select enable fast boot) on the system power control menu from the service processor main menu.

Look at the rear of the CEC drawer and locate the RIO cable connected to port 1. Refer to “CEC Drawer Rear View” on page 11 for location of RIO connectors.

Follow the RIO cable back to the secondary I/O drawer.

Is the secondary I/O drawer attached to the CEC drawer ?

NO Did you perform “Step 1540-4” on page 116?

NO Go to “Step 1540-37” on page 136.

YES Go to “Step 1540-15” on page 124.

YES Did you perform “Step 1540-4” on page 116?

NO Go to “Step 1540-12”.

YES Go to “Step 1540-13” on page 122.

Step 1540-12

The secondary I/O Drawer is attached to the CEC drawer. Isolate a faulty RIO cable by performing the following steps:

Note: Before continuing, check the cabling from the CEC drawer to I/O Drawer(s) to ensure that the system is cabled correctly. Refer to “Cabling the CEC Drawer, Primary I/O Drawer, and Secondary I/O Drawer” on page 48 for valid configurations. Record the current cabling configuration and then continue with the following steps.

1. Turn the system power off.
2. At the CEC drawer, disconnect the cable connection at RIO port 0.
3. At the primary I/O drawer, disconnect the cable connection at RIO port 0. The RIO cable that was connected to RIO port 0 should now be loose and can be removed.
4. At the CEC drawer, disconnect the cable connection at RIO port 1 and reconnect to RIO port 0.
5. Follow the RIO cable you have connected to RIO port 0 of the CEC drawer back to the secondary I/O drawer, disconnect the I/O drawer end (RIO port 1, note location) of the RIO cable and reconnect it to the primary I/O drawer RIO port 0.
6. Verify that primary I/O drawer RIO port 0 is connected to the CEC drawer RIO port 0.
7. Turn on the power to boot standalone diagnostics from CD.
8. If the Please Define System Console screen is displayed, follow directions to select the system console.

9. Use the Display Configuration and Resource List to list all attached devices and adapters (refer to the *Diagnostics Information for Multiple Bus Systems* if necessary).
10. Check that all attached devices and adapters are listed.

Did the Please define the System Console screen display and are all attached devices and adapters listed?

NO Go to “Step 1540-13”

YES The RIO cable that was removed in substep 3 above is defective. Replace the RIO cable. Connect the new RIO cable from CEC drawer RIO port 1 to the secondary I/O drawer RIO port 1 noted in substep 5 above. Reconfigure the system to its original condition. Go to “MAP 410: Repair Checkout” in the *Diagnostics Information for Multiple Bus Systems*

Step 1540-13

Isolate the primary I/O drawer by performing the following steps:

1. Turn off the system power.
2. Select fast boot mode (select enable fast boot) on the system power control menu from the service processor main menu.
3. Verify that primary I/O drawer RIO port 0 is connected to CEC drawer RIO port 0.
4. At the primary I/O drawer, remove the cable connected to RIO port 1.
5. Verify that the primary I/O drawer V/S COMM and JTAG ports are connected to the CEC V/S COMM and JTAG ports.

Note: The primary I/O drawer should be cabled as shown in “Cabling the CEC Drawer, Primary I/O Drawer, and Secondary I/O Drawer” on page 48. Be sure to examine all the RIO, V/S COMM, and JTAG cables.

6. Disconnect ac power cables from the secondary I/O drawer.

Attention: The rack that you are working on may have I/O drawers that are connected to other CEC drawers or other third-party drawers attached to the power distribution unit (PDU). To avoid removing power from drawers that are used by other systems, when you are instructed to unplug power from an I/O drawer, remove only the PDU side of the single ac cables connected to the I/O drawer in question.

7. All I/O drawers except the primary I/O drawer should now be physically disconnected from the CEC drawer.

Go to “Step 1540-14” on page 123.

Step 1540-14

The primary I/O drawer is the only remaining I/O drawer connected to the CEC drawer.

1. Turn on the power to boot standalone diagnostics from CD.
2. If the Please Define System Console screen is displayed, follow directions to select the system console.
3. Use the Display Configuration and Resource List to list all attached devices and adapters (refer to the *Diagnostics Information for Multiple Bus Systems* if necessary).
4. Check that all attached devices and adapters are listed.

If the Please Define System Console screen did not display or all attached devices and adapters are not listed, the problem is in the primary I/O drawer.

Did the Please define the System Console screen display and are all attached devices and adapters listed?

NO Go to "Step 1540-15" on page 124.

YES Go to "Step 1540-25" on page 130.

Step 1540-15

Perform the following to deconfigure the primary I/O drawer:

1. Turn off the power.
2. If you have not already done so, reset the service processor settings with the instructions in step 6 on page 113. Then return here and continue.
3. Exit the service processor menus, and remove the ac power cables from the CEC drawer and the I/O drawer.
Attention: The rack that you are working on may have I/O drawers that are connected to other CEC drawers or other third-party drawers attached to the power distribution unit (PDU). To avoid removing power from drawers that are used by other systems, when you are instructed to unplug power from an I/O drawer, remove only the PDU side of the single ac cables connected to the I/O drawer in question.
4. If a display adapter with keyboard and mouse connected to the primary I/O drawer is being used as the console, locate a standalone serial terminal (possibly a 3151) and connect to the S1 serial port.
5. Remove the keyboard and mouse, if they are attached to the primary I/O drawer.
6. Leave the remaining external cables (RIO-port0, V/S COMM, RIO-port1, and JTAG) connected.
7. Disconnect the diskette drive cable from the diskette drive connector on the primary I/O drawer backplane.
8. Disconnect the boot devices, if present, other than the device used for booting.
9. Plug in the ac power cables for the CEC drawer and the I/O drawer. The primary I/O drawer operator panel momentarily displays an OK prompt.

Are there any adapters in slots 1, 2, 3, or 4?

NO Go to "Step 1540-16".

YES Go to "Step 1540-18" on page 125.

Step 1540-16

Are there any adapters in slots 5, 6, 7, 8 or 9?

NO Go to "Step 1540-17".

YES Go to "Step 1540-19" on page 125.

Step 1540-17

Are there any adapters in slots 10, 11, 12, 13 or 14?

NO Go to "Step 1540-23" on page 129.

YES Go to "Step 1540-20" on page 126.

Step 1540-18

1. If it is not already off, turn power off.
2. Remove all adapters from slots 1, 2, 3, and 4 that are not attached to the boot device.
3. Label and record the location of any cables attached to the adapters.
4. Record the slot number of the adapters.
5. Turn on the power to boot standalone diagnostics from CD.
6. If the TTY screen displays Enter 0 to select this console, press the 0 key on the TTY terminal's keyboard.
7. If the Please Define System Console screen is displayed, follow directions to select the system console.
8. Use the Display Configuration and Resource List to list all attached devices and adapters (refer to the *Diagnostics Information for Multiple Bus Systems* if necessary).
9. Check that all attached devices and adapters are listed.

Did the Please define the System Console screen display and are all attached devices and adapters listed?

NO Go to "Step 1540-16" on page 124.

YES Go to "Step 1540-21" on page 127.

Step 1540-19

1. If it is not already off, turn power off.
2. Remove all adapters from slots 5, 6, 7, 8, and 9 that are not attached to the boot device.
3. Label and record the location of any cables attached to the adapters.
4. Record the slot number of the adapters.
5. Turn on the power to boot standalone diagnostics from CD.
6. When the TTY screen displays Enter 0 to select this console, press the 0 key on the TTY terminal's keyboard.
7. If the Please Define System Console screen is displayed, follow directions to select the system console.
8. Use the Display Configuration and Resource List to list all attached devices and adapters (refer to the *Diagnostics Information for Multiple Bus Systems* if necessary).
9. Check that all attached devices and adapters are listed.

Did the Please define the System Console screen display and are all attached devices and adapters listed?

NO Go to "Step 1540-17" on page 124.

YES Go to "Step 1540-21" on page 127.

Step 1540-20

1. If it is not already off, turn off the power.
2. Remove all adapters from slots 10, 11, 12, 13, and 14 that are not attached to the boot device.
3. Label and record the location of any cables attached to the adapters.
4. Record the slot number of the adapters.
5. Turn on the power to boot standalone diagnostics from CD.
6. If the TTY screen displays Enter 0 to select this console, press the 0 key on the TTY terminal's keyboard.
7. If the Please Define System Console screen is displayed, follow directions to select the system console.
8. Use the Display Configuration and Resource List to list all attached devices and adapters (refer to the *Diagnostics Information for Multiple Bus Systems* if necessary).
9. Check that all attached devices and adapters are listed.

Did the Please define the System Console screen display and are all attached devices and adapters listed?

NO Go to "Step 1540-23" on page 129.

YES Go to "Step 1540-21" on page 127.

Step 1540-21

The problem is with one of the adapter cards or devices that was removed or disconnected from the primary I/O drawer.

1. Turn off the power.
2. Reinstall one adapter or device that was removed. Use the original adapter cards in their original slots when reinstalling adapters.
3. Turn on the power to boot standalone diagnostics from CD.
4. If the Please Define System Console screen is displayed, follow directions to select the system console.
5. Use the Display Configuration and Resource List to list all attached devices and adapters (refer to the *Diagnostics Information for Multiple Bus Systems* if necessary).
6. Check that all attached devices and adapters are listed.

Did the Please define the System Console screen display and are all attached devices and adapters listed?

NO Go to "Step 1540-22" on page 128.

YES Reinstall the next adapter or device and return to the beginning of this step. Continue repeating this process until an adapter or device causes the Please Define System Console screen to not display or all attached devices and adapters to not be listed.

After installing all the adapters and the Please Define System Console screen does display and all attached devices and adapters are listed, return the system to its original configuration. Go to "Map 0410: Repair Checkout" in the *Diagnostics Information for Multiple Bus Systems*.

Step 1540-22

Replace the adapter or device you just installed with a new adapter or device and retry the boot to standalone diagnostics from CD.

1. If the Please Define System Console screen is displayed, follow directions to select the system console.
2. Use the Display Configuration and Resource List to list all attached devices and adapters (refer to the *Diagnostics Information for Multiple Bus Systems* if necessary).
3. Check that all attached devices and adapters are listed.

Did the Please define the System Console screen display and are all attached devices and adapters listed?

NO The I/O drawer backplane is defective. Replace the I/O drawer backplane, and then reinstall all remaining adapters and reconnect all devices. Return the system to its original configuration. Go to "Map 0410: Repair Checkout" in the *Diagnostics Information for Multiple Bus Systems*.

YES The adapter was defective. Go to "Step 1540-24" on page 130.

Step 1540-23

1. Turn off the power.
2. Disconnect the I/O drawer AC power cables.
3. Replace the parts in the list below one at a time.
 - a. Primary I/O drawer backplane
 - b. Boot device
 - c. RIO adapter card
 - d. Power supply and redundant power supply (if present)
 - e. Fan controller card
 - f. Power distribution card
4. Reconnect the I/O drawer AC power cables.
5. Turn power on.
6. Boot standalone diagnostics from CD.
7. If the Please Define System Console screen is displayed, follow directions to select the system console.
8. Use the Display Configuration and Resource List to list all attached devices and adapters (refer to the *Diagnostics Information for Multiple Bus Systems* if necessary).
9. Check that all attached devices and adapters are listed.

Did the Please define the System Console screen display and are all attached devices and adapters listed?

- NO** Reinstall the next part in the list and return to the beginning of this step. Continue repeating this process until a part causes the Please Define System Console screen to be displayed and all attached devices and adapters to be listed.
- If you have replaced all the items listed above and the Please Define System Console screen does not display or all attached devices and adapters are not listed, check any external devices and cabling. If you do not find a problem, contact your next level of support for assistance.
- YES** Go to “Step 1540-24” on page 130.

Step 1540-24

1. Turn off the power.
2. The item just replaced fixed the problem.
3. If a display adapter with keyboard and mouse were used, reinstall the display adapter card, keyboard, and mouse.
4. Reconnect the diskette drive cable to the primary I/O drawer backplane.
5. Connect all the boot devices to the SCSI cable.
6. Plug in all adapters that were previously removed but not reinstalled.
7. Reconnect the primary I/O drawer ac power cables that were previously disconnected.

Reconfigure the system to its original condition. Go to "Map 0410: Repair Checkout" in the *Diagnostics Information for Multiple Bus Systems*.

Step 1540-25

If the Please Define System Console screen does display and all attached devices and adapters are listed, the problem is with the secondary I/O drawer. Turn the power off.

Reconnect the secondary I/O drawer.

Note: The I/O drawers should be cabled as shown in "Cabling the CEC Drawer, Primary I/O Drawer, and Secondary I/O Drawer" on page 48. Be sure to look at RIO cables, SPCN cables, V/S COMM cables, and JTAG cables.

Go to "Step 1540-27" on page 131.

Step 1540-26

Connect ac power to the secondary I/O drawer.

Step 1540-27

Are there any adapters in slots 1, 2, 3, or 4?

NO Go to "Step 1540-28".

YES Go to "Step 1540-30" on page 132.

Step 1540-28

Are there any adapters in slots 5, 6, 7, 8 or 9?

NO Go to "Step 1540-29".

YES Go to "Step 1540-31" on page 132.

Step 1540-29

Are there any adapters in slots 10, 11, 12, 13 or 14?

NO Go to "Step 1540-35" on page 135.

YES Go to "Step 1540-32" on page 133.

Step 1540-30

1. If it is not already off, turn off the power.
2. Remove all adapters from slots 1, 2, 3, and 4 that are not attached to the boot device.
3. Label and record the location of any cables attached to the adapters.
4. Record the slot number of the adapters.
5. Turn on the power to boot standalone diagnostics from CD.
6. If the TTY screen displays Enter 0 to select this console, press the 0 key on the TTY terminal's keyboard.
7. If the Please Define System Console screen is displayed, follow directions to select the system console.
8. Use the Display Configuration and Resource List to list all attached devices and adapters (refer to the *Diagnostics Information for Multiple Bus Systems* if necessary).
9. Check that all attached devices and adapters are listed.

Did the Please define the System Console screen display and are all attached devices and adapters listed?

NO Go to "Step 1540-28" on page 131.

YES Go to "Step 1540-33" on page 133.

Step 1540-31

1. If it is not already off, turn off the power.
2. Remove all adapters from slots 5, 6, 7, 8, and 9 that are not attached to the boot device.
3. Label and record the location of any cables attached to the adapters.
4. Record the slot number of the adapters.
5. Turn on the power to boot standalone diagnostics from CD.
6. When the TTY screen displays Enter 0 to select this console, press the 0 key on the TTY terminal's keyboard.
7. If the Please Define System Console screen is displayed, follow directions to select the system console.
8. Use the Display Configuration and Resource List to list all attached devices and adapters (refer to the *Diagnostics Information for Multiple Bus Systems* if necessary).
9. Check that all attached devices and adapters are listed.

Did the Please define the System Console screen display and are all attached devices and adapters listed?

NO Go to "Step 1540-29" on page 131.

YES Go to "Step 1540-33" on page 133.

Step 1540-32

1. If it is not already off, turn off the power.
2. Remove all adapters from slots 10, 11, 12, 13, and 14 that are not attached to the boot device.
3. Label and record the location of any cables attached to the adapters.
4. Record the slot number of the adapters.
5. Turn on the power to boot standalone diagnostics from CD.
6. When the TTY screen displays Enter 0 to select this console, press the 0 key on the TTY terminal's keyboard.
7. If the Please Define System Console screen is displayed, follow directions to select the system console.
8. Use the Display Configuration and Resource List to list all attached devices and adapters (refer to the *Diagnostics Information for Multiple Bus Systems* if necessary).
9. Check that all attached devices and adapters are listed.

Did the Please define the System Console screen display and are all attached devices and adapters listed?

NO Go to "Step 1540-35" on page 135.

YES Go to "Step 1540-33".

Step 1540-33

If the Please Define System Console screen does display and all attached devices and adapters are listed, the problem is with one of the adapter cards or devices that was removed or disconnected from the I/O drawer.

1. Turn off the power.
2. Replace one adapter or device that was removed. Place the original adapter cards in their original slots when reinstalling adapters.
3. Turn on the power to boot standalone diagnostics from CD.
4. If the Please Define System Console screen is displayed, follow directions to select the system console.
5. Use the Display Configuration and Resource List to list all attached devices and adapters (refer to the *Diagnostics Information for Multiple Bus Systems* if necessary).
6. Check that all attached devices and adapters are listed.

Did the Please define the System Console screen display and are all attached devices and adapters listed?

NO Go to "Step 1540-34" on page 134.

YES Reinstall the next adapter or device and return to number 1 in this step. Continue repeating this process until an adapter or device causes the Please Define System Console screen to not be displayed or all attached devices and adapters to not be listed.

Step 1540-34

Replace the adapter or device that is causing the Please Define System Console screen to not be displayed or all attached devices and adapters to not be listed with a new adapter.

1. Turn on power and boot standalone diagnostics from CD.
2. If the Please Define System Console screen is displayed, follow directions to select the system console.
3. Use the Display Configuration and Resource List to list all attached devices and adapters (refer to the *Diagnostics Information for Multiple Bus Systems* if necessary).
4. Check that all attached devices and adapters are listed.

Did the Please define the System Console screen display and are all attached devices and adapters listed?

NO Go to "Step 1540-35" on page 135.

YES Reinstall all remaining adapters and reconnect all devices. Return the system to its original configuration. Go to "Map 0410: Repair Checkout" in the *Diagnostics Information for Multiple Bus Systems*.

Step 1540-35

1. Turn off the power.
2. Disconnect the I/O drawer AC power cables.
3. Replace the remaining parts (listed below) in this drawer, one at a time.
 - a. Secondary I/O drawer backplane
 - b. RIO adapter card
 - c. Secondary drawer I/O operator panel
 - d. Fan controller card
 - e. Power supply and redundant power supply (if present)
 - f. Power distribution card
4. Reconnect the I/O drawer AC power cables.
5. Turn power on.
6. Boot standalone diagnostics from CD.
7. If the Please Define System Console screen is displayed, follow directions to select the system console.
8. Use the Display Configuration and Resource List to list all attached devices and adapters (refer to the *Diagnostics Information for Multiple Bus Systems* if necessary).
9. Check that all attached devices and adapters are listed.

Did the Please define the System Console screen display and are all attached devices and adapters listed?

- NO** Reinstall the next part in the list and return to the beginning of this step. Continue repeating this process until a part causes the boot to be successful.
- If you have replaced all the items listed above and the boot is not successful, check any external devices and cabling. If you do not find a problem, contact your next level of support for assistance.
- YES** Go to "Step 1540-36".

Step 1540-36

If the Please Define System Console screen is displayed and all attached devices and adapters are listed, do the following:

1. Turn off the power.
2. The item just replaced fixed the problem.
3. Plug in all adapters that were previously removed but not installed.
4. Reconnect the secondary I/O drawer ac cables that were previously disconnected. Ensure the circuit breakers are set to the On position.

Reconfigure the system to its original condition. Go "Map 0410: Repair Checkout" in the *Diagnostics Information for Multiple Bus Systems*.

Step 1540-37

The primary I/O Drawer is the only I/O Drawer that was connected to the CEC drawer. Perform the following steps to isolate a faulty RIO cable:

Note: Before continuing, check the cabling from the CEC drawer to I/O Drawer(s) to ensure that the system is cabled correctly. Refer to "Cabling the CEC Drawer, Primary I/O Drawer and Secondary I/O Drawer(s)" on page 41 for valid configurations. Record the current cabling configuration and then continue with the following steps.

1. Turn the system power off.
2. At the CEC drawer, disconnect the cable connection at RIO port 0.
3. At the primary I/O drawer, disconnect the cable connection at RIO port 0. The RIO cable that was connected to RIO port 0 should now be loose and can be removed.
4. At the CEC drawer, disconnect the cable connection at RIO port 1 and reconnect to RIO port 0.
5. At the primary I/O drawer, disconnect the RIO connection at RIO port 1. Reconnect this RIO cable end to RIO port 0.
6. Verify that primary I/O drawer RIO port 0 is connected to the CEC drawer RIO port 0.
7. Turn on the power to boot standalone diagnostics from CD.

Did the Please define the System Console screen display and are all attached devices and adapters listed?

NO Go to "Step 1540-15" on page 124

YES The RIO cable that was removed in step 3 above is defective. Replace the RIO cable. Connect the new RIO cable from CEC drawer RIO port 1 to the primary I/O drawer RIO port 1. Reconfigure the system to its original condition. Go to "MAP 410: Repair Checkout" in *Diagnostics Information for Multiple Bus Systems*.

Chapter 4. Checkpoints

Checkpoints display on the primary I/O drawer operator panel while the system is powering on and going through the initial program load (IPL). This chapter explains the IPL flow of the system and provides a table that lists checkpoints that you might see in the primary I/O drawer operator panel.

IPL Flow

The IPL process starts when ac power is connected to the system. The IPL process has four phases:

- **Phase 1: Service Processor Initialization**

Phase 1 starts when ac power is connected to the system and ends when 0K is displayed in the primary I/O drawer operator panel. 8xxx checkpoints are displayed during this phase. Several 9xxx codes may also be displayed. Service processor menus are available at the end of this phase by pressing any key on the console keyboard.

- **Phase 2: Hardware Initialization by the Service Processor**

Phase 2 starts when system power up is initiated by pressing the power on button on the primary I/O drawer operator panel. 9xxx checkpoints are displayed during this time. 91FF, the last checkpoint in this phase, indicates the transition to Phase 3 is taking place.

- **Phase 3: System Firmware initialization**

At phase 3, a system processor takes over control and continues initializing system resources. During this phase, checkpoints in the form Exxx are displayed. E105, the last checkpoint in this phase, indicates that control is being passed to the AIX boot program. Location codes may also be displayed in the second line of the primary I/O drawer operator panel.

- **Phase 4: AIX Boot**

When AIX starts to boot, checkpoints in the form 0xxx and 2xxx are displayed. Location codes may also be displayed in the second line of the primary I/O drawer operator panel. This phase ends when the AIX login prompt displays on the AIX console. The primary I/O drawer operator panel should be blank.

The following table outlines the IPL phases from power-on to the AIX login prompt, matching the phases to corresponding operator-panel checkpoints for a typical system boot. Also listed are the approximate boot times for each phase, along with their dependencies for each phase.

Note: The table below lists the major checkpoints only.

Phase #	Checkpoints on Operator Panel	Time in phase (minutes)	Major contributors to time in phase
Phase 1	8xxx => OK	Approx. 1	
Phase 2	9xxx => 91FF	3 to 6	Number of I/O drawers
Phase 3	Exxx => E105	1 to 3	Number of bootable adapters
Phase 4	0xxx => blank	2 to 30+	Number of SSA drives Number of SCSI drives Number of Async sessions Number of processors Number of adapters Amount of memory

Checkpoints enable users and service personnel to know what the server is doing, with some detail, as it initializes. These checkpoints are not intended to be error indicators, but in some cases a server could hang at one of the checkpoints without displaying an 8-character error code. It is for these hang conditions, only, that any action should be taken with respect to checkpoints. The most appropriate action is included with each checkpoint.

Before taking actions listed with a checkpoint, check for additional symptoms in the service processor error log. See the “System Information Menu” on page 382 for information on how to access the service processor error log.

Note: Go to “MAP 1540: Minimum Configuration” on page 113 for any of the following checkpoint conditions. If mentioned as an action, remember to run the System Rack Minimum Configuration:

- A four-digit code in the range of 8xxx through EFFF not listed in the checkpoint tables.
- A four-digit code is in the checkpoint tables, but does not contain a repair action or FRU listing.
- All of the FRUs listed in the repair action have been replaced and the problem has not been corrected.

Checkpoints listed in the following tables are in the format 8xxx, 9xxx, Axxx, Bxxx, or Exxx, where x is any hexadecimal digit from 1-9 or A-F. If your system hangs with a checkpoint displayed that begins with anything other than 8, 9, A, B, or E, go to the *RS/6000 and @server pSeries Diagnostics Information for Multiple Bus Systems*.

Use the table below to determine where to find the checkpoint.

Symptom	Action
You have a code that is of the form 8xxx, 9xxx, Axxx, or Bxxx.	Go to “Service Processor Checkpoints” on page 140.
You have a code of the form Exxx.	Go to “Firmware Checkpoints” on page 147.
You have a four-character code that is NOT of the form 8xxx, 9xxx, Axxx, Bxxx, or Exxx.	Refer to the <i>RS/6000 and @server pSeries Diagnostics Information for Multiple Bus Systems</i> manual.

Service Processor Checkpoints

Service processor checkpoints are in the range 8xxx to Bxxx. **OK** in the primary I/O drawer's operator panel indicates successful service processor testing and initialization. Firmware checkpoints are listed in "Firmware Checkpoints" on page 147.

Note: A spinning (or twirling) slash will be shown in the upper right corner of the operator panel display while some checkpoints are being displayed. If the slash stops spinning, a hang condition is indicated.

Table 1. Service Processor Checkpoints

Checkpoint	Description	Action/ Possible Failing FRU
8000	Test of the service processor DRAM	See note 1 on page 144
8004	Verify base code checksum	See note 1 on page 144
8008	Verify base code mirror checksum	See note 1 on page 144
8009	Set NVRAM configuration in TITAN	See note 1 on page 144
800F	Start base code	See note 1 on page 144
8010	Start supervisor in base code	See note 1 on page 144
8012	Initialize hardware interrupts	See note 1 on page 144
8014	Allocate and initialize area in DRAM	See note 1 on page 144
8016	Initialize debugger and build VPD	See note 1 on page 144
8018	Initialize service processor interfaces	See note 1 on page 144
801A	Initialize external FLASH load	See note 1 on page 144
801B	Initialize and test ISA hub chip	See note 1 on page 144
801C	Initialize and test SUPER I/O chip	See note 1 on page 144
801F	Initialize diskette, verify VDASD and start operational loader	See note 1 on page 144
809x	Related to recovery mode system firmware update from diskette	See note 3 on page 144
8092	Diskette initialization during recovery mode system firmware update	See note 3 on page 144
8098	Firmware image being read during recovery mode system firmware update	See note 3 on page 144
809C	Firmware image being written during recovery mode system firmware update	See note 3 on page 144
809F	Diskette error during recovery mode system firmware update	See note 3 on page 144
8100	Start operational loader	See note 1 on page 144

Table 1. Service Processor Checkpoints (continued)

Checkpoint	Description	Action/ Possible Failing FRU
81xx	Load code into DRAM from VDASD (where xx = number of loads)	See note 1 on page 144
81FE	Load service processor operating system	See note 1 on page 144
81FF	Start service processor operating system	See note 1 on page 144
9000	Primary service processor task initializing	See note 1 on page 144
9009	System processor IPL has started	See note 1 on page 144
9010	Primary service processor thread waiting for response	See note 1 on page 144
9020	Service processor state set to pre-standby	See note 1 on page 144
9021	Service processor state set to standby	See note 1 on page 144
9022	Service processor state set to IPL	See note 1 on page 144
9030	Waiting for secondary thread acknowledge	See note 1 on page 144
9033	I/O base initialization	See note 1 on page 144
9034	I2C initialization	See note 1 on page 144
9035	ISA initialization	See note 1 on page 144
9036	Mailbox initialization	See note 1 on page 144
9037	SLLA initialization (VPD)	See note 1 on page 144
9038	NVRAM initialization	See note 1 on page 144
9039	Serial port initialization	See note 1 on page 144
903A	Serial I/O initialization	See note 1 on page 144
903B	SPCN initialization	See note 1 on page 144
9051	End of reset/reload operation: service processor dump has completed	See note 1 on page 144
9060	Checking/configuring modem on serial port 1	See note 4 on page 146
9061	Checking/configuring modem on serial port 2	See note 4 on page 146
906A	Create mailbox processing thread	See note 1 on page 144
906B	Create menu interface thread	See note 1 on page 144
906C	Create general thread	See note 1 on page 144
906D	Create SPCN thread	See note 1 on page 144
9080	Start VPD collection program	See note 1 on page 144

Table 1. Service Processor Checkpoints (continued)

Checkpoint	Description	Action/ Possible Failing FRU
9081	Start SC VPD data collection	See note 1 on page 144
9082	I2C/SPCN VPD data collection	See note 1 on page 144
9083	End SC VPD data collection	See note 1 on page 144
9084	End I2C VPD data collection	See note 1 on page 144
90FD	Waiting for IBIST to complete	See note 1 on page 144
9101	Create CEC box	See note 1 on page 144
9102	Open load source	See note 1 on page 144
9103	Verify open status of load source	See note 1 on page 144
9104	Load IPL LIDs	See note 1 on page 144
9105	System flush	See note 1 on page 144
9106	Scan interface BATs	See note 1 on page 144
9107	ABIST	See note 1 on page 144
9108	LBIST	See note 1 on page 144
9109	LBIST	See note 1 on page 144
910A	Configure and initialize processors	See note 1 on page 144
910B	Configure main storage (system memory)	See note 1 on page 144
910C	Initialize main storage (system memory)	See note 1 on page 144
910D	Configure and initialize I/O	See note 1 on page 144
910E	Test main storage (system memory)	See note 1 on page 144
910F	Free IPL LIDS	See note 1 on page 144
9110	Load runtime LIDS	See note 1 on page 144
9111	Load dump LIDS	See note 1 on page 144
9112	Enable attention	See note 1 on page 144
9113	Enable function 22	See note 1 on page 144
9114	Load system IPL program	See note 1 on page 144
9115	Load system data areas (NACA/PACA)	See note 1 on page 144
9116	Start system IPL program	See note 1 on page 144
9118	Waiting for VPD collection to complete	See note 1 on page 144

Table 1. Service Processor Checkpoints (continued)

Checkpoint	Description	Action/ Possible Failing FRU
9184	Firmware image being loaded into service processor's control storage during firmware update.	<ol style="list-style-type: none"> 1. Remove, then reapply power to the system. If the service processor enters recovery mode, (indicated by A1FD 0000 in the display), attempt to update the firmware again in recovery mode. If the service processor comes up to the OK prompt, try again to update the firmware using the service processor menus. 2. Call service support
91FF	Control being handed to system processor from service processor	See note 2 on page 144
9380	Built-in-self-test (BIST)	See note 2 on page 144
94B0	Wire test faulty driver status refcode	See note 2 on page 144
94B1	Wire test shorted net status refcode	See note 2 on page 144
94B2	Wire test L2 cache status refcode	See note 2 on page 144
94BB	Wire test status SRC refcode	See note 2 on page 144
9501	Main storage initialization	See note 2 on page 144
9502	Main storage L3 cache march test	See note 2 on page 144
9503	Main storage L3 connections test	See note 2 on page 144
9504	Main storage L3 cache march test	See note 2 on page 144
9505	MS extra testing (RIO, etc.)	See note 2 on page 144
9506	MS cleanup	See note 2 on page 144
99FD	Service processor receiving firmware update module	See note 1 on page 144
99FF	Service processor writing firmware update module	See note 1 on page 144
A800	Start service processor dump process	See note 1 on page 144
A801	Start dump to debug port	See note 1 on page 144
A802	Start dump to debug port	See note 1 on page 144
A803	NVRAM not usable	See note 1 on page 144
A804	NVRAM dump done	See note 1 on page 144
A805	Start dump to flash	See note 1 on page 144
A806	Flash dump area done	See note 1 on page 144
A807	Flash area not usable	See note 1 on page 144
A808	Flash error log to debug port	See note 1 on page 144

Table 1. Service Processor Checkpoints (continued)

Checkpoint	Description	Action/ Possible Failing FRU
A809	Flash erase start	See note 1
A80A	Flash erase end	See note 1
A80B	Reserved; not used	See note 1
A80C	Reserved; not used	See note 1
A80D	Reserved; not used	See note 1
A80E	Reserved; not used	See note 1
A80F	Service processor dump done	See note 1
B00B	Firmware delaying to determine if MOPs error is the result of power disturbance. After delay, SPCN is queried for CEC power status.	1. Remove, then reapply power to the system. 2. Call service support.
B0F5	Delayed power-off sequence has begun	See note 1
B0FA	Delayed power-off acknowledged	See note 1
B0FF	Power-off requested program executing	See note 1

Notes:

1. If the system fails to progress after this checkpoint is put in the display, do the following:
 - a. Activate the service processor pinhole reset switch on the system's operator panel.
 - b. If the hang repeats, check with service support to see if there is a firmware update that fixes the problem.
 - c. If not, or the update does not fix the problem, change the primary I/O backplane.
 - d. If this procedure does not fix the problem, call service support.
2. If the system fails to progress after this checkpoint is put in the display, do the following:
 - a. Activate the service processor pinhole reset switch on the system's operator panel.
 - b. If the hang repeats, check with service support to see if there is a firmware update that fixes the problem.
 - c. If not, or the update does not fix the problem, go to "MAP 1540: Minimum Configuration" on page 113.
 - d. If this procedure does not fix the problem, call service support.
3. Recovery mode flash update has failed. Do the following:
 - a. Activate the service processor pinhole reset switch on the system's operator panel and try the recovery mode flash update again.
 - b. If the system hangs again, make a new set of firmware update diskettes, using new, blank diskettes. Retry the flash update with the new diskettes.

- c. If the same hang occurs with the new diskettes, replace the following FRUs one at a time in this order:
 - 1) Diskette drive
 - 2) I/O backplane in the primary I/O drawer
- d. If this procedure does not fix the problem, call service support.

4. The service processor was unable to configure the modem(s) attached to the serial port(s). Do the following:
 - a. Check the modem, modem cable, and serial port for loose or unconnected cables. Reset the service processor using the pinhole reset switch on the primary I/O drawer operator panel.
 - b. If the hang repeats, check with service support to see if there is a firmware update that fixes the problem.
 - c. If there is not, or the update does not fix the problem, replace the following FRUs one at a time in this order:
 - 1) Modem cable
 - 2) Modem
 - 3) I/O backplane in the primary I/O drawer
 - d. If this procedure does not fix the problem, call service support.

Firmware Checkpoints

Firmware uses checkpoints (progress codes) in the range of Exxx to EFFF. These checkpoints occur during system startup and can be useful in diagnosing certain problems. Service processor checkpoints are listed in “Service Processor Checkpoints” on page 140.

If you replace FRUs and the problem is still not corrected, go to “MAP 1540: Minimum Configuration” on page 113 unless otherwise indicated in the tables.

If you replace FRUs and the problem is corrected, go to “MAP 410: Repair Checkout” in the *RS/6000 and @server pSeries Diagnostics Information for Multiple Bus Systems*.

Note: Firmware can hang due to multiple causes. In many cases, it can be caused by the primary processor or a memory problem in the first 64 MB of real memory. If a location code is not provided with the checkpoint, the following procedure will use the primary processor and low memory as the probable FRUs.

1. If firmware is hung (E100 through EFFF) and a location code is displayed on the second line of the operator panel, use that location code as the primary FRU.
2. If no location code is present or if replacing the primary FRU indicated in the location code did not fix the problem, then perform the following actions:
 - a. Power off the system and go to the service processor menus.
 - b. From the service processor main menu, select option 3, **System Information Menu**, then select option 5, **Read NVRAM**.
 - c. Enter 330 when prompted for an address.
 - d. Look at the byte of data at address 330. If value is FF, go to note 3. If the value is 00–0F, replace the processor card, location: U1.1–P1–C1. Attempt to reboot the system. If the system hangs at the same checkpoint, go to note 3. If the system hangs at a new checkpoint, perform the actions associated with the new checkpoint.
3. Power off the system. From the service processor main menu, select option 3, **System Information Menu**, then option 8, **Memory Configuration/Deconfiguration Menu**. Identify the first configured DIMM pair if DIMMs reside on a 1–way processor card, or the first configured memory riser card and quad of DIMMs. Replace the first group of DIMMs.
4. If replacing the first group of configured DIMMs doesn’t fix the problem, replace the memory riser card. If the problem is not fixed, go to “MAP 1540: Minimum Configuration” on page 113.

Table 2. Firmware Checkpoints

Checkpoint	Description	Action/ Possible Failing FRU
E100	Reserved	See the note on page 139.
E101	Create RTAS node	See the note on page 139.
E102	Load/Init RTAS	See the note on page 139.
E105	Transfer control to Operating System (normal boot).	See "Boot Problems and Concerns" on page 159.
E10A	Load RTAS device tree	See the note on page 139.
E10B	Set RTAS device properties	See the note on page 139.
E122	RTAS sensor setup complete	See the note on page 139.
E130	Build device tree	See the note on page 139.
E134	Create memory node	See the note on page 139.
E137	Create openprom node	See the note on page 139.
E138	Create options node	See the note on page 139.
E139	Create node aliases and system aliases	See the note on page 139.
E13A	Create packages node	See the note on page 139.
E140	Operating system load	See the note on page 139.
E149	Create boot mgr node	See the note on page 139.
E14C	Create terminal-emulator node	See the note on page 139.
E14D	Loading boot image	See "Boot Problems and Concerns" on page 159.
E14F	NVRAM initialization	See the note on page 139.
E150	Create host (primary) PCI controller node	<ol style="list-style-type: none"> 1. If a location code is associated with the checkpoint, replace the adapter identified by the location code. See "Checkpoint and Error Code Index" on page 165. If a network adapter is replaced, see "Replacing the Network Adapter" on page 163. 2. Replace the primary I/O backplane.
E151	Probing primary PCI bus	<ol style="list-style-type: none"> 1. If a location code is associated with the checkpoint, replace the FRU identified by the location code. See "Checkpoint and Error Code Index" on page 165. If a network adapter is replaced, see "Replacing the Network Adapter" on page 163. 2. Replace the primary I/O backplane.

Table 2. Firmware Checkpoints (continued)

Checkpoint	Description	Action/ Possible Failing FRU
E152	Probing for adapter FCODE, evaluate if present	Follow the repair action listed for checkpoint E151.
E153	End adapter FCODE, probe/evaluate	See the note on page 139.
E154	Create PCI bridge node	Follow the repair action listed for checkpoint E151.
E155	Probing PCI bridge secondary bus	Follow the repair action listed for checkpoint E151.
E156	Create PCI ethernet node	Follow the repair action listed for checkpoint E151.
E15A	Create 64-bit host (primary) PCI controller node	See the note on page 147.
E15B	Transferring control to Operating System (service mode boot)	See "Boot Problems and Concerns" on page 159.
E15C	Probe primary 64-bit PCI bus	See the note on page 147.
E15D	Create host PCI controller node	See the note on page 147.
E15F	Adapter VPD probe	Follow the repair action listed for checkpoint E151.
E162	SP node VPD creation	See the note on page 147.
E163	Create CPU VPD	See the note on page 147.
E165	Create planar-clock VPD	See the note on page 147.
E166	Create CEC VPD	See the note on page 147.
E167	Collect power cards VPD.	See the note on page 147.
E170	Start of PCI Bus Probe	Follow the repair action listed for checkpoint E151.
E172	First pass PCI device probe	Follow the repair action listed for checkpoint E151.

Table 2. Firmware Checkpoints (continued)

Checkpoint	Description	Action/ Possible Failing FRU
E174	Establishing host connection	<p>If the system is not connected to an active network or if the target server is inaccessible (this can also result from incorrect IP parameters being supplied), the system will still attempt to boot. Because time-out durations are necessarily long to accommodate retries, the system may appear to be hung.</p> <p>Restart the system and access the firmware SMS utilities. In the utilities check:</p> <ul style="list-style-type: none"> • Is the intended boot device correctly specified in the boot list? • Are the IP parameters correct? • Verify the network connection (network could be down). • Have network administrator verify the server configuration for this client. • Attempt to “ping” the target server using the SMS “Ping” utility.
E175	BootP request	Refer to checkpoint E174.
E176	TFTP file transfer	See “Boot Problems and Concerns” on page 159.
E177	Transfer failure due to TFTP error condition	See “Boot Problems and Concerns” on page 159.
E17B	Processor clock speed check measurement	<p>Primary I/O backplane.</p> <p>See the note on page 139.</p>
E180	Service processor command setup	See the note on page 139.
E183	Service processor post	See the note on page 139.
E186	Request PS1 VPD	See the note on page 139.
E187	Add PS1 VPD to NVRAM and device tree	See the note on page 139.
E188	Request PS2 VPD	See the note on page 139.
E189	Add PS2 VPD to NVRAM and device tree	See the note on page 139.
E18C	VPD and data communications with I/O planar complete	See the note on page 139.
E190	Create ISA node	See the note on page 139.
E191	Create ISA reserved node	See the note on page 139.

Table 2. Firmware Checkpoints (continued)

Checkpoint	Description	Action/ Possible Failing FRU
E193	Initialize Super I/O	See the note on page 139.
E196	Probe ISA bus	See the note on page 139.
E199	Reboot after flash	Try to boot system a second time. If this does not work, replace the primary I/O backplane. See the note on page 139.
E19B	Create service processor node	See the note on page 139.
E19C	Create tablet node	See the note on page 139.
E19D	Create NVRAM node	See the note on page 139.
E19E	Real-time clock (RTC) initialization	Refer to error code 28030xxx in “Firmware Error Codes” on page 190.
E1AD	See description of checkpoint E1DE	See the note on page 139.
E1B0	Create lpt node	See the note on page 139.
E1B1	Create serial node	See the note on page 139.
E1B2	Create audio node	See the note on page 139.
E1B3	Create 8042 node	See the note on page 139.
E1B6	Probe for (ISA) keyboard	See the note on page 139.
E1BD	Probe for (ISA) mouse	See the note on page 139.
E1BF	Create pwr-mgmt node	See the note on page 139.
E1C4	Build ISA timer chip node	See the note on page 139.
E1C5	Create ISA interrupt controller (pic) node	See the note on page 139.
E1C6	Create DMA node	See the note on page 139.
E1D0	Create PCI SCSI node	Perform Repair actions from checkpoint E156.
E1D3	Create SCSI block device node (SD)	Perform Repair actions from checkpoint E156.
E1D4	Create SCSI byte device node (ST)	Perform Repair actions from checkpoint E156.
E1DB	Create floppy controller (FDC) node	Replace the primary I/O backplane. See the note on page 139.

Table 2. Firmware Checkpoints (continued)

Checkpoint	Description	Action/ Possible Failing FRU
E1DC	Dynamic console selection.	<p>If a console is attached but nothing is displayed on it, follow the steps associated with "All display problems" in the Entry MAP tables.</p> <p>If selection screen(s) can be seen on the terminals and the appropriate key on the input device associated with the desired display or terminal is pressed, within 60 seconds, but there is no response to the keystroke:</p> <ul style="list-style-type: none"> • If selecting the console with a keyboard attached to the system, replace the keyboard. If replacing the keyboard does not fix the problem, replace the primary I/O backplane. • If selecting the console with an ASCII terminal, suspect the ASCII terminal. Use the problem determination procedures for the terminal. Replace the primary I/O backplane if these procedures do not reveal a problem. <p>Note: Terminal settings should be set to:</p> <ul style="list-style-type: none"> – 9600 Baud – No Parity – 8 Data bits – 1 Stop bit
E1DE	Alternating pattern of E1DE and E1AD is used to indicate a default catch condition before the firmware "checkpoint" word is available.	See the note on page 139.
E1DF	Create diskette drive (disk) node	See the note on page 139.
E1F0	Start O.B.E.	See the note on page 139.
E1F1	Begin selftest sequence on boot device(s). Begin SMS.	See the note on page 139.
E1F2	Power-on password prompt.	<p>Prompt should be visible on the system console.</p> <p>If a console is attached but nothing is displayed on it, go to the "Entry MAP" on page 75 with the symptom "All display problems."</p>

Table 2. Firmware Checkpoints (continued)

Checkpoint	Description	Action/ Possible Failing FRU
E1F3	Privileged-access password prompt	<p>Prompt should be visible on the system console.</p> <p>If a console is attached but nothing is displayed on it, go to the “Entry MAP” on page 75 with the symptom “All display problems.”</p>
E1F5	Build boot device list	See the note on page 139.
E1F6	Determine boot device sequence	See the note on page 139.
E1F7	No boot image located	Follow the repair actions listed for error code 20EE000B.
E1FB	Scan SCSI bus for attached devices	If a location code is available, follow the repair actions listed for error code 21A000XX.

Table 2. Firmware Checkpoints (continued)

Checkpoint	Description	Action/ Possible Failing FRU
E1FD	The operator panel will alternate between the code E1FD and another Exxx code, where Exxx is the point at which the error occurred.	<p>Checkpoint E1FD indicates that an error has occurred during system startup. The display alternates between E1FD and another checkpoint, Exxx, where the error occurred. Check the list of checkpoints for Exxx. If the description for that checkpoint does not resolve the problem, return here for more instruction.</p> <p>Checkpoint E1FD may be displayed when an adapter or peripheral device is malfunctioning. To determine which device is most likely to have caused the error, follow these steps.</p> <ol style="list-style-type: none"> 1. Check the "progress codes from last boot" in the service processor's Information menu. Look for the last location code that was displayed before the E1FD error code. 2. The device pointed to by this location is suspect. 3. If the progress code listing only contains the E1FD and Exxx checkpoints, restart the system and power off when the E1FD and Exxx codes are displayed. Repeat step 1. 4. Try removing the suspect device (if it is not integrated). Remove power from the system before changing the hardware configuration. 5. Restart the system. If it now boots normally, without stopping at checkpoint E1FD, the device that was removed in the previous step should be replaced. 6. If the above steps have not resolved the problem, go to "MAP 1540: Minimum Configuration" on page 113.

Table 2. Firmware Checkpoints (continued)

Checkpoint	Description	Action/ Possible Failing FRU
E440	Validate NVRAM, initialize partitions as needed	<ol style="list-style-type: none"> 1. Verify that the system firmware levels are at the current release levels. Update as necessary. 2. Replace primary I/O backplane if problem persists. <p>See the note on page 139.</p>
E441	Generate /options node NVRAM configuration variable properties	<ol style="list-style-type: none"> 1. Verify that the system firmware levels are at the current release levels. Update as necessary. 2. Replace primary I/O backplane if problem persists. <p>See the note on page 139.</p>
E442	Validate NVRAM partitions	<ol style="list-style-type: none"> 1. Verify that the system firmware levels are at the current release levels. Update as necessary. 2. Replace primary I/O backplane if problem persists. <p>See the note on page 139.</p>
E443	Generate NVRAM configuration variable dictionary words	<p>Suspect a system firmware problem if problem persists. Verify that the system firmware is at current release level. Update back-level system firmware.</p> <p>See the note on page 139.</p>
E500	Configure remote I/O subsystem	<ol style="list-style-type: none"> 1. Configure I/O subsystem 2. The appearance of this code indicates that the I/O subsystem configuration has started or progressed to the point where the code can be displayed. <p>See the note on page 139.</p>

Table 2. Firmware Checkpoints (continued)

Checkpoint	Description	Action/ Possible Failing FRU
<p>E5xy (E511 - E5FF) Where x is not equal to 0, and y is not equal to 0.</p>	<p>Configure remote I/O subsystem components</p>	<p>The E5xy (E511 to E5FF) codes are reserved for activities relating to configuration or testing of the I/O subsystem, or remote I/O subsystem. A hang at one of these codes implies that a severe error occurred during the programming of I/O subsystem registers or when interacting with adapters plugged into the system. The last two digits in the checkpoint can be used to help isolate the location of the I/O activity that caused the problem.</p> <p>“x” indicates the I/O drawer number. “y” indicates the PCI bus occurrence.</p> <p>If y=_, then the PCI Bus is:</p> <p>Y = PCI Bus 1 = 0 2 = 1 3 = 2 4 = 3</p> <p>See “AIX and Physical Location Code Tables” in Chapter 1, for location codes.</p> <p>Using the information above, go to “MAP 1540: Minimum Configuration” on page 113.</p>
<p>E600</p>	<p>SSA PCI adapter open firmware has run successfully.</p>	<p>Replace the adapter. See “Checkpoint and Error Code Index” on page 165 for location code information related to this error.</p>
<p>E601</p>	<p>SSA PCI adapter BIST has started but failed to complete after four seconds.</p>	<p>Replace the adapter. See “Checkpoint and Error Code Index” on page 165 for location code information related to this error.</p>
<p>E602</p>	<p>SSA PCI adapter open firmware has started.</p>	<p>Replace the adapter. See “Checkpoint and Error Code Index” on page 165 for location code information related to this error.</p>
<p>E603</p>	<p>SSA PCI adapter BIST has completed with an error.</p>	<p>Replace the adapter. See “Checkpoint and Error Code Index” on page 165 for location code information related to this error.</p>

Table 2. Firmware Checkpoints (continued)

Checkpoint	Description	Action/ Possible Failing FRU
E604	SSA PCI adapter BIST and subsequent POSTs have completed successfully.	Replace the adapter. See “Checkpoint and Error Code Index” on page 165 for location code information related to this error.
E605	SSA PCI adapter BIST has completed successfully but the subsequent POSTs have failed.	Replace the adapter. See “Checkpoint and Error Code Index” on page 165 for location code information related to this error.
E60E	SSA PCI adapter open firmware about to exit (no stack corruption).	Replace the adapter. See “Checkpoint and Error Code Index” on page 165 for location code information related to this error.
E60F	SSA PCI adapter open firmware has run unsuccessfully.	Replace the adapter. See “Checkpoint and Error Code Index” on page 165 for location code information related to this error.
E6FF	SSA PCI adapter open firmware about to exit (with stack corruption).	Replace the adapter. See “Checkpoint and Error Code Index” on page 165 for location code information related to this error.
E700	Create system firmware VPD	Replace the primary I/O drawer backplane, location: U0.1–P1.
E701	Create memory VPD.	Go to “MAP 1540: Minimum Configuration” on page 113 to isolate the failing memory components.
E702	Create processor card VPD.	Replace the processor card, location: U1.1–P1–C1. See the note on page 139.
E703	Create operator panel VPD.	<ol style="list-style-type: none"> 1. Replace the operator panel, location U0.1–L1. See “Replacing the Primary Drawer Operator Panel” on page 163. 2. Replace the primary I/O drawer backplane, location: U0.1–P1.
E704	Create CEC VPD.	See the note on page 139.
E705	Create clock card VPD.	See the note on page 139.
E706	Create RIO extender card VPD.	Replace RIO extender card. See the note on page 139.
E707	Create system VPD.	See the note on page 139.
E708	Create RIO to PCI adapter VPD.	See the note on page 139.
E709	Create VPD via SPCN.	See the note on page 139.
E70A	Create service processor VPD.	Replace the primary I/O drawer backplane, location: U0.1–P1.

Table 2. Firmware Checkpoints (continued)

Checkpoint	Description	Action/ Possible Failing FRU
E8xx	RTAS initialization problem.	Call for support.
EAA1	Probe PCI-PCI bridge.	Follow the repair actions for checkpoint E151.

Note: If you receive a four-digit code in the range of E1xx to EFFF that is not listed in the table above, go to “MAP 1540: Minimum Configuration” on page 113.

Boot Problems and Concerns

Depending on the boot device, a checkpoint may be displayed on the operator panel for an extended period of time while the boot image is retrieved from the device. This is particularly true for tape and network boot attempts. If booting from CD-ROM or tape, watch for activity on the drive's LED indicator. A blinking LED indicates that the loading of either the boot image or additional information required by the operating system being booted is still in progress. If the checkpoint is displayed for an extended period of time and the drive LED is not indicating any activity, there might be a problem loading the boot image from the device.

Note: For network boot attempts, if the system is not connected to an active network or if the target server is inaccessible (this can also result from incorrect IP parameters being supplied), the system will still attempt to boot. Because time-out durations are necessarily long to accommodate retries, the system may appear to be hung.

This procedure assumes that a CD-ROM drive is connected to internal SCSI connector in the primary I/O drawer and a diagnostic CD-ROM is available.

Step 1

Restart the system and access the firmware SMS Main Menu. Select **Multiboot**.

1. Check to see if the intended boot device is correctly specified in the boot list. If it is in the boot list:
 - a. Remove all removable media from devices in the boot list from which you do not want to boot.
 - b. If attempting to boot from the network, go to "Step 2".
 - c. If attempting to boot from a disk drive or CD-ROM, go to "Step 3" on page 160.
2. If the intended boot device is not correctly identified in the boot sequence, add it to the boot sequence using the SMS menus. If the device can be added to the boot sequence, reboot the system. If the intended boot device cannot be added to the boot list, go to "Step 3" on page 160.

Step 2

If attempting to boot from the network:

1. Verify that IP parameters are correct.
2. Attempt to "ping" the target server using the SMS Ping utility. If the ping is not successful, have the network administrator verify the server configuration for this client.
3. Check with the network administrator to ensure that the network is up.
4. Check the network cabling to the adapter.
5. Turn the power off, then on and retry the boot operation.

Step 3

Try to boot and run standalone diagnostics against the system, particularly against the intended boot device.

If diagnostics boot successfully:

1. Go to the Task Selection Menu and select Display Configuration and Resource List. If the intended boot device is not listed, go to "MAP 0290: Missing Resource Problem Resolution" in the *RS/6000 and @server pSeries Diagnostics Information for Multiple Bus Systems*.
2. If an SRN, not an 8-digit error code, is reported, go to the *RS/6000 and @server pSeries Diagnostics Information for Multiple Bus Systems* manual.
3. If the diagnostics are successful, it may be necessary to perform an operating system-specific recovery process, or reinstall the operating system.

If diagnostics do not boot successfully:

1. Verify proper SCSI bus termination.
2. Check SCSI cabling.
3. It is possible that another attached SCSI device is causing the problem. Do the following:
 - a. Disconnect the signal and power cables from the disk drive cage backplane.
 - b. Disconnect the disk drive(s) in the disk drive cage from the backplane.
 - c. Disconnect the signal and power cables from any other SCSI devices attached to the SCSI adapter that the CD-ROM drive is attached to.
 - d. Try to boot the standalone diagnostics again.
 - e. If you are still unable to load standalone diagnostics, go to "Step 4" on page 161.
 - f. If standalone diagnostics load, one of the disconnected devices is causing the problem. Reconnect the devices one at a time and retry the boot operation until the problem recurs and replace the device that caused the problem. (If the problem appears to be one of the disk drives in the disk drive cage, be aware it could be either the disk drive or the backplane.) Go to "MAP 410: Repair Checkout" in the *RS/6000 and @server pSeries Diagnostics Information for Multiple Bus Systems*.

Step 4

It is possible that another installed adapter is causing the problem. Do the following:

1. Remove all installed adapters except the one the CD-ROM drive is attached to and the one used for the console.
2. Try to boot the standalone diagnostics again.
3. If unable to load standalone diagnostics, go to "Step 5".
4. If standalone diagnostics load, reinstall adapters (and attached devices as applicable) one at a time and retry the boot operation until the problem recurs. Then replace the adapter or device that caused the problem. (The primary I/O drawer backplane can also cause the device or adapter to fail.) Go to "MAP 410: Repair Checkout" in the *RS/6000 and @server pSeries Diagnostics Information for Multiple Bus Systems*.

Step 5

The CD-ROM drive, SCSI cable, SCSI adapter, graphics adapter, or the primary I/O drawer backplane is most likely defective. A TTY terminal attached to the serial port also can be used to determine if the graphics adapter is causing the problem. This is done by removing the graphics adapter, attaching a TTY to the serial port, and retrying standalone diagnostics. If the standalone diagnostics load, replace the graphics adapter.

1. Replace the CD-ROM drive.
2. Replace the SCSI cable.
3. If the CD-ROM drive is attached to a SCSI adapter rather than the integrated SCSI on the primary I/O drawer backplane, replace the SCSI adapter.
4. Replace the primary I/O drawer backplane.
5. If you replaced the indicated FRUs and the problem is still not corrected, or the above descriptions did not address your particular situation, go to "MAP 1540: Minimum Configuration" on page 113.
6. Go to "MAP 410: Repair Checkout" in *RS/6000 and @server pSeries Diagnostics Information for Multiple Bus Systems*.

Chapter 5. Error Code to FRU Index

Attention: Start your activity in this chapter by going to “Checkpoint and Error Code Index” on page 165. In this section, you may be asked to perform additional isolation procedures before looking up the actions for a 4-character checkpoint or 8-character error code.

The Error Code to FRU Index lists fault symptoms and possible causes. The most likely cause is listed first. Use this index to help you decide which FRUs to replace when servicing the system.

- If you replace FRUs or perform an action and the problem is still not corrected, go to “MAP 1540: Minimum Configuration” on page 113 unless otherwise indicated in the tables.
- If you replace FRUs and the problem is corrected, go to “MAP 410: Repair Checkout” in the *RS/6000 and @server pSeries Diagnostics Information for Multiple Bus Systems*.

Note: Do not shut down the system if the FRU was replaced by hot swap.

Four-Character Checkpoints

Four-character progress codes and checkpoints in the form 8xxx, 9xxx, Axxx, Bxxx, and Exxx are listed in “Firmware Checkpoints” on page 147. If you have a four-character code that begins with any character other than 8, 9, A, B, or E, refer to the *RS/6000 and @server pSeries Diagnostics Information for Multiple Bus Systems*.

Replacing the Primary Drawer Operator Panel

Licensed programs frequently rely on system information that is stored in the VPD module on the primary drawer’s operator panel. If the MAPs indicate that the operator panel should be replaced, the pluggable VPD module must be swapped. If the old module is defective, or cannot be recovered, contact service support.

Replacing the Network Adapter

If a network adapter is replaced, the network administrator must be notified so that the client IP addresses used by the server can be updated. In addition, the operating system configuration of the network controller may need to be changed in order to enable system startup. Also check to ensure that any client or server that accesses this system is updated.

Analyzing SPCN Errors on Secondary Drawers

The drawer number of a secondary I/O drawer (which displays in the operator panel in the form U0.n, where n is the drawer number) does not change unless a repair action or a configuration change has occurred. However, after a secondary I/O drawer has been removed, added, or had its backplane replaced, there is a window of time during the

IPL process in which the drawer number may appear to be out of range. For example, if there is one I/O drawer in the system and one is added, it may temporarily be assigned a drawer number of 3 or greater. The drawer numbers are reallocated and finalized during the latter stages of the boot process.

If a fatal SPCN error occurs while the drawer has a temporary number, the system halts with an 8-character error code displayed in the form 10n1xxxx, where n is the drawer number. To determine the error, if n is not equal to 1, substitute the number 2 for n, then look up the error code in “SPCN Error Codes” on page 169. Perform the indicated actions on the failing drawer.

If a non-fatal SPCN error occurs while the drawer has a temporary number, this temporary number may appear as part of a location code in the service processor error log or while running AIX diagnostics. If the non-fatal error becomes fatal or is the cause of a fatal error, the drawer address will have been resolved and the original error log entry can be ignored.

Isolating the I/O Drawer Failure

The primary I/O drawer is drawer number 1, although it is not displayed on the operator panel.

To determine which I/O drawer is failing, you may find the attention LED on an I/O drawer indicates a fault. Check the LEDs on the front of each I/O drawer to isolate failures to a single drawer. See “Primary I/O Drawer Operator Panel” on page 23 and “Secondary I/O Drawer Operator Panel” on page 24 for the location and meaning of the LEDs on the I/O drawer operator panels.

Determining Location Code

If you have an error code in the form 2xxx xxxx or Exxx, and no location code associated with it, the location code may possibly be found in three places, depending on the state of the system:

- If the system will boot into AIX, the location code will be reported when error log analysis is run under AIX diagnostics.
- If the system will boot into the system management services (SMS) menus, the SMS error log will contain the location code associated with the error code. See “Display Error Log” on page 417.
- If the system halted when the error occurred, the error code and location can be found in the LCD progress indicator log, which can be accessed using the service processor menus. See “System Information Menu” on page 382, then select “Read Progress Indicator From Last System Boot”. Find the error code in the list that directed you to this note, and the location code should be a part of the entry in the log.

Checkpoint and Error Code Index

The following table is an index to the checkpoints or error codes that you may receive to help diagnose a failure. Locate the code you received, and follow the instructions to determine your next step.

Checkpoint or Error Code	What You Should Do
0000 xxxx	Operator Panel Error Codes Go to “Operator Panel Error Codes” on page 168 and follow the instructions in the Operator Panel Error Code table.
1xxx xxxx	System Power Control Network (SPCN) Error Codes Go to “SPCN Error Codes” on page 169 and follow the instructions in the SPCN Error Code table.
2xxx xxxx	Firmware Error Codes Go to “Firmware Error Codes” on page 190 and follow the instructions in the Firmware Error Code table.
4xxx xxxx	Service Processor Error Codes <ol style="list-style-type: none"> 1. Perform slow boot. See “Performing Slow Boot” on page 166. 2. If the error codes are 406x xxxx or 450x xxxx, and if their actions call out memory DIMMs or cards containing memory DIMMs, go to “Memory-Related Error Codes” on page 167. For all other error codes, go to “Confirming Initial Error Code” on page 166. 3. Go to “Service Processor Error Codes” on page 213 and follow the instructions in the Service Processor Error Codes table.
8xxx 9xxx Axxx Bxxx	Service Processor Checkpoints Go to “Service Processor Checkpoints” on page 140 for more information on these checkpoints.
B006 xxxx B1xx xxxx	Common Firmware Error Codes <ol style="list-style-type: none"> 1. Go to “Common Firmware Error Codes” on page 354 and follow the instructions in the Common Firmware Error Code table. 2. Perform slow boot. See “Performing Slow Boot” on page 166. 3. Confirm initial error code. See “Confirming Initial Error Code” on page 166.
Exxx	Firmware Checkpoints Go to “Firmware Checkpoints” on page 147 for more information on these checkpoints.
Mxxx xxxx	Problem Determination Generated Error Codes Go to “Problem Determination Generated Error Codes” on page 364 and follow the instructions in the Problem Determination Generated Error Code table.

Performing Slow Boot

On this system, the error code displayed in the operator panel may not indicate the root cause of the problem. To fully analyze all of the available information, perform the following steps before doing a hardware repair or replacement:

1. Record the 8-character error code (and location code if present) in the primary I/O drawer operator panel.
2. Do a slow-mode boot to the SMS menus. This boot can be specified using the System Power Control Menu on the service processor main menu. (A fast-mode boot skips much of the built-in diagnostic testing.) A slow-mode boot may yield a new 8-character error code on the primary I/O drawer operator panel and new errors in the service processor error log. If a new error code is reported, use it in subsequent steps to continue problem analysis. If the system hangs with the same error code, continue with the next step in the Checkpoints and Error Codes Index. If no 8-character error code is displayed in the op panel, use the original error code and continue with the next step in the Checkpoints and Error Codes Index.
3. A slow boot in service mode should result in the "Diagnostic Operating Instructions" panel being displayed.
4. Press enter to continue to the "Function Selection" menu
5. Enter option 5, "Single User Mode".
6. When prompted, enter the root password.
7. At the prompt, issue the shutdown -F command.
8. At this point, the service processor menus should be available to examine the service processor error log.

Confirming Initial Error Code

The service processor may have recorded one or more symptoms in its error log. If the system has attempted to boot since an error terminated normal operation, there may be specific fault information in the service processor error log. Examine this error log before proceeding (see "System Information Menu" on page 382).

In the service processor error log, the most recent error is at the top of the list and the oldest error is at the bottom. It is also important to look at the time stamp associated with each error. (The time stamps in the service processor error log reflect coordinated universal time (UTC), which is also referred to as Greenwich mean time.)

On this system, the error code displayed in the primary drawer op panel may not be indicative of the root cause of the problem. Find the error code in the service processor error log that directed you to this note. (If the error code is not in the error log, perform the service actions for the error code that was first reported.) Observing the timestamps, look for a group of failures that happened within minutes prior to this error code. In this group, start at the error code with the earliest timestamp. To get a list of possible FRUs, select the detail screen for each error code and perform the listed repair actions. If the repair actions for an error code are ineffective, continue to work upward through this group of errors codes (which is forward in time from the earliest timestamp to the latest) until the problem is fixed, or you reach the error code that was first reported. If the system is still not fixed, go to "MAP 1540: Minimum Configuration" on page 113.

Memory-Related Error Codes

You have been directed here because you have an 8-character error code that indicates a problem with system memory. This section will help you isolate to the failing FRU.

- If the location code or the service action calls out one DIMM:
 1. Replace the memory DIMM.
 2. Replace the memory group (pair or quad).
 3. Replace the memory card.
- If more than one DIMM is called out, go to the service processor memory configuration/deconfiguration menu to verify memory DIMM state. See "Memory Configuration/Deconfiguration Menu" on page 384 for more information.
 1. From the Memory Configuration/Deconfiguration Menu, select the card(s) specified by the location code(s) of the failing DIMM(s). If the first character of the error status of any DIMM is 1, 2, or 3 (but not 0 or 4), this is a suspect DIMM. Record its location. See "System Information Menu" on page 382 for more information on the error status of the DIMMs.
 2. If only one DIMM was recorded in the previous step:
 - a. Replace the DIMM.
 - b. Replace the memory group (pair or quad).
 - c. Replace the memory card.
 3. If more than one DIMM was recorded, and the DIMMs reside in more than one group (pair or quad):
 - a. Replace the memory card.
 - b. Replace all of the failing DIMMs.
 4. If more than one DIMM was recorded, and the DIMMs reside in one group (pair or quad):
 - a. Replace all of the failing DIMMs.
 - b. Replace the memory card.
- Boot the system to the SMS menus. Power off the system and go the service processor memory configuration/deconfiguration menu to verify that all memory DIMMs are in the configured state after the repair action. Go to "MAP 410: Repair Checkout" in the *RS/6000 and @server pSeries Diagnostics Information for Multiple Bus Systems*.

Operator Panel Error Codes

Attention: If you replace FRUs or perform an action and the problem is still not corrected, go to “MAP 1540: Minimum Configuration” on page 113 unless otherwise indicated in the tables.

If you replace FRUs and the problem is corrected, go to “MAP 410: Repair Checkout” in the *RS/6000 and @server pSeries Diagnostics Information for Multiple Bus Systems*.

Table 3. Operator Panel Error Codes.

Error Code	Description	Action/ Possible Failing FRU
0000 1111	At power on, failure of power-good signal from power supply.	<ol style="list-style-type: none"> 1. Primary I/O backplane Location: U0.1-P1 2. Primary I/O power supply Locations: U0.1-V1 U0.1-V2
0000 1112	At power off, failure of power-good signal from power supply.	<ol style="list-style-type: none"> 1. Primary I/O backplane Location: U0.1-P1 2. Primary I/O power supply Locations: U0.1-V1 U0.1-V2
0000 1113	While power on, failure of power-good signal from power supply.	<ol style="list-style-type: none"> 1. Primary I/O backplane Location: U0.1-P1 2. Primary I/O power supply Locations: U0.1-V1 U0.1-V2
0000 1114	Operator panel and service processor have been reset after main power disturbance.	Information message
0000 2222	Operator panel not communicating with service processor	<ol style="list-style-type: none"> 1. If system cannot be powered off, reset the service processor (via the pinhole reset or by disconnecting then reconnecting power). 2. Primary I/O backplane Location: U0.1-P1
0000 3333	SPCN communications error	Primary I/O backplane Location: U0.1-P1
0000 3334	I2C repeater error	Primary I/O backplane Location: U0.1-P1
0000 BBBB	TOD battery malfunction	TOD battery Location: U0.1-P1-V3

SPCN Error Codes

Attention: If a power supply or fan is hot-swapped, wait five minutes, then recheck the AIX error log. If the system has to be shut down to replace a power supply or fan, reboot the system, wait five minutes after the AIX login prompt appears, then recheck the AIX error log. If the detailed information for the most recent error with the same identifier indicates that the original problem has not been fixed by performing the first action in the action column, continue with the next action in the action column.

Attention: If you replace FRUs or perform an action and the problem is still not corrected, go to "MAP 1540: Minimum Configuration" on page 113 unless otherwise indicated in the tables.

If you replace FRUs and the problem is corrected, go to "MAP 410: Repair Checkout" in the *RS/6000 and @server pSeries Diagnostics Information for Multiple Bus Systems*.

Table 4. SPCN Error Codes

Error Code	Description	Action/ Possible Failing FRU
1011 00AC	AC loss or brownout detected	Information message
1011 00EF	Room emergency power off detected	Information message
1011 1510	Power supply 1 power source failure	<ol style="list-style-type: none"> 1. Check input power to the power supply 2. Primary I/O drawer power supply 1 Location: U0.1-V1 3. Primary I/O backplane Location: U0.1-P1
1011 1511	Power supply 1 fault	<ol style="list-style-type: none"> 1. Primary I/O drawer power supply 1 Location: U0.1-V1 2. Primary I/O backplane Location: U0.1-P1
1011 1512	Power supply 1 non-power fault	<ol style="list-style-type: none"> 1. Primary I/O drawer power supply 1 Location: U0.1-V1 2. Primary I/O backplane Location: U0.1-P1
1011 1513	Power supply 1 domain fault	<ol style="list-style-type: none"> 1. Primary I/O drawer power supply 1 Location: U0.1-V1 2. Primary I/O backplane Location: U0.1-P1
1011 1514	Power supply 1 cooling fault	<ol style="list-style-type: none"> 1. Primary I/O drawer power supply 1 Location: U0.1-V1 2. Primary I/O backplane Location: U0.1-P1

Table 4. SPCN Error Codes (continued)

Error Code	Description	Action/ Possible Failing FRU
1011 1516	Swapped power supply and cooling unit or missing power supply 1	<ol style="list-style-type: none"> 1. Verify correct installation of primary power supply and cooling unit 2. Primary I/O power supply 1 Location: U0.1-V1
1011 1520	Power supply 2 power source failure	<ol style="list-style-type: none"> 1. Check input power to the power supply 2. Primary I/O drawer power supply 2 Location: U0.1-V2 3. Primary I/O backplane Location: U0.1-P1
1011 1521	Power supply 2 fault	<ol style="list-style-type: none"> 1. Primary I/O drawer power supply 2 Location: U0.1-V2 2. Primary I/O backplane Location: U0.1-P1
1011 1522	Power supply 2 non-power fault	<ol style="list-style-type: none"> 1. Primary I/O drawer power supply 2 Location: U0.1-V2 2. Primary I/O backplane Location: U0.1-P1
1011 1523	Power supply 2 domain fault	<ol style="list-style-type: none"> 1. Primary I/O drawer power supply 2 Location: U0.1-V2 2. Primary I/O backplane Location: U0.1-P1
1011 1524	Power supply 2 cooling fault	<ol style="list-style-type: none"> 1. Primary I/O drawer power supply 2 Location: U0.1-V2 2. Primary I/O backplane Location: U0.1-P1
1011 1526	Power supply 2 missing	Primary I/O drawer power supply 2 Location: U0.1-V2
1011 1611	CEC regulator 1 fault	Processor card Location: U1.1-P1-C1
1011 1612	CEC regulator 1 non-power fault	<ol style="list-style-type: none"> 1. Processor card Location: U1.1-P1-C1 2. Primary I/O backplane Location: U0.1-P1
1011 1613	CEC regulator 1 domain fault	Processor card Location: U1.1-P1-C1
1011 1621	CEC regulator 2 fault	Processor card Location: U1.1-P1-C1

Table 4. SPCN Error Codes (continued)

Error Code	Description	Action/ Possible Failing FRU
1011 1622	CEC regulator 2 non-power fault	<ol style="list-style-type: none"> 1. Processor card Location: U1.1-P1-C1 2. Primary I/O backplane Location: U0.1-P1
1011 1623	CEC regulator 2 domain fault	Processor card Location: U1.1-P1-C1
1011 1910	Power supply 1 power source failure	<ol style="list-style-type: none"> 1. Check input power to the power supply 2. CEC drawer power supply 1 Location: U1.1-V1 3. Primary I/O backplane Location: U0.1-P1
1011 1911	Power supply 1 fault	<ol style="list-style-type: none"> 1. CEC drawer power supply 1 Location: U1.1-V1 2. Primary I/O backplane Location: U0.1-P1
1011 1912	Power supply 1 non-power fault	<ol style="list-style-type: none"> 1. CEC drawer power supply 1 Location: U1.1-V1 2. Primary I/O backplane Location: U0.1-P1
1011 1913	Power supply 1 domain fault	<ol style="list-style-type: none"> 1. CEC drawer power supply 1 Location: U1.1-V1 2. Primary I/O backplane Location: U0.1-P1
1011 1914	Power supply 1 cooling fault	<ol style="list-style-type: none"> 1. CEC drawer power supply 1 Location: U1.1-V1 2. CEC drawer fan controller card Location: U1.1-X2 3. Primary I/O backplane Location: U0.1-P1
1011 1916	Swapped power supply and cooling unit, or missing power supply 1	<ol style="list-style-type: none"> 1. Verify correct installation of power supply or cooling unit 2. CEC drawer power supply 1 Location: U1.1-V1
1011 1920	Power supply 2 power source failure	<ol style="list-style-type: none"> 1. Check input power to the power supply 2. CEC drawer power supply 2 Location: U1.1-V2 3. Primary I/O backplane Location: U0.1-P1
1011 1921	Power supply 2 fault	<ol style="list-style-type: none"> 1. CEC drawer power supply 2 Location: U1.1-V2 2. Primary I/O backplane Location: U0.1-P1

Table 4. SPCN Error Codes (continued)

Error Code	Description	Action/ Possible Failing FRU
1011 1922	Power supply 2 non-power fault	<ol style="list-style-type: none"> CEC drawer power supply 2 Location: U1.1-V2 Primary I/O backplane Location: U0.1-P1
1011 1923	Power supply 2 domain fault	<ol style="list-style-type: none"> CEC drawer power supply 2 Location: U1.1-V2 Primary I/O backplane Location: U0.1-P1
1011 1924	Power supply 2 cooling fault	<ol style="list-style-type: none"> CEC drawer power supply 2 Location: U1.1-V2 CEC drawer fan controller card Location: U1.1-X2 Primary I/O backplane Location: U0.1-P1
1011 1926	Power supply 2 missing	CEC drawer power supply 2 Location: U1.1-V2
1011 1B01	12V loading	<ol style="list-style-type: none"> Replace power supply 1 Location: U0.1-V1 If power supply 2 is present (no cooling unit), use removed power supply 1 to replace power supply 2 Primary I/O backplane Location: U0.1-P1
1011 1B02	5V loading	<ol style="list-style-type: none"> Replace power supply 1 Location: U0.1-V1 If power supply 2 is present (no cooling unit), use removed power supply 1 to replace power supply 2 Primary I/O backplane Location: U0.1-P1
1011 1B03	3.3V loading	<ol style="list-style-type: none"> Replace power supply 1 Location: U0.1-V1 If power supply 2 is present (no cooling unit), use removed power supply 1 to replace power supply 2 Primary I/O backplane Location: U0.1-P1
1011 1B04	-12V loading	<ol style="list-style-type: none"> Replace power supply 1 Location: U0.1-V1 If power supply 2 is present (no cooling unit), use removed power supply 1 to replace power supply 2 Primary I/O backplane Location: U0.1-P1

Table 4. SPCN Error Codes (continued)

Error Code	Description	Action/ Possible Failing FRU
1011 1B05	1.8V loading	<ol style="list-style-type: none"> 1. Replace power supply 1 Location: U0.1-V1 2. If power supply 2 is present (no cooling unit), use removed power supply 1 to replace power supply 2 3. Primary I/O backplane Location: U0.1-P1
1011 1B06	2.5V loading	<ol style="list-style-type: none"> 1. Replace power supply 1 Location: U0.1-V1 2. If power supply 2 is present (no cooling unit), use removed power supply 1 to replace power supply 2 3. Primary I/O backplane Location: U0.1-P1
1011 1B07	2.5V loading	<ol style="list-style-type: none"> 1. Replace power supply 1 Location: U0.1-V1 2. If power supply 2 is present (no cooling unit), use removed power supply 1 to replace power supply 2 3. Primary I/O backplane Location: U0.1-P1
1011 1C01	Load fault on +12V bus	Go to "MAP 1520: Power" on page 89.
1011 1C02	Load fault on +5V bus	Go to "MAP 1520: Power" on page 89.
1011 1C03	Load fault on +3.3V bus	Go to "MAP 1520: Power" on page 89.
1011 1C05	Load fault on +1.8V bus	Go to "MAP 1520: Power" on page 89.
1011 1C06	Load fault on +2.5V bus	Go to "MAP 1520: Power" on page 89.
1011 1C07	Load fault on +2.5V bus	Go to "MAP 1520: Power" on page 89.
1011 1C08	Load fault on +2.5V bus	Go to "MAP 1520: Power" on page 89.
1011 1F00	Power system communication fault	Primary I/O backplane Location: U0.1-P1
1011 1F01	S/N write to secondary drawer failed	<ol style="list-style-type: none"> 1. Check for system firmware update. 2. Call service support.
1011 2600	Pgood fault	Primary I/O backplane Location: U0.1-P1

Table 4. SPCN Error Codes (continued)

Error Code	Description	Action/ Possible Failing FRU
1011 2601	Pgood fault	Primary I/O backplane Location: U0.1-P1
1011 2602	Power domain fault in CEC drawer	<ol style="list-style-type: none"> 1. Verify that the V/S COMM cable is properly connected 2. CEC drawer power supply Locations: U1.1-V1 U1.1-V2 3. Power distribution board Location: U1.1-X1 4. CEC drawer backplane Location: U1.1-P1 5. Primary I/O backplane Location: U0.1-P1
1011 2603	Power domain fault in primary I/O drawer	<ol style="list-style-type: none"> 1. I/O drawer power supply Locations: U0.1-V1 U0.1-V2 2. Power distribution board Location: U0.1-X1 3. Primary I/O backplane Location: U0.1-P1
1011 2604	Power domain fault affecting CEC and primary I/O drawers	<ol style="list-style-type: none"> 1. Primary I/O drawer power supply Locations: U0.1-V1 U0.1-V2 2. CEC drawer power supply Locations: U1.1-V1 U1.1-V2 3. CEC drawer power distribution board Location: U1.1-X1 4. Primary I/O drawer power distribution board Location: U0.1-X1 5. CEC drawer backplane Location: U1.1-P1 6. Primary I/O backplane Location: U0.1-P1
1011 2610	Missing or misplugged memory	Inspect the system memory for proper installation of DIMMs and memory riser cards

Table 4. SPCN Error Codes (continued)

Error Code	Description	Action/ Possible Failing FRU
1011 2611	Regulator fault	<ol style="list-style-type: none"> 1. Verify that the VSCOMM cable is functioning and properly installed. 2. Replace the primary I/O drawer backplane Location: U0.1-P1.
1011 2612	SPCN problem	<ol style="list-style-type: none"> 1. Verify that the VSCOMM cable is functioning and properly installed. 2. Replace the primary I/O drawer backplane Location: U0.1-P1.
1011 2613	Power configuration fault	220 V ac power required
1011 3100	I2C controller fault	Primary I/O backplane Location: U0.1-P1
1011 3101	I2C bus 1 fault	<ol style="list-style-type: none"> 1. Primary drawer op panel Location: U0.1-L1 2. Primary I/O backplane Location: U0.1-P1
1011 3102	I2C bus 2 fault	Primary I/O backplane Location: U0.1-P1
1011 3104	I2C bus 4 fault	Primary I/O backplane Location: U0.1-P1
1011 3105	I2C bus 5 fault	<ol style="list-style-type: none"> 1. Primary I/O fan controller card Location: U0.1-X2 2. Primary I/O backplane Location: U0.1-P1 3. Primary I/O drawer power distribution board Location: U0.1-X1
1011 3106	I2C bus 6 fault	<ol style="list-style-type: none"> 1. CEC drawer fan controller card Location: U1.1-X2 2. Primary I/O backplane Location: U0.1-P1
1011 3113	RIO bus adapter fault	Primary I/O drawer RIO bus adapter Location: U0.1-P1.1
1011 3114	PCI backplane fault	Primary I/O PCI backplane Location: U0.1-P1
1011 3115	Operator panel fault	Operator panel Location: U0.1-L1

Table 4. SPCN Error Codes (continued)

Error Code	Description	Action/ Possible Failing FRU
1011 3116	Primary I/O drawer fan controller fault	<ol style="list-style-type: none"> Primary I/O drawer fan controller card Location: U0.1-X2 Primary I/O backplane Location: U0.1-P1
1011 3117	CEC drawer fan controller fault	<ol style="list-style-type: none"> CEC drawer fan controller card Location: U1.1-X2 Primary I/O backplane Location: U0.1-P1
1011 3118	Backplane fault	Primary I/O backplane Location: U0.1-P1
1011 311B	CEC thermal malfunction	CEC backplane Location: U1.1-P1
1011 311C	Primary I/O drawer thermal malfunction	<ol style="list-style-type: none"> Primary I/O Op Panel Location: U0.1-L1 Primary I/O backplane Location: U0.1-P1
1011 7610	Slow I/O drawer fan 1	<ol style="list-style-type: none"> Fan 1 Location: U0.1-F1 Primary fan controller Location: U0.1-X2 Power distribution card Location: U0.1-X1
1011 7611	Missing I/O drawer fan 1	Fan 1 Location: U0.1-F1
1011 7620	Slow I/O drawer fan 2	<ol style="list-style-type: none"> Fan 2 Location: U0.1-F2 Primary fan controller Location: U0.1-X2 Power distribution card Location: U0.1-X1
1011 7621	Missing I/O drawer fan 2	Fan 2 Location: U0.1-F2
1011 7630	Slow I/O drawer fan 3	<ol style="list-style-type: none"> Fan 3 Location: U0.1-F3 Primary fan controller Location: U0.1-X2 Power distribution card Location: U0.1-X1
1011 7631	Missing I/O drawer fan 3	Fan 3 Location: U0.1-F3

Table 4. SPCN Error Codes (continued)

Error Code	Description	Action/ Possible Failing FRU
1011 7640	Slow I/O drawer fan 4	<ol style="list-style-type: none"> 1. Fan 4 Location: U0.1-F4 2. Primary fan controller Location: U0.1-X2 3. Power distribution card Location: U0.1-X1
1011 7641	Missing I/O drawer fan 4	<p>Fan 4 Location: U0.1-F4</p>
1011 7650	Slow fan in primary I/O drawer power supply 1	<ol style="list-style-type: none"> 1. I/O drawer power supply 1 Location: U0.1-V1 2. Primary fan controller Location: U0.1-X2 3. Power distribution card Location: U0.1-X1
1011 7651	Missing fan 5 in primary I/O drawer power supply 1	<p>I/O drawer power supply 1 Location: U0.1-V1</p>
1011 7660	Slow fan in primary I/O drawer power supply 2	<ol style="list-style-type: none"> 1. I/O drawer power supply 2 Location: U0.1-V2 2. Primary fan controller Location: U0.1-X2 3. Power distribution card Location: U0.1-X1
1011 7661	Missing fan 6 in primary I/O drawer power supply 2	<p>I/O drawer power supply 2 Location: U0.1-V2</p>
1011 7690	Slow I/O drawer fan 9 in cooling unit	<ol style="list-style-type: none"> 1. Fan 9 (cooling unit) Location: U0.1-F9 2. Primary fan controller Location: U0.1-X2 3. Power distribution card Location: U0.1-X1
1011 7691	Missing I/O drawer fan 9 in cooling unit	<p>Fan 9 (cooling unit) Location: U0.1-F9</p>
1011 7710	Slow CEC fan 1	<ol style="list-style-type: none"> 1. Fan 1 Location: U1.1-F1 2. CEC fan controller Location: U1.1-X2 3. Power distribution card Location: U1.1-X1

Table 4. SPCN Error Codes (continued)

Error Code	Description	Action/ Possible Failing FRU
1011 7711	Missing CEC fan 1	<ol style="list-style-type: none"> 1. Check the cabling to fan 1 Location: U1.1-F1. If no problem is found with the cabling, replace the fan. Note: If the primary I/O drawer planar has been replaced recently, verify that the I/O type is set correctly before changing this fan. See "Power Control Network Utilities Menu" on 389.
1011 7720	Slow CEC fan 2	<ol style="list-style-type: none"> 1. Fan 2 Location: U1.1-F2 2. CEC fan controller Location: U1.1-X2 3. Power distribution card Location: U1.1-X1
1011 7721	Missing CEC fan 2	<p>Fan 2 Location: U1.1-F2</p>
1011 7730	Slow CEC fan 3	<ol style="list-style-type: none"> 1. Fan 3 Location: U1.1-F3 2. CEC fan controller Location: U1.1-X2 3. Power distribution card Location: U1.1-X1
1011 7731	Missing CEC fan 3	<p>Fan 3 Location: U1.1-F3</p>
1011 7740	Slow CEC fan 4	<ol style="list-style-type: none"> 1. Fan 4 Location: U1.1-F4 2. CEC fan controller Location: U1.1-X2 3. Power distribution card Location: U1.1-X1
1011 7741	Missing CEC fan 4	<p>Fan 4 Location: U1.1-F4</p>
1011 7750	Slow fan in CEC drawer power supply 1	<ol style="list-style-type: none"> 1. CEC power supply 1 Location: U1.1-V1 2. CEC fan controller Location: U1.1-X2 3. Power distribution card Location: U1.1-X1
1011 7751	Missing fan 5 in CEC drawer power supply 1	<p>CEC drawer power supply 1 Location: U1.1-V1</p>

Table 4. SPCN Error Codes (continued)

Error Code	Description	Action/ Possible Failing FRU
1011 7760	Slow fan in CEC drawer power supply 2	<ol style="list-style-type: none"> 1. CEC drawer power supply 2 Location: U1.1-V2 2. CEC fan controller Location: U1.1-X2 3. Power distribution card Location: U1.1-X1
1011 7761	Missing fan 6 in CEC drawer power supply 2	CEC drawer power supply 2 Location: U1.1-V2
1011 7770	Slow CEC fan 7	<ol style="list-style-type: none"> 1. Fan 7 Location: U1.1-F7 2. CEC fan controller Location: U1.1-X2 3. Power distribution card Location: U1.1-X1
1011 7771	Missing fan 7	Fan 7 Location: U1.1-F7
1011 7780	Slow CEC fan 8	<ol style="list-style-type: none"> 1. Fan 8 Location: U1.1-F8 2. CEC fan controller Location: U1.1-X2 3. Power distribution card Location: U1.1-X1
1011 7781	Missing fan 8	Fan 8 Location: U1.1-F8
1011 7790	Slow CEC fan 9	<ol style="list-style-type: none"> 1. Fan 9 (cooling unit) Location: U1.1-F9 2. CEC fan controller Location: U1.1-X2 3. Power distribution card Location: U1.1-X1
1011 7791	Missing CEC fan 9	Fan 9 (cooling unit) Location: U1.1-F9
1011 8400	VPD configuration problem	Ignore all location codes. Go to MAP 1540 and run CEC minimum configuration.
1011 8401	VPD access problem	Ignore all location codes. Go to MAP 1540 and run CEC minimum configuration.
1011 8402	VPD access problem	Ignore all location codes. Go to MAP 1540 and run CEC minimum configuration.
1011 8403	VPD level mismatch	Ignore all location codes. Go to MAP 1540 and run CEC minimum configuration.

Table 4. SPCN Error Codes (continued)

Error Code	Description	Action/ Possible Failing FRU
1011 8404	Processor unit VPD mismatch	<ol style="list-style-type: none"> Processor card Location: U1.1-P1-C1 Primary I/O backplane Location: U0.1-P1
1011 8409	VPD for processor card	<ol style="list-style-type: none"> Ensure that the processor assembly(s) are the correct type for the system and are properly installed. Processor card Location: U1.1-P1-C1
1011 840A	VPD +5 stuck high	Ignore all location codes. Go to MAP 1540 and run CEC minimum configuration.
1011 840B	VPD +5 stuck low	Ignore all location codes. Go to MAP 1540 and run CEC minimum configuration.
1011 840C	Memory DIMM misplugged	Inspect system memory for proper installation of DIMMs and memory cards
1011 840D	I/O type mismatch	<ol style="list-style-type: none"> Check cabling Set the I/O type to 85. See Power Control Network Utilities Menu on page 389. Primary I/O backplane Location: U0.1-P1
1011 840E	SPCN default configuration loaded	<ol style="list-style-type: none"> Check cabling Set the I/O type to 85. See Power Control Network Utilities Menu on page 389. Primary I/O backplane Location: U0.1-P1
1011 840F	I/O type not recognized	<ol style="list-style-type: none"> Check cabling Set the I/O type to 85. See Power Control Network Utilities Menu on page 389. Primary I/O backplane Location: U0.1-P1
1011 8413	Invalid processor VPD	Processor card Location: U1.1-P1-C1
1011 8423	No processor VPD	Processor card Location: U1.1-P1-C1
1011 8430	V/S Comm cable not connected	Check cabling

Table 4. SPCN Error Codes (continued)

Error Code	Description	Action/ Possible Failing FRU
1011 8431	Frame ID error	<ol style="list-style-type: none"> 1. Check cabling 2. Set the I/O type to 85. See Power Control Network Utilities Menu on page 389. 3. Primary I/O backplane Location: U0.1-P1
1011 8441	Internal SPCN error in a drawer	<ol style="list-style-type: none"> 1. Check the internal SPCN cables in the CEC drawer Location: U1.1 2. Check the internal SPCN cables in the I/O drawer Location: U0.x
10118450	I/O type set incorrectly	Set the I/O type to 85. See Power Control Network Utilities Menu on page 389.
1011 8A00	A different I/O drawer is connected to the CEC	Informational only
1011 9014	Invalid address mode	Update system firmware
1011 9038	Node fault	Primary I/O backplane Location: U0.1-P1
1011 9039	Node fault	Primary I/O backplane Location: U0.1-P1
1011 9042	EPROM failure	Primary I/O backplane Location: U0.1-P1
1011 9043	Download failure	<ol style="list-style-type: none"> 1. Check for system firmware update. 2. Call service support.
1011 9046	QDS packet sequence error	<ol style="list-style-type: none"> 1. Check for system firmware update. 2. Call service support.
1011 9047	QDS block sequence error	<ol style="list-style-type: none"> 1. Check for system firmware update. 2. Call service support.
1011 9080	Undefined status code received	Primary I/O backplane Location: U0.1-P1
1011 90F0	CEC backplane not present in configuration table	Check cabling
1011 9101	SPCN failed to respond to service processor in time	Primary I/O backplane Location: U0.1-P1
1011 9102	Permanent address assignment failed	Primary I/O backplane Location: U0.1-P1

Table 4. SPCN Error Codes (continued)

Error Code	Description	Action/ Possible Failing FRU
1011 9103	Download initialize timeout	Primary I/O backplane Location: U0.1-P1
1011 9104	Download completion timeout	Primary I/O backplane Location: U0.1-P1
1011 9105	Load damaged timeout	Primary I/O backplane Location: U0.1-P1
1011 9109	Download failure	Primary I/O backplane Location: U0.1-P1
1011 9111	Network too large for service processor	1. Check for system firmware update. 2. Call service support.
1011 9114	Firmware image corrupted	1. Reinstall system firmware 2. Primary I/O backplane Location: U0.1-P1
1011 9116	SCPN communication with operator panel failure	1. Primary I/O operator panel Location: U0.1-L1 2. Primary I/O backplane Location: U0.1-P1
1021 00AA	SPCN firmware update started	Information message
1021 1510	Power supply 1 power source failure	1. Check input power to power supply 2. Secondary I/O power supply 1 Location: U0.2-V1 3. Secondary I/O backplane Location: U0.2-P1
1021 1511	Power supply 1 fault	1. Secondary I/O power supply 1 Location: U0.2-V1 2. Secondary I/O backplane Location: U0.2-P1
1021 1512	Power supply 1 non-power fault	1. Secondary I/O power supply 1 Location: U0.2-V1 2. Secondary I/O backplane Location: U0.2-P1
1021 1513	Power supply 1 domain fault	1. Secondary I/O power supply 1 Location: U0.2-V1 2. Secondary I/O backplane Location: U0.2-P1
1021 1514	Power supply 1 cooling fault	1. Secondary I/O power supply 1 Location: U0.2-V1 2. Secondary I/O backplane Location: U0.2-P1

Table 4. SPCN Error Codes (continued)

Error Code	Description	Action/ Possible Failing FRU
1021 1516	Power supply 1 missing or swapped power supply and cooling unit	<ol style="list-style-type: none"> 1. Verify correct installation of primary power supply and cooling unit 2. Secondary I/O power supply 1 Location: U0.2-V1
1021 1520	Power supply 2 power source failure	<ol style="list-style-type: none"> 1. Check input power to power supply 2. Secondary I/O power supply 2 Location: U0.2-V2 3. Secondary I/O backplane Location: U0.2-P1
1021 1521	Power supply 2 fault	<ol style="list-style-type: none"> 1. Secondary I/O power supply 2 Location: U0.2-V2 2. Secondary I/O backplane Location: U0.2-P1
1021 1522	Power supply 2 fault	<ol style="list-style-type: none"> 1. Secondary I/O power supply 2 Location: U0.2-V2 2. Secondary I/O backplane Location: U0.2-P1
1021 1523	Power supply 2 domain fault	<ol style="list-style-type: none"> 1. Secondary I/O power supply 2 Location: U0.2-V2 2. Secondary I/O backplane Location: U0.2-P1
1021 1524	Power supply 2 cooling fault	<ol style="list-style-type: none"> 1. Secondary I/O power supply 2 Location: U0.2-V2 2. Secondary I/O backplane Location: U0.2-P1
1021 1526	Power supply 2 missing	Secondary I/O drawer power supply 2 Location: U0.2-V2
1021 1B01	12V loading	<ol style="list-style-type: none"> 1. Replace power supply 1 Location: U0.2-V1 2. If power supply 2 is present (no cooling unit), use removed power supply 1 to replace power supply 2 3. Secondary I/O backplane Location: U0.2-P1
1021 1B02	5V loading	<ol style="list-style-type: none"> 1. Replace power supply 1 Location: U0.2-V1 2. If power supply 2 is present (no cooling unit), use removed power supply 1 to replace power supply 2 3. Secondary I/O backplane Location: U0.2-P1

Table 4. SPCN Error Codes (continued)

Error Code	Description	Action/ Possible Failing FRU
1021 1B03	3.3V loading	<ol style="list-style-type: none"> 1. Replace power supply 1 Location: U0.2-V1 2. If power supply 2 is present (no cooling unit), use removed power supply 1 to replace power supply 2 3. Secondary I/O backplane Location: U0.2-P1
1021 1B04	-12V loading	<ol style="list-style-type: none"> 1. Replace power supply 1 Location: U0.2-V1 2. If power supply 2 is present (no cooling unit), use removed power supply 1 to replace power supply 2 3. Secondary I/O backplane Location: U0.2-P1
1021 1B05	1.8V loading	<ol style="list-style-type: none"> 1. Replace power supply 1 Location: U0.2-V1 2. If power supply 2 is present (no cooling unit), use removed power supply 1 to replace power supply 2 3. Secondary I/O backplane Location: U0.2-P1
1021 1B06	2.5V loading	<ol style="list-style-type: none"> 1. Replace power supply 1 Location: U0.2-V1 2. If power supply 2 is present (no cooling unit), use removed power supply 1 to replace power supply 2 3. Secondary I/O backplane Location: U0.2-P1
1021 1B07	2.5V loading	<ol style="list-style-type: none"> 1. Replace power supply 1 Location: U0.2-V1 2. If power supply 2 is present (no cooling unit), use removed power supply 1 to replace power supply 2 3. Secondary I/O backplane Location: U0.2-P1
1021 2600	Pgood fault	Secondary I/O backplane Location: U0.2-P1
1021 2601	Pgood fault	Secondary I/O backplane Location: U0.2-P1

Table 4. SPCN Error Codes (continued)

Error Code	Description	Action/ Possible Failing FRU
1021 2603	Power domain fault in secondary I/O drawer	<ol style="list-style-type: none"> 1. Secondary I/O drawer power supply Locations: U0.2-V1 U0.2-V2 2. Secondary I/O backplane Location: U0.2-P1
1021 2612	SPCN problem	Secondary I/O backplane Location: U0.2-P1
1021 3100	I2C controller fault	Secondary I/O backplane Location: U0.2-P1
1021 3101	I2C bus 1 fault	<ol style="list-style-type: none"> 1. Secondary I/O operator panel Location: U0.2-L1 2. Secondary I/O backplane Location: U0.2-P1
1021 3102	I2C bus 2 fault	Secondary I/O backplane Location: U0.2-P1
1021 3104	I2C bus 4 fault	Secondary I/O backplane Location: U0.2-P1
1021 3105	I2C bus 5 fault	<ol style="list-style-type: none"> 1. Secondary I/O fan controller card Location: U0.2-L1 2. Secondary I/O backplane Location: U0.2-P1
1021 3113	RIO bus adapter fault	RIO bus adapter Location: U0.2-P1.1
1021 3114	PCI backplane fault	Secondary I/O PCI backplane Location: U0.2-P1
1021 3115	Operator panel fault	Operator panel Location: U0.2-L1
1021 3116	Fan controller fault	<ol style="list-style-type: none"> 1. Fan controller card Location: U0.2-X2 2. Secondary I/O backplane Location: U0.2-P1
1021 3118	Backplane fault	Secondary I/O backplane Location: U0.2-P1
1021 311C	Secondary I/O thermal sensor fault	<ol style="list-style-type: none"> 1. Secondary I/O operator panel Location: U0.2-L1 2. Secondary I/O backplane Location U0.2-P1

Table 4. SPCN Error Codes (continued)

Error Code	Description	Action/ Possible Failing FRU
1021 7610	Slow I/O drawer fan 1	<ol style="list-style-type: none"> 1. Fan 1 Location: U0.2-F1 2. Secondary fan controller Location U0.2-X2 3. Power distribution card Location U0.2-X1
1021 7611	Missing I/O drawer fan 1	Fan 1 Location: U0.2-F1
1021 7620	Slow I/O drawer fan 2	<ol style="list-style-type: none"> 1. Fan 2 Location: U0.2-F2 2. Secondary fan controller Location U0.2-X2 3. Power distribution card Location U0.2-X1
1021 7621	Missing I/O drawer fan 2	Fan 2 Location: U0.2-F2
1021 7630	Slow I/O drawer fan 3	<ol style="list-style-type: none"> 1. Fan 3 Location: U0.2-F3 2. Secondary fan controller Location U0.2-X2 3. Power distribution card Location U0.2-X1
1021 7631	Missing I/O drawer fan 3	Fan 3 Location: U0.2-F3
1021 7640	Slow I/O drawer fan 4	<ol style="list-style-type: none"> 1. Fan 4 Location: U0.2-F4 2. Secondary fan controller Location U0.2-X2 3. Power distribution card Location U0.2-X1
1021 7641	Missing I/O drawer fan 4	Fan 4 Location: U0.2-F4
1021 7650	Slow fan in power supply 1	<ol style="list-style-type: none"> 1. I/O drawer power supply 1 Location: U0.2-V1 2. Secondary fan controller Location U0.2-X2 3. Power distribution card Location U0.2-X1
1021 7651	Missing fan 5 in power supply 1	I/O drawer power supply 1 Location: U0.2-V1
1021 7660	Slow fan 6 in power supply 2	<ol style="list-style-type: none"> 1. I/O drawer power supply 2 Location: U0.2-V2 2. Secondary fan controller Location U0.2-X2 3. Power distribution card Location U0.2-X1

Table 4. SPCN Error Codes (continued)

Error Code	Description	Action/ Possible Failing FRU
1021 7661	Missing fan 6 in power supply 2	I/O drawer power supply 2 Location: U0.2-V2
1021 7690	Slow secondary I/O drawer fan 9 in cooling unit	1. Fan 9 (cooling unit) Location: U0.2-F9 2. Secondary fan controller Location U0.2-X2 3. Power distribution card Location U0.2-X1
1021 7691	Missing secondary I/O drawer fan 9 in cooling unit	Fan 9 (cooling unit) Location: U0.2-F9
1021 8400	VPD configuration problem	1. Check for system firmware update. 2. Call service support.
1021 8401	VPD access problem	1. Check for system firmware update. 2. Call service support.
1021 840A	VPD +5 stuck high	Secondary I/O backplane Location: U0.2-P1
1021 840B	VPD +5 stuck low	Secondary I/O backplane Location: U0.2-P1
1021 840D	I/O type mismatch	1. Check cabling 2. Set the I/O type to 85. See Power Control Network Utilities Menu on page 389. 3. Primary I/O backplane Location: U0.1-P1
1021 840E	SPCN default configuration loaded	User error
1021 840F	I/O type not recognized	1. Check cabling 2. Set the I/O type to 85. See Power Control Network Utilities Menu on page 389. 3. Primary I/O backplane Location: U0.1-P1
1021 8A00	A different I/O drawer is connected to the CEC	Informational only
1021 9012	Invalid address	1. Check SPCN cabling 2. Secondary I/O backplane Location: U0.2-P1
1021 9013	Invalid address	1. Check SPCN cabling 2. Secondary I/O backplane Location: U0.2-P1
1021 9014	Invalid address mode	Update system firmware Note: Allow up to 30 minutes for update to take effect

Table 4. SPCN Error Codes (continued)

Error Code	Description	Action/ Possible Failing FRU
1021 9021	SPCN temporary internal error	Information message
1021 9022	Secondary I/O drawer not present	Check cabling
1021 9023	Secondary I/O drawer present but off	Information message
1021 902D	Secondary I/O drawer not present	Information message
1021 9038	Node fault	Secondary I/O backplane Location: U0.2-P1
1021 9039	Node fault	Secondary I/O backplane Location: U0.2-P1
1021 9042	EPROM Failure	Secondary I/O backplane Location: U0.2-P1
1021 9043	Download failure	1. Check for system firmware update. 2. Call service support.
1021 9046	QDS packet sequence error	1. Check for system firmware update. 2. Call service support.
1021 9047	QDS block sequence error	1. Check for system firmware update. 2. Call service support.
1021 9080	Undefined status code received	Secondary I/O backplane Location: U0.2-P1
1021 90F0	Drawer not present in configuration table	1. Check SPCN cabling 2. Reset system, then reboot 3. Secondary I/O backplane Location: U0.2-P1
1021 90F1	Drawer added to configuration table	Information message
1021 9102	Permanent address assignment failed	Secondary I/O backplane Location: U0.2-P1
1021 9109	Download failure	Secondary I/O backplane Location: U0.2-P1
1021 9113	Firmware image corrupted	Secondary I/O backplane Location: U0.2-P1
1021 9114	Firmware image corrupted	Secondary I/O backplane Location: U0.2-P1
1021 9116	SPCN communication with operator panel failure	1. Secondary I/O operator panel Location: U0.2-L1 2. Secondary I/O backplane Location: U0.2-P1

Table 4. SPCN Error Codes (continued)

Error Code	Description	Action/ Possible Failing FRU
1021 C62E	Polling error	<ol style="list-style-type: none">1. Cabling fault2. Secondary I/O backplane Location: U0.2-P13. Primary I/O backplane Location: U0.1-P1

Firmware Error Codes

Attention: If you replace FRUs or perform an action and the problem is still not corrected, go to “MAP 1540: Minimum Configuration” on page 113 unless otherwise indicated in the tables.

If you replace FRUs and the problem is corrected, go to “MAP 410: Repair Checkout” in the *RS/6000 and @server pSeries Diagnostics Information for Multiple Bus Systems*.

Table 5. Firmware Error Codes.

Error Code	Description	Action/ Possible Failing FRU
2011 00xy	I/O drawer power supply failure	<ol style="list-style-type: none"> Replace power supply “y” in I/O drawer “x”. If y=_, then the power supply is: y = power supply 3 = Both power supplies (I/O drawer) 2 = Reserved 1 = Reserved See “AIX and Physical Location Code Tables” in Chapter 1 for location codes. Check AC power source to I/O drawer “x”. See “AIX and Physical Location Code Tables” in Chapter 1 for location codes.
2022 0000	The I/O system is running slowly.	<ol style="list-style-type: none"> Check cabling Call for support

Table 5. Firmware Error Codes. (continued)

Error Code	Description	Action/ Possible Failing FRU
203w 0xyz	<p>Remote I/O (RIO) configuration warning.</p> <p>This code indicates that an RIO configuration was detected that does not result in complete loops. The system continues to boot, however, performance or recovery capability may be reduced. In some cases, the problem may result in missing I/O. Remote I/O drawers are connected in loops. Use the letters w, y, and z in the error code to isolate the location of the open loop. Check RIO cables for loose connections, and verify power on the I/O drawers by the presence of fan motion.</p> <p>The following numbers may be used to help isolate the failing component.</p> <ul style="list-style-type: none"> • w = loop number, this is either 0 or 1 in a system with 2 RIO loops. • x = Always 0. • y is either 1 or 2 on a system with 2 loops. y indicates the nearest associated RIO port number on the CEC drawer according to the following table: <p style="margin-left: 40px;">y = Nearest RIO Port 1 = 0 2 = 1</p> <ul style="list-style-type: none"> • z = B, indicates a missing return line from the I/O drawer to the CEC drawer. • z = C, indicates a missing link between two I/O drawers. • z = E, indicates an I/O drawer was found connected to RIO port 3 with no return to the CEC drawer, and no I/O drawer was found connected to RIO port 2. In this case, the I/O connected to RIO port 3 is removed from the configuration because the cause of the error and the proper location of the I/O cannot be determined. 	<ol style="list-style-type: none"> 1. Check the RIO cables 2. Go to “MAP 1540: Minimum Configuration” on page 113.
20A8 0000	Insufficient information to boot.	Verify the IP address.
20A8 0001	Client IP address is already in use by other network device	Change IP address.

Table 5. Firmware Error Codes. (continued)

Error Code	Description	Action/ Possible Failing FRU
20A8 0002	Cannot get gateway IP address	Refer to Table 2 on page 148 using code E174 .
20A8 0003	Cannot get server hardware address	Refer to Table 2 on page 148 using code E174 .
20A8 0004	Bootup failed	Refer to Table 2 on page 148 using code E175 .
20A80005	File transmission (TFTP) failed.	Check network connection, try again.
20A8 0006	Boot image too large	Contact your next level of support for assistance.
20D0 000F	Self-test failed on device, no error and/or location code information available	Refer to note "AIX and Physical Location Code Reference Tables" on page 36 to see if a location code is available for the device the error was reported against. 1. Replace device indicated by the location code (if available). 2. Go to "MAP 1540: Minimum Configuration" on page 113
20D0 0010	Self-test failed on device, cannot locate package	Contact your service support representative for assistance.
20D0 0011	Firmware RTAS attempt to allocate memory failed.	Contact your next level of support for assistance.
20E0 0001	Privileged-access password entry error.	The password has been entered incorrectly. Retry installing the password.
20E0 0004	Battery drained or needs replacement	1. Replace battery. 2. Replace primary I/O backplane Location: U0.1-P1
20E0 0009	Invalid password entered - system locked	The password has been entered incorrectly 3 times. Turn off, then turn on the system unit, then enter the password correctly.
20EE 0003	IP parameter requires 3 dots "."	Enter valid IP parameter. Example: 000.000.000.000
20EE 0004	Invalid IP parameter	Enter valid IP parameter. Example: 000.000.000.000
20EE 0005	Invalid IP parameter (>255)	Enter valid IP parameter. Example: 255.192.002.000

Table 5. Firmware Error Codes. (continued)

Error Code	Description	Action/ Possible Failing FRU
20EE 0006	No recognized SCSI adapter present	This warning occurs when the selected SMS function cannot locate any SCSI adapter supported by the function. If a supported SCSI adapter is installed: 1. Replace SCSI adapter(s). 2. Replace the I/O board in drawer(s) containing SCSI adapter(s).
20EE 0007	Keyboard not found	1. Plug in keyboard. 2. Replace primary I/O backplane Location: U0.1-P1
20EE 0008	No configurable adapters were found in the system by the remote IPL menu in the SMS utilities	This warning occurs when the remote IPL menu in the SMS utilities cannot locate any LAN adapters that are supported by the remote IPL function. If a supported device is installed: 1. Replace the adapter. 2. Replace the I/O drawer planar in the drawer(s) containing the adapter.
20EE 0009	Unable to communicate with the service processor	Replace primary I/O backplane Location: U0.1-P1
20EE 000B	The system was not able to find an operating system boot record on the devices listed in the boot list. This can be caused by the wrong devices being in the boot list, a problem that prevents the system from communicating with the device that contains the boot record, or the boot record being corrupted.	Go to "Boot Problems and Concerns" on page 159

Table 5. Firmware Error Codes. (continued)

Error Code	Description	Action/ Possible Failing FRU
20EE 000C	Pointer to the operating system not found in non-volatile storage.	<p>Values normally found in non-volatile storage that point to the location of an operating system were not found. This can happen for two reasons, either your installed operating system does not support storing the values or some event occurred that caused the system to lose non-volatile storage information (drainage or replacement of the battery). If you are running AIX, this information can be reconstructed by running the bootlist command specifying the device that the operating system is installed on. Refer to your AIX documentation for the exact syntax and usage of the bootlist command.</p> <p>To boot the operating system so that the above- mentioned values can be reconstructed, power off the system and power it on again. This should cause the system to look for the operating system in the devices contained in the custom boot list or in the default boot list, depending on the condition of the system. If this is not successful, use the System Management Services Menus to modify the Boot Sequence (also known as boot list) to include devices that are known to contain a copy of the operating system. For example, select a hard disk known to have a copy of the operating system as the first and only device in the boot sequence (boot list) and attempt to boot again.</p>
20FB 0xxx	Permanent addressing to map SPCN addresses to match RIO addresses of the I/O drawers. Note: 20FB 0xxx error codes will cause the system to hang.	
20FB 0010	Failed to find the keyword offset of SPCN configuration table in NVRAM	<ol style="list-style-type: none"> 1. Check RIO cable connections 2. Clear NVRAM and retry 3. Check for system firmware update 4. Replace primary I/O drawer backplane Location: U0.1-P1

Table 5. Firmware Error Codes. (continued)

Error Code	Description	Action/ Possible Failing FRU
20FB 0020	Invalid SPCN configuration table flag before SPCN table update	<ol style="list-style-type: none"> 1. Check RIO cable connections 2. Clear NVRAM and retry 3. Check for system firmware update 4. Replace primary I/O drawer backplane Location: U0.1-P1
20FB 0021	Invalid SPCN configuration table flag after SPCN table update	<ol style="list-style-type: none"> 1. Check RIO cable connections 2. Clear NVRAM and retry 3. Check for system firmware update 4. Replace primary I/O drawer backplane Location: U0.1-P1
20FB 0025	The number of I/O drawers reported by SPCN is not equal to the number of I/O drawers reported by RIO (remote I/O)	<ol style="list-style-type: none"> 1. If there is an error indication in any secondary I/O drawer operator panel, follow the repair action for that error indication. 2. Go to "MAP 1540: Minimum Configuration" on page 113 to isolate the failing I/O drawer, then isolate the failure within that drawer.
20FB 0030	Failure to read I/O drawer SPCN address	<ol style="list-style-type: none"> 1. Check RIO cable connections 2. Check for system firmware update 3. Replace RIO card assembly 4. Replace I/O backplane if not already replaced (location code indicates which drawer)
20FB 0031	Failure to read I/O drawer SPCN address	<ol style="list-style-type: none"> 1. Check RIO cable connections 2. Check for system firmware update 3. Replace RIO card assembly 4. Replace I/O backplane if not already replaced (location code indicates which drawer)
20FB 0032	Failure to read I/O drawer SPCN address	<ol style="list-style-type: none"> 1. Check RIO cable connections 2. Check for system firmware update 3. Replace RIO card assembly 4. Replace I/O backplane if not already replaced (location code indicates which drawer)

Table 5. Firmware Error Codes. (continued)

Error Code	Description	Action/ Possible Failing FRU
20FB 003A	Failure to read I/O drawer SPCN address	<ol style="list-style-type: none"> 1. Check RIO cable connections 2. Check for system firmware update 3. Replace RIO card assembly 4. Replace I/O backplane if not already replaced (location code indicates which drawer)
20FB 0040	Failed to match SPCN address to SPCN node entry address.	<ol style="list-style-type: none"> 1. Check RIO cable connections 2. Check for system firmware update 3. Replace RIO card assembly 4. Replace I/O backplane if not already replaced (location code indicates which drawer)
20FB 0050	Service processor mailbox failed to update SPCN configuration table.	<ol style="list-style-type: none"> 1. Check RIO cable connections 2. Check for service processor firmware update 3. Replace primary I/O drawer backplane Location: U0.1-P1
20FB 99xy	The number of I/O drawers reported by RIO does not match the number of I/O drawers reported by SPCN, where x is the number of drawers reported by RIO and y is the number of drawers reported by SPCN. This error code should cause the system to hang.	<ol style="list-style-type: none"> 1. Check RIO and SPCN cabling. 2. If there is an error code displayed by any of the secondary I/O drawers, perform the actions for that error code. 3. If there is no error code displayed by any of the secondary I/O drawers, examine the service processor error logs to obtain an error code. 4. RIO Bus Adapter Location: U0.2-P1.1 5. Secondary I/O Backplane Location: U0.2-P1
20FC 0xxx	Retrieving power, package, cooling VPD via SPCN for the CEC and I/O drawers	
20FC 0010	Failed to match RIO addressing with SPCN node entry address.	Replace I/O backplane if not already replaced (location code indicates which drawer)

Table 5. Firmware Error Codes. (continued)

Error Code	Description	Action/ Possible Failing FRU
20FC 0020	Failed to retrieve power, package, cooling VPD via SPCN for the corresponding drawer. Service processor mailbox failed to get VPD	<ol style="list-style-type: none"> 1. Check RIO cable connection 2. Check for service processor firmware update 3. Replace corresponding I/O backplane (location code indicates which drawer) 4. Replace primary I/O backplane if not already replaced Location: U0.1-P1
20FC 0021	Failed to retrieve power, package, cooling VPD via SPCN. Service processor mailbox failed to get power, packaging, and cooling device VPD	<ol style="list-style-type: none"> 1. Check for service processor firmware update 2. Replace primary I/O backplane Location: U0.1-P1
20FC 0030	Corrupted power, packaging, and cooling device VPD format in the SPCN configuration table.	<ol style="list-style-type: none"> 1. Check for system firmware update 2. Replace the I/O backplane (location code indicates which drawer)

Table 5. Firmware Error Codes. (continued)

Error Code	Description	Action/ Possible Failing FRU
2100 0001	Unsupported SCSI bus mode	<p>Before replacing any system components, refer to the notes in error code 21A0 0xxx.</p> <ol style="list-style-type: none"> 1. Disconnect the SCSI cable from the SCSI controller the location code identifies and reboot the system. 2. If the error code persists, replace the SCSI controller (or I/O planar if SCSI controller is integrated). 3. Reconnect the SCSI cable disconnected in step 1, and remove all the SCSI devices attached to the cable and reboot the system. 4. If the error code persists, replace the SCSI cable. 5. One at a time, reconnect the SCSI devices disconnected in step 3. If the error code returns, replace the last SCSI device you reconnected. <p>If all SCSI devices have been reattached and the error code has not been returned, there may have been a bad connection. Go to "MAP 410: Repair Checkout" in the <i>RS/6000 and @server pSeries Diagnostics Information for Multiple Bus Systems</i>.</p>

Table 5. Firmware Error Codes. (continued)

Error Code	Description	Action/ Possible Failing FRU
2100 0002	Unsupported SCSI bus mode - high voltage differential	<p>Before replacing any system components, refer to the notes in error code 21A0 0xxx.</p> <ol style="list-style-type: none"> 1. Disconnect the SCSI cable from the SCSI controller the location code identifies and reboot the system. 2. If the error code persists, replace the SCSI controller (or I/O planar if SCSI controller is integrated). 3. Reconnect the SCSI cable disconnected in step 1, and remove all the SCSI devices attached to the cable and reboot the system. 4. If the error code persists, replace the SCSI cable. 5. One at a time, reconnect the SCSI devices disconnected in step 3. If the error code returns, replace the last SCSI device you reconnected. <p>If all SCSI devices have been reattached and the error code has not been returned, there may have been a bad connection. Go to "MAP 410: Repair Checkout" in the <i>RS/6000 and @server pSeries Diagnostics Information for Multiple Bus Systems</i>.</p>

Table 5. Firmware Error Codes. (continued)

Error Code	Description	Action/ Possible Failing FRU
2100 0004	Cannot determine SCSI bus mode	<p>Before replacing any system components, refer to the notes in error code 21A0 0xxx.</p> <ol style="list-style-type: none"> 1. Disconnect the SCSI cable from the SCSI controller the location code identifies and reboot the system. 2. If the error code persists, replace the SCSI controller (or I/O planar if SCSI controller is integrated). 3. Reconnect the SCSI cable disconnected in step 1, and remove all the SCSI devices attached to the cable and reboot the system. 4. If the error code persists, replace the SCSI cable. 5. One at a time, reconnect the SCSI devices disconnected in step 3. If the error code returns, replace the last SCSI device you reconnected. <p>If all SCSI devices have been reattached and the error code has not been returned, there may have been a bad connection. Go to "MAP 410: Repair Checkout" in the <i>RS/6000 and @server pSeries Diagnostics Information for Multiple Bus Systems</i>.</p>

Table 5. Firmware Error Codes. (continued)

Error Code	Description	Action/ Possible Failing FRU
21A0 0001	SCSI DASD - test unit ready failed - hardware error	<p>Note:</p> <ol style="list-style-type: none"> 1. Before replacing any system components: <ol style="list-style-type: none"> a. Ensure that the controller and each device on the SCSI bus is assigned a unique SCSI ID. b. Ensure SCSI bus is properly terminated. c. Ensure SCSI signal and power cables are securely connected and not damaged. 2. The location code information is required to identify the ID of SCSI device failures as well as to indicate the location of the controller to which the device is attached. Check the system error logs to determine the location code information associated with the error code. <ol style="list-style-type: none"> a. Replace the SCSI device. b. Replace the SCSI cable. c. Replace the SCSI controller.
21A0 0002	SCSI DASD - test unit ready failed - sense data available	<p>Before replacing any system components, refer to the notes in error code 21A0 0001.</p> <ol style="list-style-type: none"> 1. Replace the media (removable media devices). 2. Replace the SCSI device.
21A0 0003	SCSI DASD - send diagnostic failed - sense data available	<p>Before replacing any system components, refer to the notes in error code 21A0 0001.</p> <p>Replace the SCSI device.</p>
21A0 0004	SCSI DASD - send diagnostic failed - DevOfI cmd	<p>Before replacing any system components, refer to the notes in error code 21A0 0001.</p> <p>Replace the SCSI device.</p>
21E0 0001	SCSI tape - test unit ready failed - hardware error	<p>Before replacing any system components, refer to the notes in error code 21A0 0001.</p> <ol style="list-style-type: none"> 1. Replace the SCSI device. 2. Replace the SCSI cable. 3. Replace the SCSI controller.

Table 5. Firmware Error Codes. (continued)

Error Code	Description	Action/ Possible Failing FRU
21E0 0002	SCSI tape - test unit ready failed - sense data available	Before replacing any system components, refer to the notes in error code 21A0 0001. 1. Replace the media. 2. Replace the SCSI device.
21E0 0003	SCSI tape - send diagnostic failed - sense data available	Before replacing any system components, refer to the notes in error code 21A0 0001. Replace the SCSI device.
21E0 0004	SCSI tape - send diagnostic failed - DevOfI cmd	Before replacing any system components, refer to the notes in error code 21A0 0001. Replace the SCSI device.
21ED 0001	SCSI changer - test unit ready failed - hardware error	Before replacing any system components, refer to the notes in error code 21A0 0001. 1. Replace the SCSI device. 2. Replace the SCSI cable. 3. Replace the SCSI controller.
21ED 0002	SCSI changer - test unit ready failed - sense data available	Before replacing any system components, refer to the notes in error code 21A0 0001. 1. Replace the media. 2. Replace the SCSI device.
21ED 0003	SCSI changer - send diagnostic failed - sense data available	Before replacing any system components, refer to the notes in error code 21A0 0001. Replace the SCSI device.
21ED 0004	SCSI changer - send diagnostic failed - DevOfI cmd	Before replacing any system components, refer to the notes in error code 21A0 0001. Replace the SCSI device.
21EE 0001	Undetermined SCSI device type - test unit ready failed - hardware error	Before replacing any system components, refer to the notes in error code 21A0 0001. 1. Replace the SCSI device. 2. Replace the SCSI cable. 3. If the missing SCSI devices are connected to the same backplane, replace the SCSI backplane. 4. Replace the SCSI controller.

Table 5. Firmware Error Codes. (continued)

Error Code	Description	Action/ Possible Failing FRU
21EE 0002	Undetermined SCSI device type - test unit ready failed - sense data available	Before replacing any system components, refer to the notes in error code 21A0 0001. 1. Replace the media (removable media devices). 2. Replace the SCSI device.
21EE 0003	Undetermined SCSI device type - send diagnostic failed - sense data available	Before replacing any system components, refer to the notes in error code 21A0 0001. Replace the SCSI device.
21EE 0004	Undetermined SCSI device type - send diagnostic failed - DevOfI cmd	Before replacing any system components, refer to the notes in error code 21A0 0001. Replace the SCSI device.
21F0 0001	SCSI CD-ROM - test unit ready failed - hardware error	Before replacing any system components, refer to the notes in error code 21A0 0001. 1. Replace the SCSI device. 2. Replace the SCSI cable. 3. Replace the SCSI controller.
21F0 0002	SCSI CD-ROM - test unit ready failed - sense data available	Before replacing any system components, refer to the notes in error code 21A0 0001. 1. Replace the media. 2. Replace the SCSI device.
21F0 0003	SCSI CD-ROM - send diagnostic failed - sense data available	Before replacing any system components, refer to the notes in error code 21A0 0001. Replace the SCSI device.
21F0 0004	SCSI CD-ROM - send diagnostic failed - DevOfI cmd	Before replacing any system components, refer to the notes in error code 21A0 0001. Replace the SCSI device.
21F2 0001	SCSI read/write optical - test unit ready failed - hardware error	Before replacing any system components, refer to the notes in error code 21A0 0001. 1. Replace the SCSI device. 2. Replace the SCSI cable. 3. Replace the SCSI controller.
21F2 0002	SCSI read/write optical - test unit ready failed - sense data available	Before replacing any system components, refer to the notes in error code 21A0 0001. 1. Replace the media. 2. Replace the SCSI device.

Table 5. Firmware Error Codes. (continued)

Error Code	Description	Action/ Possible Failing FRU
21F2 0003	SCSI read/write optical - send diagnostic failed- sense data available	Before replacing any system components, refer to the notes in error code 21A0 0001. Replace the SCSI device.
21F2 0004	SCSI read/write optical - send diagnostic failed- DevOfI cmd	Before replacing any system components, refer to the notes in error code 21A0 0001. Replace the SCSI device.
2200 0001	PCI Ethernet BNC/RJ-45 or PCI Ethernet AUI/RJ-45 Adapter internal wrap test failure	Replace the adapter. See "Checkpoint and Error Code Index" on page 165 for location code information related to this error. Also see "Replacing the Network Adapter" on page 163.
2200 1001	10/100 Mbps Ethernet PCI Adapter internal wrap test failure	Replace the adapter. See "Checkpoint and Error Code Index" on page 165 for location code information related to this error. Also see "Replacing the Network Adapter" on page 163.
2201 0001	PCI Auto LANstreamer token ring adapter Adapter failed to complete hardware initialization.	Replace the adapter. See "Checkpoint and Error Code Index" on page 165 for location code information related to this error. Also see "Replacing the Network Adapter" on page 163.
2201 1001	PCI token ring adapter Adapter failed to complete hardware initialization.	Replace the adapter. See "Checkpoint and Error Code Index" on page 165 for location code information related to this error. Also see "Replacing the Network Adapter" on page 163.
25A0 0001	Cache L2 controller failure	1. Replace the processor card. Location: U1.1-P1-C1 2. Replace the CEC backplane assembly. Location: U1.1-P1.
25A1 0001	Cache L2 SRAM failure	1. Replace the processor card. Location: U1.1-P1-C1

Table 5. Firmware Error Codes. (continued)

Error Code	Description	Action/ Possible Failing FRU
25A8 0xxx	NVRAM problems	<p>Errors reported against NVRAM can be caused by low battery voltage and (more rarely) power outages that occur during normal system usage. With the exception of the 25A80000 error, these errors are warnings that the NVRAM data content had to be re-established and do not require any FRU replacement unless the error is persistent. When one of these errors occurs, any system customization (for example, boot device list) information has been lost, the system may need to be reconfigured.</p> <p>If the error is persistent, replace primary I/O backplane Location: U0.1-P1</p>
25A8 0000	Initialization failed, device test failed	Refer to Action under error code 25A80xxx.
25A8 0001	Init-NVRAM invoked, all of NVRAM initialized	Refer to Action under error code 25A80xxx.
25A8 0002	Init-NVRAM invoked, some data partitions may have been preserved.	Refer to Action under error code 25A80xxx.
25A8 0011	Data corruption detected, all of NVRAM initialized	Refer to Action under error code 25A80xxx.
25A8 0012	Data corruption detected, some data partitions may have been preserved.	Refer to Action under error code 25A80xxx.
25A8 0100	NVRAM data validation check failed.	<p>Turn off, turn on system unit and retry the operation before replacing any system component.</p> <p>Refer to Action under error code 25A80xxx.</p>
25A8 0201	Unable to expand target partition - saving configuration variable.	Refer to Action under error code 25A80xxx.
25A8 0202	Unable to expand target partition - writing error log entry.	Refer to Action under error code 25A80xxx.
25A8 0203	Unable to expand target partition - writing VPD data.	Refer to Action under error code 25A80xxx.
25A8 0210	Setenv/\$Setenv parameter error - name contains a null character.	Refer to Action under error code 25A80xxx.
25A8 0211	Setenv/\$Setenv parameter error - value contains a null character.	Refer to Action under error code 25A80xxx.

Table 5. Firmware Error Codes. (continued)

Error Code	Description	Action/ Possible Failing FRU
25A8 0998	NVRAMRC script evaluation error - command line execution error	<p>Execution of a command line within the nvram configuration variable “nvramrc” (script) resulted in a “throw” being executed. This script can be modified by the system firmware SMS utilities, the operating system, PCI adapter ROM code or utility, or an operator (via the open firmware script editing command nvedit). It may not be possible to resolve the problem without a detailed analysis of the nvram script, the current system configuration, and device tree contents.</p> <ol style="list-style-type: none"> 1. The problem can be caused by a SCSI adapter, whose SCSI bus ID has been changed from the default setting, no longer appearing in the system. This can be caused either by removing a SCSI adapter, or a problem with a SCSI adapter. <ol style="list-style-type: none"> a. Select the SCSI ID utility from the SMS menu(s). <ol style="list-style-type: none"> 1) Verify the list of SCSI controllers/adapters. If the list is not correct, suspect a problem with the adapter(s) installed but not listed. 2) Select the option to Save the configuration information. 3) Restart the system. b. If the problem persists, boot the operating system and verify the SCSI bus IDs of any installed/available SCSI controllers (change as necessary), and restart the system. 2. Contact your support representative for further assistance.
25A8 0999	NVRAMRC script evaluation error - stack unbalanced on completion	This is a firmware debug environment error. There is no user action or FRU replacement for this error.

Table 5. Firmware Error Codes. (continued)

Error Code	Description	Action/ Possible Failing FRU
25Cy y001	DIMM is not supported	<p>Replace unsupported DIMM(s). Note that DIMMs are in groups (2, 4, 8, 16 or 32 DIMMs) but you may only receive an error for a single DIMM. Verify that all DIMMs in the group containing the specified DIMM are of the same type and size.</p> <p>yy describes the DIMM as follows:</p> <p>00 Unrecognized/unsupported DIMM</p> <p>28 512MB DIMM</p> <p>38 128MB DIMM</p> <p>58 32MB DIMM</p> <p>68 256MB DIMM</p> <p>78 1GB memory DIMM</p> <p>Note: Refer to “System Memory” on page 26 for DIMM configuration rules. A DIMM must be replaced with a supported type of DIMM, and all DIMMs in a group must be of the same size.</p> <p>Check the system error logs to determine the location code associated with the error code. Consult the “AIX and Physical Location Code Reference Tables” on page 36 to locate the DIMM and the rest of its group.</p>

Table 5. Firmware Error Codes. (continued)

Error Code	Description	Action/ Possible Failing FRU
25Cy y002	DIMM failure	<p>If one DIMM is called out:</p> <ol style="list-style-type: none"> 1. Replace the DIMM. 2. Replace the DIMM group. 3. Replace the memory riser card. <p>If more than one DIMM is called out, go to the Memory Configuration/Deconfiguration menu, which is under the System Information Menu on the main service processor menu:</p> <ol style="list-style-type: none"> 1. From the memory configuration/deconfiguration menu, select the card(s) specified by the location code(s) of the failing DIMM(s). If the first character of the error status of any DIMM is 1, 2, or 3 (but not 0 or 4), this is a suspect DIMM. Record its location. See "System Information Menu" on page 382 for more information on the error status of DIMMs. 2. If only one DIMM was recorded in step 1: <ol style="list-style-type: none"> a. Replace DIMM b. Replace the DIMM group c. Replace the memory riser card 3. If more than one DIMM was recorded in step 1 and the DIMMs reside in more than one group: <ol style="list-style-type: none"> a. Replace the memory riser card b. Replace all failing DIMMs 4. If more than 1 DIMM was recorded in step 1 and they reside in one group: <ol style="list-style-type: none"> a. Replace all failing DIMMs b. Replace the DIMM group c. Replace the memory riser card

Table 5. Firmware Error Codes. (continued)

Error Code	Description	Action/ Possible Failing FRU
2602 0001	Invalid PCI adapter vendor ID	<ol style="list-style-type: none"> 1. Move adapter to another slot (behind a different PCI bus). 2. Check for available firmware updates for adapter. Apply update if available. 3. Run AIX diagnostics on adapter. Replace if indicated. 4. Replace adapter. 5. Check for system firmware updates. Apply if update available. 6. Replace primary I/O backplane Location: U0.1-P1
2602 0002	Invalid PCI adapter device ID	<ol style="list-style-type: none"> 1. Move adapter to another slot (behind a different PCI bus). 2. Check for available firmware updates for adapter. Apply update if available. 3. Run AIX diagnostics on adapter. Replace if indicated. 4. Replace adapter. 5. Check for system firmware updates. Apply if update available. 6. Replace primary I/O backplane Location: U0.1-P1
2602 0003	Invalid PCI adapter class code	<ol style="list-style-type: none"> 1. Move adapter to another slot (behind a different PCI bus). 2. Check for available firmware updates for adapter. Apply update if available. 3. Run AIX diagnostics on adapter. Replace if indicated. 4. Replace adapter. 5. Check for system firmware updates. Apply if update available. 6. Replace primary I/O backplane Location: U0.1-P1

Table 5. Firmware Error Codes. (continued)

Error Code	Description	Action/ Possible Failing FRU
2602 0007	Failed to allocate bus resources to PCI adapter	<ol style="list-style-type: none"> 1. Move adapter to another slot (behind a different PCI bus). 2. Check for available firmware updates for adapter. Apply update if available. 3. Run AIX diagnostics on adapter. Replace if indicated. 4. Replace adapter. 5. Check for system firmware updates. Apply if update available. 6. Replace primary I/O backplane Location: U0.1-P1
2680 0Axy	MX-PCI bridge BIST Failure	<p>The problem is associated with bridge "y" in I/O drawer "x."</p> <p>Replace I/O backplane in I/O drawer "x". Location: U0.x-P1</p> <p>See "AIX and Physical Location Code Tables" in Chapter 1 for location codes.</p>
2680 0Cxx	Machine check occurred	<ol style="list-style-type: none"> 1. Replace the part identified by the location code associated with this error code. 2. If the location code associated with this error code identifies an adapter, and replacing the adapter does not correct the problem, replace primary I/O backplane Location: U0.1-P1

Table 5. Firmware Error Codes. (continued)

Error Code	Description	Action/ Possible Failing FRU
2803 0001	RTC not updating - RTC initialization required	<p>Errors reported against the real-time clock can be caused by low battery voltage and (more rarely) power outages that occur during normal system usage. These errors are warnings that the real-time clock data content needs to be re-established and do not require any FRU replacement unless the error is persistent. When one of these errors occurs, the time and date information has been lost.</p> <p>To set/restore the time and date, use the operating system facility.</p> <p>If the error is persistent:</p> <ol style="list-style-type: none"> 1. Replace the battery. 2. Replace primary I/O backplane Location: U0.1-P1
2803 0002	Bad time/date values	<ol style="list-style-type: none"> 1. Set time and date. 2. Refer to Action under error code 28030001.
2803 0003	RTC not updating - not correctable	<p>Replace primary I/O backplane Location: U0.1-P1</p>
2803 0004	RTC operating mode parameters (eg. data mode) changed	<ol style="list-style-type: none"> 1. Set time and date. 2. Refer to Action under error code 28030001.
2803 0005	RTC battery error	<ol style="list-style-type: none"> 1. Replace the battery. Note: Password, time, and date need to be set. 2. Refer to Action under error code 28030001.
2900 0002	Keyboard/mouse controller failed self-test	<p>Replace primary I/O backplane Location: U0.1-P1</p>
29A0 0003	Keyboard not present/detected	<ol style="list-style-type: none"> 1. Keyboard 2. Keyboard cable 3. Replace primary I/O backplane Location: U0.1-P1
29A0 0004	Keyboard stuck key detected	<ol style="list-style-type: none"> 1. Keyboard 2. Replace primary I/O backplane Location: U0.1-P1
29B0 0004	Mouse not present/detected	<ol style="list-style-type: none"> 1. Mouse 2. Replace primary I/O backplane Location: U0.1-P1

Table 5. Firmware Error Codes. (continued)

Error Code	Description	Action/ Possible Failing FRU
2B2x xx11	Processor is manually disabled	Use the service processor menus to re-enable the processor and reboot the system
2B20 0022	Processor is deconfigured by the system	1. Replace the processor card. Location: U1.1-P1-C1 2. CEC backplane Location: U1.1-P1
2B2x xx31	Processor is failing POST	Replace the processor card. Location: U1.1-P1-C1
2B20 0031	Processor is failing POST or is manually disabled.	1. If the processor is not enabled, then use the service processor menus to enable the processor. Then reboot the system. 2. If the processor is failing POST, then replace the processor card at the location specified in the error log. Location: U1.1-P1-C1
2B20 0042	Unknown processor card	Remove the unknown processor card.
2BA00000	Service processor POST failure	Replace primary I/O backplane Location: U0.1-P1
2BA0 0012	Service processor reports self test failure	Replace primary I/O backplane Location: U0.1-P1
2BA0 0013	Service processor reports bad NVRAM CRC	If problem persists, replace primary I/O backplane Location: U0.1-P1
2BA0 0017	Service processor reports bad or low battery.	1. Replace the battery. 2. Replace primary I/O backplane Location: U0.1-P1
2BA0 0041	Service processor VPD is corrupted.	Replace primary I/O backplane Location: U0.1-P1
2BA0 0080	Service processor reports memory riser card VPD module not present.	Replace memory card (s).
2BA0 0081	VPD data corrupted for memory riser card in slot 0.	Replace memory card in slot 0.
2BA0 0083	VPD data corrupted for memory riser card in slot 1.	Replace memory card in slot 1.

Service Processor Error Codes

Attention: Follow the procedure defined in the “Checkpoint and Error Code Index” on page 165. If you replace FRUs or perform an action and the problem is still not corrected, go to “MAP 1540: Minimum Configuration” on page 113 unless otherwise indicated in the tables.

If you replace FRUs and the problem is corrected, go to “MAP 410: Repair Checkout” in the *RS/6000 and @server pSeries Diagnostics Information for Multiple Bus Systems*.

Table 6. Service Processor Error Codes.

Error Code	Description	Action/ Possible Failing FRU
4066 0001	Scan interface basic assurance tests detected CEC backplane fault	CEC backplane Location: U1.1-P1
4066 0003	Scan interface basic assurance tests detected processor fault	1. Verify loose or defective JTAG cable or connector. 2. All processors Location: U1.1-P1-C1
4066 0009	Scan interface basic assurance tests detected memory fault	All memory Location: U1.1-P1-C1 U1.1-P1-M1 U1.1-P1-M2. Go to “MAP 1540: Minimum Configuration” on page 113 and run CEC drawer minimum configuration to isolate the failing memory component.
4066 00A0	Scan interface basic assurance tests detected service processor firmware fault	Update system firmware
4066 00A1	Scan interface basic assurance tests detected system firmware fault	1. Check for AIX updates 2. Check for system firmware update
4066 00A2	Scan interface basic assurance tests detected service processor firmware (processor runtime diagnostics) fault	Check for system firmware update
4066 00A3	Scan interface basic assurance tests detected memory plugging fault	All pluggable memory. Go to “MAP 1540: Minimum Configuration” on page 113 and run CEC drawer minimum configuration to isolate the failing memory component.
4066 00A4	Scan interface basic assurance tests detected application caused fault	Application software
4066 00A5	Scan interface basic assurance tests detected invalid system configuration	Verify system components are supported and properly installed

Table 6. Service Processor Error Codes. (continued)

Error Code	Description	Action/ Possible Failing FRU
4066 00A6	Scan interface basic assurance tests detected no usable memory	<ol style="list-style-type: none"> 1. Ensure that memory DIMMS and cards are properly installed 2. Go to service processor Memory Configuration/Deconfiguration menu to verify memory DIMMs state. See "Memory Configuration/Deconfiguration Menu" on page 384 for more information. 3. Go to "MAP 1540: Minimum Configuration" on page 113.
4066 00A7	Scan interface basic assurance tests detected hardware problem	Go to "MAP 1540: Minimum Configuration" on page 113.
4066 00B0	Scan interface basic assurance tests detected bus controller lock-unlock failure	RIO adapter Location: U0.1-P1.1
4066 00B1	Scan interface basic assurance tests detected bus controller failure	RIO adapter Location: U0.1-P1.1
4066 00B7	Scan interface basic assurance tests detected insufficient hardware resources to continue IPL	This error code appears after the initial testing by the service processor firmware on the CEC was completed correctly, but a problem occurred when the firmware tried to communicate outside the CEC. Suspect a problem with the RIO interface, either cables or adapters.
4066 0100	Scan interface basic assurance tests detected memory riser card fault	Memory riser card Location: U1.1-P1-M2
4066 0101	Scan interface basic assurance tests detected memory DIMM fault	Memory DIMM Location: U1.1-P1-M2.15
4066 0102	Scan interface basic assurance tests detected memory DIMM fault	Memory DIMM Location: U1.1-P1-M2.1
4066 0103	Scan interface basic assurance tests detected memory DIMM fault	Memory DIMM Location: U1.1-P1-M2.16
4066 0104	Scan interface basic assurance tests detected memory DIMM fault	Memory DIMM Location: U1.1-P1-M2.2
4066 010D	Scan interface basic assurance tests detected memory DIMM fault	Memory DIMM Location: U1.1-P1-M2.1 x4
4066 0111	Scan interface basic assurance tests detected memory DIMM fault	Memory DIMM Location: U1.1-P1-M2.13
4066 0112	Scan interface basic assurance tests detected memory DIMM fault	Memory DIMM Location: U1.1-P1-M2.3
4066 0113	Scan interface basic assurance tests detected memory DIMM fault	Memory DIMM Location: U1.1-P1-M2.14

Table 6. Service Processor Error Codes. (continued)

Error Code	Description	Action/ Possible Failing FRU
4066 0114	Scan interface basic assurance tests detected memory DIMM fault	Memory DIMM Location: U1.1-P1-M2.4
4066 011D	Scan interface basic assurance tests detected memory DIMM fault	Memory DIMM Location: U1.1-P1-M2.3 x4
4066 0121	Scan interface basic assurance tests detected memory DIMM fault	Memory DIMM Location: U1.1-P1-M2.11
4066 0122	Scan interface basic assurance tests detected memory DIMM fault	Memory DIMM Location: U1.1-P1-M2.5
4066 0123	Scan interface basic assurance tests detected memory DIMM fault	Memory DIMM Location: U1.1-P1-M2.12
4066 0124	Scan interface basic assurance tests detected memory DIMM fault	Memory DIMM Location: U1.1-P1-M2.6
4066 012D	Scan interface basic assurance tests detected memory DIMM fault	Memory DIMM Location: U1.1-P1-M2.5 x4
4066 0131	Scan interface basic assurance tests detected memory DIMM fault	Memory DIMM Location: U1.1-P1-M2.9
4066 0132	Scan interface basic assurance tests detected memory DIMM fault	Memory DIMM Location: U1.1-P1-M2.7
4066 0133	Scan interface basic assurance tests detected memory DIMM fault	Memory DIMM Location: U1.1-P1-M2.10
4066 0134	Scan interface basic assurance tests detected memory DIMM fault	Memory DIMM Location: U1.1-P1-M2.8
4066 013D	Scan interface basic assurance tests detected memory DIMM fault	Memory DIMM Location: U1.1-P1-M2.7 x4
4066 01FF	Scan interface basic assurance tests detected memory on riser card fault	Memory failure on riser card 2 that cannot be automatically isolated. Go to "MAP 1540: Minimum Configuration" on page 113, and run CEC drawer minimum configuration for further isolation.
4066 0200	Scan interface basic assurance tests detected memory riser card fault	Memory riser card Location: U1.1-P1-M1
4066 0201	Scan interface basic assurance tests detected memory DIMM fault	Memory DIMM Location: U1.1-P1-M1.15
4066 0202	Scan interface basic assurance tests detected memory DIMM fault	Memory DIMM Location: U1.1-P1-M1.1
4066 0203	Scan interface basic assurance tests detected memory DIMM fault	Memory DIMM Location: U1.1-P1-M1.16
4066 0204	Scan interface basic assurance tests detected memory DIMM fault	Memory DIMM Location: U1.1-P1-M1.2
4066 020D	Scan interface basic assurance tests detected memory DIMM fault	Memory DIMM Location: U1.1-P1-M1.1 x4

Table 6. Service Processor Error Codes. (continued)

Error Code	Description	Action/ Possible Failing FRU
4066 020E	Scan interface basic assurance tests detected memory pair A fault	Memory Pair A Location: U1.1-P1-M1.1 x2
4066 0211	Scan interface basic assurance tests detected memory DIMM fault	Memory DIMM Location: U1.1-P1-M1.13
4066 0212	Scan interface basic assurance tests detected memory DIMM fault	Memory DIMM Location: U1.1-P1-M1.3
4066 0213	Scan interface basic assurance tests detected memory DIMM fault	Memory DIMM Location: U1.1-P1-M1.14
4066 0214	Scan interface basic assurance tests detected memory DIMM fault	Memory DIMM Location: U1.1-P1-M1.4
4066 021D	Scan interface basic assurance tests detected memory DIMM fault	Memory DIMM Location: U1.1-P1-M1.3 x4
4066 0221	Scan interface basic assurance tests detected memory DIMM fault	Memory DIMM Location: U1.1-P1-M1.11
4066 0222	Scan interface basic assurance tests detected memory DIMM fault	Memory DIMM Location: U1.1-P1-M1.5
4066 0223	Scan interface basic assurance tests detected memory DIMM fault	Memory DIMM Location: U1.1-P1-M1.12
4066 0224	Scan interface basic assurance tests detected memory DIMM fault	Memory DIMM Location: U1.1-P1-M1.6
4066 022D	Scan interface basic assurance tests detected memory DIMM fault	Memory DIMM Location: U1.1-P1-M1.5 x4
4066 022D	Scan interface basic assurance tests detected memory DIMM fault	Memory DIMM Location: U1.1-P1-M1.5 x4
4066 0231	Scan interface basic assurance tests detected memory DIMM fault	Memory DIMM Location: U1.1-P1-M1.9
4066 0232	Scan interface basic assurance tests detected memory DIMM fault	Memory DIMM Location: U1.1-P1-M1.7
4066 0233	Scan interface basic assurance tests detected memory DIMM fault	Memory DIMM Location: U1.1-P1-M1.10
4066 0234	Scan interface basic assurance tests detected memory DIMM fault	Memory DIMM Location: U1.1-P1-M1.8
4066 023D	Scan interface basic assurance tests detected memory DIMM fault	Memory DIMM Location: U1.1-P1-M1.7 x4
4066 02FF	Scan interface basic assurance tests detected memory on riser card fault	Memory failure on riser card 1 that cannot be automatically isolated. Go to "MAP 1540: Minimum Configuration" on page 113, and run CEC drawer minimum configuration for further isolation.
4066 0300	Scan interface basic assurance tests detected processor card fault	Processor card Location: U1.1-P1-C1

Table 6. Service Processor Error Codes. (continued)

Error Code	Description	Action/ Possible Failing FRU
4066 0301	Scan interface basic assurance tests detected memory DIMM fault	Memory DIMM Location: U1.1-P1-C1-M8
4066 0302	Scan interface basic assurance tests detected memory DIMM fault	Memory DIMM Location: U1.1-P1-C1-M1
4066 030D	Scan interface basic assurance tests detected memory DIMM fault	Memory DIMM Location: U1.1-P1-C1-M1 x2
4066 0311	Scan interface basic assurance tests detected memory DIMM fault	Memory DIMM Location: U1.1-P1-C1-M7
4066 0312	Scan interface basic assurance tests detected memory DIMM fault	Memory DIMM Location: U1.1-P1-C1-M2
4066 031D	Scan interface basic assurance tests detected memory DIMM fault	Memory DIMM Location: U1.1-P1-C1-M2 x2
4066 0321	Scan interface basic assurance tests detected memory DIMM fault	Memory DIMM Location: U1.1-P1-C1-M6
4066 0322	Scan interface basic assurance tests detected memory DIMM fault	Memory DIMM Location: U1.1-P1-C1-M3
4066 032D	Scan interface basic assurance tests detected memory DIMM fault	Memory DIMM Location: U1.1-P1-C1-M3 x2
4066 0331	Scan interface basic assurance tests detected memory DIMM fault	Memory DIMM Location: U1.1-P1-C1-M5
4066 0332	Scan interface basic assurance tests detected memory DIMM fault	Memory DIMM Location: U1.1-P1-C1-M4
4066 033D	Scan interface basic assurance tests detected memory DIMM fault	Memory DIMM Location: U1.1-P1-C1-M4 x2
4066 03FF	Scan interface basic assurance tests detected memory on processor card fault	Memory failure on processor card that cannot be automatically isolated. Go to "MAP 1540: Minimum Configuration" on page 113, and run CEC drawer minimum configuration for further isolation.
4066 3101	Scan interface basic assurance tests detected RIO port 0 fault	1. Processor card Location: U1.1-P1-C1 2. CEC drawer backplane Location: U1.1-P1
4066 3102	Scan interface basic assurance tests detected RIO port 1 fault	1. Processor card Location: U1.1-P1-C1 2. CEC drawer backplane Location: U1.1-P1
4066 3121	Scan interface basic assurance tests detected RIO cable on port 0 fault	RIO cable on port 0 Location: U1.1-P1/Q3
4066 3122	Scan interface basic assurance tests detected RIO cable on port 1 fault	RIO cable on port 1 Location: U1.1-P1/Q2

Table 6. Service Processor Error Codes. (continued)

Error Code	Description	Action/ Possible Failing FRU
4066 31FF	Scan interface basic assurance tests detected RIO port fault	Processor card Location: U1.1-P1-C1
4066 3200	Scan interface basic assurance tests detected primary I/O drawer fault	Go to "MAP 1540: Minimum Configuration" on page 113.
4066 3201	Scan interface basic assurance tests detected primary I/O backplane fault	Primary I/O backplane Location: U0.1-P1
4066 3280	Scan interface basic assurance tests detected primary RIO adapter fault	Primary RIO adapter Location: U0.1-P1.1
4066 3281	Scan interface basic assurance tests detected primary RIO port 0 fault	1. Check RIO cable Location: U0.1-P1.1/Q1 2. Primary RIO adapter Location: U0.1-P1.1
4066 3282	Scan interface basic assurance tests detected primary RIO port 1 fault	1. Check RIO cable Location: U0.1-P1.1/Q2 2. Primary RIO adapter Location: U0.1-P1.1
4066 3283	Scan interface basic assurance tests detected primary RIO ports fault	Primary RIO adapter Location: U0.1-P1.1
4066 3284	Scan interface basic assurance tests detected PCI controller PHB0 fault	1. RIO adapter Location: U0.1-P1.1 2. Primary I/O backplane Location: U0.1-P1
4066 3285	Scan interface basic assurance tests detected PCI controller PHB1 fault	1. RIO adapter Location: U0.1-P1.1 2. Primary I/O backplane Location: U0.1-P1
4066 3286	Scan interface basic assurance tests detected PCI controller PHB2 fault	1. RIO adapter Location: U0.1-P1.1 2. Primary I/O backplane Location: U0.1-P1
4067 0001	6xx bus processor runtime diagnostics detected CEC backplane fault	CEC backplane Location: U1.1-P1
4067 0003	6xx bus processor runtime diagnostics detected processor fault	All processors Location: U1.1-P1-C1
4067 0009	6xx bus processor runtime diagnostics detected memory fault	All memory Locations: U1.1-P1-C1 U1.1-P1-M1 U1.1-P1-M2. Go to "MAP 1540: Minimum Configuration" on page 113 and run CEC drawer minimum configuration to isolate the failing memory component.

Table 6. Service Processor Error Codes. (continued)

Error Code	Description	Action/ Possible Failing FRU
4067 00A0	6xx bus processor runtime diagnostics detected service processor firmware fault	Update system firmware
4067 00A1	6xx bus processor runtime diagnostics detected system firmware fault	<ol style="list-style-type: none"> 1. Check for AIX updates 2. Check for system firmware update
4067 00A2	6xx bus processor runtime diagnostics detected service processor firmware (processor runtime diagnostics) fault	Check for system firmware update
4067 00A3	6xx bus processor runtime diagnostics detected memory plugging fault	All pluggable memory. Go to "MAP 1540: Minimum Configuration" on page 113 and run CEC drawer minimum configuration to isolate the failing memory component.
4067 00A4	6xx bus processor runtime diagnostics detected application caused fault	Application software
4067 00A5	6xx bus processor runtime diagnostics detected invalid system configuration	Verify system components are supported and properly installed
4067 00A6	6xx bus processor runtime diagnostics detected no usable memory	<ol style="list-style-type: none"> 1. Ensure that memory DIMMS and cards are properly installed 2. Go to service processor memory configuration/deconfiguration menu to verify memory DIMMS state. See "Memory Configuration/Deconfiguration Menu" on page 384 for more information. 3. Go to "MAP 1540: Minimum Configuration" on page 113.
4067 00A7	6xx bus processor runtime diagnostics detected hardware problem	Go to "MAP 1540: Minimum Configuration" on page 113.
4067 00B0	6xx bus processor runtime diagnostics detected bus controller lock-unlock failure	RIO adapter Location: U0.1-P1.1
4067 00B1	6xx bus processor runtime diagnostics detected bus controller failure	RIO adapter Location: U0.1-P1.1

Table 6. Service Processor Error Codes. (continued)

Error Code	Description	Action/ Possible Failing FRU
4067 00B7	6xx bus processor runtime diagnostics detected insufficient hardware resources to continue IPL	This error code appears after the initial testing by the service processor firmware on the CEC was completed correctly, but a problem occurred when the firmware tried to communicate outside the CEC. Suspect a problem with the RIO interface, either cables or adapters.
4067 0100	6xx bus processor runtime diagnostics detected memory riser card fault	Memory riser card Location: U1.1-P1-M2
4067 0101	6xx bus processor runtime diagnostics detected memory DIMM fault	Memory DIMM Location: U1.1-P1-M2.15
4067 0102	6xx bus processor runtime diagnostics detected memory DIMM fault	Memory DIMM Location: U1.1-P1-M2.1
4067 0103	6xx bus processor runtime diagnostics detected memory DIMM fault	Memory DIMM Location: U1.1-P1-M2.16
4067 0104	6xx bus processor runtime diagnostics detected memory DIMM fault	Memory DIMM Location: U1.1-P1-M2.2
4067 010D	6xx bus processor runtime diagnostics detected memory DIMM fault	Memory DIMM Location: U1.1-P1-M2.1 x4
4067 0111	6xx bus processor runtime diagnostics detected memory DIMM fault	Memory DIMM Location: U1.1-P1-M2.13
4067 0112	6xx bus processor runtime diagnostics detected memory DIMM fault	Memory DIMM Location: U1.1-P1-M2.3
4067 0113	6xx bus processor runtime diagnostics detected memory DIMM fault	Memory DIMM Location: U1.1-P1-M2.14
4067 0114	6xx bus processor runtime diagnostics detected memory DIMM fault	Memory DIMM Location: U1.1-P1-M2.4
4067 011D	6xx bus processor runtime diagnostics detected memory DIMM fault	Memory DIMM Location: U1.1-P1-M2.3 x4
4067 0121	6xx bus processor runtime diagnostics detected memory DIMM fault	Memory DIMM Location: U1.1-P1-M2.11

Table 6. Service Processor Error Codes. (continued)

Error Code	Description	Action/ Possible Failing FRU
4067 0122	6xx bus processor runtime diagnostics detected memory DIMM fault	Memory DIMM Location: U1.1-P1-M2.5
4067 0123	6xx bus processor runtime diagnostics detected memory DIMM fault	Memory DIMM Location: U1.1-P1-M2.12
4067 0124	6xx bus processor runtime diagnostics detected memory DIMM fault	Memory DIMM Location: U1.1-P1-M2.6
4067 012D	6xx bus processor runtime diagnostics detected memory DIMM fault	Memory DIMM Location: U1.1-P1-M2.5 x4
4067 0131	6xx bus processor runtime diagnostics detected memory DIMM fault	Memory DIMM Location: U1.1-P1-M2.9
4067 0132	6xx bus processor runtime diagnostics detected memory DIMM fault	Memory DIMM Location: U1.1-P1-M2.7
4067 0133	6xx bus processor runtime diagnostics detected memory DIMM fault	Memory DIMM Location: U1.1-P1-M2.10
4067 0134	6xx bus processor runtime diagnostics detected memory DIMM fault	Memory DIMM Location: U1.1-P1-M2.8
4067 013D	6xx bus processor runtime diagnostics detected memory DIMM fault	Memory DIMM Location: U1.1-P1-M2.7 x4
4067 01FF	6xx bus processor runtime diagnostics detected memory on riser card fault	Memory failure on riser card 2 that cannot be automatically isolated. Go to "MAP 1540: Minimum Configuration" on page 113, and run CEC drawer minimum configuration for further isolation.
4067 0200	6xx bus processor runtime diagnostics detected memory riser card fault	Memory riser card Location: U1.1-P1-M1
4067 0201	6xx bus processor runtime diagnostics detected memory DIMM fault	Memory DIMM Location: U1.1-P1-M1.15
4067 0202	6xx bus processor runtime diagnostics detected memory DIMM fault	Memory DIMM Location: U1.1-P1-M1.1
4067 0203	6xx bus processor runtime diagnostics detected memory DIMM fault	Memory DIMM Location: U1.1-P1-M1.16

Table 6. Service Processor Error Codes. (continued)

Error Code	Description	Action/ Possible Failing FRU
4067 0204	6xx bus processor runtime diagnostics detected memory DIMM fault	Memory DIMM Location: U1.1-P1-M1.2
4067 020D	6xx bus processor runtime diagnostics detected memory DIMM fault	Memory DIMM Location: U1.1-P1-M1.1 x4
4067 020E	6xx bus processor runtime diagnostics detected memory pair A fault	Memory pair A Location: U1.1-P1-M1.1 x2
4067 0211	6xx bus processor runtime diagnostics detected memory DIMM fault	Memory DIMM Location: U1.1-P1-M1.13
4067 0212	6xx bus processor runtime diagnostics detected memory DIMM fault	Memory DIMM Location: U1.1-P1-M1.3
4067 0213	6xx bus processor runtime diagnostics detected memory DIMM fault	Memory DIMM Location: U1.1-P1-M1.14
4067 0214	6xx bus processor runtime diagnostics detected memory DIMM fault	Memory DIMM Location: U1.1-P1-M1.4
4067 021D	6xx bus processor runtime diagnostics detected memory DIMM fault	Memory DIMM Location: U1.1-P1-M1.3 x4
4067 0221	6xx bus processor runtime diagnostics detected memory DIMM fault	Memory DIMM Location: U1.1-P1-M1.11
4067 0222	6xx bus processor runtime diagnostics detected memory DIMM fault	Memory DIMM Location: U1.1-P1-M1.5
4067 0223	6xx bus processor runtime diagnostics detected memory DIMM fault	Memory DIMM Location: U1.1-P1-M1.12
4067 0224	6xx bus processor runtime diagnostics detected memory DIMM fault	Memory DIMM Location: U1.1-P1-M1.6
4067 022D	6xx bus processor runtime diagnostics detected memory DIMM fault	Memory DIMM Location: U1.1-P1-M1.5 x4
4067 0231	6xx bus processor runtime diagnostics detected memory DIMM fault	Memory DIMM Location: U1.1-P1-M1.9
4067 0232	6xx bus processor runtime diagnostics detected memory DIMM fault	Memory DIMM Location: U1.1-P1-M1.7

Table 6. Service Processor Error Codes. (continued)

Error Code	Description	Action/ Possible Failing FRU
4067 0233	6xx bus processor runtime diagnostics detected memory DIMM fault	Memory DIMM Location: U1.1-P1-M1.10
4067 0234	6xx bus processor runtime diagnostics detected memory DIMM fault	Memory DIMM Location: U1.1-P1-M1.8
4067 023D	6xx bus processor runtime diagnostics detected memory DIMM fault	Memory DIMM Location: U1.1-P1-M1.7 x4
4067 02FF	6xx bus processor runtime diagnostics detected memory on riser card fault	Memory failure on riser card 1 that cannot be automatically isolated. Go to "MAP 1540: Minimum Configuration" on page 113, and run CEC drawer minimum configuration for further isolation.
4067 0300	6xx bus processor runtime diagnostics detected processor card fault	Processor card Location: U1.1-P1-C1
4067 0301	6xx bus processor runtime diagnostics detected memory DIMM fault	Memory DIMM Location: U1.1-P1-C1-M8
4067 0302	6xx bus processor runtime diagnostics detected memory DIMM fault	Memory DIMM Location: U1.1-P1-C1-M1
4067 030D	6xx bus processor runtime diagnostics detected memory DIMM fault	Memory DIMM Location: U1.1-P1-C1-M1 x2
4067 0311	6xx bus processor runtime diagnostics detected memory DIMM fault	Memory DIMM Location: U1.1-P1-C1-M7
4067 0312	6xx bus processor runtime diagnostics detected memory DIMM fault	Memory DIMM Location: U1.1-P1-C1-M2
4067 031D	6xx bus processor runtime diagnostics detected memory DIMM fault	Memory DIMM Location: U1.1-P1-C1-M2 x2
4067 0321	6xx bus processor runtime diagnostics detected memory DIMM fault	Memory DIMM Location: U1.1-P1-C1-M6
4067 0322	6xx bus processor runtime diagnostics detected memory DIMM fault	Memory DIMM Location: U1.1-P1-C1-M3
4067 032D	6xx bus processor runtime diagnostics detected memory DIMM fault	Memory DIMM Location: U1.1-P1-C1-M3 x2

Table 6. Service Processor Error Codes. (continued)

Error Code	Description	Action/ Possible Failing FRU
4067 0331	6xx bus processor runtime diagnostics detected memory DIMM fault	Memory DIMM Location: U1.1-P1-C1-M5
4067 0332	6xx bus processor runtime diagnostics detected memory DIMM fault	Memory DIMM Location: U1.1-P1-C1-M4
4067 033D	6xx bus processor runtime diagnostics detected memory DIMM fault	Memory DIMM Location: U1.1-P1-C1-M4 x2
4067 03FF	6xx bus processor runtime diagnostics detected memory on processor card fault	Memory failure on processor card that cannot be automatically isolated. Go to "MAP 1540: Minimum Configuration" on page 113, and run CEC drawer minimum configuration for further isolation.
4067 3101	6xx bus processor runtime diagnostics detected RIO port 0 fault	1. Processor card Location: U1.1-P1-C1 2. CEC drawer backplane Location: U1.1-P1
4067 3102	6xx bus processor runtime diagnostics detected RIO port 1 fault	1. Processor card Location: U1.1-P1-C1 2. CEC drawer backplane Location: U1.1-P1
4067 3121	6xx bus processor runtime diagnostics detected RIO cable on port 0 fault	RIO cable on port 0 Location: U1.1-P1/Q3
4067 3122	6xx bus processor runtime diagnostics detected RIO cable on port 1 fault	RIO cable on port 1 Location: U1.1-P1/Q2
4067 31FF	6xx bus processor runtime diagnostics detected RIO port fault	Processor card Location: U1.1-P1-C1
4067 3200	6xx bus processor runtime diagnostics detected primary I/O drawer fault	Go to "MAP 1540: Minimum Configuration" on page 113.
4067 3201	6xx bus processor runtime diagnostics detected primary I/O backplane fault	Primary I/O backplane Location: U0.1-P1
4067 3280	6xx bus processor runtime diagnostics detected primary RIO adapter fault	Primary RIO adapter Location: U0.1-P1.1
4067 3281	6xx bus processor runtime diagnostics detected primary RIO port 0 fault	1. Check RIO cable Location: U0.1-P1.1/Q1 2. Primary RIO adapter Location: U0.1-P1.1

Table 6. Service Processor Error Codes. (continued)

Error Code	Description	Action/ Possible Failing FRU
4067 3282	6xx bus processor runtime diagnostics detected primary RIO port 1 fault	1. Check RIO cable Location: U0.1-P1.1/Q2 2. Primary RIO adapter Location: U0.1-P1.1
4067 3283	6xx bus processor runtime diagnostics detected primary RIO ports fault	Primary RIO adapter Location: U0.1-P1.1
4067 3284	6xx bus processor runtime diagnostics detected PCI controller PHB0 fault	1. RIO adapter Location: U0.1-P1.1 2. Primary I/O backplane Location: U0.1-P1
4067 3285	6xx bus processor runtime diagnostics detected PCI controller PHB1 fault	1. RIO adapter Location: U0.1-P1.1 2. Primary I/O backplane Location: U0.1-P1
4067 3286	6xx bus processor runtime diagnostics detected PCI controller PHB2 fault	1. RIO adapter Location: U0.1-P1.1 2. Primary I/O backplane Location: U0.1-P1
4068 0001	Other bus processor runtime diagnostics detected CEC backplane fault	CEC backplane Location: U1.1-P1
4068 0003	Other bus processor runtime diagnostics detected processor fault	All processors Location: U1.1-P1-C1
4068 0009	Other bus processor runtime diagnostics detected memory fault	All memory Locations: U1.1-P1-C1 U1.1-P1-M1 U1.1-P1-M2. Go to "MAP 1540: Minimum Configuration" on page 113 and run CEC drawer minimum configuration to isolate the failing memory component.
4068 00A0	Other bus processor runtime diagnostics detected service processor firmware fault	Update system firmware
4068 00A1	Other bus processor runtime diagnostics detected system firmware fault	1. Check for AIX updates 2. Check for system firmware update
4068 00A2	Other bus processor runtime diagnostics detected service processor firmware (processor runtime diagnostics) fault	Check for system firmware update

Table 6. Service Processor Error Codes. (continued)

Error Code	Description	Action/ Possible Failing FRU
4068 00A3	Other bus processor runtime diagnostics detected memory plugging fault	All pluggable memory. Go to "MAP 1540: Minimum Configuration" on page 113 and run CEC drawer minimum configuration to isolate the failing memory component.
4068 00A4	Other bus processor runtime diagnostics detected application caused fault	Application software
4068 00A5	Other bus processor runtime diagnostics detected invalid system configuration	Verify system components are supported and properly installed
4068 00A6	Other bus processor runtime diagnostics detected no usable memory	<ol style="list-style-type: none"> 1. Ensure that memory DIMMS and cards are properly installed 2. Go to service processor memory configuration/deconfiguration menu to verify memory DIMMs state. See "Memory Configuration/Deconfiguration Menu" on page 384 for more information. 3. Go to "MAP 1540: Minimum Configuration" on page 113.
4068 00A7	Other bus processor runtime diagnostics detected hardware problem	Go to "MAP 1540: Minimum Configuration" on page 113.
4068 00B0	Other bus processor runtime diagnostics detected bus controller lock-unlock failure	RIO adapter Location: U0.1-P1.1
4068 00B1	Other bus processor runtime diagnostics detected bus controller failure	RIO adapter Location: U0.1-P1.1
4068 00B7	Other bus processor runtime diagnostics detected insufficient hardware resources to continue IPL	This error code appears after the initial testing by the service processor firmware on the CEC was completed correctly, but a problem occurred when the firmware tried to communicate outside the CEC. Suspect a problem with the RIO interface, either cables or adapters.
4068 0100	Other bus processor runtime diagnostics detected memory riser card fault	Memory riser card Location: U1.1-P1-M2
4068 0101	Other bus processor runtime diagnostics detected memory DIMM fault	Memory DIMM Location: U1.1-P1-M2.15

Table 6. Service Processor Error Codes. (continued)

Error Code	Description	Action/ Possible Failing FRU
4068 0102	Other bus processor runtime diagnostics detected memory DIMM fault	Memory DIMM Location: U1.1-P1-M2.1
4068 0103	Other bus processor runtime diagnostics detected memory DIMM fault	Memory DIMM Location: U1.1-P1-M2.16
4068 0104	Other bus processor runtime diagnostics detected memory DIMM fault	Memory DIMM Location: U1.1-P1-M2.2
4068 010D	Other bus processor runtime diagnostics detected memory DIMM fault	Memory DIMM Location: U1.1-P1-M2.1 x4
4068 0111	Other bus processor runtime diagnostics detected memory DIMM fault	Memory DIMM Location: U1.1-P1-M2.13
4068 0112	Other bus processor runtime diagnostics detected memory DIMM fault	Memory DIMM Location: U1.1-P1-M2.3
4068 0113	Other bus processor runtime diagnostics detected memory DIMM fault	Memory DIMM Location: U1.1-P1-M2.14
4068 0114	Other bus processor runtime diagnostics detected memory DIMM fault	Memory DIMM Location: U1.1-P1-M2.4
4068 011D	Other bus processor runtime diagnostics detected memory DIMM fault	Memory DIMM Location: U1.1-P1-M2.3 x4
4068 0121	Other bus processor runtime diagnostics detected memory DIMM fault	Memory DIMM Location: U1.1-P1-M2.11
4068 0122	Other bus processor runtime diagnostics detected memory DIMM fault	Memory DIMM Location: U1.1-P1-M2.5
4068 0123	Other bus processor runtime diagnostics detected memory DIMM fault	Memory DIMM Location: U1.1-P1-M2.12
4068 0124	Other bus processor runtime diagnostics detected memory DIMM fault	Memory DIMM Location: U1.1-P1-M2.6
4068 012D	Other bus processor runtime diagnostics detected memory DIMM fault	Memory DIMM Location: U1.1-P1-M2.5 x4
4068 0131	Other bus processor runtime diagnostics detected memory DIMM fault	Memory DIMM Location: U1.1-P1-M2.9

Table 6. Service Processor Error Codes. (continued)

Error Code	Description	Action/ Possible Failing FRU
4068 0132	Other bus processor runtime diagnostics detected memory DIMM fault	Memory DIMM Location: U1.1-P1-M2.7
4068 0133	Other bus processor runtime diagnostics detected memory DIMM fault	Memory DIMM Location: U1.1-P1-M2.10
4068 0134	Other bus processor runtime diagnostics detected memory DIMM fault	Memory DIMM Location: U1.1-P1-M2.8
4068 013D	Other bus processor runtime diagnostics detected memory DIMM fault	Memory DIMM Location: U1.1-P1-M2.7 x4
4068 01FF	Other bus processor runtime diagnostics detected memory on riser card fault	Memory failure on riser card 2 that cannot be automatically isolated. Go to "MAP 1540: Minimum Configuration" on page 113, and run CEC drawer minimum configuration for further isolation.
4068 0200	Other bus processor runtime diagnostics detected memory riser card fault	Memory riser card Location: U1.1-P1-M1
4068 0201	Other bus processor runtime diagnostics detected memory DIMM fault	Memory DIMM Location: U1.1-P1-M1.15
4068 0202	Other bus processor runtime diagnostics detected memory DIMM fault	Memory DIMM Location: U1.1-P1-M1.1
4068 0203	Other bus processor runtime diagnostics detected memory DIMM fault	Memory DIMM Location: U1.1-P1-M1.16
4068 0204	Other bus processor runtime diagnostics detected memory DIMM fault	Memory DIMM Location: U1.1-P1-M1.2
4068 020D	Other bus processor runtime diagnostics detected memory DIMM fault	Memory DIMM Location: U1.1-P1-M1.1 x4
4068 020E	Other bus processor runtime diagnostics detected memory pair A Fault	Memory pair A Location: U1.1-P1-M1.1 x2
4068 0211	Other bus processor runtime diagnostics detected memory DIMM fault	Memory DIMM Location: U1.1-P1-M1.13
4068 0212	Other bus processor runtime diagnostics detected memory DIMM fault	Memory DIMM Location: U1.1-P1-M1.3

Table 6. Service Processor Error Codes. (continued)

Error Code	Description	Action/ Possible Failing FRU
4068 0213	Other bus processor runtime diagnostics detected memory DIMM fault	Memory DIMM Location: U1.1-P1-M1.14
4068 0214	Other bus processor runtime diagnostics detected memory DIMM fault	Memory DIMM Location: U1.1-P1-M1.4
4068 021D	Other bus processor runtime diagnostics detected memory DIMM fault	Memory DIMM Location: U1.1-P1-M1.3 x4
4068 0221	Other bus processor runtime diagnostics detected memory DIMM fault	Memory DIMM Location: U1.1-P1-M1.11
4068 0222	Other bus processor runtime diagnostics detected memory DIMM fault	Memory DIMM Location: U1.1-P1-M1.5
4068 0223	Other bus processor runtime diagnostics detected memory DIMM fault	Memory DIMM Location: U1.1-P1-M1.12
4068 0224	Other bus processor runtime diagnostics detected memory DIMM fault	Memory DIMM Location: U1.1-P1-M1.6
4068 022D	Other bus processor runtime diagnostics detected memory DIMM fault	Memory DIMM Location: U1.1-P1-M1.5 x4
4068 0231	Other bus processor runtime diagnostics detected memory DIMM fault	Memory DIMM Location: U1.1-P1-M1.9
4068 0232	Other bus processor runtime diagnostics detected memory DIMM fault	Memory DIMM Location: U1.1-P1-M1.7
4068 0233	Other bus processor runtime diagnostics detected memory DIMM fault	Memory DIMM Location: U1.1-P1-M1.10
4068 0234	Other bus processor runtime diagnostics detected memory DIMM fault	Memory DIMM Location: U1.1-P1-M1.8
4068 023D	Other bus processor runtime diagnostics detected memory DIMM fault	Memory DIMM Location: U1.1-P1-M1.7 x4
4068 02FF	Other bus processor runtime diagnostics detected memory on riser card fault	Memory failure on riser card 1 that cannot be automatically isolated. Go to "MAP 1540: Minimum Configuration" on page 113, and run CEC drawer minimum configuration for further isolation.

Table 6. Service Processor Error Codes. (continued)

Error Code	Description	Action/ Possible Failing FRU
4068 0300	Other bus processor runtime diagnostics detected processor card fault	Processor card Location: U1.1-P1-C1
4068 0301	Other bus processor runtime diagnostics detected memory DIMM fault	Memory DIMM Location: U1.1-P1-C1-M8
4068 0302	Other bus processor runtime diagnostics detected memory DIMM fault	Memory DIMM Location: U1.1-P1-C1-M1
4068 030D	Other bus processor runtime diagnostics detected memory DIMM fault	Memory DIMM Location: U1.1-P1-C1-M1 x2
4068 0311	Other bus processor runtime diagnostics detected memory DIMM fault	Memory DIMM Location: U1.1-P1-C1-M7
4068 0312	Other bus processor runtime diagnostics detected memory DIMM fault	Memory DIMM Location: U1.1-P1-C1-M2
4068 031D	Other bus processor runtime diagnostics detected memory DIMM fault	Memory DIMM Location: U1.1-P1-C1-M2 x2
4068 0321	Other bus processor runtime diagnostics detected memory DIMM fault	Memory DIMM Location: U1.1-P1-C1-M6
4068 0322	Other bus processor runtime diagnostics detected memory DIMM fault	Memory DIMM Location: U1.1-P1-C1-M3
4068 032D	Other bus processor runtime diagnostics detected memory DIMM fault	Memory DIMM Location: U1.1-P1-C1-M3 x2
4068 0331	Other bus processor runtime diagnostics detected memory DIMM fault	Memory DIMM Location: U1.1-P1-C1-M5
4068 0332	Other bus processor runtime diagnostics detected memory DIMM fault	Memory DIMM Location: U1.1-P1-C1-M4
4068 033D	Other bus processor runtime diagnostics detected memory DIMM fault	Memory DIMM Location: U1.1-P1-C1-M4 x2
4068 03FF	Other bus processor runtime diagnostics detected memory on processor card fault	Memory failure on processor card that cannot be automatically isolated. Go to "MAP 1540: Minimum Configuration" on page 113, and run CEC drawer minimum configuration for further isolation.

Table 6. Service Processor Error Codes. (continued)

Error Code	Description	Action/ Possible Failing FRU
4068 3101	Other bus processor runtime diagnostics detected RIO port 0 Fault	1. Processor card Location: U1.1-P1-C1 2. CEC drawer backplane Location: U1.1-P1
4068 3102	Other bus processor runtime diagnostics detected RIO port 1 fault	1. Processor card Location: U1.1-P1-C1 2. CEC drawer backplane Location: U1.1-P1
4068 3121	Other bus processor runtime diagnostics detected RIO cable on port 0 fault	RIO cable on port 0 Location: U1.1-P1/Q3
4068 3122	Other bus processor runtime diagnostics detected RIO cable on port 1 fault	RIO cable on port 1 Location: U1.1-P1/Q2
4068 31FF	Other bus processor runtime diagnostics detected RIO port fault	Processor card Location: U1.1-P1-C1
4068 3200	Other bus processor runtime diagnostics detected primary I/O drawer fault	Primary I/O drawer Location: U0.1
4068 3201	Other bus processor runtime diagnostics detected primary I/O backplane fault	Primary I/O backplane Location: U0.1-P1
4068 3280	Other bus processor runtime diagnostics detected primary RIO adapter fault	Primary I/O adapter Location: U0.1-P1.1
4068 3281	Other bus processor runtime diagnostics detected primary RIO port 0 fault	1. Check RIO cable Location: U0.1-P1.1/Q1 2. Primary RIO adapter Location: U0.1-P1.1
4068 3282	Other bus processor runtime diagnostics detected primary RIO port 1 fault	1. Check RIO cable Location: U0.1-P1.1/Q2 2. Primary RIO adapter Location: U0.1-P1.1
4068 3283	Other bus processor runtime diagnostics detected primary RIO ports fault	Primary RIO adapter Location: U0.1-P1.1
4068 3284	Other bus processor runtime diagnostics detected PCI Controller PHB0 Fault	1. RIO adapter Location: U0.1-P1.1 2. Primary I/O backplane Location: U0.1-P1
4068 3285	Other bus processor runtime diagnostics detected PCI Controller PHB1 Fault	Primary I/O backplane Location: U0.1-P1

Table 6. Service Processor Error Codes. (continued)

Error Code	Description	Action/ Possible Failing FRU
4068 3286	Other bus processor runtime diagnostics detected PCI Controller PHB2 Fault	1. RIO adapter Location: U0.1-P1.1 2. Primary I/O backplane Location: U0.1-P1
4069 0001	Memory test detected CEC backplane fault	CEC backplane Location: U1.1-P1
4069 0003	Memory test detected processor fault	All processors Location: U1.1-P1-C1
4069 0009	Memory test detected memory fault	All memory Locations: U1.1-P1-C1 U1.1-P1-M1 U1.1-P1-M2. Go to "MAP 1540: Minimum Configuration" on page 113 and run CEC drawer minimum configuration to isolate the failing memory component.
4069 00A0	Memory test detected service processor firmware fault	Update system firmware
4069 00A1	Memory test detected system firmware fault	1. Check for AIX updates 2. Check for system firmware update
4069 00A2	Memory test detected service processor firmware (processor runtime diagnostics) fault	Check for system firmware update
4069 00A3	Memory test detected memory plugging fault	All pluggable memory. Go to "MAP 1540: Minimum Configuration" on page 113 and run CEC drawer minimum configuration to isolate the failing memory component.
4069 00A4	Memory test detected application caused fault	Application software
4069 00A5	Memory test detected invalid system configuration	Verify system components are supported and properly installed

Table 6. Service Processor Error Codes. (continued)

Error Code	Description	Action/ Possible Failing FRU
4069 00A6	Memory test detected no usable memory	<ol style="list-style-type: none"> 1. Ensure that memory DIMMs and cards are properly installed 2. Go to service processor memory configuration/deconfiguration menu to verify memory DIMMs state. See "Memory Configuration/Deconfiguration Menu" on page 384 for more information. 3. Go to "MAP 1540: Minimum Configuration" on page 113.
4069 00A7	Memory test detected hardware problem	Go to "MAP 1540: Minimum Configuration" on page 113.
4069 00B0	Memory test detected bus controller lock-unlock failure	RIO adapter Location: U0.1-P1.1
4069 00B1	Memory test detected bus controller failure	RIO adapter Location: U0.1-P1.1
4069 00B7	Memory test detected insufficient hardware resources to continue IPL	This error code appears after the initial testing by the service processor firmware on the CEC was completed correctly, but a problem occurred when the firmware tried to communicate outside the CEC. Suspect a problem with the RIO interface, either cables or adapters.
4069 0100	Memory test detected memory riser card fault	Memory riser card Location: U1.1-P1-M2
4069 0101	Memory test detected memory DIMM fault	Memory DIMM Location: U1.1-P1-M2.15
4069 0102	Memory test detected memory DIMM fault	Memory DIMM Location: U1.1-P1-M2.1
4069 0103	Memory test detected memory DIMM fault	Memory DIMM Location: U1.1-P1-M2.16
4069 0104	Memory test detected memory DIMM fault	Memory DIMM Location: U1.1-P1-M2.2
4069 010D	Memory test detected memory DIMM fault	Memory DIMM Location: U1.1-P1-M2.1 x4
4069 0111	Memory test detected memory DIMM fault	Memory DIMM Location: U1.1-P1-M2.13
4069 0112	Memory test detected memory DIMM fault	Memory DIMM Location: U1.1-P1-M2.3
4069 0113	Memory test detected memory DIMM fault	Memory DIMM Location: U1.1-P1-M2.14
4069 0114	Memory test detected memory DIMM fault	Memory DIMM Location: U1.1-P1-M2.4

Table 6. Service Processor Error Codes. (continued)

Error Code	Description	Action/ Possible Failing FRU
4069 011D	Memory test detected memory DIMM fault	Memory DIMM Location: U1.1-P1-M2.3 x4
4069 0121	Memory test detected memory DIMM fault	Memory DIMM Location: U1.1-P1-M2.11
4069 0122	Memory test detected memory DIMM fault	Memory DIMM Location: U1.1-P1-M2.5
4069 0123	Memory test detected memory DIMM fault	Memory DIMM Location: U1.1-P1-M2.12
4069 0124	Memory test detected memory DIMM fault	Memory DIMM Location: U1.1-P1-M2.6
4069 012D	Memory test detected memory DIMM fault	Memory DIMM Location: U1.1-P1-M2.5 x4
4069 0131	Memory test detected memory DIMM fault	Memory DIMM Location: U1.1-P1-M2.9
4069 0132	Memory test detected memory DIMM fault	Memory DIMM Location: U1.1-P1-M2.7
4069 0133	Memory test detected memory DIMM fault	Memory DIMM Location: U1.1-P1-M2.10
4069 0134	Memory test detected memory DIMM fault	Memory DIMM Location: U1.1-P1-M2.8
4069 013D	Memory test detected memory DIMM fault	Memory DIMM Location: U1.1-P1-M2.7 x4
4069 01FF	Memory test detected memory on riser card fault	Memory failure on riser card 2 that cannot be automatically isolated. Go to "MAP 1540: Minimum Configuration" on page 113, and run CEC drawer minimum configuration for further isolation.
4069 0200	Memory test detected memory riser card fault	Memory riser card Location: U1.1-P1-M1
4069 0201	Memory test detected memory DIMM fault	Memory DIMM Location: U1.1-P1-M1.15
4069 0202	Memory test detected memory DIMM fault	Memory DIMM Location: U1.1-P1-M1.1
4069 0203	Memory test detected memory DIMM fault	Memory DIMM Location: U1.1-P1-M1.16
4069 0204	Memory test detected memory DIMM fault	Memory DIMM Location: U1.1-P1-M1.2
4069 020D	Memory test detected memory DIMM fault	Memory DIMM Location: U1.1-P1-M1.1 x4
4069 020E	Memory test detected memory pair A fault	Memory pair A Location: U1.1-P1-M1.1 x2

Table 6. Service Processor Error Codes. (continued)

Error Code	Description	Action/ Possible Failing FRU
4069 0211	Memory test detected memory DIMM fault	Memory DIMM Location: U1.1-P1-M1.13
4069 0212	Memory test detected memory DIMM fault	Memory DIMM Location: U1.1-P1-M1.3
4069 0213	Memory test detected memory DIMM fault	Memory DIMM Location: U1.1-P1-M1.14
4069 0214	Memory test detected memory DIMM fault	Memory DIMM Location: U1.1-P1-M1.4
4069 021D	Memory test detected memory DIMM fault	Memory DIMM Location: U1.1-P1-M1.3 x4
4069 0221	Memory test detected memory DIMM fault	Memory DIMM Location: U1.1-P1-M1.11
4069 0222	Memory test detected memory DIMM fault	Memory DIMM Location: U1.1-P1-M1.5
4069 0223	Memory test detected memory DIMM fault	Memory DIMM Location: U1.1-P1-M1.12
4069 0224	Memory test detected memory DIMM fault	Memory DIMM Location: U1.1-P1-M1.6
4069 022D	Memory test detected memory DIMM fault	Memory DIMM Location: U1.1-P1-M1.5 x4
4069 0231	Memory test detected memory DIMM fault	Memory DIMM Location: U1.1-P1-M1.9
4069 0232	Memory test detected memory DIMM fault	Memory DIMM Location: U1.1-P1-M1.7
4069 0233	Memory test detected memory DIMM fault	Memory DIMM Location: U1.1-P1-M1.10
4069 0234	Memory test detected memory DIMM fault	Memory DIMM Location: U1.1-P1-M1.8
4069 023D	Memory test detected memory DIMM fault	Memory DIMM Location: U1.1-P1-M1.7 x4
4069 02FF	Memory test detected memory on riser card fault	Memory failure on riser card 1 that cannot be automatically isolated. Go to "MAP 1540: Minimum Configuration" on page 113, and run CEC drawer minimum configuration for further isolation.
4069 0300	Memory test detected processor card fault	Processor card Location: U1.1-P1-C1
4069 0301	Memory test detected memory DIMM fault	Memory DIMM Location: U1.1-P1-C1-M8
4069 0302	Memory test detected memory DIMM fault	Memory DIMM Location: U1.1-P1-C1-M1

Table 6. Service Processor Error Codes. (continued)

Error Code	Description	Action/ Possible Failing FRU
4069 030D	Memory test detected memory DIMM fault	Memory DIMM Location: U1.1-P1-C1-M1 x2
4069 0311	Memory test detected memory DIMM fault	Memory DIMM Location: U1.1-P1-C1-M7
4069 0312	Memory test detected memory DIMM fault	Memory DIMM Location: U1.1-P1-C1-M2
4069 031D	Memory test detected memory DIMM fault	Memory DIMM Location: U1.1-P1-C1-M2 x2
4069 0321	Memory test detected memory DIMM fault	Memory DIMM Location: U1.1-P1-C1-M6
4069 0322	Memory test detected memory DIMM fault	Memory DIMM Location: U1.1-P1-C1-M3
4069 032D	Memory test detected memory DIMM fault	Memory DIMM Location: U1.1-P1-C1-M3 x2
4069 0331	Memory test detected memory DIMM fault	Memory DIMM Location: U1.1-P1-C1-M5
4069 0332	Memory test detected memory DIMM fault	Memory DIMM Location: U1.1-P1-C1-M4
4069 033D	Memory test detected memory DIMM fault	Memory DIMM Location: U1.1-P1-C1-M4 x2
4069 03FF	Memory test detected memory on processor card fault	Memory failure on processor card that cannot be automatically isolated. Go to "MAP 1540: Minimum Configuration" on page 113, and run CEC drawer minimum configuration for further isolation.
4069 3101	Memory test detected RIO port 0 fault	1. Processor card Location: U1.1-P1-C1 2. CEC drawer backplane Location: U1.1-P1
4069 3102	Memory test detected RIO port 1 fault	1. Processor card Location: U1.1-P1-C1 2. CEC drawer backplane Location: U1.1-P1
4069 3121	Memory test detected RIO cable on port 0 fault	RIO cable on port 0 Location: U1.1-P1/Q3
4069 3122	Memory test detected RIO cable on port 1 fault	RIO cable on port 1 Location: U1.1-P1/Q2
4069 31FF	Memory test detected RIO port fault	Processor card Location: U1.1-P1-C1
4069 3200	Memory test detected primary I/O drawer fault	Go to "MAP 1540: Minimum Configuration" on page 113.

Table 6. Service Processor Error Codes. (continued)

Error Code	Description	Action/ Possible Failing FRU
4069 3201	Memory test detected primary I/O backplane fault	Primary I/O backplane Location: U0.1-P1
4069 3280	Memory test detected primary RIO adapter fault	Primary RIO adapter Location: U0.1-P1.1
4069 3281	Memory test detected primary RIO port 0 fault	1. Check RIO cable Location: U0.1-P1.1/Q1 2. Primary RIO adapter Location: U0.1-P1.1
4069 3282	Memory test detected primary RIO port 1 fault	1. Check RIO cable Location: U0.1-P1.1/Q2 2. Primary RIO adapter Location: U0.1-P1.1
4069 3283	Memory test detected primary RIO ports fault	Primary RIO adapter Location: U0.1-P1.1
4069 3284	Memory Test detected PCI controller PHB0 fault	1. RIO adapter Location: U0.1-P1.1 2. Primary I/O backplane Location: U0.1-P1
4069 3285	Memory Test detected PCI controller PHB1 fault	1. RIO adapter Location: U0.1-P1.1 2. Primary I/O backplane Location: U0.1-P1
4069 3286	Memory Test detected PCI controller PHB2 fault	1. RIO adapter Location: U0.1-P1.1 2. Primary I/O backplane Location: U0.1-P1
406A 0001	Self test detected CEC backplane fault	CEC backplane Location: U1.1-P1
406A 0003	Self test detected processor fault	All processors Location: U1.1-P1-C1
406A 0009	Self test detected memory fault	All memory Locations: U1.1-P1-C1 U1.1-P1-M1 U1.1-P1-M2. Go to "MAP 1540: Minimum Configuration" on page 113 and run CEC drawer minimum configuration to isolate the failing memory component.
406A 00A0	Self test detected service processor firmware fault	Update system firmware
406A 00A1	Self test detected system firmware fault	1. Check for AIX updates 2. Check for system firmware update

Table 6. Service Processor Error Codes. (continued)

Error Code	Description	Action/ Possible Failing FRU
406A 00A2	Self test detected service processor firmware (processor runtime diagnostics) fault	Check for system firmware update
406A 00A3	Self test detected memory plugging fault	All pluggable memory. Go to "MAP 1540: Minimum Configuration" on page 113 and run CEC drawer minimum configuration to isolate the failing memory component.
406A 00A4	Self test detected application caused fault	Application software
406A 00A5	Self test detected invalid system configuration	Verify system components are supported and properly installed
406A 00A6	Self test detected no usable memory	<ol style="list-style-type: none"> 1. Ensure that memory DIMMs and cards are properly installed. 2. Go to service processor memory configuration/deconfiguration menu to verify memory DIMMs state. See "Memory Configuration/Deconfiguration Menu" on page 384 for more information. 3. Go to "MAP 1540: Minimum Configuration" on page 113.
406A 00A7	Self test detected hardware problem	Go to "MAP 1540: Minimum Configuration" on page 113.
406A 00B0	Self test detected bus controller lock-unlock failure	RIO adapter Location: U0.1-P1.1
406A 00B1	Self test detected bus controller failure	RIO adapter bus Location: U0.1-P1.1
406A 00B7	Self test detected insufficient hardware resources to continue IPL	This error code appears after the initial testing by the service processor firmware on the CEC was completed correctly, but a problem occurred when the firmware tried to communicate outside the CEC. Suspect a problem with the RIO interface, either
406A 0100	Self test detected memory riser card fault	Memory riser card Location: U1.1-P1-M2
406A 0101	Self test detected memory DIMM fault	Memory DIMM Location: U1.1-P1-M2.15
406A 0102	Self test detected memory DIMM fault	Memory DIMM Location: U1.1-P1-M2.1
406A 0103	Self test detected memory DIMM fault	Memory DIMM Location: U1.1-P1-M2.16

Table 6. Service Processor Error Codes. (continued)

Error Code	Description	Action/ Possible Failing FRU
406A 0104	Self test detected memory DIMM fault	Memory DIMM Location: U1.1-P1-M2.2
406A 010D	Self test detected memory DIMM fault	Memory DIMM Location: U1.1-P1-M2.1 x4
406A 0111	Self test detected memory DIMM fault	Memory DIMM Location: U1.1-P1-M2.13
406A 0112	Self test detected memory DIMM fault	Memory DIMM Location: U1.1-P1-M2.3
406A 0113	Self test detected memory DIMM fault	Memory DIMM Location: U1.1-P1-M2.14
406A 0114	Self test detected memory DIMM fault	Memory DIMM Location: U1.1-P1-M2.4
406A 011D	Self test detected memory DIMM fault	Memory DIMM Location: U1.1-P1-M2.3 x4
406A 0121	Self test detected memory DIMM fault	Memory DIMM Location: U1.1-P1-M2.11
406A 0122	Self test detected memory DIMM fault	Memory DIMM Location: U1.1-P1-M2.5
406A 0123	Self test detected memory DIMM fault	Memory DIMM Location: U1.1-P1-M2.12
406A 0124	Self test detected memory DIMM fault	Memory DIMM Location: U1.1-P1-M2.6
406A 012D	Self test detected memory DIMM fault	Memory DIMM Location: U1.1-P1-M2.5 x4
406A 0131	Self test detected memory DIMM fault	Memory DIMM Location: U1.1-P1-M2.9
406A 0132	Self test detected memory DIMM fault	Memory DIMM Location: U1.1-P1-M2.7
406A 0133	Self test detected memory DIMM fault	Memory DIMM Location: U1.1-P1-M2.10
406A 0134	Self test detected memory DIMM fault	Memory DIMM Location: U1.1-P1-M2.8
406A 013D	Self test detected memory DIMM fault	Memory DIMM Location: U1.1-P1-M2.7 x4
406A 01FF	Self test detected memory on riser card fault	Memory failure on riser card 2 that cannot be automatically isolated. Go to "MAP 1540: Minimum Configuration" on page 113, and run CEC drawer minimum configuration for further isolation.
406A 0200	Self test detected memory riser card fault	Memory riser card Location: U1.1-P1-M1

Table 6. Service Processor Error Codes. (continued)

Error Code	Description	Action/ Possible Failing FRU
406A 0201	Self test detected memory DIMM fault	Memory DIMM Location: U1.1-P1-M1.15
406A 0202	Self test detected memory DIMM fault	Memory DIMM Location: U1.1-P1-M1.1
406A 0203	Self test detected memory DIMM fault	Memory DIMM Location: U1.1-P1-M1.16
406A 0204	Self test detected memory DIMM fault	Memory DIMM Location: U1.1-P1-M1.2
406A 020D	Self test detected memory DIMM fault	Memory DIMM Location: U1.1-P1-M1.1 x4
406A 020E	Self test detected memory pair A fault	Memory pair A Location: U1.1-P1-M1.1 x2
406A 0211	Self test detected memory DIMM fault	Memory DIMM Location: U1.1-P1-M1.13
406A 0212	Self test detected memory DIMM fault	Memory DIMM Location: U1.1-P1-M1.3
406A 0213	Self test detected memory DIMM fault	Memory DIMM Location: U1.1-P1-M1.14
406A 0214	Self test detected memory DIMM fault	Memory DIMM Location: U1.1-P1-M1.4
406A 021D	Self test detected memory DIMM fault	Memory DIMM Location: U1.1-P1-M1.3 x4
406A 0221	Self test detected memory DIMM fault	Memory DIMM Location: U1.1-P1-M1.11
406A 0222	Self test detected memory DIMM fault	Memory DIMM Location: U1.1-P1-M1.5
406A 0223	Self test detected memory DIMM fault	Memory DIMM Location: U1.1-P1-M1.12
406A 0224	Self test detected memory DIMM fault	Memory DIMM Location: U1.1-P1-M1.6
406A 022D	Self test detected memory DIMM fault	Memory DIMM Location: U1.1-P1-M1.5 x4
406A 0231	Self test detected memory DIMM fault	Memory DIMM Location: U1.1-P1-M1.9
406A 0232	Self test detected memory DIMM fault	Memory DIMM Location: U1.1-P1-M1.7
406A 0233	Self test detected memory DIMM fault	Memory DIMM Location: U1.1-P1-M1.10
406A 0234	Self test detected memory DIMM fault	Memory DIMM Location: U1.1-P1-M1.8
406A 023D	Self test detected memory DIMM fault	Memory DIMM Location: U1.1-P1-M1.7 x4

Table 6. Service Processor Error Codes. (continued)

Error Code	Description	Action/ Possible Failing FRU
406A 02FF	Self test detected memory on riser card fault	Memory failure on riser card 1 that cannot be automatically isolated. Go to "MAP 1540: Minimum Configuration" on page 113, and run CEC drawer minimum configuration for further isolation.
406A 0300	Self test detected processor card fault	Processor card Location: U1.1-P1-C1
406A 0301	Self test detected memory DIMM fault	Memory DIMM Location: U1.1-P1-C1-M8
406A 0302	Self test detected memory DIMM fault	Memory DIMM Location: U1.1-P1-C1-M1
406A 030D	Self test detected memory DIMM fault	Memory DIMM Location: U1.1-P1-C1-M1 x2
406A 0311	Self test detected memory DIMM fault	Memory DIMM Location: U1.1-P1-C1-M7
406A 0312	Self test detected memory DIMM fault	Memory DIMM Location: U1.1-P1-C1-M2
406A 031D	Self test detected memory DIMM fault	Memory DIMM Location: U1.1-P1-C1-M2 x2
406A 0321	Self test detected memory DIMM fault	Memory DIMM Location: U1.1-P1-C1-M6
406A 0322	Self test detected memory DIMM fault	Memory DIMM Location: U1.1-P1-C1-M3
406A 032D	Self test detected memory DIMM fault	Memory DIMM Location: U1.1-P1-C1-M3 x2
406A 0331	Self test detected memory DIMM fault	Memory DIMM Location: U1.1-P1-C1-M5
406A 0332	Self test detected memory DIMM fault	Memory DIMM Location: U1.1-P1-C1-M4
406A 033D	Self test detected memory DIMM fault	Memory DIMM Location: U1.1-P1-C1-M4 x2
406A 03FF	Self test detected memory on processor card fault	Memory failure on processor card that cannot be automatically isolated. Go to "MAP 1540: Minimum Configuration" on page 113, and run CEC drawer minimum configuration for further isolation.
406A 3101	Self test detected RIO port 0 fault	1. Processor card Location: U1.1-P1-C1 2. CEC drawer backplane Location: U1.1-P1

Table 6. Service Processor Error Codes. (continued)

Error Code	Description	Action/ Possible Failing FRU
406A 3102	Self test detected RIO port 1 fault	1. Processor card Location: U1.1-P1-C1 2. CEC drawer backplane Location: U1.1-P1
406A 3121	Self test detected RIO cable on port 0 fault	RIO cable on port 0 Location: U1.1-P1/Q3
406A 3122	Self test detected RIO cable on port 1 fault	RIO cable on port 1 Location: U1.1-P1/Q2
406A 31FF	Self test detected RIO port fault	Processor card Location: U1.1-P1-C1
406A 3200	Self test detected primary I/O drawer fault	Go to "MAP 1540: Minimum Configuration" on page 113.
406A 3201	Self test detected primary I/O backplane fault	Primary I/O backplane Location: U0.1-P1
406A 3280	Self test detected primary RIO adapter fault	Primary RIO adapter Location: U0.1-P1.1
406A 3281	Self test detected primary RIO port 0 fault	1. Check RIO cable Location: U0.1-P1.1/Q1 2. Primary RIO adapter Location: U0.1-P1.1
406A 3282	Self test detected primary RIO port 1 fault	1. Check RIO cable Location: U0.1-P1.1/Q2 2. Primary RIO adapter Location: U0.1-P1.1
406A 3283	Self test detected primary RIO ports fault	Primary RIO adapter Location: U0.1-P1.1
406A 3284	Self test detected PCI controller PHB0 fault	1. RIO adapter Location: U0.1-P1.1 2. Primary I/O backplane Location: U0.1-P1
406A 3285	Self test detected PCI controller PHB1 fault	1. RIO adapter Location: U0.1-P1.1 2. Primary I/O backplane Location: U0.1-P1
406A 3286	Self test detected PCI controller PHB2 fault	1. RIO adapter Location: U0.1-P1.1 2. Primary I/O backplane Location: U0.1-P1
406B 0001	Wire test detected CEC backplane fault	CEC backplane Location: U1.1-P1
406B 0003	Wire test detected processor fault	All processors Location: U1.1-P1-C1

Table 6. Service Processor Error Codes. (continued)

Error Code	Description	Action/ Possible Failing FRU
406B 0009	Wire test detected memory fault	All memory Locations: U1.1-P1-C1 U1.1-P1-M1 U1.1-P1-M2. Go to "MAP 1540: Minimum Configuration" on page 113 and run CEC drawer minimum configuration to isolate the failing memory component.
406B 00A0	Wire test detected service processor firmware fault	Update system firmware
406B 00A1	Wire test detected system firmware fault	1. Check for AIX updates 2. Check for system firmware update
406B 00A2	Wire test detected service processor firmware (processor runtime diagnostics) fault	Check for system firmware update
406B 00A3	Wire test detected memory plugging fault	All pluggable memory. Go to "MAP 1540: Minimum Configuration" on page 113 and run CEC drawer minimum configuration to isolate the failing memory component.
406B 00A4	Wire test detected application caused fault	Application software
406B 00A5	Wire test detected invalid system configuration	Verify system components are supported and properly installed
406B 00A6	Wire test detected no usable memory	1. Ensure that memory DIMMs and cards are properly installed. 2. Go to service processor memory configuration/deconfiguration menu to verify memory DIMMs state. See "Memory Configuration/Deconfiguration Menu" on page 384 for more information. 3. Go to "MAP 1540: Minimum Configuration" on page 113.
406B 00A7	Wire test detected hardware problem	Go to "MAP 1540: Minimum Configuration" on page 113.
406B 00B0	Wire test detected bus controller lock-unlock failure	RIO adapter Location: U0.1-P1.1
406B 00B1	Wire test detected bus controller failure	RIO adapter Location: U0.1-P1.1

Table 6. Service Processor Error Codes. (continued)

Error Code	Description	Action/ Possible Failing FRU
406B 00B7	Wire test detected insufficient hardware resources to continue IPL	This error code appears after the initial testing by the service processor firmware on the CEC was completed correctly, but a problem occurred when the firmware tried to communicate outside the CEC. Suspect a problem with the RIO interface, either cables or adapters.
406B 0100	Wire test detected memory riser card fault	Memory riser card Location: U1.1-P1-M2
406B 0101	Wire test detected memory DIMM fault	Memory DIMM Location: U1.1-P1-M2.15
406B 0102	Wire test detected memory DIMM fault	Memory DIMM Location: U1.1-P1-M2.1
406B 0103	Wire test detected memory DIMM fault	Memory DIMM Location: U1.1-P1-M2.16
406B 0104	Wire test detected memory DIMM fault	Memory DIMM Location: U1.1-P1-M2.2
406B 010D	Wire test detected memory DIMM fault	Memory DIMM Location: U1.1-P1-M2.1 x4
406B 0111	Wire test detected memory DIMM fault	Memory DIMM Location: U1.1-P1-M2.13
406B 0112	Wire test detected memory DIMM fault	Memory DIMM Location: U1.1-P1-M2.3
406B 0113	Wire test detected memory DIMM fault	Memory DIMM Location: U1.1-P1-M2.14
406B 0114	Wire test detected memory DIMM fault	Memory DIMM Location: U1.1-P1-M2.4
406B 011D	Wire test detected memory DIMM fault	Memory DIMM Location: U1.1-P1-M2.3 x4
406B 0121	Wire test detected memory DIMM fault	Memory DIMM Location: U1.1-P1-M2.11
406B 0122	Wire test detected memory DIMM fault	Memory DIMM Location: U1.1-P1-M2.5
406B 0123	Wire test detected memory DIMM fault	Memory DIMM Location: U1.1-P1-M2.12
406B 0124	Wire test detected memory DIMM fault	Memory DIMM Location: U1.1-P1-M2.6
406B 012D	Wire test detected memory DIMM fault	Memory DIMM Location: U1.1-P1-M2.5 x4
406B 0131	Wire test detected memory DIMM fault	Memory DIMM Location: U1.1-P1-M2.9

Table 6. Service Processor Error Codes. (continued)

Error Code	Description	Action/ Possible Failing FRU
406B 0132	Wire test detected memory DIMM fault	Memory DIMM Location: U1.1-P1-M2.7
406B 0133	Wire test detected memory DIMM fault	Memory DIMM Location: U1.1-P1-M2.10
406B 0134	Wire test detected memory DIMM fault	Memory DIMM Location: U1.1-P1-M2.8
406B 013D	Wire test detected memory DIMM fault	Memory DIMM Location: U1.1-P1-M2.7 x4
406B 01FF	Wire test detected memory on riser card fault	Memory failure on riser card 2 that cannot be automatically isolated. Go to "MAP 1540: Minimum Configuration" on page 113, and run CEC drawer minimum configuration for further isolation.
406B 0200	Wire test detected memory riser card fault	Memory riser card Location: U1.1-P1-M1
406B 0201	Wire test detected memory DIMM fault	Memory DIMM Location: U1.1-P1-M1.15
406B 0202	Wire test detected memory DIMM fault	Memory DIMM Location: U1.1-P1-M1.1
406B 0203	Wire test detected memory DIMM fault	Memory DIMM Location: U1.1-P1-M1.16
406B 0204	Wire test detected memory DIMM fault	Memory DIMM Location: U1.1-P1-M1.2
406B 020D	Self test detected memory DIMM fault	Memory DIMM Location: U1.1-P1-M1.1 x4
406B 020E	Wire test detected memory pair A fault	Memory pair A Location: U1.1-P1-M1.1 x2
406B 0211	Wire test detected memory DIMM fault	Memory DIMM Location: U1.1-P1-M1.13
406B 0212	Wire test detected memory DIMM fault	Memory DIMM Location: U1.1-P1-M1.3
406B 0213	Wire test detected memory DIMM fault	Memory DIMM Location: U1.1-P1-M1.14
406B 0214	Wire test detected memory DIMM fault	Memory DIMM Location: U1.1-P1-M1.4
406B 021D	Wire test detected memory DIMM fault	Memory DIMM Location: U1.1-P1-M1.3 x4
406B 0221	Wire test detected memory DIMM fault	Memory DIMM Location: U1.1-P1-M1.11
406B 0222	Wire test detected memory DIMM fault	Memory DIMM Location: U1.1-P1-M1.5

Table 6. Service Processor Error Codes. (continued)

Error Code	Description	Action/ Possible Failing FRU
406B 0223	Wire test detected memory DIMM fault	Memory DIMM Location: U1.1-P1-M1.12
406B 0224	Wire test detected memory DIMM fault	Memory DIMM Location: U1.1-P1-M1.6
406B 022D	Wire test detected memory DIMM fault	Memory DIMM Location: U1.1-P1-M1.5 x4
406B 0231	Wire test detected memory DIMM fault	Memory DIMM Location: U1.1-P1-M1.9
406B 0232	Wire test detected memory DIMM fault	Memory DIMM Location: U1.1-P1-M1.7
406B 0233	Wire test detected memory DIMM fault	Memory DIMM Location: U1.1-P1-M1.10
406B 0234	Wire test detected memory DIMM fault	Memory DIMM Location: U1.1-P1-M1.8
406B 023D	Wire test detected memory DIMM fault	Memory DIMM Location: U1.1-P1-M1.7 x4
406B 02FF	Wire test detected memory on riser card fault	Memory failure on riser card 1 that cannot be automatically isolated. Go to "MAP 1540: Minimum Configuration" on page 113, and run CEC drawer minimum configuration for further isolation.
406B 0300	Wire test detected processor card fault	Processor card Location: U1.1-P1-C1
406B 0301	Wire test detected memory DIMM fault	Memory DIMM Location: U1.1-P1-C1-M8
406B 0302	Wire test detected memory DIMM fault	Memory DIMM Location: U1.1-P1-C1-M1
406B 030D	Wire test detected memory DIMM fault	Memory DIMM Location: U1.1-P1-C1-M1 x2
406B 0311	Wire test detected memory DIMM fault	Memory DIMM Location: U1.1-P1-C1-M7
406B 0312	Wire test detected memory DIMM fault	Memory DIMM Location: U1.1-P1-C1-M2
406B 031D	Wire test detected memory DIMM fault	Memory DIMM Location: U1.1-P1-C1-M2 x2
406B 0321	Wire test detected memory DIMM fault	Memory DIMM Location: U1.1-P1-C1-M6
406B 0322	Wire test detected memory DIMM fault	Memory DIMM Location: U1.1-P1-C1-M3
406B 032D	Wire test detected memory DIMM fault	Memory DIMM Location: U1.1-P1-C1-M3 x2

Table 6. Service Processor Error Codes. (continued)

Error Code	Description	Action/ Possible Failing FRU
406B 0331	Wire test detected memory DIMM fault	Memory DIMM Location: U1.1-P1-C1-M5
406B 0332	Wire test detected memory DIMM fault	Memory DIMM Location: U1.1-P1-C1-M4
406B 033D	Wire test detected memory DIMM fault	Memory DIMM Location: U1.1-P1-C1-M4 x2
406B 03FF	Wire test detected memory on processor card fault	Memory failure on processor card that cannot be automatically isolated. Go to "MAP 1540: Minimum Configuration" on page 113, and run CEC drawer minimum configuration for further isolation.
406B 3101	Wire test detected RIO port 0 fault	1. Processor card Location: U1.1-P1-C1 2. CEC drawer backplane Location: U1.1-P1
406B 3102	Wire test detected RIO port 1 fault	1. Processor card Location: U1.1-P1-C1 2. CEC drawer backplane Location: U1.1-P1
406B 3121	Wire test detected RIO cable on port 0 fault	RIO cable on port 0 Location: U1.1-P1/Q3
406B 3122	Wire test detected RIO cable on port 1 fault	RIO cable on port 1 Location: U1.1-P1/Q2
406B 31FF	Wire test detected RIO port fault	Processor card Location: U1.1-P1-C1
406B 3200	Wire test detected primary I/O drawer fault	Go to "MAP 1540: Minimum Configuration" on page 113.
406B 3201	Wire test detected primary I/O backplane fault	Primary I/O backplane Location: U0.1-P1
406B 3280	Wire test detected primary RIO adapter fault	Primary RIO adapter Location: U0.1-P1.1
406B 3281	Wire test detected primary RIO port 0 fault	1. Check RIO cable Location: U0.1-P1.1/Q1 2. Primary RIO adapter Location: U0.1-P1.1
406B 3282	Wire test detected primary RIO port 1 fault	1. Check RIO cable Location: U0.1-P1.1/Q2 2. Primary RIO adapter Location: U0.1-P1.1
406B 3283	Wire test detected primary RIO ports fault	Primary RIO adapter Location: U0.1-P1.1

Table 6. Service Processor Error Codes. (continued)

Error Code	Description	Action/ Possible Failing FRU
406B 3284	Wire test detected PCI controller PHB0 fault	<ol style="list-style-type: none"> 1. RIO adapter Location: U0.1-P1.1 2. Primary I/O backplane Location: U0.1-P1
406B 3285	Wire test detected PCI controller PHB1 fault	<ol style="list-style-type: none"> 1. RIO adapter Location: U0.1-P1.1 2. Primary I/O backplane Location: U0.1-P1
406B 3286	Wire test detected PCI controller PHB2 fault	<ol style="list-style-type: none"> 1. RIO adapter Location: U0.1-P1.1 2. Primary I/O backplane Location: U0.1-P1
406C 0001	IPL detected CEC backplane fault	CEC backplane Location: U1.1-P1
406C 0003	IPL detected processor fault	All processors Location: U1.1-P1-C1
406C 0009	IPL detected Memory Fault	<p>All memory Locations: U1.1-P1-C1 U1.1-P1-M1 U1.1-P1-M2.</p> <p>Go to "MAP 1540: Minimum Configuration" on page 113 and run CEC drawer minimum configuration to isolate the failing memory component.</p>
406C 00A0	IPL test detected service processor firmware fault	Update system firmware
406C 00A1	IPL test detected system firmware fault	<ol style="list-style-type: none"> 1. Check for AIX updates 2. Check for system firmware update
406C 00A2	IPL test detected service processor firmware (processor runtime diagnostics) fault	Check for system firmware update
406C 00A3	IPL test detected memory plugging fault	<p>All pluggable memory. Go to "MAP 1540: Minimum Configuration" on page 113 and run CEC drawer minimum configuration to isolate the failing memory component.</p>
406C 00A4	IPL test detected application caused fault	Application software
406C 00A5	IPL test detected system firmware fault	Verify system components are supported and properly installed

Table 6. Service Processor Error Codes. (continued)

Error Code	Description	Action/ Possible Failing FRU
406C 00A6	IPL test detected no usable memory	<ol style="list-style-type: none"> 1. Ensure that memory DIMMs and cards are properly installed. 2. Go to service processor memory configuration/deconfiguration menu to verify memory DIMMs state. See "Memory Configuration/Deconfiguration Menu" on page 384 for more information. 3. Go to "MAP 1540: Minimum Configuration" on page 113.
406C 00A7	IPL test detected hardware problem	Go to "MAP 1540: Minimum Configuration" on page 113.
406C 00B0	IPL test detected bus controller lock-unlock failure	RIO adapter Location: U0.1-P1.1
406C 00B1	IPL test detected bus controller failure	RIO adapter Location: U0.1-P1.1
406C 00B7	IPL MOPS detected insufficient hardware resources to continue IPL	This error code appears after the initial testing by the service processor firmware on the CEC was completed correctly, but a problem occurred when the firmware tried to communicate outside the CEC. Suspect a problem with the RIO interface, either cables or adapters.
406C 0100	IPL test detected memory riser card fault	Memory riser card Location: U1.1-P1-M2
406C 0101	IPL test detected memory DIMM fault	Memory DIMM Location: U1.1-P1-M2.15
406C 0102	IPL test detected memory DIMM fault	Memory DIMM Location: U1.1-P1-M2.1
406C 0103	IPL test detected memory DIMM fault	Memory DIMM Location: U1.1-P1-M2.16
406C 0104	IPL test detected memory DIMM fault	Memory DIMM Location: U1.1-P1-M2.2
406C 010D	IPL test detected memory DIMM fault	Memory DIMM Location: U1.1-P1-M2.1 x4
406C 0111	IPL test detected memory DIMM fault	Memory DIMM Location: U1.1-P1-M2.13
406C 0112	IPL test detected memory DIMM fault	Memory DIMM Location: U1.1-P1-M2.3
406C 0113	IPL test detected memory DIMM fault	Memory DIMM Location: U1.1-P1-M2.14
406C 0114	IPL test detected memory DIMM fault	Memory DIMM Location: U1.1-P1-M2.4

Table 6. Service Processor Error Codes. (continued)

Error Code	Description	Action/ Possible Failing FRU
406C 011D	IPL test detected memory DIMM fault	Memory DIMM Location: U1.1-P1-M2.3 x4
406C 0121	IPL test detected memory DIMM fault	Memory DIMM Location: U1.1-P1-M2.11
406C 0122	IPL test detected memory DIMM fault	Memory DIMM Location: U1.1-P1-M2.5
406C 0123	IPL test detected memory DIMM fault	Memory DIMM Location: U1.1-P1-M2.12
406C 0124	IPL test detected memory DIMM fault	Memory DIMM Location: U1.1-P1-M2.6
406C 012D	IPL test detected memory DIMM fault	Memory DIMM Location: U1.1-P1-M2.5 x4
406C 0131	IPL test detected memory DIMM fault	Memory DIMM Location: U1.1-P1-M2.9
406C 0132	IPL test detected memory DIMM fault	Memory DIMM Location: U1.1-P1-M2.7
406C 0133	IPL test detected memory DIMM fault	Memory DIMM Location: U1.1-P1-M2.10
406C 0134	IPL test detected memory DIMM fault	Memory DIMM Location: U1.1-P1-M2.8
406C 013D	IPL test detected memory DIMM fault	Memory DIMM Location: U1.1-P1-M2.7 x4
406C 01FF	IPL detected memory on riser card fault	Memory failure on riser card 2 that cannot be automatically isolated. Go to "MAP 1540: Minimum Configuration" on page 113, and run CEC drawer minimum configuration for further isolation.
406C 0200	IPL test detected memory riser card fault	Memory riser card Location: U1.1-P1-M1
406C 0201	IPL test detected memory DIMM fault	Memory DIMM Location: U1.1-P1-M1.15
406C 0202	IPL test detected memory DIMM fault	Memory DIMM Location: U1.1-P1-M1.1
406C 0203	IPL test detected memory DIMM fault	Memory DIMM Location: U1.1-P1-M1.16
406C 0204	IPL test detected memory DIMM fault	Memory DIMM Location: U1.1-P1-M1.2
406C 020D	IPL test detected memory DIMM fault	Memory DIMM Location: U1.1-P1-M1.1 x4
406C 020E	IPL detected memory pair A fault	Memory pair A Location: U1.1-P1-M1.1 x2

Table 6. Service Processor Error Codes. (continued)

Error Code	Description	Action/ Possible Failing FRU
406C 0211	IPL test detected memory DIMM fault	Memory DIMM Location: U1.1-P1-M1.13
406C 0212	IPL test detected memory DIMM fault	Memory DIMM Location: U1.1-P1-M1.3
406C 0213	IPL test detected memory DIMM fault	Memory DIMM Location: U1.1-P1-M1.14
406C 0214	IPL test detected memory DIMM fault	Memory DIMM Location: U1.1-P1-M1.4
406C 021D	IPL test detected memory DIMM fault	Memory DIMM Location: U1.1-P1-M1.3 x4
406C 0221	IPL test detected memory DIMM fault	Memory DIMM Location: U1.1-P1-M1.11
406C 0222	IPL test detected memory DIMM fault	Memory DIMM Location: U1.1-P1-M1.5
406C 0223	IPL test detected memory DIMM fault	Memory DIMM Location: U1.1-P1-M1.12
406C 0224	IPL test detected memory DIMM fault	Memory DIMM Location: U1.1-P1-M1.6
406C 022D	IPL test detected memory DIMM fault	Memory DIMM Location: U1.1-P1-M1.5 x4
406C 0231	IPL test detected memory DIMM fault	Memory DIMM Location: U1.1-P1-M1.9
406C 0232	IPL test detected memory DIMM fault	Memory DIMM Location: U1.1-P1-M1.7
406C 0233	IPL test detected memory DIMM fault	Memory DIMM Location: U1.1-P1-M1.10
406C 0234	IPL test detected memory DIMM fault	Memory DIMM Location: U1.1-P1-M1.8
406C 023D	IPL test detected memory DIMM fault	Memory DIMM Location: U1.1-P1-M1.7 x4
406C 02FF	IPL detected memory on riser card fault	Memory failure on riser card 1 that cannot be automatically isolated. Go to "MAP 1540: Minimum Configuration" on page 113, and run CEC drawer minimum configuration for further isolation.

Table 6. Service Processor Error Codes. (continued)

Error Code	Description	Action/ Possible Failing FRU
406C 0300	IPL test detected processor card fault	Processor card Location: U1.1-P1-C1 Note: If this error occurs on a model 6H0, first verify that the correct type of processor card is installed in the system. Up to four processor are supported in a model 6H0 system; if a 6-way processor is plugged into the system, this error code will be generated and the system will not boot.
406C 0301	IPL test detected memory DIMM fault	Memory DIMM Location: U1.1-P1-C1-M8
406C 0302	IPL test detected memory DIMM fault	Memory DIMM Location: U1.1-P1-C1-M1
406C 030D	IPL test detected memory DIMM fault	Memory DIMM Location: U1.1-P1-C1-M1 x2
406C 0311	IPL test detected memory DIMM fault	Memory DIMM Location: U1.1-P1-C1-M7
406C 0312	IPL test detected memory DIMM fault	Memory DIMM Location: U1.1-P1-C1-M2
406C 031D	IPL test detected memory DIMM fault	Memory DIMM Location: U1.1-P1-C1-M2 x2
406C 0321	IPL test detected memory DIMM fault	Memory DIMM Location: U1.1-P1-C1-M6
406C 0322	IPL test detected memory DIMM fault	Memory DIMM Location: U1.1-P1-C1-M3
406C 032D	IPL test detected memory DIMM fault	Memory DIMM Location: U1.1-P1-C1-M3 x2
406C 0331	IPL test detected memory DIMM fault	Memory DIMM Location: U1.1-P1-C1-M5
406C 0332	IPL test detected memory DIMM fault	Memory DIMM Location: U1.1-P1-C1-M4
406C 033D	IPL test detected memory DIMM fault	Memory DIMM Location: U1.1-P1-C1-M4 x2
406C 03FF	IPL detected memory on processor card fault	Memory failure on processor card that cannot be automatically isolated. Go to "MAP 1540: Minimum Configuration" on page 113, and run CEC drawer minimum configuration for further isolation.
406C 3101	IPL detected RIO port 0 fault	1. Processor card Location: U1.1-P1-C1 2. CEC drawer backplane Location: U1.1-P1

Table 6. Service Processor Error Codes. (continued)

Error Code	Description	Action/ Possible Failing FRU
406C 3102	IPL detected RIO port 1 fault	1. Processor card Location: U1.1-P1-C1 2. CEC drawer backplane Location: U1.1-P1
406C 3121	IPL detected RIO cable on port 0 fault	RIO cable on port 0 Location: U1.1-P1/Q3
406C 3122	IPL detected RIO cable on port 1 fault	RIO cable on port 1 Location: U1.1-P1/Q2
406C 31FF	IPL detected RIO port fault	Processor card Location: U1.1-P1-C1
406C 3200	IPL detected primary I/O drawer fault	Go to "MAP 1540: Minimum Configuration" on page 113.
406C 3201	IPL detected primary I/O backplane fault	Primary I/O backplane Location: U0.1-P1
406C 3280	IPL detected primary RIO adapter fault	Primary RIO adapter Location: U0.1-P1.1
406C 3281	IPL detected primary RIO port 0 fault	1. Check RIO cable Location: U0.1-P1.1/Q1 2. Primary RIO adapter Location: U0.1-P1.1
406C 3282	IPL detected primary RIO port 1 fault	1. Check RIO cable Location: U0.1-P1.1/Q2 2. Primary RIO adapter Location: U0.1-P1.1
406C 3283	IPL detected primary RIO ports fault	Primary RIO adapter Location: U0.1-P1.1
406C 3284	IPL detected PCI controller PHB0 fault	1. RIO adapter Location: U0.1-P1.1 2. Primary I/O backplane Location: U0.1-P1
406C 3285	IPL detected PCI controller PHB1 fault	1. RIO adapter Location: U0.1-P1.1 2. Primary I/O backplane Location: U0.1-P1
406C 3286	IPL detected PCI controller PHB2 fault	1. RIO adapter Location: U0.1-P1.1 2. Primary I/O backplane Location: U0.1-P1
406D 0001	Attention handler detected CEC backplane fault	CEC backplane Location: U1.1-P1
406D 0003	Attention handler detected processor fault	All processors Location: U1.1-P1-C1

Table 6. Service Processor Error Codes. (continued)

Error Code	Description	Action/ Possible Failing FRU
406D 0009	Attention handler detected memory fault	All memory Locations: U1.1-P1-C1 U1.1-P1-M1 U1.1-P1-M2. Go to "MAP 1540: Minimum Configuration" on page 113 and run CEC drawer minimum configuration to isolate the failing memory component.
406D 00A0	Attention handler detected service processor firmware fault	Update system firmware
406D 00A1	Attention handler detected system firmware fault	1. Check for AIX updates 2. Check for system firmware update
406D 00A2	Attention handler detected service processor firmware (processor runtime diagnostics) Fault	Check for system firmware update
406D 00A3	Attention handler detected memory plugging fault	All pluggable memory. Go to "MAP 1540: Minimum Configuration" on page 113 and run CEC drawer minimum configuration to isolate the failing memory component.
406D 00A4	Attention handler detected application caused fault	Application software
406D 00A5	Attention handler detected invalid system configuration	Verify system components are supported and properly installed
406D 00A6	Attention handler detected no usable memory	1. Ensure that memory DIMMs and cards are properly installed. 2. Go to service processor memory configuration/deconfiguration menu to verify memory DIMMs state. See "Memory Configuration/Deconfiguration Menu" on page 384 for more information. 3. Go to "MAP 1540: Minimum Configuration" on page 113.
406D 00A7	Attention handler detected hardware problem	Go to "MAP 1540: Minimum Configuration" on page 113.
406D 00B0	Attention handler detected bus controller lock-unlock failure	RIO adapter Location: U0.1-P1.1
406D 00B1	Attention handler detected bus controller failure	RIO adapter Location: U0.1-P1.1

Table 6. Service Processor Error Codes. (continued)

Error Code	Description	Action/ Possible Failing FRU
406D 00B7	Attention handler detected insufficient hardware resources to continue IPL	This error code appears after the initial testing by the service processor firmware on the CEC was completed correctly, but a problem occurred when the firmware tried to communicate outside the CEC. Suspect a problem with the RIO interface, either cables or adapters.
406D 0100	Attention handler detected memory riser card fault	Memory riser card Location: U1.1-P1-M2
406D 0101	Attention handler detected memory DIMM fault	Memory DIMM Location: U1.1-P1-M2.15
406D 0102	Attention handler detected memory DIMM fault	Memory DIMM Location: U1.1-P1-M2.1
406D 0103	Attention handler detected memory DIMM fault	Memory DIMM Location: U1.1-P1-M2.16
406D 0104	Attention handler detected memory DIMM fault	Memory DIMM Location: U1.1-P1-M2.2
406D 010D	Attention handler detected memory DIMM fault	Memory DIMM Location: U1.1-P1-M2.1 x4
406D 0111	Attention handler detected memory DIMM fault	Memory DIMM Location: U1.1-P1-M2.13
406D 0112	Attention handler detected memory DIMM fault	Memory DIMM Location: U1.1-P1-M2.3
406D 0113	Attention handler detected memory DIMM fault	Memory DIMM Location: U1.1-P1-M2.14
406D 0114	Attention handler detected memory DIMM fault	Memory DIMM Location: U1.1-P1-M2.4
406D 011D	Attention handler detected memory DIMM fault	Memory DIMM Location: U1.1-P1-M2.3 x4
406D 0121	Attention handler detected memory DIMM fault	Memory DIMM Location: U1.1-P1-M2.11
406D 0122	Attention handler detected memory DIMM fault	Memory DIMM Location: U1.1-P1-M2.5
406D 0123	Attention handler detected memory DIMM fault	Memory DIMM Location: U1.1-P1-M2.12
406D 0124	Attention handler detected memory DIMM fault	Memory DIMM Location: U1.1-P1-M2.6
406D 012D	Attention handler detected memory DIMM fault	Memory DIMM Location: U1.1-P1-M2.5 x4
406D 0131	Attention handler detected memory DIMM fault	Memory DIMM Location: U1.1-P1-M2.9

Table 6. Service Processor Error Codes. (continued)

Error Code	Description	Action/ Possible Failing FRU
406D 0132	Attention handler detected memory DIMM fault	Memory DIMM Location: U1.1-P1-M2.7
406D 0133	Attention handler detected memory DIMM fault	Memory DIMM Location: U1.1-P1-M2.10
406D 0134	Attention handler detected memory DIMM fault	Memory DIMM Location: U1.1-P1-M2.8
406D 013D	Attention handler detected memory DIMM fault	Memory DIMM Location: U1.1-P1-M2.7 x4
406D 01FF	Attention handler detected memory on riser card fault	Memory failure on riser card 2 that cannot be automatically isolated. Go to "MAP 1540: Minimum Configuration" on page 113, and run CEC drawer minimum configuration for further isolation.
406D 0200	Attention handler detected memory riser card fault	Memory riser card Location: U1.1-P1-M1
406D 0201	Attention handler detected memory DIMM fault	Memory DIMM Location: U1.1-P1-M1.15
406D 0202	Attention handler detected memory DIMM fault	Memory DIMM Location: U1.1-P1-M1.1
406D 0203	Attention handler detected memory DIMM fault	Memory DIMM Location: U1.1-P1-M1.16
406D 0204	Attention handler detected memory DIMM fault	Memory DIMM Location: U1.1-P1-M1.2
406D 020D	Attention handler detected memory DIMM fault	Memory DIMM Location: U1.1-P1-M1.1 x4
406D 020E	Attention handler detected memory pair A fault	Memory pair A Location: U1.1-P1-M1.1 x2
406D 0211	Attention handler detected memory DIMM fault	Memory DIMM Location: U1.1-P1-M1.13
406D 0212	Attention handler detected memory DIMM fault	Memory DIMM Location: U1.1-P1-M1.3
406D 0213	Attention handler detected memory DIMM fault	Memory DIMM Location: U1.1-P1-M1.14
406D 0214	Attention handler detected memory DIMM fault	Memory DIMM Location: U1.1-P1-M1.4
406D 021D	Attention handler detected memory DIMM fault	Memory DIMM Location: U1.1-P1-M1.3 x4
406D 0221	Attention handler detected memory DIMM fault	Memory DIMM Location: U1.1-P1-M1.11
406D 0222	Attention handler detected memory DIMM fault	Memory DIMM Location: U1.1-P1-M1.5

Table 6. Service Processor Error Codes. (continued)

Error Code	Description	Action/ Possible Failing FRU
406D 0223	Attention handler detected memory DIMM fault	Memory DIMM Location: U1.1-P1-M1.12
406D 0224	Attention handler detected memory DIMM fault	Memory DIMM Location: U1.1-P1-M1.6
406D 022D	Attention handler detected memory DIMM fault	Memory DIMM Location: U1.1-P1-M1.5 x4
406D 0231	Attention handler detected memory DIMM fault	Memory DIMM Location: U1.1-P1-M1.9
406D 0232	Attention handler detected memory DIMM fault	Memory DIMM Location: U1.1-P1-M1.7
406D 0233	Attention handler detected memory DIMM fault	Memory DIMM Location: U1.1-P1-M1.10
406D 0234	Attention handler detected memory DIMM fault	Memory DIMM Location: U1.1-P1-M1.8
406D 023D	Attention handler detected memory DIMM fault	Memory DIMM Location: U1.1-P1-M1.7 x4
406D 02FF	Attention handler detected memory on riser card fault	Memory failure on riser card 1 that cannot be automatically isolated. Go to "MAP 1540: Minimum Configuration" on page 113, and run CEC drawer minimum configuration for further isolation.
406D 0300	Attention handler detected processor card fault	Processor card Location: U1.1-P1-C1
406D 0301	Attention handler detected memory DIMM fault	Memory DIMM Location: U1.1-P1-C1-M8
406D 0302	Attention handler detected memory DIMM fault	Memory DIMM Location: U1.1-P1-C1-M1
406D 030D	Attention handler detected memory DIMM fault	Memory DIMM Location: U1.1-P1-C1-M1 x2
406D 0311	Attention handler detected memory DIMM fault	Memory DIMM Location: U1.1-P1-C1-M7
406D 0312	Attention handler detected memory DIMM fault	Memory DIMM Location: U1.1-P1-C1-M2
406D 031D	Attention handler detected memory DIMM fault	Memory DIMM Location: U1.1-P1-C1-M2 x2
406D 0321	Attention handler detected memory DIMM fault	Memory DIMM Location: U1.1-P1-C1-M6
406D 0322	Attention handler detected memory DIMM fault	Memory DIMM Location: U1.1-P1-C1-M3
406D 032D	Attention handler detected memory DIMM fault	Memory DIMM Location: U1.1-P1-C1-M3 x2

Table 6. Service Processor Error Codes. (continued)

Error Code	Description	Action/ Possible Failing FRU
406D 0331	Attention handler detected memory DIMM fault	Memory DIMM Location: U1.1-P1-C1-M5
406D 0332	Attention handler detected memory DIMM fault	Memory DIMM Location: U1.1-P1-C1-M4
406D 033D	Attention handler detected memory DIMM fault	Memory DIMM Location: U1.1-P1-C1-M4 x2
406D 03FF	Attention handler detected memory on processor card fault	Memory failure on processor card that cannot be automatically isolated. Go to "MAP 1540: Minimum Configuration" on page 113, and run CEC drawer minimum configuration for further isolation.
406D 3101	Attention handler detected RIO port 0 fault	1. Processor card Location: U1.1-P1-C1 2. CEC drawer backplane Location: U1.1-P1
406D 3102	Attention handler detected RIO port 1 fault	1. Processor card Location: U1.1-P1-C1 2. CEC drawer backplane Location: U1.1-P1
406D 3121	Attention handler detected RIO cable on port 0 fault	RIO cable on port 0 Location: U1.1-P1/Q3
406D 3122	Attention handler detected RIO cable on port 1 fault	RIO cable on port 1 Location: U1.1-P1/Q2
406D 31FF	Attention handler detected RIO port fault	Processor card Location: U1.1-P1-C1
406D 3200	Attention handler detected primary I/O drawer fault	Go to "MAP 1540: Minimum Configuration" on page 113.
406D 3201	Attention handler detected primary I/O backplane fault	Primary I/O backplane Location: U0.1-P1
406D 3280	Attention handler detected primary RIO adapter fault	Primary RIO adapter Location: U0.1-P1.1
406D 3281	Attention handler detected primary RIO port 0 fault	1. Check RIO cable Location: U0.1-P1.1/Q1 2. Primary RIO adapter Location: U0.1-P1.1
406D 3282	Attention handler detected primary RIO port 1 fault	1. Check RIO cable Location: U0.1-P1.1/Q2 2. Primary RIO adapter Location: U0.1-P1.1
406D 3283	Attention handler detected primary RIO ports fault	Primary RIO adapter Location: U0.1-P1.1

Table 6. Service Processor Error Codes. (continued)

Error Code	Description	Action/ Possible Failing FRU
406D 3284	Attention handler detected PCI controller PHB0 fault	<ol style="list-style-type: none"> 1. RIO adapter Location: U0.1-P1.1 2. Primary I/O backplane Location: U0.1-P1
406D 3285	Attention handler detected PCI controller PHB1 fault	<ol style="list-style-type: none"> 1. RIO adapter Location: U0.1-P1.1 2. Primary I/O backplane Location: U0.1-P1
406D 3286	Attention handler detected PCI controller PHB2 fault	<ol style="list-style-type: none"> 1. RIO adapter Location: U0.1-P1.1 2. Primary I/O backplane Location: U0.1-P1
406E 0001	Scan control routines detected CEC backplane fault	CEC backplane Location: U1.1-P1
406E 0003	Scan control routines detected processor fault	All processors Location: U1.1-P1-C1
406E 0009	Scan control routines detected memory fault	All memory Locations: U1.1-P1-C1 U1.1-P1-M1 U1.1-P1-M2. Go to "MAP 1540: Minimum Configuration" on page 113 and run CEC drawer minimum configuration to isolate the failing memory component.
406E 00A0	Scan control routines detected service processor firmware fault	Update system firmware
406E 00A1	Scan control routines detected system firmware fault	<ol style="list-style-type: none"> 1. Check for AIX updates 2. Check for system firmware update
406E 00A2	Scan control routine detected service processor firmware (processor runtime diagnostics) Fault	Check for system firmware update
406E 00A3	Scan control routine detected memory plugging fault	All pluggable memory. Go to "MAP 1540: Minimum Configuration" on page 113 and run CEC drawer minimum configuration to isolate the failing memory component.
406E 00A4	Scan control routine detected application caused fault	Application software
406E 00A5	Scan control routine detected invalid system configuration	Verify system components are supported and properly installed

Table 6. Service Processor Error Codes. (continued)

Error Code	Description	Action/ Possible Failing FRU
406E 00A6	Scan control routine detected no usable memory	<ol style="list-style-type: none"> 1. Ensure that memory DIMMs and cards are properly installed. 2. Go to service processor memory configuration/deconfiguration menu to verify memory DIMMs state. See "Memory Configuration/Deconfiguration Menu" on page 384 for more information. 3. Go to "MAP 1540: Minimum Configuration" on page 113.
406E 00A7	Scan control routine detected hardware problem	Go to "MAP 1540: Minimum Configuration" on page 113.
406E 00B0	Scan control routine detected bus controller lock-unlock failure	RIO adapter Location: U0.1-P1.1
406E 00B1	Scan control routine detected bus controller failure	RIO adapter Location: U0.1-P1.1
406E 00B7	Scan control routines detected insufficient hardware resources to continue IPL	This error code appears after the initial testing by the service processor firmware on the CEC was completed correctly, but a problem occurred when the firmware tried to communicate outside the CEC. Suspect a problem with the RIO interface, either cables or adapters.
406E 0100	Scan control routine detected memory riser card fault	Memory riser card Location: U1.1-P1-M2
406E 0101	Scan control routine detected memory DIMM fault	Memory DIMM Location: U1.1-P1-M2.15
406E 0102	Scan control routine detected memory DIMM fault	Memory DIMM Location: U1.1-P1-M2.1
406E 0103	Scan control routine detected memory DIMM fault	Memory DIMM Location: U1.1-P1-M2.16
406E 0104	Scan control routine detected memory DIMM fault	Memory DIMM Location: U1.1-P1-M2.2
406E 010D	Scan control routine detected memory DIMM fault	Memory DIMM Location: U1.1-P1-M2.1 x4
406E 0111	Scan control routine detected memory DIMM fault	Memory DIMM Location: U1.1-P1-M2.13
406E 0112	Scan control routine detected memory DIMM fault	Memory DIMM Location: U1.1-P1-M2.3
406E 0113	Scan control routine detected memory DIMM fault	Memory DIMM Location: U1.1-P1-M2.14
406E 0114	Scan control routine detected memory DIMM fault	Memory DIMM Location: U1.1-P1-M2.4

Table 6. Service Processor Error Codes. (continued)

Error Code	Description	Action/ Possible Failing FRU
406E 011D	Scan control routine detected memory DIMM fault	Memory DIMM Location: U1.1-P1-M2.3 x4
406E 0121	Scan control routine detected memory DIMM fault	Memory DIMM Location: U1.1-P1-M2.11
406E 0122	Scan control routine detected memory DIMM fault	Memory DIMM Location: U1.1-P1-M2.5
406E 0123	Scan control routine detected memory DIMM fault	Memory DIMM Location: U1.1-P1-M2.12
406E 0124	Scan control routine detected memory DIMM fault	Memory DIMM Location: U1.1-P1-M2.6
406E 012D	Scan control routine detected memory DIMM fault	Memory DIMM Location: U1.1-P1-M2.5 x4
406E 0131	Scan control routine detected memory DIMM fault	Memory DIMM Location: U1.1-P1-M2.9
406E 0132	Scan control routine detected memory DIMM fault	Memory DIMM Location: U1.1-P1-M2.7
406E 0133	Scan control routine detected memory DIMM fault	Memory DIMM Location: U1.1-P1-M2.10
406E 0134	Scan control routine detected memory DIMM fault	Memory DIMM Location: U1.1-P1-M2.8
406E 013D	Scan control routine detected memory DIMM fault	Memory DIMM Location: U1.1-P1-M2.7 x4
406E 01FF	Scan control routine detected memory on riser card fault	Memory failure on riser card 2 that cannot be automatically isolated. Go to "MAP 1540: Minimum Configuration" on page 113, and run CEC drawer minimum configuration for further isolation.
406E 0200	Scan control routine detected memory riser card fault	Memory riser card Location: U1.1-P1-M1
406E 0201	Scan control routine detected memory DIMM fault	Memory DIMM Location: U1.1-P1-M1.15
406E 0202	Scan control routine detected memory DIMM fault	Memory DIMM Location: U1.1-P1-M1.1
406E 0203	Scan control routine detected memory DIMM fault	Memory DIMM Location: U1.1-P1-M1.16
406E 0204	Scan control routine detected memory DIMM fault	Memory DIMM Location: U1.1-P1-M1.2
406E 020D	Scan control routine detected memory DIMM fault	Memory DIMM Location: U1.1-P1-M1.1 x4
406E 020E	Scan control routine detected memory pair A fault	Memory pair A Location: U1.1-P1-M1.1 x2

Table 6. Service Processor Error Codes. (continued)

Error Code	Description	Action/ Possible Failing FRU
406E 0211	Scan control routine detected memory DIMM fault	Memory DIMM Location: U1.1-P1-M1.13
406E 0212	Scan control routine detected memory DIMM fault	Memory DIMM Location: U1.1-P1-M1.3
406E 0213	Scan control routine detected memory DIMM fault	Memory DIMM Location: U1.1-P1-M1.14
406E 0214	Scan control routine detected memory DIMM fault	Memory DIMM Location: U1.1-P1-M1.4
406E 021D	Scan control routine detected memory DIMM fault	Memory DIMM Location: U1.1-P1-M1.3 x4
406E 0221	Scan control routine detected memory DIMM fault	Memory DIMM Location: U1.1-P1-M1.11
406E 0222	Scan control routine detected memory DIMM fault	Memory DIMM Location: U1.1-P1-M1.5
406E 0223	Scan control routine detected memory DIMM fault	Memory DIMM Location: U1.1-P1-M1.12
406E 0224	Scan control routine detected memory DIMM fault	Memory DIMM Location: U1.1-P1-M1.6
406E 022D	Scan control routine detected memory DIMM fault	Memory DIMM Location: U1.1-P1-M1.5 x4
406E 0231	Scan control routine detected memory DIMM fault	Memory DIMM Location: U1.1-P1-M1.9
406E 0232	Scan control routine detected memory DIMM fault	Memory DIMM Location: U1.1-P1-M1.7
406E 0233	Scan control routine detected memory DIMM fault	Memory DIMM Location: U1.1-P1-M1.10
406E 0234	Scan control routine detected memory DIMM fault	Memory DIMM Location: U1.1-P1-M1.8
406E 023D	Scan control routine detected memory DIMM fault	Memory DIMM Location: U1.1-P1-M1.7 x4
406E 02FF	Scan control routine detected memory on riser card fault	Memory failure on riser card 1 that cannot be automatically isolated. Go to "MAP 1540: Minimum Configuration" on page 113, and run CEC drawer minimum configuration for further isolation.
406E 0300	Scan control routine detected processor card fault	Processor card Location: U1.1-P1-C1
406E 0301	Scan control routine detected memory DIMM fault	Memory DIMM Location: U1.1-P1-C1-M8
406E 0302	Scan control routine detected memory DIMM fault	Memory DIMM Location: U1.1-P1-C1-M1

Table 6. Service Processor Error Codes. (continued)

Error Code	Description	Action/ Possible Failing FRU
406E 030D	Scan control routine detected memory DIMM fault	Memory DIMM Location: U1.1-P1-C1-M1 x2
406E 0311	Scan control routine detected memory DIMM fault	Memory DIMM Location: U1.1-P1-C1-M7
406E 0312	Scan control routine detected memory DIMM fault	Memory DIMM Location: U1.1-P1-C1-M2
406E 031D	Scan control routine detected memory DIMM fault	Memory DIMM Location: U1.1-P1-C1-M2 x2
406E 0321	Scan control routine detected memory DIMM fault	Memory DIMM Location: U1.1-P1-C1-M6
406E 0322	Scan control routine detected memory DIMM fault	Memory DIMM Location: U1.1-P1-C1-M3
406E 032D	Scan control routine detected memory DIMM fault	Memory DIMM Location: U1.1-P1-C1-M3 x2
406E 0331	Scan control routine detected memory DIMM fault	Memory DIMM Location: U1.1-P1-C1-M5
406E 0332	Scan control routine detected memory DIMM fault	Memory DIMM Location: U1.1-P1-C1-M4
406E 033D	Scan control routine detected memory DIMM fault	Memory DIMM Location: U1.1-P1-C1-M4 x2
406E 03FF	Scan control routine detected memory on processor card fault	Memory failure on processor card that cannot be automatically isolated. Go to "MAP 1540: Minimum Configuration" on page 113, and run CEC drawer minimum configuration for further isolation.
406E 3101	Scan control routine detected RIO port 0 fault	1. Processor card Location: U1.1-P1-C1 2. CEC drawer backplane Location: U1.1-P1
406E 3102	Scan control routine detected RIO port 1 fault	1. Processor card Location: U1.1-P1-C1 2. CEC drawer backplane Location: U1.1-P1
406E 3121	Scan control routine detected RIO cable on port 0 fault	RIO cable on port 0 Location: U1.1-P1/Q3
406E 3122	Scan control routine detected RIO cable on port 1 fault	RIO cable on port 1 Location: U1.1-P1/Q2
406E 31FF	Scan control routine detected RIO port fault	Processor card Location: U1.1-P1-C1
406E 3200	Scan control routine detected primary I/O drawer fault	Go to "MAP 1540: Minimum Configuration" on page 113.

Table 6. Service Processor Error Codes. (continued)

Error Code	Description	Action/ Possible Failing FRU
406E 3201	Scan control routine detected primary I/O backplane fault	Primary I/O backplane Location: U0.1-P1
406E 3280	Scan control routine detected primary RIO adapter fault	Primary RIO adapter Location: U0.1-P1.1
406E 3281	Scan control routine detected primary RIO port 0 fault	1. Check RIO cable Location: U0.1-P1.1/Q1 2. Primary RIO adapter Location: U0.1-P1.1
406E 3282	Scan control routine detected primary RIO port 1 fault	1. Check RIO cable Location: U0.1-P1.1/Q2 2. Primary RIO adapter Location: U0.1-P1.1
406E 3283	Scan control routine detected primary RIO ports fault	Primary RIO adapter Location: U0.1-P1.1
406E 3284	Scan control routine detected PCI controller PHB0 fault	1. RIO adapter Location: U0.1-P1.1 2. Primary I/O backplane Location: U0.1-P1
406E 3285	Scan control routine detected PCI controller PHB1 fault	1. RIO adapter Location: U0.1-P1.1 2. Primary I/O backplane Location: U0.1-P1
406E 3286	Scan control routine detected PCI controller PHB2 fault	1. RIO adapter Location: U0.1-P1.1 2. Primary I/O backplane Location: U0.1-P1
406F 0001	Error code generation/logging detected CEC backplane fault	CEC backplane Location: U1.1-P1
406F 0003	Error code generation/logging detected processor fault	All processors Location: U1.1-P1-C1
406F 0009	Error code generation/logging detected memory fault	All memory Locations: U1.1-P1-C1 U1.1-P1-M1 U1.1-P1-M2. Go to "MAP 1540: Minimum Configuration" on page 113 and run CEC drawer minimum configuration to isolate the failing memory component.
406F 00A0	Error code generation/logging detected service processor firmware fault	Update system firmware
406F 00A1	Error code generation/logging detected system firmware fault	1. Check for AIX updates 2. Check for system firmware update

Table 6. Service Processor Error Codes. (continued)

Error Code	Description	Action/ Possible Failing FRU
406F 00A2	Error code generation/logging detected service processor Firmware (processor runtime diagnostics) Fault	Check for system firmware update
406F 00A3	Error code generation/logging detected memory plugging fault	All pluggable memory. Go to "MAP 1540: Minimum Configuration" on page 113 and run CEC drawer minimum configuration to isolate the failing memory component.
406F 00A4	Error code generation/logging detected application caused fault	Application software
406F 00A5	Error code generation/logging detected invalid system configuration	Verify system components are supported and properly installed
406F 00A6	Error code generation/logging detected no usable memory	<ol style="list-style-type: none"> 1. Ensure that memory DIMMs and cards are properly installed. 2. Go to service processor memory configuration/deconfiguration menu to verify memory DIMMs state. See "Memory Configuration/Deconfiguration Menu" on page 384 for more information. 3. Go to "MAP 1540: Minimum Configuration" on page 113.
406F 00A7	Error code generation/logging detected hardware problem	Go to "MAP 1540: Minimum Configuration" on page 113.
406F 00B0	Error code generation/logging detected bus controller lock-unlock failure	RIO adapter Location: U0.1-P1.1
406F 00B1	Error code generation/logging detected bus controller failure	RIO adapter Location: U0.1-P1.1
406F 00B7	Error code generation/logging detected insufficient hardware resources to continue IPL	This error code appears after the initial testing by the service processor firmware on the CEC was completed correctly, but a problem occurred when the firmware tried to communicate outside the CEC. Suspect a problem with the RIO interface, either cables or adapters.
406F 0100	Error code generation/logging detected memory riser card fault	Memory riser card Location: U1.1-P1-M2
406F 0101	Error code generation/logging detected memory DIMM fault	Memory DIMM Location: U1.1-P1-M2.15
406F 0102	Error code generation/logging detected memory DIMM fault	Memory DIMM Location: U1.1-P1-M2.1

Table 6. Service Processor Error Codes. (continued)

Error Code	Description	Action/ Possible Failing FRU
406F 0103	Error code generation/logging detected memory DIMM fault	Memory DIMM Location: U1.1-P1-M2.16
406F 0104	Error code generation/logging detected memory DIMM fault	Memory DIMM Location: U1.1-P1-M2.2
406F 010D	Error code generation/logging detected memory DIMM fault	Memory DIMM Location: U1.1-P1-M2.1 x4
406F 0111	Error code generation/logging detected memory DIMM fault	Memory DIMM Location: U1.1-P1-M2.13
406F 0112	Error code generation/logging detected memory DIMM fault	Memory DIMM Location: U1.1-P1-M2.3
406F 0113	Error code generation/logging detected memory DIMM fault	Memory DIMM Location: U1.1-P1-M2.14
406F 0114	Error code generation/logging detected memory DIMM fault	Memory DIMM Location: U1.1-P1-M2.4
406F 011D	Error code generation/logging detected memory DIMM fault	Memory DIMM Location: U1.1-P1-M2.3 x4
406F 0121	Error code generation/logging detected memory DIMM fault	Memory DIMM Location: U1.1-P1-M2.11
406F 0122	Error code generation/logging detected memory DIMM fault	Memory DIMM Location: U1.1-P1-M2.5
406F 0123	Error code generation/logging detected memory DIMM fault	Memory DIMM Location: U1.1-P1-M2.12
406F 0124	Error code generation/logging detected memory DIMM fault	Memory DIMM Location: U1.1-P1-M2.6
406F 012D	Error code generation/logging detected memory DIMM fault	Memory DIMM Location: U1.1-P1-M2.5 x4
406F 0131	Error code generation/logging detected memory DIMM fault	Memory DIMM Location: U1.1-P1-M2.9
406F 0132	Error code generation/logging detected memory DIMM fault	Memory DIMM Location: U1.1-P1-M2.7
406F 0133	Error code generation/logging detected memory DIMM fault	Memory DIMM Location: U1.1-P1-M2.10
406F 0134	Error code generation/logging detected memory DIMM fault	Memory DIMM Location: U1.1-P1-M2.8
406F 013D	Error code generation/logging detected memory DIMM fault	Memory DIMM Location: U1.1-P1-M2.7 x4
406F 01FF	Error code generation/logging detected memory on riser card fault	Memory failure on riser card 2 that cannot be automatically isolated. Go to "MAP 1540: Minimum Configuration" on page 113, and run CEC drawer minimum configuration for further isolation.

Table 6. Service Processor Error Codes. (continued)

Error Code	Description	Action/ Possible Failing FRU
406F 0200	Scan control routine detected memory riser card fault	Memory riser card Location: U1.1-P1-M1
406F 0201	Error code generation/logging detected memory DIMM fault	Memory DIMM Location: U1.1-P1-M1.15
406F 0202	Error code generation/logging detected memory DIMM fault	Memory DIMM Location: U1.1-P1-M1.1
406F 0203	Error code generation/logging detected memory DIMM fault	Memory DIMM Location: U1.1-P1-M1.16
406F 0204	Error code generation/logging detected memory DIMM fault	Memory DIMM Location: U1.1-P1-M1.2
406F 020D	Error code generation/logging detected memory DIMM fault	Memory DIMM Location: U1.1-P1-M1.1 x4
406F 020E	Error code generation/logging detected memory pair A fault	Memory pair A Location: U1.1-P1-M1.1 x2
406F 0211	Error code generation/logging detected memory DIMM fault	Memory DIMM Location: U1.1-P1-M1.13
406F 0212	Error code generation/logging detected memory DIMM fault	Memory DIMM Location: U1.1-P1-M1.3
406F 0213	Error code generation/logging detected memory DIMM fault	Memory DIMM Location: U1.1-P1-M1.14
406F 0214	Error code generation/logging detected memory DIMM fault	Memory DIMM Location: U1.1-P1-M1.4
406F 021D	Error code generation/logging detected memory DIMM fault	Memory DIMM Location: U1.1-P1-M1.3 x4
406F 0221	Error code generation/logging detected memory DIMM fault	Memory DIMM Location: U1.1-P1-M1.11
406F 0222	Error code generation/logging detected memory DIMM fault	Memory DIMM Location: U1.1-P1-M1.5
406F 0223	Error code generation/logging detected memory DIMM fault	Memory DIMM Location: U1.1-P1-M1.12
406F 0224	Error code generation/logging detected memory DIMM fault	Memory DIMM Location: U1.1-P1-M1.6
406F 022D	Error code generation/logging detected memory DIMM fault	Memory DIMM Location: U1.1-P1-M1.5 x4
406F 0231	Error code generation/logging detected memory DIMM fault	Memory DIMM Location: U1.1-P1-M1.9
406F 0232	Error code generation/logging detected memory DIMM fault	Memory DIMM Location: U1.1-P1-M1.7
406F 0233	Error code generation/logging detected memory DIMM fault	Memory DIMM Location: U1.1-P1-M1.10
406F 0234	Error code generation/logging detected memory DIMM fault	Memory DIMM Location: U1.1-P1-M1.8

Table 6. Service Processor Error Codes. (continued)

Error Code	Description	Action/ Possible Failing FRU
406F 023D	Error code generation/logging detected memory DIMM fault	Memory DIMM Location: U1.1-P1-M1.7 x4
406F 02FF	Error code generation/logging detected memory on riser card fault	Memory failure on riser card 1 that cannot be automatically isolated. Go to "MAP 1540: Minimum Configuration" on page 113, and run CEC drawer minimum configuration for further isolation.
406F 0300	Error code generation/logging detected processor card fault	Processor card Location: U1.1-P1-C1
406F 0301	Error code generation/logging detected memory DIMM fault	Memory DIMM Location: U1.1-P1-C1-M8
406F 0302	Error code generation/logging detected memory DIMM fault	Memory DIMM Location: U1.1-P1-C1-M1
406F 030D	Error code generation/logging detected memory DIMM fault	Memory DIMM Location: U1.1-P1-C1-M1 x2
406F 0311	Error code generation/logging detected memory DIMM fault	Memory DIMM Location: U1.1-P1-C1-M7
406F 0312	Error code generation/logging detected memory DIMM fault	Memory DIMM Location: U1.1-P1-C1-M2
406F 031D	Error code generation/logging detected memory DIMM fault	Memory DIMM Location: U1.1-P1-C1-M2 x2
406F 0321	Error code generation/logging detected memory DIMM fault	Memory DIMM Location: U1.1-P1-C1-M6
406F 0322	Error code generation/logging detected memory DIMM fault	Memory DIMM Location: U1.1-P1-C1-M3
406F 032D	Error code generation/logging detected memory DIMM fault	Memory DIMM Location: U1.1-P1-C1-M3 x2
406F 0331	Error code generation/logging detected memory DIMM fault	Memory DIMM Location: U1.1-P1-C1-M5
406F 0332	Error code generation/logging detected memory DIMM fault	Memory DIMM Location: U1.1-P1-C1-M4
406F 033D	Error code generation/logging detected memory DIMM fault	Memory DIMM Location: U1.1-P1-C1-M4 x2
406F 03FF	Error code generation/logging detected memory on processor card fault	Memory failure on processor card that cannot be automatically isolated. Go to "MAP 1540: Minimum Configuration" on page 113, and run CEC drawer minimum configuration for further isolation.
406F 3101	Error code generation/logging detected RIO port 0 fault	1. Processor card Location: U1.1-P1-C1 2. CEC drawer backplane Location: U1.1-P1

Table 6. Service Processor Error Codes. (continued)

Error Code	Description	Action/ Possible Failing FRU
406F 3102	Error code generation/logging detected RIO port 1 fault	1. Processor card Location: U1.1-P1-C1 2. CEC drawer backplane Location: U1.1-P1
406F 3121	Error code generation/logging detected RIO cable on port 0 fault	RIO cable on port 0 Location: U1.1-P1/Q3
406F 3122	Error code generation/logging detected RIO cable on port 1 fault	RIO cable on port 1 Location: U1.1-P1/Q2
406F 31FF	Error code generation/logging detected RIO port fault	Processor card Location: U1.1-P1-C1
406F 3200	Error code generation/logging detected primary I/O drawer fault	Go to "MAP 1540: Minimum Configuration" on page 113.
406F 3201	Error code generation/logging detected primary I/O backplane fault	Primary I/O backplane Location: U0.1-P1
406F 3280	Error code generation/logging detected primary RIO adapter fault	Primary RIO adapter Location: U0.1-P1.1
406F 3281	Error code generation/logging detected primary RIO port 0 fault	1. Check RIO cable Location: U0.1-P1.1/Q1 2. Primary RIO adapter Location: U0.1-P1.1
406F 3282	Error code generation/logging detected primary RIO port 1 fault	1. Check RIO cable Location: U0.1-P1.1/Q2 2. Primary RIO adapter Location: U0.1-P1.1
406F 3283	Error code generation/logging detected primary RIO ports fault	Primary RIO adapter Location: U0.1-P1.1
406F 3284	Error code generation/logging detected PCI controller PHB0 fault	1. RIO adapter Location: U0.1-P1.1 2. Primary I/O backplane Location: U0.1-P1
406F 3285	Error code generation/logging detected PCI controller PHB1 fault	1. RIO adapter Location: U0.1-P1.1 2. Primary I/O backplane Location: U0.1-P1
406F 3286	Error code generation/logging detected PCI controller PHB2 fault	1. RIO adapter Location: U0.1-P1.1 2. Primary I/O backplane Location: U0.1-P1
4506 244C	Memory system and scan interface basic assurance tests detected 1W processor fault	Processor card Location: U1.1-P1-C1
4506 244D	Memory system and scan interface basic assurance tests detected 2W processor fault	Processor card Location: U1.1-P1-C1

Table 6. Service Processor Error Codes. (continued)

Error Code	Description	Action/ Possible Failing FRU
4506 244E	Memory system and scan interface basic assurance tests detected 4W processor fault	Processor card Location: U1.1-P1-C1
4506 244F	Memory system and scan interface basic assurance tests detected 6W processor fault	Processor card Location: U1.1-P1-C1
4506 248B	Memory system and scan interface basic assurance tests detected primary I/O drawer operator panel fault	Operator Panel Location: U0.1-L1
4506 24A1	Memory system and scan interface basic assurance tests detected 1W processor fault	Processor card Location: U1.1-P1-C1
4506 24A2	Memory system and scan interface basic assurance tests detected 2W processor fault	Processor card Location: U1.1-P1-C1
4506 24A3	Memory system and scan interface basic assurance tests detected 4W processor fault	Processor card Location: U1.1-P1-C1
4506 24A4	Memory system and scan interface basic assurance tests detected 6W processor fault	Processor card Location: U1.1-P1-C1
4506 25BB	Memory system and scan interface basic assurance tests detected 1W processor fault	1W Processor card Location: U1.1-P1-C1
4506 25BD	Memory system and scan interface basic assurance tests detected 2W processor fault	2W Processor card Location: U1.1-P1-C1
4506 25BE	Memory system and scan interface basic assurance tests detected 4W processor fault	4W Processor card Location: U1.1-P1-C1
4506 25BF	Memory system and scan interface basic assurance tests detected 6W processor fault	6W Processor card Location: U1.1-P1-C1
4506 25CB	1W processor card fault	Replace the processor card Location: U1.1-P1-C1
4506 25EA	4W processor card fault	Replace the processor card Location: U1.1-P1-C1
4506 25EB	2W processor card fault	Replace the processor card Location: U1.1-P1-C1
4506 25F2	6W processor card fault	Replace the processor card Location: U1.1-P1-C1

Table 6. Service Processor Error Codes. (continued)

Error Code	Description	Action/ Possible Failing FRU
4506 263D	Memory system and scan interface basic assurance tests detected dummy riser card fault	Dummy riser card Locations: U1.1-P1-M1 U1.1-P1-M2
4506 2687	Memory system and scan interface basic assurance tests detected RIO adapter fault	RIO adapter Location: U0.1-P1.1
4506 271A	Memory system and scan interface basic assurance tests detected primary I/O backplane fault	Primary I/O backplane Location: U0.1-P1
4506 271D	Memory system and scan interface basic assurance tests detected secondary I/O backplane fault	Secondary I/O backplane Location: U0.2-P1
4506 283A	Memory system and scan interface basic assurance tests detected CEC backplane fault	1. Processor card Location: U1.1-P1-C1 2. CEC backplane Location: U1.1-P1
4506 285D	Memory system and scan interface basic assurance tests detected fan controller card fault	Fan controller card Locations: U0.1-X2 U1.1-X2
4506 288D	Memory system and scan interface basic assurance tests detected memory riser fault	1. Go to service processor memory configuration/deconfiguration menu to verify memory DIMMs state. See "Memory Configuration/Deconfiguration Menu" on page 384 for more information. 2. Riser card Locations: U1.1-P1-M1 U1.1-P1-M2
4506 2A00	Memory system and scan interface basic assurance tests detected 6W processor fault	Processor card Location: U1.1-P1-C1
4506 300A	Memory system and scan interface basic assurance tests detected 32MB DIMM fault	Memory DIMM Locations: U1.1-P1-M1.n U1.1-P1-M2.n U1.1-P1-C1-Mn
4506 300B	Memory system and scan interface basic assurance tests detected 128MB DIMM fault	Memory DIMM Locations: U1.1-P1-M1.n U1.1-P1-M2.n U1.1-P1-C1-Mn

Table 6. Service Processor Error Codes. (continued)

Error Code	Description	Action/ Possible Failing FRU
4506 300C	Memory system and scan interface basic assurance tests detected 256MB DIMM fault	Memory DIMM Locations: U1.1-P1-M1.n U1.1-P1-M2.n U1.1-P1-C1-Mn
4506 300D	Memory system and scan interface basic assurance tests detected 512MB (stacked) DIMM fault	Memory DIMM Locations: U1.1-P1-M1.n U1.1-P1-M2.n U1.1-P1-C1-Mn
4506 300E	Memory system and scan interface basic assurance tests detected 512MB (unstacked) DIMM fault	Memory DIMM Locations: U1.1-P1-M1.n U1.1-P1-M2.n U1.1-P1-C1-Mn
4506 301F	Memory system and scan interface basic assurance tests detected 128MB DIMM fault	Memory DIMM Locations: U1.1-P1-M1.n U1.1-P1-M2.n U1.1-P1-C1-Mn
4506 303A	Memory system and scan interface basic assurance tests detected 1GB DIMM fault	Memory DIMM Locations: U1.1-P1-M1.n U1.1-P1-M2.n U1.1-P1-C1-Mn
4506 51AA	Memory system and scan interface basic assurance tests detected 645W AC power supply fault	645W AC power supply Locations: U1.1-V1 U1.1-V2
4506 51AB	Memory system and scan interface basic assurance tests detected 645W DC power supply fault	645W DC power supply Locations: U1.1-V1 U1.1-V2
4506 51AC	Memory system and scan interface basic assurance tests detected 595W AC power supply fault	595W AC power supply Locations: U0.1-V1 U0.1-V2
4506 51AD	Memory system and scan interface basic assurance tests detected 595W DC power supply fault	595W DC power supply Locations: U0.1-V1 U0.1-V2
4507 244C	Memory system and 6xx bus processor runtime diagnostics detected 1W processor fault	Processor card Location: U1.1-P1-C1

Table 6. Service Processor Error Codes. (continued)

Error Code	Description	Action/ Possible Failing FRU
4507 244D	Memory system and 6xx bus processor runtime diagnostics detected 2W processor fault	Processor card Location: U1.1-P1-C1
4507 244E	Memory system and 6xx bus processor runtime diagnostics detected 4W processor fault	Processor card Location: U1.1-P1-C1
4507 244F	Memory system and 6xx bus processor runtime diagnostics detected 1W processor fault	Processor card Location: U1.1-P1-C1
4507 248B	Memory system and 6xx bus processor runtime diagnostics detected primary I/O drawer operator panel fault	Operator panel Location: U0.1-L1
4507 24A1	Memory system and 6xx bus processor runtime diagnostics detected 1W processor fault	Processor card Location: U1.1-P1-C1
4507 24A2	Memory system and 6xx bus processor runtime diagnostics detected 2W processor fault	Processor card Location: U1.1-P1-C1
4507 24A3	Memory system and 6xx bus processor runtime diagnostics detected 4W processor fault	Processor card Location: U1.1-P1-C1
4507 24A4	Memory system and 6xx bus processor runtime diagnostics detected 6W processor fault	Processor card Location: U1.1-P1-C1
4507 25BB	Memory system and 6xx bus processor runtime diagnostics detected 1W processor card fault	1W Processor card Location: U1.1-P1-C1
4507 25BD	Memory system and 6xx bus processor runtime diagnostics detected 2W processor card fault	2W Processor card Location: U1.1-P1-C1
4507 25BE	Memory system and 6xx bus processor runtime diagnostics detected 4W processor card fault	4W Processor card Location: U1.1-P1-C1
4507 25BF	Memory system and 6xx bus processor runtime diagnostics detected 6W processor card fault	6W Processor card Location: U1.1-P1-C1
4507 25CB	1W processor card fault	Replace the processor card Location: U1.1-P1-C1
4507 25EA	4W processor card fault	Replace the processor card Location: U1.1-P1-C1
4507 25EB	2W processor card fault	Replace the processor card Location: U1.1-P1-C1

Table 6. Service Processor Error Codes. (continued)

Error Code	Description	Action/ Possible Failing FRU
4507 25F2	6W processor card fault	Replace the processor card Location: U1.1-P1-C1
4507 263D	Memory system and 6xx bus processor runtime diagnostics detected dummy riser card fault	Dummy riser card Locations: U1.1-P1-M1 U1.1-P1-M2
4507 2687	Memory system and 6xx bus processor runtime diagnostics detected RIO adapter fault	RIO adapter Location: U0.1-P1.1
4507 271A	Memory system and 6xx bus processor runtime diagnostics detected primary I/O backplane fault	Primary I/O backplane Location: U0.1-P1
4507 271D	Memory system and 6xx bus processor runtime diagnostics detected secondary I/O backplane fault	Secondary I/O backplane Location: U0.2-P1
4507 283A	Memory system and 6xx bus processor runtime diagnostics detected CEC backplane fault	1. Processor card Location: U1.1-P1-C1 2. CEC backplane Location: U1.1-P1
4507 285D	Memory system and 6xx bus processor runtime diagnostics detected fan controller card fault	Fan controller card Location: U0.1-X2 Location: U1.1-X2
4507 288D	Memory system and 6xx bus processor runtime diagnostics detected memory riser fault	1. Go to service processor memory configuration/deconfiguration menu to verify memory DIMMs state. See "Memory Configuration/Deconfiguration Menu" on page 384 for more information. 2. Memory riser card Locations: U1.1-P1-M1 U1.1-P1-M2
4507 2A00	Memory system and 6xx bus processor runtime diagnostics detected 6W 4M 500 processor fault	Processor card Location: U1.1-P1-C1
4507 300A	Memory system and 6xx bus processor runtime diagnostics detected 32MB DIMM fault	Memory DIMM Locations: U1.1-P1-M1.n U1.1-P1-M2.n U1.1-P1-C1-Mn

Table 6. Service Processor Error Codes. (continued)

Error Code	Description	Action/ Possible Failing FRU
4507 300B	Memory system and 6xx bus processor runtime diagnostics detected 128MB DIMM fault	Memory DIMM Locations: U1.1-P1-M1.n U1.1-P1-M2.n U1.1-P1-C1-Mn
4507 300C	Memory system and 6xx bus processor runtime diagnostics detected 256MB DIMM fault	Memory DIMM Locations: U1.1-P1-M1.n U1.1-P1-M2.n U1.1-P1-C1-Mn
4507 300D	Memory system and 6xx bus processor runtime diagnostics detected 512MB (stacked) DIMM fault	Memory DIMM Locations: U1.1-P1-M1.n U1.1-P1-M2.n U1.1-P1-C1-Mn
4507 300E	Memory system and 6xx bus processor runtime diagnostics detected 512MB (unstacked) DIMM fault	Memory DIMM Locations: U1.1-P1-M1.n U1.1-P1-M2.n U1.1-P1-C1-Mn
4507 301F	Memory system and scan interface basic assurance tests detected 128MB DIMM fault	Memory DIMM Locations: U1.1-P1-M1.n U1.1-P1-M2.n U1.1-P1-C1-Mn
4507 303A	Memory system and 6xx bus processor runtime diagnostics detected 1GB DIMM fault	Memory DIMM Locations: U1.1-P1-M1.n U1.1-P1-M2.n U1.1-P1-C1-Mn
4507 51AA	Memory system and 6xx bus processor runtime diagnostics detected 645W AC power supply fault	645W AC power supply Locations: U1.1-V1 U1.1-V2
4507 51AB	Memory system and 6xx bus processor runtime diagnostics detected 645W DC power supply fault	645W DC power supply Locations: U1.1-V1 U1.1-V2
4507 51AC	Memory system and 6xx bus processor runtime diagnostics detected 595W AC power supply fault	595W AC power supply Locations: U0.1-V1 U0.1-V2
4507 51AD	Memory system and 6xx bus processor runtime diagnostics detected 595W DC power supply fault	595W DC power supply Locations: U0.1-V1 U0.1-V2

Table 6. Service Processor Error Codes. (continued)

Error Code	Description	Action/ Possible Failing FRU
4508 244C	Memory system and other bus processor runtime diagnostics detected 1W processor fault	Processor card Location: U1.1-P1-C1
4508 244D	Memory system and other bus processor runtime diagnostics detected 2W processor fault	Processor card Location: U1.1-P1-C1
4508 244E	Memory system and other bus processor runtime diagnostics detected 4W processor fault	Processor card Location: U1.1-P1-C1
4508 244F	Memory system and other bus processor runtime diagnostics detected 1W processor fault	Processor card Location: U1.1-P1-C1
4508 248B	Memory system and other bus processor runtime diagnostics detected primary I/O drawer operator panel fault	Operator panel Location: U0.1-L1
4508 24A1	Memory system and other bus processor runtime diagnostics detected 1W processor fault	Processor card Location: U1.1-P1-C1
4508 24A2	Memory system and other bus processor runtime diagnostics detected 2W processor fault	Processor card Location: U1.1-P1-C1
4508 24A3	Memory system and other bus processor runtime diagnostics detected 4W processor fault	Processor card Location: U1.1-P1-C1
4508 24A4	Memory system and other bus processor runtime diagnostics detected 6W processor fault	Processor card Location: U1.1-P1-C1
4508 25BB	Memory system and other bus processor runtime diagnostics detected 1W processor card fault	1W Processor card Location: U1.1-P1-C1
4508 25BD	Memory system and other bus processor runtime diagnostics detected 2W processor card fault	2W Processor card Location: U1.1-P1-C1
4508 25BE	Memory system and other bus processor runtime diagnostics detected 4W processor card fault	4W Processor card Location: U1.1-P1-C1
4508 25BF	Memory system and other bus processor runtime diagnostics detected 6W processor card fault	6W Processor card Location: U1.1-P1-C1
4508 25CB	1W processor card fault	Replace the processor card Location: U1.1-P1-C1
4508 25EA	4W processor card fault	Replace the processor card Location: U1.1-P1-C1

Table 6. Service Processor Error Codes. (continued)

Error Code	Description	Action/ Possible Failing FRU
4508 25EB	2W processor card fault	Replace the processor card Location: U1.1-P1-C1
4508 25F2	6W processor card fault	Replace the processor card Location: U1.1-P1-C1
4508 263D	Memory system and other bus processor runtime diagnostics detected dummy riser card fault	Dummy riser card Locations: U1.1-P1-M1 U1.1-P1-M2
4508 2687	Memory system and other bus processor runtime diagnostics detected RIO adapter fault	RIO adapter Location: U0.1-P1.1
4508 271A	Memory system and other bus processor runtime diagnostics detected primary I/O backplane fault	Primary I/O backplane Location: U0.1-P1
4508 271D	Memory system and other bus processor runtime diagnostics detected secondary I/O backplane fault	Secondary I/O backplane Location: U0.2-P1
4508 283A	Memory system and other bus processor runtime diagnostics detected CEC backplane fault	1. Processor card Location: U1.1-P1-C1 2. CEC backplane Location: U1.1-P1
4508 285D	Memory system and other bus processor runtime diagnostics detected fan controller card fault	Fan controller card Locations: U0.1-X2 U1.1-X2
4508 288D	Memory system and other bus processor runtime diagnostics detected memory riser fault	1. Go to service processor memory configuration/deconfiguration menu to verify memory DIMMs state. See "Memory Configuration/Deconfiguration Menu" on page 384 for more information. 2. Memory riser card Locations: U1.1-P1-M1 U1.1-P1-M2
4508 300A	Memory system and other bus processor runtime diagnostics detected 32MB DIMM fault	Memory DIMM Locations: U1.1-P1-M1.n U1.1-P1-M2.n U1.1-P1-C1-Mn

Table 6. Service Processor Error Codes. (continued)

Error Code	Description	Action/ Possible Failing FRU
4508 300B	Memory system and other bus processor runtime diagnostics detected 128MB DIMM fault	Memory DIMM Locations: U1.1-P1-M1.n U1.1-P1-M2.n U1.1-P1-C1-Mn
4508 300C	Memory system and other bus processor runtime diagnostics detected 256MB DIMM fault	Memory DIMM Locations: U1.1-P1-M1.n U1.1-P1-M2.n U1.1-P1-C1-Mn
4508 300D	Memory system and other bus processor runtime diagnostics detected 512MB (stacked) DIMM fault	Memory DIMM Locations: U1.1-P1-M1.n U1.1-P1-M2.n U1.1-P1-C1-Mn
4508 300E	Memory system and other bus processor runtime diagnostics detected 512MB (unstacked) DIMM fault	Memory DIMM Locations: U1.1-P1-M1.n U1.1-P1-M2.n U1.1-P1-C1-Mn
4508 301F	Memory system and other bus processor runtime diagnostics detected 128MB DIMM fault	Memory DIMM Locations: U1.1-P1-M1.n U1.1-P1-M2.n U1.1-P1-C1-Mn
4508 303A	Memory system and other bus processor runtime diagnostics detected 1GB DIMM fault	Memory DIMM Locations: U1.1-P1-M1.n U1.1-P1-M2.n U1.1-P1-C1-Mn
4508 51AA	Memory system and other bus processor runtime diagnostics detected 645W AC power supply fault	645W AC power supply Locations: U1.1-V1 U1.1-V2
4508 51AB	Memory system and other bus processor runtime diagnostics detected 645W DC power supply fault	645W DC power supply Locations: U1.1-V1 U1.1-V2
4508 51AC	Memory system and other bus processor runtime diagnostics detected 595W AC power supply fault	595W AC power supply Locations: U0.1-V1 U0.1-V2
4508 51AD	Memory system and other bus processor runtime diagnostics detected 595W DC power supply fault	595W DC power supply Locations: U0.1-V1 U0.1-V2

Table 6. Service Processor Error Codes. (continued)

Error Code	Description	Action/ Possible Failing FRU
4509 244C	Memory system and memory test detected 1W processor fault	Processor card Location: U1.1-P1-C1
4509 244D	Memory system and memory test detected 2W processor fault	Processor card Location: U1.1-P1-C1
4509 244E	Memory system and memory test detected 4W processor fault	Processor card Location: U1.1-P1-C1
4509 244F	Memory system and memory test detected 1W processor fault	Processor card Location: U1.1-P1-C1
4509 248B	Memory system and memory test detected primary I/O drawer operator panel	Operator panel Location: U0.1-L1
4509 24A1	Memory system and memory test detected 1W processor fault	Processor card Location: U1.1-P1-C1
4509 24A2	Memory system and memory test detected 2W processor fault	Processor card Location: U1.1-P1-C1
4509 24A3	Memory system and memory test detected 4W processor fault	Processor card Location: U1.1-P1-C1
4509 24A4	Memory system and memory test detected 6W processor fault	Processor card Location: U1.1-P1-C1
4509 25BB	Memory system and memory test detected 1W processor card fault	1W Processor card Location: U1.1-P1-C1
4509 25BD	Memory system and memory test detected 2W processor card fault	2W Processor card Location: U1.1-P1-C1
4509 25BE	Memory system and memory test detected 4W processor card fault	4W Processor card Location: U1.1-P1-C1
4509 25BF	Memory system and memory test detected 6W processor card fault	6W Processor card Location: U1.1-P1-C1
4509 25CB	1W processor card fault	Replace the processor card Location: U1.1-P1-C1
4509 25EA	4W processor card fault	Replace the processor card Location: U1.1-P1-C1
4509 25EB	2W processor card fault	Replace the processor card Location: U1.1-P1-C1
4509 25F2	6W processor card fault	Replace the processor card Location: U1.1-P1-C1
4509 263D	Memory system and memory test detected dummy riser card fault	Dummy riser card Locations: U1.1-P1-M1 U1.1-P1-M2
4509 2687	Memory system and memory test detected RIO adapter fault	RIO adapter Location: U0.1-P1.1
4509 271A	Memory system and memory test detected primary I/O backplane fault	Primary I/O backplane Location: U0.1-P1

Table 6. Service Processor Error Codes. (continued)

Error Code	Description	Action/ Possible Failing FRU
4509 271D	Memory system and memory test detected secondary I/O backplane fault	Secondary I/O backplane Location: U0.2-P1
4509 283A	Memory system and memory test detected CEC backplane fault	1. Processor card Location: U1.1-P1-C1 2. CEC backplane Location: U1.1-P1
4509 285D	Memory system and memory test detected fan controller card fault	Fan controller card Locations: U0.1-X2 U1.1-X2
4509 288D	Memory system and memory test detected memory riser fault	1. Go to service processor memory configuration/deconfiguration menu to verify memory DIMMs state. See "Memory Configuration/Deconfiguration Menu" on page 384 for more information. 2. Memory riser card Locations: U1.1-P1-M1 U1.1-P1-M2
4509 2A00	Memory system and memory test detected 6W processor fault	Processor card Location: U1.1-P1-C1
4509 300A	Memory system and memory test detected 32MB DIMM fault	Memory DIMM Locations: U1.1-P1-M1.n U1.1-P1-M2.n U1.1-P1-C1-Mn
4509 300B	Memory system and memory test detected 128MB DIMM fault	Memory DIMM Locations: U1.1-P1-M1.n U1.1-P1-M2.n U1.1-P1-C1-Mn
4509 300C	Memory system and memory test detected 256MB DIMM fault	Memory DIMM Locations: U1.1-P1-M1.n U1.1-P1-M2.n U1.1-P1-C1-Mn
4509 300D	Memory system and memory test detected 512MB (stacked) DIMM fault	Memory DIMM Locations: U1.1-P1-M1.n U1.1-P1-M2.n U1.1-P1-C1-Mn

Table 6. Service Processor Error Codes. (continued)

Error Code	Description	Action/ Possible Failing FRU
4509 300E	Memory system and memory test detected 512MB (unstacked) DIMM fault	Memory DIMM Locations: U1.1-P1-M1.n U1.1-P1-M2.n U1.1-P1-C1-Mn
4509 301F	Memory system and memory test detected 128MB DIMM fault	Memory DIMM Locations: U1.1-P1-M1.n U1.1-P1-M2.n U1.1-P1-C1-Mn
4509 303A	Memory system and memory test detected 1GB DIMM fault	Memory DIMM Locations: U1.1-P1-M1.n U1.1-P1-M2.n U1.1-P1-C1-Mn
4509 51AA	Memory system and memory test detected 645W AC power supply fault	645W AC power supply Locations: U1.1-V1 U1.1-V2
4509 51AB	Memory system and memory test detected 645W DC power supply fault	645W DC power supply Locations: U1.1-V1 U1.1-V2
4509 51AC	Memory system and memory test detected 595W AC power supply fault	595W AC power supply Locations: U0.1-V1 U0.1-V2
4509 51AD	Memory system and memory test detected 595W DC power supply fault	595W DC power supply Locations: U0.1-V1 U0.1-V2
450A 244C	Memory system and self test detected 1W processor fault	Processor card Location: U1.1-P1-C1
450A 244D	Memory system and self test detected 2W processor fault	Processor card Location: U1.1-P1-C1
450A 244E	Memory system and self test detected 4W processor fault	Processor card Location: U1.1-P1-C1
450A 244F	Memory system and self test detected 1W MHz processor fault	Processor card Location: U1.1-P1-C1
450A 248B	Memory system and self test detected primary I/O drawer operator panel	Operator panel Location: U0.1-L1
450A 24A1	Memory system and self test detected 1W processor fault	Processor card Location: U1.1-P1-C1

Table 6. Service Processor Error Codes. (continued)

Error Code	Description	Action/ Possible Failing FRU
450A 24A2	Memory system and self test detected 2W processor fault	Processor card Location: U1.1-P1-C1
450A 24A3	Memory system and self test detected 4W processor fault	Processor card Location: U1.1-P1-C1
450A 24A4	Memory system and self test detected 6W processor fault	Processor card Location: U1.1-P1-C1
450A 25BB	Memory system and self test detected 1W processor card fault	1W Processor card Location: U1.1-P1-C1
450A 25BD	Memory system and self test detected 2W processor card fault	2W Processor card Location: U1.1-P1-C1
450A 25BE	Memory system and self test detected 4W processor card fault	4W Processor card Location: U1.1-P1-C1
450A 25BF	Memory system and self test detected 6W processor card fault	6W Processor card Location: U1.1-P1-C1
450A 25CB	1W processor card fault	Replace the processor card Location: U1.1-P1-C1
450A 25EA	4W processor card fault	Replace the processor card Location: U1.1-P1-C1
450A 25EB	2W processor card fault	Replace the processor card Location: U1.1-P1-C1
450A 25F2	6W processor card fault	Replace the processor card Location: U1.1-P1-C1
450A 263D	Memory system and self test detected dummy riser card fault	Dummy riser card Locations: U1.1-P1-M1 U1.1-P1-M2
450A 2687	Memory system and self test detected RIO adapter fault	RIO adapter Location: U0.1-P1.1
450A 271A	Memory system and self test detected primary I/O backplane fault	Primary I/O backplane Location: U0.1-P1
450A 271D	Memory system and self test detected secondary I/O backplane fault	Secondary I/O backplane Location: U0.2-P1
450A 283A	Memory system and self test detected CEC backplane fault	1. Processor card Location: U1.1-P1-C1 2. CEC backplane Location: U1.1-P1
450A 285D	Memory system and self test detected fan controller card fault	Fan controller card Locations: U0.1-X2 U1.1-X2

Table 6. Service Processor Error Codes. (continued)

Error Code	Description	Action/ Possible Failing FRU
450A 288D	Memory system and self test detected memory riser fault	<ol style="list-style-type: none"> 1. Go to service processor memory configuration/deconfiguration menu to verify memory DIMMs state. See "Memory Configuration/Deconfiguration Menu" on page 384 for more information. 2. Memory riser card Locations: U1.1-P1-M1 U1.1-P1-M2
450A 2A00	Memory system and self test detected 6W processor fault	Processor card Location: U1.1-P1-C1
450A 300A	Memory system and self test detected 32MB DIMM fault	Memory DIMM Locations: U1.1-P1-M1.n U1.1-P1-M2.n U1.1-P1-C1-Mn
450A 300B	Memory system and self test detected 128MB DIMM fault	Memory DIMM Locations: U1.1-P1-M1.n U1.1-P1-M2.n U1.1-P1-C1-Mn
450A 300C	Memory system and self test detected 256MB DIMM fault	Memory DIMM Locations: U1.1-P1-M1.n U1.1-P1-M2.n U1.1-P1-C1-Mn
450A 300D	Memory system and self test detected 512MB (stacked) DIMM fault	Memory DIMM Locations: U1.1-P1-M1.n U1.1-P1-M2.n U1.1-P1-C1-Mn
450A 300E	Memory system and self test detected 512MB (unstacked) DIMM fault	All memory DIMMs Locations: U1.1-P1-M1.n U1.1-P1-M2.n U1.1-P1-C1-Mn
450A 301F	Memory system and self test detected 128MB DIMM fault	Memory DIMM Locations: U1.1-P1-M1.n U1.1-P1-M2.n U1.1-P1-C1-Mn

Table 6. Service Processor Error Codes. (continued)

Error Code	Description	Action/ Possible Failing FRU
450A 303A	Memory system and self test detected 1GB DIMM fault	Memory DIMM Locations: U1.1-P1-M1.n U1.1-P1-M2.n U1.1-P1-C1-Mn
450A 51AA	Memory system and self test detected 645W AC power supply fault	645W AC power supply Locations: U1.1-V1 U1.1-V2
450A 51AB	Memory system and self test detected 645W DC power supply fault	645W DC power supply Locations: U1.1-V1 U1.1-V2
450A 51AC	Memory system and self test detected 595W AC power supply fault	595W AC power supply Locations: U0.1-V1 U0.1-V2
450A 51AD	Memory system and self test detected 595W DC power supply fault	595W DC power supply Locations: U0.1-V1 U0.1-V2
450B 244C	Memory system and wire test detected 1W processor fault	Processor card Location: U1.1-P1-C1
450B 244D	Memory system and wire test detected 2W processor fault	Processor card Location: U1.1-P1-C1
450B 244E	Memory system and wire test detected 4W processor fault	Processor card Location: U1.1-P1-C1
450B 244F	Memory system and wire test detected 1W processor fault	Processor card Location: U1.1-P1-C1
450B 248B	Memory system and wire test detected primary I/O drawer operator panel	Operator panel Location: U0.1-L1
450B 24A1	Memory system and wire test detected 1W processor fault	Processor card Location: U1.1-P1-C1
450B 24A2	Memory system and wire test detected 2W processor fault	Processor card Location: U1.1-P1-C1
450B 24A3	Memory system and wire test detected 4W processor fault	Processor card Location: U1.1-P1-C1
450B 24A4	Memory system and wire test detected 6W processor fault	Processor card Location: U1.1-P1-C1
450B 25BB	Memory system and wire test detected 1W processor card fault	1W Processor card Location: U1.1-P1-C1
450B 25BD	Memory system and wire test detected 2W processor card fault	2W Processor card Location: U1.1-P1-C1

Table 6. Service Processor Error Codes. (continued)

Error Code	Description	Action/ Possible Failing FRU
450B 25BE	Memory system and wire test detected 4W processor card fault	4W Processor card Location: U1.1-P1-C1
450B 25BF	Memory system and wire test detected 6W processor card fault	6W Processor card Location: U1.1-P1-C1
450B 25CB	1W processor card fault	Replace the processor card Location: U1.1-P1-C1
450B 25EA	4W processor card fault	Replace the processor card Location: U1.1-P1-C1
450B 25EB	2W processor card fault	Replace the processor card Location: U1.1-P1-C1
450B 25F2	6W processor card fault	Replace the processor card Location: U1.1-P1-C1
450B 263D	Memory system and wire test detected dummy riser card fault	Dummy riser card Locations: U1.1-P1-M1 U1.1-P1-M2
450B 2687	Memory system and wire test detected RIO adapter fault	RIO adapter Location: U0.1-P1.1
450B 271A	Memory system and wire test detected primary I/O backplane fault	Primary I/O backplane Location: U0.1-P1
450B 271D	Memory system and wire test detected secondary I/O backplane fault	Secondary I/O backplane Location: U0.2-P1
450B 283A	Memory system and wire test detected CEC backplane fault	1. Processor card Location: U1.1-P1-C1 2. CEC backplane Location: U1.1-P1
450B 285D	Memory system and wire test detected fan controller card fault	Fan controller card Locations: U0.1-X2 U1.1-X2
450B 288D	Memory system and wire test detected memory riser fault	1. Go to service processor memory configuration/deconfiguration menu to verify memory DIMMs state. See "Memory Configuration/Deconfiguration Menu" on page 384 for more information. 2. Memory riser card Locations: U1.1-P1-M1 U1.1-P1-M2
450B 2A00	Memory system and wire test detected 6W processor fault	Processor card Location: U1.1-P1-C1

Table 6. Service Processor Error Codes. (continued)

Error Code	Description	Action/ Possible Failing FRU
450B 300A	Memory system and wire test detected 32MB DIMM fault	Memory DIMM Locations: U1.1-P1-M1.n U1.1-P1-M2.n U1.1-P1-C1-Mn
450B 300B	Memory system and wire test detected 128MB DIMM fault	Memory DIMM Locations: U1.1-P1-M1.n U1.1-P1-M2.n U1.1-P1-C1-Mn
450B 300C	Memory system and wire test detected 256MB DIMM fault	Memory DIMM Locations: U1.1-P1-M1.n U1.1-P1-M2.n U1.1-P1-C1-Mn
450B 300D	Memory system and wire test detected 512MB (stacked) DIMM fault	Memory DIMM Locations: U1.1-P1-M1.n U1.1-P1-M2.n U1.1-P1-C1-Mn
450B 300E	Memory system and wire test detected 512MB (unstacked) DIMM fault	Memory DIMM Locations: U1.1-P1-M1.n U1.1-P1-M2.n U1.1-P1-C1-Mn
450B 301F	Memory system and wire test detected 128MB DIMM fault	Memory DIMM Locations: U1.1-P1-M1.n U1.1-P1-M2.n U1.1-P1-C1-Mn
450B 303A	Memory system and wire test detected 1GB DIMM fault	Memory DIMM Locations: U1.1-P1-M1.n U1.1-P1-M2.n U1.1-P1-C1-Mn
450B 51AA	Memory system and wire test detected 645W AC power supply fault	645W AC power supply Locations: U1.1-V1 U1.1-V2
450B 51AB	Memory system and wire test detected 645W DC power supply fault	645W DC power supply Locations: U1.1-V1 U1.1-V2
450B 51AC	Memory system and wire test detected 595W AC power supply fault	595W AC power supply Locations: U0.1-V1 U0.1-V2

Table 6. Service Processor Error Codes. (continued)

Error Code	Description	Action/ Possible Failing FRU
450B 51AD	Memory system and wire test detected 595W DC power supply fault	595W DC power supply Locations: U0.1-V1 U0.1-V2
450C 244C	Memory system and IPL detected 1W processor fault	Processor card Location: U1.1-P1-C1
450C 244D	Memory system and IPL detected 2W processor fault	Processor card Location: U1.1-P1-C1
450C 244E	Memory system and IPL detected 4W processor fault	Processor card Location: U1.1-P1-C1
450C 244F	Memory system and IPL detected 1W processor fault	Processor card Location: U1.1-P1-C1
450C 248B	Memory system and IPL detected primary I/O drawer operator panel	Operator panel Location: U0.1-L1
450C 24A1	Memory system and IPL detected 1W processor fault	Processor card Location: U1.1-P1-C1
450C 24A2	Memory system and IPL detected 2W processor fault	Processor card Location: U1.1-P1-C1
450C 24A3	Memory system and IPL detected 4W processor fault	Processor card Location: U1.1-P1-C1
450C 24A4	Memory system and IPL detected 6W processor fault	Processor card Location: U1.1-P1-C1
450C 25BB	Memory system and IPL detected 1W processor card fault	1W Processor card Location: U1.1-P1-C1
450C 25BD	Memory system and IPL detected 2W processor card fault	2W Processor card Location: U1.1-P1-C1
450C 25BE	Memory system and IPL detected 4W processor card fault	4W Processor card Location: U1.1-P1-C1
450C 25BF	Memory system and IPL detected 6W processor card fault	6W Processor card Location: U1.1-P1-C1
450C 25CB	1W processor card fault	Replace the processor card Location: U1.1-P1-C1
450C 25EA	4W processor card fault	Replace the processor card Location: U1.1-P1-C1
450C 25EB	2W processor card fault	Replace the processor card Location: U1.1-P1-C1
450C 25F2	6W processor card fault	Replace the processor card Location: U1.1-P1-C1
450C 263D	Memory system and IPL detected dummy riser card fault	Dummy riser card Locations: U1.1-P1-M1 U1.1-P1-M2

Table 6. Service Processor Error Codes. (continued)

Error Code	Description	Action/ Possible Failing FRU
450C 2687	Memory system and IPL detected RIO adapter fault	RIO adapter Location: U0.1-P1.1
450C 271A	Memory system and IPL detected primary I/O backplane fault	Primary I/O backplane Location: U0.1-P1
450C 271D	Memory system and IPL detected secondary I/O backplane fault	Secondary I/O backplane Location: U0.2-P1
450C 283A	Memory system and IPL detected CEC backplane fault	1. Processor card Location: U1.1-P1-C1 2. CEC backplane Location: U1.1-P1
450C 285D	Memory system and IPL detected fan controller card fault	Fan controller card Locations: U0.1-X2 U1.1-X2
450C 288D	Memory system and IPL detected memory riser fault	1. Go to service processor memory configuration/deconfiguration menu to verify memory DIMMs state. See "Memory Configuration/Deconfiguration Menu" on page 384 for more information. 2. Memory riser card Locations: U1.1-P1-M1 U1.1-P1-M2
450C 2A00	Memory system and IPL detected 6W processor fault	Processor card Location: U1.1-P1-C1
450C 300A	Memory system and IPL detected 32MB DIMM fault	Memory DIMM Locations: U1.1-P1-M1.n U1.1-P1-M2.n U1.1-P1-C1-Mn
450C 300B	Memory system and IPL detected 128MB DIMM fault	Memory DIMM Locations: U1.1-P1-M1.n U1.1-P1-M2.n U1.1-P1-C1-Mn
450C 300C	Memory system and IPL detected 256MB DIMM fault	Memory DIMM Locations: U1.1-P1-M1.n U1.1-P1-M2.n U1.1-P1-C1-Mn

Table 6. Service Processor Error Codes. (continued)

Error Code	Description	Action/ Possible Failing FRU
450C 300D	Memory system and IPL detected 512MB (stacked) DIMM fault	Memory DIMM Locations: U1.1-P1-M1.n U1.1-P1-M2.n U1.1-P1-C1-Mn
450C 300E	Memory system and IPL detected 512MB (unstacked) DIMM fault	All memory DIMMs Locations: U1.1-P1-M1.n U1.1-P1-M2.n U1.1-P1-C1-Mn
450C 301F	Memory system and IPL detected 128MB DIMM fault	Memory DIMM Locations: U1.1-P1-M1.n U1.1-P1-M2.n U1.1-P1-C1-Mn
450C 303A	Memory system and IPL detected 1GB DIMM fault	Memory DIMM Locations: U1.1-P1-M1.n U1.1-P1-M2.n U1.1-P1-C1-Mn
450C 51AA	Memory system and IPL detected 645W AC power supply fault	645W AC power supply Locations: U1.1-V1 U1.1-V2
450C 51AB	Memory system and IPL detected 645W DC power supply fault	645W DC power supply Locations: U1.1-V1 U1.1-V2
450C 51AC	Memory system and IPL detected 595W AC power supply fault	595W AC power supply Locations: U0.1-V1 U0.1-V2
450C 51AD	Memory system and IPL detected 595W DC power supply fault	595W DC power supply Locations: U0.1-V1 U0.1-V2
450D 244C	Memory system and attention handler detected 1W processor fault	Processor card Location: U1.1-P1-C1
450D 244D	Memory system and attention handler detected 2W processor fault	Processor card Location: U1.1-P1-C1
450D 244E	Memory system and attention handler detected 4W processor fault	Processor card Location: U1.1-P1-C1
450D 244F	Memory system and attention handler detected 1W processor fault	Processor card Location: U1.1-P1-C1

Table 6. Service Processor Error Codes. (continued)

Error Code	Description	Action/ Possible Failing FRU
450D 248B	Memory system and attention handler detected primary I/O drawer operator panel	Operator panel Location: U0.1-L1
450D 24A1	Memory system and attention handler detected 1W processor fault	Processor card Location: U1.1-P1-C1
450D 24A2	Memory system and attention handler detected 2W processor fault	Processor card Location: U1.1-P1-C1
450D 24A3	Memory system and attention handler detected 4W processor fault	Processor card Location: U1.1-P1-C1
450D 24A4	Memory system and attention handler detected 6W processor fault	Processor card Location: U1.1-P1-C1
450D 25BB	Memory system and attention handler detected 1W processor card fault	1W Processor card Location: U1.1-P1-C1
450D 25BD	Memory system and attention handler detected 2W processor card fault	2W Processor card Location: U1.1-P1-C1
450D 25BE	Memory system and attention handler detected 4W processor card fault	4W Processor card Location: U1.1-P1-C1
450D 25BF	Memory system and attention handler detected 6W processor card fault	6W Processor card Location: U1.1-P1-C1
450D 25CB	1W processor card fault	Replace the processor card Location: U1.1-P1-C1
450D 25EA	4W processor card fault	Replace the processor card Location: U1.1-P1-C1
450D 25EB	2W processor card fault	Replace the processor card Location: U1.1-P1-C1
450D 25F2	6W processor card fault	Replace the processor card Location: U1.1-P1-C1
450D 263D	Memory system and attention handler detected dummy riser card fault	Dummy riser card Locations: U1.1-P1-M1 U1.1-P1-M2
450D 2687	Memory system and attention handler detected RIO adapter fault	RIO adapter Location: U0.1-P1.1
450D 271A	Memory system and attention handler detected primary I/O backplane fault	Primary I/O backplane Location: U0.1-P1
450D 271D	Memory system and attention handler detected secondary I/O backplane fault	Secondary I/O backplane Location: U0.2-P1
450D 283A	Memory system and attention handler detected CEC backplane fault	1. Processor card Location: U1.1-P1-C1 2. CEC backplane Location: U1.1-P1

Table 6. Service Processor Error Codes. (continued)

Error Code	Description	Action/ Possible Failing FRU
450D 285D	Memory system and attention handler detected fan controller card fault	Fan controller card Locations: U0.1-X2 U1.1-X2
450D 288D	Memory system and attention handler detected memory riser fault	1. Go to service processor memory configuration/deconfiguration menu to verify memory DIMMs state. See "Memory Configuration/Deconfiguration Menu" on page 384 for more information. 2. Memory riser card Locations: U1.1-P1-M1 U1.1-P1-M2
450D 2A00	Memory system and attention handler detected 6W processor fault	Processor card Location: U1.1-P1-C1
450D 300A	Memory system and attention handler detected 32MB DIMM fault	Memory DIMM Locations: U1.1-P1-M1.n U1.1-P1-M2.n U1.1-P1-C1-Mn
450D 300B	Memory system and attention handler detected 128MB DIMM fault	Memory DIMM Locations: U1.1-P1-M1.n U1.1-P1-M2.n U1.1-P1-C1-Mn
450D 300C	Memory system and attention handler detected 256MB DIMM fault	Memory DIMM Locations: U1.1-P1-M1.n U1.1-P1-M2.n U1.1-P1-C1-Mn
450D 300D	Memory system and attention handler detected 512MB (stacked) DIMM fault	Memory DIMM Locations: U1.1-P1-M1.n U1.1-P1-M2.n U1.1-P1-C1-Mn
450D 300E	Memory system and attention handler detected 512MB (unstacked) DIMM fault	Memory DIMM Locations: U1.1-P1-M1.n U1.1-P1-M2.n U1.1-P1-C1-Mn
450D 301F	Memory system and attention handler detected 128MB DIMM fault	Memory DIMM Locations: U1.1-P1-M1.n U1.1-P1-M2.n U1.1-P1-C1-Mn

Table 6. Service Processor Error Codes. (continued)

Error Code	Description	Action/ Possible Failing FRU
450D 303A	Memory system and attention handler detected 1GB DIMM fault	Memory DIMM Locations: U1.1-P1-M1.n U1.1-P1-M2.n U1.1-P1-C1-Mn
450D 51AA	Memory system and attention handler detected 645W AC power supply fault	645W AC power supply Locations: U1.1-V1 U1.1-V2
450D 51AB	Memory system and attention handler detected 645W DC power supply fault	645W DC power supply Locations: U1.1-V1 U1.1-V2
450D 51AC	Memory system and attention handler detected 595W AC power supply fault	595W AC power supply Locations: U0.1-V1 U0.1-V2
450D 51AD	Memory system and attention handler detected 595W DC power supply fault	595W DC power supply Locations: U0.1-V1 U0.1-V2
450E 244C	Memory system and scan control routines detected 1W processor fault	Processor card Location: U1.1-P1-C1
450E 244D	Memory system and scan control routines detected 2W processor fault	Processor card Location: U1.1-P1-C1
450E 244E	Memory system and scan control routines detected 4W processor fault	Processor card Location: U1.1-P1-C1
450E 244F	Memory system and scan control routines detected 1W processor fault	Processor card Location: U1.1-P1-C1
450E 248B	Memory system and scan control routines detected primary I/O drawer operator panel	Operator panel Location: U0.1-L1
450E 24A1	Memory system and scan control routines detected 1W processor fault	Processor card Location: U1.1-P1-C1
450E 24A2	Memory system and scan control routines detected 2W processor fault	Processor card Location: U1.1-P1-C1
450E 24A3	Memory system and scan control routines detected 4W processor fault	Processor card Location: U1.1-P1-C1
450E 24A4	Memory system and scan control routines detected 6W processor fault	Processor card Location: U1.1-P1-C1
450E 25BB	Memory system and scan control routines detected 1W processor card fault	1W Processor card Location: U1.1-P1-C1

Table 6. Service Processor Error Codes. (continued)

Error Code	Description	Action/ Possible Failing FRU
450E 25BD	Memory system and scan control routines detected 2W processor card fault	2W Processor card Location: U1.1-P1-C1
450E 25BE	Memory system and scan control routines detected 4W processor card fault	4W Processor card Location: U1.1-P1-C1
450E 25BF	Memory system and scan control routines detected 6W processor card fault	6W Processor card Location: U1.1-P1-C1
450E 25CB	1W processor card fault	Replace the processor card Location: U1.1-P1-C1
450E 25EA	4W processor card fault	Replace the processor card Location: U1.1-P1-C1
450E 25EB	2W processor card fault	Replace the processor card Location: U1.1-P1-C1
450E 25F2	6W processor card fault	Replace the processor card Location: U1.1-P1-C1
450E 263D	Memory system and scan control routines detected dummy riser card fault	Dummy riser card Locations: U1.1-P1-M1 U1.1-P1-M2
450E 2687	Memory system and scan control routines detected RIO adapter fault	RIO adapter Location: U0.1-P1.1
450E 271A	Memory system and scan control routines detected primary I/O backplane fault	Primary I/O backplane Location: U0.1-P1
450E 271D	Memory system and scan control routines detected secondary I/O backplane fault	Secondary I/O backplane Location: U0.2-P1
450E 283A	Memory system and scan control routines detected CEC backplane fault	1. Processor card Location: U1.1-P1-C1 2. CEC backplane Location: U1.1-P1
450E 285D	Memory system and scan control routines detected fan controller card fault	Fan controller card Locations: U0.1-X2 U1.1-X2

Table 6. Service Processor Error Codes. (continued)

Error Code	Description	Action/ Possible Failing FRU
450E 288D	Memory system and scan control routines detected memory riser fault	<ol style="list-style-type: none"> Go to service processor memory configuration/deconfiguration menu to verify memory DIMMs state. See "Memory Configuration/Deconfiguration Menu" on page 384 for more information. Memory riser card Locations: U1.1-P1-M1 U1.1-P1-M2
450E 2A00	Memory system and scan control routines detected 6W processor fault	Processor card Location: U1.1-P1-C1
450E 300A	Memory system and scan control routines detected 32MB DIMM fault	Memory DIMM Locations: U1.1-P1-M1.n U1.1-P1-M2.n U1.1-P1-C1-Mn
450E 300B	Memory system and scan control routines detected 128MB DIMM fault	Memory DIMM Locations: U1.1-P1-M1.n U1.1-P1-M2.n U1.1-P1-C1-Mn
450E 300C	Memory system and scan control routines detected 256MB DIMM fault	Memory DIMM Locations: U1.1-P1-M1.n U1.1-P1-M2.n U1.1-P1-C1-Mn
450E 300D	Memory system and scan control routines detected 512MB (Stacked) DIMM fault	Memory DIMM Locations: U1.1-P1-M1.n U1.1-P1-M2.n U1.1-P1-C1-Mn
450E 300E	Memory System and scan control routines detected 512MB (unstacked) DIMM fault	Memory DIMM Locations: U1.1-P1-M1.n U1.1-P1-M2.n U1.1-P1-C1-Mn
450E 301F	Memory System and scan control routines detected 128MB DIMM fault	Memory DIMM Locations: U1.1-P1-M1.n U1.1-P1-M2.n U1.1-P1-C1-Mn

Table 6. Service Processor Error Codes. (continued)

Error Code	Description	Action/ Possible Failing FRU
450E 303A	Memory System and scan control routines detected 1GB DIMM fault	Memory DIMM Locations: U1.1-P1-M1.n U1.1-P1-M2.n U1.1-P1-C1-Mn
450E 51AA	Memory system and scan control routines detected 645W AC power supply fault	645W AC power supply Locations: U1.1-V1 U1.1-V2
450E 51AB	Memory system and scan control routines detected 645W DC power supply fault	645W DC power supply Locations: U1.1-V1 U1.1-V2
450E 51AC	Memory system and scan control routines detected 595W AC power supply fault	595W AC power supply Locations: U0.1-V1 U0.1-V2
450E 51AD	Memory system and scan control routines detected 595W DC power supply fault	595W DC power supply Locations: U0.1-V1 U0.1-V2
450F 244C	Memory system and error code generation/logging detected 1W processor fault	Processor card Location: U1.1-P1-C1
450F 244D	Memory system and error code generation/logging detected 2W processor fault	Processor card Location: U1.1-P1-C1
450F 244E	Memory system and error code generation/logging detected 4W processor fault	Processor card Location: U1.1-P1-C1
450F 244F	Memory system and error code generation/logging detected 1W processor fault	Processor card Location: U1.1-P1-C1
450F 248B	Memory system and error code generation/logging detected primary I/O drawer operator panel	Operator panel Location: U0.1-L1
450F 24A1	Memory system and error code generation/logging detected 1W processor fault	Processor card Location: U1.1-P1-C1
450F 24A2	Memory system and error code generation/logging detected 2W processor fault	Processor card Location: U1.1-P1-C1
450F 24A3	Memory system and error code generation/logging detected 4W processor fault	Processor card Location: U1.1-P1-C1

Table 6. Service Processor Error Codes. (continued)

Error Code	Description	Action/ Possible Failing FRU
450F 24A4	Memory system and error code generation/logging detected 6W processor fault	Processor card Location: U1.1-P1-C1
450F 25BB	Memory system and error code generation/logging detected 1W processor card fault	1W Processor card Location: U1.1-P1-C1
450F 25BD	Memory system and error code generation/logging detected 2W processor card fault	2W Processor card Location: U1.1-P1-C1
450F 25BE	Memory system and error code generation/logging detected 4W processor card fault	4W Processor card Location: U1.1-P1-C1
450F 25BF	Memory system and error code generation/logging detected 6W processor card fault	6W Processor card Location: U1.1-P1-C1
450F 25CB	1W processor card fault	Replace the processor card Location: U1.1-P1-C1
450F 25EA	4W processor card fault	Replace the processor card Location: U1.1-P1-C1
450F 25EB	2W processor card fault	Replace the processor card Location: U1.1-P1-C1
450F 25F2	6W processor card fault	Replace the processor card Location: U1.1-P1-C1
450F 263D	Memory system and error code generation/logging detected dummy riser card fault	Dummy riser card Locations: U1.1-P1-M1 U1.1-P1-M2
450F 2687	Memory system and error code generation/logging detected RIO adapter fault	RIO adapter Location: U0.1-P1.1
450F 271A	Memory system and error code generation/logging detected primary I/O backplane fault	Primary I/O backplane Location: U0.1-P1
450F 271D	Memory system and error code generation/logging detected secondary I/O backplane fault	Secondary I/O backplane Location: U0.2-P1
450F 283A	Memory system and error code generation/logging detected CEC backplane fault	1. Processor card Location: U1.1-P1-C1 2. CEC backplane Location: U1.1-P1
450F 285D	Memory system and error code generation/logging detected fan controller card fault	Fan controller card Locations: U0.1-X2 U1.1-X2

Table 6. Service Processor Error Codes. (continued)

Error Code	Description	Action/ Possible Failing FRU
450F 288D	Memory system and error code generation/logging detected memory riser fault	<ol style="list-style-type: none"> 1. Go to service processor memory configuration/deconfiguration menu to verify memory DIMMs state. See "Memory Configuration/Deconfiguration Menu" on page 384 for more information. 2. Memory riser card Locations: U1.1-P1-M1 U1.1-P1-M2
450F 2A00	Memory system and error code generation/logging detected 6W processor fault	Processor card Location: U1.1-P1-C1
450F 300A	Memory system and error code generation/logging detected 32MB DIMM fault	Memory DIMM Locations: U1.1-P1-M1.n U1.1-P1-M2.n U1.1-P1-C1-Mn
450F 300B	Memory system and error code generation/logging detected 128MB DIMM fault	Memory DIMM Locations: U1.1-P1-M1.n U1.1-P1-M2.n U1.1-P1-C1-Mn
450F 300C	Memory system and error code generation/logging detected 256MB DIMM fault	Memory DIMM Locations: U1.1-P1-M1.n U1.1-P1-M2.n U1.1-P1-C1-Mn
450F 300D	Memory system and error code generation/logging detected 512MB (Stacked) DIMM fault	Memory DIMM Locations: U1.1-P1-M1.n U1.1-P1-M2.n U1.1-P1-C1-Mn
450F 300E	Memory System and error code generation/logging detected 1GB DIMM fault	Memory DIMM Locations: U1.1-P1-M1.n U1.1-P1-M2.n U1.1-P1-C1-Mn
450F 301F	Memory System and error code generation/logging detected 128MB DIMM fault	Memory DIMM Locations: U1.1-P1-M1.n U1.1-P1-M2.n U1.1-P1-C1-Mn

Table 6. Service Processor Error Codes. (continued)

Error Code	Description	Action/ Possible Failing FRU
450F 303A	Memory System and error code generation/logging detected 1GB DIMM fault	Memory DIMM Locations: U1.1-P1-M1.n U1.1-P1-M2.n U1.1-P1-C1-Mn
450F 51AA	Memory system and error code generation/logging detected 645W AC power supply fault	645W AC power supply Locations: U1.1-V1 U1.1-V2
450F 51AB	Memory system and error code generation/logging detected 645W DC power supply fault	645W DC power supply Locations: U1.1-V1 U1.1-V2
450F 51AC	Memory system and error code generation/logging detected 595W AC power supply fault	595W AC power supply Locations: U0.1-V1 U0.1-V2
450F 51AD	Memory system and error code generation/logging detected 595W DC power supply fault	595W DC power supply Locations: U0.1-V1 U0.1-V2
4606 244C	I/O system and scan interface basic assurance tests detected 1W processor fault	Processor card Location: U1.1-P1-C1
4606 244D	I/O system and scan interface basic assurance tests detected 2W processor fault	Processor card Location: U1.1-P1-C1
4606 244E	I/O system and scan interface basic assurance tests detected 4W processor fault	Processor card Location: U1.1-P1-C1
4606 244F	I/O system and scan interface basic assurance tests detected 1W processor fault	Processor card Location: U1.1-P1-C1
4606 248B	I/O system and scan interface basic assurance tests detected primary I/O drawer operator panel	Operator panel Location: U0.1-L1
4606 24A1	I/O system and scan interface basic assurance tests detected 1W processor fault	Processor card Location: U1.1-P1-C1
4606 24A2	I/O system and scan interface basic assurance tests detected 2W processor fault	Processor card Location: U1.1-P1-C1
4606 24A3	I/O system and scan interface basic assurance tests detected 4W processor fault	Processor card Location: U1.1-P1-C1

Table 6. Service Processor Error Codes. (continued)

Error Code	Description	Action/ Possible Failing FRU
4606 24A4	I/O system and scan interface basic assurance tests detected 6W processor fault	Processor card Location: U1.1-P1-C1
4606 25BB	I/O system and scan interface basic assurance tests detected 1W processor card fault	1W Processor card Location: U1.1-P1-C1
4606 25BD	I/O system and scan interface basic assurance tests detected 2W processor card fault	2W Processor card Location: U1.1-P1-C1
4606 25BE	I/O system and scan interface basic assurance tests detected 4W processor card fault	4W Processor card Location: U1.1-P1-C1
4606 25BF	I/O system and scan interface basic assurance tests detected 6W processor card fault	6W Processor card Location: U1.1-P1-C1
4606 263D	I/O system and scan interface basic assurance tests detected dummy riser card fault	Dummy riser card Locations: U1.1-P1-M1 U1.1-P1-M2
4606 2687	I/O system and scan interface basic assurance tests detected RIO adapter fault	RIO adapter Location: U0.1-P1.1
4606 271A	I/O system and scan interface basic assurance tests detected primary I/O backplane fault	Primary I/O backplane Location: U0.1-P1
4606 271D	I/O system and scan interface basic assurance tests detected secondary I/O backplane fault	Secondary I/O backplane Location: U0.2-P1
4606 283A	I/O system and scan interface basic assurance tests detected CEC backplane fault	1. Processor card Location: U1.1-P1-C1 2. CEC backplane Location: U1.1-P1
4606 285D	I/O system and scan interface basic assurance tests detected fan controller card fault	Fan controller card Locations: U0.1-X2 U1.1-X2

Table 6. Service Processor Error Codes. (continued)

Error Code	Description	Action/ Possible Failing FRU
4606 288D	I/O system and scan interface basic assurance tests detected memory riser fault	<ol style="list-style-type: none"> 1. Go to service processor memory configuration/deconfiguration menu to verify memory DIMMs state. See "Memory Configuration/Deconfiguration Menu" on page 384 for more information. 2. Memory riser card Locations: U1.1-P1-M1 U1.1-P1-M2
4606 2A00	I/O system and scan interface basic assurance tests detected 6W processor fault	Processor card Location: U1.1-P1-C1
4606 300A	I/O system and scan interface basic assurance tests detected 32MB DIMM fault	Memory DIMM Locations: U1.1-P1-M1.n U1.1-P1-M2.n U1.1-P1-C1-Mn
4606 300B	I/O system and scan interface basic assurance tests detected 128MB DIMM fault	Memory DIMM Locations: U1.1-P1-M1.n U1.1-P1-M2.n U1.1-P1-C1-Mn
4606 300C	I/O system and scan interface basic assurance tests detected 256MB DIMM fault	Memory DIMM Locations: U1.1-P1-M1.n U1.1-P1-M2.n U1.1-P1-C1-Mn
4606 300D	I/O system and scan interface basic assurance tests detected 512MB (stacked) DIMM fault	Memory DIMM Locations: U1.1-P1-M1.n U1.1-P1-M2.n U1.1-P1-C1-Mn
4606 300E	I/O system and scan interface basic assurance tests detected 512 MB (unstacked) DIMM fault	Memory DIMM Locations: U1.1-P1-M1.n U1.1-P1-M2.n U1.1-P1-C1-Mn
4606 301F	I/O system and scan interface basic assurance tests detected 128MB DIMM fault	Memory DIMM Locations: U1.1-P1-M1.n U1.1-P1-M2.n U1.1-P1-C1-Mn

Table 6. Service Processor Error Codes. (continued)

Error Code	Description	Action/ Possible Failing FRU
4606 303A	I/O system and scan interface basic assurance tests detected 1GB DIMM fault	Memory DIMM Locations: U1.1-P1-M1.n U1.1-P1-M2.n U1.1-P1-C1-Mn
4606 51AA	I/O system and scan interface basic assurance tests detected 645W AC power supply fault	645W AC power supply Locations: U1.1-V1 U1.1-V2
4606 51AB	I/O system and scan interface basic assurance tests detected 645W DC power supply fault	645W DC power supply Locations: U1.1-V1 U1.1-V2
4606 51AC	I/O system and scan interface basic assurance tests detected 595W AC power supply fault	595W AC power supply Locations: U0.1-V1 U0.1-V2
4606 51AD	I/O system and scan interface basic assurance tests detected 595W DC power supply fault	595W DC power supply Locations: U0.1-V1 U0.1-V2
4607 244C	I/O system and 6xx bus processor runtime diagnostics detected 1W processor fault	Processor card Location: U1.1-P1-C1
4607 244D	I/O system and 6xx bus processor runtime diagnostics detected 2W processor fault	Processor card Location: U1.1-P1-C1
4607 244E	I/O system and 6xx bus processor runtime diagnostics detected 4W processor fault	Processor card Location: U1.1-P1-C1
4607 244F	I/O system and 6xx bus processor runtime diagnostics detected 1W processor fault	Processor card Location: U1.1-P1-C1
4607 248B	I/O system and 6xx bus processor runtime diagnostics detected primary I/O drawer operator panel	Operator panel Location: U0.1-L1
4607 24A1	I/O system and 6xx bus processor runtime diagnostics detected 1W processor fault	Processor card Location: U1.1-P1-C1
4607 24A2	I/O system and 6xx bus processor runtime diagnostics detected 2W processor fault	Processor card Location: U1.1-P1-C1
4607 24A3	I/O system and 6xx bus processor runtime diagnostics detected 4W processor fault	Processor card Location: U1.1-P1-C1

Table 6. Service Processor Error Codes. (continued)

Error Code	Description	Action/ Possible Failing FRU
4607 24A4	I/O system and 6xx bus processor runtime diagnostics detected 6W processor fault	Processor card Location: U1.1-P1-C1
4607 25BB	I/O system and 6xx bus processor runtime diagnostics detected 1W processor card fault	1W Processor card Location: U1.1-P1-C1
4607 25BD	I/O system and 6xx bus processor runtime diagnostics detected 2W processor card fault	2W Processor card Location: U1.1-P1-C1
4607 25BE	I/O system and 6xx bus processor runtime diagnostics detected 4W processor card fault	4W Processor card Location: U1.1-P1-C1
4607 25BF	I/O system and 6xx bus processor runtime diagnostics detected 6W processor card fault	6W Processor card Location: U1.1-P1-C1
4607 263D	I/O system and 6xx bus processor runtime diagnostics detected dummy riser card fault	Dummy riser card Locations: U1.1-P1-M1 U1.1-P1-M2
4607 2687	I/O system and 6xx bus processor runtime diagnostics detected RIO adapter fault	RIO adapter Location: U0.1-P1.1
4607 271A	I/O system and 6xx bus processor runtime diagnostics detected primary I/O backplane fault	Primary I/O backplane Location: U0.1-P1
4607 271D	I/O system and 6xx bus processor runtime diagnostics detected secondary I/O backplane fault	Secondary I/O backplane Location: U0.2-P1
4607 283A	I/O system and 6xx bus processor runtime diagnostics detected CEC backplane fault	1. Processor card Location: U1.1-P1-C1 2. CEC backplane Location: U1.1-P1
4607 285D	I/O system and 6xx bus processor runtime diagnostics detected fan controller card fault	Fan controller card Locations: U0.1-X2 U1.1-X2

Table 6. Service Processor Error Codes. (continued)

Error Code	Description	Action/ Possible Failing FRU
4607 288D	I/O system and 6xx bus processor runtime diagnostics detected memory riser fault	<ol style="list-style-type: none"> 1. Go to service processor memory configuration/deconfiguration menu to verify memory DIMMs state. See "Memory Configuration/Deconfiguration Menu" on page 384 for more information. 2. Memory riser card Locations: U1.1-P1-M1 U1.1-P1-M2
4607 2A00	I/O system and 6xx bus processor runtime diagnostics detected 6W processor fault	Processor card Location: U1.1-P1-C1
4607 300A	I/O system and 6xx bus processor runtime diagnostics detected 32MB DIMM fault	Memory DIMM Locations: U1.1-P1-M1.n U1.1-P1-M2.n U1.1-P1-C1-Mn
4607 300B	I/O system and 6xx bus processor runtime diagnostics detected 128MB DIMM fault	Memory DIMM Locations: U1.1-P1-M1.n U1.1-P1-M2.n U1.1-P1-C1-Mn
4607 300C	I/O system and 6xx bus processor runtime diagnostics detected 256MB DIMM fault	Memory DIMM Locations: U1.1-P1-M1.n U1.1-P1-M2.n U1.1-P1-C1-Mn
4607 300D	I/O system and 6xx bus processor runtime diagnostics detected 512MB (stacked) DIMM fault	Memory DIMM Locations: U1.1-P1-M1.n U1.1-P1-M2.n U1.1-P1-C1-Mn
4607 300E	I/O system and 6xx bus processor runtime diagnostics detected 512MB (stacked) DIMM fault	Memory DIMM Locations: U1.1-P1-M1.m U1.1-P1-M2.m U1.1-P1-C1-Mn
4607 301F	I/O system and 6xx bus processor runtime diagnostics detected 128MB DIMM fault	Memory DIMM Locations: U1.1-P1-M1.n U1.1-P1-M2.n U1.1-P1-C1-Mn

Table 6. Service Processor Error Codes. (continued)

Error Code	Description	Action/ Possible Failing FRU
4607 303A	I/O system and 6xx bus processor runtime diagnostics detected 1GB DIMM fault	Memory DIMM Locations: U1.1-P1-M1.n U1.1-P1-M2.n U1.1-P1-C1-Mn
4607 51AA	I/O system and 6xx bus processor runtime diagnostics detected 645W AC power supply fault	645W AC power supply Locations: U1.1-V1 U1.1-V2
4607 51AB	I/O system and 6xx bus processor runtime diagnostics detected 645W DC power supply fault	645W DC power supply Locations: U1.1-V1 U1.1-V2
4607 51AC	I/O system and 6xx bus processor runtime diagnostics detected 595W AC power supply fault	595W AC power supply Locations: U0.1-V1 U0.1-V2
4607 51AD	I/O system and 6xx bus processor runtime diagnostics I/O system and 6xx bus processor runtime diagnostics detected 595W DC power supply fault	595W DC power supply Locations: U0.1-V1 U0.1-V2
4608 244C	I/O system and other bus processor runtime diagnostics detected 1W processor fault	Processor card Location: U1.1-P1-C1
4608 244D	I/O system and other bus processor runtime diagnostics detected 2W processor fault	Processor card Location: U1.1-P1-C1
4608 244E	I/O system and other bus processor runtime diagnostics detected 4W processor fault	Processor card Location: U1.1-P1-C1
4608 244F	I/O system and other bus processor runtime diagnostics detected 1W processor fault	Processor card Location: U1.1-P1-C1
4608 248B	I/O system and other bus processor runtime diagnostics detected primary I/O drawer operator panel	Operator panel Location: U0.1-L1
4608 24A1	I/O system and other bus processor runtime diagnostics detected 1W processor fault	Processor card Location: U1.1-P1-C1
4608 24A2	I/O system and other bus processor runtime diagnostics detected 2W processor fault	Processor card Location: U1.1-P1-C1
4608 24A3	I/O system and other bus processor runtime diagnostics detected 4W processor fault	Processor card Location: U1.1-P1-C1

Table 6. Service Processor Error Codes. (continued)

Error Code	Description	Action/ Possible Failing FRU
4608 24A4	I/O system and other bus processor runtime diagnostics detected 6W processor fault	Processor card Location: U1.1-P1-C1
4608 25BB	I/O system and other bus processor runtime diagnostics detected 1W processor card fault	1W Processor card Location: U1.1-P1-C1
4608 25BD	I/O system and other bus processor runtime diagnostics detected 2W processor card fault	2W Processor card Location: U1.1-P1-C1
4608 25BE	I/O system and other bus processor runtime diagnostics detected 4W processor card fault	4W Processor card Location: U1.1-P1-C1
4608 25BF	I/O system and other bus processor runtime diagnostics detected 6W processor card fault	6W Processor card Location: U1.1-P1-C1
4608 263D	I/O system and other bus processor runtime diagnostics detected dummy riser card fault	Dummy riser card Locations: U1.1-P1-M1 U1.1-P1-M2
4608 2687	I/O system and other bus processor runtime diagnostics detected RIO adapter fault	RIO adapter Location: U0.1-P1.1
4608 271A	I/O system and other bus processor runtime diagnostics detected primary I/O backplane fault	Primary I/O backplane Location: U0.1-P1
4608 271D	I/O system and other bus processor runtime diagnostics detected secondary I/O backplane fault	Secondary I/O backplane Location: U0.2-P1
4608 283A	I/O system and other bus processor runtime diagnostics detected CEC backplane fault	1. Processor card Location: U1.1-P1-C1 2. CEC backplane Location: U1.1-P1
4608 285D	I/O system and other bus processor runtime diagnostics detected fan controller card fault	Fan controller card Locations: U0.1-X2 U1.1-X2

Table 6. Service Processor Error Codes. (continued)

Error Code	Description	Action/ Possible Failing FRU
4608 288D	I/O system and other bus processor runtime diagnostics detected memory riser fault	<ol style="list-style-type: none"> 1. Go to service processor memory configuration/deconfiguration menu to verify memory DIMMs state. See "Memory Configuration/Deconfiguration Menu" on page 384 for more information. 2. Memory riser card Locations: U1.1-P1-M1 U1.1-P1-M2
4608 2A00	I/O system and other bus processor runtime diagnostics detected 6W processor fault	Processor card Location: U1.1-P1-C1
4608 300A	I/O system and other bus processor runtime diagnostics detected 32MB DIMM fault	Memory DIMM Locations: U1.1-P1-M1.n U1.1-P1-M2.n U1.1-P1-C1-Mn
4608 300B	I/O system and other bus processor runtime diagnostics detected 128MB DIMM fault	Memory DIMM Locations: U1.1-P1-M1.n U1.1-P1-M2.n U1.1-P1-C1-Mn
4608 300C	I/O system and other bus processor runtime diagnostics detected 256MB DIMM fault	Memory DIMM Locations: U1.1-P1-M1.n U1.1-P1-M2.n U1.1-P1-C1-Mn
4608 300D	I/O system and other bus processor runtime diagnostics detected 512MB (stacked) DIMM fault	Memory DIMM Locations: U1.1-P1-M1.n U1.1-P1-M2.n U1.1-P1-C1-Mn
4608 300E	I/O system and other bus processor runtime diagnostics detected 512MB (unstacked) DIMM fault	Memory DIMM Locations: U1.1-P1-M1.n U1.1-P1-M2.n U1.1-P1-C1-Mn
4608 301F	I/O system and other bus processor runtime diagnostics detected 128MB DIMM fault	Memory DIMM Locations: U1.1-P1-M1.n U1.1-P1-M2.n U1.1-P1-C1-Mn

Table 6. Service Processor Error Codes. (continued)

Error Code	Description	Action/ Possible Failing FRU
4608 303A	I/O system and other bus processor runtime diagnostics detected 1GB DIMM fault	Memory DIMM Locations: U1.1-P1-M1.n U1.1-P1-M2.n U1.1-P1-C1-Mn
4608 51AA	I/O system and other bus processor runtime diagnostics detected 645W AC power supply fault	645W AC power supply Locations: U1.1-V1 U1.1-V2
4608 51AB	I/O system and other bus processor runtime diagnostics detected 645W DC power supply fault	645W DC power supply Locations: U1.1-V1 U1.1-V2
4608 51AC	I/O system and other bus processor runtime diagnostics detected 595W AC power supply fault	595W AC power supply Locations: U0.1-V1 U0.1-V2
4608 51AD	I/O system and other bus processor runtime diagnostics detected 595W DC power supply fault	595W DC power supply Locations: U0.1-V1 U0.1-V2
4609 244C	I/O system and memory test detected 1W processor fault	Processor card Location: U1.1-P1-C1
4609 244D	I/O system and memory test detected 2W processor fault	Processor card Location: U1.1-P1-C1
4609 244E	I/O system and memory test detected 4W processor fault	Processor card Location: U1.1-P1-C1
4609 244F	I/O system and memory test detected 1W processor fault	Processor card Location: U1.1-P1-C1
4609 248B	I/O system and memory test detected primary I/O drawer operator panel	Operator panel Location: U0.1-L1
4609 24A1	I/O system and memory test detected 1W processor fault	Processor card Location: U1.1-P1-C1
4609 24A2	I/O system and memory test detected 2W processor fault	Processor card Location: U1.1-P1-C1
4609 24A3	I/O system and memory test detected 4W processor fault	Processor card Location: U1.1-P1-C1
4609 24A4	I/O system and memory test detected 6W processor fault	Processor card Location: U1.1-P1-C1
4609 25BB	I/O system and memory test detected 1W processor card fault	1W Processor card Location: U1.1-P1-C1
4609 25BD	I/O system and memory test detected 2W processor card fault	2W Processor card Location: U1.1-P1-C1

Table 6. Service Processor Error Codes. (continued)

Error Code	Description	Action/ Possible Failing FRU
4609 25BE	I/O system and memory test detected 4W processor card fault	4W Processor card Location: U1.1-P1-C1
4609 25BF	I/O system and memory test detected 6W processor card fault	6W Processor card Location: U1.1-P1-C1
4609 263D	I/O system and memory test detected dummy riser card fault	Dummy riser card Locations: U1.1-P1-M1 U1.1-P1-M2
4609 2687	I/O system and memory test detected RIO adapter fault	RIO adapter Location: U0.1-P1.1
4609 271A	I/O system and memory test detected primary I/O backplane fault	Primary I/O backplane Location: U0.1-P1
4609 271D	I/O system and memory test detected secondary I/O backplane fault	Secondary I/O backplane Location: U0.2-P1
4609 283A	I/O system and memory test detected CEC backplane fault	1. Processor card Location: U1.1-P1-C1 2. CEC backplane Location: U1.1-P1
4609 285D	I/O system and memory test detected fan controller card fault	Fan controller card Locations: U0.1-X2 U1.1-X2
4609 288D	I/O system and memory test detected memory riser fault	1. Go to service processor memory configuration/deconfiguration menu to verify memory DIMMs state. See "Memory Configuration/Deconfiguration Menu" on page 384 for more information. 2. Memory riser card Locations: U1.1-P1-M1 U1.1-P1-M2
4609 2A00	I/O system and memory test detected 6W processor fault	Processor card Location: U1.1-P1-C1
4609 300A	I/O system and memory test detected 32MB DIMM fault	Memory DIMM Locations: U1.1-P1-M1.n U1.1-P1-M2.n U1.1-P1-C1-Mn
4609 300B	I/O system and memory test detected 128MB DIMM fault	Memory DIMM Locations: U1.1-P1-M1.n U1.1-P1-M2.n U1.1-P1-C1-Mn

Table 6. Service Processor Error Codes. (continued)

Error Code	Description	Action/ Possible Failing FRU
4609 300C	I/O system and memory test detected 256MB DIMM fault	Memory DIMM Locations: U1.1-P1-M1.n U1.1-P1-M2.n U1.1-P1-C1-Mn
4609 300D	I/O system and memory test detected 512MB (stacked) DIMM fault	Memory DIMM Locations: U1.1-P1-M1.n U1.1-P1-M2.n U1.1-P1-C1-Mn
4609 300E	I/O system and memory test detected 512MB (unstacked) DIMM fault	Memory DIMM Locations: U1.1-P1-M1.n U1.1-P1-M2.n U1.1-P1-C1-Mn
4609 301F	I/O system and other bus processor runtime diagnostics detected 128MB DIMM fault	Memory DIMM Locations: U1.1-P1-M1.n U1.1-P1-M2.n U1.1-P1-C1-Mn
4609 303A	I/O system and other bus processor runtime diagnostics detected 1GB DIMM fault	Memory DIMM Locations: U1.1-P1-M1.n U1.1-P1-M2.n U1.1-P1-C1-Mn
4609 51AA	I/O system and memory test detected 645W AC power supply fault	645W AC power supply Locations: U1.1-V1 U1.1-V2
4609 51AB	I/O system and memory test detected 645W DC power supply fault	645W DC power supply Locations: U1.1-V1 U1.1-V2
4609 51AC	I/O system and memory test detected 595W AC power supply fault	595W AC power supply Locations: U0.1-V1 U0.1-V2
4609 51AD	I/O system and memory test detected 595W DC power supply fault	595W DC power supply Locations: U0.1-V1 U0.1-V2
460A 244C	I/O system and self test detected 1W processor fault	Processor card Location: U1.1-P1-C1
460A 244D	I/O system and self test detected 2W processor fault	Processor card Location: U1.1-P1-C1

Table 6. Service Processor Error Codes. (continued)

Error Code	Description	Action/ Possible Failing FRU
460A 244E	I/O system and self test detected 4W processor fault	Processor card Location: U1.1-P1-C1
460A 244F	I/O system and self test detected 1W processor fault	Processor card Location: U1.1-P1-C1
460A 248B	I/O system and self test detected primary I/O drawer operator panel	Operator panel Location: U0.1-L1
460A 24A1	I/O system and self test detected 1W processor fault	Processor card Location: U1.1-P1-C1
460A 24A2	I/O system and self test detected 2W processor fault	Processor card Location: U1.1-P1-C1
460A 24A3	I/O system and self test detected 4W processor fault	Processor card Location: U1.1-P1-C1
460A 24A4	I/O system and self test detected 6W processor fault	Processor card Location: U1.1-P1-C1
460A 25BB	I/O system and self test detected 1W processor card fault	1W Processor card Location: U1.1-P1-C1
460A 25BD	I/O system and self test detected 2W processor card fault	2W Processor card Location: U1.1-P1-C1
460A 25BE	I/O system and self test detected 4W processor card fault	4W Processor card Location: U1.1-P1-C1
460A 25BF	I/O system and self test detected 6W processor card fault	6W Processor card Location: U1.1-P1-C1
460A 263D	I/O system and self test detected dummy riser card fault	Dummy riser card Locations: U1.1-P1-M1 U1.1-P1-M2
460A 2687	I/O system and self test detected RIO adapter fault	RIO adapter Location: U0.1-P1.1
460A 271A	I/O system and self test detected primary I/O backplane fault	Primary I/O backplane Location: U0.1-P1
460A 271D	I/O system and self test detected secondary I/O backplane fault	Secondary I/O backplane Location: U0.2-P1
460A 283A	I/O system and self test detected CEC backplane fault	1. Processor card Location: U1.1-P1-C1 2. CEC backplane Location: U1.1-P1
460A 285D	I/O system and self test detected fan controller card fault	Fan controller card Locations: U0.1-X2 U1.1-X2

Table 6. Service Processor Error Codes. (continued)

Error Code	Description	Action/ Possible Failing FRU
460A 288D	I/O system and self test detected memory riser fault	<ol style="list-style-type: none"> 1. Go to service processor memory configuration/deconfiguration menu to verify memory DIMMs state. See "Memory Configuration/Deconfiguration Menu" on page 384 for more information. 2. Memory riser card Locations: U1.1-P1-M1 U1.1-P1-M2
460A 2A00	I/O system and self test detected 6W processor fault	Processor card Location: U1.1-P1-C1
460A 300A	I/O system and self test detected 32MB DIMM fault	Memory DIMM Locations: U1.1-P1-M1.n U1.1-P1-M2.n U1.1-P1-C1-Mn
460A 300B	I/O system and self test detected 128MB DIMM fault	Memory DIMM Locations: U1.1-P1-M1.n U1.1-P1-M2.n U1.1-P1-C1-Mn
460A 300C	I/O system and self test detected 256MB DIMM fault	Memory DIMM Locations: U1.1-P1-M1.n U1.1-P1-M2.n U1.1-P1-C1-Mn
460A 300D	I/O system and self test detected 512MB (stacked) DIMM fault	Memory DIMM Locations: U1.1-P1-M1.n U1.1-P1-M2.n U1.1-P1-C1-Mn
460A 300E	I/O system and self test detected 512MB (unstacked) DIMM fault	Memory DIMM Locations: U1.1-P1-M1.n U1.1-P1-M2.n U1.1-P1-C1-Mn
460A 301F	I/O system and self test detected 512MB DIMM fault	Memory DIMM Locations: U1.1-P1-M1.n U1.1-P1-M2.n U1.1-P1-C1-Mn

Table 6. Service Processor Error Codes. (continued)

Error Code	Description	Action/ Possible Failing FRU
460A 303A	I/O system and self test detected 1GB DIMM fault	Memory DIMM Locations: U1.1-P1-M1.n U1.1-P1-M2.n U1.1-P1-C1-Mn
460A 51AA	I/O system and self test detected 645W AC power supply fault	645W AC power supply Locations: U1.1-V1 U1.1-V2
460A 51AB	I/O system and self test detected 645W DC power supply fault	645W DC power supply Locations: U1.1-V1 U1.1-V2
460A 51AC	I/O system and self test detected 595W AC power supply fault	595W AC power supply Locations: U0.1-V1 U0.1-V2
460A 51AD	I/O system and self test detected 595W DC power supply fault	595W DC power supply Locations: U0.1-V1 U0.1-V2
460B 244C	I/O system and wire test detected 1W processor fault	Processor card Location: U1.1-P1-C1
460B 244D	I/O system and wire test detected 2W processor fault	Processor card Location: U1.1-P1-C1
460B 244E	I/O system and wire test detected 4W processor fault	Processor card Location: U1.1-P1-C1
460B 244F	I/O system and wire test detected 1W processor fault	Processor card Location: U1.1-P1-C1
460B 248B	I/O system and wire test detected primary I/O drawer operator panel	Operator panel Location: U0.1-L1
460B 24A1	I/O system and wire test detected 1W processor fault	Processor card Location: U1.1-P1-C1
460B 24A2	I/O system and wire test detected 2W processor fault	Processor card Location: U1.1-P1-C1
460B 24A3	I/O system and wire test detected 4W processor fault	Processor card Location: U1.1-P1-C1
460B 24A4	I/O system and wire test detected 6W processor fault	Processor card Location: U1.1-P1-C1
460B 25BB	I/O system and wire test detected 1W processor card fault	1W Processor card Location: U1.1-P1-C1
460B 25BD	I/O system and wire test detected 2W processor card fault	2W Processor card Location: U1.1-P1-C1

Table 6. Service Processor Error Codes. (continued)

Error Code	Description	Action/ Possible Failing FRU
460B 25BE	I/O system and wire test detected 4W processor card fault	4W Processor card Location: U1.1-P1-C1
460B 25BF	I/O system and wire test detected 6W processor card fault	6W Processor card Location: U1.1-P1-C1
460B 263D	I/O system and wire test detected dummy riser card fault	Dummy riser card Locations: U1.1-P1-M1 U1.1-P1-M2
460B 2687	I/O system and wire test detected RIO adapter fault	RIO adapter Location: U0.1-P1.1
460B 271A	I/O system and wire test detected primary I/O backplane fault	Primary I/O backplane Location: U0.1-P1
460B 271D	I/O system and wire test detected secondary I/O backplane fault	Secondary I/O backplane Location: U0.2-P1
460B 283A	I/O system and wire test detected CEC backplane fault	1. Processor card Location: U1.1-P1-C1 2. CEC backplane Location: U1.1-P1
460B 285D	I/O system and wire test detected fan controller card fault	Fan controller card Locations: U0.1-X2 U1.1-X2
460B 288D	I/O system and wire test detected memory riser fault	1. Go to service processor memory configuration/deconfiguration menu to verify memory DIMMs state. See "Memory Configuration/Deconfiguration Menu" on page 384 for more information. 2. Memory riser card Locations: U1.1-P1-M1 U1.1-P1-M2
460B 2A00	I/O system and wire test detected 6W processor fault	Processor card Location: U1.1-P1-C1
460B 300A	I/O system and wire test detected 32MB DIMM fault	Memory DIMM Locations: U1.1-P1-M1.n U1.1-P1-M2.n U1.1-P1-C1-Mn
460B 300B	I/O system and wire test detected 128MB DIMM fault	Memory DIMM Locations: U1.1-P1-M1.n U1.1-P1-M2.n U1.1-P1-C1-Mn

Table 6. Service Processor Error Codes. (continued)

Error Code	Description	Action/ Possible Failing FRU
460B 300C	I/O system and wire test detected 256MB DIMM fault	Memory DIMM Locations: U1.1-P1-M1.n U1.1-P1-M2.n U1.1-P1-C1-Mn
460B 300D	I/O system and wire test detected 512MB (stacked) DIMM fault	Memory DIMM Locations: U1.1-P1-M1.n U1.1-P1-M2.n U1.1-P1-C1-Mn
460B 300E	I/O system and wire test detected 512MB (unstacked) DIMM fault	Memory DIMM Locations: U1.1-P1-M1.n U1.1-P1-M2.n U1.1-P1-C1-Mn
460B 301F	I/O system and wire test detected 128MB DIMM fault	Memory DIMM Locations: U1.1-P1-M1.n U1.1-P1-M2.n U1.1-P1-C1-Mn
460B 303A	I/O system and wire test detected 1GB DIMM fault	Memory DIMM Locations: U1.1-P1-M1.n U1.1-P1-M2.n U1.1-P1-C1-Mn
460B 51AA	I/O system and wire test detected 645W AC power supply fault	645W AC power supply Locations: U1.1-V1 U1.1-V2
460B 51AB	I/O system and wire test detected 645W DC power supply fault	645W DC power supply Locations: U1.1-V1 U1.1-V2
460B 51AC	I/O system and wire test detected 595W AC power supply fault	595W AC power supply Locations: U0.1-V1 U0.1-V2
460B 51AD	I/O system and wire test detected 595W DC power supply fault	595W DC power supply Locations: U0.1-V1 U0.1-V2
460C 244C	I/O system and IPL detected 1W 2M processor fault	Processor card Location: U1.1-P1-C1
460C 244D	I/O system and IPL detected 2W 4M processor fault	Processor card Location: U1.1-P1-C1

Table 6. Service Processor Error Codes. (continued)

Error Code	Description	Action/ Possible Failing FRU
460C 244E	I/O system and IPL detected 4W 4M processor fault	Processor card Location: U1.1-P1-C1
460C 244F	I/O system and IPL detected 1W 2M processor fault	Processor card Location: U1.1-P1-C1
460C 248B	I/O system and IPL detected primary I/O drawer operator panel fault	Operator panel Location: U0.1-L1
460C 24A1	I/O system and IPL detected 1W processor fault	Processor card Location: U1.1-P1-C1
460C 24A2	I/O system and IPL detected 2W processor fault	Processor card Location: U1.1-P1-C1
460C 24A3	I/O system and IPL detected 4W processor fault	Processor card Location: U1.1-P1-C1
460C 24A4	I/O system and IPL detected 6W processor fault	Processor card Location: U1.1-P1-C1
460C 25BB	I/O system and IPL detected 1W processor card fault	1W Processor card Location: U1.1-P1-C1
460C 25BD	I/O system and IPL detected 2W processor card fault	2W Processor card Location: U1.1-P1-C1
460C 25BE	I/O system and IPL detected 4W processor card fault	4W Processor card Location: U1.1-P1-C1
460C 25BF	I/O system and IPL test detected 6W processor card fault	6W Processor card Location: U1.1-P1-C1
460C 263D	I/O system and IPL detected dummy riser card fault	Dummy riser card Locations: U1.1-P1-M1 U1.1-P1-M2
460C 2687	I/O system and IPL detected RIO adapter fault	RIO adapter Location: U0.1-P1.1
460C 271A	I/O system and IPL detected primary I/O backplane fault	Primary I/O backplane Location: U0.1-P1
460C 271D	I/O system and IPL detected secondary I/O backplane fault	Secondary I/O backplane Location: U0.2-P1
460C 283A	I/O system and IPL test detected CEC backplane fault	1. Processor card Location: U1.1-P1-C1 2. CEC backplane Location: U1.1-P1
460C 285D	I/O system and IPL test detected fan controller card fault	Fan controller card Locations: U0.1-X2 U1.1-X2

Table 6. Service Processor Error Codes. (continued)

Error Code	Description	Action/ Possible Failing FRU
460C 288D	I/O system and IPL detected memory riser fault	<ol style="list-style-type: none"> 1. Go to service processor memory configuration/deconfiguration menu to verify memory DIMMs state. See "Memory Configuration/Deconfiguration Menu" on page 384 for more information. 2. Memory riser card Locations: U1.1-P1-M1 U1.1-P1-M2
460C 2A00	I/O system and IPL detected 6W processor fault	Processor card Location: U1.1-P1-C1
460C 300A	I/O system and IPL detected 32MB DIMM fault	Memory DIMM Locations: U1.1-P1-M1.n U1.1-P1-M2.n U1.1-P1-C1-Mn
460C 300B	I/O system and IPL detected 128MB DIMM fault	Memory DIMM Locations: U1.1-P1-M1.n U1.1-P1-M2.n U1.1-P1-C1-Mn
460C 300C	I/O system and IPL detected 256MB DIMM fault	Memory DIMM Locations: U1.1-P1-M1.n U1.1-P1-M2.n U1.1-P1-C1-Mn
460C 300D	I/O system and IPL detected 512MB (stacked) DIMM fault	Memory DIMM Locations: U1.1-P1-M1.n U1.1-P1-M2.n U1.1-P1-C1-Mn
460C 300E	I/O system and IPL detected 512MB (unstacked) DIMM fault	Memory DIMM Locations: U1.1-P1-M1.n U1.1-P1-M2.n U1.1-P1-C1-Mn
460C 301F	I/O system and IPL detected 128MB DIMM fault	Memory DIMM Locations: U1.1-P1-M1.n U1.1-P1-M2.n U1.1-P1-C1-Mn

Table 6. Service Processor Error Codes. (continued)

Error Code	Description	Action/ Possible Failing FRU
460C 303A	I/O system and IPL detected 1GB DIMM fault	Memory DIMM Locations: U1.1-P1-M1.n U1.1-P1-M2.n U1.1-P1-C1-Mn
460C 51AA	I/O system and IPL detected 645W AC power supply fault	645W AC power supply Locations: U1.1-V1 U1.1-V2
460C 51AB	I/O system and IPL detected 645W DC power supply fault	645W DC power supply Locations: U1.1-V1 U1.1-V2
460C 51AC	I/O system and IPL detected 595W AC power supply fault	595W AC power supply Locations: U0.1-V1 U0.1-V2
460C 51AD	I/O system and IPL detected 595W DC power supply fault	595W DC power supply Locations: U0.1-V1 U0.1-V2
460D 244C	I/O system and attention handler detected 1W processor fault	Processor card Location: U1.1-P1-C1
460D 244D	I/O system and attention handler detected 2W processor fault	Processor card Location: U1.1-P1-C1
460D 244E	I/O system and attention handler detected 4W processor fault	Processor card Location: U1.1-P1-C1
460D 244F	I/O system and attention handler detected 1W processor fault	Processor card Location: U1.1-P1-C1
460D 248B	I/O system and attention handler detected primary I/O drawer operator panel	Operator panel Location: U0.1-L1
460D 24A1	I/O system and attention handler detected 1W processor fault	Processor card Location: U1.1-P1-C1
460D 24A2	I/O system and attention handler detected 2W processor fault	Processor card Location: U1.1-P1-C1
460D 24A3	I/O system and attention handler detected 4W processor fault	Processor card Location: U1.1-P1-C1
460D 24A4	I/O system and attention handler detected 6W processor fault	Processor card Location: U1.1-P1-C1
460D 25BB	I/O system and attention handler detected 1W processor card fault	1W Processor card Location: U1.1-P1-C1
460D 25BD	I/O system and attention handler detected 2W processor card fault	2W Processor card Location: U1.1-P1-C1

Table 6. Service Processor Error Codes. (continued)

Error Code	Description	Action/ Possible Failing FRU
460D 25BE	I/O system and attention handler detected 4W processor card fault	4W Processor card Location: U1.1-P1-C1
460D 25BF	I/O system and attention handler detected 6W processor card fault	6W Processor card Location: U1.1-P1-C1
460D 263D	I/O system and attention handler detected dummy riser card fault	Dummy riser card Locations: U1.1-P1-M1 U1.1-P1-M2
460D 2687	I/O system and attention handler detected RIO adapter fault	RIO adapter Location: U0.1-P1.1
460D 271A	I/O system and attention handler detected primary I/O backplane fault	Primary I/O backplane Location: U0.1-P1
460D 271D	I/O system and attention handler detected secondary I/O backplane fault	Secondary I/O backplane Location: U0.2-P1
460D 283A	I/O system and attention handler detected CEC backplane fault	1. Processor card Location: U1.1-P1-C1 2. CEC backplane Location: U1.1-P1
460D 285D	I/O system and attention handler detected fan controller card fault	Fan controller card Locations: U0.1-X2 U1.1-X2
460D 288D	I/O system and attention handler detected memory riser fault	1. Go to service processor memory configuration/deconfiguration menu to verify memory DIMMs state. See "Memory Configuration/Deconfiguration Menu" on page 384 for more information. 2. Memory riser card Locations: U1.1-P1-M1 U1.1-P1-M2
460D 2A00	I/O system and attention handler detected 6W processor fault	Processor card Location: U1.1-P1-C1
460D 300A	I/O system and attention handler detected 32MB DIMM fault	Memory DIMM Locations: U1.1-P1-M1.n U1.1-P1-M2.n U1.1-P1-C1-Mn
460D 300B	I/O system and attention handler detected 128MB DIMM fault	Memory DIMM Locations: U1.1-P1-M1.n U1.1-P1-M2.n U1.1-P1-C1-Mn

Table 6. Service Processor Error Codes. (continued)

Error Code	Description	Action/ Possible Failing FRU
460D 300C	I/O system and attention handler detected 256MB DIMM fault	Memory DIMM Locations: U1.1-P1-M1.n U1.1-P1-M2.n U1.1-P1-C1-Mn
460D 300D	I/O system and attention handler detected 512MB (stacked) DIMM fault	Memory DIMM Locations: U1.1-P1-M1.n U1.1-P1-M2.n U1.1-P1-C1-Mn
460D 300E	I/O system and attention handler detected 512MB (unstacked) DIMM fault	Memory DIMM Locations: U1.1-P1-M1.n U1.1-P1-M2.n U1.1-P1-C1-Mn
460D 301F	I/O system and attention handler detected 128MB DIMM fault	Memory DIMM Locations: U1.1-P1-M1.n U1.1-P1-M2.n U1.1-P1-C1-Mn
460D 303A	I/O system and attention handler detected 1GB DIMM fault	Memory DIMM Locations: U1.1-P1-M1.n U1.1-P1-M2.n U1.1-P1-C1-Mn
460D 51AA	I/O system and attention handler detected 645W AC power supply fault	645W AC power supply Locations: U1.1-V1 U1.1-V2
460D 51AB	I/O system and attention handler detected 645W DC power supply fault	645W DC power supply Locations: U1.1-V1 U1.1-V2
460D 51AC	I/O system and attention handler detected 595W AC power supply fault	595W AC power supply Locations: U0.1-V1 U0.1-V2
460D 51AD	I/O system and attention handler detected 595W DC power supply fault	595W DC power supply Locations: U0.1-V1 U0.1-V2
460E 244C	I/O system and scan control routines detected 1W processor fault	Processor card Location: U1.1-P1-C1
460E 244D	I/O system and scan control routines detected 2W processor fault	Processor card Location: U1.1-P1-C1

Table 6. Service Processor Error Codes. (continued)

Error Code	Description	Action/ Possible Failing FRU
460E 244E	I/O system and scan control routines detected 4W processor fault	Processor card Location: U1.1-P1-C1
460E 244F	I/O system and scan control routines detected 1W processor fault	Processor card Location: U1.1-P1-C1
460E 248B	I/O system and scan control routines detected primary I/O drawer operator panel	Operator panel Location: U0.1-L1
460E 24A1	I/O system and scan control routines detected 1W processor fault	Processor card Location: U1.1-P1-C1
460E 24A2	I/O system and scan control routines detected 2W processor fault	Processor card Location: U1.1-P1-C1
460E 24A3	I/O system and scan control routines detected 4W processor fault	Processor card Location: U1.1-P1-C1
460E 24A4	I/O system and scan control routines detected 6W processor fault	Processor card Location: U1.1-P1-C1
460E 25BB	I/O system and scan control routines detected 1W processor card fault	1W Processor card Location: U1.1-P1-C1
460E 25BD	I/O system and scan control routines detected 2W processor card fault	2W Processor card Location: U1.1-P1-C1
460E 25BE	I/O system and scan control routines detected 4W processor card fault	4W Processor card Location: U1.1-P1-C1
460E 25BF	I/O system and scan control routines detected 6W processor card fault	6W Processor card Location: U1.1-P1-C1
460E 263D	I/O system and scan control routines detected dummy riser card fault	Dummy riser card Locations: U1.1-P1-M1 U1.1-P1-M2
460E 2687	I/O system and scan control routines detected RIO adapter fault	RIO adapter Location: U0.1-P1.1
460E 271A	I/O system and scan control routines detected primary I/O backplane fault	Primary I/O backplane Location: U0.1-P1
460E 271D	I/O system and scan control routines detected secondary I/O backplane fault	Secondary I/O backplane Location: U0.2-P1
460E 283A	I/O system and scan control routines detected CEC backplane fault	1. Processor card Location: U1.1-P1-C1 2. CEC backplane Location: U1.1-P1
460E 285D	I/O system and scan control routines detected fan controller card fault	Fan controller card Locations: U0.1-X2 U1.1-X2

Table 6. Service Processor Error Codes. (continued)

Error Code	Description	Action/ Possible Failing FRU
460E 288D	I/O system and scan control routines detected memory riser fault	<ol style="list-style-type: none"> 1. Go to service processor memory configuration/deconfiguration menu to verify memory DIMMs state. See "Memory Configuration/Deconfiguration Menu" on page 384 for more information. 2. Memory riser card Locations: U1.1-P1-M1 U1.1-P1-M2
460E 2A00	I/O system and scan control routines detected 6W processor fault	Processor card Location: U1.1-P1-C1
460E 300A	I/O system and scan control routines detected 32MB DIMM fault	Memory DIMM Locations: U1.1-P1-M1.n U1.1-P1-M2.n U1.1-P1-C1-Mn
460E 300B	I/O system and scan control routines detected 128MB DIMM fault	Memory DIMM Locations: U1.1-P1-M1.n U1.1-P1-M2.n U1.1-P1-C1-Mn
460E 300C	I/O system and scan control routines detected 256MB DIMM fault	Memory DIMM Locations: U1.1-P1-M1.n U1.1-P1-M2.n U1.1-P1-C1-Mn
460E 300D	I/O system and scan control routines detected 512MB (stacked) DIMM fault	Memory DIMM Locations: U1.1-P1-M1.n U1.1-P1-M2.n U1.1-P1-C1-Mn
460E 300E	I/O system and scan control routines detected 512MB (unstacked) DIMM fault	Memory DIMM Locations: U1.1-P1-M1.n U1.1-P1-M2.n U1.1-P1-C1-Mn
460E 301F	I/O system and scan control routines detected 128MB DIMM fault	Memory DIMM Locations: U1.1-P1-M1.n U1.1-P1-M2.n U1.1-P1-C1-Mn

Table 6. Service Processor Error Codes. (continued)

Error Code	Description	Action/ Possible Failing FRU
460E 303A	I/O system and scan control routines detected 1GB DIMM fault	Memory DIMM Locations: U1.1-P1-M1.n U1.1-P1-M2.n U1.1-P1-C1-Mn
460E 51AA	I/O system and scan control routines detected 645W AC power supply fault	645W AC power supply Locations: U1.1-V1 U1.1-V2
460E 51AB	I/O system and scan control routines detected 645W DC power supply fault	645W DC power supply Locations: U1.1-V1 U1.1-V2
460E 51AC	I/O system and scan control routines detected 595W AC power supply fault	595W AC power supply Locations: U0.1-V1 U0.1-V2
460E 51AD	I/O system and scan control routines detected 595W DC power supply fault	595W DC power supply Locations: U0.1-V1 U0.1-V2
460F 244C	I/O system and error code generation/logging detected 1W processor fault	Processor card Location: U1.1-P1-C1
460F 244D	I/O system and error code generation/logging detected 2W processor fault	Processor card Location: U1.1-P1-C1
460F 244E	I/O system and error code generation/logging detected 4W processor fault	Processor card Location: U1.1-P1-C1
460F 244F	I/O system and error code generation/logging detected 1W processor fault	Processor card Location: U1.1-P1-C1
460F 248B	I/O system and error code generation/logging detected primary I/O drawer operator panel	Operator panel Location: U0.1-L1
460F 24A1	I/O system and error code generation/logging detected 1W processor fault	Processor card Location: U1.1-P1-C1
460F 24A2	I/O system and error code generation/logging detected 2W processor fault	Processor card Location: U1.1-P1-C1
460F 24A3	I/O system and error code generation/logging detected 4W processor fault	Processor card Location: U1.1-P1-C1

Table 6. Service Processor Error Codes. (continued)

Error Code	Description	Action/ Possible Failing FRU
460F 24A4	I/O system and error code generation/logging detected 6W processor fault	Processor card Location: U1.1-P1-C1
460F 25BB	I/O system and error code generation/logging detected 1W processor card fault	1W Processor card Location: U1.1-P1-C1
460F 25BD	I/O system and error code generation/logging detected 2W processor card fault	2W Processor card Location: U1.1-P1-C1
460F 25BE	I/O system and error code generation/logging detected 4W processor card fault	4W Processor card Location: U1.1-P1-C1
460F 25BF	I/O system and error code generation/logging detected 6W processor card fault	6W Processor card Location: U1.1-P1-C1
460F 263D	I/O system and error code generation/logging detected dummy riser card fault	Dummy riser card Locations: U1.1-P1-M1 U1.1-P1-M2
460F 2687	I/O system and error code generation/logging detected RIO adapter fault	RIO adapter Location: U0.1-P1.1
460F 271A	I/O system and error code generation/logging detected primary I/O backplane fault	Primary I/O backplane Location: U0.1-P1
460F 271D	I/O system and error code generation/logging detected secondary I/O backplane fault	Secondary I/O backplane Location: U0.2-P1
460F 283A	I/O system and error code generation/logging detected CEC backplane fault	1. Processor card Location: U1.1-P1-C1 2. CEC backplane Location: U1.1-P1
460F 285D	I/O system and error code generation/logging detected fan controller card fault	Fan controller card Locations: U0.1-X2 U1.1-X2

Table 6. Service Processor Error Codes. (continued)

Error Code	Description	Action/ Possible Failing FRU
460F 288D	I/O system and error code generation/logging detected memory riser fault	<ol style="list-style-type: none"> Go to service processor memory configuration/deconfiguration menu to verify memory DIMMs state. See "Memory Configuration/Deconfiguration Menu" on page 384 for more information. Memory riser card Locations: U1.1-P1-M1 U1.1-P1-M2
460F 2A00	I/O system and error code generation/logging detected 6W processor fault	Processor card Location: U1.1-P1-C1
460F 300A	I/O system and error code generation/logging detected 32MB DIMM fault	Memory DIMM Locations: U1.1-P1-M1.n U1.1-P1-M2.n U1.1-P1-C1-Mn
460F 300B	I/O system and error code generation/logging detected 128MB DIMM fault	Memory DIMM Locations: U1.1-P1-M1.n U1.1-P1-M2.n U1.1-P1-C1-Mn
460F 300C	I/O system and error code generation/logging detected 256MB DIMM fault	Memory DIMM Locations: U1.1-P1-M1.n U1.1-P1-M2.n U1.1-P1-C1-Mn
460F 300D	I/O system and error code generation/logging detected 512MB (stacked) DIMM fault	Memory DIMM Locations: U1.1-P1-M1.n U1.1-P1-M2.n U1.1-P1-C1-Mn
460F 300E	I/O system and error code generation/logging detected 512MB (unstacked) DIMM fault	Memory DIMM Locations: U1.1-P1-M1.n U1.1-P1-M2.n U1.1-P1-C1-Mn
460F 301F	I/O system and error code generation/logging detected 128MB DIMM fault	Memory DIMM Locations: U1.1-P1-M1.n U1.1-P1-M2.n U1.1-P1-C1-Mn

Table 6. Service Processor Error Codes. (continued)

Error Code	Description	Action/ Possible Failing FRU
460F 303A	I/O system and error code generation/logging detected 1GB DIMM fault	Memory DIMM Locations: U1.1-P1-M1.n U1.1-P1-M2.n U1.1-P1-C1-Mn
460F 51AA	I/O system and error code generation/logging detected 645W AC power supply fault	645W AC power supply Locations: U1.1-V1 U1.1-V2
460F 51AB	I/O system and error code generation/logging detected 645W DC power supply fault	645W DC power supply Locations: U1.1-V1 U1.1-V2
460F 51AC	I/O system and error code generation/logging detected 595W AC power supply fault	595W AC power supply Locations: U0.1-V1 U0.1-V2
460F 51AD	I/O system and error code generation/logging detected 595W DC power supply fault	595W DC power supply Locations: U0.1-V1 U0.1-V2
4B26 244C	Processor system and scan interface basic assurance tests detected 1W processor fault	Processor card Location: U1.1-P1-C1
4B26 244D	Processor system and scan interface basic assurance tests detected 2W processor fault	Processor card Location: U1.1-P1-C1
4B26 244E	Processor system and scan interface basic assurance tests detected 4W processor fault	Processor card Location: U1.1-P1-C1
4B26 244F	Processor system and scan interface basic assurance tests detected 1W processor fault	Processor card Location: U1.1-P1-C1
4B26 248B	Processor system and scan interface basic assurance tests detected primary I/O drawer operator panel	Operator panel Location: U0.1-L1
4B26 24A1	Processor system and scan interface basic assurance tests detected 1W processor fault	Processor card Location: U1.1-P1-C1
4B26 24A2	Processor system and scan interface basic assurance tests detected 2W processor fault	Processor card Location: U1.1-P1-C1
4B26 24A3	Processor system and scan interface basic assurance tests detected 4W processor fault	Processor card Location: U1.1-P1-C1

Table 6. Service Processor Error Codes. (continued)

Error Code	Description	Action/ Possible Failing FRU
4B26 24A4	Processor system and scan interface basic assurance tests detected 6W processor fault	Processor card Location: U1.1-P1-C1
4B26 25BB	Processor system and scan interface basic assurance tests detected 1W processor card fault	1W Processor card Location: U1.1-P1-C1
4B26 25BD	Processor system and scan interface basic assurance tests detected 2W processor card fault	2W Processor card Location: U1.1-P1-C1
4B26 25BE	Processor system and scan interface basic assurance tests detected 4W processor card fault	4W Processor card Location: U1.1-P1-C1
4B26 25BF	Processor system and scan interface basic assurance tests detected 6W processor card fault	6W Processor card Location: U1.1-P1-C1
4B26 25CB	1W processor card fault	Replace the processor card Location: U1.1-P1-C1
4B26 25EA	4W processor card fault	Replace the processor card Location: U1.1-P1-C1
4B26 25EB	2W processor card fault	Replace the processor card Location: U1.1-P1-C1
4B26 25F2	6W processor card fault	Replace the processor card Location: U1.1-P1-C1
4B26 263D	Processor system and scan interface basic assurance tests detected dummy riser card fault	Dummy riser card Locations: U1.1-P1-M1 U1.1-P1-M2
4B26 2687	Processor system and scan interface basic assurance tests detected RIO adapter fault	RIO adapter Location: U0.1-P1.1
4B26 271A	Processor system and scan interface basic assurance tests detected primary I/O backplane fault	Primary I/O backplane Location: U0.1-P1
4B26 271D	Processor system and scan interface basic assurance tests detected secondary I/O backplane fault	Secondary I/O backplane Location: U0.2-P1
4B26 283A	Processor system and scan interface basic assurance tests detected CEC backplane fault	1. Processor card Location: U1.1-P1-C1 2. CEC backplane Location: U1.1-P1
4B26 285D	Processor system and scan interface basic assurance tests detected fan controller card fault	Fan controller card Locations: U0.1-X2 U1.1-X2

Table 6. Service Processor Error Codes. (continued)

Error Code	Description	Action/ Possible Failing FRU
4B26 288D	Processor system and scan interface basic assurance tests detected memory riser fault	<ol style="list-style-type: none"> 1. Go to service processor memory configuration/deconfiguration menu to verify memory DIMMs state. See "Memory Configuration/Deconfiguration Menu" on page 384 for more information. 2. Memory riser card Locations: U1.1-P1-M1 U1.1-P1-M2
4B26 2A00	Processor system and scan interface basic assurance tests detected 6W processor fault	Processor card Location: U1.1-P1-C1
4B26 300A	Processor system and scan interface basic assurance tests detected 32MB DIMM fault	Memory DIMM Locations: U1.1-P1-M1.n U1.1-P1-M2.n U1.1-P1-C1-Mn
4B26 300B	Processor system and scan interface basic assurance tests detected 128MB DIMM fault	Memory DIMM Locations: U1.1-P1-M1.n U1.1-P1-M2.n U1.1-P1-C1-Mn
4B26 300C	Processor system and scan interface basic assurance tests detected 256MB DIMM fault	Memory DIMM Locations: U1.1-P1-M1.n U1.1-P1-M2.n U1.1-P1-C1-Mn
4B26 300D	Processor system and scan interface basic assurance tests detected 512MB (stacked) DIMM fault	Memory DIMM Locations: U1.1-P1-M1.n U1.1-P1-M2.n U1.1-P1-C1-Mn
4B26 300E	Processor system and scan interface basic assurance tests detected 512MB (unstacked) DIMM fault	Memory DIMM Locations: U1.1-P1-M1.n U1.1-P1-M2.n U1.1-P1-C1-Mn
4B26 301F	Processor system and scan interface basic assurance tests detected 128MB DIMM fault	Memory DIMM Locations: U1.1-P1-M1.n U1.1-P1-M2.n U1.1-P1-C1-Mn

Table 6. Service Processor Error Codes. (continued)

Error Code	Description	Action/ Possible Failing FRU
4B26 303A	Processor system and scan interface basic assurance tests detected 1GB DIMM fault	Memory DIMM Locations: U1.1-P1-M1.n U1.1-P1-M2.n U1.1-P1-C1-Mn
4B26 51AA	Processor system and scan interface basic assurance tests detected 645W AC power supply fault	645W AC power supply Locations: U1.1-V1 U1.1-V2
4B26 51AB	Processor system and scan interface basic assurance tests detected 645W DC power supply fault	645W DC power supply Locations: U1.1-V1 U1.1-V2
4B26 51AC	Processor system and scan interface basic assurance tests detected 595W AC power supply fault	595W AC power supply Locations: U0.1-V1 U0.1-V2 U0.2-V1 U0.2-V2
4B26 51AD	Processor system and scan interface basic assurance tests detected 595W DC power supply fault	595W DC power supply Locations: U0.1-V1 U0.1-V2 U0.2-V1 U0.2-V2
4B27 244C	Processor system and 6xx bus processor runtime diagnostics detected 1W processor fault	Processor card Location: U1.1-P1-C1
4B27 244D	Processor system and 6xx bus processor runtime diagnostics detected 2W processor fault	Processor card Location: U1.1-P1-C1
4B27 244E	Processor system and 6xx bus processor runtime diagnostics detected 4W processor fault	Processor card Location: U1.1-P1-C1
4B27 244F	Processor system and 6xx bus processor runtime diagnostics detected 1W processor fault	Processor card Location: U1.1-P1-C1
4B27 248B	Processor system and 6xx bus processor runtime diagnostics detected primary I/O drawer operator panel	Operator panel Location: U0.1-L1
4B27 24A1	Processor system and 6xx bus processor runtime diagnostics detected 1W processor fault	Processor card Location: U1.1-P1-C1

Table 6. Service Processor Error Codes. (continued)

Error Code	Description	Action/ Possible Failing FRU
4B27 24A2	Processor system and 6xx bus processor runtime diagnostics detected 2W processor fault	Processor card Location: U1.1-P1-C1
4B27 24A3	Processor system and 6xx bus processor runtime diagnostics detected 4W processor fault	Processor card Location: U1.1-P1-C1
4B27 24A4	Processor system and scan interface basic assurance tests detected 6W processor fault	Processor card Location: U1.1-P1-C1
4B27 25BB	Processor system and 6xx bus processor runtime diagnostics detected 1W processor card fault	1W Processor card Location: U1.1-P1-C1
4B27 25BD	Processor system and 6xx bus processor runtime diagnostics detected 2W processor card fault	2W Processor card Location: U1.1-P1-C1
4B27 25BE	Processor system and 6xx bus processor runtime diagnostics detected 4W processor card fault	4W Processor card Location: U1.1-P1-C1
4B27 25BF	Processor system and 6xx bus processor runtime diagnostics detected 6W processor card fault	6W Processor card Location: U1.1-P1-C1
4B27 25CB	1W processor card fault	Replace the processor card Location: U1.1-P1-C1
4B27 25EA	4W processor card fault	Replace the processor card Location: U1.1-P1-C1
4B27 25EB	2W processor card fault	Replace the processor card Location: U1.1-P1-C1
4B27 25F2	6W processor card fault	Replace the processor card Location: U1.1-P1-C1
4B27 263D	Processor system and 6xx bus processor runtime diagnostics detected dummy riser card fault	Dummy riser card Locations: U1.1-P1-M1 U1.1-P1-M2
4B27 2687	Processor system and 6xx bus processor runtime diagnostics detected RIO adapter fault	RIO adapter Location: U0.1-P1.1
4B27 271A	Processor system and 6xx bus processor runtime diagnostics detected primary I/O backplane fault	Primary I/O backplane Location: U0.1-P1
4B27 271D	Processor system and 6xx bus processor runtime diagnostics detected secondary I/O backplane fault	Secondary I/O backplane Location: U0.2-P1

Table 6. Service Processor Error Codes. (continued)

Error Code	Description	Action/ Possible Failing FRU
4B27 283A	Processor system and 6xx bus processor runtime diagnostics detected CEC backplane fault	<ol style="list-style-type: none"> Processor card Location: U1.1-P1-C1 CEC backplane Location: U1.1-P1
4B27 285D	Processor system and 6xx bus processor runtime diagnostics detected fan controller card fault	Fan controller card Locations: U0.1-X2 U1.1-X2
4B27 288D	Processor system and 6xx bus processor runtime diagnostics detected memory riser fault	<ol style="list-style-type: none"> Go to service processor memory configuration/deconfiguration menu to verify memory DIMMs state. See "Memory Configuration/Deconfiguration Menu" on page 384 for more information. Memory riser card Locations: U1.1-P1-M1 U1.1-P1-M2
4B27 2A00	Processor system and 6xx bus processor runtime diagnostics detected 6W processor fault	Processor card Location: U1.1-P1-C1
4B27 300A	Processor system and 6xx bus processor runtime diagnostics detected 32MB DIMM fault	Memory DIMM Locations: U1.1-P1-M1.n U1.1-P1-M2.n U1.1-P1-C1-Mn
4B27 300B	Processor system and 6xx bus processor runtime diagnostics detected 128MB DIMM fault	Memory DIMM Locations: U1.1-P1-M1.n U1.1-P1-M2.n U1.1-P1-C1-Mn
4B27 300C	Processor system and 6xx bus processor runtime diagnostics detected 256MB DIMM fault	Memory DIMM Locations: U1.1-P1-M1.n U1.1-P1-M2.n U1.1-P1-C1-Mn
4B27 300D	Processor system and 6xx bus processor runtime diagnostics detected 512MB (stacked) DIMM fault	Memory DIMM Locations: U1.1-P1-M1.n U1.1-P1-M2.n U1.1-P1-C1-Mn
4B27 300E	Processor system and 6xx bus processor runtime diagnostics detected 512MB (unstacked) DIMM fault	Memory DIMM Locations: U1.1-P1-M1.n U1.1-P1-M2.n U1.1-P1-C1-Mn

Table 6. Service Processor Error Codes. (continued)

Error Code	Description	Action/ Possible Failing FRU
4B27 301F	Processor system and 6xx bus processor runtime diagnostics detected 128MB DIMM fault	Memory DIMM Locations: U1.1-P1-M1.n U1.1-P1-M2.n U1.1-P1-C1-Mn
4B27 303A	Processor system and 6xx bus processor runtime diagnostics detected 1GB DIMM fault	Memory DIMM Locations: U1.1-P1-M1.n U1.1-P1-M2.n U1.1-P1-C1-Mn
4B27 51AA	Processor system and 6xx bus processor runtime diagnostics detected 645W AC power supply fault	645W AC power supply Locations: U1.1-V1 U1.1-V2
4B27 51AB	Processor system and 6xx bus processor runtime diagnostics detected 645W DC power supply fault	645W DC power supply Locations: U1.1-V1 U1.1-V2
4B27 51AC	Processor system and 6xx bus processor runtime diagnostics detected 595W AC power supply fault	595W AC power supply Locations: U0.1-V1 U0.1-V2
4B27 51AD	Processor system and 6xx bus processor runtime diagnostics detected 595W DC power supply fault	595W DC power supply Locations: U0.1-V1 U0.1-V2
4B28 244C	Processor system and other bus processor runtime diagnostics detected 1W processor fault	Processor card Location: U1.1-P1-C1
4B28 244D	Processor system and other bus processor runtime diagnostics detected 2W processor fault	Processor card Location: U1.1-P1-C1
4B28 244E	Processor system and other bus processor runtime diagnostics detected 4W processor fault	Processor card Location: U1.1-P1-C1
4B28 244F	Processor system and other bus processor runtime diagnostics detected 1W processor fault	Processor card Location: U1.1-P1-C1
4B28 248B	Processor system and other bus processor runtime diagnostics detected primary I/O drawer operator panel	Operator panel Location: U0.1-L1
4B28 24A1	Processor system and other bus processor runtime diagnostics detected 1W processor fault	Processor card Location: U1.1-P1-C1

Table 6. Service Processor Error Codes. (continued)

Error Code	Description	Action/ Possible Failing FRU
4B28 24A2	Processor system and other bus processor runtime diagnostics detected 2W processor fault	Processor card Location: U1.1-P1-C1
4B28 24A3	Processor system and other bus processor runtime diagnostics detected 4W processor fault	Processor card Location: U1.1-P1-C1
4B28 24A4	Processor system and other bus processor runtime diagnostics detected 6W processor fault	Processor card Location: U1.1-P1-C1
4B28 25BB	Processor system and other bus processor runtime diagnostics detected 1W processor card fault	1W Processor card Location: U1.1-P1-C1
4B28 25BD	Processor system and other bus processor runtime diagnostics detected 2W processor card fault	2W Processor card Location: U1.1-P1-C1
4B28 25BE	Processor system and other bus processor runtime diagnostics detected 4W processor card fault	4W Processor card Location: U1.1-P1-C1
4B28 25BF	Processor system and other bus processor runtime diagnostics detected 6W processor card fault	6W Processor card Location: U1.1-P1-C1
4B28 25CB	1W processor card fault	Replace the processor card Location: U1.1-P1-C1
4B28 25EA	4W processor card fault	Replace the processor card Location: U1.1-P1-C1
4B28 25EB	2W processor card fault	Replace the processor card Location: U1.1-P1-C1
4B28 25F2	6W processor card fault	Replace the processor card Location: U1.1-P1-C1
4B28 263D	Processor system and other bus processor runtime diagnostics detected dummy riser card fault	Dummy riser card Locations: U1.1-P1-M1 U1.1-P1-M2
4B28 2687	Processor system and other bus processor runtime diagnostics detected RIO adapter fault	RIO adapter Location: U0.1-P1.1
4B28 271A	Processor system and other bus processor runtime diagnostics detected primary I/O backplane fault	Primary I/O backplane Location: U0.1-P1
4B28 271D	Processor system and other bus processor runtime diagnostics detected secondary I/O backplane fault	Secondary I/O backplane Location: U0.2-P1

Table 6. Service Processor Error Codes. (continued)

Error Code	Description	Action/ Possible Failing FRU
4B28 283A	Processor system and other bus processor runtime diagnostics detected CEC backplane fault	<ol style="list-style-type: none"> Processor card Location: U1.1-P1-C1 CEC backplane Location: U1.1-P1
4B28 285D	Processor system and other bus processor runtime diagnostics detected fan controller card fault	Fan controller card Locations: U0.1-X2 U1.1-X2
4B28 288D	Processor system and other bus processor runtime diagnostics detected memory riser fault	<ol style="list-style-type: none"> Go to service processor memory configuration/deconfiguration menu to verify memory DIMMs state. See "Memory Configuration/Deconfiguration Menu" on page 384 for more information. Memory riser card Locations: U1.1-P1-M1 U1.1-P1-M2
4B28 2A00	Processor system and other bus processor runtime diagnostics detected 6W processor fault	Processor card Location: U1.1-P1-C1
4B28 300A	Processor system and other bus processor runtime diagnostics detected 32MB DIMM fault	Memory DIMM Locations: U1.1-P1-M1.n U1.1-P1-M2.n U1.1-P1-C1-Mn
4B28 300B	Processor system and other bus processor runtime diagnostics detected 128MB DIMM fault	Memory DIMM Locations: U1.1-P1-M1.n U1.1-P1-M2.n U1.1-P1-C1-Mn
4B28 300C	Processor system and other bus processor runtime diagnostics detected 256MB DIMM fault	Memory DIMM Locations: U1.1-P1-M1.n U1.1-P1-M2.n U1.1-P1-C1-Mn
4B28 300D	Processor system and other bus processor runtime diagnostics detected 512MB (stacked) DIMM fault	Memory DIMM Locations: U1.1-P1-M1.n U1.1-P1-M2.n U1.1-P1-C1-Mn
4B28 300E	Processor system and other bus processor runtime diagnostics detected 512MB (unstacked) DIMM fault	Memory DIMM Locations: U1.1-P1-M1.n U1.1-P1-M2.n U1.1-P1-C1-Mn

Table 6. Service Processor Error Codes. (continued)

Error Code	Description	Action/ Possible Failing FRU
4B28 301F	Processor system and other bus processor runtime diagnostics detected 128MB DIMM fault	Memory DIMM Locations: U1.1-P1-M1.n U1.1-P1-M2.n U1.1-P1-C1-Mn
4B28 303A	Processor system and other bus processor runtime diagnostics detected 1GB DIMM fault	Memory DIMM Locations: U1.1-P1-M1.n U1.1-P1-M2.n U1.1-P1-C1-Mn
4B28 51AA	Processor system and other bus processor runtime diagnostics detected 645W AC power supply fault	645W AC power supply Locations: U1.1-V1 U1.1-V2
4B28 51AB	Processor system and other bus processor runtime diagnostics detected 645W DC power supply fault	645W DC power supply Locations: U1.1-V1 U1.1-V2
4B28 51AC	Processor system and other bus processor runtime diagnostics detected 595W AC power supply fault	595W AC power supply Locations: U0.1-V1 U0.1-V2
4B28 51AD	Processor system and other bus processor runtime diagnostics detected 595W DC power supply fault	595W DC power supply Locations: U0.1-V1 U0.1-V2
4B29 244C	Processor system and memory test detected 1W processor fault	Processor card Location: U1.1-P1-C1
4B29 244D	Processor system and memory test detected 2W processor fault	Processor card Location: U1.1-P1-C1
4B29 244E	Processor system and memory test detected 4W processor fault	Processor card Location: U1.1-P1-C1
4B29 244F	Processor system and memory test detected 1W processor fault	Processor card Location: U1.1-P1-C1
4B29 248B	Processor system and memory test detected primary I/O drawer operator panel	Operator panel Location: U0.1-L1
4B29 24A1	Processor system and memory test detected 1W processor fault	Processor card Location: U1.1-P1-C1
4B29 24A2	Processor system and memory test detected 2W processor fault	Processor card Location: U1.1-P1-C1
4B29 24A3	Processor system and memory test detected 4W processor fault	Processor card Location: U1.1-P1-C1
4B29 24A4	Processor system and memory test detected 6W processor fault	Processor card Location: U1.1-P1-C1

Table 6. Service Processor Error Codes. (continued)

Error Code	Description	Action/ Possible Failing FRU
4B29 25BB	Processor system and memory test detected 1W processor card fault	1W Processor card Location: U1.1-P1-C1
4B29 25BD	Processor system and memory test detected 2W processor card fault	2W Processor card Location: U1.1-P1-C1
4B29 25BE	Processor system and memory test detected 4W processor card fault	4W Processor card Location: U1.1-P1-C1
4B29 25BF	Processor system and memory test detected 6W processor card fault	6W Processor card Location: U1.1-P1-C1
4B29 25CB	1W processor card fault	Replace the processor card Location: U1.1-P1-C1
4B29 25EA	4W processor card fault	Replace the processor card Location: U1.1-P1-C1
4B29 25EB	2W processor card fault	Replace the processor card Location: U1.1-P1-C1
4B29 25F2	6W processor card fault	Replace the processor card Location: U1.1-P1-C1
4B29 263D	Processor system and memory test detected dummy riser card fault	Dummy riser card Locations: U1.1-P1-M1 U1.1-P1-M2
4B29 2687	Processor system and memory test detected RIO adapter fault	RIO adapter Location: U0.1-P1.1
4B29 271A	Processor system and memory test detected primary I/O backplane fault	Primary I/O backplane Location: U0.1-P1
4B29 271D	Processor system and memory test detected secondary I/O backplane fault	Secondary I/O backplane Location: U0.2-P1
4B29 283A	Processor system and memory test detected CEC backplane fault	1. Processor card Location: U1.1-P1-C1 2. CEC backplane Location: U1.1-P1
4B29 285D	Processor system and memory test detected fan controller card fault	Fan controller card Locations: U0.1-X2 U1.1-X2

Table 6. Service Processor Error Codes. (continued)

Error Code	Description	Action/ Possible Failing FRU
4B29 288D	Processor system and memory test detected memory riser fault	<ol style="list-style-type: none"> Go to service processor memory configuration/deconfiguration menu to verify memory DIMMs state. See "Memory Configuration/Deconfiguration Menu" on page 384 for more information. Memory riser card Locations: U1.1-P1-M1 U1.1-P1-M2
4B29 2A00	Processor system and memory test detected 6W processor fault	Processor card Location: U1.1-P1-C1
4B29 300A	Processor system and memory test detected 32MB DIMM fault	Memory DIMM Locations: U1.1-P1-M1.n U1.1-P1-M2.n U1.1-P1-C1-Mn
4B29 300B	Processor system and memory test detected 128MB DIMM fault	Memory DIMM Locations: U1.1-P1-M1.n U1.1-P1-M2.n U1.1-P1-C1-Mn
4B29 300C	Processor system and memory test detected 256MB DIMM fault	Memory DIMM Locations: U1.1-P1-M1.n U1.1-P1-M2.n U1.1-P1-C1-Mn
4B29 300D	Processor system and memory test detected 512MB (stacked) DIMM fault	Memory DIMM Locations: U1.1-P1-M1.n U1.1-P1-M2.n U1.1-P1-C1-Mn
4B29 300E	Processor system and memory test detected 512MB (unstacked) DIMM fault	Memory DIMM Locations: U1.1-P1-M1.n U1.1-P1-M2.n U1.1-P1-C1-Mn
4B29 301F	Processor system and memory test detected 128MB DIMM fault	Memory DIMM Locations: U1.1-P1-M1.n U1.1-P1-M2.n U1.1-P1-C1-Mn

Table 6. Service Processor Error Codes. (continued)

Error Code	Description	Action/ Possible Failing FRU
4B29 303A	Processor system and memory test detected 1GB DIMM fault	Memory DIMM Locations: U1.1-P1-M1.n U1.1-P1-M2.n U1.1-P1-C1-Mn
4B29 51AA	Processor system and memory test detected 645W AC power supply fault	645W AC power supply Locations: U1.1-V1 U1.1-V2
4B29 51AB	Processor system and memory test detected 645W DC power supply fault	645W DC power supply Locations: U1.1-V1 U1.1-V2
4B29 51AC	Processor system and memory test detected 595W AC power supply fault	595W AC power supply Locations: U0.1-V1 U0.1-V2
4B29 51AD	Processor system and memory test detected 595W DC power supply fault	595W DC power supply Locations: U0.1-V1 U0.1-V2
4B2A 244C	Processor system and self test detected 1W processor fault	Processor card Location: U1.1-P1-C1
4B2A 244D	Processor system and self test detected 2W processor fault	Processor card Location: U1.1-P1-C1
4B2A 244E	Processor system and self test detected 4W processor fault	Processor card Location: U1.1-P1-C1
4B2A 244F	Processor system and self test detected 1W processor fault	Processor card Location: U1.1-P1-C1
4B2A 248B	Processor system and self test detected primary I/O drawer operator panel	Operator panel Location: U0.1-L1
4B2A 24A1	Processor system and self test detected 1W processor fault	Processor card Location: U1.1-P1-C1
4B2A 24A2	Processor system and self test detected 2W processor fault	Processor card Location: U1.1-P1-C1
4B2A 24A3	Processor system and self test detected 4W processor fault	Processor card Location: U1.1-P1-C1
4B2A 24A4	Processor system and self test detected 6W processor fault	Processor card Location: U1.1-P1-C1
4B2A 25BB	Processor system and self test detected 1W processor card fault	1W Processor card Location: U1.1-P1-C1

Table 6. Service Processor Error Codes. (continued)

Error Code	Description	Action/ Possible Failing FRU
4B2A 25BD	Processor system and self test detected 2W processor card fault	2W Processor card Location: U1.1-P1-C1
4B2A 25BE	Processor system and self test detected 4W processor card fault	4W Processor card Location: U1.1-P1-C1
4B2A 25BF	Processor system and self test detected 6W processor card fault	6W Processor card Location: U1.1-P1-C1
4B2A 25CB	1W processor card fault	Replace the processor card Location: U1.1-P1-C1
4B2A 25EA	4W processor card fault	Replace the processor card Location: U1.1-P1-C1
4B2A 25EB	2W processor card fault	Replace the processor card Location: U1.1-P1-C1
4B2A 25F2	6W processor card fault	Replace the processor card Location: U1.1-P1-C1
4B2A 263D	Processor system and self test detected dummy riser card fault	Dummy riser card Locations: U1.1-P1-M1 U1.1-P1-M2
4B2A 2687	Processor system and self test detected RIO adapter fault	RIO adapter Location: U0.1-P1.1
4B2A 271A	Processor system and self test detected primary I/O backplane fault	Primary I/O backplane Location: U0.1-P1
4B2A 271D	Processor system and self test detected secondary I/O backplane fault	Secondary I/O backplane Location: U0.2-P1
4B2A 283A	Processor system and self test detected CEC backplane fault	1. Processor card Location: U1.1-P1-C1 2. CEC backplane Location: U1.1-P1
4B2A 285D	Processor system and self test detected fan controller card fault	Fan controller card Locations: U0.1-X2 U1.1-X2

Table 6. Service Processor Error Codes. (continued)

Error Code	Description	Action/ Possible Failing FRU
4B2A 288D	Processor system and self test detected memory riser fault	<ol style="list-style-type: none"> 1. Go to service processor memory configuration/deconfiguration menu to verify memory DIMMs state. See "Memory Configuration/Deconfiguration Menu" on page 384 for more information. 2. Go to "Memory Configuration/Deconfiguration Menu" 384 to verify memory DIMMs state. 3. Memory riser card Locations: U1.1-P1-M1 U1.1-P1-M2
4B2A 2A00	Processor system and self test detected 6W processor fault	Processor card Location: U1.1-P1-C1
4B2A 300A	Processor system and self test detected 32MB DIMM fault	Memory DIMM Locations: U1.1-P1-M1.n U1.1-P1-M2.n U1.1-P1-C1-Mn
4B2A 300B	Processor system and self test detected 128MB DIMM fault	Memory DIMM Locations: U1.1-P1-M1.n U1.1-P1-M2.n U1.1-P1-C1-Mn
4B2A 300C	Processor system and self test detected 256MB DIMM fault	Memory DIMM Locations: U1.1-P1-M1.n U1.1-P1-M2.n U1.1-P1-C1-Mn
4B2A 300D	Processor system and self test detected 512MB (stacked) DIMM fault	Memory DIMM Locations: U1.1-P1-M1.n U1.1-P1-M2.n U1.1-P1-C1-Mn
4B2A 300E	Processor system and self test detected 512MB (unstacked) DIMM fault	Memory DIMM Locations: U1.1-P1-M1.n U1.1-P1-M2.n U1.1-P1-C1-Mn
4B2A 301F	Processor system and self test detected 128MB DIMM fault	Memory DIMM Locations: U1.1-P1-M1.n U1.1-P1-M2.n U1.1-P1-C1-Mn

Table 6. Service Processor Error Codes. (continued)

Error Code	Description	Action/ Possible Failing FRU
4B2A 303A	Processor system and self test detected 1GB DIMM fault	Memory DIMM Locations: U1.1-P1-M1.n U1.1-P1-M2.n U1.1-P1-C1-Mn
4B2A 51AA	Processor system and self test detected 645W AC power supply fault	645W AC power supply Locations: U1.1-V1 U1.1-V2
4B2A 51AB	Processor system and self test detected 645W DC power supply fault	645W DC power supply Locations: U1.1-V1 U1.1-V2
4B2A 51AC	Processor system and self test detected 595W AC power supply fault	595W AC power supply Locations: U0.1-V1 U0.1-V2
4B2A 51AD	Processor system and self test detected 595W DC power supply fault	595W DC power supply Locations: U0.1-V1 U0.1-V2
4B2B 244C	Processor system and wire test detected 1W processor fault	Processor card Location: U1.1-P1-C1
4B2B 244D	Processor system and wire test detected 2W processor fault	Processor card Location: U1.1-P1-C1
4B2B 244E	Processor system and wire test detected 4W processor fault	Processor card Location: U1.1-P1-C1
4B2B 244F	Processor system and wire test detected 1W processor fault	Processor card Location: U1.1-P1-C1
4B2B 248B	Processor system and wire test detected primary I/O drawer operator panel	Operator panel Location: U0.1-L1
4B2B 24A1	Processor system and wire test detected 1W processor fault	Processor card Location: U1.1-P1-C1
4B2B 24A2	Processor system and wire test detected 2W processor fault	Processor card Location: U1.1-P1-C1
4B2B 24A3	Processor system and wire test detected 4W processor fault	Processor card Location: U1.1-P1-C1
4B2B 24A4	Processor system and wire test detected 6W processor fault	Processor card Location: U1.1-P1-C1
4B2B 25BB	Processor system and wire test detected 1W processor card fault	1W Processor card Location: U1.1-P1-C1
4B2B 25BD	Processor system and wire test detected 2W processor card fault	2W Processor card Location: U1.1-P1-C1

Table 6. Service Processor Error Codes. (continued)

Error Code	Description	Action/ Possible Failing FRU
4B2B 25BE	Processor system and wire test detected 4W processor card fault	4W Processor card Location: U1.1-P1-C1
4B2B 25BF	Processor system and wire test detected 6W processor card fault	6W Processor card Location: U1.1-P1-C1
4B2B 25CB	1W processor card fault	Replace the processor card Location: U1.1-P1-C1
4B2B 25EA	4W processor card fault	Replace the processor card Location: U1.1-P1-C1
4B2B 25EB	2W processor card fault	Replace the processor card Location: U1.1-P1-C1
4B2B 25F2	6W processor card fault	Replace the processor card Location: U1.1-P1-C1
4B2B 263D	Processor system and wire test detected dummy riser card fault	Dummy riser card Locations: U1.1-P1-M1 U1.1-P1-M2
4B2B 2687	Processor system and wire test detected RIO adapter fault	RIO adapter Location: U0.1-P1.1
4B2B 271A	Processor system and wire test detected primary I/O backplane fault	Primary I/O backplane Location: U0.1-P1
4B2B 271D	Processor system and wire test detected secondary I/O backplane fault	Secondary I/O backplane Location: U0.2-P1
4B2B 283A	Processor system and wire test detected CEC backplane fault	1. Processor card Location: U1.1-P1-C1 2. CEC backplane Location: U1.1-P1
4B2B 285D	Processor system and wire test detected fan controller card fault	Fan controller card Locations: U0.1-X2 U1.1-X2
4B2B 288D	Processor system and wire test detected memory riser fault	1. Go to service processor memory configuration/deconfiguration menu to verify memory DIMMs state. See "Memory Configuration/Deconfiguration Menu" on page 384 for more information. 2. Memory riser card Locations: U1.1-P1-M1 U1.1-P1-M2
4B2B 2A00	Processor system and wire test detected 6W processor fault	Processor card Location: U1.1-P1-C1

Table 6. Service Processor Error Codes. (continued)

Error Code	Description	Action/ Possible Failing FRU
4B2B 300A	Processor system and wire test detected 32MB DIMM fault	Memory DIMM Locations: U1.1-P1-M1.n U1.1-P1-M2.n U1.1-P1-C1-Mn
4B2B 300B	Processor system and wire test detected 128MB DIMM fault	Memory DIMM Locations: U1.1-P1-M1.n U1.1-P1-M2.n U1.1-P1-C1-Mn
4B2B 300C	Processor system and wire test detected 256MB DIMM fault	Memory DIMM Locations: U1.1-P1-M1.n U1.1-P1-M2.n U1.1-P1-C1-Mn
4B2B 300D	Processor system and wire test detected 512MB (stacked) DIMM fault	Memory DIMM Locations: U1.1-P1-M1.n U1.1-P1-M2.n U1.1-P1-C1-Mn
4B2B 300E	Processor system and wire test detected 512MB (unstacked) DIMM fault	Memory DIMM Locations: U1.1-P1-M1.n U1.1-P1-M2.n U1.1-P1-C1-Mn
4B2B 301F	Processor system and wire test detected 128MB DIMM fault	Memory DIMM Locations: U1.1-P1-M1.n U1.1-P1-M2.n U1.1-P1-C1-Mn
4B2B 303A	Processor system and wire test detected 1GB DIMM fault	Memory DIMM Locations: U1.1-P1-M1.n U1.1-P1-M2.n U1.1-P1-C1-Mn
4B2B 51AA	Processor system and wire test detected 645W AC power supply fault	645W AC power supply Locations: U1.1-V1 U1.1-V2
4B2B 51AB	Processor system and wire test detected 645W DC power supply fault	645W DC power supply Locations: U1.1-V1 U1.1-V2
4B2B 51AC	Processor system and wire test detected 595W AC power supply fault	595W AC power supply Locations: U0.1-V1 U0.1-V2

Table 6. Service Processor Error Codes. (continued)

Error Code	Description	Action/ Possible Failing FRU
4B2B 51AD	Processor system and wire test detected 595W DC power supply fault	595W DC power supply Locations: U0.1-V1 U0.1-V2
4B2C 244C	Processor system and IPL detected 1W processor fault	Processor card Location: U1.1-P1-C1
4B2C 244D	Processor system and IPL detected 2W processor fault	Processor card Location: U1.1-P1-C1
4B2C 244E	Processor system and IPL detected 4W processor fault	Processor card Location: U1.1-P1-C1
4B2C 244F	Processor system and IPL detected 1W processor fault	Processor card Location: U1.1-P1-C1
4B2C 248B	Processor system and IPL detected primary I/O drawer operator panel	Operator panel Location: U0.1-L1
4B2C 24A1	Processor system and IPL detected 1W processor fault	Processor card Location: U1.1-P1-C1
4B2C 24A2	Processor system and IPL detected 2W processor fault	Processor card Location: U1.1-P1-C1
4B2C 24A3	Processor system and IPL detected 4W processor fault	Processor card Location: U1.1-P1-C1
4B2C 24A4	Processor system and IPL detected 6W processor fault	Processor card Location: U1.1-P1-C1
4B2C 25BB	Processor system and IPL detected 1W processor card fault	1W Processor card Location: U1.1-P1-C1
4B2C 25BD	Processor system and IPL detected 2W processor card fault	2W Processor card Location: U1.1-P1-C1
4B2C 25BE	Processor system and IPL detected 4W processor card fault	4W Processor card Location: U1.1-P1-C1
4B2C 25BF	Processor system and IPL detected 6W processor card fault	6W Processor card Location: U1.1-P1-C1
4B2C 25CB	1W processor card fault	Replace the processor card Location: U1.1-P1-C1
4B2C 25EA	4W processor card fault	Replace the processor card Location: U1.1-P1-C1
4B2C 25EB	2W processor card fault	Replace the processor card Location: U1.1-P1-C1
4B2C 25F2	6W processor card fault	Replace the processor card Location: U1.1-P1-C1
4B2C 263D	Processor system and IPL detected dummy riser card fault	Dummy riser card Locations: U1.1-P1-M1 U1.1-P1-M2

Table 6. Service Processor Error Codes. (continued)

Error Code	Description	Action/ Possible Failing FRU
4B2C 2687	Processor system and IPL detected RIO adapter fault	RIO adapter Location: U0.1-P1.1
4B2C 271A	Processor system and IPL detected primary I/O backplane fault	Primary I/O backplane Location: U0.1-P1
4B2C 271D	Processor system and IPL detected secondary I/O backplane fault	Secondary I/O backplane Location: U0.2-P1
4B2C 283A	Processor system and IPL detected CEC backplane fault	1. Processor card Location: U1.1-P1-C1 2. CEC backplane Location: U1.1-P1
4B2C 285D	Processor system and IPL detected fan controller card fault	Fan controller card Locations: U0.1-X2 U1.1-X2
4B2C 288D	Processor system and IPL detected memory riser fault	1. Go to service processor memory configuration/deconfiguration menu to verify memory DIMMs state. See "Memory Configuration/Deconfiguration Menu" on page 384 for more information. 2. Memory riser card Locations: U1.1-P1-M1 U1.1-P1-M2
4B2C 2A00	Processor system and IPL detected 6W processor fault	Processor card Location: U1.1-P1-C1
4B2C 300A	Processor system and IPL detected 32MB DIMM fault	Memory DIMM Locations: U1.1-P1-M1.n U1.1-P1-M2.n U1.1-P1-C1-Mn
4B2C 300B	Processor system and IPL detected 128MB DIMM fault	Memory DIMM Locations: U1.1-P1-M1.n U1.1-P1-M2.n U1.1-P1-C1-Mn
4B2C 300C	Processor system and IPL detected 256MB DIMM fault	Memory DIMM Locations: U1.1-P1-M1.n U1.1-P1-M2.n U1.1-P1-C1-Mn

Table 6. Service Processor Error Codes. (continued)

Error Code	Description	Action/ Possible Failing FRU
4B2C 300D	Processor system and IPL detected 512MB (stacked) DIMM fault	Memory DIMM Locations: U1.1-P1-M1.n U1.1-P1-M2.n U1.1-P1-C1-Mn
4B2C 300E	Processor system and IPL detected 512MB (unstacked) DIMM fault	Memory DIMM Locations: U1.1-P1-M1.n U1.1-P1-M2.n U1.1-P1-C1-Mn
4B2C 301F	Processor system and IPL detected 128MB DIMM fault	Memory DIMM Locations: U1.1-P1-M1.n U1.1-P1-M2.n U1.1-P1-C1-Mn
4B2C 303A	Processor system and IPL detected 1GB DIMM fault	Memory DIMM Locations: U1.1-P1-M1.n U1.1-P1-M2.n U1.1-P1-C1-Mn
4B2C 51AA	Processor system and IPL detected 645W AC power supply fault	645W AC power supply Locations: U1.1-V1 U1.1-V2
4B2C 51AB	Processor system and IPL detected 645W DC power supply fault	645W DC power supply Locations: U1.1-V1 U1.1-V2
4B2C 51AC	Processor system and IPL detected 595W AC power supply fault	595W AC power supply Locations: U0.1-V1 U0.1-V2
4B2C 51AD	Processor system and IPL detected 595W DC power supply fault	595W DC power supply Locations: U0.1-V1 U0.1-V2
4B2D 244C	Processor system and attention handler detected 1W processor fault	Processor card Location: U1.1-P1-C1
4B2D 244D	Processor system and attention handler detected 2W processor fault	Processor card Location: U1.1-P1-C1
4B2D 244E	Processor system and attention handler detected 4W processor fault	Processor card Location: U1.1-P1-C1
4B2D 244F	Processor system and attention handler detected 1W processor fault	Processor card Location: U1.1-P1-C1

Table 6. Service Processor Error Codes. (continued)

Error Code	Description	Action/ Possible Failing FRU
4B2D 248B	Processor system and attention handler detected primary I/O drawer operator panel	Operator panel Location: U0.1-L1
4B2D 24A1	Processor system and attention handler detected 1W processor fault	Processor card Location: U1.1-P1-C1
4B2D 24A2	Processor system and attention handler detected 2W processor fault	Processor card Location: U1.1-P1-C1
4B2D 24A3	Processor system and attention handler detected 4W processor fault	Processor card Location: U1.1-P1-C1
4B2D 24A4	Processor system and attention handler detected 6W processor fault	Processor card Location: U1.1-P1-C1
4B2D 25BB	Processor system and attention handler detected 1W processor card fault	1W Processor card Location: U1.1-P1-C1
4B2D 25BD	Processor system and attention handler detected 2W processor card fault	2W Processor card Location: U1.1-P1-C1
4B2D 25BE	Processor system and attention handler detected 4W processor card fault	4W Processor card Location: U1.1-P1-C1
4B2D 25BF	Processor system and attention handler detected 6W processor card fault	6W Processor card Location: U1.1-P1-C1
4B2D 25CB	1W processor card fault	Replace the processor card Location: U1.1-P1-C1
4B2D 25EA	4W processor card fault	Replace the processor card Location: U1.1-P1-C1
4B2D 25EB	2W processor card fault	Replace the processor card Location: U1.1-P1-C1
4B2D 25F2	6W processor card fault	Replace the processor card Location: U1.1-P1-C1
4B2D 263D	Processor system and attention handler detected dummy riser card fault	Dummy riser card Locations: U1.1-P1-M1 U1.1-P1-M2
4B2D 2687	Processor system and attention handler detected RIO adapter fault	RIO adapter Location: U0.1-P1.1
4B2D 271A	Processor system and attention handler detected primary I/O backplane fault	Primary I/O backplane Location: U0.1-P1
4B2D 271D	Processor system and attention handler detected secondary I/O backplane fault	Secondary I/O backplane Location: U0.2-P1

Table 6. Service Processor Error Codes. (continued)

Error Code	Description	Action/ Possible Failing FRU
4B2D 283A	Processor system and attention handler detected CEC backplane fault	<ol style="list-style-type: none"> Processor card Location: U1.1-P1-C1 CEC backplane Location: U1.1-P1
4B2D 285D	Processor system and attention handler detected fan controller card fault	Fan controller card Locations: U0.1-X2 U1.1-X2
4B2D 288D	Processor system and attention handler detected memory riser fault	<ol style="list-style-type: none"> Go to service processor memory configuration/deconfiguration menu to verify memory DIMMs state. See "Memory Configuration/Deconfiguration Menu" on page 384 for more information. Memory riser card Locations: U1.1-P1-M1 U1.1-P1-M2
4B2D 2A00	Processor system and attention handler detected 6W processor fault	Processor card Location: U1.1-P1-C1
4B2D 300A	Processor system and attention handler detected 32MB DIMM fault	Memory DIMM Locations: U1.1-P1-M1.n U1.1-P1-M2.n U1.1-P1-C1-Mn
4B2D 300B	Processor system and attention handler detected 128MB DIMM fault	Memory DIMM Locations: U1.1-P1-M1.n U1.1-P1-M2.n U1.1-P1-C1-Mn
4B2D 300C	Processor system and attention handler detected 256MB DIMM fault	Memory DIMM Locations: U1.1-P1-M1.n U1.1-P1-M2.n U1.1-P1-C1-Mn
4B2D 300D	Processor system and attention handler detected 512MB (stacked) DIMM fault	Memory DIMM Locations: U1.1-P1-M1.n U1.1-P1-M2.n U1.1-P1-C1-Mn
4B2D 300E	Processor system and attention handler detected 512MB (unstacked) DIMM fault	Memory DIMM Locations: U1.1-P1-M1.n U1.1-P1-M2.n U1.1-P1-C1-Mn

Table 6. Service Processor Error Codes. (continued)

Error Code	Description	Action/ Possible Failing FRU
4B2D 301F	Processor system and attention handler detected 128MB DIMM fault	Memory DIMM Locations: U1.1-P1-M1.n U1.1-P1-M2.n U1.1-P1-C1-Mn
4B2D 303A	Processor system and attention handler detected 1GB DIMM fault	Memory DIMM Locations: U1.1-P1-M1.n U1.1-P1-M2.n U1.1-P1-C1-Mn
4B2D 51AA	Processor system and attention handler detected 645W AC power supply fault	645W AC power supply Locations: U1.1-V1 U1.1-V2
4B2D 51AB	Processor system and attention handler detected 645W DC power supply fault	645W DC power supply Locations: U1.1-V1 U1.1-V2
4B2D 51AC	Processor system and attention handler detected 595W AC power supply fault	595W AC power supply Locations: U0.1-V1 U0.1-V2
4B2D 51AD	Processor system and attention handler detected 595W DC power supply fault	595W DC power supply Locations: U0.1-V1 U0.1-V2
4B2E 244C	Processor system and scan control routines detected 1W processor fault	Processor card Location: U1.1-P1-C1
4B2E 244D	Processor system and scan control routines detected 2W processor fault	Processor card Location: U1.1-P1-C1
4B2E 244E	Processor system and scan control routines detected 4W processor fault	Processor card Location: U1.1-P1-C1
4B2E 244F	Processor system and scan control routines detected 1W processor fault	Processor card Location: U1.1-P1-C1
4B2E 248B	Processor system and scan control routines detected primary I/O drawer operator panel	Operator panel Location: U0.1-L1
4B2E 24A1	Processor system and scan control routines detected 1W processor fault	Processor card Location: U1.1-P1-C1
4B2E 24A2	Processor system and scan control routines detected 2W processor fault	Processor card Location: U1.1-P1-C1
4B2E 24A3	Processor system and scan control routines detected 4W processor fault	Processor card Location: U1.1-P1-C1
4B2E 24A4	Processor system and scan control routines detected 6W processor fault	Processor card Location: U1.1-P1-C1

Table 6. Service Processor Error Codes. (continued)

Error Code	Description	Action/ Possible Failing FRU
4B2E 25BB	Processor system and scan control routines detected 1W processor card fault	1W Processor card Location: U1.1-P1-C1
4B2E 25BD	Processor system and scan control routines detected 2W processor card fault	2W Processor card Location: U1.1-P1-C1
4B2E 25BE	Processor system and scan control routines detected 4W processor card fault	4W Processor card Location: U1.1-P1-C1
4B2E 25BF	Processor system and scan control routines detected 6W processor card fault	6W Processor card Location: U1.1-P1-C1
4B2E 25CB	1W processor card fault	Replace the processor card Location: U1.1-P1-C1
4B2E 25EA	4W processor card fault	Replace the processor card Location: U1.1-P1-C1
4B2E 25EB	2W processor card fault	Replace the processor card Location: U1.1-P1-C1
4B2E 25F2	6W processor card fault	Replace the processor card Location: U1.1-P1-C1
4B2E 263D	Processor system and scan control routines detected dummy riser card fault	Dummy riser card Locations: U1.1-P1-M1 U1.1-P1-M2
4B2E 2687	Processor system and scan control routines detected RIO adapter fault	RIO adapter Location: U0.1-P1.1
4B2E 271A	Processor system and scan control routines detected primary I/O backplane fault	Primary I/O backplane Location: U0.1-P1
4B2E 271D	Processor system and scan control routines detected secondary I/O backplane fault	Secondary I/O backplane Location: U0.2-P1
4B2E 283A	Processor system and scan control routines detected CEC backplane fault	1. Processor card Location: U1.1-P1-C1 2. CEC backplane Location: U1.1-P1
4B2E 285D	Processor system and scan control routines detected fan controller card fault	Fan controller card Locations: U0.1-X2 U1.1-X2

Table 6. Service Processor Error Codes. (continued)

Error Code	Description	Action/ Possible Failing FRU
4B2E 288D	Processor system and scan control routines detected memory riser fault	<ol style="list-style-type: none"> 1. Go to service processor memory configuration/deconfiguration menu to verify memory DIMMs state. See "Memory Configuration/Deconfiguration Menu" on page 384 for more information. 2. Memory riser card Locations: U1.1-P1-M1 U1.1-P1-M2
4B2E 2A00	Processor system and scan control routines detected 6W processor fault	Processor card Location: U1.1-P1-C1
4B2E 300A	Processor system and scan control routines detected 32MB DIMM fault	Memory DIMM Locations: U1.1-P1-M1.n U1.1-P1-M2.n U1.1-P1-C1-Mn
4B2E 300B	Processor system and scan control routines detected 128MB DIMM fault	Memory DIMM Locations: U1.1-P1-M1.n U1.1-P1-M2.n U1.1-P1-C1-Mn
4B2E 300C	Processor system and scan control routines detected 256MB DIMM fault	Memory DIMM Locations: U1.1-P1-M1.n U1.1-P1-M2.n U1.1-P1-C1-Mn
4B2E 300D	Processor system and scan control routines detected 512MB (stacked) DIMM fault	Memory DIMM Locations: U1.1-P1-M1.n U1.1-P1-M2.n U1.1-P1-C1-Mn
4B2E 300E	Processor system and scan control routines detected 512MB (unstacked) DIMM fault	Memory DIMM Locations: U1.1-P1-M1.n U1.1-P1-M2.n U1.1-P1-C1-Mn
4B2E 301F	Processor system and scan control routines detected 128MB DIMM fault	Memory DIMM Locations: U1.1-P1-M1.n U1.1-P1-M2.n U1.1-P1-C1-Mn

Table 6. Service Processor Error Codes. (continued)

Error Code	Description	Action/ Possible Failing FRU
4B2E 303A	Processor system and scan control routines detected 1GB DIMM fault	Memory DIMM Locations: U1.1-P1-M1.n U1.1-P1-M2.n U1.1-P1-C1-Mn
4B2E 51AA	Processor system and scan control routines detected 645W AC power supply fault	645W AC power supply Locations: U1.1-V1 U1.1-V2
4B2E 51AB	Processor system and scan control routines detected 645W DC power supply fault	645W DC power supply Locations: U1.1-V1 U1.1-V2
4B2E 51AC	Processor system and scan control routines detected 595W AC power supply fault	595W AC power supply Locations: U0.1-V1 U0.1-V2
4B2E 51AD	Processor system and scan control routines detected 595W DC power supply fault	595W DC power supply Locations: U0.1-V1 U0.1-V2
4B2F 244C	Processor system and error code generation/logging detected 1W processor fault	Processor card Location: U1.1-P1-C1
4B2F 244D	Processor system and error code generation/logging detected 2W processor fault	Processor card Location: U1.1-P1-C1
4B2F 244E	Processor system and error code generation/logging detected 4W processor fault	Processor card Location: U1.1-P1-C1
4B2F 244F	Processor system and error code generation/logging detected 1W processor fault	Processor card Location: U1.1-P1-C1
4B2F 248B	Processor system and error code generation/logging detected primary I/O drawer operator panel	Operator panel Location: U0.1-L1
4B2F 24A1	Processor system and error code generation/logging detected 1W processor fault	Processor card Location: U1.1-P1-C1
4B2F 24A2	Processor system and error code generation/logging detected 2W processor fault	Processor card Location: U1.1-P1-C1
4B2F 24A3	Processor system and error code generation/logging detected 4W processor fault	Processor card Location: U1.1-P1-C1

Table 6. Service Processor Error Codes. (continued)

Error Code	Description	Action/ Possible Failing FRU
4B2F 24A4	Processor system and error code generation/logging detected 6W processor fault	Processor card Location: U1.1-P1-C1
4B2F 25BB	Processor system and error code generation/logging detected 1W processor card fault	1W Processor card Location: U1.1-P1-C1
4B2F 25BD	Processor system and error code generation/logging detected 2W processor card fault	2W Processor card Location: U1.1-P1-C1
4B2F 25BE	Processor system and error code generation/logging detected 4W processor card fault	4W Processor card Location: U1.1-P1-C1
4B2F 25BF	Processor system and error code generation/logging detected 6W processor card fault	6W Processor card Location: U1.1-P1-C1
4B2F 25CB	1W processor card fault	Replace the processor card Location: U1.1-P1-C1
4B2F 25EA	4W processor card fault	Replace the processor card Location: U1.1-P1-C1
4B2F 25EB	2W processor card fault	Replace the processor card Location: U1.1-P1-C1
4B2F 25F2	6W processor card fault	Replace the processor card Location: U1.1-P1-C1
4B2F 263D	Processor system and error code generation/logging detected dummy riser card fault	Dummy riser card Locations: U1.1-P1-M1 U1.1-P1-M2
4B2F 2687	Processor system and error code generation/logging detected RIO adapter fault	RIO adapter Location: U0.1-P1.1
4B2F 271A	Processor system and error code generation/logging detected primary I/O backplane fault	Primary I/O backplane Location: U0.1-P1
4B2F 271D	Processor system and error code generation/logging detected secondary I/O backplane fault	Secondary I/O backplane Location: U0.2-P1
4B2F 283A	Processor system and error code generation/logging detected CEC backplane fault	1. Processor card Location: U1.1-P1-C1 2. CEC backplane Location: U1.1-P1
4B2F 285D	Processor system and error code generation/logging detected fan controller card fault	Fan controller card Locations: U0.1-X2 U1.1-X2

Table 6. Service Processor Error Codes. (continued)

Error Code	Description	Action/ Possible Failing FRU
4B2F 288D	Processor system and error code generation/logging detected memory riser fault	<ol style="list-style-type: none"> 1. Go to service processor memory configuration/deconfiguration menu to verify memory DIMMs state. See "Memory Configuration/Deconfiguration Menu" on page 384 for more information. 2. Memory riser card Locations: U1.1-P1-M1 U1.1-P1-M2
4B2F 2A00	Processor system and error code generation/logging detected 6W processor fault	Processor card Location: U1.1-P1-C1
4B2F 300A	Processor system and error code generation/logging detected 32MB DIMM fault	Memory DIMM Locations: U1.1-P1-M1.n U1.1-P1-M2.n U1.1-P1-C1-Mn
4B2F 300B	Processor system and error code generation/logging detected 128MB DIMM fault	Memory DIMM Locations: U1.1-P1-M1.n U1.1-P1-M2.n U1.1-P1-C1-Mn
4B2F 300C	Processor system and error code generation/logging detected 256MB DIMM fault	Memory DIMM Locations: U1.1-P1-M1.n U1.1-P1-M2.n U1.1-P1-C1-Mn
4B2F 300D	Processor system and error code generation/logging detected 512MB (stacked) DIMM fault	Memory DIMM Locations: U1.1-P1-M1.n U1.1-P1-M2.n U1.1-P1-C1-Mn
4B2F 300E	Processor system and error code generation/logging detected 512MB (unstacked) DIMM fault	Memory DIMM Locations: U1.1-P1-M1.n U1.1-P1-M2.n U1.1-P1-C1-Mn
4B2F 301F	Processor system and error code generation/logging detected 128MB DIMM fault	Memory DIMM Locations: U1.1-P1-M1.n U1.1-P1-M2.n U1.1-P1-C1-Mn

Table 6. Service Processor Error Codes. (continued)

Error Code	Description	Action/ Possible Failing FRU
4B2F 303A	Processor system and error code generation/logging detected 1GB DIMM fault	Memory DIMM Locations: U1.1-P1-M1.n U1.1-P1-M2.n U1.1-P1-C1-Mn
4B2F 51AA	Processor system and error code generation/logging detected 645W AC power supply fault	645W AC power supply Locations: U1.1-V1 U1.1-V2
4B2F 51AB	Processor system and error code generation/logging detected 645W DC power supply fault	645W DC power supply Locations: U1.1-V1 U1.1-V2
4B2F 51AC	Processor system and error code generation/logging detected 595W AC power supply fault	595W AC power supply Locations: U0.1-V1 U0.1-V2
4B2F 51AD	Processor system and error code generation/logging detected 595W DC power supply fault	595W DC power supply Locations: U0.1-V1 U0.1-V2

System Firmware Update Messages

Table 7. System Firmware Update Messages

Error Code	Description	Action/ Possible Failing FRU
A1FD 0000	Recovery mode entered	Information message
A1FD 0001	Service processor flash recovery	Insert Diskette #1
A1FD 0002	Service processor flash recovery	Insert Diskette #2
A1FD 0003	Service processor flash recovery	Insert Diskette #3
A1FD 0004	Service processor flash recovery	Insert Diskette #4

Common Firmware Error Codes

Attention: Follow the procedure defined in “Checkpoint and Error Code Index” on page 165. If you replace FRUs or perform an action and the problem is still not corrected, go to “MAP 1540: Minimum Configuration” on page 113 unless otherwise indicated in the tables.

If you replace FRUs and the problem is corrected, go to "MAP 410: Repair Checkout" in the *RS/6000 and @server pSeries Diagnostics Information for Multiple Bus Systems*.

Table 8. Common Firmware Error Codes

Error Code	Description	Action/ Possible Failing FRU
B006 1403	Missing service processor resource	1. Update system firmware 2. Primary I/O backplane Location: U0.1-P1
B006 1404	Service processor firmware fault	1. Update system firmware 2. Primary I/O backplane Location: U0.1-P1
B006 1405	Service processor firmware fault	1. Update system firmware 2. Primary I/O backplane Location: U0.1-P1
B006 1406	Service processor program error	1. Update system firmware 2. Check for AIX updates 3. Primary I/O backplane Location: U0.1-P1
B006 1407	Service processor resource allocation problem	1. Update system firmware 2. Check for AIX updates 3. Primary I/O backplane Location: U0.1-P1
B006 1408	Service processor program error	1. Update system firmware 2. Check for AIX updates 3. Primary I/O backplane Location: U0.1-P1
B006 1409	Service processor program error	1. Update system firmware 2. Primary I/O backplane Location: U0.1-P1
B10F 1000	Service processor DRAM failure	Primary I/O drawer backplane Location: U0.1-P1
B10F 1002	Service processor failure	Primary I/O drawer backplane Location: U0.1-P1
B10F 1005	Service processor failure	Primary I/O drawer backplane Location: U0.1-P1
B10F 1007	Service processor failure	Primary I/O drawer backplane Location: U0.1-P1
B10F 1008	Service processor failure	Primary I/O drawer backplane Location: U0.1-P1
B10F 100E	Service processor boot flash corrupted	Primary I/O drawer backplane Location: U0.1-P1
B10F 100F	Service processor base flash corrupted	Primary I/O drawer backplane Location: U0.1-P1
B10F 1300	Service processor failure	Primary I/O drawer backplane Location: U0.1-P1

Table 8. Common Firmware Error Codes (continued)

Error Code	Description	Action/ Possible Failing FRU
B10F 1370	Service processor flash update failure	1. Retry flash update 2. Primary I/O drawer backplane Location: U0.1-P1
B10F 1380	Service processor program failure	1. Update system firmware 2. Primary I/O drawer backplane Location: U0.1-P1
B10F 1381	Service processor flash error	1. Update system firmware 2. Primary I/O drawer backplane Location: U0.1-P1
B10F 1384	Service processor failure	Primary I/O drawer backplane Location: U0.1-P1
B10F 1387	Service processor failure	Primary I/O drawer backplane Location: U0.1-P1
B10F 1400	Service processor failure	Primary I/O drawer backplane Location: U0.1-P1
B10F 1401	Service processor failure	Primary I/O drawer backplane Location: U0.1-P1
B10F 1670	Service processor flash update failure	1. Retry flash update 2. Primary I/O drawer backplane Location: U0.1-P1
B10F 1672	Service processor firmware update invalid	Call service support
B10F 1675	Service processor failure	Primary I/O drawer backplane Location: U0.1-P1
B10F 1681	Service processor firmware update invalid	Call service support
B10F 1682	Service processor firmware update invalid	Call service support
B10F 1683	Service processor firmware update invalid	Call service support
B1xx 0013	A firmware update has failed because the update image is invalid. The update was aborted before any changes were made to the currently installed firmware.	Install a valid firmware image for the specific type and model.
B1xx 4600	Service processor failure	Primary I/O backplane Location: U0.1-P1
B1xx 4601	System processor failure	Go to "MAP 1540: Minimum Configuration" on page 113.

Table 8. Common Firmware Error Codes (continued)

Error Code	Description	Action/ Possible Failing FRU
B1xx 4602	RIO failure	<ol style="list-style-type: none"> 1. Check RIO cables and RIO adapters seating 2. RIO adapter Location: U0.1-P1.1 3. Processor card Location: U1.1-P1-C1 4. CEC drawer backplane Location: U1.1-P1
B1xx 4603	Service processor firmware corrupted	<ol style="list-style-type: none"> 1. Reload system firmware 2. Primary I/O backplane Location: U0.1-P1
B1xx 4606	Firmware failure	<ol style="list-style-type: none"> 1. Check for system firmware updates 2. Operator panel Location: U0.1-L1 3. Primary I/O backplane Location: U0.1-P1
B1xx 4608	Service processor early termination	<ol style="list-style-type: none"> 1. Reset the system by disconnecting and reconnecting system power 2. Reload system firmware 3. Primary I/O backplane Location: U0.1-P1
B1xx 460A	TOD clock has been reset	<ol style="list-style-type: none"> 1. Set TOD clock 2. Primary I/O backplane Location: U0.1-P1
B1xx 460B	TOD battery failure	TOD battery Location: U0.1-P1-V3
B1xx 4611	Service processor failure	<ol style="list-style-type: none"> 1. Processor card Location: U1.1-P1-C1 2. Primary I/O backplane Location: U0.1-P1
B1xx 4620	Modem configuration failure	<ol style="list-style-type: none"> 1. Check modem configuration files 2. Check for system firmware update 3. Modem 4. Primary I/O backplane Location: U0.1-P1
B1xx 4621	Modem disconnect failure	<ol style="list-style-type: none"> 1. Check modem configuration files 2. Check for system firmware update 3. Modem 4. Primary I/O backplane Location: U0.1-P1

Table 8. Common Firmware Error Codes (continued)

Error Code	Description	Action/ Possible Failing FRU
B1xx 4622	Service processor failure	<ol style="list-style-type: none"> Operator panel Location: U0.1-L1 Check for system firmware update Primary I/O backplane Location: U0.1-P1
B1xx 4633	System power control network failure	<ol style="list-style-type: none"> Check for system firmware update Primary I/O backplane Location: U0.1-P1
B1xx 4634	SPCN loop fault	<ol style="list-style-type: none"> Check SPCN cabling Go to "MAP 1540: Minimum Configuration" on page 113.
B1xx 4644	Processor VPD fault	Ignore all location codes. Go to MAP 1540 and run CEC minimum configuration.
B1xx 4645	Non-processor VPD fault	Ignore all location codes. Go to MAP 1540 and run CEC minimum configuration.
B1xx 4646	General VPD fault	Ignore all location codes. Go to MAP 1540 and run CEC minimum configuration.
B1xx 4647	The machine type and model reported by the CEC hardware do not match the machine type and model stored in the VPD module on the operator panel.	Replace the operator panel, location: U0.1-L1. Do not swap the VPD module from the old operator panel onto the new operator panel; leave the new, unprogrammed VPD module on the new operator panel. Call service support for instructions on reprogramming the machine type, model, and system serial number in the VPD module.
B1xx 4648	CEC backplane VPD failure	Ignore all location codes. Go to MAP 1540 and run CEC minimum configuration.
B1xx 4649	Power supply VPD failure	CEC power supply Location: U1.1-V1
B1xx 4650	A system processor failure has been detected by the service processor. All system processors have been reset in an attempt to recover operations.	Information only. If the problem persists, check the error logs for other fault indications. If no other fault indications are found, go to "MAP 1540: Minimum Configuration" on page 113.
B1xx 4651	CPU VPD fault	Processor card Location: U1.1-P1-C1

Table 8. Common Firmware Error Codes (continued)

Error Code	Description	Action/ Possible Failing FRU
B1xx 4660	Memory subsystem failure	Go to "MAP 1540: Minimum Configuration" on page 113.
B1xx 4661	Memory card VPD failure	Go to "MAP 1540: Minimum Configuration" on page 113.
B1xx 4662	Memory DIMM VPD failure	Go to "MAP 1540: Minimum Configuration" on page 113.
B1xx 4670	Processor drawer cooling	<ol style="list-style-type: none"> 1. Check ambient temperature 2. Check air supply to fans 3. Check fans for proper installation and operation 4. Check for any unsupported cards (that may be too hot) 5. CEC backplane Location: U1.1-P1
B1xx 4671	Primary I/O drawer cooling	<ol style="list-style-type: none"> 1. Check ambient temperature 2. Check air supply to fans 3. Check fans for proper installation and operation 4. Check for any unsupported cards (that may be too hot) 5. Operator panel Location: U0.1-L1 6. I/O backplane Location: U1.1-P1
B1xx 4672	I/O cooling, drawer #2	<ol style="list-style-type: none"> 1. Check ambient temperature 2. Check air supply to fans 3. Check fans for proper installation and operation 4. Check for any unsupported cards (that may be too hot) 5. Operator panel Location: U0.2-L1 6. I/O backplane Location: U1.2-P1
B1xx 4681	JTAG scan interface	<ol style="list-style-type: none"> 1. JTAG cabling 2. Primary I/O backplane Location: U0.1-P1 3. Processor card Location: U1.1-P1-C1 4. CEC backplane Location: U1.1-P1

Table 8. Common Firmware Error Codes (continued)

Error Code	Description	Action/ Possible Failing FRU
B1xx 4690	Operating system surveillance time out (AIX to service processor interface failure)	<ol style="list-style-type: none"> <li data-bbox="888 274 1262 591">1. This error code indicates that the operating system terminated early (which usually implies an operating system crash). This error code may appear in the service processor error log by itself. However, in the AIX error log, there should be another error which points to the cause of the operating system crash. Use the other error as the starting point for your service action. <li data-bbox="888 604 1262 1269">2. The other possibility is that the operating system was not found during a prior boot attempt. To determine if this occurred, do the following: Look at the AIX error log entry containing B1xx4690. This will be a "SCAN_ERROR_CHRP" error with an identifier of BFEC0425. In the detail data, find the string "B1xx4690" (If present, it will be at byte 60 of the detail data.) Then go forward 8 bytes after the "B1" to byte 68 and look at bytes 68 and 69. If the values of bytes 68 and 69 are A2B0, this indicates that the firmware was unable to find a bootable device in the boot list that is set in the SMS menus. If the system is up, the boot list problem has been corrected and the B1xx 4690 can be treated as an informational message with no actions required. <li data-bbox="888 1281 1262 1307">3. Call service support

Table 8. Common Firmware Error Codes (continued)

Error Code	Description	Action/ Possible Failing FRU
B1xx 4691	System firmware surveillance time out (System firmware to service processor interface failure)	<ol style="list-style-type: none"> 1. Check for system firmware update Location: U0.1-P1/Y1 2. Go to the service processor main menu and select System Information Menu, then select Read Progress Indicators From Last System Boot. Begin your repair action with the error code or checkpoint immediately preceeding B1xx 4691. If a location code displays with the error code or checkpoint, replace the part at that location. If no location code is specified, and you have an 8-character error code, go to the "Checkpoint and Error Code Index" on page 165. If no location code is specified, and you have a 4-character checkpoint, go to "Firmware Checkpoints" on page 147 3. If the problem is not resolved, call service support.
B1xx 4692	Operator panel task interface failure	<ol style="list-style-type: none"> 1. Check for system firmware update Location: U0.1-P1/Y1 2. Call service support.
B1xx 4693	Service processor firmware error	<ol style="list-style-type: none"> 1. Check for system firmware updates. 2. The type and model field in the VPD module may be set incorrectly. The type and model field can be viewed using the service processor function "Read VPD Image from Last System Boot", which is option 1 in the "System Information Menu" on page 382. If the type and model field is not set correctly, call service support. 3. Call service support.
B1xx 4694	System processor firmware failure	<ol style="list-style-type: none"> 1. Check for system firmware update 2. Primary I/O backplane Location: U0.1-P1

Table 8. Common Firmware Error Codes (continued)

Error Code	Description	Action/ Possible Failing FRU
B1xx 4695	System power control network to service processor interface failure	<ol style="list-style-type: none"> 1. Check for system firmware update 2. Primary I/O backplane Location: U0.1-P1
B1xx 4696	System firmware interface failure	<ol style="list-style-type: none"> 1. Check for system firmware update. 2. Call service support.
B1xx 4698	Firmware problem	<ol style="list-style-type: none"> 1. Check for system firmware update. 2. Call service support.
B1xx 4699	Service processor firmware	<ol style="list-style-type: none"> 1. Check for system firmware update 2. Call service support.
B1xx 469A	System firmware interface	<ol style="list-style-type: none"> 1. Check for system firmware update 2. Call service support.
B1xx 469B	Firmware to I/O interface	<ol style="list-style-type: none"> 1. Check for system firmware update 2. Primary I/O backplane Location: U0.1-P1
B1xx 469C	Firmware to I/O interface	<ol style="list-style-type: none"> 1. Check for system firmware update 2. Primary I/O backplane Location: U0.1-P1
B1xx 469E	Service processor firmware failure	<ol style="list-style-type: none"> 1. Check for system firmware update 2. Go to "MAP 1540: Minimum Configuration" on page 113, CEC minimum config 3. Primary I/O backplane Location: U0.1-P1
B1xx 469F	Service processor failure	<ol style="list-style-type: none"> 1. Check for system firmware update 2. Go to "MAP 1540: Minimum Configuration" on page 113, CEC minimum config 3. Primary I/O backplane Location: U0.1-P1
B1xx 8FF0	Informational message	No action required
B1FD 0013	A firmware update has failed because the update image is invalid. The update was aborted before any changes were made to the currently installed firmware.	Reset the service processor (by activating the pinhole reset switch or by disconnecting, then reconnecting power). Install a valid firmware update image for the specific system type and model.

Table 8. Common Firmware Error Codes (continued)

Error Code	Description	Action/ Possible Failing FRU
B1FD 0015	Too many firmware update diskettes inserted (or wrong or faulty update image)	<ol style="list-style-type: none"> 1. Assure the firmware update image is correct for the specific system type and model 2. Replace the update diskettes with a new set of firmware update diskettes.
B1FD 0016	Diskette read error	<ol style="list-style-type: none"> 1. The firmware diskette may be faulty. Try another diskette. 2. Replace the diskette drive. 3. Replace the primary I/O backplane. Location: U0.1-P1
B1FD 001A	Service processor recovery mode update fault	Reset service processor (by activating pinhole reset switch or by disconnecting, then reconnecting power)
B1FD 001E	Service processor recovery mode update fault	Wrong firmware update diskette (Insert correct diskette)
B1FD 001F	Bad firmware update diskette	Replace diskette

Scan Log Dump Progress Codes

Table 9. Scan Log Dump Progress Codes

Error Code	Description	Action/ Possible Failing FRU
D130 xxxx	Scan log dump in progress	Informational message only. As the dump progresses, the xxxx characters in the display will change. When the scan log dump is complete, the system may reboot, depending on the reboot policy settings.

Problem Determination Generated Error Codes

Table 10. Problem Determination Generated Error Codes

Error Code	Description	Action/ Possible Failing FRU
M0BT 0000	The system hung during speaker POST. This error code is generated by the customer performing "Problem Determination" in the <i>RS/6000 Enterprise Server Model H80 @server pSeries 660 Models 6H0 and 6H1 User's Guide</i> .	Go to "MAP 1540: Minimum Configuration" on page 113.
M0BT 0001	The system hung during "Starting Software...". This error code is generated by the customer performing "Problem Determination" in the <i>RS/6000 Enterprise Server Model H80 @server pSeries 660 Models 6H0 and 6H1 User's Guide</i> .	Go to "MAP 1540: Minimum Configuration" on page 113.
M0KB D000	The system hung during keyboard POST. This error code is generated by the customer performing "Problem Determination" in the <i>RS/6000 Enterprise Server Model H80 @server pSeries 660 Models 6H0 and 6H1 User's Guide</i> .	Keyboard
M0KB D001	The system did not respond to a keyboard entry. This error code is generated by the customer performing "Problem Determination" in the <i>RS/6000 Enterprise Server Model H80 @server pSeries 660 Models 6H0 and 6H1 User's Guide</i> .	Type 101 keyboard.
M0KB D002	The system did not respond to a keyboard entry. This error code is generated by the customer performing "Problem Determination" in the <i>RS/6000 Enterprise Server Model H80 @server pSeries 660 Models 6H0 and 6H1 User's Guide</i> .	Type 102 keyboard.
M0KB D003	The system did not respond to a keyboard entry. This error code is generated by the customer performing "Problem Determination" in the <i>RS/6000 Enterprise Server Model H80 @server pSeries 660 Models 6H0 and 6H1 User's Guide</i> .	Kanji-type keyboard.

Table 10. Problem Determination Generated Error Codes (continued)

Error Code	Description	Action/ Possible Failing FRU
MOME M002	The system hung during memory POST. This error code is generated by the customer performing "Problem Determination" in the <i>RS/6000 Enterprise Server Model H80 @server pSeries 660 Models 6H0 and 6H1 User's Guide</i> .	Go to "MAP 1540: Minimum Configuration" on page 113.
MONE T000	The system hung during network POST. This error code is generated by the customer performing "Problem Determination" in the <i>RS/6000 Enterprise Server Model H80 @server pSeries 660 Models 6H0 and 6H1 User's Guide</i> .	Go to "MAP 1540: Minimum Configuration" on page 113.
M0PS 0000	Power failure. This error code is generated by the customer performing "Problem Determination" in the <i>RS/6000 Enterprise Server Model H80 @server pSeries 660 Models 6H0 and 6H1 User's Guide</i> .	Go to "MAP 1520: Power" on page 89.
M0SC SI00	Unable to load diagnostics. This error code is generated by the customer performing "Problem Determination" in the <i>RS/6000 Enterprise Server Model H80 @server pSeries 660 Models 6H0 and 6H1 User's Guide</i> .	Go to "MAP 1540: Minimum Configuration" on page 113.
M0SC SI01	Unable to load diagnostics. This error code is generated by the customer performing "Problem Determination" in the <i>RS/6000 Enterprise Server Model H80 @server pSeries 660 Models 6H0 and 6H1 User's Guide</i> .	Go to "MAP 1540: Minimum Configuration" on page 113.

Chapter 6. Loading the System Diagnostics In Service Mode

The system diagnostics can be booted from the default boot list or from the service mode boot list. (The service mode boot list can be modified using the system diagnostics “Display or Change Bootlist” service aid. The service mode boot list cannot be modified under the System Management Services).

For more information about using standalone or online diagnostics, see “Using the Standalone and Online Diagnostics” in *RS/6000 and @server pSeries Diagnostics Information for Multiple Bus Systems*, order number SA38-0509.

Attention: If this system unit is attached to another system, be sure you isolate this system unit before stopping the operating system or running diagnostic programs. Some system-cabling changes (such as installing wrap plugs or removing a device from the configuration) may require action by the operator of the attached system before making the cabling changes on this system.

To load **standalone diagnostics** from the default boot list, perform the following procedure:

1. Verify with the system administrator and users that all programs may be stopped, then do so.
2. Turn off the system.

Note: If AIX is running, enter the **shutdown** command.

3. Wait until the Power LED stops flashing and remains off, then press the power button to turn on the system.
4. Immediately insert the diagnostic CD-ROM into the CD-ROM drive.
5. When or after the **keyboard** indicator appears during startup, press the numeric 5 key on the keyboard.
6. Enter any requested passwords.

Online diagnostics can be loaded by booting from a hard file in the custom boot list by pressing the numeric 6 key on the keyboard.

To boot from the devices listed in the service mode boot list, perform the following procedure:

1. Verify with the system administrator and users that all programs may be stopped, then do so.
2. Turn off the system.

Note: If AIX is running, enter the **shutdown** command.

3. Wait until the Power LED stops flashing and remains off, then press the power button to turn the system on.
4. When or after the keyboard indicator appears during startup, press the numeric 6 key on the keyboard.

5. Enter any requested passwords.

After any requested passwords have been entered, the system attempts to boot from the first device of each type found on the list. If no bootable image is found on the first device of each type on the list, the system does not search through the other devices of that type for a bootable image; instead, it polls the first device of the next type.

If all types of devices in the boot list have been polled without finding a bootable image, the system restarts. This action gives the user the opportunity to start the System Management Services (by pressing the number 1 key on a directly attached keyboard or the number 1 on an ASCII terminal) before the system attempts to boot again.

Default Boot List and Service Mode Bootlist

The default boot list is:

1. Diskette
2. CD-ROM
3. Tape
4. Hard file
5. Network
 - Token-ring
 - Ethernet

Pressing the numeric 5 key on the keyboard causes the system to load **standalone diagnostics** if a diagnostic CD is present in the CD-ROM drive.

Pressing the numeric 6 key on the keyboard loads **online diagnostics** from the hard file in the customized service mode boot list. No diagnostic CD should be in the CD-ROM drive because **online diagnostics** are typically run from a hard disk. Like the default boot list, the service mode boot list can contain five entries. The numeric 6 key works like the numeric 5 key with the following exceptions:

- The system searches for a boot record according to the service mode boot list.
- If the service mode boot list is discovered by a cyclical redundancy check to be corrupted, the system rebuilds the service mode boot list according to the default boot list. (The default boot list contains five entries, and for each matching device type found in the system unit, the system makes an entry in the custom boot list.)
- If no service mode boot list is present, the system uses the default boot list.

Chapter 7. Using the Service Processor

The service processor menus make it possible for you to configure service processor options, as well as enable and disable functions.

Service processor menus are available using an ASCII terminal when 0K is displayed on the primary I/O drawer operator panel or when the service processor has detected a server problem (such as a surveillance failure).

For a summary of the service processor functions and the methods used to invoke them, see the following table.

Service Processor Functions	Service Processor Menus (ASCII terminals)	AIX Service Aids (ASCII or graphics terminals)	SMS (ASCII or graphics terminals)
Read VPD image from last system boot	Y ³		
Read System POST Errors	Y ³		
Read Service Processor Error Logs	Y ³		
View Progress Indicators from last boot	Y ³		
Power-off System	Y ²		
Read NVRAM	Y ²		
Start Talk Mode	Y ²		
Enable/Disable Console Mirroring	Y ²		
Setup Reboot/Restart Policy	Y ²	Y ¹	
Enable/Disable Modem	Y ²	Y ¹	
Setup Modem Configuration	Y ²	Y ¹	
Setup Dial-out Phone Numbers	Y ²	Y ¹	
Setup Surveillance	Y ²	Y ¹	
Select Modem Line Speed	Y ²	Y ¹	
Update System EPROMs	Y ²	Y ¹	
Save/Restore Hardware Maintenance Policies		Y ¹	
Change General-Access Password	Y ²		
Change Privileged-Access Password	Y ²		Y ²
Select Language	Y ²		Y ²
Enable/Disable Unattended Start Mode	Y ²	Y ¹	Y ²
Passwords required (if set): ¹ Operating system root password ² Privileged-access password ³ General-access (power-on) password			

Service Processor Menus

The service processor menus are divided into two groups:

- General user menus - the user must know the general-access password.
- Privileged user menus - the user must know the privileged-access password.

If the server is powered off, the service processor menus can be accessed locally or remotely.

Accessing the Service Processor Menus Locally

Service processor menus can be accessed locally by connecting an ASCII terminal to serial port 1 (S1) or serial port 2 (S2). Access to the service processor menus is not available on serial port 3 (S3) or serial port 4 (S4). Because the presence of the ASCII terminal cannot be confirmed by the service processor, you must press a key (any key) on the ASCII keyboard to confirm its presence after 0K appears in the primary drawer operator panel display.

When you gain access, the service processor prompts you for a password (if set), and when verified, displays the service processor menus.

The service processor menu prompt, represented by 0> or 1>, indicates the serial port to which the terminal is connected.

- 0> indicates serial port 1 (S1)
- 1> indicates serial port 2 (S2)

Accessing the Service Processor Menus Remotely

If your system has a modem connected and is configured for call-in (see “Modem Configuration Menu” on page 392), the service processor menus can be accessed remotely as follows:

1. With the system powered off, call in from a remote terminal.
2. The service processor detects ring-indicate and prompts you for a password (if set).
When verified, the service processor menus display remotely.

Saving and Restoring Service Processor Settings

All the settings you make (except language) from the service processor menus can be backed up either for recovering from a fault that may corrupt these settings, or for replicating these settings to other servers that include a service processor.

The AIX service aid, Save or Restore Hardware Management Policies, can be used to save your settings after initial setup or whenever the settings must be changed for system operation purposes.

It is strongly recommended that you use this AIX service aid for backing up service processor settings to protect the usefulness of the service processor and the availability of the server. Refer to “Save or Restore Hardware Management Policies,” in the “Introducing Tasks and Service Aids” section of the *RS/6000 and @server pSeries Diagnostics Information for Multiple Bus Systems*, SA38-0509.

Menu Inactivity

The service processor exits menu mode after ten minutes of inactivity, and displays a message indicating that it has done so. Pressing any key on the ASCII terminal causes the main menu to be displayed.

General User Menu

The menu options presented to the general user are a subset of the options available to the privileged user. The user must know the general-access password, if set, to access this menu.

```
GENERAL USER MENU

1. Power-on System
2. Power-off System
3. Read VPD Image from Last System Boot
4. Read Progress Indicators from Last System Boot
5. Read Service Processor Error Logs
6. Read System POST Errors
99. Exit from Menus

1>
```

- **Power-on System**

Allows the user to start the system using the current ASCII terminal as the active console.

- **Power-off System**

Allows the user to power off the system using the current ASCII terminal as the active console.

- **Read VPD Image from Last System Boot**

Displays manufacturer vital product data, such as serial numbers, part numbers, and so on, that were stored during the system boot prior to the one in progress now.

- **Read Progress Indicators from Last System Boot**

Displays a number of the boot progress indicators, which may include service processor checkpoints, IPL checkpoints, and/or AIX configuration codes, from the previous system boot. This information can be useful in diagnosing system faults.

The progress indicator codes are listed from top (latest) to bottom (oldest).

This information is not stored in non-volatile storage. If the system is powered off using the power-on button on the operator panel, this information is retained. If the ac power (dc power in a dc-powered system) is disconnected from the system, this information will be lost. For an example, refer to “LCD Progress Indicator Log” on page 410.

- **Read Service Processor Error Logs**

Displays the service processor error logs. For an example, refer to “Service Processor Error Log” on page 409.

- **Read System POST Errors**

This option should only be used by service personnel to display additional error log information.

- **Exit from Menus**

Selecting this option will exit the service processor menus. You can re-enter the menus by pressing any key on the console.

Privileged User Menus

The following menus are available to privileged users only. The user must know the privileged-access password, if set, to access these menus.

Main Menu

At the top of the Main Menu is a listing containing:

- Your system’s current firmware version
- The firmware copyright notice
- The system name given to your server during setup

You need the firmware version for reference when you either update or repair the functions of your service processor.

The system name, an optional field, is the name that your server reports in problem messages. This name helps your support team (for example, your system administrator, network administrator, or service representative) to more quickly identify the location, configuration, and history of your server. The system name is set from the Main Menu using option 6.

Note: The information under the Service Processor Firmware heading in the following Main Menu illustration is example information only.

```
Service Processor Firmware
VERSION: CM000313
Copyright 2000 IBM Corporation
SYSTEM NAME
```

MAIN MENU

1. Service Processor Setup Menu
2. System Power Control Menu
3. System Information Menu
4. Language Selection Menu
5. Call-In/Call-Out Setup Menu
6. Set System Name
99. Exit from Menus

1>

- **Service Processor Setup Menu**
See “Service Processor Setup Menu” on page 374 for more information.
- **System Power Control Menu**
See “System Power Control Menu” on page 378 for more information.
- **System Information Menu**
See “System Information Menu” on page 382 for more information.
- **Language Selection Menu**
See “Language Selection Menu” on page 390 for more information.
- **Call-In/Call-Out Setup Menu**
See “Call-In/Call-Out Setup Menu” on page 391 for more information.
- **Set System Name**
Allows setting of the system name.

Service Processor Setup Menu

The Service Processor Setup menu shown below is accessed from the Main Menu.

```
SERVICE PROCESSOR SETUP MENU
1. Change Privileged Access Password
2. Change General Access Password
3. Enable/Disable Console Mirroring:
   Currently Enabled
4. Start Talk Mode
5. OS Surveillance Setup Menu
6. Reset Service Processor
7. Reprogram Flash EPROM Menu
8. Serial Port Snoop Setup Menu
98. Return to Previous Menu
99. Exit from Menus
1>
```

Note: Unless otherwise stated in menu responses, settings become effective when a menu is exited using option 98 or 99.

Passwords

Passwords can be any combination of up to eight alphanumeric characters. You can enter longer passwords, but the entries are truncated to include only the first eight characters. The privileged-access password can be set from service processor menus or from System Management Services (SMS) utilities (see Chapter 8, “Using System Management Services” on page 415). The general-access password can be set only from service processor menus.

For security purposes, the service processor counts the number of attempts to enter correct passwords. The results of not recognizing a correct password within this error threshold are different, depending on whether the attempts are being made locally (at the server) or remotely (through a modem). The error threshold is three attempts.

If the error threshold is reached by someone entering passwords at the server, the service processor commands the server to resume the initial program load (IPL). This action is taken based on the assumption that the server is in an adequately secure location with only authorized users having access. Such users must still successfully enter a login password to access AIX.

If the error threshold is reached by someone entering passwords remotely, the service processor commands the server to power down to prevent potential security attacks on the server by unauthorized remote users. The following table lists what you can access with the privileged-access password and the general-access password.

Privileged Access Password	General Access Password	Resulting Menu
None	None	Service processor MAIN MENU displays
Set	None	Users with the password see the service processor MAIN MENU. Users without password cannot log in.
Set	Set	Users see menus associated with the entered password

Note: If you *forget* the password, you must remove the battery for at least 30 seconds to disable the password.

- **Change Privileged-Access Password**

Set or change the privileged-access password. It provides the user with access to all service processor functions. This password is usually used by the system administrator or root user.

- **Change General-Access Password**

Set or change the general-access password. It provides limited access to service processor menus, and is usually available to all users who are allowed to power on the server, especially remotely.

Note: The general-access password can only be set or changed after the privileged-access password is set.

- **Enable/Disable Console Mirroring**

Console mirroring is supported on serial port 1 (S1) and serial port 2 (S2). When console mirroring is enabled, the service processor sends information to both serial ports. The serial port from which console mirroring is enabled is referred to as the *active port*. The *mirror port* is determined when keyboard input is detected from the other port. From this point on, the service processor only sends information to the active port and the mirror port. This capability can be enabled by local or remote users, providing local users the capability to monitor remote sessions. Console mirroring can be enabled for the current session only. For more information, see “Console Mirroring” on page 408.

- **Start Talk Mode**

In a console mirroring session, it is useful for those who are monitoring the session to be able to communicate with each other. Selecting this menu item activates the keyboards and displays for such communications while console mirroring is established. This is a full duplex link, so message interference is possible. Alternating messages between users works best.

- **OS Surveillance Setup Menu**

This menu can be used to set up operating system (OS) surveillance.

```
OS Surveillance Setup Menu

1. Surveillance:
   Currently Enabled

2. Surveillance Time Interval:
   5 minutes

3. Surveillance Delay:
   10 minutes

98. Return to Previous Menu

1>
```

- **Surveillance**

Can be set to Enabled or Disabled.

- **Surveillance Time Interval**

Can be set to any number from 2 through 255.

- **Surveillance Delay**

Can be set to any number from 0 through 255.

Refer to “Service Processor System Monitoring - Surveillance” on page 405 for more information about surveillance.

- **Reset Service Processor**

If this option is selected, entering Y causes the service processor to reboot.

- **Reprogram Flash EPROM Menu**

This option updates the system EPROMs. After entering Y to indicate that you want to continue, you are prompted to enter the update diskettes. Follow the instructions on the screen. When the update is complete, the service processor reboots.

All system EPROMs that can be reprogrammed are updated at the same time. They are as follows:

- System power control network programming
- Service processor programming
- System firmware
- Run-time abstraction services

- **Serial Port Snoop Setup Menu**

This menu can be used to set up serial port snooping, in which the user can configure serial port 1 as a "catch-all" reset device.

From the service processor main menu, select option 1, Service Processor Setup Menu, then select option 8 (Serial Port Snoop Setup Menu).

```
SERIAL PORT SNOOP SETUP MENU

1. System reset string:
   Currently Unassigned

2. Snoop Serial Port:
   Currently Unassigned

98. Return to Previous Menu

1>
```

Use the system reset string option to enter the system reset string, which resets the machine when it is detected on the main console on serial port 1.

Use the snoop serial port option to select the serial port to snoop.

Note: Only serial port 1 is supported.

After serial port snooping is correctly configured, at any point after the system unit is booted to AIX, whenever the reset string is typed on the main console, the system unit reboots.

Pressing Enter after the reset string is not required, so make sure that the string is not common or trivial. A mixed-case string is recommended.

System Power Control Menu

This menu is used to set power control options. Other menus that control boot options are available here:

```
SYSTEM POWER CONTROL MENU

1. Enable/Disable Unattended Start Mode:
   Currently Enabled

2. Ring-Indicate Power-On Menu

3. Reboot/Restart Policy Setup Menu

4. Power-On System

5. Power-Off System

6. Enable/Disable Fast System Boot
   Currently Enabled

7. Boot Mode Menu

98. Return to Previous Menu

99. Exit from Menus

1>
```

- **Enable/Disable Unattended Start Mode**

Use this option to instruct the service processor to restore the power state of the server after a temporary power failure. Unattended start mode can also be set through the System Management Services (SMS) menus. It is intended to be used on servers that require automatic power-on after a power failure. For more information, see “System Power-On Methods” on page 398.

- **Ring-Indicate Power-On Menu**

```
RING-INDICATE POWER-ON MENU

1. Ring-indicate power-on :
   Currently Enabled

2. Number of rings:
   Currently 3

30. Refresh Modem Settings

98. Return to Previous Menu
```

Ring-indicate is enabled by default on both serial port 1 (S1) and serial port 2 (S2). When ring-indicate power-on is enabled, call-in is disabled.

If ring-indicate power-on is enabled and call-in is already enabled, you will be asked to confirm your choice. Refer to the message displayed on your screen.

If the ring-indicate power-on setting is changed, you must select option 30 (Refresh Modem Settings) to update the modem settings. If option 30 (Refresh Modem Setting) is selected, and the modem(s) have not been configured, you will be asked to configure the modems first. See “Call-In/Call-Out Setup Menu” on page 391 for information on configuring modems.

Option 2 is used to set the number of rings.

Note: In order for the ring-indicate power-on settings to take effect and ring-indicate power-on to be enabled, the service processor menus must be exited completely. Enter 99 at the Main Menu screen to completely exit the service processor menus.

- **Reboot/Restart Policy Setup Menu**

The following menu controls reboot/restart policy:

```
Reboot/Restart Policy Setup Menu

1. Number of reboot attempts:
   Currently 1

2. Use OS-Defined restart policy?
   Currently Yes

3. Enable supplemental restart policy?
   Currently No

4. Call-Out before restart:
   Currently Disabled

98. Return to Previous Menu

1>
```

Reboot is the process of bringing up the system hardware; for example, from a system reset or power on. *Restart* is activating the operating system after the system hardware is re-initialized. Restart must follow a successful reboot.

- **Number of reboot attempts** - If the server fails to successfully complete the boot process, it attempts to reboot the number of times specified. Values equal to or greater than 0 are valid. Only successive failed reboot/restart attempts are counted.
- **Use OS-Defined restart policy** - Allows the service processor to react or not react in the same way as the operating system to major system faults by reading the setting of the operating system parameter **Automatically Restart/Reboot After a System Crash**. This parameter may or may not be defined, depending on the operating system or its version/level. If the operating system automatic restart setting is defined, then it can be set to respond to a major fault by restarting or by not restarting. See your operating system documentation for details on setting up operating system automatic restarts. The default value is Yes.

- **Enable supplemental restart policy** - The default setting is No. If set to Yes, the service processor restarts the system when the system loses control as detected by service processor surveillance, and either:

The **Use OS-Defined restart policy** is set to No.

OR

The **Use OS-Defined restart policy** is set to Yes, and the operating system has no automatic restart policy.

Refer to “Service Processor Reboot/Restart Recovery” on page 399.

- **Call-Out before restart (enabled/disabled)** - If a restart is necessary due to a system fault, you can enable the service processor to call out and report the event. This option can be valuable if the number of these events becomes excessive, signalling a bigger problem.

- **Power-On System**

Allows immediate power-on of the system. For other power-on methods, see “Powering On the System” on page 429.

- **Power-Off System**

Allows the user to power-off the system.

- **Enable/Disable Fast System Boot**

Allows the user to select the speed of the system boot.

Attention: Selecting the fast IPL results in several diagnostic tests being skipped and a shorter memory test being run.

- **Boot Mode Menu**

The Boot Mode Menu allows you to select a boot mode.

```
Boot Mode Menu

1. Boot to SMS Menu:
   Currently Disabled

2. Service Mode Boot from Saved List:
   Currently Disabled

3. Service Mode Boot from Default List:
   Currently Disabled

4. Boot to Open Firmware Prompt:
   Currently Disabled

98. Return to Previous Menu

1>
```

To select a boot mode, select a number and press Enter. The item corresponding to the selected number toggles from disabled to enabled. If the same number is selected again, the item toggles from enabled to disabled. If a boot mode is enabled, the boot mode selected is performed, and the disabled/enabled selection is reset to disabled. Following is a description for each boot mode:

- **Boot to SMS Menu**

When this selection is enabled, the system boots to the System Management Services (SMS) menu.

- **Service Mode Boot from Saved List**

This selection causes the system to perform a service mode boot using the service mode boot list saved in NVRAM. If the system boots AIX from the disk drive and AIX diagnostics are loaded on the disk drive, AIX boots in service mode to the diagnostics menu.

Using this option to boot the system is the preferred way to run online diagnostics.

- **Service Mode Boot from Default List**

This selection is similar to “Service Mode Boot from Saved List”, except the system boots using the default boot list that is stored in the system firmware. This is normally used to try to boot customer diagnostics from the CD-ROM drive.

Using this option to boot the system is the preferred way to run standalone diagnostics.

- **Boot to Open Firmware**

When this selection is enabled, the system boots to the open firmware prompt.

This option should only be used by service personnel to obtain additional debug information.

System Information Menu

This menu provides access to system configuration information, error logs, system resources, and processor configuration.

```
SYSTEM INFORMATION MENU

1. Read VPD Image from Last System Boot
2. Read Progress Indicators from Last System Boot
3. Read Service Processor Error Logs
4. Read System POST Errors
5. Read NVRAM
6. Read Service Processor Configuration
7. Processor Configuration/Deconfiguration Menu
8. Memory Configuration/Deconfiguration Menu
9. Power Control Network Utilities Menu
98. Return to Previous Menu
99. Exit from Menus

1>
```

- **Read VPD Image from Last System Boot**

Displays manufacturer's vital product data (VPD), such as serial numbers, part numbers, and so on, that were stored during the system boot prior to the one in progress now.

- **Read Progress Indicators from Last System Boot**

Displays a number of the boot progress indicators, which may include service processor checkpoints, IPL checkpoints, and/or AIX configuration codes, from the previous system boot. This information can be useful in diagnosing system faults.

The progress indicator codes are listed from top (latest) to bottom (oldest).

This information is not stored in non-volatile storage. If the system is powered off using the power-on button on the operator panel, this information is retained. If the ac power (dc power in a dc-powered system) is disconnected from the system, this information will be lost. For an example, refer to "LCD Progress Indicator Log" on page 410.

- **Read Service Processor Error Logs**

Displays the service processor error log. Refer to "Service Processor Error Log" on page 409 for an example of this error log.

- **Read System POST Errors**

This option should only be used by service personnel to display additional error log information.

- **Read NVRAM**

Displays non-volatile random access memory (NVRAM) content.

- **Read Service Processor Configuration**

Displays current service processor configuration.

- **Processor Configuration/Deconfiguration Menu**

This menu allows the user to change the system processor configuration. If it is necessary to take one of the processors offline, this menu allows you to deconfigure a processor, and then reconfigure the processor at a later time. An example of this menu is shown below:

```
PROCESSOR CONFIGURATION/DECONFIGURATION MENU

77. Enable/Disable CPU Repeat Gard: Currently Enabled

  1. 0 3.0 (00) Configured by system
  2. 2 3.1 (31) Deconfigured by system
  3. 4 3.2 (00) Configured by system
  4. 6 3.3 (00) Configured by system
98. Return to Previous Menu

1>
```

Note: This table is built from vital product data collected during the last boot sequence. The first time the system is powered up, or after the system's non-volatile RAM (NVRAM) has been erased, this table may be empty. The table is rebuilt during the next boot into AIX.

The fields of the previous table represent the following:

- Column 1** (1.) Menu selection index.
- Column 2** (0) Logical processor device number assigned by AIX. You can display these logical device numbers by issuing the following command on the AIX command line:
`lsdev -C | grep proc`
- Column 3** (3.0) Processor address list used by the service processor and should be ignored.
- Column 4** (00) Error status of the processors.

The error status of each processor is indicated by AB, where B indicates the number of errors and A indicates the type of error according to the following table:

1. Bring-up failure
2. Run-time non-recoverable failure
3. Run-time recoverable failure

A status of 00 indicates that the CPU has not had any errors logged against it by the service processor.

To enable or disable CPU Repeat Gard, use menu option 77. CPU Repeat Gard is enabled by default.

If CPU Repeat Gard is disabled, processors that are in the deconfigured by system state will be reconfigured. These reconfigured processors are then tested during the boot process, and if they pass, they remain online. If they fail the boot testing, they are deconfigured, even though CPU Repeat Gard is disabled.

The failure history of each CPU is retained. If a processor with a history of failures is brought back online by disabling Repeat Gard, it remains online if it passes testing during the boot process. However, if Repeat Gard is enabled, the processor is taken offline again because of its history of failures.

Note: The processor numbering scheme used by the service processor is different from the numbering scheme used by AIX. Consult the AIX documentation before configuring or deconfiguring a processor to ensure that the correct processor is selected.

The AIX Documentation library is available at the following Web address: <http://www-1.ibm.com/servers/aix/library/>. Select **Technical Publications**. AIX documentation is also contained on the AIX Documentation CD. The documentation is made accessible by loading the documentation CD onto the hard disk or by mounting the CD in the CD-ROM drive.

- **Memory Configuration/Deconfiguration Menu**

These menus allow the user to change the system memory configuration. If it is necessary to take one of the memory DIMMs offline, this menu allows you to deconfigure a DIMM, and then reconfigure the DIMM at a later time.

When this option is selected, a menu displays, showing the memory riser cards in the system. Type the number of the memory riser card on which the DIMM is plugged that you want to configure or deconfigure. An example of this menu is shown below:

```
MEMORY CONFIGURATION/DECONFIGURATION MENU

77. Enable/Disable Memory Repeat Gard: Currently Enabled

    1. Memory riser card 1
    2. Memory riser card 2
    98. Return to Previous Menu
```

Note: If there is only one processor in the system, system memory may reside on that processor assembly. In that case, you are given the option to select the processor card from the list.

After you select a processor card or a memory riser card, a menu allowing the selection of a memory DIMM is displayed. The following is an example of this menu:

```
MEMORY CONFIGURATION/DECONFIGURATION MENU

77. Enable/Disable Memory Repeat Gard: Currently Enabled

  1. 11.17(00) Configured by system  2. 11.19(00) Configured by system
15. 11.16(00) Configured by system 16. 11.18(00) Configured by system

  3. 11.21(00) Configured by system  4. 11.23(00) Configured by system
13. 11.20(00) Configured by system 14. 11.24(00) Configured by system

98. Return to Previous Menu

Memory DIMMs are managed as a group.
Deconfiguring a DIMM will make the whole group unavailable.

0>
```

Note: This table is built from vital product data collected during the last boot sequence. The first time the system is powered up, or after the system's non-volatile RAM (NVRAM) has been erased, this table may be empty. The table is rebuilt during the next boot into AIX.

The system DIMMs are presented by group. If a memory riser card is present, quad A is shown first, followed by quads B, C, and D, if present. If memory is on a processor card, pair A is shown first, followed by pairs B, C, and D, if present. The menu selection index/DIMM number and the DIMM address correspond to the numbers shown in the diagrams "Memory Riser Card 1 Memory DIMM Locations for Service Processor Menus" on page 387, "Memory Riser Card 2 Memory DIMM Locations for Service Processor Menus" on page 387 and "Processor Card Memory DIMM Locations for Service Processor Menus" on page 388.

The fields in the previous table represent the following:

- Column 1** (1.) Menu selection index/DIMM number
- Column 2** (11.xx) Riser card 1
(10.xx) Riser card 2
(3.xx) Memory on processor card
- Column 3** (00) Error status

The error status of the each memory DIMM is indicated by AB, where B indicates the number of errors and A indicates the type of error according to the following table:

- 1. Bring-up failure
- 2. Run-time non-recoverable failure
- 3. Run-time recoverable failure

4. Group integrity failure

An error status of 00 indicates that the memory DIMM has not had any errors logged against it by the service processor.

To change the memory configuration, select the number of the memory DIMM. The memory DIMM state will change from configured to deconfigured or from deconfigured to configured. Memory DIMMs are managed as a group; deconfiguring a DIMM makes the whole group of four DIMMs unavailable.

In the example menu shown above, each line shows two DIMMs and indicates whether they are configured.

To enable or disable Memory Repeat Gard, use menu option 77 of the Processor Configuration/Deconfiguration Menu.

If Memory Repeat Gard is disabled, DIMMs that are in the deconfigured by system state will be reconfigured. These reconfigured DIMMs are then tested during the boot process, and if they pass, they remain online. If they fail the boot testing, they are deconfigured even though Memory Repeat Gard is disabled.

The failure history of each DIMM is retained. If a DIMM with a history of failures is brought back online by disabling Repeat Gard, it remains online if it passes testing during the boot process. However, if Repeat Gard is enabled, the DIMM is taken offline again because of its history of failures.

The physical location of a DIMM is determined by *xx.yy*, where *xx* is the riser card location (11 for riser card 1, 10 for riser card 2, and 3 for DIMMs on the processor card) followed by the DIMM location on the riser card, according to the following two illustrations.

Memory Riser Card 1 Memory DIMM Locations for Service Processor Menus

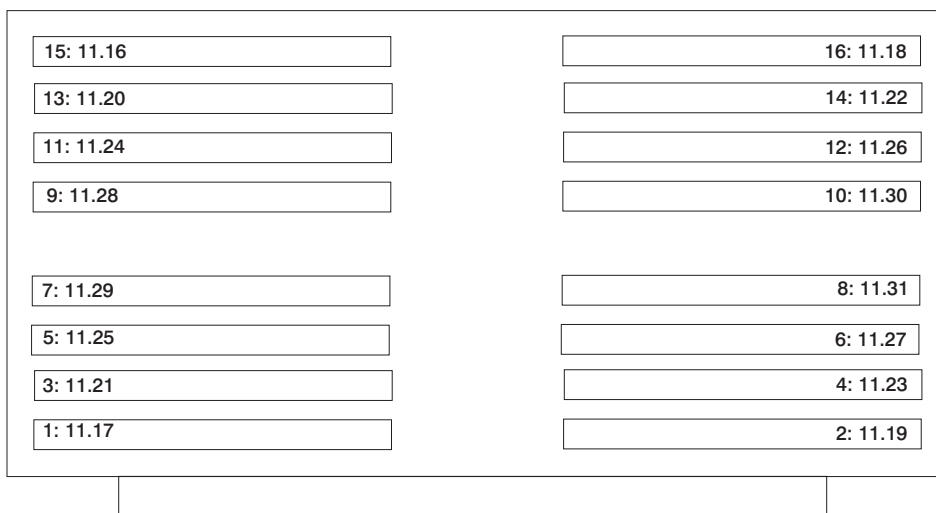

Memory Riser Card 2 Memory DIMM Locations for Service Processor Menus

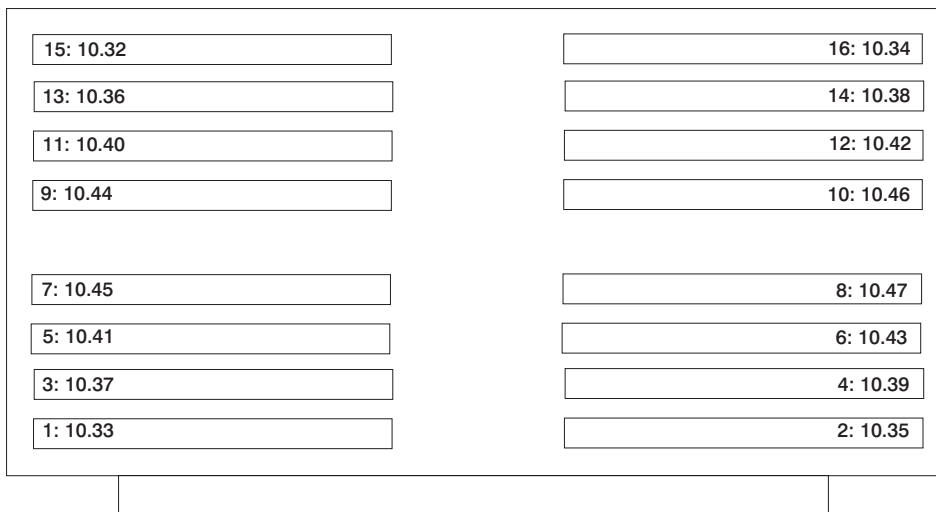

Processor Card Memory DIMM Locations for Service Processor Menus

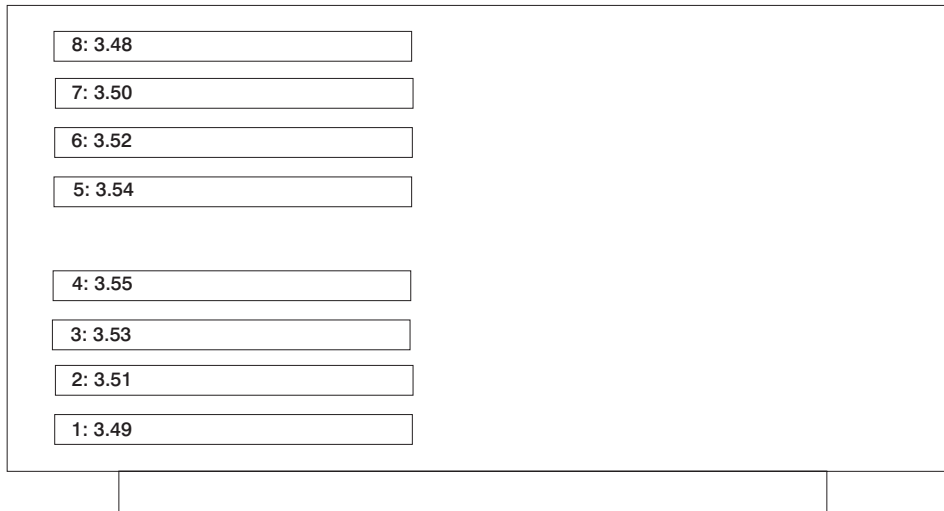

- **Power Control Network Utilities Menu**

This menu allows the user to do a lamp test on the operator panels and display, or change the I/O type.

```
POWER CONTROL NETWORK UTILITIES MENU

1. Lamp Test for all Operator Panels
2. Display I/O Type
3. Change I/O Type
98. Return to Previous Menu

1>
```

- **Lamp Test for all Operator Panels**

Selecting this option tests the operator panel indicators as follows:

Operator Panel Location	Lamp Test Results
Primary I/O drawer	Indicators blink on and off for approximately 30 seconds.
Secondary I/O drawers	Indicators come on and stay on for approximately 30 seconds.

- **Display I/O Type**

This option displays the I/O type and other data, on the operator panels of the secondary I/O drawers (blinks in one-second intervals). The I/O type is always shown as two digits in the upper-right corner of the display. All secondary I/O types are 84. Nothing displays on the primary I/O drawer operator panel. After 20-30 seconds, the Power Control Network Utilities Menu redisplay on the console.

- **Change I/O Type**

Use this option to change the I/O type of the primary I/O drawer or secondary I/O drawer after a service action or configuration change if the I/O type is incorrect. If this option is chosen, you are asked to make two entries.

1. For the I/O drawer address (drawer number), type:
 - 1 for primary I/O drawer.
 - 2 for the secondary I/O drawer.
2. For the I/O type, type:
 - 85 for the primary I/O drawer.
 - 84 for the secondary I/O drawer.

If you enter an invalid value, a failure message displays on the console. The Power Control Network Utilities Menu then redisplay on the console.

Language Selection Menu

The service processor menus and messages are available in various languages. This menu allows a language to be selected in which the service processor and system firmware menus and messages are displayed.

```
LANGUAGE SELECTION MENU

1. English
2. Francais
3. Deutsch
4. Italiano
5. Espanol
6. Svenska
98. Return to Previous Menu
99. Exit from Menus
1>
```

Note: Your ASCII terminal must support the ISO-8859 character set to correctly display languages other than English.

Call-In/Call-Out Setup Menu

This menu is used to configure a modem for the service processor to use to support the system:

```
CALL-IN/CALL-OUT SETUP MENU

1. Modem Configuration Menu
2. Serial Port Selection Menu
3. Serial Port Speed Setup Menu
4. Telephone Number Setup Menu
5. Call-Out Policy Setup Menu
6. Customer Account Setup Menu
7. Call-Out Test
98. Return to Previous Menu
99. Exit from Menus

1>
```

- **Modem Configuration Menu**, see “Modem Configuration Menu” on page 392.
- **Serial Port Selection Menu**, see “Serial Port Selection Menu” on page 393.
- **Serial Port Speed Setup Menu**, see “Serial Port Speed Setup Menu” on page 393.
- **Telephone Number Setup Menu**, see “Telephone Number Setup Menu” on page 394.
- **Call-Out Policy Setup Menu**, see “Call-Out Policy Setup Menu” on page 395.
- **Customer Account Setup Menu**, see “Customer Account Setup Menu” on page 396.
- **Call-Out Test Menu** tests the configuration after the modem is installed and configured. In order for this test to execute successfully, at least one of the following numbers must be assigned:
 - Service center telephone number
 - Customer administration center telephone number
 - Digital pager telephone number

Modem Configuration Menu

The first two lines of the Modem Configuration Menu are status lines showing the current selections. Selections are made in the two sections labeled Modem Ports and Modem Configuration File Name. Select the serial port that you want to activate and then select the modem configuration file for the modem on the port. If you want to set up both of the serial ports with modems, make your selections one port at a time.

Note: Modem configuration is only supported on serial port 1 (S1) and serial port 2 (S2).

```
Modem Configuration Menu

Port 1 Modem Configuration File Name:
Port 2 Modem Configuration File Name:

To make changes, First select the port and then the configuration file
name

Modem Ports:
1. Serial port 1
2. Serial port 2

Modem Configuration File Name:
5. none                9. modem_z_sp
6. modem_f_sp         10. modem_m1_sp
7. modem_f0_sp        11. modem_m0_sp
8. modem_f1_sp        12. modem_m1_sp

30. Save configuration to NVRAM and Configure modem
98. Return to Previous Menu

0>
```

For information on choosing a modem configuration file, see “Sample Modem Configuration Files” on page 501, and “Transfer of a Modem Session” on page 507.

Serial Port Selection Menu

This menu allows you to enable or disable the call-in and call-out functions of each serial port in any combination.

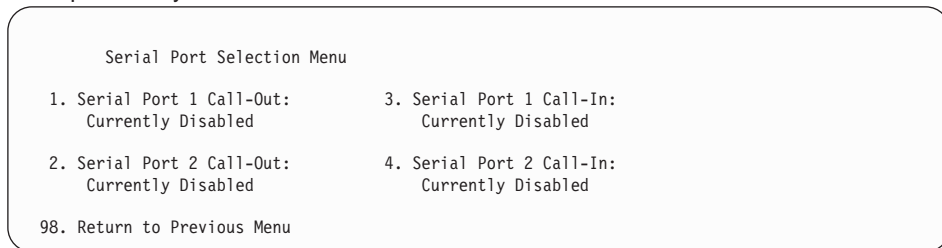

Call-in and ring-indicate power-on cannot be enabled at the same time. If ring-indicate power-on is already enabled and you try to enable call-in, a message prompts you for confirmation. Refer to the message displayed on the screen.

Serial Port Speed Setup Menu

This menu allows you to set serial port speed to enhance terminal performance or to accommodate modem capabilities.

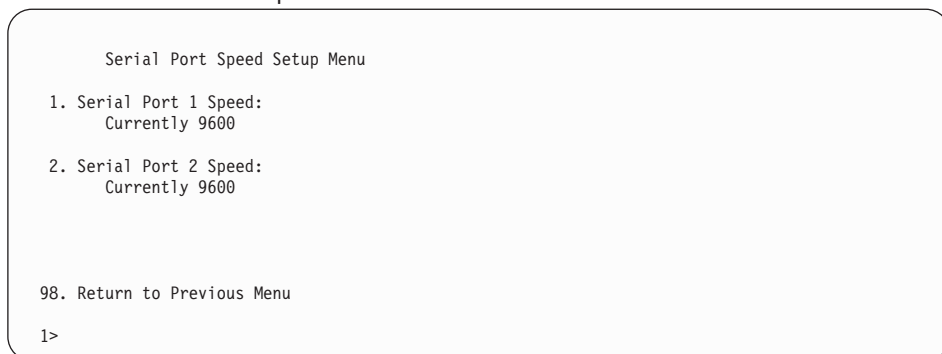

A serial port speed of 9600 baud or higher is recommended. Valid serial port speeds are as follows:

50	600	4800
75	1200	7200
110	1800	9600
134	2000	19200
150	2400	38000
300	3600	57600
		115200

Telephone Number Setup Menu

Use this menu to set or change the telephone numbers for reporting a system failure.

```
Telephone Number Setup Menu

1. Service Center Telephone Number:
   Currently Unassigned

2. Customer Administration Center Telephone Number:
   Currently Unassigned

3. Digital Pager Telephone Number:
   Currently Unassigned

4. Customer Voice Telephone Number:
   Currently Unassigned

5. Customer System Telephone Number:
   Currently Unassigned

98. Return to Previous Menu

1>
```

- **Service Center Telephone Number** is the number of the service center computer. The service center usually includes a computer that takes calls from servers with call-out capability. This computer is referred to as the "catcher." The catcher expects messages in a specific format to which the service processor conforms.
For more information about the format and catcher computers, refer to the README file in the AIX /usr/samples/syscatch directory. Contact your service provider for the correct service center telephone number to enter. Until you have that number, leave this field unassigned.
- **Customer Administration Center Telephone Number** is the number of the system administration center computer (catcher) that receives problem calls from servers. Contact your system administrator for the correct telephone number to enter here. Until you have that number, leave this field unassigned.
- **Digital Pager Telephone Number** is the number for a numeric pager carried by someone who responds to problem calls from your server. Contact your administration center representative for the correct telephone number to enter. For test purposes, use a test number, which you can change later. See the note on page 406 for information about using certain modems for paging.

Note: At least one of the preceding three telephone numbers must be assigned in order for the call-out test to execute successfully.
- **Customer Voice Telephone Number** is the telephone number of a phone near the server or answered by someone responsible for the server. This is the telephone number left on the pager for callback. For test purposes, use a test number, which you can change later.
- **Customer System Telephone Number** is the telephone number to which your server's modem is connected. The service or administration center representatives need this number to make direct contact with your server for problem investigation. This is also referred to as the *call-in* phone number.

Call-Out Policy Setup Menu

Callout settings can be set using the following menu:

```
CALL-OUT POLICY SETUP MENU

1. Call-Out policy (First/All):
   Currently First

2. Remote timeout, (in seconds):
   Currently 120

3. Remote latency, (in seconds):
   Currently 2

4. Number of retries:
   Currently 2

98. Return to Previous Menu

1>
```

- **Call-Out policy** can be set to `first` or `all`. If call-out policy is set to `first`, the service processor stops at the first successful call-out to one of the following numbers in the order listed:

1. Service center
2. Customer administrative center
3. Pager

If call-out policy is set to `all`, the service processor attempts a call-out to all of the following numbers in the order listed:

1. Service center
2. Customer administrative center
3. Pager

- **Remote timeout** and **remote latency** are functions of your service provider's catcher computer. Either use the defaults or contact your service provider for recommended settings.
- **Number of retries** is the number of times you want the server to retry calls that fail to complete.

Customer Account Setup Menu

This menu allows users to enter information that is specific to their account.

```
Customer Account Setup Menu

1. Customer Account Number:
   Currently Unassigned

2. Customer RETAIN Login userid:
   Currently Unassigned

3. Customer RETAIN login password:
   Currently Unassigned

98. Return to Previous Menu

1>
```

- **Customer Account Number** is assigned by your service provider for record-keeping and billing. If you have an account number, enter it. Otherwise, leave this field unassigned.
- **Customer RETAIN Login User ID** and **Customer RETAIN Login Password** apply to a service function to which your service provider may or may not have access. Leave these fields unassigned if your service provider does not use RETAIN.

Service Processor Procedures in Service Mode

When the system is in service mode, the following service-processor parameters are suspended:

- Unattended start mode
- Reboot/restart policy
- Call-out
- Surveillance

When service mode is exited, the service processor parameters revert to the customer settings.

Service Processor Functions

This section discusses some of the service processor functions in greater detail. The service processor supports the functions listed in the following table.

Built-in Functions	Initialization and Test	Service Processor BIST
		System Chip Initialization
	Error Data Collection	BIST/POST errors and status
		Isolation to Field Replaceable Unit (FRU) on failure
	Configuration	CPU Complex validation
		VPD Collection
	System Management	Reset and Reboot on System Firmware failure
		Reboot on system failure
Local User Function	User Interface	Local async console
		Text-based menus with NLS
		Operator Panel messages
	Power and Miscellaneous	Power On/Off
		Configurable Reboot Policy
	Status and Data Access	VPD
		Error data (SP)
		Error data (system)
	Service Processor Setup Utilities	Passwords
		Phone numbers
		Language (NLS) selection
		Call-In/Call-Out enable/disable
		System Name
		Modem Configuration
Remote User Functions	Call-Out (Call Home) Reporting	OS termination
		Boot failure
		Surveillance failure
		Checkstop
		Machine check
		Identify system by name
	Call-In	Power-on through ring-indicate
		Password/security check
		Console mirroring

System Power-On Methods

This section discusses the following system power-on methods:

- Power-on switch
- Service processor menus

Privileged users can power on the system by selecting the **System Control Power Menu** option from the main menu and then selecting the **Power-on System** option from the system power control menu. General users should select **Power-on System** on the general user menu.

- Remote power-on via ring-indicate signal

The server automatically powers on when it detects a "ring-indicate" signal from a modem attached to serial port 1 (S1) or serial port 2 (S2).

A remote user can call the server to activate ring detection by the modem. Listen for a few more rings than the threshold number for starting the system. The system powers on without answering the call.

- Unattended start mode - refer to **Enable/Disable Unattended Start Mode** on page 378.

The service processor can be enabled to recover from the loss of ac power (dc power in a dc-powered system) (see **Enable/Disable Unattended Power-On Mode** in the **System Control Power Menu**). When ac power (dc power in a dc-powered system) is restored, the system returns to the power state at the time ac loss (dc loss in a dc-powered system) occurred. For example, if the system was powered on when ac loss (dc loss in a dc-powered system) occurred, it reboots/restarts when power is restored. If the system was powered-off when ac loss (dc loss in a dc-powered system) occurred, it remains off when power is restored.

It is recommended that the CEC and I/O drawers both receive their ac power (dc power in a dc-powered system) from the same building circuit on the same circuit breaker, if not the same electrical outlet box, in such a way that primary power cannot be lost to one unit separately from the other. If such a condition occurs, unattended start mode may not be able to restart system operation when a primary power interruption is restored.

- Timed power-on - refer to the **shutdown -t** command on servers using AIX.

Working in conjunction with AIX, the service processor in your server can operate a timer, much like the wake-up timer on your clock radio. You can set the timer so that your server powers on at a certain time after shutting down. The timer is battery-operated, so power interruptions that occur while the server is off do not affect its accuracy. Refer to the AIX **shutdown -t** command for details on setting the timer.

Note: If an ac power (dc power in a dc-powered system) loss is in progress when the timed power-on attempt occurs, the server is not able to power on when ac power (dc power in a dc-powered system) is restored.

- Follow-up to a failed boot attempt

The service processor initiates a power-on sequence if a failed boot attempt is detected (due to a hardware or software failure).

- Fast/slow boot (IPL) settings

Using the service processor menus, you can select the IPL type, mode, and speed of your system boot.

Attention: Selecting fast IPL results in several diagnostic tests being skipped and a shorter memory test being run.

Service Processor Reboot/Restart Recovery

Reboot describes bringing the system hardware back up; for example, from a system reset or power-on. The boot process ends when control passes to the operating system process.

Restart describes activating the operating system after the system hardware is re-initialized. Restart must follow a successful reboot.

Boot (IPL) Speed

When the server enters reboot recovery, slow IPL is automatically started, which gives the POST an opportunity to locate and report any problems that may otherwise be undetected.

Failure During Boot Process

During the boot process, either initially after system power-on or upon reboot after a system failure, the service processor monitors the boot progress. If progress stops, the service processor can re-initiate the boot process (reboot) if enabled to do so. The service processor can re-attempt this process according to the number of retries that has been set in the Reboot/Restart Policy Setup Menu.

Failure During Normal System Operation

When the boot process completes and control transfers to the operating system (OS), the service processor can monitor operating system activity (see the **Set Surveillance Parameters** option in the Service Processor Setup Menu). If OS activity stops due to a hardware- or software-induced failure, the service processor can initiate a reboot/restart process based on the settings in the Service Processor Reboot/Restart Policy Setup Menu and the OS automatic restart settings (see the operating system documentation).

If you are using the AIX operating system, the menu item under SMIT for setting the restart policy is Automatically Reboot After Crash (True/False). The default is false. When the setting is true, and if the service processor parameter "Use OS-Defined Restart Policy" is yes (the default), the service processor takes over for AIX to reboot/restart after a hardware or surveillance failure.

Service Processor Reboot/Restart Policy Controls

The operating system's automatic restart policy (see operating system documentation) indicates the operating system response to a system crash. The service processor can be instructed to refer to that policy by the Use OS-Defined Restart Policy setup menu.

If the operating system has no automatic restart policy, or if it is disabled, then the service processor restart policy can be controlled from the service processor menus. Use the Enable Supplemental Restart Policy selection.

Use OS-Defined restart policy - The default setting is yes. This causes the service processor to refer to the OS automatic restart policy setting and take action (the same action the operating system would take if it could have responded to the problem causing the restart).

When this setting is no, or if the operating system did not set a policy, the service processor refers to enable supplemental restart policy for its action.

Enable supplemental restart policy - The default setting is no. If set to yes, the service processor restarts the server when the operating system loses control and either:

The **Use OS-Defined restart policy** is set to no.

OR

The **Use OS-Defined restart policy** is set to yes and the operating system has no automatic restart policy.

The following table describes the relationship among the operating system and service processor restart controls:

OS Automatic reboot/restart after crash setting	Service processor to use OS-Defined restart policy?	Service Processor Enable supplemental restart policy?	System response
None	No	No ¹	
None	No	Yes	Restarts
None	Yes ¹	No ¹	
None	Yes ¹	Yes	Restarts
False ²	No	No ¹	
False ²	No	Yes	Restarts
False ²	Yes ¹	No ¹	
False ²	Yes ¹	Yes	
True	No	No ¹	
True	No	Yes	Restarts
True	Yes ¹	No ¹	Restarts
True	Yes ¹	Yes	Restarts

¹ Service processor default

² AIX default

System Firmware Updates

This section provides information and instructions for updating the system firmware. You may need to perform these steps if you are installing an option or if your support representative has instructed you to update your firmware.

Always check the pSeries & RS/6000 Support Web site for the latest firmware images and update instructions. The Web address is: <http://www.rs6000.ibm.com/support/micro>

Downloading the firmware update image and update instructions from the Web is preferred.

If the system is running, but access to the Web is not available, see “System Firmware Update Using a Locally Available Image” on page 402.

If the system cannot be powered on, but the service processor menus are available, see “Updating System Firmware From the Service Processor Menus” on page 403.

If the service processor programming has been corrupted, the service processor will automatically enter recovery mode when power is applied to the system. Recovery mode is described later in this section.

To check the level of firmware that is currently on the system, see “Determining the Level of Firmware on the System” on page 402.

General Information on System Firmware Updates

All the types of system firmware that can be reprogrammed are updated at the same time. They are:

- System power control network programming
- Service processor programming
- IPL programming
- Run-time abstraction services

It is strongly recommended that you create a set of firmware update diskettes from the Web site as soon as possible after a system is installed. As noted below, the diskette images can be downloaded to any personal computer, pSeries, or RS/6000 system with Internet access. This method is the only way to acquire a set of firmware update diskettes; they cannot be created by using the service processor menus or by using AIX.

Retain and store the latest firmware diskettes each time the firmware gets updated in the event that the firmware becomes corrupted and must be reloaded.

Download the detailed instructions, as well as the latest flash images, from this Web site. Before doing a system firmware update, check the Web site for the latest code and images. Do not attempt a firmware update if you are unsure of the image you have, or of the procedure required for the update.

The images are available on the Web site in either DOS format or AIX (backup) format:

- If downloading to a PC, download the DOS image and follow the instructions. The diskettes that are created will be in AIX (backup) format.
- If downloading to a pSeries or RS/6000 system, follow the instructions to create an image on a disk drive or on diskettes.

Determining the Level of Firmware on the System

Note: This information may be superseded by the information that is available on the Web site listed below. Always check the Web site for the latest images and instructions for checking the firmware level. The Web address is:
<http://www.rs6000.ibm.com/support/micro>

The firmware level is denoted by XXYYMMDD, where XX = model designation, YY = year, MM = month, and DD = day of the release.

The firmware level can be determined by either of the following methods:

- On the AIX command line, by typing:

```
lscfg -vp|grep -F .CM
```

A line that begins with ROM level (alterable).. displays the firmware level that is currently on the system.

- Looking at the top of the service processor main menu.

System Firmware Update Using a Locally Available Image

To update the system firmware using a locally available image, perform the following steps:

1. Log in as root user.
2. If the directory **/tmp/fwupdate** does not exist, create it by issuing the following command:

```
mkdir /tmp/fwupdate
```

3. The firmware update file must be written into the **/tmp/fwupdate** directory on the system. This can be done by using the **ftp** command to get the image from an ftp server or NFS-mounting the directory on the host server, for example.

The firmware update file can also be transferred to the target system by backing up the image onto diskette from another server and restoring it into the **/tmp/fwupdate** directory.

After the firmware update file has been written into the **/tmp/fwupdate** directory, verify its existence by entering the following command:

```
ls /tmp/fwupdate/CM*.img
```

The update file will have the format CMyymmdd.img. The CM indicates that this is an update image for a system: yy is the year, mm is the month, and dd is the day of the update file.

4. After the update file has been written to the **/tmp/fwupdate** directory, enter the following commands:

```
cd /usr/lpp/diagnostics/bin  
./update_flash -f /tmp/fwupdate/CMymmdd.img
```

Attention: Do not overlook the periods (.) in the commands shown above. AIX commands are case-sensitive. Type them exactly as shown.

You will be asked for confirmation to proceed with the firmware update and the required reboot. If you confirm, the system will apply the new firmware, reboot, and return to the AIX prompt. This may take up to ten minutes depending on the configuration of the system.

Attention: On some systems, the message `Wait for rebooting before stopping` may display on the system console. Do not turn off the system until the system has fully rebooted to the AIX login prompt. If a shutdown is necessary at that time, log in as root user and issue the **shutdown** command.

While the update is in progress, you will see `Rebooting...` on the display for several minutes.

The firmware update is complete.

Updating System Firmware From the Service Processor Menus

This procedure requires a set of firmware update diskettes in backup format.

The service processor menus are available while the system is powered off. As a privileged user, from the service processor main menu, select **Service Processor Setup**, then select **Reprogram Flash EPROM Menu**. The update process requests update diskettes as needed.

Updating System Firmware from the AIX Service Aids

Note: This service aid is supported only in online diagnostics.

Refer to the detailed instructions that are provided on the Web site with the latest image.

Updating System Firmware from the AIX Command Line

Refer to the detailed instructions that are provided on the Web site with the latest image.

Note: The update process can take up to sixty minutes, and the system reboots itself during the update process.

Recovery Mode

If the service processor detects that its programming has been corrupted when it is powering up to standby mode, it will enter recovery mode. In recovery mode, it will ask for the firmware update diskettes by putting eight-digit codes on the operator panel.

The eight-digit codes are as follows:

Code	Action
A1FD 0000	System firmware has been corrupted and must be reflashed.
A1FD 0001	Insert update diskette 1.
A1FD 0002	Insert update diskette 2.
A1FD 0003	Insert update diskette 3.
A1FD 000n	Insert update diskette n.

Notes:

1. If the wrong diskette is inserted at any time, or if the diskette is left in the drive after it has been read, B1FD 001F is displayed, indicating that the wrong diskette is in the drive.
2. If B1FD 001A is displayed at any time during the process, the service processor must be reset by activating the pinhole reset switch on the primary drawer operator panel.

After the update process is complete, the service processor resets itself and goes through a complete reboot.

Configuring and Deconfiguring Processors or Memory

All failures that crash the system with a machine check or check stop, even if intermittent, are reported as a diagnostic callout for service repair. To prevent the recurrence of intermittent problems and improve the availability of the system until a scheduled maintenance window, processors and memory DIMMs with a failure history are marked "bad" to prevent their being configured on subsequent boots.

A processor or memory DIMM is marked "bad" under the following circumstances:

- A processor or memory DIMM fails built-in self-test (BIST) or power-on self-test (POST) during boot (as determined by the service processor).
- A processor or memory DIMM causes a machine check or check stop during run time, and the failure can be isolated specifically to that processor or memory DIMM (as determined by the processor run-time diagnostics in the service processor).
- A processor or memory DIMM reaches a threshold of recovered failures that results in a predictive callout (as determined by the processor run-time diagnostics in the service processor).

During boot time, the service processor does not configure processors or memory DIMMs that are marked "bad."

If a processor or memory DIMM is deconfigured, the processor or memory DIMM remains offline for subsequent reboots until it is replaced or Repeat Gard is disabled. The Repeat Gard function also allows users to manually deconfigure a processor or memory DIMM, or re-enable a previously deconfigured processor or memory DIMM. For information on configuring or deconfiguring a processor, see the Processor Configuration/Deconfiguration Menu on page 383. For information on configuring or

deconfiguring a memory DIMM, see the Memory Configuration/Deconfiguration Menu on page 384. Both of these are submenus under the System Information Menu.

You can enable or disable CPU Repeat Gard or Memory Repeat Gard using the Processor Configuration/Deconfiguration Menu, which is a submenu under the System Information Menu.

Run-Time CPU Deconfiguration (CPU Gard)

L1 instruction cache recoverable errors, L1 data cache correctable errors, and L2 cache correctable errors are monitored by the processor run time diagnostics (PRD) code running in the service processor. When a predefined error threshold is met, an error log entry with warning severity and threshold exceeded status is returned to AIX. At the same time, PRD marks the CPU for deconfiguration at the next boot. AIX will attempt to migrate all resources associated with that processor to another processor and then stop the defective processor.

Service Processor System Monitoring - Surveillance

Surveillance is a function in which the service processor monitors the system, and the system monitors the service processor. This monitoring is accomplished by periodic samplings called *heartbeats*.

Surveillance is available during two phases:

- System firmware bring-up (automatic)
- Operating system run time (optional)

System Firmware Surveillance

System firmware surveillance is automatically enabled during system power-on. It cannot be disabled by the user, and the surveillance interval and surveillance delay cannot be changed by the user.

If the service processor detects no heartbeats during system IPL (for a set time period), it cycles the system power to attempt a reboot. The maximum number of retries is set from the service processor menus. If the fail condition persists, the service processor leaves the machine powered on, logs an error, and displays menus to the user. If call-out is enabled, the service processor calls to report the failure and displays the operating system surveillance failure code on the operator panel.

Operating System Surveillance

Operating system surveillance provides the service processor with a means to detect hang conditions, as well as hardware or software failures, while the operating system is running. It also provides the operating system with a means to detect a service processor failure caused by the lack of a return heartbeat.

Operating system surveillance is not enabled by default, allowing you to run operating systems that do not support this service processor option.

You can also use the service processor menus and the AIX diagnostic service aids to enable or disable operating system surveillance.

For operating system surveillance to work correctly, you must set the following parameters:

- Surveillance enable/disable
- Surveillance interval

The maximum time the service processor waits between heartbeats from the operating system before reporting a surveillance failure.

- Surveillance delay

The maximum time the service processor waits for the first heartbeat from the operating system, after the operating system has been started, before reporting a surveillance failure.

Surveillance does not take effect until the next time the operating system is started after the parameters have been set.

You can initiate surveillance mode immediately from service aids. In addition to the three options above, a fourth option allows you to select immediate surveillance, and rebooting of the system is not necessarily required.

If operating system surveillance is enabled (and system firmware has passed control to the operating system), and the service processor does not detect any heartbeats from the operating system within the surveillance delay period, the service processor assumes the system is hung and takes action according to the reboot/restart policy settings. See “Service Processor Reboot/Restart Recovery” on page 399.

If surveillance is selected from the service processor menus that are only available at bootup, then surveillance is enabled by default as soon as the system boots. From service aids, the selection is optional.

Call-Out (Call-Home)

The service processor can call out (call-home) when it detects one of the following conditions:

- System firmware surveillance failure
- Operating system surveillance failure (if supported by operating system)
- Restarts
- Critical hardware failure
- Abnormal operating system termination

To enable the call-out feature, do the following:

1. Connect a modem to serial port 1 (S1) or serial port 2 (S2).
2. Set up the following using the service processor menus or the diagnostic service aids:
 - Enable call-out for the serial port where the modem is connected.

- Enter the modem configuration file name.
 - Set up site-specific parameters (phone numbers for call-out, call-out policy, number of call-out retries, and so on).
3. To call out before restart, set **Call-out before restart** to enabled from the Reboot/Restart Policy Setup menu.

Note: Some modems, such as IBM 7857-017, are not designed for the paging function. Although they can be used for paging, they will return an error message when they do not get the expected response from another modem. Therefore, even though the paging was successful, the error message will cause the service processor to retry, continuing to place pager calls for the number of retries specified in the Call-Out Policy Setup Menu. These retries result in redundant pages.

Console Mirroring

Console mirroring is supported on serial port 1 (S1) and serial port 2 (S2). When console mirroring is enabled, the service processor sends information to both serial ports. The serial port from which console mirroring is enabled is referred to as the *active port*. The *mirror port* is determined when keyboard input is detected from the other port. From this point on, the service processor only sends information to the active port and the mirror port. This capability can be enabled by local or remote users, providing local users the capability to monitor remote sessions. Console mirroring can be enabled for the current session only.

System Configuration

The following describes the configuration for console mirroring:

- Service processor
- Modem connected to one serial port and enabled for incoming calls
- Local ASCII terminal connected to the other serial port. This local terminal can be connected directly to your server or connected through another modem.

Console mirroring can be started in the following scenarios:

- Remote session first, then local session added:
 1. Remote session is already in progress.
 2. Remote user uses service processor menus to enable console mirroring, allowing both consoles to be active.
- Local session first, then remote session added:
 1. Local session is already in progress.
 2. The service processor receives a call from the remote user.
 3. The local user selects the option to enable console mirroring. The service processor immediately begins mirroring service processor menus.

Service Processor Error Log

The service processor error log, an example of which follows, contains information about error conditions detected by the service processor.

```
                                Error Log

1. 11/30/99   19:41:56 Service Processor Firmware Failure
   B1004999

Enter error number for more details.
Press Return to continue, or 'x' to return to menu.
Press "C" to clear error log, any other key to continue. >
```

Note: The time stamp in this error log is coordinated universal time (UTC), which is also referred to as Greenwich mean time (GMT). The AIX error log has additional information and time stamps with local time.

Entering an error number provides nine words of system reference code (SRC) data; an example screen follows:

```
Detail:   6005

SRC
-----
word11:B1004999   word12:0110005D   word13:00000000
word14:00000000   word15:00001111   word16:00000 000
word17:B1004AAA   word18:0114005D   word19:A4F1E909

B1004999

Press Return to continue, or 'x' to return to menu.
```

If Return is pressed, the contents of NVRAM will be dumped 320 bytes at a time, starting at address 0000.

LCD Progress Indicator Log

The following is an example of the LCD progress indicator log. It shows the types of entries that the log might contain, and is for example purposes only.

The progress indicator codes are listed from top (latest) to bottom (oldest).

```
                LCD Progress Indicator Log
B0FF
0539..17
0538..17
0539..17
0538..17
0539..17
0581
0538..17
0539..12
0538..12
0539..
0821..01-K1-00
0539..
0728..01-R1-00-00
0539..
0664..40-60-00-1,0
0539..
0777..U0.2-P1-I14/E1
0539..
0742..U0.2-P1-I12/E1
0539..
0776..U0.2-P1-I10/T1
E139
E1FB
E139
E183
Press Return to continue, or 'x' to return to menu. >
EAA1..U0.1-P1-I14
E172..U0.1-P1
E172..U0.1-P1-I14
E172..U0.1-P1
94BB
9109
9380
9108
9107
9106
9105
9118
9104
9103
9102
90FD
```

Service Processor Operational Phases

This section provides a high-level flow of the phases of the service processor.

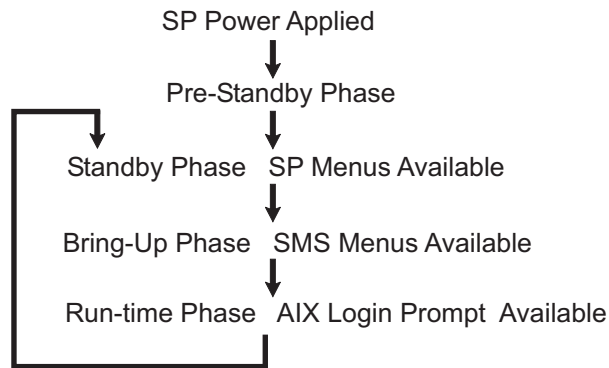

Pre-Standby Phase

This phase is entered when the server is first connected to a power source. This phase is exited when the power-on self-test (POST) and configuration tasks are completed.

The pre-standby phase components are:

- Service processor initialization - the service processor performs any necessary hardware and firmware initializations.
- Service processor POST - the service processor conducts power-on self-tests on its work and code areas.
- Service processor unattended start mode checks - To assist fault recovery. If unattended start mode is set, the service processor automatically reboots the server. The service processor does not wait for user input or a power-on command, but moves through the phase and into the bring-up phase. Access the system management services (SMS) menus or the service processor menus to reset the unattended start mode.

Standby Phase

The standby phase can be reached in either of the following ways:

- With the server off and power connected (the normal path), recognized by 0K in the LCD display.
OR
- With the server on after an operating system fault, recognized by an 8-digit code in the LCD display.

In the standby phase, the service processor takes care of some automatic duties and its menus are available. The service processor remains in the standby phase until a power-on request is detected.

The standby phase components are as follows:

- **Modem Configuration**
The service processor configures the modem (if installed) so that incoming calls can be received, or outgoing calls can be placed.
- **Dial In**
Monitor incoming phone line to answer calls, prompt for a password, verify the password, and remotely display the standby menu. The remote session can be mirrored on the local ASCII console if the server is so equipped and the user enables this function.
- **Menus**
The service processor menus are password-protected. Before you can access them, you need either the general user password or the privileged user password.

Bring-Up Phase

This phase is entered upon power-on, and exited upon loading of the operating system.

The bring-up phase components are as follows:

- **Retry request check**
The service processor checks to see if the previous boot attempt failed. If the specified number of failures is detected, the service processor displays an error code and places an outgoing call to notify an external party if the user has enabled this option.
- **Dial out**
The service processor can dial a preprogrammed telephone number in the event of a boot failure. The service processor issues an error report with the last-reported boot status and any other available error information.
- **Update operator panel**
The service processor displays operator panel data on the ASCII terminal if a remote connection is active.
- **Environmental monitoring**
The service processor provides expanded error recording and reporting.
- **System firmware surveillance (heartbeat monitoring)**
The service processor monitors and times the interval between system firmware heartbeats.
- **Responding to system processor commands**
The service processor responds to any command issued by the system processor.

Run-Time Phase

This phase includes the tasks that the service processor performs during steady-state execution of the operating system.

- Environmental monitoring

The service processor monitors voltages, temperatures, and fan speeds.

- Responding to system processor commands

The service processor responds to any command issued by the system processor.

- Run-time surveillance (heartbeat monitoring)

If the device driver is installed and surveillance enabled, the service processor monitors the system heartbeat. If the heartbeat times out, the service processor places an outgoing call. This is different from the bring-up phase scenario, where the specified number of reboot attempts is made before placing an outgoing call.

Chapter 8. Using System Management Services

Use the System Management Services menus to view information about your system and to perform tasks such as setting a password, changing the boot list, and setting the network parameters.

The text-based open firmware command line (the OK prompt), which is available from the System Management Services Utilities menu, allows you to configure certain adapters.

To start the System Management Services, do the following:

1. Turn on or restart the system.
2. Watch for the banner screen to appear on the console display. The banner screen will be lines of text in the form of repeated logos.
3. After the banner screen is displayed, the POST indicator words memory, keyboard, network, scsi and speaker appear across the bottom of the screen.
Press the numeric 1 key after the word keyboard appears, and before the last word speaker appears.
For more information on the POST indicator words, refer to "POST Indicators" on page 6.

Note: The System Management Services can also be started using the Service Processor Boot Mode Menu. See "Boot Mode Menu" on page 381.

After the System Management Services starts, the following Utilities screen displays:

```
Utilities

1 Password Utilities
2 Display Error Log
3 Remote Initial Program Load Setup
4 SCSI Utilities
5 Select Console
6 MultiBoot
7 Select Language
8 OK Prompt

                                     [X=Exit]
                                     -----

====>
```

Each option on the System Management Services Utilities menu is described in this section.

Password Utilities

Entering this selection permits access to the options shown on the following screen:

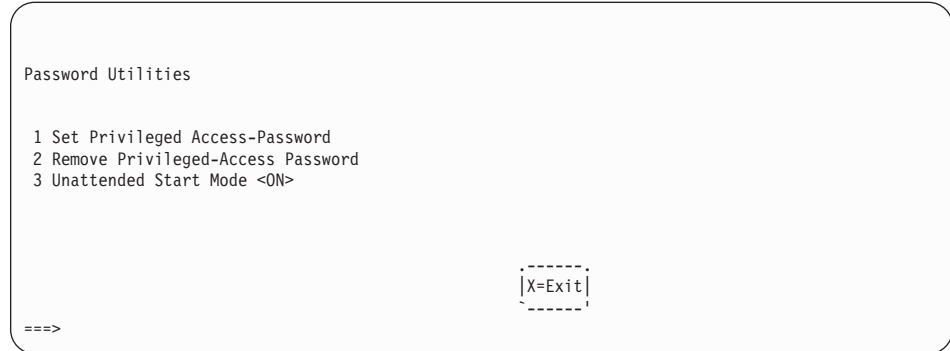

Set Privileged-Access Password: The privileged-access password protects against the unauthorized starting of the system programs. When this option is selected, another screen displays that allows the setting of a password.

You can set the password from either the service processor or System Management Services menus. After the password is set, both the service processor and System Management Services automatically use the same password. The password is limited to eight characters.

Remove Privileged-Access Password: If you previously had set a privileged-access password and want to remove it, select **Remove Privileged-Access Password**.

Note: If you *forget* your password, you must shut down the system and remove the battery for at least 30 seconds.

Unattended Start Mode <ON>: This selection is used to enable or disable unattended start mode. Use this option to instruct the service processor to restore the power state of the server after a temporary power failure, which is necessary on servers that require automatic power-on after a power failure. The default setting is ON.

Display Error Log

A screen similar to the following displays when you select this option. You can view or clear your system error log.

```

                                Error Log
-----
      Date      Time      ErrorCode  Location
Entry 1. 99/06/30 02:15:35 25a80011  U1.1-P1.1/Q1
Entry 2. 99/07/01 03:18:36 20300026  U1.1-P1.1/Q1
-----

[C=Clear Error Log]                [X=Exit Log ]

```

Note: The time stamp in this error log is Coordinated Universal Time (UCT), which is also referred to as Greenwich Mean Time (GMT). The AIX error log has more information available and time stamps with your local time.

Remote Initial Program Load Setup

This option allows you to enable and set up the remote startup of your system. You must first specify the network parameters as shown in the following screen:

```

Network Parameters
1. IP Parameters
2. Adapter Parameters
3. Ping

                                [X=Exit ]
-----
====>

```

Note: Some applications may require that IP addresses contain leading zeroes for numbers less than 100. For example, 129.132.4.20 may need to be entered as 129.132.004.020.

IP Parameters

Select the **IP Parameters** option from the Network Parameters menu to display a screen similar to the following:

```
IP Parameters

1. Client IP Address  [9.3.146.162]
2. Server IP Address [9.3.146.171]
3. Gateway IP Address [0.0.0.0]
4. Subnet Mask       [255.255.255.0]

[X=Exit]

==>
```

To set an address using this menu, do the following:

1. Type the number of the selection (1, 2, 3, or 4).
2. Enter the address on the next screen.

Attention: If the client system and the server are on the same subnet, set the gateway IP address to [0.0.0.0].

Adapter Parameters

Select the **Adapter Parameters** option from the Network Parameters menu to view an adapter's hardware address, as well as configure network adapters that require setup. A screen similar to the following displays when you make this selection:

Adapter Parameters		
Device	Slot	Hardware Address
1. Gigabit Ethernet	4: P1-I4/E1	0004ac7c0135
2. token-ring	5: P1-I5/T1	0020357a9105
3. ethernet	Integrated:P1/E1	0060949d7ac5
4. ethernet	2: P1-I2/E1	0004ac5e692b
5. token-ring	3: P1-I3/T1	0004ac634e38

[X=Exit]

(PRESS ENTER AFTER MAKING A SELECTION) ==>

Select an adapter on this screen to display configuration menus for that adapter. If ethernet is selected, you can set parameters that control how the ethernet adapter communicates with the network. For example, the following screen shows the menu for the ethernet adapter configuration:

1. Data Rate [Auto]
2. Full Duplex [No]

Ping

Select **Ping** from the Network Parameters menu to test a connection to a remote system unit. After selecting the ping option, you must first choose an adapter to communicate with the remote system.

Adapter Parameters

Device	Slot	Hardware Address
1. Gigabit Ethernet	4: P1-I4/E1	0004ac7c0135
2. token-ring	5: P1-I5/T1	0020357a9105
3. ethernet	Integrated:P1/E1	0060949d7ac5
4. ethernet	2: P1-I2/E1	0004ac5e692b
5. token-ring	3: P1-I3/T1	0004ac634e38

[X=Exit]

(PRESS ENTER AFTER MAKING A SELECTION) ==>

After determining which adapter to use to ping the remote system, you must provide the addresses needed to communicate with the remote system. Select the appropriate device from the Ping menu to display a screen similar to the following:

PING IP Address

1. Client IP Address	[9.3.146.162]
2. Server IP Address	[9.3.146.171]
3. Gateway IP Address	[0.0.0.0]
4. Subnet Mask	[0.0.0.0]

[E=Execute] [X=Exit]

==>

SCSI Utilities

SCSI Utilities allow you to set delay times for the SCSI hard disk spin-up and to set SCSI IDs for SCSI controllers installed in the system.

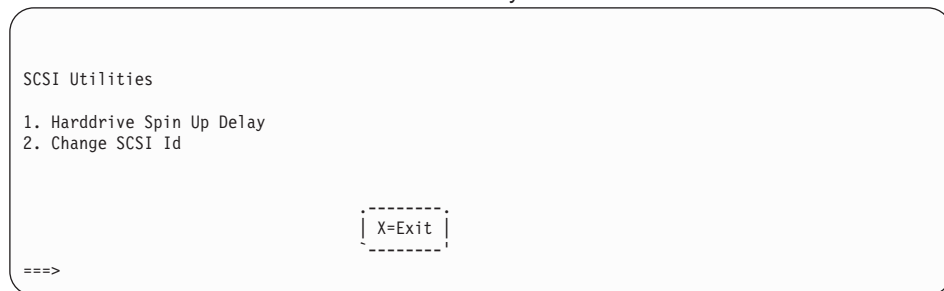

Using the Harddrive Spin Up Delay option allows you to change the spin up delay time for SCSI hard disk drives attached to your system. Spin up delay values can be entered manually, or you can use a default setting (two seconds). All values are measured in seconds.

Attention: Setting the value lower than the default can prevent successful booting because the system power handling capabilities might be exceeded. If the system no longer boots after setting this value, access this utility again and increase the value. It is also possible that adding disk drives can cause similar symptoms. Changing this value changes the surge current requirements on the system. As you increase the value, the surge current requirements on the system are decreased.

Select Console

Select this option to define which display is used by the system for system management. If no console is selected, the console defaults to serial port 1.

Selecting this option causes a screen similar to the one that follows to display on each console that can be used as a firmware console. Follow the instructions on the screen to select a particular console.

Note: The firmware console is independent from the AIX console.

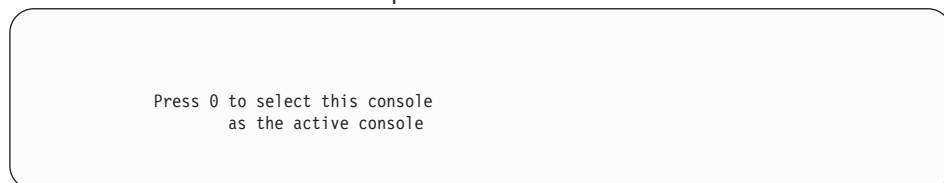

MultiBoot

Multiboot allows you to select a method for booting the system.

```
Multiboot
1  Select Software
2  Software Default
3  Select Install Device
4  Select Boot Devices
5  OK Prompt
6  Multiboot Startup <OFF>
```

```
|X=Exit|
```

```
===>
```

Select Software

If this option is supported by the operating system, the names of the operating system installed are shown. This option might not be supported by all operating systems.

If you are running AIX, and you receive the following message:

```
No Operating System Installed
```

This indicates that information in nonvolatile storage could have been lost, as would happen if the battery had been removed. To re-create this value, run the **bootlist** command under AIX with the appropriate parameters. See the **bootlist** command in your AIX documentation. The AIX Documentation library is available at the following Web address: <http://www-1.ibm.com/servers/aix/library/>. Select **Technical Publications**. AIX documentation is also contained on the AIX Documentation CD. The documentation is made accessible by loading the documentation CD onto the hard disk or by mounting the CD in the CD-ROM drive.

Software Default

If this option is supported by the operating system, you can select the default operating system to start the system. This option might not be supported by all operating systems.

Select Install Device

Produces a list of devices, such as the CD-ROM, from which the operating system may be installed. Select a device, and the system searches that device for an operating system to install.

Select Boot Devices

Select this option to view and change the custom boot list, which is the sequence of devices read at startup time. The boot list can contain up to five devices. The following is an example of this screen.

```
Select Boot Devices

1 Display Current Settings
2 Restore Default Settings
3 Configure 1st Boot Device
4 Configure 2nd Boot Device
5 Configure 3rd Boot Device
6 Configure 4th Boot Device
7 Configure 5th Boot Device

                                     |X=Exit|

====>
```

Display Current Settings

Lists the current order of devices in the boot list. The following is an example of this screen.

```
Current Boot Sequence

1. Diskette
2. SCSI CD-ROM ( loc=P1/Z1-A1 )
3. SCSI 9100 MB Harddisk ( loc=P1/Z1-A5 )
4. Ethernet ( loc=P1-I4/E1 )
5. None

                                     |X=Exit|

===>
```

Restore Default Settings

Restores the boot list to the following default sequence:

- Primary diskette drive
- CD-ROM drive
- Tape (if installed)
- Hard disk drive
- Network device

Selecting any of the **Configure Boot Device** options displays a screen similar to the following.

```
Configure Nth Boot Device

Device      Current      Device
Number      Position     Name
-----
1           1            Diskette
2           4            Ethernet ( loc=P1-I4/E1 )
3           -            Token-Ring ( loc=P1-I5/T1 )
4           2            SCSI CD-ROM ( loc=P1/Z1-A1 )
5           3            SCSI 9100 MB Harddisk ( loc=P1/Z1-A5 )

                                     [X=Exit]

===>
```

OK Prompt

Provides access to the open firmware command prompt.

This option should only be used by service personnel to obtain additional debug information.

Multiboot Startup <OFF>

Toggles between off and on to select whether Multiboot menu starts automatically on startup.

Select Language

Select this option to change the language used by the System Management Services screens and the service processor menus.

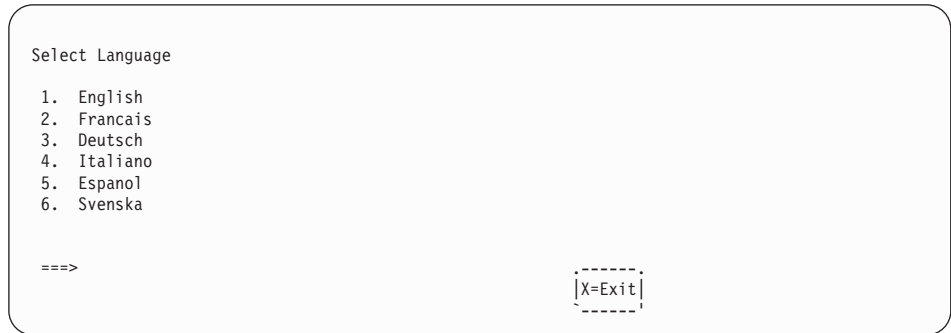

Note: To correctly display languages other than English, your ASCII terminal must support the ISO-8859 character set.

OK Prompt

This option provides access to the open firmware command prompt.

This option should only be used by service personnel to obtain additional debug information.

Exiting System Management Services

After you have finished using the System Management Services, type **x** at the utilities menu to exit the System Management Services and boot your system.

Chapter 9. Removal and Replacement Procedures

Before performing any of the removal or replacement procedures in this chapter, read the following notices.

DANGER

An electrical outlet that is not correctly wired could place hazardous voltage on metal parts of the system or the devices that attach to the system. It is the responsibility of the customer to ensure that the outlet is correctly wired and grounded to prevent an electrical shock.

Before installing or removing signal cables, ensure that the power cables for the system unit and all attached devices are unplugged.

When adding or removing any additional devices to or from the system, ensure that the power cables for those devices are unplugged before the signal cables are connected. If possible, disconnect all power cables from the existing system before you add a device.

Use one hand, when possible, to connect or disconnect signal cables to prevent a possible shock from touching two surfaces with different electrical potentials.

During an electrical storm, do not connect cables for display stations, printers, telephones, or station protectors for communications lines.

CAUTION:

This product is equipped with a three-wire power cable and plug for the user's safety. Use this power cable with a properly grounded electrical outlet to avoid electrical shock.

CAUTION:

This unit has more than one power supply cord. To reduce the risk of electrical shock, disconnect two power supply cords before servicing.

Handling Static-Sensitive Devices

Attention: Disk drives, tape drives, and CD-ROM drives are sensitive to static electricity discharge. These devices are wrapped in antistatic bags to prevent damage caused by electrostatic discharge.

Take the following precautions:

- If you have an antistatic wrist strap available, use it while handling the device.
- Do not remove the device from the antistatic bag until you are ready to install the device in the system unit.
- With the device still in its antistatic bag, touch it to a metal frame of the system.
- Grasp cards and boards by the edges. Hold drives by the frame. Avoid touching the solder joints or pins.
- If you need to lay the device down while it is out of the antistatic bag, lay it on the antistatic bag. Before picking it up again, touch the antistatic bag and the metal frame of the system unit at the same time.
- Handle the devices carefully in order to prevent permanent damage.

Powering Off and Powering On the System

This section provides procedures for powering off and powering on the system.

Powering Off the System

If the system is operating under AIX, type the **shutdown** command to power off the system.

If you cannot use this method, you can power off the system by using the following operator-panel power button procedure.

Attention: Using the primary I/O drawer operator-panel power button to power off the system might cause unpredictable results in the data files, and the next IPL will take longer to complete.

1. Open the rack door.

2. Press the power button on the primary I/O drawer operator panel.

The power LED on the primary I/O drawer operator panel starts blinking at a fast rate. B0FF appears in the primary operator panel display.

When the power-off sequence is complete, the system goes into standby mode, as evidenced by the following:

- 0K displays in the primary operator panel display.
- The primary I/O drawer operator-panel LED will start blinking at a slow rate.
- The CEC drawer power LED will start blinking at a slow rate.
- If a secondary I/O drawer is present, its power LED will go off.

3. Disconnect the ac power cords from the drawers.

Powering On the System

Perform the following steps to power on the CEC drawer and attached I/O drawers.

1. Open the rack door. Look for 0K in the primary operator panel display, which indicates that the system is in standby mode.

2. Press the power button on the primary I/O drawer operator panel.

The power LED on the primary I/O drawer operator panel starts blinking at a fast rate. 9xxx checkpoints appear in the operator panel display.

When the power-on sequence is complete:

- The power LED on the primary I/O drawer operator panel stops blinking and stays on.
- The power LED on the CEC drawer stops blinking and stays on.
- If a secondary I/O drawer is present, its power LED comes on and stays on.

Powering Off and Powering On the System Using the Service Processor

The system can be powered off and on using the System Power Control menu, which is a Service Processor menu that is available to the privileged user. See "System Power Control Menu" on page 378.

Hot-Pluggable FRUs

Note: You do not have to power off the system to remove a hot-pluggable FRU from the CEC drawer or from I/O drawers.

The following FRUs are hot-pluggable:

- Hot-pluggable PCI adapters of an I/O drawer
- Power supplies in an I/O drawer or CEC drawer (if the drawer has two power supplies and only one needs to be removed)
- Rear fans on the CEC drawers

I/O Drawer PCI Slot LED Definitions

The following table describes the possible states of the LEDs associated with the I/O drawer PCI slots. These LEDs are located at the rear of the I/O drawer. One LED is associated with each PCI slot.

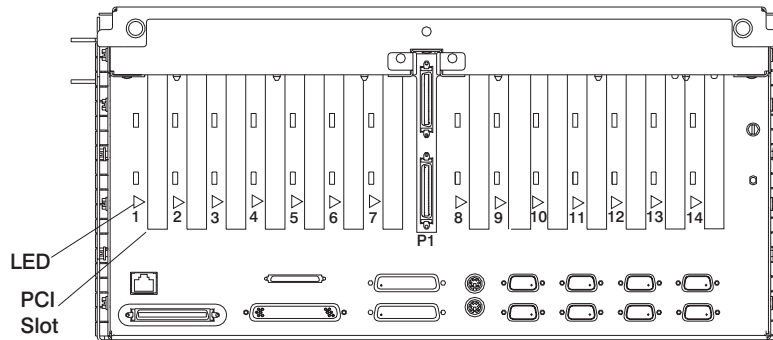

LED Indication	PCI Slot Status	Definition
Off	Off	Slot power is off. It is safe to remove or replace an adapter.
On (not flashing)	On	Slot power is on. Do not remove or replace an adapter.
Flashing slowly (one flash per second)	Identify	Indicates slot has been identified by the software. Do not remove or replace an adapter at this time.
Flashing fast (six to eight flashes per second)	Action	Indicates slot is ready for removal or replacement of an adapter.

PCI Adapters

With this system, you can install PCI adapters with the power on. These adapters are referred to as *hot-pluggable PCI adapters*. Some adapters are not hot-pluggable and power must be removed from the system for adapter installation.

Before you install the adapter, determine if the PCI adapter you are installing is hot-pluggable. See the *PCI Adapter Placement Reference*, order number SA38-0538.

If you are removing a PCI adapter that is:

- Not hot-pluggable, go to “Non-Hot-Pluggable PCI Adapter”.
- Hot-pluggable, go to “Hot-Pluggable PCI Adapter” on page 433.

Non-Hot-Pluggable PCI Adapter

Removal

To remove an adapter, perform the following steps:

1. Turn power off and unplug the system unit power cable from the electrical outlet.
If the system is operating under AIX, type the shutdown command to power off the system.

If you cannot use this method, you can power off the system by using the following operator-panel power button procedure.

Attention: Using the primary I/O drawer operator-panel power button to power off the system may cause unpredictable results in the data files, and the next IPL will take longer to complete.

- a. Open the rack door.
- b. Press the power button on the primary I/O drawer operator panel.

The primary I/O drawer operator panel Power LED starts blinking at a fast rate. B0FF appears in the primary operator panel display.

When the power-off sequence is complete, the system will go into standby mode, as evidenced by:

- 0K displays in the primary operator panel display.
 - The primary I/O drawer operator panel LED will start blinking at a slow rate.
 - The CEC drawer power LED will start blinking at a slow rate.
2. Place the I/O drawer in the rear service position, as follows:
 - a. If you have not already done so, open the front door of the rack unit.
 - b. Loosen the two thumbscrews that attach the front bezel to the drawer.
 - c. Grasp both sides of the front bezel and pull the bezel off the drawer.
 - d. If you have not already done so, open the rear door of the rack unit.
 - e. If present, remove the two retaining screws that secure the drawer to the rails.
 - f. Ensure that the cables do not restrain drawer movement.
 - g. Grasp the bar at the rear of the drawer, and pull the drawer to the rear until it is stopped by the two detents on the top of the drawer.

3. Remove the two thumbscrews, and remove the top cover from the drawer.
4. Determine the slot from which you are removing the adapter.
5. Disconnect any cables that are connected to the adapter being removed.
6. Turn the locking latch and lift the plastic stop for the adapter.
7. Carefully grasp the adapter by the edges and pull it straight out from the I/O board.
8. If you are installing another adapter in this slot, follow the instructions given under "Replacement" below.
9. If you are not installing another adapter in this slot, place a blank slot cover in the adapter slot and then lower the plastic stop over the adapter bracket. Rotate the locking latch clockwise until it clicks into the locked position.
10. Install all covers that you removed earlier and return the drawer to the normal operating position.

Replacement

To replace an adapter, perform the removal steps in the reverse order.

Hot-Pluggable PCI Adapter

Replacing a Hot-Pluggable PCI Adapter

Note: Use this procedure only when you are replacing an adapter with an identical adapter. If you are replacing an adapter with an adapter that is not identical to the adapter removed, go to “Removing a Hot-Pluggable PCI Adapter” on page 436 and “Installing a Hot-Pluggable PCI Adapter” on page 435.

To replace an adapter, perform the following steps:

1. Place the I/O drawer in the rear service position:
 - a. If you have not already done so, open the front door of the rack unit.
 - b. Loosen the two thumbscrews that attach the front bezel to the drawer.
 - c. Grasp both sides of the front bezel and pull the bezel off the drawer.
 - d. If you have not already done so, open the rear door of the rack unit.
 - e. If present, remove the two retaining screws that secure the drawer to the rails. Refer to “Rear Service Position” on page 467.
 - f. Ensure that the cables do not restrain drawer movement.
 - g. Grasp the bar at the rear of the drawer, and pull the drawer to the rear until it is stopped by the detents.
2. Remove the two thumbscrews, and remove the top cover from the drawer.
3. Determine the slot from which you are removing the adapter.
4. Ensure that any processes or applications that might use the adapter are stopped.

Note: Removing a hot-pluggable PCI adapter requires the system administrator to take the PCI adapter offline before performing any PCI adapter hot-plug procedures. Before taking an adapter offline, the devices attached to the adapter must be taken offline as well. This action prevents a service representative or user from causing an unexpected outage for system users.

For additional information about taking an adapter offline or removing it from the system configuration, see the *AIX System Management Guide: Operating System and Devices*. This publication is available at the following Web address: <http://www-1.ibm.com/servers/aix/library/>. Select **Technical Publications**. This publication is also contained on the AIX Documentation CD. The documentation is made accessible by loading the documentation CD onto the hard disk or by mounting the CD in the CD-ROM drive.

5. Refer to “PCI Hot-Plug Manager Access” on page 438, and follow the steps in the access procedure to select **PCI Hot Plug Manager**. Then return here to continue.
6. Select **Unconfigure a Device** and press Enter.

Note: If the adapter or device has a problem that prevents it from replacement by hot swap, it must be replaced non hot swap by shutting down the system. Go to the *RS/6000 and @server pSeries Diagnostics Information for Multiple Bus Systems Map 210 - 3*.

7. Press F4 to display the Device Names menu.
8. Select the adapter you are removing from the menu.
9. Answer YES to **Keep Definition**. Press Enter.
10. The ARE YOU SURE screen displays. Press Enter to verify the information. Successful unconfigure is indicated by the OK message displayed next to the **Command** field at the top of the screen.
11. Press F3 to return to the PCI Hot-Plug Manager menu.
12. Select **Replace/Remove a PCI Hot-Plug Adapter** and press Enter. The Replace/Remove a PCI Hot-Plug Adapter menu displays.
13. Move the cursor to select the adapter that you are removing and press Enter.
14. Press the Tab key until the entry field displays the replace operation and then Press the Enter key. Follow the instructions that display on the screen until you are instructed to remove the adapter.
15. When you are instructed to remove the adapter from the adapter slot, disconnect any cables that are connected to the adapter being removed.
16. Turn the locking latch and lift the plastic stop for the adapter.
17. Carefully grasp the adapter by the edges and pull it straight out from the I/O board.
18. Replace the adapter in the adapter slot. Carefully grasp the adapter by the edges and align the adapter in the slot guides. Insert the adapter fully into the adapter slot connector. If you are installing a full-length adapter, ensure that both ends of the adapter engage the card guides.
19. Lower the plastic stop over the adapter bracket and rotate the locking latch clockwise until it clicks into the locked position. Some full-length cards can be supported by rotating the blue adapter latch on the right end of the adapter counterclockwise.
20. Connect appropriate cables and devices to the adapter.
21. Continue to follow the screen instructions until you receive a message that the replacement is successful. Successful replacement is indicated by the OK message displayed next to the **Command** field at the top of the screen.
22. Press the F3 key to return to the PCI Hot-Plug Manager menu.
23. Select **Install/Configure Devices Added After IPL** and press Enter. Then follow the instructions on the screen. Successful replacement is indicated by the OK message displayed next to the **Command** field at the top of the screen.
24. If you do not have other adapters to replace, continue with the next step.
OR
If you have other adapters to replace, press the F3 key to return to the PCI Hot-Plug Manager menu and then return to step 12.
25. Press F10 to exit the Hot-Plug Manager.

If you have added, removed, or replaced any adapters, run the **diag -a** command. If the system responds with a menu or prompt, follow the instructions to complete the device configuration.

26. Install the covers that you removed earlier and return the drawer to the normal operating position.

Installing a Hot-Pluggable PCI Adapter

To install an adapter, perform the following steps:

1. Place the I/O drawer in the rear service position:
 - a. If you have not already done so, open the front door of the rack unit.
 - b. Loosen the two thumbscrews that attach the front bezel to the drawer.
 - c. Grasp both sides of the front bezel and pull the bezel off the drawer.
 - d. If you have not already done so, open the rear door of the rack unit.
 - e. If present, remove the two retaining screws at the rear of the drawer. Refer to “Rear Service Position” on page 467.
 - f. Ensure that the cables do not restrain drawer movement.
 - g. Grasp the bar at the rear of the drawer, and pull the drawer to the rear until it is stopped by the detents.
2. Remove the two thumbscrews and remove the top cover from the drawer.
3. Refer to “PCI Hot-Plug Manager Access” on page 438 and follow the steps in the access procedure to select **PCI Hot Plug Manager**. Then return here to continue.
4. From the PCI Hot-Plug Manager menu, select **Add a PCI Hot-Plug Adapter** and press Enter. The Add a Hot-Plug Adapter window displays.
5. See the *PCI Adapter Placement Reference*, order number SA38-0538, for adapter placement information. Then select an empty PCI slot for the adapter.
6. Select the appropriate empty PCI slot from the ones listed on the screen, and press Enter.
7. Turn the locking latch, lift the plastic stop, and remove the blank cover.
8. Follow the instructions on the screen to install the adapter until the visual indicator (LED) for the specified PCI slot is set to the Action state. See “I/O Drawer PCI Slot LED Definitions” on page 430.
9. When you are instructed to install the adapter in the adapter slot, carefully grasp the adapter by the edges and align the adapter in the slot guides. Insert the adapter fully into the adapter slot connector. If you are installing a full-length adapter, ensure that both ends of the adapter engage the card guides.
10. Lower the plastic stop over the adapter bracket and rotate the locking latch clockwise until it clicks into the locked position. Some full-length cards can be supported by rotating the blue adapter latch on the right end of the adapter counterclockwise.
11. Connect appropriate cables and devices to the adapter.
12. Continue to follow the screen instructions until you receive a message that the installation is successful. Successful installation is indicated by the OK message displayed next to the **Command** field at the top of the screen.
13. Press the F3 key to return to the PCI Hot-Plug Manager menu.

14. Select **Install/Configure Devices Added After IPL** and press Enter. Then follow the instructions on the screen. Successful installation is indicated by the OK message displayed next to the **Command** field at the top of the screen.
15. If you do not have other adapters to install, continue with the next step.
OR
If you have other adapters to install, press the F3 key to return to the PCI Hot-Plug Manager menu and then return to step 4 on page 435.
16. Press F10 to exit the Hot-Plug Manager.
If you have added, removed, or replaced any adapters, run the **diag -a** command. If the system responds with a menu or prompt, follow the instructions to complete the device configuration.
17. Install the covers that you removed earlier and return the drawer to the normal operating position.

Removing a Hot-Pluggable PCI Adapter

Note: If you are removing an adapter and replacing it with an adapter that is identical to the adapter removed, see “Replacing a Hot-Pluggable PCI Adapter” on page 433

To remove an adapter, perform the following steps:

1. Place the I/O drawer in the rear service position:
 - a. If you have not already done so, open the front door of the rack unit.
 - b. Loosen the two thumbscrews that attach the front bezel to the drawer.
 - c. Grasp both sides of the front bezel and pull the bezel off the drawer.
 - d. If you have not already done so, open the rear door of the rack unit.
 - e. If present, remove the two retaining screws that secure the drawer to the rails. Refer to “Rear Service Position” on page 467.
 - f. Ensure that the cables do not restrain drawer movement.
 - g. Grasp the bar at the rear of the drawer, and pull the drawer to the rear until it is stopped by the detents.
2. Remove the two thumbscrews and remove the top cover from the drawer.
3. Determine the slot from which you are removing the adapter.
4. Ensure that any processes or applications that might use the adapter are stopped.

Note: Removing a hot-pluggable PCI adapter requires the system administrator to take the PCI adapter offline before performing any PCI adapter hot-plug procedures. Before taking an adapter offline, the devices attached to the adapter must be taken offline as well. This action prevents a service representative or user from causing an unexpected outage for system users.

For additional information about taking an adapter offline or removing it from the system configuration, see the *AIX System Management Guide: Operating System and Devices*. This publication is available at the following

Web address: <http://www-1.ibm.com/servers/aix/library/>. Select **Technical Publications**. This publication is also contained on the AIX Documentation CD. The documentation is made accessible by loading the documentation CD onto the hard disk or by mounting the CD in the CD-ROM drive.

5. Refer to “PCI Hot-Plug Manager Access” on page 438, and follow the steps in the access procedure to select **PCI Hot Plug Manager**. Then return here to continue.
6. Select **Unconfigure a Device** and press Enter.
7. Press F4 to display the Device Names menu.
8. Select the adapter you are removing from the menu.
9. Use the Tab key to answer NO to **Keep Definition**. Press Enter.
10. The ARE YOU SURE screen displays. Press Enter to verify the information. Successful unconfigure is indicated by the OK message displayed next to the **Command** field at the top of the screen.
11. Press F3 to return to the PCI Hot-Plug Manager menu.
12. Select **Replace/Remove a PCI Hot-Plug Adapter** and press Enter. The Replace/Remove a PCI Hot-Plug Adapter menu displays.
13. Move the cursor to select the adapter that you are removing and press Enter. (The description entry displays as unknown).
14. Press the Tab key until the entry field displays the remove operation and then Press the Enter key. Follow the instructions that display on the screen until you are instructed to remove the adapter.
15. When you are instructed to remove the adapter from the adapter slot, disconnect any cables that are connected to the adapter being removed.
16. Turn the locking latch and lift the plastic stop for the adapter.
17. Carefully grasp the adapter by the edges and pull it straight out from the I/O board.
18. If you are not installing another adapter in this slot, place a blank slot cover in the adapter slot and then lower the plastic stop over the adapter bracket. Rotate the locking latch clockwise until it clicks into the locked position.
19. Continue to follow the screen instructions until you receive a message that the adapter removal is successful. Successful removal is indicated by the OK message displayed next to the **Command** field at the top of the screen.
20. If you do not have other adapters to remove, continue with the next step.
OR
If you have other adapters to remove, press the F3 key to return to the PCI Hot-Plug Manager menu and then return to step 12.
21. Press F10 to exit the Hot-Plug Manager.
22. If you have added, removed, or replaced any adapters, run the **diag -a** command. If the system responds with a menu or prompt, follow the instructions to complete the device configuration.
23. Install the covers that you removed earlier and return the drawer to the normal operating position.

PCI Hot-Plug Manager Access

The installation instructions for hot-pluggable PCI adapters refer you to these procedures when it is appropriate to perform them.

Note: A PCI adapter is only hot-pluggable if the PCI adapter is supported for hot-plug applications. See the *PCI Adapter Placement Reference*, order number SA38-0538.

Accessing Hot-Plug Management Functions

Note: Removing or installing a Hot-Pluggable PCI adapter requires the system administrator to take the PCI adapter offline prior to performing the operation. Before taking an adapter offline, the devices attached to the adapter must be taken offline as well. This action prevents a service representative or user from causing an unexpected outage for system users.

For additional information about taking an adapter offline or removing it from the system configuration, see the *AIX System Management Guide: Operating System and Devices*. This publication is available at the following Web address: <http://www-1.ibm.com/servers/aix/library/>. Select **Technical Publications**. This publication is also contained on the AIX Documentation CD. The documentation is made accessible by loading the documentation CD onto the hard disk or by mounting the CD in the CD-ROM drive.

To access the hot-plug menus, do the following:

1. Log in as root user.
2. At the command line, type `smitty`.
3. Select **Devices**.
4. Select **PCI Hot Plug Manager** and press Enter.
5. The PCI Hot-Plug Manager menu displays. Return to the procedure that directed you here. The following section describes the menu options.

PCI Hot-Plug Manager Menu

The following options are available from the PCI Hot Plug Manager menu:

Note: For information about the PCI slot LED states, see “I/O Drawer PCI Slot LED Definitions” on page 430.

List PCI Hot-Plug Slots

Provides a descriptive list of all slots that support PCI hot-plug capability. If the listing for a slot indicates it holds an “Unknown” device, select the **Install/Configure Devices Added after IPL** to configure the adapter in that slot.

Add a PCI Hot-Plug Adapter

Allows the user to add a new PCI hot-plug-capable adapter to the slot with the system turned on. You will be asked to identify the PCI slot that you have selected prior to the actual operation. The selected PCI slot will go into the Action state and finally into the On state.

Note: The system will indicate the slot holds an “Unknown” device until you perform the **Install/Configure Devices Added After IPL** option to configure the adapter.

Replace/Remove a PCI Hot-Plug Adapter

Allows the user to remove an existing adapter, or replace an existing adapter with an identical one. For this option to work, the adapter must be in the Defined state (see “Unconfigure a Device” option below).

You will be asked to identify the PCI slot prior to the actual operation. The selected PCI slot will go into the Action state.

Identify a PCI Hot-Plug Slot

Allows the user to identify a PCI slot. The selected PCI slot will go into the Identify state. See “I/O Drawer PCI Slot LED Definitions” on page 430.

Unconfigure a Device

Allows the user to put an existing PCI adapter into the Defined state if the device is no longer in use.

This step must be completed successfully before starting any removal or replacement operation. If this step fails, the customer must take action to release the device.

Configure a Defined Device

Allows a new PCI adapter to be configured into the system if software support is already available for the adapter. The selected PCI slot will go into the On state.

Install/Configure Devices Added After IPL

The system attempts to configure any new devices and tries to find and install any required software from a user-selected source.

The add, remove, and replace functions return information to the user indicating whether the operation was successful. If additional instructions are provided on the screen, complete the recommended actions. If the instructions do not resolve the problem, do the following:

- If the adapter is listed as Unknown, perform the **Install/Configure Devices Added After IPL** option to configure the adapter.

- If you receive a warning indicating that needed device packages are not installed, the system administrator must install the specified packages before you can configure or diagnose the adapter.
- If you receive a failure message indicating a hardware error, the problem might be either the adapter or the PCI slot. Isolate the problem by retrying the operation in a different PCI slot, or trying a different adapter in the slot. If you determine that you have failing hardware, call your service representative.

Memory Riser Cards and Memory DIMMs

Removal

1. Turn off power as described in “Powering Off the System” on page 429.
2. Place the CEC drawer in the rear service position as described in “Rear Service Position” on page 467.
3. Remove the two thumbscrews and remove the back top cover.

Note: If your system has a one-way processor installed, the memory DIMMs are located on the processor card. You must first remove the processor card to access the memory DIMMs. Refer to “One-Way Processor Card Memory DIMM Locations” on page 22 for memory DIMM locations.

4. Pull up on the release latches and carefully pull the card out of the slot.

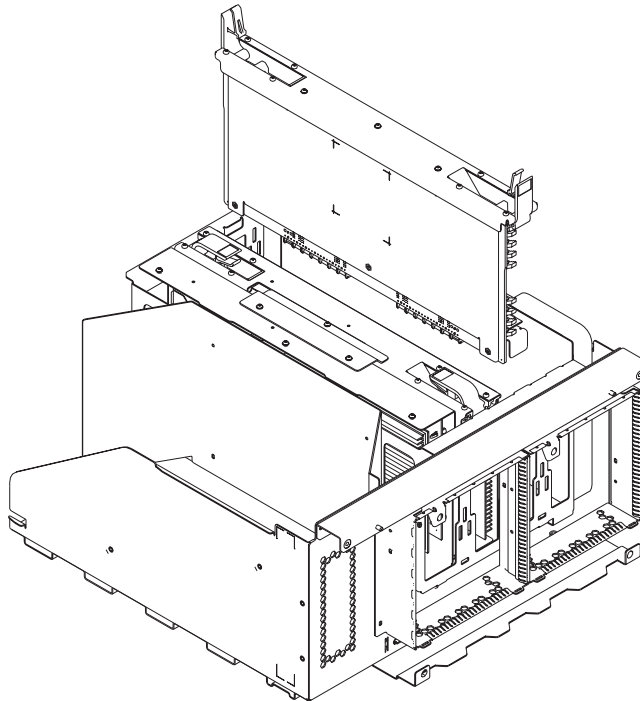

5. Locate the memory DIMM connectors and determine which memory DIMMs you want to remove. Refer to “Memory Riser Card and Memory DIMM Locations” on page 21 for memory module locations.

6. Remove the memory DIMM by pushing the tabs out on the memory connectors.

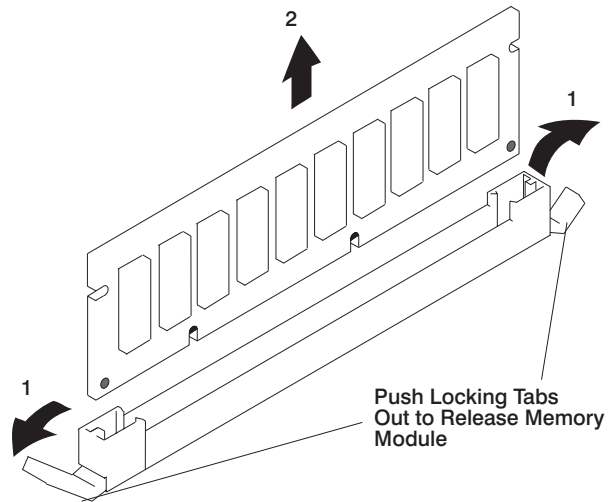

Replacement

1. With one hand, touch any metal surface of the chassis to minimize static electrical charges, and then pick up the memory DIMM.
2. Locate the memory DIMM connector on the memory card.
3. Insert the memory DIMM firmly into the connector.

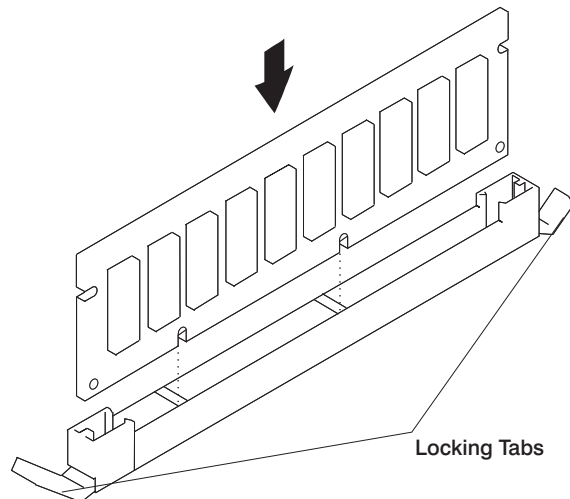

4. Secure the memory DIMM with the locking tabs located at each end of the connector.
5. Replace the memory card into the system unit.

Processor Card

Removal

1. Turn off power as described in “Powering Off the System” on page 429.
2. Place the CEC drawer in the rear service position as described in “Rear Service Position” on page 467.
3. Remove the two thumbscrews and remove the back cover.
4. Pull up on the release latches and carefully pull the card out of the slot.

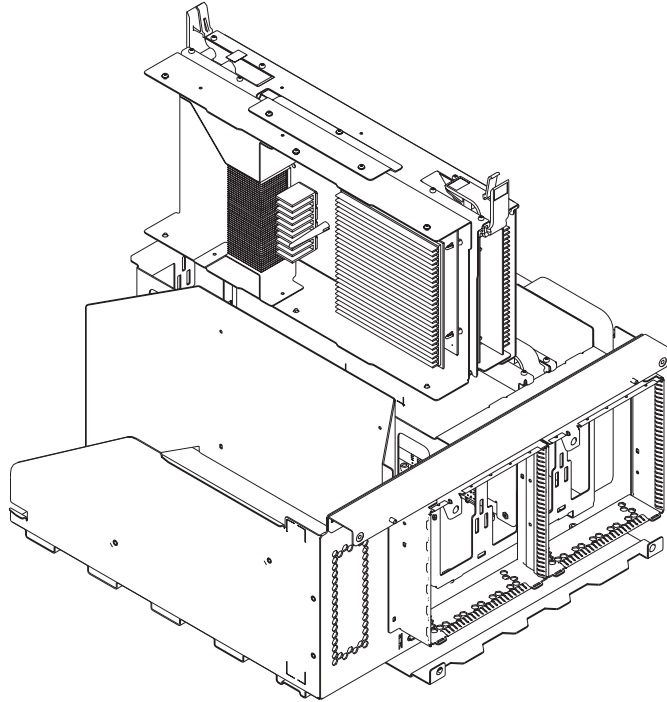

Replacement

Replace in reverse order.

CEC Fans

Removal

1. If you have not already done so, open the rear door of the rack unit.
2. Pull the snap button out on the fan you want to remove.

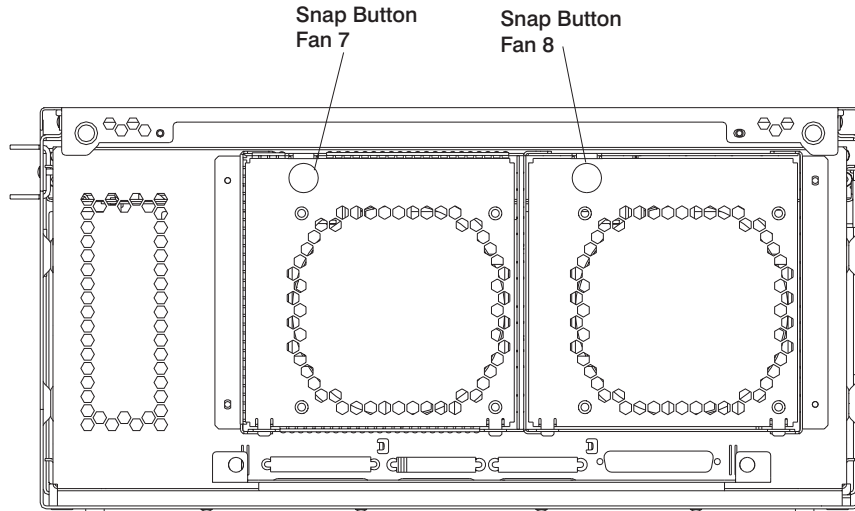

3. Remove the fan.

Replacement

Replace in reverse order.

Attention: After hot-plugging a CEC fan, wait at least 5 minutes and then examine the system error logs to make sure CEC fan errors are not being logged.

CEC Backplane

Removal

1. Turn off power as described in “Powering Off the System” on page 429.
2. Place the CEC drawer in the rear service position as described in “Rear Service Position” on page 467.
3. Disconnect and label all cables from the rear of the assembly.
4. Remove the two thumbscrews and remove the back cover.

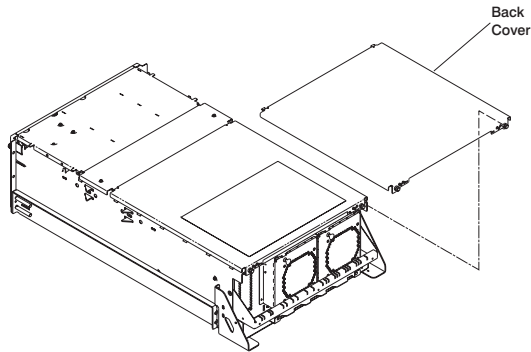

5. Remove the memory riser cards. See “Memory Riser Cards and Memory DIMMs” on page 441.
6. Remove the processor card. See “Processor Card” on page 443.
7. Remove the screws from the card cage assembly and remove the assembly.

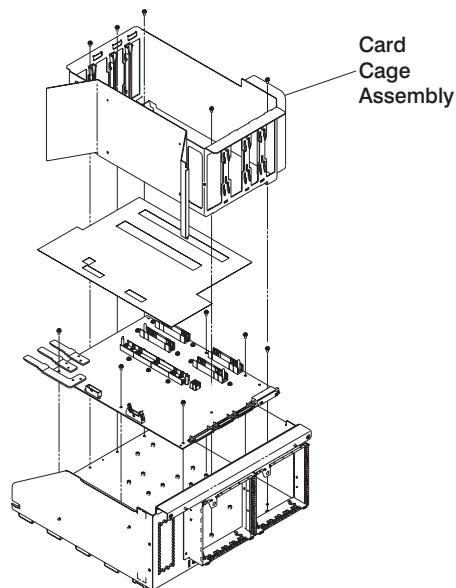

8. Remove the screws from the four backplane connectors (V/S COMM, RIO 1 & 2, and JTAG) at the rear of the backplane assembly.
9. Remove the screws from the backplane assembly and remove the backplane assembly.

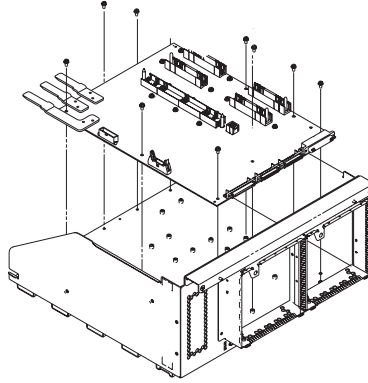

Replacement

Replace in reverse order.

I/O Drawer Backplane Assembly

Removal

Attention: If a primary I/O backplane is replaced, be aware that the service processor is integrated into the primary I/O backplane logic. Replacing the primary I/O backplane replaces the service processor.

1. Turn off power as described in “Powering Off the System” on page 429.
2. Place the I/O drawer in the rear service position as described in “Rear Service Position” on page 467.
3. Remove the two thumbscrews and remove the back cover.

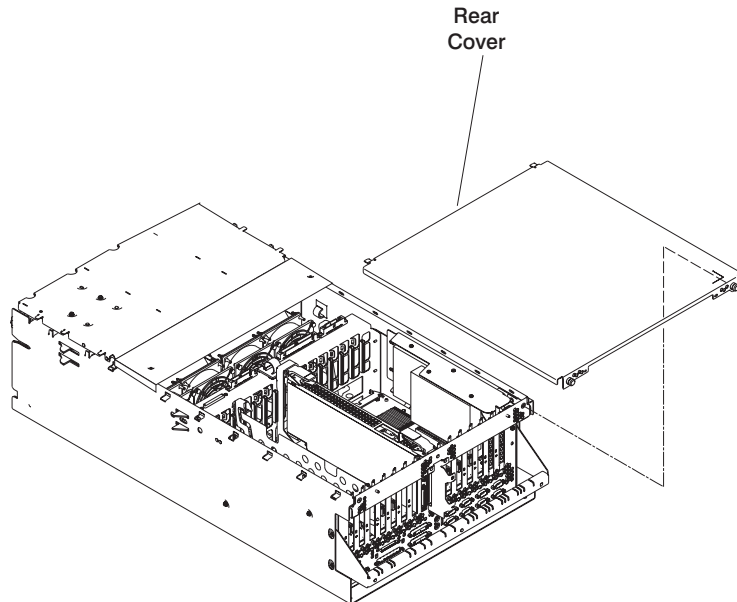

4. Disconnect and label all cables from the rear of the assembly.
5. Remove boot disk drives if installed. (See “Internal Disk Drives” on page 458.)
6. Remove and label adapters. (See “PCI Adapters” on page 431.)
7. Remove two screws from each side of the assembly.
8. Disconnect and label all cables from the front of the assembly.

- Slide the I/O drawer backplane assembly to the rear and remove the assembly.

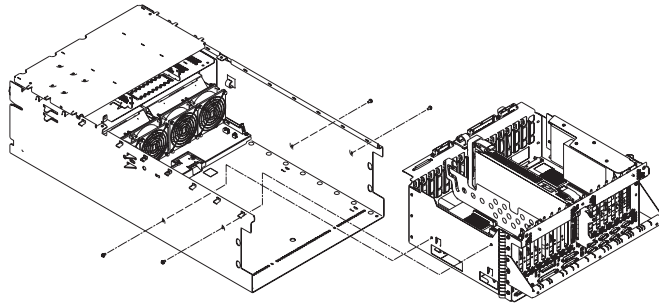

- Remove the RIO card assembly as described in “RIO Card Assembly” on page 449.

Replacement

- Replace in reverse order.
- Set the drawer type using the service processor menus.
 - From the SP Main Menu, select **System Information Menu** (option 3).
 - Select **Power Control Network Utilities Menu** (option 9).
 - Select **Change I/O Type** (option 3).
 - For the I/O drawer address (drawer number), type:
 - 1 for a primary drawer.
 - 2 for the secondary drawer.
 - For the I/O type, type:
 - 85 for the primary I/O drawer.
 - 84 for the secondary drawer.
- Check firmware level by checking the version on the title of the service processor main menu. If the firmware level is not at the correct level, proceed as follows:
 - Reprogram all system EPROMs using the Service Processor Setup Menu and selecting **Reprogram Flash EPROM Menu** option (7).
- The service processor settings have been set to default values. These settings must be restored to their original settings if they were not previously set to default values.
 - Manually reset all settings.
 - If the service processor settings had previously been saved, the settings may be restored using the procedure in “Saving and Restoring Service Processor Settings” on page 370.
 - Reset the bootlist using the SMS menus.
 - Reset the time-of-day clock using SMIT.

RIO Card Assembly

Removal

1. Turn off power as described in “Powering Off the System” on page 429.
2. Place the I/O drawer in the rear service position as described in “Rear Service Position” on page 467.
3. Remove the two thumbscrews and remove the back cover.

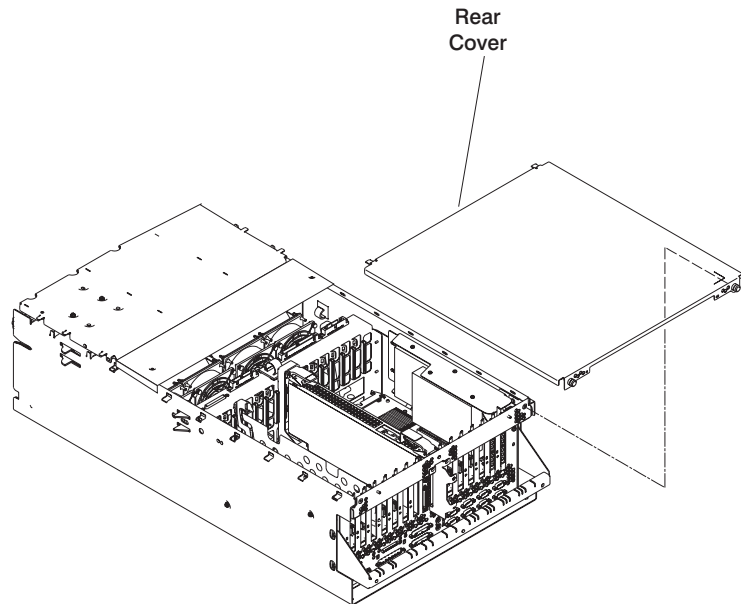

4. Disconnect all cables from the card assembly.
5. Remove the screw and remove the retainer bracket from the rear release latch.
6. Pull up on the release latches and carefully pull the card out of the slot.

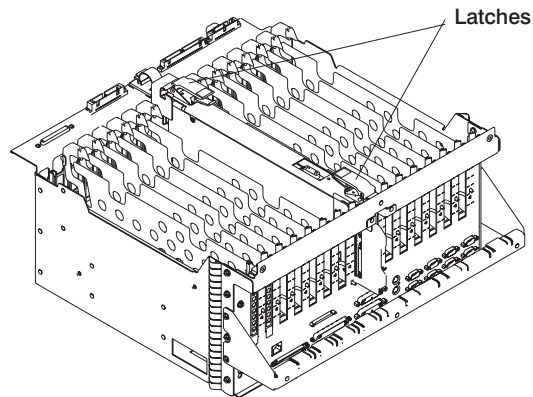

Replacement

Replace in reverse order.

CEC Drawer Power Distribution Board

Removal

1. Turn off power as described in “Powering Off the System” on page 429.
2. Remove the CEC backplane as described in “CEC Backplane” on page 445.
3. Place the CEC drawer in the front service position as described in “Front Service Position” on page 468.
4. Remove the power supplies as described in “Power Supplies and Power Supply Fan Assemblies” on page 454.
5. Loosen the two screws from the center cover and remove the cover.
6. Remove all the cables from the power distribution board.
7. Remove the screws from the power distribution board.

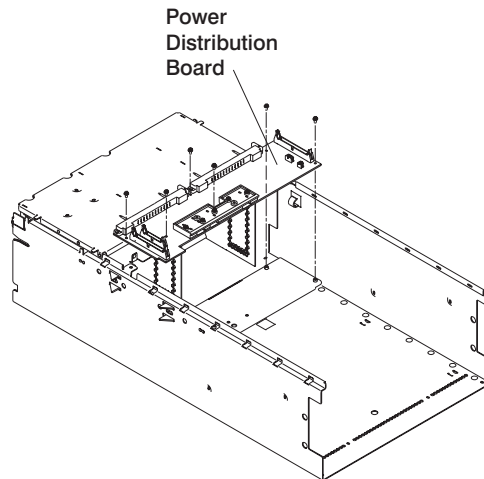

8. Remove the power distribution board.

Replacement

Replace in reverse order.

I/O Drawer Power Distribution Board

Removal

1. Turn off power as described in “Powering Off the System” on page 429.
2. Place the I/O drawer in the rear service position as described in “Rear Service Position” on page 467.
3. Remove the two thumbscrews and remove the rear cover.

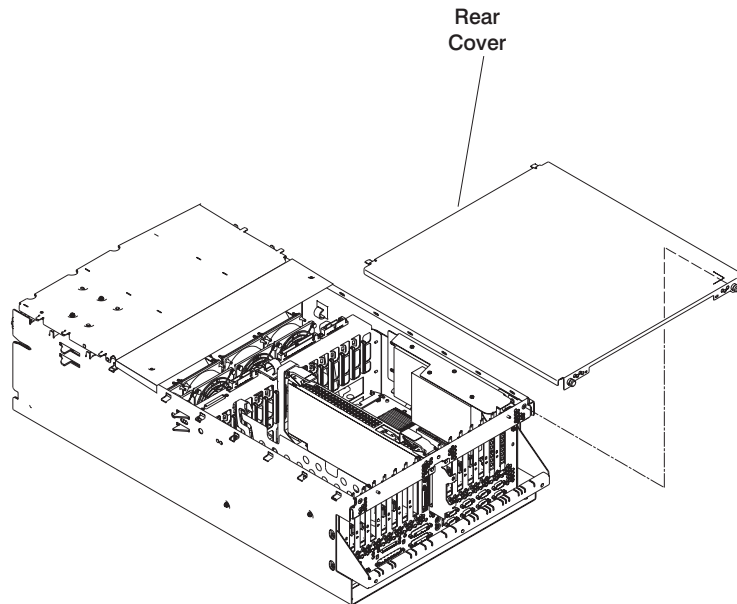

4. Remove any adapters or files installed in slots 12, 13, or 14.
5. Disconnect the four I/P cables from the I/O tray.
6. Remove the two screws from each side of the I/O drawer board assembly.
7. Disconnect the miscellaneous power cable from PCI board connector J21.
8. Slide the I/O drawer board assembly to the rear to disconnect the assembly from the power distribution board bus bar.
9. Place the I/O drawer in the front service position as described in “Front Service Position” on page 468.
10. Remove the power supplies as described in “Power Supplies and Power Supply Fan Assemblies” on page 454.

11. Loosen the two screws from the center cover and remove the cover.

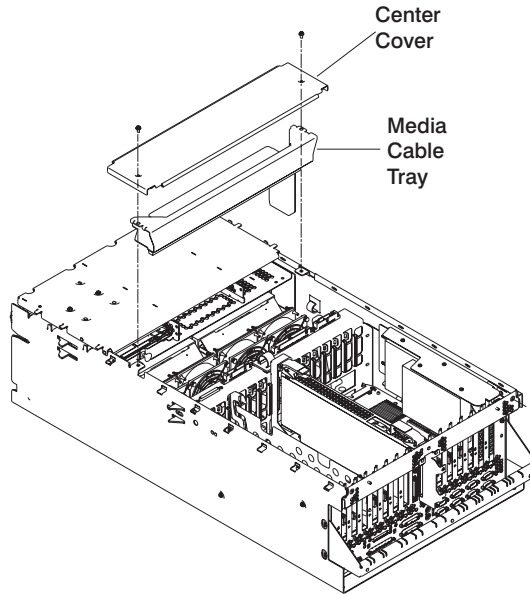

12. Remove the media cable tray.
13. Remove the screws from the power distribution board.

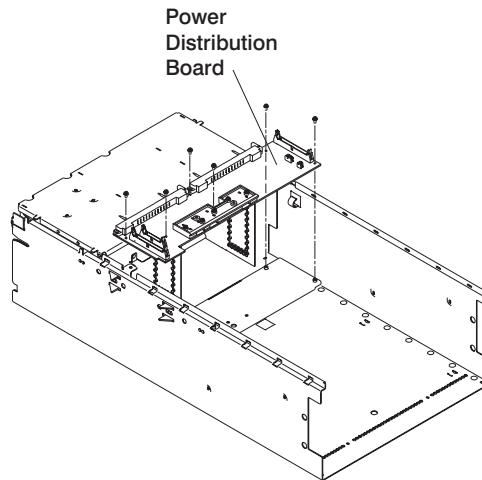

14. Remove the power distribution board.

Replacement

Replace in reverse order.

Power Supplies and Power Supply Fan Assemblies

Notes:

1. Each drawer can have up to two power supplies. You can replace each power supply separately. The removal and replacement procedures are the same for each power supply.
2. This procedure applies to the CEC and I/O drawer power supplies.
3. Power supplies for the CEC and I/O drawers cannot be interchanged.
4. If a drawer has two power supplies, each is hot-pluggable. If only one needs to be removed, you do not have to power off the system.
5. Each power supply has a test switch. See “Power Supply Test Switch Procedure” on page 457.
6. If your drawer has only one power supply, the unused power supply position must be filled with a cooling unit, which must have a power supply fan assembly attached to it.
7. Do not hot-plug a power supply if the ambient room temperature is greater than 32°C (90°F), as it can cause loss of data or data corruption.
8. Be sure that the replacement power supply (or cooling unit) is ready to install. If the power supply (or cooling unit) is removed for longer than four minutes, a **shutdown** command is issued to the operating system.
9. Power supply 1 fan assembly (fans 1 and 2) is located on the rear of the primary power supply. Power supply 2 fan assembly (fans 3 and 4) is located on the rear of the secondary power supply. If only one fan in a fan assembly is bad, the fan assembly must be replaced. Power supply fan 5 is located in the primary power supply and if that fan fails, the power supply must be replaced. Power supply fan 6 is located in the secondary power supply and if that fan fails, the power supply must be replaced. Fan 9 is located in the cooling unit.

Attention: After hot-plugging a power supply, wait at least 5 minutes and then examine the system error logs to make sure power supply or power supply fan errors are not being logged.

Removal

DANGER

Do not attempt to open the covers of the power supply. Power supplies are not serviceable and are to be replaced as a unit.

Attention: Be sure that the replacement power supply (or cooling unit) is ready to install. If the power supply (or cooling unit) is removed for longer than four minutes, a **shutdown** command is issued to the operating system.

1. If you have not already done so, open the front door of the rack unit.
2. Loosen the two thumbscrews that attach the front bezel to the drawer.
3. Grasp both sides of the front bezel and pull it off the drawer.
4. Unplug the power cord from the power supply you are removing.
5. Pull the snap button out on the power supply handle.
6. Grasp the handle of the power supply and pivot it downward.

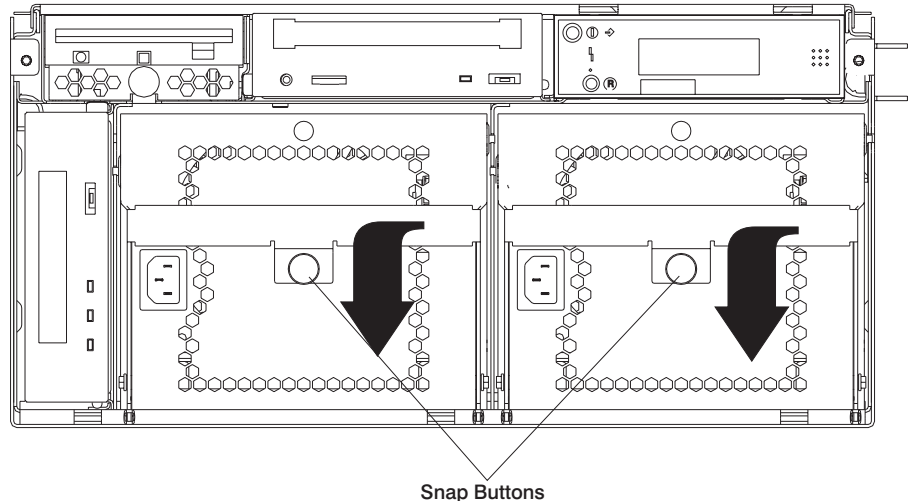

7. Pull the power supply out of the drawer.
8. Remove the external fan assembly from the power supply and save it for replacement.

9. Pull out on the snap button and remove the fan assembly from the power supply.

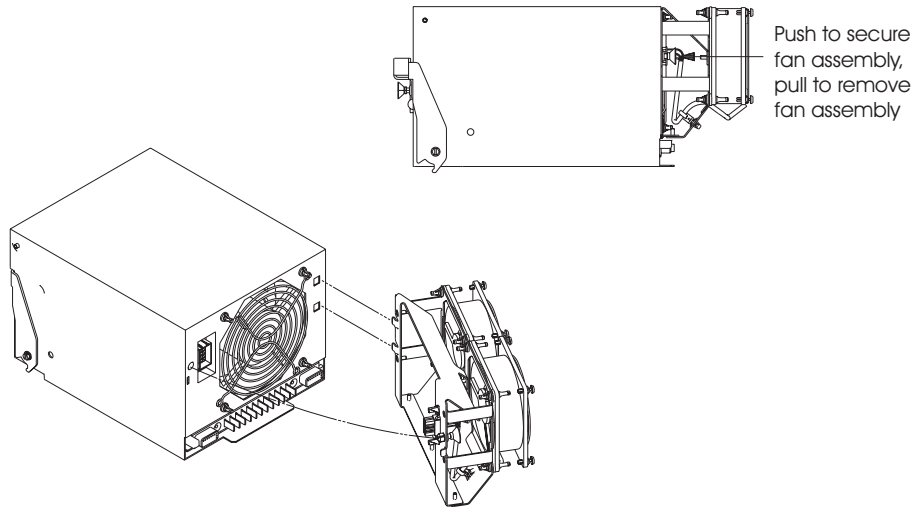

Replacement

Note: The power supply handle must be in the down position for replacement.

Replace in the reverse order.

Power Supply Test Switch Procedure

Before you replace a power supply, use this procedure to determine if the power supply needs replacing.

1. Perform steps 1 through 7 in “Power Supplies and Power Supply Fan Assemblies” on page 454.
2. Connect the power cord to the power supply and look at the front of the power supply.
 - If the LED on the front of the power supply is not blinking, the power supply is defective. Continue with step 8 in “Power Supplies and Power Supply Fan Assemblies” on page 454.
 - If the LED on the front of the power supply is blinking, go to the next step.

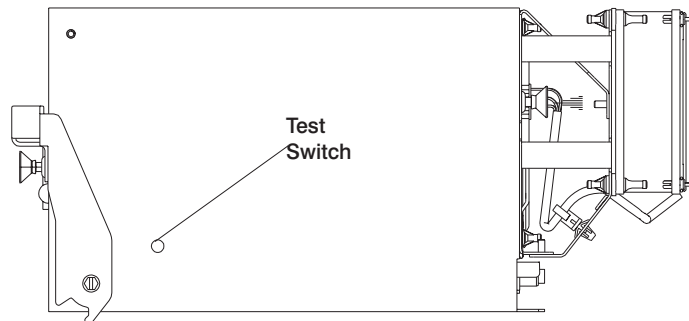

3. Use a pencil to press the test switch on the side of the power supply.
 - If the LED on the front of the power supply is on steady and the internal fan spins, the power supply is good and can be returned to the system.
 - If the LED on the front of the power supply is not on steady and the internal fan does not spin, the power supply is defective. Continue with step 8 in “Power Supplies and Power Supply Fan Assemblies” on page 454.

Internal Disk Drives

Removal

1. Turn off power as described in “Powering Off the System” on page 429.
2. Place the I/O drawer in the rear service position as described in “Rear Service Position” on page 467.
3. Remove the two thumbscrews and remove the back top cover.
4. Remove the screw from the back of the disk drive carrier.
5. Slide the carrier forward and remove. The carrier has keyed slots that engage mounting posts on the chassis.

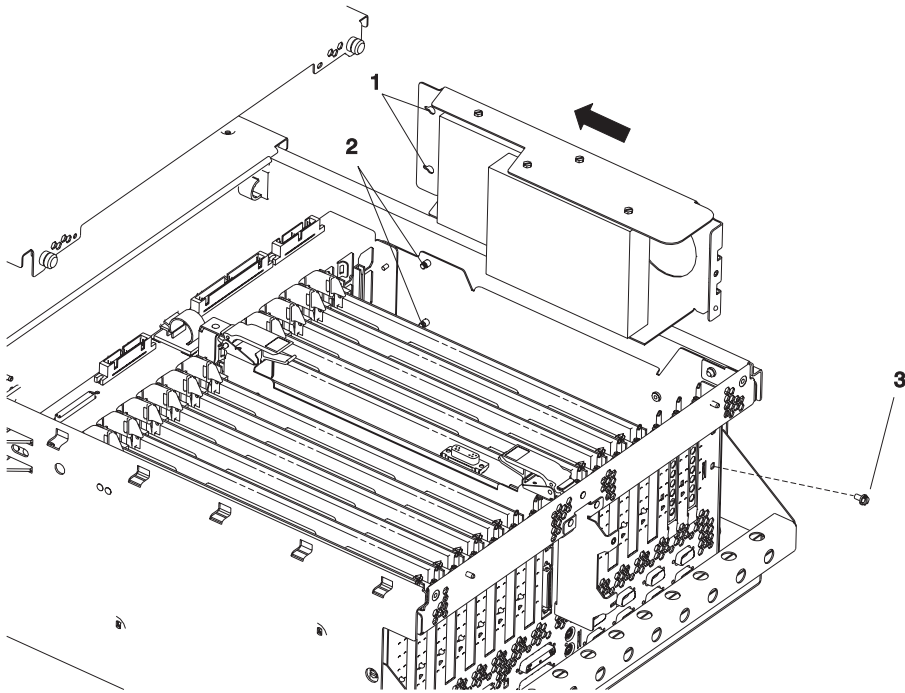

6. Make a note of how the disk drives are connected before disconnecting. Disconnect the internal cables from the drives.
7. If you are replacing a defective boot drive, remove the mounting screws from the carrier.

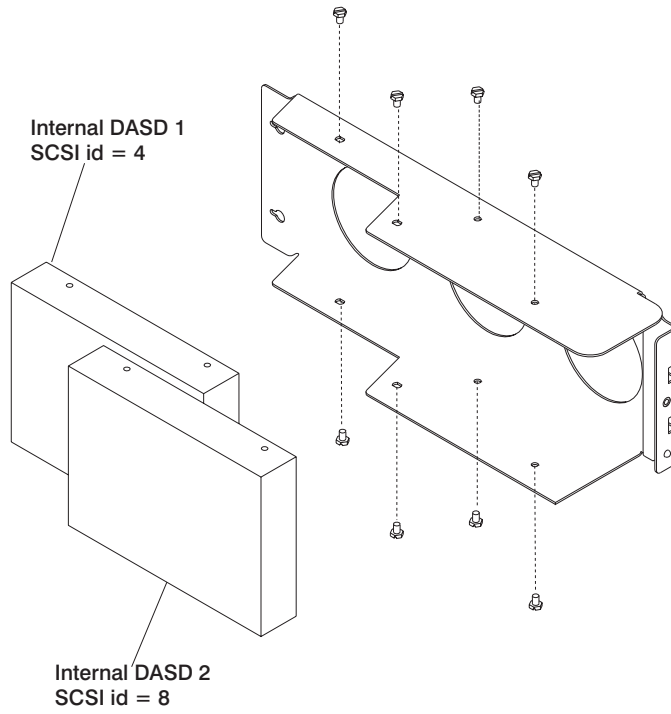

Replacement

Replace in reverse order. Refer to the following diagram for help with connecting the cables to the internal disk drives.

Alternate Internal Disk Drive Connections

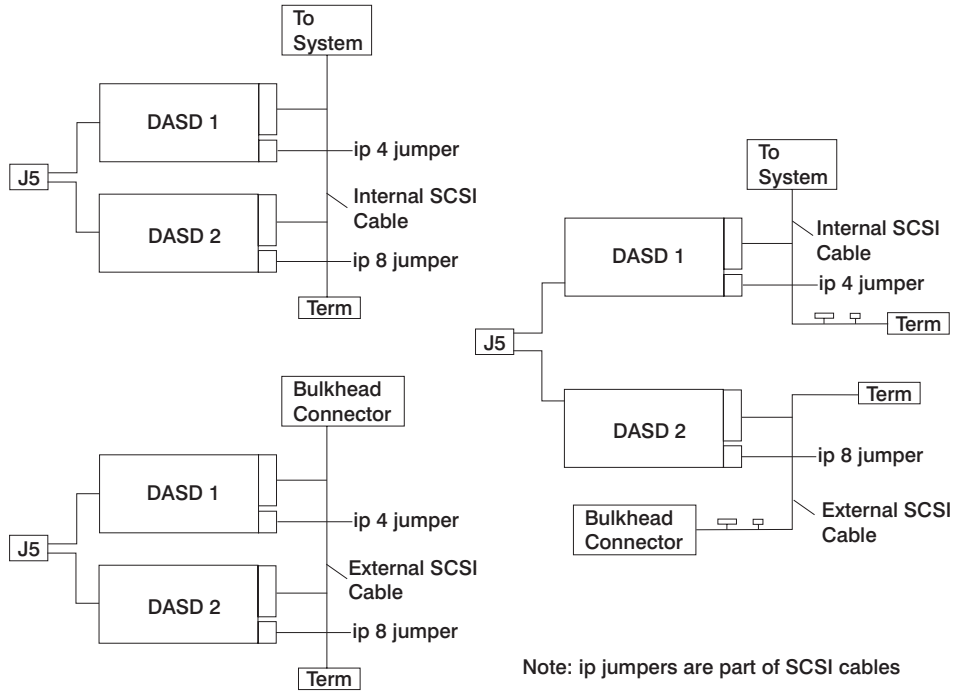

Fan Controller Card

Removal

1. Turn off power as described in “Powering Off the System” on page 429.
2. Place the appropriate drawer in the front service position as described in “Front Service Position” on page 468.
3. Remove the two screws from the center cover and remove the cover.
4. Disconnect the cable from the fan controller card.
5. Pull out the snap button.
6. Remove the fan controller card.

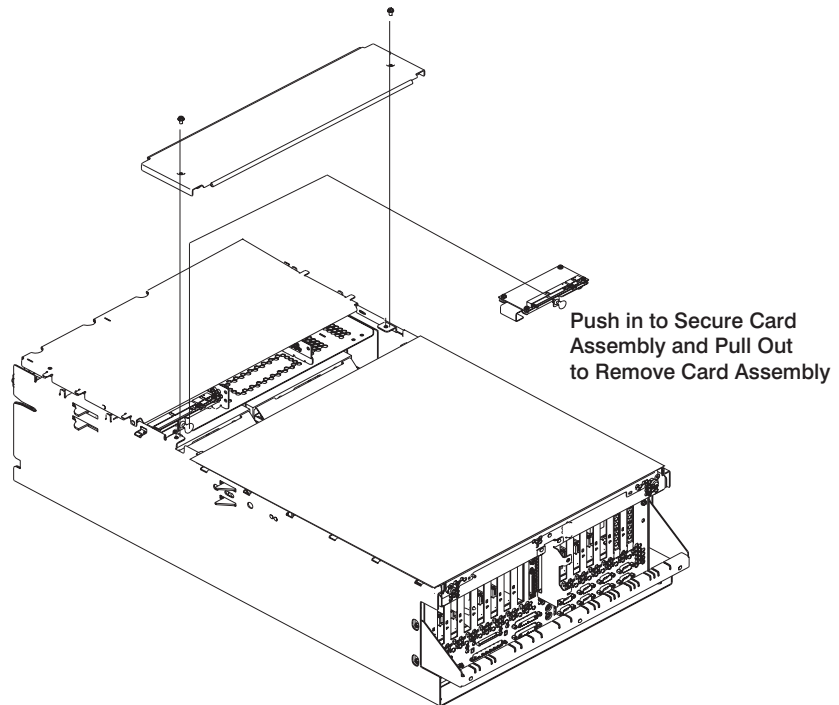

Replacement

Replace in reverse order.

CD-ROM Drive

CAUTION:

A class 1 laser is contained in the device. Do not attempt to operate the drive while it is disassembled. Do not attempt to open the covers of the drive as it is not serviceable and is replaced as a unit.

Removal

1. Turn off power as described in "Powering Off the System" on page 429.
2. If you have not already done so, open the front door of the rack unit.
3. Loosen the two thumbscrews that attach the front bezel to the I/O drawer.
4. Grasp both sides of the front bezel and pull it off the drawer.
5. Push the release lever to the left and pull the CD-ROM drive out.

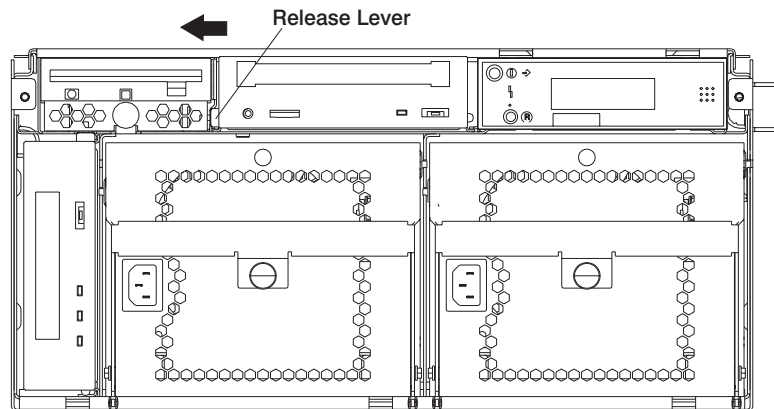

6. Disconnect the cables from the CD-ROM drive.
7. Remove the screws that connect the carrier to the CD-ROM drive.

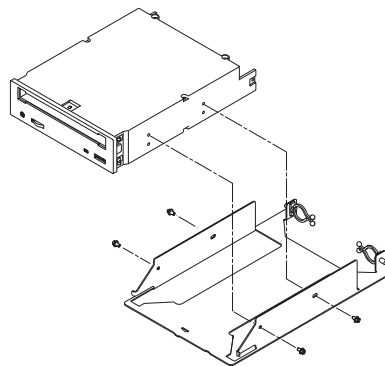

Replacement

Replace in reverse order.

Tape Drive

Removal

1. Turn off power as described in “Powering Off the System” on page 429.
2. If you have not already done so, open the front door of the rack unit.
3. Loosen the two thumbscrews that attach the front bezel to the I/O drawer.
4. Grasp both sides of the front bezel and pull it off the drawer.
5. Push up on the release lever and pull the tape drive out.

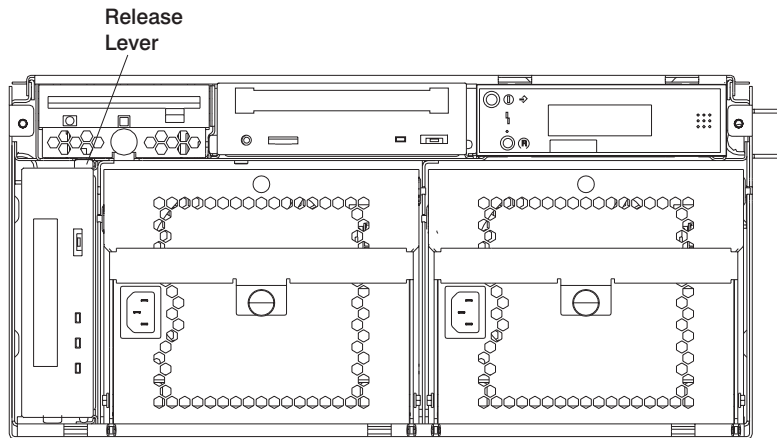

6. Disconnect the cables from the tape drive.
7. Remove the screws that connect the carrier to the tape drive.

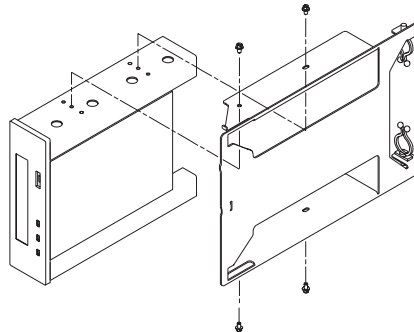

Replacement

Replace in reverse order.

Diskette Drive

Removal

1. Turn off power as described in "Powering Off the System" on page 429.
2. If you have not already done so, open the front door of the rack unit.
3. Loosen the two thumbscrews that attach the front bezel to the I/O drawer.
4. Grasp both sides of the front bezel and pull it off the drawer.
5. Pull out on the snap button and pull the diskette drive out.

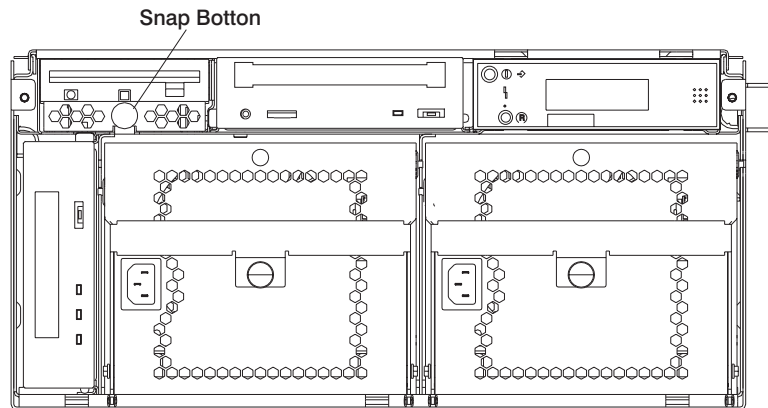

6. Disconnect the cables from the diskette drive.
7. Remove the screws that connect the carrier to the diskette drive.

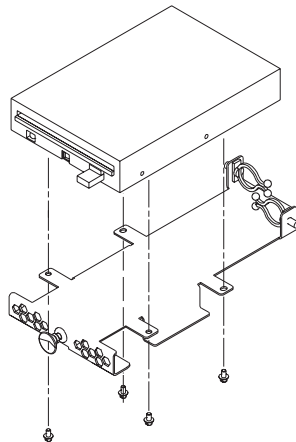

Replacement

Replace in reverse order.

Operator Panel

Removal

1. Turn off power as described in “Powering Off the System” on page 429.
2. Place the I/O drawer in the front service position as described in “Front Service Position” on page 468.
3. Loosen the two retaining screws that attach the front bezel to the drawer.
4. Grasp both sides of the front bezel and pull it off the drawer.
5. Place the drawer in the front service position as described in “Front Service Position” on page 468.
6. Remove the two screws from the top of the operator panel.

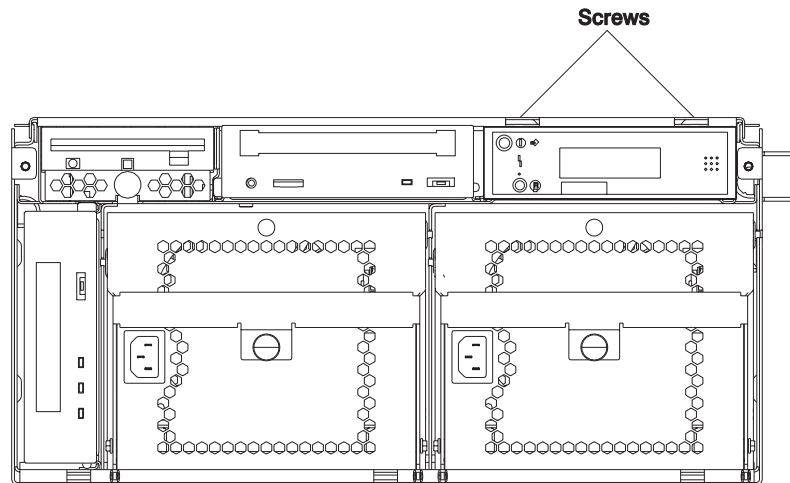

7. Pull the operator panel out.
8. Disconnect the cables from the operator panel.
9. Remove the operator panel from the mounting bracket.

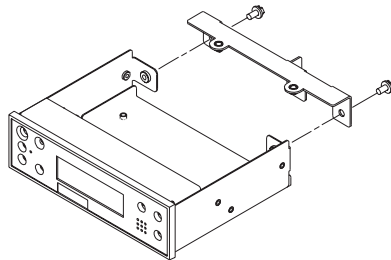

Replacement

1. Remove the VPD module from the old operator panel and insert it in the new operator panel. Make sure you insert the module in the same position as it was in the old panel.

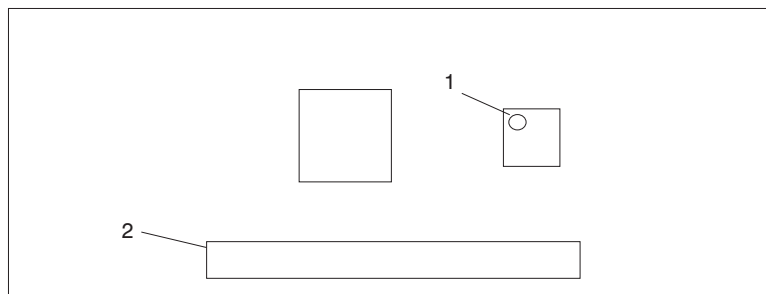

- 1 VPD Module
- 2 Cable Connector

2. To replace, perform removal steps in reverse order.

Rear Service Position

To place a drawer in the rear service position, do the following:

1. If you have not already done so, open the front door of the rack unit.
2. Loosen the two thumbscrews that attach the front bezel to the drawer.
3. Grasp both sides of the front bezel and pull it off the drawer.
4. If you have not already done so, open the rear door of the rack unit.
5. If present, remove two screws securing the drawer to the rack.

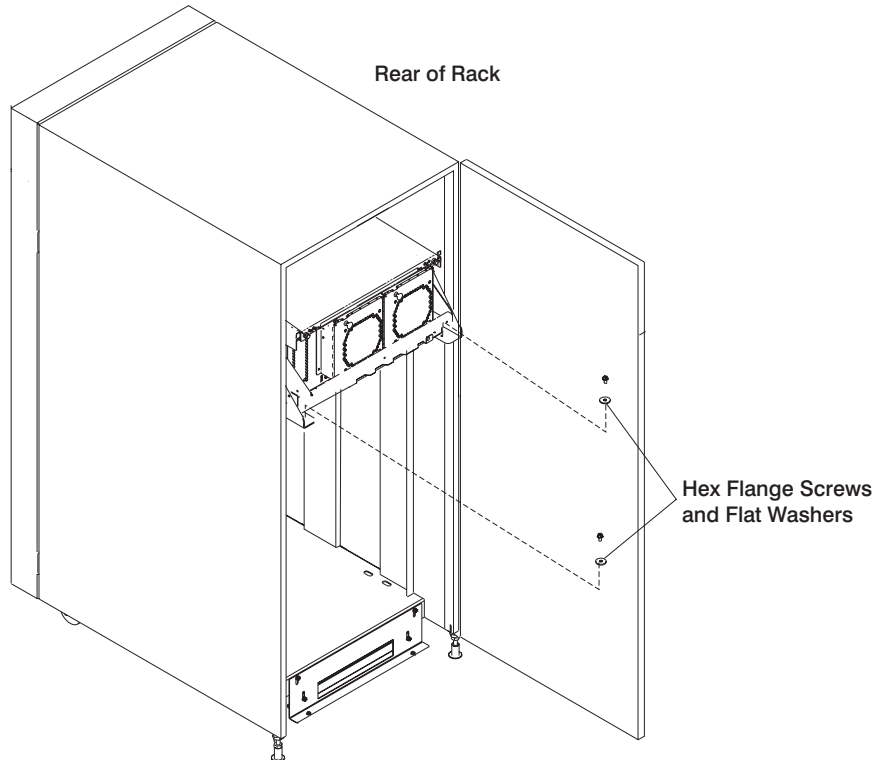

6. Grasp the bar at the rear of the drawer, and pull the drawer to the rear until it is stopped by the two detents.

Front Service Position

To place a drawer in the front service position, do the following:

Attention: Do not pull the drawer out from the front. The drawer must be pushed to the front service position from the rear of the system.

1. If you have not already done so, open the front door of the rack unit.
2. Loosen the two thumbscrews that attach the front bezel to the drawer.
3. Grasp both sides of the front bezel and pull it off the drawer.
4. Remove the screws that attach the left and right retaining brackets and remove the brackets.
5. If you have not already done so, open the rear door of the rack unit.
6. If present, remove the two screws securing the drawer to the rack. Refer to "Rear Service Position" on page 467.
7. Push the drawer forward until it is stopped by the two detents.

Battery

CAUTION:

A lithium battery can cause fire, explosion, or a severe burn. Do not recharge, disassemble, heat above 100 degrees C (212 degrees F), solder directly to the cell, incinerate, or expose cell contents to water. Keep away from children. Replace only with the part number specified for your system. Use of another battery may represent a risk of fire or explosion.

The battery connector is polarized; do not attempt to reverse the polarity.

Dispose of the battery according to local regulations.

Removal

1. Turn off power as described in “Powering Off the System” on page 429.
2. Place the I/O drawer in the rear service position, as described in “Rear Service Position” on page 467.
3. Remove the two thumbscrews and remove the back top cover.
4. Locate the battery on the PCI board.

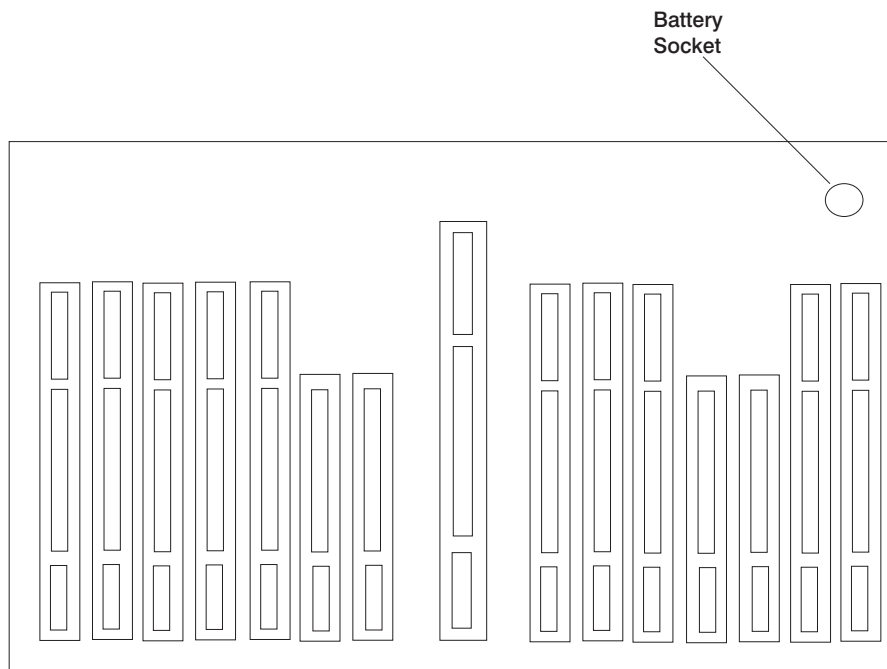

5. Remove any adapters or DASD in slots 13 and 14 to gain access to the battery.
6. Use one finger to gently slide the battery away from the notch in the battery socket. Then use your thumb and index finger to hold the battery as it pushes out of the

socket. (The spring mechanism behind the battery pushes it out.)

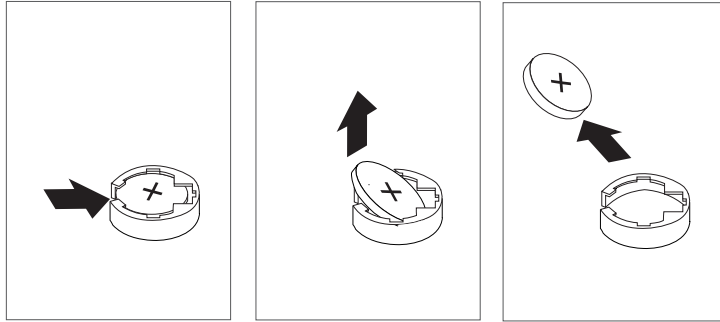

Replacement

Tilt the battery so that you can insert it into the battery socket. Slide the battery into the battery socket, then push it down into the socket.

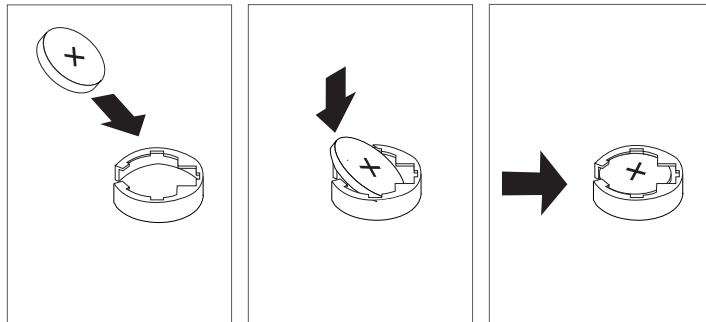

Notes:

1. Be sure to tell the customer to reset the time and date.
2. Ensure that the battery polarity is correct; place the battery in the socket with the positive side facing up.

Chapter 10. Parts Information

This chapter contains parts information for the system.

CEC Drawer

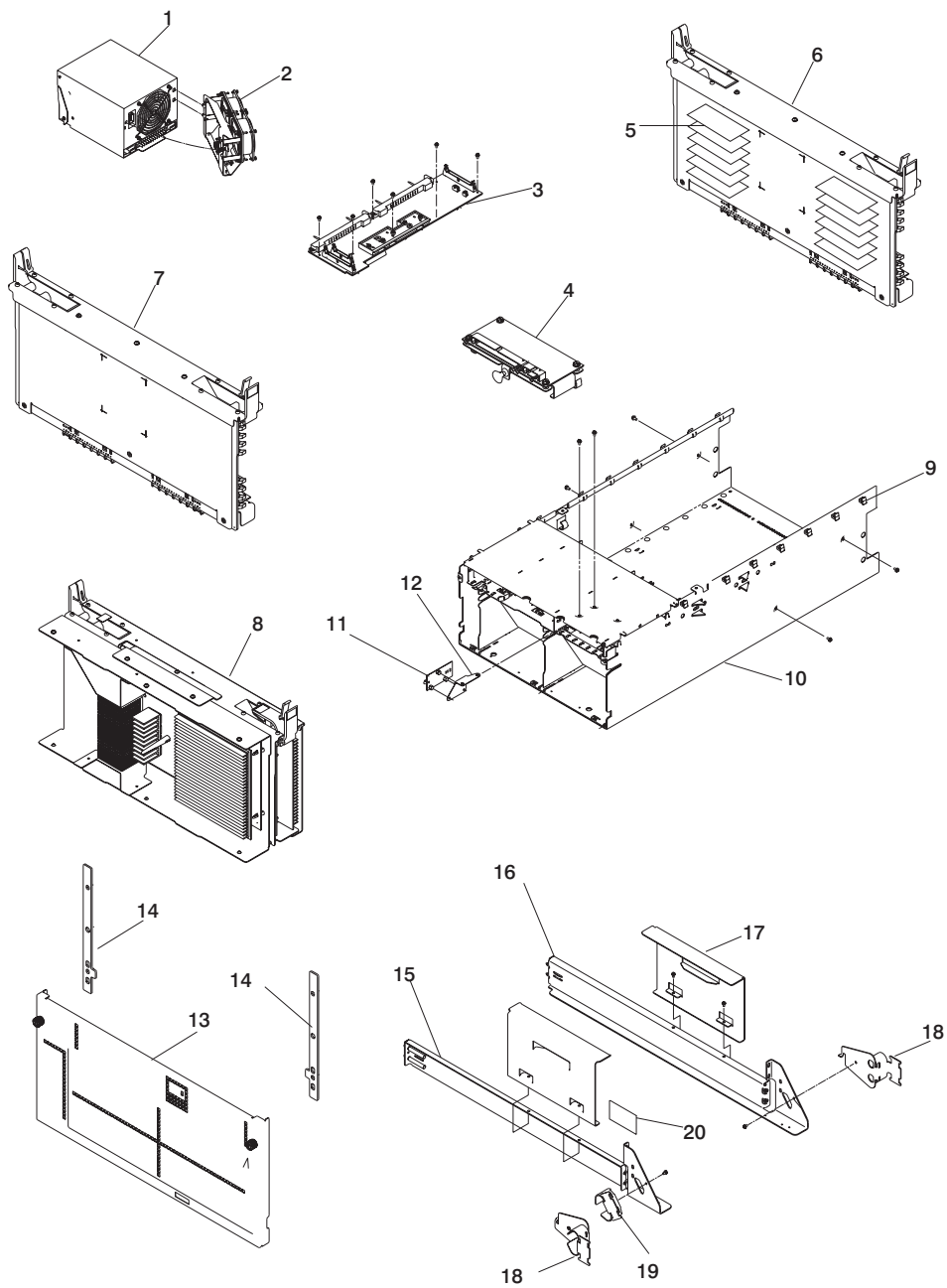

Index	Part Number	CCIN Number	Units Per Assembly	Description
1	11K0802		Up to 2	AC power supply (645 watt)
	41L5404		1	DC power supply
	03N2829		1	Cooling unit
2	41L5448		1	Fan assembly
3	41L5406		1	Power distribution board
4	11K1107		1	Fan controller card
5	07L7729		Up to 32	32MB DIMM
	93H4702		Up to 32	128MB DIMM
	09L5585		Up to 32	128MB DIMM
	07L9030		Up to 32	256MB DIMM
	10L5417		Up to 32	512MB DIMM F/C 4131 (Cannot be mixed with F/C 4100 in a quad or in a pair if memory DIMMs are installed on a 1 way CPU card)
	07L9758		Up to 32	512MB DIMM F/C 4100 (Cannot be mixed with F/C 4131 in a quad or in a pair if memory DIMMs are installed on a 1 way CPU card)
	09P0335		Up to 32	1GB DIMM
	44H8167		Up to 32	Memory DIMM filler
6	04N4808	288D	Up to 2	Memory riser card
7	23L8127	263D	Up to 2	Memory filler card
8	04N4765	24A1	1	1-way 450 MHz processor
	04N5353	25BB	1	1-way 600 MHz processor
	09P6524	25CB	1	1-way 750 MHz processor
	21P4751	24A2	1	2-way 450 MHz processor
	23L7785	25BD	1	2-way 600 MHz processor
	09P6525	25EB	1	2-way 750 MHz processor
	21P4760	24A3	1	4-way 450 MHz processor
	23L7794	25BE	1	4-way 600 MHz processor
	53P1301	25EA	1	4-way 750 MHz processor
	21P4774	24A4	1	6-way 500 MHz processor (some models)
	23L7799	25BF	1	6-way 668 MHz processor (some models)
	53P1334	25F2	1	6-way 750 MHz processor
	04N2934		1	Processor filler card
9	11K0868		14	Clip (ac cord)
10	11K0207		1	Chassis
11	44L0026		1	LED panel assembly
12	03N3174		1	LED panel bracket
13	03N3453		1	Bezel (ac systems)
	00P1749		1	Bezel OEM (ac systems)
	03N3607		1	Bezel (dc systems)
	09P0752		1	Bezel OEM (dc systems)

Index	Part Number	CCIN Number	Units Per Assembly	Description
14	11K0358		2	Trim/ship bracket
15	03N3845		1	Left rail assembly
16	03N3847		1	Right rail assembly
17	09P0327		2	Anti-tip bracket
18	00P2402		2	Channel cable bracket (T00 rack)
19	11K0826		2	Channel cable bracket (S00 rack)
20	11K0851		1	Reset bracket

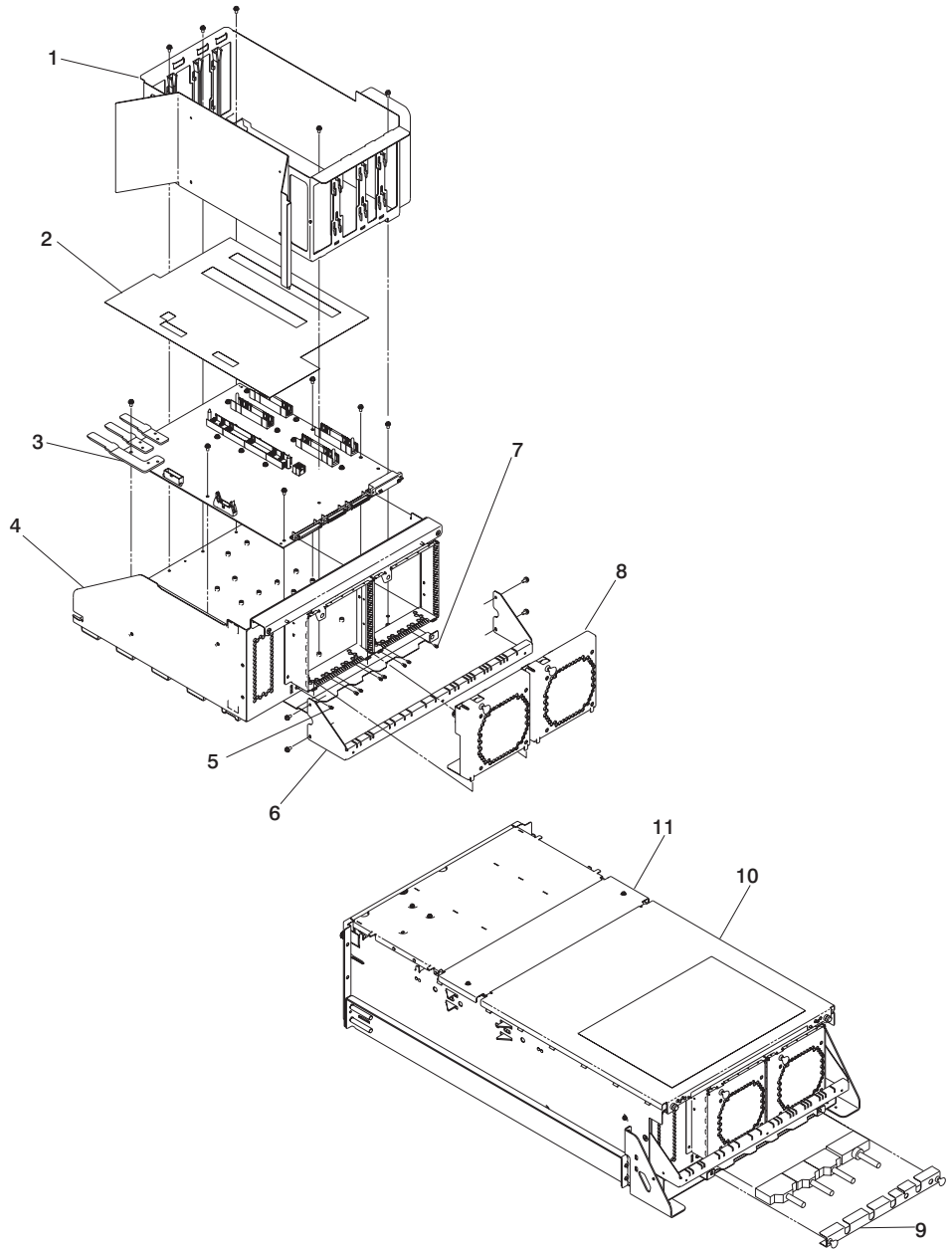

Index	Part Number	Units Per Assy	Description
1	11K0237	1	CEC cage assembly
2	11K0354	1	Insulator-CEC board
3	21P3784	1	CEC backplane
4	11K0122	1	Mech. Assembly-CEC
5	46G3537	6	Standoff
6	09P4061	1	Tie bar assembly
7	1614920	2	Standoff
8	41L5315	2	Fan assembly
9	11K0249	1	Cable bracket
10	41L5208	1	Back cover
11	41L5206	1	Center cover
	00G1268	As required	Screw - M4

I/O Drawer

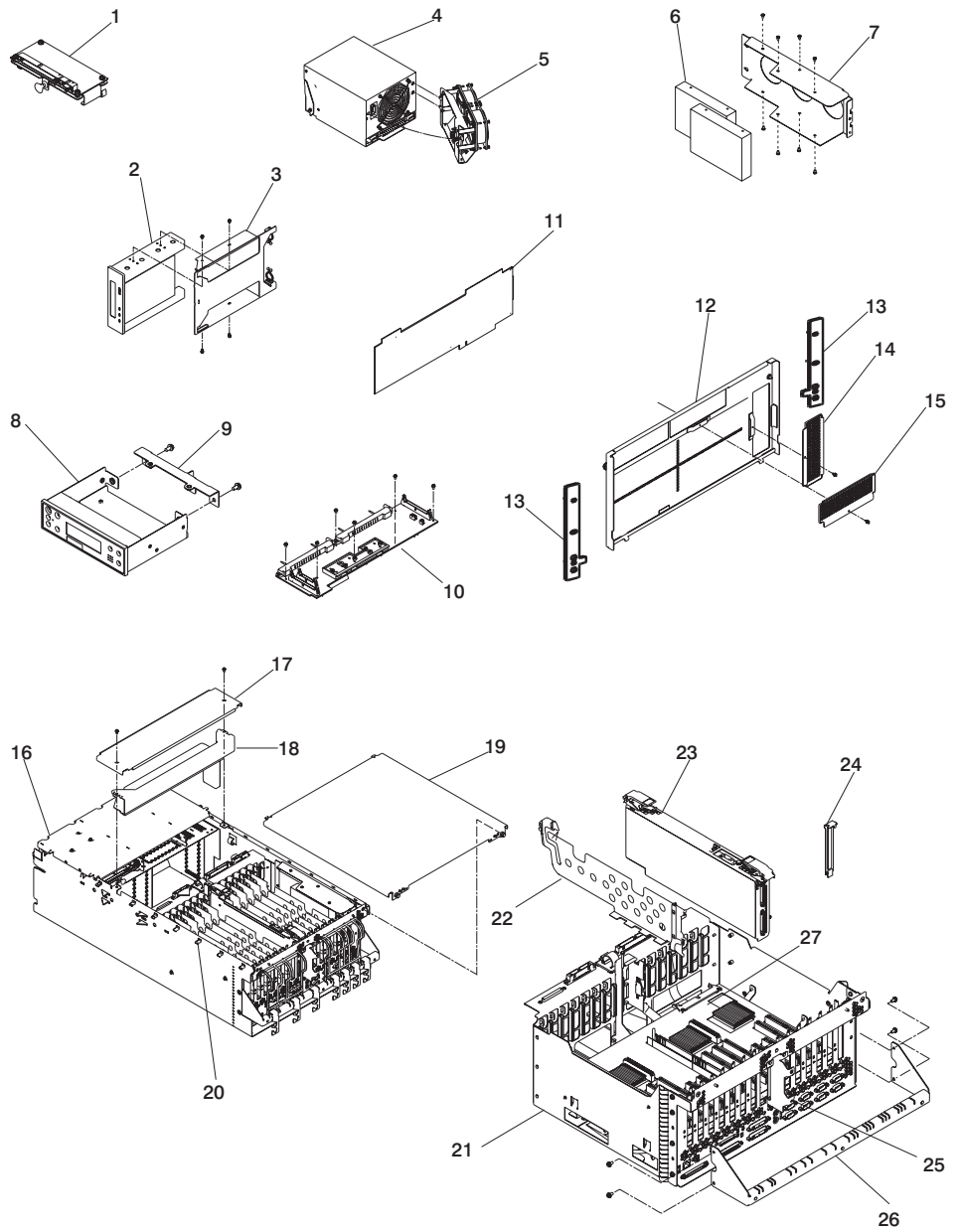

Index	Part Number	CCIN Number	Units Per Assy	Description
1	11K1107		1	Fan controller card
2	See note		1	Tape drive
3	41L5691		1	Tape drive carrier
4	11K0812		Up to 2	AC power supply (595 watt)
	41L5413		Up to 2	DC power supply
	03N2829		1	Cooling unit (Power supply filler)
5	41L5448		1	Fan assembly
6	See note		Up to 2	Disk drive
7	03N2897		1	Disk drive mounting bracket
8	24L1089		1	Primary operator panel
	24L0955		1	Secondary operator panel
9	03N2965		1	Operator panel bracket
10	00P2382		1	Power distribution board
11	See note		Up to 14	Adapter card
12	03N3176		1	Bezel (ac systems)
	00P1746		1	Bezel OEM (ac systems)
	03N3610		1	Bezel (dc systems)
	09P0751		1	Bezel OEM (dc systems)
13	11K0358		2	Trim/ship bracket
14	03N3253		1	Bezel blank (tape drive)
	59H4118		1	Bezel black (tape drive)
	94H0136		1	Bezel (tape drive)
15	03N3253		1	Bezel blank (CD-ROM)
	97H7611		1	Bezel black (CD-ROM)
16	11K0207		1	Chassis
17	41L5206		1	Center cover
18	11K0243		1	Cable tray
19	41L5208		2	Back cover
20	11K0868		14	Clip (AC cord)
21	41L5560		1	Primary I/O tray assembly
	41L5561		1	Secondary I/O tray assembly
22	44L0041		13	I/O divider
23	04N6907	2691	1	RIO card assembly
24	03K8992		As required	I/O blanks
25	11K0584		1	RIO cable bracket
26	09P4061		1	Tie bar
27	16G8095		1	Battery
	21P5041		1	SP Control W/S Adapter
	21P6323		1	SAMI CABLE, internal

Note: See RS/6000 and @server pSeries Diagnostics Information for Multiple Bus Systems for part numbers.

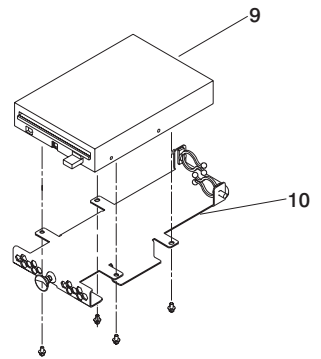
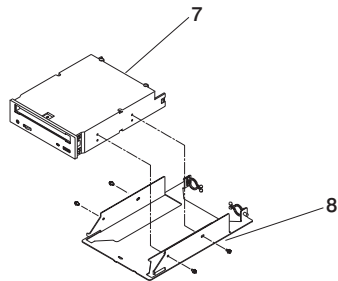
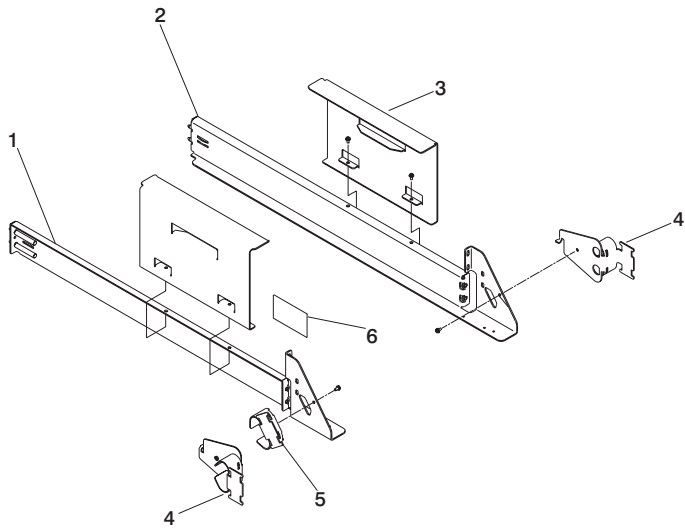

Index	Part Number	Units Per Assy	Description
1	03N3845	1	Left rail assembly
2	03N3847	1	Right rail assembly
3	09P0327	2	Anti-tip bracket
4	00P2402	2	Channel cable bracket (T00 Rack)
5	11K0826	2	Channel cable bracket (S00 Rack)
6	11K0851	1	Reset bracket
7	See note	2	CD-ROM drive
8	41L5691	1	CD-ROM carrier
9	76H4091	1	Diskette drive
10	41L5688	1	Diskette drive carrier
	00G1268	As required	Screw - M4
	33G3907	As required	Screw - M3
Note:			
See <i>RS/6000 and @server pSeries Diagnostics Information for Multiple Bus Systems</i> for part numbers.			

CEC Drawer Internal Cables

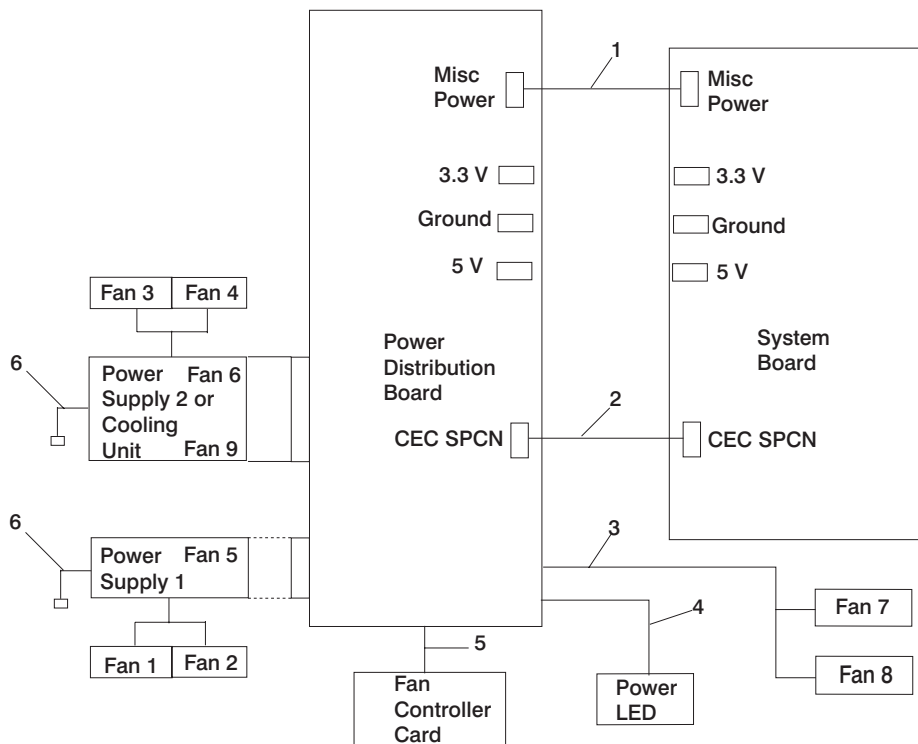

Index	Part Number	Units Per Assembly	Description
1	41L5866	1	Misc. Power Cable
2	41L5867	1	CEC SPCN Cable
3	41L5868	1	Fan Power Cable
4	03N3235	1	Power LED Cable
5	41L5652	1	Fan Controller Card Cable
6	34G0240	Up to 2	AC Power Cable
	11K0400	Up to 2	DC Power Cable

Primary I/O Drawer Internal Cables

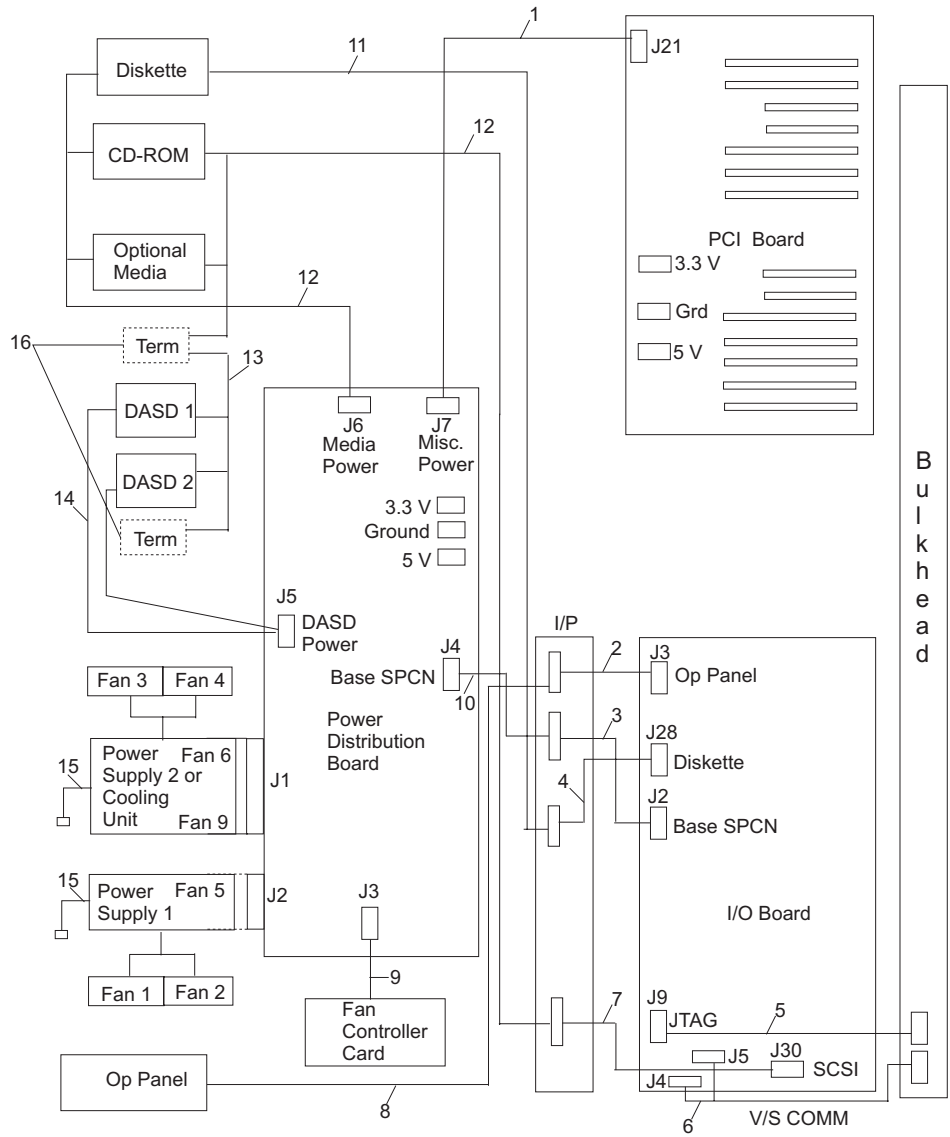

Index	Part Number	Units Per Assy	Description
1	03N3040	1	Misc. Power Cable (PDB to PCI board)
2	41L5517	1	Operator Panel Cable (I/O board to I/P)
3	41L5518	1	Base SPCN Cable (I/O board to I/P)
4	41L5516	1	Diskette Cable (I/O board to I/P)
5	41L5946	1	JTAG Cable (I/O board to bulkhead)
6	41L5521	1	V/S COMM Cable (I/O board to bulkhead)
7	41L5519	1	Internal SCSI (I/O board to I/P)
8	41L5649	1	Operator Panel Cable (I/P to Op panel)
9	42L5652	1	Fan Cont. Card Cable (PDB to FCC)
10	41L5650	1	Base SPCN Cable (I/P to PDB)
11	41L5522	1	Diskette Cable (I/P to diskette)
12	11K0233	1	Internal SCSI Cable (signal and power)
13	00P1676	1	Internal SCSI Cable (Int. to IPL DASD)
	09P1709	1	External SCSI Cable (Ext. SCSI adapter to IPL DASD)
14	09P1449	1	DASD Power Cable (PDB to IPL DASD)
15	34G0240	Up to 2	AC Power Cable
	00P1799	Up to 2	DC Power Cable
	40H6328	1	9–25 Pin adapter
16	88G3977	1	SCSI Terminator

Secondary I/O Drawer Internal Cables

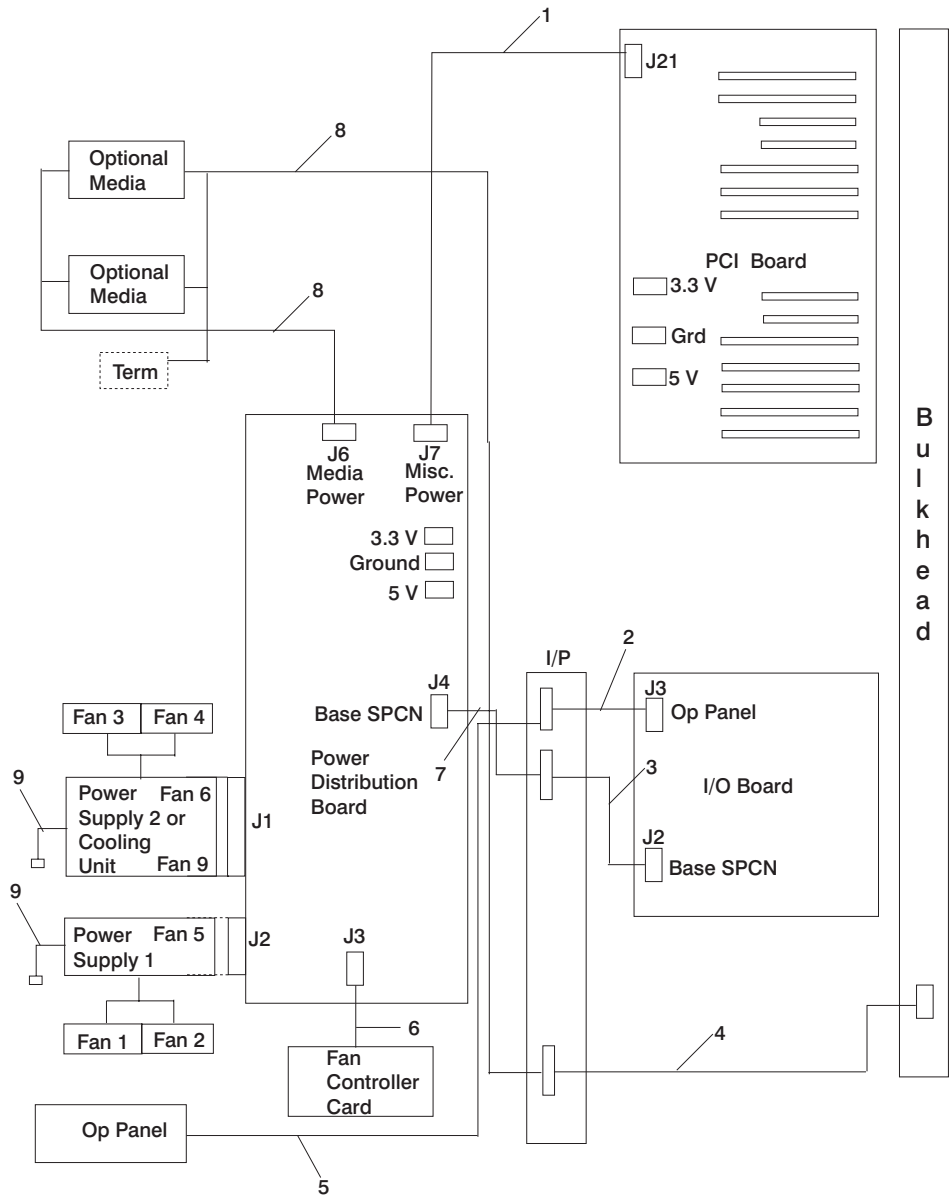

Index	Part Number	Units Per Assy	Description
1	03N3040	1	Misc. Power Cable (PDB to PCI board)
2	41L5517	1	Operator Panel Cable (I/O board to I/P)
3	41L5518	1	Base SPCN Cable (I/O board to I/P)
4	03N3448	1	SCSI Cable (bulkhead to I/P)
5	41L5649	1	Operator Panel Cable (I/P to Op panel)
6	41L5652	1	Fan Cont. Card Cable (PDB to FCC)
7	41L5650	1	Base SPCN Cable (I/P to PDB)
8	11K0233	1	Internal SCSI Cable (signal and power)
9	34G0240	1	AC Power Cable (PS to PDB) to FCC

External Cables

FRU Part Number	Units Per Assy	Description
21H7375	1	JTAG cable 3-meter
44L0033	1	V/S COMM cable 3-meter
97H7328	1	V/S COMM cable 6-meter
44L0005	Up to 6	RIO cable 3-meter
97H7490	Up to 6	RIO cable 6-meter
04N7014	Up to 6	RIO cable 15-meter
09P1251	Up to 3	SPCN cable 3-meter
21F9469	Up to 3	SPCN cable 6-meter
21F9358	Up to 3	SPCN cable 15-meter
1614920	2	JTAG cable standoff (CEC and primary I/O drawer)
46G3537	2	RIO cable standoff (CEC drawer)
46G3537	2	RIO cable standoff (I/O drawer)
44H7478	1	V/S COMM cable standoff (I/O drawer)
46G3537	1	V/S COMM cable standoff (CEC)
62X0388	10	Primary I/O drawer: parallel cable standoff debug cable standoff serial cable standoff SPCN cable standoff
07L7411	1	External SCSI cable standoff (I/O drawer)
12J4098	1	8 foot cable, mouse
00P2401	2	Power cable

Keyboards and Mouse

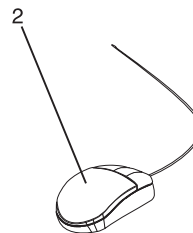
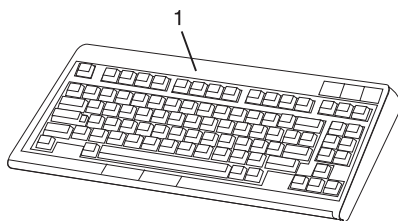

Index Number	FRU Part Number	Units Per Assy	Description
1	93H8120	1	Keyboard, 101 United States English (ID 103P)
	93H8121	1	Keyboard, 102 Canada French (ID 058)
	93H8122	1	Keyboard, 102 Canada French (ID 445)
	93H8123	1	Keyboard, 102 Spanish (ID 171)
	93H8124	1	Keyboard, 104 Brazil Portuguese (ID 275)
	93H8125	1	Keyboard, 102 Arabic (ID 238)
	93H8126	1	Keyboard, 102 Belgium French (ID 120)
	93H8127	1	Keyboard, 102 Belgium (ID 120)
	93H8128	1	Keyboard, 102 Bulgarian (ID 442)
	93H8129	1	Keyboard, 102 Czech (ID 243)
	93H8130	1	Keyboard, 102 Danish (ID 159)
	93H8131	1	Keyboard, 102 Dutch (ID 143)
	93H8132	1	Keyboard, 102 French (ID 189)
	93H8133	1	Keyboard, 102 German (ID 129)
	93H8134	1	Keyboard, 102 Greek (ID 319)
	93H8135	1	Keyboard, 101 Hebrew (ID 212)
	93H8136	1	Keyboard, 102 Hungarian (ID 208)
	93H8137	1	Keyboard, 102 Iceland (ID 197)
	93H8138	1	Keyboard, 102 Italy (ID 142)
	93H8139	1	Keyboard, 102 Norwegian (ID 155)
	93H8140	1	Keyboard, 102 Polish (ID 214)
	93H8141	1	Keyboard, 102 Portuguese (ID 163)
	93H8142	1	Keyboard, 102 Romainian (ID 446)
	93H8143	1	Keyboard, 101 Russian (ID 443)
	93H8144	1	Keyboard, 102 Serbian (ID 118)
	93H8145	1	Keyboard, 102 Slovak (ID 245)
	93H8146	1	Keyboard, 102 Spanish (ID 172)
	93H8147	1	Keyboard, 102 Sweden/Finland (ID 153)
	93H8148	1	Keyboard, 105 Swiss F/G (ID 150)
	93H8149	1	Keyboard, 102 Turkish (ID 179)
	93H8150	1	Keyboard, 102 Turkish (ID 440)
	93H8151	1	Keyboard, 102 UK English (ID 166)
	93H8152	1	Keyboard, 102 Latvia (ID 234)
	93H8153	1	Keyboard, US English ISO9995 (ID 103P)

Index Number	FRU Part Number	Units Per Assy	Description
	93H8154	1	Keyboard, 106 Japan (ID 194)
	93H8155	1	Keyboard, 101 Chinese/US (ID 467)
	93H8156	1	Keyboard, 103 Korea (ID 413)
	93H8157	1	Keyboard, 101 Thailand (ID 191)
2	76H5084	1	Three Button Mouse

Keyboards and Mouse (Black)

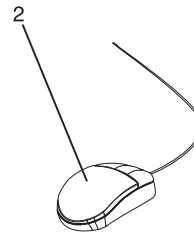
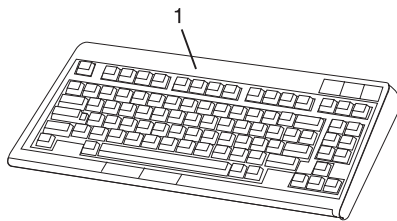

Index Number	FRU Part Number	Units Per Assy	Description
1	07L9446	1	Keyboard, 101 United States English (ID 103P)
	07L9447	1	Keyboard, 102 Canada French (ID 058)
	07L9448	1	Keyboard, 102 Canada French (ID 445)
	07L9449	1	Keyboard, 102 Spanish (ID 171)
	07L9450	1	Keyboard, 104 Brazil Portuguese (ID 275)
	07L9451	1	Keyboard, 102 Arabic (ID 238)
	07L9452	1	Keyboard, 102 Belgium French (ID 120)
	07L9453	1	Keyboard, 102 Belgium (ID 120)
	07L9454	1	Keyboard, 102 Bulgarian (ID 442)
	07L9455	1	Keyboard, 102 Czech (ID 243)
	07L9456	1	Keyboard, 102 Danish (ID 159)
	07L9457	1	Keyboard, 102 Dutch (ID 143)
	07L9458	1	Keyboard, 102 French (ID 189)
	07L9459	1	Keyboard, 102 German (ID 129)
	07L9460	1	Keyboard, 102 Greek (ID 319)
	07L9461	1	Keyboard, 101 Hebrew (ID 212)
	07L9462	1	Keyboard, 102 Hungarian (ID 208)
	07L9463	1	Keyboard, 102 Iceland (ID 197)
	07L9464	1	Keyboard, 102 Italy (ID 142)
	07L9465	1	Keyboard, 102 Norwegian (ID 155)
	07L9466	1	Keyboard, 102 Polish (ID 214)
	07L9467	1	Keyboard, 102 Portuguese (ID 163)
	07L9468	1	Keyboard, 102 Romainian (ID 446)
	07L9469	1	Keyboard, 101 Russian (ID 443)
	07L9470	1	Keyboard, 102 Serbian (ID 118)
	07L9471	1	Keyboard, 102 Slovak (ID 245)
	07L9472	1	Keyboard, 102 Spanish (ID 172)
	07L9473	1	Keyboard, 102 Sweden/Finland (ID 153)
	07L9474	1	Keyboard, 105 Swiss F/G (ID 150)
	07L9475	1	Keyboard, 102 Turkish (ID 179)
	07L9476	1	Keyboard, 102 Turkish (ID 440)
	07L9477	1	Keyboard, 102 UK English (ID 166)
	07L9478	1	Keyboard, 102 Latvia (ID 234)
	07L9479	1	Keyboard, US English ISO9995 (ID 103P)

Index Number	FRU Part Number	Units Per Assy	Description
	07L9480	1	Keyboard, 106 Japan (ID 194)
	07L9481	1	Keyboard, 101 Chinese/US (ID 467)
	07L9482	1	Keyboard, 103 Korea (ID 413)
	07L9483	1	Keyboard, 101 Thailand (ID 191)
2	08L0362	1	Three Button Mouse (Black)

Appendix A. Environmental Notices

Product Recycling and Disposal

This unit contains materials such as circuit boards, cables, electromagnetic compatibility gaskets and connectors which may contain lead and copper/beryllium alloys that require special handling and disposal at end of life. Before this unit is disposed of, these materials must be removed and recycled or discarded according to applicable regulations. IBM offers product-return programs in several countries. For country specific instructions refer to the following web site:
<http://www.ibm.com/ibm/environment/products/prp.phtml>

This product may contain a sealed lead acid, nickel cadmium, nickel metal hydride, lithium, or lithium ion battery. Consult your user manual or service manual for specific battery information. The battery must be recycled or disposed of properly. Recycling facilities may not be available in your area. For information on disposal of batteries, contact your local waste disposal facility.

In the United States, IBM has established a collection process for reuse, recycling, or proper disposal of used IBM sealed lead acid, nickel cadmium, nickel metal hydride, and other battery packs from IBM Equipment. For information on proper disposal of these batteries, please contact IBM at 1-800-426-4333. Have the IBM part number listed on the battery available prior to your call.

Environmental Design

The environmental efforts that have gone into the design of this system signify IBM's commitment to improve the quality of its products and processes. Some of these accomplishments include the elimination of the use of Class 1 ozone-depleting chemicals in the manufacturing process and reductions in manufacturing wastes. For more information, contact an IBM account representative.

Acoustical Noise Emissions

The equivalent continuous A-weighted sound pressure level at workstations (emission sound pressure level at the 1-meter bystander positions) does not exceed 70 dB(A).

Declared Acoustical Noise Emissions

Noise Emissions	Operating	Idle
With H80 CEC Drawer only		
L_{WA_d}	5.8 bels	5.8 bels
L_{pA_m}	N/A	N/A
$\langle L_{pA} \rangle_m$	45 dBA	45 dBA
Impulsive or prominent discrete tones	No	No
Noise Emissions	Operating	Idle
With H80 and Primary I/O Drawer		
L_{WA_d}	6.2 bels	6.2 bels
L_{pA_m}	N/A	N/A
$\langle L_{pA} \rangle_m$	48 dBA	48 dBA
Impulsive or prominent discrete tones	No	No
Noise Emissions¹	Operating	Idle
L_{WA_d}	5.8 bels	5.8 bels
L_{pA_m}	N/A	N/A
$\langle L_{pA} \rangle_m$	45 dBA	45 dBA
Impulsive or prominent discrete tones	No	No
1. Noise emissions data are based on the following configuration: the drawer is mounted in a T00 Rack and a power distribution unit.		

Noise Emission Notes

1. L_{WA_d} is the declared (upper limit) sound power emission level for a production series of machines.
2. L_{pA_m} is the mean value of the A-weighted sound pressure emission levels at the operator position (if any) for a production series of machines.
3. $\langle L_{pA} \rangle_m$ is the mean value of the space-averaged A-weighted sound pressure emission levels at the one-meter positions for a production series of machines.
4. N/A = Not Applicable (no operator position).
5. All measurements are made in accordance with ISO DIS 779 and reported in conformance with ISO DIS 7574/4.

Appendix B. Notices

This information was developed for products and services offered in the U.S.A.

The manufacturer may not offer the products, services, or features discussed in this document in other countries. Consult the manufacturer's representative for information on the products and services currently available in your area. Any reference to the manufacturer's product, program, or service is not intended to state or imply that only that product, program, or service may be used. Any functionally equivalent product, program, or service that does not infringe any intellectual property right of the manufacturer may be used instead. However, it is the user's responsibility to evaluate and verify the operation of any product, program, or service.

The manufacturer may have patents or pending patent applications covering subject matter described in this document. The furnishing of this document does not give you any license to these patents. You can send license inquiries, in writing, to the manufacturer.

The following paragraph does not apply to the United Kingdom or any country where such provisions are inconsistent with local law: THIS MANUAL IS PROVIDED "AS IS" WITHOUT WARRANTY OF ANY KIND, EITHER EXPRESSED OR IMPLIED, INCLUDING, BUT NOT LIMITED TO, THE IMPLIED WARRANTIES OF NON-INFRINGEMENT, MERCHANTABILITY OR FITNESS FOR A PARTICULAR PURPOSE. Some states do not allow disclaimer of express or implied warranties in certain transactions; therefore, this statement may not apply to you.

This information could include technical inaccuracies or typographical errors. Changes are periodically made to the information herein; these changes will be incorporated in new editions of the publication. The manufacturer may make improvements and/or changes in the product(s) and/or the program(s) described in this publication at any time without notice.

Information concerning products made by other than the manufacturer was obtained from the suppliers of those products, their published announcements, or other publicly available sources. The manufacturer has not tested those products and cannot confirm the accuracy of performance, compatibility or any other claims related to products made by other than the manufacturer. Questions on the capabilities of products made by other than the manufacturer should be addressed to the suppliers of those products.

Appendix C. Service Processor Setup and Test

For your convenience, an example of a basic service processor setup checklist is included here. Your setup may include more or fewer of the available features, so you can adjust this checklist for your own application so that it is helpful to you.

Service Processor Setup Checklist

1. Unplug the power cord from the server.
2. Attach a local terminal for this setup procedure.
3. Plug in the system and power on the local terminal.
Attention: Make sure that system power remains off.
4. Start the service processor menus. See Chapter 7, “Using the Service Processor” on page 369.
5. Set the system name. See “Privileged User Menus” on page 372.
6. Enable surveillance. See “Service Processor Functions” on page 397.
7. Configure Call-In/Call-Out. See “Call-In/Call-Out Setup Menu” on page 391.
8. Exit the service processor menus.
9. Unplug the power cord from the system.
10. Attach modems (if needed). See “Accessing the Service Processor Menus Remotely” on page 370.
11. Plug in the system.
Attention: Make sure that the system power remains off.
12. Test both of the following:
 - Call-In, see “Testing Call-In” on page 498
 - Call-Out, see “Testing Call-Out” on page 498
13. Use the “Save or Restore Hardware Management Policies,” in the “Introduction to Tasks and Service Aids” section of the *RS/6000 and @server pSeries Diagnostics Information for Multiple Bus Systems* to back up the service processor settings.

Note: This step is strongly recommended to protect the usefulness of the service processor and the availability of the server.

Your service processor is now ready for use.

Testing the Setup

This section contains sample testing procedures to help ensure that your setup is working.

These tests include communicating with the server operating system. Before you start, ensure that the necessary serial port(s) is configured. If you need assistance, refer to “Serial Port Configuration” on page 499.

The server should be powered off as a result of the “Service Processor Setup Checklist” on page 497.

Testing Call-In

1. At your remote terminal, call in to your server. Your server answers and offers you the Service Processor Main Menu after requesting your privileged access password.
2. Select **System Power Control**.
3. Select **Power-On System**.
When you are asked if you wish to continue powering on the system, type **Y**.
4. After the system firmware and operating system have initialized the server, the login prompt displays at your remote terminal if you set up Seamless Modem Transfer (refer to “Transfer of a Modem Session” on page 507 for more information). This may take several minutes. When the login prompt displays, you have successfully called the service processor.
5. Type `logout` to disconnect from the operating system. The message `No Carrier` displays on your remote terminal.
6. Call your server again. The operating system answers and offers you the login prompt. If these tests are successful, call-in is working.
7. Log in and type `shutdown` to shut down your server.
8. The message `No Carrier` displays on your remote terminal.

Testing Call-Out

During the setup, you entered your phone numbers for the pager (on page 394) and customer voice (on page 394). These numbers are used for this test.

1. Your remote terminal is disconnected as a result of the Call-In test.
2. Call your server again.
3. At the service processor main menu, select **Call-In/Call-Out Setup** menu, then select **Call-Out** test. This action causes a simulated error condition for the purposes of this test.
4. After a few moments, a message displays, regarding an illegal entry. Press `Enter` to clear the message and return to the main menu.
5. When your telephone rings, answer the call. You should hear the sound of a telephone being dialed. Your computer is trying to page you.

If this test is successful, call-out is working correctly.

Return to the “Telephone Number Setup Menu” on page 394 to enter the actual telephone numbers your server will use for reporting problems.

Serial Port Configuration

To configure the serial port on an AIX system, run the following from an AIX console:

1. Log in as root user.
2. To determine if you have any serial ports already configured, type:

```
lsdev -Cc tty
```

If no serial ports are configured, none are listed. If you want to configure serial ports that are not listed, continue with the remaining steps.

3. Identify the serial port(s) with the modem(s).
4. Type `smit tty`
5. Select **add tty**
6. Select **RS232**
7. Select **Baud rate 9600** or higher.
8. Select **login enable** and set the flow control to RTS.
9. Commit the selections and set up any other needed serial ports.
10. Exit SMIT.

Appendix D. Modem Configurations

The service processor is designed to place little demand on an attached modem, thereby increasing the setup and connection success rates.

Sample Modem Configuration Files

This appendix contains information about several sample modem configuration files that either work directly with your modem or provide a good starting point for a custom setup.

The sample modem configuration files are located in your service processor firmware in the **/usr/share/modems** subdirectory (if your system / server is running AIX) with the following names. A listing of each specific file is included in this appendix.

Generic Modem Configuration Files

AIX File Name	Service Processor Firmware File Name
modem_z.cfg	modem_z_sp
modem_z0.cfg	modem_z0_sp
modem_f.cfg	modem_f_sp
modem_f0.cfg	modem_f0_sp
modem_f1.cfg	modem_f1_sp

Specific Modem Configuration Files

AIX File Name	Service Processor Firmware File Name
modem_m0.cfg	modem_m0_sp
modem_m1.cfg	modem_m1_sp

Use the following selection procedures and your modem manual to determine which of the configuration files is suitable for your use.

Configuration File Selection

Use the following steps to select a configuration file:

1. Is your modem an IBM 7852-400?

If Yes, use modem configuration file **modem_m0.cfg** and go to step 7 on page 503.

Note: The IBM 7852-400 modem has DIP switches on the right side of the unit. See “IBM 7852-400 DIP Switch Settings” on page 505 for the correct switch settings.

If No, continue with step 2.

2. Is your modem an IBM 7857-017?

If Yes, use modem configuration file **modem_m1.cfg** and go to step 7 on page 503.

Note: The IBM 7857-017 modem has two telephone line connections on the back of the unit. One is marked **LL** (for Leased Line), and the other is marked **PTSN** (for Public Telephone Switched Network). The service processor expects to use the modem on the public network, so the telephone line should attach to the PTSN connector.

If No, continue with step 3.

3. Does your modem respond to the extended command set (prefixed with &)?

If Yes, go to step 5.

If No, continue with step 4.

4. Does your modem respond to:

- ATZ reset command

or

- ATZ n reset commands, where n can be 0, 1, and so on?

If ATZ, configuration file **modem_z.cfg** is recommended.

If ATZ n , configuration file **modem_z0.cfg** is recommended.

Go to step 7 on page 503.

5. Does your modem command set include a test for V.42 error correction at the remote modem (often called “Auto-Reliable Mode”)?

If Yes, disable this test. You can use sample configuration files

/usr/share/modem_m0.cfg or **/usr/share/modem_m1.cfg** as models to help you create a file for your particular modem. See “Customizing the Modem Configuration Files” on page 504 for more information. Go to step 7 on page 503.

If No, go to step 6.

6. Does your modem respond to:

- AT&F reset command

or

- AT&F n reset commands, where n can be 0, 1, and so on?

If AT&F, configuration file **modem_f.cfg** is recommended.

If AT&Fn, configuration file **modem_f0.cfg** or **modem_f1.cfg** is recommended, depending on which provides the hardware flow control profile.

7. You have completed selection of the configuration file.

If your modem configuration selection is not available in the Service Processor Modem Configuration Menu, you must access it through the Configure Remote Maintenance Policy Service Aid.

If you find it necessary to adjust any of these configuration files, use the manual provided with your modem to accomplish that task. It is recommended you select settings that enable hardware flow control and respond to DTR.

Note: Some older modems do not respond to the **X0** or **&R1** commands. Edit out these commands from the modem configuration file if yours is such a modem. See your modem manual for more information.

Some modems, such as the IBM 7857-017, are not designed for the paging function. Although they can be used for paging, they return an error message when they do not get the expected response from another modem. Therefore, even though the paging was successful, the error message causes the service processor to retry, continuing to place pager calls for the number of retries specified in the Call-Out Policy Setup Menu. These retries result in redundant pages.

Examples for Using the Generic Sample Modem Configuration Files

The following table contains information to help you determine which modem configuration file to use with various modems.

Modem	Setup Z	Setup Z0 (Rare)	Setup F	Setup F0	Setup F1
AT&T DataPort 2001 (Ring interrupt only on first ring)				X	
Bocamodem 1440E			X		
Hayes Smart Modem 300	X				
IBM 5841	X				
IBM 5843	X				
IBM 7851				X	
IBM 7852-10				X	
IBM 7855					X
USRobotics 36.6K Sportster					X
Zoom V.32			X		

Customizing the Modem Configuration Files

You can create your own modem configuration files or modify the samples provided. After you customize your modem configuration files, you *must* access them through the Configure Remote Maintenance Policy Service Aid rather than from the service processor menus.

Note: If you have already set up your serial ports, line speeds, authorizations, and telephone numbers from the service processor menus, use the service aid to specify your customized modem configuration files.

If you have not already set up your serial ports, line speeds, authorizations, and telephone numbers from the service processor menus, use the service aids to set them while you specify your customized modem configuration files.

To disable Auto-Reliable Mode testing of the remote modem, use the sample modem configuration file `/usr/share/modems/modem_f.cfg` as a model that you can modify, as follows:

1. Find the necessary command in your modem manual.
2. Copy the `/usr/share/modems/modem_f.cfg` file to a new file with a different name (for example, `modem_fx.cfg`).
3. In the new file (`modem_fx.cfg`), change the line `Send "ATE0T\r"` to `Send "ATcccE0T\r"` where `ccc` is the added command as specified in your modem manual, as follows:

Change the third line of each of the following stanzas:

- `condout`
- `condin`
- `ripo`

4. Save the changes.

IBM 7852-400 DIP Switch Settings

If you are using a 7852-400 modem to enable service processor communications, for proper operation, the dual inline package (DIP) switches must be set according to the following table:

Switch	Position	Function
1	Up	Force DTR
2	Up	Flow Control &E4
3	Down	Result Codes Enabled
4	Down	Modem Emulation Disabled
5	Up	Auto Answer Enabled
6	Up	Maximum Throughput Enabled
7	Up	RTS Normal Functions
8	Down	Enable Command Mode
9	Down	Remote Digital Loopback Test Enabled
10	Up	Dial-Up Line Enabled
11	*Up	AT Responses Enabled (Extended Responses Disabled)
12	*Down	Asynchronous Operation
13	Up	28.8KB Line Speed
14	Up	
15	Up	CD and DSR Normal Functions
16	Up	2-Wire Leased Line Enabled

* Only switches 11 and 12 are changed from the factory default settings.

Xon/Xoff Modems

Some early modems assume software flow control (Xon/Xoff) between the computer and the modem. Modems with this design send extra characters during and after the transmitted data. The service processor cannot accept these extra characters. If your configuration includes such a modem, your functional results may be unpredictable.

The sample modem configuration files included in this appendix do not support these modems, so custom configuration files are necessary. Anchor Automation 2400E is an example of such a modem.

If you experience unexplainable performance problems that may be due to Xon/Xoff characters, it is recommended that you upgrade your modem.

Ring Detection

Most modems produce an interrupt request each time they detect a ring signal. Some modems generate an interrupt only on the first ring signal that they receive. AT&T DataPort 2001 is an example of such a modem.

The service processor uses the ring interrupt request to count the number of rings when Ring Indicate Power-On (RIPO) is enabled. If your modem produces an interrupt on only the first ring, set Ring Indicate Power-On to start on the first ring. Otherwise, you can choose to start Ring Indicate Power-On on any ring count.

Terminal Emulators

The service processor is compatible with simple ASCII terminals, and therefore compatible with most emulators. When a remote session is handed off from the service processor to the operating system, agreement between terminal emulators becomes important.

The server's operating system will have some built-in terminal emulators. You may also have a commercially available terminal emulation. It is important that the local and host computers select the same or compatible terminal emulators so that the key assignments and responses match, ensuring successful communications and control.

For best formatting, choose line wrap in your terminal emulator setup.

Recovery Procedures

Situations such as line noises and power surges can sometimes cause your modem to enter an undefined state. When it is being used for dial-in, dial-out or ring indicate power-on, your modem is initialized each time one of these actions is expected. If one of these environmental conditions occur after your modem has been initialized, it might be necessary to recover your modem to a known state.

If your modem communicates correctly with remote users, it is probably in control. It may be wise to occasionally change some of the functional settings and then change them back, just for the sense of security that the modem is communicating, and to ensure it has been initialized recently.

If your system is particularly difficult to access physically, another strategy is to protect it with an Uninterruptible Power Source (UPS) and a phone-line surge protector.

In case recovery becomes necessary, shut down your system using established procedures. Disconnect the power cable and press the power button to drain capacitance while power is disconnected. Disconnect and reconnect modem power, and then reconnect system power to completely reinitialize your system.

Transfer of a Modem Session

Because many modem command variations exist, the sample modem configuration files located at the end of this appendix have been written to capture the largest number of workable modem settings.

The modem command **&Dn** (where *n* is a number) generally sets the modem response to the Data Terminal Ready (DTR) signal from the server's serial port. The desired response is that the modem will hold a connection while DTR is enabled, and drop the connection when DTR is released. Using this mechanism, the server hangs up on a connection under normal conditions.

Consult your modem manual for its specific response scheme for the **&Dn** command.

Two strategies are available for dealing with the modem's response to DTR:

- Recovery
- Prevention

Before you use one of these strategies, determine if your server's modem is set up correctly to respond to DTR.

With the remote terminal connected to serial port 1 and defined as the Primary Console Device, there are two tests you can perform:

1. Will the modem drop the connection after the System initialization complete message displays at the remote terminal?
If Yes, the modem is set up correctly.
If No, try another **&Dn** setting for your server's modem. See your modem manual for this information. The **&Dn** command appears in three places each in three of the sample modem configuration files, as follows:
2. Will the server's modem disconnect when the power drops? You can make this observation at the remote terminal by commanding your server to shut down and power off. (Use the AIX command **shutdown -F**.) Watch for the message NO CARRIER on your remote terminal.
If Yes, this is the correct response. The modem is set up correctly.
If No, try another **&Dn** setting for your server's modem. See your model manual for this information. The **&Dn** command appears in three places each in three of the sample modem configuration files. Only the following sample modem configuration files contain the **&Dn** command (in three places each):
 - modem_f.cfg
 - modem_f0.cfg
 - modem_f1.cfg

If you are using modem_z.cfg or modem_z0.cfg, you cannot control DTR response. If your remote terminal does not disconnect after logging off, you must command the remote terminal emulator to hang up. This then breaks the connection.

Recovery Strategy

The recovery strategy consists of making two calls to establish a remote session. This solution is the easiest to implement and allows more freedom for configuring your server's serial ports.

To set up a remote terminal session, dial into the service processor and start the system. After the operating system is loaded and initialized, the connection will be dropped. At this point, call the server back and the operating system will answer and offer you the login prompt.

Prevention Strategy

The disconnect is caused by the operating system when it initializes the Primary Console. The tests listed in "Transfer of a Modem Session" on page 507 are conducted with the remote terminal selected as the primary console to manifest the modem's response to DTR transitions.

- If a local ASCII terminal or a graphics console is to be a permanent part of your server, then make one of them the primary console. Your remote terminal will no longer experience the connection loss.
- If a local console is not a permanent part of your server, you can still assign either the unused graphics console or the unused serial port as the primary console. This gives you the desired seamless connection at your remote terminal.
- If you choose to use the unused serial port as the primary console, some initialization traffic will be sent to any serial device attached to that port. As a result, that serial device's connection and function could be affected. These impacts may make that port unattractive for devices other than a temporary local ASCII terminal.

Modem Configuration Sample Files

Sample File modem_m0.cfg

```
#
# COMPONENT_NAME: (ESPSETUP) ENTRY SERVICE PROCESSOR SETUP: modem_m0
#
# FUNCTIONS: Modem configuration file specifically for IBM 7852-400
# modem with Auto-Reliable feature. This feature must be turned off
# for Catcher calls. This example uses the AT&F reset command to
# choose the factory defaults.
#
# (C) COPYRIGHT International Business Machines Corp. 1996
# All Rights Reserved
# Licensed Materials - Property of IBM
#
# US Government Users Restricted Rights - Use, duplication or
# disclosure restricted by GSA ADP Schedule Contract with IBM Corp.
#
#
# The modem has configuration switches. They should be set to the
# factory default settings, except switches 11 and 12. These must be
# to UP ("AT" responses) and DOWN (Asynchronous operation), respectively.

ICDelay 1
DefaultTO 10
CallDelay 120
#
# %N Call-Out phone number %R Return phone number
#
#
# PROGRAMMING NOTE: No blanks between double quote marks (").

condout: send "AT&F&E2E0T\r" # Reset to factory defaults
# Reliable mode
# Echo off
ignore "\0\r" or "OK\r\n" timeout 2 # Ignore modem response.
send "AT&E12&E14\r" # Disable pacing
# Disable data compression
expect "\0\r" or "OK\r\n" timeout 2 # Confirm commands successful.
send "AT&SF1&S0S9=1\r" # DSR independent of CD
# Force DSR on.
# CD respond time=100ms
expect "\0\r" or "OK\r\n" timeout 2 # Confirm commands successful.
send "ATV0S0=0\r" # Numeric response code
# Auto-Answer off
expect "\0\r" or "OK\r\n" timeout 2 # Confirm commands successful.
done

connect: send "ATDT%N\r" # Tone dialing command.
# %N from Call Home setup.
# Expect a connection response.
expect "33\r" or "31\r" or "28\r" or "26\r" or "24\r" or "21\r" or
"19\r" or "13\r" or "12\r" or "1\r" busy "7\r"
timeout 60
done

retry: send "A/" # Repeat the previous command.
# Expect a connection response.
expect "33\r" or "31\r" or "28\r" or "26\r" or "24\r" or "21\r" or
"19\r" or "13\r" or "12\r" or "1\r" busy "7\r"
timeout 60
done

disconnect:
delay 2 # Separate from previous data.
```

```

send "+++" # Assure command mode.
delay 2 # Allow mode switching delay.
send "ATH0T\r" # Set modem switch-hook down
# (i.e., hang up).
ignore "0\r" or "OK\r" timeout 2 # Ignore modem response.
send "ATE0Q1\r" # Initialize modem: Echo OFF,
# Disable responses.

ignore "0\r" timeout 1
done

condin: send "AT&F&E2E0T\r" # Reset to factory defaults.
# Reliable mode
# Echo off
ignore "0\r" or "OK\r\n" timeout 2 # Ignore modem response.
send "AT&E12&E14\r" # Disable pacing
# Disable data compression
expect "0\r" or "OK\r\n" timeout 2 # Confirm commands successful
send "AT&SF1&S0S9=1\r" # DSR independent of CD.
# Force DSR on.
# CD respond time=100ms
expect "0\r" or "OK\r\n" timeout 2 # Confirm commands successful.
send "ATV0S0=2\r" # Numeric response code
# Answer on 2nd ring
expect "0\r" timeout 2 # Confirm commands successful.
done

waitcall: ignore "2\r" timeout 1 # Ignore first ring.
expect "2\r" timeout 10 # Pickup 2nd ring or timeout
# Expect a connection response.
expect "33\r" or "31\r" or "28\r" or "26\r" or "24\r" or "21\r" or
"19\r" or "13\r" or "12\r" or "1\r" busy "7\r"
timeout 60
done

page: send "ATDT%N,,,%R;\r" # %N = pager call center number
# Add enough commas to wait for
# time to enter paging number.
# %R = paging number
expect "0\r" timeout 60 # Confirm successful command.
delay 2 # Wait before hanging up.
send "ATH0\r" # Hang up.
expect "0\r" timeout 2 # Confirm successful command.
done

ripo: send "AT&F&E2E0T\r" # Reset to factory defaults.
# Reliable mode
# Echo off
ignore "0\r" or "OK\r\n" timeout 2 # Ignore modem response.
send "AT&E12&E14\r" # Disable pacing
# Disable data compression
expect "0\r" or "OK\r\n" timeout 2 # Confirm successful command.
send "AT&SF1&S0S9=1\r" # DSR independent of CD.
# Force DSR on.
# CD respond time=100ms
expect "0\r" or "OK\r\n" timeout 2 # Confirm commands successful.
send "ATV0S0=0\r" # Numeric response code
# Auto Answer OFF
expect "0\r" timeout 2 # Confirm commands successful.
done

error: # Handle unexpected modem
# responses.
expect "8\r" or "7\r" or "6\r" or "4\r" or "3\r"
delay 2
done

```

Sample File modem_m1.cfg

```
#
# COMPONENT_NAME: (ESPSETUP) ENTRY SERVICE PROCESSOR SETUP modem_m1
#
# FUNCTIONS: Modem configuration file specifically for IBM 7857-017 modem with
# Auto-Reliable feature. This feature must be turned off for Catcher calls.
# This example uses the AT&F reset command to choose the factory defaults.
#
# To allow dial commands for digital pagers, it is necessary to reduce
# the number of characters in the dial command. Each comma (delay) has
# been set to 6 seconds (S8=6) for that reason.
#
#
# (C) COPYRIGHT International Business Machines Corp. 1996
# All Rights Reserved
# Licensed Materials - Property of IBM
#
# US Government Users Restricted Rights - Use, duplication or
# disclosure restricted by GSA ADP Schedule Contract with IBM Corp.
#

ICDelay 1
DefaultTO 10
CallDelay 120
#
# %N Call-Out phone number %R Return phone number
#
#
# PROGRAMMING NOTE: No blanks between double quote marks (").

connect: send "AT&F*E0E0\r" # Reset to factory defaults.
# *E0=data compression disabled
# E0=echo disabled
ignore "0\r" or "OK\r\n" timeout 2 # Ignore modem response.
send "AT#F0*Q2S8=6\r" # Trellis modulation disabled
# Retrain with adaptive rate
# Set ,=6second
expect "0\r" or "OK\r\n" timeout 2 # Confirm commands successful
send "ATV0X0S0=0\r" # Numeric response code
# AT compatible messages
# Auto-Answer disabled
expect "0\r" or "OK\r\n" timeout 2 # Confirm commands successful.
done

connect: send "ATDT%N\r" # Tone dialing command.
# %N from Call Home setup.
expect "1\r" busy "7\r" timeout 60 # Expect a connection response.
done

retry: send "A/" # Repeat the previous command.
expect "1\r" busy "7\r" timeout 60 # Expect a connection response.
done

disconnect:
delay 2 # Separate from previous data.
send "+++" # Assure command mode.
delay 2 # Allow mode switching delay.
send "ATH0\r" # Set modem switch-hook down
# (i.e., hang up).
ignore "0\r" or "OK\r" timeout 2 # Ignore modem response.
send "ATE0Q1\r" # Initialize modem: Echo OFF,
# Disable responses.
ignore "0\r" timeout 1
done

condin: send "AT&F*E0E0\r" # Reset to factory defaults.
```

```

# *E0=data compression disabled
# E0=echo disabled
ignore "\0\r" or "OK\r\n" timeout 2 # Ignore modem response.
send "AT#F0*Q2\r" # Trellis modulation disabled
# Retrain with adaptive rate
expect "\0\r" or "OK\r\n" timeout 2 # Confirm commands successful
send "ATV0X0S0=2\r" # Numeric response code
# AT compatible messages
# Answer on 2nd ring
# Confirm commands successful.

expect "\0\r" timeout 2
done

waitcall: ignore "2\r" timeout 1 # Ignore first ring.
expect "2\r" timeout 10 # Pick up second ring
# or timeout.
# Expect a connection response.

expect "1\r" timeout 60
done

page: send "ATD%N,%R\r" # %N = pager call center number
# commas=6sec wait time to
# enter paging number.
# %R = return number
expect "\0\r" or "3\r" timeout 30 # Confirm successful command.
delay 2 # Wait before hanging up.
send "+++" # Assure command mode.
delay 2 # Allow mode switching delay.
send "ATH0\r" # Hang up.
expect "\0\r" timeout 2 # Confirm successful command.
done

ribo: send "AT&F*E0E0\r" # Reset to factory defaults.
# *E0=data compression disabled
# E0=echo disabled
ignore "\0\r" or "OK\r\n" timeout 2 # Ignore modem response.
send "AT#F0*Q2\r" # Trellis modulation disabled
# Retrain with adaptive rate
expect "\0\r" or "OK\r\n" timeout 2 # Confirm successful command.
send "ATV0X0S0=0\r" # Numeric response code
# AT compatible messages
# Auto-Answer disabled
# Confirm commands successful.
#

error: # Handle unexpected modem
# responses.

expect "8\r" or "7\r" or "4\r" or "3\r"
delay 2
done

```

Sample File modem_z.cfg

```
#
# COMPONENT_NAME: (ESPSETUP) ENTRY SERVICE PROCESSOR SETUP Z
#
# FUNCTIONS: Modem configuration file for many early Hayes* compatible modems.
# This example uses the ATZ reset command to choose the factory defaults.
# This setup will work for many modems, but it is required for early vintage
# modems which respond to neither the ATZ0 reset command nor the extended (&)
# commands. Refer to your modem manual.
#
# * Trademark of Hayes Microcomputer Products, Inc.
#
# (C) COPYRIGHT International Business Machines Corp. 1996
# All Rights Reserved
# Licensed Materials - Property of IBM
#
# US Government Users Restricted Rights - Use, duplication or
# disclosure restricted by GSA ADP Schedule Contract with IBM Corp.
#
#
# If the modem has configuration switches, they should be set to the
# factory default settings.

ICDelay 1
DefaultT0 10
CallDelay 120
# AT Attention Code           , Inserts delay in dialing commands
# Z Reset to factory defaults Q0 Turn on responses
# E0 Turn echo off           Q1 Turn off responses
# V0 Use numeric responses    S0=0 Automatic answer inhibit
# +++ Escape to command mode S0=2 Answer on second ring
# H0 Hang-up                 T = Tone mode. When used as T\r, it is a
#                             no op to maintain program synchronization
#                             when modem may/will echo the commands.
#
# %N Call-Out phone number    %P Paging phone number
# %S Modem speed (available to users)
#
# Following are common responses from a wide range of modems:
# 16, 15, 12, 10, 5 and 1 are connection responses. Add others as required.
# 7=busy; 6=no dial tone; 4=error; 3=no carrier; 2=ring; 0=OK
#
# PROGRAMMING NOTE: No blanks between double quote marks (").

condout:  send "ATZQ0T\r"           # Reset to factory defaults.
          ignore "0\r" or "OK\r\n" timeout 2 # Ignore modem response.
          send "ATE0T\r"           # Initialize modem: Echo OFF,
          expect "0\r" or "OK\r\n" timeout 2 # Enable responses (Numeric),
          send "ATQ0V0T\r"         # Limit response codes.
          expect "0\r" timeout 2     # Confirm commands successful.
          send "ATS0=0\r"          # Set AutoAnswer OFF
          expect "0\r" timeout 2     # Confirm command successful.
          done

connect:  send "ATDT%N\r"          # Tone dialing command.
          # %N from Call Home setup.

          # Expect a connection response.
          expect "16\r" or "15\r" or "14\r" or "12\r" or "10\r" or "5\r" or "1\r" busy "7\r"
          timeout 60
          done

retry:    send "A/"               # Repeat the previous command.

          # Expect a connection response.
          expect "16\r" or "15\r" or "14\r" or "12\r" or "10\r" or "5\r" or "1\r" busy "7\r"
```

```

timeout 60
done

disconnect:
delay 2 # Separate from previous data.
send "+++\" # Assure command mode.
delay 2 # Allow mode switching delay.
send "ATH0T\r\" # Set modem switch-hook down
# (i.e., hang up).

ignore "0\r\" or "OK\r\" timeout 2 # Ignore modem response.
send "ATE0Q1\r\" # Initialize modem: Echo OFF,
# Disable responses.

ignore "0\r\" timeout 1
done

condin: send "ATZ00T\r\" # Reset to factory defaults.
ignore "0\r\" or "OK\r\n\" timeout 2 # Ignore modem response.
send "ATE0T\r\" # Initialize modem: Echo OFF,
expect "0\r\" or "OK\r\n\" timeout 2 # Enable responses (Numeric),
send "ATQ0V0T\r\" # Limit response codes.
expect "0\r\" timeout 2 # Confirm commands successful.
send "ATS0=2\r\" # Set AutoAnswer ON
expect "0\r\" timeout 2 # Confirm command successful.
done

waitcall: ignore "2\r\" timeout 1 # Ignore first ring.
expect "2\r\" timeout 10 # Pick up second ring
# or timeout.
# Expect a connection response.

expect "16\r\" or "15\r\" or "14\r\" or "12\r\" or "10\r\" or "5\r\" or "1\r\"
timeout 60
done

page: send "ATDT%N,,,%R;\r\" # %N = pager call center number
# Add enough commas to wait for
# time to enter paging number.
# %R = paging number

# Confirm successful command.

expect "0\r\" timeout 60
delay 2 # Wait before hanging up.
send "ATH0T\r\" # Hang up.
expect "0\r\" timeout 2 # Confirm successful command.
done

ripo: send "ATZ00T\r\" # Reset to factory defaults.
ignore "0\r\" or "OK\r\n\" timeout 2 # Ignore modem response.
send "ATE0T\r\" # Initialize modem: Echo OFF,
expect "0\r\" or "OK\r\n\" timeout 2 # Enable responses (Numeric),
send "ATQ0V0T\r\" # Limit response codes.
expect "0\r\" timeout 2 # Confirm commands successful.
send "ATS0=0\r\" # Set AutoAnswer OFF
expect "0\r\" timeout 2 # Confirm command successful.
done

error: # Handle unexpected modem
# responses.

expect "8\r\" or "7\r\" or "6\r\" or "4\r\" or "3\r\"
delay 2
done

```

Sample File modem_z0.cfg

```
#
# COMPONENT_NAME: (ESPSETUP) ENTRY SERVICE PROCESSOR SETUP Z0
#
# FUNCTIONS: Modem configuration file for some early Hayes* compatible modems.
# This example uses the ATZ0 reset command to choose the factory defaults.
# This setup is recommended for modems that will respond to the ATZ0 command
# and which do not respond to the extended (&) commands. Refer to your modem
# manual.
#
# * Trademark of Hayes Microcomputer Products, Inc.
#
# (C) COPYRIGHT International Business Machines Corp. 1996
# All Rights Reserved
# Licensed Materials - Property of IBM
#
# US Government Users Restricted Rights - Use, duplication or
# disclosure restricted by GSA ADP Schedule Contract with IBM Corp.
#
#
# If the modem has configuration switches, they should be set to the
# factory default settings.

ICDelay 1
DefaultT0 10
CallDelay 120
# AT Attention Code           , Inserts delay in dialing commands
# Z0 Reset. Restore Profile 0 Q0 Turn on responses
# E0 Turn echo off           Q1 Turn off responses
# V0 Use numeric responses    S0=0 Automatic answer inhibit
# +++ Escape to command mode S0=2 Answer on second ring
# H0 Hang-up                 X0=0 Limit modem response codes
#                               T = Tone mode. When used as T\r, it is a
#                               no op to maintain program synchronization
#                               when modem may/will echo the commands.
#
#
# %N Call-Out phone number    %P Paging phone number
# %S Modem speed (available to users)
#
# Following are common responses from a wide range of modems:
# 16, 15, 12, 10, 5 and 1 are connection responses. Add others as required.
# 7=busy; 6=no dial tone; 4=error; 3=no carrier; 2=ring; 0=OK
#
# PROGRAMMING NOTE: No blanks between double quote marks (").

condout:  send "ATZ0Q0T\r"           # Reset modem. Select profile 0
          ignore "0\r" or "OK\r\n" timeout 2 # Ignore modem response.
          send "ATE0T\r"           # Initialize modem: Echo OFF,
          expect "0\r" or "OK\r\n" timeout 2 # Enable responses (Numeric),
          send "ATQ0V0X0T\r"       # Limit response codes.
          expect "0\r" timeout 2    # Confirm commands successful.
          send "ATS0=0\r"         # Set AutoAnswer OFF
          expect "0\r" timeout 2    # Confirm command successful.
          done

connect:  send "ATDT%N\r"           # Tone dialing command.
          # %N from Call Home setup.

          # Expect a connection response.
          expect "16\r" or "15\r" or "14\r" or "12\r" or "10\r" or "5\r" or "1\r" busy "7\r"
          timeout 60
          done

retry:    send "A/"                # Repeat the previous command.

          # Expect a connection response.
```

```

expect "16\r" or "15\r" or "14\r" or "12\r" or "10\r" or "5\r" or "1\r" busy "7\r"
timeout 60
done

disconnect:
delay 2 # Separate from previous data.
send "+++" # Assure command mode.
delay 2 # Allow mode switching delay.
send "ATH0T\r" # Set modem switch-hook down
# (i.e., hang up).
ignore "0\r" or "OK\r" timeout 2 # Ignore modem response.
send "ATE0Q1\r" # Initialize modem: Echo OFF,
# Disable responses.

ignore "0\r" timeout 1
done

condin:
send "ATZ0Q0T\r" # Reset modem. Select profile 0
ignore "0\r" or "OK\r\n" timeout 2 # Ignore modem response.
send "ATE0T\r" # Initialize modem: Echo OFF,
expect "0\r" or "OK\r\n" timeout 2 # Enable responses (Numeric),
send "ATQ0V0X0T\r" # Limit response codes.
expect "0\r" timeout 2 # Confirm commands successful.
send "ATS0=2\r" # Set AutoAnswer ON
expect "0\r" timeout 2 # Confirm command successful.
done

waitcall: ignore "2\r" timeout 1 # Ignore first ring.
expect "2\r" timeout 10 # Pick up second ring
# or timeout.
# Expect a connection response.

expect "16\r" or "15\r" or "14\r" or "12\r" or "10\r" or "5\r" or "1\r"
timeout 60
done

page:
send "ATDT%N,,,%R;\r" # %N = pager call center number
# Add enough commas to wait for
# time to enter paging number.
# %R = paging number

# Confirm successful command.

expect "0\r" timeout 60
delay 2 # Wait before hanging up.
send "ATH0T\r" # Hang up.
expect "0\r" timeout 2 # Confirm successful command.
done

ripo:
send "ATZ0Q0T\r" # Reset modem. Select profile 0
ignore "0\r" or "OK\r\n" timeout 2 # Ignore modem response.
send "ATE0T\r" # Initialize modem: Echo OFF,
expect "0\r" or "OK\r\n" timeout 2 # Enable responses (Numeric),
send "ATQ0V0X0T\r" # Limit response codes.
expect "0\r" timeout 2 # Confirm commands successful.
send "ATS0=0\r" # Set AutoAnswer OFF
expect "0\r" timeout 2 # Confirm command successful.
done # RI Power On enabled.

error: # Handle unexpected modem
# responses.
expect "8\r" or "7\r" or "6\r" or "4\r" or "3\r"
delay 2
done

```

Sample File modem_f.cfg

```
#
# COMPONENT_NAME: (ESPSETUP) ENTRY SERVICE PROCESSOR SETUP F
#
# FUNCTIONS: Modem configuration file for many recent Hayes* compatible modems.
# This example uses the AT&F reset command to choose the factory defaults.
# This set up is preferred for modems with extended (&) commands. For early
# vintage modems, setup Z or Z0 is recommended. If your modem responds to
# the extended (&) commands and to factory default choices (&Fn), setup file
# F0 or F1 is recommended.
#
# * Trademark of Hayes Microcomputer Products, Inc.
#
# (C) COPYRIGHT International Business Machines Corp. 1996
# All Rights Reserved
# Licensed Materials - Property of IBM
#
# US Government Users Restricted Rights - Use, duplication or
# disclosure restricted by GSA ADP Schedule Contract with IBM Corp.
#
#
# If the modem has configuration switches, they should be set to the
# factory default settings.

ICDelay 1
DefaultTO 10
CallDelay 120
# AT Attention Code           , Inserts delay in dialing commands
# &F Reset to default profile Q0 Turn on responses
# E0 Turn echo off           Q1 Turn off responses
# V0 Use numeric responses   S0=0 Automatic answer inhibit
# +++ Escape to command mode S0=2 Answer on second ring
# H0 Hang-up                 X0=0 Limit modem response codes
#                             T = Tone mode. When used as T\r, it is a
#                             no op to maintain program synchronization
#                             when modem may/will echo the commands.
#
# &C1 Detect CD               &D2 Respond to DTR (often the default)
#
# %N Call-Out phone number   %P Paging phone number
# %S Modem speed (available to users)
#
# Following are common responses from a wide range of modems:
# 16, 15, 12, 10, 5 and 1 are connection responses. Add others as required.
# 7=busy; 6=no dial tone; 4=error; 3=no carrier; 2=ring; 0=OK
#
# PROGRAMMING NOTE: No blanks between double quote marks (").

conduit:  send "AT&FQ0T\r"           # Reset to factory defaults.
          ignore "0\r" or "OK\r\n" timeout 2 # Ignore modem response.
          send "ATE0T\r"           # Initialize modem: Echo OFF,
          expect "0\r" or "OK\r\n" timeout 2 # Enable responses (Numeric),
          send "ATQ0V0X0T\r"       # Limit response codes.
          expect "0\r" timeout 2    # Confirm commands successful.
          send "ATS0=0\r"          # Set AutoAnswer OFF
          expect "0\r" timeout 2    # Confirm command successful.
          send "AT&C1&D2\r"        # Detect carrier and DTR.
          expect "0\r" timeout 2    # Confirm command successful.
          done

connect:  send "ATDT%N\r"          # Tone dialing command.
          # %N from Call Home setup.

          # Expect a connection response.
          expect "16\r" or "15\r" or "14\r" or "12\r" or "10\r" or "5\r" or "1\r" busy "7\r"
          timeout 60
```

```

done
retry:    send "A/"                                # Repeat the previous command.
                                                # Expect a connection response.
expect "16\r" or "15\r" or "14\r" or "12\r" or "10\r" or "5\r" or "1\r" busy "7\r"
timeout 60
done
disconnect:
delay 2                                       # Separate from previous data.
send "+++"                                   # Assure command mode.
delay 2                                       # Allow mode switching delay.
send "ATH0T\r"                               # Set modem switch-hook down
                                                # (i.e., hang up).
ignore "0\r" or "OK\r" timeout 2            # Ignore modem response.
send "ATE0Q1\r"                             # Initialize modem: Echo OFF,
                                                # Disable responses.
ignore "0\r" timeout 1
done
condin:   send "AT&FQ0T\r"                   # Reset to factory defaults.
ignore "0\r" or "OK\r\n" timeout 2          # Ignore modem response.
send "ATE0T\r"                              # Initialize modem: Echo OFF,
expect "0\r" or "OK\r\n" timeout 2          # Enable responses (Numeric),
send "ATQ0V0X0T\r"                          # Limit response codes.
expect "0\r" timeout 2                      # Confirm commands successful.
send "ATS0=2\r"                             # Set AutoAnswer ON
expect "0\r" timeout 2                      # Confirm command successful.
send "AT&C1&D2\r"                          # Detect carrier and DTR.
expect "0\r" timeout 2                      # Confirm command successful.
done
waitcall: ignore "2\r" timeout 1              # Ignore first ring.
          expect "2\r" timeout 10            # Pick up second ring
                                                # or timeout.
expect "16\r" or "15\r" or "14\r" or "12\r" or "10\r" or "5\r" or "1\r"
timeout 60
done
page:     send "ATDT%N,,,%R;\r"              # %N = pager call center number
                                                # Add enough commas to wait for
                                                # time to enter paging number.
                                                # %R = paging number
                                                # Confirm successful command.
          expect "0\r" timeout 60
          delay 2                             # Wait before hanging up.
          send "ATH0T\r"                     # Hang up.
          expect "0\r" timeout 2             # Confirm successful command.
          done
ripo:     send "AT&FQ0T\r"                   # Reset to factory defaults.
ignore "0\r" or "OK\r\n" timeout 2          # Ignore modem response.
send "ATE0T\r"                              # Initialize modem: Echo OFF,
expect "0\r" or "OK\r\n" timeout 2          # Enable responses (Numeric),
send "ATQ0V0X0T\r"                          # Limit response codes.
expect "0\r" timeout 2                      # Confirm commands successful.
send "ATS0=0\r"                             # Set AutoAnswer OFF
expect "0\r" timeout 2                      # Confirm command successful.
send "AT&C1&D2\r"                          # Detect carrier and DTR.
expect "0\r" timeout 2                      # Confirm command successful.
done
error:    # Handle unexpected modem

```



```

# responses.
expect "8\r" or "7\r" or "6\r" or "4\r" or "3\r"
delay 2
done

```

Sample File modem_f0.cfg

```

#
# COMPONENT_NAME: (ESPSETUP) ENTRY SERVICE PROCESSOR SETUP F0
#
# FUNCTIONS: Modem configuration file for many recent Hayes* compatible modems.
# This example uses the AT&F0 reset command to choose the factory defaults.
# This set up is preferred for modems with extended (&) commands. For early
# vintage modems, setup Z or Z0 is recommended. If your modem responds to
# the extended (&) commands and to factory default choices (&Fn), but doesn't
# work properly with this setup file, setup F1 is recommended.
#
# * Trademark of Hayes Microcomputer Products, Inc.
#
# (C) COPYRIGHT International Business Machines Corp. 1996
# All Rights Reserved
# Licensed Materials - Property of IBM
#
# US Government Users Restricted Rights - Use, duplication or
# disclosure restricted by GSA ADP Schedule Contract with IBM Corp.
#
#
# If the modem has configuration switches, they should be set to the
# factory default settings.

ICDelay 1
DefaultT0 10
CallDelay 120
# AT Attention Code , Inserts delay in dialing commands
# &F0 Reset. Restore profile 0 Q0 Turn on responses
# E0 Turn echo off Q1 Turn off responses
# V0 Use numeric responses S0=0 Automatic answer inhibit
# +++ Escape to command mode S0=2 Answer on second ring
# H0 Hang-up X0=0 Limit modem response codes
# T = Tone mode. When used as T\r, it is a
# no op to maintain program synchronization
# when modem may/will echo the commands.
#
# &C1 Detect CD &D2 Respond to DTR (often the default)
# &R1 Ignore RTS (CTS)
#
# %N Call-Out phone number %P Paging phone number
# %S Modem speed (available to users)
#
# Following are common responses from a wide range of modems:
# 16, 15, 12, 10, 5 and 1 are connection responses. Add others as required.
# 7=busy; 6=no dial tone; 4=error; 3=no carrier; 2=ring; 0=OK
#
# PROGRAMMING NOTE: No blanks between double quote marks (").

condout: send "AT&F0Q0T\r" # Reset modem. Select profile 0
ignore "0\r" or "OK\r\n" timeout 2 # Ignore modem response.
send "ATE0T\r" # Initialize modem: Echo OFF,
expect "0\r" or "OK\r\n" timeout 2 # Enable responses (Numeric),
send "ATQ0V0X0T\r" # Limit response codes.
expect "0\r" timeout 2 # Confirm commands successful.
send "ATS0=0\r" # Set AutoAnswer OFF
expect "0\r" timeout 2 # Confirm command successful.
send "AT&C1&D2&R1\r" # Detect carrier and DTR,
# Ignore RTS.
expect "0\r" timeout 2 # Confirm command successful.
done

```

```

connect:    send "ATDT%N\r"                # Tone dialing command.
                                                # %N from Call Home setup.

                                                # Expect a connection response.
expect "16\r" or "15\r" or "14\r" or "12\r" or "10\r" or "5\r" or "1\r" busy "7\r"
timeout 60
done

retry:     send "A/"                      # Repeat the previous command.

                                                # Expect a connection response.
expect "16\r" or "15\r" or "14\r" or "12\r" or "10\r" or "5\r" or "1\r" busy "7\r"
timeout 60
done

disconnect:
delay 2                                         # Separate from previous data.
send "+++"                                     # Assure command mode.
delay 2                                         # Allow mode switching delay.
send "ATH0T\r"                                 # Set modem switch-hook down
                                                # (i.e., hang up).
ignore "0\r" or "OK\r" timeout 2              # Ignore modem response.
send "ATE0Q1\r"                               # Initialize modem: Echo OFF,
                                                # Disable responses.

ignore "0\r" timeout 1
done

condin:   send "AT&F0Q0T\r"                 # Reset modem. Select profile 0
ignore "0\r" or "OK\r\n" timeout 2           # Ignore modem response.
send "ATE0T\r"                               # Initialize modem: Echo OFF,
expect "0\r" or "OK\r\n" timeout 2          # Enable responses (Numeric),
send "ATQ0V0X0T\r"                          # Limit response codes.
expect "0\r" timeout 2                      # Confirm commands successful.
send "ATS0=2\r"                              # Set AutoAnswer ON
expect "0\r" timeout 2                      # Confirm command successful.
send "AT&C1&D2&R1\r"                       # Detect carrier and DTR,
                                                # Ignore RTS.
                                                # Confirm command successful.
expect "0\r" timeout 2
done

waitcall: ignore "2\r" timeout 1              # Ignore first ring.
expect "2\r" timeout 10                     # Pick up second ring
                                                # or timeout.
                                                # Expect a connection response.
expect "16\r" or "15\r" or "14\r" or "12\r" or "10\r" or "5\r" or "1\r"
timeout 60
done

page:     send "ATDT%N,,,%R;\r"             # %N = pager call center number
                                                # Add enough commas to wait for
                                                # time to enter paging number.
                                                # %R = paging number

                                                # Confirm successful command.
expect "0\r" timeout 60
delay 2                                       # Wait before hanging up.
send "ATH0T\r"                               # Hang up.
expect "0\r" timeout 2                      # Confirm successful command.
done

ripo:    send "AT&F0Q0T\r"                 # Reset modem. Select profile 0
ignore "0\r" or "OK\r\n" timeout 2         # Ignore modem response.
send "ATE0T\r"                               # Initialize modem: Echo OFF,
expect "0\r" or "OK\r\n" timeout 2        # Enable responses (Numeric),
send "ATQ0V0X0T\r"                         # Limit response codes.
expect "0\r" timeout 2                     # Confirm commands successful.

```

```

send "ATS0=0\r" # Set AutoAnswer OFF
expect "0\r" timeout 2 # Confirm command successful.
send "AT&C1&D2&R1\r" # Detect carrier and DTR,
# Ignore RTS.
expect "0\r" timeout 2 # Confirm command successful.
done # RI Power On enabled.

error: # Handle unexpected modem
# responses.
expect "8\r" or "7\r" or "6\r" or "4\r" or "3\r"
delay 2
done

```

Sample File modem_f1.cfg

```

#
# COMPONENT_NAME: (ESPSETUP) ENTRY SERVICE PROCESSOR SETUP F1
#
# FUNCTIONS: Modem configuration file for many recent Hayes* compatible modems.
# This example uses the AT&F1 reset command to choose the factory defaults.
# This set up is for modems with extended (&) commands and which do not work
# properly with setup F0. For early vintage modems, setup Z or Z0 is
# recommended.
#
# * Trademark of Hayes Microcomputer Products, Inc.
#
# (C) COPYRIGHT International Business Machines Corp. 1996
# All Rights Reserved
# Licensed Materials - Property of IBM
#
# US Government Users Restricted Rights - Use, duplication or
# disclosure restricted by GSA ADP Schedule Contract with IBM Corp.
#
# If the modem has configuration switches, they should be set to the
# factory default settings.

ICDelay 1
DefaultT0 10
CallDelay 120
# AT Attention Code , Inserts delay in dialing commands
# &F1 Reset. Restore profile 1 Q0 Turn on responses
# E0 Turn echo off Q1 Turn off responses
# V0 Use numeric responses S0=0 Automatic answer inhibit
# +++ Escape to command mode S0=2 Answer on second ring
# H0 Hang-up X0=0 Limit modem response codes
# T = Tone mode. When used as T\r, it is a
# no op to maintain program synchronization
# when modem may/will echo the commands.
#
# &C1 Detect CD &D2 Respond to DTR (often the default)
# &R1 Ignore RTS (CTS)
#
# %N Call-Out phone number %P Paging phone number
# %S Modem speed (available to users)
#
# Following are common responses from a wide range of modems:
# 16, 15, 12, 10, 5 and 1 are connection responses. Add others as required.
# 7=busy; 6=no dial tone; 4=error; 3=no carrier; 2=ring; 0=OK
#
# PROGRAMMING NOTE: No blanks between double quote marks (").

condout: send "AT&F1Q0T\r" # Reset modem. Select profile 1
ignore "0\r" or "OK\r\n" timeout 2 # Ignore modem response.
send "ATE0T\r" # Initialize modem: Echo OFF,
expect "0\r" or "OK\r\n" timeout 2 # Enable responses (Numeric),
send "ATQ0V0X0T\r" # Limit response codes.

```

```

        expect "0\r" timeout 2           # Confirm commands successful.
        send "ATS0=0\r"                 # Set AutoAnswer OFF
        expect "0\r" timeout 2         # Confirm command successful.
        send "AT&C1&D2&R1\r"          # Detect carrier and DTR,
                                        # Ignore RTS.
        expect "0\r" timeout 2         # Confirm command successful.
        done

connect:  send "ATDT%N\r"              # Tone dialing command.
                                        # %N from Call Home setup.

        # Expect a connection response.
        expect "16\r" or "15\r" or "14\r" or "12\r" or "10\r" or "5\r" or "1\r" busy "7\r"
        timeout 60
        done

retry:    send "A/"                   # Repeat the previous command.

        # Expect a connection response.
        expect "16\r" or "15\r" or "14\r" or "12\r" or "10\r" or "5\r" or "1\r" busy "7\r"
        timeout 60
        done

disconnect:
        delay 2                        # Separate from previous data.
        send "+++"                    # Assure command mode.
        delay 2                        # Allow mode switching delay.
        send "ATH0T\r"                # Set modem switch-hook down
                                        # (i.e., hang up).
        ignore "0\r" or "OK\r" timeout 2 # Ignore modem response.
        send "ATE0Q1\r"               # Initialize modem: Echo OFF,
                                        # Disable responses.

        ignore "0\r" timeout 1
        done

conadin: send "AT&F1Q0T\r"            # Reset modem. Select profile 1
        ignore "0\r" or "OK\r\n" timeout 2 # Ignore modem response.
        send "ATE0T\r"                # Initialize modem: Echo OFF,
        expect "0\r" or "OK\r\n" timeout 2 # Enable responses (Numeric),
        send "ATQ0V0X0T\r"            # Limit response codes.
        expect "0\r" timeout 2         # Confirm commands successful.
        send "ATS0=2\r"               # Set AutoAnswer ON
        expect "0\r" timeout 2         # Confirm command successful.
        send "AT&C1&D2&R1\r"          # Detect carrier and DTR,
                                        # Ignore RTS.
        expect "0\r" timeout 2         # Confirm command successful.
        done

waitcall: ignore "2\r" timeout 1       # Ignore first ring.
        expect "2\r" timeout 10       # Pick up second ring
                                        # or timeout.
        # Expect a connection response.
        expect "16\r" or "15\r" or "14\r" or "12\r" or "10\r" or "5\r" or "1\r"
        timeout 60
        done

page:    send "ATDT%N,,,%R;\r"        # %N = pager call center number
                                        # Add enough commas to wait for
                                        # time to enter paging number.
                                        # %R = paging number

        # Confirm successful command.
        expect "0\r" timeout 60
        delay 2                        # Wait before hanging up.
        send "ATH0T\r"                # Hang up.
        expect "0\r" timeout 2         # Confirm successful command.
        done

```

```

ripo:      send "AT&F1Q0T\r"           # Reset modem. Select profile 1
          ignore "\r" or "OK\r\n" timeout 2 # Ignore modem response.
          send "ATE0T\r"           # Initialize modem: Echo OFF,
          expect "\r" or "OK\r\n" timeout 2 # Enable responses (Numeric),
          send "ATQ0V0X0T\r"       # Limit response codes.
          expect "\r" timeout 2     # Confirm commands successful.
          send "ATS0=0\r"           # Set AutoAnswer OFF
          expect "\r" timeout 2     # Confirm command successful.
          send "AT&C1&D2&R1\r"     # Detect carrier and DTR,
          # Ignore RTS.
          expect "\r" timeout 2     # Confirm command successful.
          done                       # RI Power On enabled.

error:      # Handle unexpected modem
          # responses.
          expect "8\r" or "7\r" or "6\r" or "4\r" or "3\r"
          delay 2
          done

```

Appendix E. Rack Drawer Rail Instructions

This appendix provides information for installing rails into your rack or system.

Read the safety information in “Safety Notices” on page xi before using these procedures.

Front Drawer-Stop Installation

Install a drawer stop **(2)**, part number 11K0358, on each side at the front of the rack to prevent the drawer from sliding out the front. Use six screws **(1)**, part number 73H2932, and four nut clips **(3)**, part number 74F1823, to attach the drawer stops.

Note: To put the drawer in the front-service position, the drawer stops have to be removed temporarily.

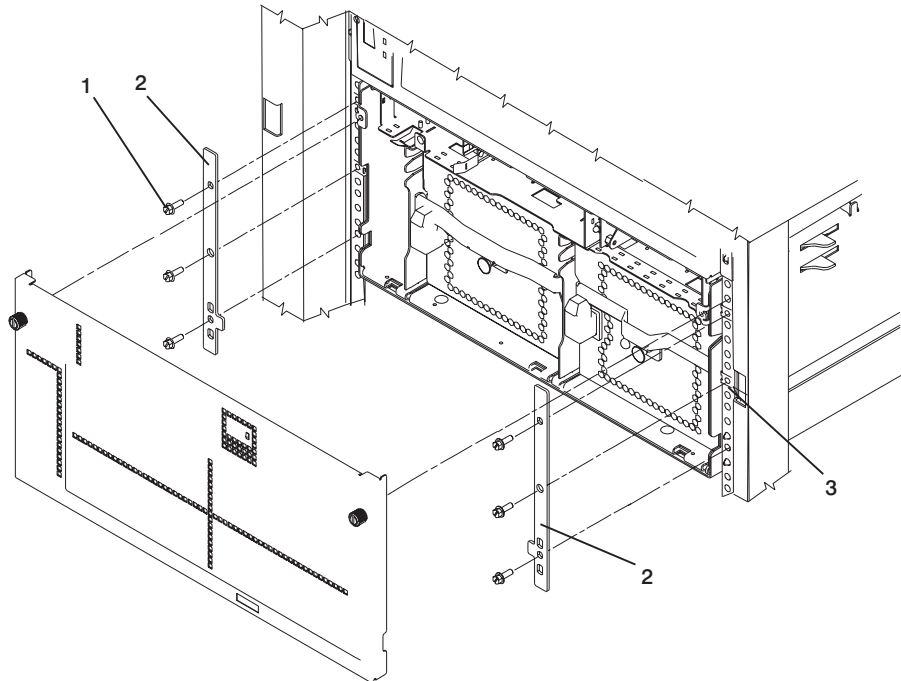

Drawer Rail Assembly and Installation

The drawer rails require assembly before you put them in your rack.

Use two screws, part number 00G1268, to attach an anti-tip guide **(2)**, part number 09P0327, to each rail. The left rail **(1)** is part number 03N3845 and the right rail **(5)** is part number 03N3847.

Rails for an S00 Type Rack

Use one screw, part number 00G1268, to attach a Model S00 type cable guide **(4)**, part number 11K0826, to the right rail. The model S00 type rack does not have enough room on the left side of the rack for a cable guide. Install a guide only on the right rails.

Rails for a T00 Type Rack

Use one screw, part number 00G1268, to attach a Model T00 type cable guide **(3)**, part number 00P2402, to each rail. The model T00 type rack has room for guides on both the left and the right rails.

Rail Installation

As you install the right rail into the rack, install the drawer latch reset bracket, part number 11K0851, above the right rail. Refer to the *Installation Guide* for your system drawers to install the rails in your rack.

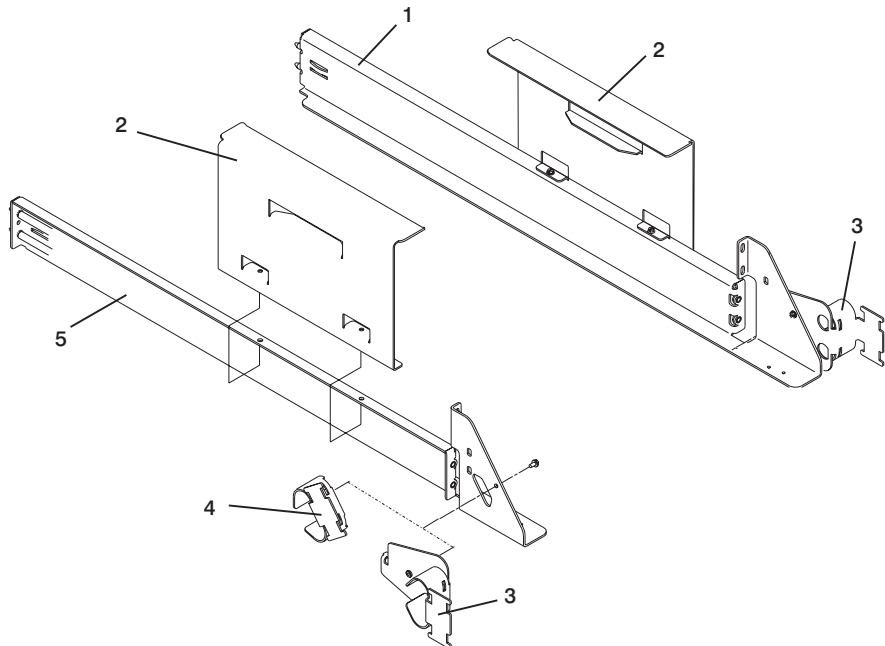

Cable Routing

Use the following descriptions to route and secure the cables in the rack drawer.

I/O Drawer Cables: If present, connect the RIO drawer cables to the I/O drawer and secure them with the RIO cable retainer **(3)**, part number 11K0584. Use two screws **(2)**, part number 00G1268.

To hold the cables, use the cable hanging brackets **(1)**, part number 11K1013, as needed.

Route the cables over the cable guides, and secure the cables with Velcro strips, part number 07H6855 or 51H9502.

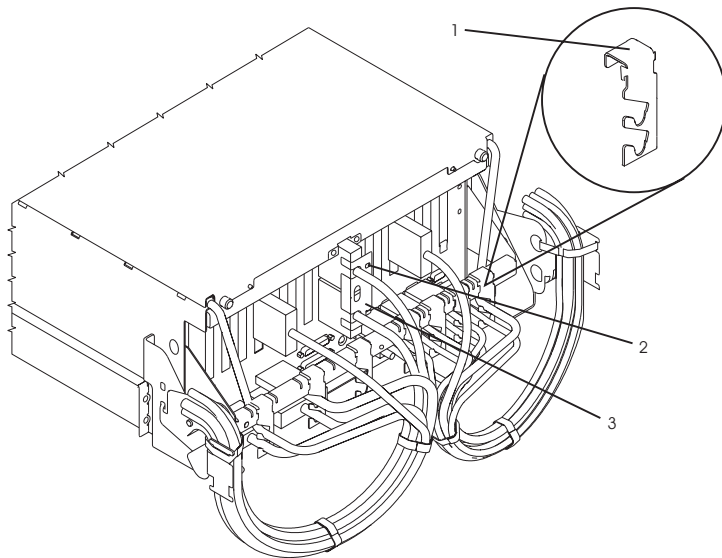

CEC Drawer Cables: Arrange the CEC drawer cables in the CEC drawer cable bracket **(3)**, part number 11K0249, and fasten the bracket to the back of the CEC drawer. (Fasteners **(1)** push in to lock and pull out to unlock.)

Route the cables over the cable guides, and secure the cables with Velcro strips **(2)**, part number 07H6855 or 51H9502.

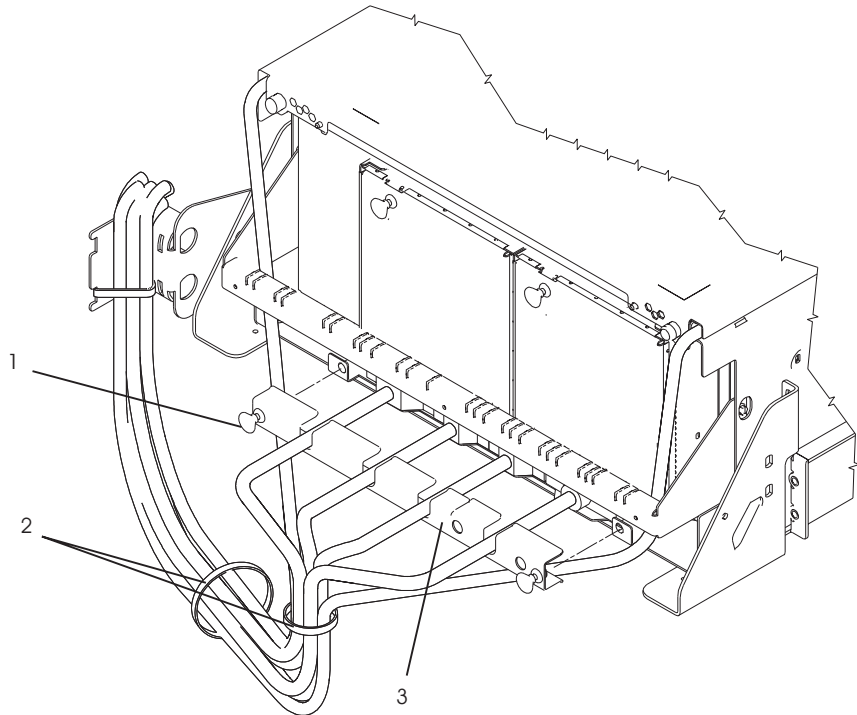

Securing Drawer Cables: Route the cables over the cable guides (2) and secure the cables with Velcro strips (1), part number 07H6855 or 51H9502. Leave a loop large enough so that the drawer can be pulled out the back.

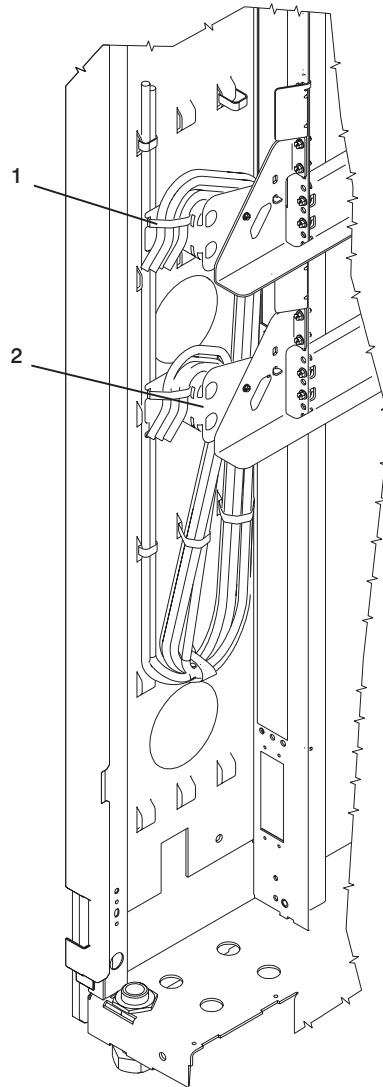

Index

A

about this book xvii
acoustical
 noise
 emissions 493
AIX location codes 34, 36
AIX operating system documentation 384, 422

B

battery
 disposal, recycling 493
battery removal 469
bay locations 25
boot list 368
boot mode menu 381
boot problems 159

C

cables
 JTAG 48
 RIO 49
 SPCN 49, 52
 V/S COMM 48
cabling 48
call-in
 testing 498
call-in/call-out setup menu 391
call-out
 testing 498
call-out (call-home) 406
call-out policy setup menu 395
CD-ROM drive removal 462
CEC drawer
 backplane 445
 cable diagram 54
 fans 444
 power distribution board 451
checkpoints 137
 description 70
 firmware 147
 service processor 140
clearances, service 65
code, error 163
common firmware error codes 354
configuration, rack 65
configure, processor/memory 404
connecting cables 48
connecting the CEC drawer and I/O drawers 48
console mirroring 408
console strategy 5
customer account setup menu 396

D

data flow 4
dc power cable routings 57
dc power cables 57
deconfigure, processor/memory 404
description, ipl flow 137
diagnostics
 online 367
 overview 69
 standalone 367
diskette drive removal 464

E

electronic service agent 72
emissions
 noise 493
entering open firmware 7
entry MAP 69, 75
error code to FRU index 163
error codes
 common firmware 354
 firmware 190
 operator panel 168
 problem determination generated 364
 service processor 213
 SPCN 169
 system firmware 354
error logs 409
external cables 487

F

fan controller card removal 461
firmware 402
 checkpoints 147
 error codes 190
 level 402
 update 402
firmware updates
 system 401
flow, data 4
flow, IPL 137
front service position 468
FRU
 hot-pluggable 430
 index 163
 isolation 71

G

general user menu 371

H

- handling static-sensitive devices 428
- hot-pluggable FRUs 430
- hot-pluggable PCI adapter installation overview 438

I

- I/O drawer backplane assembly 447
- I/O drawer features 27
- I/O drawer power distribution board 452
- index, error code to FRU 163
- indicators, POST 6
- information, reference 1
- installing cables 48
- internal disk drives removal 458
- IPL
 - flow 137
 - phases 137
- isolation, FRU 71

J

- JTAG, cable connection 48

K

- keyboards 488, 490
- keys
 - numeric 1 key 7
 - numeric 5 7
 - numeric 6 7
 - numeric 8 key 7

L

- language selection menu 390
- language, select 425
- laser compliance statement xiii, 462
- laser safety information xiii
- LCD progress indicator log 410
- LED status 23, 24
- loading the system diagnostics 367
- location codes 36
 - AIX 34
 - format 32
 - physical 32
- locations 9, 14
 - AIX 36
 - location code reference tables 36
 - physical 36

M

- maintenance analysis procedures 69
- maintenance analysis procedures (MAPs) 75, 76
 - minimum configuration MAP 113
 - power MAP 89
 - problem determination MAP 84
 - quick entry MAP 76
- memory configuration/deconfiguration menu 384, 385

- memory riser card and memory DIMM locations 21
- memory riser cards and memory modules 441
- memory, description 26
- messages, SP checkpoints 140
- minimum configuration MAP 69, 113
- Model H80 and Models 6H0 and 6H1 system unit locations 8
- modem
 - configuration file selection 502
 - configurations 501
 - transfer 507
- modem_f.cfg, sample file 517
- modem_f0.cfg, sample file 519
- modem_f1.cfg, sample file 521
- modem_m0.cfg, sample file 509
- modem_m1.cfg, sample file 511
- modem_z.cfg, sample file 513
- modem_z0.cfg, sample file 515

N

- noise
 - emissions 493
- noise emission 64, 494

O

- one-way processor card memory DIMM locations 22
- online diagnostics 367
- online publications xvii
- open firmware, entering 7
- operating system documentation, AIX 384, 422
- operator panel error codes 168
- operator panel removal 465
- overview
 - diagnostics 69
 - hot-pluggable PCI adapter 438

P

- parts 471
 - CEC drawer 472, 475
 - CEC drawer internal cables 481
 - external cables 487
 - I/O drawer 477, 479
 - keyboard 488, 490
 - primary I/O drawer internal cables 483
 - secondary I/O drawer internal cables 485
- PCI
 - adapter removal 431
 - board locations 19
 - slot LED definitions 430
- phases, ipl 137
- physical location codes 32, 36
- POST indicators 6
- POST keys
 - numeric 1 7
 - numeric 5 key 7
 - numeric 6 key 7

- POST keys *(continued)*
 - numeric 8 key 7
- power cables 66
- power control network utilities menu 389
- power MAP 69, 89
- power supply
 - fan removal 454
 - removal 454
 - test switch 457
- Power-On Self-Test 6
- powering on and off 4, 429
- preface xvii
- primary console 508
- primary I/O drawer cable diagram 55
 - cable diagram 55
- primary I/O drawer operator panel locations 23
- privileged user menus 372
- problem determination generated error codes 364
- problem determination MAP 69, 84
- processor card 443
- processor configuration/deconfiguration menu 383
- processor/memory
 - configure 404
 - deconfigure 404
- product disposal 493
- publications, online xvii

Q

- quick entry MAP 69, 76

R

- rack configuration 65
- rear service position 467
- reboot/restart policy setup menu 379
- recycling 493
- reference information 1
- reference tables
 - aix location code 36
 - physical location code 36
- related publications xvii
- removal and replacement procedures 431
 - battery 469
 - cd-rom drive 462
 - CEC drawer backplane 445
 - CEC drawer power distribution board 451
 - cec fans 444
 - diskette drive 464
 - fan controller card 461
 - I/O drawer backplane assembly 447
 - I/O drawer power distribution board 452
 - internal disk drives 458
 - memory riser cards and memory modules 441
 - operator panel 465
 - PCI adapters 431
 - power supply 454

- removal and replacement procedures *(continued)*
 - power supply fan 454
 - processor card 443
 - RIO card assembly 449
 - tape drive 463
- restart recovery 399
- RETAIN 396
- retries 395
- ring-indicate power-on menu 378
- RIO card assembly 449

S

- safety
 - electrical xii
 - laser compliance statement xiii
 - laser statement 462
 - notices xi
- saving service processor settings 497
- SCSI IDs 25
- secondary I/O drawer cable diagram 56
 - cable diagram 56
- secondary I/O drawer operator panel locations 24
- Self-Test, Power-On 6
- serial port
 - selection menu 393
 - snoop setup menu 377
 - speed setup menu 393
- service clearance 65
- service inspection guide 67
- service mode 367
- service processor
 - backup settings 497
 - boot mode menu 381
 - call-in/call-out setup menu 391
 - call-out call-home 406
 - call-out policy setup menu 395
 - checklist 497
 - checkpoints 140
 - console mirroring 408
 - customer account setup menu 396
 - error codes 213
 - error log 409
 - functions 397
 - general user menu 371
 - language selection menu 390
 - main menu 372
 - memory configuration/deconfiguration menu 384, 385
 - menus 370
 - menus list 369
 - modem configuration menu 392
 - monitoring - surveillance 405
 - operational phases 411
 - OS surveillance setup menu 376
 - passwords 375

- service processor (*continued*)
 - power control network utilities menu 389
 - power-on methods 398
 - privileged user menus 372
 - procedures in service mode 396
 - processor configuration/deconfiguration menu 383
 - reboot/restart policy setup menu 379
 - ring-indicate power-on menu 378
 - serial port selection menu 393
 - serial port snoop setup menu 377
 - serial port speed setup menu 393
 - service processor reboot/restart recovery 399
 - setup 497
 - setup checklist 497
 - setup menu 374
 - system information menu 382
 - system power control menu 378
 - telephone setup menu 394
 - test 497
- service processor feature 72
- setup menu 374
- SP checkpoints 140
- SPCN cabling 52
- SPCN error codes 169
- specifications 58
 - cec drawer 58
 - I/O drawer 62
 - Model H80 and Models 6H0 and 6H1 rack 60
 - noise emission notes 64, 494
- standalone diagnostics 367
- strategy, console 5
- system board 20
 - bays 25
 - CEC drawer front view 9
 - CEC drawer rear 11
 - locations 20
 - logical 32
 - memory riser card and memory DIMMs 21
 - one-way processor card memory DIMMs 22
 - PCI board 19
 - physical 32
 - primary I/O drawer front 12
 - primary I/O drawer front view with covers removed 15
 - primary I/O drawer operator panel 23
 - primary I/O drawer rear 14
 - SCSI IDs 25
 - secondary I/O drawer front 16
 - secondary I/O drawer operator panel 24
 - secondary I/O drawer rear view 18
 - system unit 8
- system diagnostics, loading 367
- system firmware update messages 354
- system firmware updates 401
- system information menu 382

- system management services 415
 - display error log 417
 - multiboot 422
 - OK prompt 425
 - password utilities 416
 - remote initial program load setup 417
 - SCSI utilities 421
 - select console 421
 - select language 425
- system memory 26
- system power-on methods 398
- system specifications 58
- system unit locations 8
- system, powering on and off 4

T

- tape drive removal 463
- telephone setup menu 394
- testing the setup
 - call-in 498
 - call-out 498
- trademarks xviii
- transfer of a modem session 507

U

- using
 - electronic service agent 72
 - service processor 72

V

- V/S COMM, cable connection 48

W

- Web sites
 - AIX library 384, 422
 - firmware updates 401, 402
 - microcode updates 401, 402

Readers' Comments — We'd Like to Hear from You

RS/6000 Enterprise Server Model H80
@server pSeries 660 Models 6H0 and 6H1
Service Guide

Publication No. SA38-0566-03

Overall, how satisfied are you with the information in this book?

	Very Satisfied	Satisfied	Neutral	Dissatisfied	Very Dissatisfied
Overall satisfaction	<input type="checkbox"/>	<input type="checkbox"/>	<input type="checkbox"/>	<input type="checkbox"/>	<input type="checkbox"/>

How satisfied are you that the information in this book is:

	Very Satisfied	Satisfied	Neutral	Dissatisfied	Very Dissatisfied
Accurate	<input type="checkbox"/>	<input type="checkbox"/>	<input type="checkbox"/>	<input type="checkbox"/>	<input type="checkbox"/>
Complete	<input type="checkbox"/>	<input type="checkbox"/>	<input type="checkbox"/>	<input type="checkbox"/>	<input type="checkbox"/>
Easy to find	<input type="checkbox"/>	<input type="checkbox"/>	<input type="checkbox"/>	<input type="checkbox"/>	<input type="checkbox"/>
Easy to understand	<input type="checkbox"/>	<input type="checkbox"/>	<input type="checkbox"/>	<input type="checkbox"/>	<input type="checkbox"/>
Well organized	<input type="checkbox"/>	<input type="checkbox"/>	<input type="checkbox"/>	<input type="checkbox"/>	<input type="checkbox"/>
Applicable to your tasks	<input type="checkbox"/>	<input type="checkbox"/>	<input type="checkbox"/>	<input type="checkbox"/>	<input type="checkbox"/>

Please tell us how we can improve this book:

Thank you for your responses. May we contact you? Yes No

When you send comments to IBM, you grant IBM a nonexclusive right to use or distribute your comments in any way it believes appropriate without incurring any obligation to you.

Name

Address

Company or Organization

Phone No.

Readers' Comments — We'd Like to Hear from You
SA38-0566-03



Cut or Fold
Along Line

Fold and Tape

Please do not staple

Fold and Tape



NO POSTAGE
NECESSARY
IF MAILED IN THE
UNITED STATES

BUSINESS REPLY MAIL

FIRST-CLASS MAIL PERMIT NO. 40 ARMONK, NEW YORK

POSTAGE WILL BE PAID BY ADDRESSEE

Information Development
Department H6DS-905-6C006
11501 Burnet Road
Austin, TX 78758-3493

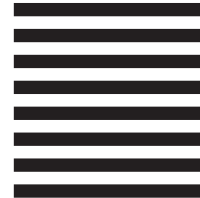

Fold and Tape

Please do not staple

Fold and Tape

SA38-0566-03

Cut or Fold
Along Line



Printed in U.S.A.

April 2002

SA38-0566-03



Spine information:

RS/6000 Enterprise Server
Model H80
eServer pSeries 660
Models 6H0 and 6H1



Service Guide

SA38-0566-03