

7015

**Model R24 CPU-Media Enclosure
Operator Guide**



7015

**Model R24 CPU-Media Enclosure
Operator Guide**

First Edition (July 1994)

This edition notice applies to the *7015 POWERserver Model R24 CPU-Media Enclosure Operator Guide*

The following paragraph does not apply to the United Kingdom or any country where such provisions are inconsistent with local law: THIS PUBLICATION IS PRINTED "AS IS" WITHOUT WARRANTY OF ANY KIND, EITHER EXPRESS OR IMPLIED, INCLUDING, BUT NOT LIMITED TO, THE IMPLIED WARRANTIES OF MERCHANTABILITY OR FITNESS FOR A PARTICULAR PURPOSE. Some states do not allow disclaimer of express or implied warranties in certain transactions; therefore, this statement may not apply to you.

This publication could include technical inaccuracies or typographical errors. Changes are periodically made to the information herein; these changes will be incorporated in new editions of the publication.

It is possible that this publication may contain reference to, or information about, products (machines and programs), programming, or services that are not announced in your country. Such references or information must not be construed to mean that such products, programming, or services will be offered in your country. Any reference to a licensed program in this publication is not intended to state or imply that you can use only the licensed program indicated. You can use any functionally equivalent program instead.

Medeco is a trademark of Medeco Company.

©Copyright International Business Machines Corporation, 1994. All rights reserved.

Note to US Government Users – Documentation and programs related to restricted rights – Use, duplication, or disclosure is subject to the restrictions set forth in the GSA ADP Schedule Contract.

Table of Contents

Communications Statements	ix
Safety Notices	xiii
About This Book	xv
Definition of Machine Names and Model Numbers	xv
Chapter 1. CPU-Media Enclosure Description	1-1
CPU-Media Enclosure	1-1
Front View	1-1
CPU-Media Enclosure with Connectors (Rear View)	1-2
Operator Panel	1-3
Media Devices	1-4
3.5-Inch Diskette Drive	1-4
CD-ROM Drive	1-4
5.0 G-byte 8-mm Tape Drive	1-5
4.0 G-byte 4-mm Tape Drive	1-6
1/4-Inch Internal Tape Drive	1-7
Chapter 2. Using the CPU-Media Enclosure	2-1
Setting the Key Mode Switch	2-1
Reading the Three-Digit Display	2-4
Using the Reset Button	2-5
Using the Remote Reset Port	2-5
Using the 3.5-Inch Diskette Drive	2-6
Handling Your Diskettes	2-6
Types of 3.5-Inch Diskettes	2-7
Setting the Write-Protect Tab on 3.5-Inch Diskettes	2-8
Loading and Unloading the 3.5-Inch Diskette	2-9
Using the CD-ROM Drive	2-10
Loading the CD-ROM Disc Caddy	2-11
Unloading the CD-ROM Disc Caddy	2-12
Cleaning the CD-ROM Drive	2-12
Using the 1/4-Inch Internal Tape Drive	2-13
Status Light	2-13
Setting the Write-Protect Tab on 1/4-Inch Tape Cartridges	2-14
Loading the 1/4-Inch Tape Cartridge	2-15
Unloading the 1/4-Inch Tape Cartridge	2-16
Cleaning	2-16
Media	2-16
Environment Considerations for 1/4-Inch Tape Cartridges	2-16
Retensioning	2-17
Tape Cartridge Compatibility	2-17
Tape Cartridge Data Efficiency	2-18
General Information for 5.0GB 8-mm Tape Drive	2-19
Recommendations	2-19

Types of 8-mm Tape Cartridges	2-19
Tape Cartridge Compatibility	2-20
Setting the Write-Protect Tab on 8 mm Tape Cartridges	2-20
Environmental Considerations for 8 mm Data Cartridges	2-20
Operating in Harsh Environments	2-21
8 mm Data Cartridge Erasure	2-21
Tape Cartridge Data Efficiency	2-21
Using the 5.0GB 8 mm Tape Drive	2-23
Status Lights	2-23
Status Light States	2-24
Loading the 8 mm Tape Cartridge	2-25
Unloading the 8 mm Tape Cartridge	2-26
Cleaning the Tape Path on the 5.0GB 8 mm Tape Drive	2-27
General Information for 4.0GB 4 mm Tape Drive	2-29
Recommendations	2-30
Types of 4 mm Tape Cartridges	2-30
Tape Cartridge Compatibility	2-31
Setting the Write-Protect Tab on 4 mm Tape Cartridges	2-31
Environmental Considerations for 4 mm Data Cartridges	2-31
Operating in Harsh Environments	2-32
4 mm Data Cartridge Erasure	2-32
Tape Cartridge Data Capacity	2-32
Using the 4.0GB 4 mm Tape Drive	2-33
Status Lights	2-33
Status Light States	2-33
Loading the 4 mm Tape Cartridge	2-35
Unloading the 4 mm Tape Cartridge	2-36
Cleaning the Tape Path on the 4.0GB 4 mm Tape Drive	2-37
Ordering Keys	2-38
Key Reorder Form	2-39
Chapter 3. AC Rack Description	3-1
AC Rack	3-1
AC Rack with CPU-Media Enclosure (Front View)	3-1
AC System Unit with Alternate Rack Features	3-2
Front View of AC 7015 Rack with External Device Container	3-2
AC 7015 Racks with Cable Channel and Rack Attachment Plate	3-3
Power Distribution Bus	3-4
Power Distribution Unit	3-5
Optional Battery Backup Unit	3-6
SCSI-2 Drawer	3-7
8 mm Tape Drive	3-7
4 mm Tape Drive	3-7
Disk Drive	3-7
Controls	3-8
System Unit Options	3-8
AC System Unit Cables and the CPU-Media Enclosure	3-9
Connectors	3-9
Cable Path	3-11
Location Identification Labels	3-12
Location Code Format for 9333 and 9334 SCSI Expansion Units	3-12

Location Code Format for SCSI Devices	3-12
SCSI Drawer ID Label	3-13
SCSI Device Address Label	3-14
Cover Label	3-14
Creating Cover Labels	3-15
Location Code Format for Non-SCSI Devices	3-17
Non-SCSI Drawer ID Label	3-17
Location Code Table for SCSI and Non-SCSI Devices	3-18
Chapter 4. Using the AC Rack	4-1
General Information about Multiple Systems	4-1
Starting the AC System Unit	4-1
Methods of Starting the AC System Unit	4-1
Manually Powering On the AC System Unit Containing a PDU	4-2
Manually Powering On the AC System Unit with a PDB	4-4
Stopping the AC System Unit	4-7
Stopping the AC System Unit Containing a PDU – Ordinary Conditions	4-7
Immediately Stopping the AC System Unit Containing a PDU	4-8
Stopping the AC System Unit Containing a PDB – Ordinary Conditions	4-9
Immediately Stopping the AC System Unit Containing a PDB	4-10
Chapter 5. Description – -48 V dc Rack	5-1
-48 V dc System Unit	5-1
Power Distribution Panel (-48 V dc Rack)	5-2
-48 V dc System Unit Power Cables and the CPU-Media Enclosure	5-3
Chapter 6. Using the -48 V dc Rack	6-1
Setting the Key Mode Switch	6-1
Starting the -48 V dc System Unit	6-1
Verify -48 V dc Power to System Unit	6-2
Setting the Circuit Breaker Switches to On	6-2
Starting the CPU-Media Enclosure (With -48 V dc Power Supply)	6-3
Stopping the -48 V dc System Unit	6-4
Stopping the System Unit under Ordinary Conditions	6-4
Stopping the -48 V dc System Unit Immediately	6-5
Chapter 7. Using the Diagnostics	7-1
Sources for the Diagnostic Programs	7-1
Diagnostic Programs Operating Considerations	7-1
Diagnostics on a System Unit Attached to Another System	7-1
Selecting a Console Display	7-1
Identifying the Terminal Type to the Operating System	7-1
Undefined Terminal Types	7-2
Running the Diagnostic Programs from Diskettes	7-2
Running the Diagnostic Programs from CD-ROM Disc	7-3
Running the Diagnostic Programs from Disk	7-3
Running the Diskette Diagnostics from a Non-RS232 Terminal	7-4
Running the Diagnostic Programs from a TTY Terminal	7-5
General Attributes Always Required	7-6
Additional Communication Attributes	7-7
Additional Keyboard Attributes	7-8

Additional Printer Attributes	7-8
Diagnostic Modes of Operation	7-9
Maintenance Mode	7-9
Running the Diagnostics in Maintenance Mode	7-9
Concurrent Mode	7-10
Running the Diagnostics in Concurrent Mode	7-10
Standalone Mode	7-11
Running the Diagnostics in Standalone Mode	7-11
System Exerciser	7-12
Starting the System Exerciser	7-12
Display Screens	7-12
Stopping the System Exerciser	7-13
Using the System Exerciser to Check Out Repairs and Intermittent Problems	7-13
Reading Flashing 888 Numbers	7-14
Crash Codes	7-15
Dump Progress Indicators (Dump Status Codes)	7-16
Chapter 8. Using the Service Aids	8-1
Introduction to Service Aids	8-1
Display Previous Diagnostic Results	8-1
Display or Change Diagnostic Test List	8-2
Display or Change Configuration or Vital Product Data	8-2
Display Configuration	8-2
Display Vital Product Data (VPD)	8-2
Display or Alter VPD	8-2
Change Configuration	8-2
Display or Alter Bootlist	8-3
Trace	8-3
Diagnostic Diskette Creation	8-3
Disk-Based Diagnostic Update	8-3
Dials and LPFK Configuration	8-3
Diskette Media	8-4
Disk Media	8-4
Format Disk	8-4
Format	8-4
Format and Certify	8-4
Certify Disk	8-4
Local Area Network	8-4
SCSI Bus	8-5
Display Test Patterns	8-5
Microcode Download	8-5
Service Hints	8-5
Multimedia Video Capture Adapter	8-5
Hardware Error Report	8-5
Product Topology	8-6
Introduction	8-6
How the Product Topology System Works	8-6
Initial Installation	8-6
MES and Other Field Action	8-7
Missing or New Resources	8-7
Installing Multiple Engineering Changes (ECs)	8-7

Using the Create (Rebuild) Function	8-7
Completing the Product Topology Process	8-8
Installation of EC A90783B	8-8
Machines without Product Topology	8-8
Chapter 9. Using the System Verification Procedure	9-1
System Verification Procedure	9-1
Chapter 10. Hardware Problem Determination	10-1
Hardware Problem Determination Procedure	10-1
Appendix A: Supplies	A-1
Appendix B. Three-Digit Display Numbers	B-1
Built-In Self-Test (BIST) Indicators	B-1
Power-On Self-Test (POST) Indicators	B-2
Configuration Program Indicators	B-4
Diagnostic Load Progress Indicators	B-8
Index	X-1

Communications Statements

The following statement applies to this product. The statement for other products intended for use with this product appears in their accompanying manuals.

Federal Communications Commission (FCC) Statement

Note: This equipment has been tested and found to comply with the limits for a Class A digital device, pursuant to Part 15 of the FCC Rules. These limits are designed to provide reasonable protection against harmful interference when the equipment is operated in a commercial environment. This equipment generates, uses, and can radiate radio frequency energy and, if not installed and used in accordance with the instruction manual, may cause harmful interference to radio communications. Operation of this equipment in a residential area is likely to cause harmful interference in which case the user will be required to correct the interference at his own expense.

Properly shielded and grounded cables and connectors must be used in order to meet FCC emission limits. Neither the provider or the manufacturer are responsible for any radio or television interference caused by using other than recommended cables and connectors or by unauthorized changes or modifications to this equipment. Unauthorized changes or modifications could void the user's authority to operate the equipment.

This device complies with Part 15 of the FCC Rules. Operation is subject to the following two conditions: (1) this device may not cause harmful interference, and (2) this device must accept any interference received, including interference that may cause undesired operation.

United Kingdom Telecommunications Safety Requirements

This equipment is manufactured to the International Safety Standard EN60950 and as such is approved in the UK under the General Approval Number NS/G/1234/J/100003 for indirect connection to the public telecommunication network.

The network adapter interfaces housed within this equipment are approved separately, each one having its own independent approval number. These interface adapters, supplied by the manufacturer, do not use or contain excessive voltages. An excessive voltage is one which exceeds 70.7 V peak ac or 120 V dc. They interface with this equipment using Safe Extra Low Voltages only. In order to maintain the separate (independent) approval of the manufacturer's adapters, it is essential that other optional cards, not supplied by the manufacturer, do not use main voltages or any other excessive voltages. Seek advice from a competent engineer before installing other adapters not supplied by the manufacturer.

EC Council Directive

This product is in conformity with the protection requirements of EC Council Directive 89/336/EEC on the approximation of the laws of the Member States relating to electromagnetic compatibility.

Neither the provider or the manufacturer can accept responsibility for any failure to satisfy the protection requirements resulting from a non-recommended modification of the product, including the fitting of option cards not supplied by the manufacturer.

International Electrotechnical Commission (IEC) Statement

This product has been designed and built to comply with IEC Standard 950.

Avis de conformité aux normes du ministère des Communications du Canada

Cet équipement ne dépasse pas les limites de Classe A d'émission de bruits radioélectriques pour les appareils numériques, telles que prescrites par le Règlement sur le brouillage radioélectrique établi par le ministère des Communications du Canada. L'exploitation faite en milieu résidentiel peut entraîner le brouillage des réceptions radio et télé, ce qui obligerait le propriétaire ou l'opérateur à prendre les dispositions nécessaires pour en éliminer les causes.

Canadian Department of Communications Compliance Statement

This equipment does not exceed Class A limits for radio noise emissions for digital apparatus, set out in Radio Interference Regulation of the Canadian Department of Communications. Operation in a residential area may cause unacceptable interference to radio and TV reception requiring the owner or operator to take whatever steps necessary to correct the interference.

電波障害自主規制 届出装置の記述

この装置は、第一種情報装置（商工業地域において使用されるべき情報装置）で商工業地域での電波障害防止を目的とした情報処理装置等電波障害自主規制協議会（VCCI）基準に適合しております。

従って、住宅地域またはその隣接した地域で使用すると、ラジオ、テレビジョン受信機等に受信障害を与えることがあります。

取扱説明書に従って正しい取り扱いをしてください。

VCCI Statement

The following is a summary of the VCCI Japanese statement in the box above.

This equipment is in the Class 1 category (information equipment to be used in commercial and/or industrial areas) and conforms to the standards set by the Voluntary Control Council For Interference by Data Processing Equipment and Electronic Office Machines aimed at preventing radio interference in commercial and/or industrial areas.

Consequently, when used in a residential area or in an adjacent area thereto, radio interference may be caused to radios and TV receivers, etc.

Read the instructions for correct handling. VCCI-1.

Radio Protection for Germany

Dieses Gerät ist berechtigt in Übereinstimmung mit dem deutschen EMVG vom 9.Nov.92 das EG-Konformitätszeichen zu führen.

Der Außsteller der Konformitätserklärung ist die IBM Germany.

Dieses Gerät erfüllt die Bedingungen der EN 55022 Klasse A. Für diese Klasse von Geräten gilt folgende Bestimmung nach dem EMVG:

Geräte dürfen an Orten, für die sie nicht ausreichend entstört sind, nur mit besonderer Genehmigung des Bundesministers für Post und Telekommunikation oder des Bundesamtes für Post und Telekommunikation betrieben werden. Die Genehmigung wird erteilt, wenn keine elektromagnetischen Störungen zu erwarten sind.

(Auszug aus dem EMVG vom 9.Nov.92, Para.3, Abs.4)

Hinweis:

Dieses Genehmigungsverfahren ist von der Deutschen Bundespost noch nicht veröffentlicht worden.

Safety Notices

Note: For a translation of these notices see the *System Unit Safety Information*, form number SA23-2652.

Definitions of Safety Notices

A *danger* notice indicates the presence of a hazard that has the potential of causing death or serious personal injury.

Danger notices appear on the following pages:
3-10, 4-2, 4-5, 4-8, 4-9, 6-1

A *caution* notice indicates the presence of a hazard that has the potential of causing moderate or minor personal injury.

Caution notices appear on the following pages:
xiii, 3-4, 3-5, 3-6, 3-10, 4-2, 4-5, 6-1

A *warning* notice indicates an action that could cause damage to a program, device, system, or data.

Lithium Battery

Note: For a translation of this notice, see the *System Unit Safety Information* manual, form number SA23-2652.

CAUTION:

A lithium battery can cause fire, explosion, or a severe burn. Do not recharge, disassemble, heat above 100°C (212°F), solder directly to the cell, incinerate, or expose cell contents to water. Keep away from children. Replace only with the part number specified for your system. Use of another battery may present a risk of fire or explosion.

The battery connector is polarized; do not attempt to reverse the polarity.

Dispose of the battery according to local regulations.

Laser Safety Information

Note: The Optical Link Card (OLC) referred to in this information is part of the Serial Optic Channel Converter assembly.

This system contains a laser product called the Optical Link Card (OLC). In the U.S., the OLC is certified as a Class 1 laser product that conforms to the requirements contained in the Department of Health and Human Services (DHHS) regulation 21 CFR Subchapter J. Internationally, the OLC is certified as a Class 1 laser product that conforms to the requirements contained in the International Electrotechnical Commission (IEC) standard 825 (1984), the Verband Deutscher Elektrotechniker (VDE) standard 0837 (1986), and the CENELEC (European Committee for Electrotechnical Standardization) Harmonization Document HD 482 S1 (1988). The German testing institute VDE assigned a certificate of conformity to DIN IEC 825/VDE 0837/02.86 and CENELEC HD 482 S1/03.88; the certificate registration number is 3642.

In addition, Statens Provningsanstalt (Swedish National Testing Institute) tested and approved the OLC for use in Sweden as a Class 1 laser product and assigned the approval number SP LA 89:184. The CDRH certification label and the VDE certificate of conformity mark are located on the plastic retainer of the OLC product. Figure 1 shows the system Class 1 information label required by IEC 825.

Class 1 laser products are not considered to be hazardous. The OLC internally contains a gallium aluminum arsenide (GaAlAs) semiconductor laser diode emitting in the wavelength range of 770 to 800 nanometers. This laser diode is a Class 3B laser that is rated at 5.0 milliwatts. The design of the OLC is such that access to laser radiation above a Class 1 level during operation, user maintenance, or service conditions is prevented.

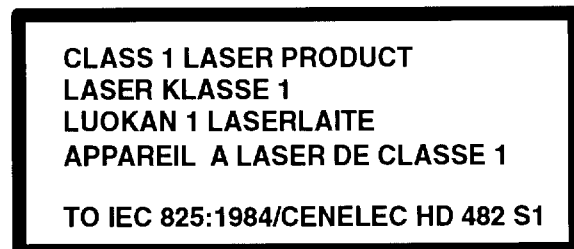

Figure 1. Class 1 System Information Label Required by the IEC 825 Standard

The Optical Link Card (OLC) must only be connected to another OLC or a compatible approved laser product. Any compatible laser product must contain the open fiber link detection and laser control safety system used in the OLC. This is a requirement for correct operation of the optical link. In addition, the OLC product is designed and certified for use in applications with point-to-point optical links only. Using this product in any other type of optical link configuration (for example, links containing optical splitters or star couplers) is considered as not using the product correctly and may require that the user certify the laser product again for conformance to the laser safety regulations.

About This Book

This book provides information about the operator controls and the devices installed in the 7015 system unit.

Definition of Machine Names and Model Numbers

The model of CPU-Media Enclosure referred to in this book is the 7015 Model R24. References to a CPU-Media Enclosure in this book applies to the 7015 Model R24 CPU-Media Enclosure.

Note: This publication is used with a system containing the 7015 CPU-Media Enclosure, or any system that is upgraded from a system containing the 7015 CPU Drawer or Enclosure to a Model R24 CPU-Media Enclosure.

Related Publications

The *AIX Problem Solving Guide and Reference* (form number SC23-2606), is the first book you should use when you have a problem with the system unit. It contains procedures for determining if the problem is hardware or software related.

The *POWERstation and POWERserver Common Diagnostics and Service Guide*, form number SA23-2687, contains reference information about adapters, devices, checkout procedures for problem determination, system verification, using the diagnostics, and cabling for the system units. This manual also contains the removal and replacement procedures for the logic boards on the disk drives and cabling information that can be used to isolate problems with customer cabling.

The *9348 Customer Information* manual, form number SA21-9567, contains operating and cleaning instructions for the tape unit.

The *RISC System/6000 System Overview and Planning*, form number GC23-2406, contains information about various hardware and software systems offerings.

The *9333 Model 010 and 011 High-Performance Disk-Drive Subsystem Operator Guide*, form number GA33-3208, contains information about operator controls and features for the serial-link expansion drawer.

The *9334 SCSI Expansion Units Operator Guide*, form number GA33-3232, provides information about the operator controls and features of the SCSI expansion drawer.

The *System Unit Safety Information* manual, form number SA23-2652, contains translations of danger and caution notices.

The *AIX System Management Guide: Operating System and Devices* manual, form number SC23-2525, contains information about using the operating system with options and devices.

The *7135 RAIDiant Array: Operator Guide*, form number GA33-3251, provides information about operator controls and features on the SCSI disk box.

The *7135 RAIDiant Array: Installation and Service Guide*, form number SY33-0181, contains information on the SCSI disk box.

Chapter 1. CPU-Media Enclosure Description

This chapter contains information about system unit features, parts, and devices on the 7015 Model R24 CPU-Media Enclosure.

CPU-Media Enclosure

The 7015 Model R24 CPU-Media Enclosure is a rack-mounted CPU containing a processor board, memory cards, cache SIMMs, 16 adapter slots, disk drives, 3.5-inch diskette drive, CD-ROM drive, 5.0GB 8 mm tape drive, an optional media position, and an operator panel.

The CPU-Media Enclosure can be installed in a 7015 Model R00 rack with other optional compatible drawers and devices such as disk drive drawers, SCSI media drawer, power distribution unit, and battery backup unit. For information about options and compatible optional drawers that can be used with the 7015 Model R24 CPU-Media Enclosure in a 7015 Model R00 rack, see the *RISC System/6000 System Overview and Planning* manual.

Front View

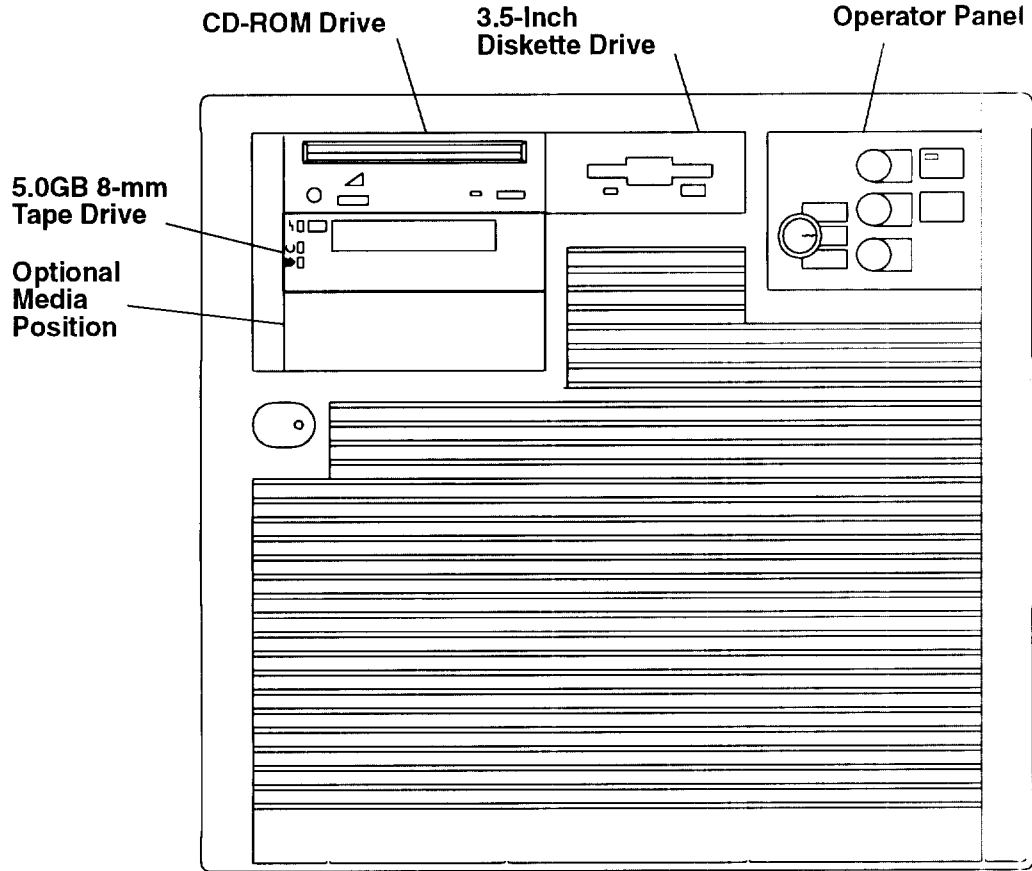

CPU-Media Enclosure with Connectors (Rear View)

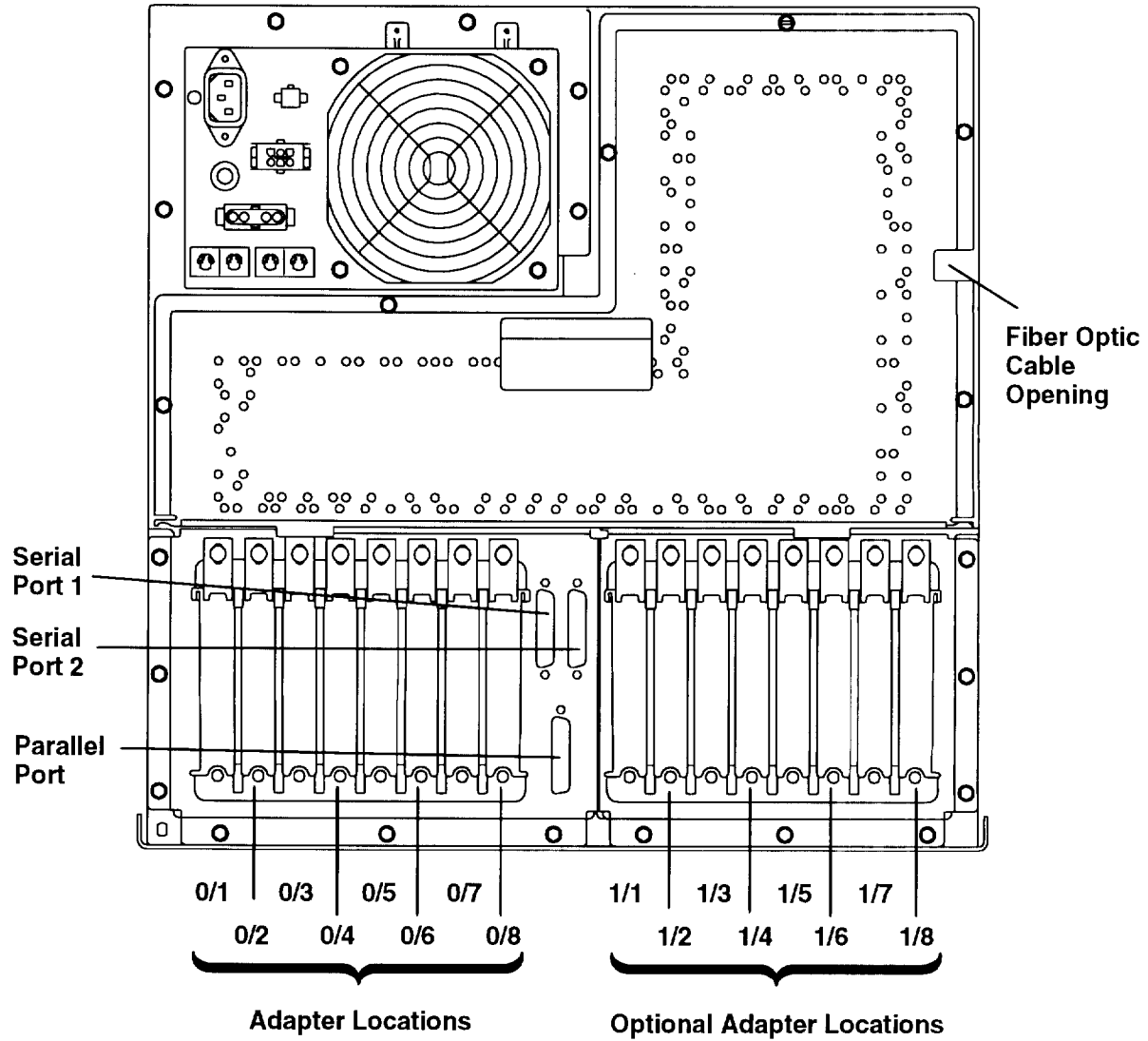

Operator Panel

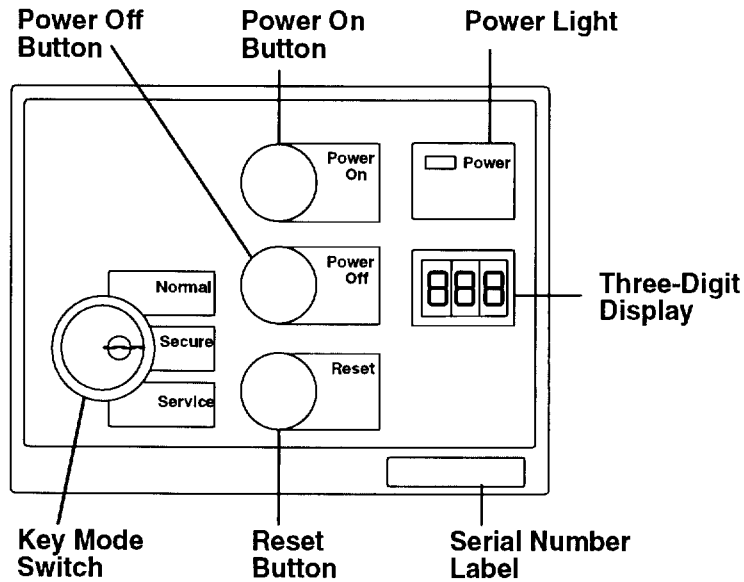

- Power Off Button** Switches off power to the system. Use this button only after you enter the appropriate **shutdown** command.
- Power On Button** Switches on power to the system.
- Power Light** Indicates that the CPU enclosure is switched on.
- Three-Digit Display** Displays up to three 7-segment characters.
- Serial Number Label** Contains the serial number of the CPU enclosure.
- Reset Button** Resets the system unit, depending on the position of the key mode switch.
- Key Mode Switch** Switches modes with a key into three positions labeled
- Normal
 - Secure
 - Service

Media Devices

3.5-Inch Diskette Drive

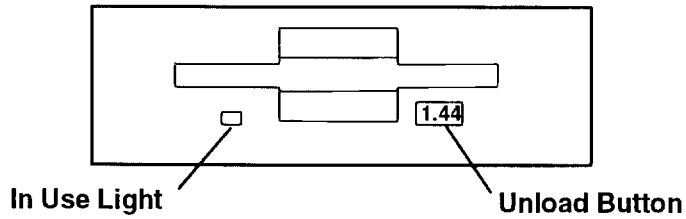

In Use Light Lights when the system is accessing the drive.

Unload Button Used to unload the diskette from the drive.

See "Using the 3.5-Inch Diskette Drive" on page 2-6 for additional information.

CD-ROM Drive

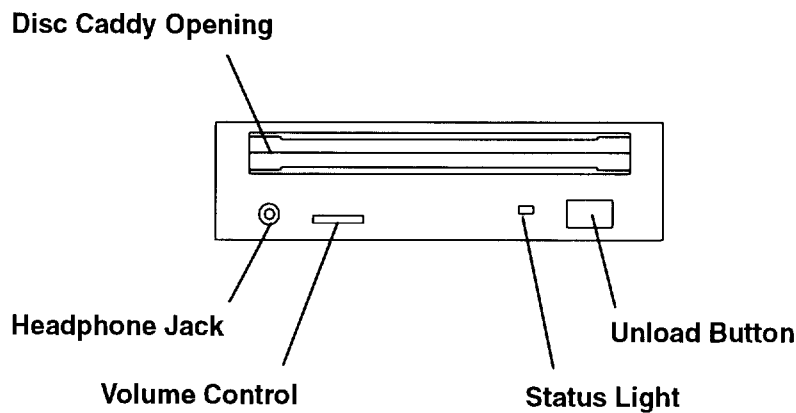

Disc Caddy Opening Receives the disc caddy.

Status Light Indicates the condition of the drive.

Unload Button Unloads the disc caddy. You must press the button for a minimum of 2 seconds to unload the disc caddy.

Volume Control Raises or lowers the volume when audio is read from the CD-ROM.

Headphone Jack Attaches headphones.

See "Using the CD-ROM Drive" on page 2-10 for additional information.

5.0 GB 8 mm Tape Drive

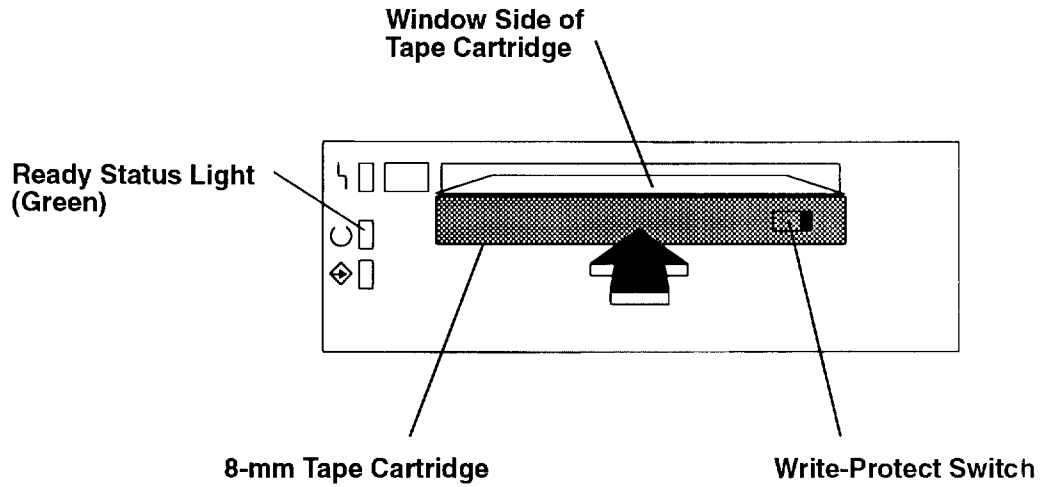

Unload Button

Used to unload the cartridge.

Status Lights

Used to indicate the status of the drive.

Drive Door

Used to receive the cartridge into the tape drive and to keep out dust.

Refer to "General Information for 5.0GB 8 mm Tape Drives" on page 2-19 and "Using the 5.0 GB 8 mm Tape Drive" on page 2-23 for additional information.

4.0 GB 4 mm Tape Drive

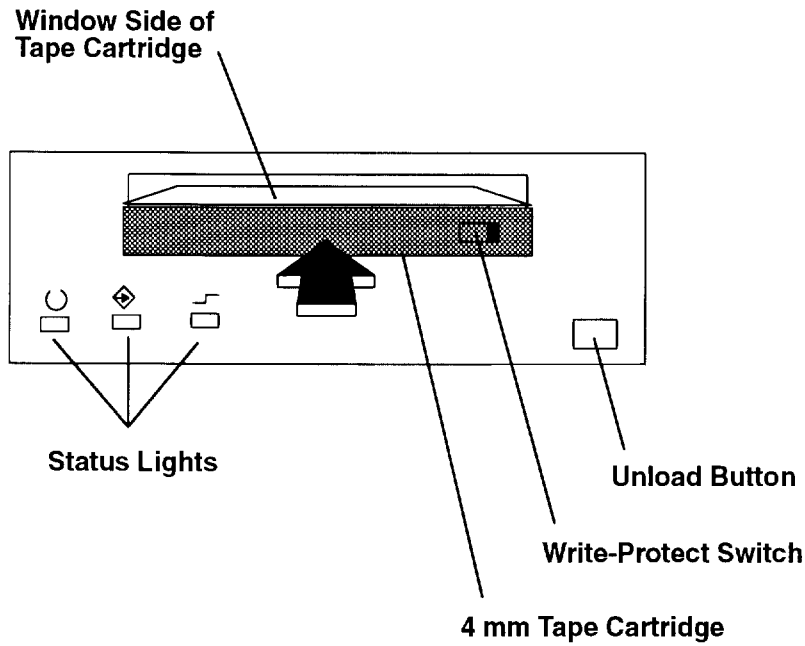

Unload Button	Used to unload the cartridge.
Status Lights	Used to indicate the status of the drive.
Drive Door	Used to receive the cartridge into the tape drive and to keep out dust.

Refer to "General Information for 4.0GB 4 mm Tape Drives" on page 2-29 and "Using the 4.0GB 4 mm Tape Drive" on page 2-33 for additional information.

1/4-Inch Internal Tape Drive

1.2GB Tape Drive

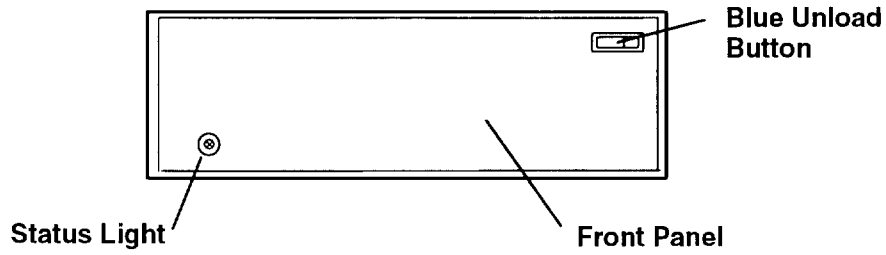

150MB Tape Drive

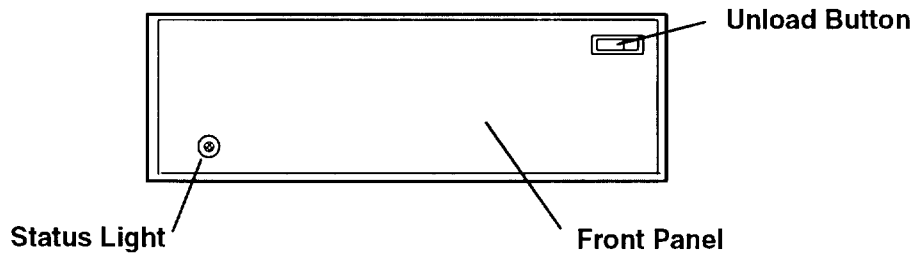

- | | |
|--------------|--|
| Green | The green light is on when the drive is in normal operation. |
| Amber | Tape-off-spool condition (1.2 GB only). |
| Red | The red light is on when there is a problem with the drive. |
| Off | The light is off when the drive is waiting in stand-by mode. The status light has no color when it is off. |

Refer to "Using the 1/4-Inch Internal Tape Drive" on page 2-13 for additional information.

Chapter 2. Using the CPU-Media Enclosure

This chapter contains information about using CPU-Media Enclosure and using devices installed in the CPU-Media Enclosure.

For information about using a -48 V dc system unit, refer to Chapter 5.

Setting the Key Mode Switch

The key mode switch has three positions:

- Normal
- Secure
- Service

The switch is used to establish the initial program load (IPL) path. The IPL loads the system programs, checks the system hardware, and prepares the system for user operation.

Before starting the system unit for normal day-to-day operation, set the key mode switch to the Normal position. This permits the operating system to load after the power-on self-tests (POSTs) are completed.

Operator Panel

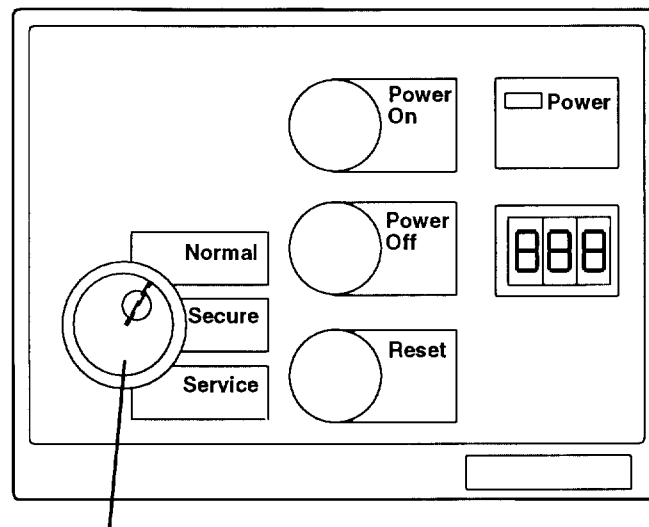

Key Mode Switch

The following table summarizes the operations possible for each key mode position for the 7015 CPU-Media Enclosure.

Operations for Key Mode Switch on 7015 CPU-Media Enclosure			
Operation	Key Mode Switch Position		
	Normal	Secure	Service
Normal IPL	Yes	No	No
Service IPL	No	No	Yes
shutdown /Program Power-Off (see note)	Yes	Yes	Yes
Program Timed Power-On	Yes	No	No
Manual Power-On	Yes	No	Yes
Manual Power-Off	No	No	Yes
Remote Power-On	Yes	No	No
Automatic Restart after Power Failure	Yes	No	No
Immediate Power-Off (IPO switch)	Yes	Yes	Yes

Note: Refer to *AIX Version 3.2.5 System Management Guide: Operating System and Devices* (form number SC23-2525) and other operating system documentation for information about the **shutdown** command and stopping the system unit.

- The Normal position:

The Normal position is used for attended operation, which is the usual or normal placement of the key mode switch when an operator is present and in control of the operation at the system unit. The Reset and Power On buttons are active and the remote power-on function is available when the switch is in the Normal position. The IPL proceeds according to the list of devices established during configuration of the operating system. When the key mode switch is in the Normal position, manual use of the Power Off button is not possible. However, the system unit can be automatically shut down and switched off with a software command. See your operating system documentation for information about software commands.

Note: If an operating system (software) is not installed, use the Service position for initial installation.

Warning: Pressing the Reset button when performing a reset via the remote reset port or when the key mode switch is in the Normal position can cause data to be damaged or lost if the operating system is running. See "Using the Reset Button" on page 2-5 for a description of the Reset button operation.

The system unit has the ability to automatically restart if the key mode switch is in the Normal position. When primary power is restored after a loss of power, the system unit automatically starts again.

- The Secure position:

The Secure position is used for unattended operation in an open environment. For example, the system unit could be used for process control in a manufacturing area where an operator responsible for the system operation is not located in the immediate area.

In the Secure position, the Reset, Power On, and Power Off buttons are not active. The Secure position prevents any IPL from completing. With the key mode switch in this position, a passerby cannot accidentally reset, switch on, or switch off the system unit.

Notes:

1. If you start the system unit and then change the key mode switch to the Secure position, the IPL of the system unit stops and 200 is displayed in the three-digit display. The system does not perform any further operations until the key mode switch is set to the Normal or Service position.
2. When the key mode switch is in the Secure position, all system functions continue to operate to allow data entry and retrieval.

- The Service position:

Warning: The Reset button and the remote reset port are active when the key mode switch is in the Service position. Pressing the Reset button can cause data to be damaged or lost if the operating system is running.

The Service position is used for attended operation when hardware or software service is conducted. The Service position activates operating system keyboard sequences that support error determination (debug) and storage printout (dump). In the Service position, the Power On and Power Off buttons are active at the system unit, but are inactive from a remote site. The Service position allows the system unit to complete a service IPL and loads the diagnostic control program (diagnostic controller) according to a list of devices established when the system unit is installed.

Reading the Three-Digit Display

The three-digit display on the drawer operator panel is used to:

- Track the progress of the system unit self-tests and configuration program.
- Display codes when the operating system comes to an abnormal end.
- Display diagnostic program messages when the display console is not working correctly

During POST, the numbers that are displayed indicate the progress of the testing. If an error is detected that requires attention, the system unit stops, and a number is displayed in the three-digit display to identify the error. If this occurs, refer to the *AIX Problem Solving Guide and References* manual.

When the self-tests complete without error, the three-digit display is blank.

Operator Panel

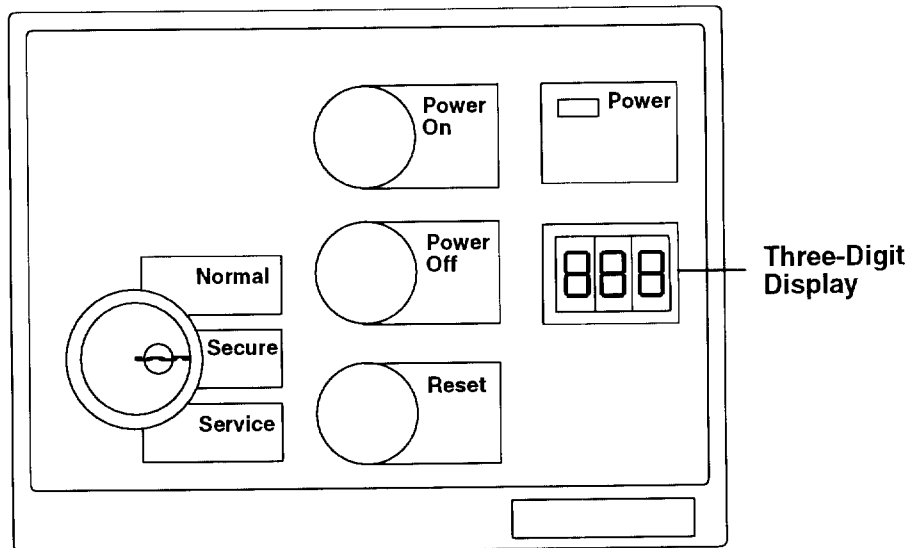

Using the Reset Button

Warning: When the key mode switch is in the Normal or Service position, pressing the Reset button or performing a reset via the remote reset port causes the unit to reset and do an initial program load (IPL). Pressing the Reset button while performing a reset via the remote reset port or while the operating system is running can result in damaged or lost data.

The Reset button has two purposes:

- To IPL the system when the key mode switch is in the Normal or Service position.
- To read out codes or diagnostic messages after a flashing 888 is displayed in the three-digit display.

When the key mode switch is in the Secure position, the Reset button is disabled, and you cannot perform an IPL by pushing the Reset button.

Operator Panel

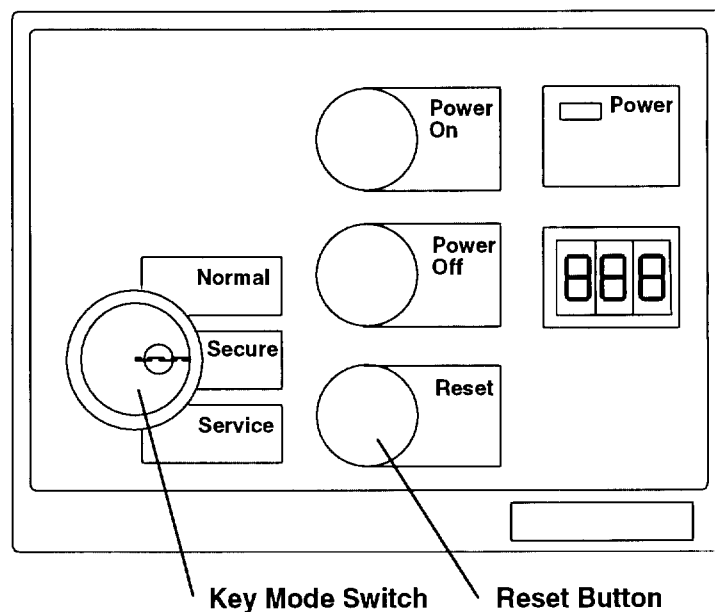

Using the Remote Reset Port

Warning: When the key mode switch is in the Normal or Service position, pressing the Reset button causes the unit to reset and do an initial program load (IPL). Pressing the Reset button while the operating system is running can result in damaged or lost data.

The Remote Reset port is used to restart the system using RS-232 output from another system unit, and the Remote Reset port is the same as the Reset button.

When the key mode switch is in the Secure position, the Remote Reset port input is disabled and you cannot perform an IPL by activating the Remote Reset port input.

Using the 3.5-Inch Diskette Drive

The diskette drive is located to the right of the CD-ROM drive on the CPU-Media Enclosure. The In Use light is on when the system is accessing the drive.

Do not stop the system unit or remove a diskette when the In Use light is on, or you may lose some of the data on the diskette.

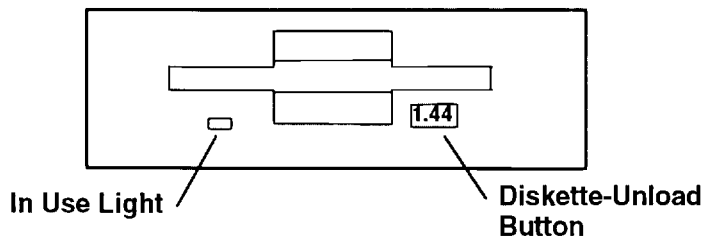

Handling Your Diskettes

Be careful with your diskettes. Because each piece of information occupies such a small area on the diskette, small scratches, dust, food, or tobacco particles can make the information unusable. Be sure to remember the following:

- Do not touch the recording surfaces.
- Keep diskettes away from magnets and magnetic field sources such as telephones, dictation equipment, and electronic calculators.
- Keep diskettes away from extreme heat and cold. The recommended temperature range is 10 to 60°C (50 to 140°F).
- Proper care helps prevent loss of information.
- Make backup copies of your diskettes regularly.

Types of 3.5-Inch Diskettes

Warning: Diskette drives and diskettes must be the correct type to store data successfully. If you use the wrong diskette in your 3.5-inch diskette drive, the data on the diskette could be destroyed. Some computers operate with 720K-byte diskette drives (no printing on the diskette-unload button) and use only 1M-byte capacity diskettes. If you are going to be transferring work between computers that have different diskette drives, be certain the diskettes are compatible. For more information, refer to your operating system manual.

The diskette drive uses the following 3.5-inch diskettes:

- 1M-byte capacity (stores approximately 720K bytes of data)
- 2M-byte capacity (stores approximately 1.44M bytes of data).

Refer to Appendix A for the diskette part numbers.

A 1M-byte diskette looks like this:

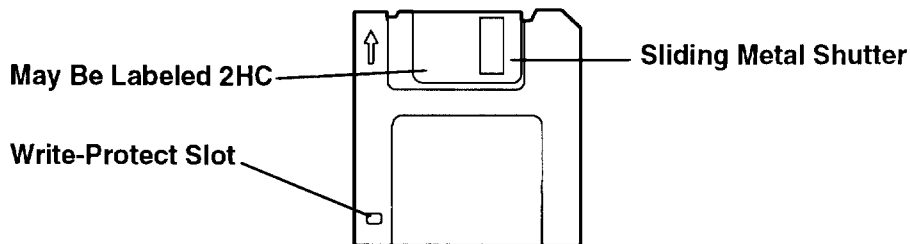

A 2M-byte diskette looks like this:

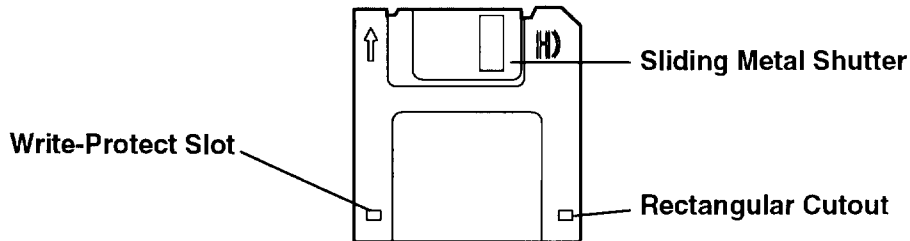

Setting the Write-Protect Tab on 3.5-Inch Diskettes

Setting the write-protect tab on a diskette is necessary so that information is not accidentally lost. When the write-protect tab is set (slot open) on a diskette, information can be read from the diskette but cannot be written to it.

There is a write-protect tab on the 3.5-inch diskette.

To locate the write-protect tab, turn the diskette over with the label facing down.

- To *prevent* writing to a diskette, slide the write-protect tab to open the slot.

Diskette with Write-Protect Tab Set

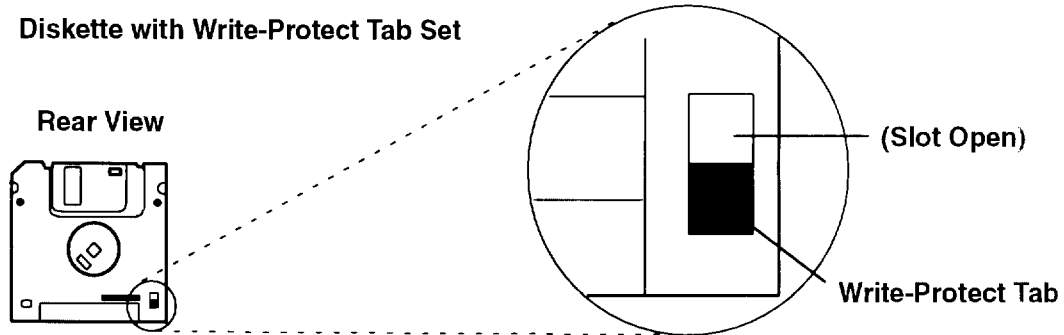

- To *allow* writing to a diskette, slide the write-protect tab to close the slot.

Diskette with Write-Protect Tab Not Set

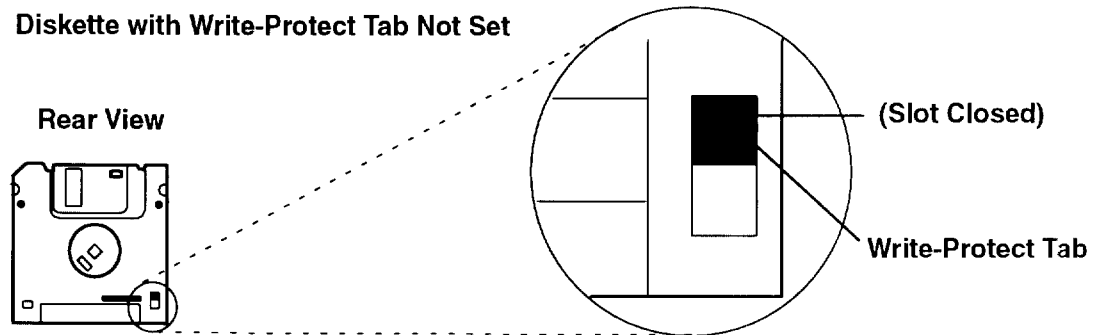

Loading and Unloading the 3.5-Inch Diskette

To load a diskette into the drive, insert the diskette in the diskette drive with the labeled metal shutter first. Push the diskette into the drive until you hear a click. The click indicates that the diskette is securely in the drive.

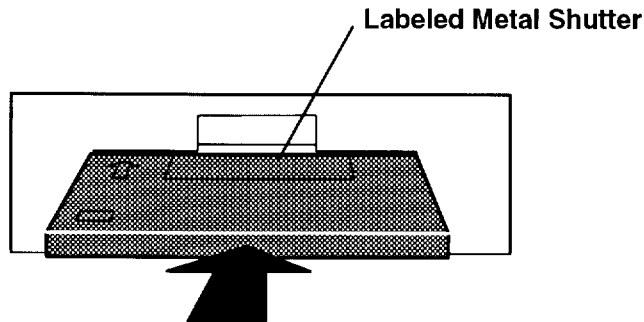

To unload the diskette, push the diskette-unload button. The diskette ejects partially so you can pull it out of the drive.

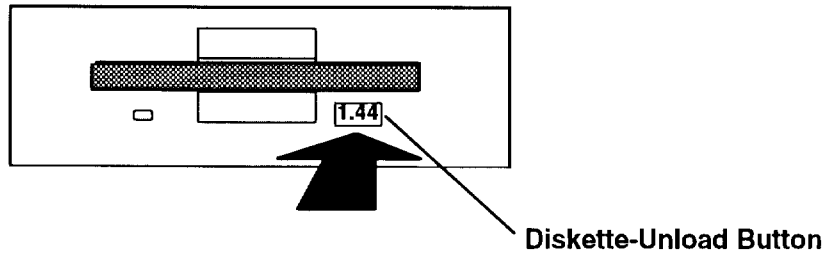

Using the CD-ROM Drive

The CD-ROM is located in the upper-left (top) position of the CPU-Media Enclosure.

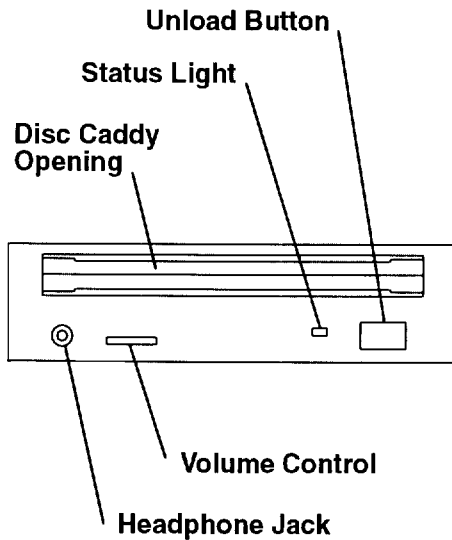

The front panel of the drive has an unload button, status light, volume control, headphone jack, and disc caddy opening.

When the CD-ROM is set to On, the status light indicates one of several conditions. The following are status light states and the respective conditions of the CD-ROM drive:

- *Off* during standby with the caddy loaded or unloaded.
- *Blinks* when the caddy is inserted and until completion of initialization.
- *Blinks slowly* when either the lens or disc is dusty (lens should be cleaned by running the cleaning device).
- *Blinks fast* when in the audio mode.
- *Lights* during data transfer operations.
- *Lights steady* when:
 - No disc is in the caddy.
 - The disc is in the caddy upside down.
 - Some condition exists that should be checked. If this occurs, contact your service representative.

Loading the CD-ROM Disc Caddy

The CD-ROM media kit contains a CD-ROM diagnostic disc and a disc caddy.

Open the disc caddy and place the CD-ROM disc in the caddy with the printed side up.

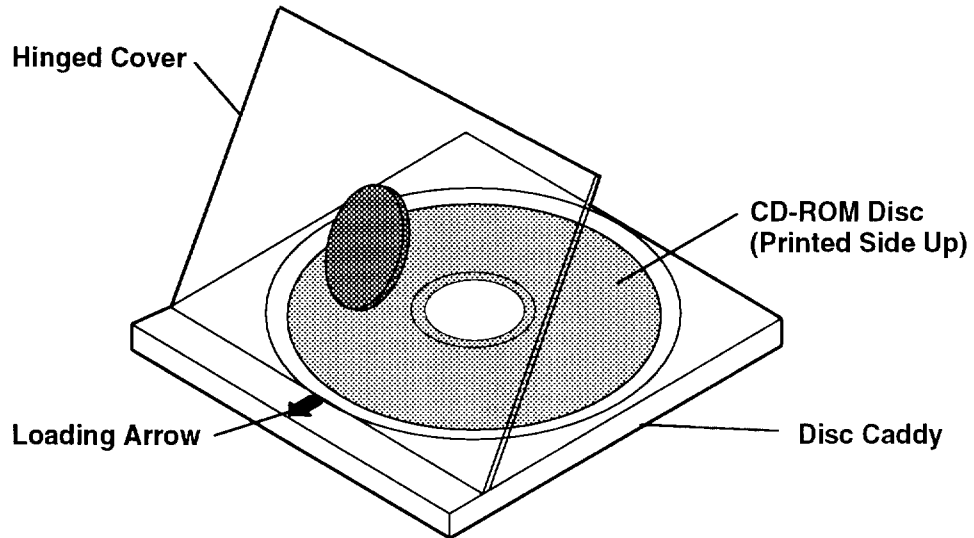

Insert the disc caddy into the disc caddy opening with the loading arrow towards the CD-ROM drive and the printed side of the disc up. Push gently on the caddy. The drive automatically pulls the caddy into the drive and prepares the disc for reading.

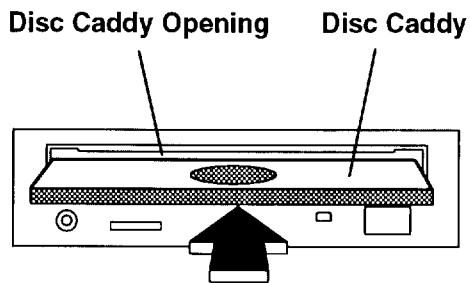

Unloading the CD-ROM Disc Caddy

Push and hold the unload button until the caddy unloads. The CD-ROM drive partially ejects the caddy from the drive opening. Pull the caddy out of the drive.

Note: The unload button must be pushed and held for a minimum of 2 seconds before the caddy unloads.

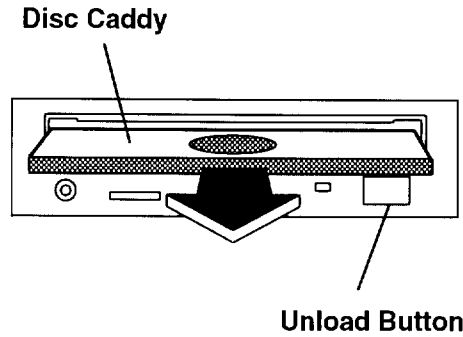

If the disc caddy cannot unload and has to be removed manually from the drive, contact your service representative.

Cleaning the CD-ROM Drive

The CD-ROM drive has an internal cleaning mechanism and does not require an external lens cleaning device.

Using the 1/4-Inch Internal Tape Drive

The 1.2 G-byte 1/4-inch tape drive, if present, is an optional device in the CPU-Media Enclosure.

The 150 M-byte 1/4-inch tape drive, if present, is an optional device in the CPU-Media Enclosure.

1.2GB Tape Drive

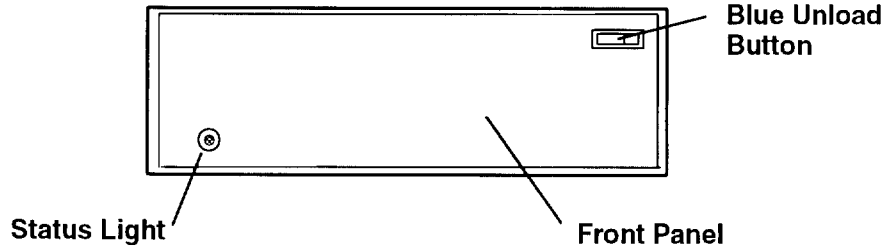

150MB Tape Drive

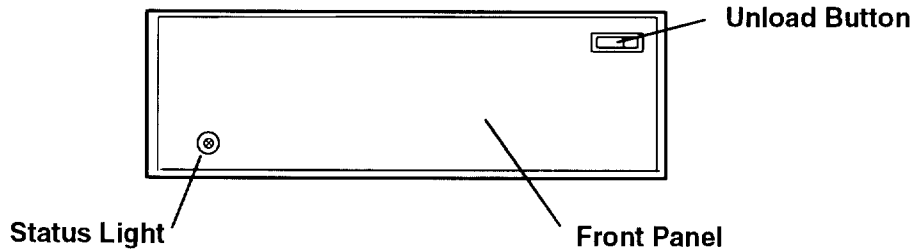

Status Light

The status light has no color when it is off. When the status light is on, it may be either green or red. The colors indicate the status of the drive as follows:

- Green The green light is on when the drive is in normal operation.
- Amber Tape-off-spool condition (1.2GB only).
- Red The red light is on when there is a problem with the drive.

Note: If the red light is on and you cannot solve the problem, see the *AIX Problem Solving Guide and Reference*.

- Off The light is off when the drive is waiting in standby mode.

Setting the Write-Protect Tab on 1/4-Inch Tape Cartridges

Setting the write-protect tab on a tape cartridge is necessary so that information is not accidentally lost. When the write-protect tab of a tape cartridge is set (pointing to **SAFE**), information can be read from the tape but cannot be written to it.

The write-protect tab positions for a typical tape cartridge are shown in the following illustration. Use a small screwdriver to turn the arrow to the desired position. The arrow must be pointing in one of the two directions shown in the illustration.

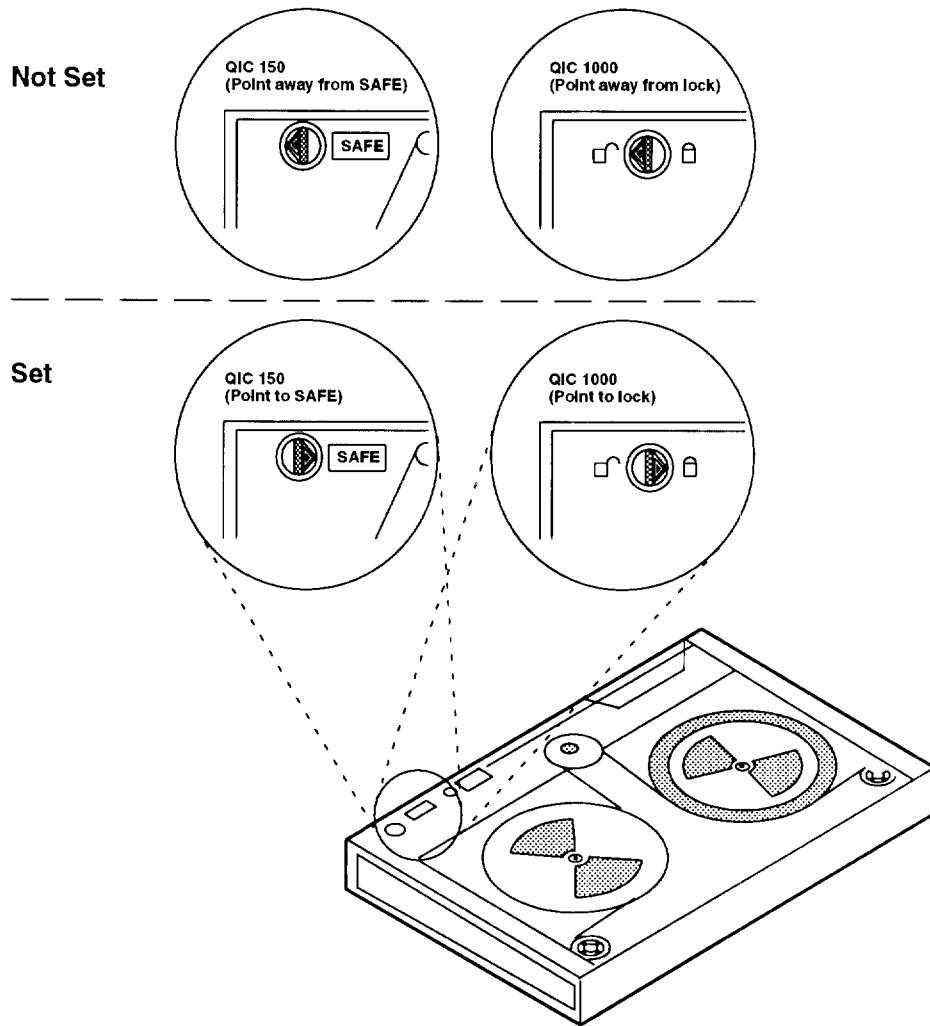

Write-Protect Tab Settings

Loading the 1/4-Inch Tape Cartridge

A diagram inside the drive opening shows how to load a tape. To load a tape cartridge, push the unload button. When the button is pushed, the front panel of the drive partially opens toward the front of the system unit.

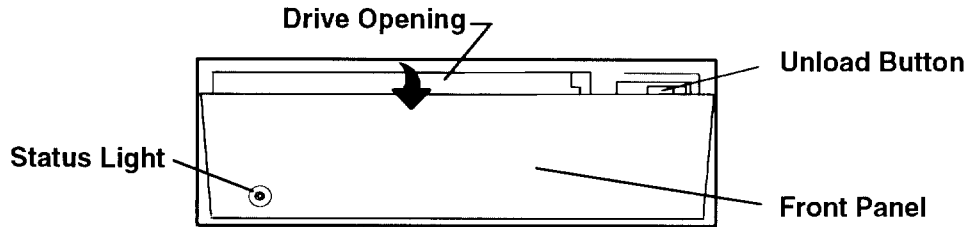

Pull the front panel open all the way to the flat position, where it will stay without having to be held open.

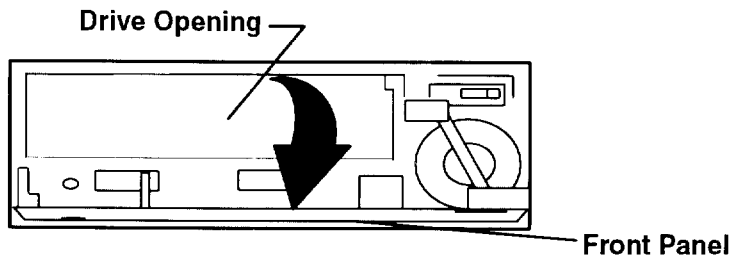

Insert the cartridge into the drive opening as shown in the following illustration. Gently push the cartridge into the drive opening until the cartridge stops.

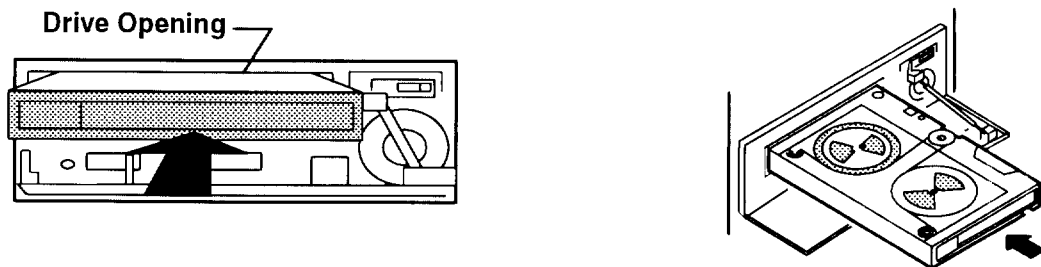

Close the front panel until you hear an audible click.

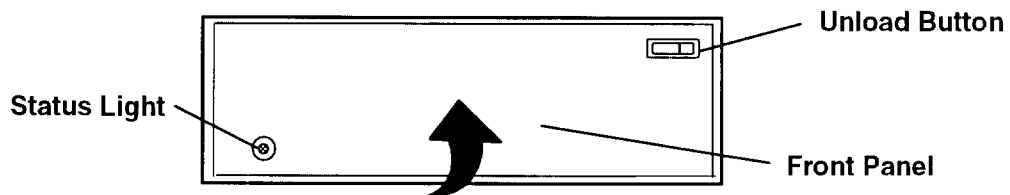

The drive loads the tape from the cartridge and prepares it for reading and writing.

Once a tape cartridge has been inserted and the front panel closed, the tape will automatically rewind to the beginning.

Unloading the 1/4-Inch Tape Cartridge

To unload the cartridge, use the same procedure as you did for loading except pull the cartridge from the drive opening.

1. Push the unload button.
2. Pull the front panel open (flat).
3. Pull the tape cartridge out of the drive.
4. Push the front panel closed.

Cleaning

Refer to Appendix A for the 1/4-inch-tape-drive cleaning-kit part number.

Clean the recording head of the tape drive after the first 2 hours of tape movement when you are using new tape cartridges. If you are using QIC-1000 cartridges and the cartridges are not new, clean the recording head after every 8 hours of tape movement. If you are using QIC-150 or QIC-525 cartridges and the cartridges are not new, clean the recording head after every 12 hours of tape movement.

Use the instructions and materials provided in the cleaning kit to ensure proper operation of the tape drive.

Media

Environment Considerations for 1/4-Inch Tape Cartridges

Information in this section describes operating and storage conditions including temperature, relative humidity, and maximum wet bulb data.

Warning: The manufacturer has specified a set of temperature and humidity ranges in which the 1/4-inch data cartridge can operate with ease. Only regular cleaning procedures are required when operating the cartridge within this range. The risk of possible data loss is increased if 1/4-inch tape cartridges are operated, stored, or shipped outside the temperature or humidity ranges shown in the following table.

Before using a cartridge, always let it adjust (acclimate) to the operating environment. Do this by placing the cartridge with its container in the operating environment for as long as it has been away from this environment or for 24 hours, whichever is less.

Acclimation is necessary for any data cartridge that has been exposed to a different humidity environment or a temperature change of 11°C or 20°F, or more.

Environment Operating Ranges		
	Operating Ranges	Non operating Ranges
Temperature Requirements	16° to 32°C (60 to 90°F)	10° to 43° C (50° to 110°F)
Relative Humidity Requirements (Non condensing)	20% to 80%	20% to 80%
Maximum Wet Bulb Limits	23°C (73°F)	27° C (80°F)

Retensioning

The tape drive works best when it is operated as a streaming tape. If the tape cartridge has been operated in the streaming mode, it is not necessary to retension the tape. If the tape is used in a nonstreaming mode (many start and stop operations), retension the tape after approximately every 30 minutes.

If the tape drive is on when a tape cartridge is inserted, the drive immediately retensions the tape; this is the default setting. Operating system commands may be used to change this default setting. Refer to the operating system commands manual for your system for more information.

Tape Cartridge Compatibility

The 1/4-inch tape drive is a medium-capacity small computer system interface (SCSI) tape drive. This drive is compatible with existing 1/4-inch streaming tape subsystems, which use the Quarter-Inch Cartridge Drive Standards, Inc. (QIC) formats.

Refer to Appendix A for the tape cartridge part numbers.

If tape cartridges other than the 1/4-inch tape cartridges listed in Appendix A are used they must meet the proposed ANSI X3B5/84-59 "Unrecorded Magnetic Tape Cartridge for Information Exchange" standard.

Note: Although the preceding ANSI standard allows three different tape lengths—47 meters (155 feet), 189 meters (620 feet), and 311 meters (1020 feet)—the 7207 Tape Drive is designed to be used only with the 189 meters (620 feet) tape length. The exception is the test tape, and it is supported only for diagnostic use.

Tape Cartridge Standard	7201-001 or 150MB Internal Tape Drive	7201-011	7201-012 or 1.2GB Internal Tape Drive	OEM Drives
QIC-24	Read-Only	Read-Only	Read-Only	Read/Write
QIC-120	Read/Write	Read/Write	Read/Write	Read/Write
QIC-150	Read/Write	Read/Write	Read/Write	Read/Write
QIC-525		Read/Write	Read/Write	Read/Write
QIC-1000			Read/Write	Read/Write

Notes:

1. Original Equipment Manufacturers (OEM) – QIC compliance.
2. Supports error correction code (ECC) error recovery.

Tape Cartridge Data Efficiency

Note: For maximum efficiency, operate the 1/4-inch tape drive in the streaming mode whenever possible.

The 1/4-inch tape cartridge efficiency is defined as the amount of data that can be stored on the cartridge and the data rate at which the data can be read from the tape cartridge. When in use, the tape in the cartridge is moved at a constant speed. The speed for the QIC-150 is 72 inches per second. The speed for the QIC-1000 is 80 inches per second. The following variables affect the amount of data that can be stored on a tape cartridge:

- Streaming mode or nonstreaming mode
- Size of the data file
- Number of file marks per file
- Tape length
- Variable post/preamble
- Compatibility mode (QIC-120/QIC-150/QIC-525/QIC-1000)

General Information for 5.0GB 8-mm Tape Drive

Recommendations

- Use only data grade 8-mm tape cartridges. These cartridges are identified by either a "Data," "D," or "D8" marking on the data cartridge. Use of video-grade cartridges can damage the 8 mm tape drive and can void the warranty of your 8 mm tape drive.
- Remove the tape cartridge from the tape drive when it is not in use, and store the cartridge in the cartridge case.
- Do not open the door on the data tape cartridge. This door covers and protects the magnetic tape material from dirt, dust, and damage.
- Avoid touching the tape since this can cause loss of data.
- Back up and then discard any tape cartridge that repeatedly produces error messages. The error information is in the system error log.
- Clean the tape path regularly according to the cleaning procedure of the 8-mm tape drive. Use only recommended cleaning cartridges; other cleaning cartridges can permanently damage your 8 mm tape drive.

Warning: Do not use video-grade cartridges in the 8 mm tape drive. Video grade tapes may be unreliable and may cause permanent damage to the 8-mm tape drive.

Types of 8-mm Tape Cartridges

Refer to Appendix A for tape-cartridge part numbers.

- **Test Tape Cartridge:** This is a specially labeled tape cartridge that is in the media kit with the 8 mm tape drive. Use this cartridge only when checking the operation of the drive or running diagnostics; do not use it to save programs or data.
- **Data Tape Cartridge:** This is a nonlabeled blank tape cartridge that is in the media kit. Use this cartridge for saving your programs or data. The same data tape cartridge can be used in a 5.0GB 8-mm tape drive.
- **Cleaning Tape Cartridge:** Use this cartridge for cleaning the 8-mm tape path. For more information, see "Cleaning the Tape Path on the 5.0GB 8-mm Tape Drive" on page 2-27.

Tape Cartridge Compatibility

The 8 mm tape drive is compatible with existing 8-mm tape subsystems that comply with the American National Standard (ANSI) X3B5/89-136, Helical-scan Digital Computer Tape Cartridge, 8 mm for Information Exchange. Data compression effectively increases the cartridge capacity and data transfer rate for the 5.0GB tape cartridges.

8 mm Tape Drive	Format Mode (C = compression mode)	
	5.0GB	5.0GB (C)
5.0GB	Read/Write	Read/Write

Setting the Write-Protect Tab on 8 mm Tape Cartridges

Setting the write-protect tab on a tape cartridge is necessary so that information is not accidentally lost. When the write-protect tab of a tape cartridge is set (window closed), information can be read from the tape but cannot be written to it.

The window on the tape cartridge controls write-protection.

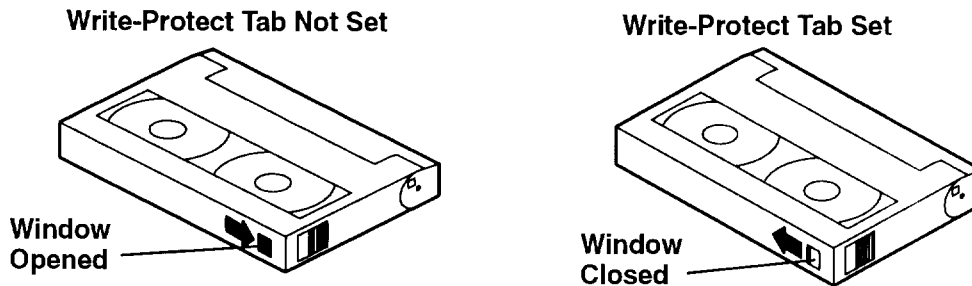

Environmental Considerations for 8 mm Data Cartridges

Information in this section describes operating and storage conditions including temperature, relative humidity, and maximum wet bulb data.

Warning: The manufacturer has specified a set of temperature and humidity ranges in which the 8 mm data cartridge can operate with ease. Only regular cleaning procedures are required when operating the cartridge within this range. The risk of possible data loss is increased if 8 mm tape cartridges are operated, stored, or shipped outside the temperature or humidity ranges shown in the following table.

Before using a cartridge, always let it adjust (acclimate) to the operating environment. Do this by placing the cartridge with its container in the operating environment for as long as it has been away from this environment or for 24 hours, whichever is less.

Acclimation is necessary for any data cartridge that has been exposed to a different humidity environment or a temperature change equal to or greater than 11°C or 20°F.

	Operating Ranges	Storage	Shipping
Temperature	16° to 32°C (60° to 90°F)	5° to 32° C (40° to 90°F)	-40° to 52° C (-40° to 125° F)
Relative Humidity (non-condensing)	20% to 80%	20% to 80%	20% to 80%
Maximum Wet Bulb	26°C (79°F)	26° C (79°F)	26° C (79°F)

Operating in Harsh Environments

The 8-mm tape drive is ideally suited to streaming operations, as opposed to tape movement operations involving multiple stop/starts and random searches. When the tape is used for frequent stop and start operations, streaming movement is beneficial and should be used whenever possible. This can be accomplished by ensuring that any save or restore operation is the only active operation performed by a device connected to this SCSI I/O controller.

Any tape that has been used outside the ranges specified in the table on this page for an extended period of time (50 passes in 40 hours of nonstop operation) should not be used as an archival tape. Exposure to the environment will deteriorate the magnetic and physical strength of the tape. Do not store important data on a tape that has been used outside the specified ranges; transfer the data to a new tape for reliable archiving.

8 mm Data Cartridge Erasure

Most bulk eraser devices do not have the capability to erase 8-mm data cartridges. To properly erase an 8 mm data cartridge with a bulk eraser device, the erasure rating must be at least 1500 oersted.

The 5.0GB 8 mm tape drives erase residual data before writing new data on the data tape.

Tape Cartridge Data Efficiency

The 8 mm tape cartridge efficiency is defined as the amount of data that can be stored on the cartridge. The following variables affect the amount of data that can be stored on a tape cartridge:

- Size of the data file
- Number of file marks per file
- File mark size used
- Compatibility mode (5.0GB)
- Media rewrites

The effects of some of these variables are listed in the charts on the following page.

8 mm Media Capacity vs File Size

5.0GB Mode

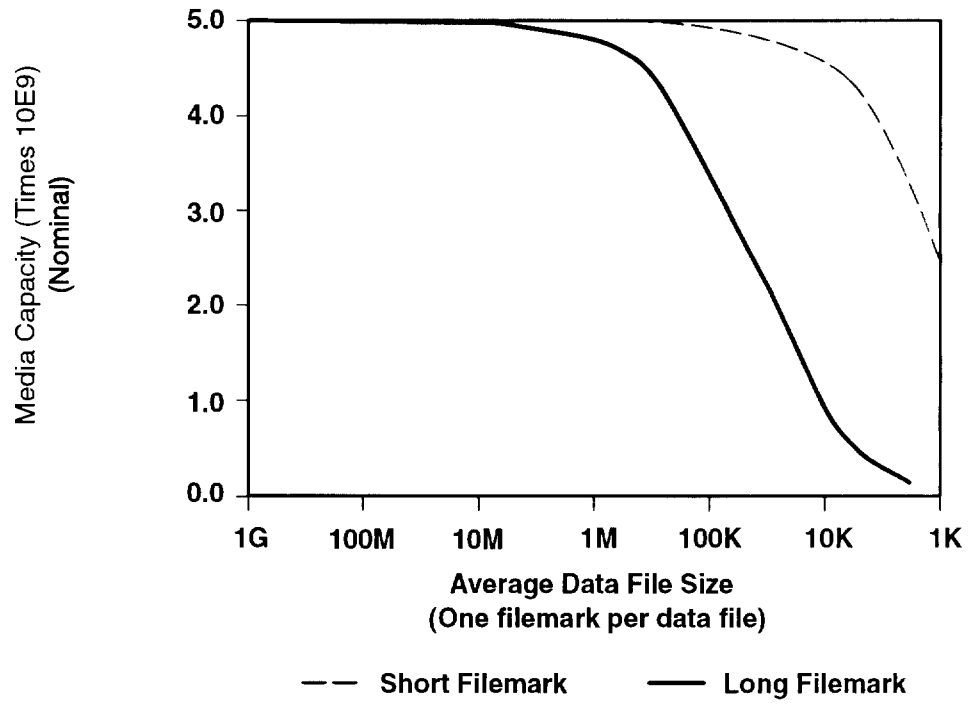



Using the 5.0GB 8 mm Tape Drive

The 8-mm tape drive is located in the top media position of the 7015 CPU-Media Enclosure when the 7015 CPU-Media Enclosure is installed in the rack.

Status Lights

The 5.0GB 8 mm tape drive has two green status lights and one amber status light. The on/off combinations of the status lights indicate the conditions of the 8 mm tape drive.





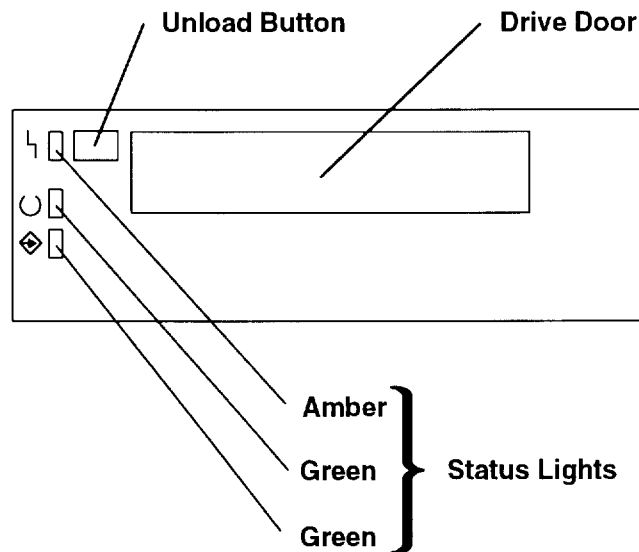















































Each of the ISO symbols located next to a status light indicates a specific condition of the tape drive as follows:

-  Disturbance (amber status light)
-  Ready (green status light)
-  Busy (green status light)



Status Light States

The following table explains the meaning of the green and amber status lights.

Status Lights on the 5.0GB 8 mm Tape Drive		
Status Lights	State	Status
     	On	The power-on self-test (POST) is running, or the system sent a Reset signal to the 8-mm tape drive.
     	Off	
     	Off Off Flashing	
     	Off On Off	A tape cartridge has been inserted and the 8-mm tape drive is ready to receive commands from the system.
     	Off On Flashing	The tape is in motion and the 8-mm tape drive is busy running a device operation.
     	Flashing Off Off	The 8-mm tape drive has detected an internal fault that requires corrective action. If this occurs, see the following note.
          	On Off or On Off or Flashing	The tape path requires cleaning. Refer to "Cleaning the Tape Path on the 5.0GB 8-mm Tape Drive" on page 2-27.
Legend:  Disturbance  Ready  Busy  On  Off  Flashing		

Note: If a fault or an error condition occurs, first try to recover by pressing the unload button. If this does not correct the fault or error condition, switch off the power to the 8 mm tape drive and then switch on the power to the drive. If the condition continues, call your service representative.

Loading the 8 mm Tape Cartridge

Before loading the tape cartridge, make sure the power is on and the write-protect switch on the tape cartridge is properly set. Refer to "Setting the Write-Protect Tab" on page 2-20. The tape drive loads the tape from the cartridge and prepares it for reading and writing.

To load the 8 mm tape cartridge, do the following:

1. Grasp the edges of the 8-mm tape cartridge with the write-protect switch towards you and the window side of the cartridge towards your left.
2. Slide the tape cartridge into the opening on the front of the 8 mm tape drive until the loading mechanism pulls the cartridge into the drive and the drive door closes. The ready status light (green) will go on if the load operation was successful.

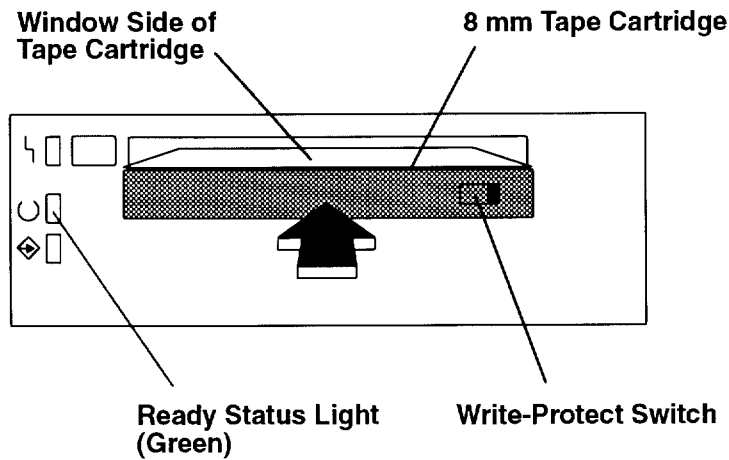

The 8 mm tape drive is ready for data operations when the tape cartridge is inserted into the 8-mm tape drive. After the cartridge is inserted into the tape drive, the tape takes about 25 seconds to load; this does not interfere with beginning the data operations.

Commands can be entered while the tape is loading. Any commands to the tape drive start running once the tape has finished loading. Commands not requiring the tape cartridge run immediately.

Unloading the 8 mm Tape Cartridge

Before performing the unload operation, make sure the power to the 8 mm tape drive is on.

To unload and eject the tape cartridge, press the unload button. The 8 mm tape drive rewinds the tape and then ejects the tape cartridge from the tape drive.

After pressing the unload button, the following will occur:

1. The ready ○ status light will go off.
2. The busy ◇ status light will flash during the unload operation.
3. The busy ◇ status light will go off when the cartridge is ejected from the tape drive.

Unload Button

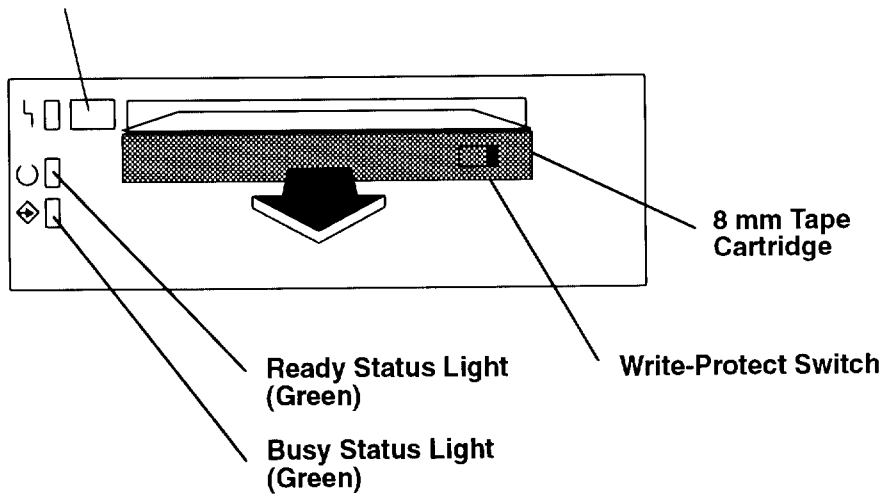

The time required for a tape to rewind and unload is between 18 seconds and 3 minutes, depending on the position of the tape when the unload button is pushed.

If the tape cartridge cannot unload and has to be removed manually from the drive, contact your service representative.

Cleaning the Tape Path on the 5.0GB 8 mm Tape Drive

Warning: Do not use video cleaning cartridges in the 8 mm tape drive. Video cleaning cartridges can damage the 8-mm tape drive. Some video cleaning cartridges are extremely abrasive. A 5.0GB 8 mm tape drive may be permanently damaged after only a few cleaning operations using an abrasive-type cleaning cartridge.

The 8-mm tape path should be cleaned either approximately every 30 hours of tape motion or once a month, whichever occurs first. The 5.0GB 8 mm tape drive counts the number of hours of tape motion and indicates when the tape path requires cleaning when the lighted disturbance status light (amber) is on.

More frequent cleaning may be required if the drive is operated in a dusty environment or in humid conditions. If the dust is allowed to accumulate, the drive has to perform more reads and writes. This can cause data loss and may be prevented by regularly scheduled cleaning of the drive.

The cleaning cartridge cleans the 5.0GB 8 mm tape drive 12 times before it needs to be discarded. If you attempt to use an 8-mm cleaning cartridge more than 12 times, the tape drive automatically detects the error and ejects the cleaning cartridge with the disturbance status light (amber) remaining on.

Before loading the cleaning cartridge, make sure the power to the 8-mm tape drive is on.

To load the 8-mm cleaning cartridge, do the following:

1. Grasp the edges of the 8 mm cleaning cartridge with the window side of the cartridge on your left.
2. Slide the cleaning cartridge into the opening on the front of the 5.0GB 8 mm tape drive until the loading mechanism pulls the cartridge into the drive.

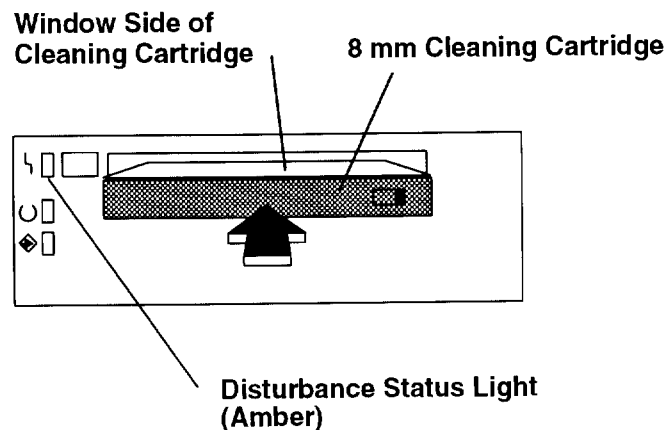

After the 8 mm cleaning cartridge has been fully inserted into the 8-mm tape drive, the following cleaning operations are performed automatically:

1. The cleaning tape is loaded into the tape path.
2. The drive is cleaned by moving the cleaning tape forward for approximately 2 minutes.
3. The tape is unloaded, and the cleaning cartridge is ejected from the tape drive when the cleaning operation is complete.
4. A successful cleaning operation is indicated when the disturbance status light (amber) goes off.

General Information for 4.0GB 4 mm Tape Drive

The 4.0GB 4 mm tape drive is an internal streaming tape drive that is used to:

- Save and restore system data files.
- Archive important records.
- Distribute operating system software upgrades.

The 4 mm tape drive can be attached to any system using a single-ended interface meeting the Small Computer System Interface II (SCSI-II) Standard ANSI X3.131-199X Rev. 10h.

The 4 mm tape drive has the following features:

- Capacity of 4.0GB per cartridge. 8 GB is typical with data compression and with DDS2 data cartridges.

The actual capacity per cartridge varies depending on the application and the type of data cartridge being used.

- Data transfer rate is 400 KBps. 800 KBps is typical with data compression.

Note: Data compression activated is the default setting from the factory. Data compression is usually controlled by the application software.

- Read and write of DDS III tape cartridges in 2.0GB per cartridge format.
- A status light that indicates when it is time to clean the tape path.
- Internal diagnostics that are activated when the 4 mm Diagnostic Cartridge is inserted and loaded into the drive.
- Media recognition system: only *data grade* media can be used with this tape drive.

The 4 mm tape drive uses a 4 mm data cartridge for saving and restoring your system data. The 4 mm tape drive is designed to use only 4 mm Digital Data Storage (DDS) cartridges. These cartridges are identified by the DDS symbols (shown below) somewhere on the data cartridge.



Recommendations

Warning: Tape cartridges that do not carry the proper DDS symbol cannot be written to and their use will cause the 4 mm tape drive to report an error.

- Use only 4 mm Digital Data Storage (DDS) cartridges.

Warning: Use of other than recommended cleaning cartridges can damage your tape drive and will void the drive warranty.

- Clean the tape path by using the recommended cleaning cartridge. Follow the instructions on the cartridge.
- Back up and then discard any tape cartridge that repeatedly produces error messages. The error information is in the system error log.
- Do *not* open the door on the data cartridge that covers the tape. This door protects the magnetic tape material from dirt, dust, and damage.
- Do *not* operate in a dusty environment.
- Do *not* touch the tape material. Any substance transferred to the tape by touching it could cause loss of data.

Types of 4 mm Tape Cartridges

The 4 mm tape drive is shipped with three 4 mm cartridges to help start your tape operations immediately. Refer to Appendix A for tape cartridge part numbers.

- | | |
|----------------------------|---|
| 4 mm Data Cartridge: | Use this non-labeled cartridge for saving or restoring your programs or data. Additional data cartridges can be ordered. |
| 4 mm Diagnostic Cartridge: | Use this specially labeled cartridge to perform diagnostics on the drive. Do <i>not</i> use it to save or restore programs or data. |
| Cleaning Cartridge: | Use this cartridge for cleaning the 4 mm tape path. For more information, see "Cleaning the Tape Path on the 4.0GB 4 mm Tape Drive" on page 2-37. |

Tape Cartridge Compatibility

The 4 mm tape drive is compatible with existing 4 mm tape subsystems that are designed to operate with Digital Data Storage approved media, which meet the following standards:

- For DDS III
 - American National Standard (ANSI) standard, X3.203-191, *Helical-scan Digital Computer Tape Cartridge, 3.81mm*.
 - European Computer Manufacturers Association (EMCA) standard, EMCA-150, *3.81mm Wide Magnetic Tape Cartridge and DDS III format*.
- For DDS2
 - European Computer Manufacturers Association (EMCA) standard, EMCA/TC17/93/20, *3.81mm Wide Magnetic Tape Cartridge for Information Interchange Helical Scan Recording, DDS2 format*.

Because the drive reconfigures itself automatically depending on the media type installed, the density setting of the drive cannot be changed.

Media Type	Device Configuration
DDS	Read-only
DDS III	Read/write in 2.0GB mode only.
DDS2	Read in either density; write in 4.0GB mode only.
Non-DDS	Not supported. The cartridge will eject.

Setting the Write-Protect Tab on 4 mm Tape Cartridges

The window on the tape cartridge controls write-protection. When the write-protect tab of a tape cartridge is set (window open), information can be read from the tape, but cannot be written to it. When the write-protect tab of a tape cartridge is not set (window closed), information can be both written to and read from the tape. Trying to write to a 4 mm data cartridge with the window open causes an error.

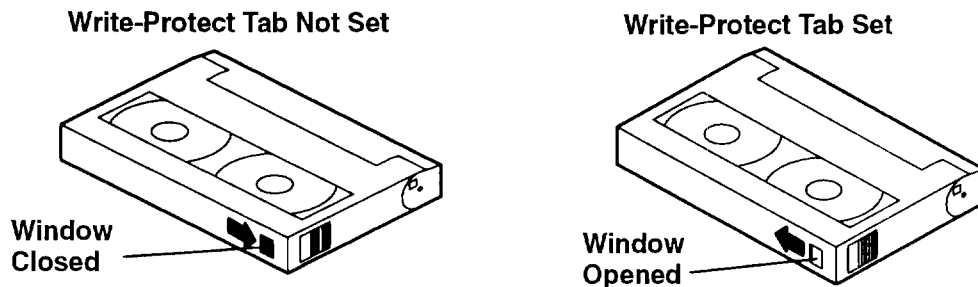

Environmental Considerations for 4 mm Data Cartridges

Information in this section describes operating and storage conditions including temperature, relative humidity, and maximum wet bulb data.

Warning: The manufacturer has specified a set of temperature and humidity ranges in which the 4 mm data cartridge can operate with ease. Only regular cleaning procedures, as described in "Cleaning the Tape Path on the 4.0GB 4 mm Tape Drive" on page 2-37, are required when operating the cartridge within this range. The risk of possible data loss is

increased if 4 mm tape cartridges are operated, stored, or shipped outside the temperature or humidity ranges shown in the following table.

Before using a cartridge, always let it adjust (acclimate) to the operating environment. Do this by placing the cartridge with its container in the operating environment for as long as it has been away from this environment or for 24 hours, whichever is less.

Acclimation is necessary for any data cartridge that has been exposed to a different humidity environment or a temperature change of 11°C or 20°F or more.

	Operating Ranges	Storage	Shipping
Temperature	16°C to 32°C (60°F to 90°F)	5°C to 32°C (40°F to 90°F)	-40°C to 52°C (-40°F to 125°F)
Relative Humidity (non-condensing)	20 to 80%	20 to 80%	5 to 80%
Maximum Wet Bulb	26°C (79°F)	26°C (79°F)	26° C (79°F)

Operating in Harsh Environments

The 4 mm tape drive is ideally suited to streaming operations, as opposed to tape movement operations involving multiple stop/starts and random searches. When the tape is used for frequent stop and start operations, streaming movement is beneficial and should be used whenever possible. This can be accomplished by ensuring that any save or restore operation is the only active operation performed by a device connected to this SCSI I/O controller.

Any tape that has been used outside the ranges specified in the previous table for an extended period of time (50 passes in 40 hours of nonstop operation) should not be used as an archival tape. Exposure to the environment will deteriorate the magnetic and physical strength of the tape. Do not store important data on a tape that has been used outside the specified ranges; transfer the data to a new tape for reliable archiving.

4 mm Data Cartridge Erasure

Most bulk eraser devices do not have the capability to erase 4 mm data cartridges. To properly erase an 4 mm data cartridge with a bulk eraser device, the erasure rating must be at least 2000 oersted.

The 4 mm tape drive erases residual data before writing new data on the data tape.

Tape Cartridge Data Capacity

The 4 mm tape cartridge capacity is defined as the amount of data that can be stored on the cartridge. The following variables affect the amount of data that can be stored on a tape cartridge:

- Size of the data file
- Number of file marks per file
- Compatibility mode (2GB or 4GB)
- Media rewrites

Using the 4.0GB 4 mm Tape Drive

The optional 4.0GB 4 mm tape drive is a half-high device that occupies drive position A or B only.

Status Lights

The 4.0GB 4 mm tape drive has two green status lights and one amber status light. The on and off combinations of the status lights indicate the conditions of the 4 mm tape drive.

Each of the International Organization for Standards (ISO) symbols located next to a status light indicates a specific condition of the tape drive as follows:



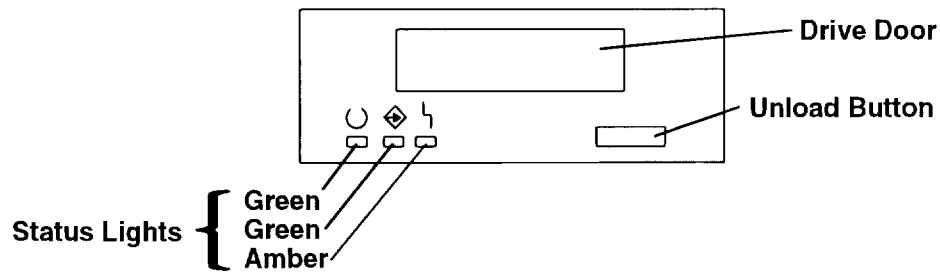







- Ready (green status light)
- ◊ Read-Write (green status light)
- ⚡ Disturbance (amber status light)



Status Light States

The following tables explain the meaning of the green and amber status lights.

	○ Ready (green)	◊ Read-Write (green)	⚡ Disturbance (amber)
Off	No cartridge installed or fault condition	No cartridge or no activity	No fault condition
Steady	Cartridge installed or loading/unloading		Cleaning required or worn media
Flashing	Power-on self-test in progress	Cartridge activity	Fault condition

Status Lights on the 4.0GB 4 mm Tape Drive			
Status	 Ready (green)	 Read-Write (green)	 Disturbance (amber)
LED test.	On 2 seconds at power on	On 2 seconds at power on	On 2 seconds at power on
The power-on self-test (POST) is running or the Diagnostic Cartridge is running.	 Flashing	<input type="checkbox"/> Off	<input type="checkbox"/> Off
One of the following has occurred: <ul style="list-style-type: none"> The power is off. The POST has completed successfully, but no tape cartridge has been loaded. 	<input type="checkbox"/> Off	<input type="checkbox"/> Off	<input type="checkbox"/> Off
A tape cartridge has been inserted and the 4 mm tape drive is ready to receive commands from the system.	 On	<input type="checkbox"/> Off	<input type="checkbox"/> Off
The tape is in motion and the 4 mm tape drive is running a device operation or cleaning.	 On	 Flashing	<input type="checkbox"/> Off
The 4 mm tape drive has detected an internal fault that requires corrective action such as tape cartridge failure, high humidity, or no SCSI terminator. Refer to the service guide or contact your service representative. (See note below)	<input type="checkbox"/> Off	<input type="checkbox"/> Off	 Flashing
The tape path requires cleaning or a poor quality tape cartridge is being used. See "Cleaning the Tape Path on the 4.0GB 4 mm Tape Drive" on page 2-37.	<input type="checkbox"/> Off or  On	<input type="checkbox"/> Off or  Flashing	 On

Note: If a fault or an error condition occurs, first try to recover by pressing the unload button. If this does not correct the fault, switch off the power to the 4 mm tape drive and then switch on the power to the drive. If the condition continues, call your service representative.

Loading the 4 mm Tape Cartridge

Before loading the tape cartridge, make sure the power is on and the write-protect switch on the tape cartridge is properly set. Refer to "Setting the Write-Protect Tab on 4 mm Tape Cartridges" on page 2-31. The tape drive loads the tape from the cartridge and prepares it for reading and writing.

To load the 4 mm tape cartridge, do the following:

1. Grasp the edges of the 4 mm tape cartridge with the write-protect tab towards you and the window side of the cartridge facing up.
2. Slide the tape cartridge into the opening on the front of the 4 mm tape drive until the loading mechanism pulls the cartridge into the drive and the drive door closes. The ready status light (green) will go on if the load operation was successful.

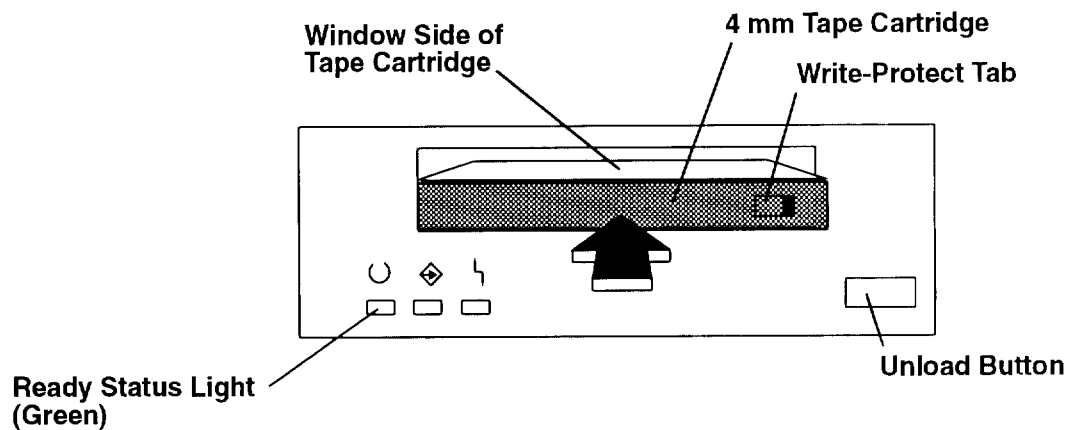



The 4 mm tape drive is ready for data operations when the tape cartridge is inserted. After the cartridge is inserted into the tape drive, the tape takes about 15 seconds to load.

Unloading the 4 mm Tape Cartridge

Before performing the unload operation, make sure the power to the 4 mm tape drive is on.

To unload and eject the tape cartridge, press the unload button. The 4 mm tape drive rewinds the tape and then ejects the tape cartridge from the tape drive.

After pressing the unload button, the following will occur:

1. The Read-Write  status light will flash during the unload operation.
2. The Ready  status light and the Read-Write  status light will turn off when the cartridge is ejected from the tape drive.

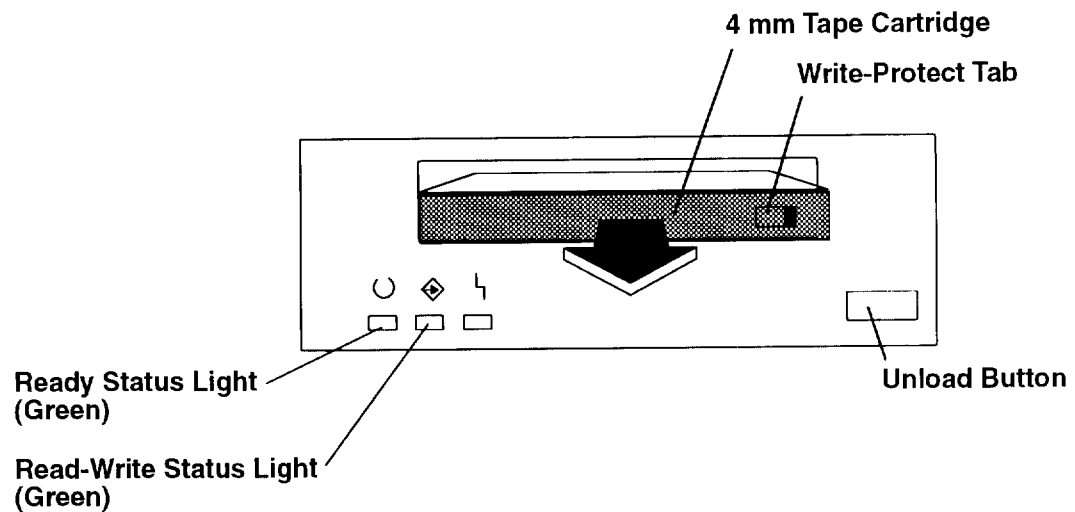

The time required for a tape to rewind and unload is between 10 seconds and 1.5 minutes, depending on the position of the tape when the unload button is pushed.

Cleaning the Tape Path on the 4.0GB 4 mm Tape Drive

The 4 mm tape path should be cleaned either approximately every 30 hours of tape motion or once a month, whichever occurs first. The 4 mm tape drive monitors the recording quality of the tape cartridge and indicates that the tape path requires cleaning when the disturbance status light (amber) is on.

More frequent cleaning may be required if the drive is operated in a dusty environment or in humid conditions. If the dust is allowed to accumulate, the drive has to perform more reads and writes. This can cause data loss, and may be prevented by regularly scheduled cleaning of the drive.

The cleaning cartridge cleans the 4 mm tape drive 50 times before it needs to be discarded. If you attempt to use a 4 mm cleaning cartridge more than 50 times, the tape drive automatically detects the error and ejects the cleaning cartridge with the disturbance status light (amber) remaining on.

Before loading the cleaning cartridge, make sure the power to the 4 mm tape drive is on.

To load the 4 mm cleaning cartridge, do the following:

1. Grasp the edges of the 4 mm cleaning cartridge with the window side of the cartridge facing up.
2. Slide the cleaning cartridge into the opening on the front of the 4 mm tape drive until the loading mechanism pulls the cartridge into the drive.

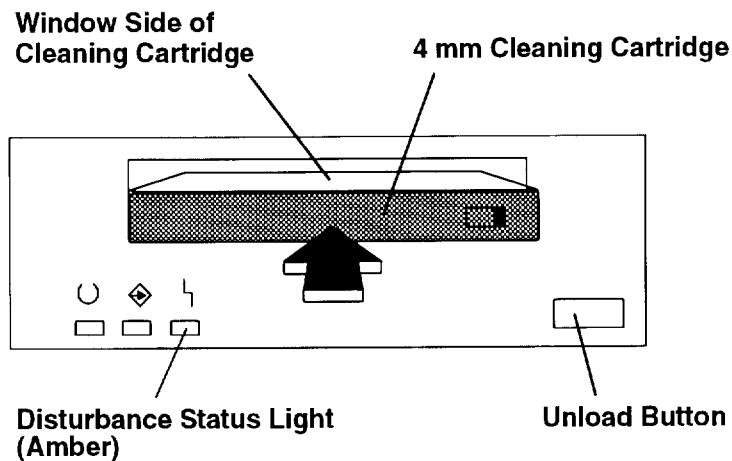

After the 4 mm cleaning cartridge has been fully inserted into the 4 mm tape drive, the following cleaning operations are performed automatically:

1. The cleaning tape is loaded into the tape path.
2. The drive is cleaned by moving the cleaning tape forward for approximately 30 seconds.
3. The tape is unloaded and the cleaning cartridge is ejected from the tape drive when the cleaning operation is complete.
4. A successful cleaning operation is indicated when the disturbance status light (amber) goes off (if it was activated before the cleaning operation).

Ordering Keys

For protection against unauthorized key duplication, the key mode switch is equipped with a Medeco® high security lock. Keys for this lock are a factory-restricted series, and duplicate keys are not available through normal commercial channels. The metal code tag supplied with your original keys authorizes you to purchase additional keys directly from the Medeco factory. The additional key supplied and the metal tag should be stored in a secured area.

To obtain information or replacement keys, use the following list to contact the Medeco distributor most convenient to you. Complete a copy of the order form on the next page and mail it to the distributor. As a security precaution, Medeco will not honor orders that do not include both the code tag and the official order form.

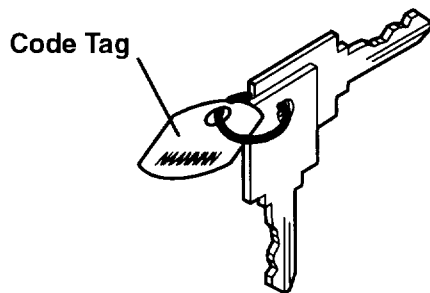

Medeco
Department KLC
P.O. Box 3075
Salem, VA 24153
United States of America

Claus Clausen
89a Authur Road
Wimbledon Park, London
SW 19 7DP England
Tel: 011-44-81-946-2823
Fax: 011-44-81-946-2286

Y.S. Chae
Geoho Corporation
2nd Floor, Kyung Bldg.
244-7 Pai-Dong
Gangnam-Yu
Seoul
Korea
Tel: 011-82-02-579-1280
Fax: 011-82-02-579-1282

Mary Burr
ATM Lock A Safe Co. Pty. Ltd.
2/48 Ourimbah Road, P. O. Box 300
Tweed Head, N.S.W. 2485
Australia
Tel: 011-61-075-36-1611
Fax: 011-61-075-36-1611

Ricardo DeCastro
Calle 22 No 3-30, Ofc. 201
P. O. Box A.A. No. 39955
Bogota, Colombia Sur America
Tel: 011-57-1-268-5827 or 6180
Fax: 011-57-1-268-2628

Moshe Rotner
R. M. Rotan Marketing
34 Nordau Street, Herzlia B
P. O. Box 5138, Herzlia
Israel
Tel: 011-972-9-545640
Fax: 011-972-9-584275

Key Reorder Form

A copy of this form, when accompanied by the metal code tag supplied with the original keys, represents an authorized order for additional factory keys.

Please indicate the quantity required, and enclose a check or money order for the appropriate amount.

Number of keys required _____

Please Type or Print Your Return Address

Name _____

Address _____

City _____

State _____ Zip _____

Country _____

Select an address from the list provided on the previous page, and mail a copy of this form to that location.

Your key code tag will be returned with your new keys.

Note: No orders will be processed without both the key tag and a copy of this form.

Chapter 3. AC Rack Description

This chapter contains information about the Model R00 7015 rack features and parts.

AC Rack

The 7015 Model R00 rack can contain the 7015 Model R24 CPU-Media Enclosure with other optional compatible drawers such as disk drive drawers, tape drive drawer, SCSI device drawer, and power distribution bus or PDU with a battery backup unit (BBU). For information about options and compatible optional drawers that can be used with the 7015 Model R24 CPU-Media Enclosure in a 7015 Model R00 rack, see the *RISC System/6000 System Overview and Planning* manual.

Notes:

1. Errors can occur in the data files if power to the rack is switched off without first using an appropriate **shutdown** command to stop the operating system. See your operating system documentation for information about the **shutdown** command.
2. A stabilizer is attached to the front of the system unit to prevent it from tipping over when a drawer is extended to the service position.

AC Rack with CPU-Media Enclosure (Front View)

7015 Model R00 Rack with CPU-Media Enclosure

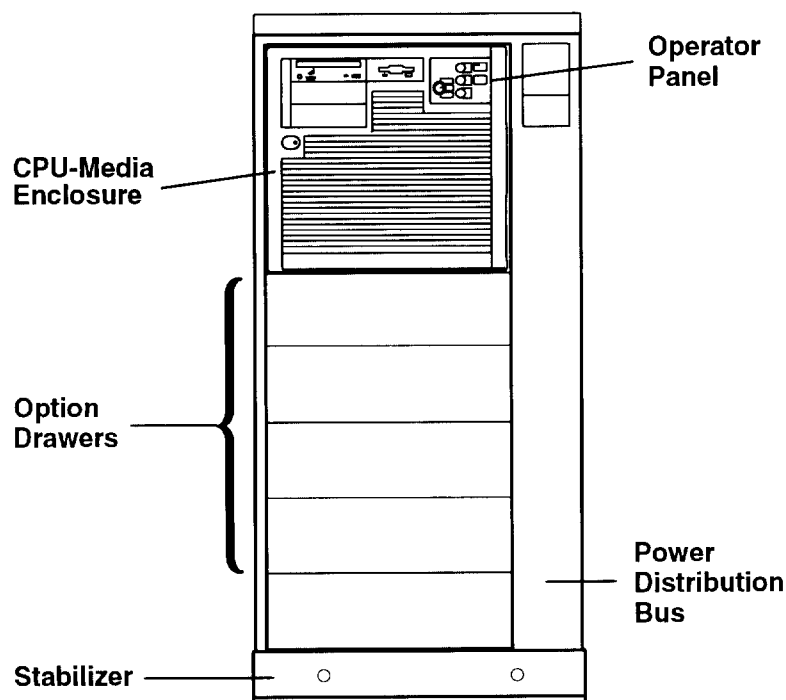

AC System Unit with Alternate Rack Features

The AC 7015 rack can contain the following alternate rack features:

- External device container
- Cable channel
- Rack attachment plate

Front View of AC 7015 Rack with External Device Container

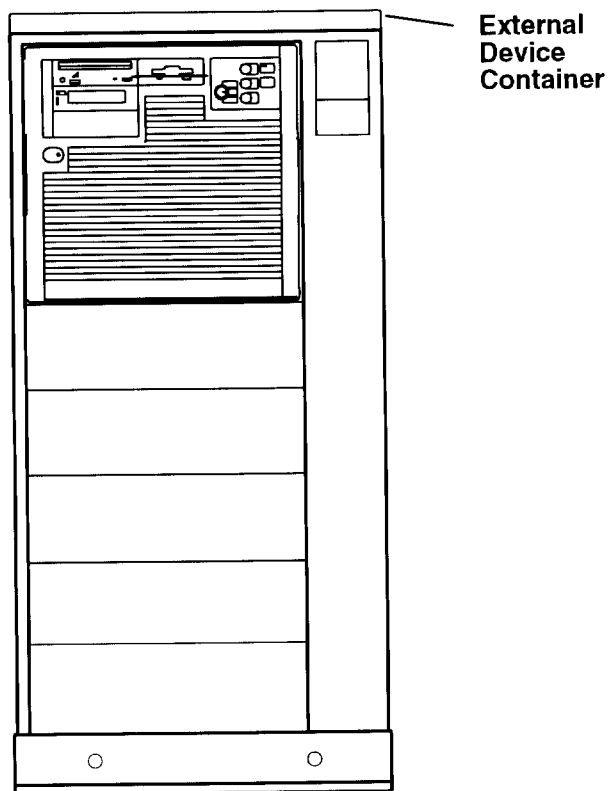

AC 7015 Racks with Cable Channel and Rack Attachment Plate

7015 AC Rack with Cable Channel

7015 AC Rack with Rack Attachment Plate

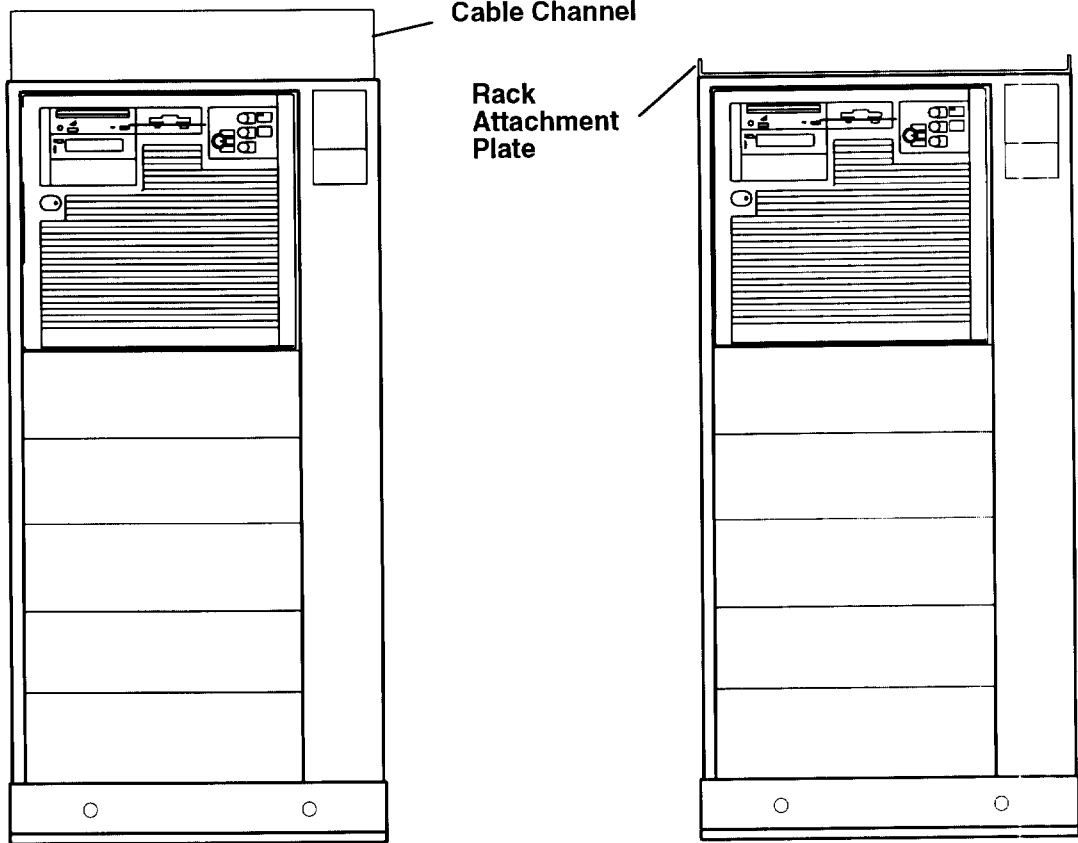

Power Distribution Bus

The power distribution bus (PDB) can be installed in a 7015 Model R00 rack with an AC 7015 Model R24 CPU-Media Enclosure. The PDB contains six 200 to 240 V ac outlets for providing power to all the drawers in the rack. Each outlet is connected to a separate circuit breaker for protection against excessive currents. A battery backup unit is not compatible with a PDB and cannot be installed in the rack with a PDB.

The power distribution bus (PDB) is located inside the rear door at the bottom of the rack to your left.

Note: For a translation of this notice, see the *System Unit Safety Information* manual.

CAUTION:

The power distribution unit outlets provide 200 to 240 V ac. Use these outlets only for devices that operate within this voltage range.

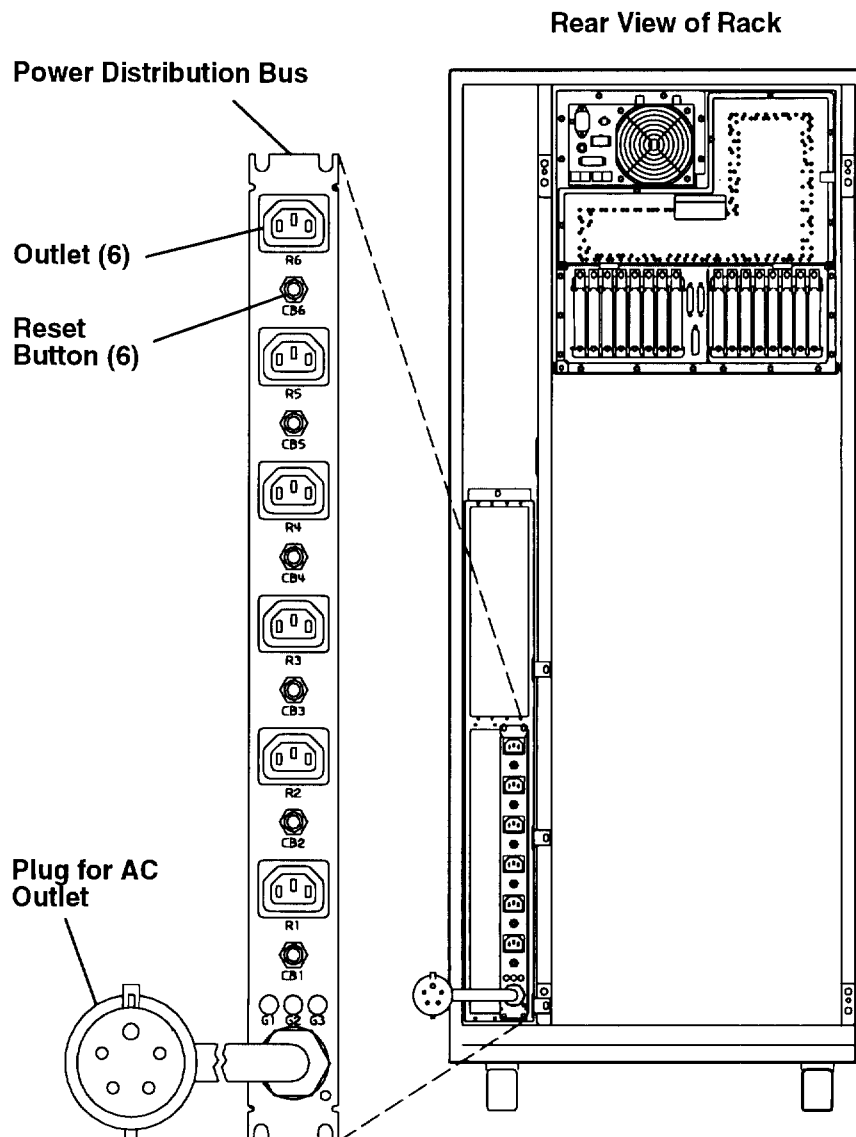

Power Distribution Unit

The power distribution unit supplies 200 to 240 V ac from each of the six AC power outlets. These outlets provide power to all the drawers in the rack. The optional battery backup unit attaches to the power distribution unit and can provide 300 V dc to three drawers for 10 minutes. You can attach up to three additional drawers to the battery backup unit by using the battery backup extender cables.

Note: The battery backup unit can provide power to drawers in your system during power outages. Power to a terminal that controls your system can be interrupted during power outages unless the terminal is connected to an uninterruptible power source.

The power distribution unit (PDU) is located inside the rear door at the bottom of the system unit. Each AC power outlet is controlled by a power select switch located under it. The switches can be set so that the outlets are either always on or switched on and off by the power control signal.

Note: For a translation of this notice, see the *System Unit Safety Information* manual

CAUTION:

The power distribution unit outlets provide 200 to 240 V ac. Use these outlets only for devices that operate within this voltage range.

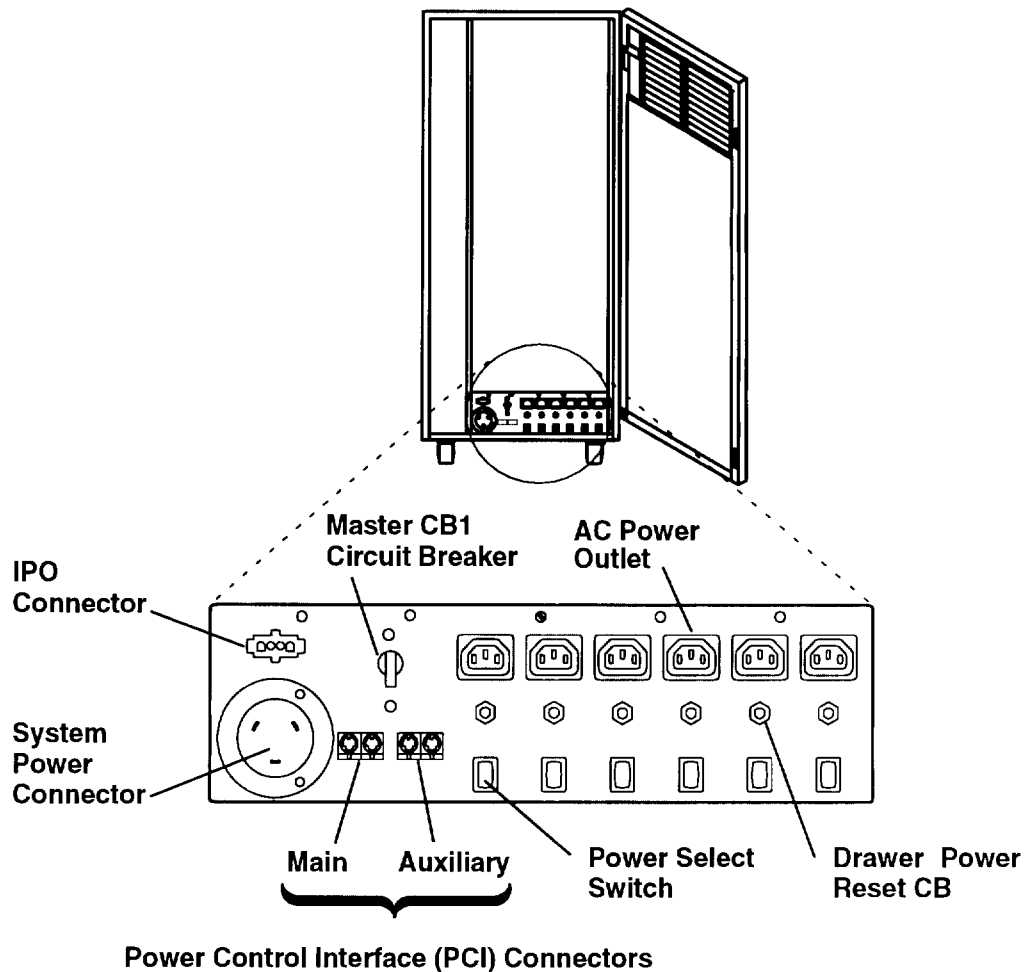

Optional Battery Backup Unit

Note: The optional battery backup unit (BBU) can only be installed in the rack with a power distribution unit. The BBU cannot be installed in a rack with a power distribution bus.

The optional battery backup unit contains four 12-volt batteries. It is connected to the power distribution unit and occupies the area immediately above and behind the PDU, as you look from the rear.

Note: For a translation of this notice, see the *System Unit Safety Information* manual.

CAUTION:

The battery backup unit outlets provide 300 V dc. Use these outlets only for devices that operate at this voltage.

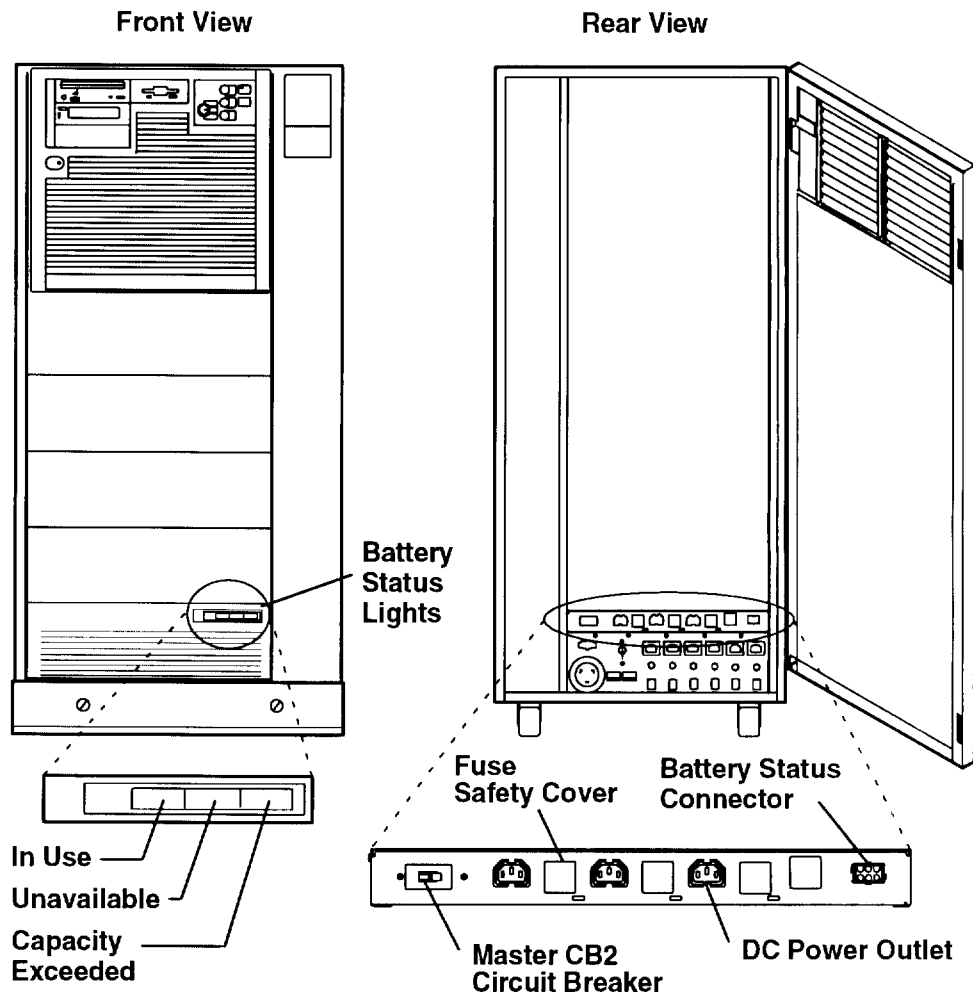

The front panel of the battery backup unit has three battery status lights to indicate if the batteries are in use, unavailable, or if their capacity has been exceeded.

If the In Use light is on, the batteries are supplying power to the attached devices.

If the Unavailable light is on, the batteries need recharging or the unit requires service; contact your service representative.

If the Capacity Exceeded light is on, the batteries cannot provide the power required by the attached devices.

SCSI-2 Drawer

Notes:

1. The SCSI drawer is optional with a 7015 CPU-Media Enclosure.
2. Compartment D of the SCSI drawer can contain a 5.0 GB 8 mm tape drive, a 4.0 GB 4 mm tape drive, 1/4-inch tape drive, or a disk drive.

The SCSI drawer shown in the following illustration contains an 5.0GB 8 mm tape drive and a disk drive. Various media devices and disk drives can be used in the four compartments of the drawer. See the *RISC System/6000 System Overview and Planning* manual for more information about the drawer configurations manual.

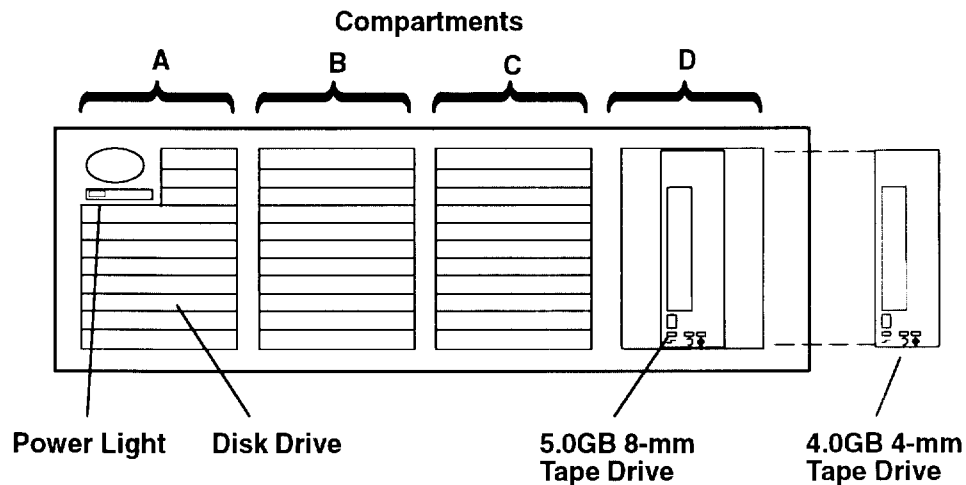

8 mm Tape Drive

Note: The SCSI drawer can contain a 5.0GB 8 mm tape drive. When a rack contains a CPU-Media Enclosure, an SCSI drawer is not installed in the rack, and the 8 mm tape drive is located in the CPU-Media Enclosure.

This tape drive uses tapes that can store 5.0 GB of information in the normal mode. When using the 5.0 GB 8 mm tape drive, tapes can store more than 5.0 GB of information in the compressed mode. For more information, see "Using the 5.0 GB 8-mm Tape Drive" on page 2-23.

4 mm Tape Drive

Note: The 4 mm tape drive is located in any compartment of the SCSI device drawer. The 4 mm tape drive is located in the bottom media position of the 7015 CPU-Media Enclosure when the 7015 CPU-Media Enclosure is installed in the rack.

This tape drive uses tapes that can store 4GB of information in the normal mode. This tape drive can store up to 8GB when using DDS2 data cartridges, or when in the compressed mode. For more information, see "Using the 4.0 GB 4 mm Tape Drive" on page 2-33.

Disk Drive

There are no operator controls on the disk drive.

Because data can become unusable because of a disk drive problem, you should back up the data stored on the disks. See your operating system documentation for information about using diskettes or tape drives to back up files.

Controls

Under normal conditions, you do not use the controls located behind the cover of the SCSI drawer. Power to the drawer is switched on and off automatically when power to the CPU drawer or CPU enclosure is switched on and off.

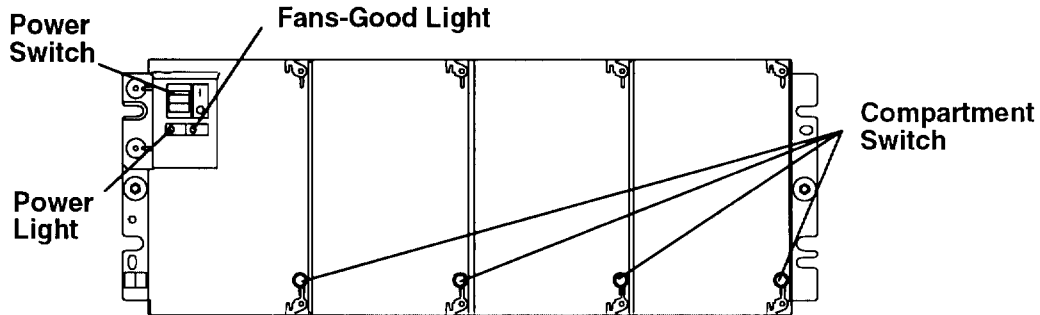

Power Switch

This switch controls electrical power to all four compartments in the drawer. Under normal conditions, the switch should be in the I (On) position.

Power Light

This light is on when the drawer receives a power signal from the CPU drawer or the CPU enclosure. The light is off when power to the CPU drawer or the CPU enclosure is switched off, the power switch on the SCSI drawer is switched off, or there is a power problem within the drawer.

Fans-Good Light

This light is on when the fans in the drawer are operating at the correct speed. The light is off when a fan operates slowly, stops, or does not start.

Compartment Switches

Each switch controls power to the compartment behind it. Power is connected to a compartment when the switch is in the On (in) position and the light within the switch is on. Power is disconnected from a compartment when the switch is in the Off (out) position and the light within the switch is off. Press the switch to change the On or Off position. Under normal conditions, these switches should be in the On (in) position.

System Unit Options

See the *RISC System/6000 System Overview and Planning* for information about the system unit options.

AC System Unit Cables and the CPU-Media Enclosure

Connectors

Rear View of CPU-Media Enclosure
Installed in a 7015 Model R00 Rack

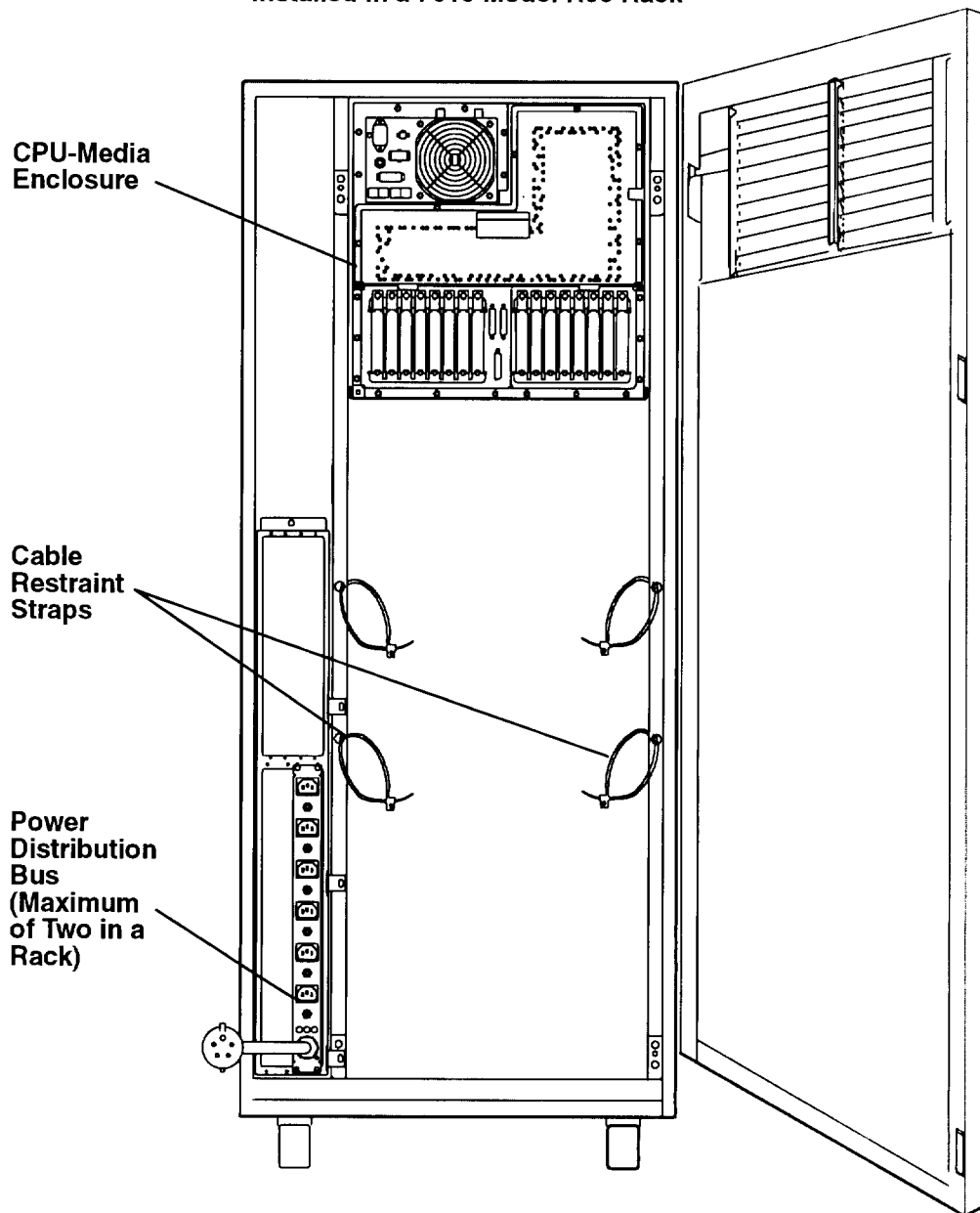

Notes:

1. It is recommended that a trained service representative connect or disconnect any cables attached to the CPU-media enclosure.

However, if you choose to connect or disconnect cables attached to the system unit, observe the following safety notices.

2. For a translation of these notices, see the *System Unit Safety Information* manual.

DANGER

An electrical outlet that is not correctly wired could place hazardous voltage on metal parts of the system or the devices that attach to the system. It is the responsibility of the customer to ensure that the outlet is correctly wired and grounded to prevent an electrical shock.

Before installing or removing signal cables, ensure that the power cables for the system unit and all attached devices are unplugged.

When adding or removing any additional devices to or from the system, ensure that the power cables for those devices are unplugged before the signal cables are connected. If possible, disconnect all power cables from the existing system before you add a device.

Use one hand, when possible, to connect or disconnect signal cables to prevent a possible shock from touching two surfaces with different electrical potentials.

During an electrical storm, do not connect cables for display stations, printers, telephones, or station protectors for communication lines.

CAUTION:

This product is equipped with a 3-wire power cable and plug for the user's safety. Use this power cable in conjunction with a properly grounded electrical outlet to avoid electrical shock.

Cable Path

Note: It is recommended that a trained service representative connect or disconnect any cables attached to the CPU-media enclosure.

However, if you choose to connect or disconnect cables attached to the system unit, observe the following information.

Use the cable restraint strap located on an attachment holes on the sides of the rack to attach the cables to the rack.

To open the cable restraint strap, press the release tab while pulling the end of the cable restraint strap through the locking mechanism.

To attach the cables to the rack, do the following:

1. Open the cable restraint strap.
2. To attach adapter cables to the rack, gather the cables attached to the adapters, and then place the cable bundle in the cable restraint strap located below the adapters on your left.

To attach optional adapter cables to the rack, gather the cables attached to the optional adapters, and then place the cable bundle in the cable restraint strap located below the optional adapters on your right.

3. Place the end of the cable restraint strap through the locking mechanism, and then pull the end of the cable restraint strap to tighten the cables against the rack.

Opening the Cable Restraint Strap

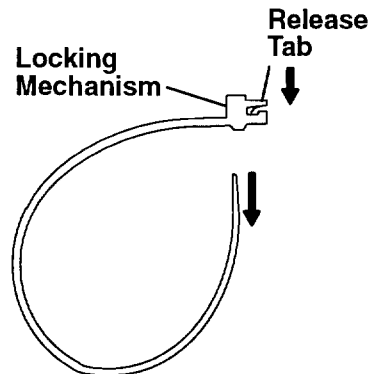

Closing the Cable Restraint Strap

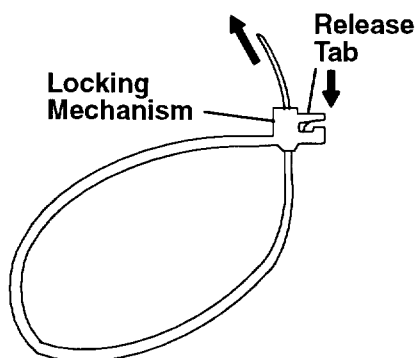

Rear View of Rack

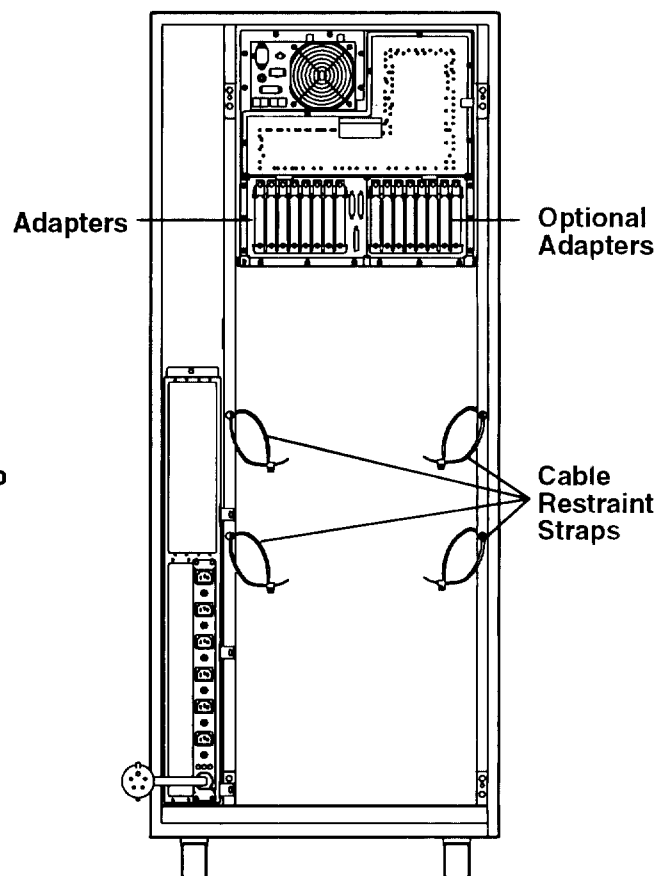

Location Identification Labels

Note: The SCSI drawer is optional in a rack with a 7015 CPU-Media Enclosure.

Several types of labels identify the locations of adapters and devices within the system unit. Numbers on these labels correspond to the location codes that are displayed when the diagnostic programs isolate a problem.

A location code is used to find the location of a failing device or unit. The location code is displayed along with the SRN when the diagnostic programs isolate a failure. If the location code is not known, you can run the Display Previous Diagnostic Results service aid to display the results of the last time the diagnostic programs were run.

The rack-type system unit has several labels on the drawers and devices. These help the operator and service person identify various drawers and devices. The drawer ID should match the slot location of the adapter that drives it. The SCSI devices may be labeled with a number that identifies the SCSI address of the device.

Location Code Format for 9333 and 9334 SCSI Expansion Units

The location code formats for the 9333 and 9334 SCSI expansion units are described in the publications for the 9333 and 9334 SCSI expansion units.

Location Code Format for SCSI Devices

The following diagram shows the format of location codes for SCSI drawers.

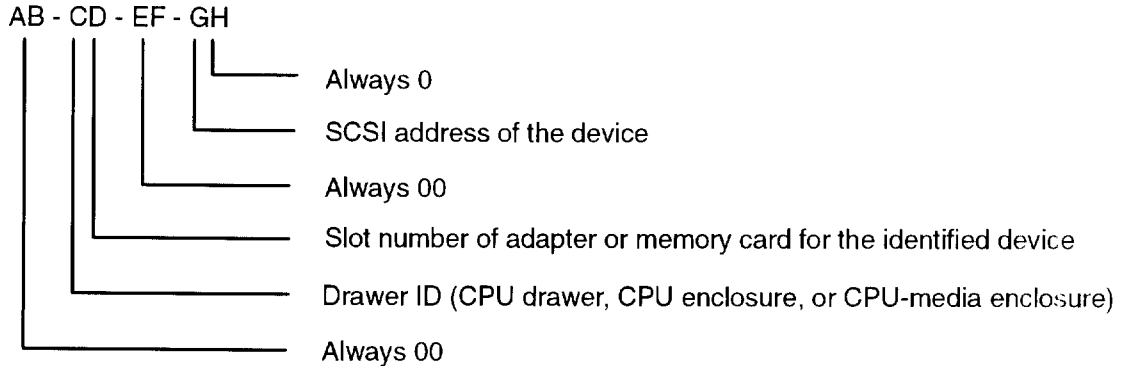

SCSI Drawer ID Label

This label contains a two-digit number that identifies the slot in the CPU-Media Enclosure where the SCSI adapter is located (drawer ID). The number on this label corresponds to the characters CD in the location code. One label is located in the lower-right corner on the rear of the drawer, and one is located in the lower-left corner on the front of the drawer (behind the cover).

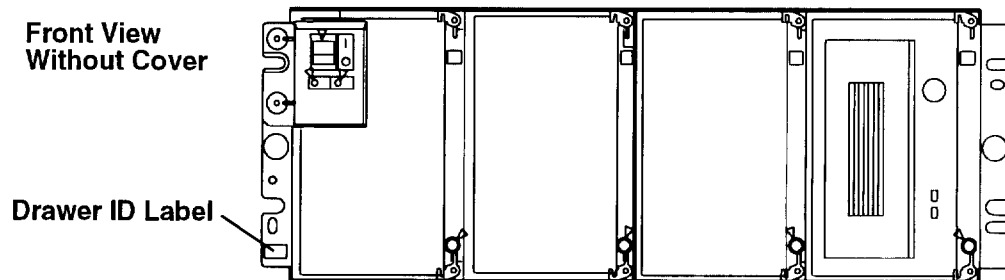
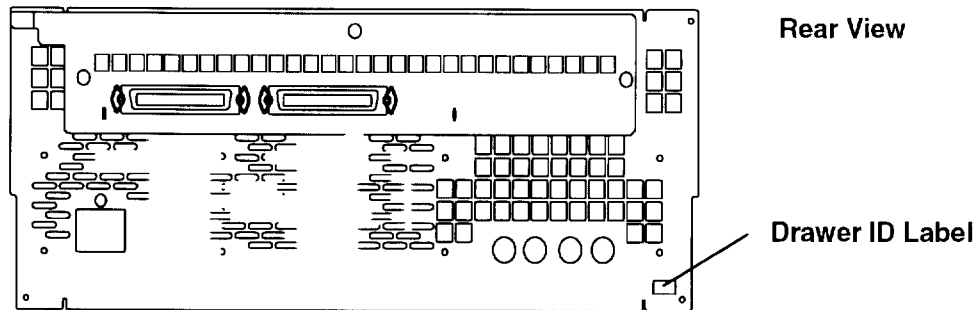

SCSI Device Address Label

This label contains a one-digit number that identifies the address of the device. The number on this label corresponds to the character G in the location code. One label is located in the upper-right corner of each device (behind the cover). A second SCSI device address label is required for media positions containing dual disk drives and is located below the other SCSI device address label.

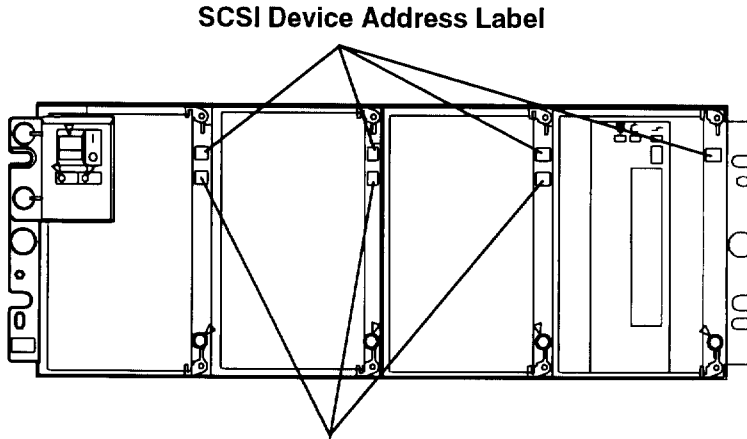

**Second SCSI Device Address Label for
Media Positions Containing Dual Disk Drives**

Cover Label

This label contains a four-digit number that identifies the slot in the CPU drawer where the SCSI adapter is located (drawer ID) and the address of the device. The first two digits of this number correspond to the characters CD in the location code; the last two digits correspond to the characters GH. At the customer's discretion, a cover label may be applied to the space provided on the cover under each compartment.

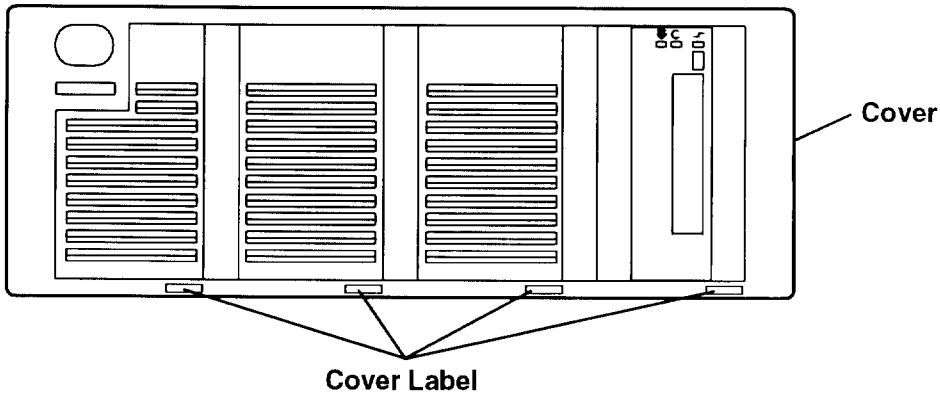

Creating Cover Labels

Note: Either a 5.0GB 8 mm tape drive or a 4.0GB 4 mm tape drive can be installed in the right media position.

Use the following steps and the sheet of peel-off numbers supplied with your system to create cover labels for SCSI drawers.

1. Remove the cover from the SCSI drawer by grasping the cover on both sides and pulling out from the drawer.
2. Look at the drawer ID label located in the lower-left corner of the drawer. The digits on this label are the first two digits of each cover label.

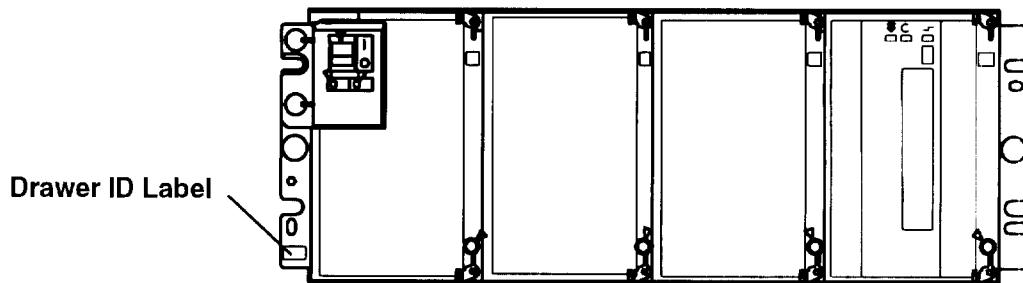

3. Apply the digits that represent the drawer ID to the left corner of each cover label.
For example: If the drawer ID is 02, apply 02 to the left corner of each cover label.

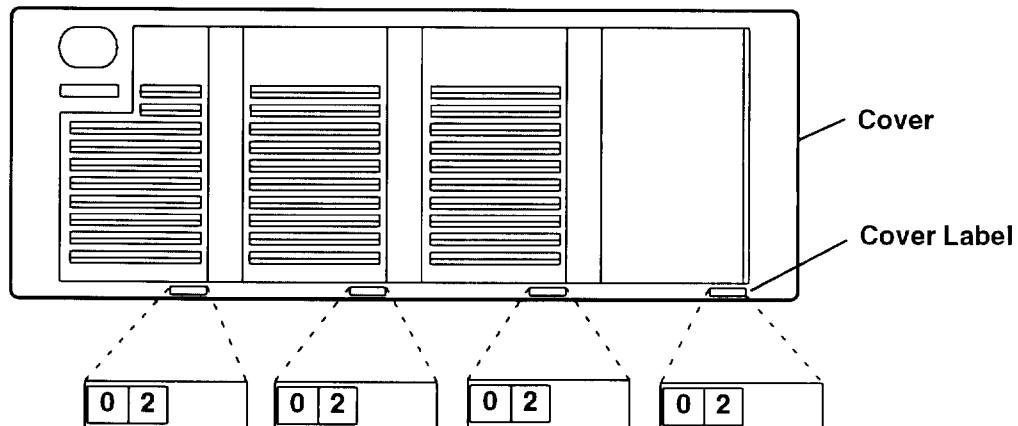

- Look at the SCSI device address label on the bracket for each device. These numbers are the third digits of the cover labels.

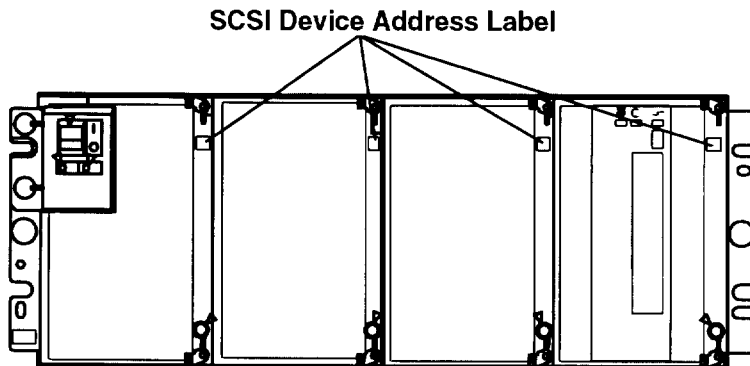

- Apply the digit that represents the SCSI address for a device to the space provided for the third digit of the cover label for that device.
For example: If the address for a device is 1, apply a 1 to the space provided for the third digit of the cover label for that device.

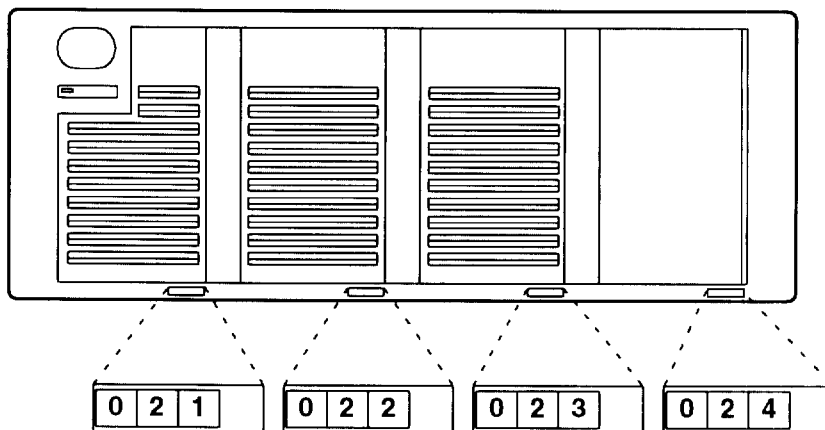

- Apply a 0 to the space provided for the fourth digit of each cover label.



- Install the cover by aligning it with the drawer and then pressing the cover into place.

Location Code Format for Non-SCSI Devices

The following diagram shows the format of location codes for non-SCSI devices.

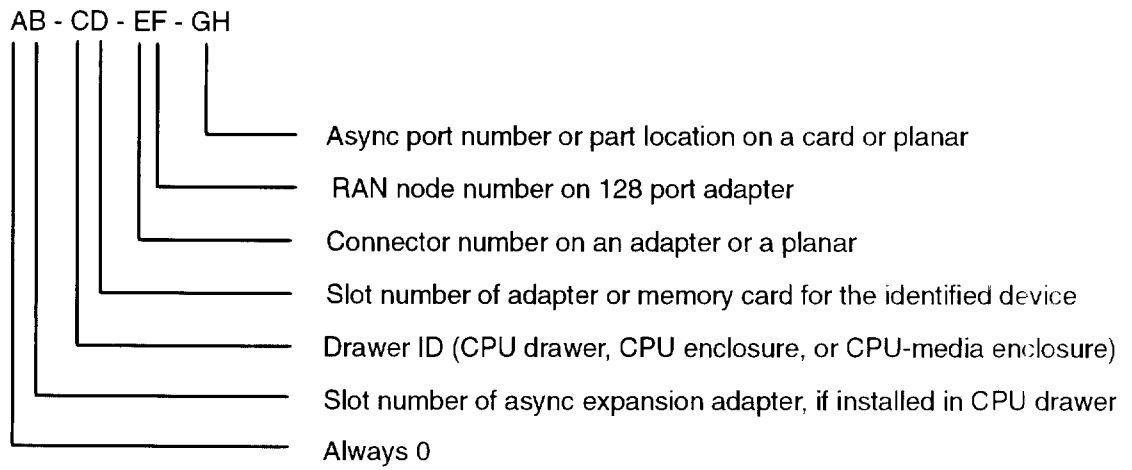

Non-SCSI Drawer ID Label

This label contains a two-digit number that identifies the slot in the 7015 CPU-Media Enclosure where the adapter that controls the drawer is located. The number on this label corresponds to the characters AB in the location code. One label is located in the lower-right corner on the back of each drawer.

Location Code Table for SCSI and Non-SCSI Devices

Use the following table to determine the physical location of a device or unit.

Note: The location code format for 9333 devices is described in the 9333 documentation.

Use the following example to identify the two-character pairs:

AB-CD-EF-GH

Location Code Table		
Pair	Value	Description
AB	00	Rack-type system unit
	00	CPU drawer in a rack-type system unit
	00	SCSI device drawer in a rack-type system unit
	00	SCSI disk drawer in a rack-type system unit
CD	00	CPU planar
	00	Combination planar
	00	A device attached to the combination planar
	01	Adapter in slot 1 of the I/O planar or combination planar
	02	Adapter in slot 2 of the I/O planar or combination planar
	03	Adapter in slot 3 of the I/O planar or combination planar
	04	Adapter in slot 4 of the I/O planar or combination planar
	05	Adapter in slot 5 of the I/O planar or combination planar
	06	Adapter in slot 6 of the I/O planar or combination planar
	07	Adapter in slot 7 of the I/O planar or combination planar
	08	Adapter in slot 8 of the I/O planar or combination planar
	10	Optional I/O planar
	11	Adapter in Slot 1 of the optional I/O planar
	12	Adapter in Slot 2 of the optional I/O planar
	13	Adapter in Slot 3 of the optional I/O planar
	14	Adapter in Slot 4 of the optional I/O planar
	15	Adapter in Slot 5 of the optional I/O planar
	16	Adapter in Slot 6 of the optional I/O planar
	17	Adapter in Slot 7 of the optional I/O planar
	18	Adapter in Slot 8 of the optional I/O planar
	0A	Memory card in slot A on the CPU planar
	0B	Memory card in slot B on the CPU planar
	0C	Memory card in slot C on the CPU planar
	0D	Memory card in slot D on the CPU planar
0E	Memory card in slot E on the CPU planar	
0F	Memory card in slot F on the CPU planar	
0G	Memory card in slot G on the CPU planar	
0H	Memory card in slot H on the CPU planar	
AA	Serial Optic Converter in slot AA of CPU planar	
AB	Serial Optic Converter in slot AB of CPU planar	

Pair	Value	Description	
EF	00	Does not have a connector or software was not able to identify the connector number	
	01 02 03 04	The number of the connector on an adapter card, distribution box, or planar. If needed, see Chapter 8 in the <i>POWERstation and POWERserver Common Diagnostics and Service Guide</i> for the connector numbering on your adapter.	
	0D	Internal diskette connector on the standard I/O planar or combination planar	
	0P	Parallel printer connector on the standard I/O planar or combination planar	
	0S	Built-in SCSI adapter	
	S1 S2	Serial port 1 connector on the combination planar Serial port 2 connector on the combination planar	
	1A 1B 2A 2B	Port A of the Serial Optic Converter in slot AA of the CPU planar Port B of the Serial Optic Converter in slot AA of the CPU planar Port A of the Serial Optic Converter in slot AB of the CPU planar Port B of the Serial Optic Converter in slot AB of the CPU planar	
	GH (Non-SCSI)	00	For devices other than those listed here
00 thru 15		Port addresses for 8 port-async, 16 port-async, and 16 port-concentrator distribution boxes	
01 02		Diskette drive 1 attached to the standard I/O planar or combination planar Diskette drive 2 attached to the standard I/O planar or combination planar	
01 02 03 04 05 06 07 08		Memory SIMM in location 1 on the memory card Memory SIMM in location 2 on the memory card Memory SIMM in location 3 on the memory card Memory SIMM in location 4 on the memory card Memory SIMM in location 5 on the memory card Memory SIMM in location 6 on the memory card Memory SIMM in location 7 on the memory card Memory SIMM in location 8 on the memory card	
GH (SCSI)		00	SCSI device set to address 0
		10	SCSI device set to address 1
		20	SCSI device set to address 2
		30	SCSI device set to address 3
	40	SCSI device set to address 4	
	50 60	SCSI device set to address 5 SCSI device set to address 6	

Chapter 4. Using the AC Rack

This chapter contains information about using, starting, and stopping the 7015 Model R00 rack containing a 7015 Model R24 CPU-Media Enclosure.

General Information about Multiple Systems

If your system is attached to another system, certain actions performed by an operator can affect either one or both systems, and these actions may require further consideration before any changes are made to either system. Some actions requiring further consideration are as follows:

- Starting and stopping the communications with the other systems
- Running diagnostics on one of the systems
- Analyzing the error log information
- Installing adapters or devices on any of the systems
- Using the wrap plugs with the diagnostics

When this system unit is attached to another system, make sure you isolate this system unit before stopping the operating system or running diagnostic programs. Some system cable changes (such as installing wrap plugs or removing a device from the configuration) may require the operator to perform an action on the attached system before making the cable changes on this system.

Starting the AC System Unit

Powering on the system unit includes:

1. Pressing the Power On button located on the operator panel of the CPU-media enclosure.

Note: The CPU-media enclosure is the source of the power control interface (PCI) signal. Depending on the signal received, power is either set to On or Off for all drawers controlled by the PCI signal.

2. Doing an IPL.

Methods of Starting the AC System Unit

The four methods of starting the CPU-Media Enclosure are as follows:

- **Manually.** The power is switched on manually, and the system unit does a normal or a service IPL. The manual method can be performed on a system unit containing either a power distribution unit (PDU) or a power distribution bus (PDB).
- **Remotely.** The power is switched on from another location, and the system unit does a normal IPL. (To use this method, a modem or equivalent device must be attached to the CPU-media enclosure with a remote bringup cable.)
- **Programmed by date and time.** On a specific day and time, the power is switched on, and the system unit does a normal IPL.
- **Programmed after a power failure.** When the power is restored, the power is switched on, and the system unit does a normal IPL.

Only the manual start is described in this book. See your operating system documentation for information about other methods of starting the system unit.

Manually Powering On the AC System Unit Containing a PDU

1. Set the key mode switch to the Service position.

Front View of CPU-Media Enclosure

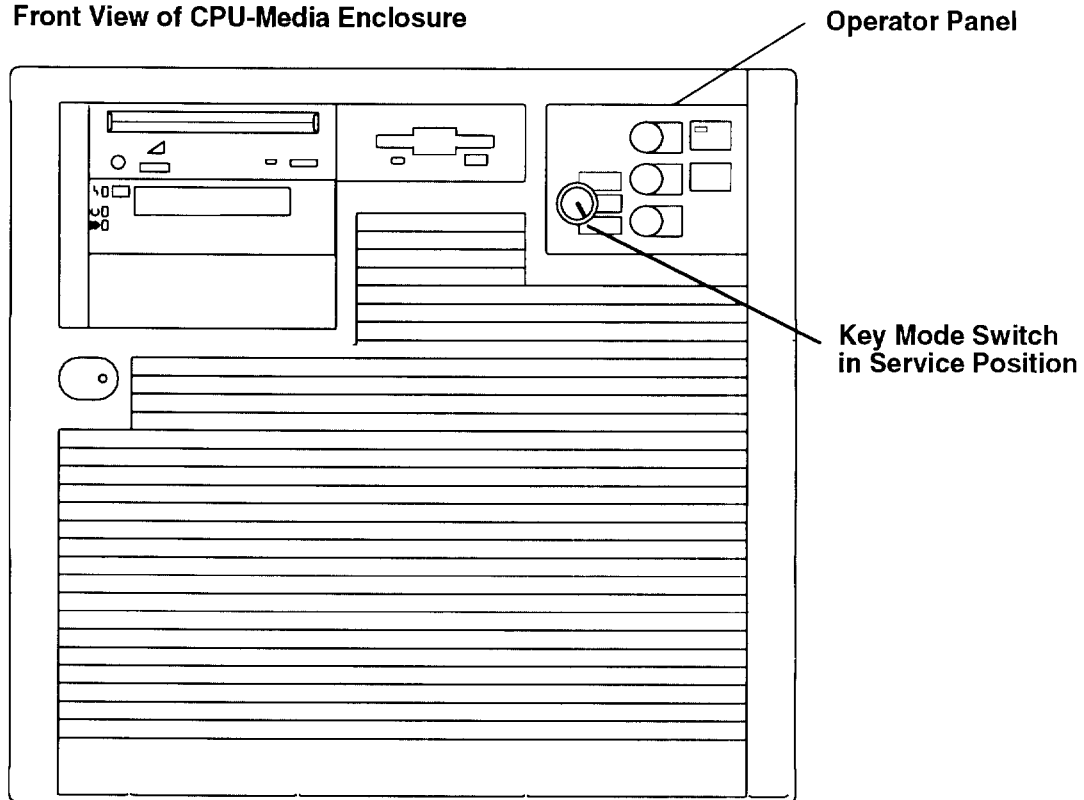

Note: For a translation of this notice, see the *System Unit Safety Information* manual.

DANGER

An electrical outlet that is not correctly wired could place hazardous voltage on metal parts of the system or the devices that attach to the system. It is the responsibility of the customer to ensure that the outlet is correctly wired and grounded to prevent an electrical shock.

Before installing or removing any additional devices to or from the system, ensure that the power cables for those devices are unplugged before the signal cables are connected. If possible, disconnect all power cables from the existing system before you add a device.

Use one hand, when possible, to connect or disconnect signal cables to prevent a possible shock from touching two surfaces with different electrical potentials.

During an electrical storm, do not connect cables for display stations, printers, telephones, or station protectors, for communications lines.

CAUTION:

This product is equipped with a 3-wire power cable and plug for the user's safety. Use this power cable in conjunction with a properly grounded electrical outlet to avoid electrical shock.

2. Plug the system unit power cord into the electrical outlet.

3. If the battery backup unit is installed, set the Master CB2 circuit breaker to On.

Note: Ensure that the key mode switch is set to the Service position to prevent system unit power from being switched on unexpectedly.

4. Set the Master CB1 circuit breaker to On.

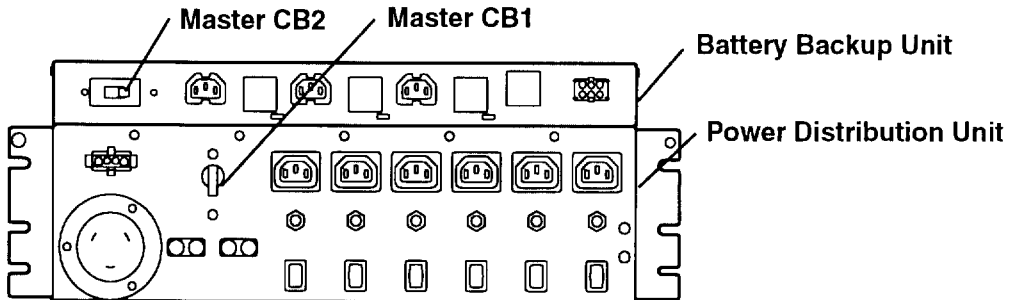

5. Close the rear door of the rack.
6. Plug all external device power cords into the electrical outlets.
7. Switch on power to all external devices attached to the system unit.
8. Press the Power On button.

Operator Panel

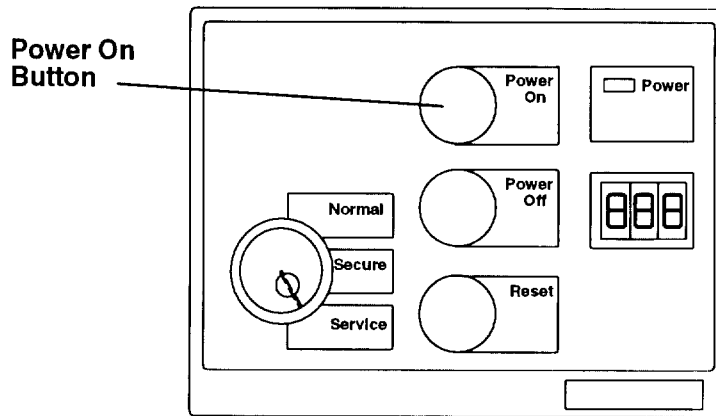

9. If power does not come on, ensure that all of the power cord is plugged into the grounded electrical outlet. If this does not solve the problem, refer to the *AIX Problem Solving Guide and Reference* manual.

When you press the Power On button, the Power light comes on and the system starts a POST. During the POST, numbers are displayed in the three-digit display.

Manually Powering On the AC System Unit with a PDB

Note: Ensure that the key mode switch is set to the Service position to prevent system unit power from being switched on unexpectedly.

1. Set the key mode switch to the Service position.

Front View of CPU-Media Enclosure

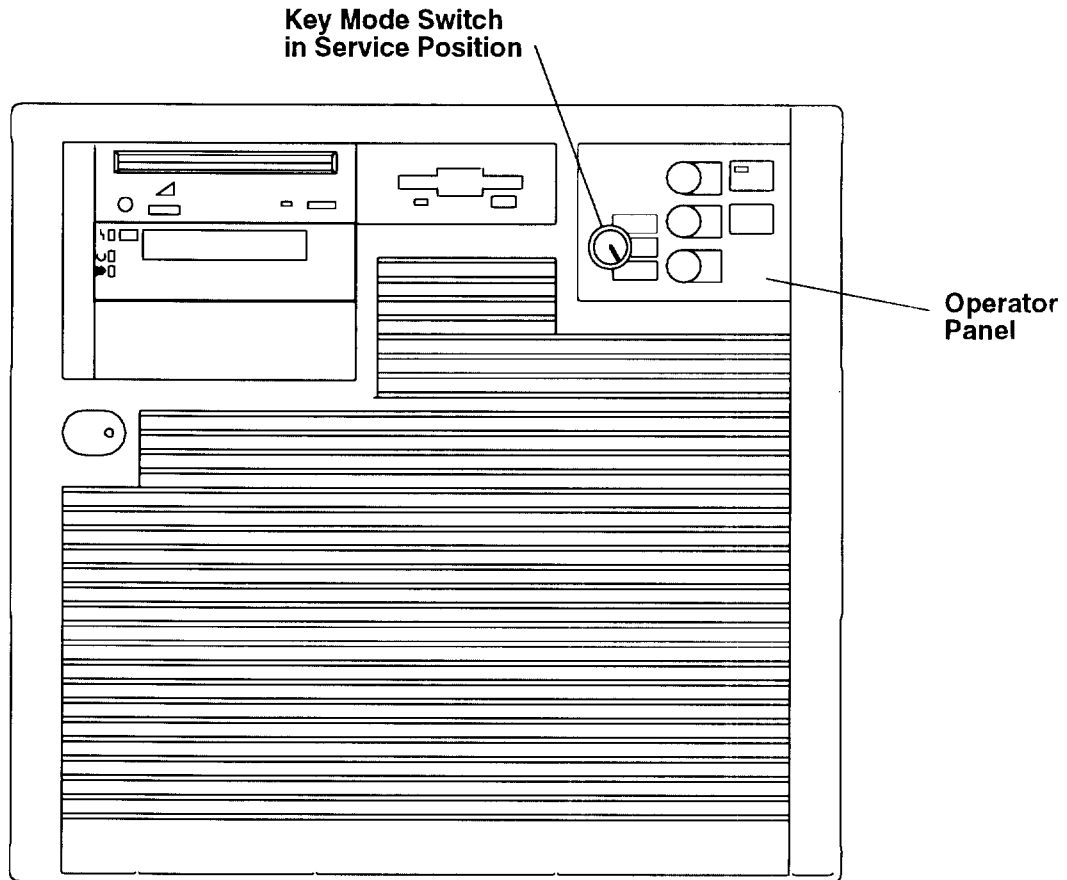

Note: For a translation of this notice, see the *System Unit Safety Information* manual

DANGER

An electrical outlet that is not correctly wired could place hazardous voltage on metal parts of the system or the devices that attach to the system. It is the responsibility of the customer to ensure that the outlet is correctly wired and grounded to prevent an electrical shock.

Before installing or removing any additional devices to or from the system, ensure that the power cables for those devices are unplugged before the signal cables are connected. If possible, disconnect all power cables from the existing system before you add a device.

Use one hand, when possible, to connect or disconnect signal cables to prevent a possible shock from touching two surfaces with different electrical potentials.

During an electrical storm, do not connect cables for display stations, printers, telephones, or station protectors, for communications lines.

CAUTION:

This product is equipped with a 3-wire power cable and plug for the user's safety. Use this power cable in conjunction with a properly grounded electrical outlet to avoid electrical shock.

Note: If two PDBs are installed in the rack, plug the power cords of both PDBs into the electrical outlets.

2. Plug the power cord for the power distribution bus into the electrical wall outlet.

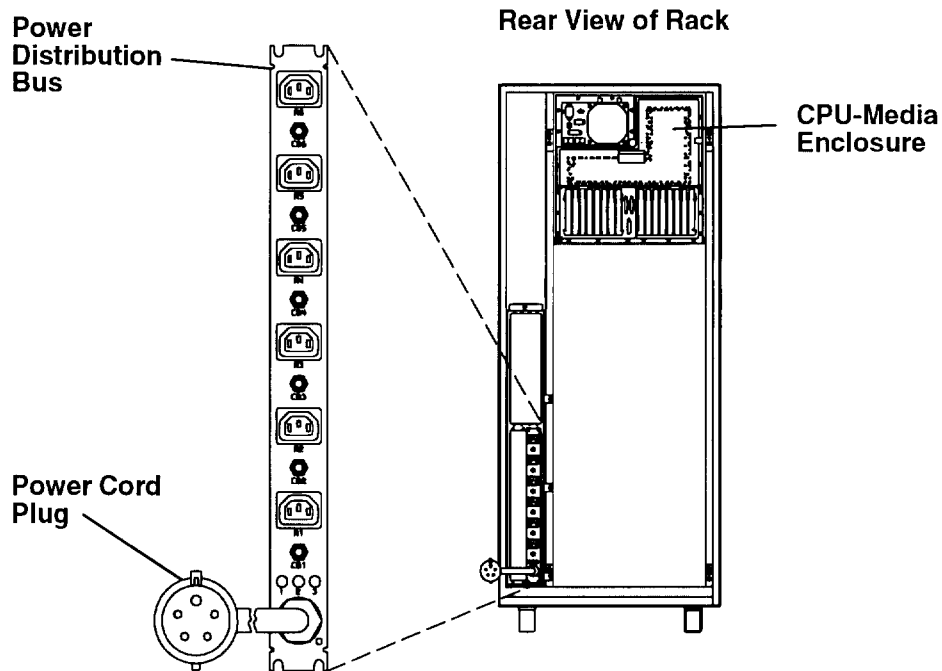

3. Plug all drawer power cords into the outlets on the PDB.
4. Close the rear door of the rack.
5. Switch on power to all drawers connected to the PDB.
6. Set the key mode switch to the Normal position.
7. Press the Power On button on the CPU-Media Enclosure.

CPU-Media-Enclosure Operator Panel

Key Mode Switch in Normal Position

Power On Button

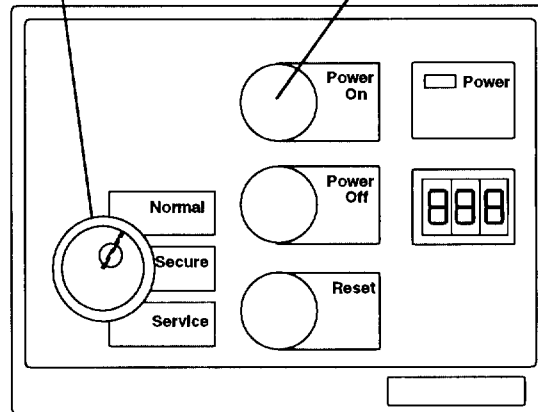

Stopping the AC System Unit

Note: The system unit can contain either a power distribution unit (PDU) or a power distribution bus (PDB).

The following methods can be used to stop (switch off power to) the system unit containing either a PDU or a PDB:

- Under ordinary conditions. Power is switched off to the CPU-Media Enclosure and to other drawers if they are connected with the power control cables.
- Immediately. All power is switched off to the drawers in the system unit.
- **shutdown** program power-off. Power is switched off to the CPU-Media Enclosure and to other drawers if they are connected with the power control cables.

Only the first two methods are described in this book. Refer to the *AIX System Management Guide: Operating System and Devices* and other operating system documentation for information about stopping the system unit and the **shutdown** program power-off method. This method can be used for any key mode position.

Stopping the AC System Unit Containing a PDU – Ordinary Conditions

Note: Before stopping the system unit, you must first shut down the operating system to prevent losing data.

Warning: Use the appropriate **shutdown** command before you stop the system unit; failure to do so may result in the loss of data. Refer to *AIX System Management Guide: Operating System and Devices* and other operating system documentation for information about the **shutdown** command and stopping the system unit.

1. Set the key mode switch to the Service position.
2. Press the Power Off button.

Front View of CPU-Media Enclosure

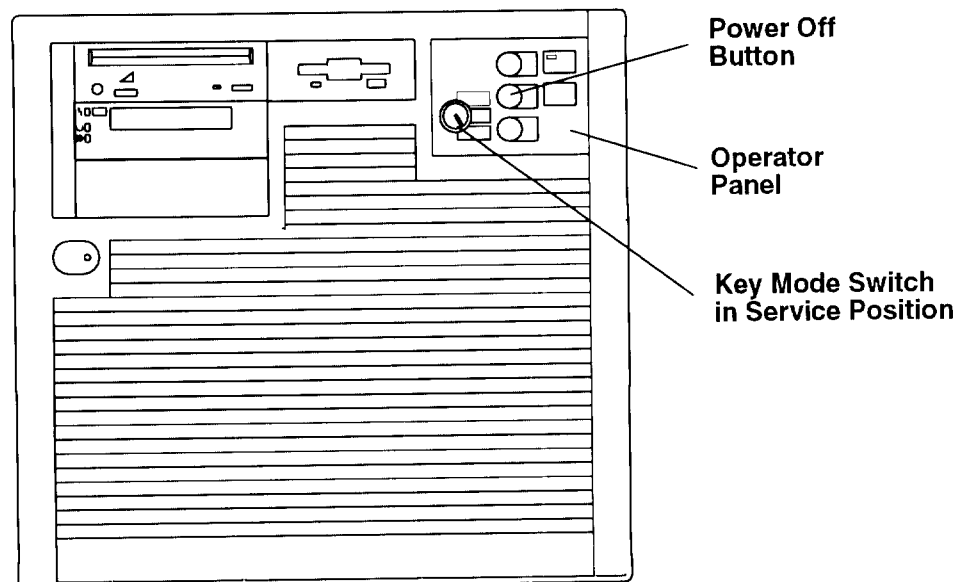

Note: For a translation of this notice, see the *System Unit Safety Information* manual.

DANGER

An electrical outlet that is not correctly wired could place hazardous voltage on metal parts of the system or the devices that attach to the system. It is the responsibility of the customer to ensure that the outlet is correctly wired and grounded to prevent an electrical shock.

Before installing or removing any additional devices to or from the system, ensure that the power cables for those devices are unplugged before the signal cables are connected. If possible, disconnect all power cables from the existing system before you add a device.

Use one hand, when possible, to connect or disconnect signal cables to prevent a possible shock from touching two surfaces with different electrical potentials.

During an electrical storm, do not connect cables for display stations, printers, telephones, or stations protectors, for communications lines.

3. Switch off power to all external devices attached to the system unit, and then unplug the device power cords from the electrical outlets.

Note: Because a large number of external devices can be connected to the system unit, it may be impractical for you to switch off power to all the devices and unplug their power cords.

4. Open the rear door of the system unit.
5. Set the Master CB1 circuit breaker to Off.
6. If the battery backup unit is installed, set the Master CB2 circuit breaker to Off.

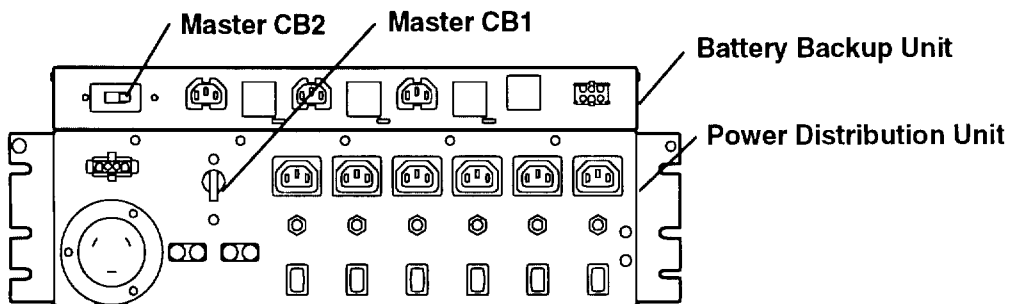

7. Unless you are servicing the system while signal cables or power cords are connected to external devices, unplug the system unit power cord from the electrical outlet.

Immediately Stopping the AC System Unit Containing a PDU

Warning: Unpredictable results can occur that affect your data files if you use this method to stop the system unit.

If you need to switch off all power to the system quickly, set the Master CB1 and CB2 circuit breakers to off. All power is switched off to the drawers connected to the PDU in this system unit. Other drawers in this system unit may be provided power from a PDU in an attached system unit.

Stopping the AC System Unit Containing a PDB – Ordinary Conditions

Note: Before stopping the system unit, you must first shut down the operating system to prevent losing data.

Before powering off the drawers or external devices, ask the customer about their system high availability requirements.

Other drawers in this system unit may be provided power from a PDB in an attached system unit.

Warning: Use the appropriate **shutdown** command before you stop the system unit; failure to do so may result in the loss of data. Refer to *AIX System Management Guide: Operating System and Devices* and other operating system documentation for information about the **shutdown** command and stopping the system unit.

1. Set the key mode switch to the Service position.
2. Press the Power Off button.

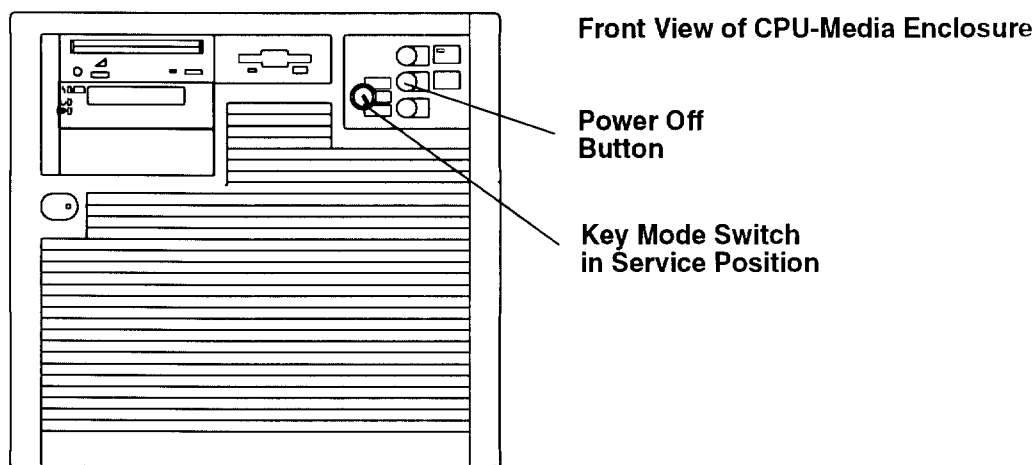

Note: For a translation of this notice, see the *System Unit Safety Information* manual

DANGER

An electrical outlet that is not correctly wired could place hazardous voltage on metal parts of the system or the devices that attach to the system. It is the responsibility of the customer to ensure that the outlet is correctly wired and grounded to prevent an electrical shock.

Before installing or removing any additional devices to or from the system, ensure that the power cables for those devices are unplugged before the signal cables are connected. If possible, disconnect all power cables from the existing system before you add a device.

Use one hand, when possible, to connect or disconnect signal cables to prevent a possible shock from touching two surfaces with different electrical potentials.

During an electrical storm, do not connect cables for display stations, printers, telephones, or stations protectors, for communications lines.

Note: Because a large number of external devices can be connected to the system unit, it may be impractical for you to switch off power to all the devices and unplug their power cords.

3. Switch off power to all external devices attached to the system unit, and then unplug the device power cords from the electrical outlets.

Immediately Stopping the AC System Unit Containing a PDB

Warning: Unpredictable results can occur that affect your data files if you use this method to stop the system unit. If drawers in an attached system unit are receiving power from the PDB of this system unit, the drawers in the attached rack will lose power when the PDB of this system unit is unplugged.

If you need to remove all power to the system unit quickly, unplug the PDB power cord from the customer's outlet. All power is switched off to the drawers in the rack.

Rear View of Rack

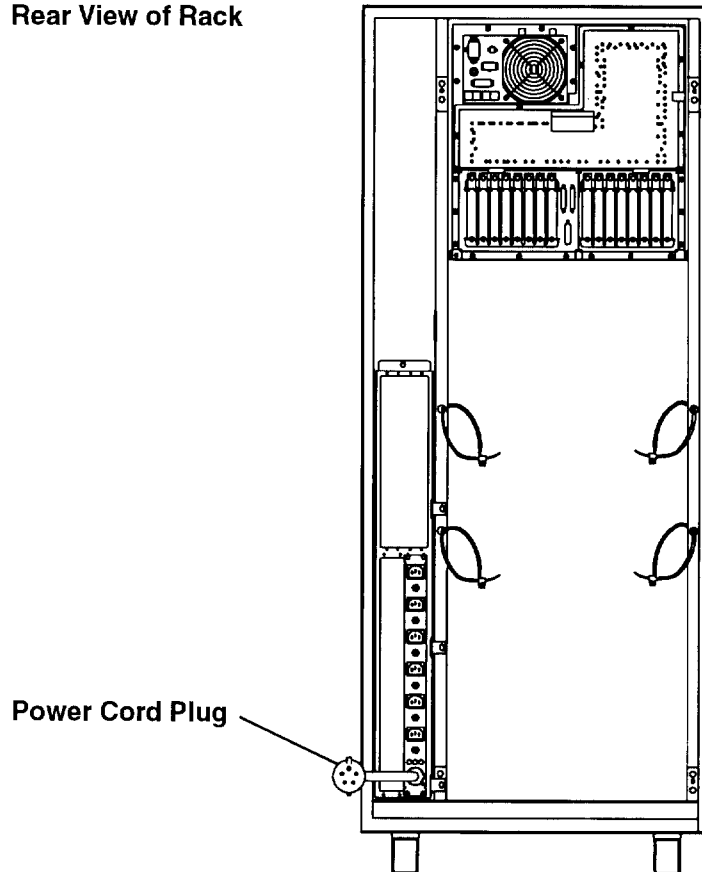

Chapter 5. Description – -48 V dc Rack

This chapter contains information about a -48 V dc rack containing a 7015 CPU-Media Enclosure.

For a description of an AC system unit, refer to Chapter 3.

-48 V dc System Unit

The 7015 system unit is a rack-mounted minicomputer. The -48 V dc system unit shown in the following illustration contains a 7015 CPU-Media Enclosure and the following features: cable channel, front and rear electrical outlet mounting plates, and a power distribution panel (PDP). Your system unit may contain additional drawers, such as a 9333 disk drive drawer. For information about options for the system unit, see the *RISC System/6000 System Overview and Planning* manual.

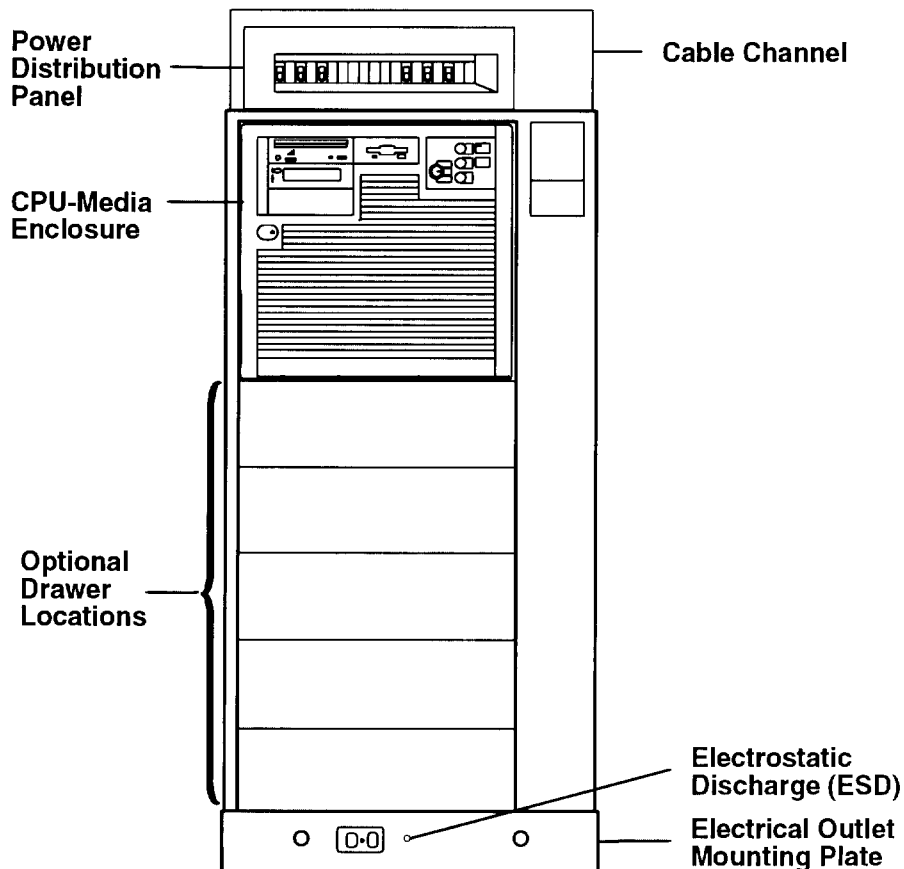

-48 V dc System Unit Power Cables and the CPU-Media Enclosure

Note: The following illustration shows the power cable path going from the top of the rack to the bottom of the rack. The power cables can be connected to the PDP from above the rack.

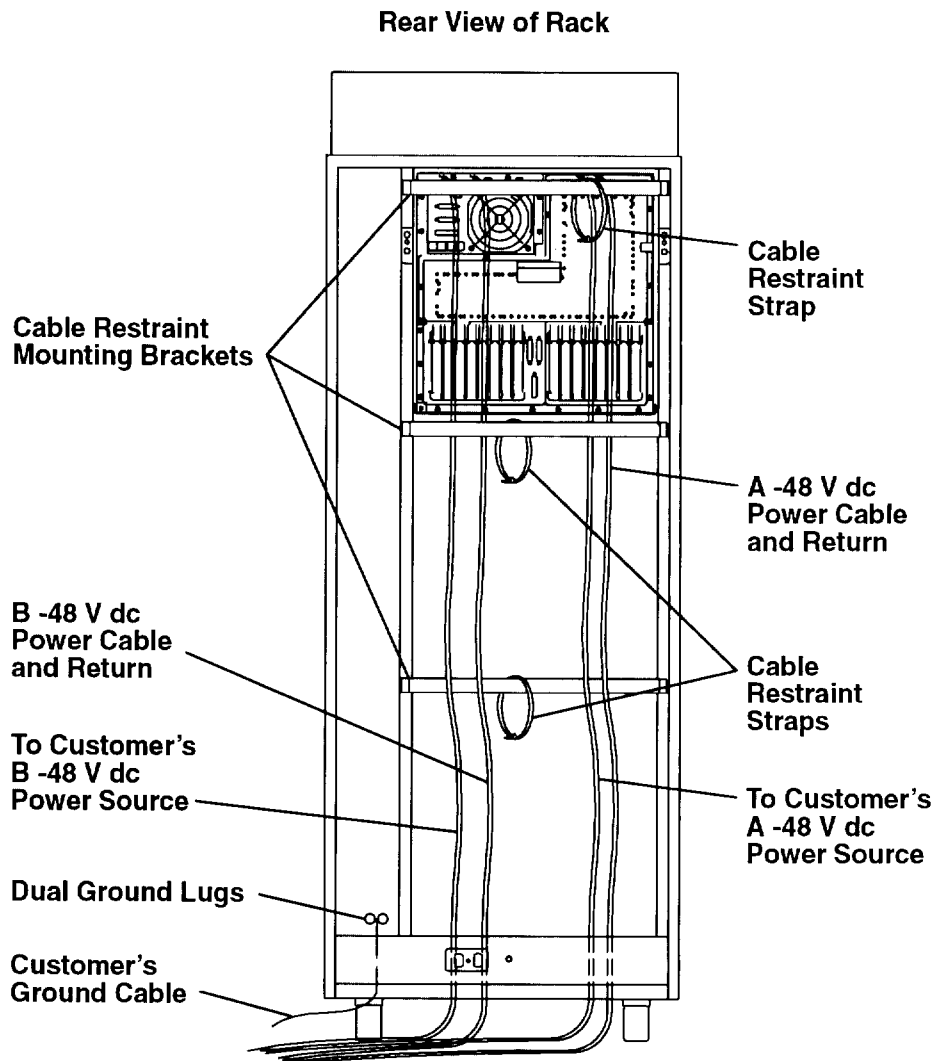

Chapter 6. Using the -48 V dc Rack

This chapter contains information about using the -48 V dc system unit.

For information about using an AC system unit and the devices installed in an AC system unit, refer to Chapter 3.

Some devices installed in an AC system unit (devices contained in the CPU-media enclosure) can be installed in a -48 V dc system unit.

Note: For information about using devices contained in the CPU-media enclosure, refer to Chapter 2.

Setting the Key Mode Switch

Refer to Chapter 2 for information about setting the key mode switch on the CPU-media enclosure.

Starting the -48 V dc System Unit

DANGER

An electrical outlet that is not correctly wired could place hazardous voltage on metal parts of the system or the devices that attach to the system. It is the responsibility of the customer to ensure that the outlet is correctly wired and grounded to prevent an electrical shock.

Before installing or removing signal cables, ensure that the power cables for the system unit and all attached devices are unplugged.

When adding or removing any additional devices to or from the system, ensure that the power cables for those devices are unplugged before the signal cables are connected. If possible, disconnect all power cables from the existing system before you add a device.

Use one hand, when possible, to connect or disconnect signal cables to prevent a possible shock from touching two surfaces with different electrical potentials.

During an electrical storm, do not connect cables for display stations, printers, telephones, or station protectors for communication lines.

CAUTION:

Energy hazard, remove power before servicing. Disconnect two power supply cords.

Note: An electrical hazard from an external -48 V dc power source exists in this unit. To prevent electrical shock, ensure that power to this unit is off before servicing.

Starting the system unit includes:

1. Verifying that power from the customer's power source is provided to the system unit.
2. Ensuring that all circuit breaker switches on the power distribution panel are set to on.
3. Starting the CPU-media enclosure (containing a -48 V dc power supply).

Verify -48 V dc Power to System Unit

1. Remove the six mounting screws holding the top cover of the power distribution panel, and then remove the top cover.
2. Ensure that power cables from the customer's -48 V dc power source are connected to the power distribution panel.
3. With a multimeter, verify that power exists between the -48 V dc bus bar (–) and the return bar (+) on both sides of the PDP.
4. Replace the top cover on the power distribution panel, and then replace the six mounting screws holding the top cover to the power distribution panel.

Setting the Circuit Breaker Switches to On

Ensure that all circuit breaker switches are set to On by setting the circuit breaker switches in the up position.

Starting the CPU-Media Enclosure (With -48 V dc Power Supply)

Starting the CPU-media enclosure includes:

1. Pressing the Power On button located on the operator panel of the CPU-media enclosure.
2. Doing an IPL.

The four methods of starting the system unit are as follows:

- **Manually.** The power is switched on manually, and the system unit does a normal or a service IPL.
- **Remotely.** The power is switched on from another location, and the system unit does a normal IPL. (To use this method, a modem or equivalent device must be attached to the CPU-media enclosure with a remote bringup cable.)
- **Programmed by date and time.** On a specific day and time, the power is switched on and the system unit does a normal IPL.
- **Programmed after a power failure.** When the power is restored, the power is switched on and the system unit does a normal IPL.

Only the manual start is described in this book. See your operating system documentation for information about other methods of starting the system unit.

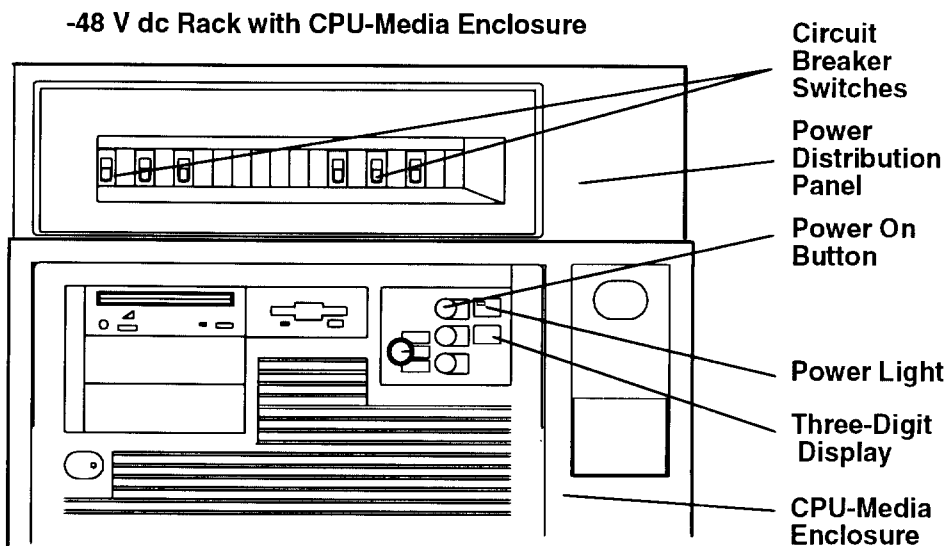

1. If the power switches of the attached devices have not been set to On, do it now.
2. Make sure that all of the circuit breaker switches, located on the front of the power distribution panel, are set to On (up position). Refer to "Setting the Circuit Breaker Switches to On" on page 6-2.
3. With the key mode switch in the Normal position, start the system unit by pressing the Power On button located on the operator panel of the CPU-media enclosure.
4. If power does not come on, ensure that the power cables from the customer's power source are correctly connected to the power distribution panel. If this does not solve the problem, refer to the *AIX Problem Solving Guide and Reference* manual.

When you press the Power On button, the Power light comes on and the system starts a power-on self-test (POST). During the POST, numbers are displayed in the three-digit display.

Stopping the -48 V dc System Unit

The following methods can be used to stop (switch off power to) the system unit:

- Under ordinary conditions. Power is switched off to the CPU-media enclosure and to other drawers if they are connected with the power control cables.
- Immediately. All power is switched off to the drawers in the system unit.
- **shutdown** program power-off. Power is switched off to the CPU-media enclosure.

Only the first two methods are described in this book. Refer to the *AIX System Management Guide: Operating System and Devices* and other operating system documentation for information about stopping the system unit and the **shutdown** program power-off method. This method can be used for any key mode position.

Stopping the System Unit under Ordinary Conditions

Note: Before stopping the system unit, you must first shut down the operating system to prevent losing data.

Warning: Use the appropriate **shutdown** command before you stop the system unit; failure to do so may result in the loss of data. Refer to *AIX System Management Guide: Operating System and Devices* and other operating system documentation for information about the **shutdown** command and stopping the system unit.

1. Set the key mode switch to the Service position.
2. Press the Power Off button.
3. Set the power switches of the attached devices to Off.

CPU-Media Enclosure Operator Panel

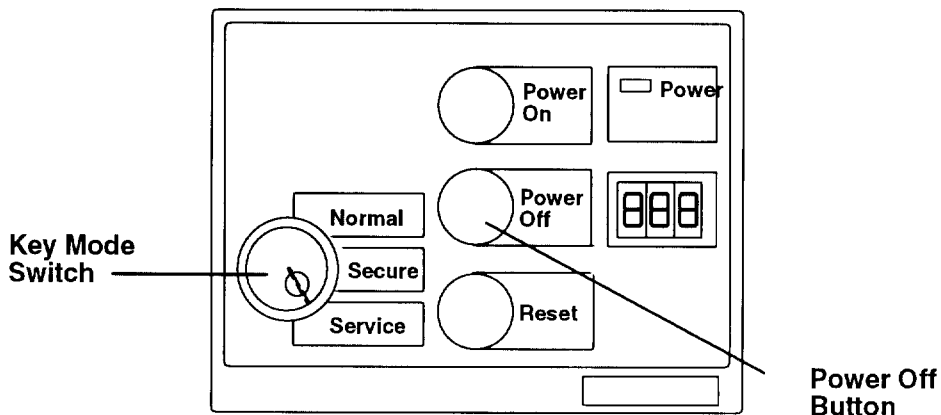

Stopping the -48 V dc System Unit Immediately

Warning: Unpredictable results that affect your data files can occur if you use this method to stop the system unit.

Note: Drawers in the rack may be receiving power from a PDP in another rack.

If you need to switch off all power to the system quickly, set all of the circuit breaker switches on the power distribution panel to Off (switches in the down position). All power is switched off to the drawers in the system unit.

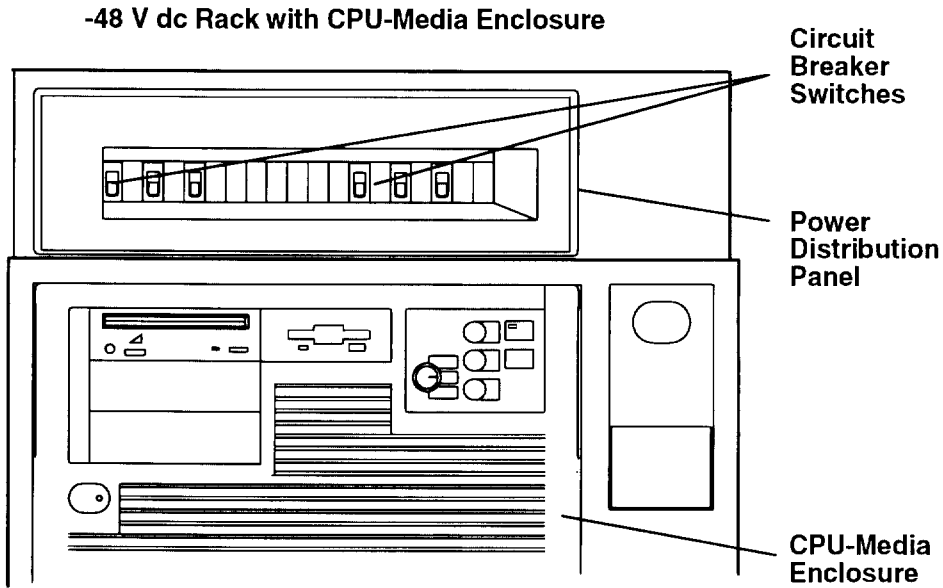

Chapter 7. Using the Diagnostics

This chapter contains information about using and interpreting the diagnostics used on the system unit.

Sources for the Diagnostic Programs

The diagnostic programs are shipped on three sources. The first source is on disk, and it is part of Version 3 of the operating system. The diagnostic programs, included as part of Version 3 of the operating system, are installed along with the operating system. These diagnostic programs are also updated with the operating system.

The second source is on diskettes shipped with the system unit. The diagnostic diskettes shipped with the system unit contain diagnostic programs that can be run in *Standalone mode* only. These diagnostic programs contain a special version of Version 3 of the operating system. The special version of the operating system only supports the diagnostic programs and cannot be used for normal system activity.

The third source is a diagnostic CD-ROM disc for systems equipped with a CD-ROM drive.

Diagnostic Programs Operating Considerations

The following items identify some things to consider before using the diagnostic programs.

Diagnostics on a System Unit Attached to Another System

If your system unit is attached to another system using a network or directly attached to the channel of another system, refer to “General Information About Multiple Systems” on page 4-1 before running any diagnostic procedures.

Selecting a Console Display

When running diagnostics from diskettes, from a CD-ROM disc, and under some conditions, from disk, select the console display. The diagnostic programs display `c31` in the three-digit display. The diagnostic programs also display instructions on any direct-attached display and on any terminal attached to the S1 port.

If `c31` is displayed, follow the instructions to select the console display. If you do not have a console display, set the key mode switch to the Normal position and then set it to Service position. This signals the diagnostic programs to use the three-digit display for instructions.

Identifying the Terminal Type to the Operating System

Note: This is a different function than selecting a console display.

When you run diagnostics, the operating system must know what type of terminal you are using. If the terminal type is not known when the FUNCTION SELECTION menu is displayed, the diagnostics do not allow you to continue until you select a terminal. Use the **DEFINE TERMINAL** option menu to select the terminal type. Select **hft** for adapter-attached displays. This option sets the **TERM** environment variable in the operating system.

Undefined Terminal Types

If an undefined terminal type from the DEFINE TERMINAL option menu is entered, the menu will prompt you to enter a valid terminal type, and the menu will be displayed again until either a valid type is entered or you exit the DEFINE TERMINAL option.

Resetting the Terminal

If you enter a terminal type that is valid (according to the DEFINE TERMINAL option menu) but it is not the correct type for the ASCII terminal being used, it may be difficult to read the screen, use the function keys, or the Enter key. If these difficulties occur, by press Ctrl-C to reset the terminal. The screen display that results from this resetting action varies with the mode in which the system is being run:

- Normal or Maintenance mode – The command prompt appears.
- Service mode – The terminal type will be reset to “dumb,” the Diagnostic Operating Instruction panel will be displayed, and you will be required to go through the DEFINE TERMINAL process again.

Running the Diagnostic Programs from Diskettes

Consider the following when you run the diagnostic programs from diskettes:

- The devices and functions contained on the diskette determine how the diagnostic diskettes are labeled. Before the words DIAGNOSTIC OPERATING INSTRUCTIONS are displayed, the diskettes must be inserted in the following order:
 1. Boot diskette
 2. Configuration diskette
 3. Graphics diskette (optional if the system does not contain a graphics adapter)
 4. Console definition diskette
- There are two different boot diskettes, one for use in systems containing only 8MB of memory and one for use in systems containing a minimum of 16MB of memory. Only one diskette can be loaded.
- There are several different graphics diskettes for configuring and testing graphics adapters. Use only the graphics diskettes for the type of graphics adapters installed in the system. For each type of graphics adapter installed in a system, you must load the graphics diskette which supports that adapter in order to test it.

The diskette containing the graphics adapter that will be used as the console for running diagnostics should be loaded first. If there are other graphics adapter types installed in the system, load the diskette supporting those adapters immediately following the first graphics diskette.

- If a device installed in a system is not supported by one of the diskettes shipped with the system, check for the existence of a supplemental diagnostic diskette shipped with the device.
- After the DIAGNOSTIC OPERATING INSTRUCTIONS are displayed, follow the displayed instructions to test the device or to run a Service Aid.
- The diagnostic programs shipped on diskettes with the system unit have a version number on the label. The *POWERstation and POWERserver Common Diagnostics and Service Guide* also has a version number on the cover. The first two digits of these version numbers should match for the diagnostics to work correctly. You can check the version of the diagnostic programs on the Diagnostic Operating Instructions.

- When you load the diagnostic programs from diskettes, you may get the following messages on the three-digit display or on the console display:

c01	Insert the first diagnostic diskette.
c02	Diskettes inserted out of sequence.
c03	The wrong diskette is in the diskette drive.
c05	A diskette error occurred.
c07	Insert the next diagnostic diskette.
c09	Diskette is being read or written.
c31	Select the console display.

Running the Diagnostic Programs from CD-ROM Disc

Consider the following when you run diagnostic programs from the CD-ROM disc:

- The diagnostic disc must remain in the CD-ROM drive while the diagnostic programs are running.
- The CD-ROM drive that the diagnostic programs were loaded from cannot be tested.
- The SCSI adapter connected to the CD-ROM drive that the diagnostic programs were loaded from cannot be tested.
- Diagnostic programs loaded from a CD-ROM disc are not supported on systems with less than 16M-bytes of memory.

To run the diagnostic programs from a CD-ROM drive, do the following:

1. If a 3.5-inch diskette is loaded in the diskette drive, remove the diskette from the drive.
2. Ensure that the power is on to the CD-ROM drive, or set the power switch on the CD-ROM drive to On if it is an externally attached device.
3. Insert the CD-ROM disc caddy containing the CD-ROM disc with the diagnostic programs into the CD-ROM drive.
4. Press the Power On button.

Running the Diagnostic Programs from Disk

Consider the following when you run the diagnostic programs from a disk:

- The diagnostics cannot be loaded and run from a disk until Version 3 of the operating system has been installed and configured. After the **installp** command is used to install and configure the operating system, all three modes of operation are available.
- When the diagnostics are loaded from disk, you must shutdown the operating system before powering the system unit off to prevent possible damage to disk data. This is done in either of the following ways:
 - If the diagnostic programs were loaded in Standalone mode, press the F3 key until the words DIAGNOSTIC OPERATING INSTRUCTIONS are displayed, then press the F3 key once to shutdown the operating system.
 - If the diagnostic programs were loaded in Maintenance or Concurrent mode, enter the **shutdown -F** command.
- Under some conditions, c31 may appear in the three-digit display with instructions displayed on attached displays and terminals. Follow the instructions to select a console display, or set the key mode switch to the Normal position, and then set it to the Service position if you do not have a console display.

Running the Diskette Diagnostics from a Non-RS232 Terminal

With Version 1.3 and later versions of the Diagnostics Diskette package, a terminal attached to any RS232 or RS-422 adapter can be selected as a console device. The default device is an RS232 TTY attached to the first standard serial port (S1). However, the console device may be changed by editing the `/etc/consdef` file that is provided on Diagnostics Diskette

4. The file format follows:

```
#
# This is the console definition file used to describe the terminal
# device to be used as the console. It is in the form
# attribute=value, one per line. The location is the location code
# seen when listing devices using lsdev. Spaces must not be entered
# around the = sign.
#
# Remove the # signs from the first column of each line to take
# effect. The location must be specified for any attribute in
# this file to be processed.
#
# For example, to define the console device as an rs232 terminal on
# port S1:
#
#connection=rs232
#location=00-00-S1
#speed=9600
#bpc=8
#stops=1
#xon=yes
#parity=non
#term=3163
```

To change this file, take the following steps:

1. Enter the following:

```
cd /tmp
mkdir diag4
cd diag4
```

2. Insert Diagnostics Diskette 4 into the diskette drive.

3. Enter the following:

```
cpio -iuvmdC36 </dev/rfd0
cd etc
```

4. To edit the file, do the following:

- a. Enter `uncompress consdef`.
- b. Edit the `consdef` file to work with your configuration.
- c. Enter `compress consdef`.

5. Enter the following:

```
cd /tmp/diag4
find . -type f -print | cpio -ouvmC36 > /dev/rfd0
```

6. Use the new Diagnostics Diskette 4 with the new configuration.

Running the Diagnostic Programs from a TTY Terminal

Consider the following when you run diagnostics programs using a TTY-type terminal as the console display:

- See the operator manual for your type of TTY terminal to find the key sequences needed to respond to the diagnostics programs. For the 3151, refer to the *3151 ASCII Display Station Guide to Operations*, order number GA18-2633. For the 3164, refer to the *3164 ASCII Color Display Station Description*, order number GA18-2617.
- When the diagnostic programs present display information through the S1 port, certain attributes are used. These attributes are set as if the diagnostic programs were using a 3161 display terminal. The following tables list attributes for the 3161 ASCII Display Terminal and for two other ASCII display terminals commonly used with the system
- If you have a TTY terminal other than a 3151, 3161, or 3164 attached to the S1 port, your terminal may have different names for the attributes. Use the attribute descriptions in the following tables to determine the settings for your terminal.

General Attributes Always Required

The following general attributes are the default settings for the diagnostics programs. Be sure your terminal is set to these attributes.

Note: These attributes should be set before the diagnostic programs are loaded.

General Setup Attributes	3151 (Models 11, 31, 41) Settings	3161/3164 Settings	Description
Machine mode	3151	3161 or 3164	The diagnostic programs are set to emulate use of the 3161 ASCII Display Terminal. If your terminal can emulate a 3151, 3161, or 3164 terminal, use the following attribute settings. Otherwise, refer to your operator's manual, compare the following attribute descriptions with those of your terminal, and then set your attributes as specified.
Screen	Normal		Uses the EIA-232 interface protocol.
Row and Column	24 x 80		Uses the EIA-232 interface protocol.
Scroll	Jump	Jump	When the last character on the bottom line is entered, the screen moves down one line.
Auto LF	Off	Off	For the On setting, pressing the Return key moves the cursor to the first character position of the next line. For the Off setting, pressing the Return key moves the cursor to the first character position of the current line. The CR and LF characters are generated by the New line setting.
CRT saver	Off	10	The 10 setting causes the display screen to go blank if there is no activity for 10 minutes. When the system unit sends data or a key is pressed, the display screen contents are displayed again.
Line wrap	Off	On	The cursor moves from the last character position of a line to the first character position of the next line in the same page.
Forcing insert	Off		
Tab	Field	Field	The column tab stops are ignored, and the tab operation depends on the field-attribute character positions.
Trace		All	When the Trace key is pressed, both inbound data (data to the system unit) and outbound data (data from the system unit) to and from the main port can be transferred to the auxiliary port without disturbing communications with the system unit.

Additional Communication Attributes

The following communication attributes are for the 3151, 3161, and 3164 terminals.

Communication Setup Attributes	3151 (Models 11, 31, 41) Settings	3161/3164 Settings	Description
Operating mode	Echo	Echo	Data entered from the keyboard on the terminal is sent to the system unit for translation and then sent back to the display screen. This is sometimes called conversational mode.
Line speed	9600 bps	9600 bps	Uses the 9600 bits per second (bps) line speed to communicate with the system unit.
Word length (bits)	8	8	Selects eight bits as a data word length (byte).
Parity	No	No	Does not add a parity bit and is used together with the word length attribute to form the 8-bit data word (byte).
Stop bit	1	1	Places a bit after a data word (byte).
Turnaround character	CR	CR	Selects the carriage return (CR) character as the line turnaround character.
Interface	EIA-232C	EIA-232C	Uses the EIA-232 interface protocol.
Line control	IPRTS	IPRTS	Uses the "permanent request to send" (IPRTS) signal to communicate with system unit.
Break signal (ms)	500	500	The terminal sends a "break signal" to the system unit within 500 ms after the Break key is pressed.
Send null suppress	On		Trailing null characters are not sent to the system unit.
Send null		On	Trailing null characters are sent to the system unit.
Response delay (ms)	100	100	The terminal waits for 100 ms for the system unit to respond.

Additional Keyboard Attributes

The following keyboard attributes are for the keyboard attached to the 3151, 3161, and 3164 terminals.

Keyboard Setup Attributes	3151 (Models 11, 31, 41) Settings	3161/3164 Settings	Description
Enter	Return	Return	The Enter key functions as the Return key.
Return	New line	New line	The cursor moves to the next line when the Return key is pressed.
New line	CR	CR	The Return key generates the carriage return (CR) and the line feed (LF) characters. The line turnaround occurs after the CR and LF characters are generated.
Send	Page	Page	The contents of the current page are sent to the system unit when the Send key is pressed.
Insert character	Space	Space	A blank character is inserted when the Insert key is pressed.

Additional Printer Attributes

The following printer attributes are for a printer attached to the 3151, 3161, and 3164 terminals.

Printer Setup Attributes	3151 (Models 11, 31, 41) Settings	3161/3164 Settings	Description
Line speed	9600	9600	Uses 19200 or 9600 bps (bits per second) line speed to communicate with the system unit.
Word length (bits)	8	8	Selects eight bits as a data word length (byte).
Parity	None	No	
Stop bit	1	1	Places a bit after a data word (byte).
Characters	ALL		
Line end		CR-LF	
Print		Viewport	
Print EOL		Off	
Print null		Off	

Diagnostic Modes of Operation

The diagnostics can be run in three modes:

- Maintenance mode allows checking of most system resources.
- Concurrent mode allows the normal system functions to continue while selected resources are being checked.
- Standalone mode allows checking of all the system devices and features.

Maintenance Mode

Maintenance mode runs the diagnostics using the customer's Version 3 of the operating system. This mode requires all activity on Version 3 of the operating system be stopped so the diagnostics have most of the resources available to check. All of the system resources except the SCSI adapters and the disk drive used for paging can be checked.

Error log analysis is done in maintenance mode when you select **the Problem Determination** option on the DIAGNOSTIC MODE SELECTION menu.

The **shutdown -m** command is used to stop all activity on Version 3 of the operating system and to put the operating system into Maintenance mode. Then the **diag** command is used to load the diagnostic controller so you can run the diagnostic programs from the menus. After the diagnostic controller is loaded, follow the normal diagnostic instructions.

Running the Diagnostics in Maintenance Mode

To run the diagnostics in Maintenance mode, you must be logged on to the customer's Version 3 of the operating system as `root` or `superuser` and use the **shutdown -m** and **diag** commands. Use the following steps to run the diagnostics in Maintenance mode

1. Stop all programs except the operating system.
2. Log onto Version 3 of the operating system as `root` or `superuser`.
3. Enter the **shutdown -m** command.
4. When a message indicates the system is in Maintenance mode, enter the **diag** command.

Note: It may be necessary to set `TERM` type again.

5. When DIAGNOSTIC OPERATING INSTRUCTIONS is displayed, follow the displayed instructions to checkout the desired resources.
6. When testing is complete, use the F3 key to return to DIAGNOSTIC OPERATING INSTRUCTIONS. Then press the F3 key again to return to the operating system prompt.
7. Press Ctrl-D to log off from `root` or `superuser`.

Concurrent Mode

Concurrent mode provides a way to run diagnostics on some of the system resources while the system is running normal system activity.

Because the system is running in normal operation, some of the resources cannot be tested in Concurrent mode. The following resources *cannot* be tested in Concurrent mode:

- SCSI adapters connected to paging devices
- The disk drive used for paging
- Some display adapters

There are three levels of testing in Concurrent mode:

- The *share-test level* tests a resource while the resource is being shared by programs running in the normal operation. This testing is mostly limited to normal commands that test for the presence of a device or adapter.
- The *sub-test level* tests a portion of a resource while the remaining part of the resource is being used in normal operation. For example, this test could test one port of a multiport device while the other ports are being used in normal operation.
- The *full-test level* requires the device must not be assigned to or used by any other operation. This level of testing on a disk drive may require the use of the **varyoff** command. The diagnostics display menus to allow you to vary off the needed resource.

The diagnostics also display a menu to assign a resource if another resource is needed.

Error log analysis is done in concurrent mode when you select **the Problem Determination** option on the DIAGNOSTIC MODE SELECTION menu.

To run the diagnostics in Concurrent mode, you must be logged onto Version 3 of the operating system and have proper authority to issue the commands.

The **diag** command loads the diagnostic controller and displays the diagnostic menus.

Running the Diagnostics in Concurrent Mode

To run diagnostics in Concurrent mode, take the following steps:

1. Log on to Version 3 of the operating system as `root` or `superuser`.
2. Enter the **diag** command.
3. When the DIAGNOSTIC OPERATING INSTRUCTIONS are displayed, follow the instructions to check out the desired resources.
4. When testing is complete, use the F3 key to return to the DIAGNOSTIC OPERATING INSTRUCTIONS. Then press the F3 key again to return to the operating system prompt. Be sure to *vary on* any disk drives that you varied off.
5. Press the Ctrl-D key sequence to log off from `root` or `superuser`.

Standalone Mode

Standalone mode provides the most complete checkout of the system resources. This mode also requires that no other programs are running on the system.

Standalone mode can be loaded in two ways:

- From diskettes or other removable load media. This method is the only method available for those systems that do not have Version 3 of the operating system installed.
- From a disk within the system unit. This loads the diagnostic programs that are a part of Version 3 of the operating system. Version 3 of the operating system must be installed and configured before the diagnostics can run from it.

Running the Diagnostics in Standalone Mode

To run diagnostics in Standalone mode, do the following steps:

1. Stop all programs including the operating system.
2. Press the Power Off button.
3. Set the key mode switch to the Service position.

Note: When the diagnostic programs are run from diskettes or from a CD-ROM disc the diagnostics do *not* check the error log entries.

4. If you want to load the standalone diagnostics from diskettes, insert the first diagnostics diskette into the diskette drive.
5. If you want to load the standalone diagnostics from a CD-ROM disc, insert the CD-ROM diagnostics disc into the CD-ROM drive.
6. If you want to load the diagnostics from the disk, leave the diskette and CD-ROM drives empty.
7. Press the Power On button.

If `c07` is displayed, insert the appropriate diagnostics diskette. If necessary, refer to the CERADME file for additional information.

If `c31` is displayed, follow the instructions to select a console display. If your system does not have a console, the diagnostics can be executed without a console. To execute the diagnostics without a console, wait for `c31` to be displayed, set the key mode switch to the Normal position, and then set the key mode switch to the Service position.

When executing diagnostics without a console, the following can occur:

- When a disk drive or a CD-ROM is used to run diagnostics, a `c99` is displayed when the diagnostics are successfully completed.
- When a diskette is used to run diagnostics, a `c07` is displayed when the diagnostics are successfully completed. Diagnostics can be run only on devices that are supported on the diagnostic diskette. To run diagnostics on additional devices when the `c07` is displayed, load the diskette that supports the devices.
- If the diagnostics detect a problem, a flashing `888` is displayed in the three-digit display. Refer to "Reading Flashing 888 Numbers" of this chapter for instructions about reading the message.

Note: If while the diagnostics are loading, some system units stop with 260, 261, or 262 displayed in the three-digit display and the console display is blank, press the 1 (one) key on the console keyboard to cause the diagnostics to continue to load.

8. After the diagnostic controller loads, the message DIAGNOSTIC OPERATING INSTRUCTIONS appears on the console display.
9. If a problem is detected while the diagnostics are loading, a flashing 888 displays in the three-digit display. See "Reading Flashing 888 Numbers" in this chapter for instructions on reading the message.
10. Follow the displayed instructions to check out the desired resources.
11. When testing is complete, use the F3 key to return to the DIAGNOSTIC OPERATING INSTRUCTIONS.
12. If you loaded the diagnostics from the disk, press the F3 key to shutdown the diagnostics before turning off the system unit.

If you loaded the diagnostics from diskettes or from a CD-ROM disc, press the Power Off button on the system unit.

System Exerciser

The System Exerciser tests and exercises devices in an overlap mode and can only be run from disk in Standalone mode or Maintenance mode.

Starting the System Exerciser

When the System Exerciser is selected from the FUNCTION SELECTION menu, another menu displays all devices to be tested. Pressing the Enter key starts tests for all of the devices.

Note: If the system contains tape devices, a CD-ROM drive, or a diskette drive, you will be prompted whether you want to use media in the devices when you are testing.

The time required to test all of the devices depends on the number of devices being tested and can range from several minutes to approximately one hour for a fully loaded system. Because some devices require less time to test than others, the System Exerciser may test a device more than once.

Display Screens

If the console is an async terminal, the standby screen will be displayed during testing. The time-of-day will be displayed at the top of the screen and is updated approximately every minute.

After all devices have been tested at least once, a results screen will be displayed until either the Enter key is pressed to restart the System Exerciser or the System Exerciser is stopped. If no errors were detected, the results screen displays the No trouble found message; if errors have been detected, the results screen displays a list of devices with corresponding errors.

Stopping the System Exerciser

Although the System Exerciser can be stopped at any time, it is best to stop it while the results screen is displayed. Stopping the System Exerciser at other times can cause the loss of test information.

When the System Exerciser is stopped, the screen displays all tested devices with errors flagged. Selecting a device that has an error flag provides details such as SRN, location code, number of times the device was tested, and the number of times an error was detected.

Using the System Exerciser to Check Out Repairs and Intermittent Problems

The System Exerciser can be used to check out the system following repairs and to identify intermittent problems.

When the System Exerciser is running, most built-in error recovery procedures are switched off. This can cause occasional errors to be reported that normally have no effect on system operation. Parts should only be replaced when:

- A high number of errors are reported in relation to the number of times the device was tested.
- Errors reported by the System Exerciser are in the same area as that reported by the customer.

Reading Flashing 888 Numbers

A flashing 888 number indicates that a hardware or software error is detected by the diagnostic programs.

The diagnostic programs display a flashing 888 to indicate a crash message or a diagnostics message is ready to be read.

Use the following procedure to read out a flashing 888 message.

Step 1. Determine the Type of Message

The three-digit display should be flashing 888 .

1. Get a Problem Report Form from the *AIX Problem Solving Guide and Reference* or a blank sheet of paper to record the numbers in the three-digit display.
2. Be sure the key mode switch is set to Normal or Service.

Note: Every time you press the Reset button, press it down for about 1 second to allow the program to sense the change.

3. Press the Reset button once. Record the number in the three-digit display. This is the message type.
4. Go to the step listed for your message type:

Type 102 Go to step 2.

Type 103 Go to step 3.

Type 105 Go to step 4.

Other Go to step 5.

Step 2. Reading the Type 102 Message

Use the following steps and information to determine the content of the type 102 message. See Appendix B for a description of the crash code and dump status.

102 = Message type
RRR = Crash code
SSS = Dump status code
888 or 103 or 105

1. Press the Reset button once and record the crash code.
2. Press the Reset button again and record the dump status code.
3. Press the Reset button again. Look at the number in the three-digit display to answer the following question.

Is 888 flashing in the three-digit display?

- NO** The message has a type 103 or type 105 message included in it. Go to Step 3 to read out the SRN and FRU information about Type 103 messages. Go to Step 4 to read out the SRN and FRU information about Type 105 messages.
- YES** This completes the read out of this message. You can repeat the message by pressing the Reset button. You must switch off the system unit to recover from this halt (press the Power Off button).

Note: There are no SRNs associated with this message type. If the crash code is 553 and you were loading the diagnostics diskettes, you might have used the incorrect diagnostic boot diskette. Try using the boot diskette for 8MB systems.

Crash Codes

The following crash codes are part of a Type 102 message. Refer to "Step 2. Reading the Type 102 Message" on this page.

000	Unexpected system interrupt.
200	Machine check because of a memory bus error.
201	Machine check because of a memory timeout.
202	Machine check because of a memory card failure.
203	Machine check because of a out of range address.
204	Machine check because of an attempt to write to ROS.
205	Machine check because of an uncorrectable address parity.
206	Machine check because of an uncorrectable ECC error.
207	Machine check because of an unidentified error.
300	Data storage interrupt from the processor.
32x	Data storage interrupt because of an I/O exception from IOCC.
38x	Data storage interrupt because of an I/O exception from SLA.
400	Instruction storage interrupt.
500	External interrupt because of a scrub memory bus error.
501	External interrupt because of an unidentified error.
51x	External interrupt because of a DMA memory bus error.
52x	External interrupt because of an IOCC channel check.
53x	External interrupt because of an IOCC bus timeout; x represents the IOCCC number.
54x	External interrupt because of an IOCC keyboard check.
558	There is not enough memory to continue the IPL..
700	Program interrupt.
800	Floating point is not available.

Dump Progress Indicators (Dump Status Codes)

The following dump progress indicators, or dump status codes, are part of a Type 102 message. Refer to "Step 2. Reading the Type 102 Message" on the previous page.

Note: When a lowercase *c* is listed, it displays in the lower half of the seven-segment character position. The leftmost position is blank on the following codes.

0c0	The dump completed successfully.
0c2	A dump, requested by the user, is started.
0c3	The dump is inhibited.
0c4	The dump did not complete. A partial dump may be present.
0c5	The dump program could not access the dump device.
0c6	A dump to the secondary dump device was requested. Make the secondary dump device ready; then press Ctrl-Alt-Numpad2.
0c7	Reserved.
0c8	The dump function is disabled.
0c9	A dump is in progress.

Step 3. Reading the Type 103 Message

Use the following steps and information to determine the content of the type 103 message. (You may have come here from a type 102 message. If so, use the same procedure.)

1. Press the Reset button, and record the first three digits of the six-digit SRN.

Note: The IBM 9333 displays four-digit SRNs that are not listed in this book. To decode these SRNs, refer to IBM 9333 documentation.

2. Press the Reset button and record the second three digits of the six-digit SRN.
3. Each time the Reset button is pressed, three digits of a FRU location code are displayed. When all FRU location codes are read out, the three-digit display returns to the flashing 888 or, if another Type 103 message is waiting to be displayed, a *ccc*. If a *ccc* is displayed, repeat this step to receive the next message. Try the first SRN listed; if it does not resolve the problem, try following SRNs in the order listed. If the message contains more than four FRUs, not all FRU location codes will be present.

Press the Reset button, and record the three-digit numbers until a flashing 888 displays. Use the following to identify the numbers being read:

```
103 = Message type
XXX-XXX = SRN
c01 1xx 2xx 3xx 4xx 5xx 6xx 7xx 8xx = First FRU location code
c02 1xx 2xx 3xx 4xx 5xx 6xx 7xx 8xx = Second FRU location code
c03 1xx 2xx 3xx 4xx 5xx 6xx 7xx 8xx = Third FRU location code
c04 1xx 2xx 3xx 4xx 5xx 6xx 7xx 8xx = Fourth FRU location code
```

4. Identify the SRN in the message, and report the SRN to the service organization. Keep the paper or form containing all of the recorded numbers for the service representative. You can cycle through the numbers again by pressing the Reset button.

5. The FRU location codes translate into an eight-digit location code (AB-CD-EF-GH). Each digit of the eight-digit location code is presented as a three-digit number in the three-digit display.

A B C D E F G H = Eight-digit location code
 c01 1xx 2xx 3xx 4xx 5xx 6xx 7xx 8xx = First FRU location code
 c02 1xx 2xx 3xx 4xx 5xx 6xx 7xx 8xx = Second FRU location code
 c03 1xx 2xx 3xx 4xx 5xx 6xx 7xx 8xx = Third FRU location code
 c04 1xx 2xx 3xx 4xx 5xx 6xx 7xx 8xx = Fourth FRU location code

To identify each digit of the location code (AB-CD-EF-GH), translate the rightmost two digits using the following table. See "Location Code Table for SCSI and Non-SCSI Devices" in Chapter 1 to determine the physical location of the resource.

Note: If a `ccx` (`x` can be any digit from 2 through 9) is encountered as part of the location code, only the part of the code that is different from the location code of the previous FRU is shown. To form the complete location code of the next FRU, substitute the information following the `ccx` into the location code of the previous FRU.

For example, if the previous FRU location is:
 c01 100 200 300 401 500 601 700 800,
 and the next FRU location is listed as:
 cc2 602,
 the complete location code of the next FRU is:
 cc2 100 200 300 401 500 602 700 800.

xx	Value	xx	Value	xx	Value	xx	Value
00	= 0	11	= A	21	= K	31	= U
01	= 1	12	= B	22	= L	32	= V
02	= 2	13	= C	23	= M	33	= W
03	= 3	14	= D	24	= N	34	= X
04	= 4	15	= E	25	= O	35	= Y
05	= 5	16	= F	26	= P	36	= Z
06	= 6	17	= G	27	= Q		
07	= 7	18	= H	28	= R		
08	= 8	19	= I	29	= S		
09	= 9	20	= J	30	= T		

6. The only way to recover from an 888 type of halt is to switch off the system unit (press the Power Off button).

Step 4. Reading the Type 105 Message

Use the following steps and information to determine the content of the type 105 message. If you were referred to this message from a Type 102 message, use this procedure.

1. Press the Reset button, and record the first three digits of the SRN.
2. Press the Reset button, and record the next three digits of the six-digit SRN.
3. Repeatedly press the Reset button; after each time, record the numbers in the three-digit display until `c01` is displayed.

- Each time the Reset button is pressed, three digits of a FRU location code are displayed. When all FRU location codes are read, the three-digit display returns to the flashing 888, or, if another message is waiting to be displayed, the three-digit display returns to a ccc. If a ccc is displayed, repeat this step to receive the next message. Try the first SRN listed; if it does not resolve the problem, try following SRNs in the order listed. If the message contains more than four FRUs, not all FRU location codes will be present.

Press the Reset button, and record the three-digit numbers until a flashing 888 displays. Use the following to identify the numbers displayed:

105 = Message type

1xx 2xx 3xx 4xx = encoded SRN

c01 1xx 2xx 3xx 4xx 5xx 6xx 7xx 8xx = First FRU location code

c02 1xx 2xx 3xx 4xx 5xx 6xx 7xx 8xx = Second FRU location code

c03 1xx 2xx 3xx 4xx 5xx 6xx 7xx 8xx = Third FRU location code

c04 1xx 2xx 3xx 4xx 5xx 6xx 7xx 8xx = Fourth FRU location code

- Determine the SRN by translating the rightmost two digits of each position within the encoded SRN (1xx 2xx 3xx 4xx), using the table on page 7-19. Report the SRN to the service organization. Keep the paper or form on which you recorded all of the numbers for the service representative. You can cycle through the numbers again by pressing the Reset button.

6. The FRU location codes translate into an eight-digit location code (AB-CD-EF-GH). Each digit of the eight-digit location code is presented as a three-digit number in the three-digit display.

A B C D E F G H = Eight-digit location code
 c01 1xx 2xx 3xx 4xx 5xx 6xx 7xx 8xx = First FRU location code
 c02 1xx 2xx 3xx 4xx 5xx 6xx 7xx 8xx = Second FRU location code
 c03 1xx 2xx 3xx 4xx 5xx 6xx 7xx 8xx = Third FRU location code
 c04 1xx 2xx 3xx 4xx 5xx 6xx 7xx 8xx = Fourth FRU location code

To identify each digit of the location code (AB-CD-EF-GH), translate the rightmost two digits of each position within the encoded SRN using the following table. See "Location Code Table For SCSI and Non-SCSI Devices" in Chapter 1 to determine the physical location of the resource.

Note: If a `ccx` (x can be any digit from 2 through 9) is encountered as part of the location code, only the part of the code that is different from the location code of the previous FRU is shown. To form the complete location code of the next FRU, substitute the information following the `ccx` into the location code of the previous FRU.

For example, if the previous FRU location is:
 c01 100 200 300 401 500 601 700 800,
 and the next FRU location is listed as:
 cc2 602,
 the complete location code of the next FRU is:
 cc2 100 200 300 401 500 602 700 800.

xx	Value	xx	Value	xx	Value	xx	Value
00	= 0	11	= A	21	= K	31	= U
01	= 1	12	= B	22	= L	32	= V
02	= 2	13	= C	23	= M	33	= W
03	= 3	14	= D	24	= N	34	= X
04	= 4	15	= E	25	= O	35	= Y
05	= 5	16	= F	26	= P	36	= Z
06	= 6	17	= G	27	= Q		
07	= 7	18	= H	28	= R		
08	= 8	19	= I	29	= S		
09	= 9	20	= J	30	= T		

7. The only way to recover from an 888 type of halt is to switch off the system unit (press the Power Off button).

Step 5. Other Numbers

If the message type is a type 104, it contains information that is not used by the service organization. Disregard this information. If you have another number displayed for the message type, do the following:

1. Press the Reset button repeatedly until a flashing 888 is displayed in the three-digit display. If you do not get a flashing 888 in the display, consider the numbers as *steady* (not flashing) numbers. Go to the *AIX Problem Solving Guide and Reference* and follow the procedures for interpreting the values in the three-digit display.
2. When the flashing 888 displays, go to Step 1.

Chapter 8. Using the Service Aids

This chapter contains information about using the service aids available in various media formats.

Introduction to Service Aids

The diagnostic programs contain programs called service aids. The service aids are used to display data and do additional testing.

The following service aids are provided:

- Display previous diagnostic results
- Display or change diagnostic test list
- Display or change configuration or vital product data
- Display or alter bootlist
- Trace
- Create diagnostics diskette package
- Disk-based diagnostic update
- Dials and LPFK configuration
- Diskette media
- Disk media
- Service aids for use with local area network (LAN)
- SCSI bus
- Display test patterns
- Microcode download
- Service hints
- M-multimedia video capture adapter
- Hardware error report
- Product topology

These service aids are described in the following topics.

Display Previous Diagnostic Results

Note: This service aid is not available when you load the diagnostics from a source other than a disk drive or a network.

Each time the diagnostics produce a service request number (SRN) to report a problem, information about that problem is logged. The service representative can look at this log to see what SRNs are recorded. This log also records the results of diagnostic tests that are run in loop mode.

When this service aid is selected, information on the last problem logged is displayed. The Page Down and Page Up keys can be used to look at information about previous problems.

This information is *not* from the error log maintained by Version 3 of the operating system. This information is stored in the `/etc/lpp/diagnostics/data/*.dat` file.

Display or Change Diagnostic Test List

During power-on self-test, the diagnostic controller uses the diagnostic test list to determine which resources to check.

With this service aid, the user can delete a resource from the diagnostic test list, add a deleted resource back into the diagnostic test list, and display the diagnostic test list.

Display or Change Configuration or Vital Product Data

Note: The following Version 3 operating system commands are not available when you load this service aid from diskettes or CD-ROM disc.

This service aid enables you to display and change configuration data and vital product data (VPD).

Use the **lscfg** command to copy the contents of the configuration and VPD files to another file or to a printer. This command identifies the resources that have diagnostic support. For more information about the **lscfg** command, see the Version 3 operating system information.

In the following examples, the first example copies the configuration data and VPD to a file named **/u/mine/VPD**. The second example prints the configuration list. The third example displays the VPD on the screen.

```
lscfg -v > /u/mine/VPD
lscfg | enq
lscfg -v | pg
```

Display Configuration

This service aid displays a list of the resources installed on this system.

Display Vital Product Data (VPD)

This service aid displays the VPD for all of the resources installed on this system. Use the Page Down and Page Up keys to see the data for all resources.

Display or Alter VPD

Warning: If this service aid was loaded from a source other than the disk drive or the network, any changes or additions you make to the VPD data will be lost when you shut down.

This service aid enables you to display and alter the VPD for any resource. When you select this service aid, a menu allows you to select the desired resource.

Change Configuration

Warning: If this service aid was loaded from any source other than the disk drive or network, any changes or additions you make to the configuration data will be lost when you press the Power Off button.

This service aid enables you to add or delete drawer data from the configuration list. This service aid is used to add nonmachine-readable data to the configuration list.

Display or Alter Bootlist

This service aid enables you to display, alter, or erase the list of IPL devices from which the system will attempt to load either Version 3 of the operating system or the diagnostics programs.

The system will attempt to perform an IPL from the first device in the list. If the device is not a valid IPL device or if the IPL fails, the system will proceed in turn to the other devices in the list to attempt an IPL.

Note: This service aid does not support additional network adapters as IPL devices.

Trace

The Trace service aid is used to correct problems with microcode on either a serial disk adapter or a serial disk controller. It is recommended that trained service representatives use this service aid.

Diagnostic Diskette Creation

Note: Before creating diagnostics diskettes with this service aid, any service update software (PTFs) should first be applied.

The Create Diagnostics Diskette Package service aid requires at least 10,000 blocks of free space in the **root** directory and 8800 blocks of free space in the **/tmp** directory. If you do not have enough free space in these directories, an error message is displayed when you run this service aid.

Note: If you receive any messages about missing files when you run this service aid, the diskettes created by this service aid may not work properly. The files identified by the messages may be necessary for these diskettes to work properly.

This service aid creates diagnostics diskettes that are customized for the system on which they are created. The diskettes created by this service aid contain the diagnostics for only the devices and the system on which the service aid diskette is created.

Disk-Based Diagnostic Update

This service aid is used to update to the most current level, the Version 3 diagnostic programs stored on the disk. The update is performed by inserting all diskettes containing the service update software (PTFs) into the diskette drive when the service aid prompts you to do so.

Dials and LPFK Configuration

This service aid configures dials or LPFK devices to be used on the S1 or S2 serial port. Until these devices are configured, they cannot be tested by the diagnostic programs. If dials or LPFK devices attached to the S1 or S2 serial port do not show on the diagnostic test list, use this service aid first to configure the device.

Diskette Media

This service aid provides a way to verify the data on a diskette. When this service aid is selected, a menu prompts you to select the type of diskette being verified. The program reads all ID and data fields on the diskette once, and then displays the total number of bad sectors found.

Disk Media

This service aid provides a Format Disk service aid and a Certify Disk service aid.

Format Disk

There are two options available to format a disk.

Format

The format option writes all of the ID fields and writes a bit pattern in all of the data fields. This option does *not* reassign data blocks that are bad.

Format and Certify

The format-and-certify option writes all of the ID fields and writes a bit pattern in all of the data fields. It also reassigns any bad data blocks found during formatting. A message is displayed when there are too many bad data blocks.

This service aid should be used to completely erase the existing data on a disk. The diagnostic programs may instruct you to use this service aid when data on a disk is badly damaged.

Certify Disk

The Certify Disk service aid reads all of the ID and data fields and checks for bad data in the ID and data fields. A message is displayed when there are too many bad data blocks.

Local Area Network

This service aid provides a way to analyze local area network (LAN) problems related to attached Ethernet, Token-Ring, and FDDI adapters. The service aid enables you to do the following:

- Monitor the ring (Token-Ring only). Abnormal conditions are reported.
- Connectivity testing. Data is transferred between two stations, and the results are reported.

SCSI Bus

This service aid provides additional testing for SCSI bus problems and should be used only after no problems are found with the normal diagnostic test programs.

A **SCSI Test Unit Ready** command is sent to a SCSI device you select from the SCSI BUS ADDRESS SELECTION menu; then, the test results are displayed. To analyze a SCSI bus problem, start with only one device attached; then, add one device at a time until you identify the failing device. *Always* use a terminator at the end of the SCSI bus.

Display Test Patterns

This service aid provides a way to display the test patterns needed to adjust the 5081, 6091, and 8517 displays. Select the pattern you need from the menu.

Note: This service aid should not be run in a multiwindow environment.

Microcode Download

Microcode download is a service aid that provides a way to copy microcode from diskettes to a disk or a tape drive. This procedure is used to update disk drive or tape drive controller microcode, and may be needed after exchanging a disk drive.

Service Hints

The Service Hints service aid reads and displays the information in the CEREAADME file from the diagnostics source (diskettes or disk).

Use this service aid to display the information in the CEREAADME (CE read me) file. This file contains information that is not in the publications for this version of the diagnostics. It also contains information about using this particular version of diagnostics.

Use the Enter key to page forward through the information or use the – (Dash) key and the Enter key to page backward through the file.

Multimedia Video Capture Adapter

The Multimedia Video Capture Adapter service aid provides a selection of patterns used for adjusting the multimedia video capture adapter. Select the appropriate pattern from the choices listed on the Multimedia Video service aid menu.

Hardware Error Report

This service aid provides a tool for viewing the system error log for hardware errors.

The service aid displays information concerning error log entries classified as hardware errors. This service aid scans the error log for hardware type errors and then displays the data to the user. The service aid has the option to format some error log entry types making them more meaningful to the user.

Product Topology

The Product Topology Data System has been created to enhance product and order quality within this system family.

Introduction

The Product Topology system records and maintains the following data:

- Machine configuration, including both Feature Code and Manufacturing Feature Bill of Material nomenclature
- Machine contents, including part numbers and EC levels
- History of actions taken with machine hardware

Data collection and recording for a machine begins with the initial order and continues through the manufacturing process into field service. This physical history, combined with the current configuration, is a valuable resource in managing product quality. Additionally, current machine configurations, as reported from the field via Update diskettes, are used as a database for developing and improving Miscellaneous Engineering Specification (MES) upgrade orders and their installability.

How the Product Topology System Works

The fundamental operation within the Product Topology system is the transfer of data from the plant of manufacture to the machine and back to the plant of manufacture.

Initial Installation

The machines leave the plant of manufacture with a Product Topology System Diskette which contains accumulated machine configuration and history. This data is installed on the machine in the customer's environment.

For machines having a disk drive with the operating system installed, the Product Topology data is installed by using the Product Topology service aid from operating-system-based diagnostics on the disk drive. Standalone diskette-based or CD-ROM-disc-based diagnostics should be used only on machines that do not have, or plan to have, the operating system installed. Even in the case of a disk drive failure, when the standalone diskette diagnostics package or the diagnostic CD-ROM disc is used, the Product Topology service aid should be run from the disk drive *after* the machine is restored to normal operation.

The Product Topology installation process transfers all prior configuration data from the System diskette to a set of files on the disk drive. Any changes made to the machine during installation will also be recorded (the service aid may ask some questions during the Product Topology installation). The new machine configuration, including the history of the changes just recorded, is then written to both the System and Update diskettes. The System diskette is written as a backup of the disk drive data in case of failure. When AIX is not resident on the machine and standalone diskette diagnostics are used, the System diskette is the only record of Product Topology data kept with the machine.

Note: It is critical that the System diskette remain with the machine and be available during upgrade or service action. The data written on the Update diskette is the data which is used to update the plant of manufacture Product Topology Data System. Any time an Update diskette is written, it must be returned to the plant of manufacture because this is the only mechanism available for recording field actions.

MES and Other Field Action

As with initial orders, data for MES action and for devices that are added to machines in the field comes with an Update diskette containing additional information about a resource. The diskette data is applied to the system by using the service aid. The data is read and then merged with the current machine configuration. Then the data is written to the System and Update diskettes. The System diskette provides a Product Topology record which must remain with the machine, and the Update diskette is returned to the plant of manufacture to update the Product Topology Data System.

Note: Always be sure that the correct diskette is used when performing the actions required by the Product Topology service aid. The recorded data on the System diskette is different from the data stored on the Update diskette. At no time should the System diskette be returned to the plant of manufacture. The System diskette must remain with the machine.

Missing or New Resources

Occasionally, when the Product Topology service aid is run during machine or MES installation, a screen may be presented which indicates that a resource has been either added or removed. This situation is normal and occurs whenever resources have been added to the machine after completion of the manufacturing test process. The most likely resources to be added are TTY (ASCII terminals), kbd (keyboards), and mous (mouse). Screens displayed for the detection of added resources come in pairs. The first is a series of fields for adding data about the newly detected resource; if the added resource data is available, enter it in the appropriate field. If the data is not available, or if the added resource cannot be identified, select **Commit**, and continue. In all cases, select **Commit** to proceed. Once the data is committed, a list of options will be presented to determine where the resource originated. Select the appropriate option based on available information.

A similar procedure should be used for resources detected as missing. Again, select the appropriate information based on available information. If the information is not known, select the option that removes the resource permanently.

Installing Multiple Engineering Changes (ECs)

When adding or removing several MESes or resources, complete all hardware changes, verify the installation, and check out the resources before using the service aid to update the Product Topology. When the Product Topology service aid is run, several questions are asked that refer to reading in data only from the new resource Update diskettes, and *not* to the Update diskettes. The Update diskettes are shipped with the original machine and are used for recording subsequent repair actions.

The Product Topology service aid prompts you for all of the Update diskettes shipped with the multiple resources. After all these diskettes have been read into the system, an Update diskette is needed to record the new overall system configuration. This diskette will be shipped to the plant of manufacture to update the Product Topology Data System. Also, be sure to return all individual diskettes that were shipped with the new resources.

Using the Create (Rebuild) Function

Warning: Use of this function can result in the total loss of Product Topology data stored on the system.

The Create, or Rebuild, function is included in the Product Topology service aid and should be used only after the service person has been instructed by the Support Center or by written instructions.

Completing the Product Topology Process

The final step of the Product Topology process is to write the new system configuration on the System and Update diskettes. When the diskette-writing procedure is finished, the Product Topology service aid menu automatically returns to the screen.

Note: Do not remove a diskette from the drive until one of the following conditions occur:

- The diskette drive light has turned off.
- You are prompted to do so by the software.
- You are prompted by the software to insert the next diskette.
- The Product Topology service aid procedure terminates, and the Product Topology service aid menu is displayed.

Installation of EC A90783B

EC A90783B corrects a problem with the Product Topology service aid, Version 1.0, which was shipped with early machines. Since Version 1.0 may have corrupted the original data, this EC is crucial to reestablish Product Topology data on the machine and to create an Update diskette for return to the plant-of-manufacture Product Topology Data System

Instructions shipped with the EC completely describe how to determine the necessity of installing the new Product Topology service aid level. If you have already acquired a higher level than 1.0, only a reinstallation of the Product Topology data is required. Instructions for this procedure are also included.

Machines without Product Topology

Some disk drive machines do not have Product Topology data installed because the Product Topology service aid has not been run from disk. When the Product Topology service aid is run from the diskette diagnostics package or from the diagnostic CD-ROM disc, the system does not record Product Topology data onto the disk drive. When the Product Topology service aid is eventually run from the disk drive following an MES installation or repair action, the program will ask for the System diskette. The System diskette configuration data is then written onto the disk drive, and the result is the same as if diagnostics had been used from the disk drive during the initial installation.

Note: It is extremely important to provide the System diskette when it is requested. Do not use the Create (Rebuild) function in place of using the System diskette.

Chapter 9. Using the System Verification Procedure

This chapter contains information about pre-procedure considerations and running system verification.

System Verification Procedure

The system verification procedure is used to check the system for correct operation.

When you are analyzing a hardware problem, you should use the "Hardware Problem Determination Procedure" in Chapter 10.

Step 1. Considerations before Running This Procedure

Notes:

1. If this system unit is directly attached to another system unit or attached to a network, be sure communications with the other system unit are stopped. If needed, refer to Chapter 2 for more information about multiple system attachments.
 2. This procedure requires use of all of the system resources. No other activity can be running on the system while you are doing this procedure.
- This procedure requires a TTY terminal attached to the S1 port.
 - Before starting this procedure, you should stop all programs and the operating system.
 - This procedure runs the diagnostic programs in Standalone mode from either a disk, diskette, or CD-ROM disc. If the diagnostic programs are installed on disk, these procedures should be run from disk. See the operator manual for your type TTY terminal to find the key sequences you need in order to respond to the diagnostic programs.

For more information about Standalone mode, see "Diagnostic Modes of Operation" on page 7-9.
 - If a console display is not selected, the diagnostics stop with `c31` in the three-digit display. The instructions for selecting a console display are displayed on any terminal attached to the S1 port. Follow the displayed instructions to select a console display.
 - If the system unit is attached to a 5085 or 5086, the DIAGNOSTIC OPERATING INSTRUCTIONS menu does *not* appear on the display attached to the 5085 or 5086.
 - Go to Step 2.

Step 2. Loading the Diagnostic Programs

1. Stop all application programs running on the operating system.
2. Stop the operating system.
3. Press the Power Off button.
4. Set the key mode switch to the Service position.
5. If you are loading the diagnostics from diskettes or a CD-ROM disc and running them from a TTY terminal, consider the following conditions:
 - The TTY terminal must be attached to the S1 port on the system unit.
 - The attributes for the terminal must be set to match the defaults of the diagnostics programs.
 - If you need to change any settings, record the normal settings, and be sure the terminal attributes are set to work with the diagnostic programs. If needed, see “Running the Diagnostic Programs from a TTY Terminal” on page 7-5.
 - Return to substep 6 when you finish checking the attributes.
6. Press the Power On button.
 - If `c07` is displayed, insert the next diagnostics diskette.
 - If `c31` is displayed, select the console display using the displayed instructions.
7. When the DIAGNOSTIC OPERATING INSTRUCTIONS is displayed, go to Step 3.

Step 3. Running System Verification

The DIAGNOSTIC OPERATING INSTRUCTIONS should be displayed.

1. Press the Enter key.
2. If the terminal type has not been defined, you must use the **Initialize Terminal** option on the FUNCTION SELECTION menu to initialize the operating system environment before you can continue with the diagnostics. This is a separate and different operation than selecting the console display.
3. If you want to do a general checkout without much operator action, select the **Diagnostic Routines** option on the FUNCTION SELECTION menu.

If you want to do a more complete checkout including the use of wrap plugs, select the **Advanced Diagnostics** option on the FUNCTION SELECTION menu. The advanced diagnostics are primarily for the service representative and may instruct you to install wrap plugs to better isolate a problem.
4. Select the **System Verification** option on the DIAGNOSTIC MODE SELECTION menu.
5. If you want to run a general checkout of all installed resources, select the **System Checkout** option on the DIAGNOSTIC SELECTION menu.

If you want to check one particular resource, select that resource on the DIAGNOSTIC SELECTION menu.
6. Go to Step 4.

Step 4. Additional System Verification

The checkout programs end with either the TESTING COMPLETE menu and a message stating `No trouble was found` or the A PROBLEM WAS DETECTED ON (Time stamp) menu with an SRN.

1. Press Enter to return to the DIAGNOSTIC SELECTION menu.
2. If you want to check other resources, select the resource. When you have checked all of the resources you need to check, go to step 5.

Step 5. Stopping the Diagnostics

1. If diagnostics are being run from disk, the system first should be shutdown using the following procedure:
 - a. Press F3 again and again until you get to the DIAGNOSTIC OPERATING INSTRUCTIONS.
 - b. Press F3 once; then, follow the display instructions to either shutdown the operating system or to continue using the diagnostic program.
2. Set the key mode switch to the Normal position.
3. If you changed any attributes on your TTY terminal to run the diagnostic programs, change the settings to normal.
4. This completes system verification. Report the SRN to the service organization if you received one. To do a normal IPL, press the Power Off button and wait 30 seconds; then, press the Power On button.

Chapter 10. Hardware Problem Determination

This chapter contains steps for obtaining a service request number (SRN) to correct hardware problems.

Hardware Problem Determination Procedure

Report the SRN to the service organization. The service organization uses the SRN to determine what field replaceable units (FRUs) are needed to restore the system to correct operation.

Step 1. Considerations before Performing This Procedure

Note: See the operator manual for your type of TTY terminal to find the key sequences you need to respond to the diagnostic programs.

- The diagnostic programs can use direct-attached displays or a TTY terminal attached to the S1 port.
- This procedure asks you to select the mode you want run the diagnostics programs in (Standalone, Maintenance, Concurrent). If you need more information about the modes, see "Diagnostic Modes of Operation" on page 7-9.
- If the system unit is attached to a 5085 or 5086, the DIAGNOSTIC OPERATING INSTRUCTIONS do *not* appear on the display attached to the 5085 or 5086.
- If the procedure instructs you to stop the operating system, refer to Chapter 2 for additional information.
- Go to step 2.

Step 2

(from Step 1)

Version 3 of the operating system contains the diagnostic programs. Other operating systems may not contain diagnostic programs.

Is Version 3 of the operating system used on this system?

NO	Go to Step 21.
YES	Go to Step 3.

Step 3

(from Step 2)

Determine if Version 3 of the operating system is accepting commands.

Is Version 3 of the operating system accepting commands?

- NO** Try the following:
1. Stop the operating system.
 2. If you cannot stop the operating system, press the Power Off button; then, go to Step 6.
- YES** Go to Step 4.

Step 4

(from Step 3)

Diagnostic tests can be run on many resources while the operating system is running. However, problem isolation is obtained by running diagnostics in Standalone mode.

Do you want to run the diagnostics in Standalone mode?

- NO** Go to Step 5.
- YES** Do the following to shut down your system:
1. At the system prompt, stop the operating system.
 2. After the operating system is stopped, press the Power Off button.
 3. Go to Step 6.

Step 5

(from Step 4)

This step loads Concurrent diagnostics.

1. Log on as `root` or as `superuser`.
2. Enter the `diag` command.
3. Wait until either the words `DIAGNOSTIC OPERATING INSTRUCTIONS` are displayed or 3 minutes have passed.

Are the `DIAGNOSTIC OPERATING INSTRUCTIONS` displayed without any obvious console display problems?

- NO** Do the following to shut down your system:
1. At the system prompt, stop the operating system.
 2. After the operating system is stopped, press the Power Off button.
 3. Go to Step 6.
- YES** Go to Step 10.

Step 6

(from Steps 3, 4, 5, and 7)

This step loads Standalone diagnostics.

1. Set the key mode switch to the Service position.
2. Be sure the power switches of the attached devices are set to On.
3. Press the Power On button.
4. If `c31` is displayed, follow the displayed instructions to select a console display. If you do not have a console display, set the key mode switch to the Normal position and then set it to the Service position to indicate to the diagnostics that there is no console display.

If you cannot select a console display, go to step 20. Otherwise, continue to the next substep.

5. Wait until one of the following conditions occurs, then go to the next substep:
 - The power-on light does not come on, or it comes on and does not stay on.
 - The same number is displayed in the three-digit display for longer than 3 minutes, and the power-on light is on.
 - The number `888` is flashing in the three-digit display.
 - The three-digit display is blank.
 - The system stops with two or more numbers between `221` and `296` alternating in the three-digit display.
 - The words DIAGNOSTIC OPERATING INSTRUCTIONS are displayed.

6. Starting at the top of the following table, find your symptom and follow the instructions given in the Action column.

Symptom	Action
The system stops with a blank three-digit display, and the words DIAGNOSTIC OPERATING INSTRUCTIONS are displayed with no obvious problem on the console display (for example, it is not distorted or blurred).	Go to step 10.
The power-on light does not come on, or it comes on and does not stay on.	<p>Ensure that the key mode switch is in the Service position. Check the power cable to the outlet. Check the circuit breakers and check for power at the outlet.</p> <p>If you do not find a problem, record SRN 111-152, and report the problem to the service organization.</p> <p>STOP. You have completed these procedures.</p>
The system stops with a steady (not flashing) number displayed in the three-digit display, and the power-on light is on.	<p>The number must be something other than c31. See substep 4 above for this number.</p> <p>Go to Step 7.</p>
The system stops with 888 flashing in the three-digit display.	Go to Step 8.
The system stops with a blank three-digit display, and the words DIAGNOSTIC OPERATING INSTRUCTIONS are <i>not</i> displayed correctly.	Go to step 9.
The three-digit display is blank and the normal system log-in screen is displayed.	<p>Be sure the key mode switch is set to the Service position.</p> <p>If the key mode switch was not in the Service position, stop the operating system, set it to the Service position, and press Reset. Then repeat this step.</p> <p>If the key mode switch was in the Service position, record and report SRN 111-132.</p> <p>STOP. You have completed these procedures.</p>
The system stops with two or more numbers between 221 and 296 alternating in the three-digit display.	Go to Step 16.

Step 7

(from Step 6 and 18)

The following steps analyze a steady (not flashing) number displayed in the three-digit display while attempting to load the diagnostics.

Three-Digit Display Number	Action
200	<p>Be sure the key mode switch is set to the Service position.</p> <p>If the key mode switch was not in the Service position, set it to the Service position, and then go to Step 6, substep 4.</p> <p>If the key mode switch was in the Service position, record and report SRN 111-200.</p> <p>STOP. You have completed these procedures.</p>
Any other number	<p>Record and report SRN 101-xxx (where xxx is the number displayed in the three-digit display).</p> <p>STOP. You have completed these procedures.</p>

Step 8

(from Steps 6 and 18)

A flashing 888 in the three-digit display indicates that a crash message or a diagnostics message is ready to be read.

1. Use the steps in "Reading Flashing 888 Numbers" on page 7-14 to do the following:
 - Read all of the message.
 - Identify the SRN, if applicable.
 - Record the remaining numbers for the service representative.
2. If you identified an SRN, go to substep 3. Otherwise, go to substep 5.
3. Record the SRN and any other numbers.
4. Report the SRN to the service organization. Report any other numbers read to the service representative to determine the location of the failing FRU.
5. **STOP.** You have completed these procedures.

Step 9

(from Steps 6, 18, and 20)

The following steps analyze a console display problem.

Find your type of console display in the following table, and then follow the specified action

Console Display	Action
Display Device	Go to the your display documentation for problem determination.
TTY terminal	Go to the documentation for problem determination for this type of terminal.

Step 10

(from Steps 5, 6, 12, and 18)

The diagnostic control program loaded correctly.

Press the Enter key.

Is the FUNCTION SELECTION menu displayed?

NO Go to Step 11.

YES Go to Step 12.

Step 11

(from Steps 10, 12, and 20)

There is a problem with the keyboard.

Find the type of keyboard you are using in the following table, and then follow the specified action:

Keyboard Type	Action
101-key keyboard. Identify by the type of Enter key used. The Enter key is within one horizontal row of keys.	Record and report service request number 111-921. STOP. You have completed these procedures.
102-key keyboard. Identify by the type of Enter key used. The Enter key extends into two horizontal rows of keys.	Record and report service request number 111-922. STOP. You have completed these procedures.
Kanji keyboard. Identify by the Japanese characters.	Record and report service request number 111-923. STOP. You have completed these procedures.
TTY-terminal keyboard. This applies to all attached terminals.	Go to the documentation for problem determination for this type terminal.

Step 12

(from Step 10)

1. If the terminal type has not been defined, you must use the **Initialize Terminal** option on the **FUNCTION SELECTION** menu to initialize the operating system environment before you can continue with the diagnostics. This is a separate and different operation from selecting the console display.
2. Select **Diagnostic Routines**.
3. Press the Enter key.
4. In the table on the following page, find the menu or system response you received when you selected **Diagnostic Routines**; then, follow the instructions given in the Action column.

System Response	Action
The DIAGNOSTIC MODE SELECTION menu is displayed.	Select Problem Determination , and then go to Step 13.
The MISSING RESOURCE menu is displayed.	<p>Follow the displayed instructions until either the DIAGNOSTIC SELECTION menu or an SRN is displayed.</p> <p>If the DIAGNOSTIC SELECTION menu is displayed, go to Step 13.</p> <p>If you get an SRN, record it, and go to Step 15.</p> <p>If you get a number in the three-digit display, go to Step 14.</p>
The NEW RESOURCE menu is displayed.	<p>Follow the displayed instructions.</p> <p>Note: Devices attached to serial ports S1 or S2 will not appear on the NEW RESOURCE menu.</p> <p>If the DIAGNOSTIC SELECTION menu is displayed, go to Step 13.</p> <p>If you get an SRN, record it, and go to Step 15.</p> <p>If you do <i>not</i> get an SRN, go to Step 19.</p>
<p>The diagnostics begin testing a resource.</p> <p>Note: If Problem Determination was selected from the DIAGNOSTIC MODE SELECTION menu, and if a recent error has been logged in the error log, the diagnostics will automatically begin testing the resource.</p>	<p>Follow the displayed instructions.</p> <p>If the No Trouble Found screen is displayed, press Enter.</p> <p>If another resource is tested, repeat this step.</p> <p>If the ADVANCED DIAGNOSTIC SELECTION menu is displayed, go to Step 10.</p> <p>If an SRN is displayed, record it, and go to Step 15.</p>

Step 13

(from Step 12)

The system checkout option checks all of the resources (available in Standalone mode only).

Select and run the diagnostic tests on the resources you are having problems with or run system checkout to check all of the configured resources. Find the response in the following table, and perform the specific action.

Diagnostic Response	Action
An SRN is displayed.	Go to Step 15.
The system stopped with a number displayed in the three-digit display.	Go to Step 14.
The TESTING COMPLETE menu and the No trouble was found message is displayed, and you have <i>not</i> tested all of the resources.	Press Enter and continue with the testing.
The TESTING COMPLETE menu and the No trouble was found message displayed and you <i>have</i> tested all of the resources.	Go to Step 19. Notes: If dials and LPFKs are attached to serial ports S1 or S2 and you are running diagnostics from disk or server, the dials and LPFKs will only appear on the selection screen if they have been configured by the user. Use the Dials and LPFKs Configuration service aid to configure these devices. If the dials and LPFKs are attached to serial ports S1 or S2, you must configure the serial ports using the Dials and LPFKs Configuration service aid before they can be tested from diskette.

Step 14

(from Steps 12 and 13)

A flashing 888 in the three-digit display indicates that a crash message or a diagnostic message is ready to be read.

1. Use the steps in "Reading Flashing 888 Numbers" in Chapter 5 to:
 - Read all of the message.
 - Identify the SRN.
 - Record the remaining numbers for the service representative.
2. Record the SRN.
3. Report the SRN to the service organization. Report any other numbers to the service representative to determine the location of the failing FRU.
4. STOP. You have completed these procedures.

Step 15

(from Steps 12 and 13)

The diagnostic programs produced an SRN for this problem.

1. Record the SRN and any other numbers.
2. Report the SRN to the service organization.
3. STOP. You have completed these procedures.

Step 16

(from Step 6)

The system stopped with two or more numbers between 221 and 296 alternating in the three-digit display. This indicates the diagnostics could not load from disk, so the load program is looking for the diagnostic programs on the diskettes or some other load device.

Are you trying to load the diagnostics programs from diskettes or a CD-ROM disc?

- NO** Go to Step 22.
- YES** Record and report SRN 111-101.
- STOP. You have completed these procedures.

Step 17

(from Steps 21 and 22)

When you load the diagnostics from diskettes or a CD-ROM disc and run them from a TTY terminal, the attributes for the terminal must be set to match the defaults of the diagnostics programs. The TTY terminal must be attached to port S1 on the system unit.

Are you going to load the diagnostics from diskettes or a CD-ROM disc and run them from a TTY terminal attached to port S1?

- NO** Go to Step 18.
- YES** Go to "Running the Diagnostic Programs from a TTY Terminal" on page 7-5 and be sure your terminal attributes are set to work with the diagnostic programs.
- Go to Step 18 when you finish checking the attributes. Record any settings that are changed.

Step 18

(from Step 17)

The following steps analyze a failure to load the diagnostic programs from a disk, or a failure to determine whether the diagnostic programs are on a disk.

1. Press the Power Off button.
2. Set the key mode switch to the Service position.
3. Insert either the first diagnostics diskette into the diskette drive or the diagnostic CD-ROM disc into the CD-ROM drive.
4. Press the Power On button.
5. If `c07` is displayed in the three-digit display, insert the next diagnostics diskette. If `c31` is displayed, follow the displayed instructions to select the console display. If no console display is available, set the key mode switch to the Normal position and then set it to the Service position to indicate to the diagnostics that there is no console display.

If you cannot select a console display, go to Step 20. Otherwise, continue to the next substep.

6. Wait until one of the following conditions occur, then go to the next substep:
 - The system stops with two or more numbers between 221 and 296 alternating in the three-digit display.
 - The same number is displayed in the three-digit display for longer than 3 minutes, and the power-on light is on.
 - The number 888 is flashing in the three-digit display.
 - The three-digit display is blank.
 - The words DIAGNOSTIC OPERATING INSTRUCTIONS are displayed.

7. Starting at the top of the following table, find your symptom; then, perform the specific action.

Symptom	Action
The system stops with a blank three-digit display, and the words DIAGNOSTIC OPERATING INSTRUCTIONS are displayed with <i>no</i> obvious problem on the console display (for example, it is <i>not</i> distorted or blurred).	Go to Step 10.
The system stops with a blank three-digit display, and the words DIAGNOSTIC OPERATING INSTRUCTIONS are <i>not</i> displayed correctly.	Go to Step 9.
The system stops with a steady (not flashing) number displayed in the three-digit display, and the power-on light is on.	The number must be something other than c07 or c31. See substep 4 above for these numbers. Go to Step 7.
The system stops with 888 flashing in the three-digit display.	Go to Step 8.
The system stops with two or more numbers between 221 and 296 alternating in the three-digit display.	Record and report SRN 111-101. STOP. You have completed these procedures.

Step 19

(from Steps 12 and 13)

The diagnostics did not find a hardware problem. If you still have a problem, contact your software support center. If you are attached to another system, refer to Chapter 2 and check your configuration before calling the software support center.

Step 20

(from Steps 6 and 18)

When the c31 halt was present, were the instructions to select a console display readable with no obvious problems with the display?

NO Go to Step 9.

YES Go to Step 11.

Step 21

(from Step 2)

An English-only version of diagnostics is provided on diskette and CD-ROM disc.

Do you want to run diagnostics from diskette or a CD-ROM disc?

NO If you have a problem, call for service and report the problem.

YES Go to Step 17.

Step 22

(from Step 16)

An English-only version of diagnostics are provided on diskette and CD-ROM disc.

Do you want to run diagnostics from diskette or a CD-ROM disc?

NO Record and report SRN 111-103. STOP. You have completed these procedures.

YES Go to Step 17.

Appendix A: Supplies

This appendix contains a list of supplies and the part numbers needed to order them.

Part Number	Description
21F8593	8-mm Cleaning Tape Cartridge
21F8595	8-mm Data Tape Cartridge (5-pack)
21F8763	4-mm Data Tape Cartridge (5-pack)
21F8758	4-mm DDS III Data Tape Cartridge (5-pack)
21F8762	4-mm DDS III Diagnostic Cartridge
8191160	4-mm DDS 2 Data Cartridge (5-pack)
8191146	4-mm DDS 2 Diagnostic Cartridge
6109660	5.25-Inch, 1.2 MB Blank Diskette
6023450	5.25-Inch, 360 KB Blank Diskette
6404088	3.5-Inch, 1.0 MB Blank Diskette (box of 10)
6404083	3.5-Inch, 2.0 MB Blank Diskette (box of 10)
0352465	1/2-Inch, Head Cleaning Kit
21F8570	1/4-Inch, Cartridge Head Cleaning Kit
21F8732	1/4-Inch, 1.2 GB Data Tape Cartridge (5-pack)
21F8587	1/4-Inch, 525 MB Data Tape Cartridge (5-pack)
21F8588	1/4-Inch, 150 MB Data Tape Cartridge (5-pack)
13F5647	Tape Cleaning Solution

Appendix B. Three-Digit Display Numbers

This appendix contains lists of the various numbers and characters that may be displayed in the three-digit display. The numbers and characters are divided into two broad categories. The first grouping is those that track power-on testing of the system unit; the second group provides information about messages that follow a *flashing* 888 number.

To form an SRN from any *steady* number that occurs during system power-on test (BIST or POST), add 101- in front of the displayed number.

For more detailed explanations of three-digit display numbers, refer to the *AIX Problem Solving Guide and Reference*.

Built-In Self-Test (BIST) Indicators

100	BIST completed successfully; control was passed to IPL ROS.
101	BIST started following Reset.
102	BIST started following Power-on Reset.
103	BIST could not determine the system model number.
104	Equipment conflict; BIST could not find the CBA.
105	BIST could not read from the OCS EPROM.
106	BIST detected a module error.
111	OCS stopped; BIST detected a module error.
112	A checkstop occurred during BIST; checkstop results could not be logged out.
113	BIST checkstop count is greater than 1.
120	BIST starting a CRC check on the 8752 EPROM.
121	BIST detected a bad CRC in the first 32K bytes of the OCS EPROM.
122	BIST started a CRC check on the first 32K bytes of the OCS EPROM.
123	BIST detected a bad CRC on the OCS area of NVRAM.
124	BIST started a CRC check on the OCS area of NVRAM.
125	BIST detected a bad CRC on the time-of-day area of NVRAM.
126	BIST started a CRC check on the time-of-day area of NVRAM.
127	BIST detected a bad CRC on the 8752 EPROM.
130	BIST presence test started.
140	BIST failed: procedure error.
142	BIST failed: procedure error.
144	BIST failed: procedure error.
151	BIST started AIPGM test code.
152	BIST started DCLST test code.
153	BIST started ACLST test code.
154	BIST started AST test code.
180	BIST logout failed.
185	A checkstop condition occurred during the BIST. Note: Possible memory problem; check FFC 210.
195	BIST logout completed.
888	BIST did not start.

Power-On Self-Test (POST) Indicators

20c	L2 cache error.
21c	L2 cache is not detected.
200	Keylock in the Secure position.
201	IPL ROM test failed or checkstop occurred (irrecoverable).
211	IPL ROM CRC comparison error (irrecoverable).
212	RAM POST memory configuration error or no memory found (irrecoverable).
213	RAM POST failure (irrecoverable).
214	Power status register failed (irrecoverable).
215	A low voltage condition is present (irrecoverable).
216	IPL ROM code being uncompressed into memory.
217	End of boot list encountered.
218	RAM POST is looking for 2MBs of good memory.
219	RAM POST bit map is being generated.
220	IPL control block is being initialized.
221	NVRAM CRC comparison error during AIX IPL(key mode switch in Normal mode). Reset NVRAM by reaccomplishing IPL in Service mode. For systems with an internal, direct-bus-attached (DBA) disk, IPL ROM attempted to perform an IPL from that disk before halting with this three-digit display value.
222	Attempting a Normal mode IPL from Standard I/O planar attached devices specified in NVRAM IPL Devices List.
223	Attempting a Normal mode IPL from SCSI-attached devices specified in NVRAM IPL Devices List.
	Note: May be caused by incorrect jumper settings for external SCSI devices or by incorrect SCSI terminator; refer to FFC B88.
224	Attempting a Normal mode IPL from 9333 subsystem device specified in NVRAM IPL Devices List.
225	Attempting a Normal mode IPL from 7012 DBA disk-attached devices specified in NVRAM IPL Devices List.
226	Attempting a Normal mode IPL from Ethernet specified in NVRAM IPL Devices List.
227	Attempting a Normal mode IPL from Token-Ring specified in NVRAM IPL Devices List.
228	Attempting a Normal mode IPL from NVRAM expansion code.
229	Attempting a Normal mode IPL from NVRAM IPL Devices List; cannot IPL from any of the listed devices, or there are no valid entries in the Devices List.
230	Attempting a Normal mode IPL from adapter feature ROM specified in IPL ROM Device List.
231	Attempting a Normal mode IPL from Ethernet specified in IPL ROM Device List.
232	Attempting a Normal mode IPL from Standard I/O planar-attached devices specified in ROM Default Device List.
233	Attempting a Normal mode IPL from SCSI-attached devices specified in IPL ROM Default Device List.
234	Attempting a Normal mode IPL from 9333 subsystem device specified in IPL ROM Device List.
235	Attempting a Normal mode IPL from 7012 DBA disk-attached devices specified in IPL ROM Default Device List.

236 Attempting a Normal mode IPL from Ethernet specified in IPL ROM Default Device List.

237 Attempting a Normal mode IPL from Token-Ring specified in IPL ROM Default Device List.

238 Attempting a Normal mode IPL from Token-Ring specified by the operator.

239 System failed to IPL from the device chosen by the operator.

240 Attempting a Service mode IPL from adapter feature ROM.

242 Attempting a Service mode IPL from Standard I/O planar attached devices specified in the NVRAM IPL Devices List.

243 Attempting a Service mode IPL from SCSI-attached devices specified in the NVRAM IPL Devices List.

244 Attempting a Service mode IPL from 9333 subsystem device specified in the NVRAM IPL Devices List.

245 Attempting a Service mode IPL from 7012 DBA disk-attached devices specified in the NVRAM IPL Devices List.

246 Attempting a Service mode IPL from Ethernet specified in the NVRAM IPL Devices List.

247 Attempting a Service mode IPL from Token-Ring specified in the NVRAM Device List.

248 Attempting a Service mode IPL from NVRAM expansion code.

249 Attempting a Service mode IPL from the NVRAM IPL Devices List; cannot IPL from any of the listed devices, or there are no valid entries in the Devices List.

250 Attempting a Service mode IPL from adapter feature ROM specified in the IPL ROM Device List.

251 Attempting a Service mode IPL from Ethernet specified in the IPL ROM Default Device List.

252 Attempting a Service mode IPL from Standard I/O planar attached devices specified in the ROM Default Device List.

253 Attempting a Service mode IPL from SCSI attached devices specified in the IPL ROM Default Device List.

254 Attempting a Service mode IPL from 9333 subsystem device specified in the IPL ROM Devices List.

255 Attempting a Service mode IPL from 7012 DBA disk-attached devices specified in IPL ROM Default Device List.

256 Attempting a Service mode IPL from Ethernet specified in the IPL ROM Devices List.

257 Attempting a Service mode IPL from Token-Ring specified in the IPL ROM Devices List.

258 Attempting a Service mode IPL from Token-Ring specified by the operator.

260 Information is being displayed on the display console.

261 No supported local system display adapter was found.

262 A keyboard was not detected as being connected to the system's keyboard port.

Note: Check for blown planar fuses or for a corrupted boot record on disk drive.

263 Attempting a Normal mode IPL from adapter feature ROM specified in the NVRAM Device List.

281 Keyboard POST executing.

282 Parallel port POST executing.

283 Serial port POST executing.

284 POWER Gt1 graphics adapter POST executing.

285 POWER Gt3 graphics adapter POST executing.

286 Token-Ring adapter POST executing.

287 Ethernet adapter POST executing.

288	Adapter card slots being queried.
290	IOCC POST error (irrecoverable).
291	Standard I/O POST running.
292	SCSI POST running.
293	7012 DBA disk POST running.
297	System model number does not compare between OCS and ROS (irrecoverable).
298	Attempting a software IPL.
299	IPL ROM passed control to the loaded program code.

Configuration Program Indicators

500	Querying Standard I/O slot.
501	Querying card in Slot 1.
502	Querying card in Slot 2.
503	Querying card in Slot 3.
504	Querying card in Slot 4.
505	Querying card in Slot 5.
506	Querying card in Slot 6.
507	Querying card in Slot 7.
508	Querying card in Slot 8.
510	Starting device configuration.
511	Device configuration completed.
512	Restoring device configuration files from media.
513	Restoring basic operating system installation files from media.
516	Contacting server during network boot.
517	Mounting client remote file system during network IPL.
518	Remote mount of the root and /usr file systems failed during network boot.
520	Bus configuration running.
521	/etc/init invoked cfgmgr with invalid options; /etc/init has been corrupted or incorrectly modified (irrecoverable error).
522	The configuration manager has been invoked with conflicting options (irrecoverable error).
523	The configuration manager is unable to access the ODM database (irrecoverable error).
524	The configuration manager is unable to access the config rules object in the ODM database (irrecoverable error).
525	The configuration manager is unable to get data from a customized device object in the ODM database (irrecoverable error).
526	The configuration manager is unable to get data from a customized device driver object in the ODM database (irrecoverable error).
527	The configuration manager was invoked with the phase 1 flag; running phase 1 at this point is not permitted (irrecoverable error).
528	The configuration manager cannot find sequence rule, or no program name was specified in the ODM database (irrecoverable error).
529	The configuration manager is unable to update ODM data (irrecoverable error).
530	The program savebase returned an error.
531	The configuration manager is unable to access the PdAt object class (irrecoverable error).
532	There is not enough memory to continue (malloc failure); irrecoverable error.
533	The configuration manager could not find a configure method for a device.
534	The configuration manager is unable to acquire database lock (irrecoverable error).

536 The configuration manager encountered more than one sequence rule specified in the same phase (irrecoverable error).

537 The configuration manager encountered an error when invoking the program in the sequence rule.

538 The configuration manager is going to invoke a configuration method.

539 The configuration method has terminated, and control has returned to the configuration manager.

551 IPL varyon is running.

552 IPL varyon failed.

553 IPL phase 1 is complete.

554 Unable to define NFS swap device during network boot.

555 Unable to create NFS swap device during network boot.

556 Logical Volume Manager encountered error during IPL varyon.

557 The root filesystem will not mount.

558 There is not enough memory to continue the system IPL.

559 Less than 2 MB of good memory are available to load the AIX kernel.

576 Generic async device driver being configured.

577 Generic SCSI device driver being configured.

578 Generic commo device driver being configured.

579 Device driver being configured for a generic device.

581 Configuring TCP/IP.

582 Configuring Token-Ring data link control.

583 Configuring an Ethernet data link control.

584 Configuring an IEEE Ethernet data link control.

585 Configuring an SDLC MPQP data link control.

586 Configuring a QLLC X.25 data link control.

587 Configuring a NETBIOS.

588 Configuring a Bisync Read-Write (BSCRW).

589 SCSI target mode device being configured.

590 Diskless remote paging device being configured.

591 Configuring an LVM device driver.

592 Configuring an HFT device driver.

593 Configuring SNA device drivers.

594 Asynchronous I/O being defined or configured.

595 X.31 pseudo device being configured.

596 SNA DLC/LAPE pseudo device being configured.

597 OCS software being configured.

598 OCS hosts being configured during system reboot.

599 Configuring FDDI data link control.

711 Unknown adapter being identified or configured.

712 Graphics slot bus configuration is executing.

720 Unknown read/write optical drive type being configured.

721 Unknown disk or SCSI device being identified or configured.

722 Unknown disk being identified or configured.

723 Unknown CD-ROM being identified or configured.

724 Unknown tape drive being identified or configured.

725 Unknown display adapter being identified or configured.

726 Unknown input device being identified or configured.

727 Unknown async device being identified or configured.

728 Parallel printer being identified or configured.

729 Unknown parallel device being identified or configured.

730 Unknown diskette drive being identified or configured.

731 PTY being identified or configured.

732 Unknown SCSI initiator type being configured.

811 Processor complex being identified or configured.
 812 Memory being identified or configured.
 813 Battery for time-of-day, NVRAM, and so on being identified or configured, or
 system I/O Control Logic being identified or configured.
 814 NVRAM being identified or configured.
 815 Floating-point processor test
 816 Operator panel logic being identified or configured.
 817 Time-of-day logic being identified or configured.
 819 Graphics input device adapter being identified or configured.
 821 Standard keyboard adapter being identified or configured.
 823 Standard mouse adapter being identified or configured.
 824 Standard tablet adapter being identified or configured.
 825 Standard speaker adapter being identified or configured.
 826 Serial Port 1 adapter being identified or configured.
 827 Parallel port adapter being identified or configured.
 828 Standard diskette adapter being identified or configured.
 831 3151 adapter being identified or configured, or Serial Port 2 being identified
 or configured.
 834 64-port async controller being identified or configured.
 835 16-port async concentrator being identified or configured.
 836 128-port async controller being identified or configured.
 837 16-port remote async node being identified or configured.
 841 8-port async adapter (EIA-232) being identified or configured.
 842 8-port async adapter (EIA-422A) being identified or configured.
 843 8-port async adapter (MIL-STD 188) being identified or configured.
 844 7135 RADiant Array disk drive subsystem controller being identified or
 configured.
 845 7135 RADiant Array disk drive subsystem drawer being identified or
 configured.
 847 16-port serial adapter (EIA-232) being identified or configured.
 848 16-port serial adapter (EIA-422) being identified or configured.
 849 X.25 Multiport/2 adapter being identified or configured.
 850 Token-Ring network adapter being identified or configured.
 851 T1/J1 Portmaster adapter being identified or configured.
 852 Ethernet adapter being identified or configured.
 854 3270 Host Connection Program/6000 connection being identified or
 configured.
 855 Portmaster Adapter/A being identified or configured.
 857 FSLA adapter being identified or configured.
 858 5085/5086/5088 adapter being identified or configured.
 859 FDDI adapter being identified or configured.
 861 Optical adapter being identified or configured.
 862 Block Multiplexer Channel Adapter being identified or configured.
 865 ESCON Channel Adapter being identified or configured.
 866 SCSI adapter being identified or configured.
 867 Async expansion adapter being identified or configured.
 868 SCSI adapter being identified or configured.
 869 SCSI adapter being identified or configured.
 870 Serial disk drive adapter being identified or configured.
 871 Graphics subsystem adapter being identified or configured.
 872 Grayscale graphics adapter being identified or configured.
 874 Color graphics adapter being identified or configured.
 876 8-bit color graphics processor being identified or configured.
 877 POWER Gt3/POWER Gt4 being identified or configured.

878 POWER Gt4 graphics processor card being configured.
 880 POWER Gt1 adapter being identified or configured.
 887 Integrated Ethernet adapter being identified or configured.
 889 SCSI adapter being identified or configured.
 891 Vendor SCSI adapter being identified or configured.
 892 Vendor display adapter being identified or configured.
 893 Vendor LAN adapter being identified or configured.
 894 Vendor async/communications adapter being identified or configured.
 895 Vendor IEEE 488 adapter being identified or configured.
 896 Vendor VME bus adapter being identified or configured.
 897 S/370 Channel Emulator adapter being identified or configured.
 898 POWER Gt1x graphics adapter being identified or configured.
 899 3490 attached tape drive being identified or configured.
 901 Vendor SCSI device being identified or configured.
 902 Vendor display device being identified or configured.
 903 Vendor async device being identified or configured.
 904 Vendor parallel device being identified or configured.
 905 Vendor other device being identified or configured.
 912 2.0 GB SCSI-2 differential disk drive being identified or configured.
 913 1.0 GB differential disk drive being identified or configured.
 914 5 GB 8 mm differential tape drive being identified or configured.
 915 4 GB 4 mm tape drive being identified or configured.
 916 Non-SCSI vendor tape adapter being identified or configured.
 920 Bridge Box being identified or configured.
 921 101 keyboard being identified or configured.
 922 102 keyboard being identified or configured.
 923 Kanji keyboard being identified or configured.
 924 Two-button mouse being identified or configured.
 925 Three-button mouse being identified or configured.
 926 5083 tablet being identified or configured.
 927 5083 tablet being identified or configured.
 928 Standard speaker being identified or configured.
 929 Dials being identified or configured.
 930 Lighted Program Function Keys (LPFK) being identified or configured.
 931 IP router being identified or configured.
 933 Async planar being identified or configured.
 934 Async expansion drawer being identified or configured.
 935 3.5-inch diskette drive being identified or configured.
 936 5.25-inch diskette drive being identified or configured.
 942 POWER GXT graphics adapter being identified or configured.
 948 Portable disk drive being identified or configured.
 949 Unknown direct bus-attach device being identified or configured.
 950 Missing SCSI device being identified or configured.
 951 670MB SCSI disk drive being identified or configured.
 952 355MB SCSI disk drive being identified or configured.
 953 320MB SCSI disk drive being identified or configured.
 954 400MB SCSI disk drive being identified or configured.
 955 857MB SCSI disk drive being identified or configured.
 956 670MB SCSI disk drive electronics card being identified or configured
 957 120MB DBA disk drive being identified or configured.
 958 160 MB DBA disk drive being identified or configured.
 959 160MB SCSI disk drive being identified or configured.
 960 1.37GB SCSI disk drive being identified or configured.
 968 1.0GB SCSI disk drive being identified or configured.

970	Half-inch, 9-track tape drive being identified or configured.
971	150MB quarter-inch tape drive being identified or configured.
972	2.3GB 8-mm SCSI tape drive being identified or configured.
973	Other SCSI tape drive being identified or configured.
974	CD-ROM drive being identified or configured.
977	M-Audio capture and playback adapter being identified or configured.
981	540 MB SCSI-2 single-ended disk drive being identified or configured.
985	M-Video Capture Adapter capture adapter being identified or configured.
986	2.4GB SCSI disk drive being identified or configured.
989	200MB SCSI disk drive being identified or configured.
990	2.0GB SCSI-2 single-ended disk drive being identified or configured.
991	525MB 1/4-inch cartridge tape drive being identified or configured.
994	5GB 8-mm tape drive being identified or configured.
995	1.2GB 1/4 inch cartridge tape drive being identified or configured.
997	FDDI adapter being identified or configured.
998	2.0GB 4-mm tape drive being identified or configured.

Diagnostic Load Progress Indicators

Note: When a lowercase `c` is listed, it displays in the lower half of the seven-segment character position.

c01	Insert the first diagnostic diskette.
c02	Diskettes inserted out of sequence.
c03	The wrong diskette is in diskette drive.
c04	The loading stopped with a nonrecoverable error.
c05	A diskette error occurred.
c07	Insert the next diagnostic diskette.
c09	The diskette drive is reading or writing a diskette.
c20	An unexpected halt occurred, and the system is configured to enter the kernel debug program instead of entering a system dump.
c21	The ifconfig command was unable to configure the network for the client network host.
c22	The tftp command was unable to read client's ClientHostName.info file during a client network boot.
c24	Unable to read client's ClientHostName.info file during a client network boot.
c25	Client did not mount remote miniroot during network install.
c26	Client did not mount the /usr file system during the network boot.
c29	The system was unable to configure the network device.
c31	Select the console display for the diagnostics. To select No console display , set the key mode switch to Normal then to Service. The diagnostic programs will then load and run the diagnostics automatically.
c32	A direct-attached display (HFT) was selected.
c33	A tty terminal attached to serial ports S1 or S2 was selected.
c34	A file was selected. The console messages store in a file.
c99	Diagnostics have completed. This code is only used when there is no console.

Note: There are no SRNs associated with this message type. If the crash code is 558 and you were loading the diagnostic diskettes, the problem may be that you used the wrong diagnostic boot diskette. Try using the boot diskette for 8MB systems. To access CEREADME file information on 8MB systems; refer to Chapter 6.

Index

A

- about this book, xv
- AC rack, 3-1
 - description, 3-1–3-11
 - power distribution bus, 3-4
 - power distribution unit, 3-5
- AC rack cable path, 3-11
- AC system unit
 - starting, 4-1
 - stopping, 4-7
- AC system unit cables, CPU-media enclosure, 3-9
- AC system unit cables and CPU-media enclosure, connectors, 3-9
- AC system unit containing a PDB
 - stopping immediately, 4-10
 - stopping under ordinary conditions, 4-9
- AC system unit containing a PDU
 - stopping immediately, 4-8
 - stopping under ordinary conditions, 4-7
- adapter locations, 1-2
- adapter, multimedia video capture, 8-5
- alternate rack features
 - cable channel, 3-2, 3-3
 - external device container, 3-2
 - front view of AC 7015 rack
 - cable channel, 3-3
 - external device container, 3-2
 - rack attachment plate, 3-3
 - rack attachment plate, 3-2, 3-3
- attributes
 - communication, 7-7
 - diagnostic programs, default settings, 7-6
 - keyboard, 7-8
 - printer, 7-8

B

- battery backup unit, 3-6
- BBU, 3-6
- BIST (Built-in Self-Test) indicators, B-1
- button, 1-3
 - Power Off, 1-3

Power On, 1-3

C

- cable channel, 3-3
- cable path, CPU-media enclosure, 3-11
- cable path, AC rack, 3-11
- cable restraint strap, 3-11
- CD-ROM drive
 - headphone jack, 1-4
 - status light, 1-4, 2-10
 - unload button, 2-10
 - volume control, 1-4, 2-10
- CD-ROM disc caddy, 2-11
 - unloading the disc, 2-12
- CD-ROM drive
 - cleaning, 2-12
 - features, 1-4
 - loading the disc, 2-11
 - unload button, 1-4
 - using, 2-10
- certify disk service aid, 8-4
- change configuration, 8-2
- circuit breakers
 - 10 amp, 5-2
 - 50 amp, 5-2
- cleaning
 - 1/4-tape drive, 2-16
 - tape path
 - 4.0 G-byte 4 mm tape drive, 2-37
 - 5.0 G-byte 8 mm tape drive, 2-27
- cleaning the CD-ROM drive, 2-12
- cleaning the tape path, 4.0GB 4 mm tape drive, 2-37
- communication attributes, 7-7
- communications statements, ix
- compatibility, 8 mm tape cartridge, 2-20
- concurrent mode, commands
 - diag, 7-10
 - varyoff, 7-10
- configuration program indicators, B-4

- connectors, CPU-media enclosure, 1-2
- cover label, SCSI, 3-14
- CPU-media enclosure
 - 3.5-inch diskette drive, 1-1
 - 8 mm tape drive, 1-1
 - adapter locations, 1-2
 - CD-ROM drive, 1-1
 - connectors, 3-9
 - description, 1-1–1-8
 - front view, 1-1, 3-1
 - location, 3-1
 - media devices, 1-4–1-8
 - media device locations, 1-1
 - operator panel, 1-3
 - optional media devices, 1-1
 - parallel port, 1-2
 - rear view, 1-2
 - serial ports, 1-2
 - using, 2-1–2-12
- crash codes, 7-15
- create (rebuild) function, 8-7
- creating cover labels, 3-15

D

- data efficiency, tape cartridge, 2-21
- definition of machine names and model numbers, xv
- diagnostic diskette creation service aid, 8-3
- diagnostic modes of operation, 7-9
- diagnostic programs
 - attributes
 - communication, 7-7
 - default settings, 7-6
 - keyboard, 7-8
 - printer, 7-8
 - modes for running, 7-9
 - concurrent mode, 7-10
 - maintenance mode, 7-9
 - standalone mode, 7-11
 - operating considerations, 7-1
 - attached to a host system, 7-1
 - identifying a terminal, 7-1
 - running from a TTY terminal, 7-5
 - running from disk, 7-3
 - running from diskettes, 7-2, 7-4
 - selecting a console, 7-1
 - service aids, 8-1
 - sources for, 7-1
 - system exerciser, 7-12

- diagnostic programs operating considerations, 7-1
- diagnostics
 - attached system units, 7-1
 - load progress indicators, B-8
 - running from CD-ROM disc, 7-3
- dials and LPFK configuration, 8-3
- disk drive, location, 3-7
- disk media service aid, 8-4
- disk-based diagnostic update, 8-3
- diskette
 - 3.5-inch
 - setting the write-protect tab, 2-8
 - types, 2-7
 - handling, 2-6
 - loading and unloading, 2-9
 - parts of, 2-7
- diskette drive, 3.5-inch, 2-6
- diskette media service aid, 8-4
- diskettes, types, 2-7
- display configuration, 8-2
- display or alter bootlist, 8-3
- display or alter VPD, 8-2
- display or change configuration or VPD, 8-2
- display or change diagnostic test list, 8-2
- display previous diagnostic results, 8-1
- display test patterns, 8-5
- display VPD, 8-2
- drawer ID label, 3-15
 - non-SCSI drawer, 3-17
- dump progress indicators, 7-16

E

- EC A90783B, 8-8
- ECs, 8-7
- environmental considerations, operating ranges 2-20
- environment considerations, 8 mm data cartridges 2-20
- environmental considerations
 - 4 mm data cartridges, 2-31
 - shipping, 2-20
 - storage, 2-20
- erasure, 4 mm data cartridge, 2-32

erasure, 8 mm data cartridge, 2-21
ethernet service aid, 8-4
external device container, 3-2

F

flashing 888 numbers, 7-14
format disk service aid, 8-4

G

general attributes always required, 7-6
general information, 4.0GB 4 mm tape drive, 2-29
general information about multiple systems, 4-1
general information, 5.0GB 8 mm tape drive, 2-19

H

hardware error report, 8-5
hardware problem determination, 10-1
hardware problem determination procedure, 10-1
harsh environments, 4 mm tape cartridges, 2-32
harsh environments, 8 mm tape drive, 2-21

I

ID label, SCSI drawer, 3-13
immediately stopping the AC system unit
containing PDB, 4-10
immediately stopping the system unit containing
PDU, 4-8
indicators, configuration program, B-4

K

key mode switch
normal IPL, 2-2
normal position, 2-1
operations, 2-2
reset button, 2-3
secure position, 2-1
service IPL, 2-2
service position, 2-1

setting, 2-1, 6-1
keyboard attributes, 7-8
keys, 2-38
ordering information, 2-38
reorder form, 2-39

L

label
non-SCSI drawer ID, 3-17
SCSI device address, 3-14
SCSI drawer ID, 3-13
labels, location identification, 3-12
loading the 1/4-inch tape drive, 2-15
loading the 4 mm tape cartridge, 2-35
loading the 8 mm tape cartridge, 2-25
loading the CD-ROM disc caddy, 2-11
location code format
for 9333 and 9334, 3-12
non-SCSI devices, 3-17
SCSI drawer, 3-12
location code table, SCSI and non-SCSI devices,
3-18
location identification labels, 3-12
LPFK and dials configuration, 8-3
lscfg command, 8-2

M

maintenance mode, commands
diag, 7-9
shutdown -m, 7-9
manual starting of AC system unit, 4-1
MES, 8-7
methods of starting the AC system unit, 4-1
manual with a PDB, 4-4
manual with a PDU, 4-2
microcode download service aid, 8-5
missing or new resources, 8-7
model R00 rack, 3-1
multimedia video capture adapter, 8-5
multiple systems, general information, 4-1

N

- non-SCSI drawer
 - ID label, 3-17
 - location code format, 3-17
- normal IPL, 2-2
- number message
 - other numbers, 7-19
 - type, 888, 7-14
 - type 102 message, 7-15
 - type 103 message, 7-16
 - type 105 message, 7-17
 - type of message, 7-14

O

- operating considerations for diagnostic programs, 7-1
- operating in harsh environments, 2-21
 - 4 mm tape cartridges, 2-32
- operator panel
 - CPU-media enclosure, 1-3
 - key mode switch, 2-1
 - reset button, 2-5
 - three-digit display, 2-4
- optional battery backup unit, 3-6
- other type number messages, 7-19

P

- parallel port, 1-2
- PDB, 3-4
- PDP (power distribution panel), 5-2
- POST (Power-On Self-Test) indicators, B-2
- power distribution, battery backup unit, 3-6
- power distribution bus, 3-4
- power distribution panel (PDP), 5-2
- power distribution unit, 3-5
- Power Off button, location, CPU-media enclosure, 1-3
- Power On button, location, CPU-media enclosure, 1-3
- powering on the AC system unit containing a PDU, manual, 4-2
- powering on the AC system unit with PDB, manual, 4-4

- printer attributes, 7-8
- problem determination procedure, 10-1
- product topology
 - create (rebuild) function, 8-7
 - EC A90783B, 8-8
 - ECs, 8-7
 - installation, 8-6
 - installing multiple ECs, 8-7
 - MES, 8-7
 - missing or new resources, 8-7
- product topology service aid, 8-6
- programmed starting of AC system unit
 - after a power failure, 4-1
 - by date and time, 4-1

Q

- QIC, 2-17

R

- rack, 3-1
- rack attachment plate, 3-3
- reading flashing 888 numbers, 7-14
- reading the three-digit display, 2-4
- related publications, xv
 - 7135 RAIDiant Array: Installation and Service Guide, xv
 - 7135 RAIDiant Array: Operator Guide, xv
 - 9333 Model 010 and 011 High-Performance Disk Drive Subsystem Operator Guide, xv
 - 9334 SCSI Expansion Unit Operator Guide, xv
 - 9348 Customer Information, xv
 - AIX System Management Guide: Operating System and Devices, xv
 - AIX Problem Solving Guide and Reference, xv
 - Common Diagnostics and Service Guide, xv
 - RISC System/6000 System Overview and Planning, xv
 - System Unit Safety Information, xv
- remote reset port, 2-5
 - using, 2-5
- remote starting of AC system unit, 4-1
- Reset button, location, 2-1
- resetting the terminal, 7-2
- retensioning, 1/4-inch tape cartridge, 2-17

- running diagnostics from a non-RS 232 terminal, 7-4
- running diagnostics from a TTY terminal, 7-5
- running diagnostics from CD-ROM disc, 7-3
- running diagnostics from disk, 7-3
- running diagnostics from diskettes, 7-2

S

- safety notices, xiii

- SCSI and non-SCSI devices, location code table, 3-18

- SCSI bus service aid, 8-5

- SCSI device address label, 3-14

- SCSI drawer

 - cover label

 - creating, 3-15

 - description, 3-14

 - description, 3-7

 - device address label, 3-14

 - features

 - 4 mm tape drive, 3-7

 - 8 mm tape drive, 3-7

 - controls, 3-8

 - disk drive, 3-7

 - ID label, 3-13

 - location code format, 3-12

- SCSI drawer ID label, 3-13

- selecting a console display, 7-1

- serial port 1, 1-2

- serial port 2, 1-2

- service aids, 8-1

 - certify disk, 8-4

 - change configuration, 8-2

 - diagnostic diskette creation service aid, 8-3

 - dials and LPFK configuration, 8-3

 - disk media, 8-4

 - disk-based diagnostic update, 8-3

 - diskette media, 8-4

 - display configuration, 8-2

 - display or alter bootlist, 8-3

 - display or alter VPD, 8-2

 - display or change configuration or VPD, 8-2

 - display or change diagnostic test list, 8-2

 - display previous diagnostic results, 8-1

 - display test patterns, 8-5

 - display VPD, 8-2

 - ethernet, 8-4

 - format disk, 8-4

 - hardware error report, 8-5

 - microcode download, 8-5

 - multimedia video capture adapter, 8-5

 - product topology, 8-6

 - missing or new resources, 8-7

 - SCSI bus, 8-5

 - service hints, 8-5

 - trace service aid, 8-3

 - types, 8-1

- service hints service aid, 8-5

- setting the circuit breaker switches to on, 6-2

- setting the write-protect tab

 - 1/4-inch tape cartridge, 2-14

 - 4 mm tape cartridge, 2-31

 - 8 mm tape cartridge, 2-20

- setting the write-protect tab, 3.5-inch diskette, 2-8

- shutdown command, 6-4

- sources for diagnostic programs

 - CD-ROM disc, 7-1

 - disk, 7-1

 - diskettes, 7-1

- starting the -48 V dc system unit, 6-1

 - setting the circuit breaker switches to on, 6-2

 - verify -48 V dc power to system unit, 6-2

 - with -48 V dc power supply, 6-3

- starting the AC system unit, 4-1

 - manually, 4-1

 - methods, 4-1

 - programmed after power failure, 4-1

 - programmed by date and time, 4-1

 - remotely, 4-1

- starting the CPU-media enclosure with -48 V dc power supply, 6-3

- status light states

 - 4.0GB 4 mm tape drive, 2-33

 - 5.0 G-byte 8 mm tape drive, 2-24

- status light, 1/4-inch tape drive, 2-13

- status lights

 - 4.0 GB 4 mm tape drive, 2-33

 - 5.0GB 8 mm tape drive, 2-23

- stopping the -48 V dc system unit, 6-4

 - circuit breakers, 6-5

 - stopping immediately, 6-5

- stopping the -48 V dc system unit immediately, power distribution panel, 6-5

- stopping the -48 V dc system unit under ordinary conditions, 6-4

- stopping the AC system unit, 4-7

- stopping the AC system unit containing a PDU, under ordinary conditions, 4-7

- stopping the AC system unit containing PDB, ordinary conditions, 4-9

- stopping the system unit, under ordinary conditions, 6-4

- supplies
 - descriptions, A-1
 - ordering information, A-1
 - part numbers, A-1

- switch
 - key mode, 1-3
 - Power Off button, 1-3
 - Power On button, 1-3
 - Reset button, 1-3

- system exerciser
 - display screens, 7-12
 - starting, 7-12
 - stopping, 7-13
 - to determine problems, 7-13

- system unit
 - 48 V dc rack, 5-1
 - CPU-media enclosure, 3-1
 - features
 - 3.5-inch diskette drive, 1-4
 - battery backup unit, 3-6
 - CD-ROM drive, 1-4
 - CPU-media enclosure, 1-1
 - operator panel, CPU enclosure, 1-3
 - power distribution bus, 3-4
 - SCSI drawer, 3-7
 - options, 3-8

- system unit cables, CPU-media enclosure, 5-3

- system unit options, 3-8

- system verification procedure, 9-1
 - considerations, 9-1
 - diagnostics
 - loading, 9-2
 - stopping, 9-3
 - running, 9-2
 - using, 9-1

T

- tape cartridge
 - 1/4-inch
 - environment consideration, 2-16
 - loading, 2-15
 - unloading, 2-16
 - 1/4-inch, setting the write-protect tab, 2-14

- 4 mm
 - compatibility, 2-31
 - data capacity, 2-32
 - environment considerations, 2-31
 - erasure, 2-32
 - loading 4.0G-byte tape drive, 2-35
 - setting the write-protect tab, 2-31
 - types, 2-30
 - unloading 4.0GB tape drive, 2-36
- 8 mm
 - compatibility, 2-20
 - data efficiency, 2-21
 - environment considerations, 2-20
 - erasure, 2-21
 - setting the write-protect tab, 2-20
 - types, 2-19
 - loading 5.0 G-byte 8 mm tape drive, 2-25
 - unloading, 2-26

- tape cartridge compatibility, 2-20
 - 4 mm tape cartridges, 2-31
 - format modes, 2-20

- tape cartridge data capacity, 4 mm tape cartridge, 2-32

- tape cartridge data efficiency, 2-21
 - file mark, 2-21

- tape drive
 - 1/4-inch, 1-7
 - 1/4-inch, 2-13
 - 4 mm
 - 4.0 gigabyte, 2-33
 - general information, 2-29
 - 8 mm, 5.0GB drive, 2-23

- terminal, resetting, 7-2

- terminal type, 7-1

- terminal types, undefined, 7-2

- three-digit display
 - BIST (Built-in Self-Test) indicators, B-1
 - diagnostic load progress indicators, B-8
 - dump progress indicators, 7-16
 - number lists, B-1
 - number lists, see three-digit display, B-1
 - POST (Power-On Self-Test) indicators, B-2
 - reading flashing 888 numbers, 7-14
 - uses, 2-4

- three-digit display, reading (using), 2-4

- trace service aid, 8-3

- type 102 message, crash codes, 7-15

- type 103 message, 7-16

- type 105 message, 7-17

U

- unloading the 4 mm tape cartridge, 2-36
- unloading the 8 mm tape cartridge, 2-26
- using the -48 V dc system unit
 - setting the circuit breaker switches to on, 6-2
 - starting, 6-1
 - starting with -48 V dc power supply, 6-3
 - stopping, 6-4
 - stopping immediately, 6-5
 - stopping under ordinary conditions, 6-4
 - verify -48 V dc power to system unit, 6-2
- using the 1/4-inch tape drive, 2-13
- using the 4.0GB tape drive, 2-33
- using the -48 V dc rack, 6-1
- using the 5.0GB 8 mm tape drive, 2-23
- using the AC rack, 4-1
 - general information about multiple systems, 4-1
- using the CD-ROM drive, 2-10
- using the CPU-media enclosure, 2-1
- using the remote reset port, 2-5
- using the reset button, 2-5
- using the service aids, 8-1
- using the system verification procedure, 9-1

V

- verification procedure, 9-1
- verify -48 V dc power to system unit, 6-2

Symbols

- 48 V dc rack
 - containing CPU-media enclosure, 5-1
 - description, 5-1
 - power distribution panel, 5-2
 - power distribution panel, 5-2
 - using, 6-1
- 48 V dc system unit
 - power cables, 5-3
 - stopping under ordinary conditions, 6-4

Numbers

- 1/4-inch tape cartridge
 - compatibility, 2-17

- efficiency, 2-18–2-23
- environment considerations, operating range 2-16
- QIC standards, 2-17
- retensioning, 2-17
- tape speed, 2-18–2-23
- 1/4-inch tape drive
 - cleaning, 2-16
 - recording head, 2-16
 - status light, 1-7, 2-13, 2-15
 - tape cartridge
 - environment consideration, 2-16
 - loading, 2-15
 - setting the write-protect tab, 2-14
 - unloading, 2-16
 - unload button, 1-7, 2-15
 - using, 1-7
- 1/4-inch tape drive, using, 2-13
- 102 message, 7-15
- 103 message, 7-16
- 105 message, 7-17
- 3.5-inch diskette drive
 - in use light, 1-4, 2-6
 - unload button, 1-4, 2-6
- 3.5-inch diskette drive
 - diskette
 - setting the write-protect tab, 2-8
 - types, 2-7
 - features, 1-4
 - using, 2-6
- 3.5-inch diskettes, loading and unloading, 2-9
- 4 mm data cartridge, erasure, 2-32
- 4 mm data cartridges
 - environmental considerations, 2-31
 - operating ranges, 2-31
 - shipping, 2-31
 - environmental considerations, storage, 2-31
- 4 mm tape cartridge
 - data capacity, 2-32
 - types, cleaning cartridge, 2-30
- 4 mm tape cartridges
 - operating in harsh environments, 2-32
 - types
 - data cartridge, 2-30
 - diagnostic cartridge, 2-30
- 4 mm tape drive
 - See 4.0 GB 4 mm tape drive, 1-6
 - tape cartridge
 - setting the write-protect tab, 2-31
 - types, 2-30

- using, 4.0 gigabyte tape drive, 2-33
- 4.0 GB 4 mm tape drive
 - location, 3-7
 - recommendations, 2-30
 - status lights, 1-6
 - unload button, 1-6
- 4.0 G-byte 4 mm tape drive, cleaning the tape path, 2-37
- 4.0GB 4 mm tape drive
 - general information, 2-29
 - status light states, 2-33
 - status lights, 2-33
 - tape cartridge
 - loading, 2-35
 - unloading, 2-36
- 4.0GB 4 mm tape drive, general information, 2-29
- 48 V dc rack
 - containing CPU-media enclosure, 5-1
 - description, 5-1
 - power distribution panel, 5-2
 - power distribution panel, 5-2
 - using, 6-1
- 48 V dc system unit
 - power cables, 5-3
 - stopping under ordinary conditions, 6-4
- 5.0 G-byte 8 mm tape drive
 - status light states, 2-24
 - status lights, 1-5
 - tape cartridge, loading, 2-25
- 5.0 GB 8 mm tape drive, general information, 2-19
- 5.0GB 8 mm tape drive
 - cleaning the tape path, 2-27
 - status lights, 2-23
 - tape cartridge, unloading, 2-26
- 7015 model R00 rack, 3-1
- 8 mm tape cartridges, types
 - cleaning tape cartridge, 2-19
 - data tape cartridge, 2-19
 - test tape cartridge, 2-19
- 8 mm tape drive
 - location, 3-7
 - operating in harsh environments, 2-21
 - tape cartridge
 - setting the write-protect tab, 2-20
 - types, 2-19
 - using, 5.0GB drive, 2-23
- 888 message, 7-14

Printed in the U.S.A.

 Place Form Number barcode
lower left corner here.