

# 7015 POWERserver Async Expansion Drawer

## **Service Guide**



# 7015 POWERserver Aysnc Expansion Drawer

## **Service Guide**

## Fourth Edition (September 1992)

This edition notice applies to the *7015 Async Expansion Drawer Service Guide*.

**The following paragraph does not apply to the United Kingdom or any country where such provisions are inconsistent with local law:** THIS PUBLICATION IS PRINTED "AS IS" WITHOUT WARRANTY OF ANY KIND, EITHER EXPRESS OR IMPLIED, INCLUDING, BUT NOT LIMITED TO, THE IMPLIED WARRANTIES OF MERCHANTABILITY OR FITNESS FOR A PARTICULAR PURPOSE. Some states do not allow disclaimer of express or implied warranties in certain transactions; therefore, this statement may not apply to you.

This publication could include technical inaccuracies or typographical errors. Changes are periodically made to the information herein; these changes will be incorporated in new editions of the publication.

It is possible that this publication may contain reference to, or information about, products (machines and programs), programming, or services that are not announced in your country. Such references or information must not be construed to mean that such products, programming, or services will be offered in your country. Any reference to a licensed program in this publication is not intended to state or imply that you can use only the licensed program. You can use any functionally equivalent program instead.

©Copyright International Business Machines Corporation, 1990, 1992. All rights reserved.

Note to U.S. Government Users – Documentation and programs related to restricted rights – Use, duplication, or disclosure is subject to the restrictions set forth in GSA ADP Schedule Contract.

---

# Table of Contents

|  |                 |
|--|-----------------|
| <b>Communications Statements</b> .....                         | <b>v</b>        |
| <b>Safety Notices</b> .....                                    | <b>vii</b>      |
| <b>About This Book</b> .....                                   | <b>ix</b>       |
| <b>Chapter 1. Reference Information</b> .....                  | <b>1-1</b>      |
| Description .....  | 1-1             |
| Locations .....  | 1-2             |
| Front View .....   | 1-2             |
| Rear View .....  | 1-3             |
| Cable Management Arm .....                                     | 1-3             |
| Planar Connectors .....  | 1-4             |
| Power Supply Connectors .....                                  | 1-5             |
| Specifications .....   | 1-6             |
| Service Inspection Guide .....                                 | 1-7             |
| <b>Chapter 2. Maintenance Analysis Procedures (MAPs)</b> ..... | <b>2-1520-1</b> |
| MAP 1520: Async Expansion Drawer – Power MAP .....             | 2-1520-1        |
| MAP 1540: Async Expansion Drawer – Minimum Configuration ..... | 2-1540-1        |
| <b>Chapter 3. Removal and Replacement Procedures</b> .....     | <b>3-3</b>      |
| Handling Static-Sensitive Devices .....                        | 3-3             |
| Service Position .....   | 3-4             |
| Operating Position .....                                       | 3-6             |
| Adapter Cable .....  | 3-7             |
| Adapter .....  | 3-8             |
| Divider Assembly .....   | 3-10            |
| Front Fan and Housing Assembly .....                           | 3-11            |
| Front Fan and Housing Assembly (Alternate Type) .....          | 3-12            |
| Planar .....   | 3-13            |
| Power Supply .....   | 3-14            |
| Power Supply Fan .....   | 3-16            |
| Bulkhead Assembly .....  | 3-17            |
| Operator Panel Assembly .....                                  | 3-18            |
| <b>Chapter 4. Parts Information</b> .....                      | <b>4-19</b>     |
| Detail 1. ....   | 4-20            |
| Detail 2. ....   | 4-22            |
| <b>Index</b> .....   | <b>X-1</b>      |



---

# Communications Statements

The following statement applies to this product. The statement for other products intended for use with this product appears in their accompanying manuals.

## Federal Communications Commission (FCC) Statement

**Note:** This equipment has been tested and found to comply with the limits for a Class A digital device, pursuant to Part 15 of the FCC Rules. These limits are designed to provide reasonable protection against harmful interference when the equipment is operated in a commercial environment. This equipment generates, uses, and can radiate radio frequency energy and, if not installed and used in accordance with the instruction manual, may cause harmful interference to radio communications. Operation of this equipment in a residential area is likely to cause interference in which case users will be required to correct the interference at their own expense.

Properly shielded and grounded cables and connectors must be used in order to meet FCC emission limits. Neither the provider nor the manufacturer of this product is responsible for any radio or television interference caused by using other than recommended cables and connectors or by unauthorized changes or modifications to this equipment. Unauthorized changes or modifications could void the user's authority to operate the equipment.

This device complies with Part 15 of the FCC Rules. Operation is subject to the following two conditions: (1) this device may not cause harmful interference, and (2) this device must accept any interference received, including interference that may cause undesired operation.

## VCCI Statement

### 電波障害自主規制 届出装置の記述

この装置は、第一種情報装置（商工業地域において使用されるべき情報装置）で商工業地域での電波障害防止を目的とした情報処理装置等電波障害自主規制協議会（VCCI）基準に適合しております。

従って、住宅地域またはその隣接した地域で使用すると、ラジオ、テレビジョン受信機等に受信障害を与えることがあります。

取扱説明書に従って正しい取り扱いをしてください。

The following is a summary of the VCCI Japanese statement in the box above.

This equipment is Type 1 Data Processing Equipment and is intended for use in commercial and industrial area. When used in residential area, or areas of proximity, radio and TV reception may be subject to radio interference. VCCI-1.

## **Avis de conformité aux normes du ministère des Communications du Canada**

Cet équipement ne dépasse pas les limites de Classe A d'émission de bruits radioélectriques pour les appareils numériques, telles que prescrites par le Règlement sur le brouillage radioélectrique établi par le ministère des Communications du Canada. L'exploitation faite en milieu résidentiel peut entraîner le brouillage des réceptions radio et télé, ce qui obligerait le propriétaire ou l'opérateur à prendre les dispositions nécessaires pour en éliminer les causes.

## **Canadian Department of Communications compliance statement**

This equipment does not exceed Class A limits for radio noise emissions for digital apparatus, set out in Radio Interference Regulation of the Canadian Department of Communications. Operation in a residential area may cause unacceptable interference to radio and TV reception requiring the owner or operator to take whatever steps necessary to correct the interference.

## **Radio Protection for Germany**

**Instructions to User:** Properly shielded and grounded cables and connectors must be used for connection to peripherals in order to meet German emission limits. Shielded, grounded cables with in-line filters are included with certain peripherals and features. These cables should be used to insure that the 7015 system will comply with the German limits.

In addition, when attaching peripherals to the parallel printer port, the cable P/N 1525612 with the in-line filter should be used for compliance to the German requirements.

## **United Kingdom Telecommunications Safety Requirements**

This apparatus is approved under approval number NS/G/1234/J/100003 for indirect connection to public telecommunication systems in the United Kingdom.

## **International Electrotechnical Commission (IEC) Statement**

This product has been designed and built to comply with (IEC) Standard 950.

## **Korean Communications Statement**

### **전자파장해에 관한 사용자 안내문**

이 기기는 업무용으로 전자파장해 검정을 받은 기기이오니 판매자 또는 사용자는 이 점을 주의하시기 바라며, 만약 잘못 구입하였을 때에는 구입한 곳에서 비업무용으로 교환하시기 바랍니다. (RSPTCSI)

This device has been approved for business use with regard to electromagnetic wave interference. If you find this is not suitable for your use, you may exchange it for one designated for non-business purposes.



---

# Safety Notices

**Note:** For a translation of danger and caution notices, see *System Unit Safety Information*, form number SA23-2652.

## Definitions of Safety Notices

A *danger* notice indicates the presence of a hazard that has the potential of causing death or serious personal injury.

*Danger* notices are on the following pages:

2-1520-2  
3-12.

A *caution* notice indicates the presence of a hazard that has the potential of causing moderate or minor personal injury.

A *caution* notice is on the following page:

3-2.

A *warning* notice indicates an action that could cause damage to a program, device, system, or data.

## Safety Notice for Servicing

For safety checks when servicing, refer to Chapter 3, "Removal and Replacement Procedures."

**Note:** Before connecting or removing any cables to or from the system, be sure to follow the steps in the installation or relocation check list specified in the installation and service guide for your system or device.



---

## About This Guide

This book uses three-digit model numbers. You may have other documentation that uses four-digit model numbers. For example, the model 93H in this book may be referred to as a model 930H in other documentation. They are the same system units.

## How to Use This Book

This book provides maintenance information that is specific to the 7015 Async Expansion Drawer. It also contains maintenance analysis procedures (MAPs) that are not common to other systems.

MAPs that are common to all systems are contained in the *Common Diagnostics and Service Guide*.

This book is used by the service technician to repair system failures. This book assumes that the service technician has had training on the 7015 system.

## Related Publications

The *POWERstation and POWERserver Common Diagnostics and Service Guide*, form number SA23-2687, contains reference information about adapters, devices, checkout procedures for problem determination, system verification, using the diagnostics, and cabling for the system units. This manual also contains the removal and replacement procedures for the logic boards on the disk drives and cabling information that can be used to isolate problems with customer cabling.

The *7015 POWERserver Operator Guide*, form number SA23-2627, provides information about the controls and features of the system unit.

The *7015 POWERserver Installation and Service Guide*, form number SA23-2628, contains information about installing the system unit, servicing the power components within the rack, and switching the system unit on and off.

The *System Unit Safety Information* manual, form number SA23-2652, contains translations of danger and caution notices.



---

# Chapter 1. Reference Information

This chapter contains information about configuration, part locations, connector locations, planar slot locations, and async expansion drawer specifications.

---

## Description

The 7015 Async Expansion Drawer provides additional slots for asynchronous adapters in the 7015 system unit.

The following table lists the types of async adapters and the number allowed in the system unit, CPU drawer, and async drawer.

Refer to the *Common Diagnostics and Service Guide* for more information on adapters.

| Async Adapter | Maximum Allowed in the System Unit | Configuration Constraints  |
|---------------|------------------------------------|--|
| 8-Port        | 8                                  | Any combination of async adapters that does not exceed the maximum allowed can be installed in the CPU and async drawers.  |
| 16-Port       | 8                                  | Any combination of async adapters that does not exceed the maximum allowed can be installed in the CPU and async drawers.  |
| 64-Port       | 16                                 | A maximum of six 64-port adapters can be installed in the CPU drawer. Otherwise, any combination of async adapters that does not exceed the maximum allowed can be installed in the CPU and async drawers. |

# Locations

## Front View

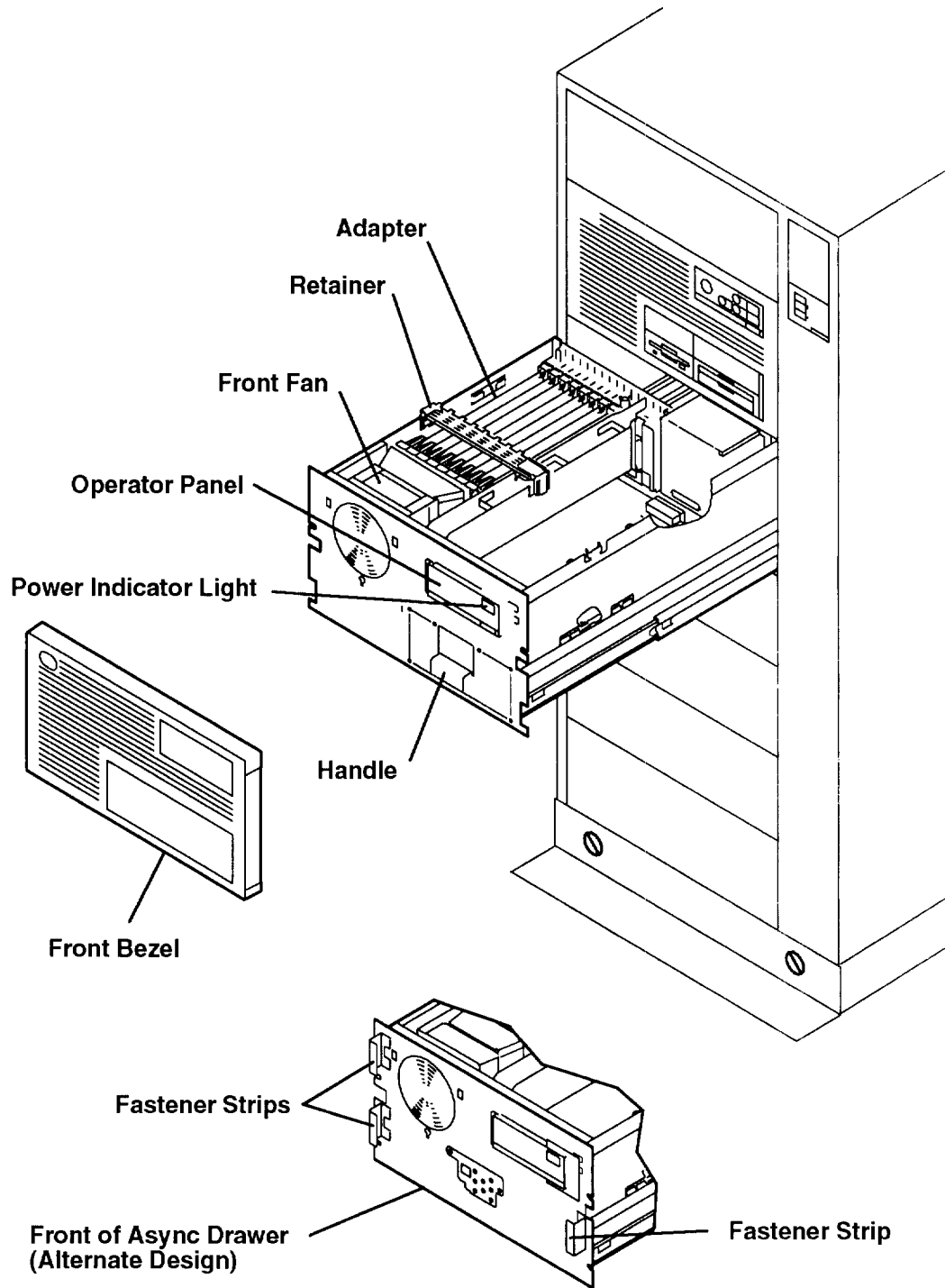

## Rear View

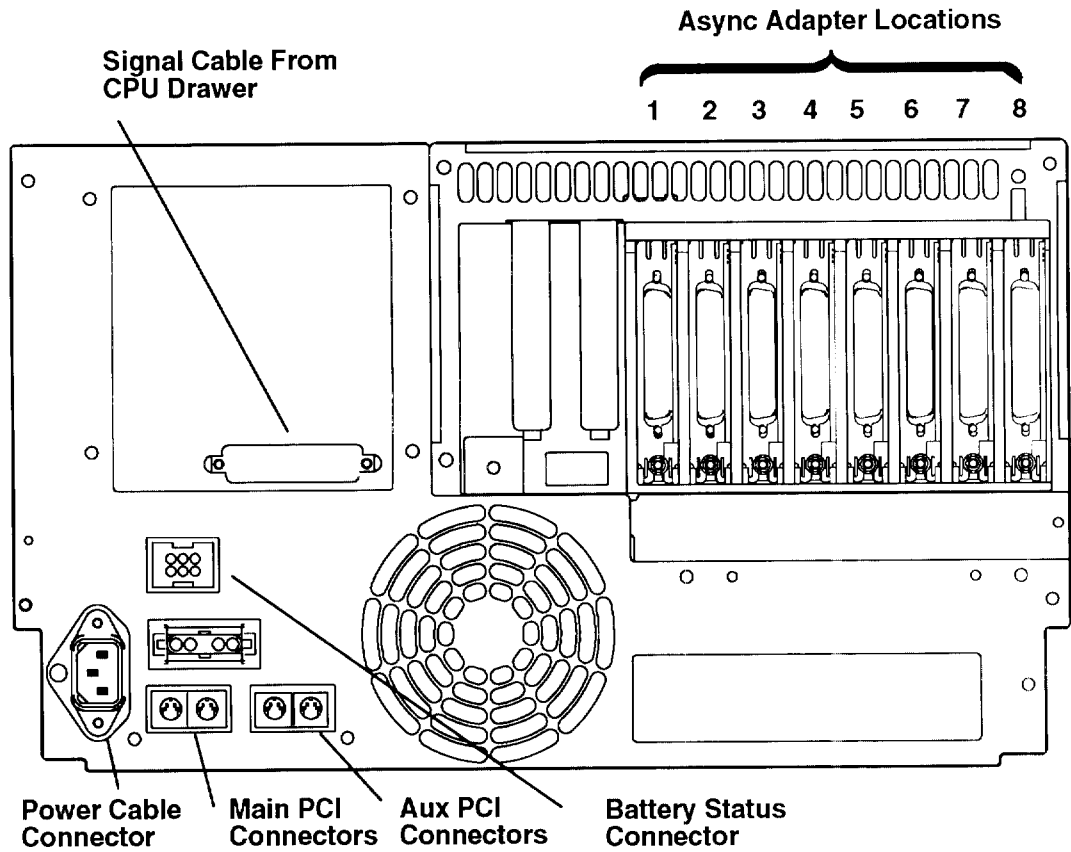

## Cable Management Arm

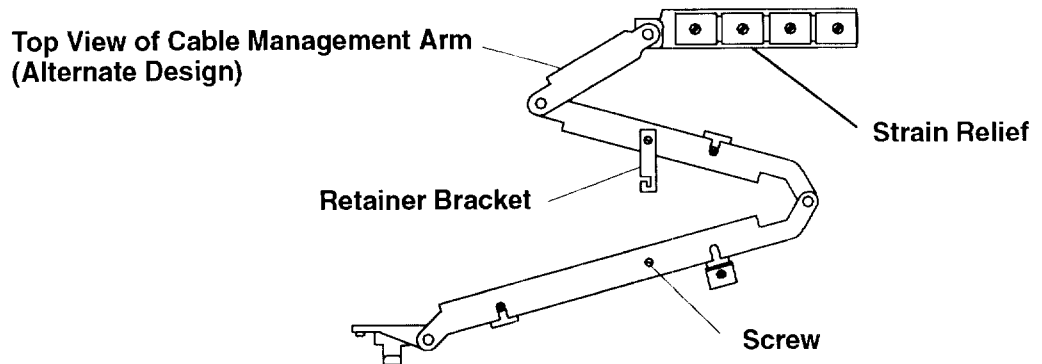
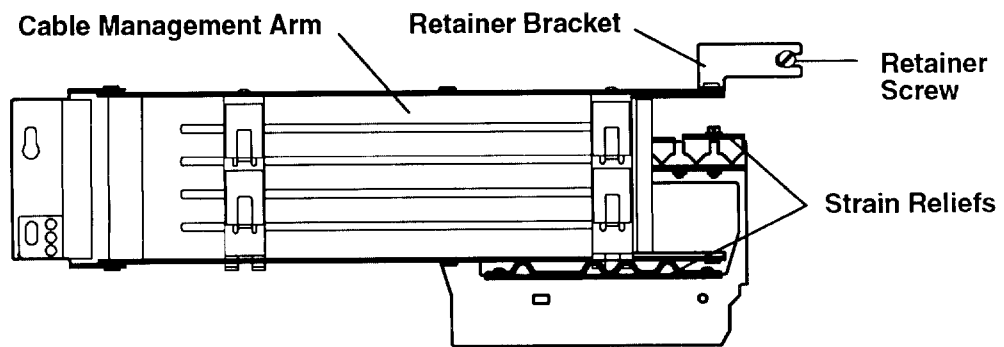

# Planar Connectors

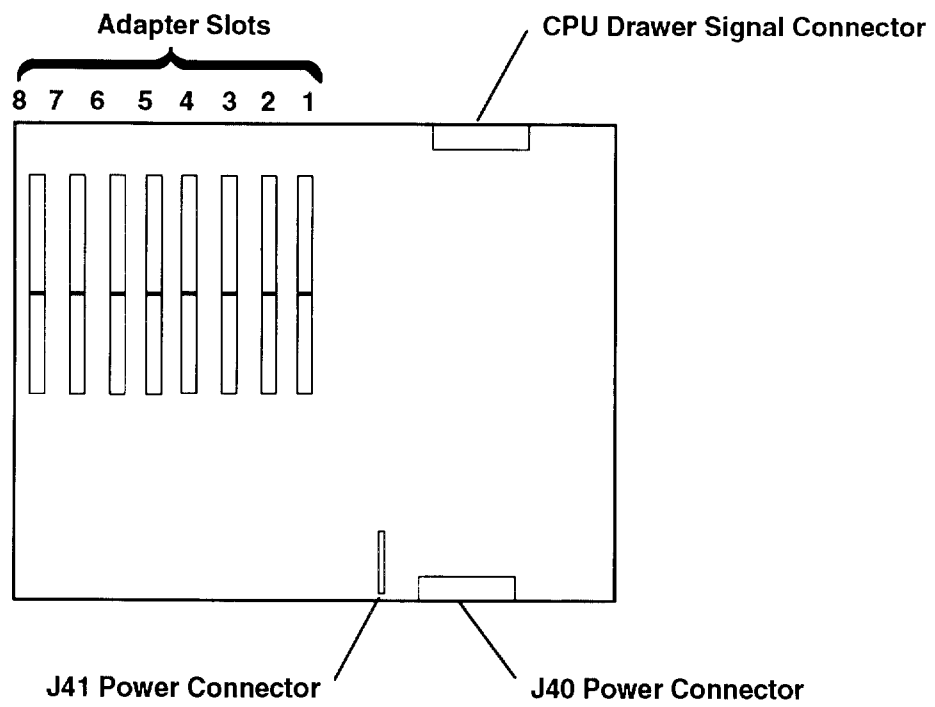



## Power Supply Connectors

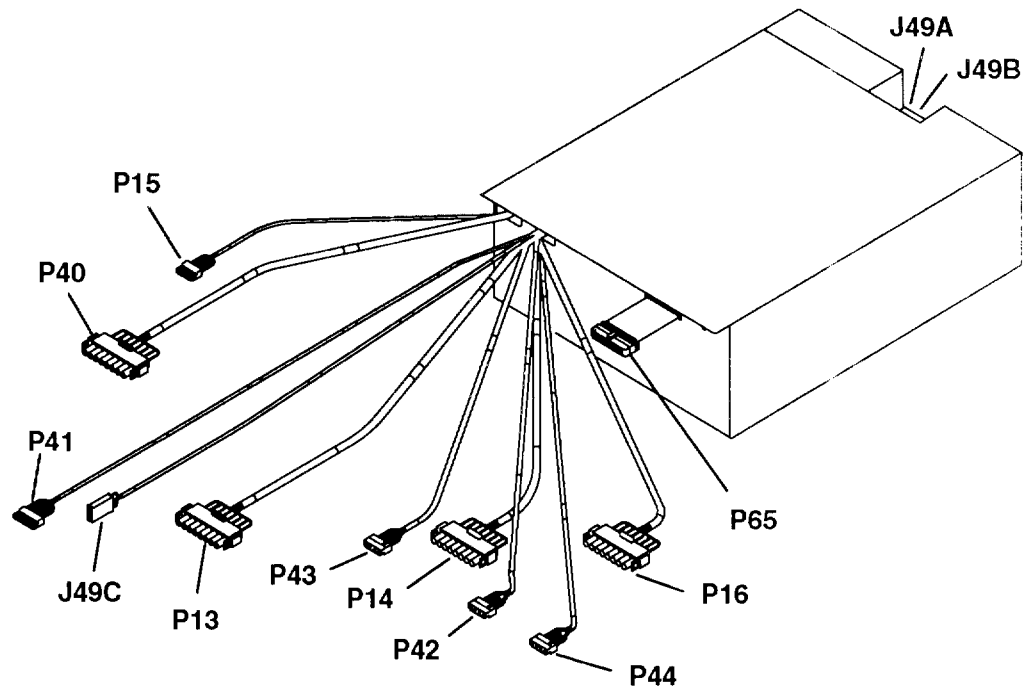

| Connector | Function                |
|-----------|-------------------------|
| P13       | No connection           |
| P14       | No connection           |
| P15       | No connection           |
| P16       | No connection           |
| P40       | To planar connector J40 |
| P41       | To planar connector J41 |
| P42       | No connection           |
| P43       | No connection           |
| P44       | No connection           |
| J49A      | To power supply fan     |
| J49B      | To power supply fan     |
| J49C      | To front fan            |
| P65       | To operator panel       |

---

## Specifications

### Dimensions

Height: 260 mm (10.25 inches)

Depth: 597 mm (23.5 inches)

Width: 444 mm (17.5 inches)

### Frequency

50 to 60 Hz

### Heat Output

195 W (665 BTU per hour)

### Operating Environment

Class C: 10 to 40°C (50 to 104°F)

Wet bulb temperature: 23°C (73°F)

### Operating Voltage

200 to 240 V ac

### Power

0.4 kVA

### Power Supply

270 W (peak)

### Weight

25 kg (55 pounds)

---

## Service Inspection Guide

Perform a service inspection on the system when:

- The system is inspected for a maintenance agreement.
- The service is requested and service has not recently been performed.
- An alterations and attachments review is performed.
- Changes have been made to the equipment that may affect the safe operation of the equipment.

If the inspection indicates an unacceptable safety condition, the condition must be corrected before the machine is serviced.

**Note:** The correction of any unsafe condition is the responsibility of the owner of the system.

Do the following checks:

1. Check the covers for sharp edges and for damage or alterations that expose the internal parts of the system unit.
2. Check the covers for proper fit to the system unit. They should be in place and secure.
3. Ensure that the rack stabilizer is installed and securely attached to the rack.
4. Do the "Service Position" procedure on page 3-2.
5. Check for alterations or attachments. If there are any, check for obvious safety hazards such as broken wires, sharp edges, or broken insulation.
6. Check the internal cables for damage.
7. Check for dirt, water, and any other contamination within the system unit.
8. Check the voltage label on the back of the system unit to ensure that it matches the voltage at the outlet.
9. Check the external power cable for damage.
10. With the external power cable connected to the system unit, check for 0.1 ohm or less resistance between the ground lug on the external power cable plug and the metal frame.
11. Do the "Operating Position" procedure on page 3-4.



---

## Chapter 2. Maintenance Analysis Procedures (MAPs)

This chapter provides diagnostic information for detecting power problems in the async expansion drawer (in MAP 1520) and for detecting defective field replaceable units (in MAP 1540).

---

### MAP 1520: Async Expansion Drawer – Power MAP

This procedure is used to locate power problems in the async expansion drawer. If a problem is detected, this procedure will help you to isolate the problem to a failing field replaceable unit (FRU).

The Power On and Power Off buttons on the CPU drawer are normally used to switch power on and off to all of the drawers in the rack. If power to the system cannot be switched off because of customer usage, you can control power to the async drawer by doing the following:

- Label and then unplug all power control interface (PCI) cables from the Main and Aux connectors in the back of the async drawer.
- You can now control power to the async drawer by using the power cable connector on the back of the drawer.

**Note:** The power cable must be unplugged from the power cable connector for at least 10 seconds before the power cable is reconnected for powering the async drawer on.

- To switch power on, plug the power cable into the power cable connector.
- To switch power off, unplug the power cable from the power cable connector.

---

## Step 1

**Note:** For a translation of this notice, see the *System Unit Safety Information* manual.

### **DANGER**

**An electrical outlet that is not correctly wired could place hazardous voltage on metal parts of the system or the products that attach to the system. It is the responsibility of the customer to ensure that the outlet is correctly wired and grounded to prevent an electrical shock.**

**Before installing or removing signal cables, ensure that the power cables for the system unit and all attached devices are unplugged.**

**When adding or removing any additional devices to or from the system, ensure that the power cables for those devices are unplugged before the signal cables are connected. If possible, disconnect all power cables from the existing system before you add a device.**

**Use one hand, when possible, to connect or disconnect signal cables to prevent a possible shock from touching two surfaces with different electrical potentials.**

**During an electrical storm, do not connect cables for display stations, printers, telephones, or station protectors for communications lines.**

Ensure that:

1. The power cable to the drawer has continuity.
2. The power cable is plugged into the drawer and the power distribution unit.
3. The circuit breaker on the power distribution unit is pushed in.
4. Voltage is available from the power distribution unit. To verify that voltage is available, measure for 20 to 30 V ac between pins 1 and 2 of the IPO connector (JD2) on the power distribution unit. Pin 1 is on the left. For the location of IPO connector (JD2) refer to "Power Distribution Unit (Rear View)" in Chapter 1 of the *7015 Installation and Service Guide*.

### **Did you find a problem?**

- NO**                      Go to Step 2.
- YES**                     Correct the problem and continue to Step 15.

---

## Step 2

(from Step 1)

1. Switch off power to the async drawer.
2. Disconnect the two power cable connectors (P40 and P41) from the planar assembly.
3. Disconnect the power cable connector (P65) from the operator panel (on the async expansion drawer).
4. Watch the fan blades while switching on power to the async drawer.

**Do the fans run at full speed for at least 20 seconds?**

**NO**                      Go to Step 3.

**YES**                      Go to Step 6.

---

## Step 3

(from Step 2)

**Did either fan start rotating and then stop?**

**NO**                      Go to Step 5.

**YES**                      Go to Step 4.

---

## Step 4

(from Step 3)

This problem can be caused by a defective fan or power supply. The power supply does not stay on if it does not detect the rotation of the cooling fans.

1. Switch off power to the async drawer.
2. Exchange the front fan assembly or the power supply fan.
3. Switch on power to the async drawer.

**Do the fans run continuously?**

**NO**                      Exchange the other fan. If both fans are exchanged, exchange the async drawer power supply, and then go to Step 15.

**YES**                      Go to Step 15.

---

## Step 5

(from Step 3)

1. Plug the drawer power cable into another outlet on the power distribution unit.
2. Switch on power to the async drawer.

### Do the fans run continuously?

- NO** Exchange the async drawer power supply, and then go to Step 15.
- YES** Use this outlet for the async drawer or replace the power distribution unit and then go to Step 15.

---

## Step 6

(from Step 2)

1. Connect the power cable connector (P65) to the operator panel (on the async expansion drawer).
2. Switch on power to the async drawer, and then wait 10 seconds.

### Did the Power light come on and stay on?

- NO** Exchange the operator panel, and then go to Step 15.
- YES** Go to Step 7.

---

## Step 7

(from Step 6)

1. Switch off power to the async drawer.
2. Connect the two power cable connectors (P40 and P41) to the planar assembly.
3. Switch on power to the async drawer and then wait 10 seconds.

### Did the Power light come on and stay on?

- NO** Go to Step 8.
- YES** Go to Step 15.



---

## Step 8

(from Step 7)

1. Switch off power to the async drawer.
2. Remove one adapter from the planar assembly.
3. Ensure that the power has been off at least 15 seconds, and then switch on power to the async drawer.
4. Wait 10 seconds.

### Did the Power light come on and stay on?

- NO**                      If all of the adapters have not been removed, repeat Step 8.  
                                 If all of the adapters have been removed, exchange the planar assembly, and then go to Step 15.
- YES**                      The last adapter that you removed is causing the problem. Go to Step 9.

---

## Step 9

(from Step 8)

Look at the adapter that you just removed.

### Are there, or were there, any cables attached to the adapter?

- NO**                      Go to Step 10.
- YES**                      Go to Step 12.

---

## Step 10

(from Step 9)

Some adapters contain additional FRUs.

### Does the failing adapter contain additional FRUs?

- NO**                      Exchange the failing adapter, and then go to Step 15.
- YES**                      Go to Step 11.

---

## Step 11

(from Step 10)

1. Switch off power to the async drawer.
2. Remove the additional FRUs.
3. Reinstall the failing option or adapter.
4. Switch on power to the async drawer.

### Did the Power light come on and stay on?

- NO** Exchange the failing option or adapter, and then go to Step 15.
- YES** One of the additional FRUs you removed is failing. If only one FRU was removed, exchange it. Otherwise, reinstall the removed FRUs, one at a time until you identify the failing FRU. Exchange the failing FRU, and then go to Step 15.

---

## Step 12

(from Step 9)

1. Switch off power to the async drawer.
2. Disconnect any cables attached to the adapter, and then reinstall the adapter.
3. Switch on power to the async drawer.

### Did the Power light come on and stay on?

- NO** Exchange the failing option or adapter, and then go to Step 15.
- YES** Go to Step 13.

---

## Step 13

(from Step 12)

1. Switch off power to the async drawer.
2. Connect one cable to the adapter.
3. Switch on power to the async drawer.

### Did the Power light come on and stay on?

- NO** Go to Step 14.
- YES** If all of the cables are not connected, repeat this step. If all of the cables are connected, go to Step 15.

---

## Step 14

(from Step 13)

1. Switch off power to the async drawer.
2. Starting with the devices, disconnect a device or cable connector.
3. Switch on power to the async drawer.

### Did the Power light come on and stay on?

- |     |  |
|-----|--|
| NO  | Repeat this step until all of the devices and cable connectors are disconnected. Exchange the adapter, and then go to Step 15. |
| YES | Exchange or repair the device or cable, and then go to Step 15.  |

---

## Step 15

(from Steps 1, 4, 5, 6, 7, 8, 10, 11, 12, 13, and 14)

This completes the repair.

Go to "MAP 410: Repair Checkout" in the *Common Diagnostics and Service Guide*.



---

## MAP 1540: Async Expansion Drawer – Minimum Configuration

This procedure is used to locate defective field replaceable units (FRUs) not found by normal diagnostics. For this procedure, diagnostics are run on a minimum system configuration. If the minimum system configuration does not work, the FRUs are exchanged one at a time until the failing FRU is identified. If the system does work, FRUs are added to the minimum configuration until the failing FRU is identified.

The components used in the minimum configuration are the I/O planar, power supply, and operator panel. Run the Async Expansion Unit Test from the CPU drawer to determine if the FRUs are working correctly.

The Power On and Power Off buttons on the CPU drawer are normally used to switch power on and off to all of the drawers in the rack. If power to the system cannot be switched off because of customer usage, you can control power to the async drawer by doing the following:

- Label and then unplug all power control interface (PCI) cables from the Main and Aux connectors in the back of the async drawer.
- You can now control power to the async drawer by using the power cable connector on the back of the drawer.
  - To switch power on, plug the power cable into the power cable connector.
  - To switch power off, unplug the power cable from the power cable connector.

---

### Step 1

1. Press the Power Off button located on the CPU drawer.
2. Remove all of the adapters from the async drawer.
3. Set the key mode switch to the Service position.
4. Press the Power On button located on the CPU drawer.
5. Run the Async Expansion Unit Test.

#### Did the test pass?

- |            |  |
|------------|--|
| <b>NO</b>  | Exchange the async drawer planar assembly, the expansion adapter, or the cable; then go to “MAP 410: Repair Checkout” in the <i>Common Diagnostics and Service Guide</i> . |
| <b>YES</b> | Go to Step 2.  |

---

## Step 2

(from Step 1)

One of the adapters is defective.

1. Switch off power to the async drawer.
2. Reinstall one of the adapters in the async drawer.
3. Switch on power to the async drawer.
4. Run the Async Expansion Unit Test.

### Did the test pass?

- NO** Exchange the adapter you just reinstalled, then go to "MAP 410: Repair Checkout" in the *Common Diagnostics and Service Guide*.
- YES** Repeat this step until all of the adapters have been reinstalled; then, if necessary, exchange the power supply. Go to "MAP 410: Repair Checkout" in the *Common Diagnostics and Service Guide*.

---

## Chapter 3. Removal and Replacement Procedures

This chapter contains information about removing and replacing various field replaceable units (FRUs) and parts.

---

### Handling Static-Sensitive Devices

**Warning:** Adapters and boards can be damaged by static electricity discharge. These devices are wrapped in antistatic bags to prevent this damage.

Take the following precautions:

- Do not remove the device from the antistatic bag until you are ready to install the device.
- If you have an antistatic wriststrap available, use it while handling the device.
- With the device still in the antistatic bag, touch it to the metal frame of the system.
- Grasp cards and boards by the edges. Avoid touching the solder joints or pins.
- If you need to lay the device down while it is out of the antistatic bag, lay it on the antistatic bag. Before you pick up the device again, touch the antistatic bag and the metal frame of the system at the same time.
- Handle the devices carefully to prevent permanent damage.

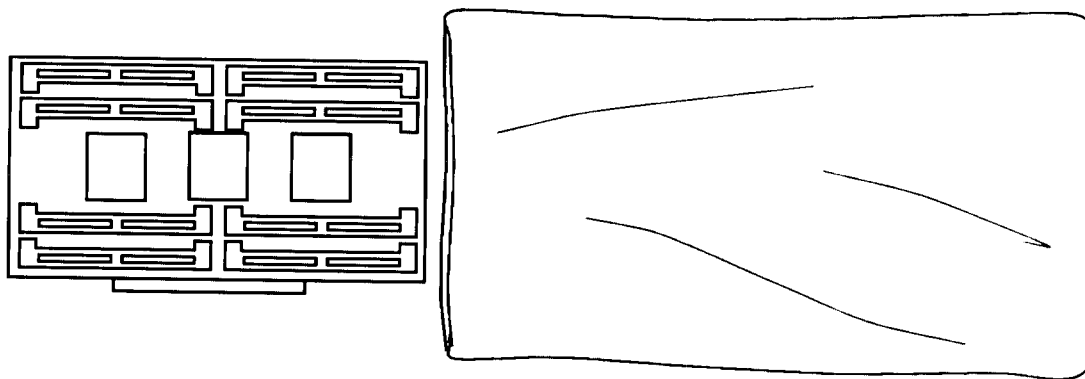

**Antistatic Bag**

---

## Service Position

**Note:** For a translation of this notice, see the *System Unit Safety Information* manual.

**CAUTION:**

When the drawer is extended, its weight can turn over a rack that is not steady. Before you pull the drawer out of the rack, ensure that a rack stabilizer is attached to the bottom front of the rack.

Do not pull out more than one drawer at a time. The rack can turn over if you pull out more than one drawer at a time.

The stabilizer must be firmly attached to the bottom front of the rack to prevent the rack from turning over when the drawers are pulled out of the rack. Do not pull out or install any drawer or feature if the stabilizer is not attached to the rack.

1. Do the "Power-Off Procedure" in Chapter 3 of the *7015 Installation and Service Guide*.
2. If the retainer bracket is attached to the rack, loosen the retainer screw so that the cable management arm moves freely when the drawer is extended.

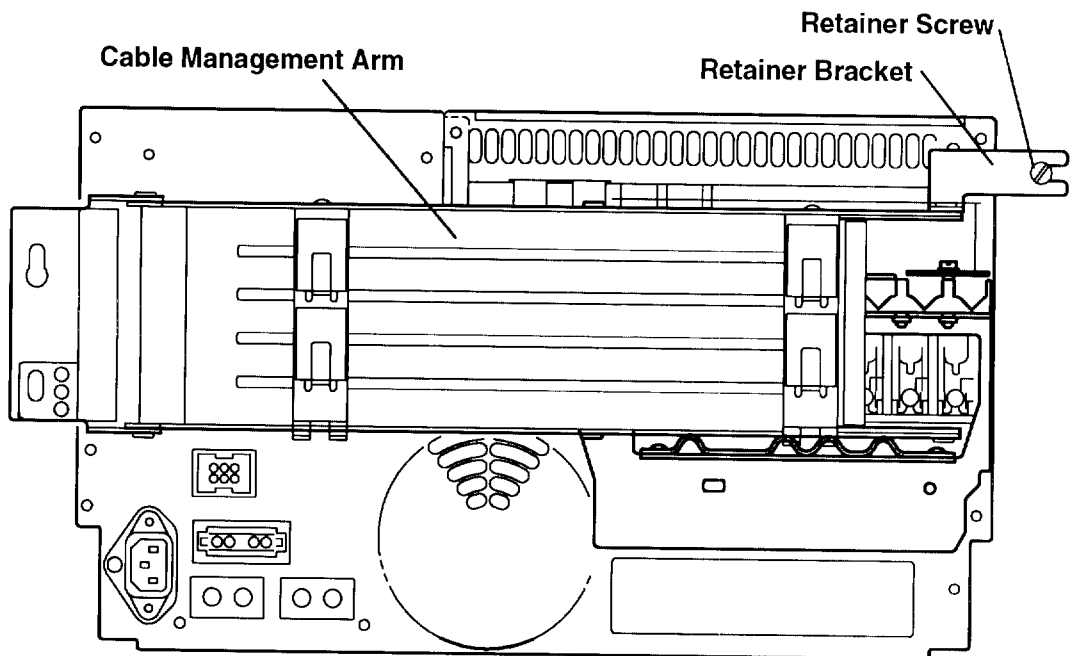



3. If a retainer bracket is attached to the top of the cable management arm, loosen the screw closest to you, and then disengage the bracket from the screw.

**Top View of Cable Management Arm (Alternate Design)**

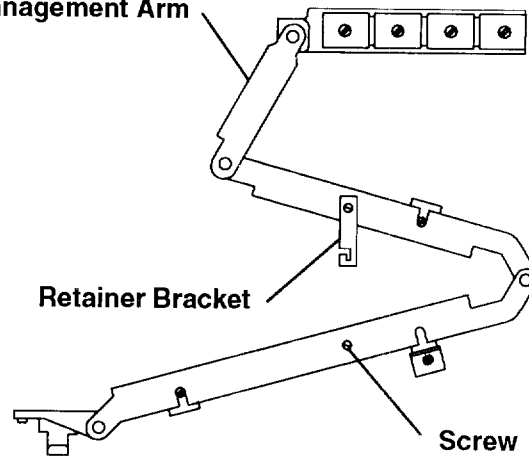

4. Grasp the front bezel on each side and pull it away from the drawer.
5. There are two types of async drawers available for the rack. Remove either two retainer screws or four retainer screws from the front of the drawer.
6. Grasp the handle and pull the drawer out until the lock buttons on the rails lock. If your machine does not have a handle, grasp a fastener strip bracket on each side of the drawer and pull the drawer out until the lock buttons on the rail lock.

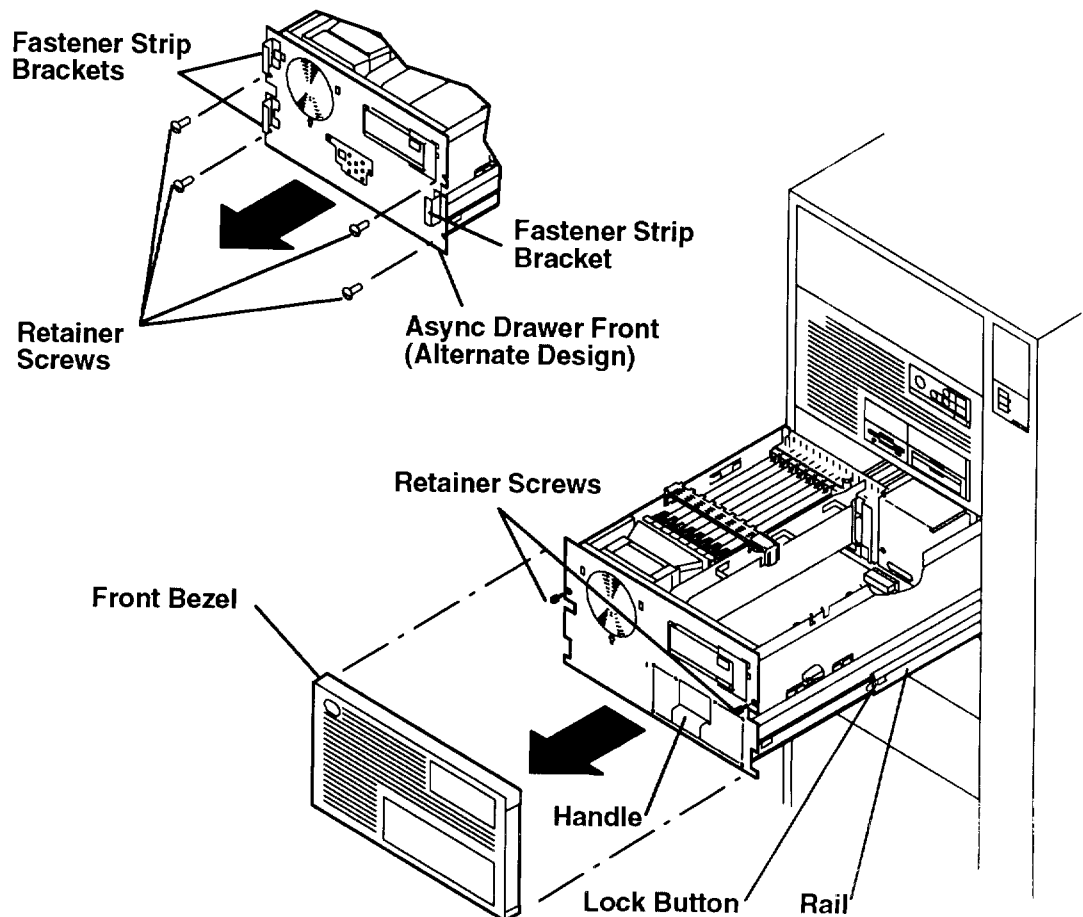

## Operating Position

1. Press the lock buttons on the rails, and then push the drawer into the system unit.
2. Install the retainer screws on the front of the drawer. One type of async drawer has two retainer screws, and an alternate type has four retainer screws.
3. Push the front bezel onto the front of the drawer. One type of front bezel attaches to the async drawer with two spring clips, and an alternate type attaches to the drawer with three fastener strips.
4. Do the "Power-On Procedure" in Chapter 3 of the *7015 Installation and Service Guide*.

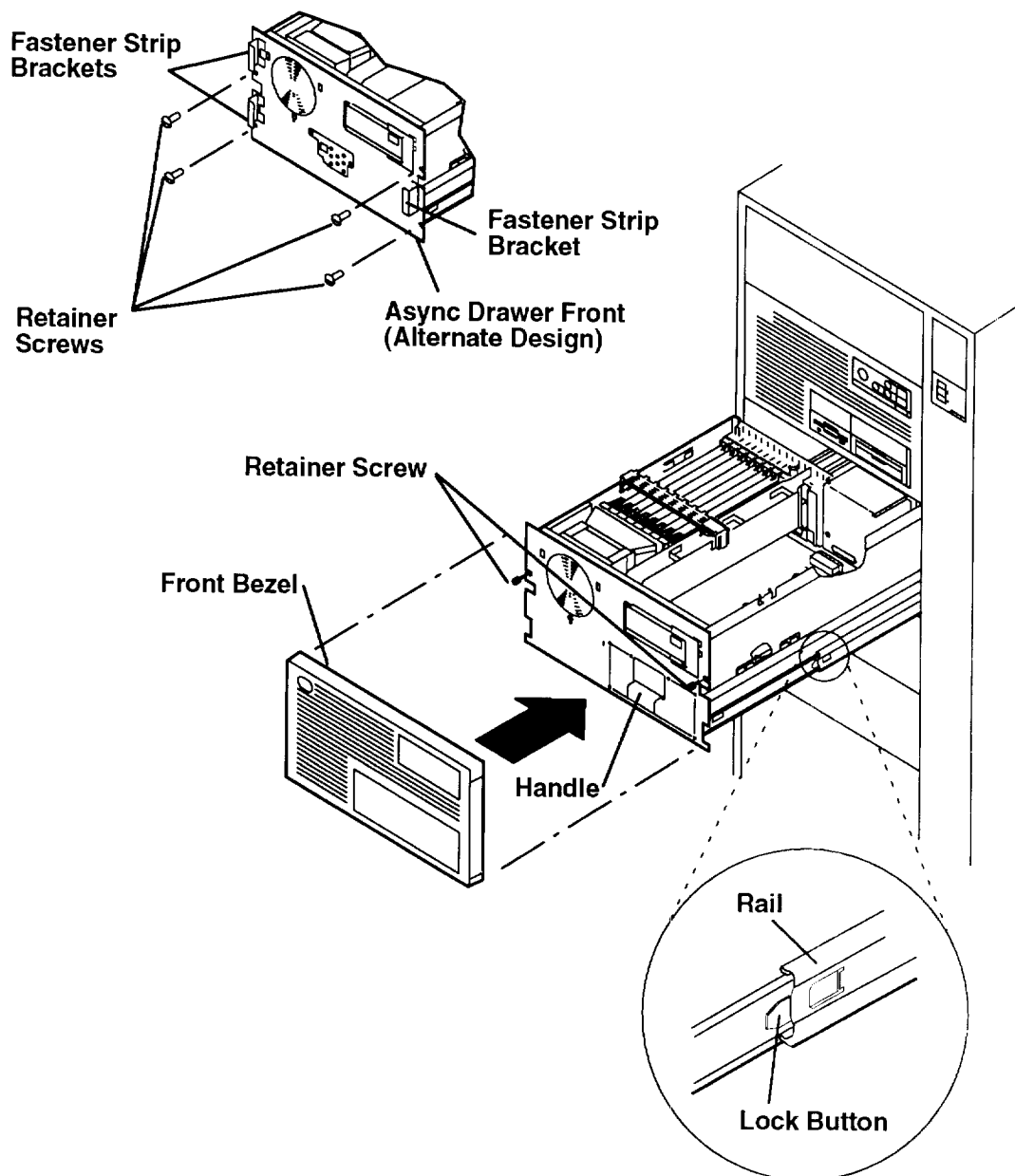

---

## Adapter Cable

### Removal

1. Do the "Power-Off Procedure" in Chapter 3 of the *7015 Installation and Service Guide*.
2. Loosen the screws on the cable connector in the back of the async drawer.

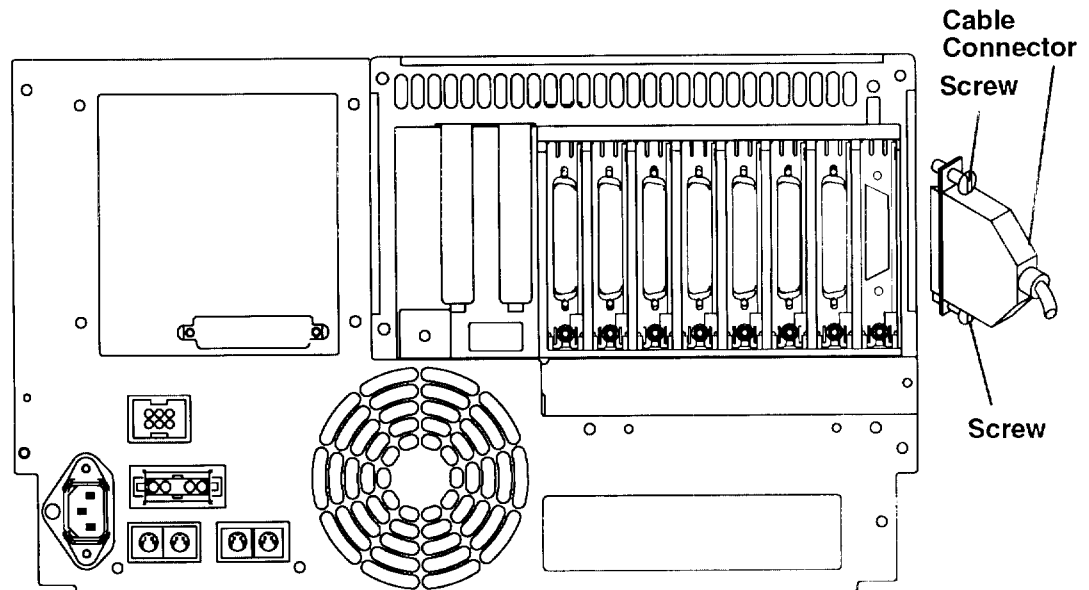

3. Loosen the screw on the appropriate strain relief, and then disconnect the device signal cable from the adapter.

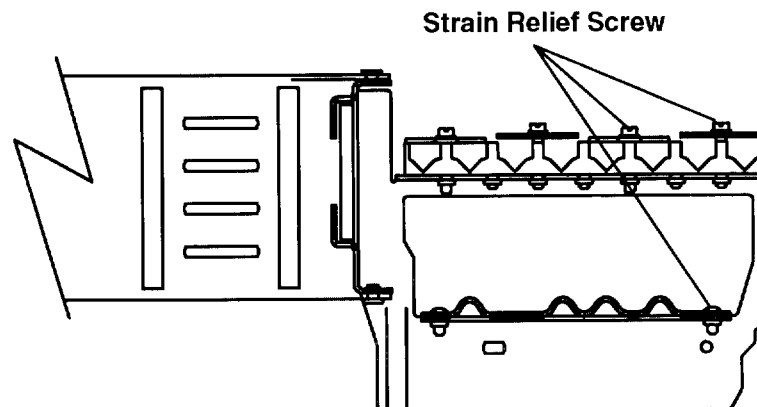

### Replacement

Replace in the reverse order, and then do the "Power-On Procedure" in Chapter 3 of the *7015 Installation and Service Guide*.

---

## Adapter

**Note:** Refer to “Handling Static-Sensitive Devices” on page 3-1 before removing or installing adapters.

## Removal

1. If a cable is attached to the adapter you are removing, do the “Adapter Cable” procedure on page 3-5.

2. Loosen the thumbscrew that holds the adapter in place.

**Note:** If you are doing this procedure as part of the “Planar” removal procedure, loosen all of the thumbscrews on the ground spring.

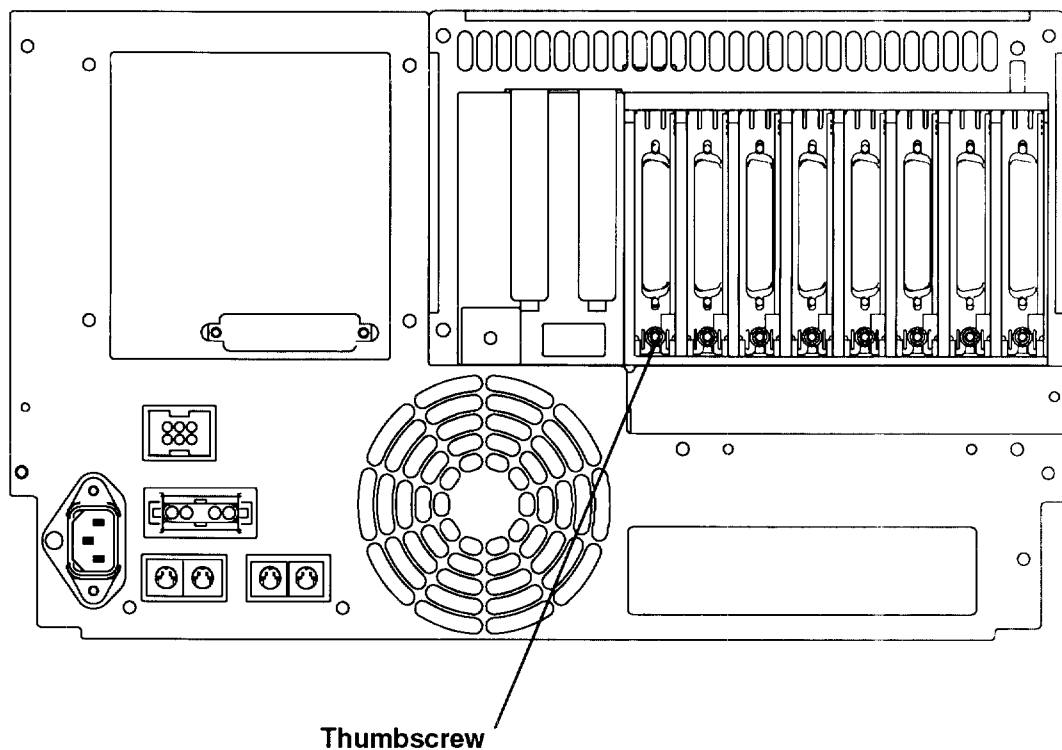

3. Do the “Service Position” procedure on page 3-2.

4. Remove the retainer screw from the retainer.
5. Press one of the tabs on the retainer with a flat-blade screwdriver, and then lift the retainer out of the retainer brackets.
6. Disconnect any internal cables attached to the adapter.
7. Record the position of the adapter, and then remove it from the drawer.

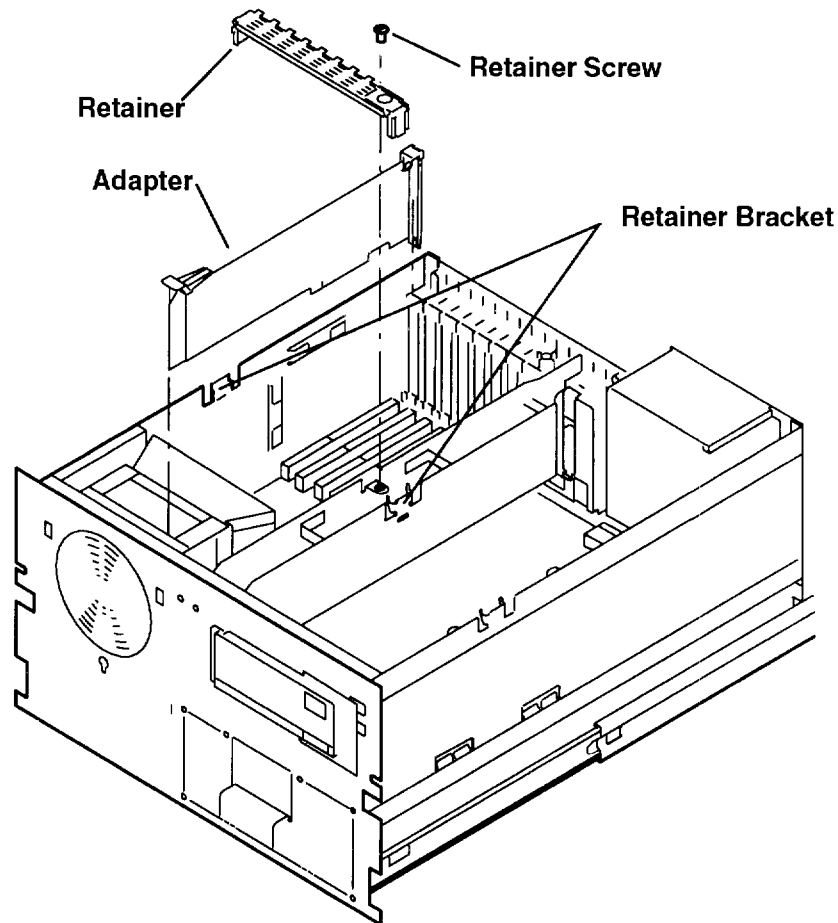

## Replacement

Replace in the reverse order. For correct grounding when replacing the adapter, ensure the adapter bracket is behind the thumbscrew and in contact with the card guide at the top of the adapter bracket. Do the "Operating Position" procedure on page 3-4.

---

# Divider Assembly

## Removal

1. Do the "Service Position" procedure on page 3-2.
2. Remove the retainer screw from the retainer.
3. Press one of the tabs on the retainer with a flat-blade screwdriver, and then lift the retainer out of the retainer brackets.
4. Remove the screw from the top of the divider assembly.
5. Remove the two screws from the front of the divider assembly, and then remove the divider assembly.

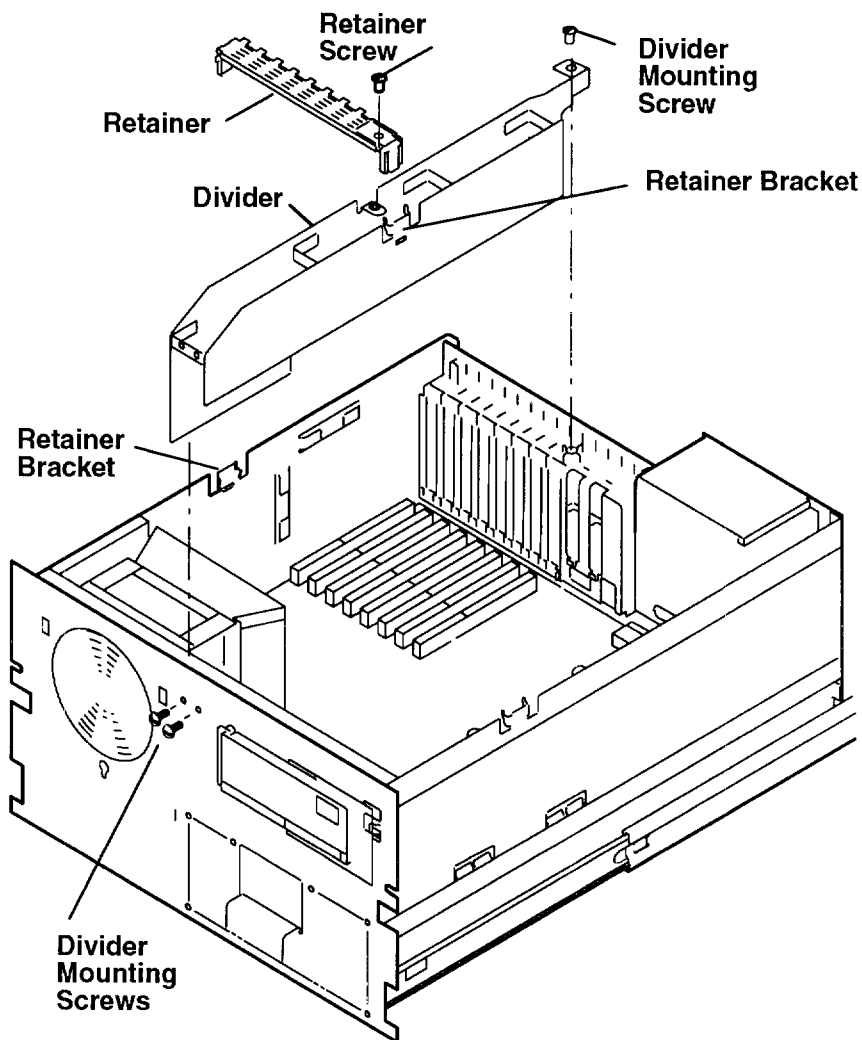

## Replacement

Replace in the reverse order, and then do the "Operating Position" procedure on page 3-4.

---

## Front Fan and Housing Assembly

**Note:** Two types of front fan and housing assemblies are used to mount the front fan in the async drawer. If the front fan and housing assembly has mounting tabs, perform the removal and replacement procedure on this page. If the front fan and housing assembly has three mounting screws, perform the removal and replacement procedure on the next page.

### Removal

1. Do the “Service Position” procedure on page 3-2.
2. Disconnect the in-line power connector (P49C). If you are removing the fan only, lift the fan out of the housing assembly.
3. Loosen the mounting screw through the access hole in the drawer.
4. Remove the housing assembly. Ensure that the mounting tabs on the housing assembly disengage from the mounting slots in the frame.

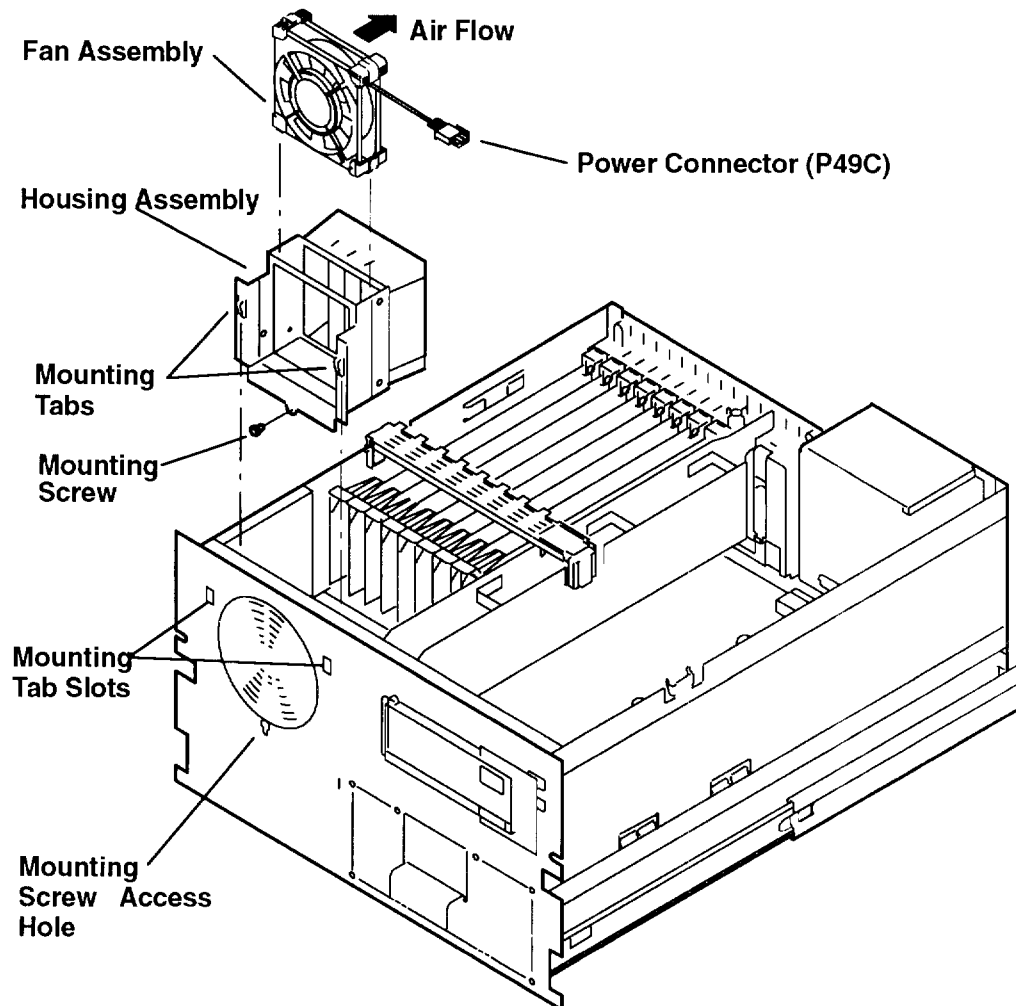

### Replacement

Replace in the reverse order, and then do the “Operating Position” procedure on page 3-4.

---

## Front Fan and Housing Assembly (Alternate Type)

**Note:** Two types of front fan and housing assemblies are used to mount the front fan in the async drawer. If the front fan and housing assembly has three mounting screws, perform the removal and replacement procedure on this page. If the front fan and housing assembly has mounting tabs, perform the removal and replacement procedure on the previous page.

### Removal

1. Do the "Service Position" procedure on page 3-2.
2. Loosen the three housing assembly mounting screws and then lift the housing assembly until the screws disengage from the mounting screw slots.
3. Lift the housing assembly out of the drawer until you have access to the fan power connector (P49C), and then disconnect the fan power connector to remove the housing assembly.
4. Pull the fan out of the housing assembly until the vibration isolators disengage from the fan or the housing assembly.

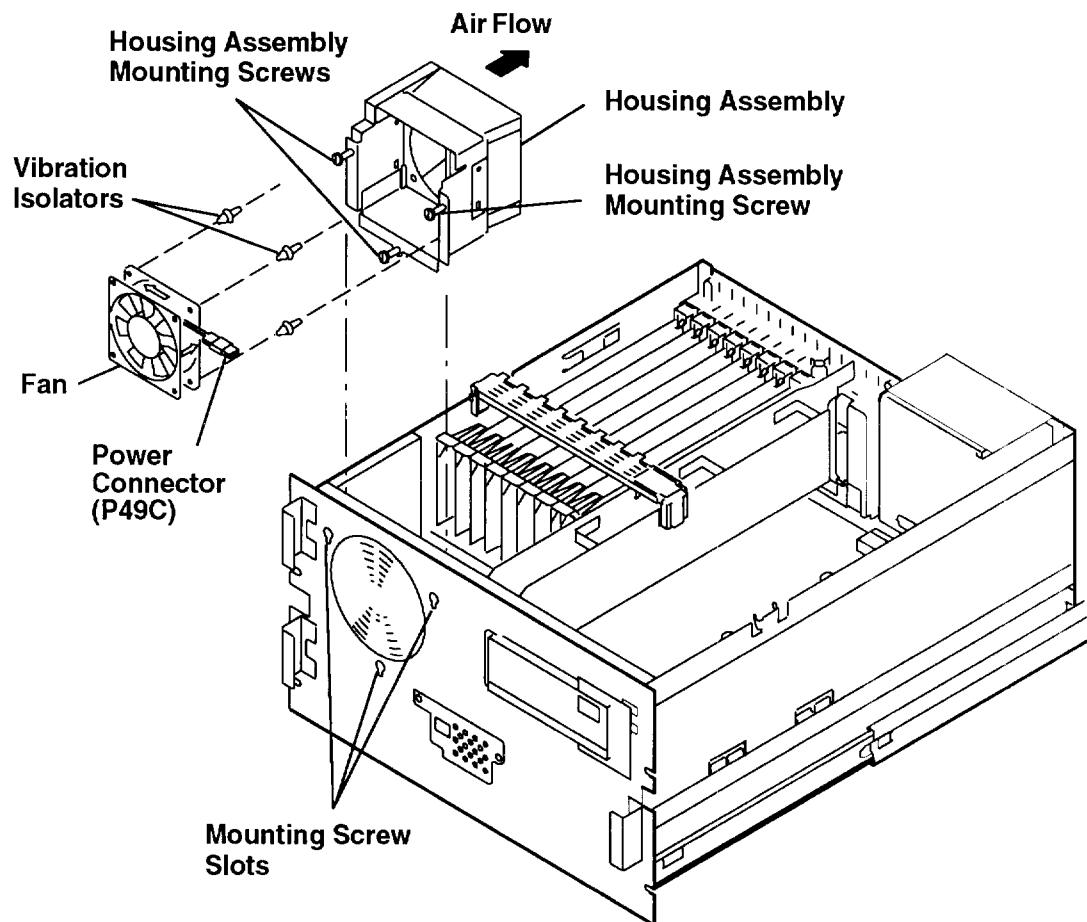

### Replacement

Replace in the reverse order, and then do the "Operating Position" procedure on page 3-4.



---

## Planar

**Note:** Refer to “Handling Static-Sensitive Devices” procedure on page 3-1 before removing or installing adapters in this system.

## Removal

1. Do the “Adapter Cable” removal procedure on page 3-5.
2. Do the “Service Position” procedure on page 3-2.
3. Remove all of the adapters. Refer to the “Adapter” removal procedure on page 3-6.
4. Do the “Divider Assembly” removal procedure on page 3-8.
5. Do the “Front Fan and Housing Assembly” removal procedure on page 3-9.
6. Disconnect the power connectors (P40 and P41) from the planar.
7. Remove the seven mounting screws from the planar, and then remove the planar.

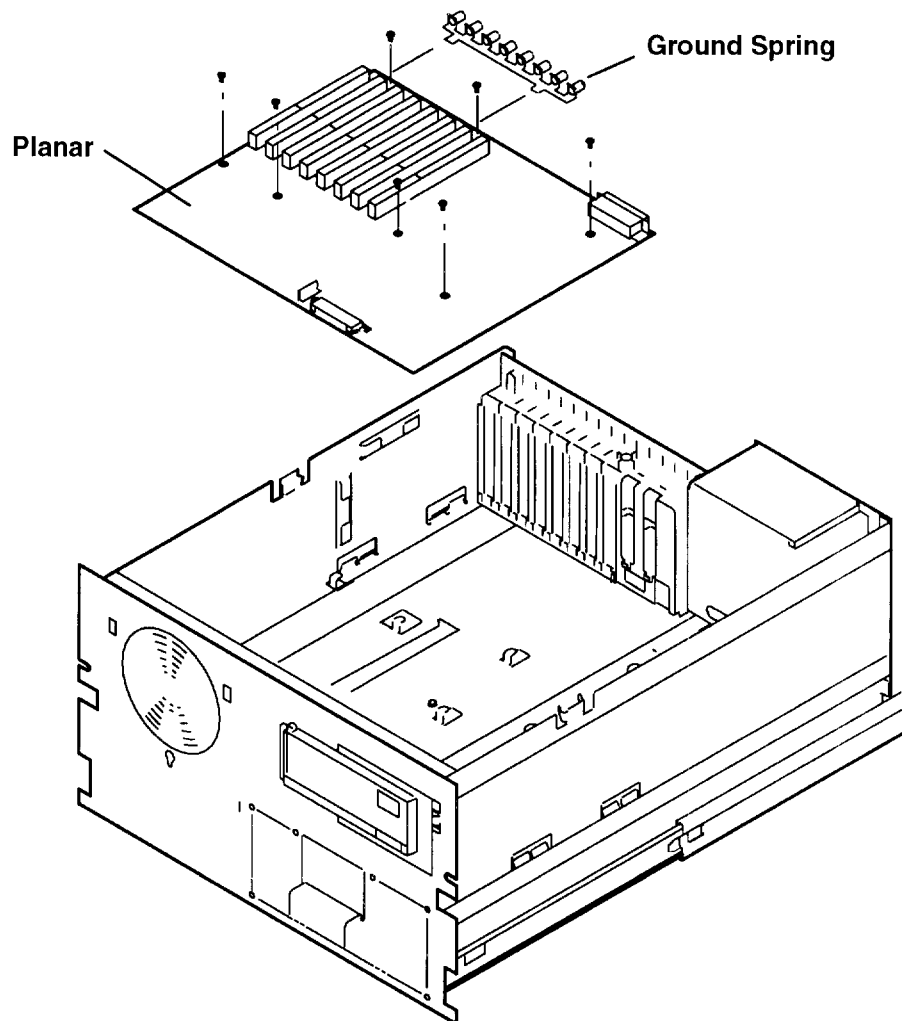

## Replacement

Replace in the reverse order, and then do the “Operating Position” procedure on page 3-4.

---

## Power Supply

**Note:** For a translation of this notice, see the *System Unit Safety Information* manual.

### DANGER

**Do not attempt to open the covers of the power supply. power supplies are not serviceable and are to be replaced as a unit.**

## Removal

1. Do the "Power-Off Procedure" in Chapter 3 of the *7015 Installation and Service Guide*
2. If the retainer bracket is attached to the rack, loosen the retainer screw so that the cable management arm moves freely when the drawer is extended.  
  
If a retainer bracket is attached to the top of the cable management arm, loosen the screw closest to you, and then disengage the bracket from the screw.
3. Label and then unplug any cables attached to the power supply connectors in the back of the drawer.
4. Remove the two power supply mounting screws from the back of the power supply.

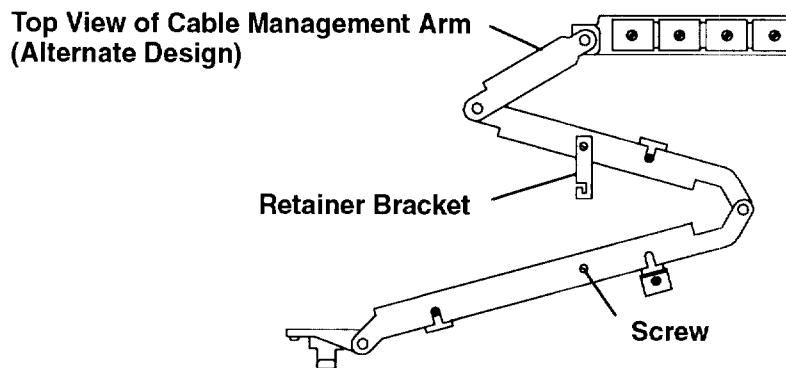
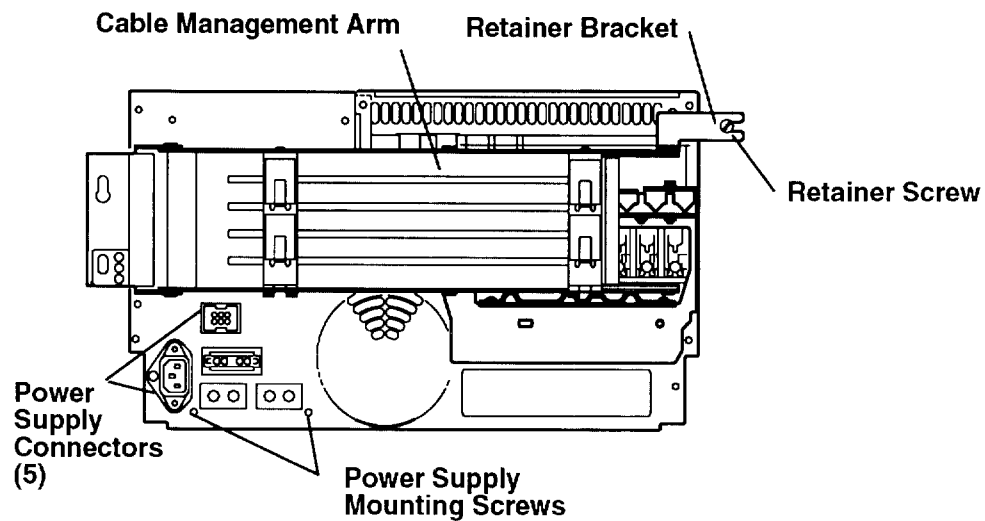

5. Do the "Service Position" procedure on page 3-2.
6. Disconnect the power connectors (P40 and P41) from the planar and the in-line power connector (P49C) from the front fan. Refer to the appropriate removal procedure for information about disconnecting the power cables from these devices.
7. Disconnect the in-line power connector to the operator panel.
8. While supporting the power supply, remove the four remaining mounting screws.
9. Slide the power supply forward so that the connectors on the back of the supply clear the frame, and then carefully guide the power supply cables out of the unit as you remove the power supply.
10. Do the "Power Supply Fan" removal procedure on page 3-14.

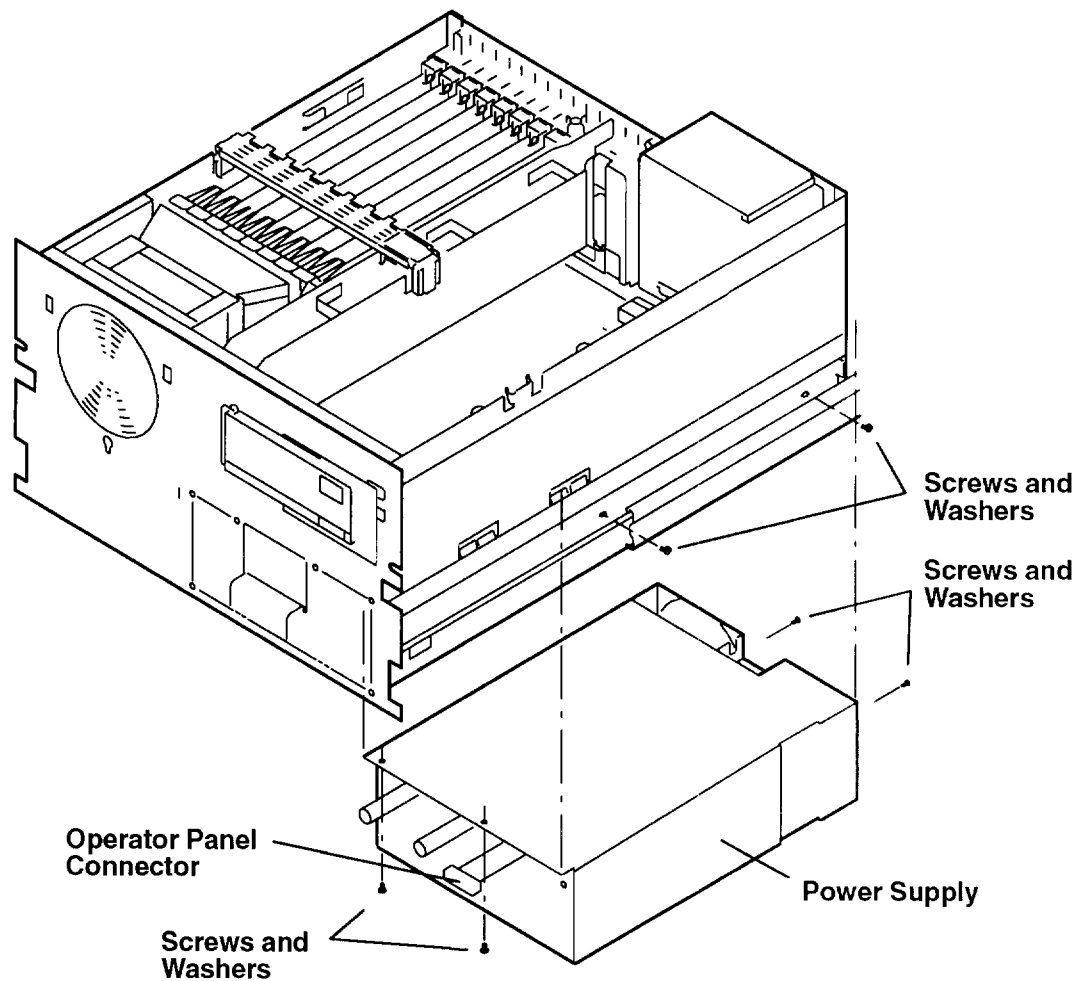

## Replacement

**Note:** Before installing the replacement power supply in the async drawer, ensure that the power supply fan is installed.

Replace in the reverse order, and then do the "Operating Position" procedure on page 3-4.

---

## Power Supply Fan

### Removal

1. Do the "Power Supply" removal procedure on page 3-12.
2. Disconnect the two power connectors from the power supply, and then remove the fan.

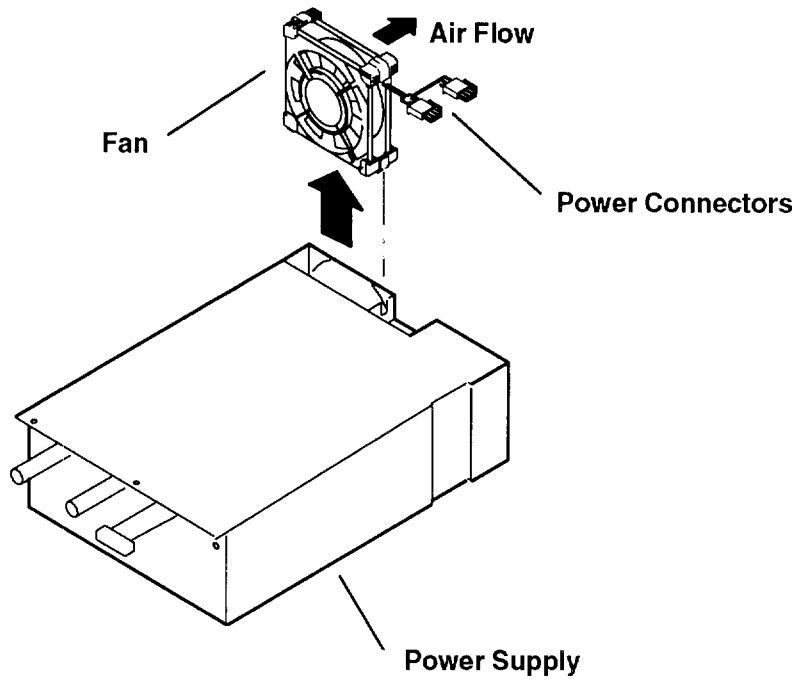

### Replacement

Replace in the reverse order, and then do the "Operating Position" procedure on page 3-4.

---

## Bulkhead Assembly

### Removal

1. Remove all the adapters from the planar. Refer to the "Adapter" removal procedure on page 3-6.
2. Do the "Divider Assembly" removal procedure on page 3-8.
3. Remove the four screws from the back of the bulkhead.
4. Remove the two screws from the ground spring.
5. Remove the ground spring and the bulkhead assembly.

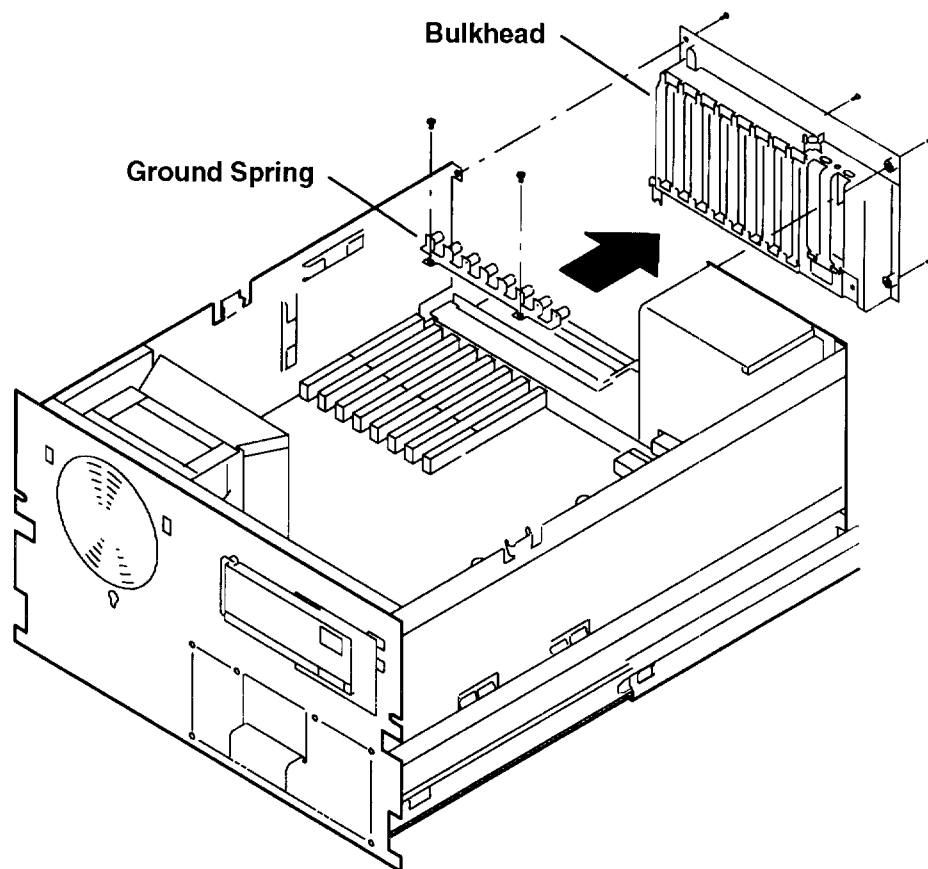

### Replacement

Replace in the reverse order, and then do the "Operating Position" procedure on page 3-5.

---

## Operator Panel Assembly

### Removal

1. Do the "Service Position" procedure on page 3-2.
2. Remove the operator panel mounting screw.
3. Slide the operator panel assembly to the left until it disengages from the mounting tab and then disconnect the power connector from the operator panel.

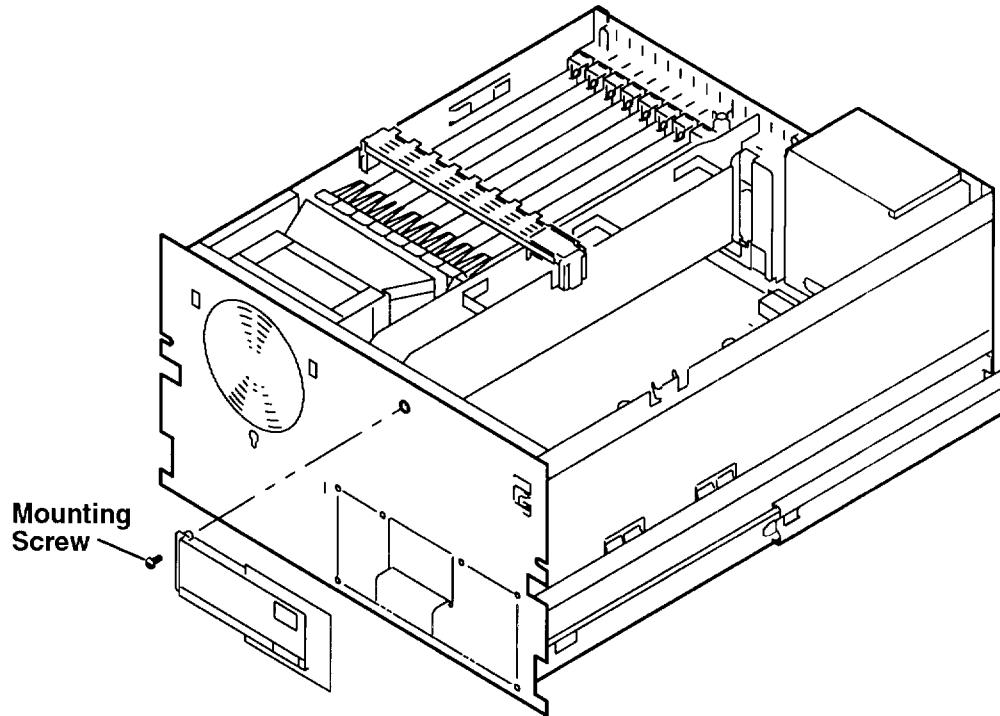

### Replacement

Replace in the reverse order, and then do the "Operating Position" procedure on page 3-4.

---

## Chapter 4. Parts Information

This chapter contains two details showing all parts and the respective part numbers for the 7015 Async Expansion Drawer.

# Detail 1.

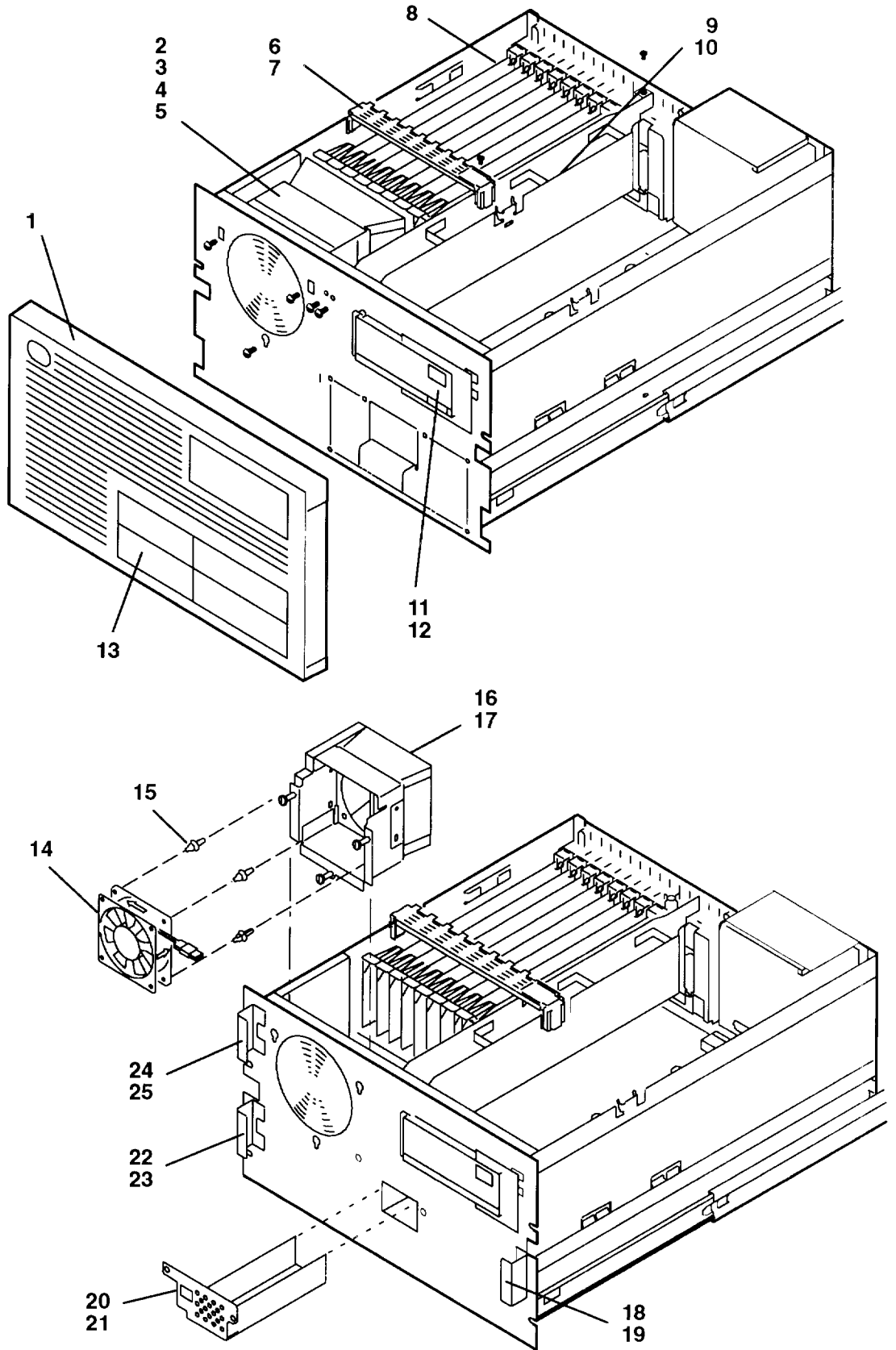



| Index Number   | Part Number | Units Per Asm | Description  |
|--|-------------|---------------|--|
| 1  | 40F9864     | 1             | Front bezel  |
| 2  | 42F7482     | 1             | Front fan assembly                                     |
| 3  | 59F2970     | 1             | Isolator   |
| 4  | 42F7476     | 1             | Front fan housing                                      |
| 5  | 1621197     | 1             | Screw  |
| 6  | 41F0663     | 1             | Retainer   |
| 7  | 1621192     | 1             | Screw, M4 x 12   |
| 8  | See note    | AR            | Adapters   |
| 9  | 42F7471     | 1             | Divider assembly                                       |
| 10   | 1621197     | 3             | Screw, M4 x 6  |
| 11   | 81F8234     | 1             | Operator panel assembly                                |
| 12   | 1621197     | 1             | Screw, M4 x 6  |
| 13   | 40F9865     | 4             | Bezel insert   |
| 14   | 42F9872     | 1             | Front fan  |
| 15   | 81F7977     | 4             | Vibration isolator                                     |
| 16   | 81F8068     | 1             | Front fan housing (alternate design)                   |
| 17   | 1621197     | 3             | Screw, M4 x 6  |
| 18   | 81F7983     | 1             | Fastener strip   |
| 19   | 81F7961     | 1             | Fastener strip (attached to right side of front bezel) |
| 20   | 81F7976     | 1             | Cable shield   |
| 21   | 1621197     | 2             | Screw, M4 x 6  |
| 22   | 81F7982     | 1             | Fastener strip   |
| 23   | 81F7960     | 1             | Fastener strip (attached to left side of front bezel)  |
| 24   | 81F7982     | 1             | Fastener strip   |
| 25   | 81F7960     | 1             | Fastener strip (attached to left side of front bezel)  |
| <p><b>Note:</b> See Chapter 4 in the <i>Common Diagnostics and Service Guide</i> for part numbers.</p> |             |               |  |

## Detail 2.

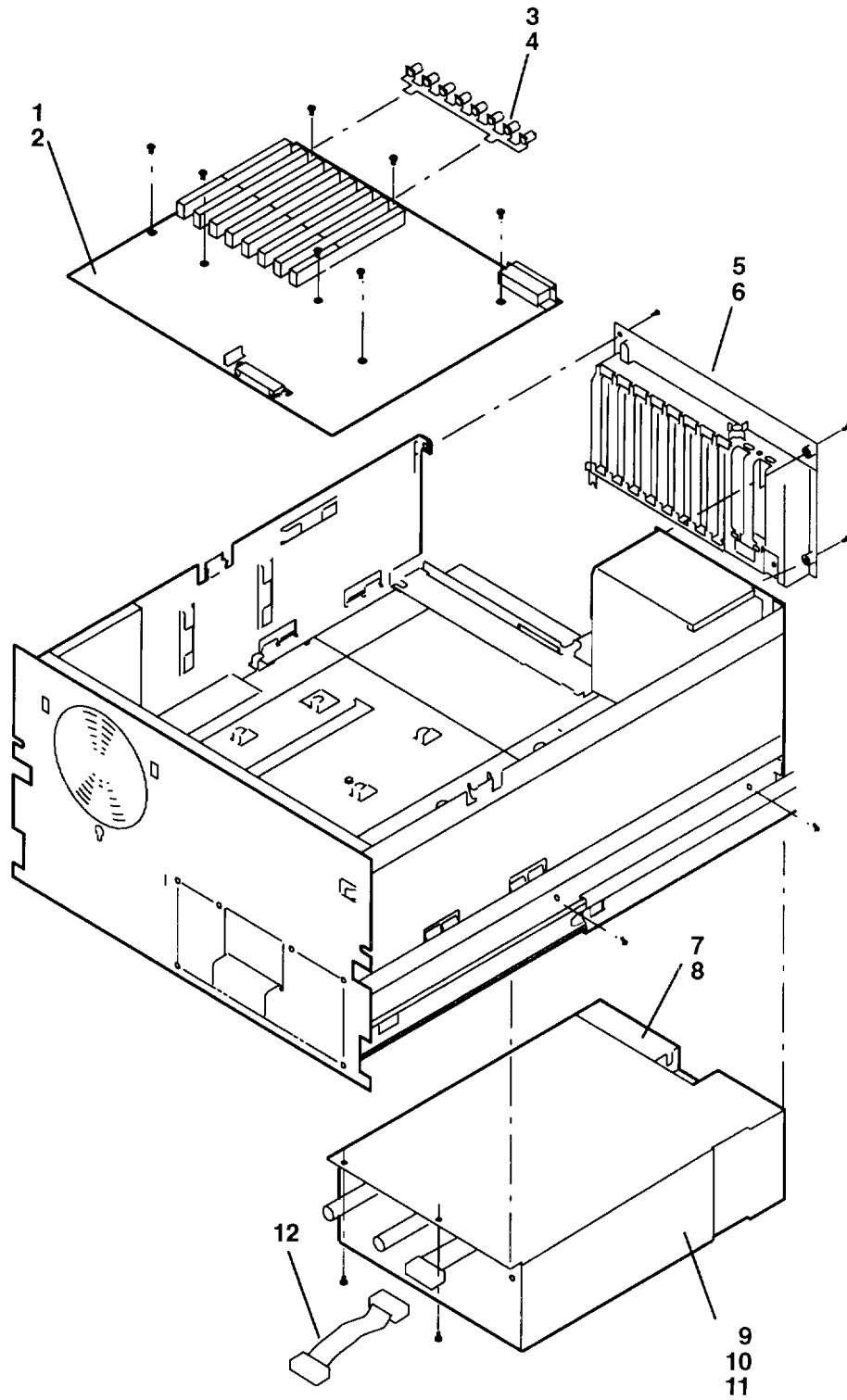

| Index Number | Part Number | Units Per Asm | Description                |
|--------------|-------------|---------------|----------------------------|
| 1            | 59F3785     | 1             | I/O planar                 |
| 2            | 1621170     | 5             | Screw, M3 x 6              |
| 3            | 22F9503     | 1             | Ground spring              |
| 4            | 1621170     | 2             | Screw, M3 x 6              |
| 5            | 59F3881     | 1             | Bulkhead assembly          |
| 6            | 1621192     | 4             | Screw, M4 x 12             |
| 7            | 59F3688     | 1             | Power supply fan           |
| 8            | 59F2971     | 4             | Isolator                   |
| 9            | 71F0067     | 1             | Power supply               |
| 10           | 1621190     | 6             | Screw, M4 x 8              |
| 11           | 1622275     | 6             | Washer                     |
| 12           | 53F3245     | 1             | Operator panel power cable |



---

# Index

## A

adapter, 3-8  
adapter cable, 3-7  
async drawer  
    front view, 1-2  
    rear view, 1-3  
        cable management arm, 1-3  
    specifications, 1-6

## B

bulkhead assembly, 3-17

## C

cable management arm, 1-3  
connectors  
    planar, 1-4  
    power supply, 1-5

## D

description, 1-1  
detail 1., 4-20  
detail 2., 4-22  
divider assembly, 3-10

## F

front fan and housing assembly, 3-11  
    alternate type, 3-12

## H

handling static-sensitive devices, 3-3

## M

maintenance analysis procedures, 2-1520-1  
MAP 1520, 2-1520-1

MAP 1520: async expansion drawer – power map,  
2-1520-1

MAP 1540, 2-1540-1

MAP 1540: async expansion drawer – minimum  
configuration, 2-1540-1

MAPs, 2-1520-1

minimum configuration MAP, 2-1540-1

## O

operating position, 3-6  
operator panel assembly, 3-18

## P

parts information, 4-19  
    detail 1., 4-20  
    detail 2., 4-22  
planar, 3-13  
planar connectors, 1-4  
power MAP, 2-1520-1  
power supply, 3-14  
power supply connectors, 1-5  
power supply fan, 3-16

## R

### removal and replacement

- adapter, 3-8
- adapter cable, 3-7
- bulkhead assembly, 3-17
- divider assembly, 3-10
- front fan and housing assembly, 3-11
  - alternate type, 3-12
- handling static-sensitive devices, 3-3
- operating position, 3-6
- operator panel assembly, 3-18
- planar, 3-13
- power supply, 3-14
- power supply fan, 3-16
- service position, 3-4

## S

- service inspection guide, 1-7
- service position, 3-4
- specifications, 1-6



Printed In U.S.A.