

7015

Model R24 CPU-Media Enclosure Service Guide



Print Graphic between registration marks



7015

**Model R24 CPU-Media Enclosure
Service Guide**

First Edition (July 1994)

This edition notice applies to the *7015 POWERserver Model R24 CPU-Media Enclosure Service Guide*.

The following paragraph does not apply to the United Kingdom or any country where such provisions are inconsistent with local law: THIS PUBLICATION IS PRINTED "AS IS" WITHOUT WARRANTY OF ANY KIND, EITHER EXPRESS OR IMPLIED, INCLUDING, BUT NOT LIMITED TO, THE IMPLIED WARRANTIES OF MERCHANTABILITY OR FITNESS FOR A PARTICULAR PURPOSE. Some states do not allow disclaimer of express or implied warranties in certain transactions; therefore, this statement may not apply to you.

This publication could include technical inaccuracies or typographical errors. Changes are periodically made to the information herein; these changes will be incorporated in new editions of the publication.

It is possible that this publication may contain reference to, or information about, products (machines and programs), programming, or services that are not announced in your country. Such references or information must not be construed to mean that such products, programming, or services will be offered in your country. Any reference to a licensed program in this publication is not intended to state or imply that you can use only the licensed program indicated. You can use any functionally equivalent program instead.

Medeco is a trademark of the Medeco Company.

©Copyright International Business Machines Corporation, 1994. All rights reserved.

Note to US Government Users – Documentation and programs related to restricted rights – Use, duplication, or disclosure is subject to the restrictions set forth in the GSA ADP Schedule Contract.

Table of Contents

Communications Statements	v
Safety Notices	ix
About This Book	xi
Chapter 1. Reference Information	1-1
Description	1-1
Locations	1-2
Front View with Bezel	1-2
Operator Panel	1-2
Rear View of CPU-Media Enclosure with Connector Locations	1-3
Front View without Bezel and Front Access Plate	1-4
Planar Fans Assembly	1-5
CPU Planar Connector Locations (Top View)	1-6
Combination Planar Connectors	1-7
Optional I/O Planar Connectors	1-7
Operator Panel Connectors	1-8
AC Power Supply Connectors	1-9
Power Distribution Board Connectors	1-10
Data and Power Flow	1-11
Typical Rail Installation	1-12
Specifications	1-13
Service Inspection Guide	1-14
Chapter 2. Maintenance Analysis Procedures (MAPs)	2-1520-1
MAP 1520: CPU-Media Enclosure – Power MAP	2-1520-1
Three-Digit Display – Power Supply Failure Status	2-1520-2
MAP 1540: CPU-Media Enclosure – Minimum Configuration	2-1540-1
Chapter 3. Removal and Replacement Procedures	3-1
Power-On Procedure with a Power Distribution Bus	3-1
Power-Off Procedure with a Power Distribution Bus	3-3
Power-On Procedure with a Power Distribution Unit	3-5
Power-Off Procedure with a Power Distribution Unit	3-7
Power-On Procedure with Power Distribution Panel	3-9
Power-Off Procedure with Power Distribution Panel	3-12
Handling Static-Sensitive Devices	3-14
Front Bezel and Front Access Plate	3-15
Memory Card	3-17
Memory SIMM	3-19
Cache SIMM	3-20
CPU Planar Assembly	3-22
Planar Fan Assembly	3-26
Operator Panel Assembly	3-28
Battery	3-30

Key Mode Switch	3-32
Media Devices, Fan, and Carrier Assembly	3-33
3.5-Inch Diskette Drive	3-37
Rear Access Plate	3-39
Remote Reset Assembly	3-41
Docking Assembly and SCSI Cables	3-44
Power Supply Fuse	3-51
Power Supply Fan	3-52
Power Supply (AC)	3-55
Power Supply (-48 V dc)	3-59
Power Distribution Board	3-63
Disk Drive, Cables, Fans, and Carrier Assembly	3-65
Adapter Cable	3-74
Adapter and Optional Adapter	3-76
Combination Planar	3-80
Optional I/O Planar	3-85
Serial Ports and Parallel Port Assembly	3-90
Chapter 4. Parts Information	4-1
Detail 1. Media Carrier Assembly	4-2
Detail 2. 3.5-Inch Diskette Drive and Operator Panel	4-4
Detail 3. Docking Assembly	4-6
Detail 4. CPU Planar Assembly and Planar Fans Assembly	4-8
Detail 5. Internal Cable Brackets and Clamps	4-10
Detail 6. Power Supply	4-12
Detail 7. Internal Power Cables	4-14
Detail 8. Combination Planar Assembly	4-16
Detail 9. Optional I/O Planar Assembly	4-18
Detail 10. Disk-Drive-Carrier Assembly	4-20
Detail 11. Rails for CPU-Media Enclosure Installation	4-22
Index	X-1

Communications Statements

The following statement applies to this product. The statement for other products intended for use with this product appears in their accompanying manuals.

Federal Communications Commission (FCC) Statement

Note: This equipment has been tested and found to comply with the limits for a Class A digital device, pursuant to Part 15 of the FCC Rules. These limits are designed to provide reasonable protection against harmful interference when the equipment is operated in a commercial environment. This equipment generates, uses, and can radiate radio frequency energy and, if not installed and used in accordance with the instruction manual, may cause harmful interference to radio communications. Operation of this equipment in a residential area is likely to cause harmful interference in which case the user will be required to correct the interference at his own expense.

Properly shielded and grounded cables and connectors must be used in order to meet FCC emission limits. Neither the provider or the manufacturer are responsible for any radio or television interference caused by using other than recommended cables and connectors or by unauthorized changes or modifications to this equipment. Unauthorized changes or modifications could void the user's authority to operate the equipment.

This device complies with Part 15 of the FCC Rules. Operation is subject to the following two conditions: (1) this device may not cause harmful interference, and (2) this device must accept any interference received, including interference that may cause undesired operation.

United Kingdom Telecommunications Safety Requirements

This equipment is manufactured to the International Safety Standard EN60950 and as such is approved in the UK under the General Approval Number NS/G/1234/J/100003 for indirect connection to the public telecommunication network.

The network adapter interfaces housed within this equipment are approved separately each one having its own independent approval number. These interface adapters, supplied by the manufacturer, do not use or contain excessive voltages. An excessive voltage is one which exceeds 70.7 V peak ac or 120 V dc. They interface with this equipment using Safe Extra Low Voltages only. In order to maintain the separate (independent) approval of the manufacturer's adapters, it is essential that other optional cards, not supplied by the manufacturer, do not use main voltages or any other excessive voltages. Seek advice from a competent engineer before installing other adapters not supplied by the manufacturer.

EC Council Directive

This product is in conformity with the protection requirements of EC Council Directive 89/336/EEC on the approximation of the laws of the Member States relating to electromagnetic compatibility.

Neither the provider or the manufacturer can accept responsibility for any failure to satisfy the protection requirements resulting from a non-recommended modification of the product, including the fitting of option cards not supplied by the manufacturer.

International Electrotechnical Commission (IEC) Statement

This product has been designed and built to comply with IEC Standard 950.

Avis de conformité aux normes du ministère des Communications du Canada

Cet équipement ne dépasse pas les limites de Classe A d'émission de bruits radioélectriques pour les appareils numériques, telles que prescrites par le Règlement sur le brouillage radioélectrique établi par le ministère des Communications du Canada.

L'exploitation faite en milieu résidentiel peut entraîner le brouillage des réceptions radio et télé, ce qui obligerait le propriétaire ou l'opérateur à prendre les dispositions nécessaires pour en éliminer les causes.

Canadian Department of Communications Compliance Statement

This equipment does not exceed Class A limits for radio noise emissions for digital apparatus, set out in Radio Interference Regulation of the Canadian Department of Communications. Operation in a residential area may cause unacceptable interference to radio and TV reception requiring the owner or operator to take whatever steps necessary to correct the interference.

電波障害自主規制 届出装置の記述

この装置は、第一種情報装置（商工業地域において使用されるべき情報装置）で商工業地域での電波障害防止を目的とした情報処理装置等電波障害自主規制協議会（VCCI）基準に適合しております。

従って、住宅地域またはその隣接した地域で使用すると、ラジオ、テレビジョン受信機等に受信障害を与えることがあります。

取扱説明書に従って正しい取り扱いをしてください。

VCCI Statement

The following is a summary of the VCCI Japanese statement in the box above.

This equipment is in the Class 1 category (information equipment to be used in commercial and/or industrial areas) and conforms to the standards set by the Voluntary Control Council For Interference by Data Processing Equipment and Electronic Office Machines aimed at preventing radio interference in commercial and/or industrial areas.

Consequently, when used in a residential area or in an adjacent area thereto, radio interference may be caused to radios and TV receivers, etc.

Read the instructions for correct handling. VCCI-1.

Radio Protection for Germany

Dieses Gerät ist berechtigt in Übereinstimmung mit dem deutschen EMVG vom 9.Nov.92 das EG-Konformitätszeichen zu führen.

Der Außsteller der Konformitätserklärung ist die IBM Germany.

Dieses Gerät erfüllt die Bedingungen der EN 55022 Klasse A. Für diese Klasse von Geräten gilt folgende Bestimmung nach dem EMVG:

Geräte dürfen an Orten, für die sie nicht ausreichend entstört sind, nur mit besonderer Genehmigung des Bundesministers für Post und Telekommunikation oder des Bundesamtes für Post und Telekommunikation betrieben werden. Die Genehmigung wird erteilt, wenn keine elektromagnetischen Störungen zu erwarten sind.

(Auszug aus dem EMVG vom 9.Nov.92, Para.3, Abs.4)

Hinweis:

Dieses Genehmigungsverfahren ist von der Deutschen Bundespost noch nicht veröffentlicht worden.

Safety Notices

Note: For a translation of danger and caution notices, see the *System Unit Safety Information* manual, form number SA23-2652.

Definitions of Safety Notices

A *danger* notice indicates the presence of a hazard that has the potential of causing death or serious personal injury. *Danger* notices appear on the following pages:

2-1520-1, 3-1, 3-4, 3-5, 3-8, 3-10, 3-13, 3-55, 3-59, 3-74.

A *caution* notice indicates the presence of a hazard that has the potential of causing moderate or minor personal injury. *Caution* notices appear on the following pages:

ix, 3-5, 3-1, 3-10, 3-13, 3-15, 3-30, 3-35, 3-59.

A *warning* notice indicates an action that could cause damage to a program, device, system, or data.

Safety Notice for Servicing

For safety checks when servicing, refer to Chapter 3, "Removal and Replacement Procedures."

Note: For a translation of this notice, see the *System Unit Safety Information* manual, order number SA23-2652.

Lithium Battery

CAUTION:

A lithium battery can cause fire, explosion, or severe burn. Do not recharge, disassemble, heat above 100 degrees C (212 degrees F), solder directly to the cell, incinerate, or expose cell contents to water. Keep away from children. Replace only with the part number specified for your system. Use of another battery may present a risk of fire or explosion.

The battery connector is polarized; do not attempt to reverse the polarity.

Dispose of the battery according to local regulations.

Laser Safety Information

Note: The Optical Link Card (OLC) referred to in this information is part of the Serial Optical Channel Converter assembly.

This system contains a laser product called the Optical Link Card (OLC). In the U.S., the OLC is certified as a Class 1 laser product that conforms to the requirements contained in the Department of Health and Human Services (DHHS) regulation 21 CFR Subchapter J. Internationally, the OLC is certified as a Class 1 laser product that conforms to the requirements contained in the International Electrotechnical Commission (IEC) standard 825 (1984), the Verband Deutscher Elektrotechniker (VDE) standard 0837 (1986), and the CENELEC (European Committee for Electrotechnical Standardization) Harmonization Document HD 482 S1 (1988). The German testing institute VDE assigned a certificate of conformity to DIN IEC 825/VDE 0837/02.86 and CENELEC HD 482 S1/03.88; the certificate registration number is 3642.

In addition, Statens Provningsanstalt (Swedish National Testing Institute) tested and approved the OLC for use in Sweden as a Class 1 laser product and assigned the approval number SP LA 89:184. The CDRH certification label and the VDE certificate of conformity mark are located on the plastic retainer of the OLC product. Figure 1 shows the system Class 1 information label required by IEC 825.

Class 1 laser products are not considered to be hazardous. The OLC internally contains a gallium aluminum arsenide (GaAlAs) semiconductor laser diode emitting in the wavelength range of 770 to 800 nanometers. This laser diode is a Class 3B laser that is rated at 5.0 milliwatts. The design of the OLC is such that access to laser radiation above a Class 1 level during operation, user maintenance, or service conditions is prevented.

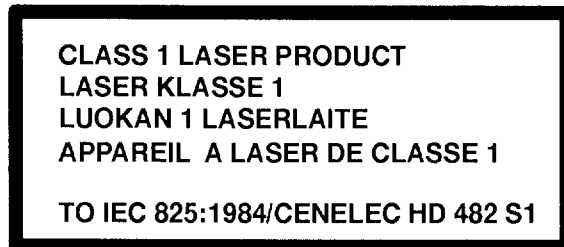

Figure 1. Class 1 System Information Label Required by the IEC 825 Standard

The Optical Link Card (OLC) must only be connected to another OLC or a compatible laser product. Any compatible laser product must contain the open fiber link detection and laser control safety system used in the OLC. This is a requirement for correct operation of the optical link. In addition, the OLC product is designed and certified for use in applications with point-to-point optical links only. Using this product in any other type of optical link configuration (for example, links containing optical splitters or star couplers) is considered as not using the product correctly and may require that the user certify the laser product again for conformance to the laser safety regulations.

About This Book

About This Book

This book provides maintenance information that is specific to the 7015 CPU-Media Enclosure. It also contains maintenance analysis procedures (MAPs) that are not common to other systems.

MAPs that are common to all systems are contained in the *POWERstation and POWERserver Common Diagnostics and Service Guide*.

This book is used by the service technician to repair system failures. It is assumed in this book that the service technician has had training on the 7015 system.

Related Publications

The *POWERstation and POWERserver Common Diagnostics and Service Guide*, order number SA23-2687, contains reference information about adapters and devices, checkout procedures for problem determination, system verification, using the diagnostics, and cabling for the system units. This manual also contains the removal-and-replacement procedures for the logic boards on the disk drives and cabling information that can be used to isolate problems with customer cabling.

The *7015 POWERserver Installation and Service Guide*, order number SA23-2628, contains information about installing the system unit, servicing the power components within the rack, and switching the system unit on and off.

The *7015 POWERserver Operator Guide*, order number SA23-2627, contains information about the controls and features of the system unit.

The *System Unit Safety Information* manual, order number SA23-2652, contains translations of danger and caution notices.

The *7135 RAIDiant Array: Operator Guide*, order number GA33-3251, provides information about operator controls and features on the SCSI disk box.

The *7135 RAIDiant Array: Installation and Service Guide*, order number SY33-0181, contains information on the SCSI disk box.

Chapter 1. Reference Information

This chapter contains information about part locations; connector locations; slot locations on the CPU planar, the combination planar, and the optional I/O planar; data and power flow; and CPU-media-enclosure specifications.

Description

The 7015 CPU-Media Enclosure equipped with the typical configuration contains the following:

- Central processing unit (CPU) planar
- Combination planar with Integrated small computer system interface (SCSI)
- SCSI-2 adapter (Fast/Wide Adapter/A or Differential Fast/Wide Adapter/A)
- Memory cards
- Power supply (240 V ac or -48 V dc)
- Operator panel
- 3.5-inch diskette drive
- CD-ROM drive
- 5.0 GB 8-mm tape drive
- Disk drives
- 16 adapter slots.

Other configurations of the CPU-media enclosure contain additional devices or adapters.

Locations

Front View with Bezel

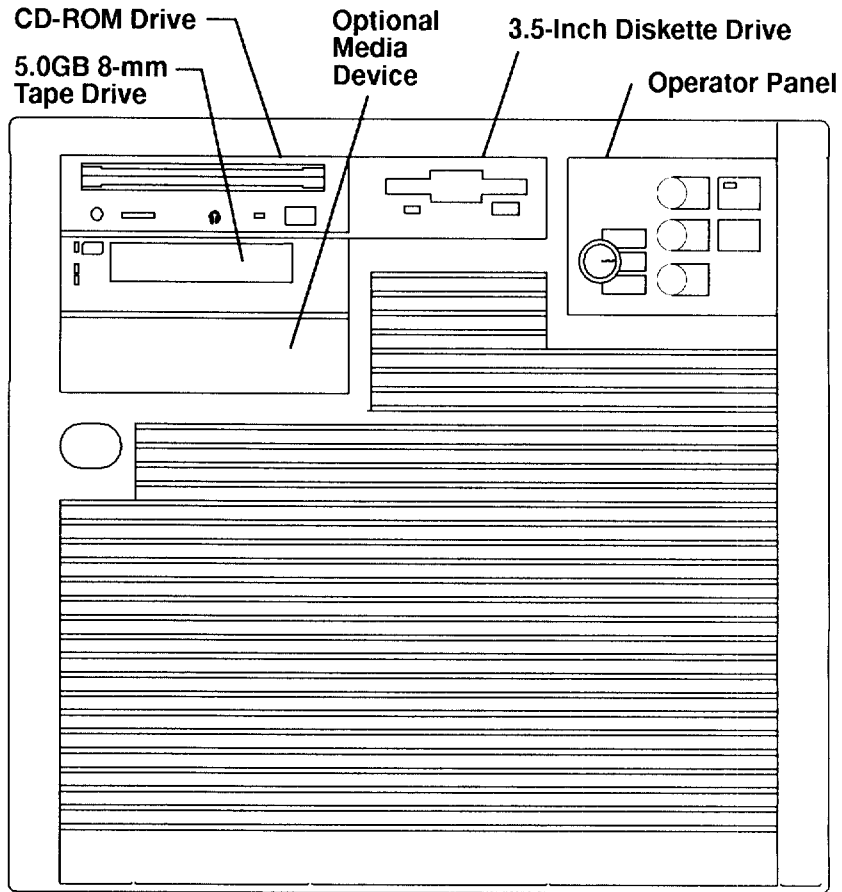

Operator Panel

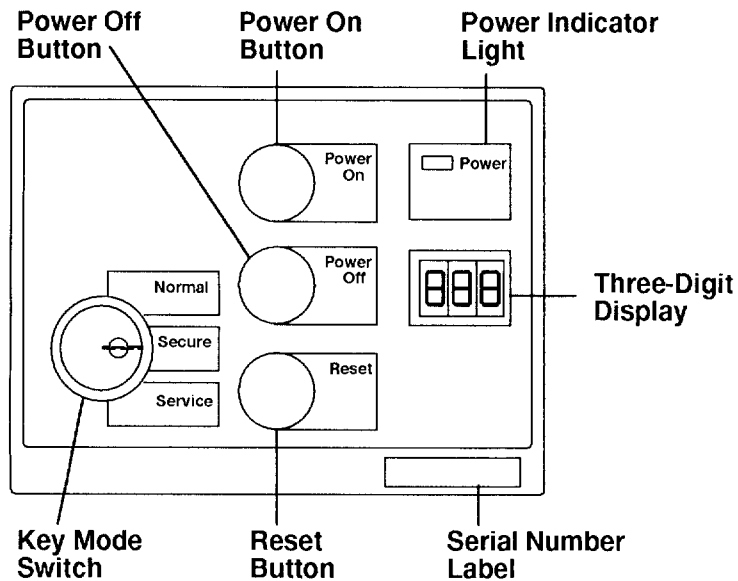

Rear View of CPU-Media Enclosure with Connector Locations

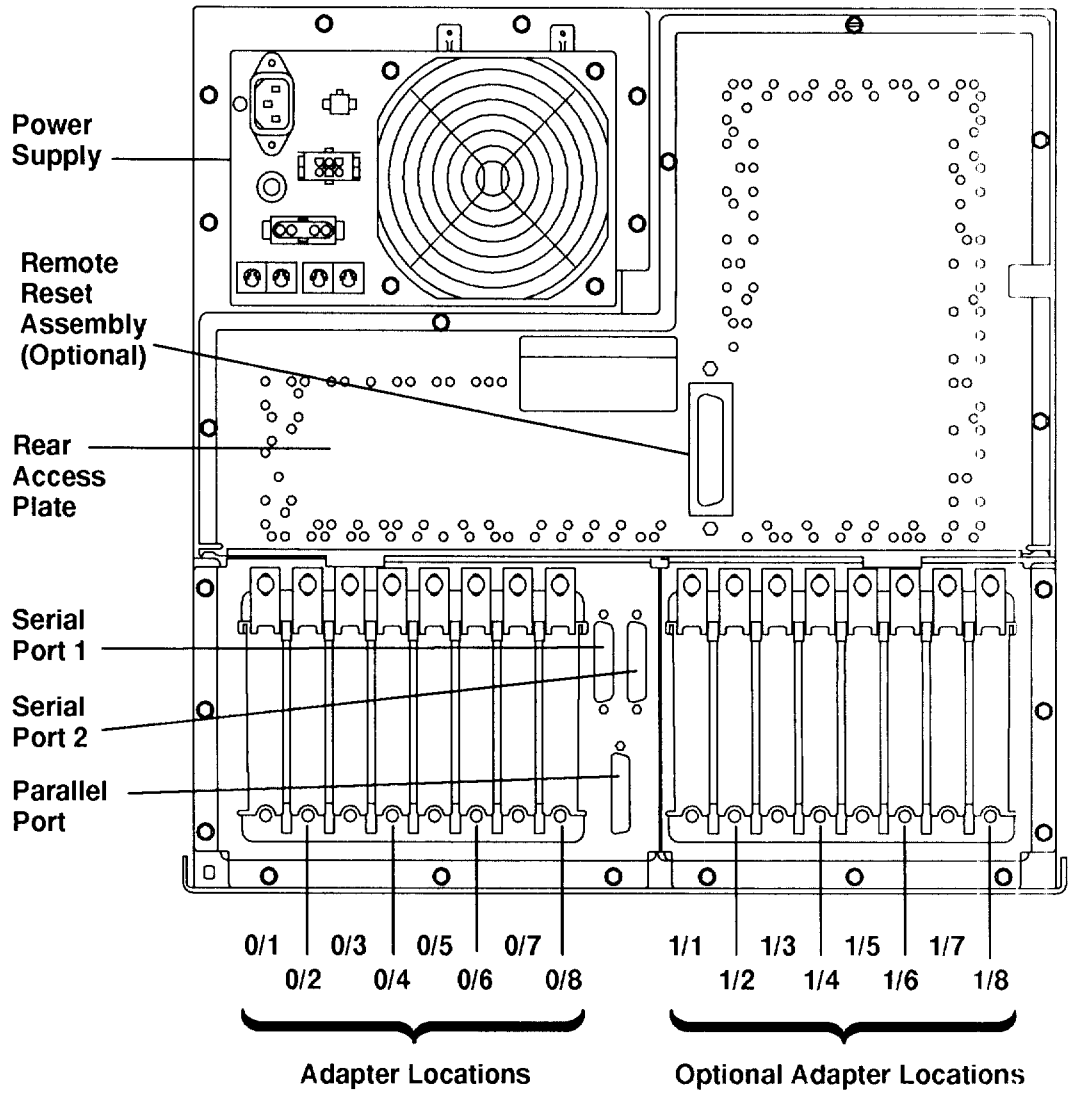

Front View without Bezel and Front Access Plate

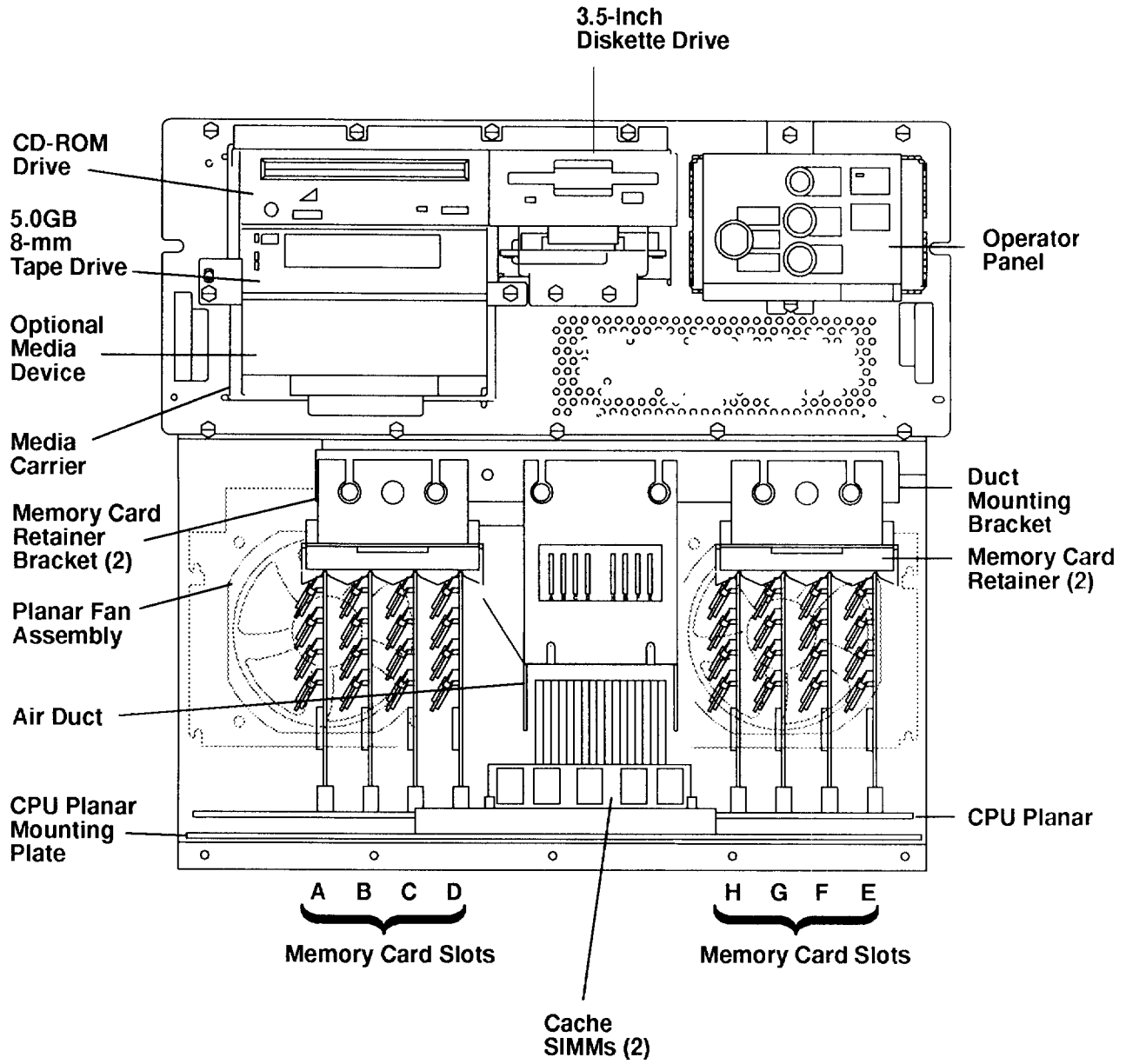

Planar Fans Assembly

Front of CPU-Media Enclosure

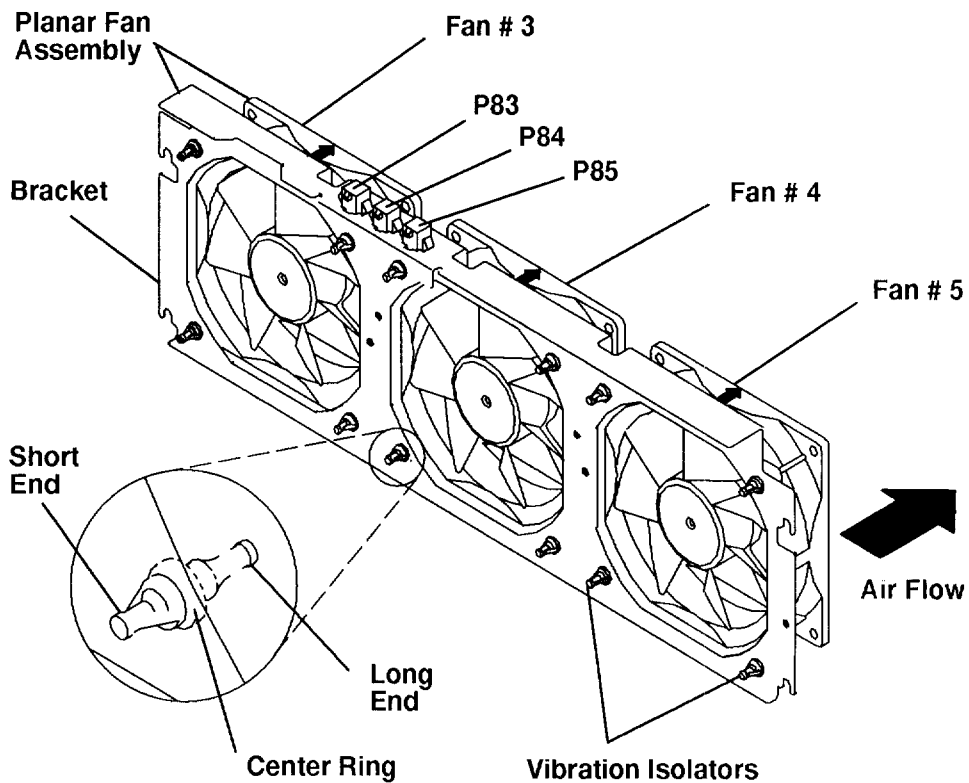
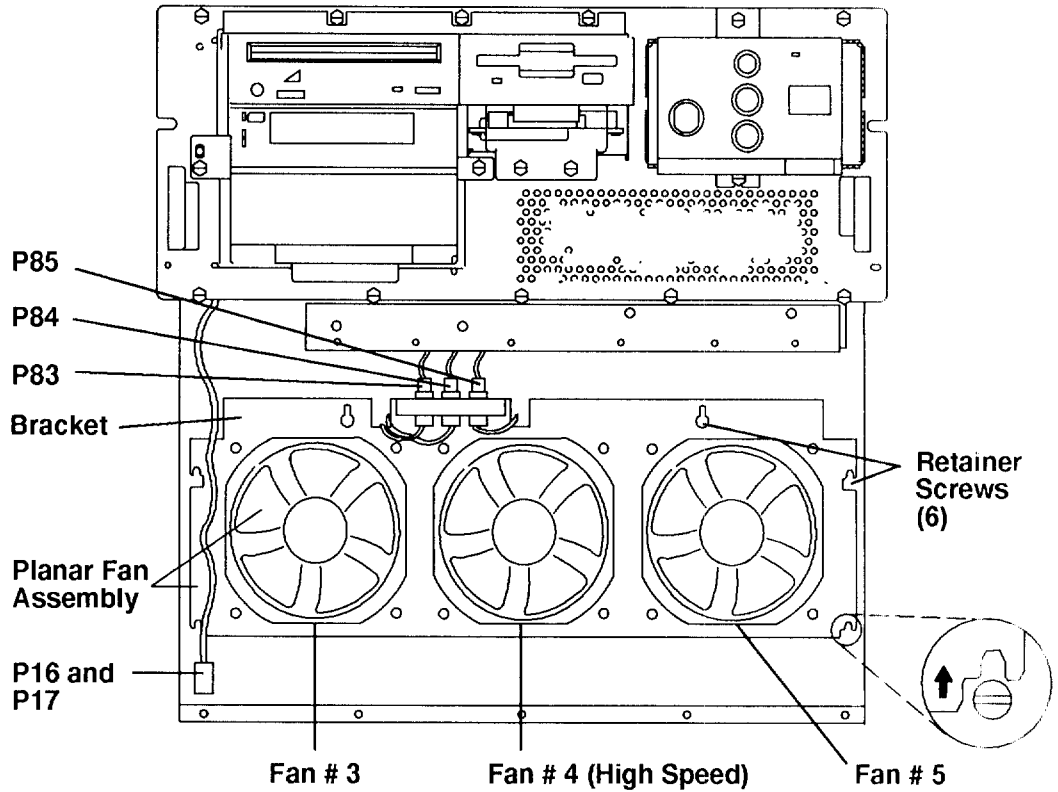

CPU Planar Connector Locations (Top View)

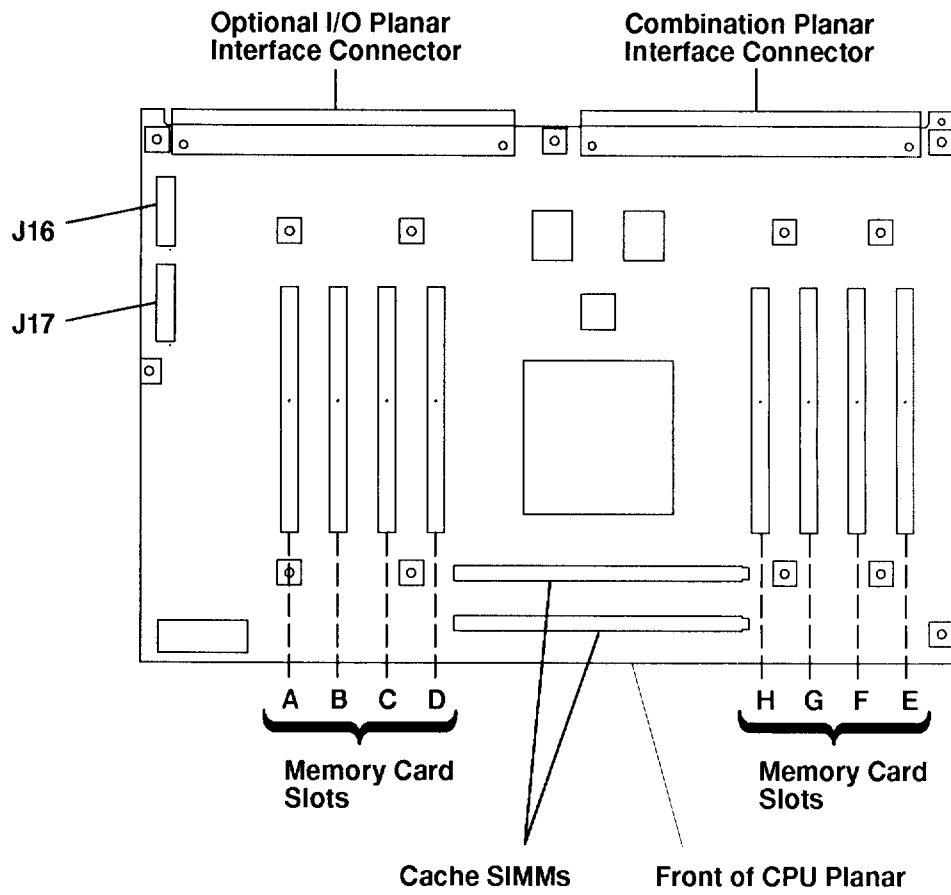

Combination Planar Connectors

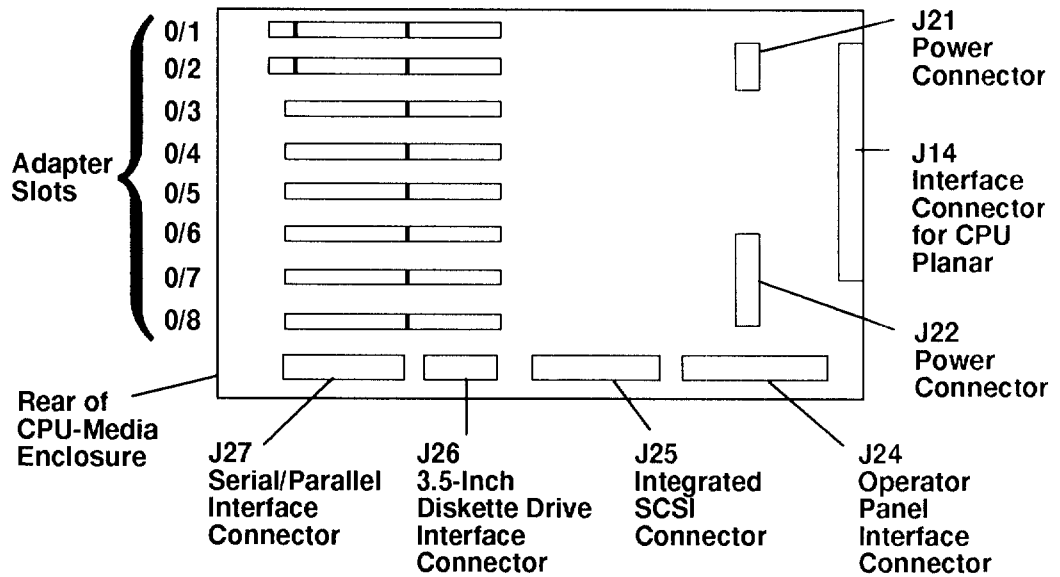

Optional I/O Planar Connectors

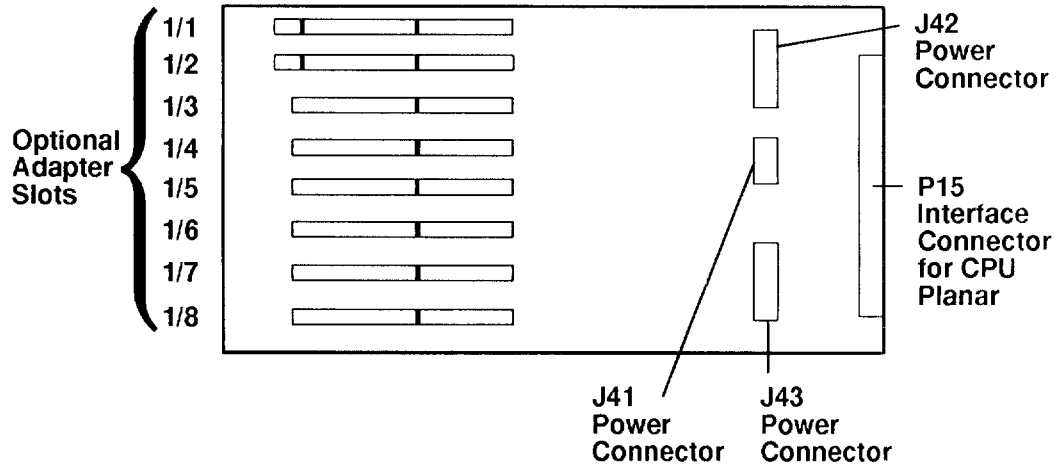

Operator Panel Connectors

Rear View of Operator Panel

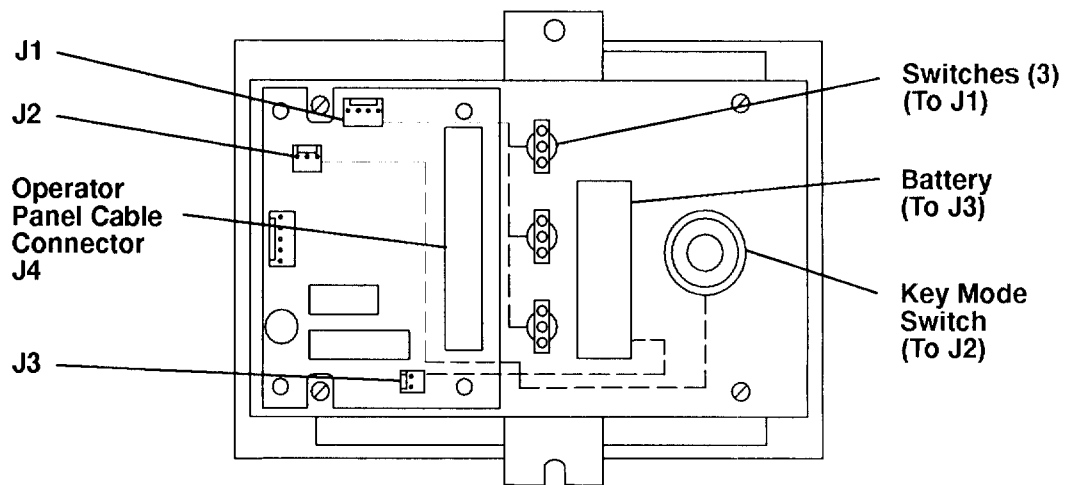

AC Power Supply Connectors

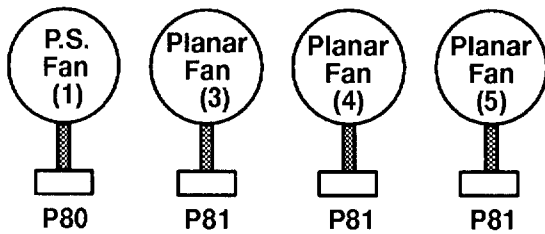
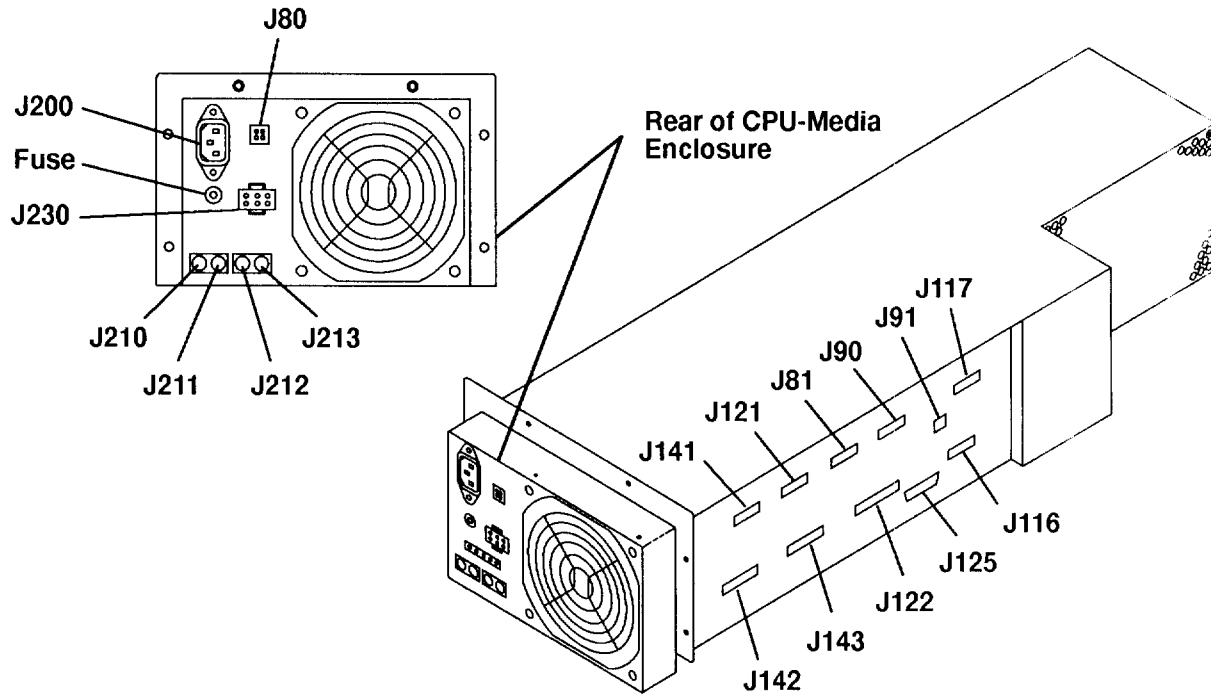

Connector	Function
J80	To power supply fan
J81	To planar fans
J90	To I/O devices
J91	To redriver card
J116	To CPU planar J16
J117	To CPU planar J17
J121	To combination planar J21
J122	To combination planar J22
J125	To combination planar J24, operator panel J4
J141	To optional I/O planar J41 and power distribution board
J142	To optional I/O planar J42
J143	To optional I/O planar J43
J200	Input power
J210, 211	Main power control channel
J212, 213	Auxiliary power control channel
J230	Battery backup status inputs

Power Distribution Board Connectors

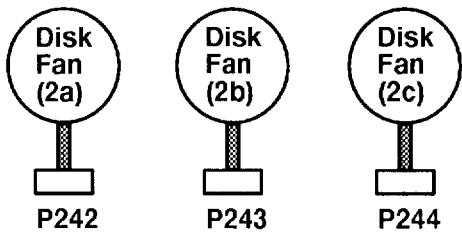
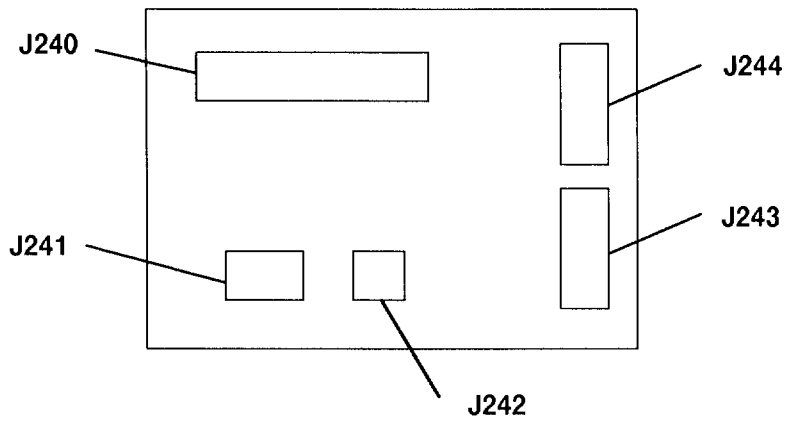

Connector	Function
J240	From power supply (J141) and combination planar (J42)
J241	From power supply (J81)
J242	To media carrier fan
J243	To disk drive carrier
J244	To disk drive carrier

Data and Power Flow

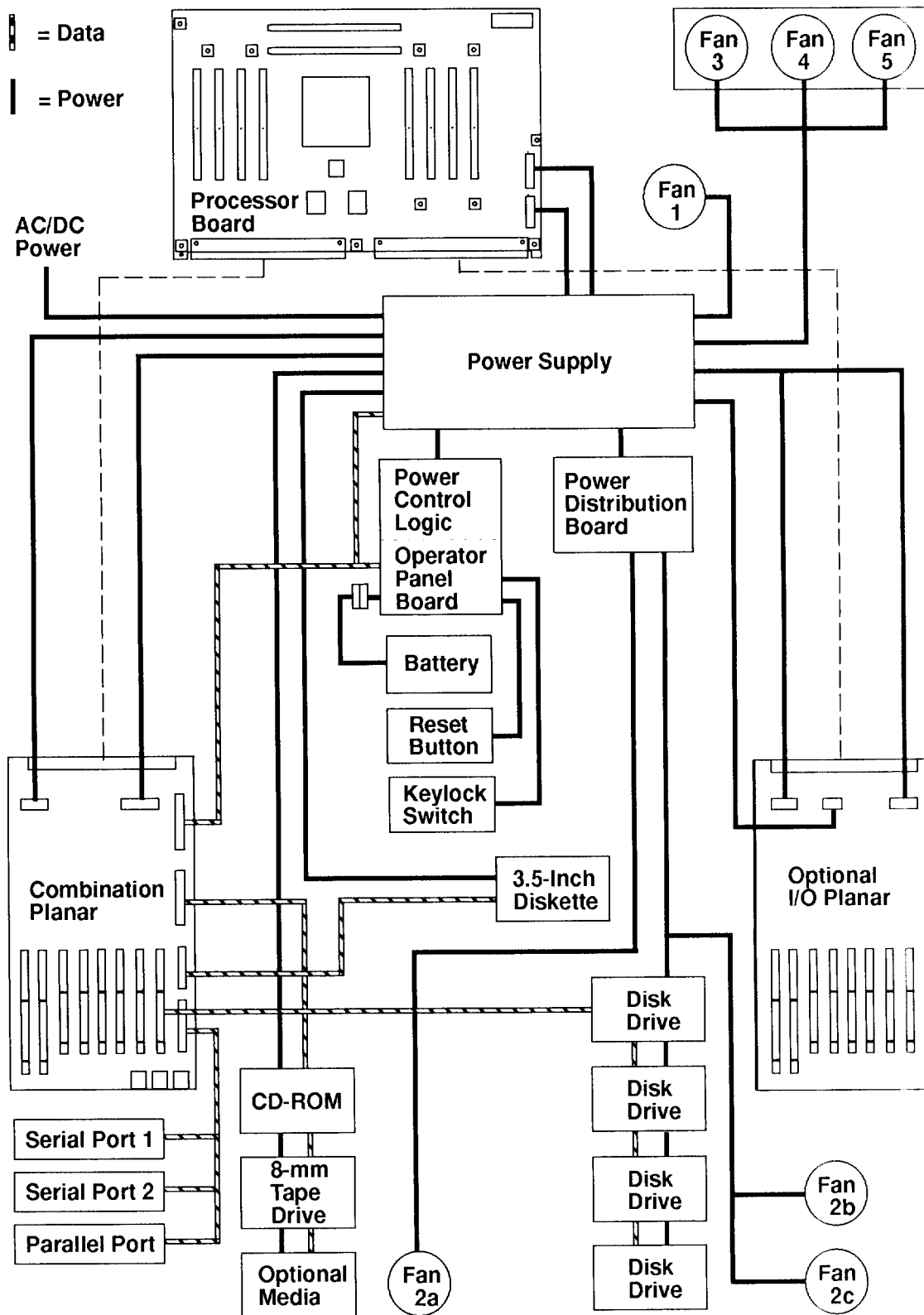

Typical Rail Installation

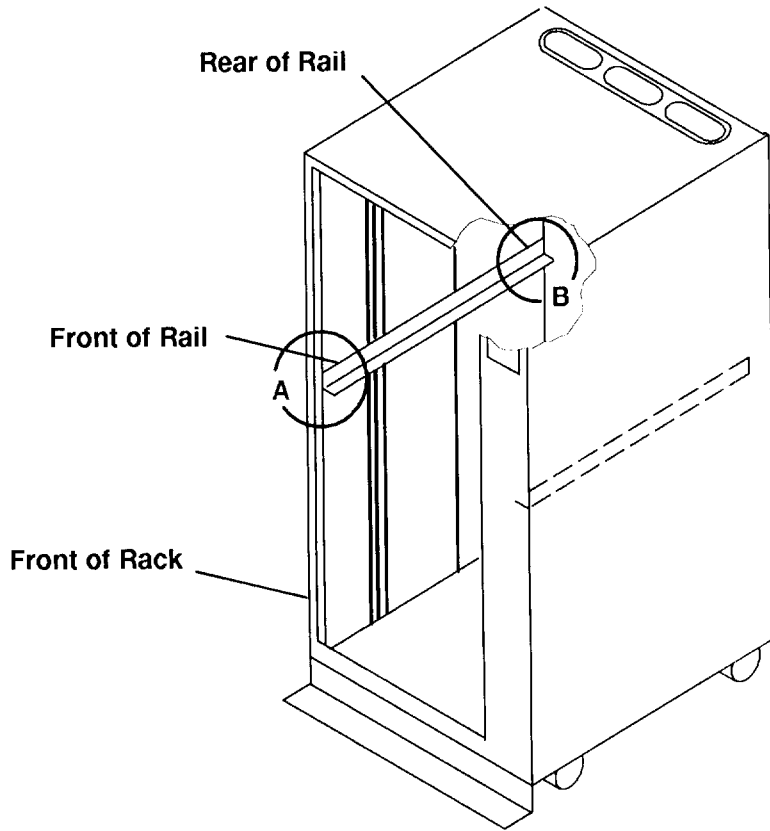

Mounting Hardware For CPU-Media Enclosure

Detail A – Front of Rail

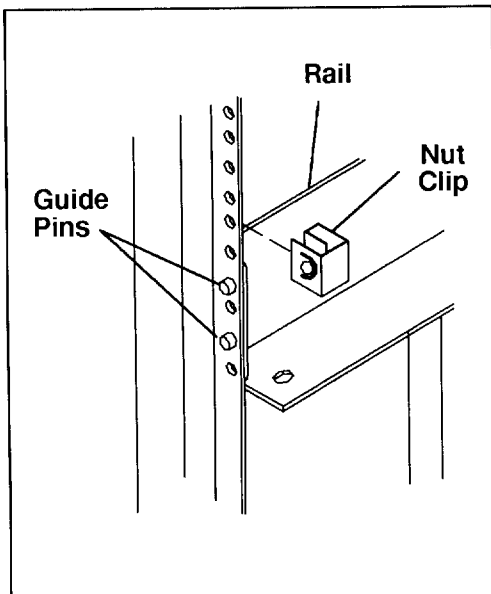

Detail B – Rear of Rail

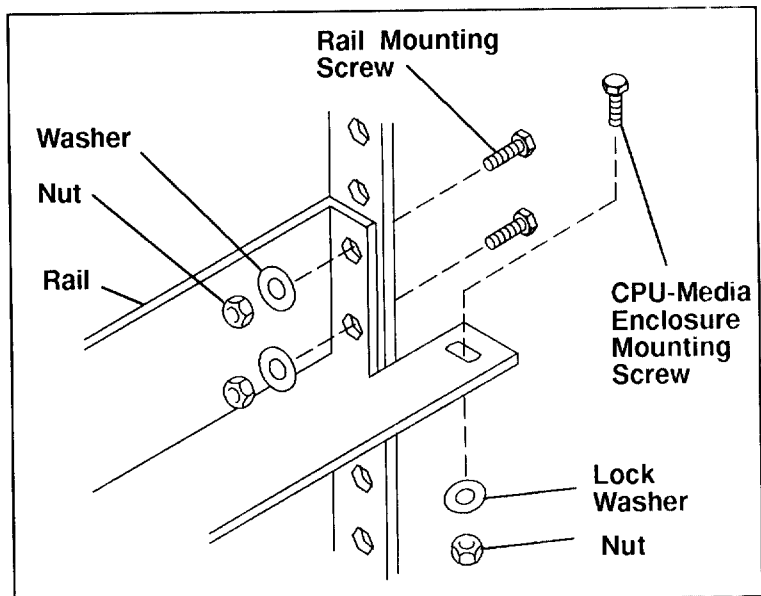

Specifications

Dimensions

Height: 439.5 mm (17.30 inches)

Depth: 781.3 mm (30.76 inches)

Width: 449.5 mm (17.70 inches)

AC Frequency

50 to 60 Hz

Heat Output

951 W (3245 BTU per hour) typical

Operating Environment

Class C: 10° to 40°C (50° to 104°F)

Wet bulb temperature: 27°C (80°F)

Operating Voltage

200 to 240 V ac (for AC system unit)

-48 V dc (for DC system unit)

Power

1.8 kVA (for AC system unit)

Power Supply

1170 W (for AC system unit)

Weight

63 kg (138 pounds) maximum configuration

Service Inspection Guide

Perform a service inspection on the system when:

- The system is inspected for a maintenance agreement.
- Service is requested and service was not recently performed.
- An alterations-and-attachments review is performed.
- Changes are made to the equipment that might affect the safe operation of the equipment.
- External devices with an attached power cord are connected to the system unit.

If the inspection indicates an unacceptable safety condition, the condition must be corrected before the machine is serviced.

Note: The correction of any unsafe condition is the responsibility of the owner of the system.

Do the following checks:

1. Check the covers for sharp edges and for damage or alterations that expose the internal parts of the system unit.
2. Check the covers for proper fit to the system unit. They should be in place and secure.
3. Ensure that the rack stabilizer is installed and securely attached to the rack.
4. Do either the “Power-Off Procedure with a Power Distribution Bus” on page 3-3 or the “Power-Off Procedure with a Power Distribuion Unit” on page 3-7.
5. Check for alterations or attachments. If there are any, check for obvious safety hazards such as broken wires, sharp edges, or broken insulation.
6. Check the internal cables for damage.
7. Check for dirt, water, and any other contamination within the system unit.
8. Check the voltage label on the rear of the system unit to ensure that it matches the voltage at the outlet.
9. Check the external power cable for damage.
10. With the external power cable connected to the system unit, check for 0.1 ohm or less resistance between the ground lug on the external power cable plug and the metal frame.
11. Do either the “Power-On Procedure with a Power Distribution Bus” on page 3-1 or the “Power-On Procedure with a Power Distribution Unit” on page 3-5.

Chapter 2. Maintenance Analysis Procedures (MAPs)

This chapter provides diagnostic information for detecting power problems in the CPU-media enclosure (in MAP 1520) and for detecting defective field replaceable units (in MAP 1540).

MAP 1520: CPU-Media Enclosure – Power MAP

Note: This MAP is not a start-of-call MAP. Use this Power MAP only if you are directed here from a MAP step in the *POWERstation and POWERserver Common Diagnostics and Service Guide*.

This procedure is used to locate power problems in the CPU-media enclosure. If a problem is detected, this procedure helps you to isolate the problem to a failing field replaceable unit (FRU). Go to Step 1.

Observe the following safety notice during service procedures.

Note: For a translation of this notice, see the *System Unit Safety Information* manual, order number SA23-2652.

DANGER

An electrical outlet that is not correctly wired could place hazardous voltage on metal parts of the system or the products that attach to the system. It is the responsibility of the customer to ensure that the outlet is correctly wired and grounded to prevent an electrical shock.

Before installing or removing signal cables, ensure that the power cables for the system unit and all attached devices are unplugged.

When adding or removing any additional devices to or from the system, ensure that the power cables for those devices are unplugged before the signal cables are connected. If possible, disconnect all power cables from the existing system before you add a device.

Use one hand, when possible, to connect or disconnect signal cables to prevent a possible shock from touching two surfaces with different electrical potentials.

During an electrical storm, do not connect cables for display stations, printers, telephones, or station protector for communications lines.

Three-Digit Display – Power Supply Failure Status

Power supply failures that occur within the CPU-media enclosure are analyzed by the CPU power supply. When the CPU-media enclosure power is off, the power to the green LED is off, and a code is displayed in the three-digit display, indicating the CPU has detected a power failure. The power failure status is represented by a digit or a symbol shown in the three-digit display.

Except for blanks occurring in all three positions at the same time, each position of the three-digit display has either a digit, a symbol, or a zero (0); a zero (0) does not represent a power failure.

The following table shows the valid power failure codes for each power failure status.

Valid Power Failure Codes			Power Failure Status
Position 1	Position 2	Position 3	
blank	blank	blank	There are no failures, or failures cannot be detected.
8			The planar fan connected to connector P84 has failed.
4			The planar fan connected to connector P85 has failed.
u			This is a combination of power failure codes 8 and 4 in Position 1.
	8		The power supply fan (#1) (connector P80) has failed.
	4		An SCSI device fan (fan 2a (connector P242), fan 2b (connector P243), or fan 2c (connector P244)) has failed.
	2		The planar fan connected to connector P83 has failed.
	6		This is a combination of power failure codes 2 and 4 in Position 2.
	c		This is a combination of power failure codes 2 and 8 in Position 2.
	u		This is a combination of power failure codes 4 and 8 in Position 2.
	Inverted F		This is a combination of power failure codes 2, 4, and 8 in Position 2.
		8	The temperature in the power supply is excessive.
		4	A power failure has occurred inside the power supply.
		2	A power failure has occurred outside the power supply.
		1	A loss of primary power has occurred.

Step 1

Notes:

1. If multiple failures are indicated in the three-digit display and one of the failures is indicated by the Position 3 (right-position) digit or symbol, first perform the task that corrects the failure indicated by the right-position digit or symbol, and then perform the other tasks.
2. Three SCSI device fans are located in the 7015 CPU-Media Enclosure. One fan is located in the media carrier; the media carrier is located in the front of the CPU-media enclosure. The other two SCSI device fans are located in the disk drive carrier; the disk drive carrier is located in the rear of the CPU-media enclosure.

If the code in the three-digit display indicates a failing SCSI device fan, test all three fans to determine which fan has failed.

Compare the code in the three-digit display to the table of valid power failure codes on page 2-1520-2, and then answer the following question.

Is a valid power failure code displayed on the three-digit display?

NO Go to Step 2.

YES Perform the task for the indicated power failure status as shown in the following table.

Power Failure Status	Task
Fan failure	Go to Step 2.
Excess temperature	Correct one or more of the following problems: <ul style="list-style-type: none">– Restricted air flow– Ineffective fans– Excess ambient temperature.
Loss of primary power	Go to Step 2.
Power failure outside the power supply	Go to Step 6.
Power failure inside the power supply	Go to Step 6.
Power failure could not be identified	Go to Step 2.

Step 2

(from Step 1)

Note: If the CPU-Media Enclosure is connected to a power distribution unit (PDU), perform substeps 1 and 2, and then answer the question. If the CPU-Media Enclosure is connected to a power distribution bus (PDB), perform substep 3 only and then answer the question.

1. Ensure the Master CB1 circuit breaker, located on the PDU, is set to the On position.
2. Ensure that voltage is available from the PDU. To verify that voltage is available, measure for 20 to 30 V ac between pins 1 and 2 of connector JD2 on the PDU. Pin 1 is on the left. For the location of Pin 1, refer to “Power Distribution Unit (Rear View)” in Chapter 1 of the *7015 POWERserver Installation and Service Guide*.
3. Ensure that voltage is being provided to the PDB. Voltage is provided to the PDB when the three LEDs are lighted.

Is voltage available from the PDU?

NO Depending on the configuration of your rack, go to either the “MAP 1520: Power Distribution Unit – Power MAP” or the “MAP 1550: Power Distribution Bus – Power MAP” in the *7015 POWERserver Installation and Service Guide*.

YES Go to Step 3.

Step 3

(from Step 2)

1. Ensure the following:
 - The power cable to the CPU-media enclosure has continuity.
 - The power cable is plugged into the CPU-media enclosure and one of the following: the PDU, the BBU, or the PDB.
 - The power supply fuse on the CPU-media enclosure has not failed.
 - The PDU power-select switch for the CPU-media enclosure is set to 1 (this pertains only to a rack containing a PDU, not a rack containing a PDB).
2. Locate the power outlet (located on the PDU or PDB) into which the CPU-media is plugged, and then press the drawer power reset CB for that power outlet.
3. Turn the key mode switch to the Service position.
4. Press the Power On button located on the CPU-media enclosure.

Did the Power light come on and stay on?

NO Go to Step 6.

YES If the problem is located, correct it. If the CPU-media enclosure was originally connected to a BBU, go to Step 4.

Go to "MAP 0410: Repair Checkout" in the *POWERstation and POWERserver Common Diagnostics and Service Guide*.

Step 4

(from Step 3)

1. Press the Power Off button.
2. Set the Master CB1 to Off.
3. Set the Master CB2 to Off.
4. Plug the CPU-Media Enclosure power cable into the BBU outlet.
5. Set the Master CB1 to On.
6. Set the Master CB2 to On.
7. Press the Power On button.

Did the Power light come on and stay on?

NO Go to Step 5.

YES Go to "MAP 0410: Repair Checkout" in the *POWERstation and POWERserver Common Diagnostics and Service Guide*.

Step 5

(from Step 4)

1. Press the Power Off button located on the CPU-media enclosure.
2. Set the Master CB1 to Off.
3. Set the Master CB2 to Off.
4. Plug the CPU-media-enclosure power cable into another BBU outlet.
5. Set the Master CB1 to On.
6. Set the Master CB2 to On.
7. Press the Power On button.

Did the Power light come on and stay on?

NO Go to the “MAP 1520: Power Distribution Unit – Power MAP” in the *7015 POWERserver Installation and Service Guide*.

YES Exchange the defective fuse by performing the following steps:

- a. Set the Master CB1 to Off.
- b. Set the Master CB2 to Off.
- c. Disconnect all power cables from the BBU.
- d. Move the fuse safety cover to the left.
- e. Push the fuse cap in while turning it counterclockwise.
- f. Remove and exchange the fuse.

Go to “MAP 0410: Repair Checkout” in the *POWERstation and POWERserver Common Diagnostics and Service Guide*.

Step 6

(from Steps 1 and 3)

1. Press the Power Off button located on the CPU-media enclosure.
2. Unplug the power cable from the CPU-media enclosure.
3. Disconnect the power cable connectors from the diskette drive, the CD-ROM drive, the disk drive, and any other media devices installed.
4. Disconnect the two power cable connectors (P16 and P17) from the CPU planar. Refer to page 1-6 for the connector locations.
5. Disconnect the three power cable connectors (P21, P22, P24) from the combination planar. Refer to page 1-7 for the connector locations.
6. Disconnect power cable connector P4 from the operator panel.
7. Disconnect the three power cable connectors (P41, P42, and P43) from the optional I/O planar. Refer to page 1-7 for the connector locations.
8. Plug the power cable into CPU-media enclosure.

Do all of the fans run continuously?

- | | |
|------------|----------------|
| NO | Go to Step 7. |
| YES | Go to Step 10. |

Step 7

(from Step 6)

Did any of the fans start rotating and then stop?

- | | |
|------------|---------------|
| NO | Go to Step 8. |
| YES | Go to Step 9. |

Step 8

(from Step 7)

This problem can be caused by a defective fan, power distribution board, or power supply. The power supply does not stay on if it fails to sense the rotation of all the cooling fans.

1. Unplug the power cable from the CPU-media enclosure.
2. Exchange a fan.
3. Plug the power cable into the CPU-media enclosure.

Do all the fans run continuously?

NO If you have not tested all the fans, including the power supply fan, repeat this step.

If you have tested all the fans, go to Step 9.

YES The fan you exchanged was defective. Go to “MAP 0410: Repair Checkout” in the *POWERstation and POWERserver Common Diagnostics and Service Guide*.

Step 9

(from Steps 7 and 8)

1. Unplug the power cable from the CPU-media enclosure.
2. Except for connectors P80, P81, and P125, disconnect all power output connectors from the power supply.
3. Plug the power cable into the CPU-media enclosure.

Do all of the fans run continuously?

NO Disconnect the operator-panel ribbon-cable connector (P125) from the power supply.

If the power supply starts working, exchange the operator panel ribbon cable, and then go to “MAP 0410: Repair Checkout” in the *POWERstation and POWERserver Common Diagnostics and Service Guide*.

If the power supply does not start working, exchange the power supply, and then go to “MAP 0410: Repair Checkout” in the *POWERstation and POWERserver Common Diagnostics and Service Guide*.

YES Connect a power output cable and then press the Power On button. Repeat this for the remaining cables until a defective cable is found. When a defective cable is found, exchange it, and then go to “MAP 0410: Repair Checkout” in the *POWERstation and POWERserver Common Diagnostics and Service Guide*.

Step 10

(from Step 6)

1. Unplug the power cable from the CPU-media enclosure.
2. Connect power cable connector P4 to the operator panel.
3. Plug in the power cable to the CPU-media enclosure.

Do all of the fans run continuously?

NO Replace the operator panel, and then go to “MAP 0410: Repair Checkout” in the *POWERstation and POWERserver Common Diagnostics and Service Guide*.

YES Go to Step 11.

Step 11

(from Step 10)

1. Unplug the power cable from the CPU-media enclosure.
2. Connect the two power cable connectors (P16 and P17) to the CPU planar.
3. Plug the power cable into the CPU-media enclosure.

Do all of the fans run continuously?

NO Go to Step 12.

YES Go to Step 13.

Step 12

(from Step 11)

1. Unplug the power cable from the CPU-media enclosure.
2. Record the slot numbers of the memory cards. If optical cards are installed, record the slot numbers.
3. Remove one card from the CPU planar.
4. Ensure that the power has been off for at least 15 seconds, and then plug the power cable into the CPU-media enclosure.

Do all of the fans run continuously?

NO If all of the cards have not been removed, repeat this step.

If all of the cards have been removed, exchange the CPU planar, and then go to “MAP 0410: Repair Checkout” in the *POWERstation and POWERserver Common Diagnostics and Service Guide*.

YES The last memory card or option that you removed is defective. Exchange the card or option, and then go to “MAP 0410: Repair Checkout” in the *POWERstation and POWERserver Common Diagnostics and Service Guide*.

Step 13

(from Step 11)

1. Unplug the power cable from the CPU-media enclosure.
2. Connect power connectors P40, P41, and the operator panel power connector P24 to the combination planar.
3. Plug the power cable into the CPU-media enclosure.
4. Press the Power On button.

Is the Power light on?

NO Go to Step 15.

YES Go to Step 14.

Step 14

(from Step 13)

1. Connect the three power connectors (P41, P42, and P43) to the optional I/O planar
2. Press the Power On button.

Do all of the fans run continuously?

NO Go to Step 18.

YES Go to Step 27.

Step 15

(from Step 13)

1. Press the Power Off button.
2. Record the slot numbers of the adapters on the combination planar.
3. Remove one of the adapters from the combination planar.
4. Ensure that the power has been off for at least 15 seconds, and then press the Power On button.

Is the Power light on?

NO If all of the adapters have not been removed, repeat Step 15.

 If all of the adapters have been removed, go to Step 16.

YES Go to Step 21.

Step 16

(from Step 15)

1. Press the Power Off button.
2. Disconnect one of the following cables from the combination planar:
 - Operator panel cable (connector P24)
 - Disk drive (SCSI) cable (connector P25)
 - 3.5-inch diskette drive cable (connector P26)
3. Press the Power On button.

Do all of the fans run continuously?

- | | |
|------------|---|
| NO | Repeat this step until all three cables have been removed, and then go to Step 17. |
| YES | Exchange the defective cable or FRU, and then go to “MAP 0410: Repair Checkout” in the <i>POWERstation and POWERserver Common Diagnostics and Service Guide</i> . |

Step 17

(from Step 16)

1. Press the Power Off button.
2. Label, record, and then disconnect any external cables from the combination planar.
3. Press the Power On button, and then wait 10 seconds.

Is the Power light on?

- | | |
|------------|---|
| NO | Exchange the combination planar, and then go to “MAP 0410: Repair Checkout” in the <i>POWERstation and POWERserver Common Diagnostics and Service Guide</i> . |
| YES | Go to Step 19. |

Step 18

(from Step 14)

1. Press the Power Off button.
2. Record the locations of the adapters on the optional I/O planar.
3. Remove one of the adapters from the optional I/O planar.
4. Ensure that the power has been off for at least 15 seconds, and then press the Power On button.

Is the Power light on?

- NO** If all of the adapters have not been removed, repeat Step 18.
If all of the adapters have been removed, exchange the optional I/O planar; and then go to “MAP 0410: Repair Checkout” in the *POWERstation and POWERserver Common Diagnostics and Service Guide*.
- YES** Go to Step 21.

Step 19

(from Step 17)

1. Connect one of the cables that you removed from the combination planar.
2. Ensure that the power has been off for at least 15 seconds, and then press the Power On button.

Is the Power light on?

- NO** Go to Step 20.
- YES** Repeat this step until you find the defective cable or device. Exchange the cable or device, and then go to “MAP 0410: Repair Checkout” in the *POWERstation and POWERserver Common Diagnostics and Service Guide*.

Step 20

(from Step 19)

1. Press the Power Off button.
2. Remove the device that is attached to the cable.
3. Press the Power On button.

Is the Power light on?

- NO** Exchange the cable, and then go to “MAP 0410: Repair Checkout” in the *POWERstation and POWERserver Common Diagnostics and Service Guide*.
- YES** Exchange the device, and then go to “MAP 0410: Repair Checkout” in the *POWERstation and POWERserver Common Diagnostics and Service Guide*.

Step 21

(from Steps 15 and 18)

Look at the adapter you just removed.

Are or were any cables attached to the adapter?

- | | |
|------------|----------------|
| NO | Go to Step 22. |
| YES | Go to Step 24. |

Step 22

(from Step 21)

Some adapters may contain additional FRUs.

Does the failing adapter have any additional FRUs?

- | | |
|------------|--|
| NO | Exchange the failing adapter, and then go to “MAP 0410: Repair Checkout” in the <i>POWERstation and POWERserver Common Diagnostics and Service Guide</i> . |
| YES | Go to Step 23. |

Step 23

(from Step 22)

1. Remove the additional FRUs.
2. Press the Power Off button.
3. Reinstall the failing adapter.
4. Press the Power On button, and then wait 10 seconds.

Is the Power light on?

- | | |
|------------|---|
| NO | Exchange the adapter, and then go to “MAP 0410: Repair Checkout” in the <i>POWERstation and POWERserver Common Diagnostics and Service Guide</i> . |
| YES | One of the additional FRUs that you removed is failing.

If you removed only one FRU, exchange it.

If you removed more than one FRU, replace them one at a time until you identify the failing FRU. Exchange the failing FRU, and then go to “MAP 0410: Repair Checkout” in the <i>POWERstation and POWERserver Common Diagnostics and Service Guide</i> . |

Step 24

(from Step 21)

1. Press the Power Off button.
2. Disconnect any cables that are attached to the adapter, and then replace the adapter.
3. Press the Power On button.

Is the Power light on?

- NO** Exchange the adapter, and then go to “MAP 0410: Repair Checkout” in the *POWERstation and POWERserver Common Diagnostics and Service Guide*.
- YES** Go to Step 25.

Step 25

(from Step 24)

1. Press the Power Off button.
2. Connect a cable to the adapter.
3. Press the Power On button, and then wait 10 seconds.

Is the Power light on?

- NO** Go to Step 26.
- YES** If all of the cables are not connected, then repeat this step.
If all of the cables are connected, go to “MAP 0410: Repair Checkout” in the *POWERstation and POWERserver Common Diagnostics and Service Guide*.

Step 26

(from Step 25)

1. Press the Power Off button.
2. Starting with the devices, disconnect a device or cable connector.
3. Press the Power On button.

Is the Power light on?

- NO** Repeat this step until all of the devices and cables have been disconnected.
If you have disconnected all of the devices and cables, exchange the adapter, and then go to “MAP 0410: Repair Checkout” in the *POWERstation and POWERserver Common Diagnostics and Service Guide*.
- YES** Exchange the device or cable, and then go to “MAP 0410: Repair Checkout” in the *POWERstation and POWERserver Common Diagnostics and Service Guide*.

Step 27

(from Step 14)

1. Press the Power Off button.
2. Connect the power cable to the diskette drive, CD-ROM, or other media devices.
3. Press the Power On button.

Is the Power light on?

- NO** Exchange the last device that you connected, and then go to “MAP 0410: Repair Checkout” in the *POWERstation and POWERserver Common Diagnostics and Service Guide*.
- YES** Repeat this step until all of the power cables are connected to the devices, and then go to “MAP 0410: Repair Checkout” in the *POWERstation and POWERserver Common Diagnostics and Service Guide*.

MAP 1540: CPU-Media Enclosure – Minimum Configuration

Notes:

1. This is not a start-of-call MAP (MAP 0010: Start of Call). Use this MAP only if you were directed here from a MAP step in the *Common Diagnostics and Service Guide*.
2. If a CD-ROM drive is used to perform diagnostics, it must be installed in the CPU-media enclosure.

This procedure is used to locate defective field replaceable units (FRUs) not found by normal diagnostics. For this procedure, diagnostics are run on a minimum system configuration. If a failure is detected on a minimum system configuration, the FRUs are exchanged one at a time until the failing FRU is identified. If a failure is not detected, FRUs are added to the minimum configuration until the failure occurs and the failing FRU is identified.

The MAP steps on the following pages instruct you to reduce the system to one or more of the following configurations:

1. CPU planar, combination planar, optional I/O planar, and three-digit display panel.

Note: Refer to “Reading Flashing 888 Numbers” in the *POWERstation and POWERserver Common Diagnostics and Service Guide* for more information about reading the flashing 888 sequences.

If no failure is detected, a flashing 888 is displayed in the three-digit display. The flashing 888 sequence should be 888-103-12X-X43 (X can be any number). Any other response indicates that one of the FRUs in this configuration is failing.

2. CPU planar, combination planar, optional I/O planar, three-digit display panel, and memory cards.

If no failure is detected, two or more numbers with values between 221 and 296 are displayed alternately in the three-digit display, or the number 262 is displayed (not flashing). Any other response indicates that one of the FRUs in this configuration is failing.

3. CPU planar, combination planar, optional I/O planar, three-digit display panel, memory cards, diskette drive or CD-ROM drive, and a terminal attached to serial port 1.

If no failure is detected, the DIAGNOSTIC OPERATING INSTRUCTIONS frame is displayed when the diagnostics are loaded, and the system console is selected. Any other response indicates that one of the FRUs in this configuration is failing.

Step 1

1. Ensure the diagnostics and the operating system are shut down.
2. Turn the key mode switch to the Service position.
3. Press the Power Off button located on the CPU-media enclosure.
4. Insert the first diagnostic diskette into the diskette drive or the diagnostic CD-ROM disc into the CD-ROM drive.
5. Press the Power On button located on the CPU-media enclosure.

6. Find the symptom in the following table that best describes the problem, and then perform the associated task.

Information in Three-Digit Display	Conditions	Task
Nothing	The Diagnostic Operating Screen is displayed.	Go to Step 16.
c07	The diskette drive "In Use" light is on.	Insert the next diagnostic diskette. Wait for one of the other symptoms in this table to occur.
888 flashing		Go to Step 2.
Two or more numbers with values between 221 and 296 are displayed alternately.	The first diagnostic diskette is loaded.	Go to Step 7.
	The diagnostic CD-ROM disc is loaded.	Go to Step 9.
c31	Instructions to select the system console are displayed on the screen.	Follow the instructions on the display to select your console display. Wait for one of the other symptoms in this table to occur.
c05	The diskette drive In Use light is on.	The diagnostic diskette is probably bad. Insert the same diskette from a duplicate diagnostic set. If the duplicate diskette causes the same symptom, go to Step 7.
299 or less	Digits remain on (not flashing) for more than 3 minutes, and the Power light is on.	Go to Step 2.
300 or greater	Digits remain on (not flashing) for more than 3 minutes, the Power light is on, and the first diagnostic diskette is loaded.	Go to Step 7.
	Digits remain on (not flashing) for more than 3 minutes, the Power light is on, and the diagnostic CD-ROM disc is loaded.	Go to Step 9.
Any symptom not previously listed.		Go to Step 2.

Step 2

(from Step 1 and Step 18)

1. Press the Power Off button.
2. Record the slot numbers of the adapters located on the combination planar and on the optional I/O planar, and label and record the location of any cables connected to the adapters.
3. Remove all adapters from the combination planar and from the optional I/O planar.
4. Disconnect the SCSI cable (P25), the 3.5-inch-diskette-drive data-signal cable (P26), and the serial-parallel data-signal cable (P27) from the combination planar.
5. Disconnect any cables connected to connectors S1, S2, and P on the rear of the CPU-media enclosure.
6. Record the slot numbers of the memory cards, and then remove all of the memory cards from the CPU planar.
7. If cache SIMMs are installed on the CPU planar, record the locations, and then remove them.
8. Press the Power On button.
9. Wait for one of the following conditions to occur:
 - The system stops for at least 3 minutes, a constant number, character, or symbol is displayed in the three-digit display, and the Power light is on.
 - The system stops, and a flashing 888 is displayed in the three-digit display.

If this occurs, record the flashing 888 message. Refer to the *POWERstation and POWERserver Common Diagnostics and Service Guide* for information on reading flashing 888 numbers.
 - The Power light does not come on, or it comes on but does not stay on.

Is the flashing sequence 888-103-12X-X43 (x can be any number) displayed in the three-digit display?

- NO** Go to Step 3.
- YES** Go to Step 4.

Step 3

(from Step 2)

One of the FRUs remaining in the CPU-media enclosure is defective.

To test each FRU, exchange the FRUs in the following order:

1. Operator panel
2. Operator panel cable
3. Combination planar
4. Optional I/O planar
5. CPU planar
6. First cache SIMM (if removed)
7. Second cache SIMM (if removed)
8. Combination planar power cables
9. Optional I/O planar power cables
10. CPU planar power cables
11. Power distribution board cables
12. Power distribution board
13. Power supply

The system is working correctly if it stops and a flashing 888-103-12X-X43 (X can be any number) is displayed in the three-digit display. If the flashing 888-103-12X-X43 occurs, the last FRU that you removed is defective.

1. Press the Power Off button.
2. Exchange one of the FRUs in the list.
3. Press the Power On button.

Is the flashing 888 sequence 888-103-12X-X43 displayed in the three-digit display?

NO Reinstall the original FRU.

Repeat this step until the defective FRU is identified or all the FRUs have been exchanged.

If the symptom did not change and all the FRUs have been exchanged, call your service support person for assistance.

YES Go to "Map 0410: Repair Checkout" in the *POWERstation and POWERserver Common Diagnostics and Service Guide*.

Step 4

(from Step 2)

No failure was detected with this configuration.

1. Press the Power Off button.
2. Install a pair of memory cards. Refer to page 3-17 for information about installing memory cards.
3. Press the Power On button.
4. Wait for one of the following conditions to occur:
 - The system stops, and two or more numbers with values between 221 and 296 are displayed alternately in the three-digit display.
 - The system stops for at least 3 minutes, and a constant number, character, or symbol is displayed in the three-digit display.
 - The system stops, and a flashing 888 is displayed in the three-digit display.
 - The Power light does not come on, or the Power light comes on but does not stay on.

Did the system stop, and are two or more numbers between the values of 221 and 296 displayed alternately in the three-digit display, or is the number 262 displayed in the three-digit display?

NO Go to Step 5.

YES Repeat this step until all of the memory cards are installed and tested. After all of the memory is installed and tested, press the Power Off button, and then do one of the following actions:

- To perform diagnostics from diskettes, do the following:
 - Connect the data-signal cable for the 3.5-inch diskette drive (P26) to the combination planar.
 - Go to Step 7, substep 6.
- To perform diagnostics from a CD-ROM disc, do the following:
 - Connect the SCSI cable (P25) to the combination planar.
 - Go to Step 9, substep 6.

Step 5

(from Step 4)

The failure may be caused by a defective SIMM on either of the last two memory cards installed. To isolate the failing SIMM in a pair of SIMMs, do the following:

1. Press the Power Off button. Using a pair of operational SIMMs for the type of memory card used, install the pair of SIMMs in locations 1 and 2 on the suspected memory card.
2. Press the Power On button. If operational, the system will stop and two or more numbers with values between 221 and 296 are displayed alternately in the three-digit display.
3. If the system still fails, continue testing the SIMMs in pairs (locations 3 and 4, 5 and 6, 7 and 8) until the system does not fail, or all the SIMMs on the suspected memory card have been tested.

Were you able to isolate the failed pair of SIMMs?

- NO** Exchange the memory cards. If this does not correct the problem, go to Step 6.
- YES** Go to "Map 0410: Repair Checkout" in the *POWERstation and POWERserver Common Diagnostics and Service Guide*.

Step 6

(from Step 5)

One of the FRUs in the CPU-media enclosure is defective.

In the following order, exchange the FRUs that have not been exchanged:

1. CPU planar
2. Power supply.

The system is working correctly if it stops and two or more numbers between the values of 221 and 296 are displayed alternately in the three-digit display. If this occurs, the last FRU you exchanged is defective.

1. Press the Power Off button.
2. Exchange one of the FRUs in the list.
3. Press the Power On button.

Did the system stop, and are two or more numbers between the values of 221 and 296 displayed alternately in the three-digit display?

NO

Reinstall the original FRU.

Repeat this step until the defective FRU is identified or all the FRUs have been exchanged.

If the symptom did not change and all the FRUs have been exchanged, call your service support person for assistance.

If the symptom changed, check for loose adapter cards, loose cables, and obvious problems. If you do not find a problem, return to Step 1 in this MAP, and then follow the instructions for the new symptom.

YES

Go to "Map 0410: Repair Checkout" in the *POWERstation and POWERserver Common Diagnostics and Service Guide*.

Step 7

(from Steps 1 and 4)

1. Press the Power Off button.
2. Record the slot numbers of the adapters located on the combination planar and on the optional I/O planar, and then label and record the location of any cables attached to the adapters.
3. Remove all adapters from the combination planar and from the optional I/O planar.
4. Disconnect the SCSI cable (P25) and the serial-parallel data-signal cable (P27) from the combination planar.
5. Disconnect any cables connected to connectors S1, S2, and P on the rear of the CPU-media enclosure.
6. Insert the first diagnostic diskette into the 3.5-inch diskette drive.
7. Press the Power On button.
8. Wait for one of the following conditions to occur:
 - The In Use light on the 3.5-inch diskette drive is on and c05 or c07 is displayed in the three-digit display.
 - The system stops for at least 3 minutes, a constant number, character, or symbol is displayed in the three-digit display, and the Power light is on.
 - The system stops, and two or more numbers with values between 22 L and 296 are displayed alternately in the three-digit display.
 - The system stops, and a flashing 888 is displayed in the three-digit display.
 - The Power light does not come on, or the Power light comes on but does not stay on.

Is the In Use light of the 3.5-inch diskette drive on, and is c07 displayed in the three-digit display?

NO

One of the FRUs in the CPU-media enclosure is defective.

In the following order, exchange the FRUs that have not been exchanged:

1. Diskette drive
2. 3.5-inch-diskette-drive data-signal cable
3. Combination planar
4. Optional I/O planar
5. CPU planar
6. Power supply

Repeat this step until the defective FRU is identified or all the FRUs have been exchanged.

If the symptom did not change and all the FRUs have been exchanged, call your service support person for assistance.

If the symptom changed, check for loose adapter cards, loose cables, and obvious problems. If you do not find a problem, return to Step 1 in this MAP, and then follow the instructions for the new symptom.

YES

Go to Step 8.

Step 8

(from Step 7)

1. Press the Power Off button.
2. Connect the SCSI cable (P25) to the combination planar.
3. Disconnect the data signal connectors and power connectors from the SCSI devices located inside the media carrier (front of CPU-media enclosure) and located inside the disk drive carrier (rear of CPU-media enclosure). Do not disconnect the fans.
4. Insert the first diagnostic diskette into the diskette drive.
5. Press the Power On button.
6. Wait for one of the following conditions to occur:
 - The In Use light on the 3.5-inch diskette drive is on, and c05 or c07 is displayed in the three-digit display.
 - The system stops for at least 3 minutes, a constant number, character, or symbol is displayed in the three-digit display, and the Power light is on.
 - The system stops, and two or more numbers with values between 221 and 296 are displayed alternately in the three-digit display.
 - The system stops, and a flashing 888 is displayed in the three-digit display.
 - The Power light does not come on, or the Power light comes on but does not stay on.

Is the In Use light on the 3.5-inch diskette drive on, and is c07 displayed in the three-digit display?

- NO** One of the FRUs in the CPU-media enclosure is defective.
- In the following order, exchange the FRUs that have not been exchanged:
1. SCSI cable (combination planar to single-media-device connector of docking assembly)
 2. SCSI cable (inside media carrier)
 3. Combination planar
 4. Optional I/O planar
 5. CPU planar
- Repeat this step until the defective FRU is identified or all the FRUs have been exchanged.
- If the symptom did not change and all the FRUs have been exchanged, call your service support person for assistance.
- If the symptom changed, check for loose adapter cards, loose cables, and obvious problems. If you do not find a problem, return to Step 1 in this MAP, and then follow the instructions for the new symptom.
- YES** Go to Step 11.

Step 9

(from Steps 1 and 4)

1. Press the Power Off button.
2. Record the slot numbers of the adapters located on the combination planar and on the optional I/O planar, label and record the location of any cables attached to the adapters, and then remove all adapters from the combination planar and from the optional I/O planar.
3. Disconnect the 3.5-inch-diskette-drive data-signal cable (P26) and the serial-parallel data signal cable (P27) from the combination planar.
4. Disconnect any cables connected to connectors S1, S2, and P on the rear of the CPU-media enclosure.
5. Except for the CD-ROM drive, disconnect the signal and power connectors from all of the SCSI devices located in the disk drive carrier and the media carrier. Do not disconnect the cooling fans.
6. Insert the diagnostic CD-ROM disc into the CD-ROM drive.
7. Press the Power On button.
8. Wait for one of the following conditions to occur:
 - The system stops, and c31 is displayed in the three-digit display.
 - The system stops for at least 3 minutes, a constant number, character, or symbol other than c31 is displayed in the three-digit display, and the Power light is on.
 - The system stops, and two or more numbers with values between 221 and 296 are displayed alternately in the three-digit display.
 - The system stops, and a flashing 888 is displayed in the three-digit display.
 - The Power light does not come on, or the Power light comes on but does not stay on.

Did the system stop, and is c31 displayed in the three-digit display?

NO One of the FRUs in the CPU-media enclosure is defective. In the following order, exchange the FRUs that have not been exchanged:

1. CD-ROM drive
2. SCSI cable (combination planar to single media device connector of docking assembly)
3. SCSI cable (inside media carrier)
4. Combination planar
5. Optional I/O planar
6. CPU planar

Repeat this step until the defective FRU is identified or all the FRUs have been exchanged.

If the symptom did not change and all the FRUs have been exchanged, call your service support person for assistance.

If the symptom changed, check for loose adapter cards, loose cables, and obvious problems. If you do not find a problem, return to Step 1 in this MAP, and then follow the instructions for the new symptom.

YES Go to Step 10.

Step 10

(from Step 9)

1. Press the Power Off button.
2. Connect the signal cable for the 3.5-inch diskette drive (P26) to the combination planar.
3. Insert the diagnostic CD-ROM disc into the CD-ROM drive.
4. Press the Power On button.
5. Wait for one of the following conditions to occur:
 - The system stops, and c31 is displayed in the three-digit display.
 - The system stops for at least 3 minutes, a constant number, character, or symbol other than c31 is displayed in the three-digit display, and the Power light is on.
 - The system stops, and two or more numbers with values between 221 and 296 are displayed alternately in the three-digit display.
 - The system stops, and a flashing 888 is displayed in the three-digit display.
 - The Power light does not come on, or the Power light comes on but does not stay on.

Did the system stop, and is c31 displayed in the three-digit display?

NO

One of the FRUs in the CPU-media enclosure is defective.

In the following order, exchange the FRUs that have not been exchanged:

1. 3.5-inch diskette drive
2. 3.5-inch-diskette-drive data-signal cable
3. Combination planar
4. Optional I/O planar
5. CPU planar

Repeat this step until the defective FRU is identified or all the FRUs have been exchanged.

If the symptom did not change and all the FRUs have been exchanged, call your service support person for assistance.

If the symptom changed, check for loose adapter cards, loose cables, and obvious problems. If you do not find a problem, return to Step 1 in this MAP, and then follow the instructions for the new symptom.

YES

Go to Step 11.

Step 11

(from Steps 8 and 10)

The system is working correctly with this configuration. One of the SCSI devices that you disconnected may be defective.

1. Press the Power Off button.
2. Connect the signal and power connectors to one of the SCSI devices located in the media carrier or the disk drive carrier (connected to the integrated SCSI controller cable).
3. Insert the first diagnostic diskette into the diskette drive or the diagnostic CD-ROM disc into the CD-ROM drive.
4. Press the Power On button.
5. Wait for one of the following conditions to occur:
 - The In-Use light of the 3.5-inch diskette drive is on, and c05 or c07 is displayed in the three-digit display.
 - The system stops, and c31 is displayed in the three-digit display.
 - The system stops for at least 3 minutes, a constant number, character, or symbol other than c31 is displayed in the three-digit display, and the Power light is on.
 - The system stops, and two or more numbers with values between 221 and 296 are displayed alternately in the three-digit display.
 - The system stops, and a flashing 888 is displayed in the three-digit display.
 - The Power light does not come on, or the Power light comes on but does not stay on.

Did the system stop, and is c07 or c31 displayed in the three-digit display?

NO The last SCSI device you connected is defective. Exchange the defective SCSI device.

Repeat this step until all of the signal and power connectors for the SCSI devices located in the media carrier and the disk drive carrier are connected.

If all of the SCSI devices have been connected, in the following order exchange the FRUs that have not been exchanged:

1. SCSI cable (combination planar to single media device connector of docking assembly)
2. SCSI cable (inside media carrier)
3. Combination planar
4. Optional I/O planar
5. CPU planar
6. Power supply

If the symptom did not change and all the FRUs have been exchanged, call your service support person for assistance.

If the symptom changed, check for loose adapter cards, loose cables, and obvious problems. If you do not find a problem, return to Step 1 in this MAP, and then follow the instructions for the new symptom.

YES Repeat this step until all of the signal and power connectors for the SCSI devices (connected to the integrated SCSI controller cable from the combination planar) are exchanged.

Go to Step 12.

Step 12

(from Step 11)

1. Press the Power Off button.
2. Connect the serial-parallel data-signal cable (P27) to the combination planar.
3. Insert the first diagnostic diskette into the diskette drive, or insert the diagnostic CD-ROM disc into the CD-ROM drive.
4. Press the Power On button.
5. Wait for one of the following conditions to occur:

- The In Use light on the 3.5-inch diskette drive is on, and c07 is displayed in the three-digit display.

Insert the next diagnostic diskette. Continue with this substep until all diskettes are loaded or c31 is displayed in the three-digit display.

- The system stops, and c31 is displayed in the three-digit display.
- The system stops for at least 3 minutes, a constant number other than c31 is displayed in the three-digit display, and the Power light is on.
- The system stops, and two or more numbers with values between 221 and 296 are displayed alternately in the three-digit display.
- The system stops, and a flashing 888 is displayed in the three-digit display.
- The Power light does not come on, or the Power light comes on but does not stay on.

Is c31 displayed in the three-digit display?

- | | |
|------------|--|
| NO | Exchange the serial-parallel data-signal cable.

Go to “MAP 0410: Repair Checkout” in the <i>POWERstation and POWERserver Common Diagnostics and Service Guide</i> . |
| YES | Go to Step 13. |

Step 13

(from Step 12)

1. Press the Power Off button.
2. Connect all cables that were plugged into serial port connector S1, serial port connector S2, and parallel port connector (P) on the rear of the CPU-media enclosure.
3. Insert the first diagnostic diskette into the diskette drive, or insert the diagnostic CD-ROM disc into the CD-ROM drive.
4. Press the Power On button.
5. Wait for one of the following conditions to occur:
 - The system stops, and c31 is displayed in the three-digit display.
 - The In Use light on the 3.5-inch diskette drive is on, and c07 is displayed in the three-digit display. Insert the next diagnostic diskette. Continue this substep until all diskettes are loaded or c31 is displayed in the three-digit display.
 - The system stops for at least 3 minutes, a constant number, character, or symbol other than c31 is displayed in the three-digit display, and the Power light is on.
 - The system stops, and two or more numbers with values between 221 and 296 are displayed alternately in the three-digit display.
 - The system stops, and a flashing 888 is displayed in the three-digit display.
 - The Power light does not come on, or the Power light comes on but does not stay on.

Is c31 displayed in the three-digit display?

- NO** Go to the “Problem Determination” procedures (test procedures) for devices attached to serial-parallel ports, and then test those devices. If a problem is found, follow the procedures for correcting the problem on that device.
- YES** Go to Step 14.

Step 14

(from Step 13)

The system is working correctly with this configuration. One of the FRUs (adapters) you removed is probably defective.

1. Press the Power Off button.
2. Install a FRU (adapter), and then connect all cables and devices that were connected to the FRU (adapter).
3. Insert the first diagnostic diskette into the diskette drive, or insert the diagnostic CD-ROM disc into the CD-ROM drive.
4. Press the Power On button.
5. Wait for one of the following conditions to occur:
 - The system stops, and c31 is displayed in the three-digit display.
 - The In Use light on the 3.5-inch diskette drive is on, and c07 is displayed in the three-digit display. Insert the next diagnostic diskette. Continue this substep until all diskettes are loaded or c31 is displayed in the three-digit display.
 - The system stops for at least 3 minutes, a constant number, character, or symbol other than c31 is displayed in the three-digit display, and the Power light is on.
 - The system stops, and two or more numbers with values between 221 and 296 are displayed alternately in the three-digit display.
 - The system stops, and a flashing 888 is displayed in the three-digit display.
 - The Power light does not come on, or the Power light comes on but does not stay on.

Is c31 displayed in the three-digit display?

NO Go to Step 15.

YES Repeat this step until all of the FRUs (adapters) are installed. Go to “MAP 0410: Repair Checkout” in the *POWERstation and POWERserver Common Diagnostics and Service Guide*.

Step 15

(from Step 14)

1. Press the Power Off button.
2. Beginning with the device that is located farthest from the FRU (adapter) you are testing disconnect the cables from the device that is connected to the FRU (adapter).
3. Insert the first diagnostic diskette into the diskette drive or the diagnostic CD-ROM disk into the CD-ROM drive.
4. Press the Power On button.
5. Wait for one of the following conditions to occur:
 - The system stops, and c31 is displayed in the three-digit display.
 - The In Use light on the 3.5-inch diskette drive is on, and c07 is displayed in the three-digit display. Insert the next diagnostic diskette. Continue this substep until all diskettes are loaded or c31 is displayed in the three-digit display.
 - The system stops for at least 3 minutes, a constant number, character, or symbol other than c31 is displayed in the three-digit display, and the Power light is on.
 - The system stops, and two or more numbers with values between 221 and 296 are displayed alternately in the three-digit display.
 - The system stops, and a flashing 888 is displayed in the three-digit display.
 - The Power light does not come on, or the Power light comes on but does not stay on.

Is c31 displayed in the three-digit display?

NO Repeat this step until the defective device or cable is identified, or all of the devices and cables are disconnected.

One of the FRUs remaining in the CPU-media enclosure is defective. To test each FRU, exchange the FRUs in the following order:

1. Adapter (last one installed)
2. Combination planar
3. Optional I/O planar
4. CPU planar
5. Power supply

If the symptom did not change and all the FRUs have been exchanged, call your service support person for assistance.

If the symptom changed, check for loose adapter cards, loose cables, and obvious problems. If you do not find a problem, return to Step 1 in this MAP, and then follow the instructions for the new symptom.

YES The last device or cable you disconnected is defective. Exchange the defective device or cable.

Go to "MAP 0410: Repair Checkout" in the *POWERstation and POWERserver Common Diagnostics and Service Guide*.

Step 16

(from Step 1)

1. Press the Power Off button.
2. Record the slot numbers of the adapters located on the combination planar and the optional I/O planar, and then label and record the location of any cables connected to the adapters.
3. Remove all the adapters from the combination planar and the optional I/O planar.
4. Disconnect any cables that are plugged into connectors S1, S2, and P on the rear of the CPU-media enclosure.

Note: If a terminal attached to S1 or S2 will be the system console, do not disconnect it.

5. Insert the first diagnostic diskette into the 3.5-inch diskette drive, or insert the diagnostic CD-ROM disc into the CD-ROM drive.
6. Press the Power On button.
7. Wait for one of the following conditions to occur:
 - The DIAGNOSTIC OPERATING INSTRUCTIONS screen is displayed.
 - The system stops, and c31 is displayed in the three-digit display. Follow the instructions on the display to select your console display.
 - The In Use light on the 3.5-inch diskette drive is on, and c07 is displayed in the three-digit display. Insert the next diagnostic diskette. Continue this substep until all diskettes are loaded, c31 is displayed in the three-digit display, or the DIAGNOSTIC OPERATING INSTRUCTIONS screen is displayed.
 - The system stops for at least 3 minutes, a constant number, character, or symbol other than c31 is displayed in the three-digit display, and the Power light is on.
 - The system stops, and two or more numbers with values between 221 and 296 are displayed alternately in the three-digit display.
 - The system stops, and a flashing 888 is displayed in the three-digit display.
 - The Power light does not come on, or the Power light comes on but does not stay on.

Is the DIAGNOSTIC OPERATING INSTRUCTIONS screen displayed?

- NO** The symptom has changed. Check for loose cards, loose cables, and obvious problems. If you do not find a problem, return to Step 1 in this MAP, and then follow the instructions for the new symptom.
- YES** Go to Step 17.

Step 17

(from Step 16)

1. Press the Enter key.
2. If the terminal type is not defined, you must use the **Initialize Terminal** option on the FUNCTION SELECTION menu to initialize the operating system environment before you can continue with the diagnostics. This is a separate and different operation than selecting the console display.
3. Select **Advanced Diagnostics Routines**.
4. When the DIAGNOSTIC MODE SELECTION menu displays, select **System Verification**.
5. Select **System Checkout**.

Did you get a service reference number (SRN)?

- NO** One of the adapters or devices you removed is causing the problem. Install the adapters and devices one at a time to determine the failing adapter or device. Test the system after each adapter or device is installed.
- YES** Go to Step 18.

Step 18

(from Step 17)

1. Look at the FRU part numbers related to the SRN.

Have you exchanged all the FRUs that correspond to the failing function codes?

- NO** Exchange the FRU with the highest failure percentage that has not been exchanged.
- Repeat this step until all the FRUs related to the SRN have been replaced, or **System Checkout** runs with no trouble found. Run **System Checkout** after each FRU is exchanged.
- Go to "MAP 0410: Repair Checkout" in the *POWERstation and POWERserver Common Diagnostics and Service Guide*.
- YES** Go to Step 2.

Chapter 3. Removal and Replacement Procedures

This chapter contains information about removing and replacing various field replaceable units (FRUs) and parts.

Power-On Procedure with a Power Distribution Bus

1. Set the key mode switch to the Service position.

CPU-Media Enclosure Operator Panel

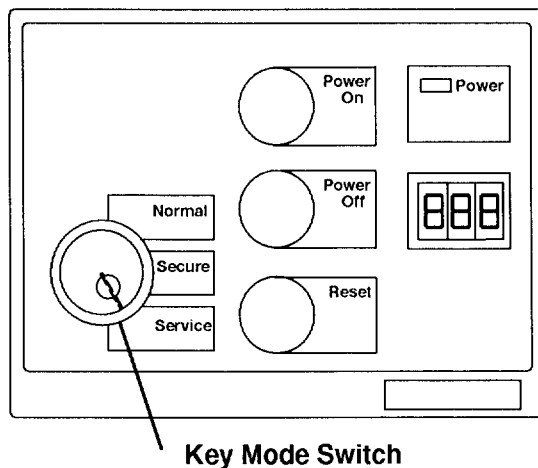

Note: For a translation of this notice, see the *System Unit Safety Information* manual

DANGER

An electrical outlet that is not correctly wired could place hazardous voltage on metal parts of the system or the devices that attach to the system. It is the responsibility of the customer to ensure that the outlet is correctly wired and grounded to prevent an electrical shock.

Before installing or removing any additional devices to or from the system, ensure that the power cables for those devices are unplugged before the signal cables are connected. If possible, disconnect all power cables from the existing system before you add a device.

Use one hand, when possible, to connect or disconnect signal cables to prevent a possible shock from touching two surfaces with different electrical potentials.

During an electrical storm, do not connect cables for display stations, printers, telephones, or station protectors for communications lines.

CAUTION:

This product is equipped with a 3-wire power cable and plug for the user's safety. Use this power cable in conjunction with a properly grounded electrical outlet to avoid electrical shock.

2. Plug the system-unit power cord into the electrical outlet.
3. Close the back door of the system unit.

4. Plug all external device power cords into the electrical outlets.
5. Switch on power to all external devices attached to the system unit.
6. Press the Power On button.

CPU-Media Enclosure Operator Panel

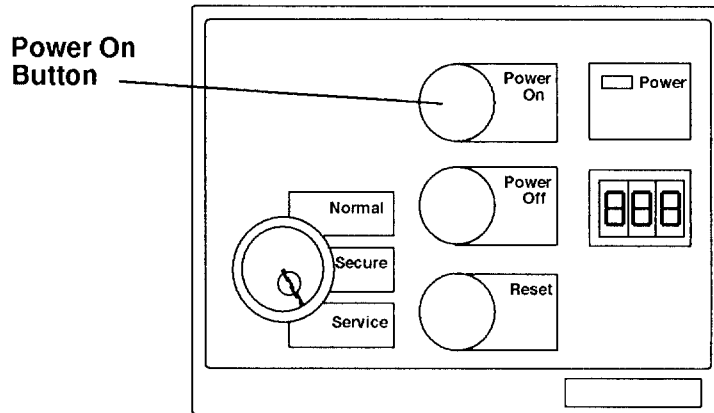

Power-Off Procedure with a Power Distribution Bus

Note: Before stopping the system unit, you must first shut down the operating system to prevent losing data.

Warning: Use the appropriate **shutdown** command before you stop the system unit; failure to do so may result in the loss of data. See your operating system documentation for information about the **shutdown** command.

1. Set the key mode switch to the Service position.
2. Press the Power Off button.

CPU-Media Enclosure Operator Panel

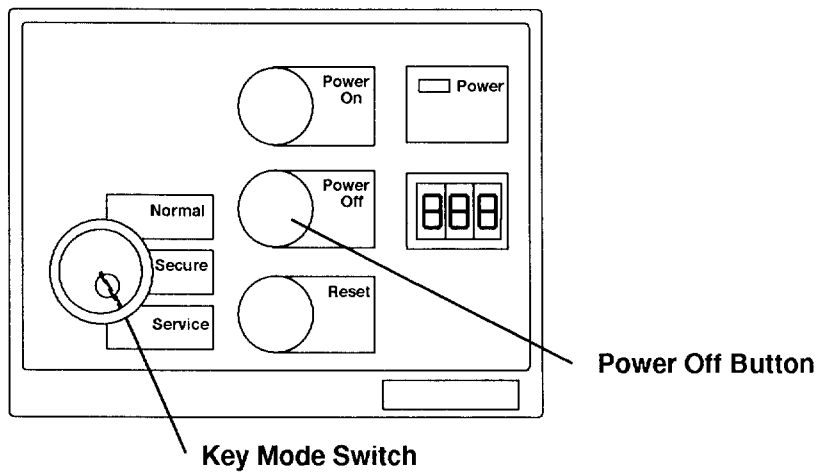

Note: For a translation of this notice, see the *System Unit Safety Information* manual.

DANGER

An electrical outlet that is not correctly wired could place hazardous voltage on metal parts of the system or the devices that attach to the system. It is the responsibility of the customer to ensure that the outlet is correctly wired and grounded to prevent an electrical shock.

Before installing or removing any additional devices to or from the system, ensure that the power cables for those devices are unplugged before the signal cables are connected. If possible, disconnect all power cables from the existing system before you add a device.

Use one hand, when possible, to connect or disconnect signal cables to prevent a possible shock from touching two surfaces with different electrical potentials.

During an electrical storm, do not connect cables for display stations, printers, telephones, or station protectors for communications lines.

Note: Because a large number of external devices can be connected to the system unit, it may be impractical for you to switch off power to all the devices and unplug their power cords.

3. Switch off power to all external devices attached to the system unit, and then unplug the device power cords from the electrical outlets.
4. Open the rear door of the system unit.

Note: If you are servicing the system with signal cables and power cords connected to the system, do not unplug the system unit power cord from the electrical outlet.

5. If you are servicing the system and signal cables and power cords are not connected to the system, unplug the system unit power cord from the electrical outlet.

Rear View of Rack

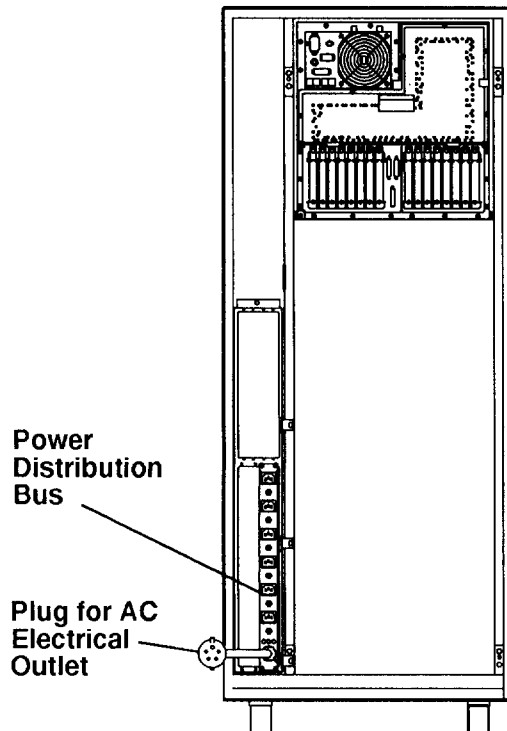

Power-On Procedure with a Power Distribution Unit

1. Set the key mode switch to the Service position.

CPU-Media Enclosure Operator Panel

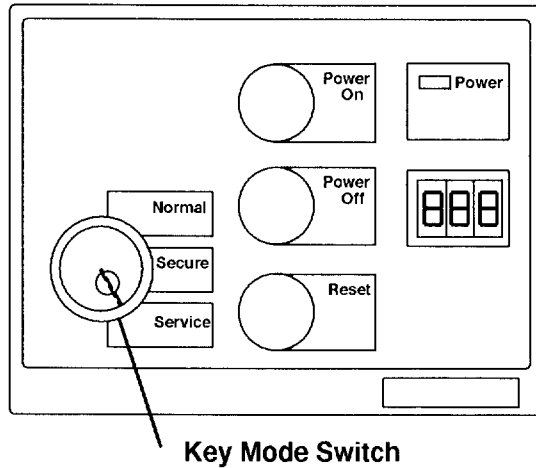

Note: For a translation of this notice, see the *System Unit Safety Information* manual.

DANGER

An electrical outlet that is not correctly wired could place hazardous voltage on metal parts of the system or the devices that attach to the system. It is the responsibility of the customer to ensure that the outlet is correctly wired and grounded to prevent an electrical shock.

Before installing or removing any additional devices to or from the system, ensure that the power cables for those devices are unplugged before the signal cables are connected. If possible, disconnect all power cables from the existing system before you add a device.

Use one hand, when possible, to connect or disconnect signal cables to prevent a possible shock from touching two surfaces with different electrical potentials.

During an electrical storm, do not connect cables for display stations, printers, telephones, or station protectors for communications lines.

CAUTION:

This product is equipped with a 3-wire power cable and plug for the user's safety. Use this power cable in conjunction with a properly grounded electrical outlet to avoid electrical shock.

2. Plug the system-unit power cord into the electrical outlet.

3. If the battery backup unit is installed, set the Master CB2 circuit breaker to On.
4. Set the Master CB1 circuit breaker to On.

Rear View of Rack

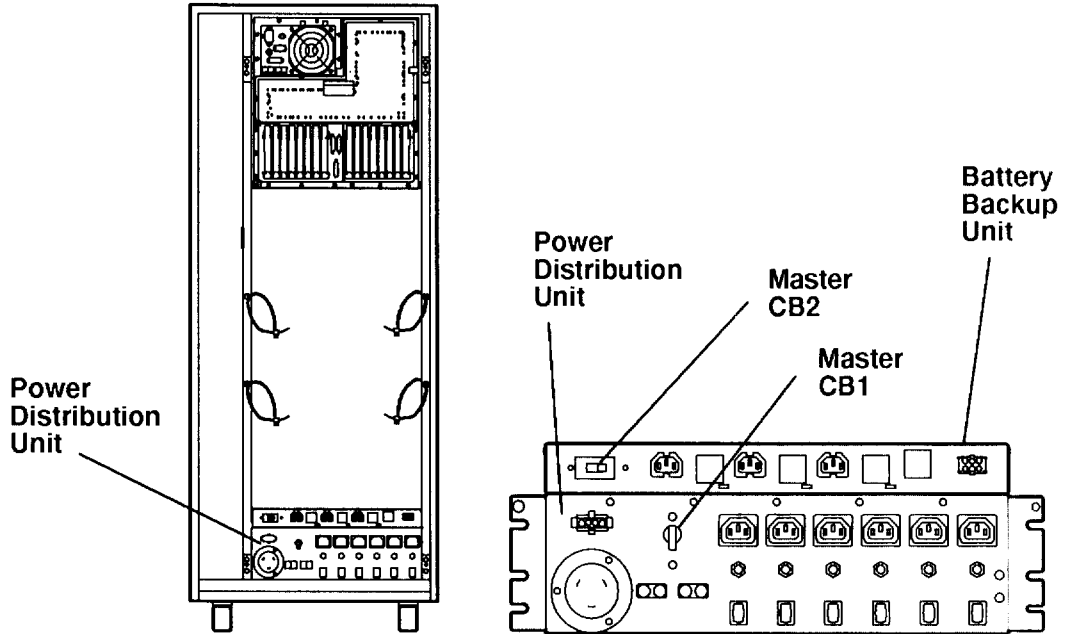

5. Close the back door of the system unit.
6. Plug all external device power cords into the electrical outlets.
7. Switch on power to all external devices attached to the system unit.

CPU-Media Enclosure Operator Panel

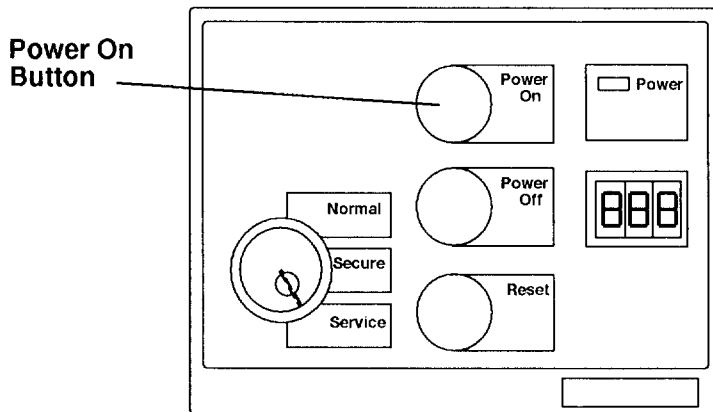

Power-Off Procedure with a Power Distribution Unit

Note: Before stopping the system unit, you must first shut down the operating system to prevent losing data.

Warning: Use the appropriate **shutdown** command before you stop the system unit; failure to do so may result in the loss of data. See your operating system documentation for information about the **shutdown** command.

1. Set the key mode switch to the Service position.
2. Press the Power Off button.

CPU-Media Enclosure Operator Panel

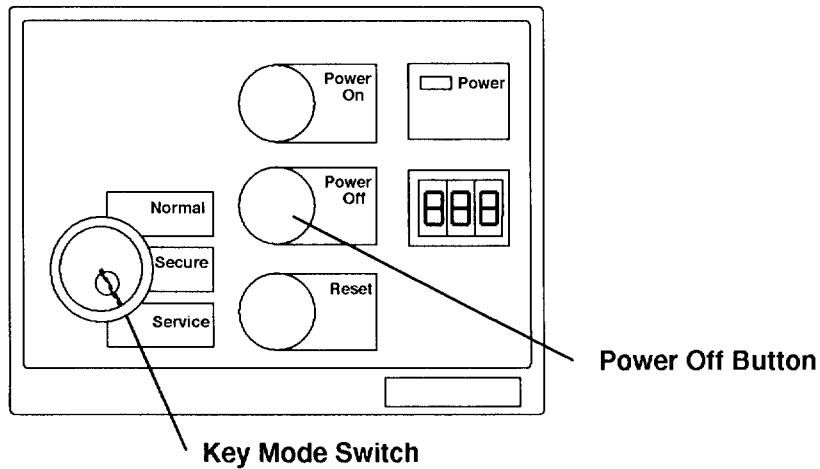

Note: For a translation of this notice, see the *System Unit Safety Information* manual.

DANGER

An electrical outlet that is not correctly wired could place hazardous voltage on metal parts of the system or the devices that attach to the system. It is the responsibility of the customer to ensure that the outlet is correctly wired and grounded to prevent an electrical shock.

Before installing or removing any additional devices to or from the system, ensure that the power cables for those devices are unplugged before the signal cables are connected. If possible, disconnect all power cables from the existing system before you add a device.

Use one hand, when possible, to connect or disconnect signal cables to prevent a possible shock from touching two surfaces with different electrical potentials.

During an electrical storm, do not connect cables for display stations, printers, telephones, or station protectors for communications lines.

3. Switch off power to all external devices attached to the system unit, and then unplug the device power cords from the electrical outlets.

Note: Because a large number of external devices can be connected to the system unit, it may be impractical for you to switch off power to all the devices and unplug their power cords.

4. Open the back door of the system unit.
5. Set the Master CB1 circuit breaker to Off.
6. If the battery backup unit is installed, set the Master CB2 circuit breaker to Off.
7. Unless you are servicing the system while signal cables or power cords are connected to external devices, unplug the system-unit power cord from the electrical outlet.

Rear View of Rack

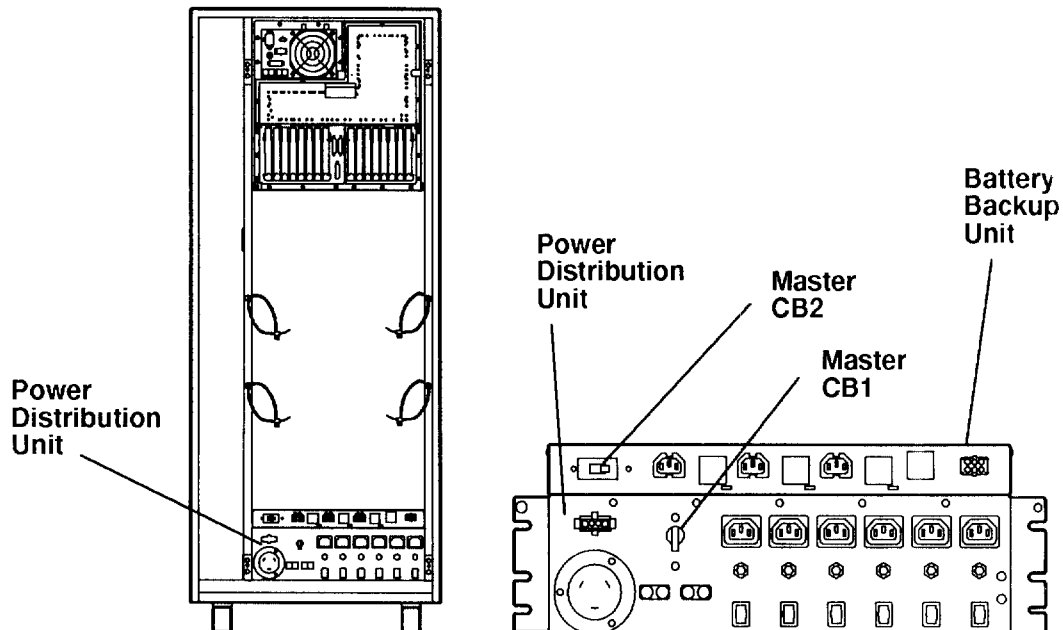

Power-On Procedure with Power Distribution Panel

1. Set the key mode switch to the Service position.

CPU-Media Enclosure Operator Panel

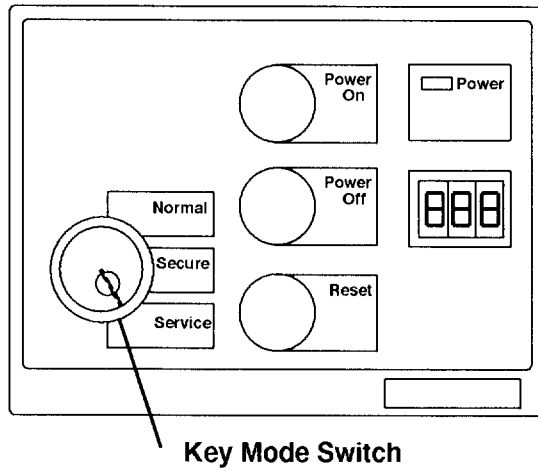

Note: For a translation of this notice, see the *System Unit Safety Information* manual.

DANGER

An electrical outlet that is not correctly wired could place hazardous voltage on metal parts of the system or the devices that attach to the system. It is the responsibility of the customer to ensure that the outlet is correctly wired and grounded to prevent an electrical shock.

Before installing or removing any additional devices to or from the system, ensure that the power cables for those devices are unplugged before the signal cables are connected. If possible, disconnect all power cables from the existing system before you add a device.

Use one hand, when possible, to connect or disconnect signal cables to prevent a possible shock from touching two surfaces with different electrical potentials.

During an electrical storm, do not connect cables for display stations, printers, telephones, or station protectors, for communications lines.

CAUTION:

Energy hazard, remove power before servicing. Disconnect two power supply cords.

2. Ensure that the four power cables (–48 V dc (–) and return (+)) from each –48 V dc power source are connected to the power distribution panel.
3. Use a multimeter to ensure that –48 V dc power is entering the rack on both A & B side.

Notes:

1. An electrical hazard from an external –48 V dc power source exists in this unit. To prevent electrical shock, ensure that power to this unit is off before servicing.
2. The customer is responsible for providing and connecting power cables from the customer's –48 V dc power source to the power distribution panel.

Rear View of Power Distribution Panel

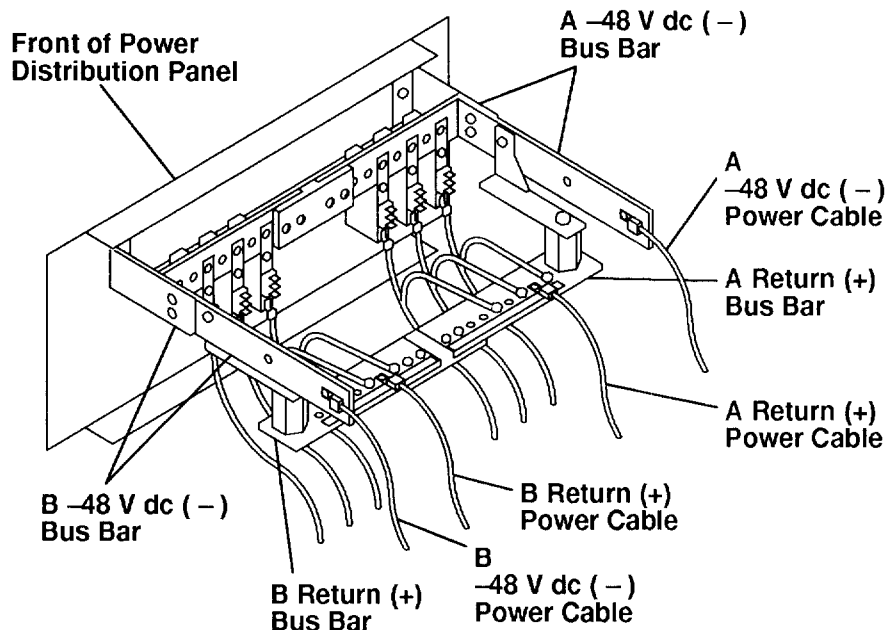

4. Ensure that all circuit breakers are on (circuit breaker switches in the up position).

Front View of Power Distribution Panel

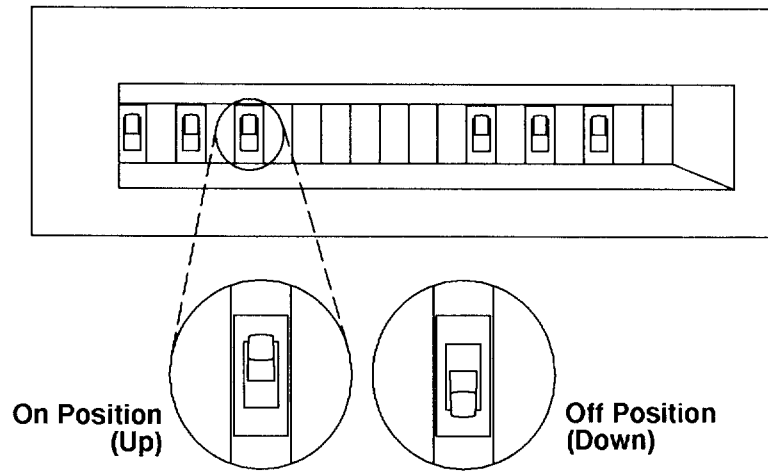

5. Plug all external device power cords into the electrical outlets.
6. Switch on power to all external devices attached to the system unit.
7. Switch on power on all of the disk drive drawers.
8. Press the Power On button.

CPU-Media-Enclosure Operator Panel

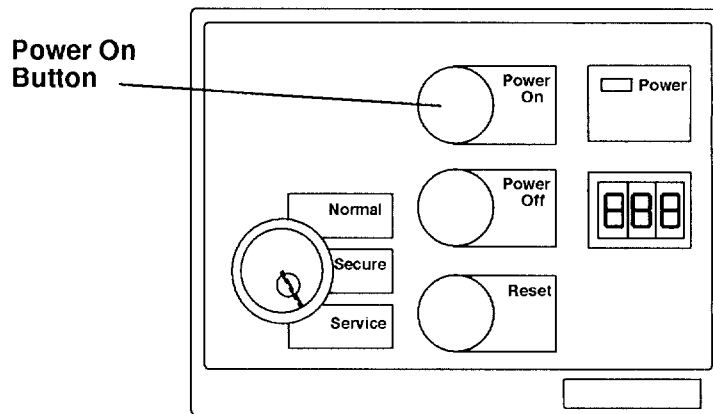

Power-Off Procedure with Power Distribution Panel

Note: Notify the customer that you are going to switch off power to the attached 7015 CPU-Media Enclosure and to all of the disk drive drawers in the rack. Notify the customer that other attached systems might be affected by this procedure.

Note: Before stopping the system unit, you must first shut down the operating system to prevent losing data.

Warning: Use the appropriate **shutdown** command before you stop the system unit; failure to do so may result in the loss of data. See your operating system documentation for information about the **shutdown** command.

1. Set the key mode switch to the Service position.
2. Press the Power Off button.

CPU-Media Enclosure Operator Panel

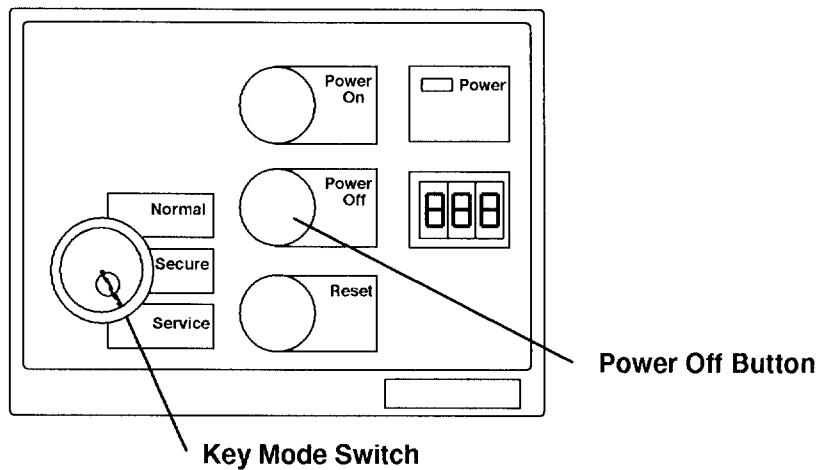

Note: For a translation of this notice, see the *System Unit Safety Information* manual.

DANGER

An electrical outlet that is not correctly wired could place hazardous voltage on metal parts of the system or the devices that attach to the system. It is the responsibility of the customer to ensure that the outlet is correctly wired and grounded to prevent an electrical shock.

Before installing or removing any additional devices to or from the system, ensure that the power cables for those devices are unplugged before the signal cables are connected. If possible, disconnect all power cables from the existing system before you add a device.

Use one hand, when possible, to connect or disconnect signal cables to prevent a possible shock from touching two surfaces with different electrical potentials.

During an electrical storm, do not connect cables for display stations, printers, telephones, or stations protectors, for communications lines.

3. Switch off power on all disk drive drawers in the rack.
4. Switch off power to all external devices attached to the system unit, and then unplug the device power cords from the electrical outlets.
5. Except for any circuit breaker that is connected to an attached system unit, set all circuit breaker switches to the off position (down).

CAUTION:

Energy hazard, remove power before servicing. Disconnect two power supply cords.

Notes:

1. An electrical hazard from an external -48 V dc power source exists in this unit. To prevent electrical shock, ensure that power to this unit is off before servicing
2. Because a large number of external devices can be connected to the system unit, it may be impractical for you to switch off power to all the devices and unplug their power cords.

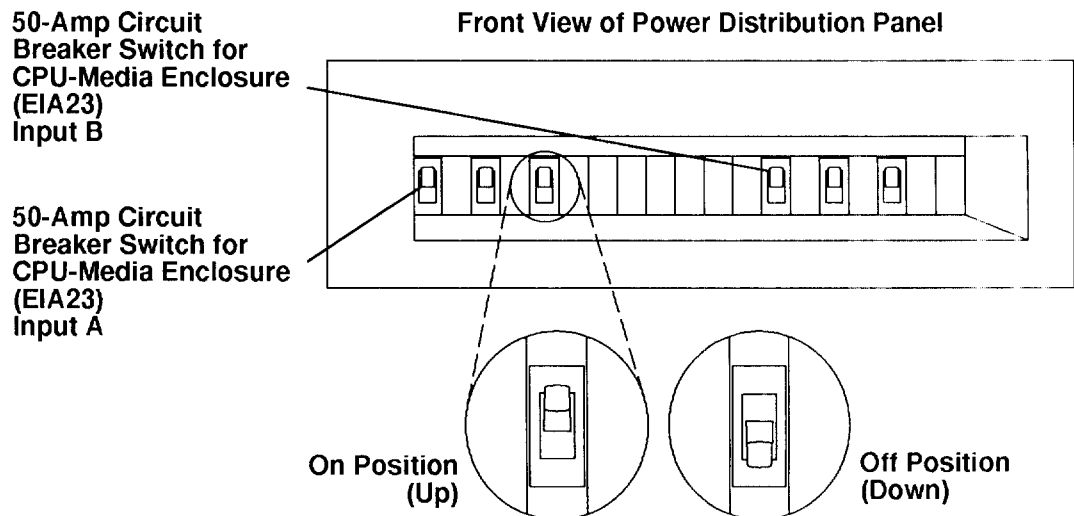

Handling Static-Sensitive Devices

Warning: Adapters, boards, diskette drives, and disk drives can be damaged by electrostatic discharge. These devices are wrapped in antistatic bags to prevent this damage. Refer to the illustration.

Take the following precautions:

- Do not remove the device from the antistatic bag until you are ready to install the device.
- If you have an antistatic wrist strap available, use it while handling the device.
- With the device still in its antistatic bag, touch it to the metal frame of the system.
- Grasp cards and boards by the edges. Hold drives by the frame. Avoid touching the solder joints or pins.
- If you need to lay the device down while it is out of the antistatic bag, lay it on the antistatic bag. Before you pick up the device again, touch the antistatic bag and the metal frame of the system at the same time.
- Handle the devices carefully to prevent permanent damage.

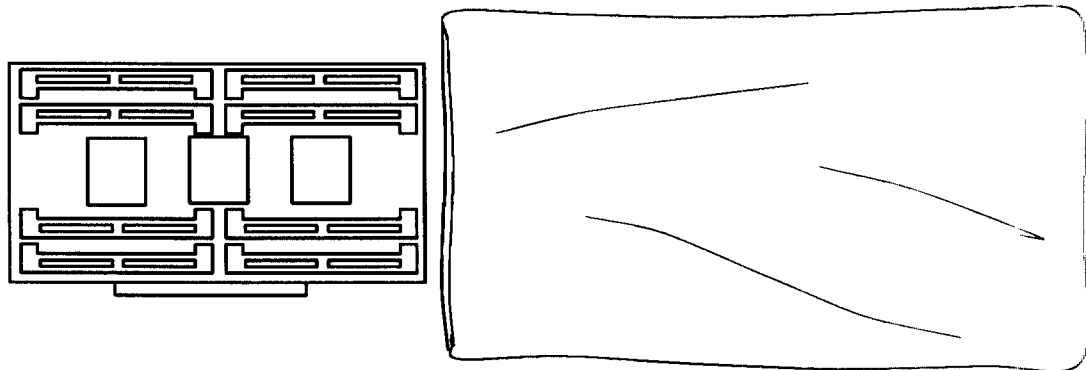

Antistatic Bag

Front Bezel and Front Access Plate

Removal

Note: For a translation of this notice, see the *System Unit Safety Information* manual, order number SA23-2652.

CAUTION:

This drawer is fixed and should not be moved for servicing. Attempting to move the drawer partially or completely out of the rack can turn over the rack or cause the drawer to fall out of the rack.

1. If your system has a power distribution unit, do the “Power-Off Procedure with a Power Distribution Unit” on page 3-7. If your system has a power distribution bus, do the “Power-Off Procedure with a Power Distribution Bus” on page 3-3.
2. To remove the front bezel, do the following:
 - a. Grasp the bottom handle on each side of the front bezel and pull the bottom of the bezel away from the enclosure until the bezel disengages.
 - b. Grasp the top handle on each side of the front bezel and pull the bezel away from the enclosure.

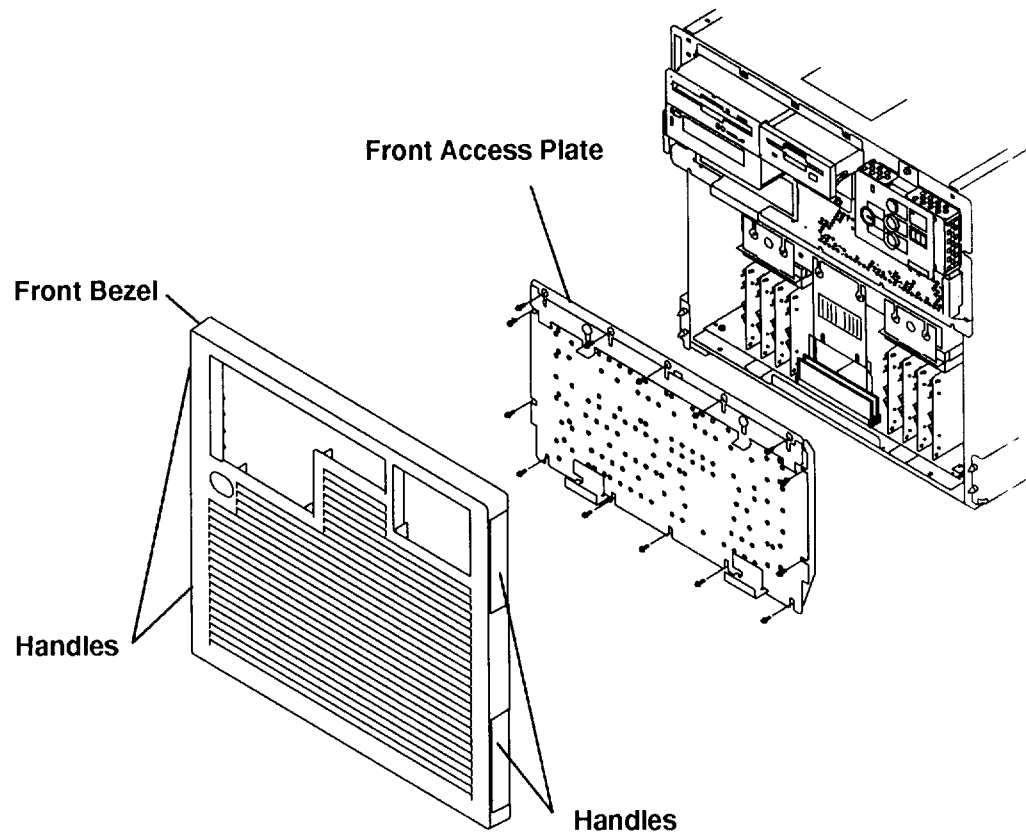

3. To remove the front access plate, do the following:
 - a. Remove the two hex head screws from the screw slots located on each side of the front access plate. The four hex head screws must be replaced when the rack is moved or shipped.
 - b. Loosen all of the mounting screws at the top and bottom of the front access plate.
 - c. Slide the sliding retainer bracket down until it disengages from the top mounting screws.
 - d. Rotate the top of the front access plate toward you until the top screw holes clear the top mounting screws, and then lift the front access plate away from the CPU-media enclosure.

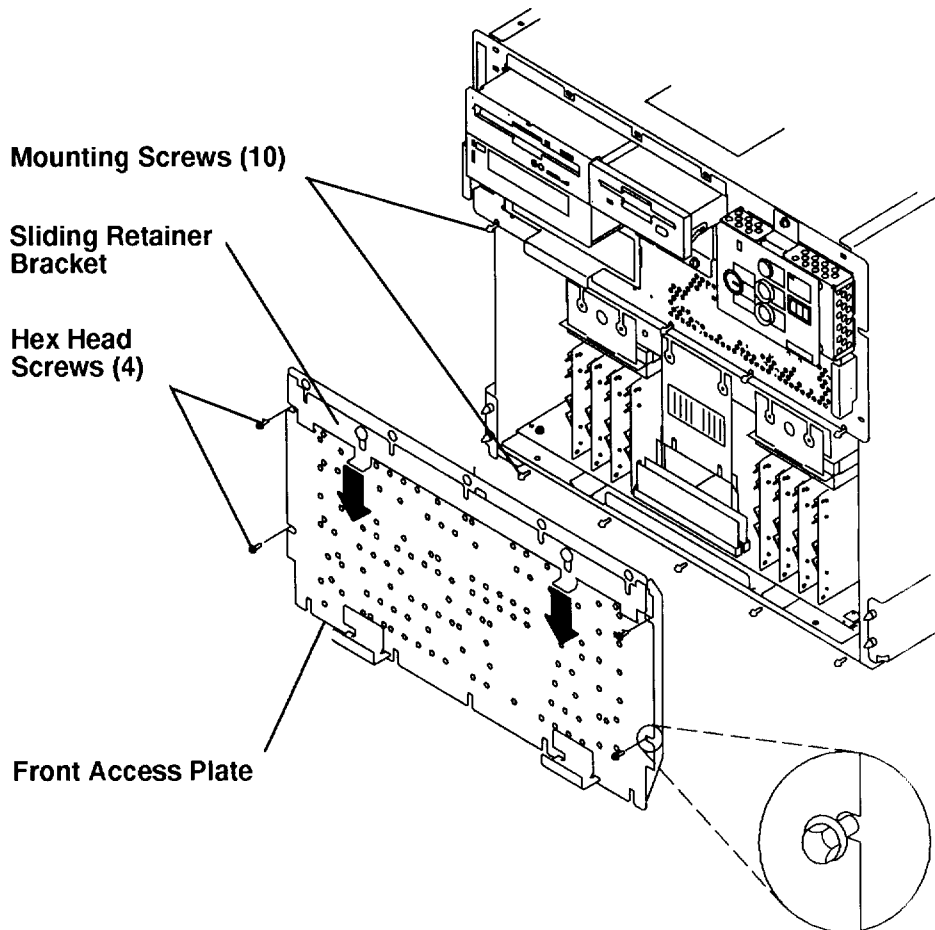

Replacement

Note: Ensure that the grounding strips located on the left and right side covers of the CPU-media enclosure are firmly attached before replacing the front access plate.

Replace in the reverse order. If the enclosure was serviced and your rack contains a power distribution unit, then do the “Power-On Procedure with a Power Distribution Unit” on page 3-5. If your rack contains a power distribution bus, do the “Power-On Procedure with a Power Distribution Bus on page 3-1.

Memory Card

Note: Refer to “Handling Static-Sensitive Devices” on page 3-14 before removing or installing memory cards.

Removal

1. Do the “Front Bezel and Front Access Plate” removal procedure on page 3-15.
2. Loosen the two screws on the memory-card-retainer bracket, and slide the bracket up until it stops; then tighten the two screws to retain the bracket in the up position.
3. Lift the memory card retainer to clear the memory cards, and then pull it out of the CPU-media enclosure.
4. Record the slot location of the memory card.
5. Lift the memory card out of the slot, and then remove it from the CPU-media enclosure.
6. If you are removing a single in-line memory module (SIMM) from the memory card, refer to the “Memory SIMM” removal and replacement procedure on page 3-19.

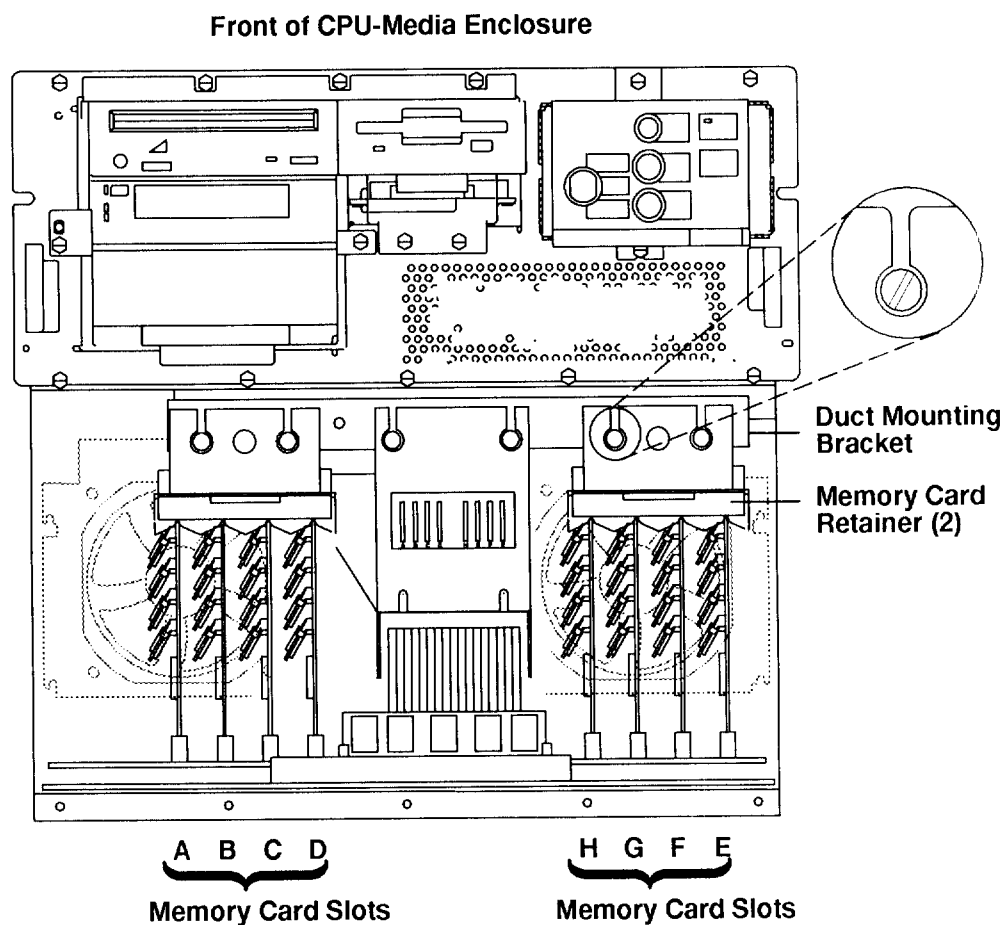

Replacement

Replace in the reverse order.

Notes:

1. Install the memory cards in pairs that have the same amount of memory. Install the first pair of memory cards in slots D and H, the second pair in slots B and F, the third pair in slots C and G, and the fourth pair in slots A and E.
2. Ensure that the memory card retainer is positioned correctly over each memory card; then, while pushing down on the memory-card-retainer bracket, tighten the two screws on the bracket.

For more information about memory cards and memory types, refer to Appendix G in the *POWERstation and POWERserver Common Diagnostics and Service Guide*.

Memory SIMM

Removal

1. Do the “Front Bezel and Front Access Panel” removal procedure on page 3-15.
2. Do the “Memory Card” removal procedure on page 3-17.
3. Release the retainer tabs by gently pulling them past the ends of the SIMM.
4. Rotate the SIMM away from the bottom of the card, and pull it away from the socket.

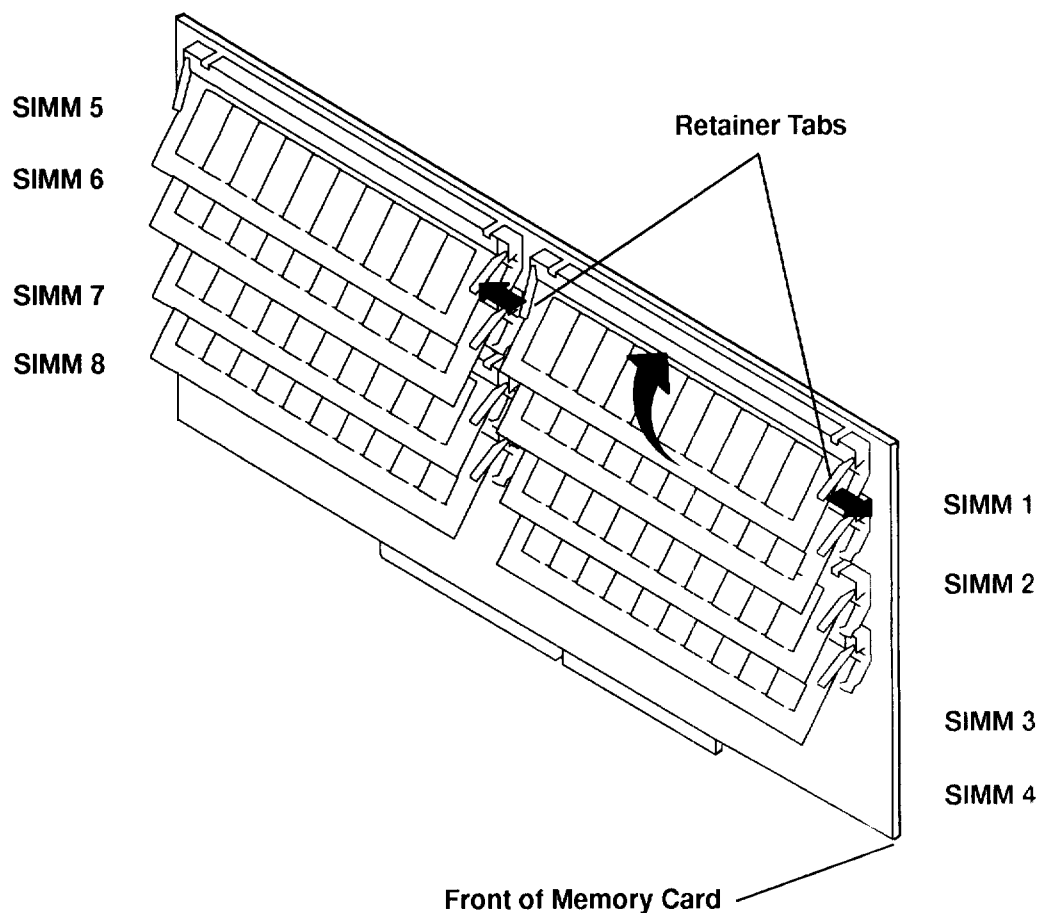

Replacement

1. Place the SIMM in the keyed socket on the memory card; then press the SIMM into the socket and toward the bottom of the memory card until the retainer tabs snap into place.
2. Replace the memory card. Refer to the “Memory Card” procedure on page 3-17.

For information about memory type, SIMM size, and SIMM part numbers, refer to Appendix G in the *POWERstation and POWERserver Common Diagnostics and Service Guide*.

Cache SIMM

Removal

1. Do the “Front Bezel and Front Access Panel” removal procedure on page 3-15.
- Note:** To access the cache SIMMs, you may need to remove some the memory cards on both sides of the cache SIMMs.
2. Remove the memory card in the H position. Refer to the “Memory Card” removal procedure on page 3-17 to remove the memory card.

Front View of CPU-Media Enclosure

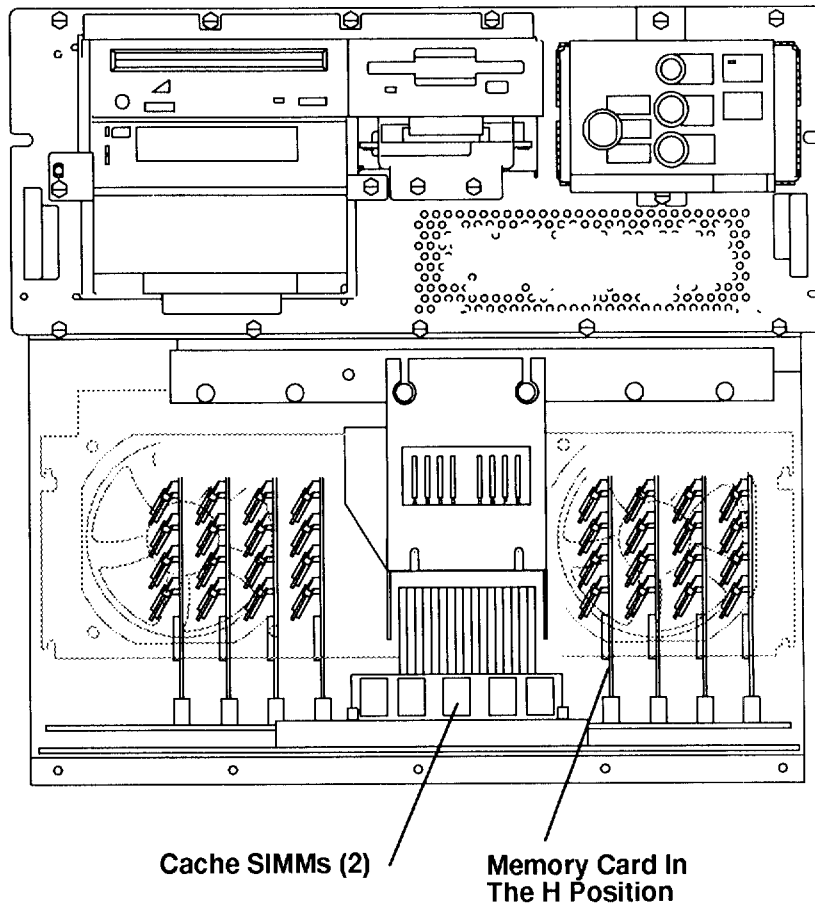

3. Lift the cache SIMM straight up, and then remove the cache SIMM.

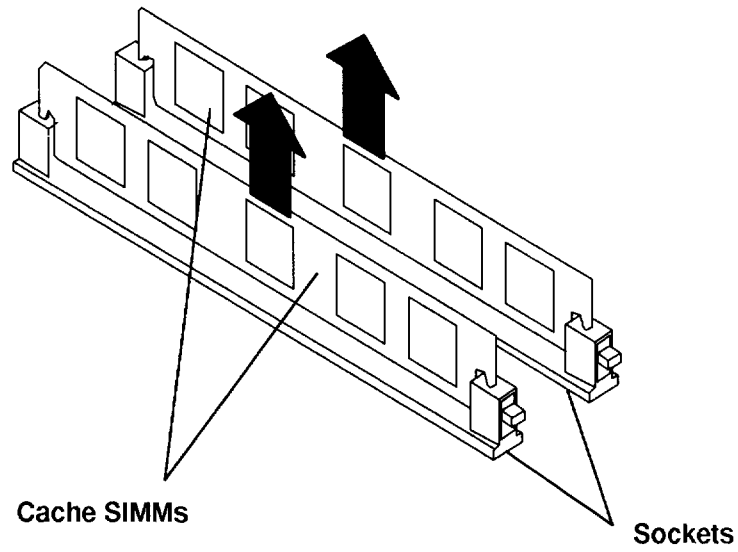

Replacement

Replace in the reverse order.

CPU Planar Assembly

Note: The lever tool (part number 43G0466) is necessary to remove and replace the CPU planar assembly. The lever tool is stored inside the rear of the rack to the right of the CPU-media enclosure.

Removal

1. Do the “Memory Card” removal procedure on page 3-17 to remove all of the memory cards from the CPU-media enclosure.
2. Do the “Cache SIMM” removal procedure on page 3-20 to remove the two cache SIMMs.
3. Loosen the two retainer screws on the air duct assembly.
4. Lift the front of the air duct assembly until the screw holes are aligned with the retainer screws, and then move the air duct assembly toward you and out of the CPU-Media Enclosure.

Front of CPU-Media Enclosure

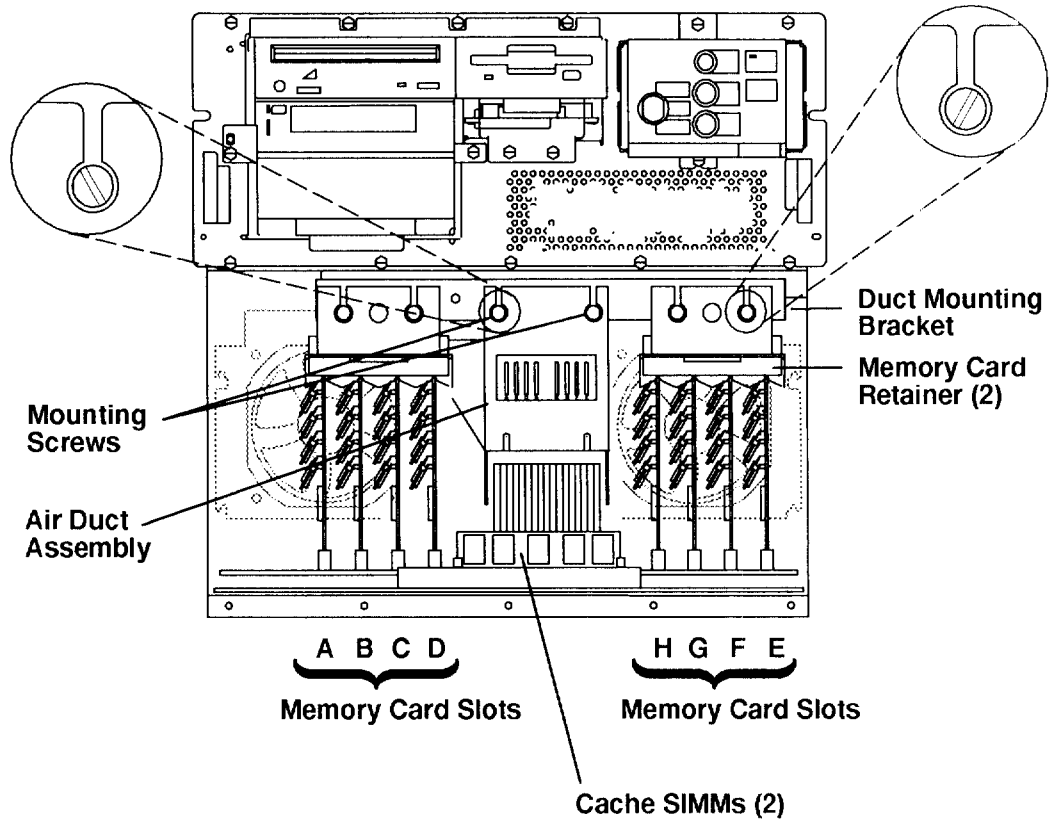

5. Disconnect power connectors P16 and P17.
6. Remove the two planar-plate mounting screws holding the CPU planar assembly in the CPU-media enclosure.

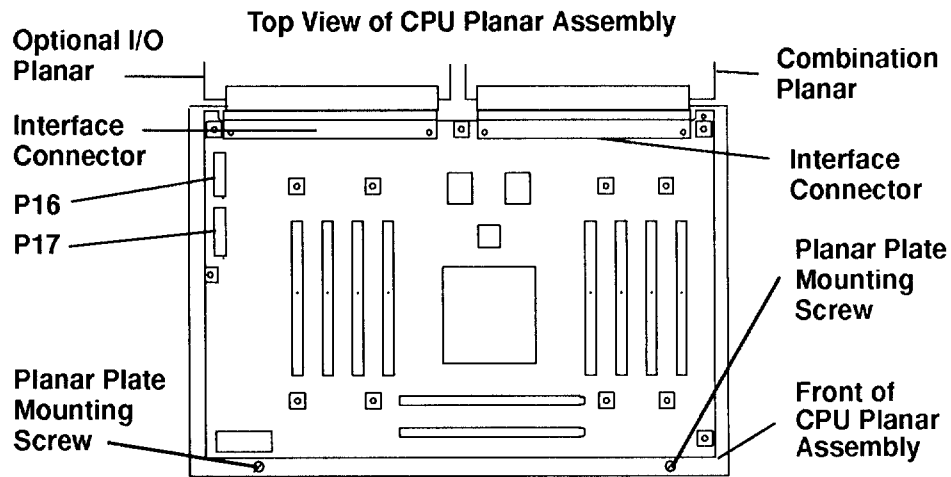

Warning: Do not lift the CPU planar until it is disconnected from the combination planar and the optional I/O planar.

7. To disconnect the interface connectors on the CPU planar from the optional I/O planar and the combination planar, do the following:
 - a. Place the lever tool over the middle of the CPU-planar-assembly handle.
 - b. With the two straight tabs of the lever tool on the outside of the CPU-planar-assembly handle and the curved tab on the inside of the handle, slide the lever tool down until the two straight tabs are positioned over the frame of the CPU-media enclosure
 - c. Pull the top of the lever tool toward you until the two interface connectors disengage, and then remove the lever tool.

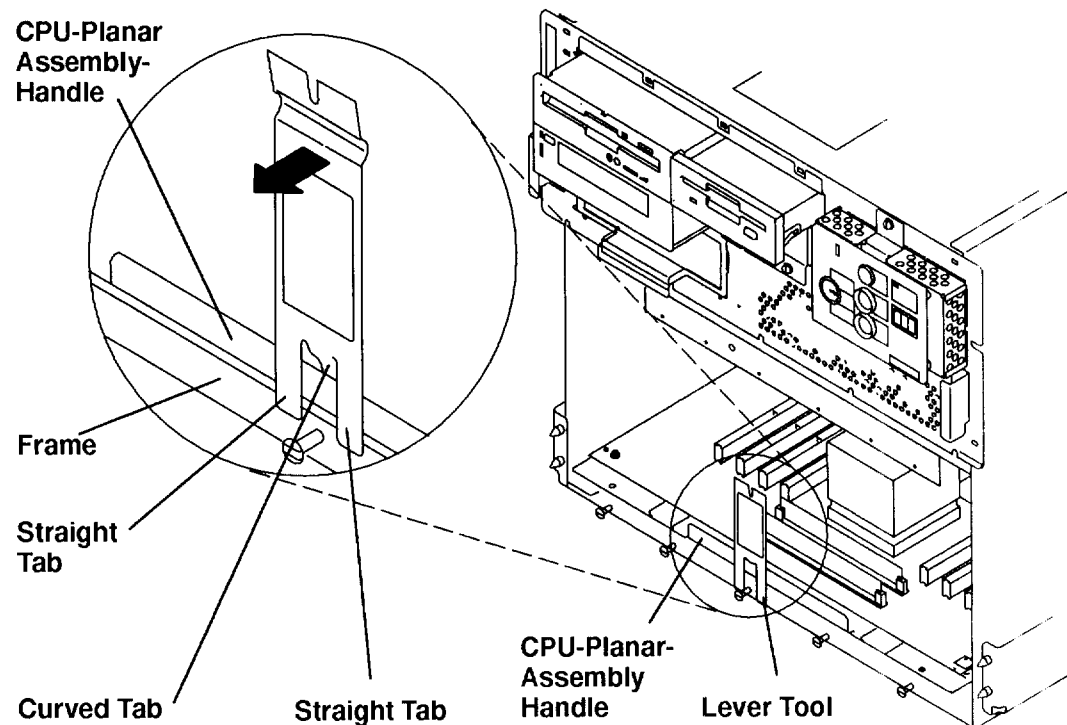

8. Grasp the handle of the CPU planar assembly, and then slide the assembly out of the CPU-media enclosure.
9. Remove the 12 mounting screws holding the CPU planar to the CPU planar plate.

Note: If you exchanged the CPU planar, notify the customer that the unique identification number of the system unit has changed. The customer must update the authorization for programs using the identification number.

Top View of CPU Planar Assembly

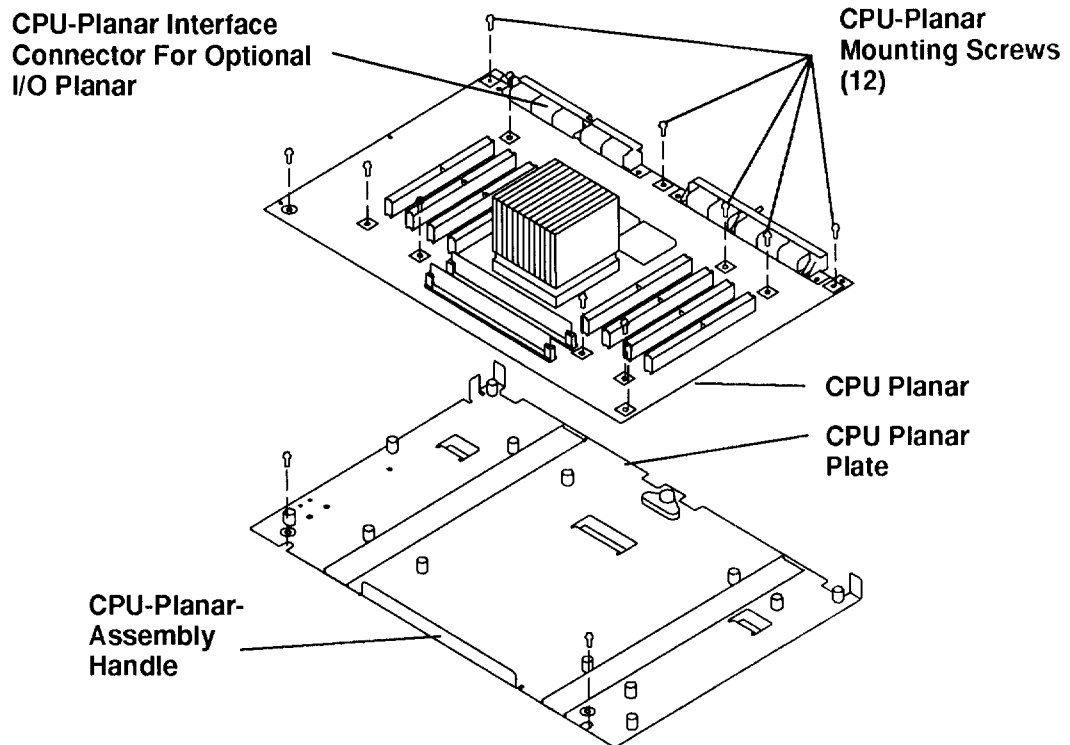

Replacement

To connect the CPU-planar interface connectors to the interface connectors on the combination planar and the optional I/O planar, do the following:

1. After the CPU planar is attached to the CPU planar plate, slide the assembly into the CPU-media enclosure, and then position the CPU-planar interface connectors against the connectors on the combination planar and the optional I/O planar until the connector pins are aligned.
2. Place the slotted end of the lever tool on the center mounting screw; the curve near the slotted end of the lever tool should be against the CPU-planar-assembly handle. In this position, the top of the lever tool is tilted away from the CPU-media enclosure.

Warning: Do not push too hard on the top of the lever tool when connecting the CPU-planar interface connectors to the interface connectors on the combination planar and the optional I/O planar. Pushing too hard on the top of the lever tool may damage the interface connector pins or the CPU planar.

3. Push the top of the lever tool toward the CPU-media enclosure until the two CPU planar interface connectors engage firmly with the interface connectors on the combination planar and the optional I/O planar.
4. Remove the lever tool and store it inside the rear of the rack to the right of the CPU-media enclosure.

Replace in reverse order.

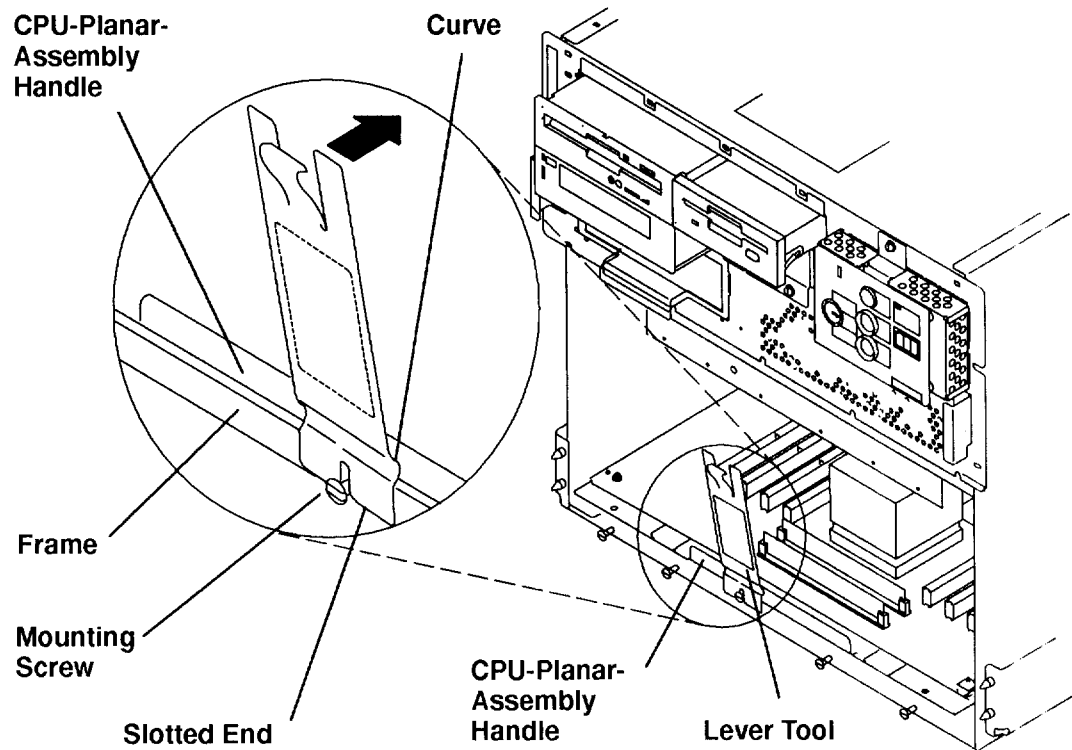

Planar Fan Assembly

Removal

1. Do the "CPU Planar Assembly" removal procedure on page 3-22 to remove the air deflector, the memory card retainer, the memory cards, and the buffer SIMMs.
Note: For diagnostic purposes, ensure that the planar-fan power connectors (P83, P84, and P85) are connected into the correct connectors on the bracket.
2. Disconnect the three power connectors (P83, P84, and P85) from the planar fan assembly.
3. Loosen the six retainer screws holding the planar fan assembly.
4. Slide the planar fan assembly upward until the screw holes are aligned with the retainer screws, and then pull the assembly out of the CPU-media enclosure.

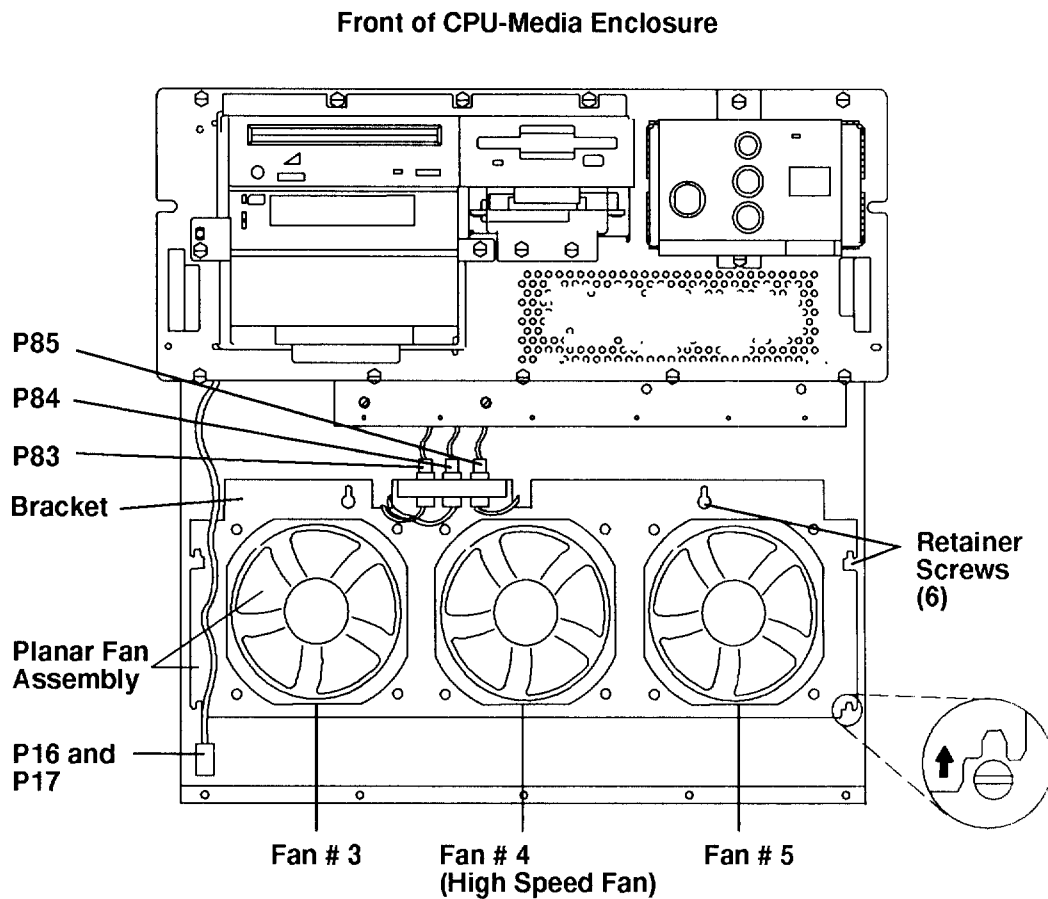

Note: The middle fan (fan #4) is a high speed fan.

5. If you are exchanging only a fan and not the planar fan assembly, do the following to remove the fan from the planar fan assembly:
 - a. Remove the fan power connector (J83, J84, or J85) from the top of the bracket.
 - b. Pull the fan away from the bracket until the vibration isolators disengage from the fan or from the bracket.

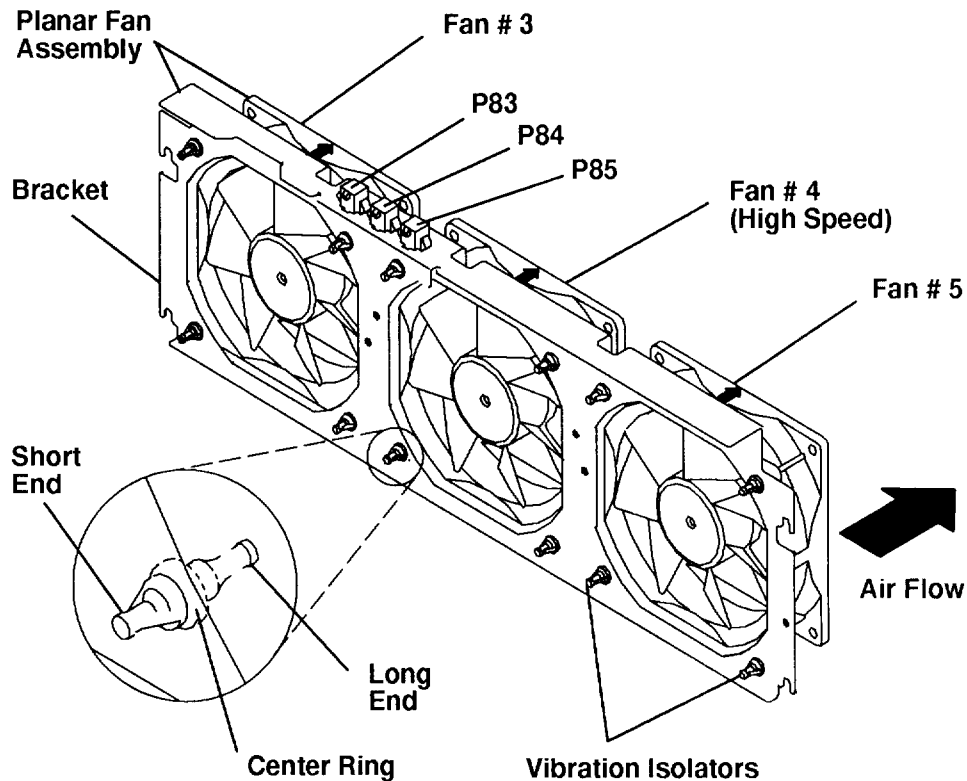

Replacement

Note: For diagnostic purposes, ensure that the planar-fan power connectors (P83, P84, and P85) are connected into the correct connectors (J83, J84, and J85) on the bracket.

To replace the vibration isolators when replacing a fan, do the following:

1. Check the direction of the air flow marked on the fan, and then place the long end of the vibration isolator through the mounting hole of the fan.
2. Pull the long end of the vibration isolator through the mounting hole until the center ring of the vibration isolator is against the fan.
3. Repeat the two previous steps until all four vibration isolators are mounted on the fan.
4. After all four vibration isolators are mounted on the fan, place the short end of each vibration isolator through the mounting holes of the planar-fan-assembly bracket.
5. Pull the short end of each vibration isolator through the mounting holes of the bracket until the center ring of the vibration isolator is against the bracket.

Replace in the reverse order.

Operator Panel Assembly

Removal

1. If your system has a power distribution unit, do the “Power-Off Procedure with a Power Distribution Unit” on page 3-7. If your system has a power distribution bus, do the “Power-Off Procedure with a Power Distribution Bus” on page 3-3.
2. Remove the front bezel from the CPU-media enclosure. Refer to the “Front Bezel and Front Access Plate” removal procedure on page 3-15 for information about removing the bezel.

Front View of CPU-Media Enclosure

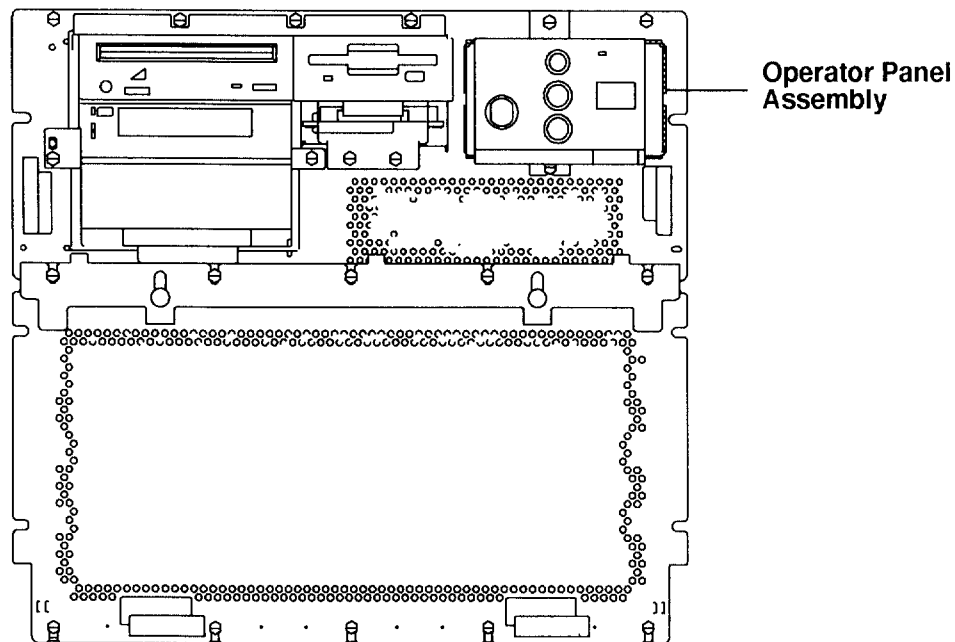

3. To remove the operator panel assembly, do the following:
 - a. Loosen the bottom mounting screw.
 - b. Remove the top mounting screw.
 - c. Slide the operator panel assembly up until the bottom mounting bracket disengages from the mounting screw.
 - d. Move the operator panel assembly away from the CPU-media enclosure to access the power connector.
 - e. To disconnect the power connector, place a finger in the pull loop of the connector, and then pull the connector straight out.
 - f. Remove the operator panel assembly.

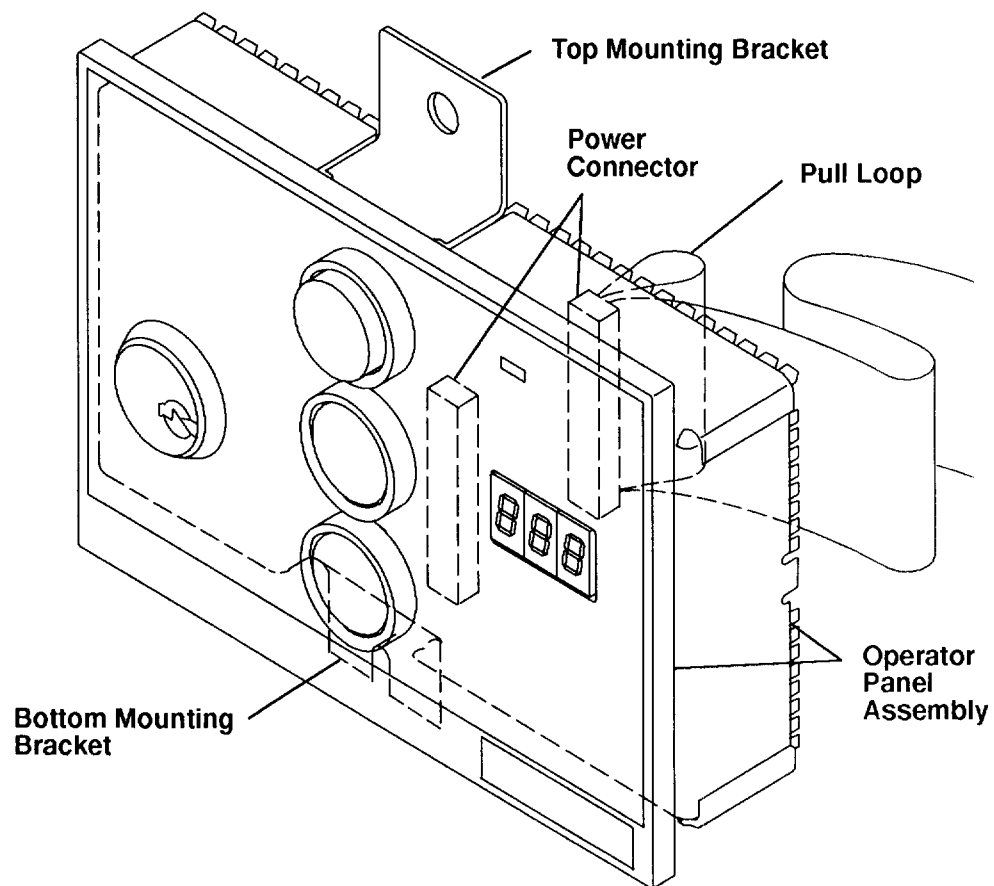

Replacement

Replace in the reverse order. If the enclosure was serviced and your rack contains a power distribution unit, then do the “Power-On Procedure with a Power Distribution Unit” on page 3-5. If your rack contains a power distribution bus, do the “Power-On Procedure with a Power Distribution Bus on page 3-1.

Note: When you have finished the removal and replacement procedure, tell the customer to set the system time and date, the alternate bootlist, and any other settings stored in NVRAM.

Battery

Note: For a translation of this notice, see the *System Unit Safety Information* manual, form number SA23-2652.

CAUTION:

A lithium battery can cause fire, explosion, or a severe burn. Do not recharge, disassemble, heat above 100°C (212°F), solder directly to the cell, incinerate, or expose cell contents to water. Keep away from children. Replace only with the part number specified for your system. Use of another battery may present a risk of fire or explosion.

The battery connector is polarized; do not attempt to reverse the polarity.

Dispose of the battery according to local regulations.

Removal

1. If your system has a power distribution unit, do the “Power-Off Procedure with a Power Distribution Unit” on page 3-7. If your system has a power distribution bus, do the “Power-Off Procedure with a Power Distribution Bus” on page 3-3.
2. Remove the front bezel from the CPU-media enclosure. Refer to the “Front Bezel and Front Access Plate” removal procedure on page 3-15 for information about removing the bezel.
3. To remove the operator panel assembly, do the following:
 - a. Loosen the bottom mounting screw, and then remove the top mounting screw.
 - b. Slide the operator panel assembly up until the bottom mounting bracket disengages from the mounting screw.

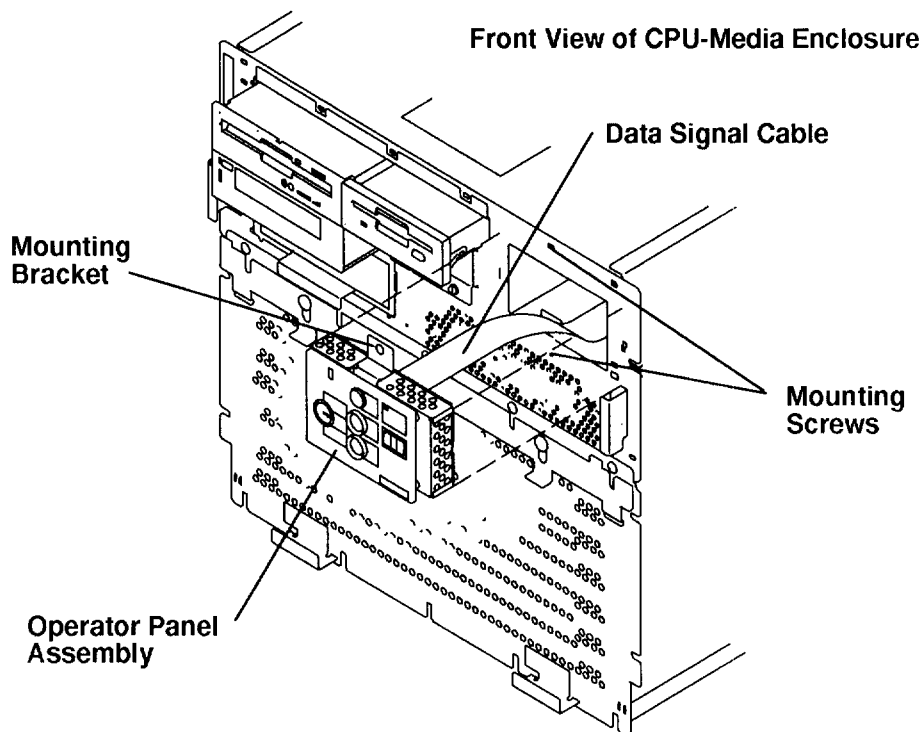

4. To access the battery, tilt the top of the operator panel assembly away from the CPU-media enclosure until the battery is exposed.
5. Disconnect power connector P3, and then remove the battery and the battery power cable by pulling the battery away from the hook and loop fastener.

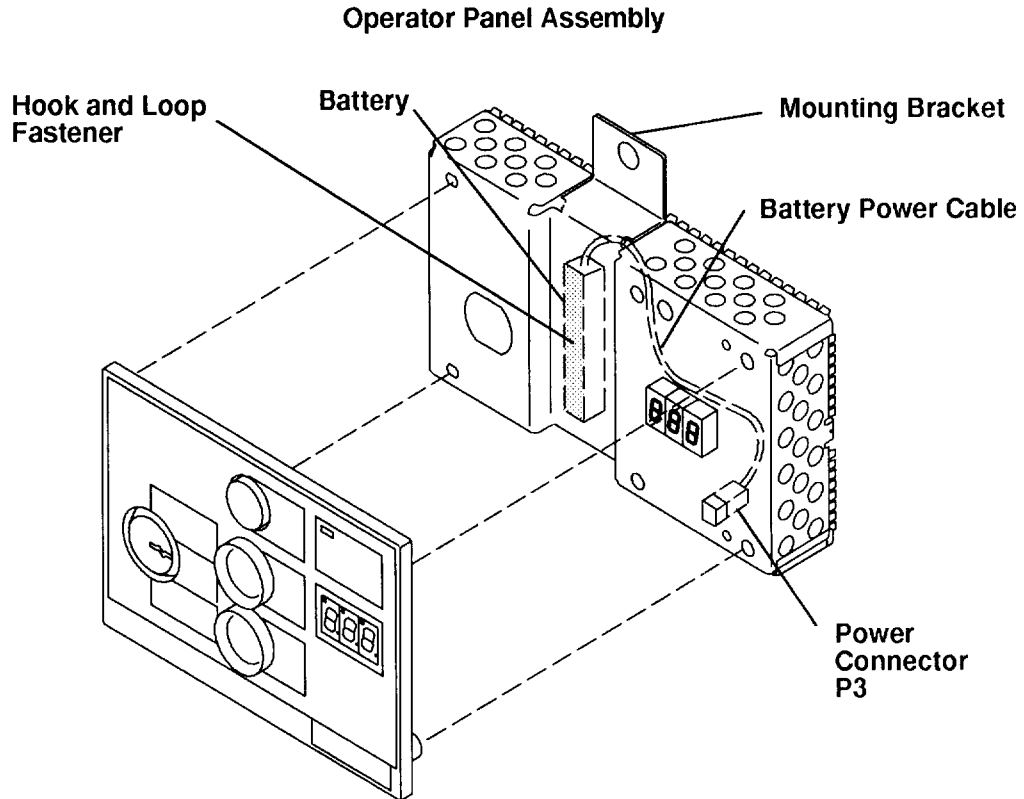

Replacement

Replace in the reverse order. If the enclosure was serviced and your rack contains a power distribution unit, then do the “Power-On Procedure with a Power Distribution Unit” on page 3-5. If your rack contains a power distribution bus, do the “Power-On Procedure with a Power Distribution Bus on page 3-1.

Note: When you have finished the removal and replacement procedure, tell the customer to set the system time and date, the alternate bootlist, and any other settings stored in NVRAM.

Key Mode Switch

Removal

1. If your system has a power distribution unit, do the “Power-Off Procedure with a Power Distribution Unit” on page 3-7. If your system has a power distribution bus, do the “Power-Off Procedure with a Power Distribution Bus” on page 3-3.
2. Remove the front bezel from the CPU-media enclosure. Refer to the “Front Bezel and Front Access Plate” removal procedure on page 3-15 for information about removing the bezel.
3. Do the “Operator Panel Assembly” removal procedure on page 3-28.
4. Disconnect power connector P2 from the operator panel card.
5. Remove the nut and lockwasher from the key mode switch, and then remove the switch.

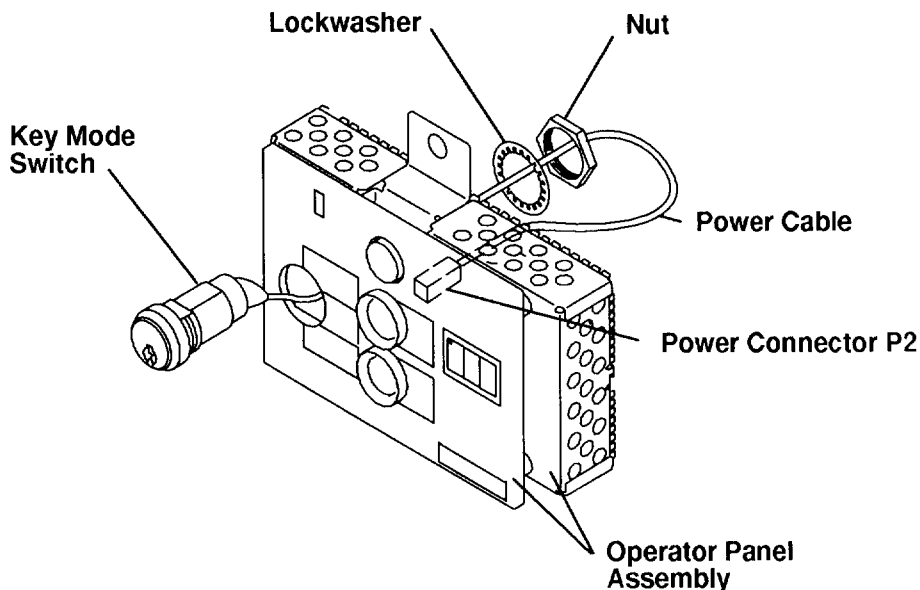

Replacement

Replace in the reverse order. If the enclosure was serviced and your rack contains a power distribution unit, then do the “Power-On Procedure with a Power Distribution Unit” on page 3-5. If your rack contains a power distribution bus, do the “Power-On Procedure with a Power Distribution Bus on page 3-1.

Note: When you have finished the removal and replacement procedure, tell the customer to set the system time and date, the alternate bootlist, and any other settings stored in NVRAM.

Media Devices, Fan, and Carrier Assembly

Removal

1. If your system has a power distribution unit, do the “Power-Off Procedure with a Power Distribution Unit” on page 3-7. If your system has a power distribution bus, do the “Power-Off Procedure with a Power Distribution Bus” on page 3-3.
2. Remove the front bezel from the CPU-media enclosure. Refer to the “Front Bezel and Front Access Plate” removal procedure on page 3-15 for information about removing the bezel.
3. Remove the two mounting screws located on the front of the media carrier.
4. Grasp the media carrier handle, and then pull the carrier toward you until the connectors at the rear of the devices disengage from the docking assembly.
5. Pull the media carrier toward you until the restraint tabs in the rear of the carrier contact the front of the CPU-media enclosure.
6. While sliding the media carrier toward you, rotate the front of the carrier upward until the restraint tabs clear the CPU-media enclosure, and then place the media carrier on a stable surface.

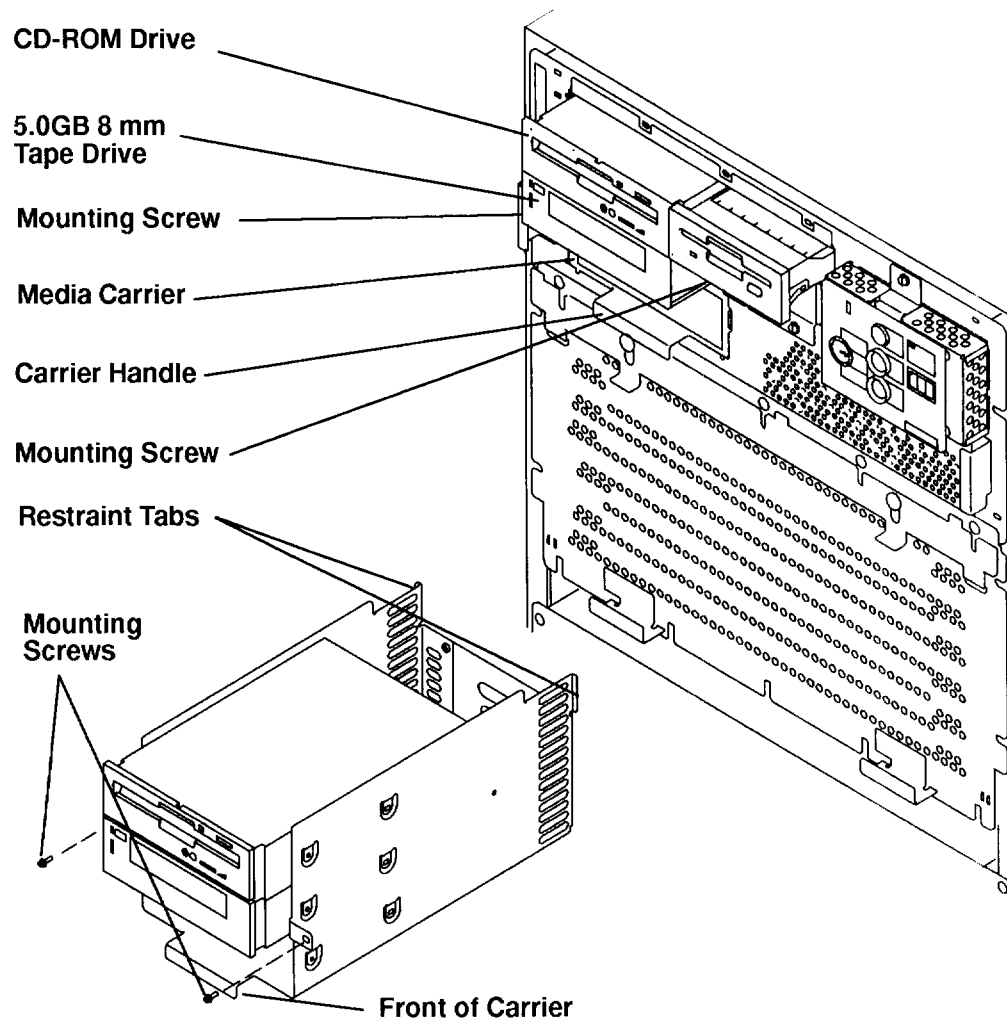

7. Remove the media fan assembly by doing the following:
 - a. Disconnect the fan power cable connector.
 - b. Remove the two mounting screws, and then lift the fan assembly out of the media carrier.
 - c. If you are removing only the fan and not the bracket, pull the fan away from the bracket until the vibration isolators disengage either from the fan or from the bracket.

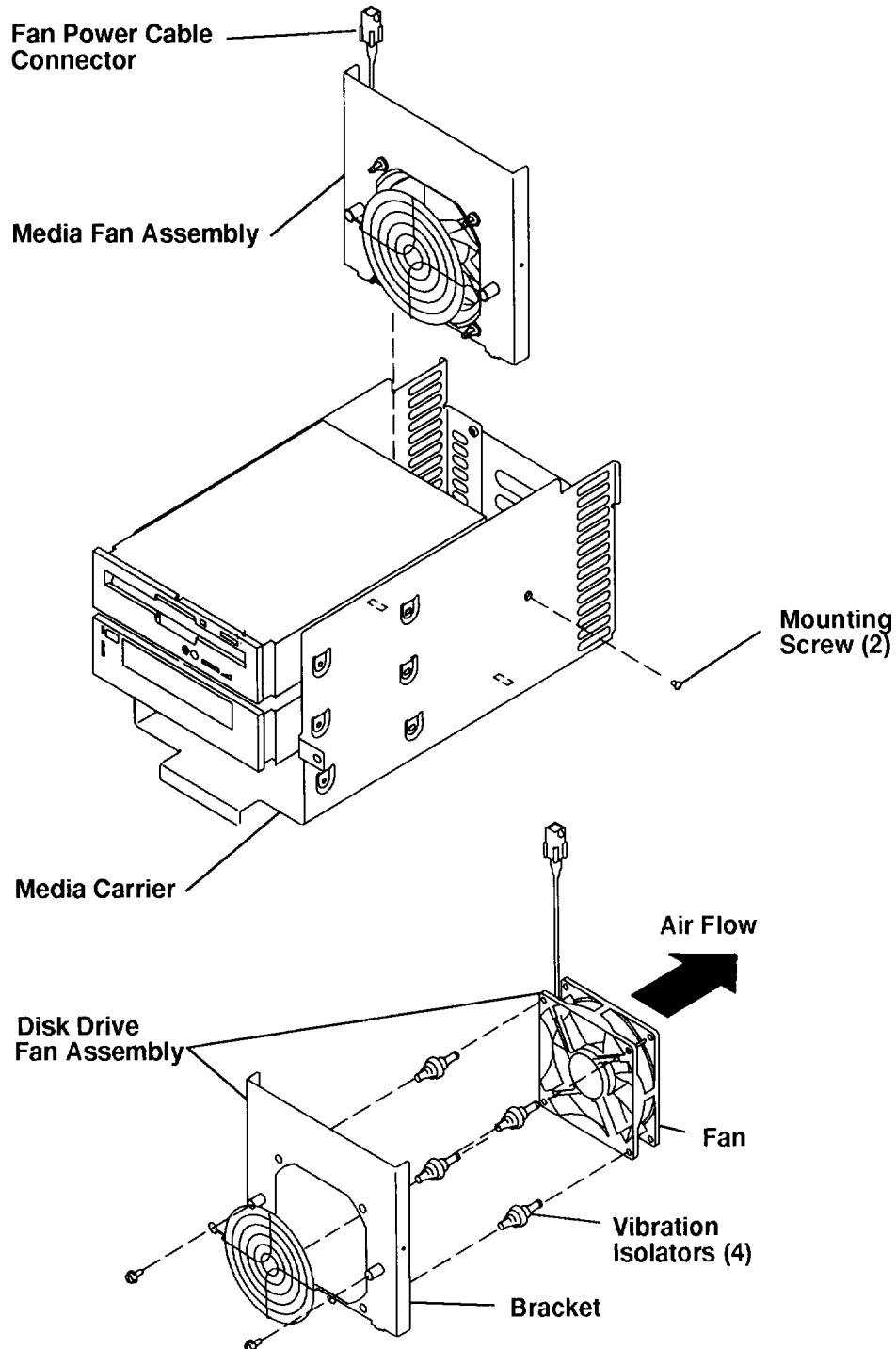

CAUTION:

A class 3 laser is contained in the device. Do not attempt to operate the drive while it is disassembled. Do not attempt to open the covers of the drive as it is not serviceable and is to be replaced as a unit.

Note: The CD-ROM drive is located in the top position and the 5.0 GB 8 mm tape drive is located in the middle position. An optional media device may be installed in the bottom position. If any media devices are located above the media device you want to remove, perform step 8 to remove the devices.

Then perform step 8 again to remove the desired media device.

8. To remove a media device, do the following:
 - a. Disconnect the data signal cable and the power cable.
 - b. Remove the four mounting screws holding the media device in the media carrier.
 - c. Pull the media device toward you, and then remove it from the media carrier.

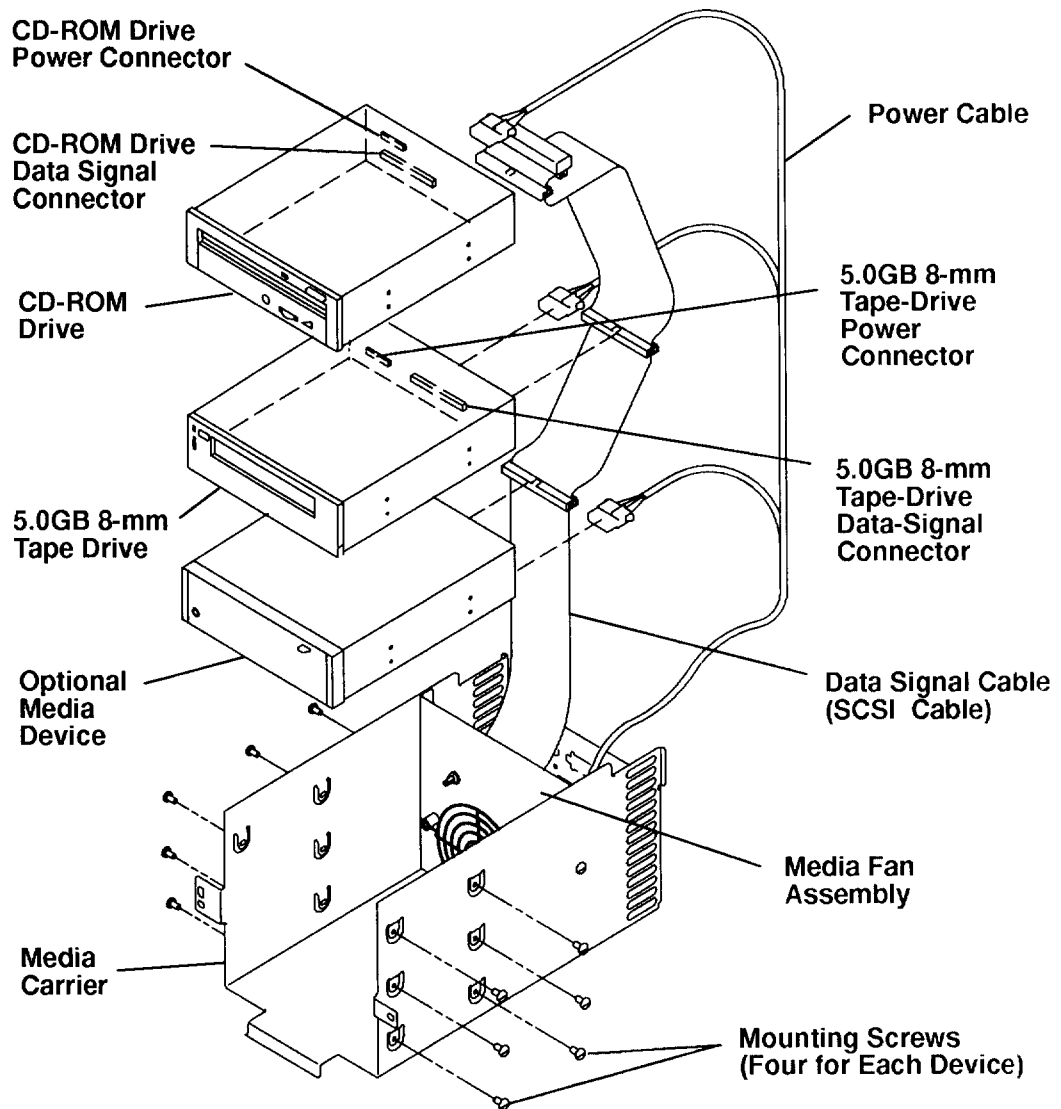

Replacement

Notes:

1. Refer to Chapter 9 of the *POWERstation and POWERserver Common Diagnostics and Service Guide* for information about setting the SCSI address or terminator resistor.
2. When replacing the media devices in the media carrier, first replace the media device in the bottom position (if used), then replace the media device in the middle position, and then replace the media device in the top position.

To align the screw holes on the media device with the mounting holes on the media carrier, perform the following steps:

1. Place the media device in the desired position in the media carrier, and then connect the data signal cable connector and power cable connector to the rear of the media device.
2. Turn the media carrier on the side to align the mounting holes of the carrier with the screw holes of the disk drive.
3. Insert two mounting screws, and then slightly tighten the screws. Do not fully tighten the mounting screws of the media devices until all media devices are installed.
4. Turn the media carrier on the other side; insert the other two mounting screws, and then slightly tighten the screws.
5. Repeat steps 1, 2, 3, and 4 of this replacement procedure to replace the media devices located in other positions of the media carrier.
6. After all media devices are installed, tighten all of the mounting screws on all media devices.

Replace in the reverse order. If the enclosure was serviced and your rack contains a power distribution unit, then do the "Power-On Procedure with a Power Distribution Unit" on page 3-5. If your rack contains a power distribution bus, do the "Power-On Procedure with a Power Distribution Bus on page 3-1.

3.5-Inch Diskette Drive

Removal

1. If your system has a power distribution unit, do the “Power-Off Procedure with a Power Distribution Unit” on page 3-7. If your system has a power distribution bus, do the “Power-Off Procedure with a Power Distribution Bus” on page 3-3.
2. Remove the front bezel from the CPU-media enclosure. Refer to the “Front Bezel and Front Access Plate” procedure on page 3-15 for information about removing the front bezel.
3. Remove the two mounting screws on the mounting bracket located below the diskette drive.

Front of CPU-Media Enclosure

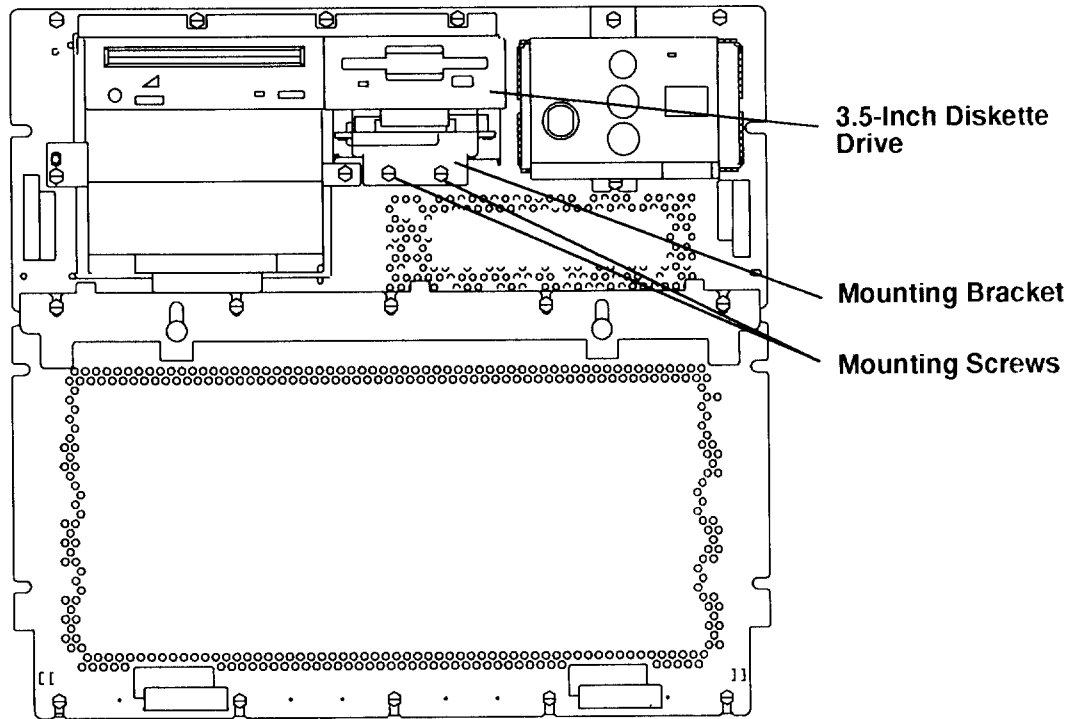

- Slide the diskette drive out of the CPU-media enclosure, and hold the drive in one hand.
- Disconnect the data signal cable connector and the power cable connector from the 3.5-inch diskette drive, and then remove the 3.5-inch diskette drive from the CPU-media enclosure.
- Remove the four mounting screws attaching the 3.5-inch diskette drive to the mounting bracket, and then remove the 3.5-inch diskette drive.

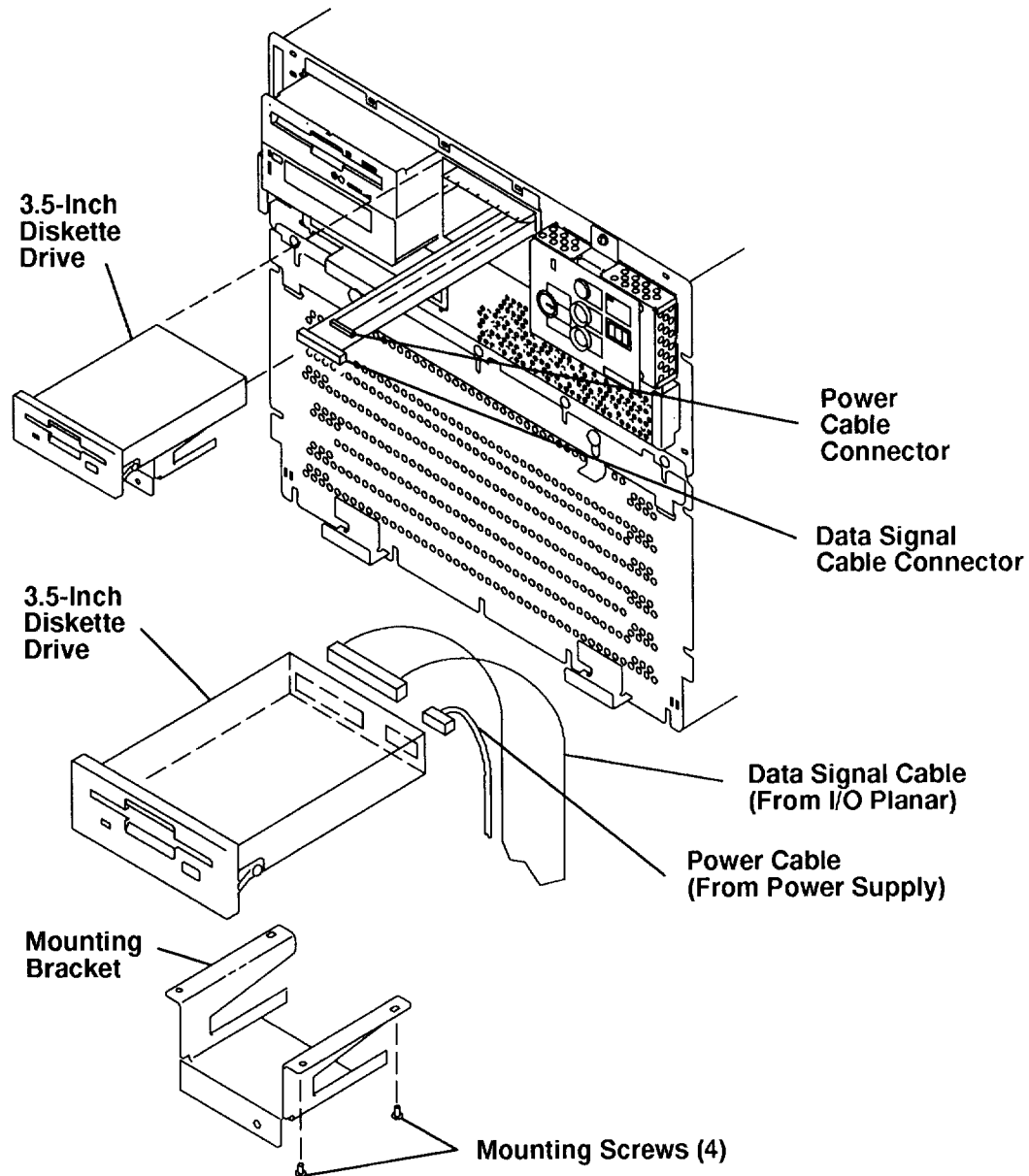

Replacement

Replace in the reverse order. If the enclosure was serviced and your rack contains a power distribution unit, then do the "Power-On Procedure with a Power Distribution Unit" on page 3-5. If your rack contains a power distribution bus, do the "Power-On Procedure with a Power Distribution Bus on page 3-1.

Rear Access Plate

Removal

1. If your system has a power distribution unit, do the “Power-Off Procedure with a Power Distribution Unit” on page 3-7. If your system has a power distribution bus, do the “Power-Off Procedure with a Power Distribution Bus” on page 3-3.
2. Remove all of the cable ties from the top cable-restraint mounting bracket.
3. Remove the two mounting screws attaching the top cable-restraint mounting bracket, and then remove the bracket.

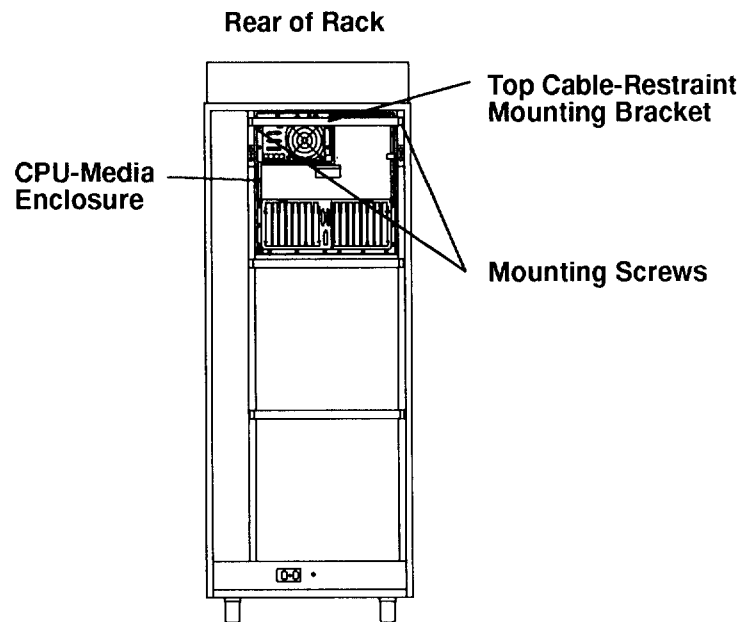

4. Remove the six mounting screws attaching the rear access plate to the CPU-media enclosure.
5. Grasp the handle of the rear access plate, and then rotate the top of the rear access plate toward you until the binding tension from the gasket is lessened.
6. Pull the rear access plate straight out, and remove it from the CPU-media enclosure.

Rear View of CPU-Media Enclosure

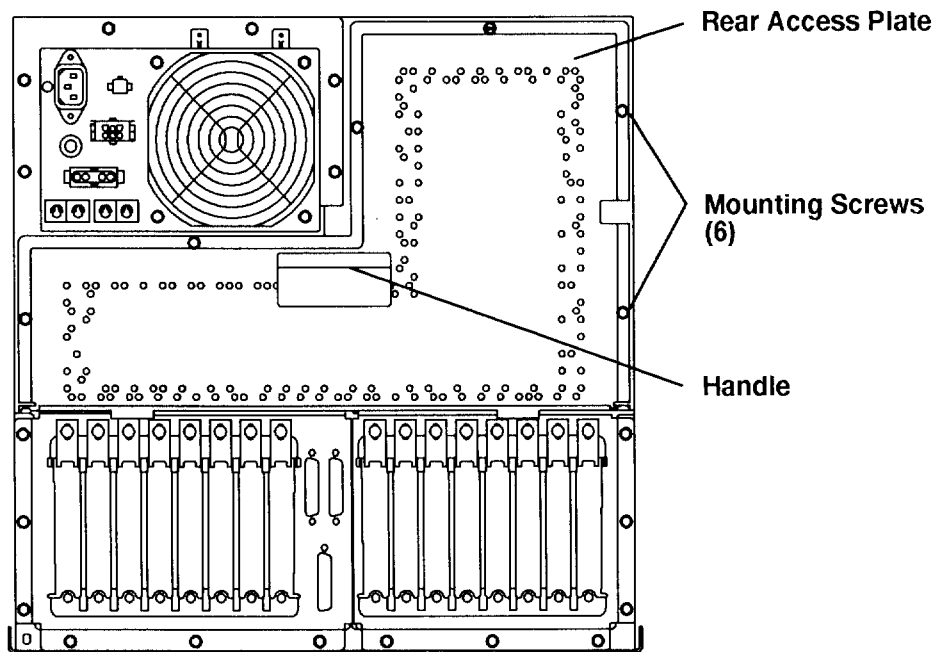

Replacement

1. With the top of the rear access plate tilted away from the CPU-media enclosure, place the bottom of the access plate onto the top of the adapter and the optional adapter bulkheads.
 Make sure the gasket on the bottom of the rear access plate is positioned on top of the bulkheads.
2. Check the alignment of the screw holes on the top of the rear access plate with the screw holes on the frame of the CPU-media enclosure by pushing the top of the rear access plate against the CPU-media enclosure.
 If the holes are not aligned, tilt the top of the rear access plate toward you, and then slide the rear access plate in the direction necessary to align the screw holes.
3. Push the top of the rear access plate toward the CPU-media enclosure, insert the six mounting screws, and then tighten all of the screws.
4. Replace the cable restraint mounting bracket.
5. Replace in the reverse order. If the enclosure was serviced and your rack contains a power distribution unit, then do the "Power-On Procedure with a Power Distribution Unit" on page 3-5. If your rack contains a power distribution bus, do the "Power-On Procedure with a Power Distribution Bus on page 3-1.

Remote Reset Assembly

Removal

1. If your system has a power distribution unit, do the “Power-Off Procedure with a Power Distribution Unit” on page 3-7. If your system has a power distribution bus, do the “Power-Off Procedure with a Power Distribution Bus” on page 3-3.
2. Disconnect the external cable connected to the remote reset assembly connector located on the outside of the rear access plate.
3. Remove the six mounting screws on the rear access plate.

Note: Because the internal cable is connected to the remote reset assembly which is mounted to the inside of the rear access plate, be careful when pulling the rear access plate away from the CPU-Media Enclosure.

4. To access the remote reset assembly, gently pull the rear access plate away from the CPU-Media Enclosure.

Rear View of CPU-Media Enclosure

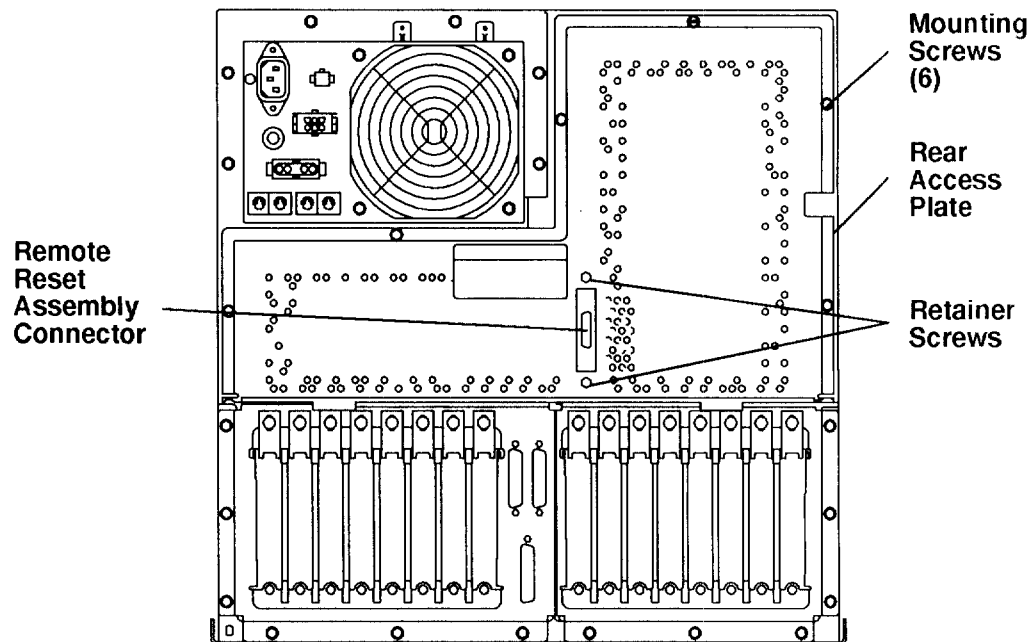

5. Disconnect the internal cable connected to the remote reset assembly, and then remove the rear access plate away from the CPU-Media Enclosure.

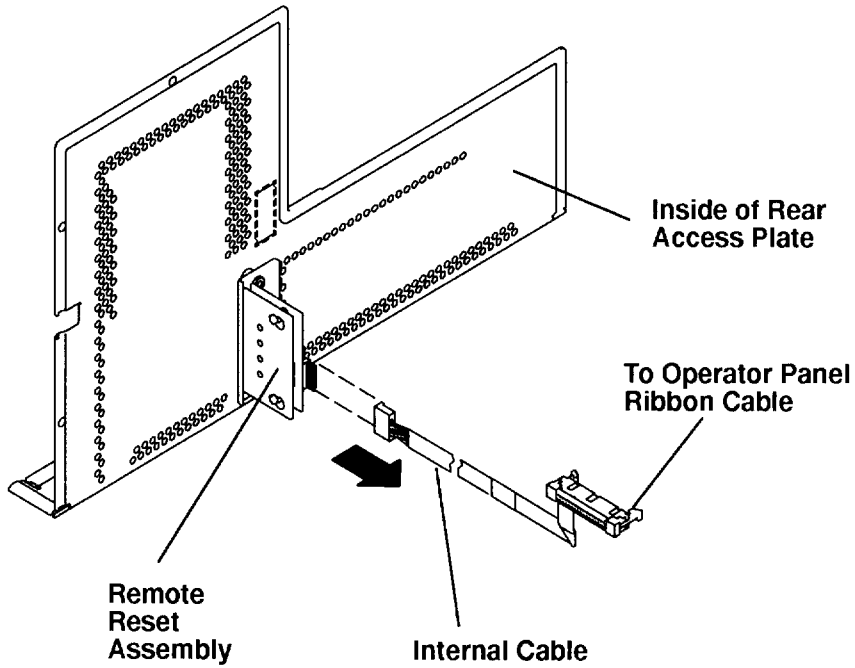

6. While holding the remote reset assembly located on the inside of the rear access plate, loosen the two retainer screws located on the outside of the rear access plate until the assembly is released from the screws, and then remove the remote reset assembly.

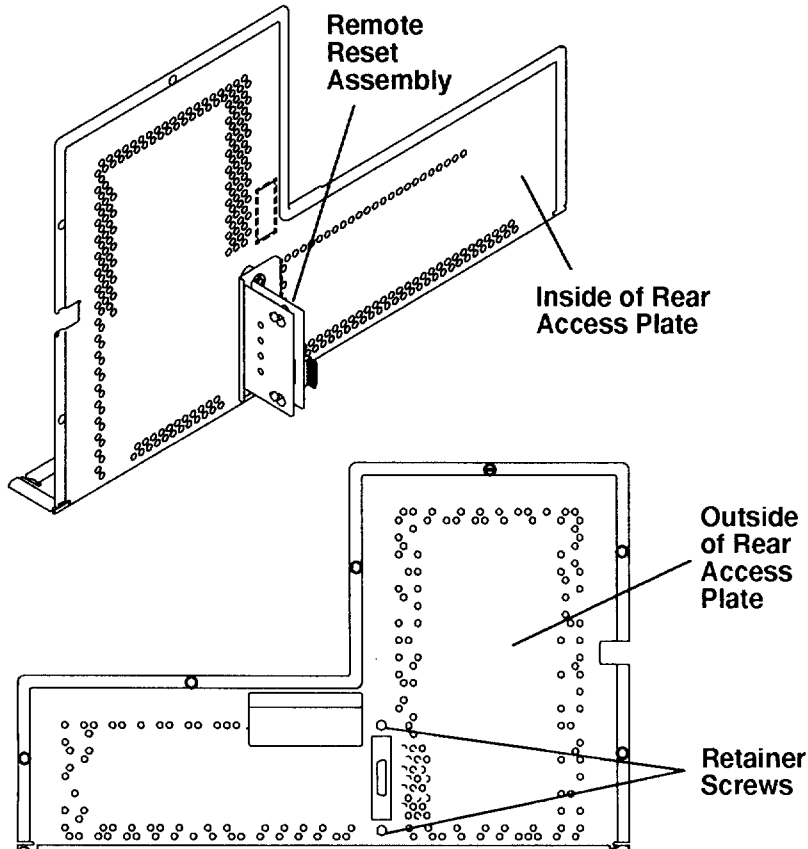

Replacement

Replace in the reverse order. If the enclosure was serviced and your rack contains a power distribution unit, then do the “Power-On Procedure with a Power Distribution Unit” on page 3-5. If your rack contains a power distribution bus, do the “Power-On Procedure with a Power Distribution Bus on page 3-1.

Docking Assembly and SCSI Cables

Removal

Note: Before you can remove the docking assembly and SCSI cables, you must remove the disk drive carrier located in the rear of the CPU-media enclosure and the media carrier located in the front of the CPU-media enclosure.

Step 1 through Step 5 explains how to remove the disk drive carrier and related connectors located in the rear of the CPU-media enclosure. Step 6 through Step 8a explains how to remove the media carrier and loosen the docking assembly mounting screws located in the front of the CPU-media enclosure. Step 8b explains how to remove the docking assembly from the rear of the CPU-media enclosure. Step 9 explains how to remove the SCSI cables from the docking assembly. Step 10 explains how to remove the power cables.

1. Do the "Rear Access Plate" removal procedure on page 3-39.
2. Remove the disk drive carrier from the CPU-media enclosure. Refer to the "Disk Drive, Cables, Fans, and Carrier Assembly" removal procedure on page 3-65 for information about removing the carrier.
3. Through the rear access opening, disconnect the integrated SCSI interface cable connector from connector J25 located on the combination planar.
4. Through the rear access opening, disconnect the SCSI cable connector from the top of the SCSI-2 adapter located in slot 0/8 on the combination planar.

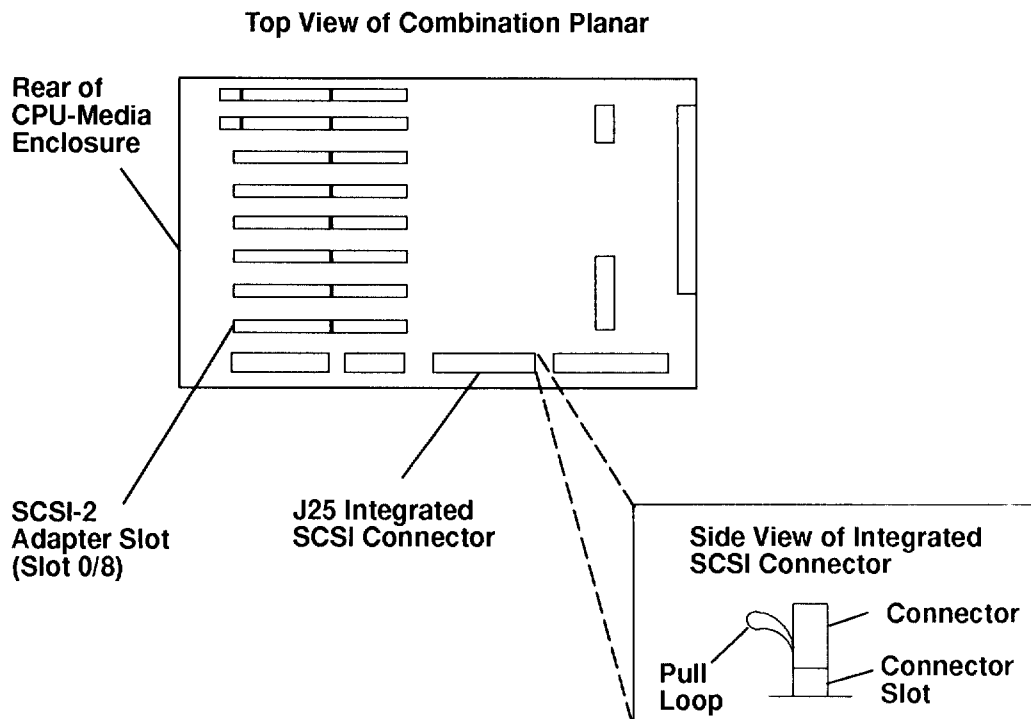

5. Remove power connectors P242, P243, and P244 from the power distribution board, and then remove power connector P90 from the side of the power supply.

**Rear View of
CPU-Media Enclosure**

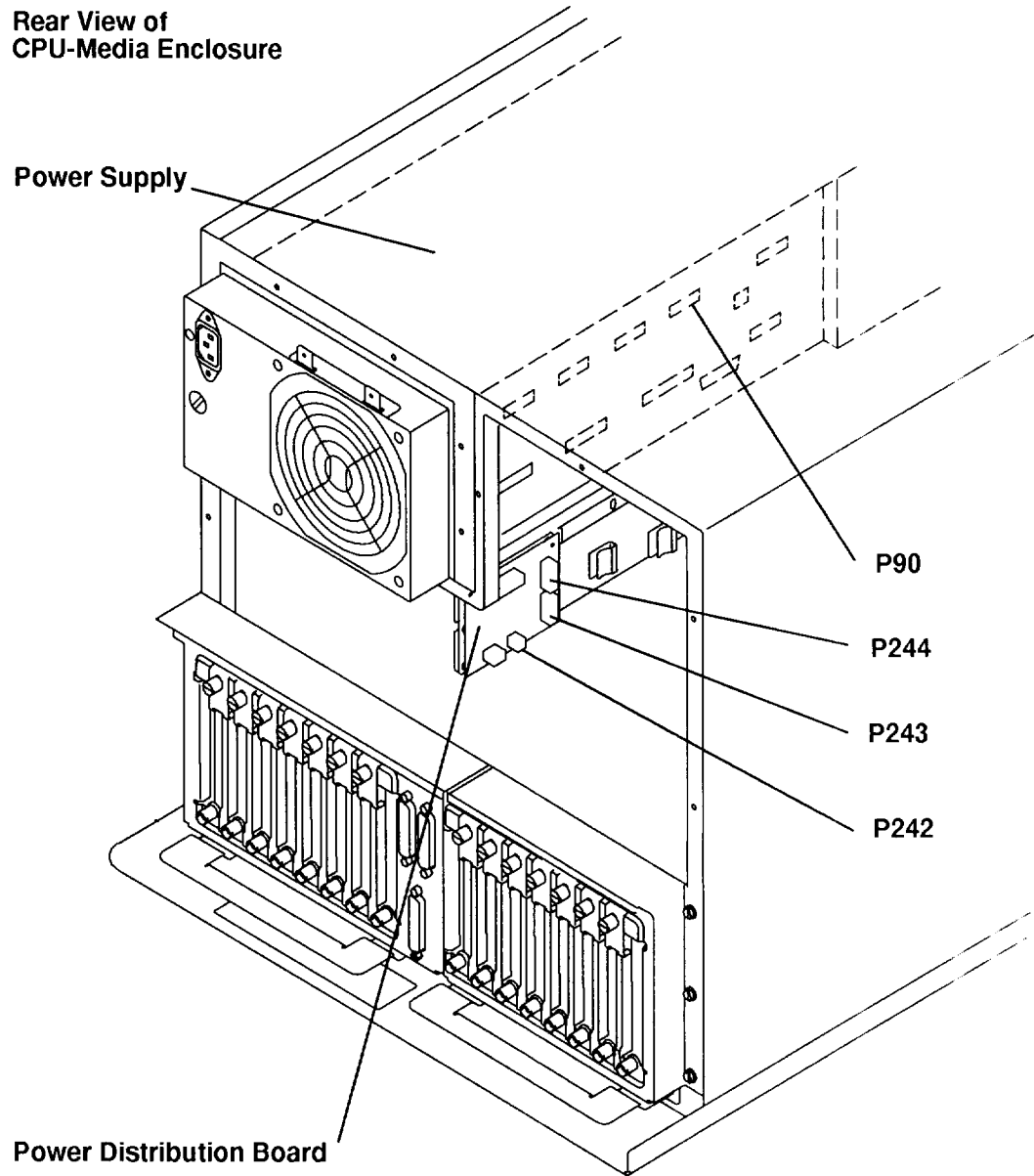

6. Remove the front bezel from the CPU-media enclosure. Refer to the “Front Bezel and Front Access Plate” removal procedure on page 3-15 for information about removing the front bezel.
7. Remove the media carrier from the CPU-media enclosure. Refer to the “Media, Fan, and Carrier Assembly” removal procedure on page 3-33 for information about removing the carrier.
8. Remove the docking assembly from the CPU-media enclosure. To remove the docking assembly, do the following:
 - a. From the inside of the media carrier location at the front of the CPU-media enclosure, loosen the four mounting screws holding the docking assembly in the CPU-media enclosure.

Front View of CPU-Media Enclosure

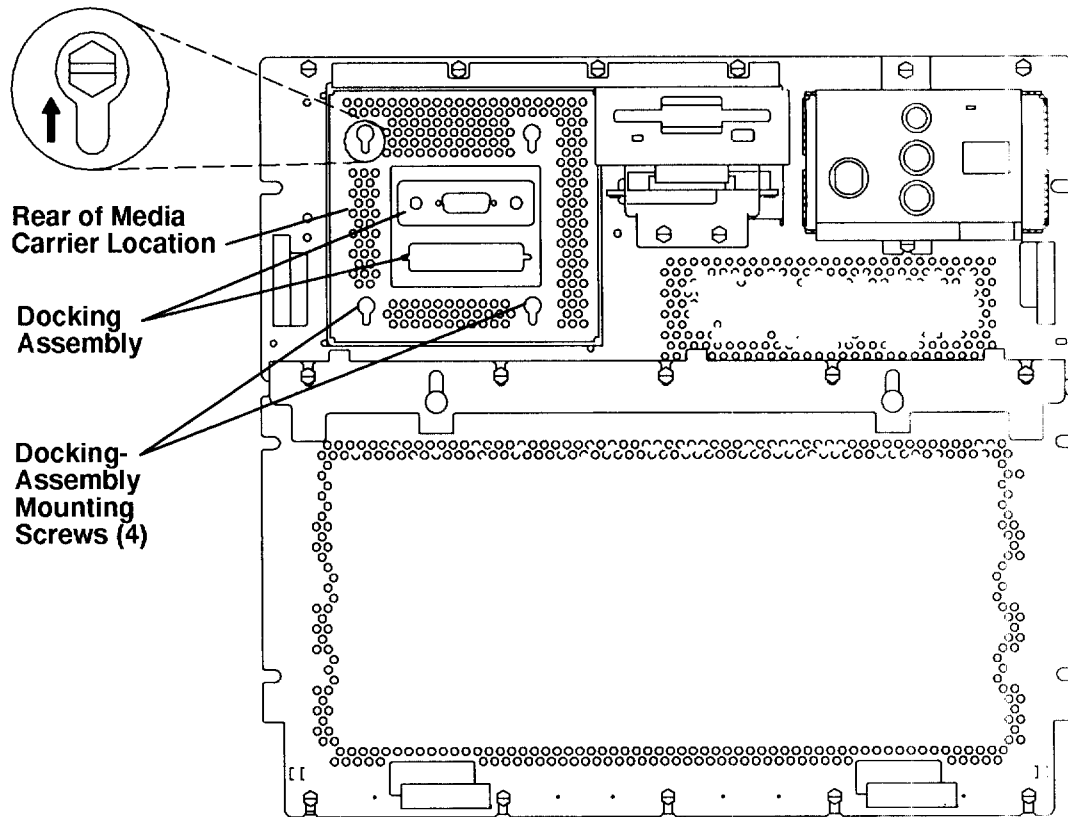

- b. From inside the rear access opening, slide the docking assembly upward until the screw holes at the rear of the media carrier location are aligned with the four mounting screws of the docking assembly, and then pull the docking assembly toward you until it is clear of the mounting screws.

You may have to move the docking assembly slightly side-to-side and up-and-down to align the four screw holes at the rear of the media carrier location with the four mounting screws of the docking assembly.

Rear View of CPU-Media Enclosure

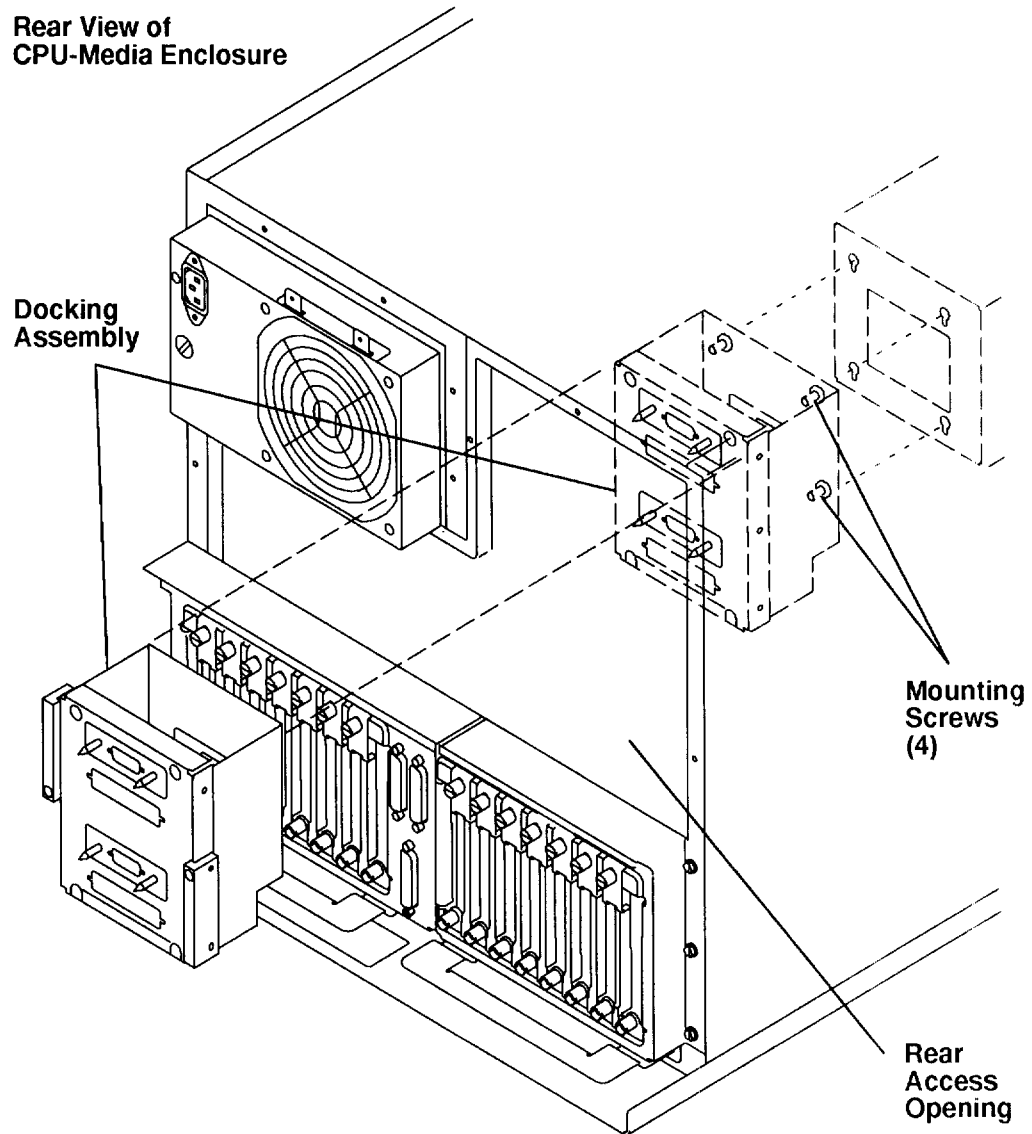

Note: To remove the SCSI cable mounted to the media-device docking bracket, perform step 9 of this procedure.

To remove the SCSI cable mounted to the disk-drive docking bracket or the power connectors (3) from the docking assembly, perform step 10 of this procedure.

9. To remove the SCSI cable connected to the media-device docking bracket, remove the two mounting screws, two washers, and two nuts from the SCSI connector on the media-device docking bracket, and then remove the SCSI connector from the media-device docking bracket.

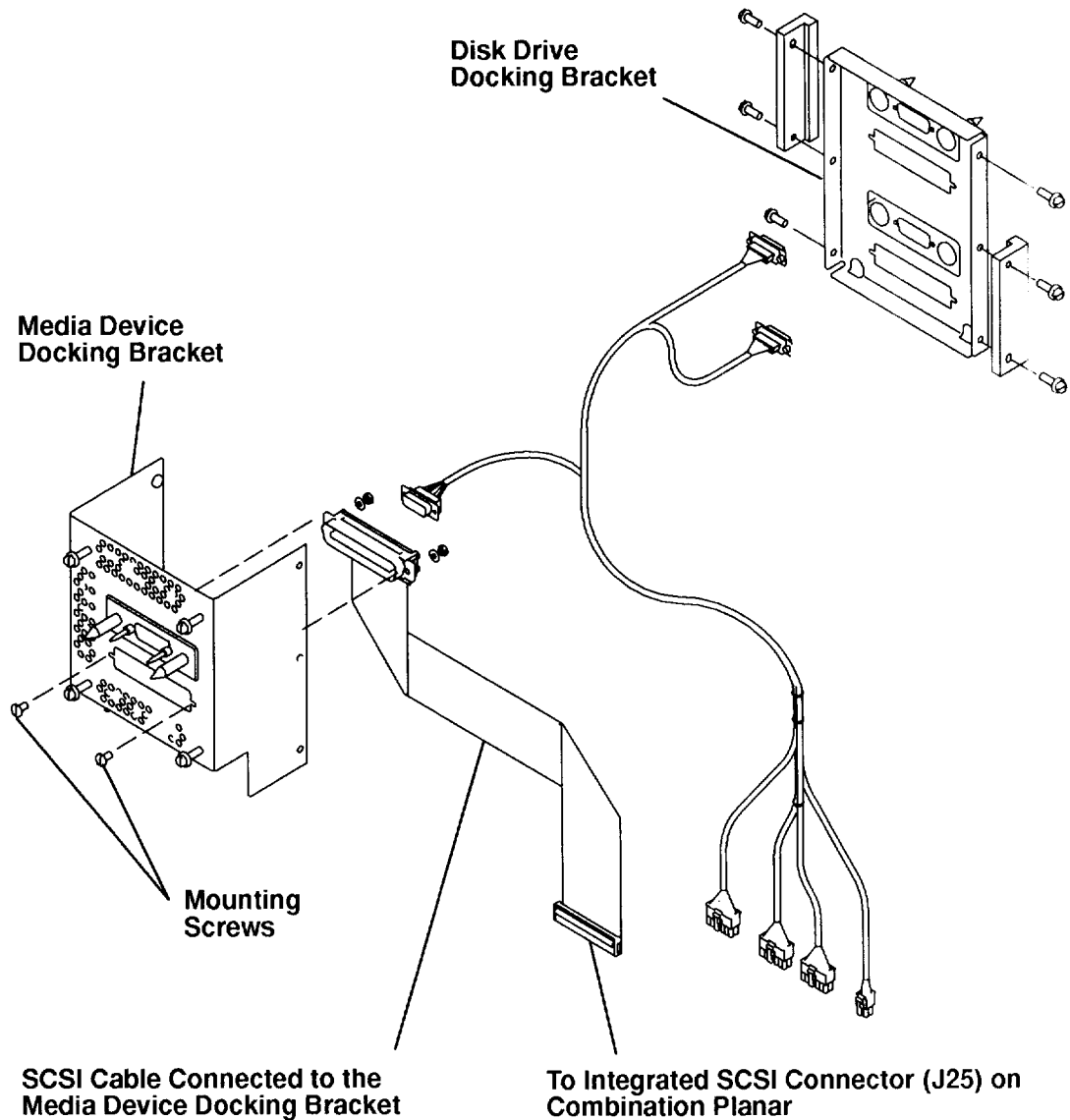

Note: The power cables located in the docking assembly are installed as a single unit and cannot be removed as single cables.

10. To remove the power cables from the docking assembly, remove the two guide-pin mounting screws from each power cable connector, and then remove the power cables from the media-device docking bracket and the disk-drive docking bracket.

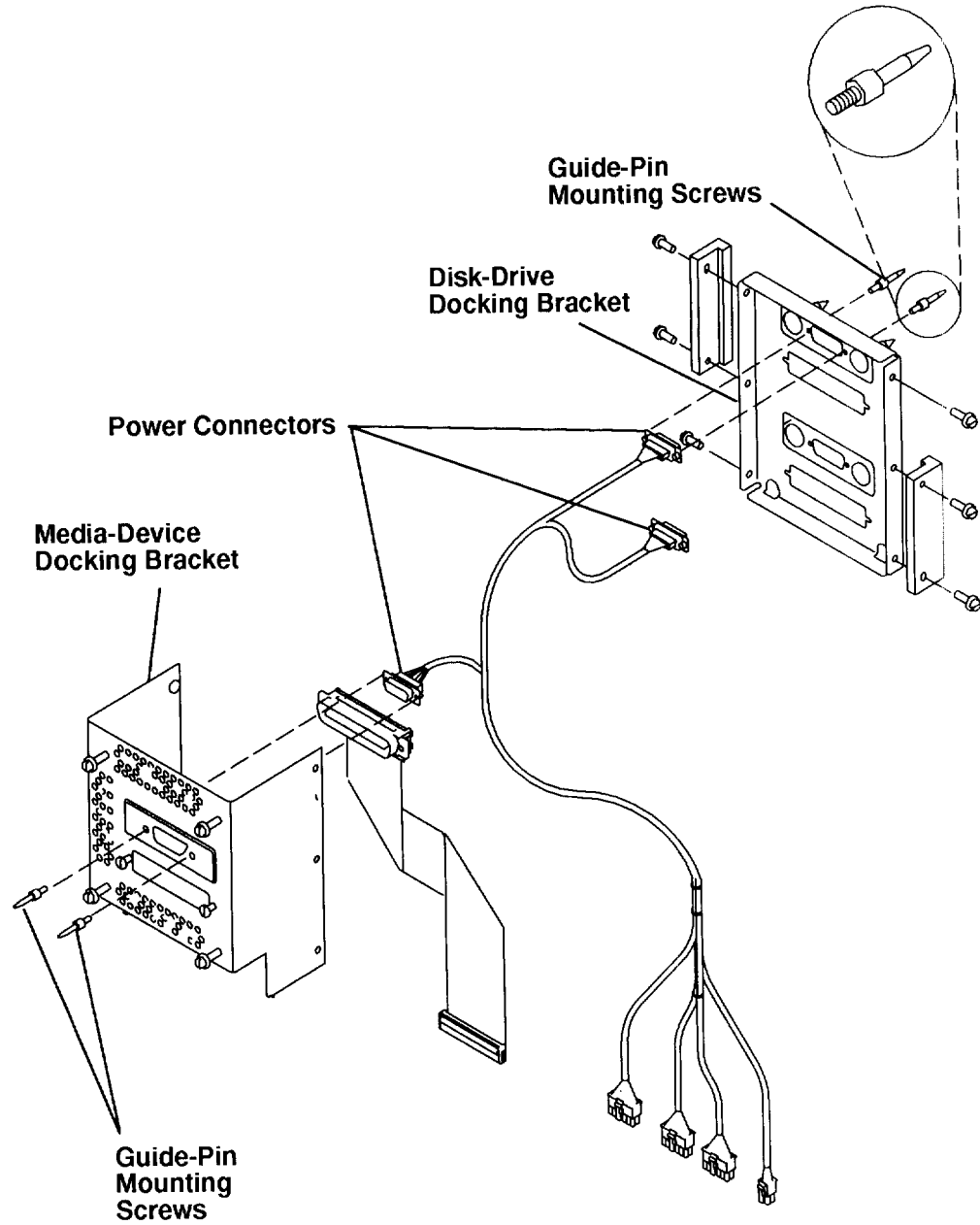

Replacement

1. Place the docking assembly mounting screws through the mounting holes. Ensure that all four mounting screws are placed through the mounting holes at the rear of the media carrier location in the CPU-media enclosure.
2. Place the four docking assembly mounting screws firmly on the bottom of the four mounting holes, and then tighten the four mounting screws.
3. Connect the power cable connectors P242, P243, and P244 to the power distribution board, connect power connector P90 to the power supply, and then connect the integrated SCSI cable connector to connector J25 on the combination planar. Ensure that all cables are securely placed in the plastic cable restraints to allow a clear path for docking the disk drive carrier.

Replace in the reverse order. If the enclosure was serviced and your rack contains a power distribution unit, then do the "Power-On Procedure with a Power Distribution Unit" on page 3-5. If your rack contains a power distribution bus, do the "Power-On Procedure with a Power Distribution Bus on page 3-1.

Front View of CPU-Media Enclosure

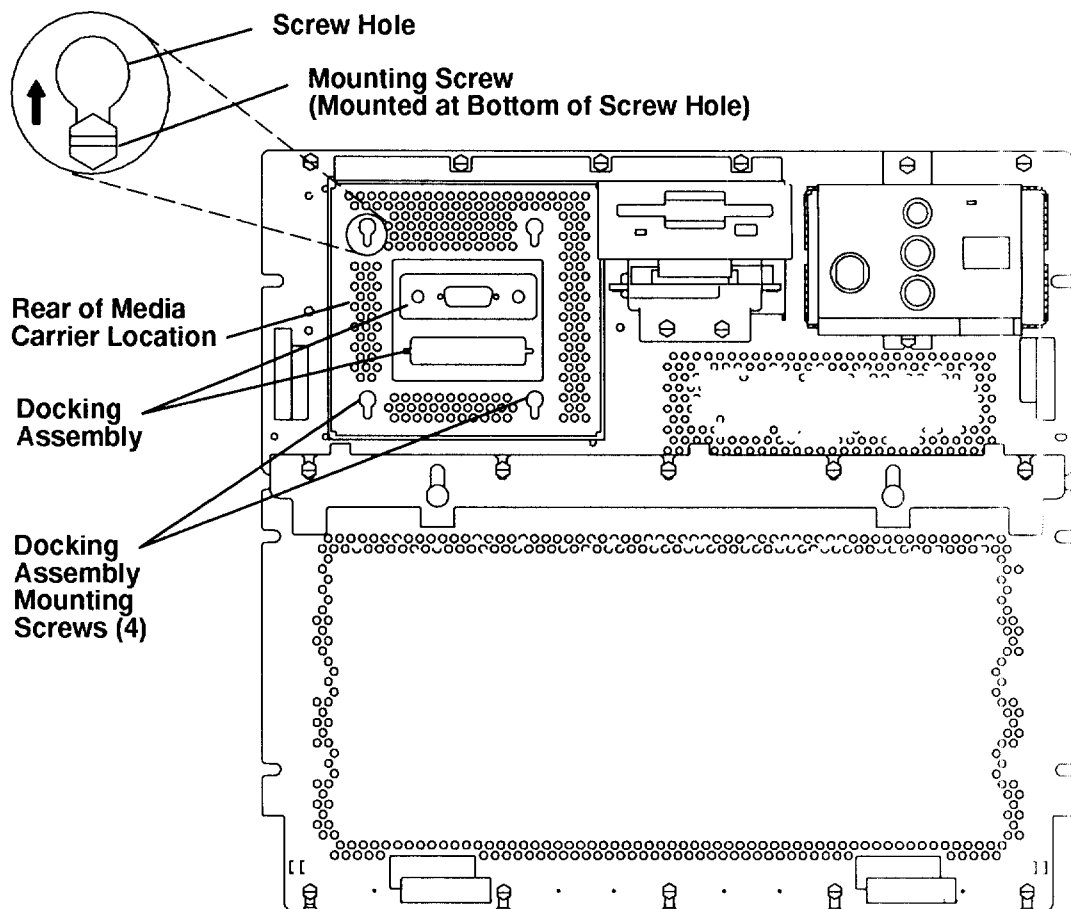

Power Supply Fuse

Removal

Note: Use only the correct fuse. Refer to Chapter 4 for the correct part number.

1. If your system has a power distribution unit, do the “Power-Off Procedure with a Power Distribution Unit” on page 3-7. If your system has a power distribution bus, do the “Power-Off Procedure with a Power Distribution Bus” on page 3-3.
2. Unplug the power cord from the power cord connector.
3. Place the head of a small flathead screwdriver into the slot of the fuse.
4. While pushing the spring-loaded fuse in with the screwdriver, turn the fuse counterclockwise until it disengages, and then remove the fuse.

Rear View of CPU-Media Enclosure

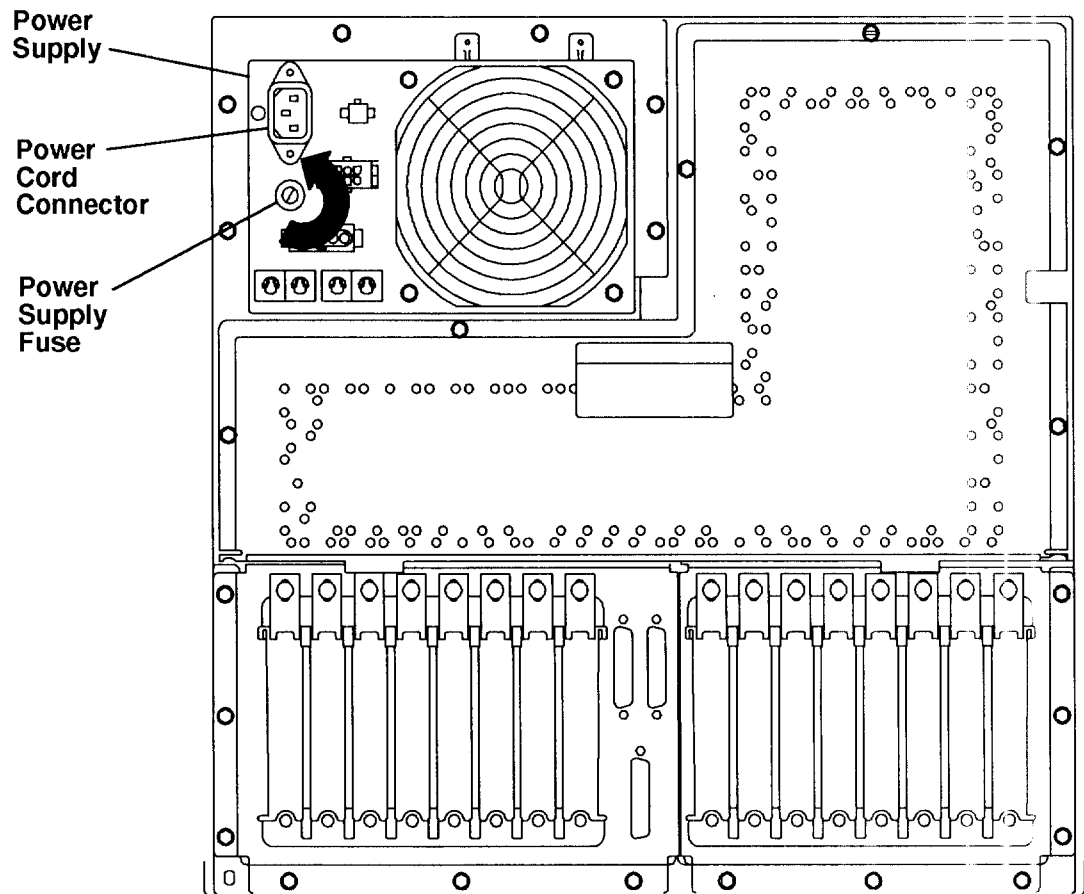

Replacement

Replace in the reverse order. If the enclosure was serviced and your rack contains a power distribution unit, then do the “Power-On Procedure with a Power Distribution Unit” on page 3-5. If your rack contains a power distribution bus, do the “Power-On Procedure with a Power Distribution Bus on page 3-1.

Power Supply Fan

Removal

1. If your system has a power distribution unit, do the “Power-Off Procedure with a Power Distribution Unit” on page 3-7. If your system has a power distribution bus, do the “Power-Off Procedure with a Power Distribution Bus” on page 3-3.
2. Remove all of the cable ties from the top cable-restraint mounting bracket.
3. Remove the two mounting screws attaching the top cable-restraint mounting bracket, and then remove the bracket.

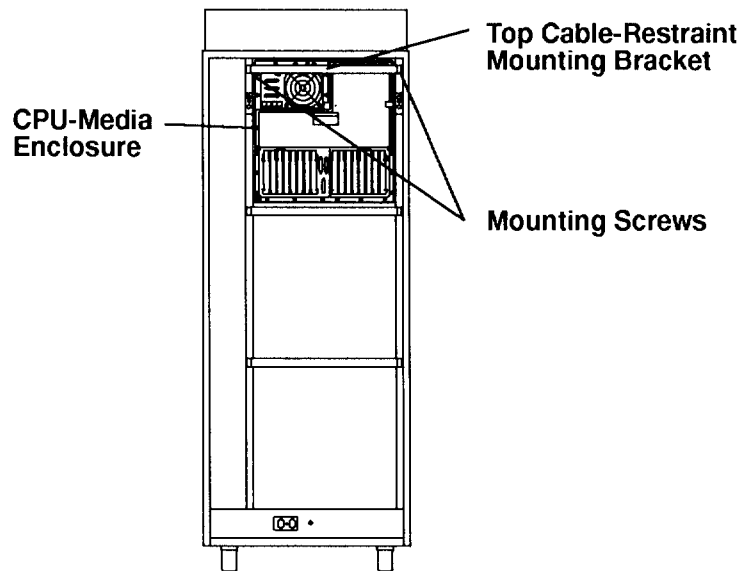

4. Disconnect power connector P80 from J80.

Rear View of CPU-Media Enclosure

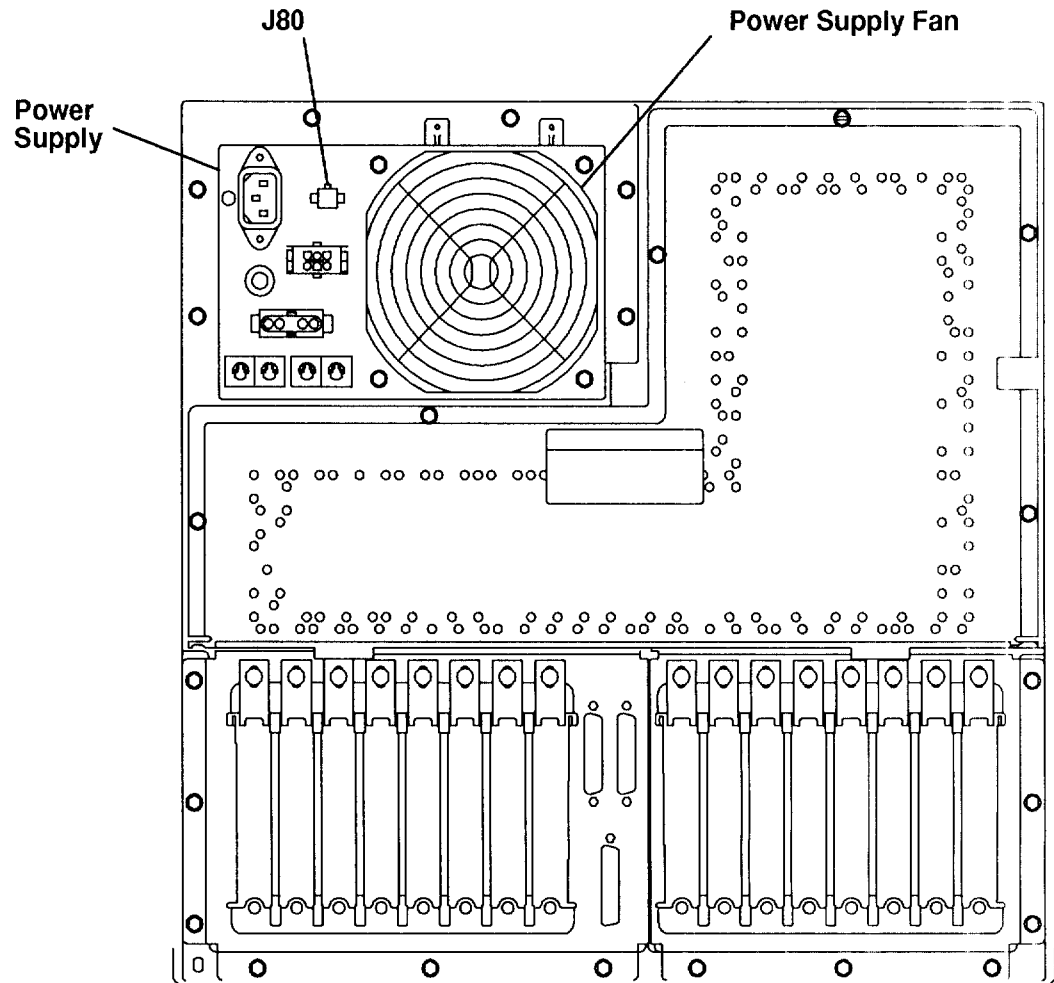

5. To remove the power supply fan, do the following:
 - a. Loosen the two top mounting screws and the two bottom mounting screws.
 - b. Pull the bottom of the power supply fan assembly away from the power supply until the bottom mounting bracket clears the bottom mounting screws.
 - c. Slide the assembly down until the top mounting bracket clears the top mounting screws, and then remove the power supply fan assembly from the power supply.
6. If you are replacing only the fan and not the mounting bracket, remove the screw, washer, lock washer, and nut from each corner of the fan, and then remove the fan.

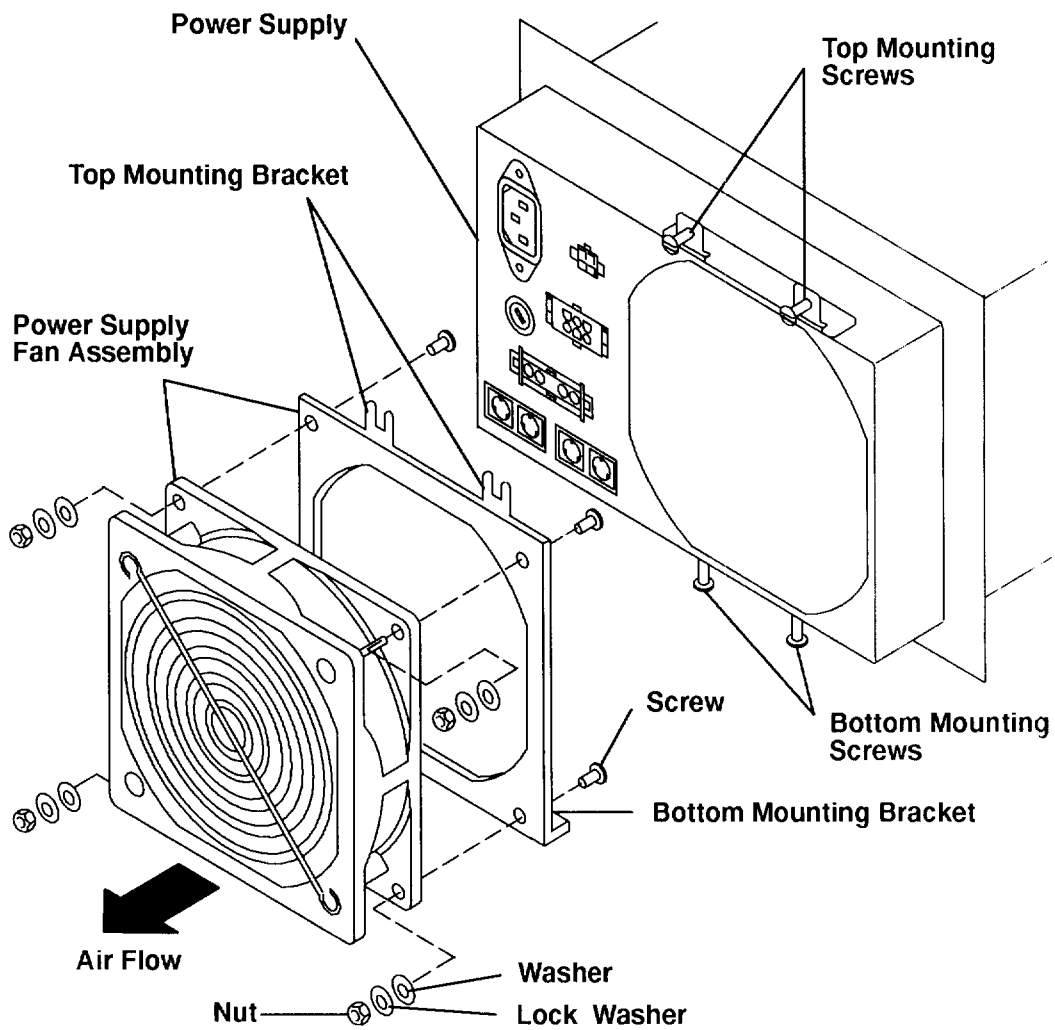

Replacement

Replace in the reverse order. If the enclosure was serviced and your rack contains a power distribution unit, then do the “Power-On Procedure with a Power Distribution Unit” on page 3-5. If your rack contains a power distribution bus, do the “Power-On Procedure with a Power Distribution Bus on page 3-1.

Power Supply (AC)

Removal

DANGER

Do not attempt to open the covers of the power supply. The power supply is not serviceable and is to be replaced as a unit.

1. If your system has a power distribution unit, do the “Power-Off Procedure with a Power Distribution Unit” on page 3-7. If your system has a power distribution bus, do the “Power-Off Procedure with a Power Distribution Bus” on page 3-3.
2. Unplug the power cord.
3. Do the “Power Supply Fan” removal procedure on page 3-52.
4. Do the “Rear Access Plate” removal procedure on page 3-39.

Rear View of CPU-Media Enclosure

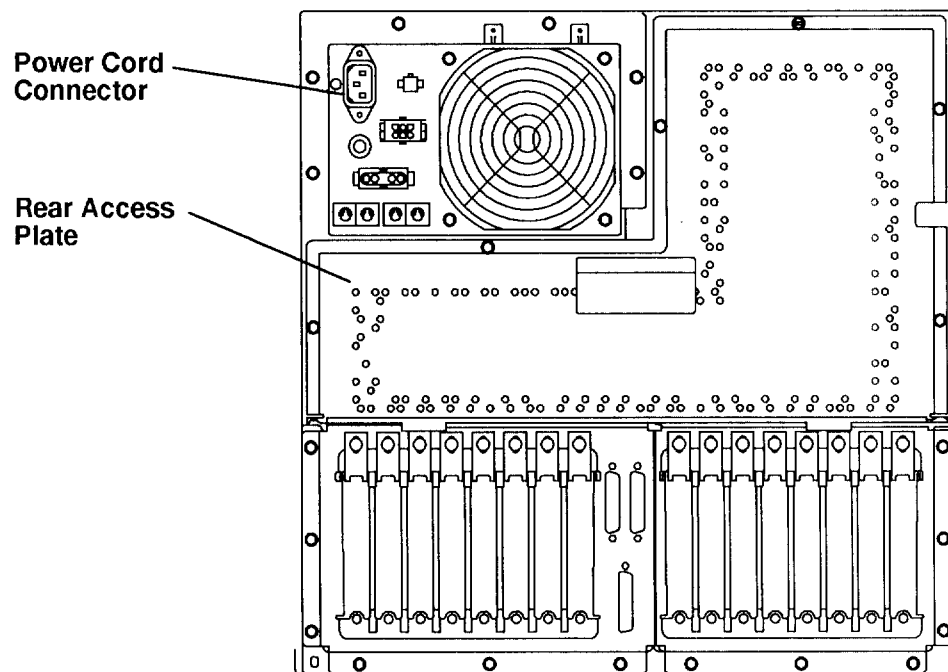

5. Remove all of the cable ties from the top cable-restraint mounting bracket.
6. Remove the two mounting screws attaching the top cable-restraint mounting bracket, and then remove the bracket.

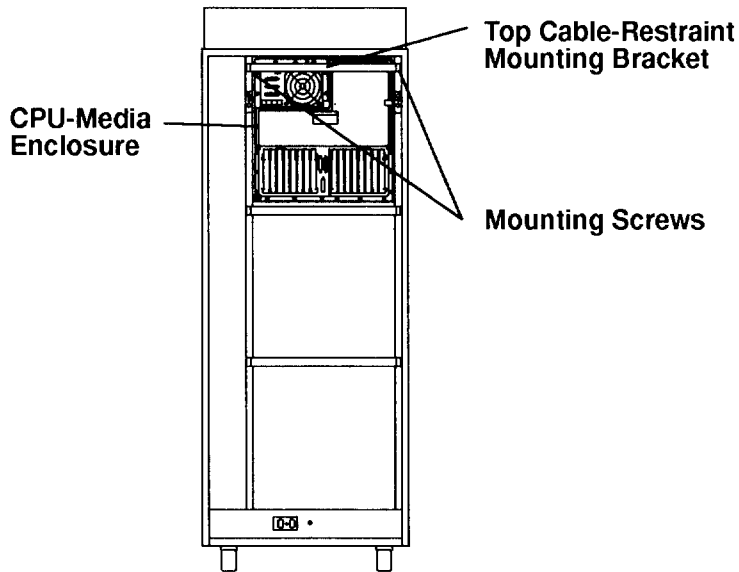

7. To access the power connectors located on the side of the power supply, do the following:
 - a. Disconnect the SCSI cable from the SCSI connector located at the bottom of the disk drive carrier.
 - b. Loosen the retainer screw located near the bottom-right corner of the disk drive carrier.
 - c. Loosen the two long retainer screws located on both sides of the disk drive carrier.
 - d. Grasp a handle of the disk drive carrier, and then pull the carrier toward you until the carrier is stopped by the safety latch.
 - e. Lift the disk drive carrier with both hands until the carrier is clear of the safety latch, and then pull the drive toward you until it is out the CPU-media enclosure.

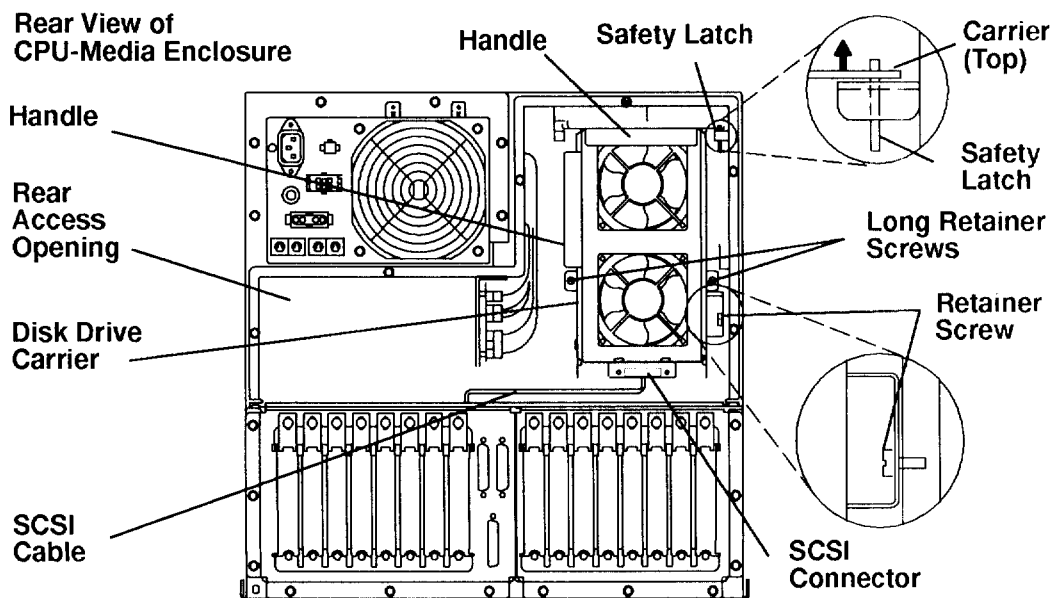

8. Place a hand through the rear access opening, and then disconnect all of the power connectors and data signal connectors from the side of the power supply.
9. Remove the six screws attaching the power supply to the CPU-media enclosure.
10. Place a hand through the rear access opening under the power supply, and then loosen the large hex head screw located under the bottom of the power supply until it disengages and hangs loosely from the frame.
11. Slide the power supply out of the CPU-media enclosure.

Rear View of CPU-Media Enclosure

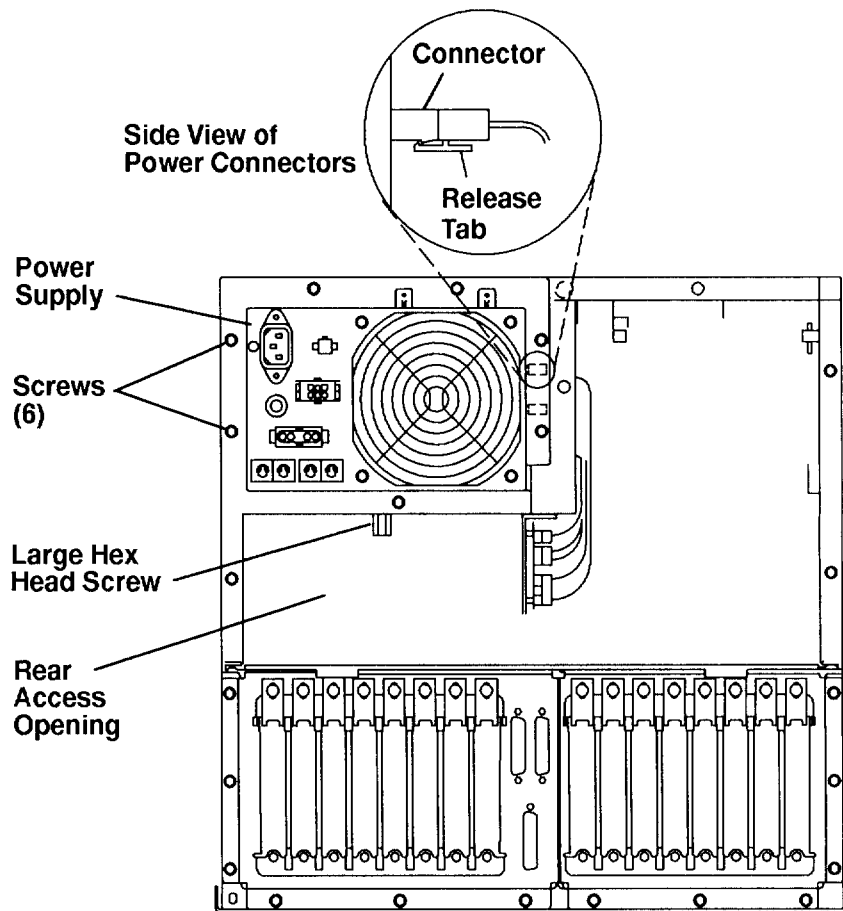

Side View of Power Supply with Power Connectors

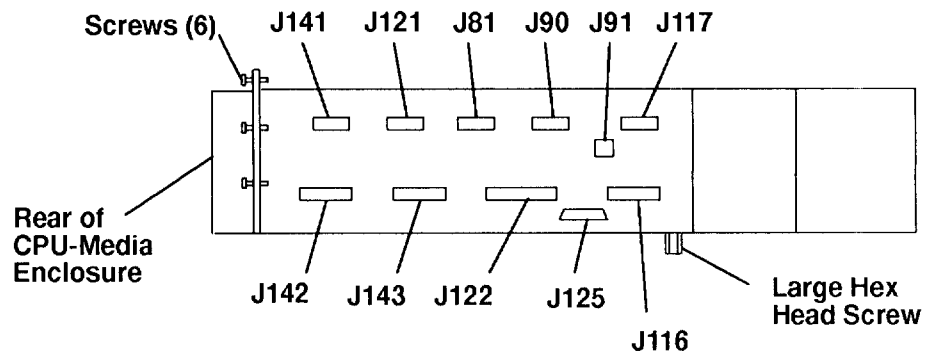

Replacement

Warning: The large hex head screw must be tightened during the “Power Supply” replacement procedure to ensure that the power supply is firmly attached in the CPU-media enclosure. Do not over-tighten the large hex head screw.

Replace in the reverse order. If the enclosure was serviced and your rack contains a power distribution unit, then do the “Power-On Procedure with a Power Distribution Unit” on page 3-5. If your rack contains a power distribution bus, do the “Power-On Procedure with a Power Distribution Bus on page 3-1.

Power Supply (-48 V dc)

Removal

Note: For a translation of these notices, refer to the *System Unit Safety Information* manual, form number SA23-2652.

DANGER

Do not attempt to open the covers of the power supply. The power supply is not serviceable and is to be replaced as a unit.

CAUTION:

This unit has more than one power supply cord. To reduce the risk of electric shock disconnect two power supply cords before servicing.

Note: This unit can have more than one power cord. To prevent electrical shock, disconnect all power cords before servicing.

1. Do the "Power-Off Procedure with a Power Distribution Panel" on page 3-12.
2. Disconnect the power cables from the Input A and Input B connectors.
3. Do the "Power Supply Fan" removal procedure on page 3-52.
4. Do the "Rear Access Plate" removal procedure on page 3-39.

Rear View of CPU-Media Enclosure

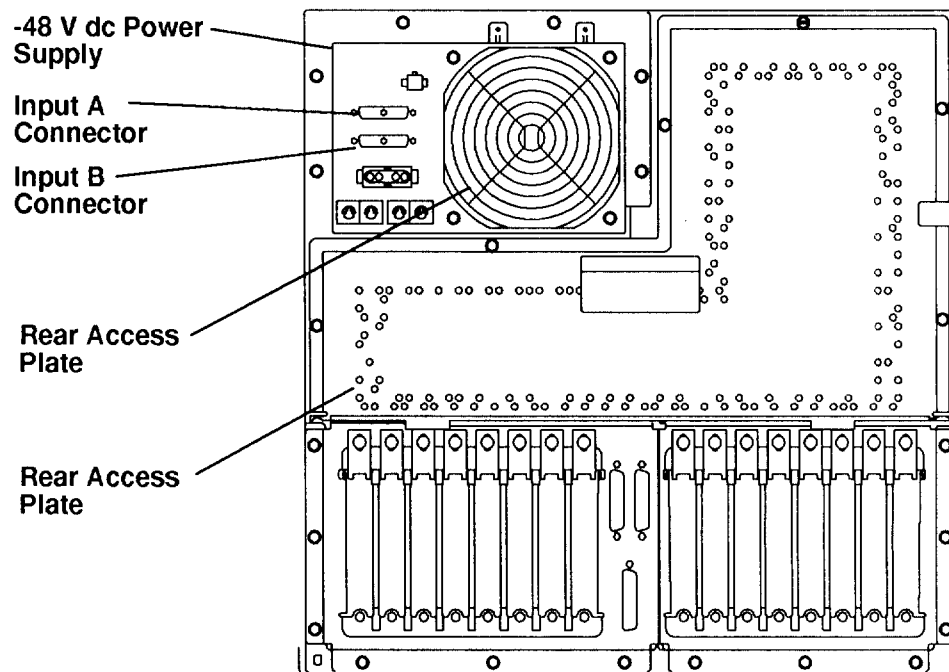

5. Remove all of the cable ties from the top cable-restraint mounting bracket.
6. Remove the two mounting screws attaching the top cable-restraint mounting bracket, and then remove the bracket.

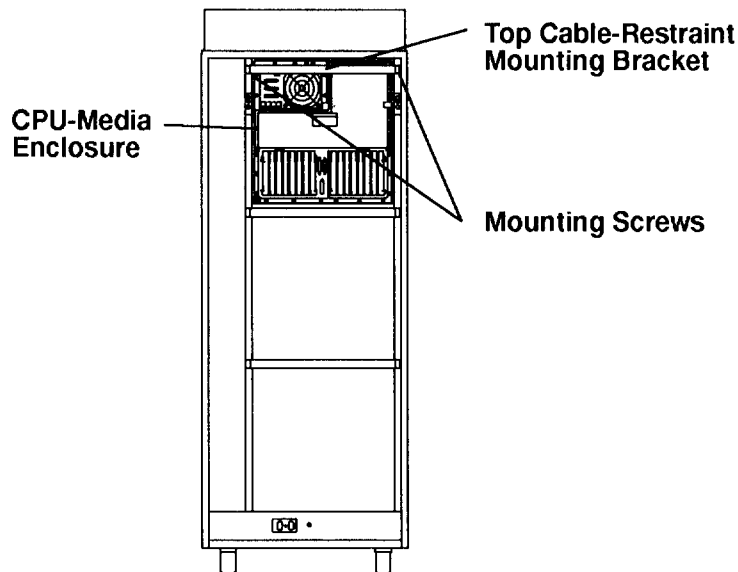

7. To access the power connectors located on the side of the power supply, do the following:
 - a. Disconnect the SCSI cable from the SCSI connector located at the bottom of the disk drive carrier.
 - b. Loosen the retainer screw located near the bottom-right corner of the disk drive carrier.
 - c. Loosen the two long retainer screws located on both sides of the disk drive carrier.
 - d. Grasp a handle of the disk drive carrier, and then pull the carrier toward you until the carrier is stopped by the safety latch.
 - e. Lift the disk drive carrier with both hands until the carrier is clear of the safety latch, and then pull the drive toward you until it is out the CPU-media enclosure.

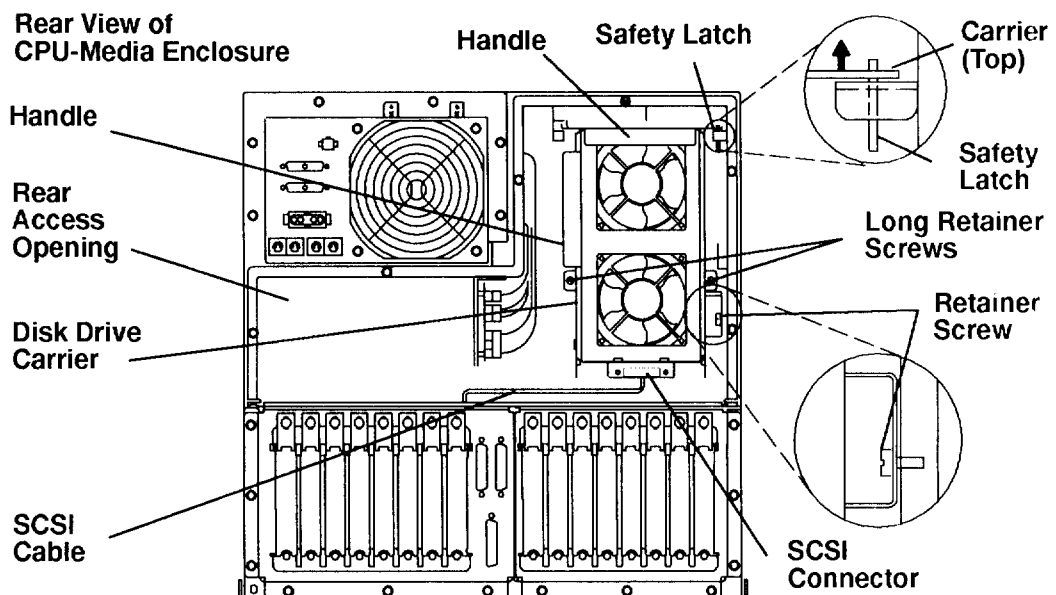

8. Place a hand through the rear access opening, and then disconnect all of the power connectors and data signal connectors from the side of the power supply.
9. Remove the six screws attaching the power supply to the CPU-media enclosure.
10. Place a hand through the rear access opening under the power supply, and then loosen the large hex head screw located under the bottom of the power supply until it disengages and hangs loosely from the frame.
11. Slide the power supply out of the CPU-media enclosure.

Rear View of CPU-Media Enclosure

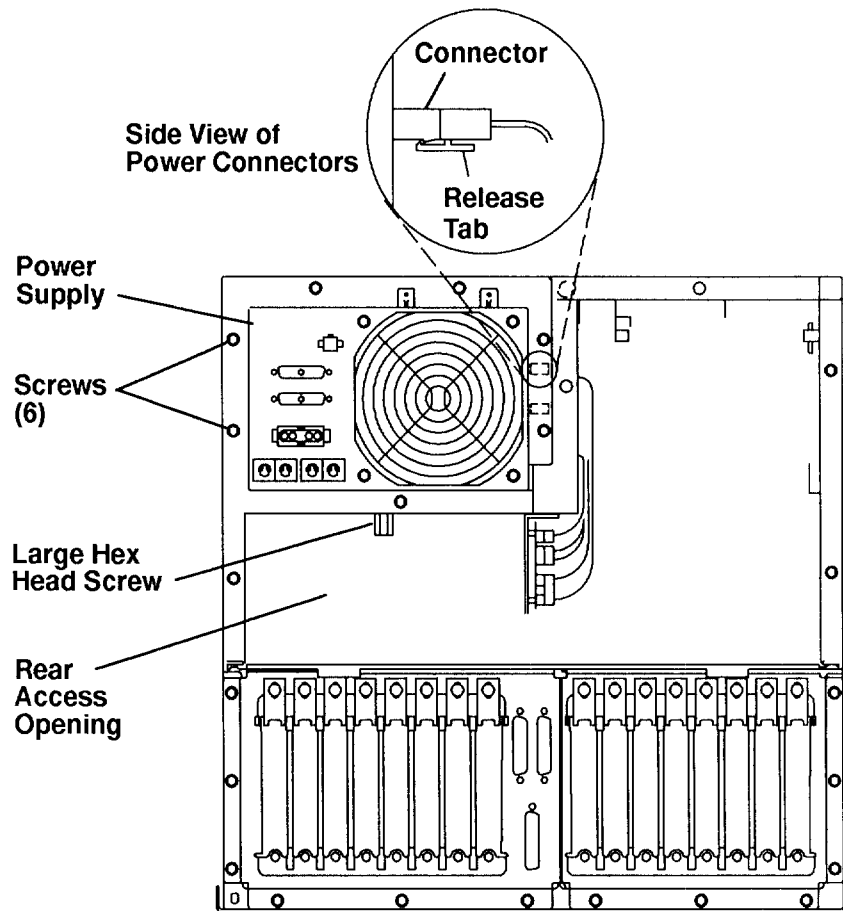

Side View of Power Supply with Power Connectors

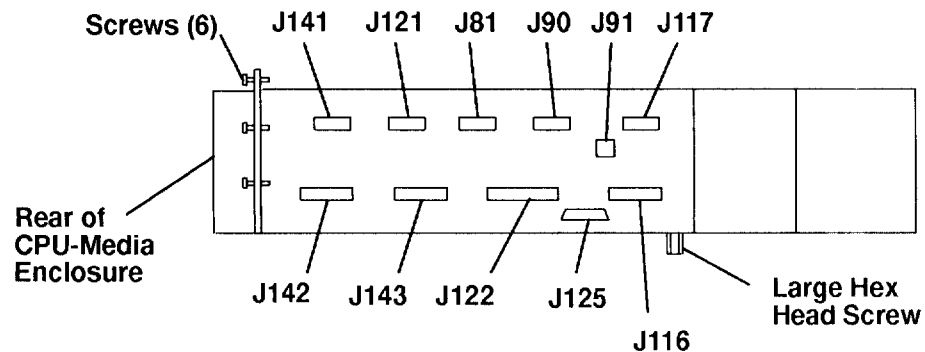

Replacement

Warning: The large hex head screw must be tightened during the “Power Supply” replacement procedure to ensure that the power supply is firmly attached in the CPU-media enclosure. Do not over-tighten the large hex head screw.

Replace in the reverse order, and then do the “Power-On Procedure with a Power Distribution Panel” on page 3-9.

Power Distribution Board

Removal

1. Do the "Rear Access Plate" removal procedure on page 3-39.
2. Place your hand through the rear access opening, and then remove connectors P240, P241, P242, P243, and P244 from the power distribution board.

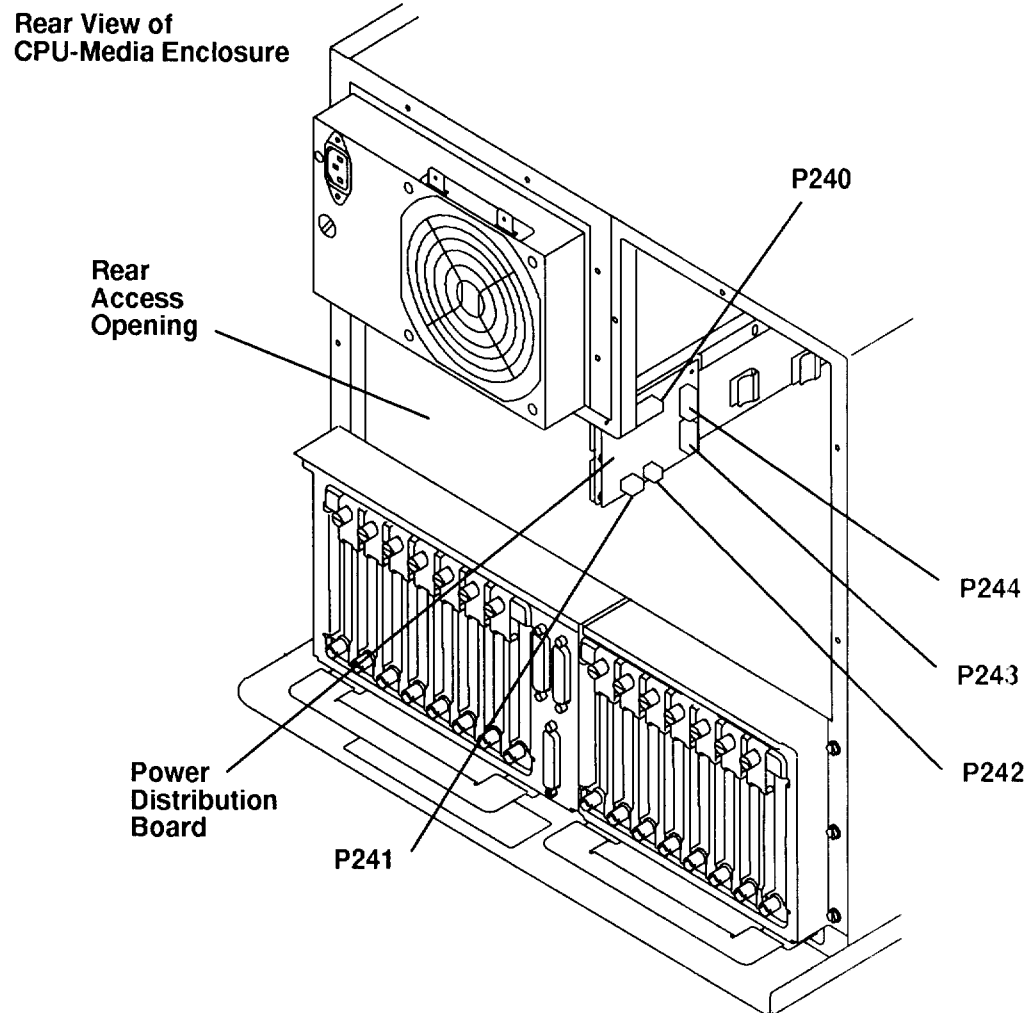

3. Loosen the two mounting screws attaching the power-distribution-board assembly to the CPU-media enclosure.
4. Slide the power-distribution-board assembly toward you until the two mounting screws are aligned with the mounting holes of the mounting bracket, and then pull the assembly straight out (to your right).
5. Remove the power-distribution-board assembly from the CPU-media enclosure.
6. If you are replacing only the power distribution board and not the mounting plate, remove the four mounting screws attaching the power distribution board to the mounting plate, and then remove the board.

Rear View of CPU-Media Enclosure

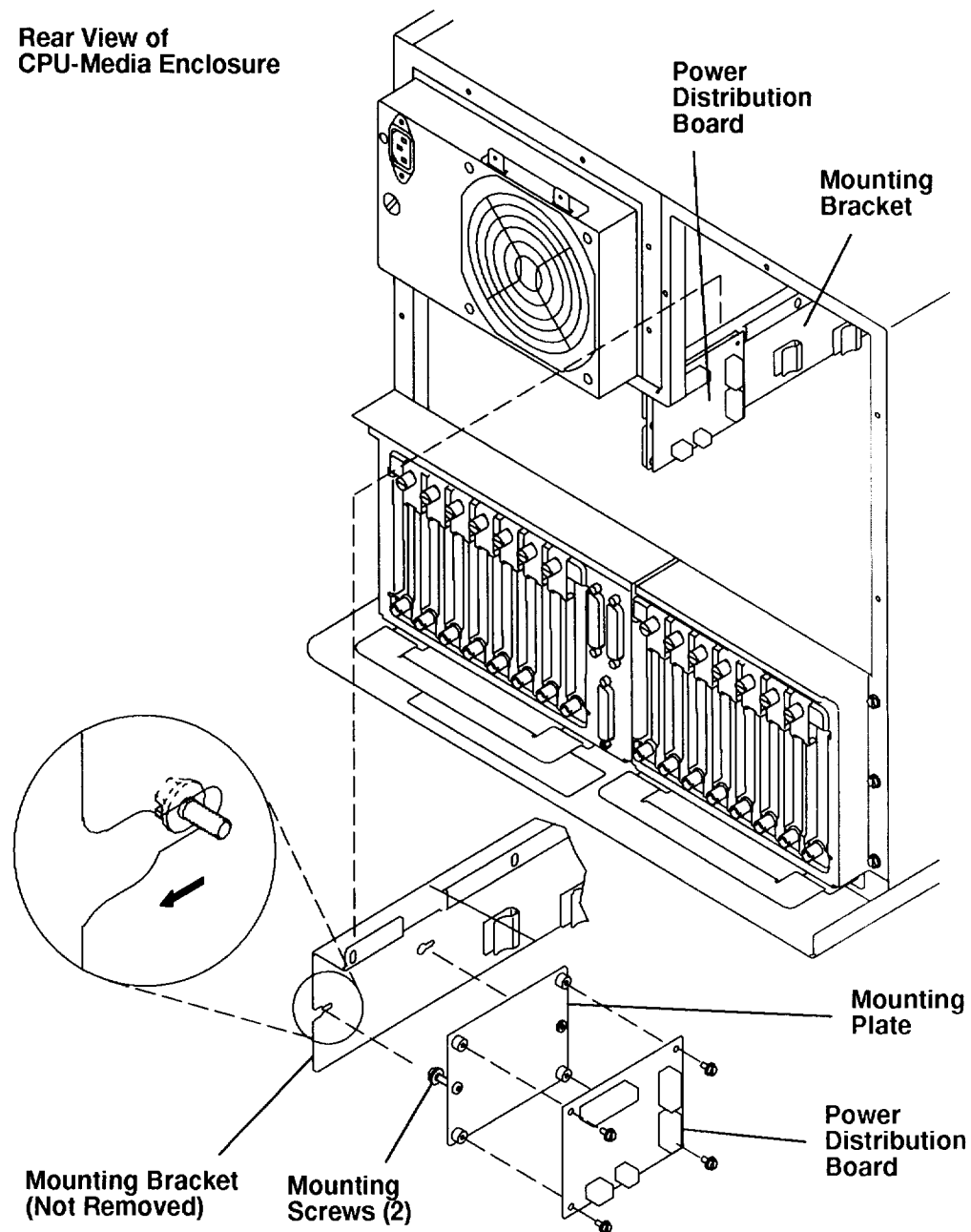

Replacement

Replace in the reverse order.

Disk Drive, Cables, Fans, and Carrier Assembly

Removal

Note: If you are removing a disk drive, perform step 1 through step 15.

If you are removing a SCSI cable, perform step 1 through step 9, and then perform step 16 through step 19.

If you are removing a power cable, perform step 1 through step 9, and then perform step 20 through step 27.

If you are removing a disk drive fan, perform step 1 through step 9, and then perform step 28 through step 32.

1. Remove all of the cable ties from the top cable-restraint mounting bracket.
2. Remove the two mounting screws attaching the top cable-restraint mounting bracket and then remove the bracket.

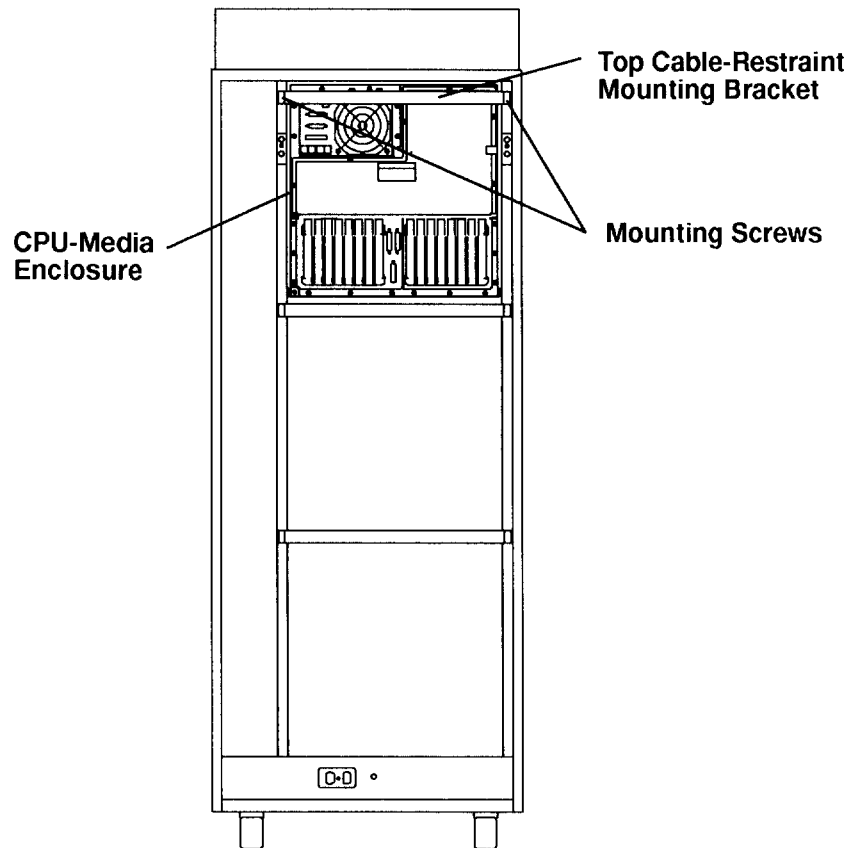

3. Do the "Rear Access Plate" removal procedure on page 3-39.
4. Disconnect the SCSI cable from the SCSI connector located at the bottom of the disk drive carrier.
5. Loosen the short retainer screw located near the bottom-right corner of the disk drive carrier.
6. Loosen the two long retainer screws located on the sides of the disk drive carrier.
7. Grasp the handle of the disk drive carrier with your left hand, and then pull the carrier toward you until the carrier is stopped by the safety latch.
8. Lift the disk drive carrier with both hands until the carrier is clear of the safety latch, holding the carrier with your left hand, use your right hand to disengage the safety latch, and then use both hands to pull the drive toward you until it is out the CPU-media enclosure.

Rear View of CPU-Media Enclosure

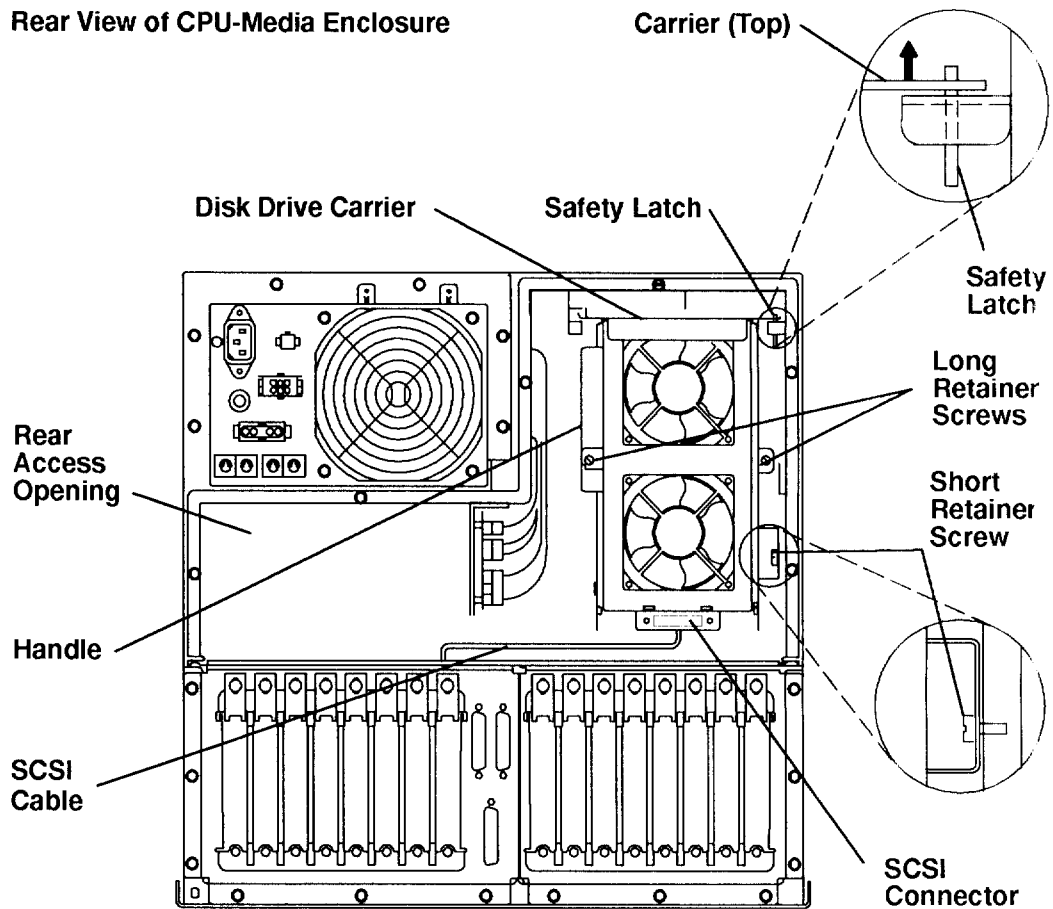

9. Loosen the two retainer screws holding the docking door in a vertical position on the carrier.
10. Lift the docking door upward until the retainer tab is clear of the retainer screws, and then rotate the top of the door downward until the door is open and perpendicular to the disk drive carrier.

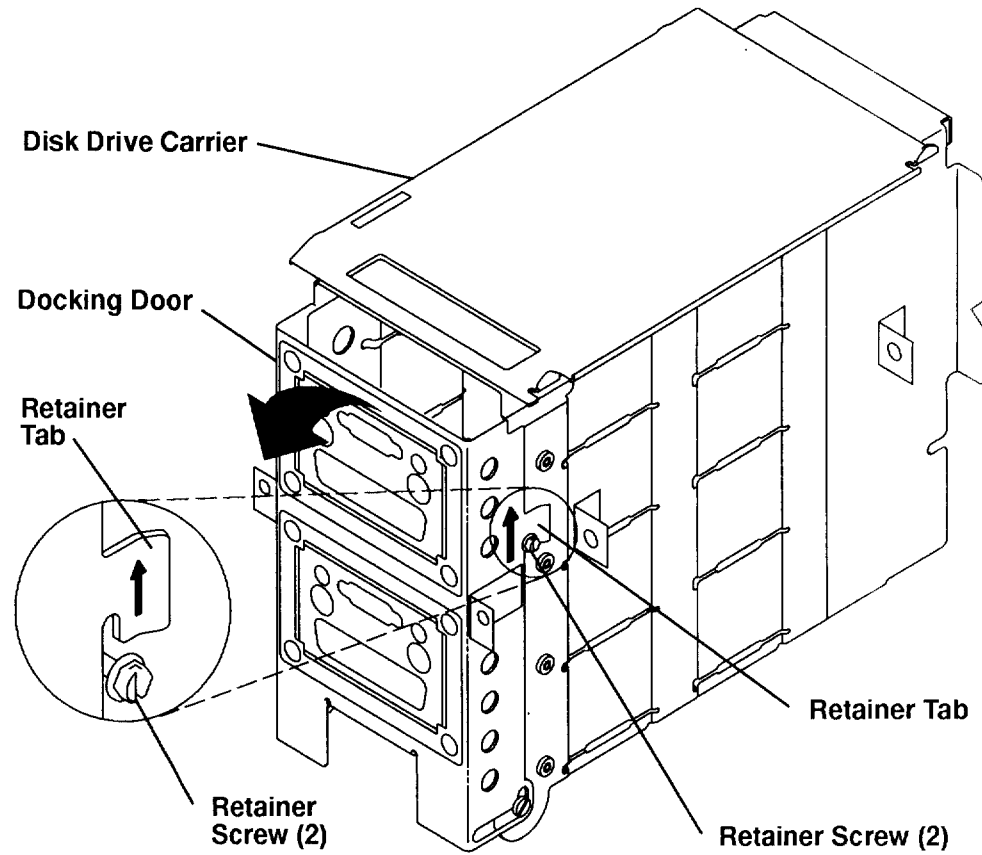

11. Record the location of the power cable connectors and the SCSI cable connectors.
12. If the disk drive you are removing is located below another disk drive, first disconnect the SCSI cable connectors and then the power cable connectors from any disk drives located above the drive you are removing.
13. Disconnect the SCSI cable connector first, and then the power cable connector from the drive you are removing.
14. Loosen the retainer screw of the disk drive mounting plate by placing a long screwdriver through the screwdriver access hole to the retainer screw located on the opposite side of the carrier.

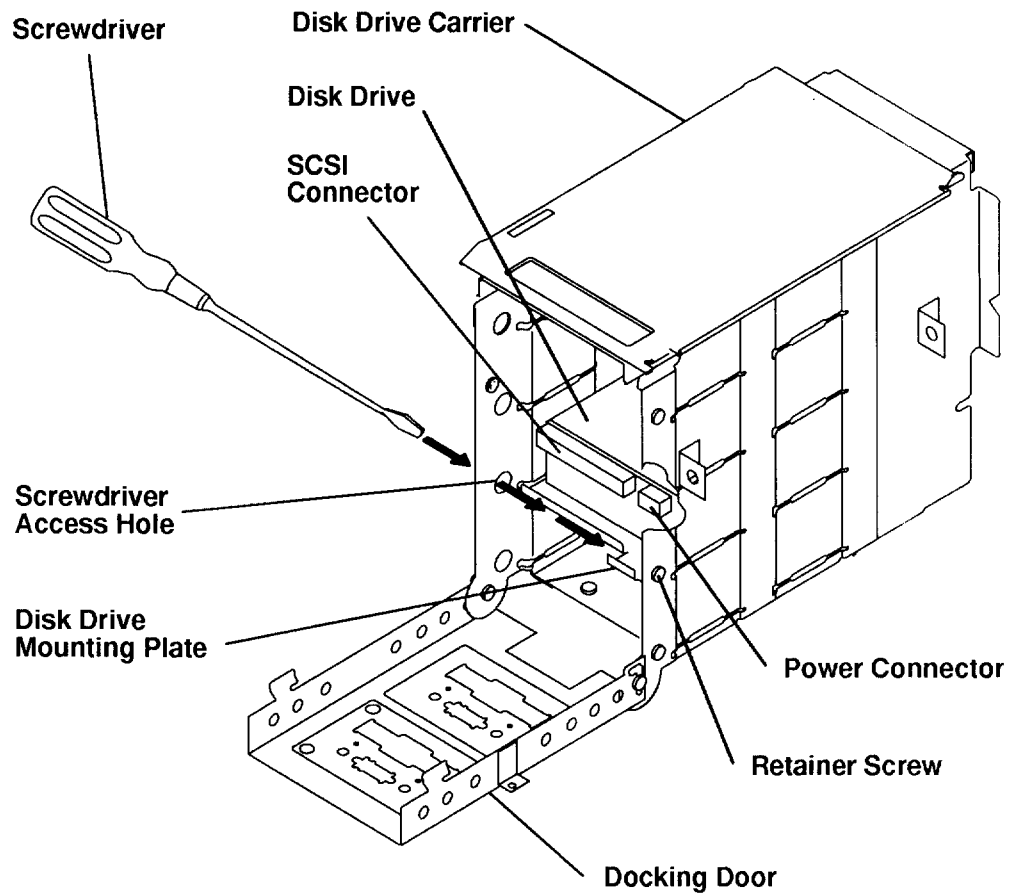

15. Grasp the handle of the disk drive mounting plate, and then pull the disk drive out of the carrier.

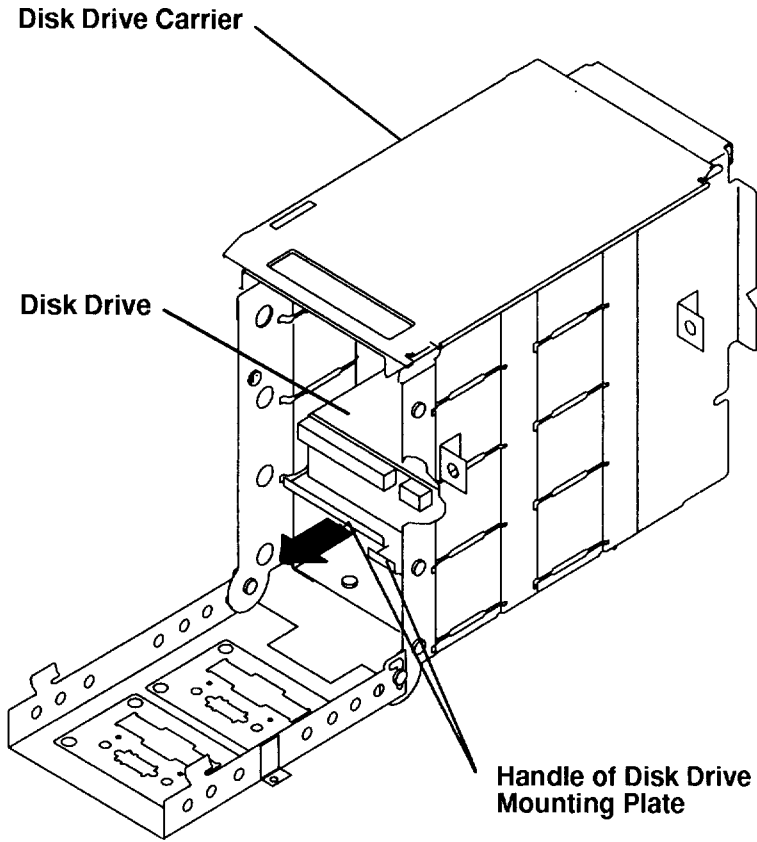

16. Remove the four mounting screws and the four isolators from the bottom of the disk drive mounting plate, and then remove the disk drive.

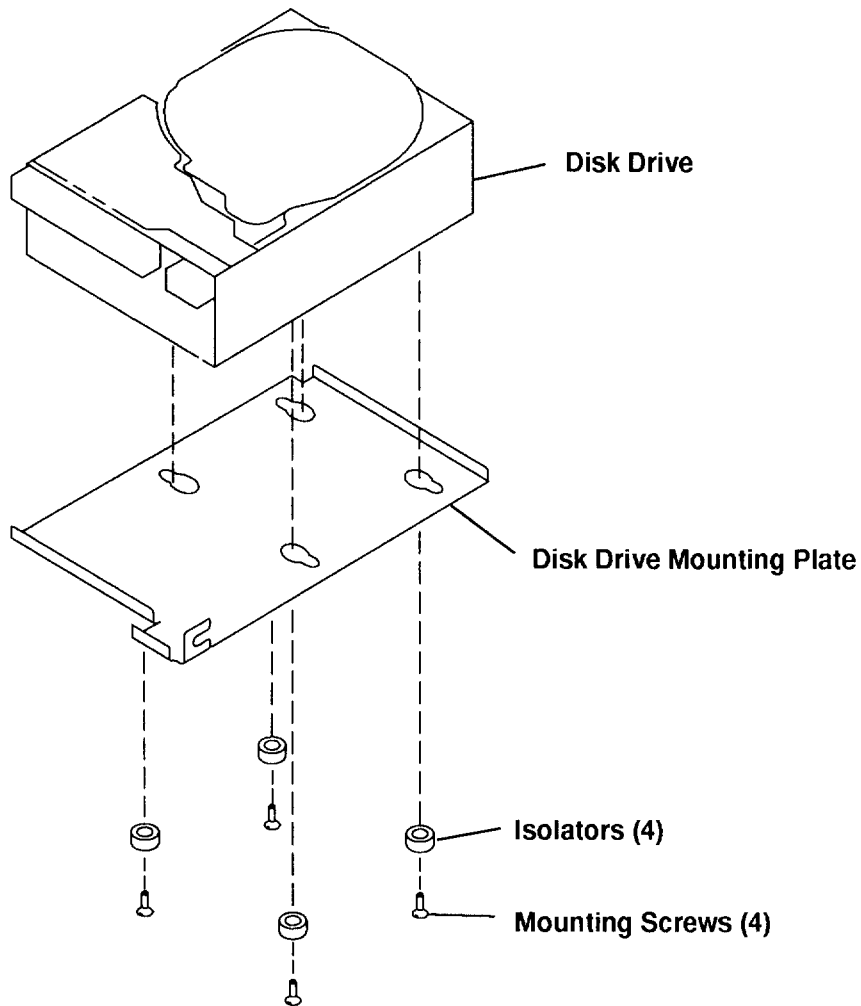

17. If you are removing the SCSI cable, record the location of the SCSI docking connector.
18. Disconnect all of the SCSI cable connectors from all of the disk drives.
19. Remove the two screws attaching the bottom retainer bracket to the bottom mounting bracket.

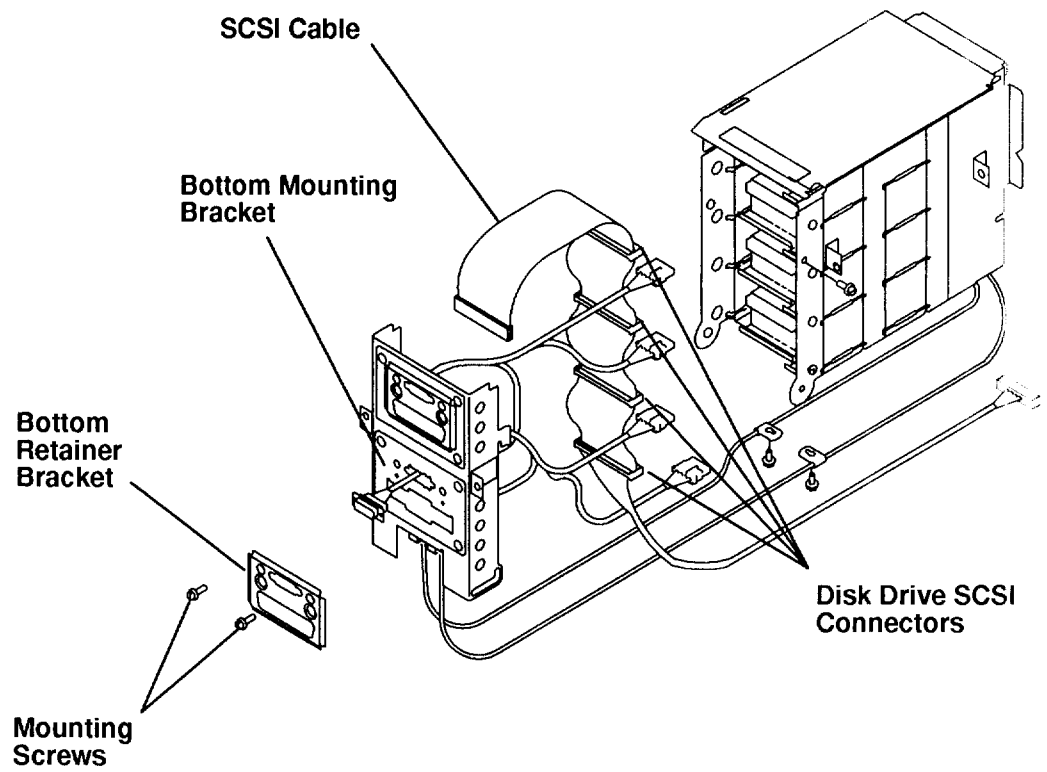

20. If you are removing the power cables, record the location of the power cable docking connectors.
21. Disconnect the power cable connectors from the disk drive or drives.
22. Locate the fan power cable connector that is part of the power cable you want to remove.
23. Disconnect the fan power cable connector (with release tab) from the mounted fan power cable connector on the docking door.
24. Remove the two docking door hinge screws located at the bottom of the docking door, and then separate the docking door from the disk drive carrier.
25. Remove the fan-power-cable connector that is mounted to the docking door. With pliers, squeeze the two tabs of the fan-power-cable connector (mounted on the docking door), and then push the fan-power-cable connector through the mounting hole in the docking door.
26. Remove the two mounting screws from the retainer bracket, and then remove the retainer bracket.
27. Pull the power cable docking connector through the mounting bracket (toward the inside of the carrier), and then remove the power cable.

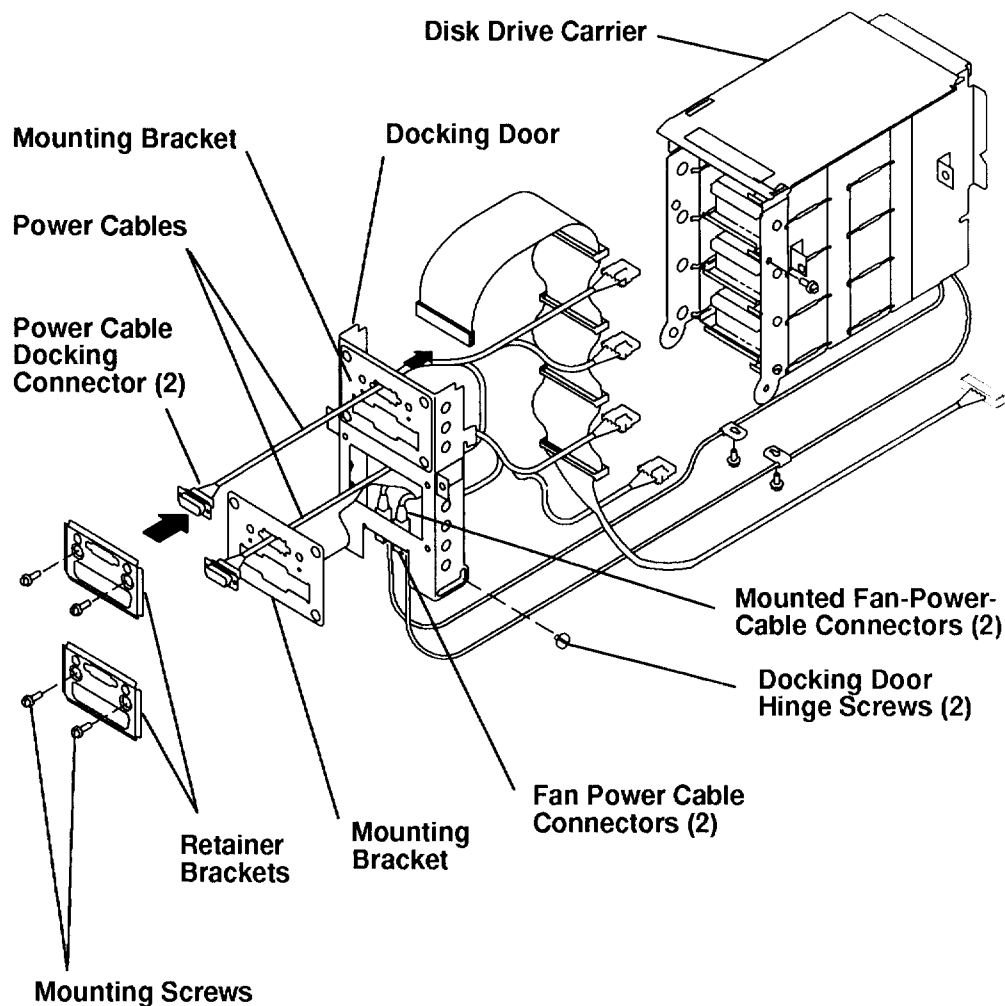

28. If you are removing a disk drive fan, disconnect the fan-power-cable connector (with release tab) from the mounted power cable connectors on the docking door.
29. Remove the two docking door hinge screws located at the bottom of the docking door, and then separate the docking door from the disk drive carrier.
30. Remove the two cable retainer clamps from the bottom of the disk drive carrier and the two cable retainer clamps from the bottom of the disk drive fan assembly.
31. Loosen the two retainer screws holding the disk drive fan assembly in the disk drive carrier, and then pull the assembly out of the carrier.
32. If you are removing a fan from the mounting bracket, pull the fan away from the bracket until the four vibration isolators disengage either from the fan or from the bracket, and then remove the fan.

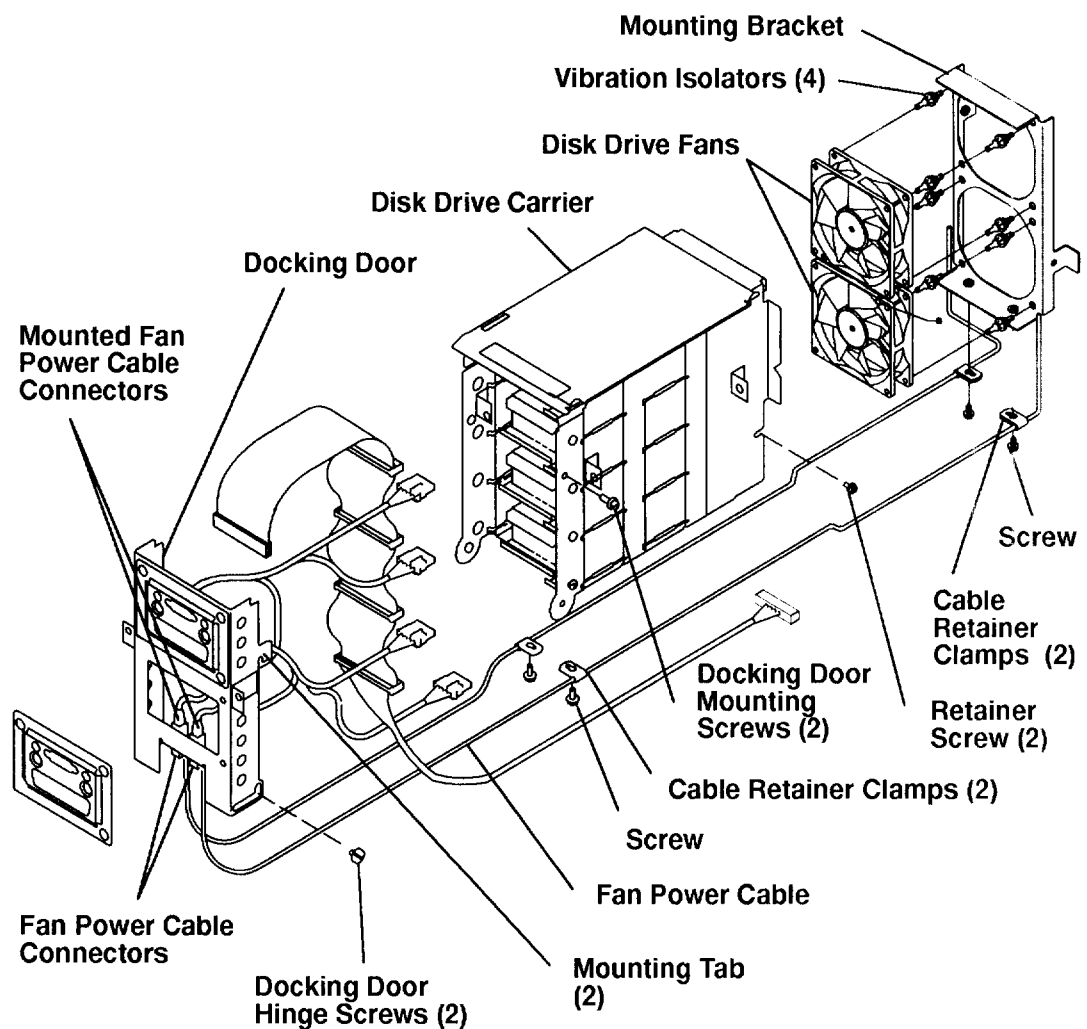

Replacement

Note: Ensure that the mounting tabs on the docking door are placed firmly down on the docking door mounting screws before tightening the mounting screws.

Replace in the reverse order.

Adapter Cable

Note: For a translation of this notice, see the *System Unit Safety Information* manual, form number SA23-2629.

DANGER

An electrical outlet that is not correctly wired could place hazardous voltage on metal parts of the system or the devices that attach to the system. It is the responsibility of the customer to ensure that the outlet is correctly wired and grounded to prevent an electrical shock.

Before installing or removing signal cables, ensure that the power cables for the system unit and all attached devices are unplugged.

When adding or removing any additional devices to or from the system, ensure that the power cables for those devices are unplugged before the signal cables are connected. If possible, disconnect all power cables from the existing system before you add a device.

Use one hand, when possible, to connect or disconnect signal cables to prevent a possible shock from touching two surfaces with different electrical potentials.

During an electrical storm, do not connect cables for display stations, printers, telephones, or station protectors for communications lines.

Removal

1. If your system has a power distribution unit, do the "Power-Off Procedure with a Power Distribution Unit" on page 3-7. If your system has a power distribution bus, do the "Power-Off Procedure with a Power Distribution Bus" on page 3-3.
2. Label each adapter cable being removed. Refer to the *Common Diagnostics and Service Guide* for information about labeling the adapter cables.
3. Record the location of the adapter cable being removed.

4. To remove the adapter cable, do either of the following:
 - a. If screws are used to connect the adapter cable connector to the adapter or the optional adapter, loosen the two screws, and then remove the cable.
 - b. If retainer clips are used to connect the adapter cable connector to the adapter or optional adapter, rotate the clips away from the cable connector, and then remove the cable.

Rear View of CPU-Media Enclosure

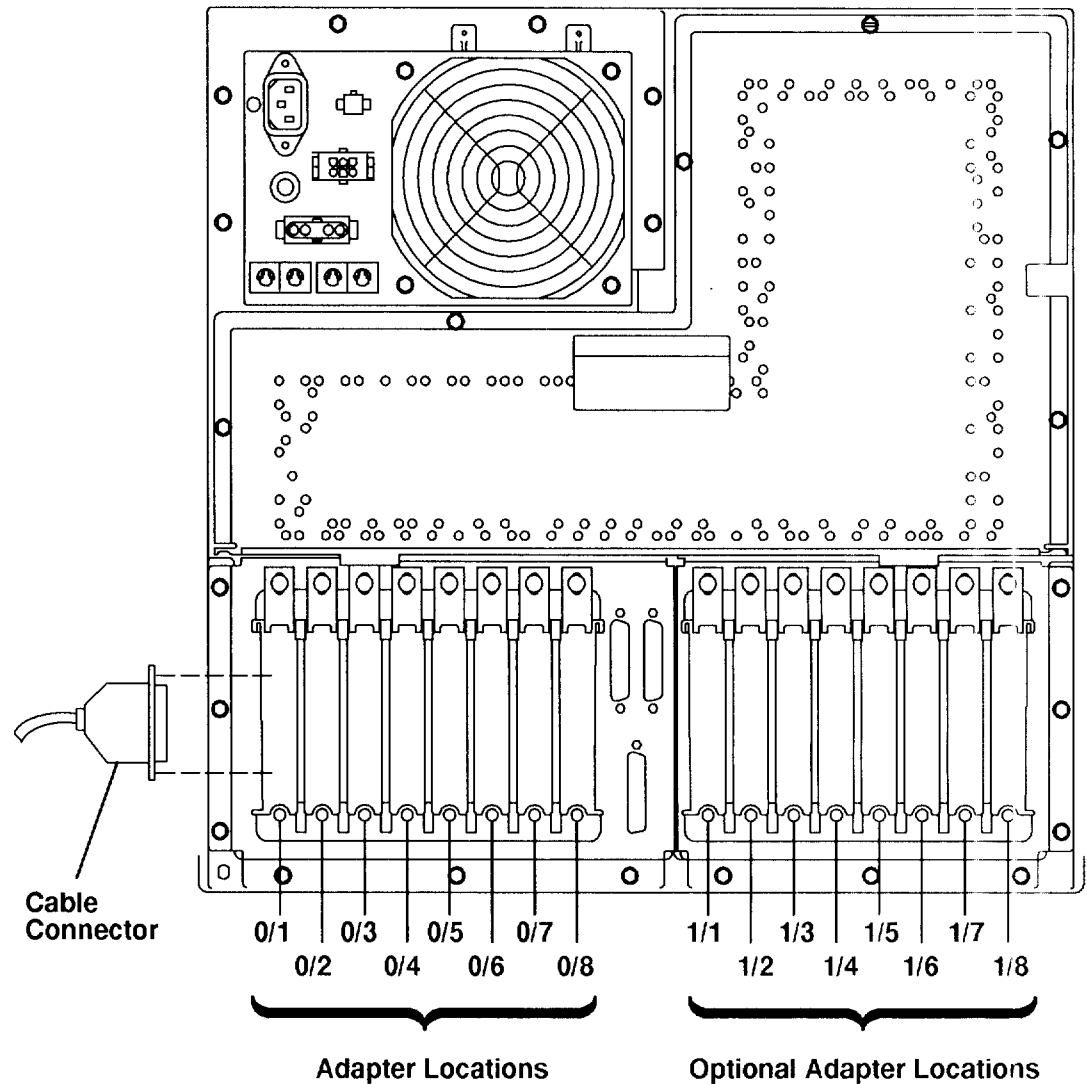

Replacement

Replace in the reverse order. If the enclosure was serviced and your rack contains a power distribution unit, then do the "Power-On Procedure with a Power Distribution Unit" on page 3-5. If your rack contains a power distribution bus, do the "Power-On Procedure with a Power Distribution Bus on page 3-1.

Adapter and Optional Adapter

Note: Refer to “Handling Static-Sensitive Devices” on page 3-14 before removing or installing adapters.

Removal

1. If your system has a power distribution unit, do the “Power-Off Procedure with a Power Distribution Unit” on page 3-7. If your system has a power distribution bus, do the “Power-Off Procedure with a Power Distribution Bus” on page 3-3.
2. If a cable is attached to the adapter or optional adapter you are removing, do the “Adapter Cable” removal procedure on page 3-74.
3. If you are removing an adapter, do the “Rear Access Plate” removal procedure on page 3-39.

If you are removing an optional adapter, remove the disk drive carrier. Refer to the “Disk Drive, Cables, Fans, and Carrier Assembly” removal procedure on page 3-65 to remove the disk drive carrier.

Rear View of CPU-Media Enclosure

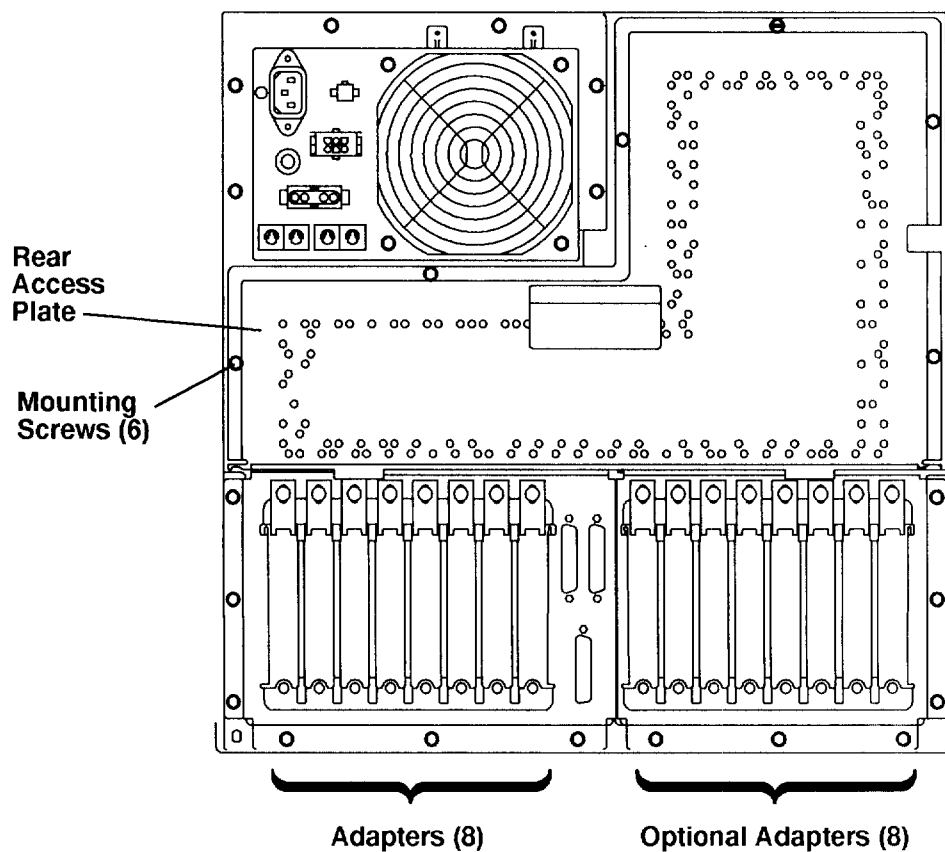

Note: If you are doing this procedure as part of the “Combination Planar” removal procedure, loosen all of the top and bottom mounting screws on all of the adapters.

If you are doing this procedure as part of the “Optional I/O Planar” removal procedure, loosen all of the top and bottom mounting screws on all of the optional adapters.

4. Record the position of the adapter or optional adapter you are removing.
5. Loosen the top and bottom mounting screws of the adapter or optional adapter.

Rear View of CPU-Media Enclosure

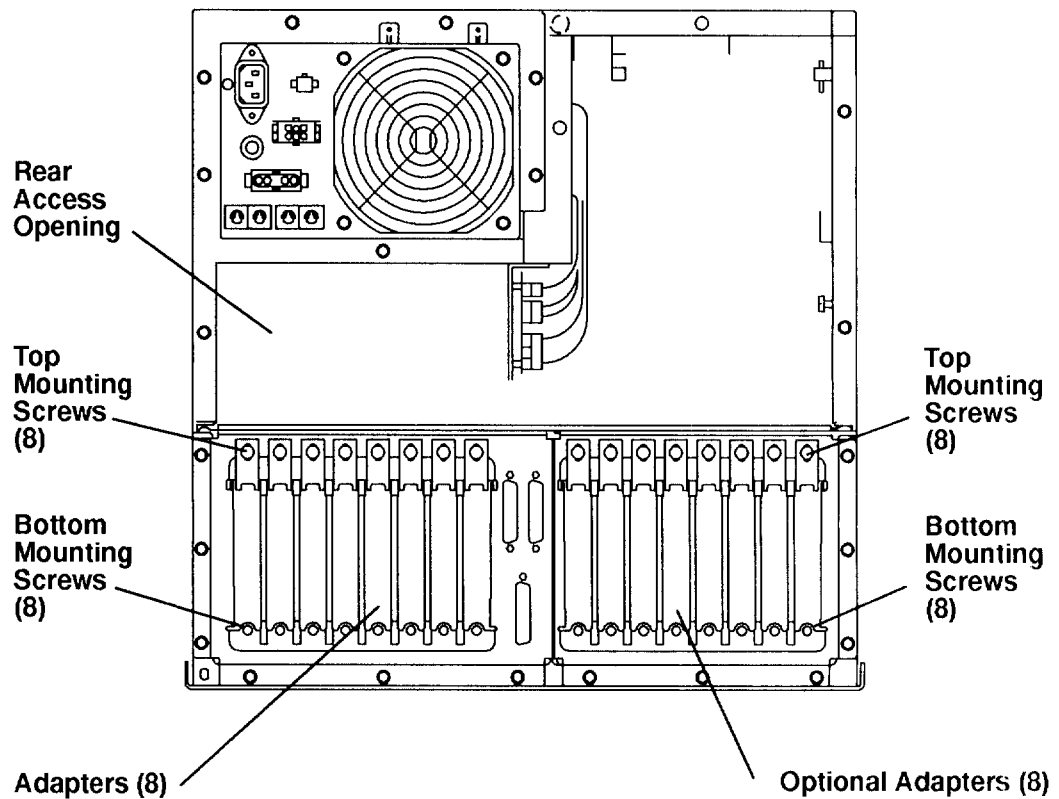

6. To remove the adapter or optional adapter, do the following:
 - a. Place a hand through the rear access opening and place a finger under the rear handle of the adapter.
 - b. Lift the rear handle with one hand and then lift the front of the adapter with the other hand until the adapter disengages from the slot.
 - c. Pull the adapter through the rear access opening and out the CPU-media enclosure.
7. If the adapter you removed has jumpers or switches on it, record the settings.

Rear View of CPU-Media Enclosure

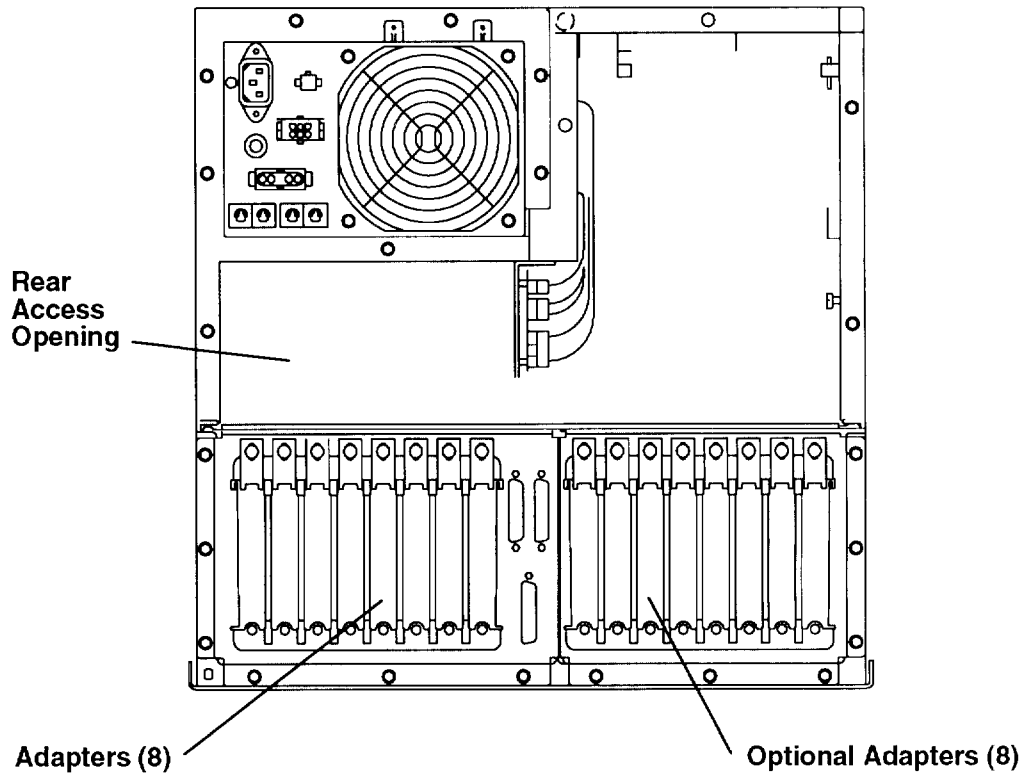

Replacement

Note: Ensure that the mounting springs of the adapter or optional adapter are securely positioned so that a firm contact is made. To replace the adapter or optional adapter, do the following:

1. Place the adapter through the rear access opening, and then position the adapter over the adapter slot.
2. Place the rear corner of the adapter connector into the rear of the slot.
3. With the front of the adapter tilted up, rotate the front of the adapter downward until the bottom mounting springs at the front of the adapter are placed behind the bottom mounting screw.

Replace in the reverse order. If the enclosure was serviced and your rack contains a power distribution unit, then do the "Power-On Procedure with a Power Distribution Unit" on page 3-5. If your rack contains a power distribution bus, do the "Power-On Procedure with a Power Distribution Bus on page 3-1.

Note: For EMI compliance, ensure that the rear access plate is mounted firmly against the CPU-media enclosure by tightening the mounting screws firmly. Do not overtighten the screws.

Combination Planar

Removal

1. Do the "Adapter Cable" removal procedure on page 3-74 to remove all of the adapter cables.
2. Remove all of the adapters on combination planar. Refer to the "Adapter or Optional Adapter" removal procedure on page 3-76 for information about removing the adapters.

Rear View of CPU-Media Enclosure

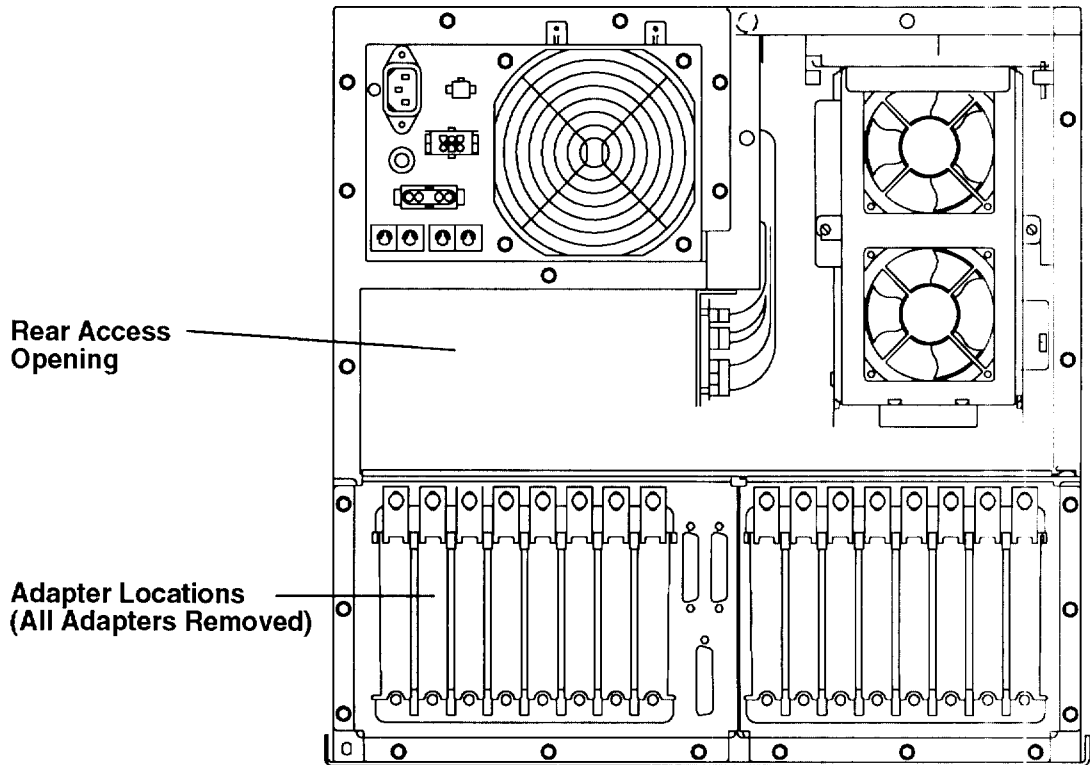

- Place a hand through the rear access opening, and then disconnect the four data signal connectors located on the right side of the combination planar.

To disconnect a data signal connector, place a finger in the pull loop, and then pull the connector straight up.

- Disconnect power connectors P21 and P22.

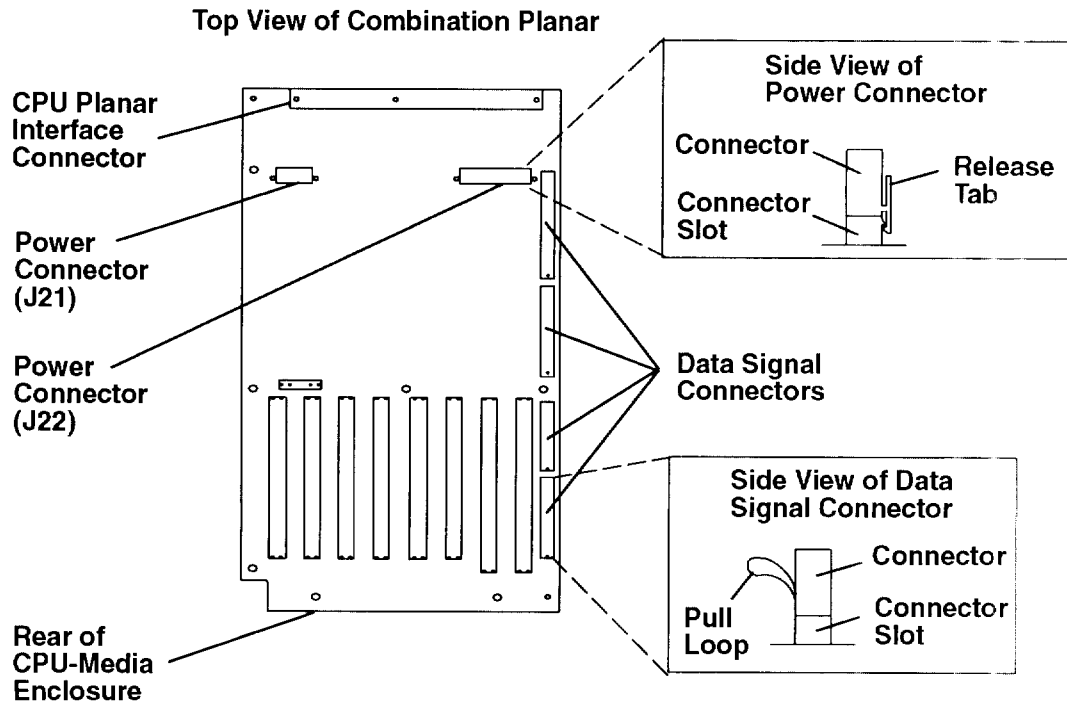
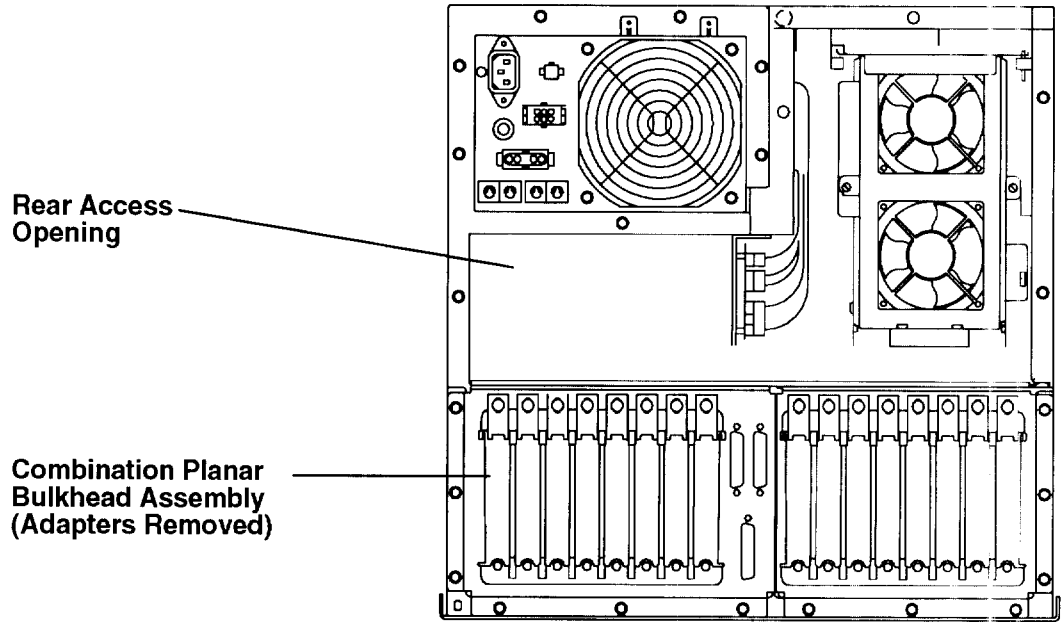

5. Remove the six mounting screws holding the combination planar bulkhead assembly in the CPU-media enclosure.

Rear View of CPU-Media Enclosure

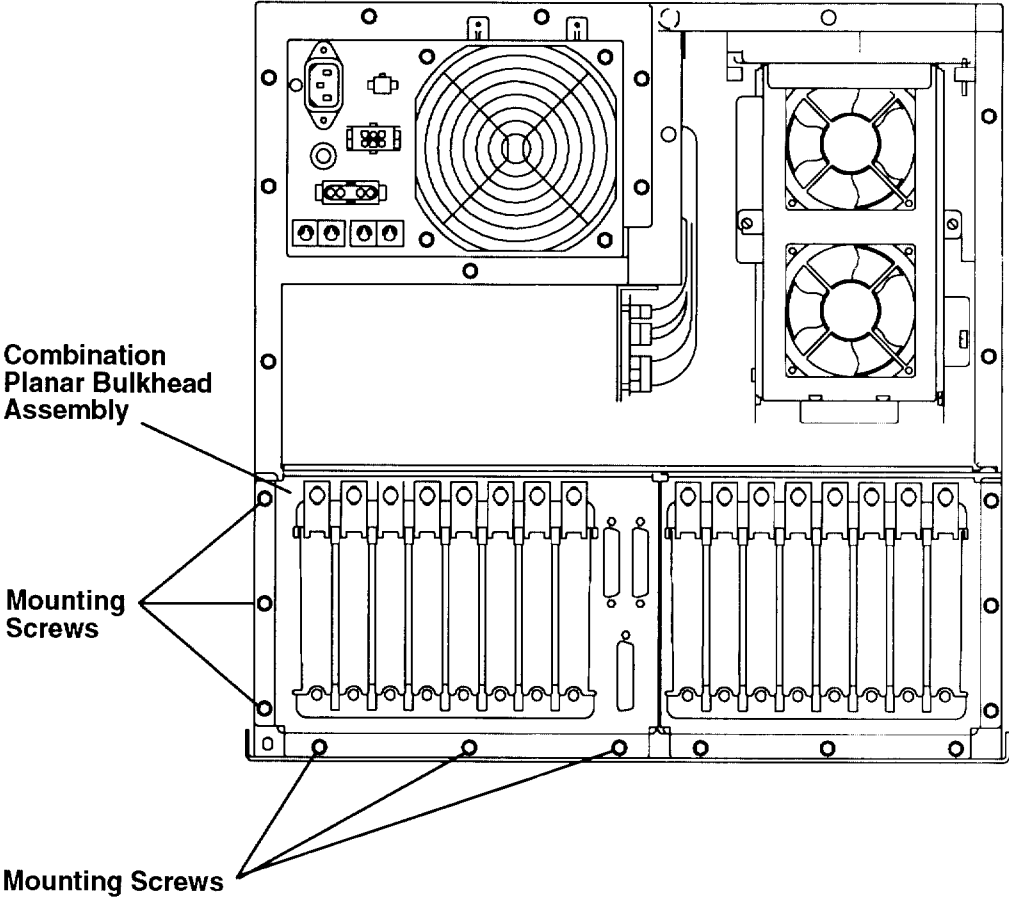

Warning: Do not lift the combination planar bulkhead assembly until the combination planar is disconnected from the CPU planar.

6. To disconnect the combination planar from the CPU planar, do the following:
 - a. Grasp the handle of the combination planar bulkhead assembly, and then pull the combination planar bulkhead assembly toward you until the CPU-planar interface connector disengages from the CPU planar.
 - b. Slide the combination planar bulkhead assembly out of the CPU-media enclosure.

Rear View of CPU-Media Enclosure

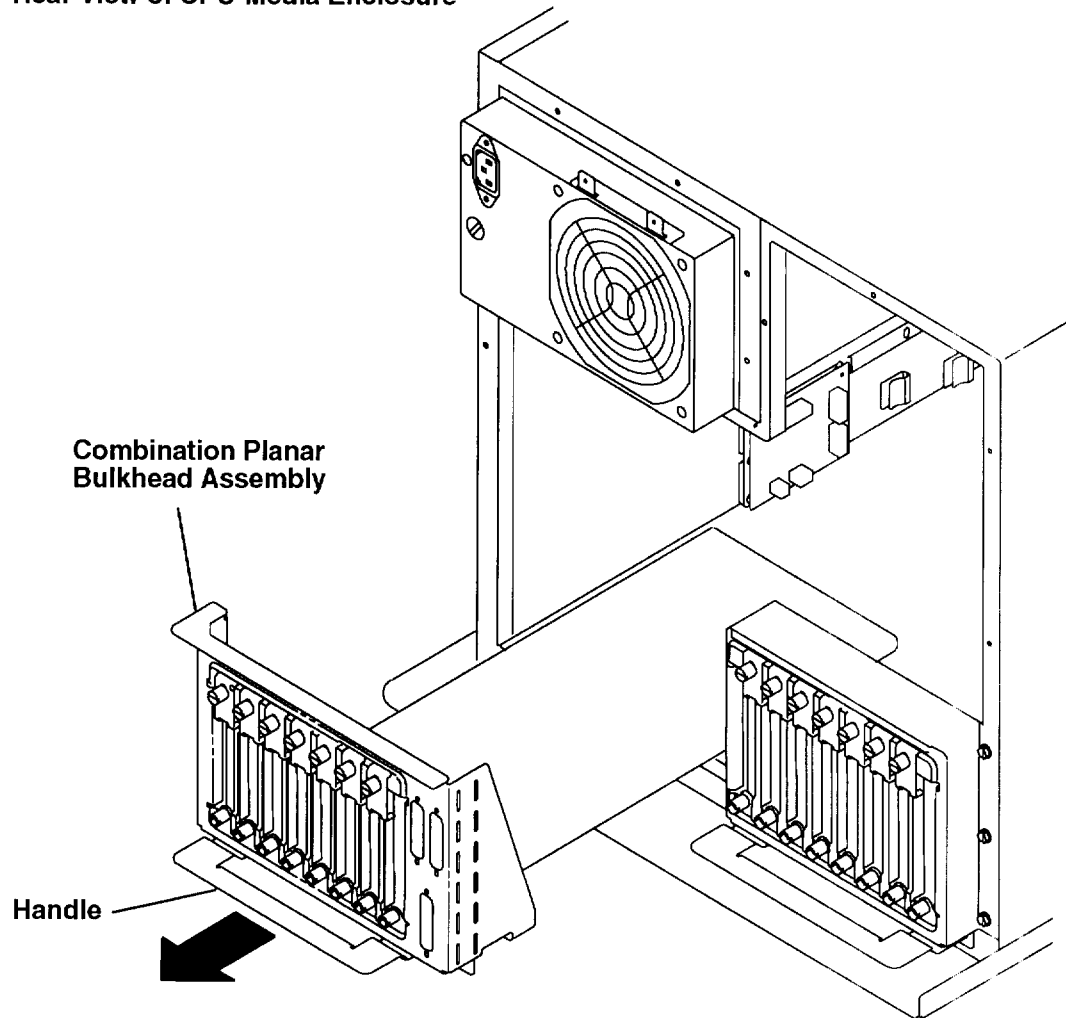

7. Remove the eight mounting screws attaching the combination planar to the combination planar plate.

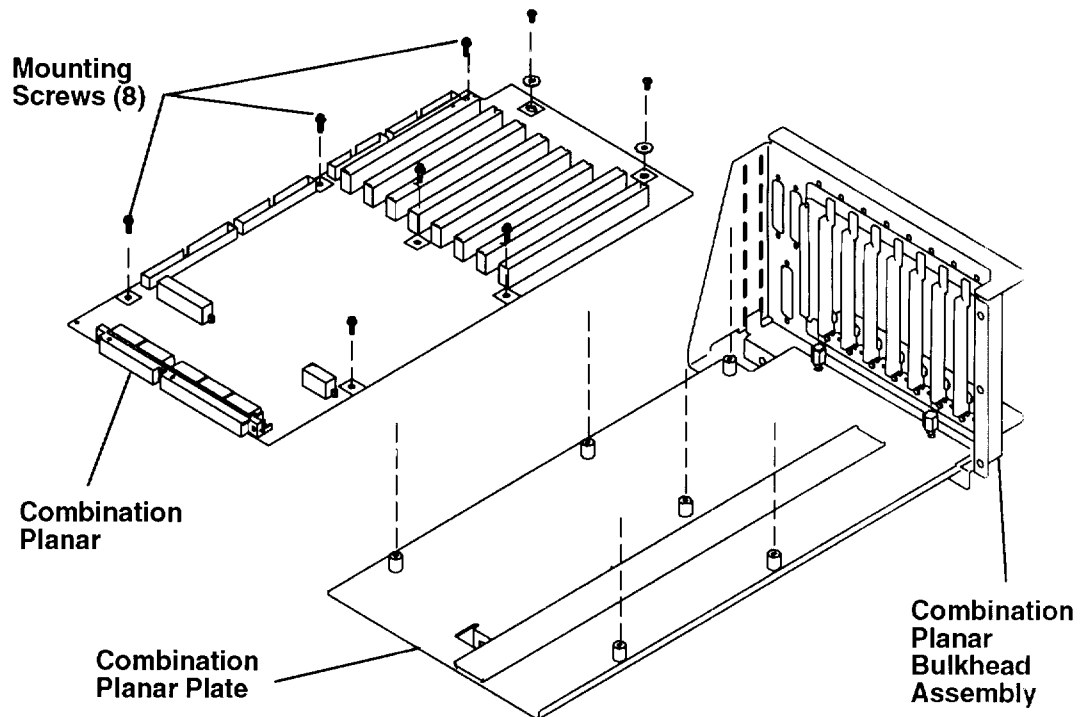

Replacement

Warning: Before attaching the combination planar bulkhead assembly (containing a new combination planar) to the CPU-media-enclosure frame, loosen the two CPU-planar-plate mounting screws that hold the CPU planar assembly in the CPU-media enclosure (refer to the illustration on page 3-22). Attaching the combination planar bulkhead assembly to the CPU-media-enclosure frame without first loosening the two CPU-planar-plate mounting screws can damage the interface connector pins, the combination planar, or the CPU planar. Refer to the “CPU Planar Assembly” removal procedure on page 3-22 for more information about the CPU planar assembly.

After the combination planar bulkhead assembly is replaced, ensure that the CPU planar assembly is in the proper mounting position. Using the lever tool, gently push the CPU planar assembly until the CPU-planar interface connectors are firmly seated. Refer to the illustration on page 3-25.

Replace in the reverse order. If your rack contains a power distribution unit, then do the “Power-On Procedure with a Power Distribution Unit” on page 3-5. If your rack contains a power distribution bus, do the “Power-On Procedure with a Power Distribution Bus on page 3-1.

Note: When you have finished the removal and replacement procedure, tell the customer to set the system time and date, the alternate bootlist, and any other settings stored in nonvolatile RAM (NVRAM).

Optional I/O Planar

Removal

1. Do the "Adapter Cable" removal procedure on page 3-74 to remove all of the optional adapter cables.
2. Remove all optional adapters. Refer to the "Adapter or Optional Adapter" removal procedure on page 3-76 for information about removing the optional adapters.

Rear View of CPU-Media Enclosure

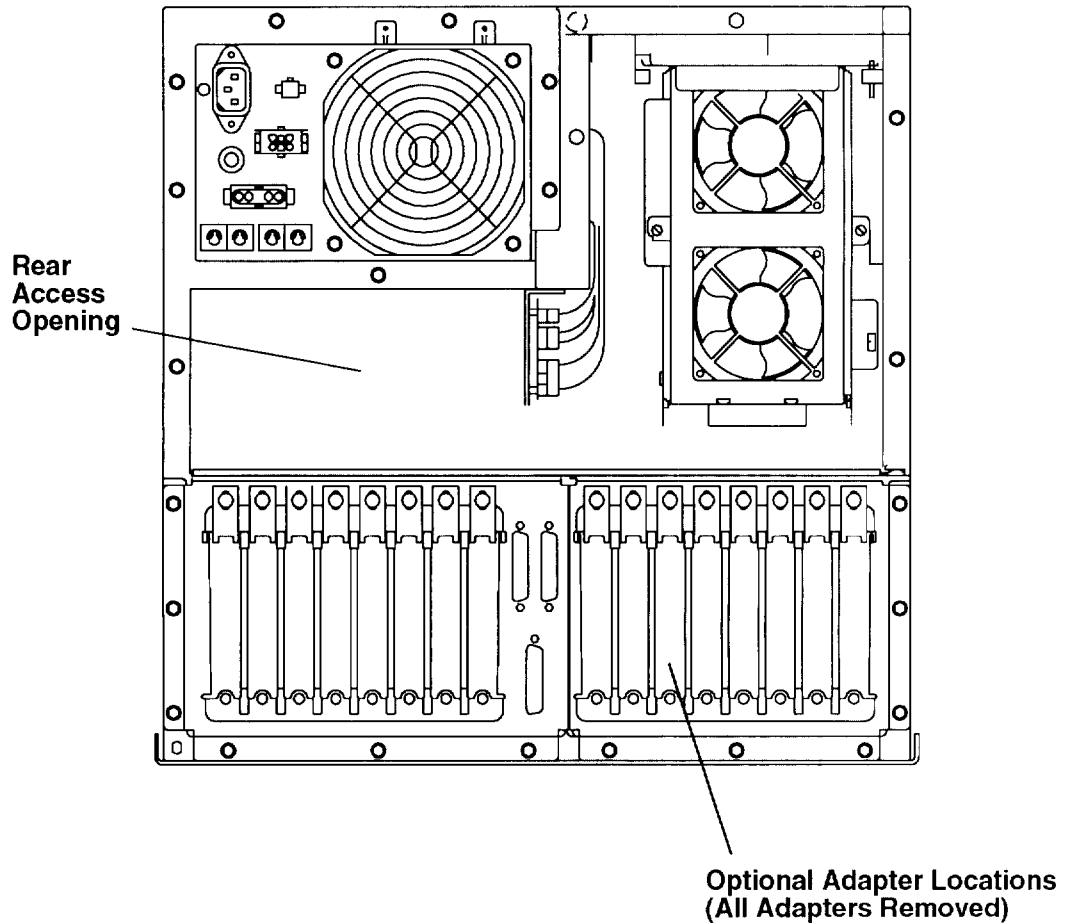

3. To disconnect the power connectors on the optional I/O planar, place a hand through the rear access opening, and then disconnect power cable connectors P41, P42, and P43 from the optional I/O planar.

Rear View of CPU-Media Enclosure

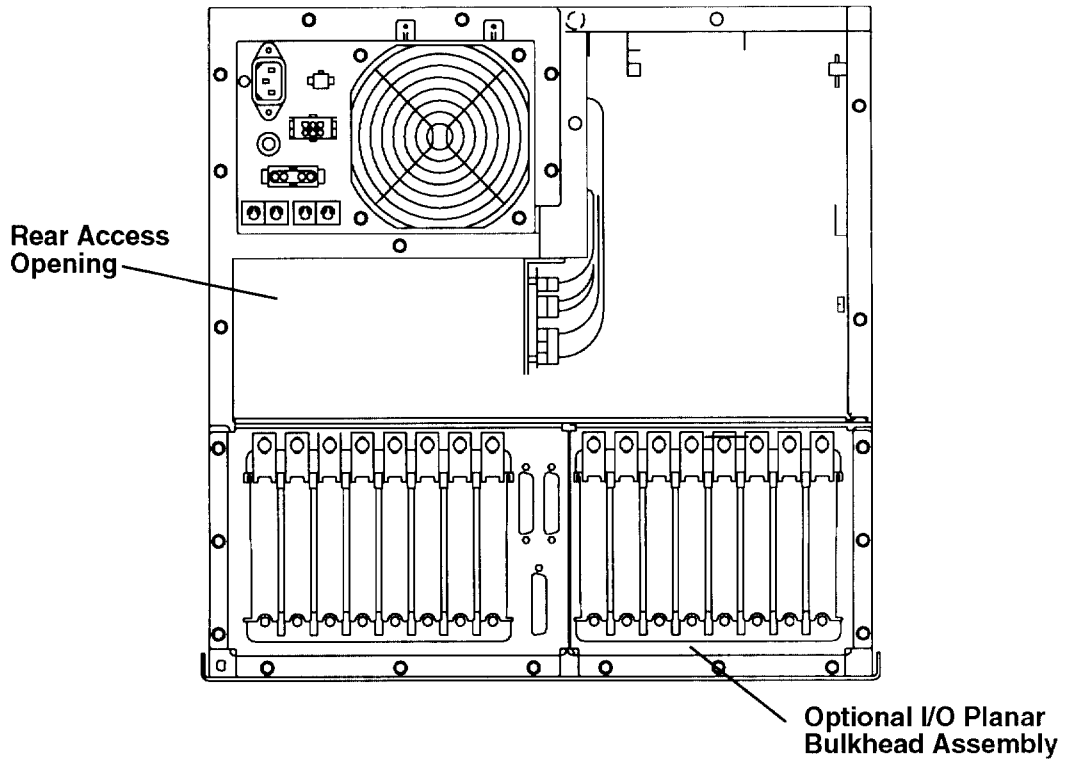

Top View of Optional I/O Planar

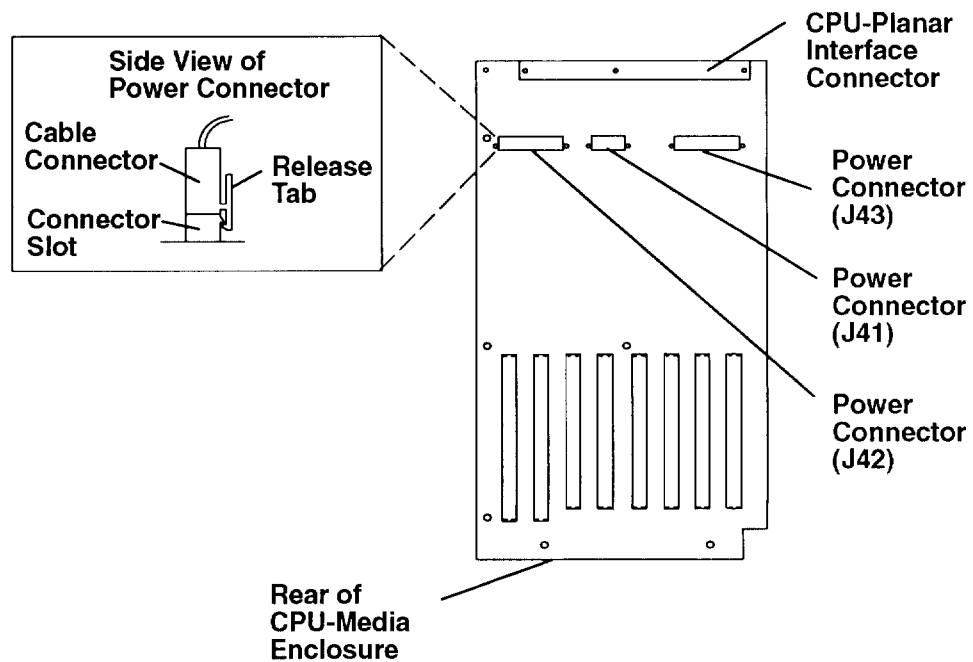

4. Remove the six mounting screws holding the optional I/O planar bulkhead assembly in the CPU-media enclosure.

Rear View of CPU-Media Enclosure

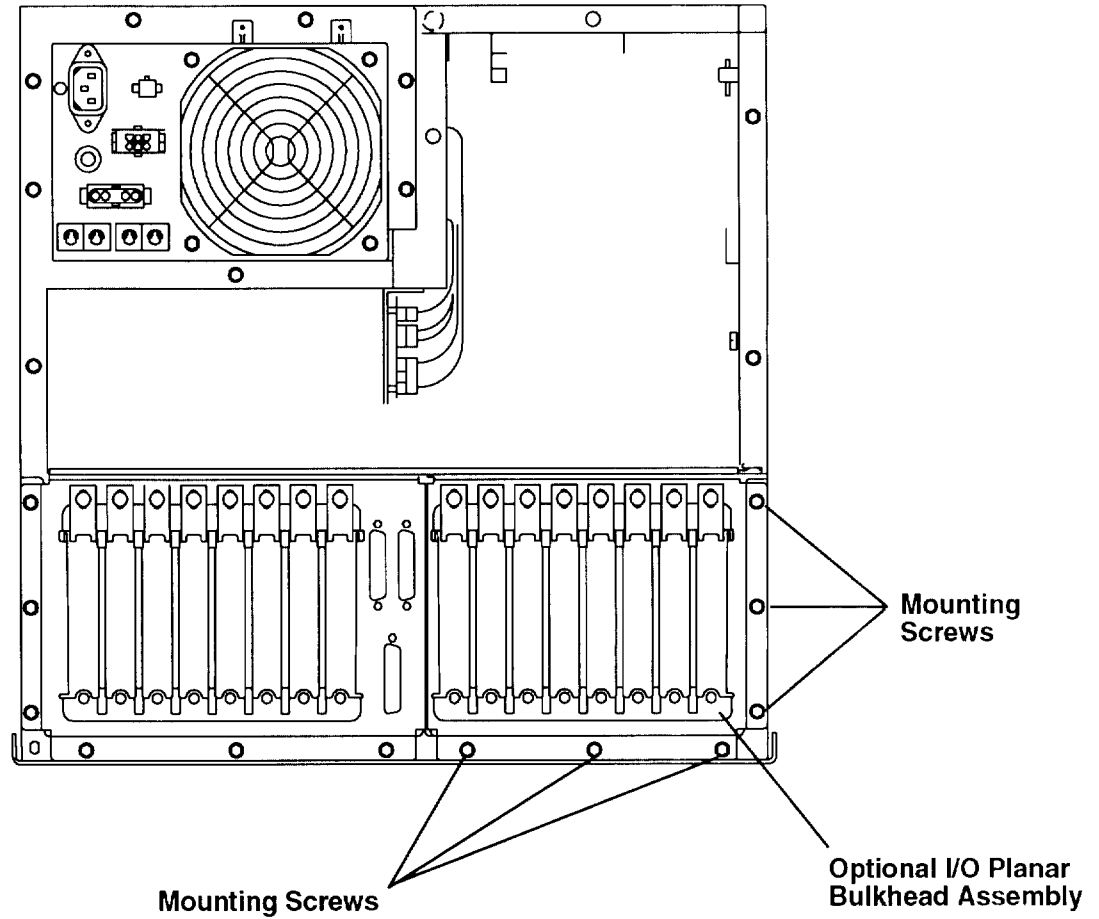

Warning: Do not lift up the optional I/O planar bulkhead assembly until the optional I/O planar is disconnected from the CPU planar.

5. To disconnect the optional I/O planar from the CPU planar, grasp the handle of the optional I/O planar bulkhead assembly and pull it toward you until the CPU planar interface connector disengages from the CPU planar.
6. Slide the optional I/O planar bulkhead assembly out of the CPU-media enclosure.

**Rear View of
CPU-Media Enclosure**

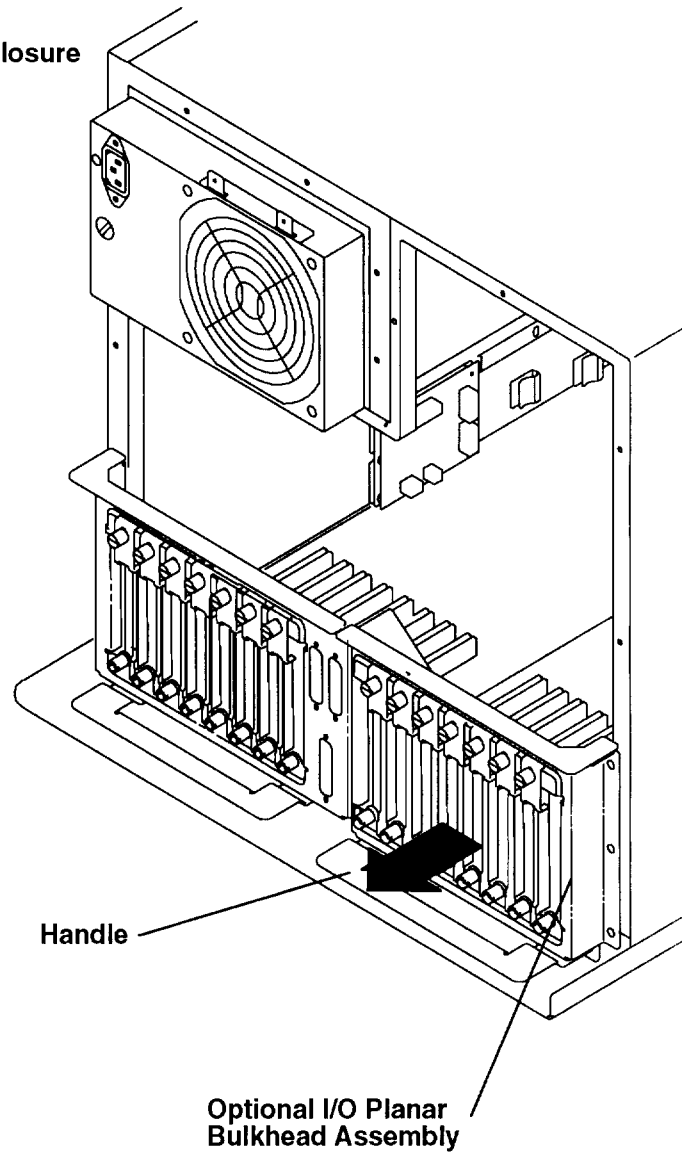

7. Remove the seven mounting screws attaching the optional I/O planar to the optional I/O planar plate.

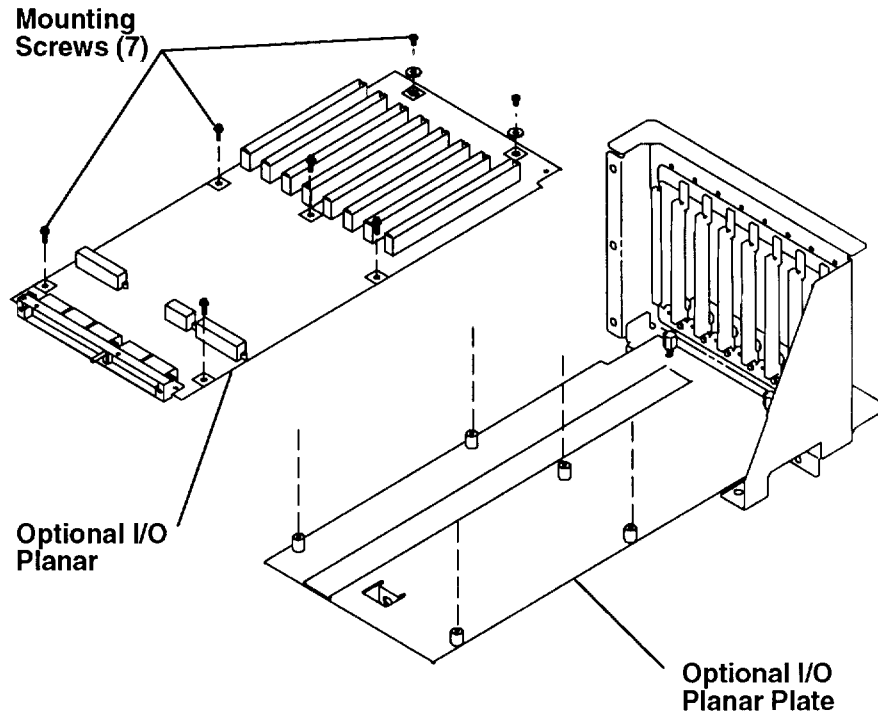

Replacement

Warning: Before attaching the optional I/O planar bulkhead assembly (containing a new optional I/O planar) to the CPU-media-enclosure frame, loosen the two CPU-planar-plate mounting screws that hold the CPU planar assembly in the CPU-media enclosure (refer to the illustration on page 3-22). Attaching the optional I/O planar bulkhead assembly to the CPU-media-enclosure frame without first loosening the two CPU-planar-plate mounting screws can damage the interface connector pins, the optional I/O planar, or the CPU planar. Refer to the “CPU Planar Assembly” removal procedure on page 3-22 for more information about the CPU planar assembly.

After the optional I/O planar bulkhead assembly is replaced, ensure that the CPU planar assembly is in the proper mounting position. Using the lever tool, gently push the CPU planar assembly until the CPU planar interface connectors are firmly seated. Refer to the illustration on page 3-25.

Replace in the reverse order. If your rack contains a power distribution unit, then do the “Power-On Procedure with a Power Distribution Unit” on page 3-5. If your rack contains a power distribution bus, do the “Power-On Procedure with a Power Distribution Bus on page 3-1.

Serial Ports and Parallel Port Assembly

Removal

1. If your system has a power distribution unit, do the “Power-Off Procedure with a Power Distribution Unit” on page 3-7. If your system has a power distribution bus, do the “Power-Off Procedure with a Power Distribution Bus” on page 3-3.
2. Remove the combination planar bulkhead assembly. Refer to the “Combination Planar Assembly” removal procedure on page 3-80 to remove the combination planar bulkhead assembly.
3. Remove the two screws on each serial port connector and parallel port connector.
4. Disconnect the data signal cable from connector J27 on the combination planar, and then remove the serial ports and parallel port assembly.

Rear View of CPU-Media Enclosure

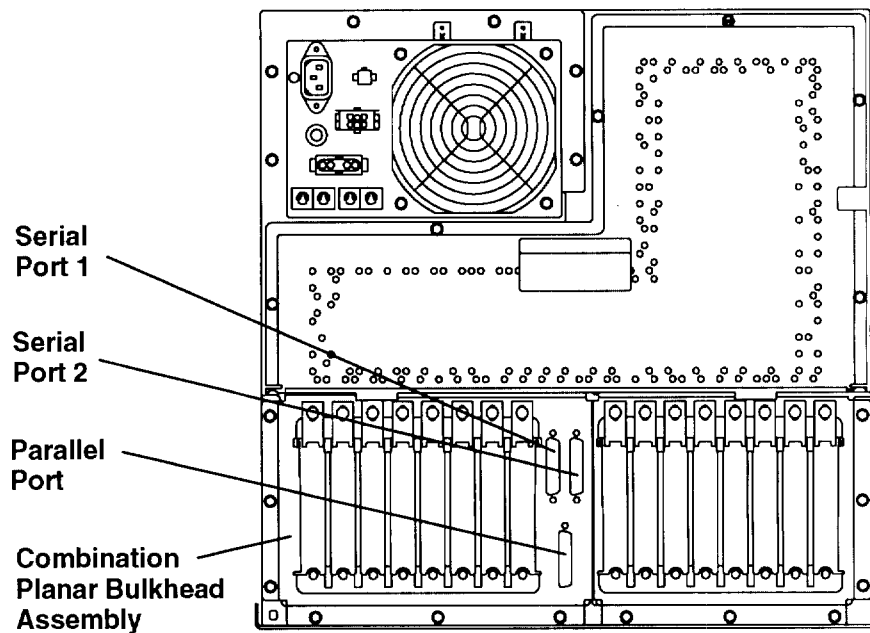

Top View of Combination Planar

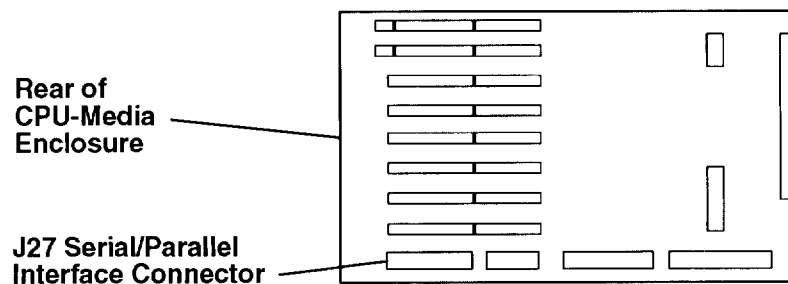

Replacement

Replace in the reverse order.

Chapter 4. Parts Information

This chapter contains eight details showing all parts and the respective part numbers for each detail. The chapter begins with details of the front of the CPU-media enclosure, continues with details of the middle of the CPU-media enclosure, and ends with details of the rear of the CPU-media enclosure.

Detail 1. Media Carrier Assembly

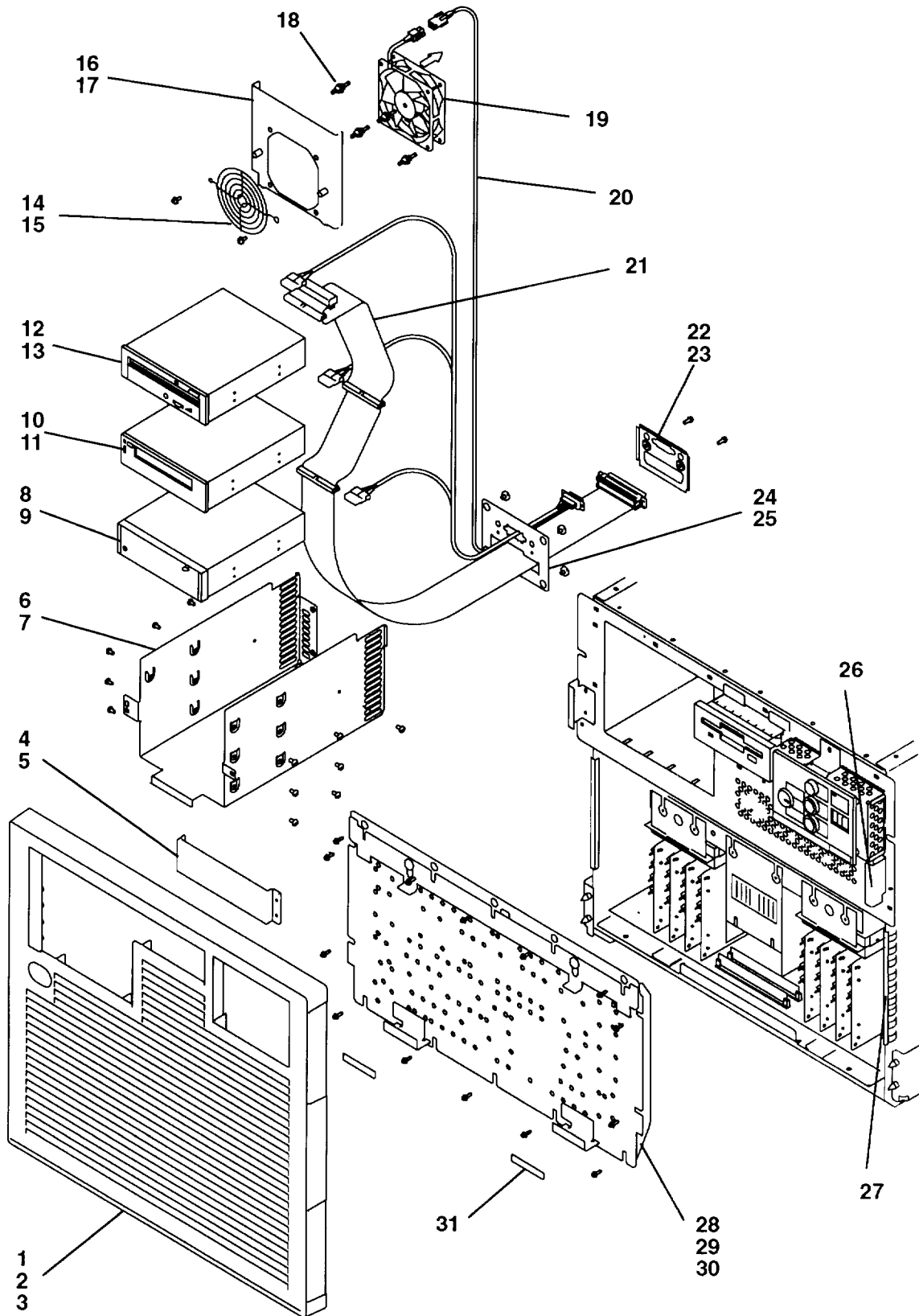

Index Number	Part Number	Units Per Assy	Description
1	52G1097	1	Front bezel
2	42F6866	1	Nameplate
3	81F7982	4	Loop fastener
4	52G1100	1	Cover (blank media position)
5	1621170	4	Screw, M3 x 6
6	52G5557	1	Media carrier
7	00G1269	2	Screw, M4 x 10
8	See note	1	Optional media device
9	1621170	4	Screw, M3 x 6
10	See note	1	5.0 GB 8 mm tape drive
11	1621170	4	Screw, M3 x 6
12	See note	1	CD-ROM drive
13	1621170	4	Screw, M3 x 6
14	32G0219	1	Fan guard
15	00G1269	2	Screw, M4 x 10
16	52G5559	1	Bracket
17	1621170	2	Screw, M3 x 6
18	81F7977	4	Vibration isolators
19	52G5560	1	Fan
20	52G5562	1	Power cable
21	52G5561	1	SCSI cable (inside media carrier)
22	52G5534	1	Retainer bracket
23	00G1268	2	Screw, M4 x 7
24	52G5791	1	Mounting bracket
25	52G5536	4	Screw, shoulder
26	81F7982	2	Hook/loop fastener
27	43G0694	2	Grounding strip
28	52G1098	1	Front access plate
29	00G1269	10	Screw, M4 x 10
30	1624779	4	Screw, M5 x 14
31	81F7982	2	Hook/loop fastener

Note: See Chapter 4 in the *POWERstation and POWERserver Common Diagnostics and Service Guide* for part numbers.

Detail 2. 3.5-Inch Diskette Drive and Operator Panel

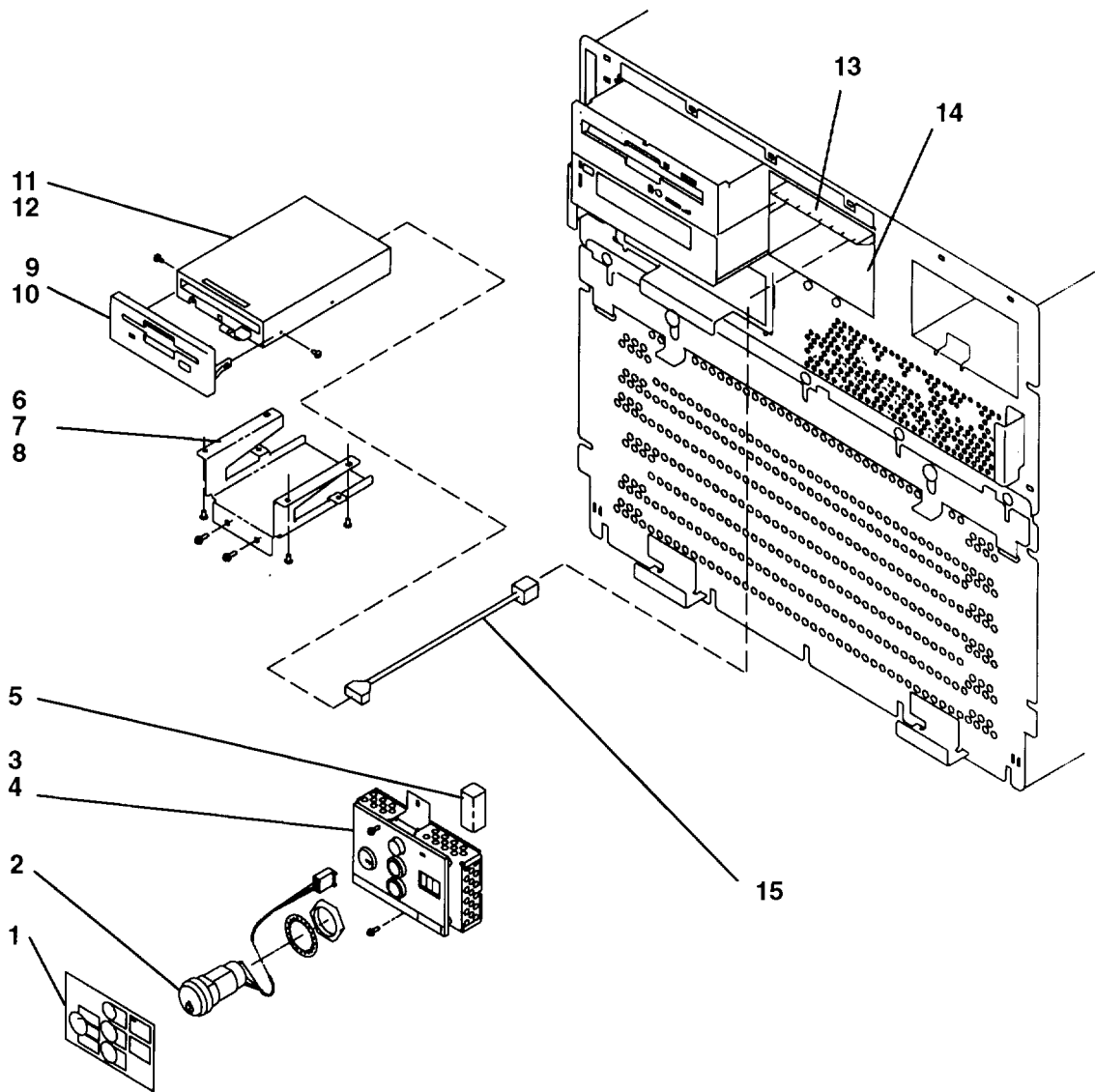

Index Number	Part Number	Units Per Assy	Description
1	02G7174	1	Label overlay – English
1	00G1977	1	Label overlay – French
1	00G1979	1	Label overlay – German
1	00G1981	1	Label overlay – Italian
2	031G9609	1	Key mode switch (locking)
2	031G9610	1	Key mode switch (nonlocking)
3	43G1803	1	Operator panel assembly
4	00G1269	2	Screw, M4 x 10
5	02G7237	1	Lithium battery
6	52G5553	1	Bracket
7	1621170	4	Screw, M3 x 6
8	00G1269	2	Screw, M4 x 10
9	02G7287	1	Bezel assembly
10	1621170	2	Screw, M3 x 6
11	See note	1	3.5-inch diskette drive
12	00G1268	4	Screw
13	65G6935	1	Long EMI gasket
14	65G6936	2	Short EMI gasket
15	52G6137	1	Power cable (to 3.5-inch diskette drive)

Note: See Chapter 4 in the *POWERstation and POWERserver Common Diagnostics and Service Guide* for part numbers.

Detail 3. Docking Assembly

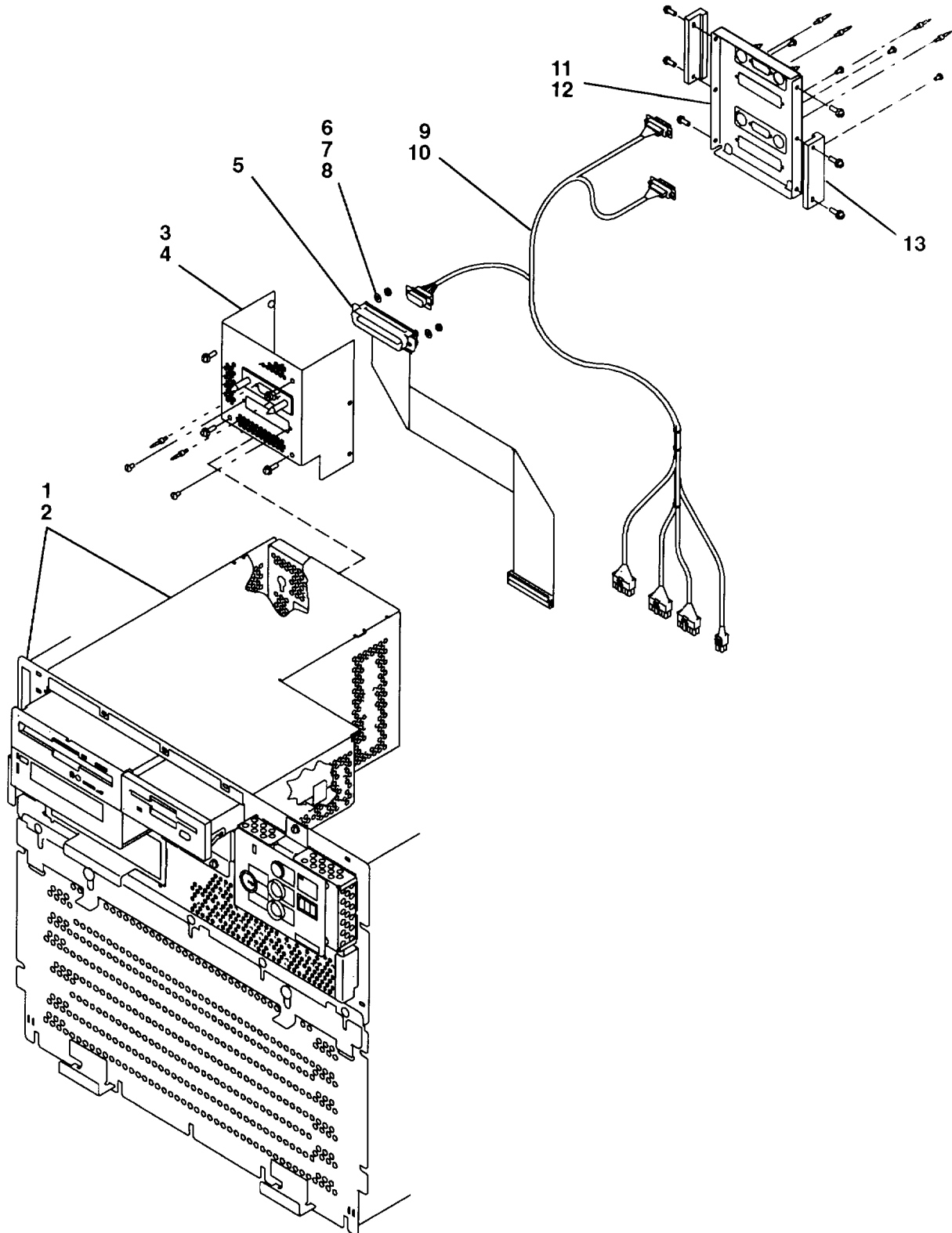

Index Number	Part Number	Units Per Assy	Description
1	52G5556	1	Device carrier
2	00G1269	6	Screw, M4 x 6
3	52G5566	1	Docking assembly bracket – single connector
4	00G1269	4	Screw, M4 x 10
5	52G5769	1	SCSI cable (single connector to combination planar)
6	1621173	2	Screw, M3 x 12
7	1622316	2	Lockwasher, M3
8	1622401	2	Nut, M3
9	52G5568	1	Power Cable
10	52G5571	6	Screw (guide pin)
11	52G5567	1	Docking assembly cover – two connector
12	00G1269	6	Screw, M4 x 10
13	65G6836	2	Bracket

Detail 4. CPU Planar Assembly and Planar Fans Assembly

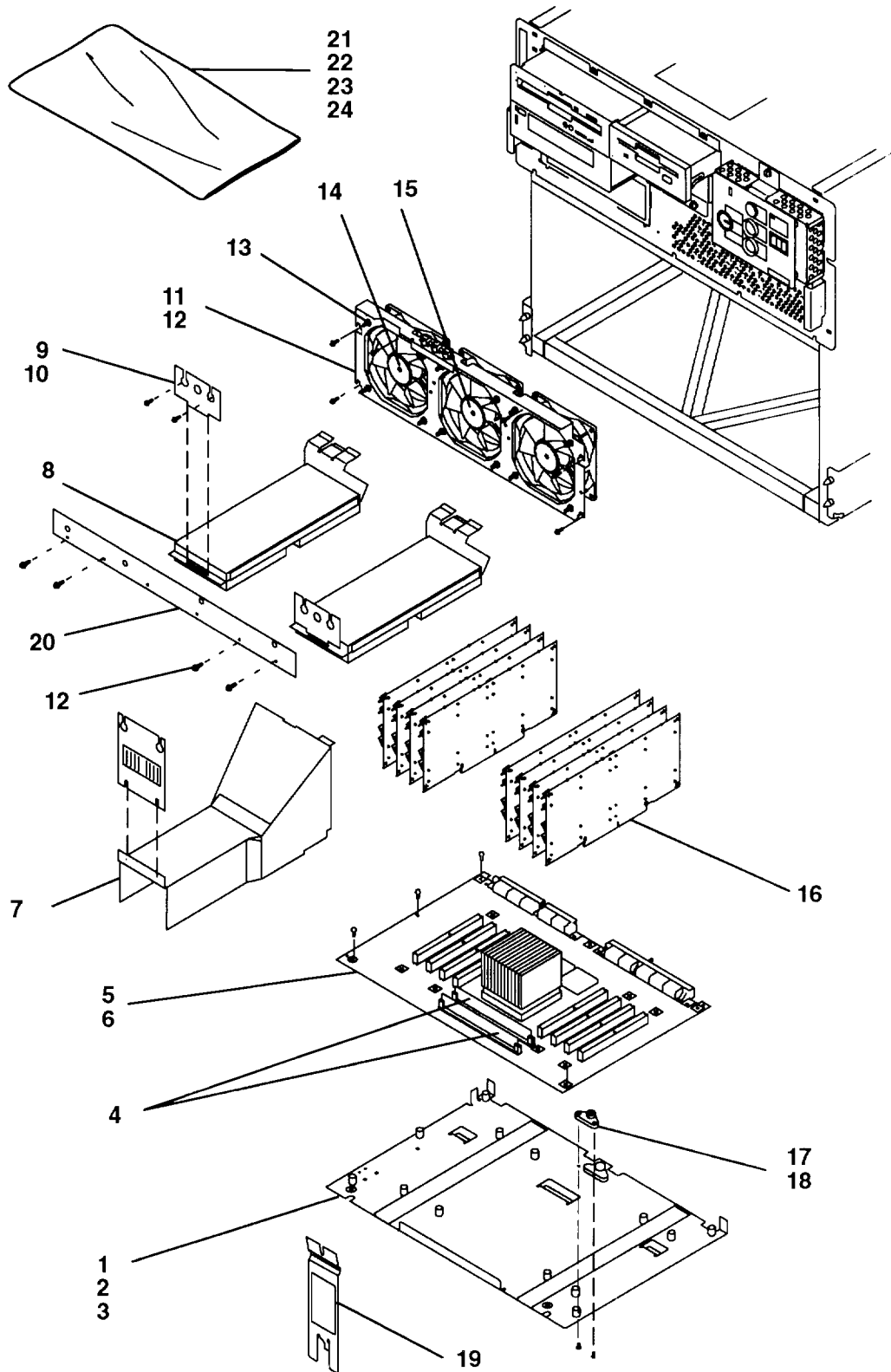

Index Number	Part Number	Units Per Assy	Description
1	8185545	1	CPU planar plate assembly
2	00G1269	2	Screw, M3 x 10
3	1622290	2	Washer, M4
4	See note	2	Cache SIMM
5	88G0007	1	CPU planar, Model R24
6	6258899	12	Screw, M3 x 10
7	8185768	1	Air deflector
8	65G3529	2	Memory card retainer assembly
9	65G3535	2	Retainer bracket
10	00G1269	4	Screw, M4 x 10 (M3 screw – 10G8854)
11	31G9450	1	Planar-fan-assembly bracket
12	00G1269	6	Screw, M4 x 10
13	81F7977	12	Vibration isolator
14	02G7253	2	Planar fan (low speed)
15	8185454	1	Planar fan (high speed)
16	See note	1	Memory card
17	00G2618	1	Standoff isolator
18	1621285	2	Screw, flat head
19	43G0466	1	Lever tool, CPU planar removal and installation
20	8185546	1	Duct mounting bracket
21	7396620	1	Antistatic bag, 8 inches x 18 inches
22	6278633	1	Antistatic bag, 14 inches x 18 inches
23	6848192	1	Antistatic bag, 20 inches x 15 inches
24	1789632	1	Antistatic bag, 24 inches x 24 inches
<p>Note: See Chapter 4 in the <i>POWERstation and POWERserver Common Diagnostics and Service Guide</i> for part numbers.</p>			

Detail 5. Internal Cable Brackets and Clamps

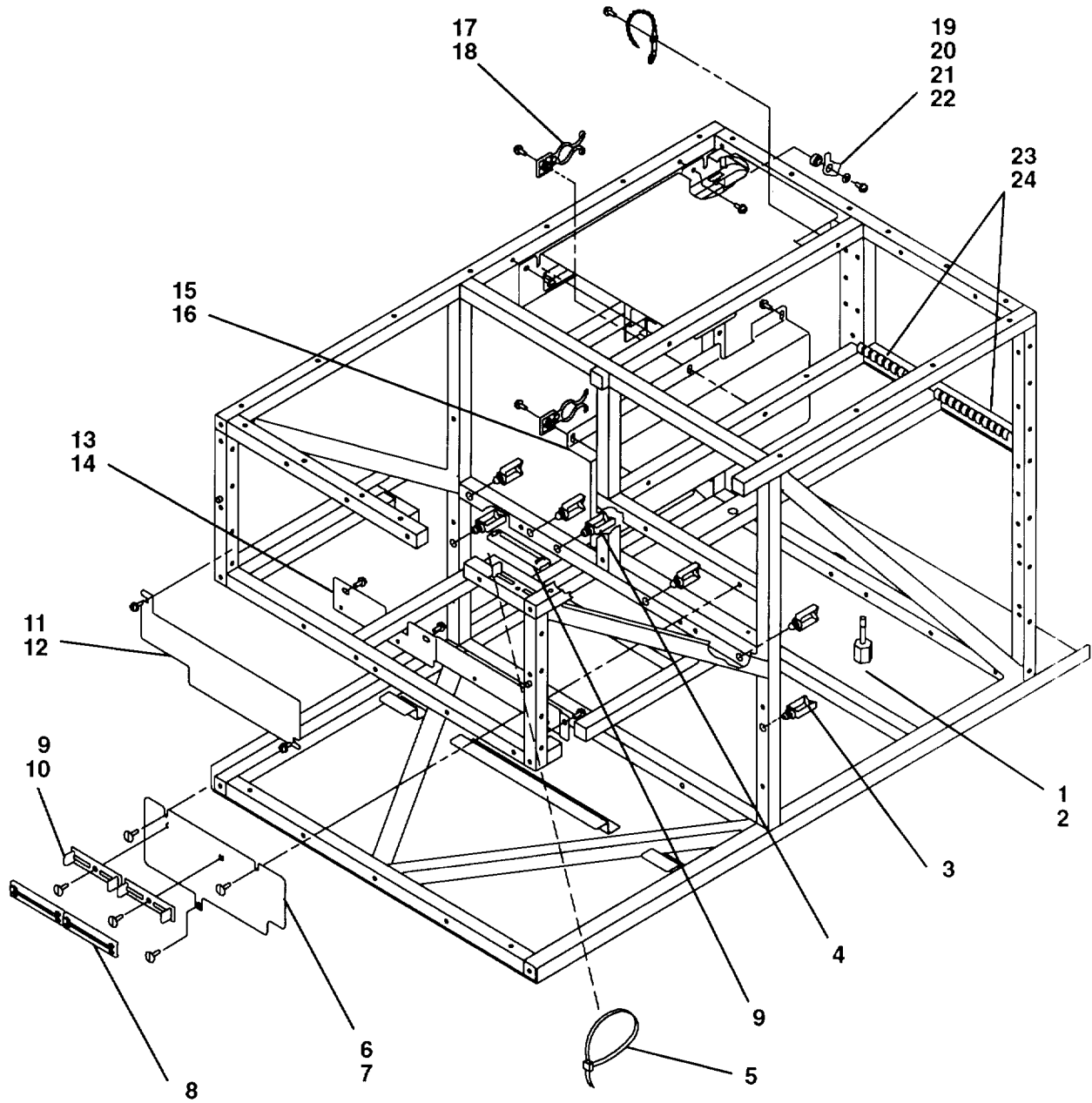

Index Number	Part Number	Units Per Assy	Description
1	02G7267	1	Hex thumbscrew
2	1622319	1	Washer
3	02G7311	6	Cable clamp, medium
4	02G7312	1	Cable clamp, large
5	0524519	1	Cable strap
6	31G9451	1	Plate
7	00G1269	3	Screw, M4 x 10
8	02G7309	1	Clamp, cable restraint
9	02G7314	1	Bracket, cable restraint
10	10G8854	2	Screw, M4 x 12
11	10G8730	1	Plate, divider
12	00G1269	2	Screw, M4 x 10
13	31G9550	1	Plate, divider
14	00G1269	3	Screw, M4 x 10
15	31G9551	1	Cable channel
16	00G1269	3	Screw, M4 x 10
17	52G5575	2	Cable retainer – two-hook
18	00G1269	2	Screw, M4 x 10
19	52G5549	1	Large washer
20	52G5548	1	Safety latch
21	1622304	1	Small washer
22	00G1270	1	Screw,
23	43G0666	2	Grounding strip, 34 mm (power supply)
24	00G1268	4	Screw, M4 x 7

Detail 6. Power Supply

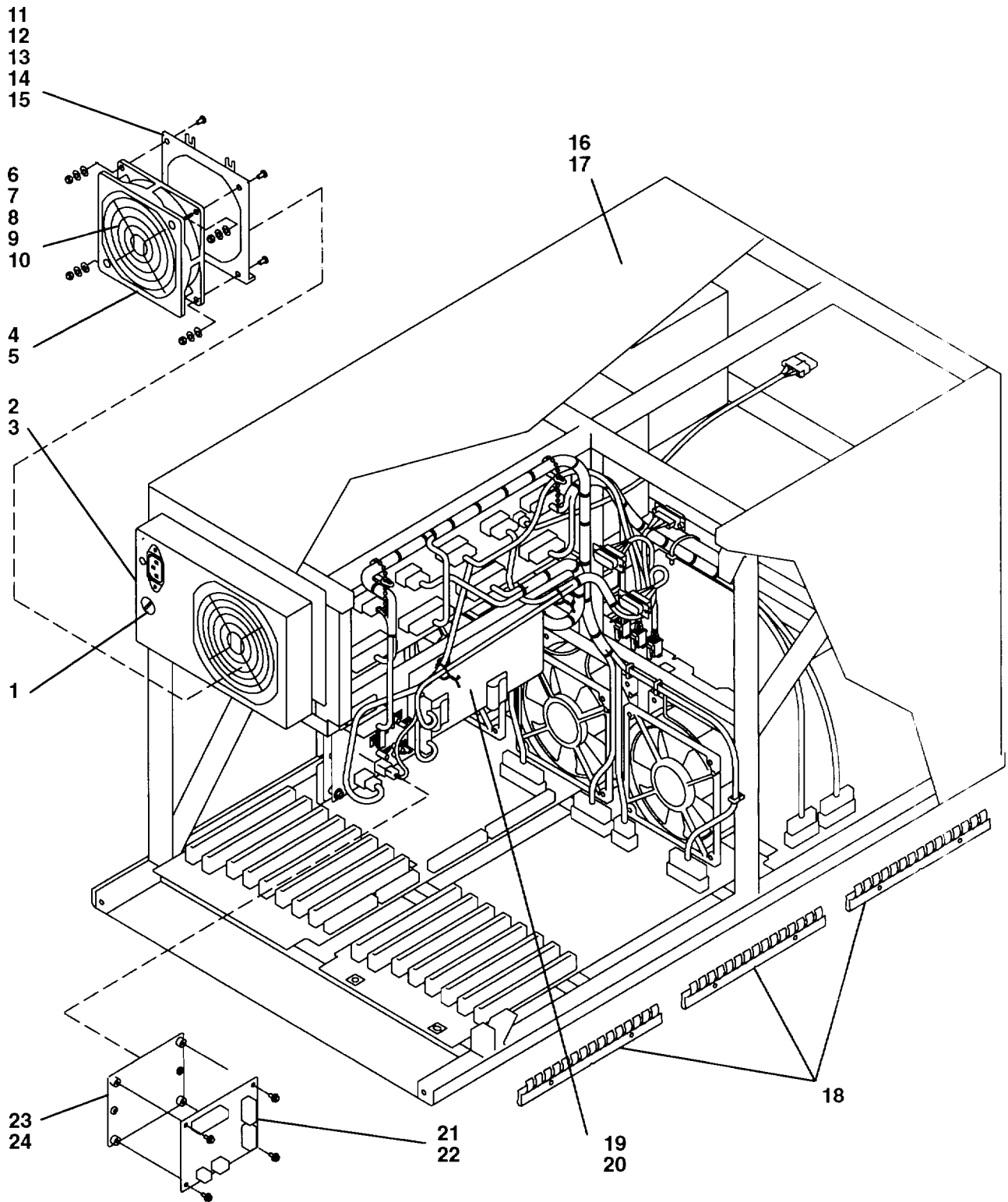

Index Number	Part Number	Units Per Assy	Description
1	43G0449	1	Fuse
2	65G6995	1	Power supply (standard AC)
2	88G0053	1	Power supply (-48 V dc)
3	00G1269	6	Screw, M4 x 10
4	02G7266	1	Power supply fan
5	10G8854	4	Screw, M3 x 12
6	2546641	1	Guard
7	00G1270	2	Screw, M4 x 17
8	1622304	2	Flat washer
9	1622318	2	Lock washer
10	1622403	2	Nut
11	02G7265	1	Bracket
12	00G1270	4	Screw, M4 x 12
13	1622403	4	Nut
14	1622318	4	Lock washer
15	1622304	4	Flat washer
16	31G9445	1	Top cover
17	1621191	12	Screw, M4 x 10
18	42G0694	6	Grounding strip
19	52G5528	1	Mounting bracket
20	00G1269	3	Screw, M4 x 10
21	52G5525	1	Power distribution board
22	32G1547	4	Screw, M4 x 7
23	52G5526	1	Mounting plate
24	32G1547	2	Screw, M4 x 7

Detail 7. Internal Power Cables

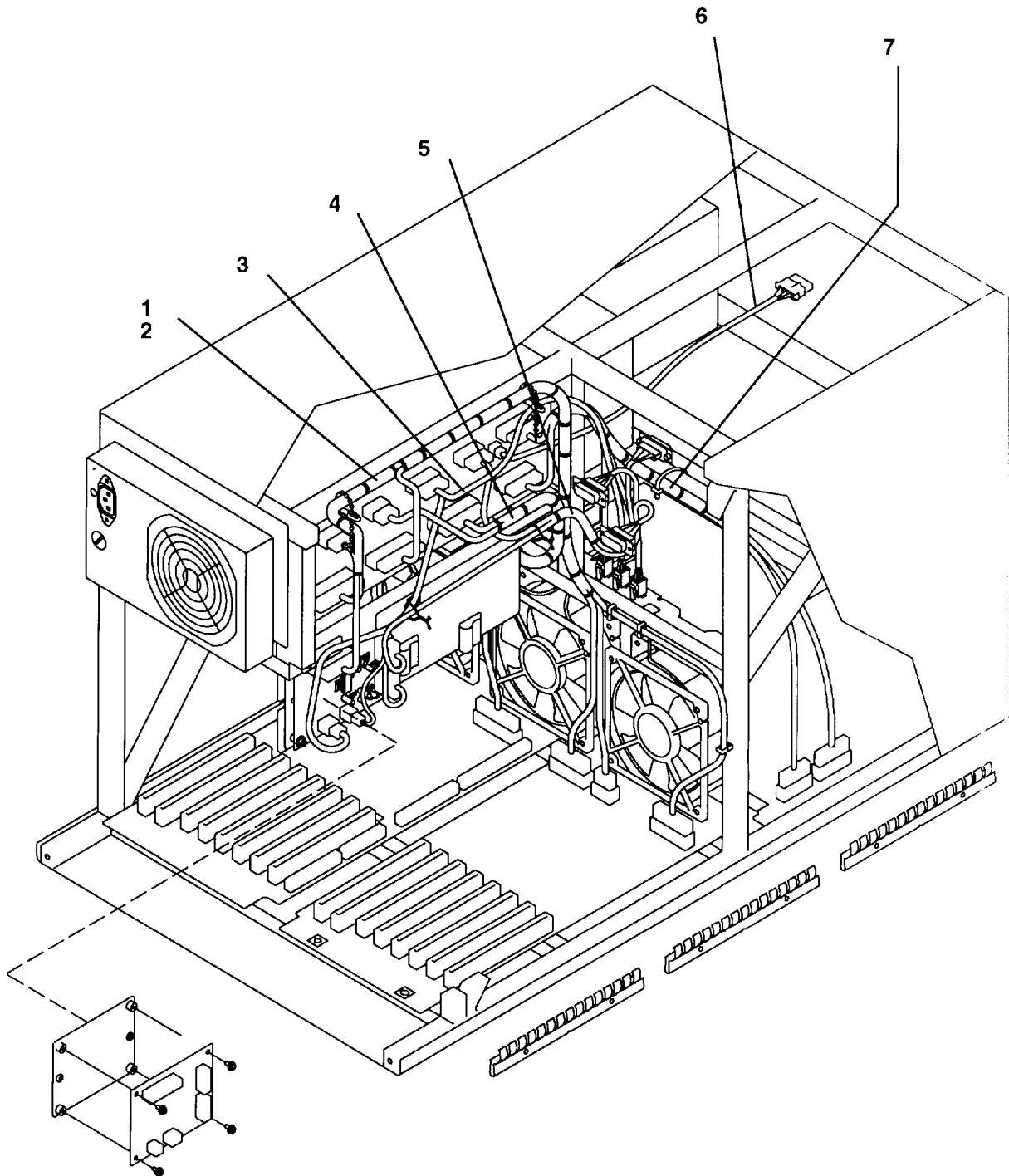

Index Number	Part Number	Units Per Assy	Description
1	52G5573	1	Power cable (to optional I/O planar)
2	52G5574	1	Wrap plug (for P42 when optional I/O planar not installed)
3	52G5572	1	Power cable (to redriver card and planar fans)
4	10G8715	1	Power cable (to combination planar)
5	52G5568	1	Power cable (to disk drives)
6	52G5554	1	Power cable (to redriver card)
7	10G8716	1	Power cable (to CPU planar)

Detail 8. Combination Planar Assembly

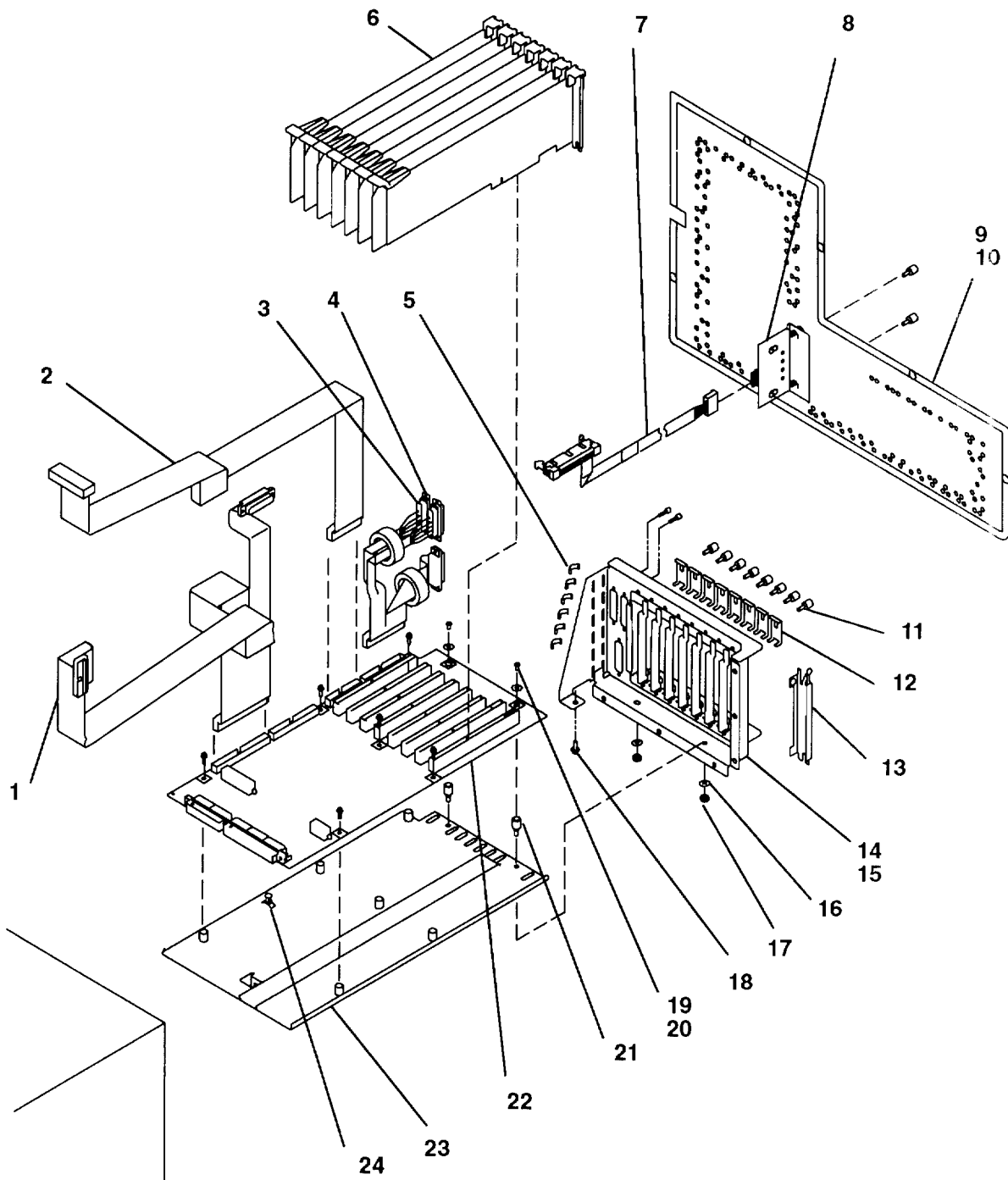

Index Number	Part Number	Units Per Assy	Description
1	65G6971	1	Data signal cable (to operator panel)
2	52G6136	1	Data signal cable (to 3.5-inch diskette drive)
3	02G7307	1	Data signal cable (to serial/parallel ports)
4	6474286	3	Screw lock assembly
5	52G5519	6	Grounding clip
6	See note	8	Adapter card
7	65G6880	1	Cable, remote reset
8	65G6874	1	Remote reset assembly
9	65G6881	1	Rear access plate (with screws for remote reset assembly)
9	52G5523	1	Rear access plate
10	00G1269	6	Screw
11	52G5517	8	Screw, M4 x 10 – top adapter card mounting
12	52G5518	8	Adapter retainer bracket
13	6279235	8	Cover, blank adapter
14	52G5511	1	Combination planar bulkhead assembly
15	00G1268	1	Screw, M4 x 7
16	1622318	2	Lockwasher
17	1622403	2	Nut
18	00G1268	6	Screw, M4 x 7
19	6258899	8	Screw, M3 x 10
20	1622288	2	Washer, M5
21	02G7270	2	Standoff
22	88G0216	1	Combination planar
23	52G5497	1	Plate (combination planar)
24	52G5520	1	Spacer

Note: See Chapter 4 in the *POWERstation and POWERserver Common Diagnostics and Service Guide* for part numbers.

Detail 9. Optional I/O Planar Assembly

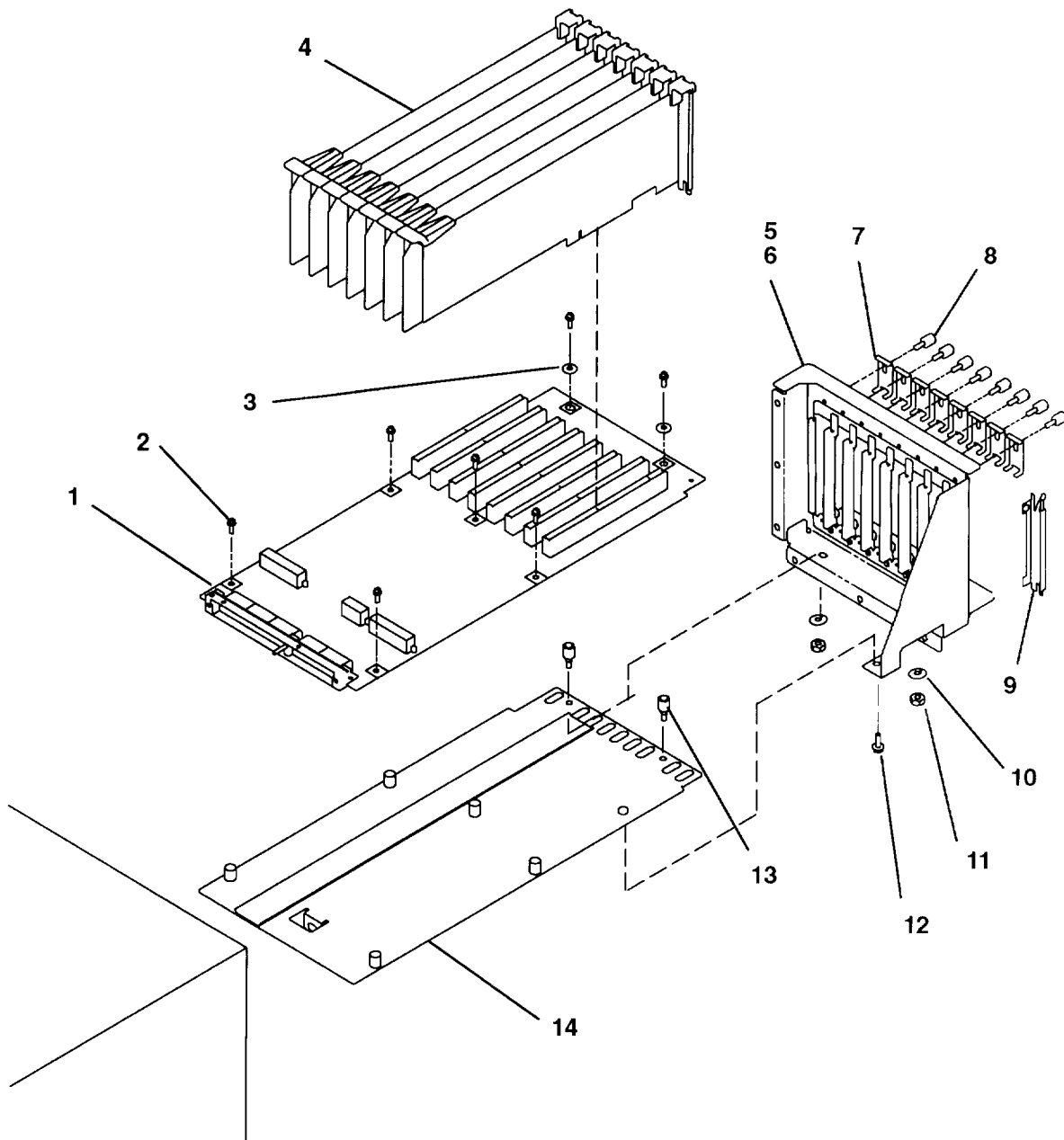

Index Number	Part Number	Units Per Assy	Description
1	31F4324	1	Optional I/O planar
2	6258899	7	Screw, M3 x 10
3	1622288	2	Washer
4	See note	8	Optional adapter
5	52G5514	1	Optional adapter bulkhead assembly
6	00G1268	6	Screw, M4 x 12
7	52G5518	8	Retainer bracket
8	52G5517	8	Screw, M4 x 10 – top optional adapter mounting
9	6279235	8	Cover, blank adapter
10	1622318	2	Lock washer
11	1622403	2	Nut
12	00G1268	1	Screw, M4 x 7
13	02G7270	2	Standoff
14	52G5496	1	Optional I/O planar plate

Note: See Chapter 4 in the *POWERstation and POWERserver Common Diagnostics and Service Guide* for part numbers.

Detail 10. Disk-Drive-Carrier Assembly

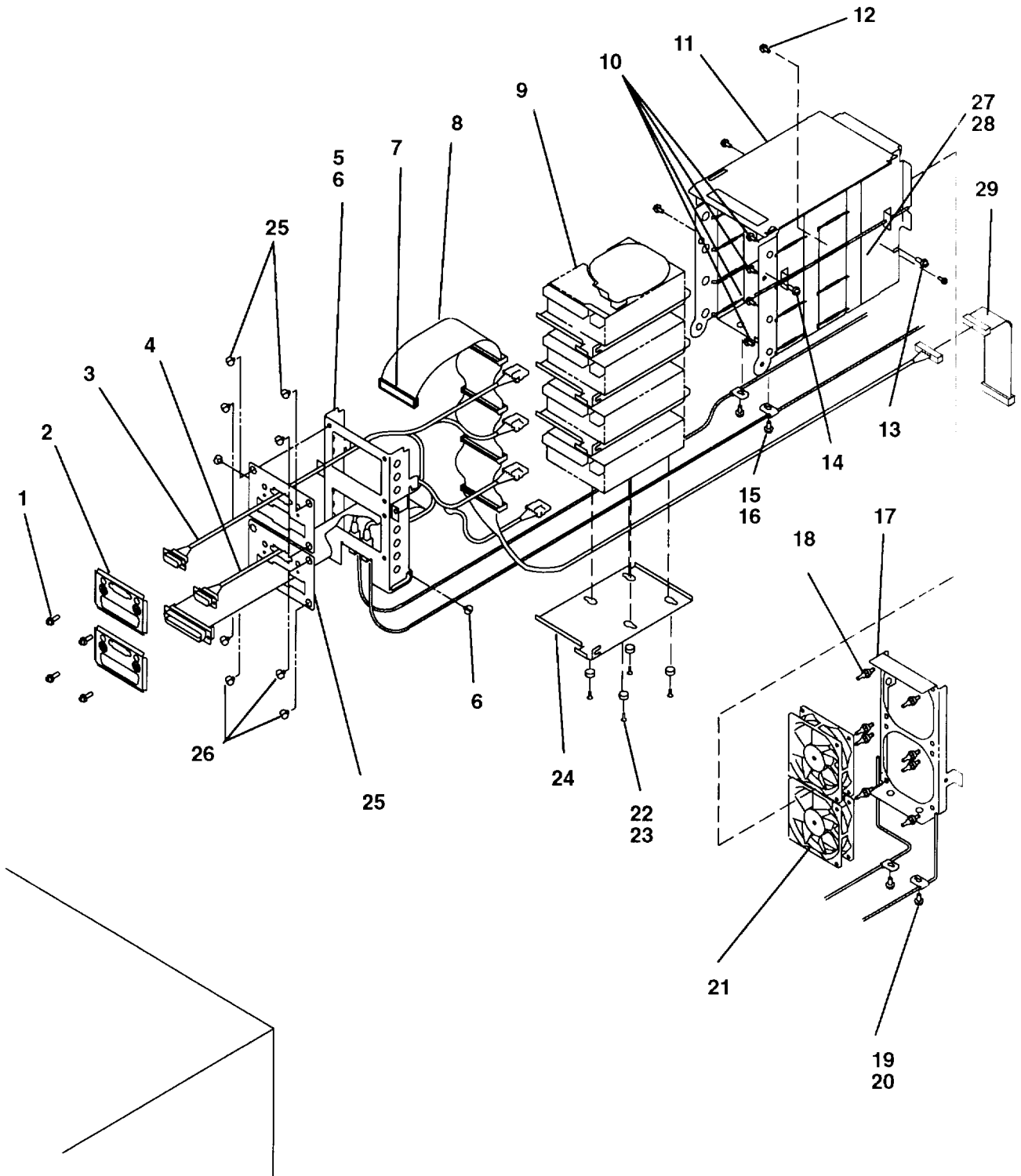

Index Number	Part Number	Units Per Assy	Description
1	00G1268	4	Screw, M4 x 7
2	52G5534	2	Retainer bracket
3	52G5538	1	Power cable (upper)
4	52G5539	1	Power cable (lower)
5	65G6840	1	Docking door
6	52G5536	2	Shoulder screw
7	92F2566	1	Terminator
8	88G4693	1	SCSI cable
9	See note	4	Disk drive
10	00G1268	4	Retainer screw (disk drive assembly), M4 x 7
11	88G4692	1	Disk drive carrier
12	00G1269	1	Retainer screw (disk drive carrier), M4 x 7
13	00G1268	2	Retainer screw (fan assembly), M4 x 7
14	00G1268	2	Retainer screw (docking door), M4 x 7
15	00G1268	2	Screw, M4 x 7
16	52G5544	2	Mounting clamp
17	52G5542	1	Fan mounting bracket
18	81F7977	4	Vibration isolators
19	00G1268	2	Screw, M4 x 7
20	52G5544	2	Mounting clamp
21	52G5543	2	Disk drive fan
22	1621309	4	Screw, M4 x 10
23	00G3272	4	Isolator
24	52G5586	4	Disk drive mounting plate
25	52G5791	2	Mounting bracket
26	52G5538	8	Shoulder screw, M4 x 4
27	65G6835	2	Long restraint screw
28	65G6836	2	Nut
29	88G4694	1	SCSI cable (to SCSI adapter)

Note: See Chapter 4 in the *POWERstation and POWERserver Common Diagnostics and Service Guide* for part numbers.

Detail 11. Rails for CPU-Media Enclosure Installation

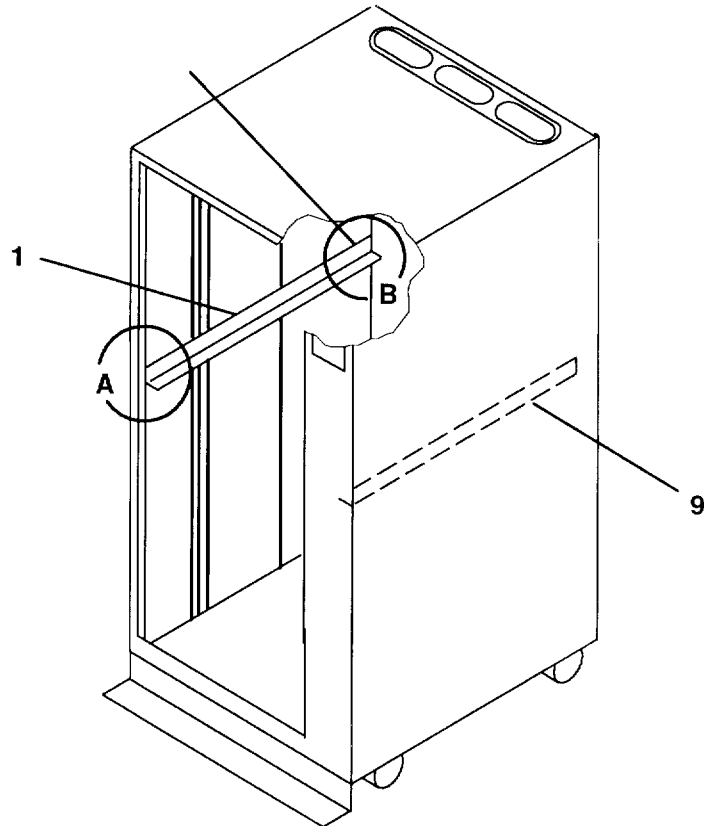

Mounting Hardware For CPU Enclosure

Detail A – Front of Rail

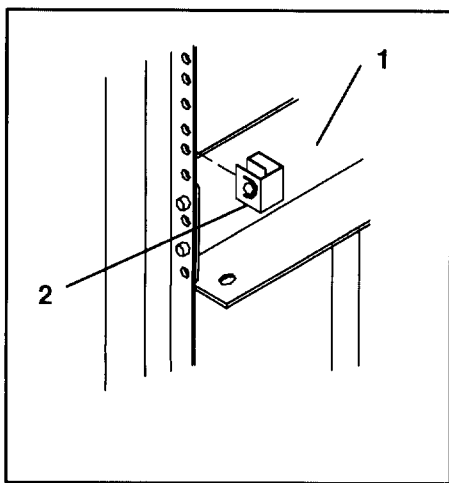

Detail B – Rear of Rail

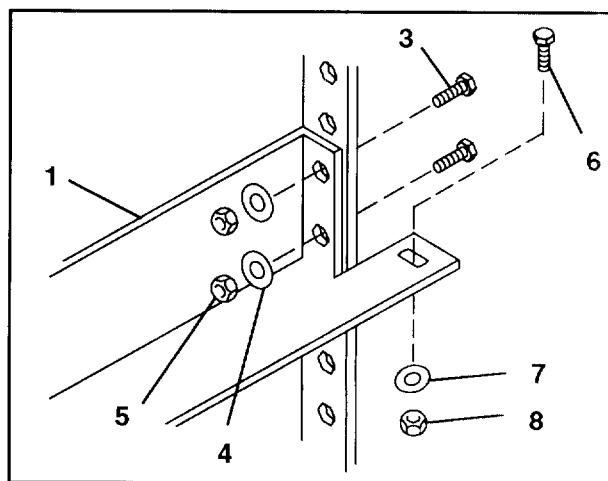

Index Number	Part Number	Units Per Asm	Description
1	02G7232	1	Rail, left
2	0375867	6	Nut clip
3	02G7295	4	Screw, rail mounting
4	1622320	4	Lock washer
5	1622405	4	Nut
6	1624779	2	Screw, CPU enclosure rear mounting
7	1622319	2	Lock washer
8	1622404	2	Nut
9	02G7263	1	Rail, right

Index

A

AC power supply, 3-55
AC power supply connectors, 1-9
adapter, 3-76
adapter and optional adapter, 3-76
adapter cable, 3-74

B

battery, 3-30

C

cable brackets, 4-10
cache SIMM, removal and replacement procedure, 3-20
CD-ROM drive, 4-2
CD-ROM drive, 8-mm tape drive, and media fan, 4-2
clamps, 4-10
combination planar, 3-80
combination planar assembly, 4-16
combination planar connectors, 1-7
connector locations, 1-3
CPU planar assembly, 3-22, 4-8
CPU planar assembly and planar fans assembly, 4-8
CPU planar connector locations, 1-6
CPU-media enclosure
 data and power flow, 1-11
 minimum configuration, 2-1540-1
 power MAP, 2-1520-1
 rails, 4-22
 service inspection guide, 1-14
 specifications, 1-13

D

data and power flow, 1-11
disk drive, 3-65, 4-20

disk drive carrier, 3-65, 4-20
disk drive fans, 3-65, 4-20
disk drive, cables, fans, and carrier assembly, 3-65, 4-20
docking assembly, 3-44, 4-6

F

front access plate, 3-15
front bezel, 1-2, 3-15
front bezel and front access plate, 3-15
front view, 1-2
front view without bezel and front access plate, 1-4

H

handling static-sensitive devices, 3-14

I

installation, rails, 1-12
internal cable brackets and clamps, 4-10

K

key mode switch, 3-32

L

locations, 1-2
 AC power supply connectors, 1-9
 combination planar connectors, 1-7
 CPU planar connector locations, 1-6
 front view with bezel, 1-2
 front view without bezel and front access plate, 1-4
 operator panel, 1-2
 operator panel connectors, 1-8
 optional I/O planar connectors, 1-7
 planar fan assembly, 1-5
 power distribution board connectors, 1-10
 rear view of CPU-media enclosure, 1-3

M

maintenance analysis procedures, see MAP, 2-1520-1

MAP 1520, 2-1520-1

- CPU-media enclosure, power MAP, 2-1520-1
- three-digit display–power supply failure status, 2-1520-2

MAP 1540, 2-1540-1

- CPU-media enclosure, minimum configuration, 2-1540-1

media carrier, 3-33

media devices, 3-33, 4-2

media fan, 3-33, 4-2

media, fan, and carrier assembly, 3-33

memory card, 3-17

memory SIMM, 3-19

O

operator panel, 1-2, 4-4

operator panel assembly, 3-28

operator panel connectors, 1-8

optional adapter, 3-76

optional I/O planar, 3-85

optional I/O planar assembly, 4-18

optional I/O planar connectors, 1-7

P

parallel port, 3-90

parts, rails, CPU-media enclosure, 4-22

parts information, 4-1

- 3.5-inch diskette drive and operator panel, 4-4
- CD-ROM drive, 8-mm tape drive, and media fan, 4-2
- combination planar assembly, 4-16
- CPU planar assembly and planar fans assembly, 4-8
- disk drive, cables, fans, and carrier assembly, 4-20
- docking assembly, 4-6
- internal cable brackets and clamps, 4-10
- optional I/O planar assembly, 4-18
- power supply and internal power cables, 4-12, 4-14

- planar fan assembly, 1-5, 3-26
- planar fans assembly, 4-8
- power cables, 4-12, 4-14
- power distribution board, 3-63
- power distribution board connectors, 1-10
- power supply, 4-12, 4-14
- power supply and internal power cables, 4-12, 4-14
- power supply failure status, 2-1520-2
- power supply fan, 3-52
- power supply fuse, 3-51
- power-off procedure with power distribution panel, 3-12
- power-off with a power distribution bus, 3-3
- power-on procedure with power distribution panel, 3-9
- power-on with a power distribution bus, 3-1
- power-off procedure with a power distribution unit, 3-7
- power-on procedure with a power distribution unit, 3-5

R

rail, 1-12

rail installation, 1-12

rails, CPU-media enclosure, 4-22

rear access plate, 3-39

rear view of CPU-media enclosure, 1-3

remote reset assembly, removal and replacement procedure, 3-41

removal and replacement procedures, 3-1

- 48 V dc power supply, 3-59
- 3.5-inch diskette drive, 3-37
- AC power supply, 3-55
- adapter and optional adapter, 3-76
- adapter cable, 3-74
- battery, 3-30
- cache SIMM, 3-20
- combination planar, 3-80
- CPU planar assembly, 3-22
- disk drive, cables, fans, and carrier assembly, 3-65
- front bezel and front access plate, 3-15
- handling static-sensitive devices, 3-14
- key mode switch, 3-32

- media, fan, and carrier assembly, 3-33
- memory card, 3-17
- memory SIMM, 3-19
- operator panel assembly, 3-28
- optional I/O planar, 3-85
- planar fan assembly, 3-26
- power distribution board, 3-63
- power supply fan, 3-52
- power supply fuse, 3-51
- power-on procedure with a power distribution unit, 3-5
- power-off procedure with a power distribution unit, 3-7
- power-off with a power distribution bus, 3-3
- power-on with a power distribution bus, 3-1
- 5.0 G-byte 8-mm tape drive, 4-2
- rear access plate, 3-39
- remote reset assembly, 3-41
- SCSI cables and docking assembly, 3-44
- serial ports and parallel port assembly, 3-90

S

- SCSI cables, 3-44
- SCSI cables and docking assembly, 3-44
- serial ports, 3-90
- serial ports and parallel port assembly, 3-90
- service inspection guide, 1-14
- specifications, 1-13

T

- three-digit display, 2-1520-2
 - power supply failure status, 2-1520-2
- typical rail installation, 1-12

Symbols

- 48 V dc power supply, 3-59

Numbers

- 3.5-inch diskette drive, 3-37, 4-4
- 3.5-inch diskette drive and operator panel, 4-4
- 48 V dc power supply
 - power-off procedure with power distribution panel, 3-12
 - power-on procedure, 3-9

Printed in the U.S.A.

 Place Form Number barcode
lower left corner here.