

7014 Series Model T00 and T42 Rack



Installation and Service Guide

Fourth Edition (July 2002)

Before using this information and the product it supports, read the information in "Safety Notices" on page v, Appendix A, "Environmental Notices" on page 119, and Appendix B, "Notices" on page 121.

A reader's comment form is provided at the back of this publication. If the form has been removed, address comments to Publications Department, Internal Zip 9561, 11400 Burnet Road, Austin, Texas 78758-3493. To send comments electronically, use this commercial internet address: aix6kpub@austin.ibm.com. Any information that you supply may be used without incurring any obligation to you.

© **International Business Machines Corporation 2000, 2002. All rights reserved.**

Note to U.S. Government Users -- Documentation related to restricted rights -- Use, duplication or disclosure is subject to restrictions set forth in GSA ADP Schedule Contract with IBM Corp.

Contents

Safety Notices	v
About This Book	ix
ISO 9000	ix
Online Publications	ix
Related Publications	ix
Trademarks	ix
Chapter 1. Rack Installation	1
Observe These Safety Notices During Installation	1
Step 1. Positioning the Rack	3
Step 2. Leveling the Rack	4
Step 3. Attaching the Stabilizers	5
Step 4. Attaching the Rack to a Concrete Floor	6
Step 5. Attaching the Rack to a Concrete Floor Beneath a Raised Floor	10
Step 6. Installing Multiple Racks	15
Step 7. Attaching the AC Outlet-Mounting Plates	18
Step 8. Attaching the Front Door	23
Step 9. Connecting the Power Distribution System	27
Step 10. Checking Customer's AC Outlets	32
Step 11. Connecting Drawer and Device Cables	34
Step 12. Powering On and Checking Out the System	35
Step 13. Relocating Rack(s)	35
Chapter 2. Reference Information	41
Types of Power Distribution	41
AC Rack Information	42
External AC Power Cables	46
DC Rack Information	47
DC Rack Power Cables	52
Specifications for Model T00 and T42 Rack	53
Service Inspection Guide	54
Chapter 3. Maintenance Analysis Procedures (MAPs)	59
MAP 1520: DC Power Distribution Panel - Power MAP	59
MAP 1522: AC Power Distribution Bus - Power MAP	67
Chapter 4. Removal and Replacement	73
Safety Notices	73
Operating System Shutdown	74
Power-On Procedure with the AC Power Distribution Bus	75

Power-Off Procedure with the AC Power Distribution Bus	77
Power-On Procedure with the DC Power Distribution Panel	78
Power-Off Procedure with the DC Power Distribution Panel	80
Removal and Replacement of the AC Power Distribution Bus	81
Removal and Replacement of the DC Power Distribution Panel	83
Removal and Replacement of the -48 V DC Circuit Breaker	88
Removal and Replacement of the Front or Rear Door	92
Relocating Rack(s)	93
Chapter 5. Parts Information	95
Covers	96
Earthquake Brace	99
Blank Fillers	101
Power Distribution Bus	103
Stabilizers	105
Power Distribution Panel Assembly	107
Power Distribution Panel Interior	109
Leveling Feet	111
Model T42 Brace	113
Model T00 and T42 Kits (For Reference Only)	115
Power Cords	116
Appendix A. Environmental Notices	119
Product Recycling and Disposal	119
Environmental Design	119
Unit Emissions	119
Appendix B. Notices	121
Index	123
Reader's Comments — We'd Like to Hear From You	125

Safety Notices

A *danger* notice indicates the presence of a hazard that has the potential of causing death or serious personal injury. *Danger* notices appear on the following pages:

v, 1, 60, 67, 73

A *caution* notice indicates the presence of a hazard that has the potential of causing moderate or minor personal injury. *Caution* notices appear on the following pages:

vi, vii, 1, 2, 5, 28, 32, 33, 35, 55, 56, 60, 61, 63, 73, 75, 78, 80, 83, 88

For a translation of the Safety Notices contained in this book, see the *System Unit Safety Information* manual, order number SA23-2652.

Note: Before connecting or removing any cables to or from the system, be sure to follow the steps in the system installation procedures specified in the installation and service guide for your system or device.

Observe the following safety instructions any time you are working on a rack or devices installed in a rack.

DANGER

An electrical outlet that is not correctly wired could place hazardous voltage on metal parts of the system or the devices that attach to the system. It is the responsibility of the customer to ensure that the outlet is correctly wired and grounded to prevent an electrical shock.

Before installing or removing signal cables, ensure that the power cables for the system unit and all attached devices are unplugged.

When adding or removing any additional devices to or from the system, ensure that the power cables for those devices are unplugged before the signal cables are connected. If possible, disconnect all power cables from the existing system before you add a device.

Use one hand, when possible, to connect or disconnect signal cables to prevent a possible shock from touching two surfaces with different electrical potentials.

During an electrical storm, do not connect cables for display stations, printers, telephones, or station protectors for communication lines.

CAUTION:

This unit may have more than one power cable. To completely remove power, you must disconnect all power cables from the unit.

CAUTION:

This product is equipped with a 3-wire power cable and plug for the user's safety. Use this power cable in conjunction with a properly grounded electrical outlet to avoid electrical shock.

CAUTION:

Energy hazard, remove power before servicing. Disconnect two power supply cords.

CAUTION:

Make sure that you do the following:

- Before you add or remove drawers, always have the leveling feet lowered and the front and rear stabilizer installed, or have the rack bolted to the floor.
- Always install drawers at the bottom of the rack first.
- Always remove drawers from the top of the rack first.
- Always install the heaviest drawers on the bottom of the rack.

CAUTION:

Make sure that you do the following:

- Remove two or three drawers from the top of the rack before you relocate it.
- Never push on the sides of the rack.

CAUTION:

The stabilizers must be firmly attached to the bottom front of the rack to prevent the rack from turning over when the drawers are pulled out of the rack. Do not pull out or install any drawer or feature if the stabilizers are not attached to the rack.

CAUTION:

The stabilizers must be firmly attached to the bottom rear of the rack to prevent the rack from turning over when the drawers are pulled out of the rack. Do not pull out or install any drawer or feature if the stabilizers are not attached to the rack.

CAUTION:

Energy hazard, remove power before servicing.

CAUTION:

Do not touch the receptacle or the receptacle face plate with anything other than your test probes before you have met the requirement in step 10.

CAUTION:

If the reading is other than infinity, do not proceed! Have the customer make necessary wiring corrections before continuing. Do not turn on the branch circuit CB until all the above steps are satisfactorily completed.

About This Book

This book contains installation and maintenance information that is specific to the Model T00 and T42 rack. It also contains Maintenance Analysis Procedures (MAPs) that are unique to this model.

MAPs that are common to all systems are contained in the *RS/6000 and eServer pSeries Diagnostics Information for Multiple Bus Systems*, order number SA38-0509.

ISO 9000

ISO 9000 registered quality systems were used in the development and manufacturing of this product.

Online Publications

RS/6000 and pSeries publications are available online. To access the online books, visit our Web site at: http://www.rs6000.ibm.com/resource/hardware_docs/

Related Publications

The following publications are available:

- The *RS/6000 and eServer pSeries Diagnostics Information for Multiple Bus Systems*, order number SA38-0509, contains service information that is common to all systems. This manual also contains the service request number (SRN) list and failing function code (FFC) list used with the diagnostic programs.
- The *RS/6000 and eServer pSeries Adapters, Devices, and Cabling Information*, order number SA38-0516, contains descriptions of the adapters, devices, and cabling information for the features.
- The *System Unit Safety Information* manual, order number SA23-2652, contains translations of danger and caution notices.

Trademarks

The following terms are trademarks of International Business Machines Corporation in the United States, other countries, or both:

- e(logo)
- IBM
- pSeries

- RS/6000

Other company, product, and service names may be trademarks or service marks of others.

Chapter 1. Rack Installation

This chapter contains information about installing and preparing a Model T00 and T42 rack for system operations.

Observe These Safety Notices During Installation

DANGER

An electrical outlet that is not correctly wired could place hazardous voltage on metal parts of the system or the devices that attach to the system. It is the responsibility of the customer to ensure that the outlet is correctly wired and grounded to prevent an electrical shock.

Before installing or removing signal cables, ensure that the power cables for the system unit and all attached devices are unplugged.

When adding or removing any additional devices to or from the system, ensure that the power cables for those devices are unplugged before the signal cables are connected. If possible, disconnect all power cables from the existing system before you add a device.

Use one hand, when possible, to connect or disconnect signal cables to prevent a possible shock from touching two surfaces with different electrical potentials.

During an electrical storm, do not connect cables for display stations, printers, telephones, or station protectors for communication lines.

CAUTION:

This product is equipped with a 3-wire power cable and grounded plug for user safety. Use this power cable in conjunction with a properly grounded electrical outlet to avoid electrical shock.

CAUTION:

This unit may have more than one power supply cord. To completely remove power, you must disconnect all power supply cords.

CAUTION:

Make sure that you do the following:

- **Before you add or remove drawers, always have the leveling feet lowered and the front and rear stabilizer installed, or have the rack bolted to the floor.**
- **Always install drawers at the bottom of the rack first.**
- **Always remove drawers from the top of the rack first.**
- **Always install the heaviest drawers on the bottom of the rack.**

CAUTION:

Make sure that you do the following:

- **Remove two or three drawers from the top of the rack before you relocate it.**
- **Never push on the sides of the rack.**

Attention: If the rack has equipment located above Electronics Industries Association (EIA) location 32, you must remove the equipment in position 32 and above from the rack before you move it. Always remove the equipment from the *top* of the rack first.

Step 1. Positioning the Rack

Note: The customer should unpack the rack and position it in the room. If this has not been done, consult the customer and the marketing representative as necessary.

The -48 V dc rack must be installed only in restricted access areas such as dedicated equipment rooms or equipment closets in accordance with Articles 110-16, 110-17, and 110-18 of the National Electrical Code, ANSI/NFPA No. 70.

1. Remove all packing and tape from the rack.
2. Position the rack according to the customer floor plan.
3. Lock each caster wheel by tightening the screw on the caster.

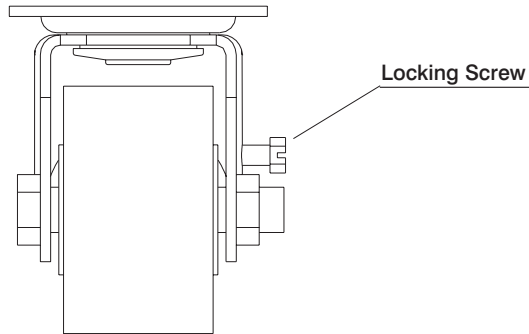

Use the following to determine the next step:

- If the rack is being bolted to a concrete floor, go to “Step 4. Attaching the Rack to a Concrete Floor” on page 6.
- If the rack is being bolted to a concrete floor beneath a raised floor, go to “Step 5. Attaching the Rack to a Concrete Floor Beneath a Raised Floor” on page 10.
- If the rack is not being attached to the floor, go to “Step 2. Leveling the Rack” on page 4.

Step 2. Leveling the Rack

Adjust the leveling feet by doing the following:

1. Loosen the jam nut on each leveling foot by turning the nut counter-clockwise (away from the bottom of the rack).
2. Rotate each leveling foot downward until it contacts the surface on which the rack is placed.
3. Adjust the leveling feet downward as needed until the rack is level. When the rack is level, tighten the jam nuts against the base by turning the nut clockwise (toward the bottom of the rack).

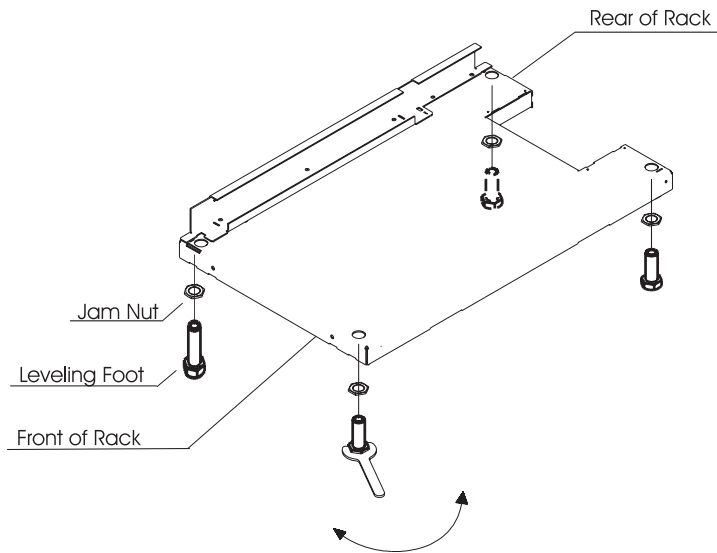

Step 3. Attaching the Stabilizers

This section covers attaching stabilizers on the bottom of the rack.

CAUTION:

The stabilizers must be firmly attached to the bottom front of the rack to prevent the rack from turning over when the drawers are pulled out of the rack. Do not pull out or install any drawer or feature if the stabilizers are not attached to the rack.

CAUTION:

The stabilizers must be firmly attached to the bottom rear of the rack to prevent the rack from turning over when the drawers are pulled out of the rack. Do not pull out or install any drawer or feature if the stabilizers are not attached to the rack.

1. Align the slots in the stabilizer with the mounting holes at the bottom front of the rack.
2. Install the two mounting screws.
3. Ensure that the base of the stabilizer rests firmly on the floor. Use the allen wrench supplied with the rack to alternately tighten the mounting screws until they are tight.

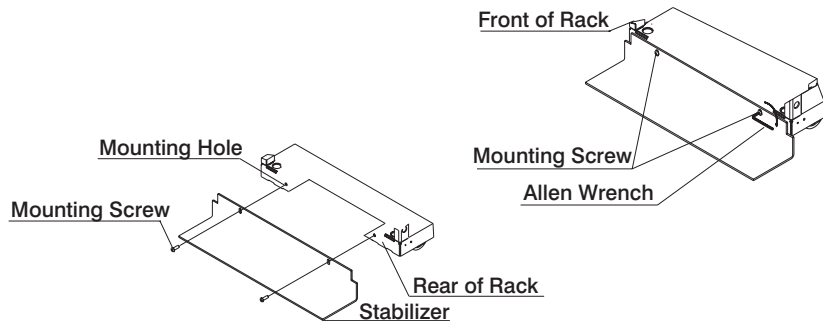

4. Repeat substeps 1 through 3 to install the stabilizer on the rear of the rack.
5. Go to "Step 9. Connecting the Power Distribution System" on page 27.

Step 4. Attaching the Rack to a Concrete Floor

This section covers attaching the rack-mounting plates to the floor.

Attention: The customer is responsible for attaching the rack-mounting plates to the concrete floor. The following steps are shown to guide the customer in aligning and installing the rack-mounting plates.

1. Be sure the rack is in the correct location.
2. If installed, remove the left and right trim panels (snap in/out).

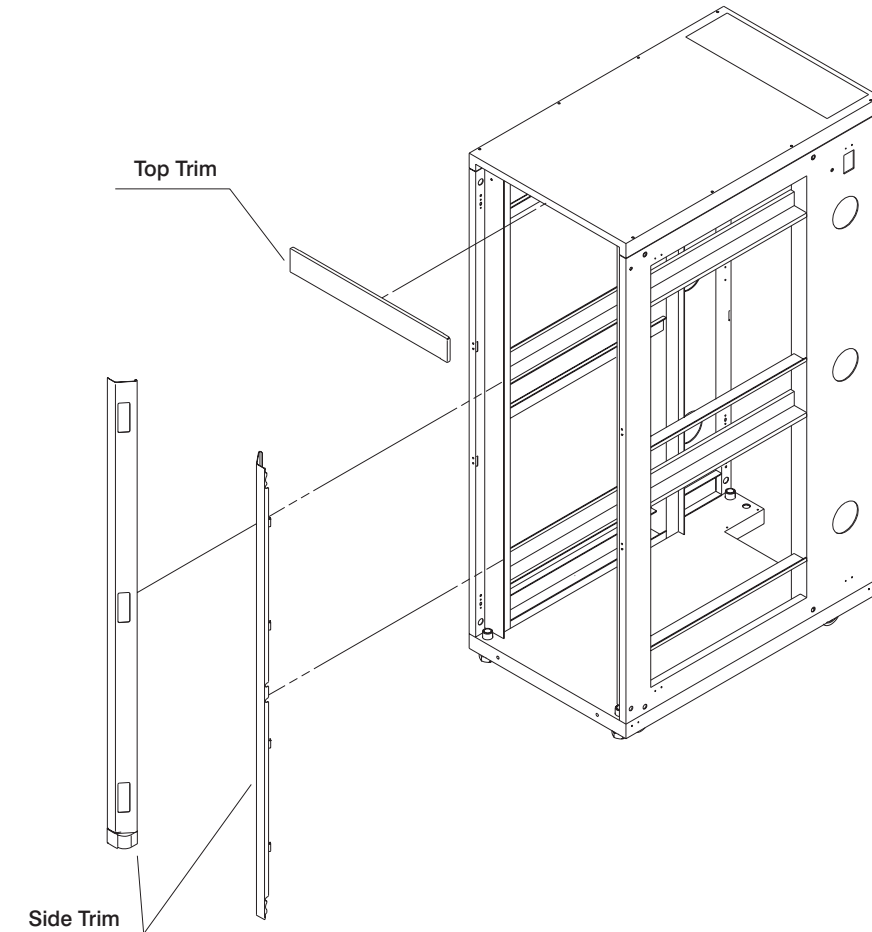

3. If this is an ac-powered rack, the bushing will be temporarily installed for plate location only.

If this is a dc-powered rack, remove the protective cover from four of the bushings and install them in each of the four leveling feet.

4. Ensure that the bushing is in the leveling foot and position the two mounting plates in the approximate mounting location under the rack. If necessary, raise the leveling feet for clearance.
5. Place a bushing on a rack-mounting bolt, and place the bolt/bushing through the leveling foot/bushing and out the bottom bushing.
6. Place the four rack-mounting bolts through the leveling feet, bushing, and out the bottom of the rack.
7. Position the rack-mounting plates under the four rack-mounting bolts so that the mounting bolts are centered directly over the tapped holes.
8. Turn the rack-mounting bolts 3 to 4 turns into the tapped holes.

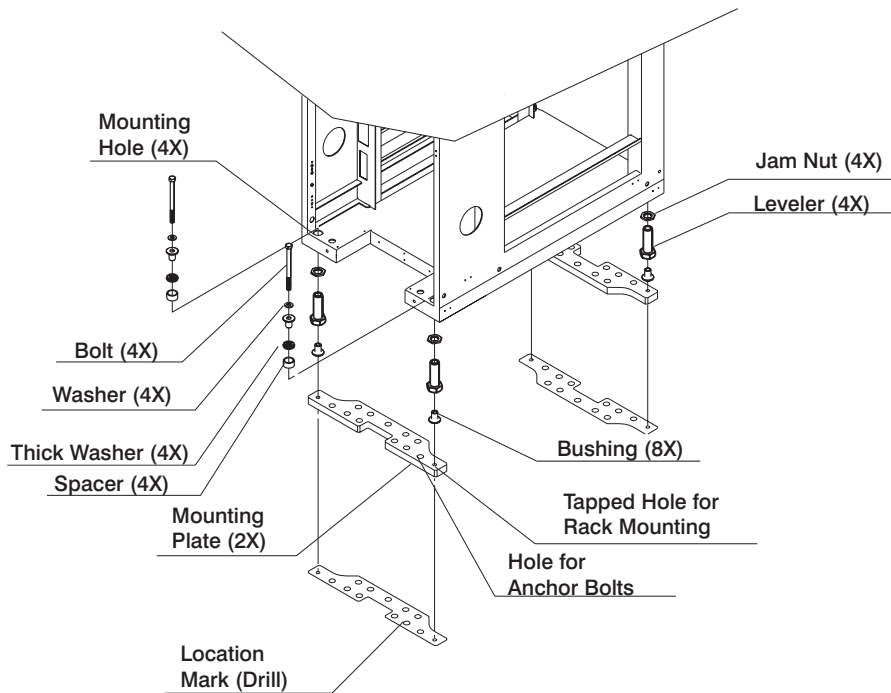

9. Mark the floor around the edges of both rack-mounting plates.
10. Mark the plate bolt-down holes that are accessible through the opening in the rear of the rack.
11. Remove the rack-mounting bolts and bushings (ac-powered racks only; bushing stays in the base of the leveling foot for dc racks.)
12. Remove the rack-mounting plates.
13. Loosen the locking screws on the casters, and move the rack so that it is clear of the marked locations of the mounting plate.
14. Position the plates within the marked areas.
15. Mark the floor at the center of each hole in the rack-mounting plates (including the tapped holes).
16. Remove the two rack-mounting plates from the marked locations.
17. At the marked location of the tapped rack-mounting bolt holes, drill four holes approximately two inches deep to allow clearance for the ends of the four rack-mounting bolts. (The ends of the rack-mounting bolts protrude past the thickness of the mounting plate.)

Note: You must use a minimum of two anchor bolts for each rack-mounting plate to attach it to the concrete floor. Because some of the holes in the rack-mounting plates may align with concrete reinforcement rods below the surface of the concrete, some of the rack-mounting plate holes may not be suitable.

18. For each rack-mounting plate, select at least two suitable holes: Select holes as close to the threaded holes as possible. Be sure the holes selected at the rear of the rack are accessible. Drill the selected holes (two for each rack-mounting plate).
19. Position the front-mounting plate within the marked area.
20. Using anchor bolts, attach the front rack-mounting plate to the concrete floor.

Note: If you are installing a dc rack, the four leveling feet must have a plastic isolator bushing installed between the leveling foot and the mounting plate.

If you are installing an ac rack, do not use the four plastic isolator bushings.

21. Position the rack over the front-mounting plate.
22. If you are installing a dc rack, ensure that the four plastic isolator bushings are under the four leveling feet.
23. Position the rear-mounting plate within the marked area.
24. Using anchor bolts, attach the rear rack-mounting plate to the concrete floor.
25. Place each of the rack-mounting bolts through a flat washer, a plastic isolator bushing and a thick washer, and through a leveling foot.
26. Align the four rack-mounting bolts with the four tapped holes in the two mounting plates and turn 3 to 4 rotations.
27. Tighten the lock screw on each caster.
28. Adjust the leveling feet downward as needed until the rack is level. When the rack is level, tighten the jam nuts against the base by turning the jam nut clockwise (toward the bottom of the rack).

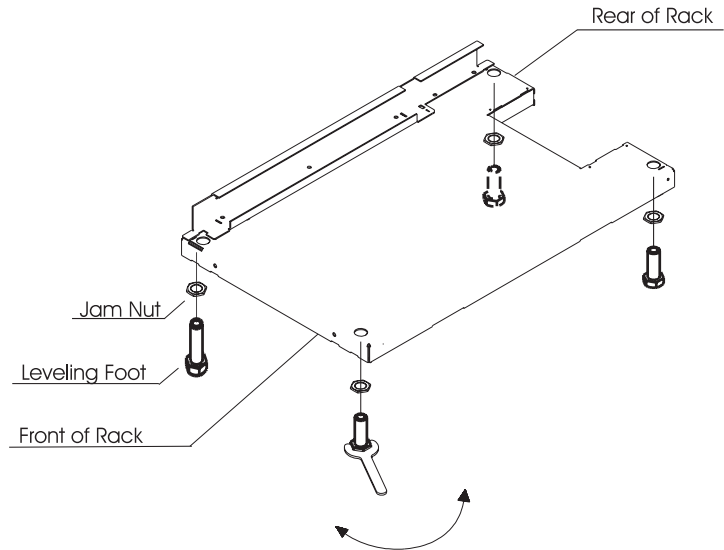

29. If you have multiple racks that are connected in a suite (bolted to each other), go to “Step 6. Installing Multiple Racks” on page 15. Otherwise, torque the four bolts to 40-50 ft-lbs (54-67 nm).
30. If the rack does not have a front door, install the top, left, and right trim panel.
31. After all racks are bolted down, go to “Step 7. Attaching the AC Outlet-Mounting Plates” on page 18.

Step 5. Attaching the Rack to a Concrete Floor Beneath a Raised Floor

This section covers attaching the rack-mounting plates to the concrete floor.

Attention: The customer is responsible for attaching the rack-mounting plates to the concrete floor. The following steps guide the customer in aligning and installing the rack-mounting plates.

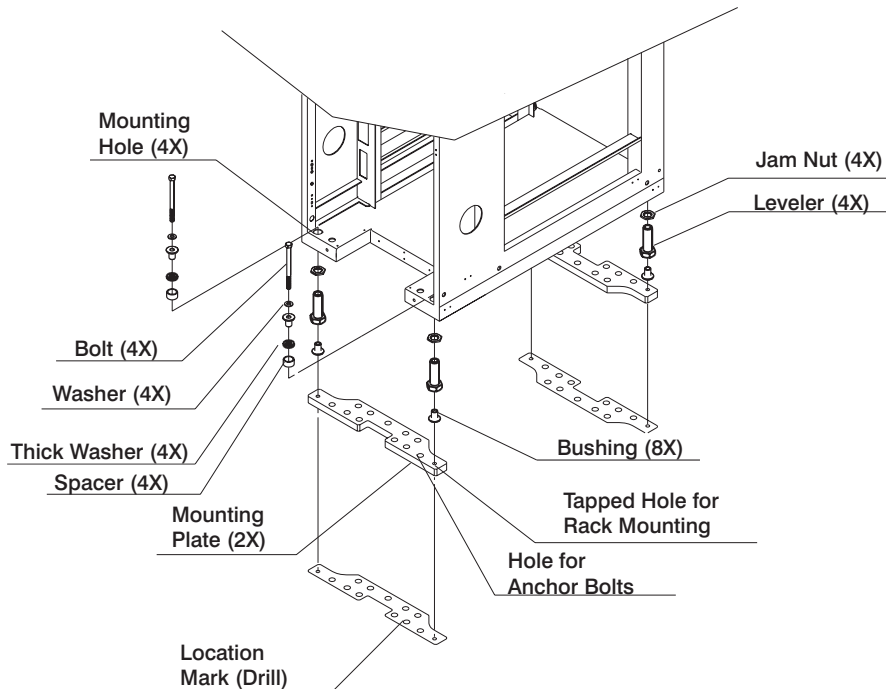

1. Be sure the rack is in the correct location.
2. If installed, remove the left and right trim panels (snap in/out).

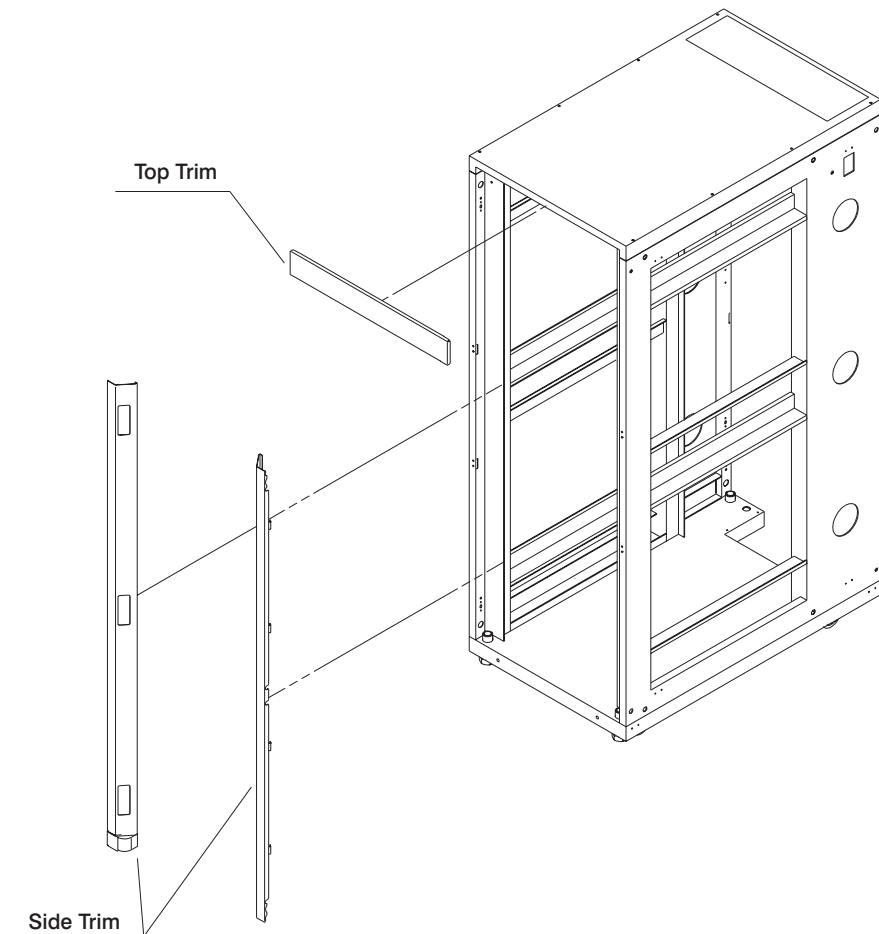

If this is an ac-powered rack, the bushing will be temporarily installed for plate location only.

3. If this is an ac-powered rack, the bushing will be temporarily installed for plate location only.

If this is a dc-powered rack, remove the protective cover from four of the bushings and install them in each of the four leveling feet.

4. Ensure the bushing is in the leveling foot and position the two mounting plates in the approximate mounting locations under the rack. If necessary, raise the leveling feet for clearance.
5. Place a bushing on a rack-mounting bolt and place the bolt/bushing through the leveling foot/bushing and out the bottom bushing.
6. Place the four rack-mounting bolts through the leveling feet, bushing, and out the bottom of the rack.

7. Position the rack-mounting plates under the four rack-mounting bolts so that the mounting bolts are centered directly over the tapped holes.
8. Turn the rack-mounting bolts 3 to 4 turns into the tapped holes.
9. Mark the raised-floor panel around the edges of both rack-mounting plates.
10. Mark the plate bolt-down holes that are accessible through the opening in the rear of the rack.
11. Remove the rack-mounting bolts and bushings (ac powered system only, bushing stays in base of the leveling foot for dc racks.)
12. Remove the rack-mounting plates.
13. Loosen the locking screws on the casters and move the rack so it is clear of the mounting plate marked locations.
14. Position plates within marked areas.
15. Mark the raised-floor panel at the center of each hole in the rack-mounting plates (including the tapped holes).
16. Remove the two rack-mounting plates from the marked locations.
17. Transfer the locations of the holes (excluding the tapped holes) from the raised-floor panel to the concrete floor directly beneath, and mark the holes there.

Note: You must use a minimum of two anchor bolts for each rack-mounting plate to attach it to the concrete floor. Because some of the holes in the rack-mounting plates may align with concrete reinforcement rods below the surface of the concrete, some of the rack-mounting plate holes may not be suitable.

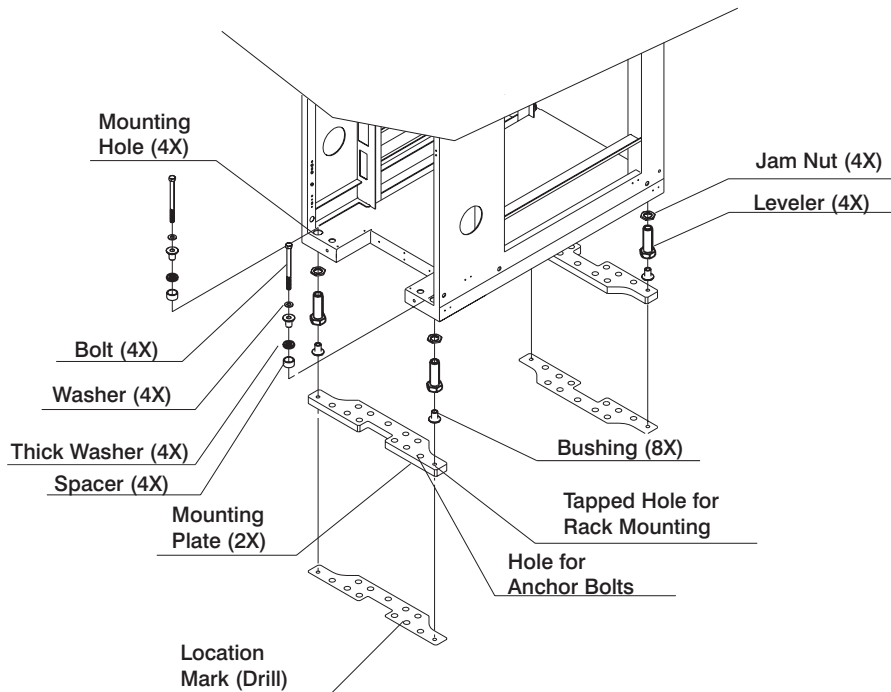

18. For each rack-mounting plate, select at least two suitable holes; select holes as close to the threaded holes as possible. Be sure the holes selected at the rear of the rack are accessible. Drill the selected holes (two for each rack-mounting plate) in the concrete floor.
19. Drill pass-through holes in the raised-floor panel that match the holes on the concrete floor.
20. Drill pass-through holes in the raised-floor panel at the location of the four rack-mounting bolts (threaded holes in the rack).
21. Position the front-mounting plate within the marked area.
22. Attach the rack-mounting plate to the concrete floor.

Note: If you are installing a dc rack, the four leveling feet must have isolator bushings installed between the leveling foot and the mounting plate.

If you are installing an ac rack, do not use the four plastic isolator bushings.
23. Position the rack on the raised-floor panel over the front-mounting plate.
24. If you are installing a dc rack, ensure that the four plastic isolator bushings are under the four leveling feet.
25. Position the rear-mounting plate within the marked area.

26. Attach the rear rack-mounting plate to the concrete floor.
27. Place each of the rack-mounting bolts through a flat washer, a plastic isolator bushing and a thick washer, and through a leveling foot.
28. Align the four rack-mounting bolts with the four tapped holes in the two mounting plates and turn 3 to 4 rotations.
29. Tighten the lock screw on each caster.
30. Adjust the leveling feet downward as needed until the rack is level. When the rack is level, tighten the jam nuts against the base by turning the jam nut clockwise (toward the bottom of the rack).
31. If you have multiple racks, connected as a suite (bolted to each other), go to “Step 6. Installing Multiple Racks” on page 15. Otherwise torque the four bolts to 40-50 ft-lbs (54-67 nm).
32. If the rack does not have a front door, install the top, left, and right trim panels.
33. After all racks are bolted down, go to “Step 7. Attaching the AC Outlet-Mounting Plates” on page 18.

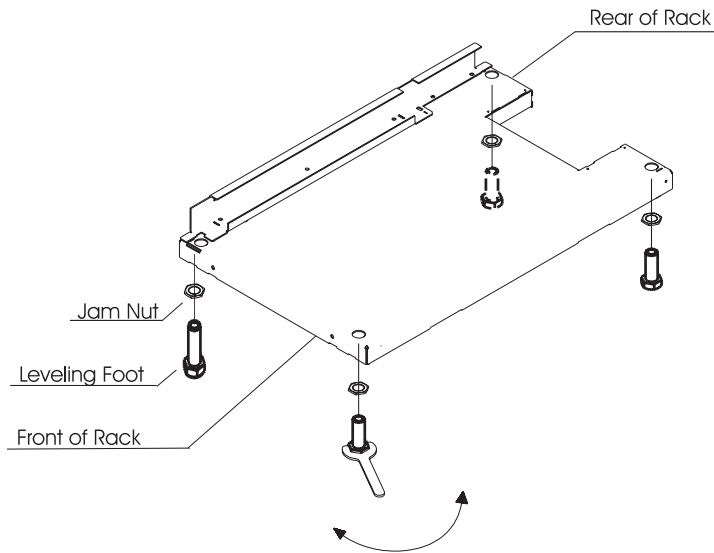

Step 6. Installing Multiple Racks

If you are installing more than one rack, do the following:

1. Remove the side covers.
2. Remove the Z brackets and J brackets (if installed). These brackets are used to hang the side covers.
3. Install the first two standoffs in the upper-left and lower-right corners of the first rack.
4. Install the second two standoffs in the upper-left and lower-right corners of the second rack.
5. Attach the long foam as shown in the following illustration. For a Model T42 rack, join the short foam to the end of the long foam, and adhere it to the frame member length of the rack.
6. Position the racks together.
7. Align the standoff holes.
Note: To align the standoff holes, you may have to adjust the leveling feet.
8. Install screw and washer in all four positions, but do not tighten.

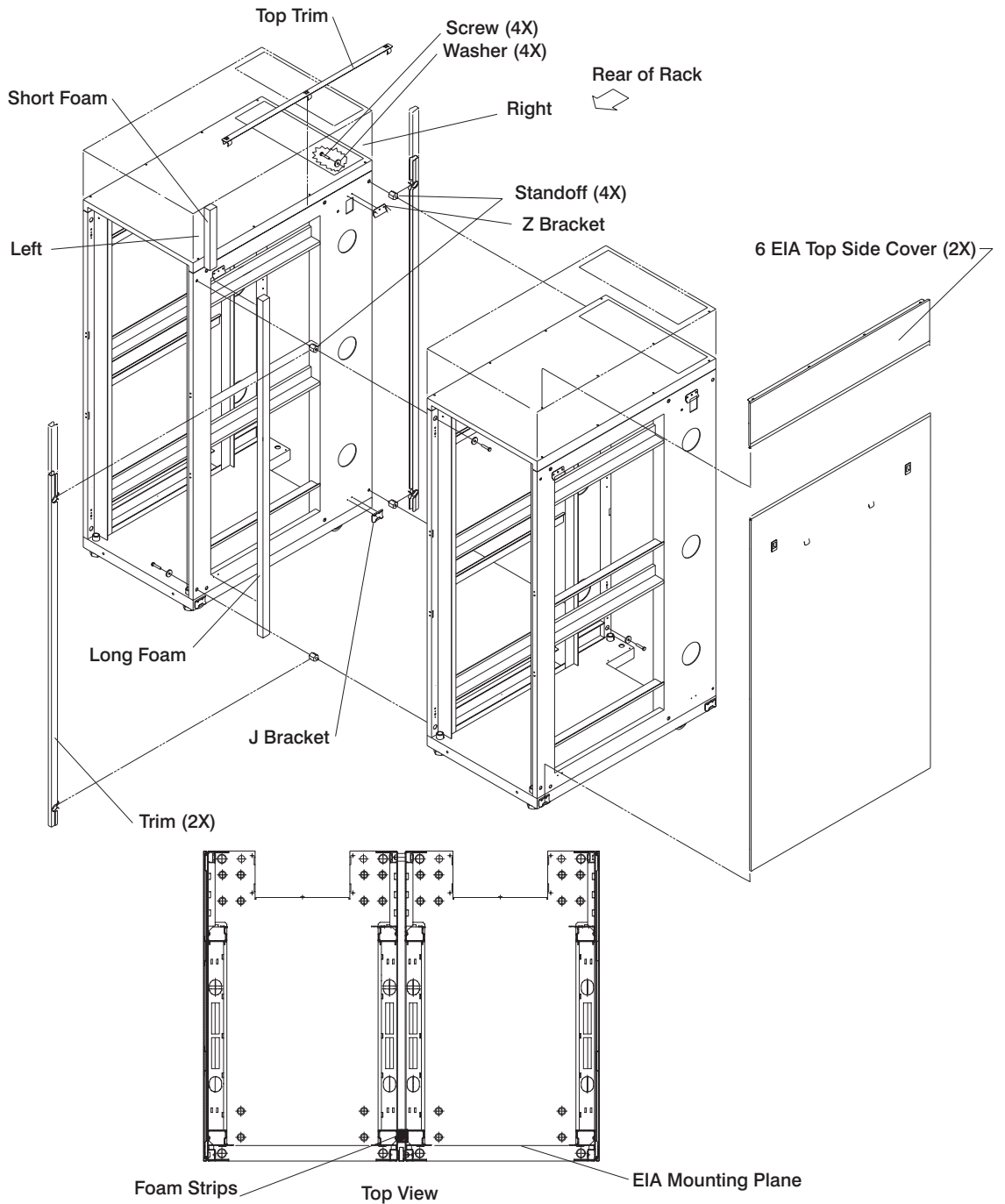

9. After all racks are bolted together, level the racks.

10. Tighten all four screws.
11. Install the trim pieces that go between the front and back racks (snap on).
12. Install the trim piece that goes on top and between the racks (snap on).
13. Install rack filler panels to cover open areas at the front of the rack(s). All the gaps in the front of the rack must also be sealed, including the gaps between equipments. This step ensures that proper airflow within the rack is maintained.
14. Connect the cables that go between the racks.
15. If you are bolting down the racks, go to either “Step 4. Attaching the Rack to a Concrete Floor” on page 6, or “Step 5. Attaching the Rack to a Concrete Floor Beneath a Raised Floor” on page 10, as appropriate.
16. If the rack does not have a front door, install the top, left, and right trim panels on all racks.
17. If you are installing stabilizers, go to “Step 3. Attaching the Stabilizers” on page 5.

Step 7. Attaching the AC Outlet-Mounting Plates

Attention: The front and rear ac outlet-mounting plates mount through the same mounting holes in which the rack stabilizers mount. Therefore, the rack must be bolted to the floor and the stabilizers removed.

Note: Install the ac outlet-mounting plates *only* if the rack is bolted to the floor and the stabilizers are removed.

The following items are installed at the customer's site:

- ac outlet-mounting plates for installing customer-supplied ac electrical outlets on the front and/or rear of the rack. The ac outlet-mounting place provides the mounting location for an ac electrical outlet.
- brass ground lug for an electrostatic discharge (ESD) connection.

Note: The customer is responsible for providing both the outlets and the power cables that attach to the customer's power source. The customer is also responsible for having the ac outlet connected correctly. These items are not field replaceable units (FRUs).

Installing the AC Outlet-Mounting Plates with AC Outlets

If the customer does not want ac outlets installed on the rack, go to “Installing the AC Outlet-Mounting Plate without AC Outlets” on page 22.

If the customer wants ac outlets installed on the front and/or rear ac outlet-mounting plate, do the following:

1. Determine the number of ac outlets that you are installing.
2. Confirm with the customer that the number and location of ac outlets to be installed are correct before starting installation.
3. Remove the blank filler plates from the ac outlet-mounting plates for the number of ac outlets being installed.
4. Install the ac outlets on the ac outlet-mounting plate as desired by the customer.
5. Install the ground lug in the ac-outlet mounting plate using only one nut. Refer to the following illustration.

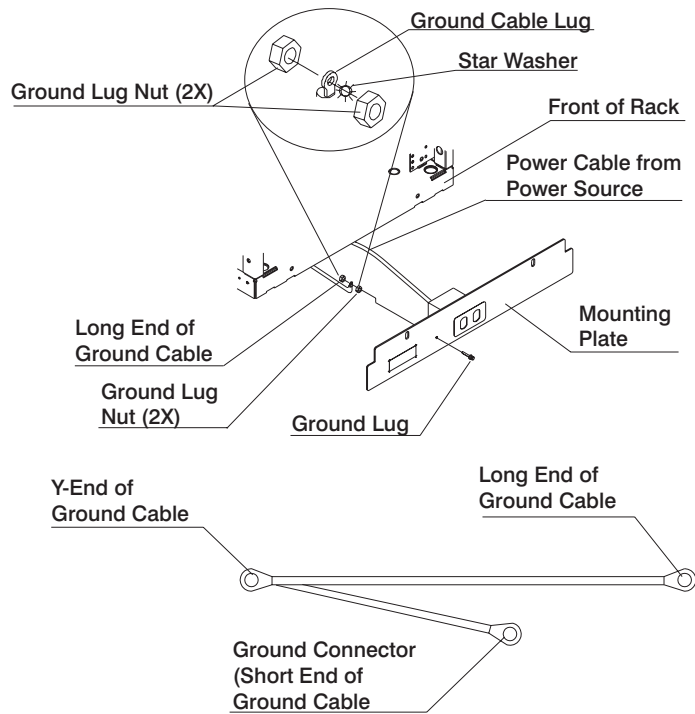

6. Securely tighten the one nut on the ground lug.
7. Locate the Y-shaped ground cable supplied with the mounting plate.

Note: The following steps describe how to install ac outlets on both the front and rear of the rack. Use the steps as applicable for either front or rear installation of outlets on the rack.
8. Place the star washer onto the ground lug of the front ac outlet-mounting plate.
9. Place the lug on the long end of the ground cable onto the ground lug.
10. Place a ground lug nut onto the ground lug and securely tighten it.
11. Position the front ac outlet-mounting plate onto the rack frame with the ground lug fully inserted through the mounting holes in the rack.
12. Route the cable under the rack.
13. Place the star washer onto the ground lug of the rear ac outlet-mounting plate.
14. Place the lug on the short end of the ground cable onto the ground lug.
15. Place a ground lug nut onto the ground lug and securely tighten it.
16. Position the rear ac outlet-mounting plate onto the rack frame with the ground lug fully inserted through the mounting holes in the rack.

17. Install the front ac outlet-mounting plate screws (stabilizer mounting screws) into the mounting plate and through the mounting holes in the rack. Securely tighten the screws.

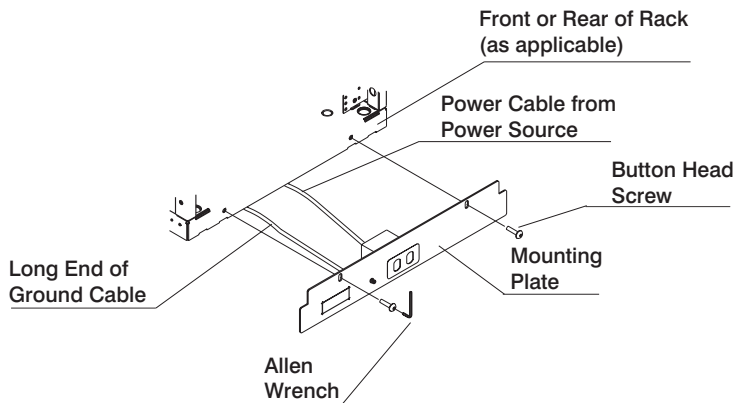

18. Connect the Y end of the ground cable to the rack frame, either near the center in the rear of the rack or to the ground bus bar at the rear of the rack.
19. Install the rear ac outlet-mounting plate screws (stabilizer mounting screws) into the mounting plate and through the mounting holes in the rack. Securely tighten the screws.

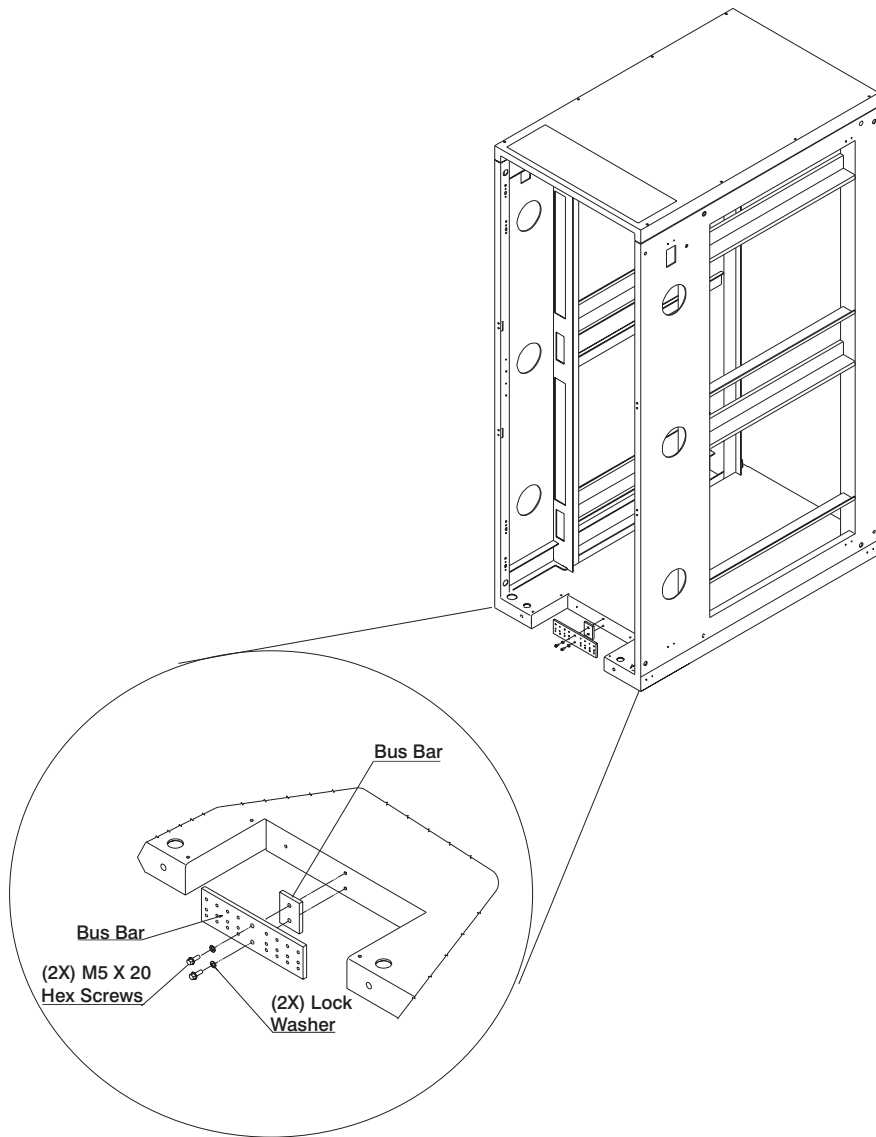

Note: The bus bar might be located at either the top or bottom of the rack.

Installing the AC Outlet-Mounting Plate without AC Outlets

If the customer does not want any ac outlets installed on the front and/or rear ac outlet-mounting plate, perform only Step 5 on page 18 through Step 19 on page 20, as applicable for front and/or rear ac outlet-mounting plates. Refer to “Installing the AC Outlet-Mounting Plates with AC Outlets” on page 18.

Step 8. Attaching the Front Door

The front door of the Model T00 and T42 rack is an optional feature. If your system already has the front door installed, or does not have a front door to install, skip this step and continue with “Step 9. Connecting the Power Distribution System” on page 27.

There are two types of front doors that are available:

- RS/6000 front door is attached to open only in one direction, from the right to the left while you are facing the front of the rack.
- pSeries front door is attached to open either from the right to the left or from the left to the right while you are facing the front of the rack.

If you are attaching an RS/6000 front door, go to “Attaching an RS/6000 Front Door” on page 23. If you are attaching a pSeries front door, go to “Attaching a pSeries Front Door” on page 25.

Attaching an RS/6000 Front Door

To install the front door, do the following:

1. Remove the top, left, and right trim panels (snap in/out).

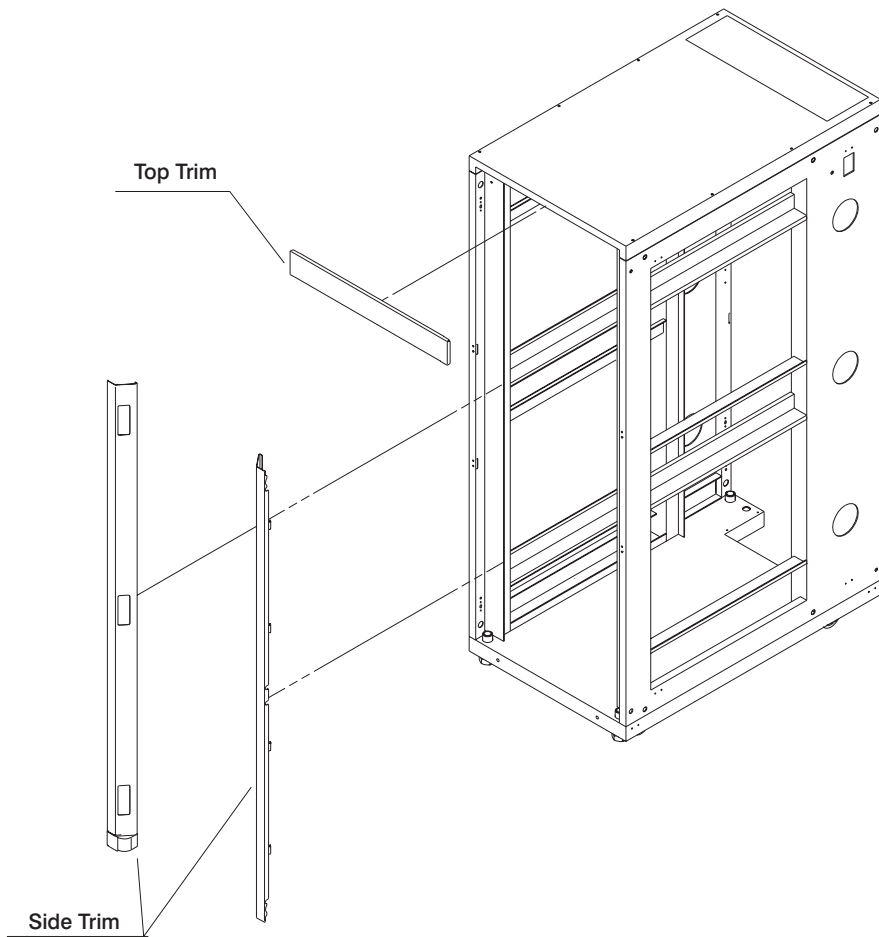

2. Install the hinges as shown in the following illustration.

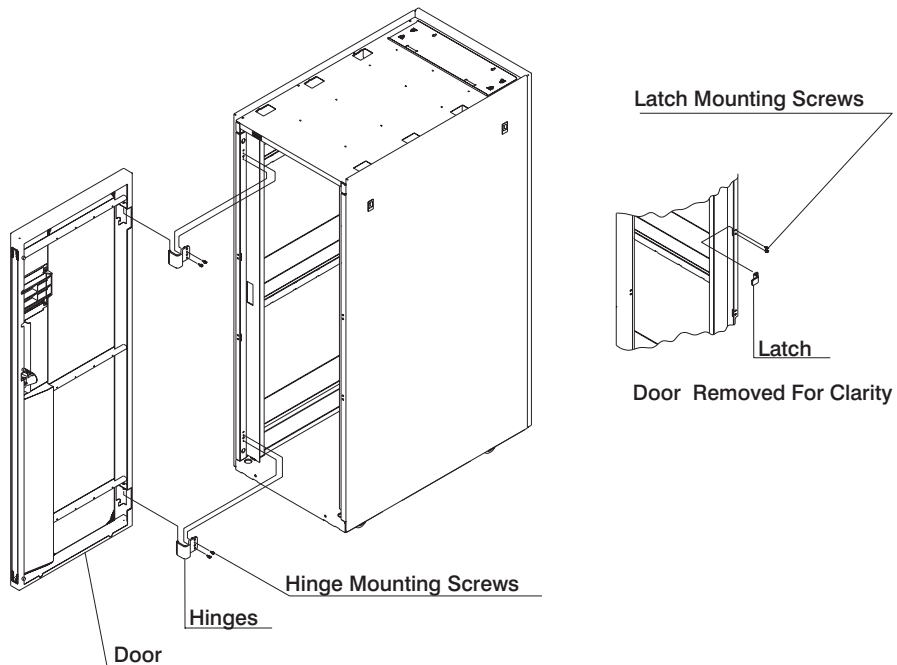

3. Install the latch as shown in the illustration shown above.

Note: Align the lower hinge pin on the front door with the hinge, and partially insert the pin into the hinge. Align the upper hinge pin with the hinge, and lower the door into position.

4. Align the front door with the hinge pins, and lower the door into position.

5. Adjust the latch so the door latches securely.

Attaching a pSeries Front Door

To install a pSeries front door to open from right to left, follow the installation steps described in “Attaching an RS/6000 Front Door” on page 23.

To install a pSeries front door to open from left to right, refer to the illustration shown, and perform the following steps:

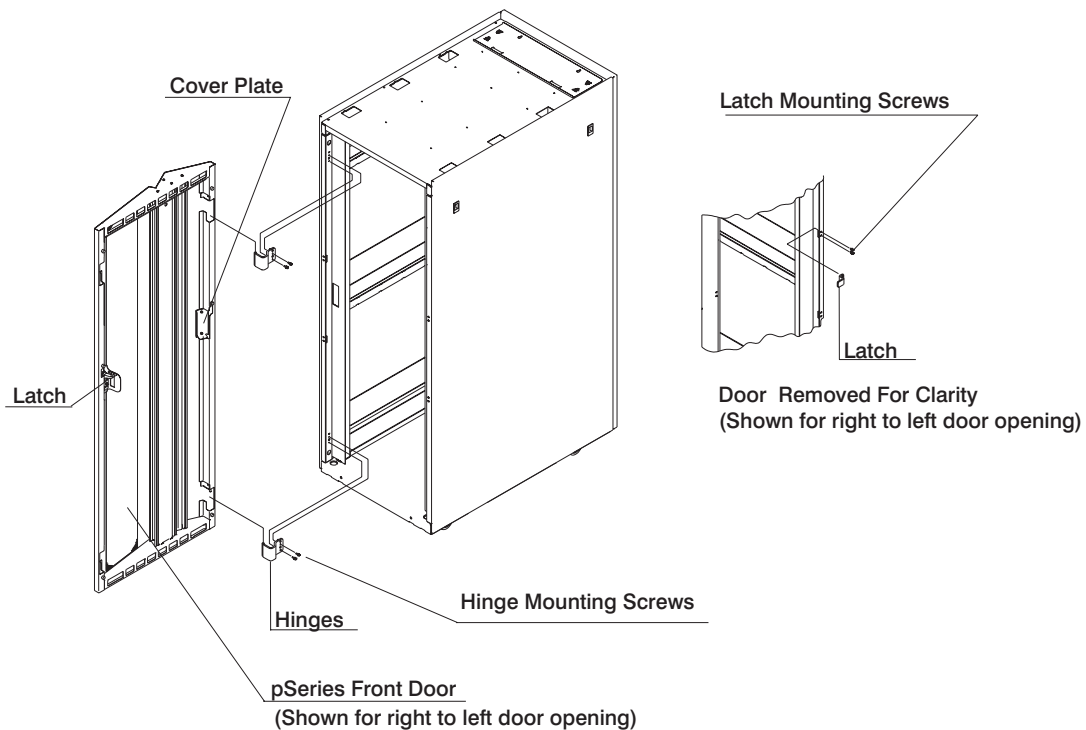

1. Interchange the door latch and cover plate by removing them and reinstalling them on the opposite side of the door.
2. Remove the door hinges and reinstall them on the opposite side of the door.
3. Install the rack latch on the opposite side of the rack.
4. Align the front door with the hinge pins, and lower the door into position.
5. Adjust the latch so the door latches securely.

Step 9. Connecting the Power Distribution System

The following power distribution systems are available with the Model T00:

- Power distribution bus for the ac power models
- Power distribution panel installed on top of the rack for the dc power models

Rear View of AC Rack
With Power Distribution Bus

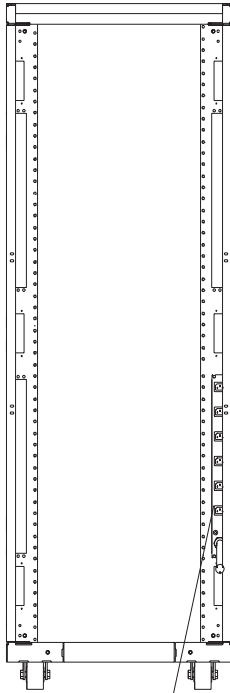

Power
Distribution
Bus

Front View of DC Rack
With Power Distribution Panel

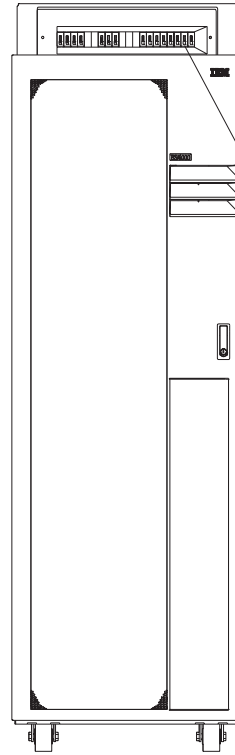

Power
Distribution
Panel

The Model T00 rack is only available with the power distribution panel installed on top of the rack for dc power models.

If your rack has a power distribution panel installed on top of the rack, go to “Connecting the Power Distribution Panel” on page 28.

If your rack has one or more power distribution buses to supply ac power to the drawers, go to “Step 10. Checking Customer’s AC Outlets” on page 32.

Connecting the Power Distribution Panel

Note: The customer is responsible for providing and connecting the -48 V dc power source and -48 V dc power return cables from the customer source -48 V dc to the bus bars in the power distribution panel. The customer also connects the customer ground cable to the rack frame. This procedure only provides information about gaining access to the power distribution panel.

CAUTION:

Energy hazard, remove power before servicing.

1. Remove the six mounting screws from the top cover of the dc power distribution panel and remove the top cover.
2. Remove the four screws from the cable channel cover.
3. Remove the cable channel cover.

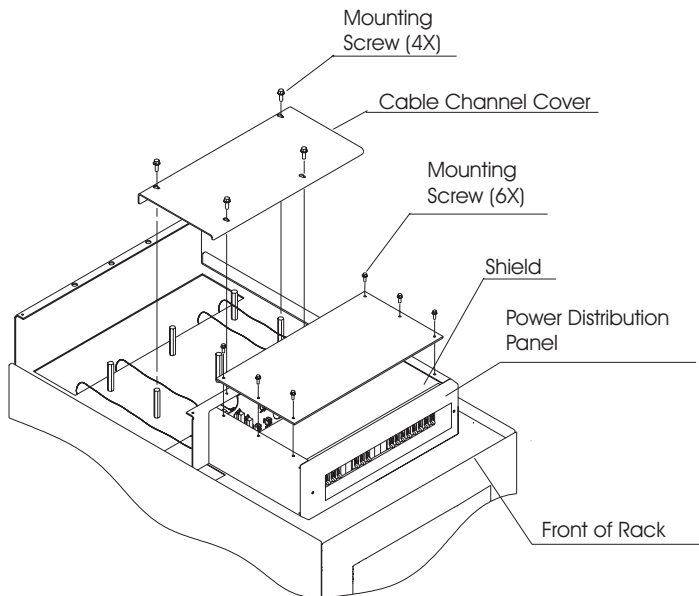

4. Remove the -48 V dc bus bar shield from the power distribution panel.

The bus bar shield must be properly reinstalled over the -48 V dc return bus bars to protect against injury while servicing the power distribution panel.

5. Ensure that the customer's service provider connects the dc source power correctly to the bus bars. Ensure that the following steps are performed. The customer may perform the steps.
 - a. At the customer's -48 V dc power source, turn off any -48 V dc power sources that will be connected to the power distribution panel.
 - b. After the customer's -48 V dc power sources are turned off, be sure there is a tag or label over the power source switches or fuses (lock-out/tag-out) to indicate that the power source is turned off intentionally.

Note: Ensure that the customer understands that the oxidation on the copper bus bars needs to be removed.

 - c. If this is a raised-floor installation, route the power cables up the right side of the rack.
 - d. Ensure that the customer properly routes and installs the external -48 V dc power cable to the -48 V dc bus bar.
 - e. Ensure that the customer properly routes and installs the external -48 V dc return cable to the return bus bar.

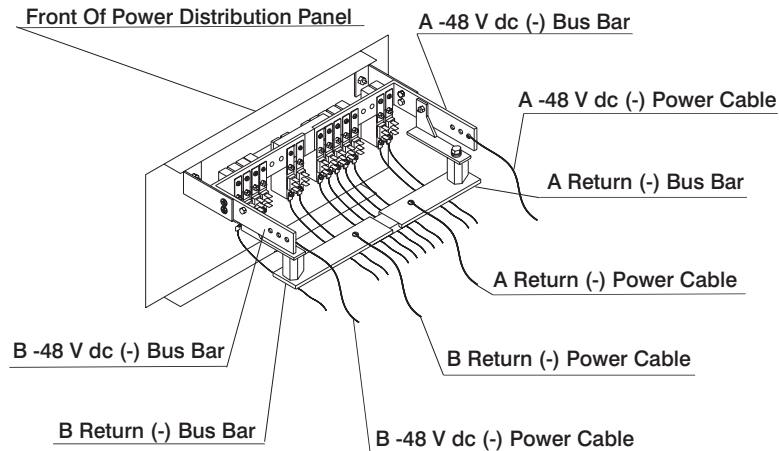
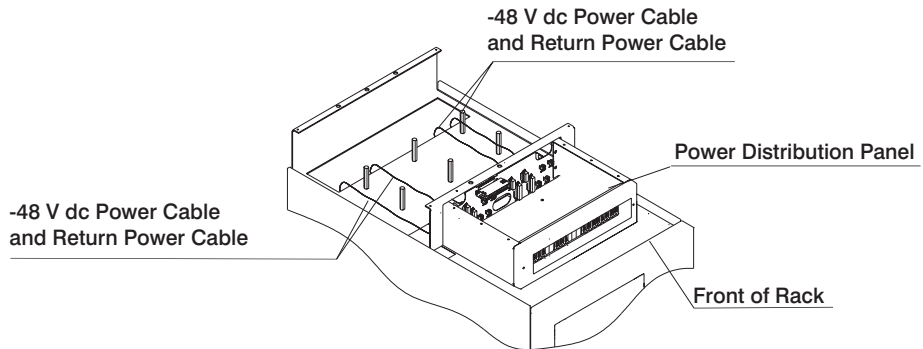

- f. If the customer wants to install a power status alarm, have the customer connect the alarm cable to the terminal board on the rear cover of the dc power distribution panel.

Note: Ensure that the customer understands that the oxidation on the copper bus bars needs to be removed.

- g. Ensure that the customer properly routes and connects the customer's power-source ground cable to the copper bar at the lower- or upper-rear center of the rack.
- h. If the rack is on a raised floor, attach the customer's -48 V dc power source cables to the rear of the rack with cable restraint straps.

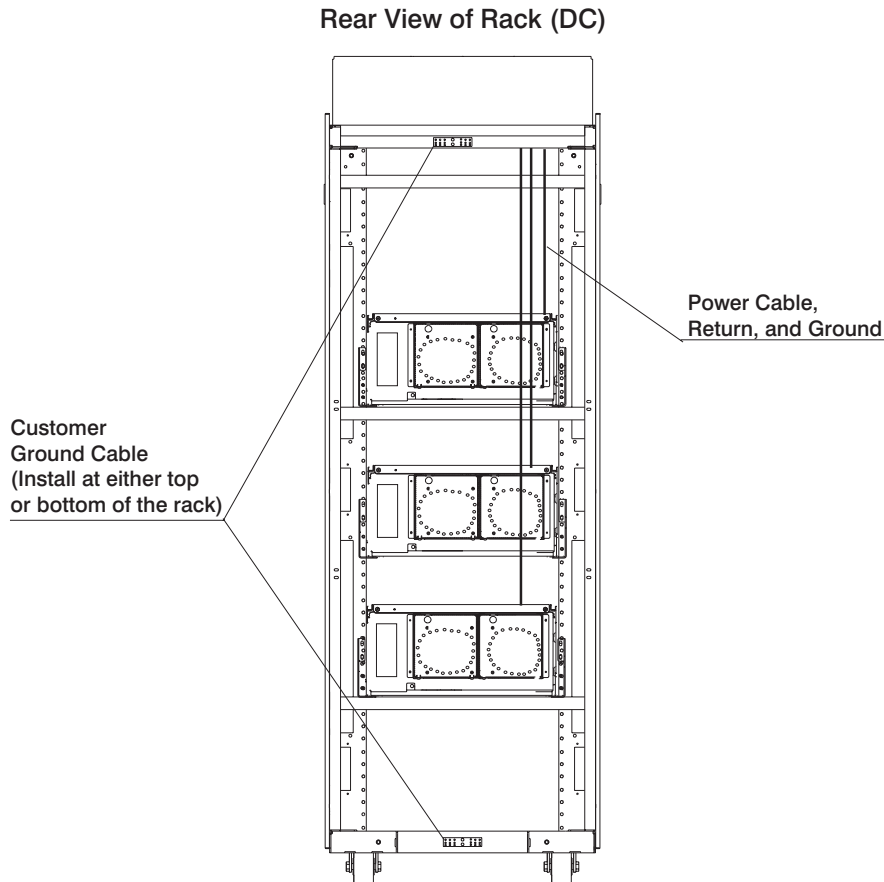

6. Reinstall the -48 V dc bus bar shield.
7. Reinstall the top cover on the dc power distribution panel.
8. Reinstall the cable channel cover.

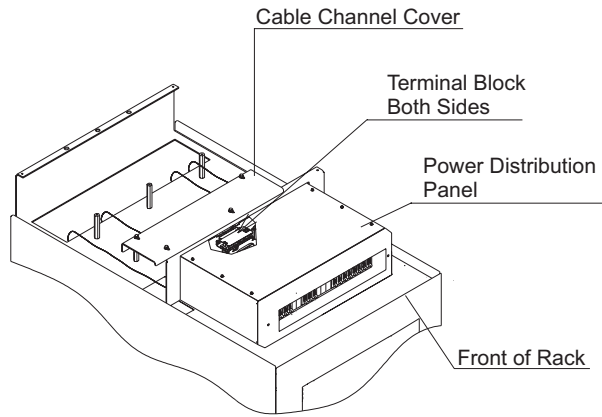

9. Go to “Step 11. Connecting Drawer and Device Cables” on page 34.

Step 10. Checking Customer's AC Outlets

Before plugging the rack into the ac power source, do the following checks on the customer's ac power source.

CAUTION:

Do not touch the receptacle or the receptacle face plate with anything other than your test probes before you have met the requirement in step 10.

1. Have the customer turn off the branch circuit breaker for the ac power outlet that the rack will plug into. To the circuit breaker switch, attach tag S229-0237, which reads "Do Not Operate."

Note: All measurements are made with the receptacle face plate in the normal installed position.

2. Some receptacles are enclosed in metal housings. For this type of receptacle, do the following:
 - a. Check for less than 1 volt from the receptacle case to any grounded metal structure in the building, such as a raised-floor metal structure, water pipe, building steel, or similar structure.
 - b. Check for less than 1 volt from the receptacle ground pin to a grounded point in the building.

Note: If the receptacle case or face plate is painted, be sure the probe tip penetrates the paint and makes good electrical contact with the metal.

- c. Check the resistance from the receptacle ground pin to the receptacle case. Check resistance from the ground pin to the building ground. The readings should be less than 1.0 ohm, which indicates the presence of a continuous grounding conductor.
3. If any of the three checks made in substep 2 are not correct, ask the customer to remove the power from the branch circuit and make the wiring corrections; then check the receptacle again.

Note: Do not use a digital multimeter to measure grounding resistance in the following steps.

4. Check for infinite resistance between the ground pin of the receptacle and each of the phase pins. This is a check for a wiring short to ground or a wiring reversal.

5. Check for infinite resistance between the phase pins. This is a check for a wiring short.

CAUTION:

If the reading is other than infinity, do not proceed! Have the customer make necessary wiring corrections before continuing. Do not turn on the branch circuit CB until all the above steps are satisfactorily completed.

6. Have the customer turn on the branch circuit breaker. Measure for the appropriate voltages between phases. If no voltage is present on the receptacle case or grounded pin, the receptacle is safe to touch.
7. With an appropriate meter, verify that the voltage at the ac outlet is correct.
8. Verify that the grounding impedance is correct by using the ECOS 1020, 1023, B7106, C7106, or an appropriately approved ground-impedance tester.

Step 11. Connecting Drawer and Device Cables

Most racks are preconfigured in the factory with all drawer and device cables installed.

If any head protectors are installed in the diskette drives, remove them.

If you need to install drawer and device cables, do the following:

1. Follow the installation instructions provided in the documentation that comes with the drawer or device being installed in the rack.
2. Using the customer planning information, the *RS/6000 and eServer pSeries Diagnostics Information for Multiple Bus Systems*, or other information supplied by the customer, connect the drawer and device cables to the system interface board ports.
3. As needed, use the cable labels included in the ship group to label the cables. For additional information about labeling the cables, refer to the *RS/6000 and eServer pSeries Diagnostics Information for Multiple Bus Systems*.
4. Open the cable restraint strap by pressing the release tab and then pulling the end of the cable restraint strap through the locking mechanism.
5. Place the cables within the cable restraint strap.
6. Close the strap by placing the end of the cable restraint strap through the locking mechanism, and then pull the end of the cable restraint strap to tighten the cables against the rack.
7. For ac devices, plug the device power distribution bus cables into the rack power distribution bus.
8. For dc devices, plug the device cables into the rack power distribution panel.

Step 12. Powering On and Checking Out the System

1. Follow the power-on procedure in “Power-On Procedure with the AC Power Distribution Bus” on page 75 for your type of rack.
2. To check out the system, refer to the *RS/6000 and eServer pSeries Diagnostics Information for Multiple Bus Systems* and follow the instructions in the installation checkout procedure.

Step 13. Relocating Rack(s)

This section covers steps to relocate a rack (or group of racks) to another location.

CAUTION:

Make sure that you do the following:

- **Before you add or remove drawers, always have the leveling feet lowered and the front and rear stabilizer installed, or have the rack bolted to the floor.**
- **Always install drawers at the bottom of the rack first.**
- **Always remove drawers from the top of the rack first.**
- **Always install the heaviest drawers on the bottom of the rack.**

CAUTION:

Make sure that you do the following:

- **Remove two or three drawers from the top of the rack before you relocate it.**
- **Never push on the sides of the rack.**

Attention: If the rack has equipment located above EIA location 32, you must remove the equipment in position 32 and above from the rack before you move it. Always remove the equipment from the *top* of the rack first.

Prerequisite Steps to Relocating a Rack

Before you relocate a rack, do the following:

1. Turn off all power to the rack(s) and system.
2. Disconnect all power cables.
3. Make sure the rack is either bolted down or has the stabilizers installed before removing any drawers from the rack.
4. Remove the equipment located above EIA location 32 from the rack.

Note: If you are relocating a Model T42 rack to another room or building, measure the doorways to make sure the Model T42 will go through doorways.

If you determine that there is sufficient clearance for relocating a Model T42 rack through doorways, go to “Moving a Rack” on page 38.

If you determine that there is not sufficient clearance for relocating a Model T42 rack through doorways, you must remove the rack top cover. Go to “Removing the Rack Top Frame and Cover” and follow the instructions.

Removing the Rack Top Frame and Cover

Follow these steps only if there is not sufficient clearance through doorways to relocate a Model T42 rack.

1. Remove the front door and the top, left, and right trim panels.
2. Remove the side panels.

Note: If the rack is locked, unlock the doors. Then, unlock the side panels by removing the locking bars from both sides of the top rear of the rack. Slide the locking bars out from the rack at the top of each side of the rack from the rear.

The locking bars may be removed from each side of the front of the rack provided the rack space in the area of the locking bars is open and the bars are easily accessible.

3. Remove one screw from the right side of the top cover and one from the left side of the top cover. Do this for both front and rear.
4. Locate the rack brace that was provided in the shipping container. Fasten a brace at the top of the rack just below the top cover with the two screws removed from the top cover. Do this in the front and rear of the rack.

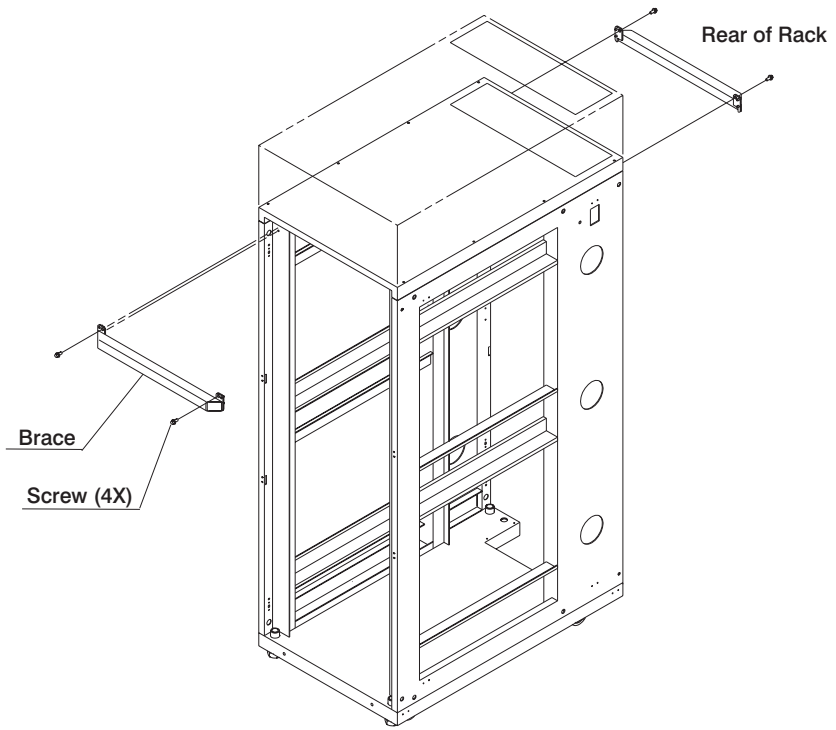

5. Remove the remaining six screws from the left and right sides of the top cover.

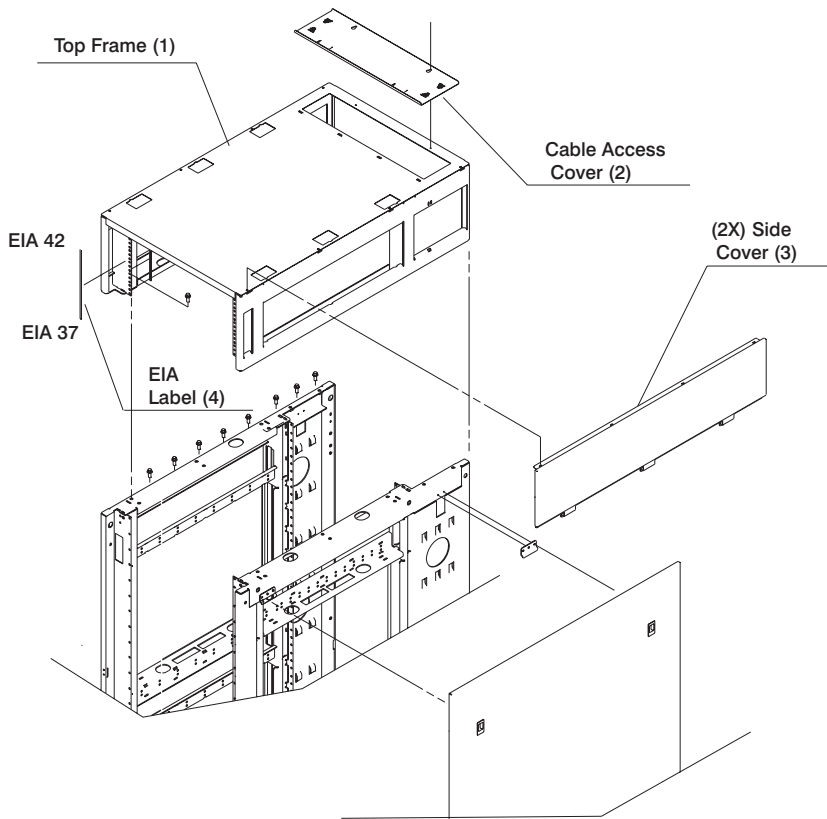

6. Lift off the top cover.

Moving a Rack

Perform the following instructions to move a rack:

1. Unbolt the rack from the floor or remove the stabilizers.
2. If installed, remove rear mounting plate.
3. Loosen jam nuts; raise all the leveling feet.
4. Unlock each caster wheel by loosening the screw on the caster.
5. If necessary, move the rack so the front mounting plate can be removed.
6. Move rack to new position.
7. If you removed the top cover, go to “Reattaching the Top Cover” on page 39. Otherwise, position the rack as described in “Step 1. Positioning the Rack” on page 3.

Reattaching the Top Cover

If you removed the top cover to provide clearance for moving a rack through doorways, reattach the top cover as follows:

1. Position the top cover on the rack.
2. Install the six screws at the left and right sides of the top cover.
3. Remove the rack braces by unfastening them at the top of the rack just below the top cover. Remove the braces at the front and rear of the rack.
4. Install the screws (removed in a previous step) at the right and left side of the top cover for both the front and rear of the rack.
5. Install rack filler panels to cover open areas at the front of the rack(s). All the gaps in the front of the rack must also be sealed, including the gaps between pieces of equipment. This step ensures that proper airflow within the rack is maintained.
6. Position the rack as described in “Step 1. Positioning the Rack” on page 3.
7. Refer to the *RS/6000 and eServer pSeries Diagnostics Information for Multiple Bus Systems* and follow the instructions in the installation checkout procedure.

Chapter 2. Reference Information

This chapter contains information about the locations of rack features, power distribution, and rack specifications.

Types of Power Distribution

Power is distributed to the devices and drawers in the rack by ac power distribution buses or by a dc power distribution panel (Model T00 only).

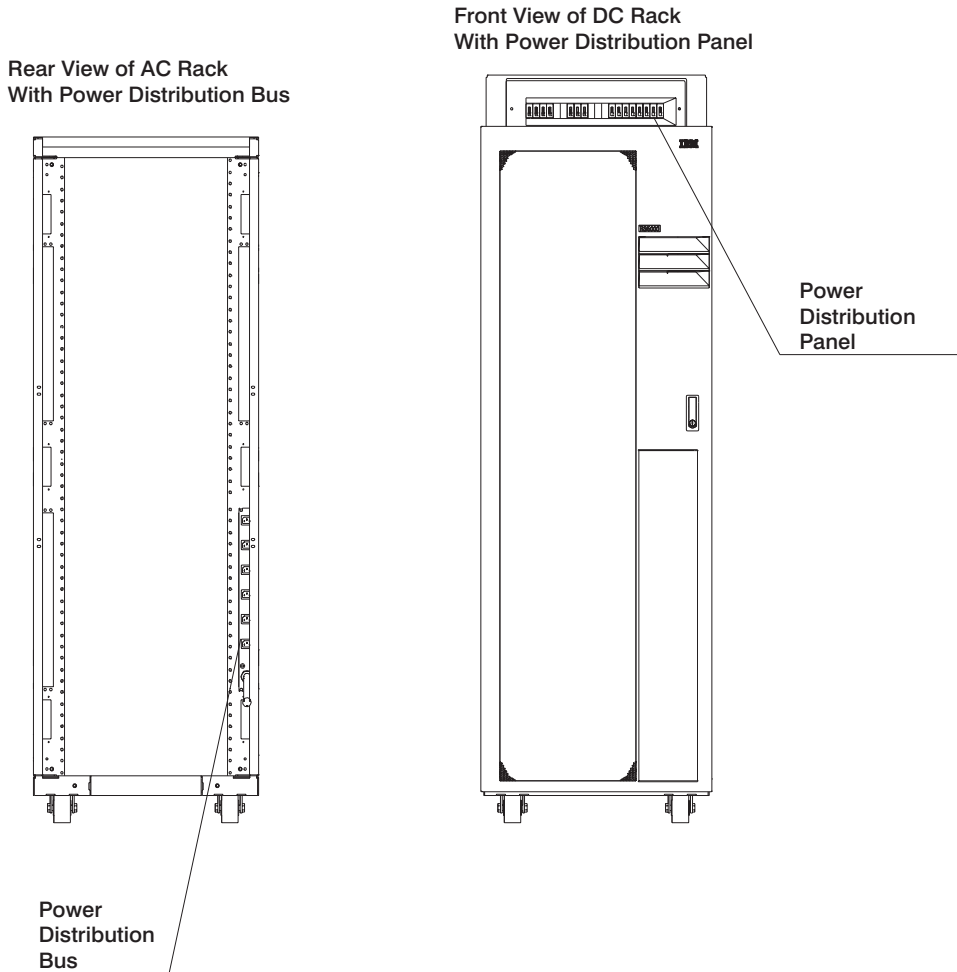

AC Rack Information

This section contains information about ac rack components.

AC Power Distribution Bus

A rack can contain up to four vertically mounted ac power distribution buses. Two additional power distribution buses (each consuming 1 EIA location) of the type shown below may be mounted horizontally in the bottom rear of a T00 rack and three additional power distribution buses (each consuming 1 EIA location) of the type shown below may be mounted horizontally in the bottom rear of a T42 rack. The four vertical mounting slots will be filled first before consuming EIA locations in the rack. Each ac power distribution bus contains eight 200 V to 240 V ac outlets to provide power to the devices and drawers. The input ac power to the bus is not switched, so each outlet has a separate circuit breaker to protect against excessive current.

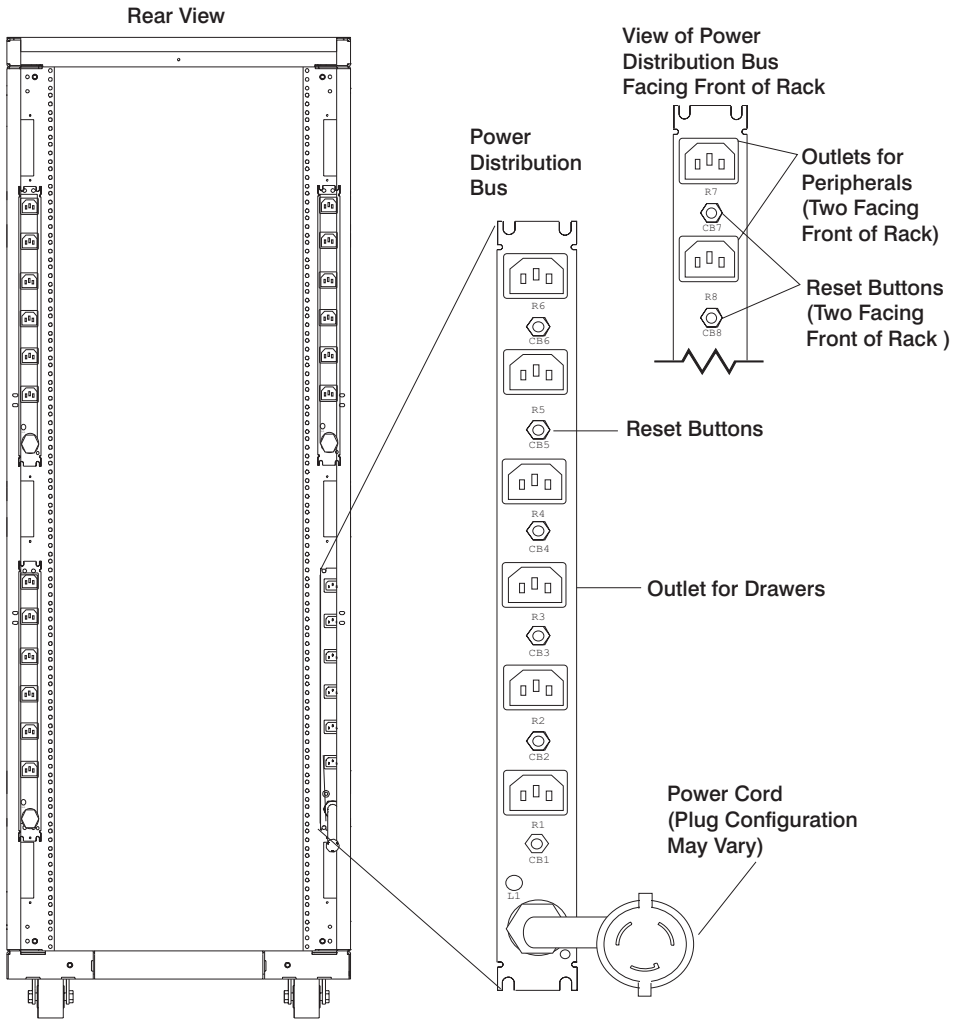

The ac power is not switched prior to the individual power outlet circuit breakers.

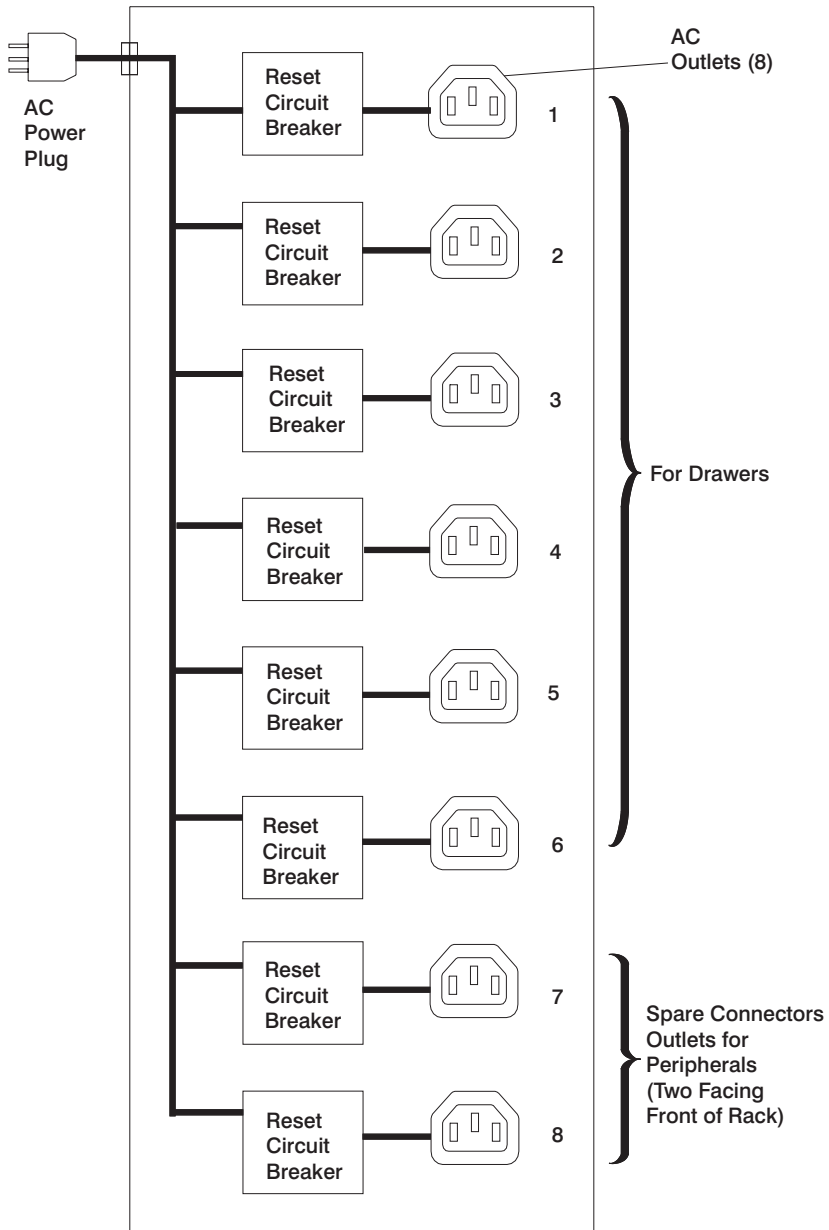

AC Power Distribution Bus Illustration

When the drawer power cords are plugged into the outlets, there should be less than 1 ohm resistance between the drawer frames or the rack frame.

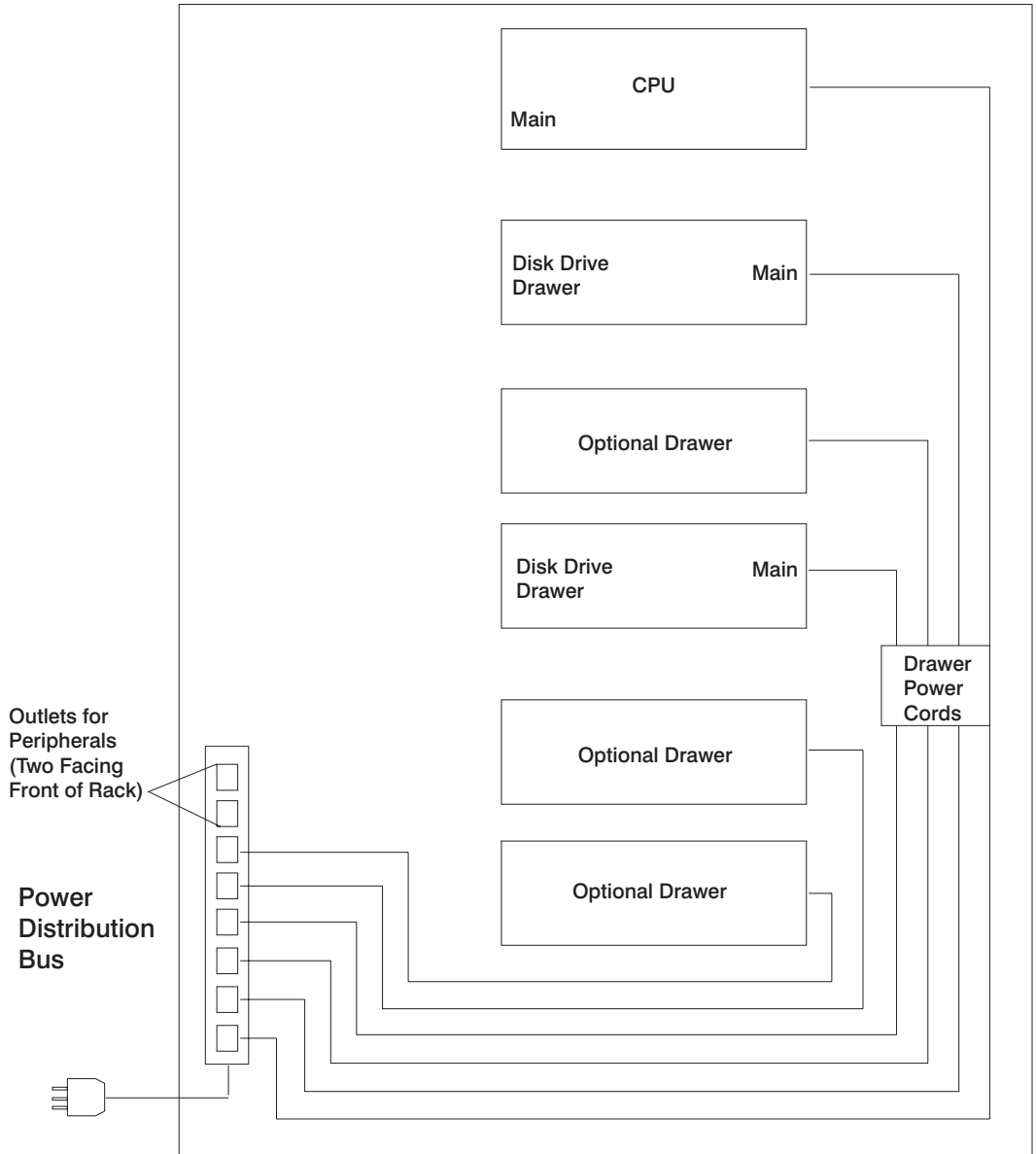

External AC Power Cables

To avoid electrical shock, the manufacturer provides a power cable with a grounded attachment plug. Use only properly grounded outlets.

Power cables used in the United States and Canada are listed by Underwriter's Laboratories (UL) and certified by the Canadian Standards Association (CSA). These power cords consist of the following:

- Electrical cables, type ST
- Attachment plugs complying with National Electrical Manufacturers Association (NEMA) L6-30P
- Appliance couplers complying with IEC Standard 320, Sheets C13 and C14.

Power cables used in other countries consist of the following:

- Electrical cables, type HD21 or HD22
- Attachment plugs approved by the appropriate testing organization for the specific countries where they are used
- Appliance couplers complying with International Electrotechnical Commission (IEC) Standard 320, Sheet C13 and C14.

Refer to "Power Cords" on page 116 to find the power cables that are available for the ac rack.

Uninterruptible Power Source

An uninterruptible power source (UPS) can be installed in the rack that contains an ac power distribution bus. The uninterruptible power source powers one drawer or device. The uninterruptible power source contains a power plug (input) and one power outlet (output).

DC Rack Information

This section contains information about dc rack components.

DC Power Distribution Panel

A dc power distribution panel can be installed on the top of the rack to distribute -48 V dc power to the drawers and devices in the rack. The dc power distribution panel provides separate circuit breakers to protect each drawer in the rack from excess current.

The dc power distribution panel configurations shown in this book are for example purposes only. The actual dc power distribution panel installed in your rack may vary in terms of circuit breaker ratings, configurations, and connections to the customer's dc power source.

The power distribution panel contains a connection on the rear of the panel for attaching a customer-supplied power alarm. This alarm is activated when any circuit breaker is tripped or is switched to the off position.

The circuit breaker is on when the handle is up, and off when the handle is down.

The following illustration shows a typical dc power distribution panel (internal view).

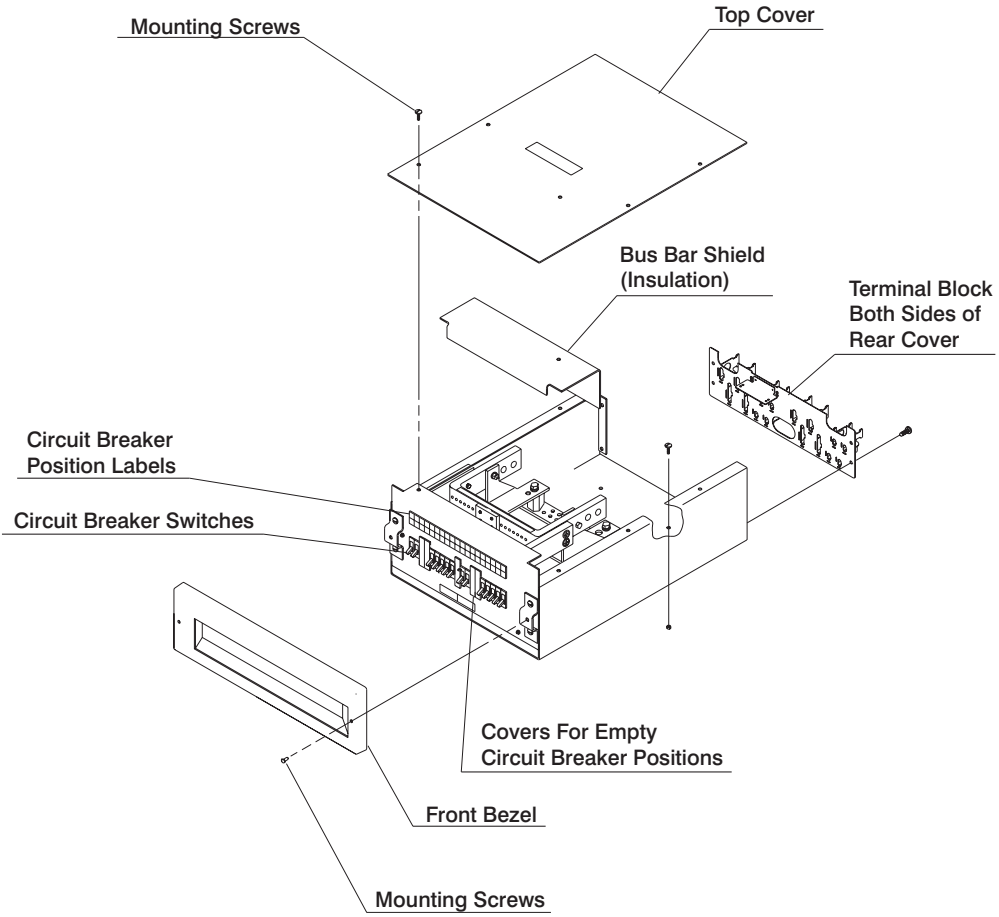

DC Rack Configuration

The dc rack must be connected to an external -48 V dc power source. The -48 V dc power source must be electrically isolated from the ac power source. In addition, the -48 V dc source must be grounded.

The dc rack can be connected to more than one -48 V dc power source, which provides redundant power backup.

The circuit breakers in the dc power distribution panel are attached to two dc power bus bars (bus bar A, bus bar B). These bus bars can be connected either to a common power source or to separate power sources (redundant power).

Typically, a dc power distribution panel contains two matching banks of circuit breakers. Each bank of circuit breakers is connected to a different power source. The -48 V dc power supply of each drawer is connected to one circuit breaker in each bank of the -48 V dc power distribution panel. Thus, when one of the -48 V dc power sources fails, the devices in the rack still receive power from the other source.

The exact configuration of the dc power distribution panel depends on the configuration of drawers and devices installed in the rack. Illustrations on the following pages show typical examples of power distribution for a standalone rack containing a CPU drawer and device drawers.

Note: Before you service the dc power distribution panel, use care to first determine the exact power configuration and distribution.

The following illustration shows a typical dc power distribution panel (external view).

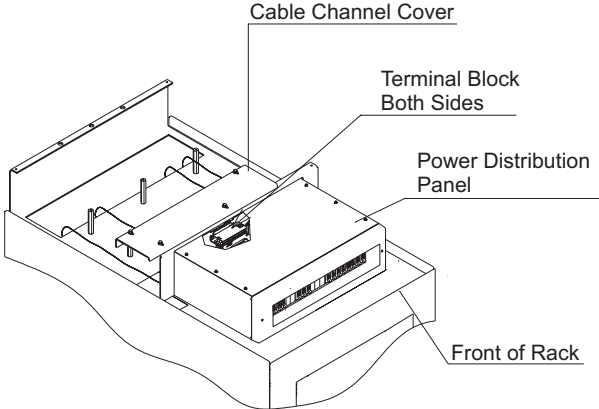

DC Power Distribution and Ground Illustration

The following illustration shows power distribution in a typical -48 V dc rack connected to two -48 V dc power sources. Note that each power supply in the CPU drawer is connected to a separate circuit breaker in the -48 V dc power distribution panel.

When the drawer power cords are connected to the dc power distribution panel, make sure there is less than 1 ohm resistance between the drawer frames or the rack frame.

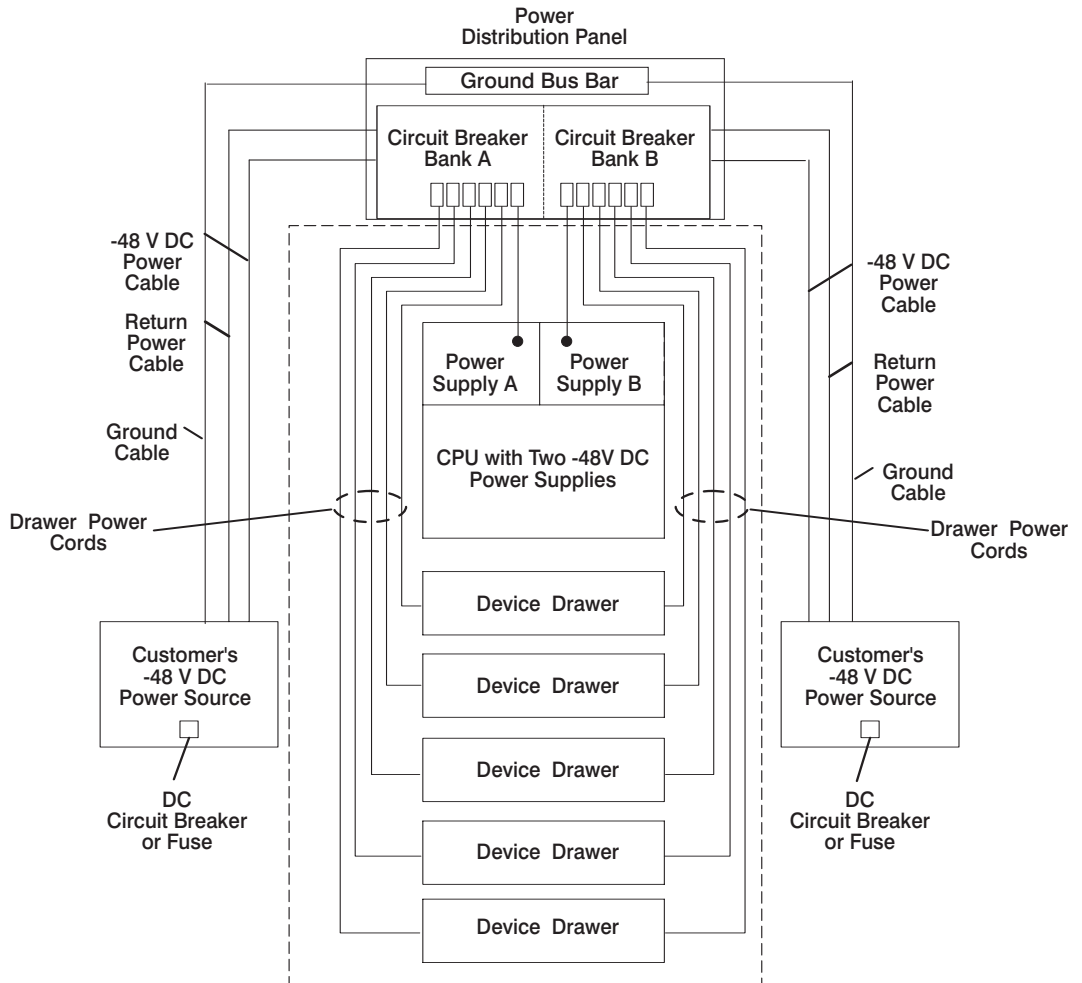

DC Rack Power Cables

The customer provides the power cables from the -48 V dc power source to the dc power distribution panel. The -48 V dc rack must be connected to a -48 V dc power source that is electrically isolated from the ac power source. In addition, the -48 V dc power source must be reliably grounded.

The -48 V dc rack may be connected to two separate -48 V dc power sources. When the rack is connected to two power sources, both power sources must be reliably grounded.

Power cables used in the United States and Canada are listed by Underwriter's Laboratories (UL) and certified by the Canadian Standards Association (CSA). These power cables have the following characteristics:

- Power cables and ground cables must be a minimum of 6 AWG stranded copper (or equivalent) for lengths up to 50 feet from the power source.
- All connectors must be the copper crimp type (compression). Connector metal must be compatible with the cable metal.

Specifications for Model T00 and T42 Rack

Dimensions

T00 Height: 1804 mm (71 in)

T00 Height with power distribution panel: 1926 mm (75.8 in)

T42 Height: 2015 mm (79.3 in)

Depth:

T00 and T42 with Rear Door: 1042 mm (41 in)

RS/6000 T00 with Rear and Front Door: 1098 mm (43.3 in) - Feature 6097

RS/6000 T42 with Rear and Front Door: 1098 mm (43.3 in) - Feature 6083

pSeries T00 with Rear and Front Door: 1147 mm (45.2 in) - Feature 6088

pSeries T42 with Rear and Front Door: 1147 mm (45.2 in) - Feature 6089

Width: 644 mm (25.4 in)

T00 and T42 without side panels: 623 mm (24.5 in)

T00 and T42 with side panels: 644 mm (25.4 in)

T00 EIA units: 36 EIA units

T42 EIA units: 42 EIA units

Weight

T00 Base Empty Rack: 244 kg (535 pounds)

T00 Full Rack: 816 kg (1795 pounds)

T42 Base Empty Rack: 261 kg (575 pounds)

T42 Full Rack: 930 kg (2045 pounds)

Install/Airflow

Rack airflow requirements are a function of the number and type of drawers installed. All rack installations require careful site and facilities planning designed to address the cumulative drawer heat output and provide the airflow volume rates necessary to comply with drawer temperature requirements. Refer to the individual drawer specifications.

Power Requirements

In the U.S., each Power Distribution Bus installed in a rack requires a dedicated power line of 200 to 240 V ac, 30 A.

In other countries, input power to each Power Distribution Bus may vary depending upon country requirements.

Service Inspection Guide

Perform a service inspection on the rack when any of the following conditions occur:

- The rack is inspected under a maintenance agreement.
- Service is requested and service has not recently been performed.
- An alterations-and-attachments review is performed.
- Changes have been made to the equipment that might affect the safe operation of the equipment.
- External devices with an attached power cord are connected to the rack.

If the inspection indicates an unacceptable safety condition, the condition must be corrected before representatives service the machine.

Note: The correction of any unsafe condition is the responsibility of the owner of the system.

Do the following checks:

1. If the rack is bolted down, do the following:
 - a. Ensure that the rack is firmly secured to the floor.

- b. Ensure that the four plastic isolator bushings are under the four leveling feet (dc only).

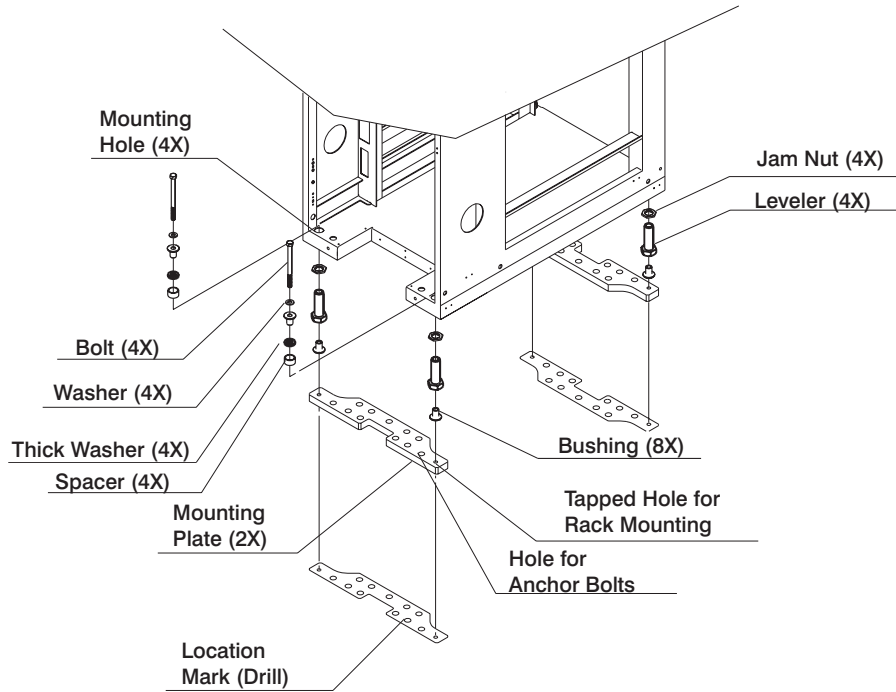

2. If the rack is not bolted down, ensure that the stabilizers are firmly attached to both the bottom front and bottom rear of the rack.

CAUTION:

The stabilizer must be firmly attached to the bottom front of the rack to prevent the rack from turning over when the drawers are pulled out of the rack. Do not pull out or install any drawer or feature if the stabilizer is not attached to the rack.

CAUTION:

The stabilizer must be firmly attached to the bottom rear of the rack to prevent the rack from turning over when the drawers are pulled out of the rack. Do not pull out or install any drawer or feature if the stabilizer is not attached to the rack.

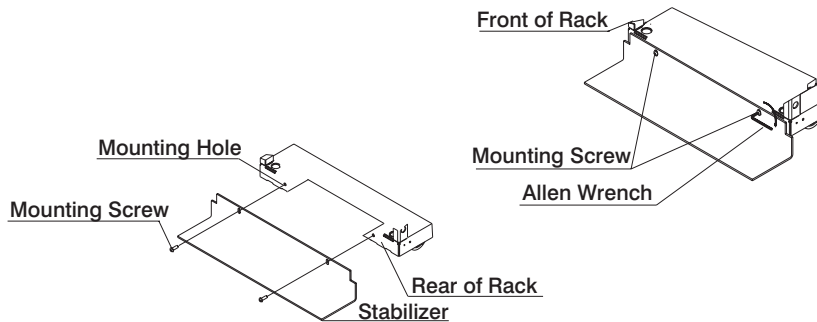

3. Check the covers for sharp edges and for damages or alterations that expose the internal parts of the rack.
4. Check the covers for a proper fit to the rack. The covers should be in place and secure.
5. Open the back door of the rack.
6. Perform the power-off procedure for the power distribution system installed in your rack. See “Power-Off Procedure with the AC Power Distribution Bus” on page 77 for ac power. See “Power-Off Procedure with the DC Power Distribution Panel” on page 80 for dc power.
7. Check for alterations or attachments. If there are any, check for obvious safety hazards such as broken wires, sharp edges, or broken insulation.
8. Check the internal cables for damage.
9. Check for dirt, water, and any other contamination within the rack.
10. Check the voltage label on the back of the system unit to ensure that it matches the voltage at the outlet.
11. Check the external power cable for damage.
12. If your rack is a dc rack, connect the customer's ground cable to the rack unit and check for 0.1 ohm or less resistance between the metal rack frame and the copper ground strip on the back of the rack.

13. If your rack is an ac rack, do the following:

- a. With the external power cable connected to the system unit, check for 0.1 ohm or less resistance between the ground lug on the external power cable plug and the metal frame.

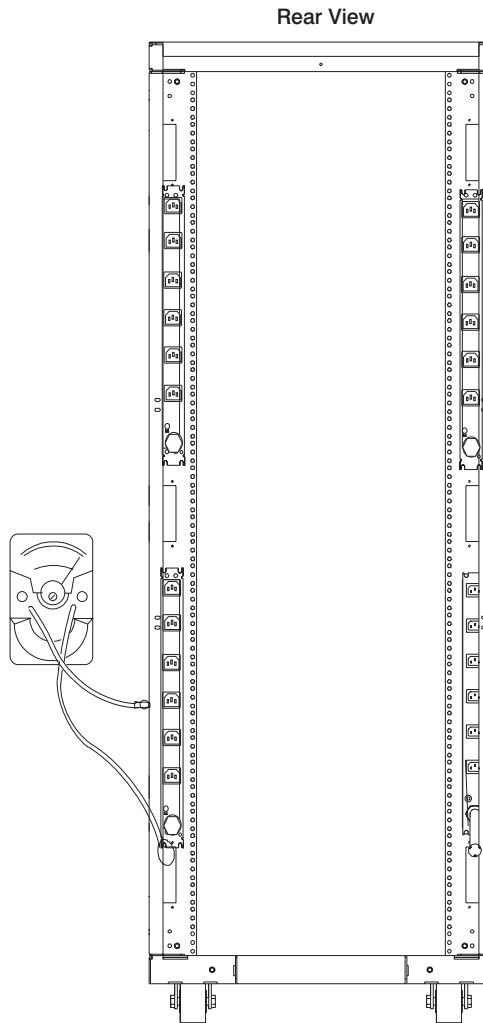

- b. Using the appropriate probe, check for 0.1 ohm or less resistance between the metal frame and the grounding pin on each of the power outlets on the power distribution bus (check each bus if there are multiple buses).

- c. Check for the following conditions for each external device that has an attached power cord:
- Damage to the power cord.
 - The correct grounded power cord.
 - With the external power cord connected to the device, check for 0.1 ohm or less resistance between the ground lug on the external power cord plug and the metal frame of the device.
14. Close the rear cover of the rack.
15. Perform the power-on procedure for the power distribution system installed in your rack. See “Power-On Procedure with the AC Power Distribution Bus” on page 75 and “Power-On Procedure with the DC Power Distribution Panel” on page 78.

Chapter 3. Maintenance Analysis Procedures (MAPs)

This chapter provides diagnostic steps for detecting power problems in the rack. Use these power MAPs *only* if you are directed here from a MAP step in the *RS/6000 and eServer pSeries Diagnostics Information for Multiple Bus Systems*.

If your rack has a power distribution panel, follow the instructions below for “MAP 1520: DC Power Distribution Panel - Power MAP.”

If your rack has a power distribution bus, follow the instructions for “MAP 1522: AC Power Distribution Bus - Power MAP” on page 67.

MAP 1520: DC Power Distribution Panel - Power MAP

Purpose of This MAP

This procedure is used to locate power problems in the dc power distribution panel. If a problem is detected, this procedure helps you isolate the failing field replaceable unit (FRU).

Safety Notices

Observe the following safety notices during service procedures.

DANGER

An electrical outlet that is not correctly wired could place hazardous voltage on metal parts of the system or the devices that attach to the system. It is the responsibility of the customer to ensure that the outlet is correctly wired and grounded to prevent an electrical shock.

Before installing or removing signal cables, ensure that the power cables for the system unit and all attached devices are unplugged.

When adding or removing any additional devices to or from the system, ensure that the power cables for those devices are unplugged before the signal cables are connected. If possible, disconnect all power cables from the existing system before you add a device.

Use one hand, when possible, to connect or disconnect signal cables to prevent a possible shock from touching two surfaces with different electrical potentials.

During an electrical storm, do not connect cables for display stations, printers, telephones, or station protectors for communication lines.

CAUTION:

Energy hazard, remove power before servicing. Disconnect two power supply cords.

Step 1520-1

Do any of the devices in the rack have their power indicator(s) lit? (front operator panel or power supply LED).

NO Go to Step 1520-10.

YES Go to Step 1520-2.

CAUTION:

Energy hazard, remove power before servicing. Disconnect two power supply cords.

Step 1520-2

Check the circuit breaker for the drawer that does not have power.

Is the circuit breaker tripped?

NO Go to Step 1520-7.

YES Reset the circuit breaker by turning the circuit breaker off, then on. Go to Step 1520-3.

Step 1520-3

Is there power to the drawer?

NO Check the circuit breaker again. Go to Step 1520-4.

YES Go to "MAP 0410: Repair Checkout" in the *RS/6000 and eServer pSeries Diagnostics Information for Multiple Bus Systems*.

Step 1520-4

Is the circuit breaker tripped again?

NO Go to Step 1520-7.

YES Go to Step 1520-5.

Step 1520-5

1. Set circuit breaker to the off position.
2. Disconnect the power cable from the device's power supply.
3. Set the circuit breaker to the on position.

Is the circuit breaker tripped again?

NO Replace the device power supply. Go to "MAP 0410: Repair Checkout" in the *RS/6000 and eServer pSeries Diagnostics Information for Multiple Bus Systems*.

YES Turn circuit breaker off and replace power cable. Set circuit breaker to the on position. Go to Step 1520-6.

Step 1520-6

Did the circuit breaker trip again?

NO Go to "MAP 0410: Repair Checkout" in the *RS/6000 and eServer pSeries Diagnostics Information for Multiple Bus Systems*.

YES Replace circuit breaker. Go to "MAP 0410: Repair Checkout" in the *RS/6000 and eServer pSeries Diagnostics Information for Multiple Bus Systems*.

Step 1520-7

Is there power to the drawer?

NO Replace device power supply. Go to Step 1520-8.

YES Go to "MAP 0410: Repair Checkout" in the *RS/6000 and eServer pSeries Diagnostics Information for Multiple Bus Systems*.

CAUTION:

Energy hazard, remove power before servicing. Disconnect two power supply cords.

Step 1520-8

Is there power to the drawer?

NO Go to Step 1520-9.

YES Go to "MAP 0410: Repair Checkout" in the *RS/6000 and eServer pSeries Diagnostics Information for Multiple Bus Systems*.

Step 1520-9

Set the circuit breaker to the off position, and replace the power cable between the circuit breaker and the device.

Is there power to the drawer?

NO Go to Step 1520-14.

YES Go to "MAP 0410: Repair Checkout" in the *RS/6000 and eServer pSeries Diagnostics Information for Multiple Bus Systems*.

Step 1520-10

Are all the circuit breakers turned on?

- NO** Turn circuit breakers on. Then go to "MAP 0410: Repair Checkout" in the *RS/6000 and eServer pSeries Diagnostics Information for Multiple Bus Systems*.
- YES** Go to Step 1520-11.

Step 1520-11

1. Set all of the circuit breaker switches to the off position (switches in the down position).
2. Locate terminal board 2 (TB2) on the outside of the rear cover of the power distribution panel.
3. Measure for -40 to -60 V dc on terminal board 2 (TB2) between positions one and two (side A circuit breaker) and between positions five and six (side B circuit breaker).

Is the voltage between -40 and -60 V dc?

- NO** Go to Step 1520-12.
- YES** Go to Step 1520-13.

Step 1520-12

1. Remove the six screws attaching the top cover of the power distribution panel.
2. Remove the top cover and then remove the insulator.
3. Using a multimeter, attach the black multimeter cable lead to the return bus bar (+), and then attach the red multimeter cable lead to the -48 V dc bus bar (-).
4. Measure for -40 to -60 V dc between the -48 V dc bus bar (upper bar) and the return bus bar (lower bar) in the power distribution panel.

Was the correct voltage present?

NO Ask the customer to check the power source for the correct voltage, and check the external power cable (from customer's power source) for continuity.

YES Go to Step 1520-13.

Step 1520-13

Set all of the circuit breaker switches on the power distribution panel to the on position.

Do all the power supplies on the devices have power?

NO Go to Step 1520-14.

YES Go to "MAP 0410: Repair Checkout" in the *RS/6000 and eServer pSeries Diagnostics Information for Multiple Bus Systems*.

Step 1520-14

1. Ensure that the circuit breaker is in the on position.
2. Using a multimeter, attach the black multimeter cable lead to the return bus bar (+), and then attach the red multimeter cable lead to the bottom terminal on the circuit breaker.
3. Measure for -40 to -60 V dc between the -48 V dc circuit breaker and the return bus bar (lower bar) in the power distribution panel.

Is the voltage between -40 and -60 V dc?

- NO** Replace circuit breaker. Then go to "MAP 0410: Repair Checkout" in the *RS/6000 and eServer pSeries Diagnostics Information for Multiple Bus Systems*.
- YES** Go to Step 1520-15.
-

Step 1520-15

Has the device power supply previously been replaced?

- NO** Replace power supply. Then go to "MAP 0410: Repair Checkout" in the *RS/6000 and eServer pSeries Diagnostics Information for Multiple Bus Systems*.
- YES** Replace cable. Then go to "MAP 0410: Repair Checkout" in the *RS/6000 and eServer pSeries Diagnostics Information for Multiple Bus Systems*.

MAP 1522: AC Power Distribution Bus - Power MAP

Purpose of This MAP

This procedure is used to locate power problems in the power distribution bus. If a problem is detected, this procedure will help you isolate the failing field replaceable unit (FRU).

If the rack contains more than one power distribution bus, use this MAP to test the power distribution bus that is connected to the failing drawer. If you cannot determine which power distribution bus is connected to the failing drawer, use this MAP to test the first power distribution bus, and then test the other power distribution bus until the problem is determined.

Safety Notices

Observe the following safety notices during service procedures.

DANGER

An electrical outlet that is not correctly wired could place hazardous voltage on metal parts of the system or the devices that attach to the system. It is the responsibility of the customer to ensure that the outlet is correctly wired and grounded to prevent an electrical shock.

Before installing or removing signal cables, ensure that the power cables for the system unit and all attached devices are unplugged.

When adding or removing any additional devices to or from the system, ensure that the power cables for those devices are unplugged before the signal cables are connected. If possible, disconnect all power cables from the existing system before you add a device.

Use one hand, when possible, to connect or disconnect signal cables to prevent a possible shock from touching two surfaces with different electrical potentials.

During an electrical storm, do not connect cables for display stations, printers, telephones, or station protectors for communication lines.

Step 1522-1

Is uninterruptible power source installed?

- NO** Go to Step 1522-4.
YES Go to Step 1522-2.
-

Step 1522-2

If the system is not receiving power and the LED on the power distribution bus is off, unplug the customer's power cable from the uninterruptible power source, and then plug the customer's power cable into the power distribution bus.

The green LEDs located on the power distribution bus indicate that power is supplied from the customer's outlet, through the customer's power cable, and to the power distribution bus.

Are the LEDs on the power distribution bus ON?

- NO** Check the customer's power cable for the proper voltage from the wall outlet to the power distribution bus or uninterruptible power source. Then go to Step 1522-3.
- YES** Replace the uninterruptible power source if necessary. Refer to the maintenance and diagnostic information in the Service Guide for the uninterruptible power source installed in your rack, and then go to Step 1522-10.

Step 1522-3

Was the voltage correct?

- NO** Check the customer's outlet for the correct voltage. If correct, exchange the power cable. Then go to Step 1522-10.
- YES** Exchange the power distribution bus and go to Step 1522-10.
-

Step 1522-4

Did any of the power lights on the devices come on and stay on?

- NO** If the LED on the power distribution panel is off, check the customer's power cable for the proper voltage from the wall outlet to the power distribution bus and go to Step 1522-5.
- YES** If a single device is not receiving power, go to Step 1522-6.
-

Step 1522-5

Was the voltage correct?

- NO** Check the customer's outlet for the correct voltage. If correct, exchange the power cable and then go to Step 1522-10.
- YES** Exchange the power distribution bus and go to Step 1522-10.

Step 1522-6

Did the drawer power reset circuit breaker on the power distribution bus go to the Off position (pop out)?

NO Go to Step 1522-7.

YES Go to Step 1522-9.

Step 1522-7

1. Plug the drawer power cable into another outlet on the power distribution bus.
2. Turn on power to the drawer.

Did the drawer power light come on and stay on?

NO Go to Step 1522-8.

YES The first outlet is defective. Use the second outlet, or exchange the power distribution bus, and then go to Step 1522-10.

Step 1522-8

1. Plug the power cable of another device or drawer into the same outlet.
2. Turn on power to the device or drawer.

The green light near the ac plug on the rear of some drawers indicates only that power is reaching the drawer and not that the power supply is operating.

Did the drawer power light come on and stay on or are the fans operating?

- NO** Exchange the power distribution bus, and then go to Step 1522-10.
- YES** The problem is probably located in the original drawer. Go to "MAP 1520: Power MAP" in the Service Guide for the system installed in your rack.

Step 1522-9

1. Plug the CPU drawer power cable into another outlet on the power distribution bus.
2. Set the power button to on (button pushed in).

Did the circuit breaker go to the Off position (pop out)?

- NO** The first circuit breaker is probably defective. Use the second outlet, or exchange the power distribution bus, and then go to Step 1522-10.
- YES** The drawer is overloading the circuit breaker. Exchange the CPU drawer power cable or power supply. Then go to Step 1522-10.

Step 1522-10

1. Connect all drawer power cables to their original power outlets on the power distribution bus.
2. This completes the repair. Go to "MAP 0410: Repair Checkout" in the *RS/6000 and eServer pSeries Diagnostics Information for Multiple Bus Systems*.

Chapter 4. Removal and Replacement

This chapter contains information about powering the rack on and off, and removing and replacing components.

Use the correct power-on and power-off procedure for the type of power distribution used in your rack.

Safety Notices

This section contains safety notices that apply to all the procedures in this chapter. Review this section carefully before performing any power-related operations.

DANGER

An electrical outlet that is not correctly wired could place hazardous voltage on metal parts of the system or the devices that attach to the system. It is the responsibility of the customer to ensure that the outlet is correctly wired and grounded to prevent an electrical shock.

Before installing or removing signal cables, ensure that the power cables for the system unit and all attached devices are unplugged.

When adding or removing any additional devices to or from the system, ensure that the power cables for those devices are unplugged before the signal cables are connected. If possible, disconnect all power cables from the existing system before you add a device.

Use one hand, when possible, to connect or disconnect signal cables to prevent a possible shock from touching two surfaces with different electrical potentials.

During an electrical storm, do not connect cables for display stations, printers, telephones, or station protectors for communication lines.

CAUTION:

This unit may have more than one power cable. To completely remove power, you must disconnect all power cables from the unit.

Operating System Shutdown

Before powering off any drawers or external devices, ask the customer if this rack is used in a high-availability system. If it is, notify the customer that other attached systems might be affected by this procedure.

Notify the customer if you are going to turn off power to any drawers that are attached to drawers or devices in another system.

Before powering off the system unit, you must first shut down the operating system to prevent losing data. Ask the customer to shut down all programs. Failure to do so can result in the loss of data. See your operating system documentation for information about the **shutdown** command.

Power-On Procedure with the AC Power Distribution Bus

This section covers the ac rack power-on procedures.

1. Plug all drawer power cables into the outlets on the ac power distribution bus or buses.
2. If more than one ac power distribution bus is installed in the rack, plug the power cable of each into the customer's ac power outlet.

CAUTION:

This product is equipped with a 3-wire power cable and plug for the user's safety. Use this power cable in conjunction with a properly grounded electrical outlet to avoid electrical shock.

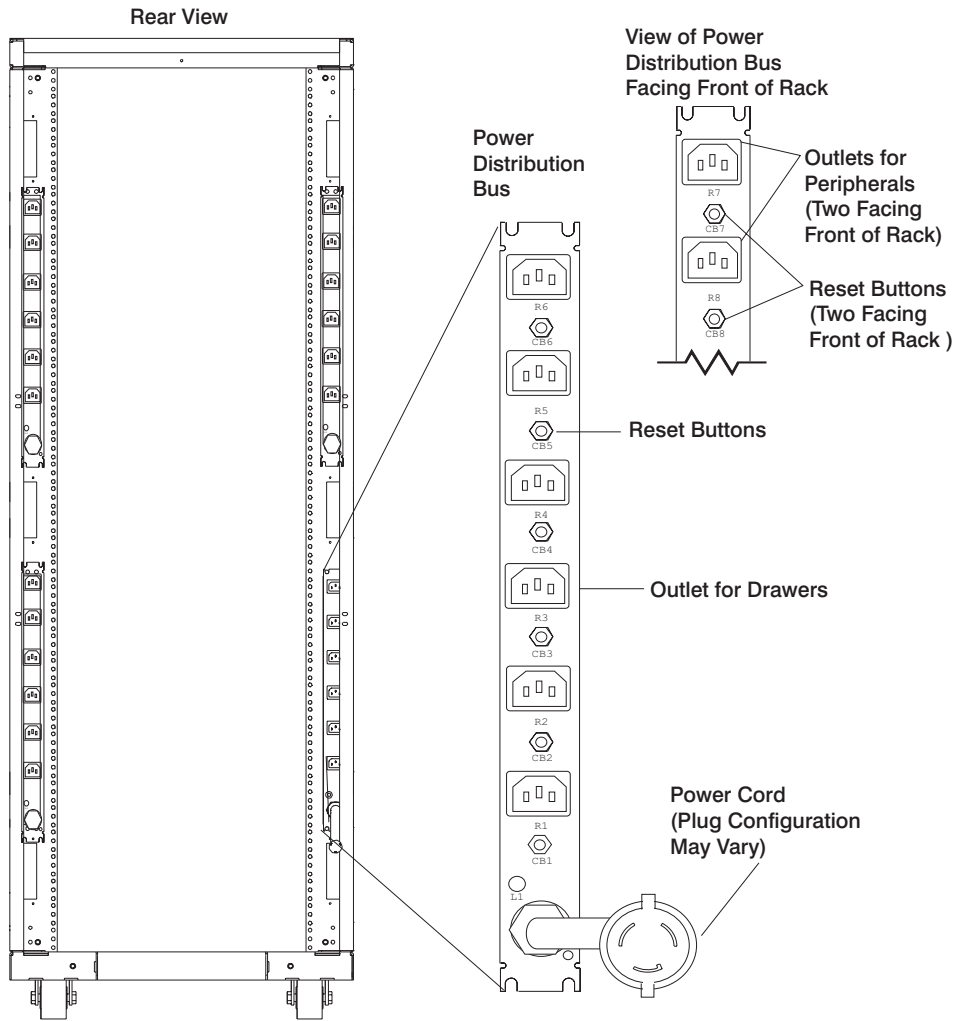

3. Follow the power-on procedures for the drawers installed in the rack. Refer to the Service Guide for the drawers installed in the rack for more information.
4. Close the back door of the rack.

Power-Off Procedure with the AC Power Distribution Bus

This section covers ac power-off procedures.

1. Be sure the operating system is shut down. See “Operating System Shutdown” on page 74.
2. Power off each of the drawers installed in the rack. Refer to the Service Guide for the drawers installed in the rack for more information.

Note: Because many drawers or devices can be connected to the system unit, it may be impractical for you to switch off power to all the drawers or devices and unplug their power cables.

3. Open the rear door of the rack.

Note: If more than one ac power distribution bus is installed in your rack and you are servicing only one, power off the drawers connected to the ac power distribution bus you are servicing.

4. Turn off power to all drawers or devices that are connected to the ac power distribution bus you are servicing.
5. Unplug all the drawer or device power cables from the ac power distribution bus you are servicing.
6. Unplug the power cable from the customer's ac power outlet.

Power-On Procedure with the DC Power Distribution Panel

This section covers the power-on procedures for the dc rack.

CAUTION:

Energy hazard, remove power before servicing. Disconnect two power supply cords.

Note: It is the customer's responsibility to provide and have a qualified technician properly install both the dc power source cables from the customer's -48 V dc power source to the dc power distribution panel. The customer is also responsible for connecting the customer-supplied ground cable to the ground bus bar on the rack frame.

1. Locate terminal board 2 (TB2) on the outside of the dc power distribution panel.

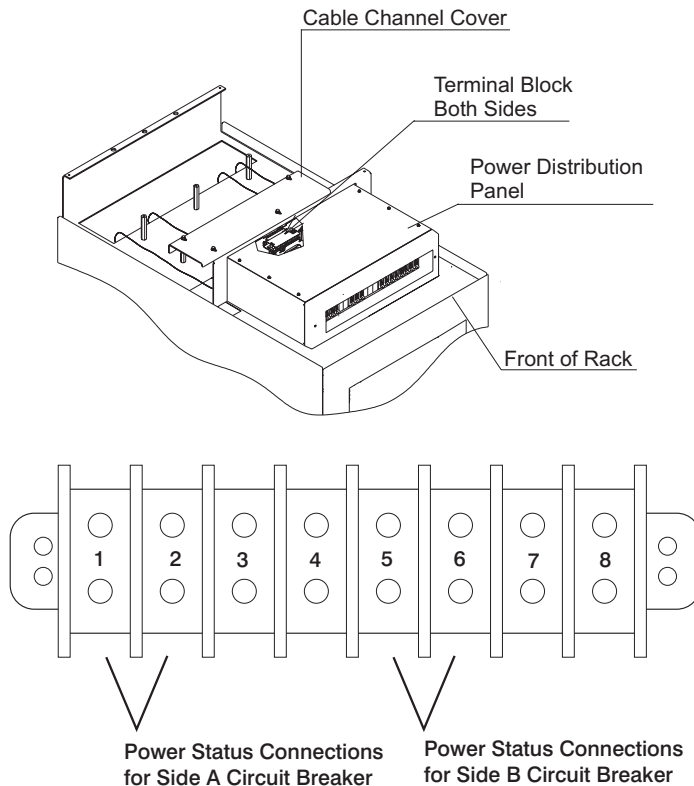

2. Using a polarity sensitive multimeter, ensure that the voltage and polarity are correct at the dc power distribution panel (check both the -48 V dc bus and the -48 V dc return bus) as follows:

- a. Ensure that all circuit breakers are off (circuit breaker switches in the down position).
- b. Measure for -40 V dc to -60 V dc between position 1 (-) and position 2 (+) on terminal board 2 to test the power for side A.
- c. Measure for -40 V dc to -60 V dc between position 5 (-) and position 6 (+) on terminal board 2 to test the power for side B.

Front View of Power Distribution Panel (PDP)

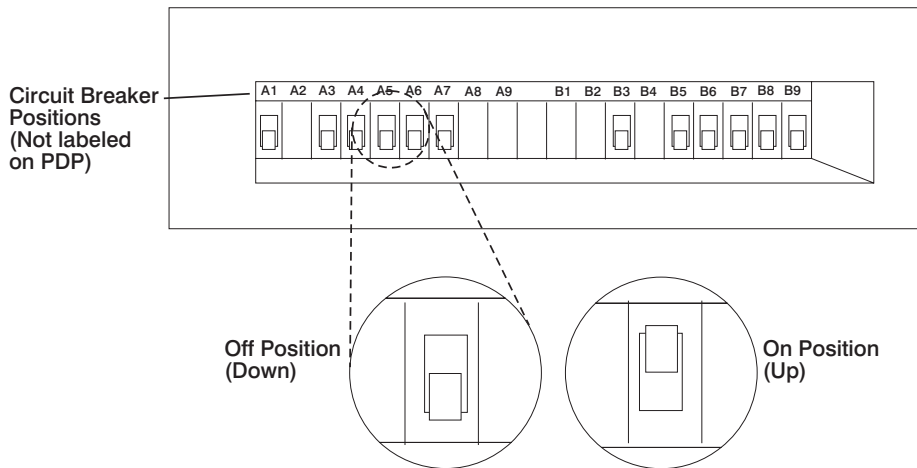

3. Plug all externally attached device power cords into the electrical outlets.
4. Turn on power to all external devices attached to the system unit. Refer to the Service Guide for more information.
5. Set all the circuit breakers to the on position (up).
6. Turn on power to all of the devices and drawers connected to the dc power distribution panel.

Power-Off Procedure with the DC Power Distribution Panel

This section covers the power-off procedures for dc rack.

1. Be sure the operating system is shut down. See “Operating System Shutdown” on page 74.
2. Turn off power to all devices and drawers in the rack. Refer to the Service Guide for more information.
3. Turn off power to all external devices attached to the system.
4. Unplug the device power cords from the electrical outlets.

Note: If drawers in attached racks are connected to circuit breakers in the dc power distribution panel of this rack, power to the drawers in attached racks will be powered off if the circuit breakers in this rack are set to off.

5. Except for circuit breakers in this rack that are connected to drawers in another rack, set all circuit breakers to the off position (down).

CAUTION:

Energy hazard, remove power before servicing. Disconnect two power supply cords.

Note: Because a large number of external devices can be connected to the system unit, it might be impractical for you to turn off power to all the devices and unplug their power cords.

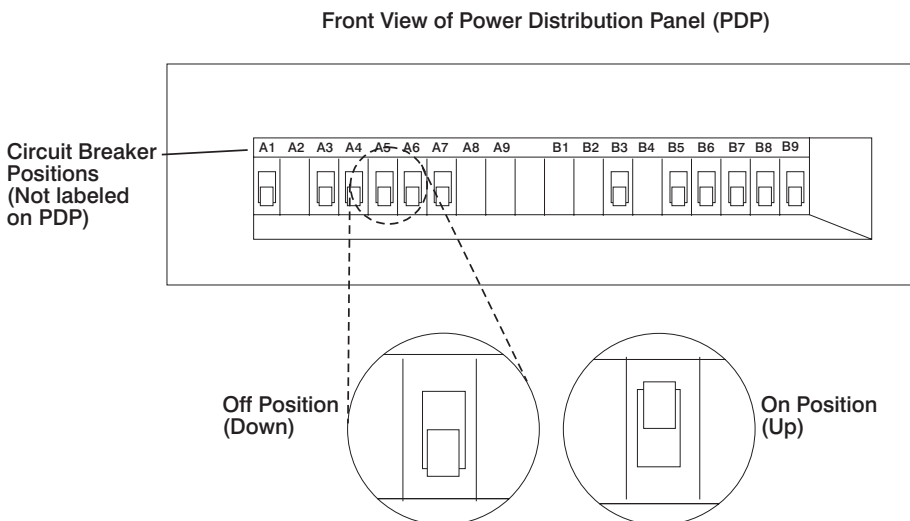

Removal and Replacement of the AC Power Distribution Bus

This section covers the removal and replacement procedures for the ac power distribution bus. The following illustration shows where the ac power distribution bus might be installed.

Note: If there are more than 4 power distribution busses in the rack, additional busses may be mounted horizontally in the rear mounting rails of the rack. enote.

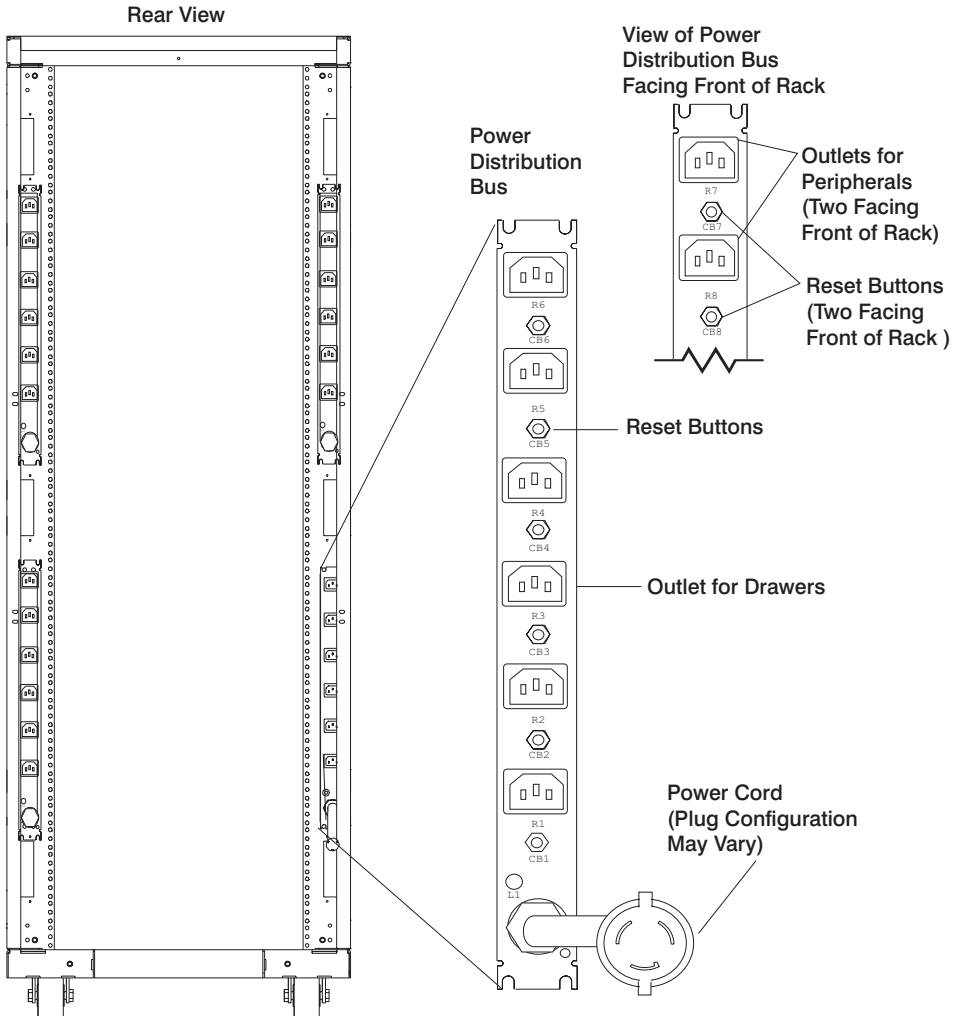

Removal

This section covers the removal procedures of the ac power distribution bus.

1. Follow the “Power-Off Procedure with the AC Power Distribution Bus” on page 77.
2. Turn off power and disconnect the ac power distribution bus from the customer's ac power outlet. Record the locations of the drawer ac power cables plugged into the ac power distribution bus.
3. Unplug the drawer ac power cables from the ac power distribution bus.
4. Remove the four mounting screws from the ac power distribution bus and pull the bus toward you to access the power connectors on the other side of the bus. Unplug the power cables from the other side of the bus.
5. Remove the ac power distribution bus from the rack.

Replacement

This section covers the replacement of the ac power distribution bus.

1. Reconnect any power cables that you disconnected from the other side of the ac power distribution bus.
2. Slide the ac power distribution bus into position and install the four mounting screws.
3. Reconnect any power cables that you disconnected from the ac power distribution bus.
4. Plug the power cables into the locations that you recorded during the removal procedure.
5. Follow the steps in “Power-On Procedure with the AC Power Distribution Bus” on page 75.

Removal and Replacement of the DC Power Distribution Panel

This section covers the removal and replacement procedures for the dc power distribution panel.

CAUTION:

Energy hazard, remove power before servicing. Disconnect two power supply cords.

Removal

This section covers the removal procedures for the dc power distribution panel.

1. Follow the steps in “Power-Off Procedure with the DC Power Distribution Panel” on page 80.

Note: Removing power to the dc power distribution panel does not remove power to drawers in this rack that are powered by the dc power distribution panel in another rack.

2. Have the customer turn off the dc power source that connects to the dc power distribution panel.
3. After the customer's -48 V dc source power is turned off, ensure that a tag or label is positioned over the switches to indicate that the power is intended to be off (lock-out/tag-out).
4. Remove the six mounting screws from the top cover of the power distribution panel. Then remove the top cover.
5. Remove the -48 V dc bus shield (insulation) from the dc power distribution panel.
6. Remove the cable channel cover.

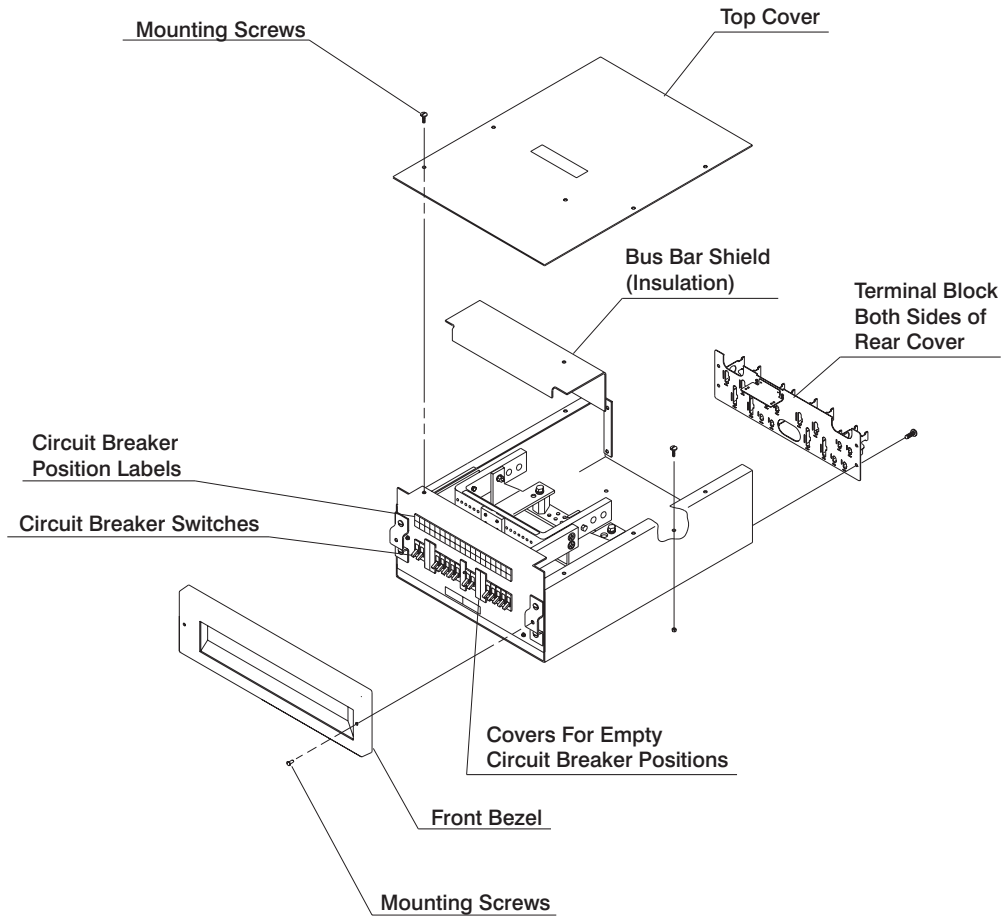

7. With a multimeter, verify that no voltage exists between the two -48 V dc bus bars and the two -48 V dc return bus bars.
8. Ensure that the customer's service provider completely disconnects the two -48 V dc power source cables from the -48 V dc bus bars, and the two -48 V dc return ground cables from the -48 V dc return bus bars.
9. Record the locations and connection points of all power cables and the ground cable.
10. Disconnect all drawer power cables and the ground cable.

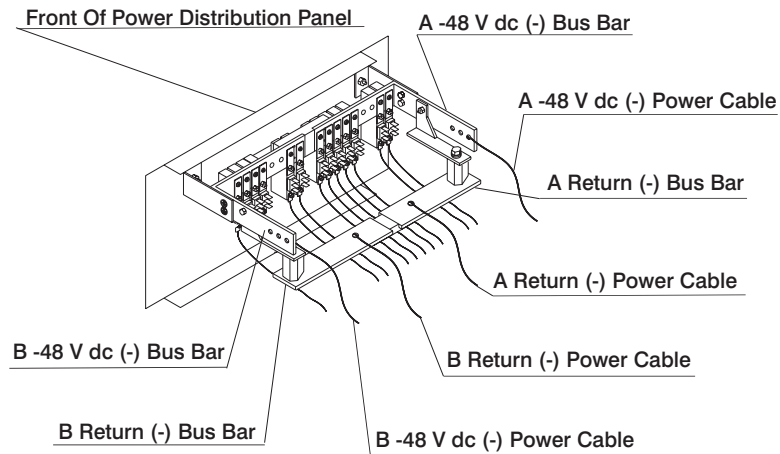

11. Remove the four mounting screws that attach the dc power distribution panel from the top of the rack, and remove the panel.

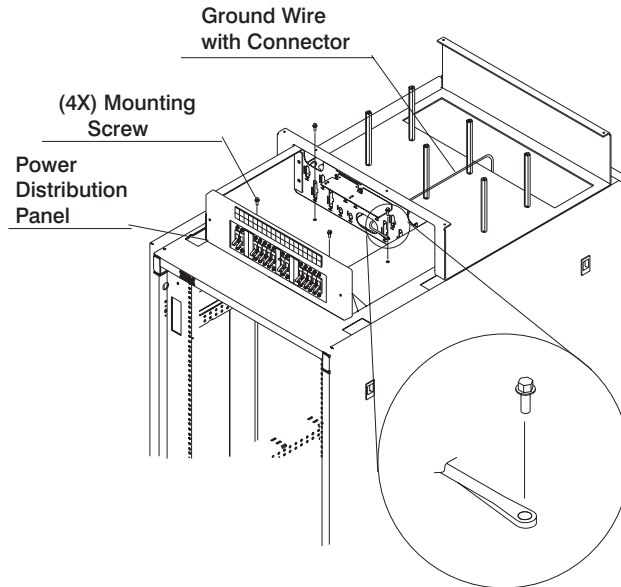

Replacement

This section covers the replacement procedures for the dc power distribution panel.

1. If it is not already off, remove the top cover of the dc power distribution panel.
2. Remove the shield.

3. Place the dc power distribution panel in position on the top of the rack, and install the four mounting screws.
4. Route and attach the ground cable and the drawer power cables to the drawers and the ground bus bar.
5. Ensure that all circuit breakers are set to off.
6. Be sure that the customer's dc power source is turned off.
7. Ensure that the customer's service provider properly connects the two -48 V dc power source cables to the -48 V dc bus bars, and the two -48 V dc return ground cables to the -48 V dc return bus bars.

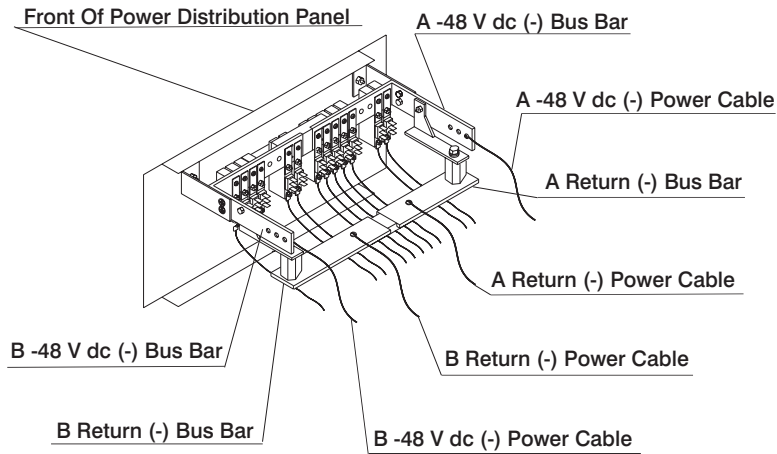

8. Replace the -48 V dc bus bar shield (insulation).
9. Replace the top cover of the dc power distribution panel.

10. Replace the cable channel cover.

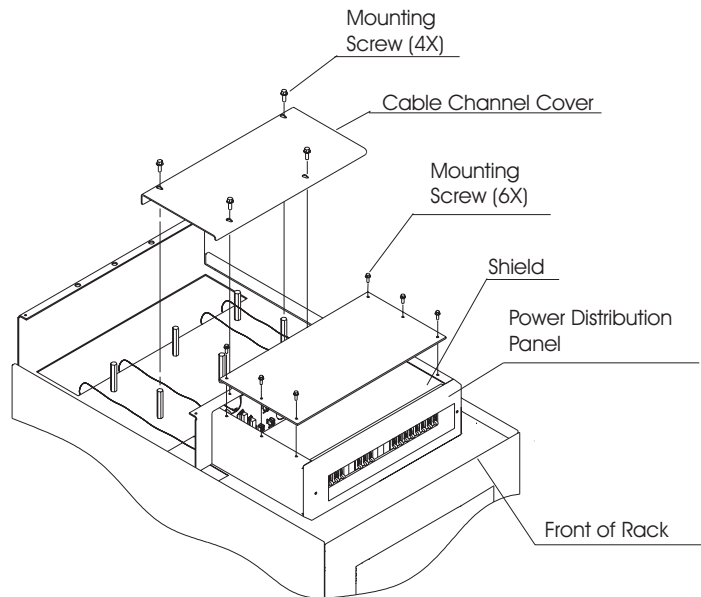

11. Have the customer turn on the -48 V dc power source.

12. Follow the steps in "Power-On Procedure with the DC Power Distribution Panel" on page 78.

Removal and Replacement of the -48 V DC Circuit Breaker

This section covers the removal and replacement procedures for the -48 V dc circuit breaker.

CAUTION:

Energy hazard, remove power before servicing. Disconnect two power supply cords.

Removal

This section covers the removal procedures for the -48 V dc circuit breaker.

1. Follow the steps in the “Power-Off Procedure with the DC Power Distribution Panel” on page 80.
2. Have the customer turn off the dc power source that connects to the dc power distribution panel.
3. After the customer's -48 V dc source power is turned off, ensure that a tag or label is positioned over the switches to indicate that the power is intended to be off (lock-out/tag-out).
4. Remove the six mounting screws from the top cover of the power distribution panel, and then remove the top cover.
5. Remove the -48 V dc bus shield (insulation).
6. Remove the bezel from the front of the dc power distribution panel.

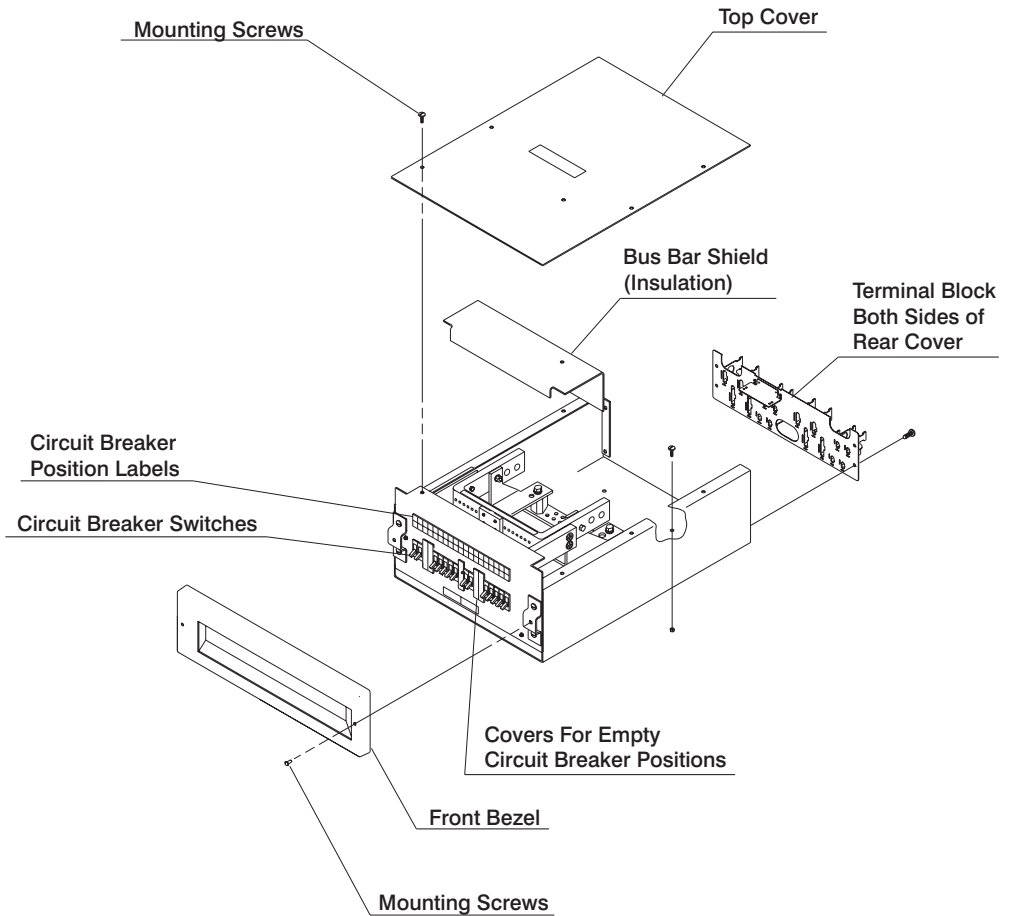

7. Using a multimeter, verify that no voltage exists between the -48 V dc bus bars and the -48 V dc return bus bars, A and B sides.
8. Record the locations of all cables or wires connected to the three connector pins on the circuit breaker being removed. Disconnect the wires from the three connector pins and the -48 V dc power connector.
9. Disconnect the wire that is attached to the bottom of the circuit breaker.
10. Disconnect the mounting nut that attaches the rear of the circuit breaker to the dc power bus bar.

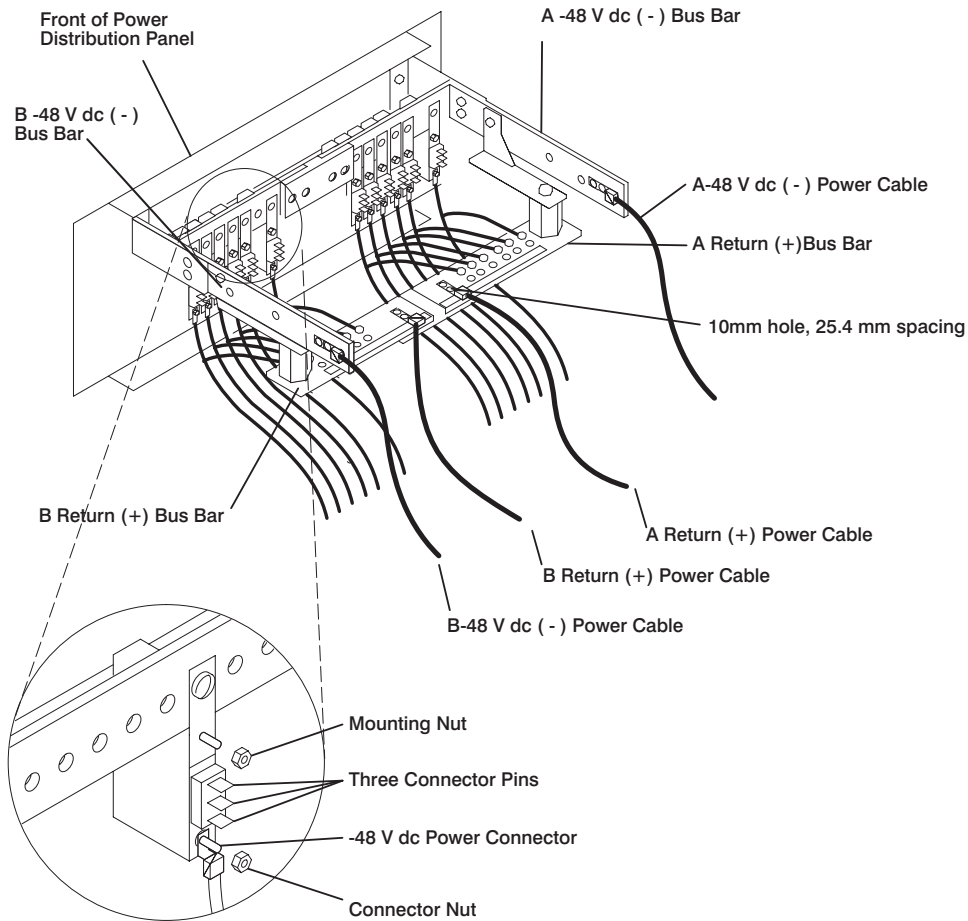

11. Remove the two mounting screws holding the circuit breaker to the panel. Then remove the circuit breaker from the inside of the panel.

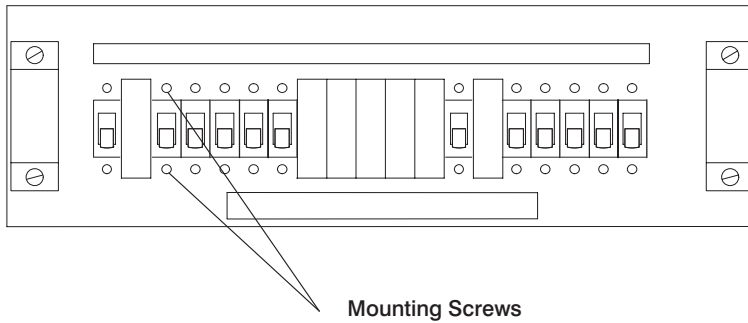

Front View of Power Distribution Panel
(Without Bezel)

Replacement

This section covers the replacement procedures for the -48 V dc circuit breaker.

1. Mount the circuit breaker to the front of the dc power distribution panel using the two mounting screws.
2. Fasten the rear of the circuit breaker to the dc power distribution panel with the mounting nut.
3. Connect the -48 V dc cable to the circuit breaker using the cable connector nut.
4. Connect the three wires to the three connector pins on the rear of the circuit breaker.
5. Be sure all circuit breakers are set to on.
6. Replace the front bezel of the dc power distribution panel.
7. Replace the -48 V dc bus bar shield (insulation).
8. Replace the top cover of the dc power distribution panel.
9. Have the customer restore power to the dc power distribution panel.
10. Follow the steps in "Power-On Procedure with the DC Power Distribution Panel" on page 78.

Removal and Replacement of the Front or Rear Door

It is possible that inspection or service procedures for certain drawers might require removing the front or rear door for better access. If this is necessary, follow these instructions.

Removal

This section covers the removal procedures for the front or rear door.

1. Open the door of the rack.
2. Remove the door by lifting it up and out.

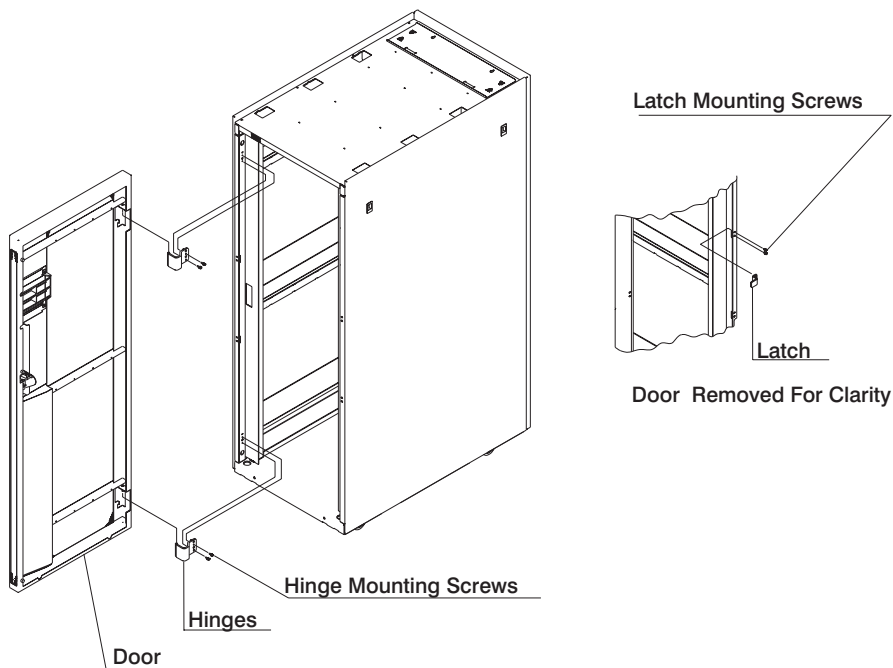

3. If necessary, remove the hinge bracket by removing the mounting screws that attach the bracket to the rack.
4. If necessary, also remove the latch plate by removing the mounting screws that attach the plate to the rack.

Replacement

This section covers the replacement procedures for the front or rear door.

1. Install the hinges on the rack by positioning them on the rack and inserting and securely tightening the screws.
2. Install the latch plate.
3. Install the bottom hinge pin on the door. The bottom hinge pin is the longest of the two hinge pins on the door.
4. Install the top hinge pin on the door. The top hinge pin is the shortest of the two hinge pins on the door.
5. Position the door at the rack with the hinge pin ends slightly above and adjacent to the hinges on the rack. Lower the door so the hinge pins slide into the hinges.
6. Close the door on the rack.

Relocating Rack(s)

To relocate a rack refer to step-by-step instructions described in “Step 13. Relocating Rack(s)” on page 35.

Chapter 5. Parts Information

This chapter contains detailed drawings, field replaceable unit (FRU) part numbers, and part descriptions for a 7014 Series Model T00 and T42 rack.

Covers

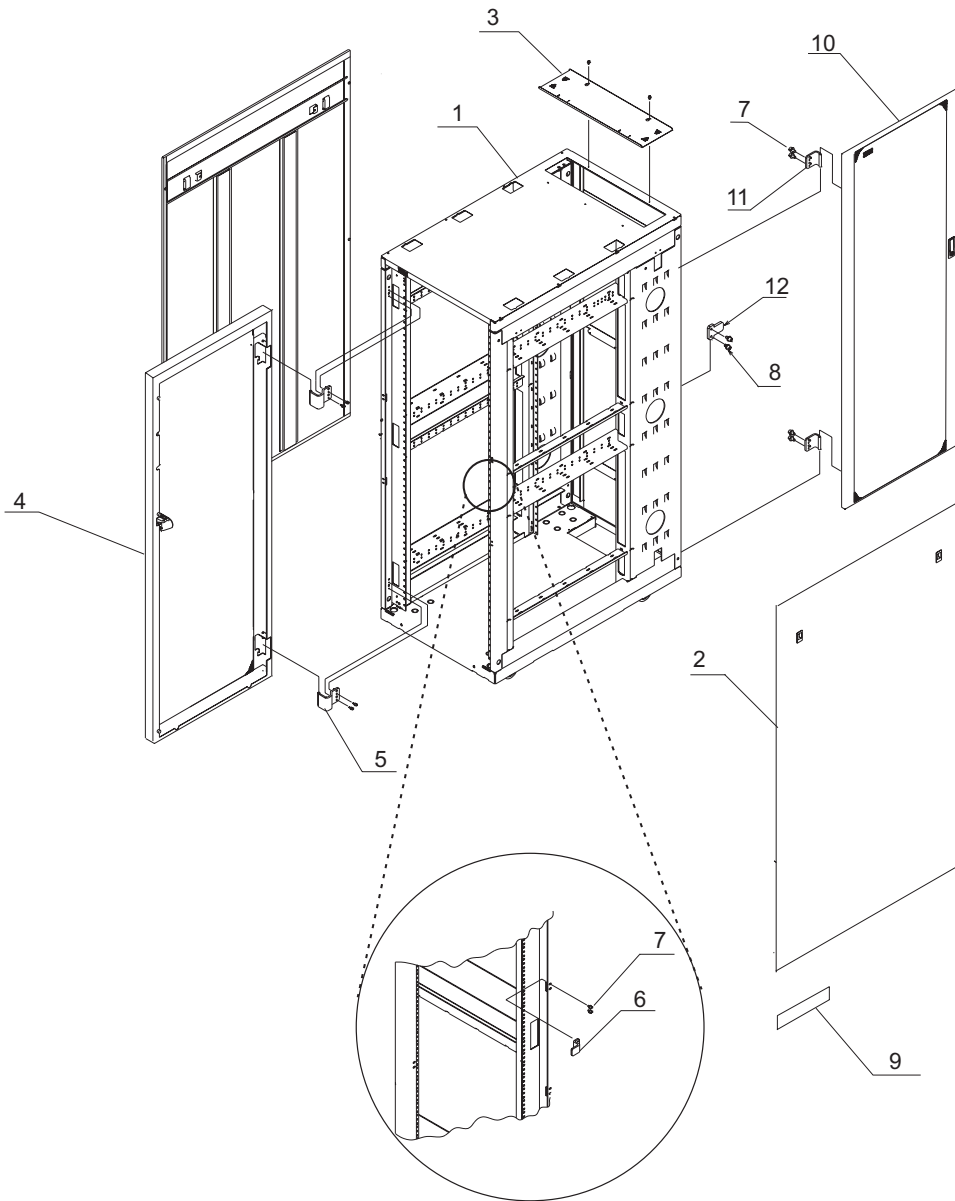

Frames, Side Panels, and Top Cover

Index Number	FRU Part Number	Units Per Assembly	Description
1	05N4868	1	Frame (T00, black, 1.8 m)
	05N4867	1	Frame (T00, white, 1.8 m)
	11P0313	1	Frame (T42, black, 2.0 m)
	11P0314	1	Frame (T42, white, 2.0 m)
2	05N6478	2	Side panel (T00 & T42, black)
	05N6477	2	Side panel (T00 & T42, white)
3	21L4290	1	Top cover (T00 & T42, white, T42 cable access)
9	51H9502	11	Velcro fastener

Front Door

Index Number	FRU Part Number	Units Per Assembly	Description
Note: See Table A for Mounting Hardware			
4	05N4863	1	T00, RS/6000, black (55 mm)
	11P0319	1	T42, RS/6000, black (55 mm)
	12K0456	1	T00, white (35 mm)
	11P0318	1	T42, white (35 mm)
	32P1029	1	T00, Optional front door for 1.8M racks, black
	45P1429	1	T42, Optional front door for 2M racks, black
Note: See Table B for Mounting Hardware			
	21P4049	1	T00, pSeries (100 mm)
	21P4729	1	T42, pSeries (100 mm)

Table A. Mounting Hardware for RS/6000 Front Door

Index Number	FRU Part Number	Units Per Assembly	Description
5	31L7547	2	Hinge (55 mm)
	05N4865	2	Hinge (35 mm)
6	31L7545	1	Latch plate (55 mm)
	05N4866	1	Latch plate (35 mm)
7	31L8594	4	Screw
8	31L7540	2	Screw

Table B. Mounting Hardware for pSeries Front Door

Index Number	FRU Part Number	Units Per Assembly	Description
5	21P4042	2	Hinge (100 mm)
6	21P4043	1	Latch plate (100 mm)
7	31L8594	4	Screw
8	31L7540	2	Screw

Rear Door

Index Number	FRU Part Number	Units Per Assembly	Description
Note: See Table C for Mounting Hardware			
10	11P0725	1	T00, with foam, round, white (20 mm)
	11P0723	1	T42, with foam, round, white (20 mm)
	21P4468	1	T00, with foam, hex, black (20 mm)
	21P4467	1	T42, with foam, hex, black (20 mm)

Table C. Mounting Hardware for Rear Door

Index Number	FRU Part Number	Units Per Assembly	Description
7	31L8594	4	Screw
8	31L7540	2	Screw
11	31L7533	2	Hinge (20 mm)
12	31L7531	1	Latch plate (20 mm)

Earthquake Brace

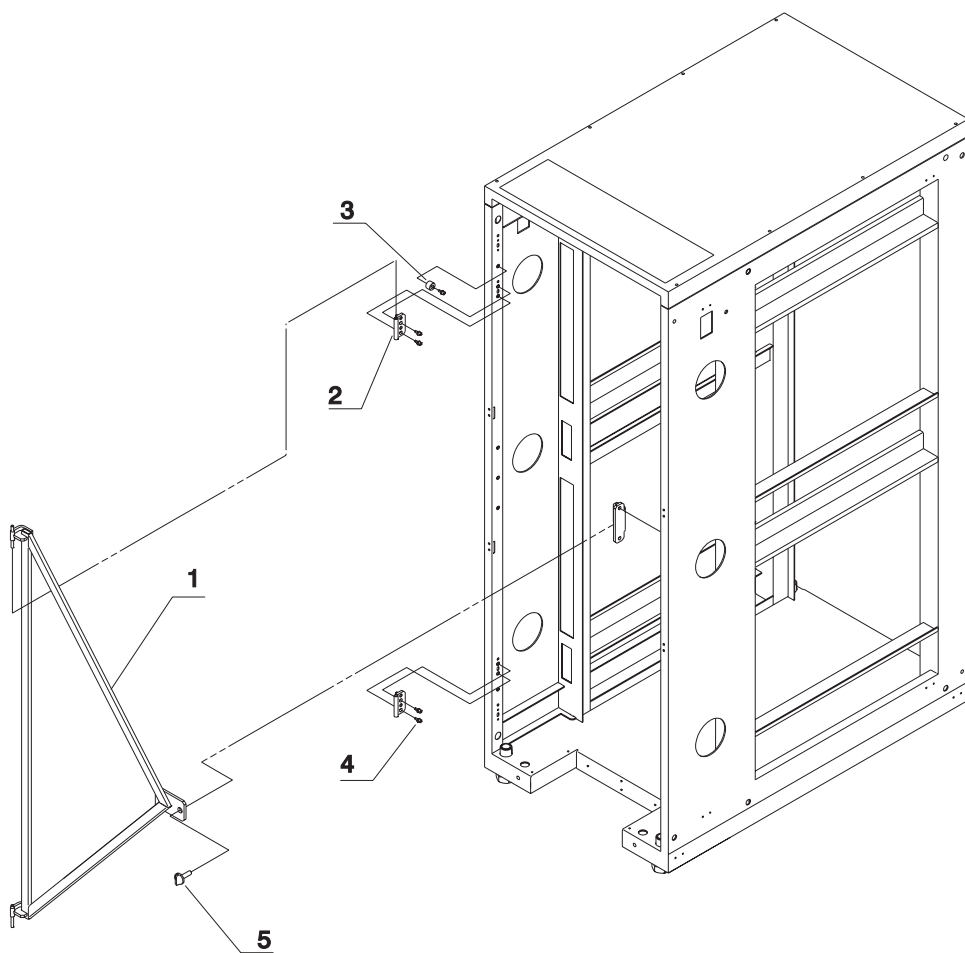

Index Number	FRU Part Number	Units Per Assembly	Description
1	05N4697	1	Earthquake brace kit
2	*	2	Hinge
3	*	1	Spacer
4	*	7	Screw
5	76X4687	1	Bolt

* Shown for reference only.

Blank Fillers

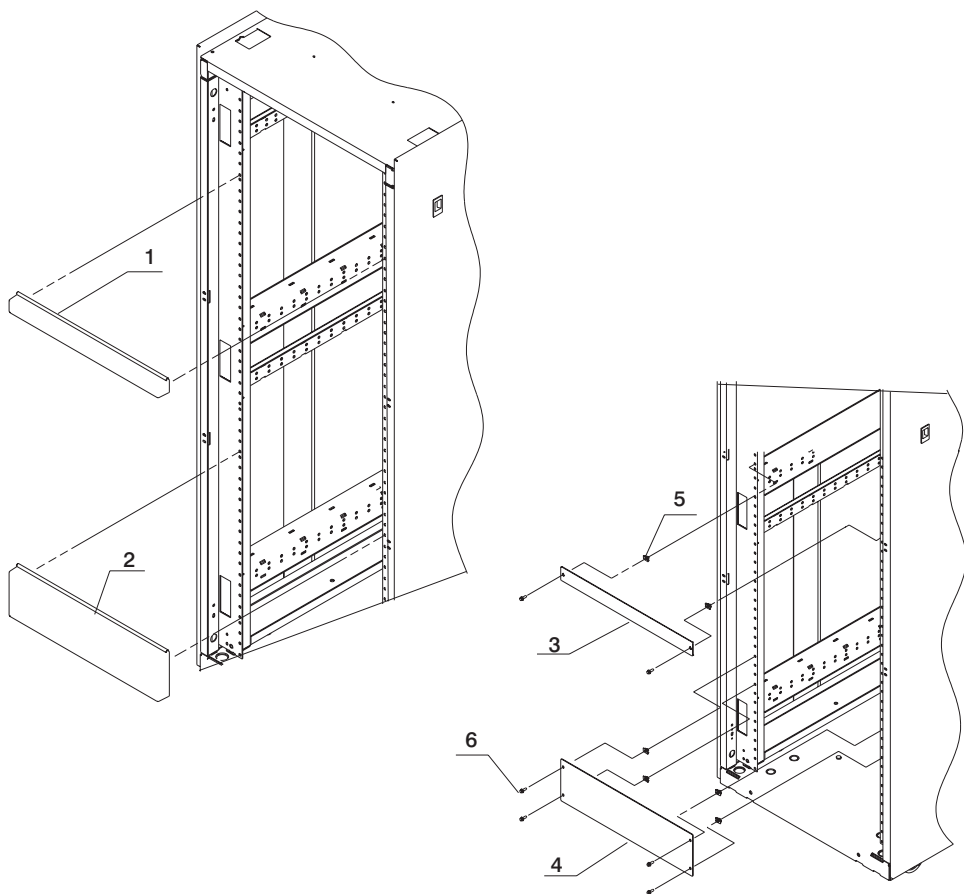

Index Number	FRU Part Number	Units Per Assembly	Description
1	97H9754	As needed	1U Filler snap (black)
	62X3443	As needed	1U Filler snap (white)
2	97H9755	As Needed	3U Filler snap (black)
	62X3444	As Needed	3U Filler snap (white)
3	12J4072	As Needed	1U Filler screw (black)
4	12J4073	As Needed	3U Filler screw (black)
5	74F1823	2/Item3	M5 Nut clip
	74F1823	4/Item4	M5 Nut clip
6	1624779	2/Item3	M5 X 14 Hex flange
	1624779	4/Item4	M5 X 14 Hex flange

Power Distribution Bus

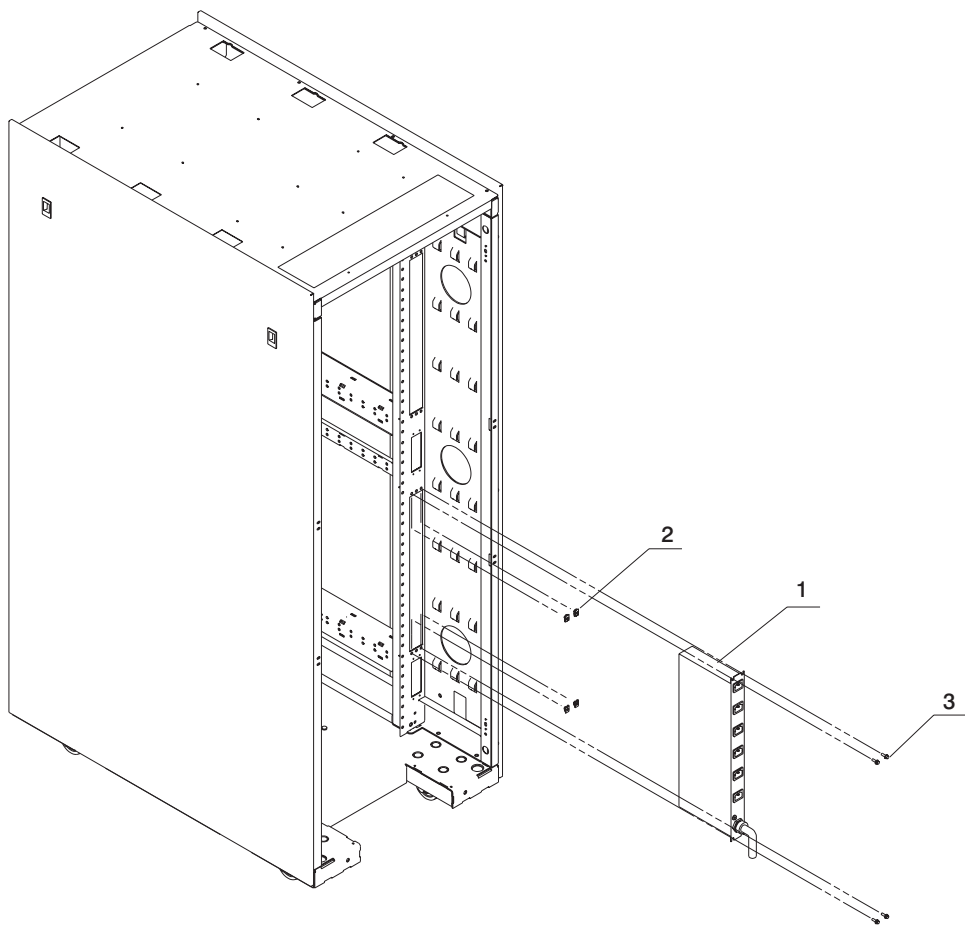

Index Number	FRU Part Number	Units Per Assembly	Description
1	00P2200	1	Power distribution panel (1 phase U.S.)
	00P2201	1	Power distribution panel (2/3 phase)
	00P2202	1	Power distribution panel (3 phase)
	00P2203	1	Power distribution panel (1 Phase World Trade)
2	1624779	4	Nut clip
3	74F1823	4	Screw

Stabilizers

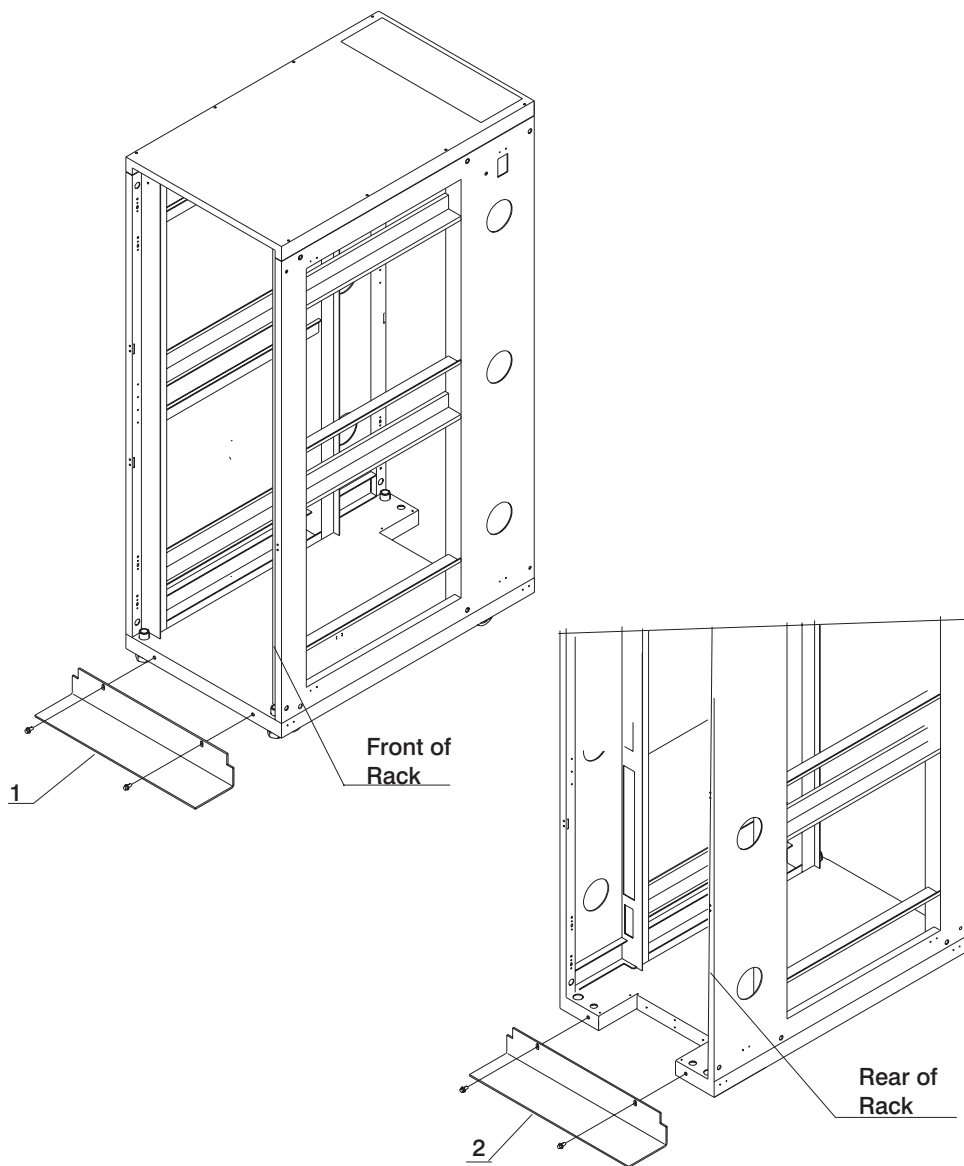

Index Number	FRU Part Number	Units Per Assembly	Description
1	31L8305	1	Front stablizer kit (black)
1	31L8306	1	Front stabilizer kit (white)
2	44P1850	1	Rear stabilizer kit (black)
2	44P1851	1	Rear stabilizer kit (white)
*	28L0558	4	Screw, M8X25 button head

* Shown for reference only. Screws are included in the stabilizer kits.

Power Distribution Panel Assembly

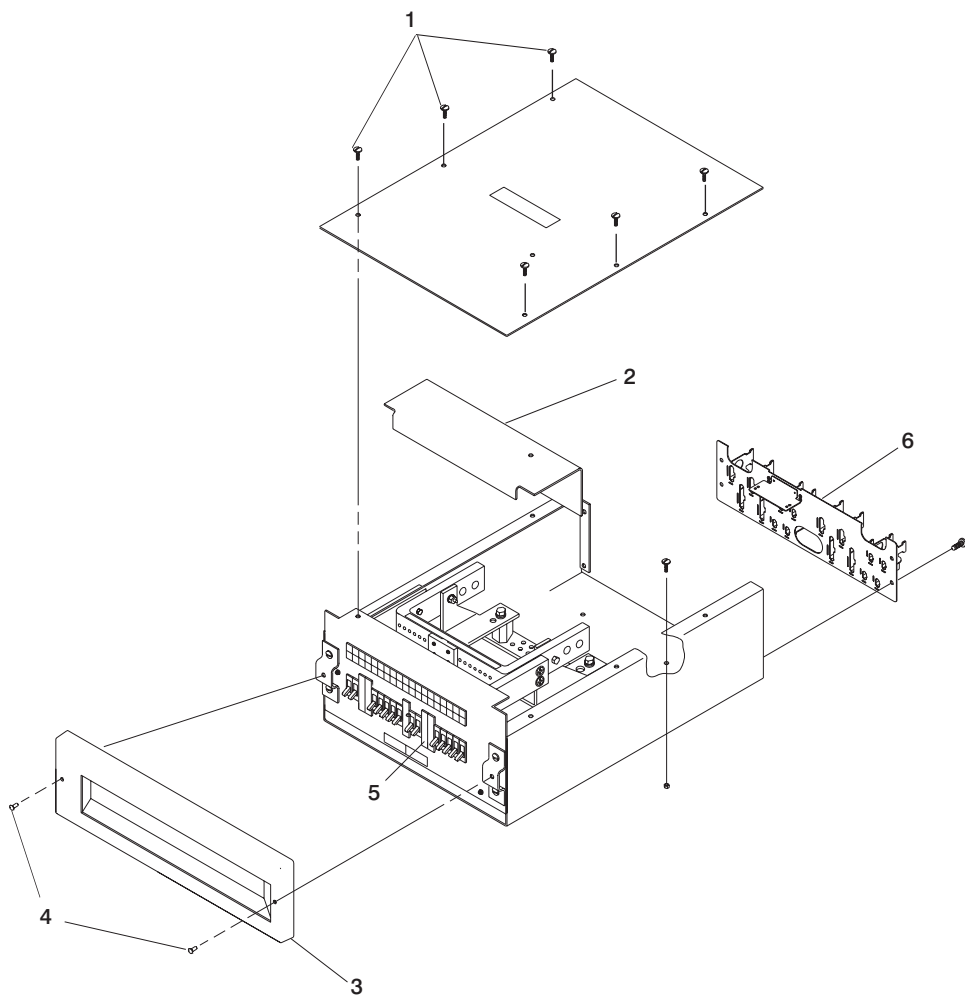

Index Number	FRU Part Number	Units Per Assembly	Description
1	1621191	6	Screw, M4 x 10
2	*	1	Bus bar shield
3	*	1	Front bezel
4	93H4919	2	Screws, 10-32 button head
5	*	varies	Filler plate for empty circuit breaker positions
6		1	I/O Panel

* Shown for reference only.

Power Distribution Panel Interior

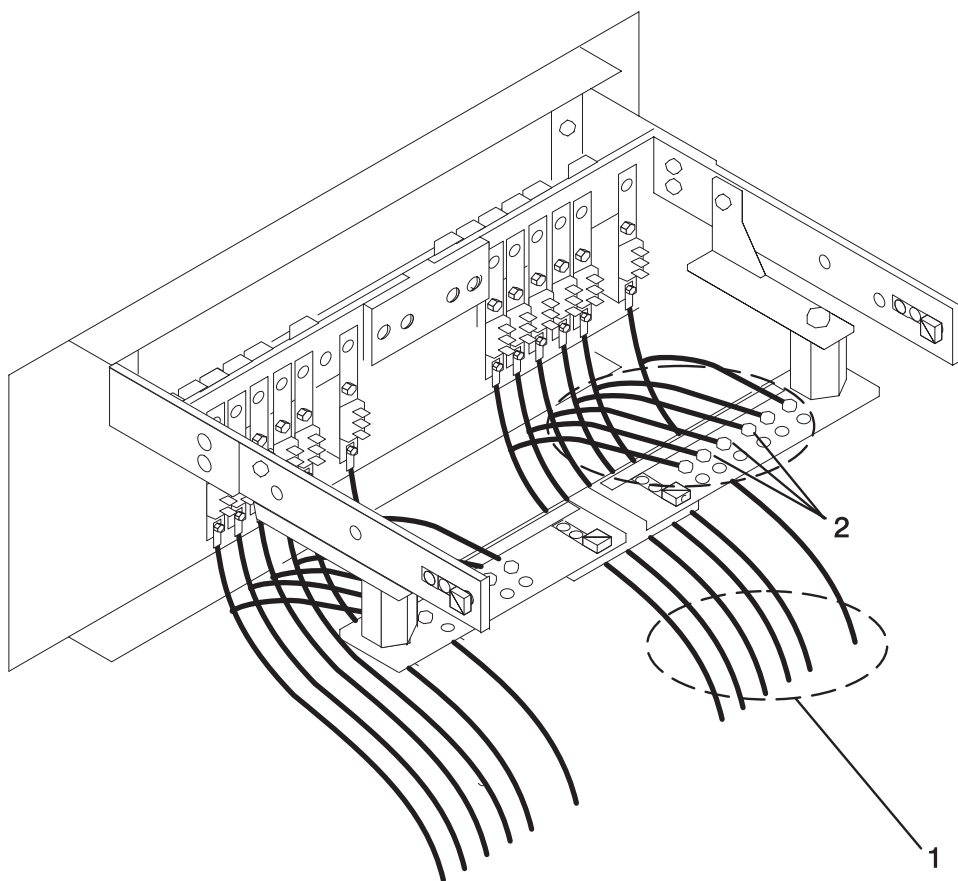

Index Number	FRU Part Number	Units Per Assembly	Description
1	93H8497	varies	15 Amp cable
	00P1793	varies	20 Amp cable
	11K0402	varies	30 Amp cable
	11K0401	varies	50 Amp cable
2	4386130	varies	Cable

Leveling Feet

:

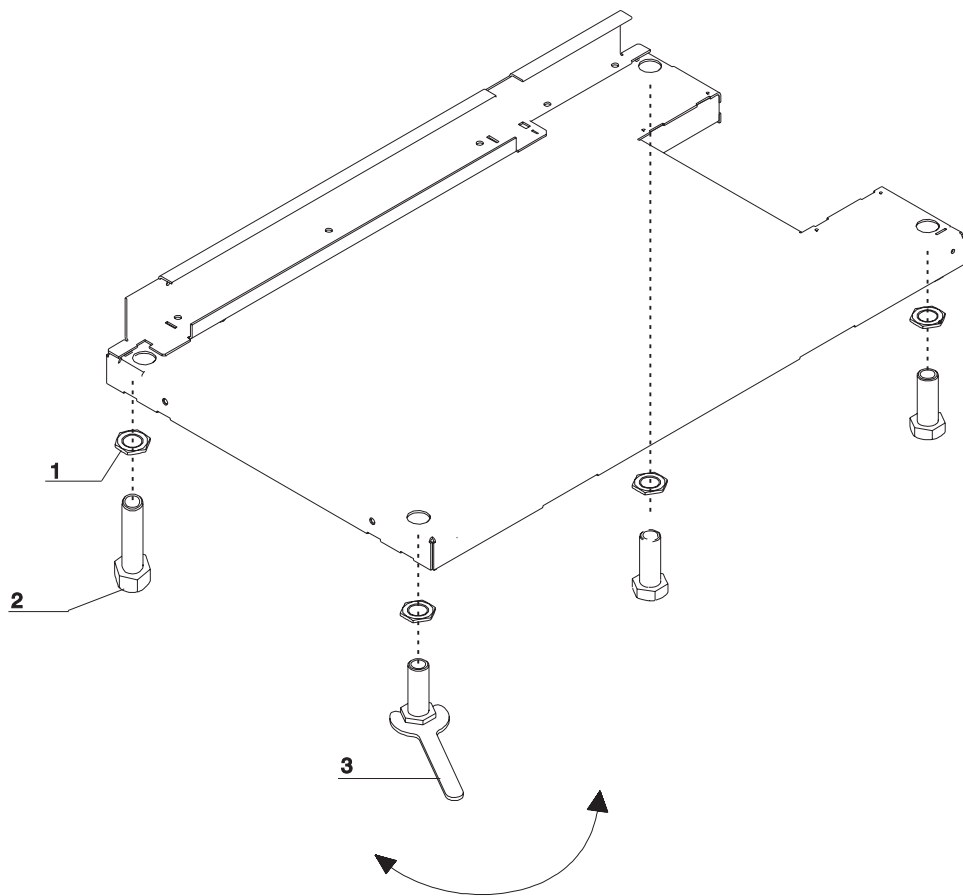

Index Number	FRU Part Number	Units Per Assembly	Description
1	*	4	Jam nut
2	*	4	Leveler
3	31L8313	1	Wrench

* Shown for reference only.

Model T42 Brace

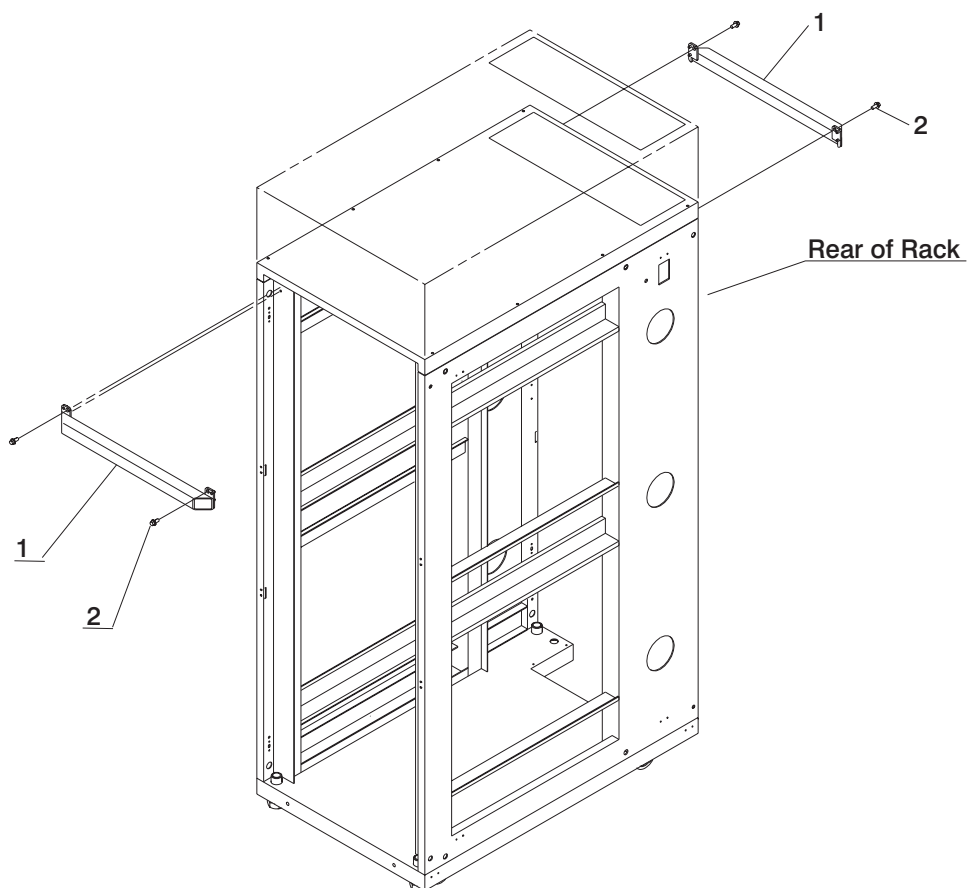

Index Number	FRU Part Number	Description
1	21L4273	Brace
2	*	Bolt

* Shown for reference only.

Model T00 and T42 Kits (For Reference Only)

Index Number	FRU Part Number	Units Per Assembly	Description
1	05N4696	2	AC plate assembly (black)
1	05N4695	2	AC plate assembly (white)
3	31L8301	1	Bolt down
4	05N6800	1	Trim decorative (black T00 only)
5	11P0488	1	Trim decorative (white T00 only)
6	11P0463	1	Trim decorative (black T42 only)
7	11P0489	1	Trim decorative (white T42 only)
8	31L8305	2	Stabilizer (black)
9	31L8306	2	Stabilizer (white)
10	05N4697	1	Earthquake brace
11	31L8302	1	Attachment (black T00 only)
12	05N4658	1	Attachment (white T00 only)
13	11P0423	1	Attachment (white T42 only)
14	11P0424	1	Attachment (white only)
15	03N3281	1	Top cable tray (white)
16	03N3726	1	Top cable tray (end cover)
17	11K0928	1	Rack ground kit

Power Cords

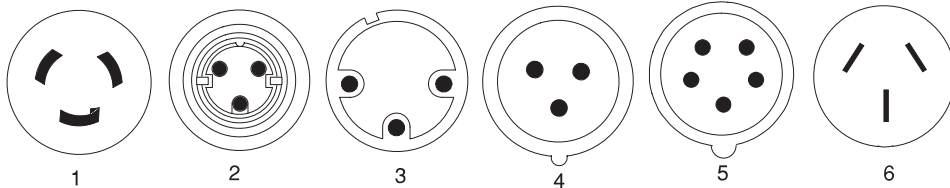

Index Number	FRU Part Number	Units Per Assembly	Country or Region
1	11F0113	1	U.S. Standard, type 12 plug, L6-30P twist-lock connector, 14' cord 30 A, single phase U.S.A., Canada Anguilla, Antigua, Cape Verde Islands, Cayman Islands, French Polynesia, Honduras, Montserrat, St. Kitts & Nevis, Tortola
1	11F0114	1	U.S., Chicago, type 12 plug, L6-30P twist-lock connector, 6' cord 30 A, single phase Chicago, Illinois, U.S.A.
1	11F0115	1	AFE, type 12 plug, L6-30P twist-lock connector, 14' cord 30 A, single phase Afghanistan, Argentina, Aruba, Bahamas, Bangladesh, Barbados, Belize, Bermuda, Bolivia, Bonaire, Brunei, Caicos Islands, Chile, China (Hong Kong S.A.R.), Colombia, Costa Rica, Curaçao, Dominican Republic, Ecuador, El Salvador, Guatemala, Indonesia, Jamaica, Japan, Malaysia, Mexico, Myanmar, Netherlands Antilles, Nicaragua, Panama, Paraguay, Peoples Republic of China, Peru, Philippines, St. Martin, Singapore, Sri Lanka, Suriname, Taiwan, Thailand, Trinidad/Tobago, Turks Island, Uruguay, Venezuela
2	46F4594	1	3 pin waterproof connector, 14' cord Type 40 plug, R&S 3750 30 A, single phase U.S.A., Canada (weatherproof)

Index Number	FRU Part Number	Units Per Assembly	Country or Region
2	46F4593	1	3-pin waterproof connector, 6' cord Type 40 plug, R&S 3750 30 A, single phase Chicago, Illinois, U.S.A.
3	11F0106	1	30 A, single phase, PDL connector Wilco WP, type PDL plug, 14' cord Australia
3	11F0107	1	30 A, single phase, PDL connector Wilco WP, type PDL plug, right angle, 14' cord New Zealand
4	21H7693	1	32 A, single phase, three pin connector IEC 309, type 46 connector (2 power + ground), 14' cord Abu Dubai, Albania, Algeria, Angola, Armenia, Bahrain, Belarus, Belgium, Benin, Bosnia, Botswana, Brazil, Bulgaria, Burkina Faso, Burundi, Cambodia, Cameroon, China (Macau S.A.R), Congo, Croatia, Cyprus, Djibouti, Dominica, Egypt, Equitorial Guinea, Ethiopia, France, French Guiana, Gabon, Gambia, Georgia, Germany, Ghana, Greece, Grenada, Grenadines, Guinea, Guinea-Bissau, Guyana, Haiti, Hungary, Iceland, India, Iran, Iraq, Ireland, Italy, Ivory Coast, Jordan, Kazakhstan, Kenya, Kirhizia, Kuwait, Lesotho, Lebanon, Liberia, Libya, Luxembourg, Macedonia, Malawi, Mali, Malta, Martinique, Mauritania, Moldova, Monaco, Morocco, Mozambique, Namibia, Nepal, Netherlands, New Caledonia, Niger, Nigeria, North Yemen, Oman, Pakistan, Poland, Principe, Qatar, Reunion, Romania, Rwanda, St. Lucia, St. Vincent, Sao Thome Island, Saudi Arabia, Senegal, Serbia, Sierra Leone, Slovakia, Slovenia, Somalia, South Yemen, Spain, Sudan, Swaziland, Syria, Tanzania, Togo, Tunisia, Uganda, Ukraine, United Arab Emirates, United Kingdom, Vietnam, Western Samoa, Zaire, Zambia, Zimbabwe

Index Number	FRU Part Number	Units Per Assembly	Country or Region
5	88G4763	1	32 A, 2 of 3 phase, five pin connector IEC 309, type 46 connector (3 power + neutral + ground), 14' cord Austria, Czech Republic, Denmark, Estonia, Finland, Israel, Latvia, Liechtenstein, Lithuania, Netherlands, Norway, Pakistan, Portugal, Russia, South Africa, Sweden, Turkey
5	88G4764	1	16 A, 3 phase, five pin connector IEC 309, type 46 connector (3 power + neutral + ground), 14' cord Switzerland
6	87G6067	1	30 A, Single Phase Type KP connector, right angle, 14' cord Korea

Appendix A. Environmental Notices

Product Recycling and Disposal

This unit contains materials such as circuit boards and connectors with lead that require special handling and disposal at end of life. Before this unit is disposed of, these materials must be removed and recycled or discarded according to applicable regulations. This manual contains specific information on batteries where applicable. This product may contain nickel-cadmium and/or lithium batteries. The battery(s) must be recycled or disposed of properly. Recycling facilities may not be available in your area. In the United States, IBM has established a collection process for reuse, recycling, or proper disposal of used sealed lead acid, nickel cadmium and nickel metal hydride batteries and battery packs from IBM equipment. For information on proper disposal of the nickel cadmium batteries in this product, please contact IBM at 1-800-426-4333. For information on battery disposal outside the United States, contact your local waste disposal facility.

Environmental Design

The environmental efforts that have gone into the design of this system signify IBM's commitment to improve the quality of its products and processes. Some of these accomplishments include the elimination of the use of Class I ozone-depleting chemicals in the manufacturing process and reductions in manufacturing wastes. For more information, contact an IBM account representative.

Unit Emissions

The unit-related emission value is equal to or lower than 70dB(A).

Der Geräuschpegel der Einheit ist kleiner oder gleich 70 db(A).

Appendix B. Notices

This information was developed for products and services offered in the U.S.A.

The manufacturer may not offer the products, services, or features discussed in this document in other countries. Consult the manufacturer's representative for information on the products and services currently available in your area. Any reference to the manufacturer's product, program, or service is not intended to state or imply that only that product, program, or service may be used. Any functionally equivalent product, program, or service that does not infringe any intellectual property right of the manufacturer may be used instead. However, it is the user's responsibility to evaluate and verify the operation of any product, program, or service.

The manufacturer may have patents or pending patent applications covering subject matter described in this document. The furnishing of this document does not give you any license to these patents. You can send license inquiries, in writing, to the manufacturer.

The following paragraph does not apply to the United Kingdom or any country where such provisions are inconsistent with local law: THIS MANUAL IS PROVIDED "AS IS" WITHOUT WARRANTY OF ANY KIND, EITHER EXPRESSED OR IMPLIED, INCLUDING, BUT NOT LIMITED TO, THE IMPLIED WARRANTIES OF NON-INFRINGEMENT, MERCHANTABILITY OR FITNESS FOR A PARTICULAR PURPOSE. Some states do not allow disclaimer of express or implied warranties in certain transactions; therefore, this statement may not apply to you.

This information could include technical inaccuracies or typographical errors. Changes are periodically made to the information herein; these changes will be incorporated in new editions of the publication. The manufacturer may make improvements and/or changes in the product(s) and/or the program(s) described in this publication at any time without notice.

Information concerning products made by other than the manufacturer was obtained from the suppliers of those products, their published announcements or other publicly available sources. The manufacturer has not tested those products and cannot confirm the accuracy of performance, compatibility or any other claims related to products made by other than the manufacturer. Questions on the capabilities of products made by other than the manufacturer should be addressed to the suppliers of those products.

Index

A

- about this book ix
- ac outlet-mounting plates 18, 22
- ac outlets
 - check customer's ac outlets 32
 - mounting plates 18
- ac power cables 46
- ac power distribution
 - bus 42
 - bus illustration 45
 - removal 82
- ac rack information 42
- airflow requirements 53
- attaching
 - ac outlet-mounting plates 18
 - front door 23
 - rack to concrete floor 6, 10
 - stabilizers 5

B

- blank fillers, rack 101
- brace
 - earthquake 99
 - rack 113
- brackets
 - J for side covers 15
 - Z for side covers 15

C

- check customer's ac outlets 32
- circuit breaker
 - 48 V dc circuit breaker 88
- connecting 27
 - drawer and device cables 34
 - power distribution panel 28
 - power distribution system 27

- covers, parts information 96

D

- dc circuit breaker
 - removal 88
 - replacement 91
- dc power distribution
 - distribution and ground illustration 51
 - panel 47
 - removal 83
 - replacement 85
- diagnostic information ix
- doors, front and rear
 - attaching 23
 - front door, parts information 97
 - mounting hardware, front door 97, 98
 - mounting hardware, rear door 98
 - pSeries installation 25
 - rear door, parts information 98
 - RS/6000 installation 23
 - types 23
- drawer and device cables, connecting 34

E

- earthquake brace 99
- electrical safety v, 73
- environmental notices
 - battery 119
 - design 119
 - disposal, recycling 119
 - product disposal 119
 - recycling 119

F

- foam strips, multiple rack 15
- frames, parts information 97
- front door
 - attaching 23
 - mounting hardware 97, 98
 - parts information 97
 - pSeries 25
 - removal 92
 - replacement 93
 - RS/6000 23

G

- ground illustration, dc power distribution 51

I

- inspection 54
- installation
 - ac outlet-mounting plates 22
 - ac outlet-mounting plates with ac outlets 18
 - multiple racks 15
 - power status alarm 30
 - procedures 1
 - pSeries front door 25
 - RS/6000 front door 23
- iso 9000 statement ix

K

- kits, parts information 115

L

- leveling feet, parts information 111
- leveling the rack 4

M

- maintenance analysis procedures (MAPs)
 - ac power distribution bus 67
 - dc power distribution panel MAP 1520 59
- mounting hardware
 - front door 97, 98
 - mounting hardware 98
 - rear door 98

O

- online publications ix
- operating system shutdown 74

P

- parts information
 - blank fillers 101
 - brace 113
 - covers 96
 - earthquake brace 99
 - front door 97, 98
 - leveling feet 111
 - mounting hardware, front door 97, 98
 - mounting hardware, rear door 98
 - mounting hardware, front door 98
 - power cords 116
 - power distribution bus 103
 - power distribution panel
 - assembly 107
 - power distribution panel interior 109
 - rear door 98
 - stabilizers 105
 - T00 and T42 kits 115
- power cables
 - 48 V dc 52
 - high voltage (AC) 46

- power cords, parts information 116
- power distribution
 - dc power distribution panel 49
 - parts information 103
- power distribution bus
 - ac power distribution bus 82
 - ac rack power-on procedure 75
 - description 42
 - maintenance analysis procedures (MAP) 67
 - power requirements 53
 - power-off procedure for the ac rack 77
- power distribution panel
 - connecting 28
 - dc power distribution panel 49, 83
 - dc power distribution panel MAP 59
 - description 47
 - parts information 107
 - power-off procedure for the dc rack 80
 - power-on procedure for the dc rack 78
- power requirements, power distribution bus 53
- power source, uninterruptible 46
- power status alarm installation 30
- power-off procedures
 - ac power distribution bus 77
 - dc power distribution panel 80
- power-on procedures
 - ac power distribution bus 75
 - dc power distribution panel 78
 - powering-on and checking out 35
- preface ix
- publications, online ix

R

- rack
 - ac power-on procedure 75
 - airflow requirements 53
 - blank fillers 101
 - brace 113
 - dc configuration 49
 - dc information 47
 - dc power cables 52
 - dimensions 53
 - frame, parts information 97
 - front door, parts information 97
 - information 42
 - leveling 4
 - leveling feet 111
 - mounting hardware, front door 97, 98
 - mounting hardware, rear door 98
 - parts information 96
 - positioning 3
 - power-off procedure, ac power distribution bus 77
 - power-off procedure, dc power distribution panel 80
 - power-on procedure, dc power distribution panel 78
 - relocate 35, 93
 - side panels, parts information 97
 - specifications 53
 - top cover, parts information 97
 - weight 53
- reference information 41
- related publications ix
- relocate rack 35, 93
- removal and replacement procedures
 - 48 V dc circuit breaker 88
 - ac power distribution bus 82
 - dc power distribution panel 83
 - front or rear door 92
 - safety notices 73

S

safety notices 1, 5, 28, 32, 33, 55, 56,
60, 67, 73, 75, 78, 80, 83, 88
service inspection guide 54
shutdown, operating system 74
side panels, parts information 97
specifications 53
stabilizers
 attaching 5
 parts information 105
system drawer emissions 119
system safety information ix

T

trademarks ix

U

uninterruptible power source
 description 46
unit emissions 119

Reader's Comments — We'd Like to Hear From You

7014 Series Model T00 and T42 Rack Installation and Service Guide

Form Number: SA38-0577-03

Overall how satisfied are you with the information in this book?

	Very Satisfied	Satisfied	Neutral	Dissatisfied	Very Dissatisfied
Overall Satisfaction	<input type="checkbox"/>	<input type="checkbox"/>	<input type="checkbox"/>	<input type="checkbox"/>	<input type="checkbox"/>

How satisfied are you that the information in this book is:

	Very Satisfied	Satisfied	Neutral	Dissatisfied	Very Dissatisfied
Accurate	<input type="checkbox"/>	<input type="checkbox"/>	<input type="checkbox"/>	<input type="checkbox"/>	<input type="checkbox"/>
Complete	<input type="checkbox"/>	<input type="checkbox"/>	<input type="checkbox"/>	<input type="checkbox"/>	<input type="checkbox"/>
Easy to find	<input type="checkbox"/>	<input type="checkbox"/>	<input type="checkbox"/>	<input type="checkbox"/>	<input type="checkbox"/>
Easy to understand	<input type="checkbox"/>	<input type="checkbox"/>	<input type="checkbox"/>	<input type="checkbox"/>	<input type="checkbox"/>
Well organized	<input type="checkbox"/>	<input type="checkbox"/>	<input type="checkbox"/>	<input type="checkbox"/>	<input type="checkbox"/>
Applicable to your tasks	<input type="checkbox"/>	<input type="checkbox"/>	<input type="checkbox"/>	<input type="checkbox"/>	<input type="checkbox"/>

Please tell us how we can improve this book:

Thank you for your response. May we contact you? Yes No

When you send comments to us, you grant us a nonexclusive right to use or distribute your comments in any way we believe appropriate without incurring any obligation to you.

Name

Address

Company or Organization

Phone Number

Cut or Fold
Along Line

Fold and Tape

Please do not Staple

Fold and Tape



NO POSTAGE
NECESSARY
IF MAILED IN THE
UNITED STATES

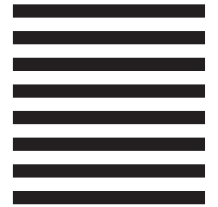

BUSINESS REPLY MAIL

POSTAGE WILL BE PAID BY ADDRESSEE

Information Development
Department H6DS-9561
11400 Burnet Road
Austin, TX 78758-3493



Fold and Tape

Please do not Staple

Fold and Tape

Cut or Fold
Along Line



Part Number: 00P3680



Printed in the United States of America
on recycled paper containing 10%
recovered post-consumer fiber.

SA38-0577-03



00P3680

