

IBM 7785

Hardware Maintenance Reference/Service

SA12-7017-05

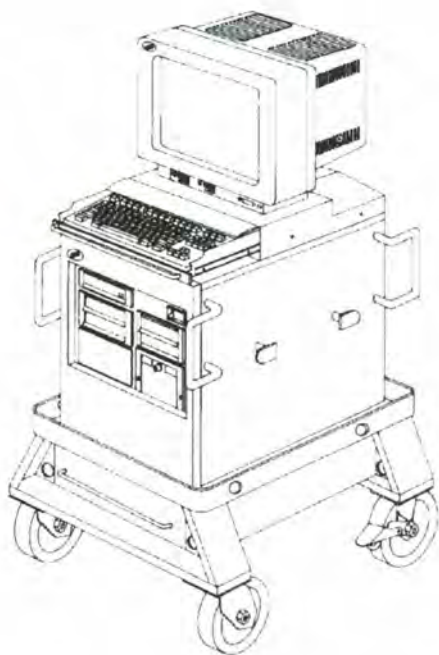

IBM

IBM 7785
Hardware Maintenance
Reference/Service

SA12-7017-05



IBM

Note

Before using this information and the product it supports, be sure to read the general information under Appendix, "Notices" on page 209.

Fifth Edition (April, 1993).

The following paragraph does not apply to the United Kingdom or any country where such provisions are inconsistent with local law: INTERNATIONAL BUSINESS MACHINES CORPORATION PROVIDES THIS PUBLICATION "AS IS" WITHOUT WARRANTY OF ANY KIND, EITHER EXPRESS OR IMPLIED, INCLUDING, BUT NOT LIMITED TO, THE IMPLIED WARRANTIES OF MERCHANTABILITY OR FITNESS FOR A PARTICULAR PURPOSE. Some states do not allow disclaimer of express or implied warranties in certain transactions, therefore, this statement may not apply to you.

This publication could include technical inaccuracies or typographical errors. Changes are periodically made to the information herein; these changes will be incorporated in new editions of the publication. IBM may make improvements and/or changes in the product(s) and/or the program(s) described in this publication at any time.

It is possible that this publication may contain reference to, or information about, IBM products (machines and programs), programming, or services that are not announced in your country. Such references or information must not be construed to mean that IBM intends to announce such IBM products, programming, or services in your country.

Requests for technical information about IBM products should be made to your IBM Authorized Dealer or your IBM Marketing Representative.

Copyright International Business Machines Corporation 1990, 1991, 1992, 1993. All rights reserved.

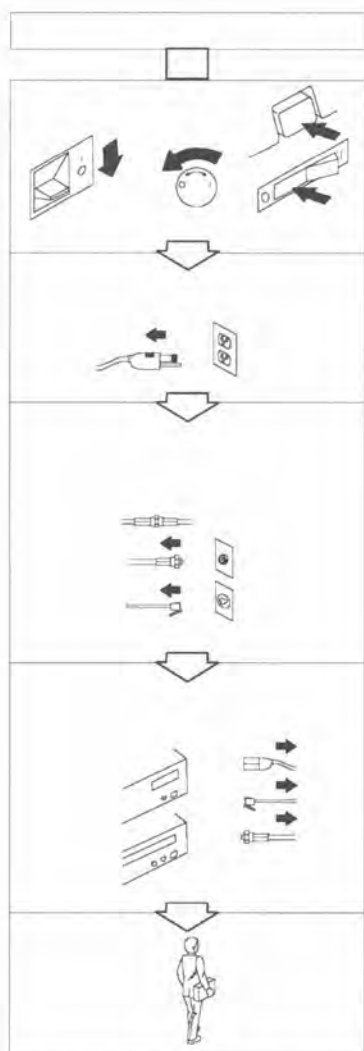
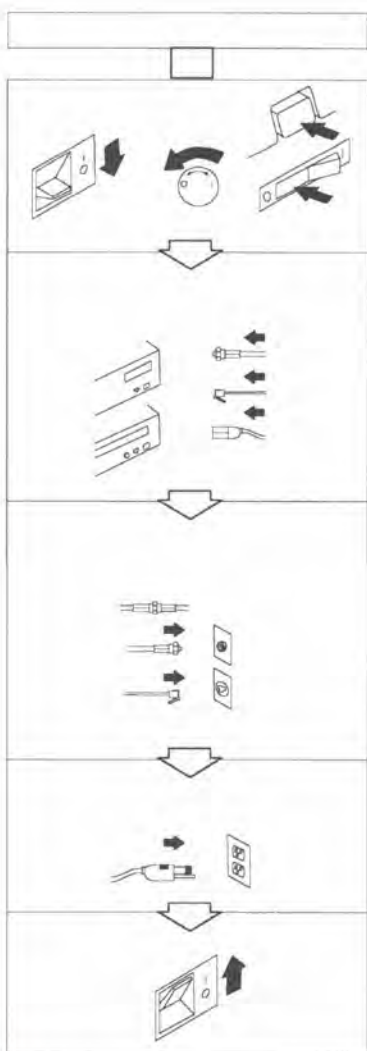

General Safety during Work

Use these rules to ensure general safety:

- Observe good housekeeping in the area of the machines during maintenance and after completing work.
- When lifting any heavy object:
 1. Ensure that you can stand safely without slipping.
 2. Distribute the weight of the object equally between your feet.
 3. Use a slow lifting force. Never move suddenly or twist when you attempt to lift.
 4. Lift by standing or by pushing up with your leg muscles; this action removes the strain from the muscles in your back. *Do not attempt to lift any objects that you think are too heavy for you.*
- Do not perform any action that causes hazards to the customer or that makes the equipment unsafe.
- Before you start the machine, ensure that other service representatives and the customer's personnel are not in a hazardous position.
- Put removed covers and other parts in a safe place, away from all personnel, while you are servicing the machine.
- Keep your tool case away from walk areas so that other people will not trip over it; for example, put it under a desk or table.
- Do not wear loose clothing that can be trapped in the moving parts of a machine. Ensure that your sleeves are fastened or rolled up above your elbows. If your hair is long, fasten it.
- Insert the ends of your necktie or scarf inside other clothing or fasten the necktie with a clip, preferably nonconductive, approximately 8 centimeters (3 inches) from the end.
- Do not wear jewelry, chains, metal-frame eyeglasses, or metal fasteners for your clothing.

Remember: A metal object lets more current flow if you touch a live conductor.

- Wear safety glasses when you are:
 - Using a hammer to drive pins or similar parts.
 - Drilling with a power, hand drill.
 - Using spring hooks or attaching springs.
 - Soldering parts.
 - Cutting wire or removing steel bands.
 - Cleaning parts with solvents, chemicals, or cleaning fluids.
 - Working in any other conditions that might be hazardous to your eyes.

- After maintenance, reinstall all safety devices such as shields, guards, labels, and ground wires. Exchange any safety device that is worn or defective for a new one.

Remember: Safety devices protect personnel from hazards. You destroy the purpose of the devices if you do not reinstall them before completing your service call.

- Reinstall all covers correctly before returning the machine to the customer.

Safety with Electricity

Observe these additional rules when working on equipment powered by electricity:

- Find the room Emergency Power-Off (EPO) switch or disconnecting switch. If an electrical accident occurs, you can then operate the switch quickly.
- Do not work alone under hazardous conditions or near equipment that has hazardous voltages.
- Disconnect all power:
 - Before removing or installing main units.
 - Before working near power supplies.
 - Before doing a mechanical inspection of power supplies.
 - Before installing changes in machine circuits.
- Before you start to work on the machine, unplug the power cable. If you cannot unplug the cable easily, ask the customer to

switch off the wall box that supplies power to the machine and to lock the wall box in the off position.

- If you need to work on a machine that has *exposed* electrical circuits, observe the following precautions:
 - Ensure that another person, who is familiar with the power-off controls, is near you.

Remember: Another person must be there to switch off the power, if necessary.

CAUTION:

Some hand tools have handles covered with a soft material that does not insulate you when working with live electrical currents. Use only tools and testers that are suitable for the job you are doing.

Attention !

Les manches de certains outils sont recouverts d'un matériau souple qui n'assure pas l'isolation lorsque vous travaillez sur des circuits électriques actifs. Utilisez uniquement les outils et les appareils de contrôle adaptés à la tâche que vous exécutez.

- Use only one hand when working with powered-on electrical equipment; keep the other hand in your pocket or behind your back.

Remember: There must be a complete circuit to cause electrical shock. By observing the above rule, you may prevent a current from passing through your body.

- When using testers, set the controls correctly and use the approved probe leads and accessories for that tester.

CAUTION:

Many customers have, near their equipment, rubber floor mats that contain small conductive fibers to decrease electrostatic discharges. Do not use this type of mat to protect yourself from electrical shock.

Attention !

Certains clients disposent, au voisinage de leur matériel, des tapis de sol en caoutchouc contenant des fibres

conductrices destinées à réduire les décharges électrostatiques. N'utilisez pas ce type de tapis pour vous protéger contre les risques électriques.

- Stand on suitable rubber mats (obtained locally, if necessary) to insulate you from grounds such as metal floor strips and machine frames.
- Observe the special safety precautions when you work with very high voltages; these instructions are in the safety sections of maintenance information. Use extreme care when measuring high voltages.
- Regularly inspect and maintain your electrical hand tools for safe operational condition.
- Do not use worn or broken tools and testers.
- *Never assume* that power has been disconnected from a circuit. First, *check* that it is powered-off.
- Always look carefully for possible hazards in your work area. Examples of these hazards are moist floors, nongrounded power extension cables, power surges, and missing safety grounds.
- Do not touch live electrical circuits with the reflective surface of a plastic dental mirror. The surface is conductive; such touching can cause personal injury and machine damage.
- Unless the maintenance information specifically lets you, do not service the following parts *with power on them* when they are removed from their normal operating places in a machine:
 - Power supply units
 - Pumps
 - Blowers and fans
 - Motor generators.
- If an electrical accident occurs:
 - **Use caution; do not become a victim yourself.**
 - **Switch off power.**
 - **Send another person to get medical aid.**

Safety Inspection Guide

The intent of this inspection guide is to assist you in identifying potentially unsafe conditions on these products. Each machine, as it was designed and built, had required safety items installed to protect users and service personnel from injury. This guide addresses only those items. However, good judgment should be used to identify potential safety hazards due to attachment of non-IBM features or options not covered by this inspection guide.

If any unsafe conditions are present, a determination must be made on how serious the apparent hazard could be and whether you can continue without first correcting the problem.

Consider these conditions and the safety hazards they present:

- Electrical hazards, especially primary power: primary voltage on the frame can cause serious or fatal electrical shock.
- Explosive hazards, such as a damaged CRT face or bulging capacitor, can cause serious injury.
- Mechanical hazards, such as loose or missing hardware, can cause serious injury.

Related Publications:

- *Hardware Maintenance Reference* manual for the IBM Personal System/2 Model 80.
- Any applicable safety publications.

Checklist:

1. Check exterior covers for damage (loose, broken, or sharp edges).
2. Power-off the system. Disconnect the power cord from the electrical outlet.
3. Check the power cord for:
 - a. A third-wire ground connector in good condition. Use a meter to measure third-wire ground continuity for 0.1 ohm or less between the external ground pin and frame ground.
 - b. The cord set should be the appropriate molded type as specified in the Parts Catalog in this manual.
 - c. Insulation must not be frayed or worn.
4. Remove the cover.
5. Check for any obvious non-IBM alterations. Use good judgment as to the safety of any non-IBM alterations.
6. Check inside the unit for any obvious unsafe conditions, such as metal filings, contamination, water or other liquids, or signs of fire or smoke damage.
7. Check for worn, frayed, or pinched cables.
8. Check that the proper fuse is installed.

CAUTION:

For continued protection against risk of fire, replace only with the same type and rating of fuse (250 V-/3A/FB).

Attention !

Sécurité incendie: Ne remplacer un fusible que par un autre fusible de même type et de même calibre (250 V-/3A/FB).

9. Check that the power supply cover fasteners (screws or rivets) have not been removed or tampered with.
10. Check for the following safety labels:
 - Battery warning (label kit 33F6191)—found on the battery and in the base of the chassis under the battery

- Voltage (part 15F7905)—on the power distribution control box
- FCC (part 33F6207)— on the back of the display and on the back of the system unit under the cover
- Power rating (part 15F7858 for Model 110, 114, and 15F7859 for Model 120)—on the back of the system unit under the cover
- Weight label (label kit 33F6191)—on the back of the system unit under the cover
- Arc and Spark (label kit 33F6191)— on the back of the system unit under the cover
- Danger label on the power supply.

About This Book

The Hardware Maintenance Library for the Service Bay System (SBS) consists of two diagnostic tools: a two-part manual and a diskette.

The first part of the manual, labeled *Hardware Maintenance Reference*, contains:

- "SECTION 1. General Information," which contains the product description, theory of operation, and environmental specifications.
- "SECTION 2. Introduction to Diagnostics," which explains the diagnostic aids.
- "SECTION 3. Removal/Replacement Procedures" which gives the location of the various components and the information needed to remove and replace any of the Field-Replaceable Units (FRUs).

The second part of the manual, labeled *Hardware Maintenance Service*, contains:

- "SECTION 4. Start," the entry point for the diagnostic tests of the SBS.
- "SECTION 5. Diagnostic MAPs," which gives step-by-step instructions to isolate the failing FRU.
- "SECTION 6. Parts Catalog," which contains illustrations and part numbers of FRUs.

A part-number index and an alphabetic index also are provided.

The *reference diskette* is self-explanatory. Help screens are available by pressing the **F1** key. The *reference diskette* is used with the MAPs to:

- Test each area of the Service Bay System
- Isolate problems to a specific FRU using error codes
- Verify correct installation and operation of the system.

Options might require supplements to this manual.

Contents

General Safety during Work	iv
Safety with Electricity	v
Safety Inspection Guide	viii

About This Book	xi
------------------------	-----------

Hardware Maintenance Reference	1
---------------------------------------	----------

SECTION 1. General Information	3
---------------------------------------	----------

General Description	4
Models	5
Microprocessor	5
2MB RAM	5
CMOS RAM	6
ROM BIOS	6
Serial Port	6
Parallel Port	7
Diskette Drive Controller	7
Keyboard Connector and Pointing Device Connector	7
Power Distribution Control Box	8
Display	9
CD-ROM Drive	11
Internal 2400-Baud Modem	11
Image Adapter/A	11
Dual Asynchronous Adapter	12
SCSI Adapter	12
General-Purpose Interface Bus Adapter	13
Ethernet Adapter	13
Diskette Compatibility	13
Hard Disk Drive	14
Terminating Resistors	15
Power Supply	15
Power-On Self-Test (POST)	16
Setting Password Security (Power-On Password)	17
System Board Memory	18
Adapter Memory	18

Environmental Specifications	20
Field Replaceable Units	21
Special Tools	21
SECTION 2. Introduction to Diagnostics	23
Diagnostic Aids	24
Using the Reference Diskette	24
Starting the Reference Diskette	27
Power-On Self-Test (POST)	27
Advanced Diagnostic Tests	28
Starting the Advanced Diagnostic Tests	29
Diagnostic Program	29
Presence Test	29
Installed Devices List	30
System Checkout	30
Error Log	30
Adapter Diagnostics	31
Memory Diagnostics	31
Formatting a Hard Disk Drive	32
Maintenance Analysis Procedures (MAPs)	32
Symptom-to-FRU Index	33
SECTION 3. Removal/Replacement Procedures	35
Using the Procedures	37
Service Position	38
Removals and Replacements	40
1005 Left Cover	40
1006 Right Cover	42
1007 Rear Cover	44
1008 Front Cover	45
1015 Memory Card	46
1020 Adapters	48
1025 Image Adapter/A Modules	49
1035 Front Bezel	50
1055 Power Supply	51
1056 Optional Power Supply	53
1057 Power Distribution Control Box	55
1058 Fan	56
1059 Fan (Optional)	58
1060 Diskette Drive	60

1061	Speaker and Battery	61
1062	Emergency Power Off (EPO) Switch	64
1065	DRB Power Supply	66
1074	CD-ROM Drive Assembly	68
1080	System Board	71
1090	Hard Disk Drive	73
1095	Display	75
1096	Keyboard	77
Locations		78
Front View		78
Rear View		79
Interior View (Left)		80
Interior View (Right)		81
Power and Internal Cables (Left)		82
Power and Internal Cables (Right)		83
System Board		84
System Board Connectors		85
Cabling and Safety Ground Wiring		86
Power Distribution Card		88
Power Distribution Control Box		88
SCSI Configuration & Switch/Jumper Settings		89

Hardware Maintenance Service

SECTION 4. Start	103
MAP 0000: Start	104
Undetermined Problem	119
SECTION 5. Diagnostic MAPs	121
MAP 0020: System Power	123
MAP 0200: Memory	140
MAP 0300: Keyboard	146
MAP 0610: Diskette Drive	152
MAP 2000: Image Adapter/A	155
MAP 2100: SCSI Devices	165
MAP 3000: DRB and Power Supply	169
MAP 4000: General-Purpose Interface Bus (GPIB)	176
SECTION 6. Parts Catalog	179

How To Use This Parts Catalog	182
Assembly <i>n</i> : Example Parts List	182
Assembly 1: Covers	183
Assembly 2: Cart/Main Chassis	184
Assembly 3: Rear Panel Cables	185
Assembly 4: Main Chassis, Left	187
Assembly 5: Main Chassis, Right	189
Assembly 6: Front Panel, Left	190
Assembly 7: Front Panel, Right	191
Assembly 8: Left Panel Cables	192
Assembly 9: Right Panel Cables	193
Assembly 10: DRB Storage Box	194
Assembly 11: DRB Power Supply	195
Assembly 12: CD-ROM Drive Type A	196
Assembly 13: CD-ROM Drive Type B	198
Assembly 14: Hard Disk Drive	199
Assembly 15: System Board	200
Assembly 16: Fan	201
Assembly 17: Display/Keyboard	202
Assembly 18: Cart/Drawer	204
Assembly 19: Tools	206
Assembly 20: Decals	207
Appendix. Notices	209
FCC Statement	209
Glossary of Terms and Abbreviations	211
Part Number Index	213
Index	217

Hardware Maintenance Reference

SECTION 1. General Information

General Description	4
Models	5
Microprocessor	5
2MB RAM	5
CMOS RAM	6
ROM BIOS	6
Serial Port	6
Parallel Port	7
Diskette Drive Controller	7
Keyboard Connector and Pointing Device Connector	7
Power Distribution Control Box	8
Display	9
CD-ROM Drive	11
Internal 2400-Baud Modem	11
Image Adapter/A	11
Dual Asynchronous Adapter	12
SCSI Adapter	12
General-Purpose Interface Bus Adapter	13
Ethernet Adapter	13
Diskette Compatibility	13
Hard Disk Drive	14
Terminating Resistors	15
Power Supply	15
Power-On Self-Test (POST)	16
Setting Password Security (Power-On Password)	17
System Board Memory	18
Adapter Memory	18
Environmental Specifications	20
Field Replaceable Units	21
Special Tools	21

General Description

The Service Bay System (SBS) consists of the following functional components:

- Power supply (one or two), 250 watts (225 watts on early systems).
- Power Distribution Control Box (Sense/Wakeup Box).
- System board:
 - 80386 20-MHz microprocessor
 - Eight expansion slots:
 - Three 32-bit slots
 - Five 16-bit slots
 - Parallel port
 - Serial port
 - Display connector
 - Keyboard connector
 - Display adapter interface
 - Diskette drive controller
 - Complementary metal-oxide semiconductor random access memory (CMOS RAM)
 - Read-only memory Basic Input/Output System (ROM BIOS)
- Battery (to keep CMOS active when power is off)
- 3.5-inch hard disk drive (one or two)
- 1.44MB, 3.5-inch diskette drive (one)
- 2MB (RAM)
- 19-inch monochrome display
- 84-key small-footprint keyboard
- Speaker
- Compact disk read-only memory (CD-ROM) drive (one to six).
- Image Adapter/A (attaches display).
- Small computer system interface (SCSI) adapter (attaches hard disk and CD-ROM drives).
- Internal modem (2400 baud) adapter.
- Ethernet adapter.
- Dual asynchronous adapter.
- General-Purpose Interface Bus (GPIB) adapter

Models

The SBS is a cart-mounted diagnostic tool for automobiles. Three models are available:

Model 110 Includes a 120MB hard disk drive, two compact disk drives, an internal modem, a dual asynchronous adapter, and the wakeup feature.

Model 114 The Model 110 with *four* CD-ROMs.

The SBS has several built-in connectors for attaching options. An option is a device that can be attached to or installed inside of the system to expand computer capabilities.

All models have locking wheels.

Microprocessor

The 80386 32-bit microprocessor interprets and carries out instructions at 20MHz.

2MB RAM

The 2 MB of RAM provides the microprocessor an area of fast-reference access to auto diagnostic applications and functional programs. (MB equals approximately 1 000 000 bytes).

CMOS RAM

The CMOS RAM, which consists of 64 bytes, maintains information about the current state of the system. The real-time clock uses 14 bytes to keep track of the date, time, and battery-charge level. The remaining 50 bytes are for system-configuration and security information.

Additional system configuration information is maintained in a 2KB (KB equals approximately 1000 bytes) *nonvolatile* RAM (NVRAM). (KB equals approximately 1 000 bytes). A battery keeps the CMOS RAM and 2KB NVRAM active when system-unit power is off. If the battery is removed, the system configuration data is lost.

To reinstall the data, insert the reference diskette and run the **Automatic configuration** program, or use the **Restore configuration** program on your backup copy of the reference diskette to restore the system-configuration information.

ROM BIOS

The ROM BIOS contains instructions and routines that control the major I/O devices (keyboard, diskette drive, and hard disk drive) in the Service Bay System. Routines for performing the power-on self-test (POST) also are contained in the ROM BIOS. Some adapters have their own ROM modules, which contain extended BIOS routines that work with the system-board ROM BIOS.

Serial Port

The serial port is fully programmable and supports asynchronous communications. The 25-pin, D-shell connector provides the signals to drive a standard RS-232C device and is identified in the system-configuration information as SERIAL 1.

If option adapters with serial ports are installed in the system unit, they can be configured as SERIAL 2 to SERIAL 8.

Note: Use the **Set configuration** option on the reference diskette to check that none of the serial ports are addressed the

same. If two or more lines are addressed the same, conflicts can occur when using multiple communication lines.

Parallel Port

The parallel port allows attachment of devices that accept eight bits of parallel data at standard transistor-transistor logic (TTL) levels. The port can be used as a general I/O port for any device or application that matches its input/output capabilities. It has a 25-pin, D-shell connector, and is primarily designed for printer interconnections. When the option adapters are installed with additional parallel ports, the Service Bay System can support three different devices, each addressed separately as PARALLEL 1, PARALLEL 2, and PARALLEL 3.

Note: Use the **Set configuration** option on the reference diskette to check that none of the parallel ports are addressed the same. Conflicts occur when using multiple devices if two or more devices are assigned the same address.

Diskette Drive Controller

The controller connects to the diskette drive assembly through a single 40-pin connector on the system board. Signals and voltages are supplied through a diskette drive cable that plugs into the connector.

Keyboard Connector and Pointing Device Connector

The two 6-pin connectors on the rear of the system board are for a pointing device (such as a mouse, although it is not needed for operation of the Service Bay System) and the keyboard. The interface logic is the same for both pointing device and keyboard. The keyboard connector is marked with a small keyboard figure molded into the back panel (top connector); the unmarked connector (bottom) is for a pointing device.

Power Distribution Control Box

The Power Distribution Control Box operates with a 125 V ac, 60 Hz input. In Models 110 and 114, it contains the wakeup control circuits and the voltage-sense control circuits. Power input to the box is routed by way of the cutout on the upper portion of the rear panel of the main chassis; the input power cord should be connected only to a drop-from-the-ceiling external power source that supplies at least 15 amperes. The input line has an indicate-and-reset circuit protector on the control-box exterior, which is accessible from the rear panel. Maximum load capacity of the box is 12 amperes, combined for all outlets.

The control box has three modes of operation:

1. As a single-control power strip:
 - System power is applied through the display, which is connected to the sense outlet. Power sensed at this outlet, allows power to be applied to the other 110 V ac outlets on the control box.
2. As a remote power source by way of a telephone line and modem connection:
 - In this mode, the box powers-on all outlets, except the sense outlet, when the telephone rings. The system stays on for 90 seconds after the telephone stops ringing, to allow POST to run and the application to load.

The incoming telephone line must be attached to the connector marked **phone**. If a modem is used, connect the telephone line to the connector marked **modem**.
3. As a remote power controller exercised by the computer (Wakeup Box):
 - The system provides a signal through the serial port cable that keeps the SBS powered on. When the system drops this signal, the Wakeup Box powers off.

Following is the list of outlets on the enclosure:

- Six power outlets:
 - Two CPU power supply outlets with a maximum load of 5 Amperes each.
 - One sense outlet used as a switch for the other outlets (3 Amperes, maximum load). This outlet requires a minimum load of 4.8 watts to power-on the remaining outlets.
 - Three auxiliary outlets with a maximum load of 2 Amperes each.
- Two telephone jacks:
 - One RJ11C for connecting into the telephone line (**phone**).
 - One RJ11C for connecting into a modem (**modem**).
- One serial port:
 - A 25-pin, D-shell connector.

A green light on the rear panel indicates when the unit has power available and is ready for operation. This light blinks after an automatic-on condition (phone activation or remote-on command) has occurred. The system returns to a steady-on condition when the display is powered on. This light is used as a visual indication that an automatic-on condition occurred.

Display

The display used for the Service Bay System is a hardened, 19-inch, monochrome unit. It has a power switch, a power-on indicator, and controls for brightness and contrast, which are located on the front of the display. The display power switch and the power-sensing circuit of the Power Distribution Control Box control power application to the system. This display has the following features:

- Self-test with a white screen test pattern
- 1600 x 1200 pels (picture elements) of addressability
- Analog video input that allows infinite shades of gray
- 31.48-, 34.61-, or 34.65kHz horizontal synchronization rate
- 1.8 m (6 ft) attached signal cable with a 15-pin, D-shell connector
- 1.8 m (6 ft) detachable power cord.

General Information

Display Connector Information

The display obtains its input through a 15-pin, analog video connector and cable assembly to the Image Adapter/A card on the system board inside the main chassis. The following table shows the connector pin numbers and signal assignments for monochrome mode. The illustration below the table shows the actual pin locations on the video connector.

Connector Pin	Signal Name
1	Reserved
2	Video
3	Reserved
4	Display ID 2
5	Self-Test
6	Reserved
7	Video Ground
8	Reserved
9	+ 12 V
10	Ground
11	Display ID 0
12	Display ID 1
13	Horizontal Synchronization (External)
14	Vertical Synchronization (External)
15	Display ID 3

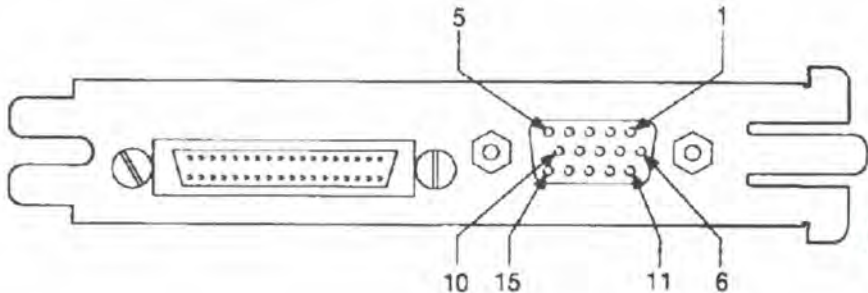

CD-ROM Drive

The CD-ROM drive is an optical storage device with a capacity of 550MB. The CD-ROM media can be replaced using the disk caddy. It is connected to the Service Bay System through the Small Computer System Interface (SCSI) adapter, which provides signal drive and protocol control.

Internal 2400-Baud Modem

The internal modem is a 2400-Baud intelligent modem. It automatically calls a remote computer, and automatically answers calls from remote systems. All circuits required for auto-answering and auto-dialing are built into the modem. Time outs are used in the controller to prevent machine operation if an error condition should occur. A repeat command is available to allow the modem to repeat the current command line (such as redial the telephone number).

The modem is compatible with 212A/103 modems communicating asynchronously. The modem also complies with CCITT (Central Committee for International Telephony and Telegraphy), recommendation V.22bis (asynchronous). It operates at 300, 1200, or 2400 baud, and communicates online in duplex or half-duplex modes.

Modular telephone receptacles are mounted on the modem. An attachment cable connects the modem to a modular jack. A direct connection eliminates the loss and distortion of data that is experienced with acoustic couplers. The modem uses pulse and touch-tone dialing (synchronous operation); both types of dialing may be combined within a single call.

Image Adapter/A

The Image Adapter/A is the graphics controller used by the Service Bay System. It is capable of driving displays with up to 128 MHz with 1600 x 1200 pels of addressability.

The Image Adapter/A drives all IBM analog display devices that use a 15-pin, direct-drive, analog interface. Install the Image Adapter/A

General Information

in the Video Feature Bus slot, slot 6 on the system board. (See "System Board Connectors" on page 85 for an illustration.)

The Image Adapter/A senses whether a monochrome or color display is attached. The system BIOS ensures that the video palette always matches the attached display.

Dual Asynchronous Adapter

The Dual Asynchronous adapter provides the communications protocol coding and decoding for interface with a satellite network. It is assigned to SERIAL 3 and 4 ports. It also provides control signals and interfacing with the power distribution Wake Up box.

SCSI Adapter

The SCSI adapter provides the drive signals and control communication protocols for the CD-ROM and hard disk drives.

General-Purpose Interface Bus Adapter

The General-Purpose Interface Bus provides a high-speed (1MB per second maximum throughput) parallel interface for the connection of test and other equipment to the Service Bay System. This adapter supports the IEEE 488.2 Standard for data transfer.

Ethernet Adapter

The Ethernet LAN adapter provides the ability to attach the 7785 Service Bay System to an Ethernet network. The adapter supports Ethernet Version 2 and IEEE 802.3 CSMA/CD with data transfers at 10 megabits per second by way of an Attachment Unit Interface (AUI). Connection to 10BASE2 (thin coaxial cable) is provided through the AUI connector and a user-provided external transceiver.

Diskette Compatibility

A variety of diskettes and diskette drives are available for the Service Bay System. The Service Bay System has a 1.44MB diskette drive installed. The following table gives the identification mark of the diskette drive.

Table 1. Diskette Drive Identification Markings

Diskette Drive	Identifying Mark
3.5-inch – 1.44MB	1.44 on the Eject Button

The following table addresses the compatibility of diskettes to diskette drives.

Table 2. 3.5-inch Diskette-to-Drive Compatibility

	720KB Drive	1.44MB Drive
1MB Diskette	Read/Write	Read/Write
2MB Diskette	Not Compatible	Read/Write

General Information

Hard Disk Drive

Models 110 and 114 have a 120MB, 3.5-inch hard disk drive installed. Each disk drive has automatic positioning that places the read/write heads in nondata areas when the system is powered off.

The SCSI adapter is the controller/driver for the hard disk drives. The system BIOS only supports two hard disk drives. Installation of the second hard disk drive requires that a second power supply, power distribution card, and fan be installed on the right side of the main chassis.

Terminating Resistors

All hard disk drives must have their terminating resistors removed.

The location and appearance of the terminating resistors may vary from drive to drive. An identification label or tag (usually "T-RES") is attached to the terminating resistor for easy identification.

The terminating resistors for the SCSI bus are in the ribbon cable.

Power Supply

The 100- to 125-V ac, 3-wire input is converted to direct current outputs that supply the Service Bay System with proper operating voltages. Whenever the power supply is powered off for a minimum of 10 seconds and then powered on again, the power supply generates a 'power good' signal. The 'power good' signal resets system logic, indicates proper operation of the power supply, and gives advance warning to the system board of a voltage loss when the Service Bay System is powered off. Once the minimum under-voltage sense levels are established and the 'power good' signal is active, all system power requirements are met.

Output (V dc)	Minimum Sense Level (V dc)
+ 5.0	+ 4.5
+12.0	+10.8
-12.0	-10.2

Power-On Self-Test (POST)

The POST is initiated automatically each time the system is powered on for its first operations, or powered on again after being off for a minimum of ten seconds.

The POST is a series of checks and initializations that verify the correct operation of the base Service Bay System. The POST detects two types of errors: *critical* and *noncritical*.

Critical errors prevent the system from operating or cause incorrect results that are apparent to the user. If the POST detects a critical error, the microprocessor attempts to display the error, and all testing stops.

Noncritical errors cause incorrect results that may not be apparent to the user. An example of a noncritical error is a serial communications failure. On a noncritical error, the microprocessor displays an error code and all testing stops; press **F1** to continue testing.

When the reference diskette is present in the diskette drive and an error is detected, the POST error message and a message generated from the reference diskette are displayed. This message instructs you to take a specific action to correct the error.

A single, short, audible beep sounds when POST completes successfully. Control is then given to a routine in BIOS called the system bootstrap loader. The bootstrap loader attempts to load an operating system or a program from either a diskette or the hard disk drive. If neither is present, the diskette prompt is displayed.

Setting Password Security (Power-On Password)

To set a password that denies access to the Service Bay System at power-on time, start the system with the reference diskette inserted in the diskette drive. Select the **Set features** option from the main menu, and follow the instructions to set a password. When a power-on password is active, the password prompt, which resembles a small key, appears on the screen each time the system is powered on.

At the password prompt, type the password and then press **Enter**. The password does not appear on the screen.

To service a system with an active but unknown power-on password, remove the speaker assembly without disconnecting the cable from the system board. Short the two pins **A** and **B**.

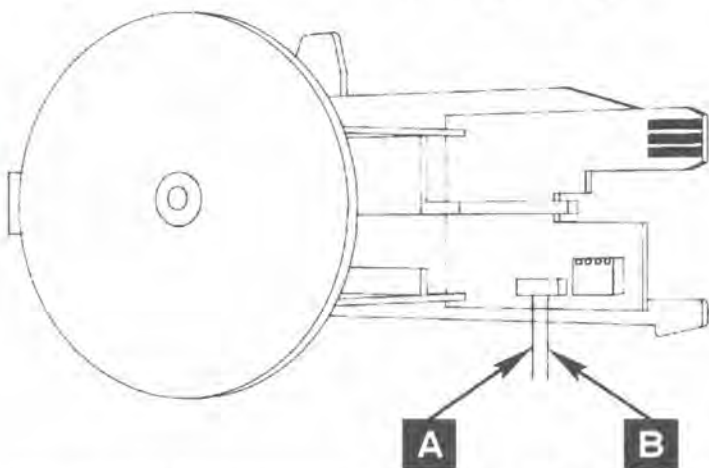

This disables the password portion of CMOS RAM. Power-on the system, but leave the two pins shorted until POST is finished. This action deactivates the password. To reactivate the password after service, you must start the reference diskette, select **Set features** from the main menu, and follow the instructions on the screen.

System Board Memory

The system board has one 2MB, 80386 Memory Expansion Card installed at the time of shipment. The 80386 Memory Expansion Card has a 3-by-32-pin connector that plugs directly into the system board at memory connector J16.

Adapter Memory

An optional memory adapter, the 80386 Memory Expansion Adapter, extends the capabilities of the Service Bay System. The 80386 Memory Expansion Adapter is shipped with two 80386 Memory Expansion Cards. Three 80386 Memory Expansion Cards may be installed on the adapter, adding 6MB for a total memory capacity of 8MB. The 80386 Memory Expansion Adapter can be plugged into any of the three long (32-bit) expansion slots on the system board.

Memory Requirements and Limitations

The system board *does not* have to be fully populated before you add 80386 Memory Expansion Adapters, nor must each memory adapter be filled before adding another memory adapter. The Service Bay System supports up to 16MB of memory. Whenever memory is added or removed from the system, the **Set configuration** program must be run.

Memory Errors

The Service Bay System activates and deactivates memory in 1MB blocks. If a memory error is detected in the first 512KB of memory by the POST, 1MB of memory is deactivated and an error code is displayed. The POST does not deactivate memory for an error detected above the first 512KB of memory. If the system is powered on with the reference diskette installed, the customer is advised that service is required, and is given the option to continue with reduced memory capacity. When the customer chooses to continue, a routine on the reference diskette reassigns the memory addresses, skipping over any defective blocks of memory. Once a block of defective memory has its address reassigned as shown in Figure 1 on page 19, it is ignored by the POST during subsequent power-ons.

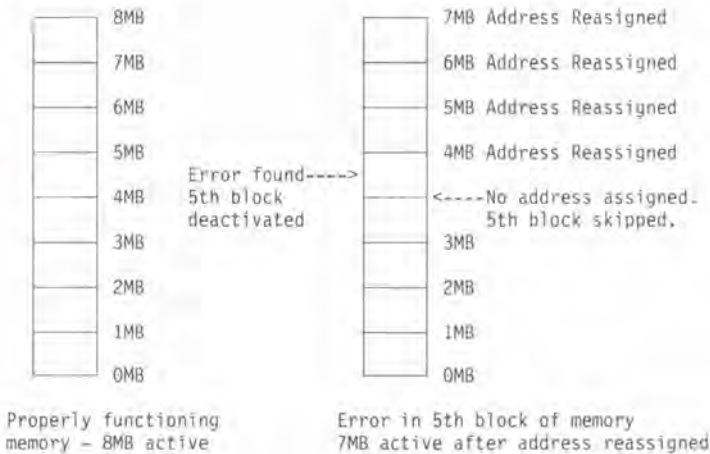

Figure 1. Memory Error Address Reassignment

As long as errors occur one at a time, the customer may deactivate 1MB blocks of memory.

There are two exceptions to the address reassignment procedure:

1. If two errors occur simultaneously on the same 80386 Memory Expansion Card, the customer *is not* given the option to continue with reduced memory capacity. When the system is powered on with the reference diskette loaded, the message

Have the system unit serviced

is displayed.

2. The first 512KB of memory accessed must be system board memory. If all system board memory is defective, the first 512KB of memory cannot be reassigned to reside on a memory adapter, the programs on the reference diskette cannot be loaded, and the POST displays an error code.

Environmental Specifications

- **Size**

- Machine Class: Industrial mobile unit
- Model 110
 - Depth: 762 mm (30 in.)
 - Height: 1528 mm (60.2 in.), including cart and display
 - Width: 635 mm (25.0 in.), including handles

- **Weight**

- Maximum configuration: 182 kg (400 lb)

- **Environment**

- Air Temperature
 - System On: 10 to 43.3°C (50 to 110°F) at 3000 ft altitude
 - System Off: 7 to 52°C (45 to 126°F)
- Humidity
 - System On: 8 to 80% (noncondensing)
 - System Off: 8 to 80% (noncondensing)
- Maximum altitude: 2134 m (7000 ft)
- Gases
 - Sulfur dioxide: 30 ppb (100 µg/m³)
 - Hydrogen chloride: 10 ppb (1.5 µg/m³)
- Particulates (Maximum Concentration)
 - Suspended: 300 µg/m³/24 hours
 - Settled: 500 µg/cm²/30 days
 - Benzene-soluble organics: 30 µg/m³

- **Heat Output (Maximum)**

- 1665 BTUH

- **Electrical**

- Voltage
 - Minimum: 100 V ac
 - Maximum: 125 V ac
- Frequency
 - 57 to 63 Hz
- Current
 - 12 Amperes (total not to exceed 4 Amperes per outlet)

Field Replaceable Units

Field Replaceable Units (FRUs) are parts that may be removed and replaced by the customer engineer at the customer's facility, and usually include any optional FRUs that may be requested for installation in a specific model. Instructions to replace a specific FRU are included in the diagnostic routines given in "SECTION 5. Diagnostic MAPs" on page 121.

Special Tools

- **Volt-Ohm Meter**—a meter similar to the Triplet Model 310.*
- **Wrap Plug**—the Tri-Connector wrap plug (part number 72X8546) is used during advanced diagnostic testing of parallel and serial ports.

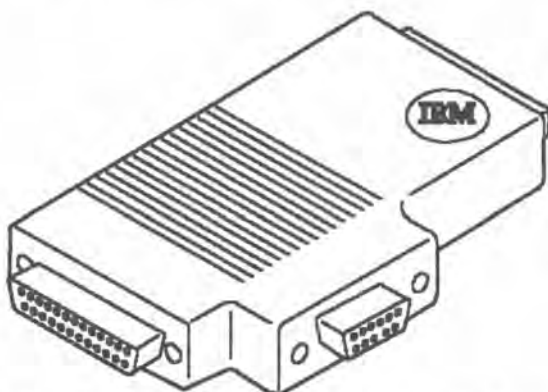

- **2.0MB Diskette**—(part number 6404078) is used during diagnostic testing of the diskette device.
- **CD-ROM Test Disk**—(part number 53F3088) is used during diagnostic testing of a Type A CD-ROM drive.
- **CD-ROM Test Disk**—(part number 81F8902) is used during diagnostic testing of a Type B CD-ROM drive.
- **CD-ROM Caddy**—(part number 22F9419) is the holder for a compact disk platter.

* Manufactured by Triplet Corporation, Bluffton, Ohio 45817, U.S.A.



SECTION 2. Introduction to Diagnostics

Diagnostic Aids	24
Using the Reference Diskette	24
Starting the Reference Diskette	27
Power-On Self-Test (POST)	27
Advanced Diagnostic Tests	28
Starting the Advanced Diagnostic Tests	29
Diagnostic Program	29
Presence Test	29
Installed Devices List	30
System Checkout	30
Error Log	30
Adapter Diagnostics	31
Memory Diagnostics	31
Formatting a Hard Disk Drive	32
Maintenance Analysis Procedures (MAPs)	32
Symptom-to-FRU Index	33

Diagnostic Aids

The diagnostic aids used to isolate a failing Field Replaceable Unit (FRU) are:

- Power-On Self-Test (POST).
- Advanced diagnostic tests, contained on the reference diskette.
- Maintenance Analysis Procedures, contained in this manual.

This section describes these diagnostic aids for problem solving.

When instructed to "Power-on the system", apply power to all externally attached devices (such as printers) **before** applying power to the display.

When instructed to "Power-off the system", remove power to all externally-attached devices **before** removing power from the display.

Note: To remove all power to the Service Bay System, disconnect the 3-wire power cord of the cart/main chassis from the user-supplied power connector.

Using the Reference Diskette

The reference diskette is a write-protected diskette located in a plastic envelope in the back of this manual. You can *read* information from the diskette, but you cannot *write* (record) information onto it. Make a backup copy of the diskette as soon as possible. Once the copy is made, put the original diskette in a safe place and always use the backup copy. The reference diskette contains the following programs:

1. **Backup the Reference Diskette**—makes a copy of the original reference diskette onto another diskette, but not onto a hard disk. To make the backup copy, you need a blank, formatted, 2 MB diskette that is not write-protected.

Always use the backup copy of the reference diskette. This ensures that the backup copy always contains the current system configuration information and testing programs.

2. **Set configuration**—is used to view, change, backup, restore, run automatic configuration, set and view SCSI configuration, and display the memory map. The computer automatically sets its configuration when the reference diskette is started or when "run automatic configuration" (see below) is selected. During automatic configuration, the computer makes a list of what is currently installed, and assigns each of those items to operate in a certain way. The configuration lists:

- The installed and usable memory size.
- The built-in connectors and their assignments.
- The installed IBM adapters with each location on the system board and slot number assigned.
- The IBM hard disk drive adapter, showing the type of drive and the system access priority.
- The SCSI adapter being used.
- The CD-ROMs attached.

The configuration information is stored in the computer memory and kept active by a battery even after the computer is turned off. However, if the battery is removed or replaced, the configuration information is lost. After you change, remove, or install either an IBM option or the battery, you must start the backup copy of the reference diskette so the computer can update the system configuration data.

Set configuration contains the following:

- **View configuration**—shows you the present configuration stored in the computer memory.
- **Change configuration**—lets you make changes to the configuration stored in memory, tailoring computer operation to your needs.
- **Backup configuration**—copies the system configuration stored in memory onto the backup copy of the reference diskette. Use this program after you make changes to the system configuration. This ensures that you have a copy of the changes if the battery is removed or replaced.

Introduction to Diagnostics

- **Restore configuration**—retrieves the system configuration copied by "Backup configuration" and restores it to the computer memory. Use "Restore configuration" after the system board or battery is removed or replaced.
 - **Run automatic configuration**—causes the system to automatically configure itself and store the information in memory.
 - **Set and View SCSI Configuration**—lets you set and view the configuration of SCSI devices attached to the system.
 - **Display Memory Map**—lets you view the memory address for adapter code loaded into memory.
3. **Set features**—is used to set the date and time, passwords, and keyboard speed.
- **Set date and time**—lets you set the date and time of your computer activities. Once the date and time are set, the computer battery keeps both current, even after the Service Bay System is turned off.
 - **Set passwords**—lets you restrict the use of the Service Bay System to those who know the password. The following are available:
 - Power-on password.
 - Keyboard password.
 - Network server password.
 - **Set keyboard speed**—lets you change the speed at which the keyboard responds when you type.
4. **Copy an option diskette**—is used when an IBM option comes with a diskette and instructions to update the backup copy of the reference diskette. The option diskette contains the testing program and configuration information for the option. Be sure to follow the instructions supplied with the option.
5. **Test the computer**—checks the computer hardware. If a problem occurs during this testing, an error message appears with the suggested cause of the problem and the recommended action.

6. **Display Revision Levels**—displays BIOS part number, date, system board model, sub model and revision number, and diagnostic level.

Starting the Reference Diskette

If the system is off:

1. Insert the reference diskette into the diskette drive.
2. Turn on the system and follow the instructions on the screen.

If the system is on:

1. Insert the reference diskette into the diskette drive.
2. Restart the system by pressing Ctrl+Alt+Del. The system should begin its initialization and run the POST routine.
3. Follow the instructions on the screen.

Power-On Self-Test (POST)

The POST begins each time you turn on the system. It compares the detected system configuration with the configuration stored in the CMOS RAM. The POST requires approximately 90 seconds to complete, depending on the installed options.

The POST checks the following:

- System board
- Memory
- Image adapter/A
- Keyboard
- Diskette drive
- Hard disk drive
- Serial port
- Parallel port
- ETHERNET adapter
- General-Purpose Interface Bus (GPIB) card

Introduction to Diagnostics

Some adapters that may be installed have ROM devices that contain extended BIOS routines; these work with the POST.

To start the POST, turn on the system. The following happens:

- While the memory is tested, the results are shown on the upper left side of the display screen. The memory is tested in increments of 64KB until all system memory is tested.
- When the POST is successfully completed, you hear one short beep.
- If an operating system is not automatically loaded from the hard disk drive and a diskette is not present in drive A, the diskette prompt and the F1 prompts are displayed. The diskette and F1 prompts are icons showing that a diskette with an operating system should be inserted into diskette drive A. Press F1 to continue loading the operating system or program from the diskette.

If POST errors are displayed, press F1 to bypass the errors, and allow the POST to attempt to complete. Depending upon the error and its severity, the POST may or may not complete.

If the reference diskette is present in drive A when a POST error is detected, the POST error message and a message generated from the reference diskette are displayed. This additional message instructs the user to take a specific action to solve the problem.

Advanced Diagnostic Tests

The advanced diagnostic tests are found on the reference diskette, located at the back of this manual. The reference diskette and this manual are used to isolate failing FRUs.

Note: Make a copy of the reference diskette, and put the original diskette in a safe place. Use the copy to run the diagnostic tests.

Starting the Advanced Diagnostic Tests

1. Insert the reference diskette into the diskette drive.
2. Turn on the system. Follow the instructions on the screen until the main menu appears.
3. Press and hold **Ctrl+A**. This selects the advanced diagnostic routine from the reference diskette.
4. Select **System Checkout** from the main menu. Follow the instructions on the screen to isolate the failing FRU.

Diagnostic Program

The diagnostic program consists of a Diagnostic Control Program (DCP) and a module of code for each supported device. As new options are developed and installed on the Service Bay System, modules of code are distributed. Copy these new modules onto the reference diskette. Select

Copy an option diskette

from the main menu, and follow the instructions on the screen.

Presence Test

During the initial program load, the DCP links in sequence to each of the code modules identified by the reference diskette. A presence test is performed for the device supported by each module. For a successful presence test, the following conditions must be met:

1. The module of diagnostic code for that device must be on the diskette.

Note: Some devices have their own stand-alone diagnostic diskette.

2. The device must be correctly installed and turned on.
3. The device must return a Ready acknowledgement to the DCP.

Introduction to Diagnostics

If these conditions are met, the DCP loads that module into memory, adds the device name to the installed devices list, and continues with the next module. These steps are repeated until the DCP has performed a presence test for each module on the diskette. When all presence tests have been performed, the DCP displays the installed devices list.

Installed Devices List

This list contains the devices that meet all conditions of the Presence Test. The servicer must verify this list.

A device may be missing from the list because:

- The module of code for a device is not on the reference diskette.
- The device is unknown to the DCP and is ignored.
- The device is not installed or attached.
- The device is not turned on.
- The device is not functioning; it has failed.

System Checkout

Run System Checkout to diagnose any problem that you may encounter. You should also run System Checkout when a new option is installed, or whenever maintenance work is done on the system and a malfunctioning FRU has been replaced.

To run System Checkout:

1. Start the advanced diagnostic tests.
2. Select **System Checkout** from the main menu.
3. Follow the instructions on the screen.

Error Log

The following steps allow you to create an Error Log, start the advanced diagnostic tests, and automatically record an error message in the Error Log. This procedure is normally used when diagnosing an intermittent problem or when you are exercising the Service Bay System.

You cannot log errors to a diskette drive that is being tested. If you plan to test a diskette drive, you must log the errors to the primary printer (if attached) or to a diskette drive not being tested.

Note: When recording errors onto a diskette, use a diskette that is not write-protected.

To create an Error Log:

1. Start the advanced diagnostic tests.
2. Select **System Checkout** from the main menu.
3. Select **Error Log**.
4. Follow the instructions on the screen.

Adapter Diagnostics

The diagnostic diskette contains programs for testing the SCSI, CD-ROM devices, hard disk drive, and hard disk drive controller circuits. No MAPs are required for these internal components since the diagnostic programs provide a check of these FRUs.

The dual asynchronous adapter is also tested by the one of the self-contained programs of the diagnostic diskette. Its wakeup and sense circuits are further analyzed and tested for failing FRUs as part of the Power MAP.

The GPIB diagnostics are run from a separate diagnostic diskette.

Memory Diagnostics

System memory diagnostics detect parity, data, and addressing errors. The microprocessor writes patterns to the memory, and then reads the patterns back to verify correct memory function. The diagnostic tests display:

- The location of the defective memory
- The slot number if the defect is on a memory expansion adapter
- The expected and actual patterns if a data error occurs.

Formatting a Hard Disk Drive

Before you replace a failing hard disk drive, try to format the drive as follows:

1. Start the advanced diagnostic tests.
2. Select **Format Fixed Disk** from the main menu.

Warning: Formatting results in complete loss of data on the hard disk drive; backup all information on the hard disk drive before formatting.

Avertissement : Le formatage entraîne la perte de toutes les données contenues sur le disque fixe; faites une copie de sauvegarde avant de reformater.

3. Follow the instructions on the screen.

Notes:

1. Hard disk drives normally contain more tracks than their stated capacity, to allow for defective tracks. The user is notified by a message on the screen when the defect limit is reached and service is recommended.
2. The diagnostic format program is different from the operating system format program. Before the user can transfer information from backup diskettes to the hard disk drive, it must be formatted by using the operating system format program.

Maintenance Analysis Procedures (MAPs)

The MAPs are a series of steps that require you to answer questions and perform actions. You determine which FRU is causing a failure by following the MAPs, and using the advanced diagnostic tests on the reference diskette.

Always start with **MAP 0000**. Depending on the failure indication, **MAP 0000** directs you to one of the other MAPs or to the advanced diagnostic tests. Some MAPs may have more than one device listed (such as more than one diskette drive type). In that case, a *device Start MAP* directs you to the proper MAP.

Symptom-to-FRU Index

The POST error messages are displayed on the screen as 3-, 4-, 5-, or 8-digit numbers; diagnostic error messages are always shown as eight digits. The Symptom-to-FRU Index on page 116 lists all error messages in the 8-digit format. Shorter POST error messages are shown in **bold print** within the 8-digit format. Some digits represent different information for SCSI versus non-SCSI errors.

Figure 2 shows which digits are the shorter POST error messages, and defines the SCSI information in an 8-digit error message.

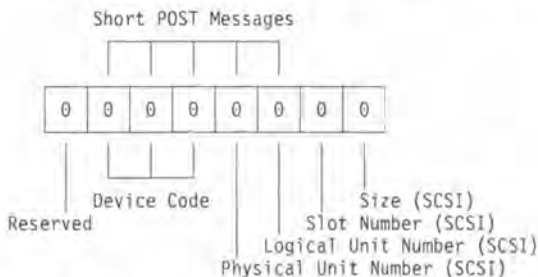

Figure 2. Format of Error Messages

The Symptom-to-FRU Index on page 116 lists the various symptoms, error numbers, and the most probable FRUs that cause specific failures. The most probable failing FRU is listed first. Use the Symptom-to-FRU Index to have the proper replacement FRUs available when you service the failing Service Bay System. **Important:** To determine which FRU is actually failing, always begin with **MAP 0000: Start** on page 104 of this manual. If an error message is displayed and an incorrect audio response is heard, the most likely failing FRUs are those listed for the error message. An **X** shown in the error messages of the Symptom-to-FRU Index can be any number.

SECTION 3. Removal/Replacement Procedures

Using the Procedures	37
Service Position	38
Removals and Replacements	40
1005 Left Cover	40
1006 Right Cover	42
1007 Rear Cover	44
1008 Front Cover	45
1015 Memory Card	46
1020 Adapters	48
1025 Image Adapter/A Modules	49
1035 Front Bezel	50
1055 Power Supply	51
1056 Optional Power Supply	53
1057 Power Distribution Control Box	55
1058 Fan	56
1059 Fan (Optional)	58
1060 Diskette Drive	60
1061 Speaker and Battery	61
1062 Emergency Power Off (EPO) Switch	64
1065 DRB Power Supply	66
1074 CD-ROM Drive Assembly	68
1080 System Board	71
1090 Hard Disk Drive	73
1095 Display	75
1096 Keyboard	77
Locations	78
Front View	78
Rear View	79
Interior View (Left)	80
Interior View (Right)	81
Power and Internal Cables (Left)	82
Power and Internal Cables (Right)	83
System Board	84
System Board Connectors	85
Cabling and Safety Ground Wiring	86
Power Distribution Card	88

Removal/Replacement Procedures

Power Distribution Control Box	88
SCSI Configuration & Switch/Jumper Settings	89

Using the Procedures

This section contains information about removals and replacements, locations, and safety grounds.

Caution:

Before removing any Field Replaceable Unit (FRU), turn power off, unplug all power cords from electrical outlets, and disconnect any cables to external units and to the FRU to be removed.

Attention:

Avant de retirer un module interchangeable sur place, mettez le système de diagnostic pour automobile hors tension, débranchez tous les cordons d'alimentation des socles de prise de courant et déconnectez tous les câbles reliés aux unités externes et au module à retirer.

The system board, adapters, and memory modules are sensitive to, and can be damaged by electrostatic discharge. Establish personal grounding by touching a ground point with one hand before touching these units. An electrostatic discharge strap may be used to establish personal grounding.

WARNING:

The side covers are top heavy; cables stored on the covers exaggerate this condition. Whenever removing and replacing the side covers, hold them in place with your hand.

Service Position

The Service Bay System must be upright and free-standing with service clearance on all sides.

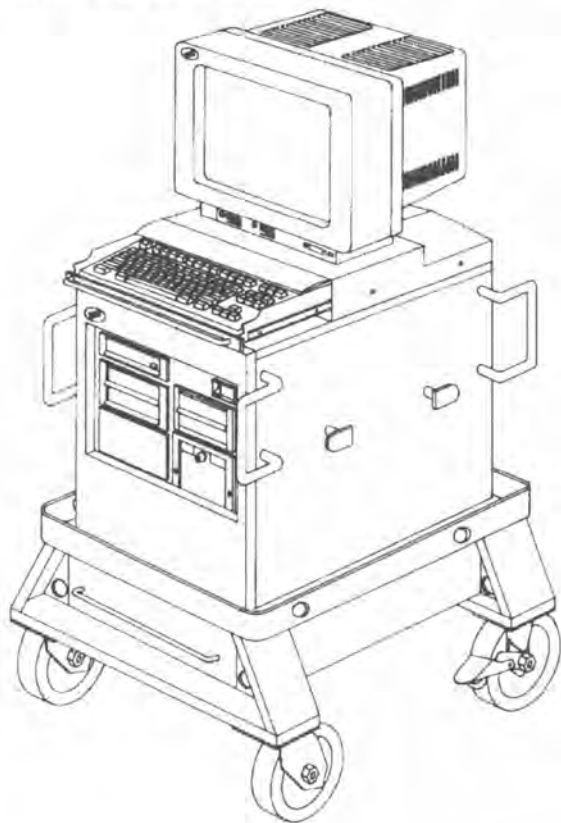

CAUTION:

Always set the foot-operated brakes after the cart is properly positioned in the working area for safety and accidental damage.

Attention !

Pour empêcher que le système de diagnostic pour automobile ne subisse des dommages ou ne blesse quelqu'un en se

déplaçant accidentellement, bloquez toujours les roues du chariot à l'aide des freins.

Removals and Replacements

1005 Left Cover

Removal

- Remove the nuts **1**, washers, and retaining plates located at the lower corners of the cover, while holding the cover in place with your hand.
- Pull the bottom of the cover away from the mounting studs **3**. Slide the cover down until it disengages from the metal fingers on the main chassis **2**.

CAUTION:

The side cover is top heavy; cables stored on the covers exaggerate this condition. Whenever removing and replacing the side cover, HOLD IT IN PLACE WITH YOUR HAND.

- Lift and pull the top of the cover away from the main chassis, and lift it from the cart.

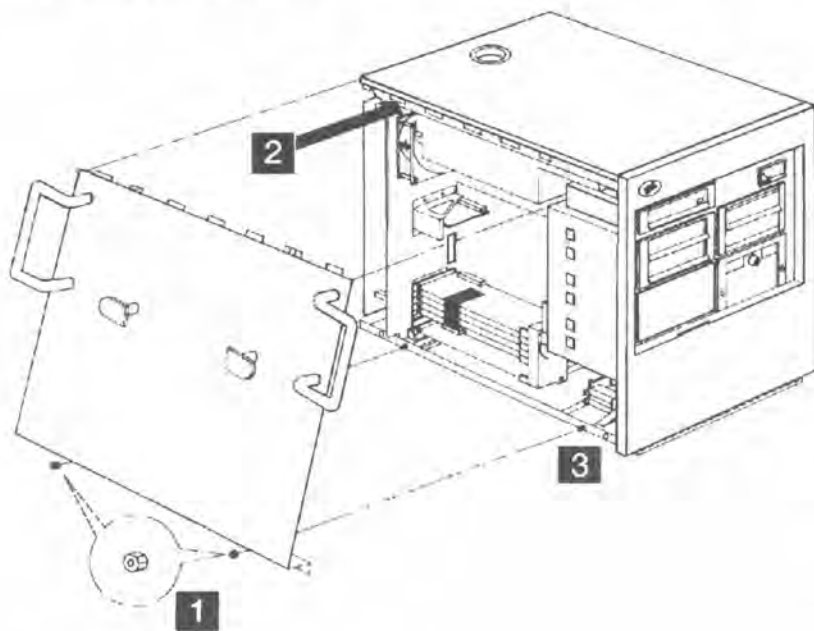

Replacement

- Position the top of the cover against the main chassis, then push the top upward until the metal fingers of the cover and top of the main chassis are firmly engaged.
- Push the bottom of the cover toward the main chassis until the cover rests on the two cover mounting studs on the main chassis.
- Reinstall the retainer plates, washers, and nuts at the bottom of the cover.

1006 Right Cover

Removal

- Remove the nuts **2**, retaining plates, and washers at the lower corners of the cover, while holding the cover in place with your hand.
- Pull the bottom of the cover away from the mounting studs **1**. Slide the cover down until the top disengages from the metal fingers of the main chassis.

CAUTION:

The side cover is top heavy; cables stored on the covers exaggerate this condition. Whenever removing and replacing the side cover, **HOLD IT IN PLACE WITH YOUR HAND.**

- Lift and pull the top of the cover away from the main chassis and lift it from the cart.

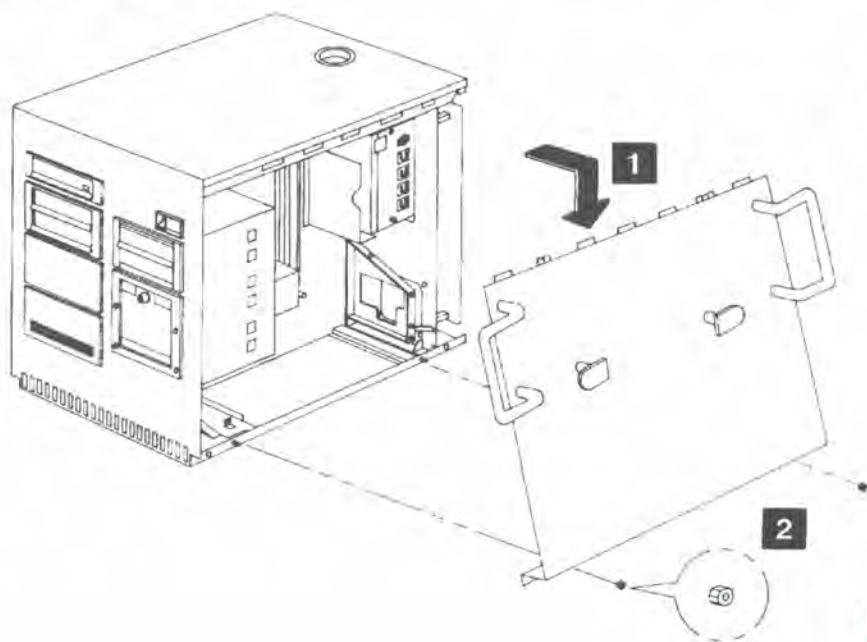

Replacement

- Position the top of the cover against the main chassis, then push the cover upward until the metal fingers of the cover and top of the main chassis are firmly engaged.
- Push the bottom of the cover toward the main chassis until the cover rests on the two cover mounting studs on the main chassis.
- Reinstall the retaining plates, washers, and nuts at the base of the cover.

1007 Rear Cover

Removal

- Remove the screws at the bottom of the cover.
- Use the handle to hold the cover while removing the top screws.
- Carefully lift the cover from the standoffs on the main chassis, until it is free of the bottom cabling.

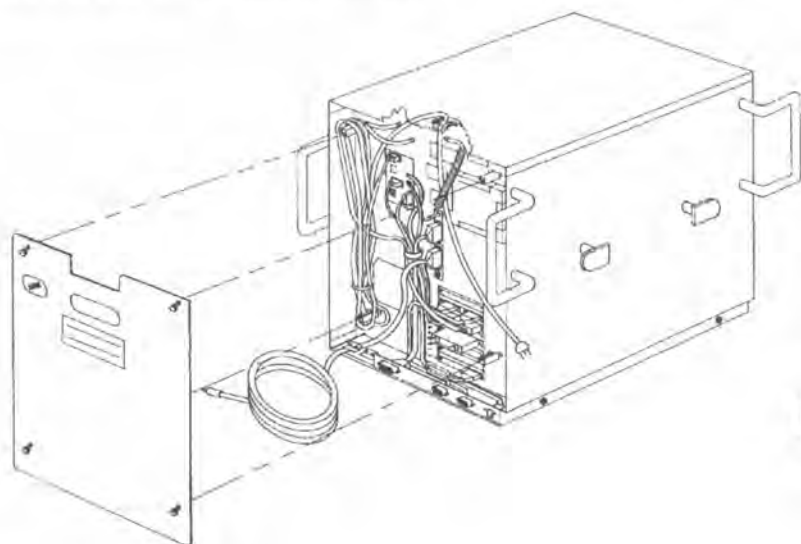

Replacement

- Position the cover against the four standoffs on the rear of the main chassis. The rectangular cutout for the cables is on the top of the rear cover. The power cord cutout is at the top of the rear cover.
- Finger-tighten the two screws at the top of the cover.
- Finger-tighten the two screws at the bottom of the cover.
- Tighten all screws.

1008 Front Cover

Removal

- Remove left cover (1005).
- Remove right cover (1006).
- There are three screws on each side of the front cover. Remove the lower four screws first.
- Brace the cover from the front while removing the two top screws, to prevent cross-threading and scoring.

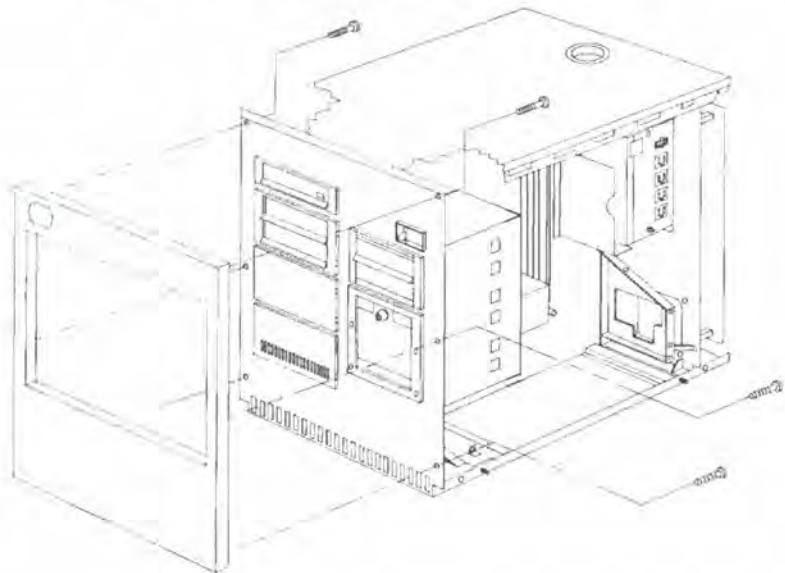

Replacement

- Position the cover against the six holes on the front of the main chassis with the logo at the upper left corner.
- Insert and finger-tighten the three screws on each side of the front cover. The screws are inserted from the inside of the main chassis.
- Tighten the screws to secure the cover against the main chassis.
- Install right cover (1006).
- Install left cover (1005).

1015 Memory Card

Removal

- Unplug the power cord from the electrical outlet.
- Remove left cover (1005).
- Remove rear cover (1007).
- Remove the telephone and telephone plate from the rear frame, if installed.
- Remove the two screws **2** that secure the retaining bracket **1** to the rear of the chassis.
- Touch a system ground (bare metal) to discharge static electricity, then carefully remove the memory card from the system board connector.

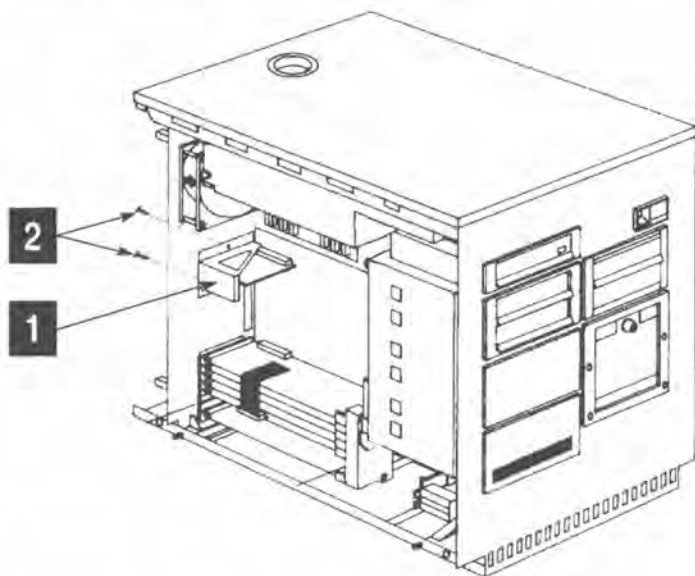

Replacement

- Touch a system ground before handling the replacement card.
- Firmly press the memory card into the top expansion slot.
- Position the retaining bracket **1** on the main chassis and secure it with the screws **2** removed earlier.
- Replace the telephone plate and telephone on the rear frame, if removed.

- Install rear cover (1007).
- Install left cover (1005).

1020 Adapters

Removal

- Unplug the power cord from the electrical outlet.
- Remove the left cover (1005).
- Remove the rear cover (1007).
- Record the adapter and cable locations for reinstallation.
- Disconnect any cables attached to the adapter.
- Loosen the top screw and remove the bottom screw securing the retaining bracket **1** near the front of the main chassis.
- Loosen the captive thumbscrew **2** on the adapter rear bracket.
- Touch a system ground (bare metal), then carefully remove the adapter from the expansion slot.

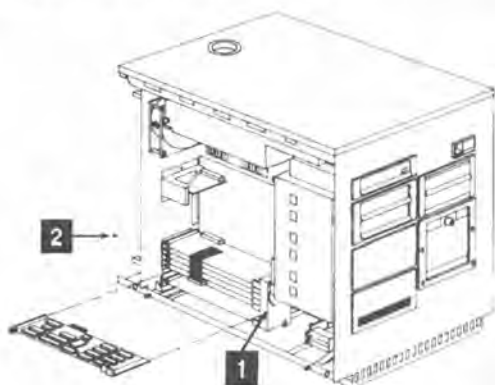

Replacement

- Touch a system ground (bare metal) before handling the adapter.
- Firmly press the adapter into the expansion slot.
- Finger-tighten the thumbscrew **2** on the back of the main chassis.
- Position the retaining bracket **1** at the front of the main chassis and secure it with the screws removed earlier.
- Reconnect any cables that may have been disconnected.
- Install rear cover (1007).
- Install left cover (1005).

1025 Image Adapter/A Modules

Removal

- Ensure that the module insertion guide has been removed. Note the location of the notch (shown below) on the modules.
- Push the module extraction tool over the center of the module until it clips onto the body of the module.
- Hold the module firmly with the extraction tool.
- Press down on the circuit board with the other hand.
- Pull the module upwards to detach it from the circuit board.

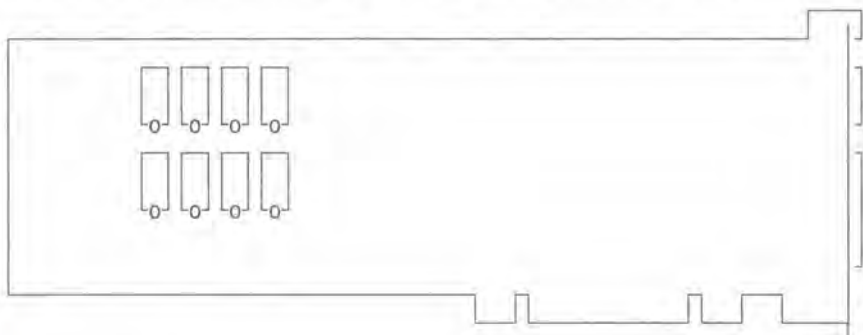

Replacement

- Check that the module pins are undamaged and correctly aligned.
- Place the module in the insertion guide.
- Check that the notch is correctly oriented before inserting the module. Press down both ends of the module simultaneously.
- Check that the module is correctly seated in the socket.

Removals and Replacements

1035 Front Bezel

All bezels are removed or installed in the same way.

Removal

- Insert a small screwdriver under either side of the bezel.
- Rotate the screwdriver to snap the bezel from the front cover of the main chassis. Bezels are held by one or two 10 mm-wide (0.4 in) retaining latches on each side, depending upon the bezel width.
- When one side of a bezel snaps out of the opening, remove the bezel and save for future use, or discard if no longer needed.

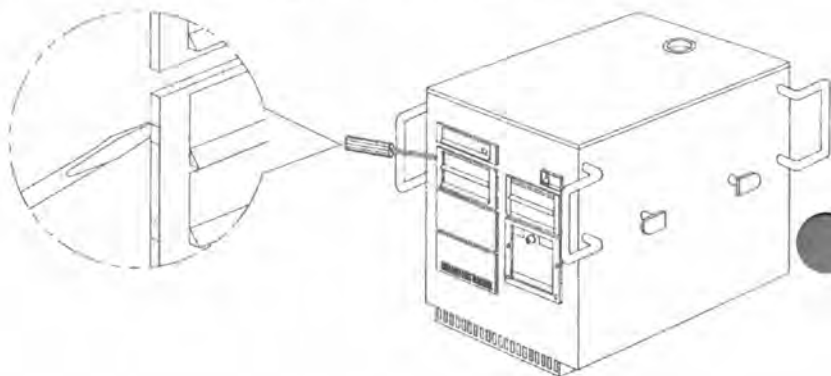

Replacement

All bezel types are installed in the same manner.

- Insert one side of the bezel into the opening of the front cover.
- Press firmly against the opposite side of the bezel until it snaps securely into place. There may be some looseness or play in the bezel after installation. If the bezel falls out, check for broken or cracked retaining latches; replace the bezel if a latch is broken or cracked.

1055 Power Supply

Removal

- Unplug the power cord from the electrical outlet.
- Remove left cover (1005).
- Remove diskette drive (1060).
- Pull the diskette cable down and under the power supply to keep it out of the way.
- Remove the front bezel from the adjacent CD-ROM drive.
- Slide the CD-ROM drive out 50 mm (2 in) by pressing the spring clip on the outside of the cage **1** and pushing from the back of the drive.
- Label and remove the power supply connector from the system board.
- Label and disconnect all cables to and from the power distribution card **2**.
- Remove the three screws from the mounting holes in the power supply bracket. Slide the power supply out from the bracket far enough to disconnect the power cord.
- Lower the power supply and tilt the outside edge down to remove it. If the input power cord **3** is suspect, remove it now; otherwise, leave it in place.

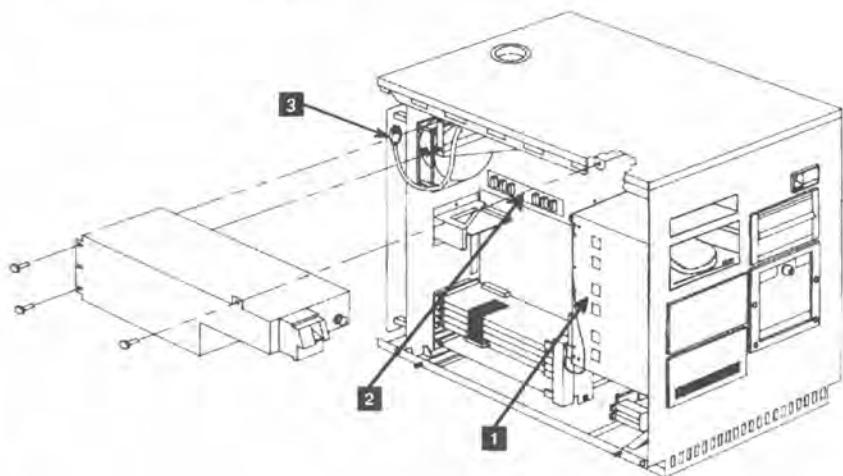

Removals and Replacements

Replacement

- Make sure the power switch is set to the **ON** position; the switch is not accessible after the power supply is installed.
- Reconnect the input power cord **3** before the power supply is secured to the mounting bracket.
- Align the holes of the power supply and bracket. The bracket has a raised alignment tab which fits into an opening on the power supply.
- Install the three screws that secure the power supply to the mounting bracket.
- Tighten all screws; the power supply should have no play in any direction.
- Connect the power cable to the system board.
- Connect the dc power cables from the power distribution card **2** to the power supply.
- Secure the CD-ROM drive in the cage **1**.
- Install the CD-ROM bezel.
- Install diskette drive (**1060**).
- Install left cover (**1005**).

1056 Optional Power Supply

Removal

- Unplug the power cord from the electrical outlet.
- Remove right cover (**1006**).
- Disconnect all cables to the power distribution card.
- Remove the three screws from the mounting holes in the power supply bracket. Slide the power supply out from the bracket until the input power cord is accessible.
- Disconnect the input power cord plug and remove the power supply from its mounting bracket. If the input power cord is suspect, remove it now; otherwise, leave it in place.

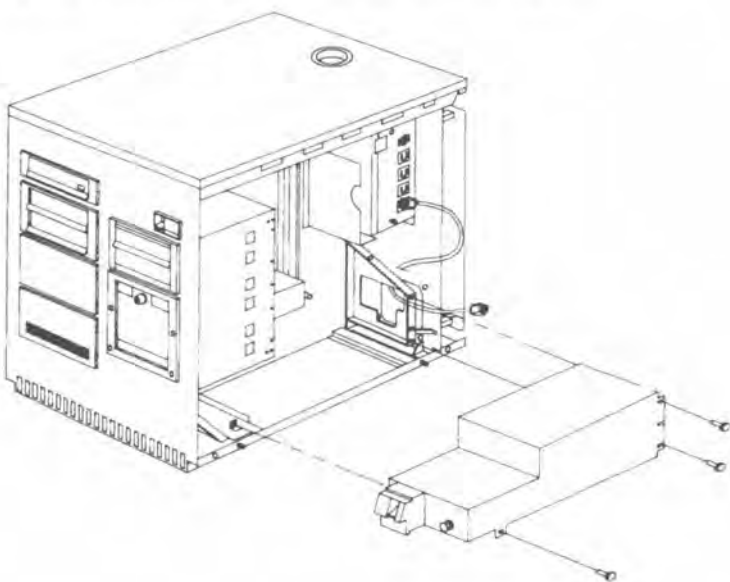

Removals and Replacements

Replacement

- Make sure the power switch is set to the **ON** position; the switch is not accessible after the power supply is installed.
- Reconnect the input power cord before the power supply is secured to the mounting bracket.
- Align the holes of the power supply and bracket. The bracket has a raised alignment tab on one end into which an opening on the power supply fits.
- Install the three screws that secure the power supply to the mounting bracket.
- Tighten all screws; the power supply should have no play in any direction.
- Connect the dc power cables from the power distribution board to the power supply.
- Install right cover (**1006**).

1057 Power Distribution Control Box

Removal

- Unplug the power cord from the electrical outlet.
- Remove right cover (1006).
- Remove rear cover (1007).
- Label and disconnect all cables from the power distribution control box **1**.
- Remove the attached ground wire **2** at the chassis frame.
- Remove the four screws while holding the box in place.

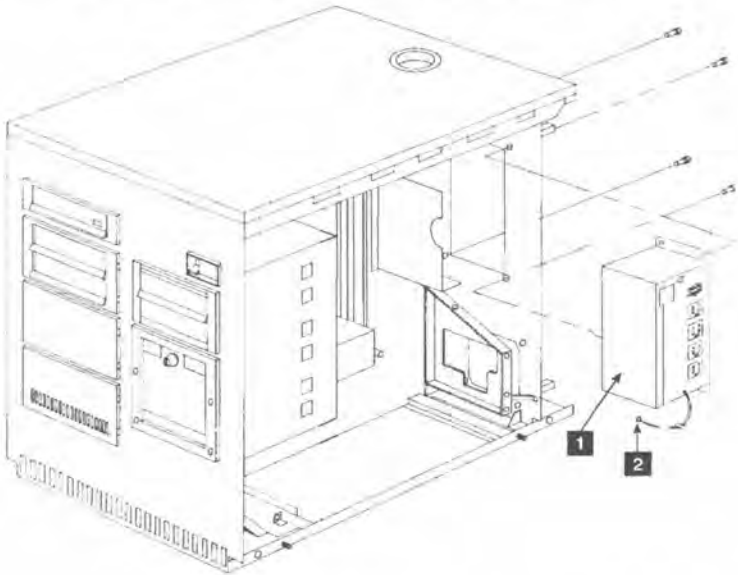

Replacement

- Secure the power distribution control box **1** with the four screws removed earlier.
- Connect all cables to the power distribution control box.
- Connect the ground wire **2** to the frame.
- Install rear cover (1007).
- Install right cover (1006).
- Plug the power cord to the electrical outlet.

1058 Fan

Removal

- Unplug the power cord from the electrical outlet.
- Remove rear cover (1007).
- Remove left cover (1005).
- Remove power supply (1055), if you cannot access the fan screws.
- Unplug the fan power cable from the power distribution board.
- Remove the four screws **2** and nuts that secure the fan **1** and fan guard to the chassis. Note that air flows into the chassis. Check for indicator arrows on fan housing.

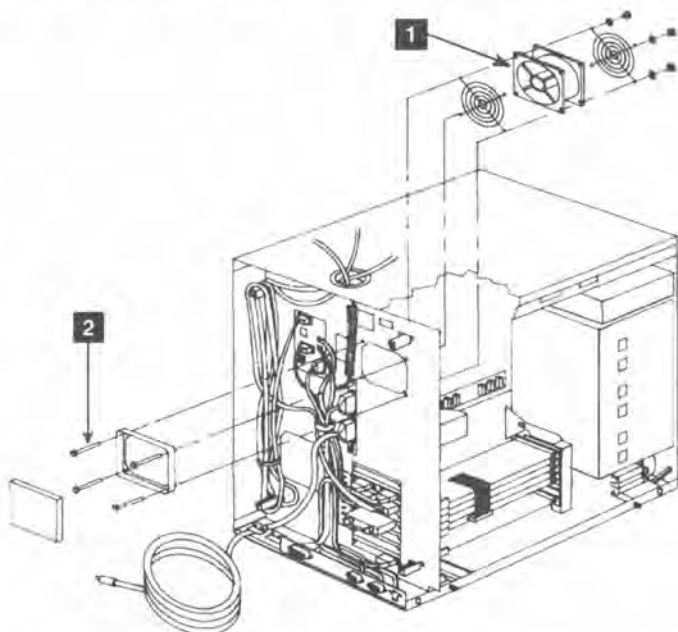

Note: Replace the filter periodically owing to the environmental conditions. The replacement interval should not exceed one year. Keep a dated record of filter replacements to ensure proper intervals.

Replacement

- Air flows into the chassis. Check for indicator arrows on the fan housing.
- Secure the fan **1** and fan guard to the chassis using the four screws **2** and nuts removed earlier. The fan guards are raised away from the blades.
- Plug the fan cable into the power distribution board.
- Install the filter.
- Install power supply (1055), if removed.
- Install left cover (1005).
- Install rear cover (1007).

1059 Fan (Optional)

Removal

- Unplug the power cord from the electrical outlet.
- Remove rear cover (1007).
- Remove right cover (1006).
- Remove power supply (1056), if you cannot access the fan screws.
- Unplug the fan power cable from the power distribution board.
- Remove the four screws **1** and nuts that secure the fan **2** and fan guard to the chassis. Note that air flows into the chassis. Check for indicator arrows on fan housing.

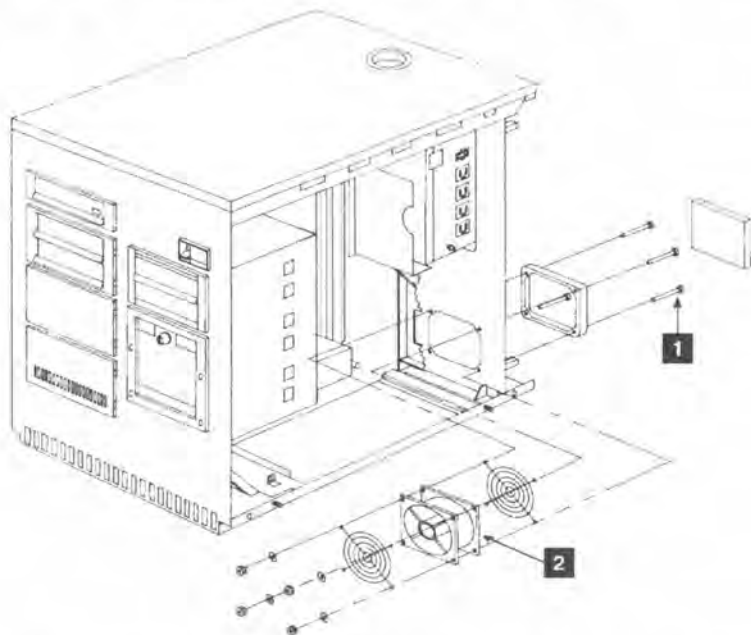

Note: Replace the filter periodically owing to the environmental conditions. The replacement interval should not exceed one year. Keep a dated record of filter replacements to ensure proper intervals.

Replacement

- Air flows into the chassis. Check for indicator arrows on the fan housing.
- Secure the fan **2** and fan guard to the chassis using the four screws **1** and nuts removed earlier. The fan guards are raised away from the blades.
- Plug the fan cable into the power distribution board.
- Install the filter.
- Install power supply (**1056**), if removed.
- Install right cover (**1006**).
- Install rear cover (**1007**).

1060 Diskette Drive

Removal

- Unplug the power cord from the electrical outlet.
- Remove left cover (1005).
- Remove front bezel (1035).
- Use a small screwdriver to lift the spring tab under the center of the drive, and simultaneously slide the drive forward approximately 50 mm (2 in.).
- Reach through the left side of the chassis to the rear of the diskette drive, and disconnect the flat cable from the drive.
- Slide the drive from the cage.

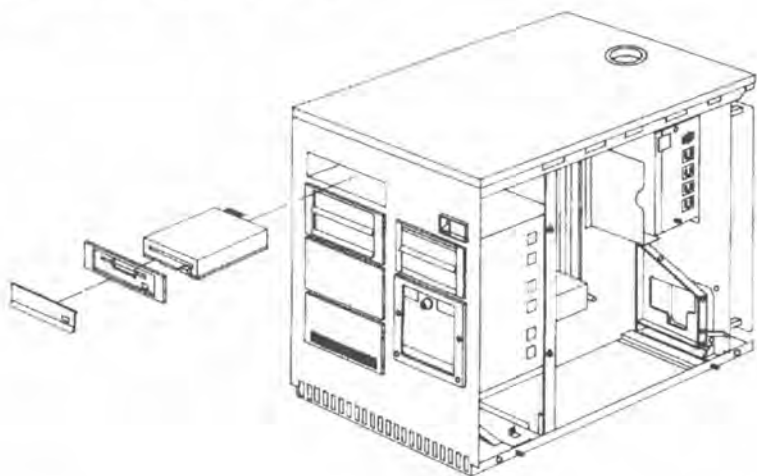

Replacement

- Slide the diskette drive into the top position of the cage.
- Connect the flat cable to the rear of the drive.
- Make sure that the drive is secured in the cage by the spring tab located under the center of the drive.
- Install front bezel (1035).
- Install left cover (1005).

1061 Speaker and Battery

WARNING:

The lithium battery presents a fire, explosion, or severe burn risk. Do not recharge it, remove the polarized connector from it, disassemble it, heat it above 100°C (212°F), incinerate it, or expose the cell contents to water. Dispose of the battery as required by local ordinances or regulations. When replacing the battery, use only P/N 72X8498. Use of another battery could result in ignition or explosion of the battery. Replacement batteries can be ordered from IBM or IBM Authorized Dealers.

AVERTISSEMENT:

Prenez garde aux risques d'incendie, d'explosion et de brûlures graves liés à l'utilisation d'une pile au lithium. Ne rechargez pas la pile, n'en retirez pas le connecteur et ne la démontez pas. Ne la chauffez pas au-delà de 100°C et n'en exposez pas le contenu à l'eau. Détruisez-la conformément à la réglementation en vigueur. Si vous la remplacez, commandez une pile de rechange sous la référence 72X8498: toute autre pile risquerait de prendre feu ou d'exploser. Les piles de rechange peuvent être obtenues auprès d'IBM ou d'un distributeur autorisé IBM.

Removals and Replacements

Caution:

To avoid accidentally discharging the battery, remove it before disconnecting the battery/speaker cable. Connect the cable before replacing the battery.

Attention:

Pour éviter que la pile ne se décharge accidentellement, retirez-la avant de déconnecter le fil haut-parleur-pile. Reconnectez le fil haut-parleur-pile avant de remettre la pile en place.

Removal

- Remove left cover (1005).
- Locate the speaker/battery assembly under the cage.
- Disconnect the speaker cable from the system board and remove the cable from the grommet. (See "System Board" on page 84.)
- Pull out the speaker assembly.
- Press and hold the latch **1** away from the battery to remove the battery **2**.

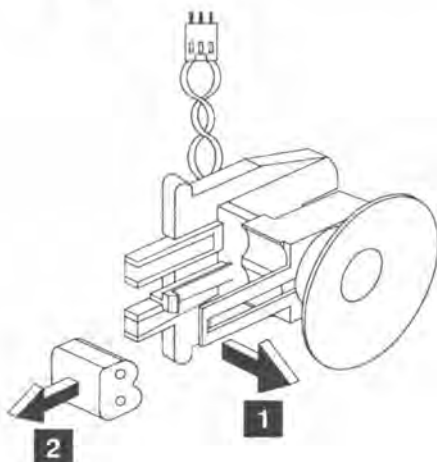

Replacement

- Replace the speaker or battery as required.
- Replace the speaker/battery assembly in the chassis.
- Route the cable through the grommet and connect it to the system board.
- Install left cover **(1005)**.

1062 Emergency Power Off (EPO) Switch

Removal

- Unplug the power cord from the electrical outlet.
- Remove right cover (1006).
- Remove front cover (1008).
- Disconnect the EPO cable from the power distribution control box.
- Remove the two cable clamps that secure the cable to the chassis.
- Remove the screw that secures the EPO ground to the chassis.
- Remove the bracket **3** and two screws that secure the bezel to the cover.
- Remove the two screws **1** that secure the EPO switch **2** to the bezel.

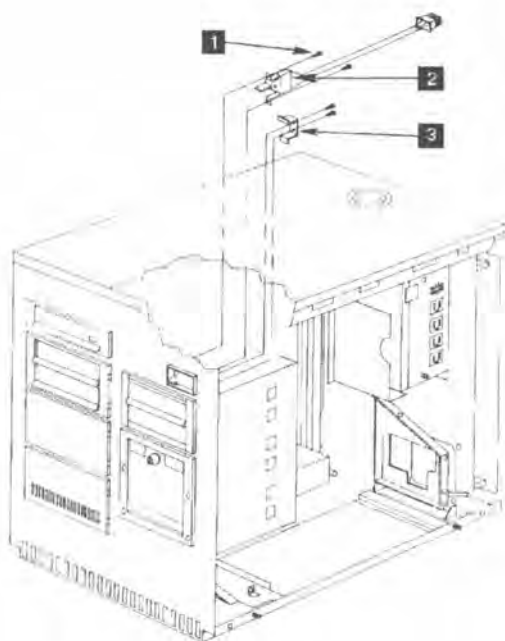

Replacement

- Secure the EPO switch **2** to the bezel using the two screws **1** removed earlier.
- Secure the bracket **3** with the two screws removed earlier.
- Route the EPO cable along the upper right side of the chassis interior and secure with the cable clamps removed earlier.
- Plug the connector into the power distribution control box.
- Secure the EPO ground wire to the chassis using the screw removed earlier.
- Install front cover (**1008**).
- Install right cover (**1006**).

1065 DRB Power Supply

Removal

- Unplug the power cord from the electrical outlet.
- Remove left cover (1005).
- Remove right cover (1006).
- Unplug the DRB hand-held unit from its power supply.
- Remove the bezel from the front of DRB power supply (1035).
- Unplug the DRB power supply from the power distribution control box (see page 83 for the location).
- Remove any cable ties that may be restraining the cable.
- Remove the plate **1** from the center frame divider.
- Unplug the DRB connector from P5 from the power distribution board on the left side of the system. See page 82 for the location. Thread this cable through to the right side of the system.
- Remove the power supply by pressing the locking pin **2** on the side of the cage and pushing the power supply forward at the same time.

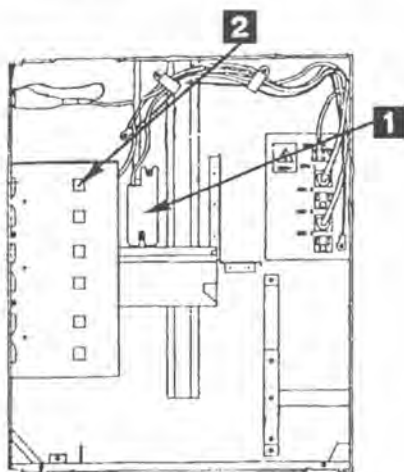

Replacement

- Slide the power supply into the frame ensuring that the locking pin **2** is engaged.
- Route the 5-volt sense cable through the center frame cutout to P5 on the power distribution card.
- Replace the plate **1** ensuring that the cable is not pinched.
- Connect the ac power cord to AUX2 on the power distribution control box.
- Replace cable ties as required.
- Replace the front bezel of the DRB power supply.
- Connect the DRB hand-held unit to the DRB power supply.
- Connect the power cord and power on the system.
- Verify correct operation of the DRB. If you have a failure, refer to "MAP 3000: DRB and Power Supply" on page 169.
- Install right cover **(1006)**.
- Install left cover **(1005)**.

1074 CD-ROM Drive Assembly

Type A versus Type B Drives

A "Type A" CD-ROM drive is the original type installed in the 7785 Service Bay System. A "Type B" CD-ROM drive is the replacement version of this unit. It can be distinguished from the Type A drive by the presence of a small audio jack and a volume control on its front panel. These controls are not present in the Type A drive.

Early 7785 systems in the field might still be equipped with Type A CD-ROM drives or, if the system's drives have been serviced, a mix of Type A and Type B. All new systems are equipped with Type B drives.

In every case, a failed CD-ROM drive (Type A or Type B) must be replaced by a Type B unit.

The procedures for removal and installation of Type A and Type B drives differ substantially. See below for details.

Removal (Type A)

- Unplug the ac power cord from the electrical outlet.
- Remove the left cover (**1005**).
- Remove and discard the front bezel (**1035**) from the defective drive unit. A new bezel is provided with the replacement Type B drive kit.
- Remove and discard the rear dust cover of the drive. Remove and discard the foam material inside.
- Disconnect the ground wire, the power connector, and the SCSI ribbon cable from the back of the drive.
- Remove the drive by pressing the spring clip on the side of the cage, then pushing from the back of the drive to slide it out the front.
- Record the SCSI ID switch settings. The replacement drive must have the same SCSI ID (logical address) as the unit removed. (See "Setting the SCSI ID for the Type A CD-ROM Drive" on page 95 or "Setting the SCSI ID for the Type B CD-ROM Drive" on page 98 for details).

- Dispose of the Type A CD-ROM drive using local branch office procedures.

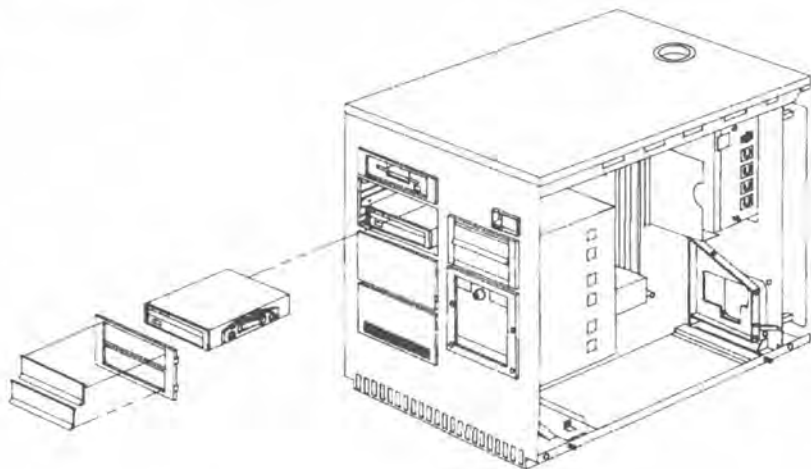

Removal (Type B)

- Unplug the system ac power cord from the electrical outlet.
- Remove the left cover (**1005**).
- Remove the front bezel (**1035**) from the defective drive unit.
- Disconnect the ground wire, the power connector, and the SCSI ribbon cable from the back of the drive.
- Remove the drive by pressing the spring clip on the side of the cage, then pushing from the back of the drive to slide it out the front.
- Record the SCSI ID switch settings. The replacement drive must have the same SCSI ID (logical address) as the unit removed. (See "Setting the SCSI ID for the Type A CD-ROM Drive" on page 95 for details).

Removals and Replacements

Replacement (Type B Only)

- Remove and discard the terminators from the new Type B drive, as shown in the following illustration.
- Set the jumpers of the new drive to match the SCSI ID (logical address) of the drive being replaced. (See "SCSI Configuration & Switch/Jumper Settings" on page 89 for details).
- Secure the drive in the cage by sliding it in until the spring clip engages. Depress the spring clip slightly to avoid jamming it against the cage during insertion.
- Connect the ground wire, the power connector, and the SCSI ribbon cable to the back of the CD-ROM drive.
- Install the front bezel (1035).
- Replace the left cover (1005).

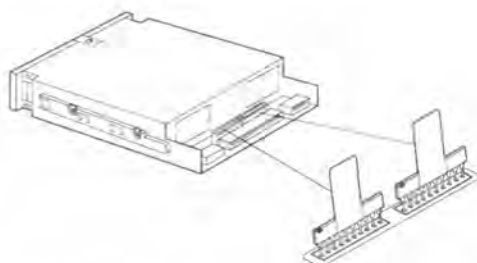

NOTE

Use the new CD-ROM test disk, part number 81F8902, for diagnostic testing of the Type B drive.

1080 System Board

Caution: To avoid accidentally discharging the battery, remove it before disconnecting the battery/speaker cable. Connect the cable before replacing the battery.

Attention: Pour éviter que la pile ne se décharge accidentellement, retirez-la avant de déconnecter le fil haut-parleur-pile. Reconnectez le fil haut-parleur-pile avant de remettre la pile en place.

Removal

- Unplug the power cord from the electrical outlet.
- Remove left cover (1005).
- Remove memory adapter (1015).
- Remove adapters (1020).
- Label all connectors and cables. See "System Board Connectors" on page 85.
- Disconnect all cables and grounds from the rear edge and component side of the system board.
- Remove the nine screws that secure the system board.
- Touch a bare metal ground before removing the system board.

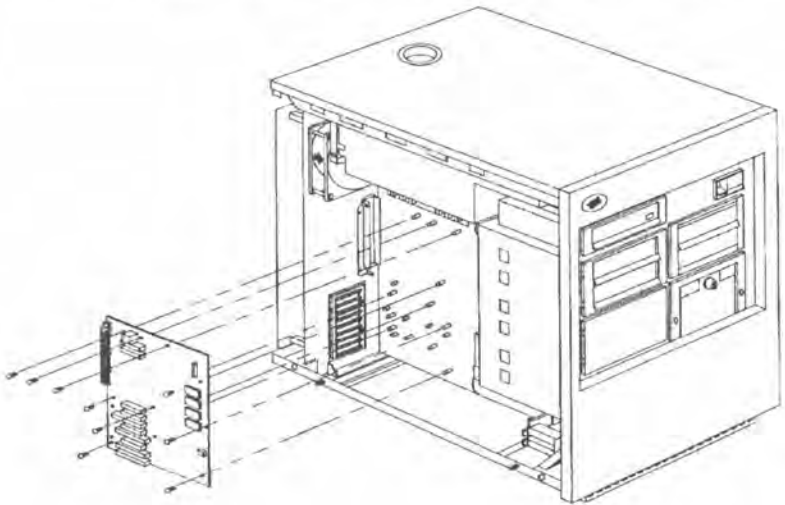

Removals and Replacements

Replacement

- Touch a system ground (bare metal), then carefully insert the left edge of the system board into the grounding bracket and the rear of the chassis.
- Secure the system board to the chassis using the nine screws removed earlier.
- Connect the ground spring bracket at the upper left corner of the system board.
- Install each adapter (**1020**) into the expansion slot from which it was removed. Adapters on your machine *may not* be plugged as shown in this manual.
- Install the memory adapter (**1015**).
- Install left cover (**1005**).
- Run **Restore configuration**, using the reference diskette to restore time, date, and other configuration data.

1090 Hard Disk Drive

Caution:

Shipping and handling can result in permanent loss of all data and formatting on the hard disk drive. Have the user backup all information from the hard disk drive before removing it.

Attention:

L'expédition et la manipulation du système de diagnostic pour automobile peut entraîner la perte définitive de toute l'information et des données de formatage contenues sur le disque fixe. Il est important que l'utilisateur fasse une copie de sauvegarde avant de retirer l'unité de disque.

Removal

- Unplug the power cord from the electrical outlet.
- Remove left cover (1005).
- Remove front cover (1008).
- Remove front bezel (1035).
- Disconnect the power and signal cables from the drive.
- The hard disk has a slide on each side; when mounted in the cage, the slide with the spring clip is exposed. Press the spring clip on the outside of the cage to remove the drive.
- Pull the hard disk drive from the front.
- Remove the four screws securing the mounting plate to the disk drive.

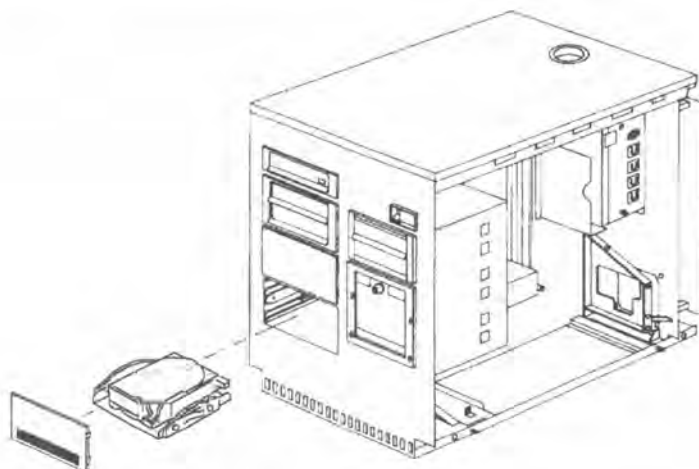

Replacement

- Remove the terminators from the new drive and discard.
Note: The terminators for the bus are built into the cable.
- Secure the mounting plate to the disk drive with the four screws.
- Set the switches to match the drive being replaced.
- Slide the disk into the bottom of the cage until the spring clip on the slide is engaged.
- Connect the cables to the hard disk drive.
- Install the front bezel (1035).
- Install the front cover (1008).
- Install the left cover (1005).

1095 Display

WARNING: Because of its weight (47.0 lb — 21.3 kg) and shape, request assistance to lift the display from its position atop the main chassis.

AVERTISSEMENT:

L'écran pèse 21,32 kg et est de forme irrégulière. Demandez l'aide de quelqu'un pour le soulever du système de diagnostic pour automobile.

Removal

- Pull the keyboard and tray **3** forward.
- Remove rear cover (1007).
- Disconnect the display ac power cord at the Power Distribution Control Box. Remove all plastic cable ties that secure the power cord.
- Disconnect the display signal cable at the Image Adapter/A connector on the rear of the main chassis. Remove any plastic cable ties securing the cable.
- Feed the cables into the keyboard enclosure **2**. Remove the four screws (two on each side of the mounting base) that secure the display and mounting base to the keyboard enclosure.
- Carefully lift the display and mounting base **1** from the keyboard enclosure **2** while pulling the signal and power cables through the hole in the top of the main chassis.
- Place the display on its side on a flat surface (a three-foot high table or cart that is braked or blocked from movement).
- Remove the screws underneath the mounting base, that attach it to the display. Remove the mounting base and save for reinstallation later.
- Cut the cable tie that secures the display power and signal cables to the mounting base. Pull the signal cable through the hole, and make sure that the power cable moves freely.
- Disconnect the right-angled power cable plug from its connector near the rear of the display. The display signal cable is permanently attached to the display assembly and cannot be removed.

Removals and Replacements

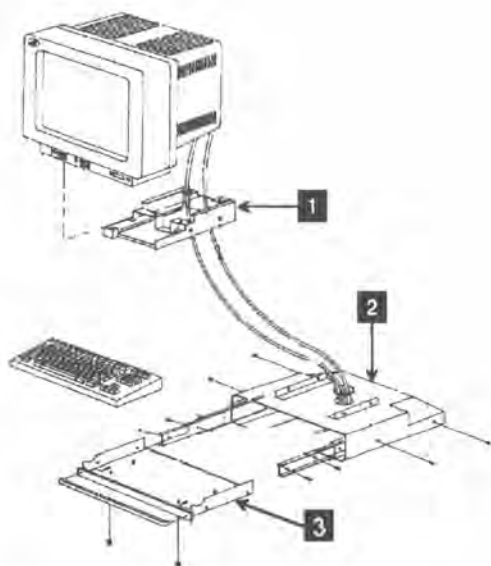

Replacement

- Insert the right-angled power cable plug into its connector. Secure the cable with a cable tie.
- Attach the mounting base **1** to the display using the four screws removed earlier.
- Place the display on the keyboard enclosure.
- Route both cables through the keyboard enclosure **2** so that it hangs down the back of the main chassis.
- Secure the display and mounting base to the keyboard enclosure **2** using the four screws removed earlier.
- Slide the keyboard and tray **3** into the keyboard enclosure.
- Connect the display signal cable at the Image Adapter/A connector on the rear of the main chassis.
- Connect the display ac power cord to the SENSE outlet on the power distribution control box.
- Replace plastic cable ties to secure the signal and power cables.
- Install the rear cover (1007).
- Verify operation of the new display by running diagnostics.
- Replace decals as required.

1096 Keyboard

Removal

- Remove the keyboard from the tray and disconnect the keyboard cable from the back of the keyboard.
- If the *keyboard cable* is being replaced, disconnect it from the system board connector at the rear of the main chassis and pull it through the hole at the top of the main chassis. Cut and discard any cable ties that secure the cables routed through the keyboard enclosure.
- If the *keyboard tray* is being replaced, pull out the tray and remove the screws (two on either side) that secure the keyboard tray to the tray slides.
- If either of the *tray slides* is being replaced, remove the screws that secure each tray slide to the right or left side of the keyboard enclosure.

Replacement

- Connect the keyboard cable connector to the back of the keyboard, and place the keyboard on the locator pins in the tray. Push the tray into the enclosure, checking that the action is smooth and the cables move freely.
- If the *keyboard cable* is being replaced, route the cable through the keyboard enclosure and the hole in the top of the main chassis. Connect it to the system board connector at the rear of the main chassis. Replace any cable ties to secure the cables to the chassis.
- If the *keyboard tray* is being replaced, secure the keyboard tray to the tray slides with the four screws (two screws on each side) removed earlier.
- If the either of the *tray slides* is being replaced, secure each tray slide to the sides of the keyboard enclosure with the two screws removed earlier.

Locations

Front View

- 1** Display
- 2** Display controls on the mounting base
- 3** Keyboard enclosure
- 4** Emergency Power Off (EPO) switch
- 5** Right cover
- 6** Cart
- 7** Wheel brake
- 8** Front and rear wheels
- 9** DRB storage drawer
- 10** Storage drawer
- 11** Front cover
- 12** CD-ROM drive expansion area
- 13** DRB power supply and connector
- 14** CD-ROM drive assemblies
- 15** Diskette drive assembly and in-use light
- 16** Keyboard

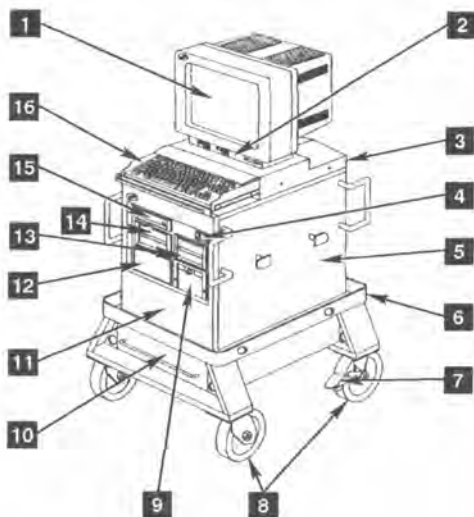

Rear View

The view shown has the cover removed.

- 1** Keyboard enclosure
- 2** Left cover
- 3** Rear cover
- 4** Connector panel
- 5** DRB cable
- 6** Power cord
- 7** Telephone cutout panel

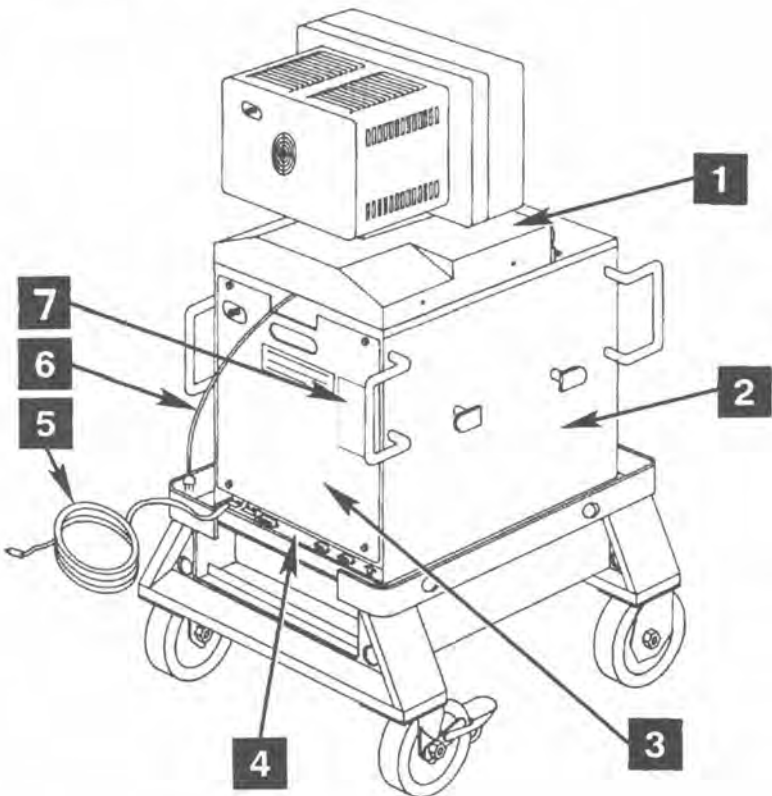

Interior View (Left)

- 1** Power supply
- 2** Cage
- 3** Diskette drive
- 4** Diskette drive in-use light
- 5** CD-ROM drives
- 6** CD-ROM drive expansion area
- 7** Hard disk drive
- 8** Battery and speaker assembly
- 9** Adapters
- 10** Expansion slots (numbered from bottom, 1 to 8)
- 11** System board
- 12** Memory adapter
- 13** Power distribution card
- 14** Fan

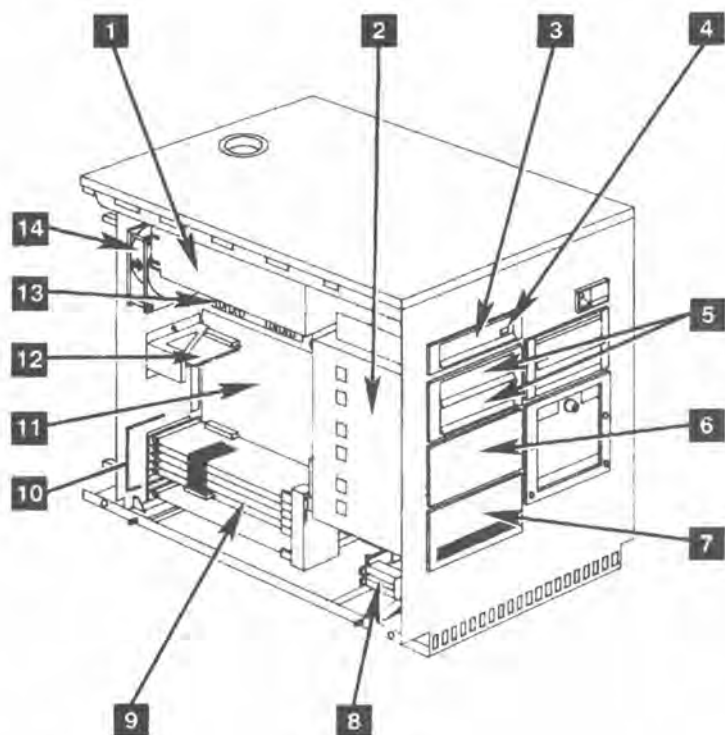

Interior View (Right)

- 1** Emergency Power Off (EPO) switch
- 2** Cage
- 3** Power distribution control box
- 4** Fan (optional) mounting area
- 5** Power supply (optional) mounting area
- 6** DRB storage drawer
- 7** DRB power supply and connector

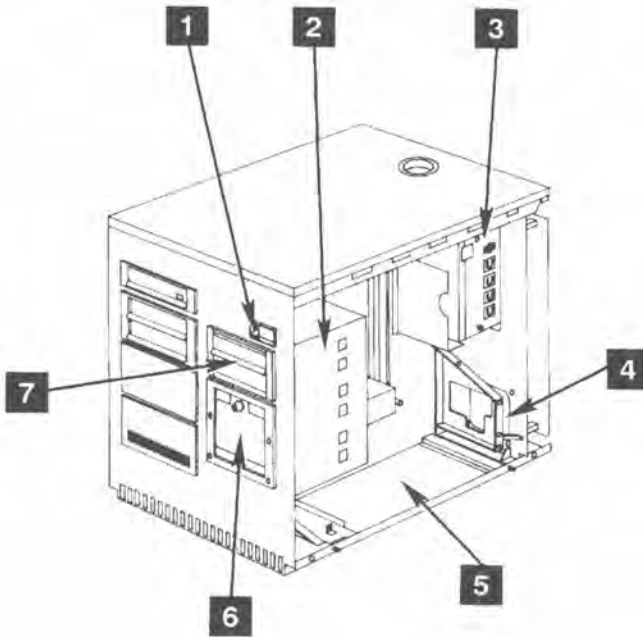

Power and Internal Cables (Left)

- 1** Power supply
- 2** CD-ROM power cable (primary)
- 3** Hard disk drive power cable
- 4** Diskette drive signal cable
- 5** Diskette drive
- 6** System board/diskette drive connector
- 7** Cage
- 8** Hard disk signal/data cable
- 9** Speaker/battery assembly
- 10** Speaker cable
- 11** Disk bus cable
- 12** Cable, ground
- 13** Cable, hard disk ground
- 14** DRB power supply cable
- 15** Line cord, power (CPU)
- 16** Fan assembly
- 17** Power supply cable (to distribution board)

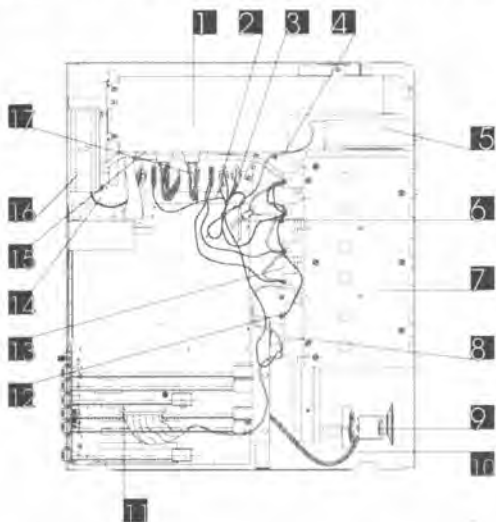

Power and Internal Cables (Right)

- 1** EPO switch
- 2** EPO switch ground wire (black)
- 3** CPU power cable
- 4** Power distribution control box
- 5** EPO cable connector
- 6** CPU power cable connection
- 7** DRB power cable
- 8** Power distribution control box ground wire
- 9** Manual storage bracket
- 10** DRB power supply
- 11** DRB power cable

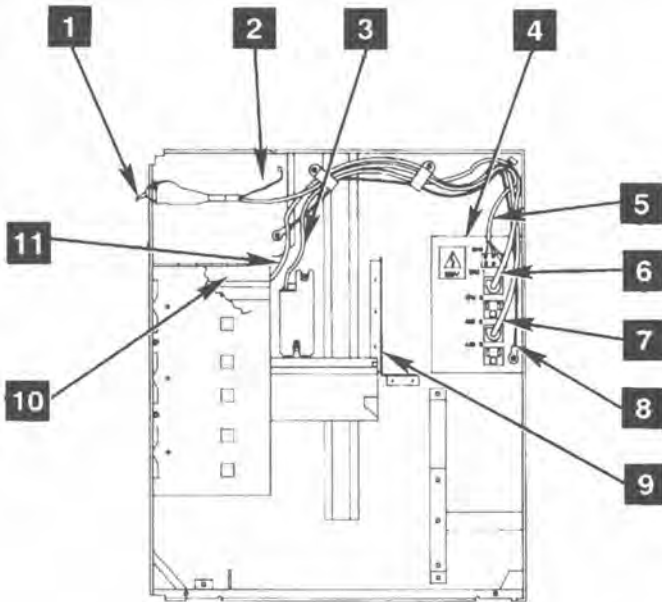

System Board

- 1** Expansion slots (8)
- 2** Power connector
- 3** Memory expansion slot
- 4** Diskette drive connector
- 5** Battery/speaker connector
- 6** Speaker cable
- 7** Speaker
- 8** Speaker battery
- 9** GPIB adapter
- 10** SCSI adapter
- 11** Modem adapter
- 12** Image adapter/A
- 13** Dual asynchronous adapter
- 14** Memory adapter
- 15** Ethernet adapter

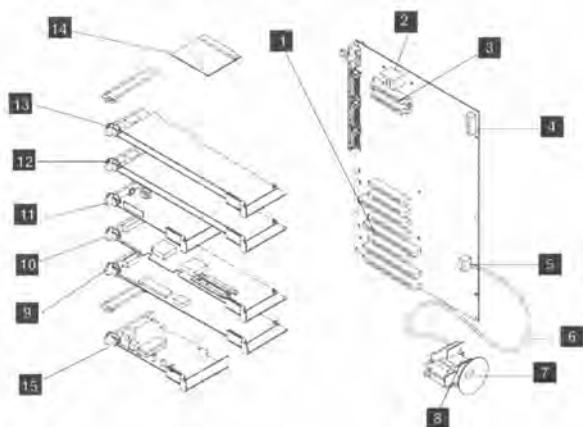

System Board Connectors

- 1** Power supply
- 2** Diskette drive
- 3** Memory expansion
- 4** Battery/speaker assembly
- 5** Ethernet adapter
- 6** SCSI adapter
- 7** Modem adapter
- 8** Image adapter/A
- 9** Dual Asynchronous adapter
- 10** Display
- 11** Serial port
- 12** Parallel port
- 13** Keyboard
- 14** GPIB adapter

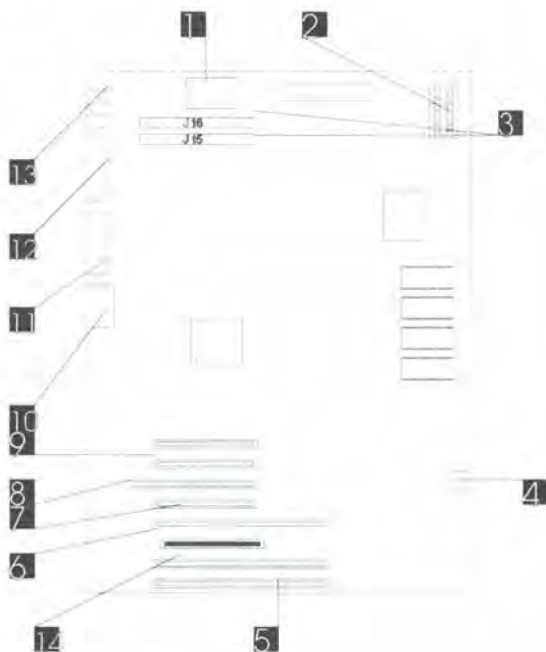

Cabling and Safety Ground Wiring

Model 114

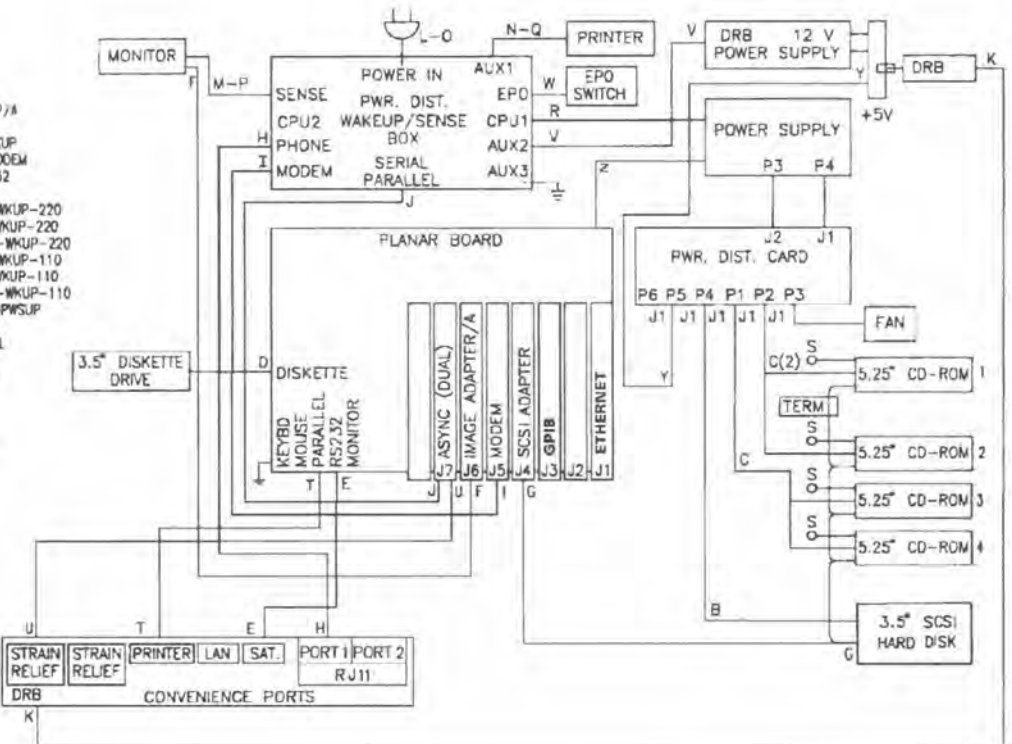

- A CON-LAN
 B PWR HDL/1
 C PWR CD/2
 D SIG FLOPPY
 E SAT-RS232
 F MON-IMG ADP/A
 G SIG CD/6
 H PHON CONV-WKUP
 I PHON WKUP-MODEM
 J SIG WKUP-RS232
 K CABLE
 L AC PWR WALL-WKUP-220
 M AC PWR MON-WKUP-220
 N AC PWR PRNTR-WKUP-220
 O AC PWR WALL-WKUP-110
 P AC PWR MON-WKUP-110
 Q AC PWR PRNTR-WKUP-110
 R AC PWR WKUP-PWSUP
 S GROUND-DASD
 T CON-PRNT-PARL
 U DRB-RS232
 V PWR SUP-DRB
 W EPO ASH
 X HDL DATA
 Y +5V DRB
 Z SYS BD PWR

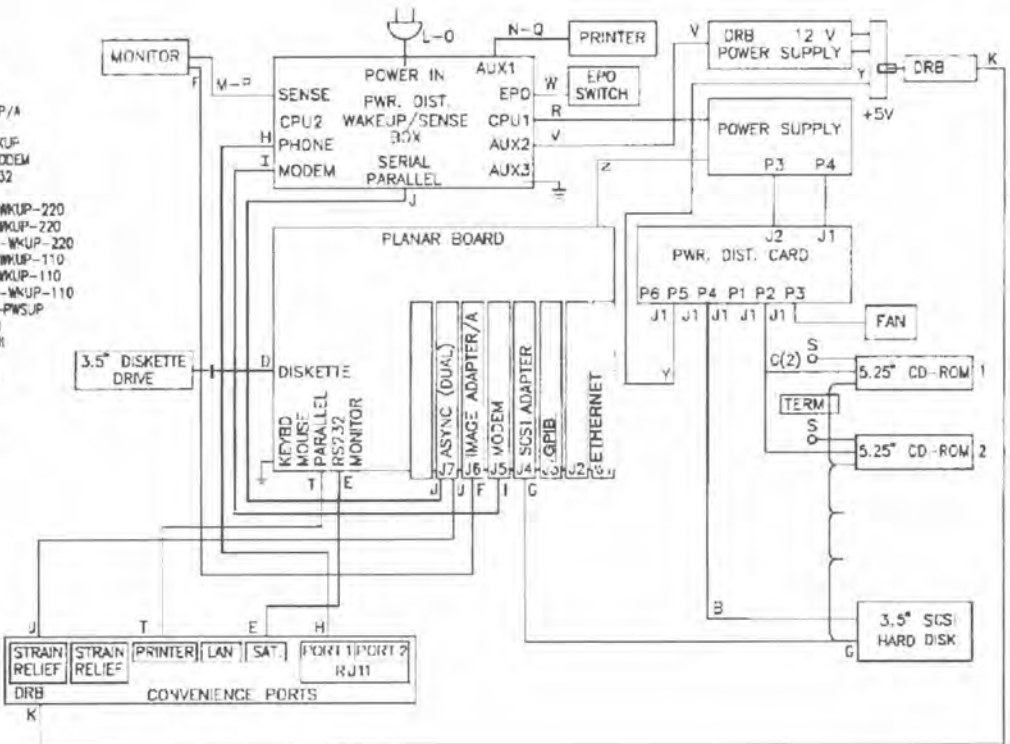

- A CON-LAN
 B PWR HOFL/1
 C PWR CD/2
 D SIG F.DIPPY
 E SAT-RS232
 F MON-IND ADP/A
 G SIG CD/6
 H PHON CONV-WKUP
 I PHON WKUP-MODEM
 J SIG WKUP-RS232
 K CABLE
 L AC PWR WALL-WKUP-220
 M AC PWR MON-WKUP-220
 N AC PWR PRNTR-WKUP-220
 O AC PWR WALL-WKUP-110
 P AC PWR MON-WKUP-110
 Q AC PWR PRNTR-WKUP-110
 R AC PWR WKUP-PWSUP
 S GRO.IND- (DAS)
 T CON-PRNT-PARI
 U DRIB-FIS232
 V PWR SUP-DRB
 W EPO ASM
 X HOFL DATA
 Y +5V DRB
 Z SYS BD PWR

Locations

Power Distribution Card

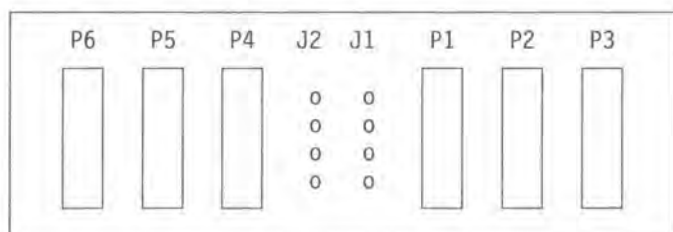

Power Distribution Control Box

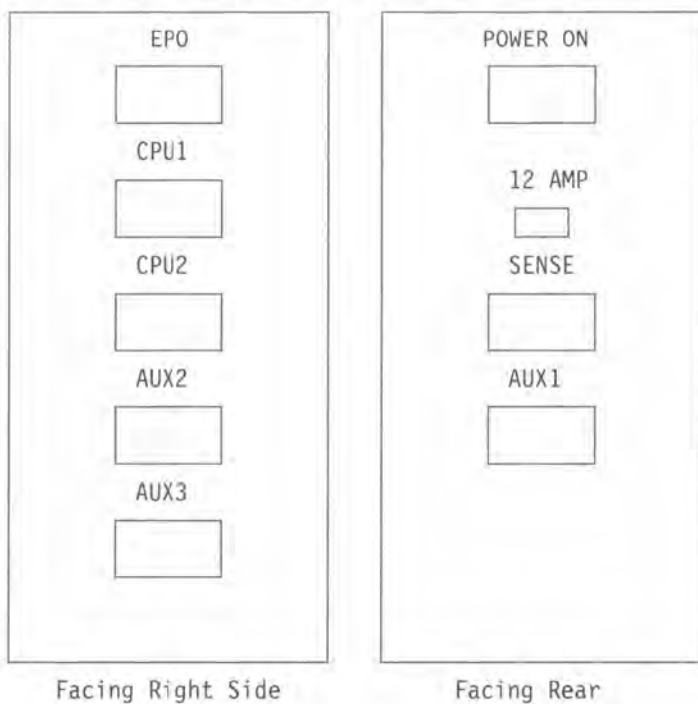

SCSI Configuration & Switch/Jumper Settings

Configuration changes might accompany your installation. This section explains how to modify the configuration program and set the switches or jumpers on the SCSI devices.

Customizing the Configuration

Refer to "Using the Reference Diskette" on page 24 to update the system configuration data. Do not use the default settings on the Reference Diskette. These settings change according to customer requirements. The Chrysler Corporation application requires the following modification:

1. Insert the Reference Diskette into the diskette drive.
2. Turn the system on. If the system is already running, turn it off briefly, then turn it back on.
3. Press **Enter** when the first screen appears.
4. Select Set Configuration and press **Enter**.
5. Select Change Configuration and press **Enter**.
6. When the **Change Configuration** menu is displayed, move the cursor to **Built in Features Serial Port**.
7. Press **F6** until the setting is changed to **Serial 2**.
8. Press **F8** to advance to the next screen.
9. Move the cursor to **IBM 300/1200/2400 Internal Modem/A Serial Configuration**.
10. Press **F6** until the setting is changed to **Serial 1**.
11. Press **F10** to save the configuration.
12. Select **Backup configuration** to copy the new configuration to the backup copy of the Reference Diskette.
13. Press **F3** several times to back out of the program.
14. Remove the Reference Diskette and restart the system by turning it off, then back on.

SCSI ID

Each SCSI device connected to a SCSI adapter must be assigned a unique identification number or logical address, called the SCSI ID, at installation time. The SCSI ID (6 through 0) that you assign to the hard disk drive depends on the number of devices attached to the adapter. The ID determines the priority of the device. A read/write device such as a hard disk drive, should be assigned a high-priority ID, such as 6 or 5. A read-only device, such as a CD-ROM, should be assigned a low-priority ID, such as 0 or 1.

Before preparing the system for modifications, touch a metal expansion-slot cover with your hand to discharge to ground any static electricity buildup from handling the hard disk drive. Unplug all power cords from electrical outlets before removing any covers.

Use the following procedure to assign a SCSI ID to a drive:

1. Insert the backup copy of the Reference Diskette into drive A and turn on the computer.
2. Select *Set configuration* from the main menu, then select **Set and view SCSI device configuration**.

The SCSI ID for each installed SCSI device is displayed on the line that begins with **Device Address**. The ID appears in a set of two numbers, separated by a comma (for example 6,0). The first number is the ID assigned to the installed SCSI device. Note the ID for each installed SCSI device.

If there are no SCSI devices connected to the SCSI adapter, the screen shows only the slot in which the adapter is installed and the ID assigned to the adapter.

3. If the system has one or more SCSI devices already connected, select the highest unused ID. If the system has no SCSI devices connected, assign SCSI ID 6 to the drive you are installing. See "Setting the SCSI ID for the Hard Disk Drive" on page 91 and "Setting the SCSI ID for the Type A CD-ROM Drive" on page 95 to set the switches.

Setting the SCSI ID for the Hard Disk Drive

The hard disk drive should always be set to SCSI ID 6.

Locate the set of four switches at the connector end of the hard disk drive. The ON position for each switch is *toward* the connector end of the drive.

1. Check that switch 4 is set to the ON position. Use a ballpoint pen, as shown, and set the switch correctly.

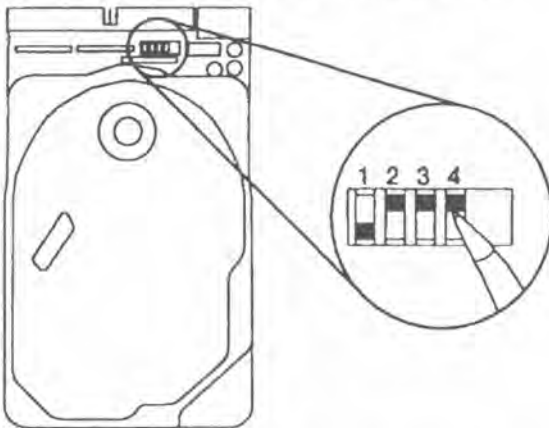

2. Set switches 1, 2, and 3 for the ID of the device, as follows:

SCSI ID	1	2	3	4
6	ON	ON	ON	OFF
5	ON	ON	OFF	OFF
4	ON	OFF	OFF	OFF
3	ON	OFF	ON	OFF

SCSI ID	1	2	3	4
2	OFF	ON	ON	OFF
1	OFF	ON	OFF	OFF
0	OFF	OFF	OFF	OFF

Locations

Terminators for the Hard Disk Drive

Locate and remove the three terminators at the back of the drive you are installing. Pull straight up on the tabs imprinted with **T-RES**. In the system unit, the terminators are on the cable.

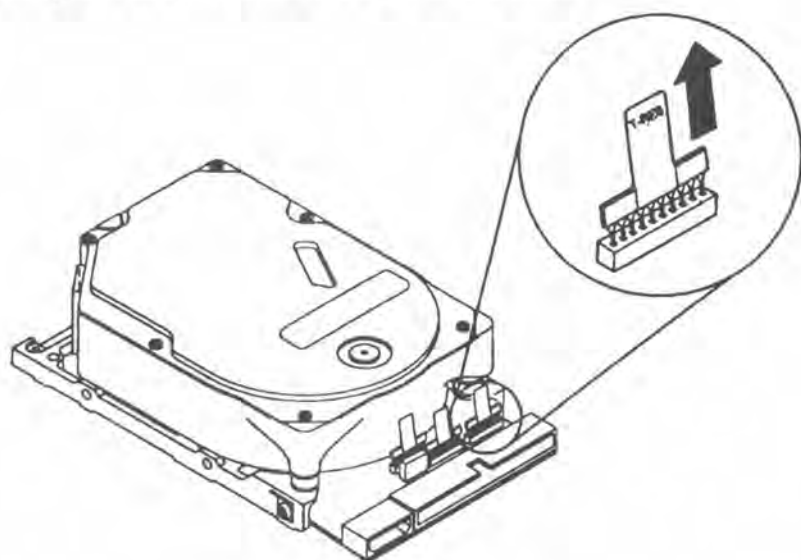

Assignment of Letter Designators

The IBM DOS operating system assigns a letter to each drive; for example, drive C:.

Note: The operating system determines the number of hard disk drives supported. The customer should contact the place of purchase or the operating system manufacturer for additional information.

If all the drives in the system are SCSI drives, the operating system assigns the drive designations based on the SCSI IDs of the drives. The drive with the highest ID receives the lowest available letter designation. For example, if the SCSI IDs for four drives were 6, 5, 4, and 3, those drives would be designated drives C:, D:, E:, and F:, respectively.

If non-SCSI hard disk drives are installed, they retain their original drive designations. The first SCSI drive installed will be assigned the next available letter designation.

Keep a record of where each drive is physically installed inside the system unit, the SCSI ID of each drive, and the letter designation that the operating system assigns to each drive.

Locations

Compact Disk Drive (Type A and Type B)

The CD-ROM drive assembly is a compact disk with a capacity of more than 500 million bytes. The surface of the compact disk is protected from oil and dirt by the *caddy*. A disk is placed in the caddy before the caddy is inserted into the loading slot **1**.

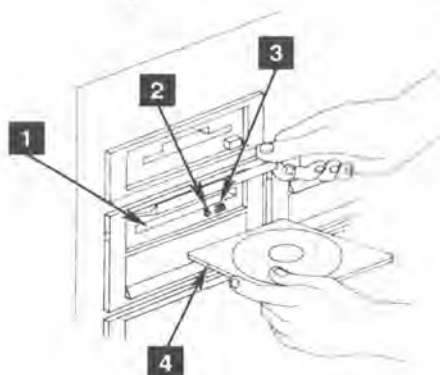

Always press the Eject switch, **3**, before inserting the disk caddy. This ejects any caddy that might be present in the disk slot even if the Busy indicator light **2** is not on. If the system is turned off, the loading function cannot be used when a disk caddy **4** is inserted into the slot.

When the system is turned on and a caddy is in the drive, pressing the Eject switch for more than one second ejects the caddy. If the switch is accidentally pressed while the drive is in use, the eject function does not operate.

The Busy indicator light stays lit during a data access operation and blinks during a data-transfer operation.

Setting the SCSI ID for the Type A CD-ROM Drive

The uppermost CD-ROM drive should always be set to SCSI ID 0.

A six-section switch at the rear of the compact disk drive provides addressing capability when multiple compact disks are used in the system.

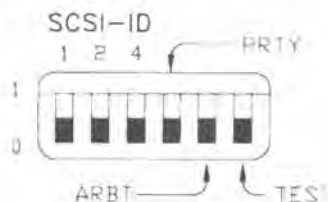

SCSI ID A 3-bit binary switch that sets the address identification (ID) for the Small Computer System Interface (SCSI) data bus when more than one compact disk drive is used. Switch 1 is the least significant bit (LSB) and switch 4 is the most significant bit (MSB). See Table 3 for the ID addresses.

Table 3. SCSI ID Switch Function Definitions

SCSI ID	Switch Position		
	1 (LSB)	2	4 (MSB)
7	1	1	1
6	0	1	1
5	1	0	1
4	0	0	1
3	1	1	0
2	0	1	0
1	1	0	0
0	0	0	0

Locations

PARITY A single switch that activates the parity-bit check function on the SCSI data bus. The switch setting is not relevant if no parity-generation function is provided. The switch is set to 0 because no parity bit is used. See Table 4 for the switch position definitions.

Table 4. PARITY Switch Function Definitions

Switch Position	Function
0	Drive does not execute parity check, but does develop an output-data parity byte.
1	Drive executes the parity-check function.

ARBT A single switch that activates the arbitration function for the data bus. The switch is set to 0. See Table 5 for the switch position definitions.

Table 5. Arbitration Switch Function Definitions

Switch Position	Function
0	No ARBITRATION system is selected.
1	ARBITRATION system is selected.

TEST A single switch that activates the test-mode function; set the switch to its 0 position for normal use of the CD-ROM drive. See Table 6 for definition of the switch settings when used with the PARITY and ARBT switches.

Table 6. TEST Switch Function Definitions

PRTY Switch	ARBT Switch	TEST Switch	Function
—	—	0	Normal operational mode.
0	0	1	Audio reproduction mode (set all SCSI ID switches to 0). Allows repeated reproduction in the audio mode from beginning to end of the program area. The output is muted on the data track. Pressing the EJECT switch for 0.1 to 1.0 second moves to the beginning of the next track number. Pressing the EJECT switch for longer than one second ejects the CD caddy.
0	1	1	Focus adjustment mode (set all SCSI ID switches to 0). Use this setup when conducting repairs or adjustments. Do not use for normal operations.
1	0	1	Tracking adjustment mode (set all SCSI ID switches to 0). Use this setup when conducting repairs or adjustments. Do not use for normal operations.

Figure 30 identifies the pins for the CD-ROM drive input power connector on the rear of the drive.

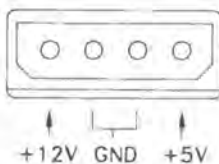

Figure 30. Input Power Connector Pins

Terminators for the Type A CD-ROM Drive

The Type A CD-ROM drive does not use internal terminators.

Locations

Setting the SCSI ID for the Type B CD-ROM Drive

The CD-ROM drives are addressed as SCSI ID 0 to 6 from top to bottom.

The pin block, at the rear of the drive, contains the jumpers used to set the SCSI ID.

1. Locate the pin block. Use the left three pairs of pins **1** to set the SCSI ID (the jumpers are preset to ID 3).
2. The right three pairs of pins **2** are jumpered as shown.

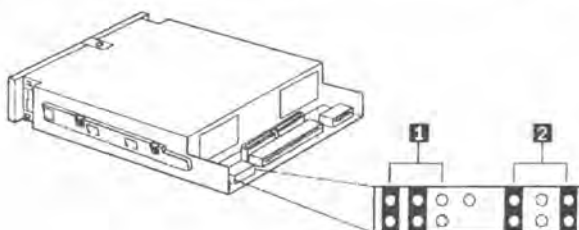

3. Refer to the figure below and note where to place the jumpers (represented by black rectangles) to set the SCSI ID for this drive.

SCSI ID	Jumper Position		SCSI ID	Jumper Position
6	: ■ ■		2	: ■ :
5	■ : ■		1	■ : :
4	: : ■		0	: : :
3	■ ■ :			

4. Remove a jumper by pulling it straight up. Replace the jumper by aligning the two holes in the bottom of the jumper with the appropriate two pins on the pin block. Then push the jumper onto the pins until it is completely seated and covers both pins. Store jumpers you do not use in a safe place in case you want to change the ID.

5. Write the ID that you assigned to this drive on the label marked "SCSI ID." The label is located on the top of the drive.

Locations

Hardware Maintenance Service

SECTION 4. Start

MAP 0000: Start	104
Undetermined Problem	119

MAP 0000: Start

These MAPs and the diagnostic diskette test *only* IBM® products. Non-IBM products, prototype adapter cards, or modified options can give false errors and invalid system responses. Remove all non-IBM attachments before running the diagnostic tests.

IMPORTANT:

- If more than one error code is shown, diagnose the first displayed error code. The cause of the first error code sometimes causes false error codes to be displayed.
- If an adapter or device consists of more than one FRU, an error code may be caused by any of the FRUs. Remove and replace the indicated FRUs one by one, to see if the symptoms change as each is replaced. If no change occurs when an indicated FRU is replaced, reinstall the original FRU.

001

– Verify that:

- All internal and external connectors are attached correctly.
- The system configuration matches the options installed in the system. If it does not match, change the configuration using the **Set configuration** option on the reference diskette. If an installed device is not recognized after you change the configuration, replace that device.

– Turn off the system.

– Insert your reference diskette into the diskette drive.

– Turn on the system.

THE FAN IS LOCATED IN THE UPPER LEFT REAR OF THE MAIN CHASSIS. IS THE FAN RUNNING?

Yes No

002

(Step 002 continues)

* IBM is a registered trademark of the International Business Machines Corporation.

002 (continued)
Go to Step 034 on page 110.

003

– Listen carefully for any audible responses during the POST.
DID YOU HEAR ONE SHORT BEEP AT THE END OF THE POST?

Yes No

004

Go to Step 006.

005

Go to Step 011 on page 106.

006

(From step 004)

DID YOU HEAR 2 SHORT BEEPS AND RECEIVE A POST ERROR MESSAGE BEFORE THE IBM LOGO SCREEN APPEARED?

Yes No

007

Go to Step 051 on page 113.

008

WAS THE ERROR MESSAGE A 161, 162, OR 163?

Yes No

009

Go to Step 011 on page 106.

010

Find your error message in Table 7 on page 106 and take the action indicated.

Note: If you received a 161, 162, or 163 error message with another error message, go to Step 011 on page 106.

Table 7. 16X Errors

Error Message:	Action:
161 (battery error)	Replace the battery, then run the Set configuration program.
162 (configuration error)	Run the Set configuration program and verify that the options are set correctly. If that does not solve the problem, go to Step 011 on page 106.
163 (time and date error)	Run the Set features program. If that does not solve the problem, replace the system board.
16X (not listed above)	Go to Step 011 on page 106.

011

(From steps 005, 009, and 010)

DID THE IBM LOGO SCREEN APPEAR?

Yes No

012

Go to Step 052 on page 114.

013

– Follow the instructions on the screen and advance to the Main Menu. At the Main Menu, press **Ctrl-A** to start the advanced diagnostic tests.

DID THE ADVANCED DIAGNOSTIC MENU APPEAR?

Yes No

014

Go to Step 048 on page 112.

015

– Follow the instructions on the screen and run all of the tests.

(Step 015 continues)

015 (continued)

- If the test indicates a specific device failure, proceed to the Device Test Menu and run the diagnostic test on the failing device.
- If you experience incorrect keyboard responses, go to "MAP 0300: Keyboard."
- If the system does not complete testing, or a 112 or 113 error message appears, replace the adapter being tested at the time the error occurred.

DID THE POST OR ADVANCED DIAGNOSTIC TESTS DETECT A FAILURE?

Yes No

016

Go to Step 025 on page 108.

017

DID YOU RECEIVE A 165 ERROR MESSAGE?

Yes No

018

Go to Step 020.

019

Go to Step 028 on page 108.

020

(From step 018)

WAS AN ACTION INDICATED BY THE TESTS?

Yes No

021

Go to the MAP that corresponds to the error message. For example, if you receive the error message 3XX, go to "MAP 0300: Keyboard." If you are unable to find the MAP that corresponds to your error message, you have an IBM device with

its own service manual or a device not supported by the advanced diagnostic tests; refer to the manual for that device. You may refer also to the "Symptom-to-FRU Index" on page 116, for additional information about the malfunctioning part.

022

– Take the action indicated by the tests.

DID THE ACTION INDICATED CORRECT THE PROBLEM?

Yes No

023

If the tests instructed you to replace a FRU and you are here for the second time for the same problem, the "Symptom-To-FRU Index" on page 116 may provide additional information.

024

Go to Step 030 on page 109.

025

(From step 016)

DID YOU NOTICE SYMPTOMS OR FAILURES THAT WERE NOT DETECTED BY THE TESTS?

Yes No

026

Go to Step 030 on page 109.

027

Go to Step 052 on page 114.

028

(From step 019)

– Run the **Set configuration** program, using "Change configuration," and correct any errors.

(Step 028 continues)

028 (continued)

– Turn off the system. Wait 10 seconds, then turn on the system.
DID RUNNING THE “SET CONFIGURATION” PROGRAM SOLVE THE PROBLEM?

Yes No

029

Go to Step 031.

030

(From steps 024 and 026)

You have finished the advanced diagnostic tests.

- If you are still experiencing a failure, check all cables and connectors for proper installation.
- If you are experiencing a problem with an IBM device not supported by the advanced diagnostic tests on the reference diskette, refer to the service manual of that device for testing instructions.
- If you are experiencing an intermittent 162 or 165 problem (system options not set), replace the battery.
- If you suspect any other intermittent problem, start an error log.

031

(From step 029)

WAS A SLOT WITH AN INSTALLED ADAPTER LISTED AS EMPTY OR AS HAVING AN UNRECOGNIZED ADAPTER?

Yes No

032

– Turn off the system.
 Replace the system board.

033

(Step **033** continues)

MAP 0000

033 (continued)

– Turn off the system.

Replace the adapter in that slot.

034

(From step 002)

IS THE EPO SWITCH SET TO THE ON POSITION?

Yes No

035

– Reset switch to **ON**.

Return to step 001 in this MAP to verify system operation.

036

Remove rear cover.

THE AC POWER GOOD LIGHT IS LOCATED ON THE REAR PANEL OF THE POWER DISTRIBUTION CONTROL BOX. IS THE LIGHT ON?

Yes No

037

Go to Step 039.

038

Go to "MAP 0020: System Power" on page 123.

039

(From step 037)

IS THE POWER CORD PLUGGED INTO A FUNCTIONING, PROPERLY GROUNDED, 3-WIRE ELECTRICAL OUTLET?

Yes No

040

(Step 040 continues)

040 (continued)

- Turn off the system.
- Plug the power cord into a functioning, properly grounded, 3-wire electrical outlet. Return to Step 001 in this MAP to verify system operation.

041

- Turn off the system.
- Disconnect the power cord from the electrical outlet, then from the cart/main chassis.
- Check the power cord for continuity.

DOES THE POWER CORD HAVE CONTINUITY?

Yes No

042

Replace the power cord.

043

- Check the circuit breaker on the rear panel of the power distribution control box.

IS THE CIRCUIT BREAKER PUSHED IN?

Yes No

044

Reset the circuit breaker and reconnect the power cord. If the circuit breaker pops out again, go to "MAP 0020: System Power."

045

- Disconnect the EPO switch cable from the power distribution control box. See "Power Distribution Control Box" on page 88.
- With the EPO switch in the ON position, check the continuity between pin 1 and pin 2 of the connector.

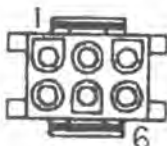

IS THERE CONTINUITY?

Yes No

046

Replace the EPO switch assembly and reconnect the power cord.

047

Reconnect the EPO switch cable and power cord, then go to "MAP 0020: Power."

048

(From step 014)

DID YOU RECEIVE A DISKETTE DRIVE ERROR MESSAGE?

Yes No

049

– Go to "MAP 0300: Keyboard."

050

Go to "MAP 0610: Diskette Drive."

051

(From step 007)

Find your error in Table 8 and take the action indicated.

- If an error message and incorrect audio response occur, take the action indicated for the error message.
- X can be any number.

Table 8. Audio Errors

Error Indication:	Go To Reference or Replace:
No Beep and:	
Blank Display	MAP 0020: Power
Unreadable Display	MAP 0020: Power
Blinking Cursor	MAP 0020: Power
Machine Not Functioning Properly	MAP 0020: Power
1XX Error	Replace: System Board
215 Error	MAP 0200: Memory
216 Error	MAP 0200: Memory
Any Other Error	MAP 0020: Power
1 Long and 2 Short Beeps	MAP 2000: Image Adapter/A
Any Audio Error and:	
Blank or Unreadable Display	MAP 2000: Image Adapter/A
Distorted Display Image	MAP 2000: Image Adapter/A
30X Error	MAP 0300: Keyboard
601 Error	MAP 0600: Diskette Drive
ROM Error	Replace: System Board
IO ROM XXXXXX (Adapter Failure)	MAP 0020: Power
Continuous Beep	MAP 0020: Power
Repeating Short Beeps	MAP 0020: Power
Any Other Audio Error	MAP 0020: Power

052

(From steps 012 and 027)

Find your error in Table 9 on page 115 or in the Symptom-to-FRU index on page 116, and take the action indicated.

Table 9. Failure Symptoms

Error Indication:	Go To Reference or Replace:
1 or 2 Short Beeps and 112 or 113 Error	Replace: System Board
Incorrect POST Memory Size	Run the memory tests
Display Problems:	
No High Intensity	Run the Image Adapter/A tests
Missing, Broken, or Incorrect Characters	Run the Image Adapter/A tests and MAP 2000
Blank Display	MAP 2000: Image Adapter/A Tests
Distorted Image	MAP 2000: Image Adapter/A Tests
Unreadable Display	MAP 2000: Image Adapter/A Tests
Other Display Problems	MAP 2000: Image Adapter/A Tests
Diskette Drive Problems:	
Loads Program from Hard Disk or C:> Prompt Appears	MAP 0610: Diskette Drive
Loads Program from Remote Station	MAP 0610: Diskette Drive
Disk Boot Failure	MAP 0610: Diskette Drive
Unable to Load Tests from Diskette	MAP 0610: Diskette Drive
Insert Diskette Prompt	MAP 0610: Diskette Drive
602 Error	Replace: reference diskette
110 or 111 (Parity Check)	MAP 0200: Memory
30X Error or Keyboard Problem	MAP 0300: Keyboard
Cannot Finish Diagnostic Tests	MAP 0020: Power
Power Good Light Is Not On	MAP 0020: Power
Data Readout Box Problems	MAP 3000: DRB Power Supply
Wakeup Box Problems	MAP 0020: Power
Internal Modem Problems	Run the internal modem tests
Dual Async Adapter Problems	Run the Dual Async Adapter tests
Printer Problems (if attached)	Go to the printer service manual.
Unable to Correct Installed Devices List	Replace FRU missing from the list. If this does not correct the problem, the "Symptom-to-FRU Index" on page 116 may provide additional information.
General-Purpose Interface Bus Problems	MAP 4000: GPIB

The Symptom-to-FRU index is on the next page.

Table 10 (Page 1 of 4). Symptom-To-FRU Index

Symptom/Error	Possible FRUs
One or more keys do not work	Keyboard Keyboard Cable System Board
No beep but system is functional.	Speaker Assembly System Board
No beep and system is nonfunctional. (See "Undetermined Problem" on page 119 before replacing any FRUs).	Power Supply System Board Speaker Assembly
Continuous beep	Power Supply System Board
Repeating short beeps	Power Supply System Board Keyboard (Stuck Key)
One long and one short beep	System Board Image Adapter/A Power Supply
One long and two short beeps	System Board Image Adapter/A Power Supply
One short beep and a blank or unreadable display (Go to "MAP 2000: Image Adapter/A" on page 155 before replacing any FRUs.)	System Board Power Supply Display Image Adapter/A
One short beep and a diskette prompt, or a program loads from the hard disk drive	Diskette Drive System Board Power Supply Diskette Adapter or Diskette Cable
DRB problems	DRB Power Supply Power Supply DRB Signal Cable DRB Unit (Customer)
GPIB problems	GPIB Card GPIB Cable GPIB Device (customer)
00011000 (Go to "MAP 0200: Memory" on page 140 before replacing any FRUs.)	System Board Memory System Board

Table 10 (Page 2 of 4), Symptom-To-FRU Index

Symptom/Error	Possible FRUs
00011100 (Go to "MAP 0200: Memory" on page 140 before replacing any FRUs.)	Adapter Memory Expansion Kit Memory Adapter
00011200, 00011300	Any Adapter System Board
00016100	Battery
00016200	Any Device
00016300, 00016400, 00016500 (If setting the configuration does not solve the problem, check the <i>Installed Devices</i>).	Set Configuration/Features System Board
00016600	Any Adapter
0001XX00 (not listed above)	System Board
00020100 (Perform "Advanced Diagnostics Tests" before replacing any FRUs).	System Board Memory Adapter Memory
00021500, 00021600, 00022100 (Go to "MAP 0200: Memory" on page 140 before replacing any FRUs.)	System Board Memory System Board
00030100, 00030200	Keyboard Keyboard Cable
00030300	System Board Keyboard Keyboard Cable
00030400	System Board Keyboard
00030500	Keyboard Cable
00040100	System Board
00060200	Defective Diskette
0006XX00	Diskette Drive System Board Power Supply Diskette Adapter or Diskette Cable
00110200, 00110600	System Board Any Serial Device
00110700	Communications Cable System Board

Table 10 (Page 3 of 4). Symptom-To-FRU Index

Symptom/Error	Possible FRUs
00110700, 00110800	System Board Any Serial Device
0011XX00 (not listed above)	System Board
00120200, 00120600	Dual Async Adapter Any Serial Device
00120700	Communications Cable Dual Async Adapter
00120800, 00120900	Dual Async Adapter Any Serial Device
0012XX00 (not listed above)	Dual Async Adapter System Board
0024XX00	Image Adapter/A System Board Display
01010200, 01010600, 01010800, 01010900	Modem Adapter Any Serial Device
0101XX00 (not listed above)	Modem Adapter System Board
0112XXXX (For power supply problems, start in MAP 0020: Power).	SCSI Adapter SCSI Hard Disk Drive Power Supply SCSI Device Power Cable SCSI Device Signal Cable System Board
012XXXXX	Modem Adapter
020001XX to 020003XX	Image Adapter/A Memory Module DRAM
020004XX	Memory Module DRAM Image Adapter/A
020005XX to 020010XX	Image Adapter/A Memory Module DRAM
0201XXXX	Image Adapter/A
0210XXXX	Hard Disk Drive SCSI Adapter Power Supply SCSI Hard Disk Drive Power Cable SCSI Hard Disk Drive Signal Cable

Table 10 (Page 4 of 4). Symptom-To-FRU Index

Symptom/Error	Possible FRUs
0215XXXX (For power supply problems, go to "MAP 0020: System Power" on page 123.)	SCSI CD-ROM Drive SCSI Adapter Power Supply SCSI CD-ROM Drive Power Cable SCSI CD-ROM Drive Signal Cable
006XXX (See <i>Adapter /A for Ethernet Twisted-Pair Networks -) Installation Instructions P/N 42G0297</i>)	Ethernet Adapter LAN Cable LAN Network

Undetermined Problem

If the failing FRU cannot be determined using the MAPs on page 104 and the Symptom-to-FRU Index on page 116, it will be necessary to:

1. Turn off the system.
2. Remove or disconnect **one** of the following adapters or devices:
 - External printer, modem, or mouse
 - Any adapter
 - Hard disk or diskette drive.
 - Memory module kits.
3. Turn on the system.

Note: If you have changed the system configuration by the removal or disconnection of a device or adapter, perform **Set configuration** portion of the diagnostic diskette.

4. If the symptom remains, repeat steps 1—3 until you find the failing adapter or device.

Note: You may replace a previously removed adapter or device that has proved not to be the malfunctioning part.

5. If all adapters and devices have been removed and the problem remains, check the power supply voltages. If the voltages are correct, replace the system board. If the voltages are not correct, replace the power supply.



SECTION 5. Diagnostic MAPs

MAP 0020: System Power	123
MAP 0200: Memory	140
MAP 0300: Keyboard	146
MAP 0610: Diskette Drive	152
MAP 2000: Image Adapter/A	155
MAP 2100: SCSI Devices	165
MAP 3000: DRB and Power Supply	169
MAP 4000: General-Purpose Interface Bus (GPIB)	176

Notes:

MAP 0020: System Power

Symptom Explanation	Conditions That Could Cause This Symptom
You have entered this MAP because you were unable to complete the POST, or you suspect a power problem.	<ul style="list-style-type: none"> • The power distribution control box is failing. • An external device is failing. • A remote power-on failure occurred. • The power supply is failing. • A diskette drive is failing. • A hard disk drive is failing. • An adapter card is failing. • The system board is failing. • The speaker is failing.

Note: If all power is to be removed from the system, unplug the power cord from the electrical outlet.

001

(From step 010)

IS THIS A REMOTE POWER-ON PROBLEM?

Yes No

002

Go to Step 016 on page 126.

003

Turn off the display. The following procedure initiates the dealership mode; do not use the reference diskette.

- Obtain the telephone number for the dealer's Service Bay System.
- Dial that number from a local telephone.

Verify system ring into the wakeup box by connecting the cable to the telephone and dialing the number. Reconnect the cable to the wakeup box and redial.

(Step 003 continues)

003 (continued)

DOES A SYSTEM RING OCCUR?

Yes No

004

Report a telephone connection failure; this is a dealer or local telephone exchange problem.

005

Power is on when the cooling fan(s) begin operating; however, the display remains off.

Listen to the rings at the calling device.

DOES THE SYSTEM POWER-ON AFTER 3 RINGS AND BEFORE 8 RINGS?

Yes No

006

Replace the power distribution control box.

007

DO THE FANS STOP RUNNING WITHIN 2 TO 3 MINUTES AFTER HANG-UP ?

Yes No

008

Replace the power distribution control box.

009

Check the Dual Asynchronous Adapter:

- Insert the reference diskette.
- Verify that the EPO switch is on.
- Power-on the main chassis and display by their switches.

(Step 009 continues)

009 (continued)

DOES THE SYSTEM INITIATE THE POWER-UP SEQUENCE?

Yes No

010

Return to Step 001 on page 123, and answer **NO** to the question.

011

- Disconnect the ASYNC Port-to-Wakeup Box Cable from the port 2 (left) connector at the Dual Asynchronous Adapter.
- Insert the 9-pin connector of the Tri-Connector wrap plug into port 2. (See "Special Tools" on page 21.) Port 2 is the communications port for control of the power-hold circuit. It keeps power on after a remote ring is recognized.
- Select port 2 testing from the advanced diagnostic menu and follow the instructions.

DID THE WRAP TEST COMPLETE WITHOUT ERRORS?

Yes No

012

Replace the Dual Asynchronous Adapter.

013

Check the continuity between the following pins of the ASYNC Port-to-Wakeup Box Cable:

- Pin 9 of the 9-pin connector and pin 20 of the 25-pin connector.
- Pin 4 of the 9-pin connector and pin 22 of the 25-pin connector.
- Pin 5 of the 9-pin connector and pin 7 of the 25-pin connector.

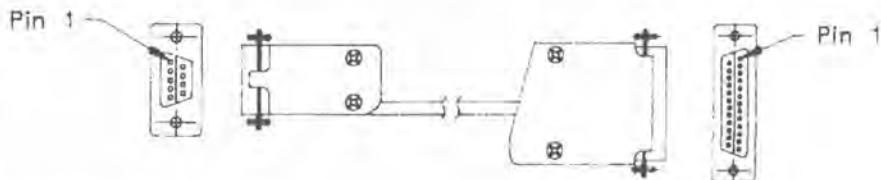

(Step 013 continues)

013 (continued)

IS THERE AN OPEN CONDITION?

Yes No

014

Replace the power distribution control box.

015

Replace the cable.

016

(From step 002)

- Turn off the system by placing the display power switch to the **OFF** position.
- Disconnect the display line cord from the power distribution control sense outlet.

CAUTION:

Line voltage is present in the power distribution control box and the EPO switch, even when the system is turned off through the EPO switch.

Attention !

Tension secteur présente dans le contrôleur de distribution de l'alimentation et dans le dispositif d'arrêt d'urgence même lorsque le système de diagnostic pour automobile est hors tension après un arrêt d'urgence.

- Measure the line voltage (110 V ac) at the sense outlet on the power distribution control box.

IS LINE VOLTAGE PRESENT?

Yes No

017

- Replace the power distribution control box.
(Step 017 continues)

017 (continued)

Go to Step 024 on page 128.

018

- Reconnect the display line cord.
- Disconnect the display signal cable from the system board.
- Turn on the system.

IS THE DISPLAY SCREEN WHITE WITH A BLACK BORDER?

Yes No

019

Go to Step 021.

020

- Power-off the system.
- Reconnect the display signal cable.

Go to Step 024 on page 128.

021

(From step 019)

- Turn off the system.
- Remove the display line cord.

DOES THE DISPLAY LINE CORD HAVE CONTINUITY?

Yes No

022

- Replace the display line cord.
- Go to Step 024 on page 128.

023

- Replace the display.
 - Reconnect the display line cord.
-

024

(From steps 017, 020, and 022)

- Turn on the system.

DID THE FAILING SYMPTOM REMAIN?

Yes No

025

Go to **MAP 0000: Start** to verify system operation.

026

- Turn off the system.
- Disconnect the line cord(s) plugged into the Power Distribution Control Box. The outlets are labelled:
 - **CPU1** (primary power supply)
 - **CPU2** (optional power supply, if installed)
 - **AUX1, AUX2, and AUX3** (if used).
- Turn on the system.
- Measure the line voltage (110 V ac) at each outlet being used.

IS LINE VOLTAGE PRESENT AT EACH OUTLET?

Yes No

027

- Replace the power distribution control box.
Go to Step 050 on page 134.

028

- Turn off the system.
- Reconnect all line cords to their proper outlet.
- Disconnect all signal cables (except display and keyboard) from the I/O connector panel.
- Turn on the system.

DID THE FAILING SYMPTOM REMAIN?

Yes No

029

CAUTION:

Turn off the system before connecting any device.

Attention !

Mettez le système de diagnostic pour automobile hors tension avant d'effectuer toute connexion.

- Connect the external devices to the system, one at a time (turn off the system each time) until the failing symptom returns.
 - Repair or replace the device causing the problem.
- Go to Step 050 on page 134.

030

- Turn off the system.
- Unplug the optional power supply from the power distribution control box at the **CPU2** outlet, if installed.
- Unplug the three dc power supply connectors from the primary power supply (P2, P3, and P4).
- Turn on the system.
- Check the 15-pin power supply connector for the following voltages.

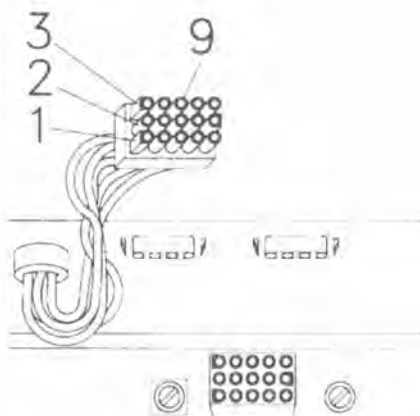

Table 11. Power Supply Voltages

(V dc) Minimum	(V dc) Maximum	Ground Pin	Power Pin
-9.0	-15.0	2	9
+9.0	+15.0	2	3
+3.7	+6.2	2	1
+2.4	+5.25	2	12

ARE THE VOLTAGES CORRECT?

Yes No

031

- Replace the power supply.
- Go to Step 050 on page 134.

032

- Turn off the system.
- Plug the power supply connector into the system board.
- Turn on the system.
- Check **both** 4-pin power supply connectors for the following voltages.

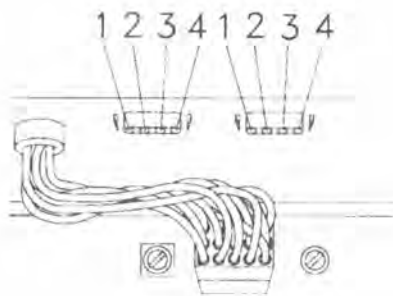

Table 12. Power Supply Voltages (4-Pin Connectors)

(V dc) Minimum	(V dc) Maximum	Ground Pin	Power Pin
+4.8	+5.2	3	4
+11.5	+12.6	2	1

ARE THE VOLTAGES CORRECT?

Yes No

033

- Replace the power supply.
Go to Step 050 on page 134.

034

- Check the voltage at the pins of each of the 4-pin connectors on the power distribution card (same as in Table 12).

ARE THE VOLTAGES CORRECT?

Yes No

035

- Replace the power distribution card.
Go to Step 050 on page 134.

036

IS THE PROBLEM WITH THE HARD DISK POWER?

Yes No

037

IS THIS A CD-ROM POWER PROBLEM?

Yes No

038

(Step 038 continues)

038 (continued)
Go to Step 045 on page 133.

039

Check continuity of the power supply cable.

– or –

Check voltages at the CD-ROM end of the power supply cable (see Table 12 on page 131 for pinout of 4-pin connector) from the back of the connector.

ARE THE CORRECT VOLTAGES PRESENT?

Yes No

040

Replace the power cable.

041

Replace the CD-ROM drive.

– or –

Replace the CD-ROM signal cable.

042

Check continuity of power supply cable.

– or –

Check voltages at the hard disk end of the power supply cable (see Table 12 on page 131 for pinout of 4-pin connector) from the back of the connector.

ARE CORRECT VOLTAGES PRESENT?

Yes No

043

Replace the cable.

044

(Step 044 continues)

044 (continued)

Replace the hard disk drive.

– or –

Replace the hard disk ribbon cable.

045

(From step 038)

IS THE SYSTEM FAN (MOUNTED TO REAR PANEL) RUNNING?

Yes No

046

– Replace the fan.

Go to Step 050 on page 134.

047

– Turn off the system.

Warning: Battery must be removed before disconnecting the speaker cable.

Avertissement : Prenez soin d'enlever la pile avant de déconnecter le fil du haut-parleur.

- Remove the speaker and disconnect both ends of the speaker cable.
- Check the continuity of the speaker cable.
- Check the continuity of the speaker between pins 1 and 2, as shown.

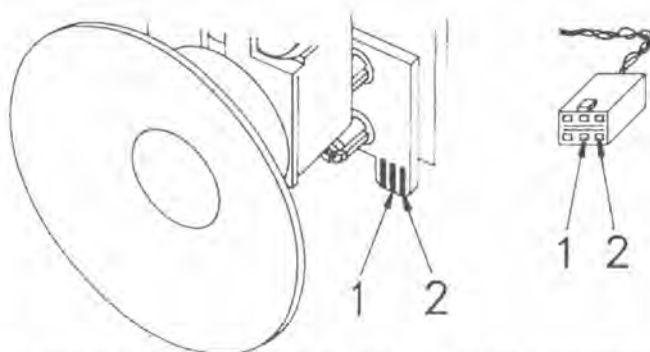

DO THE SPEAKER AND SPEAKER CABLE HAVE CONTINUITY?

Yes No

048

- Replace the failing FRU.
- Go to Step 050.

049

- Reinstall the speaker and the speaker cable.
- Go to Step 052 on page 135.

050

(From steps 027, 029, 031, 033, 035, 046, and 048)

- Turn on the system.

(Step 050 continues)

050 (continued)

DID THE FAILING SYMPTOM REMAIN?

Yes No

051

Go to "MAP 0000: Start" to verify system operation.

052

(From step 049)

IS AN OPTIONAL POWER SUPPLY INSTALLED?

Yes No

053

Go to Step 064 on page 137.

054

- Turn off the system.
- Reconnect the optional power supply to the power distribution control box at the **CPU2** outlet.

CAUTION:**Line voltage (ac) is present.****Attention !****Tension secteur c.a. présente.**

- Unplug the power supply connectors from the optional power supply.
- Turn on the system.
- Check the 15-pin power supply connector for the voltages listed in Table 11 on page 130.

ARE THE VOLTAGES CORRECT?

Yes No

055

(Step 055 continues)

055 (continued)

Go to Step 062 on page 137.

056

- Check the 4-pin power supply connectors for the voltages listed in Table 12 on page 131.

ARE THE VOLTAGES CORRECT?

Yes No

057

Go to Step 062 on page 137.

058

- Turn off the system.
- Disconnect the Power Distribution Control Box and fan power cables from the power distribution card.
- Check the continuity of the card.

IS THERE CONTINUITY?

Yes No

059

- Replace the power distribution card.
- Reconnect the power cables and the power supply connectors.

Go to Step 062 on page 137.

060

- Reconnect the power cables and the power supply connectors.
- Turn on the system.

(Step 060 continues)

060 (continued)

IS THE OPTIONAL FAN RUNNING?

Yes No

061

- Replace the optional fan.
- Go to Step 062.

062

(From steps 055, 057, 059, and 061)

- Turn on the system.

DID THE FAILING SYMPTOM REMAIN?

Yes No

063

Go to "MAP 0000: Start" to verify system operation.

064

(From step 053)

You may have a failing diskette drive, CD-ROM drive, or hard disk drive.

- Turn off the system.
- Disconnect all cables from each drive.
- Turn on the system.

DID THE FAILING SYMPTOM REMAIN?

Yes No

065

- Connect the cables to the drives, one drive at a time (turn off the system each time), until the failing symptom returns.
 - Replace the drive causing the failure.
- Go to "MAP 0000: Start" to verify system operation.

066

(Step 066 continues)

066 (continued)

ARE ANY MEMORY ADAPTERS INSTALLED?

Yes No

067

Go to Step 070.

068

You may have a failing memory adapter.

- Turn off the system.
- Remove the memory adapters. Do not remove the system board memory cards.
- Turn on the system.

DID THE FAILING SYMPTOM REMAIN?

Yes No

069

- Install the memory adapters, one at a time (turn off the system each time) until the failing symptom returns.
- Turn off the system.
- Remove all memory from the failing adapter.
- Turn on the system.

If the failure remains, replace the memory adapter; or if the failure does not remain, install the memory on the adapter, one card at a time (turn off the system each time), until the failing symptom returns. Replace the memory card causing the failure.

070

(From step 067)

- Turn off the system.
- Reinstall the memory adapters, if removed.

You may have a failing hard disk adapter, hard disk cables, diskette cable, CD-ROM cable.

- Remove the hard disk adapter, hard disk cables, diskette cable, and any adapters. Do not remove the system board memory cards.

- Turn on the system.

DID THE FAILING SYMPTOM REMAIN?

Yes No

071

- Install the hard disk adapter, hard disk cables, diskette cable, and all option adapters, one at a time (turn off the system each time), until the failing symptom returns. Replace the FRU causing the failure.

072

- Turn off the system.
- Disconnect the keyboard cable from the system.
- Turn on the system.

DID THE FAILING SYMPTOM REMAIN?

Yes No

073

Go to "MAP 0300: Keyboard Start."

074

- Turn off the system. Replace the system board.
 - or –
- If that does not correct the problem, replace the memory cards, one at a time (turn off the system each time).
-

MAP 0200: Memory

Symptom Explanation	Conditions That Could Cause This Symptom
<p>You have entered this MAP because you received one of the following error messages:</p> <ul style="list-style-type: none"> • 110 • 111 • 215 	<ul style="list-style-type: none"> • One or more memory expansion kits is failing. • Adapter memory is failing. • The system board is failing. • The standard system board memory was moved from connector J16 after configuration. • No system board memory is installed in connector J16.

001

DO YOU HAVE A 201 OR A 221 ERROR MESSAGE?

Yes No

002

Go to Step 004.

003

Run the advanced diagnostic tests and follow the instructions on the screen. If the advanced diagnostic tests do not identify a failing FRU, replace the system board.

004

Find the error message in the following table and take the action indicated.

Table 13. Error Messages

Error Message:	Action:
110 (System board parity check)	Go to Step 005 on page 141.
111 (Memory adapter parity check)	Go to Step 013 on page 143.
215	Go to Step 026 on page 145.
216	Go to Step 005 on page 141.

005

You are here because you received a 110 or 216 error message.

CAN YOU RUN THE ADVANCED DIAGNOSTIC MEMORY TESTS?

Yes No

006

Go to Step 008.

007

Replace the memory indicated by the advanced diagnostic tests.

008

ARE MEMORY CARDS INSTALLED IN CONNECTORS J16 AND J15?

Yes No

009

Replace the memory card in connector J16, found on the upper left corner of the system board. See "System Board Connectors" on page 85.

– or –

If the memory card was in connector J15, move it to connector J16. Remove the battery to erase the configuration stored in the CMOS, then reconfigure the system by using the **Set configuration** program from the reference diskette.

(Step **009** continues)

009 (continued)

– or –

If that does not correct the problem, replace the system board.

010

- Turn off the system.
- Remove the memory card installed in connector J15 (see Figure 1).
- Turn on the system.

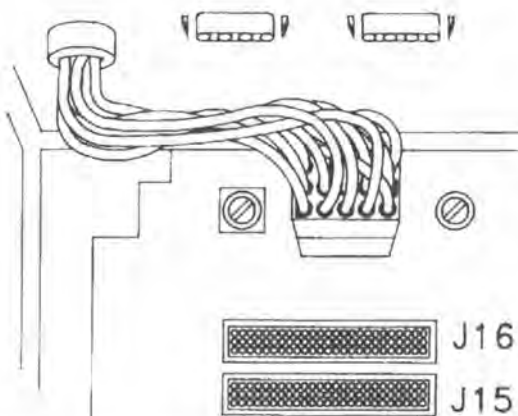

Figure 1. System Board Memory Locations

DID THE ERROR REMAIN?

Yes No

011

Replace the memory card removed from connector J15.

012

Replace the memory card in connector J16.

– or –

If that does not correct the problem, replace the system board.

013

You are here because you received a 111 error message.

CAN YOU RUN THE ADVANCED DIAGNOSTIC MEMORY TESTS?**Yes No****014**

Go to Step 016.

015

Replace the memory indicated by the advanced diagnostic tests.

016**IS MORE THAN ONE 80386 MEMORY EXPANSION ADAPTER INSTALLED?****Yes No****017**

Go to Step 021 on page 144.

018

- Turn off the system.
- Remove all memory adapters.
- Turn on the system.

DID THE ERROR REMAIN?**Yes No****019**

- Install the memory adapters, one at a time (turn off the system each time) until the failing symptom returns. The last adapter installed contains the failing memory.
- Go to Step 021 on page 144 to isolate the failing memory.

020

Replace the system board.

021

**IS MORE THAN ONE 80386 MEMORY EXPANSION KIT
INSTALLED ON THE FAILING MEMORY ADAPTER?**

Yes No

022

Replace the 80386 Memory Expansion Kit.

– or –

If that does not correct the problem, replace the 80386
Memory Expansion Adapter.

023

- Turn off the system.
- Remove all but one 80386 Memory Expansion Kit from the failing
memory adapter.
- Turn on the system.

DID THE ERROR REMAIN?

Yes No

024

- Install the 80386 Memory Expansion Kits, one at a time (turn
off the system each time) until the error returns.

Replace the 80386 Memory Expansion Kit that caused the
error to return.

025

Replace the 80386 Memory Expansion Kit installed on the adapter.

– or –

If that does not correct the problem, replace the 80386 Memory
Expansion Adapter.

026

You are here because you received a 215 error message.

ARE TWO 80386 SYSTEM BOARD MEMORY EXPANSION KITS INSTALLED?**Yes No****027**

Replace the 80386 System Board Memory Expansion Kit.

028

Replace **both** 80386 System Board Memory Expansion Kits.

– or –

If that does not correct the problem, replace the system board.

MAP 0300: Keyboard

Symptom Explanation	Conditions That Could Cause This Symptom
You have entered this MAP because you suspect a keyboard problem.	<ul style="list-style-type: none"> • The keyboard is failing. • The keyboard cable is failing. • The keyboard fuse is failing. • The system board is failing.

001

DO YOU HAVE A COMPLETELY NONFUNCTIONING KEYBOARD?

Yes No

002

Go to Step 020 on page 151.

003

IS A POINTING DEVICE CONNECTED TO THE SYSTEM?

Yes No

004

Go to Step 007 on page 147.

005

- Turn off the system.
- Disconnect the pointing device.
- Turn on the system.

IS THE KEYBOARD STILL NOT FUNCTIONING?

Yes No

006

(Step 006 continues)

006 (continued)

Replace the pointing device cable. If the cable cannot be disconnected from the pointing device, or if replacing the cable does not fix the problem, replace the pointing device.

007

(From steps 004 and 022)

- Turn off the system.
- Disconnect the keyboard cable from the keyboard.
- Turn on the system.
- Check the voltage on the keyboard connector. All voltages are $\pm 5\%$.

Pin	Voltage (V dc)
1	+5.0
2	Not Used
3	Ground
4	+5.0
5	+5.0
6	Not Used

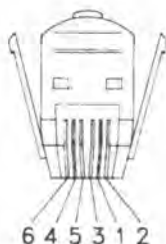
**ARE THE VOLTAGES CORRECT?**

Yes No

008

Go to Step 010 on page 148.

009

Replace the keyboard.

010

(From step 008)

- Check the keyboard cable for continuity on pins 1, 3, 4, and 5.

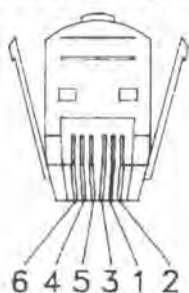

IS THERE CONTINUITY ON PINS 1, 3, 4, and 5?

Yes No

011

Replace the keyboard cable.

012

IS THERE A FUSE ON THE SYSTEM BOARD?

Yes No

013

Go to Step 017 on page 149.

014

- Turn off the system.
- Remove the fuse and check it for continuity.

DOES THE FUSE HAVE CONTINUITY?

Yes No

015

(Step 015 continues)

015 (continued)

Replace the fuse.

Note: A blown fuse may be caused by a short circuit in the keyboard cable or the pointing device cable. If replacing the fuse does not solve the problem, remove both cables from the system unit, then attach the cables one at a time until the problem returns. Replace the last cable you attached.

016

Replace the system board.

017

(From step 013)

- Turn off the system.
- Disconnect the keyboard cable from the system board.
- Turn on the system.
- Check the voltage at the system board keyboard connector. All voltages are $\pm 5\%$.

Pin	Voltage (V dc)
1	+5.0
2	Not Used
3	Ground
4	+5.0
5	+5.0
6	Not Used

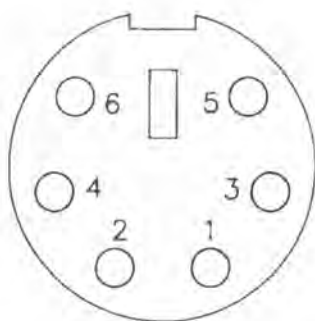

(Step 017 continues)

017 (continued)

ARE THE VOLTAGES CORRECT?

Yes No

018

Replace the system board.

019

Replace the keyboard cable.

020

(From step 002)

- Make sure your reference diskette is in the diskette drive.
- Restart the system.
- Observe the POST.

DID YOU RECEIVE A 3XX OR A KEYBOARD ERROR MESSAGE?**Yes** **No****021**

- Run the keyboard tests.
 - If you successfully completed the keyboard tests and you suspect an intermittent problem, start an error log.
Note: On systems without a fuse, a short in the keyboard cable could cause a voltage-regulating device on the system board to disable the 5 V dc to the keyboard; the keyboard is totally nonfunctional until the shorted condition is relieved.
 - If you are unable to complete the tests due to nonfunctioning keys, replace the keyboard.

022

Go to Step 007 on page 147.

MAP 0610: Diskette Drive

Symptom Explanation	Conditions That Could Cause This Symptom
You have entered this MAP because you suspect a diskette drive problem.	<ul style="list-style-type: none"> • A diskette drive is failing. • The system board is failing. • The diskette drive bus adapter or cable is failing. • The power supply is failing.

001

- Turn off the system.
- Ensure that the reference diskette is inserted in the diskette drive.
- Turn on the system.

DURING THE POST, DID THE LED ON THE DISKETTE DRIVE COME ON BEFORE THE BEEP?

Yes No

002

Go to Step 009 on page 153.

003

IS THE LED ON THE DISKETTE DRIVE LIT CONSTANTLY?

Yes No

004

Go to Step 006 on page 153.

005

Go to Step 011 on page 154.

006

IS THE IBM LOGO DISPLAYED?

Yes No

007

Go to Step 009.

008

– Run the diskette drive tests.

If you successfully complete the advanced diagnostic tests and you suspect an intermittent problem, start an error log.

009

– Remove the diskette drive, and check the drive connector voltages using the power supply frame as ground.

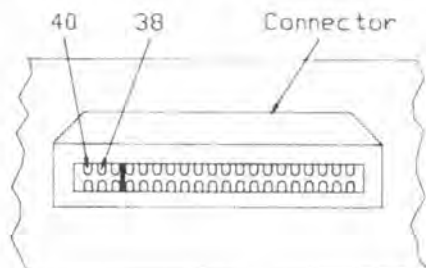

Voltage (V dc)

Pin Number

+4.8 to +5.2

38 to ground

+11.5 to +12.6

40 to ground

ARE THE VOLTAGES CORRECT?

Yes No

010

(Step 010 continues)

010 (continued)

Go to "MAP 0020: Power."

011

- With the drive removed, check the connector of the diskette drive for the voltages at pins 12 and 16 while running the POST. The voltages should increase in the range of 0 V dc to 5.5 V dc during the POST. When measuring voltages, use the power supply frame as ground.

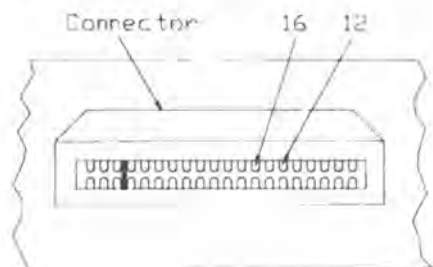

DID THE VOLTAGES INCREASE FROM APPROXIMATELY 0 V DC TO 5 V DC?

Yes No

012

Replace the system board.

- or -

If that does not solve the problem, replace the diskette drive or cable.

013

Replace the failing drive.

- or -

If that does not solve the problem, replace the system board.

- or -

If that does not solve the problem, replace the cable.

MAP 2000: Image Adapter/A

Symptom Explanation	Conditions That Could Cause This Symptom
<p>You have entered this MAP because you suspect a problem on an Image Adapter/A or with a display attached to an Image Adapter/A, you were directed here by an audible error code, or you have a 200XX error code.</p>	<ul style="list-style-type: none"> • A display attached to an Image Adapter/A is failing. • An Image Adapter/A is failing. • An Image Adapter/A repluggable memory module is failing. • You have a blank screen.

Note: If an Image Adapter/A is replaced, remove any pluggable memory modules and reinstall them on the replacement Image Adapter/A.

001

IS A DISPLAY ATTACHED TO AN IMAGE ADAPTER/A?

Yes No

002

Go to Step 007 on page 156.

003

- Turn off the system and the display attached to the Image Adapter/A.
- Set the display brightness control to its middle position.
- Set the display contrast control to its maximum position.
- Turn on the system and the display attached to the Image Adapter/A.

(Step 003 continues)

003 (continued)

IS THE SCREEN DARK (NO ILLUMINATION) WHEN TURNED ON FOR 30 SECONDS?

Yes No

004

Go to Step 033 on page 161.

005

- Disconnect the display cable from the Image Adapter/A.

DOES THE SCREEN APPEAR COMPLETELY WHITE WHEN DISCONNECTED?

Yes No

006

Go to Step 036 on page 162.

007

(From step 002)

- Turn off the system at the display.
- Insert a reference diskette that has been updated with the Image Adapter/A option diskette.
- Reconnect the display that was disconnected from the Image Adapter/A.
- Turn on the system.
- Listen for and note any audio responses during the POST.

DOES THE IBM LOGO SCREEN APPEAR AS EXPECTED?

Yes No

008

Your backup copy of the reference diskette may be faulty.
Make another copy of your reference diskette and restart this procedure.

- or -

(Step 008 continues)

008 (continued)

If the password (key) symbol is displayed, go to MAP 0000.

– or –

If a 165 error is displayed, go to MAP 0000.

– or –

Go to Step 039 on page 163.

009

(From step 043)

- Press **Enter** to display the main menu.
- Hold down the **Ctrl** key, then press the **A** key to call up the Advanced Diagnostic Menu.
- Select **System Checkout** and press **Enter**. The Installed Devices list appears on the screen.

DOES “IBM IMAGE ADAPTER/A” APPEAR ON THE LIST?

Yes **No**

010

Check that the reference diskette has been properly updated with the correct Image Adapter/A option diskette.

– or –

Install a replacement Image Adapter/A on the system board.

– or –

If the fault remains, install a replacement system board.

011

- Press the **Y** key to confirm that the Installed Devices list is correct.
- Press **Enter** to run the tests one time.

The Device Test Menu appears on the screen.

IS THE NUMBER OF IMAGE ADAPTER/A ON THE DEVICE TEST MENU THE SAME AS THE NUMBER INSTALLED IN THE SYSTEM?

Yes **No**

012

Restart the MAP and run all of the tests.
– Follow from Step 013 to go through the MAP.

013

(From step 012)

Move the highlighted line down the menu to the Image Adapter/A position and press **Enter**.

IS THE "IMAGE ADAPTER/A SELECTION MENU" DISPLAYED?

Yes No

014

Go to Step 016.

015

– Press **Enter** to test the adapter.

016

(From steps 014 and 031)

The Image Adapter/A TEST MENU appears on the screen.

- Select **All the above tests**.
- Press **Enter**.

IS AN ERROR MESSAGE DISPLAYED?

Yes No

017

Go to Step 021 on page 159.

018

(Step 018 continues)

018 (continued)

DOES THE ERROR MESSAGE INDICATE THAT A MEMORY MODULE SHOULD BE REPLACED?

Yes No

019

Replace the Image Adapter/A in the slot identified by the Error Message.

020

Replace the memory module in the slot indicated by the Error Message.

021

(From step 017)

5
DISPLAY ATTACHMENT

Is a display attached to the Image Adapter/A being tested in slot
x Y/N?

Note the slot number for the adapter that is tested successfully.

IS THIS PANEL DISPLAYED?

Yes No

022

Install a replacement Image Adapter/A card.

023

IS A DISPLAY ATTACHED TO THE IMAGE ADAPTER/A BEING TESTED?

Yes No

024

(Step 024 continues)

024 (continued)

Press the **N** key.

– or –

Go to Step 027 on page 161.

025

– If the pattern is not displayed, press the **Y** key.

The pattern is displayed in color. Check the color blocks from left to right, as white, red, yellow, green, cyan, blue, purple, and black. The outline of the pattern should be white.

If a portrait display is connected to the Image Adapter/A, the pattern is shown in different proportions.

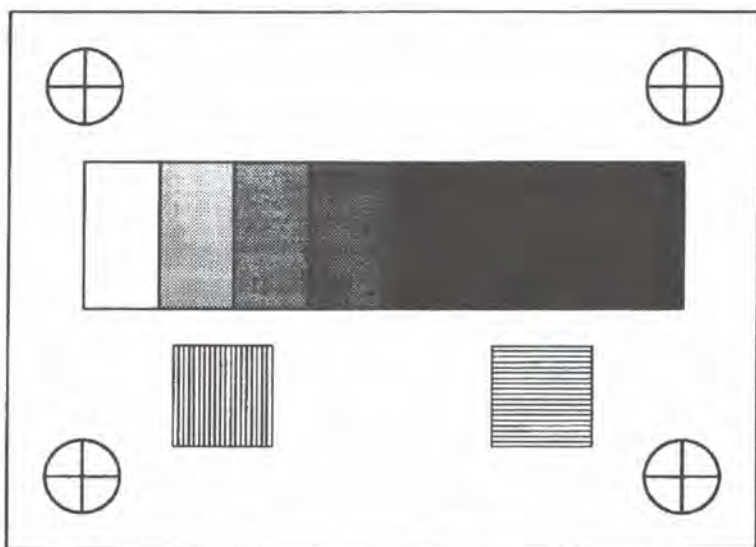

IS THE TEST PATTERN CORRECTLY DISPLAYED?

Yes No

026

Replace the Image Adapter/A to which the display is connected.

027

- (From step 024)
 – Press any key.

IS THE SELECTION MENU DISPLAYED?

Yes No

028

Go to Step 032 on page 161.

029

IS THERE ANOTHER IMAGE ADAPTER/A ON THE MENU THAT HAS NOT BEEN TESTED?

Yes No

030

Go to Step 032 on page 161.

031

- Move the highlighted line down to the next Image Adapter/A that has not been tested and press **Enter**.
 - Go to Step 016 on page 158.
-

032

(From steps 028 and 030)

- Press **ESC**.
 - The Test Selection Menu appears on the screen.
 - Press **Enter**.
 The Device Test Menu appears on the screen.
 - Go to Step 045 on page 164.
-

033

(From step 004)
 (Step 033 continues)

033 (continued)

- Check the continuity between pins 12 and 10 (ground) of the 15-pin D-shell connector on the Image Adapter/A.

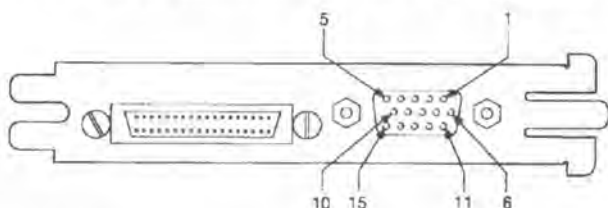

IS THERE CONTINUITY?

Yes No

034

Replace the Image Adapter/A.

035

- Replace the display.

036

(From step 006)

IS THE DISPLAY POWER-ON INDICATOR LIT?

Yes No

037

- Check that the display input power cord has continuity.
- Verify that line voltage is available at the electrical outlet.
- If the input power cord has continuity or is not removable from the display, replace the display.

038

- Install a replacement display.

039

(From step 008)

IS THERE A VISIBLE SCREEN PROBLEM SIMILAR TO ONE OF THE EXAMPLES SHOWN?

Yes No



Too Dim



Too Wide



Too Narrow



Too Short



Shrunk

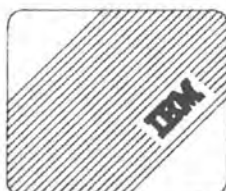

Tilted



Changes Size When
Brightness Control
Turned



Out of Focus



Characters Shifted
Left or Right or
Up and Down Off
the Display

040

Go to Step 042 on page 164.

041

— Install a replacement display.

042

(From step 040)

IS THE IMAGE ADAPTER/A (TO WHICH THE DISPLAY IS CONNECTED) INSTALLED IN SLOT 6?

Yes No

043

- Install the Image Adapter/A in slot 6.
- Go to Step 009 on page 157.

044

- Replace the Image Adapter/A in slot 6. If the problem is still present, replace the system board.
-

045

(From step 032)

You have gone through this MAP without solving your problem. The following steps may help you find additional audio and visual symptoms:

- Check the entire system for loose or damaged connectors.
 - Check that the operating environment is within specifications; check also the operation of the cooling fan for filter and airway obstructions.
 - Review **MAP 0000: Start**.
 - Select **LOG UTILITIES** in the diagnostic menu to start an error log. Select **RUN TESTS**. This lets you operate the system thoroughly to identify the symptom.
 - When you have identified the symptom, go to **MAP 0000: Start**, or the appropriate MAP for the symptom.
 - If you have gone through these procedures and still have a problem, contact your local technical support representative for the Image Adapter/A.
-

MAP 2100: SCSI Devices

Symptom Explanation	Conditions That Could Cause This Symptom
You have entered this MAP because you suspect a SCSI adapter or device problem.	<ul style="list-style-type: none"> • The SCSI device is failing. • The SCSI adapter is failing. • The SCSI adapter or device is missing.

001

- Turn off the system.
- Insert the reference diskette, and turn on the system.
- Select **Set and View SCSI Device Configuration** from the Set Configuration menu.
- Change the status of all listed *"Presence Error Reporting"* devices to "disabled" by pressing the **F5** key.
- Save them by pressing the **F10** key.

ARE ANY "PRESENCE ERROR REPORTING" DEVICES ENABLED?

Yes No

002

Go to Step 006 on page 166.

003

- Restart the system and run **Automatic Configuration**.

DOES THE LIST MATCH WHAT IS ACTUALLY CONNECTED TO THE ADAPTER?

Yes No

004

(Step 004 continues)

004 (continued)

Go to Step 006.

005

- Select **Set and View SCSI Device Configuration** from the Set Configuration menu.
 - Change the status of the *"Presence Error Reporting"* devices back to "disabled," one at a time, until you isolate the failing FRU that caused the error condition to return.
 - If the failure is isolated to an internal device, replace it.
-

006

(From steps 002 and 004)

- Turn off the system, and ensure that the terminator is installed on the adapter.
- Turn on the system, and run **Automatic Configuration**.

ARE ALL SCSI DEVICES NOW LISTED ON THE INSTALLED DEVICES LIST?

Yes No

007

Go to Step 009.

008

The problem is solved.

009

(From step 007)

- Turn off the system, disconnect the internal cable from the SCSI, and ensure that the terminator is installed on the adapter.
- Turn on the system and run **Automatic Configuration**.

(Step 009 continues)

009 (continued)

ARE ALL SCSI DEVICES NOW ON THE INSTALLED DEVICES LIST?

Yes No

010

Replace the defective adapter.

011

- Run the diagnostic tests for the adapter.

DID THE ADAPTER PASS THE DIAGNOSTIC TESTS?

Yes No

012

Replace the defective adapter.

013

- Turn off the system, and reconnect the internal cable to the SCSI adapter.
- Turn on the system and run **Automatic Configuration**.

IS THERE A DEVICE MISSING FROM THE INSTALLED DEVICES LIST?

Yes No

014

The problem is solved.

015

The device missing from the Installed Devices List is the failing FRU; replace it.

- If more than one device is missing, go to Step 016 on page 168.
- If the missing device is a hard disk drive, go to the **Set and View SCSI Device Configuration** menu to determine which device is missing.

016

(From step 015)

- Each time you connect or disconnect a device in the following steps, run the **Automatic Configuration** and verify that the Installed Devices List matches what is connected to the adapter.
- To isolate the device at the end of a cable, disconnect all devices from the cable *except* the device on the end of the cable (normally, ID 6).
- To isolate the remaining devices, add them back to the cable, one at a time.

DOES THE LIST MATCH WHAT IS ACTUALLY INSTALLED?

Yes No

017

The last device reconnected or the cable, is the failing or defective device; replace it.

018

If the problem remains, change the status of all remaining "Presence Error Reporting" devices back to "enabled"; go to "SECTION 4, Start" on page 103.

MAP 3000: DRB and Power Supply

Symptom Explanation	Conditions That Could Cause This Symptom
You have entered this MAP because you suspect a problem in the DRB power supply or with the DRB.	<ul style="list-style-type: none"> • The DRB display is not functioning. • The DRB is unable to transmit data. • The DRB is unable to receive data.

001

DOES THE DRB FUNCTION PROPERLY WHEN POWERED FROM THE VEHICLE?

Yes No

002

Go to Step 012 on page 172.

003

- Power-off the system.
- Remove the bezel from the front of the DRB power supply.
- Slide the DRB power supply out by pushing from the back of the slide to expose the card.
- Power-on the system.

MAP 3000

- Measure the voltage between the GND and +12V dc test points on the DRB power distribution card.
- Measure the voltage between the GND and +5V dc test points on the DRB power card.

Min V dc	Max V dc
4.8	5.2
11.5	12.6

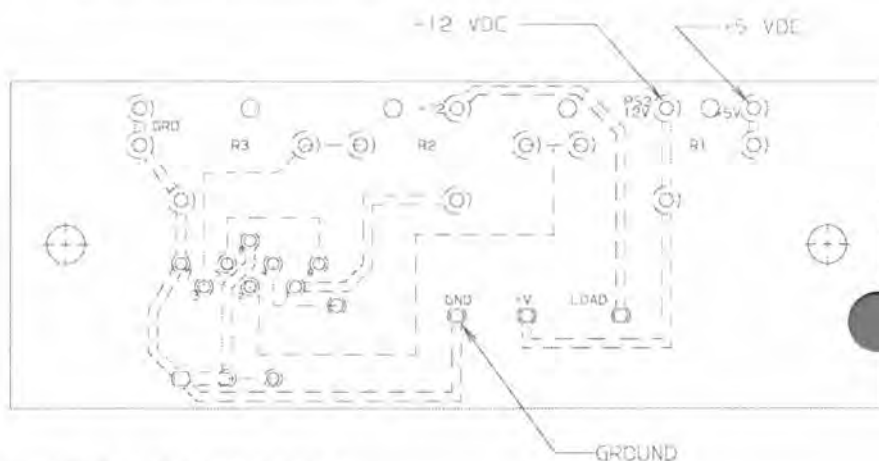

IS +12V dc \pm 10% PRESENT?

Yes No

004

Replace the DRB power supply and its attached power cable (twisted-wire pair).

005

IS +5 V dc $\pm 10\%$ PRESENT?

Yes No

006

Check for the presence of +5 V dc $\pm 10\%$ at power distribution card connector located on the left side of the main chassis above the system board.

IS +5 V dc $\pm 10\%$ PRESENT?

Yes No

007

Go to MAP 0020: Power Supply. The DRB and its power supply are not malfunctioning.

008

– Replace the DRB power supply and its attached power cable (twisted-wire pair).

009

– Check for continuity of connector to card.

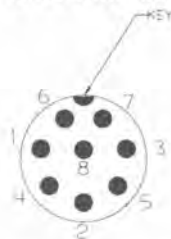

VIEW FROM FRONT
OF CONNECTOR
SCALE: 4/1

JUMPER CHART		
DIN CONN PIN NO.	P.C. CARD DIN POS.	DESCRIPTION
1	2	BUS (+)
2	4	NO CONNECTION
3	6	ENGINE RECEIVE
4	3	BUS (+)
5	5	ENGINE TRANSMIT
6	1	BATTERY
7	7	GROUND
8	8	GROUND

IS THE CONTINUITY OK?

Yes No

010

Replace the Power Supply.

011

Report that the problem is not with the IBM product.

012

(From step 002)

DO YOU HAVE A DRB II?

Yes No

013

– Go to Step 021 on page 174.

014

(Step 014 continues)

014 (continued)

IS THE CUSTOMER EXPERIENCING PROBLEMS COMMUNICATING TO THE DRB?

Yes No

015

This may be an intermittent problem; start an error log and perform the DRB power supply checks beginning at Step 003 on page 169.

- Other possible malfunctioning components are the power cable attached to the DRB; have the customer replace the DRB with a unit that is known to be good.

016

- Disconnect the DRB signal cable from the serial port of the Dual Async Card (DRB II), accessed at the rear of the main chassis.
- For Model 110/114 run the dual asynchronous diagnostic tests on the reference diskette.

DID THE DIAGNOSTIC TEST COMPLETE WITHOUT ERRORS?

Yes No

017

For Model 110/114 replace the dual async adapter.

018

- Disconnect the DRB signal cable from the DRB and check continuity on the pins identified below.

4-Pin Connector	25-Pin Connector
--------------------	---------------------

1

2

3

3

4

7

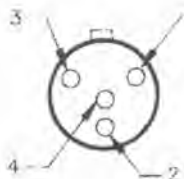

IS THERE CONTINUITY BETWEEN ALL INDICATED PINS?

Yes No

019

Replace the signal cable.

020

– Report that the IBM product is functioning properly.

021

(From step 013)

IS THE CUSTOMER EXPERIENCING PROBLEMS COMMUNICATING TO THE DRB?

Yes No

022

This may be an intermittent problem; start an error log and perform the DRB power supply checks beginning at Step 003 on page 169.

– Other possible malfunctioning components are the power cable attached to the DRB; have the customer replace the DRB with a unit that is known to be good.

023

– Disconnect the DRB signal cable from the GPIB Adapter Card (DRB III), accessed at the rear of the main chassis.
 – For Model 110/114 run the GPIB diagnostic tests.
 (Step 023 continues)

023 (continued)

DID TEST COMPLETE WITHOUT ERRORS?

Yes No

024

Replace the GPIB Adapter Card.

025

– Have the customer verify the DRB and cable are working correctly.

ARE THE DRB AND CABLE WORKING CORRECTLY?

Yes No

026

Have the customer replace the failed DRB or cable.

027

– Replace the GPIB Adapter Card.

MAP 4000: General-Purpose Interface Bus (GPIB)

Symptom Explanation	Conditions That Could Cause This Symptom
You have entered this MAP because you suspect a GPIB adapter or device problem.	<ul style="list-style-type: none"> • The GPIB adapter is failing. • The GPIB device is failing. • The GPIB adapter or device is missing.

001

- Turn off the system.
- Insert the reference diskette, and turn on the system.
- Select **View Configuration** from the Set Configuration menu.

IS THE GPIB ADAPTER REPORTED AS INSTALLED IN SLOT 3?

Yes No

002

- Turn off the system and ensure that the adapter is installed in the slot.
- Turn on the system and run Automatic Configuration.

003

- Go to step 006.

IS THE GPIB ADAPTOR NOW BEING REPORTED ON THE SYSTEM CONFIGURATION?

Yes No

004

- Replace the GPIB adapter card.

005

- Run the GPIB diagnostic diskette.

006

IS THE CUSTOMER EXPERIENCING PROBLEMS COMMUNICATING TO THE DRB?

Yes No

007

This may be an intermittent problem; start an error log and perform the DRB power supply checks.

- Other possible malfunctioning components are the power cable attached to the DRB; have the customer replace the DRB with a unit that is known to be good.

008

- Disconnect the DRB signal cable from the GPIB (DRB III) port of the system board, accessed at the rear of the main chassis.
- For Model 110/114 run the GPIB diagnostic tests.

DID TEST COMPLETE WITHOUT ERRORS?

Yes No

009

Replace the GPIB adapter card.

010

- Have the customer verify the GPIB device and cable are working correctly.

ARE THE DRB AND CABLE WORKING CORRECTLY?

Yes No

011

Have the customer replace the failed GPIB device or cable.

012

- Replace the GPIB adapter card.
-



SECTION 6. Parts Catalog

The Service Bay System assemblies are:

Cart/Drawer	204
Cart/Main Chassis	184
CD-ROM Drive Type A	196
CD-ROM Drive Type B	198
Covers	183
Decals	207
Display/Keyboard	202
DRB Power Supply	195
DRB Storage Box	194
Fan	201
Front Panel, Left	190
Front Panel, Right	191
Hard Disk Drive	199
Left Panel Cables	192
Main Chassis, Left	187
Main Chassis, Right	189
Rear Panel Cables	185
Right Panel Cables	193
System Board	200
Tools	206

Parts

LIMITED WARRANTY - IBM SERVICE PARTS (United States and Puerto Rico)

The International Business Machines Corporation warrants that each IBM Service Part will be free from defects in material and workmanship under conditions of normal use for a period of three months from the date of purchase from IBM or an IBM Authorized Dealer. Service Parts may be other than new but will be in good working order.

Should an IBM Service Part fail to be free from defects in materials or workmanship during the three-month warranty period, IBM will, at its option, repair or replace this Service Part at no additional charge in the United States or Puerto Rico. All replaced Service Parts will become the property of IBM. This limited warranty does not include service to repair damage to the Service Part resulting from accident, disaster, misuse, abuse, or non-IBM modification of the Product.

Limited Warranty service may be obtained by delivering the defective Service Part during the three-month warranty period to the IBM or IBM Authorized Dealer purchase location in the United States or Puerto Rico. A dated proof of purchase from IBM or an IBM Authorized Dealer must accompany the claim. Contact IBM by writing to IBM Corporation Parts Order Center, P.O. Box 1234, 123 New Circle Road, Lexington, Kentucky 40511 for further information.

ALL EXPRESS AND IMPLIED WARRANTIES FOR THIS SERVICE PART, INCLUDING THE WARRANTIES OF MERCHANTABILITY AND FITNESS FOR A PARTICULAR PURPOSE, ARE LIMITED IN DURATION TO A PERIOD OF THREE MONTHS FROM THE DATE OF PURCHASE, AND NO WARRANTIES, WHETHER EXPRESS OR IMPLIED, WILL APPLY AFTER THIS PERIOD.

Some states do not allow limitations on how long an implied warranty lasts, so the above limitations may not apply to you.

If this Service Part is defective in materials or workmanship under conditions of normal use, as warranted above, your sole remedy shall be repair or replacement as provided above. In no event will IBM be liable to you for any damages, including lost profits, lost savings or other incidental or consequential damages arising out of the use of or inability to use such Service Part, even if IBM or an IBM Authorized Dealer has been advised of the possibility of such damages, or for any claim by you based on any third party claim.

Some states do not allow the exclusion or limitation of accidental or consequential damages, so the above limitations or exclusions may not apply to you.

This warranty gives you specific legal rights, and you may also have other rights which vary from state to state.

How To Use This Parts Catalog

•**Similar Assemblies:** If two assemblies contain a majority of identical parts, they are broken down on the same list. Common parts are shown by one index number. Parts peculiar to one or the other of the assemblies are listed separately and identified by description.

•**AR:** (As Required) in the Units column indicates that the quantity is not the same for all machines.

•**R:** (Restricted) in the Units column indicates that the part has a restricted availability.

•**Ref:** (Reference) in the Units column indicates that the item is not available for ordering, but is being described for information only.

•**Indentation:** The indentation is marked by a series of dots located before the parts description. The indentation indicates the relationship of a part to the next higher assembly. For example:

Indentation Relationship of Parts

No dot Main Assembly

One dot • Detail part of a main assembly or,

One dot • First-level subassembly of a main assembly

Two dot • •Detail part of a first-level subassembly or,

Two dot • •Second-level subassembly of a first-level subassembly

Assembly *n*: Example Parts List

Asm-Index	Part Number	Units	Description
<i>n</i> -1	33F6154	1	Assembly, Right Cover
-2	33F6157	2	• Handle, Side Cover
-3	33F6158	2	• Cable Holder, Side Cover
-4	33F6185	1	Assembly, Front Cover
-5	33F6191	1	Label, EPO (Label Kit)
-6	33F6191	1	Label, Battery Warning (Label Kit)
-7	6279212	6	Screw, Common M4
-8	33F6213	AR	Nut, Side Cover
-9	84F6813	AR	Washer, Side Cover

Assembly 1: Covers

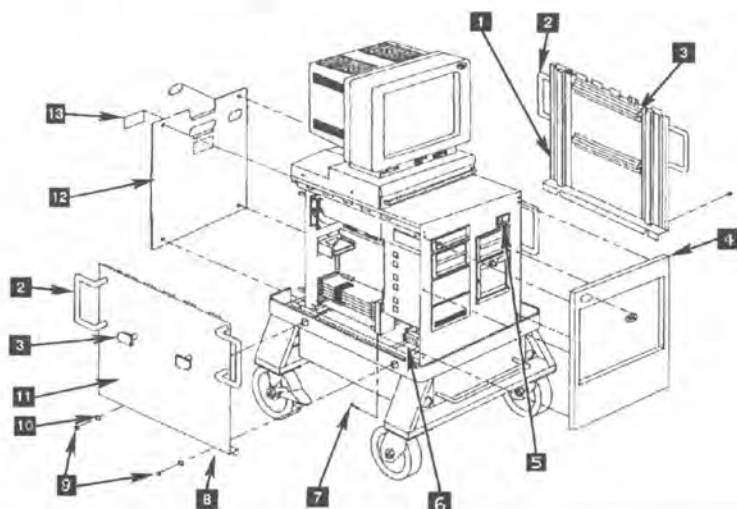

Asm-Index	Part Number	Units	Description
1-1	33F6154	1	Cover Assembly, Right
-2	33F6157	2	• Handle, Side Cover
-3	33F6158	2	• Cable Holder, Side Cover
-4	33F6185	1	Assembly, Front Cover
-5	33F6191	1	Label, EPO (Label Kit)
-6	33F6191	1	Label, Battery Warning (Label Kit)
-7	6279212	AR	Screw, Common M4
-8	10G5535	1	Kit, Side Cover Hardware
-8a		2	• Retainer Plate
-9		2	• Nut, M6
-10		2	• Lock Washer M6
-11	33F6153	1	Cover Assembly, Left
-2	33F6157	2	• Handle, Side Cover
-3	33F6158	2	• Cable Holder, Side Cover
-12	33F6136	1	• Kit, Back Cover
-13	33F6191	1	• Label, Arc & Spark (Label Kit)

Parts

Assembly 2: Cart/Main Chassis

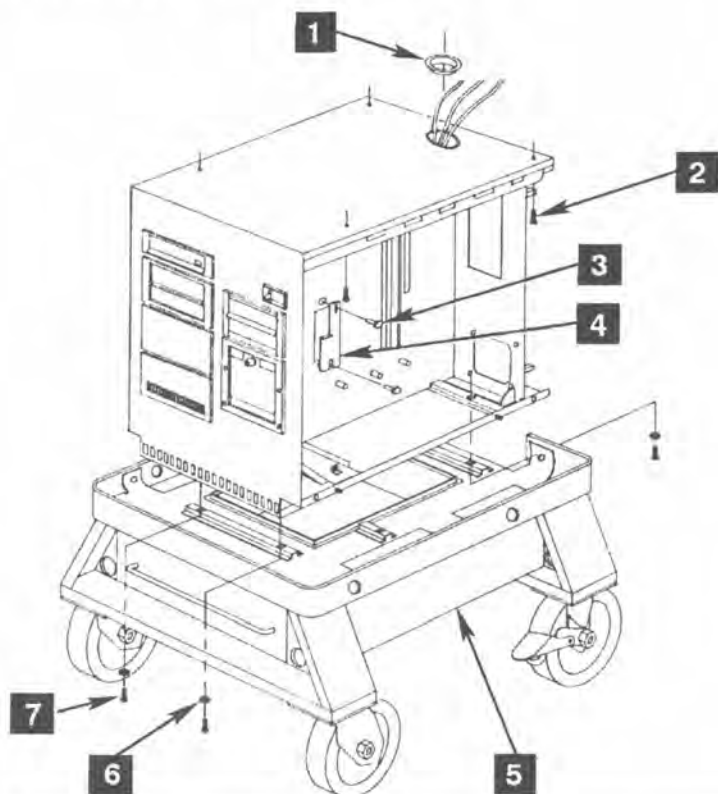

Asm-Index	Part Number	Units	Description
2-1	15F7755	1	Grommet, Main Chassis (Reference)
-2	1622418	4	Locknut, Display Base
-3	6279212	AR	Screw, Common, M4
-4	15F7779	1	Plate, Bulkhead, Middle
-5	33F6143	1	Assembly, Cart (Reference) See "Assembly 18: Cart/Drawer" on page 204.
-6	1622321	4	Lockwasher, M8
-7	1621549	4	Screw, M8 x 40

Assembly 3: Rear Panel Cables

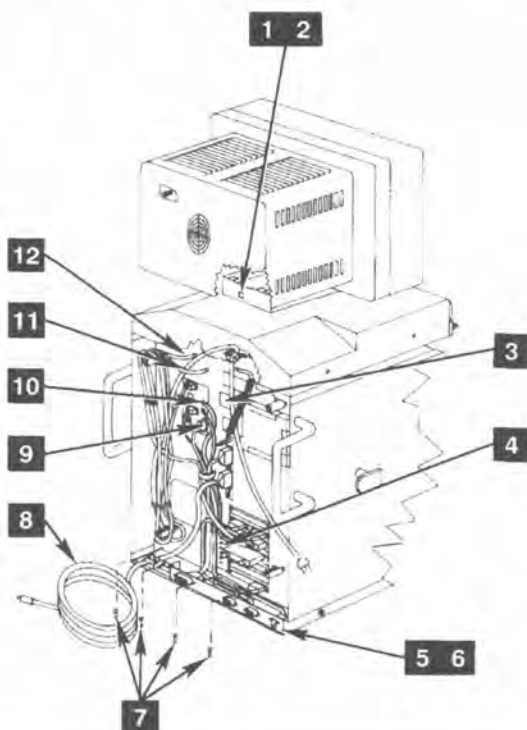

Asm-Index	Part Number	Units	Description
3-1	33F6191	1	Kit, Label
-2		1	• Label, Display Weight
-3		1	• Label, System Weight
-4		1	• Label, Card Slots
-5	15F7853	1	Bracket, Panel
-6	33F6209	1	• Kit, Panel Nut
-7	6279212	AR	Screw, Common (M4)
-8	15F7827	1	Cable, DRB Signal Cable
-9	15F7789	1	Cable, Telephone, Wakeup Box-to-Modem
-9a	15F7906	1	Splitter, Telephone cable
-10	15F7789	1	Cable, Telephone, Port-to-Wakeup Box
-11		1	Cable, Display Power (Reference)
-12		1	Cable, Display-to-Image Adapter/A See "Assembly 17: Display/Keyboard" on page 202.

Parts

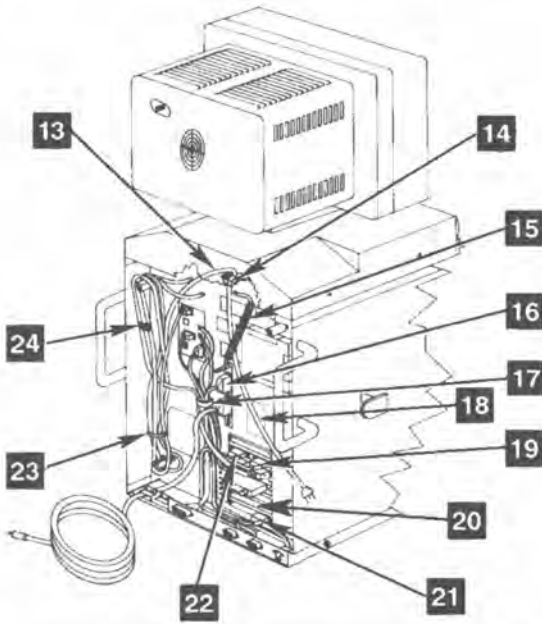

Asm-Index	Part Number	Units	Description
3-13	15F7729	1	Power Cord, System (External)
-14	84F6814	1	Retainer, Strain Relief, System Power Cord
-15		1	Cable, Keyboard
-16	15F7842	1	Cable, Printer Port-to-System Board
-17	15F7735	1	Clamp, Cable
-18	84F6818	1	Plate, Telephone Mounting
-19	15F7761	1	Cable, Satellite Port-to-ASYNC Port
-20	6279235	AR	Adapter Slot Cover
-22	15F7844	1	Cable, ASYNC Port-to-Wakeup Box
-23	0532393	AR	Tie, Cable
-24	5405736	AR	Tie Wrap, Cable

Assembly 4: Main Chassis, Left

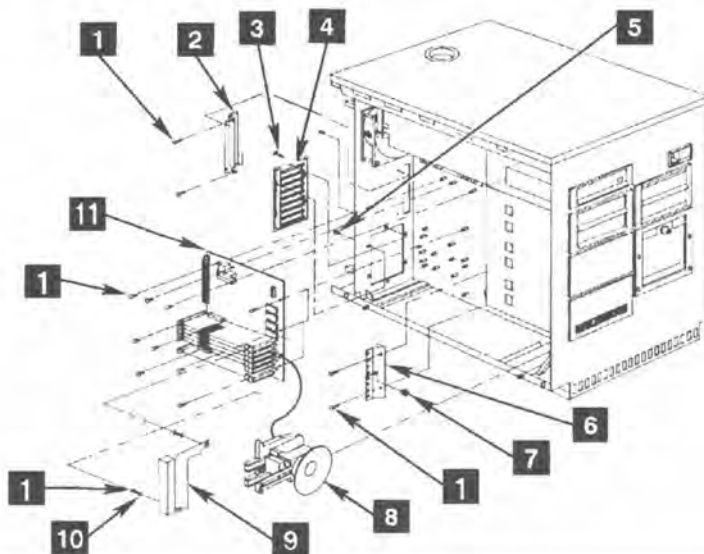

Asm-Index	Part Number	Units	Description
4-1	6279212	AR	Screw, Common, M4
-2	15F7781	1	Plate, Interposer
-3	15F7762	1	Gate, Card
-4	27F4631	AR	Thumb Screw
-5	33F6190	2	Screw, M4 x 7 (Hardware Kit)
-6	15F7730	1	Support, Adapter
-7	33F6190	1	Grommet, Rubber (Hardware Kit)
-8	33F5950	1	Assembly, Speaker (without Battery) See "Assembly 15: System Board" on page 200.
-9	15F7799	1	Retainer, Adapter
-10	15F7751	AR	Washer, Flat
-11		1	System Board See "Assembly 15: System Board" on page 200.

Parts

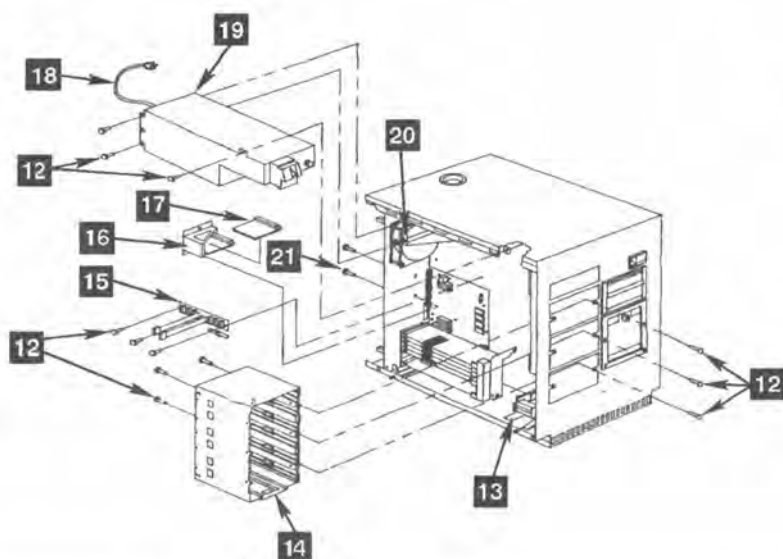

Asm-Index	Part Number	Units	Description
4-12	6279212	AR	Screw, Common, M4
-13	33F6191	1	Label, Battery Warning (Label Kit)
-14	64F0612	1	Cage, Left Side
-15	15F7731	1	Card, Power Distribution
-16	15F7798	1	Bracket, Memory Adapter
-17	92F0669	1	Adapter, 2MB Memory
-18	15F7831	1	Cord, Power Supply
-19	57F1600	1	Power Supply, 250-Watt
-20		1	Fan Assembly
			See "Assembly 16: Fan" on page 201.
-21	6279212	AR	Screw, Common, M4

Assembly 5: Main Chassis, Right

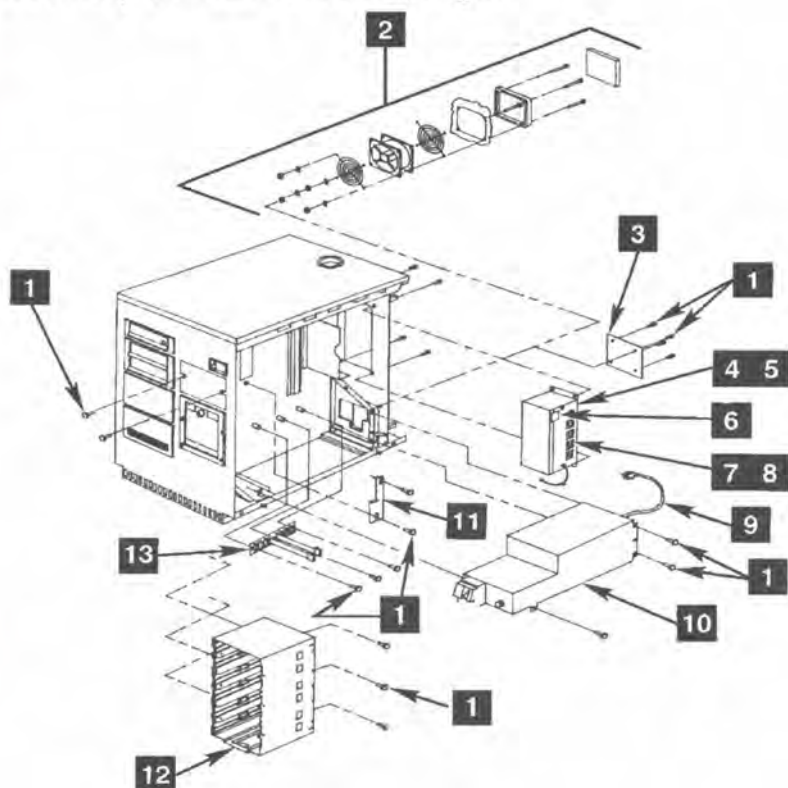

Asm-Index	Part Number	Units	Description
5-1	6279212	AR	Screw, Common, M4
-2	33F6139	1	Kit, Fan See "Assembly 16: Fan" on page 201.
-3	15F7780	1	Plate, Fan Cover (optional)
-4	33F6135	1	Kit, Wakeup Box (Models 110 and 114)
-6		1	• Label, Voltage Warning
-7		1	• Assembly, Wakeup Box
-9	15F7831	1	Cord, Power Supply (optional)
-10	57F1600	1	Power Supply, 250-Watt
-11	15F7779	1	Plate
-12	64F0612	1	Cage, Right Side
-13	15F7731	1	Card, Power Distribution (optional)

Assembly 6: Front Panel, Left

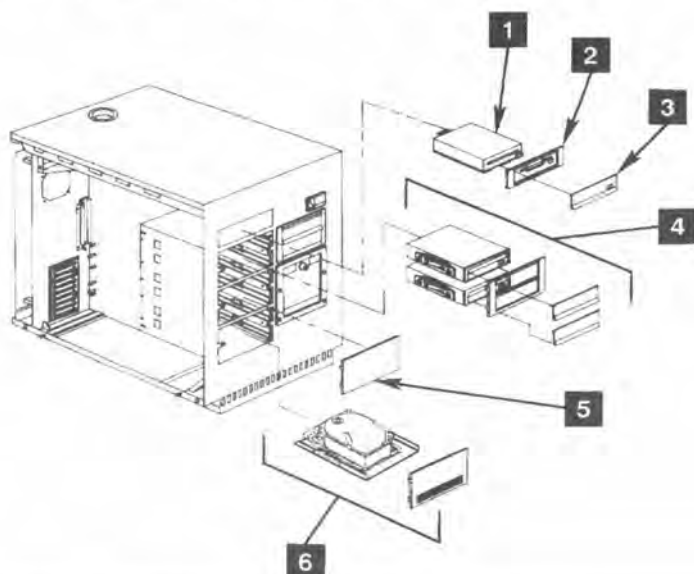

Asm-Index	Part Number	Units	Description
6-1	72X8523	1	Assembly, 3.5-inch, 1.44MB Diskette Drive
-2	15F7826	AR	Bezel, Diskette
-3	15F7742	AR	Door, Diskette
-4		1	Kit, CD-ROM Drive See "Assembly 12: CD-ROM Drive Type A" on page 196.
-5	15F7759	AR	Bezel, Blank
-6		1	Hard Disk Drive See "Assembly 14: Hard Disk Drive" on page 199.

Assembly 7: Front Panel, Right

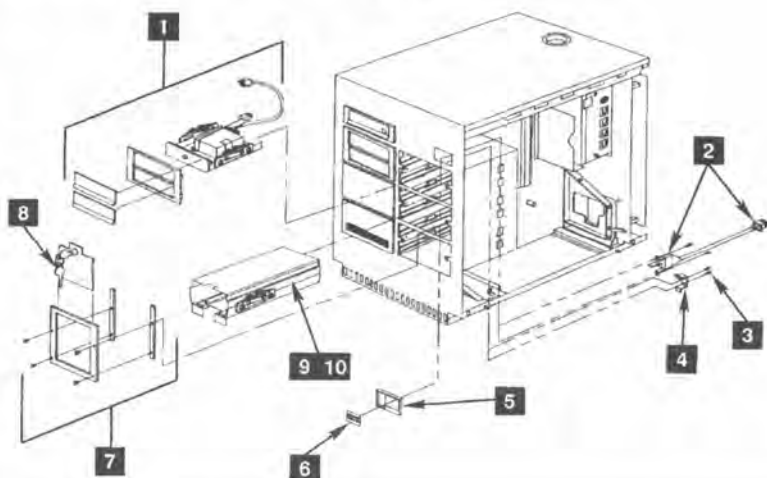

Asm-Index	Part Number	Units	Description
7-1		1	Power Supply, DRB See "Assembly 11: DRB Power Supply" on page 195.
-2	15F7732	1	Assembly, EPO Switch and Cable
-3	33F6190	4	Screw, Self-Tapping, M3 x 10 (Hardware Kit)
-4	15F7726	1	Retainer, EPO Switch
-5	15F7733	1	Bezel, EPO Switch
-6	33F6191	1	Label, EPO (Label Kit)
-7	33F6145	1	Assembly, DRB Door See "Assembly 10: DRB Storage Box" on page 194.
-8	64F0605	2	Key, DRB Storage Door
-9	15F7835	1	Box, DRB Storage
-10	64F2460	1	• Slide Kit, DRB Box and Power Supply See "Assembly 10: DRB Storage Box" on page 194.

Assembly 8: Left Panel Cables

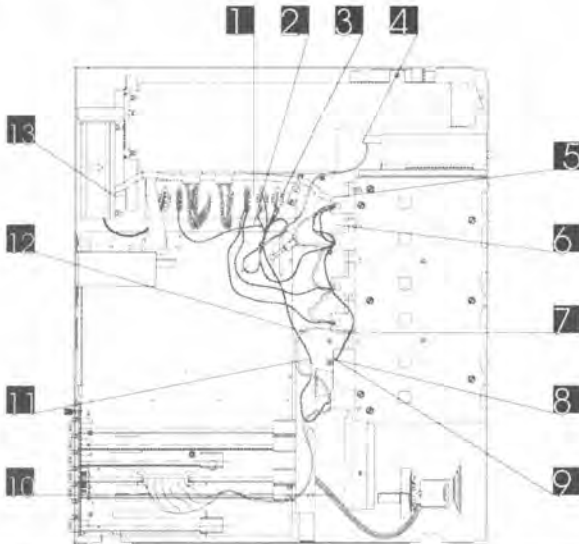

Asm-Index	Part Number	Units	Description
8-1	15F7774	1	Cable, CD-ROM Power
-2	15F7793	1	Cable, Hard Disk Power
-3	0532393	1	Tie, Cable
-4	15F7727	1	Cable, 3.5" Diskette Signal
-5	15F7757	1	Terminator, Disk Connector, 50-position
-6	15F7749	1	Cable, SCSI Device Signal
-7	15F7832	1	Cable, Disk Ground
-8	33F6190	1	Locknut, Common, M4 (Hardware Kit)
-9	33F6190	1	Washer, Star (Hardware Kit)
-10	90X6752	1	Cable, Speaker
-11	15F7832	1	Cable, CD-ROM Ground
-12	5405736	1	Wrap, Cable Tie
-13	15F7831	1	Cord, Power Supply

Assembly 9: Right Panel Cables

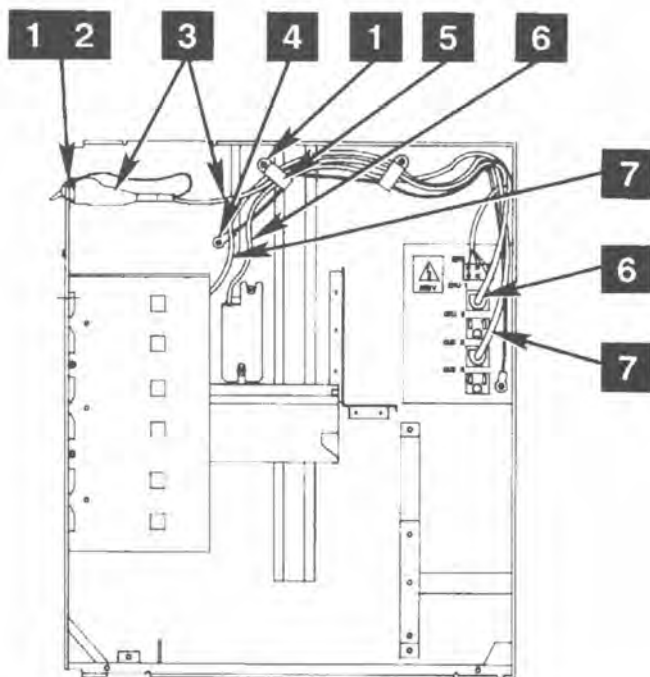

Asm-Index	Part Number	Units	Description
9-1	33F6190	AR	Nut, Common, M4 (Hardware Kit)
-2	33F6190	1	Washer, Star (Hardware Kit)
-3	15F7732	1	Assembly, EPO Switch/Cable
-4	6279212	AR	Screw, Common, M4
-5	15F7735	2	Clamp, Cable
-6	15F7831	1	Cord, Power Supply
-7		1	Cord, DRB Power Supply See "Assembly 11: DRB Power Supply" on page 195.

Assembly 10: DRB Storage Box

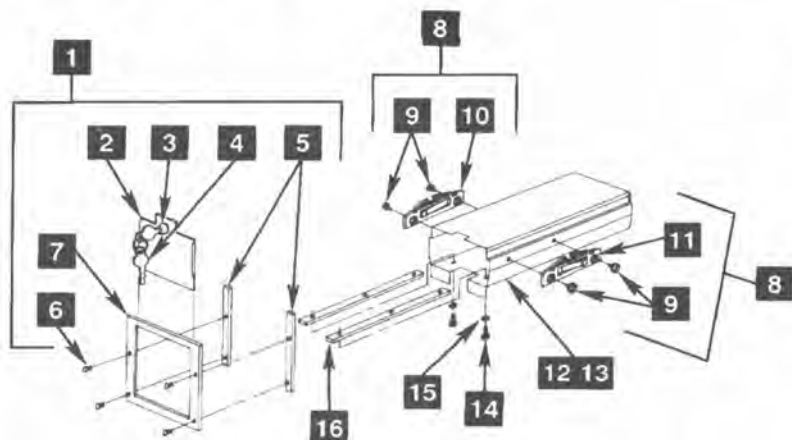

Asm-Index	Part Number	Units	Description
			For next higher assembly, see "Assembly 7: Front Panel, Right" on page 191.
10-1	33F6145	1	Door Kit, DRB Storage
-2		1	• Door, DRB Storage
-3	15F7838	1	• • Assembly, DRB Keylock (with Key)
-4	64F0605	1	• • • Key, DRB Door
-5		2	• Spacer, DRB Door
-6		4	• Screw, Button Head, M4
-7		1	• Bezel, DRB Door
-8	64F2460	1	Slide Kit, DRB Box and Power Supply
-9		4	• Screw, Shoulder, 6-32
-10		1	• Slide, Left Locking
-11		1	• Slide, Right Locking
-12	15F7835	1	Assembly, Storage Box
-13		1	• Box, Storage
-14		4	• Screw
-15		6	• Lockwasher
-16		2	• Liner

Assembly 11: DRB Power Supply

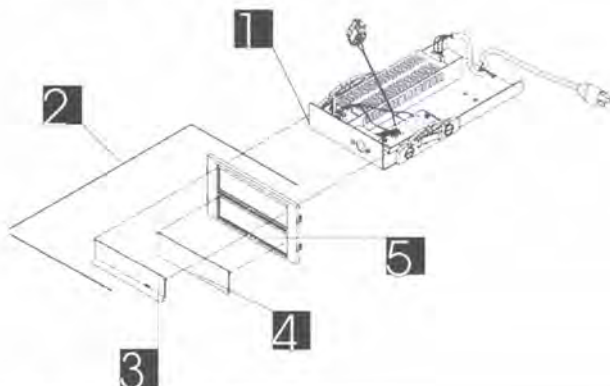

Asm-Index	Part Number	Units	Description
			For next higher assembly, see "Assembly 7: Front Panel, Right" on page 191.
11-1	61G2781	1	Assembly, DRB Power Supply
-2	64F0621	1	Assembly, Bezel/Door, DRB
-3		1	• Panel, Blank
-4		1	• Door
-5		1	• Bezel, DRB

Assembly 12: CD-ROM Drive Type A

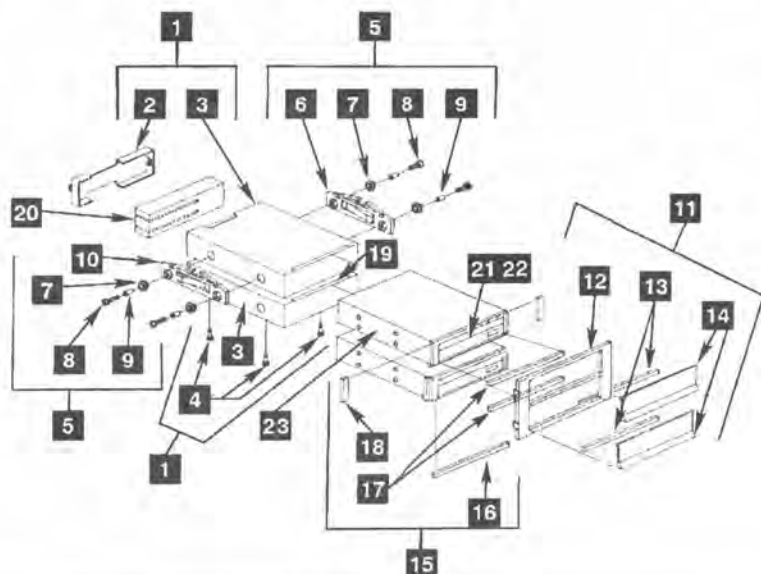

Asm-Index	Part Number	Units	Description
			This unit is now obsolete and is replaced by CD-ROM Type B. For next higher assembly, see "Assembly 6: Front Panel, Left" on page 190.
12-1	64F0607	1	Kit, CD-ROM Dust Cover
-2		1	• Door, Dust Cover
-3		1	• Dust Cover, CD-ROM
-4		4	• Screw, Slotted, 6-32 x .375
-5	64F2461	1	Kit, Slide
-6		1	• Slide, Locking, Right
-7		4	• Grommet, Rubber
-8		4	• Screw, Slotted, 6-32 x .375
-9		4	• Bushing
-10		1	• Slide, Locking, Left
-11	15F7913	1	Assembly, CD-ROM Door Bezel
-12		1	• Bezel
-13		4	• Gasket
-14		2	• Door
-15	64F0608	1	Kit, Foam, CD-ROM
-16		1	• Gasket, Foam, Bottom
-17		2	• Gasket, Foam, Front
-18		2	• Gasket, Foam, Side
-19		1	• Gasket, Foam, Top External

-20		1	• Gasket, Foam, Rear
-21	22F9419	1	Assembly, CD-ROM Caddy
-22	53F3088	1	CD-ROM Test Disk
-23		1	Assembly, CD-ROM Drive
-23a	15F7809	1	• Assembly, CD-ROM Drive

Assembly 13: CD-ROM Drive Type B

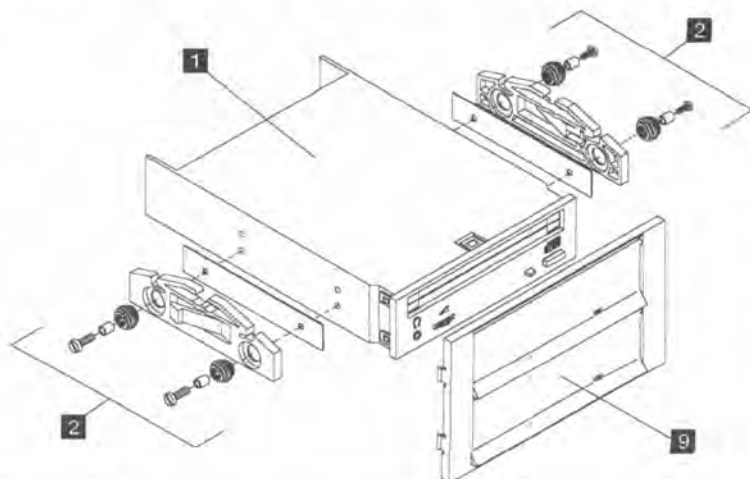

Asm-Index	Part Number	Units	Description
13-	42G0913		This unit replaces CD-ROM Type A, which is now obsolete. For next higher assembly, see "Assembly 6: Front Panel, Left" on page 190.
-1	10G5531	1	Kit, CD-ROM Drive Type B Order this P/N when replacing a Type A drive with a Type B drive.
-2	10G5534	1	• Assembly, CD-ROM Drive Order this P/N when replacing a Type B drive with another Type B drive.
-3		1	• Kit, Mounting Hardware
-4		1	• • Slide, Locking, Left
-5		1	• • Slide, Locking, Right
-6		2	• • Shim
-7		4	• • Bushing
-8		4	• • Grommet, Shock Absorbing
-9	10G5530	4	• • Screw
-10		1	• Assembly, Bezel
-11		1	• • Bezel
-12		2	• • Door
-13		2	• • Gasket
-14		1	CD-ROM Test Disk
-15		1	Diagnostic Diskette
		Ref	Installation Instructions

Assembly 14: Hard Disk Drive

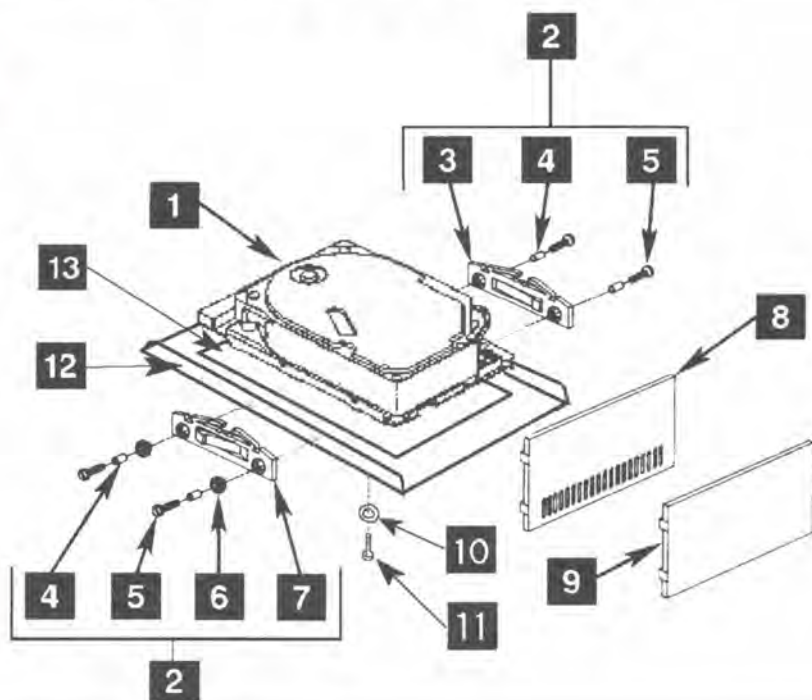

Asm-Index	Part Number	Units	Description
			For next higher assembly, see "Assembly 6: Front Panel, Left" on page 190.
14-1	6128298	1	Assembly, Hard Disk, 120MB
-2	64F2461	1	Kit, Slide
-3		1	• Slide, Locking, Right
-4		4	• Bushing
-5		4	• Screw, Slotted, 6-32 x .375
-6		4	• Grommet
-7		1	• Slide, Locking, Left
-8	15F7758	1	Bezel (with Vents)
-9	15F7759	1	Bezel (without Vents)
-10	1622346	AR	Washer
-11	1621192	AR	Screw
-12	64F5686	1	Disk Bracket
-13	33F6129	1	Insulator

Assembly 15: System Board

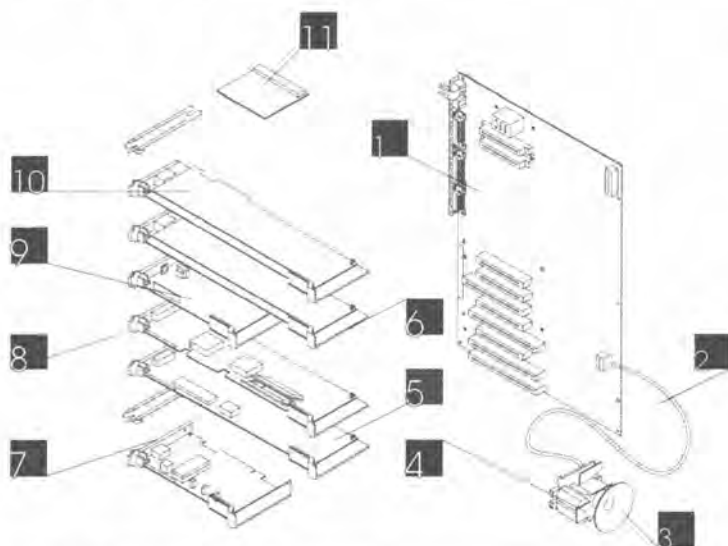

Asm-Index	Part Number	Units	Description
			For next higher assembly, see "Assembly 4: Main Chassis, Left" on page 187.
15-1	10G4148	1	Assembly, System Board
-2	90X6752	1	Cable, Speaker
-3	33F5950	1	Assembly, Speaker (without battery)
-4	72X8498	1	Battery
-5	42G0965	1	Adapter, GPIB
-6	06G8224	1	Image-Adapter/A
-6	07F4407	1	Memory, Image-Adapter/A
-7	92F0046	1	Adapter, Ethernet (Optional on Model 110)
-8	85F0002	1	Adapter, SCSI
-9	94X1755	1	Adapter, 2400-bps Modem
-10	34F0008	1	Adapter, Dual Asynch (Models 110, 114 only) (Models 110, 114 only)
-11	92F0669	1	Adapter, 2MB Memory

Assembly 16: Fan

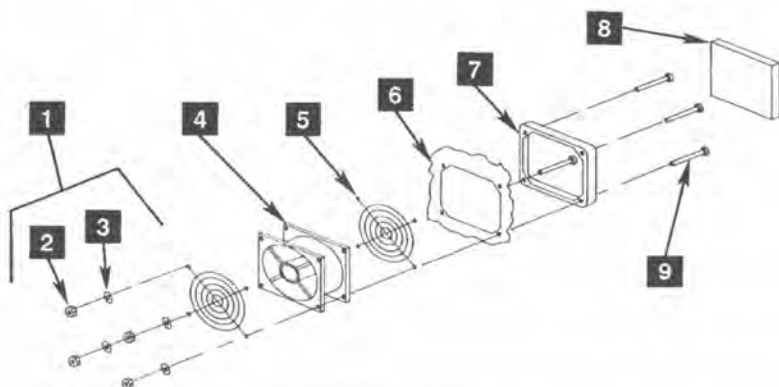

Asm-Index	Part Number	Units	Description
			For next higher assembly, see "Assembly 4: Main Chassis, Left" on page 187.
16-1	33F6139	1	Kit, Fan
-2		4	• Nut, M4
-3		4	• Washer, Star
-9		4	• Screw, M4 x 6.5
-4	15F7736	1	Assembly, Fan
-5	33F6206	2	Guard, Finger
-6		1	Frame, Main Chassis (Reference)
-7	15F7737	1	Cage, Filter
-8	15F7738	1	Filter

Parts

Assembly 17: Display/Keyboard

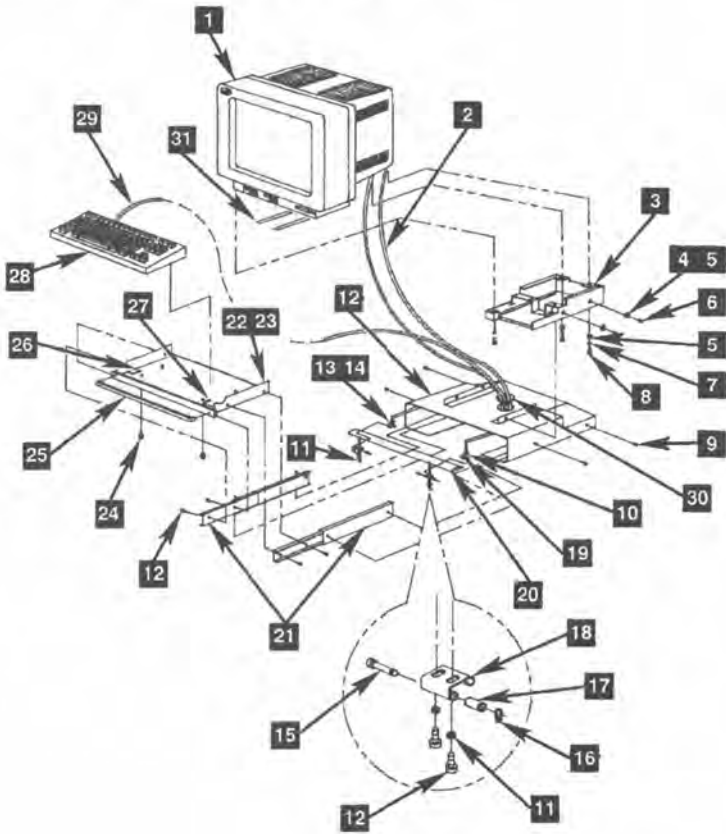

Asm- Index	Part Number	Units	Description
17-1	33F6137	1	Assembly, Display
-2	6952298	1	Cable, Display Power
-3	33F6123	1	Base, Display
-4	33F6189	1	Kit, Hardware, Keyboard Enclosure
-5		AR	• Lockwasher, M6
-6		AR	• Screw, M6 (Display Base)
-7		AR	• Washer, Flat
-8		AR	• Screw, Hex Head, M6 x 12
-9		AR	• Screw, M4
-10		AR	• Locknut, M5
-11		AR	• Screw, Pan Head, M4 x 6
-12	33F6122	1	Enclosure, Keyboard
-13	33F6187	1	Kit, Hardware, Misc. Keyboard Enclosure
-14		1	• Hinge Support, Left
-15		2	• Pin, Hinge, Keyboard Door
-16		2	• Ring, Retainer
-17		2	• Roller, Keyboard Support
-18		2	• Spring and Tab
-19		1	• Hinge Support, Right
-20	33F6128	1	Door, Keyboard Enclosure
-21	33F6133	2	Slide, Keyboard Tray
-22	64F0606	1	Assembly, Keyboard Tray
-23		1	• Tray, Keyboard
-24		2	• Bumper, Keyboard Tray
-25		1	• Handle, Keyboard Tray
-26		2	• Screw, Pan Head, M5 x 12
-27		2	• Lockwasher, M5
-28	1395691	1	Keyboard
-29		1	• Cable, Keyboard
-30	15F7755	1	Grommet, Display/Keyboard Cable
-31	15F7771	2	Stiffener brackets

Assembly 18: Cart/Drawer

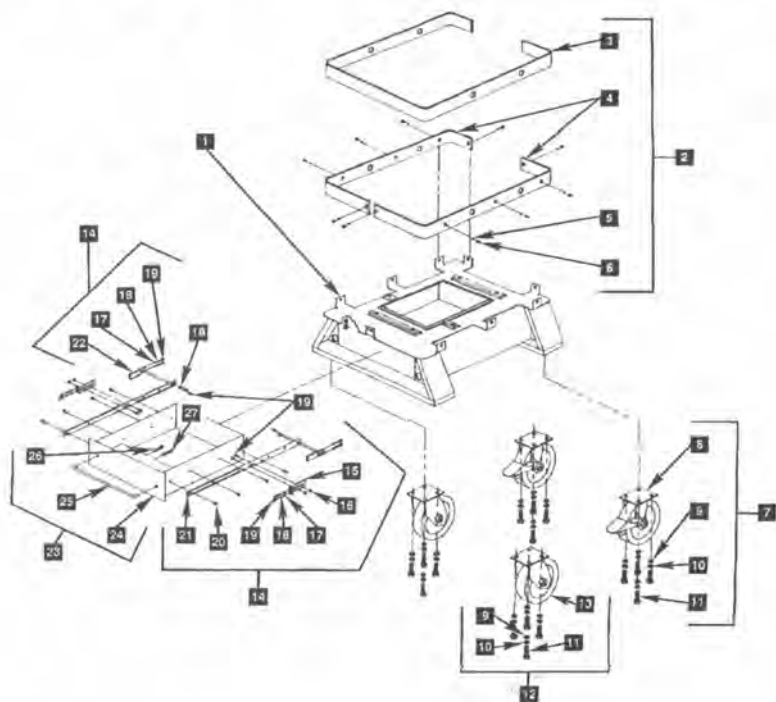

Asm- Index	Part Number	Units	Description
			For next higher assembly, see "Assembly 2: Cart/Main Chassis" on page 184.
18-0	33F6143	1	Assembly, Cart
-1		1	• Frame, Cart
-2	64F0611	1	• Kit, Cart Bumper
-3	64F2462	1	• • Strip, Bumper
-4		2	• • Bar Face
-5		10	• • Lockwasher, Common, M5
-6		10	• • Screw, Slotted Machine, M5 x 12
-7	64F2463	1	• Kit, Fixed Caster
-8		1	• • Caster, Fixed
-9		4	• • Washer, Flat, M8
-10		4	• • Lockwasher, Common, M8
-11		4	• • Bolt, Hex Head, M8 x 1.25
-12	64F2464	1	• Kit, Swivel Caster
-9		4	• • Washer, Flat, M8
-10		4	• • Lockwasher, Common, M8
-11		4	• • Bolt, Hex Head, M8 x 1.25
-13		1	• • Caster, Swivel
-14	64F0609	1	• Kit, Drawer Slide
-15		2	• • Bracket, Slide
-16		2	• • Locknut, M4
-17		8	• • Washer, Flat, M4
-18		8	• • Lockwasher, M4
-19		14	• • Screw, Machine, Slotted, M4 x 12
-20		8	• • Screw, Machine, Slotted, M4 x 6
-21		2	• Slide, Cart
-22		2	• • Block, Slide Mounting
-23	64F0610	1	• Assembly, Cart Drawer
-24		1	• • Drawer, Cart
-25	33F6147	1	• • Handle, Drawer
-26		2	• • Lockwasher, Split, M8
-27		2	• • Bolt, Hex Head, M8 x 1.25

Assembly 19: Tools

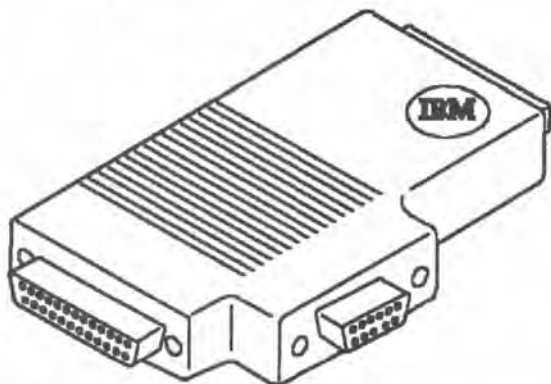

Asm-Index	Part Number	Units	Description
19-1	72X8546	1	Connector, Wrap (shown)
-2	6404078	1	Diskette, 2.0MB
-3A	53F3088	1	Test Disk, CD-ROM Type A
-3B	81F8902	1	Test Disk, CD-ROM Type B
-4	22F9419	1	Caddy, CD-ROM
-5	8310574	1	IBM Cabling System Data Connector
-6	75X5893	1	Extraction Tool, Module

Assembly 20: Decals

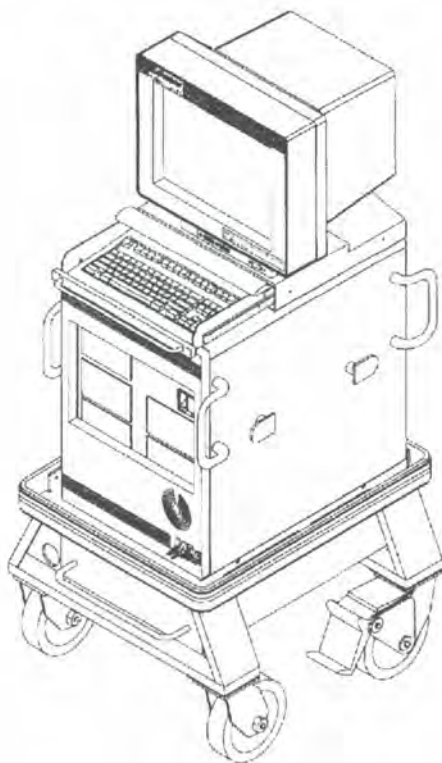

Asm-Index	Part Number	Units	Description
20-	33F6173	1	Decal kit (shown)

Appendix. Notices

FCC Statement

The following statement applies to this IBM product. The statement for other IBM products intended for use with this product will appear in their accompanying materials.

Federal Communications Commission (FCC) Statement

Warning: This equipment generates, uses, and can radiate radio-frequency energy, and if not installed and used in accordance with the instruction manual, may cause interference to radio communications. It has been tested and found to comply with the limits for a Class A computing device, pursuant to Subpart J of Part 15 of FCC rules, which are designed to provide reasonable protection against such interference when operated in a commercial environment. Operation of this equipment in a residential area is likely to cause interference, in which case the user, at his own expense, will be required to take whatever measures are needed to correct the interference.

Avertissement : Cet équipement ne dépasse pas les limites de Classe A d'émission de bruits radioélectriques pour les appareils numériques, telles que prescrites par le Règlement sur le brouillage radioélectrique établi par le ministère des Communications du Canada. L'exploitation faite en milieu résidentiel peut entraîner le brouillage des réceptions radio et télé, ce qui obligerait le propriétaire ou l'opérateur à prendre les dispositions nécessaires pour en éliminer les causes.

CAUTION

This product is equipped with a 3-wire power cord and plug for the user's safety. Use this power cord in conjunction with a properly grounded electrical outlet to avoid electrical shock.

Attention !

Pour votre sécurité, ce produit est équipé d'une fiche de prise de courant et d'un cordon d'alimentation tripolaires. Pour éviter

tout risque de choc électrique, ce cordon d'alimentation doit être branché à un socle de prise de courant correctement câblé et mis à la terre.

Glossary of Terms and Abbreviations

ac. alternating current

AUI. Attachment Unit Interface

BIOS. Basic Input/Output System

BTUH. British Thermal Unit per Hour

CCITT. Central Committee for International Telephony and Telegraphy

CD-ROM. Compact Disk - Read-Only Memory

CMOS. Complimentary Metal-Oxide Semiconductor

CRT. Cathode Ray Tube

CSMA/CD. Carrier Sense Multiple Access with Collision Detection

dc. direct current

DCP. Diagnostic Control Program

ECMA. European Computer Manufacturers Association

EPO. Emergency Power-Off

FCC. Federal Communication Commission

Hz. Hertz

IEEE. Institute of Electrical and Electronic Engineers

International Standards Organization
kg kilogram LAN Local-Area Network
lb pound (weight) ppb parts per billion
m meter (length) Mb Mega-byte
MHz MegaHertz $\mu\text{g}/\text{m}^3$ micrograms per cubic meter
mm millimeter

NetBIOS. Network Basic Input/Output System

NVRAM. Non-Volatile Random Access Memory

PC. Personal Computer

POST. Power-On Self-Test

RAM. Random-Access Memory

ROM. Read-Only Memory

SBS. Service Bay System

SCSI. Small Computer System Interface

V ac. Volts alternating current

V dc. Volts direct current

Part Number Index

Part Number	Asm-Index	Page	Part Number	Asm-Index	Page
0532393	3-23	186	15F7779	continued	
	8-3	192		5-11	189
06G8224	15-6	200	15F7780	5-3	189
07F4407	15-6	200	15F7781	4-2	187
10G4148	15-1	200	15F7789	3-9	185
10G5530	13-9	198		3-10	185
10G5531	13-1	198	15F7793	8-2	192
10G5534	13-2	198	15F7798	4-16	188
10G5535	1-8	183	15F7799	4-9	187
1395691	17-28	203	15F7809	12-23a	197
15F7726	7-4	191	15F7826	6-2	190
15F7727	8-4	192	15F7827	3-8	185
15F7729	3-13	186	15F7831	4-18	188
15F7730	4-6	187		5-9	189
15F7731	4-15	188		8-13	192
	5-13	189		9-6	193
15F7732	7-2	191	15F7832	8-7	192
	9-3	193		8-11	192
15F7733	7-5	191	15F7835	7-9	191
15F7735	3-17	186		10-12	194
	9-5	193	15F7838	10-3	194
15F7736	16-4	201	15F7842	3-16	186
15F7737	16-7	201	15F7844	3-22	186
15F7738	16-8	201	15F7853	3-5	185
15F7742	6-3	190	15F7906	3-9a	185
15F7749	8-6	192	15F7913	12-11	196
15F7751	4-10	187	1621192	14-11	199
15F7755	2-1	184	1621549	2-7	184
	17-30	203	1622321	2-6	184
15F7757	8-5	192	1622346	14-10	199
15F7758	14-8	199	1622418	2-2	184
15F7759	6-5	190	22F9419	12-21	197
	14-9	199		19-4	206
15F7761	3-19	186	27F4631	4-4	187
15F7762	4-3	187	33F5950	4-8	187
15F7771	17-31	203		15-3	200
15F7774	8-1	192	33F6122	17-12	203
15F7779	2-4	184	33F6123	17-3	203

Part Number	Asm-Index	Page	Part Number	Asm-Index	Page
33F6128	17-20	203	53F3088	continued	
33F6129	14-13	199		19-3A	206
33F6133	17-21	203	5405736	3-24	186
33F6135	5-4	189		8-12	192
33F6136	1-12	183	57F1600	4-19	188
33F6137	17-1	203		5-10	189
33F6139	5-2	189	61G2781	11-1	195
	16-1	201	6128298	14-1	199
33F6143	2-5	184	6279212	1-7	183
	18-0	205		2-3	184
33F6145	7-7	191		3-7	185
	10-1	194		4-1	187
33F6147	18-25	205		4-12	188
33F6153	1-11	183		4-21	188
33F6154	1-1	183		5-1	189
33F6157	1-2	183		9-4	193
	1-2	183	6279235	3-20	186
33F6158	1-3	183	64F0605	7-8	191
	1-3	183		10-4	194
33F6173	20-	207	64F0606	17-22	203
33F6185	1-4	183	64F0607	12-1	196
33F6187	17-13	203	64F0608	12-15	196
33F6189	17-4	203	64F0609	18-14	205
33F6190	4-5	187	64F0610	18-23	205
	4-7	187	64F0611	18-2	205
	7-3	191	64F0612	4-14	188
	8-8	192		5-12	189
	8-9	192	64F0621	11-2	195
	9-1	193	64F2460	7-10	191
	9-2	193		10-8	194
33F6191	1-5	183	64F2461	12-5	196
	1-6	183		14-2	199
	1-13	183	64F2462	18-3	205
	3-1	185	64F2463	18-7	205
	4-13	188	64F2464	18-12	205
	7-6	191	64F5686	14-12	199
33F6206	16-5	201	6404078	19-2	206
33F6209	3-6	185	6952298	17-2	203
34F0008	15-10	200	72X8498	15-4	200
42G0913	13-	198	72X8523	6-1	190
42G0965	15-5	200	72X8546	19-1	206
53F3088	12-22	197	75X5893	19-6	206

Part Number	Asm- Index	Page
81F8902	19-3B	206
8310574	19-5	206
84F6814	3-14	186
84F6818	3-18	186
85F0002	15-8	200
90X6752	8-10	192
	15-2	200
92F0046	15-7	200
92F0669	4-17	188
	15-11	200
94X1755	15-9	200

Index

A

- adapter diagnostics 31
- adapter memory 18
- addressing, CD-ROM drive 95
- advanced diagnostic tests 28
- arbitration, CD-ROM drive 96
- asynchronous adapter 12

B

- backup diskette 24

C

- cabling diagram 86
- CD-ROM drive 11
- compact disks 94
- configuration 25
- configuration error 89
- connector
 - built-in 5
 - display 10
 - keyboard 7
 - pointing device 7
- connector locations 85
- control box 8, 88
- controls, CD-ROM drive 94
- copy an option 26
- cover 40
- create error log 31

D

- diagnostic aids 24
- diagnostics 29
- diagram, safety ground wiring 86

- DIP switches 95

diskette

- compatibility 13
- drive controller 7
- reference 24
- update reference 25, 26

- display 9

- drive designation 93

E

- environmental specifications 20

- EPO switch 83, 88

error messages

- 0001XX00 115, 117
- 0002XX00 115, 117
- 0003XX00 115, 117
- 0004XX00 115, 117
- 0006XX00 115, 117
- 0011XX00 115, 117
- 0012XX00 115, 117, 118
- 0024XX00 115, 118
- 0101XX00 115, 118
- 0104XX00 115, 118
- 0112XX00 115, 118
- 016XXX00 115, 118
- 0210XXXX 115, 118
- 0215XXXX 115, 118
- 16X 105
- 1XX 113, 114, 140
- 2XX 113, 114, 140
- 30X 113, 114
- 6XX 113
- audio 113
- log 30
- memory 18

Index

Ethernet adapter 13

F

fan filter replacement interval 56,
58
field replaceable unit 21
field-replaceable unit
 adapter 48
 battery 61
 cable, keyboard 77
 CD-ROM drive 68
 diskette drive 60
 display 75
 DRB power supply 66
 EPO switch 64
 fan 56, 58
 front bezel 50
 front cover 45
 hard disk drive 73
 keyboard 77
 left cover 40
 memory adapter 46
 mounting base 75
 power distribution control box 55
 power supply 51
 power supply, optional 53
 rear cover 44
 right cover 42
 sense box 55
 slides, keyboard 77
 system board 71
 tray, keyboard 77
 video modules 49
 wakeup box 55
focus adjustment 97
formatting hard disk 32
FRU locations 78

G

ground wiring diagram 86

H

hard disk drive 14
hard disk formatting 32

I

image adapter/A 11
index, symptom-to-FRU 33
inserting disk into CD-ROM
 drives 94
installed devices list 30
internal modem 11

K

keyboard speed. 26

L

local area network 5
locations 78
 adapters 84
 EPO switch 83
 front view 78
 internal cables 82
 left interior view 80
 power cables 82
 power distribution 83
 rear view 79
 right interior view 81
 signal cables 82
 system board 84
 system board connectors 85

M

- MAPs 32
 - 16X error table 105
 - audio error table 113
 - diagnostic 121
 - diskette drive 152
 - DRB 169
 - DRB power supply 169
 - failure symptoms table 115
 - GPIO 176
 - image adapter/A 155
 - introduction 104
 - keyboard 146
 - memory 140
 - SCSI devices 165
 - start 104
 - symptom-to-FRU index 115
- measurements, voltage
 - diskette connector 153
 - power supply 129
 - power supply, 4-pin connectors 130
- memory diagnostics 31
- memory errors 18
- microprocessor 5
- multiple CD-ROM drives 95

O

- option 5

P

- parallel port 7
- parity switch, CD-ROM drive 96
- parts catalog
 - cart 204
 - cart/main chassis 184
 - CD-ROM Kit A 196
 - covers 183

parts catalog (*continued*)

- decals 207
- display/keyboard 202
- drawer 204
- DRB power supply kit 195
- DRB storage box 194
- example 182
- fan 201
- Front Panel, Left 190
- front panel, right 191
- hard disk 199
- introduction 179
- left panel cabling 192
- limited warranty 180
- main chassis, left 187, 188
- Main Chassis, Right 189
- rear panel cables 185, 186
- right panel cabling 193
- system board 200
- tools 206
- using 182
- password security 17
- passwords. 26
- POST 16, 27
- power distribution 8
- power supply 15
- power-on password. 26
- presence tests 29

R

- RAM storage 5
- rear panel connectors 85
- reference diskette 24
- remove
 - adapter 48
 - battery 61
 - cable, keyboard 77
 - CD-ROM drive 68
 - diskette drive 60
 - display 75

Index

- remove (*continued*)
 - DRB power supply 66
 - EPO switch 64
 - fan 56, 58
 - front bezel 50
 - front cover 45
 - hard disk drive 73
 - keyboard 77
 - left cover 40
 - memory adapter 46
 - mounting base 75
 - power distribution control box 55
 - power supply 51
 - power supply, optional 53
 - rear cover 44
 - right cover 42
 - sense box 55
 - slides, keyboard 77
 - system board 71
 - tray, keyboard 77
 - video modules 49
 - wakeup box 55
 - replace
 - adapter 48
 - battery 61
 - cable, keyboard 77
 - CD-ROM drive 68
 - diskette drive 60
 - display 75
 - DRB power supply 66
 - EPO switch 64
 - fan 56, 58
 - front bezel 50
 - front cover 45
 - hard disk drive 73
 - keyboard 77
 - left cover 40
 - memory adapter 46
 - mounting base 75
 - power distribution control box 55
 - replace (*continued*)
 - power supply 51
 - power supply, optional 53
 - rear cover 44
 - right cover 42
 - sense box 55
 - slides, keyboard 77
 - system board 71
 - tray, keyboard 77
 - video modules 49
 - wakeup box 55
 - ROM BIOS 6
- ## S
- safety ground wiring 86
 - SCSI adapter 12
 - SCSI address switches 95
 - SCSI device ID 90
 - SCSI terminators 92, 97
 - serial port 6
 - serial port configuration 89
 - service position 38
 - set configuration 24
 - set features 26
 - set SCSI ID 91
 - signal cables 85
 - special tools 21
 - standalone system 5
 - start MAP 104
 - start the reference diskette 27
 - symptom-to-FRU index 33
 - system
 - board 84
 - board memory 18
 - cabling 86
 - checkout 30
 - date and time 26
 - features 4
 - front view 78
 - internal cables 82

system (continued)

- left interior view 80
- MAPs 121
- models 5
- power cables 82
- rear view 79
- right interior view 81
- system board connectors 85

T

- terminating resistors 15
- test switch, CD-ROM drive 97
- test the computer 26

U

- undetermined problems 119
- update reference diskette 25

W

- wrap plug 21



Communicating Your Comments to IBM

IBM 7785

Hardware Maintenance

Reference/Service

Publication No. SA12-7017-05

If you especially like or dislike anything about this book, please use one of the methods listed below to send your comments to IBM. Whichever method you choose, make sure you send your name, address, and telephone number if you would like a reply.

Feel free to comment on specific errors or omissions, accuracy, organization, subject matter, or completeness of this book. However, the comments you send should pertain to only the information in this manual and the way in which the information is presented. To request additional publications, or to ask questions or make comments about the functions of IBM products or systems, you should talk to your IBM representative or to your IBM authorized remarketer.

When you send comments to IBM, you grant IBM a nonexclusive right to use or distribute your comments in any way it believes appropriate without incurring any obligation to you.

If you are mailing a readers' comment form (RCF) from a country other than the United States, you can give the RCF to the local IBM branch office or IBM representative for postage-paid mailing.

- If you prefer to send comments by mail, use the RCF at the back of this book.
- If you prefer to send comments by FAX, use this number:
United States & Canada: 407+443-2453

Make sure to include the following in your note:

- Title and publication number of this book
- Page number or topic to which your comment applies.



Readers' Comments — We'd Like to Hear from You

IBM 7785
Hardware Maintenance
Reference/Service
Publication No. SA12-7017-05

Overall, how satisfied are you with the information in this book?

	Very Satisfied	Satisfied	Neutral	Dissatisfied	Very Dissatisfied
Overall satisfaction					

How satisfied are you that the information in this book is:

	Very Satisfied	Satisfied	Neutral	Dissatisfied	Very Dissatisfied
Accurate					
Complete					
Easy to find					
Easy to understand					
Well organized					
Applicable to your tasks					

Please tell us how we can improve this book:

Thank you for your responses. May we contact you? Yes No

When you send comments to IBM, you grant IBM a nonexclusive right to use or distribute your comments in any way it believes appropriate without incurring any obligation to you.

Name

Address

Company or Organization

Phone No.



NO POSTAGE
NECESSARY
IF MAILED IN THE
UNITED STATES

BUSINESS REPLY MAIL

FIRST CLASS MAIL PERMIT NO. 40 ARMONK, NEW YORK

POSTAGE WILL BE PAID BY ADDRESSEE

International Business Machines Corporation
Boca Solutions Lab, GSD
Department 9B3
1000 NW 51st Street
P. O. Box 1328
BOCA RATON FL 33429-9863



Fold and Tape

Please do not staple

Fold and Tape

Readers' Comments — We'd Like to Hear from You
SA12-7017-05

IBM®

Readers' Comments — We'd Like to Hear from You

IBM 7785
Hardware Maintenance
Reference/Service

Publication No. SA12-7017-05

Overall, how satisfied are you with the information in this book?

	Very Satisfied	Satisfied	Neutral	Dissatisfied	Very Dissatisfied
Overall satisfaction					

How satisfied are you that the information in this book is:

	Very Satisfied	Satisfied	Neutral	Dissatisfied	Very Dissatisfied
Accurate					
Complete					
Easy to find					
Easy to understand					
Well organized					
Applicable to your tasks					

Please tell us how we can improve this book:

Thank you for your responses. May we contact you? Yes No

When you send comments to IBM, you grant IBM a nonexclusive right to use or distribute your comments in any way it believes appropriate without incurring any obligation to you.

Name _____

Address _____

Company or Organization _____

Phone No. _____



NO POSTAGE
NECESSARY
IF MAILED IN THE
UNITED STATES

BUSINESS REPLY MAIL

FIRST CLASS MAIL PERMIT NO. 40 ARMONK, NEW YORK

POSTAGE WILL BE PAID BY ADDRESSEE

International Business Machines Corporation
Boca Solutions Lab, GSD
Department 9B3
1000 NW 51st Street
P. O. Box 1328
BOCA RATON FL 33429-9863



Fold and Tape

Please do not staple

Fold and Tape

Readers' Comments — We'd Like to Hear from You
SA12-7017-05

IBM®

Readers' Comments — We'd Like to Hear from You

IBM 7785
Hardware Maintenance
Reference/Service
Publication No. SA12-7017-05

Overall, how satisfied are you with the information in this book?

	Very Satisfied	Satisfied	Neutral	Dissatisfied	Very Dissatisfied
Overall satisfaction					

How satisfied are you that the information in this book is:

	Very Satisfied	Satisfied	Neutral	Dissatisfied	Very Dissatisfied
Accurate					
Complete					
Easy to find					
Easy to understand					
Well organized					
Applicable to your tasks					

Please tell us how we can improve this book:

Thank you for your responses. May we contact you? Yes No

When you send comments to IBM, you grant IBM a nonexclusive right to use or distribute your comments in any way it believes appropriate without incurring any obligation to you.

Name

Address

Company or Organization

Phone No.



NO POSTAGE
NECESSARY
IF MAILED IN THE
UNITED STATES

BUSINESS REPLY MAIL

FIRST CLASS MAIL PERMIT NO. 40 ARMONK, NEW YORK

POSTAGE WILL BE PAID BY ADDRESSEE

International Business Machines Corporation
Boca Solutions Lab, GSD
Department 9B3
1000 NW 51st Street
P. O. Box 1328
BOCA RATON FL 33429-9863



Fold and Tape

Please do not staple

Fold and Tape

Readers' Comments — We'd Like to Hear from You
SA12-7017-05

Readers' Comments — We'd Like to Hear from You

IBM 7785

Hardware Maintenance
Reference/Service

Publication No. SA12-7017-05

Overall, how satisfied are you with the information in this book?

	Very Satisfied	Satisfied	Neutral	Dissatisfied	Very Dissatisfied
Overall satisfaction					

How satisfied are you that the information in this book is:

	Very Satisfied	Satisfied	Neutral	Dissatisfied	Very Dissatisfied
Accurate					
Complete					
Easy to find					
Easy to understand					
Well organized					
Applicable to your tasks					

Please tell us how we can improve this book:

Thank you for your responses. May we contact you? Yes No

When you send comments to IBM, you grant IBM a nonexclusive right to use or distribute your comments in any way it believes appropriate without incurring any obligation to you.

Name

Address

Company or Organization

Phone No.



NO POSTAGE
NECESSARY
IF MAILED IN THE
UNITED STATES

BUSINESS REPLY MAIL

FIRST CLASS MAIL PERMIT NO. 40 ARMONK, NEW YORK

POSTAGE WILL BE PAID BY ADDRESSEE

International Business Machines Corporation
Boca Solutions Lab, GSD
Department 9B3
1000 NW 51st Street
P. O. Box 1328
BOCA RATON FL 33429-9863

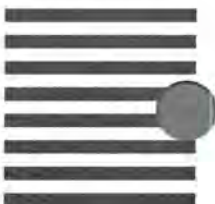

Fold and Tape

Please do not staple

Fold and Tape

Readers' Comments — We'd Like to Hear from You
SA12-7017-05

IBM®