



By David C. Wyland

Abstract

High-performance controller designs use bit-slice components for their speed and design flexibility. Speeds of 10-20 million instructions per second (MIPS) are common and the designer can use bit-slice design flexibility to perform speed-critical operations in one instruction. Bit-slice designs have the drawback, however, of requiring microcode design for their implementation, often with a long development cycle. The problem is that the microcode resides in a separate, stand-alone control memory which prevents use of the kind of interactive prototyping and debugging tools associated with conventional microprocessors. The problem can be eliminated by using a dual-port SRAM for the control memory, making it part of the data memory address space, and converting the controller to a CPU by borrowing some techniques from Reduced Instruction Set Computer (RISC) designs. The result is a RISC controller where the microinstructions of the bit-slice approach become the instructions of a computer. The design approach provides all the speed and architectural flexibility of microcoded bit-slice designs, while allowing the use of interactive debugging methods associated with microprocessors.

Bit-Slice Versus RISC Architectures

An example of a typical bit-slice controller design is shown in Figure 1. It consists of a control flow section and a data flow section. The control flow section has a microinstruction counter and the control memory. The data flow section has a register and ALU element—the bit-slice—plus a data memory and I/O registers on a data bus. Note that the control and data memories are separate. The use of separate data and instruction memories is called the Harvard architecture. The separate control memory provides some of the speed associated with bit-slice designs because it operates in parallel with the data memory. This allows the next microinstruction to be fetched from the control memory while data for the current instruction may be read from the data memory. This contrasts with conventional microprocessors which alternately get instructions and data from the same memory. This use of a single memory for instructions and data is called the Von Neumann architecture.

There is a remarkable similarity between the bit-slice controller block diagram and a block diagram of a typical RISC CPU, comparing Figures 1 and 2. The difference is that the control memory and the data memory

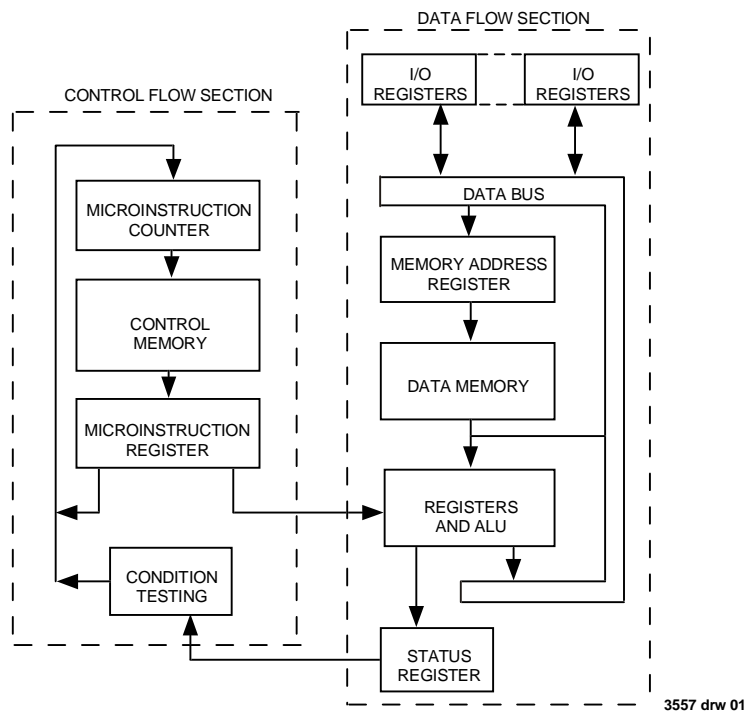

Figure 1. Bit-Slice Controller Block Diagram

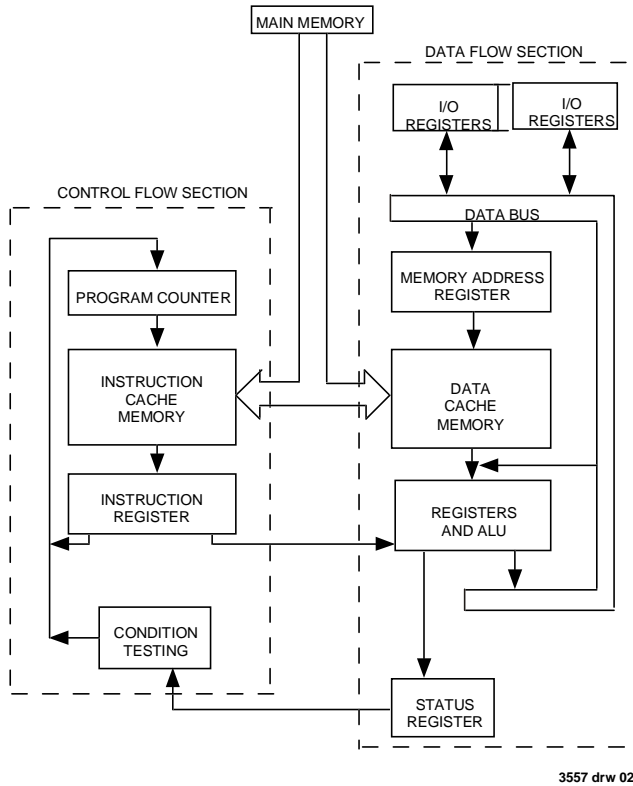

Figure 2. RISC CPU Block Diagram

of the controller have been replaced by an instruction cache memory and a data cache memory in the RISC CPU. The instruction and data cache memories work the same as their microcode counterparts except that they both contain copies of data in the common main memory. The programmer sees a single memory—the main memory—while the hardware works as if it has two independent memories. In this manner, the RISC computer has the speed advantage of the Harvard architecture and the single memory for programs and data of the Von Neumann architecture.

The instruction and data caches of the RISC architecture are equivalent to having two ports on one memory. We can apply this concept to bit-slice controllers by using a high-speed dual-port memory in place of the cache memories, as shown in Figure 3. The dual-port SRAM allows the instruction and data ports to be active simultaneously and independently, while providing both sides access to a common set of SRAM cells. Since both ports are working from the same memory, the data flow section can load and move both data and instructions in the same manner as a conventional microprocessor. As a result, this design functions as a conventional CPU with a long instruction word. This allows conventional interactive software tools, such as interpreters and monitors, to be used in system development and debugging

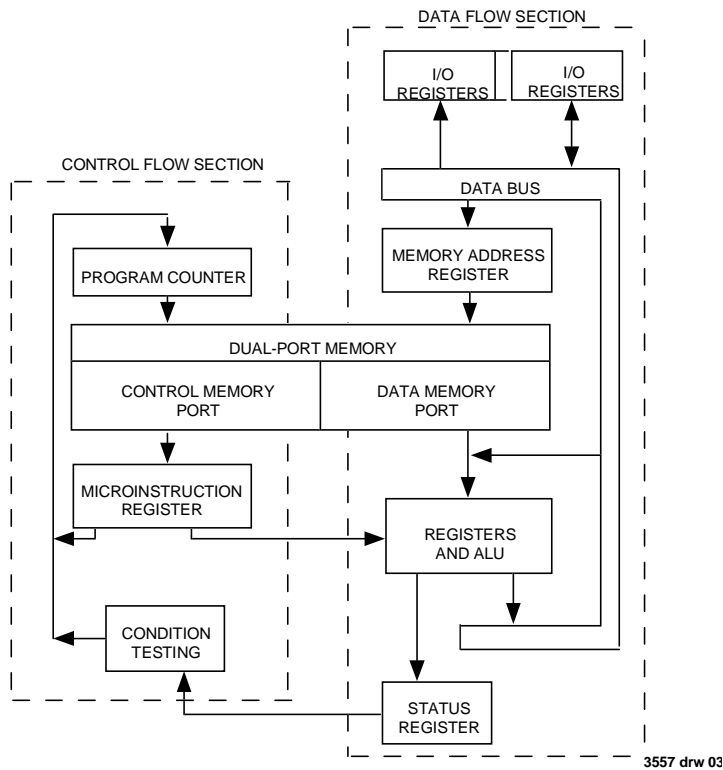

Figure 3. Bit-Slice Controller With Dual-Port Control Store

memory. The mapping for instructions and the mapping for data are different, however, as is shown in Figure 5. The eight dual-port RAMs are mapped as 2K words of 64 bits/word on the instruction port and as 8K words of 16 bits/word on the data port. Each 64-bit instruction word corresponds to four sequential 16-bit data words. The instruction at address 0000 on the instruction port corresponds to locations 0000, 0001, 0002 and 0003 on the data port. On the instruction port, all eight chips are enabled, resulting in 64 bits of instruction output. Only the upper 14 bits of the PC are used to address the RAM so that the address in the PC is consistent with the addressing on the data side. On the data port, the least significant two bits of the address in MAR select the appropriate 16-bit word by selecting the chip enable for the appropriate one of four pairs of dual-port SRAMs.

RISC Controller Instruction Format

The 64-bit instruction word is shown in Figure 6. Fifty of the 64 bits are used to control the basic data and control flow of the controller and 14 bits are available as additional control bits for the specific controller application. Each 64-bit instruction word from the control port of the RAM is mapped as four 16-bit words on the data memory port. A larger instruction word can be used in the same manner as in microcoded designs. It is convenient if the word width is a power of two, such as 64 or 128 bits, so that there are no gaps in the memory space as seen from the data flow side.

The IDT49C402 is controlled by the A and B fields, I0-9, CN, Stat Enable field and the Shift Gating field. The A and B fields provide the 6-

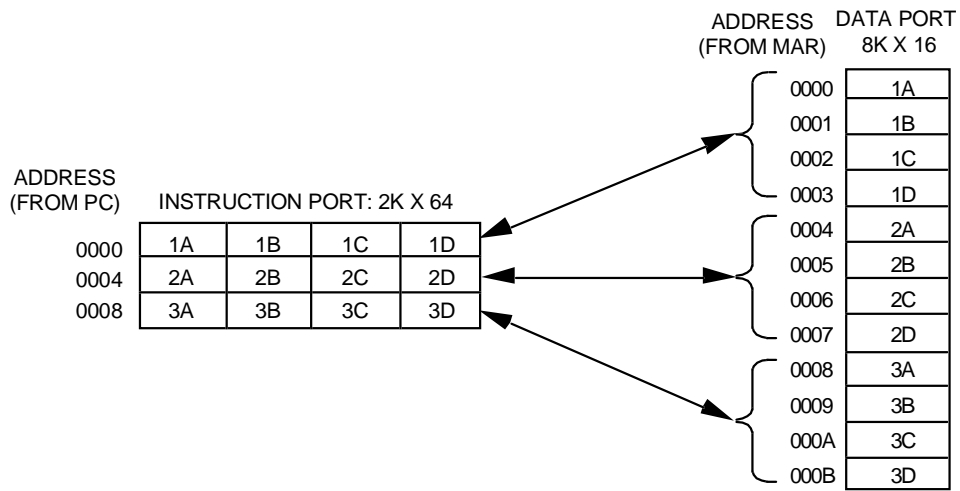

3557 drw 05

Figure 5. Dual-Port Controller Memory Map

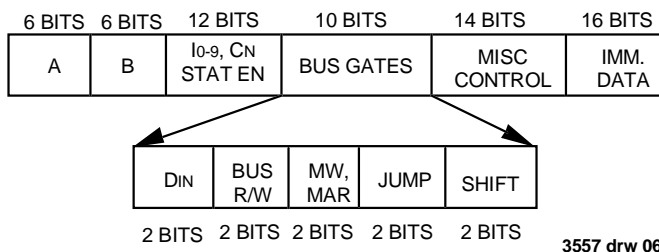

3557 drw 06

FIELD	FUNCTION
A	402 reg address, bus read select, or jump condition select
B	402 reg address or bus write select
I0-9	49C402 instructions + carry-in
Stat EN	Enable Status reg load
DIN	402 D Bus: Memory, PC. Bus, 1 field
Bus R/W	Gate Bus read @ A, write @ B
MW, MAR	Memory write enable, Id MAR enable
Jump	Enable PC load, enable condition test
Shift	402 shift/rotate gating
Imm Data	Immediate Data - address, etc.
Misc Control	Misc bits for controller functions

Figure 6. Dual-Port Controller Instruction Format

3557 tbl 01

bit addresses for the A and B register inputs on the IDT49C402. The I₀₋₉, CN and Stat EN field provide the 10 control bits to the IDT49C402, the carry-in bit and a status register load enable, respectively, and the Shift Gating field controls the shift-in/shift-out gating for shift operations. The data source for the D_{IN} pins of the IDT49C402 is selected by the D_{IN} field. This field can choose the data bus, the immediate data field or the PC as the data source.

The data bus is controlled by the A and B fields as well, which provide 6-bit select codes for bus read and write operations, respectively, and by the bus read/write, memory write and load MAR bits. The default operation is to gate the data from the IDT49C402 onto the data bus. The load MAR and memory write bits allow writing this data into the memory and/or MAR from the bus. The bus read bit disables the IDT49C402 outputs and gates an I/O register onto the bus as determined by the 6-bit A field. The bus write bit causes bus data to be written into an I/O register selected by the B field.

Branch operations are controlled by the Jump and A fields. The Jump field enables loading of the PC from the bus, which is the branch operation.

The A field provides the 6-bit condition select code for conditional branch operations.

The Misc Control field provides 14 bits for direct control of additional devices. This field would typically be used for gates and strobes to additional devices such as parallel multipliers, FIFOs, disk controller chips and other devices which communicate with, and are controlled by, the RISC controller.

Implementing Minimal Instruction Set

The RISC controller design must now be checked to ensure that it implements each instruction in the minimal instruction set.

Load and Store

Load and Store register operations are done in two instructions: load MAR and load or store register. The load MAR instruction places register

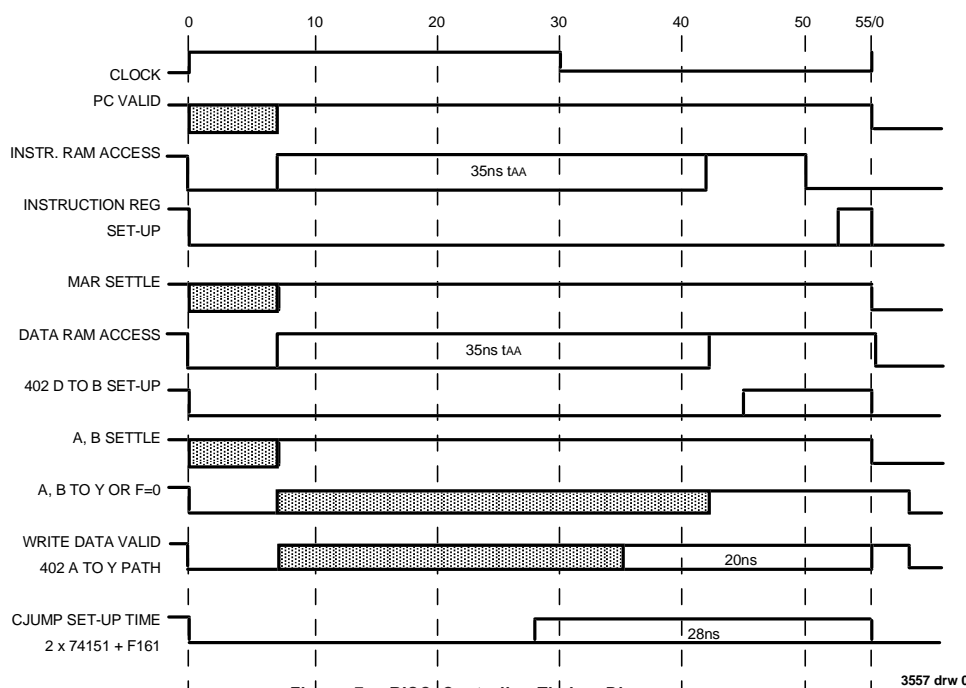

Figure 7. RISC Controller Timing Diagram

Table 2. Critical Path Timing

CONTROL PATH		DATA PATH	
PC Settle: FCT161A	6.5ns	MAR Settle: FCT161A	6.5ns
SRAM Access	35.0ns	SRAM Access	35.0ns
I reg set-up: FCT374A	2.5ns	IDT49C402A, Din Set-up	10.0ns
Total	44.0ns		51.5ns

data from the IDT49C402 or data from the immediate data field on the bus and enables MAR load. The load register instruction gates memory data into the data inputs of the IDT49C402. The store register instruction gates register data onto the bus and writes it into memory.

Move, Combine and Shift Register

Register-to-register and shift operations are performed directly by the IDT49C402 bit-slice.

Status Register Read/Write

Read and Write Status register operations select the Status Register and bus read and write, respectively.

Jump and Conditional Jump

Jump operations are done by enabling the PC to be loaded from the bus using either immediate or register data for the jump address. Conditional Jump is done by enabling a conditions select multiplexer to conditionally enable the PC load.

Jump and Save Return

The Jump and Save Return operation is performed by using the immediate data field to provide the jump address and simultaneously storing the PC in a register selected by the B field. The immediate datafield is gated to the bus, the PC is gated to the IDT49C402 data inputs and the IDT49C402 is instructed to perform a D-input-to-register-load operation.

RISC Controller Timing

The design in Figure 4 is capable of a 55ns cycle time. A timing diagram for a 55ns cycle time, assuming the 35ns dual-port SRAMs, is shown in Figure 7. The critical timing path, in this case, is the data path from the Memory Address Register (MAR) through the data port of the memory into the IDT49C402. If the dual-port SRAMs are slower than 35ns, the

cycle is extended proportionately.

RISC Controller Application

The utility of the RISC controller design approach is that it allows interactive system development, debugging and diagnostic testing. It also provides the potential for high-level language support of the bit-slice design. Powerful interactive access to the RISC controller can be provided by an RS-232 interface and a FORTH language interpreter program. This allows interactive coding and testing of the system, speeding up the test-and-analyze debug cycles. This RS-232 interface can exist on a separate board external to the RISC controller, connected to the bus by a connector on the controller board. No additional hardware is required for access by the designer to the system and this access can allow direct activation and sensing of controller hardware, setting up timing loops for oscilloscope checks and on-line development of routines. If a floppy disk controller is included in the external I/O board, the RISC controller can function as a stand-alone development system in the same fashion as other stand-alone FORTH systems.

The RISC controller's ability to load programs also means that diagnostics can be loaded from the initial load EPROM. The initial load EPROM can hold both the normal control program and various test programs. The controller can load diagnostic programs from the EPROM for board and system test without requiring permanent space for them in the control memory. This allows self-diagnostics at the hardware level with minimum cost impact on the hardware.

Summary

The RISC controller uses high-speed dual-port SRAMs to blend the features of a bit-slice controller with the capabilities of a RISC computer, allowing the microinstructions of the bit-slice approach to become the instructions of a computer. This design approach provides all the speed and architectural flexibility of microcoded bit-slice designs, while allowing the use of interactive debugging methods associated with microprocessors to shorten development time.



CORPORATE HEADQUARTERS
2975 Stender Way
Santa Clara, CA 95054

for SALES:
800-345-7015 or 408-727-6116
fax: 831-754-4608
www.idt.com

for Tech Support:
831-754-4613
DualPortHelp@idt.com

The IDT logo are registered trademarks of Integrated Device Technology, Inc.