



Hot-Swap SCSI Disk Drive Carrier Installation Guide

Note

Before using this information and the product it supports, be sure to read the general information under "Product Warranties and Notices" included with your system unit.

First Edition (February 1996)

The following paragraph does not apply to the United Kingdom or any country where such provisions are inconsistent with local law: THIS PUBLICATION IS PROVIDED "AS IS" WITHOUT WARRANTY OF ANY KIND, EITHER EXPRESS OR IMPLIED, INCLUDING, BUT NOT LIMITED TO, THE IMPLIED WARRANTIES OF MERCHANTABILITY OR FITNESS FOR A PARTICULAR PURPOSE. Some states do not allow disclaimer of express or implied warranties in certain transactions, therefore, this statement may not apply to you.

This publication could include technical inaccuracies or typographical errors. Changes are periodically made to the information herein; these changes will be incorporated in new editions of the publication. The manufacturer may make improvements and/or changes in the product(s) and/or the program(s) described in this publication at any time, without notice.

It is possible that this publication may contain reference to, or information about, products (machines and programs), programming, or services that are not announced in your country. Such references or information must not be construed to mean that these products, programming, or services will be announced in your country. Any reference to a specific licensed program in this publication is not intended to state or imply that you can use only that licensed program. You can use any functionally equivalent program instead.

Requests for technical information about products should be made to your authorized reseller or marketing representative.

© **International Business Machines Corporation 1998. All rights reserved.**

Note to U.S. Government Users -- Documentation related to restricted rights -- Use, duplication or disclosure is subject to restrictions set forth in GSA ADP Schedule Contract with IBM Corp.

Contents

About This Book	v
Related Publications	v
Chapter 1. Overview	1-1
Installation Requirements	1-1
Handling Static-Sensitive Devices	1-3
Chapter 2. Installing a Hot-Swap SCSI Disk Drive into a Carrier	2-1
Chapter 3. Adding a Disk Drive Using the Hot-Swap Feature	3-1
Diagnostics	3-2
Appendix A. Communications Statements	A-1
Federal Communications Commission (FCC) Statement	A-1
European Union (EU) Statement	A-2
International Electrotechnical Commission (IEC) Statement	A-2
United Kingdom Telecommunications Safety Requirements	A-2
Avis de conformité aux normes du ministère des Communications du Canada	A-4
Canadian Department of Communications Compliance Statement	A-4
VCCI Statement	A-4
Radio Protection for Germany	A-4

About This Book

This book (when used with your system unit documentation) will help you install the Hot-Swap SCSI Disk Drive Carrier.

Related Publications

This book refers to the documentation that came with your system unit.

Chapter 1. Overview

This manual contains instructions for attaching the disk drive onto the Hot-Swap SCSI Disk Drive Carrier and preparing the drive and carrier for installation in your system. The instructions for installing the carrier into your system are in the documentation that came with your computer.

The Hot-Swap SCSI Disk Drive Carrier is a tray with built-in small computer system interface (SCSI) connectors that can hold one of several disk drives. The Hot-Swap SCSI Disk Drive Carrier is used in systems in which disk drives may be swapped in and out of the system without powering off. This is called *hot-swapping*. For additional information about hot-swap configurations, see the documentation that came with your computer and operating system.

Note: The illustrations in this publication might be slightly different from your hardware.

The option package contains:

- A Hot-Swap SCSI Disk Drive Carrier with signal cable and power cable
- SCSI address (ID) cables
- Screws

Contact your place of purchase if any parts are missing or damaged.

Important: Be sure to retain your proof of purchase because it might be required to receive warranty service.

Installation Requirements

To assemble the Hot-Swap SCSI Disk Drive Carrier option with a disk drive you must have:

- Flat-blade screwdriver
- The Hot-Swap SCSI Disk Drive Carrier
- A Fast/Wide Hot-Swap 3.5" SCSI-2 disk drive that supports 16-bit data and data rates up to 10MHz, resulting in a maximum transfer rate of 20MB per second.
- The documentation that came with your computer, storage enclosure, and operating system.

Attention: The Hot-Swap SCSI Disk Drive Carrier is a sensitive electronic device. Handle the Hot-Swap SCSI Disk Drive Carrier and disk drive with care.

- Do not drop the disk drive or subject it to excessive shock.

- Do not expose the disk drive to temperatures lower than -40°C (-40°F) or higher than 70°C (158°F).

Failure to observe these precautions might lead to product failure, damage, and invalidation of all warranties.

Handling Static-Sensitive Devices

Attention

Static electricity can damage your equipment. Do not take the option out of its static-protective bag until the instructions tell you to do so.

When you handle options and other computer components, take these precautions to avoid damage from electrostatic discharge.

- Limit your movement. Movement can cause static electricity to build up around you.
- Always handle options carefully. Handle adapters and memory-module kits by the edges.
- Never touch any exposed circuitry.
- Prevent others from touching the option.
- Before opening the static-protective bag containing the option, touch the bag to any unpainted metal surface on the computer, such as the metal expansion-slot covers, for at least 2 seconds. (The location of the metal expansion-slot covers is shown in the documentation that came with your computer.) Touching an unpainted metal surface reduces the static electricity in the bag and in your body.
- When possible, remove the option from the bag and install it directly into the computer without putting the option down. If you must put the option down, place the static-protective bag the option came in on a smooth, level surface and place the option, component side up, on the bag. If a static-protective bag is not available, use a piece of paper.
- Do not place the option on the computer cover or other metal surface.

Chapter 2. Installing a Hot-Swap SCSI Disk Drive into a Carrier

Before installing a disk drive into the Hot-Swap SCSI Disk Drive Carrier, be sure to read the information in “Handling Static-Sensitive Devices” on page 1-3.

Important: Do not operate the latch mechanism until the disk drive is secured in the tray. The latch mechanism is used to lock the tray in place after it is inserted into the computer or storage enclosure.

Latch Mechanism

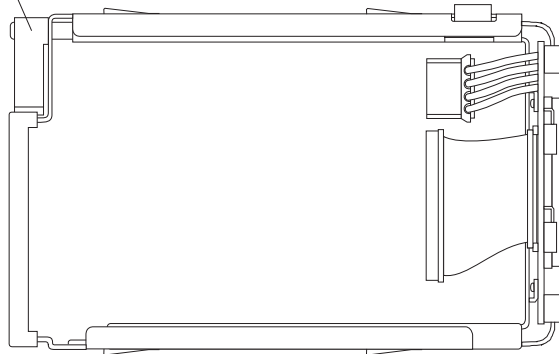

Use the following steps to assemble the Hot-Swap SCSI Disk Drive into the carrier.

1. Refer to the documentation that came with your disk drive to determine the location of the SCSI ID connector on the drive.
2. Remove any of the following SCSI jumpers on the disk drive.
 - SCSI ID
 - Enable termination
 - Termination power (*term power*)

See the documentation that came with your disk drive for information about where these jumpers are located.

3. Connect the SCSI ID cable to the SCSI ID connector on the rear of the disk drive as shown.

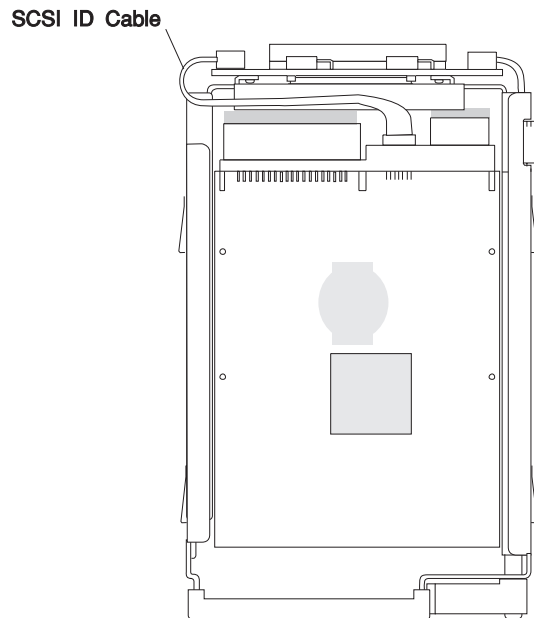

Note: On some disk drives, the SCSI ID connector on the disk drive might be different than the one shown. See the documentation that came with the disk drive for specific information about the SCSI ID connector on the disk drive.

4. Attach the power cable to the disk drive.
5. Attach the signal cable to the disk drive.

Important: Ensure that the spring clip that holds the tray latch in place along the tray rail is secure. Do *not* operate the latch mechanism until the disk drive is secured in the tray.

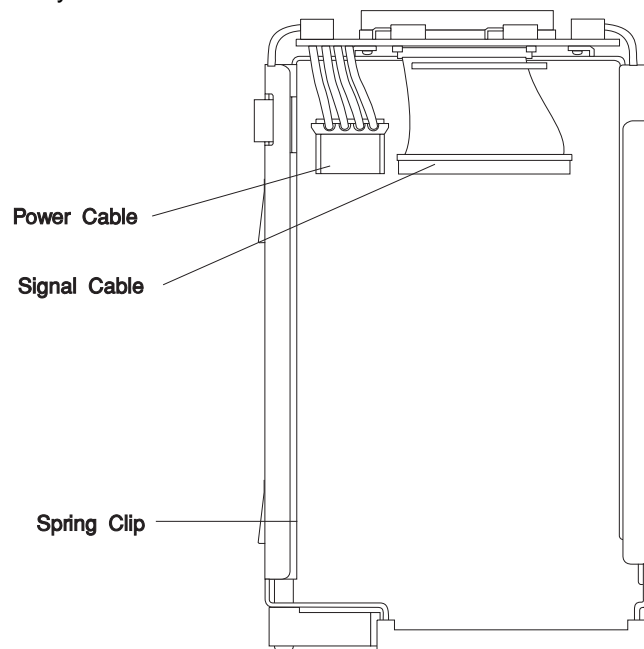

6. Install the disk drive into the tray as shown. Align the screw holes in the disk drive with the holes in the tray rails.

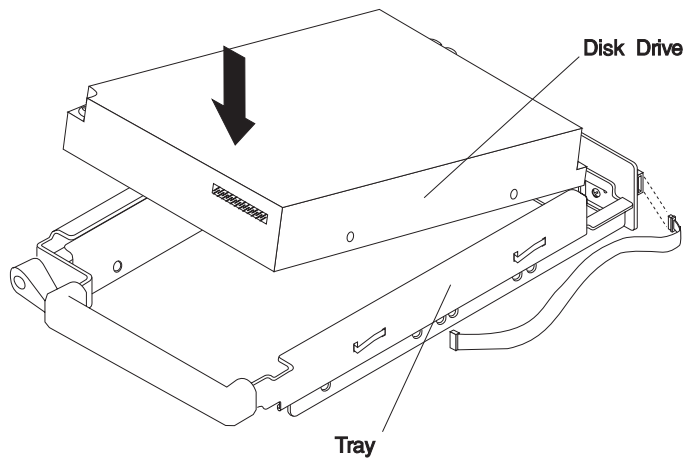

Attention: Ensure you are using the correct size screws to attach the disk drive to the tray. If the screws are longer than 5 mm (3/16 inch) you might damage the disk drive.

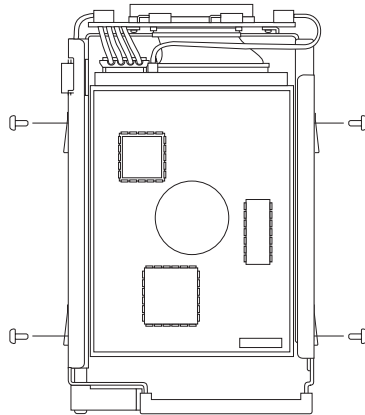

7. Install the four screws (2 on each side) using the flat blade screwdriver. The screws should be snug. Do not tighten the screws excessively, or you might bend the tray rails.
8. To install the assembled Hot-Swap SCSI Disk Drive Carrier and drive into your system unit, refer to the documentation that came with your system unit for instructions.

Chapter 3. Adding a Disk Drive Using the Hot-Swap Feature

For systems running AIX, the following procedure describes how to add a disk without turning the system unit off.

1. See your system unit documentation for instructions for installing the Hot-Swap SCSI Disk Drive Carrier.
2. Install the drive and rotate the locking lever 90 degrees counter-clockwise to lock the drive in place. The Green status light should be on. If the Green status light is blinking there is a problem with the drive. For example, make sure the drive is a 16 bit device.

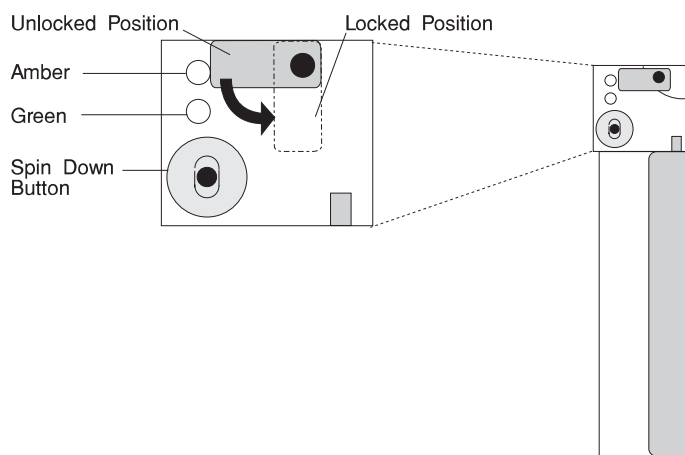

Note: You must have root authority to perform the following command.

3. Enter `cfgmgr -v`.
This configures the devices and the Amber status light should be on solid. If the Amber status light is not on solid, this indicates a device error, run the diagnostics.
4. To confirm the configuration of the device, do the following:
 - a. On the command line, enter `smit`.
 - b. Select **Devices**.
 - c. Select **Fixed Disk**.
 - d. Select **List all Defined Disks**.
 - e. Verify that the disk you installed is Available
5. If the disk drive has no data, go to "Adding a Physical Volume to a Volume Group" in the *System Management Guide: Operating System and Devices*.
6. If the disk drive contains data, go to "Logical Volumes" in the *System Management Guide: Operating System and Devices*.

7. Reinstall the covers. Refer to your system unit documentation for the procedure to reinstall the front covers.

If you have a problem after installing the drive, check that:

- The green LED for that drive is continuously on (not blinking).
- The amber LED for that drive is on.
- The cables are installed correctly on the hot–swap carrier.
- No jumpers or cables are loose.
- The drive is inserted into an active bay for the SCSI adapter you are using.

Diagnostics

Diagnostics may be supplied with your device driver, or may be found in a separate package. Refer to your system unit documentation for more information about running diagnostics.

Run diagnostics on the newly installed disk drive to reduce the possibility of:

- Unpredictable SCSI errors
- System hangs
- System damage (devices, backplane, or an adapter)

Appendix A. Communications Statements

The following statement applies to this product. The statement for other products intended for use with this product appears in their accompanying documentation.

Federal Communications Commission (FCC) Statement

Note: The &typemod. been tested and found to comply with the limits for a Class B digital device, pursuant to Part 15 of the FCC Rules. These limits are designed to provide reasonable protection against harmful interference in a residential installation. This equipment generates, uses, and can radiate radio frequency energy and, if not installed and used in accordance with the instructions, may cause harmful interference to radio communications. However, there is no guarantee that interference will not occur in a particular installation. If this equipment does cause harmful interference to radio or television reception, which can be determined by turning the equipment off and on, the user is encouraged to try to correct the interference by one or more of the following measures:

- Reorient or relocate the receiving antenna.
- Increase the separation between the equipment and receiver.
- Connect the equipment into an outlet on a circuit different from that to which the receiver is connected.
- Consult an authorized dealer or service representative for help.

Properly shielded and grounded cables and connectors must be used in order to meet FCC emission limits. Proper cables and connectors are available from authorized dealers. Neither the provider nor the manufacturer are responsible for any radio or television interference caused by using other than recommended cables and connectors or by unauthorized changes or modifications to this equipment. Unauthorized changes or modifications could void the user's authority to operate the equipment.

This device complies with Part 15 of the FCC Rules. Operation is subject to the following two conditions: (1) this device may not cause harmful interference, and (2) this device must accept any interference received, including interference that may cause undesired operation.

Responsible Party:

International Business Machines Corporation
New Orchard Road
Armonk, New York 10504
Telephone: (919) 543-2193



Tested to Comply
With FCC Standards

FOR HOME OR OFFICE USE

European Union (EU) Statement

This product is in conformity with the protection requirements of EU Council Directive 89/336/EEC on the approximation of the laws of the Member States relating to electromagnetic compatibility. The manufacturer cannot accept responsibility for any failure to satisfy the protection requirements resulting from a non-recommended modification of the product, including the fitting of option cards supplied by third parties. Consult with your dealer or sales representative for details on your specific hardware.

This product has been tested and found to comply with the limits for Class B Information Technology Equipment according to CISPR 22 / European Standard EN 55022. The limits for Class B equipment were derived for typical residential environments to provide reasonable protection against interference with licensed communication devices.

International Electrotechnical Commission (IEC) Statement

This product has been designed and built to comply with IEC Standard 950.

United Kingdom Telecommunications Safety Requirements

This equipment is manufactured to the International Safety Standard EN60950 and as such is approved in the UK under the General Approval Number NS/G/1234/J/100003 for indirect connection to the public telecommunication network.

The network adapter interfaces housed within this equipment are approved separately, each one having its own independent approval number. These interface adapters, supplied by the manufacturer, do not use or contain excessive voltages. An excessive voltage is one which exceeds 70.7 V peak ac or 120 V dc. They interface with this equipment using Safe Extra Low Voltages only. In order to

maintain the separate (independent) approval of the manufacturer's adapters, it is essential that other optional cards, not supplied by the manufacturer, do not use main voltages or any other excessive voltages. Seek advice from a competent engineer before installing other adapters not supplied by the manufacturer.

Avis de conformité aux normes du ministère des Communications du Canada

Cet appareil numérique de la classe B est conform à la norme NMB-003 du Canada.

Canadian Department of Communications Compliance Statement

This Class B digital apparatus complies with Canadian ICES-003.

VCCI Statement

この装置は、情報処理装置等電波障害自主規制協議会（VCCI）の基準に基づきクラスB情報技術装置です。この装置は、家庭環境で使用することを目的としていますが、この装置がラジオやテレビジョン受信機に近接して使用されると、受信障害を引き起こすことがあります。
取扱説明書に従って正しい取り扱いをして下さい。

The following is a summary of the VCCI Japanese statement in the box above.

This product is a Class B Information Technology Equipment and conforms to the standards set by the Voluntary Control Council for Interference by Information Technology Equipment (VCCI). This product is aimed to be used in a domestic environment. When used near a radio or TV receiver, it may become the cause of radio interference. Read the instructions for correct handling.

Radio Protection for Germany

Dieses Gerät ist berechtigt in Übereinstimmung mit dem deutschen EMVG vom 9.Nov.92 das EG-Konformitätszeichen zu führen.

Der Aussteller der Konformitätserklärung ist die IBM Germany.

Dieses Gerät erfüllt die Bedingungen der EN 55022 Klasse B.



Part Number: 39H9787



Printed in the United States of America
on recycled paper containing 10%
recovered post-consumer fiber.

39H9787

