

60/150GB 8MM Internal Tape Drive

Installation and Using Guide

Note

Before you install this product and use this information, be sure to read the product warranties and notices information included with the system unit into which you are installing the product.

Second Edition (December 2002)

Before using this information and the product it supports, read the information in "Safety Information" on page v and Appendix B, "Notices" on page 31.

© **International Business Machines Corporation 2002. All rights reserved.**

Note to U.S. Government Users Restricted Rights--Use, duplication or disclosure restricted by GSA ADP Schedule Contract with IBM Corp.

Contents

Safety Information.	v
Handling Static-Sensitive Devices.	vii
About This Book	ix
ISO 9000	ix
References to AIX Operating System	ix
Related Publications	ix
Trademarks	ix
Chapter 1. Overview	1
Tape Drive Environment and Use	3
Media Grades	3
Tape Handling and Storage	3
Environmental Issues	3
Tape Drive Cleaning	4
SCSI Hardware Issues	4
Microcode Updates	4
Summary	4
Front View of the 60/150GB 8MM Internal Tape Drive	5
Chapter 2. Preparing to Install the 60/150GB 8MM Internal Tape Drive	7
Verifying Your Software Requirements	7
Checking Prerequisites	7
Gathering Tools and Documentation	7
Planning Your SCSI Device Layout	8
Determining Your SCSI Address	8
Chapter 3. Installing the 60/150GB 8MM Internal Tape Drive.	11
Handling Recommendations	11
Setting the SCSI Address	11
Jumper Pin Positions on the 60/150GB 8MM Internal Tape Drive	12
Installing and Connecting the Tape Drive	13
Configuring the 60/150GB 8MM Internal Tape Drive	13
Verifying the Installation	14
Updating Microcode Levels.	14
Chapter 4. Using the 60/150GB 8MM Internal Tape Drive	15
Operator Controls	15
Status Lights	16
Liquid Crystal Display	16
Loading and Unloading a Tape Cartridge	18
Loading a Tape Cartridge	19
Unloading a Tape Cartridge	19
Emergency Eject Feature	20
Cleaning the Tape Drive.	20

Chapter 5. Using the Media	23
Types of 8-mm Cartridges	23
Storage and Shipping Environments.	24
Tape Cartridge Storage	24
Operating in Harsh Environments.	25
Setting the Write-Protect Switch	25
Ordering Tape Cartridges	26
Appendix A. Communications Statements	27
Federal Communications Commission (FCC) Statement	27
European Union (EU) Statement	28
International Electrotechnical Commission (IEC) Statement	28
United Kingdom Telecommunications Safety Requirements	28
Avis de conformité aux normes du ministère des Communications du Canada	28
Canadian Department of Communications Compliance Statement	28
VCCI Statement	29
Radio Protection for Germany	29
Appendix B. Notices	31
Appendix C. Fault Symptom Codes and Error Recovery Procedure Numbers	33
Appendix D. Error Recovery Procedures	41

Safety Information

DANGER

An electrical outlet that is not correctly wired could place hazardous voltage on metal parts of the system or the devices that attach to the system. It is the responsibility of the customer to ensure that the outlet is correctly wired and grounded to prevent an electrical shock.

Before installing or removing signal cables, ensure that the power cables for the system unit and all attached devices are unplugged.

When adding or removing any additional devices to or from the system, ensure that the power cables for those devices are unplugged before the signal cables are connected. If possible, disconnect all power cables from the existing system before you add a device.

Use one hand, when possible, to connect or disconnect signal cables to prevent a possible shock from touching two surfaces with different electrical potentials.

During an electrical storm, do not connect cables for display stations, printers, telephones, or station protectors for communication lines.

Handling Static-Sensitive Devices

Attention: Static electricity can damage the device and your system unit. To avoid damage, keep this device in its anti-static protective bag until you are ready to install it. To reduce the possibility of electrostatic discharge, follow the precautions listed below:

- Limit your movement. Movement can cause static electricity to build up around you.
- Handle the device carefully, holding it by its edges or its frame.
- Do not touch solder joints, pins, or exposed printed circuitry.
- Do not leave the device where others can handle and possibly damage the device.
- While the tape drive is still in its anti-static package, touch it to an unpainted metal part of the system unit for at least two seconds. (This drains static electricity from the package and from your body.)
- Remove the device from its package and install it directly into your system unit without setting it down. If it is necessary to set the device down, place it on its static-protective package. (If your device is an adapter, place it component-side up.) Do not place the device on your system unit cover or on a metal table.
- Take additional care when handling devices during cold weather, as heating reduces indoor humidity and increases static electricity.

About This Book

This book provides information about the 60/150GB 8MM Internal Tape Drive, and how to plan your SCSI device layout, set the SCSI address, install the tape drive, and use the tape drive. Use this book along with your specific system unit and operating system documentation.

ISO 9000

ISO 9000 registered quality systems were used in the development and manufacturing of this product.

References to AIX Operating System

This document may contain references to the AIX operating system. If you are using another operating system, consult the appropriate documentation for that operating system.

This document may describe hardware features and functions. While the hardware supports them, the realization of these features and functions depends upon support from the operating system. AIX provides this support. If you are using another operating system, consult the appropriate documentation for that operating system regarding support for those features and functions.

Related Publications

The following publications contain related information:

- System unit documentation for information specific to your hardware configuration
- AIX operating system documentation for information specific to your software configuration

The AIX documentation library is available at the following Web address:

http://publib16.boulder.ibm.com/pseries/en_US/infocenter/base. Select **AIX documentation**. AIX documentation is also contained on the AIX Documentation CD which was shipped with your AIX operating system. The documentation is made accessible by loading the documentation CD onto the hard disk or by mounting the CD into a CD-ROM compatible drive.

Trademarks

The following terms are trademarks of International Business Machines Corporation in the United States, other countries, or both:

- AIX
- IBM

Other company, product, and service names may be trademarks or service marks of others.

Chapter 1. Overview

Note: This document may contain references to the AIX operating system. If you are using another operating system, consult the appropriate documentation for that operating system.

This document may describe hardware features and functions. While the hardware supports them, the realization of these features and functions depends upon support from the operating system. AIX provides this support. If you are using another operating system, consult the appropriate documentation for that operating system regarding support for those features and functions.

The 60/150GB 8MM Internal Tape Drive is an internal streaming tape drive that provides medium-to high-capacity backup and archival capability, as well as a high data-transfer rate. The 60/150GB 8MM Internal Tape Drive uses wide bus (16-bit) architecture. Communications on the SCSI bus can be either asynchronous or synchronous. The 60/150GB 8MM Internal Tape Drive can read 8-mm tape cartridges that are written by a 20 GB drive. The 60/150GB 8MM Internal Tape Drive can be used as a boot device.

Note: This device is available as an auto-docking feature on some systems. See your system documentation for information about the auto-docking feature.

The tape drive is used primarily for:

- Saving and restoring system data files
- Archiving important records
- Distributing operating system software upgrades

The drive conforms to the American National Standards Institute (ANSI) SCSI-2 standard. You can attach the drive to any system that uses a single-ended interface/LVD that meets SCSI-2 Standard ANSI X3.131-1994.Rev 10h.

The 60/150GB 8MM Internal Tape Drive features include:

- Use of 60/150 GB 8-mm data cartridges
- Data rate of 12 MB per second
- Capacity of 60 GB
- Compression capability, which increases the native capacity of 60 GB and the effective data rate by using a compression ration of 2.5 to 1. The actual capacity per cartridge varies depending on the application and the type of data cartridge being used. The default setting is for compression. Use the System Management Interface Tool (SMIT) to change the default.

Note: The factory default setting is *Activated*. Data compression is usually controlled by the application software.

- A half-high 5.25-inch form-factor
- A liquid crystal display (LCD)

- Status lights that indicate:
 - When it is time to clean the tape drive
 - When the tape is in motion
 - When the drive is ready to accept tape motion commands

Tape Drive Environment and Use

Tape drives require specific maintenance and environmental conditions to operate well over time. Using high-quality, data-grade media, handling and storing this media properly, operating the tape drive in a clean environment and keeping the tape drive properly cleaned can help you to avoid problems with your tape drive.

Media Grades

The following grades of media can be used with your 60/150GB 8MM Internal Tape Drive:

- Tape containing Program Transmittal Fixes (PTF) - PTFs are tapes designed to be written to only once and read from a few times. PTF tapes are not designed to be used as a backup medium.
- Storage tapes - Storage tapes are designed to be used for backing up files that may be reused numerous times and also for long-term storage.

Note: Your system supplier may only support the media they sell. If the representative's analysis indicates that your problem is caused by inferior media usage, it is your (the customer's) responsibility to replace the inferior media.

Tape Handling and Storage

Most tape is supplied in a sealed cartridge. It is provided this way so that the tape will remain in a clean environment. Opening the cartridge allows dirt and airborne particles to enter and then become a source of contamination. The cartridge should only be opened by the tape drive and not an operator. The tape also is held under proper tension inside the cartridge. If the cartridge is dropped, this tension will be relaxed. Inserting a dropped cartridge into a tape drive can cause incorrect loading and result in a jam. This will ruin the tape and can cause physical damage if the cartridge is not removed properly.

When the tapes are stored, they must be replaced in their protective containers and stored on their end. The storage area must be clean, dry, normal room temperature and away from any magnetic fields.

Environmental Issues

Tape drives are designed to operate in a clean environment. Problem factors are dirt, dust, fibers and airborne particles. Airborne particles are the most difficult to address. When a tape is installed into the tape drive, the clearance between the heads and the tape is measured in microns. Particles can damage the tape or the head if they come in contact with either. Your service representative offers a tape drive filter enclosure for some systems to solve this problem. The enclosure draws air in through a filter and supplies the tape drive with clean air. Customers are responsible to provide a clean operating environment for the tape drive and system.

Tape Drive Cleaning

No matter how clean the environment, debris can build up on the heads of any tape drive. Every time tape motion occurs, some of the media surface comes off on the heads. Over time, this builds up and causes errors in reading and writing. Customers are responsible to clean the tape drive in accordance with the cleaning information provided with the tape drive.

Note: To identify the only media supported on this tape drive, refer to “Ordering Tape Cartridges” on page 26.

Cleaning cartridges can be used a limited number of times. After a cleaning cartridge has been used to its maximum number of times, the cartridge is considered expired. When cartridges expire, they must be replaced. Never reuse an expired cleaning cartridge. Doing so allows previously removed dirt to be reintroduced to the tape drive. Place a mark on the cleaning cartridge after each use, to best determine when your cleaning cartridge has expired.

SCSI Hardware Issues

Note: If you are installing the auto-docking version of this device on your system, this section does not apply to your system. See your system documentation for information about the auto-docking feature.

SCSI bus cables and terminators can affect tape drive performance. Use cables and terminators that are designed specifically to keep the SCSI bus as free of noise as possible. Generic cables or terminators can adversely affect the SCSI bus performance. If your service representative’s analysis indicates a problem with inferior cables, it may be necessary for the customer to replace them.

Microcode Updates

Your system supplier constantly works to provide the best possible tape drive products. To make certain that the tape drives work their very best, your system supplier may release changed microcode for the tape drives. When a microcode change is developed, your system supplier makes the change available to you through its service organization or by electronic delivery.

Microcode changes are available from service Web sites. For more information about supporting Web sites, contact your local service representative.

Microcode can be installed by your service representative or your system administrator.

Summary

Your tape drive must be installed in the cleanest possible environment. Your 60/150GB 8MM Internal Tape Drive requires high-quality, data-grade tapes and cleaning on a regular basis. Media must also be stored and handled properly. Improper use, storage, or handling of tape drives or media may void your warranty or service agreement.

If a tape drive stops functioning due to a component failure during the tape drive warranty or maintenance time, the service provider will replace the tape drive unit. The service provider will replace any defective tape drive under the terms and conditions of its warranty or service agreement. It is the service provider's objective to work with you to identify the cause of any tape-drive problem and provide a solution.

Front View of the 60/150GB 8MM Internal Tape Drive

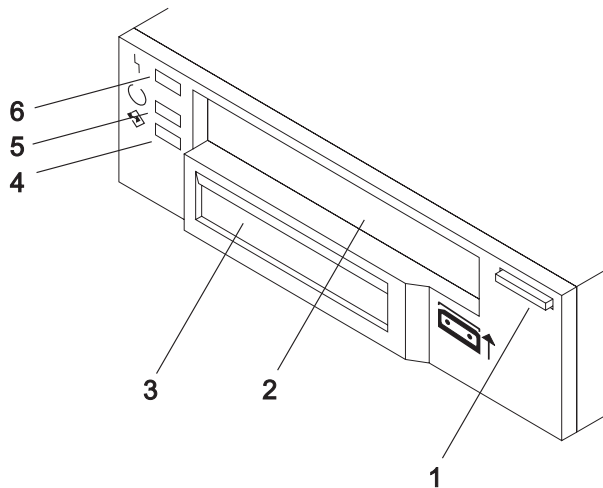

- 1 Unload button
- 2 Tape drive door
- 3 Liquid crystal display (LCD)
- 4 Activity (green) status light
- 5 Ready (green) status light
- 6 Fault (amber) status light

Chapter 2. Preparing to Install the 60/150GB 8MM Internal Tape Drive

This chapter covers the things that you should do before installing the 60/150GB 8MM Internal Tape Drive. Preparing to install the tape drive involves the following tasks:

- Verifying your software requirements
- Checking Prerequisites
- Gathering tools and documentation
- Planning your SCSI device layout
- Determining your SCSI address

Verifying Your Software Requirements

The 60/150GB 8MM Internal Tape Drive is supported on AIX 5.1 or later.

Checking Prerequisites

Check that your package contains the following items:

- The 60/150GB 8MM Internal Tape Drive
- Media kit containing:
 - 1 data cartridge
 - 1 cleaning cartridge
 - 1 test tape
 - Jumpers (located in a plastic bag)
- Specific hardware for attaching the tape drive to your specific system, as detailed on the parts listing provided with your 60/150GB 8MM Internal Tape Drive

Gathering Tools and Documentation

The following tools and documentation are needed to complete the installation:

- A flat-blade screwdriver (if this device is not an auto-docking feature on your system)
- Your system unit documentation, including any service documentation
- Your operating system documentation

Contact the place of purchase if an item is missing or damaged.

Note: If you are installing the auto-docking version of this device on your system, the remainder of this chapter does not apply to your system. See your system documentation for information about the auto-docking feature.

Planning Your SCSI Device Layout

SCSI devices are attached in a daisy-chain configuration to a SCSI adapter inside your system unit. SCSI devices can be installed inside your system unit or connected externally. When you connect more than one SCSI device, it is important that you plan the layout of your SCSI chain. Each device in the chain has a unique SCSI address (also called a *SCSI ID*). A terminator is required at each end of the SCSI chain.

Determining Your SCSI Address

Before you install the 60/150GB 8MM Internal Tape Drive, you must set the SCSI address on the drive. First, determine which SCSI addresses are available to use. Then you choose an address and install jumpers on the drive to set the selected address. The 60/150GB 8MM Internal Tape Drive supports addresses 6 through 0 and 8 through 15. You can use any available SCSI address as long as no two SCSI devices on the same chain use the same address. Usually, no device can use address 7, which is reserved for the SCSI adapter.

SCSI addresses are in sequential order from highest to lowest priority. Refer to Table 1 on page 9 for the priority associated with each address. All SCSI devices can use SCSI addresses 6 through 0. If your system unit and adapter support the wide (16-data bit, 68-conductor cable) SCSI interface, you may see addresses in the range of 0 through 15.

To determine what SCSI adapters are in your system, type the following at the system prompt:

- `lsdev -C | grep scsi`

Press Enter. All SCSI adapters in the system are displayed in the following format:

```
scsi0    Available 00-00-0S    Standard SCSI I/O Controller
scsi1    Available 00-01    SCSI I/O Controller
```

To determine the SCSI address for the adapter you will attach to, type the following at the system prompt:

- `lsattr -El scsi0 | grep id`

Where *scsi0* is the adapter that the tape drive is to be attached to. Press Enter. The SCSI ID is displayed in the following format:

```
id      7                Adapter card SCSI I        True
```

To find an available SCSI address, do the following:

1. To identify the SCSI addresses used by all other devices, type:

```
lsdev -Cs scsi
```

and press Enter. A list of devices displays in the following format:

```
hdisk0    Available 00-00-0S-0,0    2.0GB SCSI Disk Drive
hdisk1    Available 00-02-01-2,0    4.5GB 16 Bit SCSI Disk Drive
hdisk2    Available 00-02-01-3,0    SCSI Disk Drive
rmt0      Available 00-02-01-4,0    SCSI 8mm Tape Drive
```

In the fourth position of the third column, locate all instances of the port that you chose in step 1 on page 8. (The list may contain multiple instances of a port. In the following example, for port 2 (identified in step 1 on page 8) there are three instances.) The addresses of the other SCSI devices appear in the seventh position, as highlighted in the example.

For the port chosen in step 1 on page 8, note the addresses of the other SCSI devices attached to your system (in this case, for port 2, the addresses are 2, 3, and 4).

2. Select the highest-priority unused SCSI address for your 60/150GB 8MM Internal Tape Drive. Use Table 1 to record the address you chose for your 60/150GB 8MM Internal Tape Drive and the names and addresses of any other installed SCSI devices. Save this information for future reference.

Table 1. Data Access Priorities for SCSI Addresses

Priority	SCSI Address	SCSI Device Name
Highest Priority	7 (Default)	Adapter
↓	6	
↓	5	
↓	4	
↓	3	
↓	2	
↓	1	
↓	0	
↓	15	
↓	14	
↓	13	
↓	12	
↓	11	
↓	10	
↓	9	
Lowest Priority	8	

Chapter 3. Installing the 60/150GB 8MM Internal Tape Drive

This chapter takes you through the steps of installing your 60/150GB 8MM Internal Tape Drive, which involves the following tasks:

- Handling recommendations
- Setting the SCSI address
- Installing and connecting the tape drive
- Configuring the tape drive
- Verifying the installation
- Updating the microcode levels

Note: Before you install and connect your 60/150GB 8MM Internal Tape Drive, refer to your system unit documentation for safety information .

Handling Recommendations

Attention: Be sure to read “Handling Static-Sensitive Devices” on page vii before you remove the 60/150GB 8MM Internal Tape Drive from its anti-static bag or any time you handle it.

For optimum performance, always follow these recommendations:

- Handle the drive carefully and by its external metal chassis. Keep your hands away from the printed circuit boards, components, and printed circuit (flex) cables.
- If possible, work on a cushioned surface, and do not drop the tape drive onto the work surface.
- If you move the tape drive to an environment that is colder or warmer than its previous environment, keep the drive in its package and allow the package to reach the current room temperature. This prevents potential data loss or damage to the tape drive. Allow one hour of acclimatization for each 10 degrees C (18 degrees F) difference between the ship or storage temperature and the room temperature.

Note: If you are installing the auto-docking version of this device on your system, the remainder of this chapter does not apply to your system. See your system documentation for information about the auto-docking feature.

Setting the SCSI Address

The 60/150GB 8MM Internal Tape Drive is shipped with jumpers packaged in a small plastic bag. After you choose an available SCSI address, you can install the jumpers on the tape drive to match the selected address. If you need instructions for selecting the SCSI address, refer to “Determining Your SCSI Address” on page 8.

To set a SCSI address, insert jumpers onto pin positions reserved on the jumper block specifically for setting the address. To set a position to On, insert a jumper onto both the top and bottom pins. To set a position to Off, either insert a jumper onto the top pin only or remove the jumper from the jumper block.

Refer to the figure on page 12 and to Table 2 as you go through the following steps to set the SCSI address on your 60/150GB 8MM Internal Tape Drive:

Attention: Be sure to read the handling instructions in “Handling Static-Sensitive Devices” on page vii before you begin.

1. Remove the tape drive from its anti-static bag.
2. Find pin positions **1-2**, **3-4**, **5-6**, and **7-8** located on the jumper block on the back of the tape drive. These positions are always used to set the SCSI address on the 60/150GB 8MM Internal Tape Drive.
3. Refer to Table 2 to determine in which positions you install the jumpers to correctly set the SCSI address you chose in step 2 on page 9.

Jumper Pin Positions on the 60/150GB 8MM Internal Tape Drive

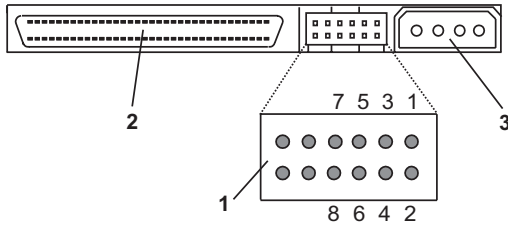

- 1 SCSI Address Block
- 2 68-pin SCSI Connector
- 3 Power Connector

Note: The 60/150GB 8MM Internal Tape Drive is shipped with four jumpers.

Table 2. SCSI Address Settings

Address	Jumper 7-8	Jumper 5-6	Jumper 3-4	Jumper 1-2
0	Off	Off	Off	Off
1	Off	Off	Off	On
2	Off	Off	On	Off
3	Off	Off	On	On
4	Off	On	Off	Off
5	Off	On	Off	On
6	Off	On	On	Off
7*	Off	On	On	On
8	On	Off	Off	Off
9	On	Off	Off	On
10	On	Off	On	Off
11	On	Off	On	On
12	On	On	Off	Off

Table 2. SCSI Address Settings (continued)

Address	Jumper 7-8	Jumper 5-6	Jumper 3-4	Jumper 1-2
13	On	On	Off	On
14	On	On	On	Off
15	On	On	On	On

Note: * = Address 7 is reserved for the adapter.

Installing and Connecting the Tape Drive

After you set the SCSI address on your drive, you can install the tape drive into your system unit. Follow the instructions provided in your system unit documentation for shutting down your system and for installing an internal device into your system unit.

To install and connect the 60/150GB 8MM Internal Tape Drive, do the following:

1. Install the tape drive, following the instructions provided in your system unit documentation for installing devices.
2. Attach the 68-pin SCSI cable connector to the tape drive.
3. Attach the 5/12 V power plug to the drive.
4. Ensure there is a SCSI terminator on the end of the cable or that a terminator is supplied by the last physical SCSI device on the internal chain.

Configuring the 60/150GB 8MM Internal Tape Drive

To configure the tape drive after installation, boot your system unit. Device drivers are provided in the AIX operating system and other operating systems that support the 60/150GB 8MM Internal Tape Drive. Your operating system recognizes the drive and automatically updates your system unit configuration.

Verifying the Installation

To verify the successful installation of the 60/150GB 8MM Internal Tape Drive, see the instructions provided in your operating system documentation. To verify the installation on an AIX system, type:

```
lsdev -Cs scsi
```

Press Enter. A list of SCSI devices displays. An *Available* status indicates that the drive is installed and ready to use.

Updating Microcode Levels

This device contains microcode that you can update. Contact your service representative for instructions on how to get the latest microcode levels for your device. To install the microcode, follow the instructions in the readme file included with the update.

Chapter 4. Using the 60/150GB 8MM Internal Tape Drive

This chapter describes the operator controls and status lights on the 60/150GB 8MM Internal Tape Drive. It also gives instructions for loading and unloading a tape cartridge, and describes how to clean the tape drive.

The following figure shows the front view of the 60/150GB 8MM Internal Tape Drive.

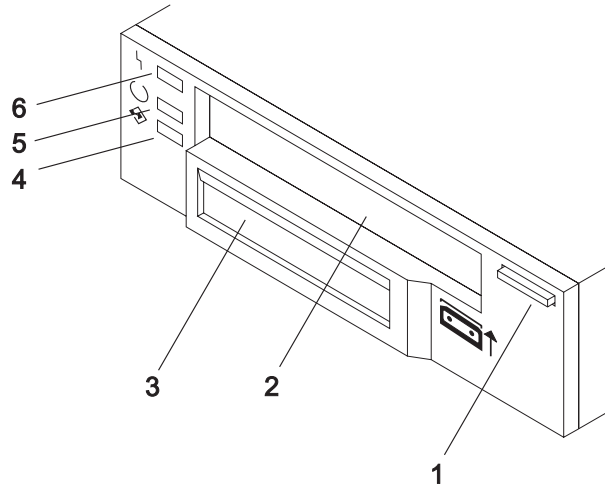

- 1 Unload button
- 2 Tape drive door
- 3 Liquid crystal display (LCD)
- 4 Activity (green) status light
- 5 Ready (green) status light
- 6 Fault (amber) status light

Operator Controls

The 60/150GB 8MM Internal Tape Drive has the following operator control.

Unload Button

The Unload button enables the tape cartridge to be ejected. The Unload button operates only when the 60/150GB 8MM Internal Tape Drive's power is on. To remove a cartridge, press and hold the Unload button for approximately one second.

Status Lights

The following status lights and their ISO symbols display on the 60/150GB 8MM Internal Tape Drive:

- ⌋ **Fault** (amber)
- **Ready** (green)
- ↻ **Activity** (green)

The combinations of the status lights and their definitions are shown in Table 3.

Table 3. Status Lights on the 60/150GB 8MM Internal Tape Drive

Status Light	Tape Drive State							
	POST or Reset	Error or Failed POST	Ready (No Tape Loaded)	Ready (Tape Loaded)	Normal Tape Motion	High Speed Motion	Time to Clean	Clean in Progress
Fault	on	flash	n/a	n/a	n/a	n/a	on	on
Ready	on	off	off	on	on	on	n/a	on
Activity	on	off	off	off	flash	fast flash	n/a	flash

Liquid Crystal Display

The 60/150GB 8MM Internal Tape Drive contains a liquid crystal display (LCD) that provides operating and error messages. Table 4 shows a list of messages that display on the LCD.

Table 4. LCD Messages

Reset Messages	
RESET	The first message to display during the power-on sequence.
MODEL:	Variable information about the tape drive, in this case IBM-60GB.
SUBMOD:	The submodel number of the tape drive.
SN:	The serial number of the tape drive.
CODE:	The level of the tape drive's firmware.
LAST CLN:	The number of tape motion hours since the last cleaning.
COMPRESSION:	Whether data compression is turned on (the default) or turned off.
SINGLE ENDED or DIFFERENTIAL	The type of SCSI input/output electrical interface.
WIDE	The width of the SCSI bus (measured in bits or bytes).
SCSI ID:	The SCSI address of the tape drive (0 through 15). The default is 0.

Table 4. LCD Messages (continued)

LANGUAGE:	The current language used on the LCD. To change the language, turn off the power to the tape drive. Press and hold the Unload button immediately after turning the power back on. When the desired language displays, release the Unload button.
Tape Drive Status Messages	
READY-NOTAPE	The tape drive is ready to accept a cartridge.
○ ⁻ ○ LOADING...	The tape drive is loading the tape.
○ ⁻ ○ READY-TAPE	The tape drive successfully loaded the tape and is ready for read or write operations.
○ ⁻ ○ ILLEGAL TAPE	An unsuitable tape has been loaded and rejected.
○ ⁻ ○ WORN TAPE	This message is displayed when the tape in the drive is beyond the end of its useful life (20,000 passes of the tape drive head over any spot on the tape). This counter is an internal counter that is not accessible to the user. To avoid the possibility of data loss, copy the data that you need from this tape to a new tape as soon as possible.
<< EJECT=====	The Unload button was pressed. The tape drive will eject the cartridge as soon as it finishes the current operation.
○ ⁻ ○ EJECT PREVNT	The Unload button was pressed, and the system software has issued a command to prevent the eject function.
OVER TEMP	The tape drive detected an internal temperature of 47°C or greater. If a data cartridge is in the tape drive when this condition occurs, the tape drive will complete the current tape operation, and then rewind and eject the data cartridge. After the tape drive temperature returns to a normal operating temperature of 42°C or less, the OVER TEMP message continues to display until one of the following occurs: <ul style="list-style-type: none"> • front-panel reset (press and hold the Unload button) • power cycle (tape drive power is turned off and then on) • tape load (load a tape in the tape drive)
Tape Motion Messages	
○↑○ READ+*****=	The tape drive is reading data. The + sign displays when the data is compressed. The boxes (•) represent the amount of tape processed (out of a total of six boxes). The = sign represents the amount of unprocessed tape.
○↓○ WRITE+*****=	The tape drive is writing data. The + sign displays when the data is compressed.
○/○ PROTECTED	The tape drive cannot write data because the data cartridge is write-protected.
○/○ ILLEGAL WRT	The tape drive cannot write to the type of data cartridge inserted. This message remains until a proper tape is inserted or a tape motion command is issued.

Table 4. LCD Messages (continued)

>> SEARCH*****	A high-speed search is in progress.
<< SEARCH*****	
<< REWIND*****	The rewind function is in progress.
○×○ ERASE*****	The tape drive is erasing data on the tape. As the data is erased, the equal signs (=) change to boxes (•).
Cleaning Messages	
○``○ CLEAN SOON	The tape drive needs to be cleaned.
○``○ CLEANING	Cleaning is in progress.
○``○ DEPLETED	The cleaning tape in the cartridge is depleted and the tape drive will eject it. Insert a new cleaning cartridge.
Error Conditions	
LAST 3 ERRORS ERR 1: xx yy zz ERR 2: xx yy zz ERR 3: xx yy zz	A hardware error has occurred. The LCD displays the last three error codes, with ERR 1: xx yy zz as the most recent. xx = the fault symptom code (FSC). yy and zz = additional information for product support personnel (the information may or may not be present). To resolve the error, refer to Appendix C, "Fault Symptom Codes and Error Recovery Procedure Numbers" on page 33.

Loading and Unloading a Tape Cartridge

Use the following instructions to load and unload a tape cartridge. For information about the type of media to use, refer to Chapter 5, "Using the Media" on page 23.

Note: To avoid problems with loading and unloading, use only one label on a cartridge. Multiple or poorly placed labels can clog the drive-load mechanism.

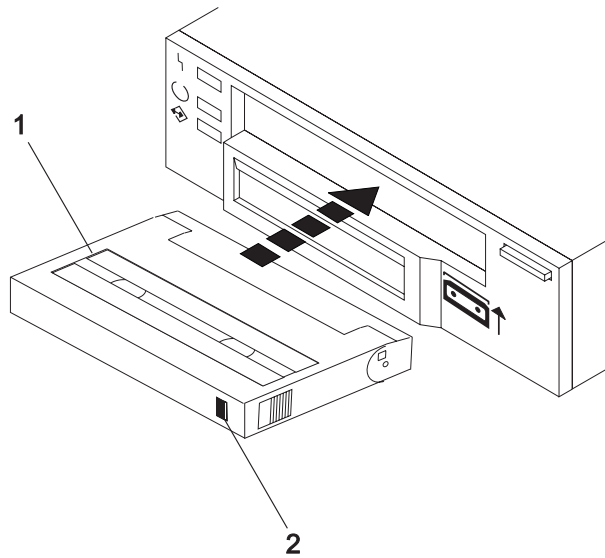

- 1 Tape cartridge
- 2 Write-protection switch

Loading a Tape Cartridge

To load a tape cartridge, do the following:

1. Make sure that the 60/150GB 8MM Internal Tape Drive power is on.
2. Grasp the cartridge by the outer edges, with the window-side up and the write-protect switch facing you.

Note: See “Setting the Write-Protect Switch” on page 25 to make sure that the write-protect switch is properly set.

3. Slide the cartridge into the opening on the front of the 60/150GB 8MM Internal Tape Drive until the loading mechanism pulls the cartridge into the drive and the drive door closes.

To indicate that the load operation was successful, the message READY-TAPE displays, and the Ready status light comes on.

Unloading a Tape Cartridge

To unload a tape cartridge, do the following:

1. Make sure that the tape drive power is on.
2. Press the Unload button.

The 60/150GB 8MM Internal Tape Drive rewinds, unloads, and ejects the tape cartridge. The process may take from 15 seconds to several minutes, depending on the position of the tape and the amount of data written. The message EJECT displays, and then the message READY-NOTAPE displays. During this task, the status lights do the following:

- The Ready status light turns off.
- The Activity status light flashes during the unload operation.
- The Activity status light turns off when the cartridge is ejected from the tape drive.

Emergency Eject Feature

Attention: This procedure may result in loss of data.

The 60/150GB 8MM Internal Tape Drive includes an emergency eject and reset feature that releases the tape cartridge and resets the drive. Use the emergency eject feature if the cartridge does not move properly or if the unload process fails.

To perform an emergency eject of the tape cartridge or a reset of the drive, press and hold the Unload button for at least 10 seconds. If a cartridge is in the drive, it automatically ejects without rewinding the tape.

Cleaning the Tape Drive

Clean the 60/150GB 8MM Internal Tape Drive when the Fault status light comes on or a device-related system I/O error occurs. If you are using SmartClean data cartridges, the tape drive will start an automatic cleaning operation when a condition that requires cleaning is detected or the tape heads have 30 hours of tape usage since the last cleaning. If you are not using SmartClean data cartridges, you must manually clean the tape drive when either of these conditions occurs.

Attention: Use only the recommended cleaning cartridge to clean the tape drive. Use of other cleaning cartridges can damage your drive and may void the warranty.

To clean the 60/150GB 8MM Internal Tape Drive, do the following:

1. Make sure that tape drive power is on.
2. If a tape cartridge is in the tape drive, eject and remove the cartridge.

Note: Some cleaning cartridges have small rectangles on the window side that can be used to log the use of the cartridge. Each time the cartridge is used, mark one of the rectangles on the cartridge with a pen or marker. When all of the rectangles have been marked, discard the cleaning cartridge.

3. Grasp the cleaning cartridge by the outer edges, with the window side up and the write-protect switch facing you.
4. Slide the cartridge into the opening on the front of the tape drive until the loading mechanism pulls the cartridge into the drive and the drive door closes.

After the cleaning cartridge is inserted, the remainder of the cleaning process is automatic. The 60/150GB 8MM Internal Tape Drive does the following:

1. Loads the cleaning cartridge into the tape drive.

2. Cleans the drive by moving the cleaning tape forward for approximately 30 seconds.
3. Unloads the cleaning cartridge when the cleaning operation is complete.
4. Indicates a successful cleaning operation by turning off the Fault status light (if the Fault status light was on prior to the cleaning process. Otherwise, the Fault status light remains solid to indicate that the cleaning cartridge is no longer usable. Obtain a new cleaning cartridge and repeat the process.)

Note: If the cleaning operation completes but the Fault status light remains on, repeat the cleaning procedure with a new cleaning cartridge. If the status light still remains on, contact your authorized service representative.

To determine how many times a cleaning cartridge can be used, check the information printed on the cartridge. If you attempt to use a depleted cleaning cartridge, the 60/150GB 8MM Internal Tape Drive automatically detects the error and ejects the cartridge. If the Fault status light was on prior to the cleaning process, it stays on; if the Fault status light was off, the depleted cartridge causes the status light to come on.

If a system error occurs, clean the drive and retry the operation. If the operation fails, replace the data cartridge, clean the drive again, then retry the operation.

Chapter 5. Using the Media

Use only 8-mm cartridges with the 60/150GB 8MM Internal Tape Drive.

Note: Your system supplier may only support the media they sell. If the representative's analysis indicates that a problem is caused by inferior media usage, it is your (the customer's) responsibility to replace the inferior media.

Types of 8-mm Cartridges

The 60/150GB 8MM Internal Tape Drive is shipped with an advanced metal-evaporated (AME) SmartClean data cartridge, an AME test cartridge, and a cleaning cartridge.

The 60/150GB 8MM Internal Tape Drive reads and writes to new AME data cartridges with SmartClean technology. SmartClean cartridges are designed to combine the AME recording media with a short segment of tape-drive head-cleaning material. The new SmartClean cartridges are easily identified by their cobalt-blue color and are available from in 75m, 150m, and 225m lengths.

Although extensive use is not recommended, the 60/150GB 8MM Internal Tape Drive can write to AME cartridges designed for the first-generation technology tape drives. When these cartridges are used, the 60/150GB 8MM Internal Tape Drive requires regularly scheduled manual cleaning using a cleaning cartridge listed in Table 6 on page 26. Such maintenance is greatly reduced by using only SmartClean media in the 60/150GB 8MM Internal Tape Drive.

Data Cartridge

Use the AME data cartridge for saving or restoring your programs or data.

Large and small labels are shipped with the data cartridge. To avoid problems with loading and unloading a tape, use only the small label on the tape cartridge, as shown in the following illustration. Place the large label on the cartridge container.

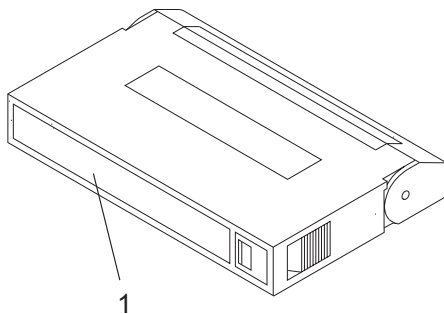

1 Location for small label

Storage and Shipping Environments

Before using a tape cartridge, let it acclimatize to the operating environment by placing the cartridge in the operating environment for as long as it has been away from the environment or for 24 hours, whichever is less. (To determine the appropriate operating environment, see “Tape Drive Environment and Use” on page 3.)

Acclimatization is necessary for any data cartridge exposed to a different humidity environment or to temperature changes of 11°C (20°F) or more.

Retrieval of archived data should be performed on a tape unit that is clean and fully operational. Try to make the recovery environment the same as the operating environment. Allow tapes at least 24 hours to acclimatize to the environment of the tape unit.

The recommended environment for storage and shipment of cartridges is shown in Table 5.

Table 5. Recommended Environment for 8-mm Data Cartridges

Environmental Factor	Storage	Shipping
Temperature	5°C to 32°C (41° to 90°F)	–40 to 52°C (–40 to 125°F)
Relative Humidity (noncondensing)	20 to 60%	5 to 80%
Maximum Wet Bulb	26°C (79°F)	26°C (79°F)

Tape Cartridge Storage

Tape drives record data using densities similar to hard disk drives. Because most computer systems are not located in a dust-free, climate-controlled environment, you must exercise special care when dealing with tape cartridges and tape drives. They must be treated as a valuable asset used to protect your business data.

Use the following guidelines for storing your tape cartridges:

- Temperature and humidity should be kept constant at levels listed in Table 5.
- Tape cartridges should always be stored in their protective cases. The storage case helps prevent damage from dust and physical misuse. When the tape cartridges are not in use or being stored, they should be in their storage cases and stood on edge in a designated storage location. Do not stack cartridges on the flat side or stack other items on top of the tape cartridges. Handle your tape cartridges with care to reduce archival problems.
- Protective cases for tape cartridges should be kept closed except when inserting or removing a cartridge. Contamination can build up and be transferred to the tape cartridge if the protective case is left open.

- Stored tapes should be exercised at least once every 12 months. Run the tape from Beginning of Data (BOD) to End of Data (EOD) and back to BOD at normal operating speeds. Tapes stored in a warmer environment should be exercised more frequently.
- Sunlight can damage the tape and the cartridge shell. Store tape cartridges out of the direct sunlight.

Attention: Operation outside of the recommended environment can result in possible loss of data or failure of the drive.

Operating in Harsh Environments

The 60/150GB 8MM Internal Tape Drive is suited to streaming operations, as opposed to multiple stop-and-start, random-search tape operations. When the tape is used for frequent stop-and-start operations, it is beneficial to still have as much streaming movement as possible. This can be accomplished by ensuring that any save or restore operation is the only active operation being performed.

Do not use any tape for archival purposes if it has been used outside of the ranges specified in Table 5 on page 24 for an extended period of time. The magnetic and physical strength of the tape will have deteriorated as a result of its exposure to the environment. Do not store important data on such a tape; transfer the data to a newer tape for reliable archiving.

Setting the Write-Protect Switch

The position of the write-protect switch on the 8-mm tape cartridge determines when you can write to the tape.

- When the switch is set to the right (REC), data can be written to and read from the tape.
- When the switch is set to the left (SAVE), data can only be read.

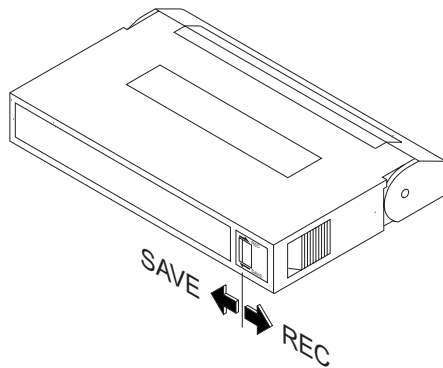

Ordering Tape Cartridges

All tape cartridges are not alike. The tape composition and length, and the construction of the cartridge itself, can all affect the quality and capacity of the recording and the performance of your tape drive. A poor-quality tape cartridge might appear to work adequately in your system, yet it can leave contamination in the tape path or impede the speed of the recording.

Data-grade tape media is the only type of tape media that should be used for backup and data processing. Do not use generic media for data purposes.

Table 6 lists quality tape cartridges that you can order for the 60/150GB 8MM Internal Tape Drive. To order cartridges contact your local provider of storage products. The following table provides you with part numbers of quality tape cartridges that can be purchased from your local provider.

Table 6. Recommended 8-mm Data Cartridges

Part Number	Type of Cartridge	Length
35L1044	20 GB 8-mm AME with SmartClean Data Cartridge	75 m (246 ft)
09L5323	40 GB 8-mm AME with SmartClean Data Cartridge	150 m (492 ft)
18P6484	60 GB 8-mm AME with SmartClean Data Cartridge	225 m (738 ft)
35L1409	8-mm Cleaning Cartridge	

Appendix A. Communications Statements

The following statement applies to this product. The statement for other products intended for use with this product appears in their accompanying documentation.

Federal Communications Commission (FCC) Statement

Note: The 8mm Tape Drive been tested and found to comply with the limits for a Class B digital device, pursuant to Part 15 of the FCC Rules. These limits are designed to provide reasonable protection against harmful interference in a residential installation. This equipment generates, uses, and can radiate radio frequency energy and, if not installed and used in accordance with the instructions, may cause harmful interference to radio communications. However, there is no guarantee that interference will not occur in a particular installation. If this equipment does cause harmful interference to radio or television reception, which can be determined by turning the equipment off and on, the user is encouraged to try to correct the interference by one or more of the following measures:

- Reorient or relocate the receiving antenna.
- Increase the separation between the equipment and receiver.
- Connect the equipment into an outlet on a circuit different from that to which the receiver is connected.
- Consult an authorized dealer or service representative for help.

Properly shielded and grounded cables and connectors must be used in order to meet FCC emission limits. Proper cables and connectors are available from authorized dealers. Neither the provider nor the manufacturer are responsible for any radio or television interference caused by using other than recommended cables and connectors or by unauthorized changes or modifications to this equipment. Unauthorized changes or modifications could void the user's authority to operate the equipment.

This device complies with Part 15 of the FCC Rules. Operation is subject to the following two conditions: (1) this device may not cause harmful interference, and (2) this device must accept any interference received, including interference that may cause undesired operation.

Responsible Party:

- International Business Machines Corporation
- New Orchard Road
- Armonk, New York 10504
- Telephone: (919) 543-2193



European Union (EU) Statement

This product is in conformity with the protection requirements of EU Council Directive 89/336/EEC on the approximation of the laws of the Member States relating to electromagnetic compatibility. The manufacturer cannot accept responsibility for any failure to satisfy the protection requirements resulting from a non-recommended modification of the product, including the fitting of option cards supplied by third parties. Consult with your dealer or sales representative for details on your specific hardware.

This product has been tested and found to comply with the limits for Class B Information Technology Equipment according to CISPR 22 / European Standard EN 55022. The limits for Class B equipment were derived for typical residential environments to provide reasonable protection against interference with licensed communication devices.

International Electrotechnical Commission (IEC) Statement

This product has been designed and built to comply with IEC Standard 950.

United Kingdom Telecommunications Safety Requirements

This equipment is manufactured to the International Safety Standard EN60950 and as such is approved in the UK under the General Approval Number NS/G/1234/J/100003 for indirect connection to the public telecommunication network.

The network adapter interfaces housed within this equipment are approved separately, each one having its own independent approval number. These interface adapters, supplied by the manufacturer, do not use or contain excessive voltages. An excessive voltage is one which exceeds 70.7 V peak ac or 120 V dc. They interface with this equipment using Safe Extra Low Voltages only. In order to maintain the separate (independent) approval of the manufacturer's adapters, it is essential that other optional cards, not supplied by the manufacturer, do not use main voltages or any other excessive voltages. Seek advice from a competent engineer before installing other adapters not supplied by the manufacturer.

Avis de conformité aux normes du ministère des Communications du Canada

Cet appareil numérique de la classe B est conforme à la norme NMB-003 du Canada.

Canadian Department of Communications Compliance Statement

This Class B digital apparatus complies with Canadian ICES-003.

VCCI Statement

この装置は、情報処理装置等電波障害自主規制協議会（VCCI）の基準に基づくクラスB情報技術装置です。この装置は、家庭環境で使用することを目的としていますが、この装置がラジオやテレビジョン受信機に近接して使用されると、受信障害を引き起こすことがあります。
取扱説明書に従って正しい取り扱いをして下さい。

The following is a summary of the VCCI Japanese statement in the box above.

This product is a Class B Information Technology Equipment and conforms to the standards set by the Voluntary Control Council for Interference by Information Technology Equipment (VCCI). This product is aimed to be used in a domestic environment. When used near a radio or TV receiver, it may become the cause of radio interference. Read the instructions for correct handling.

Radio Protection for Germany

Dieses Gerät ist berechtigt in Übereinstimmung mit dem deutschen EMVG vom 9.Nov.92 das EG-Konformitätszeichen zu führen.

Der Aussteller der Konformitätserklärung ist die IBM Germany.

Dieses Gerät erfüllt die Bedingungen der EN 55022 Klasse B.

Appendix B. Notices

This information was developed for products and services offered in the U.S.A.

The manufacturer may not offer the products, services, or features discussed in this document in other countries. Consult the manufacturer's representative for information on the products and services currently available in your area. Any reference to the manufacturer's product, program, or service is not intended to state or imply that only that product, program, or service may be used. Any functionally equivalent product, program, or service that does not infringe any intellectual property right of the manufacturer may be used instead. However, it is the user's responsibility to evaluate and verify the operation of any product, program, or service.

The manufacturer may have patents or pending patent applications covering subject matter described in this document. The furnishing of this document does not give you any license to these patents. You can send license inquiries, in writing, to the manufacturer.

The following paragraph does not apply to the United Kingdom or any country where such provisions are inconsistent with local law: THIS MANUAL IS PROVIDED "AS IS" WITHOUT WARRANTY OF ANY KIND, EITHER EXPRESSED OR IMPLIED, INCLUDING, BUT NOT LIMITED TO, THE IMPLIED WARRANTIES OF NON-INFRINGEMENT, MERCHANTABILITY OR FITNESS FOR A PARTICULAR PURPOSE. Some states do not allow disclaimer of express or implied warranties in certain transactions; therefore, this statement may not apply to you.

This information could include technical inaccuracies or typographical errors. Changes are periodically made to the information herein; these changes will be incorporated in new editions of the publication. The manufacturer may make improvements and/or changes in the product(s) and/or the program(s) described in this publication at any time without notice.

Information concerning products made by other than the manufacturer was obtained from the suppliers of those products, their published announcements, or other publicly available sources. The manufacturer has not tested those products and cannot confirm the accuracy of performance, compatibility or any other claims related to products made by other than the manufacturer. Questions on the capabilities of products made by other than the manufacturer should be addressed to the suppliers of those products.

Appendix C. Fault Symptom Codes and Error Recovery Procedure Numbers

Use Table 7 to resolve error messages that appear on the LCD of the 60/150GB 8MM Internal Tape Drive:

1. Determine the fault symptom code (FSC) in the error message (the first two digits in the message). For example, in error message ERR 1: AD 58 C0, the FSC is AD.
2. Locate the FSC in Table 7 and identify the error recovery procedure (ERP) number for that FSC.
3. Locate the ERP number in Table 8 on page 41, and identify the recommended error recovery procedure.

Note: Abbreviations in the Description column are defined as follows:

EOD End Of Data
EOT End Of Tape
LBOP Logical Beginning Of Partition
LBOT Logical Beginning Of Tape
LEOP Logical End Of Partition
LEOT Logical End Of Tape
PBOP Physical Beginning Of Partition
PBOT Physical Beginning Of Tape
PEOT Physical End Of Tape
PEOP Physical End Of Partition

Note: Items in the Cause column are defined as follows:

A = Application software
 B = Bus (SCSI)
 D = Drive
 I = Informational message
 O = Operator
 S = System
 T = Tape

Table 7. Fault Symptom Codes (FSC) and Error Recovery Procedure (ERP) Numbers

FSC	Description	ERP Number	Cause
02	The tape is at an incorrect position to perform a WRITE operation.	2	O = 50% S = 50%
03	Tape is write protected for the requested WRITE operation.	5	D = 5% O = 90% T = 5%

Table 7. Fault Symptom Codes (FSC) and Error Recovery Procedure (ERP) Numbers (continued)

FSC	Description	ERP Number	Cause
04	An LEOT or LEOP was encountered on the current WRITE operation.	10	I
05	The operation has aborted (as requested).	11	D = 50% O = 50%
06	An LEOT or LEOP was encountered on the last WRITE operation.	10	I
08	The compression data integrity check failed.	12	D = 100%
09	An LEOT or LEOP was detected during a READ operation.	10	I
0A	A length mismatch was encountered on a READ operation.	15	I
0B	An uncorrectable block was encountered on a READ operation.	8,6	D = 10% T = 90%
0C	An EOD mark was encountered on a READ operation.	13	I
0D	A filemark was encountered during a READ or VERIFY operation.	10	I
0E	An illegal condition exists that prohibits a READ or VERIFY operation.	2	D = 50% S = 50%
0F	A READ operation was issued to blank tape.	4	I
10	The READ operation has aborted (as requested).	11	D = 50% O = 50%
11	Too many permanent READ errors occurred. The drive cannot synchronize the data.	8,6	D = 10% T = 90%
14	PEOT or PEOP was encountered on a READ or VERIFY operation.	2,8,6	D = 50% O = 50%
15	An incorrect filemark was encountered during a READ operation.	8,6	T = 100%
16	A media error was detected during a READ operation.	8,6	D = 10% T = 90%
17	A hardware error occurred during a READ operation.	12	D = 100%
18	READ decompression failed — HW error.	12	D = 100%
19	Cyclic Redundancy Check (CRC) failed during the read operation after decompression	12	D = 100%
1C	The tape is in an unknown or incompatible format.	14	T = 100%
1D	A setmark was encountered during a READ or VERIFY operation. A setmark is a location finding mark that is set on the tape.	10	I

Table 7. Fault Symptom Codes (FSC) and Error Recovery Procedure (ERP) Numbers (continued)

FSC	Description	ERP Number	Cause
26	A WRITE FILEMARKS (WFM) command was received when the tape was not at a legal position to write.	2	O = 50% S = 50%
27	The tape is write-protected for WRITE FILEMARKS (WFM).	5	I
28	An LEOT or LEOP was encountered during a WRITE FILEMARKS (WFM).	10	I
31	A setmark was encountered during a SPACE or LOCATE operation.	10	I
32	A filemark was detected during SPACE or LOCATE operation.	10	I
33	An EOD was encountered on a SPACE or LOCATE operation.	10	I
34	A PEOT or PEOP was encountered on a SPACE or LOCATE operation.	8,6	T = 100%
35	A PBOT or PBOP was encountered on a SPACE or LOCATE operation.	2	I
36	A format error occurred during a SPACE or LOCATE operation.	8,6	D = 20% T = 80%
37	An uncorrectable block was encountered during a SPACE or LOCATE operation.	8,6	D = 10% T = 90%
38	A media error occurred during a SPACE or LOCATE operation.	8,6	D = 20% T = 80%
3A	An incorrect filemark was encountered during a SPACE operation.	3	T = 100%
3B	The SPACE/LOCATE operation has aborted (as requested).	11	D = 50% O = 50%
3D	There is no information at this position on tape. The tape drive cannot perform a space operation.	8,6	D = 20% T = 80%
47	An incompatible media cartridge was rejected after loading.	14	O = 90% T = 10%
4B	The tape is at an illegal position for an ERASE operation.	2	O = 50% S = 50%
4C	The tape is write-protected for an ERASE operation.	5	D = 5% O = 90% T = 5%

Table 7. Fault Symptom Codes (FSC) and Error Recovery Procedure (ERP) Numbers (continued)

FSC	Description	ERP Number	Cause
4E	The ERASE operation has aborted (as requested).	11	D = 5% O = 90% S = 5%
58	A hardware error occurred during the SEND DIAGNOSTIC operation.	12	D = 100%
61	The microcode header was not valid when loading firmware.	8,6	T = 100%
63	The CONTROL LOAD image is not valid.	8,6	T = 100%
65	The EEPROM load image is not valid.	8,6	T = 100%
66	The Boot microcode is downlevel.	8,6	T = 100%
67	The drive cannot program one of the memory areas.	12	D = 100%
69	Cyclic Redundancy Check (CRC) in the LOAD IMAGE operation was not correct.	8,6	T = 100%
6D	The READ BUFFER command failed.	12	D = 100%
71	The tape is at an illegal position to format the partition.	2	D = 50% O = 50%
72	The partitions are too big for the tape.	2	O = 100%
74	The partition format of the tape failed.	8,6	T = 100%
75	The partition format was aborted.	8,6	D = 5% O = 90% S = 5%
79	The drive failed to position the tape to a new partition.	8,6	T = 100%
7A	The partition switch operation was aborted.	11	D = 5% O = 90% S = 5%
8C	A controller firmware logic error occurred.	12	D = 100%
8D	The software detected a hardware problem.	12	D = 100%
93	A PEOP was detected.	10	A = 100%
94	The drive failed to perform the WRITE SETMARK operation.	6	T = 100%
95	A WRITE failure occurred after the retry limit was exceeded.	8,6	D = 30% T = 70%
96	A WFM failure occurred after the retry limit was exceeded.	8,6	D = 30% T = 70%

Table 7. Fault Symptom Codes (FSC) and Error Recovery Procedure (ERP) Numbers (continued)

FSC	Description	ERP Number	Cause
97	A WRITE EOD failure occurred after the retry limit was exceeded.	8,6	D = 30% T = 70%
98	The Buffer Record Table (BRT), which is a list of block addresses, contains an incorrect value.	12	D = 100%
99	The buffer is empty, which caused a fill error.	12	D = 100%
9A	A timeout occurred during the search function because the data interpreter did not encounter the required text.	12	D = 100%
9B	The read-back-check operation detected a different block type from what was written (old data is not being fully overwritten).	8,6	D = 50% T = 50%
9C	A formatter interrupt timeout occurred during a WRITE operation.	12	D = 100%
9D	A permanent write error was encountered, causing the write recovery to fail. ¹	8,6	D = 30% T = 70%
9E	The permanent write error rewrite threshold has been reached. ¹	8,6	D = 30% T = 70%
9F	Servo zone read-back-check failure on a write. The servo zone is a written section on the tape that verifies that the tape is correctly aligned with the drive head.	8,6	D = 30% T = 70%
A1	A tape drive head synchronization error occurred during a WRITE operation.	8,6	D = 90% T = 10%
A2	An underrun error occurred during a WRITE operation.	12	D = 100%
A3	An Logical Port write buffer CRC error occurred.	12	D = 100%
A4	A Physical Port WRITE buffer CRC error occurred.	12	D = 100%
A5	Buffer positioning was lost during a WRITE about process.	12	D = 100%
A6	An Logical Port READ buffer CRC error occurred.	12	D = 100%
A7	A Physical Port READ buffer CRC error occurred.	12	D = 100%
A8	A Physical Port parity error occurred.	12	D = 100%
AC	A servo software error occurred.	12	D = 100%
AD	A servo hardware error occurred.	8,6	D = 10% T = 90%
AE	The drive is not tracking correctly.	8,6	D = 40% T = 60%
AF	An PEOT or PEOP was encountered during a motion command	2	D = 100%

Table 7. Fault Symptom Codes (FSC) and Error Recovery Procedure (ERP) Numbers (continued)

FSC	Description	ERP Number	Cause
B0	The drive is not tracking — the tape is damaged.	8,6	D = 40% T = 60%
B3	A LBOT or LBOP WRITE failure occurred	8,6	D = 30% T = 70%
B4	A LBOT failure occurred.	8,6	D = 30% T = 70%
B5	The read manager could not read the LBOT or LBOP.	8,6	D = 30% T = 70%
B6	And End Of Tape (EOT) mark was encountered when the buffer was being emptied.	2	I
C0	A power-on reset occurred.	3	I
C1	The tape may have been changed.	3	I
C2	The MODE SELECT parameters have changed.	3	I
C3	New microcode was loaded.	3	I
C4	The operator requested media removal.	11	I
C5	An incompatible media that was inserted was rejected.	14	I
C6	The drive is not ready, the cause is not known.	7,3	I
C7	The drive is not ready, but it is in process of becoming ready.	3	I
C8	A backup positioning command is required.	2	I
C9	The specified command requires a tape and none is loaded.	7,3	I
CA	The log threshold was met.	3	I
CB	The log Parameter was changed.	3	I
CC	The length of the parameter has caused an error in Command Descriptor Block (CDB).	2	D = 50% S = 50%
CD	An illegal Operation Code was used.	2	D = 50% S = 50%
CE	An incorrect field or reserved bits were set in the CDB.	2	D = 50% S = 50%
CF	This Logical Unit (LUN) is not supported.	2	D = 50% S = 50%
D0	An incorrect field exists in the Parameter List (Mode Data).	2	D = 50% S = 50%

Table 7. Fault Symptom Codes (FSC) and Error Recovery Procedure (ERP) Numbers (continued)

FSC	Description	ERP Number	Cause
D1	An illegal bit is set in the identify message.	2	D = 50% S = 50%
D2	Media removal is prevented.	2	D = 50% S = 50%
D3	The command issued has a mode mismatch (variable/fixed).	2	D = 50% S = 50%
D4	An illegal Transfer Length in was encountered in the CDB.	2	D = 50% S = 50%
D6	Could not change the MODE SELECT parameters since the tape was not at Logical Beginning Of Tape (LBOT) (or Logical Beginning Of Partition (LBOP)).	2	D = 50% S = 50%
D7	The drive cannot read the media because it is in an incompatible format.	14	D = 50% S = 50%
D8	The commands overlapped and caused a bad Initiator-Target-Logical Unit (ITL) connection.	2	D = 50% S = 50%
DA	Illegal bits were set in an ID message.	2	D = 50% S = 50%
DB	The drive cannot write to tape because the cartridge is not AME format.	14	I
DC	A parameter was out of range in the last LOG SELECT or MODE SELECT command. The parameter was rounded to a valid value and the operation was completed.	7	T = 100%
DD	The drive is not ready. The head cannot locate the file marks on the tape.	2	D = 50% S = 50%
DF	A host error exists in the message system.	10	I
DE	The density specified is not supported.	2	D = 50% S = 50%
E0	The command was aborted in the Command Descriptor Block (CDB) phase (because of a parity or other error), or a reconnect attempt failed after the allowed number of retries.	12	B = 100%
E1	The operation was aborted prior to the Data phase because of an incorrect message.	12	B = 100%
E2	The operation was aborted in the Data phase because of an initialize error was detected.	12	B = 100%

Table 7. Fault Symptom Codes (FSC) and Error Recovery Procedure (ERP) Numbers (continued)

FSC	Description	ERP Number	Cause
E3	The operation was aborted in the Data phase because of an incorrect message.	12	B = 100%
E4	The operation was aborted after the Data phase because of an incorrect message.	12	B = 100%
E5	The operation was aborted after the Data phase because of an unspecified error.	12	B = 100%
E6	An ABORT operation occurred which was caused by a SCSI Bus Parity Error.	12	B = 100%
E7	An ABORT operation sent by the initiator has been completed.	12	B = 100%
E8	The drive needs cleaning.	1	I
E9	Cleaning has occurred.	10	I
EA	An incorrect mode was specified for data compression.	2	D = 50% S = 50%
EB	Download in progress.	3	D = 50% S = 50%
EC	Log parameter overflow (recovered error).	10	I
ED	The tape history log indicates a worn tape; replace the tape.	6	T=100%
EE	Service may be required.	12	D = 90% T = 10%
F0	Tape alert async notification test.	10	I
F1	Tape alert async notification.	10	I
FA	The serial number is incorrect or blank.	12	D = 100%
FC	The head synchronization value in the EEPROM is out of range.	12	D = 100%
FD	The EEPROM contains meaningless information.	12	D = 100%

¹ If the read-back-check criteria are not met for a data or short filemark block (that is, if the block is not perfect), the block is rewritten. If rewrite activity is excessive, the tape drive moves the tape backward, reads the tape to verify that blocks are written, and then moves the tape backward again. It then performs a write splice operation and rewrites the blocks. If the rewrite threshold is exceeded for any block, the tape drive returns Check Condition status with the sense key set to Medium Error (3h) and the FSC set to 9Eh. If the recovery splice operation cannot be completed, the FSC is 9Dh.

Appendix D. Error Recovery Procedures

Use Table 8 to resolve error messages that appear on the LCD of the 60/150GB 8MM Internal Tape Drive:

1. Determine the fault symptom code (FSC) in the error message (the first two digits in the message). For example, in error message ERR 1: AD 58 C0, the FSC is AD.
2. Locate the FSC in Table 7 on page 33 and identify the error recovery procedure (ERP) number for that FSC.
3. Locate the ERP number in Table 8, and identify the recommended error recovery procedure. If two or more ERP codes are listed for the fault symptom code in Table 7 on page 33, perform the action for the first code, then perform the action for the second code, and so on.

Table 8. Error Recovery Procedures

ERP Number	Recommended Error Recovery Procedure
1	Warning Message, clean drive.
2	Application program error or user error using application. Retry operation. If this problem continues, notify application provider.
3	Reissue the failed command or command sequence.
4	Application attempted to read a blank tape. Either write to the tape or replace the tape with a tape containing data.
5	Tape is write protected and a write or erase was attempted. Either write-enable the tape or insert a write-enabled tape.
6	Perform the following until the operation can be completed: <ol style="list-style-type: none"> 1. Clean the drive 2. Retry the operation 3. Clean the drive 4. Replace the tape cartridge 5. If the error persists and there is an error in the system error log, call your service representative
7	Insert a data cartridge into the tape drive.
8	Perform one of the following actions: <ul style="list-style-type: none"> • Reset the tape drive by holding down the unload button until the RESET message appears; then release the button. • Send a SCSI bus reset (a hard reset).
9	Clean the tape drive and repeat the operation.
10	No action is necessary.
11	User has pushed the unload button. No action is required; the tape drive performed the requested operation.
12	The tape drive requires maintenance.
13	The tape drive has encountered the end of the media on a read or write operation. Mount the next tape and continue the tape operation.
14	The media type is not supported. Clean the drive and retry the operation with supported media.

Table 8. Error Recovery Procedures (continued)

ERP Number	Recommended Error Recovery Procedure
15	The block size requested on the read operation does not match the block size that the tape was written at. Change the application's block size.

Part Number: 00P5088

Printed in U.S.A.

SA23-1282-01



(1P) P/N: 00P5088

